

# MARKS PUBLISHED FOR OPPOSITION

The following marks are published in compliance with section 12(a) of the Trademark Act of 1946. Applications for the registration of marks in more than one class have been filed as provided in section 30 of said act as amended by Public Law 772, 87th Congress, approved Oct. 9, 1962, 76 Stat. 769. Opposition under section 13 may be filed within thirty days of the date of this publication. See rules 2.101 to 2.105.

A separate fee of three hundred dollars (\$300.00) for opposing each mark in each class must accompany the opposition.

## SECTION 1.— INTERNATIONAL CLASSIFICATION

The short titles associated below with the international class numbers are terms designed merely for quick identification and are not an official part of the international classification. The full names of international classes are given in section 6.1 of the trademark rules of practice.

The designation "U.S. Cl." appearing in this section refers to the U.S. class in effect prior to Sep. 1, 1973 rather than the international class which applies to applications filed on or after that date. For adoption of international classification see notice in the OFFICIAL GAZETTE of Jun. 26, 1973 (911 O.G. TM 210).

### Application in more than one class

SN 76-472,384. PITONYAK MACHINERY CORPORATION,  
CARLISLE, AR. FILED 12-4-2002.

**BRANDT**

SEC. 2(F).

#### CLASS 7—MACHINERY

FOR AGRICULTURAL MACHINES, NAMELY, LAND LEVELERS, LOADER FORKS FOR AGRICULTURAL TRACTORS, UTILITY LAND LEVELERS, BOX SCRAPERS, HEAVY DUTY STUBBLE ROLLERS, HYDRAULIC FOLDING FIELD ROLLERS, HIPPER ROLLERS (U.S. CLS. 13, 19, 21, 23, 31, 34 AND 35).  
FIRST USE 0-0-1913; IN COMMERCE 0-0-1945.

#### CLASS 12—VEHICLES

FOR AGRICULTURAL TRACTOR-TOWED NON-MOTORIZED GRAIN CARTS; QUICK HITCHES FOR TRACTORS; PERSONNEL WORK PLATFORMS FOR FORKLIFTS (U.S. CLS. 19, 21, 23, 31, 35 AND 44).  
FIRST USE 0-0-1913; IN COMMERCE 0-0-1945.  
WILLIAM VERHOSEK, EXAMINING ATTORNEY

SN 76-701,074. HOWARD BERGER CO., INC., CRANBURY,  
NJ. FILED 1-4-2010.

**BRIGHT-WAY**

THE MARK CONSISTS OF STANDARD CHARACTERS WITHOUT CLAIM TO ANY PARTICULAR FONT, STYLE, SIZE, OR COLOR.

#### CLASS 9—ELECTRICAL AND SCIENTIFIC APPARATUS

FOR ADAPTER PLUGS; ELECTRIC PLUGS; ELECTRIC SOCKETS; ELECTRIC SWITCH PLATES; ELECTRIC SWITCHES; ELECTRICAL OUTLET PLATES; ELECTRICAL POWER EXTENSION CORDS; VOLTAGE SURGE PROTECTORS; AND SAFETY CONTACT PLUGS (U.S. CLS. 21, 23, 26, 36 AND 38).  
FIRST USE 12-31-2006; IN COMMERCE 12-31-2006.

#### CLASS 11—ENVIRONMENTAL CONTROL APPARATUS

FOR FLUORESCENT ELECTRIC LIGHT BULBS; HALOGEN LIGHT BULBS, AND INCANDESCENT LIGHT BULBS (U.S. CLS. 13, 21, 23, 31 AND 34).  
FIRST USE 12-31-2006; IN COMMERCE 12-31-2006.  
KATHERINE M. DUBRAY, EXAMINING ATTORNEY

SN 76-701,257. MICHIGAN STATE MEDICAL SOCIETY,  
EAST LANSING, MI. FILED 1-19-2010.



NO CLAIM IS MADE TO THE EXCLUSIVE RIGHT TO USE "MEDICAL SOCIETY" AND THE STAFF OF AESCULAPIUS, APART FROM THE MARK AS SHOWN.  
SEC. 2(F).

**CLASS 16—PAPER GOODS AND PRINTED MATTER**

FOR PERIODICALS, NAMELY, A PROFESSIONAL MEDICAL JOURNAL (U.S. CLS. 2, 5, 22, 23, 29, 37, 38 AND 50).

FIRST USE 1-1-1866; IN COMMERCE 1-1-1866.

**CLASS 35—ADVERTISING AND BUSINESS**

FOR PROMOTING PUBLIC AWARENESS OF THE NEED FOR THE SCIENCE, ART AND PRACTICE OF MEDICINE (U.S. CLS. 100, 101 AND 102).

FIRST USE 1-1-1866; IN COMMERCE 1-1-1866.

**CLASS 44—MEDICAL, BEAUTY AND AGRICULTURAL SERVICES**

FOR PROVIDING INFORMATION IN THE FIELD OF MEDICINE, NAMELY, THE NEEDS OF THE PUBLIC FOR MEDICAL SERVICES (U.S. CLS. 100 AND 101).

FIRST USE 1-1-1866; IN COMMERCE 1-1-1866.

**CLASS 200—COLLECTIVE MEMBERSHIP**

FOR INDICATING MEMBERSHIP IN A PROFESSIONAL ORGANIZATION OF PHYSICIANS AND MEDICAL PRACTITIONERS IN THE STATE OF MICHIGAN.

FIRST USE 1-1-1866; IN COMMERCE 1-1-1866.

ANNE E. GUSTASON, EXAMINING ATTORNEY

---

SN 76-702,524. EVRI INC., SEATTLE, WA. FILED 4-16-2010.

**FUEL YOUR FASCINATION**

THE MARK CONSISTS OF STANDARD CHARACTERS WITHOUT CLAIM TO ANY PARTICULAR FONT, STYLE, SIZE, OR COLOR.

**CLASS 9—ELECTRICAL AND SCIENTIFIC APPARATUS**

FOR COMPUTER SOFTWARE FOR ACCESSING POPULAR CULTURE TOPICS VIA THE INTERNET WHICH IS DERIVED FROM A SOFTWARE SEARCH TOOL SERVICE FOR COLLECTING AND CORRELATING INFORMATION REGARDING A SEARCH SUBJECT (U.S. CLS. 21, 23, 26, 36 AND 38).

**CLASS 42—SCIENTIFIC AND COMPUTER SERVICES**

FOR SOFTWARE SEARCH TOOL SERVICE, NAMELY, PROVIDING INTERNET SEARCH ENGINES AND PROVIDING TEMPORARY USE OF NON-DOWNLOADABLE COMPUTER SOFTWARE FOR COLLECTING AND CORRELATING INFORMATION REGARDING POPULAR CULTURE TOPICS (U.S. CLS. 100 AND 101).

TINA BROWN, EXAMINING ATTORNEY

SN 76-702,758. FRANK'S CASING CREW & RENTAL TOOLS, INC., LAFAYETTE, LA. FILED 5-3-2010.

**C.M.A.R.T.****CLASS 7—MACHINERY**

FOR POWER OPERATED TOOLS AND MACHINE TOOLS, NAMELY, CASING MAKE-UP AND RUNNING TOOLS FOR USE IN THE OIL AND GAS EXPLORATION AND PRODUCTION INDUSTRY FOR FACILITATING THE MAKE-UP, INSERTION, INSTALLATION, REMOVAL, BREAK-OUT, RUNNING, PULLING, PICK-UP, LAY DOWN, TRIPPING, DRIVING, JETTING, DRILLING, OR ROTATING OF STRINGS OF TUBULARS IN THE NATURE OF DRILL PIPE, CASING, TUBING, AND LANDING STRINGS (U.S. CLS. 13, 19, 21, 23, 31, 34 AND 35).

**CLASS 8—HAND TOOLS**

FOR HAND OPERATED TOOLS, NAMELY, CASING MAKE-UP AND RUNNING TOOLS FOR USE IN THE OIL AND GAS EXPLORATION AND PRODUCTION INDUSTRY FOR FACILITATING THE MAKE-UP, INSERTION, INSTALLATION, REMOVAL, BREAK-OUT, RUNNING, PULLING, PICK-UP, LAY DOWN, TRIPPING, DRIVING, JETTING, DRILLING, OR ROTATING OF STRINGS OF TUBULARS IN THE NATURE OF DRILL PIPE, CASING, TUBING, AND LANDING STRINGS (U.S. CLS. 23, 28 AND 44).

TRACY FLETCHER, EXAMINING ATTORNEY

---

SN 76-702,772. UNITED ROYAL LINEN, INC., BROOKLYN, NY. FILED 5-3-2010.

**VIGHANO**

THE MARK CONSISTS OF STANDARD CHARACTERS WITHOUT CLAIM TO ANY PARTICULAR FONT, STYLE, SIZE, OR COLOR.

THE WORDING "VIGHANO" HAS NO MEANING IN A FOREIGN LANGUAGE.

**CLASS 20—FURNITURE AND ARTICLES NOT OTHERWISE CLASSIFIED**

FOR KITCHEN PRODUCTS, NAMELY, SEAT CUSHIONS (U.S. CLS. 2, 13, 22, 25, 32 AND 50).

FIRST USE 4-0-2007; IN COMMERCE 4-0-2007.

**CLASS 21—HOUSEWARES AND GLASS**

FOR BATHROOM PRODUCTS, NAMELY, WASTE BASKETS, TOOTHBRUSH HOLDERS, CUPS, SOAP DISHES, SOAP DISPENSERS; CERAMIC TISSUE BOX COVERS (U.S. CLS. 2, 13, 23, 29, 30, 33, 40 AND 50).

FIRST USE 4-0-2007; IN COMMERCE 4-0-2007.

**CLASS 24—FABRICS**

FOR LINENS, CURTAINS, BEDSPREADS, TEXTILE TABLECLOTHS, TOWELS; BATH ACCESSORIES, NAMELY, BATH MITTS; KITCHEN PRODUCTS, NAMELY, OVEN MITTS, TEXTILE NAPKINS, KITCHEN CURTAINS; BATHROOM PRODUCTS, NAMELY, SHOWER CURTAINS, BATHROOM CURTAINS, AND TOILET SEAT COVERS OF TEXTILE (U.S. CLS. 42 AND 50).

FIRST USE 1-0-2008; IN COMMERCE 1-0-2008.

**CLASS 27—FLOOR COVERINGS**

FOR BATHROOM PRODUCTS, NAMELY, FLOOR MATS (U.S. CLS. 19, 20, 37, 42 AND 50).

FIRST USE 4-0-2007; IN COMMERCE 4-0-2007.  
TASNEEM HUSSAIN, EXAMINING ATTORNEY

SN 76-703,132. LONESTAR SOCCER CLUB OF AUSTIN, INC., AUSTIN, TX. FILED 5-27-2010.



NO CLAIM IS MADE TO THE EXCLUSIVE RIGHT TO USE DESIGN OF THE OUTLINE OF THE STATE OF TEXAS, APART FROM THE MARK AS SHOWN.

THE MARK CONSISTS OF A FIVE-SIDED DESIGN DIVIDED INTO THREE SECTIONS BY A LINE, WITH A SOCCER BALL IN THE UPPER RIGHT PORTION FEATURING A DESIGN OF THE OUTLINE OF THE STATE OF TEXAS, WITH A STAR IN THE LEFT PORTION, AND A BLANK LOWER PORTION.

SN 76-703,087. CARROLL HALL SHELBY TRUST, LOS ANGELES, CA. FILED 5-24-2010.

**SHELBY THE SNAKE**

THE MARK CONSISTS OF STANDARD CHARACTERS WITHOUT CLAIM TO ANY PARTICULAR FONT, STYLE, SIZE, OR COLOR.

OWNER OF U.S. REG. NOS. 1,538,090, 1,768,020 AND OTHERS.

THE NAME "SHELBY" IDENTIFIES "CARROLL HALL SHELBY" A LIVING INDIVIDUAL WHOSE CONSENT IS OF RECORD.

**CLASS 36—INSURANCE AND FINANCIAL**

FOR CHARITABLE FUNDRAISING (U.S. CLS. 100, 101 AND 102).

FIRST USE 4-0-2004; IN COMMERCE 4-0-2004.

**CLASS 41—EDUCATION AND ENTERTAINMENT**

FOR YOUTH SPORT SERVICES IN THE NATURE OF SOCCER GAMES AND SOCCER TRAINING CAMPS; ENTERTAINMENT IN THE NATURE OF SOCCER GAMES AND SOCCER TRAINING CAMPS (U.S. CLS. 100, 101 AND 107).

FIRST USE 4-0-2004; IN COMMERCE 4-0-2004.  
LAURA HAMMEL, EXAMINING ATTORNEY

**CLASS 7—MACHINERY**

FOR VEHICLE PARTS, NAMELY, ALTERNATORS, CAM SHAFTS, ENGINE CYLINDERS, GENERATORS FOR LAND VEHICLES, CARBURETORS, AND INTAKE MANIFOLDS; VEHICLE ENGINE PARTS, NAMELY, EXHAUST HEADERS, RADIATORS, ENGINE CRANK-CASE BREATHERS, ENGINE OIL COOLERS, ENGINE PUSH RODS, ENGINE ROCKER ARMS, ENGINE CAM COVERS (U.S. CLS. 13, 19, 21, 23, 31, 34 AND 35).

SN 76-703,386. ROLLS-ROYCE PLC, LONDON, SW1E 6AT, ENGLAND, FILED 6-15-2010.

**ROLLS-ROYCE****CLASS 12—VEHICLES**

FOR AUTOMOBILES, LAND VEHICLES, ENGINES FOR LAND VEHICLES, WHEELS AND RIMS FOR VEHICLES (U.S. CLS. 19, 21, 23, 31, 35 AND 44).

THE MARK CONSISTS OF STANDARD CHARACTERS WITHOUT CLAIM TO ANY PARTICULAR FONT, STYLE, SIZE, OR COLOR.

OWNER OF U.S. REG. NOS. 325,316, 912,848 AND OTHERS.

**CLASS 25—CLOTHING**

FOR CLOTHING, NAMELY, JACKETS, CAPS, BELTS, SHIRTS, GOLF SHIRTS, HEAVY JACKETS, HOODS, JEANS, JERSEYS, LEATHER JACKETS, POLO SHIRTS, RAIN JACKETS, SHORT-SLEEVED SHIRTS, LONG SLEEVE SHIRTS, SKI JACKETS, AND TIES (U.S. CLS. 22 AND 39).

**CLASS 35—ADVERTISING AND BUSINESS**

FOR CLUB SERVICES, NAMELY, PROMOTING THE INTERESTS OF MOTOR CAR ENTHUSIASTS; ADVERTISING SERVICES (U.S. CLS. 100, 101 AND 102).

FIRST USE 9-25-1997; IN COMMERCE 9-25-1997.

**CLASS 28—TOYS AND SPORTING GOODS**

FOR TOY MODEL CARS, INCLUDING DIE-CAST METAL CARS; PLAY MOTOR CARS; RADIO CONTROL MODEL VEHICLES; AND TOY MODEL HOBBYCRAFT KITS (U.S. CLS. 22, 23, 38 AND 50).

MYRIAH HABEEB, EXAMINING ATTORNEY

**CLASS 37—CONSTRUCTION AND REPAIR**

FOR TECHNICAL ADVISORY SERVICES IN THE FIELD OF MAINTENANCE AND REPAIR OF MOTOR CARS (U.S. CLS. 100, 103 AND 106).

FIRST USE 9-25-1997; IN COMMERCE 9-25-1997.

**CLASS 41—EDUCATION AND ENTERTAINMENT**

FOR EDUCATIONAL SERVICES, NAMELY, CONDUCTING DISCUSSION FORUMS AND PROVIDING COURSES OFFERING TECHNICAL INFORMATION IN THE FIELD OF MAINTENANCE AND REPAIR OF MOTOR CARS; MUSEUM SERVICES; LIBRARY SERVICES; SERVICES OF A MOTOR CAR CLUB, NAMELY, ORGANIZING AND CONDUCTING MEETINGS AND EVENTS OF A SOCIAL NATURE (U.S. CLS. 100, 101 AND 107).

FIRST USE 9-25-1997; IN COMMERCE 9-25-1997.

**CLASS 43—HOTEL AND RESTAURANT SERVICES**

FOR RESERVATION OF TOURIST ACCOMMODATION, NAMELY, ARRANGING TEMPORARY HOUSING ACCOMMODATION (U.S. CLS. 100 AND 101).

FIRST USE 9-25-1997; IN COMMERCE 9-25-1997.  
ALLISON SCHRODY, EXAMINING ATTORNEY

SN 76-703,387. MERINSKY, SHAYLA, SWARTZ CREEK, MI.  
FILED 6-15-2010.

# SAVINGS MANIA

THE MARK CONSISTS OF STANDARD CHARACTERS WITHOUT CLAIM TO ANY PARTICULAR FONT, STYLE, SIZE, OR COLOR.

NO CLAIM IS MADE TO THE EXCLUSIVE RIGHT TO USE "SAVINGS", APART FROM THE MARK AS SHOWN.

**CLASS 35—ADVERTISING AND BUSINESS**

FOR A PERSONAL SAVINGS CLUB THAT PROMOTES THE GOODS AND SERVICES OF OTHERS BY PROVIDING INFORMATION ABOUT COUPON SHOPPING AND BY PROVIDING A WEB SITE FEATURING COUPONS, STORE INFORMATION, NAMELY, LINKS TO RETAIL WEBSITES OF OTHERS, REBATES, VOUCHERS, AND DISCOUNT INFORMATION (U.S. CLS. 100, 101 AND 102).

**CLASS 41—EDUCATION AND ENTERTAINMENT**

FOR PROVIDING CLASSES AND DISTRIBUTING COURSE PACKETS THEREWITH TO TEACH THE ART OF COUPON SHOPPING (U.S. CLS. 100, 101 AND 107).

ALLISON SCHRODY, EXAMINING ATTORNEY

SN 76-703,455. ASD SPECIALTY HEALTHCARE, INC.,  
FRISCO, TX. FILED 6-21-2010.

# ION

THE MARK CONSISTS OF STANDARD CHARACTERS WITHOUT CLAIM TO ANY PARTICULAR FONT, STYLE, SIZE, OR COLOR.

**CLASS 9—ELECTRICAL AND SCIENTIFIC APPARATUS**

FOR DOWNLOADABLE ELECTRONIC PUBLICATIONS IN THE FIELD OF ONCOLOGY, NAMELY, PERIODICAL MAGAZINES AND NEWSLETTERS FEATURING ARTICLES ABOUT CANCER TREATMENTS, AND FEATURING BUSINESS AND INDUSTRY NEWS OF INTEREST IN THE OPERATION OF ONCOLOGY PRACTICES (U.S. CLS. 21, 23, 26, 36 AND 38).

FIRST USE 8-31-2005; IN COMMERCE 8-31-2005.

**CLASS 16—PAPER GOODS AND PRINTED MATTER**

FOR PUBLICATIONS IN THE FIELD OF ONCOLOGY, NAMELY, PERIODICAL MAGAZINES AND NEWSLETTERS IN PRINT FORM FEATURING ARTICLES ABOUT CANCER TREATMENTS, AND FEATURING BUSINESS AND INDUSTRY NEWS OF INTEREST IN THE OPERATION OF ONCOLOGY PRACTICES (U.S. CLS. 2, 5, 22, 23, 29, 37, 38 AND 50).

FIRST USE 12-31-1998; IN COMMERCE 12-31-1998.

**CLASS 35—ADVERTISING AND BUSINESS**

FOR HEALTHCARE COST CONTAINMENT SERVICES IN THE FIELD OF ONCOLOGY, NAMELY, PROVIDING GROUP PURCHASING OF PHARMACEUTICALS AND CHEMOTHERAPEUTICS FOR COMMUNITY-BASED ONCOLOGISTS AND ONCOLOGY PRACTICES; CONSULTATION SERVICES IN THE FIELD OF REIMBURSEMENT FOR MEDICAL SERVICES RENDERED (U.S. CLS. 100, 101 AND 102).

FIRST USE 12-31-1998; IN COMMERCE 12-31-1998.

**CLASS 41—EDUCATION AND ENTERTAINMENT**

FOR EDUCATIONAL SERVICES IN THE FIELD OF ONCOLOGY, NAMELY, PROVIDING WEB-BASED AND LIVE CLASSES, SEMINARS AND WORKSHOPS, TO HEALTHCARE PROVIDERS; NON-DOWNLOADABLE ELECTRONIC PUBLICATIONS IN THE FIELD OF ONCOLOGY, NAMELY, PERIODICAL MAGAZINES AND NEWSLETTERS FEATURING ARTICLES ABOUT CANCER TREATMENTS, AND FEATURING BUSINESS AND INDUSTRY NEWS OF INTEREST IN THE OPERATION OF ONCOLOGY PRACTICES; AND EDUCATIONAL SERVICES, NAMELY, PROVIDING ONLINE AND LIVE TUTORIAL SESSIONS IN THE FIELD OF PATIENT CARE AND OFFICE PRACTICES (U.S. CLS. 100, 101 AND 107).

FIRST USE 12-31-1998; IN COMMERCE 12-31-1998.

AISHA SALEM, EXAMINING ATTORNEY

SN 76-703,469. FAIRFIELD TERCHNOLOGIES, INC., CHANTILLY, VA. FILED 6-22-2010.

CUSTOMER-FOCUSED, RESULTS-DRIVEN

THE MARK CONSISTS OF STANDARD CHARACTERS WITHOUT CLAIM TO ANY PARTICULAR FONT, STYLE, SIZE, OR COLOR.

**CLASS 35—ADVERTISING AND BUSINESS**

FOR BUSINESS MANAGEMENT CONSULTING, BUSINESS OPERATION AND MANAGEMENT ADVISORY SERVICES (U.S. CLS. 100, 101 AND 102).

FIRST USE 7-22-2003; IN COMMERCE 7-22-2003.

**CLASS 42—SCIENTIFIC AND COMPUTER SERVICES**

FOR INFORMATION TECHNOLOGY AND IT MANAGEMENT CONSULTING AND ADVISORY SERVICES, SPECIFICALLY SOFTWARE SPECIFICATION, DESIGN, PROGRAMMING, SUPPORT, OPERATIONS, MAINTENANCE, AND TROUBLESHOOTING OF COMPUTER SOFTWARE PROBLEMS (U.S. CLS. 100 AND 101).  
FIRST USE 7-22-2003; IN COMMERCE 7-22-2003.  
DOMINIC FATHY, EXAMINING ATTORNEY

SN 76-704,242. PROCURA, LLC, SAN DIMAS, CA. FILED 8-25-2010.

# HSA PROTRAK

THE MARK CONSISTS OF STANDARD CHARACTERS WITHOUT CLAIM TO ANY PARTICULAR FONT, STYLE, SIZE, OR COLOR.

NO CLAIM IS MADE TO THE EXCLUSIVE RIGHT TO USE "HSA", APART FROM THE MARK AS SHOWN.

**CLASS 36—INSURANCE AND FINANCIAL**

FOR FINANCIAL SERVICES, NAMELY, ADMINISTERING THE PAYMENT OF MEDICAL EXPENSES FROM HEALTH SAVINGS ACCOUNTS; FINANCIAL SERVICES, NAMELY, PROVIDING ONLINE ACCESS TO HEALTH SAVINGS ACCOUNT INFORMATION IN THE NATURE OF TRACKING AND REPORTING SERVICES FOR CONTRIBUTIONS TO AND EXPENDITURES FROM HEALTH SAVINGS ACCOUNTS; MANUAL ENTRY OF DATA FOR REPORTING EXPENDITURES FROM HEALTH SAVINGS ACCOUNTS; ONLINE PAYROLL DEDUCTION AND REIMBURSEMENT FOR HEALTH SAVINGS ACCOUNT TRANSACTIONS; SWEEPING FUNDS FROM A HEALTH SAVINGS ACCOUNT TO A DEMAND DEPOSIT ACCOUNT (U.S. CLS. 100, 101 AND 102).

FIRST USE 10-1-2009; IN COMMERCE 10-1-2009.

**CLASS 39—TRANSPORTATION AND STORAGE**

FOR ELECTRONIC STORAGE OF IMAGES OF RECEIPT FOR HEALTH SAVINGS ACCOUNT TRANSACTIONS (U.S. CLS. 100 AND 105).

FIRST USE 10-1-2009; IN COMMERCE 10-1-2009.  
JULIE GUTTADAURO, EXAMINING ATTORNEY

SN 76-704,275. P.A. CHA-FONG & ASSOCIATES, PEMBROKE PINES, FL. FILED 8-27-2010.

# MRS. CHRIS

THE MARK CONSISTS OF STANDARD CHARACTERS WITHOUT CLAIM TO ANY PARTICULAR FONT, STYLE, SIZE, OR COLOR.

THE NAME "MRS. CHRIS" DOES NOT IDENTIFY ANY PARTICULAR LIVING INDIVIDUAL.

**CLASS 29—MEATS AND PROCESSED FOODS**

FOR JAMS; JELLIES; CANNED FRUITS; CANNED VEGETABLES; DRIED FRUIT; PROCESSED EDIBLE ROOTS (U.S. CL. 46).

FIRST USE 0-0-1998; IN COMMERCE 0-0-1998.

**CLASS 30—STAPLE FOODS**

FOR SAUCES; SPICES; PROCESSED HERBS; BREAKFAST CEREALS (U.S. CL. 46).  
FIRST USE 0-0-1998; IN COMMERCE 0-0-1998.

**CLASS 32—LIGHT BEVERAGES**

FOR SOFT DRINKS; FRUIT DRINKS; COCONUT MILK (U.S. CLS. 45, 46 AND 48).  
FIRST USE 0-0-1998; IN COMMERCE 0-0-1998.  
EDWARD FENNESSY, EXAMINING ATTORNEY

SN 76-704,710. P.A. CHA-FONG & ASSOCIATES, PEMBROKE PINES, FL. FILED 9-29-2010.



NO CLAIM IS MADE TO THE EXCLUSIVE RIGHT TO USE THE REPRESENTATION OF AFRICA AND "BRAND", APART FROM THE MARK AS SHOWN.

THE COLOR(S) RED, ORANGE, GREEN, GOLD AND BLACK IS/ARE CLAIMED AS A FEATURE OF THE MARK.

THE MARK CONSISTS OF THE WORDS "LION OF JUDAH BRAND" IN A STYLIZED BLACK FONT BENEATH AN ORANGE CIRCLE TRIMMED IN RED AND GREEN INSIDE OF WHICH APPEARS BLACK SHADING ON WHICH APPEARS A GREEN, ORANGE AND RED REPRESENTATION OF THE CONTINENT OF AFRICA WITH A GOLD HERALDIC LION WEARING A GOLD CROWN BEARING A GOLD SPEAR WITH A RED, ORANGE AND GREEN PENNANT.

**CLASS 32—LIGHT BEVERAGES**

FOR SOFT DRINKS; FRUIT DRINKS; COCONUT MILK (U.S. CLS. 45, 46 AND 48).  
FIRST USE 11-21-1989; IN COMMERCE 11-21-1989.

**CLASS 34—SMOKERS' ARTICLES**

FOR CIGARETTE PAPER (U.S. CLS. 2, 8, 9 AND 17).  
FIRST USE 11-21-1989; IN COMMERCE 11-21-1989.  
EDWARD FENNESSY, EXAMINING ATTORNEY

SN 76-705,779. HARTZ MOUNTAIN INDUSTRIES, INC., SECAUCUS, NJ. FILED 12-23-2010.

# HARTZ MOUNTAIN

THE MARK CONSISTS OF STANDARD CHARACTERS WITHOUT CLAIM TO ANY PARTICULAR FONT, STYLE, SIZE, OR COLOR.

OWNER OF U.S. REG. NO. 2,524,782.

**CLASS 36—INSURANCE AND FINANCIAL**

FOR MANAGEMENT AND LEASING OF COMMERCIAL, INDUSTRIAL, RESIDENTIAL AND RETAIL STORE PROPERTIES (U.S. CLS. 100, 101 AND 102).  
FIRST USE 0-0-1969; IN COMMERCE 0-0-1969.

SN 76-706,146. FLOORTEX EUROPE LIMITED, GLOUCESTERSHIRE GL20 8DN, UNITED KINGDOM, FILED 1-26-2011.

**CLASS 37—CONSTRUCTION AND REPAIR**

FOR DEVELOPMENT OF COMMERCIAL, INDUSTRIAL, RESIDENTIAL AND RETAIL STORE PROPERTIES (U.S. CLS. 100, 103 AND 106).  
FIRST USE 0-0-1969; IN COMMERCE 0-0-1969.  
DANIEL CAPSHAW, EXAMINING ATTORNEY

# ECOTEX

THE MARK CONSISTS OF STANDARD CHARACTERS WITHOUT CLAIM TO ANY PARTICULAR FONT, STYLE, SIZE, OR COLOR.

SN 76-705,895. FLOORTEX EUROPE LIMITED, GLOUCESTERSHIRE, UNITED KINGDOM, FILED 1-4-2011.

# FLOORTEX

**CLASS 16—PAPER GOODS AND PRINTED MATTER**

FOR DESK PROTECTION, NAMELY, DESK PADS (U.S. CLS. 2, 5, 22, 23, 29, 37, 38 AND 50).

THE MARK CONSISTS OF STANDARD CHARACTERS WITHOUT CLAIM TO ANY PARTICULAR FONT, STYLE, SIZE, OR COLOR.

**CLASS 27—FLOOR COVERINGS**

FOR FLOOR PROTECTION, NAMELY, FLOOR MATS (U.S. CLS. 19, 20, 37, 42 AND 50).  
JENNIFER VASQUEZ, EXAMINING ATTORNEY

**CLASS 16—PAPER GOODS AND PRINTED MATTER**

FOR DESK PROTECTION, NAMELY, DESK PADS (U.S. CLS. 2, 5, 22, 23, 29, 37, 38 AND 50).  
FIRST USE 11-10-2010; IN COMMERCE 11-10-2010.

SN 77-116,854. THE STAFFING EDGE INC., BRAMPTON, CANADA, FILED 2-27-2007.

**CLASS 27—FLOOR COVERINGS**

FOR FLOOR PROTECTION, NAMELY, FLOOR MATS (U.S. CLS. 19, 20, 37, 42 AND 50).  
FIRST USE 11-10-2010; IN COMMERCE 11-10-2010.  
JENNIFER VASQUEZ, EXAMINING ATTORNEY

# THE STAFFING EDGE

THE MARK CONSISTS OF STANDARD CHARACTERS WITHOUT CLAIM TO ANY PARTICULAR FONT, STYLE, SIZE, OR COLOR.

SN 76-706,145. FLOORTEX EUROPE LIMITED, GLOUCESTERSHIRE GL20 8DN, UNITED KINGDOM, FILED 1-26-2011.

OWNER OF CANADA REG. NO. TMA763962, DATED 4-12-2010, EXPIRES 4-12-2025.

NO CLAIM IS MADE TO THE EXCLUSIVE RIGHT TO USE "STAFFING", APART FROM THE MARK AS SHOWN.

# COLORTEX

THE MARK CONSISTS OF STANDARD CHARACTERS WITHOUT CLAIM TO ANY PARTICULAR FONT, STYLE, SIZE, OR COLOR.

**CLASS 16—PAPER GOODS AND PRINTED MATTER****CLASS 16—PAPER GOODS AND PRINTED MATTER**

FOR DESK PROTECTION, NAMELY, DESK PADS (U.S. CLS. 2, 5, 22, 23, 29, 37, 38 AND 50).

FOR BOND PAPER; CARD FILES; DRAWING INSTRUMENTS; JOURNALS CONCERNING HUMAN RESOURCES, HEALTH AND SAFETY, AND WORKER'S COMPENSATION; LEAFLETS ABOUT HUMAN RESOURCES, HEALTH AND SAFETY, AND WORKER'S COMPENSATION; MAGAZINES FEATURING ARTICLES IN THE FIELD OF EMPLOYMENT, HEALTH AND SAFETY TRAINING, STAFFING AND PERSONNEL MANAGEMENT; MANUALS IN THE FIELD OF EMPLOYMENT, HEALTH AND SAFETY TRAINING, STAFFING AND PERSONNEL MANAGEMENT; NEWSLETTERS IN THE FIELD OF EMPLOYMENT, HEALTH AND SAFETY TRAINING, STAFFING AND PERSONNEL MANAGEMENT; PAPER EXPANDING FILES; PAPER SHOPPING BAGS; PEN AND PENCIL CASES AND BOXES; PENCILS; PLASTIC SHOPPING BAGS; PRINTING PAPER; PUBLICATIONS, NAMELY, BROCHURES, BOOKLETS, AND TEACHING MATERIALS IN THE FIELD OF HUMAN RESOURCES, HEALTH AND SAFETY, AND WORKER'S COMPENSATION; STATIONERY WRITING PAPER AND ENVELOPES (U.S. CLS. 2, 5, 22, 23, 29, 37, 38 AND 50).

**CLASS 27—FLOOR COVERINGS**

FOR FLOOR PROTECTION, NAMELY, FLOOR MATS (U.S. CLS. 19, 20, 37, 42 AND 50).  
JENNIFER VASQUEZ, EXAMINING ATTORNEY

**CLASS 18—LEATHER GOODS**

FOR LEATHER SHOPPING BAGS; MESH SHOPPING BAGS; UMBRELLAS (U.S. CLS. 1, 2, 3, 22 AND 41).

**CLASS 21—HOUSEWARES AND GLASS**

FOR BEER MUGS; BEVERAGE GLASSWARE; BOWLS; EGG CUPS; FLOWER POTS; ICE BUCKETS; PITCHERS; PORCELAIN MUGS; VASES (U.S. CLS. 2, 13, 23, 29, 30, 33, 40 AND 50).

**CLASS 25—CLOTHING**

FOR HEADWEAR; T-SHIRTS (U.S. CLS. 22 AND 39).

**CLASS 35—ADVERTISING AND BUSINESS**

FOR ADMINISTRATION OF BUSINESS PAYROLL FOR OTHERS; BUSINESS INVESTIGATIONS, EVALUATIONS, EXPERT APPRAISALS, INFORMATION AND RESEARCH; BUSINESS MANAGEMENT CONSULTANCY SERVICES; EMPLOYEE LEASING; EMPLOYMENT AGENCIES; EMPLOYMENT HIRING, RECRUITING, PLACEMENT, STAFFING AND CAREER NETWORKING SERVICES; INSURANCE LEAD COLLECTION AND MATCHING SERVICES, NAMELY, MATCHING CONSUMER REQUESTS FOR INSURANCE POLICY QUOTES COLLECTED OVER THE INTERNET TO PRE-QUALIFIED INSURANCE BROKERS, AGENTS AND AGENCIES INTERESTED IN THOSE REQUESTS; MANAGEMENT AND BUSINESS CONSULTING SERVICES IN THE FIELD OF HUMAN RESOURCES DEVELOPMENT, NAMELY, FOR THE PROMOTION OF EMPLOYEE RETENTION, CAREER GROWTH, AND INCREASED PRODUCTIVITY FOR EMPLOYEES AND EMPLOYERS; PROMOTION OF FINANCIAL AND INSURANCE SERVICES, ON BEHALF OF THIRD PARTIES; PROVIDING INFORMATION IN THE FIELD OF TIME MANAGEMENT FOR BUSINESS PURPOSES; PROVIDING INSURANCE AGENT REFERRALS; SERVICES INCLUDING RECORDING, TRANSCRIPTION, TRANSFORMATION, COMPOSITION, COMPILATION AND SYSTEMIZATION OF INFORMATION USED IN ELECTRONIC TRANSMISSIONS; STENOGRAPHIC TRANSCRIPTION; TEMPORARY EMPLOYMENT AGENCIES; TESTING TO DETERMINE EMPLOYMENT SKILLS; TESTING TO DETERMINE JOB COMPETENCY; TESTING TO DETERMINE PROFESSIONAL COMPETENCY (U.S. CLS. 100, 101 AND 102).

**CLASS 36—INSURANCE AND FINANCIAL**

FOR FACTORING AGENCIES; FINANCIAL SERVICES IN THE FIELD OF MONEY LENDING; FINANCIAL SERVICES, NAMELY, PROVIDING INFORMATION IN THE FIELDS OF FOREIGN CURRENCY, COMMODITIES, FINANCIAL DERIVATIVES, INTEREST RATE PRODUCTS, AND EQUITIES VIA THE INTERNET AND INTRANET SYSTEMS; LOANS AND DISCOUNT OF BILLS; ON-LINE BANKING SERVICES (U.S. CLS. 100, 101 AND 102).

**CLASS 41—EDUCATION AND ENTERTAINMENT**

FOR EDUCATION SERVICES, NAMELY, PROVIDING CLASSES, SEMINARS AND WORKSHOPS IN THE FIELDS OF EMPLOYEE TRAINING IN THE PREVENTION OF WORKPLACE INJURY AND IN THE PROVISION OF CUSTOMER SERVICE (U.S. CLS. 100, 101 AND 107).

**CLASS 42—SCIENTIFIC AND COMPUTER SERVICES**

FOR COMPUTER CONSULTATION; DEVELOPMENT OF NEW TECHNOLOGY FOR OTHERS IN THE FIELD OF HUMAN RESOURCES, RECRUITING, ACCOUNTING, AND WORKER'S COMPENSATION; TECHNICAL WRITING FOR OTHERS (U.S. CLS. 100 AND 101).  
SOPHIA S. KIM, EXAMINING ATTORNEY

SN 77-141,962. BATLEY, ROBERT M., WEST CHESTER, PA. FILED 3-27-2007.



NO CLAIM IS MADE TO THE EXCLUSIVE RIGHT TO USE "SPORTS BURGERS BBQ", APART FROM THE MARK AS SHOWN.

THE COLOR(S) RED, YELLOW AND ORANGE IS/ARE CLAIMED AS A FEATURE OF THE MARK.

THE MARK CONSISTS OF A LARGE RED AND YELLOW STYLIZED LETTER "S" FOLLOWED BY ORANGE MEDIUM-SIZED STYLIZED LETTERS "T", "A", AND "D", FOLLOWED BY AN ORANGE MEDIUM-SIZED STYLIZED LETTER "I" ABOVE WHICH APPEARS A SMALL YELLOW FLAME, FOLLOWED BY ORANGE MEDIUM-SIZED STYLIZED LETTERS "U" AND "M"; UNDERNEATH THE ABOVE DESCRIBED DESIGN THERE APPEARS A LARGE RED AND YELLOW STYLIZED LETTER "G" BEING THE SAME SIZE AS AND INTERLOCKING WITH THE LETTER "S" DESCRIBED ABOVE, FOLLOWED BY RED MEDIUM-SIZED STYLIZED LETTERS "R", "I", "L", "L", AND "E", FOLLOWED BY A YELLOW AND RED STYLIZED IMAGE OF FLAMES; UNDERNEATH THE ABOVE DESCRIBED DESIGN, IN SMALLER SIZED STYLIZED ORANGE LETTERS, ARE THE WORDS "SPORTS", "BURGERS", AND "BBQ", OVERLAYING A RED RECTANGLE.

**CLASS 35—ADVERTISING AND BUSINESS**

FOR (BASED ON INTENT TO USE) FRANCHISING, NAMELY, OFFERING TECHNICAL ASSISTANCE IN THE ESTABLISHMENT AND/OR OPERATION OF RESTAURANTS; (BASED ON USE IN COMMERCE) OFFERING TECHNICAL ASSISTANCE IN THE ESTABLISHMENT AND/OR OPERATION OF RESTAURANTS; (BASED ON INTENT TO USE) RESTAURANT FRANCHISING; (BASED ON USE IN COMMERCE) RESTAURANT MANAGEMENT FOR OTHERS (U.S. CLS. 100, 101 AND 102).

FIRST USE 1-1-2004; IN COMMERCE 1-1-2004.

**CLASS 43—HOTEL AND RESTAURANT SERVICES**

FOR CARRY-OUT RESTAURANTS; RESTAURANT SERVICES; RESTAURANTS; CATERING; CATERING OF FOOD AND DRINKS (U.S. CLS. 100 AND 101).

FIRST USE 11-8-2001; IN COMMERCE 11-8-2001.  
PATRICIA EVANKO, EXAMINING ATTORNEY

SN 77-153,111. CACHE, INC., NEW YORK, NY. FILED 4-10-2007.

CACHÉ

THE MARK CONSISTS OF STANDARD CHARACTERS WITHOUT CLAIM TO ANY PARTICULAR FONT, STYLE, SIZE, OR COLOR.

OWNER OF U.S. REG. NOS. 1,194,124, 1,382,406 AND OTHERS.

**CLASS 9—ELECTRICAL AND SCIENTIFIC APPARATUS**

FOR MAGNETICALLY ENCODED CREDIT CARDS (U.S. CLS. 21, 23, 26, 36 AND 38).

**CLASS 35—ADVERTISING AND BUSINESS**

FOR PROMOTING THE SALE OF CREDIT CARD ACCOUNTS THROUGH THE ADMINISTRATION OF INCENTIVE AWARD PROGRAMS; PROMOTING THE SALE OF GOODS AND SERVICES OF OTHERS BY AWARDED PURCHASE POINTS FOR CREDIT CARD USE; CREDIT CARD REGISTRATION (U.S. CLS. 100, 101 AND 102).

**CLASS 36—INSURANCE AND FINANCIAL**

FOR CREDIT CARD SERVICES (U.S. CLS. 100, 101 AND 102).

TEJBIR SINGH, EXAMINING ATTORNEY

SN 77-159,360. METANOIA CHILE S.A., LAS CONDES, SANTIAGO, CHILE, FILED 4-18-2007.

**CLASS 9—ELECTRICAL AND SCIENTIFIC APPARATUS**

FOR DATA PROCESSORS; COMPUTER SOFTWARE FOR ASSET INFORMATION ENVIRONMENTS; AND OPERATING SYSTEM PROGRAMS (U.S. CLS. 21, 23, 26, 36 AND 38).

**CLASS 42—SCIENTIFIC AND COMPUTER SERVICES**

FOR CONSULTING SERVICES IN THE FIELD OF ENGINEERING; CONSULTING SERVICES IN THE FIELD OF DESIGN, SELECTION, IMPLEMENTATION AND USE OF COMPUTER HARDWARE AND SOFTWARE SYSTEMS FOR OTHERS; AND RENTAL OF COMPUTERS AND SOFTWARE (U.S. CLS. 100 AND 101).

PAUL E. FAHRENKOPF, EXAMINING ATTORNEY

SN 77-153,137. CACHE, INC., NEW YORK, NY. FILED 4-10-2007.



OWNER OF U.S. REG. NOS. 1,194,124, 1,382,406 AND OTHERS.

**CLASS 9—ELECTRICAL AND SCIENTIFIC APPARATUS**

FOR MAGNETICALLY ENCODED CREDIT CARDS (U.S. CLS. 21, 23, 26, 36 AND 38).

**CLASS 35—ADVERTISING AND BUSINESS**

FOR PROMOTING THE SALE OF CREDIT CARD ACCOUNTS THROUGH THE ADMINISTRATION OF INCENTIVE AWARD PROGRAMS; PROMOTING THE SALE OF GOODS AND SERVICES OF OTHERS BY AWARDED PURCHASE POINTS FOR CREDIT CARD USE; CREDIT CARD REGISTRATION (U.S. CLS. 100, 101 AND 102).

**CLASS 36—INSURANCE AND FINANCIAL**

FOR CREDIT CARD SERVICES (U.S. CLS. 100, 101 AND 102).

TEJBIR SINGH, EXAMINING ATTORNEY

SN 77-209,294. JAFFE LIFE DESIGN, LLC, WESTPORT, CT. FILED 6-19-2007.

**HUMAN WAKEUP CALL**

THE MARK CONSISTS OF STANDARD CHARACTERS WITHOUT CLAIM TO ANY PARTICULAR FONT, STYLE, SIZE, OR COLOR.

**CLASS 41—EDUCATION AND ENTERTAINMENT**

FOR CONSULTATION AND SPEAKING SERVICES IN THE FIELDS OF PERSONAL AND PROFESSIONAL EDUCATION AND EDUCATIONAL ASSESSMENT; LIFE COACHING IN THE FIELDS OF SELF-DISCOVERY, SELF-IMPROVEMENT, GOAL SETTING AND ATTAINMENT, LIFE TRANSITIONS, AND OTHER ISSUES RELATING TO PERSONAL AND PROFESSIONAL BEHAVIOR, AWARENESS, MOTIVATION AND ACHIEVEMENT; PROVIDING A WEBSITE THAT FEATURES INFORMATION IN THE FIELDS PERSONAL AND PROFESSIONAL EDUCATION, AND LIFE-COACHING IN THE FIELDS OF SELF-DISCOVERY, SELF-IMPROVEMENT, GOAL SETTING AND ATTAINMENT, LIFE TRANSITIONS, AND OTHER ISSUES RELATING TO PERSONAL AND PROFESSIONAL BEHAVIOR, AWARENESS, MOTIVATION AND ACHIEVEMENT; EDUCATIONAL SERVICES, NAMELY, PROVIDING RETREATS, SEMINARS, WORKSHOPS, ON-LINE SEMINARS, AND ON-LINE WORKSHOPS RELATING TO SELF-IMPROVEMENT, PERSONAL AND PROFESSIONAL EDUCATION, ASSESSMENT AND EMPOWERMENT SUBJECT MATTERS, AND LIFE-COACHING IN THE FIELDS OF SELF-DISCOVERY, SELF-IMPROVEMENT, GOAL SETTING AND ATTAINMENT, LIFE TRANSITIONS, AND OTHER ISSUES RELATING TO PERSONAL AND PROFESSIONAL BEHAVIOR, AWARENESS, MOTIVATION AND ACHIEVEMENT (U.S. CLS. 100, 101 AND 107).



**CLASS 45—PERSONAL AND LEGAL SERVICES**

FOR PROVIDING A WEBSITE THAT FEATURES INFORMATION IN THE FIELDS OF SELF-IMPROVEMENT, SELF-EMPOWERMENT, AND SELF-ASSESSMENT RELATED THERETO; CONSULTATION SERVICES IN THE FIELDS OF SELF-IMPROVEMENT, SELF-EMPOWERMENT, AND SELF-ASSESSMENT RELATED THERETO (U.S. CLS. 100 AND 101).  
JOHN KELLY, EXAMINING ATTORNEY

SN 77-339,571. AMT&C GROUP LTD, LONDON, UNITED KINGDOM, FILED 11-29-2007.



PRIORITY CLAIMED UNDER SEC. 44(D) ON ERPNTY TM OFC APPLICATION NO. 006075519, FILED 7-6-2007, REG. NO. 006075519, DATED 10-17-2008, EXPIRES 7-6-2017.

THE COLOR(S) RED, SKY BLUE AND BLUE IS/ARE CLAIMED AS A FEATURE OF THE MARK.

THE MARK CONSISTS OF LETTERS "AMT" AND "C" DIVIDED BY SYMBOL "&". THESE ELEMENTS ARE PRESENTED AGAINST THE BACKGROUND OF A BAND WHICH CONVERGES IN THE CENTER. LETTER "M" IS STYLIZED AND PRESENTED IN RED. THE BAND HAS A BLEND FROM BLUE IN THE CENTER TO SKY BLUE IN THE PERIPHERAL PARTS. OTHER ELEMENTS OF THE MARK ARE PRESENTED IN BLUE.

**CLASS 6—METAL GOODS**

FOR COMMON METALS, UNWROUGHT AND SEMI-WORKED, FOR FURTHER MANUFACTURE; METAL ALLOYS FOR FURTHER MANUFACTURING; IRON ORES; CHROME IRON ORES; VANADIUM IRON ORES; TITANIUM IRON ORES; MANGANESE ORES; NICKEL ORES; TIN ORES; TUNGSTEN ORES; TITANIUM ORES; GOLD ORES; URANIUM ORES; NIOBIUM ORES; TANTALUM ORES; ZIRCONIUM ORES; THORIUM ORES (U.S. CLS. 2, 12, 13, 14, 23, 25 AND 50).

**CLASS 7—MACHINERY**

FOR ELECTRIC MOTORS FOR MACHINES, OTHER THAN FOR LAND VEHICLES; ELECTRICAL EQUIPMENT FOR VEHICLES, NAMELY, ELECTRIC MOTORS FOR OPERATION OF POWER STEERING, SCREEN WIPERS, WINDOW RAISERS, HEADLIGHT WASHERS, SCREEN WASHERS, DIRECTION INDICATORS, SEAT HEATING, GLASS HEATING; GENERATORS OF ELECTRICITY; STARTERS FOR MOTORS AND ENGINES; COMPONENT REPLACEMENT PARTS OF THE FOREMENTIONED GOODS, INCLUDING PERMANENT MAGNETS AND SOFT MAGNETIC MATERIALS; CENTRIFUGAL IRON SEPARATORS; DRUM MAGNETIC CYCLONE SEPARATORS; MAGNETIC STREET SWEEPERS (U.S. CLS. 13, 19, 21, 23, 31, 34 AND 35).

**CLASS 8—HAND TOOLS**

FOR HAND TOOLS AND IMPLEMENTS, NAMELY, EXPANDABLE HAND TOOLS WITH MAGNETIC ENDS FOR USE IN GRASPING OBJECTS (U.S. CLS. 23, 28 AND 44).

**CLASS 9—ELECTRICAL AND SCIENTIFIC APPARATUS**

FOR NON-POWER OPERATED APPARATUS AND INSTRUMENTS IN THE NATURE OF MAGNETIC SEPARATION APPARATUS, NAMELY, HANDING IRON SEPARATORS FOR CONVEYOR LINES, SELF-EMPTYING IRON SEPARATORS, MAGNETIC LATTICES, PULLEY-TYPE SEPARATORS AND IRON SEPARATORS, DRUM MAGNETIC SEPARATORS FOR BULK MATERIALS, DRUM MAGNETIC SEPARATORS FOR LIQUIDS, PERMANENT-MAGNETIC CHUCKS, MAGNETIC SEPARATORS FOR PIPING SYSTEMS FOR LIQUIDS FOR INDUSTRIAL USE; DEVICES FOR GENERATING MAGNETIC FIELDS, NAMELY, AXIAL MAGNETIC FIELD SOURCES, MAGNETIC FIELD SOURCES FOR MAGNETIC FLAW DETECTION, HIGH-INTENSITY MAGNETIC FIELD SOURCES, CONTROLLED RATE MAGNETIC FIELD SOURCES, MAGNETIC FIELD SOURCES FOR NONDESTRUCTIVE INSPECTION, SOURCES FOR PREDETERMINED CONFIGURATION MAGNETOSTATIC FIELD; MAGNETIC BLOCKS FOR INDUSTRIAL USE; MAGNETIC PROBES FOR DETECTING FERROMAGNETIC INCLUSIONS IN NON-MAGNETIC MATERIALS; SUSPENDED MAGNETIC PLATES FOR MAGNETIC SEPARATION; MAGNETIC FIXATION DEVICES FOR WELDING, NAMELY, MAGNETIC WELDING HOLDERS; AUTOMATED COMPACT VIBRATING SAMPLE MAGNETOMETER; MAGNETIC WELDING POSITIONERS; HAND OPERATED CLAMPS, NAMELY, MAGNETIC FIXATION DEVICES, MAGNETIC DEVICES FOR WELDING (U.S. CLS. 21, 23, 26, 36 AND 38).

**CLASS 10—MEDICAL APPARATUS**

FOR SURGICAL, MEDICAL DENTAL AND VETERINARY MAGNETIC APPARATUS FOR INTRODUCTION AND EXTRACTION OF INSTRUMENTS FROM THE BODY OF A PATIENT AND ELECTROMAGNETIC DRUG DELIVERY APPARATUS FOR MEDICAL USE; MEDICAL MAGNETIC APPARATUS IN THE NATURE OF CONTROLLABLE SOURCES OF ALTERNATING ELECTROMAGNETIC AND CONSTANT MAGNETIC FIELDS OF HIGH INTENSITY FOR MAGNETO-LIQUID HYPERTHERMIA EQUIPMENT SYSTEMS; DIAGNOSTIC APPARATUS, NAMELY, MAGNETIC DIAGNOSTIC APPARATUS FOR USE IN NEUROSURGERY AND CARDIOLOGY; PROBES FOR MEDICAL PURPOSES; SURGICAL IMPLANTS COMPRISING ARTIFICIAL MATERIALS; ARTIFICIAL MAGNETIC SETS OF TEETH (U.S. CLS. 26, 39 AND 44).

**CLASS 35—ADVERTISING AND BUSINESS**

FOR ADVERTISING SERVICES (U.S. CLS. 100, 101 AND 102).

**CLASS 40—MATERIAL TREATMENT**

FOR MAGNETIZATION OF METALS; METAL TREATING; METAL ORE TREATING; METAL MATERIAL PROCESSING BY MEANS OF MAGNETIC SEPARATIONS (U.S. CLS. 100, 103 AND 106).

**CLASS 42—SCIENTIFIC AND COMPUTER SERVICES**

FOR SCIENTIFIC AND TECHNICAL CONSULTING SERVICES AND RESEARCH AND DESIGN RELATING THERETO IN THE FIELD OF USING MAGNETS FOR INDUSTRY, SCIENCE, MEDICINE, ADVERTISING; INDUSTRIAL ANALYSIS AND RESEARCH SERVICES IN THE FIELD OF USING MAGNETS FOR INDUSTRY, SCIENCE, MEDICINE, ADVERTISING; DESIGN AND DEVELOPMENT OF COMPUTER HARDWARE AND SOFTWARE (U.S. CLS. 100 AND 101).

**CLASS 44—MEDICAL, BEAUTY AND AGRICULTURAL SERVICES**

FOR MEDICAL SERVICES INCLUDING ADMINISTERING ELECTROMAGNETIC DRUG DELIVERY TO PATIENTS; ADMINISTERING ELECTROMAGNETIC DELIVERY OF PHOTOSENSITIZERS AND RADIOACTIVE ISOTOPES FOR MEDICAL TREATMENT PURPOSES; MEDICAL IMAGING SERVICES, NAMELY, OPERATION OF POSITRON EMISSION TOMOGRAPHY APPARATUS; TREATMENT OF CANCER; DETOXIFICATION OF BLOOD, USING MAGNETIC NANOSTRUCTURES FOR SORPTION OF TOXINS (U.S. CLS. 100 AND 101).

ANTHONY RINKER, EXAMINING ATTORNEY

SN 77-414,859. NGRID INTELLECTUAL PROPERTY LIMITED, LONDON, UNITED KINGDOM, FILED 3-6-2008.

# BlueGrid

THE MARK CONSISTS OF STANDARD CHARACTERS WITHOUT CLAIM TO ANY PARTICULAR FONT, STYLE, SIZE, OR COLOR.

OWNER OF FED REP GERMANY REG. NO. 006741649, DATED 2-29-2008, EXPIRES 2-28-2018.

SN 77-360,729. FATHEAD, LLC, LIVONIA, MI. FILED 12-28-2007.

## FATHEAD GAMETIME

THE MARK CONSISTS OF STANDARD CHARACTERS WITHOUT CLAIM TO ANY PARTICULAR FONT, STYLE, SIZE, OR COLOR.

OWNER OF U.S. REG. NOS. 3,322,568, 3,328,425 AND 3,337,998.

**CLASS 16—PAPER GOODS AND PRINTED MATTER**

FOR TRADING CARDS (U.S. CLS. 2, 5, 22, 23, 29, 37, 38 AND 50).

**CLASS 28—TOYS AND SPORTING GOODS**

FOR TRADING CARD GAMES (U.S. CLS. 22, 23, 38 AND 50).

**CLASS 35—ADVERTISING AND BUSINESS**

FOR ARRANGING AND CLOSING COMMERCIAL TRANSACTIONS FOR OTHERS VIA THE INTERNET; PROVIDING WEB SITES FEATURING BUYING CLUBS (U.S. CLS. 100, 101 AND 102).

**CLASS 41—EDUCATION AND ENTERTAINMENT**

FOR SWEEPSTAKES SERVICES, ARRANGING GAMES OF CHANCE AND CONTESTS VIA THE INTERNET, PROVIDING WEB SITES FEATURING FAN CLUBS, AND ENTERTAINMENT SERVICES IN THE NATURE OF FANTASY SPORTS LEAGUES (U.S. CLS. 100, 101 AND 107).

GINA FINK, EXAMINING ATTORNEY

**CLASS 7—MACHINERY**

FOR MACHINES AND APPARATUS FOR ENERGY TECHNOLOGY, ELECTRICAL ENGINEERING BUILDING TECHNOLOGY, ENVIRONMENTAL TECHNOLOGY, NAMELY, ENGINES AND MOTORS FOR THE GENERATION OF ELECTRICITY AND STATIONARY ENGINES FOR CO-GENERATION UNITS, NAMELY, AC GENERATORS, DC GENERATORS, ELECTRIC GENERATORS AND ELECTROSTATIC GENERATORS; APPARATUS AND MACHINES FOR POWER GENERATION, NAMELY, ELECTRIC GENERATORS, GAS TURBINE DRIVEN GENERATORS, INTERNAL COMBUSTION ENGINE DRIVEN GENERATORS, WATER POWER DRIVEN GENERATORS, GEOTHERMAL ELECTRIC GENERATORS, WIND POWER DRIVEN GENERATORS AND MECHANICAL FLYWHEELS; TURBINES; APPARATUS FOR GENERATING ELECTRICITY FROM WAVE POWER OR WIND POWER; DEVICES FOR INPUT OF BIOMASS COMBUSTIBLES FOR ENERGY GENERATION PURPOSES, NAMELY, INTERNAL COMBUSTION ENGINES FOR POWER GENERATION; BLOWING MACHINES FOR THE COMPRESSION, EXHAUSTION AND TRANSPORT OF GASES; PUMPS FOR COMPRESSED GAS; GAS COMPRESSORS; PARTS AND FITTINGS FOR ALL OF THE AFORESAID GOODS (U.S. CLS. 13, 19, 21, 23, 31, 34 AND 35).

**CLASS 9—ELECTRICAL AND SCIENTIFIC APPARATUS**

FOR APPARATUS AND INSTRUMENTS FOR CONDUCTING, SWITCHING, TRANSFORMING, ACCUMULATING, REGULATING OR CONTROLLING ELECTRICITY, NAMELY, ELECTRIC CONDUCTORS, ELECTRIC SWITCHES, ELECTRIC TRANSFORMERS, ELECTRIC ACCUMULATORS, VOLTAGE REGULATORS, AND ELECTRICAL CONTROLLING DEVICES; APPARATUS AND INSTRUMENTS FOR CHECKING AND MEASURING ELECTRICITY AND ENERGY CONSUMPTION; REMOTE CONTROLS FOR MEASURING ENERGY AND ELECTRICITY IN POWER STATIONS; ELECTRIC CABLES FOR USE IN GENERATING OR DISTRIBUTING ELECTRICITY; ELECTRIC CONNECTIONS FOR USE IN GENERATING OR DISTRIBUTING ELECTRICITY; TRANSFORMERS FOR USE IN GENERATING OR DISTRIBUTING ELECTRICITY; PHOTOVOLTAIC APPARATUS AND INSTALLATIONS FOR GENERATING SOLAR ELECTRICITY, NAMELY, PHOTOVOLTAIC SOLAR MODULES, PHOTOVOLTAIC CLADDING PANELS, SOLAR CELLS; SCIENTIFIC, NAUTICAL, SURVEYING, PHOTOGRAPHIC, CINEMATOGRAPHIC, OPTICAL, WEIGHING, MEASURING, SIGNALING, CHECKING, SUPERVISION, LIFE-SAVING AND TEACHING APPARATUS AND INSTRUMENTS, NAMELY, CONDUCTIVITY METERS, SURVEYING INSTRUMENTS FOR USE IN THE PRODUCTION AND DISTRIBUTION OF GASES; APPARATUS AND INSTRUMENTS, NAMELY, GAS METERS, GAS SENSORS FOR MEASURING GAS CONCENTRATION, GAS TESTING INSTRUMENTS FOR USE IN THE PRODUCTION AND DISTRIBUTION OF GASES; PARTS AND FITTINGS FOR ALL OF THE AFORESAID GOODS (U.S. CLS. 21, 23, 26, 36 AND 38).

**CLASS 11—ENVIRONMENTAL CONTROL APPARATUS**

FOR MACHINES FOR GENERATION OF GAS, NAMELY, ELECTROCHEMICAL GAS GENERATORS, GAS GENERATING FURNACES FOR INDUSTRIAL PURPOSES, HEAT ACCUMULATORS, GAS BURNERS FOR INDUSTRIAL USE, GAS REGULATORS; GEOTHERMAL HEAT PUMPS; HYDROGEN GENERATORS; SOLAR ELECTRIC INSTALLATIONS FOR USE IN PROVIDING POWER TO COMMERCIAL, RESIDENTIAL AND INDUSTRIAL PREMISES, NAMELY, SOLAR HEAT COLLECTION PANELS (U.S. CLS. 13, 21, 23, 31 AND 34).

**CLASS 16—PAPER GOODS AND PRINTED MATTER**

FOR PRINTED MATTER, NAMELY, NEWSPAPERS, BROCHURES, MAGAZINES AND BOOKS, ALL IN THE FIELD OF ENERGY; PERIODICAL PUBLICATIONS IN THE FIELD OF ENERGY; MANUALS IN THE FIELD OF ENERGY, NAMELY, GAS METER MANUALS, ELECTRICITY METER MANUALS AND WATER METER MANUALS (U.S. CLS. 2, 5, 22, 23, 29, 37, 38 AND 50).

**CLASS 35—ADVERTISING AND BUSINESS**

FOR BUSINESS MANAGEMENT; BUSINESS CONSULTANCY SERVICES RELATING TO THE ENERGY AND POWER INDUSTRIES; BUSINESS CONSULTANCY SERVICES RELATING TO WATER INFRASTRUCTURE NETWORKS; BUSINESS MANAGEMENT FOR OTHERS TO ENSURE THAT THEY ARE MEETING ENERGY REQUIREMENTS; MARKET RESEARCH; MARKETING STUDIES; PUBLIC RELATIONS; PROCUREMENT, NAMELY, PURCHASING ELECTRICITY AND GAS FOR OTHERS VIA THE INTERNET; ORGANIZATION AND CONDUCTING OF PROMOTIONAL CAMPAIGNS; ORGANIZATION OF TRADE FAIRS FOR COMMERCIAL OR ADVERTISING PURPOSES; PROMOTING PUBLIC AWARENESS OF THE NEED FOR ENERGY CONSERVATION AND PROVIDING INFORMATION IN THE FIELD OF ENERGY EFFICIENCY AND ENERGY AUDITING SERVICES; BUSINESS MANAGEMENT IN THE FIELD OF POWER PLANTS; ADVICE, INFORMATION AND CONSULTANCY SERVICES RELATING TO ALL OF THE AFORESAID SERVICES (U.S. CLS. 100, 101 AND 102).

**CLASS 37—CONSTRUCTION AND REPAIR**

FOR BUILDING CONSTRUCTION; CONSTRUCTION, MAINTENANCE AND REPAIR OF POWER STATIONS AND POWER PLANTS; MAINTENANCE AND REPAIR OF ENERGY AND POWER GENERATING APPARATUS AND INSTALLATIONS; INSTALLATION OF ELECTRICAL AND ELECTRICITY GENERATING EQUIPMENT; INSTALLATION, MAINTENANCE, REPAIR AND SERVICING OF GAS SUPPLY AND DISTRIBUTION APPARATUS AND INSTRUMENTS; INSTALLATION, MAINTENANCE AND REPAIR OF INSTALLATIONS, APPARATUS, INSTRUMENTS AND PIPELINES FOR UTILIZATION OF GEO-THERMAL POWER; ADVICE, INFORMATION AND CONSULTANCY SERVICES RELATING TO ALL OF THE AFORESAID SERVICES (U.S. CLS. 100, 103 AND 106).

**CLASS 39—TRANSPORTATION AND STORAGE**

FOR DISTRIBUTION AND SUPPLY OF ELECTRICITY AND OTHER FORMS OF ENERGY OR SOURCES OF POWER; DISTRIBUTION, SUPPLY, TRANSPORTATION AND STORAGE OF FUEL AND GAS; TRANSMISSION, SUPPLY AND DISTRIBUTION OF ELECTRICITY TO AND FROM COMMERCIAL, RESIDENTIAL AND INDUSTRIAL PREMISES; ADVICE, INFORMATION AND CONSULTANCY SERVICES RELATING TO ALL OF THE AFORESAID SERVICES (U.S. CLS. 100 AND 105).

**CLASS 40—MATERIAL TREATMENT**

FOR GENERATION OF POWER AND ELECTRICITY; PRODUCTION OF GAS; WASTE PROCESSING AND TREATMENT; INDUSTRIAL TOXIC WASTE DISPOSAL; CHEMICAL TREATMENT OF BIOMASS; PRODUCTION OF ENERGY FROM HEAT FROM GEO-THERMAL POWER SOURCES; CUSTOM MANUFACTURE OF ENERGY AND POWER GENERATING APPARATUS AND INSTALLATIONS; CUSTOM MANUFACTURE OF INSTALLATIONS, APPARATUS, INSTRUMENTS AND PIPELINES FOR UTILIZATION OF GEO-THERMAL POWER; CONSULTANCY SERVICES RELATING TO THE GENERATION OF ELECTRICITY, GAS AND WATER TREATMENT; ADVICE, INFORMATION AND CONSULTANCY SERVICES RELATING TO ALL OF THE AFORESAID SERVICES (U.S. CLS. 100, 103 AND 106).

**CLASS 42—SCIENTIFIC AND COMPUTER SERVICES**

FOR SCIENTIFIC AND TECHNOLOGICAL SERVICES AND RESEARCH AND DESIGN SERVICES IN THE FIELD OF ENERGY; SCIENTIFIC AND TECHNOLOGICAL CONSULTANCY SERVICES RELATING TO ENERGY AND POWER; INDUSTRIAL ANALYSIS AND RESEARCH SERVICES IN THE FIELD OF ENERGY; DESIGN OF ENERGY AND POWER SYSTEMS; ANALYSIS RELATING TO ENERGY AND POWER NEEDS OF OTHERS, NAMELY, DATA ANALYSIS OF ENERGY SYSTEMS; DEVELOPMENT OF ENERGY AND POWER MANAGEMENT SYSTEMS; SCIENTIFIC RESEARCH RELATING TO THE ENVIRONMENTAL IMPACT OF ENERGY AND POWER SYSTEMS; DESIGN SERVICES FOR POWER PLANTS; RESEARCH AND DEVELOPMENT SERVICES FOR GAS; TECHNICAL DESIGN AND TECHNICAL PLANNING OF PHOTOVOLTAIC INSTALLATIONS; RESEARCH IN THE FIELD OF ENERGY USAGE; COMPUTER SOFTWARE CONSULTANCY; DEVELOPMENT OF ENVIRONMENTALLY-FRIENDLY FORMS OF ENERGY AND POWER; ADVICE, INFORMATION AND CONSULTANCY SERVICES RELATING TO ALL OF THE AFORESAID SERVICES (U.S. CLS. 100 AND 101).

JAY FLOWERS, EXAMINING ATTORNEY

SN 77-469,344. NGRID INTELLECTUAL PROPERTY LIMITED, LONDON WC2N 5EH, UNITED KINGDOM, FILED 5-8-2008.

 The logo for bluegrid, featuring the word "bluegrid" in a lowercase, blue, sans-serif font. The letter "i" in "grid" has a small blue square above it, resembling a dot or a stylized eye.

OWNER OF FED REP GERMANY REG. NO. 006918461, DATED 2-2-2009, EXPIRES 2-2-2019.

THE COLOR(S) BLUE IS/ARE CLAIMED AS A FEATURE OF THE MARK.

THE MARK CONSISTS OF THE WORD "BLUEGRID", WHICH APPEARS IN THE COLOR BLUE.

**CLASS 7—MACHINERY**

FOR MACHINES AND APPARATUS FOR ENERGY TECHNOLOGY, ELECTRICAL ENGINEERING BUILDING TECHNOLOGY, ENVIRONMENTAL TECHNOLOGY, NAMELY, ENGINES AND MOTORS FOR THE GENERATION OF ELECTRICITY AND STATIONARY ENGINES FOR CO-GENERATION UNITS, NAMELY, AC GENERATORS, DC GENERATORS, ELECTRIC GENERATORS AND ELECTROSTATIC GENERATORS; APPARATUS AND MACHINES FOR POWER GENERATION, NAMELY, ELECTRIC GENERATORS, GAS TURBINE DRIVEN GENERATORS, INTERNAL COMBUSTION ENGINE DRIVEN GENERATORS, WATER POWER DRIVEN GENERATORS, GEO-THERMAL ELECTRIC GENERATORS, WIND POWER DRIVEN GENERATORS AND MECHANICAL FLYWHEELS; TURBINES; APPARATUS FOR GENERATING ELECTRICITY FROM WAVE POWER OR WIND POWER; DEVICES FOR INPUT OF BIOMASS COMBUSTIBLES FOR ENERGY GENERATION PURPOSES, NAMELY, INTERNAL COMBUSTION ENGINES FOR POWER GENERATION; BLOWING MACHINES FOR THE COMPRESSION, EXHAUSTION AND TRANSPORT OF GASES; PUMPS FOR COMPRESSED GAS; GAS COMPRESSORS; PARTS AND FITTINGS FOR ALL OF THE AFORESAID GOODS (U.S. CLS. 13, 19, 21, 23, 31, 34 AND 35).

**CLASS 9—ELECTRICAL AND SCIENTIFIC APPARATUS**

FOR APPARATUS AND INSTRUMENTS FOR CONDUCTING, SWITCHING, TRANSFORMING, ACCUMULATING, REGULATING OR CONTROLLING ELECTRICITY, NAMELY, ELECTRIC CONDUCTORS, ELECTRIC SWITCHES, ELECTRIC TRANSFORMERS, ELECTRIC ACCUMULATORS, VOLTAGE REGULATORS, AND ELECTRICAL CONTROLLING DEVICES; APPARATUS AND INSTRUMENTS FOR CHECKING AND MEASURING ELECTRICITY AND ENERGY CONSUMPTION; REMOTE CONTROLS FOR MEASURING ENERGY AND ELECTRICITY IN POWER STATIONS; ELECTRIC CABLES FOR USE IN GENERATING OR DISTRIBUTING ELECTRICITY; ELECTRIC CONNECTIONS FOR USE IN GENERATING OR DISTRIBUTING ELECTRICITY; TRANSFORMERS FOR USE IN GENERATING OR DISTRIBUTING ELECTRICITY; PHOTOVOLTAIC APPARATUS AND INSTALLATIONS FOR GENERATING SOLAR ELECTRICITY, NAMELY, PHOTOVOLTAIC SOLAR MODULES, PHOTOVOLTAIC CLADDING PANELS, SOLAR CELLS; SCIENTIFIC, NAUTICAL, SURVEYING, PHOTOGRAPHIC, CINEMATOGRAPHIC, OPTICAL, WEIGHING, MEASURING, SIGNALING, CHECKING, SUPERVISION, LIFE-SAVING AND TEACHING APPARATUS AND INSTRUMENTS, NAMELY, CONDUCTIVITY METERS, SURVEYING INSTRUMENTS FOR USE IN THE PRODUCTION AND DISTRIBUTION OF GASES; APPARATUS AND INSTRUMENTS, NAMELY, GAS METERS, GAS SENSORS FOR MEASURING GAS CONCENTRATION, GAS TESTING INSTRUMENTS FOR USE IN THE PRODUCTION AND DISTRIBUTION OF GASES; PARTS AND FITTINGS FOR ALL OF THE AFORESAID GOODS (U.S. CLS. 21, 23, 26, 36 AND 38).

**CLASS 11—ENVIRONMENTAL CONTROL APPARATUS**

FOR MACHINES FOR GENERATION OF GAS, NAMELY, ELECTROCHEMICAL GAS GENERATORS, GAS GENERATING FURNACES FOR INDUSTRIAL PURPOSES, HEAT ACCUMULATORS, GAS BURNERS FOR INDUSTRIAL USE, GAS REGULATORS; GEOTHERMAL HEAT PUMPS; HYDROGEN GENERATORS; SOLAR ELECTRIC INSTALLATIONS FOR USE IN PROVIDING POWER TO COMMERCIAL, RESIDENTIAL AND INDUSTRIAL PREMISES, NAMELY, SOLAR HEAT COLLECTION PANELS (U.S. CLS. 13, 21, 23, 31 AND 34).

**CLASS 16—PAPER GOODS AND PRINTED MATTER**

FOR PRINTED MATTER, NAMELY, NEWSPAPERS, BROCHURES, MAGAZINES AND BOOKS, ALL IN THE FIELD OF ENERGY; PERIODICAL PUBLICATIONS IN THE FIELD OF ENERGY; MANUALS IN THE FIELD OF ENERGY, NAMELY, GAS METER MANUALS, ELECTRICITY METER MANUALS AND WATER METER MANUALS (U.S. CLS. 2, 5, 22, 23, 29, 37, 38 AND 50).

**CLASS 35—ADVERTISING AND BUSINESS**

FOR BUSINESS MANAGEMENT; BUSINESS MANAGEMENT FOR OTHERS TO ENSURE THEY ARE MEETING ENERGY REQUIREMENTS; MARKET RESEARCH; MARKETING STUDIES; PUBLIC RELATIONS; PROCUREMENT, NAMELY, PURCHASING ELECTRICITY AND GAS FOR OTHERS VIA THE INTERNET; ORGANIZATION AND CONDUCTING OF PROMOTIONAL CAMPAIGNS; ORGANIZATION OF TRADE FAIRS FOR COMMERCIAL OR ADVERTISING PURPOSES; PROMOTING PUBLIC AWARENESS OF THE NEED FOR ENERGY CONSERVATION AND PROVIDING INFORMATION IN THE FIELD OF ENERGY EFFICIENCY AND ENERGY AUDITING SERVICES; BUSINESS MANAGEMENT IN THE FIELD OF POWER PLANTS; ADVICE, INFORMATION AND CONSULTANCY SERVICES RELATING TO ALL OF THE AFORESAID SERVICES (U.S. CLS. 100, 101 AND 102).

**CLASS 37—CONSTRUCTION AND REPAIR**

FOR BUILDING CONSTRUCTION; CONSTRUCTION, MAINTENANCE AND REPAIR OF POWER STATIONS AND POWER PLANTS; MAINTENANCE AND REPAIR OF ENERGY AND POWER GENERATING APPARATUS AND INSTALLATIONS; INSTALLATION OF ELECTRICAL AND ELECTRICITY GENERATING EQUIPMENT; INSTALLATION, MAINTENANCE, REPAIR AND SERVICING OF GAS SUPPLY AND DISTRIBUTION APPARATUS AND INSTRUMENTS; INSTALLATION, MAINTENANCE AND REPAIR OF INSTALLATIONS, APPARATUS, INSTRUMENTS AND PIPELINES FOR UTILIZATION OF GEO-THERMAL POWER; ADVICE, INFORMATION AND CONSULTANCY SERVICES RELATING TO ALL OF THE AFORESAID SERVICES (U.S. CLS. 100, 103 AND 106).

**CLASS 39—TRANSPORTATION AND STORAGE**

FOR DISTRIBUTION AND SUPPLY OF ELECTRICITY AND OTHER FORMS OF ENERGY OR SOURCES OF POWER; DISTRIBUTION, SUPPLY, TRANSPORTATION AND STORAGE OF FUEL AND GAS; TRANSMISSION, SUPPLY AND DISTRIBUTION OF ELECTRICITY TO AND FROM COMMERCIAL, RESIDENTIAL AND INDUSTRIAL PREMISES; ADVICE, INFORMATION AND CONSULTANCY SERVICES RELATING TO ALL OF THE AFORESAID SERVICES (U.S. CLS. 100 AND 105).

**CLASS 40—MATERIAL TREATMENT**

FOR GENERATION OF POWER AND ELECTRICITY; PRODUCTION OF GAS; PRODUCTION OF ENERGY FROM HEAT FROM GEO-THERMAL POWER SOURCES; CUSTOM MANUFACTURE OF ENERGY AND POWER GENERATING APPARATUS AND INSTALLATIONS; CUSTOM MANUFACTURE OF INSTALLATIONS, APPARATUS, INSTRUMENTS AND PIPELINES FOR UTILIZATION OF GEO-THERMAL POWER; CONSULTANCY SERVICES RELATING TO THE GENERATION OF ELECTRICITY AND GAS; ADVICE, INFORMATION AND CONSULTANCY SERVICES RELATING TO ALL OF THE AFORESAID SERVICES (U.S. CLS. 100, 103 AND 106).

**CLASS 42—SCIENTIFIC AND COMPUTER SERVICES**

FOR SCIENTIFIC AND TECHNOLOGICAL SERVICES AND RESEARCH AND DESIGN SERVICES IN THE FIELD OF ENERGY; SCIENTIFIC AND TECHNOLOGICAL CONSULTANCY SERVICES RELATING TO ENERGY AND POWER; SCIENTIFIC AND TECHNOLOGICAL CONSULTANCY SERVICES RELATING TO WATER INFRASTRUCTURE NETWORKS; INDUSTRIAL ANALYSIS AND RESEARCH SERVICES IN THE FIELD OF ENERGY; DESIGN OF ENERGY AND POWER SYSTEMS; DATA ANALYSIS OF ENERGY SYSTEMS RELATING TO ENERGY AND POWER NEEDS OF OTHERS; DEVELOPMENT OF ENERGY AND POWER MANAGEMENT SYSTEMS; SCIENTIFIC RESEARCH RELATING TO THE ENVIRONMENTAL IMPACT OF ENERGY AND POWER SYSTEMS; DESIGN SERVICES FOR POWER PLANTS; RESEARCH AND DEVELOPMENT SERVICES FOR GAS; TECHNICAL DESIGN AND TECHNICAL PLANNING OF PHOTOVOLTAIC INSTALLATIONS; RESEARCH IN THE FIELD OF ENERGY USAGE; COMPUTER SOFTWARE CONSULTANCY; DEVELOPMENT OF ENVIRONMENTALLY-FRIENDLY FORMS OF ENERGY POWER; METERING OF GAS AND ELECTRICITY; WATER METER READING SERVICES; MEASURING OF GAS, NAMELY, DATA COLLECTION IN RELATION TO MEASURING OF GAS CONSUMPTION; ADVICE, INFORMATION AND CONSULTANCY SERVICES RELATING TO ALL OF THE AFORESAID SERVICES (U.S. CLS. 100 AND 101).

JAY FLOWERS, EXAMINING ATTORNEY

SN 77-490,903. THE OLSON COMPANY, SEAL BEACH, CA. FILED 6-4-2008.

**VILLAGE WALK**

THE MARK CONSISTS OF STANDARD CHARACTERS WITHOUT CLAIM TO ANY PARTICULAR FONT, STYLE, SIZE, OR COLOR.

THE RESTRICTION IS SOUGHT BY APPLICANT FOR THE SERVICES IDENTIFIED IN CALIFORNIA, OREGON, WASHINGTON, ARIZONA, NEVADA, UTAH, COLORADO, IDAHO, MONTANA AND WYOMING. THUS, APPLICANT IS REQUESTING A CONCURRENT USE REGISTRATION LIMITED TO THE GEOGRAPHIC REGION DEFINED BY THESE STATES.

THE REGISTRATION IS SOUGHT BY APPLICANT FOR THE SERVICES IDENTIFIED IN CALIFORNIA, OREGON, WASHINGTON, ARIZONA, NEVADA, UTAH, AND COLORADO. THUS, APPLICANT IS REQUESTING A CONCURRENT USE REGISTRATION LIMITED TO THE GEOGRAPHIC REGION DEFINED BY THESE STATES.

OWNER OF U.S. REG. NO. 3,246,361.

NO CLAIM IS MADE TO THE EXCLUSIVE RIGHT TO USE "VILLAGE", APART FROM THE MARK AS SHOWN.

**CLASS 37—CONSTRUCTION AND REPAIR**

FOR REAL ESTATE DEVELOPMENT AND CONSTRUCTION SERVICES, NAMELY, PLANNING, LAYING OUT AND CONSTRUCTION OF SINGLE FAMILY AND MULTI-FAMILY COMMUNITIES (U.S. CLS. 100, 103 AND 106).

FIRST USE 10-25-1999; IN COMMERCE 10-25-1999.

**CLASS 42—SCIENTIFIC AND COMPUTER SERVICES**

FOR URBAN MASTER PLANNING (U.S. CLS. 100 AND 101).

FIRST USE 10-25-1999; IN COMMERCE 10-25-1999.  
DAVID MURRAY, EXAMINING ATTORNEY

SN 77-496,310. AMERICAN SOCIETY OF CLINICAL ONCOLOGY, ALEXANDRIA, VA. FILED 6-11-2008.

**MAKING A WORLD OF DIFFERENCE IN CANCER CARE**

THE MARK CONSISTS OF STANDARD CHARACTERS WITHOUT CLAIM TO ANY PARTICULAR FONT, STYLE, SIZE, OR COLOR.

**CLASS 16—PAPER GOODS AND PRINTED MATTER**

FOR PUBLICATIONS, NAMELY, MAGAZINES, JOURNALS, NEWSLETTERS, AND BROCHURES CONCERNING AND IN THE FIELD OF ONCOLOGY (U.S. CLS. 2, 5, 22, 23, 29, 37, 38 AND 50).

FIRST USE 4-2-2008; IN COMMERCE 4-2-2008.

**CLASS 35—ADVERTISING AND BUSINESS**

FOR PUBLIC ADVOCACY TO PROMOTE AWARENESS OF CANCER, CANCER RESEARCH AND THE FIELD OF CLINICAL ONCOLOGY; ADMINISTRATION AND MANAGEMENT OF RESEARCH GRANTS AND AWARDS; PROMOTING THE EXCHANGE OF CLINICAL, RESEARCH, AND PATIENT INFORMATION AND RESOURCES WITHIN THE SCIENTIFIC RESEARCH AND MEDICAL COMMUNITIES TO ACHIEVE ADVANCES IN THE FIELD OF ONCOLOGY; ASSOCIATION SERVICES, NAMELY, PROMOTING, PROTECTING, AND ADVANCING THE INTERESTS OF PHYSICIANS AND HEALTH CARE PROVIDERS IN THE FIELD OF CLINICAL ONCOLOGY (U.S. CLS. 100, 101 AND 102).

FIRST USE 4-2-2008; IN COMMERCE 4-2-2008.

**CLASS 36—INSURANCE AND FINANCIAL**

FOR CHARITABLE FUNDRAISING SERVICES FOR CANCER EDUCATION AND RESEARCH (U.S. CLS. 100, 101 AND 102).

FIRST USE 4-2-2008; IN COMMERCE 4-2-2008.

**CLASS 41—EDUCATION AND ENTERTAINMENT**

FOR EDUCATIONAL SERVICES, NAMELY, PROVIDING CLASSES, SEMINARS, CONFERENCES, SYMPOSIA, AND WORKSHOPS FOR THE EXCHANGE AND DIFFUSION OF INFORMATION AND IDEAS RELATING TO NEOPLASTIC DISEASES, AND PROVIDING TRAINING IN THE PRACTICE OF CLINICAL RESEARCH AND MEDICAL CARE OF PATIENTS WITH NEOPLASTIC DISEASES; EDUCATIONAL SERVICES, NAMELY, CONDUCTING SEMINARS IN THE FIELD OF MEDICAL CARE OF PATIENTS WITH CANCER; ARRANGING AND CONDUCTING EDUCATIONAL CONFERENCES AND PROVIDING CONTINUING EDUCATION MATERIALS AND PUBLICATIONS IN THE FIELD OF ONCOLOGY IN CONNECTION THEREWITH (U.S. CLS. 100, 101 AND 107).

FIRST USE 4-2-2008; IN COMMERCE 4-2-2008.

**CLASS 42—SCIENTIFIC AND COMPUTER SERVICES**

FOR MEDICAL RESEARCH, NAMELY, PATIENT-ORIENTED RESEARCH IN THE FIELD OF CANCER; PROVIDING CLINICAL AND RESEARCH INFORMATION IN THE FIELD OF CLINICAL ONCOLOGY VIA A MULTI-USER GLOBAL COMPUTER INFORMATION NETWORK (U.S. CLS. 100 AND 101).

FIRST USE 4-2-2008; IN COMMERCE 4-2-2008.

**CLASS 44—MEDICAL, BEAUTY AND AGRICULTURAL SERVICES**

FOR PROVIDING A WEBSITE THAT FEATURES CANCER-RELATED INFORMATION FOR PATIENTS AND THEIR FAMILIES AND FOR PHYSICIANS, NAMELY, AN INTERNET WEB PORTAL FOR INTERACTIVE CANCER-RELATED DIAGNOSIS AND TREATMENT DATA AND INFORMATION INCLUDING CANCER-RELATED TRADE PUBLICATIONS FOR PATIENTS AND THEIR FAMILIES, FOR PHYSICIANS, AND FOR DONORS; THAT FEATURES INTERACTIVE CANCER-RELATED MEDICAL AND PATIENT INFORMATION; THAT FEATURES STATIC AND INTERACTIVE MEDICAL, INFORMATION, AND CONSULTANCY RELATING TO ALLEVIATION, DIAGNOSIS, PREVENTION AND TREATMENT OF DISEASES INCLUDING BUT NOT LIMITED TO CANCER; PROVIDING INFORMATION FOR USE BY PHYSICIANS, OTHER HEALTH CARE PROVIDERS, AND RESEARCHERS IN THE FIELD OF NEOPLASTIC DISEASES; PROVIDING PATIENT INFORMATION IN THE FIELD OF CLINICAL ONCOLOGY VIA A MULTI-USER GLOBAL COMPUTER INFORMATION NETWORK (U.S. CLS. 100 AND 101).

FIRST USE 4-2-2008; IN COMMERCE 4-2-2008.

WILLIAM BRECKENFELD, EXAMINING ATTORNEY

**CLASS 45—PERSONAL AND LEGAL SERVICES**

FOR PROVIDING REGULATORY COMPLIANCE SUPPORT TO INDEPENDENT INVESTMENT ADVISORS, NAMELY, COMPLIANCE CONSULTING SERVICES THAT ASSIST INVESTMENT ADVISORS IN ENSURING THAT THEY ARE OPERATING WITHIN FEDERAL AND STATE SECURITIES AND INVESTMENT ADVISOR-RELATED LAWS AND REGULATIONS (U.S. CLS. 100 AND 101).

KATHLEEN LORENZO, EXAMINING ATTORNEY

SN 77-576,952. DE BEERS CENTENARY AG, 6000 LUZERN 6, SWITZERLAND, FILED 9-23-2008.

SN 77-536,976. COMMONWEALTH EQUITY SERVICES, LLP, WALTHAM, MA. FILED 8-1-2008.

RIA ONLY DOES NOT MEAN RIA  
ALONE

THE MARK CONSISTS OF STANDARD CHARACTERS WITHOUT CLAIM TO ANY PARTICULAR FONT, STYLE, SIZE, OR COLOR.

**CLASS 35—ADVERTISING AND BUSINESS**

FOR PROVIDING MARKETING SUPPORT FOR INDEPENDENT INVESTMENT ADVISORS, NAMELY, CREATING AND DESIGNING WEB-BASED AND PAPER-BASED PROMOTIONAL MATERIALS FOR OTHERS FOR DISSEMINATION BY INDEPENDENT INVESTMENT ADVISORS TO THEIR CLIENTS AND SUPPLYING PAPER-BASED MARKETING MATERIALS FOR DISSEMINATION BY INDEPENDENT INVESTMENT ADVISORS TO THEIR CLIENTS; PROVIDING CENTRALIZED BUSINESS SUPPORT FOR A NETWORK OF INDEPENDENT INVESTMENT ADVISORS, NAMELY, CENTRALIZED ACCOUNT BILLING, PREPARATION AND DISSEMINATION OF PERIODIC ASSET-HOLDINGS STATEMENTS, AND PREPARATION AND DISSEMINATION OF MARKET REPORTS (U.S. CLS. 100, 101 AND 102).

**CLASS 36—INSURANCE AND FINANCIAL**

FOR INVESTMENT ADVISORY SERVICES; PROVIDING INVESTMENT, FINANCIAL AND FINANCIAL ASSET MANAGEMENT ADVICE; FINANCIAL PLANNING AND FINANCIAL CONSULTING SERVICES; PROVIDING INVESTMENT MARKET RESEARCH SUPPORT FOR INDEPENDENT INVESTMENT ADVISORS, NAMELY, PROVIDING LINKS TO THE WEBSITES OF OTHERS IN THE FIELD OF INVESTMENT MARKET RESEARCH AND FINANCIAL CONSULTING PROVIDED BY INVESTMENT MARKET ANALYSTS (U.S. CLS. 100, 101 AND 102).

**FOREVERMARK DIAMOND  
INSTITUTE**

THE MARK CONSISTS OF STANDARD CHARACTERS WITHOUT CLAIM TO ANY PARTICULAR FONT, STYLE, SIZE, OR COLOR.

PRIORITY CLAIMED UNDER SEC. 44(D) ON ERPNCMNTY TM OFC APPLICATION NO. 006793699, FILED 3-31-2008, REG. NO. 006793699, DATED 5-13-2009, EXPIRES 3-31-2018.

OWNER OF U.S. REG. NO. 3,423,034.

NO CLAIM IS MADE TO THE EXCLUSIVE RIGHT TO USE "DIAMOND INSTITUTE", APART FROM THE MARK AS SHOWN.

**CLASS 9—ELECTRICAL AND SCIENTIFIC APPARATUS**

FOR ELECTRICAL AND ELECTRONIC MACHINES FOR USE IN CONNECTION WITH TESTING, ANALYSIS, INSPECTION AND CERTIFICATION OF GEMS AND GEMSTONES, NAMELY, ELECTRONIC INSTRUMENTS COMPRISING A CAMERA INTERFACING WITH A COMPUTER, THE CAMERA UTILIZING ILLUMINATION FROM AN ULTRAVIOLET LAMP, SAID INSTRUMENTS USED TO CREATE ELECTRONIC IMAGES OF DIAMONDS SO THAT THE NATURAL OR SYNTHETIC ORIGIN THEREOF CAN BE VERIFIED, ELECTRONIC INSTRUMENTS COMPRISING AN ANALYTICAL SPECTROMETER, AND ASSOCIATED OPTICAL AND ELECTRONIC PARTS, COUPLED TO A FIBRE-OPTIC PROBE, WHICH MEASURE THE INTENSITY OF RETRO-REFLECTED LIGHT, AND PROPRIETARY SOFTWARE TO VERIFY THE NATURAL OR SYNTHETIC ORIGIN OF DIAMONDS SOLD AS A UNIT THEREWITH, ELECTRONIC INSTRUMENTS COMPRISING PHOTOLUMINESCENCE SPECTROSCOPY APPARATUS INTERFACED WITH A PROCESSOR FOR ANALYZING THE SPECTRAL DATA FROM THE SPECTROMETER, FOR INDICATING WHETHER GEMSTONES ARE UNTREATED OR TREATED OR FOR VERIFYING THE NATURAL OR SYNTHETIC ORIGIN OF GEMSTONES; DATA CARRIERS FEATURING EDUCATIONAL MATERIALS IN THE FIELD OF DIAMONDS, JEWELLERY, PRECIOUS AND SEMI-PRECIOUS STONES, PRECIOUS METALS AND SEMI-PRECIOUS METALS, NAMELY, VIDEOTAPES, CD-ROMS, AUDIOTAPES AND TRANSMITTERS AND REPRODUCERS OF SOUND, IMAGES OR DATA; STRUCTURAL PARTS AND FITTINGS FOR ALL THE AFORESAID GOODS (U.S. CLS. 21, 23, 26, 36 AND 38).

**CLASS 35—ADVERTISING AND BUSINESS**

FOR TECHNICAL BUSINESS CONSULTANCY AND ADVISORY SERVICES RELATING TO THE ESTABLISHMENT OF RETAIL STORES, MAIL ORDER SERVICES, PRODUCT CATALOGUE ORDER SERVICES AND COMPUTER ORDER SERVICES, ALL IN THE FIELD OF DIAMONDS, JEWELRY, PRECIOUS AND SEMI-PRECIOUS STONES, PRECIOUS METALS AND SEMI-PRECIOUS METALS; REGISTERING DIAMONDS, JEWELRY, PRECIOUS AND SEMI-PRECIOUS STONES FOR OTHERS (U.S. CLS. 100, 101 AND 102).

**CLASS 37—CONSTRUCTION AND REPAIR**

FOR GEM AND JEWELLERY REPAIR AND CLEANING SERVICES, NAMELY, REMOUNTING, REPAIRING, MAINTAINING, TREATMENT AND CLEANING OF SEMI-PRECIOUS STONES, PRECIOUS STONES AND JEWELLERY (U.S. CLS. 100, 103 AND 106).

**CLASS 40—MATERIAL TREATMENT**

FOR ENGRAVING AND CUTTING OF DIAMONDS, JEWELLERY, PRECIOUS AND SEMI-PRECIOUS STONES; ENGRAVING OF SEMI-PRECIOUS METALS AND PRECIOUS METALS; ENGRAVING OF JEWELLERY IN SEMI-PRECIOUS AND PRECIOUS METALS; CUTTING AND INSCRIBING OF DIAMONDS, JEWELRY, PRECIOUS AND SEMI-PRECIOUS STONES (U.S. CLS. 100, 103 AND 106).

**CLASS 41—EDUCATION AND ENTERTAINMENT**

FOR EDUCATIONAL SERVICES, NAMELY, PROVIDING LIVE AND ON-LINE CLASSES COLLOQUIUMS, CONFERENCES, CONGRESSES, SEMINARS, SYMPOSIUMS AND WORKSHOPS IN THE FIELD OF PRECIOUS AND SEMI-PRECIOUS STONES AND JEWELLERY, INCLUDING DIAMONDS AND DIAMOND JEWELLERY; TRAINING SERVICES, NAMELY PROVIDING CLASSES COLLOQUIUMS, CONFERENCES, CONGRESSES, SEMINARS, SYMPOSIUMS AND WORKSHOPS IN THE FIELD OF PRECIOUS AND SEMI-PRECIOUS STONES AND JEWELLERY, INCLUDING DIAMONDS AND DIAMOND JEWELLERY; INSTRUCTION SERVICES IN THE FIELD OF PRECIOUS AND SEMI-PRECIOUS STONES AND JEWELLERY, INCLUDING DIAMONDS AND DIAMOND JEWELLERY; ARRANGING AND CONDUCTING OF SEMINARS AND CONFERENCES FOR TRAINING AND EDUCATIONAL PURPOSES IN THE FIELD OF PRECIOUS AND SEMI-PRECIOUS STONES AND JEWELLERY, INCLUDING DIAMONDS AND DIAMOND JEWELLERY; ARRANGING AND CONDUCTING OF WORKSHOPS FOR TRAINING AND EDUCATIONAL PURPOSES IN THE FIELD OF PRECIOUS AND SEMI-PRECIOUS STONES AND JEWELLERY, INCLUDING DIAMONDS AND DIAMOND JEWELLERY; PUBLISHING AND PUBLICATION OF BOOKS JOURNALS AND PRINTED MATTER, NAMELY MAGAZINES; PUBLISHING AND PUBLICATION OF CD-ROMS NAMELY, ELECTRONIC PUBLISHING SERVICES NAMELY, PUBLICATION OF TEXT AND GRAPHIC WORK OF OTHERS ON CD, DVD AND ON-LINE FEATURING INFORMATION ABOUT PRECIOUS AND SEMI-PRECIOUS STONES AND JEWELLERY INCLUDING DIAMONDS AND DIAMOND JEWELLERY (U.S. CLS. 100, 101 AND 107).

**CLASS 42—SCIENTIFIC AND COMPUTER SERVICES**

FOR SCIENTIFIC AND LABORATORY RESEARCH SERVICES IN THE FIELD OF MINERALS AND GEMS; QUALITY CONTROL SERVICES FOR OTHERS; MATERIALS TESTING AND ANALYSIS SERVICES; DESIGN, TESTING, INSPECTION OF SCIENTIFIC AND LABORATORY INSTRUMENTS FOR OTHERS; TECHNICAL RESEARCH IN THE FIELD OF MINERALS AND GEMS; MATERIAL TESTING, NAMELY, TESTING OF MINERALS AND GEMS; DESIGN AND DEVELOPMENT OF COMPUTER SOFTWARE FOR USE IN RELATION TO GEMOLOGICAL INSTRUMENTS AND SERVICES; GEMOLOGICAL SERVICES NAMELY, THE IDENTIFICATION AND GRADING OF DIAMONDS, JEWELLERY, PRECIOUS AND SEMI-PRECIOUS STONES; RESEARCH AND DEVELOPMENT SERVICES ALL IN THE FIELD OF IDENTIFYING, GRADING, REGISTERING, AND INSCRIBING DIAMONDS, JEWELLERY, PRECIOUS AND SEMI-PRECIOUS STONES, PRECIOUS METALS AND SEMI-PRECIOUS METALS (U.S. CLS. 100 AND 101).

MATTHEW EINSTEIN, EXAMINING ATTORNEY

SN 77-599,276, CHEIL INDUSTRIES INC., KYUNGSANG-  
BUK-DO, REPUBLIC OF KOREA, FILED 10-23-2008.

# 33 BY KUHO

THE MARK CONSISTS OF STANDARD CHARACTERS WITHOUT CLAIM TO ANY PARTICULAR FONT, STYLE, SIZE, OR COLOR.

PRIORITY CLAIMED UNDER SEC. 44(D) ON REPUBLIC OF KOREA APPLICATION NO. 2008-0027671, FILED 10-22-2008, REG. NO. 0195987, DATED 4-12-2010, EXPIRES 4-12-2020.

PRIORITY CLAIMED UNDER SEC. 44(D) ON REPUBLIC OF KOREA APPLICATION NO. 2008-0050195, FILED 10-22-2008, REG. NO. 0805826, DATED 11-10-2009, EXPIRES 11-10-2019.

PRIORITY CLAIMED UNDER SEC. 44(D) ON REPUBLIC OF KOREA APPLICATION NO. 2008-0050194, FILED 10-22-2008, REG. NO. 0805825, DATED 11-10-2009, EXPIRES 11-10-2019.

PRIORITY CLAIMED UNDER SEC. 44(D) ON REPUBLIC OF KOREA APPLICATION NO. 2008-0050193, FILED 10-22-2008, REG. NO. 0805824, DATED 11-10-2009, EXPIRES 11-10-2019.

THE NAME(S), PORTRAIT(S), AND/OR SIGNATURE(S) SHOWN IN THE MARK IDENTIFIES A LIVING INDIVIDUAL, WHOSE CONSENT(S) TO REGISTER IS MADE OF RECORD.

THE WORDING "KUHO" HAS NO MEANING IN A FOREIGN LANGUAGE.

**CLASS 14—JEWELRY**

FOR CLOCKS AND WATCHES; PARTS FOR WATCHES, NAMELY, BUCKLES FOR WATCHSTRAPS; INGOTS OF PRECIOUS METAL; PERSONAL ORNAMENTS OF PRECIOUS METAL, NAMELY, EARRINGS OF PRECIOUS METAL, ORNAMENTAL PINS OF PRECIOUS METAL AND BRACELETS OF PRECIOUS METAL; PERSONAL ORNAMENTS OF JEWELRY, NAMELY, PINS BEING JEWELRY, NECKLACES BEING JEWELRY, RINGS BEING JEWELRY AND BROOCHES BEING JEWELRY (U.S. CLS. 2, 27, 28 AND 50).

**CLASS 18—LEATHER GOODS**

FOR IMITATION LEATHER; BAGS, NAMELY, SCHOOL BAGS, BACKPACKS, RUCKSACKS, HANDBAGS, SHOULDER BAGS, ATHLETIC BAGS, WAIST BAGS, TRAVELING BAGS, BRIEFCASES AND SUITCASES; PURSES AND WALLETS; UMBRELLAS; PARASOLS (U.S. CLS. 1, 2, 3, 22 AND 41).

**CLASS 25—CLOTHING**

FOR FOOTWEAR, NAMELY, BOOTS, SHOES, SANDALS, SLIPPERS, GOLF SHOES, MOUNTAIN CLIMBING SHOES, FOOTBALL SHOES, SPORTS SHOES AND RUNNING SHOES; CLOTHING, NAMELY, TROUSERS, SUITS, DRESSES, SKIRTS, COATS, JACKETS, PARKAS, JUMPERS, SWEATERS, VESTS, PANTS, SHIRTS, CLOTHING FOR GYMNASTICS, NAMELY, UNITARD, LEOTARD AND LEG WARMERS, BATHING SUITS, DRESS SHIRTS, WHITE SHIRTS, POLO SHIRTS, T-SHIRTS, BLUE JEANS AND CARDIGANS; NECKTIES; SCARVES; SOCKS; STOCKINGS; GLOVES; HEADWEAR, NAMELY, CAPS AND SUN VISORS; WATERPROOF CLOTHING, NAMELY, WATERPROOF JACKETS AND RAIN COATS; BELTS FOR CLOTHING (U.S. CLS. 22 AND 39).

**CLASS 35—ADVERTISING AND BUSINESS**

FOR WHOLESALE STORES FEATURING WATCHES, CLOCKS, ORNAMENTS OF PRECIOUS METAL, ORNAMENTS OF JEWELRY, WALLETS, UMBRELLAS, PARASOLS, CLOTHING, SHOES AND CAPS; RETAIL STORES FEATURING WATCHES, CLOCKS, ORNAMENTS OF PRECIOUS METAL, ORNAMENTS OF JEWELRY, BAGS, WALLETS, UMBRELLAS, PARASOLS, CLOTHING, SHOES AND CAPS (U.S. CLS. 100, 101 AND 102).  
ALYSSA STEEL, EXAMINING ATTORNEY

SN 77-601,535. CLEARCANVAS INC., TORONTO, ONTARIO, CANADA, FILED 10-27-2008.



PRIORITY CLAIMED UNDER SEC. 44(D) ON CANADA APPLICATION NO. 1,394,309, FILED 4-29-2008, REG. NO. 792,389, DATED 3-9-2011, EXPIRES 3-9-2026.

THE MARK CONSISTS OF THREE SQUARES SURROUNDED BY A RING WITH THE WORDING "CLEAR-CANVAS" TO THE RIGHT OF THE DESIGN.

**CLASS 9—ELECTRICAL AND SCIENTIFIC APPARATUS**

FOR COMPUTER SOFTWARE, NAMELY, MEDICAL IMAGING SOFTWARE TO CAPTURE, STORE, RETRIEVE, READ, PROCESS, MANIPULATE AND ANALYZE DIGITAL INTERNAL IMAGES OF THE HUMAN BODY FOR USE IN DIAGNOSING AND TREATING MEDICAL CONDITIONS AND IMAGE-GUIDED SURGERY; COMPUTER SOFTWARE, NAMELY, COMPUTER FILING AND DATABASE SOFTWARE TO STORE, MANIPULATE, TRACK, SCHEDULE AND DISTRIBUTE PATIENT DATA; COMPUTER SOFTWARE, NAMELY, COMPUTER FILING AND DATABASE SOFTWARE TO MANAGE A RADIOLOGY INFORMATION SYSTEM; COMPUTER SOFTWARE, NAMELY, SOFTWARE THAT PERMITS THE USER TO DELIVER MEDICAL IMAGING FUNCTIONS OVER A GLOBAL COMPUTER NETWORK OR INTERNAL CORPORATE COMPUTER NETWORKS; COMPUTER SOFTWARE, NAMELY, COMPUTER PLATFORM SOFTWARE IN THE FIELD OF MEDICAL IMAGING TO PERMIT THE INTEGRATION OF COMMON MEDICAL IMAGING FUNCTIONS WITH SOPHISTICATED MEDICAL IMAGING SOFTWARE; COMPUTER SOFTWARE TOOL KIT CONTAINING A LIBRARY OF APPLICATION COMPONENT PARTS FOR USE IN DEVELOPING COMPUTER SOFTWARE APPLICATIONS (U.S. CLS. 21, 23, 26, 36 AND 38).

**CLASS 41—EDUCATION AND ENTERTAINMENT**

FOR EDUCATIONAL SERVICES, NAMELY, PROVIDING TRAINING IN THE USE OF MEDICAL IMAGING SOFTWARE TO MANUFACTURERS OR USERS OF SOPHISTICATED MEDICAL IMAGING SOFTWARE (U.S. CLS. 100, 101 AND 107).

**CLASS 42—SCIENTIFIC AND COMPUTER SERVICES**

FOR COMPUTER PROGRAMMING SERVICES, NAMELY, PROGRAMMING MEDICAL IMAGING SOFTWARE TO THE SPECIFICATIONS OF MANUFACTURERS OR USERS OF SOPHISTICATED MEDICAL IMAGING AND DIAGNOSTIC EQUIPMENT; COMPUTER CONSULTING SERVICES, NAMELY, TECHNICAL SUPPORT AND ADVISING MANUFACTURERS OR USERS OF SOPHISTICATED MEDICAL IMAGING AND DIAGNOSTIC EQUIPMENT; COMPUTER SUPPORT SERVICES, NAMELY, PROVIDING INSTALLATION AND TECHNICAL SUPPORT FOR COMPUTER MEDICAL IMAGING SOFTWARE (U.S. CLS. 100 AND 101).  
REGINA DRUMMOND, EXAMINING ATTORNEY

SN 77-611,493. ALL OF THE ABOVE, SASKATOON, CANADA, FILED 11-10-2008.

**ALL OF THE ABOVE**

THE MARK CONSISTS OF STANDARD CHARACTERS WITHOUT CLAIM TO ANY PARTICULAR FONT, STYLE, SIZE, OR COLOR.

PRIORITY CLAIMED UNDER SEC. 44(D) ON CANADA APPLICATION NO. 1417589, FILED 11-7-2008.

OWNER OF CANADA REG. NO. TMA790132, DATED 2-9-2011, EXPIRES 2-9-2026.



**CLASS 9—ELECTRICAL AND SCIENTIFIC APPARATUS**

FOR MUSICAL SOUND RECORDINGS, NAMELY, PRE-RECORDED CDS FEATURING MUSICAL PERFORMANCES (U.S. CLS. 21, 23, 26, 36 AND 38).

FIRST USE 12-31-2005; IN COMMERCE 10-21-2006.

**CLASS 41—EDUCATION AND ENTERTAINMENT**

FOR ENTERTAINMENT SERVICES IN THE NATURE OF LIVE PERFORMANCES BY A MUSICAL GROUP (U.S. CLS. 100, 101 AND 107).

FIRST USE 12-31-2005; IN COMMERCE 10-21-2006.

MARIAM MAHMOUDI, EXAMINING ATTORNEY

**CLASS 35—ADVERTISING AND BUSINESS**

FOR PROVIDING INDEXES OF SECURITIES VALUES AND FINANCIAL DATA RELATED TO SECURITIES VALUES VIA A GLOBAL COMPUTER NETWORK (U.S. CLS. 100, 101 AND 102).

**CLASS 36—INSURANCE AND FINANCIAL**

FOR PROVIDING FINANCIAL INFORMATION (U.S. CLS. 100, 101 AND 102).

ARETHA SOMERVILLE, EXAMINING ATTORNEY

SN 77-649,172. LA COLMENA, INC., MIAMI, FL. FILED 1-14-2009.

# LA COLMENA

THE MARK CONSISTS OF STANDARD CHARACTERS WITHOUT CLAIM TO ANY PARTICULAR FONT, STYLE, SIZE, OR COLOR.

THE ENGLISH TRANSLATION OF THE WORD "LA COLMENA" IN THE MARK IS "BEEHIVE".

**CLASS 29—MEATS AND PROCESSED FOODS**

FOR PROCESSED BEE POLLEN FOR FOOD USE, PROCESSED CHICKPEAS, LENTILS, SOYBEANS (U.S. CL. 46).

FIRST USE 4-24-1989; IN COMMERCE 12-31-1989.

**CLASS 30—STAPLE FOODS**

FOR HONEY, ROYAL JELLIES, PROPOLIS FOR FOOD PURPOSES, OAT BRAN, AND WHEAT GERM (U.S. CL. 46).

FIRST USE 4-24-1989; IN COMMERCE 12-31-1989.

APRIL ROACH, EXAMINING ATTORNEY

SN 77-661,593. DOW JONES & COMPANY, INC., NEW YORK, NY. FILED 2-2-2009.

# iStats

THE MARK CONSISTS OF STANDARD CHARACTERS WITHOUT CLAIM TO ANY PARTICULAR FONT, STYLE, SIZE, OR COLOR.

**CLASS 9—ELECTRICAL AND SCIENTIFIC APPARATUS**

FOR COMPUTER SOFTWARE FOR PROVIDING AN ON-LINE DATABASE OF INDEXES OF SECURITIES VALUES AND RELATED FINANCIAL DATA (U.S. CLS. 21, 23, 26, 36 AND 38).

SN 77-664,680. HIGHER COLLEGE OF TECHNOLOGY, ABU DHABI, UNITED ARAB EMIR., FILED 2-5-2009.



NO CLAIM IS MADE TO THE EXCLUSIVE RIGHT TO USE "EDUCATION", APART FROM THE MARK AS SHOWN.

THE COLOR(S) BLUE, BLACK AND RED IS/ARE CLAIMED AS A FEATURE OF THE MARK.

THE MARK CONSISTS OF THE WORDS "EDUCATION WITHOUT BORDERS" IN STYLIZED FORM. THE "E" IN THE WORD "EDUCATION" IS BLUE, SURROUNDED BY A BLACK OVAL AND BLUE SQUARES AND OUTLINED IN BLACK. THE LETTERS "DUCATION" ARE IN RED, AND BENEATH THEM ARE THE WORDS "WITHOUT BORDERS" IN BLUE. ABOVE THE "DUCATION" IS ARABIC WRITING IN BLUE.

THE ENGLISH TRANSLATION OF THE ARABIC WRORDING IN THE MARK IS EDUCATION WITHOUT BORDERS.

THE NON-LATIN CHARACTERS IN THE MARK TRANSLITERATE TO "TAALEEM BILA HODOOD" AND THIS MEANS "EDUCATION WITHOUT BORDERS" IN ENGLISH.

**CLASS 16—PAPER GOODS AND PRINTED MATTER**

FOR PAPER, CARDBOARD AND GOODS MADE FROM THESE MATERIALS, NAMELY, SIGN BOARDS; BOOKLETS WITH INFORMATION ON EDUCATIONAL FORUMS AND THE SPEAKERS AND TOPICS COVERED AT SUCH FORUMS; NOTE PADS; AND PAPER NAME BADGES (U.S. CLS. 2, 5, 22, 23, 29, 37, 38 AND 50).

**CLASS 41—EDUCATION AND ENTERTAINMENT**

FOR EDUCATION AND TRAINING SERVICES, NAMELY, PROVIDING CLASSES, SEMINARS AND DISTANCE LEARNING INSTRUCTION AT THE UNIVERSITY AND POST-GRADUATE LEVELS IN THE FIELDS OF SCIENCE AND TECHNOLOGY; CONDUCTING EDUCATIONAL FORUMS TO DISCUSS THE LATEST DEVELOPMENTS IN CREATIVE SCIENCES AND SCIENTIFIC, LOGICAL AND INFLUENTIAL THINKING (U.S. CLS. 100, 101 AND 107).

EUGENIA MARTIN, EXAMINING ATTORNEY

SN 77-679,460. VERSAFLEX, INC., DBA BRIDGE PRESERVATION, KANSAS CITY, KS. FILED 2-26-2009.



NO CLAIM IS MADE TO THE EXCLUSIVE RIGHT TO USE "BRIDGE PRESERVATION", APART FROM THE MARK AS SHOWN.

THE MARK CONSISTS OF THE LITERAL ELEMENT "BRIDGE PRESERVATION" IN STYLIZED LETTERS AND A DESIGN.

#### CLASS 2—PAINTS

FOR SPRAY COATINGS, NAMELY, SPRAY COATINGS FOR USE ON BUILDING STRUCTURES AND ROADWAY STRUCTURES AS CONCRETE SEALERS, CORROSION INHIBITANTS, EXTERIOR SURFACE PROTECTIVE COATINGS, AND ELASTOMERIC-BASED COATINGS FOR USE ON BUILDING STRUCTURES AND ROADWAY STRUCTURES; COATINGS IN THE NATURE OF SPRAY COATINGS, NAMELY, CONCRETE SEALERS, CORROSION INHIBITANTS, EXTERIOR SURFACE PROTECTIVE COATINGS, AND ELASTOMERIC-BASED COATINGS FOR USE ON BUILDING STRUCTURES AND ROADWAY STRUCTURES; POLYUREA ELASTOMER SPRAY COATING MATERIAL FOR USE ON BUILDING STRUCTURES AND ROADWAY STRUCTURES (U.S. CLS. 6, 11 AND 16).

#### CLASS 17—RUBBER GOODS

FOR SEALANTS, NAMELY, WATERPROOFING AND WEATHERIZING SEALANTS FOR USE ON BUILDING STRUCTURES AND ROADWAY STRUCTURES; POLYUREA SEALANTS, NAMELY, WATERPROOFING AND WEATHERIZING SEALANTS FOR USE ON BUILDING STRUCTURES AND ROADWAY STRUCTURES; BRIDGE DECK MEMBRANE FOR WEATHERIZING AND WATER PROOFING ROADWAY STRUCTURES; CATHODIC DISBONDMENT RESISTANT MEMBRANE FOR WEATHERIZING AND WATER PROOFING ROADWAY STRUCTURES (U.S. CLS. 1, 5, 12, 13, 35 AND 50).  
ANGELA M. MICHELL, EXAMINING ATTORNEY

SN 77-681,984. THERMTROL CORPORATION, NORTH CANTON, OH. FILED 3-3-2009.

**THERMTROL**

THE MARK CONSISTS OF STANDARD CHARACTERS WITHOUT CLAIM TO ANY PARTICULAR FONT, STYLE, SIZE, OR COLOR.

#### CLASS 9—ELECTRICAL AND SCIENTIFIC APPARATUS

FOR ELECTRICAL WIRING ASSEMBLIES COMPRISED OF WIRE/CABLE, TERMINALS, CONNECTORS, LABELS, CABLE TIES, TAPE, HEAT SHRINKABLE INSULATION, MOLDED PLUGS/GROMMETS, AND ELECTRONIC DEVICES, NAMELY, FUSES, FERRITE BEADS, RESISTERS, CAPACITORS, DIODES, POWER SUPPLIES, LIGHT-EMITTING DIODES (LED'S), LIQUID CRYSTAL DISPLAYS (LCD'S), PRESSURE SENSORS, TEMPERATURE SENSORS, PRINTED CIRCUIT BOARDS, AND FLEXIBLE CIRCUITS, AND COMPONENTS FOR USE IN ELECTRONIC DEVICES, NAMELY, SWITCHES, BATTERIES, ANTENNAS, ELECTRIC MOTORS, THERMOSTATS, SPEAKERS, MICROPHONES, FANS, PUMPS, LAMPS, BALLASTS, SOLENOIDS, ELECTRICAL OUTLETS AND LIGHT SOCKETS; ALL OF THE FOREGOING SOLD TOGETHER AS ELECTRICAL WIRING ASSEMBLY UNITS; ELECTRICAL WIRING HARNESES FOR USE WITH APPLIANCES, HEATING VENTILATING AIR CONDITIONING EQUIPMENT, INDUSTRIAL EQUIPMENT, ELECTRONICS, LIGHTING, AND FLOOR CARE DEVICES, NAMELY, VACUUM CLEANERS AND CARPET STEAMERS; ELECTRICAL WIRING HARNESES FOR USE WITH AGRICULTURAL EQUIPMENT, NAMELY, SEED PLANTERS, MOISTURE ANALYZERS OF GRAIN ELEVATORS, AND LEVELING APPARATUS OF GRAIN HOLDING BINS OF HARVESTING COMBINES; AND ELECTRICAL WIRING HARNESES FOR USE IN MEDICAL DEVICES (U.S. CLS. 21, 23, 26, 36 AND 38).

FIRST USE 3-31-1987; IN COMMERCE 3-31-1987.

#### CLASS 12—VEHICLES

FOR MOTORIZED LAND VEHICLE PARTS IN THE NATURE OF ELECTRICAL WIRE HARNESES, NAMELY, WIRES, TERMINALS AND CONNECTORS BUNDLED TOGETHER TO TRANSMIT ELECTRIC POWER AND SIGNALS TO ELECTRIC OR ELECTRONIC EQUIPMENT MOUNTED ON THE BODY PARTS OF AUTOMOBILES (U.S. CLS. 19, 21, 23, 31, 35 AND 44).

FIRST USE 3-31-1987; IN COMMERCE 3-31-1987.  
MARGARET POWER, EXAMINING ATTORNEY

SN 77-689,152. DENTACO DENTALINDUSTRIE UND - MARKETING GMBH, 61352 BAD HOMBURG, FED REP GERMANY, FILED 3-12-2009.

**scan'dry**

THE MARK CONSISTS OF STANDARD CHARACTERS WITHOUT CLAIM TO ANY PARTICULAR FONT, STYLE, SIZE, OR COLOR.

PRIORITY CLAIMED UNDER SEC. 44(D) ON ERPNTY TM OFC APPLICATION NO. 008115883, FILED 2-20-2009, REG. NO. 008115883, DATED 10-21-2009, EXPIRES 2-20-2019.

OWNER OF U.S. REG. NO. 3,297,502.

#### CLASS 1—CHEMICALS

FOR DIAGNOSTICS MEANS, NAMELY, DIAGNOSTIC PREPARATIONS FOR MEDICAL AND DENTISTRY LABORATORY USE; DELUSTERING MEANS, NAMELY, DIAGNOSTIC REAGENTS FOR MEDICAL LABORATORY USE (U.S. CLS. 1, 5, 6, 10, 26 AND 46).

**CLASS 5—PHARMACEUTICALS**

FOR DIAGNOSTIC PREPARATIONS FOR MEDICAL AND DENTISTRY PURPOSES; DELUSTERING MEANS, NAMELY, DELUSTERING AGENTS IN THE NATURE OF DIAGNOSTIC AGENTS FOR MEDICAL AND DENTISTRY PURPOSES (U.S. CLS. 6, 18, 44, 46, 51 AND 52).  
KATHERINE E. HALMEN, EXAMINING ATTORNEY

SN 77-691,270. ALPHA MEDIA GROUP, INC., NEW YORK, NY. FILED 3-15-2009.

# MAXIM

THE MARK CONSISTS OF STANDARD CHARACTERS WITHOUT CLAIM TO ANY PARTICULAR FONT, STYLE, SIZE, OR COLOR.

**CLASS 41—EDUCATION AND ENTERTAINMENT**

FOR NIGHT CLUB SERVICES; ON-LINE JOURNALS, NAMELY, BLOGS FEATURING GAMING, HUMOR, BEAUTY CONTESTS, MOVIES, BOOKS, SPORTS, VIDEOS, POPULAR CULTURE AND MEN'S LIFESTYLES; ENTERTAINMENT SERVICES, NAMELY, PROVIDING A WEB SITE FEATURING VIDEO REVIEWS, RELATED FILM CLIPS, AND PHOTOGRAPHS FEATURING MEN'S LIFESTYLES AND POPULAR CULTURE; ENTERTAINMENT SERVICES, NAMELY, PROVIDING A WEBSITE FEATURING ONLINE MAGAZINES, NEWS AND ARTICLES ON THE CONCERNS AND INTERESTS OF MEN, NAMELY, HISTORY, PHYSICAL FITNESS, SPORTS, BOOKS, MUSIC, POPULAR CULTURE, MOVIES, VIDEO GAMES, LITERATURE, FINE ARTS, COMPUTER GAME REVIEWS AND HUMOR-ORIENTED WRITINGS (U.S. CLS. 100, 101 AND 107).

**CLASS 43—HOTEL AND RESTAURANT SERVICES**

FOR COCKTAIL LOUNGE SERVICES (U.S. CLS. 100 AND 101).  
ROBERT C. CLARK JR., EXAMINING ATTORNEY

SN 77-705,354. EGALAX—EMPIA TECHNOLOGY INC., TAIPEI 114, TAIWAN, FILED 4-2-2009.



**eGalax Touch**

PRIORITY CLAIMED UNDER SEC. 44(D) ON TAIWAN APPLICATION NO. 097059086, FILED 12-30-2008, REG. NO. 01376954, DATED 9-1-2009, EXPIRES 8-31-2019.

PRIORITY CLAIMED UNDER SEC. 44(D) ON TAIWAN APPLICATION NO. 097059085, FILED 12-30-2008, REG. NO. 01367815, DATED 7-1-2009, EXPIRES 6-30-2019.

NO CLAIM IS MADE TO THE EXCLUSIVE RIGHT TO USE "TOUCH", APART FROM THE MARK AS SHOWN.

THE MARK CONSISTS OF THE WORDING "EGALAX TOUCH" IN ITALIC SCRIPT BELOW A CURVED LINE DRAWING.

**CLASS 9—ELECTRICAL AND SCIENTIFIC APPARATUS**

FOR COMPUTER HARDWARE, COMPUTER SOFTWARE FOR COMPUTER SYSTEM AND APPLICATION DEVELOPMENT, DEPLOYMENT AND MANAGEMENT, COMPUTER STYLUS, INTERFACES FOR COMPUTERS, INPUT DEVICES FOR COMPUTERS, ELECTRONIC TOUCH SENSITIVE SWITCHES FOR COMPUTERS, COMPUTER DIGITAL LCD PANELS, DIGITAL AUDIO PLAYERS, TELEVISION SET, WIRELESS TELEVISION SET FOR PROVIDING VIDEO CONFERENCING AND TELEPHONE SERVICE OVER THE INTERNET, COMPUTER CHIPS, SEMI-CONDUCTORS, INTEGRATED CIRCUITS, COMPUTER BUS SLOT, COMPUTER BUSES, CONTROL PANELS, NAMELY, ELECTRIC CONTROL PANELS; PLATES FOR MONITORS, NAMELY, GLASS SCREEN PLATES FOR COMPUTER MONITOR SCREENS; INFRARED RAY SENSORS, VENDING MACHINES, METERS FOR MEASURING ELECTRIC CAPACITY AND ELECTRICAL RESISTANCE (U.S. CLS. 21, 23, 26, 36 AND 38).

**CLASS 42—SCIENTIFIC AND COMPUTER SERVICES**

FOR ANIMATION AND SPECIAL-EFFECTS DESIGN FOR COMPUTERS, COMPUTER DRAFTING, COMPUTER PROGRAMMING, COMPUTER SOFTWARE DESIGN, UPDATING OF COMPUTER SOFTWARE, COMPUTER SOFTWARE INSTALLATION AND MAINTENANCE, COMPUTER SOFTWARE RENTAL, CONSULTATION IN THE FIELD OF COMPUTER SOFTWARE DESIGN, COMPUTER SOFTWARE CONSULTATION, COMPUTER SYSTEM ANALYSIS, COMPUTER SYSTEMS DESIGN, DUPLICATION OF COMPUTER PROGRAMS, CONVERSION OF PHYSICAL IMAGES INTO DIGITAL FORMATS, PROVIDING TECHNICAL INFORMATION IN THE FIELD OF COMPUTER TECHNOLOGY AND PROGRAMMING VIA THE GLOBAL COMPUTER NETWORK, DESIGN OF NEW PRODUCTS IN THE FIELD OF INDUSTRY, DESIGN AND DEVELOPMENT OF COMPUTER HARDWARE, DESIGN AND INSPECTION OF INTEGRATED CIRCUITS, DESIGN AND DEVELOPMENT IN THE FIELD OF AUTOMATIC CONTROL SYSTEM, DESIGN AND DEVELOPMENT IN THE FIELD OF AUDIO AND VIDEO EQUIPMENT, DESIGN AND DEVELOPMENT IN THE FIELD OF COMMUNICATION SYSTEM AND EQUIPMENT, DESIGN AND DEVELOPMENT OF CENTRAL MONITOR CONTROL SYSTEM, DESIGN AND DEVELOPMENT OF METER CONTROL EQUIPMENT, DESIGN OF REFILL EQUIPMENT AT GAS STATION, DESIGN AND DEVELOPMENT OF ANTI-THEFT SYSTEM, DESIGN AND DEVELOPMENT OF VIDEO CONFERENCING PROGRAM (U.S. CLS. 100 AND 101).

ELLEN PERKINS, EXAMINING ATTORNEY

SN 77-711,826. WYNRIGHT CORPORATION, ELK GROVE VILLAGE, IL. FILED 4-10-2009.



THE MARK CONSISTS OF THE TERM "WYNRIGHT" WITH A LINE OF SMALL DIAMONDS ABOVE THE FIRST FOUR LETTERS AND A LARGER CUBE FORMING THE DOT ABOVE THE LETTER "I" IN THE TERM "WYNRIGHT".

#### CLASS 7—MACHINERY

FOR INTEGRATED MATERIALS HANDLING SYSTEMS AND EQUIPMENT COMPRISED OF ONE OR MORE OF THE FOLLOWING: CONVEYORS, SORTATION EQUIPMENT IN THE NATURE OF TRAP ARM, PUSHER, BOW ARM, FLAT FACE ARM, POP-UP WHEEL, LINE, SLIDING SHOE AND MULTI-BELT SORTATION CONVEYORS TO MERGE, SORT, DISCHARGE, DIVERT AND MOVE CARTONS OR PRODUCT; DIRECTED PICKING SYSTEMS COMPRISED OF UNIT LOAD AND/OR MINI-LOAD AUTOMATED STORAGE AND RETRIEVAL MACHINERY, CAROUSELS, CARTON FLOW RACKS, PICK-TO-LIGHT, PUT-TO-LIGHT AND OTHER PICK STRUCTURES IN THE NATURE OF PICK MODULES AND MACHINERY TO RETRIEVE ITEMS OR PACKAGES, TOGETHER WITH OPERATIONAL SOFTWARE, HARDWARE AND OPERATORS' CONSOLES COMPRISING A COMPUTER MONITOR AND/OR ELECTRICAL CONTROL PANEL ALL SOLD AS A UNIT WITH THE SYSTEM; ELECTRICAL AND PNEUMATIC EQUIPMENT IN THE NATURE OF ROBOTIC MATERIAL HANDLING MACHINERY, NAMELY, ROBOTIC PALLETIZERS AND ROBOTIC TRUCK LOADERS FOR AUTOMATIC AND SEMI-AUTOMATIC STACKING OF CARTONS AND PRODUCT ON PALLETS AND FOR AUTOMATIC AND SEMI-AUTOMATIC LOADING OF CARTONS AND PRODUCT INTO TRUCKS; AND STRUCTURAL PARTS FOR THE FOREGOING, NAMELY, METAL STORAGE RACKS AND MEZZANINES (U.S. CLS. 13, 19, 21, 23, 31, 34 AND 35).

#### CLASS 9—ELECTRICAL AND SCIENTIFIC APPARATUS

FOR WAREHOUSE CONTROL SYSTEMS COMPRISED OF PROGRAMMABLE LOGIC CONTROLLERS (PLC) AND PERSONAL COMPUTERS (PC) AND RELATED OPERATIONAL SOFTWARE, INCLUDING PROPRIETARY PLC TO PC INTERFACE, AND HARDWARE SOLD AS A UNIT WITH THE SYSTEM; OPERATORS' CONSOLES COMPRISING A COMPUTER MONITOR AND/OR ELECTRIC CONTROL PANEL (U.S. CLS. 21, 23, 26, 36 AND 38).

#### CLASS 37—CONSTRUCTION AND REPAIR

FOR INSTALLATION, INSPECTION, SERVICE, MAINTENANCE AND REPAIR OF MATERIAL HANDLING SYSTEMS AND EQUIPMENT; TECHNICAL SUPPORT SERVICES IN THE NATURE OF TECHNICAL ADVICE RELATED TO ALL OF THE FOREGOING (U.S. CLS. 100, 103 AND 106).

#### CLASS 42—SCIENTIFIC AND COMPUTER SERVICES

FOR ENGINEERING, DESIGN AND TESTING FOR OTHERS OF MATERIAL HANDLING SYSTEMS AND EQUIPMENT; INSPECTION OF MATERIAL HANDLING SYSTEMS AND EQUIPMENT; TECHNICAL SUPPORT SERVICES IN THE NATURE OF TECHNICAL ADVICE RELATED TO THE INSPECTION OF MATERIAL HANDLING SYSTEMS AND EQUIPMENT (U.S. CLS. 100 AND 101).

ALICIA COLLINS, EXAMINING ATTORNEY

SN 77-760,807. AMERICAN ISRAEL EDUCATION FOUNDATION, WASHINGTON, DC. FILED 6-16-2009.

# AIEF

THE MARK CONSISTS OF STANDARD CHARACTERS WITHOUT CLAIM TO ANY PARTICULAR FONT, STYLE, SIZE, OR COLOR.

#### CLASS 16—PAPER GOODS AND PRINTED MATTER

FOR PUBLICATIONS, NAMELY, BROCHURES, HAND-OUTS, NEWSLETTERS, AND REPORTS IN THE FIELD OF PROMOTING THE RELATIONSHIP BETWEEN THE UNITED STATES AND ISRAEL ON A BROAD RANGE OF TOPICS (U.S. CLS. 2, 5, 22, 23, 29, 37, 38 AND 50).

#### CLASS 35—ADVERTISING AND BUSINESS

FOR ASSOCIATION SERVICES, NAMELY, PROMOTING THE INTERESTS OF AMERICANS INTERESTED IN MAINTAINING AND IMPROVING FRIENDSHIP AND GOODWILL BETWEEN THE UNITED STATES AND ISRAEL (U.S. CLS. 100, 101 AND 102).

#### CLASS 41—EDUCATION AND ENTERTAINMENT

FOR PUBLICATION OF BROCHURES, HAND-OUTS, NEWSLETTERS, AND REPORTS FOR THE PRESS AND MEDIA IN THE FIELD OF PROMOTING THE RELATIONSHIP BETWEEN THE UNITED STATES AND ISRAEL; EDUCATIONAL CONFERENCES RELATING TO THE RELATIONSHIP BETWEEN THE UNITED STATES AND ISRAEL (U.S. CLS. 100, 101 AND 107).

NAKIA HENRY, EXAMINING ATTORNEY

SN 77-790,591. SYNTOPIX GROUP PLC, BRADFORD, UNITED KINGDOM, FILED 7-27-2009.

# SYNTOPIX

THE MARK CONSISTS OF STANDARD CHARACTERS WITHOUT CLAIM TO ANY PARTICULAR FONT, STYLE, SIZE, OR COLOR.

PRIORITY CLAIMED UNDER SEC. 44(D) ON ERPNCMNTY TM OFC APPLICATION NO. 00838184, FILED 6-23-2009.

OWNER OF UNITED KINGDOM REG. NO. 2554451, DATED 6-23-2009, EXPIRES 6-23-2019.  
OWNER OF ERPN CMNTY TM OFC REG. NO. 004800116, DATED 12-11-2006, EXPIRES 12-22-2015.

### CLASS 1—CHEMICALS

FOR CHEMICALS FOR USE IN INDUSTRY AND SCIENCE; CHEMICAL SUBSTANCES FOR PRESERVING FOODSTUFFS; CHEMICALS FOR USE IN THE MANUFACTURE OF BIOTECHNOLOGICAL PRODUCTS, COSMETICS, DENTAL PRODUCTS, HEALTHCARE PRODUCTS, HYGIENE PRODUCTS, MEDICINAL PRODUCTS, ORAL CARE PRODUCTS, PERSONAL CARE PRODUCTS, PHARMACEUTICALS, SANITARY PRODUCTS AND TOILETRIES; CHEMICALS FOR USE IN BIOTECHNOLOGICAL PRODUCT DEVELOPMENT AND MANUFACTURING PROCESSES; CHEMICAL ADDITIVES FOR USE AS ANTIMICROBIAL INGREDIENTS IN THE MANUFACTURE OF A WIDE VARIETY OF GOODS IN THE BIOTECHNOLOGY, COSMETICS, MEDICINE, PHARMACEUTICAL, SANITARY AND TOILETRY INDUSTRIES; ACTIVE CHEMICAL INGREDIENTS FOR USE IN THE MANUFACTURE OF ANTIMICROBIAL BALMS, COATINGS, CREAMS, GELS, LINIMENTS, LIQUIDS, LOTIONS, OINTMENTS, POWDERS, SALVES AND SPRAYS; ACTIVE CHEMICAL INGREDIENTS FOR USE IN THE MANUFACTURE OF PHARMACEUTICALS FOR TREATING DENTAL AND DERMATOLOGICAL CONDITIONS AND INFECTIONS; ACTIVE CHEMICAL INGREDIENTS FOR USE IN THE MANUFACTURE OF COSMETICS AND PERSONAL CARE COMPOSITIONS (U.S. CLS. 1, 5, 6, 10, 26 AND 46).

### CLASS 3—COSMETICS AND CLEANING PREPARATIONS

FOR BLEACHING PREPARATIONS FOR LAUNDRY USE; DETERGENTS AND SOAPS FOR LAUNDRY USE; CLEANING PREPARATIONS; SOAPS; ESSENTIAL OILS; COSMETICS, HAIR LOTIONS; DENTIFRICES; ANTIPERSPIRANTS; CLEANSING PREPARATIONS, NAMELY, FACIAL CLEANSERS AND SKIN CLEANSERS; DENTAL CARE PREPARATIONS, NAMELY, TOOTHPASTES AND NON-MEDICATED DENTAL RINSES; DEODORANTS FOR PERSONAL USE; PERSONAL CARE PREPARATIONS, NAMELY, BODY LOTIONS, BODY AND FOOT SCRUBS, HAIR CONDITIONERS, SKIN CONDITIONERS, LIP BALMS, NON-MEDICATED SKIN CREAMS, SHAVING GELS AND SHAVING LOTIONS; PREPARATIONS FOR CLEANING DENTURES; PREPARATIONS FOR PERSONAL HYGIENE, NAMELY, BABY WIPES, DISPOSABLE WIPES IMPREGNATED WITH CLEANSING CHEMICALS OR COMPOUNDS FOR PERSONAL HYGIENE USE, FEMININE HYGIENE CLEANSING TOWELETTES, NON-MEDICATED FEMININE HYGIENE WASHES, AND PRE-MOISTENED COSMETIC WIPES; NON-MEDICATED PREPARATIONS FOR THE CARE OF THE SKIN, HAIR AND SCALP; NON-MEDICATED ACNE TREATMENT PREPARATIONS; TOILET PREPARATIONS, NAMELY, BATH AND SHOWER CREAMS, BATH AND SHOWER FOAMS, BATH AND SHOWER GELS, BATH LOTIONS, BATH OILS, BATH SALTS AND TOILET WATERS; NON-MEDICATED TOILETRIES; WASHING PREPARATIONS, NAMELY, WASHING POWDER AND WASHING-UP LIQUIDS; FACE CLEANSING WASHES, HAND CLEANSING WASHES, MOUTH WASHES (U.S. CLS. 1, 4, 6, 50, 51 AND 52).

### CLASS 5—PHARMACEUTICALS

FOR PHARMACEUTICAL PREPARATIONS FOR THE TREATMENT OF DENTAL CONDITIONS, DERMATOLOGICAL CONDITIONS, SKIN INFECTIONS AND WOUNDS; VETERINARY PREPARATIONS FOR THE TREATMENT OF SKIN INFECTIONS AND WOUNDS IN PETS, FARM ANIMALS AND LIVESTOCK; SANITARY PREPARATIONS FOR MEDICAL PURPOSES; DIETETIC SUBSTANCES ADAPTED FOR MEDICAL USE, FOOD FOR BABIES; MEDICAL PLASTERS, MEDICAL DRESSINGS; MATERIAL FOR STOPPING TEETH, DENTAL WAX; ALL PURPOSE DISINFECTANTS; DISINFECTANTS FOR HYGIENIC AND SANITARY PURPOSES; PREPARATIONS FOR DESTROYING VERMIN; FUNGICIDES; ANTIMICROBIAL COATINGS TO TREAT

THE GROWTH OF MOLD, MILDEW, BACTERIA AND FUNGUS ON VARIOUS SURFACES; ANTIMICROBIAL PREPARATIONS FOR INHIBITING MICROBIOLOGICAL DECOMPOSITION IN FOOD, BEVERAGES, ANIMAL FEED AND PHARMACEUTICALS; ANTIMICROBIAL ADDITIVES IN THE NATURE OF PRESERVATIVES FOR COSMETICS AND PHARMACEUTICALS; ANTIMICROBIALS FOR DERMATOLOGIC USE; ANTIMICROBIAL FORMULATIONS AND PREPARATIONS, NAMELY, BALMS, CREAMS, GELS, LINIMENTS, LIQUIDS, LOTIONS, OINTMENTS, POWDERS, SALVES AND SPRAYS; ANTISEPTICS; BACTERICIDES; BIOLOGICAL PREPARATIONS FOR USE IN BIOTECHNOLOGY; BIOTECHNOLOGICAL PREPARATIONS FOR MEDICAL OR VETERINARY USE; DENTAL AND ORAL CARE PREPARATIONS, NAMELY, MEDICATED DENTAL HEALTH GUM, MEDICATED DENTAL FLOSS, MEDICATED MOUTH CARE AND TREATMENT PREPARATIONS, AND MEDICATED THROAT SPRAYS; HOUSEHOLD DEODORANTS; DERMATOLOGICAL PHARMACEUTICAL PRODUCTS; MEDICATED SKIN CLEANING PREPARATIONS; MEDICATED HAIR AND SKIN WASHING PREPARATIONS; MEDICATED FACE WASHES, HAND WASHES AND MOUTH WASHES; MEDICATED TOILET PREPARATIONS, NAMELY, MEDICATED BATH PREPARATIONS, MEDICATED COSMETICS AND MEDICATED SHAMPOO; NUTRACEUTICALS FOR USE AS A DIETARY SUPPLEMENT; NUTRACEUTICALS FOR THE TREATMENT OF SKIN CONDITIONS; PREPARATIONS FOR PERSONAL CARE AND HYGIENE, NAMELY, ANTIBACTERIAL SPRAYS, MEDICATED PREPARATIONS FOR THE CARE OF THE SKIN, HAIR AND SCALP, MEDICATED BODY LOTIONS, MEDICATED LIP BALMS, MEDICATED PRE-MOISTENED WIPES AND TOWELETTES, MEDICATED SHAVING PREPARATIONS, AND SPRAY SANITIZERS FOR PERSONAL USE; PREPARATIONS FOR THE TREATMENT OF ACNE; ANTIMICROBIAL PRESERVATIVES FOR USE IN THE MANUFACTURE OF COSMETICS, PERSONAL CARE COMPOSITIONS AND PHARMACEUTICALS (U.S. CLS. 6, 18, 44, 46, 51 AND 52).

### CLASS 42—SCIENTIFIC AND COMPUTER SERVICES

FOR SCIENTIFIC AND TECHNOLOGICAL SERVICES, NAMELY, ANTIMICROBIAL DISCOVERY SERVICES AND SCIENTIFIC RESEARCH, PRODUCT DESIGN AND PRODUCT DEVELOPMENT IN THE FIELDS OF COSMETICS, TOILETRIES, PHARMACEUTICALS, MEDICINAL PRODUCTS AND HEALTHCARE; SCIENTIFIC RESEARCH; INDUSTRIAL RESEARCH SERVICES IN THE FIELDS OF COSMETICS, TOILETRIES, PHARMACEUTICALS, MEDICINAL PRODUCTS AND HEALTHCARE; MEDICAL RESEARCH; SCIENTIFIC CONSULTATION IN THE FIELDS OF RESEARCH AND DEVELOPMENT OF COSMETICS, TOILETRIES, PHARMACEUTICALS, MEDICINAL PRODUCTS AND HEALTHCARE PRODUCTS; PRODUCT TESTING AND EVALUATION IN THE NATURE OF SCIENTIFIC RESEARCH INTO THE EFFECTIVENESS OF PHARMACEUTICAL, BIOTECH, MEDICINAL AND HEALTHCARE PRODUCTS FOR THEIR STATED PURPOSE OR DESIGN; PRODUCT DESIGN CONSULTANCY IN THE FIELDS OF COSMETICS, TOILETRIES, PHARMACEUTICALS, MEDICINAL PRODUCTS AND HEALTHCARE; QUALITY ASSURANCE CONSULTANCY IN THE FIELDS OF COSMETICS, TOILETRIES, PHARMACEUTICALS, MEDICINAL PRODUCTS AND HEALTHCARE; SCIENTIFIC CONSULTANCY IN THE FIELDS OF MICROBIOLOGY, THE DISCOVERY OF ANTIMICROBIALS AND COSMETICS RESEARCH; CONSULTANCY RELATING TO BIOTECHNOLOGY; DRUG AND ANTIMICROBIAL DEVELOPMENT SERVICES; DEVELOPMENT OF PRODUCTS FOR THE TREATMENT OF DERMATOLOGICAL AND MEDICAL CONDITIONS; ANTIMICROBIAL AND PHARMACOLOGICAL SCREENING FOR FORENSIC RESEARCH PURPOSES; PROVIDING MEDICAL AND SCIENTIFIC RESEARCH INFORMATION IN THE FIELD OF PHARMACEUTICALS, NAMELY, PROVISION OF IN VITRO MODELS OF TOXICITY AND OF PHARMACOLOGICAL ACTIVITIES; CONDUCTING CLINICAL TRIALS, NAMELY, IN VITRO AND IN VIVO EVALUATION OF PHARMACEUTICALS, MEDICINAL PRODUCTS AND HEALTHCARE; MEDICAL AND SCIENTIFIC RESEARCH, NAMELY, CLINICAL TRIALS; ADVISORY

AND CONSULTANCY SERVICES RELATING TO ALL THE AFORESAID SERVICES; CONSULTANCY RELATING TO SKIN MICROBIOLOGY AND ANTIBIOTIC RESISTANCE EVALUATION AND RESEARCH (U.S. CLS. 100 AND 101).

#### **CLASS 44—MEDICAL, BEAUTY AND AGRICULTURAL SERVICES**

FOR MEDICAL SERVICES; VETERINARY SERVICES; ADVISORY AND CONSULTANCY SERVICES RELATING TO ALL THE AFORESAID SERVICES; CONSULTANCY RELATING TO HEALTH CARE, VETERINARY SERVICES AND NUTRITION; PROFESSIONAL CONSULTANCY RELATING TO THE USE OF PHARMACEUTICAL, BIOTECH AND MEDICINAL PRODUCTS; ANTIMICROBIAL AND PHARMACOLOGICAL SCREENING FOR MEDICAL AND VETERINARY PURPOSES; SCIENTIFIC CONSULTANCY IN THE FIELD OF HEALTHCARE; CONSULTANCY RELATING TO PHARMACEUTICALS AND MEDICINAL PRODUCTS (U.S. CLS. 100 AND 101).

KATHERINE CHANG, EXAMINING ATTORNEY

#### **CLASS 9—ELECTRICAL AND SCIENTIFIC APPARATUS**

FOR COMPUTER SOFTWARE FOR DATA MODELING; COMPUTER SOFTWARE FOR THE VALIDATION OF MODEL PREDICTIONS; COMPUTER SOFTWARE FOR SCIENTIFIC DATA ANALYSIS; DATA, NAMELY, ASSAY DATA IN THE FIELD OF THE PETROLEUM AND PETROCHEMICAL INDUSTRIES, RECORDED ON ELECTRONIC, OPTICAL OR MAGNETIC MEDIA; MAGNETIC DATA CARRIERS THAT ARE PRE-RECORDED WITH ELECTRONIC DATA AND ASSAY DATA AND COMPUTER SOFTWARE FOR DATA PROCESSING AND DATA ANALYSIS; RECORDING COMPACT DISCS, AND DVDS THAT ARE PRE-RECORDED WITH ELECTRONIC DATA AND ASSAY DATA AND COMPUTER SOFTWARE FOR DATA PROCESSING AND DATA ANALYSIS; DOWNLOADABLE ELECTRONIC PUBLICATIONS IN THE NATURE OF MANUALS, BROCHURES AND PRODUCT INFORMATION SHEETS IN THE FIELD OF THE PETROLEUM AND PETROCHEMICAL INDUSTRIES; CD-ROMS, DVD-ROMS AND COMPUTER DISCS BEARING SOFTWARE FOR THE EXPLORATION, PRODUCTION, REFINING AND TRADING OF CRUDE OIL AND CRUDE OIL PRODUCTS, AND PROCESS MANUFACTURING INDUSTRIES AND LOGISTICS RELATING TO THESE INDUSTRIES AND ELECTRONIC DATA, NAMELY, DATA RELATING TO CRUDE OIL IN THE FIELD OF OIL REFINING, PETROCHEMICAL ENGINEERING AND GAS AND OIL PROSPECTING, EXTRACTION AND RECOVERY, AND ASSAY DATA (U.S. CLS. 21, 23, 26, 36 AND 38).

SN 77-791,504. SPIRAL SOFTWARE LIMITED, CAMBRIDGE, UNITED KINGDOM, FILED 7-28-2009.



PRIORITY CLAIMED UNDER SEC. 44(D) ON ERPN CMNTY TM OFC APPLICATION NO. 008455511, FILED 7-28-2009, REG. NO. 008455511, DATED 4-26-2010, EXPIRES 7-28-2019.

THE MARK CONSISTS OF THE WORD "SPIRAL" IN STYLIZED FORMAT WITH A SPIRAL DESIGN INSIDE OF A SQUARE POSITIONED ON TOP OF THE WORDING.

#### **CLASS 35—ADVERTISING AND BUSINESS**

FOR COMPILATION, ANALYSIS, RETRIEVAL AND PROVISION OF BUSINESS DATA AND STATISTICAL INFORMATION FOR BUSINESS AND COMMERCIAL PURPOSES; MARKET ANALYSIS AND RESEARCH; MANAGEMENT OF COMMUNICATION NETWORKS; THE COMPILATION, ANALYSIS, RETRIEVAL AND PROVISION OF BUSINESS DATA AND STATISTICAL INFORMATION FOR BUSINESS AND COMMERCIAL PURPOSES, MARKET ANALYSIS AND RESEARCH AND MANAGEMENT OF COMMUNICATION NETWORKS, AND THAT ARE ALSO PROVIDED VIA THE INTERNET; PROVIDING INFORMATION ABOUT THE COST ASSESSMENT OF OIL FIELDS (U.S. CLS. 100, 101 AND 102).

#### **CLASS 42—SCIENTIFIC AND COMPUTER SERVICES**

FOR INSTALLATION OF COMPUTER SOFTWARE, RELATING ONLY TO MODELING, DETERMINING AND PREDICTING MATERIALS, MODELLING, SCHEDULING AND OPTIMISING PROCESSES, ALL SUCH DATA, INFORMATION, MATERIALS AND PROCESSES RELATING TO AND/OR USED IN THE EXPLORATION, PRODUCTION, REFINING AND TRADING OF CRUDE OIL AND CRUDE OIL PRODUCTS, AND PROCESS MANUFACTURING INDUSTRIES AND LOGISTICS RELATING TO THESE INDUSTRIES; MAINTENANCE AND TECHNICAL SUPPORT SERVICES, NAMELY, TROUBLESHOOTING OF COMPUTER SOFTWARE PROBLEMS; INSTALLATION, MAINTENANCE AND TECHNICAL SUPPORT SERVICES, NAMELY, IDENTIFYING, DIAGNOSING, ADVISING ON, CORRECTING, WORKING AROUND, REPAIRING COMPUTER SOFTWARE FAILURES, DEFECTS, BUGS AND ERRORS; PROVIDING INFORMATION ABOUT THE TECHNICAL ANALYSIS OF OIL FIELDS; PROVISION OF CONSULTANCY AND ADVISORY SERVICES IN THE FIELDS OF OIL PROSPECTING, PETROCHEMICAL ENGINEERING, AND GAS AND OIL LOCATION AND SURVEYING ALL BASED UPON ASSAYS FEATURING DETAILED ANALYSES AND EVALUATION (U.S. CLS. 100 AND 101).

RON FAIRBANKS, EXAMINING ATTORNEY

SN 77-791,507. SPIRAL SOFTWARE LIMITED, CAMBRIDGE, UNITED KINGDOM, FILED 7-28-2009.

## SPIRAL SOFTWARE

THE MARK CONSISTS OF STANDARD CHARACTERS WITHOUT CLAIM TO ANY PARTICULAR FONT, STYLE, SIZE, OR COLOR.

OWNER OF ERPN CMNTY TM OFC REG. NO. 008455289, DATED 4-26-2010, EXPIRES 7-28-2019.

NO CLAIM IS MADE TO THE EXCLUSIVE RIGHT TO USE "SOFTWARE" IN CLASSES 9 AND 42 ONLY, APART FROM THE MARK AS SHOWN.

### CLASS 9—ELECTRICAL AND SCIENTIFIC APPARATUS

FOR COMPUTER SOFTWARE FOR DATA MODELING; COMPUTER SOFTWARE FOR THE VALIDATION OF MODEL PREDICTIONS; COMPUTER SOFTWARE FOR SCIENTIFIC DATA ANALYSIS; DATA, NAMELY, ASSAY DATA IN THE FIELD OF THE PETROLEUM AND PETROCHEMICAL INDUSTRIES, RECORDED ON ELECTRONIC, OPTICAL OR MAGNETIC MEDIA; MAGNETIC DATA CARRIERS THAT ARE PRE-RECORDED WITH ELECTRONIC DATA AND ASSAY DATA AND COMPUTER SOFTWARE FOR DATA PROCESSING AND DATA ANALYSIS; RECORDING COMPACT DISCS, AND DVDS THAT ARE PRE-RECORDED WITH ELECTRONIC DATA AND ASSAY DATA AND COMPUTER SOFTWARE FOR DATA PROCESSING AND DATA ANALYSIS; DOWNLOADABLE ELECTRONIC PUBLICATIONS IN THE NATURE OF MANUALS, BROCHURES AND PRODUCT INFORMATION SHEETS IN THE FIELD OF THE PETROLEUM AND PETROCHEMICAL INDUSTRIES; CD-ROMS, DVD-ROMS AND COMPUTER DISCS BEARING SOFTWARE FOR THE EXPLORATION, PRODUCTIONS, REFINING AND TRADING OF CRUDE OIL AND CRUDE OIL PRODUCTS, AND PROCESS MANUFACTURING INDUSTRIES AND LOGISTICS RELATING TO THESE INDUSTRIES AND ELECTRONIC DATA, NAMELY, DATA RELATING TO CRUDE OIL IN THE FIELD OF OIL REFINING, PETROCHEMICAL ENGINEERING AND GAS AND OIL PROSPECTING, EXTRACTION AND RECOVERY, AND ASSAY DATA (U.S. CLS. 21, 23, 26, 36 AND 38).

### CLASS 35—ADVERTISING AND BUSINESS

FOR COMPILATION, ANALYSIS, RETRIEVAL AND PROVISION OF BUSINESS DATA AND STATISTICAL INFORMATION FOR BUSINESS AND COMMERCIAL PURPOSES; MARKET ANALYSIS AND RESEARCH; MANAGEMENT OF COMMUNICATION NETWORKS; THE COMPILATION, ANALYSIS, RETRIEVAL AND PROVISION OF BUSINESS DATA AND STATISTICAL INFORMATION FOR BUSINESS AND COMMERCIAL PURPOSES, MARKET ANALYSIS AND RESEARCH AND MANAGEMENT OF COMMUNICATION NETWORKS; AND THAT ARE ALSO PROVIDED VIA THE INTERNET; PROVIDING INFORMATION ABOUT THE COST ASSESSMENT OF OIL FIELDS (U.S. CLS. 100, 101 AND 102).

### CLASS 42—SCIENTIFIC AND COMPUTER SERVICES

FOR INSTALLATION OF COMPUTER SOFTWARE, RELATING ONLY TO MODELING, DETERMINING AND PREDICTING MATERIALS, MODELLING, SCHEDULING AND OPTIMISING PROCESSES, ALL SUCH DATA, INFORMATION, MATERIALS AND PROCESSES RELATING TO AND/OR USED IN THE EXPLORATION, PRODUCTION, REFINING AND TRADING OF CRUDE OIL AND CRUDE OIL PRODUCTS, AND PROCESS MANUFACTURING INDUSTRIES AND LOGISTICS RELATING TO THESE INDUSTRIES; MAINTENANCE AND TECHNICAL SUPPORT SERVICES, NAMELY, TROUBLESHOOTING OF COMPUTER SOFTWARE PROBLEMS; INSTALLATION, MAINTENANCE AND TECHNICAL SUPPORT SERVICES, NAMELY, IDENTIFYING, DIAGNOSING, ADVISING ON, CORRECTING, WORKING AROUND, REPAIRING COMPUTER SOFTWARE FAILURES, DEFECTS, BUGS AND ERRORS; PROVIDING INFORMATION ABOUT THE TECHNICAL ANALYSIS OF OIL FIELDS; PROVISION OF CONSULTANCY AND ADVISORY SERVICES IN THE FIELDS OF OIL PROSPECTING, PETROCHEMICAL ENGINEERING, AND GAS AND OIL LOCATION AND SURVEYING ALL BASED UPON ASSAYS FEATURING DETAILED ANALYSES AND EVALUATION (U.S. CLS. 100 AND 101).  
RON FAIRBANKS, EXAMINING ATTORNEY

SN 77-791,514. SPIRAL SOFTWARE LIMITED, CAMBRIDGE, UNITED KINGDOM, FILED 7-28-2009.

## CRUDESUITE

THE MARK CONSISTS OF STANDARD CHARACTERS WITHOUT CLAIM TO ANY PARTICULAR FONT, STYLE, SIZE, OR COLOR.

PRIORITY CLAIMED UNDER SEC. 44(D) ON ERPN CMNTY TM OFC APPLICATION NO. 008455611, FILED 7-28-2009, REG. NO. 8455611, DATED 4-26-2010, EXPIRES 7-28-2019.

**CLASS 9—ELECTRICAL AND SCIENTIFIC APPARATUS**

FOR COMPUTER SOFTWARE FOR DATA PROCESSING AND DATA ANALYSIS; COMPUTER PROGRAMS FOR DATA PROCESSING AND DATA ANALYSIS; COMPUTER SOFTWARE FOR USE IN SIMULATING, MODELLING, DESIGNING, OPTIMIZING, OPERATING AND MANAGING INFORMATION AND DATA RELATING TO CRUDE OIL AND TO THE PREDICTION OF CRUDE OIL PROPERTIES; COMPUTER SOFTWARE FOR ELECTRONIC DATABASES IN THE FIELD OF THE PETROLEUM AND PETROCHEMICAL INDUSTRIES RECORDED ON COMPUTER MEDIA; COMPUTER SOFTWARE FOR DATA PROCESSING AND DATA ANALYSIS FOR USE OVER COMPUTER NETWORKS AND BY REMOTE COMPUTER ACCESS; COMPUTER SOFTWARE FOR THE EXTRACTION, ANALYSIS, MANAGEMENT AND MANIPULATION OF INFORMATION FROM SMALL AND LARGE DATA SETS BY THE APPLICATION OF MATHEMATICAL AND DATA VISUALIZATION TECHNIQUES; COMPUTER SOFTWARE FOR THE VALIDATION AND RECONCILIATION OF DATA IN THE FIELD OF THE PETROLEUM AND PETROCHEMICAL INDUSTRIES; COMPUTER SOFTWARE FOR DATA MODELLING; COMPUTER SOFTWARE FOR THE VALIDATION OF MODEL PREDICTIONS; COMPUTER SOFTWARE TO ENABLE SEARCHING OF DATA AND DETAILED VIEWING AND REPORTING OF DATA; COMPUTER SOFTWARE FOR SCIENTIFIC DATA ANALYSIS; DATA, NAMELY, ASSAY DATA IN THE FIELD OF THE PETROLEUM AND PETROCHEMICAL INDUSTRIES, RECORDED ON ELECTRONIC, OPTICAL OR MAGNETIC MEDIA; MAGNETIC DATA CARRIERS THAT ARE PRE-RECORDED WITH ELECTRONIC DATA AND ASSAY DATA AND COMPUTER SOFTWARE FOR DATA PROCESSING AND DATA ANALYSIS; RECORDING COMPACT DISCS, AND DVDS THAT ARE PRE-RECORDED WITH ELECTRONIC DATA AND ASSAY DATA AND COMPUTER SOFTWARE FOR DATA PROCESSING AND DATA ANALYSIS; DOWNLOADABLE ELECTRONIC PUBLICATIONS IN THE NATURE OF MANUALS, BROCHURES AND PRODUCT INFORMATION SHEETS IN THE FIELD OF THE PETROLEUM AND PETROCHEMICAL INDUSTRIES; CD-ROMS, DVD-ROMS AND COMPUTER DISCS BEARING SOFTWARE FOR THE EXPLORATION, PRODUCTION, REFINING AND TRADING OF CRUDE OIL AND CRUDE OIL PRODUCTS, AND PROCESS MANUFACTURING INDUSTRIES AND LOGISTICS RELATING TO THESE INDUSTRIES AND ELECTRONIC DATA, NAMELY, DATA RELATING TO CRUDE OIL IN THE FIELD OF OIL REFINING, PETROCHEMICAL ENGINEERING AND GAS AND OIL PROSPECTING, EXTRACTION AND RECOVERY, AND ASSAY DATA (U.S. CLS. 21, 23, 26, 36 AND 38).

**CLASS 35—ADVERTISING AND BUSINESS**

FOR COMPILATION, ANALYSIS, RETRIEVAL AND PROVISION OF BUSINESS DATA AND STATISTICAL INFORMATION FOR BUSINESS AND COMMERCIAL PURPOSES; DATA PROCESSING SERVICES; DATA MANAGEMENT SERVICES; MARKET ANALYSIS AND RESEARCH; MANAGEMENT OF COMMUNICATION NETWORKS; CONSULTING AND ADVISORY SERVICES RELATING TO THE COMPILATION, ANALYSIS, RETRIEVAL AND PROVISION OF BUSINESS DATA AND STATISTICAL INFORMATION FOR BUSINESS AND COMMERCIAL PURPOSES, DATA PROCESSING SERVICES, DATA MANAGEMENT SERVICES, MARKET ANALYSIS AND RESEARCH AND MANAGEMENT OF COMMUNICATION NETWORKS, AND THAT ARE ALSO PROVIDED VIA THE INTERNET; PROVIDING INFORMATION ABOUT THE COST ASSESSMENT OF OIL FIELDS; DATABASE MANAGEMENT SERVICES FOR OTHERS FEATURING INFORMATION RELATING TO CRUDE OIL IN THE FIELD OF OIL REFINING, PETROCHEMICAL ENGINEERING AND GAS AND OIL PROSPECTING, EXTRACTION AND RECOVERY (U.S. CLS. 100, 101 AND 102).

**CLASS 39—TRANSPORTATION AND STORAGE**

FOR ELECTRONIC STORAGE OF DATA AND STATISTICAL INFORMATION (U.S. CLS. 100 AND 105).

**CLASS 42—SCIENTIFIC AND COMPUTER SERVICES**

FOR INSTALLATION OF COMPUTER SOFTWARE, RELATING ONLY TO MODELING, DETERMINING AND PREDICTING MATERIALS, MODELLING, SCHEDULING AND OPTIMISING PROCESSES, ALL SUCH DATA, INFORMATION, MATERIALS AND PROCESSES RELATING TO AND/OR USED IN THE EXPLORATION, PRODUCTION, REFINING AND TRADING OF CRUDE OIL AND CRUDE OIL PRODUCTS, AND PROCESS MANUFACTURING INDUSTRIES AND LOGISTICS RELATING TO THESE INDUSTRIES; MAINTENANCE AND TECHNICAL SUPPORT SERVICES, NAMELY, TROUBLESHOOTING OF COMPUTER SOFTWARE PROBLEMS; INSTALLATION, MAINTENANCE AND TECHNICAL SUPPORT SERVICES, NAMELY, IDENTIFYING, DIAGNOSING, ADVISING ON, CORRECTING, WORKING AROUND, REPAIRING COMPUTER SOFTWARE FAILURES, DEFECTS, BUGS AND ERRORS; PROVIDING INFORMATION ABOUT THE TECHNICAL ANALYSIS OF OIL FIELDS; PROVISION OF CONSULTANCY AND ADVISORY SERVICES IN THE FIELDS OF OIL PROSPECTING, PETROCHEMICAL ENGINEERING, AND GAS AND OIL LOCATION AND SURVEYING ALL BASED UPON ASSAYS FEATURING DETAILED ANALYSES AND EVALUATION (U.S. CLS. 100 AND 101).  
RON FAIRBANKS, EXAMINING ATTORNEY

---

SN 77-796,294. WISON GROUP HOLDING LIMITED, SHANGHAI, CHINA, FILED 8-4-2009.

**GENOR**

THE MARK CONSISTS OF STANDARD CHARACTERS WITHOUT CLAIM TO ANY PARTICULAR FONT, STYLE, SIZE, OR COLOR.



**CLASS 5—PHARMACEUTICALS**

FOR BIOCHEMICAL PREPARATIONS FOR PHARMACEUTICAL USE; BIOLOGICAL PREPARATIONS FOR PHARMACEUTICAL PURPOSES; SANITARY PREPARATIONS FOR MEDICAL USE; MEDICINES FOR TREATMENT OF VIRAL AND BACTERIAL INFECTIONS FOR THE TREATMENTS OF HEPATITIS, EPSTEIN-BARR VIRUS, TUBERCULOSIS, INFLAMMATORY AND BLOOD DISORDERS, NUTRITIONAL DISORDERS, IMMUNOLOGICAL, DERMATOLOGICAL, GENETIC, INFLUENZA, NEURODEGENERATIVE, VIRAL, AND INFECTIOUS DISEASES, PARASITES, CANCERS, OBESITY AND DIABETES; ACTIVE PHARMACEUTICAL INGREDIENTS FOR THE THERAPEUTICAL, PREVENTATIVE AND IN VITRO DIAGNOSTIC USE FOR TREATMENTS OF HEPATITIS, EPSTEIN-BARR VIRUS, TUBERCULOSIS, INFLAMMATORY AND BLOOD DISORDERS, NUTRITIONAL DISORDERS, IMMUNOLOGICAL, DERMATOLOGICAL, GENETIC, INFLUENZA, NEURODEGENERATIVE, VIRAL, AND INFECTIOUS DISEASES, PARASITES, CANCERS, OBESITY AND DIABETES; BIOLOGICAL PREPARATIONS FOR MEDICAL PURPOSES; VACCINES; MEDICAL DIAGNOSTIC REAGENTS, NAMELY, MONOCLONAL ANTIBODIES; RECOMBINANT PHARMACEUTICALS FOR THE TREATMENTS OF HEPATITIS, EPSTEIN-BARR VIRUS, TUBERCULOSIS, INFLAMMATORY AND BLOOD DISORDERS, NUTRITIONAL DISORDERS, IMMUNOLOGICAL, DERMATOLOGICAL, GENETIC, INFLUENZA, NEURODEGENERATIVE, VIRAL, AND INFECTIOUS DISEASES, PARASITES, CANCERS, OBESITY AND DIABETES; BIOTECHNOLOGICAL PREPARATIONS FOR MEDICAL USE, NAMELY, BIOPHARMACEUTICALS FOR THERAPEUTIC, IN VITRO AND IN VIVO DIAGNOSTIC PURPOSES; AND PHARMACEUTICAL PROTEINS FOR USE IN HUMANS FOR MEDICAL TREATMENT OF HEPATITIS A, INFLAMMATORY, BLOOD DISORDERS, NUTRITIONAL DISORDERS, IMMUNOLOGICAL, DERMATOLOGICAL, GENETIC, NEURODEGENERATIVE, VIRAL, AND INFECTIOUS DISEASES, PARASITES, CANCER, OBESITY AND DIABETES, NAMELY, FC-FUSION PROTEINS AND RECOMBINANT THERAPEUTIC PROTEINS (U.S. CLS. 6, 18, 44, 46, 51 AND 52).

**CLASS 39—TRANSPORTATION AND STORAGE**

FOR TRANSPORT AND DELIVERY OF GOODS; PACKAGING AND STORAGE OF GOODS; DELIVERY OF GOODS; FREIGHT FORWARDING; GARAGE RENTAL; STORAGE OF GOODS; STORAGE OF PHARMACEUTICALS; TRANSPORTATION SERVICES, NAMELY, FOR PHARMACEUTICALS AND BIOTECHNOLOGICAL PHARMACEUTICALS; STORAGE OF BIOTECHNOLOGICAL PHARMACEUTICALS; BIOMEDICAL SERVICES, NAMELY, CRYOGENIC STORAGE OF BIOLOGICAL TISSUE INTENDED FOR SUBSEQUENT IMPLANTATION (U.S. CLS. 100 AND 105).

**CLASS 40—MATERIAL TREATMENT**

FOR TREATMENT OF BIOCHEMICAL PREPARATIONS, SANITARY PREPARATIONS, MEDICINE PREPARATIONS, BIOLOGICAL PREPARATIONS, AND BIOTECHNOLOGICAL PREPARATIONS FOR BIOTECHNICAL PHARMACEUTICALS (U.S. CLS. 100, 103 AND 106).

**CLASS 42—SCIENTIFIC AND COMPUTER SERVICES**

FOR SCIENTIFIC AND TECHNOLOGICAL RESEARCH SERVICES AND RESEARCH OF BACTERIOLOGY; BIOLOGICAL RESEARCH; RESEARCH IN THE AREA OF VACCINES, MONOCLONAL ANTIBODIES, RECOMBINANT PHARMACEUTICALS, PROTEIN PHARMACEUTICALS, AND BIOTECHNOLOGICAL PHARMACEUTICALS; PROVIDING QUALITY CONTROL AND QUALITY ASSURANCE SERVICES IN THE FIELD OF BIOTECHNOLOGICAL PHARMACEUTICALS; TECHNOLOGY CONSULTATION IN THE FIELD OF BIOTECHNOLOGICAL PHARMACEUTICALS (U.S. CLS. 100 AND 101).

**CLASS 44—MEDICAL, BEAUTY AND AGRICULTURAL SERVICES**

FOR MEDICAL SERVICES; HEALTH CARE; MEDICAL ASSISTANCE SERVICES; PHARMACEUTICAL ADVICE; TELEMEDICINE SERVICES (U.S. CLS. 100 AND 101).

LESLIE RICHARDS, EXAMINING ATTORNEY

SN 77-797,632. LG ELECTRONICS INC., SEOUL, REPUBLIC OF KOREA, FILED 8-5-2009.

# True Wash

THE MARK CONSISTS OF STANDARD CHARACTERS WITHOUT CLAIM TO ANY PARTICULAR FONT, STYLE, SIZE, OR COLOR.

PRIORITY CLAIMED UNDER SEC. 44(D) ON REPUBLIC OF KOREA APPLICATION NO. 402009003615, FILED 7-28-2009, REG. NO. 0836574, DATED 9-16-2010, EXPIRES 9-16-2020.

OWNER OF U.S. REG. NO. 3,635,856.

NO CLAIM IS MADE TO THE EXCLUSIVE RIGHT TO USE "WASH" FOR INTERNATIONAL CLASS 7, APART FROM THE MARK AS SHOWN.

**CLASS 7—MACHINERY**

FOR ELECTRIC CLOTHES WASHING MACHINES (U.S. CLS. 13, 19, 21, 23, 31, 34 AND 35).

**CLASS 11—ENVIRONMENTAL CONTROL APPARATUS**

FOR ELECTRIC LAUNDRY DRYERS (U.S. CLS. 13, 21, 31 AND 34).

JASON BLAIR, EXAMINING ATTORNEY

SN 77-806,501. MASTERPIECE FLOWER COMPANY, BYRON CENTER, MI. FILED 8-17-2009.

**MASTERPIECE FLOWER COMPANY**

THE MARK CONSISTS OF STANDARD CHARACTERS WITHOUT CLAIM TO ANY PARTICULAR FONT, STYLE, SIZE, OR COLOR.

NO CLAIM IS MADE TO THE EXCLUSIVE RIGHT TO USE "FLOWER COMPANY", APART FROM THE MARK AS SHOWN.

**CLASS 21—HOUSEWARES AND GLASS**

FOR FLOWER BASKETS; FLOWER BOWLS; FLOWER POTS; FLOWER VASES; FLOWER VASES AND BOWLS; HOLDERS FOR FLOWERS AND PLANTS; PLANTERS FOR FLOWERS AND PLANTS (U.S. CLS. 2, 13, 23, 29, 30, 33, 40 AND 50).

FIRST USE 8-30-2002; IN COMMERCE 8-30-2002.

**CLASS 31—NATURAL AGRICULTURAL PRODUCTS**

FOR CUT FLOWERS; DRIED FLOWER ARRANGEMENTS; DRIED FLOWER WREATHS; DRIED FLOWERS; DRIED PLANTS; LIVE FLOWER ARRANGEMENTS; LIVE FLOWER WREATHS; LIVE FLOWERS; NATURAL FLOWERS; WREATHS OF NATURAL FLOWERS (U.S. CLS. 1 AND 46).

FIRST USE 8-30-2002; IN COMMERCE 8-30-2002.  
VERNA BETH RIRIE, EXAMINING ATTORNEY

MINISTRATIVE PROCESSING OF PURCHASE ORDERS; ARRANGING SUBSCRIPTIONS TO TELECOMMUNICATION SERVICES FOR OTHERS; TRANSPORTATION LOGISTICS SERVICES, NAMELY, ARRANGING THE TRANSPORTATION OF GOODS FOR OTHERS (U.S. CLS. 100, 101 AND 102).

**CLASS 39—TRANSPORTATION AND STORAGE**

FOR TRANSPORT, INTERMEDIATE STORAGE, STORAGE AND SAFE-KEEPING OF PRODUCTS AND THEIR COMPONENTS, INCLUDING PACKAGING, AND OF WASTE OF ALL KINDS, IN PARTICULAR ELECTRIC AND ELECTRONIC APPARATUS; COLLECTION AND TRANSPORT OF WASTE OF ALL KINDS AND OF PRODUCTS AND THEIR COMPONENTS, INCLUDING PACKAGING, IN PARTICULAR ELECTRIC AND ELECTRONIC APPARATUS; TRANSPORT OF GOODS BY MOTOR VEHICLES, RAIL VEHICLES, SHIPS AND AIRPLANES; LOGISTICS AND REVERSE LOGISTICS SERVICES, NAMELY, STORAGE, TRANSPORTATION AND DELIVERY OF GOODS OF OTHERS BY AIR, RAIL, SHIP OR TRUCK (U.S. CLS. 100 AND 105).

SN 77-808,178. CCR LOGISTICS SYSTEMS AG, DORNACH, FED REP GERMANY, FILED 8-19-2009.

**RELECTRA**

THE MARK CONSISTS OF STANDARD CHARACTERS WITHOUT CLAIM TO ANY PARTICULAR FONT, STYLE, SIZE, OR COLOR.

OWNER OF ERPN CMNTY TM OFC REG. NO. 008881146, DATED 6-28-2010, EXPIRES 2-12-2020.

THE WORDING "RELECTRA" HAS NO MEANING IN A FOREIGN LANGUAGE.

**CLASS 35—ADVERTISING AND BUSINESS**

FOR ADVERTISING; BUSINESS MANAGEMENT; BUSINESS ADMINISTRATION; OFFICE FUNCTIONS; PROVIDING ASSISTANCE IN BUSINESS ACTIVITIES, NAMELY, CONDUCTING FLOW RATE TESTS IN THE NATURE OF BUSINESS SURVEYS OF MARKETED OR SOLD, AS WELL AS RETURNED, RECYCLED OR DISPOSED PRODUCTS; BUSINESS ADMINISTRATION, NAMELY, MANAGING FLOW-RATE CERTIFICATES FOR OTHERS; BUSINESS PROJECT MANAGEMENT SERVICES, NAMELY, PERFORMING BUSINESS RESEARCH, COLLECTING BUSINESS DATA, CONDUCTING BUSINESS AND STATISTICAL DATA ANALYSIS AND REPORTING, PREPARING BUSINESS REPORTS, AND PERFORMING BUSINESS RECORDS MANAGEMENT IN THE FIELD OF FLOW-RATE CERTIFICATES FOR OTHERS OF MARKETED OR SOLD, AS WELL AS RETURNED, RECYCLED OR DISPOSED PRODUCTS; CONDUCTING BUSINESS RESEARCH AND SURVEYS TO OBTAIN DOCUMENTATION AND DATA THAT EVIDENCES AND VERIFIES FLOWS OF AMOUNTS OF MARKETED OR SOLD, AS WELL AS RETURNED, RECYCLED OR DISPOSED PRODUCTS; STATISTICAL EVALUATIONS AND ANALYSIS FOR BUSINESS PURPOSES; ECONOMIC FEASIBILITY, FORECASTING AND ANALYSIS CONSULTATION IN THE FIELDS OF ENVIRONMENT AND WASTE DISPOSAL; ECONOMIC CONSULTING IN THE FIELDS OF ENVIRONMENT AND WASTE DISPOSAL; OUTSOURCING SERVICES; HUMAN RESOURCES SERVICES, NAMELY, TEMPORARY LETTING OF EMPLOYEES; PERSONNEL SERVICES, NAMELY, TEMPORARY LETTING OF EMPLOYEES; ADMINISTRATION OF INFORMATION TECHNOLOGY, NAMELY, COLLECTION, COMPILATION, SYSTEMATIZATION AND UPDATING OF DATA IN COMPUTER DATABASES; COMPILATION AND SYSTEMATIZATION OF DATA INTO COMPUTER DATABASES; BUSINESS RESEARCH SERVICES, NAMELY, SEARCH IN COMPUTER FILES FOR OTHERS; COMPUTERIZED FILE MANAGEMENT; BUSINESS MANAGEMENT ASSISTANCE; BUSINESS ECONOMIC FORECASTING AND ANALYSIS; BUSINESS CONSULTANCY; BUSINESS INFORMATION; BUSINESS INQUIRIES AND INVESTIGATIONS; RELOCATION SERVICES FOR BUSINESSES; ACCOUNTING SERVICES; BOOK-KEEPING; PAY-ROLL PREPARATION; ACCOUNT AUDITING; INVOICING; BILLING; WORD PROCESSING; DOCUMENT REPRODUCTION; SECRETARIAL SERVICES; TELEPHONE ANSWERING FOR UNAVAILABLE SUBSCRIBERS; PERSONNEL MANAGEMENT CONSULTANCY; PERSONNEL RECRUITMENT; AD-

**CLASS 40—MATERIAL TREATMENT**

FOR RECYCLING AND MATERIAL TREATMENT SERVICES, NAMELY, CONDITIONING AND PROCESSING OF PRODUCTS AND THEIR COMPONENTS, INCLUDING PACKAGING, AND OF WASTE OF ALL KINDS, IN PARTICULAR ELECTRIC AND ELECTRONIC APPARATUS; RECYCLING; RECLAMATION OF ELECTRIC AND ELECTRONIC APPARATUS AND PACKAGING FOR THE PRODUCTION OF POST RECYCLING PRODUCTS; RE-USE IN THE NATURE OF RECYCLING; SORTING OF WASTE AND RECYCLABLE MATERIAL, INCLUDING PACKAGING, AND OF WASTE OF ALL KINDS, IN PARTICULAR ELECTRIC AND ELECTRONIC APPARATUS (U.S. CLS. 100, 103 AND 106).

**CLASS 42—SCIENTIFIC AND COMPUTER SERVICES**

FOR DEVELOPMENT OF NEW TECHNOLOGY FOR THE RETURN, TREATMENT, UTILIZATION, EXPLOITATION AND DISPOSAL OF PRODUCTS AND THEIR COMPONENTS, INCLUDING PACKAGING, AND OF WASTE OF ALL KINDS, IN PARTICULAR ELECTRIC AND ELECTRONIC APPARATUS; SCIENTIFIC AND TECHNOLOGICAL SERVICES AND RESEARCH AND DESIGN RELATING THERETO IN THE FIELD OF RETURN, TREATMENT, UTILIZATION, EXPLOITATION AND DISPOSAL OF PRODUCTS AND THEIR COMPONENTS, INCLUDING PACKAGING, AND OF WASTE OF ALL KINDS, IN PARTICULAR ELECTRIC AND ELECTRONIC APPARATUS; INDUSTRIAL TECHNICAL ANALYSIS AND RESEARCH SERVICES IN THE FIELDS OF MANAGEMENT, COLLECTION, RECYCLING AND RE-USE OF WASTE AND PROTECTION AND REMEDIATION OF THE ENVIRONMENT; DESIGN AND DEVELOPMENT OF COMPUTER HARDWARE AND SOFTWARE; COMPUTER PROGRAMMING; TECHNICAL CONSULTING IN THE FIELD OF ENVIRONMENTAL SCIENCE; INSPECTION, QUANTITY AND QUALITY CONTROL, SUPERVISION AND VERIFICATION OF THE QUALITY AND QUANTITY OF FLOW AMOUNTS IN THE WASTE INDUSTRY AND THEIR CONFORMITY WITH NATIONAL AND INTERNATIONAL NORMS, LAWS, RULES, PRACTICE AND STANDARDS AND WITH CLIENTS' CONTRACTUAL REQUIREMENTS (U.S. CLS. 100 AND 101).

KATHLEEN M. VANSTON, EXAMINING ATTORNEY

SN 77-814,028. NAXOS RIGHTS INTERNATIONAL LIMITED, 100 CYBERPORT ROAD, HONG KONG, FILED 8-27-2009.



OWNER OF U.S. REG. NO. 2,075,306.  
THE MARK CONSISTS OF THE STYLIZED WORDING "NAXOS" APPEARING IN THE MIDDLE OF FIVE COLUMNS, WITH LINES APPEARING AT THE TOP AND BOTTOM OF THE COLUMNS.

#### **CLASS 16—PAPER GOODS AND PRINTED MATTER**

FOR PRINTED MATTER, NAMELY, BOOKS, PERIODICALS, MANUALS, CATALOGUES AND NEWSLETTERS IN THE FIELD OF MUSIC AND PERFORMING ARTS; INSTRUCTIONAL AND TEACHING MATERIALS IN THE FIELD OF MUSIC AND PERFORMING ARTS, NAMELY, BOOKS AND MANUALS; PRINTED MATTER, NAMELY, BOOKS, PERIODICALS, MANUALS AND PUBLICATIONS, NAMELY, NEWSLETTERS AND CATALOGUES IN THE FIELD OF MUSIC AND OTHER PERFORMING ARTS IN RELATION TO AUDIO AND VIDEO RECORDINGS; PAPER AND PAPER ARTICLES, NAMELY, STATIONERY AND PACKAGING MATERIALS; CARDBOARD AND CARDBOARD ARTICLES, NAMELY, CASES FOR PACKAGING BOOKS, MANUALS AND PUBLICATIONS, BOXES AND PACKAGING MATERIALS; NEWSPAPERS AND PRINTED PERIODICALS IN THE FIELD OF MUSIC AND PERFORMING ARTS; BOOKS IN THE FIELD OF MUSIC AND PERFORMING ARTS AND PHOTOGRAPHS; CATALOGUES IN THE FIELD OF MUSIC AND PERFORMING ARTS; INLAY CARDS, NAMELY, PRINTED CD AND DVD CASE INSERTS FEATURING ADVERTISING; PRINTED BOOKLETS IN THE FIELD OF MUSIC AND PERFORMING ARTS FOR INCLUSION IN COMPACT DISC AND DVD CASES; PRINTED BOOKLETS IN THE FIELD OF MUSIC AND PERFORMING ARTS; ALBUMS FOR CDS AND DVDS; PRINTED ALBUM COVERS; PAPER LABELS; HANDBOOKS IN THE FIELD OF MUSIC AND PERFORMING ARTS; JACKETS FOR PAPERS, NAMELY, O-CARDS, SLIP-CASES AND BELLY BANDS; BINDERS; PAMPHLETS IN THE FIELD OF MUSIC AND PERFORMING ARTS; PLACARDS OF PAPER AND CARDBOARD; POSTERS; PRINTED PROSPECTUSES; SONG BOOKS; BROCHURES IN THE FIELD OF MUSIC AND OTHER PERFORMING ARTS; STATIONERY, NAMELY, LETTERHEAD PAPERS AND ENVELOPES (U.S. CLS. 2, 5, 22, 23, 29, 37, 38 AND 50).

#### **CLASS 41—EDUCATION AND ENTERTAINMENT**

FOR ARRANGING OF MUSICAL PERFORMANCES, NAMELY, PLANNING ARRANGEMENT OF MUSICAL PERFORMANCES; DIGITAL AUDIO AND VIDEO PROVIDED FROM THE INTERNET, NAMELY, ENTERTAINMENT SERVICES, NAMELY, PROVIDING NON-DOWNLOADABLE PRERECORDED MUSIC ON-LINE VIA A GLOBAL COMPUTER NETWORK; EDUCATION SERVICES, NAMELY, PROVIDING ONLINE COURSES IN THE FIELD OF MUSIC; ENTERTAINMENT SERVICES, NAMELY, PROVIDING A WEBSITE FEATURING HISTORICAL AND INSTRUCTIONAL INFORMATION ABOUT AUDIO AND VIDEO RECORDINGS OF MUSIC, FICTION AND NON-FICTION LITERATURE AND DRAMATIC PERFORMANCES; ENTERTAINMENT SERVICES, NAMELY, PROVIDING NON-DOWNLOADABLE PRE-RECORDED MUSIC, INFORMATION IN THE FIELD OF MUSIC, AND COM-

MENTARY AND ARTICLES ABOUT MUSIC, AND INFORMATION ABOUT COMPOSERS, FICTION AND NON-FICTION LITERATURE AND OF DRAMA AND ENTERTAINMENT IN THE FORM OF NON-DOWNLOADABLE RECORDED AUDIO AND VIDEO OF MUSIC, ALL ONLINE VIA A GLOBAL COMPUTER NETWORK; ONLINE LIBRARY SERVICES, NAMELY, PROVIDING LENDING OF NON-DOWNLOADABLE AUDIO AND VIDEO RECORDINGS; PUBLICATION AND ELECTRONIC PUBLICATION OF MUSICAL WORKS, NAMELY, MULTI-MEDIA PUBLICATION OF MUSIC; PUBLICATION OF BOOKS; PUBLICATION OF MUSIC, NAMELY, MUSICAL TEXTS; PROVIDING MUSICAL ENTERTAINMENT IN THE NATURE OF PODCASTS AND VIDEO PODCASTS IN THE FIELD OF OPERA, BALLET, LIVE CONCERTS AND DOCUMENTARIES RELATING TO CLASSICAL MUSIC; PROVIDING ONLINE ENTERTAINMENT, NAMELY, PROVIDING NON-DOWNLOADABLE AUDIO AND VIDEO RECORDINGS OF MUSIC, FICTION AND NON-FICTION LITERATURE IN THE FIELD OF CLASSICAL MUSIC AND CLASSICAL MUSICAL-BASED ENTERTAINMENT AND OF DRAMA, NAMELY, THEATRICAL PERFORMANCES; PRODUCTION OF AUDIO AND VIDEO RECORDINGS; TUITION IN MUSIC AND MUSIC APPRECIATION, NAMELY, EDUCATION SERVICES, NAMELY, PROVIDING CLASSES IN MUSIC INSTRUCTION AND MUSIC APPRECIATION (U.S. CLS. 100, 101 AND 107).

DAVID HOFFMAN, EXAMINING ATTORNEY

SN 77-824,661. NOVELLINI FINANCE S.A., LUXEMBOURG, LUXEMBOURG, FILED 9-11-2009.

# NOVELLINI

THE MARK CONSISTS OF STANDARD CHARACTERS WITHOUT CLAIM TO ANY PARTICULAR FONT, STYLE, SIZE, OR COLOR.

THE ENGLISH TRANSLATION OF THE WORD "NOVELLINI" IN THE MARK IS "NOVICE" OR "INEXPERIENCED" OR "EARLY".

#### **CLASS 3—COSMETICS AND CLEANING PREPARATIONS**

FOR PERFUMES; ESSENTIAL OILS; FUMIGATION PREPARATIONS IN THE NATURE OF INCENSES; AROMATICS, NAMELY, AROMATHERAPY CREAMS, AROMATHERAPY OILS AND AROMATHERAPY SPRAYS; OILS FOR PERFUMES AND SCENTS; SOAPS; BATH SALTS, NOT FOR MEDICAL PURPOSES; NON-MEDICATED TOILETRIES (U.S. CLS. 1, 4, 6, 50, 51 AND 52).

#### **CLASS 10—MEDICAL APPARATUS**

FOR MASSAGE APPARATUSES, NAMELY, HYDROMASSAGE AND HYDRO-MASSAGE DEVICES FOR BATHTUBS (U.S. CLS. 26, 39 AND 44).

**CLASS 11—ENVIRONMENTAL CONTROL APPARATUS**

FOR APPARATUS FOR HEATING, STEAM GENERATING, VENTILATING, WATER SUPPLY AND SANITARY PURPOSES, NAMELY, VENTILATING EXHAUST FANS, STEAM HEATING APPARATUS, WATER PURIFYING APPARATUS; SANITARY INSTALLATIONS, NAMELY, BATHROOMS; SHOWERS; APPARATUS FOR TURKISH BATHS AND STEAM BATHS, NAMELY, BATH INSTALLATIONS; BATH TUBS, BATH AND SHOWER FITTINGS, NAMELY, BATHTUB SURROUNDS, BATH AND SHOWER INSTALLATIONS, RADIATORS FOR HEATING; DECORATIVE RADIATORS, NAMELY, TOWEL DRIERS; WATER SOFTENING APPARATUS AND INSTALLATIONS; SPA BATHS, NAMELY, BATHS AND WHIRLPOOL BATHS; BATH FITTINGS, NAMELY, BATHTUB SCREENS, BATHTUB LININGS AND EMBEDDED BATHTUBS; WATER HEATERS FOR BATHS; BIDETS; SHOWER CUBICLES; FOUNTAINS, NAMELY, WATER FOUNTAINS; TAPS; HAIR DRIERS; BATH AND SHOWER INSTALLATIONS, THEIR STRUCTURAL PARTS AND FITTINGS IN THIS CLASS (U.S. CLS. 13, 21, 23, 31 AND 34).

TINA MAI, EXAMINING ATTORNEY

SN 77-827,148. HEWLETT-PACKARD DEVELOPMENT COMPANY, L.P., HOUSTON, TX. FILED 9-15-2009.



OWNER OF U.S. REG. NOS. 3,063,759, 3,115,389 AND OTHERS.

THE MARK CONSISTS OF THE LETTERS "H" AND "P" IN A CIRCLE.

**CLASS 35—ADVERTISING AND BUSINESS**

FOR BUSINESS CONSULTING SERVICES IN THE FIELD OF INFORMATION TECHNOLOGY; BUSINESS MANAGEMENT CONSULTING SERVICES; STRATEGIC PLANNING SERVICES FOR THE INFORMATION TECHNOLOGY FIELD; ONLINE RETAIL STORE SERVICES AND ORDERING SERVICES FEATURING COMPUTERS, COMPUTER SOFTWARE, COMPUTER PERIPHERALS; BUSINESS SERVICES, NAMELY, ASSISTING OTHERS IN THE NEGOTIATION AND DEVELOPMENT OF BUSINESS PARTNERSHIPS AND BUSINESS ALLIANCES; ADVERTISING SERVICES; MARKETING AND PROMOTIONAL PROGRAM SERVICES IN THE FIELD OF INFORMATION AND COMPUTER TECHNOLOGY; HUMAN RESOURCES AND HUMAN CAPITAL MANAGEMENT OUTSOURCING SERVICES; ADMINISTRATION OF BUSINESS PAYROLL FOR OTHERS; HUMAN RESOURCES CONSULTATION SERVICES; BUSINESS AND EMPLOYEE RELOCATION AND INFORMATION SERVICES; DATA COLLECTION SERVICES FOR EMPLOYERS FOR THE PURPOSE OF MAINTAINING EMPLOYEE INFORMATION; DATABASE MANAGEMENT SERVICES; BUSINESS PROCESS OUTSOURCING SERVICES IN THE FIELD OF INFORMATION TECHNOLOGY; CUSTOMER RELATIONSHIP MANAGEMENT SERVICES; ELECTRONIC COMMERCE SERVICES, NAMELY, PROVIDING INFORMATION ABOUT PRODUCTS AND SERVICES VIA TELECOMMUNICATION NETWORKS FOR ADVERTISING AND SALE PURPOSES; TAXONOMY SERVICES, NAMELY, CLASSIFICATION AND ORGANIZATION OF DATA FOR RECORDS MANAGEMENT PURPOSES (U.S. CLS. 100, 101 AND 102).

**CLASS 36—INSURANCE AND FINANCIAL**

FOR PURCHASE FINANCING AND LEASE FINANCING SERVICES; PROCESSING, MANAGEMENT AND ADMINISTRATION OF EMPLOYEE HEALTH AND WELFARE BENEFIT PLANS; PROVIDING CREDIT CARD TRANSACTION PROCESSING SERVICES FOR OTHERS; PROVIDING INSURANCE CLAIM PROCESSING SERVICES FOR OTHERS; FINANCIAL ANALYSIS AND CONSULTATION SERVICES FOR THE ORGANIZATION AND ADMINISTRATION OF BANKING AND FINANCIAL OPERATIONS (U.S. CLS. 100, 101 AND 102).

**CLASS 37—CONSTRUCTION AND REPAIR**

FOR INSTALLATION, MAINTENANCE AND REPAIR OF COMPUTER HARDWARE AND TELECOMMUNICATIONS EQUIPMENT (U.S. CLS. 100, 103 AND 106).

**CLASS 38—COMMUNICATION**

FOR TELECOMMUNICATIONS SERVICES, NAMELY, TRANSMISSION OF VOICE, DATA, GRAPHICS, IMAGES, AUDIO AND VIDEO BY MEANS OF TELECOMMUNICATIONS NETWORKS, WIRELESS COMMUNICATION NETWORKS, AND THE INTERNET; TELECOMMUNICATION CONSULTATION IN THE NATURE OF TECHNICAL CONSULTING IN THE FIELD OF AUDIO, TEXT AND VISUAL DATA TRANSMISSION AND COMMUNICATION; TELEPRESENCE SERVICES; PROVIDING ONLINE CHAT ROOMS, BULLETIN BOARDS AND FORUMS FOR TRANSMISSION OF MESSAGES AMONG USERS IN THE FIELDS OF INFORMATION TECHNOLOGY AND GENERAL INTEREST; PROVIDING ACCESS TO TELECOMMUNICATIONS NETWORKS; STREAMING OF VIDEO MATERIAL ON THE INTERNET; VOICE OVER INTERNET PROTOCOL (VOIP) SERVICES; FILE SHARING SERVICES, NAMELY, ELECTRONIC TRANSMISSION OF DATA VIA GLOBAL COMPUTER NETWORKS (U.S. CLS. 100, 101 AND 104).

**CLASS 39—TRANSPORTATION AND STORAGE**

FOR ELECTRONIC STORAGE OF DIGITAL CONTENT, NAMELY, IMAGES, TEXT, VIDEO AND AUDIO DATA; PROVIDING A WEBSITE FOR THE STORAGE OF DIGITAL IMAGES AND PHOTOGRAPHS (U.S. CLS. 100 AND 105).

**CLASS 40—MATERIAL TREATMENT**

FOR PHOTOGRAPHIC AND DIGITAL IMAGE PROCESSING, DEVELOPING AND PRINTING SERVICES; CUSTOM IMPRINTING OF DIGITAL AND PHOTOGRAPHIC IMAGES ONTO PHOTOGRAPHIC PAPER AND MERCHANDISE; PROVIDING A WEBSITE FOR ELECTRONIC IMAGING, EDITING, ALTERATION, AND CAPTIONING OF DIGITAL IMAGES; PRINTING SERVICES; PRINT-ON-DEMAND SERVICES; CUSTOM MANUFACTURE OF COMPUTERS FOR OTHERS; RECYCLING OF COMPUTER HARDWARE, COMPUTER PERIPHERALS AND ELECTRONICS (U.S. CLS. 100, 103 AND 106).

**CLASS 41—EDUCATION AND ENTERTAINMENT**

FOR EDUCATIONAL AND TRAINING SERVICES, NAMELY, CONDUCTING CLASSES, WORKSHOPS, SEMINARS AND CONFERENCES IN THE FIELD OF COMPUTERS, ELECTRONIC COMMERCE AND INFORMATION TECHNOLOGY; DIGITAL IMAGING SERVICES; ELECTRONIC PUBLISHING SERVICES, NAMELY, PUBLICATION OF TEXT AND GRAPHIC WORKS OF OTHERS ONLINE IN THE FIELD OF GENERAL INTEREST; ONLINE JOURNALS, NAMELY, BLOGS FEATURING INFORMATION IN THE FIELDS OF COMPUTERS, ELECTRONIC COMMERCE AND INFORMATION TECHNOLOGY (U.S. CLS. 100, 101 AND 107).

**CLASS 42—SCIENTIFIC AND COMPUTER SERVICES**

FOR COMPUTER SERVICES, NAMELY, COMPUTER SYSTEMS ANALYSIS, COMPUTER SYSTEMS PLANNING, COMPUTER SYSTEMS INTEGRATION AND COMPUTER DESIGN; INTERNET CONSULTING SERVICES, NAMELY, PROVIDING ASSISTANCE TO OTHERS IN DEVELOPING INTERNET PORTALS; COMPUTER SECURITY CONSULTING SERVICES IN THE FIELD OF INFORMATION TECHNOLOGY; COMPUTER INFRASTRUCTURE HOSTING SERVICES, NAMELY, INFRASTRUCTURE-AS-A-SERVICE (IAAS), NAMELY, PROVIDING COMPUTER HARDWARE, COMPUTER SOFTWARE, COMPUTER PERIPHERALS TO OTHERS ON A SUBSCRIPTION OR PAY-PER-USE BASIS; SOFTWARE-AS-A-SERVICE; DESIGN, INSTALLATION, MAINTENANCE AND REPAIR OF COMPUTER SOFTWARE; INTEGRATION OF COMPUTER SYSTEMS AND NETWORKS; DATABASE DEVELOPMENT SERVICES; COMPUTER PROGRAMMING SERVICES; PROVIDING WEBSITE HOSTING SERVICES, WEBSITE DEVELOPMENT FOR OTHERS AND CUSTOMIZED ONLINE WEB PAGES FEATURING USER-DEFINED INFORMATION INCLUDING ONLINE WEB LINKS TO OTHER WEB SITES; CONSULTING SERVICES FOR OTHERS IN THE SELECTION, IMPLEMENTATION AND USE OF COMPUTER SOFTWARE USED TO MONITOR AND MANAGE TRANSACTIONS AND ACTIVITIES IN A MISSION CRITICAL ENVIRONMENT; TECHNICAL SUPPORT SERVICES, NAMELY, SERVICE DESK/HELP DESK AND TROUBLESHOOTING SERVICES FOR IT INFRASTRUCTURE, COMPUTER HARDWARE, COMPUTER SOFTWARE AND COMPUTER PERIPHERALS; DATA MINING SERVICES; INFORMATION MANAGEMENT SERVICES, NAMELY, ACTING AS AN APPLICATION SERVICE PROVIDER IN THE FIELD OF KNOWLEDGE MANAGEMENT TO HOST COMPUTER APPLICATION SOFTWARE FOR THE COLLECTION, EDITING, ORGANIZING, MODIFYING, BOOKMARKING, TRANSMISSION, STORAGE AND SHARING OF DATA AND INFORMATION; CUSTOM DESIGN OF COMPUTERS FOR OTHERS; DATA BACKUP AND DATA RESTORATION SERVICES; DATA MIGRATION SERVICES; DATA ENCRYPTION SERVICES; COMPUTER SERVICES, NAMELY, COMPUTER SYSTEM ADMINISTRATION FOR OTHERS, RENTAL AND LEASING OF COMPUTER HARDWARE AND COMPUTER PERIPHERALS; PROVIDING GRAPHIC ART DESIGN SERVICES VIA COMMUNICATIONS NETWORKS; PHOTO SHARING SERVICES, NAMELY, PROVIDING A WEBSITE FOR THE UPLOADING, SHARING, VIEWING AND POSTING OF PHOTOGRAPHS AND DIGITAL IMAGES; PROVIDING A WEBSITE FEATURING TECHNOLOGY THAT ENABLES USERS TO UPLOAD AND

SHARE USER-GENERATED VIDEOS ON A WIDE VARIETY OF TOPICS AND SUBJECTS; COMPUTER SERVICES, NAMELY, CLOUD COMPUTING SERVICES IN THE NATURE OF AN ASP PROVIDER OVER A DISTRIBUTED NETWORK OF COMPUTERS AND SERVERS THAT HOSTS THE PRODUCTIVITY AND ADMINISTRATIVE SOFTWARE APPLICATIONS OF OTHERS (U.S. CLS. 100 AND 101).

JOHN KELLY, EXAMINING ATTORNEY

SN 77-828,500. TRACE TV, PARIS, FRANCE, FILED 9-17-2009.

**TRACE SPORTS**

THE MARK CONSISTS OF STANDARD CHARACTERS WITHOUT CLAIM TO ANY PARTICULAR FONT, STYLE, SIZE, OR COLOR.

PRIORITY CLAIMED UNDER SEC. 44(D) ON FRANCE APPLICATION NO. 093637320, FILED 3-17-2009, REG. NO. 093637320, DATED 8-21-2009, EXPIRES 3-17-2019.

NO CLAIM IS MADE TO THE EXCLUSIVE RIGHT TO USE "SPORTS", APART FROM THE MARK AS SHOWN.

**CLASS 38—COMMUNICATION**

FOR TELECOMMUNICATIONS ACCESS SERVICES; COMMUNICATIONS BY FIBREOPTIC NETWORKS, COMMUNICATIONS BY COMPUTER TERMINALS, RADIO COMMUNICATIONS, COMMUNICATIONS BY TELEPHONE COMMUNICATIONS, BROADCASTING OF TELEVISION PROGRAMMES, BROADCASTING OF DOCUMENTARIES, RADIO BROADCASTING, TELEVISION BROADCASTING, PROVIDING ACCESS TO A GLOBAL COMPUTER NETWORK, ELECTRONIC MAIL, TRANSMISSION OF MESSAGES, COMPUTER-AIDED TRANSMISSION OF MESSAGES AND IMAGES, TRANSMISSION USING MOBILE RADIOTELEPHONY, CABLE TELEVISION BROADCASTING, TRANSMISSION BY SATELLITE (U.S. CLS. 100, 101 AND 104).

**CLASS 41—EDUCATION AND ENTERTAINMENT**

FOR ENTERTAINMENT SERVICES, NAMELY, PROVIDING A SERIES OF PROGRAMS ABOUT SPORTS, ACCESSIBLE BY RADIO, TELEVISION, SATELLITE, AUDIO, VIDEO AND COMPUTER NETWORKS, PROVIDING A SERIES OF PROGRAMS ABOUT MUSIC, ACCESSIBLE BY RADIO, TELEVISION, SATELLITE, AUDIO, VIDEO AND COMPUTER NETWORKS, PROVIDING A SERIES OF PROGRAMS ABOUT MOVIES, ACCESSIBLE BY RADIO, TELEVISION, SATELLITE, AUDIO, VIDEO AND COMPUTER NETWORKS, PROVIDING A SERIES OF PROGRAMS ABOUT FASHION, ACCESSIBLE BY RADIO, TELEVISION, SATELLITE, AUDIO, VIDEO AND COMPUTER NETWORKS, PROVIDING A SERIES OF PROGRAMS COMPOSED OF FICTION AND MUSICAL, VARIETY, SPORTS, CIRCUS AND COMEDY SHOWS, ACCESSIBLE BY RADIO, TELEVISION, SATELLITE, AUDIO, VIDEO AND COMPUTER NETWORKS; ENTERTAINMENT SERVICES, NAMELY, PROVIDING A WEBSITE THAT DISPLAYS VARIOUS REQUESTS, REVIEWS, RECOMMENDATIONS, RANKINGS, TRACKINGS, VOTES, AND INFORMATION RELATING TO UNCREATED, UNRELEASED, NEW, SPECIAL, POPULAR, AND RARE PRODUCTS, SERVICES, AND EVENTS IN THE FIELDS OF MUSIC, MOVIES, FASHION, CULTURE, ENTERTAINMENT, EDUCATION, AND SPORTS, ALL EXCLUSIVELY FOR NON-BUSINESS AND NON-COMMERCIAL TRANSACTIONS AND PURPOSES; ENTERTAINMENT AND EDUCATIONAL SERVICES IN THE NATURE OF ON-LINE COMPETITIONS IN THE FIELD OF ENTERTAINMENT, EDUCATION, CULTURE, SPORTS, AND OTHER NON-BUSINESS AND NON-COMMERCIAL FIELDS; ENTER-

TAINMENT AND EDUCATION SERVICES IN THE NATURE OF LIVE DANCE AND MUSICAL PERFORMANCES; ENTERTAINMENT AND EDUCATIONAL SERVICES, NAMELY, THE PRESENTATION OF SEMINARS, LECTURES, WORKSHOPS AND PANEL DISCUSSIONS, AND ONGOING TELEVISION AND RADIO TALK SHOWS ALL IN THE FIELD OF PUBLIC INTEREST CONCERNING SPORTING EVENTS, MUSIC, POP CULTURE, AND SPORTS; VIDEOTAPING; PROVIDING INFORMATION AND NEWS IN THE FIELD OF SPORTS; RENTAL OF VIDEOTAPES; VIDEOTAPE EDITING; VIDEOTAPE FILM PRODUCTION; PROVIDING FACILITIES FOR PRODUCING CINEMA PRODUCTIONS; MOVIE STUDIOS; RENTAL OF MOTION PICTURES; ORGANIZATION OF EDUCATIONAL AND ENTERTAINMENT COMPETITIONS FEATURING MUSIC, DANCING, VARIETY, COMEDY AND POETRY SLAMMING; MUSIC COMPOSITION SERVICES FOR OTHERS; ORGANIZING AND CONDUCTING OF EDUCATIONAL CONFERENCES IN THE FIELD OF ENTERTAINMENT; ENTERTAINMENT INFORMATION; RADIO ENTERTAINMENT PRODUCTION; ENTERTAINMENT SERVICES, NAMELY, AN ONGOING TELEVISION SERIES FEATURING SPORTS, SPORTS CELEBRITIES, MUSIC, URBAN AND POP CULTURE, FAMILY MANAGEMENT AND RELATIONSHIPS, FASHION AND MOVIES; RENTAL OF SOUND RECORDINGS; PROVIDING ONLINE PUBLICATIONS IN THE NATURE OF MAGAZINES IN THE FIELD OF SPORTS, SPORTS CELEBRITIES, MUSIC, URBAN AND POP CULTURE, FAMILY MANAGEMENT AND RELATIONSHIPS, FASHION AND MOVIES; PRODUCTION OF FILMS; PRODUCTION OF FILM ON OPTICAL DATA MEDIA; DIGITAL IMAGING SERVICES; PUBLICATION OF BOOKS; RENTAL OF SOUND RECORDINGS; ENTERTAINMENT SERVICES, NAMELY, PROVIDING VIRTUAL ENVIRONMENTS IN WHICH USERS CAN INTERACT FOR RECREATIONAL, LEISURE OR ENTERTAINMENT PURPOSES; EDITING IMAGES ON OPTICAL DATA MEDIA; PRODUCTION OF RADIO AND TELEVISION PROGRAMS; ORGANIZATION OF SPORT COMPETITIONS; ORGANIZATION OF SPORTING AND MUSICAL SHOWS FOR ENTERTAINMENT PURPOSES; ORGANIZATION OF EXHIBITIONS FOR CULTURAL OR EDUCATIONAL PURPOSES; PUBLICATION OF TEXTS; PUBLICATION OF ELECTRONIC BOOKS AND PERIODICALS ACCESSIBLE VIA A GLOBAL COMPUTER NETWORK; EDITING SCRIPTS; PHOTOGRAPHIC REPORTING; NEWS REPORTERS SERVICES; AND RECORDING STUDIOS (U.S. CLS. 100, 101 AND 107).

TINA L. SNAPP, EXAMINING ATTORNEY

SN 77-840,260. NOMURA INTERNATIONAL PLC, LONDON, ENGLAND, FILED 10-2-2009.

**PharmaForecasts**

PRIORITY CLAIMED UNDER SEC. 44(D) ON ERPN CMNTY TM OFC APPLICATION NO. 8388894, FILED 6-25-2009, REG. NO. 8388894, DATED 1-21-2010, EXPIRES 6-25-2019.

NO CLAIM IS MADE TO THE EXCLUSIVE RIGHT TO USE "FORECASTS", APART FROM THE MARK AS SHOWN.

THE COLOR(S) RED, PINK, BLACK, AND WHITE IS/ARE CLAIMED AS A FEATURE OF THE MARK.

THE MARK CONSISTS OF THE WORD "PHARMAFORECASTS" IN A STYLIZED FONT, WITH "PHARMA" BEING OF THE COLOR RED AND "FORECASTS" BEING OF THE COLOR WHITE AND OUTLINED IN BLACK. FIVE DOTS ARE ALIGNED HORIZONTALLY, GRADATING FROM PINK TO RED, AND RUNNING FROM ABOVE THE SECOND LETTER "R" IN "PHARMAFORECASTS" TO ABOVE THE FINAL LETTER "S".

### CLASS 35—ADVERTISING AND BUSINESS

FOR MARKET RESEARCH SERVICES; ANALYSIS OF MARKET RESEARCH DATA; COMPILATION OF BUSINESS STATISTICAL MODELS FOR THE PROVISION OF MARKET DYNAMICS INFORMATION; PREPARATION AND COMPILATION OF BUSINESS STATISTICS; BUSINESS AND COMMERCIAL INFORMATION SERVICES; BUSINESS RESEARCH; ANALYSIS OF MARKET RESEARCH DATA AND STATISTICS; COMPILATION AND SYSTEMIZATION OF INFORMATION INTO COMPUTER DATABASES; DATABASE MANAGEMENT; ECONOMIC AND MARKET FORECASTING AND ANALYSIS; INFORMATION, CONSULTANCY AND ADVISORY SERVICES RELATING TO THE AFORESAID (U.S. CLS. 100, 101 AND 102).

### CLASS 36—INSURANCE AND FINANCIAL

FOR FINANCIAL INFORMATION SERVICES PROVIDED ONLINE FROM A COMPUTER DATABASE OR THE INTERNET; FINANCIAL VALUATIONS; PROVISION OF FINANCIAL INFORMATION RELATING TO STOCKS AND SHARES; PROVIDING AN ONLINE COMPUTER DATABASE IN THE FIELD OF STOCK, SHARES AND SECURITIES MARKET INFORMATION; ECONOMIC FINANCIAL RESEARCH SERVICES; FINANCIAL ANALYSIS AND FINANCIAL INVESTMENT RESEARCH SERVICES; INFORMATION, CONSULTANCY AND ADVISORY SERVICES RELATED TO BANKING, FINANCE, INVESTMENT AND INSURANCE (U.S. CLS. 100, 101 AND 102).

NAKIA HENRY, EXAMINING ATTORNEY

SN 77-843,214. ECO PROMOTIONAL PRODUCTS, INC., VERNON HILLS, IL. FILED 10-7-2009.



NO CLAIM IS MADE TO THE EXCLUSIVE RIGHT TO USE "ECO", APART FROM THE MARK AS SHOWN.

THE COLOR(S) GREEN AND BLUE IS/ARE CLAIMED AS A FEATURE OF THE MARK.

THE MARK CONSISTS OF "SHOW RESPECT" IN GREEN COLOR OVER A BLUE CURVED HEMISPHERE THAT IS ON TOP OF A GREEN CURVED HEMISPHERE WITH THE WORDS "ECO" IN A GREEN COLOR SET OFF TO THE RIGHT OF THE BLUE AND GREEN CURVED HEMISPHERES. THE WHITE BACK GROUND OF THE LOGO IS NOT BEING CLAIMED AS FEATURE OR ELEMENT OF THE MARK.

### CLASS 25—CLOTHING

FOR WEARABLE GARMENTS AND CLOTHING, NAMELY, T-SHIRTS, HATS, BLOUSES, DRESSES, PANTS, SHIRTS, TIES, SOCKS, UNDERWEAR, HEADBANDS, JEANS, DRESS SHIRTS, DRESS GOWNS, NIGHT GOWNS, HATS, BELTS, JERSEYS, AND JACKETS; AND, ATHLETIC APPAREL, NAMELY, T-SHIRTS, HATS, POLO-SHIRTS, SKIRTS, SWEATERS, SWEAT-SHIRTS, SWEATPANTS, FLEECE JACKETS, WARM UP JACKETS AND PANTS, HEADBANDS, WRISTBANDS, SHORTS, AND SWIMSUITS (U.S. CLS. 22 AND 39).

FIRST USE 10-15-2008; IN COMMERCE 10-15-2008.

**CLASS 35—ADVERTISING AND BUSINESS**

FOR ONLINE RETAIL STORE SERVICES FEATURING THE SALE OF GOODS MADE USING BIODEGRADABLE, ENVIRONMENTALLY FRIENDLY, SOCIALLY RESPONSIBLE, GREEN, RECYCLED OR RECYCLABLE MATERIALS; PROMOTING PUBLIC AWARENESS RELATING TO THE USE OF BIODEGRADABLE, ENVIRONMENTALLY FRIENDLY, SOCIALLY RESPONSIBLE, GREEN, RECYCLED OR RECYCLABLE MATERIALS (U.S. CLS. 100, 101 AND 102).

FIRST USE 10-15-2008; IN COMMERCE 10-15-2008.

WILLIAM P. SHANAHAN, EXAMINING ATTORNEY

SN 77-845,401. UBUNGEE, INC., SANTA MONICA, CA. FILED 10-9-2009.

UBUNGEE

THE MARK CONSISTS OF STANDARD CHARACTERS WITHOUT CLAIM TO ANY PARTICULAR FONT, STYLE, SIZE, OR COLOR.

**CLASS 35—ADVERTISING AND BUSINESS**

FOR PROVIDING AN ONLINE DIRECTORY INFORMATION SERVICES FEATURING A WIDE VARIETY OF TOPICS IN THE FIELDS OF SHOPPING, RETAILING, ELECTRONIC COMMERCE, MOBILE COMMUNICATION PRODUCTS AND MOBILE COMMUNICATION SERVICES AND ENTERTAINMENT PRODUCTS AND ENTERTAINMENT SERVICES; PROVIDING REFERRALS TO WEB SITES, NAMELY, PROMOTING THE GOODS AND SERVICES OF OTHERS BY PROVIDING HYPERTEXT LINKS TO THE WEB SITES OF OTHERS AT WHICH USERS CAN LINK TO A WIDE VARIETY OF INFORMATION ON PRODUCTS AND SERVICES IN THE FIELDS OF SHOPPING, RETAILING, ELECTRONIC COMMERCE, MOBILE COMMUNICATION PRODUCTS AND MOBILE COMMUNICATION PRODUCTS SERVICES, AND ENTERTAINMENT PRODUCTS AND ENTERTAINMENT SERVICES; OPERATING ONLINE MARKETPLACES FOR SELLERS OF GOODS AND SERVICES ACCESSIBLE VIA MOBILE PHONES AND COMPUTER AND TELECOMMUNICATION NETWORKS; ONLINE RETAIL STORE SERVICES FEATURING APPAREL, CDS, DVDS, TOYS, CONSUMER ELECTRONICS PRODUCTS AND GENERAL MERCHANDISE; PROVIDING A WEBSITE THAT ENABLES USERS TO PROVIDE RATINGS AND FEEDBACK ON PRODUCTS, THE BUYERS AND SELLERS OF PRODUCTS, NAMELY, PROVIDING AN ONLINE COMPUTER DATABASE IN THE FIELD OF LOCATING PRODUCTS, DESCRIBING PRODUCTS, RATING PRODUCTS, PRICING PRODUCTS AND COMPARING PRICES OF PRODUCTS (U.S. CLS. 100, 101 AND 102).

**CLASS 38—COMMUNICATION**

FOR PROVIDING CHAT ROOMS FOR THE TRANSMISSION OF MESSAGES AMONG USERS IN THE FIELD OF LOCATING PRODUCTS, DESCRIBING PRODUCTS, RATING PRODUCTS, PRICING PRODUCTS AND COMPARING PRICES OF PRODUCTS, ALL OF WHICH IS ACCESSIBLE VIA MOBILE PHONES AND COMPUTER AND TELECOMMUNICATION NETWORKS (U.S. CLS. 100, 101 AND 104).

**CLASS 42—SCIENTIFIC AND COMPUTER SERVICES**

FOR PROVIDING A SECURED-ACCESS WEBSITE ENABLING USERS TO UPLOAD, VIEW, COMMENT ON, POST AND SHARE PHOTOS OF PRODUCTS FOR SALE AND PRODUCTS PLACED ON WISH LISTS AND REGISTRIES (U.S. CLS. 100 AND 101).

MARLENE BELL, EXAMINING ATTORNEY

SN 77-848,611. N.V. HOLMATRO, 4941 VX RAAMSDONKSV-EER, NETHERLANDS, FILED 10-14-2009.



OWNER OF U.S. REG. NO. 3,580,624.

NO CLAIM IS MADE TO THE EXCLUSIVE RIGHT TO USE "TECHNOLOGY", APART FROM THE MARK AS SHOWN.

THE COLOR(S) ORANGE, WHITE AND BLACK IS/ARE CLAIMED AS A FEATURE OF THE MARK.

THE MARK CONSISTS OF THE WORDING "CORE TECHNOLOGY" WITH THE "C" IN "CORE" SHOWN IN THE SHAPE OF A HOSE IN ORANGE AND OUTLINED IN BLACK, WITH WHITE ACCENTS AND A BLACK AND WHITE HOSE COMING OUT OF EITHER SIDE OF THE "C". THE REMAINING LETTERS ARE IN BLACK.

**CLASS 6—METAL GOODS**

FOR COUPLINGS IN THE NATURE OF METAL COUPLINGS FOR USE WITH HYDRAULIC EQUIPMENT AND TOOLS AND HYDRAULIC RESCUE TOOLS; COUPLING PIECES IN THE NATURE OF METAL COUPLING PIECES FOR USE WITH HYDRAULIC EQUIPMENT AND TOOLS AND HYDRAULIC RESCUE TOOLS; METAL COVERING CAPS FOR TUBING ENDS FOR USE WITH HYDRAULIC EQUIPMENT AND TOOLS AND HYDRAULIC RESCUE TOOLS (U.S. CLS. 2, 12, 13, 14, 23, 25 AND 50).

**CLASS 7—MACHINERY**

FOR HYDRAULIC EQUIPMENT, NAMELY, HANDHELD AND PORTABLE HYDRAULIC RESCUE SYSTEMS CONSISTING OF HYDRAULIC PUMPS, HYDRAULIC CUTTING, SPREADING AND LIFTING TOOLS FOR EXTRICATION PURPOSES WITH INTEGRATED COUPLINGS FOR ATTACHING SYNTHETIC HOSES IN WHICH A HIGH PRESSURE HOSE HAS BEEN INTEGRATED; ELECTRICAL HYDRAULIC PUMPS; HYDRAULIC TOOLS, NAMELY, HANDHELD AND PORTABLE HYDRAULIC PUMPS, HANDHELD AND PORTABLE HYDRAULIC CUTTING, SPREADING AND LIFTING MACHINES FOR USE WITH RESCUE SYSTEMS, ALL OF WHICH HAVE A COUPLING FOR ATTACHING SYNTHETIC HOSES IN WHICH A HIGH-PRESSURE HOSE HAS BEEN INTEGRATED (U.S. CLS. 13, 19, 21, 23, 31, 34 AND 35).

**CLASS 17—RUBBER GOODS**

FOR NON-METAL FLEXIBLE HOSES FOR USE WITH HYDRAULIC EQUIPMENT AND TOOLS AND HYDRAULIC RESCUE TOOLS; NON-METAL FLEXIBLE HOSES IN WHICH A HIGH-PRESSURE HOSE IS INCORPORATED FOR USE IN HYDRAULIC EQUIPMENT AND TOOLS AND HYDRAULIC RESCUE TOOLS; NON-METAL FLEXIBLE HOSES FOR USE IN HYDRAULIC EQUIPMENT AND TOOLS AND HYDRAULIC RESCUE TOOLS IN WHICH A HIGH-PRESSURE HOSE IS INCORPORATED WHERE THE HOSE, FITTED WITH A COUPLING, CAN BE USED IN COMBINATION WITH HYDRAULIC TOOLS AND HYDRAULIC RESCUE TOOLS (U.S. CLS. 1, 5, 12, 13, 35 AND 50).

DEZMONA MIZELLE, EXAMINING ATTORNEY

---

SN 77-857,025. DIFFINITY GENOMICS, INC., WEST HENRIETTA, NY. FILED 10-26-2009.

**DIFFINITY**

THE MARK CONSISTS OF STANDARD CHARACTERS WITHOUT CLAIM TO ANY PARTICULAR FONT, STYLE, SIZE, OR COLOR.

**CLASS 1—CHEMICALS**

FOR DIAGNOSTIC PREPARATIONS FOR IN-VITRO SCIENTIFIC, RESEARCH, CLINICAL, OR MEDICAL LABORATORY USE, NAMELY, PREPARATIONS FOR NUCLEIC ACID PURIFICATION AND PREPARATIONS FOR DETECTION OF SPECIFIC GENE MUTATIONS OR SEQUENCES; DIAGNOSTIC ASSAYS FOR IN-VITRO SCIENTIFIC OR RESEARCH USE, NAMELY, DIAGNOSTIC ASSAYS FOR NUCLEIC ACID PURIFICATION AND FOR THE DETECTION OF SPECIFIC GENE MUTATIONS OR SEQUENCES; DIAGNOSTIC ASSAYS FOR USE IN IN-VITRO RESEARCH AND DIAGNOSTIC TESTING (U.S. CLS. 1, 5, 6, 10, 26 AND 46).

**CLASS 9—ELECTRICAL AND SCIENTIFIC APPARATUS**

FOR LABORATORY CONSUMABLES, APPARATUS AND INSTRUMENTS, NAMELY, COLUMNS, PIPETTE TIPS, AND WELL PLATES USED FOR ISOLATING NUCLEIC ACIDS; LABORATORY CONSUMABLES, NAMELY, PIPETTE TIPS; PIPETTES; LABORATORY APPARATUS AND INSTRUMENTS, NAMELY, PREPACKED COLUMNS FOR USE IN SEPARATION AND PURIFICATION (U.S. CLS. 21, 23, 26, 36 AND 38).

BARBARA A. GOLD, EXAMINING ATTORNEY

---

SN 77-857,027. DIFFINITY GENOMICS, INC., WEST HENRIETTA, NY. FILED 10-26-2009.

**DIFFINITY GENOMICS**

THE MARK CONSISTS OF STANDARD CHARACTERS WITHOUT CLAIM TO ANY PARTICULAR FONT, STYLE, SIZE, OR COLOR.

NO CLAIM IS MADE TO THE EXCLUSIVE RIGHT TO USE "GENOMICS", APART FROM THE MARK AS SHOWN.

**CLASS 1—CHEMICALS**

FOR DIAGNOSTIC PREPARATIONS FOR IN-VITRO SCIENTIFIC, RESEARCH, CLINICAL, OR MEDICAL LABORATORY USE, NAMELY, PREPARATIONS FOR NUCLEIC ACID PURIFICATION AND PREPARATIONS FOR DETECTION OF SPECIFIC GENE MUTATIONS OR SEQUENCES; DIAGNOSTIC ASSAYS FOR IN-VITRO SCIENTIFIC OR RESEARCH USE, NAMELY, DIAGNOSTIC ASSAYS FOR NUCLEIC ACID PURIFICATION AND FOR THE DETECTION OF SPECIFIC GENE MUTATIONS OR SEQUENCES; DIAGNOSTIC ASSAYS FOR USE IN IN-VITRO RESEARCH AND DIAGNOSTIC TESTING (U.S. CLS. 1, 5, 6, 10, 26 AND 46).

**CLASS 9—ELECTRICAL AND SCIENTIFIC APPARATUS**

FOR LABORATORY CONSUMABLES, APPARATUS AND INSTRUMENTS, NAMELY, COLUMNS, PIPETTE TIPS, AND WELL PLATES USED FOR ISOLATING NUCLEIC ACIDS; LABORATORY CONSUMABLES, NAMELY, PIPETTE TIPS; PIPETTES; LABORATORY APPARATUS AND INSTRUMENTS, NAMELY, PREPACKED COLUMNS FOR USE IN SEPARATION AND PURIFICATION (U.S. CLS. 21, 23, 26, 36 AND 38).

BARBARA A. GOLD, EXAMINING ATTORNEY

---

SN 77-858,169. MILUX HOLDING S.A., LUXEMBOURG, LUXEMBOURG, FILED 10-27-2009.

**RESURFICA**

THE MARK CONSISTS OF STANDARD CHARACTERS WITHOUT CLAIM TO ANY PARTICULAR FONT, STYLE, SIZE, OR COLOR.

PRIORITY CLAIMED UNDER SEC. 44(D) ON ERPNTY TM OFC APPLICATION NO. 008245995, FILED 4-27-2009, REG. NO. 008245995, DATED 1-28-2010, EXPIRES 4-27-2019.



**CLASS 9—ELECTRICAL AND SCIENTIFIC APPARATUS**

FOR APPARATUS, DEVICES AND INSTRUMENTS, ALL NOT USED IN DIRECT ASSOCIATION WITH ACTIVE IMPLANTS, FOR MEASURING, RECEIVING, SENDING, CHECKING, CONTROLLING, DRIVING, TRANSFERRING, TRANSMITTING, PROCESSING, ANALYZING, CONDUCTING, SWITCHING, TRANSFORMING, ACCUMULATING, AND REGULATING ELECTRICITY, ENERGY AND/OR DATA, INCLUDING PHYSICAL PARAMETERS, NAMELY, ELECTRONIC STORAGE DEVICES IN THE NATURE OF BLANK MEMORY DISCS, MEMORY CARDS AND DATA STORAGE MEDIA, NAMELY, PACKAGED SEMICONDUCTORS, ELECTRONIC CONTROL UNIT AND PROGRAMMER WHICH CONTROLS THE WORKING PARAMETERS OF WIRELESS COMMUNICATION SYSTEMS AND WIRELESS POWERING SYSTEMS, CHARGERS IN THE NATURE OF BATTERY CHARGERS, DIGITAL CHARGERS AND ELECTRONIC CHARGERS, ELECTRONIC TRANSMITTERS AND ELECTRONIC RECEIVERS OF ELECTRONIC SIGNALS, AND ELECTRONIC CIRCUITS; REMOTE CONTROLS FOR WIRELESS CONTROLLING, AND PROGRAMMING WIRELESS CHARGER APPARATUS FOR WIRELESS ENERGIZING AND CONTROL STATIONS FOR WIRELESS CONTROLLING, PROGRAMMING AND ENERGIZING OF ACTIVE IMPLANTS; SOFTWARE, IN PARTICULAR FOR ACTIVE MEDICAL IMPLANTS, FOR MEASURING, RECEIVING, SENDING, CHECKING, TRANSFERRING, CALCULATING, PROCESSING, CONTROLLING, PRESENTING AND ANALYZING OF DATA, NAMELY, DATA ABOUT ELECTRICITY, ENERGY, PHYSICAL PARAMETERS, AND COMMUNICATION AND PROGRAMMING DATA IN MEDICAL IMPLANTS; SOFTWARE, IN PARTICULAR FOR MEASURING, RECEIVING, SENDING, CHECKING, TRANSFERRING, CALCULATING, PROCESSING, CONTROLLING, PRESENTING AND ANALYZING OF DATA, NAMELY, DATA ABOUT ELECTRICITY, ENERGY, PHYSICAL PARAMETERS, COMMUNICATION AND PROGRAMMING DATA IN APPARATUS, DEVICES AND INSTRUMENTS FOR COMMUNICATING WITH, ENERGIZING AND PROGRAMMING OF MEDICAL IMPLANTS; AND DATA PROCESSING EQUIPMENT AND COMPUTERS (U.S. CLS. 21, 23, 26, 36 AND 38).

**CLASS 10—MEDICAL APPARATUS**

FOR MEDICAL AND SURGICAL APPARATUS, INSTRUMENTS AND DEVICES, INCLUDING ACTIVE AND NON-ACTIVE MEDICAL IMPLANTS, NAMELY, MEDICAL IMPLANTS COMPRISED OF ARTIFICIAL MATERIAL; MEDICAL AND SURGICAL APPARATUS, INSTRUMENTS AND DEVICES INTENDED FOR USE INSIDE THE MAMMAL OR HUMAN BODY, IN PARTICULAR MANUAL, ELECTRICAL OR A COMBINATION OF MANUAL AND ELECTRICAL APPARATUS, DEVICES AND INSTRUMENTS, IN ALL GOODS INCLUDING MEDICAL HYDRAULIC, MECHANICAL, AND PNEUMATIC APPARATUS, DEVICES AND INSTRUMENTS, NAMELY, MEDICAL IMPLANTS COMPRISED OF ARTIFICIAL MATERIAL; MEDICAL AND SURGICAL APPARATUS, INSTRUMENTS AND DEVICES FOR REPLACING AND ADDING ONE OR MORE BODILY FUNCTIONS AND PARTS INSIDE THE BODY, NAMELY, MEDICAL IMPLANTS COMPRISED OF ARTIFICIAL MATERIAL; MEDICAL AND SURGICAL APPARATUS, INSTRUMENTS AND DEVICES DESIGNED FOR WIRELESS PROGRAMMING, WIRELESS CONTROLLING, WIRELESS COMMUNICATING AND WIRELESS ENERGIZING, NAMELY, ACTIVE IMPLANTS IN THE NATURE OF IMPLANTS CONSISTING OF ARTIFICIAL MATERIALS, AND A WIRELESS TRANSMITTER AND A RECEIVER AS AN INTEGRAL COMPONENT OF A SURGICAL IMPLANT; WIRELESS COMMUNICATION SYSTEMS, APPARATUS, DEVICES, AND INSTRUMENTS AND WIRELESS ENERGIZING SYSTEMS, APPARATUS, DEVICES, AND INSTRUMENTS FOR MEASURING, RECEIVING, SENDING, SWITCHING, TRANSFORMING, ACCUMULATING, REGULATING, STORING, CHECKING, CONTROLLING, DRIVING, TRANSFERRING, TRANSMITTING, PROCESSING AND ANALYZING, IN ALL THE APPLICABLE AFOREMENTIONED GOODS, OF DATA INCLUDING PHYSICAL PARAMETERS, ELECTRICITY, ENERGY AND DATA, NAMELY, ELECTRONIC TRANS-

MITTERS FOR COMMUNICATING WITH, AND ENERGIZING OF, AND USED IN DIRECT ASSOCIATION WITH, ACTIVE MEDICAL IMPLANTS CONSISTING OF ARTIFICIAL MATERIALS; SURGICAL INSTRUMENTS IN PARTICULAR TO BE USED DURING OPERATIONS OF ACTIVE OR NON-ACTIVE MEDICAL IMPLANTS; VETERINARY MEDICAL AND SURGICAL APPARATUS, INSTRUMENTS AND DEVICES, FOR USE IN IMPLANT SURGERIES; MEDICAL AND SURGICAL APPARATUS, INSTRUMENTS AND DEVICES FOR ORTHOPAEDIC JOINT IMPLANTS; AND MEDICAL IMPLANTS FOR COLLECTING, RECEIVING, SENDING, STORING, PREPARING, CONTROLLING, ANALYZING AND PROCESSING OF DATA AND ENERGY TO AND FROM SAID MEDICAL IMPLANTS (U.S. CLS. 26, 39 AND 44).

**CLASS 44—MEDICAL, BEAUTY AND AGRICULTURAL SERVICES**

FOR MEDICAL SERVICES IN RELATION TO MEDICAL IMPLANTS FOR COLLECTING, SENDING, RECEIVING, STORING, PREPARING, CONTROLLING, PRESENTING, CALCULATING, ANALYZING AND PROCESSING OF DATA TO AND FROM PATIENTS AND TO AND FROM MEDICAL IMPLANTS AND TO AND FROM REMOTE CONTROLS, WIRELESS CHARGER APPARATUS AND CONTROL STATIONS FOR ACTIVE IMPLANTS; SURGICAL AND HEALTH SERVICES, NAMELY, IMPLANTATION OF ARTIFICIAL IMPLANTS TO ALLOW THE IMPLANTS TO COLLECT, SEND, RECEIVE, STORE, PREPARE, CONTROL, PRESENT, CALCULATE, ANALYZE, AND PROCESS OF DATA TO AND FROM PATIENTS AND TO AND FROM MEDICAL IMPLANTS AND TO AND FROM MEDICAL IMPLANTS AND TO AND FROM REMOTE CONTROLS, WIRELESS CHARGER APPARATUS AND CONTROL STATIONS FOR ACTIVE IMPLANTS; PROVIDING A MEDICAL, SURGICAL AND HEALTH DATABASE FEATURING MEDICAL, SURGICAL AND HEALTH INFORMATION RELATING TO MEDICAL IMPLANTS THAT HAS BEEN INPUT, COLLECTED, RECEIVED, PREPARED, CONTROLLED, PROGRAMMED, CALCULATED, AND ANALYZED, FROM MEDICAL IMPLANTS, REMOTE CONTROLS OR CONTROL STATIONS FOR USE BY MEDICAL, SURGICAL AND HEALTH PROFESSIONALS FOR THE PURPOSES OF MONITORING AND DIAGNOSING MEDICAL CONDITIONS; MEDICAL AND SURGICAL SERVICES, NAMELY, IMPLANTATION OF ARTIFICIAL IMPLANTS IN RELATION TO MEDICAL IMPLANTS FOR PROGRAMMING, CONTROLLING, COMMUNICATING WITH, AND ENERGIZING OF, ACTIVE IMPLANTS; AND MEDICAL AND SURGICAL SERVICES, NAMELY, ARTIFICIAL IMPLANTATION SERVICES FOR PERSONS HAVING A MEDICAL RELATED CONDITION AND BEING CANDIDATES FOR OR BEING OPERATED ON WITH AN ACTIVE OR A NON-ACTIVE IMPLANT (U.S. CLS. 100 AND 101).

ALEX KEAM, EXAMINING ATTORNEY

SN 77-858,209. MILUX HOLDING S.A., LUXEMBOURG, LUXEMBOURG, FILED 10-27-2009.

**MEDICALTREE**

THE MARK CONSISTS OF STANDARD CHARACTERS WITHOUT CLAIM TO ANY PARTICULAR FONT, STYLE, SIZE, OR COLOR.

PRIORITY CLAIMED UNDER SEC. 44(D) ON ERPN CMNTY TM OFC APPLICATION NO. 008246407, FILED 4-27-2009, REG. NO. 008246407, DATED 1-27-2010, EXPIRES 4-27-2019.

**CLASS 9—ELECTRICAL AND SCIENTIFIC APPARATUS**

FOR APPARATUS, DEVICES AND INSTRUMENTS, ALL NOT USED IN DIRECT ASSOCIATION WITH ACTIVE IMPLANTS, FOR MEASURING, RECEIVING, SENDING, CHECKING, CONTROLLING, DRIVING, TRANSFERRING, TRANSMITTING, PROCESSING, ANALYZING, CONDUCTING, SWITCHING, TRANSFORMING, ACCUMULATING, AND REGULATING ELECTRICITY, ENERGY AND/OR DATA, INCLUDING PHYSICAL PARAMETERS, NAMELY, ELECTRONIC STORAGE DEVICES IN THE NATURE OF BLANK MEMORY DISCS, MEMORY CARDS AND DATA STORAGE MEDIA, NAMELY, PACKAGED SEMICONDUCTORS, ELECTRONIC CONTROL UNIT AND PROGRAMMER WHICH CONTROLS THE WORKING PARAMETERS OF WIRELESS COMMUNICATION SYSTEMS AND WIRELESS POWERING SYSTEMS, CHARGERS IN THE NATURE OF BATTERY CHARGERS, DIGITAL CHARGERS AND ELECTRONIC CHARGERS, ELECTRONIC TRANSMITTERS AND ELECTRONIC RECEIVERS OF ELECTRONIC SIGNALS, AND ELECTRONIC CIRCUITS; REMOTE CONTROLS FOR WIRELESS CONTROLLING, AND PROGRAMMING WIRELESS CHARGER APPARATUS FOR WIRELESS ENERGIZING AND CONTROL STATIONS FOR WIRELESS CONTROLLING, PROGRAMMING AND ENERGIZING OF ACTIVE IMPLANTS; SOFTWARE, IN PARTICULAR FOR ACTIVE MEDICAL IMPLANTS, FOR MEASURING, RECEIVING, SENDING, CHECKING, TRANSFERRING, CALCULATING, PROCESSING, CONTROLLING, PRESENTING AND ANALYZING OF DATA, NAMELY, DATA ABOUT ELECTRICITY, ENERGY, PHYSICAL PARAMETERS, AND COMMUNICATION AND PROGRAMMING DATA IN MEDICAL IMPLANTS; SOFTWARE, IN PARTICULAR FOR MEASURING, RECEIVING, SENDING, CHECKING, TRANSFERRING, CALCULATING, PROCESSING, CONTROLLING, PRESENTING AND ANALYZING OF DATA, NAMELY, DATA ABOUT ELECTRICITY, ENERGY, PHYSICAL PARAMETERS, COMMUNICATION AND PROGRAMMING DATA IN APPARATUS, DEVICES AND INSTRUMENTS FOR COMMUNICATING WITH, ENERGIZING AND PROGRAMMING OF MEDICAL IMPLANTS; AND DATA PROCESSING EQUIPMENT AND COMPUTERS (U.S. CLS. 21, 23, 26, 36 AND 38).

**CLASS 10—MEDICAL APPARATUS**

FOR MEDICAL AND SURGICAL APPARATUS, INSTRUMENTS AND DEVICES, INCLUDING ACTIVE AND NON-ACTIVE MEDICAL IMPLANTS, NAMELY, MEDICAL IMPLANTS COMPRISED OF ARTIFICIAL MATERIAL; MEDICAL AND SURGICAL APPARATUS, INSTRUMENTS AND DEVICES INTENDED FOR USE INSIDE THE MAMMAL OR HUMAN BODY, IN PARTICULAR MANUAL, ELECTRICAL OR A COMBINATION OF MANUAL AND ELECTRICAL APPARATUS, DEVICES AND INSTRUMENTS, IN ALL GOODS INCLUDING MEDICAL HYDRAULIC, MECHANICAL, AND PNEUMATIC APPARATUS, DEVICES AND INSTRUMENTS, NAMELY, MEDICAL IMPLANTS COMPRISED OF ARTIFICIAL MATERIAL; MEDICAL AND SURGICAL APPARATUS, INSTRUMENTS AND DEVICES DESIGNED FOR REPLACING AND ADDING ONE OR MORE BODILY FUNCTIONS AND PARTS INSIDE THE BODY, NAMELY, MEDICAL IMPLANTS COMPRISED OF ARTIFICIAL MATERIAL; MEDICAL AND SURGICAL APPARATUS, INSTRUMENTS AND DEVICES DESIGNED FOR WIRELESS PROGRAMMING, WIRELESS CONTROLLING, WIRELESS COMMUNICATING AND WIRELESS ENERGIZING, NAMELY, ACTIVE IMPLANTS IN THE NATURE OF IMPLANTS CONSISTING OF ARTIFICIAL MATERIALS, AND A WIRELESS TRANSMITTER AND A RECEIVER AS AN INTEGRAL COMPONENT OF A SURGICAL IMPLANT; WIRELESS COMMUNICATION SYSTEMS, APPARATUS, DEVICES, AND INSTRUMENTS AND WIRELESS ENERGIZING SYSTEMS, APPARATUS, DEVICES, AND INSTRUMENTS FOR MEASURING, RECEIVING, SENDING, SWITCHING, TRANSFORMING, ACCUMULATING, REGULATING, STORING, CHECKING, CONTROLLING, DRIVING, TRANSFERRING, TRANSMITTING, PROCESSING AND ANALYZING, IN ALL THE APPLICABLE AFOREMENTIONED GOODS, OF DATA INCLUDING PHYSICAL PARAMETERS, ELECTRICITY, ENERGY AND DATA, NAMELY, ELECTRONIC TRANS-

MITTERS FOR COMMUNICATING WITH, AND ENERGIZING OF, AND USED IN DIRECT ASSOCIATION WITH, ACTIVE MEDICAL IMPLANTS CONSISTING OF ARTIFICIAL MATERIALS; SURGICAL INSTRUMENTS IN PARTICULAR TO BE USED DURING OPERATIONS OF ACTIVE OR NON-ACTIVE MEDICAL IMPLANTS; VETERINARY MEDICAL AND SURGICAL APPARATUS, INSTRUMENTS AND DEVICES, FOR USE IN IMPLANT SURGERIES; MEDICAL AND SURGICAL APPARATUS, INSTRUMENTS AND DEVICES FOR ORTHOPAEDIC JOINT IMPLANTS; AND MEDICAL IMPLANTS FOR COLLECTING, RECEIVING, SENDING, STORING, PREPARING, CONTROLLING, ANALYZING AND PROCESSING OF DATA AND ENERGY TO AND FROM SAID MEDICAL IMPLANTS (U.S. CLS. 26, 39 AND 44).

**CLASS 36—INSURANCE AND FINANCIAL**

FOR INSURANCE, NAMELY, UNDERWRITING HEALTH INSURANCE IN THE HEALTH CARE SECTOR; PROVIDING INSURANCE SERVICES, NAMELY, UNDERWRITING LIFE, HEALTH, FLOOD AND CASUALTY INSURANCE IN THE HEALTH CARE, SECURITIES, BONDS, STOCKS AND REAL ESTATE SECTORS; FINANCIAL AFFAIRS, NAMELY, PROVIDING FUNDS INVESTMENT IN THE HEALTH CARE SECTOR; PROVIDING A MIXED MUTUAL FUND INVESTMENT, PARTLY IN THE HEALTH CARE SECTOR AND PARTLY IN THE SECURITIES, BOND, STOCK AND REAL ESTATE SECTORS; PROVIDING INVESTMENT OPPORTUNITIES IN THE HEALTH CARE SECTOR, SECURITIES, BONDS, STOCKS AND REAL ESTATE SECTORS, NAMELY, MUTUAL FUNDS INVESTMENT, AND SECURITIES, BONDS, STOCKS AND REAL ESTATE INVESTMENT; PROVIDING FINANCIAL INFORMATION IN THE HEALTH CARE SECTOR; PROVIDING FINANCIAL INFORMATION, PARTLY IN THE HEALTH CARE SECTOR AND PARTLY IN ONE OR MORE OF THE FOLLOWING SECTORS: SECURITY, BOND, STOCK AND REAL ESTATE; PROVIDING FINANCIAL INFORMATION INCLUDING ONE OR MORE OF THE FOLLOWING SECTORS: HEALTH CARE, SECURITY, BOND, STOCK AND REAL ESTATE; MONETARY AFFAIRS, NAMELY, FINANCIAL ADVICE WITHIN ONE OR MORE OF THE FOLLOWING SECTORS: HEALTH CARE, SECURITY, BOND, STOCK AND REAL ESTATE; AND REAL ESTATE AFFAIRS, NAMELY, INVESTMENTS IN REAL ESTATE; MANAGEMENT OF REAL ESTATE; SECURITY AND STOCK INVESTMENT AND MANAGEMENT; PROVIDING MUTUAL FUND INVESTMENTS IN THE FIELD OF REAL ESTATE; PROVIDING MUTUAL FUND INVESTMENTS IN THE HEALTH CARE, SECURITY, BOND, STOCK AND REAL ESTATE SECTORS (U.S. CLS. 100, 101 AND 102).

**CLASS 44—MEDICAL, BEAUTY AND AGRICULTURAL SERVICES**

FOR MEDICAL SERVICES IN RELATION TO MEDICAL IMPLANTS FOR COLLECTING, SENDING, RECEIVING, STORING, PREPARING, CONTROLLING, PRESENTING, CALCULATING, ANALYZING AND PROCESSING OF DATA TO AND FROM PATIENTS AND TO AND FROM MEDICAL IMPLANTS AND TO AND FROM REMOTE CONTROLS, WIRELESS CHARGER APPARATUS AND CONTROL STATIONS FOR ACTIVE IMPLANTS; SURGICAL AND HEALTH SERVICES, NAMELY, IMPLANTATION OF ARTIFICIAL IMPLANTS TO ALLOW THE IMPLANTS TO COLLECT, SEND, RECEIVE, STORE, PREPARE, CONTROL, PRESENT, CALCULATE, ANALYZE, AND PROCESS OF DATA TO AND FROM PATIENTS AND TO AND FROM MEDICAL IMPLANTS AND TO AND FROM MEDICAL IMPLANTS AND TO AND FROM REMOTE CONTROLS, WIRELESS CHARGER APPARATUS AND CONTROL STATIONS FOR ACTIVE IMPLANTS; PROVIDING A MEDICAL, SURGICAL AND HEALTH DATABASE FEATURING MEDICAL, SURGICAL AND HEALTH INFORMATION RELATING TO MEDICAL IMPLANTS THAT HAS BEEN INPUT, COLLECTED, RECEIVED, PREPARED, CONTROLLED, PROGRAMMED, CALCULATED, AND ANALYZED, FROM MEDICAL IMPLANTS, REMOTE CONTROLS OR CONTROL STATIONS FOR USE BY MEDICAL, SURGICAL AND HEALTH PROFESSIONALS FOR THE PURPOSES OF

MONITORING AND DIAGNOSING MEDICAL CONDITIONS; MEDICAL AND SURGICAL SERVICES, NAMELY, IMPLANTATION OF ARTIFICIAL IMPLANTS IN RELATION TO MEDICAL IMPLANTS FOR PROGRAMMING, CONTROLLING, COMMUNICATING WITH, AND ENERGIZING OF, ACTIVE IMPLANTS; AND MEDICAL AND SURGICAL SERVICES, NAMELY, ARTIFICIAL IMPLANTATION SERVICES FOR PERSONS HAVING A MEDICAL RELATED CONDITION AND BEING CANDIDATES FOR OR BEING OPERATED ON WITH AN ACTIVE OR A NON-ACTIVE IMPLANT (U.S. CLS. 100 AND 101).

ALEX KEAM, EXAMINING ATTORNEY

SN 77-865,719. RUBEN, MARSHALL, HARTFORD, CT. FILED 11-5-2009.

## BLUE STATE

THE MARK CONSISTS OF STANDARD CHARACTERS WITHOUT CLAIM TO ANY PARTICULAR FONT, STYLE, SIZE, OR COLOR.

OWNER OF U.S. REG. NOS. 3,230,366 AND 3,477,087.

SN 77-862,804. ECAMPUSNATION, LP, CENTER, TX. FILED 11-2-2009.



THE MARK CONSISTS OF THE WORD "PEERPROF.COM" WITH A STYLIZED GLOWING LIGHTBULB AND GRADUATION CAP SITUATED OVER THE SECOND LETTER "E".

### CLASS 38—COMMUNICATION

FOR PROVIDING ON-LINE CHAT ROOMS AND ELECTRONIC BULLETIN BOARDS FOR REGISTERED USERS FOR TRANSMISSION OF MESSAGES CONCERNING ACADEMIC NETWORKING AND VIRTUAL COMMUNITY; PROVIDING ON-LINE COMPUTER DATABASES AND ON-LINE SEARCHABLE DATABASES IN THE FIELD OF TRANSMISSION OF DOCUMENTS AND IMAGES AND PROVISION OF ON-LINE FORUMS FOR TRANSMISSION OF MESSAGES AMONG COMPUTER USERS IN THE FIELD OF ACADEMIC NETWORKING AND ACADEMIC DEVELOPMENT (U.S. CLS. 100, 101 AND 104).

FIRST USE 4-15-2009; IN COMMERCE 4-15-2009.

### CLASS 41—EDUCATION AND ENTERTAINMENT

FOR PROVIDING ON-LINE COMPUTER DATABASES AND ON-LINE SEARCHABLE DATABASES FOR USE BY REGISTERED USERS TO PROVIDE OR SEEK EDUCATIONAL ASSISTANCE FROM OTHER REGISTERED USERS ON ACADEMIC COURSES AND SUBJECT MATTER (U.S. CLS. 100, 101 AND 107).

FIRST USE 4-15-2009; IN COMMERCE 4-15-2009.

### CLASS 42—SCIENTIFIC AND COMPUTER SERVICES

FOR COMPUTER SERVICES, NAMELY, HOSTING ON-LINE WEB FACILITIES FOR OTHERS FOR ORGANIZING AND CONDUCTING ON-LINE INTERACTIVE DISCUSSIONS (U.S. CLS. 100 AND 101).

FIRST USE 4-15-2009; IN COMMERCE 4-15-2009.

### CLASS 45—PERSONAL AND LEGAL SERVICES

FOR INTERNET BASED SOCIAL INTRODUCTION AND ACADEMIC NETWORKING SERVICES; PROVIDING ON-LINE COMPUTER DATABASES AND ON-LINE SEARCHABLE DATABASES IN THE FIELD OF SOCIAL ACADEMIC NETWORKING (U.S. CLS. 100 AND 101).

FIRST USE 4-15-2009; IN COMMERCE 4-15-2009.

PAUL MORENO, EXAMINING ATTORNEY

### CLASS 16—PAPER GOODS AND PRINTED MATTER

FOR PAPER NAPKINS (U.S. CLS. 2, 5, 22, 23, 29, 37, 38 AND 50).

### CLASS 21—HOUSEWARES AND GLASS

FOR (BASED ON USE IN COMMERCE) COFFEE CUPS, TEA CUPS AND MUGS; CUPS AND MUGS; MUGS; PORCELAIN MUGS (BASED ON INTENT TO USE) CUPS; INSULATED CONTAINERS FOR FOOD OR BEVERAGE FOR DOMESTIC USE; INSULATING SLEEVE HOLDER FOR BEVERAGE CUPS (U.S. CLS. 2, 13, 23, 29, 30, 33, 40 AND 50).

FIRST USE 5-1-2008; IN COMMERCE 5-1-2008.

### CLASS 25—CLOTHING

FOR (BASED ON USE IN COMMERCE) SHIRTS; SHORT-SLEEVED OR LONG-SLEEVED T-SHIRTS; T-SHIRTS (BASED ON INTENT TO USE) BELTS; BOW TIES; GOLF SHIRTS; HATS; POLO SHIRTS; SOCKS; TIES (U.S. CLS. 22 AND 39).

FIRST USE 5-1-2008; IN COMMERCE 5-1-2008.

### CLASS 30—STAPLE FOODS

FOR (BASED ON USE IN COMMERCE) BEVERAGES MADE OF COFFEE; COFFEE; COFFEE AND TEA; COFFEE BEANS (BASED ON INTENT TO USE) COFFEE FLAVORED SYRUP USED IN MAKING FOOD BEVERAGES (U.S. CL. 46).

FIRST USE 9-28-2006; IN COMMERCE 9-28-2006.

### CLASS 32—LIGHT BEVERAGES

FOR BEER; BOTTLED WATER; CARBONATED WATERS; COLAS; CONCENTRATES, SYRUPS OR POWDERS USED IN THE PREPARATION OF SOFT DRINKS; DRINKING WATER; FLAVORED BOTTLED WATER; FLAVORED WATERS; MINERAL AND AERATED WATERS; MINERAL AND CARBONATED WATERS; PURIFIED BOTTLED DRINKING WATER; SYRUPS FOR BEVERAGES (U.S. CLS. 45, 46 AND 48).

### CLASS 33—WINES AND SPIRITS

FOR ALCOHOLIC BEVERAGES, NAMELY, VODKA; COFFEE-BASED LIQUEURS; DISTILLED SPIRITS; LIQUEURS (U.S. CLS. 47 AND 49).

### CLASS 43—HOTEL AND RESTAURANT SERVICES

FOR (BASED ON USE IN COMMERCE) RESTAURANT AND CAFE SERVICES; RESTAURANT SERVICES, NAMELY, PROVIDING OF FOOD AND BEVERAGES FOR CONSUMPTION ON AND OFF THE PREMISES (BASED ON INTENT TO USE) BAR AND COCKTAIL LOUNGE SERVICES; BAR AND RESTAURANT SERVICES; BAR SERVICES (U.S. CLS. 100 AND 101).

FIRST USE 8-1-2007; IN COMMERCE 8-1-2007.

MARY I. SPARROW, EXAMINING ATTORNEY

SN 77-866.343. U-NICA INTERNATIONAL AG, MALANS, SWITZERLAND, FILED 11-5-2009.

### scryptoTRACE FINGERPRINT

THE MARK CONSISTS OF STANDARD CHARACTERS WITHOUT CLAIM TO ANY PARTICULAR FONT, STYLE, SIZE, OR COLOR.

OWNER OF SWITZERLAND REG. NO. 586986, DATED 5-26-2009, EXPIRES 5-26-2019.

### CLASS 9—ELECTRICAL AND SCIENTIFIC APPARATUS

FOR OPTICAL READERS, DATA PROCESSING EQUIPMENT; INFRARED AND VISIBLE LIGHT DETECTORS, NAMELY, ELECTRONIC COMPONENTS IN THE NATURE OF INFRARED DETECTORS FOR USE IN FURTHER MANUFACTURE; ROUTE CONTROL DEVICES, NAMELY, NETWORK ROUTERS; TRACKING DEVICES, NAMELY, ENCODED MICRO PARTICULATES, TAGS AND TAGGANTS OF PLASTIC, METAL OR SILICATE FOR USE IN THE FIELD OF PASSIVE LABELING, TRACKING OR TRACKING OF PERSONS, ANIMALS, VEHICLES OR GOODS OF ANY KIND; DEVICES FOR ENCRYPTION, NAMELY, ELECTRONIC ENCRYPTION UNITS FOR USE IN THE FIELD OF AUTHENTICITY AND PROOF OF ORIGIN FOR GENUINE PRODUCTS, PACKAGING AND DOCUMENTS, AS WELL AS THE PROTECTION OF BRANDED PRODUCTS AGAINST COUNTERFEITING, IMITATION, TAMPERING, AND GRAY-MARKET IMPORTS; SOFTWARE FOR TRACKING DEVICES WHICH TRACKS PEOPLE, OBJECTS AND PETS USING OPTICAL AND VISUAL ASCERTAINABLE DATA FROM A DEVICE ON THE TRACKED PEOPLE, OBJECTS AND PETS; LASERS FOR INDUSTRIAL USE (U.S. CLS. 21, 23, 26, 36 AND 38).

### CLASS 16—PAPER GOODS AND PRINTED MATTER

FOR MARKING DEVICES, NAMELY, MARKING INK CONTAINING BIOLOGICS FOR USE IN THE FIELD OF AUTHENTICITY AND PROOF OF ORIGIN FOR GENUINE PRODUCTS, PACKAGING AND DOCUMENTS, AS WELL AS THE PROTECTION OF BRANDED PRODUCTS AGAINST COUNTERFEITING, IMITATION, TAMPERING, AND GRAY-MARKET IMPORTS (U.S. CLS. 2, 5, 22, 23, 29, 37, 38 AND 50).

### CLASS 37—CONSTRUCTION AND REPAIR

FOR VARNISHING, NAMELY, TREATMENT OF MATERIALS BY VARNISHING (U.S. CLS. 100, 103 AND 106).

### CLASS 40—MATERIAL TREATMENT

FOR TREATMENT OF MATERIALS, NAMELY, LASER SCRIBING AND CHEMICAL MARKING OF SPARE PARTS, MACHINES, LUXURY GOODS, PHARMACEUTICALS, FOOD, CONSUMER GOODS, CONSUMABLES, TEXTILES, CERAMICS, POLYMERS AND COMPOSITES TO PROTECT AGAINST COUNTERFEITING, TAMPERING, AND DIVERSION, AND TO ENSURE THE INTEGRITY OF GENUINE PRODUCTS AND DOCUMENTS; TREATMENT OF MATERIALS BY SURFACE FORMING TOOLS, NAMELY, PRINTING, EMBOSSING, GRINDING, MACHINING, MOLDING, HEAT TREATMENT AND COATING OF SPARE PARTS, MACHINES, LUXURY GOODS, PHARMACEUTICALS, FOOD, CONSUMER GOODS, CONSUMABLES, TEXTILES, CERAMICS, POLYMERS AND COMPOSITES TO PROTECT AGAINST COUNTERFEITING, TAMPERING, AND DIVERSION, AND TO ENSURE THE INTEGRITY OF GENUINE PRODUCTS AND DOCUMENTS (U.S. CLS. 100, 103 AND 106).

### CLASS 42—SCIENTIFIC AND COMPUTER SERVICES

FOR INSPECTION OF THE QUALITY OF SPARE PARTS, MACHINES, LUXURY GOODS, PHARMACEUTICALS, FOOD, CONSUMER GOODS, AND TEXTILES TO ENSURE THEIR CONFORMITY WITH NATIONAL AND INTERNATIONAL ANTI-COUNTERFEITING NORMS AND STANDARDS; ENGINEERING SERVICES, NAMELY, THE PLANNING AND DEVELOPMENT OF PRODUCT IDENTIFICATIONS SYSTEMS, SECURITY SYSTEMS AND PRODUCT TRACKING SYSTEMS (U.S. CLS. 100 AND 101).

### CLASS 45—PERSONAL AND LEGAL SERVICES

FOR CONSULTATION IN THE FIELD OF SECURITY; INTELLECTUAL PROPERTY WATCH SERVICES, NAMELY, TRADEMARK AUTHENTICATION AND PROTECTION FOR METAL GOODS AND CONSTITUENT PARTS (U.S. CLS. 100 AND 101).

GRETCHEN ULRICH, EXAMINING ATTORNEY

SN 77-868.742. ELIAS, MICHAEL JOSEPH, SANDYFORD, DUBLIN, IRELAND, FILED 11-9-2009.

# BOXER

THE MARK CONSISTS OF STANDARD CHARACTERS WITHOUT CLAIM TO ANY PARTICULAR FONT, STYLE, SIZE, OR COLOR.

### CLASS 29—MEATS AND PROCESSED FOODS

FOR POTATO CHIPS, VEGETABLE CHIPS, BANANA CHIPS, SOY CHIPS; NUT CRISPS, POTATO CRISPS; NUT-BASED SNACK FOODS, ROASTED NUTS, CANDIED NUTS, SEASONED NUTS; CANDIED FRUIT SNACKS, POTATO-BASED SNACK FOODS, SNACK DIPS, SNACK MIX CONSISTING OF DEHYDRATED FRUIT AND PROCESSED NUTS, SOY-BASED SNACK FOODS AND VEGETABLE-BASED SNACK FOODS (U.S. CL. 46).

### CLASS 30—STAPLE FOODS

FOR BAGEL CHIPS, CORN CHIPS, CHOCOLATE-COVERED POTATO CHIPS, PITA CHIPS, TORTILLA CHIPS; CHOCOLATE-COVERED NUTS, SNACK MIX CONSISTING PRIMARILY OF CRACKERS, PRETZELS, CANDIED NUTS AND/OR POPPED POPCORN; CEREAL-BASED SNACK FOOD, CHEESE-FLAVOURED SNACKS, NAMELY, PUFFED CHEESE BALLS AND CHEESE CURLS, CHOCOLATES, CORN-BASED SNACK FOODS, GRAIN-BASED SNACK FOODS AND SNACK CAKES (U.S. CL. 46).

### CLASS 31—NATURAL AGRICULTURAL PRODUCTS

FOR UNPROCESSED NUTS (U.S. CLS. 1 AND 46).  
DAVID ELTON, EXAMINING ATTORNEY

SN 77-870,556. MAFIA OUTDOORS, LLC., RUSSELLVILLE, AR. FILED 11-11-2009.

CAROLINE WOOD, EXAMINING ATTORNEY

## WHITETAIL MAFIA

THE MARK CONSISTS OF STANDARD CHARACTERS WITHOUT CLAIM TO ANY PARTICULAR FONT, STYLE, SIZE, OR COLOR.

NO CLAIM IS MADE TO THE EXCLUSIVE RIGHT TO USE "WHITETAIL", APART FROM THE MARK AS SHOWN.

### CLASS 7—MACHINERY

FOR ELECTRONIC FEEDER FOR DEER (U.S. CLS. 13, 19, 21, 23, 31, 34 AND 35).

### CLASS 8—HAND TOOLS

FOR HUNTING KNIVES; SIDE ARMS, NOT INCLUDING FIREARMS, NAMELY, HUNTING KNIVES (U.S. CLS. 23, 28 AND 44).

### CLASS 9—ELECTRICAL AND SCIENTIFIC APPARATUS

FOR VEHICLE SAFETY EQUIPMENT, NAMELY, ELECTRONIC DEER ALERTS (U.S. CLS. 21, 23, 26, 36 AND 38).

### CLASS 13—FIREARMS

FOR HUNTING GUN CARTRIDGES; HUNTING RIFLES (U.S. CLS. 2 AND 9).

### CLASS 18—LEATHER GOODS

FOR HUNTING BAGS; HUNTING CROPS; SPORTSMAN'S HUNTING BAGS (U.S. CLS. 1, 2, 3, 22 AND 41).

### CLASS 28—TOYS AND SPORTING GOODS

FOR ANIMAL HUNTING DECOYS; CAMOUFLAGE NETTING USED IN HUNTING; CAMOUFLAGE SCREENS FOR HUNTING PURPOSES; CAMOUFLAGE TAPE USED IN HUNTING; CONTAINERS USED IN PLAYING THE TREASURE HUNT GAME OF GEOCACHING; DEER ATTRACTANTS; DEER HUNTING DECOYS; DEER LURES; ELECTRONIC HUNTING GAME CALL WITH INTERCHANGEABLE SOUND CARTRIDGES; FIELD BLINDS USED IN HUNTING; GAME STRAPS USED IN BIRD HUNTING; HUNTING BLINDS; HUNTING CAMOUFLAGE USED AS HUNTING BLINDS; HUNTING DECOY BAGS; HUNTING EQUIPMENT, NAMELY, SCENT DISPENSER FOR ATTRACTING OR REPELLING ANIMALS; HUNTING GAME CALLS; HUNTING STANDS; LURES FOR HUNTING; LURES FOR HUNTING OR FISHING; SCENT LURES FOR HUNTING OR FISHING; TREESTANDS FOR HUNTING; TREESTANDS FOR HUNTING HAVING A CONSTRUCTION THAT MECHANICALLY JOINS THE COMPONENTS OF THE STAND TOGETHER FOR A SECURED CONNECTION; TURKEY HUNTING DECOYS; WATERFOWL HUNTING DECOYS; WILD GAME HUNTING DECOYS (U.S. CLS. 22, 23, 38 AND 50).

### CLASS 41—EDUCATION AND ENTERTAINMENT

FOR HUNTING GUIDE SERVICES; PROVIDING INFORMATION IN THE FIELD OF HUNTING AND FISHING VIA THE INTERNET; RECREATIONAL SERVICES, NAMELY, PROVIDING HUNTING PRESERVES (U.S. CLS. 100, 101 AND 107).

SN 77-877,002. JIANLIANG LIN, ARCADIA, CA. FILED 11-19-2009.

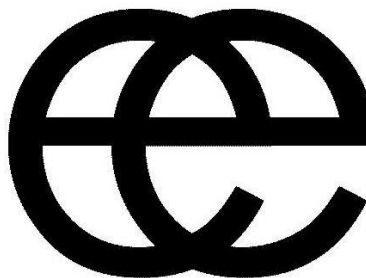

OWNER OF U.S. REG. NO. 3,646,928.

THE MARK CONSISTS OF TWO LOWER CASE LETTERS "EE", THE RIGHT SIDE LETTER "E" OVERLAPS THE LEFT SIDE LETTER "E" STARTING FROM THE MIDDLE OF THE LEFT SIDE LETTER "E".

### CLASS 3—COSMETICS AND CLEANING PREPARATIONS

FOR PERFUMES; PERFUMES AND COLOGNES (U.S. CLS. 1, 4, 6, 50, 51 AND 52).

### CLASS 9—ELECTRICAL AND SCIENTIFIC APPARATUS

FOR EYE GLASSES; SUN GLASSES (U.S. CLS. 21, 23, 26, 36 AND 38).

### CLASS 14—JEWELRY

FOR ANKLE BRACELETS; BRACELETS; JEWELLERY AND WATCHES; NECKLACES; WATCHES (U.S. CLS. 2, 27, 28 AND 50).

### CLASS 18—LEATHER GOODS

FOR HANDBAGS; LEATHER AND IMITATION LEATHER BAGS; LEATHER BAGS AND WALLETS; PURSES (U.S. CLS. 1, 2, 3, 22 AND 41).

THEODORE MCBRIDE, EXAMINING ATTORNEY

SN 77-877,462. LELAND FAUST, SAN FRANCISCO, CA. FILED 11-20-2009.

## WALL STREET PORNOGRAPHY

THE MARK CONSISTS OF STANDARD CHARACTERS WITHOUT CLAIM TO ANY PARTICULAR FONT, STYLE, SIZE, OR COLOR.

NO CLAIM IS MADE TO THE EXCLUSIVE RIGHT TO USE "WALL STREET", APART FROM THE MARK AS SHOWN.

**CLASS 9—ELECTRICAL AND SCIENTIFIC APPARATUS**

FOR AUDIOVISUAL RECORDINGS IN THE FIELD OF FINANCE AND FINANCIAL INVESTMENTS; AUDIO RECORDINGS IN THE FIELD OF FINANCE AND FINANCIAL INVESTMENTS (U.S. CLS. 21, 23, 26, 36 AND 38).

**CLASS 16—PAPER GOODS AND PRINTED MATTER**

FOR BOOKS AND NEWSLETTERS IN THE FIELD OF FINANCE AND FINANCIAL INVESTMENTS; DAILY PLANNERS IN THE FIELD OF FINANCE; WORKBOOKS IN THE FIELD OF FINANCE AND FINANCIAL INVESTMENTS (U.S. CLS. 2, 5, 22, 23, 29, 37, 38 AND 50).  
LINDA M. KING, EXAMINING ATTORNEY

SN 77-878,456. METRO CORP., PHILADELPHIA, PA. FILED 11-23-2009.

# Be Well Philly

THE MARK CONSISTS OF STANDARD CHARACTERS WITHOUT CLAIM TO ANY PARTICULAR FONT, STYLE, SIZE, OR COLOR.

NO CLAIM IS MADE TO THE EXCLUSIVE RIGHT TO USE "PHILLY", APART FROM THE MARK AS SHOWN.

**CLASS 16—PAPER GOODS AND PRINTED MATTER**

FOR PUBLICATIONS, NAMELY, MAGAZINES, BOOKS, PRINTED PERIODICALS, NEWSLETTERS IN THE FIELDS OF HEALTH AND WELLNESS (U.S. CLS. 2, 5, 22, 23, 29, 37, 38 AND 50).

**CLASS 41—EDUCATION AND ENTERTAINMENT**

FOR ON-LINE PUBLICATION OF MAGAZINES, ELECTRONIC PUBLICATIONS IN THE NATURE OF BOOKS AND NEWSLETTERS AND MULTI-MEDIA PUBLICATIONS IN THE NATURE OF MAGAZINES, BOOKS, PERIODICALS, AND BROCHURES IN THE FIELD OF HEALTH AND WELLNESS (U.S. CLS. 100, 101 AND 107).  
ANDREA BUTLER, EXAMINING ATTORNEY

SN 77-880,056. TPC ACQUISITION LLC, RAHWAY, NJ. FILED 11-24-2009.

# EKIDS

THE MARK CONSISTS OF STANDARD CHARACTERS WITHOUT CLAIM TO ANY PARTICULAR FONT, STYLE, SIZE, OR COLOR.

OWNER OF U.S. REG. NOS. 3,042,106, 3,042,107 AND 3,042,108.

**CLASS 9—ELECTRICAL AND SCIENTIFIC APPARATUS**

FOR ELECTRONIC PRODUCTS, NAMELY, RADIOS, RADIOS INCORPORATING CLOCKS, AUDIO SPEAKERS WITH MP3 DOCKING AND CONNECTIVITY, BOOM BOXES, NAMELY, PERSONAL STEREOS, WALKIE-TALKIES, HEADPHONES, AUDIO SPEAKERS, DIGITAL CAMERAS, VIDEO CAMERAS, DIGITAL PHOTO FRAMES FOR DISPLAYING DIGITAL PICTURES, VIDEO CLIPS AND MUSIC; PROTECTIVE CARRYING CASES SPECIALLY ADAPTED FOR AUDIO SPEAKERS; COMPUTER AND LAPTOP ACCESSORIES, NAMELY, CARRYING CASES, COMPUTER CAMERAS, NAMELY, WEBCAMS, NOTEBOOK COMPUTER COOLING PADS, KEYBOARDS, COMPUTER MICE, HEADSETS FOR USE WITH COMPUTERS; PORTABLE MEDIA PLAYERS, NAMELY, MP3 PLAYERS; PROTECTIVE CARRYING CASES FOR PORTABLE MEDIA PLAYERS, NAMELY, PORTABLE MEDIA PLAYERS, SMARTPHONES AND MP3 PLAYERS; CELL PHONE ACCESSORIES, NAMELY, PROTECTIVE CARRYING CASES SPECIALLY ADAPTED FOR CELL PHONES AND CELL PHONE BATTERY CHARGERS FOR USE IN VEHICLES; VIDEO GAME ACCESSORIES, NAMELY, PROTECTIVE CARRYING CASES SPECIALLY ADAPTED FOR VIDEO GAME CONSOLES FOR USE WITH AN EXTERNAL DISPLAY SCREEN OR MONITOR (U.S. CLS. 21, 23, 26, 36 AND 38).

**CLASS 28—TOYS AND SPORTING GOODS**

FOR ELECTRONIC LEARNING TOYS; ELECTRONIC EDUCATIONAL GAME MACHINES FOR CHILDREN; ELECTRONIC ACTION TOYS; ROLE PLAYING GAMES; FANTASY CHARACTER TOYS; INTERACTIVE ELECTRONIC TOYS, NAMELY, TOY PHONES, TOY CELL PHONES, TOY CAMERAS, TOY MP3 PLAYERS, TOY CD PLAYERS, TOY LAPTOP COMPUTERS, TOY CASH REGISTERS, TOY WALKIE-TALKIES, TOY KARAOKE PLAYERS, TOY MUSICAL INSTRUMENTS; PLUSH TOYS; PROTECTIVE CARRYING CASES SPECIALLY ADAPTED FOR HANDHELD VIDEO GAMES (U.S. CLS. 22, 23, 38 AND 50).

RONALD MCMORROW, EXAMINING ATTORNEY

SN 77-881,793. SONY CORPORATION, TOKYO, JAPAN, FILED 11-29-2009.

# ZIRIS

THE MARK CONSISTS OF STANDARD CHARACTERS WITHOUT CLAIM TO ANY PARTICULAR FONT, STYLE, SIZE, OR COLOR.

THE WORDING "ZIRIS" HAS NO MEANING IN A FOREIGN LANGUAGE.

**CLASS 9—ELECTRICAL AND SCIENTIFIC APPARATUS**

FOR COMPUTER SOFTWARE FOR CREATING AND OPERATING DIGITAL SIGNS FOR DISPLAY ON ELECTRONIC MONITORS (U.S. CLS. 21, 23, 26, 36 AND 38).

**CLASS 42—SCIENTIFIC AND COMPUTER SERVICES**

FOR COMPUTER PROGRAMMING; DESIGN OF COMPUTER SOFTWARE; CONSULTANCY RELATING TO COMPUTER SYSTEMS, COMPUTER HARDWARE, COMPUTER SOFTWARE, COMPUTER SOFTWARE DESIGN AND PROGRAMMING (U.S. CLS. 100 AND 101).

KRISTIN DAHLING, EXAMINING ATTORNEY

SN 77-882,408. NATIONAL UNIVERSITY OF SINGAPORE, SINGAPORE, SINGAPORE, FILED 11-30-2009.



THE MARK CONSISTS OF A SHIELD LIKE DESIGN, THE UPPER PORTION OF WHICH IS BLACK AND CONTAINS AN OPEN BOOK AND THREE RING INTERLOCKING CIRCLE DESIGN, THE LOWER PORTION OF WHICH HAS A WHITE BACKGROUND AND CONTAINS A HERALDIC LION DESIGN.

#### **CLASS 35—ADVERTISING AND BUSINESS**

FOR BUSINESS ADMINISTRATION OF EDUCATIONAL AND CULTURAL EXCHANGE PROGRAMS; BUSINESS ADMINISTRATION OF INTERNATIONAL STUDENT AND PROFESSIONAL EXCHANGE PROGRAMS, AND POLICY CONFERENCES AND RESEARCH PROGRAMS; BUSINESS ADMINISTRATION OF INTERNATIONAL FELLOWSHIP GRANT PROGRAMS; ADVISORY AND CONSULTANCY SERVICES RELATING TO BUSINESS DEVELOPMENT, BUSINESS PLANNING AND BUSINESS TECHNOLOGY COMMERCIALIZATION; ADMINISTERING STUDY ABROAD PROGRAMS, NAMELY, CONDUCTING STUDY PROGRAMS; PROVIDING INFORMATION AND CONSULTING IN THE FIELD OF HIGHER EDUCATION ADMINISTRATION; BUSINESS ASSISTANCE SERVICES, NAMELY, PATENT COMMERCIALIZATION IN THE FORM OF THE BUSINESS ADMINISTRATION AND MANAGEMENT, ADVERTISING AND BUSINESS ADVICE AND BUSINESS APPRAISAL CONSULTATION OF THE PATENTS OF OTHERS (U.S. CLS. 100, 101 AND 102).

#### **CLASS 36—INSURANCE AND FINANCIAL**

FOR FINANCIAL ASSISTANCE IN THE NATURE OF PROVIDING EDUCATION SCHOLARSHIPS FOR RESEARCH AND STUDY; CHARITABLE SERVICES, NAMELY, PROVIDING GRANTS OF FINANCIAL SUPPORT FOR EDUCATIONAL PROGRAMS; CAPITAL INVESTMENT SERVICES; FINANCIAL INFORMATION; CAPITAL INVESTMENT SERVICES IN THE NATURE OF FUNDING DEVELOPMENT SERVICES; FINANCIAL GRANT SERVICES IN THE FIELDS OF EDUCATION, ENTREPRENEURSHIP AND COMMUNITY DEVELOPMENT; FINANCIAL GRANT SERVICES TO MULTILATERAL OR BILATERAL AGENCIES, NONGOVERNMENTAL ORGANIZATIONS, ACADEMIC INSTITUTIONS, PUBLIC COMPANIES, AND PRIVATE BUSINESSES; FINANCIAL ADMINISTRATION SERVICES, NAMELY, PROVIDING FINANCIAL SPONSORSHIP OF EDUCATIONAL AND CULTURAL EXCHANGE PROGRAMS; FINANCIAL ADMINISTRATION SERVICES, NAMELY, PROVIDING FINANCIAL SPONSORSHIP OF INTERNATIONAL STUDENT AND PROFESSIONAL EXCHANGE PROGRAMS, POLICY CONFERENCES AND RESEARCH PROGRAMS; CHARITABLE FUND RAISING; CHARITABLE FUNDRAISING ACTIVITIES THROUGH ORGANIZING AND HOLDING SOCIAL AND CULTURAL EVENTS (U.S. CLS. 100, 101 AND 102).

#### **CLASS 41—EDUCATION AND ENTERTAINMENT**

FOR EDUCATION SERVICES, NAMELY, PROVIDING CLASSES, SEMINARS, LECTURES, TUTORIALS AND WORKSHOPS AT THE UNDERGRADUATE, GRADUATE, POST-GRADUATE AND PROFESSIONAL LEVELS; CULTURAL ACTIVITIES, NAMELY, ORGANIZING CULTURAL EVENTS AND EXHIBITIONS FOR CULTURAL PURPOSES; EDUCATIONAL SERVICES, NAMELY, CONDUCTING PROGRAMS IN THE FIELD OF STUDENT EXCHANGE PROGRAMS; PROVIDING INFORMATION ABOUT EDUCATION AND CONSULTING SERVICES IN THE FIELD OF EDUCATION INFORMATION; ARRANGING AND CONDUCTING CONFERENCES, SEMINARS AND ALUMNI EVENTS IN THE FIELDS OF EDUCATION, CULTURE, SPORTS AND ENTERTAINMENT FOR NON-BUSINESS AND NON-COMMERCIAL PURPOSES; ORGANIZATION AND CONDUCTING OF CULTURAL EVENTS; ORGANIZATION AND CONDUCTING OF EDUCATIONAL EVENTS, NAMELY, PROVIDING EDUCATIONAL SPEAKERS, CONDUCTING EDUCATIONAL CONFERENCES AND HOLDING EDUCATIONAL CONFERENCES; ARRANGING INTERNATIONAL EDUCATIONAL EXCHANGE PROGRAMS, NAMELY, SPONSORING, DEVELOPING, AND CARRYING OUT INTERNATIONAL STUDENT AND PROFESSIONAL EDUCATIONAL EXCHANGE PROGRAMS; TEACHING, TRAINING, TUTORING AND COURSES OF INSTRUCTION AT THE UNDERGRADUATE, GRADUATE AND POST-GRADUATE LEVEL; EDUCATIONAL PERSONAL ENRICHMENT SERVICES, NAMELY, PROVIDING MOTIVATIONAL AND EDUCATIONAL SPEAKERS IN THE FIELD OF SELF-AND PERSONAL IMPROVEMENT (U.S. CLS. 100, 101 AND 107).

#### **CLASS 42—SCIENTIFIC AND COMPUTER SERVICES**

FOR SCIENTIFIC AND TECHNOLOGICAL SERVICES AND RESEARCH AND DESIGN IN THE FIELD OF ENGINEERING, PHYSICAL AND CHEMICAL SCIENCES, INFORMATICS AND MATHEMATICS, BIOMEDICAL ENGINEERING AND LIFE SCIENCES, MEDICINE, ARCHITECTURE, ACCOUNTANCY AND BUSINESS; NEW PRODUCT DESIGN SERVICES; INDUSTRIAL DESIGN SERVICES; INDUSTRIAL ANALYSIS AND RESEARCH IN THE FIELD OF ENGINEERING, PHYSICAL AND CHEMICAL SCIENCES, INFORMATICS AND MATHEMATICS, BIOMEDICAL ENGINEERING AND LIFE SCIENCES, MEDICINE, ARCHITECTURE, ACCOUNTANCY AND BUSINESS; DESIGN AND DEVELOPMENT OF COMPUTER HARDWARE AND SOFTWARE; PRODUCT RESEARCH AND DEVELOPMENT SERVICES; RESEARCH AND DEVELOPMENT OF TECHNOLOGY IN THE FIELD OF DIGITAL AND INTERACTIVE MEDIA; RESEARCH AND DEVELOPMENT FOR OTHERS IN THE FIELD OF NEW PRODUCTS, COMPUTER SOFTWARE AND BIOTECHNOLOGY (U.S. CLS. 100 AND 101).

#### **CLASS 45—PERSONAL AND LEGAL SERVICES**

FOR LICENSING OF INTELLECTUAL PROPERTY (U.S. CLS. 100 AND 101).  
AMY C. KEAN, EXAMINING ATTORNEY

SN 77-882,649. U-NICA INTERNATIONAL AG, MALANS, SWITZERLAND, FILED 11-30-2009.

# IXBEAM

THE MARK CONSISTS OF STANDARD CHARACTERS WITHOUT CLAIM TO ANY PARTICULAR FONT, STYLE, SIZE, OR COLOR.

OWNER OF SWITZERLAND REG. NO. 591851, DATED 7-8-2009, EXPIRES 7-8-2019.

## CLASS 2—PAINTS

FOR COLOR PIGMENTS CREATED BY LASER ENGRAVING (U.S. CLS. 6, 11 AND 16).

## CLASS 9—ELECTRICAL AND SCIENTIFIC APPARATUS

FOR LASERS NOT FOR MEDICAL USE; OPERATIONAL SOFTWARE FOR LASER DEVICES FOR USE IN THE OPTICAL PERSONALIZATION OF SECURITY DOCUMENTS; OPERATIONAL SOFTWARE FOR COMPUTERS FOR USE IN THE OPTICAL PERSONALIZATION OF SECURITY DOCUMENTS (U.S. CLS. 21, 23, 26, 36 AND 38).

## CLASS 42—SCIENTIFIC AND COMPUTER SERVICES

FOR ENGINEERING SERVICES, NAMELY, THE PLANNING AND DEVELOPMENT OF PRODUCT IDENTIFICATION SYSTEMS, SECURITY SYSTEMS AND PRODUCT TRACKING SYSTEMS (U.S. CLS. 100 AND 101).

GRETCHEN ULRICH, EXAMINING ATTORNEY

SN 77-882,863. MINNESOTA PUBLIC RADIO, ST. PAUL, MN, FILED 12-1-2009.

## MINNESOTA PUBLIC MEDIA

THE MARK CONSISTS OF STANDARD CHARACTERS WITHOUT CLAIM TO ANY PARTICULAR FONT, STYLE, SIZE, OR COLOR.

OWNER OF U.S. REG. NOS. 2,609,285, 2,821,241 AND 3,217,246.

NO CLAIM IS MADE TO THE EXCLUSIVE RIGHT TO USE "PUBLIC MEDIA", APART FROM THE MARK AS SHOWN.

SEC. 2(F).

## CLASS 35—ADVERTISING AND BUSINESS

FOR PROVIDING A WEBSITE THAT FEATURES ARTICLES AND AUDIO AND VIDEO PRESENTATIONS IN THE FIELD OF BUSINESS AND POLITICAL NEWS; AND PROVIDING ONLINE INFORMATION ABOUT BUSINESS AND POLITICAL NEWS; PROVIDING ONLINE INTERACTIVE INFORMATION SERVICES IN CONJUNCTION WITH EDUCATIONAL AND ENTERTAINMENT PROGRAMS, NAMELY, PROVIDING A WEBSITE THAT FEATURES ARTICLES AND AUDIO AND VIDEO PRESENTATIONS FEATURING NATIONAL, STATE AND LOCAL NEWS (U.S. CLS. 100, 101 AND 102).

## CLASS 41—EDUCATION AND ENTERTAINMENT

FOR EDUCATIONAL AND ENTERTAINMENT SERVICES, NAMELY, PRODUCTION AND DISTRIBUTION OF RADIO PROGRAMS TO BE BROADCAST VIA RADIO AND THE INTERNET IN THE FIELDS OF NEWS, MUSIC, CURRENT EVENTS, TECHNOLOGY, COMMENTARY, INTERVIEWS, CULTURE, POLITICS, SPORTS AND HUMOR; PROVIDING ONLINE COLUMNS AND BLOGS IN THE FIELDS OF NEWS, MUSIC, CURRENT EVENTS, TECHNOLOGY, COMMENTARY, INTERVIEWS, CULTURE, POLITICS, SPORTS AND HUMOR; PROVIDING ONLINE INTERACTIVE INFORMATION SERVICES IN CONJUNCTION WITH EDUCATIONAL AND ENTERTAINMENT PROGRAMS, NAMELY, PROVIDING A WEBSITE THAT FEATURES ARTICLES AND AUDIO AND VIDEO PRESENTATIONS FEATURING MUSIC, CURRENT EVENTS, CULTURE, SPORTS AND HUMOR; PROVIDING ONLINE INFORMATION ABOUT MUSIC, CURRENT EVENTS, CULTURE, SPORTS AND HUMOR (U.S. CLS. 100, 101 AND 107).

DAVID MURRAY, EXAMINING ATTORNEY

SN 77-883,325. TRUCO, INC., CLEVELAND, OH, FILED 12-1-2009.



NO CLAIM IS MADE TO THE EXCLUSIVE RIGHT TO USE "INC.", APART FROM THE MARK AS SHOWN.

THE COLOR(S) RED, BLACK WHITE AND GREY IS/ARE CLAIMED AS A FEATURE OF THE MARK.

THE MARK CONSISTS OF THE STYLIZED WORDING "TRUCO" OUTLINED IN BLACK. EACH LETTER'S OUTLINE IS FILLED IN WITH COLOR, AND EACH LETTER PARTIALLY OVERLAPS THE LETTER ON EITHER SIDE, WITH THE LETTER "T" IN RED, THE LETTERS "R" AND "C" IN WHITE, THE LETTER "U" IN BLACK AND THE LETTER "O" IN GREY. THE STYLIZED WORDING "INC." APPEARS TO THE RIGHT IN BLACK.

## CLASS 2—PAINTS

FOR EXTERIOR SURFACE PROTECTIVE COATINGS FOR ROOFS (U.S. CLS. 6, 11 AND 16).

FIRST USE 7-1-1978; IN COMMERCE 7-1-1978.

## CLASS 37—CONSTRUCTION AND REPAIR

FOR ROOFING CONSULTATION, NAMELY, CREATING CUSTOMIZED ROOF GUIDE SPECIFICATIONS FOR INSTALLATION AND APPLICATION OF ELASTOMERIC PROTECTIVE COATINGS (U.S. CLS. 100, 103 AND 106).

FIRST USE 7-1-1978; IN COMMERCE 7-1-1978.

FONG HSU, EXAMINING ATTORNEY



SN 77-885,674. MICROFABRICA INC., VAN NUYS, CA.  
FILED 12-3-2009.

## RESIZE YOUR THINKING

THE MARK CONSISTS OF STANDARD CHARACTERS WITHOUT CLAIM TO ANY PARTICULAR FONT, STYLE, SIZE, OR COLOR.

### CLASS 7—MACHINERY

FOR COMPONENT PARTS FOR MACHINES IN THE NATURE OF MICRO ELECTRO-MECHANICAL OR MEMS DEVICES, SYSTEMS AND COMPONENTS, AND OTHER DEVICES, SYSTEMS AND COMPONENTS HAVING MICRO-SCALE OR MILLIMETER SCALE FEATURES, COMPRISED OF MECHANICAL, ELECTRICAL, OPTICAL, OR FLUIDIC ELEMENTS OR ANY COMBINATION THEREOF, NAMELY, GEARS, SPRINGS, BLADES, NEEDLES AND THREADS (U.S. CLS. 13, 19, 21, 23, 31, 34 AND 35).

### CLASS 9—ELECTRICAL AND SCIENTIFIC APPARATUS

FOR MECHANICAL COMPONENT PARTS FOR USE IN SEMICONDUCTOR TESTING EQUIPMENT IN THE NATURE OF MICRO ELECTRO-MECHANICAL OR MEMS DEVICES, SYSTEMS AND COMPONENTS, AND OTHER DEVICES, SYSTEMS AND COMPONENTS HAVING MICRO-SCALE OR MILLIMETER SCALE FEATURES, COMPRISED OF MECHANICAL, ELECTRICAL, OPTICAL, OR FLUIDIC ELEMENTS OR ANY COMBINATION THEREOF (U.S. CLS. 21, 23, 26, 36 AND 38).

### CLASS 10—MEDICAL APPARATUS

FOR MEDICAL EQUIPMENT IN THE NATURE OF MICRO ELECTRO-MECHANICAL OR MEMS DEVICES, SYSTEMS AND COMPONENTS, AND OTHER DEVICES, SYSTEMS AND COMPONENTS HAVING MICRO-SCALE OR MILLIMETER SCALE FEATURES, COMPRISED OF MECHANICAL, ELECTRICAL, OPTICAL, OR FLUIDIC ELEMENTS OR ANY COMBINATION THEREOF, NAMELY, SURGICAL INSTRUMENTS AND INTEGRAL COMPONENT PARTS THEREFOR, INSTRUMENTS FOR MINIMALLY INVASIVE SURGERY AND INTEGRAL COMPONENT PARTS THEREFOR, SURGICAL AND MEDICAL INSTRUMENTS FOR USE IN IMPLANTATION PROCEDURES AND INTEGRAL COMPONENT PARTS THEREFOR, AND INTEGRAL COMPONENT PARTS FOR DRUG DELIVERY SYSTEMS; SURGICAL AND MEDICAL IMPLANT DEVICES, FOR NEURAL, VASCULAR AND SKELETAL PURPOSES (U.S. CLS. 26, 39 AND 44).

### CLASS 13—FIREARMS

FOR INTEGRAL COMPONENT PARTS FOR MUNITIONS HAVING MICRO-SCALE OR MILLIMETER SCALE FEATURES THAT ARE COMPRISED OF MECHANICAL, ELECTRICAL, OPTICAL, OR FLUIDIC ELEMENTS OR ANY COMBINATION THEREOF (U.S. CLS. 2 AND 9).

### CLASS 40—MATERIAL TREATMENT

FOR MANUFACTURE OF PRODUCTS TO ORDER AND SPECIFICATION OF OTHERS IN THE NATURE OF MICRO ELECTRO-MECHANICAL OR MEMS DEVICES, SYSTEMS AND COMPONENTS, AND OTHER DEVICES, SYSTEMS AND COMPONENTS HAVING MICRO-SCALE OR MILLIMETER SCALE FEATURES, COMPRISED OF MECHANICAL, ELECTRICAL, OPTICAL, OR FLUIDIC ELEMENTS, OR ANY COMBINATION THEREOF, NAMELY, DEVICES USED IN SEMICONDUCTOR TEST EQUIPMENT, MECHANICAL COMPONENT PARTS, MUNITIONS COMPONENTS, SURGICAL INSTRUMENTS, INSTRUMENTS FOR MINIMALLY INVASIVE SURGERY, SURGICAL AND MEDICAL IMPLANT DEVICES, COMPONENT PARTS FOR ALL OF THE AFORESAID GOODS, AND COMPONENTS FOR DRUG DELIVERY SYSTEMS (U.S. CLS. 100, 103 AND 106).

ALYSSA STEEL, EXAMINING ATTORNEY

SN 77-888,059. SOUTHWEST GENERAL HEALTH CENTER,  
CLEVELAND, OH. FILED 12-7-2009.

## SOUTHWEST GENERAL

THE MARK CONSISTS OF STANDARD CHARACTERS WITHOUT CLAIM TO ANY PARTICULAR FONT, STYLE, SIZE, OR COLOR.  
SEC. 2(F).

### CLASS 41—EDUCATION AND ENTERTAINMENT

FOR EDUCATIONAL SERVICES, NAMELY, CLASSES AND SEMINARS IN THE FIELD OF MEDICAL AND WELLNESS TREATMENT; EDUCATIONAL SERVICES, NAMELY, CLASSES AND SEMINARS IN THE FIELD OF NUTRITION (U.S. CLS. 100, 101 AND 107).  
FIRST USE 3-1-1968; IN COMMERCE 3-1-1968.

### CLASS 42—SCIENTIFIC AND COMPUTER SERVICES

FOR MEDICAL SERVICES, NAMELY, BLOOD ANALYSIS SERVICES (U.S. CLS. 100 AND 101).  
FIRST USE 3-1-1968; IN COMMERCE 3-1-1968.

**CLASS 44—MEDICAL, BEAUTY AND AGRICULTURAL SERVICES**

FOR HOSPITAL AND HEALTH CARE SERVICES FOR TREATMENT OF PATIENTS, NAMELY, ASSESSMENT SERVICES RELATING TO PATIENTS' HEALTH STATUS, ILLNESS STATUS OF PATIENTS, PHYSICAL STATUS OF PATIENTS AS A RESULT OF INJURY, AND HEALTH ASSESSMENT AND SCREENING FOR VASCULAR DISEASE; ACUTE INPATIENT PHYSICAL REHABILITATION; HEARING THERAPY, NAMELY, TREATMENT AND THERAPY FOR VESTIBULAR BALANCE DISORDER; BLOOD TRANSFUSION SERVICES; BREAST CANCER SCREENING AND TREATMENT, EMERGENCY MEDICAL AND URGENT MEDICAL CARE SERVICES, CARDIAC CARE AND REHABILITATION, CHEMICAL DEPENDENCY SERVICES, CORONARY CARE, HEART AND VASCULAR ASSESSMENT AND TREATMENT SERVICES, DIABETIC REHABILITATION AND TREATMENT; EMS SERVICES; SURGERY; MEDICAL EVALUATION SERVICES, NAMELY, GERIATRIC HEALTH ASSESSMENT AND ELDER EVALUATION; HOSPICE SERVICES; MEDICAL SERVICES, NAMELY, ONCOLOGY AND CARDIOLOGY; MAMMOGRAPHY; MEDICAL SERVICES, NAMELY, PRE-NATAL AND POST-BIRTH MATERNITY SERVICES; MENTAL HEALTH SERVICES; MUSIC THERAPY; NEUROLOGICAL AND STROKE ASSESSMENT AND TREATMENT, NEUROSURGERY, BEHAVIORAL HEALTH SERVICES, ORTHOPEDIC SERVICES, PAIN MANAGEMENT, PEDIATRIC SERVICES, PHYSICAL MEDICINE AND REHABILITATION SERVICES, PULMONARY REHABILITATION, JOINT TREATMENT AND REPLACEMENT SERVICES, SCOLIOSIS TREATMENT, SPINE REHABILITATION, SPORTS INJURY TREATMENT, SLEEP DISORDER TREATMENT, MEDICAL SERVICES IN THE FIELDS OF WOMEN'S HEALTH, UPPER EXTREMITY AND HAND REHABILITATION, MEDICAL DIAGNOSTIC TESTING, MEDICAL RECORD CREATION AND MAINTENANCE, AND WELLNESS CLINICS; MEDICAL COUNSELING, WELLNESS SERVICES, NAMELY, COUNSELING (U.S. CLS. 100 AND 101).

FIRST USE 3-1-1968; IN COMMERCE 3-1-1968.  
GISELLE AGOSTO, EXAMINING ATTORNEY

SN 77-888,996. SOUTHWEST GENERAL HEALTH CENTER, CLEVELAND, OH. FILED 12-8-2009.



NO CLAIM IS MADE TO THE EXCLUSIVE RIGHT TO USE "SOUTHWEST GENERAL" AND "PARTNERING WITH UNIVERSITY HOSPITALS", APART FROM THE MARK AS SHOWN.

THE COLOR(S) BLACK, RED, WHITE AND GREEN IS/ARE CLAIMED AS A FEATURE OF THE MARK.

THE MARK CONSISTS OF A GREEN TREE NEXT TO THE WORDS "SOUTHWEST GENERAL" IN BLACK ABOVE THE WORDS "PARTNERING WITH" IN BLACK, SMALLER FONT LETTERS, FOLLOWED BY A RED SHIELD BEARING THE LETTERS "UH" IN WHITE, FOLLOWED BY THE WORDS "UNIVERSITY HOSPITALS" IN BLACK IN SLIGHTLY LARGER FONT.

**CLASS 41—EDUCATION AND ENTERTAINMENT**

FOR EDUCATIONAL SERVICES, NAMELY, CLASSES AND SEMINARS IN THE FIELDS OF DIABETIC EDUCATION, HEALTH CARE EDUCATION AND NUTRITION EDUCATION (U.S. CLS. 100, 101 AND 107).

FIRST USE 9-1-2008; IN COMMERCE 9-1-2008.

**CLASS 42—SCIENTIFIC AND COMPUTER SERVICES**

FOR LABORATORY SERVICES IN THE FIELD OF ONCOLOGY, MAMMOGRAPHY, NEUROLOGY, AND MEDICAL DIAGNOSIS (U.S. CLS. 100 AND 101).

FIRST USE 9-1-2008; IN COMMERCE 9-1-2008.

**CLASS 44—MEDICAL, BEAUTY AND AGRICULTURAL SERVICES**

FOR HOSPITAL AND HEALTH CARE SERVICES FOR TREATMENT OF PATIENTS, NAMELY, ASSESSMENT SERVICES RELATING TO PATIENTS' HEALTH STATUS, ILLNESS STATUS OF PATIENTS, PHYSICAL STATUS OF PATIENTS AS A RESULT OF INJURY, AND HEALTH ASSESSMENT AND SCREENING FOR VASCULAR DISEASE; ACUTE INPATIENT REHABILITATION; MEDICAL SERVICES, NAMELY, HEARING THERAPY, NAMELY, TREATMENT AND THERAPY FOR VESTIBULAR BALANCE DISORDER, BREAST CANCER SCREENING AND TREATMENT, EMERGENCY MEDICAL AND URGENT MEDICAL CARE SERVICES; MEDICAL SERVICES, NAMELY, CARDIOLOGY AND ONCOLOGY; CARDIAC CARE AND REHABILITATION, CHEMICAL DEPENDENCY SERVICES, CORONARY CARE, HEART AND VASCULAR ASSESSMENT AND TREATMENT SERVICES, DIABETIC REHABILITATION, EMS SERVICES; SURGERY; MEDICAL SERVICES, NAMELY, GERIATRIC HEALTH ASSESSMENT AND ELDER EVALUATION, HOSPICE SERVICES, MAMMOGRAPHY, OBSTETRIC AND GYNECOLOGY SERVICES, MENTAL HEALTH SERVICES, MUSIC THERAPY, NEUROLOGICAL AND STROKE ASSESSMENT AND TREATMENT, NEUROSURGERY, BEHAVIORAL HEALTH SERVICES, ORTHOPEDIC SERVICES, PAIN MANAGEMENT, PEDIATRIC SERVICES, PHYSICAL MEDICINE AND REHABILITATION SERVICES, PULMONARY REHABILITATION, JOINT TREATMENT AND REPLACEMENT SERVICES, SCOLIOSIS TREATMENT, SPINE REHABILITATION, SPORTS INJURY TREATMENT, SLEEP DISORDER TREATMENT, MEDICAL SERVICES IN THE FIELDS OF WOMEN'S HEALTH, UPPER EXTREMITY AND HAND REHABILITATION, MEDICAL DIAGNOSTIC TESTING, MEDICAL RECORD CREATION AND MAINTENANCE, AND WELLNESS CLINICS (U.S. CLS. 100 AND 101).

FIRST USE 9-1-2008; IN COMMERCE 9-1-2008.

GISELLE AGOSTO, EXAMINING ATTORNEY

SN 77-893,886. KAM MAN FOOD INC., EDISON, NJ. FILED 12-15-2009.



NO CLAIM IS MADE TO THE EXCLUSIVE RIGHT TO USE "SPECIALTY FOODS" AND THE NON-LATIN CHARACTERS THAT MEAN "BRAND", APART FROM THE MARK AS SHOWN.

THE NAME(S), PORTRAIT(S), AND/OR SIGNATURE(S) SHOWN IN THE MARK IDENTIFIES WELLMAN WU, WHOSE CONSENT(S) TO REGISTER IS MADE OF RECORD.

THE COLOR(S) BLACK, WHITE AND RED IS/ARE CLAIMED AS A FEATURE OF THE MARK.

THE MARK CONSISTS OF A BLACK AND WHITE PORTRAIT OF AN ASIAN MAN WITH GLASSES ON A RED, OVAL-SHAPED BACKGROUND OUTLINED IN WHITE AND RED; AT THE LEFT EDGE OF THE RED OVAL BACKGROUND APPEAR WRITTEN ASIAN CHARACTERS IN THE COLOR WHITE; ABOVE THE OVAL BACKGROUND APPEARS A CURVED RED ARC, ATOP WHICH SITS THE WORDING "WELL MAN" IN THE COLORS BLACK AND WHITE; BENEATH THE RED OVAL DESIGN APPEARS A CURVED RED ARC ATOP WHICH APPEARS THE BLACK WORDING "SPECIALTY FOODS" IN INITIAL CAPS TYPEFACE.

THE WORDING "WELL MAN" HAS NO MEANING IN A FOREIGN LANGUAGE.

THE NON-LATIN CHARACTERS IN THE MARK TRANSLITERATE TO "HAO REN PAI" AND THIS MEANS "GOOD PERSON BRAND" IN ENGLISH.

#### **CLASS 29—MEATS AND PROCESSED FOODS**

FOR FROZEN VEGETABLES, NAMELY, EDAMAME, SOY BEANS, BROAD BEANS, BAMBOO SHOOTS, CHINESE SPINACH, MASTER GREENS IN THE NATURE OF MUSTARD GREENS AND COLLARD GREENS, CALTROP, CABBAGE, CARROTS, CORN KERNELS, PEAS, WATER CHESTNUTS, MUSHROOMS, MIXED VEGETABLES, ASTER INDICUS, AND TARO; FROZEN, PROCESSED NUTS, NAMELY, PEELED CHESTNUTS; PROCESSED NUTS; PROCESSED YELLOW EEL STRIP; TOFU, NAMELY, SOYA SHEETS AND SOYA SHEET KNOTS; PROCESSED SOY BEANS; BEAN CURD, NAMELY, SHREDDED BEAN CURD; TOFU, NAMELY, CHICKEN AND VEGETARIAN TOFU CAKES; MEAT, FISH, POULTRY; DRIED BEANS, NAMELY, DRIED RED BEANS, DRIED MUNG BEANS, DRIED SOY BEANS, DRIED BLACK BEANS; DRIED PEANUTS; DRIED JUJUBE FRUITS; DRIED RED DATES; DRIED MUSHROOMS; DRIED BLACK FUNGUS; DRIED EDIBLE SEAWEED; DRIED LOTUS NUTS; PROCESSED ROOTS FOR HUMAN CONSUMPTION, NAMELY, LOTUS ROOTS (U.S. CL. 46).

#### **CLASS 30—STAPLE FOODS**

FOR DRIED EDIBLE SPICES, NAMELY, ANISEED, FIVE SPICE POWDER, PEPPER, MUSTARD, GARLIC, GINGER; BARLEY, NAMELY, CRUSHED BARLEY, HUSKED BARLEY, PEARLED BARLEY, EGG BARLEY, BEAN STICK IN THE NATURE OF BEAN PASTE IN STICK FORM; GLUTEN (U.S. CL. 46).

KEVIN CORWIN, EXAMINING ATTORNEY

SN 77-894,327. GIVE KIDS THE WORLD, INC., KISSIMMEE, FL. FILED 12-16-2009.

A SCOOP OF HOPE

THE MARK CONSISTS OF STANDARD CHARACTERS WITHOUT CLAIM TO ANY PARTICULAR FONT, STYLE, SIZE, OR COLOR.

#### **CLASS 41—EDUCATION AND ENTERTAINMENT**

FOR CHARITABLE SERVICES FOR CHILDREN WITH LIFE-THREATENING ILLNESSES AND THEIR FAMILIES, NAMELY, PROVIDING CHILDREN WITH LIFE-THREATENING ILLNESSES AND THEIR FAMILIES WITH TICKETS TO AMUSEMENT PARKS AT NO COST TO THEM AS PART OF A WEEK-LONG DREAM VACATION (U.S. CLS. 100, 101 AND 107).

#### **CLASS 43—HOTEL AND RESTAURANT SERVICES**

FOR CHARITABLE SERVICES FOR CHILDREN WITH LIFE-THREATENING ILLNESSES AND THEIR FAMILIES, NAMELY, PROVIDING TEMPORARY ACCOMMODATIONS AND PROVIDING MEALS (U.S. CLS. 100 AND 101).

RUDY R. SINGLETON, EXAMINING ATTORNEY

SN 77-894,717. COGNIZANT TECHNOLOGY SOLUTIONS U.S. CORPORATION, TEANECK, NJ. FILED 12-16-2009.

GOVERNANCE-IN-A-BOX

THE MARK CONSISTS OF STANDARD CHARACTERS WITHOUT CLAIM TO ANY PARTICULAR FONT, STYLE, SIZE, OR COLOR.

#### **CLASS 35—ADVERTISING AND BUSINESS**

FOR BUSINESS MANAGEMENT, CONSULTING AND ADVISORY SERVICES (U.S. CLS. 100, 101 AND 102). FIRST USE 3-0-2009; IN COMMERCE 3-0-2009.

#### **CLASS 42—SCIENTIFIC AND COMPUTER SERVICES**

FOR COMPUTER SOFTWARE AND HARDWARE CONSULTING SERVICES (U.S. CLS. 100 AND 101). FIRST USE 3-0-2009; IN COMMERCE 3-0-2009. JACQUELINE A. LAVINE, EXAMINING ATTORNEY

SN 77-897,751. PDMA-CDMA EDUCATIONAL FOUNDATION, MOUNT LAUREL, NJ. FILED 12-20-2009.

BizSprouts

THE MARK CONSISTS OF STANDARD CHARACTERS WITHOUT CLAIM TO ANY PARTICULAR FONT, STYLE, SIZE, OR COLOR.

#### **CLASS 9—ELECTRICAL AND SCIENTIFIC APPARATUS**

FOR DOWNLOADABLE EDUCATIONAL AND ENCYCLOPEDIA MATERIALS, NAMELY, DOWNLOADABLE ENCYCLOPEDIAS, AUDIO VISUAL PRESENTATION MATERIALS, CHECKLISTS AND PEER REVIEW ARTICLES IN THE FIELD OF BUSINESS DEVELOPMENT (U.S. CLS. 21, 23, 26, 36 AND 38).

**CLASS 38—COMMUNICATION**

FOR PROVIDING A MECHANISM FOR ARRANGING INFORMAL GROUP DISCUSSION SESSIONS, NAMELY, PROVIDING A WEBSITE FOR TRANSMISSION OF MESSAGES AMONG COMPUTER USERS WITH COMMON INTERESTS TO ASSIST THESE USERS IN COORDINATING GROUP MEETINGS AND ACTIVITIES VIA A WEBSITE ON THE INTERNET IN THE FIELD OF BUSINESS DEVELOPMENT, AND PROVIDING ONLINE FORUMS FOR DISCUSSIONS IN THE FIELD OF BUSINESS DEVELOPMENT, AND PROVIDING ON-LINE CHAT ROOMS FOR TRANSMISSION OF MESSAGES AMONG COMPUTER USERS WITH VARIED COMMON INTERESTS TO ASSIST THESE GROUPS IN COORDINATING GROUP MEETINGS AND ACTIVITIES VIA A WEBSITE ON THE INTERNET IN THE FIELD OF BUSINESS DEVELOPMENT (U.S. CLS. 100, 101 AND 104).

**CLASS 41—EDUCATION AND ENTERTAINMENT**

FOR EDUCATION INFORMATION; EDUCATION SERVICES, NAMELY, PROVIDING ON-LINE WEBINARS IN THE FIELD OF BUSINESS DEVELOPMENT; EDUCATIONAL SERVICES, NAMELY, PROVIDING CONTINUING PROFESSIONAL EDUCATION COURSES IN THE FIELD OF BUSINESS DEVELOPMENT (U.S. CLS. 100, 101 AND 107).

TRACY FLETCHER, EXAMINING ATTORNEY

**CLASS 9—ELECTRICAL AND SCIENTIFIC APPARATUS**

FOR EYEGLASSES AND SUNGLASSES; ACCESSORIES FOR SWIMMING AND DIVING, NAMELY, SWIMMING GOGGLES, MASKS, DIVING GLOVES, DIVING HELMETS, SCUBA DIVING MASKS, DIVING SUITS, NOSE CLIPS FOR DIVERS AND SWIMMERS, SNORKEL TUBES, EAR PLUGS; EYE PROTECTION WEAR FOR SPORTS, NAMELY, GOGGLES FOR WATER SKIING, SURFING, SAILING, BOARD SAILING, BOATING, SNOW SKIING, SNOW BOARDING, HIKING, CLIMBING, RACQUET SPORTS, CYCLING; CORRECTIVE LENSES FOR EYE PROTECTION WEAR FOR SPORTS, NAMELY, GOGGLES WITH CORRECTIVE LENSES FOR WATER SKIING, SURFING, SAILING, BOARD SAILING, BOATING, SNOW SKIING, SNOW BOARDING, HIKING, CLIMBING, RACQUET SPORTS, CYCLING; SUNGLASSES; SPECTACLE CASES; EYEGLASS NECK CORDS; PROTECTION AND SAFETY SWIMMING AIDS, NAMELY, INFLATABLE FLOTATION DEVICES AND SWIMMING TRAINING LIFE BUOYS INFLATABLE OR NOT, FLOTATION LIFE BELTS, SWIM FLOTATION VESTS; SPORTS HELMETS, DIVING GLOVES; PROTECTIVE CLOTHING (U.S. CLS. 21, 23, 26, 36 AND 38).

**CLASS 18—LEATHER GOODS**

FOR SPORT BAGS, TRUNKS, TRAVELLING BAGS, LEISURE BAGS, NAMELY, ALL-PURPOSE CARRYING BAGS, ALL PURPOSE SPORTS BAGS AND HANDBAGS, RUCKSACKS, CARRYING BAGS FOR BATHING TRUNKS (U.S. CLS. 1, 2, 3, 22 AND 41).

**CLASS 25—CLOTHING**

FOR CLOTHING FOR LEISURE WEAR, NAMELY, SWIMWEAR, BEACHWEAR, TRACKSUITS, SHIRTS, SHORTS, POLO SHIRTS, SPORTS AND LEISURE SHOES, SANDALS, SWIMMING CAPS, HATS, SWIMMING SUITS FOR COMPETITION, SWIMMING SUITS FOR MEN, WOMEN AND CHILDREN, SWIMMING TRUNKS, T-SHIRTS, SPORT SHORTS, WARM UP SUITS, GYMNASIIC SUITS FOR WOMEN, SLIPPERS, BOOTS, LEGGINGS, SOCKS, SWEAT SHORTS, SKIRTS, DRESSES, BATHING COSTUMES, BATHING GARMENTS, NAMELY, BATHING SUITS, TENNIS SHORTS, GOLF TROUSERS AND GOLF PULLOVERS, SKI OVER GARMENTS, NAMELY, SKI WEAR, AND SKI UNDERGARMENTS, PANTS, BATH WRAPS, BEACH ARTICLES, NAMELY, BEACH FOOTWEAR, DRESSING GOWNS, BATHING CAPS, SPORT GLOVES, IN PARTICULAR SKI AND GOLF GLOVES; CAPS, BONNETS (U.S. CLS. 22 AND 39).

**CLASS 28—TOYS AND SPORTING GOODS**

FOR HAND-PADDLES, NAMELY, PADDLES FOR USE WITH PADDLE BALL GAMES; SWIMMING AND DIVING ACCESSORIES, NAMELY, FINS; GYMNASIIC AND SPORTS ARTICLES, NAMELY, SMALL PADDLE BALLS, BALLS FOR WATER POLO, VOLLEYBALL AND BEACH VOLLEYBALL; SCUBA FLIPPERS, PADDLE BOARDS, KICK BOARDS, SWIMMING BOARDS, SWIMMING AND DIVING DEVICES, NAMELY, FLIPPERS AND SWIMMING GLOVES, RACKETS, IN PARTICULAR FOR TENNIS AND TABLE-TENNIS, GOLF CLUBS, HOCKEY STICKS, SKIS, ICE SKATES, SWIM FINS, ROLLER SKATES, ROLLER BOARDS AND FITTINGS THEREOF, ICE SKATES, BOWS FOR ARCHERY AND ACCESSORIES, NAMELY, ARCHERY IMPLEMENTS, BALLS FOR FRENCH PETANQUE; CARRYING BAGS FOR SPORT EQUIPMENT; BAGS SPECIFICALLY ADAPTED FOR SPORT (U.S. CLS. 22, 23, 38 AND 50).

JOHN DWYER, EXAMINING ATTORNEY

SN 77-899.081. ARENA DISTRIBUTION S.A., LUGANO, SWITZERLAND, FILED 12-22-2009.

**arena**

OWNER OF U.S. REG. NOS. 920,759, 1,255,900 AND OTHERS.

THE MARK CONSISTS OF THE WORDING "ARENA".

SN 77-899,945. PLANET MUSIC USA CORPORATION,  
CLEARWATER, FL. FILED 12-23-2009.

## PLANET EDUCATION

THE MARK CONSISTS OF STANDARD CHARACTERS  
WITHOUT CLAIM TO ANY PARTICULAR FONT, STYLE,  
SIZE, OR COLOR.

### CLASS 15—MUSICAL INSTRUMENTS

FOR MUSICAL INSTRUMENTS (U.S. CLS. 2, 21 AND  
36).  
FIRST USE 8-10-2007; IN COMMERCE 8-10-2007.

### CLASS 28—TOYS AND SPORTING GOODS

FOR MUSICAL TOYS (U.S. CLS. 22, 23, 38 AND 50).  
FIRST USE 8-10-2007; IN COMMERCE 8-10-2007.  
SAIMA MAKHDOOM, EXAMINING ATTORNEY

---

SN 77-901,523. TRUIST, INC., WASHINGTON, DC. FILED 12-  
28-2009.

## INDIGO

THE MARK CONSISTS OF STANDARD CHARACTERS  
WITHOUT CLAIM TO ANY PARTICULAR FONT, STYLE,  
SIZE, OR COLOR.

### CLASS 35—ADVERTISING AND BUSINESS

FOR PROVIDING EXPERT BUSINESS CONSULTING  
SERVICES RELATED TO THE OPERATION OF WORK-  
PLACE-BASED CHARITABLE FUNDRAISING AND DIS-  
TRIBUTION PROGRAMS; PROVIDING BUSINESS  
SUPPORT STAFF SERVICES RELATED TO THE OPERA-  
TION OF WORKPLACE-BASED CHARITABLE FUN-  
DRAISING AND DISTRIBUTION PROGRAMS,  
FINANCIAL ADMINISTRATIVE SUPPORT SERVICES  
RELATED TO THE OPERATION OF WORKPLACE-  
BASED CHARITABLE FUNDRAISING AND DISTRIBUTION  
PROGRAMS NAMELY, ISSUANCE OF CHARITA-  
BLE RECEIPTS AND DATA PROCESSING SERVICES,  
NAMELY, COLLECTION AND MANAGEMENT OF PA-  
PER AND ELECTRONIC PLEDGE INFORMATION;  
DATA ENTRY, NAMELY, DATA PROCESSING; CHECK  
WRITING AND MAILING, REMITTANCE REPORTING,  
NAMELY, PROVIDING HIGH VOLUME PAYMENT IN-  
FORMATION DETAILS TO PAYEES (U.S. CLS. 100, 101  
AND 102).

### CLASS 36—INSURANCE AND FINANCIAL

FOR FINANCIAL CONSULTATION TO COMPANIES  
IN THE FIELD OF CHARITABLE FUNDRAISING TO  
ENABLE THEM TO CONDUCT WORKPLACE-BASED  
CHARITABLE FUNDRAISING AND DISTRIBUTION  
PROGRAMS; PROVIDING EXPERT FINANCIAL CON-  
SULTING RELATED TO THE OPERATION OF WORK-  
PLACE-BASED CHARITABLE FUNDRAISING AND  
DISTRIBUTION PROGRAMS; AND FINANCIAL AD-  
MINISTRATIVE SUPPORT SERVICES RELATED TO  
THE OPERATION OF WORKPLACE-BASED CHARITA-  
BLE FUNDRAISING AND DISTRIBUTION PROGRAMS,  
NAMELY, COLLECTION, PROCESSING AND DISTRI-  
BUTION OF FINANCIAL DONATIONS, FUND DISTRI-  
BUTION SERVICES VIA EFT (U.S. CLS. 100, 101 AND  
102).

### CLASS 42—SCIENTIFIC AND COMPUTER SERVICES

FOR PROVIDING TEMPORARY USE OF ONLINE  
NON-DOWNLOADABLE DATABASE MANAGEMENT  
SOFTWARE WHICH ALLOWS CLIENTS TO BRAND,  
CONFIGURE AND INTEGRATE CHARITABLE GIVING,  
VOLUNTEER SERVICES AND OTHER COMMUNITY  
INVOLVEMENT PROGRAMS OFFERED IN THE WORK-  
PLACE, NAMELY, SOFTWARE PROGRAMS THAT AS-  
SIST WITH PLEDGE CAPTURE, PLEDGE PROCESSING  
AND DISTRIBUTION; PROVIDING TEMPORARY USE  
OF ONLINE NON-DOWNLOADABLE DATABASE MAN-  
AGEMENT SOFTWARE THAT IS USED TO MATCH  
GRANTS, USED TO SOLICIT VOLUNTEERS, USED FOR  
EVENT MANAGEMENT, USED IN ASSISTING VOLUN-  
TEERS IN FINDING BOARD-LEVEL OPPORTUNITIES  
AT LOCAL CHARITIES, USED TO ASSIST ORGANIZA-  
TIONS IN MAKING THEIR PRODUCTS AVAILABLE TO  
LOCAL CHARITIES, USED TO COLLECT CREDIT  
CARD DONATIONS THROUGH THEIR WEBSITES,  
AND USED IN PERFORMING ONLINE SURVEY; PRO-  
VIDING TECHNICAL SUPPORT SERVICES RELATED  
TO THE OPERATION OF WORKPLACE-BASED CHARI-  
TABLE FUNDRAISING AND DISTRIBUTION PRO-  
GRAMS, NAMELY, INFORMATION TECHNOLOGY  
CONSULTATION; ONGOING MAINTENANCE OF THE  
PRIMARY CHARITY DATABASES AND THEIR SYN-  
CHRONIZATION WITH THE OTHER DATABASES (U.S.  
CLS. 100 AND 101).

### CLASS 45—PERSONAL AND LEGAL SERVICES

FOR CHARITY COMPLIANCE VETTING, NAMELY,  
LEGAL SERVICES FOR CONFIRMATION OF CHARI-  
TABLE TAX STATUS, LEGAL SERVICES REGARDING  
COMPLIANCE OF CHARITIES WITH FEDERAL LAWS  
AND GUIDELINES REGARDING AVOIDANCE OF SUP-  
PORT OF TERRORIST ORGANIZATIONS AND PROVID-  
ING USER AUTHENTICATION IN E-COMMERCE  
TRANSACTIONS (U.S. CLS. 100 AND 101).  
RUDY R. SINGLETON, EXAMINING ATTORNEY

---

SN 77-908,746. KUSHNER IP HOLDINGS LLC, NEW YORK,  
NY. FILED 1-11-2010.

## KUSHNER RESIDENTIAL

THE MARK CONSISTS OF STANDARD CHARACTERS  
WITHOUT CLAIM TO ANY PARTICULAR FONT, STYLE,  
SIZE, OR COLOR.

OWNER OF U.S. REG. NO. 2,706,063.  
NO CLAIM IS MADE TO THE EXCLUSIVE RIGHT TO  
USE "RESIDENTIAL", APART FROM THE MARK AS  
SHOWN.

SEC. 2(F) AS TO "KUSHNER".

**CLASS 36—INSURANCE AND FINANCIAL**

FOR RENTAL OF APARTMENTS; MANAGEMENT OF APARTMENTS; DEVELOPMENT OF APARTMENT BUILDINGS; SALE OF RESIDENTIAL APARTMENTS AND CONDOS FOR THE BENEFIT OF OTHERS; BROKERAGE OF RESIDENTIAL APARTMENTS AND CONDOS; SALE OF SINGLE FAMILY HOMES FOR THE BENEFIT OF OTHERS; BROKERAGE OF SINGLE FAMILY HOMES; PROVIDING A WEBSITE FEATURING INFORMATION ABOUT REAL ESTATE RENTAL, SALE, DEVELOPMENT AND BROKERAGE (U.S. CLS. 100, 101 AND 102).

**CLASS 37—CONSTRUCTION AND REPAIR**

FOR REAL ESTATE DEVELOPMENT, NAMELY, DEVELOPMENT OF RESIDENTIAL CONDOMINIUMS AND SINGLE FAMILY HOMES; PROVIDING INFORMATION IN THE FIELD OF REAL ESTATE DEVELOPMENT (U.S. CLS. 100, 103 AND 106).

ELI HELLMAN, EXAMINING ATTORNEY

**CLASS 42—SCIENTIFIC AND COMPUTER SERVICES**

FOR SCIENTIFIC AND TECHNOLOGICAL SERVICES, NAMELY, SCIENTIFIC RESEARCH AND ANALYSIS IN THE FIELD OF BANKING AND INVESTMENT; DESIGN AND DEVELOPMENT OF COMPUTER HARDWARE AND SOFTWARE; COMPUTER PROGRAMMING; COMPUTER SOFTWARE CONSULTANCY; COMPUTER SYSTEMS ANALYSIS; PROVISION OF NON-DOWNLOADABLE ONLINE COMPUTER SOFTWARE FOR ACCESSING FINANCIAL INFORMATION AND SERVICES THROUGH AN ONLINE GLOBAL COMPUTER NETWORK (U.S. CLS. 100 AND 101).

JULIE WATSON, EXAMINING ATTORNEY

---

SN 77-911,090. MCEWAN, JOHN A., ALEXANDRIA, VA. FILED 1-13-2010.

---

SN 77-910,930. BANK OF AMERICA CORPORATION, CHARLOTTE, NC. FILED 1-13-2010.

**MOUNT VERNON PROJECT**

# BOFA

THE MARK CONSISTS OF STANDARD CHARACTERS WITHOUT CLAIM TO ANY PARTICULAR FONT, STYLE, SIZE, OR COLOR.

NO CLAIM IS MADE TO THE EXCLUSIVE RIGHT TO USE "MOUNT VERNON", APART FROM THE MARK AS SHOWN.

THE MARK CONSISTS OF STANDARD CHARACTERS WITHOUT CLAIM TO ANY PARTICULAR FONT, STYLE, SIZE, OR COLOR.

PRIORITY CLAIMED UNDER SEC. 44(D) ON ICELAND APPLICATION NO. 1911/2009, FILED 7-16-2009. OWNER OF U.S. REG. NO. 847,761.

**CLASS 35—ADVERTISING AND BUSINESS**

FOR CONSULTING SERVICES, NAMELY, BUSINESS CONSULTATION; CONSULTING SERVICES IN THE FIELD OF ENERGY CONSUMPTION AND RESOURCE USAGE CONSERVATION TO IMPROVE ENERGY EFFICIENCY (U.S. CLS. 100, 101 AND 102).

**CLASS 36—INSURANCE AND FINANCIAL**

FOR INSURANCE AGENCIES AND INSURANCE BROKERAGE SERVICES; FINANCIAL AFFAIRS AND MONETARY AFFAIRS, NAMELY, FINANCIAL INFORMATION, MANAGEMENT AND ANALYSIS SERVICES; REAL ESTATE AGENCIES AND REAL ESTATE BROKERAGE SERVICES; BANKING SERVICES; FINANCIAL SERVICES, NAMELY, WEALTH MANAGEMENT SERVICES, MANAGEMENT AND BROKERAGE IN THE FIELDS OF STOCKS, BONDS, OPTIONS, COMMODITIES, FUTURES AND OTHER SECURITIES, AND THE INVESTMENT OF FUNDS OF OTHERS; FINANCIAL ANALYSIS; FINANCIAL MANAGEMENT AND CONSULTING; CAPITAL INVESTMENT SERVICES; BROKERAGE SERVICE IN THE FIELDS OF STOCKS, BONDS, OPTIONS, COMMODITIES, FUTURES AND OTHER SECURITIES; TRANSACTING AND TRADING OF FINANCIAL INSTRUMENTS; PROVIDING FINANCIAL INFORMATION; FINANCIAL, SECURITIES AND COMMODITIES EXCHANGE SERVICES; FINANCIAL SERVICES IN THE NATURE OF INVESTMENT SERVICES; CREDIT AND DEBIT CARD SERVICES; FINANCIAL RESEARCH; AND PROVISION OF THESE SERVICES THROUGH AN ONLINE GLOBAL COMPUTER NETWORK; INVESTMENT AND FINANCIAL BANKING RESEARCH AND ANALYSIS (U.S. CLS. 100, 101 AND 102).

**CLASS 40—MATERIAL TREATMENT**

FOR MANUFACTURING SERVICES FOR OTHERS IN THE FIELD OF IN THE FIELD OF ENERGY CONSUMPTION AND RESOURCE USAGE CONSERVATION DEVICES AND SYSTEMS TO IMPROVE ENERGY EFFICIENCY (U.S. CLS. 100, 103 AND 106).

**CLASS 42—SCIENTIFIC AND COMPUTER SERVICES**

FOR DESIGN AND DEVELOPMENT OF NATURAL RESOURCE CONSERVATION DEVICES (U.S. CLS. 100 AND 101).

**CLASS 45—PERSONAL AND LEGAL SERVICES**

FOR LICENSING OF INTELLECTUAL PROPERTY; CONSULTING IN THE FIELD OF INTELLECTUAL PROPERTY LICENSING (U.S. CLS. 100 AND 101).

JAY BESCH, EXAMINING ATTORNEY

SN 77-912,732. REAL STYLE NETWORK, INC., TORONTO, ONTARIO, CANADA, FILED 1-15-2010.

## REAL STYLE NETWORK

THE MARK CONSISTS OF STANDARD CHARACTERS WITHOUT CLAIM TO ANY PARTICULAR FONT, STYLE, SIZE, OR COLOR.

PRIORITY CLAIMED UNDER SEC. 44(D) ON CANADA APPLICATION NO. 1464822, FILED 12-29-2009.

NO CLAIM IS MADE TO THE EXCLUSIVE RIGHT TO USE "STYLE NETWORK", APART FROM THE MARK AS SHOWN.

### CLASS 35—ADVERTISING AND BUSINESS

FOR ADVERTISING OF GOODS AND SERVICES OF OTHERS (U.S. CLS. 100, 101 AND 102).

FIRST USE 12-1-2009; IN COMMERCE 12-1-2009.

### CLASS 38—COMMUNICATION

FOR BROADCASTING PROGRAMS VIA A GLOBAL COMPUTER NETWORK (U.S. CLS. 100, 101 AND 104).

FIRST USE 12-1-2009; IN COMMERCE 12-1-2009.

### CLASS 41—EDUCATION AND ENTERTAINMENT

FOR ON-LINE JOURNALS, NAMELY, BLOGS FEATURING FASHION NEWS, FASHION DESIGNER PROFILE AND STYLE TIPS, CELEBRITY NEWS, BEAUTY AND COSMETICS, ENTERTAINMENT AND POPULAR CULTURE NEWS AND INFORMATION, SHOPPING TIPS, PRODUCT PROFILES AND INFORMATION, LIFE-STYLE NEWS (U.S. CLS. 100, 101 AND 107).

FIRST USE 12-1-2009; IN COMMERCE 12-1-2009.

ROBERT C. CLARK JR., EXAMINING ATTORNEY

SN 77-913,990. ELLISON EDUCATIONAL EQUIPMENT, INC., DBA SIZZIX, LAKE FOREST, CA. FILED 1-18-2010.

## ECLIPS

THE MARK CONSISTS OF STANDARD CHARACTERS WITHOUT CLAIM TO ANY PARTICULAR FONT, STYLE, SIZE, OR COLOR.

OWNER OF U.S. REG. NOS. 3,822,318 AND 3,868,662.

### CLASS 8—HAND TOOLS

FOR HAND TOOLS AND HAND-OPERATED IMPLEMENTS, NAMELY, SPATULAS FOR LIFTING MATERIAL TEMPORARILY AFFIXED TO A WORK PIECE OR AREA; HAND TOOLS, NAMELY, PICKS, NAMELY, DIE PICKS; KNIVES FOR HOBBY USE, NAMELY, CRAFT KNIVES (U.S. CLS. 23, 28 AND 44).

### CLASS 9—ELECTRICAL AND SCIENTIFIC APPARATUS

FOR APPARATUS FOR RECORDING, TRANSMISSION OR REPRODUCTION OF IMAGES, NAMELY, MACHINE READABLE MEDIA CARTRIDGES; DATA PROCESSING EQUIPMENT; RECORDED MEDIA, NAMELY, DVDS FEATURING GRAPHICAL DATA IN THE FIELD OF PERSONAL CRAFTING AND CHILD EDUCATION; COMPUTER SOFTWARE FOR USE IN AUTHORIZING, DOWNLOADING, TRANSMITTING, RECEIVING, EDITING, EXTRACTING, ENCODING, DECODING, PLAYING, STORING AND ORGANIZING GRAPHICAL DATA IN THE FIELD OF PERSONAL CRAFTING AND CHILD EDUCATION; MEASURING APPARATUS AND INSTRUMENTS, NAMELY, GRADUATED RULERS; STRUCTURAL PARTS AND STRUCTURAL FITTINGS FOR ALL THE AFORESAID GOODS (U.S. CLS. 21, 23, 26, 36 AND 38).

### CLASS 18—LEATHER GOODS

FOR TRUNKS AND TRAVELLING BAGS, NAMELY, TOTE BAGS (U.S. CLS. 1, 2, 3, 22 AND 41).

LINDSEY RUBIN, EXAMINING ATTORNEY

SN 77-914,002. ELLISON EDUCATIONAL EQUIPMENT, INC., DBA SIZZIX, LAKE FOREST, CA. FILED 1-18-2010.



OWNER OF U.S. REG. NOS. 3,822,318 AND 3,868,662.

THE MARK CONSISTS OF A STYLIZED, LOWERCASE LETTER "E" INSIDE A HEART WITH WINGS, FOLLOWED BY THE REMAINDER OF THE LITERAL ELEMENT, NAMELY, "CLIPS".

### CLASS 8—HAND TOOLS

FOR HAND TOOLS AND HAND-OPERATED IMPLEMENTS, NAMELY, SPATULAS FOR LIFTING MATERIAL TEMPORARILY AFFIXED TO A WORK PIECE OR AREA; HAND TOOLS, NAMELY, PICKS, NAMELY, DIE PICKS; KNIVES FOR HOBBY USE, NAMELY, CRAFT KNIVES (U.S. CLS. 23, 28 AND 44).

### CLASS 9—ELECTRICAL AND SCIENTIFIC APPARATUS

FOR APPARATUS FOR RECORDING, TRANSMISSION OR REPRODUCTION OF IMAGES, NAMELY, MACHINE READABLE MEDIA CARTRIDGES; DATA PROCESSING EQUIPMENT; RECORDED MEDIA, NAMELY, DVDS FEATURING GRAPHICAL DATA IN THE FIELD OF PERSONAL CRAFTING AND CHILD EDUCATION; COMPUTER SOFTWARE FOR USE IN AUTHORIZING, DOWNLOADING, TRANSMITTING, RECEIVING, EDITING, EXTRACTING, ENCODING, DECODING, PLAYING, STORING AND ORGANIZING GRAPHICAL DATA IN THE FIELD OF PERSONAL CRAFTING AND CHILD EDUCATION; MEASURING APPARATUS AND INSTRUMENTS, NAMELY, GRADUATED RULERS; STRUCTURAL PARTS AND STRUCTURAL FITTINGS FOR ALL THE AFORESAID GOODS (U.S. CLS. 21, 23, 26, 36 AND 38).

### CLASS 18—LEATHER GOODS

FOR TRUNKS AND TRAVELLING BAGS, NAMELY, TOTE BAGS (U.S. CLS. 1, 2, 3, 22 AND 41).

LINDSEY RUBIN, EXAMINING ATTORNEY

SN 77-914,388. ANUE SYSTEMS, INC., AUSTIN, TX. FILED 1-19-2010.



NO CLAIM IS MADE TO THE EXCLUSIVE RIGHT TO USE "SYSTEMS", APART FROM THE MARK AS SHOWN.

THE MARK CONSISTS OF THE WORDS "ANUE SYSTEMS" SURROUNDED BY AN OVAL DESIGN.

THE ENGLISH TRANSLATION OF "ANUE" IN THE MARK IS "RAINBOW".

#### **CLASS 9—ELECTRICAL AND SCIENTIFIC APPARATUS**

FOR COMPUTER HARDWARE AND SOFTWARE FOR TESTING AND MONITORING NETWORKS, APPLICATIONS BEING RUN ON THOSE NETWORKS, AND NETWORKING EQUIPMENT; COMPUTER HARDWARE AND SOFTWARE FOR SETTING UP AND CONFIGURING NETWORKS; COMPUTER HARDWARE AND SOFTWARE FOR NETWORK IMPAIRMENT EMULATION; COMPUTER HARDWARE AND SOFTWARE FOR TESTING AND MEASURING NETWORK IMPAIRMENT LEVELS; COMPUTER HARDWARE AND SOFTWARE FOR PROVIDING SECURITY TO NETWORKS; COMPUTER HARDWARE AND SOFTWARE TO IMPROVE THE PERFORMANCE OF NETWORKS; COMPUTER HARDWARE AND SOFTWARE FOR TROUBLESHOOTING ISSUES ON NETWORKS; COMPUTER HARDWARE AND SOFTWARE TO PROVIDE ACCESS TO MONITOR NETWORKS (U.S. CLS. 21, 23, 26, 36 AND 38).

#### **CLASS 42—SCIENTIFIC AND COMPUTER SERVICES**

FOR COMPUTER HARDWARE AND SOFTWARE CONSULTING SERVICES; CONSULTING SERVICES IN THE FIELD OF DESIGN, SELECTION, IMPLEMENTATION AND USE OF COMPUTER HARDWARE AND SOFTWARE SYSTEMS FOR OTHERS; COMPUTER SYSTEMS ANALYSIS; PROFESSIONAL COMPUTER SERVICES, NAMELY, NETWORK ANALYSIS, LAN/WAN DESIGN, WIRELESS ENGINEERING, VIRTUALIZATION AND COMPUTER PROJECT MANAGEMENT; MONITORING THE COMPUTER SYSTEMS OF OTHERS FOR TECHNICAL PURPOSES; TECHNICAL CONSULTING AND ASSISTANCE WITH COMPUTER-BASED INFORMATION SYSTEMS AND COMPONENTS; TECHNICAL SUPPORT SERVICES, NAMELY, TROUBLESHOOTING OF COMPUTER NETWORK, HARDWARE AND SOFTWARE PROBLEMS; TECHNICAL CONSULTING TO HELP COMPANIES SECURE THEIR NETWORKS; TECHNICAL CONSULTING TO HELP COMPANIES IMPROVE THE PERFORMANCE OF THE NETWORKS (U.S. CLS. 100 AND 101).

SCOTT BIBB, EXAMINING ATTORNEY

SN 77-917,191. COGNIZANT TECHNOLOGY SOLUTIONS U.S. CORPORATION, TEANECK, NJ. FILED 1-21-2010.



THE MARK CONSISTS OF THE WORDS "GOVERNANCE-IN-A-BOX" BELOW A DEPICTION OF A BUILDING WITH THE LETTER "G" INSIDE THE BUILDING.

#### **CLASS 35—ADVERTISING AND BUSINESS**

FOR BUSINESS MANAGEMENT, CONSULTING AND ADVISORY SERVICES (U.S. CLS. 100, 101 AND 102).  
FIRST USE 3-0-2009; IN COMMERCE 3-0-2009.

#### **CLASS 42—SCIENTIFIC AND COMPUTER SERVICES**

FOR COMPUTER SOFTWARE AND HARDWARE CONSULTING SERVICES (U.S. CLS. 100 AND 101).  
FIRST USE 3-0-2009; IN COMMERCE 3-0-2009.  
JACQUELINE A. LAVINE, EXAMINING ATTORNEY

SN 77-917,819. VIRTUELEE AMAZING STUDIOS, INC., CONCORD, CA. FILED 1-22-2010.

#### **VIRTUALLY AMAZING STUDIOS**

THE MARK CONSISTS OF STANDARD CHARACTERS WITHOUT CLAIM TO ANY PARTICULAR FONT, STYLE, SIZE, OR COLOR.

NO CLAIM IS MADE TO THE EXCLUSIVE RIGHT TO USE "STUDIOS", APART FROM THE MARK AS SHOWN.

#### **CLASS 39—TRANSPORTATION AND STORAGE**

FOR DISTRIBUTION SERVICES, NAMELY, DELIVERY OF TOYS, COLLECTIBLES, ACTION FIGURES, DIE-CAST VEHICLES, PENDANTS, KEY CHAINS, PENS, STATUETTES, DOLLS, AND CLOTHING (U.S. CLS. 100 AND 105).



**CLASS 41—EDUCATION AND ENTERTAINMENT**

FOR ENTERTAINMENT SERVICES, NAMELY, CONDUCTING ALTERNATE REALITY GAMES VIA THE INTERNET; ENTERTAINMENT SERVICES, NAMELY, PROVIDING AN ON-LINE COMPUTER GAME; ENTERTAINMENT SERVICES, NAMELY, PROVIDING ON-LINE COMPUTER GAMES; ENTERTAINMENT SERVICES, NAMELY, PROVIDING ON-LINE, NON-DOWNLOADABLE VIRTUAL PEOPLE, ANIMALS, CREATURES AND OTHER CHARACTERS FOR USE IN VIRTUAL ENVIRONMENTS CREATED FOR ENTERTAINMENT PURPOSES; ENTERTAINMENT SERVICES, NAMELY, PROVIDING ONLINE ELECTRONIC GAMES; ENTERTAINMENT SERVICES, NAMELY, PROVIDING ONLINE VIDEO GAMES; ENTERTAINMENT SERVICES, NAMELY, PROVIDING TEMPORARY USE OF NON-DOWNLOADABLE COMPUTER GAMES; ENTERTAINMENT SERVICES, NAMELY, PROVIDING TEMPORARY USE OF NON-DOWNLOADABLE ELECTRONIC GAMES; ENTERTAINMENT SERVICES, NAMELY, PROVIDING TEMPORARY USE OF NON-DOWNLOADABLE INTERACTIVE GAMES; ENTERTAINMENT SERVICES, NAMELY, PROVIDING TEMPORARY USE OF NON-DOWNLOADABLE VIDEO GAMES; ENTERTAINMENT SERVICES, NAMELY, PROVIDING VIRTUAL ENVIRONMENTS IN WHICH USERS CAN INTERACT FOR RECREATIONAL, LEISURE OR ENTERTAINMENT PURPOSES; PROVIDING A WEBSITE FEATURING EDUCATION AND ENTERTAINMENT FOR CHILDREN (U.S. CLS. 100, 101 AND 107).

NICHOLAS ALTREE, EXAMINING ATTORNEY

**CLASS 5—PHARMACEUTICALS**

FOR CHEMICALS REAGENTS FOR MEDICAL PURPOSES; NUCLEIC ACID SEQUENCES AND CHEMICAL REAGENTS FOR MEDICAL PURPOSES; ADHESIVES USED IN MEDICINE, NAMELY, ADHESIVE TAPES, ADHESIVE FOAMS, ADHESIVE HYDROCOLLOIDS, ADHESIVE HYDROGELS, ADHESIVE GELS, TOPICAL TISSUE ADHESIVES, TISSUE SEALANTS, POST-SURGICAL ADHESION BARRIERS AND HEMOSTATS; ADHESIVES USED IN WOUND MANAGEMENT, OSTOMY AND DIAGNOSTICS; ADHESIVES USED IN MEDICINE, NAMELY, ADHESIVES FOR ADHESIVE WOUND DRESSINGS AND TISSUE ADHESIVES (U.S. CLS. 6, 18, 44, 46, 51 AND 52).

**CLASS 17—RUBBER GOODS**

FOR PLASTICS IN EXTRUDED FORM FOR USE IN MANUFACTURE (U.S. CLS. 1, 5, 12, 13, 35 AND 50).  
ELLEN BURNS, EXAMINING ATTORNEY

SN 77-919,755. PORTLAND ENERGY CONSERVATION, INC., PORTLAND, OR. FILED 1-25-2010.

## Energy for Change

THE MARK CONSISTS OF STANDARD CHARACTERS WITHOUT CLAIM TO ANY PARTICULAR FONT, STYLE, SIZE, OR COLOR.

NO CLAIM IS MADE TO THE EXCLUSIVE RIGHT TO USE "ENERGY", APART FROM THE MARK AS SHOWN.

**CLASS 35—ADVERTISING AND BUSINESS**

FOR CONSULTATION IN THE FIELD OF ENERGY EFFICIENCY; PROVIDING MARKETING AND BUSINESS CONSULTATION SERVICES IN THE FIELDS OF BUILDING COMMISSIONING, PROGRAM MARKETING AND PROGRAM DESIGN IMPLEMENTATION; CONSULTING SERVICES IN THE FIELDS OF ENERGY EFFICIENCY (U.S. CLS. 100, 101 AND 102).

FIRST USE 11-29-2009; IN COMMERCE 11-29-2009.

**CLASS 41—EDUCATION AND ENTERTAINMENT**

FOR TRAINING AND EDUCATION SERVICES, NAMELY, PROVIDING WORKFORCE EDUCATIONAL TRAINING IN THE FIELD OF ENERGY EFFICIENCY (U.S. CLS. 100, 101 AND 107).

FIRST USE 1-15-2010; IN COMMERCE 1-15-2010.

**CLASS 42—SCIENTIFIC AND COMPUTER SERVICES**

FOR PROVIDING ENGINEERING SERVICES IN THE FIELD OF ENERGY EFFICIENCY THROUGH DEMONSTRATION AND PILOT PHASES OF AN ENGINEERING PROJECT; TOOLS RESOURCE DEVELOPMENT, NAMELY, DESIGN AND DEVELOPMENT OF COMPUTER SOFTWARE AND METHODS IN THE FIELD OF ENERGY EFFICIENCY; ENGINEERING RESEARCH AND ANALYSIS IN THE FIELDS OF BUILDING COMMISSIONING, PROGRAM MARKETING, AND PROGRAM DESIGN IMPLEMENTATION, DEVELOPMENT OF COMMISSIONING GUIDELINES OR CODE STANDARDS IN THE FIELD OF ENERGY EFFICIENCY (U.S. CLS. 100 AND 101).

FIRST USE 11-29-2009; IN COMMERCE 11-29-2009.  
SEAN CROWLEY, EXAMINING ATTORNEY

SN 77-919,678. BAYER AKTIENGESELLSCHAFT, 51373 LEVERKUSEN, FED REP GERMANY, FILED 1-25-2010.

## BAYMEDIX

THE MARK CONSISTS OF STANDARD CHARACTERS WITHOUT CLAIM TO ANY PARTICULAR FONT, STYLE, SIZE, OR COLOR.

PRIORITY CLAIMED UNDER SEC. 44(D) ON FED REP GERMANY APPLICATION NO. 302009075940, FILED 12-29-2009, REG. NO. 302009075940, DATED 2-4-2010, EXPIRES 12-31-2019.

OWNER OF U.S. REG. NOS. 989,973 AND 1,445,807.

**CLASS 1—CHEMICALS**

FOR CHEMICALS USED IN THE MANUFACTURE OF MEDICAL DEVICES; UNPROCESSED ARTIFICIAL RESINS; UNPROCESSED PLASTICS; CHEMICAL PREPARATIONS, NAMELY, SILICA BASED DENSITY CENTRIFUGATION MEDIA TO BE USED IN BIOCHEMICAL AND CLINICAL RESEARCH; ACTIVE CHEMICAL INGREDIENTS FOR USE IN THE MANUFACTURE OF PHARMACEUTICALS FOR TREATING ACUTE AND CHRONIC WOUNDS, CARDIOVASCULAR DISEASES, UROLOGICAL DISEASES, GYNECOLOGICAL DISEASES AND CANCER (U.S. CLS. 1, 5, 6, 10, 26 AND 46).

**CLASS 2—PAINTS**

FOR POLYMER COATINGS, SOLD SEPARATELY, FOR USE IN THE FUNCTIONAL OPERATION OF MEDICAL DEVICES (U.S. CLS. 6, 11 AND 16).

SN 77-921,497. LYNNEL, ART TO FORM, INC., DENVER, CO. FILED 1-27-2010.

## LYNNEL Art to Form

THE MARK CONSISTS OF STANDARD CHARACTERS WITHOUT CLAIM TO ANY PARTICULAR FONT, STYLE, SIZE, OR COLOR.

### CLASS 20—FURNITURE AND ARTICLES NOT OTHERWISE CLASSIFIED

FOR FURNITURE PARTITIONS, NAMELY, PANELS AND HANGINGS OF GLASS, POLYMER AND FABRIC OR COMBINATION THEREOF PRINTED WITH ARTWORK AND DESIGNS FOR INTERIOR AND EXTERIOR RESIDENTIAL AND COMMERCIAL USE; FURNITURE PARTS, NAMELY, GLASS AND POLYMER PANELS OR COMBINATION THEREOF PRINTED WITH ARTWORK AND DESIGNS FOR INTERIOR AND EXTERIOR RESIDENTIAL AND COMMERCIAL USE (U.S. CLS. 2, 13, 22, 25, 32 AND 50).

### CLASS 24—FABRICS

FOR WALL HANGINGS OF TEXTILE, NAMELY, FABRIC PANELS PRINTED WITH ARTWORK AND DESIGNS FOR INTERIOR AND EXTERIOR RESIDENTIAL AND COMMERCIAL USE (U.S. CLS. 42 AND 50).

### CLASS 27—FLOOR COVERINGS

FOR WALL COVERINGS, NAMELY, GLASS, POLYMER AND FABRIC PANELS OR COMBINATION THEREOF PRINTED WITH ARTWORK AND DESIGNS FOR INTERIOR AND EXTERIOR RESIDENTIAL AND COMMERCIAL USE; NON-TEXTILE WALL HANGINGS, NAMELY, GLASS AND POLYMER PANELS OR COMBINATION THEREOF PRINTED WITH ARTWORK AND DESIGNS FOR INTERIOR AND EXTERIOR RESIDENTIAL AND COMMERCIAL USE (U.S. CLS. 19, 20, 37, 42 AND 50).

MARIA-VICTORIA SUAREZ, EXAMINING ATTORNEY

SN 77-921,528. LYNNEL, ART TO FORM, INC., DENVER, CO. FILED 1-27-2010.

## LYNNEL

THE MARK CONSISTS OF STANDARD CHARACTERS WITHOUT CLAIM TO ANY PARTICULAR FONT, STYLE, SIZE, OR COLOR.

### CLASS 20—FURNITURE AND ARTICLES NOT OTHERWISE CLASSIFIED

FOR FURNITURE PARTITIONS, NAMELY, PANELS AND HANGINGS OF GLASS, POLYMER AND FABRIC OR COMBINATION THEREOF PRINTED WITH ARTWORK AND DESIGNS FOR INTERIOR AND EXTERIOR RESIDENTIAL AND COMMERCIAL USE; FURNITURE PARTS, NAMELY, GLASS AND POLYMER PANELS OR COMBINATION THEREOF PRINTED WITH ARTWORK AND DESIGNS FOR INTERIOR AND EXTERIOR RESIDENTIAL AND COMMERCIAL USE (U.S. CLS. 2, 13, 22, 25, 32 AND 50).

### CLASS 24—FABRICS

FOR WALL HANGINGS OF TEXTILE, NAMELY, FABRIC PANELS PRINTED WITH ARTWORK AND DESIGNS FOR INTERIOR AND EXTERIOR RESIDENTIAL AND COMMERCIAL USE (U.S. CLS. 42 AND 50).

### CLASS 27—FLOOR COVERINGS

FOR WALL COVERINGS, NAMELY, GLASS, POLYMER AND FABRIC PANELS OR COMBINATION THEREOF PRINTED WITH ARTWORK AND DESIGNS FOR INTERIOR AND EXTERIOR RESIDENTIAL AND COMMERCIAL USE; NON-TEXTILE WALL HANGINGS, NAMELY, GLASS AND POLYMER PANELS OR COMBINATION THEREOF PRINTED WITH ARTWORK AND DESIGNS FOR INTERIOR AND EXTERIOR RESIDENTIAL AND COMMERCIAL USE (U.S. CLS. 19, 20, 37, 42 AND 50).

MARIA-VICTORIA SUAREZ, EXAMINING ATTORNEY

SN 77-922,726. HEADSTRONG FOUNDATION, HOLMES, PA. FILED 1-28-2010.

## RELENTLESS 27

THE MARK CONSISTS OF STANDARD CHARACTERS WITHOUT CLAIM TO ANY PARTICULAR FONT, STYLE, SIZE, OR COLOR.

### CLASS 35—ADVERTISING AND BUSINESS

FOR CHARITABLE SERVICES, NAMELY, CONDUCTING VOLUNTEER PROGRAMS, COMMUNITY SERVICE PROJECTS AND SPECIAL EVENTS, BUT NOT ENTERTAINMENT-BASED SPECIAL EVENTS; ON-LINE RETAIL STORE SERVICES FEATURING CLOTHING AND APPAREL (U.S. CLS. 100, 101 AND 102).

FIRST USE 9-0-2007; IN COMMERCE 9-0-2007.

### CLASS 36—INSURANCE AND FINANCIAL

FOR CHARITABLE SERVICES, NAMELY, RAISING MONEY FOR BLOOD CANCER RESEARCH AND PROVIDING FINANCIAL ASSISTANCE TO BLOOD CANCER PATIENTS AND THEIR FAMILIES (U.S. CLS. 100, 101 AND 102).

FIRST USE 9-0-2007; IN COMMERCE 9-0-2007.

KARANENDRA S. CHHINA, EXAMINING ATTORNEY

SN 77-924,710. R BABY FOUNDATION, INC., NEW YORK, NY. FILED 2-1-2010.

## R BABY MEDEXCHANGE

THE MARK CONSISTS OF STANDARD CHARACTERS WITHOUT CLAIM TO ANY PARTICULAR FONT, STYLE, SIZE, OR COLOR.

OWNER OF U.S. REG. NOS. 3,415,087, 3,415,089 AND 3,415,116.

NO CLAIM IS MADE TO THE EXCLUSIVE RIGHT TO USE "BABY", APART FROM THE MARK AS SHOWN.

**CLASS 41—EDUCATION AND ENTERTAINMENT**

FOR (BASED ON INTENT TO USE) EDUCATIONAL SERVICES, NAMELY, PROVIDING ON-LINE CONTINUING MEDICAL EDUCATION WEBINARS IN THE FIELD OF PEDIATRIC EMERGENCY CARE (U.S. CLS. 100, 101 AND 107).

**CLASS 42—SCIENTIFIC AND COMPUTER SERVICES**

FOR (BASED ON USE IN COMMERCE) PROVIDING A WEBSITE AND INTERNET WEBSITE PORTAL THAT FEATURES MEDICAL RESEARCH FINDINGS; PROVIDING A WEBSITE AND AN INTERNET WEBSITE PORTAL THAT FEATURES MEDICAL RESEARCH AND HEALTHCARE RESEARCH FINDINGS FROM RESEARCH GRANT PROGRAMS (U.S. CLS. 100 AND 101).  
FIRST USE 9-14-2009; IN COMMERCE 9-14-2009.

**CLASS 44—MEDICAL, BEAUTY AND AGRICULTURAL SERVICES**

FOR (BASED ON USE IN COMMERCE) PROVIDING A WEBSITE AND AN INTERNET WEBSITE PORTAL THAT FEATURES MEDICAL NEWS, MEDICAL INFORMATION AND LINKS TO INFORMATION IN THE FIELD OF PEDIATRIC EMERGENCY CARE (U.S. CLS. 100 AND 101).  
FIRST USE 9-14-2009; IN COMMERCE 9-14-2009.  
INGRID C. EULIN, EXAMINING ATTORNEY

SN 77-924,744. R BABY FOUNDATION, INC., NEW YORK, NY. FILED 2-1-2010.



OWNER OF U.S. REG. NOS. 3,415,087, 3,415,089 AND 3,415,116.

NO CLAIM IS MADE TO THE EXCLUSIVE RIGHT TO USE "FOUNDATION", APART FROM THE MARK AS SHOWN.

THE MARK CONSISTS OF THE LITERAL ELEMENTS "RBABY FOUNDATION MEDEXCHANGE" WITH A BABY'S CAP RESTING ON THE LETTER "Y" IN "BABY".

**CLASS 41—EDUCATION AND ENTERTAINMENT**

FOR (BASED ON INTENT TO USE) EDUCATIONAL SERVICES, NAMELY, PROVIDING ON-LINE CONTINUING MEDICAL EDUCATION WEBINARS IN THE FIELD OF PEDIATRIC EMERGENCY CARE (U.S. CLS. 100, 101 AND 107).

**CLASS 42—SCIENTIFIC AND COMPUTER SERVICES**

FOR (BASED ON USE IN COMMERCE) PROVIDING A WEBSITE AND INTERNET WEBSITE PORTAL THAT FEATURES MEDICAL RESEARCH FINDINGS; PROVIDING A WEBSITE AND AN INTERNET WEBSITE PORTAL THAT FEATURES MEDICAL RESEARCH AND HEALTHCARE RESEARCH FINDINGS FROM RESEARCH GRANT PROGRAMS (U.S. CLS. 100 AND 101).  
FIRST USE 9-14-2009; IN COMMERCE 9-14-2009.

**CLASS 44—MEDICAL, BEAUTY AND AGRICULTURAL SERVICES**

FOR (BASED ON USE IN COMMERCE) PROVIDING A WEBSITE AND AN INTERNET WEBSITE PORTAL THAT FEATURES MEDICAL NEWS, MEDICAL INFORMATION AND LINKS TO INFORMATION IN THE FIELD OF PEDIATRIC EMERGENCY CARE (U.S. CLS. 100 AND 101).  
FIRST USE 9-14-2009; IN COMMERCE 9-14-2009.  
INGRID C. EULIN, EXAMINING ATTORNEY

SN 77-929,314. VETERANSADVANTAGE, INC., GREENWICH, CT. FILED 2-5-2010.

**VETERANS ADVANTAGE**

THE MARK CONSISTS OF STANDARD CHARACTERS WITHOUT CLAIM TO ANY PARTICULAR FONT, STYLE, SIZE, OR COLOR.

NO CLAIM IS MADE TO THE EXCLUSIVE RIGHT TO USE "VETERANS", APART FROM THE MARK AS SHOWN.

**CLASS 16—PAPER GOODS AND PRINTED MATTER**

FOR PRINTED MATTER, NAMELY, BOOKS, MAGAZINES, NEWSLETTERS, AND INSTRUCTIONAL MANUALS IN THE FIELD OF VETERANS' BENEFITS AND SERVICES, USED TO PROMOTE BENEFITS AND SERVICES FOR MILITARY VETERANS AND THEIR FAMILIES AND THE HONOR OF SERVICE; NEWSPAPERS, INSTRUCTIONAL MANUALS, GREETING CARDS, COUPONS AND POSTERS USED TO PROMOTE BENEFITS AND SERVICES FOR MILITARY VETERANS AND THEIR FAMILIES AND THE HONOR OF SERVICE (U.S. CLS. 2, 5, 22, 23, 29, 37, 38 AND 50).  
FIRST USE 9-19-1999; IN COMMERCE 9-19-1999.

**CLASS 35—ADVERTISING AND BUSINESS**

FOR CONDUCTING AN INCENTIVE AWARD PROGRAM FOR PARTICIPATING MERCHANTS TO PROMOTE CUSTOMER LOYALTY; BUYING CLUB SERVICES RENDERED TO MILITARY VETERANS AND THEIR FAMILIES; PROVIDING COMPUTERIZED ONLINE BUYING CLUB SERVICES AND BENEFITS FOR VETERANS AND THEIR FAMILIES RECEIVED BY PROMOTING THE GOODS AND SERVICES OF OTHERS AND PROMOTING VETERANS LOYALTY THROUGH THE DISTRIBUTION OF DISCOUNT CARDS THAT ENTITLE VETERANS TO RECEIVE DISCOUNTS ON DINING, TAKE-OUT FOOD, HOTEL ACCOMMODATIONS, CONSUMER MERCHANDISE, MAGAZINES, TRAVEL, MOVIES, THEATER, AUTO CARE AND INSURANCE (U.S. CLS. 100, 101 AND 102).  
FIRST USE 9-19-1999; IN COMMERCE 9-19-1999.

**CLASS 36—INSURANCE AND FINANCIAL**

FOR PROVIDING FINANCIAL INFORMATION, NAMELY, INFORMATION ABOUT MILITARY VETERANS BENEFITS (U.S. CLS. 100, 101 AND 102).  
FIRST USE 9-19-1999; IN COMMERCE 9-19-1999.  
CARRIE GENOVESE, EXAMINING ATTORNEY

SN 77-929,388. VETERANSADVANTAGE, INC., GREENWICH, CT. FILED 2-5-2010.

SN 77-930,571. BLUE BELL COUNTRY CLUB COMMUNITY ASSOCIATION, BLUE BELL, PA. FILED 2-8-2010.



THE MARK CONSISTS OF A FREE-FORM TRIANGULAR SHAPE THAT FORMS AN ABSTRACT "V" AND BOUNDED BY THREE SOLID CIRCLES. ONE CIRCLE APPEARS IN THE NOTCH OF THE "V", ONE CIRCLE APPEARS TO THE LEFT BOTTOM SIDE OF THE "V" (SLIGHTLY ELEVATED ABOVE THE BASELINE OF THE BOTTOM OF THE "V") AND THE THIRD CIRCLE AT THE RIGHT BOTTOM SIDE OF THE "V" (ALSO SLIGHTLY ELEVATED ABOVE THE BASELINE). THE THREE CIRCLES SUGGEST A TRIANGLE OR THE SHAPE OF THE GREEK LETTER "ALPHA." TOGETHER, THE "V" AND THE CIRCLES CREATE AN ABSTRACT REPRESENTATION OF THE LETTERS "V" AND "A" INTERTWINED.

#### **CLASS 16—PAPER GOODS AND PRINTED MATTER**

FOR PRINTED MATTER, NAMELY, BOOKS, MAGAZINES, NEWSLETTERS, AND INSTRUCTIONAL MANUALS IN THE FIELD OF VETERANS' BENEFITS AND SERVICES USED TO PROMOTE BENEFITS AND SERVICES FOR MILITARY VETERANS AND THEIR FAMILIES AND THE HONOR OF SERVICE; NEWSPAPERS, INSTRUCTIONAL MANUALS, GREETING CARDS, COUPONS AND POSTERS USED TO PROMOTE BENEFITS AND SERVICES FOR MILITARY VETERANS AND THEIR FAMILIES AND THE HONOR OF SERVICE (U.S. CLS. 2, 5, 22, 23, 29, 37, 38 AND 50).

FIRST USE 9-19-1999; IN COMMERCE 9-19-1999.

#### **CLASS 35—ADVERTISING AND BUSINESS**

FOR CONDUCTING AN INCENTIVE AWARD PROGRAM FOR PARTICIPATING MERCHANTS TO PROMOTE CUSTOMER LOYALTY; BUYING CLUB SERVICES RENDERED TO MILITARY VETERANS AND THEIR FAMILIES; PROVIDING COMPUTERIZED ONLINE BUYING CLUB SERVICES AND BENEFITS FOR VETERANS AND THEIR FAMILIES RECEIVED BY PROMOTING THE GOODS AND SERVICES OF OTHERS AND PROMOTING VETERANS LOYALTY THROUGH THE DISTRIBUTION OF DISCOUNT CARDS THAT ENTITLE VETERANS TO RECEIVE DISCOUNTS ON DINING, TAKE-OUT FOOD, HOTEL ACCOMMODATIONS, CONSUMER MERCHANDISE, MAGAZINES, TRAVEL, MOVIES, THEATER, AUTO CARE AND INSURANCE (U.S. CLS. 100, 101 AND 102).

FIRST USE 9-19-1999; IN COMMERCE 9-19-1999.

#### **CLASS 36—INSURANCE AND FINANCIAL**

FOR PROVIDING FINANCIAL INFORMATION, NAMELY, INFORMATION ABOUT MILITARY VETERANS BENEFITS (U.S. CLS. 100, 101 AND 102).

FIRST USE 9-19-1999; IN COMMERCE 9-19-1999.  
CARRIE GENOVESE, EXAMINING ATTORNEY

#### **BLUE BELL COUNTRY CLUB COMMUNITY ASSOCIATION**

THE MARK CONSISTS OF STANDARD CHARACTERS WITHOUT CLAIM TO ANY PARTICULAR FONT, STYLE, SIZE, OR COLOR.

NO CLAIM IS MADE TO THE EXCLUSIVE RIGHT TO USE "COUNTRY CLUB COMMUNITY ASSOCIATION", APART FROM THE MARK AS SHOWN.

SEC. 2(F).

#### **CLASS 36—INSURANCE AND FINANCIAL**

FOR REAL ESTATE MANAGEMENT OF RESIDENTIAL COMMUNITIES (U.S. CLS. 100, 101 AND 102).

FIRST USE 0-0-1992; IN COMMERCE 0-0-1992.

#### **CLASS 41—EDUCATION AND ENTERTAINMENT**

FOR PROVIDING RECREATIONAL SERVICES IN THE NATURE OF PLAYGROUNDS, BASKETBALL COURTS AND SOCCER FIELDS (U.S. CLS. 100, 101 AND 107).

FIRST USE 0-0-1992; IN COMMERCE 0-0-1992.

BARNEY CHARLON, EXAMINING ATTORNEY

SN 77-931,112. JADE SOFTWARE CORPORATION LIMITED, CHRISTCHURCH, NEW ZEALAND, FILED 2-9-2010.

# JOOB

THE MARK CONSISTS OF STANDARD CHARACTERS WITHOUT CLAIM TO ANY PARTICULAR FONT, STYLE, SIZE, OR COLOR.

OWNER OF NEW ZEALAND REG. NO. 819282, DATED 8-2010, EXPIRES 2-8-2020.

THE WORDING "JOOB" HAS NO MEANING IN A FOREIGN LANGUAGE.

#### **CLASS 9—ELECTRICAL AND SCIENTIFIC APPARATUS**

FOR COMPUTER HARDWARE; COMPUTER SOFTWARE FOR USE IN CREATING, DESIGNING, MANAGING AND OPTIMIZING COMPUTER DATABASES, AND RELATED INSTRUCTION MANUALS AND GUIDES SOLD AS A UNIT THEREWITH; RECORDED COMPUTER GAME DISCS; COMPUTER HARD DISCS FEATURING INFORMATION IN THE FIELD OF CREATING, DESIGNING, MANAGING AND OPTIMIZING COMPUTER DATABASES; DATA PROCESSORS; AND ELECTRONIC ENCRYPTION DEVICES (U.S. CLS. 21, 23, 26, 36 AND 38).

**CLASS 42—SCIENTIFIC AND COMPUTER SERVICES**

FOR COMPUTER SERVICES, NAMELY, COMPUTER DATABASE DESIGN; COMPUTER PROGRAMMING IN THE FIELD OF COMPUTER DATABASES; COMPUTER CONSULTATION IN THE FIELD OF COMPUTER DATABASE IMPLEMENTATION, COMPUTER DATABASE HOSTING, COMPUTER DATABASE OPTIMIZATION, COMPUTER DATABASE PERFORMANCE MANAGEMENT, AND COMPUTER DATABASE CONFIGURATION; COMPUTER CONSULTATION SERVICES IN THE FIELD OF COMPUTER DATABASES; COMPUTER SOFTWARE DESIGN AND DEVELOPMENT FOR OTHERS; COMPUTER SOFTWARE PROGRAMMING FOR OTHERS; COMPUTER SOFTWARE INSTALLATION, REPAIR, AND MAINTENANCE; COMPUTER SOFTWARE CONSULTATION SERVICES IN THE FIELD OF SOFTWARE OPTIMIZATION, PERFORMANCE MANAGEMENT AND CONFIGURATION; COMPUTER SITE DESIGN AND WEBSITE AND WEBPAGE DESIGN FOR OTHERS; COMPUTER CODE CONVERSION FOR OTHERS; RECOVERY OF COMPUTER DATA; UPDATING OF COMPUTER SOFTWARE; DUPLICATION OF COMPUTER PROGRAMS; COMPUTER CONSULTANCY SERVICES (U.S. CLS. 100 AND 101).

MICHAEL GAAFAR, EXAMINING ATTORNEY

SN 77-935,430. YOUTH HOUSE INC, DBA YOUTH HOUSE ATLANTA, ATLANTA, GA. FILED 2-14-2010.



NO CLAIM IS MADE TO THE EXCLUSIVE RIGHT TO USE "YOUTH" AND "ALTERNATE AFTERSCHOOL CENTER", APART FROM THE MARK AS SHOWN.

THE COLOR(S) OCEAN BLUE, SKY BLUE, NORTHERN AIR BLUE, FRESH WATER BLUE, HEARTHSTONE BLUE, NAVY BLUE, AND HUNTER GREEN IS/ARE CLAIMED AS A FEATURE OF THE MARK.

THE MARK CONSISTS OF 11 STONES OF VARIOUS SIZES IN OCEAN BLUE, SKY BLUE, NORTHERN AIR BLUE, FRESH WATER BLUE, HEARTHSTONE BLUE, AND NAVY BLUE TO FORM THE MAIN BODY OF A HOUSE WITH A BOOMERANG SHAPED ROOF ABOVE IN HUNTER GREEN; THE STYLIZED WORDS "YOUTH" OVER "HOUSE" ARE TO THE RIGHT IN OCEAN BLUE; AND THE NAVY BLUE STYLIZED WORDS "AN ALTERNATIVE AFTERSCHOOL CENTER, BUILDING TOMORROW'S FUTURE ONE LIFE AT A TIME." BELOW IN TWO LINES.

**CLASS 35—ADVERTISING AND BUSINESS**

FOR CHARITABLE SERVICES, NAMELY, ORGANIZING YOUTH GROUPS TO UNDERTAKE CHARITABLE PROJECTS IN THE FIELD OF DISASTER RESPONSE; CHARITABLE SERVICES, NAMELY, ORGANIZING YOUTH GROUPS TO UNDERTAKE PROJECTS TO BENEFIT THE NEEDY AND THE COMMUNITY TO ENCOURAGE LEADERSHIP, CHARACTER, COMPASSION, AND GOOD CITIZENSHIP; PROMOTING THE INTERESTS OF PEOPLE INVOLVED AND CONCERNED WITH YOUTH SPORTS; WRITING OF GRANT PROPOSALS FOR NON-PROFIT ORGANIZATIONS, EDUCATIONAL INSTITUTIONS AND OTHER COMMUNITY ORGANIZATIONS (U.S. CLS. 100, 101 AND 102).

**CLASS 36—INSURANCE AND FINANCIAL**

FOR FINANCIAL SERVICES, NAMELY, SAVINGS PROGRAMS FOR YOUTHS; FUND RAISING SERVICES, NAMELY, ORGANIZING, ARRANGING AND CONDUCTING FUND RAISING PROGRAMS FOR THE BENEFIT OF SCHOOLS AND NON-PROFIT ORGANIZATIONS (U.S. CLS. 100, 101 AND 102).

MAYUR VAGHANI, EXAMINING ATTORNEY

SN 77-949,284. ECLIPSE AEROSPACE, INC., ALBUQUERQUE, NM. FILED 3-3-2010.

**ECLIPSE AEROSPACE**

THE MARK CONSISTS OF STANDARD CHARACTERS WITHOUT CLAIM TO ANY PARTICULAR FONT, STYLE, SIZE, OR COLOR.

OWNER OF U.S. REG. NOS. 3,169,023, 3,557,904 AND OTHERS.

NO CLAIM IS MADE TO THE EXCLUSIVE RIGHT TO USE "AEROSPACE", APART FROM THE MARK AS SHOWN.

**CLASS 9—ELECTRICAL AND SCIENTIFIC APPARATUS**

FOR FIRE SUPPRESSION SYSTEMS COMPRISING SENSORS, ELECTRONIC CONTROLS, CIRCUIT BREAKERS, HARNESSSES FOR ELECTRICAL CONTROLS, DISTRIBUTION TUBES AND NOZZLES FOR CHEMICALS AND GASES IN THE NATURE OF FIRE EXTINGUISHING COMPOSITIONS, PYROTECHNICS, FIRE EXTINGUISHING CANISTERS; ALL OF THE FOREGOING FOR INSTALLATION IN AIRCRAFT (U.S. CLS. 21, 23, 26, 36 AND 38).

**CLASS 12—VEHICLES**

FOR AIRPLANES (U.S. CLS. 19, 21, 23, 31, 35 AND 44).

FONG HSU, EXAMINING ATTORNEY

SN 77-951,594. MY PARA-KIN,LLC, FORMERLY PARAMORE,LLC, WAKEFIELD, RI. FILED 3-5-2010.

**PARA-KIN**

THE MARK CONSISTS OF STANDARD CHARACTERS WITHOUT CLAIM TO ANY PARTICULAR FONT, STYLE, SIZE, OR COLOR.

**CLASS 16—PAPER GOODS AND PRINTED MATTER**

FOR GREETING CARDS (U.S. CLS. 2, 5, 22, 23, 29, 37, 38 AND 50).

FIRST USE 1-15-2010; IN COMMERCE 6-1-2010.

**CLASS 25—CLOTHING**

FOR ATHLETIC APPAREL, NAMELY, SHIRTS, PANTS, JACKETS, FOOTWEAR, HATS AND CAPS, ATHLETIC UNIFORMS; GIFT PACKAGES SOLD AS A UNIT CONSISTING PRIMARILY OF A SWEATSHIRT AND ALSO INCLUDING A PHOTO FRAME, A COFFEE MUG, AND A TOTE BAG (U.S. CLS. 22 AND 39).

FIRST USE 1-15-2010; IN COMMERCE 6-1-2010.  
STEVEN PEREZ, EXAMINING ATTORNEY

SN 77-952,990. EAST WEST SALES CORP., WESTBURY, NY.  
FILED 3-8-2010.

**LIVING CONCEPTS**

SN 77-951,711. FIGMENT MEDIA LLC, GLEN RIDGE, NJ.  
FILED 3-5-2010.



THE MARK CONSISTS OF A HAND FORMING DEVIL HORNS WITHIN A BUBBLE-TYPE FORMATION TO THE LEFT OF THE WORD "FIGMENT" AND THE PHRASE "ALL BANDS, NO MUSIC" APPEARING UNDERNEATH THE WORD "FIGMENT", IN A SMALLER FONT.

**CLASS 35—ADVERTISING AND BUSINESS**

FOR ON-LINE RETAIL STORE SERVICES FEATURING PHYSICAL MERCHANDISE, NAMELY, CLOTHING, POSTERS, BOOKS, COLLECTIBLE CARDS, BUTTONS, AND VIRTUAL GOODS AND MERCHANDISE, NAMELY, DOWNLOADABLE IMAGE FILES, ALL FOR USE BY MEMBERS OF AN ON-LINE COMMUNITY IN CONNECTION WITH A DESIGNATED WEBSITE FEATURING FICTIONAL BANDS AND FICTIONAL MUSIC ALBUMS WHICH DO NOT CONTAIN ACTUAL MUSIC; PROMOTING THE GOODS AND SERVICES OF OTHERS BY FEATURING ON ITS WEBSITE LINKS TO THE WEBSITES OF OTHERS (U.S. CLS. 100, 101 AND 102).

FIRST USE 2-13-2008; IN COMMERCE 2-13-2008.

**CLASS 41—EDUCATION AND ENTERTAINMENT**

FOR ENTERTAINMENT SERVICES, NAMELY, PROVIDING ON-LINE, NON-DOWNLOADABLE, VIRTUAL MUSIC GAME FOR THE PURPOSES OF CREATING FICTIONAL BANDS AND FICTIONAL MUSIC ALBUMS, AND MARKETING THEM TO FANS IN VIRTUAL ENVIRONMENTS CREATED FOR ENTERTAINMENT PURPOSES; AND PROVIDING ON-LINE REVIEWS BY REGISTERED USERS OF FICTIONAL BANDS AND FICTIONAL MUSIC ALBUMS WHICH DO NOT CONTAIN ACTUAL MUSIC (U.S. CLS. 100, 101 AND 107).

FIRST USE 2-13-2008; IN COMMERCE 2-13-2008.

**CLASS 42—SCIENTIFIC AND COMPUTER SERVICES**

FOR CREATING AN ON-LINE COMMUNITY FOR REGISTERED USERS TO PARTICIPATE IN DISCUSSIONS AND GET FEEDBACK FROM THEIR PEERS IN THE FIELD OF FICTIONAL BANDS AND FICTIONAL MUSIC ALBUMS WHICH DO NOT CONTAIN ACTUAL MUSIC (U.S. CLS. 100 AND 101).

FIRST USE 2-13-2008; IN COMMERCE 2-13-2008.  
CHARLOTTE CORWIN, EXAMINING ATTORNEY

THE MARK CONSISTS OF STANDARD CHARACTERS WITHOUT CLAIM TO ANY PARTICULAR FONT, STYLE, SIZE, OR COLOR.

**CLASS 3—COSMETICS AND CLEANING PREPARATIONS**

FOR CLEANING ITEMS, NAMELY, CLEANING AND WASHING PREPARATIONS; PREPARATIONS FOR CLEANING, PROTECTING AND PRESERVING VEHICLE SURFACES; ABRASIVE CLOTH AND PAPER, SPONGES IMPREGNATED WITH MARINE AND AUTOMOTIVE WAXES AND WASHES (U.S. CLS. 1, 4, 6, 50, 51 AND 52).

**CLASS 8—HAND TOOLS**

FOR PLASTIC OR BIODEGRADABLE CUTLERY, NAMELY, KNIVES, FORKS AND SPOONS; HAND TOOLS, NAMELY, TONGS, FIRE TONGS, HAMMERS AND SAWS (U.S. CLS. 23, 28 AND 44).

**CLASS 16—PAPER GOODS AND PRINTED MATTER**

FOR PAPER NAPKINS, PAPER TABLE CLOTHS AND PAPER BAGS (U.S. CLS. 2, 5, 22, 23, 29, 37, 38 AND 50).

**CLASS 20—FURNITURE AND ARTICLES NOT OTHERWISE CLASSIFIED**

FOR DRINKING STRAWS, WOODEN HANGERS FOR CLOTHES, OUTDOOR HOLIDAY DECORATIONS MADE OF CLEAR OR TRANSLUCENT PVC OR POLYPROPYLENE DIE CUT FORMS HAVING HOLIDAY THEMED SHAPES AND ICONS; HAND SPRAY FANS; HOLIDAY ORNAMENTS OF PLASTIC AND CLOTHES DRYING PRODUCT, NAMELY, RUBBER DRYER BALLS THAT ARE PLACED IN THE CLOTHES-DRYING MACHINE WITH THE CLOTHING TO ASSIST IN THE DRYING PROCESS (U.S. CLS. 2, 13, 22, 25, 32 AND 50).

**CLASS 21—HOUSEWARES AND GLASS**

FOR HOUSEHOLD ITEMS, NAMELY, NAMELY, POT AND PAN SCRAPERS, ROLLING PINS, SPATULAS, TURNERS, WHISKS; CONTAINERS FOR HOUSEHOLD USE; GENERAL PURPOSE STORAGE BINS FOR HOUSEHOLD USE; NON-MODULAR CONTAINERS FOR USE IN TRANSPORTATION AND STORAGE FOR HOUSEHOLD USE; SPONGES FOR HOUSEHOLD USE; EXFOLIATING MITTS, EXFOLIATING PADS; EMPTY SPRAY BOTTLES, PLASTIC CUP, FLY SWATTERS, PORTABLE BEVERAGE COOLERS, PLASTIC AND COLLAPSIBLE BUCKETS, CUTTING BOARDS, HAIR-BRUSHES; TOOTHBRUSHES; LINT BRUSHES; CLOTHES PINS; FOOD BASTERS; NAIL BRUSHES (U.S. CLS. 2, 13, 23, 29, 30, 33, 40 AND 50).

**CLASS 24—FABRICS**

FOR FLEECE BLANKETS; PLASTIC TABLE COVERS; TABLE CLOTHS NOT OF PAPER (U.S. CLS. 42 AND 50).  
JAMES A. RAUEN, EXAMINING ATTORNEY

SN 77-956,627. EAGLE ROCK ENERGY PARTNERS, L.P., HOUSTON, TX. FILED 3-11-2010.



NO CLAIM IS MADE TO THE EXCLUSIVE RIGHT TO USE "ENERGY PARTNERS", APART FROM THE MARK AS SHOWN.

THE MARK CONSISTS OF THE TERM "EAGLE ROCK ENERGY PARTNERS" IN STYLIZED FONT BELOW A STYLIZED PROFILE OF AN EAGLE.

#### CLASS 35—ADVERTISING AND BUSINESS

FOR MANAGING THE EXPLORATION, PRODUCTION AND OPERATION OF OIL AND NATURAL GAS PROPERTIES FOR OTHERS (U.S. CLS. 100, 101 AND 102).

FIRST USE 3-17-2008; IN COMMERCE 3-17-2008.

#### CLASS 36—INSURANCE AND FINANCIAL

FOR INVESTMENT MANAGEMENT SERVICES, NAMELY, ACQUIRING AND MANAGING FEE MINERAL, OVERRIDING ROYALTY AND ROYALTY INTERESTS (U.S. CLS. 100, 101 AND 102).

FIRST USE 3-17-2008; IN COMMERCE 3-17-2008.

#### CLASS 39—TRANSPORTATION AND STORAGE

FOR THE FRACTIONATING AND TRANSMISSION OF NATURAL GAS THROUGH PIPELINES (U.S. CLS. 100 AND 105).

FIRST USE 3-17-2008; IN COMMERCE 3-17-2008.

#### CLASS 40—MATERIAL TREATMENT

FOR NATURAL GAS INDUSTRY SERVICES, NAMELY, THE GATHERING, COMPRESSING, AND TREATING OF NATURAL GAS (U.S. CLS. 100, 103 AND 106).

FIRST USE 3-17-2008; IN COMMERCE 3-17-2008.  
JILL C. ALT, EXAMINING ATTORNEY

SN 77-956,924. TARGET BRANDS, INC., MINNEAPOLIS, MN. FILED 3-11-2010.



OWNER OF U.S. REG. NOS. 2,858,069, 3,259,178 AND OTHERS.

NO CLAIM IS MADE TO THE EXCLUSIVE RIGHT TO USE "HOME", APART FROM THE MARK AS SHOWN.

THE MARK CONSISTS OF A DESIGN WITH CONCENTRIC CIRCLES REPRESENTING A TARGET OR BULLSEYE DESIGN FOLLOWED BY THE WORD "HOME".

#### CLASS 6—METAL GOODS

FOR METAL LAWN AND GARDEN STRUCTURES, NAMELY, ARCHES, ARBORS, GAZEBOS, TRELLISES, FENCING, TRELLISES IN THE NATURE OF TUTEURS, GATES AND LANDSCAPE EDGING; METAL TUBS; METAL GREENHOUSE FRAMES; METAL WEATHER VANES; BASKETS OF COMMON METALS; DECORATIVE BOXES MADE OF NON-PRECIOUS METAL; DESKTOP STATUARY MADE OF NON-PRECIOUS METAL; METAL DOOR HARDWARE, NAMELY, KEYS, KEY CYLINDERS, CLASPS AND CHAIN DOOR GUARDS; DOOR STOPS OF METAL; FIREPLACE GRATES; METAL GAZEBOS; METAL BATHROOM AND KITCHEN HARDWARE, NAMELY, PULLS AND KNOBS; METAL HOOKS; METAL KEY HOOKS; PIGGY BANKS OF METAL; WROUGHT IRON DECORATIVE ARTWORK; DECORATIVE HARDWARE AND FIXTURES MADE OF METAL, NAMELY, MAILBOXES, HOUSE NUMBERS, METAL ADDRESS PLATES, DOOR-KNOBS, CLOTHING HOOKS, DRAWER PULLS, DRAWER KNOBS, DRAWER HANDLES, CABINET PULLS, CABINET KNOBS AND CABINET HANDLES; METAL PLANT HANGERS; HOSE HANGERS OF METAL; METAL STORAGE CONTAINERS, NAMELY, HOSE POTS; METAL GARDEN STAKES (U.S. CLS. 2, 12, 13, 14, 23, 25 AND 50).

#### CLASS 9—ELECTRICAL AND SCIENTIFIC APPARATUS

FOR WEATHER THERMOMETERS; RAIN AND SNOW GAUGES; DECORATIVE MAGNETS; DECORATIVE SWITCH PLATE COVERS; DECORATIVE COVERS FOR SMOKE DETECTORS; ELECTRICAL OUTLET PLATES; EXTENSION CORDS; RADIOS; ELECTRIC IRONS; PRINTERS; MEASURING SPOONS AND CUPS; MOUSE PADS (U.S. CLS. 21, 23, 26, 36 AND 38).

#### CLASS 18—LEATHER GOODS

FOR BAGS, NAMELY, TOTE BAGS AND TOOL BAGS SOLD EMPTY; UMBRELLAS; PATIO UMBRELLAS; UMBRELLA BASES; UMBRELLA COVERS; UMBRELLA FRAMES; UMBRELLA HANDLES; UMBRELLA RINGS; TRUNKS; FOOTLOCKERS (U.S. CLS. 1, 2, 3, 22 AND 41).

#### CLASS 19—NON-METALLIC BUILDING MATERIALS

FOR POTTERY STONE; STONE SCULPTURES; NON-PRECIOUS STONES FOR GARDEN OR ORNAMENTAL USE; FIGURINES OF CLAY, STONE, CONCRETE, OR MARBLE; GEOTEXTILES, NAMELY, FABRIC AND SHEETING FOR LANDSCAPING; NON-METAL FENCE PANELS; STAIR TREADS NOT OF METAL; GAZEBOS NOT PRIMARILY OF METAL; NON-METAL STORAGE SHEDS (U.S. CLS. 1, 12, 33 AND 50).

JOHN GARTNER, EXAMINING ATTORNEY

SN 77-959,782. AMERICATEL CORPORATION, IRVING, TX. FILED 3-16-2010.



NO CLAIM IS MADE TO THE EXCLUSIVE RIGHT TO USE "011 WIRELESS", APART FROM THE MARK AS SHOWN.

THE MARK CONSISTS OF THE STYLIZED WORDING "ZERO11 WIRELESS" AND DESIGN. THE TERM "ZERO11" APPEARS ABOVE THE TERM "WIRELESS" AND A STYLIZED GLOBE APPEARS TO THE RIGHT AND JUST ABOVE THE TERM "ZERO11".

**CLASS 9—ELECTRICAL AND SCIENTIFIC APPARATUS**

FOR TELECOMMUNICATIONS EQUIPMENT, COMPONENTS, SUPPLIES AND SYSTEMS, NAMELY, CELLULAR TELEPHONES; AND MACHINE-READABLE, MAGNETICALLY ENCODED SIM CARDS (U.S. CLS. 21, 23, 26, 36 AND 38).

**CLASS 38—COMMUNICATION**

FOR TELECOMMUNICATIONS, NAMELY, THE TRANSMISSION OF VOICE, TEXT, DATA, IMAGES, AUDIO, VIDEO, AND INFORMATION VIA TELEPHONE AND GLOBAL COMMUNICATIONS NETWORKS; ELECTRONIC MAIL SERVICES; PROVIDING MULTIPLE-USER ACCESS TO A GLOBAL COMMUNICATIONS NETWORK; CONSULTING SERVICES IN THE FIELD OF TELECOMMUNICATIONS (U.S. CLS. 100, 101 AND 104).

MARLENE BELL, EXAMINING ATTORNEY

SN 77-960,452. ZERO MOTORCYCLES, INC., SCOTTS VALLEY, CA. FILED 3-16-2010.

**DISCOVER THE EXPERIENCE**

THE MARK CONSISTS OF STANDARD CHARACTERS WITHOUT CLAIM TO ANY PARTICULAR FONT, STYLE, SIZE, OR COLOR.

**CLASS 12—VEHICLES**

FOR ELECTRIC MOTORCYCLES; ELECTRIC VEHICLES, NAMELY, MOTORCYCLES; MOTORCYCLES; MOTORCYCLES AND STRUCTURAL PARTS THEREFOR; MOTORCYCLES FOR MOTOCROSS (U.S. CLS. 19, 21, 23, 31, 35 AND 44).

**CLASS 35—ADVERTISING AND BUSINESS**

FOR ON-LINE RETAIL STORE SERVICES FEATURING MOTORCYCLES, MOTORCYCLE ACCESSORIES, APPAREL FOR MOTORCYCLISTS, AND PARTS FOR MOTORCYCLES (U.S. CLS. 100, 101 AND 102).

MARIAM MAHMOUDI, EXAMINING ATTORNEY

SN 77-961,845. BG DIRECT, LLC, SHELTON, CT. FILED 3-18-2010.

**DOODADZZ COUTURE**

THE MARK CONSISTS OF STANDARD CHARACTERS WITHOUT CLAIM TO ANY PARTICULAR FONT, STYLE, SIZE, OR COLOR.

NO CLAIM IS MADE TO THE EXCLUSIVE RIGHT TO USE "COUTURE", APART FROM THE MARK AS SHOWN.

**CLASS 14—JEWELRY**

FOR JEWELRY AND JEWELRY BOXES; AND KEY-CHAINS MADE OF PRECIOUS METAL (U.S. CLS. 2, 27, 28 AND 50).

**CLASS 18—LEATHER GOODS**

FOR PET ACCESSORIES, NAMELY, CHARMS USED ON COLLARS, HARNESSES AND LEASHES; PET ACCESSORIES, NAMELY, SPECIALLY DESIGNED CANVAS, VINYL OR LEATHER BAGS TO HOLD SMALL TO MEDIUM ITEMS SUCH AS KEYS, CREDIT CARDS, MONEY, PET WASTE BAGS, PET WATER DISHES OR PET WATER BOTTLES; PET CLOTHING; ANIMAL COLLARS, HARNESSES AND LEASHES; HANDBAGS, PURSES, KEYCASES AND WALLETS; AND PET CARRIERS (U.S. CLS. 1, 2, 3, 22 AND 41).

JENNIFER VASQUEZ, EXAMINING ATTORNEY

SN 77-961,861. PRICELINE.COM INCORPORATED, NORWALK, CT. FILED 3-18-2010.



THE COLOR(S) DARK BLUE, MEDIUM BLUE, LIGHT BLUE, ORANGE, WHITE AND BLACK IS/ARE CLAIMED AS A FEATURE OF THE MARK.

THE MARK CONSISTS OF THE DARK BLUE SILHOUETTE OF A LARGE MAN WITH LONG WAVY HAIR WEARING AN OVERCOAT AND A SMALL DERBY HAT, WHO IS STANDING TO THE SIDE AND SLIGHTLY IN FRONT OF A MEDIUM BLUE SEAL. INSIDE THE BLUE SEAL ARE TWO LIGHT BLUE HORIZONTAL LINES WITH THE WHITE WORDING "BOOK YOUR" ABOVE THEM. BETWEEN THESE LINES ARE THE WORDING "BIG DEAL"; THE WORDING "BIG" AND THE FOUR STARS TO ITS SIDES ARE IN WHITE; AND THE WORDING "DEAL" IS ORANGE, WITH A BLACK SHADOW.

**CLASS 39—TRANSPORTATION AND STORAGE**

FOR TRAVEL AGENCY SERVICES, NAMELY, MAKING RESERVATIONS AND BOOKINGS FOR TRANSPORTATION VIA THE INTERNET (U.S. CLS. 100 AND 105).

FIRST USE 1-20-2010; IN COMMERCE 1-20-2010.

**CLASS 43—HOTEL AND RESTAURANT SERVICES**

FOR TRAVEL AGENCY SERVICES, NAMELY, MAKING RESERVATIONS AND BOOKINGS FOR TEMPORARY LODGING VIA THE INTERNET (U.S. CLS. 100 AND 101).

FIRST USE 1-20-2010; IN COMMERCE 1-20-2010.  
DAWN HAN, EXAMINING ATTORNEY



SN 77-965,935. KNOX FERTILIZER COMPANY, INC.,  
KNOX, IN. FILED 3-23-2010.

SN 77-966,564. MAGIC BROTHERS ASSOCIATE, INCORPORATED,  
DBA KOI PALACE, MILLBRAE, CA. FILED 3-23-2010.

### BED & EDGE WEED CONTROL

THE MARK CONSISTS OF STANDARD CHARACTERS WITHOUT CLAIM TO ANY PARTICULAR FONT, STYLE, SIZE, OR COLOR.

NO CLAIM IS MADE TO THE EXCLUSIVE RIGHT TO USE "BED" AND "WEED CONTROL", APART FROM THE MARK AS SHOWN.

#### CLASS 1—CHEMICALS

FOR FERTILIZERS THAT ALSO CONTAIN HERBICIDES (U.S. CLS. 1, 5, 6, 10, 26 AND 46).

#### CLASS 5—PHARMACEUTICALS

FOR HERBICIDES (U.S. CLS. 6, 18, 44, 46, 51 AND 52).  
TARA PATE, EXAMINING ATTORNEY

SN 77-966,241. PHOTOGRAPHIC SOCIETY OF AMERICA,  
INC., OKLAHOMA CITY, OK. FILED 3-23-2010.



OWNER OF U.S. REG. NOS. 1,012,488 AND 2,913,102.  
NO CLAIM IS MADE TO THE EXCLUSIVE RIGHT TO USE "PHOTOGRAPHIC SOCIETY", APART FROM THE MARK AS SHOWN.

THE MARK CONSISTS OF THE WORDS "PSA PHOTOGRAPHIC SOCIETY OF AMERICA" ENCLOSED WITHIN AN INCOMPLETE CIRCULAR SHAPE

SEC. 2(F) AS TO "PHOTOGRAPHIC SOCIETY OF AMERICA".

#### CLASS 35—ADVERTISING AND BUSINESS

FOR ASSOCIATION SERVICES, NAMELY, PROMOTING THE INTERESTS OF MEMBERS AND NON-MEMBERS FOR THE PURPOSE OF FOSTERING, ENCOURAGING AND TEACHING PHOTOGRAPHY (U.S. CLS. 100, 101 AND 102).

FIRST USE 11-2-2002; IN COMMERCE 11-2-2002.

#### CLASS 41—EDUCATION AND ENTERTAINMENT

FOR EDUCATION SERVICES, NAMELY, PROVIDING EDUCATION AND INSTRUCTIONAL PROGRAMS IN THE FIELD OF PHOTOGRAPHY (U.S. CLS. 100, 101 AND 107).

FIRST USE 11-2-2002; IN COMMERCE 11-2-2002.  
KHANH LE, EXAMINING ATTORNEY



THE MARK CONSISTS OF THREE CHINESE LANGUAGE CHARACTERS DISPLAYED IN A HORIZONTAL FORMAT.

THE NON-LATIN CHARACTERS IN THE MARK TRANSLITERATE TO "LAY YU MOON" AND THIS MEANS "KOI ENTRANCE" IN ENGLISH.

#### CLASS 29—MEATS AND PROCESSED FOODS

FOR PREPARED, FROZEN, CANNED AND DRIED MEAT, POULTRY, GAME, SEAFOOD, VEGETABLES AND FRUIT; SHELLFISH; FROZEN OR PREPARED MEALS IN THE NATURE OF DIM SUM CONSISTING PRIMARILY OF MEAT, POULTRY, GAME, SEAFOOD, VEGETABLES AND/OR FRUIT; FROZEN OR PREPARED SOUP (U.S. CL. 46).

#### CLASS 30—STAPLE FOODS

FOR CAKES; FROZEN OR PREPARED MEALS IN THE NATURE OF DIM SUM CONSISTING PRIMARILY OF PASTA, RICE, BREAD, CEREALS, NOODLES AND/OR PASTRIES; TEA (U.S. CL. 46).

RENEE SERVANCE, EXAMINING ATTORNEY

SN 77-966,574. MAGIC BROTHERS ASSOCIATE, INCORPORATED,  
DBA KOI PALACE, MILLBRAE, CA. FILED 3-23-2010.



OWNER OF U.S. REG. NO. 3,596,729.

THE MARK CONSISTS OF A STYLIZED FISH AND CRESTED WAVE DESIGN DISPLAYED WITH THREE CHINESE CHARACTERS CONTAINED WITHIN A STYLIZED RECTANGLE, WITH AN ADDITIONAL SINGLE CHINESE CHARACTER DISPLAYED TO THE RIGHT OF THE RECTANGLE.

THE NON-LATIN CHARACTERS IN THE MARK TRANSLITERATE TO "LAY YU MOON" AND THIS MEANS "KOI ENTRANCE" IN ENGLISH.

**CLASS 29—MEATS AND PROCESSED FOODS**

FOR PREPARED, FROZEN, CANNED AND DRIED MEAT, POULTRY, GAME, SEAFOOD, VEGETABLES AND FRUIT; SHELLFISH; FROZEN OR PREPARED MEALS IN THE NATURE OF DIM SUM CONSISTING PRIMARILY OF MEAT, POULTRY, GAME, SEAFOOD, VEGETABLES AND/OR FRUIT; FROZEN OR PREPARED SOUP (U.S. CL. 46).

**CLASS 30—STAPLE FOODS**

FOR CAKES; FROZEN OR PREPARED MEALS IN THE NATURE OF DIM SUM CONSISTING PRIMARILY OF PASTA, RICE, BREAD, CEREALS, NOODLES AND/OR PASTRIES; TEA (U.S. CL. 46).

RENEE SERVANCE, EXAMINING ATTORNEY

**CLASS 21—HOUSEWARES AND GLASS**

FOR (BASED ON USE IN COMMERCE) NON-MECHANIZED METAL LIVESTOCK FEEDERS, NAMELY, BALE FEEDERS AND FEED BUNKS (U.S. CLS. 2, 13, 23, 29, 30, 33, 40 AND 50).

FIRST USE 7-2-2009; IN COMMERCE 7-2-2009.

NAKIA HENRY, EXAMINING ATTORNEY

SN 77-981,517. BRANDING EMPIRE, LLC, MIAMI, FL. FILED 11-13-2009.

**RUMBLE BEES**

THE MARK CONSISTS OF STANDARD CHARACTERS WITHOUT CLAIM TO ANY PARTICULAR FONT, STYLE, SIZE, OR COLOR.

NO CLAIM IS MADE TO THE EXCLUSIVE RIGHT TO USE "BEES", APART FROM THE MARK AS SHOWN.

**CLASS 16—PAPER GOODS AND PRINTED MATTER**

FOR BOOKS, NAMELY, CHILDREN'S BOOKS, AND COLORING BOOKS (U.S. CLS. 2, 5, 22, 23, 29, 37, 38 AND 50).

**CLASS 25—CLOTHING**

FOR APPAREL, NAMELY, HATS, DRESSES, TANK TOPS, T-SHIRTS, ONE PIECE GARMENTS FOR INFANTS AND TODDLERS, AND HOODED SWEATSHIRTS (U.S. CLS. 22 AND 39).

**CLASS 41—EDUCATION AND ENTERTAINMENT**

FOR ENTERTAINMENT SERVICES IN THE NATURE OF ON-GOING ANIMATED TELEVISION PROGRAMS FOR CHILDREN; PROVIDING A WEBSITE FEATURING INFORMATION IN THE FIELDS OF EDUCATION AND ENTERTAINMENT FOR CHILDREN (U.S. CLS. 100, 101 AND 107).

KATHRYN COWARD, EXAMINING ATTORNEY

SN 77-981,535. COSCO MANAGEMENT, INC., WILMINGTON, DE. FILED 1-26-2010.

**PROGRADE**

THE MARK CONSISTS OF STANDARD CHARACTERS WITHOUT CLAIM TO ANY PARTICULAR FONT, STYLE, SIZE, OR COLOR.

**CLASS 8—HAND TOOLS**

FOR FINGERNAIL FILERS (U.S. CLS. 23, 28 AND 44). FIRST USE 12-1-2008; IN COMMERCE 12-1-2008.

**CLASS 10—MEDICAL APPARATUS**

FOR FEVER THERMOMETERS; EAR SCOPE, NAMELY, OTOSCOPE; NASAL ASPIRATOR (U.S. CLS. 26, 39 AND 44).

FIRST USE 12-1-2008; IN COMMERCE 12-1-2008.

SN 77-966,978. APPLGATE LIVESTOCK EQUIPMENT, INC., UNION CITY, IN. FILED 3-24-2010.



OWNER OF U.S. REG. NOS. 3,398,016 AND 3,398,019. THE MARK CONSISTS OF THE WORD "APPLGATE" POSITIONED TO THE RIGHT OF A DRAWING OF A PORTION OF A GATE.

**CLASS 6—METAL GOODS**

FOR (BASED ON USE IN COMMERCE) METAL LIVESTOCK AND FARM ANIMAL RETENTION AND FEEDING EQUIPMENT, NAMELY, GATES AND FENCING PANELS; NON-MECHANIZED CORRAL PANELS; CALF SHELTERS; EARTH ANCHORS; METAL EQUINE AND PET RETENTION EQUIPMENT, NAMELY, METAL FRAME HORSE STALLS AND HORSE SHELTERS (U.S. CLS. 2, 12, 13, 14, 23, 25 AND 50).

FIRST USE 7-2-2009; IN COMMERCE 7-2-2009.

**CLASS 7—MACHINERY**

FOR (BASED ON INTENT TO USE) PORTABLE GRAIN AND FEED CONVEYING EQUIPMENT, NAMELY, GRAIN AUGERS; AGRICULTURAL IMPLEMENT, NAMELY, BALE CARRIER (U.S. CLS. 13, 19, 21, 23, 31, 34 AND 35).

**CLASS 8—HAND TOOLS**

FOR (BASED ON INTENT TO USE) HAND TOOLS, NAMELY, METAL POST DRIVERS (U.S. CLS. 23, 28 AND 44).

**CLASS 11—ENVIRONMENTAL CONTROL APPARATUS**

FOR (BASED ON USE IN COMMERCE) NON-MECHANIZED LIVESTOCK WATERING UNITS, NAMELY, WATERING TANKS (U.S. CLS. 13, 21, 23, 31 AND 34).

FIRST USE 7-2-2009; IN COMMERCE 7-2-2009.

**CLASS 20—FURNITURE AND ARTICLES NOT OTHERWISE CLASSIFIED**

FOR (BASED ON USE IN COMMERCE) DOG KENNELS (U.S. CLS. 2, 13, 22, 25, 32 AND 50).

FIRST USE 7-2-2009; IN COMMERCE 7-2-2009.

**CLASS 12—VEHICLES**

FOR MIRRORS FOR VEHICLES, NAMELY, BACK-SEAT BABY AND CHILD VIEW MIRRORS; AUTOMOBILE WINDOW SHADE SCREENS (U.S. CLS. 19, 21, 23, 31, 35 AND 44).

FIRST USE 12-1-2008; IN COMMERCE 12-1-2008.  
KATHERINE CHANG, EXAMINING ATTORNEY

**CLASS 9—ELECTRICAL AND SCIENTIFIC APPARATUS**

FOR BODY ARMOR; BALLISTIC VESTS; RADIO HOLDERS; CASSETTE RECORDER CASES; GAS MASK POUCHES; CONCEALED BULLET-RESISTANT PANELS USED IN BODY ARMOR; PORTABLE BALLISTIC SHIELDS; NIGHT VISION SCOPES; REFLECTIVE ULTRA-VIOLET IMAGING SYSTEMS COMPRISED OF NIGHT VISION SCOPES, SHORTWAVE ULTRA-VIOLET LIGHTS AND LENSES; SCALES; PLASTIC SAFETY RESTRAINTS (U.S. CLS. 21, 23, 26, 36 AND 38).

FIRST USE 1-0-1973; IN COMMERCE 1-0-1973.

**CLASS 13—FIREARMS**

FOR HOLSTERS; MILITARY AND POLICE DUTY GEAR, NAMELY, HOLSTERS, REVOLVER PARTS IN THE NATURE OF REVOLVER SPEEDLOADER HOLDERS, AMMO CADDIES, MAGAZINE HOLDERS FOR WEAPONS, GUN CASES, CARTRIDGE POUCHES, FIREARM ATTACHMENTS, NAMELY, MOUNTING DEVICES CONSISTING OF BASES, RINGS AND FASTENERS FOR MOUNTING SCOPES ON HANDGUNS AND RIFLES, ALL SOLD AS INDIVIDUAL PIECES AND AS ASSEMBLIES; AMMO CADDIES; CARTRIDGE POUCHES; GUN CASES; CARTRIDGE BELTS; HOLSTER ADAPTERS; MAGAZINE HOLDERS FOR WEAPONS; NON-EXPLOSIVE DEFENSIVE WEAPONS IN THE NATURE OF AN IRRITANT PACKAGED IN AEROSOL CONTAINERS; KITS FOR CLEANING AND PRESERVING FIREARMS, NAMELY, KITS CONTAINING BRUSHES AND RODS AND ALSO CONTAINING CLEANING RAGS AND GUN-CLEANING PREPARATIONS; CASES SOLD EMPTY FOR CANISTERS OF PEPPER GAS AND OTHER DEFENSIVE IRRITANTS (U.S. CLS. 2 AND 9).

FIRST USE 4-6-1983; IN COMMERCE 4-6-1983.

**CLASS 18—LEATHER GOODS**

FOR ALL-PURPOSE UTILITY BAGS AND GEAR BAGS (U.S. CLS. 1, 2, 3, 22 AND 41).

FIRST USE 4-6-1983; IN COMMERCE 4-6-1983.

**CLASS 20—FURNITURE AND ARTICLES NOT OTHERWISE CLASSIFIED**

FOR NONMETAL KEY HOLDERS; PLASTIC LEG RESTRAINTS (U.S. CLS. 2, 13, 22, 25, 32 AND 50).

FIRST USE 4-6-1983; IN COMMERCE 4-6-1983.

**CLASS 25—CLOTHING**

FOR GLOVES; APPAREL, NAMELY, SHIRTS, HATS, CAPS, PANTS AND OUTERWEAR, NAMELY, JACKETS, COATS AND WIND-RESISTANT JACKETS (U.S. CLS. 22 AND 39).

FIRST USE 1-0-2000; IN COMMERCE 1-0-2000.  
MARCIE MILONE, EXAMINING ATTORNEY

SN 77-981,553. SAFARILAND, LLC, JACKSONVILLE, FL.  
FILED 1-13-2009.

# SAFARILAND

THE MARK CONSISTS OF STANDARD CHARACTERS WITHOUT CLAIM TO ANY PARTICULAR FONT, STYLE, SIZE, OR COLOR.

OWNER OF U.S. REG. NOS. 1,808,879, 1,873,761 AND OTHERS.

**CLASS 3—COSMETICS AND CLEANING PREPARATIONS**

FOR DEGREASING PREPARATIONS AND CLEANERS FOR USE ON VEHICLES; FIREARM CLEANING PREPARATIONS IN THE NATURE OF SOLVENTS FOR REMOVING CARBON BUILDUP (U.S. CLS. 1, 4, 6, 50, 51 AND 52).

FIRST USE 2-1-2009; IN COMMERCE 2-1-2009.

**CLASS 4—LUBRICANTS AND FUELS**

FOR FOOTPRINT IMPRESSION FORMULATIONS FOR FORENSIC USE, NAMELY, CHEMICAL BASED WAXES AND ORGANIC-BASE WAXES; GUN OIL; LUBRICATING OILS AND ALL-PURPOSE LUBRICANTS (U.S. CLS. 1, 6 AND 15).

FIRST USE 2-1-2009; IN COMMERCE 2-1-2009.

**CLASS 6—METAL GOODS**

FOR HANDCUFFS; HANDCUFF CASES; LEG RESTRAINTS OF METAL; STRUCTURAL STEEL GUARD BOOTHS AND FORTIFIED ARMORED POSITIONS PRIMARILY COMPRISING STEEL TUBING AND ARMOR PLATE FOR EXTERIOR WALL AND ROOF SYSTEMS AND ALSO CONTAINING GLASS POLYCARBONATE COMPOSITE ARMOR FOR WINDOWS; BULLET-RESISTANT MODULAR WALL SYSTEMS PRIMARILY COMPRISING STEEL TUBING AND ARMOR PLATE AND ALSO CONTAINING GLASS POLYCARBONATE ARMOR FOR WINDOWS (U.S. CLS. 2, 12, 13, 14, 23, 25 AND 50).

FIRST USE 4-6-1983; IN COMMERCE 4-6-1983.

**CLASS 8—HAND TOOLS**

FOR UTILITY KNIFE CASES; LEATHER TOOL BELTS; BATONS FOR SELF-DEFENSE; POLICE BATONS AND METAL TIPS FOR POLICE BATONS SOLD AS A UNIT (U.S. CLS. 23, 28 AND 44).

FIRST USE 4-6-1983; IN COMMERCE 4-6-1983.

SN 78-446,403. GERRESHEIMER GLAS GMBH, DUSSELDORF, FED REP GERMANY, FILED 7-6-2004.

# GERRESHEIMER

PRIORITY CLAIMED UNDER SEC. 44(D) ON ERP CMNTY TM OFC APPLICATION NO. 003883981, FILED 6-14-2004, REG. NO. 003883981, DATED 11-23-2005, EXPIRES 6-14-2014.

THE MARK CONSISTS OF THE STYLIZED WORD "GERRESHEIMER".

**CLASS 6—METAL GOODS**

FOR FLACONS, CANS, TUBES AND FLASKS, ALL SOLD EMPTY, CLOSURES FOR THE FOREGOING GOODS, AND CLAMPS, THE FOREGOING GOODS BEING ESPECIALLY FOR THE PERFUME, COSMETIC, BEVERAGE AND FOOD INDUSTRIES, AND ALL MADE OF NON-PRECIOUS METAL (U.S. CLS. 2, 12, 13, 14, 23, 25 AND 50).

**CLASS 9—ELECTRICAL AND SCIENTIFIC APPARATUS**

FOR LABORATORY GLASSWARE, NAMELY, JARS, FLACONS, GLASS TUBES, AMPULS, BEAKERS, BURETS, FLASKS, FUNNELS, PIPETTES, CUVETTES, ELECTRICAL CONNECTORS, ACCUMULATOR JARS (U.S. CLS. 21, 23, 26, 36 AND 38).

**CLASS 10—MEDICAL APPARATUS**

FOR MEDICAL INSTRUMENTS AND APPARATUS, NAMELY, CUVETTES, TABLET AND OINTMENT APPLICATORS, INHALERS, MEASURING SPOONS AND CAPS; SYRINGES AND NEEDLES FOR MEDICAL PURPOSES; MEDICAL SYSTEMS COMPRISING BOTTLES, DROPPER BOTTLES, SPRAY AND PUMP BOTTLES OR PUMPS FOR INFUSION, TRANSFUSION AND DOSING PURPOSES OF DIAGNOSTIC AND PHARMACEUTICAL SUBSTANCES; AEROSOL DISPENSERS FOR MEDICAL USE; CATHETERS; INJECTORS, NAMELY, INJECTION SYRINGES, INJECTION INSTRUMENTS AND INJECTION NEEDLES, SYRINGE ACCESSORIES; BOTTLES FOR MEDICAL USE, NAMELY, BOTTLES FOR INTRAVENOUS APPLICATION, FEEDING BOTTLES, TABLET BOTTLES, PET BOTTLES FOR LIQUIDS, SERUM BOTTLES (U.S. CLS. 26, 39 AND 44).

**CLASS 20—FURNITURE AND ARTICLES NOT OTHERWISE CLASSIFIED**

FOR PLASTIC CLOSURES FOR CONTAINERS AND PLASTIC CLAMPS, BEING ESPECIALLY FOR THE PERFUME, COSMETIC, PHARMACEUTICAL, BEVERAGE AND FOOD INDUSTRIES (U.S. CLS. 2, 13, 22, 25, 32 AND 50).

**CLASS 21—HOUSEWARES AND GLASS**

FOR FUNNELS; TUBES AND TUBINGS; STORAGE JARS, FLACONS, AMPULS, BEAKERS, FLASKS, CONTAINERS, VIALS, CANS, REACTORS, JOINTS, CARTRIDGES, INJECTORS, RODS, ALL OF THE FOREGOING MADE OF GLASS BEING ESPECIALLY FOR THE PERFUME, COSMETIC, PHARMACEUTICAL, BEVERAGE AND FOOD INDUSTRIES, AND GLASS STOPPERS FOR THE FOREGOING GOODS; BOTTLES SOLD EMPTY, NAMELY, SPRAY BOTTLES, SYRUP BOTTLES, DROPPER BOTTLES, TABLET BOTTLES, SERUM BOTTLES, TRANSFUSION BOTTLES, SCREW-CAP BOTTLES, CROWN-CAP BOTTLES, SCREW-TOP BOTTLES AND BOTTLES FOR STORAGE PURPOSES BEING ESPECIALLY FOR THE PERFUME, COSMETIC, PHARMACEUTICAL, BEVERAGE OR FOOD INDUSTRIES, ALL OF THE FOREGOING BOTTLES BEING BOTTLES BEING MADE FROM GLASS OR PLASTIC (U.S. CLS. 2, 13, 23, 29, 30, 33, 40 AND 50).

**CLASS 42—SCIENTIFIC AND COMPUTER SERVICES**

FOR TECHNICAL CONSULTATION AND RESEARCH AND NEW PRODUCT DEVELOPMENT FOR OTHERS IN THE FIELD OF BOTTLES, JARS, FLACONS, CANS, TUBES, PODS, ADAPTERS, AMPULS, BEAKERS, BURETS, CLAMPS, DISPENSERS, REACTORS, FLASKS, SYRINGES, FUNNELS, JOINTS, PIPETTES, CONNECTORS, CARTRIDGES, INJECTORS, DOSING AND SPRAY PUMPS, CUVETTES AND CLOSURES FOR THE FOREGOING GOODS, BEING ESPECIALLY FOR THE PERFUME, COSMETIC, PHARMACEUTICAL, MEDICAL, LABORATORY, BEVERAGE AND FOOD INDUSTRIES (U.S. CLS. 100 AND 101).

JOHN DWYER, EXAMINING ATTORNEY

SN 78-559,851. STARZ ENTERTAINMENT, LLC, ENGLEWOOD, CO. FILED 2-3-2005.

# EDGE

THE MARK CONSISTS OF STANDARD CHARACTERS WITHOUT CLAIM TO ANY PARTICULAR FONT, STYLE, SIZE, OR COLOR.

OWNER OF U.S. REG. NO. 3,096,752.

**CLASS 38—COMMUNICATION**

FOR VIDEO AND AUDIO BROADCASTING AND TRANSMISSION; TELEVISION BROADCASTING AND TRANSMISSION; CABLE AND SATELLITE TELEVISION BROADCASTING; SUBSCRIPTION TELEVISION BROADCASTING AND TRANSMISSION; VIDEO-ON-DEMAND TRANSMISSION; COMMUNICATION SERVICES, NAMELY, TRANSMISSION OF VISUAL IMAGES AND AUDIO VIA A GLOBAL COMPUTER NETWORK (U.S. CLS. 100, 101 AND 104).

**CLASS 41—EDUCATION AND ENTERTAINMENT**

FOR ENTERTAINMENT SERVICES IN THE NATURE OF VIDEO AND AUDIO PROGRAMMING, TELEVISION PROGRAMMING; PRODUCTION AND DISTRIBUTION OF MOTION PICTURES; TELEVISION PROGRAMMING ON A GLOBAL COMPUTER NETWORK; PRODUCTION AND DISTRIBUTION OF TELEVISION AND MOTION PICTURE PROGRAMMING FOR TELEVISION BROADCASTING AND TRANSMISSION VIA A GLOBAL COMPUTER NETWORK (U.S. CLS. 100, 101 AND 107).

LINDA ORNDORFF, EXAMINING ATTORNEY

SN 78-887,017. RECKITT & COLMAN (OVERSEAS) LIMITED, HULL, UNITED KINGDOM, FILED 5-18-2006.



OWNER OF ERPN CMNTY TM OFC REG. NO. 005040977, DATED 5-18-2007, EXPIRES 4-26-2016.

OWNER OF U.S. REG. NOS. 972,682, 1,808,772 AND 2,668,653.

### CLASS 3—COSMETICS AND CLEANING PREPARATIONS

FOR CLEANING, SCOURING AND ABRASIVE PREPARATIONS FOR HOUSEHOLD PURPOSES; BLEACHING PREPARATIONS FOR HOUSEHOLD USE; DISH AND LAUNDRY DETERGENTS; PREPARATIONS FOR LAUNDRY USE, NAMELY, LAUNDRY DETERGENT, LAUNDRY SOAP, AND LAUNDRY BLEACH; DISPOSABLE WIPES AND TISSUES IMPREGNATED WITH CLEANING PREPARATIONS FOR HOUSEHOLD USE; NON-MEDICATED TOILETRIES; SOAPS; TALCUM POWDER; COSMETICS; NON-MEDICATED SKIN CARE PREPARATIONS; SHAMPOOS; HAIR SHAVING PREPARATIONS; SHAVING CREAMS, GELS, SPRAYS, LOTIONS AND BALMS; AFTERSHAVE PREPARATIONS; AFTERSHAVE BALMS, GELS, SPRAYS, LOTIONS AND CREAMS; DEODORANTS FOR PERSONAL USE; DENTIFRICES; PREPARATIONS FOR USE IN ORAL HYGIENE, NAMELY, TOOTHPASTE AND NON-MEDICATED MOUTH WASH AND RINSE; PERFUMING PREPARATIONS FOR THE ATMOSPHERE, NAMELY, ROOM FRAGRANCES; ESSENTIAL OILS; MEDICATED SOAP (U.S. CLS. 1, 4, 6, 50, 51 AND 52).

### CLASS 5—PHARMACEUTICALS

FOR PHARMACEUTICAL PREPARATIONS, NAMELY, PREPARATIONS FOR THE TREATMENT OF OPIATE, COCAINE AND ALCOHOL ADDICTION; ANALGESICS; PHARMACEUTICAL PREPARATIONS, NAMELY, ANTI-INFLAMMATORY AND ANTI-PYRETIC PREPARATIONS, ANTI-CONVULSANTS, CEREBRAL METABOLIC ACTIVATORS, PREPARATIONS FOR USE IN IMMOBILIZING AND REVIVING ANIMALS, AND MEDICATED PREPARATIONS FOR THE RELIEF OF COUGH AND COLD SYMPTOMS; GASTRIC REFLUX SUPPRESSANTS; LAXATIVES; ANTACIDS; MEDICATED BEVERAGES AND INGREDIENTS FOR MAKING SUCH BEVERAGES ALL FOR THE USE IN THE TREATMENT OF COLDS, COUGHS, INFLUENZA AND SORE THROATS; PREPARATIONS FOR MAKING MEDICATED BEVERAGES, NAMELY, COLDS, COUGHS, INFLUENZA AND SORE THROAT TREATMENT PREPARATIONS; NATURAL FIBER BULKING AGENTS, NAMELY, DIETARY FIBER AS AN ADDITIVE FOR FOOD PRODUCTS; HERBAL TEA FOR MEDICINAL PURPOSES; VETERINARY PREPARATIONS, NAMELY, ANTISEPTIC PREPARATIONS FOR TREATMENT OF CUTS, GRAZES, BITES AND STINGS AND SKIN AND SCALP CONDITIONS AND PAIN RELIEF MEDICATION; MEDICATED HAND WASH; MEDICATED HAIR CARE PREPARATIONS; MEDICATED MOUTHWASH; SANITARY PREPARATIONS FOR MEDICAL USE; DISINFECTANTS FOR SANITARY PURPOSES; ANTISEPTIC PREPARATIONS, ANTIBACTERIAL PREPARATIONS, NAMELY, ANTIBACTERIAL CLEANERS, HANDWASH, PHARMACEUTICALS AND SPRAY; DISINFECTING PREPARATIONS, NAMELY, DISINFECTANTS FOR HYGIENIC AND SANITARY PURPOSES; GERMICIDES; ARTICLES IMPREGNATED WITH A DISINFECTANT OR ANTIBACTERIAL PRODUCT, NAMELY, SANITIZING WIPES; INSECTICIDES AND MITICIDES FOR HOUSEHOLD USE; INSECT REPELLANTS; PREPARATIONS FOR DESTROYING AND REPELLING VERMIN; FUNGICIDES; AIR FRESHENING PREPARATIONS, AIR PURIFYING PREPARATIONS, NAMELY, AIR DEODORANTS AND AIR DEODORIZERS; ODOR NEUTRALIZERS FOR USE ON CARPETS, TEXTILES AND IN THE AIR; SPRAYS AND AEROSOLS FOR NEUTRALIZING, CONTROLLING AND REDUCING ALLERGENS; MEDICATED TOILETRIES; MEDICATED TALCUM POWDER; MEDICAL PLASTERS; MATERIALS FOR DRESSINGS, NAMELY, GAUZE AND MEDICAL ADHESIVE TAPE; CLOTHS, WIPES, TISSUES AND SPONGES IMPREGNATED WITH DISINFECTANT FOR CLEANING, NAMELY, SANITIZING WIPES; MEDICINAL DRINKS AND PREPARATIONS FOR MAKING UP SUCH DRINKS, NAMELY, DIETARY SUPPLEMENTAL DRINKS; MEDICATED BEVERAGES AND PREPARATIONS FOR MAKING MEDICATED BEVERAGES, NAMELY, NUTRITIONALLY FORTIFIED BEVERAGES; VITAMIN PREPARATIONS; MEDICATED PREPARA-

TIONS FOR TREATMENT OF ORAL AILMENTS, NAMELY, MEDICATED MOUTHWASH; MINERAL PREPARATIONS FOR MEDICINAL USE; HERBAL PREPARATIONS FOR MEDICINAL USE, NAMELY, HERBAL TEAS FOR MEDICINAL PURPOSES AND MEDICINAL HERBAL EXTRACTS FOR MEDICAL PURPOSES; PADS OR PATCHES IMPREGNATED WITH OR CONTAINING SUBSTANCES FOR THE RELIEF OF SYMPTOMS OF COLDS, AND INFLUENZA; DECONGESTANTS; PREPARATIONS FOR DISPERSING DECONGESTANTS, NAMELY, DECONGESTANT CAPSULES AND NASAL SPRAYS; MEDICATED THROAT LOZENGES; MEDICATED CONFECTIONERY; MEDICATED SKIN CARE PREPARATIONS (U.S. CLS. 6, 18, 44, 46, 51 AND 52).

ROBERT STRUCK, EXAMINING ATTORNEY

SN 79-046,844. EGIS PROJECTS, FRANCE, FILED 4-10-2007.

# EGIS PROJECTS

THE MARK CONSISTS OF STANDARD CHARACTERS WITHOUT CLAIM TO ANY PARTICULAR FONT, STYLE, SIZE, OR COLOR.

PRIORITY DATE OF 10-10-2006 IS CLAIMED.

OWNER OF INTERNATIONAL REGISTRATION 0945074 DATED 4-10-2007, EXPIRES 4-10-2017.

NO CLAIM IS MADE TO THE EXCLUSIVE RIGHT TO USE "PROJECTS", APART FROM THE MARK AS SHOWN.

### CLASS 9—ELECTRICAL AND SCIENTIFIC APPARATUS

FOR MAGNETIC CARDS; MAGNETIC IDENTITY CARDS; MEMORY CARDS; BLANK MAGNETIC DATA CARRIERS; BLANK OPTICAL DATA CARRIERS; STORED VALUES ELECTRONIC PURSE CARDS; COIN OR TOKEN-OPERATED AUTOMATIC APPARATUS, NAMELY, GATES FOR CAR PARKING FACILITIES; AUTOMATIC VENDING MACHINES AND MECHANISMS FOR COIN-OPERATED APPARATUS; DATA PROCESSING EQUIPMENT; ALL OF THE FOREGOING FOR USE ONLY WITH ELECTRONIC TOLL COLLECTION AND TRANSPORTATION CONCESSIONS AND NOT INCORPORATING DOWNLOADABLE COMPUTER SOFTWARE (U.S. CLS. 21, 23, 26, 36 AND 38).

### CLASS 35—ADVERTISING AND BUSINESS

FOR ADVERTISING ON BEHALF OF COMPANIES IN THE CONSTRUCTION AND MANAGEMENT OF ROAD, PORT AND AIRPORT INFRASTRUCTURES, BRIDGES AND TUNNELS AND GROUND TRANSPORT NETWORKS FOR PERSONS; COMPUTER FILE MANAGEMENT; DATA COMPILATION AND SYSTEMATIZATION IN A DATABASE IN THE FIELD OF CONSTRUCTION, OPERATION, AND MANAGEMENT OF ROAD, PORT AND AIRPORT INFRASTRUCTURES, BRIDGES AND TUNNELS AND GROUND TRANSPORT NETWORKS FOR PERSONS; ARRANGING SUBSCRIPTIONS TO TELECOMMUNICATION SERVICES, NAMELY, REMOTE TOLL BOOTH SUBSCRIPTION SERVICES; ARRANGING SUBSCRIPTION TO SERVICES OF LOCATING AND TRACKING OF VEHICLES AND FLEETS BY ELECTRONIC, COMPUTING AND SATELLITE MEANS (U.S. CLS. 100, 101 AND 102).

**CLASS 36—INSURANCE AND FINANCIAL**

FOR FINANCIAL AND MONETARY AFFAIRS, NAMELY, FINANCING THE CONSTRUCTION, OPERATION, AND MANAGEMENT OF ROAD, PORT AND AIRPORT INFRASTRUCTURES, BRIDGES AND TUNNELS AND GROUND TRANSPORT NETWORKS FOR PERSONS; ROAD AND MOTORWAY TOLL COLLECTION SERVICES; ELECTRONIC TOLL COLLECTION SERVICES, NAMELY, COLLECTION OF ELECTRONIC TOLL FEES AND TRANSPORTATION CONCESSIONS BY DIRECT DEBIT FROM A BANKING ACCOUNT; CREDIT CARD AND PAYMENT CARD SERVICES RELATED TO THE COLLECTION OF ELECTRONIC TOLL FEES AND TRANSPORTATION CONCESSIONS; FINANCIAL CONSULTING AND FINANCING, FINANCIAL PLANNING, AND FINANCIAL MANAGEMENT OF PROJECTS REGARDING THE CONSTRUCTION OF ROAD, PORT AND AIRPORT INFRASTRUCTURES, BRIDGES AND TUNNELS AND GROUND TRANSPORT NETWORKS FOR PERSONS, EXCLUDING FINANCIAL SERVICES IN THE NATURE OF INVESTMENT SECURITIES (U.S. CLS. 100, 101 AND 102).

**CLASS 37—CONSTRUCTION AND REPAIR**

FOR CONSTRUCTION OF ROAD AND MOTORWAY INFRASTRUCTURES, BRIDGES AND TUNNELS, AIRPORT AND PORT INFRASTRUCTURES; CONSTRUCTION OF PUBLIC GROUND TRANSPORTATION NETWORKS; HEAVY OR ROUTINE MAINTENANCE SERVICES FOR ROADS AND MOTORWAYS, BRIDGES, TUNNELS, AIRPORT BUILDINGS, PORT FACILITIES, GROUND TRANSPORTATION SYSTEMS FOR PERSONS AND GROUND TRANSPORTATION VEHICLES; VEHICLE SERVICE STATIONS; VEHICLE REFUELING AND VEHICLE WASHING SERVICES (U.S. CLS. 100, 103 AND 106).

**CLASS 39—TRANSPORTATION AND STORAGE**

FOR PROVIDING INFORMATION REGARDING TRAFFIC, INCIDENTS AND JOURNEY TIMES ON ROAD AND MOTORWAY NETWORKS; VEHICLE TOWING SERVICES FOR USE IN CASE OF VEHICLE BREAKDOWN; SERVICES FOR RENTAL OF SURFACE OR UNDERGROUND PARKING PLACES; TRANSPORTATION SERVICES, NAMELY, PROVIDING PRIVATE ROADS OR MOTORWAY FOR OTHERS; OPERATING SERVICES FOR ROAD AND MOTORWAY TOLLS OR REMOTE TOLLS, NAMELY, PROVIDING TOLL ROADS AND TOLL MOTORWAYS FOR OTHERS (U.S. CLS. 100 AND 105).

**CLASS 42—SCIENTIFIC AND COMPUTER SERVICES**

FOR ENGINEERING AND PROJECT DESIGN SERVICES FOR THE DESIGN, CONSTRUCTION, OPERATING AND HEAVY OR ROUTINE MAINTENANCE OF ROAD AND MOTORWAY, PORT AND AIRPORT INFRASTRUCTURES, BRIDGES AND TUNNELS AND GROUND TRANSPORTATION NETWORKS FOR PERSONS AND RELATED FIXED OR MOBILE EQUIPMENT; TECHNICAL SERVICES IN THE CONTEXT OF PROJECT DEVELOPMENT CONCERNING THE DESIGN, CONSTRUCTION, FINANCING, OPERATING, HEAVY OR ROUTINE MAINTENANCE OF ROAD AND MOTORWAY, PORT AND AIRPORT INFRASTRUCTURES, BRIDGES AND TUNNELS AND GROUND TRANSPORTATION NETWORKS FOR PERSONS AND RELATED FIXED OR MOBILE EQUIPMENT; COMPUTER PROGRAMMING; SOFTWARE DESIGN AND DEVELOPMENT, INSTALLATION, MAINTENANCE, DESIGN, UPDATING AND RENTAL OF SOFTWARE; TECHNICAL INSPECTION OF MOTOR CARS; SETTING UP OF PROJECTS RELATING TO THE CONSTRUCTION AND MAINTENANCE OF ROAD, MOTORWAY, PORT, AIRPORT INFRASTRUCTURES, BRIDGES AND TUNNELS AND GROUND TRANSPORTATION NETWORKS FOR PERSONS (U.S. CLS. 100 AND 101).

**CLASS 45—PERSONAL AND LEGAL SERVICES**

FOR LEGAL SERVICES IN THE CONTEXT OF DEVELOPING PROJECTS CONCERNING THE DESIGN, CONSTRUCTION, FINANCING, OPERATING, HEAVY OR ROUTINE MAINTENANCE, OF ROAD, MOTORWAY, PORT, AIRPORT INFRASTRUCTURES, BRIDGES AND TUNNELS AND GROUND TRANSPORTATION NETWORKS FOR PERSONS AND RELATED FIXED OR MOBILE EQUIPMENT (U.S. CLS. 100 AND 101).

KRISTIN CARLSON, EXAMINING ATTORNEY

SN 79-056,078. ISHII KAZUYOSHI, JAPAN, FILED 4-23-2008.



PRIORITY DATE OF 10-30-2007 IS CLAIMED.  
OWNER OF INTERNATIONAL REGISTRATION 0970221 DATED 4-23-2008, EXPIRES 4-23-2018.  
OWNER OF U.S. REG. NO. 2,396,105.  
THE MARK CONSISTS OF THE WORDING "K-1" NEXT TO A DESIGN OF A PARTIALLY SHADED SQUARE.

**CLASS 35—ADVERTISING AND BUSINESS**

FOR ADVERTISING AND PUBLICITY SERVICES; RETAIL STORE SERVICES OR WHOLESALE STORES FOR WOVEN FABRICS AND BEDDINGS; RETAIL STORE SERVICES OR WHOLESALE STORES FOR CLOTHING; RETAIL STORE SERVICES OR WHOLESALE STORES FOR FOOTWEAR; RETAIL STORE SERVICES OR WHOLESALE STORES FOR BAGS AND POUCHES; RETAIL STORE SERVICES OR WHOLESALE STORES FOR PERSONAL ARTICLES, NAMELY, TOWELS, PERSONAL ORNAMENTS, ACCESSORIES, FANS, BANDANAS AND HEADBANDS; RETAIL STORE SERVICES OR WHOLESALE STORES FOR FOODS AND BEVERAGES (U.S. CLS. 100, 101 AND 102).

**CLASS 41—EDUCATION AND ENTERTAINMENT**

FOR EDUCATIONAL AND INSTRUCTION SERVICES RELATING TO ARTS, CRAFTS AND SPORTS, NAMELY, EDUCATIONAL SERVICES, NAMELY, CONDUCTING CLASSES IN THE FIELDS OF ARTS, CRAFTS AND SPORTS; ARRANGING, CONDUCTING AND ORGANIZATION OF SEMINARS; PROVIDING OF ELECTRONIC PUBLICATIONS, NAMELY, ELECTRONIC PUBLICATIONS FOR TELEVISION PROGRAM, NAMELY, PROVIDING A WEBSITE FEATURING NON-DOWNLOADABLE PUBLICATIONS IN THE NATURE OF BOOKS, MAGAZINES AND BROCHURES IN THE FIELDS OF ARTS, CRAFTS AND SPORTS; SERVICES OF REFERENCE LIBRARIES FOR LITERATURE AND DOCUMENTARY RECORDS; PRODUCTION OF RADIO OR TELEVISION PROGRAMS; PRODUCTION OF VIDEO TAPE FILM IN THE FIELDS OF EDUCATION, CULTURE, ENTERTAINMENT OR SPORTS, NOT FOR MOVIES, RADIO OR TELEVISION PROGRAMS AND NOT FOR ADVERTISING AND PUBLICITY; ORGANIZATION, MANAGEMENT, NAMELY, ADMINISTRATION FOR PLANNING AND HOSTING, AND ARRANGEMENT OF MARTIAL ARTS TOURNAMENTS AND CONTESTS; BOOKING OF SEATS FOR SHOWS; RENTAL OF CINEMATOGRAPHIC MACHINES AND APPARATUS; RENTAL OF CINE-FILMS; RENTAL OF RECORDS OR SOUND-RECORDED MAGNETIC TAPES, RENTAL OF IMAGE-RECORDED MAGNETIC TAPES (U.S. CLS. 100, 101 AND 107).

ADA HAN, EXAMINING ATTORNEY

SN 79-058,836. NETVIEWER AG, 76133 KARLSRUHE, FED REP GERMANY, FILED 6-20-2008.



OWNER OF INTERNATIONAL REGISTRATION 0977171 DATED 6-20-2008, EXPIRES 6-20-2018.

OWNER OF U.S. REG. NO. 3,159,013.

THE COLOR(S) WHITE AND RED IS/ARE CLAIMED AS A FEATURE OF THE MARK.

THE MARK CONSISTS OF THE COLOURS RED AND WHITE, WITH THE COLOUR RED APPEARING IN THE WORDING "NETVIEWER" AND IN THE DESIGN OF A THOUGHT/SPEECH BOX, ALL ON A WHITE BACKGROUND.

#### CLASS 9—ELECTRICAL AND SCIENTIFIC APPARATUS

FOR SOFTWARE, NAMELY, SOFTWARE FOR THE PURPOSES OF AND IN CONNECTION WITH UNIFIED COMMUNICATIONS, VISUAL COMMUNICATIONS IN REALTIME, WEB-CONFERENCING AND COLLABORATION, DESKTOP-SHARING, REMOTE-SUPPORT- AND CONTROL-SERVICES, ONLINE MEETINGS, RESPECTIVELY REALIZED VIA AN INTRANET NETWORK OR THE INTERNET (U.S. CLS. 21, 23, 26, 36 AND 38).

#### CLASS 42—SCIENTIFIC AND COMPUTER SERVICES

FOR CONSULTANCY IN THE FIELD OF COMPUTER HARDWARE, MAINTENANCE, DESIGN AND UPDATES OF SOFTWARE, RESPECTIVELY FOR THE PURPOSES OF AND IN CONNECTION WITH UNIFIED COMMUNICATIONS, VISUAL COMMUNICATIONS IN REALTIME, WEB-CONFERENCING AND COLLABORATION, DESKTOP-SHARING, REMOTE-SUPPORT- AND CONTROL-SERVICES, ONLINE MEETINGS, RESPECTIVELY REALIZED VIA AN INTRANET NETWORK OR THE INTERNET (U.S. CLS. 100 AND 101).

DAVID HOFFMAN, EXAMINING ATTORNEY

SN 79-064,065. OBSHESTVO S OGRANICHENNOJ OTVETSTVENNOSTJU "ALPHALINER", RUSSIAN FED., FILED 10-23-2008.



OWNER OF INTERNATIONAL REGISTRATION 0989872 DATED 10-23-2008, EXPIRES 10-23-2018.

THE MARK CONSISTS OF THE WORDING "ALPHALINER" IN CYRILLIC CHARACTERS (RUSSIAN) AND DESIGNS OF AN OCEAN LINER, PLANE, BUS AND TRAIN WITH HEAT LINES COMING FROM THE PLANE AND ALL OF THE DESIGNS SURROUNDED BY A BROKEN CONCENTRIC CIRCLE IN STYLIZED FONT.

THE NON-LATIN CHARACTERS IN THE MARK TRANSLITERATE TO "ALPHALINER", AND THIS HAS NO MEANING IN A FOREIGN LANGUAGE.

#### CLASS 36—INSURANCE AND FINANCIAL

FOR CUSTOMS BROKERAGE; RENT COLLECTION; INSURANCE INFORMATION; INSURANCE CONSULTANCY; INSURANCE BROKERAGE; LEASING OF REAL ESTATE; REAL ESTATE MANAGEMENT (U.S. CLS. 100, 101 AND 102).

#### CLASS 39—TRANSPORTATION AND STORAGE

FOR AIR TRANSPORT; BOAT RENTAL; BOOKING OF SEATS FOR TRAVEL; TOWING MARINE; VEHICLE TOWING; MESSAGE DELIVERY; PARCEL DELIVERY; DELIVERY OF GOODS; DELIVERY OF GOODS BY MAIL ORDER; TRANSPORTATION INFORMATION; ARRANGING OF CRUISES; ARRANGING OF TOURS; TRUCK HAULING; TRANSPORT AND STORAGE OF TRASH, NAMELY, GARBAGE COLLECTION IN THE NATURE OF TRASH PICKUP; TRANSPORTING FURNITURE, NAMELY, FURNITURE DELIVERY; BARGE TRANSPORT; FERRY-BOAT TRANSPORT; TRANSPORT OF TRAVELERS; FREIGHT BROKERAGE; SHIPPING OF GOODS; ARMORED-CAR TRANSPORT; BUS TRANSPORT; CAR TRANSPORT; BOAT TRANSPORT; RAILWAY TRANSPORT; MARINE TRANSPORT; PASSENGER TRANSPORT; RIVER TRANSPORT BY BOAT; PORTERAGE; SHIP BROKERAGE; TRANSPORT BROKERAGE; FREIGHT BROKERAGE; CAR RENTAL; TRUCK RENTAL; RENTAL OF STORAGE CONTAINERS; MOTOR COACH RENTAL; REFRIGERATOR RENTAL; VEHICLE RENTAL; STEVEDORING; UNLOADING CARGO; PACKAGING OF GOODS FOR TRANSPORTATION; GARAGE RENTAL; RENTAL OF VEHICLE ROOF RACKS; RENTAL OF WAREHOUSES; TAXI TRANSPORT; TRANSPORT BY PIPELINE; CAR PARKING; CHAUFFEUR SERVICES; PLEASURE BOAT TRANSPORT; COURIER SERVICES MESSAGES OR MERCHANDISE; TRAVEL BOOKING AGENCIES EXCEPT FOR BOOKING HOTEL AND BOARDING HOUSES; STORAGE OF GOODS; WAREHOUSING; SIGHTSEEING TOURISM; FREIGHT FORWARDING (U.S. CLS. 100 AND 105).

WILLIAM ROSSMAN, EXAMINING ATTORNEY

SN 79-065,439. HAUZER TECHNO COATING BV, NETHERLANDS, FILED 11-28-2008.



PRIORITY DATE OF 9-5-2008 IS CLAIMED.

OWNER OF INTERNATIONAL REGISTRATION 0993645 DATED 11-28-2008, EXPIRES 11-28-2018.

THE COLOR(S) RED AND BLACK IS/ARE CLAIMED AS A FEATURE OF THE MARK.

THE MARK CONSISTS OF A BLACK CIRCLE WITHIN TWO GENERALLY POLYGONAL RED BRACKETS.

**CLASS 7—MACHINERY**

FOR MACHINES FOR COATING GOODS OF METAL, CERAMIC, PLASTIC AND GLASS, IN PARTICULAR BY MEANS OF PHYSICAL VAPOUR DEPOSITION, CHEMICAL VAPOUR DEPOSITION OR A COMBINATION OF PHYSICAL VAPOUR DEPOSITION AND CHEMICAL VAPOUR DEPOSITION; SPUTTERING MACHINES WITH INTEGRATED VACUUM PUMPS AND POWER SUPPLIES; MAGNETRON SPUTTERING MACHINES; ARC COATING MACHINES; MACHINE PARTS, NAMELY, SPUTTERING SOURCES; MACHINE PARTS, NAMELY, MAGNETRON SPUTTERING SOURCES AND TARGETS OF METAL AND/OR CERAMICS FOR MAGNETRON SPUTTERING SOURCES; MACHINE PARTS, NAMELY, ARC SOURCES AND TARGETS OF METAL AND/OR CERAMICS FOR ARC SOURCES; VACUUM GENERATION MACHINES WITH INTEGRATED PLASMA SOURCES FOR USE IN PVD AND CVD COATING, AND STRUCTURAL PARTS FOR ALL THE FOREGOING MACHINES; TREATMENT CHAMBERS FOR PHYSICAL COATING DEVICES AND/OR CHEMICAL COATING DEVICES, NAMELY, VACUUM CHAMBERS FOR DISCONTINUOUS OPERATIONS AND VACUUM CHAMBERS FOR CONTINUOUS OPERATIONS (U.S. CLS. 13, 19, 21, 23, 31, 34 AND 35).

**CLASS 40—MATERIAL TREATMENT**

FOR COATING METALS AND PLASTICS TO COAT AND TO IMPROVE WEAR BEHAVIOR; METAL TEMPERING (U.S. CLS. 100, 103 AND 106).

JAMES MACFARLANE, EXAMINING ATTORNEY

SN 79-065,654. REPOWER SYSTEMS AG, FED REP GERMANY, FILED 10-31-2008.



The logo for PowerBlades features the word "PowerBlades" in a bold, italicized, sans-serif font. A stylized, curved blade shape arches over the text, starting from the left and ending with a small hook on the right.

PRIORITY DATE OF 6-25-2008 IS CLAIMED.

OWNER OF INTERNATIONAL REGISTRATION 0994285 DATED 10-31-2008, EXPIRES 10-31-2018.

NO CLAIM IS MADE TO THE EXCLUSIVE RIGHT TO USE "POWER BLADES" FOR CLASSES 6, 7, 37 AND 42, APART FROM THE MARK AS SHOWN.

THE MARK CONSISTS OF THE WORDING "POWER-BLADES" IN STYLIZED FONT WITH A STYLIZED HORIZONTAL BLADE ABOVE THE WORDING.

**CLASS 6—METAL GOODS**

FOR MASTS AND TOWERS OF METAL FOR WIND POWER PLANTS; BUILDING MATERIALS OF METAL FOR CONSTRUCTING OF MACHINE FOUNDATIONS OF WIND POWER PLANTS, NAMELY, FOUNDATION PLATES, FOUNDATION FLANGES, FOUNDATION MOUNTING MATERIAL, METAL REINFORCEMENT MATERIALS FOR BUILDING (U.S. CLS. 2, 12, 13, 14, 23, 25 AND 50).

**CLASS 7—MACHINERY**

FOR MACHINES FOR GENERATING AND CONVERTING ENERGY AND INSTALLATIONS CONSTRUCTED THEREFROM, NAMELY, WIND TURBINES, WIND POWERED ELECTRICITY GENERATORS AND WIND-POWERED MACHINES FOR GENERATING ELECTRICAL AND MECHANICAL ENERGY, IN PARTICULAR WIND TURBINES, EXCEPT FOR LAND VEHICLES; REPLACEMENT PARTS AND ACCESSORIES FOR THE AFORESAID WIND POWERED MACHINES, IN PARTICULAR ROTOR BLADES, ROTOR CONSOLES, BLADE HUBS, MACHINE HOUSINGS, YAW RINGS, YAW GEARS, BRAKES, MAIN DRIVE SHAFTS, UNIVERSAL JOINTS, GEARS FOR WIND POWER GENERATING MACHINES, GEAR BOXES, COUPLINGS, MOTORS, MECHANICAL ROTOR ADJUSTERS, ELECTRIC GENERATORS AND EMERGENCY POWER SUPPLIES (U.S. CLS. 13, 19, 21, 23, 31, 34 AND 35).

**CLASS 9—ELECTRICAL AND SCIENTIFIC APPARATUS**

FOR SWITCH CABINETS FOR RECORDING, PROCESSING, STORAGE AND TRANSMISSION OF DATA FROM WIND POWER PLANTS AND WIND FARMS; SWITCH CABINETS FOR CONTROLLING ACTUATOR SYSTEMS FOR WIND POWER PLANTS AND WIND FARMS, ELECTRICAL VOLTAGE AND CURRENT REGULATORS FOR WIND POWER PLANTS; ELECTRIC OR ELECTRONIC CONTROLLERS FOR WIND POWER PLANTS, ELECTRIC OR ELECTRONIC MONITORS, METERS AND SENSORS FOR MEASURING TURBINE PERFORMANCE AND POWER GENERATION IN WIND POWER PLANTS, INSTRUMENTS FOR REGULATING, CHECKING, CONTROLLING AND MONITORING ENERGY PRODUCED BY WIND POWER PLANTS; COMPUTER OPERATING SOFTWARE, DATA PROCESSING EQUIPMENT AND COMPUTERS; COMPUTER INTERFACES AND COMPUTER PROGRAMS FOR MONITORING AND REGULATING WIND POWER PLANTS AND WIND FARMS; VOLTAGE SURGE PROTECTORS AND SUPPRESSORS FOR LIGHTNING PROTECTION; ELECTRIC OR ELECTRONIC VIBRATION SENSORS FOR INSTALLATION IN WIND POWER PLANTS; ELECTRIC OR ELECTRONIC WATT-HOUR METERS; ELECTRIC CONVERTERS AND TRANSFORMERS FOR WIND POWER PLANTS (U.S. CLS. 21, 23, 26, 36 AND 38).

**CLASS 35—ADVERTISING AND BUSINESS**

FOR PROFESSIONAL BUSINESS CONSULTANCY WITH REGARD TO WIND POWER PLANTS AND WIND FARMS (U.S. CLS. 100, 101 AND 102).

**CLASS 37—CONSTRUCTION AND REPAIR**

FOR BUILDING CONSTRUCTION IN THE FIELD OF WIND POWER PLANTS; INSTALLATION SERVICES, NAMELY, INSTALLATION OF TOWERS, TURBINES, ELECTRICAL AND COMPUTER SYSTEMS FOR WIND POWER PLANTS AND FARMS; MAINTENANCE AND REBUILDING MACHINES THAT HAVE BEEN WORN OR PARTIALLY DESTROYED; CARE AND REPAIR OF WIND POWER PLANTS; ASSEMBLY OF ROTOR BLADES DURING AND AS PART OF INSTALLATION OF EQUIPMENT FOR WIND POWER PLANTS AND WIND FARMS (U.S. CLS. 100, 103 AND 106).

**CLASS 38—COMMUNICATION**

FOR TELECOMMUNICATIONS, IN PARTICULAR ELECTRONIC TRANSMISSION OF DATA OF WIND POWER PLANTS AND WIND FARMS (U.S. CLS. 100, 101 AND 104).

**CLASS 42—SCIENTIFIC AND COMPUTER SERVICES**

FOR REMOTE MAINTENANCE, REMOTE CONTROL AND REMOTE MONITORING THROUGH COMPUTERIZED RETRIEVAL OF WIND POWER PLANTS AND WIND FARMS, IN PARTICULAR VIA THE INTERNET; PERFORMING TECHNICAL MEASUREMENTS IN THE FIELD OF WIND POWER PLANTS AND WIND FARMS, INSPECTIONS OF WIND POWER PLANTS AND WIND FARMS, CALCULATING WIND FLOW PRODUCED BY WIND POWER AND WIND FARMS; ELECTRONIC DATA STORAGE; SURVEYING AND ANALYZING DATA FROM WIND POWER PLANTS AND WIND FARMS; DESIGN AND DEVELOPMENT OF COMPUTER SOFTWARE IN THE FIELD OF WIND POWER PLANTS AND WIND FARMS; TECHNICAL CONSULTANCY, TECHNICAL PLANNING AND DEVELOPMENT SERVICES AS WELL AS TECHNICAL PROJECT MANAGEMENT IN MATTERS OF WIND POWER PLANTS PROJECTS; ENGINEERING SERVICES FOR CALCULATION, LAYOUT AND DESIGN OF ROTOR BLADES; TECHNICAL RESEARCH IN THE FIELD OF WIND POWER PLANTS AND WIND FARMS; PROVIDING TECHNICAL INFORMATION IN THE FIELD OF ENERGY PRODUCTION THROUGH POWER PLANTS AND WIND FARM; TECHNICAL MONITORING OF THE CONDITION OF ROTOR BLADES (U.S. CLS. 100 AND 101).



SUZANNE BLANE, EXAMINING ATTORNEY

SN 79-066,339, RSL LOGISTIK GMBH &amp; CO. KG, FED REP GERMANY, FILED 8-6-2008.



# SCHÖNENBERGER

PRIORITY DATE OF 2-6-2008 IS CLAIMED.  
OWNER OF INTERNATIONAL REGISTRATION 0996242  
DATED 8-6-2008, EXPIRES 8-6-2018.

THE MARK CONSISTS OF THE STYLIZED WORD "SCHÖNENBERGER" WITH A SQUARE DESIGN ABOVE THE WORDING WITH TWO HORIZONTAL LINES EMANATING FROM OPPOSITE CENTER SIDES OF THE SQUARE WITH A SOLID CIRCLE DESIGN IN THE UPPER RIGHT CORNER OF THE SQUARE.

## CLASS 6—METAL GOODS

FOR METAL BUILDING MATERIALS, NAMELY, METAL STRUCTURAL PARTS FOR STORAGE AND CONVEYING SYSTEMS; TRANSPORTABLE BUILDINGS OF METAL; MATERIALS OF METAL FOR RAILWAY TRACK CONSTRUCTION; BICYCLE STORAGE RACKS OF METAL; IRONMONGERY, NAMELY, FIXTURES AND FITTINGS, SMALL ITEMS OF METAL HARDWARE, NAMELY, METAL FASTENING ELEMENTS AND ACCESSORIES, NAMELY, BOLTS, NAILS, RIVETS, SCREWS, METAL BARS AND CHAINS AND METAL THREADED FASTENERS (U.S. CLS. 2, 12, 13, 14, 23, 25 AND 50).

## CLASS 7—MACHINERY

FOR MACHINES AND MECHANICAL EQUIPMENT FOR THE INTERNAL CONVEYING, SORTING, LOADING AND UNLOADING OF LIGHTWEIGHT GOODS, AND PARTS THEREFOR, NAMELY, MECHANICAL RAILED LIFTING CONVEYORS, IGNITIONS PARTS FOR INTERNAL COMBUSTION ENGINES, NAMELY, POINTS, SERVO-DRIVES AND BEARING INSERTS, AND INSTALLATIONS CONSTRUCTED THEREFROM, NAMELY, DRIVE UNITS FOR CONVEYORS AND GOODS SORTERS; INDUSTRIAL ROBOTS; CONVEYERS AND MACHINE TOOLS FOR THE CUTTING AND FORMING OF MATERIALS; MOTORS AND ENGINES EXCEPT FOR LAND VEHICLES; MACHINE COUPLING AND TRANSMISSION COMPONENTS EXCEPT FOR LAND VEHICLES; GENERATORS FOR GENERATING ENERGY, IN PARTICULAR FOR DRIVING MACHINES; MACHINES FOR THE PRODUCTION OF ENERGY, NAMELY, ELECTRIC GENERATORS, AIR COMPRESSORS AND HYDRAULIC TURBINES (U.S. CLS. 13, 19, 21, 23, 31, 34 AND 35).

## CLASS 9—ELECTRICAL AND SCIENTIFIC APPARATUS

FOR ELECTROTECHNICAL, WEIGHING, MEASURING, SIGNALING AND CHECKING, SUPERVISING APPARATUS AND INSTRUMENTS, NAMELY, APPARATUS AND INSTRUMENTS FOR STORAGE AND CONVEYING SYSTEMS, NAMELY, ELECTRICAL CONTROLLERS, ELECTRONIC SCALES, LOAD INDICATORS, BRAKE CONTROLLERS; DATA PROCESSING EQUIPMENT AND COMPUTERS, AND APPARATUS THEREFOR, NAMELY, CALCULATORS, SCREENS, KEYBOARDS, PRINTERS AND CONNECTION FITTINGS THEREFOR; MECHANICAL, OPTICAL, MAGNETIC AND ELECTRONIC IDENTIFICATION, ENCODING AND DECODING APPARATUS, NAMELY, ELECTRONIC AND OPTICAL SENSORS FOR THE DIS-

PATCHING, IDENTIFICATION AND TRACKING OF GOODS IN CONNECTION WITH STORAGE AND CONVEYING SYSTEMS; ELECTRIC AND ELECTRONIC CONTROL AND REGULATING APPARATUS FOR STORAGE AND CONVEYING SYSTEMS; ELECTRONIC APPARATUS FOR THE REMOTE CONTROL OF INDUSTRIAL OPERATIONS; MACHINE-READABLE DATA CARRIERS OF ALL TYPES WITH PROGRAMS INSTALLED, NAMELY, CDS, CD-ROMS, DVDS, FLASHDRIVES, USB-STICKS AND RFID CARDS FOR USE WITH STORAGE AND CONVEYING SYSTEMS IN THE FIELD OF LOGISTICS; ELECTROTECHNICAL AND ELECTRONIC PROCESS CONTROL APPARATUS, NAMELY, SIGNAL CONDITIONING AND COMMUNICATION DEVICES FOR INDUSTRIAL PROCESS CONTROL AND ELECTRONIC AND ELECTRIC REGULATING APPARATUS AND APPARATUS FOR SIGNAL CONVERSION FOR STORAGE AND CONVEYING SYSTEMS, ELECTRIC, MAGNETIC AND OPTICAL SENSORS FOR STORAGE AND CONVEYING SYSTEMS, NAMELY, FOR SENSING LOADS, SPEED, WEIGHT, TEMPERATURE AND CONTENTS OF CONTAINERS; ELECTRONIC SECURITY TAGS FOR GOODS; APPARATUS FOR RECORDING, TRANSMISSION, PROCESSING AND REPRODUCTION OF SOUND, IMAGES AND DATA; SOLAR ENERGY COLLECTORS FOR ELECTRICITY GENERATION, NAMELY, APPARATUS FOR CONVERTING ELECTRONIC RADIATION TO ELECTRICAL ENERGY, NAMELY, PHOTOVOLTAIC SOLAR MODULES (U.S. CLS. 21, 23, 26, 36 AND 38).

## CLASS 12—VEHICLES

FOR STORAGE SYSTEMS ADAPTED FOR USE IN TRANSPORT VEHICLES, INCLUDING DRIVERLESS VEHICLES, NAMELY, CARGO STORAGE BINS ESPECIALLY ADAPTED TO FIT IN CARS (U.S. CLS. 19, 21, 23, 31, 35 AND 44).

## CLASS 16—PAPER GOODS AND PRINTED MATTER

FOR PRINTED MATTER, NAMELY, MANUALS AND INSTRUCTIONAL GUIDES, DIRECTORIES, REPORTS AND PERIODICALS IN THE FIELD OF STORAGE AND CONVEYING SYSTEMS, CALENDARS, ADDRESS BOOKS, NOTEBOOKS FOR PERSONAL RECORDS AND DATA; INSTRUCTIONAL AND TEACHING MATERIAL, NAMELY, MANUALS AND INSTRUCTION BOOKS FOR TEACHING PROGRAMS IN THE FIELD OF STORAGE AND CONVEYING SYSTEMS; ARCHITECTURAL MODELS OF INDUSTRIAL INSTALLATIONS AND BUILDINGS (U.S. CLS. 2, 5, 22, 23, 29, 37, 38 AND 50).

## CLASS 35—ADVERTISING AND BUSINESS

FOR BUSINESS CONSULTANCY AND ADMINISTRATION; BUSINESS MANAGEMENT, INCLUDING BUSINESS MANAGEMENT AND ORGANIZATION CONSULTANCY; PROFESSIONAL BUSINESS EXPERTISE IN THE FIELD OF LOGISTICS AND GOODS STORAGE NAMELY, BUSINESS MANAGEMENT AND CONSULTING SERVICES FOR THE LOGISTICS AND GOODS STORAGE INDUSTRY, NAMELY, PROVIDING INDUSTRY EXPERTISE; MARKET RESEARCH; MARKET ANALYSIS; FINANCIAL FORECASTING; PROCUREMENT, NAMELY, PURCHASING OF STORAGE AND CONVEYING SYSTEMS FOR OTHERS (U.S. CLS. 100, 101 AND 102).

**CLASS 36—INSURANCE AND FINANCIAL**

FOR LEASING, FUND INVESTMENTS SERVICES IN THE FIELD OF INDUSTRIAL INSTALLATIONS AND REAL ESTATE; MERGERS AND ACQUISITIONS, NAMELY, FINANCIAL CONSULTANCY WITH REGARD TO THE PURCHASE OR SALE OF BUSINESSES AND BUSINESS INVESTMENTS; REAL ESTATE APPRAISAL AND VALUATION, NAMELY, APPRAISAL OF INDUSTRIAL INSTALLATIONS AND REAL ESTATE; ARRANGING CREDIT AND CORPORATE FINANCING; ARRANGING CONTRACTS FOR THE BUYING AND/OR SELLING OF INDUSTRIAL INSTALLATIONS AND REAL ESTATE, NAMELY, STORAGE FACILITIES AND WAREHOUSES (U.S. CLS. 100, 101 AND 102).

**CLASS 37—CONSTRUCTION AND REPAIR**

FOR INSTALLATION OF STORAGE AND CONVEYING SYSTEMS ; MAINTAINING, REPAIRING AND RETROFITTING OF MACHINES AND INDUSTRIAL INSTALLATIONS FOR OTHERS; CONSTRUCTION OF STOREHOUSES AND CONVEYING SYSTEMS FOR OTHERS; MAINTENANCE AND REPAIR OF INDUSTRIAL INSTALLATIONS AND MACHINES; MAINTENANCE AND REPAIR OF TRANSPORTABLE BUILDINGS; COMBUSTION ENGINE END COVER OVERHAUL SERVICES, NAMELY, OVERHAULING MACHINES AND/OR MOTORS AND ENGINES THAT HAVE BEEN WORN OR PARTIALLY DESTROYED; RENTAL OF CONSTRUCTION MACHINES AND APPARATUS; REPAIR INFORMATION IN THE FIELD OF STORAGE AND CONVEYING SYSTEMS; FACTORY CONSTRUCTION, INCLUDING BUILDING INSPECTION SERVICES, NAMELY, CONDUCTING BUILDING PROJECTS, NAMELY, BUILDING CONSTRUCTION SUPERVISION (U.S. CLS. 100, 103 AND 106).

**CLASS 39—TRANSPORTATION AND STORAGE**

FOR SUPPLY CHAIN LOGISTICS AND REVERSE LOGISTICS SERVICES, NAMELY, STORAGE, TRANSPORTATION AND DELIVERY OF GOODS FOR OTHERS BY AIR, RAIL, SHIP OR TRUCK; SERVICES FOR THE STORAGE OF GOODS; PHYSICAL STORAGE OF ELECTRONICALLY STORED DATA AND DOCUMENTS; MASS TRANSIT FOR THE GENERAL PUBLIC; FREIGHT BROKERAGE AND STORAGE INFORMATION; RENTAL OF WAREHOUSES AND STORAGE CONTAINERS; PACKAGING ARTICLES FOR TRANSPORTATION; TRAVEL BOOKING AGENCIES (U.S. CLS. 100 AND 105).

**CLASS 41—EDUCATION AND ENTERTAINMENT**

FOR TRAINING SERVICES IN THE FIELD OF LOGISTICS, TRANSPORTATION AND STORING; PROFESSIONAL COACHING SERVICES IN THE FIELD OF LOGISTICS, TRANSPORTATION AND STORING; EDUCATION IN THE FIELDS OF LOGISTICS, TRANSPORTATION AND STORING RENDERED THROUGH CORRESPONDENCE COURSES; TRAINING SERVICES IN THE FIELD OF HUMAN RESOURCES DEVELOPMENT; ARRANGING AND CONDUCTING OF EDUCATIONAL CONFERENCES, CONGRESSES AND SYMPOSIUMS; PROVIDING ON-LINE PUBLICATIONS IN THE NATURE OF MAGAZINES AND BOOKS IN THE FIELD OF LOGISTICS, TRANSPORTATION AND STORING (U.S. CLS. 100, 101 AND 107).

**CLASS 42—SCIENTIFIC AND COMPUTER SERVICES**

FOR CONSTRUCTION DRAFTING AND CONSULTANCY, COMPUTER PROGRAMMING AND UPGRADING OF OPERATING PROGRAMS FOR INTERNAL CONVEYOR INSTALLATIONS; TECHNICAL PROJECT MANAGEMENT IN THE FIELD OF ELECTRONIC DATA PROCESSING; ELECTRONIC DATA PROCESSING CONSULTANCY; ENGINEERING, IN PARTICULAR MECHANICAL ENGINEERING, PROCESS ENGINEERING AND COMPUTER PROGRAMMING; DEVELOPMENT OF TECHNICAL USAGE CONCEPTS FOR INDUSTRIAL STORAGE AND CONVEYING SYSTEMS; PLANNING, DESIGN AND CONSTRUCTION OF INDUSTRIAL INSTALLATIONS AND MACHINES; TECHNICAL MEASURING AND TESTING LABORATORY SERVICES, NAMELY, PRODUCT TESTING; SCIENTIFIC AND INDUSTRIAL RESEARCH AND CONDUCTING SCIENTIFIC RESEARCH IN THE FIELD OF STORAGE AND CONVEYING SYSTEMS SURVEYING; CONSULTATION IN THE FIELD OF ENVIRONMENT PROTECTION; ENVIRONMENTAL ASSESSMENT SERVICES; BUILDING, NAMELY, THE TECHNICAL PREPARATION OF BUILDING PROJECTS, NAMELY, WAREHOUSES AND STORAGE FACILITIES (U.S. CLS. 100 AND 101).

**CLASS 45—PERSONAL AND LEGAL SERVICES**

FOR LICENSING OF INTELLECTUAL PROPERTY, NAMELY, ISSUING LICENSES FOR FRANCHISING CONCEPTS; LICENSING OF INDUSTRIAL INTELLECTUAL PROPERTY RIGHTS AND COPYRIGHT MANAGEMENT (U.S. CLS. 100 AND 101).  
SCOTT BIBB, EXAMINING ATTORNEY

SN 79-070,792. FERRARI S.P.A., I-41100 MODENA, ITALY, FILED 12-24-2008.

**SCUDERIA FERRARI AUTO-AVIO COSTRUZIONI**

THE MARK CONSISTS OF STANDARD CHARACTERS WITHOUT CLAIM TO ANY PARTICULAR FONT, STYLE, SIZE, OR COLOR.

PRIORITY DATE OF 10-7-2008 IS CLAIMED.  
OWNER OF INTERNATIONAL REGISTRATION 1007375 DATED 12-24-2008, EXPIRES 12-24-2018.

OWNER OF U.S. REG. NOS. 2,531,201 AND 3,715,335.  
NO CLAIM IS MADE TO THE EXCLUSIVE RIGHT TO USE "AUTO-AVIO COSTRUZIONI" FOR INTERNATIONAL CLASSES 035, 037 AND 042, APART FROM THE MARK AS SHOWN.

THE ENGLISH TRANSLATION OF THE FOREIGN WORD(S) IN THE MARK IS: "SCUDERIA" IS STABLE OR TEAM; "AUTO" IS AUTOMOBILE; "AVIO" IS RELATIVE TO AVIATION; "COSTRUZIONI" IS CONSTRUCTIONS.

**CLASS 9—ELECTRICAL AND SCIENTIFIC APPARATUS**

FOR AMUSEMENT APPARATUS AND GAMES ADAPTED FOR USE WITH TELEVISION RECEIVERS AND WITH AN EXTERNAL DISPLAY SCREEN OR MONITOR; APPARATUS FOR GAMES ADAPTED FOR USE WITH TELEVISION RECEIVERS AND WITH AN EXTERNAL DISPLAY SCREEN OR MONITOR; VIDEO OUTPUT GAME MACHINES FOR USE WITH TELEVISION AND WITH AN EXTERNAL DISPLAY SCREEN OR MONITOR; COMPUTER GAME EQUIPMENT IN THE NATURE OF STEERING WHEELS FOR PCS WITH DOUBLE GEAR-SHIFTING SYSTEMS; VIDEO GAMES CARTRIDGES, DISCS AND CASSETTES FOR USE WITH AUTOMATIC OR TOKEN-OPERATED MACHINES; CONTROLLERS, JOYSTICKS, CONSOLES, MEMORY CARDS, VOLUME CONTROLLERS AND MICE FOR CONSUMER VIDEO GAME MACHINES ADAPTED FOR USE WITH TELEVISION RECEIVERS AND WITH AN EXTERNAL DISPLAY SCREEN OR MONITOR; MEDIA-RECORDED VIDEO GAME PROGRAMS FOR HAND-HELD GAMES WITH LIQUID CRYSTAL DISPLAYS; PROGRAMS FOR ARCADE VIDEO GAME

MACHINES; COMPUTER GAME CARTRIDGES; VIDEO GAME CARTRIDGES; CARTRIDGES FOR ELECTRONIC GAMES; COMPUTER GAME CASSETTES; CASSETTES FOR ELECTRONIC GAMES; COMPUTER GAME EQUIPMENT CONTAINING MEMORY DISCS; COMPUTER GAME PROGRAMS; RECORDED VIDEO GAME PROGRAMS FOR ELECTRONIC GAMES; RECORDED COMPUTER SOFTWARE FOR VIDEO GAMES TO BE USED IN CONNECTION WITH AUTOMATIC AND COIN OPERATED MACHINES; EXCLUSIVE EARPHONES, CONNECTED AND USED FOR HAND-HELD GAMES WITH LIQUID CRYSTAL DISPLAYS; JOYSTICK CHARGERS; EYEGLASSES; SUNGLASSES; ANTI-GLARE GLASSES; ANTI-GLARE VISORS; ANTI-DAZZLE SHADES, NAMELY, ANTI-DAZZLE GLASSES AND VISORS; PROTECTIVE EYEGLASSES; SAFETY EYEGLASSES; GOGGLES FOR SPORTS; OPERA GLASSES; REPLACEMENT EYEGLASSES; EYEGLASS AND SUNGLASS CASES; EYEGLASS AND SUNGLASS LENSES; EYEGLASS AND SUNGLASS FRAMES; EYEGLASS AND SUNGLASS CORDS; EYEGLASS AND SUNGLASS CHAINS; EYEGLASS AND SUNGLASS EAR-STEMS AND NOSE PIECES; CONTACT LENSES; CONTAINERS FOR CONTACT LENSES; PINCE-NEZ; PINCE-NEZ CASES; PINCE-NEZ CHAINS; PINCE-NEZ CORDS; PINCE-NEZ MOUNTINGS; BINOCULARS; TELESCOPES; MICROSCOPES; SAFETY HELMETS FOR MOTORISTS, MOTORCYCLISTS AND CYCLISTS; PROTECTIVE HELMETS FOR CHILDREN; PROTECTIVE HELMETS FOR SPORTS; FIREPROOF AUTOMOBILE RACING SUITS FOR SAFETY PURPOSES; PROTECTIVE SUITS FOR AVIATORS; JACKETS, VESTS, SUITS, BIBS, SHIELDS, TROUSERS, GLOVES, SOCKS, BALACLAVA HELMETS, SHOES, BOOTS ALL FOR PROTECTION AGAINST ACCIDENTS, IRRADIATION AND FIRE; RIDING HELMETS; PROTECTION DEVICES FOR PERSONAL USE AGAINST ACCIDENTS, NAMELY, PROTECTION MASKS; DOWNLOADABLE IMAGES AND CHARACTER FILES CONTAINING ARTWORK AND TEXT FROM MAGAZINES, BOOKS, NEWSPAPERS, MAPS, PICTURES AND DRAWINGS; DOWNLOADABLE MUSIC; DOWNLOADABLE VIDEO IMAGES; DOWNLOADABLE ELECTRONIC MAGAZINES FEATURING ENTERTAINMENT AND INFORMATION ABOUT AUTOMOBILES, AUTOMOBILE RACES AND RACING TEAMS, SPORTS COMPETITIONS AND SPORTS; AUDIO-VIDEO COMPACT DISCS FEATURING CAR RACES AND THE HISTORY OF AUTOMOBILE MANUFACTURERS AND FEATURING HIGH-PERFORMANCE CARS AND AUTOMOBILES; AUDIO-VIDEO PRE-RECORDED VIDEO CASSETTES FEATURING CAR RACES AND THE HISTORY OF AUTOMOBILE MANUFACTURERS, CD-ROMS AND DVD FEATURING CAR RACES AND THE HISTORY OF AUTOMOBILE MANUFACTURERS; AUDIO-VIDEO PRE-RECORDED VIDEO CASSETTES, CD-ROMS AND DVD FEATURING HIGH-PERFORMANCE CARS AND AUTOMOBILES; CD PLAYERS; DVD PLAYERS; MP3 PLAYERS; ELECTRONIC HANDHELD UNITS IN THE NATURE OF HANDHELD COMPUTERS, HANDHELD UNITS FOR PLAYING ELECTRONIC GAMES NOT FOR USE WITH EXTERNAL DISPLAY SCREEN OR MONITOR AND ACCESSORIES THEREFORE COMPRISED OF BATTERIES, CHARGERS, HEADSETS, STANDS, CARRYING CASES, PROTECTIVE CASES, COVERS, HOLSTERS AND DOCKING STATIONS FOR THE WIRELESS RECEIPT, TRANSMISSION, AND STORAGE OF DATA, VOICE TRANSMISSIONS AND EMAIL MESSAGES; BATTERY CHARGERS; HI-FI STEREO SYSTEMS COMPRISED OF STEREOS, CD PLAYERS, LOUDSPEAKERS, AUDIO SPEAKERS, LIQUID CRYSTAL DISPLAY AND HEADPHONES; TELEVISION APPARATUS; LIQUID CRYSTAL DISPLAY TELEVISION APPARATUS; LIQUID CRYSTAL DISPLAY SCREENS; HOME THEATER SYSTEMS COMPRISED OF SPEAKER, CUBE SUBWOOFERS, DVD CHARGERS AND AUDIO-VIDEO HOME THEATER RECEIVERS; TELEVISION CAMERAS; RADIOS WALKIE-TALKIES; MICROPHONES; BAGS AND CASES ADAPTED FOR CD PLAYERS, MP3 PLAYERS, DVD PLAYERS; PERSONAL COMPUTERS; PORTABLE COMPUTERS; PALM TOP COMPUTERS; LAPTOP COMPUTERS; COMPUTER SCREEN SAVERS SOFTWARE; MOUSE PADS; COMPUTER MOUSE BEING DATA PROCESSING EQUIPMENT; WRIST RESTS FOR USE WITH COMPUTER; DESKTOP COMPUTERS; NOTEBOOK COMPUTERS; COMPUTER KEYBOARDS; COMPUTER MEMORIES; TABLET PCS; COMPUTER MONITORS; LIQUID CRYSTAL DISPLAY COMPUTER MONITORS; COMPUTER SCREEN SAVERS SOFTWARE;

RECORDED COMPUTER SOFTWARE FOR WORD PROCESSING; RECORDED COMPUTER OPERATING PROGRAMS; LAN MAGNETIC AND ENCODED CARDS FOR CONNECTING PORTABLE COMPUTERS TO COMPUTER NETWORKS; MEMORY, FAX AND MODEM CARDS FOR PORTABLE COMPUTERS; PRINTERS FOR USE WITH COMPUTERS; MODEMS; SCANNERS, BEING DATA PROCESSING EQUIPMENT; CARRYING BAGS AND CASES ADAPTED FOR COMPUTER BATTERIES FOR NOTEBOOK COMPUTERS AND PROTECTIVE BAGS AND CASES ADAPTED FOR COMPUTER BATTERIES FOR NOTEBOOK COMPUTERS; CARRYING BAGS AND CASES ADAPTED FOR COMPUTERS AND PROTECTIVE BAGS AND CASES ADAPTED FOR COMPUTERS; DISK DRIVES FOR COMPUTERS; PHOTOGRAPHIC CAMERAS; ONE USE CAMERAS; DIGITAL CAMERAS; DIGITAL VIDEO CAMERAS; ZOOM CAMERA LENSES; CASES ESPECIALLY MADE FOR PHOTOGRAPHIC APPARATUS AND INSTRUMENTS; DIGITAL MOVIE PROJECTORS; MOVIE PROJECTORS; VIDEO PROJECTORS; DIGITAL VIDEO PROJECTORS; SLIDE DIGITAL PROJECTORS; DIGITAL PHOTO PROJECTORS; PHOTO PRINTERS; CORDLESS TELEPHONES; TELEPHONES; TELEPHONE APPARATUS; TELEPHONE RECEIVERS; CELLULAR PHONES; CELLULAR PHONE COVERS; CARRYING BAGS AND CASES ADAPTED FOR CELLULAR PHONES AND PROTECTIVE BAGS AND CASES ADAPTED FOR CELLULAR PHONES; CELLULAR PHONE HANDS-FREE KITS COMPRISED OF MOBILE PHONE ACCESSORIES IN THE NATURE OF HANDS-FREE HOLDERS, HANDS-FREE MICROPHONES, HEADSETS, MICROPHONES AND SPEAKERS FOR MOBILE PHONE CAR-KITS FOR THE ADAPTATION OF MOBILE PHONES FOR VEHICULAR USE; DECORATIVE CHARMS FOR CELLULAR PHONES; BANDS, SLINGS AND STRAPS FOR CARRYING CELLULAR PHONES AND MP3 PLAYERS, CAMERAS AND VIDEO CAMERAS; BAROMETERS; BAROMETERS WITH PROJECTION DEVICES INCORPORATED THEREIN; REMOTE TEMPERATURE SENSORS; TEMPERATURE INDICATORS; THERMOMETERS NOT FOR MEDICAL USE; HUMIDITY AND ATMOSPHERIC PRESSURE MONITORS WITH LIQUID CRYSTAL DISPLAYS; WIRELESS WEATHER STATIONS WITH WEATHER FORECASTING, WITH BAROMETRIC, INDOOR AND OUTDOOR TEMPERATURE AND HUMIDITY FUNCTIONS FOR DOMESTIC USE; CALCULATING MACHINES; POCKET CALCULATORS; CHRONOGRAPHS AND TIME CLOCKS, BEING TIME RECORDING APPARATUS; DIRECTIONAL COMPASSES; COMPASSES BEING MEASURING INSTRUMENTS; HYGROMETERS; PRECISION BALANCES; SCALES; FIRE EXTINGUISHERS FOR AUTOMOBILES, ELECTRONIC KEYS FOR AUTOMOBILES, ELECTRIC DOOR OPENERS AND CLOSERS; ELECTRIC LOCKS; CONTROL UNITS FOR NAVIGATION SYSTEMS FOR VEHICLES; CONTROL UNITS OF CENTRAL LOCKING SYSTEMS FOR VEHICLES; NAVIGATION APPARATUS FOR VEHICLES BEING ON-BOARD COMPUTERS; SATELLITE NAVIGATIONAL APPARATUS, THAT IS GLOBAL POSITIONING SYSTEM; GLOBAL POSITIONING SYSTEM (GPS) CONSISTING OF COMPUTERS, COMPUTER SOFTWARE, TRANSMITTERS, RECEIVERS, AND NETWORK INTERFACE DEVICES; COMPUTER HARDWARE AND SOFTWARE SYSTEM FOR TRACKING PEOPLE AND OBJECTS USING GPS DATA ON A DEVICE ON THE TRACKED PEOPLE AND OBJECTS; ELECTRIC ACCUMULATORS FOR VEHICLES; ELECTRIC BATTERIES FOR VEHICLES; CIGAR LIGHTERS FOR VEHICLES; KILOMETER RECORDERS FOR VEHICLES; VEHICLE RADIOS; REMOTE CONTROL APPARATUS FOR TELEVISION, RADIOS; SPEED CHECKING APPARATUS FOR VEHICLES; STARTER JUMPER CABLES FOR MOTORS; AUTOMATIC STEERING APPARATUS FOR VEHICLES COMPRISED OF THE COMPUTER HARDWARE AND ELECTRONIC COMPONENTS TO CONTROL A VEHICLE'S STEERING; THERMOSTATS FOR VEHICLES; AUTOMATIC INDICATORS OF LOW PRESSURE IN VEHICLE TYRES; VEHICLE BREAKDOWN WARNING TRIANGLES; VOLTAGE REGULATORS FOR VEHICLES; ACOUSTIC SOUND ALARMS; ANTENNAS; SIMULATORS FOR THE STEERING AND CONTROL OF VEHICLES; ELECTRONIC PERSONAL ORGANIZERS; ELECTRONIC AGENDAS; ELECTRONIC CALENDARS; ELECTRONIC ALBUMS FOR PHOTOGRAPHS AND STAMPS; ELECTRONIC DIARIES; DIGITAL VOICE RECORDERS; POCKET OR HANDHELD ELECTRONIC LANGUAGE TRANSLATORS; ELECTRONIC TIME AND DATE RE-

CORDING APPARATUS; ELECTRONIC NOTICE BOARDS; ELECTRONIC PENS BEING VISUAL DISPLAY UNITS; MAGNETS; DECORATIVE MAGNETS; 3D MAGNETS; FIBER OPTICS LIGHT UP COMPUTER MONITOR FRAMES; FIBER OPTICS LIGHT UP DIGITAL PHOTOGRAPH FRAMES; FIBER OPTICS GLOWING NECKLACES; FIBER OPTICS GLOWING RINGS; FIBER OPTICS GLOWING BRACELETS; FIBER OPTICS GLOWING STICKS FOR FANS; FIBER OPTICS GLOWING FLAGS; INSTRUMENTS FOR MEASURING HEIGHT OR LENGTH OF BABIES; CREDIT CARD CASES; SCUBA MASKS, SKIN DIVING MASKS, FACE MASKS FOR DIVING; DIVING SUITS; GLOVES FOR DIVERS; EAR PLUGS NOT FOR MEDICAL PURPOSES; FLOATS FOR BATHING AND SWIMMING FOR SAFETY PURPOSES; LANYARDS ESPECIALLY ADAPTED FOR HOLDING EYEGLASSES, SUNGLASSES, CELL PHONES, MP3 PLAYERS, MAGNETIC CARDS, CAMERAS, AND VIDEO CAMERAS; LASERS NOT FOR MEDICAL PURPOSES (U.S. CLS. 21, 23, 26, 36 AND 38).

### CLASS 12—VEHICLES

FOR LAND MOTOR VEHICLES, ALL-TERRAIN VEHICLES; AUTOMOBILES, MOTOR CARS, SPORTS CARS, CONVERTIBLE CARS, CARS, PASSENGER CARS, DINING CARS, BEING RAILWAY CARRIAGES, BUSES, VANS, BEING VEHICLES, TRUCKS, LORRIES, LIGHT LORRIES, TWO-WHEELED PERSONAL TRANSPORTERS, BEING MOTOR VEHICLE; MOTORCYCLES, MOTORBIKES, MOTOR BICYCLES, MOPEDS, SCOOTERS, BEING VEHICLES; AIR CUSHION VEHICLES, ELECTRIC VEHICLES, NAMELY, ELECTRIC CARS, ELECTRIC BICYCLES, ELECTRIC MOTORCYCLES, ELECTRIC BOATS, MILITARY VEHICLES FOR TRANSPORT, REFRIGERATED VEHICLES, REMOTE CONTROL VEHICLES OTHER THAN TOYS, WATER VEHICLES, NAMELY, WATER SCOOTERS; CARAVANS, DINNER WAGONS, BEING CARRIAGES, MOTORIZED GOLF CARTS, GOODS HANDLING CARTS, LUGGAGE TRUCKS, TRACTORS FOR AGRICULTURAL USE, MOTOR BUSES, MOTOR COACHES, SLEIGHS, BEING VEHICLES, SNOWMOBILES, SPRINKLING TRUCKS, TROLLEYS, BEING VEHICLES, TWO-WHEELED TROLLEYS, WAGONS, REFRIGERATED WAGONS, BEING RAILROAD VEHICLES, MOTOR BOATS, YACHTS; AEROPLANES, AIRCRAFTS; PASSENGER SHIPS; SAILING SHIPS; DREDGERS, BEING BOATS, CANOES, LAUNCHES, BARGES, SCULLS, PONTOONS, CAISONS, BEING VEHICLES, FERRY BOATS, VEHICULAR AIR BALLOONS, DIRIGIBLE BALLOONS, BEING AIRSHIPS, AMPHIBIOUS AIRPLANES, HYDROPLANES, HELICOPTERS, TRAMCARS, ELECTRIC LOCOMOTIVES, STEAM LOCOMOTIVES, AMBULANCES, OMNIBUSES, CLEANING CARS, CONCRETE MIXING VEHICLES, CARTS, RICKSHAWS, SPACE VEHICLES, TRAINS; FORK LIFT TRUCKS; AIRSHIPS; RAILWAY CARRIAGES; CASTING CARRIAGES; FUNICULARS, BEING RAILCARS; SEAPLANES; TELPHER RAILWAYS, BEING CABLE CARS; WHEELBARROWS; BICYCLES, CYCLES, NAMELY, UNICYCLES, TRICYCLES, DELIVERY TRICYCLES, CARRIER TRICYCLES; BELLS FOR BICYCLES AND MOTORCYCLES, BRAKES FOR BICYCLES AND MOTORCYCLES, CHAINS FOR BICYCLES AND MOTORCYCLES, CRANKS FOR BICYCLES AND MOTORCYCLES, FRAMES FOR BICYCLES AND MOTORCYCLES, HANDLE BARS FOR BICYCLES AND MOTORCYCLES, HUBS FOR BICYCLES AND MOTORCYCLES, INNER TUBES FOR BICYCLES AND MOTORCYCLES, MUDGUARDS FOR BICYCLES AND MOTORCYCLES, PUMPS FOR BICYCLES AND MOTORCYCLES, RIMS FOR BICYCLES AND MOTORCYCLES, SADDLES FOR BICYCLES AND MOTORCYCLES, STANDS FOR BICYCLES AND MOTORCYCLES, TIRES FOR BICYCLES AND MOTORCYCLES, BASKETS ADAPTED FOR BICYCLES AND MOTORCYCLES, DIRECTION INDICATORS FOR BICYCLES AND MOTORCYCLES, DRESS GUARDS FOR BICYCLES AND MOTORCYCLES, GEARS FOR BICYCLES AND MOTORCYCLES, MOTORS FOR CYCLES AND MOTORCYCLES, PANNIERS ADAPTED FOR BICYCLES AND MOTORCYCLES, PEDALS FOR BICYCLES AND MOTORCYCLES, RIMS FOR WHEELS OF BICYCLES AND MOTORCYCLES, SADDLE COVERS FOR BICYCLES AND MOTORCYCLES, TUBELESS TIRES FOR BICYCLES AND MOTORCYCLES, AUDIBLE WARNING SYSTEMS FOR BICYCLES AND MOTORCYCLES, WHEELS FOR BICYCLES AND MOTORCYCLES;

BODIES FOR AUTOMOBILES AND VEHICLES, CHAINS FOR AUTOMOBILES AND VEHICLES, CHASSIS FOR AUTOMOBILES AND VEHICLES, HOODS FOR AUTOMOBILES AND VEHICLES, BUMPER FOR AUTOMOBILES AND VEHICLES, CLUTCHES FOR LAND VEHICLES, DIRECTION SIGNALS FOR AUTOMOBILES AND VEHICLES, DOORS FOR AUTOMOBILES AND VEHICLES, DRIVING CHAINS FOR LAND VEHICLES, ELECTRIC MOTORS FOR LAND VEHICLES, ALTERNATING CURRENT MOTORS FOR LAND VEHICLES, SERVO MOTORS FOR LAND VEHICLES, DIRECT CURRENT MOTORS FOR LAND VEHICLES, DRIVING MOTORS FOR LAND VEHICLES, GASOLINE ENGINES FOR LAND VEHICLES, DIESEL ENGINES FOR LAND VEHICLES, COMPRESSED AIR ENGINES FOR LAND VEHICLES, JET ENGINES FOR LAND VEHICLES, RAM JET ENGINES FOR LAND VEHICLES, TURBO-JET ENGINES FOR LAND VEHICLES, TURBO-PROP ENGINES FOR LAND VEHICLES, STEAM ENGINES FOR LAND VEHICLES, TRACTION ENGINES, GEAR BOXES FOR LAND VEHICLES, GEARING FOR LAND VEHICLES, INNER TUBES FOR PNEUMATIC TIRES, MUDGUARDS, POWER TAILGATES, BEING PARTS OF LAND VEHICLES, PROPULSION MECHANISMS FOR LAND VEHICLES, REARVIEW MIRRORS, SIDE MIRRORS FOR VEHICLES, REDUCTION GEARS FOR LAND VEHICLES, SCREW-PROPELLERS, STEERING WHEELS FOR AUTOMOBILES AND VEHICLES, TAILBOARD LIFTS, BEING PARTS OF LAND VEHICLES, ELEVATING POWER TAILGATES, BEING PARTS OF LAND VEHICLES, TIPPING APPARATUS, BEING PARTS OF TRUCKS AND WAGONS, TIPPING BODIES FOR LORRIES AND TRUCKS, TORQUE CONVERTERS FOR LAND VEHICLES, TORSION BARS FOR AUTOMOBILES AND VEHICLES, TRANSMISSION CHAINS FOR LAND VEHICLES, TRANSMISSION SHAFTS FOR LAND VEHICLES, TRANSMISSIONS FOR LAND VEHICLES, GAS TURBINES FOR LAND VEHICLES, AIR TURBINES FOR LAND VEHICLES, HYDRAULIC TURBINES FOR LAND VEHICLES, STEAM TURBINES FOR LAND VEHICLES, TURN SIGNALS FOR AUTOMOBILES AND VEHICLES, WINDOWS FOR AUTOMOBILES AND VEHICLES, SAFE WINDOWS FOR AUTOMOBILES AND VEHICLES, WINDSCREENS, WINDSHIELDS, AXLES FOR AUTOMOBILES AND VEHICLES; BRAKES FOR AUTOMOBILES AND VEHICLES, DISK BRAKES FOR AUTOMOBILES AND VEHICLES, BAND BRAKES FOR AUTOMOBILES AND VEHICLES, BLOCK BRAKES FOR AUTOMOBILES AND VEHICLES, CONE BRAKES FOR AUTOMOBILES AND VEHICLES, BRAKE LININGS FOR AUTOMOBILES AND VEHICLES, BRAKE SEGMENTS FOR AUTOMOBILES AND VEHICLES, BRAKE SHOES FOR AUTOMOBILES AND VEHICLES, CAPS FOR VEHICLE PETROL AND GAS TANKS; FUEL TANKS FOR VEHICLES; CONNECTING RODS FOR LAND VEHICLES, OTHER THAN PARTS OF MOTORS AND ENGINES; COUPLINGS FOR LAND VEHICLES, HOODS FOR VEHICLE AND AUTOMOBILE ENGINES, HORNS FOR AUTOMOBILES AND VEHICLES, HYDRAULIC CIRCUITS FOR AUTOMOBILES AND VEHICLES, VEHICLE AND AUTOMOBILE RUNNING BOARDS; SAFETY BELTS FOR VEHICLE SEATS AND FOR AUTOMOBILE SEATS, 4-POINT SAFETY BELTS FOR VEHICLE SEATS AND FOR AUTOMOBILE SEATS, SHOCK ABSORBERS FOR AUTOMOBILES AND VEHICLES, SUSPENSION SHOCK ABSORBERS FOR AUTOMOBILES AND VEHICLES, SHOCK ABSORBING SPRINGS FOR AUTOMOBILES AND VEHICLES, SUSPENSION SPRINGS FOR AUTOMOBILES AND VEHICLES, UNDERCARRIAGES FOR AUTOMOBILES AND VEHICLES, UPHOLSTERY FOR AUTOMOBILES AND VEHICLES; CRANKCASES FOR LAND VEHICLE COMPONENTS, OTHER THAN FOR ENGINES; ELEVATING TAILGATES FOR AUTOMOBILES AND VEHICLES; HOSE CARTS, HUB CAPS; WHEELS FOR AUTOMOBILES AND VEHICLES; HUBS FOR VEHICLE AND AUTOMOBILE WHEELS, RIMS FOR VEHICLE AND AUTOMOBILE WHEELS, PLATED RIMS FOR VEHICLE AND AUTOMOBILE WHEELS, MODULAR RIMS FOR VEHICLE AND AUTOMOBILE WHEELS, WHEEL SPOKES FOR AUTOMOBILES AND VEHICLES; SPOKE CLIPS FOR WHEELS, BALANCE WEIGHTS FOR VEHICLE AND AUTOMOBILE WHEELS, BANDS FOR WHEEL HUBS; TIRES FOR VEHICLE AND AUTOMOBILE WHEELS, AUTOMOBILE TIRES, PNEUMATIC TIRES, STUDS FOR TIRES, SPIKES FOR TIRES, SOLID TIRES FOR VEHICLE AND AUTOMOBILE WHEELS, CASINGS FOR PNEUMATIC TIRES, TREADS FOR RETREADING TIRES, TREADS FOR AUTOMO-

BILES AND VEHICLES, BEING ROLLER BELTS, TREADS FOR AUTOMOBILES AND VEHICLES, BEING TRACTOR TYPE, VALVES FOR TIRES OF AUTOMOBILES AND VEHICLES; SEATS FOR AUTOMOBILES AND VEHICLES, RACING SEATS FOR AUTOMOBILES AND VEHICLES, SECURITY HARNESS FOR VEHICLE AND AUTOMOBILE SEATS; DIRECTION INDICATORS FOR AUTOMOBILES AND VEHICLES; OPENABLE SUNROOFS FOR AUTOMOBILES AND VEHICLES; REMOVABLE ROOFS FOR AUTOMOBILES AND VEHICLES; SLIDING SUNROOFS FOR AUTOMOBILES AND VEHICLES; TOPS FOR AUTOMOBILES AND VEHICLES; REMOVABLE TOPS FOR AUTOMOBILES AND VEHICLES; CAPOTES FOR AUTOMOBILES AND VEHICLES; CONVERTIBLE TOPS FOR AUTOMOBILES AND VEHICLES; SUN VISORS, BEING PARTS OF AUTOMOBILES AND VEHICLES, ASHTRAYS, BEING PARTS OF AUTOMOBILES AND VEHICLES, GLASS-HOLDERS, BEING PARTS OF AUTOMOBILES AND VEHICLES, DASHBOARD DRAWERS, BEING PARTS OF AUTOMOBILES AND VEHICLES, DASHBOARD HATCHES, BEING PARTS OF AUTOMOBILES AND VEHICLES, GLOVE COMPARTMENTS, BEING PARTS OF AUTOMOBILES AND VEHICLES, GLOVE BOXES, BEING PARTS OF AUTOMOBILES AND VEHICLES, COVERS FOR BAGGAGE COMPARTMENTS, BEING PARTS OF AUTOMOBILES AND VEHICLES, DOOR SILL COVERS, BEING PARTS OF AUTOMOBILES AND VEHICLES, ORNAMENTAL STRIPS, BEING PARTS OF AUTOMOBILES AND VEHICLES, DECORATIVE STRIPS, BEING PARTS OF AUTOMOBILES AND VEHICLES, PROFILE LATHS OF METAL OR SYNTHETIC MATERIALS FOR VEHICLES FOR DECORATIVE PURPOSE, PARTS OF AUTOMOBILES AND VEHICLES, GEAR LEVER COVERINGS, BEING PARTS OF AUTOMOBILES AND VEHICLES, CARBON INTERIOR TRIMS FOR AUTOMOBILES, BEING PARTS OF AUTOMOBILES AND VEHICLES, INTERIOR TRIMMING DETAILS, BEING PARTS OF AUTOMOBILES AND VEHICLES; RUBBER BELTS FOR LAND VEHICLES; SPIRAL SPRINGS FOR VEHICLES, PNEUMATIC SPRINGS FOR VEHICLES; HYDRAULIC, ELECTRICAL AND MECHANICAL SPRINGS FOR VEHICLES; BOAT HOOKS, FENDERS FOR SHIPS, MINE CART WHEELS; AIR BAGS, BEING SAFETY DEVICES FOR AUTOMOBILES AND VEHICLES, AIR-BAG SWITCH-OFF KITS FOR AUTOMOBILES AND VEHICLES, NON-SKID DEVICES FOR VEHICLE TIRES, SHAPED COVERS FOR AUTOMOBILES AND VEHICLES, SEAT COVERS FOR AUTOMOBILES AND VEHICLES, ADHESIVE RUBBER FOR REPAIRING INNER TUBES, REPAIR OUTFITS FOR INNER TUBES, AIR PUMPS FOR CAR TIRES, ANTI-DAZZLE DEVICES FOR AUTOMOBILES AND VEHICLES, OTHER THAN PARTS OF LIGHTING APPARATUS, ANTI-GLARE DEVICES FOR AUTOMOBILES AND VEHICLES, ANTI-SKID CHAINS, ANTI-THEFT ALARMS FOR AUTOMOBILES AND VEHICLES, REVERSING ALARMS FOR AUTOMOBILES AND VEHICLES, ANTI-THEFT DEVICES FOR AUTOMOBILES AND VEHICLES, SUN-BLINDS ADAPTED FOR AUTOMOBILES AND VEHICLES, COVERS FOR STEERING WHEELS OF AUTOMOBILES AND VEHICLES, FREEWHEELS FOR LAND VEHICLES, HEAD-RESTS FOR SEATS OF AUTOMOBILES AND VEHICLES, ARMRESTS FOR SEATS OF AUTOMOBILES AND VEHICLES, LUGGAGE CARRIERS FOR AUTOMOBILES AND VEHICLES, LUGGAGE NETS FOR AUTOMOBILES AND VEHICLES, SKI CARRIERS FOR AUTOMOBILES AND VEHICLES, SLEEPING BERTHS FOR AUTOMOBILES AND VEHICLES, TRAILERS, BEING VEHICLES, TRAILERS FOR TRACTORS, BEING VEHICLES; TRAILER HITCHES FOR AUTOMOBILES AND VEHICLES, WINDSCREEN WIPERS, WINDSHIELD WIPERS FOR AUTOMOBILES AND VEHICLES, SAFETY SEATS FOR CHILDREN FOR AUTOMOBILES AND VEHICLES; TILTING-CARTS; SAFETY ROLL-BARS FOR AUTOMOBILES AND VEHICLES; ANTI-SLIPPING DEVICES FOR AUTOMOBILES AND VEHICLES; ABS ANTILOCKING BRAKING SYSTEMS, TRACTION CONTROL SYSTEMS AS PARTS OF VEHICLES IN THE NATURE OF BRAKE SYSTEMS, ELECTRONIC STABILITY SYSTEMS FOR MANEUVERABILITY SOLD AS AN INTEGRAL COMPONENT OF TRUCKS SPOILERS FOR AUTOMOBILES AND VEHICLES; HANDS-FREE HOLDERS FOR TELEPHONES, BEING PARTS OF AUTOMOBILES AND VEHICLES, SPARE WHEEL KIT; OARS; DAVITS FOR BOATS, SCREWS FOR SHIPS, PADDLES FOR CANOES, EJECTOR SEATS FOR AIRCRAFTS, BOGIES FOR RAILWAY CARS, RAILWAY COUPLINGS, BUFFERS FOR RAIL FOR VEHICLES,

AXLE JOURNALS; BUFFERS FOR RAILWAY ROLLING STOCK, NAUTICAL CLEATS, DISENGAGING GEARS FOR BOATS, FLANGES FOR RAILWAY WHEEL TIRES, FUNNELS FOR LOCOMOTIVES, FUNNELS FOR SHIPS, INCLINED WAYS FOR BOATS, MASTS FOR BOATS, PORTHOLES, ROLLING STOCK FOR FUNICULAR RAILWAYS, ROLLING STOCK FOR RAILWAYS, SCREW-PROPELLERS FOR BOATS, SHIPS' HULLS, SHIPS' STEERING GEARS, TIMBERS FOR SHIPS, BEING FRAMES, SPARS FOR SHIPS, STERN OARS; BABY CARRIAGES, COVERS FOR BABY CARRIAGES, HOODS FOR BABY CARRIAGES, PRAMS, BEING BABY CARRIAGES, PUSHCHAIRS, PUSHCHAIR COVERS, PUSHCHAIR HOODS, STROLLERS, STROLLER COVERS, BEING PUSHCHAIRS, FITTED PERAMBULATOR COVERS; PARACHUTES, SHOPPING TROLLEYS, BEING CARTS; WHEELCHAIRS; AERIAL CONVEYORS, BEING UNMANNED AERIAL VEHICLES; SKI LIFTS, CHAIRLIFTS, AERONAUTICAL APPARATUS, MACHINES AND APPLIANCES, NAMELY, AEROSTATS; CABLE TRANSPORT APPARATUS AND INSTALLATIONS, CASTERS FOR TROLLEYS, BEING VEHICLES, CLEANING TROLLEYS, LADLE CARRIAGES, MOTOR HOMES, ROWLOCKS, BEING STRUCTURAL PARTS OF SHIPS OR BOATS, RUDDERS, SACK-BARROWS, NAMELY, DOLLIES, HAND TRUCKS (U.S. CLS. 19, 21, 23, 31, 35 AND 44).

## CLASS 25—CLOTHING

FOR AUTOMOBILE RACING SUITS NOT IN THE NATURE OF PROTECTIVE CLOTHING; COVERALLS FOR CAR RACING; POLO SHIRTS, SHIRTS, BODY SHIRTS, UNDERSHIRTS, SPORT SHIRTS, DRESS SHIRTS, BLOUSES, CAMISOLES, CHASUBLES, CHEMISETTES, SHIRT FRONTS, SHIRT YOKES, T-SHIRTS, VESTS, SINGLETS, SWEATSHIRTS, HOODED SWEATSHIRTS, SWEATERS, SWEAT-ABSORBENT SWEATERS, PULLOVERS, JUMPERS, CARDIGAN JACKETS, TWIN SET, JERKINS, BOMBER JACKETS, HOODED BOMBER JACKETS, REVERSIBLE BOMBER JACKETS, JACKETS, RAIN JACKETS, LEATHER JACKETS, PADDED JACKETS, WIND-RESISTANT JACKETS, WINDCHEATERS, WATERPROOF JACKETS, STUFF JACKETS, BLAZERS, LONG COATS, HALF COATS, DRESS COATS, RAINCOATS, OVERCOATS, ANORAKS NOT FOR SPORTS, PARKAS, PADDED VESTS, TROUSERS, JOGGING SUIT TROUSERS, SWEAT PANTS, SLIM PANTS, JEANS, SHORTS, BERMUDA SHORTS, BATHING SUITS, SWIMMING COSTUMES, BATHING DRAWERS, BATHING TRUNKS, BIKINI, BEACHWEAR; JOGGING SUITS, TRAINING SUITS, TRACK SUITS; FLEECE PULLOVERS, FLEECE JACKETS, FLEECE SHORTS, FLEECE VESTS; OVERALLS, WORKING OVERALLS, BABIES' OVERALLS, INFANTS' TRAINING OUTFITS, RACING ROMPER SUITS FOR BABIES, BIBS, NOT OF PAPER, RAIN-CAPES, BATH ROBES; BRASSIERES, BODICES, BEING LINGERIE ARTICLES; COMBINATIONS, BEING CLOTHING; CORSELETS, CORSETS, BEING UNDERCLOTHING; GAITERS, GARTERS; BODY LINEN, BEING GARMENTS; UNDERPANTS; DRAWERS, BEING CLOTHING; BOXER SHORTS; SLIPS, BEING UNDERGARMENTS; PANTIES, G-STRINGS, PETTICOATS, TEDDIES, BEING UNDERGARMENTS; LEOTARDS, SUSPENDERS; PYJAMAS, DRESSING GOWNS, NIGHTGOWNS; NECKTIES, SCARVES; FOULARDS, BEING CLOTHING; ASCOTS, BEING CLOTHING; BANDANAS, BEING NECKERCHIEFS; NECK WARMERS, BEING CLOTHING; BOAS, BEING NECKLETS; SASHES FOR WEAR, SHAWLS; BELTS, BEING CLOTHING; GLOVES FOR PROTECTION AGAINST COLD, DRIVING GLOVES, FINGERLESS GLOVES FOR PROTECTION AGAINST COLD, FINGERLESS DRIVING GLOVES; MITTENS, SPATS, APRONS, BEING CLOTHING; BABIES' DIAPERS OF TEXTILE, BABIES' PANTS; BRACES FOR CLOTHING, BEING SUSPENDERS; BREECHES FOR WEAR; COLLAR PROTECTORS, BEING CLOTHING; COLLARS, BEING CLOTHING; DETACHABLE COLLARS, CUFFS, DRESS SHIELDS; EAR MUFFS, BEING CLOTHING; FISHING VESTS, FOOTMUFFS, NOT ELECTRICALLY HEATED, FROCKS, FUR STOLES; FURS, NAMELY, FUR COATS, FUR HATS; GABARDINES, BEING CLOTHING; GAITER STRAPS, GALOSHES, GIRDLES; JERSEYS, BEING CLOTHING; SPORTS JERSEYS, BEING CLOTHING; LAYETTES, BEING CLOTHING; LEGGINGS; READY-MADE LININGS, BEING PARTS OF CLOTHING; LIVERIES, MANIPLES, MANTILLAS, CLOAKS, MASQUERADE

COSTUMES; MONEY BELTS, BEING CLOTHING; MUFFS, BEING CLOTHING; PELERINES, PELISSES, POCKET SQUARES, POCKETS FOR CLOTHING, SARIS, SHOULDER WRAPS, SKIRTS, SLEEP MASKS, SMOCKS, SOCKS, STOCKINGS, STOCKINGS FOR SPORTS, TIGHTS, SWEAT-ABSORBENT STOCKINGS, SOCK SUSPENDERS, STOCKING SUSPENDERS, HEELPIECES FOR STOCKINGS, SUITS, ONE-PIECE DRESSES, EVENING DRESSES, TOGAS, TOPCOATS, TROUSER STRAPS, UNIFORMS, UNIFORMS FOR SPORTS; VEILS, BEING CLOTHING; WAISTCOATS, WET SUITS FOR WATER-SKIING, WIMPLES; WRISTBANDS, BEING CLOTHING; SARONGS, DUNGAREES, TUNICS, DANCE CLOTHES, NAMELY, PANTS, SHORTS, SHIRTS, TROUSERS, SKIRTS, T-SHIRTS, JUMPERS, SHOES; WATER-PROOF CLOTHING, NAMELY, WATERPROOF PANTS; SPORTING ANORAKS, AEROBIC CLOTHES, NAMELY, PANTS, SHORTS, SHIRTS, TROUSERS, T-SHIRTS, JUMPERS, CYCLISTS' CLOTHING, NAMELY, PANTS, SHORTS, SHIRTS, TROUSERS, T-SHIRTS, CLOTHING FOR GYMNASTICS, NAMELY, PANTS, SHORTS, SHIRTS, TROUSERS, T-SHIRTS, JUMPERS, UNITARDS; KOREAN COATS, KOREAN OVERCOATS, KOREAN TROUSERS, KOREAN UNDERWEAR, KOREAN JACKETS, KOREAN SKIRTS, KOREAN SOCKS; LEATHER SHOES, RUBBER SHOES, DRESS SHOES, GOLF SHOES, BASKETBALL SHOES, HIKING SHOES, RUGBY SHOES, BOXING SHOES, BASEBALL SHOES, ANGLER SHOES, HOCKEY SHOES, TRACK-RACING SHOES, TRAINING SHOES, GYMNASIAC SHOES, BEACH SHOES, ESPARTO SHOES AND SANDALS, MOUNTAIN CLIMBING SHOES, RUNNING SHOES, SNEAKERS, SLIPPERS, BATH SLIPPERS, SANDALS, BATH SANDALS, FLIP-FLOPS, CLOGS, BOOTS, HALF-BOOTS, LACE BOOTS, SKI BOOTS, AFTER SKI BOOTS, SNOW BOARD SHOES AND BOOTS, FOOTBALL BOOTS, FOOTBALL SHOES; WOODEN SHOES; HORSE RIDING BOOTS; SOLES FOR FOOTWEAR, INNER SOLES FOR FOOTWEAR, TIPS FOR FOOTWEAR, HEELPIECES FOR BOOTS AND SHOES, FOOTWEAR UPPERS, HEELS, FITTINGS OF METAL FOR BOOTS AND SHOES, HEELS, STUDS FOR FOOTBALL BOOTS AND SHOES; TIPS FOR FOOTWEAR; WELTS FOR BOOTS AND SHOES; CAPS, GLOWING CAPS, ROARING CAPS, BASEBALL CAPS, BATHING CAPS, SHOWER CAPS, SKULL CAPS; VISORS, BEING HATMAKING; SUN VISORS, BEING CLOTHING; BERETS, HATS, TOP HATS; PAPER HATS, BEING CLOTHING; CAP PEAKS; HAT FRAMES; HEADBANDS, BEING CLOTHING; HOODS, BEING CLOTHING; TURBANS (U.S. CLS. 22 AND 39).

#### **CLASS 28—TOYS AND SPORTING GOODS**

FOR APPARATUS FOR GAMES OTHER THAN THOSE ADAPTED FOR USE WITH AN EXTERNAL DISPLAY SCREEN OR MONITOR; ELECTRONIC GAMES AND AMUSEMENT MACHINES OTHER THAN THOSE ADAPTED FOR USE WITH TELEVISION SETS AND WITH AN EXTERNAL DISPLAY SCREEN OR MONITOR; STAND ALONE VIDEO GAME MACHINES AND HAND HELD UNITS FOR PLAYING ELECTRONIC GAMES OTHER THAN THOSE ADAPTED FOR USE WITH AN EXTERNAL DISPLAY SCREEN OR MONITOR; COIN OR TOKEN-OPERATED SLOT MACHINES IN SHOPPING ARCADES NOT FOR USE WITH TELEVISION RECEIVERS; HAND-HELD UNITS FOR PLAYING ELECTRONIC GAMES; HAND-HELD VIDEO GAMES WITH LIQUID CRYSTAL DISPLAYS; PORTABLE ELECTRONIC GAMES AND TOYS, NAMELY, PORTABLE ELECTRONIC GAMES FOR THE TEACHING OF CHILDREN, ELECTRONIC ACTION TOYS; HAND-HELD UNITS FOR PLAYING VIDEO GAMES; STAND ALONE VIDEO GAME MACHINES; CARTRIDGES AND DISKS FOR ELECTRONIC GAMES; COIN OR TOKEN-OPERATED GAME MACHINES USED IN STORES AND NOT FOR USE WITH TELEVISION SETS AND WITH AN EXTERNAL DISPLAY SCREEN OR MONITOR; GAMING MACHINES AND SLOT MACHINES; TOY BUILDING BLOCKS; SCALE MODEL VEHICLES; SCALE MODEL CARS; WOOD SCALE MODEL CARS; WOOD SCALE MODEL VEHICLES; SCALE MODEL CLASSIC CARS; SCALE MODEL CLASSIC VEHICLES; SCALE MODEL FI RACING CARS; SCALE MODEL FI RACING VEHICLES; FULL-SIZE CAR REPLICAS FOR ORNAMENT AND ENTERTAINMENT PURPOSES; FULL-SIZE VEHICLE REPLICAS FOR ORNAMENT AND ENTERTAINMENT PURPOSES; FULL-SIZE CAR REPLICAS FOR SPORTING EXHIBITIONS;

FULL-SIZE VEHICLE REPLICAS FOR SPORTING EXHIBITIONS; MODULAR STRUCTURES CONSTRUCTION TOYS AND CONNECTING LINKS THEREFOR; TOY CONSTRUCTION BLOCK KITS; TOY CAR CONSTRUCTION BLOCK KITS; TOY VEHICLE CONSTRUCTION BLOCK KITS; CONSTRUCTION SETS MADE UP OF BARS AND SPHERES THAT CAN BE LINKED MAGNETICALLY TO FORM THREE-DIMENSIONAL STRUCTURES; TOY VEHICLE TRUCKS; TOY VEHICLES; TOY GASOLINE SERVICE STATIONS; TOY RACING CARS TRACKS; TOY CAR GARAGES; TOY CUBES FEATURING VINTAGE BLACK AND WHITE IMAGES OF FERRARI'S STORY; COT MUSICAL TOYS FOR BABIES; TOY PLUSH STEERING WHEELS; WOOD PULLALONG CARS; WOOD TRUCKS WITH CARS, BEING TOYS; TOY PEDAL KARTS FOR KIDS; RIDE-ON TOY CARS, FI CARS AND GO-KARTS FOR CHILDREN IN PEDAL VERSION OR WORKING WITH BATTERIES; BABY TALL MEASURING PLUSH TOYS, BEING PLUSH TOYS USED TO MEASURE THE HEIGHT OR LENGTH OF BABIES; TOY GLOWING FRAMES; TOY GLOWING NECKLACES; TOY GLOWING RINGS; TOY GLOWING BRACELETS; TOY GLOWING STICKS FOR FANS; TOY GLOWING FLAGS; TOY GLOWING YO YO; RUBBER, RESIN AND PLASTIC CHARACTER TOYS; ANIMATED AND NON-ANIMATED TOY FIGURES; TOY PORTABLE TELEPHONES; TOY TELEPHONES; TOY WRISTWATCHES; TOY BEACH KITS COMPRISING TOY BEACH SHOVELS, TOY BEACH BUCKETS, TOY BEACH LITTLE MOULDS, TOY BEACH RAKES; FITTED TOY HAND TOOLS BOXES; TODDLERS' MULTIPLE ACTIVITY TOYS MADE OF PVC; TOY SNOW GLOBES; TOY RESIN SNOW GLOBES; RESIN MODELS FEATURING FI RACING SCENE; TOY KEY RINGS FOR BABIES; ROARING TOY LEATHER KEY RINGS; PADDED TOYS FOR SEATBELTS; TOY BACK SEAT ORGANIZERS; AIR PISTOLS BEING TOYS; ARCHERY IMPLEMENTS; BACKGAMMON GAMES; PLAY BALLOONS; PLAYING BALLS; BALLS FOR GAMES; SMALL BALLS FOR GAMES; BAR-BELLS; BATS FOR GAMES; BATTING GLOVES BEING ACCESSORIES FOR GAMES; BILLIARDS BALLS; BILLIARD CUE TIPS; BILLIARD CUES; BILLIARD MARKERS; BILLIARD TABLE CUSHIONS; BILLIARD TABLES; COIN-OPERATED BILLIARD TABLES; CHALK FOR BILLIARD CUES; BLADDERS OF BALLS FOR GAMES; BOARD GAMES; BOWLING APPARATUS AND MACHINERY; BOWS FOR ARCHERY; BUILDING GAMES; CAPS FOR PISTOLS BEING TOYS; BINGO CARDS; PLAYING CARDS; PLAYING CARD CASES; CHECKERBOARDS; CHECKERS BEING GAMES; CHESS GAMES; CUPS FOR DICE; DARTS; CHESSBOARDS; COSAQUES BEING TOY FIREWORKS; COUNTERS, BEING DISCS, FOR GAMES; DETONATING CAPS BEING TOYS; DOLLS; DOLLS' BEDS; DOLLS' CLOTHES; DOLLS' FEEDING BOTTLES; DOLLS' HOUSES; DOLLS' ROOMS; DOMINOES; DRAUGHTBOARDS; DRAUGHTS BEING GAMES; DUMB-BELLS; FAIRGROUND RIDE APPARATUS; FLYING DISCS BEING TOYS; HUNTING GAME CALLS; MARBLES FOR GAMES; GLOVES FOR GAMES; HANG GLIDERS; HORSESHOE GAMES; JIGSAW PUZZLES; KALEIDOSCOPIES; KITE REELS; KITES; MAH-JONGG; MARIONETTES; THEATRICAL MASKS; TOY MASKS; MOBILES BEING TOYS; NINEPINS; NOVELTIES FOR PARTIES, DANCES BEING PARTY FAVOURS IN THE NATURE OF SMALL TOYS; PARLOR GAMES; PERCUSSION CAPS BEING TOYS; PIÑATAS; TOY PISTOLS; MOVING PLUSH TOYS; PLUSH TOYS; SOFT TOYS; SWIMMING POOLS BEING PLAY ARTICLES; PUNCHING BAGS; PUPPETS; QUOITS; RATTLES BEING PLAYTHINGS; RADIO-CONTROLLED TOY VEHICLES; RING GAMES; BEECHWOOD ROCKING HORSES; ROCKING HORSES; SCOOTERS BEING TOYS; SLIDES BEING PLAYTHINGS; SOAP BUBBLES BEING TOYS; SPINNING TOPS BEING TOYS; SWINGS; TABLES FOR TABLE TENNIS; TEDDY BEARS; TOYS; TOYS FOR DOMESTIC PETS; ELECTRIC ACTION TOYS, INFLATABLE TOYS, MECHANICAL TOYS, MUSICAL TOYS; ROULETTE WHEELS; TABLES FOR INDOOR FOOTBALL; WEIGHT LIFTING BELTS BEING SPORT ARTICLES; STATIONARY EXERCISE BICYCLES; BODY BOARDS; BODY-BUILDING APPARATUS; BODY-TRAINING APPARATUS; CHEST EXPANDERS BEING EXERCISERS; ROLLERS FOR STATIONARY EXERCISE BICYCLES; EXERCISERS BEING EXPANDERS; MACHINES FOR PHYSICAL EXERCISES; ELBOW PADS AND GUARDS BEING SPORTS ARTICLES; PROTECTIVE SUPPORTS FOR SHOULDERS AND ELBOW, BEING SPORTS ARTICLES; KNEE PADS

AND GUARDS, BEING SPORTS ARTICLES; PROTECTIVE PADDINGS FOR SHOULDERS, ELBOW, WRIST, KNEES AND SHINS, BEING PARTS OF SPORTS SUITS; SHIN PADS AND GUARDS, BEING SPORTS ARTICLES; GOLF GLOVES; GOLF BAGS, WITH OR WITHOUT WHEELS; GOLF POUCHES; GOLF MARKERS; GOLF TEES; GOLF CLUBS; GOLF CLUB COVERS; GOLF BALLS; DIVOT REPAIR TOOLS BEING GOLF ACCESSORIES; PITCH MARK REPAIR TOOLS BEING GOLF ACCESSORIES; SKIS; SKI BINDINGS; SKI POLES; MONOSKIS; SURF SKIS; SOLE COVERINGS FOR SKIS; EDGES OF SKIS; WAX FOR SKIS; SCRAPERS FOR SKIS; BAGS ESPECIALLY DESIGNED FOR SKIS, SURFBOARDS AND SKI BOOTS; BOBSLEIGHS; SLEIGHS BEING SPORTS ARTICLES; CLIMBERS' HARNESS; ROSIN USED BY ATHLETES; SEAL SKINS BEING COVERINGS FOR SKIS; SNOW RACKETS; SKATING BOOTS WITH SKATES ATTACHED; ICE SKATES; ROLLER SKATES; IN-LINE ROLLER SKATES; HOCKEY STICKS; SNOWSHOES; WATERSKIS; TENNIS RACKETS; TENNIS BALLS; TENNIS NETS; TENNIS BAGS; GUT FOR RACKETS; STRINGS FOR RACKETS; SOCCER BALLS; BASEBALL GLOVES; BOXING GLOVES; CAMOUFLAGE SCREENS BEING SPORTS ARTICLES; CRICKET BAGS; FENCING GAUNTLETS; FENCING MASKS; FENCING WEAPONS; FOILS FOR FENCING; DISCUSSES FOR SPORTS; HARPOONS GUNS BEING SPORTS ARTICLES; PAINTBALL GUNS BEING SPORTS APPARATUS; SPORTS APPARATUS, NAMELY, PAINTBALLS BEING AMMUNITION FOR PAINTBALL GUNS; HARNESS FOR SAILBOARDS; MASTS FOR SAILBOARDS; SAILBOARDS; MEN'S ATHLETIC SUPPORTERS BEING SPORTS ARTICLES; NETS FOR SPORTS; PARAGLIDERS; RACKETS; SHUTTLECOCKS; SKATEBOARDS; SKITTLES BEING GAMES; SLING SHOTS BEING SPORTS ARTICLES; SPRING BOARDS BEING SPORTS ARTICLES; STARTING BLOCKS FOR SPORTS; SURF BOARDS; SURFBOARD LEASHES; TARGETS; ELECTRONIC TARGETS; TWIRLING BATONS; FLIPPERS FOR SWIMMING; SWIMMING WEBS BEING FLIPPERS; ARTIFICIAL FISHING BAIT; FISHING TACKLE; BITE INDICATORS BEING FISHING TACKLE; BITE SENSORS BEING FISHING TACKLE; CREELS BEING FISHING EQUIPMENT; DECOYS FOR HUNTING OR FISHING; FISH HOOKS; FLOATS FOR FISHING; GUT FOR FISHING; LANDING NETS FOR ANGLERS; LINES FOR FISHING; LURES FOR HUNTING OR FISHING; REELS FOR FISHING; RODS FOR FISHING; BELLS FOR CHRISTMAS TREES; EXPLOSIVE BONBONS BEING CHRISTMAS CRACKERS; BUTTERFLY NETS, BEING TOY NETS; CANDLE HOLDERS FOR CHRISTMAS TREES; CHRISTMAS TREE STANDS; CHRISTMAS TREES OF SYNTHETIC MATERIAL; ORNAMENTS FOR CHRISTMAS TREES, EXCEPT ILLUMINATION ARTICLES AND CONFECTIONERY; CLAY PIGEON TRAPS; CLAY PIGEONS BEING TARGETS; CONFETTI; ARTIFICIAL SNOW FOR CHRISTMAS TREES; TOY LANYARDS (U.S. CLS. 22, 23, 38 AND 50).

### CLASS 35—ADVERTISING AND BUSINESS

FOR ON-LINE AND NON-ON-LINE RETAIL AND WHOLESALE SERVICES, BEING STORE SERVICES OF ELECTRONIC GAMES AND AMUSEMENT MACHINES AND APPARATUS, ADAPTED AND NOT ADAPTED FOR USE WITH TELEVISION RECEIVERS AND WITH AN EXTERNAL DISPLAY SCREEN OR MONITOR AND THEIR ACCESSORIES, RECORDED PROGRAMS FOR ELECTRONIC GAMES, AMUSEMENT MACHINES AND APPARATUS, SPECTACLES AND THEIR PARTS AND ACCESSORIES, OPTICAL APPARATUS AND INSTRUMENTS, PROTECTIVE HELMETS, PROTECTIVE CLOTHING AND ITS ACCESSORIES, PROTECTIVE FOOTWEAR, PROTECTION APPARATUS AND DEVICES FOR PERSONAL USE AGAINST ACCIDENTS, MULTIMEDIA LIBRARY AND CONTENTS, DOWNLOADABLE AND NOT DOWNLOADABLE, MAGNETIC DATA CARRIERS, RECORDING DISCS, APPARATUS AND INSTRUMENTS FOR RECORDING, TRANSMISSION, REPRODUCTION OF SOUND AND IMAGES AND THEIR ACCESSORIES, COMPUTERS AND COMPUTER INPUT AND OUTPUT PERIPHERAL DEVICES, COMPUTER SOFTWARE, PHOTOGRAPHIC AND CINEMATOGRAPHIC APPARATUS, TELEPHONES AND THEIR ACCESSORIES, TELECOMMUNICATION APPARATUS, SCIENTIFIC, NAUTICAL, SURVEYING, WEIGHING, MEASURING, SIGNALLING, CHECKING LIFE-SAVING APPARATUS AND INSTRUMENTS, ELECTRIC AND

ELECTRONIC APPARATUS AND INSTRUMENTS FOR VEHICLES, ELECTRIC AND ELECTRONIC APPARATUS AND INSTRUMENTS FOR PERSONAL USE, MAGNETS, CALCULATING MACHINES, CASES ESPECIALLY MADE FOR CONTAINING THE AFOREMENTIONED GOODS, FIRE-EXTINGUISHERS, AUTOMOBILES AND VEHICLES IN GENERAL AND THEIR PARTS AND ACCESSORIES, BABY CARRIAGES AND THEIR ACCESSORIES, PARACHUTES, CLOTHING ARTICLES, FOOTWEAR, HEADGEAR, SCALE MODEL CARS AND SCALE MODEL VEHICLES IN GENERAL, GAMES, PLAYTHINGS, GYMNASTIC AND SPORTING ARTICLES, CHRISTMAS TREES AND RELATIVE DECORATIONS; FRANCHISING, NAMELY, SERVICES RENDERED BY A FRANCHISOR, THAT IS TRANSFER OF BUSINESS AND ORGANISATIONAL KNOW-HOW; ASSISTANCE IN THE DEVELOPMENT AND MANAGEMENT OF A COMMERCIAL ENTERPRISE, OF A CHAIN OF RETAIL SHOPS, RESTAURANTS, BARS, CAFES AND OTHER ESTABLISHMENTS FOR FACILITIES ENGAGED IN PROVIDING FOOD AND DRINKS PREPARED FOR CONSUMPTION; RETAIL OUTLET MANAGEMENT ASSISTANCE; BUSINESS ASSISTANCE, BUSINESS CONSULTANCY AND ORGANIZATION IN CONNECTION WITH THE ESTABLISHMENT OF ON-LINE RETAIL SALE SERVICES AND THE LAUNCHING OF ON-LINE RETAIL TRADING ACTIVITIES; AUCTIONEERING, AUCTION SALE ACTIVITY ON A COMPUTER NETWORK AND/OR BY MEANS OF MOBILE TELEPHONY SERVICES; SUPPLY OF AN ON-LINE NOTICE FOR THE SHIPMENT, THE PROMOTION, THE SALE AND THE RESALE OF ARTICLES ON A COMPUTER NETWORK AND/OR BY MEANS OF MOBILE TELEPHONY SERVICES; IMPORT-EXPORT AGENCIES, PUBLIC OR MARKET OPINION POLLING, ORGANIZATION OF EXHIBITIONS FOR COMMERCIAL OR ADVERTISING PURPOSES, ORGANIZATION OF TRADE FAIRS FOR COMMERCIAL OR ADVERTISING PURPOSES, PUBLIC RELATIONS, SHOP WINDOW DRESSING IN THE NATURE OF SHOP WINDOW DISPLAY ARRANGING, PRICE COMPARISON SERVICES, COMMERCIAL INFORMATION AGENCIES, MARKETING RESEARCH, MARKETING STUDIES, BUSINESS INQUIRIES, BUSINESS INVESTIGATIONS, BUSINESS RESEARCH, BUSINESS MANAGEMENT RESEARCH, COST PRICE ANALYSIS; CONSUMER LOYALTY SERVICES AND CUSTOMER CLUB SERVICES, FOR COMMERCIAL, PROMOTIONAL AND/OR ADVERTISING PURPOSES; MARKET RESEARCH SURVEYS AND BUSINESS MARKET SURVEYS; PROVIDING AN ON-LINE DIRECTORY INFORMATION SERVICE ON THE INTERNET WITH THE PURPOSE OF GIVING THE USERS A LIST OF CAR DEALERS, RETAIL STORES AND ASSISTANCE CENTRES; ADVERTISING, ADVERTISING OF GOODS AND SERVICES ON THE INTERNET AND BY MEANS OF MOBILE TELEPHONY SERVICES AND BY ELECTRONIC MAIL, ADMINISTRATIVE PROCESSING OF PURCHASE ORDERS; ADVERTISING AGENCIES, ADVERTISING BY MAIL ORDER, COMMERCIAL INFORMATION AND ADVICE FOR CONSUMERS, BEING CONSUMER ADVICE SHOP, DEMONSTRATION OF GOODS BY ELECTRONIC MEANS FOR THE BENEFIT OF TEleshopping AND HOME SHOPPING CONSUMERS, DIRECT MAIL ADVERTISING, DISSEMINATION OF ADVERTISING MATTER, DISTRIBUTION OF SAMPLES, LAYOUT SERVICES FOR ADVERTISING PURPOSES, MODELLING FOR ADVERTISING OR SALES PROMOTION, ON-LINE ADVERTISING ON A COMPUTER NETWORK, OUTDOOR ADVERTISING, PRESENTATION OF GOODS ON COMMUNICATION MEDIA FOR RETAIL PURPOSES, PUBLICITY AGENCIES, PUBLICITY, PUBLICITY COLUMNS PREPARATION, PUBLICITY MATERIAL RENTAL, PUBLICATION OF PUBLICITY TEXTS, RADIO ADVERTISING, RADIO COMMERCIALS, RENTAL OF ADVERTISING TIME ON COMMUNICATION MEDIA, SALES PROMOTION FOR OTHERS, SPONSORSHIP SEARCH, TELEVISION ADVERTISING, TELEVISION COMMERCIALS, UPDATING OF ADVERTISING MATERIAL, WRITING OF PUBLICITY TEXTS; RENTAL OF ADVERTISING SPACE; PROMOTION OF GOODS AND SERVICES BY PREPARING AND ORGANIZING PROMOTIONAL CONTESTS AND COMPETITIONS WITH PRIZES TO BE WON, ON A GLOBAL COMPUTER NETWORK AND/OR BY MEANS OF MOBILE TELEPHONY SERVICES; PROMOTION OF GOODS AND SERVICES BY PLACING ADVERTISEMENTS AND ADVERTISING DISPLAYS ON AN ON-LINE ELECTRONIC SITE ACCESSIBLE VIA A GLOBAL COMPUTER NETWORK AND/OR BY MEANS

OF MOBILE TELEPHONY SERVICES; PROMOTION OF WEBSITES FOR THIRD PARTIES; ADVISORY SERVICES FOR BUSINESS MANAGEMENT, ARRANGING SUBSCRIPTIONS TO TELECOMMUNICATION SERVICES FOR OTHERS, BUSINESS APPRAISALS, BUSINESS INFORMATION, BUSINESS INFORMATION SERVICES PROVIDED ONLINE FROM A GLOBAL COMPUTER NETWORK OR THE INTERNET; BUSINESS INFORMATION SERVICES ON GOODS AND SERVICES PROVIDED IN THE FORM OF A BUYING GUIDE ON A GLOBAL COMPUTER NETWORK AND/OR BY MEANS OF MOBILE TELEPHONY SERVICES, BUSINESS MANAGEMENT AND ORGANIZATION CONSULTANCY, BUSINESS MANAGEMENT ASSISTANCE, BUSINESS MANAGEMENT CONSULTANCY, BUSINESS MANAGEMENT OF HOTELS, BUSINESS ORGANIZATION CONSULTANCY, COMMERCIAL ADMINISTRATION OF THE LICENSING OF THE GOODS AND SERVICES OF OTHERS, COMMERCIAL OR INDUSTRIAL MANAGEMENT ASSISTANCE, ECONOMIC FORECASTING, EFFICIENCY EXPERTS, OUTSOURCING SERVICES, BEING BUSINESS ASSISTANCE, PROFESSIONAL BUSINESS CONSULTANCY; EXPERTISE SERVICES FOR COMMERCIAL OR INDUSTRIAL PRODUCTS; COMPILATION OF INFORMATION INTO COMPUTER DATABASES, COMPILATION OF STATISTICS, SYSTEMIZATION OF INFORMATION INTO COMPUTER DATABASES; COMPUTERIZED FILE MANAGEMENT; DATABASE MANAGEMENT SERVICES; EMPLOYMENT AGENCIES, PERSONNEL RECRUITMENT, PERSONNEL MANAGEMENT CONSULTANCY, PSYCHOLOGICAL TESTING FOR THE SELECTION OF PERSONNEL; EVALUATION OF STANDING TIMBER, EVALUATION OF WOOL, GRADING OF WOOL, RENTAL OF PHOTOCOPYING MACHINES, RENTAL OF VENDING MACHINES, OFFICE MACHINES AND EQUIPMENT RENTAL; NEWS CLIPPING SERVICES; ARRANGING NEWSPAPER SUBSCRIPTIONS FOR OTHERS, BUSINESS MANAGEMENT OF PERFORMING ARTISTS, RELOCATION SERVICES FOR BUSINESSES (U.S. CLS. 100, 101 AND 102).

### CLASS 37—CONSTRUCTION AND REPAIR

FOR INSTALLATION SERVICES IN CONNECTION WITH CARS AND VEHICLES IN GENERAL; MOTOR VEHICLE MAINTENANCE AND REPAIR; PERSONALIZED MOTOR VEHICLE MAINTENANCE AND REPAIR; VEHICLE MAINTENANCE; VEHICLE REPAIR; REBUILDING ENGINES OF AUTOMOBILES AND VEHICLES IN GENERAL THAT HAVE BEEN WORN OR PARTIALLY DESTROYED; INSTALLATION, MAINTENANCE AND REPAIR OF HEATING AND AIR CONDITIONING APPARATUS FOR VEHICLES; AIRPLANE MAINTENANCE AND REPAIR, SHIPBUILDING; MOTOR VEHICLE WASHING; CAR WASHING; VEHICLE CLEANING; VEHICLE WASHING; VEHICLE POLISHING; RENTAL OF CLEANING EQUIPMENT; ANTI-RUST TREATMENT FOR VEHICLES; VEHICLE GREASING; VEHICLE LUBRICATION; VEHICLE SERVICE STATIONS, BEING REFUELLING AND MAINTENANCE SERVICES; VULCANIZING OF AUTOMOBILE TIRES AND OF VEHICLE TIRES IN GENERAL, BEING REPAIR SERVICES; TIRE RETREADING; VEHICLE PAINTING, INTERIOR AND EXTERIOR; RUSTPROOFING; UPHOLSTERING; UPHOLSTERY REPAIR; VARNISHING; BURGLAR ALARM INSTALLATION AND REPAIR; SECURITY LOCKS REPAIR SERVICES; ELECTRIC APPLIANCE INSTALLATION AND REPAIR; MACHINERY INSTALLATION, MAINTENANCE AND REPAIR; REBUILDING MACHINES THAT HAVE BEEN WORN OR PARTIALLY DESTROYED; PROVIDING INFORMATION ON REPAIR SERVICES IN THE FIELD OF AUTOMOBILES AND VEHICLES IN GENERAL; FIRE ALARM INSTALLATION AND REPAIR; INSTALLATION, MAINTENANCE AND REPAIR OF COMPUTER HARDWARE; UNDERWATER REPAIR; BUILDING OF FAIR STALLS AND SHOPS; INTERFERENCE SUPPRESSION IN ELECTRICAL APPARATUS; CLOCK AND WATCH REPAIR; MOVIE PROJECTOR REPAIR AND MAINTENANCE; PHOTOGRAPHIC APPARATUS REPAIR; REPAIR OR MAINTENANCE OF OPTICAL MACHINES AND INSTRUMENTS; TELEPHONE INSTALLATION AND REPAIR; PAINTING, INTERIOR AND EXTERIOR; SPECTACLES REPAIR; REPAIR OF SPORTS EQUIPMENT; REPAIR OF MEASURING APPA-

RATUS AND INSTRUMENTS; REFUELLING EQUIPMENT REPAIR; FIRE-PROOF CLOTHES REPAIR (U.S. CLS. 100, 103 AND 106).

### CLASS 42—SCIENTIFIC AND COMPUTER SERVICES

FOR FRANCHISING, NAMELY, SERVICES RENDERED BY A FRANCHISOR, THAT IS TRANSFER OF TECHNICAL KNOW-HOW; CONSULTANCY RELATING TO THE PLANNING AND LAYOUT DESIGN OF SHOPS, THE INTERIOR DECOR OF SHOPS AND RELATED SIGNS; ARCHITECTURAL CONSULTATION, ARCHITECTURAL SERVICES, CONSTRUCTION DRAFTING, ENGINEERING, INDUSTRIAL DESIGN, MECHANICAL RESEARCH, CALIBRATION IN THE NATURE OF MEASURING, PHYSICS RESEARCH, SURVEYING; TECHNICAL PROJECT STUDIES IN THE FIELD OF THE CONSTRUCTION AND THE DESIGN OF CARS, F1 RACING CARS AND VEHICLES IN GENERAL THAT IS CONSTRUCTION DRAFTING; VEHICLE ROAD-WORTHINESS TESTING; RESEARCH AND DEVELOPMENT OF NEW PRODUCTS FOR OTHERS; TECHNICAL CONSULTANCY AND RESEARCH IN THE DESIGN AND PLANNING OF CARS, F1 RACING CARS AND VEHICLES IN GENERAL; DESIGN OF INTERIOR DECOR, DRESS DESIGNING, GRAPHIC ARTS DESIGNING, PACKAGING DESIGN, PACKAGING DESIGN SERVICES, INDUSTRIAL DESIGN IN THE NATURE OF STYLING; PERSONALIZED TECHNICAL DESIGN OF CARS; MATERIAL TESTING, TEXTILE TESTING, QUALITY CONTROL FOR OTHERS; CERTIFICATION SERVICES, NAMELY, TESTING, ANALYSIS AND EVALUATION OF THE GOODS AND SERVICES OF OTHERS FOR THE PURPOSE OF CERTIFICATION; TESTING, ANALYSIS AND EVALUATION OF CARS OF OTHERS FOR THE PURPOSE OF CERTIFICATION; COMPUTER PROGRAMMING, COMPUTER SOFTWARE CONSULTANCY, COMPUTER SOFTWARE DESIGN, COMPUTER SYSTEM DESIGN, COMPUTER SYSTEMS ANALYSIS, CONSULTANCY IN THE FIELD OF COMPUTER HARDWARE, CREATING AND MAINTAINING WEB SITES FOR OTHERS, HOSTING COMPUTER SITES IN THE NATURE OF WEB SITES, INSTALLATION OF COMPUTER SOFTWARE, MAINTENANCE OF COMPUTER SOFTWARE; PROVIDING SEARCH ENGINES FOR THE INTERNET; COMPUTER RENTAL, COMPUTER VIRUS PROTECTION SERVICES, CONVERSION OF DATA OR DOCUMENTS FROM PHYSICAL TO ELECTRONIC MEDIA, DATA CONVERSION OF COMPUTER PROGRAMS AND DATA, BEING NOT PHYSICAL CONVERSION, DUPLICATION OF COMPUTER PROGRAMS, RECOVERY OF COMPUTER DATA, RENTAL OF COMPUTER SOFTWARE, RENTAL OF WEB SERVERS, UPDATING OF COMPUTER SOFTWARE (U.S. CLS. 100 AND 101).

TOBY BULLOFF, EXAMINING ATTORNEY

SN 79-071,797. HUMMING HEADS KABUSHIKI KAISHA, TOKYO 104-0052, JAPAN, FILED 2-2-2009.

## Humming Heads Security Platform

PRIORITY DATE OF 12-25-2008 IS CLAIMED.  
OWNER OF INTERNATIONAL REGISTRATION 1010164 DATED 2-2-2009, EXPIRES 2-2-2019.

OWNER OF U.S. REG. NOS. 3,340,212 AND 3,445,361.  
NO CLAIM IS MADE TO THE EXCLUSIVE RIGHT TO USE "SECURITY PLATFORM", APART FROM THE MARK AS SHOWN.



**CLASS 9—ELECTRICAL AND SCIENTIFIC APPARATUS**

FOR BLUEPRINTING MACHINES; CASH REGISTERS; COIN COUNTING OR SORTING MACHINES; ELECTRIC SIGN BOARDS FOR DISPLAYING CURRENT OUTPUTS; PHOTO-COPYING MACHINES; TIME AND DATE STAMPING MACHINES; TIME CLOCKS; PUNCHED CARD OFFICE MACHINES, NAMELY, PUNCH CLOCKS; VOTING MACHINES; POSTAGE STAMP CHECKING APPARATUS MEASURING OR TESTING MACHINES AND INSTRUMENTS, NAMELY, POSTAGE STAMP METERS; STANDARD-UNIT MEASURING MACHINES AND APPARATUS, NAMELY, WEIGHING APPARATUS AND INSTRUMENTS, TEMPERATURE INDICATORS, THERMOMETERS, WATER METERS, WEIGHING BALANCES, PLANIMETERS, MEASURING RULES, DERIVED-UNIT MEASURING MACHINES AND APPARATUS, PRESSURE GAUGES, LEVEL INDICATORS, ACOUSTIC METERS, TACHOMETERS, ACCELEROMETERS, REFRACTOMETERS, LUMINOUS FLUX METERS, PHOTOMETERS, ALTIMETERS, HYGROMETERS, ILLUMINOMETERS, VIBRATION METERS, NOISEMETERS, SPEED INDICATORS, CALORIMETERS, VISCOSIMETERS, CONCENTRATION METERS, GRAVIMETERS, DENSITYMETERS, DYNAMOMETERS, FLOWMETERS, PROFILE PROJECTORS; GRADUATION CHECKERS; AUTOMATED MACHINES AND INSTRUMENTS THAT ADJUST OR REGULATE THE PHYSICAL OR CHEMICAL PROPERTIES OF MATERIALS OR MACHINES, NAMELY, VAPOR REGULATORS, ILLUMINATION REGULATORS, VOLTAGE REGULATORS, FLOW REGULATORS, SPEED REGULATORS, PRESSURE REGULATORS, CONCENTRATION REGULATORS FOR DOMESTIC, COMMERCIAL, AGRICULTURAL, ACADEMIC USE; MACHINES AND INSTRUMENTS USED TO TEST PHYSICAL PROPERTIES OF METALLIC, CERAMIC, CONCRETE, AND ORGANIC MATERIALS, NAMELY, ELECTRONIC APPARATUS FOR TESTING COMPRESSION, STRENGTH, HARDNESS AND TENSILE CHARACTERISTICS OF INDUSTRIAL MATERIALS BEING METALLIC, CERAMIC, CONCRETE, AND ORGANIC MATERIALS; SURVEYING MACHINES AND INSTRUMENTS; DISTANCE MEASURING APPARATUS; ANALYSIS INSTRUMENTS FOR PHOTOGRAMMETRIC PURPOSES; PRECISION THEODOLITES; TELEPHONE APPARATUS; MOBILE PHONE; TELETYPEWRITERS; AUTOMATIC TELEGRAPH APPARATUS; PHOTOTELEGRAPHY APPARATUS; TELEGRAPH APPARATUS OPERATED MANUALLY; COMPUTER HARDWARE, NAMELY, WIRELESS NETWORK REPEATERS; TELECOMMUNICATION SWITCHES; AUTOMATIC TELEPHONE EXCHANGE APPARATUS; APPARATUS FOR BROADCASTING, RECORDING, TRANSMISSION OR REPRODUCTION OF, TRANSMISSION SOUND OR IMAGES AND TRANSMITTERS OF ELECTRONIC SIGNALS; DEVICES FOR WIRELESS RADIO TRANSMISSION; AERONAUTICAL RADIO COMMUNICATION MACHINES AND APPARATUS; MULTICHANNEL RADIO COMMUNICATION MACHINES AND APPARATUS FOR FIXED STATIONS; SINGLE-CHANNEL RADIO COMMUNICATION MACHINES AND APPARATUS FOR FIXED STATIONS; MARINE RADIO COMMUNICATION MACHINES AND APPARATUS; EMERGENCY POSITION-INDICATING RADIO BEACON; RADIO DIRECTION FINDERS; REMOTE CONTROLLED TELEMETERS; COMPACT DISC PLAYERS; TAPE RECORDERS; RECORD PLAYERS; SOUND RECORDING MACHINES AND APPARATUS, NAMELY, AUDIO FREQUENCY APPARATUS IN THE NATURE OF ELECTRONIC PRODUCTS FOR THE MANIPULATION OF THE FREQUENCY OF AUDIO SIGNALS, NAMELY, AUDIO PROCESSORS; VIDEO FREQUENCY MACHINES AND APPARATUS, NAMELY, DIGITAL CAMERAS, VIDEO CAMERAS, VIDEO DISC PLAYERS, VIDEOTAPE RECORDERS, DVD PLAYERS, DVD BURNERS; LOUDSPEAKERS; TELECOMMUNICATION CABLES, MICROPHONES FOR TELECOMMUNICATION APPARATUS; ELECTROSTATIC COPYING MACHINES; COMPUTERS; ELECTRONIC DESK CALCULATORS; HARD DISK DRIVES; WORD PROCESSORS; INTEGRATED CIRCUITS; VIDEO GAME MACHINES FOR USE WITH AN EXTERNAL DISPLAY SCREEN OR MONITOR; ELECTRONIC CIRCUITS AND MULTIMEDIA SOFTWARE RECORDED ON CD-ROM FEATURING VIDEO GAME PROGRAMS FOR USE WITH HANDHELD ELECTRONIC VIDEO GAME WITH EXTERNAL LIQUID CRYSTAL DISPLAY SCREEN OR

MONITOR; SOUND RECORDED MAGNETIC CARDS, SHEETS AND TAPES; COMPUTER GAME DISCS; ELECTRONIC CIRCUITS AND CD-ROMS RECORDED WITH AUTOMATIC PERFORMANCE PROGRAMS FOR ELECTRONIC MUSIC; DOWNLOADABLE MUSIC FILES VIA THE INTERNET OR WIRELESS DEVICES; EXPOSED CINEMATOGRAPHIC FILMS; EXPOSED SLIDE FILMS; SLIDE FILM MOUNTS; DOWNLOADABLE IMAGE FILES, NAMELY, ART WORK, TEXT, GAMES FOR BUSINESS, ENTERTAINMENT AND EDUCATION PURPOSES; ELECTRONIC PUBLICATIONS, NAMELY, BOOKS OF POEMS, SHORT STORIES AND PLAYS, BOOKS IN THE FIELDS OF SOCIAL SCIENCE, POLITICS, BUSINESS, ECONOMICS, SCIENCE, TECHNOLOGY, ART, AND HOBBIES, GUIDE BOOKS, DICTIONARIES, AND ENCYCLOPEDIAS, AND MAGAZINES IN THE FIELD OF SOCIAL SCIENCE, POLITICS, BUSINESS, ECONOMICS, SCIENCE, TECHNOLOGY, ART AND HOBBIES AND NEWSPAPERS (U.S. CLS. 21, 23, 26, 36 AND 38).

**CLASS 42—SCIENTIFIC AND COMPUTER SERVICES**

FOR DESIGN OF COMPUTERS; DESIGN, TESTING AND RESEARCH OF COMPUTER-AIDED MACHINES, APPARATUS AND INSTRUMENTS, NAMELY, ROBOTS, GAUGING AND CONTROL APPARATUS FOR TEMPERATURE, PRESSURE, DISTANCE, SPEED, FLOW RATE, LIGHT QUALITY AND CONSISTENCY, AUTOMOBILES, TRAINS, AIRPLANES AND SHIPS, MEDICAL EQUIPMENTS, COOKING APPLIANCES, TELECOMMUNICATIONS EQUIPMENTS, FILMING EQUIPMENTS, VIDEO EQUIPMENTS AND SOUND EQUIPMENTS AND STRUCTURAL PARTS THEREOF; COMPUTER SOFTWARE DESIGN, COMPUTER PROGRAMMING AND MAINTENANCE OF COMPUTER SOFTWARE; TECHNICAL ADVICE RELATING TO PERFORMANCE AND OPERATION OF COMPUTERS; TECHNICAL ADVICE RELATING TO THE PERFORMANCE AND OPERATION OF COMPUTER-AIDED MACHINES, APPARATUS AND INSTRUMENTS, NAMELY, ROBOTS, GAUGING AND CONTROL APPARATUS FOR TEMPERATURE, PRESSURE, DISTANCE, SPEED, FLOW RATE, LIGHT QUALITY AND CONSISTENCY, AUTOMOBILES, TRAINS, AIRPLANES AND SHIPS, MEDICAL EQUIPMENTS, COOKING APPLIANCES, TELECOMMUNICATIONS EQUIPMENTS, FILMING EQUIPMENTS, VIDEO EQUIPMENTS AND SOUND EQUIPMENTS AND THEIR STRUCTURAL PARTS THEREOF; RENTAL OF COMPUTERS (U.S. CLS. 100 AND 101).

NAPOLEON SHARMA, EXAMINING ATTORNEY

SN 79-071,798. HUMMING HEADS KABUSHIKI KAISHA, TOKYO 104-0052, JAPAN, FILED 2-2-2009.

**Humming Heads Intelligence Platform**

PRIORITY DATE OF 12-25-2008 IS CLAIMED.  
OWNER OF INTERNATIONAL REGISTRATION 1010165 DATED 2-2-2009, EXPIRES 2-2-2019.  
OWNER OF U.S. REG. NOS. 3,340,212 AND 3,445,361.  
NO CLAIM IS MADE TO THE EXCLUSIVE RIGHT TO USE "INTELLIGENCE PLATFORM", APART FROM THE MARK AS SHOWN.

**CLASS 9—ELECTRICAL AND SCIENTIFIC APPARATUS**

FOR BLUEPRINTING MACHINES; CASH REGISTERS; COIN COUNTING OR SORTING MACHINES; ELECTRIC SIGN BOARDS FOR DISPLAYING CURRENT OUTPUTS; PHOTO-COPYING MACHINES; TIME AND DATE STAMPING MACHINES; TIME CLOCKS; PUNCHED CARD OFFICE MACHINES, NAMELY, PUNCH CLOCKS; VOTING MACHINES; POSTAGE STAMP CHECKING APPARATUS MEASURING OR TESTING MACHINES AND INSTRUMENTS, NAMELY, POSTAGE STAMP METERS; STANDARD-UNIT MEASURING MACHINES AND APPARATUS, NAMELY, WEIGHING APPARATUS AND INSTRUMENTS, TEMPERATURE INDICATORS, THERMOMETERS, WATER

METERS, WEIGHING BALANCES, PLANIMETERS, MEASURING RULES, DERIVED-UNIT MEASURING MACHINES AND APPARATUS, PRESSURE GAUGES, LEVEL INDICATORS, ACOUSTIC METERS, TACHOMETERS, ACCELEROMETERS, REFRACTOMETERS, LUMINOUS FLUX METERS, PHOTOMETERS, ALTIMETERS, HYGROMETERS, ILLUMINOMETERS, VIBRATION METERS, NOISEMETERS, SPEED INDICATORS, CALORIMETERS, VISCOSIMETERS, CONCENTRATION METERS, GRAVIMETERS, DENSIMETERS, DYNAMOMETERS, FLOWMETERS, PROFILE PROJECTORS; GRADUATION CHECKERS; AUTOMATED MACHINES AND INSTRUMENTS THAT ADJUST OR REGULATE THE PHYSICAL OR CHEMICAL PROPERTIES OF MATERIALS OR MACHINES, NAMELY, VAPOR REGULATORS, ILLUMINATION REGULATORS, VOLTAGE REGULATORS, FLOW REGULATORS, SPEED REGULATORS, PRESSURE REGULATORS, CONCENTRATION REGULATORS FOR DOMESTIC, COMMERCIAL, AGRICULTURAL, ACADEMIC USE; MACHINES AND INSTRUMENTS USED TO TEST PHYSICAL PROPERTIES OF METALLIC, CERAMIC, CONCRETE, AND ORGANIC MATERIALS, NAMELY, ELECTRONIC APPARATUS FOR TESTING COMPRESSION, STRENGTH, HARDNESS AND TENSILE CHARACTERISTICS OF INDUSTRIAL MATERIALS BEING METALLIC, CERAMIC, CONCRETE, AND ORGANIC MATERIALS; SURVEYING MACHINES AND INSTRUMENTS; DISTANCE MEASURING APPARATUS; ANALYSIS INSTRUMENTS FOR PHOTOGRAMMETRIC PURPOSES; PRECISION THEODOLITES; TELEPHONE APPARATUS; MOBILE PHONE; TELETYPEWRITERS; AUTOMATIC TELEGRAPH APPARATUS; PHOTOTELEGRAPHY APPARATUS; TELEGRAPH APPARATUS OPERATED MANUALLY; COMPUTER HARDWARE, NAMELY, WIRELESS NETWORK REPEATERS; TELECOMMUNICATION SWITCHES; AUTOMATIC TELEPHONE EXCHANGE APPARATUS; APPARATUS FOR BROADCASTING, RECORDING, TRANSMISSION OR REPRODUCTION OF, TRANSMISSION SOUND OR IMAGES AND TRANSMITTERS OF ELECTRONIC SIGNALS; DEVICES FOR WIRELESS RADIO TRANSMISSION; AERONAUTICAL RADIO COMMUNICATION MACHINES AND APPARATUS; MULTICHANNEL RADIO COMMUNICATION MACHINES AND APPARATUS FOR FIXED STATIONS; SINGLE-CHANNEL RADIO COMMUNICATION MACHINES AND APPARATUS FOR FIXED STATIONS; MARINE RADIO COMMUNICATION MACHINES AND APPARATUS; EMERGENCY POSITION-INDICATING RADIO BEACON; RADIO DIRECTION FINDERS; REMOTE CONTROLLED TELEMETERS; COMPACT DISC PLAYERS; TAPE RECORDERS; RECORD PLAYERS; SOUND RECORDING MACHINES AND APPARATUS, NAMELY, AUDIO FREQUENCY APPARATUS IN THE NATURE OF ELECTRONIC PRODUCTS FOR THE MANIPULATION OF THE FREQUENCY OF AUDIO SIGNALS, NAMELY, AUDIO PROCESSORS; VIDEO FREQUENCY MACHINES AND APPARATUS, NAMELY, DIGITAL CAMERAS, VIDEO CAMERAS, VIDEO DISC PLAYERS, VIDEOTAPE RECORDERS, DVD PLAYERS, DVD BURNERS; LOUDSPEAKERS; TELECOMMUNICATION CABLES, MICROPHONES FOR TELECOMMUNICATION APPARATUS; ELECTROSTATIC COPYING MACHINES; COMPUTERS; ELECTRONIC DESK CALCULATORS; HARD DISK DRIVES; WORD PROCESSORS; INTEGRATED CIRCUITS; VIDEO GAME MACHINES FOR USE WITH AN EXTERNAL DISPLAY SCREEN OR MONITOR; ELECTRONIC CIRCUITS AND MULTIMEDIA SOFTWARE RECORDED ON CD-ROM FEATURING VIDEO GAME PROGRAMS FOR USE WITH HANDHELD ELECTRONIC VIDEO GAME WITH EXTERNAL LIQUID CRYSTAL DISPLAY SCREEN OR MONITOR; SOUND RECORDED MAGNETIC CARDS, SHEETS AND TAPES; COMPUTER GAME DISCS; ELECTRONIC CIRCUITS AND CD-ROMS RECORDED WITH AUTOMATIC PERFORMANCE PROGRAMS FOR ELECTRONIC MUSIC; DOWNLOADABLE MUSIC FILES VIA THE INTERNET OR WIRELESS DEVICES; EXPOSED CINEMATOGRAPHIC FILMS; EXPOSED SLIDE FILMS; SLIDE FILM MOUNTS; DOWNLOADABLE IMAGE FILES, NAMELY, ART WORK, TEXT, GAMES FOR BUSINESS, ENTERTAINMENT AND EDUCATION PURPOSES; ELECTRONIC PUBLICATIONS, NAMELY, BOOKS OF POEMS, SHORT STORIES AND PLAYS, BOOKS IN THE FIELDS OF SOCIAL SCIENCE, POLITICS, BUSINESS, ECONOMICS, SCIENCE, TECHNOLOGY, ART, AND HOBBIES, GUIDE BOOKS, DICTIONARIES, AND ENCYCLOPEDIAS, AND MAGA-

ZINES IN THE FIELD OF SOCIAL SCIENCE, POLITICS, BUSINESS, ECONOMICS, SCIENCE, TECHNOLOGY, ART AND HOBBIES AND NEWSPAPERS (U.S. CLS. 21, 23, 26, 36 AND 38).

#### CLASS 42—SCIENTIFIC AND COMPUTER SERVICES

FOR DESIGN OF COMPUTERS; DESIGN, TESTING AND RESEARCH OF COMPUTER-AIDED MACHINES, APPARATUS AND INSTRUMENTS, NAMELY, ROBOTS, GAUGING AND CONTROL APPARATUS FOR TEMPERATURE, PRESSURE, DISTANCE, SPEED, FLOW RATE, LIGHT QUALITY AND CONSISTENCY, AUTOMOBILES, TRAINS, AIRPLANES AND SHIPS, MEDICAL EQUIPMENTS, COOKING APPLIANCES, TELECOMMUNICATIONS EQUIPMENTS, FILMING EQUIPMENTS, VIDEO EQUIPMENTS AND SOUND EQUIPMENTS AND STRUCTURAL PARTS THEREOF; COMPUTER SOFTWARE DESIGN, COMPUTER PROGRAMMING AND MAINTENANCE OF COMPUTER SOFTWARE; TECHNICAL ADVICE RELATING TO PERFORMANCE AND OPERATION OF COMPUTERS; TECHNICAL ADVICE RELATING TO THE PERFORMANCE AND OPERATION OF COMPUTER-AIDED MACHINES, APPARATUS AND INSTRUMENTS, NAMELY, ROBOTS, GAUGING AND CONTROL APPARATUS FOR TEMPERATURE, PRESSURE, DISTANCE, SPEED, FLOW RATE, LIGHT QUALITY AND CONSISTENCY, AUTOMOBILES, TRAINS, AIRPLANES AND SHIPS, MEDICAL EQUIPMENTS, COOKING APPLIANCES, TELECOMMUNICATIONS EQUIPMENTS, FILMING EQUIPMENTS, VIDEO EQUIPMENTS AND SOUND EQUIPMENTS AND THEIR STRUCTURAL PARTS THEREOF; RENTAL OF COMPUTERS (U.S. CLS. 100 AND 101).

NAPOLEON SHARMA, EXAMINING ATTORNEY

SN 79-071,799. HUMMING HEADS KABUSHIKI KAISHA, TOKYO 104-0052, JAPAN, FILED 2-2-2009.



PRIORITY DATE OF 12-24-2008 IS CLAIMED.  
OWNER OF INTERNATIONAL REGISTRATION 1010166 DATED 2-2-2009, EXPIRES 2-2-2019.

NO CLAIM IS MADE TO THE EXCLUSIVE RIGHT TO USE "INTELLIGENCE PLATFORM", APART FROM THE MARK AS SHOWN.

THE COLOR(S) GREEN, BLACK AND WHITE IS/ARE CLAIMED AS A FEATURE OF THE MARK.

THE MARK CONSISTS OF TWO DIFFERENT SIZED RECTANGULAR FRAMES IN THE COLOR GREEN LOCATED ON TOP OF EACH OTHER. THE BACKGROUND WITHIN EACH RECTANGULAR FRAME IS WHITE. WITHIN THE UPPER RECTANGULAR FRAME, THERE IS AN INNER RECTANGULAR FRAME IN GREEN LOCATED ON THE WHITE BACKGROUND SPACE. WITHIN THE INNER GREEN FRAME IS THE STYLIZED DESIGN ELEMENT

REPRESENTING AN EYE IN THE COLOR WHITE. WITHIN THE DESIGN ELEMENT OF THE EYE IS A CIRCULAR DESIGN ELEMENT REPRESENTING THE EYE BALL OF THE EYE IN THE COLOR BLACK. WITHIN THE CIRCULAR DESIGN ELEMENT REPRESENTING THE EYE BALL IS THE DESIGN ELEMENT OF A PLUS SYMBOL REPRESENTING THE IRIS OF THE EYE. IN THE LOWER RECTANGULAR FRAME, THERE IS THE WORDING "INTELLIGENCE PLATFORM" IN BLACK LOCATED ON THE WHITE BACKGROUND SPACE.

### CLASS 9—ELECTRICAL AND SCIENTIFIC APPARATUS

FOR BLUEPRINTING MACHINES; CASH REGISTERS; COIN COUNTING OR SORTING MACHINES; ELECTRIC SIGN BOARDS FOR DISPLAYING CURRENT OUTPUTS; PHOTO-COPYING MACHINES; TIME AND DATE STAMPING MACHINES; TIME CLOCKS; PUNCHED CARD OFFICE MACHINES, NAMELY, PUNCH CLOCKS; VOTING MACHINES; POSTAGE STAMP CHECKING APPARATUS MEASURING OR TESTING MACHINES AND INSTRUMENTS, NAMELY, POSTAGE STAMP METERS; STANDARD-UNIT MEASURING MACHINES AND APPARATUS, NAMELY, WEIGHING APPARATUS AND INSTRUMENTS, TEMPERATURE INDICATORS, THERMOMETERS, WATER METERS, WEIGHING BALANCES, PLANIMETERS, MEASURING RULES, DERIVED-UNIT MEASURING MACHINES AND APPARATUS, PRESSURE GAUGES, LEVEL INDICATORS, ACOUSTIC METERS, TACHOMETERS, ACCELEROMETERS, REFRACTOMETERS, LUMINOUS FLUX METERS, PHOTOMETERS, ALTIMETERS, HYGROMETERS, ILLUMINOMETERS, VIBRATION METERS, NOISE METERS, SPEED INDICATORS, CALORIMETERS, VISCOSIMETERS, CONCENTRATION METERS, GRAVIMETERS, DENSIMETERS, DYNAMOMETERS, FLOWMETERS, PROFILE PROJECTORS; GRADUATION CHECKERS; AUTOMATED MACHINES AND INSTRUMENTS THAT ADJUST OR REGULATE THE PHYSICAL OR CHEMICAL PROPERTIES OF MATERIALS OR MACHINES, NAMELY, VAPOR REGULATORS, ILLUMINATION REGULATORS, VOLTAGE REGULATORS, FLOW REGULATORS, SPEED REGULATORS, PRESSURE REGULATORS, CONCENTRATION REGULATORS FOR DOMESTIC, COMMERCIAL, AGRICULTURAL, ACADEMIC USE; MACHINES AND INSTRUMENTS USED TO TEST PHYSICAL PROPERTIES OF METALLIC, CERAMIC, CONCRETE, AND ORGANIC MATERIALS, NAMELY, ELECTRONIC APPARATUS FOR TESTING COMPRESSION, STRENGTH, HARDNESS AND TENSILE CHARACTERISTICS OF INDUSTRIAL MATERIALS BEING METALLIC, CERAMIC, CONCRETE, AND ORGANIC MATERIALS; SURVEYING MACHINES AND INSTRUMENTS; DISTANCE MEASURING APPARATUS; ANALYSIS INSTRUMENTS FOR PHOTOGRAMMETRIC PURPOSES; PRECISION THEODOLITES; TELEPHONE APPARATUS; MOBILE PHONE; TELETYPEWRITERS; AUTOMATIC TELEGRAPH APPARATUS; PHOTOTELEGRAPHY APPARATUS; TELEGRAPH APPARATUS OPERATED MANUALLY; COMPUTER HARDWARE, NAMELY, WIRELESS NETWORK REPEATERS; TELECOMMUNICATION SWITCHES; AUTOMATIC TELEPHONE EXCHANGE APPARATUS; APPARATUS FOR BROADCASTING, RECORDING, TRANSMISSION OR REPRODUCTION OF, TRANSMISSION SOUND OR IMAGES AND TRANSMITTERS OF ELECTRONIC SIGNALS; DEVICES FOR WIRELESS RADIO TRANSMISSION; AERONAUTICAL RADIO COMMUNICATION MACHINES AND APPARATUS; MULTICHANNEL RADIO COMMUNICATION MACHINES AND APPARATUS FOR FIXED STATIONS; SINGLE-CHANNEL RADIO COMMUNICATION MACHINES AND APPARATUS FOR FIXED STATIONS; MARINE RADIO COMMUNICATION MACHINES AND APPARATUS; EMERGENCY POSITION-INDICATING RADIO BEACON; RADIO DIRECTION FINDERS; REMOTE CONTROLLED TELEMETERS; COMPACT DISC PLAYERS; TAPE RECORDERS; RECORD PLAYERS; SOUND RECORDING MACHINES AND APPARATUS, NAMELY, AUDIO FREQUENCY APPARATUS IN THE NATURE OF ELECTRONIC PRODUCTS FOR THE MANIPULATION OF THE FREQUENCY OF AUDIO SIGNALS, NAMELY, AUDIO PROCESSORS; VIDEO FREQUENCY MACHINES AND APPARATUS, NAMELY, DIGITAL CAMERAS, VIDEO CAMERAS, VIDEODISC PLAYERS, VIDEOTAPE RECORDERS, DVD PLAYERS, DVD BUR-

NERS; LOUDSPEAKERS; TELECOMMUNICATION CABLES, MICROPHONES FOR TELECOMMUNICATION APPARATUS; ELECTROSTATIC COPYING MACHINES; COMPUTERS; ELECTRONIC DESK CALCULATORS; HARD DISK DRIVES; WORD PROCESSORS; INTEGRATED CIRCUITS; VIDEO GAME MACHINES FOR USE WITH AN EXTERNAL DISPLAY SCREEN OR MONITOR; ELECTRONIC CIRCUITS AND MULTIMEDIA SOFTWARE RECORDED ON CD-ROM FEATURING VIDEO GAME PROGRAMS FOR USE WITH HANDHELD ELECTRONIC VIDEO GAME WITH EXTERNAL LIQUID CRYSTAL DISPLAY SCREEN OR MONITOR; SOUND RECORDED MAGNETIC CARDS, SHEETS AND TAPES; COMPUTER GAME DISCS; ELECTRONIC CIRCUITS AND CD-ROMS RECORDED WITH AUTOMATIC PERFORMANCE PROGRAMS FOR ELECTRONIC MUSIC; DOWNLOADABLE MUSIC FILES VIA THE INTERNET OR WIRELESS DEVICES; EXPOSED CINEMATOGRAPHIC FILMS; EXPOSED SLIDE FILMS; SLIDE FILM MOUNTS; DOWNLOADABLE IMAGE FILES, NAMELY, ART WORK, TEXT, GAMES FOR BUSINESS, ENTERTAINMENT AND EDUCATION PURPOSES; ELECTRONIC PUBLICATIONS, NAMELY, BOOKS OF POEMS, SHORT STORIES AND PLAYS, BOOKS IN THE FIELDS OF SOCIAL SCIENCE, POLITICS, BUSINESS, ECONOMICS, SCIENCE, TECHNOLOGY, ART, AND HOBBIES, GUIDE BOOKS, DICTIONARIES, AND ENCYCLOPEDIAS, AND MAGAZINES IN THE FIELD OF SOCIAL SCIENCE, POLITICS, BUSINESS, ECONOMICS, SCIENCE, TECHNOLOGY, ART AND HOBBIES AND NEWSPAPERS (U.S. CLS. 21, 23, 26, 36 AND 38).

### CLASS 42—SCIENTIFIC AND COMPUTER SERVICES

FOR DESIGN OF COMPUTERS; DESIGN, TESTING AND RESEARCH OF COMPUTER-AIDED MACHINES, APPARATUS AND INSTRUMENTS, NAMELY, ROBOTS, GAUGING AND CONTROL APPARATUS FOR TEMPERATURE, PRESSURE, DISTANCE, SPEED, FLOW RATE, LIGHT QUALITY AND CONSISTENCY, AUTOMOBILES, TRAINS, AIRPLANES AND SHIPS, MEDICAL EQUIPMENTS, COOKING APPLIANCES, TELECOMMUNICATIONS EQUIPMENTS, FILMING EQUIPMENTS, VIDEO EQUIPMENTS AND SOUND EQUIPMENTS AND STRUCTURAL PARTS THEREOF; COMPUTER SOFTWARE DESIGN, COMPUTER PROGRAMMING AND MAINTENANCE OF COMPUTER SOFTWARE; TECHNICAL ADVICE RELATING TO PERFORMANCE AND OPERATION OF COMPUTERS; TECHNICAL ADVICE RELATING TO THE PERFORMANCE AND OPERATION OF COMPUTER-AIDED MACHINES, APPARATUS AND INSTRUMENTS, NAMELY, ROBOTS, GAUGING AND CONTROL APPARATUS FOR TEMPERATURE, PRESSURE, DISTANCE, SPEED, FLOW RATE, LIGHT QUALITY AND CONSISTENCY, AUTOMOBILES, TRAINS, AIRPLANES AND SHIPS, MEDICAL EQUIPMENTS, COOKING APPLIANCES, TELECOMMUNICATIONS EQUIPMENTS, FILMING EQUIPMENTS, VIDEO EQUIPMENTS AND SOUND EQUIPMENTS AND THEIR STRUCTURAL PARTS THEREOF; RENTAL OF COMPUTERS (U.S. CLS. 100 AND 101).

NAPOLEON SHARMA, EXAMINING ATTORNEY

SN 79-071,800. HUMMING HEADS KABUSHIKI KAISHA, TOKYO 104-0052, JAPAN, FILED 2-2-2009.



PRIORITY DATE OF 12-24-2008 IS CLAIMED.  
OWNER OF INTERNATIONAL REGISTRATION 1010167  
DATED 2-2-2009, EXPIRES 2-2-2019.

NO CLAIM IS MADE TO THE EXCLUSIVE RIGHT TO USE "INTELLIGENCE PLATFORM", APART FROM THE MARK AS SHOWN.

THE COLOR(S) GREEN, BLACK AND WHITE IS/ARE CLAIMED AS A FEATURE OF THE MARK.

THE MARK CONSISTS OF TWO DIFFERENT SIZED RECTANGULAR FRAMES IN THE COLOR GREEN LOCATED NEXT TO EACH OTHER. THE BACKGROUND WITHIN EACH RECTANGULAR FRAME IS WHITE. WITHIN THE RECTANGULAR FRAME ON THE LEFT, THERE IS AN INNER RECTANGULAR FRAME IN GREEN LOCATED ON THE WHITE BACKGROUND SPACE. WITHIN THE INNER GREEN FRAME IS THE STYLIZED DESIGN ELEMENT REPRESENTING AN EYE IN THE COLOR WHITE. WITHIN THE DESIGN ELEMENT OF THE EYE IS A CIRCULAR DESIGN ELEMENT REPRESENTING THE EYE BALL OF THE EYE IN THE COLOR BLACK. WITHIN THE CIRCULAR DESIGN ELEMENT REPRESENTING THE OR EYE BALL IS THE DESIGN ELEMENT OF A PLUS SYMBOL REPRESENTING THE IRIS OF THE EYE. IN THE RECTANGULAR FRAME ON THE RIGHT, THERE IS THE WORDING "INTELLIGENCE PLATFORM" IN BLACK LOCATED ON THE WHITE BACKGROUND SPACE.

### CLASS 9—ELECTRICAL AND SCIENTIFIC APPARATUS

FOR BLUEPRINTING MACHINES; CASH REGISTERS; COIN COUNTING OR SORTING MACHINES; ELECTRIC SIGN BOARDS FOR DISPLAYING CURRENT OUTPUTS; PHOTO-COPYING MACHINES; TIME AND DATE STAMPING MACHINES; TIME CLOCKS; PUNCHED CARD OFFICE MACHINES, NAMELY, PUNCH CLOCKS; VOTING MACHINES; POSTAGE STAMP CHECKING APPARATUS MEASURING OR TESTING MACHINES AND INSTRUMENTS, NAMELY, POSTAGE STAMP METERS; STANDARD-UNIT MEASURING MACHINES AND APPARATUS, NAMELY, WEIGHING APPARATUS AND INSTRUMENTS, TEMPERATURE INDICATORS, THERMOMETERS, WATER METERS, WEIGHING BALANCES, PLANIMETERS, MEASURING RULES, DERIVED-UNIT MEASURING MACHINES AND APPARATUS, PRESSURE GAUGES, LEVEL INDICATORS, ACOUSTIC METERS, TACHOMETERS, ACCELEROMETERS, REFRACTOMETERS, LUMINOUS FLUX METERS, PHOTOMETERS, ALTIMETERS, HYGROMETERS, ILLUMINOMETERS, VIBRATION METERS, NOISEMETERS, SPEED INDICATORS, CALORIMETERS, VISCOSIMETERS, CONCENTRATION METERS, GRAVIMETERS, DENSITYMETERS, DYNAMOMETERS, FLOWMETERS, PROFILE PROJECTORS; GRADUATION CHECKERS; AUTOMATED MACHINES AND INSTRUMENTS THAT ADJUST OR REGULATE THE PHYSICAL OR CHEMICAL PROPERTIES OF MATERIALS OR MACHINES, NAMELY, VAPOR REGULATORS, ILLUMINATION REGULATORS, VOLTAGE REGULATORS, FLOW REGULATORS, SPEED REGULATORS, PRESSURE REGULATORS, CONCENTRATION REGULATORS FOR DOMESTIC, COMMERCIAL, AGRICULTURAL, ACADEMIC USE; MACHINES AND INSTRUMENTS USED TO TEST PHYSICAL PROPERTIES OF METALLIC, CERAMIC, CONCRETE, AND ORGANIC MATERIALS, NAMELY, ELECTRONIC APPARATUS FOR TESTING COMPRESSION, STRENGTH, HARDNESS AND TENSILE CHARACTERISTICS OF INDUSTRIAL MATERIALS BEING METALLIC, CERAMIC, CONCRETE, AND ORGANIC MATERIALS; SURVEYING MACHINES AND INSTRUMENTS; DISTANCE MEASURING APPARATUS; ANALYSIS INSTRUMENTS FOR PHOTOGRAMMETRIC PURPOSES; PRECISION THEODOLITES; TELEPHONE APPARATUS; MOBILE PHONE; TELETYPEWRITERS; AUTOMATIC TELEGRAPH APPARATUS; PHOTOTELEGRAPHY APPARATUS; TELEGRAPH APPARATUS OPERATED MANUALLY; COMPUTER HARDWARE, NAMELY, WIRELESS NETWORK REPEATERS; TELECOMMUNICATION SWITCHES; AUTOMATIC TELEPHONE EXCHANGE APPARATUS; APPARATUS FOR BROADCASTING, RECORDING, TRANSMISSION OR REPRODUCTION OF, TRANSMISSION SOUND OR IMAGES AND TRANSMITTERS OF ELECTRONIC SIGNALS; DEVICES FOR WIRELESS RADIO TRANSMISSION; AERONAUTICAL RADIO COMMUNICATION MACHINES AND APPARATUS; MULTICHANNEL RADIO COMMUNICATION MACHINES AND APPARATUS FOR FIXED STATIONS; SINGLE-CHANNEL RADIO COMMUNICATION MACHINES AND APPARATUS FOR FIXED STATIONS; MARINE RADIO COMMU-

NICATION MACHINES AND APPARATUS; EMERGENCY POSITION-INDICATING RADIO BEACON; RADIO DIRECTION FINDERS; REMOTE CONTROLLED TELEMETERS; COMPACT DISC PLAYERS; TAPE RECORDERS; RECORD PLAYERS; SOUND RECORDING MACHINES AND APPARATUS, NAMELY, AUDIO FREQUENCY APPARATUS IN THE NATURE OF ELECTRONIC PRODUCTS FOR THE MANIPULATION OF THE FREQUENCY OF AUDIO SIGNALS, NAMELY, AUDIO PROCESSORS; VIDEO FREQUENCY MACHINES AND APPARATUS, NAMELY, DIGITAL CAMERAS, VIDEO CAMERAS, VIDEODISC PLAYERS, VIDEOTAPE RECORDERS, DVD PLAYERS, DVD BURNERS; LOUDSPEAKERS; TELECOMMUNICATION CABLES, MICROPHONES FOR TELECOMMUNICATION APPARATUS; ELECTROSTATIC COPYING MACHINES; COMPUTERS; ELECTRONIC DESK CALCULATORS; HARD DISK DRIVES; WORD PROCESSORS; INTEGRATED CIRCUITS; VIDEO GAME MACHINES FOR USE WITH AN EXTERNAL DISPLAY SCREEN OR MONITOR; ELECTRONIC CIRCUITS AND MULTIMEDIA SOFTWARE RECORDED ON CD-ROM FEATURING VIDEO GAME PROGRAMS FOR USE WITH HANDHELD ELECTRONIC VIDEO GAME WITH EXTERNAL LIQUID CRYSTAL DISPLAY SCREEN OR MONITOR; SOUND RECORDED MAGNETIC CARDS, SHEETS AND TAPES; COMPUTER GAME DISCS; ELECTRONIC CIRCUITS AND CD-ROMS RECORDED WITH AUTOMATIC PERFORMANCE PROGRAMS FOR ELECTRONIC MUSIC; DOWNLOADABLE MUSIC FILES VIA THE INTERNET OR WIRELESS DEVICES; EXPOSED CINEMATOGRAPHIC FILMS; EXPOSED SLIDE FILMS; SLIDE FILM MOUNTS; DOWNLOADABLE IMAGE FILES, NAMELY, ART WORK, TEXT, GAMES FOR BUSINESS, ENTERTAINMENT AND EDUCATION PURPOSES; ELECTRONIC PUBLICATIONS, NAMELY, BOOKS OF POEMS, SHORT STORIES AND PLAYS, BOOKS IN THE FIELDS OF SOCIAL SCIENCE, POLITICS, BUSINESS, ECONOMICS, SCIENCE, TECHNOLOGY, ART, AND HOBBIES, GUIDE BOOKS, DICTIONARIES, AND ENCYCLOPEDIAS, AND MAGAZINES IN THE FIELD OF SOCIAL SCIENCE, POLITICS, BUSINESS, ECONOMICS, SCIENCE, TECHNOLOGY, ART AND HOBBIES AND NEWSPAPERS (U.S. CLS. 21, 23, 26, 36 AND 38).

### CLASS 42—SCIENTIFIC AND COMPUTER SERVICES

FOR DESIGN OF COMPUTERS; DESIGN, TESTING AND RESEARCH OF COMPUTER-AIDED MACHINES, APPARATUS AND INSTRUMENTS, NAMELY, ROBOTS, GAUGING AND CONTROL APPARATUS FOR TEMPERATURE, PRESSURE, DISTANCE, SPEED, FLOW RATE, LIGHT QUALITY AND CONSISTENCY, AUTOMOBILES, TRAINS, AIRPLANES AND SHIPS, MEDICAL EQUIPMENTS, COOKING APPLIANCES, TELECOMMUNICATIONS EQUIPMENTS, FILMING EQUIPMENTS, VIDEO EQUIPMENTS AND SOUND EQUIPMENTS AND STRUCTURAL PARTS THEREOF; COMPUTER SOFTWARE DESIGN, COMPUTER PROGRAMMING AND MAINTENANCE OF COMPUTER SOFTWARE; TECHNICAL ADVICE RELATING TO PERFORMANCE AND OPERATION OF COMPUTERS; TECHNICAL ADVICE RELATING TO THE PERFORMANCE AND OPERATION OF COMPUTER-AIDED MACHINES, APPARATUS AND INSTRUMENTS, NAMELY, ROBOTS, GAUGING AND CONTROL APPARATUS FOR TEMPERATURE, PRESSURE, DISTANCE, SPEED, FLOW RATE, LIGHT QUALITY AND CONSISTENCY, AUTOMOBILES, TRAINS, AIRPLANES AND SHIPS, MEDICAL EQUIPMENTS, COOKING APPLIANCES, TELECOMMUNICATIONS EQUIPMENTS, FILMING EQUIPMENTS, VIDEO EQUIPMENTS AND SOUND EQUIPMENTS AND THEIR STRUCTURAL PARTS THEREOF; RENTAL OF COMPUTERS (U.S. CLS. 100 AND 101).

NAPOLEON SHARMA, EXAMINING ATTORNEY

SN 79-071,801. HUMMING HEADS KABUSHIKI KAISHA, TOKYO 104-0052, JAPAN, FILED 2-2-2009.

**Humming Heads Quality Evaluation Center**

PRIORITY DATE OF 12-25-2008 IS CLAIMED.

OWNER OF INTERNATIONAL REGISTRATION 1010168 DATED 2-2-2009, EXPIRES 2-2-2019.

OWNER OF U.S. REG. NOS. 3,340,212 AND 3,445,361.

NO CLAIM IS MADE TO THE EXCLUSIVE RIGHT TO USE "QUALITY EVALUATION CENTER", APART FROM THE MARK AS SHOWN.

### CLASS 9—ELECTRICAL AND SCIENTIFIC APPARATUS

FOR BLUEPRINTING MACHINES; CASH REGISTERS; COIN COUNTING OR SORTING MACHINES; ELECTRIC SIGN BOARDS FOR DISPLAYING CURRENT OUTPUTS; PHOTO-COPYING MACHINES; TIME AND DATE STAMPING MACHINES; TIME CLOCKS; PUNCHED CARD OFFICE MACHINES, NAMELY, PUNCH CLOCKS; VOTING MACHINES; POSTAGE STAMP CHECKING APPARATUS MEASURING OR TESTING MACHINES AND INSTRUMENTS, NAMELY, POSTAGE STAMP METERS; STANDARD-UNIT MEASURING MACHINES AND APPARATUS, NAMELY, WEIGHING APPARATUS AND INSTRUMENTS, TEMPERATURE INDICATORS, THERMOMETERS, WATER METERS, WEIGHING BALANCES, PLANIMETERS, MEASURING RULES, DERIVED-UNIT MEASURING MACHINES AND APPARATUS, PRESSURE GAUGES, LEVEL INDICATORS, ACOUSTIC METERS, TACHOMETERS, ACCELEROMETERS, REFRACTOMETERS, LUMINOUS FLUX METERS, PHOTOMETERS, ALTIMETERS, HYGROMETERS, ILLUMINOMETERS, VIBRATION METERS, NOISEMETERS, SPEED INDICATORS, CALORIMETERS, VISCOSIMETERS, CONCENTRATION METERS, GRAVIMETERS, DENSIMETERS, DYNAMOMETERS, FLOWMETERS, PROFILE PROJECTORS; GRADUATION CHECKERS; AUTOMATED MACHINES AND INSTRUMENTS THAT ADJUST OR REGULATE THE PHYSICAL OR CHEMICAL PROPERTIES OF MATERIALS OR MACHINES, NAMELY, VAPOR REGULATORS, ILLUMINATION REGULATORS, VOLTAGE REGULATORS, FLOW REGULATORS, SPEED REGULATORS, PRESSURE REGULATORS, CONCENTRATION REGULATORS FOR DOMESTIC, COMMERCIAL, AGRICULTURAL, ACADEMIC USE; MACHINES AND INSTRUMENTS USED TO TEST PHYSICAL PROPERTIES OF METALLIC, CERAMIC, CONCRETE, AND ORGANIC MATERIALS, NAMELY, ELECTRONIC APPARATUS FOR TESTING COMPRESSION, STRENGTH, HARDNESS AND TENSILE CHARACTERISTICS OF INDUSTRIAL MATERIALS BEING METALLIC, CERAMIC, CONCRETE, AND ORGANIC MATERIALS; SURVEYING MACHINES AND INSTRUMENTS; DISTANCE MEASURING APPARATUS; ANALYSIS INSTRUMENTS FOR PHOTOGRAMMETRIC PURPOSES; PRECISION THEODOLITES; TELEPHONE APPARATUS; MOBILE PHONE; TELETYPEWRITERS; AUTOMATIC TELEGRAPH APPARATUS; PHOTOTELEGRAPHY APPARATUS; TELEGRAPH APPARATUS OPERATED MANUALLY; COMPUTER HARDWARE, NAMELY, WIRELESS NETWORK REPEATERS; TELECOMMUNICATION SWITCHES; AUTOMATIC TELEPHONE EXCHANGE APPARATUS; APPARATUS FOR BROADCASTING, RECORDING, TRANSMISSION OR REPRODUCTION OF, TRANSMISSION SOUND OR IMAGES AND TRANSMITTERS OF ELECTRONIC SIGNALS; DEVICES FOR WIRELESS RADIO TRANSMISSION; AERONAUTICAL RADIO COMMUNICATION MACHINES AND APPARATUS; MULTICHANNEL RADIO COMMUNICATION MACHINES AND APPARATUS FOR FIXED STATIONS; SINGLE-CHANNEL RADIO COMMUNICATION MACHINES AND APPARATUS FOR FIXED STATIONS; MARINE RADIO COMMUNICATION MACHINES AND APPARATUS; EMERGENCY POSITION-INDICATING RADIO BEACON; RADIO DIRECTION FINDERS; REMOTE CONTROLLED TELEMETERS; COMPACT DISC PLAYERS; TAPE RECORDERS; RECORD PLAYERS; SOUND RECORDING MACHINES AND APPARATUS, NAMELY, AUDIO FREQUENCY APPARATUS IN THE NATURE OF ELECTRONIC PRODUCTS FOR THE MANIPULATION OF THE FREQUENCY OF AUDIO SIGNALS, NAMELY, AUDIO PROCESSORS; VIDEO FREQUENCY MACHINES AND APPARATUS, NAMELY, DIGITAL CAMERAS, VIDEO CAMERAS, VIDEO DISC PLAYERS, VIDEOTAPE RECORDERS, DVD PLAYERS, DVD BURNERS; LOUDSPEAKERS; TELECOMMUNICATION CABLES, MICROPHONES FOR TELECOMMUNICATION APPARATUS; ELECTROSTATIC COPYING MACHINES; COMPUTERS; ELECTRONIC DESK

CALCULATORS; HARD DISK DRIVES; WORD PROCESSORS; INTEGRATED CIRCUITS; VIDEO GAME MACHINES FOR USE WITH AN EXTERNAL DISPLAY SCREEN OR MONITOR; ELECTRONIC CIRCUITS AND MULTIMEDIA SOFTWARE RECORDED ON CD-ROM FEATURING VIDEO GAME PROGRAMS FOR USE WITH HANDHELD ELECTRONIC VIDEO GAME WITH EXTERNAL LIQUID CRYSTAL DISPLAY SCREEN OR MONITOR; SOUND RECORDED MAGNETIC CARDS, SHEETS AND TAPES; COMPUTER GAME DISCS; ELECTRONIC CIRCUITS AND CD-ROMS RECORDED WITH AUTOMATIC PERFORMANCE PROGRAMS FOR ELECTRONIC MUSIC; DOWNLOADABLE MUSIC FILES VIA THE INTERNET OR WIRELESS DEVICES; EXPOSED CINEMATOGRAPHIC FILMS; EXPOSED SLIDE FILMS; SLIDE FILM MOUNTS; DOWNLOADABLE IMAGE FILES, NAMELY, ART WORK, TEXT, GAMES FOR BUSINESS, ENTERTAINMENT AND EDUCATION PURPOSES; ELECTRONIC PUBLICATIONS, NAMELY, BOOKS OF POEMS, SHORT STORIES AND PLAYS, BOOKS IN THE FIELDS OF SOCIAL SCIENCE, POLITICS, BUSINESS, ECONOMICS, SCIENCE, TECHNOLOGY, ART, AND HOBBIES, GUIDE BOOKS, DICTIONARIES, AND ENCYCLOPEDIAS, AND MAGAZINES IN THE FIELD OF SOCIAL SCIENCE, POLITICS, BUSINESS, ECONOMICS, SCIENCE, TECHNOLOGY, ART AND HOBBIES AND NEWSPAPERS (U.S. CLS. 21, 23, 26, 36 AND 38).

### CLASS 42—SCIENTIFIC AND COMPUTER SERVICES

FOR DESIGN OF COMPUTERS; DESIGN, TESTING AND RESEARCH OF COMPUTER-AIDED MACHINES, APPARATUS AND INSTRUMENTS, NAMELY, ROBOTS, GAUGING AND CONTROL APPARATUS FOR TEMPERATURE, PRESSURE, DISTANCE, SPEED, FLOW RATE, LIGHT QUALITY AND CONSISTENCY, AUTOMOBILES, TRAINS, AIRPLANES AND SHIPS, MEDICAL EQUIPMENTS, COOKING APPLIANCES, TELECOMMUNICATIONS EQUIPMENTS, FILMING EQUIPMENTS, VIDEO EQUIPMENTS AND SOUND EQUIPMENTS AND STRUCTURAL PARTS THEREOF; COMPUTER SOFTWARE DESIGN, COMPUTER PROGRAMMING AND MAINTENANCE OF COMPUTER SOFTWARE; TECHNICAL ADVICE RELATING TO PERFORMANCE AND OPERATION OF COMPUTERS; TECHNICAL ADVICE RELATING TO THE PERFORMANCE AND OPERATION OF COMPUTER-AIDED MACHINES, APPARATUS AND INSTRUMENTS, NAMELY, ROBOTS, GAUGING AND CONTROL APPARATUS FOR TEMPERATURE, PRESSURE, DISTANCE, SPEED, FLOW RATE, LIGHT QUALITY AND CONSISTENCY, AUTOMOBILES, TRAINS, AIRPLANES AND SHIPS, MEDICAL EQUIPMENTS, COOKING APPLIANCES, TELECOMMUNICATIONS EQUIPMENTS, FILMING EQUIPMENTS, VIDEO EQUIPMENTS AND SOUND EQUIPMENTS AND THEIR STRUCTURAL PARTS THEREOF; RENTAL OF COMPUTERS (U.S. CLS. 100 AND 101).

NAPOLEON SHARMA, EXAMINING ATTORNEY

SN 79-071,936. BARIX AG, SWITZERLAND, FILED 4-24-2009.

# Instreamer

THE MARK CONSISTS OF STANDARD CHARACTERS WITHOUT CLAIM TO ANY PARTICULAR FONT, STYLE, SIZE, OR COLOR.

PRIORITY DATE OF 3-31-2009 IS CLAIMED.

OWNER OF INTERNATIONAL REGISTRATION 1010510 DATED 4-24-2009, EXPIRES 4-24-2019.

OWNER OF U.S. REG. NO. 2,899,352.

**CLASS 9—ELECTRICAL AND SCIENTIFIC APPARATUS**

FOR ELECTRIC AND ELECTRONIC DEVICES AND INSTRUMENTS FOR INFORMATION PROCESSING AND DATA COLLECTION AND TRANSMISSION IN THE NATURE OF DATA COLLECTION TERMINALS AND COMPUTER HARDWARE FOR USE IN NETWORKS, NAMELY, FOR USE IN AUDIO-VIDEO SYSTEMS, FOR USE IN AUDIO SYSTEMS, AND FOR USE IN ANNOUNCEMENT AND PAGING SYSTEMS; COMPUTER PROGRAMS RECORDED ON COMPUTER MEDIA FOR USE IN PROVIDING AUDIO, VIDEO AND MULTIMEDIA DATA OVER A NETWORK; COMPUTER FIRMWARE AND SOFTWARE FOR USE IN NETWORK COMMUNICATIONS, NAMELY, FOR USE IN DISTRIBUTING AUDIO, VIDEO AND MULTIMEDIA DATA; DEVICES FOR RECORDING, TRANSMITTING AND REPRODUCING SOUND AND IMAGES, NAMELY, NETWORK INTERFACE CARDS, DIGITAL AUDIO PLAYERS, AND ALARM DEVICES, COMPRISED OF SPEAKERS, SENSORS, SIRENS AND AMPLIFIERS, EXCLUDING ALARMS FOR VEHICLES (U.S. CLS. 21, 23, 26, 36 AND 38).

**CLASS 42—SCIENTIFIC AND COMPUTER SERVICES**

FOR DEVELOPMENT AND DESIGN AND MAINTENANCE OF COMPUTER PROGRAMS FOR DATA COLLECTION AND DATA TRANSMISSION FOR OTHERS; TECHNICAL RESEARCH AND CONSULTATION IN THE FIELD OF DATA COLLECTION (U.S. CLS. 100 AND 101).

SUZANNE BLANE, EXAMINING ATTORNEY

**CLASS 35—ADVERTISING AND BUSINESS**

FOR BUSINESS CONSULTANCY, BUSINESS INVESTIGATIONS, BUSINESS MANAGEMENT ASSISTANCE; PERSONNEL MANAGEMENT CONSULTANCY; EFFICIENCY EXPERTS; MARKETING SERVICES, NAMELY, CONSUMER MARKETING RESEARCH; MARKET OPINION POLLING STUDIES, NAMELY, CONDUCTING OPINION POLLS OF SPECIFIC SOCIAL, CULTURAL OR ORGANIZATIONAL GROUPS; PSYCHOLOGICAL TESTING FOR THE SELECTION OF PERSONNEL; PROVIDING STATISTICAL DATA AND STATISTICAL ANALYSIS, NAMELY, PROVIDING MARKET, SOCIAL, PERSONNEL STATISTICAL INFORMATION FOR BUSINESS OR COMMERCIAL PURPOSES; CONDUCTING MARKETING STUDIES; BUSINESS ORGANIZATION CONSULTING AND MANAGEMENT CONSULTING IN THE FIELD OF HUMAN RESOURCES; MARKET ANALYSIS AND BUSINESS MANAGEMENT CONSULTING IN THE FIELD OF TEAM DEVELOPMENT; SYSTEMATIZATION OF INFORMATION IN COMPUTER DATABASES; PROVIDING INFORMATION IN RELATION TO THE AFOREMENTIONED FIELDS THROUGH A GLOBAL COMPUTER NETWORK; THE AFOREMENTIONED SERVICES ALSO PROVIDED ELECTRONICALLY (U.S. CLS. 100, 101 AND 102).

**CLASS 41—EDUCATION AND ENTERTAINMENT**

FOR ELECTRONIC PUBLISHING, NAMELY, PUBLISHING OF ELECTRONIC PUBLICATIONS; EDUCATIONAL SERVICES, NAMELY, ORGANIZING AND MANAGEMENT OF EDUCATIONAL COLLOQUIA, CONFERENCES, SEMINARS, SYMPOSIA AND COURSES IN THE FIELD OF TEAM BUILDING, SOCIAL RELATIONSHIPS, BUSINESS ORGANIZATION AND MANAGEMENT; VOCATIONAL GUIDANCE; EDUCATIONAL INFORMATION; EDUCATIONAL ADVISORY SERVICES IN THE RELATION TO THE AFORESAID SERVICES; TRAINING SEMINARS IN THE FIELD OF PSYCHOLOGICAL TESTING AND ITS EVALUATION; EDUCATION AND TRAINING OF ADMINISTRATION PERSONNEL, NAMELY, PROVIDING CLASSES, SEMINARS AND WORKSHOPS IN THE FIELD OF TEAM BUILDING, SOCIAL RELATIONSHIPS, BUSINESS ORGANIZATION AND MANAGEMENT (U.S. CLS. 100, 101 AND 107).

SN 79-073,905. QED GROUP A.S., CZECH REPUBLIC, FILED 4-22-2009.

# 4Elements Testing

THE MARK CONSISTS OF STANDARD CHARACTERS WITHOUT CLAIM TO ANY PARTICULAR FONT, STYLE, SIZE, OR COLOR.

PRIORITY DATE OF 4-22-2009 IS CLAIMED.

OWNER OF INTERNATIONAL REGISTRATION 1016025 DATED 4-22-2009, EXPIRES 4-22-2019.

NO CLAIM IS MADE TO THE EXCLUSIVE RIGHT TO USE "TESTING", APART FROM THE MARK AS SHOWN.

**CLASS 9—ELECTRICAL AND SCIENTIFIC APPARATUS**

FOR COMPUTER SOFTWARE FOR PROCESSING AND ANALYZING DATA FROM STATISTICAL, SOCIOLOGICAL, INTELLECTUAL, BEHAVIORAL AND SIMILAR TESTS AND FOR DEPICTING THE RESULTS, CONTENTS, DATA, VALUES AND OTHER RELATIONS IN A GRAPHIC OR VERBAL FORM; COMPUTER PROGRAMS FOR PROCESSING AND ANALYZING DATA FROM STATISTICAL, SOCIOLOGICAL, INTELLECTUAL, BEHAVIORAL AND SIMILAR TESTS AND FOR DEPICTING THE RESULTS, CONTENTS, DATA, VALUES AND OTHER RELATIONS IN A GRAPHIC OR VERBAL FORM; COMPACT DISCS AND PRERECORDED MAGNETIC DATA CARRIERS FEATURING COMPUTER SOFTWARE AND/ OR COMPUTER PROGRAMS FOR PROCESSING AND ANALYZING DATA FROM STATISTICAL, SOCIOLOGICAL, INTELLECTUAL, BEHAVIORAL AND SIMILAR TESTS AND FOR DEPICTING THE RESULTS, CONTENTS, DATA, VALUES AND OTHER RELATIONS IN A GRAPHIC OR VERBAL FORM; COMPACT DISCS AND PRERECORDED MAGNETIC DATA CARRIERS FEATURING DATA FOR DEPICTING RESULTS OF STATISTICAL, SOCIOLOGICAL, INTELLECTUAL, BEHAVIORAL AND SIMILAR TESTS (U.S. CLS. 21, 23, 26, 36 AND 38).

**CLASS 42—SCIENTIFIC AND COMPUTER SERVICES**

FOR COMPUTER SYSTEM ANALYSIS, DESIGN, INSTALLATION AND UPDATING OF COMPUTER PROGRAMS; COMPUTER PROGRAMMING; COMPUTER SYSTEMS DESIGN SERVICES; CONVERSION OF DATA FROM PHYSICAL DOCUMENTS TO ELECTRONIC MEDIA; SCIENTIFIC RESEARCH IN THE FIELDS OF SOCIOLOGY, PSYCHOLOGY AND DEMOGRAPHICS; GRAPHIC ART DESIGNING FOR GRAPHIC REPRESENTATION OF PSYCHOLOGICAL INFORMATION; COMPUTER PROGRAMMING FOR RESEARCH IN THE FIELD OF PSYCHOLOGY INCLUDING GATHERING AND ASSESSING INFORMATION RELATING TO CHARACTER TYPES AND PERSONALITY TYPES; CONSULTANCY IN THE AFOREMENTIONED FIELDS (U.S. CLS. 100 AND 101).

KATHERINE E. HALMEN, EXAMINING ATTORNEY

SN 79-075,445. FUTURE TECHNOLOGY DEVICES; INTERNATIONAL LIMITED, UNITED KINGDOM, FILED 10-13-2009.

SN 79-075,599. COMAU SPA, ITALY, FILED 7-29-2009.



PRIORITY DATE OF 4-15-2009 IS CLAIMED.  
OWNER OF INTERNATIONAL REGISTRATION 1019711  
DATED 10-13-2009, EXPIRES 10-13-2019.

NO CLAIM IS MADE TO THE EXCLUSIVE RIGHT TO  
USE "CHIP", APART FROM THE MARK AS SHOWN.

THE MARK CONSISTS OF THE LETTERS "FTDI" OVER  
THE WORD "CHIP" WHICH ARE TO THE RIGHT OF A  
CYLINDER.

#### CLASS 9—ELECTRICAL AND SCIENTIFIC APPARATUS

FOR UNIVERSAL SERIAL BUS HARDWARE,  
NAMELY, INTEGRATED CIRCUITS, SEMICONDUCTORS;  
PHOTOLITHOGRAPHIC MASKS FOR USE IN  
SEMICONDUCTOR MANUFACTURE; SEMICONDUCTOR  
CHIPS; COMPUTER INTERFACE BOARDS;  
MOTHERBOARDS; SILICON WAFERS; COMPUTER  
HARDWARE; COMPUTER SOFTWARE FOR DATA  
PROCESSING IN THE FIELD OF UNIVERSAL SERIAL  
BUS HARDWARE; MEMORY MODULES; COMPUTER  
DATA STORAGE APPARATUS; BLANK MAGNETIC  
DATA CARRIERS; BLANK OPTICAL DATA CARRIERS;  
FLASH MEMORY CARDS; COMPUTER FIRMWARE  
FOR INTERFACING UNIVERSAL SERIAL BUS HARD-  
WARE WITH SOFTWARE (U.S. CLS. 21, 23, 26, 36 AND  
38).

#### CLASS 16—PAPER GOODS AND PRINTED MATTER

FOR PAPER, CARDBOARD AND GOODS MADE  
FROM THESE MATERIALS, NAMELY, CARDBOARD  
BOXES AND PROMOTIONAL MATERIAL, NAMELY,  
PRINTED INFORMATIONAL FLYERS IN THE FIELD  
OF COMPUTERS, COMPUTER SOFTWARE, COMPUTER  
FIRMWARE AND COMPUTER PERIPHERALS; POS-  
TERS; PRINTED SHEETS, PRODUCT CATALOGS,  
PRINTED MATERIALS, NAMELY, PRESS RELEASES,  
BOOKS AND MAGAZINES, TRAINING MANUALS,  
INSTRUCTION MANUALS, INSTRUCTION LEAFLETS,  
PERIODICALS, HANDOUTS, HANDBOOKS, PRINTED  
PUBLICATIONS, NAMELY, PRESS RELEASES AND  
NEWSLETTERS, BROCHURES AND BOOKLETS, ALL  
IN THE FIELD OF COMPUTERS, COMPUTER SOFT-  
WARE AND COMPUTER PERIPHERALS; PRINTED  
OPERATION MANUALS, DATA BOOKS, MEMORAN-  
DUM BOOKS, NOTE PADS, BLANK FORMS, PAPER  
FOR RECORDING COMPUTER PROGRAMS, STICK-  
ERS, STATIONERY, PACKAGING MATERIALS OF PA-  
PER AND CARDBOARD (U.S. CLS. 2, 5, 22, 23, 29, 37, 38  
AND 50).

#### CLASS 42—SCIENTIFIC AND COMPUTER SERVICES

FOR DESIGN OF COMPUTER PROGRAMS; DESIGN-  
ING OF DATA PROCESSING SYSTEMS; DESIGN OF  
INTEGRATED CIRCUITS, DESIGN OF COMPUTER  
HARDWARE EQUIPMENT; DESIGN OF UNIVERSAL  
SERIAL BUS HARDWARE AND SOFTWARE; PROVID-  
ING TECHNICAL RESEARCH FOR OTHERS IN THE  
FIELD OF UNIVERSAL SERIAL BUS, AND CONSUL-  
TANCY THEREOF (U.S. CLS. 100 AND 101).

DEZMONA MIZELLE, EXAMINING ATTORNEY

PRIORITY DATE OF 7-13-2009 IS CLAIMED.  
OWNER OF INTERNATIONAL REGISTRATION 1020125  
DATED 7-29-2009, EXPIRES 7-29-2019.

#### CLASS 7—MACHINERY

FOR MACHINES AND MACHINE TOOLS, NAMELY,  
MACHINE TOOLS FOR METAL CUTTING, ASSEM-  
BLING MACHINES AND SYSTEMS IN THE NATURE  
MODULE BASED ASSEMBLY MACHINES FOR ASSEM-  
BLING ENGINES, TRANSMISSIONS AND COMPONENT  
PARTS THEREOF; WELDING MACHINES AND SYS-  
TEMS, NAMELY, GAS, ELECTRIC AND LASER WELD-  
ING MACHINES, WELDING GUNS AND WELDING  
MACHINE TOOLS; ROBOTS FOR INDUSTRIAL USE  
(U.S. CLS. 13, 19, 21, 23, 31, 34 AND 35).

#### CLASS 9—ELECTRICAL AND SCIENTIFIC APPARATUS

FOR ELECTRIC AND ELECTRONIC TESTING MA-  
CHINES, NAMELY, TESTING MACHINES FOR MEA-  
SURING QUALITY OF ASSEMBLY, SIZE AND  
MATERIAL OF ENGINES, TRANSMISSIONS AND COM-  
ONENT PARTS THEREOF (U.S. CLS. 21, 23, 26, 36 AND  
38).

APRIL ROACH, EXAMINING ATTORNEY

SN 79-075,692. SEN CORPORATION LIMITED, UNITED  
KINGDOM, FILED 10-8-2009.

The logo for SEN consists of the letters "SEN" in a large, bold, sans-serif font. The letters are solid black and have a slightly distressed or textured appearance.

THE MARK CONSISTS OF STANDARD CHARACTERS  
WITHOUT CLAIM TO ANY PARTICULAR FONT, STYLE,  
SIZE, OR COLOR.

OWNER OF INTERNATIONAL REGISTRATION 1020443  
DATED 10-8-2009, EXPIRES 10-8-2019.

**CLASS 38—COMMUNICATION**

FOR TELECOMMUNICATIONS SERVICES, NAMELY, CELLULAR TELEPHONE SERVICES; PROVIDING INTERNET CHAT ROOMS FOR SOCIAL NETWORKING AND FOR TRANSMISSION OF MESSAGES AMONG USERS IN THE FIELD OF SPACE AND ITS EXPLORATION, ASTRONOMY, COSMOLOGY, ASTROPHYSICS AND PLANETARY SCIENCE; E-MAIL SERVICES; PROVIDING USER ACCESS TO THE INTERNET; RADIO, TELEVISION AND ONLINE BROADCASTING; TRANSMISSION OF RADIO PROGRAMS, TELEVISION PROGRAMS, AND AUDIO AND VISUAL MATERIAL BY INTERNET STREAMING; TELEVISION AND RADIO BROADCASTING; TRANSMISSION OF TEXT, MESSAGES, SOUND AND PICTURES VIA THE INTERNET AND CELLULAR TELECOMMUNICATION NETWORKS; COMMUNICATION OF INFORMATION AND DATA BY RADIO AND SATELLITE; INSTANT MESSAGING SERVICES, NAMELY, SENDING, RECEIVING AND FORWARDING MESSAGES IN THE FORM OF TEXT, AUDIO, GRAPHIC IMAGES OR VIDEO OR A COMBINATION OF THESE FORMATS SUCH AS SHORT MESSAGE SERVICES (SMS) AND MULTIMEDIA MESSAGING SERVICES (MMS); PROVIDING INTERNET CHAT ROOMS FOR INTERACTION WITH OTHER COMPUTER USERS CONCERNING TOPICS OF SPACE AND GENERAL INTEREST; PROVISION OF ACCESS TO THE INTERNET FOR RETRIEVAL AND REVIEW OF INFORMATION ON NEWS, CURRENT AFFAIRS RELATING TO SPACE AND ITS EXPLORATION, ASTRONOMY, COSMOLOGY, ASTROPHYSICS AND PLANETARY SCIENCE; PROVISION OF TELECOMMUNICATIONS LINKS TO COMPUTER DATABASES AND WEBSITES ON THE INTERNET; INTERACTIVE TELEVISION BROADCASTING SERVICES, NAMELY, INTERACTIVE SERVICES FOR TELEVISION VIEWERS INCLUDING THOSE WATCHING ON MOBILE TELEPHONES AND PCS; TRANSMISSION OF INFORMATION BY ELECTRONIC COMMUNICATIONS NETWORKS, NAMELY, DELIVERY OF MESSAGES VIA TELECOMMUNICATIONS AND DELIVERY OF RADIO PROGRAMS, TELEVISION PROGRAMS, FILMS, PRE-RECORDED VIDEO TAPES, AUDIO AND VISUAL MATERIAL OR MOTION PICTURES VIA TELECOMMUNICATIONS; WIRELESS COMMUNICATION SERVICES, NAMELY, CELLULAR TELEPHONE SERVICES, WIRELESS INTERNET COMMUNICATION SERVICES; CONSULTANCY, ADVISING OR PROVIDING INFORMATION IN RELATION TO THE FOREGOING (U.S. CLS. 100, 101 AND 104).

**CLASS 39—TRANSPORTATION AND STORAGE**

FOR ORGANIZING, ARRANGING, RESERVING, AND BOOKING FOR SPACE TRAVEL, SUB-ORBITAL SPACE FLIGHTS, AND ADVENTURES, NAMELY, EXCURSIONS TO SITES OF ASTRONOMICAL INTEREST TO VIEW METEORITE IMPACT CRATERS, PARTIAL AND FULL ECLIPSES, COMETS AND METEORITE SHOWERS; INFORMATION AND ADVISORY SERVICES RELATING TO THE AFORESAID SERVICES; SPACE TRAVEL TICKET RESERVATION SERVICES; ORGANIZATION, BOOKING, AND ARRANGEMENT OF EXCURSIONS TO SITES OF ASTRONOMICAL INTEREST TO VIEW METEORITE IMPACT CRATERS, PARTIAL AND FULL ECLIPSES, COMETS AND METEORITE SHOWERS; SERVICES OF A TRAVEL AGENCY, IN PARTICULAR CONSULTANCY AND BOOKING SERVICES FOR SPACE TRAVEL; INFORMATION AND ADVISORY SERVICES RELATING TO THE AFORESAID SERVICES; INFORMATION RELATING TO ALL THE AFORESAID SERVICES PROVIDED ON-LINE FROM A COMPUTER DATABASE OR VIA THE INTERNET (U.S. CLS. 100 AND 105).

**CLASS 41—EDUCATION AND ENTERTAINMENT**

FOR PROVIDING TRAINING FOR SPACE TRAVEL, SUB-ORBITAL SPACE FLIGHTS, AND EXCURSIONS TO SITES OF ASTRONOMICAL INTEREST TO VIEW METEORITE IMPACT CRATERS, PARTIAL AND FULL ECLIPSES, COMETS AND METEORITE SHOWERS; EDUCATION AND ENTERTAINMENT SERVICES, NAMELY, PROVISION OF TRAINING, COURSES, SEMINARS, AND CONFERENCES IN THE FIELD OF SPACE EXPLORATION, THE SCIENTIFIC, SOCIAL, ECONOMIC, GOVERNMENTAL, LEGAL AND POLITICAL ASPECTS OF SPACE EXPLORATION, ASTRONOMY, COSMOLOGY, SPACE TRAVEL, SPACE LAW, THE SEARCH FOR EXTRA-TERRESTRIAL LIFE, PLANET EARTH AND THE SOLAR SYSTEM, THE GALAXIES AND THE KNOWN UNIVERSE, ALL THROUGH TELEVISION AND RADIO PROGRAMS, LECTURES, CONFERENCES, SEMINARS, PODCASTS, ONLINE WEBSITES, PRINTED PUBLICATIONS, AND MOBILE DEVICES; PRODUCTION AND DISTRIBUTION OF RADIO AND TELEVISION PROGRAMS IN THE FIELD OF SPACE EXPLORATION; PUBLISHING ON-LINE ELECTRONIC PUBLICATIONS; PUBLICATION OF MAGAZINES, BOOKS, TEXTS AND PRINTED MATTER; PUBLICATION OF ELECTRONIC BOOKS AND JOURNALS ON-LINE; LIVE SHOWS FOR NEWS RELATING TO SPACE AND SPACE EXPLORATION; ENTERTAINMENT INFORMATION, NAMELY, PROVIDING INFORMATION ABOUT TELEVISION PROGRAMMING FOR USE IN INTERACTIVE TELEVISION PROGRAM SELECTION SERVICES FOR VIEWERS AND VIEWING GUIDE SERVICES; TELEVISION PROGRAM RECORDING SERVICES AUTOMATICALLY INITIATED ON THE BASIS OF CUSTOMER VIEWING HABITS AND PREFERENCES; ARRANGING AND ORGANIZING CONVENTIONS FOR EDUCATIONAL AND ENTERTAINMENT PURPOSES IN RELATION TO SPACE AND ITS EXPLORATION, ASTRONOMY, COSMOLOGY, ASTROPHYSICS AND PLANETARY SCIENCE; ENTERTAINMENT SERVICES, NAMELY, ARRANGING AND CONDUCTING COMPETITIONS AND QUIZZES THAT TEST KNOWLEDGE OF SPACE VIA WEB SITES, TELEVISION, RADIO OR MOBILE DEVICES; ELECTRONIC NONDOWNLOADABLE GAMES SERVICES PROVIDED ONLINE BY MEANS OF THE INTERNET; DISTRIBUTION OF RADIO PROGRAMS, TELEVISION PROGRAMS, FILMS, AND MOTION PICTURES FOR OTHERS; PRODUCTION OF RADIO PROGRAMS, TELEVISION PROGRAMS, FILMS, MOTION PICTURES; TICKET RESERVATION SERVICES FOR EDUCATIONAL AND CULTURAL EVENTS; ARRANGING AND CONDUCTING OF SEMINARS AND WORKSHOPS IN THE FIELD OF SPACE AND SPACE EXPLORATION; CONSULTANCY, INFORMATION AND ADVISORY SERVICES RELATING TO ALL THE AFORESAID SERVICES; ORGANIZATION OF EXHIBITIONS FOR CULTURAL, ENTERTAINMENT OR EDUCATIONAL PURPOSES IN THE FIELDS OF SPACE AND ITS EXPLORATION, ASTRONOMY, COSMOLOGY, ASTROPHYSICS, PLANETARY SCIENCE; INFORMATION RELATING TO ALL THE AFORESAID SERVICES, EXPRESSLY EXCLUDING THOSE RELATED WITH THE FIELD OF MEDICINE, PROVIDED ON-LINE FROM A COMPUTER DATABASE OR VIA THE INTERNET (U.S. CLS. 100, 101 AND 107).

**CLASS 45—PERSONAL AND LEGAL SERVICES**

FOR LICENSING OF TELEVISION PROGRAMS, RADIO PROGRAMS, FILMS, MOTION PICTURES, PRE-RECORDED VIDEO TAPES, AUDIO AND/OR VISUAL MATERIAL, PRE-RECORDED VIDEO CASSETTES, DVDS OR PRE-RECORDED VIDEO DISCS; LEGAL ADVICE CONCERNING INTERNATIONAL AND NATIONAL LAWS, DISCUSSIONS, AND DEBATES RELATING TO THE EXPLORATION OF SPACE; PROVIDING SOCIAL NETWORKING WEBSITES FOR EDUCATIONAL, ENTERTAINMENT AND COMMUNITY BUILDING PURPOSES; DATING SERVICES INCLUDING ON LINE DATING; INFORMATION RELATING TO ALL THE AFORESAID SERVICES PROVIDED ON-LINE FROM A COMPUTER DATABASE OR VIA THE INTERNET (U.S. CLS. 100 AND 101).

KRISTIN DAHLING, EXAMINING ATTORNEY



SN 79-076.312. THE BALTIC EXCHANGE LIMITED, LONDON EC3A 8BH, UNITED KINGDOM, FILED 11-6-2009.

### **BALTIC EXCHANGE SUPRAMAX INDEX**

THE MARK CONSISTS OF STANDARD CHARACTERS WITHOUT CLAIM TO ANY PARTICULAR FONT, STYLE, SIZE, OR COLOR.

OWNER OF INTERNATIONAL REGISTRATION 1022043 DATED 11-6-2009, EXPIRES 11-6-2019.

NO CLAIM IS MADE TO THE EXCLUSIVE RIGHT TO USE "EXCHANGE SUPRAMAX INDEX", APART FROM THE MARK AS SHOWN.

### **CLASS 9—ELECTRICAL AND SCIENTIFIC APPARATUS**

FOR DATA MEDIA IN THE FORM OF PRE-RECORDED MAGNETIC COMPUTER TAPES, PRE-RECORDED FLOPPY COMPUTER DISCS AND PRE-RECORDED HARD COMPUTER DISCS, ALL FEATURING TRADE INFORMATION, BUSINESS PRICE INFORMATION AND STATISTICAL INFORMATION, ALL RELATING TO SEA-BORNE CARGOES, SHIP BROKERING, CHARTERING AND LEASING OF TRANSPORT FOR THE CARRIAGE OF BULK GOODS AND CARGOES BY SEA, AND THE SALE AND PURCHASE OF VESSELS; DOWNLOADABLE PUBLICATIONS IN ELECTRONIC FORM SUPPLIED ON-LINE FROM A COMPUTER DATABASE OR THE INTERNET IN THE FORM OF MAGAZINES, NEWSLETTERS, PRESS RELEASES, BUSINESS REPORTS, MARKET REPORTS, CARGO FIXTURE LISTS, ALL RELATING TO SEA-BORNE CARGOES, SHIP BROKERING, CHARTERING AND LEASING OF TRANSPORT FOR THE CARRIAGE OF BULK GOODS AND CARGOES BY SEA, AND THE SALE AND PURCHASE OF VESSELS (U.S. CLS. 21, 23, 26, 36 AND 38).

### **CLASS 35—ADVERTISING AND BUSINESS**

FOR COMPILATION AND PROVISION OF TRADE INFORMATION AND BUSINESS INFORMATION IN THE FIELD OF SEA-BORNE CARGOES, SHIP BROKERING, THE CHARTERING AND LEASING OF TRANSPORT FOR THE CARRIAGE OF BULK GOODS AND CARGOES BY SEA, AND THE SALE AND PURCHASE OF VESSELS, AND BUSINESS PRICE INFORMATION AND STATISTICAL INFORMATION; COMPILATION AND PROVISION OF TRADE INFORMATION AND BUSINESS INFORMATION IN THE FIELD OF SEA-BORNE CARGOES, SHIP BROKERING, THE CHARTERING AND LEASING OF TRANSPORT FOR THE CARRIAGE OF BULK GOODS AND CARGOES BY SEA, AND THE SALE AND PURCHASE OF VESSELS AND BUSINESS PRICE INFORMATION AND STATISTICAL INFORMATION, ALL OFFERED OR PROVIDED ON-LINE FROM A COMPUTER DATABASE OR THE INTERNET; PROVIDING ONLINE COMPUTER DATABASES, ALL WITH TRADE INFORMATION, BUSINESS INFORMATION, BUSINESS PRICE INFORMATION AND STATISTICAL INFORMATION, AND ALL IN THE FIELDS OF SEA-BORNE CARGOES, SHIP BROKERING, THE CHARTERING AND LEASING OF TRANSPORT FOR THE CARRIAGE OF BULK GOODS AND CARGOES BY SEA, AND THE SALE AND PURCHASE OF VESSELS; COMPUTERIZED DATABASE MANAGEMENT; PROVISION OF BUSINESS INFORMATION RELATING TO SHIP BROKERING, CHARTERING AND LEASING OF TRANSPORT FOR THE CARRIAGE OF BULK GOODS AND CARGOES BY SEA, AND THE SALE AND PURCHASE OF VESSELS; PROVISION OF BUSINESS INFORMATION RELATING TO SHIP BROKERING, CHARTERING AND LEASING OF TRANSPORT FOR THE CARRIAGE OF BULK GOODS AND CARGOES BY SEA, AND THE SALE AND PURCHASE OF VESSELS, OFFERED OR PROVIDED ON-LINE FROM A COMPUTER DATABASE OR THE INTERNET; PREPARATION AND COMPILATION OF BUSINESS REPORTS, PREPARATION AND COMPILATION OF FINANCIAL REPORTS FOR OTHERS, PREPARATION AND COMPILATION OF MARKET REPORTS; PREPARATION AND COMPILATION OF BUSINESS REPORTS, PREPARATION AND COMPILATION OF FINANCIAL REPORTS FOR OTHERS, PREPARATION AND COMPILATION OF MARKET REPORTS, ALL OFFERED OR PROVIDED ON-LINE FROM A COMPUTER DATA-

BASE OR THE INTERNET; BUSINESS INFORMATION SERVICES RELATING TO SEA-BORNE CARGOES, SHIP BROKERING, THE CHARTERING AND LEASING OF TRANSPORT FOR THE CARRIAGE OF BULK GOODS AND CARGOES BY SEA, AND THE SALE AND PURCHASE OF VESSELS; BUSINESS INFORMATION SERVICES RELATING TO SEA-BORNE CARGOES, SHIP BROKERING, THE CHARTERING AND LEASING OF TRANSPORT FOR THE CARRIAGE OF BULK GOODS AND CARGOES BY SEA, AND THE SALE AND PURCHASE OF VESSELS, OFFERED OR PROVIDED ON-LINE FROM A COMPUTER DATABASE OR THE INTERNET (U.S. CLS. 100, 101 AND 102).

### **CLASS 36—INSURANCE AND FINANCIAL**

FOR COMPILATION AND PROVISION OF FINANCIAL INFORMATION RELATING TO SHIPPING CARGO; COMPILATION AND PROVISION OF FINANCIAL INFORMATION RELATING TO SHIPPING CARGO, OFFERED PROVIDED ON-LINE FROM A COMPUTER DATABASE OR THE INTERNET; COMPILATION AND PROVISION OF FINANCIAL INFORMATION; COMPILATION AND PROVISION OF FINANCIAL INFORMATION, OFFERED OR PROVIDED ON-LINE FROM A COMPUTER DATABASE OR THE INTERNET; PREPARATION OF FINANCIAL REPORTS; PREPARATION OF FINANCIAL REPORTS, OFFERED OR PROVIDED ONLINE FROM A COMPUTER DATABASE OR THE INTERNET; PREPARATION OF FINANCIAL ANALYSES; PREPARATION OF FINANCIAL ANALYSES, OFFERED OR PROVIDED ONLINE FROM A COMPUTER DATABASE OR THE INTERNET; QUOTATION OF INFORMATION RELATING TO SHIP BROKERING; QUOTATION OF INFORMATION RELATING TO SHIP BROKERING, OFFERED OR PROVIDED ON-LINE FROM A COMPUTER DATABASE OR THE INTERNET (U.S. CLS. 100, 101 AND 102).

MICHAEL WIENER, EXAMINING ATTORNEY

SN 79-076.313. THE BALTIC EXCHANGE LIMITED, LONDON EC3A 8BH, UNITED KINGDOM, FILED 11-6-2009.

### **BALTIC EXCHANGE PANAMAX INDEX**

THE MARK CONSISTS OF STANDARD CHARACTERS WITHOUT CLAIM TO ANY PARTICULAR FONT, STYLE, SIZE, OR COLOR.

OWNER OF INTERNATIONAL REGISTRATION 1022044 DATED 11-6-2009, EXPIRES 11-6-2019.

NO CLAIM IS MADE TO THE EXCLUSIVE RIGHT TO USE "EXCHANGE PANAMAX INDEX", APART FROM THE MARK AS SHOWN.

### **CLASS 9—ELECTRICAL AND SCIENTIFIC APPARATUS**

FOR DATA MEDIA IN THE FORM OF PRE-RECORDED MAGNETIC COMPUTER TAPES, PRE-RECORDED FLOPPY COMPUTER DISCS AND PRE-RECORDED HARD COMPUTER DISCS, ALL FEATURING TRADE INFORMATION, BUSINESS PRICE INFORMATION AND STATISTICAL INFORMATION, ALL RELATING TO SEA-BORNE CARGOES, SHIP BROKERING, CHARTERING AND LEASING OF TRANSPORT FOR THE CARRIAGE OF BULK GOODS AND CARGOES BY SEA, AND THE SALE AND PURCHASE OF VESSELS; DOWNLOADABLE PUBLICATIONS IN ELECTRONIC FORM SUPPLIED ON-LINE FROM A COMPUTER DATABASE OR THE INTERNET IN THE FORM OF MAGAZINES, NEWSLETTERS, PRESS RELEASES, BUSINESS REPORTS, MARKET REPORTS, CARGO FIXTURE LISTS, ALL RELATING TO SEA-BORNE CARGOES, SHIP BROKERING, CHARTERING AND LEASING OF TRANSPORT FOR THE CARRIAGE OF BULK GOODS AND CARGOES BY SEA, AND THE SALE AND PURCHASE OF VESSELS (U.S. CLS. 21, 23, 26, 36 AND 38).

**CLASS 35—ADVERTISING AND BUSINESS**

FOR COMPILATION AND PROVISION OF TRADE INFORMATION AND BUSINESS INFORMATION IN THE FIELD OF SEA-BORNE CARGOES, SHIP BROKERING, THE CHARTERING AND LEASING OF TRANSPORT FOR THE CARRIAGE OF BULK GOODS AND CARGOES BY SEA, AND THE SALE AND PURCHASE OF VESSELS, AND BUSINESS PRICE INFORMATION AND STATISTICAL INFORMATION; COMPILATION AND PROVISION OF TRADE INFORMATION AND BUSINESS INFORMATION IN THE FIELD OF SEA-BORNE CARGOES, SHIP BROKERING, THE CHARTERING AND LEASING OF TRANSPORT FOR THE CARRIAGE OF BULK GOODS AND CARGOES BY SEA, AND THE SALE AND PURCHASE OF VESSELS, AND BUSINESS PRICE INFORMATION AND STATISTICAL INFORMATION, ALL OFFERED OR PROVIDED ON-LINE FROM A COMPUTER DATABASE OR THE INTERNET; PROVIDING ONLINE COMPUTER DATABASES, ALL WITH TRADE INFORMATION, BUSINESS INFORMATION, BUSINESS PRICE INFORMATION AND STATISTICAL INFORMATION, AND ALL IN THE FIELDS OF SEA-BORNE CARGOES, SHIP BROKERING, THE CHARTERING AND LEASING OF TRANSPORT FOR THE CARRIAGE OF BULK GOODS AND CARGOES BY SEA, AND THE SALE AND PURCHASE OF VESSELS; COMPUTERIZED DATABASE MANAGEMENT; PROVISION OF BUSINESS INFORMATION RELATING TO SHIP BROKERING, CHARTERING AND LEASING OF TRANSPORT FOR THE CARRIAGE OF BULK GOODS AND CARGOES BY SEA, AND THE SALE AND PURCHASE OF VESSELS; PROVISION OF BUSINESS INFORMATION RELATING TO SHIP BROKERING, CHARTERING AND LEASING OF TRANSPORT FOR THE CARRIAGE OF BULK GOODS AND CARGOES BY SEA, AND THE SALE AND PURCHASE OF VESSELS, OFFERED OR PROVIDED ON-LINE FROM A COMPUTER DATABASE OR THE INTERNET; PREPARATION AND COMPILATION OF BUSINESS REPORTS, PREPARATION AND COMPILATION OF FINANCIAL REPORTS FOR OTHERS, PREPARATION AND COMPILATION OF MARKET REPORTS; PREPARATION AND COMPILATION OF BUSINESS REPORTS, PREPARATION AND COMPILATION OF FINANCIAL REPORTS FOR OTHERS, PREPARATION AND COMPILATION OF MARKET REPORTS, ALL OFFERED OR PROVIDED ON-LINE FROM A COMPUTER DATABASE OR THE INTERNET; BUSINESS INFORMATION SERVICES RELATING TO SEA-BORNE CARGOES, SHIP BROKERING, THE CHARTERING AND LEASING OF TRANSPORT FOR THE CARRIAGE OF BULK GOODS AND CARGOES BY SEA, AND THE SALE AND PURCHASE OF VESSELS; BUSINESS INFORMATION SERVICES RELATING TO SEA-BORNE CARGOES, SHIP BROKERING, THE CHARTERING AND LEASING OF TRANSPORT FOR THE CARRIAGE OF BULK GOODS AND CARGOES BY SEA, AND THE SALE AND PURCHASE OF VESSELS, OFFERED OR PROVIDED ON-LINE FROM A COMPUTER DATABASE OR THE INTERNET (U.S. CLS. 100, 101 AND 102).

**CLASS 36—INSURANCE AND FINANCIAL**

FOR COMPILATION AND PROVISION OF FINANCIAL INFORMATION RELATING TO SHIPPING CARGO; COMPILATION AND PROVISION OF FINANCIAL INFORMATION RELATING TO SHIPPING CARGO, OFFERED PROVIDED ON-LINE FROM A COMPUTER DATABASE OR THE INTERNET; COMPILATION AND PROVISION OF FINANCIAL INFORMATION; COMPILATION AND PROVISION OF FINANCIAL INFORMATION, OFFERED OR PROVIDED ON-LINE FROM A COMPUTER DATABASE OR THE INTERNET; PREPARATION OF FINANCIAL REPORTS; PREPARATION OF FINANCIAL REPORTS, OFFERED OR PROVIDED ONLINE FROM A COMPUTER DATABASE OR THE INTERNET; PREPARATION OF FINANCIAL ANALYSES; PREPARATION OF FINANCIAL ANALYSES, OFFERED OR PROVIDED ONLINE FROM A COMPUTER DATABASE OR THE INTERNET; QUOTATION OF INFORMATION RELATING TO SHIP BROKERING; QUOTATION OF INFORMATION RELATING TO SHIP BROKERING, OFFERED OR PROVIDED ON-LINE FROM A COMPUTER DATABASE OR THE INTERNET (U.S. CLS. 100, 101 AND 102).

MICHAEL WIENER, EXAMINING ATTORNEY

SN 79-076,314. THE BALTIC EXCHANGE LIMITED, LONDON EC3A 8BH, UNITED KINGDOM, FILED 11-6-2009.

**BALTIC EXCHANGE HANDYSIZE INDEX**

THE MARK CONSISTS OF STANDARD CHARACTERS WITHOUT CLAIM TO ANY PARTICULAR FONT, STYLE, SIZE, OR COLOR.

OWNER OF INTERNATIONAL REGISTRATION 1022045 DATED 11-6-2009, EXPIRES 11-6-2019.

NO CLAIM IS MADE TO THE EXCLUSIVE RIGHT TO USE "EXCHANGE HANDYSIZE INDEX", APART FROM THE MARK AS SHOWN.

**CLASS 9—ELECTRICAL AND SCIENTIFIC APPARATUS**

FOR DATA MEDIA IN THE FORM OF PRE-RECORDED MAGNETIC COMPUTER TAPES, PRE-RECORDED FLOPPY COMPUTER DISCS AND PRE-RECORDED HARD COMPUTER DISCS, ALL FEATURING TRADE INFORMATION, BUSINESS PRICE INFORMATION AND STATISTICAL INFORMATION, ALL RELATING TO SEA-BORNE CARGOES, SHIP BROKERING, CHARTERING AND LEASING OF TRANSPORT FOR THE CARRIAGE OF BULK GOODS AND CARGOES BY SEA, AND THE SALE AND PURCHASE OF VESSELS; DOWNLOADABLE PUBLICATIONS IN ELECTRONIC FORM SUPPLIED ON-LINE FROM A COMPUTER DATABASE OR THE INTERNET IN THE FORM OF MAGAZINES, NEWSLETTERS, PRESS RELEASES, BUSINESS REPORTS, MARKET REPORTS, CARGO FIXTURE LISTS, ALL RELATING TO SEA-BORNE CARGOES, SHIP BROKERING, CHARTERING AND LEASING OF TRANSPORT FOR THE CARRIAGE OF BULK GOODS AND CARGOES BY SEA, AND THE SALE AND PURCHASE OF VESSELS (U.S. CLS. 21, 23, 26, 36 AND 38).

**CLASS 35—ADVERTISING AND BUSINESS**

FOR COMPILATION AND PROVISION OF TRADE INFORMATION AND BUSINESS INFORMATION IN THE FIELD OF SEA-BORNE CARGOES, SHIP BROKERING, THE CHARTERING AND LEASING OF TRANSPORT FOR THE CARRIAGE OF BULK GOODS AND CARGOES BY SEA, AND THE SALE AND PURCHASE OF VESSELS, AND BUSINESS PRICE INFORMATION AND STATISTICAL INFORMATION; COMPILATION AND PROVISION OF TRADE INFORMATION AND BUSINESS INFORMATION IN THE FIELD OF SEA-BORNE CARGOES, SHIP BROKERING, THE CHARTERING AND LEASING OF TRANSPORT FOR THE CARRIAGE OF BULK GOODS AND CARGOES BY SEA, AND THE SALE AND PURCHASE OF VESSELS AND BUSINESS PRICE INFORMATION AND STATISTICAL INFORMATION, ALL OFFERED OR PROVIDED ON-LINE FROM A COMPUTER DATABASE OR THE INTERNET; PROVIDING ONLINE COMPUTER DATABASES, ALL WITH TRADE INFORMATION, BUSINESS INFORMATION, BUSINESS PRICE INFORMATION AND STATISTICAL INFORMATION, AND ALL IN THE FIELDS OF SEA-BORNE CARGOES, SHIP BROKERING, THE CHARTERING AND LEASING OF TRANSPORT FOR THE CARRIAGE OF BULK GOODS AND CARGOES BY SEA, AND THE SALE AND PURCHASE OF VESSELS; COMPUTERIZED DATABASE MANAGEMENT; PROVISION OF BUSINESS INFORMATION RELATING TO SHIP BROKERING, CHARTERING AND LEASING OF TRANSPORT FOR THE CARRIAGE OF BULK GOODS AND CARGOES BY SEA, AND THE SALE AND PURCHASE OF VESSELS; PROVISION OF BUSINESS INFORMATION RELATING TO SHIP BROKERING, CHARTERING AND LEASING OF TRANSPORT FOR THE CARRIAGE OF BULK GOODS AND CARGOES BY SEA, AND THE SALE AND PURCHASE OF VESSELS, OFFERED OR PROVIDED ON-LINE FROM A COMPUTER DATABASE OR THE INTERNET; PREPARATION AND COMPILATION OF BUSINESS REPORTS, PREPARATION AND COMPILATION OF FINANCIAL REPORTS FOR OTHERS, PREPARATION AND COMPILATION OF MARKET REPORTS; PREPARATION AND COMPILATION OF BUSINESS REPORTS, PREPARATION AND COMPILATION OF FINANCIAL REPORTS FOR OTHERS, PREPARATION AND COMPILATION OF MARKET REPORTS, ALL OFFERED OR PROVIDED ON-LINE FROM A COMPUTER DATA-

BASE OR THE INTERNET; BUSINESS INFORMATION SERVICES RELATING TO SEA-BORNE CARGOES, SHIP BROKERING, THE CHARTERING AND LEASING OF TRANSPORT FOR THE CARRIAGE OF BULK GOODS AND CARGOES BY SEA, AND THE SALE AND PURCHASE OF VESSELS; BUSINESS INFORMATION SERVICES RELATING TO SEA-BORNE CARGOES, SHIP BROKERING, THE CHARTERING AND LEASING OF TRANSPORT FOR THE CARRIAGE OF BULK GOODS AND CARGOES BY SEA, AND THE SALE AND PURCHASE OF VESSELS, OFFERED OR PROVIDED ON-LINE FROM A COMPUTER DATABASE OR THE INTERNET (U.S. CLS. 100, 101 AND 102).

#### **CLASS 36—INSURANCE AND FINANCIAL**

FOR COMPILATION AND PROVISION OF FINANCIAL INFORMATION RELATING TO SHIPPING CARGO; COMPILATION AND PROVISION OF FINANCIAL INFORMATION RELATING TO SHIPPING CARGO, OFFERED PROVIDED ON-LINE FROM A COMPUTER DATABASE OR THE INTERNET; COMPILATION AND PROVISION OF FINANCIAL INFORMATION; COMPILATION AND PROVISION OF FINANCIAL INFORMATION, OFFERED OR PROVIDED ON-LINE FROM A COMPUTER DATABASE OR THE INTERNET; PREPARATION OF FINANCIAL REPORTS; PREPARATION OF FINANCIAL REPORTS, OFFERED OR PROVIDED ONLINE FROM A COMPUTER DATABASE OR THE INTERNET; PREPARATION OF FINANCIAL ANALYSES; PREPARATION OF FINANCIAL ANALYSES, OFFERED OR PROVIDED ONLINE FROM A COMPUTER DATABASE OR THE INTERNET; QUOTATION OF INFORMATION RELATING TO SHIP BROKERING; QUOTATION OF INFORMATION RELATING TO SHIP BROKERING, OFFERED OR PROVIDED ON-LINE FROM A COMPUTER DATABASE OR THE INTERNET (U.S. CLS. 100, 101 AND 102).

MICHAEL WIENER, EXAMINING ATTORNEY

SN 79-076,705. OXLEY DEVELOPMENTS COMPANY LIMITED, ULVERSTON, CUMBRIA, UNITED KINGDOM, FILED 11-25-2009.

THE MARK CONSISTS OF STANDARD CHARACTERS WITHOUT CLAIM TO ANY PARTICULAR FONT, STYLE, SIZE, OR COLOR.

PRIORITY DATE OF 11-20-2009 IS CLAIMED.  
OWNER OF INTERNATIONAL REGISTRATION 1023139 DATED 11-25-2009, EXPIRES 11-25-2019.

#### **CLASS 9—ELECTRICAL AND SCIENTIFIC APPARATUS**

FOR LIGHT EMITTING DIODES (U.S. CLS. 21, 23, 26, 36 AND 38).

#### **CLASS 11—ENVIRONMENTAL CONTROL APPARATUS**

FOR ANTI-COLLISION LIGHTS, NAMELY, VERTICAL FIN, WING TIP, ENCLOSED WING TIP AND FUSELAGE MOUNTED FLASHING STROBE LIGHT APPARATUS FITTED TO AIRCRAFT, ALL TO BE MOUNTED IN A MANNER THAT PERMITS VESSELS TO DETERMINE THE TYPE AND RELATIVE ANGLE OF THE AIRCRAFT AND THUS DETERMINE THE RISK OF COLLISION; ANTI-COLLISION LIGHTS, NAMELY, ELECTRIC WARNING LIGHTS, FLASHING STROBE LIGHT APPARATUS, MOUNTED ON SEA VESSELS, TO BE MOUNTED IN A MANNER THAT PERMITS VESSELS TO DETERMINE THE TYPE AND RELATIVE ANGLE OF A VESSEL AND THUS DETERMINE THE RISK OF COLLISION; ANTI-COLLISION LIGHTS, NAMELY, ELECTRIC WARNING LIGHTS, FLASHING STROBE LIGHT APPARATUS, MOUNTED ON BUILDINGS OR TRANSMISSION MASTS, ALL TO BE MOUNTED IN A MANNER THAT PERMITS VESSELS TO DETERMINE THE RELATIVE ANGLE OF A MAST OR BUILDING AND THUS DETERMINE THE RISK OF COLLISION; LED LIGHTS, NAMELY, LED LIGHTING FIXTURES; LIGHTING FIXTURES USING LIGHT EMITTING DIODES (U.S. CLS. 13, 21, 23, 31 AND 34).

CARYN GLASSER, EXAMINING ATTORNEY

SN 79-076,706. OXLEY DEVELOPMENTS COMPANY LIMITED, UNITED KINGDOM, FILED 11-25-2009.

THE MARK CONSISTS OF STANDARD CHARACTERS WITHOUT CLAIM TO ANY PARTICULAR FONT, STYLE, SIZE, OR COLOR.

PRIORITY DATE OF 11-20-2009 IS CLAIMED.  
OWNER OF INTERNATIONAL REGISTRATION 1023140 DATED 11-25-2009, EXPIRES 11-25-2019.

#### **CLASS 9—ELECTRICAL AND SCIENTIFIC APPARATUS**

FOR LIGHT EMITTING DIODES (U.S. CLS. 21, 23, 26, 36 AND 38).

#### **CLASS 11—ENVIRONMENTAL CONTROL APPARATUS**

FOR ANTI-COLLISION LIGHTS, NAMELY, VERTICAL FIN, WING TIP, ENCLOSED WING TIP AND FUSELAGE MOUNTED FLASHING STROBE LIGHT APPARATUS FITTED TO AIRCRAFT, ALL TO BE MOUNTED IN A MANNER THAT PERMITS VESSELS TO DETERMINE THE TYPE AND RELATIVE ANGLE OF THE AIRCRAFT AND THUS DETERMINE THE RISK OF COLLISION; ANTI-COLLISION LIGHTS, NAMELY, ELECTRIC WARNING LIGHTS, FLASHING STROBE LIGHT APPARATUS, MOUNTED ON SEA VESSELS, TO BE MOUNTED IN A MANNER THAT PERMITS VESSELS TO DETERMINE THE TYPE AND RELATIVE ANGLE OF A VESSEL AND THUS DETERMINE THE RISK OF COLLISION; ANTI-COLLISION LIGHTS, NAMELY, ELECTRIC WARNING LIGHTS, FLASHING STROBE LIGHT APPARATUS, MOUNTED ON BUILDINGS OR TRANSMISSION MASTS, ALL TO BE MOUNTED IN A MANNER THAT PERMITS VESSELS TO DETERMINE THE RELATIVE ANGLE OF A MAST OR BUILDING AND THUS DETERMINE THE RISK OF COLLISION; LED LIGHTS, NAMELY, LED LIGHTING FIXTURES; LIGHTING FIXTURES USING LIGHT EMITTING DIODES (U.S. CLS. 13, 21, 23, 31 AND 34).

CARYN GLASSER, EXAMINING ATTORNEY

SN 79-076,773. METSÄ TISSUE OYJ, FINLAND, FILED 11-19-2009.

SN 79-076,774. METSÄ TISSUE OYJ, FI-02100 ESPOO, FINLAND, FILED 11-19-2009.

# LAMBI

THE MARK CONSISTS OF STANDARD CHARACTERS WITHOUT CLAIM TO ANY PARTICULAR FONT, STYLE, SIZE, OR COLOR.

PRIORITY DATE OF 5-20-2009 IS CLAIMED.

OWNER OF INTERNATIONAL REGISTRATION 1023383 DATED 11-19-2009, EXPIRES 11-19-2019.

THE WORDING "LAMBI" HAS NO MEANING IN A FOREIGN LANGUAGE.

### CLASS 3—COSMETICS AND CLEANING PREPARATIONS

FOR CLEANING PREPARATIONS; SOAPS; PERFUMERY, ESSENTIAL OILS, COSMETICS, NAMELY, PRE-MOISTENED COSMETIC WIPES FOR SANITARY AND COSMETIC PURPOSES; HAIR LOTIONS (U.S. CLS. 1, 4, 6, 50, 51 AND 52).

### CLASS 4—LUBRICANTS AND FUELS

FOR CANDLES AND WICKS FOR CANDLES AND OIL LAMPS FOR LIGHTING (U.S. CLS. 1, 6 AND 15).

### CLASS 16—PAPER GOODS AND PRINTED MATTER

FOR PAPER, CARDBOARD AND GOODS MADE FROM THESE MATERIALS, NOT INCLUDED IN OTHER CLASSES, NAMELY, SOFT PAPER PRODUCTS IN THE NATURE OF PAPER TOWELS FOR DRYING AND CLEANING FOR USE IN SERVICE INSTALLATIONS AND IN INDUSTRY, PAPER NAPKINS, PAPER TABLE CLOTHS; WRAPPING AND PACKAGING MATERIALS, NAMELY, WRAPPING PAPER; FACE TOWELS OF PAPER, TOILET PAPER, DISPOSABLE WIPES NOT IMPREGNATED WITH CHEMICALS OR COMPOUNDS, CELLULOSE WIPES, PAPER HANDKERCHIEFS, AND BABIES' DIAPERS OF PAPER CELLULOSE; PRINTED MATTER, NAMELY, INFORMATIONAL LEAFLETS IN THE FIELD OF PAPER AND TISSUE PRODUCTS, CHILDREN'S BOOKS, COLORING BOOKS; PLASTIC MATERIALS FOR PACKAGING NOT INCLUDED IN OTHER CLASSES, NAMELY, PLASTIC BAGS; CLOTHS OF PAPER, NAMELY, PAPER TOWELS (U.S. CLS. 2, 5, 22, 23, 29, 37, 38 AND 50).

### CLASS 21—HOUSEWARES AND GLASS

FOR HOUSEHOLD AND KITCHEN UTENSILS AND CONTAINERS, NAMELY, DISPOSABLE TABLEWARE OTHER THAN KNIVES, FORKS AND SPOONS IN THE NATURE OF PLASTIC STORAGE CONTAINERS FOR HOUSEHOLD USE; HOLDERS, CONTAINERS AND DISPENSERS FOR KITCHEN ROLLS, TOILET PAPER, NAPKINS AND HAND TOWELS; ARTICLES FOR CLEANING PURPOSES, NAMELY, SOAP DISHES, SOAP BOXES, SOAP DISPENSERS, TOWELS AND CLOTHS FOR CLEANING, NOT OF WOVEN FABRICS (U.S. CLS. 2, 13, 23, 29, 30, 33, 40 AND 50).

### CLASS 28—TOYS AND SPORTING GOODS

FOR GAMES AND PLAYTHINGS, NAMELY, CARD GAMES, BOARD GAMES, TOY ANIMALS, STUFFED TOYS, TOY FIGURES, DOLLS; DECORATIONS, NAMELY, PAPER PARTY HATS (U.S. CLS. 22, 23, 38 AND 50).

RAMONA ORTIGA, EXAMINING ATTORNEY



PRIORITY DATE OF 5-20-2009 IS CLAIMED.

OWNER OF INTERNATIONAL REGISTRATION 1023384 DATED 11-19-2009, EXPIRES 11-19-2019.

THE MARK CONSISTS OF A PICTURE OF A LAMB AND A BANNER WITH THE WORD "LAMBI" THEREON.

THE WORDING "LAMBI" HAS NO MEANING IN A FOREIGN LANGUAGE.

### CLASS 3—COSMETICS AND CLEANING PREPARATIONS

FOR CLEANING PREPARATIONS; SOAPS; PERFUMERY, ESSENTIAL OILS, COSMETICS, NAMELY, PRE-MOISTENED COSMETIC WIPES FOR SANITARY AND COSMETIC PURPOSES; HAIR LOTIONS (U.S. CLS. 1, 4, 6, 50, 51 AND 52).

### CLASS 4—LUBRICANTS AND FUELS

FOR CANDLES AND WICKS FOR CANDLES AND OIL LAMPS FOR LIGHTING (U.S. CLS. 1, 6 AND 15).

### CLASS 16—PAPER GOODS AND PRINTED MATTER

FOR PAPER, CARDBOARD AND GOODS MADE FROM THESE MATERIALS, NOT INCLUDED IN OTHER CLASSES, NAMELY, SOFT PAPER PRODUCTS IN THE NATURE OF PAPER TOWELS FOR DRYING AND CLEANING FOR USE IN SERVICE INSTALLATIONS AND IN INDUSTRY, PAPER NAPKINS, PAPER TABLE CLOTHS; WRAPPING AND PACKAGING MATERIALS, NAMELY, WRAPPING PAPER; FACE TOWELS OF PAPER, TOILET PAPER, DISPOSABLE WIPES NOT IMPREGNATED WITH CHEMICALS OR COMPOUNDS, CELLULOSE WIPES, PAPER HANDKERCHIEFS, AND BABIES' DIAPERS OF PAPER CELLULOSE; PRINTED MATTER, NAMELY, INFORMATIONAL LEAFLETS IN THE FIELD OF PAPER AND TISSUE PRODUCTS, CHILDREN'S BOOKS, COLORING BOOKS; PLASTIC MATERIALS FOR PACKAGING NOT INCLUDED IN OTHER CLASSES, NAMELY, PLASTIC BAGS; CLOTHS OF PAPER, NAMELY, PAPER TOWELS (U.S. CLS. 2, 5, 22, 23, 29, 37, 38 AND 50).

### CLASS 21—HOUSEWARES AND GLASS

FOR HOUSEHOLD AND KITCHEN UTENSILS AND CONTAINERS, NAMELY, DISPOSABLE TABLEWARE OTHER THAN KNIVES, FORKS AND SPOONS IN THE NATURE OF PLASTIC STORAGE CONTAINERS FOR HOUSEHOLD USE; HOLDERS, CONTAINERS AND DISPENSERS FOR KITCHEN ROLLS, TOILET PAPER, NAPKINS AND HAND TOWELS; ARTICLES FOR CLEANING PURPOSES, NAMELY, SOAP DISHES, SOAP BOXES, SOAP DISPENSERS, TOWELS AND CLOTHS FOR CLEANING, NOT OF WOVEN FABRICS (U.S. CLS. 2, 13, 23, 29, 30, 33, 40 AND 50).

**CLASS 28—TOYS AND SPORTING GOODS**

FOR GAMES AND PLAYTHINGS, NAMELY, CARD GAMES, BOARD GAMES, TOY ANIMALS, STUFFED TOYS, TOY FIGURES, DOLLS; DECORATIONS, NAMELY, PAPER PARTY HATS (U.S. CLS. 22, 23, 38 AND 50).

RAMONA ORTIGA, EXAMINING ATTORNEY

---

SN 79-077,014. MEDIAMONKS MULTIMEDIA HOLDING B.V., NETHERLANDS, FILED 11-16-2009.

# MediaMonks

THE MARK CONSISTS OF STANDARD CHARACTERS WITHOUT CLAIM TO ANY PARTICULAR FONT, STYLE, SIZE, OR COLOR.

OWNER OF INTERNATIONAL REGISTRATION 1024069 DATED 11-16-2009, EXPIRES 11-16-2019.

**CLASS 35—ADVERTISING AND BUSINESS**

FOR ON-LINE ADVERTISING ON A COMPUTER NETWORK (U.S. CLS. 100, 101 AND 102).

**CLASS 38—COMMUNICATION**

FOR SERVICE PROVIDERS, NAMELY, PROVIDING USER ACCESS TO A GLOBAL COMPUTER NETWORK (U.S. CLS. 100, 101 AND 104).

**CLASS 42—SCIENTIFIC AND COMPUTER SERVICES**

FOR CREATING AND MAINTAINING WEB SITES FOR OTHERS; COMPUTER SYSTEM DESIGN (U.S. CLS. 100 AND 101).

TINA BROWN, EXAMINING ATTORNEY

---

SN 79-077,429. SIEMENS AKTIENGESELLSCHAFT, FED REP GERMANY, FILED 11-20-2009.

# CAPPA C-Nav

THE MARK CONSISTS OF STANDARD CHARACTERS WITHOUT CLAIM TO ANY PARTICULAR FONT, STYLE, SIZE, OR COLOR.

OWNER OF INTERNATIONAL REGISTRATION 1025206 DATED 11-20-2009, EXPIRES 11-20-2019.

**CLASS 10—MEDICAL APPARATUS**

FOR SURGICAL AND MEDICAL APPARATUS AND INSTRUMENTS FOR COMPUTER-ASSISTED SPINE SURGERY, TRAUMA SURGERY, AND GENERAL SURGERY AND FOR THE LOCATION OF ANATOMICAL STRUCTURES AND PLACEMENT OF INSTRUMENTS AND PEDICLE/FIXATION SCREWS IN OPEN AND PERCUTANEOUS SURGICAL PROCEDURES; APPARATUS OF MEDICAL PHYSICS, NAMELY, COMPUTED TOMOGRAPHY AND MEDICAL NUCLEAR MEDICINE DIAGNOSTIC IMAGING APPARATUS; SURGICAL IMPLANTS COMPRISING ARTIFICIAL MATERIALS, ARTIFICIAL LIMBS; X-RAY APPARATUS AND TUBES FOR MEDICAL PURPOSES; COMPUTER DISPLAYS AND COMPUTER MONITORS AND CONTROLLERS THEREFOR USED IN DIRECT ASSOCIATION WITH MEDICAL DIAGNOSIS APPARATUS FOR USE IN RETRIEVING, PROCESSING AND DISPLAYING PATIENT DATA AND VIEWING IMAGES OF ANATOMICALLY RELEVANT REGIONS OF PATIENTS, TRACKING INSTRUMENTS AND SCREW IMPLANTS, PLANNING TRAJECTORIES AND DISPLAYING PLANNING INFORMATION TOGETHER WITH THE SIMULATED IMAGES FOR COMPUTER ASSISTED SURGICAL PROCEDURES; NONE OF THE AFORESAID GOODS FOR USE IN CONNECTION WITH DEVICES FOR THE HEART OR PACEMAKERS, OR FOR THE DIAGNOSIS OR TREATMENT OF HEART DISORDERS (U.S. CLS. 26, 39 AND 44).

**CLASS 41—EDUCATION AND ENTERTAINMENT**

FOR ORGANISATION AND CONDUCTING OF SEMINARS AND TRAINING IN THE FIELD OF MEDICAL PHYSICS AND COMPUTER ASSISTED SURGERY; NONE OF THE AFORESAID SERVICES FOR USE IN CONNECTION WITH DEVICES FOR THE HEART OR PACEMAKERS, OR FOR THE DIAGNOSIS OR TREATMENT OF HEART DISORDERS (U.S. CLS. 100, 101 AND 107).

**CLASS 42—SCIENTIFIC AND COMPUTER SERVICES**

FOR DEVELOPMENT OF COMPUTER PROGRAMS FOR DATA PROCESSING, ESPECIALLY FOR MEDICAL PURPOSES; SERVICES OF A DATA BANK, NAMELY, DESIGN, DEVELOPMENT, MAINTENANCE, AND UPDATING OF DATABASES FOR OTHERS; RESEARCH AND DEVELOPMENT IN THE FIELD OF DATA PROCESSING; CONSULTANCY IN THE FIELD OF COMPUTERS; UPDATING OF COMPUTER SOFTWARE; COMPUTER SOFTWARE DESIGN; COMPUTER SOFTWARE RENTAL; DEVELOPMENT AND ESTABLISHMENT OF TESTING PROCEDURES OF MEDICAL PHYSICS, NAMELY, COMPUTER ASSISTED SURGICAL PROCEDURES; DEVELOPMENT OF NEW MEDICAL APPARATUS TECHNOLOGY IN THE FIELD OF MEDICAL PHYSICS; SCIENTIFIC AND INDUSTRIAL RESEARCH IN THE FIELD OF MEDICAL PHYSICS; ENGINEERING SERVICES; PHYSICS RESEARCH; NONE OF THE AFORESAID SERVICES FOR USE IN CONNECTION WITH DEVICES FOR THE HEART OR PACEMAKERS, OR FOR THE DIAGNOSIS OR TREATMENT OF HEART DISORDERS (U.S. CLS. 100 AND 101).

MARIAM MAHMOUDI, EXAMINING ATTORNEY

---

SN 79-077,650. MARKS AND SPENCER PLC, UNITED KINGDOM, FILED 12-18-2009.

**MARKS & SPENCER INDIGO COLLECTION**

THE MARK CONSISTS OF STANDARD CHARACTERS WITHOUT CLAIM TO ANY PARTICULAR FONT, STYLE, SIZE, OR COLOR.

PRIORITY DATE OF 6-24-2009 IS CLAIMED.

OWNER OF INTERNATIONAL REGISTRATION 1025838 DATED 12-18-2009, EXPIRES 12-18-2019.

OWNER OF U.S. REG. NO. 3,737,016.

NO CLAIM IS MADE TO THE EXCLUSIVE RIGHT TO USE "COLLECTION", APART FROM THE MARK AS SHOWN.

SN 79-077,795. BMG RIGHTS MANAGEMENT GMBH, 10178 BERLIN, FED REP GERMANY, FILED 10-20-2009.

### CLASS 3—COSMETICS AND CLEANING PREPARATIONS

FOR COSMETICS; PERFUMES; ESSENTIAL OILS; NON-MEDICATED TOILETRIES; DEODORANTS FOR PERSONAL USE; ANTIPERSPIRANTS; EAU DE COLOGNE; SOAPS; DETERGENTS FOR HOUSEHOLD USE NOT BEING FOR USE IN INDUSTRIAL OR MANUFACTURING PROCESSES OR FOR MEDICAL USE; WASHING POWDERS; WASHING UP LIQUID; PREPARATIONS FOR LAUNDRY USE, NAMELY, BLEACH AND LAUNDRY DETERGENT; FABRIC SOFTENER; CLEANSING AND POLISHING PREPARATIONS; CLEANING PREPARATIONS FOR HOUSEHOLD PURPOSES, NAMELY, BLEACH; HAIR SHampoos; COSMETIC PREPARATIONS FOR THE HAIR; DENTIFRICES; DEPILATORY PREPARATIONS; FALSE NAILS; PREPARATIONS FOR THE CARE OF THE SKIN, BATH PREPARATIONS, AFTERSHAVE LOTIONS AND SHAVING CREAMS, ALL BEING NON-MEDICATED; ROOM FRAGRANCES (U.S. CLS. 1, 4, 6, 50, 51 AND 52).

### CLASS 14—JEWELRY

FOR PRECIOUS METALS AND THEIR ALLOYS, NAMELY, PLATINUM, GOLD, SILVER, PALLADIUM, RHODIUM, ELECTRUM, ROSE GOLD, STERLING SILVER, WHITE GOLD; AND GOODS IN PRECIOUS METALS OR COATED THEREWITH, NAMELY, RINGS, NECKLACES, PENDANTS, BRACELETS, EARRINGS, BANGLES, BROACHES, CUFFLINKS, TIEPINS, WATCHES; JEWELRY, PRECIOUS STONES, HOROLOGICAL AND CHRONOMETRIC INSTRUMENTS (U.S. CLS. 2, 27, 28 AND 50).

### CLASS 18—LEATHER GOODS

FOR ARTICLES MADE OF LEATHER OR IMITATION LEATHER, NAMELY, LEATHER BAGS, IMITATION LEATHER BAGS, WALLETS, PURSES, LEATHER SHOPPING BAGS, IMITATION LEATHER SHOPPING BAGS, BRIEFCASES, LEATHER KEY BAGS, IMITATION LEATHER KEY BAGS, LEATHER COSMETIC BAGS SOLD EMPTY, IMITATION LEATHER BAGS SOLD EMPTY, LEATHER BAGS FOR TOILETRIES SOLD EMPTY, IMITATION LEATHER BAGS FOR TOILETRIES SOLD EMPTY, BUMBAGS, AND SUITCASES; SKINS AND HIDES; REUSABLE SHOPPING BAGS; HANDBAGS; TRUNKS IN THE NATURE OF LUGGAGE; TRAVELLING BAGS, UMBRELLAS, PARASOLS, WALKING STICKS, RUCKSACKS, HAVERSACKS; ALL-PURPOSE SPORT BAGS, NAMELY, BAGS FOR CAMPERS OR CLIMBERS; BEACH BAGS; LUGGAGE STRAPS; LUGGAGE TAGS; FABRIC CARRIER BAGS, NAMELY SUIT CARRIERS (U.S. CLS. 1, 2, 3, 22 AND 41).

### CLASS 25—CLOTHING

FOR CLOTHING FOR MEN, WOMEN, CHILDREN, AND BABIES, NAMELY, TROUSERS, JEANS, SKIRTS, DRESSES, SHORTS, BLOUSES, SHIRTS, JACKETS, SUITS, COATS, T-SHIRTS, JUMPERS, CARDIGANS, FLEECE TOPS, BELTS, SOCKS, UNDERWEAR, LINGERIE, HOSIERY, TIES, BOW-TIES, SCARVES, SWIMMING COSTUMES, SWIMMING PANTS, BIKINIS, PAJAMAS, GLOVES, JOGGING PANTS, TRACK SUITS, AEROBIC GEAR, NAMELY, MOISTURE-WICKING SPORTS SHIRTS, PANTS AND BRAS; FOOTWEAR; HEADGEAR, NAMELY, HEADWEAR, HATS, CAPS, SCARVES (U.S. CLS. 22 AND 39).

TRACY WHITTAKER-BROWN, EXAMINING ATTORNEY

THE MARK CONSISTS OF STANDARD CHARACTERS WITHOUT CLAIM TO ANY PARTICULAR FONT, STYLE, SIZE, OR COLOR.

PRIORITY DATE OF 4-21-2009 IS CLAIMED.

OWNER OF INTERNATIONAL REGISTRATION 1026148 DATED 10-20-2009, EXPIRES 10-20-2019.

### CLASS 9—ELECTRICAL AND SCIENTIFIC APPARATUS

FOR MUSICAL SOUND RECORDINGS; AUDIOVISUAL RECORDINGS FEATURING MUSIC AND MUSICAL ENTERTAINMENT; DOWNLOADABLE MUSICAL SOUND RECORDINGS; DOWNLOADABLE AUDIOVISUAL RECORDINGS FEATURING MUSIC AND MUSICAL ENTERTAINMENT; PRE-RECORDED DVDS, CDS FEATURING MUSIC AND MUSICAL ENTERTAINMENT; INTERACTIVE APPLICATIONS INCLUDED IN THIS CLASS, NAMELY, CD-ROMS FEATURING MUSIC AND MUSICAL ENTERTAINMENT; COMPUTER SOFTWARE AND COMPUTER PROGRAMS USED TO ACCESS AND DOWNLOAD SOUND RECORDINGS AND AUDIO-VISUAL RECORDINGS IN THE FIELD OF MUSIC; COMPUTER GAME SOFTWARE AND COMPUTER GAME PROGRAMS; DOWNLOADABLE ELECTRONIC PUBLICATIONS IN THE NATURE OF MAGAZINES, NEWSLETTERS, CATALOGS, AND BOOKLETS IN THE FIELDS OF MUSIC, THE MUSIC INDUSTRY, MUSICAL ENTERTAINMENT, MUSICAL RECORDINGS, AND MUSICAL ARTISTS; SOUND FILES IN MACHINE-READABLE FORM, RECORDED AND DOWNLOADABLE, NAMELY, MUSICAL RECORDINGS INCLUDED IN THIS CLASS; IMAGE AND SOUND FILES IN MACHINE-READABLE FORM, RECORDED AND DOWNLOADABLE, NAMELY, MUSICAL AUDIO-VISUAL RECORDINGS INCLUDED IN THIS CLASS; DOWNLOADABLE RING TONES VIA THE INTERNET AND WIRELESS DEVICES; MAGNETICALLY ENCODED PRE-PAID TELEPHONE CARDS; SMART CARDS CONTAINING PROGRAMMING USED TO DOWNLOAD RECORDINGS AND AUDIO-VISUAL RECORDINGS IN THE FIELD OF MUSIC (U.S. CLS. 21, 23, 26, 36 AND 38).

### CLASS 16—PAPER GOODS AND PRINTED MATTER

FOR PRINTED MATTER, NAMELY, BOOKS, MAGAZINES, NEWSLETTERS, CATALOGS, AND BOOKLETS IN THE FIELDS OF MUSIC, THE MUSIC INDUSTRY, MUSICAL ENTERTAINMENT, MUSICAL RECORDINGS, AND MUSICAL ARTISTS; SHEET MUSIC; PHOTOGRAPHS; POSTERS; STATIONERY; TRANSFERS, STICKERS, DECALS, TEMPORARY TATTOOS; OFFICE REQUISITES, NAMELY, ENVELOPES, WRITING PADS, OFFICE STATIONERY; PRINTED INSTRUCTIONAL AND TEACHING MATERIAL IN THE FIELDS OF THE MUSIC INDUSTRY, MUSICAL ENTERTAINMENT, MUSICAL RECORDINGS, AND MUSICAL ARTISTS, NONE OF THE FOREGOING INCLUDING APPARATUS; PACKAGING MATERIALS OF PLASTIC, INCLUDED IN THIS CLASS, NAMELY, CORRUGATED BOXES, PLASTIC WRAP; PRINTED TELEPHONE CARDS, NAMELY, TELEPHONE CALLING CARDS, NOT MAGNETICALLY ENCODED; ENTRY TICKETS (U.S. CLS. 2, 5, 22, 23, 29, 37, 38 AND 50).

**CLASS 35—ADVERTISING AND BUSINESS**

FOR ADVERTISING SERVICES; MARKETING SERVICES; SALES PROMOTION SERVICES FOR OTHERS; MARKETING AND SALES PROMOTION SERVICES, NAMELY, ONLINE RETAIL STORE SERVICES FEATURING SOUND RECORDINGS, AUDIO-VISUAL RECORDINGS, MUSIC MERCHANDISE, MERCHANDISE OF BANDS, MERCHANDISE FROM MUSICAL TOURS, RINGTONES; PUBLIC RELATIONS; BUSINESS MANAGEMENT OF PERFORMING ARTISTS; PRODUCT MERCHANDISING; COMMERCIAL MANAGEMENT IN THE NATURE OF COMMERCIAL ADMINISTRATION OF THE LICENSING OF GOODS AND SERVICES, FOR OTHERS (U.S. CLS. 100, 101 AND 102).

**CLASS 38—COMMUNICATION**

FOR TELECOMMUNICATION ACCESS SERVICE; TELECOMMUNICATIONS BY MEANS OF PORTALS AND PLATFORMS ON THE INTERNET; PROVIDING ACCESS TO INFORMATION NETWORK ON THE INTERNET; PROVIDING CHATROOMS ON THE INTERNET; ELECTRONIC MESSAGE AND IMAGE SENDING; PROVIDING CHATROOMS FOR THE ELECTRONIC EXCHANGE OF MESSAGES BY MEANS OF CHATLINES ON THE INTERNET, CHATROOMS ON THE INTERNET AND INTERNET FORUMS; RENTAL OF ACCESS TIME TO GLOBAL COMPUTER NETWORKS; BROADCASTING AND TRANSMISSION OF TELEVISION AND RADIO PROGRAMS; TRANSMISSION OF MESSAGES, INFORMATION, SOUND, IMAGES, MUSIC, SIGNALS AND DATA VIA THE INTERNET, NAMELY, STREAMING OF AUDIO, VISUAL AND AUDIOVISUAL MATERIAL VIA A GLOBAL COMPUTER NETWORK, STREAMING OF MUSIC AND VIDEO MATERIAL ON THE INTERNET (U.S. CLS. 100, 101 AND 104).

**CLASS 41—EDUCATION AND ENTERTAINMENT**

FOR EDUCATIONAL SERVICES, NAMELY, PROVIDING CLASSES, SEMINARS, WORKSHOPS, TRAINING IN THE FIELDS OF MUSIC, THE MUSIC INDUSTRY, MUSICAL ENTERTAINMENT, MUSICAL RECORDINGS, AND MUSICAL ARTISTS, PRODUCING RECORDINGS AND ORGANIZING MUSICAL TOURS; ENTERTAINMENT SERVICES, NAMELY, PROVIDING A WEBSITE FEATURING INFORMATION IN THE FIELD OF MUSIC AND PROVIDING A WEBSITE FEATURING INFORMATION IN THE FIELD OF MUSICAL SOUND RECORDINGS, VIDEO CLIPS, AUDIOVISUAL RECORDINGS FEATURING MUSIC AND MUSICAL ARTISTS, THEIR HISTORIES, THEIR PROFESSIONAL ENGAGEMENTS AND THEIR MUSICAL RECORDINGS AND OTHER ENTERTAINMENT INFORMATION; ENTERTAINMENT SERVICES, NAMELY, ARRANGING AND CONDUCTING CONCERTS, PRESENTATION OF LIVE SHOW PERFORMANCES, ORGANIZING A MUSICAL FESTIVAL, CONCERTS AND TOURS OF MUSICAL GROUPS FOR CONCERTS, LIVE MUSICAL PERFORMANCES AND PROVIDING INFORMATION ON MUSICAL FESTIVALS, MUSIC GROUPS AND INFORMATION ON THE MUSICAL GROUPS APPEARING IN SUCH A FESTIVAL BY MEANS OF A WEBSITE AND A GLOBAL COMPUTER NETWORK; ORGANIZING COMMUNITY SPORTING AND CULTURAL ACTIVITIES; MUSIC PUBLISHING SERVICES; PUBLISHING ELECTRONIC PUBLICATIONS, NOT DOWNLOADABLE; PUBLICATION OF TEXTS OTHER THAN PUBLICITY TEXTS; SERVICES OF A PUBLISHING FIRM, EXCEPT PRINTING, IN THE NATURE OF PUBLISHING OF ELECTRONIC PUBLICATIONS, BOOKS AND MAGAZINES; PUBLISHING PRINTED MATTER OTHER THAN FOR ADVERTISING PURPOSES IN ELECTRONIC FORM, NAMELY, ONLINE ELECTRONIC PUBLISHING OF BOOKS, SONGBOOKS, AND SHEET MUSIC; ORGANIZATION OF SPORTS COMPETITIONS FOR EDUCATION AND ENTERTAINMENT; EDITING OF RADIO AND TELEVISION PROGRAMS; ENTERTAINMENT SERVICES, NAMELY, ARTISTS' SERVICES IN THE NATURE OF LIVE MUSICAL PERFORMANCES; TICKET RESERVATION AND BOOKING SERVICES FOR ENTERTAINMENT IN THE FIELDS OF SPORTING, ENTERTAINMENT, AND CULTURAL EVENTS AND SCIENCE EXPOSITIONS; PROVIDING RADIO AND TELEVISION PROGRAMS IN THE

FIELD OF MUSIC, THE MUSIC INDUSTRY, MUSICAL ENTERTAINMENT, MUSICAL RECORDINGS, AND MUSICAL ARTISTS; EDUCATIONAL AND ENTERTAINMENT SERVICES, NAMELY, CONTINUING PROGRAMS ABOUT MUSIC, MUSICAL GROUPS, MUSICAL RECORDINGS, MUSICAL VIDEO RECORDINGS ACCESSIBLE BY RADIO, TELEVISION, MOBILE PHONES, AND COMPUTER NETWORKS; PRESENTATION OF MUSICAL PERFORMANCES; PRODUCTION OF TELEVISION SHOWS, FILMS, TELEVISION PROGRAMS, AUDIO, VIDEO AND CINEMATOGRAPHIC RECORDINGS; ORGANIZATION OF ENTERTAINMENT SHOWS, NAMELY, PRODUCTION OF TELEVISION SHOWS; MUSIC PRODUCTION SERVICES; SOUND RECORDING STUDIO SERVICES; COMPOSING OF MUSIC FOR OTHERS, FILM PRODUCTION (U.S. CLS. 100, 101 AND 107).

**CLASS 45—PERSONAL AND LEGAL SERVICES**

FOR LICENSING OF INTELLECTUAL PROPERTY RIGHTS AND COPYRIGHTS; COPYRIGHT MANAGEMENT; LICENSING OF INTELLECTUAL PROPERTY AND LEGAL RIGHTS IN FILM, TELEVISION AND VIDEO (U.S. CLS. 100 AND 101).  
 NAPOLEON SHARMA, EXAMINING ATTORNEY

SN 79-077,831. BIJOU BRIGITTE MODISCHE ACCESSOIRES AG, FED REP GERMANY, FILED 12-10-2009.



PRIORITY DATE OF 9-12-2009 IS CLAIMED.  
 OWNER OF INTERNATIONAL REGISTRATION 1026234 DATED 12-10-2009, EXPIRES 12-10-2019.

OWNER OF U.S. REG. NOS. 3,142,386, 3,211,516 AND 3,725,800.

NO CLAIM IS MADE TO THE EXCLUSIVE RIGHT TO USE "BEADS", "BIJOU" AND "925 SILVER", APART FROM THE MARK AS SHOWN.

THE NAME(S), PORTRAIT(S), AND/OR SIGNATURE(S) SHOWN IN THE MARK DOES NOT IDENTIFY A PARTICULAR LIVING INDIVIDUAL.

THE COLOR(S) RED, BLACK AND GREY IS/ARE CLAIMED AS A FEATURE OF THE MARK.

THE MARK CONSISTS OF "BEADS 925 SILVER BY BIJOU BRIGITTE" IN STYLIZED WORDING WITH THE LETTERS "BB" FAINTLY DISPLAYED IN THE BACKGROUND. THE TERM "BEADS" IS IN RED, THE TERMS "925 SILVER" IS IN BLACK, THE TERMS "BY BIJOU BRIGITTE" IS IN RED, AND THE LETTERS "BB" IS IN GRAY.

THE ENGLISH TRANSLATION OF "BIJOU" IN THE MARK IS JEWEL.

**CLASS 14—JEWELRY**

FOR JEWELER'S GOODS, NAMELY, JEWELRY CHAINS CONTAINING 925 SILVER AND ASSORTED SILVER ITEMS CONTAINING 925 SILVER IN THE NATURE OF SILVER BRACELETS, SILVER BEADS, SILVER NECKLETS, SILVER KEY CHAINS, JEWELRY CONTAINING 925 SILVER, PRECIOUS STONES CONTAINING 925 SILVER (U.S. CLS. 2, 27, 28 AND 50).

**CLASS 16—PAPER GOODS AND PRINTED MATTER**

FOR PRINTED MATTER, NAMELY, INSTRUCTIONAL MATERIALS IN THE NATURE OF BOOKLETS AND BROCHURES IN THE FIELD OF JEWELRY-MAKING (U.S. CLS. 2, 5, 22, 23, 29, 37, 38 AND 50).  
JAMES STEIN, EXAMINING ATTORNEY

SN 79-077,935. SMART TRADE TECHNOLOGIES, F-13855  
AIX-EN-PROVENCE, FRANCE, FILED 8-10-2009.

# SMART TRADE TECHNOLOGIES

THE MARK CONSISTS OF STANDARD CHARACTERS WITHOUT CLAIM TO ANY PARTICULAR FONT, STYLE, SIZE, OR COLOR.

PRIORITY DATE OF 2-10-2009 IS CLAIMED.  
OWNER OF INTERNATIONAL REGISTRATION 1026514  
DATED 8-10-2009, EXPIRES 8-10-2019.

NO CLAIM IS MADE TO THE EXCLUSIVE RIGHT TO USE "TECHNOLOGIES", APART FROM THE MARK AS SHOWN.  
SEC. 2(F).

**CLASS 9—ELECTRICAL AND SCIENTIFIC APPARATUS**

FOR COMPUTER SERVERS FOR DATABASES; WIRELESS TRANSMITTERS AND RECEIVERS FOR USE IN COMPUTING AND COMMUNICATIONS; BLANK MAGNETIC DATA CARRIERS AND BLANK OPTICAL DATA CARRIERS FOR USE IN DATABASE DATA STORAGE; SEMI-CONDUCTOR MEMORY UNITS; MAGNETIC CARDS AND ELECTRONIC CIRCUIT CARDS, NAMELY, BANK CARDS AND CREDIT CARDS; MAGNETICALLY ENCODED DEBIT CARDS; COMPUTER SOFTWARE FOR ELECTRONIC FINANCIAL TRANSACTIONS, NAMELY, FOR PROCESSING AND AUTHENTICATING ELECTRONIC PAYMENTS; COMMUNICATIONS SOFTWARE FOR PROVIDING ACCESS TO COMPUTER OR DATA TRANSMISSION NETWORKS, NAMELY, PRIVATE INTRANET NETWORKS AND TO THE GLOBAL INTERNET; COMPUTERS, NAMELY, COMPUTER SERVERS FOR USE WITH ELECTRONIC FINANCIAL TRANSACTIONS; MODEMS; CONNECTORS FOR COMPUTER AND TELEPHONE NETWORK CABLES; ELECTRICAL AND OPTICAL CABLES; TELECOMMUNICATION AND MULTIMEDIA TERMINALS IN THE NATURE OF COMPUTERS; COMPUTER NETWORK HUBS, SWITCHES AND ROUTERS (U.S. CLS. 21, 23, 26, 36 AND 38).

**CLASS 37—CONSTRUCTION AND REPAIR**

FOR INSTALLATION, MAINTENANCE AND REPAIR OF DATABASE SERVERS AND TELECOMMUNICATIONS AND COMPUTER EQUIPMENT, NAMELY, EQUIPMENT FOR PROVIDING ACCESS TO COMPUTER OR DATA TRANSMISSION NETWORKS AND COMPUTERIZED ELECTRONIC TERMINALS USED FOR CONDUCTING ELECTRONIC FINANCIAL TRANSACTIONS; PROVIDING INFORMATION REGARDING THE INSTALLATION, MAINTENANCE AND REPAIR OF DATABASE SERVERS AND TELECOMMUNICATIONS AND COMPUTER EQUIPMENT, NAMELY, EQUIPMENT FOR PROVIDING ACCESS TO COMPUTER OR DATA TRANSMISSION NETWORKS AND COMPUTERIZED ELECTRONIC TERMINALS USED FOR CONDUCTING ELECTRONIC FINANCIAL TRANSACTIONS (U.S. CLS. 100, 103 AND 106).

**CLASS 38—COMMUNICATION**

FOR PROVIDING ACCESS TO DATABASES FOR USE IN CONNECTION WITH ELECTRONIC FINANCIAL TRANSACTIONS; PROVISION OF ACCESS TO DATA OR DOCUMENTS STORED ELECTRONICALLY IN CENTRAL FILES FOR REMOTE CONSULTATION IN CONNECTION WITH ELECTRONIC FINANCIAL TRANSACTIONS; COMMUNICATIONS BY COMPUTER TERMINALS IN CONNECTION WITH ELECTRONIC FINANCIAL TRANSACTIONS; ELECTRONIC TRANSMISSION OF MAIL, MESSAGES AND DATA VIA PRIVATE AND GLOBAL COMMUNICATION NETWORKS; SECURED ELECTRONIC TRANSMISSION OF DATA, SOUND OR IMAGES, PARTICULARLY IN CONNECTION WITH ELECTRONIC FINANCIAL TRANSACTIONS; ELECTRONIC MESSAGE SENDING; PROVISION OF TELECOMMUNICATION ACCESS TO DATA STORED ELECTRONICALLY IN A CENTRAL DATA BANK FOR REMOTE CONSULTATION VIA PRIVATE AND GLOBAL COMMUNICATION NETWORKS (U.S. CLS. 100, 101 AND 104).

**CLASS 42—SCIENTIFIC AND COMPUTER SERVICES**

FOR COMPUTER CONSULTATION RELATING TO COMPUTER EQUIPMENT, SOFTWARE AND SYSTEMS USED IN THE FIELD OF ELECTRONIC FINANCIAL TRANSACTIONS; TECHNICAL CONSULTING AND ASSISTANCE WITH COMPUTER-BASED INFORMATION SYSTEMS AND COMPONENTS, NAMELY, ASSISTANCE WITH SETTING UP AND OPTIMIZING DATABASE SERVERS, COMPUTER NETWORKING AND TELECOMMUNICATIONS SYSTEMS AND COMPUTERIZED ELECTRONIC TERMINALS USED IN CONNECTION WITH ELECTRONIC FINANCIAL TRANSACTIONS, AND PROVIDING COMPUTER MONITORING SERVICES WHICH TRACK THE HARDWARE PERFORMANCE AND PROCESSES OF THE SUCH EQUIPMENT; LEASING OF COMPUTERS; COMPUTER PROGRAMMING IN CONNECTION WITH ELECTRONIC FINANCIAL TRANSACTIONS; CONSULTING SERVICES IN CONNECTION WITH COMPUTERS; COMPUTER SOFTWARE DESIGN AND DEVELOPMENT, COMPUTER SOFTWARE MAINTENANCE SERVICES, COMPUTER SOFTWARE UPDATING SERVICES, ALL IN CONNECTION WITH ELECTRONIC FINANCIAL TRANSACTIONS; SCIENTIFIC RESEARCH IN CONNECTION WITH ELECTRONIC FINANCIAL TRANSACTIONS (U.S. CLS. 100 AND 101).

STEVEN PEREZ, EXAMINING ATTORNEY

SN 79-078,175. SCHLEICH GMBH, FED REP GERMANY,  
FILED 12-18-2009.

## Anywhere's a Playground

THE MARK CONSISTS OF STANDARD CHARACTERS WITHOUT CLAIM TO ANY PARTICULAR FONT, STYLE, SIZE, OR COLOR.

PRIORITY DATE OF 8-24-2009 IS CLAIMED.  
OWNER OF INTERNATIONAL REGISTRATION 1027024  
DATED 12-18-2009, EXPIRES 12-18-2019.



**CLASS 16—PAPER GOODS AND PRINTED MATTER**

FOR PAPER AND CARDBOARD; PAPER BOXES, PAPER BUNTING, PAPER DOILIES; PRINTED PAPER COLORING SHEETS; CARDBOARD SCORE CARDS FOR USE IN PLAY; PRINTED CARDBOARD COLLECTOR CARDS; CARDBOARD BOXES, CARDBOARD CARTONS; CARDBOARD PACKAGING; PRINTED MATTER, NAMELY, CATALOGUES IN THE FIELD OF TOYS, CHILDREN'S BOOKS, BOOKLETS FOR USE IN EDUCATIONAL CENTERS ON A VARIETY OF EDUCATIONAL DISCIPLINES IN PRE-SCHOOL THROUGH EIGHTH GRADE; BOOKBINDING MATERIALS; BOOKS, NAMELY, PAINTING BOOKS, NOTEBOOKS, AND CHILDREN'S BOOKS; PAPER DIE CUT SHAPES; PHOTOGRAPHS; STATIONERY; PAPER ADHESIVES FOR STATIONERY OR FOR HOUSEHOLD PURPOSES; ARTISTS MATERIALS, NAMELY, PAINT STIRRERS, PAINT ROLLERS, PENCILS, PENS, MARKERS; PAINT BRUSHES; TYPEWRITERS AND OFFICE REQUISITES, NAMELY, RUBBER BANDS, FRANKING MACHINES; PRINTED INSTRUCTIONAL AND TEACHING MATERIAL IN THE FIELD OF TOYS; PACKAGING MATERIALS MADE OF PLASTIC, NAMELY, BAGS, BUBBLE PACKS, PACKAGING MATERIAL MADE OF RECYCLED PAPER FOR TOYS; PRINTERS' TYPE, PRINTING BLOCKS (U.S. CLS. 2, 5, 22, 23, 29, 37, 38 AND 50).

**CLASS 28—TOYS AND SPORTING GOODS**

FOR GAMES, NAMELY, CARD GAMES; TOYS AND PLAYTHINGS, NAMELY, TOY ACTION FIGURES, TOY FIGURES, TOY FURNITURE, TOY HOUSES, TOY BUILDING BLOCKS CAPABLE OF INTERCONNECTION, TOY CONSTRUCTION SETS, DOLLS FOR PLAYING; TOYS, NAMELY, PLASTIC FIGURINES, PLASTIC ANIMALS AND FLEXIBLE FIGURINES (U.S. CLS. 22, 23, 38 AND 50).

**CLASS 41—EDUCATION AND ENTERTAINMENT**

FOR EDUCATION SERVICES, NAMELY, EDUCATION SERVICES IN THE NATURE OF EARLY CHILDHOOD INSTRUCTION; PUBLICATION OF BOOKS; EDUCATIONAL AND ENTERTAINMENT SERVICES FOR CHILDREN, NAMELY, PROVIDING INTERACTIVE PLAY AREAS, INSTRUCTIONAL CLASSES IN THE FIELD OF HISTORY, NATURE, MATH, SCIENCE, LANGUAGE, ART, LOGIC, AND GEOGRAPHY, AND SOCIAL GATHERINGS FOR CHILDREN; PROVIDING OF TRAINING OF CHILDREN IN THE FIELD OF USING ONE'S IMAGINATION AND OF STORYTELLING, MANUAL SKILLS AND DRAWING; ORGANIZING COMMUNITY SPORTING AND CULTURAL EVENTS; PUBLICATION OF MUSICAL TEXTS; PRODUCTION OF FILMS AND VIDEOS, INCLUDING ON THE INTERNET, IN PARTICULAR FOR CHILDREN; ENTERTAINMENT, NAMELY, PRODUCTION OF PLAYS, MUSICALS AND ENTERTAINMENT SHOWS, INCLUDING THE PRESENTATION OF PLAYS, MUSICALS AND ENTERTAINMENT SHOWS FOR CHILDREN (U.S. CLS. 100, 101 AND 107).

VIVIAN MICZNIK FIRST, EXAMINING ATTORNEY

SN 79-078,229, HUSKY INJECTION MOLDING SYSTEMS LTD., CANADA, FILED 11-12-2009.

# TARGETZERO

THE MARK CONSISTS OF STANDARD CHARACTERS WITHOUT CLAIM TO ANY PARTICULAR FONT, STYLE, SIZE, OR COLOR.

OWNER OF INTERNATIONAL REGISTRATION 1027165 DATED 11-12-2009, EXPIRES 11-12-2019.

**CLASS 35—ADVERTISING AND BUSINESS**

FOR ADVERTISING AND PROMOTION SERVICES IN THE NATURE OF ORGANIZATION OF EMPLOYEE INCENTIVE ENVIRONMENT AWARDS TO PROMOTE ON THE JOB ENVIRONMENTAL PROTECTION AND CONSERVATION (U.S. CLS. 100, 101 AND 102).

**CLASS 42—SCIENTIFIC AND COMPUTER SERVICES**

FOR ENVIRONMENTAL ADVISORY, SCIENTIFIC AND TECHNICAL SERVICES, NAMELY, TECHNICAL CONSULTING AND SCIENTIFIC RESEARCH RELATING TO TECHNOLOGY AND PROCESSES TO PRESERVE THE ENVIRONMENT FROM HUMAN INDUSTRIAL ACTIVITY (U.S. CLS. 100 AND 101).

HEATHER THOMPSON, EXAMINING ATTORNEY

SN 79-078,365, NORDMECCANICA S.P.A., ITALY, FILED 11-4-2009.



PRIORITY DATE OF 8-5-2009 IS CLAIMED.  
OWNER OF INTERNATIONAL REGISTRATION 1027412 DATED 11-4-2009, EXPIRES 11-4-2019.

NO CLAIM IS MADE TO THE EXCLUSIVE RIGHT TO USE "TRIPLEX" "1 SHOT", APART FROM THE MARK AS SHOWN.

THE MARK CONSISTS OF THE WORDING TRIPLEX SL 1 SHOT IN STYLIZED FORM, WITH A DESIGN OF CURVED BANDS ORIGINATING BETWEEN THE LETTERS "H" AND "O".

**CLASS 7—MACHINERY**

FOR MACHINES AND INSTALLATIONS FOR THE GRAPHICAL AND CARDBOARD INDUSTRIES, NAMELY, MACHINES FOR BONDING FILMS AND/OR PAPER AND PARTS THEREOF; ADHESIVE SPREADING MACHINES; PRINTING MACHINES FOR COMMERCIAL OR INDUSTRIAL USE; FLEXOGRAPHIC PRINTING MACHINES AND PARTS THEREOF; PRINTING ROLLERS; STOCKS FOR PRINTING ROLLERS, NAMELY, RACKS FOR SUPPORTING PRINTING ROLLERS (U.S. CLS. 13, 19, 21, 23, 31, 34 AND 35).

**CLASS 9—ELECTRICAL AND SCIENTIFIC APPARATUS**

FOR METERING MACHINES, NAMELY, CONTROLLED-VOLUME METERING PUMPS FOR DISPENSING ADHESIVES AND SEALANTS; AUTOMATED DISPENSING MACHINES FOR DISPENSING MIXED, METERED QUANTITIES OF ADHESIVES (U.S. CLS. 21, 23, 26, 36 AND 38).

ALLISON HOLTZ, EXAMINING ATTORNEY

SN 79-078,402. SOLAR-FABRIK AG, FED REP GERMANY,  
FILED 10-2-2009.



PRIORITY DATE OF 9-23-2009 IS CLAIMED.

OWNER OF INTERNATIONAL REGISTRATION 1027513  
DATED 10-2-2009, EXPIRES 10-2-2019.

NO CLAIM IS MADE TO THE EXCLUSIVE RIGHT TO  
USE "SOLAR", APART FROM THE MARK AS SHOWN.

THE COLOR(S) YELLOW AND GREY IS/ARE CLAIMED  
AS A FEATURE OF THE MARK.

THE MARK CONSIST OF THE FOLLOWING: A SQUARE  
WITH THE TOP HALF IN YELLOW AND THE BOTTOM  
HALF IN GREY, WITH THE GREY WORD "SOLAR" ON  
THE TOP HALF AND YELLOW WORD "FABRIK" IN THE  
BOTTOM HALF. BETWEEN THE TWO HALVES ARE  
THREE DIAGONAL GREY QUADRILATERALS OUT-  
LINED IN YELLOW.

THE ENGLISH TRANSLATION OF "FABRIK" IN THE  
MARK IS "FACTORY".

#### CLASS 9—ELECTRICAL AND SCIENTIFIC APPARATUS

FOR APPARATUS AND INSTRUMENTS FOR CON-  
DUCTING, SWITCHING, TRANSFORMING, ACCUMU-  
LATING, REGULATING OR CONTROLLING  
ELECTRICITY, NAMELY, ELECTRIC CONDUCTORS,  
ELECTRIC SWITCHES, ELECTRIC TRANSFORMERS,  
ELECTRIC ACCUMULATORS, VOLTAGE REGULA-  
TORS, ELECTRIC CONTROLLERS; APPARATUS FOR  
CONVERTING ELECTRONIC RADIATION TO ELEC-  
TRICAL ENERGY, NAMELY, PHOTOVOLTAIC SOLAR  
MODULES, SOLAR CELLS, AND SOLAR PANELS  
BEING FACADE ELEMENTS OR ROOF ELEMENTS;  
ELECTRIC AND/OR ELECTRONIC MEASURING AND  
CHECKING APPARATUS AND INSTRUMENTS,  
NAMELY, ELECTRONICAL SENSORS FOR MEASUR-  
ING SOLAR RADIATION; ELECTRIC AND/OR ELEC-  
TRONIC MEASURING AND CHECKING APPARATUS  
AND INSTRUMENTS FOR SUPERVISION PURPOSES,  
NAMELY, ELECTRONICAL SENSORS FOR MEASUR-  
ING SOLAR RADIATION; ELEMENTS, MODULES AND  
INSTALLATIONS FOR CONVERTING SOLAR RADI-  
ATION INTO ELECTRICITY, NAMELY, SOLAR MOD-  
ULES FOR PRODUCTION OF ELECTRICITY, SOLAR  
PANELS FOR PRODUCTION OF ELECTRICITY, SOLAR  
CELLS; INVERTERS; SOUND, IMAGE AND DATA  
CARRIERS OF ALL KINDS, NAMELY, SOUND TAPES,  
CASSETTES, CDS, RECORDING DISCS, MAGNETIC  
DATA CARRIERS, VIDEO TAPES, FLOPPY DISCS, CD-  
ROMS, DVDS FEATURING INFORMATION AND PRO-  
GRAMS IN THE FIELD OF RENEWABLE ENERGY, ALL  
THE AFORESAID GOODS IN RECORDED FORM; COM-  
PUTER PROGRAMS, SOFTWARE AND CONTROL  
SOFTWARE, FOR OPERATING RENEWABLE ENERGY  
INSTALLATIONS; APPARATUS FOR CONVERTING  
ELECTRONIC RADIATION TO ELECTRICAL ENERGY,  
NAMELY, PHOTOVOLTAIC SOLAR HYBRID MODULES  
AND SOLAR PANELS FOR PRODUCTION OF ELEC-  
TRICITY (U.S. CLS. 21, 23, 26, 36 AND 38).

#### CLASS 11—ENVIRONMENTAL CONTROL AP- PARATUS

FOR APPARATUS FOR LIGHTING, HEATING,  
STEAM GENERATING, COOKING, DRYING, VENTI-  
LATING, WATER SUPPLY AND SANITARY PURPOSES,  
NAMELY, SOLAR HEAT COLLECTION PANELS, SOLAR  
WATER HEATERS, SOLAR POWERED ALL  
WEATHER LIGHTS, ELECTRIC STOVES; SOLAR COL-  
LECTORS FOR HEATING; SOLAR FURNACES, HEAT  
PUMPS; INCINERATORS; PELLET FURNACES (U.S.  
CLS. 13, 21, 23, 31 AND 34).

REBECCA GILBERT, EXAMINING ATTORNEY

SN 79-078,578. FIBA; FÉDÉRATION INTERNATIONALE DE  
BASKETBALL, SWITZERLAND, FILED 9-24-2009.



PRIORITY DATE OF 3-27-2009 IS CLAIMED.

OWNER OF INTERNATIONAL REGISTRATION 1027959  
DATED 9-24-2009, EXPIRES 9-24-2019.

OWNER OF U.S. REG. NOS. 3,039,973 AND 3,144,161.

NO CLAIM IS MADE TO THE EXCLUSIVE RIGHT TO  
USE "BASKETBALL", APART FROM THE MARK AS  
SHOWN.

THE MARK CONSISTS OF A BASKET BALL COVERED  
WITH MULTIPLE HANDS WITHIN A SQUARE ABOVE  
ANOTHER SQUARE CONTAINING THE STYLIZED INITI-  
ALS "FIBA" ABOVE THE STYLIZED WORDS "WE ARE  
BASKETBALL".

#### CLASS 25—CLOTHING

FOR CLOTHING, NAMELY, JERSEYS, JOGGING  
SUITS, SHORTS, TRACK PANTS, SWIMSUITS, GLOVES,  
JACKETS, TROUSERS, SUITS, COATS, UNDERWEAR,  
COTTON TRUNKS, PYJAMAS AND NIGHT WEAR,  
BATH AND HOUSE ROBES, RAIN WEAR, BANDANAS,  
SCARVES AND MUFFLERS, SOCKS, BELTS, SUSPEN-  
DERS, NECKWEAR, TIES, BIBS NOT OF PAPER, BABY  
BIBS NOT OF PAPER, APRONS; ACTIVE WEAR CLOTH-  
ING, NAMELY, SHIRTS, T-SHIRTS, SPORT SHIRTS,  
SWEATSHIRTS, SWEATERS AND JUMPERS, FLEECE  
JACKETS, TOPS, RAIN WEAR, BANDANAS, TROU-  
SERS, TRACKING SUITS, SOCKS; FOOTWEAR, HEAD-  
WEAR (U.S. CLS. 22 AND 39).

#### CLASS 28—TOYS AND SPORTING GOODS

FOR BOARD GAMES, CARD GAMES, PARLOUR  
GAMES, TOYS, NAMELY, DOLLS, INFLATABLE TOYS,  
MECHANICAL TOYS, MOLDED TOY FIGURES; PLUSH  
TOY ANIMALS; TOY FOAM NOVELTY ITEMS,  
NAMELY, RUBBER-FOAM HANDS; SNOW GLOBES;  
TOYS FOR DOMESTIC PETS; APPARATUS FOR ELEC-  
TRONIC GAMES OTHER THAN THOSE ADAPTED FOR  
USE WITH AN EXTERNAL DISPLAY SCREEN OR A  
MONITOR; GYMNASTIC AND SPORTING ARTICLES,  
NAMELY, BASKETBALLS; BALLS FOR GAMES, BAS-  
KETBALL NETS, HOOPS, AND BACKBOARDS (U.S.  
CLS. 22, 23, 38 AND 50).

**CLASS 35—ADVERTISING AND BUSINESS**

FOR ADVERTISING AND TELEVISION ADVERTISING; BUSINESS MANAGEMENT; BUSINESS ADMINISTRATION; OFFICE FUNCTIONS; PROVIDING CONSULTING SERVICES WITH REGARD TO PERSONNEL MANAGEMENT FOR SPORTS TEAMS; PROMOTION OF SPORTS EVENTS IN THE FIELD OF BASKETBALL; RENTAL OF ADVERTISING SPACE, ALSO IN THE FORM OF ADVERTISEMENT BANNERS; SPONSORSHIP SEARCH; ADVERTISING FOR GOODS AND SERVICES ON BEHALF OF THIRD PARTIES AS A RESULT OF CONTRACTS, ESTABLISHING AND INCREASING RENOWN AND IMAGE BY MEANS OF ASSOCIATION WITH CULTURAL AND SPORTING EVENTS; MARKETING AND ADVERTISING, PARTICULARLY THROUGH CUSTOMER LOYALTY AND BONUS SCHEMES; ADMINISTRATION OF CUSTOMER LOYALTY AND BUYING INDUCEMENT SCHEMES THROUGH ADVERTISING; CONSULTANCY IN ARRANGING AND CONDUCTING INCENTIVE REWARD PROGRAM IN THE NATURE OF CUSTOMER BONUS SCHEMES, IN PARTICULAR IN THE FIELD OF CUSTOMER LOYALTY AND BONUS PROGRAMS; ISSUING DATA MEDIA FOR TRANSACTION ACCOUNTING, NAMELY, CUSTOMER CARDS AND LOYALTY CARDS IN CONNECTION WITH CUSTOMER LOYALTY AND BONUS PROGRAMME CAMPAIGNS; CONSUMER LOYALTY SERVICES FOR COMMERCIAL, PROMOTIONAL AND/OR ADVERTISING PURPOSES; PROMOTING THE GOODS AND SERVICES OF OTHERS BY MEANS OF THE ISSUANCE OF LOYALTY REWARDS CARDS; MOBILE RETAIL STORE SERVICES, MAIL ORDER CATALOGUE SERVICES, ONLINE RETAIL STORE SERVICES AND RETAIL STORE SERVICES FEATURING COSMETICS, PERFUMERY PREPARATIONS, CANDLES, BANDAGES, PLASTERS, PRODUCTS FOR REFRESHING THE AIR IN THE HOME AND IN CARS, GOODS MADE OF METAL AND THEIR ALLOYS, HAND-OPERATED TOOLS, CUTLERY, FORKS AND SPOONS, SOFTWARE, APPARATUS FOR RECORDING, TRANSMISSION OR REPRODUCTION OF SOUND OR IMAGES, MAGNETIC DATA MEDIA OF ALL KINDS, SPECTACLES, SUNGLASSES, HELMETS, DECORATIVE MAGNETS, ELECTRIC BATTERIES, APPARATUS FOR LIGHTING, HEATING, STEAM GENERATING, COOKING, REFRIGERATING, DRYING, VENTILATING, WATER SUPPLY AND SANITARY PURPOSES, VEHICLES FOR LOCOMOTION BY LAND, BY WATER AND BY AIR, ARTICLES MADE OF PRECIOUS METALS OR COATED THEREWITH, PINS AS JEWELRY, MEDALLIONS, METAL KEY RINGS, COLLARS, KEY HOLDERS, BRACELETS, TIE PINS, CUFF LINKS, PRIZE CUPS AND DECORATIONS, JEWELLERY, WATCHES, MUSICAL INSTRUMENTS, MUSICAL BOXES, PRINTED MATTER, PHOTOGRAPHS, OFFICE EQUIPMENT, FILING TRAYS AND OTHER PAPER TRAYS, DESK PADS, SCRATCH PADS, BLANK CHARTS, CALENDARS, GEOGRAPHIC MAPS, POSTERS, GREETING CARDS, POSTCARDS, PAPER FLAGS, BOOKMARKERS, TRANSFERS, STICKERS, DRAWING PINS, OFFICE STAPLES, BANKNOTE CLIPS, PAPERWEIGHTS, WRITING INSTRUMENTS, PENCIL SHARPENERS, COVERING CAPS FOR PENS AND PENCILS, TOPS FOR PENCILS AND PENS, RUBBER STAMPS AND STAMP PADS, STAPLERS, INSTRUCTIONAL AND TEACHING MATERIAL EXCEPT APPARATUS, LEATHER AND IMITATIONS OF LEATHER AND GOODS MADE FROM THESE MATERIALS, BAGS, RUCKSACKS, BAGS FOR SKIERS, SCHOOL BAGS, WALLETS, BANANA POUCHES IN THE NATURE OF BELT BAGS, BASKETBALL BAGS, TRUNKS AND SUITCASES, GARMENT BAGS FOR TRAVEL, UMBRELLAS, PARASOLS AND WALKING STICKS, COLLARS, LEASHES AND HARNESES FOR ANIMALS, FLOOR TILES, FURNITURE, MIRRORS, PICTURE FRAMES, GOODS OF WOOD AND/OR PLASTIC MATERIAL, SLEEPING BAGS FOR CAMPING, SEATS, CONTAINERS OF PLASTIC, FIGURINES OF WOOD, WAX, PLASTER OR PLASTIC, BASKETS FOR PETS, OBJECTS MADE OF GLASS, PORCELAIN AND EARTHENWARE, CROCKERY, KITCHEN UTENSILS, DRINKING VESSELS, BOTTLES, JUGS, BREAD BINS, THERMAL BOTTLES, INSULATING BAGS, TRAYS, PIGGY BANKS, CANDLESTICKS, CORKSCREWS, BOTTLE OPENERS, TIN OPENERS, FIGURINES IN THE NATURE OF STATUETTES OF PORCELAIN, TERRA-COTTA OR GLASS, TENTS, TEXTILES AND TEXTILE GOODS, WALL HANGINGS, FELT PENNANTS, FLAGS, CLOTHING, FOOTWEAR, HEADWEAR, CLOTHING FOR DOMESTIC PETS, LACE

AND EMBROIDERY, RIBBONS AND BRAID, BUTTONS, TAB PULLS, PINS AND NEEDLES, BADGES, SEWING SETS, HAIRPINS, WIGS, CARPETS, MATS, WALLPAPER, GAMES, TOYS, CUDDLY TOY ANIMALS, SNOW GLOBES, TOYS FOR DOMESTIC PETS, AUTOMATIC OR PREPAID ENTERTAINMENT APPARATUS, GYMNASIUM AND SPORTING ARTICLES, MEAT, FISH, POULTRY AND GAME, MEAT EXTRACTS, PRESERVED, DRIED AND COOKED FRUITS AND VEGETABLES, JELLIES, JAMS, COMPOTES, EGGS, MILK AND MILK PRODUCTS, SNACKS, SNACK FOOD, CRISPS, COFFEE, TEAS, COCOA, CHOCOLATE, SUGAR, RICE, FLOURS AND CEREAL PREPARATIONS, BREADS, PASTRY AND CONFECTIONERY, EDIBLE ICES, HONEY, TREACLE, YEAST, BAKING-POWDER, SALT, MUSTARD, VINEGAR, SAUCES BEING CONDIMENTS, SPICES, ICES FOR REFRESHMENT, SMOKERS' ARTICLES, MATCHES, SMOKERS' LIGHTERS, SMOKERS' ASHTRAYS; COMPILATION AND SYSTEMATIZATION OF INFORMATION IN DATABANKS THROUGH WIRELESS OR CABLE NETWORKS; COLLECTION AND SYSTEMATISATION OF INFORMATION INTO A DATA BANK FOR THE PURPOSES OF INFORMATION IN THE FIELD OF SPORT; PROVIDING INFORMATION IN THE FIELD OF CUSTOMER LOYALTY AND BONUS SCHEMES (U.S. CLS. 100, 101 AND 102).

**CLASS 38—COMMUNICATION**

FOR TELECOMMUNICATION SERVICES, NAMELY, LOCAL AND LONG DISTANCE TRANSMISSION OF VOICE, DATA, GRAPHICS BY MEANS OF TELEPHONE, TELEGRAPHIC, CABLE, AND SATELLITE TRANSMISSIONS; TRANSMISSION OF VOICE, DATA, GRAPHICS, SOUND, AND VIDEO BY MEANS OF WIRELESS OR CABLE NETWORKS; WIRELESS TRANSMISSION OF DATA, IMAGES, TELEPHONE VOICE MESSAGING SERVICES; DIGITAL NETWORK TELECOMMUNICATION SERVICES; TRANSMISSION OF INFORMATION IN THE FIELD OF CUSTOMER LOYALTY AND BONUS SCHEMES; SERVICES OF AN INTERNET ACCESS PROVIDER, NAMELY, PROVIDING ACCESS TO THE INTERNET; PROVIDING INTERNET ACCESS TO SEARCH ENGINES AND TO SEARCH PORTALS ON THE INTERNET; PROVIDING ON-LINE FORUMS FOR TRANSMISSION OF MESSAGES AMONG COMPUTER USERS, NAMELY, INTERNET DISCUSSION FORUMS; ELECTRONIC EXCHANGE OF DATA STORED IN DATABASES ACCESSIBLE VIA TELECOMMUNICATION NETWORKS VIA CHATLINES, CHATROOMS AND OTHER INTERNET FORUMS; PROVIDING INTERACTIVE FOR A FOR TRANSMISSION OF MESSAGES AMONG USERS IN THE FIELD OF GENERAL INTEREST; PROVISION OF INTERNET ACCESS TO DATA BANKS, IN PARTICULAR ONLINE DATA BANKS ON SPORT; ELECTRONIC TRANSMISSION OF MESSAGES AND IMAGES VIA COMPUTER, SMS, UMPTS AND WAP; TELEVISION AND RADIO BROADCASTING; INTERNET BROADCASTING; PROVISION OF INTERNET ACCESS TO DATA BANKS OF DIGITAL MUSIC AND TO MP3 WEB SITES (U.S. CLS. 100, 101 AND 104).

**CLASS 41—EDUCATION AND ENTERTAINMENT**

FOR EDUCATION SERVICES, NAMELY, PROVIDING SEMINARS, WORKSHOPS, IN THE FIELD OF BASKETBALL; TRAINING IN THE FIELD OF SPORT EVENTS ORGANIZATION; ENTERTAINMENT, NAMELY, BASKETBALL GAMES; ORGANIZING SPORTING AND CULTURAL EVENTS; PUBLICATION AND ELECTRONIC PUBLICATION OF PRINTED MATTER; ENTERTAINMENT THROUGH TELEVISION, RADIO AND THE INTERNET, NAMELY, BASKETBALL EVENTS, BASKETBALL CHAMPIONSHIPS, BASKETBALL GAMES, INTERVIEWS AND HIGHLIGHTS; INTERACTIVE ENTERTAINMENT, NAMELY, PROVIDING TEMPORARY USE OF NON-DOWNLOADABLE INTERACTIVE GAMES, ONLINE CONTESTS; PROVIDING GAMES, NAMELY, PROVIDING ON-LINE COMPUTER GAMES; OPERATING LOTTERIES; ORGANIZATION OF SPORT COMPETITIONS; BETTING SERVICES REGARDING OR CONCERNING SPORT, ALSO ON THE INTERNET; FILM PRODUCTION; PRODUCTION OF AUDIO AND VIDEO RECORDINGS, RENTAL OF FILMS, AUDIO

AND VIDEO RECORDINGS; PRODUCTION OF INTERACTIVE EDUCATIONAL AND ENTERTAINMENT COMPUTER GAMES; RENTAL OF CDS AND INTERACTIVE CD-ROMS AND COMPUTER GAMES; INFORMATION SERVICES IN THE FIELD OF SPORTS AND SPORTS EVENTS, NAMELY, PROVIDING ONLINE INFORMATION VIA DATA BANKS, ON THE INTERNET AND VIA SATELLITE OR CABLE, PORTABLE TELEPHONE OR WIRELESS NETWORKS; RESERVATION OF TICKETS FOR SPORTING AND CULTURAL ACTIVITIES; PROVIDING AN INTERNET WEBSITE FEATURING DIGITAL MUSIC (U.S. CLS. 100, 101 AND 107).

DAVID TOOLEY, EXAMINING ATTORNEY

SN 79-078,662. VEOLIA ENVIRONNEMENT, FRANCE, FILED 9-16-2009.



OWNER OF INTERNATIONAL REGISTRATION 0914460 DATED 2-2-2007, EXPIRES 2-2-2017.

OWNER OF U.S. REG. NOS. 2,991,640, 3,000,764 AND 3,543,738.

NO CLAIM IS MADE TO THE EXCLUSIVE RIGHT TO USE "ENVIRONNEMENT", APART FROM THE MARK AS SHOWN.

THE COLOR(S) LIGHT GRAY, RED, AND DARK GRAY IS/ARE CLAIMED AS A FEATURE OF THE MARK.

THE MARK CONSISTS OF THE DARK GRAY STYLIZED WORDING, "CAMPUS" WITH THE LETTER "C" IN CAPS AND "AMPUS" IN LOWER CASE LETTERS, WITH A STYLIZED RED CIRCLE BELOW CONTAINING A RED WATER DROP INSIDE AT THE BOTTOM OF THE STYLIZED RED CIRCLE, GIVING THE APPEARANCE OF A HUMAN FORM, NAMELY, A PERSON'S HEAD WITH ARMS ENCIRCLING IT, WITH THE RED WORDING "VEOLIA" IN ALL CAPS, TO THE RIGHT, WITH THE LIGHT GRAY WORDING "ENVIRONNEMENT" BELOW. THE COLOR WHITE REPRESENTS BACKGROUND AND IS NOT PART OF THE MARK.

THE ENGLISH TRANSLATION OF "ENVIRONNEMENT" IN THE MARK IS ENVIRONMENT.

#### CLASS 9—ELECTRICAL AND SCIENTIFIC APPARATUS

FOR DOWNLOADABLE SOFTWARE FOR USE IN DATA MANAGEMENT, FOR USE IN CREATING, DEVELOPING, DELIVERING AND MANAGING TRAINING AND EDUCATIONAL PROGRAMS AND MATERIALS, FOR USE IN SEARCHING AND DISPLAYING INFORMATION, FOR USE IN TRAINING, IN THE FIELDS OF WATER RESOURCES, WATER TREATING AND PURIFYING, TREATMENT OF WASTE, DESTRUCTION OF WASTE AND TRASH, URBAN CLEANSING, WASTE COLLECTION, SEWERAGE MAINTENANCE, MAINTENANCE VEHICLES AND EQUIPMENT, WASTE MANAGEMENT, CUSTOMER RECEPTION, TRANSPORTATION, MAINTENANCE OF INDUSTRIAL INSTALLATIONS, MAINTENANCE OF ENERGY AND CLIMATE CONTROL SYSTEMS, ENVIRONMENTAL PROTECTION, SUSTAINABLE DEVELOPMENT AND TRANSPORT SERVICES, AND FOR WORD PROCESSING; RECORDED COMPUTER PROGRAMS FEATURING ON LINE MANUALS AND OTHER TRAINING MEDIA, NAMELY, DVD'S, CD ROMS, PRE-RECORDED AUDIO AND VIDEO TAPES IN THE FIELDS OF WATER RESOURCES, WATER TREATING AND PURIFYING, TREATMENT OF WASTE, DESTRUCTION OF WASTE AND TRASH, URBAN CLEANSING, WASTE COLLECTION, SEWERAGE MAINTENANCE, MAINTENANCE VEHICLES AND EQUIPMENT, WASTE MANAGEMENT, CUSTOMER RECEPTION, TRANSPORTATION, MAINTENANCE OF INDUSTRIAL INSTALLATIONS, MAINTENANCE OF ENERGY AND CLIMATE CONTROL SYSTEMS, ENVIRONMENTAL PROTECTION, SUSTAINABLE DEVELOPMENT AND TRANSPORT SERVICE (U.S. CLS. 2, 5, 22, 23, 29, 37, 38 AND 50).

PROTECTION, SUSTAINABLE DEVELOPMENT AND TRANSPORT SERVICES; COMPUTER GAMES SOFTWARE FOR TRAINING OR EDUCATIONAL PURPOSES; PRE-RECORDED VIDEOTAPES IN THE FIELDS OF WATER RESOURCES, WATER TREATING AND PURIFYING, TREATMENT OF WASTE, DESTRUCTION OF WASTE AND TRASH, URBAN CLEANSING, WASTE COLLECTION, SEWERAGE MAINTENANCE, MAINTENANCE VEHICLES AND EQUIPMENT, WASTE MANAGEMENT, CUSTOMER RECEPTION, TRANSPORTATION, MAINTENANCE OF INDUSTRIAL INSTALLATIONS, MAINTENANCE OF ENERGY AND CLIMATE CONTROL SYSTEMS, ENVIRONMENTAL PROTECTION, SUSTAINABLE DEVELOPMENT AND TRANSPORT SERVICES; MAGNETIC DATA MEDIA, NAMELY, SOFTWARE, PRE-RECORDED AUDIO TAPES, PRE-RECORDED VIDEOTAPES, PRE-RECORDED COMPACT DISCS, COMPUTER GAME CARTRIDGES OR PRE-RECORDED AUDIO CASSETTES FEATURING INFORMATION ON AND FOR USE IN TRAINING IN THE FIELDS OF WATER RESOURCES, WATER TREATING AND PURIFYING, TREATMENT OF WASTE, DESTRUCTION OF WASTE AND TRASH, URBAN CLEANSING, WASTE COLLECTION, SEWERAGE MAINTENANCE, MAINTENANCE VEHICLES AND EQUIPMENT, WASTE MANAGEMENT, CUSTOMER RECEPTION, TRANSPORTATION, MAINTENANCE OF INDUSTRIAL INSTALLATIONS, MAINTENANCE OF ENERGY AND CLIMATE CONTROL SYSTEMS, ENVIRONMENTAL PROTECTION, SUSTAINABLE DEVELOPMENT AND TRANSPORT SERVICES; PRE-RECORDED AUDIO AND VIDEO COMPACT DISCS AND PRE-RECORDED COMPACT OPTICAL DISCS IN THE FIELDS OF WATER RESOURCES, WATER TREATING AND PURIFYING, TREATMENT OF WASTE, DESTRUCTION OF WASTE AND TRASH, URBAN CLEANSING, WASTE COLLECTION, SEWERAGE MAINTENANCE, MAINTENANCE VEHICLES AND EQUIPMENT, WASTE MANAGEMENT, CUSTOMER RECEPTION, TRANSPORTATION, MAINTENANCE OF INDUSTRIAL INSTALLATIONS, MAINTENANCE OF ENERGY AND CLIMATE CONTROL SYSTEMS, ENVIRONMENTAL PROTECTION, SUSTAINABLE DEVELOPMENT AND TRANSPORT SERVICES (U.S. CLS. 21, 23, 26, 36 AND 38).

#### CLASS 16—PAPER GOODS AND PRINTED MATTER

FOR BOOKS, MAGAZINES, NEWSPAPER, AND JOURNALS IN THE FIELDS OF WATER RESOURCES, WATER TREATING AND PURIFYING, TREATMENT OF WASTE, DESTRUCTION OF WASTE AND TRASH, URBAN CLEANSING, WASTE COLLECTION, SEWERAGE MAINTENANCE, MAINTENANCE VEHICLES AND EQUIPMENT, WASTE MANAGEMENT, CUSTOMER RECEPTION, TRANSPORTATION, MAINTENANCE OF INDUSTRIAL INSTALLATIONS, MAINTENANCE OF ENERGY AND CLIMATE CONTROL SYSTEMS, ENVIRONMENTAL PROTECTION, SUSTAINABLE DEVELOPMENT AND TRANSPORT SERVICES; PRINTED INSTRUCTIONAL AND TEACHING MATERIAL IN THE FIELDS OF WATER RESOURCES, WATER TREATING AND PURIFYING, TREATMENT OF WASTE, DESTRUCTION OF WASTE AND TRASH, URBAN CLEANSING, WASTE COLLECTION, SEWERAGE MAINTENANCE, MAINTENANCE VEHICLES AND EQUIPMENT, WASTE MANAGEMENT, CUSTOMER RECEPTION, TRANSPORTATION, MAINTENANCE OF INDUSTRIAL INSTALLATIONS, MAINTENANCE OF ENERGY AND CLIMATE CONTROL SYSTEMS, ENVIRONMENTAL PROTECTION, SUSTAINABLE DEVELOPMENT AND TRANSPORT SERVICES; PRINTED MATTER, NAMELY, CARDS, INDEX CARDS, QUESTIONNAIRES, MANUALS, WORKBOOKS, ANSWER SHEETS, ALL IN THE FIELDS OF WATER RESOURCES, WATER TREATING AND PURIFYING, TREATMENT OF WASTE, DESTRUCTION OF WASTE AND TRASH, URBAN CLEANSING, WASTE COLLECTION, SEWERAGE MAINTENANCE, MAINTENANCE VEHICLES AND EQUIPMENT, WASTE MANAGEMENT, CUSTOMER RECEPTION, TRANSPORTATION, MAINTENANCE OF INDUSTRIAL INSTALLATIONS, MAINTENANCE OF ENERGY AND CLIMATE CONTROL SYSTEMS, ENVIRONMENTAL PROTECTION, SUSTAINABLE DEVELOPMENT AND TRANSPORT SERVICE (U.S. CLS. 2, 5, 22, 23, 29, 37, 38 AND 50).

**CLASS 35—ADVERTISING AND BUSINESS**

FOR BUSINESS MANAGEMENT ASSISTANCE; ACCOUNTING SERVICES, BUSINESS MANAGEMENT AND PERSONNEL CONSULTANCY; PERSONNEL RECRUITMENT; BUSINESS MANAGEMENT CONSULTANCY SERVICES, COMPUTER FILE MANAGEMENT; BUSINESS ORGANIZATION AND MANAGEMENT CONSULTING; CONDUCTING BUSINESS RESEARCH AND ANALYSES, NAMELY, SOCIO-ECONOMIC STUDIES, ANALYSES, RESEARCH AND LONG-RANGE PLANNING; SOCIO-ECONOMIC FORECASTING; MARKETING RESEARCH SERVICES; CONDUCTING MARKETING STUDIES AND MARKET OPINION POLLING, AND PROVIDING STATISTICAL INFORMATION FOR BUSINESS PURPOSES (U.S. CLS. 100, 101 AND 102).

**CLASS 41—EDUCATION AND ENTERTAINMENT**

FOR TEACHING IN THE FIELDS OF WATER RESOURCES, WATER TREATING AND PURIFYING, TREATMENT OF WASTE, DESTRUCTION OF WASTE AND TRASH, URBAN CLEANSING, WASTE COLLECTION, SEWERAGE MAINTENANCE, MAINTENANCE VEHICLES AND EQUIPMENT, WASTE MANAGEMENT, CUSTOMER RECEPTION, TRANSPORTATION, MAINTENANCE OF INDUSTRIAL INSTALLATIONS, MAINTENANCE OF ENERGY AND CLIMATE CONTROL SYSTEMS, ENVIRONMENTAL PROTECTION, SUSTAINABLE DEVELOPMENT AND TRANSPORT SERVICES; EDUCATIONAL TRAINING SERVICES, NAMELY, THE PROVISION OF APPRENTICESHIPS IN THE FIELDS OF WATER RESOURCES, WATER TREATING AND PURIFYING, TREATMENT OF WASTE, DESTRUCTION OF WASTE AND TRASH, URBAN CLEANSING, WASTE COLLECTION, SEWERAGE MAINTENANCE, MAINTENANCE VEHICLES AND EQUIPMENT, WASTE MANAGEMENT, CUSTOMER RECEPTION, TRANSPORTATION, MAINTENANCE OF INDUSTRIAL INSTALLATIONS, MAINTENANCE OF ENERGY AND CLIMATE CONTROL SYSTEMS, ENVIRONMENTAL PROTECTION, SUSTAINABLE DEVELOPMENT AND TRANSPORT SERVICES; ARRANGING AND CONDUCTING OF SEMINARS, CONFERENCES AND COLLOQUIUMS IN THE FIELDS OF WATER RESOURCES, WATER TREATING AND PURIFYING, TREATMENT OF WASTE, DESTRUCTION OF WASTE AND TRASH, URBAN CLEANSING, WASTE COLLECTION, SEWERAGE MAINTENANCE, MAINTENANCE VEHICLES AND EQUIPMENT, WASTE MANAGEMENT, CUSTOMER RECEPTION, TRANSPORTATION, MAINTENANCE OF INDUSTRIAL INSTALLATIONS, MAINTENANCE OF ENERGY AND CLIMATE CONTROL SYSTEMS, ENVIRONMENTAL PROTECTION, SUSTAINABLE DEVELOPMENT AND TRANSPORT SERVICES; PUBLISHING OF BOOKS, MAGAZINES, JOURNALS ON ENVIRONMENTAL PROTECTION AND ON THE TRAINING AND TEACHING OF INDIVIDUALS IN THE FIELDS OF WATER RESOURCES, WATER TREATING AND PURIFYING, TREATMENT OF WASTE, DESTRUCTION OF WASTE AND TRASH, URBAN CLEANSING, WASTE COLLECTION, SEWERAGE MAINTENANCE, MAINTENANCE VEHICLES AND EQUIPMENT, WASTE MANAGEMENT, CUSTOMER RECEPTION, TRANSPORTATION, MAINTENANCE OF INDUSTRIAL INSTALLATIONS, MAINTENANCE OF ENERGY AND CLIMATE CONTROL SYSTEMS, ENVIRONMENTAL PROTECTION, SUSTAINABLE DEVELOPMENT AND TRANSPORT SERVICES; MULTIMEDIA PUBLISHING OF BOOKS, MAGAZINES, JOURNALS, SOFTWARE, GAMES, AND ELECTRONIC PUBLICATIONS ON ENVIRONMENTAL PROTECTION AND ON THE TRAINING AND TEACHING OF INDIVIDUALS IN THE FIELDS OF WATER RESOURCES, WATER TREATING AND PURIFYING, TREATMENT OF WASTE, DESTRUCTION OF WASTE AND TRASH, URBAN CLEANSING, WASTE COLLECTION, SEWERAGE MAINTENANCE, MAINTENANCE VEHICLES AND EQUIPMENT, WASTE MANAGEMENT, CUSTOMER RECEPTION, TRANSPORTATION, MAINTENANCE OF INDUSTRIAL INSTALLATIONS, MAINTENANCE OF ENERGY AND CLIMATE CONTROL SYSTEMS, ENVIRONMENTAL PROTECTION, SUSTAINABLE DEVELOPMENT AND TRANSPORT SERVICES; EDUCATIONAL ENTERTAINMENT SERVICES, NAMELY, ARRANGING OF GAME COMPETITIONS ON THE TOPICS OF WATER RESOURCES, ENVIRONMENTAL PROTECTION, SUS-

TAINABLE DEVELOPMENT; PROVIDING ONLINE NON-DOWNLOADABLE ELECTRONIC PUBLICATIONS USED FOR TRAINING IN THE FIELD OF WATER RESOURCES, WATER TREATING AND PURIFYING, TREATMENT OF WASTE, DESTRUCTION OF WASTE AND TRASH, URBAN CLEANSING, WASTE COLLECTION, SEWERAGE MAINTENANCE, MAINTENANCE VEHICLES AND EQUIPMENT, WASTE MANAGEMENT, CUSTOMER RECEPTION, TRANSPORTATION, MAINTENANCE OF INDUSTRIAL INSTALLATIONS, MAINTENANCE OF ENERGY AND CLIMATE CONTROL SYSTEMS, ENVIRONMENTAL PROTECTION, SUSTAINABLE DEVELOPMENT AND TRANSPORT SERVICES; ARRANGING AND CONDUCTING OF EDUCATIONAL EXAMINATION IN THE FIELD OF WATER RESOURCES, WATER TREATING AND PURIFYING, TREATMENT OF WASTE, DESTRUCTION OF WASTE AND TRASH, URBAN CLEANSING, WASTE COLLECTION, SEWERAGE MAINTENANCE, MAINTENANCE VEHICLES AND EQUIPMENT, WASTE MANAGEMENT, CUSTOMER RECEPTION, TRANSPORTATION, MAINTENANCE OF INDUSTRIAL INSTALLATIONS, MAINTENANCE OF ENERGY AND CLIMATE CONTROL SYSTEMS, ENVIRONMENTAL PROTECTION, SUSTAINABLE DEVELOPMENT AND TRANSPORT SERVICES; VIDEOTAPE RECORDING AND FILMING SERVICES FOR OTHERS; FILM PRODUCTION; PROVIDING INFORMATION ON TRAINING IN THE FIELDS OF WATER RESOURCES, WATER TREATING AND PURIFYING, TREATMENT OF WASTE, DESTRUCTION OF WASTE AND TRASH, URBAN CLEANSING, WASTE COLLECTION, SEWERAGE MAINTENANCE, MAINTENANCE VEHICLES AND EQUIPMENT, WASTE MANAGEMENT, CUSTOMER RECEPTION, TRANSPORTATION, MAINTENANCE OF INDUSTRIAL INSTALLATIONS, MAINTENANCE OF ENERGY AND CLIMATE CONTROL SYSTEMS, ENVIRONMENTAL PROTECTION, SUSTAINABLE DEVELOPMENT AND TRANSPORT SERVICES; ELECTRONIC DESKTOP PUBLISHING FOR OTHERS; PROVIDING ADVICE ON TRAINING IN THE FIELDS OF WATER RESOURCES, WATER TREATING AND PURIFYING, TREATMENT OF WASTE, DESTRUCTION OF WASTE AND TRASH, URBAN CLEANSING, WASTE COLLECTION, SEWERAGE MAINTENANCE, MAINTENANCE VEHICLES AND EQUIPMENT, WASTE MANAGEMENT, CUSTOMER RECEPTION, TRANSPORTATION, MAINTENANCE OF INDUSTRIAL INSTALLATIONS, MAINTENANCE OF ENERGY AND CLIMATE CONTROL SYSTEMS, ENVIRONMENTAL PROTECTION, SUSTAINABLE DEVELOPMENT AND TRANSPORT SERVICES (U.S. CLS. 100, 101 AND 107).

ODESSA BIBBINS, EXAMINING ATTORNEY

SN 79-078,885. OBCHTCHESTVO S OGRANITCHENNOI; OTVETSTVENOSTYOU; "DORKHAN", RUSSIAN FED., FILED 6-23-2009.



OWNER OF INTERNATIONAL REGISTRATION 1028739 DATED 6-23-2009, EXPIRES 6-23-2019.

THE COLOR(S) NAVY BLUE AND WHITE IS/ARE CLAIMED AS A FEATURE OF THE MARK.

THE MARK CONSISTS OF THE WORD "DOORHAN" SHOWN IN NAVY BLUE WITHIN A WHITE OVAL SURROUNDED BY A NAVY BLUE RECTANGLE WITH CURVED CORNERS AGAINST A WHITE BACKGROUND ALL ENCAPSULATED BY A NAVY BLUE OUTER RECTANGULAR OUTLINE WITH CURVED CORNERS.

THE WORDING "DOORHAN" HAS NO MEANING IN A FOREIGN LANGUAGE.

**CLASS 6—METAL GOODS**

FOR GATES OF METAL; WASHERS OF METAL FOR GATES OF METAL AND DOORS; DOORS OF METAL; METAL DOOR BOLTS; METAL BOLTS; LATCHES OF METAL; NON-ELECTRIC METAL DOOR BELLS; DOOR FITTINGS OF METAL; DOOR FRAMES OF METAL; METAL DOOR KNOCKERS; METAL IRONWORK FOR DOORS, NAMELY, WROUGHT IRON DECORATIVE ARTWORK, DOOR STOPS, DOOR PANELS AND DOOR JAMBS; LINTELS OF METAL; STRAP-HINGES OF METAL; NON-ELECTRIC DOOR OPENER HARDWARE, NAMELY, NON-POWERED ACTUATORS; RUNNERS OF METAL FOR SLIDING DOORS; DOOR HANDLES OF METAL; DOOR STOPS OF METAL; DOOR PANELS OF METAL (U.S. CLS. 2, 12, 13, 14, 23, 25 AND 50).

SN 79-079,180. VON ROLL UMWELTTECHNIK AG, SWITZERLAND, FILED 12-18-2009.

# DyNOR

**CLASS 42—SCIENTIFIC AND COMPUTER SERVICES**

FOR TECHNICAL PROJECT STUDIES, NAMELY, TECHNICAL CONSULTATION IN THE FIELD OF ENVIRONMENTAL ENGINEERING SCIENCES; ENGINEERING; MECHANICAL RESEARCH; TECHNICAL RESEARCH IN THE FIELD OF ENGINEERING; ARCHITECTURAL CONSULTING; DESIGN OF INTERIOR DECOR; DESIGN OF GATES OF METAL AND DOORS; CONSTRUCTION DRAFTING; INDUSTRIAL DESIGN STYLING SERVICES; CONDUCTING ENGINEERING SURVEYS (U.S. CLS. 100 AND 101).

DAVID YONTEF, EXAMINING ATTORNEY

THE MARK CONSISTS OF STANDARD CHARACTERS WITHOUT CLAIM TO ANY PARTICULAR FONT, STYLE, SIZE, OR COLOR.

PRIORITY DATE OF 8-6-2009 IS CLAIMED.

OWNER OF INTERNATIONAL REGISTRATION 1029564 DATED 12-18-2009, EXPIRES 12-18-2019.

THE ENGLISH TRANSLATION OF "DYNOR" IN THE MARK IS "CUSHIONS".

**CLASS 6—METAL GOODS**

FOR METAL REGULATING VALVES AND INJECTORS NOT BEING PARTS OF MACHINES (U.S. CLS. 2, 12, 13, 14, 23, 25 AND 50).

**CLASS 11—ENVIRONMENTAL CONTROL APPARATUS**

FOR WASTE INCINERATION PLANTS; INSTALLATIONS AND APPARATUS FOR PURIFICATION OF GAS, INDUSTRIAL WASTE GAS AND SMOKE GAS; PARTS FOR THE AFOREMENTIONED GOODS; REGULATING VALVES FOR WASTE INCINERATION PLANTS AND FOR INSTALLATIONS AND APPARATUS FOR PURIFICATION OF GAS, INDUSTRIAL WASTE GAS AND SMOKE GAS (U.S. CLS. 13, 21, 23, 31 AND 34).

**CLASS 37—CONSTRUCTION AND REPAIR**

FOR INSTALLATION, MAINTENANCE AND REPAIR OF WASTE INCINERATION PLANTS AND OF INSTALLATIONS AND APPARATUS FOR THE TREATMENT OF GAS, INDUSTRIAL WASTE GAS AND SMOKE GAS (U.S. CLS. 100, 103 AND 106).

DAVID TOOLEY, EXAMINING ATTORNEY

SN 79-079,015. SHANE TAYLOR, AUSTRALIA, FILED 1-4-2010.

# Valkry

THE MARK CONSISTS OF STANDARD CHARACTERS WITHOUT CLAIM TO ANY PARTICULAR FONT, STYLE, SIZE, OR COLOR.

OWNER OF INTERNATIONAL REGISTRATION 1029052 DATED 1-4-2010, EXPIRES 1-4-2020.

**CLASS 25—CLOTHING**

FOR MEN'S AND WOMEN'S CLOTHING, NAMELY, SWIMWEAR, TANK TOPS, SHIRTS, JACKETS, SKIRTS, DRESSES, SHORTS, JUMPERS, LEGGINGS, PAJAMAS, JERSEYS, SOCKS, UNDERWEAR, GLOVES, BELTS, TIES, VESTS; HEADWEAR, NAMELY, CAPS AND BEANIES; SKI WEAR; AND FOOTWEAR, NAMELY, SANDALS, SLIPPERS, BOOTS, AND ATHLETIC SHOES (U.S. CLS. 22 AND 39).

**CLASS 28—TOYS AND SPORTING GOODS**

FOR SPORTING GOODS, NAMELY, SKATEBOARDS; SKATEBOARD PADS (U.S. CLS. 22, 23, 38 AND 50).

**CLASS 35—ADVERTISING AND BUSINESS**

FOR PROVIDING ONLINE AND RETAIL STORE SERVICES FEATURING SKATEBOARDS, SURFBOARDS, SNOWBOARDS, WAKEBOARDS, CLOTHING, SKI WEAR, WETSUITS, HEADWEAR, FOOTWEAR, SWIMWEAR AND RELATED ACCESSORIES, SUNGLASSES, SPORTS BAGS, BACKPACKS, PURSES, WALLET, AND MUSIC (U.S. CLS. 100, 101 AND 102).

MARILYN IZZI, EXAMINING ATTORNEY

SN 79-079,238. OBEGI RIAD, BEYROUTH, LEBANON, FILED 1-6-2010.

**CERTIFICAT HYPOTHECAIRE OBEGI**

PRIORITY DATE OF 7-21-2009 IS CLAIMED.

OWNER OF INTERNATIONAL REGISTRATION 1029757 DATED 1-6-2010, EXPIRES 1-6-2020.

NO CLAIM IS MADE TO THE EXCLUSIVE RIGHT TO USE "CERTIFICAT HYPOTHECAIRE", APART FROM THE MARK AS SHOWN.

THE ENGLISH TRANSLATION OF "CERTIFICAT HYPOTHECAIRE" IS MORTGAGE CERTIFICATE.

**CLASS 35—ADVERTISING AND BUSINESS**

FOR ADVERTISING; ONLINE ADVERTISING ON A COMPUTER COMMUNICATIONS NETWORK; BUSINESS MANAGEMENT; BUSINESS ADMINISTRATION CONSULTANCY; BUSINESS ORGANIZATION AND MANAGEMENT CONSULTING; BUSINESS INFORMATION; DISTRIBUTION AND DISSEMINATION OF ADVERTISING MATERIALS, NAMELY, PAMPHLETS, PROSPECTUSES, PRINTED MATTER, SAMPLES; BUSINESS ADVERTISING; ACCOUNTING SERVICES; COMPUTERIZED FILE MANAGEMENT; DATA PROCESSING; FINANCIAL INCENTIVE AWARDS PROGRAM TO PROMOTE THE SALE OF PRODUCTS AND SERVICES TO CUSTOMERS; PUBLIC RELATIONS; MARKETING STUDIES AND RESEARCH, BUSINESS RESEARCH AND INVESTIGATIONS; EFFICIENCY EXPERTS; ELECTRONIC DATA COLLECTION AND DATA SUBMISSION SERVICES FOR BUSINESS PURPOSES IN THE FIELDS OF BANKING, MONETARY EXCHANGE, REAL ESTATE APPRAISAL AND FISCAL ASSESSMENT; ECONOMIC FORECASTING; ACCOUNTS RECEIVABLE SERVICES (U.S. CLS. 100, 101 AND 102).

**CLASS 36—INSURANCE AND FINANCIAL**

FOR BANKING SERVICES; REAL ESTATE AFFAIRS, NAMELY, FISCAL EVALUATIONS AND ASSESSMENTS IN THE FIELD OF REAL ESTATE, FINANCIAL SPONSORSHIP OF SALES AND RESALE AND MORTGAGE OF REAL ESTATE; FINANCIAL CONSULTING; FISCAL EVALUATIONS AND ASSESSMENTS IN THE FIELD OF INSURANCE, BANKING AND REAL ESTATE; REAL ESTATE ASSESSMENTS; REAL ESTATE APPRAISAL; MANAGEMENT OF REAL ESTATE; FINANCIAL ANALYSES AND EVALUATIONS IN THE FIELD OF INSURANCE, BANKING AND REAL ESTATE; FINANCIAL AND BANKING INFORMATION; SURETY SERVICES; SURETY BOND SERVICES; CREDIT AGENCIES; CREDIT BUREAUS; FINANCIAL MANAGEMENT; REAL ESTATE PORTFOLIO MANAGEMENT; SAVINGS AND LOAN SERVICES; SAVINGS BANKS; BROKERAGE COMMISSIONS IN THE NATURE OF REAL ESTATE LOAN SERVICES; FINANCING SERVICES; MUTUAL FUNDS AND CAPITAL INVESTMENTS; PROVISION OF FUNDS AND CAPITAL INVESTMENTS; REAL ESTATE INVESTMENTS; REAL ESTATE BROKERS; BANKING OPERATIONS; LOAN FINANCING; PAWN BROKERAGE; FINANCIAL SERVICES, NAMELY, INVESTMENT FUND TRANSFER AND TRANSACTIONS SERVICES; ELECTRONIC FUNDS TRANSFER; FINANCIAL AND BANKING MANAGEMENT; FINANCIAL SPONSORSHIP OF SALES AND RESALE AND MORTGAGE OF REAL ESTATE; FINANCIAL MARKET RESEARCH AND ASSESSMENT; CREDIT SERVICES PROVIDED ONLINE OR IN NON-REAL TIME FROM DATA PROCESSING SYSTEMS, FROM COMPUTER DATABASES OR FROM COMPUTER OR TELEMATIC NETWORKS, INCLUDING THE WORLD WIDE WEB; INFORMATION AND CONSULTATION SERVICES IN THE FIELD OF BANKING, FINANCING AND MONETARY ASSISTANCE SERVICES; ALL THESE SERVICES MADE AVAILABLE PARTICULARLY ONLINE VIA TELECOMMUNICATION NETWORKS, MOBILE TELEPHONES, TELEMATIC NETWORKS AND INTERNET OR INTRANET COMPUTER COMMUNICATIONS NETWORKS VIA ELECTRONIC SITES (U.S. CLS. 100, 101 AND 102).

JULIE WATSON, EXAMINING ATTORNEY

SN 79-079,239, OBEGI RIAD, BEYROUTH, LEBANON, FILED 1-6-2010.

**OBEGI MORTGAGE CERTIFICATE**

PRIORITY DATE OF 7-21-2009 IS CLAIMED.  
OWNER OF INTERNATIONAL REGISTRATION 1029758 DATED 1-6-2010, EXPIRES 1-6-2020.  
NO CLAIM IS MADE TO THE EXCLUSIVE RIGHT TO USE "MORTGAGE CERTIFICATE", APART FROM THE MARK AS SHOWN.

**CLASS 35—ADVERTISING AND BUSINESS**

FOR ADVERTISING; ONLINE ADVERTISING ON A COMPUTER COMMUNICATIONS NETWORK; BUSINESS MANAGEMENT; BUSINESS ADMINISTRATION CONSULTANCY; BUSINESS ORGANIZATION AND MANAGEMENT CONSULTING; BUSINESS INFORMATION; DISTRIBUTION AND DISSEMINATION OF ADVERTISING MATERIALS, NAMELY, PAMPHLETS, PROSPECTUSES, PRINTED MATTER, SAMPLES; BUSINESS ADVERTISING; ACCOUNTING SERVICES; COMPUTERIZED FILE MANAGEMENT; DATA PROCESSING; FINANCIAL INCENTIVE AWARDS PROGRAM TO PROMOTE THE SALE OF PRODUCTS AND SERVICES TO CUSTOMERS; PUBLIC RELATIONS; MARKETING STUDIES AND RESEARCH, BUSINESS RESEARCH AND INVESTIGATIONS; EFFICIENCY EXPERTS; ELECTRONIC DATA COLLECTION AND DATA SUBMISSION SERVICES FOR BUSINESS PURPOSES IN THE FIELDS OF BANKING, MONETARY EXCHANGE, REAL ESTATE APPRAISAL AND FISCAL ASSESSMENT; ECONOMIC FORECASTING; ACCOUNTS RECEIVABLE SERVICES (U.S. CLS. 100, 101 AND 102).

**CLASS 36—INSURANCE AND FINANCIAL**

FOR BANKING SERVICES; REAL ESTATE AFFAIRS, NAMELY, FISCAL EVALUATIONS AND ASSESSMENTS IN THE FIELD OF REAL ESTATE, FINANCIAL SPONSORSHIP OF SALES AND RESALE AND MORTGAGE OF REAL ESTATE; FINANCIAL CONSULTING; FISCAL EVALUATIONS AND ASSESSMENTS IN THE FIELD OF INSURANCE, BANKING AND REAL ESTATE; REAL ESTATE ASSESSMENTS; REAL ESTATE APPRAISAL; MANAGEMENT OF REAL ESTATE; FINANCIAL ANALYSES AND EVALUATIONS IN THE FIELD OF INSURANCE, BANKING AND REAL ESTATE; FINANCIAL AND BANKING INFORMATION; SURETY SERVICES; SURETY BOND SERVICES; CREDIT AGENCIES; CREDIT BUREAUS; FINANCIAL MANAGEMENT; REAL ESTATE PORTFOLIO MANAGEMENT; SAVINGS AND LOAN SERVICES; SAVINGS BANKS; BROKERAGE COMMISSIONS IN THE NATURE OF REAL ESTATE LOAN SERVICES; FINANCING SERVICES; MUTUAL FUNDS AND CAPITAL INVESTMENTS; PROVISION OF FUNDS AND CAPITAL INVESTMENTS; REAL ESTATE INVESTMENTS; REAL ESTATE BROKERS; BANKING OPERATIONS; LOAN FINANCING; PAWN BROKERAGE; FINANCIAL SERVICES, NAMELY, INVESTMENT FUND TRANSFER AND TRANSACTIONS SERVICES; ELECTRONIC FUNDS TRANSFER; FINANCIAL AND BANKING MANAGEMENT; FINANCIAL SPONSORSHIP OF SALES AND RESALE AND MORTGAGE OF REAL ESTATE; FINANCIAL MARKET RESEARCH AND ASSESSMENT; CREDIT SERVICES PROVIDED ONLINE OR IN NON-REAL TIME FROM DATA PROCESSING SYSTEMS, FROM COMPUTER DATABASES OR FROM COMPUTER OR TELEMATIC NETWORKS, INCLUDING THE WORLD WIDE WEB; INFORMATION AND CONSULTATION SERVICES IN THE FIELD OF BANKING, FINANCING AND MONETARY ASSISTANCE SERVICES; ALL THESE SERVICES MADE AVAILABLE PARTICULARLY ONLINE VIA TELECOMMUNICATION NETWORKS, MOBILE TELEPHONES, TELEMATIC NETWORKS AND INTERNET OR INTRANET COMPUTER COMMUNICATIONS NETWORKS VIA ELECTRONIC SITES (U.S. CLS. 100, 101 AND 102).

JULIE WATSON, EXAMINING ATTORNEY

SN 79-079,543, AMEFA FRANCE, F-42440 NOIRÉTABLE, FRANCE, FILED 9-28-2009.

# CUISINOX

OWNER OF INTERNATIONAL REGISTRATION 0251920 DATED 1-29-1962, EXPIRES 1-29-2012.  
THE MARK CONSISTS OF THE WORD "CUISINOX" IN STYLIZED FORM.

**CLASS 6—METAL GOODS**

FOR COMMON METALS, UNWROUGHT OR SEMI-WROUGHT, AND ALLOYS THEREOF; ANCHORS; ANVILS; METAL BELLS; METAL RAILS AND OTHER RAILWAY MATERIAL OF METAL; METAL CHAINS EXCLUDING TRANSMISSION CHAINS FOR VEHICLES; NON-ELECTRIC CABLES AND WIRES OF COMMON METAL; PIPES AND TUBES OF METAL; METAL SAFES AND METAL CASHBOXES; BALLS OF STEEL; HORSESHOES; NAILS; METAL SCREWS; OTHER GOODS OF COMMON METAL NOT INCLUDED IN OTHER CLASSES, NAMELY, METAL KNIFE HANDLES, REMOVABLE METAL HANDLES AND NON-REMOVABLE METAL HANDLES FOR SAUCEPANS, COOKING POTS, FRYING PANS, FRYERS AND BOWLS (U.S. CLS. 2, 12, 13, 14, 23, 25 AND 50).

**CLASS 8—HAND TOOLS**

FOR HAND TOOLS AND IMPLEMENTS, NAMELY, TABLE CUTLERY, KNIVES, FORKS, SPOONS, CAKE-SLICERS, PRECIOUS METAL KNIVES, AND SILVERWARE, NAMELY, FORKS, KNIVES, AND SPOONS THAT ARE SILVER OR SILVER-PLATED; STERLING SILVER MADE CUTLERY (U.S. CLS. 23, 28 AND 44).

**CLASS 21—HOUSEWARES AND GLASS**

FOR PORTABLE UTENSILS FOR HOUSEHOLD AND KITCHEN PURPOSES, NAMELY, SAUCEPANS, COOKING POTS, FRYING PANS, FRYERS, BOWLS, DISHES, DISHES LIDS, STEAMERS TO STEAM FOOD, TABLE KNIFE RESTS, HAND-SHAKERS IN THE NATURE OF SALT SHAKERS, COCKTAIL SHAKERS, BREADBASKETS FOR DOMESTIC USE, FRUIT BASKETS OF WICKER, STRAW FOR DOMESTIC USE, ICE BUCKETS, COOLERS FOR WINE, CHAMPAGNE BUCKETS, TRAYS FOR DOMESTIC-USE, TRAYS MADE WITH PRECIOUS METAL, TRAYS MADE WITH PRECIOUS METAL, APPETIZER PICKS, SALAD BOWLS MADE WITH NON-PRECIOUS MATERIAL, FRUIT BOWLS OR CONTAINERS FOR HOUSEHOLD AND KITCHEN PURPOSES, COMBS AND SPONGES, BRUSHES EXCEPT PAINT BRUSHES, BRUSHMAKING MATERIALS, STEELWOOL, BEVERAGE GLASSWARE, PORCELAIN AND EARTHENWARE COFFEE CUP, PLATES, SAUCERS, MUGS, BUTTER DISHES, BOWLS, WATER POT, TEAPOTS, CARAFE, FRUIT CUPS, CAKE TINS, SALAD BOWLS, SUGAR BOWLS, GLASSES (U.S. CLS. 2, 13, 23, 29, 30, 33, 40 AND 50).

ALLISON HOLTZ, EXAMINING ATTORNEY

**CLASS 6—METAL GOODS**

FOR STEEL CONSTRUCTIONS, NAMELY, SINGLE AND MULTI-FLOOR CONSTRUCTIONS COMPRISED OF VERTICAL AND HORIZONTAL LOAD BEARING MEMBERS, NAMELY, BEAMS, COLUMNS, WALL AND CABLES MADE OF STEEL, STAIRS AND STAIRWELLS, FAÇADE CONSTRUCTIONS, NAMELY, STEEL FRAMES FOR SUPPORTING NON-LOAD BEARING FAÇADE ELEMENTS, NAMELY, ELEMENTS MADE OF GLASS, PANELS MADE OF METAL AND SANDWICH PANELS MADE OF METAL, INTERIOR STRUCTURES AND INSTALLATIONS, NAMELY, RAILINGS MADE OF METAL, ESCALATORS, NON-LOAD BEARING COLUMNS AND PANELS MADE OF METAL THAT ARE USED FOR CREATING ADDITIONAL DESIGN VALUE, WALL, FLOOR AND CEILING CONSTRUCTIONS, NAMELY, NON-LOAD BEARING WALLS THAT ARE SOLD AS A UNIT COMPRISED OF VERTICAL STEEL MEMBERS AND SHEET METAL COVERING, STAGES MADE OF STEEL PROVIDING AN ELEVATED SURFACE IN ORDER TO IMPROVE VISIBILITY OF THE PRESENTED GOODS, CEILINGS THAT ARE SOLD AS A UNIT COMPRISED OF PANELS MADE OF METAL THAT ARE ATTACHED TO HORIZONTAL STEEL BEAMS, SUSPENDED CEILINGS THAT ARE SOLD AS A UNIT COMPRISED OF STEEL PANELS AND CABLES; BUILDINGS AND PORTABLE BUILDINGS, NAMELY, SUPPORTING AND NON-SUPPORTING STRUCTURES MADE OF METAL, NAMELY, SUPPORTING COLUMNS, NON-SUPPORTING COLUMNS, SUPPORTING WALLS, NON-SUPPORTING DIVIDING WALLS AND BRACING ELEMENTS, NAMELY, STEEL CABLES; PORTABLE CONSTRUCTIONS FOR EXHIBITION AND TRADE FAIR STANDS, NAMELY, SINGLE AND MULTI FLOOR CONSTRUCTIONS COMPRISED OF PORTABLE VERTICAL AND HORIZONTAL LOAD BEARING MEMBERS, NAMELY, PORTABLE COLUMNS MADE OF STEEL, PORTABLE BEAMS MADE OF STEEL AND PORTABLE WALL ELEMENTS MADE OF SHEET METAL, STAIRS AND STAIRWELLS, FAÇADE CONSTRUCTIONS, NAMELY, PORTABLE STEEL FRAMES FOR SUPPORTING A GLASS FAÇADE, PORTABLE PANELS AND PORTABLE SANDWICH PANELS MADE OF METAL, INTERIOR STRUCTURES AND INSTALLATIONS, NAMELY, RAILINGS MADE OF METAL, PORTABLE NON-LOAD BEARING COLUMNS AND PANELS MADE OF METAL THAT ARE USED FOR CREATING ADDITIONAL DESIGN VALUE, WALL, FLOOR AND CEILING CONSTRUCTIONS, NAMELY, PORTABLE NON-LOAD BEARING WALLS THAT ARE SOLD AS A UNIT COMPRISED OF VERTICAL STEEL MEMBERS AND SHEET METAL COVERING, PORTABLE STAGES MADE OF STEEL PROVIDING AN ELEVATED SURFACE IN ORDER TO IMPROVE VISIBILITY OF THE PRESENTED EXHIBIT, CEILINGS THAT ARE SOLD AS A UNIT COMPRISED OF PORTABLE PANELS MADE OF METAL THAT ARE ATTACHED TO PORTABLE HORIZONTAL STEEL BEAMS, SUSPENDED CEILINGS THAT ARE SOLD AS A UNIT COMPRISED OF STEEL PANELS AND STEEL CABLES; SCAFFOLDS, NAMELY, SPECIAL CONSTRUCTIONS MADE OF STEEL FOR TECHNICAL INSTALLATIONS FOR SOUND, LIGHT AND PICTURE TECHNOLOGY FOR STAGE SYSTEMS; STAGES AND PRODIUMS MADE OF METAL (U.S. CLS. 2, 12, 13, 14, 23, 25 AND 50).

SN 79-079,690, DISPLAY INTERNATIONAL SCHWENDINGER; GMBH & CO. KG, FED REP GERMANY, FILED 12-15-2009.



PRIORITY DATE OF 8-6-2009 IS CLAIMED.  
OWNER OF INTERNATIONAL REGISTRATION 1030862 DATED 12-15-2009, EXPIRES 12-15-2019.

NO CLAIM IS MADE TO THE EXCLUSIVE RIGHT TO USE "DISPLAY INTERNATIONAL", APART FROM THE MARK AS SHOWN.

THE COLOR(S) LIGHT GRAY, RED AND BLACK IS/ARE CLAIMED AS A FEATURE OF THE MARK.

THE MARK CONSISTS OF THE LETTER "D" IN RED WITH A LIGHT GRAY "I" INSIDE THE "D" NEXT TO THE WORDS "DISPLAYINTERNATIONAL" IN BLACK ALL ON A LIGHT GRAY RECTANGULAR BACKGROUND.

**CLASS 19—NON-METALLIC BUILDING MATERIALS**

FOR BUILDINGS AND PORTABLE BUILDINGS, NAMELY, SUPPORTING AND NON-SUPPORTING STRUCTURES NOT MADE OF METAL, NAMELY, SUPPORTING COLUMNS, NON-SUPPORTING COLUMNS, SUPPORTING WALLS, NON-SUPPORTING DIVIDING WALLS AND BRACING ELEMENTS NOT MADE OF METAL; PORTABLE CONSTRUCTIONS, NAMELY, SINGLE AND MULTI-FLOOR CONSTRUCTIONS COMPRISED OF VERTICAL AND HORIZONTAL LOAD BEARING MEMBERS, NAMELY, BEAMS, COLUMNS AND WALLS NOT MADE OF METAL, STAIRS AND STAIRWELLS, FAÇADE CONSTRUCTIONS, NAMELY, PANELS AND SANDWICH PANELS NOT MADE OF METAL, INTERIOR STRUCTURES AND INSTALLATIONS, NOT MADE OF METAL FOR EXHIBITION AND TRADE FAIR STANDS, NAMELY, RAILINGS, NON-LOAD BEARING COLUMNS AND PANELS THAT ARE USED FOR CREATING ADDITIONAL DE-



SIGN VALUE; COVER PARTS FOR BUILDINGS, NAMELY, WALL, FLOOR AND CEILING CONSTRUCTIONS NOT MADE OF METAL, NAMELY, NON-LOAD BEARING WALLS THAT ARE SOLD AS A UNIT COMPRISED OF VERTICAL LOAD BEARING MEMBERS AND PANELS, STAGES PROVIDING AN ELEVATED SURFACE IN ORDER TO IMPROVE VISIBILITY OF THE PRESENTED EXHIBIT, CEILINGS THAT ARE SOLD AS A UNIT COMPRISED OF PANELS THAT ARE ATTACHED TO HORIZONTAL LOAD BEARING MEMBERS, SUSPENDED CEILINGS THAT ARE SOLD AS A UNIT COMPRISED OF PANELS AND CABLES (U.S. CLS. 1, 12, 33 AND 50).

SN 79-080,730, ANSALDO STS S.P.A., I-16151 GENOVA, ITALY, FILED 12-3-2009.

#### **CLASS 20—FURNITURE AND ARTICLES NOT OTHERWISE CLASSIFIED**

FOR PARTS OF FURNITURE; FURNITURE AND DECORATIVE MOBILES FOR TRADE FAIR STANDS AND FOR EXHIBITIONS FOR THE PRESENTATION OF GOODS AND FOR PROMOTION, IN PARTICULAR RACKS FOR GOODS, EXHIBITION RACKS, FURNITURE PARTITIONS AND SALES' WALLS IN THE NATURE OF BROCHURE AND LEAFLET DISPLAYS, SCREEN WALLS AS MOBILE FURNITURE WALLS, RACKS, FURNITURE FOR PRESENTATION AND FURNITURE, NAMELY, COUNTERS, RACKS FOR FLYERS, SIGNS MADE FROM WOOD OR PLASTICS, TABLES, CHAIRS, BAR STOOLS; FURNITURE AND COMBINATIONS THEREOF; DISPLAYS FOR TRADE FAIRS, NAMELY, PRODUCT DISPLAY CASES, BROCHURE AND LEAFLET DISPLAY RACKS; EXHIBIT DISPLAY CASES AND DISPLAY CASES (U.S. CLS. 2, 13, 22, 25, 32 AND 50).

THE MARK CONSISTS OF STANDARD CHARACTERS WITHOUT CLAIM TO ANY PARTICULAR FONT, STYLE, SIZE, OR COLOR.

OWNER OF INTERNATIONAL REGISTRATION 1033691 DATED 12-3-2009, EXPIRES 12-3-2019.

#### **CLASS 9—ELECTRICAL AND SCIENTIFIC APPARATUS**

FOR SCIENTIFIC APPARATUS AND INSTRUMENTS, NAMELY, GLASSWARE FOR SCIENTIFIC EXPERIMENTS IN LABORATORIES; NAUTICAL APPARATUS AND INSTRUMENTS, NAMELY, MARINE COMPASSES; SURVEYING APPARATUS AND INSTRUMENTS; PHOTOGRAPHIC APPARATUS AND INSTRUMENTS, NAMELY, PHOTOGRAPHIC CAMERAS AND FILTERS; CINEMATOGRAPHIC APPARATUS; OPTICAL APPARATUS AND INSTRUMENTS, NAMELY, OPTICAL SCANNERS; WEIGHING APPARATUS AND INSTRUMENTS; MEASURING APPARATUS AND INSTRUMENTS, NAMELY, MEASURING TAPES AND RULES; SIGNALING APPARATUS AND INSTRUMENTS, NAMELY, ROTATING SIGNALLING LIGHTS; CHECKING APPARATUS AND INSTRUMENTS, NAMELY, CALIBRATION CHECKERS; COMPUTER SOFTWARE AND HARDWARE INSTALLED ON BOARD VEHICLES OR ON GROUND, ABLE TO CARRY OUT COMMAND AND CONTROL FUNCTIONS IN THE RAILWAY, TRAM, BUS AND UNDERGROUND SECTOR; LIFE-SAVING APPARATUS AND INSTRUMENTS, NAMELY, LIFE-SAVING RAFTS; TEACHING APPARATUS AND INSTRUMENTS, NAMELY, EDUCATIONAL SOFTWARE FEATURING INSTRUCTION IN THE RAILWAY, TRAM, BUS AND UNDERGROUND SECTOR; ROBOTS FOR EDUCATIONAL USE AND STRUCTURAL PARTS THEREFOR; VEHICLE DRIVE TRAINING SIMULATORS; APPARATUS FOR SWITCHING ELECTRICITY, NAMELY, ADAPTERS; APPARATUS FOR RECORDING, TRANSMISSION OR REPRODUCTION OF SOUND OR IMAGES; COMPACT DISCS FEATURING MUSICAL SOUND RECORDINGS; AUTOMATIC VENDING MACHINES AND MECHANISMS FOR COIN-OPERATED APPARATUS; CASH REGISTER, CALCULATING MACHINES, DATA PROCESSING EQUIPMENT AND COMPUTERS; FIRE-EXTINGUISHING APPARATUS (U.S. CLS. 21, 23, 26, 36 AND 38).

#### **CLASS 35—ADVERTISING AND BUSINESS**

FOR LEASING OF TRADE FAIR STANDS AND SALES STALLS (U.S. CLS. 100, 101 AND 102).

#### **CLASS 37—CONSTRUCTION AND REPAIR**

FOR CONSTRUCTION OF TRADE FAIR STANDS AND SHOPS (U.S. CLS. 100, 103 AND 106).

#### **CLASS 42—SCIENTIFIC AND COMPUTER SERVICES**

FOR SERVICES OF A DESIGNER IN THE FIELD OF EXHIBITION STAND CONSTRUCTION, FURNITURE CONSTRUCTION AND FURNISHING, NAMELY, FOR PROVIDING A PLANNING AND DESIGN SERVICE FOR THE REALIZATION OF EXHIBITION AND TRADE SHOW STANDS AND BOOTHS; SERVICES OF AN ARCHITECT AND INTERIOR DESIGNER; CONSULTING IN THE FIELD OF FURNISHING, NAMELY, PLANNING AND DESIGN SERVICES FOR THE REALIZATION OF EXHIBITION AND TRADE SHOW STANDS AND BOOTHS; TECHNICAL PROJECT PLANNING (U.S. CLS. 100 AND 101).

#### **CLASS 37—CONSTRUCTION AND REPAIR**

FOR BUILDING CONSTRUCTION, REPAIR, INSTALLATION AND MAINTENANCE SERVICES IN THE RAILWAY, TRAM, BUS AND UNDERGROUND SECTOR (U.S. CLS. 100, 103 AND 106).

#### **CLASS 43—HOTEL AND RESTAURANT SERVICES**

FOR LEASING OF PORTABLE BUILDINGS IN THE NATURE OF PERMANENT AND NON-PERMANENT EXHIBITION AND TRADE SHOW STANDS AND BOOTHS, LEASING OF TENTS (U.S. CLS. 100 AND 101).  
EUGENIA MARTIN, EXAMINING ATTORNEY

#### **CLASS 38—COMMUNICATION**

FOR TELECOMMUNICATION SERVICES, NAMELY, LOCAL AND LONG DISTANCE TRANSMISSION OF VOICE, DATA, GRAPHICS BY MEANS OF TELEPHONE, TELEGRAPHIC, RADIO, CABLE, AND SATELLITE TRANSMISSIONS (U.S. CLS. 100, 101 AND 104).

**CLASS 42—SCIENTIFIC AND COMPUTER SERVICES**

FOR SCIENTIFIC AND TECHNOLOGICAL SERVICES AND RESEARCH, NAMELY, ENGINEERING SERVICES AND DESIGN AND DEVELOPMENT SERVICES RELATING TO THE RAILWAY, TRAM, BUS AND UNDERGROUND SECTOR; INDUSTRIAL ANALYSIS AND RESEARCH SERVICES IN THE FIELD OF RAILWAY TRAM BUS AND UNDERGROUND SECTOR (U.S. CLS. 100 AND 101).

MARIA-VICTORIA SUAREZ, EXAMINING ATTORNEY

SN 79-080,837. SMETHURST NICHOLAS, FRANCE, FILED 11-4-2009.



PRIORITY DATE OF 5-13-2009 IS CLAIMED. OWNER OF INTERNATIONAL REGISTRATION 1034003 DATED 11-4-2009, EXPIRES 11-4-2019.

THE COLOR(S) BLACK, BLUE, GREEN, FUCHSIA RED AND ORANGE-YELLOW IS/ARE CLAIMED AS A FEATURE OF THE MARK.

THE MARK CONSISTS OF THE STYLIZED WORDING "BORA" IN BLACK WITH THE LETTER "O" COMPOSED OF FOUR PUZZLE PIECES IN BLUE, GREEN, FUCHSIA RED AND ORANGE-YELLOW.

**CLASS 9—ELECTRICAL AND SCIENTIFIC APPARATUS**

FOR SCIENTIFIC APPARATUS AND INSTRUMENTS, NAMELY, ELECTRICAL AND/OR ELECTRONIC CONTROL SYSTEMS CONSISTING OF INTEGRATED CIRCUITS OR MICROCHIPS DRIVEN BY SOFTWARE INTEGRATED INTO THE HARDWARE THAT IT CONTROLS FOR AUTOMOTIVE, TRANSPORT, COMPUTER, ELECTRONIC AND ENERGY AND MEDICAL INDUSTRIES INCLUDING THESE GOODS DEDICATED TO DISABLED PEOPLE; SPECTROMETERS; OPTICAL APPARATUS AND INSTRUMENTS, NAMELY, OPTICAL CABLES; MEASURING APPARATUS AND INSTRUMENTS, NAMELY, VELOCIMETERS, ULTRASONIC DOPPLER VELOCIMETER; EQUIPMENT FOR THE AMPLIFICATION AND FILTERING OF AUDIO SIGNALS, NAMELY, AMPLIFIERS; EQUIPMENT FOR THE MODULATION AND DEMODULATION OF SIGNALS, NAMELY, COMPUTER MODEMS; EQUIPMENT FOR INSPECTION APPARATUS AND INSTRUMENTS, NAMELY, OPTICAL INSPECTION APPARATUS FOR INDUSTRIAL USE; APPARATUS FOR IDENTIFYING AND ENCODING COMPUTER TRANSMISSION; ELECTRONIC MONITORING APPARATUS, NAMELY, ENERGY METERS FOR TRACKING AND MONITORING ENERGY USAGE; TRANSMITTERS FOR TELECOMMUNICATIONS; APPARATUS FOR RECORDING, TRANSMITTING AND REPRODUCING SOUNDS OR IMAGES; TELECOMMUNICATIONS APPARATUS, NAMELY, ELECTRIC CAPACITORS; SCANNERS FOR CAPTURING, STORING, PROCESSING DATA OR SIGNALS; APPARATUS FOR CONTROLLING ACCESS, NAMELY, ACCESS CONTROL AND ALARM MONITORING SYSTEMS VIA TELEPHONE; WRITING AND/OR READING APPARATUS NAMELY, CARD READING EQUIPMENT FOR USE WITH MEMORY, MICROCHIP OR MAGNETIC CARDS, IN PARTICULAR USED WITH A REMOTE RECEIVER, TELECOMMUNICATION TRANSMITTERS AND STRUCTURAL PARTS OF TELECOMMUNICATION TRANSMITTERS FOR THE REMOTE TRANSMISSION OF DATA AND SIGNALS; COMPUTERS FOR THE INPUT, COUNTING, COLLECTION, STORAGE; CONVERSION, PROCESSING, ENTERING, EMISSION, TRANSMISSION OF DATA, SOUNDS, IMAGES AND/OR SIGNALS; COMPUTER TRANSMISSION AUTHENTICATION AND ENCODING

APPARATUS; AUDIO AND VIDEO INTERACTIVE SERVERS; COMPUTER SERVERS; DATA AND WORD-PROCESSING COMPUTERS; VIDEO DISPLAYS, NAMELY, FLAT PANEL DISPLAY SCREENS; VISUAL DISPLAY UNITS, NAMELY, FLAT PANEL DISPLAY SCREENS; COMPUTER CONNECTION EQUIPMENT, NAMELY, MODEMS; MESSAGE TRANSMISSION APPARATUS; COMPUTER TERMINALS; TELECOMMUNICATIONS TERMINALS; MULTIMEDIA, NAMELY, MOBILE DATA TERMINALS; COMPUTER PROGRAMS FOR DATABASE MANAGEMENT; COMPUTER PROGRAMS FOR ENGINEERS, NAMELY, FOR REAL-TIME AND/OR SIGNAL PROCESSING APPLICATION DEVELOPMENT; SOFTWARE FOR CALCULATING, REAL-TIME, CREATING ALGORITHMS, ACOUSTICS AND VIBRATION, AUDIO, SIGNAL PROCESSING, CONTROLLING, INTERPRETING AND COMPILATION; BUSINESS MANAGEMENT AND ORGANISATION SOFTWARE; MICROCOMPUTERS; POCKET COMPUTERS; COMPUTER PROGRAMMES FOR DATA MANAGEMENT, NAMELY, DATABASES; DATA BANKS, NAMELY, MEMORIES FOR DATA PROCESSING EQUIPMENT; INTERFACES SOFTWARE; IMAGE BANKS SOFTWARE; MAGNETIC RECORDING MEDIA, NAMELY, BLANK CD-ROMS FOR SOUND OR VIDEO RECORDING; BLANK OPTICAL OR MAGNETIC DISCS FOR INFORMATION; BLANK DIGITAL STORAGE MEDIA FOR RECORDING AND REPRODUCING DATA, SOUNDS, IMAGES, OR SIGNALS; BLANK SOUND RECORDING DISCS; BLANK MAGNETIC AND OPTICAL DISCS; BLANK DIGITAL OPTICAL DISCS; BLANK DIGITAL VIDEO DISCS; BLANK VIDEO DISCS; BLANK RECORDING DISCS AND DISKETTES; BLANK MAGNETIC TAPES; ON-BOARD ELECTRONIC SYSTEM COMPRISED OF COMPUTERS AND SOFTWARE EMBEDDED IN THE EQUIPMENT IT CONTROLS; INTEGRATED CIRCUIT MODULES; PRINTED CIRCUITS; CIRCUIT BOARD CARDS FOR CONVERTING, PROCESSING, ENTERING, EMITTING AND TRANSMITTING OF DATA, SOUNDS, IMAGES OR SIGNALS; RECORDED INTEGRATED CIRCUIT CARDS; MAGNETIC OR CHIP MEMORY CARDS CONTAINING COMPUTER PROGRAMMES; ELECTRONIC CIRCUIT CARDS; ELECTRONIC IDENTITY CARDS (U.S. CLS. 21, 23, 26, 36 AND 38).

**CLASS 38—COMMUNICATION**

FOR COMMUNICATIONS VIA TELECOMMUNICATIONS NETWORKS AND COMPUTER NETWORKS; COMMUNICATIONS VIA COMPUTER TERMINALS; TRANSMISSION, VIA PUBLIC OR PRIVATE COMPUTER NETWORKS, OF MESSAGES, INFORMATION, DATA, SOUNDS, IMAGES, VIDEO; ELECTRONIC MESSAGING SERVICES; RENTAL OF ACCESS TIME TO GLOBAL COMPUTER NETWORKS; SERVICES FOR TRANSMISSION OF INFORMATION, NAMELY, DISPATCH AND NEWS INFORMATION USED BY ENGINEERS FOR REMOTE CONTROL OF TRANSPORT, COMPUTER, ELECTRIC, OR ELECTRONIC EQUIPMENT, REMOTELY VIA COMPUTER TERMINALS; RENTAL OF ACCESS TIME TO COMPUTING SERVICES, NAMELY, GLOBAL COMPUTER NETWORKS, PROVIDED REMOTELY VIA COMPUTER TERMINALS; RENTAL OF TELECOMMUNICATIONS EQUIPMENT; COMPUTER-ASSISTED TRANSMISSION OF MESSAGES AND IMAGES; TELECOMMUNICATIONS ACCESS SERVICES; TELEPHONE COMMUNICATIONS SERVICES, RADIOTELEPHONY COMMUNICATIONS SERVICES VIA ALL MEANS OF TELECOMPUTING; TELECOMMUNICATIONS, NAMELY, COMMUNICATIONS VIA COMPUTER TERMINALS OR VIA FIBRE-OPTIC NETWORKS; ELECTRONIC BULLETIN BOARD SERVICES; RADIOTELECOMMUNICATIONS SERVICES, NAMELY, SERVICES OF TRANSMISSION OF DATA TO BE USED BY ENGINEERS FOR REMOTE CONTROL OF TRANSPORT, COMPUTER, ELECTRIC, OR ELECTRONIC EQUIPMENT (U.S. CLS. 100, 101 AND 104).

**CLASS 42—SCIENTIFIC AND COMPUTER SERVICES**

FOR DESIGN AND DEVELOPMENT OF COMPUTERS, SERVERS AND SOFTWARE; TECHNOLOGICAL AND SCIENTIFIC STUDIES IN THE TECHNOLOGY FIELD OF COMPUTER SOFTWARE SYSTEM FOR COMPANIES; SCIENTIFIC RESEARCH AND DEVELOPMENT SERVICES IN CONNECTION WITH THE PROCESSING OF SIGNALS, COMPUTING, AUDIO, VIBRATION, VIDEO; DESIGN AND DEVELOPMENT OF COMPUTER HARDWARE AND SOFTWARE; DESIGN, INSTALLATION, MAINTENANCE, UPDATING AND RENTAL OF COMPUTER SOFTWARE; DESIGN OF COMPUTER SYSTEMS AND ON-BOARD SYSTEMS, NAMELY, ELECTRONIC SYSTEM DRIVEN BY SOFTWARE EMBEDDED IN THE EQUIPMENT IT CONTROLS; ENGINEERING SERVICES; DESIGN AND DEVELOPMENT OF ELECTRONICS, NAMELY, SIGNAL PROCESSING EQUIPMENT AND COMPUTER EQUIPMENT; COMPUTER PROGRAMMING SERVICES; TECHNICAL PROJECT STUDIES, NAMELY, TECHNICAL PROJECT PLANNING AND DESIGN ENGINEERING FOR AUTOMOTIVE, TRANSPORT, COMPUTER, ELECTRONIC AND ENERGY AND MEDICAL INDUSTRIES INCLUDING THESE GOODS DEDICATED TO DISABLED PEOPLE; TECHNICAL PROJECT PLANNING AND DESIGN ENGINEERING OF SIGNAL PROCESSING HARDWARE AND SOFTWARE APPLICATIONS; CREATION AND MAINTENANCE OF INTERNET SITES AND CHAT FORUMS (U.S. CLS. 100 AND 101).

TASNEEM HUSSAIN, EXAMINING ATTORNEY

**CLASS 41—EDUCATION AND ENTERTAINMENT**

FOR EDUCATION SERVICES AND TRAINING SERVICES, NAMELY, CLASSES, WORKSHOPS, SEMINARS, WEBINARS, SYMPOSIUMS, CONGRESSES, COLLOQUIUMS AND PRESENTATIONS RELATING TO ENVIRONMENTAL ISSUES; ARRANGING OF EDUCATIONAL CONFERENCES, LECTURES, DISPLAYS, EXHIBITIONS, PRESENTATIONS, SEMINARS AND COMPUTER-BASED EDUCATION ALL RELATING TO CARBON AND GREENHOUSE GASES IN THE NATURE OF TESTING, MEASUREMENT, REDUCTION AND OFFSETTING OF CARBON AND GREENHOUSE GAS EMISSIONS AND FOOTPRINTS AND METHODOLOGIES FOR TESTING, MEASUREMENT, REDUCTION AND OFFSETTING OF CARBON AND GREENHOUSE GAS EMISSIONS AND FOOTPRINTS; ALL OF THE AFOREMENTIONED SERVICES ALSO PROVIDED VIA INTERNET (U.S. CLS. 100, 101 AND 107).

**CLASS 42—SCIENTIFIC AND COMPUTER SERVICES**

FOR ENVIRONMENTAL CONSERVATION AND CONSULTANCY SERVICE, NAMELY, EVALUATING, TESTING AND CALCULATING THE ENVIRONMENTAL QUALITIES AND IMPACT OF CONSUMER PRODUCTS OF OTHERS; RESEARCH RELATING TO ENVIRONMENTAL PROTECTION; ADVISORY SERVICES RELATING TO ENVIRONMENTAL ISSUES, NAMELY, ADVICE ON MEASURING AND REDUCING CARBON FOOTPRINT, ADVICE ON RULES ON EMISSION AND WASTE MANAGEMENT; ENVIRONMENTAL TESTING AND INSPECTION SERVICES, NAMELY, DESIGNING METHODS OF TESTING, MEASUREMENT, REDUCTION AND OFFSETTING OF CARBON AND GREENHOUSE GAS EMISSIONS AND FOOTPRINTS AND THE CHANGE IN SUCH EMISSIONS AND FOOTPRINTS OVER TIME; DESIGN OF MODELS AND METHODOLOGIES FOR TESTING, MEASUREMENT, REDUCTION AND OFFSETTING OF CARBON AND GREENHOUSE GAS EMISSIONS AND FOOTPRINTS AND CHANGE IN SUCH EMISSIONS AND FOOTPRINTS OVER TIME; TESTING AND MEASUREMENT SERVICES IN RELATION TO CARBON AND GREENHOUSE GAS EMISSIONS AND FOOTPRINTS AND CHANGE IN SUCH EMISSIONS AND FOOTPRINTS OVER TIME; PREDICTION MEASUREMENT IN RELATION TO CARBON AND GREENHOUSE GAS EMISSIONS AND FOOTPRINTS AND CHANGE IN SUCH EMISSIONS AND FOOTPRINTS OVER TIME; INFORMATION, ADVISORY AND CONSULTANCY SERVICES, ALL IN THE FIELD OF ENVIRONMENTAL SCIENCE, NAMELY, THE REDUCTION OF CARBON AND GREENHOUSE GAS EMISSIONS AND FOOTPRINTS; ALL OF THE AFOREMENTIONED SERVICES ALSO PROVIDED VIA INTERNET (U.S. CLS. 100 AND 101).

SUZANNE BLANE, EXAMINING ATTORNEY

SN 79-081,324. CARBON TRUST FOOTPRINTING; COMPANY LIMITED, UNITED KINGDOM, FILED 12-10-2009.

**FOOTPRINT EXPERT**

THE MARK CONSISTS OF STANDARD CHARACTERS WITHOUT CLAIM TO ANY PARTICULAR FONT, STYLE, SIZE, OR COLOR.

OWNER OF INTERNATIONAL REGISTRATION 1035403 DATED 12-10-2009, EXPIRES 12-10-2019.

NO CLAIM IS MADE TO THE EXCLUSIVE RIGHT TO USE "FOOTPRINT", APART FROM THE MARK AS SHOWN.

**CLASS 16—PAPER GOODS AND PRINTED MATTER**

FOR PRINTED MATERIALS, NAMELY, BOOKS, PAMPHLETS, LEAFLETS, GUIDELINES AND TRAINING MANUALS, ALL RELATING TO ENVIRONMENTAL ISSUES; PRINTED MATERIALS, NAMELY, BOOKS, PAMPHLETS, LEAFLETS, GUIDELINES AND TRAINING MANUALS, ALL RELATING TO CARBON AND GREENHOUSE GASES IN THE NATURE OF TESTING, MEASUREMENT, REDUCTION AND OFFSETTING OF CARBON AND GREENHOUSE GAS EMISSIONS AND FOOTPRINTS AND METHODOLOGIES FOR TESTING, MEASUREMENT, REDUCTION AND OFFSETTING OF CARBON AND GREENHOUSE GAS EMISSIONS AND FOOTPRINTS (U.S. CLS. 2, 5, 22, 23, 29, 37, 38 AND 50).

**CLASS 35—ADVERTISING AND BUSINESS**

FOR COLLECTION OF DATA, DATA ANALYSIS, DATA PREPARATION, DATA VERIFICATION AND PREPARATION OF STATISTICS FOR MATHEMATICAL MODELS, ALL RELATING TO CARBON AND GREENHOUSE GAS EMISSIONS AND FOOTPRINTS AND CHANGE IN SUCH EMISSIONS AND FOOTPRINTS OVER TIME (U.S. CLS. 100, 101 AND 102).

SN 79-081,855. SCHOCK GMBH, FED REP GERMANY, FILED 2-22-2010.

**CRISTASTONE**

THE MARK CONSISTS OF STANDARD CHARACTERS WITHOUT CLAIM TO ANY PARTICULAR FONT, STYLE, SIZE, OR COLOR.

OWNER OF INTERNATIONAL REGISTRATION 1036737 DATED 2-22-2010, EXPIRES 2-22-2020.

OWNER OF U.S. REG. NOS. 1,785,413, 3,189,650 AND 3,746,966.

**CLASS 1—CHEMICALS**

FOR CHEMICALS USED IN INDUSTRY AND SCIENCE; UNPROCESSED ARTIFICIAL RESINS, UNPROCESSED PLASTICS; FIRE EXTINGUISHING COMPOSITIONS OF POLYMER PLASTICS CONTAINING FILLING MATERIALS (U.S. CLS. 1, 5, 6, 10, 26 AND 46).

**CLASS 11—ENVIRONMENTAL CONTROL APPARATUS**

FOR APPARATUS FOR LIGHTING, HEATING, STEAM GENERATING, COOKING, REFRIGERATING, DRYING, VENTILATING, WATER SUPPLY AND SANITARY PURPOSES AND PARTS THEREFOR, NAMELY, TAP WATER FAUCETS; FITTED DECORATIVE COVER SPECIALLY ADAPTED FOR SINKS; FITTED DECORATIVE COVER MADE OF POLYMER PLASTICS CONTAINING INORGANIC FILLING MATERIALS SPECIALLY ADAPTED FOR SINKS; FITTED DECORATIVE COVER SPECIALLY ADAPTED FOR TOILETS; FITTED DECORATIVE COVER SPECIALLY ADAPTED FOR TAP WATER FAUCETS AND MIXER TAPS, GAS COOKING OVENS, CLOTHES DRYING MACHINES, ELECTRIC HEATING FANS; BATH TUBS; SHOWER TRAYS; TOILETS; TOILET BOWLS; TOILET SEATS; WATER FLUSHING INSTALLATIONS, NAMELY, FLUSH LEVERS; PORTABLE TOILETS; BIDETS; SANITARY FIXTURES, NAMELY, URINALS; SINKS; EXTRACTOR HOODS FOR KITCHENS; SHOWERS; SHOWER CUBICLES AND ENCLOSURES; ELECTRIC RICE COOKERS AND INDUCTION RANGES; COOKING APPARATUS AND INSTALLATIONS, NAMELY, INDUSTRIAL COOKING OVENS; COOKING UTENSILS, NAMELY, ELECTRIC BREAD COOKERS; OVENS, NAMELY, KITCHEN COOKING RANGES; COOKING RINGS; GAS COOKERS; INDUCTION OVENS; BATH TUBS FOR SITZ BATHS; WASHBASINS BEING PARTS OF SANITARY INSTALLATIONS, NAMELY, SINKS; INSTALLATION SINKS; BUILT-IN SINKS, WASHBASINS, NAMELY, SINKS; LAVATORY BOWLS, SINK UNITS COMPRISED OF SINKS AND FAUCETS SOLD TOGETHER AS A UNIT; FITTED SINKS; MIXER TAPS FOR WATER PIPES (U.S. CLS. 13, 21, 23, 31 AND 34).

**CLASS 19—NON-METALLIC BUILDING MATERIALS**

FOR BUILDING MATERIALS IN SHEET FORM FOR INTERIOR DECORATION, NAMELY, MODIFIED SHEET GLASS; WALL PANELS OF POLYMER PLASTICS CONTAINING INORGANIC FILLINGS MATERIALS; ARTIFICIAL STONE; CONCRETE BUILDING MATERIALS, NAMELY, NON-METAL SLABS; SLABS OF POLYMER PLASTICS CONTAINING INORGANIC FILLINGS MATERIALS; NON-METAL TILES; LAMINATE FLOORING; NON-METAL TILES FOR FLOORING; ARTIFICIAL STONE SLABS AND TILES; WALL BOARDS MADE OF POLYMER PLASTICS CONTAINING INORGANIC FILLINGS MATERIALS; STEPS, NAMELY, STAIR TREADS NOT OF METAL; NON-METAL STAIRS; NON-METAL STAIRCASE PARTS, NAMELY, STRINGERS; NON-METAL WALL CLADDINGS FOR CONSTRUCTION AND BUILDING; NON-METAL CLADDINGS FOR BUILDINGS, NON-METAL WALL CLADDING PARTS, NAMELY, WALL STONE AND WALL TILES; NON-METAL FACADE CLADDINGS FOR CONSTRUCTION AND BUILDING; ARTIFICIAL STONE OF POLYMER PLASTICS CONTAINING INORGANIC FILLING MATERIALS (U.S. CLS. 1, 12, 33 AND 50).

**CLASS 20—FURNITURE AND ARTICLES NOT OTHERWISE CLASSIFIED**

FOR FURNITURE AND PARTS THEREFOR, IN PARTICULAR KITCHEN FURNITURE, AND PARTS FOR THE AFORESAID GOODS; WORK TOPS; TABLETOPS; FURNITURE SHELVES; DRESSING TABLES; RINSING TABLES; FURNITURE FITTINGS, NOT OF METAL; FURNITURE MADE OF POLYMER PLASTICS CONTAINING INORGANIC FILLING MATERIALS (U.S. CLS. 2, 13, 22, 25, 32 AND 50).

**CLASS 27—FLOOR COVERINGS**

FOR TOP FLOORS, NAMELY, FLOOR COVERINGS; FLOOR COVERINGS OF POLYMER PLASTICS CONTAINING INORGANIC FILLING MATERIALS (U.S. CLS. 19, 20, 37, 42 AND 50).

COLLEEN DOMBROW, EXAMINING ATTORNEY

SN 79-082.703. MOULD TECHNOLOGIES HOLDING AG, SWITZERLAND, FILED 3-24-2010.



**MOULD TECHNOLOGIES GROUP**

PRIORITY DATE OF 11-24-2009 IS CLAIMED. OWNER OF INTERNATIONAL REGISTRATION 1039109 DATED 3-24-2010, EXPIRES 3-24-2020.

NO CLAIM IS MADE TO THE EXCLUSIVE RIGHT TO USE "MOULD TECHNOLOGIES GROUP", APART FROM THE MARK AS SHOWN.

THE COLOR(S) BLUE AND RED IS/ARE CLAIMED AS A FEATURE OF THE MARK.

THE MARK CONSISTS OF A BLUE STYLIZED LETTER "M" ABOVE A RED SQUARE ABOVE THE BLUE WORDING "MOULD TECHNOLOGIES GROUP".

**CLASS 7—MACHINERY**

FOR LIFTING GEAR, MACHINES AND MECHANIZED APPARATUS INTENDED FOR HANDLING ARTICLES TO BE WORKED ON AND OBJECTS IN INDUSTRIAL MACHINING PROCESSES TO MAKE THEM PIVOT AND TURN, NAMELY, INDUSTRIAL MANIPULATORS FOR FORGING PRESSES AND FOR FORGING MACHINES; ELECTRICALLY, HYDRAULICALLY AND PNEUMATICALLY OPERATED MACHINE PARTS, NAMELY, GRIPPERS; MACHINE PARTS FOR HANDLING AND MACHINING PURPOSES IN INDUSTRIAL MACHINING AND MANUFACTURING PROCESSES, NAMELY, DISPLACEMENT, PIVOTING, LIFTING AND ROTATION MODULES; MACHINE PARTS FOR HANDLING AND MACHINING PURPOSES IN INDUSTRIAL MACHINING AND MANUFACTURING PROCESSES, NAMELY, PIVOT HEADS AND PIVOTING TABLES; ROBOTS FOR USE IN INDUSTRIAL MANUFACTURING PROCESSES; INDUSTRIAL ROBOT AXLES; TRANSMISSIONS FOR THE AFORESAID GOODS USING ELECTRIC MOTORS; COMPONENTS PARTS OF THE AFORESAID GOODS; MOLDING MACHINES AND COMPONENTS PARTS THEREOF FOR MANUFACTURING CORES AND MOLDS FOR FOUNDRY PURPOSES AND FOR CASTING METAL ARTICLES; MACHINES, MECHANIZED APPARATUS AND THEIR COMPONENTS AS WELL AS TOOLS FOR MANUFACTURING AND MACHINING FOUNDRY MOLDS AND FOUNDRY CORES OR BLOCKS OF MOLDING MATERIALS FROM MOLDING COMPOSITIONS AND CORES FOR MANUFACTURING CAST METAL ARTICLES; MILLING MACHINES AND POWER-OPERATED MILLING TOOLS FOR THREE-DIMENSIONAL MACHINING OF ARTICLES TO BE WORKED; CNC MILLING MACHINES FOR MILLING MOLDING MATERIALS INTENDED FOR FOUNDRY MOLDS OF METAL; METALWORKING MACHINE TOOLS AND THEIR COMPONENTS; HIGH-SPEED METALWORKING MACHINE TOOLS (U.S. CLS. 13, 19, 21, 23, 31, 34 AND 35).

**CLASS 42—SCIENTIFIC AND COMPUTER SERVICES**

FOR TECHNICAL ENGINEERING; INDUSTRIAL RESEARCH IN THE FIELD OF DEVELOPMENT OF SOFTWARE FOR USE WITH MACHINE TOOLS FOR MACHINING OF METALS AND PLASTICS; DESIGN, AND TECHNOLOGICAL CONSULTING IN THE RESEARCH AND DEVELOPMENT SECTOR IN THE FIELDS OF FOUNDRY TECHNOLOGY, CAST ARTICLES MANUFACTURING AND PLASTICS TECHNOLOGY; DEVELOPMENT OF DATA PROCESSING SOFTWARE; DEVELOPMENT OF SOFTWARE FOR USE WITH MACHINE TOOLS FOR MACHINING OF METALS AND PLASTICS AND FOR THREE-DIMENSIONAL MACHINING OF ARTICLES TO BE WORKED AS WELL AS FOR MILLING OF MOLDING MATERIALS FOR FOUNDRY MOLDS OF METAL; TECHNOLOGICAL CONSULTING; INDUSTRIAL ANALYSIS AND RESEARCH SERVICES IN THE FIELD OF DEVELOPMENT OF SOFTWARE FOR USE WITH MACHINE TOOLS FOR MACHINING OF METALS AND PLASTICS; SCIENTIFIC RESEARCH; LABORATORY RESEARCH IN THE FIELD OF DEVELOPMENT OF SOFTWARE FOR USE WITH MACHINE TOOLS FOR MACHINING OF METALS AND PLASTICS; ENGINEERING SERVICES IN THE FIELD OF MACHINE TOOLS AND CASTING TECHNOLOGY RELATING TO METALS AND PLASTICS (U.S. CLS. 100 AND 101).

**CLASS 45—PERSONAL AND LEGAL SERVICES**

FOR LEGAL SERVICES, NAMELY, LICENSING OF INDUSTRIAL PROPERTY LICENSES (U.S. CLS. 100 AND 101).

TRACY FLETCHER, EXAMINING ATTORNEY

SN 79-082,730. FLUIDRA COMMERCIAL, S.A.U., SPAIN, FILED 4-21-2010.

# SPAECIAL

THE MARK CONSISTS OF STANDARD CHARACTERS WITHOUT CLAIM TO ANY PARTICULAR FONT, STYLE, SIZE, OR COLOR.

PRIORITY DATE OF 4-15-2010 IS CLAIMED.

OWNER OF INTERNATIONAL REGISTRATION 1039196 DATED 4-21-2010, EXPIRES 4-21-2020.

THE WORDING "SPAECIAL" HAS NO MEANING IN A FOREIGN LANGUAGE.

**CLASS 11—ENVIRONMENTAL CONTROL APPARATUS**

FOR HEAT ACCUMULATORS, STEAM ACCUMULATORS, PRESSURE HOT WATER TANKS, REGULATING AND SAFETY ACCESSORIES FOR WATER FILTERING APPARATUS IN THE NATURE OF SWIMMING POOLS, BATHTUBS AND SPA BATHS, WATER INTAKE APPARATUS IN THE NATURE OF SWIMMING POOLS, BATHTUBS AND SPA BATHS, WATER FLUSHING INSTALLATIONS AND APPARATUS IN THE NATURE OF SWIMMING POOLS, BATHTUBS AND SPA BATHS, WATER FILTERING APPARATUS, APPARATUS AND MACHINES FOR PURIFYING WATER, WATER HEATERS, WATER STERILIZERS, INSTALLATIONS FOR PURIFYING, DISTRIBUTING AND SUPPLYING OF WATER; WATER FILTERS, BATHTUBS, SPA BATHS (VESSELS), PORTABLE TURKISH BATH CABINETS IN THE NATURE OF SPA BATHS, PORTABLE TANNING APPARATUS IN THE NATURE OF TANNING LAMPS, SHOWER ENCLOSURES, WHIRLPOOL-JET APPARATUS, SWIMMING-POOL CHLORINATION UNITS, SAUNA BATH INSTALLATIONS, STEAM GENERATING INSTALLATIONS, STEAM ACCUMULATORS (U.S. CLS. 13, 21, 23, 31 AND 34).

**CLASS 37—CONSTRUCTION AND REPAIR**

FOR BUILDING CONSTRUCTION, REPAIR, AND INSTALLATION SERVICES, PUMP REPAIR, BOILER CLEANING AND REPAIR, HEATING EQUIPMENT INSTALLATION AND REPAIR, DISINFECTING, RAT EXTERMINATING, ELECTRIC APPLIANCE INSTALLATION AND REPAIR, WATER AND DAMPROOFING, PLUMBING, RUSTPROOFING, INFORMATION CONCERNING CONSTRUCTION AND REPAIR OF SWIMMING POOLS, BATHTUBS AND SPA BATHS, CLEANING SWIMMING POOLS AND BATHTUBS, AND INSTALLATION, MAINTENANCE AND REPAIR OF SWIMMING POOLS, BATHTUBS AND SPA BATHS (U.S. CLS. 100, 103 AND 106).

**CLASS 44—MEDICAL, BEAUTY AND AGRICULTURAL SERVICES**

FOR AROMATHERAPY SERVICES, PUBLIC BATHS FOR HYGIENE PURPOSES, TURKISH BATHS, BEAUTY SALONS, SOLARIUM SERVICES, CONVALESCENT HOMES, PLASTIC SURGERY, MEDICAL, BEAUTY AND HEALTH SPA SERVICES IN THE NATURE OF COSMETIC BODY CARE SERVICES, PHYSIOTHERAPY, MANICURE, MASSAGES, HEALTH CARE, SAUNA SERVICES, HEALTH SPA SERVICES IN THE NATURE OF COSMETIC BODY CARE SERVICES (U.S. CLS. 100 AND 101).

MICHAEL WIENER, EXAMINING ATTORNEY

SN 79-082,822. GUANGZHOU SHUOJIN MECHATRONICS; CO., LTD., CHINA, FILED 5-11-2010.

# GOTO

OWNER OF INTERNATIONAL REGISTRATION 1039484 DATED 5-11-2010, EXPIRES 5-11-2020.

THE MARK CONSISTS OF THE WORDING "GOTO" IN STYLIZED FORM.

**CLASS 7—MACHINERY**

FOR BEARINGS FOR TRANSMISSION SHAFTS, BEING PARTS OF MACHINES; PARALLEL ADHESIVE BANDS FOR USE AS CONVEYOR BELTS, TRANSMISSION BELTS, NOT FOR USE AS TRANSMISSION BELTS FOR ENGINES OF LAND VEHICLES; CENTRIFUGAL SEPARATORS; BALL RINGS FOR BEARINGS FOR INDUSTRIAL MACHINES; MACHINE PARTS, NAMELY, GUIDES; ANTI-FRICTION BEARINGS FOR MACHINES; BEARING BRACKETS FOR MACHINES; MECHANICAL SEALS FOR MACHINES; LUBRICATION MACHINES; TRIANGLE ADHESIVE BANDS FOR PULLEYS; UNIVERSAL JOINTS FOR MACHINES, NOT LAND VEHICLES; MACHINE PARTS, NAMELY, BEARINGS; MACHINE PARTS, NAMELY, BALL RINGS FOR BEARINGS; JOURNAL BOXES (U.S. CLS. 13, 19, 21, 23, 31, 34 AND 35).

**CLASS 12—VEHICLES**

FOR SHOCK ABSORBING SPRINGS FOR VEHICLES; UNDERCARRIAGES FOR VEHICLES; AUTOMOBILE BUMPERS; HYDRAULIC CIRCUITS FOR VEHICLES; CLUTCHES FOR LAND VEHICLES; BRAKES FOR VEHICLES; DRIVING MOTORS FOR LAND VEHICLES; AUTOMOBILE BODIES; TRANSMISSIONS, FOR LAND VEHICLES; CONNECTING RODS FOR LAND VEHICLES, OTHER THAN PARTS OF MOTORS AND ENGINES; PROPULSION MECHANISMS FOR LAND VEHICLES, NAMELY, MOTORS AND ENGINES; VEHICLE WHEELS; AUTOMOBILE TRANSMISSION CHAINS; DRIVE GEARS FOR LAND VEHICLES; REDUCTION GEARS FOR LAND VEHICLES; AIR PUMPS OF AUTOMOBILES; REARVIEW MIRRORS; HIGH VOLTAGE DAMPERS FOR LAND VEHICLES; UPHOLSTERY FOR VEHICLES; HORNS FOR VEHICLES; DIRECTION SIGNALS FOR VEHICLES; HUBS FOR VEHICLE WHEELS; TIRES FOR VEHICLE WHEELS; DOORS FOR VEHICLES; HOODS FOR VEHICLE ENGINES; AXLES FOR LAND VEHICLES; DRIVING MOTORS FOR LAND VEHICLES; CARS (U.S. CLS. 19, 21, 23, 31, 35 AND 44).  
FRED CARL, EXAMINING ATTORNEY

SN 79-082,973. BRECO ANTRIEBSTECHNIK BREHER GMBH + CO, FED REP GERMANY, FILED 5-14-2010.

# BRECObasic

THE MARK CONSISTS OF STANDARD CHARACTERS WITHOUT CLAIM TO ANY PARTICULAR FONT, STYLE, SIZE, OR COLOR.

PRIORITY DATE OF 12-14-2009 IS CLAIMED.  
OWNER OF INTERNATIONAL REGISTRATION 1039906 DATED 5-14-2010, EXPIRES 5-14-2020.

**CLASS 7—MACHINERY**

FOR MACHINE COUPLING AND TRANSMISSION COMPONENTS EXCEPT FOR LAND VEHICLES; PARTS OF MACHINES AND MACHINE TOOLS, NAMELY, DRIVING BELTS AND CONVEYOR BELTS, IN PARTICULAR TOOTHED BELTS, TRACKED TOOTHED BELTS AND TOOTHED LOCK WASHERS; CONVEYOR BELTS AND BELTS FOR CONVEYERS, CAM BELTS, CAMS; TENSION ROLLERS FOR BANDS AND BELTS, CONNECTING ELEMENTS, CLAMPING JOINTS AND CLAMPING PLATES FOR TOOTHED BELTS INCLUDED IN THIS CLASS (U.S. CLS. 13, 19, 21, 23, 31, 34 AND 35).

**CLASS 12—VEHICLES**

FOR PARTS FOR VEHICLES AND APPARATUS FOR LOCOMOTION BY LAND, AIR OR WATER, NAMELY, DRIVING BELTS, TOOTHED BELTS AND V-BELTS, AS WELL AS TENSION ROLLERS, SYNCHRONISING SHAFTS, SYNCHRONISING DISCS AND TOOTHED LOCK WASHERS INCLUDED IN THIS CLASS (U.S. CLS. 19, 21, 23, 31, 35 AND 44).  
PRISCILLA MILTON, EXAMINING ATTORNEY

SN 79-083,123. LANDWIRTSCHAFTLICHE RENTENBANK -; ANSTALT DES ÖFFENTLICHEN RECHTS, 60313 FRANKFURT AM MAIN, FED REP GERMANY, FILED 3-4-2010.



# rentenbank

OWNER OF INTERNATIONAL REGISTRATION 1040281 DATED 3-4-2010, EXPIRES 3-4-2020.

OWNER OF U.S. REG. NO. 3,683,328.  
THE COLOR(S) GREEN, WHITE AND BLACK IS/ARE CLAIMED AS A FEATURE OF THE MARK.

SQUARE IN GREEN WITH WHITE LINES; WORD "RENTENBANK" IN BLACK.

THE MARK CONSISTS OF THE STYLIZED BLACK WORDING "RENTENBANK" WITH A SQUARE APPEARING ABOVE THE LETTERS "BA". THE SQUARE IS GREEN WITH SETS OF OVERLAPPING WHITE LINES COMING FROM THE TOP AND UPPER LEFT AND RIGHT SIDES.

THE WORDING "RENTENBANK" HAS NO MEANING IN A FOREIGN LANGUAGE.

**CLASS 35—ADVERTISING AND BUSINESS**

FOR BUSINESS MANAGEMENT, BUSINESS ADMINISTRATION (U.S. CLS. 100, 101 AND 102).

**CLASS 36—INSURANCE AND FINANCIAL**

FOR FINANCIAL AFFAIRS AND MONETARY AFFAIRS, NAMELY, ARRANGING OF DEVELOPMENT LOANS IN THE FIELD OF AGRICULTURE BY MEANS OF REFINANCING OF FINANCIAL AND CREDIT INSTITUTES, NAMELY, PURCHASE AND SALE OF DEBT AND SECURITIES, SECURITIES TRADING, DEPOSIT AND GIRO BUSINESS FOR ITS OWN ACCOUNT, ISSUE OF COVERED AND UNSECURED BONDS IN BEARER OR REGISTERED FORM (U.S. CLS. 100, 101 AND 102).  
ANDREA HACK, EXAMINING ATTORNEY

SN 79-083,157. PRIME; RESEARCH INTERNATIONAL AG & CO KG, FED REP GERMANY, FILED 3-2-2010.

# web.Analysis

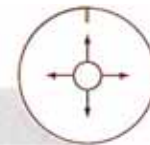

PRIORITY DATE OF 9-3-2009 IS CLAIMED.  
OWNER OF INTERNATIONAL REGISTRATION 1040387 DATED 3-2-2010, EXPIRES 3-2-2020.

NO CLAIM IS MADE TO THE EXCLUSIVE RIGHT TO USE "WEB ANALYSIS", APART FROM THE MARK AS SHOWN.

THE COLOR(S) CLARET AND GREY IS/ARE CLAIMED AS A FEATURE OF THE MARK.

THE MARK CONSISTS OF THE COLOR CLARET APPEARS IN THE WORDING "WEB.ANALYSIS" AND THE STYLED COMPASS SYMBOL; THE COLOR GREY APPEARS IN THE BACKGROUND OF THE RECTANGLE. THE COLOR WHITE REPRESENTS TRANSPARENT AREAS AND IS NOT PART OF THE MARK.

**CLASS 35—ADVERTISING AND BUSINESS**

FOR PROVIDING BUSINESS INFORMATION VIA COMPUTER RESEARCH; COMPILATION, SYSTEMIZATION AND UPDATING OF BUSINESS MEDIA INFORMATION IN COMPUTER DATABASES VIA A COMPUTER SUPPORTED INFORMATION SERVICE, PARTLY IN REAL-TIME; COMPUTERIZED BUSINESS INFORMATION RESEARCH AND BUSINESS INFORMATION RESEARCH PERTAINING TO THE MEDIA, PARTLY IN REAL-TIME; COMPILATION, SYSTEMIZATION AND UPDATING INTO COMPUTER DATABASES OF BUSINESS INFORMATION AND BUSINESS INFORMATION PERTAINING TO THE MEDIA FROM COMPUTERS AND PARTLY IN REAL-TIME; PROVIDING ONLINE DATABASES IN THE FIELD OF BUSINESS INFORMATION AND BUSINESS INFORMATION PERTAINING TO THE MEDIA, PARTLY IN REAL-TIME (U.S. CLS. 100, 101 AND 102).

**CLASS 38—COMMUNICATION**

FOR PROVIDING MULTIPLE USER ACCESS TO PROPRIETARY COLLECTIONS OF BUSINESS AND MEDIA INFORMATION BY MEANS OF GLOBAL COMPUTER INFORMATION NETWORKS, PARTLY IN REAL-TIME; MESSAGE COLLECTION AND TRANSMISSION OF MEDIA INFORMATION VIA THE INTERNET, PARTLY IN REAL-TIME; PROVIDING ONLINE FACILITIES FOR REAL-TIME INTERACTION WITH AN INFORMATION SERVICE ON THE INTERNET CONCERNING TOPICS OF MEDIA INFORMATION AND MEDIA NEWS, PARTLY IN REAL-TIME (U.S. CLS. 100, 101 AND 104).

**CLASS 42—SCIENTIFIC AND COMPUTER SERVICES**

FOR MEDIA ANALYSIS VIA INTERNET FOR INFORMATION PURPOSES, ESPECIALLY MEDIA RESPONSE ANALYSIS FOR INFORMATION PURPOSES, NAMELY, PROVIDING AN INTERACTIVE WEB SITE FEATURING TECHNOLOGY THAT ENABLES USERS TO ANALYZE MEDIA NEWS OUTLETS AND RESPONSES FROM MEDIA NEWS OUTLETS FOR INFORMATIONAL PURPOSES; PROVIDING AN INTERACTIVE WEB SITE FEATURING TECHNOLOGY THAT ENABLES USERS TO MONITOR MEDIA NEWS OUTLETS, PARTLY IN REAL-TIME; PROVIDER'S SERVICES, NAMELY, PROVIDING TEMPORARY USE OF ONLINE NON-DOWNLOADABLE MEDIA ANALYSIS SOFTWARE OF AN INTERACTIVE INFORMATION SERVICE, RELATED TO MEDIA INFORMATION AND MEDIA NEWS, PARTLY IN REAL TIME; PROVIDER'S SERVICES, NAMELY, UPDATING OF MEDIA ANALYSIS SOFTWARE WITHIN THE SCOPE OF AN INTERACTIVE INFORMATION SERVICE, RELATED TO MEDIA INFORMATION AND MEDIA NEWS, PARTLY IN REAL TIME (U.S. CLS. 100 AND 101).

LEIGH LOWRY, EXAMINING ATTORNEY

SN 79-083,537. VAHÉ KELPENTIDJIAN, SWITZERLAND,  
FILED 4-29-2010.



THE MARK CONSISTS OF STANDARD CHARACTERS WITHOUT CLAIM TO ANY PARTICULAR FONT, STYLE, SIZE, OR COLOR.

PRIORITY DATE OF 4-1-2010 IS CLAIMED.  
OWNER OF INTERNATIONAL REGISTRATION 1041396  
DATED 4-29-2010, EXPIRES 4-29-2020.

**CLASS 6—METAL GOODS**

FOR TRANSPORTABLE BUILDINGS OF METAL; METAL BUILDING MATERIALS, NAMELY, SOFFITS, FASCIA, CEILING BOARDS AND FLOOR BOARDS, METAL COUNTERTOPS FOR FURTHER INSTALLATION, STAIR NOSING OF METAL; STEEL BUILDINGS (U.S. CLS. 2, 12, 13, 14, 23, 25 AND 50).

**CLASS 11—ENVIRONMENTAL CONTROL APPARATUS**

FOR ELECTRONIC LIGHT FIXTURES, CENTRAL HEATING RADIATORS, STEAM GENERATING INSTALLATIONS, COOKING OVENS, AIR PURIFYING APPARATUS, IONIZATION APPARATUS FOR THE TREATMENT OF AIR, ELECTRIC ROOM DEODORIZING UNITS, AIR CONDITIONING APPARATUS, AIR FILTERING INSTALLATIONS AND NON-MEDICAL STERILIZERS (U.S. CLS. 13, 21, 23, 31 AND 34).

**CLASS 19—NON-METALLIC BUILDING MATERIALS**

FOR TRANSPORTABLE BUILDINGS, NOT OF METAL; BUILDING MATERIALS, NOT OF METAL, NAMELY, NON-METAL COUNTERTOPS FOR FURTHER INSTALLATION, NON-METAL FLOORING MATERIALS, FASCIA, SOFFITS; GLASS AND GLASS PANES, FOR BUILDING; BUILDINGS, NOT OF METAL; INSULATING GLASS PANES FOR BUILDING (U.S. CLS. 1, 12, 33 AND 50).

**CLASS 20—FURNITURE AND ARTICLES NOT OTHERWISE CLASSIFIED**

FOR FURNITURE EXCEPT BATHROOM FURNITURE, FURNITURE MIRRORS, PICTURE FRAMES (U.S. CLS. 2, 13, 22, 25, 32 AND 50).

**CLASS 35—ADVERTISING AND BUSINESS**

FOR BUSINESS ADMINISTRATION, NAMELY, ASSISTING THE OWNERS OF INTELLECTUAL PROPERTY IN FINDING INVESTORS; ADVICE, EXPERT ASSESSMENTS AND PROFESSIONAL CONSULTANCY IN BUSINESS, NAMELY, BUSINESS RISK ASSESSMENTS AND BUSINESS CONSULTING SERVICES; DISSEMINATION OF ADVERTISING MATTER; DEMONSTRATION OF GOODS; MARKETING STUDIES, ORGANIZATION OF EXHIBITIONS FOR COMMERCIAL OR ADVERTISING PURPOSES; COMPUTERIZED FILE MANAGEMENT; RENTAL OF ADVERTISING SPACE; SALES PROMOTION FOR OTHERS; ADVERTISING, PUBLIC RELATIONS (U.S. CLS. 100, 101 AND 102).

**CLASS 37—CONSTRUCTION AND REPAIR**

FOR BUILDING CONSTRUCTION; REPAIR AND INSTALLATION SERVICES OF BUSINESS AND OFFICE MACHINERY AND EQUIPMENT, FREEZING APPARATUS, HEATING, VENTILATING AND AIR CONDITIONING EQUIPMENT, HEATING EQUIPMENT; BUILDING CONSTRUCTION INFORMATION; CLEANING OF BUILDINGS; AIR CONDITIONING APPARATUS INSTALLATION AND REPAIR; BUILDING CONSTRUCTION SUPERVISION; INFORMATION ON BUILDING CONSTRUCTION, REPAIR AND MAINTENANCE (U.S. CLS. 100, 103 AND 106).

**CLASS 40—MATERIAL TREATMENT**

FOR AIR PURIFYING, DEODORIZING AND FRESHENING, CUSTOM ASSEMBLING OF PRODUCTS FOR OTHERS (U.S. CLS. 100, 103 AND 106).

**CLASS 41—EDUCATION AND ENTERTAINMENT**

FOR NIGHT CLUBS; PROVIDING FITNESS AND EXERCISE FACILITIES; ENTERTAINMENT SERVICES, NAMELY, MOVIE THEATERS, CIRCUSES, AND CASINOS; PROVIDING AMUSEMENT ARCADE SERVICES; ORGANIZATION OF EXHIBITIONS FOR CULTURAL OR EDUCATIONAL PURPOSES; PHYSICAL EDUCATION; PROVIDING PHYSICAL FITNESS CENTERS (U.S. CLS. 100, 101 AND 107).

**CLASS 42—SCIENTIFIC AND COMPUTER SERVICES**

FOR ARCHITECTURAL DESIGN SERVICES, ARCHITECTURAL CONSULTATION; CONSTRUCTION DRAFTING; DESIGN OF INTERIOR DECOR; MATERIAL TESTING; SURVEYING; ENGINEERING; SOFTWARE DESIGN AND DEVELOPMENT (U.S. CLS. 100 AND 101).

**CLASS 43—HOTEL AND RESTAURANT SERVICES**

FOR SERVICES FOR PROVIDING FOOD AND DRINK; TEMPORARY ACCOMMODATION; BAR SERVICES, CAFETERIAS, CANTEN SERVICES, DAY NURSERIES, RENTAL OF TRANSPORTABLE BUILDINGS, HOTELS; RENTAL OF PORTABLE ROOMS THAT CAN BE ASSEMBLED AND DISMANTLED, NAMELY, ROOMS AND PORTABLE STRUCTURES FITTED WITH AIR PURIFICATION, DEODORIZING, AND FRESHENING SYSTEMS TO ALLOW SMOKING OF CIGARS, PIPES, AND CIGARETTES WITHOUT DISTURBING THOSE OUTSIDE THE ROOM OR STRUCTURE (U.S. CLS. 100 AND 101).

**CLASS 44—MEDICAL, BEAUTY AND AGRICULTURAL SERVICES**

FOR MEDICAL SERVICES; VETERINARY SERVICES; HYGIENIC AND BEAUTY CARE FOR HUMAN BEINGS OR ANIMALS; BEAUTY SALONS, HAIRDRESSING SALONS, HEALTHCARE (U.S. CLS. 100 AND 101).  
DAVID C. REIHNER, EXAMINING ATTORNEY

**CLASS 7—MACHINERY**

FOR MOTORS AND ENGINES FOR THE GENERATION OF ELECTRICITY, NOT FOR LAND VEHICLES; MACHINE COUPLING AND TRANSMISSION COMPONENTS NOT FOR LAND VEHICLES, NAMELY, COUPLINGS FOR MACHINES, TRANSMISSION BELTS, TRANSMISSION GEARS FOR MACHINES, GENERATORS FOR WIND TURBINES, BLADES FOR THE GENERATION OF ELECTRICITY, POWER TRANSMISSION SHAFTS FOR MACHINES, WIND-POWERED ELECTRICITY GENERATORS, WINDMILLS, OFFSHORE WINDMILLS, WIND POWER PLANTS, OFFSHORE WIND POWER PLANTS, WIND TURBINES, AND STRUCTURAL PARTS AND ACCESSORIES THEREFOR, NOT INCLUDED IN OTHER CLASSES, NAMELY, MILL TOWERS AND MASTS, BLADES, BLADE HUBS, MILL HOUSINGS, MACHINE BEDS, ROTATION DEVICES, YAW RINGS AND GEARS; DEVICES FOR SETTING THE PITCH OF THE WINGS, BRAKES AND BRAKING DEVICES, MAIN SHAFTS, UNIVERSAL JOINTS, TRANSMISSION CASES, CLUTCHES AND ELECTRIC GENERATORS AND RESERVE POWER SUPPLY PLANTS ELECTRIC GENERATORS, SOLAR-POWERED ELECTRICITY GENERATORS, WIND-POWERED ELECTRICITY GENERATORS, HYDROELECTRIC GENERATING STATIONS, WIND DRIVEN ELECTRIC APPARATUS, NAMELY, WIND TURBINES, WIND/DIESEL DRIVEN ELECTRICAL ENERGY APPARATUS FOR CONVERSION OF WIND POWER TO ELECTRIC ENERGY, FREQUENCY CONVERTERS, ROTOR BLADES AND ROTORS (U.S. CLS. 13, 19, 21, 23, 31, 34 AND 35).

**CLASS 9—ELECTRICAL AND SCIENTIFIC APPARATUS**

FOR ELECTRIC AND ELECTRONIC APPARATUS AND INSTRUMENTS FOR WIND TURBINES, WIND GENERATORS, WIND POWER PLANTS, HYDROELECTRIC POWER PLANTS, PHOTOVOLTAIC-BASED POWER PLANTS AND WIND TURBINE GENERATORS, NAMELY, APPARATUS AND COMPUTERS FOR CONTROL, MONITORING AND AUTOMATICALLY TURNING ON OR OFF THE GENERATOR AND FOR AUTOMATIC STARTING AFTER A PUBLIC POWER BREAKDOWN, FOR OVERVOLTAGE PROTECTION AGAINST STROKES OF LIGHTNING; MICROPROCESSORS FOR CONTROLLING AND MONITORING CONSTANT VOLTAGE, FREQUENCY, PHASE CONDITIONS, ROTOR SPEED CONTROL OF THE EFFICIENCY AND THICKNESS OF BRAKE PADS AND OF THE TEMPERATURE, DIRECTION AND SPEED OF WIND; VIBRATION SENSORS FOR INSTALLATION IN MILL HOUSINGS, WATT-HOUR METERS; ALL THE AFORESAID GOODS FOR USE IN CONNECTION WITH WIND TURBINES, WIND GENERATORS, WIND POWER PLANTS AND WIND TURBINE GENERATORS ONLY; APPARATUS FOR CONVERTING ELECTRONIC RADIATION TO ELECTRICAL ENERGY, NAMELY, PHOTOVOLTAIC SOLAR MODULES; APPARATUS FOR CONVERTING ELECTRONIC RADIATION TO ELECTRICAL ENERGY, NAMELY, PHOTOVOLTAIC SOLAR HYBRID MODULES; ELECTRONICAL SENSORS FOR MEASURING SOLAR RADIATION; PHOTOVOLTAIC CELLS ALSO INCLUDING A SOLAR THERMAL COLLECTOR SOLD AS A UNIT; SOLAR PANELS FOR PRODUCTION OF ELECTRICITY; SOLAR COLLECTORS; APPARATUS AND INSTRUMENTS FOR CONDUCTING, SWITCHING, TRANSFORMING, ACCUMULATING, REGULATING OR CONTROLLING ELECTRICITY, NAMELY, ELECTRIC SWITCHES, ADAPTERS, VOLTAGE REGULATORS FOR ELECTRIC POWER; CENTRAL PROCESSING UNITS FOR PROCESSING INFORMATION, DATA, SOUND OR IMAGES; DATA PROCESSING COMPUTERS, COMPUTERS, ALL FOR OPERATING AND CONTROL OF WIND TURBINES (U.S. CLS. 21, 23, 26, 36 AND 38).

SN 79-083,594. WIND TO POWER SYSTEM, S.L., E-28108  
ALCOBENDAS, SPAIN, FILED 5-6-2010.



PRIORITY DATE OF 4-9-2010 IS CLAIMED.  
OWNER OF INTERNATIONAL REGISTRATION 1041510  
DATED 5-6-2010, EXPIRES 5-6-2020.  
THE COLOR(S) BLUE IS/ARE CLAIMED AS A FEATURE  
OF THE MARK.  
THE MARK CONSISTS OF THE STYLIZED LETTERS  
"W2PS" IN THE COLOR BLUE.



**CLASS 11—ENVIRONMENTAL CONTROL APPARATUS**

FOR PARABOLIC MIRRORS DESIGNED FOR THE COLLECTION OF SOLAR ENERGY; SOLAR COLLECTORS; SOLAR ENERGY BASED COOLING APPARATUS; SOLAR HEAT COLLECTION PANELS; SOLAR ENERGY RECEIVERS; SOLAR THERMAL INSTALLATIONS, NAMELY, SOLAR THERMAL MODULES; SOLAR THERMAL-BASED POWER PLANTS; SOLAR WATER HEATERS; SOLAR-POWERED ALL-WEATHER LIGHTS; SOLAR-POWERED COOLING UNITS (U.S. CLS. 13, 21, 23, 31 AND 34).

**CLASS 37—CONSTRUCTION AND REPAIR**

FOR CONSTRUCTION SERVICES, NAMELY, CONSTRUCTION OF WIND POWER GENERATION PARKS AND MACHINERY, SOLAR POWER GENERATION PARKS AND MACHINERY AND CONSTRUCTION OF PHOTOVOLTAIC GENERATION PARKS AND MACHINERY; REPAIR SERVICES, NAMELY, REPAIR OF SOLAR COLLECTORS, REPAIR OF WIND TURBINES; INSTALLATION, UPKEEP AND MAINTENANCE SERVICES FOR WIND AND SOLAR PARK MACHINERY AND INSTALLATIONS, NAMELY, INSTALLATION, REPAIR AND MAINTENANCE OF WIND AND SOLAR ENERGY GENERATION PARKS, WIND AND SOLAR ENERGY GENERATION PLANTS, WIND AND SOLAR ELECTRICAL GENERATORS, WIND TURBINES, AND SOLAR COLLECTORS FOR OTHERS (U.S. CLS. 100, 103 AND 106).

**CLASS 40—MATERIAL TREATMENT**

FOR GENERATION OF ENERGY, NAMELY, PRODUCTION OF ELECTRIC ENERGY AND RENEWABLE ENERGIES; TRANSFORMATION OF ENERGY, NAMELY, GENERATION OF ENERGY BY CONVERTING SUNLIGHT INTO SOLAR POWER, GENERATION OF ENERGY BY CONVERTING WIND INTO ELECTRICAL POWER (U.S. CLS. 100, 103 AND 106).

**CLASS 42—SCIENTIFIC AND COMPUTER SERVICES**

FOR RESEARCH AND DEVELOPMENT INTO, AS WELL AS TECHNICAL INFORMATION AND ADVICE ON, ENERGY EFFICIENCY, ENERGY POVERTY, GREENHOUSES GASES AND EMISSIONS, GLOBAL WARMING, ENERGY AND THE ENVIRONMENT, SUSTAINABLE DEVELOPMENT AND THE USE OF THE NEW TECHNOLOGIES IN THE FIELD OF ENERGY; PREPARATION OF ENVIRONMENTAL COMPLIANCE REPORTS IN RESPECT OF THE AFORESAID; RESEARCH, INFORMATION AND ADVICE ON INDUSTRIAL AND ENGINEERING SERVICES AND RESEARCH AND DEVELOPMENT SERVICES IN THE FIELD OF ENERGY, NAMELY, HYDROGEN AS AN ENERGY SOURCE; ANALYTICAL SERVICES, NAMELY, THE SAMPLING AND REPORTING OF TECHNICAL DATA FROM ENERGY SOURCES; TECHNICAL INFORMATION AND ADVICE RELATING TO THE AUDITING OF ENERGY CONSUMPTION AND ENERGY EFFICIENCY, NEW PRODUCT DEVELOPMENT POLICY AND NEW PRODUCT PLANNING STRATEGY CONSULTATION IN THE FIELD OF ENERGY; CONDUCTING FEASIBILITY STUDIES RELATING TO EXPLORATION AND EXPLOITATION OF ENERGY, RENEWABLE ENERGY, SOLAR AND WIND POWER; INFORMATION, ADVICE AND CONSULTATION IN THE FIELDS OF ENERGY, RENEWABLE ENERGY, SOLAR AND WIND POWER (U.S. CLS. 100 AND 101).

PAUL MORENO, EXAMINING ATTORNEY

SN 79-083,614. GSMN VAUD SA, SWITZERLAND, FILED 5-4-2010.



PRIORITY DATE OF 12-15-2009 IS CLAIMED.

OWNER OF INTERNATIONAL REGISTRATION 1041567 DATED 5-4-2010, EXPIRES 5-4-2020.

NO CLAIM IS MADE TO THE EXCLUSIVE RIGHT TO USE "LABORATOIRES", APART FROM THE MARK AS SHOWN.

THE MARK CONSISTS OF THE WORDING "GENOLIER LABORATOIRES" BENEATH TWO HORIZONTAL LINES, AND A DESIGN OF AN HOURGLASS SURROUNDED BY THREE CURVED BANDS SYMBOLIZING THE DNA CHAIN.

THE ENGLISH TRANSLATION OF "LABORATOIRES" IN THE MARK IS "LABORATORIES".

**CLASS 3—COSMETICS AND CLEANING PREPARATIONS**

FOR COSMETICS, SOAPS, PERFUMERY, ESSENTIAL OILS; COSMETICS, NAMELY, COSMETIC PREPARATIONS FOR THE TREATMENT OF AGE-RELATED SKIN ALTERATION; BODY DEODORANTS; CREAMS, MILKS, LOTIONS, GELS, POWDERS, SERUMS, MASKS AND SCRUBS FOR COSMETIC USE FOR FACE AND BODY CARE; RESTRUCTURING CREAMS, LOTIONS AND SERUMS FOR COSMETIC USE; COSMETIC PREPARATIONS FOR SLIMMING PURPOSES; COSMETIC PREPARATIONS FOR THE SHOWER AND/OR BATH; TANNING AND AFTER-SUN MILKS, GELS AND OILS; MAKE-UP; MAKE-UP REMOVING PREPARATIONS; DEPILATORY PREPARATIONS; PREPARATIONS FOR HAIR CLEANSING AND CARING, NAMELY, SHAMPOOS, CREAMS, MASKS, SERUMS, AND MOUSSES; HAIR DYES; DENTIFRICES; ALL THE AFOREMENTIONED GOODS OF SWISS ORIGIN (U.S. CLS. 1, 4, 6, 50, 51 AND 52).

**CLASS 5—PHARMACEUTICALS**

FOR PHARMACEUTICAL PREPARATIONS FOR THE TREATMENT OF AGE-RELATED SKIN ALTERATION; FOOD AND NUTRITIONAL SUPPLEMENTS FOR MEDICAL USE, IN THE FORM OF SOLIDS, LIQUIDS, GELS, CREAMS OR PASTES; DIETETIC FOODS AND BEVERAGES FOR MEDICAL USE; VITAMIN PREPARATIONS; ALL THE AFOREMENTIONED GOODS OF SWISS ORIGIN (U.S. CLS. 6, 18, 44, 46, 51 AND 52).

**CLASS 44—MEDICAL, BEAUTY AND AGRICULTURAL SERVICES**

FOR MEDICAL SERVICES; VETERINARY SERVICES; HYGIENIC AND BEAUTY CARE FOR HUMAN BEINGS AND ANIMALS; HEALTH SERVICES, NAMELY, MASSAGES, WITH A WATER BASE OR NOT, FOR RELAXATION OR HEALTH PURPOSES; SAUNA SERVICES; MASSAGE SERVICES; MANICURE SERVICES; PEDICURES SERVICES; MAKE-UP APPLICATION SERVICES; PHYSICAL THERAPY SERVICES; BEAUTY SALONS; ADVICE ON HYGIENIC AND BEAUTY CARE; PROVIDING INFORMATION ON THE INTERNET AS REGARDS BEAUTY CARE; ADVICE ON NUTRITION (U.S. CLS. 100 AND 101).

LIEF MARTIN, EXAMINING ATTORNEY

SN 79-083,651. LENZING AKTIENGESELLSCHAFT, AUSTRIA, FILED 10-27-2009.

# TENCEL

THE MARK CONSISTS OF STANDARD CHARACTERS WITHOUT CLAIM TO ANY PARTICULAR FONT, STYLE, SIZE, OR COLOR.

PRIORITY DATE OF 4-30-2009 IS CLAIMED.  
OWNER OF INTERNATIONAL REGISTRATION 1041701 DATED 10-27-2009, EXPIRES 10-27-2019.  
OWNER OF U.S. REG. NOS. 1,539,373 AND 2,208,268.

## CLASS 1—CHEMICALS

FOR CHEMICALS USED IN INDUSTRY, SCIENCE AND PHOTOGRAPHY, AS WELL AS IN AGRICULTURE, HORTICULTURE AND FORESTRY, NAMELY, CHEMICAL INTENSIFIERS FOR PAPER, FILTERING MATERIALS IN THE NATURE OF CHEMICAL PREPARATIONS, CELLULOSE POWDERS, FIBRE-LIKE PARTICLES OF CELLULOSE FOR NON-TEXTILE APPLICATIONS AND SHORT FIBRES OF CELLULOSE FOR NON-TEXTILE APPLICATIONS (U.S. CLS. 1, 5, 6, 10, 26 AND 46).

## CLASS 3—COSMETICS AND CLEANING PREPARATIONS

FOR CLEANING, POLISHING, SCOURING AND ABRASIVE PREPARATIONS; COSMETICS, NAMELY, IMPREGNATED CLEANSING WIPES FOR COSMETIC PURPOSES AND CELLULOSE BASED HYDRO GELS FOR COSMETIC PURPOSES (U.S. CLS. 1, 4, 6, 50, 51 AND 52).

## CLASS 5—PHARMACEUTICALS

FOR SANITARY PREPARATIONS FOR MEDICAL PURPOSES; PLASTERS, MATERIALS FOR DRESSINGS, NAMELY, CELLULOSE-BASED HYDRO GELS FOR MEDICAL PURPOSES, MEDICAL DRESSINGS, SURGICAL DRESSINGS, ABSORBENT COTTON FOR MEDICAL PURPOSES (U.S. CLS. 6, 18, 44, 46, 51 AND 52).

## CLASS 16—PAPER GOODS AND PRINTED MATTER

FOR PAPER, CARDBOARD AND GOODS MADE FROM THESE MATERIALS, NOT INCLUDED IN OTHER CLASSES, NAMELY, STATIONERY; ADHESIVES FOR STATIONERY OR HOUSEHOLD PURPOSES; PLASTIC MATERIALS FOR PACKAGING NOT INCLUDED IN OTHER CLASSES, NAMELY, PLASTIC BAGS, PLASTIC BUBBLE BAGS; NAPKINS OF PAPER FOR REMOVING MAKE-UP, DISPOSABLE BABIES' NAPKINS OF PAPER AND CELLULOSE, PAPER FILTERING MATERIALS, FILTER PAPER, TOILET PAPER, FACE TOWELS OF PAPER, TOWELS OF PAPER, SHEETS OF RECLAIMED CELLULOSE FOR WRAPPING (U.S. CLS. 2, 5, 22, 23, 29, 37, 38 AND 50).

## CLASS 17—RUBBER GOODS

FOR PLASTICS IN EXTRUDED FORM FOR USE IN MANUFACTURE; PACKING, STOPPING AND INSULATING MATERIALS; FLEXIBLE PIPES, NOT OF METAL; VISCOSE SHEETS, OTHER THAN FOR PACKING; FOILS OF REGENERATED CELLULOSE OTHER THAN FOR PACKING, ALSO IN THE FORM OF FLEXIBLE PIPES, INSULATING FELT, FILTERING MATERIALS OF SEMI-PROCESSED FOAMS OR FILMS OF PLASTIC, SEMI-PROCESSED FOAMS CONTAINING CELLULOSE PARTICLES, NAMELY, POWDERS, FIBRE-LIKE PARTICLES OF CELLULOSE OR SHORT FIBRES OF CELLULOSE, FOR THE FURNITURE, MATTRESS, VEHICLE, FOOTWEAR AND CLOTHING INDUSTRY, SEMI-PROCESSED FOAMS CONSISTING OF CELLULOSE (U.S. CLS. 1, 5, 12, 13, 35 AND 50).

## CLASS 22—CORDAGE AND FIBERS

FOR ROPES, STRING, TENTS, AWNINGS, TARPAULINS, SAILS, SACKS FOR THE TRANSPORTATION OR STORAGE OF MATERIALS IN BULK; PADDING AND STUFFING MATERIALS NOT OF RUBBER, PAPER OR PLASTICS; RAW FIBROUS TEXTILE MATERIALS, WADDING FOR FILTERING, FLOCK, NAMELY, FLOCK FOR STUFFING (U.S. CLS. 1, 2, 7, 19, 22, 42 AND 50).

## CLASS 24—FABRICS

FOR TEXTILES AND TEXTILE GOODS, NOT INCLUDED IN OTHER CLASSES, NAMELY, BED AND TABLE COVERS; TISSUES OF TEXTILE FOR REMOVING MAKE-UP, BED COVERS OF PAPER, TABLE NAPKINS OF TEXTILE, TEXTILE SERVIETTES, PLACE MATS, NOT OF PAPER, TABLECLOTHS, NOT OF PAPER, TABLEMATS, NOT OF PAPER, NON-WOVEN TEXTILE FABRICS (U.S. CLS. 42 AND 50).

## CLASS 25—CLOTHING

FOR CLOTHING, NAMELY, SHIRTS, BLOUSES, HOSIERY, SUITS, SHIRTS, PANTS, SLEEPWEAR, BODY SUITS, BRAS, PANTIES AND UNDERWEAR, DRESSES, JACKETS, COATS, SWEATSHIRTS, SWEATPANTS, SWEATSUITS, SHORTS, T-SHIRTS AND PULLOVERS, FOOTWEAR, INNER SOLES, HEADGEAR, NAMELY, CAPS, HATS (U.S. CLS. 22 AND 39).

## CLASS 27—FLOOR COVERINGS

FOR CARPETS, RUGS, MATS AND MATTING, LINOLEUM AND OTHER MATERIALS FOR COVERING EXISTING FLOORS, NAMELY, FLOOR COVERINGS CONTAINING LYOCCELL FIBERS; NON-TEXTILE WALL HANGINGS (U.S. CLS. 19, 20, 37, 42 AND 50).

## CLASS 42—SCIENTIFIC AND COMPUTER SERVICES

FOR SCIENTIFIC AND TECHNOLOGICAL SERVICES AND RESEARCH AND DESIGN RELATING THERETO, NAMELY, DEVELOPMENT OF MANUFACTURING PROCESSES AND OF NEW APPLICATIONS FOR THE CELLULOSE INDUSTRY, PARTICULARLY FOR TEXTILE FIBERS, NON WOVEN FIBERS, NON WOVEN WEBS, FILM, FOILS AND OTHER CELLULOSIC MOULDED BODIES (U.S. CLS. 100 AND 101).

GRETTA YAO, EXAMINING ATTORNEY

SN 79-083,715. AFFIVAL, FRANCE, FILED 5-4-2010.

# PAPCAL

THE MARK CONSISTS OF STANDARD CHARACTERS WITHOUT CLAIM TO ANY PARTICULAR FONT, STYLE, SIZE, OR COLOR.

PRIORITY DATE OF 3-31-2010 IS CLAIMED.

OWNER OF INTERNATIONAL REGISTRATION 1041909 DATED 5-4-2010, EXPIRES 5-4-2020.

THE WORDING "PAPCAL" HAS NO MEANING IN A FOREIGN LANGUAGE.

## CLASS 1—CHEMICALS

FOR CHEMICALS USED IN INDUSTRY; TEMPERING AND SOLDERING PREPARATIONS, NAMELY, CHEMICALS FOR TEMPERING AND SOLDERING; CHEMICAL COMPOSITIONS FOR THE TREATMENT OF METALLIC BATHS; FINISHING PREPARATIONS IN THE NATURE OF TEMPERING CHEMICALS FOR USE IN THE MANUFACTURE OF STEEL; CHEMICAL PREPARATIONS FOR FACILITATING THE ALLOYING OF METALS; GALVANIZING BATHS; ALKALINE-EARTH METALS; ANTIMONY; NITROGEN; BISMUTH; CALCIUM CARBIDE; CALCIUM SALTS; CARBON AND GRAPHITE POWDER FOR INDUSTRIAL PURPOSES; LANTHANUM; METALLOIDS, NAMELY, SILICON, BORON, TELLURIUM; SALTS FROM RARE EARTH METALS; METAL EARTHS; SELENIUM; SILICON; SULPHUR; TELLURIUM; YTTRIUM; BORON; BRAZING CHEMICALS; BRAZING FLUXES; FLUXES FOR USE IN A FOUNDRY; CHEMICAL GALVANIZING PREPARATIONS (U.S. CLS. 1, 5, 6, 10, 26 AND 46).

## CLASS 6—METAL GOODS

FOR COMMON METALS, UNWROUGHT OR SEMI-WROUGHT, AND THEIR ALLOYS; NON-ELECTRIC CABLES OF METAL; METAL TUBES; NON-ELECTRIC METAL CABLES AND WIRES; NON-ELECTRIC METAL CABLES, WIRES, PIPES, AND TUBES WITH A FILLING; METAL TUBES AND PIPES; IRON ORES; ROLLED AND CAST CONSTRUCTION MATERIALS, NAMELY, IRON AND STEEL PIPES AND BARS; METAL BUILDING MATERIALS, NAMELY, STEEL PIPES AND BARS; STEEL; ALUMINUM; IRON, UNWROUGHT OR SEMI-WROUGHT; LEAD, UNWROUGHT OR SEMI-WROUGHT; CHROMIUM; MANGANESE METAL AND FERRO-MANGANESE; FERRO-NIOBIUM; MOLYBDENUM; TITANIUM; WOLFRAM, NAMELY, TUNGSTEN METAL AND FERRO-TUNGSTEN; FERRO-VANADIUM (U.S. CLS. 2, 12, 13, 14, 23, 25 AND 50).

LIEF MARTIN, EXAMINING ATTORNEY

SN 79-083,786. OPTRIMA, NAAMLOZE VENNOOTSCHAP, BELGIUM, FILED 5-17-2010.

# DepthSense

THE MARK CONSISTS OF STANDARD CHARACTERS WITHOUT CLAIM TO ANY PARTICULAR FONT, STYLE, SIZE, OR COLOR.

OWNER OF INTERNATIONAL REGISTRATION 1042130 DATED 5-17-2010, EXPIRES 5-17-2020.

## CLASS 9—ELECTRICAL AND SCIENTIFIC APPARATUS

FOR OPTICAL INSTRUMENTS, NAMELY, OPTICAL SENSORS, OPTICAL COMMUNICATIONS SYSTEMS COMPRISED OF OPTICAL AND ELECTRONIC HARDWARE AND COMPUTER SOFTWARE FOR THE TRANSMISSION OF DATA BETWEEN TWO POINTS, OPTICAL SYSTEMS COMPRISED OF ONE OR MORE CAMERAS AND SENSORS IN COMMUNICATION WITH COMPUTER SOFTWARE AND HARDWARE, CABLES FOR OPTICAL SIGNAL TRANSMISSION; APPARATUS FOR RECORDING, TRANSMISSION OR REPRODUCTION OF SOUND OR IMAGES; CHIPS, NAMELY, INTEGRATED CIRCUITS, VIDEO CAMERAS; DATA PROCESSING EQUIPMENT AND COMPUTERS (U.S. CLS. 21, 23, 26, 36 AND 38).

## CLASS 42—SCIENTIFIC AND COMPUTER SERVICES

FOR SCIENTIFIC AND TECHNOLOGICAL SERVICES AND RESEARCH AND DESIGN RELATING THERETO, NAMELY, SCIENTIFIC RESEARCH, ANALYSIS AND TESTING IN THE FIELD OF 3D SENSORS AND RESEARCH AND DESIGN RELATING THERETO; INDUSTRIAL ANALYSIS AND RESEARCH SERVICES IN THE FIELD OF 3D SENSORS; DESIGN AND DEVELOPMENT OF COMPUTERS AND SOFTWARE (U.S. CLS. 100 AND 101).

APRIL HESIK, EXAMINING ATTORNEY

SN 79-083,961. PIRELLI & C.S.P.A., I-20126 MILANO, ITALY, FILED 5-21-2010.

# PRELIOS

THE MARK CONSISTS OF STANDARD CHARACTERS WITHOUT CLAIM TO ANY PARTICULAR FONT, STYLE, SIZE, OR COLOR.

PRIORITY DATE OF 5-4-2010 IS CLAIMED.

OWNER OF INTERNATIONAL REGISTRATION 1042648 DATED 5-21-2010, EXPIRES 5-21-2020.

THE MARK "PRELIOS" HAS NO MEANING IN A FOREIGN LANGUAGE.

## CLASS 35—ADVERTISING AND BUSINESS

FOR ADVERTISING; BUSINESS MANAGEMENT; BUSINESS ADMINISTRATION; OFFICE FUNCTIONS (U.S. CLS. 100, 101 AND 102).

**CLASS 36—INSURANCE AND FINANCIAL**

FOR INSURANCE ADMINISTRATION, INSURANCE INFORMATION AND CONSULTATION, REAL ESTATE INSURANCE UNDERWRITING SERVICES, REAL ESTATE TITLE INSURANCE UNDERWRITING SERVICES, INSURANCE CONSULTANCY SERVICES, NAMELY, PROVIDING ADVICE IN THE FIELD OF PROPERTY AND CASUALTY INSURANCE, INSURANCE SERVICES, NAMELY, WRITING PROPERTY AND CASUALTY INSURANCE, APPRAISALS FOR INSURANCE CLAIMS OF PERSONAL PROPERTY; FINANCIAL AND MONETARY AFFAIRS, NAMELY, FINANCIAL INFORMATION, MANAGEMENT AND ANALYSIS SERVICES; FINANCIAL VALUATION OF PERSONAL PROPERTY AND REAL ESTATE; FINANCIAL VALUATION OF REAL ESTATE; FINANCIAL DUE DILIGENCE SERVICES IN THE FIELD OF REAL ESTATE; FINANCIAL INVESTMENT IN THE FIELD OF REAL ESTATE; MONETARY AFFAIRS, NAMELY, ACQUISITION AND TRANSFER OF MONETARY CLAIMS; MONETARY STRATEGY CONSULTATION AND RESEARCH; REAL ESTATE AFFAIRS, NAMELY, REAL ESTATE INVESTMENT SERVICES IN THE NATURE OF PURCHASING AND SELLING OF REAL ESTATE FOR OTHERS; ASSESSMENT AND MANAGEMENT OF REAL ESTATE; LAND ACQUISITION, NAMELY, REAL ESTATE BROKERAGE; REAL ESTATE ACQUISITION SERVICES; REAL ESTATE APPRAISAL AND VALUATION; REAL ESTATE CONSULTATION; REAL ESTATE INVESTMENT SERVICES; REAL ESTATE INVESTMENT TRUST SERVICES; REAL ESTATE INVESTMENT TRUST MANAGEMENT SERVICES; REAL ESTATE INVESTMENT TRUST ADVISORY SERVICES; REAL ESTATE MANAGEMENT SERVICES; REAL ESTATE PROCUREMENT FOR OTHERS; REAL ESTATE TRUSTEE SERVICES (U.S. CLS. 100, 101 AND 102).

**CLASS 37—CONSTRUCTION AND REPAIR**

FOR BUILDING CONSTRUCTION; REPAIR OF BUILDINGS; ELECTRICAL REPAIRS, MAINTENANCE, AND INSTALLATION OF ELECTRICAL WIRING, OUTLETS, LIGHT FIXTURES, AND ELECTRICAL PANELS; INSTALLATION OF ELECTRICAL SYSTEMS; CONSTRUCTION AND INSTALLATION OF MASONRY WALLS AND STRUCTURES; CONSTRUCTION AND INSTALLATION OF ELECTRICAL WIRING, OUTLETS, LIGHT FIXTURES, AND ELECTRICAL PANELS; INSTALLATIONS AND MAINTENANCE OF PHOTOVOLTAIC INSTALLATIONS; INSTALLATION AND MAINTENANCE OF SOLAR THERMAL INSTALLATIONS; INSTALLATION AND MAINTENANCE OF PHOTOVOLTAIC/SOLAR THERMAL HYBRID INSTALLATIONS; INSTALLATION, REPAIR AND MAINTENANCE OF HEATING, VENTILATING AND AIR CONDITIONING EQUIPMENT AND SYSTEMS; INSTALLATION OF BASEMENT WATERPROOFING PRODUCTS; INSTALLATION OF BUILDING INSULATION; INSTALLATION OF SOLAR ENERGY SYSTEMS AND ALTERNATIVE ENERGY PRODUCTS FOR RESIDENTIAL AND COMMERCIAL USE; INSTALLATION OF WIRING IN ACCESSIBLE GEOGRAPHICAL LOCATIONS FOR DISTRIBUTION OF ELECTRICITY SUITABLE FOR ELECTRIC VEHICLE RECHARGING STATIONS; INSTALLATION, REPAIR AND MAINTENANCE OF HEATING EQUIPMENT; TECHNICAL CONSULTING RELATED TO THE INSTALLATION OF OIL AND GAS EQUIPMENT, CONTROL SYSTEMS, AND MACHINERY (U.S. CLS. 100, 103 AND 106).

**CLASS 42—SCIENTIFIC AND COMPUTER SERVICES**

FOR SCIENTIFIC AND TECHNOLOGICAL SERVICES, NAMELY, SCIENTIFIC RESEARCH, DESIGN AND ANALYSIS IN THE FIELD OF BUILDING, CONSTRUCTION, ARCHITECTURE, BUILDING TECHNOLOGY, BUILDING DESIGN, INFRASTRUCTURE SYSTEMS FOR BUILDINGS, URBAN DEVELOPMENT, LAND USE PLANNING, CIVIL ENGINEERING; INDUSTRIAL ANALYSIS AND RESEARCH IN THE FIELD OF BUILDING, CONSTRUCTION, ARCHITECTURE, BUILDING TECHNOLOGY, BUILDING DESIGN, INFRASTRUCTURE SYSTEMS FOR BUILDINGS, URBAN DEVELOPMENT, LAND USE PLANNING, CIVIL ENGINEERING; BUILDING TECHNOLOGY, BUILDING DESIGN, INFRASTRUCTURE SYSTEMS FOR BUILDINGS, URBAN DEVELOPMENT, LAND USE PLANNING, CIVIL ENGINEERING; DESIGN AND DEVELOPMENT OF COMPUTER HARDWARE AND SOFTWARE (U.S. CLS. 100 AND 101).

ALEXANDER L. POWERS, EXAMINING ATTORNEY

SN 79-084,001. HAMON & CIE (INTERNATIONAL) S.A., BELGIUM, FILED 4-19-2010.

**RESEARCH-COTTRELL DRY COOLING**

THE MARK CONSISTS OF STANDARD CHARACTERS WITHOUT CLAIM TO ANY PARTICULAR FONT, STYLE, SIZE, OR COLOR.

PRIORITY DATE OF 10-27-2009 IS CLAIMED.

OWNER OF INTERNATIONAL REGISTRATION 1042763 DATED 4-19-2010, EXPIRES 4-19-2020.

NO CLAIM IS MADE TO THE EXCLUSIVE RIGHT TO USE "DRY COOLING", APART FROM THE MARK AS SHOWN.

**CLASS 7—MACHINERY**

FOR INDUSTRIAL MACHINERY AND MACHINE TOOLS, NAMELY, AIR CONDENSERS, WATER CONDENSERS, DE-AERATORS FOR FEED WATER, STEAM SEPARATORS, FEED WATER PUMPS, EXTRACTION PUMPS FOR EXTRACTING CONDENSATE FOR CONDENSERS; MOTORS, OTHER THAN FOR LAND VEHICLES; FANS FOR MOTORS AND ENGINES, MOTORS AND ENGINES FOR FANS AND FOR AIR CONDITIONING APPARATUS AND INSTALLATIONS; HEAT EXCHANGERS BEING PARTS OF MACHINES; FILTERS BEING PARTS OF MACHINES OR ENGINES (U.S. CLS. 13, 19, 21, 23, 31, 34 AND 35).

**CLASS 11—ENVIRONMENTAL CONTROL APPARATUS**

FOR APPARATUS FOR LIGHTING, HEATING, STEAM GENERATING, COOKING, REFRIGERATING, DRYING, VENTILATING, WATER SUPPLY AND SANITARY PURPOSES, NAMELY, DESALINATION PLANTS; COOLING APPLIANCES AND INSTALLATIONS, NAMELY, WATER COOLING TOWERS, AIR CONDENSERS, WATER CONDENSERS AND STEAM CONDENSERS; DISTILLATION APPARATUS; HEAT EXCHANGERS NOT BEING PARTS OF MACHINES; AIR CONDITIONING APPARATUS AND INSTALLATIONS; AIR COOLING APPARATUS AND INSTALLATIONS; AIR CONDITIONING FANS, FANS AS PARTS OF AIR CONDITIONING INSTALLATIONS; ELECTROSTATIC PRECIPITATORS; APPARATUS AND INSTALLATIONS FOR FLUE GAS DESULFURIZATION; AIR PURIFICATION APPARATUS AND INSTALLATIONS; AIR FILTERING INSTALLATIONS; FILTERS FOR AIR CONDITIONING APPARATUS AND INSTALLATIONS; FILTERS FOR AIR COOLING APPARATUS AND INSTALLATIONS; APPARATUS FOR GAS PURIFICATION IN THE NATURE OF GAS SCRUBBERS; FILTERS BEING PARTS OF INDUSTRIAL INSTALLATIONS (U.S. CLS. 13, 21, 23, 31 AND 34).

**CLASS 37—CONSTRUCTION AND REPAIR**

FOR REPAIR AND MAINTENANCE OF CONSTRUCTIONS, NAMELY, OF WATER COOLING TOWERS, AIR CONDENSERS, WATER CONDENSERS, AND STEAM CONDENSERS; SERVICES FOR ASSEMBLING, CLEANING, MAINTENANCE AND REPAIR OF HEATING INSTALLATIONS, VENTILATION INSTALLATIONS, AIR CONDITIONING INSTALLATIONS, REFRIGERATION INSTALLATIONS, HEAT EXCHANGERS, AS WELL AS COOLING INSTALLATIONS AND COOLING TOWERS; REPAIR OR MAINTENANCE OF MACHINES; RENTAL OF CONSTRUCTION MACHINES AND TOOLS; TURNKEY CONSTRUCTION OF COOLING INSTALLATIONS AND COOLING TOWERS (U.S. CLS. 100, 103 AND 106).

**CLASS 42—SCIENTIFIC AND COMPUTER SERVICES**

FOR CONSTRUCTION DRAFTING AND ADVICE IN THE FIELD OF CONSTRUCTION; CONSTRUCTION DRAFTING AND ADVICE IN THE FIELD OF ASSEMBLING HEAT EXCHANGERS, COOLING INSTALLATIONS AND COOLING TOWERS; SERVICES OF ARCHITECTS, CHEMISTS, PHYSICISTS, ENGINEERS AND LAND SURVEYORS; COMPUTER PROGRAMMING SERVICES; SURVEYS DRAWN UP BY ENGINEERS OR LABORATORIES; TECHNICAL CONSULTING SERVICES IN THE FIELD OF CIVIL ENGINEERING; MATERIALS TESTING; HEAT PERFORMANCE TESTING; INSPECTION SERVICES FOR QUALITY CONTROL OF HEATING, VENTILATING, REFRIGERATING INSTALLATIONS, HEAT EXCHANGERS AS WELL AS COOLING INSTALLATIONS AND COOLING TOWERS; TECHNICAL PROJECT STUDIES AND MANAGEMENT OF TECHNICAL PROJECTS FOR DESIGNING AND IMPROVING QUALITY OF COOLING TOWERS AND COOLING INSTALLATIONS, AIR MONITORING SYSTEMS AND HEAT EXCHANGERS; FEASIBILITY STUDIES IN THE FIELD OF CONSTRUCTION, ASSEMBLY AND IMPROVEMENT OF COOLING TOWERS, COOLING INSTALLATIONS AND AIR MONITORING SYSTEMS; ENGINEERING SERVICES; RESEARCH AND ANALYSIS PERTAINING TO THE MONITORING OF AIR CONTAMINATION AND COOLING PROCESSES (U.S. CLS. 100 AND 101).

BRIAN NEVILLE, EXAMINING ATTORNEY

**CLASS 9—ELECTRICAL AND SCIENTIFIC APPARATUS**

FOR APPARATUS FOR RECORDING, TRANSMITTING OR REPRODUCING SOUNDS OR IMAGES; APPARATUS AND INSTRUMENTS FOR THE ANALYSIS OF BUILDING AND CIVIL ENGINEERING STRUCTURES, NAMELY, APPARATUS AND INSTRUMENTS FOR MEASURING STRAIN TENSION APPLIED BY A PRESTRESSED BAR; TILTMETERS; ACCELEROMETERS; THERMOMETERS; DYNAMOMETERS, DYNAMOMETERS FOR MEASURING STRAIN OF PRESTRESSED OR REINFORCED CONCRETE, DYNAMOMETERS FOR MEASURING STRAIN OF STEEL WIRES, CABLES AND STRANDS; DATA PROCESSING EQUIPMENT AND COMPUTERS; ELECTRONIC INSTRUMENTS FOR USE IN INSPECTION AND MEASUREMENT OF BUILDINGS AND CIVIL ENGINEERING STRUCTURES; PROGRAMMABLE OR NON-PROGRAMMABLE ELECTRONIC CONTROLS FOR MEASURING APPARATUS USED TO MEASURE BUILDING AND CIVIL ENGINEERING STRUCTURES; COMPUTER SOFTWARE FOR THE ANALYSIS OF BUILDING AND CIVIL ENGINEERING STRUCTURES; COMPUTER SOFTWARE FOR APPARATUS FOR RECORDING, TRANSMITTING AND REPRODUCING SOUNDS OR IMAGES; COMPUTER SOFTWARE FOR THE ACQUISITION, PARAMETERIZATION AND TRANSFER OF DATA FROM MEASURING, WEIGHING, CHECKING, INSPECTING APPARATUS AND INSTRUMENTS AND APPARATUS FOR RECORDING, TRANSMITTING AND REPRODUCING SOUNDS OR IMAGES; COMPUTER SOFTWARE ENABLING ACCESS VIA A LOCAL OR GLOBAL COMPUTER NETWORK TO AN INTERFACE FOR THE ACQUISITION, PARAMETERIZATION AND TRANSFER OF DATA FROM MEASURING, WEIGHING, CHECKING, INSPECTING APPARATUS AND INSTRUMENTS AND APPARATUS FOR RECORDING, TRANSMITTING AND REPRODUCING SOUNDS OR IMAGES; COMPUTER SOFTWARE FOR MONITORING AND BROADCASTING ALARMS IN CONNECTION WITH BUILDING AND CIVIL ENGINEERING STRUCTURES; OPERATING SOFTWARE FOR WEIGHING AND MEASURING OF PRESTRESSED BARS USED IN BUILDING AND CIVIL ENGINEERING; OPERATING SOFTWARE USED FOR WEIGHING, NAMELY, FOR THE MEASURING OF RESIDUAL TENSILE STRENGTH OF PRESTRESSED BARS USED IN BUILDING AND CIVIL ENGINEERING (U.S. CLS. 21, 23, 26, 36 AND 38).

**CLASS 37—CONSTRUCTION AND REPAIR**

FOR CONSULTING CONSISTING OF PROFESSIONAL INFORMATION FOR THE PROACTIVE MAINTENANCE OF BUILDING AND CIVIL ENGINEERING STRUCTURES; REPAIR, UPDATE AND MAINTENANCE OF APPARATUS AND ELECTRONIC INSTRUMENTS FOR USE IN INSPECTION AND MEASUREMENT OF BUILDINGS AND CIVIL ENGINEERING STRUCTURES, OF APPARATUS AND INSTRUMENTS FOR MEASURING STRAIN TENSION APPLIED BY A PRESTRESSED BAR, TILTMETERS, ACCELEROMETERS, THERMOMETERS, DYNAMOMETERS, DYNAMOMETERS FOR MEASURING STRAIN OF PRESTRESSED OR REINFORCED CONCRETE, DYNAMOMETERS FOR MEASURING STRAIN OF STEEL WIRES, CABLES AND STRANDS FOR USE IN THE ANALYSIS OF BUILDING AND CIVIL ENGINEERING STRUCTURES (U.S. CLS. 100, 103 AND 106).

**CLASS 42—SCIENTIFIC AND COMPUTER SERVICES**

FOR ANALYSIS AND EXPERT APPRAISAL SERVICES CONSISTING OF ENGINEERING WORK IN THE FIELD OF PRESTRESSING; ANALYSIS AND EXPERT APPRAISAL SERVICES CONSISTING OF ENGINEERING WORK IN THE FIELD OF BUILDING AND CIVIL ENGINEERING STRUCTURES; PROFESSIONAL ENGINEERING CONSULTATION IN THE FIELD OF PRESTRESSING CONSTRUCTION; PROFESSIONAL ENGINEERING CONSULTATION IN CONNECTION WITH MEASURING, WEIGHING, CHECKING, INSPECTING, ANALYSIS AND EXPERT APPRAISALS OF BUILDING AND CIVIL ENGINEERING STRUCTURES; ENGINEERING CONSULTATION IN CONNECTION WITH THE PROAC-

SN 79-084,125. SOLETANCHE FREYSSINET, FRANCE,  
FILED 3-12-2010.

# EverSense

PRIORITY DATE OF 10-7-2009 IS CLAIMED.  
OWNER OF INTERNATIONAL REGISTRATION 1042950  
DATED 3-12-2010, EXPIRES 3-12-2020.

THE MARK CONSISTS OF THE STYLIZED WORDING "EVERSENSE"; THE FIRST AND FIFTH LETTERS ARE UPPER CASE CHARACTERS, THE OTHER LETTERS ARE LOWER CASE CHARACTERS.

TIVE MAINTENANCE OF BUILDING AND CIVIL ENGINEERING STRUCTURES; DESIGN, DEVELOPMENT, INSTALLATION, RENTAL, REPAIR, UPKEEP, UPDATING AND MAINTENANCE OF SOFTWARE AND OF COMPUTER SYSTEMS FOR THE ANALYSIS OF BUILDING AND CIVIL ENGINEERING STRUCTURES; DESIGN, DEVELOPMENT AND RENTAL OF APPARATUS AND INSTRUMENTS FOR THE ANALYSIS OF BUILDING AND CIVIL ENGINEERING STRUCTURES, NAMELY, APPARATUS AND ELECTRONIC INSTRUMENTS FOR USE IN INSPECTION AND MEASUREMENT OF BUILDINGS AND CIVIL ENGINEERING STRUCTURES, APPARATUS AND INSTRUMENTS MEASURING STRAIN TENSION APPLIED BY A PRESTRESSED BAR, TILTMETERS, ACCELEROMETERS, THERMOMETERS, DYNAMOMETERS, DYNAMOMETERS FOR MEASURING STRAIN OF PRESTRESSED OR REINFORCED CONCRETE, DYNAMOMETERS FOR MEASURING STRAIN OF STEEL WIRES, CABLES AND STRANDS; ENGINEERING CONSULTATION, NAMELY, PROVIDING PROFESSIONAL ENGINEERING IN CONNECTION WITH PRESTRESSING; CONSULTING CONSISTING OF PROFESSIONAL ENGINEERING AND DESIGN INFORMATION IN CONNECTION WITH MEASURING, WEIGHING, CHECKING, INSPECTING, ANALYSIS AND EXPERT APPRAISALS OF BUILDING AND CIVIL ENGINEERING STRUCTURES (U.S. CLS. 100 AND 101).  
KELLEY WELLS, EXAMINING ATTORNEY

### CLASS 35—ADVERTISING AND BUSINESS

FOR OUTSOURCING SERVICES; ADMINISTRATIVE PROCESSING OF PURCHASE ORDERS; ACCOUNTING SERVICES; COMMERCIAL ADMINISTRATION OF THE LICENSING OF GOODS AND SERVICES FOR THIRD PARTIES; COMPILATION OF STATISTICS; COLLECTION AND SYSTEMIZATION OF INFORMATION INTO COMPUTER DATABASES; SYSTEMIZATION OF DATA IN COMPUTER DATABASES; COMPUTERIZED FILE MANAGEMENT; DATA PROCESSING SERVICES FOR THIRD PARTIES; ARRANGING OF BUYING AND SELLING CONTRACTS FOR THIRD PARTIES; ARRANGING OF CONTRACTS FOR THIRD PARTIES FOR THE PROVIDING OF SERVICES; ARRANGING OF COMMERCIAL TRANSACTIONS FOR THIRD PARTIES, ALSO WITHIN THE FRAMEWORK OF E-COMMERCE; PROVISION OF AUCTIONEERING SERVICES, ALSO ON THE INTERNET; ARRANGING OF TRADING TRANSACTIONS AND COMMERCIAL CONTRACTS, ALSO VIA THE INTERNET; BUSINESS ORGANIZATION AND OPERATION CONSULTANCY; PLANNING AND MONITORING OF BUSINESS DEVELOPMENTS WITH REGARD TO ORGANIZATIONAL MATTERS; BUSINESS ORGANIZATIONAL CONSULTANCY SERVICES; BUSINESS MANAGEMENT CONSULTANCY; BUSINESS INFORMATION SERVICES; BUSINESS INVESTIGATIONS; PROVISION OF PROFESSIONAL BUSINESS EXPERTISE, NAMELY BUSINESS ORGANIZATION AND OPERATION CONSULTANCY; COST PRICE ANALYSIS; MARKETING RESEARCH SERVICES; SERVICES OF ADVERTISING AGENCIES; ON-LINE ADVERTISING ON COMPUTER NETWORKS; PRESENTATION OF COMPANIES ON THE INTERNET AND OTHER MEDIA, NAMELY, ORGANIZATION AND CONDUCTING OF PRODUCT PRESENTATIONS; PRESENTATION OF GOODS ON COMMUNICATION MEDIA FOR RETAIL PURPOSES; COLLECTION OF GOODS FOR THIRD PARTIES FOR PRESENTATION AND SALE PURPOSES, NAMELY, PREPARING AUDIOVISUAL PRESENTATIONS FOR USE IN ADVERTISING; SALES PROMOTION FOR THIRD PARTIES; RENTAL OF ADVERTISING SPACE ON THE INTERNET; SYSTEMIZATION OF DATA INTO COMPUTER DATABASES (U.S. CLS. 100, 101 AND 102).

SN 79-084.171. KATRIN KLEYBOLDT, FED REP GERMANY, FILED 12-31-2009.

### CLASS 36—INSURANCE AND FINANCIAL

FOR MONETARY AFFAIRS, ALSO ON THE INTERNET, NAMELY, FINANCIAL INFORMATION, MANAGEMENT AND ANALYSIS SERVICES; BANKING, ALSO ON THE INTERNET; ELECTRONIC FUNDS TRANSFER; FINANCIAL CLEARING HOUSES; PROVIDING FINANCIAL INFORMATION; FINANCIAL ANALYSES; FINANCIAL CONSULTATION (U.S. CLS. 100, 101 AND 102).

# Veryflow

### CLASS 38—COMMUNICATION

FOR PROVIDING USER ACCESS TO COMPUTER PROGRAMS IN DATA NETWORKS, NAMELY, LOCAL OR GLOBAL, PUBLIC OR PRIVATE DATA NETWORKS, FOR INDUSTRY SECTOR SPECIFIC AND HIGHLY INTEGRATED BUSINESS PROCESSES FOR A LARGE NUMBER OF USERS; PROVIDING TELECOMMUNICATION CONNECTIONS TO THE INTERNET; COMMUNICATION SERVICES VIA COMPUTER TERMINALS, NAMELY, TRANSMITTING STREAMED SOUND AND AUDIOVISUAL RECORDINGS VIA THE INTERNET; PROVIDING ON-LINE FORUMS FOR TRANSMISSION OF MESSAGES AMONG COMPUTER USERS; TELEPHONE COMMUNICATION SERVICES IN THE FIELD OF SOFTWARE; ELECTRONIC TRANSMISSION OF ENCODED MESSAGES AND IMAGES; LONG-DISTANCE DATA TRANSMISSION BY MEANS OF BROADBAND, COPPER AND OPTICAL OR WIRELESS; PROVIDING USER ACCESS TO COMPUTER PRO-

THE MARK CONSISTS OF STANDARD CHARACTERS WITHOUT CLAIM TO ANY PARTICULAR FONT, STYLE, SIZE, OR COLOR.

PRIORITY DATE OF 7-3-2009 IS CLAIMED.  
OWNER OF INTERNATIONAL REGISTRATION 1043063 DATED 12-31-2009, EXPIRES 12-31-2019.

GRAMS IN DATA NETWORKS; PROVIDING MULTIPLE USER ACCESS TO PROPRIETARY COLLECTIONS OF INFORMATION BY MEANS OF GLOBAL COMPUTER INFORMATION NETWORKS; PROVIDING ACCESS TO DATABASES; RENTAL OF ACCESS TIME TO GLOBAL COMPUTER NETWORK DATABASES; RENTAL OF ACCESS TIME TO GLOBAL COMPUTER NETWORKS; ELECTRONIC EXCHANGE OF DATA VIA CHAT LINES, CHAT ROOMS AND INTERNET FORUMS; ELECTRONIC MAIL; COMPUTER-AIDED TRANSMISSION OF MESSAGES AND IMAGES; WEB MESSAGING; PROVIDING E-MAIL SERVICES (U.S. CLS. 100, 101 AND 104).

SN 79-084,172. KATRIN KLEYBOLDT, FED REP GERMANY, FILED 12-31-2009.

# Vetaflow

## CLASS 42—SCIENTIFIC AND COMPUTER SERVICES

FOR APPLICATION SERVICE PROVIDER (ASP) FEATURING SOFTWARE FOR SERVER ADMINISTRATION AND TECHNICAL ADMINISTRATION OF INTERNET-BASED SOFTWARE; RENTAL OF COMPUTER PROGRAMS AND SOFTWARE TO A LARGE NUMBER OF USERS FOR EXTERNAL USE VIA RECALLABLE CUSTOMER SERVERS; RENTAL OF WEB SERVERS; RECORDING DATA FOR OTHERS ON OPTICAL, DIGITAL AND MAGNETIC MEDIA FOR ELECTRONIC STORAGE; CONVERSION OF COMPUTER PROGRAMS AND DATA, EXCEPT PHYSICAL CONVERSION; DATA WAREHOUSING ON THE INTERNET FOR EXTERNAL USE; COMPUTER PROGRAMMING; INSTALLATION AND MAINTENANCE OF SOFTWARE; UPDATING OF COMPUTER SOFTWARE; UPDATING OF WEBSITES; COMPUTER SERVICES, NAMELY, REMOTE MANAGEMENT OF COMPUTER APPLICATIONS FOR OTHERS; COMPUTER SOFTWARE CONSULTANCY; TECHNICAL SUPPORT SERVICES, NAMELY, TROUBLESHOOTING OF COMPUTER SOFTWARE PROBLEMS OVER THE PHONE; PROVIDING A WEB SITE FEATURING TECHNOLOGY THAT ENABLES USERS TO AUTOMATE BUSINESS PROCESSES, NAMELY, LEAD GENERATION PROCESSES, LEAD MANAGEMENT PROCESSES, LEAD TRACKING PROCESSES, TELEMARKETING PROCESSES, CUSTOMER RELATIONSHIP MANAGEMENT PROCESSES, CONTRACT ADMINISTRATION PROCESSES, SALES FORCE MANAGEMENT PROCESSES, ORDER MANAGEMENT PROCESSES, LOGISTICS MANAGEMENT PROCESSES, DISTRIBUTION MANAGEMENT PROCESSES, CUSTOMER SUPPORT PROCESSES, COMPLAINT MANAGEMENT PROCESSES AND RETURN MERCHANDISE MANAGEMENT PROCESSES; PLATFORM AS A SERVICE FEATURING COMPUTER SOFTWARE PLATFORMS FOR USE IN THE AUTOMATION OF BUSINESS PROCESSES, NAMELY, LEAD GENERATION PROCESSES, LEAD MANAGEMENT PROCESSES, LEAD TRACKING PROCESSES, TELEMARKETING PROCESSES, CUSTOMER RELATIONSHIP MANAGEMENT PROCESSES, CONTRACT ADMINISTRATION PROCESSES, SALES FORCE MANAGEMENT PROCESSES, ORDER MANAGEMENT PROCESSES, LOGISTICS MANAGEMENT PROCESSES, DISTRIBUTION MANAGEMENT PROCESSES, CUSTOMER SUPPORT PROCESSES, COMPLAINT MANAGEMENT PROCESSES AND RETURN MERCHANDISE MANAGEMENT PROCESSES; COMPUTER SERVICES, NAMELY, PROVIDING A WEB-BASED SYSTEM AND ONLINE PORTAL FEATURING ON-LINE NON-DOWNLOADABLE SOFTWARE THAT ENABLES USERS TO AUTOMATE BUSINESS PROCESSES, NAMELY, LEAD GENERATION PROCESSES, LEAD MANAGEMENT PROCESSES, LEAD TRACKING PROCESSES, TELEMARKETING PROCESSES, CUSTOMER RELATIONSHIP MANAGEMENT PROCESSES, CONTRACT ADMINISTRATION PROCESSES, SALES FORCE MANAGEMENT PROCESSES, ORDER MANAGEMENT PROCESSES, LOGISTICS MANAGEMENT PROCESSES, DISTRIBUTION MANAGEMENT PROCESSES, CUSTOMER SUPPORT PROCESSES, COMPLAINT MANAGEMENT PROCESSES AND RETURN MERCHANDISE MANAGEMENT PROCESSES (U.S. CLS. 100 AND 101).

PAUL MORENO, EXAMINING ATTORNEY

THE MARK CONSISTS OF STANDARD CHARACTERS WITHOUT CLAIM TO ANY PARTICULAR FONT, STYLE, SIZE, OR COLOR.

PRIORITY DATE OF 7-3-2009 IS CLAIMED.

OWNER OF INTERNATIONAL REGISTRATION 1043064 DATED 12-31-2009, EXPIRES 12-31-2019.

## CLASS 35—ADVERTISING AND BUSINESS

FOR OUTSOURCING SERVICES; ADMINISTRATIVE PROCESSING OF PURCHASE ORDERS; ACCOUNTING SERVICES; COMMERCIAL ADMINISTRATION OF THE LICENSING OF GOODS AND SERVICES FOR THIRD PARTIES; COMPILATION OF STATISTICS; COLLECTION AND SYSTEMIZATION OF INFORMATION INTO COMPUTER DATABASES; SYSTEMIZATION OF DATA IN COMPUTER DATABASES; COMPUTERIZED FILE MANAGEMENT; DATA PROCESSING SERVICES FOR THIRD PARTIES; ARRANGING OF BUYING AND SELLING CONTRACTS FOR THIRD PARTIES; ARRANGING OF CONTRACTS FOR THIRD PARTIES FOR THE PROVIDING OF SERVICES; ARRANGING OF COMMERCIAL TRANSACTIONS FOR THIRD PARTIES, ALSO WITHIN THE FRAMEWORK OF E-COMMERCE; PROVISION OF AUCTIONEERING SERVICES, ALSO ON THE INTERNET; ARRANGING OF TRADING TRANSACTIONS AND COMMERCIAL CONTRACTS, ALSO VIA THE INTERNET; BUSINESS ORGANIZATION AND OPERATION CONSULTANCY; PLANNING AND MONITORING OF BUSINESS DEVELOPMENTS WITH REGARD TO ORGANIZATIONAL MATTERS; BUSINESS ORGANIZATIONAL CONSULTANCY SERVICES; BUSINESS MANAGEMENT CONSULTANCY; BUSINESS INFORMATION SERVICES; BUSINESS INVESTIGATIONS; PROVISION OF PROFESSIONAL BUSINESS EXPERTISE, NAMELY BUSINESS ORGANIZATION AND OPERATION CONSULTANCY; COST PRICE ANALYSIS; MARKETING RESEARCH SERVICES; SERVICES OF ADVERTISING AGENCIES; ON-LINE ADVERTISING ON COMPUTER NETWORKS; PRESENTATION OF COMPANIES ON THE INTERNET AND OTHER MEDIA, NAMELY, ORGANIZATION AND CONDUCTING OF PRODUCT PRESENTATIONS; PRESENTATION OF GOODS ON COMMUNICATION MEDIA FOR RETAIL PURPOSES; COLLECTION OF GOODS FOR THIRD PARTIES FOR PRESENTATION AND SALE PURPOSES, NAMELY, PREPARING AUDIOVISUAL PRESENTATIONS FOR USE IN ADVERTISING; SALES PROMOTION FOR THIRD PARTIES; RENTAL OF ADVERTISING SPACE ON THE INTERNET; SYSTEMIZATION OF DATA INTO COMPUTER DATABASES (U.S. CLS. 100, 101 AND 102).

## CLASS 36—INSURANCE AND FINANCIAL

FOR MONETARY AFFAIRS, ALSO ON THE INTERNET, NAMELY, FINANCIAL INFORMATION, MANAGEMENT AND ANALYSIS SERVICES; BANKING, ALSO ON THE INTERNET; ELECTRONIC FUNDS TRANSFER; FINANCIAL CLEARING HOUSES; PROVIDING FINANCIAL INFORMATION; FINANCIAL ANALYSES; FINANCIAL CONSULTATION (U.S. CLS. 100, 101 AND 102).

**CLASS 38—COMMUNICATION**

FOR PROVIDING USER ACCESS TO COMPUTER PROGRAMS IN DATA NETWORKS, NAMELY, LOCAL OR GLOBAL, PUBLIC OR PRIVATE DATA NETWORKS, FOR INDUSTRY SECTOR SPECIFIC AND HIGHLY INTEGRATED BUSINESS PROCESSES FOR A LARGE NUMBER OF USERS; PROVIDING TELECOMMUNICATION CONNECTIONS TO THE INTERNET; COMMUNICATION SERVICES VIA COMPUTER TERMINALS, NAMELY, TRANSMITTING STREAMED SOUND AND AUDIOVISUAL RECORDINGS VIA THE INTERNET; PROVIDING ON-LINE FORUMS FOR TRANSMISSION OF MESSAGES AMONG COMPUTER USERS; TELEPHONE COMMUNICATION SERVICES IN THE FIELD OF SOFTWARE; ELECTRONIC TRANSMISSION OF ENCODED MESSAGES AND IMAGES; LONG-DISTANCE DATA TRANSMISSION BY MEANS OF BROADBAND, COPPER AND OPTICAL OR WIRELESS; PROVIDING USER ACCESS TO COMPUTER PROGRAMS IN DATA NETWORKS; PROVIDING MULTIPLE USER ACCESS TO PROPRIETARY COLLECTIONS OF INFORMATION BY MEANS OF GLOBAL COMPUTER INFORMATION NETWORKS; PROVIDING ACCESS TO DATABASES; RENTAL OF ACCESS TIME TO GLOBAL COMPUTER NETWORK DATABASES; RENTAL OF ACCESS TIME TO GLOBAL COMPUTER NETWORKS; ELECTRONIC EXCHANGE OF DATA VIA CHAT LINES, CHAT ROOMS AND INTERNET FORUMS; ELECTRONIC MAIL; COMPUTER-AIDED TRANSMISSION OF MESSAGES AND IMAGES; WEB MESSAGING; PROVIDING E-MAIL SERVICES (U.S. CLS. 100, 101 AND 104).

**CLASS 42—SCIENTIFIC AND COMPUTER SERVICES**

FOR APPLICATION SERVICE PROVIDER (ASP) FEATURING SOFTWARE FOR SERVER ADMINISTRATION AND TECHNICAL ADMINISTRATION OF INTERNET-BASED SOFTWARE; RENTAL OF COMPUTER PROGRAMS AND SOFTWARE TO A LARGE NUMBER OF USERS FOR EXTERNAL USE VIA RECALLABLE CUSTOMER SERVERS; RENTAL OF WEB SERVERS; RECORDING DATA FOR OTHERS ON OPTICAL, DIGITAL AND MAGNETIC MEDIA FOR ELECTRONIC STORAGE; CONVERSION OF COMPUTER PROGRAMS AND DATA, EXCEPT PHYSICAL CONVERSION; DATA WAREHOUSING ON THE INTERNET FOR EXTERNAL USE; COMPUTER PROGRAMMING; INSTALLATION AND MAINTENANCE OF SOFTWARE; UPDATING OF COMPUTER SOFTWARE; UPDATING OF WEBSITES; COMPUTER SERVICES, NAMELY, REMOTE MANAGEMENT OF COMPUTER APPLICATIONS FOR OTHERS; COMPUTER SOFTWARE CONSULTANCY; TECHNICAL SUPPORT SERVICES, NAMELY, TROUBLESHOOTING OF COMPUTER SOFTWARE PROBLEMS OVER THE PHONE; PROVIDING A WEB SITE FEATURING TECHNOLOGY THAT ENABLES USERS TO AUTOMATE BUSINESS PROCESSES, NAMELY, LEAD GENERATION PROCESSES, LEAD MANAGEMENT PROCESSES, LEAD TRACKING PROCESSES, TELEMARKETING PROCESSES, CUSTOMER RELATIONSHIP MANAGEMENT PROCESSES, CONTRACT ADMINISTRATION PROCESSES, SALES FORCE MANAGEMENT PROCESSES, ORDER MANAGEMENT PROCESSES, LOGISTICS MANAGEMENT PROCESSES, DISTRIBUTION MANAGEMENT PROCESSES, CUSTOMER SUPPORT PROCESSES, COMPLAINT MANAGEMENT PROCESSES AND RETURN MERCHANDISE MANAGEMENT PROCESSES; PLATFORM AS A SERVICE FEATURING COMPUTER SOFTWARE PLATFORMS FOR USE IN THE AUTOMATION OF BUSINESS PROCESSES, NAMELY, LEAD GENERATION PROCESSES, LEAD MANAGEMENT PROCESSES, LEAD TRACKING PROCESSES, TELEMARKETING PROCESSES, CUSTOMER RELATIONSHIP MANAGEMENT PROCESSES, CONTRACT ADMINISTRATION PROCESSES, SALES FORCE MANAGEMENT PROCESSES, ORDER MANAGEMENT PROCESSES, LOGISTICS MANAGEMENT PROCESSES, DISTRIBUTION MANAGEMENT PROCESSES, CUSTOMER SUPPORT PROCESSES, COMPLAINT MANAGEMENT PROCESSES AND RETURN MERCHANDISE MANAGEMENT PROCESSES; COMPUTER SERVICES, NAMELY, PROVIDING A WEB-BASED SYSTEM AND ONLINE PORTAL FEATURING ON-LINE NON-DOWNLOADABLE SOFTWARE THAT ENABLES USERS TO AUTOMATE BUSINESS PROCESSES, NAMELY, LEAD GENERATION PROCESSES, LEAD MANAGEMENT

PROCESSES, LEAD TRACKING PROCESSES, TELEMARKETING PROCESSES, CUSTOMER RELATIONSHIP MANAGEMENT PROCESSES, CONTRACT ADMINISTRATION PROCESSES, SALES FORCE MANAGEMENT PROCESSES, ORDER MANAGEMENT PROCESSES, LOGISTICS MANAGEMENT PROCESSES, DISTRIBUTION MANAGEMENT PROCESSES, CUSTOMER SUPPORT PROCESSES, COMPLAINT MANAGEMENT PROCESSES AND RETURN MERCHANDISE MANAGEMENT PROCESSES (U.S. CLS. 100 AND 101).  
PAUL MORENO, EXAMINING ATTORNEY

SN 79-084,246. MINISTERO DELLE POLITICHE AGRICOLE.; ALIMENTARI E FORESTALI -; DIPARTIMENTO DELLE POLITICHE; COMPETITIVE DEL MONDO RURALE; E DELLA QUALITA' -; DIREZIONE GENERALE PER LO SVILUPPO AGROALIMENTARE.; LA QUALITA' E LA TUTELA; DEL CONSUMATORE, ROMA, ITALY, FILED 4-19-2010.

**FUNGO DI BORGOTARO**

THE MARK CONSISTS OF STANDARD CHARACTERS WITHOUT CLAIM TO ANY PARTICULAR FONT, STYLE, SIZE, OR COLOR.

PRIORITY DATE OF 2-8-2010 IS CLAIMED.

OWNER OF INTERNATIONAL REGISTRATION 1043265 DATED 4-19-2010, EXPIRES 4-19-2020.

NO CLAIM IS MADE TO THE EXCLUSIVE RIGHT TO USE "FUNGO", APART FROM THE MARK AS SHOWN.

THE ENGLISH TRANSLATION OF "FUNGO DI BORGOTARO" IN THE MARK IS "BORGOTARO MUSHROOM".

THE CERTIFICATION MARK, AS INTENDED TO BE USED BY PERSONS AUTHORIZED BY THE CERTIFIER, IS INTENDED TO CERTIFY THAT THE GOODS PROVIDED ORIGINATE IN THE APPROPRIATE AREAS OF THE PROVINCES OF PARMA AND MASSA CARRARA, WHICH INCLUDE THE COMMUNES OF BORGOTARO AND ALBARETO IN THE PROVINCE OF PARMA AND THE COMMUNE OF PONTREMOLI IN THE PROVINCE OF MASSA CARRARA IN ITALY, AND THAT THE PREPARATION, PRODUCTION, AND/OR PROCESSING OF THE GOODS TAKE PLACE ACCORDING TO THE STANDARD OF RECORD.

**CLASS 29—MEATS AND PROCESSED FOODS**

FOR PROCESSED MUSHROOMS (U.S. CL. 46).

**CLASS 31—NATURAL AGRICULTURAL PRODUCTS**

FOR FRESH MUSHROOMS (U.S. CLS. 1 AND 46).

JUDITH HELFMAN, EXAMINING ATTORNEY

SN 79-084,377. CELLMADE SAS, F-74160 ARCHAMPS, FRANCE, FILED 5-19-2010.

**CELLMADE**

THE MARK CONSISTS OF STANDARD CHARACTERS WITHOUT CLAIM TO ANY PARTICULAR FONT, STYLE, SIZE, OR COLOR.

PRIORITY DATE OF 11-20-2009 IS CLAIMED.

OWNER OF INTERNATIONAL REGISTRATION 1043473 DATED 5-19-2010, EXPIRES 5-19-2020.



**CLASS 5—PHARMACEUTICALS**

FOR PHARMACEUTICAL PREPARATION FOR THE TREATMENT OF INFLAMMATORY DISEASE IN HUMAN TISSUE, CELLS AND CELL COMPONENTS; SANITARY PREPARATIONS FOR MEDICAL USE; DIETETIC FOODS ADAPTED FOR MEDICAL USE; MEDICAL PLASTERS; ALL PURPOSE DISINFECTANTS; DIETETIC SUGAR FOR MEDICAL USE; ALLOYS OF PRECIOUS METALS FOR DENTAL USE (U.S. CLS. 6, 18, 44, 46, 51 AND 52).

**CLASS 42—SCIENTIFIC AND COMPUTER SERVICES**

FOR SCIENTIFIC RESEARCH AND DEVELOPMENT IN THE PHARMACEUTICAL AND BIOTECHNOLOGY FIELDS PROVIDED BY ENGINEERS, NAMELY, CONDUCTING SCIENTIFIC RESEARCH AND TESTS ON HUMAN AND ANIMAL CELLS, AND THE PROCESSES IN CELLS, TO DETERMINE THE TOXIC PROFILES AND INFLUENCES OF MOLECULES ON CELLS AND THE CONSEQUENCES FOR THE USE OF SPECIFIC MOLECULES IN THE PHARMACEUTICAL, COSMETICS, AND FOOD INDUSTRIES; DESIGN AND DEVELOPMENT OF COMPUTER HARDWARE AND SOFTWARE; RESEARCH AND DEVELOPMENT SERVICES WITH REGARD TO NEW PRODUCTS FOR OTHERS; DEVELOPMENT, DESIGN, INSTALLATION, MAINTENANCE, UPDATING OR RENTAL OF COMPUTER SOFTWARE; COMPUTER PROGRAMMING SERVICES; CONSULTANCY IN THE FIELD OF COMPUTER HARDWARE; CONVERSION OF COMPUTER PROGRAMS AND DATA OTHER THAN PHYSICAL CONVERSION; CONVERSION OF DATA OR DOCUMENTS FROM PHYSICAL TO ELECTRONIC MEDIA (U.S. CLS. 100 AND 101).

**CLASS 44—MEDICAL, BEAUTY AND AGRICULTURAL SERVICES**

FOR MEDICAL SERVICES; VETERINARY SERVICES; HYGIENIC AND BEAUTY CARE FOR HUMAN BEINGS OR ANIMALS; MEDICAL ASSISTANCE SERVICES; PLASTIC SURGERY; HOSPITAL SERVICES; OPTICIAN SERVICES (U.S. CLS. 100 AND 101).

KATHERINE E. HALMEN, EXAMINING ATTORNEY

SN 79-084,508. ARCE S.P.A., ITALY, FILED 5-28-2010.



PRIORITY DATE OF 5-7-2010 IS CLAIMED.

OWNER OF INTERNATIONAL REGISTRATION 1043809 DATED 5-28-2010, EXPIRES 5-28-2020.

THE COLOR(S) RED PANTONE C1 M98 Y98 K0, GREEN PANTONE C56 M3 Y100 K0, AND WHITE IS/ARE CLAIMED AS A FEATURE OF THE MARK.

THE MARK CONSISTS OF THE WORD "ARCE" IN GREEN PANTONE C56 M3 Y100 K0 BOLD CAPITAL LETTERS AND WITH SOME WHITE SHADES. ON THE LEFT SIDE OF THE WORD "ARCE" THERE IS A STYLIZED REPRESENTATION OF A TRIANGLE WITHOUT ITS BASIS IN RED COLOUR WITH SOME WHITE SHADES AND INSIDE THERE IS A SMALLER TRIANGLE WITH A RED BACKGROUND. THIS DRAWING RECALLS THE LETTER "A" OF THE WORD "ARCE".

**CLASS 4—LUBRICANTS AND FUELS**

FOR FUELS, BIOMASSES USED AS FUEL, NAMELY, A LIGNOCELLULOSIC MATERIAL USED AS A FUEL FOR GENERATING ENERGY AND ELECTRICITY (U.S. CLS. 1, 6 AND 15).

**CLASS 11—ENVIRONMENTAL CONTROL APPARATUS**

FOR HOUSEHOLD HEATING EQUIPMENT, NAMELY, WOOD-FIRED STOVES AND THERMO STOVES, WOOD-FIRED COOKERS, NAMELY, WOOD-FIRED KITCHENS AND WOOD-FIRED THERMO KITCHENS, PELLET-FIRED STOVES, HYDRO-PELLET STOVES, WOOD-FIRED FIREPLACE INSERTS IN THE NATURE OF WOOD-FIRED INSERT NATURALLY AND FORCED VENTILATED, MIXED-COMBUSTION INSERT AND HYDRO-INSERT; MIXED-COMBUSTION THERMO FIREPLACE (U.S. CLS. 13, 21, 23, 31 AND 34).

**CLASS 37—CONSTRUCTION AND REPAIR**

FOR REPAIR AND INSTALLATION SERVICES FOR HOUSEHOLD HEATING EQUIPMENT INCLUDING WOOD-FIRED STOVES AND THERMOSTOVES, WOOD-FIRED COOKERS, PELLET-FIRED STOVES, HYDRO-PELLET STOVES, WOOD OR PELLET FIRED FIREPLACE INSERTS, MIXED-COMBUSTION THERMO FIREPLACE, SOLAR ENERGY AND SOLID FUEL COMBINED HEATING PLANTS (U.S. CLS. 100, 103 AND 106).

SCOTT BIBB, EXAMINING ATTORNEY

SN 79-084,513. GIGI OERI, CH-4059 BASEL, SWITZERLAND, FILED 5-31-2010.

# SCORT

THE MARK CONSISTS OF STANDARD CHARACTERS WITHOUT CLAIM TO ANY PARTICULAR FONT, STYLE, SIZE, OR COLOR.

PRIORITY DATE OF 12-1-2009 IS CLAIMED.

OWNER OF INTERNATIONAL REGISTRATION 1043826 DATED 5-31-2010, EXPIRES 5-31-2020.

THE WORDING "SCORT" HAS NO MEANING IN A FOREIGN LANGUAGE.

**CLASS 36—INSURANCE AND FINANCIAL**

FOR FINANCIAL MANAGEMENT; CHARITABLE FUNDRAISING SERVICES, NAMELY, FINANCIAL PROMOTION OF SPORTING ACTIVITIES FOR EDUCATIONAL, TRAINING AND PEACE PROMOTION PURPOSES (U.S. CLS. 100, 101 AND 102).

**CLASS 41—EDUCATION AND ENTERTAINMENT**

FOR ORGANIZATION OF SPORTING ACTIVITIES FOR EDUCATIONAL, TRAINING AND PEACE PROMOTION PURPOSES (U.S. CLS. 100, 101 AND 107).

ANNE MADDEN, EXAMINING ATTORNEY

SN 79-084,543. SANASWEET GMBH, CH-8700 KÜSNACHT, SWITZERLAND, FILED 6-14-2010.



PRIORITY DATE OF 12-15-2009 IS CLAIMED.  
OWNER OF INTERNATIONAL REGISTRATION 1043911 DATED 6-14-2010, EXPIRES 6-14-2020.  
THE COLOR(S) GREY, GREEN AND WHITE IS/ARE CLAIMED AS A FEATURE OF THE MARK.  
THE MARK CONSISTS OF THE WORDING "SANASWEET" IN GREY AND A GREEN DROP CONTAINING THE LETTER "S" IN WHITE.

#### CLASS 1—CHEMICALS

FOR INDUSTRIAL CHEMICALS; CHEMICALS FOR USE IN THE COSMETICS, PHARMACEUTICALS, FOOD AND FODDER INDUSTRIES, NAMELY, CHEMICALS USED IN THE MANUFACTURE OF COSMETICS, PHARMACEUTICALS, FOOD AND FODDER; CHEMICALS INTENDED TO PRESERVE AND MAINTAIN THE FRESHNESS OF FOOD; CHEMICALS, NAMELY, CHEMICALS USED IN THE MANUFACTURE OF FOODS FOR HUMAN CONSUMPTION AND FOR ANIMAL FOODSTUFFS WITH FLAVORINGS AND FLAVOR ENHANCING PROPERTIES; ARTIFICIAL SWEETENERS (U.S. CLS. 1, 5, 6, 10, 26 AND 46).

#### CLASS 5—PHARMACEUTICALS

FOR DIETETIC PRODUCTS, NAMELY, DIETETIC FOODS FOR MEDICAL USE AND DIETETIC SUGAR FOR MEDICAL USE; NUTRITIONAL ADDITIVES FOR MEDICAL PURPOSES USED IN FOODS FOR HUMAN CONSUMPTION AND IN ANIMAL FOODSTUFF; ADDITIVES MADE WITH HERBS, FOR MEDICAL PURPOSES USED IN FOODS FOR HUMAN CONSUMPTION AND IN ANIMAL FOODSTUFF; ADDITIVES TO FODDER, FOR MEDICO-VETERINARY PURPOSES; VITAMIN PREPARATIONS AND PREPARATIONS CONSISTING MAINLY OF TRACE ELEMENTS OR MINERALS FOR HUMAN BEINGS AND ANIMALS FOR USE AS NUTRITIONAL SUPPLEMENTS (U.S. CLS. 6, 18, 44, 46, 51 AND 52).

#### CLASS 30—STAPLE FOODS

FOR NON-NUTRITIONAL FLAVOR ENHANCERS AND FLAVORINGS EXCLUDING ESSENTIAL OILS, ESPECIALLY FOR FOOD AND BEVERAGES; NATURAL SWEETENERS; NON-NUTRITIONAL FLAVOR ADDITIVES AND EXTRACTS FOR FOOD MADE WITH COFFEE, TEA, COCOA, SUGAR, RICE, TAPIOCA, SAGO, CEREALS, YEAST, HONEY AND MOLASSES (U.S. CL. 46).

#### CLASS 31—NATURAL AGRICULTURAL PRODUCTS

FOR ADDITIVES TO FODDER, NOT FOR MEDICAL PURPOSES; ADDITIVES AND EXTRACTS MADE WITH PLANTS, NAMELY, NON-MEDICAL ADDITIVES FOR USE IN ANIMAL FOODSTUFF (U.S. CLS. 1 AND 46).

#### CLASS 35—ADVERTISING AND BUSINESS

FOR WHOLESALE AND RETAIL SERVICES OF COSMETICS, PHARMACEUTICALS, FOOD AND FODDER INDUSTRY PRODUCTS, NAMELY, GATHERING COSMETICS, PHARMACEUTICALS, FOOD AND FODDER INDUSTRY PRODUCTS FOR OTHERS, EXCLUDING THE TRANSPORT THEREOF, ENABLING CONSUMERS TO SEE AND PURCHASE THEM CONVENIENTLY (U.S. CLS. 100, 101 AND 102).  
HEATHER BIDDULPH, EXAMINING ATTORNEY

SN 79-084,713. UPSIDE SHOPPING GMBH, FED REP GERMANY, FILED 1-26-2010.

## DEALSTREET

THE MARK CONSISTS OF STANDARD CHARACTERS WITHOUT CLAIM TO ANY PARTICULAR FONT, STYLE, SIZE, OR COLOR.  
PRIORITY DATE OF 7-27-2009 IS CLAIMED.  
OWNER OF INTERNATIONAL REGISTRATION 1044284 DATED 1-26-2010, EXPIRES 1-26-2020.

#### CLASS 35—ADVERTISING AND BUSINESS

FOR OPERATING ONLINE MARKETPLACES FOR SELLERS AND BUYERS OF GOODS AND SERVICES; ADVERTISING, BUSINESS MANAGEMENT, BUSINESS ADMINISTRATION, OFFICE FUNCTIONS (U.S. CLS. 100, 101 AND 102).

#### CLASS 38—COMMUNICATION

FOR E-MAIL SERVICES; ELECTRONIC MAIL; COMMUNICATIONS SERVICES, NAMELY, TRANSMITTING SOUND AND AUDIO-VISUAL RECORDINGS THROUGH STREAMING; MOBILE TELEPHONE SERVICES, INCLUDING TRANSMISSION OF TEXT AND VOICE MESSAGES; PROVIDING ACCESS TO DATABASES FOR PERSONAL INFORMATION AND DATA, IN PARTICULAR IMAGES, VIDEOS AND PUBLICATIONS (U.S. CLS. 100, 101 AND 104).  
LAURA HAMMEL, EXAMINING ATTORNEY

SN 79-084,798. TRYANE, FRANCE, FILED 4-30-2010.

## COLLABORATION INTELLIGENCE

THE MARK CONSISTS OF STANDARD CHARACTERS WITHOUT CLAIM TO ANY PARTICULAR FONT, STYLE, SIZE, OR COLOR.  
OWNER OF INTERNATIONAL REGISTRATION 1044510 DATED 4-30-2010, EXPIRES 4-30-2020.  
NO CLAIM IS MADE TO THE EXCLUSIVE RIGHT TO USE "INTELLIGENCE", APART FROM THE MARK AS SHOWN.

#### CLASS 9—ELECTRICAL AND SCIENTIFIC APPARATUS

FOR DATA PROCESSING EQUIPMENT AND COMPUTERS; COMPUTER SOFTWARE FOR THE COLLECTION, EDITING, ORGANIZING, MODIFYING, BOOK MARKING, TRANSMISSION, STORAGE AND SHARING OF DATA AND INFORMATION (U.S. CLS. 21, 23, 26, 36 AND 38).

**CLASS 42—SCIENTIFIC AND COMPUTER SERVICES**

FOR SCIENTIFIC RESEARCH PROVIDED BY ENGINEERS IN THE NATURE OF EVALUATIONS, ASSESSMENTS AND RESEARCH IN THE FIELDS OF SCIENCE AND TECHNOLOGY; DESIGN AND DEVELOPMENT OF COMPUTER HARDWARE AND SOFTWARE; RESEARCH AND DEVELOPMENT OF NEW PRODUCTS FOR OTHERS; DESIGN, DEVELOPMENT, INSTALLATION, MAINTENANCE, UPDATING AND RENTAL OF COMPUTER SOFTWARE; COMPUTER PROGRAMMING; COMPUTER SOFTWARE CONSULTANCY; DATA CONVERSION OF COMPUTER PROGRAMS AND DATA OTHER THAN PHYSICAL CONVERSION; CONVERSION OF DATA OR DOCUMENTS FROM PHYSICAL TO ELECTRONIC MEDIA (U.S. CLS. 100 AND 101).

AMY KERTGATE, EXAMINING ATTORNEY

SN 79-084,818. MAGNETI MARELLI S.P.A., ITALY, FILED 4-7-2010.



**GREEN ENGAGEMENT**

PRIORITY DATE OF 3-31-2010 IS CLAIMED.  
OWNER OF INTERNATIONAL REGISTRATION 1044557  
DATED 4-7-2010, EXPIRES 4-7-2020.

NO CLAIM IS MADE TO THE EXCLUSIVE RIGHT TO USE "GREEN", APART FROM THE MARK AS SHOWN.

THE MARK CONSISTS OF THE WORDING "GREEN ENGAGEMENT" WRITTEN IN A STYLIZED FONT UNDERNEATH A STYLIZED DESIGN OF A LEAF.

**CLASS 12—VEHICLES**

FOR VEHICLES, NAMELY, APPARATUS FOR LOCOMOTION BY LAND, NAMELY, AUTOMOBILES, CARS, MOTOR HOMES, TRUCKS; LAND MOTOR VEHICLES; AIR BAGS; ANTI-THEFT ALARMS FOR VEHICLES; ANTI-THEFT DEVICES FOR VEHICLES; TORSION BARS FOR VEHICLES; BRAKES FOR VEHICLES; BUMPERS FOR AUTOMOBILES; CLUTCHES FOR LAND VEHICLES; CONNECTING RODS FOR LAND VEHICLES, OTHER THAN PARTS OF MOTORS AND ENGINES; COUPLINGS FOR LAND VEHICLES; ELECTRIC VEHICLES, NAMELY, ELECTRIC CARS, ELECTRIC CAMPERS, ELECTRIC LOCOMOTIVES, ELECTRIC TRUCKS; ENGINES AND MOTORS FOR LAND VEHICLES; LORRIES; MOPEDS; MOTORCYCLES; ELECTRIC MOTORS FOR LAND VEHICLES; REDUCTION GEARS FOR LAND VEHICLES; STEERING GEARS FOR SHIPS; SUSPENSION SHOCK ABSORBERS FOR VEHICLES; SHOCK ABSORBERS FOR AUTOMOBILES; STEERING WHEELS FOR VEHICLES; SUSPENSION SPRINGS FOR VEHICLES; TRANSMISSIONS FOR LAND VEHICLES (U.S. CLS. 19, 21, 23, 31, 35 AND 44).

**CLASS 25—CLOTHING**

FOR CLOTHING, NAMELY, T-SHIRTS, SWEAT-SHIRTS, POLO SHIRTS, JERSEY, OVERALLS, JACKETS, PULLOVERS, SUITS, COATS, TIES, SCARVES, SWEATERS, BLOUSES, SHORTS, SKIRTS, TROUSERS, JEANS, RAINCOATS, TRACK SUITS, GLOVES, INFANT SLEEPERS, FOULARDS, WIND-RESISTANT JACKETS, WATERPROOF JACKETS, BLAZERS, BELTS, PAJAMAS, UNDERWEAR, SWIMWEAR; FOOTWEAR; HEADGEAR, NAMELY, HATS, CAPS (U.S. CLS. 22 AND 39).

**CLASS 35—ADVERTISING AND BUSINESS**

FOR ADVERTISING AND MARKETING; BUSINESS MANAGEMENT; BUSINESS ADMINISTRATION; PROVIDING OFFICE FUNCTIONS, ADVERTISING AGENCY SERVICES, NAMELY, UPDATING OF ADVERTISING MATERIAL, FOR THIRD-PARTIES; DEMONSTRATION OF PRODUCTS; DISTRIBUTION OF SAMPLES; ORGANIZATION OF EXHIBITIONS FOR COMMERCIAL OR ADVERTISING PURPOSES; MARKETING RESEARCH SERVICES; CONDUCTING MARKETING STUDIES; OPINION POLLING, NAMELY, PUBLIC OPINION POLLING, MARKET OPINION POLLING; ORGANIZATION OF TRADE FAIRS FOR COMMERCIAL AND ADVERTISING PURPOSES; PREPARING AND PLACING OUTDOOR ADVERTISEMENTS FOR OTHERS; PUBLICATION OF PUBLICITY TEXTS; AND RENTAL OF ADVERTISING SPACE (U.S. CLS. 100, 101 AND 102).

**CLASS 41—EDUCATION AND ENTERTAINMENT**

FOR EDUCATIONAL SERVICES, NAMELY, PROVIDING OF TRAINING IN THE FIELD OF VEHICLES, ENVIRONMENT, POLLUTION, REDUCTION OF WASTE; ENTERTAINMENT SERVICES, NAMELY, SPORTING AND CULTURAL ACTIVITIES; ENTERTAINMENT AND EDUCATIONAL SERVICES, NAMELY, ARRANGING OR CONDUCTING OF CONFERENCES, CONGRESSES, SEMINARS, SYMPOSIUMS AND TRAINING WORKSHOPS IN THE FIELD OF VEHICLES, ENVIRONMENTAL PROTECTION, POLLUTION AND REDUCTION OF WASTE; ORGANIZATION OF EXHIBITIONS FOR CULTURAL AND EDUCATIONAL PURPOSES; PUBLICATION OF PRINTED MATTER OTHER THAN PUBLICITY TEXTS; AND ORGANIZATION OF SPORTS EVENTS IN THE FIELD OF LAND VEHICLES (U.S. CLS. 100, 101 AND 107).

RICHARD WHITE, EXAMINING ATTORNEY

SN 79-084,840. AUTOMOBILES PEUGEOT, FRANCE, FILED 5-21-2010.



**PEUGEOT**

PRIORITY DATE OF 12-16-2009 IS CLAIMED.  
OWNER OF INTERNATIONAL REGISTRATION 1044614  
DATED 5-21-2010, EXPIRES 5-21-2020.

OWNER OF U.S. REG. NOS. 850,899 AND 3,291,190.

THE MARK CONSISTS OF THE STYLIZED WORDING "PEUGEOT" UNDER AN IMAGE OF A LION IN PROFILE STANDING ON ITS HIND PAWS WITH ITS FRONT PAWS REACHING TO THE LEFT.

**CLASS 12—VEHICLES**

FOR LAND VEHICLES; APPARATUS FOR LOCOMOTION BY LAND, AIR OR WATER, NAMELY, AUTOMOBILES, VANS, BICYCLES, MOTORIZED SCOOTERS, AND MOPEDS; MOTORCYCLES; STRUCTURAL COMPONENT PARTS FOR LAND VEHICLES, AUTOMOBILES, VANS, BICYCLES, MOTORIZED SCOOTERS, MOPEDS AND MOTORCYCLES, NAMELY, ENGINES, GEARBOXES, BODIES, CHASSIS, STEERING SYSTEMS COMPRISED OF STEERING WHEELS, STEERING COLUMN ASSEMBLIES, RACKS AND PINIONS, TRACK RODS, TIE RODS, AND STEERING ARMS, SHOCK ABSORBERS, TRANSMISSIONS FOR LAND VEHICLES, BRAKES, WHEELS, WHEEL RIMS, HUB CAPS, SEATS, ANTI-THEFT WARNING APPARATUS, SIGNALING HORNS, COVERS FOR SEATS, HEAD RESTS FOR SEATS, REARVIEW MIRRORS, STEERING WHEELS, PROTECTIVE TRIM IN THE NATURE OF MOLDING RODS, WINDSHIELD WIPERS, TORSION BARS, VEHICLE PETROL TANK CAPS, BUMPER GUARDS, TRAILER HITCHES, LUGGAGE CARRIERS, SKI CARRIERS, SPOILERS, DOORS, SUNROOFS, AND WINDOWS (U.S. CLS. 19, 21, 23, 31, 35 AND 44).

**CLASS 36—INSURANCE AND FINANCIAL**

FOR PROPERTY AND CASUALTY INSURANCE UNDERWRITING SERVICES; BANKING; FINANCING AND LOAN SERVICES; HIRE PURCHASE FINANCING SERVICES; LIFE INSURANCE UNDERWRITING; ACCIDENT INSURANCE UNDERWRITING; INSURANCE BROKERAGE; CONSULTANCY, INFORMATION AND ADVICE ON INSURANCE; CREDIT CARD SERVICES, DEBIT CARD SERVICES, AND ELECTRONIC PAYMENT SERVICES USED TO PURCHASE FUEL AND LUBRICANTS, AND TO CARRY OUT MAINTENANCE AND REPAIRS TO VEHICLES; FINANCING RELATING TO AUTOMOBILE RENTALS; ARRANGING FINANCIAL LOANS FOR REPAIRING VEHICLES; FINANCIAL GUARANTEE SERVICES BEING SURETIES FOR VEHICLES (U.S. CLS. 100, 101 AND 102).

**CLASS 37—CONSTRUCTION AND REPAIR**

FOR MAINTENANCE AND REPAIR SERVICES FOR AUTOMOBILES; VEHICLE REPAIR (U.S. CLS. 100, 103 AND 106).

**CLASS 39—TRANSPORTATION AND STORAGE**

FOR TRANSPORTATION OF PEOPLE BY MEANS OF VEHICLES; VEHICLE RENTAL SERVICES; PROVIDING TEMPORARY USE OF MOTOR VEHICLES VIA VEHICLE LENDING OR TEMPORARY VEHICLE REPLACEMENT SERVICES; VEHICLE TOWING, GARAGE AND PARKING PLACE RENTAL (U.S. CLS. 100 AND 105).  
ANDREA HACK, EXAMINING ATTORNEY

SN 79-084,925. MARKER VÖLKL (INTERNATIONAL) GMBH, SWITZERLAND, FILED 5-14-2010.

# Squire

THE MARK CONSISTS OF STANDARD CHARACTERS WITHOUT CLAIM TO ANY PARTICULAR FONT, STYLE, SIZE, OR COLOR.

PRIORITY DATE OF 11-16-2009 IS CLAIMED.  
OWNER OF INTERNATIONAL REGISTRATION 1044747 DATED 5-14-2010, EXPIRES 5-14-2020.

**CLASS 18—LEATHER GOODS**

FOR LUGGAGE, TOTE BAGS, FANNY PACKS, DUFFEL BAGS, ALL-PURPOSE SPORTS BAGS, BEACH BAGS, CLUTCH BAGS, TRAVEL BAGS, DRAWSTRING POUCHES; RUCKSACKS (U.S. CLS. 1, 2, 3, 22 AND 41).

**CLASS 25—CLOTHING**

FOR SHIRTS, SPORTS SUITS, SKIRTS, SHORTS, SOCKS, VESTS, JACKETS AND PANTS FOR SKIING AND SNOWBOARDING; HEADWEAR, NAMELY, SKIING CAPS, SNOWBOARDING CAPS AND TENNIS CAPS; SKI BOOTS, SNOWBOARD BOOTS AND TENNIS SHOES (U.S. CLS. 22 AND 39).

**CLASS 28—TOYS AND SPORTING GOODS**

FOR SKIS, SNOWBOARDS, SKI POLES, SKI BINDINGS, SNOWBOARD BINDINGS, TENNIS RACQUETS AND COMPONENT PARTS FOR ALL OF THE AFOREMENTIONED GOODS; SKI AND SNOWBOARDING HELMETS; PROTECTIVE PADDING FOR SKIING AND SNOWBOARDING; TENNIS RACQUET FRAMES, STRINGS AND GRIP TAPE; BAGS SPECIFICALLY ADAPTED FOR THE AFOREMENTIONED SPORTS EQUIPMENT AND SPORTING GOODS (U.S. CLS. 22, 23, 38 AND 50).

WENDY GOODMAN, EXAMINING ATTORNEY

SN 79-085,031. BROADCASTCROWN HOLDINGS PLC, STAFFORD ST18 0PF, UNITED KINGDOM, FILED 5-26-2010.

# BROADCASTCROWN

THE MARK CONSISTS OF STANDARD CHARACTERS WITHOUT CLAIM TO ANY PARTICULAR FONT, STYLE, SIZE, OR COLOR.

OWNER OF INTERNATIONAL REGISTRATION 1045092 DATED 5-26-2010, EXPIRES 5-26-2020.

**CLASS 7—MACHINERY**

FOR ELECTRICITY GENERATORS; DIESEL POWERED ELECTRICITY GENERATORS; GAS POWERED ELECTRICITY GENERATORS; ELECTRICITY GENERATORS WITH HEAT GENERATORS; STAND BY ELECTRICITY GENERATORS; ENCLOSURES AND CANOPIES FOR ELECTRICITY GENERATORS; COMPONENT PARTS FOR THE AFORESAID GOODS (U.S. CLS. 13, 19, 21, 23, 31, 34 AND 35).

**CLASS 37—CONSTRUCTION AND REPAIR**

FOR REPAIR, MAINTENANCE AND INSTALLATIONS SERVICES IN RESPECT OF ELECTRICITY GENERATORS (U.S. CLS. 100, 103 AND 106).

HEATHER BIDDULPH, EXAMINING ATTORNEY

SN 79-085,093. JPCI CONTROLS FOSHAN GAOMING CO., LTD., 528350 FOSHAN CITY, GUANGDONG PROVINCE, CHINA, FILED 5-11-2010.

# ULTIMHEAT

PRIORITY DATE OF 12-17-2009 IS CLAIMED.  
OWNER OF INTERNATIONAL REGISTRATION 1045296 DATED 5-11-2010, EXPIRES 5-11-2020.

**CLASS 9—ELECTRICAL AND SCIENTIFIC APPARATUS**

FOR SCIENTIFIC, NAUTICAL, SURVEYING, PHOTOGRAPHIC, CINEMATOGRAPHIC, OPTICAL, WEIGHING, MEASURING, SIGNALLING, CHECKING, EMERGENCY AND TEACHING APPARATUS AND INSTRUMENTS, NAMELY, THERMOMETERS, ELECTRICAL THERMOSTATS, PRESSURE SWITCHES AND SENSORS FOR MONITORING, CONTROLLING, AND SWITCHING HYDRAULIC OR PNEUMATIC SYSTEMS, TEMPERATURE SWITCHES AND SENSORS FOR MONITORING, CONTROLLING, AND SWITCHING HYDRAULIC OR PNEUMATIC SYSTEMS, LEVEL SWITCHES AND LEVEL INDICATORS FOR MONITORING AND CONTROLLING LIQUIDS IN TANKS AND VESSELS, FLOW SWITCHES FOR MONITORING AND CONTROLLING THE FLOW OF LIQUIDS, APPARATUS AND INSTRUMENTS FOR CONDUCTING, SWITCHING, TRANSFORMING, ACCUMULATING, REGULATING OR CONTROLLING ELECTRICITY, NAMELY, ELECTRIC CONDUCTORS, ELECTRIC ACCUMULATORS (U.S. CLS. 21, 23, 26, 36 AND 38).

**CLASS 11—ENVIRONMENTAL CONTROL APPARATUS**

FOR APPARATUS FOR LIGHTING, HEATING, STEAM GENERATING, COOKING, REFRIGERATING, DRYING, VENTILATING, WATER SUPPLY AND SANITARY PURPOSES, NAMELY, ELECTRIC HEATING ELEMENTS, ELECTRICAL WATER HEATERS, GAS WATER HEATERS, SPA AND SWIMMING POOLS HEATERS (U.S. CLS. 13, 21, 23, 31 AND 34).

**CLASS 20—FURNITURE AND ARTICLES NOT OTHERWISE CLASSIFIED**

FOR PLASTIC BOXES, PLASTIC PACKAGING CONTAINERS, PLASTIC CASES AND COVERINGS FOR THE HEATING INDUSTRY (U.S. CLS. 2, 13, 22, 25, 32 AND 50).

MARILYN IZZI, EXAMINING ATTORNEY

SN 79-085,229. ENSWICO IP AG, CH-6060 SARNEN, SWITZERLAND, FILED 5-19-2010.



PRIORITY DATE OF 11-20-2009 IS CLAIMED. OWNER OF INTERNATIONAL REGISTRATION 1045502 DATED 5-19-2010, EXPIRES 5-19-2020.

THE COLOR(S) RED, GREEN AND WHITE IS/ARE CLAIMED AS A FEATURE OF THE MARK.

THE MARK CONSISTS OF THE WORD "SET" APPEARING IN WHITE ON A GREEN RECTANGLE; THE LEFT SIDE OF THE RECTANGLE IS ROUNDED AND CONTAINS A RED CIRCLE.

**CLASS 3—COSMETICS AND CLEANING PREPARATIONS**

FOR DISINFECTANT CLEANING PRODUCTS, NAMELY, DISINFECTANT SOAP (U.S. CLS. 1, 4, 6, 50, 51 AND 52).

**CLASS 11—ENVIRONMENTAL CONTROL APPARATUS**

FOR SANITARY INSTALLATIONS, NAMELY, TOILETS AND URINALS; PLUMBING FITTINGS, NAMELY, ODORLESS TRAPS AS SANITARY INSTALLATION COMPONENTS; SANITARY COMPONENTS FOR THE CONSTRUCTION OF TRAPS, NAMELY, PLUMBING FITTINGS IN THE NATURE OF VALVES AND VALVE ADAPTERS (U.S. CLS. 13, 21, 23, 31 AND 34).

KATHERINE E. HALMEN, EXAMINING ATTORNEY

SN 79-085,240. INFOS GMBH INVESTMENT FONDS SELECTION, FED REP GERMANY, FILED 4-27-2010.



OWNER OF INTERNATIONAL REGISTRATION 1045522 DATED 4-27-2010, EXPIRES 4-27-2020.

NO CLAIM IS MADE TO THE EXCLUSIVE RIGHT TO USE "GOLD", APART FROM THE MARK AS SHOWN.

THE COLOR(S) BLACK, WHITE AND GOLD IS/ARE CLAIMED AS A FEATURE OF THE MARK.

THE MARK CONSISTS OF THE WORDING "GOLD TO GO", WITH THE WORD "GOLD" IN THE COLOR GOLD AND THE WORDS "TO GO" IN WHITE ON A BLACK RECTANGLE, WITH A GOLD SHADOW.

**CLASS 2—PAINTS**

FOR GOLD IN FOIL AND POWDER FORM FOR PAINTERS, DECORATORS, PRINTERS AND ARTISTS FOR USE IN GILDINGS (U.S. CLS. 6, 11 AND 16).

**CLASS 9—ELECTRICAL AND SCIENTIFIC APPARATUS**

FOR VENDING MACHINES FOR SELLING GOLD (U.S. CLS. 21, 23, 26, 36 AND 38).

**CLASS 14—JEWELRY**

FOR GOODS MADE OF GOLD OR COATED THEREWITH, NAMELY, GOLD BARS, GOLD BULLION, GOLD INGOTS AND GOLD COINS MADE IN WHOLE OR SIGNIFICANT PART OF GOLD (U.S. CLS. 2, 27, 28 AND 50).

**CLASS 36—INSURANCE AND FINANCIAL**

FOR FINANCIAL AFFAIRS, NAMELY, CAPITAL INVESTMENTS IN GOLD (U.S. CLS. 100, 101 AND 102).

**CLASS 40—MATERIAL TREATMENT**

FOR TREATMENT OF MATERIALS, NAMELY, GOLD PLATING AND GILDING (U.S. CLS. 100, 103 AND 106).

FRED CARL, EXAMINING ATTORNEY

SN 79-085,254. FLOW TRADERS B.V., NETHERLANDS, FILED 6-2-2010.

# FLOW TRADERS

THE MARK CONSISTS OF STANDARD CHARACTERS WITHOUT CLAIM TO ANY PARTICULAR FONT, STYLE, SIZE, OR COLOR.

PRIORITY DATE OF 12-3-2009 IS CLAIMED.

OWNER OF INTERNATIONAL REGISTRATION 1045551 DATED 6-2-2010, EXPIRES 6-2-2020.

NO CLAIM IS MADE TO THE EXCLUSIVE RIGHT TO USE "TRADERS", APART FROM THE MARK AS SHOWN.

## CLASS 36—INSURANCE AND FINANCIAL

FOR FINANCIAL AND MONETARY AFFAIRS, NAMELY, ELECTRONIC FINANCIAL TRADING SERVICES; PROVIDING FINANCIAL INFORMATION (U.S. CLS. 100, 101 AND 102).

## CLASS 38—COMMUNICATION

FOR TRANSMISSION OF INFORMATION VIA A GLOBAL COMMUNICATIONS NETWORK OR OVER THE INTERNET (U.S. CLS. 100, 101 AND 104).

MARTHA SANTOMARTINO, EXAMINING ATTORNEY

SN 79-085,265. RUFUS & COCO PTY LTD, AUSTRALIA, FILED 6-24-2010.

# Rufus & Coco

THE MARK CONSISTS OF STANDARD CHARACTERS WITHOUT CLAIM TO ANY PARTICULAR FONT, STYLE, SIZE, OR COLOR.

OWNER OF INTERNATIONAL REGISTRATION 1045592 DATED 6-24-2010, EXPIRES 6-24-2020.

## CLASS 3—COSMETICS AND CLEANING PREPARATIONS

FOR ANIMAL CARE PRODUCTS OTHER THAN FOR VETERINARY USE, NAMELY, NON-MEDICATED GROOMING AND CLEANING PRODUCTS FOR PETS AND LIVESTOCK, NAMELY, LOTIONS, DROPS, SHAMPOOS AND CONDITIONERS, SOAPS, PERFUMES, DETANGLERS AND FINISHING SPRAYS, DEODORANTS AND SUNSCREENS FOR PETS AND LIVESTOCK (U.S. CLS. 1, 4, 6, 50, 51 AND 52).

## CLASS 5—PHARMACEUTICALS

FOR ANIMAL CARE PRODUCTS FOR VETERINARY USE, NAMELY, EAR DROPS, WOUND DRESSINGS, WOUND HEALING CREAMS, MEDICATED CLEANSERS FOR WOUNDS, FLEA COLLARS, FLEA POWDERS AND PREPARATIONS, MEDICATED FLEA SHAMPOOS AND CONDITIONERS, ANTI-BACTERIAL SHAMPOO, ANTI-ITCH CREAMS, ANTI-ITCH OINTMENTS, MEDICATED ANTI-ITCH SHAMPOOS AND CONDITIONERS, LICE TREATMENT PREPARATIONS, TICK TREATMENT PREPARATIONS, INSECT REPELLENTS, INSECTICIDES, VITAMIN AND MINERAL SUPPLEMENTS FOR PETS AND LIVESTOCK, PREPARATIONS FOR THE TREATMENT OF ARTHRITIS, PREPARATIONS FOR THE TREATMENT OF THE JOINTS, DIGESTION, STRESS AND ANXIETY, SKIN AND COAT AND GENERAL WELLBEING OF PETS AND LIVESTOCK; PREPARATIONS FOR USE AS NUTRITIONAL SUPPLEMENTS FOR ANIMAL FOODSTUFFS, NAMELY, VITAMINS; PREPARATIONS FOR USE AS ADDITIVES TO ANIMAL FOODSTUFFS, NAMELY, VITAMINS (U.S. CLS. 6, 18, 44, 46, 51 AND 52).

AISHA CLARKE, EXAMINING ATTORNEY

SN 79-085,306. LAUTSPRECHER TEUFEL GMBH, FED REP GERMANY, FILED 6-23-2010.

# Inizio

THE MARK CONSISTS OF STANDARD CHARACTERS WITHOUT CLAIM TO ANY PARTICULAR FONT, STYLE, SIZE, OR COLOR.

PRIORITY DATE OF 1-28-2010 IS CLAIMED.

OWNER OF INTERNATIONAL REGISTRATION 1045687 DATED 6-23-2010, EXPIRES 6-23-2020.

THE ENGLISH TRANSLATION OF THE WORD "INIZIO" IN THE MARK IS "BEGINNING".

## CLASS 9—ELECTRICAL AND SCIENTIFIC APPARATUS

FOR APPARATUS FOR RECORDING, TRANSMISSION OR REPRODUCTION OF SOUND OR IMAGES; LOUDSPEAKERS, HOME-CINEMA LOUDSPEAKER SYSTEMS; ELECTRIC BATTERY CHARGING SYSTEMS COMPRISED OF BATTERY CHARGE DEVICES, ELECTRIC CORDS FOR LOUDSPEAKERS AND ELECTRONIC APPARATUS FOR IMAGE AND SOUND REPRODUCTION; STEREO MUSIC SYSTEMS COMPRISED OF STEREO AMPLIFIERS, STEREO TUNERS, LOUDSPEAKERS; CD, DVD, OPTICAL AND MAGNETO-OPTICAL DISC PLAYERS; RADIOS; AMPLIFIERS; TUNERS, NAMELY, CAR BROADCASTING TUNERS, STEREO TUNERS, MP3 PLAYERS AND COMPUTER DOCKING STATIONS; MP3 PLAYERS AND COMPUTER DOCKING STATIONS FEATURING RADIOS AND/OR LOUDSPEAKERS; RADIOS INCORPORATING ALARM CLOCKS; HEADPHONES; HARD DISK RECORDERS; TV AND DVBT RECEIVERS; MEDIA SERVERS, NAMELY, VIDEO SERVERS, INTERNET SERVERS; ELECTRIC CABLES AND CONDUITS FOR APPARATUS FOR RECORDING, TRANSMISSION OR REPRODUCTION OF SOUND OR IMAGES (U.S. CLS. 21, 23, 26, 36 AND 38).

## CLASS 35—ADVERTISING AND BUSINESS

FOR ADVERTISING; DIRECT MAIL ADVERTISING USING TRACTS, PROSPECTUSES, PRINTED MATTER, AND SAMPLES; ADVERTISING IN ALL MEDIA, INCLUDING RADIO, TELEVISION, CINEMA, PRINT, VIDEOTEXT, ONLINE AND TELETXT ADVERTISING, INCLUDING CUSTOMER MARKETING; DISPLAY SERVICES FOR MERCHANDISING; PUBLIC RELATIONS; ADVERTISING ON THE INTERNET, FOR OTHERS; SPONSORING IN THE FORM OF ADVERTISING; RETAIL AND WHOLESALE STORE SERVICES, INCLUDING BY MAIL ORDER, VIA THE INTERNET AND BY MEANS OF TEleshopping PROGRAMS, IN RELATION TO GOODS IN THE FIELD OF ELECTRONIC ENTERTAINMENT; ONLINE SERVICES AND E-COMMERCE PROVIDER SERVICES, NAMELY, PRESENTATION OF GOODS AND SERVICES FOR ADVERTISING PURPOSES, ORDER PLACEMENT, NAMELY, ELECTRONIC PROCESSING OF ORDERS FOR OTHERS, DELIVERY SERVICES, NAMELY, BUSINESS ADMINISTRATION IN THE FIELD OF TRANSPORT AND DELIVERY, BUSINESS MANAGEMENT IN THE FIELD OF TRANSPORT AND DELIVERY AND INVOICE MANAGEMENT, NAMELY, PREPARING AND MANAGING INVOICES FOR OTHERS, INCLUDING WITHIN THE FRAMEWORK OF E-COMMERCE; ACCOUNTING FOR ELECTRONIC ORDER SYSTEMS (U.S. CLS. 100, 101 AND 102).

**CLASS 41—EDUCATION AND ENTERTAINMENT**

FOR ENTERTAINMENT, NAMELY, LIVE PERFORMANCES BY A MUSICAL BAND; ENTERTAINMENT IN THE NATURE OF VISUAL AND AUDIO PERFORMANCES; LIGHT SHOWS; ORGANIZING CULTURAL ACTIVITIES IN THE NATURE OF VISUAL AND AUDIO PERFORMANCES, RENTAL OF APPARATUS FOR RECORDING, TRANSMISSION OR REPRODUCTION OF SOUND OR IMAGES, AS WELL AS LOUDSPEAKERS AND HOME-CINEMA LOUDSPEAKER SYSTEMS (U.S. CLS. 100, 101 AND 107).

ALLISON SCHRODY, EXAMINING ATTORNEY

SN 79-085,344. REDPIXIE LIMITED, UNITED KINGDOM, FILED 4-22-2010.



PRIORITY DATE OF 12-2-2009 IS CLAIMED.

OWNER OF INTERNATIONAL REGISTRATION 1045782 DATED 4-22-2010, EXPIRES 4-22-2020.

THE COLOR(S) RED IS/ARE CLAIMED AS A FEATURE OF THE MARK.

THE MARK CONSISTS OF A CIRCLE BETWEEN TWO ARCS, ALL IN RED.

**CLASS 9—ELECTRICAL AND SCIENTIFIC APPARATUS**

FOR COMPUTER HARDWARE AND SOFTWARE FOR BUILDING HIGHLY AUTOMATED IT INFRASTRUCTURE SOLUTIONS DEPLOYED IN CORPORATE DATA CENTERS, COMPUTER HARDWARE AND SOFTWARE FOR INTEGRATING SYSTEMS THAT ARE FOUND IN CORPORATE DATA CENTERS, FOR INTEGRATING PRIVATE AND PUBLIC CLOUD TECHNOLOGIES VIA CLOUD MANUFACTURERS PROGRAMMING INTERFACES, AUTOMATING THE PROVISIONING PROCESS ASSOCIATED WITH VIRTUALIZATION TECHNOLOGIES, FOR CONTROLLING AND RESPONDING TO SYSTEM EVENTS RELATED TO CLOUD AND VIRTUALIZATION SYSTEMS, FOR INTEGRATION OR AUTOMATION OF SYSTEMS AND TECHNOLOGIES USED AT HOME INCLUDING COMPUTER SYSTEMS AND ALARMS, LIGHTING SYSTEMS AND NETWORK ENABLED HOME APPLIANCES (U.S. CLS. 21, 23, 26, 36 AND 38).

**CLASS 37—CONSTRUCTION AND REPAIR**

FOR INSTALLATION, MAINTENANCE AND REPAIR OF COMPUTER HARDWARE FOR BUILDING HIGHLY AUTOMATED IT INFRASTRUCTURE SOLUTIONS DEPLOYED IN CORPORATE DATA CENTERS, USED FOR INTEGRATING SYSTEMS THAT ARE FOUND IN CORPORATE DATA CENTERS, FOR INTEGRATING PRIVATE AND PUBLIC CLOUD TECHNOLOGIES VIA CLOUD MANUFACTURERS PROGRAMMING INTERFACES, AUTOMATING THE PROVISIONING PROCESS ASSOCIATED WITH VIRTUALIZATION TECHNOLOGIES, FOR CONTROLLING AND RESPONDING TO SYSTEM EVENTS RELATED TO CLOUD AND VIRTUALIZATION SYSTEMS, FOR INTEGRATION OR AUTOMATION OF SYSTEMS AND TECHNOLOGIES USED AT HOME INCLUDING COMPUTER SYSTEMS AND ALARMS, LIGHTING SYSTEMS AND NETWORK ENABLED HOME APPLIANCES (U.S. CLS. 100, 103 AND 106).

**CLASS 42—SCIENTIFIC AND COMPUTER SERVICES**

FOR RESEARCH, DESIGN AND DEVELOPMENT OF COMPUTER SOFTWARE AND HARDWARE, FOR INTEGRATING SYSTEMS THAT ARE FOUND IN CORPORATE DATA CENTERS, FOR INTEGRATING PRIVATE AND PUBLIC CLOUD TECHNOLOGIES VIA CLOUD MANUFACTURERS PROGRAMMING INTERFACES, AUTOMATING THE PROVISIONING PROCESS ASSOCIATED WITH VIRTUALIZATION TECHNOLOGIES, FOR CONTROLLING AND RESPONDING TO SYSTEM EVENTS RELATED TO CLOUD AND VIRTUALIZATION SYSTEMS, FOR INTEGRATION AND AUTOMATION OF SYSTEMS AND TECHNOLOGIES USED AT HOME INCLUDING COMPUTER SYSTEMS AND ALARMS, LIGHTING SYSTEMS AND NETWORK ENABLED HOME APPLIANCES (U.S. CLS. 100 AND 101).

ADA HAN, EXAMINING ATTORNEY

SN 79-085,376. GIVAUDAN S.A., SWITZERLAND, FILED 7-2-2010.

# SYLKOLIDE

THE MARK CONSISTS OF STANDARD CHARACTERS WITHOUT CLAIM TO ANY PARTICULAR FONT, STYLE, SIZE, OR COLOR.

PRIORITY DATE OF 6-4-2010 IS CLAIMED.

OWNER OF INTERNATIONAL REGISTRATION 1045878 DATED 7-2-2010, EXPIRES 7-2-2020.

**CLASS 1—CHEMICALS**

FOR CHEMICALS USED IN THE MANUFACTURE OF COMPOSITIONS OF PERFUMERY, OF COSMETICS, OF SOAPS, OF DETERGENTS, OF DEODORANTS FOR PERSONAL USE AND OF DEODORANTS OTHER THAN FOR PERSONAL USE (U.S. CLS. 1, 5, 6, 10, 26 AND 46).

**CLASS 3—COSMETICS AND CLEANING PREPARATIONS**

FOR PERFUMERY, PERFUMES, COSMETICS, SOAPS, AND DETERGENTS, DEODORANTS FOR PERSONAL USE (U.S. CLS. 1, 4, 6, 50, 51 AND 52).

RONALD AIKENS, EXAMINING ATTORNEY

SN 79-085,402. AUTOMOBILES PEUGEOT, FRANCE, FILED 6-11-2010.



**PEUGEOT**  
MOTION & EMOTION

PRIORITY DATE OF 1-6-2010 IS CLAIMED.

OWNER OF INTERNATIONAL REGISTRATION 1045951 DATED 6-11-2010, EXPIRES 6-11-2020.

OWNER OF U.S. REG. NOS. 850,899 AND 3,291,190.

THE MARK CONSISTS OF THE STYLIZED WORDING "PEUGEOT" ABOVE THE STYLIZED WORDING "MOTION & EMOTION" ABOVE THE "PEUGEOT" WORDING IS AN IMAGE OF A LION IN PROFILE STANDING ON ITS HIND PAWS WITH ITS FRONT PAWS REACHING TO THE LEFT.

### CLASS 12—VEHICLES

FOR LAND VEHICLES; APPARATUS FOR LOCOMOTION BY LAND, AIR OR WATER, NAMELY, AUTOMOBILES, VANS, BICYCLES, MOTORIZED SCOOTERS, AND MOPEDS; MOTORCYCLES; STRUCTURAL COMPONENT PARTS FOR LAND VEHICLES, AUTOMOBILES, VANS, BICYCLES, MOTORIZED SCOOTERS, MOPEDS AND MOTORCYCLES, NAMELY, MOTORS AND ENGINES, GEARBOXES, BODIES FOR VEHICLES, CHASSIS, STEERING SYSTEMS COMPRISED OF STEERING WHEELS, STEERING COLUMN ASSEMBLIES, RACKS AND PINIONS, TRACK RODS, TIE RODS, AND STEERING ARMS, SHOCK ABSORBERS, TRANSMISSIONS FOR LAND VEHICLES, BRAKES, WHEELS, WHEEL RIMS, HUB CAPS, SEATS, ANTI-THEFT WARNING APPARATUS, SIGNALING HORNS, SEAT COVERS, HEAD RESTS FOR SEATS, REARVIEW MIRRORS, STEERING WHEELS, PROTECTIVE TRIM IN THE NATURE OF MOLDING RODS, WINDSHIELD WIPERS, TORSION BARS, PETROL TANK CAPS, BUMPER GUARDS, TRAILER HITCHES, LUGGAGE CARRIERS, SKI CARRIERS, SPOILERS, DOORS, SUNROOFS, AND WINDOWS (U.S. CLS. 19, 21, 23, 31, 35 AND 44).

### CLASS 37—CONSTRUCTION AND REPAIR

FOR MAINTENANCE AND REPAIR SERVICES FOR AUTOMOBILES; VEHICLE REPAIR (U.S. CLS. 100, 103 AND 106).

### CLASS 39—TRANSPORTATION AND STORAGE

FOR TRANSPORTATION OF PEOPLE BY MEANS OF VEHICLES; VEHICLE RENTAL SERVICES; PROVIDING TEMPORARY USE OF MOTOR VEHICLES VIA VEHICLE LENDING OR TEMPORARY VEHICLE REPLACEMENT SERVICES; VEHICLE BREAKDOWN ASSISTANCE IN THE NATURE OF TOWING; GARAGE AND CAR PARKING RENTAL (U.S. CLS. 100 AND 105).  
ANDREA HACK, EXAMINING ATTORNEY

### CLASS 3—COSMETICS AND CLEANING PREPARATIONS

FOR HYGIENIC, BEAUTY, TOILETRY AND CARE PREPARATIONS, NAMELY, PERFUMERY, PERFUME OILS FOR USE AS BASES FOR FLOWER PERFUMES AND FOR PLANT PERFUMES; SOAPS, NAMELY, SOAPS FOR PERSONAL USE, LIQUID SOAP, BATH SOAP, BAR SOAP, GEL SOAP; NON-MEDICATED PROTECTIVE CREAMS FOR CHANGING BABIES' DIAPERS; LOTIONS FOR SKIN, HAIR, FACE, BODY; OILS FOR HAIR CONDITIONING, COSMETIC PURPOSES; GELS FOR HAIR AND EYES; CREAMS FOR HAIR, FACE, BODY, SKIN; BALMS FOR HAIR CARE AND HAIR STYLING FOR MEN, WOMEN AND CHILDREN; COSMETIC CARE PREPARATIONS FOR CLEANING, NOURISHING, MOISTURIZING AND TREATING SKIN FOR MEN, WOMEN AND CHILDREN; COSMETIC CREAMS FOR THE FACE, THE CONTOURS OF THE EYES, THE BODY, THE HANDS, THE NECK AND THE CHEST; TOILET MILKS, LOTIONS AND GELS FOR COSMETIC AND CLEANSING PURPOSES; ENERGIZING WATERS FOR THE BODY, NAMELY, SEAWATER-BASED SKIN CARE PREPARATIONS FOR SKIN RENEWAL; ALMOND OIL FOR COSMETIC PURPOSES; COTTON PADS AND WIPES IMPREGNATED WITH COSMETIC LOTIONS OR WITH COSMETIC TOILET MILK (U.S. CLS. 1, 4, 6, 50, 51 AND 52).

### CLASS 5—PHARMACEUTICALS

FOR PHARMACEUTICAL PREPARATIONS FOR MEDICAL PURPOSES FOR THE TREATMENT OF ARTICULAR DISORDER, CHOLESTEROL; SANITARY PREPARATIONS FOR MEDICAL PURPOSES; DIETETIC PREPARATIONS FOR MEDICAL PURPOSES, NAMELY, DIETETIC FOODS ADAPTED FOR MEDICAL USE; PREPARED FOOD SUPPLEMENTS FOR HUMAN CONSUMPTION FOR MEDICAL PURPOSES; NUTRITIONAL AND DIETETIC FOODS IN POWDER OR LIQUID FORM FOR DIABETICS, MEDICALLY RESTRICTED DIETS; NUTRITIONALLY FORTIFIED BEVERAGES IN POWDER OR LIQUID FORM; TONICS, RECONSTITUENTS, STIMULANTS, SNACKS IN THE FORM OF PROTEIN-RICH DIETETIC FOOD PREPARATIONS FOR MEDICAL USE; VITAMIN PREPARATIONS, HERBAL TEAS FOR MEDICINAL PURPOSES, MEDICINAL TEAS, MEDICINAL INFUSIONS, NAMELY, MEDICINAL TEA FOR INFUSIONS; TRACE ELEMENT PREPARATIONS IN THE NATURE OF VITAMINS FOR HUMAN CONSUMPTION; MATERIALS FOR WOUND AND SURGICAL DRESSINGS (U.S. CLS. 6, 18, 44, 46, 51 AND 52).  
JAMES MACFARLANE, EXAMINING ATTORNEY

SN 79-085,403. INSTITUT DE RECHERCHE BIOLOGIQUE, BOUFFERE, FRANCE, FILED 6-14-2010.

## LABORATOIRES YVES PONROY

THE MARK CONSISTS OF STANDARD CHARACTERS WITHOUT CLAIM TO ANY PARTICULAR FONT, STYLE, SIZE, OR COLOR.

OWNER OF INTERNATIONAL REGISTRATION 1045952 DATED 6-14-2010, EXPIRES 6-14-2020.

NO CLAIM IS MADE TO THE EXCLUSIVE RIGHT TO USE "LABORATOIRES", APART FROM THE MARK AS SHOWN.

THE NAME(S), PORTRAIT(S), AND/OR SIGNATURE(S) SHOWN IN THE MARK IDENTIFIES "YVES PONROY", WHOSE CONSENT(S) TO REGISTER IS MADE OF RECORD.

THE ENGLISH TRANSLATION OF "LABORATOIRES" IN THE MARK IS "LABORATORIES".

SN 79-085,553. CONTURA A/S, DENMARK, FILED 3-3-2010.

## ARTHROSAMID

THE MARK CONSISTS OF STANDARD CHARACTERS WITHOUT CLAIM TO ANY PARTICULAR FONT, STYLE, SIZE, OR COLOR.

PRIORITY DATE OF 9-7-2009 IS CLAIMED.

OWNER OF INTERNATIONAL REGISTRATION 1046325 DATED 3-3-2010, EXPIRES 3-3-2020.

### CLASS 5—PHARMACEUTICALS

FOR INJECTABLE SURGICAL GELS FOR MEDICAL USE FOR THE ALLEVIATION OF ARTHRITIS SYMPTOMS AND FOR TREATMENT OF ARTHRITIS AND DEGENERATIVE JOINT DISEASES; INJECTABLE GELS FOR THE TREATMENT OF ARTHRITIS; MEDICAL AND SURGICAL GELS FOR SURGICAL USE FOR THE ALLEVIATION OF ARTHRITIS SYMPTOMS AND FOR TREATMENT OF ARTHRITIS AND DEGENERATIVE JOINT DISEASES; INJECTABLE GELS FOR SURGICAL USE FOR THE ALLEVIATION OF ARTHRITIS SYMPTOMS AND FOR TREATMENT OF ARTHRITIS AND DEGENERATIVE JOINT DISEASES (U.S. CLS. 6, 18, 44, 46, 51 AND 52).



**CLASS 10—MEDICAL APPARATUS**

FOR MEDICAL AND SURGICAL IMPLANTS MADE OF ARTIFICIAL MATERIALS; INJECTABLE IMPLANTS MADE OF ARTIFICIAL MATERIALS FOR SURGICAL USE; INJECTABLE IMPLANTS MADE OF ARTIFICIAL MATERIALS FOR THE TREATMENT OF ARTHRITIS (U.S. CLS. 26, 39 AND 44).

ANNE MADDEN, EXAMINING ATTORNEY

SN 79-085,559. RHODIA OPERATIONS, FRANCE, FILED 6-1-2010.

SN 79-085,555. INTERSEAL DIPL.-ING. ROLF SCHMITZ GMBH, FED REP GERMANY, FILED 4-12-2010.

**dry9000**

THE MARK CONSISTS OF STANDARD CHARACTERS WITHOUT CLAIM TO ANY PARTICULAR FONT, STYLE, SIZE, OR COLOR.

PRIORITY DATE OF 10-15-2009 IS CLAIMED.

OWNER OF INTERNATIONAL REGISTRATION 1046328 DATED 4-12-2010, EXPIRES 4-12-2020.

**CLASS 7—MACHINERY**

FOR MECHANICAL SEALS AS MACHINE PARTS; SHAFT SEALS AND WIPERS AS PARTS OF ELECTRIC MIXERS, BLENDERS, INDUSTRIAL DRYERS, SCREW GRINDING MACHINES, FILTERS FOR ROTATING FILTERS, ELECTRIC PUMPS, FOR THE CHEMICAL, PHARMACEUTICAL AND FOOD INDUSTRY; ACCESSORIES FOR SHAFT SEALS, NAMELY, ELASTOMERS, O-RINGS, SEAL LIPS, RADIAL SEALS, GASKETS, NAMELY, FLAT SEALS, METAL BELLOWS, SEALING AND CONNECTING PLUGS, PRESSURE CONNECTION HOSES TO SHAFT SEALS; VALVES FOR MACHINES, NAMELY, BALL VALVES AND VALVES WITH METALLIC AND/OR COAL HIGH-PERFORMANCE PLASTIC SEALING SYSTEMS; ROTARY UNIONS AS MACHINE PARTS (U.S. CLS. 13, 19, 21, 23, 31, 34 AND 35).

**CLASS 9—ELECTRICAL AND SCIENTIFIC APPARATUS**

FOR MEASURING INSTRUMENTS FOR LEAK DETECTION OF SHAFT SEALS AND GAUGES FOR MONITORING THE TEMPERATURE OF SHAFT SEALS (U.S. CLS. 21, 23, 26, 36 AND 38).

**CLASS 17—RUBBER GOODS**

FOR SEALANTS FOR STATIC AND ROTATING APPLICATIONS, NAMELY, PACKAGES FOR ROTATING APPLICATIONS; PRODUCTS, NAMELY, SEALANTS, MADE OF GRAPHITE, CARBON, PTFE, PTFE COMPOUNDS, PAROFLON, PTFE O-RINGS AND HIGH-TEMPERATURE COMPOUNDS FOR SEALING PURPOSES; METALLIC MELTDOWN COATINGS AND HIGH-SPEED COATINGS AND NANO-COATINGS FOR SURFACE FINISHING ON SEALING SYSTEMS, NAMELY, PROTECTIVE LAYER COATINGS USED FOR PROTECTING PARTS AND SURFACES OF SEALANTS (U.S. CLS. 1, 5, 12, 13, 35 AND 50).

ANNE MADDEN, EXAMINING ATTORNEY



PRIORITY DATE OF 12-3-2009 IS CLAIMED. OWNER OF INTERNATIONAL REGISTRATION 1046333 DATED 6-1-2010, EXPIRES 6-1-2020.

NO CLAIM IS MADE TO THE EXCLUSIVE RIGHT TO USE "ECO EFFICIENCY EVALUATIONS", APART FROM THE MARK AS SHOWN.

THE COLOR(S) GREEN, YELLOW, BLUE, ORANGE AND GRAY IS/ARE CLAIMED AS A FEATURE OF THE MARK.

THE MARK CONSISTS OF THE WORDING "3 E ECO EFFICIENCY EVALUATIONS" WITH THE NUMBER "3" IN GREEN, THE LETTER "E" IN ORANGE, THE WORDING "ECO EFFICIENCY EVALUATIONS" IN BLUE, ALL ENCOMPASSED BY AN OVAL SHADED IN YELLOW AND GRAY.

**CLASS 9—ELECTRICAL AND SCIENTIFIC APPARATUS**

FOR APPARATUS FOR RECORDING, TRANSMISSION OR REPRODUCTION OF SOUND OR IMAGES, CALCULATING MACHINES, DATA PROCESSING EQUIPMENT AND COMPUTERS IN THE FIELDS OF ECOLOGICAL EVALUATION, SURVEYING AND ENGINEERING (U.S. CLS. 21, 23, 26, 36 AND 38).

**CLASS 35—ADVERTISING AND BUSINESS**

FOR BUSINESS MANAGEMENT AND ORGANIZATION CONSULTANCY IN THE FIELDS OF ECOLOGICAL EVALUATION, SURVEYING AND ENGINEERING; COMMERCIAL AND INDUSTRIAL MANAGEMENT ASSISTANCE RELATING TO ECOLOGICAL EVALUATIONS, SURVEYING AND ENGINEERING; BUSINESS MANAGEMENT ASSISTANCE TO INDUSTRIAL OR COMMERCIAL COMPANIES RELATING TO ECOLOGICAL EVALUATIONS, SURVEYING AND ENGINEERING; EFFICIENCY EXPERTS IN THE FIELDS OF ECOLOGICAL EVALUATION, SURVEYING AND ENGINEERING; CONDUCTING MARKETING STUDIES AND RESEARCH IN THE FIELDS OF ECOLOGICAL EVALUATION, SURVEYING AND ENGINEERING (U.S. CLS. 100, 101 AND 102).

**CLASS 42—SCIENTIFIC AND COMPUTER SERVICES**

FOR EVALUATIONS, ESTIMATES, RESEARCH, AND REPORTS IN THE FIELDS OF SCIENCE AND TECHNOLOGY, NAMELY, ECOLOGICAL EVALUATION, SURVEYING AND ENGINEERING; DESIGN AND DEVELOPMENT OF COMPUTER HARDWARE AND SOFTWARE RELATING TO ECOLOGICAL EVALUATIONS, SURVEYING AND ENGINEERING; TECHNICAL PROJECT STUDIES IN THE FIELDS OF ECOLOGICAL EVALUATION, SURVEYING AND ENGINEERING; SURVEYING (U.S. CLS. 100 AND 101).

BRIAN CALLAGHAN, EXAMINING ATTORNEY

SN 79-085,595. LAUTSPRECHER TEUFEL GMBH, FED REP GERMANY, FILED 6-23-2010.

# Aureol

THE MARK CONSISTS OF STANDARD CHARACTERS WITHOUT CLAIM TO ANY PARTICULAR FONT, STYLE, SIZE, OR COLOR.

PRIORITY DATE OF 1-28-2010 IS CLAIMED. OWNER OF INTERNATIONAL REGISTRATION 1046427 DATED 6-23-2010, EXPIRES 6-23-2020.

THE WORDING "AUREOL" HAS NO MEANING IN A FOREIGN LANGUAGE.

## CLASS 9—ELECTRICAL AND SCIENTIFIC APPARATUS

FOR APPARATUS FOR RECORDING, TRANSMISSION OR REPRODUCTION OF SOUND OR IMAGES; LOUDSPEAKERS, HOME-CINEMA LOUDSPEAKER SYSTEMS; ELECTRIC BATTERY CHARGING SYSTEMS COMPRISED OF BATTERY CHARGE DEVICES, ELECTRIC CORDS FOR LOUDSPEAKERS AND ELECTRONIC APPARATUS FOR IMAGE AND SOUND REPRODUCTION; STEREO MUSIC SYSTEMS COMPRISED OF STEREO AMPLIFIERS, STEREO TUNERS, LOUDSPEAKERS; CD, DVD, OPTICAL AND MAGNETO-OPTICAL DISC PLAYERS; RADIOS; AMPLIFIERS; TUNERS, NAMELY, CAR BROADCASTING TUNERS, STEREO TUNERS, MP3 PLAYERS AND COMPUTER DOCKING STATIONS; MP3 PLAYERS AND COMPUTER DOCKING STATIONS FEATURING RADIOS AND/OR LOUDSPEAKERS; RADIOS INCORPORATING ALARM CLOCKS; HEADPHONES; HARD DISK RECORDERS; TV AND DVBT RECEIVERS; MEDIA SERVERS, NAMELY, VIDEO SERVERS, INTERNET SERVERS; ELECTRIC CABLES AND CONDUITS FOR APPARATUS FOR RECORDING, TRANSMISSION OR REPRODUCTION OF SOUND OR IMAGES (U.S. CLS. 21, 23, 26, 36 AND 38).

## CLASS 35—ADVERTISING AND BUSINESS

FOR ADVERTISING; DIRECT MAIL ADVERTISING USING TRACTS, PROSPECTUSES, PRINTED MATTER, AND SAMPLES; ADVERTISING IN ALL MEDIA, INCLUDING RADIO, TELEVISION, CINEMA, PRINT, VIDEOTEXT, ONLINE AND TELETXT ADVERTISING, INCLUDING CUSTOMER MARKETING; DISPLAY SERVICES FOR MERCHANDISING; PUBLIC RELATIONS; ADVERTISING ON THE INTERNET, FOR OTHERS; SPONSORING IN THE FORM OF ADVERTISING; RETAIL AND WHOLESALE STORE SERVICES, INCLUDING BY MAIL ORDER, VIA THE INTERNET AND BY MEANS OF TEleshopping PROGRAMS, IN RELATION TO GOODS IN THE FIELD OF ELECTRONIC ENTERTAINMENT; ONLINE SERVICES AND E-COMMERCE PROVIDER SERVICES, NAMELY, PRESENTATION OF GOODS AND SERVICES FOR ADVERTISING PURPOSES, ORDER PLACEMENT, NAMELY, ELECTRONIC PROCESSING OF ORDERS FOR OTHERS, DELIVERY SERVICES, NAMELY, BUSINESS ADMINISTRATION IN THE FIELD OF TRANSPORT AND DELIVERY, BUSINESS MANAGEMENT IN THE FIELD OF TRANSPORT AND DELIVERY AND INVOICE MANAGEMENT, NAMELY, PREPARING AND MANAGING INVOICES FOR OTHERS, INCLUDING WITHIN THE FRAMEWORK OF E-COMMERCE; ACCOUNTING FOR ELECTRONIC ORDER SYSTEMS (U.S. CLS. 100, 101 AND 102).

## CLASS 41—EDUCATION AND ENTERTAINMENT

FOR ENTERTAINMENT, NAMELY, LIVE PERFORMANCES BY A MUSICAL BAND; ENTERTAINMENT IN THE NATURE OF VISUAL AND AUDIO PERFORMANCES; LIGHT SHOWS; ORGANIZING CULTURAL ACTIVITIES IN THE NATURE OF VISUAL AND AUDIO PERFORMANCES, RENTAL OF APPARATUS FOR RECORDING, TRANSMISSION OR REPRODUCTION OF SOUND OR IMAGES, AS WELL AS LOUDSPEAKERS AND HOME-CINEMA LOUDSPEAKER SYSTEMS (U.S. CLS. 100, 101 AND 107).

ALLISON SCHRODY, EXAMINING ATTORNEY

SN 79-085,596. LAUTSPRECHER TEUFEL GMBH, FED REP GERMANY, FILED 6-23-2010.

# Consono

THE MARK CONSISTS OF STANDARD CHARACTERS WITHOUT CLAIM TO ANY PARTICULAR FONT, STYLE, SIZE, OR COLOR.

PRIORITY DATE OF 2-9-2010 IS CLAIMED. OWNER OF INTERNATIONAL REGISTRATION 1046428 DATED 6-23-2010, EXPIRES 6-23-2020.

THE ENGLISH TRANSLATION OF THE WORD "CONSONO" IN THE MARK IS "CONSISTENT WITH".

## CLASS 9—ELECTRICAL AND SCIENTIFIC APPARATUS

FOR APPARATUS FOR RECORDING, TRANSMISSION OR REPRODUCTION OF SOUND OR IMAGES; LOUDSPEAKERS, HOME-CINEMA LOUDSPEAKER SYSTEMS; ELECTRIC BATTERY CHARGING SYSTEMS COMPRISED OF BATTERY CHARGE DEVICES, ELECTRIC CORDS FOR LOUDSPEAKERS AND ELECTRONIC APPARATUS FOR IMAGE AND SOUND REPRODUCTION; STEREO MUSIC SYSTEMS COMPRISED OF STEREO AMPLIFIERS, STEREO TUNERS, LOUDSPEAKERS; CD, DVD, OPTICAL AND MAGNETO-OPTICAL DISC PLAYERS; RADIOS; AMPLIFIERS; TUNERS, NAMELY, CAR BROADCASTING TUNERS, STEREO TUNERS, MP3 PLAYERS AND COMPUTER DOCKING STATIONS; MP3 PLAYERS AND COMPUTER DOCKING STATIONS FEATURING RADIOS AND/OR LOUDSPEAKERS; RADIOS INCORPORATING ALARM CLOCKS; HEADPHONES; HARD DISK RECORDERS; TV AND DVBT RECEIVERS; MEDIA SERVERS, NAMELY, VIDEO SERVERS, INTERNET SERVERS; ELECTRIC CABLES AND CONDUITS FOR APPARATUS FOR RECORDING, TRANSMISSION OR REPRODUCTION OF SOUND OR IMAGES (U.S. CLS. 21, 23, 26, 36 AND 38).

**CLASS 35—ADVERTISING AND BUSINESS**

FOR ADVERTISING; DIRECT MAIL ADVERTISING USING TRACTS, PROSPECTUSES, PRINTED MATTER, AND SAMPLES; ADVERTISING IN ALL MEDIA, INCLUDING RADIO, TELEVISION, CINEMA, PRINT, VIDEO TEXT, ONLINE AND TELETEX ADVERTISING, INCLUDING CUSTOMER MARKETING; DISPLAY SERVICES FOR MERCHANDISING; PUBLIC RELATIONS; ADVERTISING ON THE INTERNET, FOR OTHERS; SPONSORING IN THE FORM OF ADVERTISING; RETAIL AND WHOLESALE STORE SERVICES, INCLUDING BY MAIL ORDER, VIA THE INTERNET AND BY MEANS OF TEleshopping PROGRAMS, IN RELATION TO GOODS IN THE FIELD OF ELECTRONIC ENTERTAINMENT; ONLINE SERVICES AND E-COMMERCE PROVIDER SERVICES, NAMELY, PRESENTATION OF GOODS AND SERVICES FOR ADVERTISING PURPOSES, ORDER PLACEMENT, NAMELY, ELECTRONIC PROCESSING OF ORDERS FOR OTHERS, DELIVERY SERVICES, NAMELY, BUSINESS ADMINISTRATION IN THE FIELD OF TRANSPORT AND DELIVERY, BUSINESS MANAGEMENT IN THE FIELD OF TRANSPORT AND DELIVERY AND INVOICE MANAGEMENT, NAMELY, PREPARING AND MANAGING INVOICES FOR OTHERS, INCLUDING WITHIN THE FRAMEWORK OF E-COMMERCE; ACCOUNTING FOR ELECTRONIC ORDER SYSTEMS (U.S. CLS. 100, 101 AND 102).

**CLASS 41—EDUCATION AND ENTERTAINMENT**

FOR ENTERTAINMENT, NAMELY, LIVE PERFORMANCES BY A MUSICAL BAND; ENTERTAINMENT IN THE NATURE OF VISUAL AND AUDIO PERFORMANCES; LIGHT SHOWS; ORGANIZING CULTURAL ACTIVITIES IN THE NATURE OF VISUAL AND AUDIO PERFORMANCES, RENTAL OF APPARATUS FOR RECORDING, TRANSMISSION OR REPRODUCTION OF SOUND OR IMAGES, AS WELL AS LOUDSPEAKERS AND HOME-CINEMA LOUDSPEAKER SYSTEMS (U.S. CLS. 100, 101 AND 107).

ALLISON SCHRODY, EXAMINING ATTORNEY

SN 79-085,635. GEA PROCESS ENGINEERING A/S, DK-2860 SØBORG, DENMARK, FILED 6-28-2010.



PRIORITY DATE OF 1-20-2010 IS CLAIMED.  
OWNER OF INTERNATIONAL REGISTRATION 1046553 DATED 6-28-2010, EXPIRES 6-28-2020.

THE MARK CONSISTS OF THE DESIGN OF A MAN IN SILHOUETTE RUNNING AND THE DESIGN IS SHADED WITH A PATTERN OF UNSHADED HORIZONTAL STRIPES RUNNING THROUGH IT.

**CLASS 6—METAL GOODS**

FOR NOZZLES OF METAL AND WEAR PARTS OF METAL OR THEIR ALLOYS IN THE NATURE OF NOZZLE INSERTS, ROTARY ATOMIZER WEAR PLATES, FLUID BED GAS DISTRIBUTOR PLATES, CLEANING COVERS, ALL AFOREMENTIONED TO BE USED IN THE DAIRY INDUSTRY, THE FOOD INDUSTRY, THE BEVERAGE INDUSTRY, THE CHEMICAL INDUSTRY, THE PHARMACEUTICAL INDUSTRY AND THE ENERGY INDUSTRY (U.S. CLS. 2, 12, 13, 14, 23, 25 AND 50).

**CLASS 7—MACHINERY**

FOR ROTARY ATOMIZERS, SPARE PARTS IN THE NATURE OF GEARS, SPINDLES, OIL-PUMPS, ROTARY ATOMIZER CHANNEL INSERTS FOR ROTARY ATOMIZERS AND SPARE PARTS IN THE NATURE OF HOUSINGS, GEARS, ROTORS FOR ROTARY POWDER VALVES FOR INDUSTRIAL DRYERS, ALL AFOREMENTIONED TO BE USED IN THE DAIRY INDUSTRY, THE FOOD INDUSTRY, THE BEVERAGE INDUSTRY, THE CHEMICAL INDUSTRY, THE PHARMACEUTICAL INDUSTRY AND THE ENERGY INDUSTRY (U.S. CLS. 13, 19, 21, 23, 31, 34 AND 35).

**CLASS 11—ENVIRONMENTAL CONTROL APPARATUS**

FOR GAS FILTERS, PRESSURE RELIEF MEMBRANE VALVES AND FILTER UNIT DIAPHRAGM VALVES AS PART OF INDUSTRIAL INSTALLATIONS AND SPARE PARTS AND WEAR PARTS IN THE NATURE OF BAG-FILTERS AND MEMBRANES FOR INDUSTRIAL INSTALLATIONS, ALL AFOREMENTIONED TO BE USED IN THE DAIRY INDUSTRY, THE FOOD INDUSTRY, THE BEVERAGE INDUSTRY, THE CHEMICAL INDUSTRY, THE PHARMACEUTICAL INDUSTRY AND THE ENERGY INDUSTRY (U.S. CLS. 13, 21, 23, 31 AND 34).

**CLASS 37—CONSTRUCTION AND REPAIR**

FOR INSTALLATION, PLANT INSPECTION, MAINTENANCE AND REPAIR OF MACHINERY AND EQUIPMENT IN THE PROCESS INDUSTRY, NAMELY, THE DAIRY INDUSTRY, THE FOOD INDUSTRY, THE BEVERAGE INDUSTRY, THE CHEMICAL INDUSTRY, THE PHARMACEUTICAL INDUSTRY, AND THE ENERGY INDUSTRY (U.S. CLS. 100, 103 AND 106).

**CLASS 42—SCIENTIFIC AND COMPUTER SERVICES**

FOR MATERIALS TESTING AND EVALUATION, PRODUCTION OPTIMIZATION SERVICES, ENGINEERING AND TECHNOLOGICAL SERVICES IN THE NATURE OF TECHNOLOGICAL CONSULTATION SERVICES IN RELATION TO LIQUID AND POWDER TECHNOLOGY, ALL OF THE SERVICES RELATED TO MACHINERY AND EQUIPMENT IN THE PROCESS INDUSTRY, NAMELY, THE DAIRY INDUSTRY, THE FOOD INDUSTRY, THE BEVERAGE INDUSTRY, THE CHEMICAL INDUSTRY, THE PHARMACEUTICAL INDUSTRY, AND THE ENERGY INDUSTRY (U.S. CLS. 100 AND 101).

MARILYN IZZI, EXAMINING ATTORNEY

SN 79-085,664. FARCHIONI OLII S.P.A., ITALY, FILED 3-19-2010.

OWNER OF INTERNATIONAL REGISTRATION 0732683 DATED 3-17-2000, EXPIRES 3-17-2020.

OWNER OF U.S. REG. NO. 3,077,132.  
THE ENGLISH TRANSLATION OF THE FOREIGN WORD(S) IN THE MARK IS: FARMHOUSE.

**CLASS 29—MEATS AND PROCESSED FOODS**

FOR OLIVE OIL; PRODUCTS DERIVED FROM OLIVE OIL, NAMELY, OLIVE OIL INFUSED WITH GARLIC AND PEPPER, OLIVE OIL INFUSED WITH HERBS, AND OLIVE OIL INFUSED WITH LEMON; FISH, FRUIT AND VEGETABLES BEING COOKED AND PRESERVED; FOODSTUFFS PRESERVED IN OIL AND VINEGAR, NAMELY, FRUITS AND VEGETABLES; JAMS; MARMALADE; DAIRY PRODUCTS, EXCLUDING ICE CREAM, ICE MILK AND FROZEN YOGURT (U.S. CL. 46).

**CLASS 30—STAPLE FOODS**

FOR VINEGAR; SEASONINGS; SAUCES; SALAD DRESSINGS; TOMATO SAUCE; FLOUR AND CEREAL PREPARATIONS, NAMELY, BREAD, CRACKERS, BREADSTICKS, RUSKS, COOKIES, BISCUITS, TARTS AND PASTRIES (U.S. CL. 46).

**CLASS 33—WINES AND SPIRITS**

FOR WINES, LIQUEURS, SPARKLING WINES (U.S. CLS. 47 AND 49).  
ADA HAN, EXAMINING ATTORNEY

SN 79-085,674. SANSET GIDA TURIZM SANAYI VE TICARET ANONIM SIRKETI, TURKEY, FILED 3-1-2010.



OWNER OF INTERNATIONAL REGISTRATION 0810615 DATED 7-7-2003, EXPIRES 7-7-2013.

**CLASS 29—MEATS AND PROCESSED FOODS**

FOR PROCESSED HAZELNUTS AND HAZELNUT BUTTER; DRIED FRUITS; PREPARED NUTS; HAZELNUT BUTTER WITH OR WITHOUT CACAO; DRIED FIGS; PROCESSED APRICOTS AND RAISINS NON-COATED WITH CACAO; ALL KINDS OF HAZELNUT BUTTER COATED OR NON-COATED WITH CACAO (U.S. CL. 46).

**CLASS 30—STAPLE FOODS**

FOR COFFEE; PROCESSED CACAO; TEA; NOUGATS; ALL KINDS OF CHOCOLATES AND CHOCOLATE PRODUCTS, NAMELY, CACAO-BASED SPREADS; ALL KINDS OF DRAGEES; ALL KINDS OF PRALINES; CHOCOLATE BARS; ALL KINDS OF FONDANTS; ALL KINDS OF CHOCOLATE BATONS COATED WITH CACAO AND HAZELNUT; ALL KINDS OF BISCUITS; WAFERS; ALL KINDS OF CANDIES; CAKES; CHOCOLATE COVERED RAISINS; APRICOTS AND RAISINS COATED WITH CACAO (U.S. CL. 46).

MARY I. SPARROW, EXAMINING ATTORNEY

SN 79-085,686. SIX GROUP AG, ZÜRICH, SWITZERLAND, FILED 3-8-2010.

# SIX Telekurs

THE MARK CONSISTS OF STANDARD CHARACTERS WITHOUT CLAIM TO ANY PARTICULAR FONT, STYLE, SIZE, OR COLOR.

OWNER OF INTERNATIONAL REGISTRATION 0997190 DATED 2-11-2009, EXPIRES 2-11-2019.

**CLASS 35—ADVERTISING AND BUSINESS**

FOR COMPUTER DATA PROCESSING IN CONNECTION WITH STOCK EXCHANGE AND COMMERCIAL INFORMATION; COMPILING AND SYSTEMATIZATION OF FINANCIAL, STOCK EXCHANGE AND COMMERCIAL INFORMATION AND DATA INTO COMPUTER DATABASES; MARKET ANALYSIS OF STOCK EXCHANGE INFORMATION VIA COMPUTER; BUSINESS RECORD KEEPING SERVICES IN THE FIELD OF FINANCIAL, STOCK EXCHANGE AND COMMERCIAL INFORMATION, BUSINESS RECORD KEEPING SERVICES IN THE FIELD OF SHARES, BUSINESS RECORD KEEPING SERVICES IN THE FIELD OF INDICES AND SECURITIES (U.S. CLS. 100, 101 AND 102).

**CLASS 36—INSURANCE AND FINANCIAL**

FOR QUOTATIONS OF STOCK MARKET PRICES; PROVISION OF FINANCIAL INFORMATION CONCERNING STOCK MARKETS; PROVIDING INFORMATION AND DATA RELATING TO STOCK EXCHANGES; PROVIDING FINANCIAL INFORMATION AND FINANCIAL DATA ON COMPANIES; FINANCIAL SERVICES, NAMELY, PROVIDING BILL PAYMENT SERVICES FOR GOODS AND SERVICES OF OTHERS VIA THE ISSUANCE, DISTRIBUTION AND SETTLEMENT OF VOUCHERS, TICKETS, COUPONS, COUNTERFOILS, PREPAID OR DEBIT/CREDIT CARDS VIA COMPUTER NETWORKS; ELECTRONIC PAYMENT SERVICES, NAMELY, ELECTRONIC PROCESSING AND TRANSMISSION OF BILL PAYMENT DATA; CREDIT CARD SERVICES; ELECTRONIC PAYMENT SERVICES BY MEANS OF A BANK CARD, A PRIVATE CARD OR A CHEQUE, NAMELY, BY MEANS OF CUSTOMER-OPERATED ELECTRONIC TERMINALS AVAILABLE ON-SITE IN RETAIL STORES (U.S. CLS. 100, 101 AND 102).

**CLASS 38—COMMUNICATION**

FOR PROVIDING COMPUTER NETWORK SERVICES AMONG BANKS, FINANCIAL INSTITUTIONS AND SECURITIES EXCHANGES, NAMELY, PROVIDING A HIGH SPEED ACCESS TO AREA NETWORKS AND A GLOBAL COMPUTER INFORMATION NETWORK; PROVISION OF ACCESS TIME TO ELECTRONIC COMPUTER NETWORKS DESIGNED FOR TEMPORARY SHARING OF USER TIME ON COMPUTERS BY SEVERAL USERS; PROVIDING ACCESS TO COMPUTER DATABASES OF INFORMATION IN THE FINANCIAL, BANKING AND SECURITIES FIELDS (U.S. CLS. 100, 101 AND 104).

**CLASS 41—EDUCATION AND ENTERTAINMENT**

FOR PUBLICATION AND ON-LINE PUBLICATION OF NEWSLETTERS, BROCHURES, FACT SHEETS, GRAPHICS, FIGURES, STATISTICS, PAMPHLETS AND LEAFLETS IN THE FIELD OF STOCK EXCHANGE AND FINANCIAL INDICES AND OTHER ECONOMIC INDICES (U.S. CLS. 100, 101 AND 107).

**CLASS 42—SCIENTIFIC AND COMPUTER SERVICES**

FOR DEVELOPMENT OF MEANS OF PAYMENT AND ELECTRONIC SYSTEMS FOR PAYMENTS FOR OTHERS; TECHNICAL CONSULTING CONCERNING THE DEVELOPMENT OF ELECTRONIC PAYMENT SYSTEMS; COMPUTER SERVICES, NAMELY, RESEARCH, DEVELOPMENT, CONSULTING AND SUPERVISION RELATING TO COMPUTER USE AND PROGRAM DEVELOPMENT FOR DATA PROCESSING; TECHNOLOGICAL CONSULTING IN THE TECHNOLOGY FIELD OF ELECTRONIC SETTLEMENT OF COMMERCIAL TRANSACTIONS, OR OF PAYMENT SYSTEMS; PROFESSIONAL TECHNOLOGICAL CONSULTING IN THE TECHNOLOGY FIELD OF BANKS AND REMOTE COMPUTING FIRMS SPECIALIZING IN ELECTRONIC SIGNATURES AND IN IDENTIFICATION; DATA ENCRYPTION AND DECODING SERVICES; DATA ENCRYPTION OF ELECTRONIC AND OPTICAL TRANSMISSIONS (U.S. CLS. 100 AND 101).

LEIGH CAROLINE CASE, EXAMINING ATTORNEY

SN 79-085,710. RABO VASTGOEDGROEP HOLDING N.V., NETHERLANDS, FILED 3-25-2010.



PRIORITY DATE OF 11-24-2009 IS CLAIMED.

OWNER OF INTERNATIONAL REGISTRATION 1046632 DATED 3-25-2010, EXPIRES 3-25-2020.

THE COLOR(S) BLUE, LIGHT BLUE, GREEN, LIGHT GREEN, RED, AND DARK RED IS/ARE CLAIMED AS A FEATURE OF THE MARK.

THE MARK CONSISTS OF A STYLIZED DESIGN OF THREE OPENED ENVELOPES OVER LAPPING ONE ANOTHER - THE FRONT ENVELOPE APPEARS IN LIGHT BLUE, WITH THE UPPER LEFT TRIANGULAR SECTION A DARKER SHADE OF BLUE; THE SECOND ENVELOPE IN LIGHT GREEN, WITH THE UPPER LEFT TRIANGULAR SECTION A DARKER SHADE OF GREEN; AND THE LAST ENVELOPE APPEARS IN RED, WITH THE UPPER LEFT TRIANGULAR SECTION A DARKER SHADE OF RED.

**CLASS 16—PAPER GOODS AND PRINTED MATTER**

FOR PRINTED MATTER, NAMELY, NEWSPAPERS, PHOTOGRAPHS, MAGAZINES, BOOKS, PRINTED PERIODICALS, NEWSLETTERS, AND BROCHURES, ALL FEATURING INFORMATION IN THE FIELD OF FINANCING, INSURANCE BROKERAGE AND REAL ESTATE; BOOK BINDING MATERIAL; PHOTOGRAPHS; STATIONERY; ADHESIVES FOR STATIONERY OR HOUSEHOLD PURPOSES; PRINTERS' TYPE; PRINTING BLOCKS (U.S. CLS. 2, 5, 22, 23, 29, 37, 38 AND 50).

**CLASS 35—ADVERTISING AND BUSINESS**

FOR ADVERTISING SERVICES AND MANAGEMENT OF COMMERCIAL AFFAIRS; BUSINESS MANAGEMENT AND BUSINESS ECONOMICS CONSULTANCY; CONSULTANCY IN THE FIELD OF MERGER MEDIATION; BUSINESS MANAGEMENT OF COMPANIES; BOOK-KEEPING; PROVIDING OFFICE FUNCTIONS; COMPILATION OF STATISTICS; HOLDING OF AUCTIONS AND PUBLIC SALES; COMMERCIAL INFORMATION SERVICES; EFFICIENCY EXPERTS; BUSINESS INTERMEDIARY SERVICES IN THE FIELD OF MERGERS AND CONSULTANCY THEREON (U.S. CLS. 100, 101 AND 102).

**CLASS 36—INSURANCE AND FINANCIAL**

FOR FINANCIAL AFFAIRS, NAMELY, FINANCIAL INFORMATION, MANAGEMENT AND ANALYSIS SERVICES; INSURANCE AGENCIES; BANKING, INCLUDING MORTGAGE LENDING; PAYMENT PROCESSING SERVICES, NAMELY CREDIT CARD AND DEBIT CARD TRANSACTION PROCESSING SERVICES; FINANCIAL ANALYSIS, FINANCIAL CONSULTATION; FINANCING; FISCAL ASSESSMENTS AND VALUATIONS; FINANCIAL CONSULTANCY WITH REGARD TO FISCAL PROBLEMS; FINANCIAL INTERMEDIARY SERVICES AND CONSULTANCY RELATED TO STOCK, SECURITY AND BOND TRANSACTIONS; FINANCIAL INVESTMENT SERVICES, NAMELY, ADMINISTERING THE ISSUANCE, UNDERWRITING AND DISTRIBUTION OF SECURITIES; FINANCIAL INTERMEDIARY SERVICES AND CONSULTANCY REGARDING REAL ESTATE TRANSACTIONS; FINANCIAL MANAGEMENT; FINANCIAL ASSET MANAGEMENT; REAL ESTATE APPRAISALS (U.S. CLS. 100, 101 AND 102).

**CLASS 37—CONSTRUCTION AND REPAIR**

FOR CONSTRUCTION, REPAIR AND INSTALLATION OF RESIDENTIAL PREMISES, APARTMENTS, OFFICES, SHOPS AND BUILDINGS; PROVISION OF INFORMATION AND ADVICE REGARDING BUILDING CONSTRUCTION; GENERAL BUILDING CONTRACTOR SERVICES; PROVISION OF INFORMATION IN THE FIELD OF CONSTRUCTION WORK ON BUILDINGS, COMMERCIAL BUILDINGS, RESIDENTIAL BUILDINGS, LAND, ROADS AND WATER PROJECTS; BUILDING CONSTRUCTION SUPERVISION (U.S. CLS. 100, 103 AND 106).

**CLASS 42—SCIENTIFIC AND COMPUTER SERVICES**

FOR DESIGN OF RESIDENTIAL PREMISES, APARTMENTS, OFFICES, SHOPS AND BUILDINGS; COMPUTER PROGRAMMING FOR ELECTRONIC DATA PROCESSING; CONSULTING IN THE FIELDS OF ENGINEERING AND ARCHITECTURE; COMPUTER CONSULTATION (U.S. CLS. 100 AND 101).

**CLASS 45—PERSONAL AND LEGAL SERVICES**

FOR LEGAL SERVICES, NAMELY, PROVIDING CUSTOMIZED COUNSELLING AND ADVICE SERVICES IN THE AREA OF FISCAL PROBLEMS (U.S. CLS. 100 AND 101).

RON FAIRBANKS, EXAMINING ATTORNEY

SN 79-085,726. BASF SE, FED REP GERMANY, FILED 6-10-2010.

# DAXUR

THE MARK CONSISTS OF STANDARD CHARACTERS WITHOUT CLAIM TO ANY PARTICULAR FONT, STYLE, SIZE, OR COLOR.

PRIORITY DATE OF 3-4-2010 IS CLAIMED.  
OWNER OF INTERNATIONAL REGISTRATION 1046675 DATED 6-10-2010, EXPIRES 6-10-2020.

## CLASS 1—CHEMICALS

FOR CHEMICALS USED IN AGRICULTURE, HORTICULTURE AND FORESTRY, ESPECIALLY PLANT FORTIFYING PREPARATIONS, PLANT GROWTH REGULATING PREPARATIONS, CHEMICAL PREPARATIONS FOR THE TREATMENT OF SEEDS, SURFACTANTS, NATURAL OR ARTIFICIAL CHEMICALS TO BE USED AS SEXUAL BAITS OR AGENTS TO CONFUSE INSECTS (U.S. CLS. 1, 5, 6, 10, 26 AND 46).

## CLASS 5—PHARMACEUTICALS

FOR PREPARATIONS FOR DESTROYING AND COMBATING VERMIN, FUNGICIDES, HERBICIDES, PESTICIDES (U.S. CLS. 6, 18, 44, 46, 51 AND 52).  
KEVIN CORWIN, EXAMINING ATTORNEY

SN 79-085,748. AGR SUBSEA AS, NORWAY, FILED 4-9-2010.



PRIORITY DATE OF 11-25-2009 IS CLAIMED.  
OWNER OF INTERNATIONAL REGISTRATION 1046768 DATED 4-9-2010, EXPIRES 4-9-2020.

OWNER OF U.S. REG. NO. 3,357,079.  
THE MARK CONSISTS OF AN ILLUSTRATION OF A FLOATING OFFSHORE DRILL ENCLOSED IN A CIRCLE, ALL APPEARING ABOVE THE LETTERS "CMP".

## CLASS 7—MACHINERY

FOR WELL DRILLING MACHINES; SUBMERSIBLE PUMPS (U.S. CLS. 13, 19, 21, 23, 31, 34 AND 35).

## CLASS 37—CONSTRUCTION AND REPAIR

FOR INSTALLATION, REPAIR, MAINTENANCE AND RENTAL OF MACHINERY FOR DRILLING FLUID RELIEF, PUMPS, AND PRESSURE GAUGES (U.S. CLS. 100, 103 AND 106).  
RON FAIRBANKS, EXAMINING ATTORNEY

SN 79-085,765. "KRONOPOL" SPÓLKA Z OGRANICZONA ODPOWIEDZIALNOSCIA, POLAND, FILED 6-18-2010.



PRIORITY DATE OF 3-12-2010 IS CLAIMED.  
OWNER OF INTERNATIONAL REGISTRATION 1046864 DATED 6-18-2010, EXPIRES 6-18-2020.

OWNER OF U.S. REG. NO. 3,435,282.  
THE COLOR(S) WHITE, ORANGE AND CLARET RED IS/ARE CLAIMED AS A FEATURE OF THE MARK.

THE MARK CONSISTS OF "KRONOPOL" IN STYLIZED WHITE LETTERING WITH THREE WHITE BARS ABOVE IT ON AN ORANGE RECTANGULAR BACKGROUND. A WHITE UNDERLINE APPEARS BENEATH THE WORD "KRONOPOL" AND ON TOP OF A CLARET RED RECTANGLE.

## CLASS 19—NON-METALLIC BUILDING MATERIALS

FOR BOARDS OF WOOD, NAMELY, WOODEN STRIPS FOR PANELLING; WOOD PANELLING; SEMI-WORKED SHAPED WOOD; NON-METAL FLOOR TILES; FLOOR BOARDS IN THE NATURE OF PARQUET FLOORING; FLOORING BOARDS OF WOOD; NON-METAL LATHS; MOSAIC OF GLASS, NATURAL STONE AND STONE TILE FOR CONSTRUCTION PURPOSES; PARQUET FLOORS; NON-METAL FLOORS (U.S. CLS. 1, 12, 33 AND 50).

## CLASS 37—CONSTRUCTION AND REPAIR

FOR MAINTENANCE AND REPAIR OF FLOORING AND PARQUET FLOORING; INSTALLATION SERVICES, NAMELY, LAYING OF FLOORS; CARPENTRY SERVICES (U.S. CLS. 100, 103 AND 106).

KATHLEEN M. VANSTON, EXAMINING ATTORNEY

SN 79-085,951. AQUAFIL S.P.A., ITALY, FILED 6-9-2010.



PRIORITY DATE OF 2-18-2010 IS CLAIMED.  
OWNER OF INTERNATIONAL REGISTRATION 1047373 DATED 6-9-2010, EXPIRES 6-9-2020.

## CLASS 1—CHEMICALS

FOR UNPROCESSED PLASTICS; UNPROCESSED ARTIFICIAL RESINS; UNPROCESSED SYNTHETIC RESINS; UNPROCESSED POLYMERS IN PELLET FORM; UNPROCESSED POLYMER MIXTURES IN PELLET FORM; UNPROCESSED POLYMER ADDITIVES IN PELLET FORM; UNPROCESSED THERMOPLASTICS IN PELLET FORM; AND POLYMERS FOR TEXTILE USE, NAMELY, POLYMER BASE COMPOSITIONS USED IN THE MANUFACTURE OF TEXTILES; POLYMER BASE COMPOSITIONS USED IN THE MANUFACTURE OF TEXTILE COATINGS; POLYAMIDE; UNPROCESSED PLASTIC COMPOUNDS; CHEMICALS FOR RUBBER AND PLASTICS PROCESSING APPLICATIONS (U.S. CLS. 1, 5, 6, 10, 26 AND 46).

**CLASS 17—RUBBER GOODS**

FOR PLASTIC IN EXTRUDED FORM FOR GENERAL INDUSTRIAL USE; EXTRUDED POLYMERS, NAMELY, EXTRUDED PLASTICS USED IN PRODUCTION; MATERIALS MADE FROM PLASTICS, POLYMERS AND RESINS FOR USE IN MANUFACTURE, NAMELY, EXTRUDED RESINS FOR GENERAL INDUSTRIAL USE; PLASTIC BARS, BLOCKS, PELLETS, RODS, SHEETS, TUBES OR EXTRUDED FORM FOR GENERAL INDUSTRIAL USE; SEMI-PROCESSED PLASTIC SUBSTANCES; RECYCLED POLYAMIDE PLASTIC RESIN IN PELLET FORM FOR USE IN FURTHER MANUFACTURE (U.S. CLS. 1, 5, 12, 13, 35 AND 50).

**CLASS 22—CORDAGE AND FIBERS**

FOR TEXTILE FIBERS; PLASTIC FIBERS FOR TEXTILE USE; THREAD, NOT OF METAL, FOR WRAPPING OR BINDING; RAW FIBROUS TEXTILE MATERIALS; RECLAIMED FIBERS FOR TEXTILE USE; POLYAMIDE TEXTILE FIBERS; SYNTHETIC FIBERS FOR TEXTILE USE (U.S. CLS. 1, 2, 7, 19, 22, 42 AND 50).

**CLASS 23—YARNS AND THREADS**

FOR SPUN THREAD AND YARN; YARNS AND THREADS FOR TEXTILE USE; THREADS OF PLASTIC MATERIALS FOR TEXTILE USE; ELASTIC THREAD AND YARN FOR TEXTILE USE; POLYAMIDE YARNS AND THREADS FOR TEXTILE USE; SYNTHETIC YARNS FOR TEXTILE USE (U.S. CL. 43).

REBECCA POVARCHUK, EXAMINING ATTORNEY

SN 79-085,991. SKY CHAIN TRADING LIMITED, CHINA, FILED 6-11-2010.

# AMBROSIA

THE MARK CONSISTS OF STANDARD CHARACTERS WITHOUT CLAIM TO ANY PARTICULAR FONT, STYLE, SIZE, OR COLOR.

OWNER OF INTERNATIONAL REGISTRATION 1047489 DATED 6-11-2010, EXPIRES 6-11-2020.

**CLASS 8—HAND TOOLS**

FOR DOMESTIC AND KITCHEN UTENSILS, NAMELY, NUT CRACKERS, SUGAR TONGS, ICE TONGS, EGG SLICERS, CHEESE SLICERS, NON-ELECTRIC FRUIT AND VEGETABLE PEELERS, ICE PICKS AND OYSTER OPENERS; NON-ELECTRIC CAN OPENERS; TABLEWARE, FLATWARE AND CUTLERY, NAMELY, KNIVES, STEAK KNIVES, FORKS AND SPOONS; SCISSORS; KNIVES, NAMELY, CHEF KNIVES, CARVING KNIVES, PRUNING KNIVES, SERVING KNIVES, VEGETABLE KNIVES AND PARING KNIVES; PIZZA SLICES AND CUTTERS; HAND-OPERATED CHOPPERS AND CLEAVERS AND MORTAR AND PESTLES (U.S. CLS. 23, 28 AND 44).

**CLASS 21—HOUSEWARES AND GLASS**

FOR CONTAINERS FOR HOUSEHOLD OR KITCHEN USE; HOUSEHOLD OR KITCHEN UTENSILS, NAMELY, BOTTLE OPENERS, NON-ELECTRIC COFFEE GRINDERS, CHEESE GRATERS, COOKING GRATERS, CORK SCREWS, NON-ELECTRIC EGG BEATERS, NON-ELECTRIC FRUIT SQUEEZERS, GARLIC PRESSES, KITCHEN TONGS, POT AND PAN SCRAPERS, ROLLING PINS, SCOOPS, SKIMMERS, SPATULAS, TURNERS, VEGETABLE MASHERS AND WHISKS; KITCHENWARE, NAMELY, SPLATTER SCREENS, KITCHEN LADLES AND CHOPPING BOARDS FOR KITCHEN USE; DINERWARE AND COOKWARE, NAMELY, BASINS, CASEROLE DISHES, DUTCH OVENS, NON-ELECTRIC GRIDDLES, POTS AND PANS, NON-ELECTRIC PRESSURE COOKERS, ROASTING PANS, STEAMERS, FRYING PANS AND NON-ELECTRIC WOKS; SERVING WARE, NAMELY, CHEESE PLATES, PASTA SERVING FORKS, SERVING SPOONS, SERVING TONGS, SERVING FORKS, SERVING LADLES AND SERVING PLATTERS AND TRAYS; TABLEWARE, NAMELY, BOWLS, DISHES, DISH COVERS, PLATES AND SUGAR BOWLS; CANISTER SETS; CHEESE BOARD AND KNIFE SETS; CHEESE PLATES AND SERVING PLATTERS; NON-ELECTRIC COFFEE PERCOLATORS; NON-ELECTRIC COFFEE MAKERS AND COFFEE POTS; COOKING UTENSILS, NAMELY, COOKERY MOULDS, GRILL COVERS, WIRE BASKETS AND BATTER DISPENSER; COCKTAIL SHAKERS; CUPS, MUGS AND SAUCERS; CUTTING BOARDS; DECANTERS; DEWAR VESSELS OF METAL FOR MAKING ICES AND ICED DRINKS; DRINKING VESSELS; EGG POACHERS AND EGG SEPARATORS; FLASKS; GOBLETS; GLASSES, NAMELY, SHOT GLASSES, WINE GLASSES, DRINKING GLASSES AND TUMBLERS; ICE PAILS; JARS, NAMELY, GLASS JARS, COOKIE JARS AND INSULATING JARS; NON-ELECTRIC FRUIT AND/OR VEGETABLE JUICERS; JUGS; NON-ELECTRIC KETTLES; KNIFE RESTS; LAZY SUSANS; LIQUEUR SETS COMPRISED OF WINE GLASSES AND WINE OPENERS; LUNCH BOXES; NAPKIN HOLDERS AND NAPKIN RINGS; PIE SERVERS; PITCHERS; PORTABLE COOLERS; TABLE SERVING IMPLEMENTS, NAMELY, SERVING SPOONS, SERVING TONGS, SERVING FORKS, SERVING LADLES; SALT AND PEPPER GRINDERS; SALT AND PEPPER SHAKERS; SPICE SETS, NAMELY, SPICE RACKS; SPOONS FOR KITCHEN USE; STOPPERS, NAMELY, GLASS STOPPERS, VACUUM BOTTLE STOPPERS, DRAIN STOPPERS FOR SINKS AND DRAINS; STRAINERS; TEA POTS, INFUSERS AND STRAINERS; TEA SERVICES; TOOTHPICK HOLDERS FOR HOUSEHOLD PURPOSES; TRIVET; URNS; VASES; WAFFLE IRONS AND WINE TASTERS (U.S. CLS. 2, 13, 23, 29, 30, 33, 40 AND 50).

CHARISMA HAMPTON, EXAMINING ATTORNEY

SN 79-085,992. MARS DRINKS UK LTD., UNITED KINGDOM, FILED 5-10-2010.

# Hardworking Coffee

THE MARK CONSISTS OF STANDARD CHARACTERS WITHOUT CLAIM TO ANY PARTICULAR FONT, STYLE, SIZE, OR COLOR.

PRIORITY DATE OF 2-18-2010 IS CLAIMED.

OWNER OF INTERNATIONAL REGISTRATION 1047491 DATED 5-10-2010, EXPIRES 5-10-2020.

NO CLAIM IS MADE TO THE EXCLUSIVE RIGHT TO USE "COFFEE", APART FROM THE MARK AS SHOWN.

**CLASS 30—STAPLE FOODS**

FOR COFFEE, ESPRESSO; TEA, HERBAL TEA; COCOA, HOT CHOCOLATE; ARTIFICIAL COFFEE, COFFEE SUBSTITUTES, CHICORY AND CHICORY MIXTURES; MIXTURES OF COFFEE; WHOLE BEAN, GROUND AND ROASTED COFFEE; BEVERAGES, MIXES, EXTRACTS AND CONCENTRATES BASED ON COFFEE, ESPRESSO, TEA, HERBAL TEA, COCOA, CHOCOLATE, ARTIFICIAL COFFEE, COFFEE SUBSTITUTES AND CHICORY; FLAVORING SYRUPS AND POWDERS FOR BEVERAGES (U.S. CL. 46).

**CLASS 35—ADVERTISING AND BUSINESS**

FOR RETAIL STORE SERVICES, MAIL ORDER, CATALOG AND ONLINE RETAIL STORE SERVICES FEATURING COFFEE, ESPRESSO, TEA, HERBAL TEA, COCOA, ARTIFICIAL COFFEE, COFFEE SUBSTITUTES, CHICORY AND CHICORY MIXES, WHOLE BEAN, GROUND AND ROASTED COFFEE, BEVERAGES, MIXES, EXTRACTS AND CONCENTRATES BASED ON COFFEE, ESPRESSO, TEA, HERBAL TEA, COCOA, CHOCOLATE, ARTIFICIAL COFFEE, COFFEE SUBSTITUTES AND CHICORY, FOOD AND BEVERAGES, FLAVORING SYRUPS AND POWDERS FOR BEVERAGES, ELECTRIC AND NON-ELECTRIC COFFEE, ESPRESSO, TEA AND HOT CHOCOLATE BREWERS, MAKERS AND PREPARATION EQUIPMENT AND ACCESSORIES, BEVERAGE CUPS AND CONTAINERS (U.S. CLS. 100, 101 AND 102).

**CLASS 43—HOTEL AND RESTAURANT SERVICES**

FOR SERVICES FOR PROVIDING FOOD AND DRINK; RESTAURANT, CAFE, COFFEE SHOP, COFFEE BAR, TEA ROOM, CAFETERIA, CANTEEN, FAST FOOD, DELI, SNACK BAR, SELF-SERVICE RESTAURANT, CARRY-OUT RESTAURANT, DRIVE-THROUGH RESTAURANT SERVICES; CATERING SERVICES; FOOD AND BEVERAGE PREPARATION SERVICES; OFFICE AND INSTITUTIONAL COFFEE SUPPLY SERVICES (U.S. CLS. 100 AND 101).

SAMUEL E. SHARPER JR., EXAMINING ATTORNEY

SN 79-086,077. ADALBERTO GROSSI, ITALY, FILED 2-19-2010.

# HI-HEAD

THE MARK CONSISTS OF STANDARD CHARACTERS WITHOUT CLAIM TO ANY PARTICULAR FONT, STYLE, SIZE, OR COLOR.

OWNER OF INTERNATIONAL REGISTRATION 1047687 DATED 2-19-2010, EXPIRES 2-19-2020.

**CLASS 9—ELECTRICAL AND SCIENTIFIC APPARATUS**

FOR BATTERY CHARGERS; LOUDSPEAKERS; EARPHONES; IN-EAR MONITORS NOT FOR MEDICAL PURPOSES; CD PLAYERS; AND MP3 PLAYERS (U.S. CLS. 21, 23, 26, 36 AND 38).

**CLASS 25—CLOTHING**

FOR HATS DESIGNED WITH INTEGRAL HEARING-AID MOUNTS, SOLD WITHOUT HEARING AIDS (U.S. CLS. 22 AND 39).

ALICE BENMAMAN, EXAMINING ATTORNEY

SN 79-086,141. VATECH CO., LTD., GYEONGGI-DO, REPUBLIC OF KOREA, FILED 3-24-2010.

# Art'ncare

THE MARK CONSISTS OF STANDARD CHARACTERS WITHOUT CLAIM TO ANY PARTICULAR FONT, STYLE, SIZE, OR COLOR.

PRIORITY DATE OF 1-15-2010 IS CLAIMED.

OWNER OF INTERNATIONAL REGISTRATION 1047841 DATED 3-24-2010, EXPIRES 3-24-2020.

**CLASS 5—PHARMACEUTICALS**

FOR MATERIAL FOR TOOTH CROWNS AND TOOTH BRIDGES FOR DENTAL AND DENTAL TECHNICAL PURPOSES, NAMELY, DENTAL ZIRCONIA; DENTAL WAXES; ACRYLIC RESIN FOR RELINING DENTAL PROSTHESES; DENTAL RESINS FOR TEMPORARY BRIDGES, CROWNS AND VENEERS; DENTAL COMPOSITE RESIN (U.S. CLS. 6, 18, 44, 46, 51 AND 52).

**CLASS 7—MACHINERY**

FOR PROSTHETIC PROCESSING MACHINES AND APPARATUS FOR DENTAL PURPOSES, NAMELY, GRINDING MACHINES OR MILLING MACHINES FOR THE TREATMENT OF CERAMICS USED IN DENTAL PROSTHETICS (U.S. CLS. 13, 19, 21, 23, 31, 34 AND 35).

**CLASS 9—ELECTRICAL AND SCIENTIFIC APPARATUS**

FOR COMPUTER SOFTWARE FOR USE IN COMPUTER AIDED DESIGN AND COMPUTER AIDED MANUFACTURING FOR DENTAL PURPOSES; SCANNER FOR PRODUCTION OF DENTAL CROWNS AND BRIDGES (U.S. CLS. 21, 23, 26, 36 AND 38).

**CLASS 11—ENVIRONMENTAL CONTROL APPARATUS**

FOR MICROWAVE-FURNACE FOR PRODUCTION OF DENTAL CROWNS AND BRIDGES (U.S. CLS. 13, 21, 23, 31 AND 34).

JULIE VEPPUMTHARA, EXAMINING ATTORNEY

SN 79-086,145. RENAULT-SAMSUNG MOTORS CO., LTD., BUSAN, REPUBLIC OF KOREA, FILED 6-28-2010.

# RSM

THE MARK CONSISTS OF STANDARD CHARACTERS WITHOUT CLAIM TO ANY PARTICULAR FONT, STYLE, SIZE, OR COLOR.

OWNER OF INTERNATIONAL REGISTRATION 1047854 DATED 6-28-2010, EXPIRES 6-28-2020.



**CLASS 12—VEHICLES**

FOR AUTOMOBILES; AIR BAGS; WINDSCREEN WIPERS; ANTI-THEFT ALARMS FOR AUTOMOBILES; DOORS FOR VEHICLES; DIRECTION SIGNALS FOR VEHICLES; REARVIEW MIRRORS FOR AUTOMOBILES; BUMPERS FOR AUTOMOBILES; AUTOMOBILE BODIES; AUTOMOBILE CHASSIS; SKI CARRIERS FOR CARS; SEAT COVERS FOR AUTOMOBILES; VEHICLE WINDSCREENS; CAR SAFETY SEATS FOR CHILDREN; STEERING WHEELS FOR AUTOMOBILES; AUTOMOBILE SEATS; AUTOMOBILE RUNNING BOARDS; AUTOMOBILE WHEELS; SUN-BLINDS ADAPTED FOR AUTOMOBILES; AUTOMOBILE WINDOWS; AUTOMOBILE TIRE CHAINS; MUDGUARD FOR AUTOMOBILES; HEAD-RESTS FOR AUTOMOBILE SEATS; SAFETY BELTS FOR AUTOMOBILE SEATS; ELECTRIC CARS; SCOOTERS; BICYCLES; TIRES FOR VEHICLE WHEELS; SHOCK ABSORBERS FOR VEHICLES; BRAKES FOR VEHICLES; ENGINES FOR LAND VEHICLES; GEARS FOR LAND VEHICLES; TRANSMISSION CHAINS FOR LAND VEHICLES; TRANSMISSION SHAFTS FOR LAND VEHICLES; CLUTCHES FOR LAND VEHICLES; TORQUE CONVERTERS FOR LAND VEHICLES; TRANSMISSIONS, FOR LAND VEHICLES; MOTORS FOR LAND VEHICLES (U.S. CLS. 19, 21, 23, 31, 35 AND 44).

**CLASS 37—CONSTRUCTION AND REPAIR**

FOR MOTOR VEHICLE REPAIR; MOTOR VEHICLE MAINTENANCE; VEHICLE POLISHING; ANTI-RUST TREATMENT FOR VEHICLES; VEHICLE WASHING; VEHICLE CLEANING (U.S. CLS. 100, 103 AND 106).  
JAMES GRIFFIN, EXAMINING ATTORNEY

SN 79-086,331. SILFAB S.P.A., ITALY, FILED 4-19-2010.

# SILFAB

THE MARK CONSISTS OF STANDARD CHARACTERS WITHOUT CLAIM TO ANY PARTICULAR FONT, STYLE, SIZE, OR COLOR.

PRIORITY DATE OF 1-13-2010 IS CLAIMED.  
OWNER OF INTERNATIONAL REGISTRATION 1048370 DATED 4-19-2010, EXPIRES 4-19-2020.

THE WORDING "SILFAB" HAS NO MEANING IN A FOREIGN LANGUAGE.

**CLASS 1—CHEMICALS**

FOR CHEMICALS FOR USE IN INDUSTRY AND SCIENCE, NAMELY, SILICON, MONOCRYSTALLINE SILICON AND POLYSILICON; CHEMICALS USED IN THE MANUFACTURE OF PHOTOVOLTAIC CELLS, PHOTOVOLTAIC MODULES, PHOTOVOLTAIC PANELS; SILICON; SILICON FOR INDUSTRIAL USE, INCLUDING FOR USE IN SOLAR CELL TECHNOLOGY AND FOR MAKING SOLAR CELLS, SILICON WAFERS, SOLAR CELL MODULES AND SOLAR PANELS (U.S. CLS. 1, 5, 6, 10, 26 AND 46).

**CLASS 7—MACHINERY**

FOR MACHINES FOR ASSEMBLING, PROCESSING AND MANUFACTURING OF PHOTOVOLTAIC MODULES; SOLAR POWERED ELECTRICITY GENERATORS; SOLAR INSTALLATIONS FOR ENERGY GENERATION IN THE NATURE OF SOLAR-POWERED ELECTRICITY GENERATORS; SOLAR TRACKERS, NAMELY, MOTORS, GEARS AND DRIVES FOR ORIENTATING SOLAR PANELS AND STRUCTURAL PARTS THEREFOR; MACHINES, NAMELY, MACHINES FOR THE MANUFACTURE OF PHOTOVOLTAIC MODULES IN THE NATURE OF SOLAR CELLS AND SOLAR MODULES (U.S. CLS. 13, 19, 21, 23, 31, 34 AND 35).

**CLASS 9—ELECTRICAL AND SCIENTIFIC APPARATUS**

FOR PHOTOVOLTAIC CELLS; PHOTOVOLTAIC MODULES; APPARATUS FOR CONVERTING ELECTROMAGNETIC RADIATION INTO ELECTRICITY, NAMELY, PHOTOVOLTAIC CLADDING PANELS; APPARATUS FOR CONVERTING ELECTROMAGNETIC RADIATION TO ELECTRICAL ENERGY, NAMELY, PHOTOVOLTAIC SHEETS; SOLAR WAFERS FEATURING PURIFIED SILICON USED FOR TRANSFORMING ELECTROMAGNETIC RADIATION INTO ELECTRICITY; SOLAR WAFERS FEATURING MONO-CRYSTALLINE AND MULTI-CRYSTALLINE SILICON PHOTOVOLTAIC CELL MATERIAL FOR ELECTRICITY GENERATION; MULTI-CRYSTALLINE SILICON WAFERS, NAMELY, MULTI-CRYSTALLINE SILICON SLICES; MULTI-CRYSTALLINE AND MONO-CRYSTALLINE SILICON INGOTS; COMPUTER SOFTWARE AND PROGRAMS FOR CONTROLLING, REGULATING AND MONITORING OF PHOTOVOLTAIC MODULES AND SOLAR TRACKERS; SILICON SUBSTRATES IN THE NATURE OF SILICON WAFERS; SOLAR CELLS; MONO-CRYSTALLINE AND MULTI-CRYSTALLINE SILICON WAFERS; MONO-CRYSTALLINE AND MULTI-CRYSTALLINE SILICON SOLAR CELL MATERIAL FOR ELECTRICITY GENERATION IN THE NATURE OF SILICON WAFERS; SILICON WAFERS; ELECTRIC INVERTERS; ENERGY METERS FOR TRACKING AND MONITORING ENERGY USAGE (U.S. CLS. 21, 23, 26, 36 AND 38).

**CLASS 37—CONSTRUCTION AND REPAIR**

FOR REPAIR AND INSTALLATION OF PHOTOVOLTAIC CELLS, PHOTOVOLTAIC MODULES, PHOTOVOLTAIC PANELS, SOLAR PANELS, PARTS AND FITTINGS THEREOF IN THE NATURE OF PHOTOVOLTAIC PLANTS; MAINTENANCE IN THE NATURE OF REPAIR OF PHOTOVOLTAIC CELLS, PHOTOVOLTAIC MODULES, PHOTOVOLTAIC PANELS AND OF SOLAR PANELS (U.S. CLS. 100, 103 AND 106).

**CLASS 40—MATERIAL TREATMENT**

FOR TREATMENT AND PROCESSING OF SILICON; PRODUCTION OF ENERGY; PRODUCTION OF ELECTRIC ENERGY FROM PHOTOVOLTAIC CELLS AND RENEWABLE ENERGY SOURCES; PRODUCTION OF ENERGY, NAMELY, OPERATING ENERGY GENERATING INSTALLATIONS, IN PARTICULAR SOLAR INSTALLATIONS; PRODUCTION OF PHOTOVOLTAIC OR SOLAR ELECTRICAL ENERGY (U.S. CLS. 100, 103 AND 106).

**CLASS 42—SCIENTIFIC AND COMPUTER SERVICES**

FOR DESIGN OF PHOTOVOLTAIC CELLS, PHOTOVOLTAIC MODULES, PHOTOVOLTAIC PANELS AND SOLAR PANELS; DRAFTING AND DEVELOPMENT OF PHOTOVOLTAIC CELLS, PHOTOVOLTAIC MODULES, PHOTOVOLTAIC PANELS AND SOLAR PANELS; QUALITY EVALUATION FOR OTHERS IN THE FIELD OF MAINTENANCE, REPAIR AND INSTALLATION OF PHOTOVOLTAIC CELLS, PHOTOVOLTAIC MODULES, PHOTOVOLTAIC PANELS AND SOLAR PANELS; TECHNICAL PLANNING OF PHOTOVOLTAIC CELLS, PHOTOVOLTAIC MODULES, PHOTOVOLTAIC PANELS AND SOLAR PANELS; TECHNOLOGY PLANNING AND CONSULTING IN THE FIELD OF SOLAR ENERGY AND RENEWABLE ENERGY SPECIFICALLY SPECIALIZING IN SUBSTRATES PRIMARILY OF POLYSILICON FOR ELECTRICAL OR THERMAL INSULATION OF PHOTOVOLTAIC CELLS, PHOTOVOLTAIC MODULES, PHOTOVOLTAIC PANELS AND SOLAR PANELS; SCIENTIFIC RESEARCH AND DEVELOPMENT IN THE FIELD OF ELECTRICAL ENGINEERING, PRODUCTION OF ELECTRIC, SOLAR, HYDROELECTRIC, THERMAL AND RENEWABLE ENERGIES; ENGINEERING STUDIES, RESEARCH AND EXPERT REPORTS IN THE FIELD OF ENERGY; MATERIAL TESTING (U.S. CLS. 100 AND 101).

KRISTINA MORRIS, EXAMINING ATTORNEY

SN 79-086,454. DAMART-SERVIPOSTE, F-59100 ROUBAIX, FRANCE, FILED 5-6-2010.

SN 79-086,475. EDATAUNITED GMBH, FED REP GERMANY, FILED 4-15-2010.



# docusuite

PRIORITY DATE OF 11-16-2009 IS CLAIMED.  
OWNER OF INTERNATIONAL REGISTRATION 1048659 DATED 5-6-2010, EXPIRES 5-6-2020.  
OWNER OF U.S. REG. NOS. 694,627, 694,970 AND 2,451,062.

THE COLOR(S) RED IS/ARE CLAIMED AS A FEATURE OF THE MARK.

THE MARK CONSISTS OF THE FOLLOWING: THE WORDING "THERMOLACTYL" IN RED POLYGON CARRIER. IN THE BACKGROUND OF THE CARRIER IS THE OUTLINE OF A RECTANGLE IN RED. IN THE LOWER PORTION OF THE RECTANGLE, THE WORDING "EVOLUTION" APPEARS IN RED. THE WHITE DEPICTED IN THE MARK IS NOT CLAIMED AS A FEATURE OF THE MARK AND IS USED TO INDICATE BACKGROUND.

#### CLASS 22—CORDAGE AND FIBERS

FOR PADDING AND STUFFING MATERIALS EXCEPT OF RUBBER, PLASTICS OR PAPER; RAW FIBROUS TEXTILE; PACKING CUSHIONING AND STUFFING MATERIALS, NOT OF RUBBER, PLASTICS OR PAPER; TEXTILE FIBERS; BAGS IN THE NATURE OF ENVELOPES AND POUCHES MADE OF TEXTILE MATERIAL FOR PACKAGING PURPOSES (U.S. CLS. 1, 2, 7, 19, 22, 42 AND 50).

#### CLASS 24—FABRICS

FOR FABRICS FOR TEXTILE USE; TEXTILE FABRICS FOR USE IN MAKING CLOTHING AND HOUSEHOLD FURNISHINGS; DENIM FABRIC, COTTON FABRIC, LINEN, SYNTHETIC FIBER FABRICS, FLAX FABRICS, HEMP-BASE MIXED FABRICS, KNITTED FABRICS, LINGERIE FABRIC, MIXED-FIBER FABRICS, PILED FABRIC, RAMIE FABRIC, WOOLEN FABRIC, FURNISHING AND UPHOLSTERY FABRICS, BED COVERS; TABLE COVERS, NOT OF PAPER; ELASTIC WOVEN MATERIAL, NAMELY, ELASTIC THREAD, VELVET; BED LINEN; HOUSEHOLD LINEN; TABLE LINEN, NOT OF PAPER; BATH LINEN, EXCEPT CLOTHING; LINING FABRIC FOR SHOES; FABRIC FOR BOOTS AND SHOES; TOWELS OF TEXTILE; MATTRESS COVERS; LOOSE COVERS OF FABRIC FOR FURNITURE; COTTON CLOTH, BILLIARD CLOTH, BOLTING CLOTH, CREPE CLOTH, FACE CLOTHS, FELT CLOTH, FLAX CLOTH, GUMMED WATERPROOF CLOTH, HEMP CLOTH, JUTE CLOTH, LINEN CLOTH, OIL CLOTHS, PRAYER CLOTH, RUBBERIZED CLOTH, SAIL CLOTH, SILK CLOTH, WOOLEN CLOTH (U.S. CLS. 42 AND 50).

#### CLASS 25—CLOTHING

FOR CLOTHING, NAMELY, SHIRTS, BELTS, GLOVES, FOULARDS, WIMPLES, HOSIERY, SOCKS, UNDERWEAR, SKIRTS, BOTTOMS, DUSTERS, EYE-SHADES, HOODS, JACKETS, JERSEYS, MANTLES, MUFFLERS, POCKET SQUARES, SHIFTS, SHORT SETS, SHOULDER WRAPS, TIES, TOPS, TEDDIES, BLOUSES, SHAWLS, SCARVES, JUMPERS, COATS, LAYETTES, PYJAMAS, SINGLETS, MUFFS, PANTS, DRESSING GOWNS, DRESSES, SWEATERS, PULLOVERS, DRESS SUITS, MEN'S SUITS, LADIES' SUITS, NIGHT DRESSES; GIRDLES; FOOTWEAR; HEADGEAR FOR WEAR, NAMELY, HATS, CAPS, SWIM CAPS, BERETS, CAP PEAKS, HOODS; BABIES' DIAPERS OF TEXTILE (U.S. CLS. 22 AND 39).

MARILYN IZZI, EXAMINING ATTORNEY

THE MARK CONSISTS OF STANDARD CHARACTERS WITHOUT CLAIM TO ANY PARTICULAR FONT, STYLE, SIZE, OR COLOR.

PRIORITY DATE OF 11-19-2009 IS CLAIMED.  
OWNER OF INTERNATIONAL REGISTRATION 1048727 DATED 4-15-2010, EXPIRES 4-15-2020.

#### CLASS 9—ELECTRICAL AND SCIENTIFIC APPARATUS

FOR RECORDED COMPUTER PROGRAMS FOR COLLECTING AND TRACKING PRINT JOBS AND ANALYZING ASSOCIATED COSTS (U.S. CLS. 21, 23, 26, 36 AND 38).

#### CLASS 35—ADVERTISING AND BUSINESS

FOR PERSONNEL MANAGEMENT SERVICES, NAMELY, DEVELOPING OF PERSONNEL MANAGEMENT CONCEPTS; PROVIDING EXPERT STAFF, NAMELY, PERSONNEL RECRUITMENT AND TEMPORARY PERSONNEL SERVICES; PERSONNEL SERVICES, NAMELY, PERSONNEL MANAGEMENT; TEMPORARY EMPLOYMENT AGENCIES; EMPLOYMENT AGENCY SERVICES; EMPLOYEE LEASING; PERSONNEL MANAGEMENT CONSULTING; PROVIDING EMPLOYERS WITH TEMPORARY EMPLOYEES; BUSINESS ORGANIZATION AND MANAGEMENT CONSULTING; PROFESSIONAL BUSINESS ORGANIZATION CONSULTING; EFFICIENCY EXPERTS; COMMERCIAL OR INDUSTRIAL MANAGEMENT ASSISTANCE; MARKETING RESEARCH SERVICES; ORGANIZATIONAL PROJECT MANAGEMENT FOR BUSINESS PURPOSES IN THE FIELD OF DATA PROCESSING; PLANNING AND MONITORING OF BUSINESS DEVELOPMENTS WITH REGARD TO ORGANIZATIONAL MATTERS; SYSTEMIZATION OF INFORMATION INTO COMPUTER DATABASES; BUSINESS APPRAISALS; COMPILATION OF INFORMATION INTO COMPUTER DATABASES (U.S. CLS. 100, 101 AND 102).

#### CLASS 38—COMMUNICATION

FOR PROVIDING USER ACCESS TO COMPUTER PROGRAMS IN DATA NETWORKS (U.S. CLS. 100, 101 AND 104).

#### CLASS 42—SCIENTIFIC AND COMPUTER SERVICES

FOR COMPUTER SOFTWARE DEVELOPMENT; COMPUTER PROGRAMMING SERVICES; COMPUTER PROGRAMMING; RESEARCH AND DEVELOPMENT FOR NEW PRODUCTS FOR OTHERS; PROGRAMMING OF COMPUTER ANIMATIONS, COMPUTER HARDWARE AND SOFTWARE CONSULTING; IMPLEMENTATION OF COMPUTER SOFTWARE INTO NETWORKS; INSTALLATION OF COMPUTER SOFTWARE; MAINTENANCE AND INSTALLATION OF COMPUTER SOFTWARE; ENGINEERING SERVICES, NAMELY, TECHNICAL PROJECT PLANNING FOR THE PROCESSING OF WEB PRODUCTS; TECHNICAL COMPUTER PROJECT MANAGEMENT IN THE FIELD OF DATA PROCESSING (U.S. CLS. 100 AND 101).

MAYUR VAGHANI, EXAMINING ATTORNEY

SN 79-086,519. BLOCKMASTER AB, SWEDEN, FILED 6-16-2010.

# BLOCKMASTER

THE MARK CONSISTS OF STANDARD CHARACTERS WITHOUT CLAIM TO ANY PARTICULAR FONT, STYLE, SIZE, OR COLOR.

PRIORITY DATE OF 12-16-2009 IS CLAIMED.

OWNER OF INTERNATIONAL REGISTRATION 1048860 DATED 6-16-2010, EXPIRES 6-16-2020.

## CLASS 9—ELECTRICAL AND SCIENTIFIC APPARATUS

FOR COMPUTER SECURITY SOFTWARE; COMPUTER MEMORIES; PORTABLE DATA MEMORY UNITS, NAMELY, FLASH DRIVES, USB-MEMORY DRIVES, EXTERNAL COMPUTER HARD DRIVES; BLANK MAGNETIC AND OPTICAL DATA CARRIERS; COMPUTER SOFTWARE FOR MANAGEMENT OF FLASH DRIVES, USB-MEMORY DRIVES, EXTERNAL HARD DRIVES AND FOR MANAGEMENT OF CONTENT AND FEATURES ON SUCH DRIVES; COMPUTER SOFTWARE FOR ENCRYPTION, FOR USE IN THE SAFEGUARDING OF DIGITAL FILES, FOR CREATING SEARCHABLE DATABASES OF INFORMATION AND DATA, FOR USE IN COMPUTER MEMORIES AND PORTABLE INFORMATION STORAGE DEVICE (U.S. CLS. 21, 23, 26, 36 AND 38).

## CLASS 42—SCIENTIFIC AND COMPUTER SERVICES

FOR CONSULTANCY WITH REGARD TO COMPUTER SECURITY AND COMPUTER DATA SECURITY; DESIGN AND DEVELOPMENT OF COMPUTER HARDWARE AND SOFTWARE; COMPUTER PROGRAMMING; COMPUTER HARDWARE AND SOFTWARE CONSULTANCY SERVICES (U.S. CLS. 100 AND 101).  
WILLIAM ROSSMAN, EXAMINING ATTORNEY

SN 79-086,558. PAULINE, FRANCE, FILED 5-26-2010.

# PATRICE BREAL

THE MARK CONSISTS OF STANDARD CHARACTERS WITHOUT CLAIM TO ANY PARTICULAR FONT, STYLE, SIZE, OR COLOR.

PRIORITY DATE OF 11-26-2009 IS CLAIMED.

OWNER OF INTERNATIONAL REGISTRATION 1048958 DATED 5-26-2010, EXPIRES 5-26-2020.

THE NAME(S), PORTRAIT(S), AND/OR SIGNATURE(S) SHOWN IN THE MARK DOES NOT IDENTIFY A PARTICULAR LIVING INDIVIDUAL.

## CLASS 14—JEWELRY

FOR PRECIOUS METALS AND THEIR ALLOYS OTHER THAN FOR DENTAL USE, JEWELRY, PRECIOUS STONES, TIMEPIECES AND CHRONOMETRIC INSTRUMENTS; WATCHES, WATCH CASES, WATCH STRAPS, ALARM CLOCKS, CLOCKS; JEWELRY, NAMELY, RINGS, EARRINGS, BRACELETS, JEWELRY, NAMELY, BROOCHES, NECKLACES, COSTUME JEWELRY, CHARMS, TIE CLIPS, TIE PINS, JEWELRY CASES OF PRECIOUS METAL; BOXES OF PRECIOUS METAL; JEWELRY CASKETS OF PRECIOUS METAL; STATUES OF PRECIOUS METAL (U.S. CLS. 2, 27, 28 AND 50).

## CLASS 18—LEATHER GOODS

FOR LEATHER AND IMITATION LEATHER AND GOODS MADE OF THESE MATERIALS NOT INCLUDED IN OTHER CLASSES, NAMELY, TRAVEL CHESTS, BAGS, TRAVEL BAGS AND TRAVEL CASES, UNFITTED VANITY CASES, TRUNKS, ATTACHE CASES, SCHOOL BAGS, BRIEFCASES AND SUITCASES, VALISES, BUSINESS CARD CASES, CREDIT CARD CASES, PURSES AND POCKET WALLETS NOT OF PRECIOUS MATERIALS, RUCKSACKS, HANDBAGS; UMBRELLAS, PARASOLS, SUNSHADE PARASOLS AND WALKING STICKS; WHIPS, HARNESSES AND SADDLERY; KEY CASES OF LEATHER; SCHOOL BAGS; BEACH BAGS; CANVAS SHOPPING BAGS, MESH SHOPPING BAGS, TEXTILE SHIPPING BAGS, LEATHER SHOPPING BAGS, REUSABLE SHOPPING BAGS AND SHOPPING BAGS MADE OF SKIN; WHEELED SHOPPING BAGS; TRAVEL CASES FOR CARRYING CLOTHES; SPORTS BAGS OTHER THAN THOSE ADAPTED FOR THEIR CONTENTS; BOXES OF LEATHER OR IMITATION LEATHER; THONGS OF LEATHER OR IMITATION LEATHER; BANDS OF LEATHER OR IMITATION LEATHER OR LEATHERBOARD; COLLARS FOR ANIMALS OF LEATHER OR IMITATION LEATHER; CLOTHING FOR PETS; LEATHER LEASHES; MUZZLE; ANIMAL SKINS (U.S. CLS. 1, 2, 3, 22 AND 41).

## CLASS 25—CLOTHING

FOR CLOTHING, CLOTHING FOR MEN, CLOTHING FOR WOMEN, AND CLOTHING FOR CHILDREN, NAMELY, BERMUDA SHORTS, SHORTS, BOXER SHORTS, SWEATERS, CARDIGANS, DRESS SHIRTS, UNDERSHIRTS, JACKETS, COATS, STUFF JACKETS, LINGERIE, STOCKINGS, MUFFS, SHAWLS, PONCHOS, BODY LINEN, BODY LINGERIE, FOOTWEAR, SUITS, CLOTHING, NAMELY, COMBINATIONS; CLOTHING OF LEATHER OR IMITATION LEATHER, NAMELY, COATS, T-SHIRTS, DRESS SHIRTS, TROUSERS, JACKETS, BERMUDA SHORTS; FROCKS, SKIRTS, PETTI-COATS, TROUSERS, BERMUDA SHORTS, SHORTS; SHIRTS, CHEMISETTES, OVERALLS, SINGLET, TEE-SHIRTS, TANK TOPS; WAISTCOATS, SWEATERS, PULLOVERS, KNITWEAR, NAMELY, JACKETS, PULLOVERS, DRESSES, SKIRTS, SHIRTS, BERMUDA SHORTS, AND JACKETS, GABARDINE CLOTHING, NAMELY, RAINCOATS, WATERPROOF CLOTHING, NAMELY, COATS, OVERCOATS, PARKAS, STUFF JACKETS, AND JUMPERS, SPORTSWEAR, NAMELY, SPORTS JACKETS, SPORTS FOOTWEAR, NOT ORTHOPEDIC, CYCLING SHORTS; BATHING CAPS, BATHING TRUNKS, BATHING SUITS, BATH ROBES, BATH SANDALS, BATH SLIPPERS; PAJAMAS, NIGHTGOWNS, DRESSING GOWNS, SUSPENDERS, CLOTHING, NAMELY, BELTS, SOCKS, TIGHTS; COLLAR PROTECTORS, CLOTHING, NAMELY, SASHES, FOULARDS, FURS, NAMELY, FUR CLOAKS, FUR COATS AND JACKETS, FUR HATS, FUR MUFFS, FUR STOLES, AND FUR GLOVES, MUFFS, MITTENS, CLOTHING, NAMELY, GLOVES; SHAWLS, PONCHOS; UNDERWEAR, BODY WEAR, NAMELY, SHORTS, SHIRTS, LINGERIE, UNDERGARMENTS, PANTS, BREECHES FOR CLOTHING, UNDERGARMENTS, NAMELY, SLIPS, UNDERGARMENTS, NAMELY, TEDDIES, CROP TOPS, UNDERPANTS, BRASSIERES; LAYETTES; HEADGEAR, NAMELY, CAPS, HATS; HEADBANDS FOR CLOTHING, BERETS, HEAD COVERINGS, NAMELY, TURBANS, HEAD SCARVES, HEAD SWEATBANDS, CAPS, HATS, EAR MUFFS, HOODS, CAP PEAKS; FOOTWEAR EXCLUDING ORTHOPEDIC FOOTWEAR; SANDALS, BOOTS, ESPADRILLES, SLIPPERS, BED-ROOM SLIPPERS (U.S. CLS. 22 AND 39).

KARANENDRA S. CHHINA, EXAMINING ATTORNEY

SN 79-086,638, EVERSTONE CAPITAL ASIA PTE. LTD., SINGAPORE, FILED 8-6-2010.

# INDIVISION

THE MARK CONSISTS OF STANDARD CHARACTERS WITHOUT CLAIM TO ANY PARTICULAR FONT, STYLE, SIZE, OR COLOR.

PRIORITY DATE OF 2-9-2010 IS CLAIMED. OWNER OF INTERNATIONAL REGISTRATION 1049161 DATED 8-6-2010, EXPIRES 8-6-2020.

## CLASS 35—ADVERTISING AND BUSINESS

FOR ACCOUNTING; BOOK-KEEPING; BUSINESS APPRAISALS; BUSINESS MANAGEMENT ASSISTANCE; BUSINESS MANAGEMENT CONSULTANCY; BUSINESS RESEARCH; PROFESSIONAL BUSINESS CONSULTANCY (U.S. CLS. 100, 101 AND 102).

## CLASS 36—INSURANCE AND FINANCIAL

FOR FINANCIAL CONSULTING SERVICES, NAMELY, INVESTMENT ADVICE, INVESTMENT MANAGEMENT, INVESTMENT CONSULTATION, MANAGEMENT OF PRIVATE EQUITY FUNDS, FINANCIAL INVESTMENT ANALYSIS AND STOCK RESEARCH AND INVESTMENT OF FUNDS FOR OTHERS; FINANCIAL SPONSORSHIP OF FINANCIAL SEMINARS, EDUCATIONAL EVENTS, CONFERENCES, ATHLETIC GAMES AND EVENTS, PARKS AND RECREATIONAL FACILITIES, PUBLIC WORKS PROJECTS, CULTURAL EVENTS, ART EXHIBITIONS, TELEVISION PROGRAMS AND RADIO PROGRAMS; FINANCING SERVICES; REAL ESTATE APPRAISAL (U.S. CLS. 100, 101 AND 102).  
H. M. FISHER, EXAMINING ATTORNEY

SN 79-086,641, ENZYMPRO AG, APPENZELL, SWITZERLAND, FILED 7-7-2010.

# ENZYMPRO

THE MARK CONSISTS OF STANDARD CHARACTERS WITHOUT CLAIM TO ANY PARTICULAR FONT, STYLE, SIZE, OR COLOR.

OWNER OF INTERNATIONAL REGISTRATION 1049174 DATED 7-7-2010, EXPIRES 7-7-2020.

## CLASS 3—COSMETICS AND CLEANING PREPARATIONS

FOR BODY-CARE PRODUCTS AND COSMETIC PRODUCTS, NAMELY, BODY LOTION, BODY DEODORANTS, BODY OILS, SOAPS FOR BODY CARE, AND COSMETICS; SUBSTANCES FOR LAUNDRY USE, NAMELY, LAUNDRY BLEACH, LAUNDRY DETERGENT, AND LAUNDRY SOAP; HAIR LOTIONS; CLEANING, POLISHING, SCOURING AND ABRASIVE PREPARATIONS; SOAP; PERFUMERY, ESSENTIAL OILS; AND DENTIFRICES (U.S. CLS. 1, 4, 6, 50, 51 AND 52).

## CLASS 5—PHARMACEUTICALS

FOR PREPARATIONS FOR THE CARE OF HEALTH, NAMELY, HEALTH FOOD SUPPLEMENTS, NUTRITIONAL SUPPLEMENTS FOR BOOSTING ENERGY AND DECREASING VITAMIN DEFICIENCIES; DIETETIC BEVERAGES AND FOODS ADAPTED FOR MEDICAL USE; FOOD FOR BABIES; MINERAL FOOD-SUPPLEMENTS; FOOD SUPPLEMENTS MADE WITH AMINO ACIDS; FOOD SUPPLEMENTS MADE WITH MINERALS; FOOD SUPPLEMENTS MADE WITH TRACE ELEMENTS; FOOD SUPPLEMENTS FOR MEDICAL PURPOSES; VITAMIN PREPARATIONS; AND FOOD SUPPLEMENTS BASED ON VITAMINS (U.S. CLS. 6, 18, 44, 46, 51 AND 52).

## CLASS 29—MEATS AND PROCESSED FOODS

FOR DIETETIC SUBSTANCES OR FOOD SUPPLEMENTS NOT FOR MEDICAL PURPOSES MADE WITH PROTEINS, FATS, FATTY ACIDS, ADDED VITAMINS, MINERAL SUBSTANCES, TRACE ELEMENTS, EITHER ALONE OR IN COMBINATIONS, NAMELY, ALBUMEN FOR USE IN FOOD, ALMOND SKINS, MILK PROTEINS, MILK POWDER FOR NUTRITIONAL PURPOSES, NUTRITIONAL OILS FOR FOOD PURPOSES, MILK PRODUCTS EXCLUDING ICE CREAM, ICE MILK AND FROZEN YOGURT, MEAT, FISH, POULTRY AND GAME; MEAT EXTRACTS; PRESERVED, DRIED AND COOKED FRUIT AND VEGETABLES; JELLIES; JAMS, COMPOTES; EGGS, MILK; EDIBLE OILS AND FATS (U.S. CL. 46).

## CLASS 30—STAPLE FOODS

FOR DIETETIC SUBSTANCES OR FOOD SUPPLEMENTS NOT FOR MEDICAL PURPOSES MADE WITH CARBOHYDRATES, DIETARY FIBER, ADDED VITAMINS, MINERAL SUBSTANCES, TRACE ELEMENTS, EITHER ALONE OR IN COMBINATIONS, NAMELY, CHOCOLATES CONTAINING NUTRIENTS, GRANOLA-BASED SNACK BARS, CHOCOLATE-BASED READY-TO-EAT FOOD BARS; PREPARATIONS MADE FROM CEREALS, NAMELY, ENERGY BARS; CONFECTIONERY MADE OF SUGAR; FROZEN CONFECTIONERY; CHOCOLATE GOODS, NAMELY, CHOCOLATE CHIPS, CHOCOLATE FONDUE, CHOCOLATE MOUSSE, CHOCOLATE SAUCE, CHOCOLATE SYRUP, AND HOT CHOCOLATE; SAUCES, COFFEE, TEA, COCOA, SUGAR, RICE, TAPIOCA, SAGO, ARTIFICIAL COFFEE; FLOURS; BREAD, PASTRY; EDIBLE ICES; CHOCOLATES; HONEY, TREACLE; YEAST, BAKING-POWDER; SALT, MUSTARD; VINEGAR, SPICES; AND ICE FOR REFRESHMENT (U.S. CL. 46).

## CLASS 44—MEDICAL, BEAUTY AND AGRICULTURAL SERVICES

FOR MEDICAL SERVICES; VETERINARY SERVICES; HYGIENIC AND BEAUTY CARE FOR HUMAN BEINGS OR ANIMALS (U.S. CLS. 100 AND 101).  
ADA HAN, EXAMINING ATTORNEY

SN 79-086,665, BOUD VAN ROMPAY, UNITED STATES, FILED 8-19-2010.



PRIORITY DATE OF 8-5-2010 IS CLAIMED.  
OWNER OF INTERNATIONAL REGISTRATION 1049252 DATED 8-19-2010, EXPIRES 8-19-2020.  
OWNER OF U.S. REG. NO. 1,531,280.  
THE COLOR(S) BLACK, WHITE AND BLUE IS/ARE CLAIMED AS A FEATURE OF THE MARK.

THE MARK CONSISTS OF THE WORD "HYDREX" WITH THREE DIMENSIONAL LETTERS AND SHADOWING. WAVE-LIKE RIPPLES APPEAR ACROSS THE BOTTOM HALF OF EACH LETTER. THE WAVES APPEAR IN BLUE WITH WHITE STRIPES. THE WORDING APPEARS IN WHITE WITH BLACK SHADOWING.

#### CLASS 2—PAINTS

FOR PAINTS, VARNISHES, LACQUERS; PRESERVATIVES AGAINST RUST AND AGAINST DETERIORATION OF WOOD; DYESTUFFS; MORDANTS FOR USE ON BOATS, PIPES, PIPE-LINES, OIL PLATFORMS; RAW NATURAL RESINS; METALS IN FOIL AND POWDER FORM FOR PAINTERS, DECORATORS, PRINTERS AND ARTISTS (U.S. CLS. 6, 11 AND 16).

#### CLASS 37—CONSTRUCTION AND REPAIR

FOR BOAT REPAIR AND MAINTENANCE (U.S. CLS. 100, 103 AND 106).

#### CLASS 40—MATERIAL TREATMENT

FOR UNDERWATER TREATMENT AND FORMING OF BOATS, NAMELY, WEATHERPROOFING AND WATERPROOFING OF WOOD, PLASTIC, AND ACRYLIC (U.S. CLS. 100, 103 AND 106).

ARETHA SOMERVILLE, EXAMINING ATTORNEY

SN 79-086,792. DR. ING. H.C. F. PORSCHE AKTIENGESELLSCHAFT, FED REP GERMANY, FILED 6-30-2010.

# ROADSTER

THE MARK CONSISTS OF STANDARD CHARACTERS WITHOUT CLAIM TO ANY PARTICULAR FONT, STYLE, SIZE, OR COLOR.

OWNER OF INTERNATIONAL REGISTRATION 0673355 DATED 5-23-1997, EXPIRES 5-23-2017.

OWNER OF U.S. REG. NOS. 3,334,523, 3,799,645 AND OTHERS.

#### CLASS 3—COSMETICS AND CLEANING PREPARATIONS

FOR PERFUMERY, COSMETICS (U.S. CLS. 1, 4, 6, 50, 51 AND 52).

#### CLASS 25—CLOTHING

FOR CLOTHING, NAMELY, ANORAKS, BEACHWEAR, BLAZERS, BLOUSES, BLOUSONS, BODY SUITS, CARDIGANS, COATS, DRESSES, FOUL WEATHER GEAR, INFANT WEAR, JACKETS, JEANS, JOGGING SUITS, LEATHER COATS, LEATHER JACKETS, OVERALLS, PANTS, PARKAS, POLO SHIRTS, SCARVES, SHIRTS, SHORTS, SKI WEAR, SKIRTS, SLACKS, SLEEPWEAR, SNOW SUITS, SOCKS, SUITS, SWEATSHIRTS, SWEATERS, T-SHIRTS, TENNIS WEAR, NECKTIES, TIGHTS, TOPS, TRACKSUITS, TROUSERS, UNDERWEAR, VESTS, WRIST BANDS, FOOTWEAR; HEADGEAR, NAMELY, HATS, CAPS, SUN VISORS AND SWEAT BANDS; GLOVES AS CLOTHING AND BELTS AS CLOTHING (U.S. CLS. 22 AND 39).

#### CLASS 28—TOYS AND SPORTING GOODS

FOR SPORTING GOODS, NAMELY, TENNIS RACKETS, GOLF BAGS, SKIS, SNOWBOARDS, SKATEBOARDS, INLINE SKATES, JUMP ROPES, GOLF CLUBS, GOLF BALLS, GOLF GLOVES, GOLF ACCESSORY POUCHES, HEAD COVERS FOR GOLF CLUBS, GOLF PUTTERS, GOLF DRIVERS (U.S. CLS. 22, 23, 38 AND 50).

JOHN DALIER, EXAMINING ATTORNEY

SN 79-086,916. C. C. & C. - CORALLO CACAU & CAFÉ, LDA, PORTUGAL, FILED 7-28-2010.

# CLAUDIO CORALLO

THE MARK CONSISTS OF STANDARD CHARACTERS WITHOUT CLAIM TO ANY PARTICULAR FONT, STYLE, SIZE, OR COLOR.

OWNER OF INTERNATIONAL REGISTRATION 1049880 DATED 7-28-2010, EXPIRES 7-28-2020.

THE NAME(S), PORTRAIT(S), AND/OR SIGNATURE(S) SHOWN IN THE MARK IDENTIFIES A SPECIFIC LIVING INDIVIDUAL, WHOSE CONSENT(S) TO REGISTER IS MADE OF RECORD.

#### CLASS 30—STAPLE FOODS

FOR COCOA, CHOCOLATE, COFFEE, SWEETMEATS, SHERBETS (U.S. CL. 46).

#### CLASS 35—ADVERTISING AND BUSINESS

FOR ADVERTISING SERVICES, BUSINESS MANAGEMENT, PROVIDING OFFICE FUNCTIONS, ACCOUNTING SERVICES (U.S. CLS. 100, 101 AND 102).

#### CLASS 43—HOTEL AND RESTAURANT SERVICES

FOR PROVIDING FOOD AND DRINK; AGENCY SERVICES FOR THE RESERVATION OF TEMPORARY ACCOMMODATION (U.S. CLS. 100 AND 101).

LINDA ORNDORFF, EXAMINING ATTORNEY

SN 79-086,968. EVERSTONE CAPITAL ASIA PTE. LTD., SINGAPORE, FILED 8-6-2010.

# EVERSTONE

THE MARK CONSISTS OF STANDARD CHARACTERS WITHOUT CLAIM TO ANY PARTICULAR FONT, STYLE, SIZE, OR COLOR.

PRIORITY DATE OF 2-9-2010 IS CLAIMED.

OWNER OF INTERNATIONAL REGISTRATION 1050062 DATED 8-6-2010, EXPIRES 8-6-2020.

#### CLASS 35—ADVERTISING AND BUSINESS

FOR ACCOUNTING; BOOK-KEEPING; BUSINESS APPRAISALS; BUSINESS MANAGEMENT ASSISTANCE; BUSINESS MANAGEMENT CONSULTANCY; BUSINESS RESEARCH; PROFESSIONAL BUSINESS CONSULTANCY (U.S. CLS. 100, 101 AND 102).

**CLASS 36—INSURANCE AND FINANCIAL**

FOR FINANCIAL CONSULTING SERVICES, NAMELY, INVESTMENT ADVICE, INVESTMENT MANAGEMENT, INVESTMENT CONSULTATION, MANAGEMENT OF PRIVATE EQUITY FUNDS, FINANCIAL INVESTMENT ANALYSIS AND STOCK RESEARCH AND INVESTMENT OF FUNDS FOR OTHERS; FINANCIAL SPONSORSHIP OF FINANCIAL SEMINARS, EDUCATIONAL EVENTS, CONFERENCES, ATHLETIC GAMES AND EVENTS, PARKS AND RECREATIONAL FACILITIES, PUBLIC WORKS PROJECTS, CULTURAL EVENTS, ART EXHIBITIONS, TELEVISION PROGRAMS AND RADIO PROGRAMS; FINANCING SERVICES; REAL ESTATE APPRAISAL (U.S. CLS. 100, 101 AND 102).  
H. M. FISHER, EXAMINING ATTORNEY

SN 79-087,569. NEUF, FRANCE, FILED 6-22-2010.

**MARTIN MARGIELA**

THE MARK CONSISTS OF STANDARD CHARACTERS WITHOUT CLAIM TO ANY PARTICULAR FONT, STYLE, SIZE, OR COLOR.

OWNER OF INTERNATIONAL REGISTRATION 1051735 DATED 6-22-2010, EXPIRES 6-22-2020.

OWNER OF U.S. REG. NOS. 2,947,676 AND 3,512,768.

THE NAME "MARTIN MARGIELA" IDENTIFIES A LIVING INDIVIDUAL WHOSE CONSENT IS OF RECORD.

**CLASS 11—ENVIRONMENTAL CONTROL APPARATUS**

FOR LIGHTING FIXTURES, LAMPS, STREET LAMPS, LAMP SHADES, CHANDELIERS, STEAM GENERATING INSTALLATIONS, APPARATUS FOR COOKING, NAMELY, COOKTOPS, CLOTHES DRYING MACHINES (U.S. CLS. 13, 21, 23, 31 AND 34).

SN 79-086,996. RENOLIT AG, FED REP GERMANY, FILED 4-28-2010.

**RENOLIT COVAREN**

THE MARK CONSISTS OF STANDARD CHARACTERS WITHOUT CLAIM TO ANY PARTICULAR FONT, STYLE, SIZE, OR COLOR.

PRIORITY DATE OF 11-2-2009 IS CLAIMED.

OWNER OF INTERNATIONAL REGISTRATION 1050134 DATED 4-28-2010, EXPIRES 4-28-2020.

OWNER OF U.S. REG. NOS. 3,382,046, 3,654,810 AND OTHERS.

THE WORDING "RENOLIT COVAREN" HAS NO MEANING IN A FOREIGN LANGUAGE.

**CLASS 16—PAPER GOODS AND PRINTED MATTER**

FOR PAPER, CARDBOARD, PAPER AND PLASTIC BAGS FOR PACKAGING, PACKAGING CONTAINERS OF PAPER, CARDBOARD PACKAGING AND PLASTIC PACKAGING, NAMELY, PLASTIC BAGS FOR PACKAGING, PLASTIC BUBBLE PACKS FOR PACKAGING; PRINTED MATTER, NAMELY, GREETING CARDS; POSTERS, ALBUMS, NAMELY, PHOTOGRAPH ALBUMS, ALMANACS, DIARIES, CATALOGUES IN THE FIELD OF FASHION, INTERIOR DESIGN AND ART, BOOKS IN THE FIELD OF FASHION, INTERIOR DESIGN AND ART, BOOKBINDING MATERIAL; PHOTOGRAPHS; STATIONERY, BOXES OF CARDBOARD OR PAPER, FLOWER-POT COVERS OF PAPER, SCHOOL WRITING BOOKS, DRAWING BOOKS IN THE NATURE OF SKETCHBOOKS, CALENDARS, CARDS, NAMELY, GREETING CARDS, FOLDERS FOR PAPERS, PATTERNS FOR DRESSMAKING, PAPER CUTTERS, LETTER TRAYS, PENCILS, STATIONERY ENVELOPES, BOND PAPER, PENCIL HOLDERS, POSTCARDS, PENS; ADHESIVES AND GLUES FOR STATIONERY OR HOUSEHOLD PURPOSES; PRINTING TYPE; PRINTING BLOCKS; HANDKERCHIEFS OF PAPER, NAPKINS OF PAPER FOR REMOVING MAKE-UP, TABLE LINEN OF PAPER; PLASTIC MATERIALS FOR PACKAGING NAMELY BAGS, SMALL BAGS AND POCKET FOLDERS; WRAPPING PAPER; CREDIT CARDS WITHOUT MAGNETIC CODING, WRITING CASE SETS COMPRISED OF A CASE CONTAINING PENS, STATIONERY, AND PENCILS (U.S. CLS. 2, 5, 22, 23, 29, 37, 38 AND 50).

**CLASS 17—RUBBER GOODS**

FOR SEMI-FINISHED GOODS OF PLASTIC IN THE FORM OF SINGLE OR MULTILAYERED SHEETS AND FILMS FOR GENERAL INDUSTRIAL AND MANUFACTURING USE; FILMS AND SHEETS OF PLASTICS OTHER THAN FOR PACKAGING, NAMELY, FOR LAMINATION FOR FURNITURE, FOR COATING BUILDING COMPONENTS, NAMELY, PROFILES, PANES, DOORS, CEILING PANELS, STAIRS, AND PARTITION WALLS, AND FOR COATING HOUSEHOLD APPLIANCES; SEMI-FINISHED GOODS OF PLASTIC IN THE FORM OF SHEETS AND FILMS FOR COVERING FURNITURE; FILMS OF PLASTIC, NOT FOR PACKAGING, ATTACHED TO OTHER FILMS OR SHEETS OF PLASTICS BY ADHESION BY GLUE-LAMINATION, THERMO-LAMINATION AND HOT MELT APPLICATION; LAMINATES IN THE NATURE OF PLASTIC FILMS AND SHEETS FOR USE AS A COATING FOR FURNITURE (U.S. CLS. 1, 5, 12, 13, 35 AND 50).

**CLASS 20—FURNITURE AND ARTICLES NOT OTHERWISE CLASSIFIED**

FOR FURNITURE, MIRRORS, PICTURE FRAMES; DISPLAY STANDS, COAT HANGERS, SHOULDER COVERS FOR CLOTHING STORAGE, WARDROBES, UMBRELLA STANDS, MAGAZINE RACKS; SEATS, CHAIRS, ARMCHAIRS, SETTEES, DIVANS, SOFAS, BEDS, CUPBOARDS, CHESTS OF DRAWERS, SIDEBARDS, TABLES, WASHSTANDS, DESKS, SHOWCASES IN THE NATURE OF FURNITURE; LIBRARY SHELVES, DISPLAY RACKS, STOOLS, OTTOMANS, CUSHIONS; WORKS OF ART OF WOOD, WAX, PLASTER OR PLASTIC, FIGURINES OF WOOD, WAX, PLASTER OR PLASTIC, NON-METAL BINS, MAIL BOXES NEITHER OF METAL NOR OF MASONRY, BASKETS NOT OF METAL FOR TRANSPORTING GOODS FOR COMMERCIAL PURPOSES, SCREENS, COATSTANDS, DECORATIVE MOBILES, SPRING MATTRESSES, MATTRESSES, SLATTED INDOOR BLINDS, TAILORS' DUMMIES, MOBILES IN THE NATURE OF DECORATIVE OBJECTS (U.S. CLS. 2, 13, 22, 25, 32 AND 50).

**CLASS 19—NON-METALLIC BUILDING MATERIALS**

FOR BUILDING MATERIALS OF PLASTIC, NAMELY, PLASTIC FILMS FOR COATING BUILDING COMPONENTS, NAMELY, PROFILES, PANES, DOORS, CEILING PANELS, STAIRS, AND PARTITION WALLS (U.S. CLS. 1, 12, 33 AND 50).

**CLASS 20—FURNITURE AND ARTICLES NOT OTHERWISE CLASSIFIED**

FOR EDGINGS FOR FURNITURE IN THE FORM OF FILMS AND SHEETS OF PLASTIC, NAMELY, DECORATIVE EDGE PROTECTIONS (U.S. CLS. 2, 13, 22, 25, 32 AND 50).

AMY HELLA, EXAMINING ATTORNEY

**CLASS 28—TOYS AND SPORTING GOODS**

FOR ELECTRONIC ACTION TOYS AND APPARATUS FOR ELECTRONIC GAMES OTHER THAN THOSE ADAPTED FOR USE WITH AN EXTERNAL DISPLAY SCREEN OR MONITOR, DECORATIONS FOR CHRISTMAS TREES EXCLUDING LIGHTING AND CONFECTIONERY, CANDLE HOLDERS FOR CHRISTMAS TREES, SNOW GLOBES, PLAY BALLS, PLAYING CARDS, TOY MASKS, THEATRICAL MASKS, PLUSH TOYS, DOLLS, DOLLS' CLOTHES, TOY SCOOTERS, STATIONARY EXERCISE BICYCLES, GOLF CLUBS, GOLF BAGS WITH OR WITHOUT WHEELS, GOLF GLOVES, PUPPETS, TENNIS RACKETS, WATER SKIS, SKIS, CUSTOM DESIGNED CASES FOR SKIS AND CASES SPECIALLY ADAPTED FOR SURF BOARDS, BILLIARD TABLES, BILLIARD CUES, BILLIARD BALLS, ICE SKATES, ROLLER SKATES, MINIATURE COSTUMES FOR TOY DOLLS; KITES, TOY MOBILES (U.S. CLS. 22, 23, 38 AND 50).

AMY HELLA, EXAMINING ATTORNEY

SN 79-087,760. ERICH SCHEUGENPFLUG, FED REP GERMANY, FILED 6-1-2010.



OWNER OF INTERNATIONAL REGISTRATION 0734259 DATED 4-27-2000, EXPIRES 4-27-2020.

THE MARK CONSISTS OF A RECTANGLE WITH ROUNDED EDGES. AT THE UPPER RIGHT CORNER OF THE RECTANGLE IS A DARK CIRCLE CONTAINING A STYLIZED NOZZLE POINTING DOWNWARD.

**CLASS 7—MACHINERY**

FOR MACHINES FOR TRANSPORTING AND MEASURING LIQUID OR VISCOUS SUBSTANCES; MACHINES FOR USE IN THE ELECTRICAL INDUSTRY, PARTICULARLY FOR GLUING AND CASTING ELECTRIC COMPONENTS (U.S. CLS. 13, 19, 21, 23, 31, 34 AND 35).

**CLASS 42—SCIENTIFIC AND COMPUTER SERVICES**

FOR ENGINEERING SERVICES (U.S. CLS. 100 AND 101).

MICHAEL KEATING, EXAMINING ATTORNEY

SN 79-087,794. NIDYON COSTRUZIONI S.R.L. -, ITALY, FILED 7-13-2010.

**NIDYON**

THE MARK CONSISTS OF STANDARD CHARACTERS WITHOUT CLAIM TO ANY PARTICULAR FONT, STYLE, SIZE, OR COLOR.

PRIORITY DATE OF 3-5-2010 IS CLAIMED.

OWNER OF INTERNATIONAL REGISTRATION 1052334 DATED 7-13-2010, EXPIRES 7-13-2020.

THE WORDING "NIDYON" HAS NO MEANING IN A FOREIGN LANGUAGE.

**CLASS 6—METAL GOODS**

FOR BUILDING PANELS OF METAL, NAMELY, COMPOSITE PANELS COMPOSED PRIMARILY OF METAL, CEILING PANELS, FLOOR PANELS, ROOFING PANELS, LOAD BEARING WALL PANELS, AND PARTITION WALL PANELS (U.S. CLS. 2, 12, 13, 14, 23, 25 AND 50).

**CLASS 7—MACHINERY**

FOR MACHINES, MACHINE TOOLS AND INSTALLATIONS, NAMELY, BLADES AND MACHINE TOOL HOLDERS, ALL FOR THE PRODUCTION OF BUILDING PANELS (U.S. CLS. 13, 19, 21, 23, 31, 34 AND 35).

**CLASS 19—NON-METALLIC BUILDING MATERIALS**

FOR NON-METAL BOARDS FOR BUILDING, NAMELY, COMPOSITE PANELS FOR BUILDING COMPOSED PRIMARILY OF NON-METAL MATERIALS, CEILING PANELS, FLOOR PANELS, ROOFING PANELS, LOAD BEARING WALL PANELS, AND PARTITION WALL PANELS (U.S. CLS. 1, 12, 33 AND 50).

LINDSEY RUBIN, EXAMINING ATTORNEY

SN 79-087,826. RAUMEDIC AG, FED REP GERMANY, FILED 9-1-2010.

**MPR2Log0**

THE MARK CONSISTS OF STANDARD CHARACTERS WITHOUT CLAIM TO ANY PARTICULAR FONT, STYLE, SIZE, OR COLOR.

OWNER OF INTERNATIONAL REGISTRATION 1052423 DATED 9-1-2010, EXPIRES 9-1-2020.

**CLASS 9—ELECTRICAL AND SCIENTIFIC APPARATUS**

FOR MEASURING APPARATUS, NAMELY, CLINICAL LABORATORY ANALYSERS FOR MEASURING, TESTING AND ANALYSING BLOOD AND OTHER BODILY FLUIDS, INSTRUMENTS FOR DETECTING AND MEASURING TWO-DIMENSIONAL DISTRIBUTION OF FORCE AND PRESSURE, TECHNICAL MEASURING, TESTING AND CHECKING APPARATUS AND INSTRUMENTS FOR MEASURING, TESTING AND CHECKING THE TEMPERATURE, PRESSURE, QUANTITY AND CONCENTRATION OF GAS AND LIQUIDS (U.S. CLS. 21, 23, 26, 36 AND 38).

**CLASS 10—MEDICAL APPARATUS**

FOR MEDICAL INSTRUMENTS AND APPARATUS, IN PARTICULAR MEASURING CATHETERS (U.S. CLS. 26, 39 AND 44).

CAROLYN CATALDO, EXAMINING ATTORNEY

SN 79-087,959. FAST RETAILING CO., LTD., JAPAN, FILED 9-7-2010.

**MADE FOR ALL**

THE MARK CONSISTS OF STANDARD CHARACTERS WITHOUT CLAIM TO ANY PARTICULAR FONT, STYLE, SIZE, OR COLOR.

PRIORITY DATE OF 8-19-2010 IS CLAIMED.

OWNER OF INTERNATIONAL REGISTRATION 1052768 DATED 9-7-2010, EXPIRES 9-7-2020.

**CLASS 9—ELECTRICAL AND SCIENTIFIC APPARATUS**

FOR BATTERIES; ELECTRIC CABLES; OPTICAL FIBERS; ELECTRIC IRONS; ELECTRONIC NOTICE BOARDS; CELLULAR TELEPHONES; ELECTRIC INSTALLATIONS FOR THE REMOTE CONTROL OF INDUSTRIAL OPERATIONS; REMOTE CONTROL APPARATUS FOR RADIOS, TELEVISIONS, STEREOs; COMPUTERS; ELECTRONIC CHIPS FOR THE MANUFACTURER OF INTEGRATED CIRCUITS; X-RAYS PRODUCING APPARATUS AND INSTALLATIONS, NOT FOR MEDICAL PURPOSES; ELECTRONIC TAGS FOR GOODS; SEMI-CONDUCTORS; EYEGASSES; SUNGLASSES; GOGGLES FOR SPORTS; ANIMATED CARTOONS, NAMELY, VIDEO DISKS AND VIDEO TAPES WITH RECORDED ANIMATED CARTOONS (U.S. CLS. 21, 23, 26, 36 AND 38).

**CLASS 18—LEATHER GOODS**

FOR POUCHES OF LEATHER; WALLETS; HANDBAGS; TRAVELLING BAGS; VANITY CASES, NOT FITTED; UMBRELLAS; WALKING STICKS; SADDLERY; LEATHER STRAPS; FUR (U.S. CLS. 1, 2, 3, 22 AND 41).

**CLASS 25—CLOTHING**

FOR CLOTHING, NAMELY, PANTS, SHIRTS, SKIRTS, SHORTS, DRESSES, JACKETS, SWIMWEAR, UNDERWEAR, SLEEPWEAR, ROBES, T-SHIRTS, JEANS, COATS, SOCKS, TIGHTS, GLOVES, VESTS, ANORAKS, RAINWEAR, WIND RESISTANT JACKETS, SWEATSHIRTS, TANK TOPS, PULLOVERS, SWEATERS, KNIT SHIRTS, CARDIGANS, PARKAS, HATS, CAPS, AND MUFFLERS; BABY LAYETTES FOR CLOTHING; WATERPROOF CLOTHING, NAMELY, WATERPROOF SHIRTS, PANTS, JACKETS AND FOOTWEAR; WEDDING DRESSES; BATHING SUITS; HOSIERY; GLOVES AS CLOTHING; SCARVES; GARTERS; SOCK SUSPENDERS; SUSPENDERS; WAISTBANDS; BELTS FOR CLOTHING; SHOES; MASQUERADE COSTUMES; FOOTBALL SHOES (U.S. CLS. 22 AND 39).

ADA HAN, EXAMINING ATTORNEY

SN 79-088,066. HAKRO GMBH, FED REP GERMANY, FILED 9-13-2010.



OWNER OF INTERNATIONAL REGISTRATION 1053063 DATED 9-13-2010, EXPIRES 9-13-2020.

OWNER OF U.S. REG. NO. 3,864,299.

NO CLAIM IS MADE TO THE EXCLUSIVE RIGHT TO USE "ACTIVEWEAR", APART FROM THE MARK AS SHOWN.

**CLASS 23—YARNS AND THREADS**

FOR THREAD AND YARN FOR TEXTILE USE (U.S. CL. 43).

**CLASS 25—CLOTHING**

FOR CLOTHING, NAMELY, SHIRTS, T-SHIRTS, POLO SHIRTS, BLOUSES, SWEATERS, PULLOVERS, FLEECE PULLOVERS, JACKETS, COATS, WAISTCOATS, PANTS, SPORT SHIRTS, SPORT COATS, SPORT JACKETS AND SPORTS PANTS; FOOTWEAR; HEADWEAR AND CAPS (U.S. CLS. 22 AND 39).

MATTHEW MCDOWELL, EXAMINING ATTORNEY

SN 79-088,083. WORKOUT FACTORY B.V., NETHERLANDS, FILED 4-6-2010.



PRIORITY DATE OF 3-19-2010 IS CLAIMED.  
OWNER OF INTERNATIONAL REGISTRATION 1053119 DATED 4-6-2010, EXPIRES 4-6-2020.

THE MARK CONSISTS OF A HORIZONTALLY POSITIONED OVAL THAT VARIES IN THICKNESS WITH A CAPITAL LETTER "S" IN THE MIDDLE.

**CLASS 9—ELECTRICAL AND SCIENTIFIC APPARATUS**

FOR APPARATUS FOR RECORDING, TRANSMISSION OR REPRODUCTION OF SOUND, IMAGES OR DATA; PRERECORDED DVD'S AND VIDEOTAPES FEATURING TELEVISION SERIES FOR CHILDREN AND INFORMATION RELATED TO SPORTS AND HEALTH TO INSPIRE CHILDREN TO EXERCISE MORE; PRERECORDED MAGNETIC DATA CARRIERS FEATURING TELEVISION SERIES FOR CHILDREN AND INFORMATION RELATED TO SPORTS AND HEALTH TO INSPIRE CHILDREN TO EXERCISE MORE; PRERECORDED CDS AND DVD'S FEATURING TELEVISION SERIES FOR CHILDREN AND INFORMATION RELATED TO SPORTS AND HEALTH TO INSPIRE CHILDREN TO EXERCISE MORE; MULTIMEDIA SOFTWARE RECORDED ON CD-ROM FEATURING TELEVISION SERIES FOR CHILDREN AND INFORMATION RELATED TO SPORTS AND HEALTH TO INSPIRE CHILDREN TO EXERCISE MORE; RECORDING DISCS, NAMELY, BLANK CD-ROMS FOR SOUND OR VIDEO RECORDING; DOWNLOADABLE ELECTRONIC PUBLICATIONS IN THE NATURE OF BOOKS, NEWSPAPERS, MAGAZINES, GUIDES, BROCHURES AND LEAFLETS IN THE FIELD OF SPORTS AND HEALTH TO INSPIRE CHILDREN TO EXERCISE MORE; ELECTRONIC PUBLICATIONS IN THE NATURE OF BOOKS, NEWSPAPERS, MAGAZINES, GUIDES, BROCHURES AND LEAFLETS IN THE FIELD OF SPORTS AND HEALTH TO INSPIRE CHILDREN TO EXERCISE MORE RECORDED ON COMPUTER MEDIA; DATA PROCESSORS; COMPUTERS; PERIPHERAL DEVICES FOR COMPUTERS; TELEVISIONS; TELEPHONE APPARATUS; RECORDED COMPUTER SOFTWARE FOR GAMING; GAME COMPUTERS, NAMELY, VIDEO OUTPUT GAME MACHINES FOR USE WITH TELEVISIONS; COMPUTER GAME PROGRAMS (U.S. CLS. 21, 23, 26, 36 AND 38).



**CLASS 16—PAPER GOODS AND PRINTED MATTER**

FOR PAPER AND CARDBOARD; PRINTED MATTER, NAMELY, EDUCATIONAL BOOKS, NEWSPAPERS, MAGAZINES IN THE FIELD OF SPORTS AND HEALTH TO INSPIRE CHILDREN TO EXERCISE MORE, PRINTED GUIDES FOR SPORTS AND HEALTH TO INSPIRE CHILDREN TO EXERCISE MORE, PRINTED BROCHURES ABOUT SPORTS AND HEALTH TO INSPIRE CHILDREN TO EXERCISE MORE AND LEAFLETS ABOUT SPORTS AND HEALTH TO INSPIRE CHILDREN TO EXERCISE MORE; POSTERS; BOOKBINDING MATERIAL; PHOTOGRAPHS; PRINTED INSTRUCTIONAL AND TEACHING MATERIAL IN THE FIELD OF SPORTS AND HEALTH TO INSPIRE CHILDREN TO EXERCISE MORE; PLASTIC BAGS FOR PACKAGING; PRINTERS' TYPE (U.S. CLS. 2, 5, 22, 23, 29, 37, 38 AND 50).

**CLASS 25—CLOTHING**

FOR CLOTHING, NAMELY, COATS, JACKETS, SWEATERS, SHIRTS, UNDERSHIRTS AND SPORT SHIRTS, T-SHIRTS, PANTS, UNDERPANTS AND SPORT PANTS, TROUSERS, SUITS, SHORTS, SCARVES, SOCKS, SWIMMING SUITS, BIKINIS, DRESSES, SKIRTS, PULL-OVERS, BLOUSES; SPORTSWEAR, NAMELY, JOGGING SUITS, FOOTWEAR, HEADWEAR (U.S. CLS. 22 AND 39).

**CLASS 28—TOYS AND SPORTING GOODS**

FOR GAMES AND PLAYTHINGS, NAMELY, BOARD GAMES, ARCADE GAMES, DOLLS, PLAYING CARDS AND CARD GAMES; GYMNAS TIC AND SPORTING ARTICLES, NAMELY, GYMNAS TIC APPARATUS, SPORT BALLS AND JUMP ROPES (U.S. CLS. 22, 23, 38 AND 50).

**CLASS 35—ADVERTISING AND BUSINESS**

FOR ADVERTISING SERVICES; BUSINESS MANAGEMENT; BUSINESS ADMINISTRATION; OFFICE FUNCTIONS; RETAIL STORE SERVICES AND ONLINE RETAIL STORE SERVICES FEATURING DEVICES FOR RECORDING, BROADCASTING AND REPRODUCING SOUND, IMAGES AND DATA, DVD-VIDEO AND VIDEOTAPES, VIDEO MEDIA, DIGITIZED IMAGES AND SOUNDS, IN ELECTRONIC FORM OR ON MAGNETIC, OPTICAL, OR OTHER MEDIA, CDS, CD-ROMS, DIGITAL VERSATILE DISKS, RECORDING DISKS, ELECTRONIC AND DIGITAL PUBLICATIONS, APPARATUS FOR DATA PROCESSING, PERIPHERAL COMPUTERS FOR COMPUTERS, TELEVISION SETS, TELEPHONE EQUIPMENT, RECORDED COMPUTER SOFTWARE PROGRAMS, COMPUTERS FOR GAMES, COMPUTER GAMES, PAPER, CARDBOARD AND GOODS MADE FROM THESE MATERIALS, PRINTED MATTER, INCLUDING BOOKS, PERIODIC NEWSPAPERS, GUIDE BOOKS, PROGRAMS, PLAYBILLS, PAMPHLETS AND LEAFLETS, BOOKBINDING MATERIAL, PHOTOGRAPHS, OFFICE MATERIAL, EXCEPT FURNITURE, INSTRUCTIONAL OR TEACHING MATERIAL, EXCEPT APPARATUS, PLASTIC PACKAGING MATERIALS PRINTERS' TYPE, CLOTHING, FOOTWEAR, HEADGEAR, GAMES, TOYS, GYMNAS TIC AND SPORTING ARTICLES (U.S. CLS. 100, 101 AND 102).

**CLASS 38—COMMUNICATION**

FOR TELECOMMUNICATION SERVICES, NAMELY, COMMUNICATION BY COMPUTER AND DIGITAL AND ELECTRONIC TRANSMISSION OF VOICE, DATA, IMAGES, SIGNALS AND MESSAGES; RADIO AND TELEVISION BROADCASTING; TRANSMISSION OF SOUND AND IMAGES VIA SATELLITE; TELEGRAPH SERVICES, MOBILE TELEPHONE SERVICES, MOBILE RADIO TELEPHONE SERVICES AND TELECOMMUNICATION SERVICES BY MEANS OF RADIO TELEGRAPH; RENTAL OF TELECOMMUNICATION EQUIPMENT (U.S. CLS. 100, 101 AND 104).

**CLASS 41—EDUCATION AND ENTERTAINMENT**

FOR EDUCATION SERVICES, NAMELY, PROVIDING WORKSHOPS, CLASSES AND CAMPS FOR CHILDREN IN THE FIELD OF SPORTS AND HEALTH TO INSPIRE CHILDREN TO EXERCISE MORE; PROVIDING OF TRAINING IN THE FIELD OF SPORTS AND HEALTH TO INSPIRE CHILDREN TO EXERCISE MORE; ENTERTAINMENT SERVICES IN THE NATURE OF LIVE PERFORMANCES BY ACTORS; ORGANIZING COMMUNITY SPORTING AND CULTURAL EVENTS; ORGANIZATION OF SPORT EVENTS, NAMELY, SPORTS DEMONSTRATIONS FOR CHILDREN; ORGANIZATION OF CULTURAL EVENTS AND MUSIC EVENTS IN THE NATURE OF LIVE MUSIC CONCERTS; PRODUCTION OF AND DIRECTION OF MAKING RADIO AND TELEVISION PROGRAMS; FILM PRODUCTION; PUBLISHING OF BOOKS, NEWSPAPERS AND MAGAZINES; PROVIDING INFORMATION IN THE FIELD OF ENTERTAINMENT, RADIO AND TELEVISION PROGRAMS, MOTION PICTURE FILMS, POPULAR CULTURE, EDUCATION, LEISURE ACTIVITIES AND SPORTS; DEVELOPING CONCEPTS FOR RADIO AND TELEVISION PROGRAMS; FILM AND VIDEO FILM RENTAL; RENTAL OF SHOW SCENERY; RENTAL OF RADIO AND TELEVISION RECEIVING SETS; PUBLISHING AND LENDING OF BOOKS, NEWSPAPERS, MAGAZINES, GUIDES, PROGRAM LISTINGS AND OTHER PUBLICATIONS; EDITORIAL REPORTING SERVICES; PHOTOGRAPHIC, FILM AND VIDEO REPORTING SERVICES; PHOTOGRAPHY (U.S. CLS. 100, 101 AND 107).

**CLASS 42—SCIENTIFIC AND COMPUTER SERVICES**

FOR DESIGN AND DEVELOP COMPUTER GAMES AND SOFTWARE; COMPUTER SOFTWARE DEVELOPMENT; MAINTENANCE AND UPDATING OF COMPUTER SOFTWARE; CREATING, DEVELOPING AND HOSTING OF INTERNET WEBSITES; GRAPHIC DESIGN; CONSULTING RELATING TO THESE SERVICES (U.S. CLS. 100 AND 101).

KATHRYN COWARD, EXAMINING ATTORNEY

SN 79-088,156. UNIVERSAL ENTERTAINMENT CORPORATION, JAPAN, FILED 8-5-2010.

O I R A N

THE MARK CONSISTS OF STANDARD CHARACTERS WITHOUT CLAIM TO ANY PARTICULAR FONT, STYLE, SIZE, OR COLOR.

PRIORITY DATE OF 8-4-2010 IS CLAIMED.  
OWNER OF INTERNATIONAL REGISTRATION 1053371 DATED 8-5-2010, EXPIRES 8-5-2020.

THE ENGLISH TRANSLATION OF THE FOREIGN WORD(S) IN THE MARK IS: A COURTESAN.

**CLASS 9—ELECTRICAL AND SCIENTIFIC APPARATUS**

FOR ELECTRONIC CIRCUITS, OPTICAL DISKS, MAGNETIC TAPES, MAGNETIC DISKS, MAGNETIC CARDS, MAGNETO-OPTICAL DISKS, CD-ROMS, ROM CARTRIDGES AND DVDS, ALL OF WHICH STORE INTERACTIVE GAME PROGRAMS FOR ARCADE VIDEO GAME MACHINES; DOWNLOADABLE INTERACTIVE GAME PROGRAMS FOR ARCADE VIDEO GAME MACHINES; GAMING MACHINES ADAPTED FOR USE WITH AN EXTERNAL DISPLAY SCREEN OR MONITOR; GAMING MACHINES WITH MULTI-TERMINALS ADAPTED FOR USE WITH AN EXTERNAL DISPLAY SCREEN OR MONITOR; ELECTRONIC CIRCUITS, OPTICAL DISKS, MAGNETIC TAPES, MAGNETIC DISKS, MAGNETIC CARDS, MAGNETO-OPTICAL DISKS, CD-ROMS, ROM CARTRIDGES AND DVDS, ALL OF WHICH STORE PROGRAMS FOR GAMING MACHINES, NAMELY, INTERACTIVE GAME PROGRAMS, VIDEO AND COMPUTER GAME PROGRAMS AND ELECTRONIC GAME PROGRAMS; DOWNLOADABLE PROGRAMS FOR GAMING MACHINES, NAMELY, INTERACTIVE GAME PROGRAMS, VIDEO AND COMPUTER GAME PROGRAMS AND ELECTRONIC GAME PROGRAMS; ELECTRONIC CIRCUITS, OPTICAL DISKS, MAGNETIC TAPES, MAGNETIC DISKS, MAGNETIC CARDS, MAGNETO-OPTICAL DISKS, CD-ROMS, ROM CARTRIDGES AND DVDS, ALL OF WHICH STORE PROGRAMS FOR SLOT MACHINES; DOWNLOADABLE PROGRAMS FOR SLOT MACHINES, NAMELY, INTERACTIVE GAME PROGRAMS, VIDEO AND COMPUTER GAME PROGRAMS AND ELECTRONIC GAME PROGRAMS; APPARATUS FOR GAMES FOR HOME USE ADAPTED FOR USE WITH AN EXTERNAL DISPLAY SCREEN OR MONITOR; ELECTRONIC CIRCUITS, OPTICAL DISKS, MAGNETIC TAPES, MAGNETIC DISKS, MAGNETIC CARDS, MAGNETO-OPTICAL DISKS, CD-ROMS, ROM CARTRIDGES AND DVDS, ALL OF WHICH STORE INTERACTIVE GAME PROGRAMS FOR HOME USE ADAPTED FOR USE WITH AN EXTERNAL DISPLAY SCREEN OR MONITOR; DOWNLOADABLE INTERACTIVE GAME PROGRAMS, VIDEO AND COMPUTER GAME PROGRAMS AND ELECTRONIC GAME PROGRAMS FOR HOME USE ADAPTED FOR USE WITH AN EXTERNAL DISPLAY SCREEN OR MONITOR; ELECTRONIC CIRCUITS, OPTICAL DISKS, MAGNETIC TAPES, MAGNETIC DISKS, MAGNETIC CARDS, MAGNETO-OPTICAL DISKS, CD-ROMS, ROM CARTRIDGES AND DVDS, ALL OF WHICH STORE INTERACTIVE GAME PROGRAMS AND ELECTRONIC GAME PROGRAMS FOR HAND-HELD GAMES WITH LIQUID CRYSTAL DISPLAYS; DOWNLOADABLE INTERACTIVE GAME PROGRAMS AND ELECTRONIC GAME PROGRAMS FOR HAND-HELD GAMES WITH LIQUID CRYSTAL DISPLAYS (U.S. CLS. 21, 23, 26, 36 AND 38).

**CLASS 28—TOYS AND SPORTING GOODS**

FOR COIN-OPERATED ARCADE VIDEO GAME MACHINES; MAGNETIC CARD OPERATED ARCADE VIDEO GAME MACHINES; ARCADE VIDEO GAME MACHINES WITH MULTI-TERMINALS; CABINETS FOR ARCADE VIDEO GAME MACHINES; ARCADE VIDEO GAME MACHINES; SLOT MACHINES; CABINETS FOR SLOT MACHINES; GAMING MACHINES OTHER THAN THOSE ADAPTED FOR USE WITH AN EXTERNAL DISPLAY SCREEN OR MONITOR; GAMING MACHINES WITH MULTI-TERMINALS OTHER THAN THOSE ADAPTED FOR USE WITH AN EXTERNAL DISPLAY SCREEN OR MONITOR; HAND-HELD GAMES WITH LIQUID CRYSTAL DISPLAYS (U.S. CLS. 22, 23, 38 AND 50).

FRANK LATTUCA, EXAMINING ATTORNEY

SN 79-088.302. OSRAM GESELLSCHAFT MIT BESCHRÄNKTER HAFTUNG, DBA OSRAM GMBH, 81543 MÜNCHEN, FED REP GERMANY, FILED 7-6-2010.

# SubstiTUBE

THE MARK CONSISTS OF STANDARD CHARACTERS WITHOUT CLAIM TO ANY PARTICULAR FONT, STYLE, SIZE, OR COLOR.

PRIORITY DATE OF 2-19-2010 IS CLAIMED.  
OWNER OF INTERNATIONAL REGISTRATION 1053778 DATED 7-6-2010, EXPIRES 7-6-2020.

**CLASS 9—ELECTRICAL AND SCIENTIFIC APPARATUS**

FOR LIGHT-EMITTING DIODE MODULES, AND ELECTRONIC CONTROL AND POWER SUPPLY CIRCUITS THEREFOR, FOR WARNING AND SAFETY APPLICATIONS (U.S. CLS. 21, 23, 26, 36 AND 38).

**CLASS 11—ENVIRONMENTAL CONTROL APPARATUS**

FOR APPARATUS FOR LIGHTING, NAMELY, ELECTRIC LAMPS AND LUMINAIRES, INCORPORATING LIGHT-EMITTING DIODES (U.S. CLS. 13, 21, 23, 31 AND 34).

STEVEN PEREZ, EXAMINING ATTORNEY

SN 79-088.378. VECTORWISE B.V., NETHERLANDS, FILED 8-4-2010.



PRIORITY DATE OF 2-17-2010 IS CLAIMED.  
OWNER OF INTERNATIONAL REGISTRATION 1054019 DATED 8-4-2010, EXPIRES 8-4-2020.

THE MARK CONSISTS OF THE WORDING "VECTORWISE" TO THE RIGHT OF A SPHERE WITHIN AN OVAL.

**CLASS 9—ELECTRICAL AND SCIENTIFIC APPARATUS**

FOR COMPUTER SOFTWARE, NAMELY, DATABASE MANAGEMENT SOFTWARE FOR THE FILING, ORGANIZATION, MODIFICATION, RESEARCH, RECALLING AND ANALYSIS OF DATA; COMPUTER SOFTWARE FOR STATISTICAL ANALYSIS (U.S. CLS. 21, 23, 26, 36 AND 38).

**CLASS 42—SCIENTIFIC AND COMPUTER SERVICES**

FOR COMPUTER PROGRAMMING, NAMELY, PROGRAMMING OF DATABASE MANAGEMENT SOFTWARE; CONSULTING REGARDING THE DESIGN, INSTALLATION, DEVELOPMENT, MAINTENANCE AND USE OF DATABASE MANAGEMENT SOFTWARE; PROVIDING COMPUTER SOFTWARE VIA CLOUD COMPUTING FEATURING SOFTWARE FOR USE IN DATABASE MANAGEMENT AND FOR THE FILING, ORGANIZATION, MODIFICATION, RESEARCH, RECALLING AND ANALYSIS OF DATA AND FOR STATISTICAL ANALYSIS; TECHNICAL SUPPORT SERVICES, NAMELY, TROUBLESHOOTING OF COMPUTER SOFTWARE PROBLEMS FOR DATABASE MANAGEMENT SOFTWARE (U.S. CLS. 100 AND 101).

LEIGH LOWRY, EXAMINING ATTORNEY

SN 79-088,436. SPOTON S.R.L., ITALY, FILED 8-26-2010.

# ADMANTX

THE MARK CONSISTS OF STANDARD CHARACTERS WITHOUT CLAIM TO ANY PARTICULAR FONT, STYLE, SIZE, OR COLOR.

PRIORITY DATE OF 7-27-2010 IS CLAIMED.

OWNER OF INTERNATIONAL REGISTRATION 1054205 DATED 8-26-2010, EXPIRES 8-26-2020.

## CLASS 9—ELECTRICAL AND SCIENTIFIC APPARATUS

FOR ELECTRONIC PROCESSORS, NAMELY, MICRO-PROCESSORS, DATA PROCESSORS; MEMORIES FOR ELECTRONIC PROCESSORS, NAMELY, ELECTRONIC MEMORIES; BLANK MAGNETIC DISKS, OPTICAL DISCS, AND OPTICAL COMPACT DISCS; COMPUTER PRINTERS FOR ELECTRONIC WORD PROCESSORS; BLANK COMPACT DISCS, PERIPHERAL DEVICES FOR ELECTRONIC PROCESSORS, NAMELY, MOUSE, MONITOR, KEYBOARD (U.S. CLS. 21, 23, 26, 36 AND 38).

## CLASS 35—ADVERTISING AND BUSINESS

FOR ADVERTISING; BUSINESS MANAGEMENT; BUSINESS ADMINISTRATION; OFFICE FUNCTIONS (U.S. CLS. 100, 101 AND 102).

## CLASS 42—SCIENTIFIC AND COMPUTER SERVICES

FOR RESEARCH AND DEVELOPMENT OF PROGRAMS FOR MICROPROCESSORS, DATA PROCESSORS; COMPUTER SOFTWARE CONSULTING; UPDATE OF COMPUTER SOFTWARE; DESIGN AND DEVELOPMENT OF COMPUTER SOFTWARE; RENTAL OF COMPUTER SOFTWARE; COMPUTER PROGRAMMING (U.S. CLS. 100 AND 101).

ROSELLE HERRERA, EXAMINING ATTORNEY

SN 79-088,666. MARICAP OY, FINLAND, FILED 6-7-2010.

# M-TYPHOON

PRIORITY DATE OF 6-3-2010 IS CLAIMED.

OWNER OF INTERNATIONAL REGISTRATION 1054764 DATED 6-7-2010, EXPIRES 6-7-2020.

OWNER OF U.S. REG. NOS. 3,662,582, 3,727,134 AND 3,771,891.

## CLASS 7—MACHINERY

FOR MACHINES AND MACHINE TOOLS, NAMELY, SEPARATING MACHINES FOR CHEMICAL PROCESSING; MOTORS AND ENGINES EXCEPT FOR LAND VEHICLES; MACHINE COUPLING AND TRANSMISSION COMPONENTS EXCEPT FOR LAND VEHICLES; PNEUMATIC TUBE CONVEYORS; VACUUM PUMPS; FOOD WASTE DISPOSALS AND FOOD WASTE DISPOSERS; WASTE HANDLING SYSTEMS, COMPRISED OF WASTE COMPACTING MACHINES AND MACHINE TOOLS FOR REMOVING WASTE MATERIAL; WASTE CONVEYING SYSTEMS, COMPRISED OF WASTE MATERIAL CONVEYING MACHINES AND MACHINE TOOLS FOR REMOVING WASTE MATERIAL (U.S. CLS. 13, 19, 21, 23, 31, 34 AND 35).

## CLASS 37—CONSTRUCTION AND REPAIR

FOR BUILDING CONSTRUCTION; REPAIR SERVICES, NAMELY, REPAIR OF WASTE COMPACTING MACHINES AND APPARATUS, WASTE CONVEYING MACHINES AND APPARATUS, FOOD WASTE DISPOSALS AND FOOD WASTE DISPOSERS, CONVEYORS AND CONVEYOR ACCESSORIES, NAMELY, VACUUM TUBE CONVEYORS AND VACUUM PUMPS; INSTALLATION SERVICES, NAMELY, INSTALLATION OF WASTE COMPACTING MACHINES AND APPARATUS, WASTE CONVEYING MACHINES AND APPARATUS, FOOD WASTE DISPOSALS, FOOD WASTE DISPOSERS, CONVEYORS AND CONVEYOR ACCESSORIES, NAMELY, VACUUM TUBE CONVEYORS AND VACUUM PUMPS (U.S. CLS. 100, 103 AND 106).

## CLASS 39—TRANSPORTATION AND STORAGE

FOR TRANSPORT SERVICES, NAMELY, TRANSPORTATION OF TRASH, WASTE, MEDICAL WASTE, SPECIAL WASTE, FOOD WASTE; STORAGE OF TRASH AND WASTE FOR SUBSEQUENT REMOVAL AND DESTRUCTION; PACKAGING ARTICLES FOR TRANSPORTATION; TRANSPORT AND STORAGE OF TRASH; TRANSPORT AND STORAGE OF WASTE; TRANSPORTATION BY PIPELINE (U.S. CLS. 100 AND 105).

ROSELLE HERRERA, EXAMINING ATTORNEY

SN 79-088,741. AGENNIX AG, FED REP GERMANY, FILED 7-19-2010.



PRIORITY DATE OF 3-18-2010 IS CLAIMED.

OWNER OF INTERNATIONAL REGISTRATION 1054991 DATED 7-19-2010, EXPIRES 7-19-2020.

THE COLOR(S) TURQUOISE AND ANTHRACITE IS/ARE CLAIMED AS A FEATURE OF THE MARK.

THE MARK CONSISTS OF THE STYLIZED TERM "AGENNIX" WHEREIN THE LETTERS "AG" ARE IN TURQUOISE AND THE LETTERS "ENNIX" ARE IN BLACK.

## CLASS 5—PHARMACEUTICALS

FOR PHARMACEUTICAL PREPARATIONS FOR THE TREATMENT OF CANCER, SEPSIS, TUMORS, SKIN ULCERS AND BACTERIAL INFECTION AND TO MODULATE THE IMMUNE SYSTEM (U.S. CLS. 6, 18, 44, 46, 51 AND 52).

## CLASS 42—SCIENTIFIC AND COMPUTER SERVICES

FOR SCIENTIFIC RESEARCH AND DEVELOPMENT SERVICES IN THE FIELD OF CHEMISTRY, BIOTECHNOLOGY, BIO-PHARMACEUTICS AND MEDICAL SCIENCE; TECHNOLOGY CONSULTATION AND RESEARCH IN THE FIELD OF CHEMISTRY, BIOTECHNOLOGY, BIO-PHARMACEUTICS AND MEDICAL SCIENCE; CHEMICAL, BIOCHEMICAL, BIOLOGICAL AND BACTERIOLOGICAL RESEARCH AND ANALYSIS; PREPARING BIOTECHNOLOGICAL AND BIOPHARMACEUTICAL ANALYSIS; PHARMACEUTICAL DRUG DEVELOPMENT SERVICES; BIOLOGICAL RESEARCH; SCIENTIFIC RESEARCH (U.S. CLS. 100 AND 101).

JAMES STEIN, EXAMINING ATTORNEY

SN 79-088,862. VEGITALIA S.P.A., ITALY, FILED 7-16-2010.

# DOLCEVEGI

THE MARK CONSISTS OF STANDARD CHARACTERS WITHOUT CLAIM TO ANY PARTICULAR FONT, STYLE, SIZE, OR COLOR.

PRIORITY DATE OF 1-27-2010 IS CLAIMED.  
OWNER OF INTERNATIONAL REGISTRATION 1055328 DATED 7-16-2010, EXPIRES 7-16-2020.

## CLASS 29—MEATS AND PROCESSED FOODS

FOR VEGETABLE SALADS; PREPARATIONS FOR MAKING SOUP; VEGETABLE SOUP PREPARATIONS; VEGETABLE JUICES FOR COOKING; VEGETABLES, COOKED; VEGETABLES, DRIED; VEGETABLES, PRESERVED; PICKLES (U.S. CL. 46).

## CLASS 30—STAPLE FOODS

FOR DRESSINGS FOR SALAD; MACARONI; PASTA; PIZZAS; RAVIOLI; RICE; SAUCES IN THE NATURE OF CONDIMENTS; SPAGHETTI; SUSHI; TOMATO SAUCE; SANDWICHES (U.S. CL. 46).

## CLASS 32—LIGHT BEVERAGES

FOR TOMATO JUICE; VEGETABLE JUICES (U.S. CLS. 45, 46 AND 48).  
MARILYN IZZI, EXAMINING ATTORNEY

SN 79-088,964. ZETT OPTICS GMBH, FED REP GERMANY, FILED 8-4-2010.

# ZLED

THE MARK CONSISTS OF STANDARD CHARACTERS WITHOUT CLAIM TO ANY PARTICULAR FONT, STYLE, SIZE, OR COLOR.

PRIORITY DATE OF 2-12-2010 IS CLAIMED.  
OWNER OF INTERNATIONAL REGISTRATION 1055598 DATED 8-4-2010, EXPIRES 8-4-2020.

## CLASS 9—ELECTRICAL AND SCIENTIFIC APPARATUS

FOR OPTICAL GOODS, APPARATUS, AND INSTRUMENTS, NAMELY, CAMERAS, MICROSCOPES AND PARTS THEREOF, OPTICAL LENSES, MICROSCOPE ILLUMINATING DEVICES; OPTICAL DATA MEDIA AND FIBERS BEING LIGHT CONDUCTING FILAMENTS, NAMELY, FIBRE-OPTIC CABLES; LIGHT EMITTING DIODES (U.S. CLS. 21, 23, 26, 36 AND 38).

## CLASS 10—MEDICAL APPARATUS

FOR LAMPS, NAMELY, QUARTZ AND ULTRAVIOLET LAMPS FOR MEDICAL PURPOSES; HEAT RADIATORS, IN PARTICULAR INFRARED HEAT RADIATORS, FOR MEDICAL PURPOSES; ILLUMINATION UNITS AND LIGHTING DEVICES INCORPORATED INTO MEDICAL INSTRUMENTS AND MICROSCOPES FOR OPERATIONS (U.S. CLS. 26, 39 AND 44).

## CLASS 11—ENVIRONMENTAL CONTROL APPARATUS

FOR APPARATUS AND INSTALLATIONS FOR LIGHTING, NAMELY, ELECTRIC LIGHTING FIXTURES, LED (LIGHT EMITTING DIODE) LIGHTING FIXTURES; ELECTRIC LAMPS, LAMP CHIMNEYS (U.S. CLS. 13, 21, 23, 31 AND 34).

KRISTINA MORRIS, EXAMINING ATTORNEY

SN 79-089,138. MARLAFIN AG, SWITZERLAND, FILED 9-20-2010.

# TAMIA

THE MARK CONSISTS OF STANDARD CHARACTERS WITHOUT CLAIM TO ANY PARTICULAR FONT, STYLE, SIZE, OR COLOR.

PRIORITY DATE OF 7-26-2010 IS CLAIMED.  
OWNER OF INTERNATIONAL REGISTRATION 1056106 DATED 9-20-2010, EXPIRES 9-20-2020.

THE NAME SHOWN IN THE MARK DOES NOT IDENTIFY A PARTICULAR LIVING INDIVIDUAL.

## CLASS 5—PHARMACEUTICALS

FOR HEALTH CARE PREPARATIONS AND SANITARY PREPARATIONS FOR MEDICAL PURPOSES, ESPECIALLY FOR MENSTRUATION, IN PARTICULAR, MENSTRUATION TAMPONS; PREPARATIONS FOR TREATING SYMPTOMS OF MENSTRUATION AND MENSTRUATION TAMPONS COMPRISING VIBRATORS FOR TREATING SYMPTOMS OF MENSTRUATION; VAGINAL TAMPONS FOR ADMINISTERING PHARMACEUTICAL PREPARATIONS (U.S. CLS. 6, 18, 44, 46, 51 AND 52).

## CLASS 10—MEDICAL APPARATUS

FOR MEDICAL APPARATUS AND INSTRUMENTS FOR TREATING SYMPTOMS OF MENSTRUATION, IN PARTICULAR, VIBRATORS FOR USE IN MENSTRUATION TAMPONS; MEDICAL APPARATUS FOR ANALYSIS AND DIAGNOSIS OF MENSTRUATION SYMPTOMS FOR MEDICAL PURPOSES (U.S. CLS. 26, 39 AND 44).

TINA BROWN, EXAMINING ATTORNEY

SN 79-089,495. JIMTEN, S.A., SPAIN, FILED 9-16-2010.



OWNER OF INTERNATIONAL REGISTRATION 1056991 DATED 9-16-2010, EXPIRES 9-16-2020.

THE COLOR(S) BLACK AND RED IS/ARE CLAIMED AS A FEATURE OF THE MARK.

THE MARK CONSISTS OF "LINNUM" IN STYLIZED BLACK LETTERS "LIN" AND "UM" AND RED LETTER "N". THE COLOR GRAY REPRESENTS BACKGROUND AND IS NOT PART OF THE MARK.

THE WORDING "LINNUM" HAS NO MEANING IN A FOREIGN LANGUAGE.

**CLASS 6—METAL GOODS**

FOR COMMON METALS AND THEIR ALLOYS; BUILDING MATERIALS OF METAL, NAMELY, METAL SOFFITS, METAL FASCIA, METAL STAIR NOSING; TRANSPORTABLE BUILDINGS, OF METAL; RAILWAY MATERIAL OF METAL FOR RAILWAY CONSTRUCTION, METAL RAILS AND METAL RAILROAD TIES; NON-ELECTRIC CABLES AND WIRES OF COMMON METAL; IRONMONGERY AND SMALL ITEMS OF METAL HARDWARE, NAMELY, NUTS, WASHERS, DRAWER PULLS, DOOR LATCHES; TUBES OF METAL; METAL SAFES; GOODS OF COMMON METAL, NAMELY, METAL CONTAINERS FOR THE STORAGE AND TRANSPORTATION OF GOODS; ORES, NAMELY, COPPER ORE, NICKEL ORE, TIN ORE; LAMINATED AND CAST BUILDING MATERIALS, NAMELY, REINFORCING MATERIALS COMPOSED PRIMARILY OF METAL FOR BUILDING PURPOSES, METAL BEAMS; METAL CHAINS, EXCLUDING TRANSMISSION CHAINS FOR VEHICLES; PIPES OF METAL, DRAINS OF METAL FOR USE IN CONSTRUCTION OF BASEMENT WATERPROOFING SYSTEMS, DRAINS OF METAL NOT BEING PARTS OF PLUMBING INSTALLATIONS; METAL VALVES FOR WATER PIPES (U.S. CLS. 2, 12, 13, 14, 23, 25 AND 50).

**CLASS 11—ENVIRONMENTAL CONTROL APPARATUS**

FOR WATER FLUSHING APPARATUS AND INSTALLATIONS BEING PARTS OF SANITARY INSTALLATIONS; BATH INSTALLATIONS; WATER PIPE INSTALLATIONS BEING PARTS OF PLUMBING INSTALLATIONS; WASH-HAND BASINS BEING PARTS OF SANITARY INSTALLATIONS; BIDETS; SHOWERS (U.S. CLS. 13, 21, 23, 31 AND 34).

KATHY DE JONGE, EXAMINING ATTORNEY

SN 79-089,838. TOSHIBA MEDICAL SYSTEMS CORPORATION, JAPAN, FILED 10-28-2010.

T i s s u e P u r e

THE MARK CONSISTS OF STANDARD CHARACTERS WITHOUT CLAIM TO ANY PARTICULAR FONT, STYLE, SIZE, OR COLOR.

OWNER OF INTERNATIONAL REGISTRATION 1057931 DATED 10-28-2010, EXPIRES 10-28-2020.

**CLASS 9—ELECTRICAL AND SCIENTIFIC APPARATUS**

FOR COMPUTER PROGRAMS FOR PROCESSING AND DISPLAYING IMAGES FOR USE WITH ULTRASONIC DIAGNOSTIC APPARATUS FOR MEDICAL USE (U.S. CLS. 21, 23, 26, 36 AND 38).

**CLASS 10—MEDICAL APPARATUS**

FOR ULTRASONIC DIAGNOSTIC APPARATUS FOR MEDICAL USE (U.S. CLS. 26, 39 AND 44).

MARIAM MAHMOUDI, EXAMINING ATTORNEY

SN 79-090,001. MIR SRL MEDICAL INTERNATIONAL RESEARCH, ITALY, FILED 7-15-2010.



PRIORITY DATE OF 4-8-2010 IS CLAIMED. OWNER OF INTERNATIONAL REGISTRATION 1058324 DATED 7-15-2010, EXPIRES 7-15-2020.

THE MARK CONSISTS OF A SHADED RECTANGLE, WITH TERM "SPIRODOC" AND A CURVED LINE UNDERNEATH THE TERM INSIDE THE SHADED RECTANGLE.

**CLASS 9—ELECTRICAL AND SCIENTIFIC APPARATUS**

FOR SOFTWARE FOR USE IN SPIROMETERS AND OXIMETERS WHICH CHECKS AIR PARAMETERS CONCERNING SPIROMETRY TESTS AND OXIMETERS TESTS (U.S. CLS. 21, 23, 26, 36 AND 38).

**CLASS 10—MEDICAL APPARATUS**

FOR MEDICAL APPARATUS AND INSTRUMENTS, NAMELY, SPIROMETERS AND PULSE OXIMETERS (U.S. CLS. 26, 39 AND 44).

MICHAEL WIENER, EXAMINING ATTORNEY

SN 79-090,046. DACOROGNA, DUBUIS, EMMA & FRAGNIERE, GENEVE, SWITZERLAND, FILED 10-14-2010.



PRIORITY DATE OF 8-31-2010 IS CLAIMED. OWNER OF INTERNATIONAL REGISTRATION 1058465 DATED 10-14-2010, EXPIRES 10-14-2020.

THE MARK CONSISTS OF THE WORDING "UNITED VII SPIRIT" WITH A FLEUR-DE-LIS DESIGN.

**CLASS 25—CLOTHING**

FOR CLOTHING, NAMELY, SHIRTS, SHORTS AND PANTS (U.S. CLS. 22 AND 39).

**CLASS 35—ADVERTISING AND BUSINESS**

FOR ADVERTISING AGENCIES; BUSINESS MANAGEMENT; BUSINESS ADMINISTRATION AND MANAGEMENT; PROVIDING OFFICE FUNCTIONS (U.S. CLS. 100, 101 AND 102).

WILLIAM BRECKENFELD, EXAMINING ATTORNEY

SN 79-090,085. INFINEON TECHNOLOGIES AG, FED REP GERMANY, FILED 9-9-2010.

SN 79-090,103. ANDREAS FISCHER, NUREMBURG, FED REP GERMANY, FILED 8-25-2010.

# CIPURSE

THE MARK CONSISTS OF STANDARD CHARACTERS WITHOUT CLAIM TO ANY PARTICULAR FONT, STYLE, SIZE, OR COLOR.

PRIORITY DATE OF 6-9-2010 IS CLAIMED.

OWNER OF INTERNATIONAL REGISTRATION 1058604 DATED 9-9-2010, EXPIRES 9-9-2020.

## CLASS 9—ELECTRICAL AND SCIENTIFIC APPARATUS

FOR INTEGRATED CIRCUIT CHIPS; ENCODED IDENTIFICATION CARDS, NAMELY, ENCODED SMART CARDS CONTAINING PROGRAMMING AND BEING USED FOR ELECTRONIC PAYMENT OF TRANSPORTATION FARES, PAYMENT OF GOODS AND SERVICES AND FINANCIAL TRANSACTIONS; ENCODED SERVICE CARDS, NAMELY, ELECTRONIC AND MAGNETIC ID CARDS BEING USED FOR ELECTRONIC PAYMENT OF TRANSPORTATION FARES, PAYMENT OF GOODS AND SERVICES AND FINANCIAL TRANSACTIONS; OPERATING SOFTWARE FOR ELECTRONIC COMPONENTS AND MICROPROCESSORS; SOFTWARE FOR ELECTRONIC PAYMENTS, NAMELY, SOFTWARE USED IN ELECTRONIC PLATFORMS ACCOMMODATING PAYMENT OF TRANSPORTATION FARES, PAYMENT OF GOODS AND SERVICES AND FINANCIAL TRANSACTIONS VIA ENCODED IDENTIFICATION CARDS, ENCODED SERVICE CARDS, MOBILE PHONES, PDAS AND WEB BASED ENVIRONMENTS; SOFTWARE FOR ELECTRONIC FARE MANAGEMENT SYSTEMS, NAMELY, COMPUTER OPERATING SOFTWARE FOR ELECTRONIC FARE MANAGEMENT SYSTEMS, AND COMPUTER DATABASE MANAGEMENT SOFTWARE FOR MANAGING ELECTRONIC FARE SYSTEMS DATA; OPERATING SOFTWARE FOR SMART CARD READERS; DATA PROCESSORS; DATA PROCESSORS FOR ELECTRONIC FARE MANAGEMENT SYSTEMS; SEMICONDUCTORS; INTEGRATED CIRCUIT CARDS; CARD READERS, NAMELY, CONTACTLESS CHIP CARD READERS, ELECTRONIC CARD READERS, SMART CARD READERS; MICROPROCESSORS; RADIO FREQUENCY TRANSMITTERS; TRANSPONDERS, NAMELY, RADIO FREQUENCY IDENTIFICATION (RFID) TAGS (U.S. CLS. 21, 23, 26, 36 AND 38).

## CLASS 16—PAPER GOODS AND PRINTED MATTER

FOR PRINTED TICKETS (U.S. CLS. 2, 5, 22, 23, 29, 37, 38 AND 50).

## CLASS 36—INSURANCE AND FINANCIAL

FOR ELECTRONIC FUNDS TRANSFERS; ELECTRONIC CASH TRANSACTIONS; SERVICES RELATING TO CASH TRANSACTIONS WITH SMARTCARDS, NAMELY PROCESSING ELECTRONIC PAYMENTS THROUGH PRE-PAID CARDS AND DEBIT CARDS (U.S. CLS. 100, 101 AND 102).

## CLASS 42—SCIENTIFIC AND COMPUTER SERVICES

FOR PRODUCT RESEARCH AND DEVELOPMENT SERVICES FOR OTHERS (U.S. CLS. 100 AND 101).  
JENNIFER MARTIN, EXAMINING ATTORNEY



OWNER OF INTERNATIONAL REGISTRATION 1058669 DATED 8-25-2010, EXPIRES 8-25-2020.

THE MARK CONSISTS OF A STYLIZED CYCLIST IN A CIRCLE.

## CLASS 25—CLOTHING

FOR CLOTHING, NAMELY, JOGGING SUITS, EXERCISE TOPS AND BOTTOMS, BRAS, BUSTIERS, COATS, JACKETS, PANTS, SHORTS, SHIRTS, DRESSES, SKIRTS, VESTS, SWEATERS, BLOUSES, BODY SUITS, SWEAT SUITS, HOSIERY, SOCKS AND STOCKINGS, UNDERWEAR, LINGERIE, SLIPS, UNDERCLOTHES, BELTS, SCARVES AND SHAWLS, KERCHIEFS, TIES AND BOW TIES, FASHION AND DRESS GLOVES; FOOTWEAR; HEADGEAR, NAMELY, HATS AND CAPS; SWEATBANDS, HEADSCARVES (U.S. CLS. 22 AND 39).

## CLASS 28—TOYS AND SPORTING GOODS

FOR STATIONARY BICYCLES FOR SPORTS AS APPARATUS FOR FITNESS TRAINING; PARTS OF STATIONARY BICYCLES FOR SPORTS AS APPARATUS FOR FITNESS TRAINING, NAMELY, HANDLEBARS, SADDLES AND PEDALS (U.S. CLS. 22, 23, 38 AND 50).

## CLASS 41—EDUCATION AND ENTERTAINMENT

FOR PROVIDING OF TRAINING AND FURTHER TRAINING IN THE FIELD OF SPORTS WITH STATIONARY BICYCLES; ENTERTAINMENT SERVICES, NAMELY, PROVIDING MOTIVATIONAL AND EDUCATIONAL SPEAKERS IN THE FIELD OF SPORTS WITH STATIONARY BICYCLES AND PROVIDING LIVE CONTESTS, GAMES, PERFORMANCES AND SHOWS IN THE FIELD OF SPORTS WITH STATIONARY BICYCLES; SPORTING AND CULTURAL ACTIVITIES, NAMELY, ORGANIZING, SANCTIONING, CONDUCTING, REGULATING AND GOVERNING SPORT PROGRAMS AND ACTIVITIES IN THE FIELD OF SPORTS WITH STATIONARY BICYCLES (U.S. CLS. 100, 101 AND 107).

MICHAEL WIENER, EXAMINING ATTORNEY

SN 79-090,208. WHOOP'-DE-DOO' CO., LTD, JAPAN, FILED 8-20-2010.

# Whoop'EE'

OWNER OF INTERNATIONAL REGISTRATION 1058930 DATED 8-20-2010, EXPIRES 8-20-2020.

**CLASS 18—LEATHER GOODS**

FOR BAGS, NAMELY, FOLDING BRIEFCASES, SHOULDER BAGS, GLADSTONE BAGS, JAPANESE WICKER TRUNKS (KORI), BRIEFCASES, SUITCASES, CARRY-ON BAGS, TRUNKS, HANDBAGS, BOSTON BAGS, SCHOOLCHILDRENS' BACKPACKS, BACKPACKS; POUCHES, NAMELY, CHARM BAGS (OMAMORI-IRE); CREDIT CARD CASES, NAME CARD CASES; SHOPPING BAGS, NAMELY, WHEELED SHOPPING BAGS; PURSES, KEY CASES, WALLETS, JAPANESE UTILITY POUCHES (SHINGEN-BUKURO), WALLETS FOR COMMUTER TICKETS, BUSINESS CARD CASES; UMBRELLAS, NAMELY, TELESCOPIC UMBRELLAS, JAPANESE PAPER UMBRELLAS (KARAKASA), JAPANESE OILED-PAPER UMBRELLAS (JANOME-GASA), RAINPROOF PARASOLS, BEACH UMBRELLAS, PARASOLS, UMBRELLAS, UMBRELLA COVERS, UMBRELLA HANDLES, METAL PARTS OF UMBRELLAS, FRAMES FOR UMBRELLAS, BAGS FOR UMBRELLAS; WALKING STICKS; CANES; METAL PARTS OF CANES AND WALKING-STICKS; HANDLES FOR CANES AND WALKING-STICKS (U.S. CLS. 1, 2, 3, 22 AND 41).

SN 79-090,294. BRÜTTING & CO. EB-SPORT-INTERNATIONAL GMBH, FED REP GERMANY, FILED 4-15-2010.

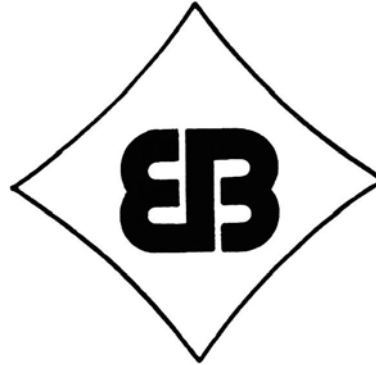

OWNER OF INTERNATIONAL REGISTRATION 1059262 DATED 4-15-2010, EXPIRES 4-15-2020.

THE MARK CONSISTS OF THE STYLIZED LETTERS "EB" INSIDE A DIAMOND SHAPE.

**CLASS 18—LEATHER GOODS**

FOR LEATHERWARE, NAMELY, BRIEFCASES, LEATHER BAGS, LEATHER PURSES; BAGS, NAMELY, ALL-PURPOSE CARRYING BAGS, ATHLETIC BAGS, TRAVELLING BAGS; SUITCASES, UMBRELLAS, ANIMAL HIDES, HORSE BLANKETS (U.S. CLS. 1, 2, 3, 22 AND 41).

**CLASS 25—CLOTHING**

FOR SHOES, SPORTS SHOES, HIKING SHOES, FOOTBALL BOOTS, BATH SLIPPERS, SANDALS, ANKLE BOOTS, BOOTS, SHOE SOLES, INSOLES, CLOTHING, NAMELY, PANTS, SHIRTS, DRESSES; CAPS, HATS, HOODS, HEADBANDS, GLOVES, JACKETS, T-SHIRTS, STOCKINGS, BELTS, KNITWEAR, NAMELY, KNIT BOTTOMS, KNIT DRESSES; SWEATERS, COATS, JUMPERS, SWIMMING TRUNKS (U.S. CLS. 22 AND 39).

**CLASS 25—CLOTHING**

FOR SHOES AND BOOTS OTHER THAN SHOE DOWELS, SHOE PEGS, SHOE HANDLES, HOBNAILED AND SHOE PROTECTIVE METAL MEMBERS, NAMELY, RAIN BOOTS, LACE BOOTS, TRAINING SHOES, OVERSHOES, WOODEN SHOES, WORK SHOES AND BOOTS, SANDALS, SHOES, JAPANESE SPLIT-TOED WORK FOOTWEAR (JIKATABI), ANGLERS' SHOES, BOOTS, HALF-BOOTS, WOMEN'S SHOES, WINTER BOOTS, HOSIERY SHOES, CANVAS SHOES, INFANTS' SHOES AND BOOTS, INNER SOLES FOR SHOES AND BOOTS, HEELPIECES FOR SHOES AND BOOTS, INSOLES FOR SHOES AND BOOTS, WELTS FOR SHOES AND BOOTS, RUBBER SOLES FOR JIKATABI, FOOTWEAR UPPERS, TIPS FOR FOOTWEAR, SHOE SOLES FOR REPAIR; TONGUE OR PULLSTRAP FOR SHOES AND BOOTS; PROTECTIVE METAL MEMBERS FOR SHOES AND BOOTS; JAPANESE STYLE WOODEN CLOGS (GETA), NAMELY, HIGH RAIN CLOGS (ASHIDA), LOW WOODEN CLOGS (KOMA-GETA), SANDAL-CLOGS, LOW WOODEN CLOGS (HIYORI-GETA), METAL FITTINGS FOR JAPANESE STYLE WOODEN CLOGS, WOODEN MAIN BODIES FOR JAPANESE STYLE WOODEN CLOGS, WOODEN SUPPORTS FOR JAPANESE STYLE WOODEN CLOGS, TOE STRAPS FOR JAPANESE STYLE WOODEN CLOGS; JAPANESE STYLE SANDALS (ZORI), NAMELY, JAPANESE TOE-STRAP SANDALS (ASAURAZORI), JAPANESE STYLE SANDALS OF LEATHER, SLIPPERS, JAPANESE STYLE SANDALS OF FELT, JAPANESE FOOTWEAR OF RICE STRAW (WARAJI), SLIPPER SOLES, UPPERS FOR JAPANESE STYLE SANDALS, SOLES FOR JAPANESE STYLE SANDALS, TOE STRAPS FOR JAPANESE STYLE SANDALS, UPPERS OF WOVEN RATTAN FOR JAPANESE STYLE SANDALS; GARTERS; SOCK SUSPENDERS; SUSPENDERS; WAISTBANDS; BELTS FOR CLOTHING (U.S. CLS. 22 AND 39).  
AISHA SALEM, EXAMINING ATTORNEY

**CLASS 35—ADVERTISING AND BUSINESS**

FOR BUSINESS MANAGEMENT AND ORGANIZATION CONSULTANCY, BUSINESS MANAGEMENT CONSULTANCY, PROFESSIONAL BUSINESS CONSULTANCY, PROFESSIONAL BUSINESS MANAGEMENT AND ORGANIZATION CONSULTANCY, BUSINESS INFORMATION, ADVERTISING SERVICES WITH REGARD TO PRESENTATION OF GOODS AND SERVICES TO THE PUBLIC (U.S. CLS. 100, 101 AND 102).  
KRISTIN CARLSON, EXAMINING ATTORNEY

SN 79-090,614. SBI MANAGEMENT GMBH, AUSTRIA, FILED 9-23-2010.

**TOMORROW UNLIMITED**

THE MARK CONSISTS OF STANDARD CHARACTERS WITHOUT CLAIM TO ANY PARTICULAR FONT, STYLE, SIZE, OR COLOR.

PRIORITY DATE OF 4-7-2010 IS CLAIMED.

OWNER OF INTERNATIONAL REGISTRATION 1060115 DATED 9-23-2010, EXPIRES 9-23-2020.

**CLASS 35—ADVERTISING AND BUSINESS**

FOR ADVERTISING AGENCIES; BUSINESS MANAGEMENT; BUSINESS ADMINISTRATION; PROVIDING OFFICE FUNCTIONS; PUBLIC RELATIONS; PRODUCTION OF TELEVISION AND RADIO ADVERTISING, PUBLICATION OF PUBLICITY TEXTS; CONSULTANCY REGARDING THE USE OF MEDIA FOR ADVERTISING PURPOSES; TELEVISION ADVERTISING AGENCIES; ADVERTISING BY MAIL FOR THE PURPOSE OF ACQUIRING CUSTOMERS AND COMMUNICATIONS REGARDING CUSTOMER SERVICE; MARKETING RESEARCH SERVICES; ONLINE ADVERTISING ON A COMPUTER NETWORK; ORGANIZING AND CONDUCTING OF BUSINESS AND SALES PROMOTIONS; PERSONNEL RECRUITMENT SERVICES; BILL-POSTING IN THE NATURE OF ADVERTISING SERVICES; PLANNING OF ADVERTISING TACTICS FOR OTHERS; ADVERTISING IN THE NATURE OF PRESENTATION OF BUSINESSES ON THE INTERNET AND OTHER MEDIA; ADVERTISING IN THE NATURE OF PRESENTATION OF GOODS ON COMMUNICATION MEDIA FOR RETAIL PURPOSES; PRODUCTION OF RADIO ADVERTISING; ADVERTISING THROUGH ALL PUBLIC COMMUNICATION MEANS; ADVERTISING BY MAIL; DISTRIBUTION OF ADVERTISING MATERIAL; ADVERTISING BY THE DISTRIBUTION OF PROMOTIONAL MATERIALS FOR OTHERS; ONLINE ADVERTISING FOR OTHERS (U.S. CLS. 100, 101 AND 102).

**CLASS 41—EDUCATION AND ENTERTAINMENT**

FOR EDUCATION, NAMELY, PROVIDING CLASSES AND SEMINARS IN THE FIELD OF BUSINESS ADMINISTRATION; PROVIDING OF TRAINING IN COMPUTER PROGRAMMING; ENTERTAINMENT IN THE NATURE OF LIVE PERFORMANCES BY A MUSICAL BAND; SPORTING AND CULTURAL ACTIVITIES, NAMELY, PROVIDING ART EXHIBITIONS AND TENNIS TOURNAMENTS (U.S. CLS. 100, 101 AND 107).

**CLASS 42—SCIENTIFIC AND COMPUTER SERVICES**

FOR SCIENTIFIC RESEARCH AND TECHNOLOGICAL SERVICES AND RESEARCH AND DESIGN RELATING THERETO, NAMELY, GEOLOGICAL SURVEYS AND RESEARCH; INDUSTRIAL ANALYSIS AND RESEARCH SERVICES IN THE FIELD OF FACTORY DESIGN; DESIGN AND DEVELOPMENT OF COMPUTER HARDWARE AND SOFTWARE (U.S. CLS. 100 AND 101).  
FRED CARL, EXAMINING ATTORNEY

SN 79-090,770, BYK-CHEMIE GMBH, FED REP GERMANY,  
FILED 9-7-2010.

# CARBOBYK

THE MARK CONSISTS OF STANDARD CHARACTERS WITHOUT CLAIM TO ANY PARTICULAR FONT, STYLE, SIZE, OR COLOR.

PRIORITY DATE OF 8-10-2010 IS CLAIMED.  
OWNER OF INTERNATIONAL REGISTRATION 1060561  
DATED 9-7-2010, EXPIRES 9-7-2020.  
OWNER OF U.S. REG. NOS. 874,526 AND 3,554,205.

**CLASS 1—CHEMICALS**

FOR CHEMICAL PRODUCTS FOR INDUSTRIAL PURPOSES; CHEMICAL PRODUCTS FOR SCIENTIFIC PURPOSES; CARBON ALLOTROPES, NAMELY CARBON FOR INDUSTRIAL PURPOSES; CARBON NANOTUBE DISPERSIONS FOR USE IN THE MANUFACTURE OF PAINTS, VARNISHES, LACQUERS AND FOR APPLICATIONS IN THE PRINTING, ELECTRICAL AND ELECTRONIC INDUSTRIES; CARBON FOR INDUSTRIAL PURPOSES; CHEMICAL DISPERSIONS OF GRAPHITE FOR USE IN THE MANUFACTURE OF PAINTS, VARNISHES, LACQUERS AND FOR APPLICATIONS IN THE PRINTING, ELECTRICAL AND ELECTRONIC INDUSTRIES; GRAPHENE; CARBON BLACK AND/OR CARBON, NAMELY CARBON FOR INDUSTRIAL PURPOSES; CARBON BLACK FOR INDUSTRIAL PURPOSES; GRAPHITE AND GRAPHENE FOR INDUSTRIAL PURPOSES; UNPROCESSED SYNTHETIC RESINS AND PLASTICS; ADHESIVES FOR COMMERCIAL PURPOSES; EMULSION AGENTS, DISPERSING AGENT; DISPERSANTS; CONDUCTIVE ADHESIVES; CHEMICAL ADHESIVES COMPRISING CARBON ALLOTROPES, ESPECIALLY FOR THE ELECTRONIC INDUSTRY, FOR INCREASING OF ELECTRICAL AND THERMAL CONDUCTION AND FOR INCREASING OF MECHANICAL MEANS; CASTING COMPOUNDS COMPRISING CARBON ALLOTROPES, NAMELY COMPRISING CARBON FOR INDUSTRIAL PURPOSES (U.S. CLS. 1, 5, 6, 10, 26 AND 46).

**CLASS 2—PAINTS**

FOR PAINTS, VARNISHES, LACQUERS; CARBON BLACK AS PAINTS; PIGMENTS, IN PARTICULAR IRON PIGMENTS, PEARL GLOSS PIGMENTS, METAL EFFECT PIGMENTS, INTERFERENCE PIGMENTS; POWDER LACQUERS; ANTI-CORROSIVES, NAMELY CORROSION INHIBITORS IN THE NATURE OF A COATING, ANTI-RUST PREPARATIONS, NAMELY RUST PREVENTATIVES IN THE NATURE OF A COATING, NATURAL AND SYNTHETIC DYES; UNPROCESSED NATURAL RESINS; PROTECTIVE, SEALER, ULTRAVIOLET RAYS-RESISTANT, HEAT-RESISTANT, HIGH-VOLTAGE RESISTANT AND DIELECTRIC COATINGS FOR METALS, SYNTHETIC MATERIALS AND PAPER, NAMELY DIP COAT COATING COMPOSITIONS IN THE NATURE OF A PAINT FOR INDUSTRIAL APPLICATIONS; METALS IN FOIL AND POWDER FORM FOR PAINTERS, DECORATORS, PRINTERS AND ARTISTS; ADDITIVES FOR PAINTS, NAMELY EMULSIFYING AGENTS, DISPERSING AGENTS, WETTING AGENTS, PROCESS AGENTS, HARDENERS, DRYING AGENTS, BONDING AGENTS, THICKENERS, FASTENERS, THINNERS AND MATERIAL FOR BLEEDING OF PAINTS AND LACQUERS; COMMON METALS AND THEIR ALLOYS IN GROUND, FOIL, POWDER AND PASTE FORMS FOR PAINTERS, DECORATORS, PRINTERS AND ARTISTS; CUT UP FOILS OF COMMON METALS IN REGULAR FORMS, IN PARTICULAR IN LEAF SHAPE FOR PAINTERS, DECORATORS, PRINTERS AND ARTISTS; WIRE ENAMEL, NAMELY ENAMEL PAINTS; CONDUCTIVE INKS FOR USE IN THE ELECTRIC, ELECTRONIC AND PRINTING INDUSTRY AND CONDUCTIVE COATING COMPOUNDS FOR USE IN THE ELECTRIC, ELECTRONIC AND PRINTING INDUSTRY AND CONDUCTIVE LACQUERS (U.S. CLS. 6, 11 AND 16).

**CLASS 9—ELECTRICAL AND SCIENTIFIC APPARATUS**

FOR PRINTED CIRCUITS, PRINTED ELECTRONIC CIRCUITS FOR APPARATUS AND CARDS BEARING INTEGRATED CIRCUITS; ELECTRONIC AND ELECTRIC COMPONENTS AND ELECTRONIC AND ELECTRIC CIRCUITS FOR ELECTRONIC APPLICATIONS USING CONDUCTIVE POLYMERS, CONDUCTIVE PLASTICS OR SMALL CONDUCTIVE MOLECULES; ELECTRONIC AND ELECTRIC COMPONENTS AND CIRCUITS, IN PARTICULAR MADE OF PLASTICS (U.S. CLS. 21, 23, 26, 36 AND 38).



**CLASS 17—RUBBER GOODS**

FOR NATURAL AND SYNTHETIC RUBBER, GUTTA-PERCHA, GUM, MICA AND ELECTRICAL INSULATING MICA PRODUCTS; PACKING, SEALING AND INSULATING MATERIAL; LIQUID ELECTRONIC INSULATING MATERIALS; NON-METAL SEALS FOR BOTTLE, GLASS AND CAN CAPS; NON-METAL HOSES FOR USE IN ELECTRICAL AND ELECTRONIC CABLE AND COMPONENTS; CARBON FIBERS, EXCEPT FOR TEXTILE PURPOSES; ANTISTATIC PLASTICS IN EXTRUDED FORM FOR USE IN PRODUCTION; ELECTRIC CONDUCTIVE PLASTICS IN EXTRUDED FORM FOR USE IN PRODUCTION; PLASTICS CONTAINING CARBON IN EXTRUDED FORM FOR USE IN PRODUCTION (U.S. CLS. 1, 5, 12, 13, 35 AND 50).

**CLASS 19—NON-METALLIC BUILDING MATERIALS**

FOR CEMENT MIXES; CONCRETE; ELECTRIC CONDUCTIVE CONCRETE AND CEMENT MIXES; NON METALLIC BUILDING MATERIALS CONTAINING CARBON ALLOTROPES, NAMELY CONTAINING GRAPHITE, GRAPHENE, CARBON BLACK, CARBON FIBERS, CARBON NANOTUBES (U.S. CLS. 1, 12, 33 AND 50).

**CLASS 40—MATERIAL TREATMENT**

FOR TREATMENT OF MATERIAL, IN PARTICULAR MANUFACTURE OF CHEMICAL DISPERSIONS TO THE ORDER AND SPECIFICATION OF OTHERS; MANUFACTURE OF MATERIALS CONTAINING CARBON ALLOTROPES TO THE ORDER AND SPECIFICATION OF OTHERS (U.S. CLS. 100, 103 AND 106).

JOHN DWYER, EXAMINING ATTORNEY

SN 79-090,773. UTA SCHNAPPINGER, FED REP GERMANY, FILED 10-25-2010.

**lipoweg**

THE MARK CONSISTS OF STANDARD CHARACTERS WITHOUT CLAIM TO ANY PARTICULAR FONT, STYLE, SIZE, OR COLOR.

PRIORITY DATE OF 4-30-2010 IS CLAIMED.

OWNER OF INTERNATIONAL REGISTRATION 1060569 DATED 10-25-2010, EXPIRES 10-25-2020.

**CLASS 35—ADVERTISING AND BUSINESS**

FOR ONLINE AND LIVE WHOLESALE AND RETAIL STORE SERVICES; FEATURING HOMEOPATHIC PRODUCTS, HERBAL TEAS AND BOOKS; PROVIDING BUSINESS INFORMATION; ADVERTISING SERVICES; BUSINESS MANAGEMENT ADVISORY SERVICES RELATING TO FRANCHISING OF HEALTH CONSULTANCIES (U.S. CLS. 100, 101 AND 102).

**CLASS 41—EDUCATION AND ENTERTAINMENT**

FOR HEALTH CLUB SERVICES, NAMELY, PROVIDING INSTRUCTION AND EQUIPMENT IN THE FIELD OF PHYSICAL EXERCISE; ONLINE PUBLICATION OF ELECTRONIC BOOKS AND PERIODICALS, PUBLICATION OF PRINTED BOOKS, ALMANACS, JOURNALS AND PERIODICALS; TRAINING SERVICES IN THE FIELD OF PHYSICAL EXERCISE; ARRANGING AND CONDUCTING OF SEMINARS AND WORKSHOPS IN THE FIELD OF PHYSICAL EXERCISE AND PHYSICAL TRAINING (U.S. CLS. 100, 101 AND 107).

**CLASS 44—MEDICAL, BEAUTY AND AGRICULTURAL SERVICES**

FOR FOOD NUTRITION CONSULTATION; CONSULTING SERVICES IN THE FIELD OF HEALTH, INCLUDING THE USE OF HOMEOPATHIC TREATMENT; BODYWORK, COGNITIVE AND MASSAGE THERAPY, HYGIENIC BEAUTY CARE; CONSULTING SERVICES IN THE FIELD OF HEALTH (U.S. CLS. 100 AND 101).

IRA J. GOODSaid, EXAMINING ATTORNEY

SN 79-090,810. SPORTAS GMBH SPORANLAGEN-SPORT-BODENBAU, FED REP GERMANY, FILED 10-27-2010.

**Tennis Force**

THE MARK CONSISTS OF STANDARD CHARACTERS WITHOUT CLAIM TO ANY PARTICULAR FONT, STYLE, SIZE, OR COLOR.

OWNER OF INTERNATIONAL REGISTRATION 1049610 DATED 7-3-2010, EXPIRES 7-3-2020.

NO CLAIM IS MADE TO THE EXCLUSIVE RIGHT TO USE "TENNIS" FOR INTERNATIONAL CLASS 19, APART FROM THE MARK AS SHOWN.

**CLASS 19—NON-METALLIC BUILDING MATERIALS**

FOR TENNIS COURT COVERING CONSISTING OF CRUSHED CLAY BRICKS (U.S. CLS. 1, 12, 33 AND 50).

**CLASS 27—FLOOR COVERINGS**

FOR CARPETS; FLOOR CARPETS; LINOLEUM AND OTHER FLOOR COVERINGS (U.S. CLS. 19, 20, 37, 42 AND 50).

JASON BLAIR, EXAMINING ATTORNEY

SN 79-090,825. AVERAHAMI BOAZ, NETHERLANDS, FILED 9-16-2010.

**ROBIN RUTH**

THE MARK CONSISTS OF STANDARD CHARACTERS WITHOUT CLAIM TO ANY PARTICULAR FONT, STYLE, SIZE, OR COLOR.

PRIORITY DATE OF 6-17-2010 IS CLAIMED.

OWNER OF INTERNATIONAL REGISTRATION 1060627 DATED 9-16-2010, EXPIRES 9-16-2020.

OWNER OF U.S. REG. NO. 3,362,655.

THE NAME(S), PORTRAIT(S), AND/OR SIGNATURE(S) SHOWN IN THE MARK DOES NOT IDENTIFY A PARTICULAR LIVING INDIVIDUAL.

**CLASS 18—LEATHER GOODS**

FOR LEATHER AND IMITATIONS OF LEATHER, AND GOODS MADE OF THESE MATERIALS AND NOT INCLUDED IN OTHER CLASSES, NAMELY, LUGGAGE TAGS, TRAVEL BAGS, BACKPACKS, WALLETS, PURSES, BOOK BAGS, SHOULDER BAGS, CASUAL BAGS, SHOPPING BAGS, ATHLETIC BAGS, BEACH BAGS, LEATHER BAGS, SPORTS BAGS, TOILETRY BAGS SOLD EMPTY, PASSPORT HOLDERS; UMBRELLAS, PARASOLS (U.S. CLS. 1, 2, 3, 22 AND 41).

**CLASS 25—CLOTHING**

FOR CLOTHING, NAMELY, GLOVES, PANTS, SHIRTS, SKIRTS, SHORTS, UNDERWEAR, TOPS, JERSEYS, SHAWLS, SOCKS, NECKTIES, BOW TIES, PONCHOS, TEE-SHIRTS; FOOTWEAR; HEADWEAR, NAMELY, HATS, CAPS, BASEBALL CAPS, KNITTED CAPS (U.S. CLS. 22 AND 39).

SN 79-091,166. DANIELA VERONICA GUSA DE DRAGAN, ITALY, FILED 8-2-2010.

**CLASS 35—ADVERTISING AND BUSINESS**

FOR RETAIL STORE SERVICES FEATURING LEATHER AND IMITATIONS OF LEATHER AND GOODS MADE THEREOF, BAGS FOR PACKAGING, TOILET CASES, BEAUTY CASES, UMBRELLAS, SUNSHADES, CLOTHING, FOOTWEAR, HELMETS, HOODS, BASEBALL CAPS, SHAWLS, SOCKS, BOW TIES, NECKTIES, PONCHOS AND TEE-SHIRTS (U.S. CLS. 100, 101 AND 102).

STEVEN JACKSON, EXAMINING ATTORNEY



SN 79-091,165. DANIELA VERONICA GUSA DE DRAGAN, ITALY, FILED 8-2-2010.

# VEROWIND

THE MARK CONSISTS OF STANDARD CHARACTERS WITHOUT CLAIM TO ANY PARTICULAR FONT, STYLE, SIZE, OR COLOR.

PRIORITY DATE OF 6-24-2010 IS CLAIMED.  
OWNER OF INTERNATIONAL REGISTRATION 1061414 DATED 8-2-2010, EXPIRES 8-2-2020.

PRIORITY DATE OF 6-24-2010 IS CLAIMED.  
OWNER OF INTERNATIONAL REGISTRATION 1061415 DATED 8-2-2010, EXPIRES 8-2-2020.

THE MARK CONSISTS OF A UNICORN ABOVE THE WORDING "VEROWIND" WHICH IS ABOVE A HORIZONTAL BAR DESIGN.

**CLASS 1—CHEMICALS**

FOR CHEMICAL DERIVED FROM PETROLEUM AND GAS, NAMELY, PROPANE AND BUTANE (U.S. CLS. 1, 5, 6, 10, 26 AND 46).

**CLASS 1—CHEMICALS**

FOR CHEMICAL DERIVED FROM PETROLEUM AND GAS, NAMELY, PROPANE AND BUTANE (U.S. CLS. 1, 5, 6, 10, 26 AND 46).

**CLASS 4—LUBRICANTS AND FUELS**

FOR GASEOUS AND LIQUEFIED HYDROCARBONS, NAMELY, PROPANE AND BUTANE FOR PRIVATE AND INDUSTRIAL USE (U.S. CLS. 1, 6 AND 15).

**CLASS 4—LUBRICANTS AND FUELS**

FOR GASEOUS AND LIQUEFIED HYDROCARBONS, NAMELY, PROPANE AND BUTANE FOR PRIVATE AND INDUSTRIAL USE (U.S. CLS. 1, 6 AND 15).

**CLASS 6—METAL GOODS**

FOR METAL FLUID STORAGE TANKS AND CONTAINERS FOR CHEMICALS (U.S. CLS. 2, 12, 13, 14, 23, 25 AND 50).

**CLASS 6—METAL GOODS**

FOR METAL FLUID STORAGE TANKS AND CONTAINERS FOR CHEMICALS (U.S. CLS. 2, 12, 13, 14, 23, 25 AND 50).

**CLASS 11—ENVIRONMENTAL CONTROL APPARATUS**

FOR APPARATUS FOR LIGHTING, HEATING, STEAM GENERATING, COOKING AND REFRIGERATING, NAMELY, LIGHTING FIXTURES, HOT WATER HEATERS, STEAM ACCUMULATORS, COOKING RANGES, REFRIGERATORS AND FREEZERS; GAS AND OIL BURNERS FOR DOMESTIC AND INDUSTRIAL USE; SOLAR ENERGY COLLECTORS FOR HEATING; PHOTOVOLTAIC ENERGY COLLECTORS FOR HEATING; SOLAR ENERGY POWERED HEATING APPARATUS FOR HEATING AIR AND DEFROSTING WINDOWS OF VEHICLES; PHOTOVOLTAIC ENERGY POWERED HEATING INSTALLATIONS; SOLAR ENERGY POWERED HEATING INSTALLATIONS; SOLAR HEAT COLLECTION APPARATUS AND INSTRUMENTS; SOLAR HEAT COLLECTION PANELS; PHOTOVOLTAIC HEAT COLLECTION PANELS (U.S. CLS. 13, 21, 23, 31 AND 34).

**CLASS 11—ENVIRONMENTAL CONTROL APPARATUS**

FOR APPARATUS FOR LIGHTING, HEATING, STEAM GENERATING, COOKING AND REFRIGERATING, NAMELY, LIGHTING FIXTURES, HOT WATER HEATERS, STEAM ACCUMULATORS, COOKING RANGES, REFRIGERATORS AND FREEZERS; GAS AND OIL BURNERS FOR DOMESTIC AND INDUSTRIAL USE; SOLAR ENERGY COLLECTORS FOR HEATING; PHOTOVOLTAIC ENERGY COLLECTORS FOR HEATING; SOLAR ENERGY POWERED HEATING APPARATUS FOR HEATING AIR AND DEFROSTING WINDOWS OF VEHICLES; PHOTOVOLTAIC ENERGY POWERED HEATING INSTALLATIONS; SOLAR ENERGY POWERED HEATING INSTALLATIONS; SOLAR HEAT COLLECTION APPARATUS AND INSTRUMENTS; SOLAR HEAT COLLECTION PANELS; PHOTOVOLTAIC HEAT COLLECTION PANELS (U.S. CLS. 13, 21, 23, 31 AND 34).

**CLASS 21—HOUSEWARES AND GLASS**

FOR CONTAINERS FOR HOUSEHOLD OR KITCHEN USE (U.S. CLS. 2, 13, 23, 29, 30, 33, 40 AND 50).  
ANDREA HACK, EXAMINING ATTORNEY

**CLASS 21—HOUSEWARES AND GLASS**

FOR CONTAINERS FOR HOUSEHOLD OR KITCHEN USE (U.S. CLS. 2, 13, 23, 29, 30, 33, 40 AND 50).  
ANDREA HACK, EXAMINING ATTORNEY

SN 79-091,167. DANIELA VERONICA GUSA DE DRAGAN, ITALY, FILED 8-2-2010.

# VEROGAS

THE MARK CONSISTS OF STANDARD CHARACTERS WITHOUT CLAIM TO ANY PARTICULAR FONT, STYLE, SIZE, OR COLOR.

PRIORITY DATE OF 6-24-2010 IS CLAIMED.  
OWNER OF INTERNATIONAL REGISTRATION 1061416 DATED 8-2-2010, EXPIRES 8-2-2020.

## CLASS 1—CHEMICALS

FOR CHEMICAL DERIVED FROM PETROLEUM AND GAS, NAMELY, PROPANE AND BUTANE (U.S. CLS. 1, 5, 6, 10, 26 AND 46).

## CLASS 4—LUBRICANTS AND FUELS

FOR GASEOUS AND LIQUEFIED HYDROCARBONS, NAMELY, PROPANE AND BUTANE FOR PRIVATE AND INDUSTRIAL USE (U.S. CLS. 1, 6 AND 15).

## CLASS 6—METAL GOODS

FOR METAL FLUID STORAGE TANKS AND CONTAINERS FOR CHEMICALS (U.S. CLS. 2, 12, 13, 14, 23, 25 AND 50).

## CLASS 11—ENVIRONMENTAL CONTROL APPARATUS

FOR APPARATUS FOR LIGHTING, HEATING, STEAM GENERATING, COOKING AND REFRIGERATING, NAMELY, LIGHTING FIXTURES, HOT WATER HEATERS, STEAM ACCUMULATORS, COOKING RANGES, REFRIGERATORS AND FREEZERS; GAS AND OIL BURNERS FOR DOMESTIC AND INDUSTRIAL USE; SOLAR ENERGY COLLECTORS FOR HEATING; PHOTOVOLTAIC ENERGY COLLECTORS FOR HEATING; SOLAR ENERGY POWERED HEATING APPARATUS FOR HEATING AIR AND DEFROSTING WINDOWS OF VEHICLES; PHOTOVOLTAIC ENERGY POWERED HEATING INSTALLATIONS; SOLAR ENERGY POWERED HEATING INSTALLATIONS; SOLAR HEAT COLLECTION APPARATUS AND INSTRUMENTS; SOLAR HEAT COLLECTION PANELS; PHOTOVOLTAIC HEAT COLLECTION PANELS (U.S. CLS. 13, 21, 23, 31 AND 34).

## CLASS 21—HOUSEWARES AND GLASS

FOR CONTAINERS FOR HOUSEHOLD OR KITCHEN USE (U.S. CLS. 2, 13, 23, 29, 30, 33, 40 AND 50).  
ANDREA HACK, EXAMINING ATTORNEY

SN 79-091,283. NV BEKAERT SA, B-8550 ZWEVEGEM, BELGIUM, FILED 10-18-2010.

# ARMOFOR

THE MARK CONSISTS OF STANDARD CHARACTERS WITHOUT CLAIM TO ANY PARTICULAR FONT, STYLE, SIZE, OR COLOR.

PRIORITY DATE OF 7-13-2010 IS CLAIMED.  
OWNER OF INTERNATIONAL REGISTRATION 1061776 DATED 10-18-2010, EXPIRES 10-18-2020.

## CLASS 6—METAL GOODS

FOR METAL WIRES; METAL CORDS FOR REINFORCEMENT OF SYNTHETIC STRIPS; STEEL WIRES; STEEL CORDS FOR REINFORCEMENT OF SYNTHETIC STRIPS (U.S. CLS. 2, 12, 13, 14, 23, 25 AND 50).

## CLASS 17—RUBBER GOODS

FOR SYNTHETIC STRIPS, NAMELY, THERMOPLASTIC STRIPS REINFORCED WITH STEEL CORD FOR USE IN THE MANUFACTURE OF FLEXIBLE PIPES (U.S. CLS. 1, 5, 12, 13, 35 AND 50).

JAY FLOWERS, EXAMINING ATTORNEY

SN 79-091,532. ODEON TURIZM ISLETMECILIGI A.S., ISTANBUL, TURKEY, FILED 3-5-2010.



OWNER OF INTERNATIONAL REGISTRATION 0997790 DATED 2-2-2009, EXPIRES 2-2-2019.

NO CLAIM IS MADE TO THE EXCLUSIVE RIGHT TO USE "TRAVEL", APART FROM THE MARK AS SHOWN.

THE COLOR(S) BLUE, ORANGE AND WHITE IS/ARE CLAIMED AS A FEATURE OF THE MARK.

FONT IS BLUE, "CORAL TRAVEL" IS WHITE AND THE GEOMETRIC SHAPE ABOVE "CORAL TRAVEL" WORD IS ORANGE.

THE MARK CONSISTS OF THE FOLLOWING: AN ORANGE SEMI-CIRCLE CENTERED OVER THE WORDING "CORAL", WHICH APPEARS IN WHITE LETTERS ABOVE THE WORDING "TRAVEL", WHICH APPEARS IN WHITE LETTERS, ALL ON A BLUE BACKGROUND.

## CLASS 36—INSURANCE AND FINANCIAL

FOR ACCIDENT INSURANCE UNDERWRITING, LIFE INSURANCE UNDERWRITING, FIRE INSURANCE UNDERWRITING, HEALTH INSURANCE UNDERWRITING, MARINE INSURANCE UNDERWRITING, ACTUARIAL SERVICES, INSURANCE INFORMATION, BANKING, FINANCIAL MANAGEMENT, FINANCIAL SPONSORSHIP, FINANCIAL EVALUATION, FINANCIAL INFORMATION, FACTORING, LEASE-PURCHASE FINANCING, CREDIT CARD SERVICES, MONEY EXCHANGING, REAL ESTATE BROKERS, APARTMENT HOUSE MANAGEMENT, ANTIQUE APPRAISAL, JEWELLERY APPRAISAL, STAMP APPRAISAL, ART APPRAISAL, NUMISMATIC APPRAISAL, CUSTOMS BROKERAGE (U.S. CLS. 100, 101 AND 102).

## CLASS 39—TRANSPORTATION AND STORAGE

FOR AIR TRANSPORT, AMBULANCE TRANSPORT, ARRANGING OF TOURS, BOAT TRANSPORT, CAR PARKING, CAR TRANSPORT, DELIVERY OF GOODS BY MAIL ORDER, MESSAGE DELIVERY, DELIVERY OF GOODS, DELIVERY OF NEWSPAPERS, ELECTRICITY DISTRIBUTION, GARAGE RENTAL, PARKING PLACE RENTAL, PILOTING, REFLOATING OF SHIPS, RENTAL OF DIVING SUITS, RENTAL OF DIVING BELLS, TRAVEL RESERVATION, RESCUE OPERATIONS, SHIP BROKERAGE, STORAGE OF GOODS TRANSPORT BROKERAGE, TRANSPORT AND STORAGE OF TRASH, TRANSPORT AND STORAGE OF WASTE, TRANSPORT BY PIPELINE, WATER SUPPLYING (U.S. CLS. 100 AND 105).

SUZANNE BLANE, EXAMINING ATTORNEY

SN 79-091,824. SIEMENS AKTIENGESELLSCHAFT, FED REP GERMANY, FILED 11-17-2010.

# SIPExpress

THE MARK CONSISTS OF STANDARD CHARACTERS WITHOUT CLAIM TO ANY PARTICULAR FONT, STYLE, SIZE, OR COLOR.

OWNER OF INTERNATIONAL REGISTRATION 1063083 DATED 11-17-2010, EXPIRES 11-17-2020.

## CLASS 9—ELECTRICAL AND SCIENTIFIC APPARATUS

FOR DATA PROCESSING PROGRAMS FOR DIAGNOSING THE PERFORMANCE CHARACTERISTIC OF LINEAR ACCELERATORS (U.S. CLS. 21, 23, 26, 36 AND 38).

## CLASS 42—SCIENTIFIC AND COMPUTER SERVICES

FOR DEVELOPMENT AND IMPLEMENTATION OF DATA PROCESSING PROGRAMS FOR DIAGNOSING THE PERFORMANCE CHARACTERISTIC OF LINEAR ACCELERATORS (U.S. CLS. 100 AND 101).

KIMBERLY FRYE, EXAMINING ATTORNEY

SN 79-093,558. ISABEL ARAGON VILLACASTIN, SPAIN, FILED 10-20-2010.



OWNER OF INTERNATIONAL REGISTRATION 0981490 DATED 9-24-2007, EXPIRES 9-24-2017.

NO CLAIM IS MADE TO THE EXCLUSIVE RIGHT TO USE "SERVICIOS DE IMAGEN", APART FROM THE MARK AS SHOWN.

THE MARK CONSISTS OF THE LETTERS "CM" ABOVE THE WORDING "SERVICIOS DE IMAGEN" WHICH APPEARS ABOVE THE WORKING "CLASSMAKERS." BELOW THIS WORDING IS AN UNDERLINE WITH A SCROLL DESIGN. UNDERNEATH THIS IS A SOLID LINE WITH THE LARGE STYLIZED LETTERS "CM" UNDERNEATH IT. ALL THE WORDING AND DESIGNS ARE ENCOMPASSED IN A RECTANGLE.

THE ENGLISH TRANSLATION OF "SERVICIOS DE IMAGEN" IN THE MARK IS "SERVICES OF IMAGE."

## CLASS 35—ADVERTISING AND BUSINESS

FOR ADVERTISING SERVICES, MARKETING AND PUBLIC RELATIONS; ORGANISATION OF FAIRS AND EXHIBITIONS FOR COMMERCIAL PURPOSES AND CONSULTING RELATING THERETO (U.S. CLS. 100, 101 AND 102).

## CLASS 45—PERSONAL AND LEGAL SERVICES

FOR PERSONAL SERVICES RENDERED BY OTHERS TO MEET THE NEEDS OF INDIVIDUALS, NAMELY, CONSULTING IN PERSONAL IMAGE (U.S. CLS. 100 AND 101).

COURTNEY ALVAREZ, EXAMINING ATTORNEY

SN 79-093,979. RAQUALIA PHARMA INC., JAPAN, FILED 11-30-2010.



OWNER OF INTERNATIONAL REGISTRATION 1068185 DATED 11-30-2010, EXPIRES 11-30-2020.

THE COLOR(S) THE COLORS ORANGE AND WHITE ARE CLAIMED AS A FEATURE OF THE MARK IS/ARE CLAIMED AS A FEATURE OF THE MARK.

THE MARK CONSISTS OF A LARGE WHITE STYLIZED LETTER STANDING OUT ON THE SURFACE OF AN ORANGE SPHERE; THE LETTER REPRESENTS COALESCENT LETTERS "R" AND "Q".

## CLASS 5—PHARMACEUTICALS

FOR PHARMACEUTICAL PREPARATIONS FOR THE TREATMENT OF PAIN, GASTROINTESTINAL DISEASE, CANCER, AND CENTRAL NERVOUS SYSTEM DISORDER, INFECTIOUS, METABOLIC, CARDIOVASCULAR, DERMATOLOGICAL AND EYE DISEASE, URINARY DISEASE, INFLAMMATORY DISEASE, AUTOIMMUNE DISEASE, AND CACHEXIA; SANITARY PREPARATIONS FOR MEDICAL USE (U.S. CLS. 6, 18, 44, 46, 51 AND 52).

## CLASS 42—SCIENTIFIC AND COMPUTER SERVICES

FOR TESTING, RESEARCH OR DEVELOPMENT OF PHARMACEUTICAL, VETERINARY AND SANITARY PREPARATIONS; CONSULTANCY AND PROVIDING INFORMATION RELATING TO TESTING, RESEARCH OR DEVELOPMENT OF PHARMACEUTICAL, VETERINARY AND SANITARY PREPARATIONS (U.S. CLS. 100 AND 101).

CHRISIE B. KING, EXAMINING ATTORNEY

SN 79-094,031. SUNCOVER S.P.A., ITALY, FILED 10-22-2010.



PRIORITY DATE OF 10-13-2010 IS CLAIMED. OWNER OF INTERNATIONAL REGISTRATION 1068293 DATED 10-22-2010, EXPIRES 10-22-2020.

THE TRADEMARK CONSISTS OF THE WORDING "SUN-COVER" AND, ON THE LEFT, THERE IS THE REPRESENTATION OF A STYLISED SUN COVERED FOR A HALF BY A DARKENING CURTAIN; THIS CURTAIN HAS A GUY ROPE FOR THE SLIDING; ALL THE AFOREMENTIONED ELEMENTS ARE INSIDE A SQUARE FRAME.

**CLASS 20—FURNITURE AND ARTICLES NOT OTHERWISE CLASSIFIED**

FOR CURTAIN RAILS, RINGS, RODS, TRAVERSE RODS, POLES, HOOKS, CURTAIN FINIALS, ROLLERS; VENETIAN BLINDS; WINDOW INTERIOR BLINDS; WINDOW SHADES (U.S. CLS. 2, 13, 22, 25, 32 AND 50).

**CLASS 24—FABRICS**

FOR CURTAINS OF TEXTILE AND PLASTIC; CURTAIN FABRIC; INDOOR AND OUTDOOR CURTAINS; MOSQUITO NETS (U.S. CLS. 42 AND 50).  
SUE LAWRENCE, EXAMINING ATTORNEY

SN 79-094,314. SHANGHAI BAOSIGHT SOFTWARE CO., LTD., CHINA, FILED 12-29-2010.

**BAOSIGHT**

OWNER OF INTERNATIONAL REGISTRATION 1069019 DATED 12-29-2010, EXPIRES 12-29-2020.

THIS TRADEMARK CONSISTS OF AN INVENTED LATIN WORD "BAOSIGHT" WHICH IS THE TRADE NAME OF THE APPLICANT AND HAS NO SIGNIFICANCE IN THE RELEVANT TRADE OR INDUSTRY OR AS APPLIED TO THE GOODS LISTED IN THE APPLICATION, NO GEOGRAPHICAL SIGNIFICANCE.

**CLASS 9—ELECTRICAL AND SCIENTIFIC APPARATUS**

FOR MAGNETIC ENCODERS; COMPUTERS; COMPUTER OPERATING SOFTWARE; COMPUTER PERIPHERAL DEVICES; MICROPROCESSORS, BEING COMPUTER HARDWARE; COMPUTER CENTRAL PROCESSING UNITS; COMPUTER OPERATING PROGRAMS, RECORDED (U.S. CLS. 21, 23, 26, 36 AND 38).

**CLASS 42—SCIENTIFIC AND COMPUTER SERVICES**

FOR COMPUTER PROGRAMMING; RENTAL OF COMPUTER SOFTWARE; UPDATING AND DESIGN OF COMPUTER SOFTWARE; MAINTENANCE OF COMPUTER SOFTWARE; RECOVERY OF COMPUTER DATA; COMPUTER SYSTEMS ANALYSIS; RENTAL OF COMPUTERS (U.S. CLS. 100 AND 101).

SUZANNE BLANE, EXAMINING ATTORNEY

SN 85-002,152. ADELPHOI LIMITED, LONDON, UNITED KINGDOM, FILED 3-30-2010.

**SILVERMOUSE**

THE MARK CONSISTS OF STANDARD CHARACTERS WITHOUT CLAIM TO ANY PARTICULAR FONT, STYLE, SIZE, OR COLOR.

OWNER OF ERPN CMNTY TM OFC REG. NO. 5598578, DATED 1-29-2008, EXPIRES 1-5-2017.

**CLASS 9—ELECTRICAL AND SCIENTIFIC APPARATUS**

FOR APPARATUS FOR RECORDING, TRANSMISSION OR REPRODUCTION OF SOUND AND IMAGES; RECORDINGS OF SOUND OR IMAGES, NAMELY, VISUAL RECORDINGS AND AUDIOVISUAL RECORDINGS FEATURING MUSIC AND ANIMATION AND MUSICAL SOUND RECORDING; COMPUTER MULTIMEDIA PRODUCTS, NAMELY, INTERACTIVE MULTIMEDIA COMPUTER GAME PROGRAM; MAGNETIC AND OPTICAL PROGRAM BEARING MEDIA, NAMELY, BLANK ELECTRONIC STORAGE MEDIA; COMPUTER GAME SOFTWARE, VIDEO GAME SOFTWARE, INTERACTIVE VIDEO GAME PROGRAMS; COMPUTER GAME EQUIPMENT, NAMELY, VIDEO OUTPUT GAME MACHINES FOR USE WITH TELEVISION; COMPUTER SOFTWARE FOR USE IN THE COLLECTION, EDITING, ORGANIZING, MODIFYING, BOOK MARKING, TRANSMISSION, STORAGE AND SHARING OF DATA AND INFORMATION; COMPUTER SOFTWARE FOR CREATING AND EDITING MUSIC AND SOUNDS AND FOR USE IN PROCESSING DIGITAL MUSIC FILES; COMPUTER SEARCH ENGINE SOFTWARE; COMPUTER SOFTWARE FEATURING MUSICAL SOUND RECORDINGS AND MUSICAL VIDEO RECORDINGS; DOWNLOADABLE MUSICAL SOUND RECORDINGS; DOWNLOADABLE VIDEO RECORDINGS FEATURING MUSIC; DIGITAL MUSIC DOWNLOADABLE FROM THE INTERNET (U.S. CLS. 21, 23, 26, 36 AND 38).

**CLASS 35—ADVERTISING AND BUSINESS**

FOR PROVIDING INFORMATION AND NEWS IN THE FIELD OF BUSINESS, NAMELY, INFORMATION AND NEWS ON CURRENT EVENTS AND ON ECONOMIC, LEGISLATIVE, AND REGULATORY DEVELOPMENTS AS IT RELATES TO AND CAN IMPACT BUSINESSES; PROVIDING AN ON-LINE COMMERCIAL INFORMATION DIRECTORY ON THE INTERNET; COMPILATION AND SYSTEMIZATION OF INFORMATION INTO COMPUTER DATABASES; COMPUTERIZED FILE MANAGEMENT; DATABASE MANAGEMENT; DATABASE MANAGEMENT SERVICES FOR DATA RELATING TO MUSIC WORKS USED IN MEDIA; COMMERCIAL ADMINISTRATION OF THE LICENSING OF MUSICAL OR LYRICAL WORKS OF OTHERS; AND ADVISORY AND CONSULTANCY SERVICES RELATING TO ANY OF THE AFORESAID SERVICES, NAMELY, BUSINESS MANAGEMENT CONSULTING AND ADVISORY SERVICES (U.S. CLS. 100, 101 AND 102).

**CLASS 42—SCIENTIFIC AND COMPUTER SERVICES**

FOR SCIENTIFIC RESEARCH; SCIENTIFIC AND TECHNOLOGICAL SERVICES AND RESEARCH AND DESIGN IN THE FIELD OF INTEGRATED SYSTEM ARCHITECTURE THAT ALLOWS FOR THE RAPID DEVELOPMENT OF HIGHLY INTERACTIVE AND CUSTOMIZABLE LEARNING APPLICATIONS; CREATING, MAINTAINING AND HOSTING WEBSITES FOR OTHERS; TECHNICAL CONSULTING AND ASSISTANCE WITH COMPUTER-BASED INFORMATION SYSTEMS AND COMPONENTS (U.S. CLS. 100 AND 101).

**CLASS 45—PERSONAL AND LEGAL SERVICES**

FOR LICENSING OF RIGHTS FOR PRODUCTION OF MUSICAL AND/OR LYRICAL WORKS, NAMELY, LICENSING OF INTELLECTUAL PROPERTY; COPYRIGHT MANAGEMENT OF COPYRIGHTS IN MUSICAL AND LYRICAL WORKS FOR AND ON BEHALF OF AUTHORS, COMPOSERS OR CONDUCTORS OF SUCH WORKS; LICENSING IN THE NATURE OF PROFESSIONAL LICENSE PROTECTION SERVICES, NAMELY, THE DEFENSE OF PROFESSIONAL LICENSES OR PROFESSIONAL CERTIFICATIONS BY MEANS OF AN INDEPENDENT NETWORK OF LEGAL PROFESSIONALS; PROFESSIONAL LEGAL CONSULTATIONS RELATING TO MUSIC COPYRIGHT AND MUSIC LICENSING (U.S. CLS. 100 AND 101).

JENNIFER MARTIN, EXAMINING ATTORNEY

SN 85-002,295. ASIATIC FIBER CORPORATION, TAIPEI, TAIWAN, FILED 3-30-2010.

SN 85-003,030. INTRUST SERVICES LLC, LAKE MARY, FL. FILED 3-31-2010.

# A F C

THE MARK CONSISTS OF THE LETTERS "A" "F" "C" IN STYLIZED FORMAT.

## CLASS 9—ELECTRICAL AND SCIENTIFIC APPARATUS

FOR GLOVES FOR PROTECTION AGAINST FIRE; SCIENTIFIC MEASURING INSTRUMENTS, NAMELY, CONDUCTIVITY METERS; BULLET-PROOF CLOTHING (U.S. CLS. 21, 23, 26, 36 AND 38).

## CLASS 10—MEDICAL APPARATUS

FOR SURGICAL CAPS; DRAW-SHEETS FOR SICK BEDS; SURGICAL MASKS; GLOVES FOR MEDICAL PURPOSES; DISPOSABLE GLOVES FOR MEDICAL PURPOSES; AIR CUSHIONS FOR MEDICAL PURPOSES; AIR MATTRESSES FOR MEDICAL PURPOSES; AIR PILLOWS FOR MEDICAL PURPOSES; SURGICAL GOWNS (U.S. CLS. 26, 39 AND 44).

## CLASS 22—CORDAGE AND FIBERS

FOR NATURAL FIBERS, NAMELY, RAW TEXTILE FIBERS, YARN FIBERS; SYNTHETIC FIBERS FOR TEXTILE USE; GLASS FIBERS FOR TEXTILE USE; METAL FIBERS FOR TEXTILE USE; CERAMIC FIBERS FOR TEXTILE USE; POLYESTER FIBERS; PLASTIC FIBERS FOR TEXTILE USE; VITREOUS SILICA FIBERS FOR TEXTILE USE; NYLON FIBERS FOR TEXTILE USE (U.S. CLS. 1, 2, 7, 19, 22, 42 AND 50).

## CLASS 23—YARNS AND THREADS

FOR THREAD; YARN; SYNTHETIC FIBER THREAD AND YARN; FIBERGLASS THREAD FOR TEXTILE USE; ELASTIC THREAD FOR TEXTILE USE; HEMP THREAD; SILK THREAD; RAYON THREAD AND YARN; PLASTIC THREAD FOR TEXTILE USE (U.S. CL. 43).

## CLASS 24—FABRICS

FOR FABRIC FOR TEXTILE USE; COTTON FABRICS; JERSEY FABRICS FOR CLOTHING; WOVEN FABRICS AND KNITTED FABRICS; SILK FABRICS FOR PRINTING PATTERNS; NON-WOVEN TEXTILE FABRICS; ELASTIC FABRICS FOR CLOTHING; RAYON FABRICS; NON-WOVEN TEXTILE USED AS LINING FOR CLOTHING; WATERPROOF FABRIC FOR MANUFACTURING CLOTHING, FURNITURE AND AUTOMOBILE UPHOLSTERY, AND LUGGAGE; NON-WOVEN FABRICS MADE OF FIBERGLASS; SYNTHETIC FIBER FABRICS; NON-WOVEN FABRICS MADE OF POLYPROPYLENE (U.S. CLS. 42 AND 50).

## CLASS 25—CLOTHING

FOR CLOTHING FOR USE BY CLEANROOM, SAFETY AND HEALTHCARE PROFESSIONALS, NAMELY, PANTS, SHIRTS, LONG COATS, SHORT COATS, JACKETS, SUITS, TROUSERS, SKIRTS, SWIMSUITS, SPORT SHIRTS, T-SHIRTS, UNDERWEAR, SHOES, HATS, CAPS, SUN VISORS, SOCKS, GLOVES, NECKTIES, SCARVES, BELTS, OVERALLS, NURSE OVERALLS, DOCTORS' COATS, BOOTS; ANTI-STATIC CLOTHING, NAMELY, PANTS, SHIRTS; ANTI-STATIC SHOES; SAFETY SHOES; HEEL PIECES FOR SHOES (U.S. CLS. 22 AND 39).

BARNEY CHARLON, EXAMINING ATTORNEY

# MY MSA CARD

THE MARK CONSISTS OF STANDARD CHARACTERS WITHOUT CLAIM TO ANY PARTICULAR FONT, STYLE, SIZE, OR COLOR.

NO CLAIM IS MADE TO THE EXCLUSIVE RIGHT TO USE "MSA CARD", APART FROM THE MARK AS SHOWN.

## CLASS 35—ADVERTISING AND BUSINESS

FOR BUSINESS ADMINISTRATION FOR OTHERS OF AUTOMATED AND ON-LINE MEDICARE SET-ASIDE ACCOUNTS FOR SETTLEMENTS BASED UPON INSURANCE, WORKERS COMPENSATION AND NON-FAULT CLAIMS RECOVERY (U.S. CLS. 100, 101 AND 102).

## CLASS 36—INSURANCE AND FINANCIAL

FOR ADMINISTRATION OF AUTOMATED AND ON-LINE MEDICARE SET-ASIDE MEDICAL SAVINGS ACCOUNTS FOR SETTLEMENTS OF INSURANCE, WORKERS COMPENSATION, AND NON-FAULT CLAIMS RECOVERY (U.S. CLS. 100, 101 AND 102).

RAMONA ORTIGA, EXAMINING ATTORNEY

---

SN 85-003,302. ALCYONE LIMITED, NASSAU, BAHAMAS, FILED 3-31-2010.

# SOIL TO SOUL

THE MARK CONSISTS OF STANDARD CHARACTERS WITHOUT CLAIM TO ANY PARTICULAR FONT, STYLE, SIZE, OR COLOR.

OWNER OF ERPN CMNTY TM OFC REG. NO. 001308576, DATED 12-11-2000, EXPIRES 9-14-2019.

OWNER OF U.S. REG. NO. 2,826,877.

## CLASS 3—COSMETICS AND CLEANING PREPARATIONS

FOR COSMETICS; NON-MEDICATED SKIN, SCALP AND HAIR CARE PREPARATIONS; TOILET SOAP AND PERFUMED SOAP; SOAPS FOR BODY CARE; DEPILATORY PREPARATIONS AND SUBSTANCES; BATH HERBS; ETHEREAL OILS; ESSENTIAL OILS FOR PERSONAL USE; BATH OILS; MASSAGE OILS; PERFUMES AND COLOGNES; HAND CREAMS, BODY LOTIONS, AROMATHERAPY CREAMS; FRAGRANCES; POTPOURRI; FRAGRANT SACHETS; EAU DE COLOGNE, DENTIFRICES, TALCUM POWDER (U.S. CLS. 1, 4, 6, 50, 51 AND 52).

## CLASS 4—LUBRICANTS AND FUELS

FOR CANDLES; PERFUMED CANDLES (U.S. CLS. 1, 6 AND 15).

SHARON MEIER, EXAMINING ATTORNEY

SN 85-004,476. EPIR TECHNOLOGIES, INC., BOLING-BROOK, IL. FILED 4-1-2010.

SN 85-009,144. ADBASE INC., TORONTO, ONTARIO, CANADA, FILED 4-8-2010.

WE DEFEND THOSE WHO DEFEND  
US

THE MARK CONSISTS OF STANDARD CHARACTERS WITHOUT CLAIM TO ANY PARTICULAR FONT, STYLE, SIZE, OR COLOR.

**CLASS 9—ELECTRICAL AND SCIENTIFIC APPARATUS**

FOR COMPOUND SEMICONDUCTOR EPITAXIAL FILMS FORMED ONTO SUBSTRATES AND SOLD TOGETHER AS A UNIT; PHOTOVOLTAIC DEVICES, NAMELY, PHOTOVOLTAIC CELLS AND ARRAYS (U.S. CLS. 21, 23, 26, 36 AND 38).

**CLASS 42—SCIENTIFIC AND COMPUTER SERVICES**

FOR RESEARCH AND DEVELOPMENT SERVICES IN THE FIELD OF SEMICONDUCTOR MATERIALS AND DEVICES (U.S. CLS. 100 AND 101).  
RUDY R. SINGLETON, EXAMINING ATTORNEY

---

SN 85-005,245. BERNATZ, THOMAS H., ORANGE, CA. FILED 4-2-2010.

YARD VARK

THE MARK CONSISTS OF STANDARD CHARACTERS WITHOUT CLAIM TO ANY PARTICULAR FONT, STYLE, SIZE, OR COLOR.

**CLASS 25—CLOTHING**

FOR CLOTHING, NAMELY, SHIRTS, HATS, BELTS AND PANTS (U.S. CLS. 22 AND 39).  
FIRST USE 10-6-1998; IN COMMERCE 10-6-1998.

**CLASS 28—TOYS AND SPORTING GOODS**

FOR GOLF COURSE DEVICES, NAMELY, MARKING SYSTEMS COMPRISING DISTANCE MARKERS FOR GOLF COURSES AND PRACTICE AREA DEVICES IN THE NATURE OF DISTANCE MARKERS FOR GOLFING RANGES (U.S. CLS. 22, 23, 38 AND 50).  
FIRST USE 10-6-1998; IN COMMERCE 10-6-1998.  
REBECCA EISINGER, EXAMINING ATTORNEY

FOUND

THE MARK CONSISTS OF STANDARD CHARACTERS WITHOUT CLAIM TO ANY PARTICULAR FONT, STYLE, SIZE, OR COLOR.

**CLASS 16—PAPER GOODS AND PRINTED MATTER**

FOR PRINTED PUBLICATIONS, NAMELY, SOURCE BOOKS FEATURING THE WORK OF PHOTOGRAPHERS, ILLUSTRATORS, AND PRODUCTION COMPANIES THAT ARE MARKETED TOWARD BUYERS IN THE COMMERCIAL COMMUNICATIONS INDUSTRY (U.S. CLS. 2, 5, 22, 23, 29, 37, 38 AND 50).  
FIRST USE 10-0-2009; IN COMMERCE 10-0-2009.

**CLASS 35—ADVERTISING AND BUSINESS**

FOR ON-LINE GALLERIES FOR ADVERTISING AND MARKETING PURPOSES FEATURING THE WORK OF PHOTOGRAPHERS, ILLUSTRATORS, AND PRODUCTION COMPANIES THAT ARE MARKETED TOWARD BUYERS IN THE COMMERCIAL COMMUNICATIONS INDUSTRY; PROMOTIONAL SERVICES, NAMELY, PROVIDING A WEBSITE AT WHICH ARTISTS CAN SHOWCASE TALENTS VIA AN ONLINE PORTFOLIO; PROMOTIONAL SERVICES, NAMELY, PROVIDING A WEBSITE TO ALLOW A PHOTOGRAPHER, ILLUSTRATOR, PRODUCTION COMPANY OR CREATIVE SUPPLIER TO THE COMMUNICATIONS INDUSTRY TO SHOWCASE THEIR TALENTS VIA AN ONLINE PORTFOLIO AND TO MARKET THEMSELVES VIA EMAIL AND PHOTO FEEDS TO BUYERS IN THE COMMERCIAL COMMUNICATIONS INDUSTRY (U.S. CLS. 100, 101 AND 102).  
FIRST USE 10-0-2009; IN COMMERCE 10-0-2009.

**CLASS 41—EDUCATION AND ENTERTAINMENT**

FOR ON-LINE NON-DOWNLOADABLE PUBLICATIONS, NAMELY, SOURCE BOOKS CONTAINING ON-LINE GALLERIES FEATURING THE WORK OF PHOTOGRAPHERS, ILLUSTRATORS, AND PRODUCTION COMPANIES THAT ARE MARKETED TOWARD BUYERS IN THE COMMERCIAL COMMUNICATIONS INDUSTRY; ON-LINE ELECTRONIC NEWSLETTERS DELIVERED BY E-MAIL PERTAINING TO THE COMMERCIAL COMMUNICATIONS INDUSTRY (U.S. CLS. 100, 101 AND 107).  
FIRST USE 10-0-2009; IN COMMERCE 10-0-2009.  
JAMES LOVELACE, EXAMINING ATTORNEY

---

SN 85-010,526. KURTZ JR., WILLIAM G., PALM HARBOR, FL. FILED 4-9-2010.

FOR BRIGHTIES

THE MARK CONSISTS OF STANDARD CHARACTERS WITHOUT CLAIM TO ANY PARTICULAR FONT, STYLE, SIZE, OR COLOR.

**CLASS 9—ELECTRICAL AND SCIENTIFIC APPARATUS**

FOR PRE-RECORDED ELECTRONIC AND DIGITAL MEDIA FEATURING AUDIO AND VIDEO CASSETTES, COMPACT DISKS, DVDS, DOWNLOADABLE AUDIO AND VIDEO RECORDINGS, HIGH DEFINITION DIGITAL DISCS IN THE FIELDS OF FINANCE, STOCK MARKET INVESTING, BOND, COMMODITIES AND FOREIGN EXCHANGE MARKET INVESTING, AND INSTRUCTION AND ANALYSIS REGARDING THE THEORY AND PRACTICE OF THE CANDLESTICK METHOD OF FINANCIAL PRICE PRESENTATION (U.S. CLS. 21, 23, 26, 36 AND 38).

SN 85-011,858. EATING WELL, INC., CHARLOTTE, VT. FILED 4-12-2010.

# EATINGWELL

THE MARK CONSISTS OF STANDARD CHARACTERS WITHOUT CLAIM TO ANY PARTICULAR FONT, STYLE, SIZE, OR COLOR.

OWNER OF U.S. REG. NO. 3,106,102.

**CLASS 16—PAPER GOODS AND PRINTED MATTER**

FOR A SERIES OF BOOKS AND WRITTEN ARTICLES IN THE FIELD OF FINANCE, STOCK MARKET INVESTING, BOND, COMMODITIES AND FOREIGN EXCHANGE MARKET INVESTING, AND INSTRUCTION AND ANALYSIS REGARDING THE THEORY AND PRACTICE OF THE CANDLESTICK METHOD OF FINANCIAL PRICE PRESENTATION; BOOKLETS IN THE FIELD OF FINANCE, STOCK MARKET INVESTING, BOND, COMMODITIES AND FOREIGN EXCHANGE MARKET INVESTING, AND INSTRUCTION AND ANALYSIS REGARDING THE THEORY AND PRACTICE OF THE CANDLESTICK METHOD OF FINANCIAL PRICE PRESENTATION; BOOKS IN THE FIELD OF FINANCE, STOCK MARKET INVESTING, BOND, COMMODITIES AND FOREIGN EXCHANGE MARKET INVESTING, AND INSTRUCTION AND ANALYSIS REGARDING THE THEORY AND PRACTICE OF THE CANDLESTICK METHOD OF FINANCIAL PRICE PRESENTATION; MANUALS IN THE FIELD OF FINANCE, STOCK MARKET INVESTING, BOND, COMMODITIES AND FOREIGN EXCHANGE MARKET INVESTING, AND INSTRUCTION AND ANALYSIS REGARDING THE THEORY AND PRACTICE OF THE CANDLESTICK METHOD OF FINANCIAL PRICE PRESENTATION; MONOGRAPHS IN THE FIELD OF FINANCE, STOCK MARKET INVESTING, BOND, COMMODITIES AND FOREIGN EXCHANGE MARKET INVESTING, AND INSTRUCTION AND ANALYSIS REGARDING THE THEORY AND PRACTICE OF THE CANDLESTICK METHOD OF FINANCIAL PRICE PRESENTATION; PRINTED PERIODICALS IN THE FIELD OF FINANCE, STOCK MARKET INVESTING, BOND, COMMODITIES AND FOREIGN EXCHANGE MARKET INVESTING, AND INSTRUCTION AND ANALYSIS REGARDING THE THEORY AND PRACTICE OF THE CANDLESTICK METHOD OF FINANCIAL PRICE PRESENTATION (U.S. CLS. 2, 5, 22, 23, 29, 37, 38 AND 50).

**CLASS 29—MEATS AND PROCESSED FOODS**

FOR PREPARED FOOD IN THE NATURE OF MEALS, ENTREES, AND SIDE DISHES CONSISTING PRIMARILY OF MEAT, FISH, POULTRY AND/OR VEGETABLES, BASED ON AND MARKETED IN RELATION TO COPYRIGHTED RECIPES THAT HAVE BEEN TESTED IN A TEST KITCHEN AND PUBLISHED IN PUBLICATIONS. THE PREPARED FOODS ARE MADE WITH NATURAL, WHOLESOME INGREDIENTS AND HAVE BEEN THOROUGHLY ANALYZED TO ENSURE HEALTHY NUTRITIONAL CONTENT AND TO CONTROL CALORIES, SATURATED FAT AND SODIUM. THE PREPARED FOODS ARE FORMULATED TO MINIMIZE OR EXCLUDE ADDED SUGARS, TRANS FATS AND REFINED GRAINS (U.S. CL. 46).

FIRST USE 4-29-2008; IN COMMERCE 4-29-2008.

**CLASS 30—STAPLE FOODS**

FOR PREPARED FOOD IN THE NATURE OF MEALS, ENTREES, AND SIDE DISHES CONSISTING PRIMARILY OF PASTA, RICE, NOODLES OR GRAINS, BASED ON AND MARKETED IN RELATION TO COPYRIGHTED RECIPES THAT HAVE BEEN TESTED IN A TEST KITCHEN AND PUBLISHED IN PUBLICATIONS. THE PREPARED FOODS ARE MADE WITH NATURAL, WHOLESOME INGREDIENTS AND HAVE BEEN THOROUGHLY ANALYZED TO ENSURE HEALTHY NUTRITIONAL CONTENT AND TO CONTROL CALORIES, SATURATED FAT AND SODIUM. THE PREPARED FOODS ARE FORMULATED TO MINIMIZE OR EXCLUDE ADDED SUGARS, TRANS FATS AND REFINED GRAINS (U.S. CL. 46).

FIRST USE 4-29-2008; IN COMMERCE 4-29-2008.

MARK RADEMACHER, EXAMINING ATTORNEY

**CLASS 41—EDUCATION AND ENTERTAINMENT**

FOR EDUCATIONAL SERVICES, NAMELY, CONDUCTING CLASSES, SEMINARS, CONFERENCES, WORKSHOPS IN THE FIELD OF FINANCE, STOCK MARKET INVESTING, BOND, COMMODITIES AND FOREIGN EXCHANGE MARKET INVESTING, AND INSTRUCTION AND ANALYSIS REGARDING THE THEORY AND PRACTICE OF THE CANDLESTICK METHOD OF FINANCIAL PRICE PRESENTATION; ENTERTAINMENT AND EDUCATIONAL SERVICES, NAMELY, THE PRESENTATION OF SEMINARS, LECTURES, WORKSHOPS AND PANEL DISCUSSIONS, AND ONGOING TELEVISION AND RADIO TALK SHOWS ALL IN THE FIELD OF PUBLIC INTEREST CONCERNING FINANCE, STOCK MARKET INVESTING, BOND, COMMODITIES AND FOREIGN EXCHANGE MARKET INVESTING, AND INSTRUCTION AND ANALYSIS REGARDING THE THEORY AND PRACTICE OF THE CANDLESTICK METHOD OF FINANCIAL PRICE PRESENTATION (U.S. CLS. 100, 101 AND 107).

SUSAN STIGLITZ, EXAMINING ATTORNEY

SN 85-013,106. VETERINARY PET INSURANCE COMPANY, BREA, CA. FILED 4-13-2010.



THE MARK CONSISTS OF A STYLIZED RENDITION OF A HAM ON A PEDESTAL.



**CLASS 35—ADVERTISING AND BUSINESS**

FOR PROVIDING A WEBSITE FEATURING INFORMATION FOR CONSUMERS IN THE FIELD OF PETS AND PET HEALTH (U.S. CLS. 100, 101 AND 102).  
FIRST USE 9-1-2009; IN COMMERCE 9-1-2009.

SN 85-013,811. SAPIENT CORPORATION, BOSTON, MA.  
FILED 4-14-2010.

**CLASS 36—INSURANCE AND FINANCIAL**

FOR INSURANCE UNDERWRITING IN THE FIELD OF PETS (U.S. CLS. 100, 101 AND 102).

**CLASS 42—SCIENTIFIC AND COMPUTER SERVICES**

FOR COMPUTER SERVICES, NAMELY, CREATING AN ON-LINE COMMUNITY FOR REGISTERED USERS TO PARTICIPATE IN DISCUSSIONS, GET FEEDBACK FROM THEIR PEERS, FORM VIRTUAL COMMUNITIES, AND ENGAGE IN SOCIAL NETWORKING FEATURING SOCIAL MEDIA AND TOPICS RELATING TO PETS AND PET HEALTH (U.S. CLS. 100 AND 101).

FIRST USE 9-1-2009; IN COMMERCE 9-1-2009.  
WENDY GOODMAN, EXAMINING ATTORNEY

# IONOS

SN 85-013,591. ASSESSMENT TECHNOLOGIES INSTITUTE, L.L.C., STILWELL, KS. FILED 4-14-2010.

# HOBET

THE MARK CONSISTS OF STANDARD CHARACTERS WITHOUT CLAIM TO ANY PARTICULAR FONT, STYLE, SIZE, OR COLOR.

OWNER OF U.S. REG. NOS. 3,552,760 AND 3,571,293.  
SEC. 2(F).

**CLASS 16—PAPER GOODS AND PRINTED MATTER**

FOR PRINTED PUBLICATIONS IN THE NATURE OF TESTS FOR CANDIDATES FOR ADMISSION TO EDUCATIONAL PROGRAMS TO BECOME A HEALTH OCCUPATION WORKER (U.S. CLS. 2, 5, 22, 23, 29, 37, 38 AND 50).

FIRST USE 0-0-1993; IN COMMERCE 0-0-1993.

**CLASS 41—EDUCATION AND ENTERTAINMENT**

FOR NON-DOWNLOADABLE PUBLICATIONS IN THE NATURE OF TESTS FOR CANDIDATES FOR ADMISSION TO EDUCATIONAL PROGRAMS TO BECOME A HEALTH OCCUPATION WORKER (U.S. CLS. 100, 101 AND 107).

FIRST USE 0-0-1994; IN COMMERCE 0-0-1994.  
DAVID I, EXAMINING ATTORNEY

THE MARK CONSISTS OF STANDARD CHARACTERS WITHOUT CLAIM TO ANY PARTICULAR FONT, STYLE, SIZE, OR COLOR.

**CLASS 9—ELECTRICAL AND SCIENTIFIC APPARATUS**

FOR COMPUTER SOFTWARE FOR MANAGEMENT, CREATION, DELIVERY, SYNDICATION, MULTICHANNEL DISTRIBUTION AND DISPLAY OF MOBILE, WEB AND DIGITAL CONTENT INCLUDING ADVERTISING; COMPUTER SOFTWARE, NAMELY, CONTENT MANAGEMENT SOFTWARE FOR DIGITAL CONTENT INCLUDING ADVERTISING TO MANAGE, GENERATE REPORTS AND OPTIMIZE PAY-PER-CLICK AND OTHER ADVERTISING CAMPAIGNS; COMPUTER SOFTWARE, NAMELY, CONTENT MANAGEMENT SOFTWARE FOR ADVERTISING CAMPAIGN FULFILLMENT; COMPUTER SOFTWARE FOR USE WITH PERSONAL MOBILE WIRELESS INTERNET DIGITAL ELECTRONIC DEVICES FOR RECEIPT, TRANSMISSION AND DISPLAY OF AUDIO, AUDIO/VISUAL, MULTIMEDIA CONTENT, TEXTUAL CONTENT AND OTHER DIGITAL DATA (U.S. CLS. 21, 23, 26, 36 AND 38).

**CLASS 35—ADVERTISING AND BUSINESS**

FOR BUSINESS CONSULTATION AND RESEARCH IN THE FIELD OF DIGITAL CONTENT AND ADVERTISING; MARKETING SUPPORT SERVICES, NAMELY, THE DESIGN AND EXECUTION OF ADVERTISING, MARKETING CAMPAIGNS AND PROGRAMS (U.S. CLS. 100, 101 AND 102).

**CLASS 42—SCIENTIFIC AND COMPUTER SERVICES**

FOR SOFTWARE AS A SERVICE (SAAS) SERVICES FEATURING SOFTWARE IN THE FIELD OF ADVERTISING FOR MANAGEMENT, CREATION, DELIVERY, SYNDICATION, MULTICHANNEL DISTRIBUTION AND DISPLAY OF MOBILE, WEB AND DIGITAL CONTENT INCLUDING ADVERTISING; SOFTWARE AS A SERVICE (SAAS) SERVICES FEATURING SOFTWARE TO MANAGE, GENERATE REPORTS AND OPTIMIZE PAY-PER-CLICK AND OTHER ADVERTISING CAMPAIGNS AND TO MANAGE AND DISTRIBUTE DIGITAL CONTENT INCLUDING ADVERTISING THROUGH MULTIPLE CHANNELS; SOFTWARE AS A SERVICE (SAAS) SERVICES FEATURING CONTENT MANAGEMENT SOFTWARE FOR ADVERTISING CAMPAIGN FULFILLMENT; DESIGN AND DEVELOPMENT OF COMPUTER SOFTWARE FOR ADVERTISING, CONTENT MANAGEMENT, AND DISTRIBUTION OF ADVERTISING, ADVERTISING CAMPAIGNS, PROMOTIONS, OFFERS, OFFER CODES, BARCODES, CONTENT, RATINGS, REVIEWS, ADVERTISEMENT PERFORMANCE REPORTS AND ADVERTISEMENT BILLING REPORTS FOR OTHERS; SOFTWARE AS A SERVICE (SAAS) SERVICES FEATURING SOFTWARE FOR MANAGING, CREATING, DELIVERING, SYNDICATING, DISTRIBUTING AND DISPLAYING MOBILE, WEB AND DIGITAL CONTENT; SOFTWARE DESIGN AND DEVELOPMENT FOR OTHERS; TECHNICAL CONSULTING AND PROVIDING TECHNICAL ASSISTANCE WITH COMPUTER-BASED INFORMATION SYSTEMS AND COMPONENTS; TECHNICAL SUPPORT SERVICES, NAMELY, TROUBLESHOOTING OF COMPUTER HARDWARE AND SOFTWARE PROBLEMS; TECHNOLOGY ADVICE AND INFORMATION PROVIDED TO NETWORK USERS BY MEANS OF MOBILE, WEB AND DIGITAL SIGNAGE; WEBSITE DEVELOPMENT SERVICES; TECHNICAL CONSULTATION IN THE FIELD OF DIGITAL CONTENT WITH RESPECT TO: STRATEGY, DESIGN, DEVELOPMENT, IMPLEMENTATION AND QUALITY ASSURANCE (U.S. CLS. 100 AND 101).  
ESTHER BELENKER, EXAMINING ATTORNEY

SN 85-015,885, MYSONGTOYOU, INC., MENLO PARK, CA.  
FILED 4-16-2010.

**MYSONG TO YOU**

THE MARK CONSISTS OF STANDARD CHARACTERS WITHOUT CLAIM TO ANY PARTICULAR FONT, STYLE, SIZE, OR COLOR.

SN 85-014,717, NASCO GROUP, LLC, CORAL GABLES, FL.  
FILED 4-15-2010.



THE MARK CONSISTS OF THE WORDING "DAUER" IN STYLIZED LETTERING AND A CIRCLE DESIGN ABOVE THE LETTER "U".

THE WORDING DAUER HAS NO MEANING IN A FOREIGN LANGUAGE.

**CLASS 4—LUBRICANTS AND FUELS**

FOR MOTOR OIL AND FUEL (U.S. CLS. 1, 6 AND 15).

**CLASS 7—MACHINERY**

FOR OIL FILTERS, FUEL FILTERS, AND AIR FILTERS FOR VEHICLE MOTORS AND ENGINES (U.S. CLS. 13, 19, 21, 23, 31, 34 AND 35).

**CLASS 12—VEHICLES**

FOR AUTOMOBILE PARTS, NAMELY, BRAKES, SHOCK ABSORBERS, SUSPENSION COMPONENTS, NAMELY, RACK END, TIE ROD END, BALL JOINT (U.S. CLS. 19, 21, 23, 31, 35 AND 44).

WILLIAM ROSSMAN, EXAMINING ATTORNEY

**CLASS 9—ELECTRICAL AND SCIENTIFIC APPARATUS**

FOR COMPUTER SOFTWARE FOR MUSICAL CREATION, EDITING, AUTHORING, AND EDITING; COMPUTER SOFTWARE FOR PLAYING AND SHARING MUSIC OF OTHERS FROM THE INTERNET; DOWNLOADABLE MUSIC VIA THE INTERNET (U.S. CLS. 21, 23, 26, 36 AND 38).

**CLASS 35—ADVERTISING AND BUSINESS**

FOR ADVERTISING SERVICES; INTERNET ADVERTISING SERVICES; ADVERTISING SERVICES TO DISTRIBUTE ADVERTISEMENTS OF OTHERS FOR DISPLAY ON INTERNET, NAMELY, IN WEBSITES, SOCIAL CONVERSATIONS OVER THE INTERNET, BLOGS, ELECTRONIC MESSAGES, INSTANT MESSAGES, TEXT MESSAGES, MULTIMEDIA MESSAGES, AUDIO FILES, SOCIAL NETWORKS; PROMOTING THE GOODS AND SERVICES OF OTHERS BY MEANS OF DISTRIBUTING ADVERTISING ON THE INTERNET (U.S. CLS. 100, 101 AND 102).

**CLASS 41—EDUCATION AND ENTERTAINMENT**

FOR ENTERTAINMENT SERVICES, NAMELY, PROVIDING NON-DOWNLOADABLE PRERECORDED MUSIC, INFORMATION IN THE FIELD OF MUSIC, ALL ON-LINE VIA A GLOBAL COMPUTER NETWORK; ENTERTAINMENT SERVICES, NAMELY, AN ON-LINE ACTIVITY WHERE YOU CREATE AND RECORD YOUR OWN MUSIC; ENTERTAINMENT SERVICES IN THE NATURE OF RECORDING, PRODUCTION AND POST-PRODUCTION SERVICES IN THE FIELDS OF MUSIC (U.S. CLS. 100, 101 AND 107).

FIRST USE 2-1-2010; IN COMMERCE 2-1-2010.

**CLASS 42—SCIENTIFIC AND COMPUTER SERVICES**

FOR COMPUTER SERVICES, NAMELY, HOSTING ON-LINE WEB FACILITIES FOR OTHERS TO SHOW-CASE SONGWRITING AND MUSICAL TALENTS AND FOR FACILITATING AND CONDUCTING ONLINE CONNECTIONS, COLLABORATIONS, AND INTERACTIVE DISCUSSIONS ABOUT SONGWRITING AND MUSIC; APPLICATION SERVICE PROVIDER (ASP) FEATURING SOFTWARE FOR USE IN CREATING, EDITING, ACCESSING DIGITAL AUDIO CONTENT AND THE SHARING THEREOF; APPLICATION SERVICE PROVIDER FEATURING SOFTWARE FOR CREATING AND SHARING MUSIC; APPLICATION SERVICE PROVIDER FEATURING SOFTWARE FOR CREATING MUSICAL TOOLS AND BEATS FOR USERS TO CREATE MUSIC AND/OR TO SHARE MUSIC WITH OTHERS; COMPUTER SERVICES, NAMELY, CREATING AN ON-LINE COMMUNITY FOR REGISTERED USERS TO DEVELOP AND COLLABORATE ON MAKING MUSIC AND TO SHARE CONTENT WITH OTHER REGISTERED USERS AND WITH OTHERS VIA LINKS TO THIRD-PARTY WEB SITES; HOSTING AN ON-LINE COMMUNITY WEB SITE FEATURING A PLACE WHERE USERS CAN COLLABORATE IN MAKING MUSIC; HOSTING ON-LINE RETAIL WEBSITES OF OTHERS IN THE FIELD OF MUSIC (U.S. CLS. 100 AND 101).

FIRST USE 2-1-2010; IN COMMERCE 2-1-2010.

**CLASS 45—PERSONAL AND LEGAL SERVICES**

FOR ONLINE SOCIAL NETWORKING SERVICES; ONLINE SOCIAL NETWORKING SERVICES PROVIDED FOR USERS TO SHARE MUSIC (U.S. CLS. 100 AND 101).  
MICHAEL SOUDERS, EXAMINING ATTORNEY

SN 85-016,954. MOBIATA, LLC, ANN ARBOR, MI. FILED 4-19-2010.

# HOTELPAL

THE MARK CONSISTS OF STANDARD CHARACTERS WITHOUT CLAIM TO ANY PARTICULAR FONT, STYLE, SIZE, OR COLOR.

**CLASS 9—ELECTRICAL AND SCIENTIFIC APPARATUS**

FOR DOWNLOADABLE COMPUTER SOFTWARE FOR MAKING RESERVATIONS AND BOOKINGS FOR TEMPORARY ACCOMMODATIONS, FOR PROVIDING ACCOMMODATION INFORMATION SERVICES, FOR PROVIDING ACCOMMODATION INFORMATION OVER COMPUTER NETWORKS, GLOBAL COMPUTER COMMUNICATION NETWORKS AND MOBILE NETWORKS (U.S. CLS. 21, 23, 26, 36 AND 38).

FIRST USE 7-31-2009; IN COMMERCE 7-31-2009.

**CLASS 43—HOTEL AND RESTAURANT SERVICES**

FOR TRAVEL AGENCY SERVICES, NAMELY, MAKING RESERVATIONS AND BOOKINGS FOR TEMPORARY ACCOMMODATIONS; PROVIDING TEMPORARY ACCOMMODATION INFORMATION SERVICES; MAKING RESERVATIONS AND BOOKINGS FOR TEMPORARY ACCOMMODATIONS AND PROVIDING TEMPORARY ACCOMMODATION INFORMATION OVER COMPUTER NETWORKS, GLOBAL COMPUTER COMMUNICATION NETWORKS AND MOBILE NETWORKS (U.S. CLS. 100 AND 101).

FIRST USE 7-31-2009; IN COMMERCE 7-31-2009.

JENNIFER VASQUEZ, EXAMINING ATTORNEY

SN 85-017,268. ZIGI ENTERPRISES, INC., HUNTINGTON, NY. FILED 4-19-2010.



THE MARK CONSISTS OF A STYLIZED IMAGE OF A TIGER.

**CLASS 14—JEWELRY**

FOR JEWELRY AND WATCHES (U.S. CLS. 2, 27, 28 AND 50).

**CLASS 18—LEATHER GOODS**

FOR BAGS, NAMELY, HANDBAGS, PURSES, SPORTS BAGS, ATHLETIC BAGS, BEACH BAGS, COSMETIC BAGS SOLD EMPTY, GARMENT BAGS FOR TRAVEL, LAUNDRY BAGS, OVERNIGHT BAGS, SCHOOL BAGS, SHOE BAGS FOR TRAVEL, TRAVEL BAGS (U.S. CLS. 1, 2, 3, 22 AND 41).

**CLASS 25—CLOTHING**

FOR FOOTWEAR, NAMELY, SHOES, BOOTS, SLIPPERS, THONGS, SANDALS, ATHLETIC FOOTWEAR, BEACH FOOTWEAR, CASUAL FOOTWEAR, EVENING FOOTWEAR, EXERCISE FOOTWEAR; CLOTHING, NAMELY, COATS, JACKETS, VESTS, AND BELTS (U.S. CLS. 22 AND 39).

TRACY CROSS, EXAMINING ATTORNEY

SN 85-018,016. MEREDITH CORPORATION, DES MOINES, IA. FILED 4-20-2010.

## MARKETEYE

THE MARK CONSISTS OF STANDARD CHARACTERS WITHOUT CLAIM TO ANY PARTICULAR FONT, STYLE, SIZE, OR COLOR.

### CLASS 36—INSURANCE AND FINANCIAL

FOR NEWS REPORTING SERVICES IN THE FIELD OF AGRICULTURAL COMMODITIES MARKETS VIA COMPUTER; PROVIDING NEWS AND INFORMATION ON AGRICULTURAL COMMODITIES MARKETS USING AN INTERACTIVE ELECTRONIC FORMAT VIA A GLOBAL COMPUTER NETWORK (U.S. CLS. 100, 101 AND 102).

FIRST USE 11-15-2009; IN COMMERCE 11-15-2009.

### CLASS 41—EDUCATION AND ENTERTAINMENT

FOR ENTERTAINMENT SERVICES, NAMELY, THE PROVISION OF CONTINUING VIDEO SEGMENTS FEATURING AGRICULTURAL COMMODITY PRICING AND AGRICULTURAL COMMODITY MARKET INFORMATION DELIVERED VIA THE INTERNET (DATE OF FIRST USE IS 11/15/2009); PROVIDING NEWSLETTERS VIA EMAIL IN THE FIELD OF AGRICULTURAL COMMODITY PRICING, THE MARKETING STRATEGIES OF OTHERS IN THE AGRICULTURAL COMMODITY INDUSTRY AND MARKET INFORMATION FOR AGRICULTURAL COMMODITIES (DATE OF FIRST USE IS 6/22/2009) (U.S. CLS. 100, 101 AND 107).

FIRST USE 11-15-2009; IN COMMERCE 11-15-2009.  
MARY CRAWFORD, EXAMINING ATTORNEY

SN 85-019,841. WISE WINDOW, INC., IRVINE, CA. FILED 4-21-2010.

## MOBI MASS OPINION BUSINESS INTELLIGENCE

THE MARK CONSISTS OF STANDARD CHARACTERS WITHOUT CLAIM TO ANY PARTICULAR FONT, STYLE, SIZE, OR COLOR.

NO CLAIM IS MADE TO THE EXCLUSIVE RIGHT TO USE "MASS OPINION BUSINESS INTELLIGENCE", APART FROM THE MARK AS SHOWN.

### CLASS 9—ELECTRICAL AND SCIENTIFIC APPARATUS

FOR COMPUTER SOFTWARE AND DOWNLOADABLE COMPUTER SOFTWARE AND APPLICATIONS USED TO ENABLE CUSTOMERS FOR BUSINESS AND MARKETING INFORMATION PURPOSES TO ACCESS DATA, BELIEFS, USER GENERATED CONTENT AND DERIVED INSIGHTS THEREFROM RELEVANT TO THEM AND MAPPING, CLASSIFYING, AGGREGATING, AND SORTING AND EXTRACTING THE INFORMATION IN RAW, PACKAGED AND/OR VISUALIZED FORM (U.S. CLS. 21, 23, 26, 36 AND 38).

### CLASS 35—ADVERTISING AND BUSINESS

FOR BUSINESS AND MARKETING SERVICES, NAMELY, MAPPING, CLASSIFYING, AGGREGATING, AND SORTING DATA, BELIEFS, USER GENERATED CONTENT AND DERIVED INSIGHTS THEREFROM RELEVANT TO CUSTOMERS AND REPORTING THE INFORMATION IN RAW, PACKAGED AND/OR VISUALIZED FORM (U.S. CLS. 100, 101 AND 102).

### CLASS 42—SCIENTIFIC AND COMPUTER SERVICES

FOR PROVIDING TEMPORARY USE OF ON-LINE NONDOWNLOADABLE SOFTWARE, TOOLS AND APPLICATIONS TO CUSTOMERS TO ENABLE THEM FOR BUSINESS AND MARKETING INFORMATION PURPOSES TO ACCESS DATA, BELIEFS, USER GENERATED CONTENT AND DERIVED INSIGHTS THEREFROM RELEVANT TO THEM AND MAPPING, CLASSIFYING, AGGREGATING, AND SORTING AND EXTRACTING THE INFORMATION IN RAW, PACKAGED AND/OR VISUALIZED FORM (U.S. CLS. 100 AND 101).

HEATHER SAPP, EXAMINING ATTORNEY

SN 85-020,284. PLYO POWER, LLC, KEENE, NH. FILED 4-22-2010.

## PLYO POWER

THE MARK CONSISTS OF STANDARD CHARACTERS WITHOUT CLAIM TO ANY PARTICULAR FONT, STYLE, SIZE, OR COLOR.

OWNER OF U.S. REG. NO. 2,734,599.

### CLASS 9—ELECTRICAL AND SCIENTIFIC APPARATUS

FOR DVDS AND OTHER MEDIA FOR ELECTRONICALLY STORING INFORMATION AND DATA, NAMELY, PRE-RECORDED DVDS FEATURING INFORMATION RELATING TO EXERCISE, PHYSICAL FITNESS, HEALTH, WEIGHT LOSS AND ATHLETICS (U.S. CLS. 21, 23, 26, 36 AND 38).

### CLASS 16—PAPER GOODS AND PRINTED MATTER

FOR PRINTED MATTER AND PUBLICATIONS, NAMELY, INSTRUCTIONAL MANUALS AND TEACHING MATERIALS, ALL IN THE FIELDS OF EXERCISE, PHYSICAL FITNESS, HEALTH, WEIGHT LOSS, AND ATHLETICS (U.S. CLS. 2, 5, 22, 23, 29, 37, 38 AND 50).

FRED CARL, EXAMINING ATTORNEY

SN 85-020,673. BIOPATH LABORATORIES, INC., OKLAHOMA CITY, OK. FILED 4-22-2010.

SN 85-021,793. SWIPELY, INC., PROVIDENCE, RI. FILED 4-23-2010.

# IPLUS

THE MARK CONSISTS OF STANDARD CHARACTERS WITHOUT CLAIM TO ANY PARTICULAR FONT, STYLE, SIZE, OR COLOR.

## CLASS 1—CHEMICALS

FOR SOLUTION FOR BINDING A BIOLOGICAL SPECIMEN TO A MICROSCOPE SLIDE, NAMELY, AN ADHESIVE COATING SOLUTION FOR MEDICAL RESEARCH AND LABORATORY USE (U.S. CLS. 1, 5, 6, 10, 26 AND 46).

## CLASS 5—PHARMACEUTICALS

FOR SOLUTION FOR BINDING A BIOLOGICAL SPECIMEN TO A MICROSCOPE SLIDE, NAMELY, AN ADHESIVE COATING SOLUTION FOR MEDICAL DIAGNOSTIC USE (U.S. CLS. 6, 18, 44, 46, 51 AND 52).  
JAMES STEIN, EXAMINING ATTORNEY

---

SN 85-021,378. CANNING, CANDRA, NOVATO, CA. FILED 4-23-2010.

# CURIOSITY CLUB

THE MARK CONSISTS OF STANDARD CHARACTERS WITHOUT CLAIM TO ANY PARTICULAR FONT, STYLE, SIZE, OR COLOR.

## CLASS 16—PAPER GOODS AND PRINTED MATTER

FOR PHOTOGRAPHS; STATIONERY (U.S. CLS. 2, 5, 22, 23, 29, 37, 38 AND 50).

## CLASS 25—CLOTHING

FOR CLOTHING, NAMELY, HATS, CAPS, PANTS, FOOTWEAR (U.S. CLS. 22 AND 39).

## CLASS 28—TOYS AND SPORTING GOODS

FOR GAMES, NAMELY, BOARD GAMES (U.S. CLS. 22, 23, 38 AND 50).  
JOHN HWANG, EXAMINING ATTORNEY

# SWIPELY

THE MARK CONSISTS OF STANDARD CHARACTERS WITHOUT CLAIM TO ANY PARTICULAR FONT, STYLE, SIZE, OR COLOR.

## CLASS 9—ELECTRICAL AND SCIENTIFIC APPARATUS

FOR DOWNLOADABLE SOFTWARE APPLICATIONS FOR SOCIAL NETWORKING, INCENTIVE PROGRAMS, AND PAYMENT SYSTEMS (U.S. CLS. 21, 23, 26, 36 AND 38).

## CLASS 35—ADVERTISING AND BUSINESS

FOR PROVIDING AN ONLINE BUSINESS DIRECTORY FEATURING BUSINESS ORGANIZATIONS AND SERVICE PROVIDERS; PROVIDING AN ONLINE INTERACTIVE WEBSITE OBTAINING USERS' COMMENTS CONCERNING BUSINESS ORGANIZATIONS AND SERVICE PROVIDERS; PROVIDING INFORMATION, NAMELY, COMPILATIONS, RANKINGS, RATINGS, REVIEWS, REFERRALS AND RECOMMENDATIONS RELATING TO BUSINESS ORGANIZATIONS AND SERVICE PROVIDERS USING A GLOBAL COMPUTER NETWORK; PROVIDING BUSINESS MONITORING AND CONSULTING SERVICES, NAMELY, SHOPPER ANALYTIC DATA; PROVIDING INCENTIVE PROGRAMS FOR CUSTOMERS THROUGH THE ISSUANCE AND PROCESSING OF LOYALTY REWARDS, DISCOUNTS, AND PRIVILEGES BASED ON PURCHASES FROM PARTICIPATING BUSINESSES (U.S. CLS. 100, 101 AND 102).

## CLASS 36—INSURANCE AND FINANCIAL

FOR PROVIDING PERSONAL FINANCIAL MANAGEMENT SERVICES; PROVIDING ELECTRONIC PROCESSING OF CREDIT CARD AND DEBIT CARD TRANSACTIONS VIA A GLOBAL COMPUTER NETWORK (U.S. CLS. 100, 101 AND 102).

## CLASS 38—COMMUNICATION

FOR PROVIDING ACCESS TO COMPUTER DATABASES; INSTANT MESSAGING SERVICES AND ELECTRONIC TRANSMISSION OF DATA (U.S. CLS. 100, 101 AND 104).

## CLASS 41—EDUCATION AND ENTERTAINMENT

FOR ELECTRONIC PUBLISHING SERVICES, NAMELY, PUBLISHING OF ONLINE WORKS OF OTHERS FEATURING USER-CREATED TEXT, AUDIO, VIDEO, AND GRAPHICS; ON-LINE JOURNALS; NAMELY, BLOGS FEATURING CONSUMER REVIEWS OF PRODUCTS, BUSINESSES, AND SERVICE PROVIDERS (U.S. CLS. 100, 101 AND 107).

**CLASS 42—SCIENTIFIC AND COMPUTER SERVICES**

FOR COMPUTER SERVICES, NAMELY, CREATING AN ON-LINE COMMUNITY FOR REGISTERED USERS TO DISCUSS AND EVALUATE PRODUCTS, SERVICES, AND BUSINESSES, SHARE RECENT PURCHASES, PARTICIPATE IN DISCUSSIONS, GET FEEDBACK FROM THEIR PEERS, FORM VIRTUAL COMMUNITIES, AND ENGAGE IN SOCIAL NETWORKING FEATURING CONSUMER HABITS AND PREFERENCES; COMPUTER SERVICES, NAMELY, CREATING ON-LINE VIRTUAL COMMUNITIES FOR REGISTERED USERS TO BROWSE LOYALTY REWARDS AND DISCOUNTS; PROVIDING AN ONLINE NETWORK SERVICE THAT ENABLES USERS TO TRANSFER PERSONAL IDENTITY DATA AND SHOPPING HISTORY AND TO SHARE PERSONAL IDENTITY DATA AND SHOPPING HISTORY WITH AND AMONG MULTIPLE RETAILERS AND SERVICE PROVIDERS (U.S. CLS. 100 AND 101).

CHRIS WELLS, EXAMINING ATTORNEY

SN 85-021,993. BRITE HELLAS AE, AKA BRITE SOLAR TECHNOLOGIES, PYLAIA-THESSALONIKI, GREECE, FILED 4-23-2010.

# PanePower

THE MARK CONSISTS OF STANDARD CHARACTERS WITHOUT CLAIM TO ANY PARTICULAR FONT, STYLE, SIZE, OR COLOR.

**CLASS 6—METAL GOODS**

FOR DOORS AND WINDOWS OF METAL FEATURING PHOTOVOLTAIC PANES; METAL STRUCTURES FOR MOUNTING SOLAR PANELS; METAL WINDOWS FEATURING PHOTOVOLTAIC SOLAR MODULES; METALLIC DOORS, OR WINDOWS, HAVING PHOTOVOLTAIC PANES; SOLAR PANEL MOUNTS MADE OF METAL; SUBSTRATES PRIMARILY OF METAL FOR SUPPORTING SOLAR CELLS; PHOTOVOLTAIC CELLS AND SOLAR COLLECTORS (U.S. CLS. 2, 12, 13, 14, 23, 25 AND 50).

**CLASS 9—ELECTRICAL AND SCIENTIFIC APPARATUS**

FOR PHOTOVOLTAIC SOLAR MODULES AND PANELS IN THE FORM OF TRANSPARENT PARTITIONS, SUCH AS MADE OF GLASS, AND SUCH AS FOR USE AS WALLS, RAILINGS, AND FENCES; APPARATUS FOR CONVERTING ELECTRONIC RADIATION TO ELECTRICAL ENERGY, NAMELY, PHOTOVOLTAIC SOLAR HYBRID MODULES; APPARATUS FOR CONVERTING ELECTRONIC RADIATION TO ELECTRICAL ENERGY, NAMELY, PHOTOVOLTAIC SOLAR MODULES; ELECTRONICAL SENSORS FOR MEASURING SOLAR RADIATION; PHOTOVOLTAIC CELLS; PHOTOVOLTAIC CELLS AND MODULES; SOLAR BATTERIES; SOLAR CELLS; SOLAR PANELS FOR PRODUCTION OF ELECTRICITY; SOLAR WAFERS (U.S. CLS. 21, 23, 26, 36 AND 38).

**CLASS 11—ENVIRONMENTAL CONTROL APPARATUS**

FOR PHOTOVOLTAIC-BASED POWER PLANTS; SOLAR COLLECTORS; SOLAR ENERGY RECEIVERS; SOLAR ENERGY COLLECTION PANELS (U.S. CLS. 13, 21, 23, 31 AND 34).

**CLASS 12—VEHICLES**

FOR BOAT ACCESSORIES, NAMELY, WINDOWS FEATURING PHOTOVOLTAIC SOLAR MODULES SOLD AS A UNIT AND AFFIXED TO THE BOAT FOR RECREATIONAL BOATING AND MARINE USE; GLASS WINDOWS FEATURING PHOTOVOLTAIC SOLAR MODULES FOR VEHICLES; MOTOR CAR WINDOWS FEATURING PHOTOVOLTAIC SOLAR MODULES; VEHICLE WINDOWS FEATURING PHOTOVOLTAIC SOLAR MODULES (U.S. CLS. 19, 21, 23, 31, 35 AND 44).

**CLASS 19—NON-METALLIC BUILDING MATERIALS**

FOR NON-METAL STRUCTURES FOR MOUNTING SOLAR PANELS; NON-METAL WINDOWS FEATURING PHOTOVOLTAIC SOLAR MODULES; VINYL WINDOWS FEATURING PHOTOVOLTAIC SOLAR MODULES; WINDOW CASEMENTS NOT OF METAL, FOR USE WITH PHOTOVOLTAIC WINDOW PANES; WINDOW GLASS FEATURING PHOTOVOLTAIC SOLAR MODULES; WINDOW PANES FEATURING PHOTOVOLTAIC SOLAR MODULES (U.S. CLS. 1, 12, 33 AND 50).

**CLASS 37—CONSTRUCTION AND REPAIR**

FOR INSTALLATION AND MAINTENANCE OF PHOTOVOLTAIC INSTALLATIONS; INSTALLATION AND MAINTENANCE OF SOLAR ENERGY BASED POWER PLANTS; INSTALLATION OF ELECTRICAL SYSTEMS RELATING TO ELECTRICITY-PRODUCING SOLAR WINDOWS; INSTALLATION OF PHOTOVOLTAIC DOORS AND PHOTOVOLTAIC WINDOWS; INSTALLATION OF SOLAR ENERGY SYSTEMS AND ALTERNATIVE ENERGY PRODUCTS FOR RESIDENTIAL AND COMMERCIAL USE (U.S. CLS. 100, 103 AND 106).

KÉVIN DINALLO, EXAMINING ATTORNEY

SN 85-022,699. PERFECT FIT INDUSTRIES, INC., CHARLOTTE, NC. FILED 4-26-2010.

# ALWAYS FRESH

THE MARK CONSISTS OF STANDARD CHARACTERS WITHOUT CLAIM TO ANY PARTICULAR FONT, STYLE, SIZE, OR COLOR.

**CLASS 20—FURNITURE AND ARTICLES NOT OTHERWISE CLASSIFIED**

FOR PILLOWS (U.S. CLS. 2, 13, 22, 25, 32 AND 50).

**CLASS 24—FABRICS**

FOR MATTRESS COVERS; MATTRESS PADS (U.S. CLS. 42 AND 50).

Laurie Kaufman, Examining Attorney

SN 85-023,097, FIELDING CHEMICAL TECHNOLOGIES INC., MISSISSAUGA, ONTARIO, CANADA, FILED 4-26-2010.

## THE SCIENCE OF SUSTAINABILITY

THE MARK CONSISTS OF STANDARD CHARACTERS WITHOUT CLAIM TO ANY PARTICULAR FONT, STYLE, SIZE, OR COLOR.

PRIORITY CLAIMED UNDER SEC. 44(D) ON CANADA APPLICATION NO. 1470125, FILED 2-18-2010.

### CLASS 1—CHEMICALS

FOR ASPHALT RELEASE AGENTS, MONO ESTERS, DIBASIC ESTERS, MINERAL SPIRITS USED AS A DEGREASING AGENT; INDUSTRIAL SOLVENTS FOR VAPOR DEGREASING PLATE WASH AND CLEANING EQUIPMENT; RECYCLED AND RECLAIMED CHEMICALS AND SOLVENTS, NAMELY, ALCOHOLS, ACETIC ACID ESTERS, METHYL ESTERS, KETONES, ALIPHATIC HYDROCARBONS, AROMATIC HYDROCARBONS, PLASTICIZERS, GLYCOLS, GLYCOL ETHERS, CHLORINATED SOLVENTS, FLUORINATED SOLVENTS AND ALKANOLAMINES; VIRGIN CHEMICALS AND SOLVENTS FOR USE IN THE MANUFACTURE OF FOOD PRODUCTS, FOOD INGREDIENTS AND ADDITIVES, PERSONAL CARE PRODUCTS, COATINGS, RESINS, INKS, ADHESIVES, AUTOMOTIVE FLUIDS AND LUBRICANTS, PLASTICS, RUBBER, WATER TREATMENT PRODUCTS, BOTANICALS, NEUTRACEUTICALS, FUELS, BIOFUELS, INDUSTRIAL CHEMICALS AND AROMATIC SOLVENTS; VIRGIN CHEMICALS AND SOLVENTS USED IN THE ENVIRONMENTAL SERVICES, WATER TREATMENT, AGRICULTURE, FORESTRY, MINING, CONSTRUCTION AND OIL AND GAS INDUSTRIES; REFRIGERANT ADDITIVES FOR COOLANTS IN AIR CONDITIONING SYSTEMS; DEGREASING PREPARATIONS FOR USE IN MANUFACTURING PROCESSES FOR PLATE WASHING AND CLEANING MACHINES (U.S. CLS. 1, 5, 6, 10, 26 AND 46).

### CLASS 2—PAINTS

FOR MINERAL SPIRITS USED FOR THINNING PAINT (U.S. CLS. 6, 11 AND 16).

### CLASS 3—COSMETICS AND CLEANING PREPARATIONS

FOR PAINT STRIPPER; CLEANER FOR USE ON PAINT SPRAY GUNS; DEGREASING PREPARATIONS NOT USED IN MANUFACTURING FOR PLATE WASHING AND CLEANING (U.S. CLS. 1, 4, 6, 50, 51 AND 52).

### CLASS 35—ADVERTISING AND BUSINESS

FOR CONSULTING SERVICES RELATING TO MANAGEMENT OF EMERGENCY SITUATIONS; MARKET RESEARCH AND ANALYSIS SERVICES RELATING TO CHEMICALS; CONSULTING SERVICES RELATING TO SELECTION OF CHEMICAL SUPPLIERS, NAMELY, BUSINESS ADVISORY SERVICES, NAMELY, SEARCH FOR AND SELECTION OF THE BEST POTENTIAL CHEMICAL SUPPLIERS FOR OTHERS; WHOLESALE SOURCING AND PROCUREMENT OF CHEMICALS, NAMELY, BUSINESS SERVICES, NAMELY, COMBINED STRATEGIC GOODS OR SERVICES SOURCING AND COOPERATED PURCHASING FOR OTHERS IN THE FIELD OF CHEMICALS AND PROCUREMENT, NAMELY, PURCHASING CHEMICALS FOR OTHERS; BUSINESS MANAGEMENT SERVICES, NAMELY, MANAGEMENT LOGISTICS, REVERSE LOGISTICS, SUPPLY CHAIN SERVICES, SUPPLY CHAIN VISIBILITY AND SYNCHRONIZATION, SUPPLY AND DEMAND FORECASTING AND PRODUCTION DISTRIBUTION PROCESSING FOR OTHERS IN THE FIELD OF CHEMICALS; PROCUREMENT OF CONTRACTS FOR OTHERS FOR THE PURCHASE OF CHEMICALS; DISTRIBUTORSHIP SERVICES FEATURING CHEMICALS (U.S. CLS. 100, 101 AND 102).

### CLASS 37—CONSTRUCTION AND REPAIR

FOR HAZARDOUS WASTE DISPOSAL; ENVIRONMENTAL SITE CLEAN-UP; AND ENVIRONMENTAL REMEDIATION SERVICES, NAMELY, WASTE DISPOSAL OF CHEMICAL SPILLS (U.S. CLS. 100, 103 AND 106).

### CLASS 39—TRANSPORTATION AND STORAGE

FOR TRANSPORTATION SERVICES RELATING TO HAZARDOUS WASTE AND HAZARDOUS MATERIALS; CHEMICAL STORAGE SERVICES AND CONSULTING SERVICES RELATING TO STORAGE OF CHEMICALS; CHEMICAL SPILL CONTAINMENT, NAMELY, STORAGE OF CHEMICAL SPILLS; TOLL MANUFACTURING OF CHEMICALS, NAMELY, STORAGE OF MATERIALS SENT BY WASTE GENERATORS; CHEMICAL AND REFRIGERANT PACKAGING FOR OTHERS, NAMELY, MERCHANDISE PACKAGING FOR OTHERS IN THE FIELD OF CHEMICALS AND REFRIGERANTS; CUSTOM PACKAGING OF CHEMICALS TO THE ORDER AND SPECIFICATION OF OTHERS (U.S. CLS. 100 AND 105).

### CLASS 40—MATERIAL TREATMENT

FOR RECYCLING AND RECLAMATION OF CHEMICALS, SOLVENTS, REFRIGERANTS, CARBON AND GASEOUS CHEMICALS; CHEMICAL NEUTRALIZATION, NAMELY, NEUTRALIZATION OF HIGH OR LOW PH SOLUTIONS; BLENDING OF VIRGIN AND RECLAIMED SOLVENTS AND CHEMICALS; TOLL MANUFACTURING OF CHEMICALS, NAMELY, RECYCLING OF MATERIAL SENT BY WASTE GENERATORS; CUSTOM MANUFACTURING OF CHEMICALS, NAMELY, MANUFACTURING CHEMICALS BASED ON THE FORMULATIONS OR SPECIFICATIONS PROVIDED BY CUSTOMERS; CHEMICAL PROCESSING SERVICES UTILIZING DISTILLATION, FRACTIONATION, PERVAPORATION, ESTERIFICATION, DEHYDRATION, CHEMICAL DRYING AND FILTRATION PROCESSES; CHEMICAL SEPARATION, NAMELY, DISTILLATION, FRACTIONATION, PERVAPORATION, DEHYDRATION, CHEMICAL DRYING, FILTRATION AND SETTLING BY GRAVITY; OIL BLOWING, NAMELY, PROCESSES TO INCREASE VISCOSITY OF VEGETABLE OILS; HAZARDOUS WASTE TREATMENT; WATER TREATMENT SERVICES; PROCESSING OF CHEMICALS; ENVIRONMENTAL REMEDIATION SERVICES, NAMELY, WASTE TREATMENT OF CHEMICAL SPILLS; INDUSTRIAL TOXIN WASTE DISPOSAL OF GASEOUS CHEMICALS; CONSULTING IN REGARDS TO RECYCLING OF CHEMICALS AND PROCESSING OF CHEMICALS (U.S. CLS. 100, 103 AND 106).

**CLASS 41—EDUCATION AND ENTERTAINMENT**

FOR TRAINING SERVICES RELATING TO SPILL RESPONSE, TRANSPORTATION OF DANGEROUS GOODS, ENVIRONMENTAL SAFETY, HAZARDOUS MATERIALS RESPONSE AND HANDLING, FIRST AID, AIR MONITORING, CHEMICAL SPECIFIC TRAINING, ENVIRONMENTAL INCIDENT MANAGEMENT AND COMPLIANCE WITH ENVIRONMENTAL LEGISLATION AND REGULATORY REQUIREMENTS (U.S. CLS. 100, 101 AND 107).

**CLASS 42—SCIENTIFIC AND COMPUTER SERVICES**

FOR RESEARCH AND DEVELOPMENT SERVICES RELATING TO SAFE USE AND RE-USE OF CHEMICALS AND CHEMICAL ANALYSIS AND SAMPLING; WORKING ON AND EVALUATION OF CHEMICAL SYNTHESSES; CONSULTING SERVICES RELATING TO PERFORMANCE OF AND EXECUTION OF CHEMICAL ANALYSES; LABORATORY SERVICES, NAMELY, SCIENTIFIC RESEARCH (U.S. CLS. 100 AND 101).

**CLASS 45—PERSONAL AND LEGAL SERVICES**

FOR REVIEWING STANDARDS AND PRACTICES TO ASSURE COMPLIANCE WITH ENVIRONMENTAL LAWS AND REGULATIONS, AND CONSULTING SERVICES RELATED THERETO (U.S. CLS. 100 AND 101).  
SAMUEL E. SHARPER JR., EXAMINING ATTORNEY

---

SN 85-023,312. PABISAN, S.A. DE C.V., PUEBLA, MEXICO, FILED 4-26-2010.



NO CLAIM IS MADE TO THE EXCLUSIVE RIGHT TO USE "KVALITET", APART FROM THE MARK AS SHOWN. THE COLOR(S) BLUE AND GOLD IS/ARE CLAIMED AS A FEATURE OF THE MARK.

THE MARK CONSISTS OF THE WORD "KVALITET" IN GOLD LETTERING IN AN ARC WITH A SOLID GOLD ARC ABOVE AND BELOW THE WORDING AND A GOLD DOT BEFORE AND AFTER THE WORDING ALL WITHIN A BLUE ARC. GOLD FILIGREE DESIGN IN SMALL ARC ATTACHED TO LOWER GOLD ARC.

THE ENGLISH TRANSLATION OF THE WORD "KVALITET" IN THE MARK IS QUALITY.

**CLASS 5—PHARMACEUTICALS**

FOR DIETETIC FOODS ADAPTED FOR MEDICAL USE (U.S. CLS. 6, 18, 44, 46, 51 AND 52).

**CLASS 30—STAPLE FOODS**

FOR CEREALS, BREAD, PASTRY, FLOUR AND PREPARATIONS MADE FROM FLOUR, NAMELY, BREAD, PASTRY AND COOKIES (U.S. CL. 46).  
CAROLYN CATALDO, EXAMINING ATTORNEY

SN 85-024,932. YOUR BABY CAN, LLC, CARLSBAD, CA. FILED 4-28-2010.

**DEVELOPING MINDS**

THE MARK CONSISTS OF STANDARD CHARACTERS WITHOUT CLAIM TO ANY PARTICULAR FONT, STYLE, SIZE, OR COLOR.

**CLASS 9—ELECTRICAL AND SCIENTIFIC APPARATUS**

FOR PRE-RECORDED AUDIO AND VIDEO COMPACT DISKS, DIGITAL VIDEO DISKS, CD ROMS, AND DOWNLOADABLE CHILDREN'S EDUCATIONAL SOFTWARE AND ELECTRONIC GAME SOFTWARE FEATURING LEARNING AND ENTERTAINMENT ACTIVITIES ALL OF WHICH RELATE TO A VARIETY OF EDUCATIONAL SUBJECTS FOR INFANTS, TODDLERS AND CHILDREN IN A PRE-K THROUGH 12TH GRADE EDUCATIONAL CURRICULUM, AND FEATURING INFORMATION IN THE FIELD OF TEACHING SKILLS IN THE FIELD OF EDUCATION FOR PARENTS; APPARATUS FOR RECORDING, TRANSMITTING, PLAYING AND DISPLAYING SOUND OR IMAGES (U.S. CLS. 21, 23, 26, 36 AND 38).

**CLASS 16—PAPER GOODS AND PRINTED MATTER**

FOR EDUCATIONAL KITS SOLD AS A UNIT IN THE FIELDS OF MATH, READING, SCIENCE, FOREIGN LANGUAGES AND SOCIAL STUDIES FOR INFANTS, TODDLERS, AND CHILDREN CONSISTING PRIMARILY OF BOOKS, FLASH CARDS, AND ALSO INCLUDING AN EDUCATIONAL DVD; PRE-PRINTED BOOKS, FLASH CARDS, GRAPHIC PRINTS AND REPRESENTATIONS, AND PHOTOGRAPHIC DISPLAYS, PRINTED CHARTS AND PAPER PLACE MATS ALL OF WHICH RELATE TO A VARIETY OF EDUCATIONAL SUBJECTS FOR INFANTS, TODDLERS, AND CHILDREN IN A PRE-K THROUGH 12TH GRADE EDUCATIONAL CURRICULUM, AND FEATURE LEARNING AND ENTERTAINMENT ACTIVITIES FOR TODDLERS AND YOUNG CHILDREN AND INFORMATION IN THE FIELD OF TEACHING SKILLS IN THE FIELD OF EDUCATION FOR PARENTS; WRITING PAPER; PENS; PENCILS; AND STICKERS (U.S. CLS. 2, 5, 22, 23, 29, 37, 38 AND 50).

**CLASS 28—TOYS AND SPORTING GOODS**

FOR EDUCATIONAL TOYS AND GAMES FOR INFANTS AND TODDLERS, AND CHILDREN, NAMELY, BOARD GAMES, CARD GAMES, NUMBER AND LETTER RECOGNITION WHEELS AND BLOCKS, ELECTRONIC EDUCATIONAL GAME MACHINES, CRIB TOYS, BATH TOYS, PUPPETS, PLUSH TOYS AND PUZZLES (U.S. CLS. 22, 23, 38 AND 50).

**CLASS 35—ADVERTISING AND BUSINESS**

FOR ONLINE RETAIL STORE SERVICES FEATURING PRODUCTS IN THE NATURE OF AUDIO AND VIDEO DISKS, BOOKS, PRINTED MATTER, TOYS, GAMES AND PLAYTHINGS FEATURING LEARNING AND ENTERTAINMENT ACTIVITIES FOR INFANTS, TODDLERS, AND CHILDREN; AND INFORMATION IN THE FIELD OF TEACHING SKILLS IN THE FIELD OF EDUCATION FOR PARENTS (U.S. CLS. 100, 101 AND 102).



**CLASS 41—EDUCATION AND ENTERTAINMENT**

FOR PROVIDING A WEBSITE FEATURING INFORMATION IN THE FIELD OF EDUCATION, NAMELY, MATH, READING, SCIENCE, FOREIGN LANGUAGES AND SOCIAL STUDIES FOR INFANTS, TODDLERS, AND CHILDREN, AND FEATURING LEARNING AND EDUCATIONAL GAMES AND ACTIVITIES FOR INFANTS, TODDLERS AND CHILDREN IN A PRE-K THROUGH 12TH GRADE EDUCATIONAL CURRICULUM, AND FEATURING INFORMATION IN THE FIELD OF TEACHING SKILLS IN THE FIELD OF EDUCATION FOR PARENTS; AND NEWS IN THE FIELD OF EDUCATION AND TEACHING METHODOLOGY (U.S. CLS. 100, 101 AND 107).

**CLASS 42—SCIENTIFIC AND COMPUTER SERVICES**

FOR PROVIDING TEMPORARY USE OF NON-DOWNLOADABLE SOFTWARE, NAMELY, CHILDREN'S EDUCATIONAL SOFTWARE FOR INFANTS, TODDLERS, AND CHILDREN FEATURING LEARNING AND EDUCATIONAL ACTIVITIES FOR INFANTS AND TODDLERS; AND FOR USE IN DEVELOPING TEACHING SKILLS FOR PARENTS (U.S. CLS. 100 AND 101).

JOHN DWYER, EXAMINING ATTORNEY

SN 85-026,312. SCANDINAVIAN INTERNET GROUP AB, SE-102 64 STOCKHOLM, SWEDEN, FILED 4-29-2010.

# EDUWAY

THE MARK CONSISTS OF STANDARD CHARACTERS WITHOUT CLAIM TO ANY PARTICULAR FONT, STYLE, SIZE, OR COLOR.

PRIORITY CLAIMED UNDER SEC. 44(D) ON ERPN CMNTY TM OFC APPLICATION NO. 009011065, FILED 4-7-2010, REG. NO. 009011065, DATED 2-21-2011, EXPIRES 4-7-2020.

**CLASS 35—ADVERTISING AND BUSINESS**

FOR MARKET RESEARCH SERVICES IN THE FIELDS OF EDUCATION AND TRAINING; COMPILATION AND SYSTEMIZATION OF INFORMATION IN THE FIELD OF EDUCATION INTO COMPUTER DATABASES; ONLINE MEDIA MONITORING SERVICES USING COMPUTER SOFTWARE TO AUTOMATICALLY MONITOR INTERNET WEBSITES AND ONLINE PUBLICATIONS FOR CUSTOMER-SPECIFIC TOPICS AND TO CAPTURE RELEVANT CONTENT ON THOSE TOPICS, AND PROVIDING DOCUMENTATION AND ANALYSIS OF THAT ONLINE CONTENT TO OTHERS FOR BUSINESS PURPOSES; PROMOTING THE GOODS AND SERVICES OF EDUCATION PROVIDERS VIA COMPUTER AND COMMUNICATION NETWORKS; PROVIDING ONLINE PROFESSIONAL AND CAREER NETWORKING SERVICES IN THE FIELDS OF EDUCATION AND TRAINING; ADVERTISING AND MARKETING, INCLUDING VIA GLOBAL COMPUTER NETWORKS, OF TRAINING INSTITUTES AND TRAINING ACTIVITIES (U.S. CLS. 100, 101 AND 102).

**CLASS 38—COMMUNICATION**

FOR PROVIDING ACCESS TO INTERACTIVE DATABASES RELATING TO INFORMATION IN THE FIELD OF EDUCATION, ENROLLMENT OF STUDENTS, AND COMMUNICATION OF RESPONSES THERETO, ALL THROUGH A GLOBAL COMPUTER NETWORK; PROVIDING ON-LINE FORUMS FOR TRAINING SEEKERS AND TRAINING PROVIDERS (U.S. CLS. 100, 101 AND 104).

**CLASS 41—EDUCATION AND ENTERTAINMENT**

FOR PROVIDING ON-LINE INFORMATION AND NEWS IN THE FIELD OF EMPLOYMENT TRAINING; PROVIDING ON-LINE INTERACTIVE EDUCATION COUNSELING SERVICES; PROVIDING AN ONLINE SEARCHABLE DATABASE FEATURING EDUCATION AND TRAINING OPPORTUNITIES (U.S. CLS. 100, 101 AND 107).

GINA FINK, EXAMINING ATTORNEY

SN 85-027,006. SCHAEFFLER TECHNOLOGIES GMBH & CO. KG, HERZOGENAURACH, FED REP GERMANY, FILED 4-30-2010.

# ELGOTEX

THE MARK CONSISTS OF STANDARD CHARACTERS WITHOUT CLAIM TO ANY PARTICULAR FONT, STYLE, SIZE, OR COLOR.

**CLASS 7—MACHINERY**

FOR MACHINE PARTS, NAMELY, BEARINGS AND COMPONENTS THEREOF, NAMELY, INNER RINGS, OUTER RINGS, ROLLING ELEMENTS, HUBS, CAGES, SEALINGS; CLUTCHES AND COMPONENTS THEREOF FOR MACHINES, NAMELY, CLUTCH RELEASE BEARINGS, CLUTCH DISKS, CLUTCH FORKS; FLYWHEELS FOR MACHINES; HYDRAULIC CLUTCH ACTUATORS NOT FOR LAND VEHICLES AND PARTS FOR THESE, NAMELY, DUCTS, TUBES, MASTER AND SLAVE CYLINDERS; MACHINE PARTS, NAMELY, BEARING BUSHINGS, ROD ENDS, AND AXLES FOR MACHINES (U.S. CLS. 13, 19, 21, 23, 31, 34 AND 35).

**CLASS 12—VEHICLES**

FOR PARTS FOR LAND AND MOTOR VEHICLES, NAMELY, INNER AND OUTER TIE ROD ENDS USED IN STEERING AND SUSPENSION SYSTEMS; CLUTCHES AND COMPONENTS THEREOF FOR LAND VEHICLES, NAMELY, CLUTCH RELEASE BEARINGS, CLUTCH DISKS, CLUTCH FORKS; FLYWHEELS FOR LAND VEHICLES; HYDRAULIC CLUTCH ACTUATORS FOR LAND VEHICLES AND PARTS FOR THESE, NAMELY, DUCTS, TUBES, MASTER AND SLAVE CYLINDERS; GEARSHIFT MECHANISMS AND COMPONENTS THEREOF, NAMELY, ELECTRONIC TRANSMISSIONS FOR LAND VEHICLES, HYDRAULIC TRAILER COUPLINGS; AUTOMATIC TRANSMISSIONS FOR LAND VEHICLES AND REPLACEMENT PARTS THEREOF; BRAKING SYSTEMS CONSISTING OF HYDRAULIC AND MECHANICAL CONTROLS FOR BRAKING SYSTEMS FOR VEHICLES AND THEIR STRUCTURAL PARTS; HYDRAULIC TRAILER COUPLINGS; BRAKE COMPONENTS FOR VEHICLES, NAMELY, BRAKE DISKS, BRAKES BRAKE FACINGS AND STRUCTURAL PARTS THEREOF, BRAKE LININGS; AXLES AND AXLE COMPONENTS FOR LAND VEHICLES, NAMELY, AXLE BOXES, HUBS, COUPLINGS; STEERING SYSTEMS AND STEERING SYSTEM COMPONENTS FOR LAND VEHICLES, NAMELY, STEERING BOX BEARINGS, STEERING COLUMN BEARINGS, STEERING WHEEL ADJUSTMENTS (U.S. CLS. 19, 21, 23, 31, 35 AND 44).

JOHN DWYER, EXAMINING ATTORNEY

SN 85-027,348. IBOCO SA, STABIO, SWITZERLAND, FILED 4-30-2010.

SN 85-027,352. ONGO, INC., CUPERTINO, CA. FILED 4-30-2010.



PRIORITY CLAIMED UNDER SEC. 44(D) ON SWITZERLAND APPLICATION NO. 54275/2010, FILED 4-30-2010, REG. NO. 605423, DATED 9-16-2010, EXPIRES 4-30-2020.

THE COLOR(S) LIGHT BLUE, WHITE, FUCHSIA, BLUE, YELLOW, BLACK AND GREY IS/ARE CLAIMED AS A FEATURE OF THE MARK.

THE MARK CONSISTS OF THE WORD "SIGLO" DISPLAYED USING A SAN-SERIF FONT TYPE. EACH LETTER OF THE WORD "SIGLO" IS ENCAPSULATED IN A SEPARATE RECTANGLE WITH SLIGHTLY ROUNDER CORNERS. THE RECTANGLES ARE SLIGHTLY TILTED TO THE LEFT OR TO THE RIGHT. SOME RECTANGLES PARTIALLY OVERLAP THE ADJACENT RECTANGLE. THE LETTER "S" IS WHITE IN A BLUE RECTANGLE; THE LETTER "I" IS WHITE IN A FUCHSIA RECTANGLE; THE LETTER "G" IS BLUE IN A WHITE RECTANGLE WHOSE BORDERS ARE OUTLINED IN BLUE; THE LETTER "L" IS BLUE IN A YELLOW RECTANGLE. THE LETTER "O" IS WHITE IN A BLACK RECTANGLE. A LIGHT GRAY-COLORED SHADE SURROUNDS THE RECTANGLES.

THE ENGLISH TRANSLATION OF "SIGLO" IN THE MARK IS I PUT MY INITIALS.

#### **CLASS 7—MACHINERY**

FOR PRINTING SYSTEMS COMPRISED OF PRINTING MACHINES FOR COMMERCIAL OR INDUSTRIAL USE AND REPLACEMENT PARTS THEREFOR, USED FOR LABELLING CABLES, CONNECTORS, NAMELY, TERMINAL BLOCKS, AND OTHER ELEMENTS OF COMMAND AND CONTROL IN THE FIELD OF ELECTRICAL ENGINEERING (U.S. CLS. 13, 19, 21, 23, 31, 34 AND 35).

#### **CLASS 9—ELECTRICAL AND SCIENTIFIC APPARATUS**

FOR SOFTWARE FOR CONTROLLING AND CONFIGURING PRINTING SYSTEMS (U.S. CLS. 21, 23, 26, 36 AND 38).

#### **CLASS 42—SCIENTIFIC AND COMPUTER SERVICES**

FOR DESIGN, DEVELOPMENT AND INSTALLATION SERVICES OF SOFTWARE FOR CONTROLLING AND CONFIGURING PRINTING SYSTEMS (U.S. CLS. 100 AND 101).

TRACY CROSS, EXAMINING ATTORNEY

# ONGO

THE MARK CONSISTS OF STANDARD CHARACTERS WITHOUT CLAIM TO ANY PARTICULAR FONT, STYLE, SIZE, OR COLOR.

#### **CLASS 9—ELECTRICAL AND SCIENTIFIC APPARATUS**

FOR COMPUTER AND TELECOMMUNICATIONS SOFTWARE FOR USE IN AGGREGATING AND VIEWING NEWS AND SYNDICATION FEEDS (U.S. CLS. 21, 23, 26, 36 AND 38).

#### **CLASS 35—ADVERTISING AND BUSINESS**

FOR PROVIDING PERSONALIZED ONLINE INFORMATION AND NEWS IN THE FIELD OF BUSINESS; PROVIDING PERSONALIZED ONLINE NEWS AND INFORMATION IN THE FIELD OF POLITICS (U.S. CLS. 100, 101 AND 102).

#### **CLASS 41—EDUCATION AND ENTERTAINMENT**

FOR PROVIDING PERSONALIZED ONLINE NEWS AND INFORMATION IN THE FIELD OF SPORTS; PROVIDING PERSONALIZED ONLINE NEWS AND INFORMATION IN THE FIELD OF CURRENT EVENTS REPORTING; PROVIDING PERSONALIZED ONLINE INFORMATION AND NEWS IN THE FIELD OF EMPLOYMENT TRAINING; PROVIDING PERSONALIZED ONLINE NEWS AND INFORMATION IN THE FIELD OF EDUCATION; PROVIDING PERSONALIZED ONLINE NEWS AND INFORMATION IN THE FIELD OF ENTERTAINMENT (U.S. CLS. 100, 101 AND 107).

#### **CLASS 42—SCIENTIFIC AND COMPUTER SERVICES**

FOR SEARCHING AND RETRIEVING INFORMATION AND DATA RESOURCES AVAILABLE ON COMPUTER NETWORKS FOR OTHERS; PROVIDING CUSTOMIZED ONLINE WEB PAGES FEATURING USER-DEFINED INFORMATION; COMPUTER SERVICES, NAMELY, PROVIDING INTERNET SEARCH ENGINES AND CREATING INDEXES OF INFORMATION, SITES, AND OTHER RESOURCES AVAILABLE ON COMPUTER NETWORKS RELATING TO NEWS AND SYNDICATION FEEDS; PROVIDING TEMPORARY USE OF ONLINE NONDOWNLOADABLE SOFTWARE FOR SENDING AND SHARING NEWS ARTICLES VIA OPTICAL, ELECTRONIC AND WIRELESS COMMUNICATIONS NETWORKS; PROVIDING PERSONALIZED ONLINE NEWS AND INFORMATION IN THE FIELDS OF SCIENCE AND TECHNOLOGY (U.S. CLS. 100 AND 101).

TRACY CROSS, EXAMINING ATTORNEY

SN 85-028,547. COURREGES DESIGN, PARIS, FRANCE, FILED 5-3-2010.

## COURREGES

THE MARK CONSISTS OF STANDARD CHARACTERS WITHOUT CLAIM TO ANY PARTICULAR FONT, STYLE, SIZE, OR COLOR.

OWNER OF FRANCE REG. NO. 1.310.817, DATED 5-30-1985, EXPIRES 5-30-2015.

OWNER OF U.S. REG. NOS. 3,285,587, 3,593,633 AND OTHERS.  
SEC. 2(F).

### CLASS 9—ELECTRICAL AND SCIENTIFIC APPARATUS

FOR SPECTACLES AND SPECTACLE CASES, SUNGLASSES AND FRAMES FOR SPECTACLES (U.S. CLS. 21, 23, 26, 36 AND 38).

### CLASS 24—FABRICS

FOR BED COVERS, PLASTIC TABLE COVERS, NAPERY HOUSE LINEN, TOILET AND BATH LINEN, SPONGE CLOTH LINEN, SPONGE TOWELS FOR THE BEACH, BED BLANKETS (U.S. CLS. 42 AND 50).  
NATALIE POLZER, EXAMINING ATTORNEY

SN 85-028,731. EARTHSPACE LLC, NEW YORK, NY. FILED 5-3-2010.

## EARTH GIRL

THE MARK CONSISTS OF STANDARD CHARACTERS WITHOUT CLAIM TO ANY PARTICULAR FONT, STYLE, SIZE, OR COLOR.

### CLASS 16—PAPER GOODS AND PRINTED MATTER

FOR PRINTED AND RELATED MATTER, NAMELY, MAGAZINES, COMIC BOOKS, BOOKS FEATURING SHORT STORIES, BOOKS PRINCIPALLY COVERING SUBJECTS RELATED TO ENTERTAINMENT, EDUCATION, RESEARCH, COMPUTER SCIENCE, COMPUTER PROGRAMMING, SCIENCE, ENVIRONMENT AND SCIENCE-FICTION, NOVELS, GRAPHIC NOVELS, POSTERS, CALENDARS, TEMPORARY TATTOOS, STICKERS, BUMPER STICKERS, DECALS, POSTCARDS, TRADING CARDS, SCRAPBOOKS, STATIONERY, NOTE PADS, NOTE BOOKS, PERSONAL ORGANIZERS, DESK TOP ORGANIZERS; PHOTOGRAPHIC PRINTS; PHOTOGRAPHS; LITHOGRAPHS; CATALOGS, NEWSLETTERS, JOURNALS, LEAFLETS, BROCHURES AND MAGAZINES PRINCIPALLY COVERING SUBJECTS RELATED TO ENTERTAINMENT, EDUCATION, RESEARCH, COMPUTER SCIENCE, COMPUTER PROGRAMMING, SCIENCE, ENVIRONMENT AND SCIENCE-FICTION (U.S. CLS. 2, 5, 22, 23, 29, 37, 38 AND 50).

### CLASS 28—TOYS AND SPORTING GOODS

FOR GAMES AND RELATED ACCESSORIES, NAMELY, HAND HELD UNITS FOR PLAYING ELECTRONIC GAMES OTHER THAN THOSE ADAPTED FOR USE WITH AN EXTERNAL DISPLAY SCREEN OR MONITOR AND ASSOCIATED GAME CARTRIDGES SOLD AS A UNIT; ELECTRONIC GAMES OTHER THAN THOSE ADAPTED FOR USE WITH TELEVISION RECEIVERS ONLY; COIN-OPERATED VIDEO GAMES, STAND ALONE VIDEO GAME MACHINES, STAND ALONE VIDEO OUTPUT GAME MACHINES, ELECTRONIC EDUCATIONAL GAME MACHINES FOR CHILDREN, ACTION SKILL GAMES, ACTION TARGET GAMES, PARTY GAMES, PROMOTIONAL GAME CARDS AND MATERIALS, RING GAMES, ROLE PLAYING GAMES, TARGET GAMES, ARCADE GAMES, ARCADE-TYPE ELECTRONIC EDUCATION VIDEO GAMES, BOARD GAMES, CUBE TYPE PUZZLES, JIGSAW PUZZLES, MANIPULATIVE PUZZLES, CARD GAMES, PLAYING CARDS, AND PLAYING CARD CASES; EQUIPMENT SOLD AS A UNIT FOR PLAYING BOARD GAMES, CARD GAMES AND MEMORY GAMES; EQUIPMENT SOLD AS A UNIT FOR PLAYING ACTION TYPE TARGET GAMES; LCD GAME MACHINES; TOYS AND PLAYTHINGS, NAMELY, CONSTRUCTION TOYS, ELECTRONICALLY OPERATED TOY MOTOR VEHICLES, INFLATABLE TOYS, SQUEEZABLE SQUEAKING TOYS, SQUEEZE TOYS, POP UP TOYS, MUSICAL TOYS, MUSIC BOX TOYS, PRINTING TOYS, PULL TOYS, PUSH TOYS, PUNCHING TOYS, RIDE-ON TOYS, SAND TOYS, SANDBOX TOYS, SKETCHING TOYS, PARTY FAVORS IN THE NATURE OF SMALL TOYS, CASES FOR TOY STRUCTURES, CASES FOR TOY VEHICLES, TOY BANKS, TOY BOXES, BALLOONS; SPORTING GOODS, NAMELY, BEACH BALLS (U.S. CLS. 22, 23, 38 AND 50).  
CHRIS WELLS, EXAMINING ATTORNEY

SN 85-029,369. VERTEX DATA SCIENCE LTD., PRESCOT, UNITED KINGDOM, FILED 5-4-2010.

## VERTEXVIAHOME

THE MARK CONSISTS OF STANDARD CHARACTERS WITHOUT CLAIM TO ANY PARTICULAR FONT, STYLE, SIZE, OR COLOR.

PRIORITY CLAIMED UNDER SEC. 44(D) ON UNITED KINGDOM APPLICATION NO. 2545978, FILED 4-27-2010, REG. NO. 2545978, DATED 10-15-2010, EXPIRES 4-27-2020.  
OWNER OF U.S. REG. NO. 3,412,593.

### CLASS 35—ADVERTISING AND BUSINESS

FOR CUSTOMER RELATIONSHIP MANAGEMENT SERVICES, NAMELY, OPERATING AND MANAGING CUSTOMER SERVICE TELEPHONE CALL CENTERS AND COMPUTERIZED CUSTOMER SERVICE CONTACT CENTERS FOR OTHERS (U.S. CLS. 100, 101 AND 102).

### CLASS 41—EDUCATION AND ENTERTAINMENT

FOR TRAINING SERVICES IN THE FIELD OF CUSTOMER SERVICE; PROFESSIONAL COACHING SERVICES IN THE FIELD OF CUSTOMER SERVICE (U.S. CLS. 100, 101 AND 107).  
ELISSA GARBER KON, EXAMINING ATTORNEY

SN 85-029,756. CLARK, MINDY, PARADISE VALLEY, AZ.  
FILED 5-4-2010.

SN 85-030,595. CHYNNA DOLLS, LLC, FULLERTON, CA.  
FILED 5-5-2010.

## GOLF DOC

THE MARK CONSISTS OF STANDARD CHARACTERS WITHOUT CLAIM TO ANY PARTICULAR FONT, STYLE, SIZE, OR COLOR.

### CLASS 5—PHARMACEUTICALS

FOR DIETARY AND NUTRITIONAL SUPPLEMENTS, NUTRACEUTICALS (U.S. CLS. 6, 18, 44, 46, 51 AND 52).

### CLASS 41—EDUCATION AND ENTERTAINMENT

FOR ATHLETIC TRAINING SERVICES (U.S. CLS. 100, 101 AND 107).  
ZACHARY BELLO, EXAMINING ATTORNEY

SN 85-029,923. CIW ENTERPRISES, MOUNTAINTOP, PA.  
FILED 5-4-2010.

## EXTREME

THE MARK CONSISTS OF STANDARD CHARACTERS WITHOUT CLAIM TO ANY PARTICULAR FONT, STYLE, SIZE, OR COLOR.

### CLASS 6—METAL GOODS

FOR METAL FIRE DOORS AND METAL FIRE GRILLE CURTAINS BEING PART OF METAL DOORS; METAL SECURITY DOORS AND METAL SECURITY GRILLE CURTAINS BEING PART OF METAL DOORS (U.S. CLS. 2, 12, 13, 14, 23, 25 AND 50).  
FIRST USE 3-5-2010; IN COMMERCE 3-5-2010.

### CLASS 19—NON-METALLIC BUILDING MATERIALS

FOR NON-METAL ROLLING DOORS MADE OF RUBBER; RUBBER DOOR PANELS USED IN ROLLING DOORS (U.S. CLS. 1, 12, 33 AND 50).  
FIRST USE 3-5-2010; IN COMMERCE 3-5-2010.  
KRISTINA MORRIS, EXAMINING ATTORNEY

## DOLL & CO.

THE MARK CONSISTS OF STANDARD CHARACTERS WITHOUT CLAIM TO ANY PARTICULAR FONT, STYLE, SIZE, OR COLOR.

NO CLAIM IS MADE TO THE EXCLUSIVE RIGHT TO USE "CO.", APART FROM THE MARK AS SHOWN.

### CLASS 25—CLOTHING

FOR WOMEN'S APPAREL, NAMELY, SHIRTS, PANTS, SWIMSUITS, WRAPS/SARONGS, DRESSES, SKIRTS, AND BELTS (U.S. CLS. 22 AND 39).

### CLASS 35—ADVERTISING AND BUSINESS

FOR RETAIL STORE SERVICES, MAIL ORDER CATALOG SERVICES, AND INTERNET RETAIL STORE SERVICES FEATURING WOMEN'S APPAREL, NAMELY, SHIRTS, PANTS, SWIMSUITS, WRAPS/SARONGS, DRESSES, SKIRTS, AND ACCESSORIES (U.S. CLS. 100, 101 AND 102).

MICHELLE DUBOIS, EXAMINING ATTORNEY

SN 85-030,653. ABSOLUTE COMMERCE, INC., BRISTOL, RI.  
FILED 5-5-2010.

## ABSOLUTE COMMERCE

THE MARK CONSISTS OF STANDARD CHARACTERS WITHOUT CLAIM TO ANY PARTICULAR FONT, STYLE, SIZE, OR COLOR.

NO CLAIM IS MADE TO THE EXCLUSIVE RIGHT TO USE "COMMERCE", APART FROM THE MARK AS SHOWN.

### CLASS 9—ELECTRICAL AND SCIENTIFIC APPARATUS

FOR COMPUTER SOFTWARE FOR FACILITATING BUSINESS-TO-BUSINESS PROCUREMENT AND PURCHASING; AND COMPUTER E-COMMERCE SOFTWARE TO ENABLE USERS WITHIN AN ENTERPRISE TO PROCURE GOODS AND SERVICES AND PERFORM CORPORATE PROCUREMENT TRANSACTIONS FOR GOODS AND SERVICES VIA A GLOBAL COMPUTER NETWORK (U.S. CLS. 21, 23, 26, 36 AND 38).

### CLASS 42—SCIENTIFIC AND COMPUTER SERVICES

FOR SERVICES FOR FACILITATING BUSINESS-TO-BUSINESS PROCUREMENT AND PURCHASING, NAMELY, HOSTING SOFTWARE FOR USE BY OTHERS WITHIN AN ENTERPRISE FOR PROCURING GOODS AND SERVICES AND PERFORMING CORPORATE PROCUREMENT TRANSACTIONS FOR GOODS AND SERVICES VIA A GLOBAL COMPUTER NETWORK (U.S. CLS. 100 AND 101).

SARA BENJAMIN, EXAMINING ATTORNEY

SN 85-030,781. JOHNSON & JOHNSON, NEW BRUNSWICK, NJ. FILED 5-5-2010.



THE MARK CONSISTS OF A FLOWER DESIGN OF SOUTHERNWOOD.

**CLASS 3—COSMETICS AND CLEANING PREPARATIONS**

FOR NON-MEDICATED SKIN CARE PREPARATIONS; SKIN LOTIONS; FACIAL CLEANSER; SKIN CLEANSING PREPARATIONS; NON-MEDICATED SUN CARE PREPARATIONS (U.S. CLS. 1, 4, 6, 50, 51 AND 52).

**CLASS 5—PHARMACEUTICALS**

FOR MEDICATED SKIN CARE PREPARATIONS; MEDICATED SKIN LOTIONS; MEDICATED FACIAL CLEANSER; MEDICATED SKIN CLEANSING PREPARATIONS; MEDICATED SUN CARE PREPARATIONS; NON-MEDICATED, THERAPEUTIC SKIN CREAMS FOR THE TREATMENT OF ECZEMA (U.S. CLS. 6, 18, 44, 46, 51 AND 52).

MARY BOAGNI, EXAMINING ATTORNEY

SN 85-030,785. JOHNSON & JOHNSON, NEW BRUNSWICK, NJ. FILED 5-5-2010.



THE COLOR(S) RED, ORANGE, YELLOW AND GREEN IS/ARE CLAIMED AS A FEATURE OF THE MARK.

THE MARK CONSISTS OF A FLOWER DESIGN OF SOUTHERNWOOD. THE HEADS OF THE SOUTHERNWOOD ON THE UPPER AND LEFT PORTION OF THE DESIGN ARE YELLOW AND ORANGE. THE MIDDLE SOUTHERNWOOD FLOWERS ARE ORANGE. THE LOWER SOUTHERNWOOD FLOWERS ARE RED. THE STEMS OF THE FLOWERS ARE GREEN WITH ORANGE, YELLOW, OR RED HIGHLIGHTS.

**CLASS 3—COSMETICS AND CLEANING PREPARATIONS**

FOR NON-MEDICATED SKIN CARE PREPARATIONS; SKIN LOTIONS; FACIAL CLEANSER; SKIN CLEANSING PREPARATIONS; NON-MEDICATED SUN CARE PREPARATIONS (U.S. CLS. 1, 4, 6, 50, 51 AND 52).

**CLASS 5—PHARMACEUTICALS**

FOR MEDICATED SKIN CARE PREPARATIONS; MEDICATED SKIN LOTIONS; MEDICATED FACIAL CLEANSER; MEDICATED SKIN CLEANSING PREPARATIONS; MEDICATED SUN CARE PREPARATIONS; NON-MEDICATED, THERAPEUTIC SKIN CREAMS FOR THE TREATMENT OF ECZEMA (U.S. CLS. 6, 18, 44, 46, 51 AND 52).

MARY BOAGNI, EXAMINING ATTORNEY

SN 85-030,982. ADBRITE, INC., SAN FRANCISCO, CA. FILED 5-5-2010.



THE MARK CONSISTS OF THE LETTER "A" COMPRISED OF SMALL INDIVIDUAL SQUARES.

**CLASS 35—ADVERTISING AND BUSINESS**

FOR RENTAL OF ONLINE ADVERTISING SPACE; ADVERTISING CONSULTATION; ADVERTISING AND MARKETING; ADVERTISING AGENCIES; ADVERTISING NETWORKS, NAMELY, SERVICES WHICH CONNECT ONLINE SITES THAT WANT TO HOST ADVERTISEMENTS WITH ADVERTISERS WHO WANT TO RUN ADVERTISEMENTS; DISSEMINATION OF ADVERTISING FOR OTHERS VIA THE INTERNET OR OTHER COMMUNICATIONS NETWORK; ONLINE ADVERTISING SERVICES FOR OTHERS, NAMELY, PROVIDING ADVERTISING SPACE ON INTERNET WEBSITES; COLLECTION OF USER DATA FOR ADVERTISING PURPOSES, NAMELY, CONDUCTING CONSUMER TRACKING BEHAVIOR RESEARCH AND CONSUMER BEHAVIOR ANALYSIS (U.S. CLS. 100, 101 AND 102).

**CLASS 42—SCIENTIFIC AND COMPUTER SERVICES**

FOR APPLICATION SERVICE PROVIDER FEATURING SOFTWARE FOR USE IN DISPLAYING AND DISTRIBUTING ELECTRONIC MEDIA OVER THE INTERNET FOR ADVERTISING AND MARKETING PURPOSES (U.S. CLS. 100 AND 101).

JENNIFER MARTIN, EXAMINING ATTORNEY

SN 85-032,487. OASIS STOP 'N GO, LLC, TWIN FALLS, ID.  
FILED 5-7-2010.

## FRESH KRAVINGS

THE MARK CONSISTS OF STANDARD CHARACTERS WITHOUT CLAIM TO ANY PARTICULAR FONT, STYLE, SIZE, OR COLOR.

NO CLAIM IS MADE TO THE EXCLUSIVE RIGHT TO USE "FRESH", APART FROM THE MARK AS SHOWN.

### CLASS 29—MEATS AND PROCESSED FOODS

FOR COMBINATION MEAL CONSISTING PRIMARILY OF A MEAT OR VEGETABLE-BASED ENTREE AND A SOUP OR SALAD FOR CONSUMPTION ON OR OFF THE PREMISES; SOUPS; VEGETABLE SALADS; FOOD PACKAGE COMBINATIONS CONSISTING PRIMARILY OF CHEESE AND MEAT; PREPARED FRUIT SALADS IN PORTABLE CONTAINERS (U.S. CL. 46).

### CLASS 30—STAPLE FOODS

FOR PREPARED COLD SANDWICHES; PASTRIES; PARFAITS (U.S. CL. 46).

COLLEEN KEARNEY, EXAMINING ATTORNEY

SN 85-033,865. GLOBALVIEW BUSINESS CONSULTANTS LIMITED, KWUN TONG, HONG KONG, FILED 5-10-2010.

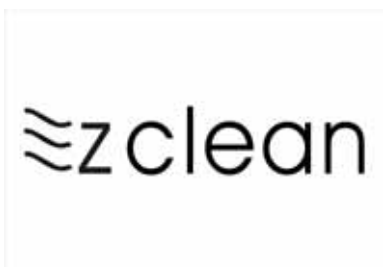

NO CLAIM IS MADE TO THE EXCLUSIVE RIGHT TO USE "CLEAN", APART FROM THE MARK AS SHOWN.

THE MARK CONSISTS OF THE WORD "E Z CLEAN" WITH THE LETTER "E" APPEARING AS THREE STYLIZED WAVY HORIZONTAL LINES.

### CLASS 1—CHEMICALS

FOR CHEMICALS FOR THE PURIFICATION OF WATER USED IN SWIMMING POOLS; WATER SOFTENING CHEMICALS FOR USE IN SWIMMING POOLS; WATER PURIFYING CHEMICALS FOR SWIMMING POOLS; WATER TREATMENT CHEMICALS FOR USE IN SWIMMING POOLS AND SPAS (U.S. CLS. 1, 5, 6, 10, 26 AND 46).

### CLASS 7—MACHINERY

FOR AUTOMATIC SWIMMING POOL CLEANERS; AUTOMATIC SWIMMING POOL SWEEPERS; BOTTOM CLEANING MACHINES IN THE NATURE OF VACUUMS FOR SWIMMING POOLS; SKIMMERS, NAMELY, DIVERTERS, FOR CLEANING SWIMMING POOLS; WATER PUMPS FOR RECYCLING WATER IN SWIMMING POOLS; ROBOTIC SWIMMING POOL VACUUM CLEANING MACHINES; SWIMMING POOL SWEEPING MACHINES; AUTOMATIC SWIMMING POOL CLEANING APPARATUS IN THE NATURE OF SWEEPERS; AUTOMATIC SWIMMING POOL CLEANING MACHINES (U.S. CLS. 13, 19, 21, 23, 31, 34 AND 35).

### CLASS 11—ENVIRONMENTAL CONTROL APPARATUS

FOR WATER FILTERS FOR USE WITH SWIMMING POOLS; INSTALLATIONS FOR THE TREATMENT OF WATER USED IN SWIMMING POOLS, NAMELY, WATER CLEANING AND FILTERING UNITS; FILTERS FOR WATER PURIFIERS; WATER PURIFIERS (U.S. CLS. 13, 21, 23, 31 AND 34).

DAVID COLLIER, EXAMINING ATTORNEY

SN 85-034,093. CHILDREN'S BUREAU OF SOUTHERN CALIFORNIA, LOS ANGELES, CA. FILED 5-10-2010.



THE MARK CONSISTS OF A HEART, A BOOK, A HALF APPLE AND A PIGGY BANK DESIGN WITH A CURVED LINE ON EITHER SIDE OF THE DESIGNS, ALL ABOVE THE WORDS "MAGNOLIA PLACE".

### CLASS 41—EDUCATION AND ENTERTAINMENT

FOR SOCIAL WELFARE SERVICES IN THE NATURE OF AIDING AT-RISK CHILDREN AND THEIR FAMILIES, NAMELY, PROVIDING EDUCATIONAL PROGRAMS IN THE NATURE OF CLASSES, COUNSELING PROGRAMS, AND INDIVIDUAL AND GROUP INSTRUCTION, FOR PARENTS AND CHILDREN IN THE FIELDS OF CHILD AND PARENT DEVELOPMENT, PARENTING SKILLS, EDUCATION, HEALTH, AND COMMUNITY RESOURCES; PROVIDING INFORMATION AND NEWS IN THE FIELD OF EMPLOYMENT TRAINING (U.S. CLS. 100, 101 AND 107).

FIRST USE 9-0-2009; IN COMMERCE 9-0-2009.

### CLASS 45—PERSONAL AND LEGAL SERVICES

FOR PROVIDING EMOTIONAL COUNSELING AND EMOTIONAL SUPPORT SERVICES FOR TROUBLED AND AT-RISK YOUTH AND THEIR FAMILIES; PROVIDING COUNSELING FOR VICTIMS OF CHILD ABUSE COMPRISING INTERVIEWING THE VICTIM, IDENTIFYING WHAT THE PROBLEM IS AND SUGGESTING WHERE HELP MAY BE OBTAINED; INFORMATION IN THE FIELD OF PARENTING CONCERNING INTRAFAMILY RELATIONSHIPS (U.S. CLS. 100 AND 101).

FIRST USE 9-9-2009; IN COMMERCE 9-9-2009.  
MORGAN WYNNE, EXAMINING ATTORNEY

SN 85-034,295. TWS PARTNERSHIP, LLC, BOCA RATON, FL. FILED 5-10-2010.

## STARTING THEM UP

THE MARK CONSISTS OF STANDARD CHARACTERS WITHOUT CLAIM TO ANY PARTICULAR FONT, STYLE, SIZE, OR COLOR.

### CLASS 16—PAPER GOODS AND PRINTED MATTER

FOR BOOKS IN THE FIELD OF BUSINESS (U.S. CLS. 2, 5, 22, 23, 29, 37, 38 AND 50).

### CLASS 35—ADVERTISING AND BUSINESS

FOR INCUBATION SERVICES, NAMELY, PROVIDING WORK SPACE CONTAINING BUSINESS EQUIPMENT TO FREELANCERS, START-UPS, EXISTING BUSINESSES AND NON-PROFITS; CONSULTING SERVICES IN THE FIELD OF BUSINESS (U.S. CLS. 100, 101 AND 102).

### CLASS 36—INSURANCE AND FINANCIAL

FOR INCUBATION SERVICES, NAMELY, PROVIDING FINANCING TO FREELANCERS, START-UPS, EXISTING BUSINESSES AND NON-PROFITS; INCUBATION SERVICES, NAMELY, RENTAL OF OFFICE SPACE TO FREELANCERS, START-UPS, EXISTING BUSINESSES AND NON-PROFITS (U.S. CLS. 100, 101 AND 102).

### CLASS 41—EDUCATION AND ENTERTAINMENT

FOR EDUCATIONAL AND ENTERTAINMENT SERVICES IN THE NATURE OF AN ON-GOING TELEVISION PROGRAM FEATURING A REALITY SHOW; EDUCATIONAL SERVICES, NAMELY, PROVIDING ON-LINE SEMINARS AND WEBINARS IN THE FIELD OF BUSINESS (U.S. CLS. 100, 101 AND 107).

ROBIN MITTLER, EXAMINING ATTORNEY

SN 85-034,409. G.T.S. CORPORATION PTY LTD, MIDVALE WA 6056, AUSTRALIA, FILED 5-10-2010.



PRIORITY CLAIMED UNDER SEC. 44(D) ON AUSTRALIA APPLICATION NO. 1331012, FILED 11-12-2009, REG. NO. 1331012, DATED 6-28-2010, EXPIRES 11-12-2019.

THE COLOR(S) BLUE, WHITE, AND GRAY IS/ARE CLAIMED AS A FEATURE OF THE MARK.

THE MARK CONSISTS OF THE FOLLOWING: A BLUE BACKGROUND WITH A WHITE AND GRAY HARD HAT AND THREE WHITE AND GRAY FIGURES DEPICTING TWO PARENTS AND A CHILD.

### CLASS 42—SCIENTIFIC AND COMPUTER SERVICES

FOR CONSUMER PRODUCT SAFETY TESTING AND CONSULTATION; PRODUCT SAFETY TESTING; CONSULTATION IN THE FIELD OF ERGONOMICS, NAMELY, DESIGNING WORKPLACE FACILITIES AND EQUIPMENT TO OPTIMIZE EFFICIENCY AND SAFETY; CONDUCTING WORKSITE SURVEYS TO DETERMINE IF WORKSITES MEET EMPLOYEE HEALTH CONDITION REQUIREMENTS AND STANDARDS; DESIGN AND TESTING FOR NEW PRODUCT DEVELOPMENT; DESIGN AND TESTING OF NEW PRODUCTS FOR OTHERS (U.S. CLS. 100 AND 101).

### CLASS 45—PERSONAL AND LEGAL SERVICES

FOR ANALYSIS AND CONSULTATION PERTAINING TO JOB SITE SAFETY; CONSULTANCY ON REGULATIONS ON SAFETY AT WORK; CONSULTATION SERVICES IN THE FIELD OF THE SAFETY NEEDS OF COMMERCIAL AND INDUSTRIAL COMPANIES; CONSULTING IN THE FIELD OF WORKPLACE SAFETY; PROVIDING INFORMATION CONCERNING CONSUMER PRODUCT SAFETY; SAFETY CONSULTING SERVICES IN THE FIELDS OF HAZARD ASSESSMENTS AND ABATEMENT PROCEDURES; SAFETY INSPECTION AUDITS TO IMPROVE SAFETY OF CONSTRUCTION WORKERS ON RESIDENTIAL CONSTRUCTION SITES (U.S. CLS. 100 AND 101).

DORITT L. CARROLL, EXAMINING ATTORNEY

SN 85-035,117. PIROZZI, BRETT, LAS VEGAS, NV. FILED 5-11-2010.

# Kreep

THE MARK CONSISTS OF STANDARD CHARACTERS WITHOUT CLAIM TO ANY PARTICULAR FONT, STYLE, SIZE, OR COLOR.

### CLASS 9—ELECTRICAL AND SCIENTIFIC APPARATUS

FOR AUDIO AND VIDEO RECORDINGS FEATURING PERFORMANCES BY A MUSICAL BAND (U.S. CLS. 21, 23, 26, 36 AND 38).

FIRST USE 3-3-2003; IN COMMERCE 3-3-2003.

### CLASS 41—EDUCATION AND ENTERTAINMENT

FOR ENTERTAINMENT SERVICES IN THE NATURE OF LIVE MUSICAL PERFORMANCES (U.S. CLS. 100, 101 AND 107).

FIRST USE 3-3-2003; IN COMMERCE 3-3-2003.

NATALIE POLZER, EXAMINING ATTORNEY

SN 85-035,147. JETNET, L.L.C., UTICA, NY. FILED 5-11-2010.

SN 85-035,185. GOVEA, MARK, OVERLAND PARK, KS. FILED 5-11-2010.

## YACHTSPOT

THE MARK CONSISTS OF STANDARD CHARACTERS WITHOUT CLAIM TO ANY PARTICULAR FONT, STYLE, SIZE, OR COLOR.

### CLASS 35—ADVERTISING AND BUSINESS

FOR PROVIDING CONSUMER PRODUCT INFORMATION FOR THE PURPOSE OF ALLOWING INDIVIDUALS AND BUSINESS ENTITIES TO SELECT YACHTS TO MEET THEIR DESIRED SPECIFICATIONS; COLLECTION OF MARKET RESEARCH INFORMATION CONCERNING YACHTS; PROVIDING CONFIGURATION DATA AND ENGINE INFORMATION REGARDING THE OEM ASSESSMENT OF OPERATIONAL HISTORY, NAMELY, PARTS, REPAIRS, CONFIGURATIONS AND MAINTENANCE PRACTICES, FOR SPECIFICALLY IDENTIFIED YACHT ENGINES FOR THE PURPOSE OF CONSUMERS TO MAKE INFORMED PURCHASING DECISIONS (U.S. CLS. 100, 101 AND 102).

### CLASS 36—INSURANCE AND FINANCIAL

FOR PROVIDING INFORMATION CONCERNING OFFERING YACHT FRACTIONAL OWNERSHIP PROGRAMS TO OTHERS (U.S. CLS. 100, 101 AND 102).  
SAMUEL E. SHARPER JR., EXAMINING ATTORNEY

SN 85-035,181. COMEDY EXCHANGE ASSOCIATION, PHILADELPHIA, PA. FILED 5-11-2010.

## CXA

THE MARK CONSISTS OF STANDARD CHARACTERS WITHOUT CLAIM TO ANY PARTICULAR FONT, STYLE, SIZE, OR COLOR.

### CLASS 35—ADVERTISING AND BUSINESS

FOR BUSINESS CONSULTING SERVICES, NAMELY, PROVIDING ASSISTANCE FOR COMEDIANS; BUSINESS ADMINISTRATION CONSULTATION (U.S. CLS. 100, 101 AND 102).

### CLASS 36—INSURANCE AND FINANCIAL

FOR FINANCIAL ADMINISTRATION OF THE LICENSING OF COPYRIGHTED COMEDIC WORKS AND RECORDINGS, NAMELY, COLLECTING LICENSE FEES ON BEHALF OF INDEPENDENT COMEDIANS AND MAKING PAYMENTS TO THE COPYRIGHT OWNERS OF THE COMEDY FOR DUPLICATION OR PERFORMANCES OF THEIR COMEDIC WORKS AND RECORDINGS; COLLECTION OF LICENSE FEES AND PAYMENT OF ROYALTIES (U.S. CLS. 100, 101 AND 102).

### CLASS 45—PERSONAL AND LEGAL SERVICES

FOR LICENSING OF COPYRIGHTED COMEDIC WORKS AND RECORDINGS (U.S. CLS. 100 AND 101).  
CAROLINE WOOD, EXAMINING ATTORNEY



THE COLOR(S) LIGHT GREEN, DARK GREEN AND KHAKI GREEN IS/ARE CLAIMED AS A FEATURE OF THE MARK.

THE MARK CONSISTS OF THE WORDING "10 20 30 GO!" WITH A "+" APPEARING IN THE "O" OF "GO" IN SHADES OF GREEN INTENSIFYING IN COLOR FROM LIGHT GREEN TO DARK GREEN FROM TOP TO BOTTOM AND INCREASING IN SIZE PROGRESSIVELY IN STANDARD TYPEFACE OUTLINED IN CLOUD FORMAT IN A LIGHTER SHADE OF GREEN. THE WORDING "FAMILIES FUNCTIONING FAITHFULLY" UNDERLINED IN LOWER CASE STANDARD TYPEFACE IN KHAKI GREEN APPEARS BELOW "10 20 30 GO+!".

### CLASS 16—PAPER GOODS AND PRINTED MATTER

FOR PARENTING KIT CONTAINING A BOOK, DAILY PRAYER AND MEDITATION CHARTS, PRINTED ACCOUNTABILITY CARDS, AND PROGRESS BOARD USED AS PART OF A PROGRAM TO TEACH CHILDREN ACHIEVEMENT, CONFIDENCE, INTEGRITY, MOTIVATION, RESPONSIBILITY, SELF-DISCIPLINE AND VALUES (U.S. CLS. 2, 5, 22, 23, 29, 37, 38 AND 50).

### CLASS 41—EDUCATION AND ENTERTAINMENT

FOR EDUCATIONAL SERVICES, NAMELY, PROVIDING A PROGRAM TO TEACH ACHIEVEMENT, CONFIDENCE, INTEGRITY, MOTIVATION, RESPONSIBILITY, SELF-DISCIPLINE AND VALUES TO PARENTS AND THEIR CHILDREN; ENTERTAINMENT SERVICES, NAMELY, CONDUCTING WORKSHOPS, SEMINARS AND LIVE SPEAKING ENGAGEMENTS IN THE FIELDS OF ACHIEVEMENT, ACCOUNTABILITY, CONFIDENCE, INTEGRITY, MOTIVATION, RESPONSIBILITY, SELF-DISCIPLINE AND VALUES TO PARENTS AND THEIR CHILDREN (U.S. CLS. 100, 101 AND 107).  
CAROLINE WOOD, EXAMINING ATTORNEY

SN 85-035,246. AQMETRIX RATINGS GLOBAL, S.L.U., BILBAO, SPAIN, FILED 5-11-2010.



PRIORITY CLAIMED UNDER SEC. 44(D) ON ERPNCMNTY TM OFC APPLICATION NO. 009003815, FILED 4-5-2010.

OWNER OF ERPNCMNTY TM OFC REG. NO. 9003815, DATED 9-27-2010, EXPIRES 4-5-2020.

NO CLAIM IS MADE TO THE EXCLUSIVE RIGHT TO USE "RATINGS & BENCHMARKS", APART FROM THE MARK AS SHOWN.



THE COLOR(S) WHITE, BLUE AND DARK GRAY IS/ARE CLAIMED AS A FEATURE OF THE MARK.

THE MARK CONSISTS OF THE WORD "AQMETRIX" IN LOWER CASE LETTERS. THE LETTERS "AQ" ARE WHITE AND THE LETTERS "METRIX" ARE BLUE. BELOW ARE THE BLUE WORDS "RATINGS & BENCHMARKS. ALL OF THIS IN A DARK GRAY BACKGROUND.

THE WORDING AQMETRIX HAS NO MEANING IN A FOREIGN LANGUAGE.

#### **CLASS 35—ADVERTISING AND BUSINESS**

FOR ANALYSIS OF MARKET RESEARCH DATA AND STATISTICS; ANALYZING AND COMPILING DATA FOR MEASURING THE PERFORMANCE OF FINANCIAL MARKETS; ASSISTANCE, ADVISORY SERVICES AND CONSULTANCY WITH REGARD TO BUSINESS PLANNING, BUSINESS ANALYSIS, BUSINESS MANAGEMENT, AND BUSINESS ORGANIZATION; BUSINESS DATA ANALYSIS; BUSINESS INVESTIGATIONS; PROVIDING AN ON-LINE COMPUTER WEB SITE THAT PROVIDES COMMERCIAL FINANCIAL TRANSACTION DATA, ACCOUNT MANAGEMENT, FINANCIAL REPORTING, ACCOUNTING FEATURES AND RELATED REFERENCE INFORMATION; PUBLICITY AND SALES PROMOTION SERVICES (U.S. CLS. 100, 101 AND 102).

#### **CLASS 36—INSURANCE AND FINANCIAL**

FOR CREDIT AND FINANCIAL CONSULTATION; FINANCIAL ADVICE AND CONSULTANCY SERVICES; FINANCIAL AFFAIRS AND MONETARY AFFAIRS, NAMELY, FINANCIAL INFORMATION, MANAGEMENT AND ANALYSIS SERVICES; FINANCIAL ANALYSIS AND CONSULTATION; FINANCIAL ANALYSIS AND RESEARCH SERVICES; FINANCIAL INFORMATION AND EVALUATIONS (U.S. CLS. 100, 101 AND 102).

#### **CLASS 38—COMMUNICATION**

FOR DIGITAL NETWORK TELECOMMUNICATIONS SERVICES; PROVIDING ACCESS TO TELECOMMUNICATION NETWORKS; PROVIDING ELECTRONIC TELECOMMUNICATION CONNECTIONS; PROVIDING ON-LINE COMMUNICATIONS LINKS WHICH TRANSFER THE WEB SITE USER TO OTHER LOCAL AND GLOBAL WEB PAGES; WEB CONFERENCING SERVICES; WEB SITE FORWARDING SERVICES (U.S. CLS. 100, 101 AND 104).

STEPHANIE ALI, EXAMINING ATTORNEY

#### **CLASS 41—EDUCATION AND ENTERTAINMENT**

FOR CHARITABLE SERVICES, NAMELY, PROVIDING TRAINING IN THE FIELD OF DOG TRAINING STANDARDS FOR SERVICE DOGS; DOG TRAINING; PROVIDING INFORMATION AND ADVICE IN THE FIELD OF PET TRAINING; TRAINING ANIMALS FOR OTHERS; TRAINING SERVICES IN THE FIELD OF DOG TRAINING STANDARDS FOR SERVICE DOGS (U.S. CLS. 100, 101 AND 107).

FIRST USE 9-30-2009; IN COMMERCE 9-30-2009.

#### **CLASS 44—MEDICAL, BEAUTY AND AGRICULTURAL SERVICES**

FOR CHARITABLE SERVICES, NAMELY, PROVIDING TRAINED SERVICE DOGS TO DISABLED OR CHALLENGED PEOPLE (U.S. CLS. 100 AND 101).

FIRST USE 9-30-2009; IN COMMERCE 9-30-2009.

JOHN WILKE, EXAMINING ATTORNEY

SN 85-036,271, MITSUBISHI ELECTRIC CORPORATION, CHIYODA-KU, TOKYO, JAPAN, FILED 5-12-2010.

SN 85-035,598, ANGEL SERVICE DOGS, INC., COLORADO SPRINGS, CO. FILED 5-11-2010.

# eco changes

## ALLERGY ALERT

THE MARK CONSISTS OF STANDARD CHARACTERS WITHOUT CLAIM TO ANY PARTICULAR FONT, STYLE, SIZE, OR COLOR.

NO CLAIM IS MADE TO THE EXCLUSIVE RIGHT TO USE "ALLERGY", APART FROM THE MARK AS SHOWN.

#### **CLASS 31—NATURAL AGRICULTURAL PRODUCTS**

FOR DOGS (U.S. CLS. 1 AND 46).

FIRST USE 9-30-2009; IN COMMERCE 9-30-2009.

THE MARK CONSISTS OF STANDARD CHARACTERS WITHOUT CLAIM TO ANY PARTICULAR FONT, STYLE, SIZE, OR COLOR.

NO CLAIM IS MADE TO THE EXCLUSIVE RIGHT TO USE "ECO", APART FROM THE MARK AS SHOWN.

#### **CLASS 7—MACHINERY**

FOR ELEVATORS; ESCALATORS; COMPRESSORS FOR MACHINES; WASTE COMPACTING MACHINES; WASTE SHREDDING MACHINES; INDUSTRIAL WASTE DISPOSALS; STARTERS FOR MOTORS AND ENGINES; CURRENT GENERATORS, ALTERNATORS; ELECTRIC MOTORS OTHER THAN FOR LAND VEHICLES; DISHWASHERS (U.S. CLS. 13, 19, 21, 23, 31, 34 AND 35).

**CLASS 9—ELECTRICAL AND SCIENTIFIC APPARATUS**

FOR ELECTRIC CONTROL PANELS; ELECTRIC DISTRIBUTION CONSOLES; ELECTRIC DISTRIBUTION BOARDS; ELECTRIC CURRENT TRANSFORMERS; INVERTERS; ELECTRIC CONVERTERS; ELECTRICAL TRANSducers; ELECTROMAGNETIC CONTACTORS; CONDENSERS; VOLTAGE REGULATORS; CIRCUIT BREAKERS; VOLTAGE STABILIZERS; VOLTAGE SURGE PROTECTORS; SYNCHRONOUS PHASE MODIFIER; UNINTERRUPTIBLE POWER SUPPLIES; ELECTRIC INSTALLATIONS FOR THE REMOTE CONTROL OF INDUSTRIAL OPERATIONS; SOLAR PHOTOVOLTAIC POWER GENERATION SYSTEMS COMPRISED OF SOLAR PHOTOVOLTAIC MODULES, CURRENT-COLLECTING JUNCTION BOXES, CURRENT TRANSFORMERS, ELECTRIC DISTRIBUTION BOARDS AND WATTMETERS; SOLAR BATTERIES; ELECTRONIC INDICATOR BOARDS; AMMETERS; VOLTMETERS; WATTMETERS; TELECOMMUNICATION APPARATUS, NAMELY, DATA SIGNAL CONTROLLERS, DATA TRANSMITTERS AND LASER DIODES, ALL FOR OPTICAL TELECOMMUNICATION; NETWORK TERMINATORS; ELECTRICAL NETWORK CHANNEL TERMINATING EQUIPMENT; COMPUTERIZED NUMERICAL CONTROLLERS FOR FACTORY AUTOMATION; INTEGRATED CIRCUITS (IC), LARGE SCALE INTEGRATED CIRCUITS (LSI); COMPUTER SYSTEMS COMPRISED OF COMPUTERS, COMPUTER PROGRAMS, ELECTRONIC DATABASES, INTERFACE UNIT AND TELECOMMUNICATION NETWORKS FOR MONITORING AND CONTROL APPARATUS FOR PLANT FACILITIES, MONITORING AND COLLECTION OF ENERGY CONSUMPTION DATA OF PLANT FACILITIES AND MONITORING AND MANAGEMENT OF ENERGY DEMAND OF FACTORIES; COMPUTERS; COMPUTER PROGRAMS FOR CONTROLLING INDUSTRIAL MACHINES, LAND VEHICLES, ELECTRICAL POWER INSTALLATIONS, AND, AIR CONDITIONING, ANTICRIME OR DISASTER-PREVENTING EQUIPMENT OF BUILDINGS OR FACILITIES; AUTOMATED SECURITY GATES; MONITORING AND CONTROLLING APPARATUS FOR SECURITY GATES, NAMELY, CAMERAS, LCD MONITORS AND STORAGE DEVICES OF PERSONAL ID, ALL FOR SECURITY PURPOSES; SWITCHES AND CONTROLLERS FOR LIGHTING APPARATUS AND INSTALLATIONS (U.S. CLS. 21, 23, 26, 36 AND 38).

**CLASS 11—ENVIRONMENTAL CONTROL APPARATUS**

FOR LIGHTING APPARATUS, NAMELY, LIGHTING FIXTURES AND LIGHTING INSTALLATIONS; ELECTRIC LAMPS; LEDS FOR LIGHTING; WATER HEATERS; AIR-CONDITIONING, AIR COOLING AND VENTILATION APPARATUS AND INSTRUMENTS; AIR CONDITIONERS; HEATING INSTALLATIONS; CHILLERS FOR AIR CONDITIONING; AIR PURIFIERS; HUMIDIFIERS; DEHUMIDIFIERS; ELECTRIC FANS; REMOTE CONTROL APPARATUS FOR AIR CONDITIONING INSTALLATIONS; HEAT PUMPS; REFRIGERATING DISPLAY CABINETS; ELECTRIC HAND DRIERS FOR REST ROOM; ELECTRIC RICE COOKERS; ELECTRIC TOASTERS; MICROWAVE OVENS; INDUCTION HEATING RANGES, HOBBS AND COOKTOPS; REFRIGERATORS (U.S. CLS. 13, 21, 23, 31 AND 34).

**CLASS 12—VEHICLES**

FOR ELECTRIC MOTORS FOR RAILCARS; ELECTRIC MOTORS FOR ELECTRIC POWER STEERING SYSTEMS OF AUTOMOBILES (U.S. CLS. 19, 21, 23, 31, 35 AND 44).

**CLASS 36—INSURANCE AND FINANCIAL**

FOR REAL ESTATE MANAGEMENT (U.S. CLS. 100, 101 AND 102).

**CLASS 37—CONSTRUCTION AND REPAIR**

FOR MAINTENANCE AND REPAIR OF AIR CONDITIONING APPARATUS AND INSTALLATION (U.S. CLS. 100, 103 AND 106).

**CLASS 40—MATERIAL TREATMENT**

FOR SORTING OF WASTE AND RECYCLABLE MATERIAL; DESTRUCTION OF WASTE AND TRASH; INCINERATION OF WASTE AND TRASH; RECYCLING OF WASTE AND TRASH (U.S. CLS. 100, 103 AND 106).

**CLASS 42—SCIENTIFIC AND COMPUTER SERVICES**

FOR REMOTE MONITORING SERVICES OF HEATING, VENTILATING AND AIR CONDITIONING APPARATUS; REMOTE MONITORING SERVICES OF ELECTRIC POWER SUPPLY (U.S. CLS. 100 AND 101).

**CLASS 45—PERSONAL AND LEGAL SERVICES**

FOR MONITORING OF SECURITY SYSTEMS OF BUILDINGS AND FACILITIES (U.S. CLS. 100 AND 101).  
KELLY TRUSILO, EXAMINING ATTORNEY

---

SN 85-037,257. WINGITS INNOVATIONS, LLC, BRADLEY BEACH, NJ. FILED 5-13-2010.

**WORLD'S STRONGEST FASTENER**

THE MARK CONSISTS OF STANDARD CHARACTERS WITHOUT CLAIM TO ANY PARTICULAR FONT, STYLE, SIZE, OR COLOR.

NO CLAIM IS MADE TO THE EXCLUSIVE RIGHT TO USE "FASTENER", APART FROM THE MARK AS SHOWN. SEC. 2(F).

**CLASS 6—METAL GOODS**

FOR METAL FASTENING ANCHORS (U.S. CLS. 2, 12, 13, 14, 23, 25 AND 50).  
FIRST USE 5-0-1997; IN COMMERCE 5-0-1997.

**CLASS 20—FURNITURE AND ARTICLES NOT OTHERWISE CLASSIFIED**

FOR NON-METAL FASTENING ANCHORS (U.S. CLS. 2, 13, 22, 25, 32 AND 50).  
FIRST USE 5-0-1997; IN COMMERCE 5-0-1997.  
MARY BOAGNI, EXAMINING ATTORNEY

SN 85-037,275. ID SOFTWARE LLC, MESQUITE, TX. FILED 5-13-2010.



THE MARK CONSISTS OF THE STYLIZED WORD "RAGE" WHERE THE LETTER "A" APPEARS TO BE THE CENTER OF AN IMPACT THAT CREATES A SHATTERING OR CRACKING EFFECT UPON THE OTHER LETTERS IN THE MARK.

**CLASS 9—ELECTRICAL AND SCIENTIFIC APPARATUS**

FOR DOWNLOADABLE PUBLICATIONS, NAMELY, COMPUTER AND VIDEO GAME STRATEGY GUIDES (U.S. CLS. 21, 23, 26, 36 AND 38).

**CLASS 16—PAPER GOODS AND PRINTED MATTER**

FOR COMPUTER AND VIDEO GAME USER INSTRUCTION MANUALS; MAGAZINES, BOOKS, AND PAMPHLETS CONCERNING VIDEO GAMES; PRINTED GUIDES FEATURING COMPUTER AND VIDEO GAME STRATEGY (U.S. CLS. 2, 5, 22, 23, 29, 37, 38 AND 50).  
CHRISTINE COOPER, EXAMINING ATTORNEY

---

SN 85-037,372. THE MCGRAW-HILL COMPANIES, INC., NEW YORK, NY. FILED 5-13-2010.



OWNER OF U.S. REG. NOS. 727,724, 1,948,434 AND OTHERS.

THE COLOR(S) BLUE, PURPLE, RED, AND WHITE IS/ ARE CLAIMED AS A FEATURE OF THE MARK.

THE MARK CONSISTS OF THE UPPERCASE WHITE LETTERS "S", "R", AND "A" DISPLAYED IN SMALL SQUARES COLORED BLUE, PURPLE, AND RED RESPECTIVELY; ALL OF THIS IS SHOWN ABOVE THE TERMS "IMAGINE IT!" IN WHITE WITH A BLUE OUTLINE. THE INITIAL LETTER "I" IN EACH TERM IS SHOWN IN UPPERCASE LETTERS AND THE REMAINING LETTERS ARE IN LOWERCASE WITH A FIVE-POINTED WHITE STAR OUTLINED IN BLUE ABOVE THE LOWERCASE LETTER "I".

**CLASS 9—ELECTRICAL AND SCIENTIFIC APPARATUS**

FOR COMPUTER SOFTWARE AND CD-ROMS THAT CONDUCT EDUCATIONAL ASSESSMENTS, CREATE TESTS, CREATE TEST QUESTION BANKS, CREATE STUDENT REPORTS, CLASS REPORTS, AND ADMINISTRATIVE REPORTS, AND CONTAIN EDUCATIONAL AND INSTRUCTIONAL MATERIALS IN THE FIELD OF READING AND LANGUAGE ARTS FOR PRE-K THROUGH 6TH GRADE STUDENTS; DVDS AND AUDIO COMPACT DISCS CONTAINING EDUCATIONAL AND INSTRUCTIONAL MATERIALS IN THE FIELD OF READING AND LANGUAGE ARTS FOR PRE-K THROUGH 6TH GRADE STUDENTS (U.S. CLS. 21, 23, 26, 36 AND 38).

FIRST USE 4-1-2007; IN COMMERCE 4-1-2007.

**CLASS 16—PAPER GOODS AND PRINTED MATTER**

FOR PRINTED EDUCATIONAL MATERIALS IN THE FORM OF TEXTBOOKS, WORKBOOKS, ANSWER KEYS, READERS, FLASHCARDS, AND TEACHER'S EDITIONS, ALL OF THE FOREGOING IN THE FIELD OF READING AND LANGUAGE ARTS FOR PRE-K THROUGH 6TH GRADE STUDENTS (U.S. CLS. 2, 5, 22, 23, 29, 37, 38 AND 50).

FIRST USE 4-1-2007; IN COMMERCE 4-1-2007.

**CLASS 28—TOYS AND SPORTING GOODS**

FOR MANIPULATIVE GAMES FOR EDUCATIONAL PURPOSES IN THE FIELD OF READING AND LANGUAGE ARTS (U.S. CLS. 22, 23, 38 AND 50).

FIRST USE 4-1-2007; IN COMMERCE 4-1-2007.

**CLASS 41—EDUCATION AND ENTERTAINMENT**

FOR PROVIDING AN EDUCATIONAL WEBSITE IN THE FIELD OF READING AND LANGUAGE ARTS FOR PRE-K THROUGH 6TH GRADE STUDENTS CONTAINING EDUCATIONAL CONTENT, EDUCATIONAL ASSESSMENTS, ASSIGNMENT MANAGERS, TEST BUILDERS, INSTRUCTION PLANNERS, AND REPORT GENERATORS (U.S. CLS. 100, 101 AND 107).

FIRST USE 4-1-2007; IN COMMERCE 4-1-2007.

MARGARET POWER, EXAMINING ATTORNEY

---

SN 85-037,441. PAWS ABOARD, LLC, TAMPA, FL. FILED 5-13-2010.

**PAWS REPUBLIC**

THE MARK CONSISTS OF STANDARD CHARACTERS WITHOUT CLAIM TO ANY PARTICULAR FONT, STYLE, SIZE, OR COLOR.

**CLASS 18—LEATHER GOODS**

FOR PET CARRIERS; ANIMAL BEDDING MADE OF FOAM ENCAPSULATED BY FABRIC; PET TRAVEL EQUIPMENT AND ACCESSORIES, NAMELY, STROLLERS, BAGS AND SEATBELTS; PET COLLAR ACCESSORIES, NAMELY, LEASHES, COLLARS AND HARNESSSES; RETRACTABLE PET LEASHES (U.S. CLS. 1, 2, 3, 22 AND 41).

**CLASS 28—TOYS AND SPORTING GOODS**

FOR PET TOYS AND TOYS MADE OF ROPE; CHEW TOYS; PLUSH TOYS, WATER FLOATING TOYS, FLYING DISCS AND RETRIEVER TOYS FOR PETS (U.S. CLS. 22, 23, 38 AND 50).

JOSETTE BEVERLY, EXAMINING ATTORNEY

SN 85-037,788. RELIANT ENERGY RETAIL HOLDINGS, LLC, HOUSTON, TX. FILED 5-13-2010.

**energywise**

THE COLOR(S) GREEN AND GRAY IS/ARE CLAIMED AS A FEATURE OF THE MARK.

THE MARK CONSISTS OF THE WORD "ENERGY" IN BOLD AND ITALIC PROVIDED IN THE COLOR GREEN NEXT TO THE WORD "WISE" IN ITALIC PROVIDED IN THE COLOR GRAY.

**CLASS 35—ADVERTISING AND BUSINESS**

FOR PROVIDING ON-LINE INFORMATION IN THE FIELD OF ENERGY EFFICIENCY (U.S. CLS. 100, 101 AND 102).

FIRST USE 6-1-2010; IN COMMERCE 6-1-2010.

**CLASS 41—EDUCATION AND ENTERTAINMENT**

FOR ON-LINE ELECTRONIC NEWSLETTERS DELIVERED BY EMAIL IN THE FIELD OF ENERGY EFFICIENCY AND INITIATIVES RELATED TO ALTERNATIVE ENERGY SOURCES (U.S. CLS. 100, 101 AND 107).

FIRST USE 6-1-2010; IN COMMERCE 6-1-2010.  
FONG HSU, EXAMINING ATTORNEY

SN 85-038,361. KARMISSIE, LLC, LAS VEGAS, CA. FILED 5-13-2010.

**KARMISSIE**

THE MARK CONSISTS OF STANDARD CHARACTERS WITHOUT CLAIM TO ANY PARTICULAR FONT, STYLE, SIZE, OR COLOR.

**CLASS 3—COSMETICS AND CLEANING PREPARATIONS**

FOR BODY AND BEAUTY CARE COSMETICS; CHALK FOR COSMETIC USE; COSMETIC CREAMS FOR SKIN CARE; COSMETIC PREPARATIONS; COSMETICS AND COSMETIC PREPARATIONS; EYEBROW COSMETICS; NON-MEDICATED HAIR TREATMENT PREPARATIONS FOR COSMETIC PURPOSES; NON-MEDICATED SKIN CARE CREAMS AND LOTIONS; NON-MEDICATED SKIN CARE PREPARATIONS (U.S. CLS. 1, 4, 6, 50, 51 AND 52).

FIRST USE 5-7-2010; IN COMMERCE 5-7-2010.

**CLASS 5—PHARMACEUTICALS**

FOR MEDICATED COSMETICS (U.S. CLS. 6, 18, 44, 46, 51 AND 52).

FIRST USE 5-7-2010; IN COMMERCE 5-7-2010.

**CLASS 8—HAND TOOLS**

FOR EPILATORY APPLIANCES (U.S. CLS. 23, 28 AND 44).

FIRST USE 5-7-2010; IN COMMERCE 5-7-2010.

DANNEAN HETZEL, EXAMINING ATTORNEY

SN 85-038,577. COSMIC RADICALS, LLC, AMITYVILLE, NY. FILED 5-14-2010.



THE COLOR(S) RED, BLACK AND WHITE IS/ARE CLAIMED AS A FEATURE OF THE MARK.

THE MARK CONSISTS OF THE WORDS "COSMIC RADICALS" IN BLOCK LETTERS PRIMARILY OF WHITE WITH BLACK SHADING; A CIRCLE IN WHITE WITH BLACK ACCENTS AND SHADING, WHICH IS OPEN AT THE TOP; A DESIGN IN THE MIDDLE OF THE CIRCLE PRIMARILY IN RED, WITH BLACK SHADING AND BACKGROUND; ALL ON A BLACK BACKGROUND.

**CLASS 9—ELECTRICAL AND SCIENTIFIC APPARATUS**

FOR RECORDABLE MEDIA, NAMELY, CD'S AND DVD'S FEATURING CONTINUING ANIMATED AND LIVE-ACTION SHOWS, PROGRAMS, SEGMENTS, MOVIES AND PERFORMANCES (U.S. CLS. 21, 23, 26, 36 AND 38).

**CLASS 41—EDUCATION AND ENTERTAINMENT**

FOR ENTERTAINMENT SERVICES, NAMELY, THE PROVISION OF CONTINUING ANIMATED AND LIVE-ACTION PROGRAMS, SEGMENTS, MOVIES, PERFORMANCES AND SHOWS, DELIVERED BY THE INTERNET, TELEVISION, AND OTHER WIRED AND WIRELESS COMMUNICATION NETWORKS (U.S. CLS. 100, 101 AND 107).

KEVIN CORWIN, EXAMINING ATTORNEY

SN 85-038,675. MINDSPARK INTERACTIVE NETWORK, INC., WHITE PLAINS, NY. FILED 5-14-2010.

# HOPSCOTCH

THE MARK CONSISTS OF STANDARD CHARACTERS WITHOUT CLAIM TO ANY PARTICULAR FONT, STYLE, SIZE, OR COLOR.

## CLASS 9—ELECTRICAL AND SCIENTIFIC APPARATUS

FOR DOWNLOADABLE COMPUTER SOFTWARE FOR USE IN PROVIDING SEARCH ENGINE SERVICES PROVIDED THROUGH A BROWSER TOOL BAR; DOWNLOADABLE INTERNET BROWSER PLUG-INS AND CLIENT SERVER APPLICATIONS IN THE NATURE OF MULTI-FUNCTION TOOL BAR PLUG-INS; COMPUTER SOFTWARE FOR OPERATING AND MAINTAINING AN ONLINE VIRTUAL WORLD FEATURING AVATAR-BASED COMMUNICATIONS FOR TRANSMISSION OF ELECTRONIC MESSAGES AMONG COMPUTER USERS, CHAT ROOMS, ELECTRONIC BULLETIN BOARDS, COMPUTER GAMES AND ACTIVITIES, A VIRTUAL ECONOMY AND A VIRTUAL CURRENCY FOR TRANSACTION OF VIRTUAL COMMERCE, AND DELIVERY OF AUDIO, VIDEO AND MULTIMEDIA CONTENT; COMPUTER SOFTWARE FOR CREATING CUSTOMIZED AVATARS AND DOWNLOADING SUCH AVATARS TO PERSONAL COMPUTERS AND MOBILE DEVICES; DOWNLOADABLE SOFTWARE, NAMELY, BROWSER TOOL BARS; DOWNLOADABLE COMPUTER SOFTWARE FOR USE IN ATTACHING FANCIFUL DESIGNS, ICONS OR SYMBOLS IN E-MAIL CORRESPONDENCE; DOWNLOADABLE COMPUTER SOFTWARE FOR USE IN INSTANT MESSAGING AND ONLINE CHAT; DOWNLOADABLE COMPUTER SOFTWARE FOR USE IN CUSTOMIZING GRAPHICAL APPEARANCES FOR USE GENERATED PERSONALIZED WEB PAGES; SOFTWARE FOR USE IN PERSONALIZING CELL PHONES (U.S. CLS. 21, 23, 26, 36 AND 38).

## CLASS 35—ADVERTISING AND BUSINESS

FOR BUSINESS SERVICES, NAMELY, PROVIDING LINKS TO THE WEBSITES OF OTHERS, NAMELY, RETAIL SERVICE PROVIDERS IN THE FIELD OF CONSUMER ELECTRONICS, COMPUTERS, CLOTHING, AUTOMOBILES, TOYS AND GAMES AND A WIDE VARIETY OF OTHER GENERAL CONSUMER PRODUCTS; PROVIDING LINKS TO WEBSITES OF OTHERS IN THE FIELD OF CONSUMER PRODUCTS AND SERVICES; PROVIDING CONSUMER PRODUCT INFORMATION VIA THE INTERNET; PROVIDING COMPARISON SHOPPING INFORMATION; PROVIDING ONLINE CONSUMER AND RETAIL DIRECTORY INFORMATION SERVICES ALSO FEATURING HYPERLINKS TO OTHER WEBSITES; DISSEMINATION OF ADVERTISING FOR OTHERS VIA THE INTERNET; ONLINE ADVERTISING SERVICES FOR OTHERS, NAMELY, PROVIDING ADVERTISING SPACE ON INTERNET WEB SITES; PROMOTING THE GOODS AND SERVICES OF OTHERS BY PLACING ADVERTISEMENTS AND PROMOTIONAL DISPLAYS ON ELECTRONIC SITES ACCESSED THROUGH COMPUTER NETWORKS; PROVIDING ONLINE BUSINESS DIRECTORIES FEATURING INFORMATION ON LOCAL BUSINESSES, INCLUDING ADDRESS, PHONE NUMBERS AND WEBSITES (U.S. CLS. 100, 101 AND 102).

## CLASS 38—COMMUNICATION

FOR TELECOMMUNICATIONS SERVICES, NAMELY, TELEPHONE COMMUNICATIONS SERVICES AND DELIVERY OF MESSAGES BY ELECTRONIC MAIL; PROVIDING ON-LINE ELECTRONIC BULLETIN BOARDS AND ONLINE CHAT ROOMS FOR THE TRANSMISSION OF MESSAGES AMONG COMPUTER USERS IN THE FIELD OF GENERAL INTEREST; BROADCASTING AND DELIVERY OF AUDIO, VIDEO AND MULTIMEDIA CONTENT BY MEANS OF CELLULAR AND WIRELESS COMMUNICATIONS AND COMPUTER NETWORKS; ELECTRONIC TRANSMISSION OF DATA, IMAGES, DOCUMENTS AND MESSAGES VIA COMPUTER TERMINALS; ELECTRONIC DATA MESSAGING; OPERATING AND MAINTAINING AN ONLINE VIRTUAL WORLD, NAMELY, PROVIDING AVATAR-BASED COMMUNICATIONS FOR TRANSMISSION OF ELECTRONIC MESSAGES AMONG COMPUTER USERS, PROVIDING ONLINE CHAT ROOMS AND ELECTRONIC BULLETIN BOARDS, IN THE FIELD OF GENERAL INTEREST, AUDIO, VIDEO AND MULTIMEDIA CONTENT (U.S. CLS. 100, 101 AND 104).

## CLASS 41—EDUCATION AND ENTERTAINMENT

FOR ENTERTAINMENT SERVICES, NAMELY, PROVIDING ON-LINE COMPUTER GAMES, FILMS AND ENTERTAINMENT CONTENT; PROVIDING LINKS TO WEB SITES OF OTHERS IN THE FIELD OF ENTERTAINMENT; OPERATING AND MAINTAINING AN ONLINE VIRTUAL WORLD FOR ENTERTAINMENT PURPOSES, NAMELY, PROVIDING ONLINE COMPUTER GAMES AND ENTERTAINMENT CONTENT IN THE NATURE OF PROVIDING A VIRTUAL ECONOMY AND A VIRTUAL CURRENCY FOR TRANSACTION OF VIRTUAL COMMERCE (U.S. CLS. 100, 101 AND 107).

## CLASS 42—SCIENTIFIC AND COMPUTER SERVICES

FOR COMPUTER SERVICES, NAMELY, PROVIDING SEARCH ENGINES FOR OBTAINING DATA ON A GLOBAL COMPUTER NETWORK; PROVIDING CUSTOMIZED ON-LINE WEB PAGES FEATURING USER-DEFINED INFORMATION, WHICH INCLUDES SEARCH ENGINES AND ONLINE WEB LINKS TO OTHER WEBSITES; PROVIDING SEARCH ENGINES FOR SEARCHING INDICES AND DATABASES OF WEBSITES AND COMPUTER NETWORKS; PROVIDING LINKS TO WEB SITES OF OTHERS IN THE FIELD OF COMPUTERS AND TECHNOLOGY (U.S. CLS. 100 AND 101).

CIMMERIAN COLEMAN, EXAMINING ATTORNEY

SN 85-038,874. HERITAGE PRESERVATION CORPORATION, SPARTANBURG, SC. FILED 5-14-2010.

## TRANSFORMING THE LANDSCAPE OF PRINT

THE MARK CONSISTS OF STANDARD CHARACTERS WITHOUT CLAIM TO ANY PARTICULAR FONT, STYLE, SIZE, OR COLOR.

## CLASS 40—MATERIAL TREATMENT

FOR PROVIDING CUSTOMIZED DIGITAL ON-DEMAND PRINTING SERVICES OF DOCUMENTS IN THE FIELD OF COMMERCIAL PRINTING (U.S. CLS. 100, 103 AND 106).

**CLASS 41—EDUCATION AND ENTERTAINMENT**

FOR PUBLICATION OF CUSTOMIZED, PRINTED DOCUMENTS FOR OTHERS (U.S. CLS. 100, 101 AND 107).

MORGAN WYNNE, EXAMINING ATTORNEY

---

SN 85-038,976. DOUGHNUT CORPORATION OF AMERICA, SEATTLE, WA. FILED 5-14-2010.

**TOP POT COFFEE**

THE MARK CONSISTS OF STANDARD CHARACTERS WITHOUT CLAIM TO ANY PARTICULAR FONT, STYLE, SIZE, OR COLOR.

OWNER OF U.S. REG. NOS. 2,751,146, 2,834,594 AND 2,895,455.

NO CLAIM IS MADE TO THE EXCLUSIVE RIGHT TO USE "COFFEE", APART FROM THE MARK AS SHOWN.

**CLASS 30—STAPLE FOODS**

FOR COFFEE BEANS; ROASTED COFFEE BEANS; GROUND COFFEE BEANS (U.S. CL. 46).

FIRST USE 9-29-2005; IN COMMERCE 9-29-2005.

**CLASS 43—HOTEL AND RESTAURANT SERVICES**

FOR CARRY OUT RESTAURANT SERVICES FEATURING FOOD AND BEVERAGES; RESTAURANT AND COFFEE BAR SERVICES (U.S. CLS. 100 AND 101).

FIRST USE 9-29-2005; IN COMMERCE 9-29-2005.

MARY BOAGNI, EXAMINING ATTORNEY

---

SN 85-039,042. RECKITT BENCKISER LLC, PARSIPPANY, NJ. FILED 5-14-2010.

**SUNSHINE FRESH**

THE MARK CONSISTS OF STANDARD CHARACTERS WITHOUT CLAIM TO ANY PARTICULAR FONT, STYLE, SIZE, OR COLOR.

NO CLAIM IS MADE TO THE EXCLUSIVE RIGHT TO USE "FRESH", APART FROM THE MARK AS SHOWN.

**CLASS 3—COSMETICS AND CLEANING PREPARATIONS**

FOR ALL PURPOSE BATHROOM CLEANING PREPARATIONS WITH DEODORIZING AND DISINFECTANT PROPERTIES; SCOURING LIQUIDS; LIME, RUST AND STAIN REMOVERS FOR BATH TUBS, SINKS, TILES AND FLOORS (U.S. CLS. 1, 4, 6, 50, 51 AND 52).

FIRST USE 7-15-2009; IN COMMERCE 7-15-2009.

**CLASS 5—PHARMACEUTICALS**

FOR ALL PURPOSE DISINFECTING PREPARATIONS; ALL PURPOSE DISINFECTANT SPRAY; SANITIZING PREPARATIONS FOR HOUSEHOLD USE; GERMICIDES; DEODORIZERS AND SANITIZERS FOR BATHROOMS AND TOILETS; ROOM DEODORIZERS; PREPARATIONS FOR NEUTRALIZING ODORS FOR GENERAL USE ON VARIOUS SURFACES; SANITIZING WIPES (U.S. CLS. 6, 18, 44, 46, 51 AND 52).

FIRST USE 7-15-2009; IN COMMERCE 7-15-2009.

KATHERINE E. HALMEN, EXAMINING ATTORNEY

---

SN 85-039,143. PREPAK PRODUCTS, INC., OCEANSIDE, CA. FILED 5-14-2010.

**HEALTH REFLECTION**

THE MARK CONSISTS OF STANDARD CHARACTERS WITHOUT CLAIM TO ANY PARTICULAR FONT, STYLE, SIZE, OR COLOR.

NO CLAIM IS MADE TO THE EXCLUSIVE RIGHT TO USE "HEALTH", APART FROM THE MARK AS SHOWN.

**CLASS 16—PAPER GOODS AND PRINTED MATTER**

FOR BOOKS IN THE FIELDS OF DIET, NUTRITION AND HEALTH; MAGAZINES IN THE FIELDS OF DIET, NUTRITION AND HEALTH; NEWSLETTERS IN THE FIELDS OF DIET, NUTRITION AND HEALTH (U.S. CLS. 2, 5, 22, 23, 29, 37, 38 AND 50).

**CLASS 44—MEDICAL, BEAUTY AND AGRICULTURAL SERVICES**

FOR PROVIDING INFORMATION VIA ONLINE WEBSITES AND INFORMATION FEEDS RELATING TO DIET AND NUTRITION (U.S. CLS. 100 AND 101).

DANIEL CAPSHAW, EXAMINING ATTORNEY

---

SN 85-039,997. RESTORZ LLC, WESTLAKE, OH. FILED 5-17-2010.



NO CLAIM IS MADE TO THE EXCLUSIVE RIGHT TO USE "RESTORES", APART FROM THE MARK AS SHOWN.

THE MARK CONSISTS OF THE WORD "RESTORZ" IN STYLIZED FONT WITH A DROP OF WATER SURROUNDING THE LETTER "O" AND A RIPPLE OF WATER FORMED BY AN OVAL AND TWO CONCENTRIC CURVED LINES UNDERLINING THE WORD.

**CLASS 37—CONSTRUCTION AND REPAIR**

FOR FIRE AND WATER DAMAGE RESTORATION OF BUILDINGS AND BUILDING SURFACES AND DISASTER RECOVERY SERVICES FOR BUILDINGS AND BUILDING SURFACES, NAMELY, WATER EXTRACTION, STRUCTURAL DRYING, INTERIOR SURFACE STAIN REMOVAL, AND APPLICATION OF PAINT; APPLYING SEALERS TO BUILDING INTERIORS FOR PREVENTION OF ABSORPTION OF MOISTURE, WATER, STAIN, AND SUCCEEDING COATINGS (U.S. CLS. 100, 103 AND 106).

FIRST USE 8-9-2005; IN COMMERCE 8-9-2005.

**CLASS 40—MATERIAL TREATMENT**

FOR MOLD PREVENTION TREATMENT OF BUILDING WALLS AND BUILDING INTERIORS; MOLD REMEDIATION SERVICES; ODOR NEUTRALIZATION SERVICES, NAMELY, ODOR REMEDIATION AND REMOVAL; DRY ICE BLASTING CLEANING SERVICES; APPLICATION OF ANTIMICROBIALS AND SEALERS, NAMELY, TREATMENT OF BUILDING INTERIORS WITH ANTIMICROBIAL AGENTS AND APPLYING SEALERS TO BUILDING INTERIORS FOR MILDEW PROOFING (U.S. CLS. 100, 103 AND 106).

FIRST USE 8-9-2005; IN COMMERCE 8-9-2005.  
TINA BROWN, EXAMINING ATTORNEY

SN 85-040,372. CENTER FOR ORANGUTAN AND CHIMPANZEE CONSERVATION, INC., WAUCHULA, FL. FILED 5-17-2010.



NO CLAIM IS MADE TO THE EXCLUSIVE RIGHT TO USE "CENTER", APART FROM THE MARK AS SHOWN.

THE MARK CONSISTS OF THE WORDS "CENTER FOR" OVER A LINE WITH A GAP OVER THE WORDS "GREAT APES" OVER THE IMAGE OF AN APE IN A BOX OVER A SHADED RECTANGULAR BOX CONTAINING THE WORDS "ORANGUTAN AND CHIMPANZEE" OVER THE WORD "CONSERVATION".

SEC. 2(F).

**CLASS 35—ADVERTISING AND BUSINESS**

FOR PROMOTING PUBLIC AWARENESS OF THE NEED FOR PROTECTION OF ANIMAL WELFARE (U.S. CLS. 100, 101 AND 102).

FIRST USE 3-1-2004; IN COMMERCE 3-1-2004.

**CLASS 36—INSURANCE AND FINANCIAL**

FOR CHARITABLE FUND RAISING SERVICES; CHARITABLE SERVICES, NAMELY, ORGANIZING FUNDRAISING SERVICES AND EVENTS TO RAISE FUNDS IN THE FIELD OF THE PROTECTION OF WILDLIFE (U.S. CLS. 100, 101 AND 102).

FIRST USE 3-1-2004; IN COMMERCE 3-1-2004.

MICHAEL WIENER, EXAMINING ATTORNEY

SOLUTIONS FOR LIFE'S  
TRANSITIONS

THE MARK CONSISTS OF STANDARD CHARACTERS WITHOUT CLAIM TO ANY PARTICULAR FONT, STYLE, SIZE, OR COLOR.

**CLASS 36—INSURANCE AND FINANCIAL**

FOR FINANCIAL CONSULTING; FINANCIAL PLANNING; FINANCIAL PLANNING CONSULTATION (U.S. CLS. 100, 101 AND 102).

**CLASS 45—PERSONAL AND LEGAL SERVICES**

FOR LEGAL SERVICES (U.S. CLS. 100 AND 101).  
JEFF DEFORD, EXAMINING ATTORNEY

SN 85-040,469. ALLOY MEDIA, LLC, NEW YORK, NY. FILED 5-17-2010.

ALLOY DIGITAL

THE MARK CONSISTS OF STANDARD CHARACTERS WITHOUT CLAIM TO ANY PARTICULAR FONT, STYLE, SIZE, OR COLOR.

OWNER OF U.S. REG. NOS. 3,100,259, 3,192,045 AND OTHERS.

NO CLAIM IS MADE TO THE EXCLUSIVE RIGHT TO USE "DIGITAL", APART FROM THE MARK AS SHOWN.

**CLASS 35—ADVERTISING AND BUSINESS**

FOR DISSEMINATION OF ADVERTISING FOR OTHERS VIA COMMUNICATION NETWORKS; ADVERTISING AND MARKETING SERVICES, NAMELY, PROMOTING THE GOODS AND SERVICES OF OTHERS, AND SPECIALIZING IN THE DESIGN AND EXECUTION OF WORD OF MOUTH, VIRAL, BUZZ AND EXPERIENTIAL MARKETING PROGRAMS (U.S. CLS. 100, 101 AND 102).

FIRST USE 6-0-2009; IN COMMERCE 6-0-2009.

**CLASS 41—EDUCATION AND ENTERTAINMENT**

FOR ENTERTAINMENT AND EDUCATION SERVICES, NAMELY, DISTRIBUTION VIA THE INTERNET OF A SERIES OF SHORT SHOWS FEATURING DRAMA AND COMEDY (U.S. CLS. 100, 101 AND 107).

FIRST USE 6-0-2009; IN COMMERCE 6-0-2009.  
SALLY SHIH, EXAMINING ATTORNEY

---

SN 85-040,643. SOCIETE DES PRODUITS NESTLE S.A., VEVEY, SWITZERLAND, FILED 5-17-2010.

**SHELTER CHAMPIONS**

THE MARK CONSISTS OF STANDARD CHARACTERS WITHOUT CLAIM TO ANY PARTICULAR FONT, STYLE, SIZE, OR COLOR.

NO CLAIM IS MADE TO THE EXCLUSIVE RIGHT TO USE "SHELTER", APART FROM THE MARK AS SHOWN.

**CLASS 36—INSURANCE AND FINANCIAL**

FOR CHARITABLE SERVICES, NAMELY, CHARITABLE FUNDRAISING (U.S. CLS. 100, 101 AND 102).

**CLASS 41—EDUCATION AND ENTERTAINMENT**

FOR ENTERTAINMENT SERVICES, NAMELY, PROVIDING ON-GOING TELEVISION PROGRAMS IN THE FIELD OF ANIMAL WELFARE; AND ENTERTAINMENT SERVICES, NAMELY, ARRANGING AND CONDUCTING OF COMPETITIONS FOR SHELTER PETS (U.S. CLS. 100, 101 AND 107).

LINDA ESTRADA, EXAMINING ATTORNEY

---

SN 85-040,825. EATING WELL, INC., CHARLOTTE, VT. FILED 5-17-2010.

**EATINGWELL WHERE GOOD  
TASTE MEETS GOOD HEALTH**

THE MARK CONSISTS OF STANDARD CHARACTERS WITHOUT CLAIM TO ANY PARTICULAR FONT, STYLE, SIZE, OR COLOR.

OWNER OF U.S. REG. NO. 3,106,102.

**CLASS 29—MEATS AND PROCESSED FOODS**

FOR PREPARED FOOD IN THE NATURE OF MEALS, ENTREES, AND SIDE DISHES CONSISTING PRIMARILY OF MEAT, FISH, POULTRY AND/OR VEGETABLES, BASED ON AND MARKETED IN RELATION TO COPYRIGHTED RECIPES THAT HAVE BEEN TESTED IN A TEST KITCHEN AND PUBLISHED IN PUBLICATIONS. THE PREPARED FOODS ARE MADE WITH NATURAL, WHOLESOME INGREDIENTS AND HAVE BEEN THOROUGHLY ANALYZED TO ENSURE HEALTHY NUTRITIONAL CONTENT AND TO CONTROL CALORIES, SATURATED FAT AND SODIUM. THE PREPARED FOODS ARE FORMULATED TO MINIMIZE OR EXCLUDE ADDED SUGARS, TRANS FATS AND REFINED GRAINS (U.S. CL. 46).

**CLASS 30—STAPLE FOODS**

FOR PREPARED FOOD IN THE NATURE OF MEALS, ENTREES, AND SIDE DISHES CONSISTING PRIMARILY OF PASTA, RICE, NOODLES OR GRAINS, BASED ON AND MARKETED IN RELATION TO COPYRIGHTED RECIPES THAT HAVE BEEN TESTED IN A TEST KITCHEN AND PUBLISHED IN PUBLICATIONS. THE PREPARED FOODS ARE MADE WITH NATURAL, WHOLESOME INGREDIENTS AND HAVE BEEN THOROUGHLY ANALYZED TO ENSURE HEALTHY NUTRITIONAL CONTENT AND TO CONTROL CALORIES, SATURATED FAT AND SODIUM. THE PREPARED FOODS ARE FORMULATED TO MINIMIZE OR EXCLUDE ADDED SUGARS, TRANS FATS AND REFINED GRAINS (U.S. CL. 46).

MARK RADEMACHER, EXAMINING ATTORNEY

---

SN 85-041,139. EARLY ALERT, INC., TAMPA, FL. FILED 5-18-2010.

**EARLY ALERT**

THE MARK CONSISTS OF STANDARD CHARACTERS WITHOUT CLAIM TO ANY PARTICULAR FONT, STYLE, SIZE, OR COLOR.

OWNER OF U.S. REG. NO. 2,722,316.

**CLASS 41—EDUCATION AND ENTERTAINMENT**

FOR TRAINING SERVICES IN THE FIELD OF CRISIS AND DISASTER EVENTS, RESPONSE TO DISASTER EVENTS, AND DISASTER RECOVERY; CONDUCTING CLASSES AND WORKSHOPS IN THE FIELD OF EMERGENCY MANAGEMENT, NAMELY, HAZARD TRAINING AND EXERCISE PROGRAMS, INTEROPERABILITY ANALYSIS AND PLANNING, AND SITUATIONAL AWARENESS PROVIDING WEATHER AND DISASTER ALERTS FOR DECISION MAKING ASSISTANCE, ALL RELATING TO CRISIS DISASTER EVENTS (U.S. CLS. 100, 101 AND 107).

FIRST USE 0-0-1998; IN COMMERCE 0-0-1999.

**CLASS 45—PERSONAL AND LEGAL SERVICES**

FOR CONSULTATION SERVICES CONCERNING EMERGENCY MANAGEMENT SERVICES; AND SECURITY SERVICES, NAMELY, THREAT SIMULATION VULNERABILITY ANALYSIS AND MITIGATION AND EMERGENCY AND CRISIS RESPONSE; SAFETY CONSULTING SERVICES IN THE FIELDS OF HAZARD ASSESSMENTS; AND SECURITY SERVICES, NAMELY, CBRN-CHEMICAL, BIOLOGICAL, RADIOLOGICAL AND NUCLEAR VULNERABILITY ASSESSMENT SERVICES (U.S. CLS. 100 AND 101).

FIRST USE 0-0-1998; IN COMMERCE 0-0-1999.



STEVEN JACKSON, EXAMINING ATTORNEY

SN 85-041,205. BAY CITIES CONTAINER CORPORATION, PICO RIVERA, CA. FILED 5-18-2010.

# BAY CITIES

THE MARK CONSISTS OF STANDARD CHARACTERS WITHOUT CLAIM TO ANY PARTICULAR FONT, STYLE, SIZE, OR COLOR.

## CLASS 16—PAPER GOODS AND PRINTED MATTER

FOR CARDBOARD PACKAGING; CORRUGATED CARDBOARD PACKAGING (U.S. CLS. 2, 5, 22, 23, 29, 37, 38 AND 50).

## CLASS 20—FURNITURE AND ARTICLES NOT OTHERWISE CLASSIFIED

FOR POINT OF PURCHASE DISPLAYS; PLASTIC COMMERCIAL PACKAGING MATERIALS, NAMELY, CORRUGATED TRAYS, CORRUGATED BINS, CORRUGATED BOXES AND CORRUGATED DISPLAY STANDS; PACKAGING CONTAINERS OF PLASTIC; PLASTIC BOXES FOR PACKAGING CONSUMER AND RETAIL ITEMS (U.S. CLS. 2, 13, 22, 25, 32 AND 50).

## CLASS 35—ADVERTISING AND BUSINESS

FOR ORDER FULFILLMENT SERVICES (U.S. CLS. 100, 101 AND 102).

## CLASS 39—TRANSPORTATION AND STORAGE

FOR MERCHANDISE PACKAGING FOR OTHERS (U.S. CLS. 100 AND 105).

## CLASS 42—SCIENTIFIC AND COMPUTER SERVICES

FOR DESIGN SKETCHING OF PACKAGING; DESIGN OF PACKAGING AND POINT OF PURCHASE DISPLAYS FOR OTHERS (U.S. CLS. 100 AND 101). WENDY GOODMAN, EXAMINING ATTORNEY

SN 85-041,219. TGR BIOSCIENCES PTY LTD, THEBARTON, SO. AUSTR., AUSTRALIA, FILED 5-18-2010.

# ELISA-ONE

THE MARK CONSISTS OF STANDARD CHARACTERS WITHOUT CLAIM TO ANY PARTICULAR FONT, STYLE, SIZE, OR COLOR.

## CLASS 1—CHEMICALS

FOR REAGENT KITS FOR RESEARCH PURPOSES COMPRISING ANTIBODIES FOR CONDUCTING IMMUNOASSAYS FOR AGRICULTURAL, HORTICULTURAL, FORESTRY, ENVIRONMENTAL OR FOOD-TESTING (U.S. CLS. 1, 5, 6, 10, 26 AND 46).

## CLASS 5—PHARMACEUTICALS

FOR REAGENT KITS COMPRISING ANTIBODIES FOR CONDUCTING IMMUNOASSAYS FOR MEDICAL OR VETERINARY DIAGNOSTIC PURPOSES (U.S. CLS. 6, 18, 44, 46, 51 AND 52). CHERYL CLAYTON, EXAMINING ATTORNEY

SN 85-041,589. STUDIO IP HOLDINGS, LLC, WILMINGTON, DE. FILED 5-18-2010.

# WAVERLY

THE MARK CONSISTS OF STANDARD CHARACTERS WITHOUT CLAIM TO ANY PARTICULAR FONT, STYLE, SIZE, OR COLOR. OWNER OF U.S. REG. NOS. 2,011,559, 2,908,925 AND OTHERS.

## CLASS 3—COSMETICS AND CLEANING PREPARATIONS

FOR BATH BEADS; BATH CRYSTALS; BATH GEL; BATH PEARLS; BATH SOAPS; BODY OIL; BODY SCRUB; BODY SPRAYS; FACE AND BODY LOTIONS; PERFUME (U.S. CLS. 1, 4, 6, 50, 51 AND 52).

## CLASS 4—LUBRICANTS AND FUELS

FOR CANDLES; SCENTED CANDLES (U.S. CLS. 1, 6 AND 15). JENNIFER VASQUEZ, EXAMINING ATTORNEY

SN 85-041,700. MBF AND ASSOCIATES, INC., NEW YORK, NY. FILED 5-18-2010.

# JUMP

THE MARK CONSISTS OF STANDARD CHARACTERS WITHOUT CLAIM TO ANY PARTICULAR FONT, STYLE, SIZE, OR COLOR. OWNER OF U.S. REG. NO. 2,303,565.

## CLASS 41—EDUCATION AND ENTERTAINMENT

FOR DIGITAL EDITING, NAMELY, FILM AND VIDEO DIGITAL EDITING SERVICES; SOUND DESIGN SERVICES, NAMELY, AUDIO AND VIDEO RECORDING AND PRODUCTION FOR OTHERS (U.S. CLS. 100, 101 AND 107). FIRST USE 9-19-1997; IN COMMERCE 9-19-1997.

**CLASS 42—SCIENTIFIC AND COMPUTER SERVICES**

FOR GRAPHIC ART DESIGN (U.S. CLS. 100 AND 101).  
FIRST USE 9-19-1997; IN COMMERCE 9-19-1997.  
BARBARA BROWN, EXAMINING ATTORNEY

SN 85-042,245. TPC GROUP LLC, HOUSTON, TX. FILED 5-19-2010.

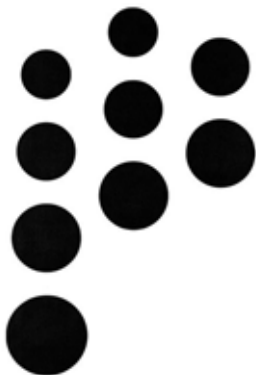

THE MARK CONSISTS OF A SERIES OF NINE DOTS FORMING A STYLIZED "P" SHAPE.

**CLASS 1—CHEMICALS**

FOR CHEMICALS, NAMELY, BUTADIENE AND BUTYLENE FOR USE IN A WIDE VARIETY OF INDUSTRIES; CHEMICALS, NAMELY, PETROCHEMICALS, FOR USE AS RAW MATERIALS IN THE MANUFACTURE OF A WIDE VARIETY OF GOODS; CHEMICAL ADDITIVES, NAMELY, PETROCHEMICALS FOR ENHANCING THE PERFORMANCE OF LUBRICATING OILS, GREASES, AND INTERNAL COMBUSTION ENGINE FUELS; POLYMER COMPOSITIONS USED IN THE MANUFACTURE OF COMMERCIAL AND INDUSTRIAL GOODS (U.S. CLS. 1, 5, 6, 10, 26 AND 46).

FIRST USE 10-1-2008; IN COMMERCE 10-1-2008.

**CLASS 40—MATERIAL TREATMENT**

FOR TECHNICAL SUPPORT SERVICES FOR OTHERS, NAMELY, PROVIDING TECHNICAL ADVICE RELATED TO THE MANUFACTURE OF PRODUCTS USING AND CONTAINING BUTADIENE, BUTYLENES, POLYMERS AND OTHER PETROCHEMICAL RAW MATERIALS (U.S. CLS. 100, 103 AND 106).

FIRST USE 10-1-2008; IN COMMERCE 10-1-2008.  
KIM MONINGHOFF, EXAMINING ATTORNEY

SN 85-042,319. MANNATECH, INCORPORATED, COPPELL, TX. FILED 5-19-2010.

# LIVE FOR REAL

THE MARK CONSISTS OF STANDARD CHARACTERS WITHOUT CLAIM TO ANY PARTICULAR FONT, STYLE, SIZE, OR COLOR.

**CLASS 35—ADVERTISING AND BUSINESS**

FOR BUSINESS MANAGEMENT AND SALES PROMOTION SERVICES FOR A LINE OF DIETARY AND NUTRITIONAL SUPPLEMENTS AND SKIN CARE PRODUCTS (U.S. CLS. 100, 101 AND 102).

FIRST USE 3-17-2010; IN COMMERCE 3-17-2010.

**CLASS 41—EDUCATION AND ENTERTAINMENT**

FOR TRAINING AND EDUCATIONAL SERVICES, NAMELY, PROVIDING LIVE AND RECORDED COURSES, SEMINARS AND CLASSES IN THE FIELD OF DIETARY, NUTRITIONAL HEALTH AND SKIN CARE ADVISE (U.S. CLS. 100, 101 AND 107).

FIRST USE 3-17-2010; IN COMMERCE 3-17-2010.  
GIANCARLO CASTRO, EXAMINING ATTORNEY

SN 85-042,344. SIDE TRIP, L.L.C., LEON, IA. FILED 5-19-2010.

# GET VERTICAL

THE MARK CONSISTS OF STANDARD CHARACTERS WITHOUT CLAIM TO ANY PARTICULAR FONT, STYLE, SIZE, OR COLOR.

**CLASS 18—LEATHER GOODS**

FOR DUFFLE BAGS, TOTE BAGS, SHOULDER BAGS, AND BACKPACKS (U.S. CLS. 1, 2, 3, 22 AND 41).

**CLASS 25—CLOTHING**

FOR CLOTHING, NAMELY, SWEATSHIRTS, POLO SHIRTS, PULLOVERS, BUTTON SHIRTS, T-SHIRTS; HATS (U.S. CLS. 22 AND 39).

MARY ROSSMAN, EXAMINING ATTORNEY

SN 85-042,375. CENTER FOR INTERNET SECURITY, EAST GREENBUSH, NY. FILED 5-19-2010.

# USCC U S CYBER CHALLENGE

THE MARK CONSISTS OF STANDARD CHARACTERS WITHOUT CLAIM TO ANY PARTICULAR FONT, STYLE, SIZE, OR COLOR.

NO CLAIM IS MADE TO THE EXCLUSIVE RIGHT TO USE "U S CYBER CHALLENGE", APART FROM THE MARK AS SHOWN.

**CLASS 35—ADVERTISING AND BUSINESS**

FOR ORGANIZING BUSINESS COMPETITIONS IN THE FIELD OF CYBER SECURITY; INTERNSHIP PLACEMENT SERVICES IN THE FIELD OF CYBER SECURITY; PROVIDING NETWORKING OPPORTUNITIES FOR INDIVIDUALS SEEKING EMPLOYMENT IN THE FIELD OF CYBER SECURITY (U.S. CLS. 100, 101 AND 102).

FIRST USE 4-12-2010; IN COMMERCE 4-12-2010.

**CLASS 36—INSURANCE AND FINANCIAL**

FOR PROVIDING EDUCATIONAL SCHOLARSHIPS IN THE FIELD OF CYBER SECURITY; PROVIDING INFORMATION IN THE FIELD OF EDUCATIONAL SCHOLARSHIPS (U.S. CLS. 100, 101 AND 102).

FIRST USE 4-12-2010; IN COMMERCE 4-12-2010.

**CLASS 41—EDUCATION AND ENTERTAINMENT**

FOR SUMMER TRAINING CAMPS IN THE FIELD OF CYBER SECURITY; ORGANIZING AND CONDUCTING EDUCATIONAL COMPETITIONS IN THE FIELD OF CYBER SECURITY; ORGANIZING AND CONDUCTING COMPETITIONS FOR ENTERTAINMENT PURPOSES IN THE FIELD OF CYBER SECURITY; EDUCATIONAL SERVICES, NAMELY, PROVIDING INTERNSHIPS AND APPRENTICESHIPS IN THE FIELD OF CYBER SECURITY (U.S. CLS. 100, 101 AND 107).

FIRST USE 4-12-2010; IN COMMERCE 4-12-2010.

ELLEN BURNS, EXAMINING ATTORNEY

SN 85-042,511. MAESTRO SUISSE HOLDING (H.K.) LIMITED, CENTRAL, HONG KONG, FILED 5-19-2010.



OWNER OF HONG KONG REG. NO. 301479745, DATED 11-19-2009, EXPIRES 11-19-2019.

THE MARK CONSISTS OF THE STYLIZED WORD "VICAKÓ".

THE WORDING "VICAKO" HAS NO MEANING IN A FOREIGN LANGUAGE.

**CLASS 29—MEATS AND PROCESSED FOODS**

FOR MEAT, FISH, POULTRY AND GAME; MEAT EXTRACTS; PRESERVED, FROZEN, DRIED AND COOKED FRUITS AND VEGETABLES; JELLIES, JAMS, COMPOTES; EGGS, MILK AND MILK PRODUCTS, EXCLUDING ICE CREAM, ICE MILK AND FROZEN YOGURT; EDIBLE OILS AND FATS (U.S. CL. 46).

**CLASS 30—STAPLE FOODS**

FOR COFFEE, TEA, COCOA, SUGAR, RICE, TAPIOCA, SAGO, ARTIFICIAL COFFEE; FLOUR; PREPARATIONS MADE FROM CEREALS, NAMELY, NOODLES AND PIZZA; BREAD, PASTRY; CONFECTIONERY; EDIBLE ICES; HONEY, TREACLE; YEAST, BAKING-POWDER; SALT, MUSTARD; VINEGAR, SAUCES; SPICES; ICE (U.S. CL. 46).

**CLASS 32—LIGHT BEVERAGES**

FOR BEERS; MINERAL AND AERATED WATERS AND OTHER NON-ALCOHOLIC DRINKS, NAMELY, FRUIT JUICES, CARBONATED AND NON-CARBONATED SOFT DRINKS; FRUIT DRINKS AND FRUIT JUICES; SYRUPS AND OTHER PREPARATIONS FOR MAKING BEVERAGES (U.S. CLS. 45, 46 AND 48).

ROBIN CHOSID, EXAMINING ATTORNEY

SN 85-042,757. JOHNSON & JOHNSON, NEW BRUNSWICK, NJ. FILED 5-19-2010.

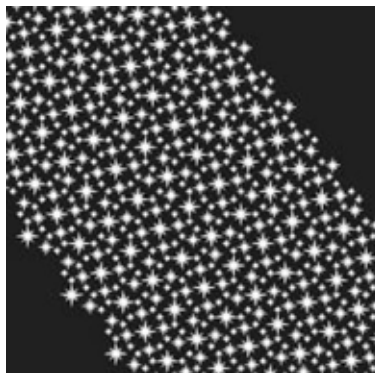

THE MARK CONSISTS OF A SOLID VERTICAL RECTANGLE WITH A DIAGONAL STRIPE OF MULTI-POINT STAR LIKE DESIGNS CREATING AN OVERALL SPARKLE EFFECT.

**CLASS 3—COSMETICS AND CLEANING PREPARATIONS**

FOR NON-MEDICATED MOUTHWASH, COSMETIC TOOTH WHITENING PREPARATIONS, TOOTHPASTE, BREATH FRESHENERS, NON-MEDICATED ORAL CARE MIST BREATH SPRAY (U.S. CLS. 1, 4, 6, 50, 51 AND 52).

**CLASS 5—PHARMACEUTICALS**

FOR MEDICATED MOUTHWASH, NAMELY, MOUTHWASH CONTAINING FLUORIDE (U.S. CLS. 6, 18, 44, 46, 51 AND 52).

COLLEEN KEARNEY, EXAMINING ATTORNEY

SN 85-042,760. JOHNSON & JOHNSON, NEW BRUNSWICK, NJ. FILED 5-19-2010.

LISTERINE WHITENING GOOD  
FOR YOUR TEETH GREAT FOR  
YOUR SMILE

THE MARK CONSISTS OF STANDARD CHARACTERS WITHOUT CLAIM TO ANY PARTICULAR FONT, STYLE, SIZE, OR COLOR.

OWNER OF U.S. REG. NOS. 3,056,511, 3,218,073 AND OTHERS.

NO CLAIM IS MADE TO THE EXCLUSIVE RIGHT TO USE "WHITENING", APART FROM THE MARK AS SHOWN.

**CLASS 3—COSMETICS AND CLEANING PREPARATIONS**

FOR NON-MEDICATED MOUTHWASH, COSMETIC TOOTH WHITENING PREPARATIONS, TOOTHPASTE (U.S. CLS. 1, 4, 6, 50, 51 AND 52).

**CLASS 5—PHARMACEUTICALS**

FOR MEDICATED FLUORIDE MOUTHWASH (U.S. CLS. 6, 18, 44, 46, 51 AND 52).  
COLLEEN KEARNEY, EXAMINING ATTORNEY

SN 85-042,961. ALEXANDER G. WEBBE, WELLINGTON, FL.  
FILED 5-19-2010.



SN 85-042,855. HOMEAWAY.COM, INC., AUSTIN, TX.  
FILED 5-19-2010.



NO CLAIM IS MADE TO THE EXCLUSIVE RIGHT TO USE "INTERNATIONAL BEACH POLO ASSOCIATION", APART FROM THE MARK AS SHOWN.

THE MARK CONSISTS OF SEAHORSE AND CROSSED POLO MALLETS ENCIRCLED BY THE WORDING "INTERNATIONAL BEACH POLO ASSOCIATION".

**CLASS 25—CLOTHING**

FOR CLOTHING, NAMELY, POLO SHIRTS AND T-SHIRTS (U.S. CLS. 22 AND 39).  
FIRST USE 4-16-2010; IN COMMERCE 4-16-2010.

**CLASS 41—EDUCATION AND ENTERTAINMENT**

FOR POLO CLUB SERVICES (U.S. CLS. 100, 101 AND 107).  
FIRST USE 4-22-2010; IN COMMERCE 4-22-2010.  
KAPIL BHANOT, EXAMINING ATTORNEY

SN 85-043,339. QUALITY NEON SIGN COMPANY, DBA HARBINGER, JACKSONVILLE, FL. FILED 5-20-2010.

OWNER OF U.S. REG. NOS. 3,596,173 AND 3,596,175.  
THE COLOR(S) BLUE AND WHITE IS/ARE CLAIMED AS A FEATURE OF THE MARK.

THE MARK CONSISTS OF A BLUE BIRDHOUSE DESIGN WITH A WHITE FRONT WALL AND WHITE WINDOWS ON THE SIDE WALL.

THE COLOR(S) RED IS/ARE CLAIMED AS A FEATURE OF THE MARK.

THE MARK CONSISTS OF THE STYLIZED WORD "HARBINGER" IN THE COLOR RED.

**CLASS 36—INSURANCE AND FINANCIAL**

FOR VACATION REAL ESTATE LISTING SERVICES; PROVIDING VACATION REAL ESTATE LISTING SERVICES VIA A GLOBAL COMPUTER NETWORK; PROVIDING VACATION HOME RENTAL INFORMATION VIA THE INTERNET (U.S. CLS. 100, 101 AND 102).  
FIRST USE 7-12-2006; IN COMMERCE 7-12-2006.

**CLASS 43—HOTEL AND RESTAURANT SERVICES**

FOR PROVIDING TEMPORARY LODGING INFORMATION REGARDING VACATION HOMES VIA THE INTERNET (U.S. CLS. 100 AND 101).  
FIRST USE 7-12-2006; IN COMMERCE 7-12-2006.  
BERYL GARDNER, EXAMINING ATTORNEY

**CLASS 9—ELECTRICAL AND SCIENTIFIC APPARATUS**

FOR NON-LUMINOUS AND NON-MECHANICAL METAL SIGNS; BACKLIT SIGNS; ELECTRIC SIGNS; ELECTRONIC LED SIGNS; LUMINOUS SIGNS; LUMINOUS VARIABLE/DYNAMIC SIGNS USING LIGHT EMITTING DIODES AND ELECTRONIC CONTROLLERS TO PRODUCE REAL-TIME AND PROGRAMMABLE MESSAGES AND INFORMATION DISPLAYS; MECHANICAL SIGNS; NEON SIGNS; ELECTRONIC ADVERTISEMENT BOARDS FEATURING A NEON LAMP; LIGHT EMITTING DIODE (LED) DISPLAYS; ELECTRIC LUMINESCENT DISPLAY PANELS; ELECTRONIC DISPLAYS, NAMELY, DIGITAL SIGNAGE (U.S. CLS. 21, 23, 26, 36 AND 38).

**CLASS 37—CONSTRUCTION AND REPAIR**

FOR INSTALLATION, MAINTENANCE AND REPAIR OF MECHANICAL, NON-MECHANICAL, LUMINOUS AND NON-LUMINOUS SIGNS AND SIGNAGE; CONSULTATION IN THE FIELD OF INSTALLATION, MAINTENANCE AND REPAIR OF MECHANICAL, NON-MECHANICAL, LUMINOUS AND NON-LUMINOUS SIGNS AND SIGNAGE (U.S. CLS. 100, 103 AND 106).

SN 85-043,424. SOUTHERN GROUP ENTERPRISES, LLC, MIAMI, FL. FILED 5-20-2010.

ELEVATE YOUR PERFORMANCE

**CLASS 40—MATERIAL TREATMENT**

FOR FABRICATION, NAMELY, CUSTOM MANUFACTURING OF MECHANICAL, NON-MECHANICAL, LUMINOUS AND NON-LUMINOUS SIGNS AND SIGNAGE TO THE ORDER AND SPECIFICATION OF OTHERS; CONSULTATION IN THE FIELD OF CUSTOM MANUFACTURING OF MECHANICAL, NON-MECHANICAL, LUMINOUS AND NON-LUMINOUS SIGNS AND SIGNAGE TO THE ORDER AND SPECIFICATION OF OTHERS (U.S. CLS. 100, 103 AND 106).

KATHRYN COWARD, EXAMINING ATTORNEY

THE MARK CONSISTS OF STANDARD CHARACTERS WITHOUT CLAIM TO ANY PARTICULAR FONT, STYLE, SIZE, OR COLOR.

**CLASS 5—PHARMACEUTICALS**

FOR DIETARY AND NUTRITIONAL SUPPLEMENTS (U.S. CLS. 6, 18, 44, 46, 51 AND 52).  
FIRST USE 11-1-2001; IN COMMERCE 11-1-2001.

SN 85-043,366. SERENE ART LLC, HENDERSON, NV. FILED 5-20-2010.

**CLASS 32—LIGHT BEVERAGES**

FOR SPORTS DRINKS, NAMELY, ENERGY DRINKS (U.S. CLS. 45, 46 AND 48).  
FIRST USE 2-1-2002; IN COMMERCE 2-1-2002.  
NELSON SNYDER, EXAMINING ATTORNEY

Beautify Your Game

THE MARK CONSISTS OF STANDARD CHARACTERS WITHOUT CLAIM TO ANY PARTICULAR FONT, STYLE, SIZE, OR COLOR.

SN 85-043,442. NATIONAL MARINE ELECTRONICS ASSOCIATION, SEVERNA PARK, MD. FILED 5-20-2010.

NMEA ONE NET

**CLASS 14—JEWELRY**

FOR JEWELRY (U.S. CLS. 2, 27, 28 AND 50).

**CLASS 25—CLOTHING**

FOR CLOTHING, NAMELY, GOLF PANTS, GOLF SHORTS, GOLF SKORTS, GOLF SHIRTS, GOLF VESTS, GOLF SWEATERS, GOLF SOCKS, GOLF SHOES, TENNIS SHIRTS, TENNIS SKIRTS, TENNIS SHORTS, TENNIS DRESSES, TENNIS SHOES, HATS, VISORS, HEADBANDS, WRISTBANDS, SCARVES, AND BELTS (U.S. CLS. 22 AND 39).

THE MARK CONSISTS OF STANDARD CHARACTERS WITHOUT CLAIM TO ANY PARTICULAR FONT, STYLE, SIZE, OR COLOR.

OWNER OF U.S. REG. NOS. 2,103,048, 2,121,136 AND OTHERS.

**CLASS 26—FANCY GOODS**

FOR BELT BUCKLES (U.S. CLS. 37, 39, 40, 42 AND 50).  
FIRST USE 5-18-2010; IN COMMERCE 5-18-2010.

**CLASS 9—ELECTRICAL AND SCIENTIFIC APPARATUS**

FOR COMPUTER MARINE ELECTRONICS EQUIPMENT MONITORING SOFTWARE FOR USE IN IMPLEMENTING INDUSTRY STANDARDS FOR THE MARINE ELECTRONICS INDUSTRY (U.S. CLS. 21, 23, 26, 36 AND 38).

**CLASS 28—TOYS AND SPORTING GOODS**

FOR GOLF AND TENNIS ACCESSORIES, NAMELY, GOLF BALLS, GOLF BALL MARKERS, GOLF TEES, GOLF GLOVES, GOLF BAGS, GOLF CLUB COVERS, GOLF BAG COVERS, GOLF BAG TAGS, GOLF CLUB LABELS, GOLF CLUB GRIPS, DIVOT REPAIR TOOLS, HOLDERS SPECIALLY ADAPTED FOR HOLDING GOLF BALL MARKERS, CLIPS FOR ATTACHING GOLF BALL MARKERS TO ARTICLES OF CLOTHING, BAGS FOR GOLF TEES, TENNIS RACKET COVERS, BAGS SPECIALLY ADAPTED FOR CARRYING TENNIS RACKETS, AND TENNIS RACKET STRING DAMPERS (U.S. CLS. 22, 23, 38 AND 50).

FIRST USE 5-12-2010; IN COMMERCE 5-12-2010.  
MARK RADEMACHER, EXAMINING ATTORNEY

**CLASS 16—PAPER GOODS AND PRINTED MATTER**

FOR PRINTED MATTER, NAMELY, MANUALS AND INSTRUCTION MATERIALS RELATING TO THE INDUSTRY STANDARDS FOR THE MARINE ELECTRONICS INDUSTRY (U.S. CLS. 2, 5, 22, 23, 29, 37, 38 AND 50).

**CLASS 35—ADVERTISING AND BUSINESS**

FOR ASSOCIATION SERVICES, NAMELY, PROMOTING THE INTERESTS OF THE MARINE ELECTRONICS INDUSTRY (U.S. CLS. 100, 101 AND 102).

**CLASS 42—SCIENTIFIC AND COMPUTER SERVICES**

FOR DEVELOPMENT OF VOLUNTARY STANDARDS FOR THE MARINE ELECTRONICS INDUSTRY; ACCREDITATION SERVICES, NAMELY, DEVELOPING, EVALUATING AND TESTING STANDARDS FOR THE MARINE ELECTRONICS INDUSTRY FOR THE PURPOSE OF ACCREDITATION; ACCREDITATION SERVICES, NAMELY, DEVELOPING AND ADMINISTERING STANDARDS FOR CERTIFYING PROFESSIONALS IN THE FIELD OF THE MARINE ELECTRONICS INDUSTRY (U.S. CLS. 100 AND 101).

NELSON SNYDER, EXAMINING ATTORNEY

SN 85-043,961. CORRELL, KARIN ELIZABETH, FORT LAUDERDALE, FL. FILED 5-20-2010.

**YOU IN A NUTSHELL**

THE MARK CONSISTS OF STANDARD CHARACTERS WITHOUT CLAIM TO ANY PARTICULAR FONT, STYLE, SIZE, OR COLOR.

**CLASS 35—ADVERTISING AND BUSINESS**

FOR ONLINE RETAIL GIFT SHOP SERVICES (U.S. CLS. 100, 101 AND 102).

SN 85-043,910. STARTER CHEF LLC, MANAHAWKIN, NJ. FILED 5-20-2010.

**CLASS 45—PERSONAL AND LEGAL SERVICES**

FOR ORGANIZATIONAL SERVICES FOR HOME OR PERSONAL PURPOSES, NAMELY, GATHERING INFORMATION VIA EMAIL OR DIRECT MAIL ABOUT AN INDIVIDUAL'S LIFE AND ACCOMPLISHMENTS INCLUDING MEMORABILIA, KEEPSAKES, PHOTOGRAPHS, LETTERS, SENTIMENTAL ITEMS, YEARBOOKS, REPORT CARDS, AND CHILDHOOD MEMORIES; PERSONAL GIFT SELECTION FOR OTHERS (U.S. CLS. 100 AND 101).

DAVID H. STINE, EXAMINING ATTORNEY

SN 85-044,101. BLACKROCK, INC., NEW YORK, NY. FILED 5-20-2010.

NO CLAIM IS MADE TO THE EXCLUSIVE RIGHT TO USE "CHEF", APART FROM THE MARK AS SHOWN.

THE COLOR(S) ROYAL BLUE, BLACK AND WHITE IS/ARE CLAIMED AS A FEATURE OF THE MARK.

THE MARK CONSISTS OF THE WORDING "STARTER CHEF" AND DESIGN. THE WORDING "STARTER CHEF" IS IN ROYAL BLUE AND APPEARS WITHIN THE DESIGN OF A CHEF'S HAT. THE TERM "STARTER" APPEARS ABOVE THE TERM "CHEF". THE CHEF'S HAT IS OUTLINED IN BLACK, AND THE BACKGROUND IS WHITE.

**BLACKROCK ELITE ADVISOR**

THE MARK CONSISTS OF STANDARD CHARACTERS WITHOUT CLAIM TO ANY PARTICULAR FONT, STYLE, SIZE, OR COLOR.

OWNER OF U.S. REG. NOS. 2,417,737, 3,592,375 AND OTHERS.

NO CLAIM IS MADE TO THE EXCLUSIVE RIGHT TO USE "ADVISOR", APART FROM THE MARK AS SHOWN.

**CLASS 25—CLOTHING**

FOR APRONS; BASEBALL CAPS AND HATS; LONG-SLEEVED SHIRTS; POLO SHIRTS; T-SHIRTS (U.S. CLS. 22 AND 39).

**CLASS 30—STAPLE FOODS**

FOR COOKIE DOUGH; FROZEN COOKIE DOUGH; FROZEN PIE CRUSTS; MUFFINS (U.S. CL. 46).

**CLASS 41—EDUCATION AND ENTERTAINMENT**

FOR ENTERTAINMENT SERVICES, NAMELY, PROVIDING PODCASTS IN THE FIELD OF COOKING AND FOOD; ENTERTAINMENT SERVICES, NAMELY, PROVIDING VIDEO PODCASTS IN THE FIELD OF COOKING AND FOOD (U.S. CLS. 100, 101 AND 107).

MARLENE BELL, EXAMINING ATTORNEY

**CLASS 16—PAPER GOODS AND PRINTED MATTER**

FOR MAGAZINES IN THE FIELD OF FINANCIAL INVESTMENT (U.S. CLS. 2, 5, 22, 23, 29, 37, 38 AND 50). FIRST USE 8-17-2010; IN COMMERCE 8-17-2010.

**CLASS 36—INSURANCE AND FINANCIAL**

FOR PROVIDING INFORMATION IN THE FIELD OF FINANCIAL INVESTMENT (U.S. CLS. 100, 101 AND 102). FIRST USE 8-17-2010; IN COMMERCE 8-17-2010.

PAULA MAHONEY, EXAMINING ATTORNEY

SN 85-044,229. NEW SEASONS MARKET LLC, PORTLAND, OR. FILED 5-20-2010.

SN 85-044,276. KOLON INDUSTRIES, INC., KWACHON-CITYKYUNGGI-DO, REPUBLIC OF KOREA, FILED 5-20-2010.

# couronne

## NEW SEASONS MARKET

THE MARK CONSISTS OF STANDARD CHARACTERS WITHOUT CLAIM TO ANY PARTICULAR FONT, STYLE, SIZE, OR COLOR.

OWNER OF U.S. REG. NOS. 3,112,256 AND 3,112,257. NO CLAIM IS MADE TO THE EXCLUSIVE RIGHT TO USE "MARKET", APART FROM THE MARK AS SHOWN.

### CLASS 29—MEATS AND PROCESSED FOODS

FOR FROZEN AND PROCESSED FRUIT; JELLIES AND JAMS; DAIRY PRODUCTS EXCLUDING ICE CREAM, ICE MILK, AND FROZEN YOGURT; MEAT AND MEAT SUBSTITUTES; PROCESSED MEAT; DRIED FRUIT; NUT BUTTERS; CANNED FRUITS AND VEGETABLES; COOKING OILS; PICKLED VEGETABLES; CANNED MEATS; FROZEN VEGETABLES; ROASTED AND SEASONED NUTS; CHIPS, NAMELY, BANANA CHIPS, FRUIT CHIPS, POTATO CHIPS, AND VEGETABLE CHIPS; FRUIT-BASED SNACK FOODS; SNACK MIX CONSISTING PRIMARILY OF PROCESSED FRUITS, PROCESSED NUTS, AND/OR RAISINS; BREAKFAST BARS, NAMELY, FRUIT-BASED FOOD BARS; SOY MILK; RICE MILK; HEMP MILK; ALMOND MILK; SIDE DISHES, NAMELY, PREPARED VEGETABLE SIDE DISHES, CHEESE SPREADS, DAIRY-BASED SPREADS, MEAT-BASED SPREADS, AND VEGETABLE-BASED SPREADS; TOFU; SOY PRODUCTS, NAMELY, TEMPEH; SLICED FRUITS; SLICED VEGETABLES; ALL OF THE ABOVE TO BE SOLD AS PRIVATE-LABEL FOOD PRODUCTS IN THE APPLICANT'S OWN STORES OR AS PRIVATE-LABEL FOOD PRODUCTS FOR SALE SOLELY THROUGH RETAIL GROCERY STORES (U.S. CL. 46).

### CLASS 30—STAPLE FOODS

FOR DAIRY PRODUCTS, NAMELY, ICE CREAM, ICE MILK, AND FROZEN YOGURT; BAKERY PRODUCTS; TEA; COOKIES; CRACKERS; BREAKFAST CEREALS; TABLE SYRUP; RICE; PROCESSED GRAINS; PASTA; SUGAR; FLOUR; BAKING POWDER; BAKING SPICES; BAKING SODA; YEAST; HONEY; VINEGAR; SALAD DRESSINGS; GRAVY; SALSAS; YOGURT-COVERED NUTS; CHIPS, NAMELY, TORTILLA CHIPS; MULTI-GRAIN-BASED SNACK FOODS; SNACK MIX CONSISTING PRIMARILY OF CRACKERS, PRETZELS, AND/OR POPPED POPCORN; PUFFED GRAIN SNACK FOODS; BREAKFAST BARS, NAMELY, CEREAL-BASED FOOD BARS; SIDE DISHES, NAMELY, PREPARED GRAIN AND PASTA SIDE DISHES; NON-DAIRY FROZEN DESSERTS, NAMELY, NON-DAIRY FROZEN CONFECTIONS, FROZEN SOY-BASED DESSERTS, FROZEN RICE-BASED DESSERTS, FROZEN COCONUT-BASED DESSERTS, FROZEN HEMP MILK-BASED DESSERTS, AND FROZEN ALMOND MILK-BASED DESSERTS; ALL OF THE ABOVE TO BE SOLD AS PRIVATE-LABEL FOOD PRODUCTS IN THE APPLICANT'S OWN STORES OR AS PRIVATE-LABEL FOOD PRODUCTS FOR SALE SOLELY THROUGH RETAIL GROCERY STORES (U.S. CL. 46).

CORY BOONE, EXAMINING ATTORNEY

THE MARK CONSISTS OF STANDARD CHARACTERS WITHOUT CLAIM TO ANY PARTICULAR FONT, STYLE, SIZE, OR COLOR.

THE ENGLISH TRANSLATION OF "COURRONE" IS "CROWN".

### CLASS 18—LEATHER GOODS

FOR VANITY CASES SOLD EMPTY, LEATHER KEY CASES, SCHOOL CHILDREN'S BACKPACKS, BACKPACKS, BOSTON BAGS, PURSES NOT OF PRECIOUS METAL, BEACH BAGS, BRIEFCASES, SUITCASES, LEATHER CASES FOR CREDIT CARDS, TRAVELING BAGS, TRAVELING TRUNKS, LEATHER PACKING BAGS, SCHOOL BAGS, HAND BAGS, BEACH UMBRELLAS AND BEACH PARASOLS, PARASOLS, SUN UMBRELLAS, UMBRELLAS FOR GOLF, RUCKSACKS FOR MOUNTAINEERING, SHOULDER BAGS (U.S. CLS. 1, 2, 3, 22 AND 41).

### CLASS 25—CLOTHING

FOR LEATHER SHOES, GOLF SHOES, HEELPIECES FOR BOOTS AND SHOES, MOUNTAINEERING BOOTS, HALF-BOOTS, WINTER BOOTS, BOOTS, SANDALS, SLIPPERS, TRAINING SHOES, ESPARTO SHOES OR SANDALS, ANORAKS FOR EXERCISES, SCHOOL UNIFORMS, RAINCOATS, OVERCOATS, KNEE TROUSERS, HALF-COATS, SAFARIS SUITS, SUITS, SKIRTS, SLACKS, MEN'S SUITS, ANORAKS NOT FOR EXERCISES, CHILDREN'S CLOTHING, NAMELY, SHIRTS, PANTS, SWEATERS, SHORTS, TROUSERS, CEREMONIAL DRESSES, ONE PIECE SUITS, JACKETS, JUMPERS, BLUE JEANS, PARKAS, BRASSIERES, UNDERWEAR, UNDERSHIRTS, UNDERPANTS, SWIMSUITS, BATHING CAPS, BATHING TRUNKS, NIGHTWEAR, VESTS, CARDIGANS, TEE-SHIRTS, POLO SHIRTS, PULLOVERS, UNIFORMS FOR EXERCISES, SWEATERS, SWEAT SHIRTS, SWEAT PANTS, WHITE SHIRTS, NECKTIES, MUFFS, MUFFLERS, WINTER GLOVES, MITTENS, SHAWLS, SCARVES, SOCKS, TIGHTS, CAPS, TOP HATS, SUSPENDERS FOR CLOTHING, LEATHER BELTS, COMBINATIONS, SHIRT FRONTS, BATH ROBES, DRESSES, DRESS SUITS, CLOTHES FOR MOUNTAINEERING, NAMELY, SHIRTS, PANTS, VESTS, JUMPERS (U.S. CLS. 22 AND 39).

LINDA MICKLEBURGH, EXAMINING ATTORNEY

SN 85-044,555. JOYENT, INC., SAN FRANCISCO, CA. FILED 5-21-2010.

# JOYENT

THE MARK CONSISTS OF STANDARD CHARACTERS WITHOUT CLAIM TO ANY PARTICULAR FONT, STYLE, SIZE, OR COLOR.

THE WORD "JOYENT" HAS NO MEANING IN A FOREIGN LANGUAGE.

**CLASS 42—SCIENTIFIC AND COMPUTER SERVICES**

FOR APPLICATION SERVICE PROVIDER, NAMELY, HOSTING, MANAGING, AND MAINTAINING WEBSITES AND COMPUTER SOFTWARE APPLICATIONS FOR OTHERS; COMPUTER APPLICATION DEVELOPMENT AND MANAGEMENT FOR OTHERS (U.S. CLS. 100 AND 101).

FIRST USE 7-0-2005; IN COMMERCE 12-0-2005.

**CLASS 45—PERSONAL AND LEGAL SERVICES**

FOR COMPUTER SOFTWARE LICENSING (U.S. CLS. 100 AND 101).

FIRST USE 2-5-2010; IN COMMERCE 2-5-2010.

KATHY DE JONGE, EXAMINING ATTORNEY

**CLASS 9—ELECTRICAL AND SCIENTIFIC APPARATUS**

FOR COMPUTER SOFTWARE DEVELOPMENT TOOLS FOR SOCIAL NETWORKING, BUILDING SOCIAL NETWORKING APPLICATIONS AND FOR ALLOWING DATA RETRIEVAL, UPLOAD, ACCESS AND MANAGEMENT (U.S. CLS. 21, 23, 26, 36 AND 38).

**CLASS 35—ADVERTISING AND BUSINESS**

FOR ADVERTISING SERVICES, NAMELY, PROVIDING ADVERTISING SPACE ON THE INTERNET VIA THE GLOBAL COMPUTER NETWORK AND PROMOTING THE GOODS AND SERVICES OF OTHERS OVER THE INTERNET; PROVIDING ON-LINE SEARCHABLE DATABASES IN THE FIELD OF ADVERTISING FEATURING CLASSIFIED LISTINGS PROMOTING THE GOODS AND SERVICES OF OTHERS; MULTI-LEVEL BUSINESS MARKETING SERVICES (U.S. CLS. 100, 101 AND 102).

**CLASS 36—INSURANCE AND FINANCIAL**

FOR CHARITABLE FUND RAISING SERVICES (U.S. CLS. 100, 101 AND 102).

**CLASS 38—COMMUNICATION**

FOR PROVISION OF ACCESS TO A GLOBAL COMPUTER NETWORK; INSTANT MESSAGING SERVICES, NAMELY, ELECTRONIC TRANSMISSION OF INSTANT MESSAGES AND DATA; PROVIDING ONLINE CHAT ROOMS FOR SOCIAL NETWORKING; PROVIDING ONLINE CHAT ROOMS AND ELECTRONIC BULLETIN BOARDS FOR TRANSMISSION OF MESSAGES AMONG USERS IN THE FIELD OF GENERAL INTEREST (U.S. CLS. 100, 101 AND 104).

**CLASS 41—EDUCATION AND ENTERTAINMENT**

FOR ENTERTAINMENT SERVICES, NAMELY, PROVIDING TEMPORARY USE OF ONLINE NON-DOWNLOADABLE INTERACTIVE GAMES; PROVIDING A WEBSITE FOR ENTERTAINMENT PURPOSES WHERE USERS CAN VIEW AND POST PICTURES FEATURING POPULAR CULTURE, MUSIC, ART, MOVIES, CURRENT EVENTS AND SPORTS; ELECTRONIC PUBLISHING SERVICES, NAMELY, PUBLISHING OF ONLINE TEXT, AUDIO, VIDEO AND GRAPHIC WORKS OF OTHERS FEATURING POPULAR CULTURE, MUSIC, ART, MOVIES, CURRENT EVENTS AND SPORTS; PROVIDING ONLINE JOURNALS FEATURING USER-CREATED CONTENT IN THE FIELD OF POPULAR CULTURE, MUSIC, ART, MOVIES, CURRENT EVENTS AND SPORTS (U.S. CLS. 100, 101 AND 107).

**CLASS 42—SCIENTIFIC AND COMPUTER SERVICES**

FOR PROVIDING TEMPORARY USE OF NON-DOWNLOADABLE COMPUTER SOFTWARE APPLICATIONS FOR USE IN CREATING CLASSIFIED ADVERTISEMENTS AND LISTINGS, PHOTO SHARING AND TRANSMISSION OF PHOTOGRAPHIC IMAGES; COMPUTER SERVICES, NAMELY, HOSTING ONLINE WEB FACILITIES FOR OTHERS FOR ORGANIZING AND CONDUCTING ONLINE MEETINGS, GATHERINGS, AND INTERACTIVE DISCUSSIONS; COMPUTER SERVICES IN THE NATURE OF CUSTOMIZED WEB PAGES FEATURING USER-DEFINED INFORMATION, PERSONAL PROFILES AND INFORMATION; COMPUTER SERVICES, NAMELY, CREATING AN ONLINE COMMUNITY FOR REGISTERED USERS TO ENGAGE IN SOCIAL NETWORKING; APPLICATION SERVICE PROVIDER FEATURING APPLICATION PROGRAMMING INTERFACE (API) SOFTWARE FOR THIRD-PARTY AND ONLINE SERVICES FOR SOCIAL NETWORKING, BUILDING SOCIAL NETWORKING APPLICATIONS AND FOR ALLOWING DATA RETRIEVAL, UPLOAD, ACCESS AND MANAGEMENT (U.S. CLS. 100 AND 101).

RENEE MCCRAY, EXAMINING ATTORNEY

SN 85-044,866. S.E.A. MEDICAL SYSTEMS, INC., SUNNYVALE, CA. FILED 5-21-2010.

Sotivia

THE MARK CONSISTS OF STANDARD CHARACTERS WITHOUT CLAIM TO ANY PARTICULAR FONT, STYLE, SIZE, OR COLOR.

**CLASS 9—ELECTRICAL AND SCIENTIFIC APPARATUS**

FOR INSTRUMENTS AND APPARATUS, NAMELY, ELECTRONIC DEVICES AND SENSORS USED TO IDENTIFY INTRAVENOUS DRUGS IN SOLUTIONS FOR USE BY HOSPITALS, PHARMACIES AND MANUFACTURERS; SOFTWARE USED TO IDENTIFY INTRAVENOUS DRUGS IN SOLUTIONS FOR USE BY HOSPITALS, PHARMACIES AND MANUFACTURERS (U.S. CLS. 21, 23, 26, 36 AND 38).

**CLASS 10—MEDICAL APPARATUS**

FOR MEDICAL INSTRUMENTS AND APPARATUS USED TO IDENTIFY INTRAVENOUS DRUGS IN SOLUTIONS FOR USE BY HOSPITALS, PHARMACIES AND MANUFACTURERS; AND RELATED SOFTWARE SOLD AS A UNIT (U.S. CLS. 26, 39 AND 44).

WENDY GOODMAN, EXAMINING ATTORNEY

SN 85-044,956. CRAZYGOOD, LLC, TULSA, OK. FILED 5-21-2010.

CRAZYGOOD

THE MARK CONSISTS OF STANDARD CHARACTERS WITHOUT CLAIM TO ANY PARTICULAR FONT, STYLE, SIZE, OR COLOR.



SN 85-045,049. MIDWEST INDUSTRIAL SUPPLY, INC.,  
CANTON, OH. FILED 5-21-2010.

# MIDWEST

THE MARK CONSISTS OF STANDARD CHARACTERS WITHOUT CLAIM TO ANY PARTICULAR FONT, STYLE, SIZE, OR COLOR.

OWNER OF U.S. REG. NO. 3,250,823.  
SEC. 2(F).

## CLASS 1—CHEMICALS

FOR CHEMICAL WATER REPELLENT TREATMENT FOR USE OF CONVEYOR BELTS; CHEMICAL ADHESIVE USED IN CEMENTING SURFACE DUST PARTICLES TOGETHER AND THEN CEMENTING THE BOUND SURFACE LAYER TO THE ROAD BED SUBBASE; CHEMICALS, NAMELY, DE-ICING, ANTI-ICING, AND SNOW MELTING FORMULATIONS FOR USE ON RAILROAD SWITCHES; CHEMICAL DE-ICER AND PREVENTOR FOR USE OF COAL MINING EQUIPMENT; CHEMICAL BLEND OF IONIC AND NON-IONIC SURFACTANTS FOR USE IN ENHANCING THE EFFECTIVENESS OF WATER TO SUPPRESS DUST ON ROADWAY BED SURFACES; CHEMICAL COMPOSITIONS FOR SUPPRESSING LEAD BEARING DUST PARTICLES; CHEMICAL PRODUCT APPLIED TO ROAD SURFACES FOR DUST SUPPRESSION; CHEMICAL PRODUCT APPLIED TO COAL TO CREATE A WIND AND FRACTURE-RESISTANT SURFACE COATING AND TO ELIMINATE WIND-BLOWN DUST AND MATERIAL LOSS FROM UNIT COAL TRAINS; CHEMICAL COMPOSITIONS APPLIED TO COAL, COKE, LIMESTONE, CINDER AND OTHER MATERIALS FOR SHORT-TERM DUST SUPPRESSION; CHEMICAL USED FOR DUST SUPPRESSION, SPECIFICALLY FORMULATED FOR SUPPRESSION OF PM10 AND TSP AT THE SOURCE WITH DOWNSTREAM EFFECTIVENESS; CHEMICAL PRODUCT, NAMELY, SIDE RELEASE AGENT FOR PREVENTING COAL, ORE, SINTER AND OTHER MINERALS FROM FREEZING TO STORAGE AND TRANSPORTATION CONTAINERS; SOIL STABILIZING AGENTS FOR STABILIZING SOILS AND SOIL SURFACE SEALING AGENTS FOR DUST CONTROL; ENVIRONMENTALLY FRIENDLY ANTI-ICING AND DE-ICING LIQUID PREPARATIONS COMPRISING A NON-TOXIC FREEZING POINT DEPRESSANT AND A THICKENER FOR USE ON EXPOSED SURFACES OF RAILWAY EQUIPMENT, MATERIALS HANDLING EQUIPMENT AND MANUFACTURING EQUIPMENT, AND ON ROADWAYS, PARKING LOTS, RUNWAYS AND AIRPLANES FOR THE PREVENTION AND REMOVAL OF ICE ACCUMULATION ON SUCH SURFACES; POLYMER SPRAY-ON FUME AND ODOR SEALANT FOR USE IN MANAGING CONTAMINATED WASTE SITES; CHEMICAL SURFACTANT FOR THE COLLECTION AND SUPPRESSION OF AIRBORNE DUST PARTICLES FOR USE IN COAL MINING OPERATIONS; CHEMICAL SURFACTANT ADHESIVE FOR COAL; SOIL STABILIZATION CHEMICALS FOR EROSION CONTROL AND CONSTRUCTION OF GOLF COURSE SAND TRAPS AND BUNKERS; DUST CONTROL CHEMICAL FOR USE ON INDOOR AND OUTDOOR SPORTS PLAYING FIELDS; CHEMICAL SYNTHETIC FLUID BASED ANTI-STICKING AGENT AND EQUIPMENT MATERIAL FLOW LUBRICANT; DUST SUPPRESSION COMPOSITIONS MADE UP OF SYNTHETIC ORGANIC MATERIAL IN LIQUID FORM FOR COAL, MINERALS, ORES AND SYN-FUEL; CHEMICAL ADHESIVE FOR USE IN COMBINATION WITH RECYCLED ASPHALT PAVEMENT TO FORM A PROSCRIBED DENSE COMPACTED DURABLE DUST-FREE SURFACE; DE-ICER FOR RAILROAD SWITCHES; CHEMICAL ADHESIVE USED IN CEMENTING SURFACE DUST AND SURFACE PARTICLES TOGETHER AND THEN CEMENTING THE BOUND SURFACE LAYER TO A SUBBASE, INCLUDING ROAD BASE EARTHWORK, BARE GROUND ENVIRONMENTS, CLEAR CUT OR EXCAVATED AREAS, AND SUBBASE WHICH IS SUBJECT TO WIND, WATER AND VEHICLE EROSION;

CHEMICALS, NAMELY A DUST STABILIZING AGENT SPECIFICALLY FOR USE IN HORSE ARENAS, STABLE AREAS AND RUNNING TRACKS; CHEMICALS USED TO STABILIZE SOIL, PROVIDE DUST CONTROL AND PREVENT EROSION; CHEMICAL SPRAYS FOR TREATING AND BINDING MULCH FIBERS TO PREVENT LOSS DUE TO WIND AND RAIN EROSION; DE-ICING LIQUIDS FOR USE ON RAILWAY EQUIPMENT, MATERIAL HANDLING EQUIPMENT, MANUFACTURING EQUIPMENT, ROADWAYS, PARKING LOTS, RUNWAYS AND AIRPLANES, AND CHEMICAL ADDITIVES FOR USE THEREWITH (U.S. CLS. 1, 5, 6, 10, 26 AND 46).  
FIRST USE 12-31-1976; IN COMMERCE 12-31-1976.

## CLASS 3—COSMETICS AND CLEANING PREPARATIONS

FOR FOAMABLE LIQUID CLEANING MATERIAL TO REMOVE DUST AND DIRT FROM WALLS, CEILINGS, CEILING GIRDERS AND FRAMEWORK OF MANUFACTURING AND STORAGE FACILITIES, INCLUDING COAL BUNKERS (U.S. CLS. 1, 4, 6, 50, 51 AND 52).  
FIRST USE 10-31-1999; IN COMMERCE 10-31-1999.

## CLASS 4—LUBRICANTS AND FUELS

FOR ALL-PURPOSE PENETRATING AND LUBRICATING OILS FOR SURFACE TREATMENTS OF METALS; ORGANIC AND INORGANIC DUST ABSORBING AND STABILIZING COMPOSITIONS FOR USE IN ROAD BUILDING AND COAL MINING APPLICATIONS; ORGANIC AND INORGANIC DUST SUPPRESSION COMPOSITIONS FOR USE IN ROAD BUILDING AND COAL MINING APPLICATIONS; DUST LAYING AND ABSORBING COMPOSITIONS FOR USE ON UNPAVED ROADS (U.S. CLS. 1, 6 AND 15).  
FIRST USE 9-25-2000; IN COMMERCE 9-25-2000.

## CLASS 7—MACHINERY

FOR PUMPS AND APPLICATORS FOR MACHINES, NAMELY, PUMP AND APPLICATOR FOR LIQUIDS, NAMELY, FOR APPLYING DUST SUPPRESSING COMPOUNDS; POWER OPERATED SPRAY SYSTEMS COMPRISED OF CONTROL PANELS, POWER SUPPLY MODULES, STORAGE TANKS, PUMPS, MOTORS, PRESSURE REGULATORS, CONTROL VALVES, ELECTRIC SOLENOID VALVES AND HOSES, FOR DELIVERING ANTI-ICERS AND DE-ICERS THROUGH ELECTRONIC RAILS USED WITH RAILED TRANSPORT VEHICLES; PORTABLE DUST SUPPRESSION MACHINES FOR APPLYING DUST SUPPRESSION CHEMICALS TO THE GROUND FOR USE IN MINING, STOCK PILES, OPEN AREAS, LANDFILLS, ROAD CONSTRUCTION, UNPAVED ROADWAYS, AISLE WAYS, PARKING LOTS, VEHICLE STAGING AREAS, AIRPORT RUNWAYS, AVIATION TAKE OFF AND LANDING ZONES, CAMPGROUNDS, TRAILS, PATHS, WALKWAYS, ARENAS AND TRUCK TERMINALS; AND POWER OPERATED SELF-CONTAINED VEHICLE MOUNTED SPRAYER SYSTEMS COMPRISED OF HOSES, SPRAYER NOZZLES, STORAGE TANKS AND CONTROL VALVES FOR DUST SUPPRESSING COMPOUNDS (U.S. CLS. 13, 19, 21, 23, 31, 34 AND 35).  
FIRST USE 9-16-1977; IN COMMERCE 9-16-1977.

## CLASS 9—ELECTRICAL AND SCIENTIFIC APPARATUS

FOR MACHINE FOR TESTING THE QUALITY AND STRENGTH OF SOIL (U.S. CLS. 21, 23, 26, 36 AND 38).  
FIRST USE 2-28-2000; IN COMMERCE 2-28-2000.

**CLASS 17—RUBBER GOODS**

FOR SELF-CONTAINED PORTABLE FOAM INSULATION GENERATING SYSTEM COMPRISED OF CONTROL PANELS, POWER SUPPLY MODULES, STORAGE TANKS, PUMPS, MOTORS, PRESSURE REGULATORS, CONTROL VALVES, NOZZLES, AND HOSES TO SPRAY A DRY CONTENT FOAM ON WALLS, CEILINGS, GIRDERS AND FRAMEWORK OF INDUSTRIAL FACILITIES AND STORAGE AREAS (U.S. CLS. 1, 5, 12, 13, 35 AND 50).

FIRST USE 10-31-1999; IN COMMERCE 10-31-1999.

**CLASS 19—NON-METALLIC BUILDING MATERIALS**

FOR RESIN MODIFIED EMULSION USED AS FLEXIBLE PAVEMENT (U.S. CLS. 1, 12, 33 AND 50).

FIRST USE 3-19-1998; IN COMMERCE 3-19-1998.

**CLASS 37—CONSTRUCTION AND REPAIR**

FOR INSTALLATION SERVICES, NAMELY, THE INSTALLATION OF FOOTING AND FLOORING IN INDOOR AND OUTDOOR EQUINE RIDING ARENAS (U.S. CLS. 100, 103 AND 106).

FIRST USE 7-19-2002; IN COMMERCE 7-19-2002.

ANNE FARRELL, EXAMINING ATTORNEY

**CLASS 42—SCIENTIFIC AND COMPUTER SERVICES**

FOR PROVIDING TEMPORARY USE OF ONLINE NONDOWNLOADABLE SOFTWARE FOR LAWYERS AND LEGAL PROFESSIONALS, FOR USE IN ONLINE TIMEKEEPING FOR OTHERS, BILLING, ELECTRONIC SIGNATURE VERIFICATION, AND CREATION, PREPARING, EDITING AND DATABASE MANAGEMENT OF LEGAL DOCUMENTS AND FORMS; PROVIDING A WEBSITE THAT GIVES MULTIPLE COMPUTER USERS SIMULTANEOUSLY THE ABILITY TO UPLOAD, CREATE AND EDIT DOCUMENTS (U.S. CLS. 100 AND 101).

FIRST USE 11-0-2006; IN COMMERCE 11-0-2006.

**CLASS 45—PERSONAL AND LEGAL SERVICES**

FOR PROVIDING ONLINE INFORMATION TO LAWYERS AND NON-LAWYERS IN THE FIELD OF LAW, CUSTOMIZABLE LEGAL FORMS, LEGAL SELF-HELP, AND LEGAL NEWS AND COMMENTARY; LEGAL DOCUMENT CREATION, PREPARATION, AND EDITING VIA AN INTERACTIVE WEBSITE ON THE INTERNET (U.S. CLS. 100 AND 101).

FIRST USE 11-0-2006; IN COMMERCE 11-0-2006.

BARBARA A. GOLD, EXAMINING ATTORNEY

SN 85-045,051. ROCKET LAWYER INCORPORATED, SAN FRANCISCO, CA. FILED 5-21-2010.

SN 85-045,337. KIRSHENBAUM BOND SENEAL & PARTNERS LLC, NEW YORK, NY. FILED 5-21-2010.

**SPIES & ASSASSINS****ROCKET LAWYER**

THE MARK CONSISTS OF STANDARD CHARACTERS WITHOUT CLAIM TO ANY PARTICULAR FONT, STYLE, SIZE, OR COLOR.

THE MARK CONSISTS OF STANDARD CHARACTERS WITHOUT CLAIM TO ANY PARTICULAR FONT, STYLE, SIZE, OR COLOR.

NO CLAIM IS MADE TO THE EXCLUSIVE RIGHT TO USE "LAWYER", APART FROM THE MARK AS SHOWN.

**CLASS 35—ADVERTISING AND BUSINESS**

FOR PROVIDING ONLINE LAWYER REFERRALS; COOPERATIVE ADVERTISING SERVICES FOR LAWYERS; BUSINESS MANAGEMENT SERVICES FOR OTHERS, NAMELY, ONLINE TIMEKEEPING FOR LAWYERS AND LEGAL PROFESSIONALS, BILLING, ELECTRONIC SIGNATURE VERIFICATION SERVICES PROVIDED IN CONNECTION WITH LEGAL SERVICES, AND DATABASE MANAGEMENT FOR OTHERS OF A DATABASE COMPRISED OF LEGAL DOCUMENTS AND FORMS (U.S. CLS. 100, 101 AND 102).

FIRST USE 11-0-2006; IN COMMERCE 11-0-2006.

**CLASS 39—TRANSPORTATION AND STORAGE**

FOR ELECTRONIC STORAGE OF LEGAL DOCUMENTS AND FORMS (U.S. CLS. 100 AND 105).

FIRST USE 11-0-2006; IN COMMERCE 11-0-2006.

**CLASS 35—ADVERTISING AND BUSINESS**

FOR ADVERTISING AGENCIES; ADVERTISING AND MARKETING; ADVERTISING AND PROMOTION SERVICES AND RELATED CONSULTING; BRANDING SERVICES, NAMELY, CONSULTING, DEVELOPMENT, MANAGEMENT AND MARKETING OF BRANDS FOR BUSINESSES; IP DEVELOPMENT, NAMELY, CONCEPT AND BRAND DEVELOPMENT SERVICES FOR CORPORATE AND INDIVIDUAL CLIENTS (U.S. CLS. 100, 101 AND 102).

**CLASS 42—SCIENTIFIC AND COMPUTER SERVICES**

FOR TECHNOLOGY DEVELOPMENT, NAMELY, COMPUTER PROGRAMMING AND COMPUTER SOFTWARE DEVELOPMENT IN THE FIELD OF MOBILE APPLICATIONS; AGENCY DIGITAL PRODUCTION, NAMELY, DESIGN AND DEVELOPMENT OF ONLINE COMPUTER SOFTWARE SYSTEMS AND ONLINE WEBSITES FOR THIRD PARTIES, GRAPHIC DESIGN SERVICES, DATABASE DESIGN AND DEVELOPMENT, AND PROGRAMMING OF MULTIMEDIA APPLICATIONS; IP DEVELOPMENT, NAMELY, PRODUCT DEVELOPMENT FOR OTHERS (U.S. CLS. 100 AND 101).

JANICE KIM, EXAMINING ATTORNEY

SN 85-045,808. JOYENT, INC., SAN FRANCISCO, CA. FILED 5-23-2010.



THE COLOR(S) ORANGE AND WHITE IS/ARE CLAIMED AS A FEATURE OF THE MARK.

THE MARK CONSISTS OF THE WORD "JOYENT" IN STYLIZED FONT TO THE RIGHT OF A WHITE CROSS ON AN ORANGE CIRCLE. THE COLOR BLACK IN THE WORD "JOYENT" REPRESENTS BACKGROUND, OUTLINING, SHADING AND/OR TRANSPARENT AREAS AND IS NOT CLAIMED AS PART OF THE MARK.

THE WORD "JOYENT" HAS NO MEANING IN A FOREIGN LANGUAGE.

#### CLASS 42—SCIENTIFIC AND COMPUTER SERVICES

FOR APPLICATION SERVICE PROVIDER, NAMELY, HOSTING, MANAGING, AND MAINTAINING WEBSITES AND COMPUTER SOFTWARE APPLICATIONS FOR OTHERS; COMPUTER APPLICATION DEVELOPMENT AND MANAGEMENT FOR OTHERS (U.S. CLS. 100 AND 101).

FIRST USE 4-8-2010; IN COMMERCE 5-15-2010.

#### CLASS 45—PERSONAL AND LEGAL SERVICES

FOR COMPUTER SOFTWARE LICENSING (U.S. CLS. 100 AND 101).

FIRST USE 4-8-2010; IN COMMERCE 5-15-2010.  
KATHY DE JONGE, EXAMINING ATTORNEY

SN 85-046,011. WELL FLOW INTERNATIONAL, W.L.L., MANAMA, BAHRAIN, FILED 5-24-2010.

# WELL FLOW

THE MARK CONSISTS OF STANDARD CHARACTERS WITHOUT CLAIM TO ANY PARTICULAR FONT, STYLE, SIZE, OR COLOR.

NO CLAIM IS MADE TO THE EXCLUSIVE RIGHT TO USE "WELL", APART FROM THE MARK AS SHOWN.

#### CLASS 1—CHEMICALS

FOR CHEMICALS FOR USE IN THE FIELD OF OIL AND GAS EXPLORATION, COMPLETION, PRODUCTION, AND WORKOVER; DRILLING MUDS FOR USE IN OIL WELL DRILLING; AND DEGREASING AGENTS (U.S. CLS. 1, 5, 6, 10, 26 AND 46).

FIRST USE 7-10-1999; IN COMMERCE 7-10-1999.

#### CLASS 7—MACHINERY

FOR POWER OPERATED OIL AND GAS EXPLORATION, COMPLETION, PRODUCTION, AND WORKOVER TOOLS AND EQUIPMENT, NAMELY, CASING BRUSHES, CASING SCRAPERS, MAGNETIC TOOLS FOR RETRIEVING METALLIC DEBRIS FROM A WELLBORE, REAMERS, DRILL STRING MILLS, POLISH MILLS, PARTS FOR POWER OPERATED OIL AND GAS MACHINES IN THE NATURE OF CROSSOVERS, AND POWER CLEANING TOOLS SPECIFICALLY DESIGNED FOR CLEANING ALL OF THE FOLLOWING BLOW-OUT PREVENTERS, WELLHEADS, WELL CASINGS, WELL TUBULARS, WELL COIL TUBING, WELLBORES, WELL BYPASS TOOLS, AND OFFSHORE RISERS; AND MACHINE PARTS, NAMELY, GAS AND OILFIELD FLOAT SHOES, FLOAT COLLARS, FLOAT VALVES, REAMER SHOES, AND CENTRALIZERS (U.S. CLS. 13, 19, 21, 23, 31, 34 AND 35).

FIRST USE 7-10-1999; IN COMMERCE 7-10-1999.

#### CLASS 37—CONSTRUCTION AND REPAIR

FOR RENTAL OF GAS AND OIL FIELD WELL DRILLING TOOLS; RENTAL OF HAND AND POWER TOOLS USED IN GAS AND OIL FIELDS FOR EXPLORATION, DRILLING, COMPLETION, PRODUCTION, WORKOVER, AND CLEANING; AND CLEANING SERVICES IN THE FIELD OF OIL AND GAS EXPLORATION, COMPLETION, PRODUCTION, AND WORKOVER, NAMELY, CLEANING OF BLOW OUT PREVENTERS (BOPS), WELLHEADS, CASINGS, TUBULARS, COIL TUBING, WELLBORES, BYPASS TOOLS, AND RISERS (U.S. CLS. 100, 103 AND 106).

FIRST USE 7-10-1999; IN COMMERCE 7-10-1999.  
REBECCA GILBERT, EXAMINING ATTORNEY

SN 85-046,156. TRINITY, INC., SAITAMA-KEN, JAPAN, FILED 5-24-2010.

# FINGERIST

THE MARK CONSISTS OF STANDARD CHARACTERS WITHOUT CLAIM TO ANY PARTICULAR FONT, STYLE, SIZE, OR COLOR.

PRIORITY CLAIMED UNDER SEC. 44(D) ON JAPAN APPLICATION NO. 2009098011, FILED 12-25-2009, REG. NO. 5325976, DATED 5-28-2010, EXPIRES 5-28-2020.

PRIORITY CLAIMED UNDER SEC. 44(D) ON JAPAN APPLICATION NO. 2009098010, FILED 12-25-2009, REG. NO. 5343987, DATED 8-6-2010, EXPIRES 8-6-2020.

**CLASS 9—ELECTRICAL AND SCIENTIFIC APPARATUS**

FOR COMPUTER SOFTWARE FEATURING MUSICAL SOUND RECORDINGS AND MUSICAL VIDEO RECORDINGS; DOWNLOADABLE MUSICAL SOUND RECORDINGS; ELECTRICAL CABLES FOR MUSICAL INSTRUMENTS; ELECTRICAL PICKUPS FOR USE WITH MUSICAL INSTRUMENTS; JUKE BOXES; MUSICAL INSTRUMENT ADAPTERS; MUSICAL INSTRUMENT AMPLIFIERS; MUSICAL INSTRUMENT CONNECTORS; MUSICAL SOUND RECORDINGS; MUSICAL VIDEO RECORDINGS; PORTABLE MEDIA PLAYERS; BATTERY CHARGERS; ACCESSORIES FOR DIGITAL AUDIO PLAYERS, NAMELY, DIGITAL AUDIO PLAYER CASES, CHARGERS, PROTECTIVE SLEEVES, AND ADAPTERS; ACCESSORIES FOR PORTABLE PHONES, NAMELY, PORTABLE TELEPHONE CASES, CHARGERS, PROTECTIVE SLEEVES, AND ADAPTERS; HOME THEATER PRODUCTS, NAMELY, ELECTRONIC SWITCHERS FOR AUDIO AND VISUAL SIGNALS; BATTERIES; AUDIO CABLES; RADIO TRANSMITTERS; LOUD SPEAKERS; EAR PHONES; HEAD PHONES; STANDS FOR PHOTOGRAPHIC APPARATUS (U.S. CLS. 21, 23, 26, 36 AND 38).

FIRST USE 1-7-2010; IN COMMERCE 1-7-2010.

**CLASS 15—MUSICAL INSTRUMENTS**

FOR ELECTRIC AND ELECTRONIC MUSICAL INSTRUMENTS; MUSICAL INSTRUMENTS; FITTED BAGS AND CASES FOR MUSICAL INSTRUMENTS; MUSICAL INSTRUMENT STANDS (U.S. CLS. 2, 21 AND 36).

FIRST USE 1-7-2010; IN COMMERCE 1-7-2010.  
STEVEN PEREZ, EXAMINING ATTORNEY

SN 85-046,182. DONOVAN MARINE, INC., HARAHAH, LA. FILED 5-24-2010.

**MARPAC PREMIER**

THE MARK CONSISTS OF STANDARD CHARACTERS WITHOUT CLAIM TO ANY PARTICULAR FONT, STYLE, SIZE, OR COLOR.

NO CLAIM IS MADE TO THE EXCLUSIVE RIGHT TO USE "PREMIER", APART FROM THE MARK AS SHOWN.

**CLASS 7—MACHINERY**

FOR BILGE PUMPS (U.S. CLS. 13, 19, 21, 23, 31, 34 AND 35).

FIRST USE 9-1-2004; IN COMMERCE 9-1-2004.

**CLASS 9—ELECTRICAL AND SCIENTIFIC APPARATUS**

FOR ANTENNAS; POWER PANELS, NAMELY, POWER DISTRIBUTION PANELS; ELECTRICAL TERMINAL BLOCKS; MARINE MEASURING INSTRUMENTS, NAMELY, TACHOMETERS, SPEEDOMETERS, VOLTMETERS, HOURMETERS, FUEL GAUGES, TRIM GAUGES, OIL PRESSURE GAUGES, WATER TEMPERATURE GAUGES, AND PRESSURE GAUGES (U.S. CLS. 21, 23, 26, 36 AND 38).

FIRST USE 12-31-2000; IN COMMERCE 12-31-2000.

**CLASS 11—ENVIRONMENTAL CONTROL APPARATUS**

FOR RUNNING LIGHTS AND TRAILER LIGHTS FOR BOATS (U.S. CLS. 13, 21, 23, 31 AND 34).

FIRST USE 6-1-2003; IN COMMERCE 6-1-2003.

**CLASS 12—VEHICLES**

FOR STEERING SYSTEMS FOR BOATS AND COMPRISED OF BEZEL, CONNECTING CABLES AND HELM AND PARTS THEREFOR; FUEL LINES FOR BOATS; TRAILER PARTS (U.S. CLS. 19, 21, 23, 31, 35 AND 44).

FIRST USE 8-1-2007; IN COMMERCE 8-1-2007.

**CLASS 22—CORDAGE AND FIBERS**

FOR ROPES; NON-METAL TIE DOWNS (U.S. CLS. 1, 2, 7, 19, 22, 42 AND 50).

FIRST USE 1-1-2004; IN COMMERCE 1-1-2004.

FRANK LATTUCA, EXAMINING ATTORNEY

SN 85-046,215. DONOVAN MARINE, INC., HARAHAH, LA. FILED 5-24-2010.

**MARPRO**

THE MARK CONSISTS OF STANDARD CHARACTERS WITHOUT CLAIM TO ANY PARTICULAR FONT, STYLE, SIZE, OR COLOR.

**CLASS 1—CHEMICALS**

FOR ACETONE; HYDRAULIC FLUID; POLYESTER RESINS; EPOXY RESINS (U.S. CLS. 1, 5, 6, 10, 26 AND 46).

FIRST USE 7-1-2003; IN COMMERCE 7-1-2003.

**CLASS 2—PAINTS**

FOR PAINTS, LACQUERS, VARNISHES; PAINT THINERS; PRIMERS; ANTI-RUST GREASES (U.S. CLS. 6, 11 AND 16).

FIRST USE 10-1-2004; IN COMMERCE 10-1-2004.

**CLASS 3—COSMETICS AND CLEANING PREPARATIONS**

FOR STAIN REMOVERS; BOAT WAX; BOAT CLEANERS (U.S. CLS. 1, 4, 6, 50, 51 AND 52).

FIRST USE 7-1-2003; IN COMMERCE 7-1-2003.

**CLASS 4—LUBRICANTS AND FUELS**

FOR ALL PURPOSE LUBRICANTS; LUBRICATING GREASES (U.S. CLS. 1, 6 AND 15).

FIRST USE 6-1-2008; IN COMMERCE 6-1-2008.

**CLASS 20—FURNITURE AND ARTICLES NOT OTHERWISE CLASSIFIED**

FOR DISPLAY RACKS (U.S. CLS. 2, 13, 22, 25, 32 AND 50).

FIRST USE 6-1-2006; IN COMMERCE 6-1-2006.

**CLASS 24—FABRICS**

FOR FIBERGLASS REINFORCEMENT FABRIC FOR USE IN LAND, SEA AND AEROSPACE APPLICATIONS (U.S. CLS. 42 AND 50).

FIRST USE 10-1-2005; IN COMMERCE 10-1-2005.

FRANK LATTUCA, EXAMINING ATTORNEY

SN 85-046,678. BENSUSSEN DEUTSCH & ASSOCIATES, INC., WOODINVILLE, WA. FILED 5-24-2010.

### AMPLIFY YOUR EXPERIENCE

THE MARK CONSISTS OF STANDARD CHARACTERS WITHOUT CLAIM TO ANY PARTICULAR FONT, STYLE, SIZE, OR COLOR.

### CLASS 9—ELECTRICAL AND SCIENTIFIC APPARATUS

FOR VIDEO GAME, MOBILE PHONE AND HANDHELD ELECTRONIC DEVICE ACCESSORIES, NAMELY, SPEAKERS, AUDIO/VISUAL HEADSETS FOR USE IN PLAYING VIDEO GAMES, DEVICES FOR HANDS-FREE USE OF MOBILE PHONES, AND STANDS FOR HANDHELD DIGITAL ELECTRONIC DEVICES; PLUG ADAPTORS; FLASH MEMORY CARDS FOR HANDHELD ELECTRONIC DEVICES, VIDEO GAME CONSOLES AND MOBILE PHONES; CABLES, NAMELY, COAXIAL CABLES AND FIBER OPTIC CABLES; BATTERY CHARGERS FOR VIDEO GAME CONTROLLERS, REMOTES, MOBILE PHONES, HANDHELD ELECTRONIC DEVICES AND COMPUTER HARDWARE AND PERIPHERALS USED IN PLAYING VIDEO GAMES; VIDEO GAME INTERACTIVE REMOTE CONTROL UNITS, NAMELY, SENSOR BARS FOR USE WITH WIRELESS VIDEO REMOTES; VIDEO GAME INTERACTIVE HAND HELD REMOTE CONTROLS FOR PLAYING ELECTRONIC GAMES; VIDEO GAME REMOTE CONTROLS; VIDEO GAME INTERACTIVE REMOTE CONTROL UNITS COMPRISED OF CASES CONFIGURED TO CONVERT MOBILE PHONES INTO REMOTE CONTROLLERS; CASES FOR MOBILE PHONES FOR HOLDING ADDITIONAL BATTERY SUPPLIES, CONNECTOR HUBS, DOCKING STATIONS, LIGHTS, SPEAKERS, HEADPHONES, EARBUDS, STYLUSES, KEYPADS, SCREEN FILTERS AND SCREEN PROTECTORS; ACCESSORIES, NAMELY, CLUTCH BAGS, SHOULDER BAGS, HANDBAGS, TOTE BAGS, BRIEFCASE-TYPE PORTFOLIOS, PURSES, HARD-SIDED CASES AND WALLETS, ALL SPECIALLY ADAPTED TO CARRY VIDEO GAME CASSETTES, VIDEO GAME DISCS OR CARTRIDGES, OR HANDHELD ELECTRONIC DEVICES, NAMELY, HANDHELD ELECTRONIC GAMES ADAPTED FOR USE WITH TELEVISION RECEIVERS ONLY; ACCESSORIES, NAMELY, SLEEVES FOR VIDEO GAME CARTRIDGES, CASSETTES AND DISCS; CLEAR PROTECTIVE COVERS SPECIALLY ADAPTED FOR PERSONAL ELECTRONIC DEVICES, NAMELY, FOR HANDHELD VIDEO GAME CONTROLLERS AND REMOTE CONTROLS; ACCESSORIES, NAMELY, CASES SPECIALLY ADAPTED FOR CARRYING VIDEO GAME DISCS AND CARTRIDGES; FITTED PLASTIC FILMS KNOWN AS SKINS FOR COVERING AND PROTECTING HANDHELD ELECTRONIC APPARATUS, NAMELY, VIDEO GAME CONTROLLERS AND REMOTE CONTROLS; PROTECTIVE CASES, NAMELY, SLEEVES, JACKETS AND GLOVES SPECIALLY ADAPTED TO COVER HANDHELD ELECTRONIC DEVICES, NAMELY, VIDEO GAME CONTROLLERS AND REMOTE CONTROLS; VIDEO GAME JOYSTICKS IN THE SHAPE OF TOY MUSICAL INSTRUMENTS, TOY WEAPONS, TOY ATHLETIC EQUIPMENT, TOY STEERING WHEELS AND OTHER TOYS SPECIALLY ADAPTED TO HOLD VIDEO GAME REMOTES DURING GAME PLAY; ACCESSORIES FOR VIDEO GAMES, NAMELY, WRIST STRAPS FOR CARRYING VIDEO GAME CONTROLLERS; FITTED DECORATIVE PLASTIC FILMS KNOWN AS SKINS FOR COVERING AND PROTECTING ELECTRONIC APPARATUS, NAMELY, VIDEO GAME CONTROLLERS (U.S. CLS. 21, 23, 26, 36 AND 38).

### CLASS 18—LEATHER GOODS

FOR ACCESSORIES FOR VIDEO GAMES, NAMELY, SHOULDER STRAPS (U.S. CLS. 1, 2, 3, 22 AND 41).

### CLASS 21—HOUSEWARES AND GLASS

FOR ACCESSORIES FOR VIDEO GAMES, NAMELY, CLEANING CLOTHS (U.S. CLS. 2, 13, 23, 29, 30, 33, 40 AND 50).  
KATHERINE M. DUBRAY, EXAMINING ATTORNEY

SN 85-046,893. JOHNSON & JOHNSON, NEW BRUNSWICK, NJ. FILED 5-25-2010.

### BEAUTY FOR ALL AGES

THE MARK CONSISTS OF STANDARD CHARACTERS WITHOUT CLAIM TO ANY PARTICULAR FONT, STYLE, SIZE, OR COLOR.

### CLASS 3—COSMETICS AND CLEANING PREPARATIONS

FOR SKINCARE PREPARATIONS, NAMELY, FACIAL CREAMS, FACIAL MOISTURIZERS, FACIAL CLEANSERS; NON-MEDICATED SUN CARE PREPARATIONS; BODY CARE PREPARATIONS, NAMELY, BODY WASH; HAIR CARE PREPARATIONS, NAMELY, SHAMPOO, CONDITIONER, DETANGLER, HAIR SPRAY (U.S. CLS. 1, 4, 6, 50, 51 AND 52).

### CLASS 5—PHARMACEUTICALS

FOR MEDICATED SKINCARE PREPARATIONS, NAMELY, FACIAL CREAMS, FACIAL MOISTURIZERS, FACIAL CLEANSERS; MEDICATED SUN CARE PREPARATIONS (U.S. CLS. 6, 18, 44, 46, 51 AND 52).

### CLASS 44—MEDICAL, BEAUTY AND AGRICULTURAL SERVICES

FOR PROVIDING INFORMATION IN THE FIELD OF BEAUTY CARE (U.S. CLS. 100 AND 101).  
COLLEEN KEARNEY, EXAMINING ATTORNEY

SN 85-047,009. DALE OPERATING COMPANY, DALLAS, TX. FILED 5-25-2010.



THE MARK CONSISTS OF THE LETTER "D" WITH CONTRASTING, THIN HORIZONTAL LINES GOING THROUGH SAID LETTER, DEPICTING MOTION.

**CLASS 36—INSURANCE AND FINANCIAL**

FOR LAND LEASING; ARRANGING OF LEASES OF REAL ESTATE FOR THE PURPOSE OF OIL AND GAS DRILLING (U.S. CLS. 100, 101 AND 102).  
FIRST USE 6-1-1993; IN COMMERCE 6-1-1993.

**CLASS 42—SCIENTIFIC AND COMPUTER SERVICES**

FOR OIL AND GAS EXPLORATION (U.S. CLS. 100 AND 101).  
FIRST USE 6-1-1993; IN COMMERCE 6-1-1993.  
CAROLINE WOOD, EXAMINING ATTORNEY

SN 85-047,042. DOREL JUVENILE GROUP, INC., FOXBORO, MA. FILED 5-25-2010.

---

# SAFETY 1ST

THE MARK CONSISTS OF STANDARD CHARACTERS WITHOUT CLAIM TO ANY PARTICULAR FONT, STYLE, SIZE, OR COLOR.  
OWNER OF U.S. REG. NOS. 2,798,315, 3,138,169 AND OTHERS.

**CLASS 25—CLOTHING**

FOR CLOTHING, NAMELY, SWIM SUITS, BABY BIBS NOT OF PAPER, JUMPERS, SHORTS, SKIRTS, SKORTS, DRESSES, PANTS, JEANS, COVERALLS, OVERALLS, WARM-UP SUITS, SLEEPWEAR, PAJAMAS, BODY SUITS, CREEPERS, BOTTOMS, SHIRTS, BLOUSES, TOPS, TOPS WITH HOODS, TANK TOPS, SWEATERS, SWEATSHIRTS, SWEATPANTS, CARDIGANS, VESTS, COATS, JACKETS, SNOW SUITS, T-SHIRTS, SOCKS, TIGHTS, LEGGINGS, UNDERWEAR, MITTENS, GLOVES AND SCARVES; HEADWEAR, NAMELY, HATS, CAPS, VISORS, HEADBANDS AND BANDANAS; SUSPENDERS AND BELTS; FOOTWEAR, NAMELY, BOOTS, SHOES, SANDALS, SLIPPERS AND BOOTIES (U.S. CLS. 22 AND 39).

**CLASS 28—TOYS AND SPORTING GOODS**

FOR JUNGLE GYMS; RIDE ON TOYS (U.S. CLS. 22, 23, 38 AND 50).  
MARY CRAWFORD, EXAMINING ATTORNEY

SN 85-047,125. NEXTMEDIA OPERATING, INC., GREENWOOD VILLAGE, CO. FILED 5-25-2010.

---

## HIGH OCTANE SOCIAL SHOPPING

THE MARK CONSISTS OF STANDARD CHARACTERS WITHOUT CLAIM TO ANY PARTICULAR FONT, STYLE, SIZE, OR COLOR.  
NO CLAIM IS MADE TO THE EXCLUSIVE RIGHT TO USE "SOCIAL SHOPPING", APART FROM THE MARK AS SHOWN.

**CLASS 9—ELECTRICAL AND SCIENTIFIC APPARATUS**

FOR CONSUMER COUPONS DOWNLOADED FROM A GLOBAL COMPUTER NETWORK (U.S. CLS. 21, 23, 26, 36 AND 38).

**CLASS 35—ADVERTISING AND BUSINESS**

FOR PROMOTING THE GOODS AND SERVICES OF OTHERS THROUGH A WEB SITE, SOCIAL MEDIA PLATFORM AND E-BLASTS THAT ADVERTISE, PROMOTE AND DISTRIBUTE DISCOUNT OFFERS, SPECIAL PRICING PROMOTIONS, COUPONS AND REBATES; PROMOTING THE GOODS AND SERVICES OF OTHERS BY PROVIDING A WEB SITE FEATURING PRODUCT REVIEWS, LINKS TO THE RETAIL WEB SITES OF OTHERS, AND DISCOUNT INFORMATION; ADVERTISING AND COMMERCIAL INFORMATION SERVICES VIA THE INTERNET; ADVERTISING VIA ELECTRONIC MEDIA AND SPECIFICALLY THE INTERNET, RADIO BROADCASTS ON TERRESTRIAL SIGNALS, ONLINE AND MOBILE STREAMING; PROVIDING ADVERTISING SPACE ON THE INTERNET; ON-LINE RETAIL STORE SERVICES IN THE FIELD OF FOODS, SPA AND BEAUTY PRODUCTS, HOUSEWARES, HOME FURNISHINGS, ELECTRICAL APPLIANCES, ELECTRONICS AND APPAREL (U.S. CLS. 100, 101 AND 102).

**CLASS 38—COMMUNICATION**

FOR COMPUTER SERVICES, NAMELY, PROVIDING ON-LINE FORUMS FOR TRANSMISSION OF MESSAGES AMONG COMPUTER USERS CONCERNING CONSUMER PRODUCTS, DISCUSSION OF PRODUCT DEALS, DISCOUNTS, PRICING, AND PROMOTIONS (U.S. CLS. 100, 101 AND 104).  
DEZMONA MIZELLE, EXAMINING ATTORNEY

SN 85-047,203. PATRICK ROLL, SR., BIRMINGHAM, AL. AND RYAN SNUGGS, BIRMINGHAM, AL. FILED 5-25-2010.

---

# Changing Hearts

THE MARK CONSISTS OF STANDARD CHARACTERS WITHOUT CLAIM TO ANY PARTICULAR FONT, STYLE, SIZE, OR COLOR.

**CLASS 20—FURNITURE AND ARTICLES NOT OTHERWISE CLASSIFIED**

FOR BOXES MADE OF PLASTIC THAT DELIVER BRIEF RECORDED MESSAGES THAT MAY BE PRE-RECORDED OR RECORDED BY THE USER (U.S. CLS. 2, 13, 22, 25, 32 AND 50).

**CLASS 26—FANCY GOODS**

FOR BUTTONS MADE OF PLASTIC THAT DELIVER BRIEF RECORDED MESSAGES THAT MAY BE PRE-RECORDED OR RECORDED BY THE USER (U.S. CLS. 37, 39, 40, 42 AND 50).  
MARY BOAGNI, EXAMINING ATTORNEY

SN 85-047,224. CHARTPATTERN.COM, INC., LAS VEGAS, NV. FILED 5-25-2010.

## DAN ZANGER

THE MARK CONSISTS OF STANDARD CHARACTERS WITHOUT CLAIM TO ANY PARTICULAR FONT, STYLE, SIZE, OR COLOR.

THE NAME(S), PORTRAIT(S), AND/OR SIGNATURE(S) SHOWN IN THE MARK IDENTIFIES "DANIEL J. ZANGER", WHOSE CONSENT(S) TO REGISTER IS MADE OF RECORD.

### CLASS 36—INSURANCE AND FINANCIAL

FOR PROVISION OF FINANCIAL RESEARCH, ANALYSIS AND INFORMATION RELATING TO THE STOCK MARKET AND FINANCIAL NEWS AND INFORMATION RELATING TO STOCK TRADING (U.S. CLS. 100, 101 AND 102).

FIRST USE 0-0-1996; IN COMMERCE 0-0-1996.

### CLASS 41—EDUCATION AND ENTERTAINMENT

FOR EDUCATIONAL AND ENTERTAINMENT SERVICES, NAMELY, PROVIDING A CONTINUING PRE-RECORDED AUDIO PROGRAM IN THE FIELD OF STOCK MARKET INFORMATION AND ANALYSIS AND STOCK TRADING NEWS AND INFORMATION VIA THE INTERNET; EDUCATION AND ENTERTAINMENT SERVICES, NAMELY, CONDUCTING SEMINARS, WORKSHOPS AND PERFORMING LIVE SPEAKING ENGAGEMENTS, ALL IN THE FIELDS OF STOCK MARKET INFORMATION AND ANALYSIS AND STOCK TRADING NEWS AND INFORMATION (U.S. CLS. 100, 101 AND 107).

FIRST USE 0-0-1996; IN COMMERCE 0-0-1998.  
MARGARET POWER, EXAMINING ATTORNEY

SN 85-047,530. HATCH BEAUTY, LLC, SANTA MONICA, CA. FILED 5-25-2010.

### ECOSYNTHESIS PEPTIC COMPLEX

THE MARK CONSISTS OF STANDARD CHARACTERS WITHOUT CLAIM TO ANY PARTICULAR FONT, STYLE, SIZE, OR COLOR.

NO CLAIM IS MADE TO THE EXCLUSIVE RIGHT TO USE "PEPTIC COMPLEX" AS TO CLASS 1 AND "COMPLEX" AS TO CLASS 3 AND 5, APART FROM THE MARK AS SHOWN.

### CLASS 1—CHEMICALS

FOR ANTIOXIDANTS AND PROTEINS USED IN THE MANUFACTURE OF COSMETICS, BEVERAGES, FOOD PRODUCTS AND FOOD SUPPLEMENTS; BOTANICAL EXTRACTS FOR USE IN MAKING COSMETICS; FATTY ACIDS FOR USE IN COSMETIC APPLICATIONS; PLANT AND HERB EXTRACTS FOR USE IN THE MANUFACTURE OF COSMETICS; PLANT EXTRACTS FOR USE IN THE MANUFACTURE OF CREAMS, LOTIONS AND COSMETIC PRODUCTS (U.S. CLS. 1, 5, 6, 10, 26 AND 46).

### CLASS 3—COSMETICS AND CLEANING PREPARATIONS

FOR ALOE VERA GEL FOR COSMETIC PURPOSES; COCOA BUTTER FOR COSMETIC PURPOSES; COSMETIC CREAMS FOR SKIN CARE; COSMETIC OILS; COSMETIC OILS FOR THE EPIDERMIS; COSMETIC PREPARATIONS; COSMETIC PREPARATIONS FOR BODY CARE; COSMETIC PREPARATIONS FOR SKIN RENEWAL; COSMETIC PREPARATIONS, NAMELY, FIRMS CREAMS; COSMETIC PREPARATIONS, NAMELY, FIRMS LOTIONS; COSMETIC PREPARATIONS, NAMELY, SKIN BALSAMS; COSMETIC SOAPS; COSMETICS AND COSMETIC PREPARATIONS; COSMETICS AND MAKE-UP; ESSENTIAL OILS FOR USE IN MANUFACTURING OF COSMETIC APPLICATIONS; FACE CREAMS FOR COSMETIC USE; NATURAL ESSENTIAL OILS; NON-MEDICATED COSMETIC SKIN CARE PREPARATIONS CONSISTING OF ORGANIC COCONUT VIRGIN OIL AND COCONUT VIRGIN OIL; NUTRITIONAL OILS FOR COSMETIC PURPOSES; OILS FOR COSMETIC PURPOSES; SHEA BUTTER FOR COSMETIC PURPOSES; WRINKLE-MINIMIZING COSMETIC PREPARATIONS FOR TOPICAL FACIAL USE (U.S. CLS. 1, 4, 6, 50, 51 AND 52).

### CLASS 5—PHARMACEUTICALS

FOR ALMOND OIL FOR THE TREATMENT OF DRY AND DAMAGED SKIN (U.S. CLS. 6, 18, 44, 46, 51 AND 52).

COLLEEN DOMBROW, EXAMINING ATTORNEY

SN 85-047,851. MONOPOLY B.V., NL-1075 GV AMSTERDAM, NETHERLANDS, FILED 5-26-2010.



NO CLAIM IS MADE TO THE EXCLUSIVE RIGHT TO USE "GUARD", APART FROM THE MARK AS SHOWN.

THE COLOR(S) GREEN IS/ARE CLAIMED AS A FEATURE OF THE MARK.

THE MARK CONSISTS OF THE WORDING "E GUARD" IN GREEN LETTERING WITH THE "G" IN "GUARD" FORMING A GREEN OVAL RECTANGULAR SHAPE ENCOMPASSING THE WORDING AND A GREEN SHADED SECTION HAVING AN HOURGLASS-LIKE SHAPE LOCATED BETWEEN THE "E" AND THE "G" IN "GUARD".

### CLASS 2—PAINTS

FOR PAINTS, VARNISHES, LACQUERS, BEING PROTECTIVE COATINGS AND PRIMERS AGAINST CORROSION; PRESERVATIVES AGAINST RUST IN THE NATURE OF COATINGS (U.S. CLS. 6, 11 AND 16).

### CLASS 37—CONSTRUCTION AND REPAIR

FOR CLEANING, MAINTENANCE AND REPAIR OF APPARATUS FOR HEATING, VENTILATING, AIR CONDITIONING, REFRIGERATING AND FREEZING; APPLICATION OF PROTECTIVE COATINGS ON APPARATUS FOR HEATING, VENTILATING, AIR CONDITIONING, REFRIGERATING AND FREEZING (U.S. CLS. 100, 103 AND 106).

AMY KERTGATE, EXAMINING ATTORNEY

SN 85-047,908. ROBELL RESEARCH, INC., NEW YORK, NY.  
FILED 5-26-2010.

## SYSTEM ONE

THE MARK CONSISTS OF STANDARD CHARACTERS WITHOUT CLAIM TO ANY PARTICULAR FONT, STYLE, SIZE, OR COLOR.

NO CLAIM IS MADE TO THE EXCLUSIVE RIGHT TO USE "SYSTEM", APART FROM THE MARK AS SHOWN.

### CLASS 3—COSMETICS AND CLEANING PREPARATIONS

FOR TOOTHPASTE, TOOTH GEL, TOOTH POWDER, MOUTHWASH, NON-MEDICATED MOUTH RINSE, TOOTH WHITENING PREPARATIONS, DENTURE CLEANING PREPARATIONS; MINTS USED TO CLEAN TEETH, MOUTH AND BREATH (U.S. CLS. 1, 4, 6, 50, 51 AND 52).

### CLASS 10—MEDICAL APPARATUS

FOR TONGUE SCRAPERS (U.S. CLS. 26, 39 AND 44).

### CLASS 21—HOUSEWARES AND GLASS

FOR TOOTHBRUSHES; NON-MEDICATED DENTAL FLOSS (U.S. CLS. 2, 13, 23, 29, 30, 33, 40 AND 50).

### CLASS 30—STAPLE FOODS

FOR CHEWING GUM, NON-MEDICATED LOZENGES (U.S. CL. 46).  
JAMES MACFARLANE, EXAMINING ATTORNEY

SN 85-048,050. CAMELBAK PRODUCTS, LLC, PETALUMA, CA. FILED 5-26-2010.

## ALL CLEAR

THE MARK CONSISTS OF STANDARD CHARACTERS WITHOUT CLAIM TO ANY PARTICULAR FONT, STYLE, SIZE, OR COLOR.

### CLASS 20—FURNITURE AND ARTICLES NOT OTHERWISE CLASSIFIED

FOR NON-METAL FILTER BOTTLE CAPS FOR WATER BOTTLES AND SPORTS BOTTLES; NON-METAL PURIFICATION BOTTLE CAPS FOR WATER BOTTLES AND SPORTS BOTTLES; NON-METAL ULTRAVIOLET FILTRATION BOTTLE CAPS FOR WATER BOTTLES AND SPORTS BOTTLES (U.S. CLS. 2, 13, 22, 25, 32 AND 50).

### CLASS 21—HOUSEWARES AND GLASS

FOR SPORTS BOTTLES, SOLD EMPTY; SPORTS BOTTLES CONTAINING A WATER FILTER, SOLD EMPTY; SPORTS BOTTLES CONTAINING A WATER PURIFIER, SOLD EMPTY; SPORTS BOTTLES CONTAINING AN ULTRAVIOLET WATER PURIFIER, SOLD EMPTY; WATER BOTTLES, SOLD EMPTY; WATER BOTTLES CONTAINING A WATER FILTER, SOLD EMPTY; WATER BOTTLES CONTAINING A WATER PURIFIER, SOLD EMPTY; WATER BOTTLES CONTAINING AN ULTRAVIOLET WATER PURIFIER, SOLD EMPTY (U.S. CLS. 2, 13, 23, 29, 30, 33, 40 AND 50).

CHRISTINA SOBRAL, EXAMINING ATTORNEY

SN 85-048,365. HELO-ILLUMINATION LTD., DA-AN DIST.,  
TAIPEI, TAIWAN, FILED 5-26-2010.

NO CLAIM IS MADE TO THE EXCLUSIVE RIGHT TO USE "ILLUMINATION", APART FROM THE MARK AS SHOWN.

THE MARK CONSISTS OF THE WORD "HÉLO", WITH AN AURA SURROUNDING THE LETTER "O" ABOVE THE CAPITALIZED WORD "ILLUMINATION".

### CLASS 9—ELECTRICAL AND SCIENTIFIC APPARATUS

FOR ELECTRONIC PUBLICATIONS, NAMELY, MAGAZINES FEATURING COMPUTER AND TECHNOLOGY INFORMATION RECORDED ON COMPUTER MEDIA; COMPUTER HARDWARE; COMPUTER SOFTWARE FOR USE IN NETWORK COMMUNICATION; INTERFACES FOR COMPUTERS; COMPUTER CURSOR CONTROL DEVICES, NAMELY, TOUCH PADS; ELECTRONIC NOTE BOOK COMPUTERS; ELECTRONIC BOOK READER; PERSONAL DIGITAL ASSISTANTS; HAND-HELD ELECTRONIC DICTIONARIES; COMPUTER BAGS; VIDEO GAME CARTRIDGES AND CASSETTES; COMPUTER GAME PROGRAMS RECORDED ON MAGNETIC DISKS AND STORAGE MEDIA; COMPUTER GAME PROGRAMS RECORDED ON OPTICAL DISKS AND STORAGE MEDIA; COMPUTER GAME PROGRAM CARTRIDGES AND CASSETTES; VIDEO GAME SOFTWARE; COMPUTER GAME PROGRAMS DOWNLOADABLE VIA THE INTERNET; VIDEO CAMERAS; SLIDE PROJECTORS; FILM CAMERAS; VIDEO CASSETTE RECORDERS; TELEVISIONS; PERSONAL STEREOS; VIDEO GAME MACHINES FOR USE WITH TELEVISIONS; FLUORESCENT LAMP BALLAST FOR ELECTRIC LIGHTS; BATTERIES; ACCUMULATOR JARS; TELEPHONES; FACSIMILE MACHINES; MONITORS, NAMELY, COMPUTER MONITORS AND VIDEO MONITORS; LIQUID CRYSTAL DISPLAYS; SATELLITE NAVIGATIONAL SYSTEM, NAMELY, A GLOBAL POSITIONING SYSTEM (GPS); LIGHT EMITTING DIODES; LIGHT EMITTING DIODE DISPLAYS; GLOBAL POSITIONING SYSTEM (GPS) CONSISTING OF COMPUTERS, COMPUTER SOFTWARE, TRANSMITTERS, RECEIVERS, AND NETWORK INTERFACE DEVICES; DISCHARGE TUBES, ELECTRIC, OTHER THAN FOR LIGHTING; TELEPHONE RECEIVERS; TELEPHONE TRANSMITTERS; WIRELESS TELEVISION SET FOR PROVIDING VIDEO CONFERENCING AND TELEPHONE SERVICE OVER THE INTERNET; INTEROPERABLE COMMUNICATION SYSTEM DESIGNED TO PROVIDE RADIO, STREAMING VIDEO, WIRELESS



INTERNET, AND VOIP PHONE; NAVIGATION APPARATUS FOR VEHICLES IN THE NATURE OF ON-BOARD COMPUTERS; SOUND TRANSMITTING APPARATUS; COMPUTER CHIPS; SEMICONDUCTORS; INTEGRATED CIRCUITS; LIGHTING BALLASTS; ELECTRICAL INDUCTORS; BATTERY CHARGERS; LIGHTING CONTROLS; ELECTRICAL CONDUCTORS (U.S. CLS. 21, 23, 26, 36 AND 38).

#### CLASS 11—ENVIRONMENTAL CONTROL APPARATUS

FOR LANTERNS; LIGHT BULBS; LIGHTING FIXTURES; LIGHTING APPARATUS FOR VEHICLES; ELECTRIC KETTLES; ELECTRIC COFFEE PERCOLATORS; ELECTRIC COFFEE POTS; COFFEE FILTERS NOT OF PAPER BEING PART OF ELECTRIC COFFEE MAKERS; ELECTRIC FANS; WATER FOUNTAINS; WATER STERILIZERS AND STERILIZERS NOT FOR INDUSTRY PURPOSES; AIR CONDITIONING INSTALLATIONS; SOLAR ENERGY RECEIVERS (U.S. CLS. 13, 21, 23, 31 AND 34).

KELLY BOULTON, EXAMINING ATTORNEY

SN 85-048,444, AMOEBA MUSIC, INC., BERKELEY, CA. FILED 5-26-2010.



OWNER OF U.S. REG. NO. 2,363,690.

NO CLAIM IS MADE TO THE EXCLUSIVE RIGHT TO USE "MUSIC", APART FROM THE MARK AS SHOWN.

THE MARK CONSISTS OF THE DESIGN OF A STAR WITH AN OUTLINE. IN THE CENTER OF THE STAR ARE THE STYLIZED WORDS "AMOEBA MUSIC" OUTLINED AND SHADOWED HEAVILY. COLOR IS NOT CLAIMED AS A FEATURE OF THE MARK.

#### CLASS 9—ELECTRICAL AND SCIENTIFIC APPARATUS

FOR A SERIES OF MUSICAL SOUND RECORDINGS; DOWNLOADABLE MUSICAL SOUND RECORDINGS; DOWNLOADABLE ELECTRONIC NEWSLETTERS FEATURING NEWS, SPECIAL PROMOTIONS, CONTESTS, INFORMATION ON IN-STORE MUSICAL PERFORMANCES, AND OTHER INFORMATION ABOUT RECORD STORE RECOMMENDATIONS FOR RECORDINGS AND MOVIES AND RECORDING ARTISTS; CASES FOR HOLDING COMPACT DISCS; SLIP MATS, NAMELY, COVERS USED ON TURN TABLES; MAGNETS; DOWNLOADABLE ELECTRONIC PUBLICATIONS IN THE FORM OF BOOKLETS PROVIDING INFORMATION ON MUSICAL PERFORMERS AND THEIR RECORDINGS, INFORMATION ON MOVIES, RECOMMENDATIONS FOR RECORDINGS AND MOVIES (U.S. CLS. 21, 23, 26, 36 AND 38).

FIRST USE 0-0-1990; IN COMMERCE 0-0-1990.

#### CLASS 12—VEHICLES

FOR LICENSE PLATE FRAMES (U.S. CLS. 19, 21, 23, 31, 35 AND 44).

FIRST USE 0-0-2002; IN COMMERCE 0-0-2002.

#### CLASS 16—PAPER GOODS AND PRINTED MATTER

FOR BOOKLETS PROVIDING INFORMATION ON MUSICAL PERFORMERS AND THEIR RECORDINGS, INFORMATION ON MOVIES, RECOMMENDATIONS FOR RECORDINGS AND MOVIES; POSTCARDS; BUMPER STICKERS; POSTERS (U.S. CLS. 2, 5, 22, 23, 29, 37, 38 AND 50).

FIRST USE 0-0-1991; IN COMMERCE 0-0-1991.

#### CLASS 18—LEATHER GOODS

FOR TOTE BAGS (U.S. CLS. 1, 2, 3, 22 AND 41).

FIRST USE 0-0-1990; IN COMMERCE 0-0-1990.

#### CLASS 25—CLOTHING

FOR SHIRTS, T-SHIRTS, TANK TOPS, CAPS, JACKETS, BEANIES, SWEATSHIRTS (U.S. CLS. 22 AND 39).

FIRST USE 0-0-1990; IN COMMERCE 0-0-1990.

#### CLASS 26—FANCY GOODS

FOR ORNAMENTAL NOVELTY BUTTONS; ORNAMENTAL CLOTH PATCHES (U.S. CLS. 37, 39, 40, 42 AND 50).

FIRST USE 0-0-1990; IN COMMERCE 0-0-1990.

#### CLASS 35—ADVERTISING AND BUSINESS

FOR RETAIL STORE SERVICES FEATURING SOUND RECORDINGS, CDS, LPS, DVDS, LASER DISCS, AUDIO-VISUAL RECORDINGS, VIDEOS TAPES, AUDIO TAPES, POSTERS, LICENSE PLATE FRAMES, CLOTHING, HEADWEAR, TOTE BAGS, AUDIO ACCESSORIES, SLIPMATS FOR TURNTABLES, PRINTED MATERIALS, MUSICAL INSTRUMENTS, PATCHES, POSTCARDS; ISSUING GIFT CERTIFICATES WHICH MAY THEN BE REDEEMED FOR GOODS; PROVIDING A WEB SITE WHERE USERS CAN POST ITEMS FOR SALE AND BUY ITEMS POSTED BY OTHERS IN THE FIELD OF USED SOUND RECORDINGS, VIDEOS AND OTHER MUSIC MERCHANDISE FOR RESALE; CHARITABLE SERVICES, NAMELY, ARRANGING AND CONDUCTING CHARITY AUCTIONS FOR THE BENEFIT OF OTHERS; ONLINE RETAIL STORE SERVICES FEATURING MUSICAL SOUND RECORDINGS, CDS, LPS, DVDS, PRINTED MATERIALS, POSTERS, LICENSE PLATE FRAMES, CLOTHING, HEADWEAR, TOTE BAGS, AUDIO ACCESSORIES, SLIPMATS FOR TURNTABLES; MAIL ORDER SERVICES FEATURING MUSICAL SOUND RECORDINGS AND AUDIO-VISUAL RECORDINGS FEATURING MUSIC; PROVIDING INFORMATION ON A RECORD STORE OFFERINGS RELATED TO MUSIC-RELATED MERCHANDISE FOR RETAIL PURPOSES (U.S. CLS. 100, 101 AND 102).

FIRST USE 0-0-1990; IN COMMERCE 0-0-1990.

#### CLASS 41—EDUCATION AND ENTERTAINMENT

FOR ENTERTAINMENT SERVICES, NAMELY, HOSTING LIVE MUSICAL PERFORMANCES, PRODUCING PROGRAMS OF MUSIC AND INTERVIEWS FOR USE ON THE INTERNET, ALL FOR ENTERTAINMENT PURPOSES; PROVIDING WEBCASTS OF LIVE MUSICAL EVENTS; ONLINE SERVICES FEATURING INFORMATION ON SOUND RECORDINGS, MOTION PICTURES AND OTHER ENTERTAINMENT EVENTS IN THE NATURE OF LIVE MUSICAL PERFORMANCES, PERSONAL APPEARANCES BY ENTERTAINERS AND ART SHOWS; PROVIDING ENTERTAINMENT INFORMATION ON A RECORD STORE AND ITS ENTERTAINMENT HISTORY; ENTERTAINMENT SERVICES, NAMELY, PROVIDING A WEBSITE FEATURING NON-

DOWNLOADABLE PRERECORDED MUSICAL PERFORMANCES, MUSIC VIDEOS, RELATED VIDEO CLIPS, PHOTOGRAPHS, AND DISCOGRAPHIES OF MUSICAL ARTISTS; PROVIDING AN INTERNET WEBSITE PORTAL FEATURING LINKS RELATING TO MUSICAL ARTISTS AND MUSICAL ENTERTAINMENT; PROVIDING NON-DOWNLOADABLE PRERECORDED MUSIC AND AUDIOVISUAL RECORDINGS FEATURING MUSIC AND SPOKEN WORD ALL ONLINE VIA A GLOBAL COMPUTER NETWORK; KIOSKS FOR LISTENING TO RECORDED MUSIC (U.S. CLS. 100, 101 AND 107).

FIRST USE 0-0-1997; IN COMMERCE 0-0-1997.  
BARBARA RUTLAND, EXAMINING ATTORNEY

SN 85-048,488. AMOEBA MUSIC, INC., BERKELEY, CA.  
FILED 5-26-2010.

# AMOEBA

THE MARK CONSISTS OF STANDARD CHARACTERS WITHOUT CLAIM TO ANY PARTICULAR FONT, STYLE, SIZE, OR COLOR.

OWNER OF U.S. REG. NO. 2,363,690.

## CLASS 9—ELECTRICAL AND SCIENTIFIC APPARATUS

FOR A SERIES OF MUSICAL SOUND RECORDINGS; DOWNLOADABLE MUSICAL SOUND RECORDINGS; DOWNLOADABLE ELECTRONIC NEWSLETTERS FEATURING NEWS, SPECIAL PROMOTIONS, CONTESTS, INFORMATION ON IN-STORE MUSICAL PERFORMANCES, AND OTHER INFORMATION ABOUT RECORD STORE RECOMMENDATIONS FOR RECORDINGS AND MOVIES AND RECORDING ARTISTS; CASES FOR HOLDING COMPACT DISCS; SLIP MATS, NAMELY, COVERS USED ON TURN TABLES; MAGNETS; DOWNLOADABLE ELECTRONIC PUBLICATIONS IN THE FORM OF BOOKLETS PROVIDING INFORMATION ON MUSICAL PERFORMERS AND THEIR RECORDINGS, INFORMATION ON MOVIES, RECOMMENDATIONS FOR RECORDINGS AND MOVIES (U.S. CLS. 21, 23, 26, 36 AND 38).

FIRST USE 0-0-1990; IN COMMERCE 0-0-1990.

## CLASS 12—VEHICLES

FOR LICENSE PLATE FRAMES (U.S. CLS. 19, 21, 23, 31, 35 AND 44).

FIRST USE 0-0-2002; IN COMMERCE 0-0-2002.

## CLASS 16—PAPER GOODS AND PRINTED MATTER

FOR BOOKLETS PROVIDING INFORMATION ON MUSICAL PERFORMERS AND THEIR RECORDINGS, INFORMATION ON MOVIES, RECOMMENDATIONS FOR RECORDINGS AND MOVIES; POSTCARDS; BUMPER STICKERS; POSTERS (U.S. CLS. 2, 5, 22, 23, 29, 37, 38 AND 50).

FIRST USE 0-0-1990; IN COMMERCE 0-0-1990.

## CLASS 18—LEATHER GOODS

FOR TOTE BAGS (U.S. CLS. 1, 2, 3, 22 AND 41).  
FIRST USE 0-0-1990; IN COMMERCE 0-0-1990.

## CLASS 25—CLOTHING

FOR SHIRTS, T-SHIRTS, TANK TOPS, CAPS, JACKETS, BEANIES, SWEATSHIRTS (U.S. CLS. 22 AND 39).  
FIRST USE 0-0-1990; IN COMMERCE 0-0-1990.

## CLASS 26—FANCY GOODS

FOR ORNAMENTAL NOVELTY BUTTONS; ORNAMENTAL CLOTH PATCHES (U.S. CLS. 37, 39, 40, 42 AND 50).

FIRST USE 0-0-2002; IN COMMERCE 0-0-2002.

## CLASS 35—ADVERTISING AND BUSINESS

FOR RETAIL STORE SERVICES FEATURING SOUND RECORDINGS, CDS, LPS, DVDS, LASER DISCS, AUDIO-VISUAL RECORDINGS, VIDEOS TAPES, AUDIO TAPES, POSTERS, LICENSE PLATE FRAMES, CLOTHING, HEADWEAR, TOTE BAGS, AUDIO ACCESSORIES, SLIPMATS FOR TURNTABLES, PRINTED MATERIALS, MUSICAL INSTRUMENTS, PATCHES, POSTCARDS; ISSUING GIFT CERTIFICATES WHICH MAY THEN BE REDEEMED FOR GOODS; PROVIDING A WEB SITE WHERE USERS CAN POST ITEMS FOR SALE AND BUY ITEMS POSTED BY OTHERS IN THE FIELD OF USED SOUND RECORDINGS, VIDEOS AND OTHER MUSIC MERCHANDISE FOR RESALE; CHARITABLE SERVICES, NAMELY, ARRANGING AND CONDUCTING CHARITY AUCTIONS FOR THE BENEFIT OF OTHERS; ONLINE RETAIL STORE SERVICES FEATURING MUSICAL SOUND RECORDINGS, CDS, LPS, DVDS, PRINTED MATERIALS, POSTERS, LICENSE PLATE FRAMES, CLOTHING, HEADWEAR, TOTE BAGS, AUDIO ACCESSORIES, SLIPMATS FOR TURNTABLES; MAIL ORDER SERVICES FEATURING MUSICAL SOUND RECORDINGS AND AUDIO-VISUAL RECORDINGS FEATURING MUSIC; PROVIDING INFORMATION ON A RECORD STORE OFFERINGS RELATED TO MUSIC-RELATED MERCHANDISE FOR RETAIL PURPOSES (U.S. CLS. 100, 101 AND 102).

FIRST USE 0-0-1990; IN COMMERCE 0-0-1990.

## CLASS 41—EDUCATION AND ENTERTAINMENT

FOR ENTERTAINMENT SERVICES, NAMELY, HOSTING LIVE MUSICAL PERFORMANCES, PRODUCING PROGRAMS OF MUSIC AND INTERVIEWS FOR USE ON THE INTERNET, ALL FOR ENTERTAINMENT PURPOSES; PROVIDING WEBCASTS OF LIVE MUSICAL EVENTS; ONLINE SERVICES FEATURING INFORMATION ON SOUND RECORDINGS, MOTION PICTURES AND OTHER ENTERTAINMENT EVENTS IN THE NATURE OF LIVE MUSICAL PERFORMANCES, PERSONAL APPEARANCES BY ENTERTAINERS AND ART SHOWS; PROVIDING ENTERTAINMENT INFORMATION ON A RECORD STORE AND ITS ENTERTAINMENT HISTORY; ENTERTAINMENT SERVICES, NAMELY, PROVIDING A WEBSITE FEATURING NON-DOWNLOADABLE PRERECORDED MUSICAL PERFORMANCES, MUSIC VIDEOS, RELATED VIDEO CLIPS, PHOTOGRAPHS, AND DISCOGRAPHIES OF MUSICAL ARTISTS; PROVIDING AN INTERNET WEBSITE PORTAL FEATURING LINKS RELATING TO MUSICAL ARTISTS AND MUSICAL ENTERTAINMENT; PROVIDING NON-DOWNLOADABLE PRERECORDED MUSIC AND AUDIOVISUAL RECORDINGS FEATURING MUSIC AND SPOKEN WORD ALL ONLINE VIA A GLOBAL COMPUTER NETWORK; KIOSKS FOR LISTENING TO RECORDED MUSIC (U.S. CLS. 100, 101 AND 107).

FIRST USE 0-0-1997; IN COMMERCE 0-0-1997.  
BARBARA RUTLAND, EXAMINING ATTORNEY

SN 85-048,583. TANGI-PAC, L.L.C., PONCHATOULA, LA.  
FILED 5-26-2010.

SN 85-048,731. KID MADE MODERN, LLC, DALLAS, TX.  
FILED 5-26-2010.

# TRIPRO

THE MARK CONSISTS OF STANDARD CHARACTERS WITHOUT CLAIM TO ANY PARTICULAR FONT, STYLE, SIZE, OR COLOR.

OWNER OF U.S. REG. NO. 2,562,417.

## CLASS 1—CHEMICALS

FOR FERTILIZERS AND SOIL AMENDMENTS (U.S. CLS. 1, 5, 6, 10, 26 AND 46).

## CLASS 5—PHARMACEUTICALS

FOR PESTICIDES (U.S. CLS. 6, 18, 44, 46, 51 AND 52).  
BRIAN CALLAGHAN, EXAMINING ATTORNEY

---

SN 85-048,618. LOOMSTATE, LLC, NEW YORK, NY. FILED  
5-26-2010.

# ACT NATURAL

THE MARK CONSISTS OF STANDARD CHARACTERS WITHOUT CLAIM TO ANY PARTICULAR FONT, STYLE, SIZE, OR COLOR.

## CLASS 24—FABRICS

FOR HOME TEXTILE PRODUCTS, NAMELY, BED LINENS, BEDSHEETS, BEDSPREADS, BED BLANKETS, COMFORTERS, BATH TOWELS, DINING LINENS, NAMELY, NAPKINS AND TABLE CLOTHS, WINDOW COVERINGS, NAMELY, CURTAINS AND DRAPERIES (U.S. CLS. 42 AND 50).

## CLASS 25—CLOTHING

FOR CLOTHING, NAMELY, MEN'S JEANS, PANTS, SHORTS, SHIRTS, T-SHIRTS, OUTERWEAR, NAMELY, JACKETS, SWEATSHIRTS AND SWEATERS; WOMEN'S JEANS, PANTS, LEGGINGS, SHORTS, SKIRTS, TOPS, T-SHIRTS, TANK TOPS, DRESSES, OUTERWEAR, NAMELY, JACKETS, SWEATSHIRTS AND SWEATERS; AND CHILDREN'S WEAR JEANS, PANTS, SHORTS, SKIRTS, SHIRTS, T-SHIRTS, TANK TOPS, DRESSES, OUTERWEAR, NAMELY, JACKETS, SWEATSHIRTS AND SWEATERS (U.S. CLS. 22 AND 39).

MATTHEW EINSTEIN, EXAMINING ATTORNEY

# KID MADE MODERN

THE MARK CONSISTS OF STANDARD CHARACTERS WITHOUT CLAIM TO ANY PARTICULAR FONT, STYLE, SIZE, OR COLOR.

## CLASS 16—PAPER GOODS AND PRINTED MATTER

FOR ARTS AND CRAFT PAINT KITS COMPRISING AN ACRYLIC PAINT SET; ARTS AND CRAFT PAINT KITS FOR PAINTING ON CANVAS INCLUDING CANVAS AND HOW TO PAINT BOOK; ARTS AND CRAFT PAINT KITS COMPRISING PAINT BRUSH SETS (U.S. CLS. 2, 5, 22, 23, 29, 37, 38 AND 50).

## CLASS 28—TOYS AND SPORTING GOODS

FOR EDUCATIONAL HOBBY CRAFT KITS COMPRISING PRINTED INSTRUCTIONAL MATERIALS AND/OR BOOKS TO TEACH AND MAKE ART, NAMELY, KITS FOR T-SHIRT PRINTING; HOBBY CRAFT KITS FOR MAKING BEADED FLOWERS; HOBBY CRAFT KITS COMPRISING MATERIALS FOR AN ART STUDIO IN A STORAGE BOX; HOBBY CRAFT KITS COMPRISING MULTI-COLOR CRAYONS; HOBBY CRAFT KITS COMPRISING SELF INKING FABRIC STAMPS; HOBBY CRAFT KITS FOR MAKING WALL PAPER INCLUDING MARKERS AND EASY CLING WALLPAPER; HOBBY CRAFT KITS CONTAINING MATERIALS FOR MAKING COMIC BOOKS INCLUDING STAMPS AND STENCILS; HOBBY CRAFT KITS FOR MAKING SELF STICK WALL MURALS INCLUDING PATTERNS AND ROLLS OF EASY STICK CONTACT PAPER; HOBBY CRAFT KITS COMPRISING FABRIC DIP DYE INCLUDING DYE COLORS, GLOVES, CLOTH, STRING, PLASTIC BAGS, RUBBER BANDS, ALUMINUM PAN AND SPRAY BOTTLES; HOBBY CRAFT KITS COMPRISING BAKING PAN TRAYS FOR USE IN ART PROJECTS; HOBBY CRAFT KITS FOR MAKING IRON ON FABRIC PATTERNS; HOBBY CRAFT KITS COMPRISING MULTI-COLORED PENCILS; HOBBY CRAFT KITS COMPRISING COLOR PENCIL SETS; HOBBY CRAFT KITS COMPRISING MULTI-COLOR TAPE; HOBBY CRAFT KITS FOR MAKING DUCT TAPE BAGS INCLUDING ROLLS OF COLORED DUCT TAPE; HOBBY CRAFT KITS FOR MAKING MOON ROCK JEWELRY; HOBBY CRAFT KITS FOR MAKING JEWELRY; HOBBY CRAFT KITS, NAMELY, JAPANESE FELTING KITS (U.S. CLS. 22, 23, 38 AND 50).

ANNE FARRELL, EXAMINING ATTORNEY

---

SN 85-049,052. THE W.E. BASSETT COMPANY, SHELTON, CT. FILED 5-27-2010.

# TRIM ITOOLS

THE MARK CONSISTS OF STANDARD CHARACTERS WITHOUT CLAIM TO ANY PARTICULAR FONT, STYLE, SIZE, OR COLOR.

OWNER OF U.S. REG. NOS. 614,895, 695,409 AND OTHERS.

SEC. 2(F).

THE 2(F) CLAIM IS RESTRICTED TO CLASS(ES) 008

**CLASS 8—HAND TOOLS**

FOR TWEEZERS, EYEBROW SHAPERS, SCISSORS AND EYELASH CURLERS; MANICURE AND PEDICURE IMPLEMENTS, NAMELY, NAIL CLIPPERS, NIPPERS, NAIL FILES, FOOT FILES, NAIL SMOOTHERS, NAIL BUFFERS, CUTICLE SCISSORS, CUTICLE PUSHERS, CUTICLE REMOVERS, CUTICLE CLEANERS, CALLUS REDUCERS, FOOT FILES, FOOT SANDING BLOCKS, FOOT SMOOTHERS, FOOT CALLUS RASPS, CALLUS CUTTERS AND NON-ELECTRIC CALLUS SHAVERS (U.S. CLS. 23, 28 AND 44).

**CLASS 16—PAPER GOODS AND PRINTED MATTER**

FOR EYEBROW PENCIL SHARPENERS (U.S. CLS. 2, 5, 22, 23, 29, 37, 38 AND 50).

**CLASS 20—FURNITURE AND ARTICLES NOT OTHERWISE CLASSIFIED**

FOR MAGNIFYING MIRRORS USED FOR PERSONAL GROOMING (U.S. CLS. 2, 13, 22, 25, 32 AND 50).  
MATTHEW KLINE, EXAMINING ATTORNEY

**CLASS 41—EDUCATION AND ENTERTAINMENT**

FOR ORGANIZING AND CONDUCTING RECOGNITION AWARDS PROGRAM TO HONOR ORAL CARE AND MEDICAL HEALTH CARE PROFESSIONALS; EDUCATIONAL SERVICES, NAMELY, PROVIDING INTERACTIVE AND INFORMATIVE PROGRAMS REGARDING PROPER DENTAL ROUTINES USING CONSUMER PRODUCTS FOR NEW DENTISTS (U.S. CLS. 100, 101 AND 107).

**CLASS 44—MEDICAL, BEAUTY AND AGRICULTURAL SERVICES**

FOR PROVIDING INFORMATION IN THE FIELD OF ORAL CARE (U.S. CLS. 100 AND 101).  
KEVON CHISOLM, EXAMINING ATTORNEY

---

SN 85-049,065. COLLEEN KARIS DESIGNS, LLC, LOS ANGELES, CA. FILED 5-27-2010.

---

SN 85-049,378. T AND O PROPERTIES, LLC, MYRTLE BEACH, SC. FILED 5-27-2010.

**ASHTON & ELSA**

THE MARK CONSISTS OF STANDARD CHARACTERS WITHOUT CLAIM TO ANY PARTICULAR FONT, STYLE, SIZE, OR COLOR.

**CLASS 16—PAPER GOODS AND PRINTED MATTER**

FOR PRINTS, ARTWORK ON CANVAS, PRINTED GROWTH CHARTS, MEMO BOARDS (U.S. CLS. 2, 5, 22, 23, 29, 37, 38 AND 50).

**CLASS 20—FURNITURE AND ARTICLES NOT OTHERWISE CLASSIFIED**

FOR MIRRORS, STOOLS, TABLES AND CHAIRS (U.S. CLS. 2, 13, 22, 25, 32 AND 50).  
LINDA M. KING, EXAMINING ATTORNEY

**Myrtle Beach Diet**

THE MARK CONSISTS OF STANDARD CHARACTERS WITHOUT CLAIM TO ANY PARTICULAR FONT, STYLE, SIZE, OR COLOR.

NO CLAIM IS MADE TO THE EXCLUSIVE RIGHT TO USE "DIET", APART FROM THE MARK AS SHOWN.  
SEC. 2(F).

---

SN 85-049,353. JOHNSON & JOHNSON, NEW BRUNSWICK, NJ. FILED 5-27-2010.

**CLASS 5—PHARMACEUTICALS**

FOR DIETARY SUPPLEMENTS (U.S. CLS. 6, 18, 44, 46, 51 AND 52).  
FIRST USE 1-1-1981; IN COMMERCE 1-1-1981.

**BECAUSE YOU CARE BEYOND  
THE CHAIR**

THE MARK CONSISTS OF STANDARD CHARACTERS WITHOUT CLAIM TO ANY PARTICULAR FONT, STYLE, SIZE, OR COLOR.

**CLASS 44—MEDICAL, BEAUTY AND AGRICULTURAL SERVICES**

FOR MEDICAL CENTERS, NAMELY, DIET AND WEIGHT CONTROL CENTER FOR PROVIDING WEIGHT REDUCTION DIET PLANNING AND SUPERVISION; MEDICAL SERVICES, NAMELY, REGENERATIVE MEDICINE SERVICES (U.S. CLS. 100 AND 101).  
FIRST USE 1-1-1981; IN COMMERCE 1-1-1981.

TRACY CROSS, EXAMINING ATTORNEY

SN 85-049,982. CORVIS ENERGY S.L., GETAFE ( MADRID ), SPAIN, FILED 5-28-2010.



NO CLAIM IS MADE TO THE EXCLUSIVE RIGHT TO USE "ENERGY SAVING", APART FROM THE MARK AS SHOWN.

THE COLOR(S) RED, BLUE AND WHITE IS/ARE CLAIMED AS A FEATURE OF THE MARK.

THE MARK CONSISTS OF A CIRCLE WITH A RED SQUARE WITH WHITE SHEET, UNDER THE BLUE WORDS "NITIDE". UNDER THE WHITE WORDS ENERGY SAVING.

#### CLASS 9—ELECTRICAL AND SCIENTIFIC APPARATUS

FOR ELECTRIC CONDUCTORS, ELECTRIC ACCUMULATORS, ELECTRIC CONTROLLERS, ELECTRIC TRANSFORMERS, VOLTAGE REGULATORS FOR ELECTRIC POWER, COMPUTERS (U.S. CLS. 21, 23, 26, 36 AND 38).

#### CLASS 35—ADVERTISING AND BUSINESS

FOR PUBLICITY, ADVERTISING AND BUSINESS MANAGEMENT (U.S. CLS. 100, 101 AND 102).

#### CLASS 37—CONSTRUCTION AND REPAIR

FOR ELECTRIC APPLIANCE INSTALLATION AND REPAIR (U.S. CLS. 100, 103 AND 106).  
PAM WILLIS, EXAMINING ATTORNEY

SN 85-050,147. LORD WILLY'S LLC, NEW YORK, NY. FILED 5-28-2010.



OWNER OF U.S. REG. NO. 3,522,680.

THE MARK CONSISTS OF A SILHOUETTE OF A MAN HOLDING AN UMBRELLA WEARING A FORMAL JACKET, BOXER SHORTS, AND SHOES.

#### CLASS 3—COSMETICS AND CLEANING PREPARATIONS

FOR NON-MEDICATED TOILETRIES; HAND SOAP, BATH SOAP; AFTER-SHAVE LOTIONS; HAIR CARE LOTIONS; SHAVING CREAM; PERFUMES, AFTER-SHAVES AND COLOGNES (U.S. CLS. 1, 4, 6, 50, 51 AND 52).

#### CLASS 9—ELECTRICAL AND SCIENTIFIC APPARATUS

FOR EYEWEAR, EYEWEAR CASES, SUNGLASSES (U.S. CLS. 21, 23, 26, 36 AND 38).

#### CLASS 14—JEWELRY

FOR JEWELRY, WATCHES, CUFF-LINKS, TIE CLIPS AND TIE BARS (U.S. CLS. 2, 27, 28 AND 50).

#### CLASS 18—LEATHER GOODS

FOR LUGGAGE, TRUNKS, TRAVEL BAGS, UMBRELLAS, SUIT CARRIERS, WALLETS, LEATHER SHOULDER BELTS, BRIEFCASES, ATTACHE CASES, ATHLETIC BAGS, TOILETRY BAGS SOLD EMPTY, GARMENT BAGS FOR TRAVEL, MESSENGER BAGS, SUITCASES; LEATHER AND IMITATION LEATHER BAGS (U.S. CLS. 1, 2, 3, 22 AND 41).

#### CLASS 24—FABRICS

FOR HAND TOWELS, BATH TOWELS, KITCHEN TOWELS, DRAPERY, CURTAINS, BED LINENS, BED SHEETS, COMFORTERS, DUVETS, DINING LINENS, TEXTILE TABLECLOTHS, TEXTILE NAPKINS; CUSTOM TEXTILE FABRICS FOR USE IN MAKING CLOTHING AND HOUSEHOLD FURNISHINGS (U.S. CLS. 42 AND 50).

#### CLASS 26—FANCY GOODS

FOR BELT BUCKLES, COLLAR STAYS, BUTTONS, ORNAMENTAL NOVELTY BADGES (U.S. CLS. 37, 39, 40, 42 AND 50).  
ALEXANDER L. POWERS, EXAMINING ATTORNEY

SN 85-050,351. TATA SONS LIMITED, MUMBAI, INDIA, FILED 5-28-2010.

## TATA WATER PLUS

THE MARK CONSISTS OF STANDARD CHARACTERS WITHOUT CLAIM TO ANY PARTICULAR FONT, STYLE, SIZE, OR COLOR.

OWNER OF U.S. REG. NO. 789,432.

NO CLAIM IS MADE TO THE EXCLUSIVE RIGHT TO USE "WATER", APART FROM THE MARK AS SHOWN.

#### CLASS 16—PAPER GOODS AND PRINTED MATTER

FOR ADVERTISEMENT AND PROMOTIONAL PAMPHLETS (U.S. CLS. 2, 5, 22, 23, 29, 37, 38 AND 50).

**CLASS 32—LIGHT BEVERAGES**

FOR MINERAL WATER, AERATED WATER, FRUIT DRINKS AND NON ALCOHOLIC WATER BEVERAGES (U.S. CLS. 45, 46 AND 48).

GRETTA YAO, EXAMINING ATTORNEY

---

SN 85-050,475. NEXT ADVENTURE, INC., BERKELEY, CA.  
FILED 5-28-2010.

**NEXT ADVENTURE**

THE MARK CONSISTS OF STANDARD CHARACTERS WITHOUT CLAIM TO ANY PARTICULAR FONT, STYLE, SIZE, OR COLOR.

NO CLAIM IS MADE TO THE EXCLUSIVE RIGHT TO USE "ADVENTURE", APART FROM THE MARK AS SHOWN.

**CLASS 39—TRANSPORTATION AND STORAGE**

FOR TRAVEL AGENCY SERVICES, NAMELY, MAKING RESERVATIONS AND BOOKINGS FOR TRANSPORTATION (U.S. CLS. 100 AND 105).

FIRST USE 7-1-1996; IN COMMERCE 7-1-1996.

**CLASS 43—HOTEL AND RESTAURANT SERVICES**

FOR TRAVEL AGENCY SERVICES, NAMELY, MAKING RESERVATIONS AND BOOKINGS FOR TEMPORARY LODGING (U.S. CLS. 100 AND 101).

FIRST USE 7-1-1996; IN COMMERCE 7-1-1996.

HOWARD B. LEVINE, EXAMINING ATTORNEY

---

SN 85-050,603. PAUL D. GERBER, MILL VALLEY, CA.  
FILED 5-28-2010.

**VIRTUAL PLANET**

THE MARK CONSISTS OF STANDARD CHARACTERS WITHOUT CLAIM TO ANY PARTICULAR FONT, STYLE, SIZE, OR COLOR.

NO CLAIM IS MADE TO THE EXCLUSIVE RIGHT TO USE "VIRTUAL", APART FROM THE MARK AS SHOWN.

**CLASS 9—ELECTRICAL AND SCIENTIFIC APPARATUS**

FOR AUDIO AND VIDEO RECORDINGS FEATURING A BROAD SPECTRUM OF INFORMATION AND KNOWLEDGE ABOUT NATIONS, STATES, PROVINCES AND/OR CITIES WORLDWIDE; MOTION PICTURE FILMS ABOUT NATIONS, STATES, PROVINCES AND/OR CITIES WORLDWIDE AND PRE-RECORDED COMPACT DISCS, LASER DISCS, CD ROMS, DVDS, DVD ROMS, VIDEOTAPES, CASSETTES, AND OTHER PRE-RECORDED OPTICAL, ELECTRONIC AND MAGNETIC MEDIA FEATURING PUBLIC RELATIONS CONTENT FOR NATIONS, STATES, PROVINCES AND/OR CITIES WORLDWIDE INCLUDING INFORMATION FOR THE PROMOTION OF TRAVEL, AND THE GOODS AND SERVICES OF OTHERS IN THOSE NATIONS, STATES, PROVINCES, REGIONS AND/OR CITIES WORLDWIDE (U.S. CLS. 21, 23, 26, 36 AND 38).

**CLASS 35—ADVERTISING AND BUSINESS**

FOR PUBLIC RELATIONS; PROMOTING THE GOODS AND SERVICES OF OTHERS IN THE FIELD OF TRAVEL AND PROMOTING THE GOODS AND SERVICES OF OTHERS, ALL VIA A WEBSITE ON A GLOBAL COMPUTER NETWORK AND THROUGH THE DISTRIBUTION OF PRE-RECORDED MEDIA, MOTION PICTURE FILMS, AND PRE-RECORDED COMPACT DISCS, LASER DISCS, CD ROMS, DVDS, DVD ROMS, VIDEOTAPES, AND CASSETTES, AUDIO AND VIDEO RECORDINGS, AND OTHER OPTICAL, MAGNETIC AND ELECTRONIC PLAYBACK MEDIA FEATURING PUBLIC RELATIONS CONTENT PROMOTING THE GOODS AND SERVICES OF OTHERS, THE PROMOTION OF TRAVEL, AND THE GOODS AND SERVICES OF OTHERS IN NATIONS, STATES, PROVINCES AND/OR CITIES WORLDWIDE; PROMOTING THE GOODS AND SERVICES OF OTHERS THROUGH THE DISTRIBUTION OF AUDIO AND VIDEO RECORDINGS OVER A GLOBAL COMPUTER NETWORK FEATURING PUBLIC RELATIONS CONTENT, THE PROMOTION OF TRAVEL, AND THE GOODS AND SERVICES OF OTHERS IN NATIONS, STATES, PROVINCES AND/OR CITIES WORLDWIDE; ADVERTISING SERVICES, NAMELY, PROVIDING AUDIO AND VIDEO RECORDINGS OVER A GLOBAL COMPUTER NETWORK, AND OTHER OPTICAL, MAGNETIC AND ELECTRONIC PLAYBACK MEDIA, ALL FEATURING PUBLIC RELATIONS CONTENT PROMOTING THE GOODS AND SERVICES OF OTHERS, THE PROMOTION OF TRAVEL, AND THE GOODS AND SERVICES OF OTHERS IN NATIONS, STATES, PROVINCES AND/OR CITIES WORLDWIDE (U.S. CLS. 100, 101 AND 102).

**CLASS 41—EDUCATION AND ENTERTAINMENT**

FOR PRODUCTION AND DISTRIBUTION OF MOTION PICTURE FILMS; PRODUCTION OF MOTION PICTURE FILMS, PRODUCTION OF AUDIO AND VIDEO RECORDINGS, PRODUCTION OF COMPACT DISCS, LASER DISCS, CD ROMS, DVDS, DVD ROMS AND VIDEOTAPE CASSETTES FEATURING A BROAD SPECTRUM OF INFORMATION AND KNOWLEDGE ABOUT NATIONS, STATES, PROVINCES AND/OR CITIES WORLDWIDE (U.S. CLS. 100, 101 AND 107).

ANDREA K. NADELMAN, EXAMINING ATTORNEY

---

SN 85-050,636. CIW ENTERPRISES, MOUNTAINTOP, PA.  
FILED 5-28-2010.

**Cycle-Master**

THE MARK CONSISTS OF STANDARD CHARACTERS WITHOUT CLAIM TO ANY PARTICULAR FONT, STYLE, SIZE, OR COLOR.

**CLASS 6—METAL GOODS**

FOR METAL FIRE DOORS AND METAL FIRE GRILLE CURTAINS BEING PART OF METAL DOORS; METAL SECURITY DOORS AND METAL SECURITY GRILLE CURTAINS BEING PART OF METAL DOORS (U.S. CLS. 2, 12, 13, 14, 23, 25 AND 50).

FIRST USE 6-1-2010; IN COMMERCE 6-1-2010.

**CLASS 19—NON-METALLIC BUILDING MATERIALS**

FOR NON-METAL ROLLING DOORS MADE OF RUBBER; RUBBER DOOR PANELS USED IN ROLLING DOORS (U.S. CLS. 1, 12, 33 AND 50).

FIRST USE 6-1-2010; IN COMMERCE 6-1-2010.

KRISTINA MORRIS, EXAMINING ATTORNEY

**CLASS 35—ADVERTISING AND BUSINESS**

FOR ADVERTISING AND INFORMATION DISTRIBUTION SERVICES, NAMELY, PROVIDING ADVERTISING SPACE VIA A GLOBAL COMPUTER NETWORK; ADVERTISING AND MARKETING SERVICES, NAMELY, PROMOTING THE GOODS AND SERVICES OF OTHERS; ELECTRONIC COMMERCE SERVICES, NAMELY, PROVIDING INFORMATION ABOUT PRODUCTS VIA TELECOMMUNICATION NETWORKS FOR ADVERTISING AND SALES PURPOSES; PROMOTING THE PARTIES AND SPECIAL EVENTS OF OTHERS; SPECIAL EVENT PLANNING FOR BUSINESS PURPOSES (U.S. CLS. 100, 101 AND 102).

SN 85-050,710. HDR ENGINEERING, INC., OMAHA, NE. FILED 5-28-2010.

**ENERGY UNDERSTOOD**

THE MARK CONSISTS OF STANDARD CHARACTERS WITHOUT CLAIM TO ANY PARTICULAR FONT, STYLE, SIZE, OR COLOR.

NO CLAIM IS MADE TO THE EXCLUSIVE RIGHT TO USE "ENERGY", APART FROM THE MARK AS SHOWN.

**CLASS 40—MATERIAL TREATMENT**

FOR CONSULTING SERVICES IN THE FIELD OF POWER GENERATION (U.S. CLS. 100, 103 AND 106).

FIRST USE 4-1-2010; IN COMMERCE 4-1-2010.

**CLASS 42—SCIENTIFIC AND COMPUTER SERVICES**

FOR ENGINEERING SERVICES IN THE FIELD OF POWER GENERATION, POWER DELIVERY AND RENEWABLE ENERGY; TECHNOLOGICAL CONSULTING SERVICES IN THE FIELD OF ENERGY GENERATION; CONSULTING SERVICES IN THE FIELD OF THE DEVELOPMENT OF RENEWABLE ENERGY RESOURCES (U.S. CLS. 100 AND 101).

FIRST USE 4-1-2010; IN COMMERCE 4-1-2010.

CHRISTINE MARTIN, EXAMINING ATTORNEY

SN 85-050,872. SMILEY, BRODERICK, DBA RICKEY SMILEY, DALLAS, TX. FILED 5-29-2010.

**RICKEY SMILEY IN THE MORNINGS**

THE MARK CONSISTS OF STANDARD CHARACTERS WITHOUT CLAIM TO ANY PARTICULAR FONT, STYLE, SIZE, OR COLOR.

NO CLAIM IS MADE TO THE EXCLUSIVE RIGHT TO USE "IN THE MORNINGS", APART FROM THE MARK AS SHOWN.

THE NAME(S), PORTRAIT(S), AND/OR SIGNATURE(S) SHOWN IN THE MARK IDENTIFIES "RICKEY SMILEY", WHOSE CONSENT(S) TO REGISTER IS MADE OF RECORD.

**CLASS 41—EDUCATION AND ENTERTAINMENT**

FOR ENTERTAINMENT SERVICES IN THE NATURE OF LIVE MUSICAL PERFORMANCES; ENTERTAINMENT SERVICES, NAMELY, PROVIDING A RADIO PROGRAM IN THE FIELD OF RELATIONSHIPS, BUSINESS, HEALTH, BOOKS, MUSIC, AND POLITICS VIA A GLOBAL COMPUTER NETWORK; ENTERTAINMENT SERVICES, NAMELY, PROVIDING A TELEVISION PROGRAM IN THE FIELD OF RELATIONSHIPS, BUSINESS, HEALTH, BOOKS, MUSIC, AND POLITICS VIA A GLOBAL COMPUTER NETWORK; ENTERTAINMENT SERVICES, NAMELY, PUBLISHING ONLINE REVIEWS ON THE SUBJECTS OF BOOKS, MUSIC, TV, FILM, MOVIES, SHOW TOPICS, RELATIONSHIPS, BUSINESS, HEALTH, POLITICS, COMPUTER GAMES; ONLINE JOURNALS, NAMELY, BLOGS FEATURING DISCUSSIONS OF BOOKS, MUSIC, BUSINESS, RELATIONSHIPS, HEALTH, RADIO SHOW TOPICS, FAN CLUB, EVENTS, POEMS, INTERVIEWS, AND POLITICS; PRODUCTION OF TELEVISION PROGRAMS; PROVIDING A WEB SITE WHERE USERS CAN POST RATINGS, REVIEWS AND RECOMMENDATIONS ON EVENTS AND ACTIVITIES IN THE FIELD OF ENTERTAINMENT AND EDUCATION; TICKET RESERVATION AND BOOKING SERVICES FOR ENTERTAINMENT, SPORTING AND CULTURAL EVENTS; ENTERTAINMENT SERVICES, NAMELY, PROVIDING PODCASTS IN THE FIELD OF NEWS, MUSIC, RELATIONSHIPS, INTERVIEWS, POLITICS, SOCIAL COMMENTARY, AND POP CULTURE; ENTERTAINMENT SERVICES, NAMELY, PERSONAL APPEARANCES BY A NATIONALLY SYNDICATED RADIO PERSONALITY, COMEDIAN, AND ACTOR; ENTERTAINMENT SERVICES, NAMELY, PROVIDING A RADIO PROGRAM IN THE FIELD OF RELATIONSHIPS, BUSINESS, HEALTH, BOOKS, MUSIC, NEWS, SOCIAL COMMENTARY, AND POLITICS; PRODUCTION OF RADIO PROGRAMS; PROVIDING INFORMATION, NEWS AND COMMENTARY IN THE FIELD OF ENTERTAINMENT, AND LIFE; RADIO ENTERTAINMENT SERVICES, NAMELY, RADIO PROGRAMS FEATURING PERFORMANCES BY A NATIONALLY SYNDICATED RADIO PERSONALITY, COMEDIAN, AND ACTOR; SPECIAL EVENT PLANNING FOR SOCIAL AND ENTERTAINMENT PURPOSES; RADIO ENTERTAINMENT SERVICES, NAMELY, RADIO PROGRAMS FEATURING PERFORMANCES BY A RADIO PERSONALITY; ENTERTAINMENT SERVICES, NAMELY, PROVIDING A WEBSITE FOR THE GENERAL PUBLIC TO FOLLOW THE ENDEAVORS AND COMMENTARY OF RADIO PERSONALITY RICKEY SMILEY (U.S. CLS. 100, 101 AND 107).

JEFFREY LOOK, EXAMINING ATTORNEY

SN 85-050,964. INNOVENTUM, INC., FISHERS, IN. FILED 5-29-2010.

## Copyright In A Box

THE MARK CONSISTS OF STANDARD CHARACTERS WITHOUT CLAIM TO ANY PARTICULAR FONT, STYLE, SIZE, OR COLOR.

NO CLAIM IS MADE TO THE EXCLUSIVE RIGHT TO USE "COPYRIGHT", APART FROM THE MARK AS SHOWN.

### CLASS 9—ELECTRICAL AND SCIENTIFIC APPARATUS

FOR DOWNLOADABLE MULTIMEDIA FILE CONTAINING ARTWORK, TEXT, AUDIO, VIDEO, GAMES, AND INTERNET WEB LINKS RELATING TO LAW, BUSINESS, AND TECHNOLOGY; DOWNLOADABLE VIDEO RECORDINGS FEATURING LAW, BUSINESS, AND TECHNOLOGY INSTRUCTION; ELECTRONIC PUBLICATIONS, NAMELY, BOOKS, ARTICLES, AND HANDOUTS FEATURING LAW, BUSINESS, AND TECHNOLOGY INSTRUCTION RECORDED ON COMPUTER MEDIA; VIDEO DISCS FEATURING LAW, BUSINESS, AND TECHNOLOGY INSTRUCTION (U.S. CLS. 21, 23, 26, 36 AND 38).

### CLASS 35—ADVERTISING AND BUSINESS

FOR BUSINESS ADVISORY SERVICES, CONSULTANCY AND INFORMATION; PROVIDING A WEB SITE FEATURING BUSINESS INFORMATION IN THE FORM OF AUDIO AND VIDEO INTERVIEWS, TRANSCRIPTS AND OTHER EDUCATIONAL MATERIALS (U.S. CLS. 100, 101 AND 102).

### CLASS 45—PERSONAL AND LEGAL SERVICES

FOR PROVIDING AN ON-LINE INTERACTIVE DATABASE FEATURING LEGAL INFORMATION (U.S. CLS. 100 AND 101).

RENEE SERVANCE, EXAMINING ATTORNEY

SN 85-050,972. KARADJIAN ZARMINAH CAROLINE, REDDA, CA. FILED 5-29-2010.

## Breakup Bootcamp

THE MARK CONSISTS OF STANDARD CHARACTERS WITHOUT CLAIM TO ANY PARTICULAR FONT, STYLE, SIZE, OR COLOR.

NO CLAIM IS MADE TO THE EXCLUSIVE RIGHT TO USE "BOOTCAMP", APART FROM THE MARK AS SHOWN.

### CLASS 41—EDUCATION AND ENTERTAINMENT

FOR EDUCATIONAL SERVICES, NAMELY, PROVIDING PHYSICAL FITNESS TRAINING PROGRAMS IN A FULLY EQUIPPED EXERCISE FACILITY (U.S. CLS. 100, 101 AND 107).

### CLASS 45—PERSONAL AND LEGAL SERVICES

FOR POST-RELATIONSHIP COUNSELING FEATURING INTENSE FITNESS TRAINING TO RE-EMPOWER THE INDIVIDUAL AND GUIDE HIM OR HER AWAY FROM POSSIBLE SELF-DESTRUCTIVE BEHAVIORS (U.S. CLS. 100 AND 101).

JILL C. ALT, EXAMINING ATTORNEY

SN 85-051,048. ABDULLAEVA INTERNATIONAL TRADE COMPANY, DBA SLEEP & BEYOND, RANCHO CUCAMONGA, CA. FILED 5-30-2010.

## It's Merino Magic!

THE MARK CONSISTS OF STANDARD CHARACTERS WITHOUT CLAIM TO ANY PARTICULAR FONT, STYLE, SIZE, OR COLOR.

NO CLAIM IS MADE TO THE EXCLUSIVE RIGHT TO USE "MERINO", APART FROM THE MARK AS SHOWN.

### CLASS 20—FURNITURE AND ARTICLES NOT OTHERWISE CLASSIFIED

FOR BED PRODUCTS MADE IN WHOLE OR IN PART OF MERINO WOOL, NAMELY, BED PILLOWS, MATTRESSES, PILLOWS AND BOLSTERS, MATTRESS TOPPERS (U.S. CLS. 2, 13, 22, 25, 32 AND 50).

FIRST USE 1-1-2010; IN COMMERCE 1-1-2010.

### CLASS 24—FABRICS

FOR BEDDING MADE IN WHOLE OR IN PART OF MERINO WOOL, NAMELY, BED BLANKETS AND COMFORTERS (U.S. CLS. 42 AND 50).

FIRST USE 1-1-2010; IN COMMERCE 1-1-2010.

ANGELA M. MICHELI, EXAMINING ATTORNEY

SN 85-051,337. ARTIFICIAL LIFE ASIA LIMITED, HONG KONG, HONG KONG, FILED 6-1-2010.

## Green Cortex, Inc

THE MARK CONSISTS OF STANDARD CHARACTERS WITHOUT CLAIM TO ANY PARTICULAR FONT, STYLE, SIZE, OR COLOR.

NO CLAIM IS MADE TO THE EXCLUSIVE RIGHT TO USE "GREEN" AND "INC", APART FROM THE MARK AS SHOWN.



**CLASS 9—ELECTRICAL AND SCIENTIFIC APPARATUS**

FOR COMPUTER SOFTWARE FOR SYSTEM MANAGEMENT IN THE FIELDS OF CLIMATE CHANGE, GLOBAL WARMING AND ASSOCIATED RELATED FIELDS INCLUDING GREEN BUILDING, PLANNING, RENEWABLE ENERGY, SUSTAINABLE COMMUNITIES, CONSERVATION, AND OTHER HUMAN ACTIVITIES AFFECTING CARBON USE AND ITS IMPACTS ON THE WORLD AND THE ENVIRONMENT (U.S. CLS. 21, 23, 26, 36 AND 38).

FIRST USE 6-1-2010; IN COMMERCE 6-1-2010.

**CLASS 38—COMMUNICATION**

FOR MOBILE TELEPHONE SERVICES (U.S. CLS. 100, 101 AND 104).

FIRST USE 6-1-2010; IN COMMERCE 6-1-2010.

**CLASS 42—SCIENTIFIC AND COMPUTER SERVICES**

FOR APPLICATION SERVICE PROVIDER, NAMELY, PROVIDING, HOSTING, MANAGING, DEVELOPING, AND MAINTAINING APPLICATIONS, SOFTWARE, WEB SITES, AND DATABASES IN THE FIELDS OF PERSONAL PRODUCTIVITY, WIRELESS COMMUNICATION, MOBILE INFORMATION ACCESS, AND REMOTE DATA MANAGEMENT FOR WIRELESS DELIVERY OF CONTENT TO HANDHELD COMPUTERS, LAPTOPS AND MOBILE ELECTRONIC DEVICES (U.S. CLS. 100 AND 101).

FIRST USE 6-1-2010; IN COMMERCE 6-1-2010.  
CAROLINE WOOD, EXAMINING ATTORNEY

SN 85-051,978. JPMORGAN CHASE & CO., NEW YORK, NY.  
FILED 6-1-2010.

**STAYING POWER**

THE MARK CONSISTS OF STANDARD CHARACTERS WITHOUT CLAIM TO ANY PARTICULAR FONT, STYLE, SIZE, OR COLOR.

**CLASS 35—ADVERTISING AND BUSINESS**

FOR PROMOTING THE SALE OF GOODS AND SERVICES OF OTHERS BY AWARDING PURCHASE POINTS FOR CREDIT CARD USE (U.S. CLS. 100, 101 AND 102).

FIRST USE 7-1-2009; IN COMMERCE 7-1-2009.

**CLASS 36—INSURANCE AND FINANCIAL**

FOR PROVIDING CASH AND OTHER REBATES FOR CREDIT CARD USE AS PART OF A CUSTOMER LOYALTY PROGRAM (U.S. CLS. 100, 101 AND 102).

FIRST USE 7-1-2009; IN COMMERCE 7-1-2009.

SALLY SHIH, EXAMINING ATTORNEY

SN 85-051,836. RUE21, INC., WARRENDALE, PA. FILED 6-1-2010.

SN 85-052,079. DIRECT SUPPLY, INC., MILWAUKEE, WI.  
FILED 6-1-2010.

**TWENTYONE BLACK**

THE MARK CONSISTS OF STANDARD CHARACTERS WITHOUT CLAIM TO ANY PARTICULAR FONT, STYLE, SIZE, OR COLOR.

NO CLAIM IS MADE TO THE EXCLUSIVE RIGHT TO USE "BLACK", APART FROM THE MARK AS SHOWN.

**CLASS 9—ELECTRICAL AND SCIENTIFIC APPARATUS**

FOR SUNGLASSES (U.S. CLS. 21, 23, 26, 36 AND 38).

**CLASS 14—JEWELRY**

FOR ACCESSORIES, NAMELY, JEWELRY (U.S. CLS. 2, 27, 28 AND 50).

**CLASS 25—CLOTHING**

FOR CLOTHING AND ACCESSORIES, NAMELY, T-SHIRTS, DENIM JEANS, SHORTS, SKIRTS, DRESSES, BELTS, HATS; ACTIVEWEAR, NAMELY, T-SHIRTS AND SHORTS; OUTERWEAR, NAMELY, COATS AND JACKETS (U.S. CLS. 22 AND 39).

REBECCA EISINGER, EXAMINING ATTORNEY

**APTURA TRANSFORMATIONS**

THE MARK CONSISTS OF STANDARD CHARACTERS WITHOUT CLAIM TO ANY PARTICULAR FONT, STYLE, SIZE, OR COLOR.

NO CLAIM IS MADE TO THE EXCLUSIVE RIGHT TO USE "TRANSFORMATIONS", APART FROM THE MARK AS SHOWN.

**CLASS 35—ADVERTISING AND BUSINESS**

FOR BUSINESS CONSULTING SERVICES, NAMELY, ASSISTING OTHERS IN ANALYZING AND IMPLEMENTING BUSINESS IMPROVEMENT PROJECTS (U.S. CLS. 100, 101 AND 102).

FIRST USE 4-26-2010; IN COMMERCE 4-26-2010.

**CLASS 41—EDUCATION AND ENTERTAINMENT**

FOR DEVELOPING EDUCATIONAL MANUALS FOR OTHERS IN THE FIELD OF TRAINING, CORPORATE STANDARDS AND BEST PRACTICES; EDUCATIONAL SERVICES, NAMELY, PROVIDING INDIVIDUAL AND CLASS INSTRUCTION IN THE FIELD OF BUSINESS IMPROVEMENT; TRAINING SERVICES IN THE FIELD OF BUSINESS IMPROVEMENT (U.S. CLS. 100, 101 AND 107).

FIRST USE 4-26-2010; IN COMMERCE 4-26-2010.

LOURDES AYALA, EXAMINING ATTORNEY

SN 85-052,127. RUE21, INC., WARRENDALE, PA. FILED 6-1-2010.

## CARBON ELEMENTS

THE MARK CONSISTS OF STANDARD CHARACTERS WITHOUT CLAIM TO ANY PARTICULAR FONT, STYLE, SIZE, OR COLOR.

OWNER OF U.S. REG. NOS. 3,332,888, 3,437,484 AND 3,636,753.

### CLASS 3—COSMETICS AND CLEANING PREPARATIONS

FOR FRAGRANCE FOR PERSONAL USE; COLOGNE, BODY AND BATH PRODUCTS, NAMELY, SOAPS, BODY LOTIONS, BATH LOTIONS, BODY SPRAY AND BODY SPLASH; GIFT SETS SOLD AS A UNIT COMPRISING SOME OR ALL OF THE AFOREMENTIONED GOODS, NAMELY, FRAGRANCE FOR PERSONAL USE, COLOGNE, SOAPS, BODY LOTIONS, BATH LOTIONS, BODY SPRAY AND BODY SPLASH (U.S. CLS. 1, 4, 6, 50, 51 AND 52).

### CLASS 9—ELECTRICAL AND SCIENTIFIC APPARATUS

FOR SUNGLASSES (U.S. CLS. 21, 23, 26, 36 AND 38).

### CLASS 14—JEWELRY

FOR JEWELRY, WATCHES (U.S. CLS. 2, 27, 28 AND 50).

### CLASS 25—CLOTHING

FOR CLOTHING AND ACCESSORIES, NAMELY, BELTS, HATS, GLOVES, SCARVES, SOCKS, UNDERWEAR, FOOTWEAR, COATS, VESTS (U.S. CLS. 22 AND 39).

REBECCA EISINGER, EXAMINING ATTORNEY

SN 85-052,171. ORTECH INDUSTRIES INC., SURREY, CANADA, FILED 6-1-2010.

## ORTECH

THE MARK CONSISTS OF STANDARD CHARACTERS WITHOUT CLAIM TO ANY PARTICULAR FONT, STYLE, SIZE, OR COLOR.

PRIORITY CLAIMED UNDER SEC. 44(D) ON CANADA APPLICATION NO. 1,461,764, FILED 1-7-2010.

### CLASS 9—ELECTRICAL AND SCIENTIFIC APPARATUS

FOR DECORATIVE SWITCH PLATE COVERS; ELECTRIC JUNCTION BOXES; ELECTRIC LIGHT DIMMERS; ELECTRIC SWITCH PLATES; ELECTRICAL CONNECTOR HOUSINGS; ELECTRICAL CONNECTORS; ELECTRICAL OUTLETS; ELECTRICAL LIGHT SWITCHES; GROUND-FAULT ELECTRIC SWITCHES; ELECTRICAL LIGHTING RECEPTACLES; SCREW-ON ELECTRICAL WIRE CONNECTORS; JUNCTION BOX COVERS; ELECTRIC SWITCH PLATES; ELECTRICAL OUTLET PLATES (U.S. CLS. 21, 23, 26, 36 AND 38).

### CLASS 11—ENVIRONMENTAL CONTROL APPARATUS

FOR FAUCETS; LIGHT BULBS; LIGHTING FIXTURES; SINKS; TOILET BOWLS; TOILET SEATS; TOILETS; VENTILATING EXHAUST FANS; PLUMBING FIXTURES, NAMELY, SINK TRAPS, SINK SPRAYERS, SHOWER SPRAYERS AND SHOWER MIXERS; LAMP REFLECTORS (U.S. CLS. 13, 21, 23, 31 AND 34).

SAMUEL E. SHARPER JR., EXAMINING ATTORNEY

SN 85-052,174. BIOGAIA AB, STOCKHOLM, SWEDEN, FILED 6-1-2010.

## LIFETOP

THE MARK CONSISTS OF STANDARD CHARACTERS WITHOUT CLAIM TO ANY PARTICULAR FONT, STYLE, SIZE, OR COLOR.

OWNER OF ERPN CMNTY TM OFC REG. NO. 008195919, DATED 5-12-2010, EXPIRES 4-2-2019.

### CLASS 16—PAPER GOODS AND PRINTED MATTER

FOR PLASTIC MATERIALS FOR PACKAGING IN THE FORM OF FOILS, NAMELY, PLASTIC FOILS; PLASTIC MATERIALS FOR PACKAGING IN THE FORM OF BAGS, NAMELY, PLASTIC BAGS FOR PACKAGING (U.S. CLS. 2, 5, 22, 23, 29, 37, 38 AND 50).

### CLASS 20—FURNITURE AND ARTICLES NOT OTHERWISE CLASSIFIED

FOR CLOSURES OF PLASTIC FOR CONTAINERS; DRINKING STRAWS; PACKAGING MATERIAL OF PLASTICS, NAMELY, PLASTIC SHIPPING AND STORAGE BOXES, RIGID PLASTIC TRAYS, COMMERCIAL PLASTIC BINS, PLASTIC BOXES AND PLASTIC TRAYS (U.S. CLS. 2, 13, 22, 25, 32 AND 50).

### CLASS 21—HOUSEWARES AND GLASS

FOR CONTAINERS FOR HOUSEHOLD PURPOSES, NOT OF PRECIOUS METAL (U.S. CLS. 2, 13, 23, 29, 30, 33, 40 AND 50).

SAMUEL E. SHARPER JR., EXAMINING ATTORNEY

SN 85-052,565. STEELE, LORI JEAN, MANHATTAN BEACH, CA. AND KABABIE, ALBERTO, MANHATTAN BEACH, CA. FILED 6-2-2010.

SN 85-052,771. BIG CANOE CO., LLC, BIG CANOE, GA. FILED 6-2-2010.

## BACKNBLOOM

THE MARK CONSISTS OF STANDARD CHARACTERS WITHOUT CLAIM TO ANY PARTICULAR FONT, STYLE, SIZE, OR COLOR.

### CLASS 9—ELECTRICAL AND SCIENTIFIC APPARATUS

FOR AUDIO RECORDINGS FEATURING A SERIES OF PRE-RECORDED PHONOGRAPH RECORDS CONSISTING OF MUSICAL PERFORMANCES (U.S. CLS. 21, 23, 26, 36 AND 38).

### CLASS 41—EDUCATION AND ENTERTAINMENT

FOR ENTERTAINMENT SERVICES IN THE NATURE OF LIVE MUSICAL PERFORMANCES (U.S. CLS. 100, 101 AND 107).  
FIRST USE 4-23-2009; IN COMMERCE 4-23-2009.  
WILLIAM BRECKENFELD, EXAMINING ATTORNEY

SN 85-052,571. STATE OF IDAHO POTATO COMMISSION, EAGLE, ID. FILED 6-2-2010.

## SPUDDY BUDDY

THE MARK CONSISTS OF STANDARD CHARACTERS WITHOUT CLAIM TO ANY PARTICULAR FONT, STYLE, SIZE, OR COLOR.

### CLASS 16—PAPER GOODS AND PRINTED MATTER

FOR COLORING BOOKS (U.S. CLS. 2, 5, 22, 23, 29, 37, 38 AND 50).  
FIRST USE 0-0-1999; IN COMMERCE 0-0-1999.

### CLASS 28—TOYS AND SPORTING GOODS

FOR PLUSH TOYS (U.S. CLS. 22, 23, 38 AND 50).  
FIRST USE 0-0-1999; IN COMMERCE 0-0-1999.

### CLASS 35—ADVERTISING AND BUSINESS

FOR PROMOTING PUBLIC AWARENESS OF THE HIGH QUALITY AND NUTRITIONAL VALUE OF POTATOES GROWN IN IDAHO; ADVERTISING SERVICES, NAMELY, PROMOTING THE GOODS OF OTHERS THROUGH PUBLIC COMMUNICATION MEANS (U.S. CLS. 100, 101 AND 102).  
FIRST USE 0-0-1999; IN COMMERCE 0-0-1999.  
CHARISMA HAMPTON, EXAMINING ATTORNEY

## BIG CANOE ATLANTA'S PREMIER MOUNTAIN HOME

THE MARK CONSISTS OF STANDARD CHARACTERS WITHOUT CLAIM TO ANY PARTICULAR FONT, STYLE, SIZE, OR COLOR.

OWNER OF U.S. REG. NOS. 2,886,872, 3,223,127 AND 3,239,861.

NO CLAIM IS MADE TO THE EXCLUSIVE RIGHT TO USE "ATLANTA'S PREMIER MOUNTAIN HOME", APART FROM THE MARK AS SHOWN.  
SEC. 2(F) AS TO "BIG CANOE".

### CLASS 36—INSURANCE AND FINANCIAL

FOR REAL ESTATE BROKERAGE; REAL ESTATE MANAGEMENT SERVICES (U.S. CLS. 100, 101 AND 102).  
FIRST USE 5-0-2009; IN COMMERCE 5-0-2009.

### CLASS 37—CONSTRUCTION AND REPAIR

FOR REAL ESTATE DEVELOPMENT (U.S. CLS. 100, 103 AND 106).  
FIRST USE 5-0-2009; IN COMMERCE 5-0-2009.  
LINDA LAVACHE, EXAMINING ATTORNEY

SN 85-052,998. SEMICONDUCTOR ENERGY LABORATORY CO., LTD., KANAGAWA, JAPAN, FILED 6-2-2010.

## SEL

THE MARK CONSISTS OF STANDARD CHARACTERS WITHOUT CLAIM TO ANY PARTICULAR FONT, STYLE, SIZE, OR COLOR.

OWNER OF JAPAN REG. NO. 3272847, DATED 3-12-1997, EXPIRES 3-12-2017.

### CLASS 9—ELECTRICAL AND SCIENTIFIC APPARATUS

FOR SEMICONDUCTOR DEVICES (U.S. CLS. 21, 23, 26, 36 AND 38).

### CLASS 42—SCIENTIFIC AND COMPUTER SERVICES

FOR TECHNICAL CONSULTING AND RESEARCH IN THE FIELD OF SEMICONDUCTOR DEVICES (U.S. CLS. 100 AND 101).

### CLASS 45—PERSONAL AND LEGAL SERVICES

FOR LICENSING OF INTELLECTUAL PROPERTY IN THE FIELD OF SEMICONDUCTOR DEVICES (U.S. CLS. 100 AND 101).  
RUSS HERMAN, EXAMINING ATTORNEY

SN 85-053,187. S&R TECHNOLOGY HOLDINGS, LLC,  
BETHESDA, MD. FILED 6-2-2010.

SN 85-053,714. NIKE, INC., BEAVERTON, OR. FILED 6-3-2010.

## Terroir on Eighth Street

THE MARK CONSISTS OF STANDARD CHARACTERS WITHOUT CLAIM TO ANY PARTICULAR FONT, STYLE, SIZE, OR COLOR.

THE ENGLISH TRANSLATION OF "TERROIR" IN THE MARK IS SOIL.

### CLASS 41—EDUCATION AND ENTERTAINMENT

FOR ENTERTAINMENT SERVICES IN THE NATURE OF LIVE MUSICAL PERFORMANCES (U.S. CLS. 100, 101 AND 107).

### CLASS 43—HOTEL AND RESTAURANT SERVICES

FOR BAR AND RESTAURANT SERVICES (U.S. CLS. 100 AND 101).  
MARLENE BELL, EXAMINING ATTORNEY

SN 85-053,194. ABBOTT DIABETES CARE INC., ALAMEDA, CA. FILED 6-2-2010.



THE COLOR(S) BLACK, BLUE, WHITE, YELLOW, ORANGE AND SILVER IS/ARE CLAIMED AS A FEATURE OF THE MARK.

THE MARK CONSISTS OF A BUTTERFLY WITH A SILVER BODY, BLACK WINGS, YELLOW AND ORANGE OBLONG SHAPES ON THE WINGS WITH TWO ROWS OF WHITE SPOTS GOING AROUND THE OBLONG SHAPES AND WITH BLUE SHADING.

### CLASS 5—PHARMACEUTICALS

FOR MEDICAL DIAGNOSTIC TEST STRIPS FOR USE IN THE FIELD OF MONITORING BLOOD GLUCOSE LEVELS (U.S. CLS. 6, 18, 44, 46, 51 AND 52).

### CLASS 10—MEDICAL APPARATUS

FOR MEDICAL MACHINES AND APPARATUS, NAMELY, GLUCOSE METERS (U.S. CLS. 26, 39 AND 44).  
FONG HSU, EXAMINING ATTORNEY



THE COLOR(S) BLACK AND RED IS/ARE CLAIMED AS A FEATURE OF THE MARK.

THE MARK CONSISTS OF FROM LEFT TO RIGHT, STYLIZED NUMBERS TWO AND ZERO NEXT TO THE CAPITALIZED LETTERS "X" AND "I"; THE LETTERS "X" AND "I" ARE MORE BOLD THAN THE NUMBERS; THE ZERO HAS A RED DOT IN THE CENTER OF IT. THE NUMBERS AND LETTERS ARE SHOWN IN BLACK. THE BACKGROUND IS WHITE, AND THIS COLOR IS NOT PART OF THE MARK.

### CLASS 18—LEATHER GOODS

FOR BAGS, NAMELY, ALL-PURPOSE SPORTS BAGS, TOTE BAGS, DUFFLE BAGS, MESSENGER BAGS, BACKPACKS, PURSES, UMBRELLAS, LUGGAGE, COSMETIC AND TOILETRY CASES SOLD EMPTY (U.S. CLS. 1, 2, 3, 22 AND 41).

### CLASS 25—CLOTHING

FOR FOOTWEAR; APPAREL, NAMELY, PANTS, SHORTS, SHIRTS, T-SHIRTS, PULLOVERS, SWEAT SHIRTS, SWEAT PANTS, UNDERWEAR, SPORTS BRAS, DRESSES, SKIRTS, SWEATERS, JACKETS, SOCKS, SWEATBANDS, GLOVES, BELTS, HOSIERY, ARMBANDS, COATS, VESTS, HEADWEAR, NAMELY, HATS, CAPS; CLEATS FOR PLAYING FOOTBALL, BASEBALL, SOFTBALL, GOLF, CRICKET (U.S. CLS. 22 AND 39).

### CLASS 28—TOYS AND SPORTING GOODS

FOR SPORTS BALLS; BAGS FOR SPORTING EQUIPMENT, NAMELY, BALLS; BATS, NAMELY, BASEBALL, SOFTBALL, CRICKET; GLOVES USED IN BASEBALL, SOFTBALL, GOLF; GOLF CLUBS, GOLF BALLS, GOLF CLUB GRIPS, GOLF BAGS, GOLF TEES, HEAD COVERS FOR GOLF CLUBS, GOLF BALL MARKERS; PROTECTIVE PADDING FOR PLAYING BASEBALL, FOOTBALL, HOCKEY, SOFTBALL, CRICKET, BASKETBALL; HOCKEY STICKS, BASEBALL MITTS, SOFTBALL MITTS, PERSONAL EXERCISE MATS, SNOWBOARDS, SKATEBOARDS, STUMPS FOR PLAYING CRICKET (U.S. CLS. 22, 23, 38 AND 50).

### CLASS 35—ADVERTISING AND BUSINESS

FOR RETAIL STORE SERVICES IN THE FIELD OF APPAREL, HEADWEAR, FOOTWEAR, BAGS OF ALL KINDS, ACCESSORIES MADE OF LEATHER AND IMITATION LEATHER, UMBRELLAS, SPORTS EQUIPMENT, GOLF EQUIPMENT, AND ACCESSORIES FOR ALL THE AFORESAID GOODS; ADVERTISING AND MARKETING (U.S. CLS. 100, 101 AND 102).

SUSAN LESLIE DUBOIS, EXAMINING ATTORNEY

SN 85-054,058. KATE'S GOURMET SALSA, LLC, ASHLAND, MO. FILED 6-3-2010.

## KATE'S GOURMET SALSA

THE MARK CONSISTS OF STANDARD CHARACTERS WITHOUT CLAIM TO ANY PARTICULAR FONT, STYLE, SIZE, OR COLOR.

NO CLAIM IS MADE TO THE EXCLUSIVE RIGHT TO USE "GOURMET SALSA", APART FROM THE MARK AS SHOWN.

### CLASS 29—MEATS AND PROCESSED FOODS

FOR CONDIMENTS, NAMELY, JAMS AND JELLIES (U.S. CL. 46).

### CLASS 30—STAPLE FOODS

FOR CONDIMENTS, NAMELY, SALSAS (U.S. CL. 46).  
TINA MAI, EXAMINING ATTORNEY

SN 85-054,218. KILPATRICK STOCKTON LLP, ATLANTA, GA. FILED 6-3-2010.

## FOGBEETLE

THE MARK CONSISTS OF STANDARD CHARACTERS WITHOUT CLAIM TO ANY PARTICULAR FONT, STYLE, SIZE, OR COLOR.

### CLASS 9—ELECTRICAL AND SCIENTIFIC APPARATUS

FOR DOWNLOADABLE COMPUTER SOFTWARE FOR SEARCHING AND ACCESSING A DATABASE OF AGGREGATED INFORMATION IN THE FIELDS OF CONSTRUCTION AND RISK MANAGEMENT (U.S. CLS. 21, 23, 26, 36 AND 38).

### CLASS 35—ADVERTISING AND BUSINESS

FOR BUSINESS CONSULTING; BUSINESS RISK MANAGEMENT SERVICES; PROVIDING BUSINESS INFORMATION AND BUSINESS RISK MANAGEMENT INFORMATION ONLINE; PROVIDING A WEBSITE FEATURING INFORMATION IN THE FIELD OF BUSINESS INFORMATION AND BUSINESS RISK MANAGEMENT (U.S. CLS. 100, 101 AND 102).

### CLASS 37—CONSTRUCTION AND REPAIR

FOR CONSTRUCTION CONSULTING; PROVIDING CONSTRUCTION INFORMATION ONLINE; PROVIDING A WEBSITE FEATURING INFORMATION IN THE FIELD OF CONSTRUCTION (U.S. CLS. 100, 103 AND 106).

### CLASS 42—SCIENTIFIC AND COMPUTER SERVICES

FOR PROVIDING ONLINE NON-DOWNLOADABLE INTERNET BASED SOFTWARE FOR SEARCHING AND ACCESSING A DATABASE OF AGGREGATED INFORMATION IN THE FIELDS OF CONSTRUCTION AND RISK MANAGEMENT (U.S. CLS. 100 AND 101).

### CLASS 45—PERSONAL AND LEGAL SERVICES

FOR LEGAL SERVICES; PROVIDING LEGAL CONSULTATION AND INFORMATION IN THE AREA OF CONSTRUCTION; PROVIDING A WEBSITE FEATURING INFORMATION IN THE FIELD OF CONSTRUCTION LAW (U.S. CLS. 100 AND 101).

C. DIONNE CLYBURN, EXAMINING ATTORNEY

SN 85-054,238. SUPREME OIL COMPANY, INC., ENGLEWOOD, NJ. FILED 6-3-2010.

## BEVERLY HILLS

THE MARK CONSISTS OF STANDARD CHARACTERS WITHOUT CLAIM TO ANY PARTICULAR FONT, STYLE, SIZE, OR COLOR.

### CLASS 29—MEATS AND PROCESSED FOODS

FOR SALAD OILS, EDIBLE OILS, OLIVE OIL, MARGARINE, SHORTENING, SOUP MIXES, PICKLE PRODUCTS, NAMELY, SWEET MIX PICKLES, GIARDINIERA AND PEPPERONCINI, PROCESSED CHERRIES, PICKLED ONIONS, PROCESSED BEANS, PROCESSED OLIVES, PROCESSED VEGETABLES, MARINATED MUSHROOMS AND COLESLAW ALL SOLD TO THE INSTITUTIONAL TRADE (U.S. CL. 46).  
FIRST USE 12-31-1978; IN COMMERCE 12-31-1978.

### CLASS 30—STAPLE FOODS

FOR VINEGARS, SPICES, CAPERS, RICE, CONDIMENTS, NAMELY, MAYONNAISE, MUSTARDS, FOOD FLAVORINGS, RELISH, TARTAR SAUCE, AND SALAD DRESSINGS ALL SOLD TO THE INSTITUTIONAL TRADE (U.S. CL. 46).

FIRST USE 12-31-1978; IN COMMERCE 12-31-1978.  
TRICIA SONNEBORN, EXAMINING ATTORNEY

SN 85-055,825. PHARMASOL CORPORATION, SOUTH EASTON, MA. FILED 6-7-2010.

## DERMAESTHETICS

THE MARK CONSISTS OF STANDARD CHARACTERS WITHOUT CLAIM TO ANY PARTICULAR FONT, STYLE, SIZE, OR COLOR.

**CLASS 3—COSMETICS AND CLEANING PREPARATIONS**

FOR COSMETICS AND CLEANING PRODUCTS, NAMELY, BLEACHING PREPARATIONS AND OTHER SUBSTANCES FOR LAUNDRY USE; CLEANING, POLISHING, SCOURING AND ABRASIVE PREPARATIONS; SOAPS; PERFUMERY, ESSENTIAL OILS, COSMETICS, HAIR LOTIONS AND DENTIFRICES FOR CONSUMERS (U.S. CLS. 1, 4, 6, 50, 51 AND 52).

**CLASS 5—PHARMACEUTICALS**

FOR PHARMACEUTICAL PRODUCTS, NAMELY, PHARMACEUTICAL AND VETERINARY PREPARATIONS; SANITARY PREPARATIONS FOR MEDICAL PURPOSES; DIETETIC SUBSTANCES ADAPTED FOR MEDICAL USE, FOOD FOR BABIES; PLASTERS, MATERIALS FOR DRESSINGS; MATERIAL FOR STOPPING TEETH, DENTAL WAX; DISINFECTANTS; PREPARATIONS FOR DESTROYING VERMIN; FUNGICIDES AND HERBICIDES FOR CONSUMERS (U.S. CLS. 6, 18, 44, 46, 51 AND 52).

HOWARD B. LEVINE, EXAMINING ATTORNEY

SN 85-055,847. BRISTOL-MYERS SQUIBB COMPANY, NEW YORK, NY. FILED 6-7-2010.

博路定

OWNER OF U.S. REG. NOS. 3,024,352 AND 3,204,519.  
THE MARK CONSISTS OF THE WORD BARACLUE IN CHINESE CHARACTERS.

THE NON-LATIN CHARACTERS IN THE MARK TRANSLITERATE TO BO LU DING OR BARACLUE AND THIS HAS NO MEANING IN A FOREIGN LANGUAGE.

**CLASS 16—PAPER GOODS AND PRINTED MATTER**

FOR PRINTED MATERIALS, NAMELY, NEWSLETTERS, BROCHURES, FLYERS AND PACKETS COMPRISED PRIMARILY OF BROCHURES, PRINTED INSTRUCTIONAL AND EDUCATIONAL MATERIALS ON THE SUBJECT OF HEPATITIS (U.S. CLS. 2, 5, 22, 23, 29, 37, 38 AND 50).

**CLASS 41—EDUCATION AND ENTERTAINMENT**

FOR PATIENT EDUCATION PROGRAM IN CONNECTION WITH HEPATITIS TREATMENTS (U.S. CLS. 100, 101 AND 107).

MAUREN DALL, EXAMINING ATTORNEY

SN 85-056,280. THE AMERICAN RED CROSS, DBA AMERICAN RED CROSS AND RED CROSS, WASHINGTON, DC. FILED 6-7-2010.



THE MARK CONSISTS OF THE STYLIZED WORD "READY" ABOVE THE WORDS "WHEN THE TIME COMES" WITH AN INCOMPLETE CIRCLE PARTIALLY SURROUNDING THE LETTERS "REA" IN THE WORD "READY" AND CONNECTED ON ONE SIDE TO THE LETTERS "A" AND "D".

**CLASS 35—ADVERTISING AND BUSINESS**

FOR DEVELOPING AND COORDINATING VOLUNTEERS FOR DISASTER RELIEF AND RECOVERY, NAMELY, SHELTERING, MASS CARE AND FEEDING, DAMAGE ASSESSMENT, BULK DISTRIBUTION, CALL CENTER SERVICES, AND OTHER DISASTER RELIEF AND RECOVERY RELATED SERVICES; ORGANIZING AND CONDUCTING VOLUNTEER PROGRAMS AND COMMUNITY SERVICE PROJECTS IN THE FIELD OF DISASTER RELIEF AND RECOVERY (U.S. CLS. 100, 101 AND 102).

FIRST USE 8-0-2000; IN COMMERCE 7-0-2006.

**CLASS 41—EDUCATION AND ENTERTAINMENT**

FOR EDUCATIONAL SERVICES, NAMELY, TRAINING OF VOLUNTEERS IN THE AREAS OF EMERGENCY PREPAREDNESS AND DISASTER RELIEF (U.S. CLS. 100, 101 AND 107).

FIRST USE 8-0-2000; IN COMMERCE 7-0-2006.

JERI J. FICKES, EXAMINING ATTORNEY

SN 85-056,308. MACTEC, INC., ALPHARETTA, GA. FILED 6-7-2010.

iFrastructure

THE MARK CONSISTS OF STANDARD CHARACTERS WITHOUT CLAIM TO ANY PARTICULAR FONT, STYLE, SIZE, OR COLOR.

**CLASS 35—ADVERTISING AND BUSINESS**

FOR DATABASE MANAGEMENT; DATABASE MANAGEMENT IN THE FIELDS OF CONSTRUCTION, ENVIRONMENTAL, MANAGEMENT AND REMEDIATION, ARCHITECTURE, ENGINEERING AND FACILITIES MANAGEMENT; PROVIDING AN ON-LINE COMPUTER DATABASE FOR THE REPORTING AND TRACKING OF DATA IN THE FIELDS OF CONSTRUCTION, ENVIRONMENTAL, MANAGEMENT AND REMEDIATION, ARCHITECTURE, ENGINEERING AND FACILITIES MANAGEMENT FOR BUSINESS PURPOSES; PROJECT MANAGEMENT SERVICES FOR OTHERS FOR BUSINESS PURPOSES IN THE FIELDS OF CONSTRUCTION, ENVIRONMENTAL, MANAGEMENT AND REMEDIATION, ARCHITECTURE, ENGINEERING AND FACILITIES MANAGEMENT; BUSINESS RECORDS MANAGEMENT SERVICES; BUSINESS MANAGEMENT CONSULTATION SERVICES IN THE FIELD OF CRISIS MANAGEMENT IN CONNECTION WITH HEALTH, SAFETY OR ENVIRONMENTAL PROBLEMS, INCIDENTS AND HAZARDS (U.S. CLS. 100, 101 AND 102).

**CLASS 42—SCIENTIFIC AND COMPUTER SERVICES**

FOR APPLICATION SERVICE PROVIDER, NAMELY, HOSTING COMPUTER SOFTWARE APPLICATIONS OF OTHERS; ASP SERVICES FEATURING SOFTWARE FOR USE IN THE FIELD OF CONSTRUCTION MANAGEMENT; ASP SERVICES FEATURING SOFTWARE FOR USE IN THE FIELD OF LEGAL COMPLIANCE FOR THE CONSTRUCTION, ENVIRONMENTAL AND ENGINEERING AND DESIGN INDUSTRIES; ASP SERVICES FEATURING SOFTWARE FOR USE IN THE FIELD OF ENVIRONMENTAL COMPLIANCE, MANAGEMENT, AND REMEDIATION; ASP SERVICES FEATURING SOFTWARE FOR USE IN THE FIELDS OF ARCHITECTURE, ENGINEERING, AND FACILITIES-MANAGEMENT; APPLICATION SERVICE PROVIDER, NAMELY, PROVIDING, HOSTING, MANAGING, DEVELOPING, RESEARCHING, ANALYZING, REPORTING, AND MAINTAINING APPLICATIONS, SOFTWARE, WEB SITES, AND DATABASES OF OTHERS IN THE FIELDS OF CONSTRUCTION, ENVIRONMENTAL, MANAGEMENT AND REMEDIATION, ARCHITECTURE, ENGINEERING AND FACILITIES MANAGEMENT; DESIGN, DEVELOPMENT AND CONSULTING SERVICES IN THE FIELDS OF CONSTRUCTION, ENVIRONMENTAL, MANAGEMENT AND REMEDIATION, ARCHITECTURE, ENGINEERING AND FACILITIES MANAGEMENT; WEB-BASED DESIGN FOR OTHERS IN THE FIELDS OF CONSTRUCTION, ENVIRONMENTAL, MANAGEMENT AND REMEDIATION, ARCHITECTURE, ENGINEERING AND FACILITIES MANAGEMENT; INSTALLATION OF COMPUTER SOFTWARE; DATA WAREHOUSING (U.S. CLS. 100 AND 101).

VIVIAN MICZNIK FIRST, EXAMINING ATTORNEY

SN 85-056,922. HANSGROHE AG, SCHILTACH, FED REP GERMANY, FILED 6-8-2010.

# PHARO

THE MARK CONSISTS OF STANDARD CHARACTERS WITHOUT CLAIM TO ANY PARTICULAR FONT, STYLE, SIZE, OR COLOR.

OWNER OF ERPN CMNTY TM OFC REG. NO. 008251035, DATED 12-24-2009, EXPIRES 12-24-2019.

OWNER OF U.S. REG. NOS. 1,638,998 AND 2,098,540.

**CLASS 6—METAL GOODS**

FOR LININGS FOR BUILDING PURPOSES, MAINLY OF METAL; METAL PIPE FITTINGS IN THE NATURE OF ROSETTES, JUNCTIONS OF METAL FOR PIPES, PIPES AND WATER PIPES OF METAL, FLEXIBLE PIPES, MAINLY OF METAL; VALVES OF METAL NOT BEING MACHINE PARTS, METAL PLUG-IN PIPE COUPLINGS AND METAL PLUG-IN COUPLINGS FOR USE WITH PLUMBING HOSES; FITTINGS OF METAL FOR FURNITURE, METAL HOSE AND PIPE FITTINGS FOR SANITARY INSTALLATIONS, WALL HOOKS OF METAL (U.S. CLS. 2, 12, 13, 14, 23, 25 AND 50).

**CLASS 9—ELECTRICAL AND SCIENTIFIC APPARATUS**

FOR THERMOSTATS; COMPUTER PROGRAMS FOR ACTIVATING WATER SUPPLY APPARATUS FOR SANITARY INSTALLATIONS (U.S. CLS. 21, 23, 26, 36 AND 38).

**CLASS 10—MEDICAL APPARATUS**

FOR MASSAGE APPARATUS FOR BATHS AND SHOWERS (U.S. CLS. 26, 39 AND 44).

**CLASS 11—ENVIRONMENTAL CONTROL APPARATUS**

FOR APPARATUS FOR LIGHTING, HEATING, STEAM GENERATING, WATER SUPPLY AND SANITARY PURPOSES, NAMELY, WATER HEATING INSTALLATIONS, HOT WATER TANKS AND HEAT ACCUMULATORS, STEAM GENERATORS FOR SHOWER CABINS, WATER CONDITIONING UNITS, WATER FILTER INSTALLATIONS IN THE NATURE OF WATER FILTERING UNITS FOR DOMESTIC AND COMMERCIAL USE; PLUMBING FITTINGS FOR SANITARY INSTALLATIONS, NAMELY, MIXING VALVES AND WATER SUPPLY AND WATER OUTLET FITTINGS WITH MANUAL AND AUTOMATIC CONTROLS IN THE NATURE OF MANUALLY AND AUTOMATICALLY OPERATED MIXING VALVES; MIXER TAPS FOR WASHSTANDS, BIDETS, SINKS, BATH TUBS AND SHOWER TUBS; SANITARY TUBS AND BASINS IN THE NATURE OF BATH TUBS, SHOWER TRAYS, WHIRLPOOL TUBS, URINALS, BIDETS, SHOWER SYSTEMS COMPRISED OF SHOWER HEADS AND SHOWER CONTROL VALVES, AND SHOWER CUBICLES; SHOWER COMBINATIONS IN THE NATURE OF PRE-ASSEMBLED MULTIFUNCTION SHOWERS, SHOWER SETS WITH ATTACHMENTS, NAMELY, OVERHEAD SHOWERS, LATERAL SHOWERS AND HAND SHOWER SPRAY NOZZLES; PREASSEMBLED MULTIFUNCTION SHOWERS; SHOWERS AND SHOWER FITTINGS, NAMELY, SHOWER CONTROL VALVES, SHOWER SPRAYERS, SHOWER STANDS, BODY SHOWERS, OVERHEAD SHOWERS, LATERAL-JET SHOWERS, FLEXIBLE TUBES FOR SHOWERS SOLD AS AN INTEGRAL COMPONENT OF SANITARY INSTALLATIONS, SPRAY NOZZLES AND WATER JET AERATORS FOR FAUCETS AND SHOWERS, ALL BEING PARTS OF SANITARY INSTALLATIONS, SHOWERS AND BATHS; BATHS, MASSAGE BATHS, SPA BATHS, WHIRLPOOLS; INTAKE AND OUTLET FITTINGS FOR SANITARY BASINS, WASHSTANDS, SINKS, BIDETS, BATH TUBS AND SHOWER TRAYS; PLUMBING FITTINGS IN THE NATURE OF TRAPS, PIPES FOR SUPPLYING AND REMOVING WATER BEING PARTS OF SANITARY INSTALLATIONS, PLUMBING FITTINGS IN THE NATURE OF WATER-PIPE FITTINGS OF METAL BEING PARTS FOR SANITARY INSTALLATIONS; REGULATING ACCESSORIES FOR WATER SUPPLY, NAMELY, METERED VALVES ; VALVES OF PLASTIC FOR WATER PIPES; HOUSINGS FOR PLUMBING FITTINGS; PARTS OF THE AFORESAID GOODS (U.S. CLS. 13, 21, 23, 31 AND 34).

**CLASS 17—RUBBER GOODS**

FOR NON-METAL PIPE CONNECTION PARTS IN THE NATURE OF PIPE COUPLINGS AND COUPLINGS FOR USE WITH PLUMBING HOSES; HOSES MAINLY NOT OF METAL FOR PLUMBING USE, PIPE GASKETS; INSULATING MATERIALS; NON-METAL PLUG-IN COUPLINGS IN THE NATURE OF PIPE COUPLINGS AND COUPLINGS FOR USE WITH PLUMBING HOSES; NON-METAL PIPE FITTINGS FOR SANITARY INSTALLATIONS (U.S. CLS. 1, 5, 12, 13, 35 AND 50).

**CLASS 19—NON-METALLIC BUILDING MATERIALS**

FOR LININGS FOR BUILDING PURPOSES, MAINLY NOT OF METAL; NON-METAL FLEXIBLE PIPES AND WATER CONDUITS (U.S. CLS. 1, 12, 33 AND 50).

**CLASS 20—FURNITURE AND ARTICLES NOT OTHERWISE CLASSIFIED**

FOR SHAVING MIRRORS AND MIRRORS, NON-METAL SHELF BRACKETS, FURNITURE, BATHROOM FURNITURE, MIRRORING CABINETS AND SMALL ITEMS OF BATHROOM FURNITURE; NON-METAL PLUG-IN COUPLINGS, FOR CONNECTING FLEXIBLE PIPES AND WATER PIPE FITTINGS; PARTS FOR THE AFORESAID GOODS; NON-METAL FITTINGS FOR FURNITURE, NON-METAL HOSE FITTINGS FOR SANITARY INSTALLATIONS, WALL HOOKS, NOT OF METAL, TOWEL HOOKS NOT OF METAL, TOWEL RACKS, TOWEL STANDS (U.S. CLS. 2, 13, 22, 25, 32 AND 50).

**CLASS 21—HOUSEWARES AND GLASS**

FOR SOAP DISHES, MUGS, TOOTHBRUSH MUGS, COUNTERTOP HOLDERS FOR PAPER TOWELS, RAILS AND RINGS FOR TOWELS, TOWEL BARS, WALL BARS FOR TOWELS, HOLDERS FOR TOILET PAPER ROLLS AND TOILET BRUSHES, TOILET BRUSHES, TOOTHBRUSH HOLDERS, HOLDERS AND BRACKETS FOR BATHROOM AND TOILET UTENSILS IN THE NATURE OF SOAP HOLDERS AND SHOWER CADDIES, WATER APPARATUS FOR CLEANING TEETH AND GUMS FOR HOME USE; DRAIN STOPPERS FOR SINKS AND DRAINS (U.S. CLS. 2, 13, 23, 29, 30, 33, 40 AND 50).

**CLASS 41—EDUCATION AND ENTERTAINMENT**

FOR TRAINING IN THE FIELDS OF SANITARY AND HEATING TECHNOLOGY, WATER HEATING TECHNOLOGY, SOLAR TECHNOLOGY AND WATER TREATMENT TECHNOLOGY; PLANNING, ARRANGING AND CONDUCTING OF CULTURAL AND SOCIAL ENTERTAINMENT EVENTS (U.S. CLS. 100, 101 AND 107).  
ELIZABETH HUGHITT, EXAMINING ATTORNEY

SN 85-057,368. SACHENBACHER, MICHAELA, MUNICH, FED REP GERMANY, AND HUGH, ERROLSON, MUNICH, FED REP GERMANY, FILED 6-8-2010.

# ACRONYM

THE MARK CONSISTS OF STANDARD CHARACTERS WITHOUT CLAIM TO ANY PARTICULAR FONT, STYLE, SIZE, OR COLOR.

OWNER OF ERPN CMNTY TM OFC REG. NO. 000720474, DATED 3-3-1999, EXPIRES 1-7-2018.  
OWNER OF U.S. REG. NO. 2,339,694.

**CLASS 9—ELECTRICAL AND SCIENTIFIC APPARATUS**

FOR (BASED ON INTENT TO USE) SMALL ACCESSORY BAGS, NAMELY, CAMERA BAGS, CELL PHONE CASES, PDA CASES, MP3 PLAYER CASES; PORTABLE EQUIPMENT BAGS, NAMELY, BAGS FOR PHOTOGRAPHIC EQUIPMENT; BAG-INLAYS BEING PROTECTIVE COVERS AND CARRYING CASES FOR LAPTOPS, CAMERAS AND PORTABLE MUSIC DEVICES; MODULAR BAGS ADAPTED FOR HOLDING LAPTOPS (U.S. CLS. 21, 23, 26, 36 AND 38).

**CLASS 18—LEATHER GOODS**

FOR (BASED ON SECTION 44(E)) TRAVEL BAGS; (BASED ON INTENT TO USE) BAGS AND BAG ACCESSORIES, NAMELY, SHOULDER BAGS, COURIER BAGS BEING MESSENGER BAGS, BACKPACKS, SUITCASES, GARMENT BAGS FOR TRAVEL, WAIST-BAGS, ALL-PURPOSE SMALL ACCESSORY CARRYING BAGS, WALLET, ALL-PURPOSE CARRYING BAGS, MODULAR BAGS BEING ALL-PURPOSE CARRYING BAGS, ALL-PURPOSE TEXTILE POUCHES BEING SMALL MODULAR POCKETS WHICH ATTACH TO MODULAR ALL-PURPOSE CARRYING BAGS OR CAN BE USED INDEPENDENTLY, BAG ATTACHMENTS TO BE USED AS SUPPORT SYSTEMS FOR VARIOUS BAGS, NAMELY, HARNESS, SHOULDER STRAP, BELT CLIP, BELT LEASH, AND CHEST RIG BEING CHEST STRAPS FOR CARRYING BAGS (U.S. CLS. 1, 2, 3, 22 AND 41).

**CLASS 25—CLOTHING**

FOR (BASED ON SECTION 44(E)) COATS, SWEATSHIRTS, SHORT AND LONG SLEEVE T-SHIRTS, SHORTS, SOCKS, SCARVES, NECKGAIERS (U.S. CLS. 22 AND 39).

CHARLOTTE CORWIN, EXAMINING ATTORNEY

SN 85-058,040. UBISOFT ENTERTAINMENT, RENNES, FRANCE, FILED 6-9-2010.

# BATTLE TAG

THE MARK CONSISTS OF STANDARD CHARACTERS WITHOUT CLAIM TO ANY PARTICULAR FONT, STYLE, SIZE, OR COLOR.

**CLASS 9—ELECTRICAL AND SCIENTIFIC APPARATUS**

FOR GAME SOFTWARE AND ELECTRONIC GAME PROGRAMS, NAMELY, SOFTWARE GAMES RECORDED ON CD-ROM AND DIGITAL VIDEO DISCS FOR COMPUTERS; SOFTWARE GAMES RECORDED ON CD-ROMS, DIGITAL VIDEO DISCS, AND CARTRIDGES FOR CONSOLE AND INDIVIDUAL, PORTABLE GAMING SYSTEMS; SOFTWARE GAMES THAT ARE DOWNLOADABLE FROM A REMOTE COMPUTER SITE AND ELECTRONIC GAME SOFTWARE FOR MOBILE PHONES, PERSONAL DIGITAL ASSISTANTS, AND HANDHELD COMPUTERS; HAND HELD UNITS FOR PLAYING ELECTRONIC GAMES FOR USE WITH EXTERNAL DISPLAY SCREEN OR MONITOR (U.S. CLS. 21, 23, 26, 36 AND 38).



**CLASS 28—TOYS AND SPORTING GOODS**

FOR TOYS AND PLAYTHINGS, NAMELY, DOLLS, TOY ACTION FIGURES, PLUSH TOYS AND ACCESSORIES THEREOF, PLAYSETS FOR DOLLS AND TOY ACTION FIGURES, TOY VEHICLES AND HAND HELD UNITS FOR PLAYING ELECTRONIC GAMES OTHER THAN ADAPTED FOR USE WITH AN EXTERNAL DISPLAY SCREEN OR MONITOR (U.S. CLS. 22, 23, 38 AND 50).

**CLASS 41—EDUCATION AND ENTERTAINMENT**

FOR ENTERTAINMENT SERVICES, NAMELY, PROVIDING AN ON-LINE COMPUTER GAME FOR OTHERS OVER LOCAL AREA COMPUTER NETWORKS AND PROVIDING TECHNICAL INFORMATION ON-LINE RELATING TO COMPUTER GAMES, VIDEO GAMES AND COMPUTER AND VIDEO GAMES RELATED PRODUCTS, NAMELY, COMPUTER MONITORS, COMPUTER PROCESSORS, COMPUTER CONTROLLERS FOR ELECTRONIC VIDEO GAMES, GRAPHIC CARDS, SPEAKERS, CONSOLE VIDEO GAME MACHINES, CONSOLE VIDEO GAME CONTROLLERS, AND MOBILE PHONES (U.S. CLS. 100, 101 AND 107).

JENNY PARK, EXAMINING ATTORNEY

SN 85-058,804. ARMSTRONG, HELEN, CARLTON VIC 3053, AUSTRALIA, FILED 6-9-2010.

# ATRIONA

THE MARK CONSISTS OF STANDARD CHARACTERS WITHOUT CLAIM TO ANY PARTICULAR FONT, STYLE, SIZE, OR COLOR.

PRIORITY CLAIMED UNDER SEC. 44(D) ON AUSTRALIA APPLICATION NO. 1365469, FILED 6-8-2010, REG. NO. 1365469, DATED 6-8-2010, EXPIRES 6-8-2020.

THE WORD(S) "ATRIONA" HAS NO MEANING IN A FOREIGN LANGUAGE

**CLASS 24—FABRICS**

FOR FABRICS FOR TEXTILE USE; TEXTILE FABRICS FOR USE IN THE MANUFACTURE OF CLOTHING, NAMELY, PANTS, SHIRTS, SKIRTS, DRESSES, VESTS, SWEATERS AND JACKETS, HEADGEAR, NAMELY, HATS, CAPS AND BERETS, SCARVES, SHOULDER WRAPS, GLOVES, MITTENS, BAGS, HOME AND COMMERCIAL INTERIORS AND BLANKETS, NAMELY, BABY BLANKETS, CRIB BLANKETS, BED BLANKETS, BLANKET TROWS, BLANKETS FOR OUTDOOR USE, CASHMERE BLANKETS, CHILDREN'S BLANKETS, LAP BLANKETS, PET BLANKETS, RECEIVING BLANKETS, AND TRAVELLING BLANKETS; COT BLANKETS IN THE NATURE OF CRIB BLANKETS AND BED BLANKETS ADAPTED FOR USE ON COTS AND CHILDREN'S BLANKETS ADAPTED FOR USE ON COTS AND CRIBS; BED COVERS, RUGS FOR BABIES, NAMELY, LAP RUGS (U.S. CLS. 42 AND 50).

**CLASS 25—CLOTHING**

FOR CLOTHING, NAMELY, PANTS, SHIRTS, SKIRTS, DRESSES, VESTS, SWEATERS AND JACKETS; HEADGEAR, NAMELY, HATS, CAPS AND BERETS; SCARVES; SHOULDER WRAPS; GLOVES; MITTENS (U.S. CLS. 22 AND 39).

TINA BROWN, EXAMINING ATTORNEY

SN 85-059,730. KCD IP, LLC, HOFFMAN ESTATES, IL. FILED 6-10-2010.

# KENMORE ONCALL

THE MARK CONSISTS OF STANDARD CHARACTERS WITHOUT CLAIM TO ANY PARTICULAR FONT, STYLE, SIZE, OR COLOR.

OWNER OF U.S. REG. NOS. 2,893,535, 2,941,746 AND OTHERS.

NO CLAIM IS MADE TO THE EXCLUSIVE RIGHT TO USE "ONCALL", APART FROM THE MARK AS SHOWN.

**CLASS 7—MACHINERY**

FOR COMPONENT FEATURE SOLD AS AN INTEGRAL PART OF CLOTHES WASHING MACHINES, DISHWASHERS, SEWING MACHINES, BLENDERS, FOOD PROCESSORS, MIXERS, ELECTRIC CAN OPENERS, VACUUM CLEANERS AND TRASH COMPACTORS, NAMELY, ONBOARD CIRCUITRY, NAMELY, COMPUTER HARDWARE AND ELECTRONIC TRANSMITTERS WHICH PROVIDE INFORMATION AND DATA TO A CUSTOMER SERVICE FACILITY OR NETWORK VIA TELEPHONE, INTERNET OR OTHER TELECOMMUNICATION MEANS TO ENABLE THE PROVISION OF DIAGNOSTIC INFORMATION AND OTHER INFORMATION OR RECOMMENDATIONS TO APPLIANCE OWNERS (U.S. CLS. 13, 19, 21, 23, 31, 34 AND 35).

**CLASS 11—ENVIRONMENTAL CONTROL APPARATUS**

FOR COMPONENT FEATURE SOLD AS AN INTEGRAL PART OF CLOTHES DRYERS, REFRIGERATORS, FREEZERS, GAS AND ELECTRIC STOVES, GAS AND ELECTRIC RANGES, GAS AND ELECTRIC COOKTOPS, HUMIDIFIERS, MICROWAVE OVENS, EVAPORATIVE AIR COOLERS, WATER HEATERS, WATER SOFTENING UNITS, AIR CONDITIONERS, DEHUMIDIFIERS, GAS AND ELECTRIC GRILLS, RANGE HOODS, CEILING FANS, HOUSEHOLD AIR CLEANERS, FURNACES, WATER PURIFICATION UNITS, CENTRAL AIR CONDITIONERS, ICE MAKING MACHINES, ELECTRIC WINE CHILLERS, ELECTRIC TEA KETTLES, ELECTRIC GRIDDLES, ELECTRIC FOOD STEAMERS, BREAD BAKING MACHINES, TOASTERS AND TOASTER OVENS, ELECTRIC COFFEE MAKERS, ELECTRIC SLOW COOKERS, ELECTRIC WAFFLE MAKERS, AND WATER COOLERS, NAMELY, ONBOARD CIRCUITRY, NAMELY, COMPUTER HARDWARE AND ELECTRONIC TRANSMITTERS WHICH PROVIDE INFORMATION AND DATA TO A CUSTOMER SERVICE FACILITY OR NETWORK VIA TELEPHONE, INTERNET OR OTHER TELECOMMUNICATION MEANS TO ENABLE THE PROVISION OF DIAGNOSTIC INFORMATION AND OTHER INFORMATION OR RECOMMENDATIONS TO APPLIANCE OWNERS (U.S. CLS. 13, 21, 23, 31 AND 34).

**CLASS 42—SCIENTIFIC AND COMPUTER SERVICES**

FOR DIAGNOSTIC SERVICES IN THE FIELD OF HOUSEHOLD APPLIANCES, NAMELY, PROVIDING DIAGNOSTIC INFORMATION AND INFORMATION OR RECOMMENDATIONS REGARDING THE OPERATION, MAINTENANCE OR REPAIR OF SUCH APPLIANCES VIA TELEPHONE, INTERNET OR OTHER TELECOMMUNICATION MEANS BASED ON INFORMATION AND DATA RECEIVED FROM CUSTOMER-OWNED APPLIANCE UNITS (U.S. CLS. 100 AND 101).

LESLEY LAMOTHE, EXAMINING ATTORNEY

SN 85-059,736. GAME BITES INC., LIDO BEACH, NY. FILED 6-10-2010.

SN 85-060,523. OVERSEE.NET, LOS ANGELES, CA. FILED 6-11-2010.



THE MARK CONSISTS OF THE TERM "PLAYPEN" APPEARS IN ALL CAPITAL LETTERS. ABOVE THE TERM "PLAYPEN" APPEARS AN OPAQUE CIRCLE WITH A CURVED LINE ON EITHER SIDE OF THE CIRCLE, EXTENDING ABOVE THE CIRCLE ON THE LEFT SIDE, AND BELOW THE CIRCLE ON THE RIGHT SIDE.

#### CLASS 21—HOUSEWARES AND GLASS

FOR SHOT GLASSES, WINE GLASSES, MARTINI GLASSES, BEER GLASSES, HI BALL GLASSES PINT BEVERAGE GLASSES, BOTTLE OPENERS, DRINKING GLASSES, MUGS, DRINKING WATER BOTTLES SOLD EMPTY, SPORTS BOTTLES SOLD EMPTY, INSULATING SLEEVE HOLDERS FOR BEVERAGE CANS; COMPACTS SOLD EMPTY (U.S. CLS. 2, 13, 23, 29, 30, 33, 40 AND 50).

#### CLASS 25—CLOTHING

FOR CLOTHING, NAMELY, SHIRTS, T-SHIRTS, UNDER SHIRTS, NIGHT SHIRTS, RUGBY SHIRTS, MOCK TURTLENECK SHIRTS, POLO SHIRTS, JERSEYS, PANTS, JEANS, DENIM JEANS, HOT PANTS, JUMPERS, JUMP SUITS, SHORTS, BOXER SHORTS, TOPS, CROP TOPS, TANK TOPS, HALTER TOPS, SWEAT SHIRTS, SWEAT SHORTS, SWEAT PANTS, SWEATSUITS, WARM-UP SUITS, JOGGING SUITS, SWEATERS, PULL-OVERS, JACKETS, COATS, TURTLENECKS, BEACHWEAR, SURF WEAR, HATS, VISORS, HEADBANDS, HEADWEAR, BANDANAS, UNDERWEAR, BATHING SUITS, BIKINIS, SWIM AND BATHING TRUNKS, BRAS, SPORTS BRAS, BRASSIERES, BUSTIERS, CORSETS, PANTIES, THONGS, GARTERS AND GARTER BELTS, TEDDIES, LOUNGEWEAR, ROBES, UNDERCLOTHES, LINGERIE, CAMISOLES, BODY STOCKINGS, BODY SUITS, GLOVES (U.S. CLS. 22 AND 39).

#### CLASS 41—EDUCATION AND ENTERTAINMENT

FOR NIGHT CLUB SERVICES; RECORDING STUDIO SERVICES; ENTERTAINMENT SERVICES, NAMELY, ARRANGING AND CONDUCTING OF COMPETITIONS FOR VIDEO GAME PLAYERS, PROVIDING AMUSEMENT FACILITIES FOR USE OF GAME CONSOLES, INTERACTIVE MOBILE DEVICES, COMPUTER GAMES AND ONLINE VIDEO GAMES FOR COMPETITION AND ENTERTAINMENT, WHERE INDIVIDUALS CAN PLAY VIDEO GAMES AND PARTICIPATE IN COMPETITIONS WITHIN A LOUNGE/NIGHT CLUB ATMOSPHERE, AND INTERACTIVE COMPUTER KIOSK SERVICES IN THE NATURE OF PROVIDING AMUSEMENT FACILITIES FEATURING TERMINALS/EQUIPMENT FOR PLAYING ONLINE VIDEO GAMES WITHIN A LOUNGE/NIGHT CLUB ATMOSPHERE (U.S. CLS. 100, 101 AND 107).

GISELLE AGOSTO, EXAMINING ATTORNEY

## HOTEL HOSTESS

THE MARK CONSISTS OF STANDARD CHARACTERS WITHOUT CLAIM TO ANY PARTICULAR FONT, STYLE, SIZE, OR COLOR.

NO CLAIM IS MADE TO THE EXCLUSIVE RIGHT TO USE "HOTEL", APART FROM THE MARK AS SHOWN.

#### CLASS 35—ADVERTISING AND BUSINESS

FOR PRICE COMPARISON SERVICES FOR ACCOMMODATIONS, VACATION PACKAGES, TRAVEL BY LAND, WATER AND/OR AIR, AND TRAVEL PACKAGES VIA THE INTERNET (U.S. CLS. 100, 101 AND 102).

#### CLASS 43—HOTEL AND RESTAURANT SERVICES

FOR MAKING HOTEL RESERVATIONS FOR OTHERS; BOOKING AND PROVIDING INFORMATION SERVICES FOR, REGARDING OR RELATING TO TEMPORARY ACCOMMODATIONS VIA THE INTERNET (U.S. CLS. 100 AND 101).

JASON TURNER, EXAMINING ATTORNEY

SN 85-061,004. NRG ENERGY, INC., PRINCETON, NJ. FILED 6-11-2010.



OWNER OF U.S. REG. NOS. 2,178,691, 3,379,296 AND OTHERS.

NO CLAIM IS MADE TO THE EXCLUSIVE RIGHT TO USE "GLOBAL GIVING", APART FROM THE MARK AS SHOWN.

THE COLOR(S) BLUE, GREEN AND WHITE IS/ARE CLAIMED AS A FEATURE OF THE MARK.

THE MARK CONSISTS OF THE CAPITAL LETTERS "NRG" IN BLUE, THE WORD "GLOBAL" IN GREEN WITH A CAPITAL "G", AND THE WORD "GIVING" IN BLUE WITH A CAPITAL "G", ALONG WITH A BLUE AND GREEN GLOBE WITH MERIDIANS AND PARALLEL LINES, AND LAYERED ON TOP OF THE GLOBE IS AN ARTISTIC "G" IN GREEN AND WHITE AND A REVERSED ARTISTIC "G" IN BLUE AND WHITE CONNECTING NEAR THE CENTER.

#### CLASS 35—ADVERTISING AND BUSINESS

FOR CHARITABLE SERVICES, NAMELY, CONDUCTING VOLUNTEER PROGRAMS TO AID CHARITABLE ORGANIZATIONS WITH THEIR PROGRAMS FOCUSED ON PROTECTING THE ENVIRONMENT, IMPROVING EDUCATION, ADDRESSING HUMAN WELFARE AND ASSISTING COMMUNITY AND ECONOMIC DEVELOPMENT (U.S. CLS. 100, 101 AND 102).

FIRST USE 1-1-2005; IN COMMERCE 1-1-2005.

**CLASS 36—INSURANCE AND FINANCIAL**

FOR PHILANTHROPIC SERVICES, NAMELY, PROVIDING MONETARY DONATIONS TO AID CHARITABLE ORGANIZATIONS WITH THEIR PROGRAMS FOCUSED ON PROTECTING THE ENVIRONMENT, IMPROVING EDUCATION, ADDRESSING HUMAN WELFARE AND ASSISTING COMMUNITY AND ECONOMIC DEVELOPMENT (U.S. CLS. 100, 101 AND 102).

FIRST USE 1-1-2005; IN COMMERCE 1-1-2005.

TINA L. SNAPP, EXAMINING ATTORNEY

**CLASS 41—EDUCATION AND ENTERTAINMENT**

FOR ENTERTAINMENT IN THE NATURE OF LIVE PERFORMANCES BY A MUSICAL GROUP (U.S. CLS. 100, 101 AND 107).

FIRST USE 2-1-2009; IN COMMERCE 2-1-2009.

LAURA KOVALSKY, EXAMINING ATTORNEY

SN 85-061,386. SHIMANO INC., SAKAI CITY, OSAKA, JAPAN, FILED 6-12-2010.

**CLASS 9—ELECTRICAL AND SCIENTIFIC APPARATUS**

FOR COMPUTERS, BICYCLE COMPUTERS, BICYCLE BATTERIES, BATTERY CHARGERS, BATTERY HOLDERS, BICYCLE COMPUTERS AND BATTERY HOLDERS SOLD IN COMBINATION, ELECTRIC WIRES, AND COMPUTER INTERFACE DEVICES, ALL FOR ELECTRICALLY ASSISTED BICYCLES (U.S. CLS. 21, 23, 26, 36 AND 38).

**CLASS 11—ENVIRONMENTAL CONTROL APPARATUS**

FOR LAMPS; BICYCLE LAMPS (U.S. CLS. 13, 21, 23, 31 AND 34).

**CLASS 12—VEHICLES**

FOR ELECTRIC MOTORS FOR ELECTRICALLY ASSISTED BICYCLES; INTERNAL HUB GEARS, ELECTRIC MOTOR UNITS FOR USE AS AUXILIARY POWER SOURCES, HUB MOTORS, FRONT CHAIN WHEELS, CRANK SETS, TORQUE SENSORS, BRAKE LEVERS, AND HUB BRAKES, ALL FOR ELECTRICALLY ASSISTED BICYCLES (U.S. CLS. 19, 21, 23, 31, 35 AND 44).

JUDITH HELFMAN, EXAMINING ATTORNEY

SN 85-061,480. HORNYAK, DAVID M, CHICAGO, IL. FILED 6-13-2010.



THE MARK CONSISTS OF STANDARD CHARACTERS WITHOUT CLAIM TO ANY PARTICULAR FONT, STYLE, SIZE, OR COLOR.

**CLASS 9—ELECTRICAL AND SCIENTIFIC APPARATUS**

FOR AUDIO RECORDINGS FEATURING MUSIC (U.S. CLS. 21, 23, 26, 36 AND 38).

FIRST USE 1-1-2009; IN COMMERCE 1-1-2009.

SN 85-061,511. KATHLEEN ANN ADAMICK-DIAZ, AKA KATE ADAMICK, NEW YORK, NY. FILED 6-13-2010.



THE MARK CONSISTS OF STANDARD CHARACTERS WITHOUT CLAIM TO ANY PARTICULAR FONT, STYLE, SIZE, OR COLOR.

**CLASS 41—EDUCATION AND ENTERTAINMENT**

FOR VOCATIONAL EDUCATION IN THE FIELDS OF CULINARY ARTS AND SCIENCES (U.S. CLS. 100, 101 AND 107).

**CLASS 43—HOTEL AND RESTAURANT SERVICES**

FOR CONSULTING SERVICES IN THE FIELD OF CULINARY ARTS (U.S. CLS. 100 AND 101).

BARBARA BROWN, EXAMINING ATTORNEY

SN 85-062,184. HUMANETICS INNOVATIVE SOLUTIONS, INC., PLYMOUTH, MI. FILED 6-14-2010.



NO CLAIM IS MADE TO THE EXCLUSIVE RIGHT TO USE "INNOVATIVE SOLUTIONS", APART FROM THE MARK AS SHOWN.

THE MARK CONSISTS OF A SHADED CIRCLE CONTAINING A STYLIZED LETTER "H" TO THE LEFT OF THE WORD "HUMANETICS", WHICH IS ABOVE THE WORDS "INNOVATIVE SOLUTIONS". THE CROSS BAR IN THE LETTER "H" WITHIN THE CIRCLE CARRIES ACROSS TO BIsect THE WORD "HUMANETICS".

**CLASS 9—ELECTRICAL AND SCIENTIFIC APPARATUS**

FOR CRASH TEST DUMMIES AND OTHER ANTHROPOMORPHIC CRASH TEST DEVICES AND PARTS AND FITTINGS THEREFOR; IMPACT SIMULATION TEST EQUIPMENT IN THE NATURE OF CRASH TEST DUMMIES AND OTHER ANTHROPOMORPHIC CRASH TEST DEVICES; CRASH BARRIERS AND CRASH TRACKS; CRASH TEST WALLS, POLES AND TROLLEYS WITH SENSORS TO DETECT AND MEASURE FORCE; COMPUTER SOFTWARE FOR SIMULATION, DATA ACQUISITION, MODELING, ANALYSIS AND REPORTING IN CRASH TESTS; COMPUTER APPARATUS FOR TRANSMITTING DATA; TRANSDUCERS; ACCELEROMETERS; POTENTIOMETERS; INFRA-RED TELESCOPING RODS FOR THE ASSESSMENT OF CHEST COMPRESSION; CRASH TEST EQUIPMENT OTHER THAN FOR MEDICAL USE; DATA ACQUISITION SYSTEMS FOR USE IN CRASH TESTS; CRASH TEST CALIBRATION SOFTWARE (U.S. CLS. 21, 23, 26, 36 AND 38).

**CLASS 12—VEHICLES**

FOR VEHICLE SEATS AND SEAT SHELLS FOR USE IN CRASH TESTING (U.S. CLS. 19, 21, 23, 31, 35 AND 44).

**CLASS 37—CONSTRUCTION AND REPAIR**

FOR REPAIR AND REMOLDING SERVICES FOR CRASH TEST DUMMIES (U.S. CLS. 100, 103 AND 106).

**CLASS 42—SCIENTIFIC AND COMPUTER SERVICES**

FOR ENGINEERING AND CONSULTING SERVICES IN THE FIELDS OF CRASH TESTING, AND AUTOMOTIVE SAFETY AND COMFORT; CALIBRATION OF CRASH TEST DUMMIES AND RELATED INSTRUMENTS, EQUIPMENT AND SYSTEMS; RENTAL OF CRASH TEST DUMMIES AND OTHER ANTHROPOMORPHIC CRASH TEST DEVICES AND PARTS AND FITTINGS THEREFOR (U.S. CLS. 100 AND 101).

JOHN WILKE, EXAMINING ATTORNEY

---

SN 85-062,359. PROFESSIONAL TRANSIT MANAGEMENT OF TUCSON, INC., TUCSON, AZ. FILED 6-14-2010.

# SUNGO

THE MARK CONSISTS OF STANDARD CHARACTERS WITHOUT CLAIM TO ANY PARTICULAR FONT, STYLE, SIZE, OR COLOR.

**CLASS 9—ELECTRICAL AND SCIENTIFIC APPARATUS**

FOR PRE-PAID ELECTRONIC AND MAGNETIC ID CARDS FOR USE IN CONNECTION WITH PAYMENT FOR TRANSIT AND PARKING SERVICES (U.S. CLS. 21, 23, 26, 36 AND 38).

**CLASS 39—TRANSPORTATION AND STORAGE**

FOR TRANSPORTATION SERVICES, NAMELY, MASS TRANSIT SERVICES FOR THE GENERAL PUBLIC AND PARKING SERVICES (U.S. CLS. 100 AND 105).

LINDA ORNDORFF, EXAMINING ATTORNEY

SN 85-063,616. VIVINT, INC., PROVO, UT. FILED 6-15-2010.

# APX

THE MARK CONSISTS OF STANDARD CHARACTERS WITHOUT CLAIM TO ANY PARTICULAR FONT, STYLE, SIZE, OR COLOR.

**CLASS 7—MACHINERY**

FOR POWER TOOLS, NAMELY, ELECTRIC SCREWDRIVERS, DISTRIBUTED PRIMARILY IN CONNECTION WITH THE PROMOTION AND INSTALLATION OF BURGLAR, TROUBLE, FIRE, SECURITY ALARM SYSTEMS AND/OR BUILDING AUTOMATION SYSTEMS (U.S. CLS. 13, 19, 21, 23, 31, 34 AND 35).

**CLASS 8—HAND TOOLS**

FOR HAND OPERATED TOOLS, NAMELY, SCREWDRIVERS, DISTRIBUTED PRIMARILY IN CONNECTION WITH THE PROMOTION AND INSTALLATION OF BURGLAR, TROUBLE, FIRE, SECURITY ALARM SYSTEMS AND/OR BUILDING AUTOMATION SYSTEMS (U.S. CLS. 23, 28 AND 44).

TINA BROWN, EXAMINING ATTORNEY

---

SN 85-063,724. HIGHER BALANCE INSTITUTE, AKA HIGHER BALANCE, PORTLAND, OR. FILED 6-15-2010.

# Eric Pepin

THE MARK CONSISTS OF STANDARD CHARACTERS WITHOUT CLAIM TO ANY PARTICULAR FONT, STYLE, SIZE, OR COLOR.

THE NAME(S), PORTRAIT(S), AND/OR SIGNATURE(S) SHOWN IN THE MARK IDENTIFIES "ERIC PEPIN", WHOSE CONSENT(S) TO REGISTER IS MADE OF RECORD.

**CLASS 9—ELECTRICAL AND SCIENTIFIC APPARATUS**

FOR AUDIO AND VIDEO RECORDINGS FEATURING RECORDINGS IN THE FIELD OF SPIRITUALITY, NEW AGE, PHILOSOPHY, PERSONAL GROWTH AND MEDITATION (U.S. CLS. 21, 23, 26, 36 AND 38).

FIRST USE 3-1-2005; IN COMMERCE 3-1-2005.

**CLASS 16—PAPER GOODS AND PRINTED MATTER**

FOR PUBLICATIONS, NAMELY, BOOKS, MANUALS, NEWSLETTERS, AND PRINTED INSTRUCTIONAL AND TEACHING MATERIALS IN THE FIELDS OF SPIRITUALITY, NEW AGE, PHILOSOPHY, PERSONAL GROWTH AND MEDITATION (U.S. CLS. 2, 5, 22, 23, 29, 37, 38 AND 50).

FIRST USE 3-1-2004; IN COMMERCE 3-1-2004.

KIM SAITO, EXAMINING ATTORNEY

SN 85-064,227. PIERRE FABRE DERMO-COSMETIQUE,  
BOULOGNE, FRANCE, FILED 6-16-2010.

SN 85-065,774. DONOVAN MARINE, INC., HARAHAN, LA.  
FILED 6-17-2010.

## EFFECTIOSE

THE MARK CONSISTS OF STANDARD CHARACTERS  
WITHOUT CLAIM TO ANY PARTICULAR FONT, STYLE,  
SIZE, OR COLOR.

OWNER OF FRANCE REG. NO. 093695083, DATED 12-1-  
2009, EXPIRES 12-1-2019.

### CLASS 1—CHEMICALS

FOR ACTIVE CHEMICAL INGREDIENT FOR USE IN  
THE COMPOSITION OF COSMETIC PREPARATIONS  
(U.S. CLS. 1, 5, 6, 10, 26 AND 46).

### CLASS 3—COSMETICS AND CLEANING PRE- PARATIONS

FOR COSMETIC PREPARATIONS; NON-MEDICATED  
INGREDIENTS SOLD AS AN INTEGRAL COMPONENT  
PART OF FINISHED COSMETIC PREPARATIONS,  
NAMELY, AN ANTI-IRRITANT TO THE SKIN (U.S.  
CLS. 1, 4, 6, 50, 51 AND 52).

### CLASS 5—PHARMACEUTICALS

FOR MEDICATED INGREDIENT SOLD AS AN INTE-  
GRAL PART OF DERMATOLOGICALS OR MEDICATED  
DERMO-COSMETIC PREPARATIONS FOR THE TREAT-  
MENT OF SKIN DISORDERS AND ACNE, NAMELY, AN  
ANTI-IRRITANT TO THE SKIN (U.S. CLS. 6, 18, 44, 46,  
51 AND 52).

ELI HELLMAN, EXAMINING ATTORNEY

SN 85-065,715. APL LIMITED, SCOTTSDALE, AZ. FILED 6-  
17-2010.

## SMARTEMP

THE MARK CONSISTS OF STANDARD CHARACTERS  
WITHOUT CLAIM TO ANY PARTICULAR FONT, STYLE,  
SIZE, OR COLOR.

### CLASS 39—TRANSPORTATION AND STO- RAGE

FOR TRANSPORTATION AND STORAGE OF GOODS  
IN REFRIGERATED CONDITIONS (U.S. CLS. 100 AND  
105).

### CLASS 42—SCIENTIFIC AND COMPUTER SERVICES

FOR REMOTE MONITORING OF ENVIRONMENTAL  
CONTROL SYSTEMS FOR SHIPPING CONTAINERS  
(U.S. CLS. 100 AND 101).

INGA ERVIN, EXAMINING ATTORNEY

## MARPAC

THE MARK CONSISTS OF STANDARD CHARACTERS  
WITHOUT CLAIM TO ANY PARTICULAR FONT, STYLE,  
SIZE, OR COLOR.

### CLASS 6—METAL GOODS

FOR METAL FASTENERS, NAMELY, SCREWS, PINS,  
HOOKS, NUTS, AND WASHERS; METAL LADDERS;  
METAL BELLS; METAL HINGES; METAL HOSE  
CLAMPS; METAL PLUGS; COTTER PINS; METAL  
CHAINS (U.S. CLS. 2, 12, 13, 14, 23, 25 AND 50).  
FIRST USE 12-1-1982; IN COMMERCE 12-1-1982.

### CLASS 7—MACHINERY

FOR FUEL FILTERS; PUMPS AS PARTS OF MA-  
CHINES, MOTORS FOR BOATS, AND ENGINES FOR  
BOATS; WINDLASSES (U.S. CLS. 13, 19, 21, 23, 31, 34  
AND 35).  
FIRST USE 6-1-1990; IN COMMERCE 6-1-1990.

### CLASS 9—ELECTRICAL AND SCIENTIFIC APPARATUS

FOR ELECTRICAL FUSES; CIRCUIT BREAKERS;  
ELECTRIC SWITCHES; ELECTRIC WIRES; ELECTRICAL  
TERMINAL BLOCKS; FLOTATION VESTS; MAR-  
INE SURVIVAL KITS COMPRISING LIFE VESTS,  
ANCHOR SHACKLES, ANCHOR LINES, ANCHOR  
HOOKS, ANCHOR CHAINS, CUSHIONS, DOCKLINES,  
COAST GUARD BOOKLETS, AIR HORNS, GEAR BAGS,  
FIRST AID KITS, PADDLES, FIRE EXTINGUISHERS,  
AND WHISTLES (U.S. CLS. 21, 23, 26, 36 AND 38).  
FIRST USE 12-1-1982; IN COMMERCE 12-1-1982.

### CLASS 11—ENVIRONMENTAL CONTROL AP- PARATUS

FOR ELECTRIC FANS; RUNNING LIGHTS AND  
TRAILER LIGHTS FOR BOATS; LIGHT BULBS (U.S.  
CLS. 13, 21, 23, 31 AND 34).  
FIRST USE 12-1-1982; IN COMMERCE 12-1-1982.

### CLASS 12—VEHICLES

FOR FITTED COVERS FOR BOATS; BOAT FENDERS;  
WINDSCREEN WIPERS; BOAT CLEATS; FUEL LINES  
FOR BOATS; TRAILER PARTS; STEERING SYSTEM  
PARTS FOR BOATS (U.S. CLS. 19, 21, 23, 31, 35 AND 44).  
FIRST USE 12-1-1982; IN COMMERCE 12-1-1982.

### CLASS 16—PAPER GOODS AND PRINTED MATTER

FOR PAINT BRUSHES; PAINT ROLLERS; ADHESIVE-  
BACKED LETTERS AND NUMBERS, NAMELY, STICK-  
ERS, FOR USE IN MARKING BOATS (U.S. CLS. 2, 5, 22,  
23, 29, 37, 38 AND 50).  
FIRST USE 12-1-1982; IN COMMERCE 12-1-1982.

### CLASS 17—RUBBER GOODS

FOR NON-METAL HOSES FOR MARINE USE (U.S.  
CLS. 1, 5, 12, 13, 35 AND 50).  
FIRST USE 12-1-1982; IN COMMERCE 12-1-1982.

**CLASS 20—FURNITURE AND ARTICLES NOT OTHERWISE CLASSIFIED**

FOR DECK CHAIRS; DISPLAY RACKS (U.S. CLS. 2, 13, 22, 25, 32 AND 50).  
FIRST USE 6-1-2002; IN COMMERCE 6-1-2002.

**CLASS 22—CORDAGE AND FIBERS**

FOR ROPES; BIMINI TOPS; NON-METAL TIE DOWNS (U.S. CLS. 1, 2, 7, 19, 22, 42 AND 50).  
FIRST USE 12-1-1982; IN COMMERCE 12-1-1982.

**CLASS 35—ADVERTISING AND BUSINESS**

FOR WHOLESALE ORDERING SERVICES IN THE FIELD OF MARINE PRODUCTS (U.S. CLS. 100, 101 AND 102).  
FIRST USE 12-1-1982; IN COMMERCE 12-1-1982.  
FRANK LATTUCA, EXAMINING ATTORNEY

SN 85-067,312. MOMOI SEIMO KABUSHIKI KAISHA, DBA MOMOI FISHING NET MFG. CO., LTD., HYOGO-KEN, JAPAN, FILED 6-21-2010.

# MOMOI

THE MARK CONSISTS OF STANDARD CHARACTERS WITHOUT CLAIM TO ANY PARTICULAR FONT, STYLE, SIZE, OR COLOR.

OWNER OF U.S. REG. NOS. 1,680,479, 1,732,131 AND 1,773,721.

THE ENGLISH TRANSLATION OF "MOMOI" IN THE MARK IS "WATER WELLS OF PEACH".

**CLASS 22—CORDAGE AND FIBERS**

FOR FISHING NETS; SNARE NETS FOR COMMERCIAL FISHING; SYNTHETIC ROPE AND WEBBING; ROPES; ROPE FOR MARINE USE; TEXTILE FIBERS; TWINE; STRING; AND CASTING NETS FOR FISHING (U.S. CLS. 1, 2, 7, 19, 22, 42 AND 50).  
FIRST USE 0-0-1905; IN COMMERCE 0-0-1935.

**CLASS 28—TOYS AND SPORTING GOODS**

FOR LINES FOR FISHING; FISHING CREELS; REELS FOR FISHING; FISH HOOKS; GUT FOR FISHING; BITE INDICATORS FOR FISHING; BITE SENSORS FOR FISHING; FISHING FLOATS; DECOYS FOR FISHING; ARTIFICIAL FISHING BAIT; ARTIFICIAL FISHING LURES; LANDING NETS FOR ANGLERS; RODS FOR FISHING; FISHING TACKLE BOXES; NETS FOR SPORTS; FISHING BUOYS; AND FISHING TACKLE IN THE NATURE OF LIGHTED BOBBERS (U.S. CLS. 22, 23, 38 AND 50).  
FIRST USE 0-0-1905; IN COMMERCE 0-0-1935.  
RONALD MCMORROW, EXAMINING ATTORNEY

SN 85-068,244. ESCROW ASSOCIATES, LLC, ATLANTA, GA. FILED 6-22-2010.

# SNOWBABIES

THE MARK CONSISTS OF STANDARD CHARACTERS WITHOUT CLAIM TO ANY PARTICULAR FONT, STYLE, SIZE, OR COLOR.

OWNER OF U.S. REG. NO. 2,837,678.

**CLASS 21—HOUSEWARES AND GLASS**

FOR CERAMIC CHRISTMAS ORNAMENTS (U.S. CLS. 2, 13, 23, 29, 30, 33, 40 AND 50).  
FIRST USE 5-0-2008; IN COMMERCE 5-0-2008.

**CLASS 28—TOYS AND SPORTING GOODS**

FOR CHRISTMAS TREE ORNAMENTS (U.S. CLS. 22, 23, 38 AND 50).  
FIRST USE 1-1-1986; IN COMMERCE 1-1-1986.  
ERNEST SHOSHO, EXAMINING ATTORNEY

SN 85-068,333. MACRIE BROTHERS BLUEBERRY FARM LLC, HAMMONTON, NJ. FILED 6-22-2010.



NO CLAIM IS MADE TO THE EXCLUSIVE RIGHT TO USE "BLUE" AND "BLUEBERRIES", APART FROM THE MARK AS SHOWN.

THE COLOR(S) PMS REFLEX BLUE AND WHITE IS/ARE CLAIMED AS A FEATURE OF THE MARK.

THE MARK CONSISTS OF A STYLIZED BUCKS HEAD APPEARING IN PMS REFLEX BLUE WITH WHITE ACCENTS ON THE ANTLERS, EARS, EYES, SNOUT, AND NECK THAT IS CENTERED BETWEEN THE WORDS "BLUE BUCK" APPEARING ABOVE IT AND THE WORD "BLUEBERRIES" APPEARING BELOW IT, ALL WRITTEN IN A PMS REFLEX BLUE OLD ENGLISH PLAIN FONT.

**CLASS 29—MEATS AND PROCESSED FOODS**

FOR PROCESSED BLUEBERRIES (U.S. CL. 46).  
FIRST USE 1-1-1955; IN COMMERCE 1-1-1955.

**CLASS 31—NATURAL AGRICULTURAL PRODUCTS**

FOR FRESH BLUEBERRIES; RAW BLUEBERRIES; UNPROCESSED BLUEBERRIES (U.S. CLS. 1 AND 46).  
FIRST USE 1-1-1955; IN COMMERCE 1-1-1955.  
ANTHONY RINKER, EXAMINING ATTORNEY

SN 85-068,636. KENEXA CORPORATION, WAYNE, PA.  
FILED 6-22-2010.

## KENEXA 2x ONBOARD

THE MARK CONSISTS OF STANDARD CHARACTERS WITHOUT CLAIM TO ANY PARTICULAR FONT, STYLE, SIZE, OR COLOR.

OWNER OF U.S. REG. NOS. 2,632,896, 2,672,952 AND OTHERS.

NO CLAIM IS MADE TO THE EXCLUSIVE RIGHT TO USE "ONBOARD", APART FROM THE MARK AS SHOWN.

### CLASS 9—ELECTRICAL AND SCIENTIFIC APPARATUS

FOR COMPUTER SOFTWARE FOR RECRUITING MANAGEMENT IN THE FIELD OF EMPLOYEE RECRUITING AND ONBOARDING (U.S. CLS. 21, 23, 26, 36 AND 38).

FIRST USE 12-0-2009; IN COMMERCE 12-0-2009.

### CLASS 42—SCIENTIFIC AND COMPUTER SERVICES

FOR PROVIDING TEMPORARY USE OF ON-LINE NON-DOWNLOADABLE SOFTWARE FOR RECRUITING MANAGEMENT IN THE FIELD OF EMPLOYEE RECRUITING AND ONBOARDING (U.S. CLS. 100 AND 101).

FIRST USE 12-0-2009; IN COMMERCE 12-0-2009.

MARY I. SPARROW, EXAMINING ATTORNEY

SN 85-069,076. HARRY'S CAFE DE WHEELS (HOLDINGS) PTY LTD, NEW SOUTH WALES 2007, AUSTRALIA, FILED 6-22-2010.

## HARRY'S CAFE DE WHEELS

THE MARK CONSISTS OF STANDARD CHARACTERS WITHOUT CLAIM TO ANY PARTICULAR FONT, STYLE, SIZE, OR COLOR.

OWNER OF AUSTRALIA REG. NO. 870870, DATED 3-28-2001, EXPIRES 3-28-2021.

OWNER OF U.S. REG. NO. 2,833,625.

NO CLAIM IS MADE TO THE EXCLUSIVE RIGHT TO USE "CAFE DE WHEELS", APART FROM THE MARK AS SHOWN.

### CLASS 30—STAPLE FOODS

FOR PASTRY PRODUCTS, NAMELY, MEAT AND FRUIT PIES, PASTIES, DONUTS, SAUSAGE ROLLS; CONFECTIONERY, NAMELY, CANDY, CHOCOLATE, CHOCOLATE CHIP COOKIES, CUSTARD TARTS AND BANANA BREAD; SAUCES AND POWDERED GRAVIES; ICE CREAM CONFECTIONS; TEA AND COFFEE (U.S. CL. 46).

### CLASS 35—ADVERTISING AND BUSINESS

FOR RETAIL AND WHOLESALE STORE SERVICES FEATURING FOOD AND DRINK INCLUDING FAST FOOD (U.S. CLS. 100, 101 AND 102).

### CLASS 43—HOTEL AND RESTAURANT SERVICES

FOR FOOD AND DRINK CATERING AND RESTAURANT SERVICES AND TAKE-OUT RESTAURANT SERVICES (U.S. CLS. 100 AND 101).

RAMONA ORTIGA, EXAMINING ATTORNEY

SN 85-069,933. DUN & BRADSTREET, INC., SHORT HILLS, NJ. FILED 6-23-2010.

## IUPDATE

THE MARK CONSISTS OF STANDARD CHARACTERS WITHOUT CLAIM TO ANY PARTICULAR FONT, STYLE, SIZE, OR COLOR.

### CLASS 35—ADVERTISING AND BUSINESS

FOR PROVIDING BUSINESS INFORMATION, NAMELY, BUSINESS CREDIT, IDENTIFYING, HISTORICAL AND OPERATING INFORMATION TO BUSINESS ENTITIES VIA GLOBAL COMPUTER NETWORK (U.S. CLS. 100, 101 AND 102).

### CLASS 36—INSURANCE AND FINANCIAL

FOR PROVIDING FINANCIAL INFORMATION TO BUSINESS ENTITIES VIA GLOBAL COMPUTER NETWORK (U.S. CLS. 100, 101 AND 102).

WILLIAM ROSSMAN, EXAMINING ATTORNEY

SN 85-069,953. GATEWAY MANUFACTURING, INC., MT. STERLING, KY. FILED 6-23-2010.

## GMI

THE MARK CONSISTS OF STANDARD CHARACTERS WITHOUT CLAIM TO ANY PARTICULAR FONT, STYLE, SIZE, OR COLOR.

### CLASS 6—METAL GOODS

FOR METAL GATES (U.S. CLS. 2, 12, 13, 14, 23, 25 AND 50).

FIRST USE 1-31-2003; IN COMMERCE 1-31-2003.

### CLASS 19—NON-METALLIC BUILDING MATERIALS

FOR NON-METAL GATES (U.S. CLS. 1, 12, 33 AND 50).

FIRST USE 1-31-2003; IN COMMERCE 1-31-2003.

SAIMA MAKHDOOM, EXAMINING ATTORNEY

SN 85-069,965. BÜCHI LABORTECHNIK AG, 9230 FLAWIL, SWITZERLAND, FILED 6-23-2010.

## NIRMASTER

THE MARK CONSISTS OF STANDARD CHARACTERS WITHOUT CLAIM TO ANY PARTICULAR FONT, STYLE, SIZE, OR COLOR.

PRIORITY CLAIMED UNDER SEC. 44(D) ON SWITZERLAND APPLICATION NO. 56510/2010, FILED 6-23-2010, REG. NO. 609532, DATED 12-21-2010, EXPIRES 6-23-2020.

OWNER OF U.S. REG. NOS. 2,836,056, 3,835,344 AND OTHERS.

### CLASS 9—ELECTRICAL AND SCIENTIFIC APPARATUS

FOR MEASURING INSTRUMENTS AND OPTICAL INSTRUMENTS AND SCIENTIFIC APPARATUS, NAMELY, SPECTROMETERS AND SPECTROPHOTOMETERS; INSTRUMENTS FOR ANALYZING SUBSTANCES, NAMELY, SPECTROMETERS AND SPECTROPHOTOMETERS; DATA PROCESSORS AND COMPUTER SOFTWARE FOR EVALUATING MEASUREMENT DATA, PARTICULARLY FOR SPECTRAL ANALYSIS MAINLY IN LABORATORIES (U.S. CLS. 21, 23, 26, 36 AND 38).

### CLASS 42—SCIENTIFIC AND COMPUTER SERVICES

FOR SCIENTIFIC AND TECHNOLOGICAL SERVICES, NAMELY, ANALYSIS OF SCIENTIFIC MEASUREMENT DATA IN THE FIELD OF SPECTROMETRY; COMPUTER SOFTWARE DESIGN AND UPDATING, AND COMPUTER PROGRAMMING THEREFOR (U.S. CLS. 100 AND 101).

KATHERINE E. HALMEN, EXAMINING ATTORNEY

SN 85-070,365. FISSION LLC, NEW YORK, NY. FILED 6-24-2010.

## NOOK CONNECT

THE MARK CONSISTS OF STANDARD CHARACTERS WITHOUT CLAIM TO ANY PARTICULAR FONT, STYLE, SIZE, OR COLOR.

NO CLAIM IS MADE TO THE EXCLUSIVE RIGHT TO USE "CONNECT", APART FROM THE MARK AS SHOWN.

### CLASS 9—ELECTRICAL AND SCIENTIFIC APPARATUS

FOR PORTABLE ELECTRONIC APPARATUS FOR DISPLAYING, RECEIVING, READING AND STORING DOWNLOADABLE ELECTRONIC PUBLICATIONS, NAMELY, BOOKS, E-BOOKS, MAGAZINES, NEWSPAPERS, TEXT, IMAGES, DIGITAL WEB SITE CONTENT AND DIGITAL MEDIA FEATURING MUSIC THROUGH WIRED AND WIRELESS INTERNET ACCESS, ACCESSORIES THEREFOR AND INSTRUCTIONAL MANUALS, SOLD AS A UNIT; PROVIDING DOWNLOADABLE COMPUTER SOFTWARE FOR SOCIAL NETWORKING SITES AND EMAIL (U.S. CLS. 21, 23, 26, 36 AND 38).

### CLASS 42—SCIENTIFIC AND COMPUTER SERVICES

FOR PROVIDING TEMPORARY USE OF NON-DOWNLOADABLE SOFTWARE FOR SOCIAL NETWORKING SITES AND EMAIL (U.S. CLS. 100 AND 101).

DAWN FELDMAN, EXAMINING ATTORNEY

SN 85-070,367. FISSION LLC, NEW YORK, NY. FILED 6-24-2010.

## NOOKCONNECT

THE MARK CONSISTS OF STANDARD CHARACTERS WITHOUT CLAIM TO ANY PARTICULAR FONT, STYLE, SIZE, OR COLOR.

### CLASS 9—ELECTRICAL AND SCIENTIFIC APPARATUS

FOR PORTABLE ELECTRONIC APPARATUS FOR DISPLAYING, RECEIVING, READING AND STORING DOWNLOADABLE ELECTRONIC PUBLICATIONS, NAMELY, BOOKS, E-BOOKS, MAGAZINES, NEWSPAPERS, TEXT, IMAGES, DIGITAL WEB SITE CONTENT AND DIGITAL MEDIA FEATURING MUSIC THROUGH WIRED AND WIRELESS INTERNET ACCESS, ACCESSORIES THEREFOR AND INSTRUCTIONAL MANUALS, SOLD AS A UNIT; PROVIDING DOWNLOADABLE COMPUTER SOFTWARE FOR SOCIAL NETWORKING SITES AND EMAIL (U.S. CLS. 21, 23, 26, 36 AND 38).

### CLASS 42—SCIENTIFIC AND COMPUTER SERVICES

FOR PROVIDING TEMPORARY USE OF NON-DOWNLOADABLE SOFTWARE FOR SOCIAL NETWORKING SITES AND EMAIL (U.S. CLS. 100 AND 101).

DAWN FELDMAN, EXAMINING ATTORNEY

SN 85-070,392. FISSION LLC, NEW YORK, NY. FILED 6-24-2010.

## NOOK STUDY

THE MARK CONSISTS OF STANDARD CHARACTERS WITHOUT CLAIM TO ANY PARTICULAR FONT, STYLE, SIZE, OR COLOR.

NO CLAIM IS MADE TO THE EXCLUSIVE RIGHT TO USE "STUDY", APART FROM THE MARK AS SHOWN.



**CLASS 9—ELECTRICAL AND SCIENTIFIC APPARATUS**

FOR PORTABLE ELECTRONIC APPARATUS FOR DISPLAYING, RECEIVING, READING AND STORING DOWNLOADABLE ELECTRONIC PUBLICATIONS, NAMELY, BOOKS, E-BOOKS, MAGAZINES, NEWSPAPERS, TEXT, IMAGES, DIGITAL WEB SITE CONTENT AND DIGITAL MEDIA FEATURING MUSIC THROUGH WIRED AND WIRELESS INTERNET ACCESS, ACCESSORIES THEREFOR AND INSTRUCTIONAL MANUALS, SOLD AS A UNIT; COMPUTER SOFTWARE FOR EDUCATION; COMPUTER SOFTWARE FOR EDUCATION, NAMELY, TEST PREPARATION, COLLEGE COURSE NOTE TAKING AND COLLEGE PAPER WRITING; DOWNLOADABLE COMPUTER SOFTWARE FOR EDUCATION, NAMELY, TEST PREPARATION, COLLEGE COURSE NOTE TAKING AND COLLEGE PAPER WRITING; DOWNLOADABLE ELECTRONIC PUBLICATIONS, NAMELY, ELECTRONIC COLLEGE TEXTBOOKS AND COURSE MATERIAL FOR USE IN COLLEGE COURSES (U.S. CLS. 21, 23, 26, 36 AND 38).

**CLASS 41—EDUCATION AND ENTERTAINMENT**

FOR ONLINE EDUCATIONAL SERVICES, NAMELY, CLASSES, SEMINARS IN THE FIELD OF COLLEGE-LEVEL CURRICULUM; NON-DOWNLOADABLE ELECTRONIC PUBLICATIONS, NAMELY, ELECTRONIC COLLEGE TEXTBOOKS AND COURSE MATERIAL; PROVIDING A WEB SITE FEATURING EDUCATION AND ENTERTAINMENT INFORMATION, NAMELY, INFORMATION ON COLLEGE-LEVEL COURSES AND CURRICULUM, TEST PREPARATION AND COLLEGE PAPER WRITING (U.S. CLS. 100, 101 AND 107).

DAWN FELDMAN, EXAMINING ATTORNEY

SN 85-070,409. WOODLINE SOLUTIONS, LLC, ATLANTA, GA. FILED 6-24-2010.



NO CLAIM IS MADE TO THE EXCLUSIVE RIGHT TO USE "SOLUTIONS", APART FROM THE MARK AS SHOWN.

THE MARK CONSISTS OF A STYLIZED "W" IN A BOX WITH HORIZONTAL LINES ABOVE AND BELOW THE "W" WITH THE WORDS "WOODLINE SOLUTIONS" TO THE RIGHT OF THE BOX. THE WORD "SOLUTIONS" IS DIRECTLY BELOW THE WORD "WOODLINE".

**CLASS 35—ADVERTISING AND BUSINESS**

FOR CONSULTING SERVICES IN THE FIELD OF GREEN ENERGY AND ENERGY EFFICIENCY STRATEGIES FOR COMPANIES; CONSUMER PRODUCT CONSULTING IN THE FIELD OF GREEN ENERGY AND ENERGY EFFICIENCY PRODUCTS FOR CONSTRUCTION; PROVIDING INFORMATION IN THE FIELD OF GREEN ENERGY EFFICIENCY (U.S. CLS. 100, 101 AND 102).

FIRST USE 1-13-2008; IN COMMERCE 1-15-2008.

**CLASS 42—SCIENTIFIC AND COMPUTER SERVICES**

FOR TECHNICAL CONSULTING IN THE FIELD OF DESIGN FOR OTHERS IN THE FIELD OF ENERGY ENGINEERING (U.S. CLS. 100 AND 101).

FIRST USE 1-13-2008; IN COMMERCE 1-15-2008.  
TRACY CROSS, EXAMINING ATTORNEY

SN 85-071,751. LUIZ SÉRGIO ALVARES DE ROSE, SÃO PAULO, BRAZIL, FILED 6-25-2010.

The logo for Uni-Yoga features the word 'Uni-Yoga' in a stylized, rounded font. The 'Y' is significantly larger and more prominent than the other letters.

NO CLAIM IS MADE TO THE EXCLUSIVE RIGHT TO USE "YOGA", APART FROM THE MARK AS SHOWN.

THE MARK CONSISTS OF THE TERM "UNI-YOGA" WITH "UNI" IN WHITE WITH BLACK OUTLINE AND "YOGA" IN BLACK FONT. THERE IS AN IMAGE OF A PERSON IN A YOGA SITTING POSITION SUPERIMPOSED ON THE HEART-SHAPED LETTER "O".

**CLASS 9—ELECTRICAL AND SCIENTIFIC APPARATUS**

FOR COMPUTER SOFTWARE FOR USE IN TRAINING AND INSTRUCTION IN YOGA COURSES, EXERCISE COURSES, PHYSICAL FITNESS AND GYMNAS TIC EXERCISES; VISUAL AND AUDIO RECORDINGS FEATURING YOGA COURSES, EXERCISE COURSES, PHYSICAL FITNESS AND GYMNAS TIC EXERCISES (U.S. CLS. 21, 23, 26, 36 AND 38).

**CLASS 16—PAPER GOODS AND PRINTED MATTER**

FOR EXERCISE BOOKS; PRINTED INSTRUCTIONAL, EDUCATIONAL, AND TEACHING MATERIALS IN THE FIELD OF YOGA COURSES, EXERCISE COURSES, PHYSICAL FITNESS AND GYMNAS TIC EXERCISES; PRINTED VISUALS IN THE NATURE OF YOGA COURSES, EXERCISE COURSES, PHYSICAL FITNESS AND GYMNAS TIC EXERCISES (U.S. CLS. 2, 5, 22, 23, 29, 37, 38 AND 50).

**CLASS 25—CLOTHING**

FOR FOOTWEAR; T-SHIRTS; YOGA PANTS; YOGA SHIRTS (U.S. CLS. 22 AND 39).

**CLASS 41—EDUCATION AND ENTERTAINMENT**

FOR CONSULTING SERVICES IN THE FIELDS OF FITNESS AND EXERCISE; GYMNAS TIC INSTRUCTION; PHYSICAL FITNESS STUDIO SERVICES, NAMELY, PROVIDING EXERCISE CLASSES, BODY SCULPTING CLASSES, AND GROUP FITNESS CLASSES; PROVIDING ASSISTANCE, PERSONAL TRAINING AND PHYSICAL FITNESS CONSULTATION TO INDIVIDUALS TO HELP THEM MAKE PHYSICAL FITNESS, STRENGTH, CONDITIONING, AND EXERCISE IMPROVEMENT IN THEIR DAILY LIVING; PROVIDING INFORMATION IN THE FIELD OF EXERCISE TRAINING; YOGA INSTRUCTION (U.S. CLS. 100, 101 AND 107).

ZACHARY BELLO, EXAMINING ATTORNEY

SN 85-071,768. LUIZ SÉRGIO ALVARES DE ROSE, SÃO PAULO, BRAZIL, FILED 6-25-2010.

SN 85-071,826. THE AMERICAN LEGION, INDIANAPOLIS, IN. FILED 6-25-2010.



NO CLAIM IS MADE TO THE EXCLUSIVE RIGHT TO USE "METHOD", APART FROM THE MARK AS SHOWN.

THE MARK CONSISTS OF THE TERM "DEROSE METHOD" IN TWO LINES, A SILHOUETTE OF A PERSON IN A YOGA SITTING POSITION, AND TWO PARALLEL LINES—ONE ABOVE THE WORD "DEROSE" AND THE OTHER BELOW THE WORD "METHOD".

#### **CLASS 9—ELECTRICAL AND SCIENTIFIC APPARATUS**

FOR COMPUTER SOFTWARE FOR USE IN TRAINING AND INSTRUCTION IN YOGA COURSES, EXERCISE COURSES, PHYSICAL FITNESS AND GYMNAS TIC EXERCISES; VISUAL AND AUDIO RECORDINGS FEATURING YOGA COURSES, EXERCISE COURSES, PHYSICAL FITNESS AND GYMNAS TIC EXERCISES (U.S. CLS. 21, 23, 26, 36 AND 38).

#### **CLASS 16—PAPER GOODS AND PRINTED MATTER**

FOR EXERCISE BOOKS; PRINTED INSTRUCTIONAL, EDUCATIONAL, AND TEACHING MATERIALS IN THE FIELD OF YOGA COURSES, EXERCISE COURSES, PHYSICAL FITNESS AND GYMNAS TIC EXERCISES; PRINTED VISUALS IN THE NATURE OF YOGA COURSES, EXERCISE COURSES, PHYSICAL FITNESS AND GYMNAS TIC EXERCISES (U.S. CLS. 2, 5, 22, 23, 29, 37, 38 AND 50).

#### **CLASS 25—CLOTHING**

FOR FOOTWEAR; T-SHIRTS; YOGA PANTS; YOGA SHIRTS (U.S. CLS. 22 AND 39).

#### **CLASS 41—EDUCATION AND ENTERTAINMENT**

FOR CONSULTING SERVICES IN THE FIELDS OF FITNESS AND EXERCISE; GYMNAS TIC INSTRUCTION; PHYSICAL FITNESS STUDIO SERVICES, NAMELY, PROVIDING EXERCISE CLASSES, BODY SCULPTING CLASSES, AND GROUP FITNESS CLASSES; PROVIDING ASSISTANCE, PERSONAL TRAINING AND PHYSICAL FITNESS CONSULTATION TO INDIVIDUALS TO HELP THEM MAKE PHYSICAL FITNESS, STRENGTH, CONDITIONING, AND EXERCISE IMPROVEMENT IN THEIR DAILY LIVING; PROVIDING INFORMATION IN THE FIELD OF EXERCISE TRAINING; YOGA INSTRUCTION (U.S. CLS. 100, 101 AND 107).

ZACHARY BELLO, EXAMINING ATTORNEY

## **GIRLS STATE**

THE MARK CONSISTS OF STANDARD CHARACTERS WITHOUT CLAIM TO ANY PARTICULAR FONT, STYLE, SIZE, OR COLOR.

NO CLAIM IS MADE TO THE EXCLUSIVE RIGHT TO USE "GIRLS", APART FROM THE MARK AS SHOWN.

#### **CLASS 9—ELECTRICAL AND SCIENTIFIC APPARATUS**

FOR (BASED ON INTENT TO USE) COMPUTER STORAGE DEVICES, NAMELY, BLANK FLASH DRIVES (U.S. CLS. 21, 23, 26, 36 AND 38).

#### **CLASS 16—PAPER GOODS AND PRINTED MATTER**

FOR (BASED ON USE IN COMMERCE) BUMPER STICKERS, STICKERS, PRINTED CERTIFICATES, PENS, STATIONERY, ENVELOPES (U.S. CLS. 2, 5, 22, 23, 29, 37, 38 AND 50).

FIRST USE 12-31-1988; IN COMMERCE 12-31-1988.

#### **CLASS 18—LEATHER GOODS**

FOR (BASED ON INTENT TO USE) DRAW STRING TOTE BAGS, TOTE BAGS (U.S. CLS. 1, 2, 3, 22 AND 41).

#### **CLASS 20—FURNITURE AND ARTICLES NOT OTHERWISE CLASSIFIED**

FOR (BASED ON INTENT TO USE) NONMETAL KEY RINGS; NONMETAL KEY CHAINS; NONMETAL KEY FOBS, NONMETAL KEY CLIPS IN THE NATURE OF NONMETAL KEY HOLDERS AND NONMETAL KEY RINGS (U.S. CLS. 2, 13, 22, 25, 32 AND 50).

#### **CLASS 21—HOUSEWARES AND GLASS**

FOR (BASED ON INTENT TO USE) PLASTIC WATER BOTTLES SOLD EMPTY; ALUMINUM WATER BOTTLES SOLD EMPTY (U.S. CLS. 2, 13, 23, 29, 30, 33, 40 AND 50).

#### **CLASS 25—CLOTHING**

FOR (BASED ON INTENT TO USE) SWEATSHIRTS, T-SHIRTS, LONG SLEEVE SHIRTS, SHORTS, PAJAMA PANTS, YOGA PANTS, SWEAT PANTS, HATS, JACKETS, FLIP FLOPS (U.S. CLS. 22 AND 39).

#### **CLASS 26—FANCY GOODS**

FOR ORNAMENTAL CLOTH PATCHES (U.S. CLS. 37, 39, 40, 42 AND 50).

FIRST USE 12-31-2001; IN COMMERCE 12-31-2001.  
MARY CRAWFORD, EXAMINING ATTORNEY

SN 85-071,959. SUNRAY GAMING OF NEW MEXICO, LLC, DBA SUNRAY PARK & CASINO, FARMINGTON, NM. FILED 6-25-2010.

# SUNRAY

THE MARK CONSISTS OF STANDARD CHARACTERS WITHOUT CLAIM TO ANY PARTICULAR FONT, STYLE, SIZE, OR COLOR.

#### CLASS 41—EDUCATION AND ENTERTAINMENT

FOR ENTERTAINMENT IN THE NATURE OF SIMULCAST PRESENTATIONS OF LIVE SPORTING AND MUSICAL EVENTS; ENTERTAINMENT SERVICES, NAMELY, CASINO GAMING, COMEDY SHOWS, LIVE MUSICAL PERFORMANCES, AND CONDUCTING HORSE RACES (U.S. CLS. 100, 101 AND 107).

FIRST USE 7-2-1999; IN COMMERCE 7-2-1999.

#### CLASS 43—HOTEL AND RESTAURANT SERVICES

FOR RESTAURANT SERVICES, NAMELY, PROVIDING FOOD AND BEVERAGES FOR CONSUMPTION; PROVIDING SOCIAL MEETING, BANQUET, SOCIAL FUNCTION, CONFERENCE, EXHIBITION, AND MEETING FACILITIES (U.S. CLS. 100 AND 101).

FIRST USE 7-2-1999; IN COMMERCE 7-2-1999.  
KAREN BRACEY, EXAMINING ATTORNEY

SN 85-071,984. SUNRAY GAMING OF NEW MEXICO, LLC, DBA SUNRAY PARK & CASINO, FARMINGTON, NM. FILED 6-25-2010.

# X-RAYS

THE MARK CONSISTS OF STANDARD CHARACTERS WITHOUT CLAIM TO ANY PARTICULAR FONT, STYLE, SIZE, OR COLOR.

#### CLASS 41—EDUCATION AND ENTERTAINMENT

FOR ENTERTAINMENT IN THE NATURE OF SIMULCAST PRESENTATIONS OF LIVE SPORTING AND MUSICAL EVENTS (U.S. CLS. 100, 101 AND 107).

FIRST USE 12-19-2009; IN COMMERCE 12-19-2009.

#### CLASS 43—HOTEL AND RESTAURANT SERVICES

FOR PROVIDING SOCIAL MEETING, BANQUET, SOCIAL FUNCTION, CONFERENCE, EXHIBITION, AND MEETING FACILITIES (U.S. CLS. 100 AND 101).

FIRST USE 12-19-2009; IN COMMERCE 12-19-2009.  
KAREN BRACEY, EXAMINING ATTORNEY

SN 85-074,541. CELLARDOOR WINERY, INC., LINCOLNVILLE, ME. FILED 6-30-2010.

Live your life. Be who  
you are. Drink good wine  
along the way.

THE MARK CONSISTS OF STANDARD CHARACTERS WITHOUT CLAIM TO ANY PARTICULAR FONT, STYLE, SIZE, OR COLOR.

#### CLASS 21—HOUSEWARES AND GLASS

FOR WINE-RELATED HOUSEHOLD PRODUCTS, NAMELY, BEVERAGE GLASSWARE AND COOLERS FOR WINE (U.S. CLS. 2, 13, 23, 29, 30, 33, 40 AND 50).

#### CLASS 24—FABRICS

FOR TEXTILE GOODS, NAMELY, TOWELS, TABLE CLOTHS AND TABLE LINENS (U.S. CLS. 42 AND 50).

#### CLASS 25—CLOTHING

FOR CLOTHING, NAMELY, T-SHIRTS, SWEATSHIRTS, HATS AND APRONS (U.S. CLS. 22 AND 39).  
WARREN L. OLANDRIA, EXAMINING ATTORNEY

SN 85-074,549. LPS IP HOLDING COMPANY, LLC, JACKSONVILLE, FL. FILED 6-30-2010.

# PARAGON

THE MARK CONSISTS OF STANDARD CHARACTERS WITHOUT CLAIM TO ANY PARTICULAR FONT, STYLE, SIZE, OR COLOR.

OWNER OF U.S. REG. NO. 2,731,623.

#### CLASS 35—ADVERTISING AND BUSINESS

FOR REAL ESTATE AND MARKETING SERVICES FOR REAL ESTATE PROFESSIONALS, NAMELY, ONLINE DISPLAY OF RESIDENTIAL REAL ESTATE LISTINGS FEATURING VIRTUAL TOURS, PHOTOGRAPHS AND INFORMATION ABOUT THE LISTED PROPERTY; AND PROVIDING REAL ESTATE MARKET RESEARCH AND ANALYSIS FOR REAL ESTATE PROFESSIONALS (U.S. CLS. 100, 101 AND 102).

FIRST USE 10-1-2001; IN COMMERCE 10-1-2001.

#### CLASS 36—INSURANCE AND FINANCIAL

FOR PROVIDING A DATABASE OF INFORMATION ABOUT RESIDENTIAL REAL ESTATE LISTINGS IN DIFFERENT NEIGHBORHOODS AND COMMUNITIES FOR SALE, RENT AND LEASE, FOR USE BY REAL ESTATE PROFESSIONALS (U.S. CLS. 100, 101 AND 102).

FIRST USE 10-1-2001; IN COMMERCE 10-1-2001.

**CLASS 42—SCIENTIFIC AND COMPUTER SERVICES**

FOR PROVIDING TEMPORARY USE OF NON-DOWNLOADABLE SOFTWARE FOR REAL ESTATE PROFESSIONALS FOR USE IN CONDUCTING MORTGAGE ANALYSIS FEATURING ESTIMATES OF LOCAL LENDING RATES FOR MORTGAGES AND CLOSING RATES FOR REAL ESTATE SALES, AMORTIZATION, INVESTMENT AND PRICE ANALYSES (U.S. CLS. 100 AND 101).  
FIRST USE 10-1-2001; IN COMMERCE 10-1-2001.  
LESLEY LAMOTHE, EXAMINING ATTORNEY

SN 85-074.603. MIA'S MESSAGE, LLC, LONG BEACH, CA.  
FILED 6-30-2010.



THE COLOR(S) PINK, BLUE, BLACK AND WHITE IS/ARE CLAIMED AS A FEATURE OF THE MARK.

THE MARK CONSISTS OF A WHIMSICAL DRAWING OF A GIRL WITH A WHITE FACE AND ARM OUTLINED IN BLACK AND FEATURING BLACK FACIAL FEATURES AND HAIR WEARING A PINK DRESS HOLDING A BLUE ENVELOPE.

**CLASS 16—PAPER GOODS AND PRINTED MATTER**

FOR PRINTED MATERIALS, NAMELY, POSTCARDS, GREETING CARDS, NOTE CARDS, AND BUSINESS CARDS FOR MARKETING AND ADVERTISING, INCLUDING THOSE FOR THE INSURANCE INDUSTRY (U.S. CLS. 2, 5, 22, 23, 29, 37, 38 AND 50).

**CLASS 35—ADVERTISING AND BUSINESS**

FOR BUSINESS MANAGEMENT AND CONSULTING SERVICES REGARDING MARKETING AND ADVERTISING STRATEGIES, ACTIVITIES, TOOLS AND PROGRAMS, INCLUDING THOSE FOR THE INSURANCE INDUSTRY (U.S. CLS. 100, 101 AND 102).

KRISTINA MORRIS, EXAMINING ATTORNEY

SN 85-075.674. ABLENET, INC., ROSEVILLE, MN. FILED 7-1-2010.

# EQUALS

THE MARK CONSISTS OF STANDARD CHARACTERS WITHOUT CLAIM TO ANY PARTICULAR FONT, STYLE, SIZE, OR COLOR.

**CLASS 9—ELECTRICAL AND SCIENTIFIC APPARATUS**

FOR EDUCATIONAL SOFTWARE FEATURING INSTRUCTION IN THE FIELD OF MATH (U.S. CLS. 21, 23, 26, 36 AND 38).

**CLASS 16—PAPER GOODS AND PRINTED MATTER**

FOR PRINTED EDUCATIONAL MATERIALS IN THE FIELD OF MATH (U.S. CLS. 2, 5, 22, 23, 29, 37, 38 AND 50).

CHRISTINA SOBRAL, EXAMINING ATTORNEY

SN 85-076.672. AMERICAN TRAFFIC SOLUTIONS, SCOTTSDALE, AZ. FILED 7-2-2010.



THE COLOR(S) BLACK, WHITE AND YELLOW IS/ARE CLAIMED AS A FEATURE OF THE MARK.

THE MARK CONSISTS OF THE LETTERS "I","F","A","C","S", ALL IN BLACK, EXCEPT THE "A" WHICH IS IN YELLOW AND IN THE SHAPE OF A HIGHWAY WITH A WHITE LINE DOWN THE CENTER. THE BACKGROUND OF THE MARK IS TRANSPARENT.

**CLASS 9—ELECTRICAL AND SCIENTIFIC APPARATUS**

FOR COMPUTER SOFTWARE AND HARDWARE FOR PROCESSING TRAFFIC CITATIONS ON BEHALF OF FLEET AND RENTAL CAR COMPANIES; COMPUTER E-COMMERCE SOFTWARE TO ALLOW USERS TO PERFORM ELECTRONIC BUSINESS TRANSACTIONS VIA A GLOBAL COMPUTER NETWORK; COMPUTER SOFTWARE FOR COMPUTER SYSTEM AND APPLICATION DEVELOPMENT, DEPLOYMENT AND MANAGEMENT; COMPUTER SOFTWARE THAT PROVIDES WEB-BASED ACCESS TO APPLICATIONS AND SERVICES THROUGH A WEB OPERATING SYSTEM OR PORTAL INTERFACE; GLOBAL POSITIONING SYSTEM (GPS) CONSISTING OF COMPUTERS, COMPUTER SOFTWARE, TRANSMITTERS, RECEIVERS, AND NETWORK INTERFACE DEVICES; PATTERN RECOGNITION SYSTEMS COMPOSED OF COMPUTER CHIPS, COMPUTER HARDWARE AND SOFTWARE; COMPUTER PROGRAMS FOR TRAFFIC MANAGEMENT AND ENFORCEMENT; COMPUTER SOFTWARE FOR PROVIDING AN ON-LINE DATABASE IN THE FIELD OF TRANSACTION PROCESSING TO UPLOAD TRANSACTIONAL DATA, PROVIDE STATISTICAL ANALYSIS, AND PRODUCE NOTIFICATIONS AND REPORTS; COMPUTER HARDWARE AND SOFTWARE SYSTEMS FOR PROCESSING TRAFFIC CITATIONS ON BEHALF OF FLEET AND RENTAL CAR COMPANIES; COMPUTER PERIPHERAL AND DATA PROCESSING EQUIPMENT (U.S. CLS. 21, 23, 26, 36 AND 38).

**CLASS 35—ADVERTISING AND BUSINESS**

FOR PREPARATION OF BUSINESS REPORTS IN THE NATURE OF ISSUANCE OF REPORTS AND CITATIONS REGARDING VIOLATIONS OF CUSTOMERS OF FLEET AND RENTAL CAR COMPANIES TO SUCH COMPANIES (U.S. CLS. 100, 101 AND 102).

MORGAN WYNNE, EXAMINING ATTORNEY

SN 85-078,462. CARLISLE INTANGIBLE COMPANY, SYRACUSE, NY. FILED 7-6-2010.

**PERFORMANCE  
PROVEN.....PERFORMANCE  
DRIVEN**

THE MARK CONSISTS OF STANDARD CHARACTERS WITHOUT CLAIM TO ANY PARTICULAR FONT, STYLE, SIZE, OR COLOR.

#### **CLASS 7—MACHINERY**

FOR TRANSMISSION BELTS NOT FOR LAND VEHICLES (U.S. CLS. 13, 19, 21, 23, 31, 34 AND 35).

#### **CLASS 12—VEHICLES**

FOR TRANSMISSION BELTS FOR ATVS AND SNOWMOBILES (U.S. CLS. 19, 21, 23, 31, 35 AND 44).  
BILL DAWE, EXAMINING ATTORNEY

SN 85-078,862. DELTA EDUCATION, LLC, NASHUA, NH. FILED 7-6-2010.



**INQUIRY  
INVESTIGATIONS**

NO CLAIM IS MADE TO THE EXCLUSIVE RIGHT TO USE "INQUIRY INVESTIGATIONS", APART FROM THE MARK AS SHOWN.

THE MARK CONSISTS OF THE WORD "INQUIRY" ON TOP OF THE WORD "INVESTIGATIONS" WITH A SWIRL PATTERN AROUND THE "I" IN "INQUIRY".

#### **CLASS 9—ELECTRICAL AND SCIENTIFIC APPARATUS**

FOR TEACHER RESOURCE SOFTWARE FOR USE IN FACILITATING STUDENT LEARNING INVOLVING OBJECT-BASED VIRTUAL LABS, SUBJECT-SPECIFIC TUTORIALS, ASSESSMENT QUESTIONS, HANDOUT GRAPHICS, ANIMATIONS, UTILITY ALLOWING FOR MODIFICATION OF EDITORIAL CONTENT AND WEB DELIVERY, GLOSSARY OF SUBJECT-RELATED TERMS, CORRELATION OF RELATED KIT MATERIALS AND SOFTWARE CONTENT TO NATIONAL SCIENCE EDUCATION STANDARDS, WEB-LINKS FOR STATE STANDARDS ALL FOR USE WITH A SERIES OF MIDDLE SCHOOL AND HIGH-SCHOOL INVESTIGATION KITS (U.S. CLS. 21, 23, 26, 36 AND 38).

#### **CLASS 16—PAPER GOODS AND PRINTED MATTER**

FOR SERIES OF MIDDLE SCHOOL AND HIGH SCHOOL INVESTIGATION KITS COMPRISED OF PRINTED PAPER MATERIALS, NAMELY, CURRICULUM GUIDES, STUDENT COPYMASTER WORKSHEETS, TEACHER'S GUIDE BOOKLETS, STUDENT GUIDE SHEETS, MATERIAL SAFETY DATA SHEETS, LAMINATED PAPER POSTERS, PRINTED ARTICLES FOR STUDENTS, CHEMICALS AND CHEMICAL REAGENTS, NAMELY, ACIDS, BASES, SALTS, INORGANICS, ORGANICS, INDICATORS AND BUFFERS, STRAWS, STRING, MAGNIFIERS AND MAGNETS, SOLD TOGETHER AS A UNIT (U.S. CLS. 2, 5, 22, 23, 29, 37, 38 AND 50).

KATHY DE JONGE, EXAMINING ATTORNEY

SN 85-079,126. ADESSO INC., NEW YORK, NY. FILED 7-7-2010.

**SHAPING THE FUTURE OF HOME  
DESIGN**

THE MARK CONSISTS OF STANDARD CHARACTERS WITHOUT CLAIM TO ANY PARTICULAR FONT, STYLE, SIZE, OR COLOR.

#### **CLASS 11—ENVIRONMENTAL CONTROL APPARATUS**

FOR LAMPS, ELECTRIC LIGHTING FIXTURES, ELECTRIC LANTERNS, TORCHIERES, PORTABLE ELECTRIC LIGHTING, NAMELY, DESK LAMPS, TABLE LAMPS AND FLOOR LAMPS (U.S. CLS. 13, 21, 23, 31 AND 34).

FIRST USE 12-31-1999; IN COMMERCE 12-31-1999.

#### **CLASS 20—FURNITURE AND ARTICLES NOT OTHERWISE CLASSIFIED**

FOR READY TO ASSEMBLE FURNITURE, NAMELY, TABLES, CHAIRS, STOOLS, DESKS, FOLDING SCREENS, FOOT STOOLS, SHELVES, TV STANDS, PEDESTALS, MAGAZINE RACKS (U.S. CLS. 2, 13, 22, 25, 32 AND 50).

FIRST USE 12-31-1999; IN COMMERCE 12-31-1999.

JAMES GRIFFIN, EXAMINING ATTORNEY

SN 85-079,606. JARED COOPER, JERICHO, NY. FILED 7-7-2010.

**Sports Power Weekends**

THE MARK CONSISTS OF STANDARD CHARACTERS WITHOUT CLAIM TO ANY PARTICULAR FONT, STYLE, SIZE, OR COLOR.

NO CLAIM IS MADE TO THE EXCLUSIVE RIGHT TO USE "SPORTS" AND "WEEKENDS", APART FROM THE MARK AS SHOWN.

**CLASS 39—TRANSPORTATION AND STORAGE**

FOR PROVIDING A WEB SITE AND WEB SITE LINKS TO TRAVEL INFORMATION, GEOGRAPHIC INFORMATION, MAPS, MAP IMAGES AND TRIP ROUTING; ORGANIZING AND ARRANGING TRAVEL ACTIVITIES, NAMELY, FOR TOURS, TRAVEL TO SPORTING EVENTS AND TRAVEL ATTRACTIONS; PROVIDING INFORMATION ABOUT TRAVEL TO SPORTING EVENTS AND ATTRACTIONS AND TOURS; ORGANIZING SITE-SEEING TOURS; TRAVEL AGENCY SERVICES, NAMELY, MAKING RESERVATIONS AND BOOKINGS FOR TRANSPORTATION; TRAVEL AND TOUR TICKET RESERVATION SERVICES TO SPORTING EVENTS; PROVIDING NEWS IN THE FIELD OF SPORTS TRAVEL (U.S. CLS. 100 AND 105).

**CLASS 41—EDUCATION AND ENTERTAINMENT**

FOR COMPUTER SERVICES, NAMELY, PROVIDING ONLINE ARTICLES, BLOGS, AND AUDIO VISUAL PRESENTATIONS IN THE FIELDS OF SPORTS, TRAVEL PLANNING, BARS AND CLUBS, FOOD AND DRINK, NEIGHBORHOODS AND CULTURE, AND RESTAURANTS (U.S. CLS. 100, 101 AND 107).

H. M. FISHER, EXAMINING ATTORNEY

SN 85-079,947. FAIGEN, STEVE, WASHINGTON, DC. FILED 7-8-2010.

**HEALTHCENTIVE**

THE MARK CONSISTS OF STANDARD CHARACTERS WITHOUT CLAIM TO ANY PARTICULAR FONT, STYLE, SIZE, OR COLOR.

**CLASS 41—EDUCATION AND ENTERTAINMENT**

FOR EDUCATION SERVICES, NAMELY, SERVICES PROVIDING INCENTIVES TO ENCOURAGE INDIVIDUALS TO SET UP AND ACHIEVE HEALTH GOALS RELATING TO PHYSICAL WELLNESS, WORKPLACE HABITS, AND SOCIAL ENGAGEMENT BEHAVIORS THROUGH STUDENT PERFORMANCE EVALUATION, AND PHYSICAL FITNESS TRAINING; EDUCATION SERVICES THAT PROVIDE EVALUATION AND ONLINE TRACKING OF STUDENT PERFORMANCE IN FOREGOING INCENTIVE PROGRAM FOR HEALTH INSURERS, MEDICAL SERVICE PROVIDERS, HUMAN RESOURCE SERVICE PROVIDERS, EMPLOYERS AND GOVERNMENT AGENCIES (U.S. CLS. 100, 101 AND 107). FIRST USE 12-31-2007; IN COMMERCE 2-5-2008.

**CLASS 42—SCIENTIFIC AND COMPUTER SERVICES**

FOR PROVIDING A WEBSITE FEATURING TECHNOLOGY THAT ENABLES HEALTH INSURERS, MEDICAL SERVICE PROVIDERS, HUMAN RESOURCE SERVICE PROVIDERS, EMPLOYERS AND GOVERNMENT AGENCIES TO MANAGE HEALTH ASSESSMENT RESULTS, AS WELL AS ADMINISTER AND MANAGE INCENTIVE AWARD PROGRAMS AND OTHER MEANS TO ENABLE BEHAVIOR CHANGE AS TO HEALTH FOR INDIVIDUALS AND GROUPS IN THE NATURE OF SOFTWARE SYSTEMS AND RELATED SOFTWARE TECHNOLOGIES IN THE AREAS OF PHYSICAL WELLNESS, WORKPLACE HABITS RELATING TO HEALTH, AND SOCIAL ENGAGEMENT BEHAVIORS RELATING TO HEALTH (U.S. CLS. 100 AND 101). FIRST USE 12-31-2007; IN COMMERCE 2-5-2008.

TINA MAI, EXAMINING ATTORNEY

SN 85-080,029. STEVENSON UNIVERSITY, INC., STEVENSON, MD. FILED 7-8-2010.



THE MARK CONSISTS OF A STYLIZED LETTER "S" WITH CURVED LINED AREAS ON EACH SIDE.

**CLASS 25—CLOTHING**

FOR CLOTHING, NAMELY, SHIRTS, T-SHIRTS, BLOUSES, PANTS, SHORTS, SWEATSHIRTS, SWEATPANTS, WARM-UP SUITS, SLEEPWEAR, SWEATERS, JACKETS, COATS, HATS, VISORS, UNIFORMS, UNDERGARMENTS, SCARVES, SOCKS, TIES, APRONS, INFANTWEAR, CLOTH BIBS (U.S. CLS. 22 AND 39).

**CLASS 41—EDUCATION AND ENTERTAINMENT**

FOR ARRANGING AND CONDUCTING ATHLETIC EVENTS IN THE NATURE OF BASEBALL, BASKETBALL, CHEER, CROSS COUNTRY, FIELD HOCKEY, FOOTBALL, GOLF, ICE HOCKEY, LACROSSE, SOFTBALL, SOCCER, TENNIS, TRACK AND FIELD, AND VOLLEYBALL, RECREATION PROGRAMS IN THE NATURE OF ATHLETIC TRAINING, INTRAMURALS AND SPORTS CAMPS, AND BASEBALL, BASKETBALL, CHEER, CROSS COUNTRY, FIELD HOCKEY, FOOTBALL, GOLF, ICE HOCKEY, LACROSSE, SOFTBALL, SOCCER, TENNIS, TRACK AND FIELD, AND VOLLEYBALL TOURNAMENTS; ARRANGING AND CONDUCTING EDUCATIONAL CONFERENCES; ENTERTAINMENT SERVICES, NAMELY, ATHLETIC PERFORMANCES IN THE NATURE OF COMPETITIONS IN THE FIELD OF ATHLETICS, CULTURAL EVENTS IN THE NATURE OF DANCE PERFORMANCES AND LIVE MUSICAL PERFORMANCES, LIVE MUSICAL AND LIVE DRAMATIC PERFORMANCES (U.S. CLS. 100, 101 AND 107). BRENDAN MCCAULEY, EXAMINING ATTORNEY

SN 85-080,039. STEVENSON UNIVERSITY, INC., STEVENSON, MD. FILED 7-8-2010.



THE MARK CONSISTS OF A PROFILE OF THE HEAD AND NECK OF A MUSTANG HORSE WITH A STYLIZED LETTER "S" INSIDE THE HORSE'S HEAD AND NECK AREA.

**CLASS 25—CLOTHING**

FOR CLOTHING, NAMELY, SHIRTS, T-SHIRTS, BLOUSES, PANTS, SHORTS, SWEATSHIRTS, SWEATPANTS, WARM-UP SUITS, SLEEPWEAR, SWEATERS, JACKETS, COATS, HATS, VISORS, UNIFORMS, UNDERGARMENTS, SCARVES, SOCKS, TIES, APRONS, INFANTWEAR, CLOTH BIBS (U.S. CLS. 22 AND 39).

**CLASS 41—EDUCATION AND ENTERTAINMENT**

FOR ARRANGING AND CONDUCTING ATHLETIC EVENTS IN THE NATURE OF BASEBALL, BASKETBALL, CHEER, CROSS COUNTRY, FIELD HOCKEY, FOOTBALL, GOLF, ICE HOCKEY, LACROSSE, SOFTBALL, SOCCER, TENNIS, TRACK AND FIELD, AND VOLLEYBALL, RECREATION PROGRAMS IN THE NATURE OF ATHLETIC TRAINING, INTRAMURALS AND SPORTS CAMPS, AND BASEBALL, BASKETBALL, CHEER, CROSS COUNTRY, FIELD HOCKEY, FOOTBALL, GOLF, ICE HOCKEY, LACROSSE, SOFTBALL, SOCCER, TENNIS, TRACK AND FIELD, AND VOLLEYBALL TOURNAMENTS; ARRANGING AND CONDUCTING EDUCATIONAL CONFERENCES; ENTERTAINMENT SERVICES, NAMELY, ATHLETIC PERFORMANCES IN THE NATURE OF COMPETITIONS IN THE FIELD OF ATHLETICS, CULTURAL EVENTS IN THE NATURE OF DANCE PERFORMANCES AND LIVE MUSICAL PERFORMANCES, LIVE MUSICAL AND LIVE DRAMATIC PERFORMANCES (U.S. CLS. 100, 101 AND 107).

BRENDAN MCCAULEY, EXAMINING ATTORNEY

SN 85-081,127. ACFIN LICENSING LTD, LONDON, UNITED KINGDOM, FILED 7-9-2010.



PRIORITY CLAIMED UNDER SEC. 44(D) ON ERP N CMNTY TM OFC APPLICATION NO. 008870206, FILED 2-9-2010, REG. NO. 008870206, DATED 6-28-2010, EXPIRES 9-2-2020.

THE MARK CONSISTS OF THE WORDS "NO HUNGER" WITH A DARK RECTANGULAR WRAPPER DESIGN BEHIND THE WORD "NO".

**CLASS 35—ADVERTISING AND BUSINESS**

FOR ADVERTISING; BUSINESS ADMINISTRATION; PROVIDING OFFICE FUNCTIONS; BUSINESS SERVICES, NAMELY, BUSINESS MANAGEMENT SERVICES IN CONNECTION WITH FUND RAISING CAMPAIGNS; CHARITABLE SERVICES, NAMELY, ORGANIZING AND CONDUCTING VOLUNTEER PROGRAMS AND COMMUNITY SERVICE PROJECTS; PROMOTING PUBLIC AWARENESS CAMPAIGNS AIMED AT NUTRITION, FOOD SECURITY AND SUSTAINABILITY, WATER AND SANITATION AND PUBLIC HYGIENE; BUSINESS SERVICES, NAMELY, DEVELOPING FUNDRAISING CAMPAIGNS FOR OTHERS; PROMOTING PUBLIC AWARENESS OF PUBLIC HEALTH ISSUES AS AFFECTED BY NUTRITION, FOOD SECURITY AND SUSTAINABILITY, WATER AND SANITATION AND PUBLIC HYGIENE; ORGANIZING AND CONDUCTING CHARITY EVENTS IN THE NATURE OF AUCTIONS FOR CHARITABLE FUND RAISING PURPOSES (U.S. CLS. 100, 101 AND 102).

**CLASS 36—INSURANCE AND FINANCIAL**

FOR PROVIDING FINANCIAL SUPPORT SERVICES TO THOSE IN NEED FOR CHARITABLE PURPOSES; MONETARY AFFAIRS, NAMELY, PROVIDING FINANCIAL INFORMATION; MANAGEMENT AND ANALYSIS SERVICES; CHARITABLE FUNDRAISING SERVICES, NAMELY, ORGANIZING AND COLLECTING MONETARY DONATIONS FOR CHARITABLE PURPOSES; CHARITABLE SERVICES, NAMELY, PROVIDING FINANCIAL AID TO THOSE IN NEED; CHARITABLE SERVICES, NAMELY, RAISING AND COLLECTING MONEY FOR THE FUNDING OF MEDICAL ATTENTION AND NUTRITION COUNSELING PROGRAMS; CHARITABLE FUND RAISING SERVICES; FINANCIAL SPONSORSHIP OF INTERNATIONAL AID AND DEVELOPMENT PROJECTS; CHARITABLE FUNDRAISING SERVICES BY MEANS OF ORGANIZING AND CONDUCTING SPECIAL EVENTS (U.S. CLS. 100, 101 AND 102).

**CLASS 41—EDUCATION AND ENTERTAINMENT**

FOR EDUCATIONAL SERVICES, NAMELY, PROVIDING TRAINING IN THE NATURE OF WORKSHOPS, CONFERENCES AND SEMINARS IN THE FIELDS OF NUTRITION, FOOD SECURITY AND SUSTAINABILITY, WATER AND SANITATION, PUBLIC HYGIENE AND PUBLIC HEALTH ADVOCACY ISSUES; ENTERTAINMENT SERVICES, NAMELY, ORGANIZING COMMUNITY SPORTING AND CULTURAL EVENTS; EDUCATIONAL SERVICES, NAMELY, CONDUCTING EDUCATIONAL PROGRAMS IN THE FIELDS OF NUTRITION, FOOD SECURITY AND SUSTAINABILITY, WATER AND SANITATION, PUBLIC HYGIENE, PUBLIC HEALTH AND RELATED ADVOCACY ISSUES (U.S. CLS. 100, 101 AND 107).

STEVEN JACKSON, EXAMINING ATTORNEY

SN 85-081,365. WORLD PAC, INC., NEWARK, CA. FILED 7-9-2010.



THE MARK CONSISTS OF THE LETTERS "W","S","O" WITH THE PICTURE OF A GLOBE UNDERNEATH, BOTH OF WHICH ARE INSIDE A RECTANGULAR BOX WITH ROUNDED EDGES.

**CLASS 7—MACHINERY**

FOR WINDOW LIFT MOTORS; IGNITION PARTS FOR LAND VEHICLES, NAMELY, IGNITION COILS; IGNITION DEVICES FOR MOTORS OF LAND VEHICLES COMPRISED OF IGNITION COILS AND RELAYS; ALTERNATORS FOR LAND VEHICLES; STARTERS FOR MOTORS AND ENGINES (U.S. CLS. 13, 19, 21, 23, 31, 34 AND 35).

FIRST USE 2-18-2010; IN COMMERCE 2-18-2010.

**CLASS 12—VEHICLES**

FOR WINDOW REGULATORS FOR LAND VEHICLES (U.S. CLS. 19, 21, 23, 31, 35 AND 44).  
FIRST USE 2-16-2010; IN COMMERCE 2-16-2010.  
KATHLEEN LORENZO, EXAMINING ATTORNEY

SN 85-083,946. LINE SHIFT MANAGEMENT GROUP, INC.,  
CENTENNIAL, CO. FILED 7-13-2010.



THE MARK CONSISTS OF STYLIZED WORDS "I WAS THERE" IN THREE ROWS, WITH THE WORD "I" IN THE FIRST ROW, "WAS" IN THE SECOND ROW, "THERE" IN THE THIRD ROW AND A DOT UNDER LETTER "H" IN THE WORD "THERE".

**CLASS 25—CLOTHING**

FOR A-SHIRTS; APPAREL FOR DANCERS, NAMELY, TEE SHIRTS, SWEATSHIRTS, PANTS, LEGGINGS, SHORTS AND JACKETS; AQUA SHOES; ATHLETIC APPAREL, NAMELY, SHIRTS, PANTS, JACKETS, FOOTWEAR, HATS AND CAPS, ATHLETIC UNIFORMS; ATHLETIC SHOES; BABY BOTTOMS; BABY TOPS; BASEBALL CAPS AND HATS; BASE LAYER BOTTOMS; BASE LAYER TOPS; BEACH SHOES; BELTS, NAMELY BELTS FOR CLOTHING; BELTS MADE FROM IMITATION LEATHER; BELTS MADE OF LEATHER; BELTS MADE OUT OF CLOTH; BELTS OF TEXTILE; BOAT SHOES; BODY SHIRTS; BOTTOMS; BUTTON-FRONT ALOHA SHIRTS; CAMOUFLAGE PANTS; CAMOUFLAGE SHIRTS; CAMP SHIRTS; CANVAS SHOES; CAPRI PANTS; CARGO PANTS; CHEF'S HATS; CLIMBING SHOES; CLOTHING FOR ATHLETIC USE, NAMELY, PADDED PANTS; CLOTHING FOR ATHLETIC USE, NAMELY, PADDED SHIRTS; COSTUMES FOR USE IN CHILDREN'S DRESS UP PLAY; CROP TOPS; CYCLING SHOES; DANCE SHOES; DECK-SHOES; DENIMS; DISPOSABLE UNDERWEAR; DRESS SHIELDS; DRESS SHIRTS; DRESSES THAT MAY ALSO BE USED AS TOWELS; DRESSING GOWNS; DRESSING GOWNS AND BATH ROBES; DRIVERS; FISHING SHIRTS; FITTED SHOE OR BOOT COVERING TO PROTECT THE SHOES OR BOOT FROM WATER OR OTHER DAMAGE; FUR HATS; GOLF PANTS, SHIRTS AND SKIRTS; GOLF SHIRTS; GOLF SHOES; GYM PANTS; GYMNASTIC SHOES; HALTER TOPS; HAT BANDS; HATS; HATS FOR INFANTS, BABIES, TODDLERS AND CHILDREN; HOODED SWEAT SHIRTS; HUNTING PANTS; HUNTING SHIRTS; INFANTS' SHOES AND BOOTS; JACKETS AND SOCKS; JEANS; JOGGING PANTS; KNIT SHIRTS; KNITTED UNDERWEAR; LADIES' UNDERWEAR; LEATHER BELTS; LEATHER HATS; LEATHER PANTS; LEATHER SHIRTS; LEISURE SHOES; LONG UNDERWEAR; LONG-SLEEVED SHIRTS; LOUNGE PANTS; MEN'S DRESS SOCKS; MEN'S SOCKS; MEN'S UNDERWEAR; MOISTURE-WICKING SPORTS BRAS; MOISTURE-WICKING SPORTS PANTS; MOISTURE-WICKING SPORTS SHIRTS; MONEY BELTS; MOUNTAINEERING SHOES; MUSCLE TOPS; NIGHT SHIRTS; NON-DISPOSABLE CLOTH TRAINING PANTS; NURSE DRESSES; NURSE PANTS; OPEN-NECKED SHIRTS; OVER SHIRTS; PAJAMA BOTTOMS; PANTIES; SHORTS AND BRIEFS; PANTS; PAPER HATS FOR USE AS CLOTHING ITEMS; PARTY HATS; PERSPIRATION ABSORBENT UNDERWEAR CLOTHING; PETTI-PANTS; PIQUE SHIRTS; POLO KNIT TOPS; POLO SHIRTS; RACE NUMBER BELTS THAT HOLD A PAPER NUMBER ON THE RACE PARTICIPANT'S FRONT OR BACK

DURING COMPETITION; RAIN HATS; RIDING SHOES; RUBBER SHOES; RUGBY SHIRTS; RUGBY SHOES; RUGBY TOPS; RUNNING PADS THAT STRAP ONTO SHOES; RUNNING SHOES; SANDALS AND BEACH SHOES; SCIENTIFIC AND TECHNOLOGICAL APPAREL, NAMELY, SHIRTS, PANTS, JACKETS, FOOTWEAR, HATS AND CAPS, UNIFORMS; SEDGE HATS (SUGE-GASA); SHIRT FRONTS; SHIRT YOKES; SHIRTS AND SHORT-SLEEVED SHIRTS; SHIRTS FOR INFANTS, BABIES, TODDLERS AND CHILDREN; SHIRTS FOR SUITS; SHOE COVERS FOR USE WHEN WEARING SHOES; SHOES; SHORT-SLEEVED OR LONG-SLEEVED T-SHIRTS; SHORT-SLEEVED SHIRTS; SKI AND SNOWBOARD SHOES AND PARTS THEREOF; SKI PANTS; SKIING SHOES; SKIRTS AND DRESSES; SLEEP PANTS; SLEEP SHIRTS; SLIPPER SOCKS; SMALL HATS; SNOW PANTS; SNOWBOARD PANTS; SOCCER SHOES; SOCKS AND STOCKINGS; SPORT SHIRTS; SPORTS CAPS AND HATS; SPORTS PANTS; SPORTS SHIRTS; SPORTS SHIRTS WITH SHORT SLEEVES; STRETCH PANTS; SUSPENDER BELTS; SUSPENDER BELTS FOR MEN; SUSPENDER BELTS FOR WOMEN; SWEAT PANTS; SWEAT SHIRTS; SWIMSUITS; SWIMWEAR; T-SHIRTS; TANK TOPS; TAP PANTS; TAP SHOES; TENNIS DRESSES; TENNIS SHOES; THERMAL SOCKS; THERMAL UNDERWEAR; THONGS; TOBOGGAN HATS, PANTS AND CAPS; TONGUE OR PULL STRAP FOR SHOES AND BOOTS; TOP COATS; TOPS; TRACK AND FIELD SHOES; TRACK PANTS; TRAINING SHOES; TRAVEL CLOTHING CONTAINED IN A PACKAGE COMPRISING REVERSIBLE JACKETS, PANTS, SKIRTS, TOPS AND A BELT OR SCARF. TRIATHLON CLOTHING, NAMELY, TRIATHLON TIGHTS, TRIATHLON SHORTS, TRIATHLON SHIRTS, TRIATHLON SUITS; TUBE TOPS; TURTLE NECK SHIRTS; TUXEDO BELTS; UNDERWEAR, NAMELY, BOY SHORTS; VOLLEYBALL SHOES; WAIST BELTS; WATER REPELLING LEATHER SHOES AND BOOTS; WATER SOCKS; WATERPROOF JACKETS AND PANTS; WATERPROOF LEATHER SHOES; WATERPROOF LEATHER SHOES AND BOOTS; WEARABLE GARMENTS AND CLOTHING, NAMELY, SHIRTS; WIND PANTS; WIND SHIRTS; WOMEN'S HATS AND HOODS; WOMEN'S SHOES; WOMEN'S TOPS, NAMELY, CAMIS; WOOLEN SOCKS; WOOLLY HATS; WORK SHOES AND BOOTS; YOGA PANTS; YOGA SHIRTS (U.S. CLS. 22 AND 39).

**CLASS 35—ADVERTISING AND BUSINESS**

FOR PROMOTING THE GOODS AND SERVICES OF OTHERS BY PROVIDING A WEBSITE AT WHICH USERS CAN LINK TO THE WEBSITES OF OTHERS AND BY PROVIDING INFORMATION; PROMOTING THE SPECIAL EVENTS OF OTHERS; PROMOTING CULTURAL EVENTS, RESTAURANTS, SHOPPING, AND TRAVEL BY MEANS OF PROVIDING AN ONLINE EVENTS CALENDAR AND INFORMATION ABOUT CULTURAL EVENTS, RESTAURANTS, SHOPPING, AND TRAVEL EVENTS VIA AN INTERNET WEBSITE; PROVIDING ADVERTISING SPACE TO DISTRIBUTE ADVERTISEMENT REGARDING CULTURAL EVENTS, RESTAURANTS, SHOPPING, AND TRAVEL EVENT INFORMATION FOR DISPLAY ELECTRONICALLY, NAMELY, IN WEBSITES, EVENT LISTINGS, BLOGS, MULTIMEDIA MESSAGES, AND SOCIAL NETWORKS; CREATION OF MARKETING TOOLS DESIGNED TO INCREASE A CLIENT COMPANY'S KNOWLEDGE OF CUSTOMER NEEDS, AND ITS COMPETITORS' PRODUCTS AND SERVICES, PRICING, ADVERTISING STRATEGY AND SALES STRATEGY; PROVIDING ANALYTICS REPORTS RELATING TO BUSINESS MATTERS; BUSINESS INFORMATION MANAGEMENT, NAMELY, ELECTRONIC REPORTING OF BUSINESS INFORMATION; ADVERTISING SERVICES, NAMELY, PROMOTING AND MARKETING THE GOODS AND SERVICES OF OTHERS IN THE FIELD OF UPSCALE CHOICES SUCH AS CULTURAL EVENTS, RESTAURANTS, SHOPPING, AND TRAVEL VIA PRINT AND ELECTRONIC MEDIA; MARKETING, ADVERTISING AND PROMOTING THE GOODS AND SERVICES OF OTHERS IN THE FIELD OF TRAVEL AND TOURISM, NAMELY, PROVIDING INFORMATION VIA MAIL AND ELECTRONIC MAIL; PROVIDING BUSINESS AND COMMERCIAL INFORMATION IN THE FIELD OF BUSINESS TRAVEL MANAGEMENT AND THE BUSINESS TRAVEL INDUSTRY; PUBLIC RELATIONS, ADVERTISING AND MARKETING SERVICES FOR THE VARIOUS PUBLIC EVENTS (U.S. CLS. 100, 101 AND 102).



JANICE KIM, EXAMINING ATTORNEY

---

SN 85-084,223. BASF CORPORATION, FLORHAM PARK, NJ.  
FILED 7-14-2010.

# SELECT

THE MARK CONSISTS OF STANDARD CHARACTERS WITHOUT CLAIM TO ANY PARTICULAR FONT, STYLE, SIZE, OR COLOR.

## **CLASS 9—ELECTRICAL AND SCIENTIFIC APPARATUS**

FOR COMPUTER SOFTWARE FOR DATABASE MANAGEMENT OF DATA RELATED TO ENVIRONMENTAL CERTIFICATION PROGRAMS, ENVIRONMENTAL REGULATIONS AND ENVIRONMENTAL CERTIFICATION STANDARDS (U.S. CLS. 21, 23, 26, 36 AND 38).

## **CLASS 35—ADVERTISING AND BUSINESS**

FOR PROVIDING AN ON-LINE SEARCHABLE DATABASE FOR IDENTIFYING CERTIFICATION OR LABELING CRITERIA AND OTHER INFORMATION RELATED TO REVIEWING OR COMPLYING WITH STANDARDS APPLICABLE TO ENVIRONMENTAL PERFORMANCE PROGRAMS, ENVIRONMENTAL REGULATIONS, AND ENVIRONMENTAL CERTIFICATIONS (U.S. CLS. 100, 101 AND 102).

JIM RINGLE, EXAMINING ATTORNEY

---

SN 85-084,936. ERICSSON FEDERAL INC., RESTON, VA.  
FILED 7-14-2010.

# OCEUS NETWORKS

THE MARK CONSISTS OF STANDARD CHARACTERS WITHOUT CLAIM TO ANY PARTICULAR FONT, STYLE, SIZE, OR COLOR.

NO CLAIM IS MADE TO THE EXCLUSIVE RIGHT TO USE "NETWORKS", APART FROM THE MARK AS SHOWN.

## **CLASS 9—ELECTRICAL AND SCIENTIFIC APPARATUS**

FOR TELECOMMUNICATIONS AND DATA NETWORKING HARDWARE, NAMELY, DEVICES FOR TRANSPORTING AND AGGREGATING VOICE, DATA, AND VIDEO COMMUNICATIONS ACROSS MULTIPLE NETWORK INFRASTRUCTURES AND COMMUNICATIONS PROTOCOLS; WIRELESS ADAPTERS USED TO LINK COMPUTERS TO A TELECOMMUNICATIONS NETWORK; COMPUTER HARDWARE EQUIPMENT USED IN COMMUNICATIONS TECHNOLOGY NETWORKS AND COMPUTER SOFTWARE FOR OPERATING COMMUNICATIONS TECHNOLOGY NETWORKS; BROADBAND POWER LINE COMMUNICATION SYSTEMS FOR TRANSFERRING BROADBAND DATA OVER ELECTRICAL POWER LINES, COMPRISED OF COMPUTER HARDWARE, SOFTWARE AND MODEMS; BROADBAND RADIOS; BROADBAND WIRELESS EQUIPMENT, NAMELY, TELECOMMUNICATIONS BASE STATION EQUIPMENT FOR CELLULAR AND FIXED NETWORKING AND COMMUNICATIONS APPLICATIONS; WIRELESS BROADBAND RADIOS (U.S. CLS. 21, 23, 26, 36 AND 38).

## **CLASS 35—ADVERTISING AND BUSINESS**

FOR TELECOMMUNICATIONS NETWORK MANAGEMENT SERVICES, NAMELY, THE OPERATION AND ADMINISTRATION OF TELECOMMUNICATION SYSTEMS AND NETWORKS FOR OTHERS (U.S. CLS. 100, 101 AND 102).

## **CLASS 38—COMMUNICATION**

FOR COMMUNICATION SERVICES, NAMELY, TRANSMISSION OF VOICE, AUDIO, VISUAL IMAGES AND DATA BY TELECOMMUNICATIONS NETWORKS, WIRELESS COMMUNICATION NETWORKS, THE INTERNET, INFORMATION SERVICES NETWORKS AND DATA NETWORKS; DIGITAL NETWORK TELECOMMUNICATIONS SERVICES; ELECTRONIC EXCHANGE OF DATA STORED IN DATABASES ACCESSIBLE VIA TELECOMMUNICATION NETWORKS; PROVIDING ACCESS TO TELECOMMUNICATION NETWORKS; PROVIDING TELECOMMUNICATIONS CONNECTIONS TO A GLOBAL COMPUTER NETWORK; TELECOMMUNICATION SERVICES, NAMELY, TRANSMISSION OF VOICE, DATA, GRAPHICS, SOUND AND VIDEO BY MEANS OF BROADBAND POWER LINE OR WIRELESS NETWORKS; TELECOMMUNICATION SERVICES, NAMELY, TRANSMISSION OF VOICE, DATA, GRAPHICS, IMAGES, AUDIO AND VIDEO BY MEANS OF TELECOMMUNICATIONS NETWORKS, WIRELESS COMMUNICATION NETWORKS, AND THE INTERNET; WIRELESS BROADBAND COMMUNICATION SERVICES; BROADBAND RADIO COMMUNICATION SERVICES (U.S. CLS. 100, 101 AND 104).

## **CLASS 42—SCIENTIFIC AND COMPUTER SERVICES**

FOR COMPUTER PROJECT MANAGEMENT SERVICES IN THE FIELD OF TELECOMMUNICATION NETWORKS FOR OTHERS; DESIGNING ENHANCED COMPUTER HARDWARE FOR COMMUNICATIONS TECHNOLOGY NETWORKS; COMPUTER SERVICES, NAMELY, OPERATING COMMUNICATION COMPUTER NETWORKS FEATURING BROADBAND TRANSMISSION SOFTWARE FOR OTHERS; TECHNICAL SUPPORT SERVICES, NAMELY, TROUBLESHOOTING OF COMPUTER SOFTWARE PROBLEMS RELATING TO BROADBAND (U.S. CLS. 100 AND 101).

SIMON TENG, EXAMINING ATTORNEY

SN 85-085,117. NATIONAL MARINE ELECTRONICS ASSOCIATION, SEVERNA PARK, MD. FILED 7-15-2010.

SN 85-086,033. TRUSTEE OF THE HERMAN FAMILY TRUST, LOS ANGELES, CA. FILED 7-15-2010.

# NMEA 1 NET

THE MARK CONSISTS OF STANDARD CHARACTERS WITHOUT CLAIM TO ANY PARTICULAR FONT, STYLE, SIZE, OR COLOR.

OWNER OF U.S. REG. NOS. 2,103,048, 2,121,136 AND OTHERS.

## CLASS 9—ELECTRICAL AND SCIENTIFIC APPARATUS

FOR COMPUTER MARINE ELECTRONICS EQUIPMENT MONITORING SOFTWARE FOR USE IN IMPLEMENTING INDUSTRY STANDARDS FOR THE MARINE ELECTRONICS INDUSTRY (U.S. CLS. 21, 23, 26, 36 AND 38).

## CLASS 16—PAPER GOODS AND PRINTED MATTER

FOR PRINTED MATTER, NAMELY, MANUALS AND INSTRUCTION MATERIALS RELATING TO THE INDUSTRY STANDARDS FOR THE MARINE ELECTRONICS INDUSTRY (U.S. CLS. 2, 5, 22, 23, 29, 37, 38 AND 50).

## CLASS 35—ADVERTISING AND BUSINESS

FOR ASSOCIATION SERVICES, NAMELY, PROMOTING THE INTERESTS OF THE MARINE ELECTRONICS INDUSTRY (U.S. CLS. 100, 101 AND 102).

## CLASS 42—SCIENTIFIC AND COMPUTER SERVICES

FOR DEVELOPMENT OF VOLUNTARY STANDARDS FOR THE MARINE ELECTRONICS INDUSTRY; ACCREDITATION SERVICES, NAMELY, DEVELOPING, EVALUATING AND TESTING STANDARDS FOR THE MARINE ELECTRONICS INDUSTRY FOR THE PURPOSE OF ACCREDITATION; ACCREDITATION SERVICES, NAMELY, DEVELOPING AND ADMINISTERING STANDARDS FOR CERTIFYING PROFESSIONALS IN THE FIELD OF THE MARINE ELECTRONICS INDUSTRY (U.S. CLS. 100 AND 101).  
NELSON SNYDER, EXAMINING ATTORNEY



THE MARK CONSISTS OF A CAPITAL "R" WITHIN TWO CONCENTRIC CIRCLES.

## CLASS 18—LEATHER GOODS

FOR HANDBAGS; PURSES; WALLETS (U.S. CLS. 1, 2, 3, 22 AND 41).

## CLASS 25—CLOTHING

FOR BLOUSES; COVERUPS; DRESSES; FOOTWEAR; HEADWEAR; JACKETS; PANTS; SHIRTS; SHORTS; SKIRTS; SOCKS; SWEAT PANTS; SWEAT SHIRTS; SWEATERS; T-SHIRTS; VESTS (U.S. CLS. 22 AND 39).

## CLASS 35—ADVERTISING AND BUSINESS

FOR ON-LINE RETAIL STORE SERVICES FEATURING CLOTHING AND CLOTHING ACCESSORIES; RETAIL STORES FEATURING CLOTHING AND CLOTHING ACCESSORIES (U.S. CLS. 100, 101 AND 102).  
CHERYL CLAYTON, EXAMINING ATTORNEY

SN 85-086,034. TRUSTEE OF THE HERMAN FAMILY TRUST, LOS ANGELES, CA. FILED 7-15-2010.

# COAST PEOPLE

THE MARK CONSISTS OF STANDARD CHARACTERS WITHOUT CLAIM TO ANY PARTICULAR FONT, STYLE, SIZE, OR COLOR.

## CLASS 18—LEATHER GOODS

FOR HANDBAGS; PURSES; WALLETS (U.S. CLS. 1, 2, 3, 22 AND 41).

## CLASS 25—CLOTHING

FOR BLOUSES; COVERUPS; DRESSES; FOOTWEAR; HEADWEAR; JACKETS; PANTS; SHIRTS; SHORTS; SKIRTS; SOCKS; SWEAT PANTS; SWEAT SHIRTS; SWEATERS; T-SHIRTS; VESTS (U.S. CLS. 22 AND 39).

**CLASS 35—ADVERTISING AND BUSINESS**

FOR ON-LINE RETAIL STORE SERVICES FEATURING CLOTHING AND CLOTHING ACCESSORIES; RETAIL STORES FEATURING CLOTHING AND CLOTHING ACCESSORIES (U.S. CLS. 100, 101 AND 102).  
CHERYL CLAYTON, EXAMINING ATTORNEY

SN 85-087,388. CORSO, KERRY A., PALATINE, IL. FILED 7-19-2010.

## Return to Youth

THE MARK CONSISTS OF STANDARD CHARACTERS WITHOUT CLAIM TO ANY PARTICULAR FONT, STYLE, SIZE, OR COLOR.

**CLASS 3—COSMETICS AND CLEANING PREPARATIONS**

FOR (BASED ON USE IN COMMERCE) ORGANIC SKIN CARE PREPARATIONS, NAMELY, NON-MEDICATED SKIN SERUMS AND BALMS (U.S. CLS. 1, 4, 6, 50, 51 AND 52).  
FIRST USE 1-0-2003; IN COMMERCE 1-0-2008.

**CLASS 16—PAPER GOODS AND PRINTED MATTER**

FOR (BASED ON USE IN COMMERCE) LITERATURE, NAMELY, PAMPHLETS IN THE FIELD OF SKIN CARE (U.S. CLS. 2, 5, 22, 23, 29, 37, 38 AND 50).  
FIRST USE 1-0-2003; IN COMMERCE 1-0-2008.

**CLASS 44—MEDICAL, BEAUTY AND AGRICULTURAL SERVICES**

FOR (BASED ON INTENT TO USE) COSMETIC SKIN CARE SERVICES (U.S. CLS. 100 AND 101).  
KATHLEEN LORENZO, EXAMINING ATTORNEY

SN 85-088,935. BILL KREUTZMANN, SAN FRANCISCO, CA. FILED 7-20-2010.

## 7 WALKERS

THE MARK CONSISTS OF STANDARD CHARACTERS WITHOUT CLAIM TO ANY PARTICULAR FONT, STYLE, SIZE, OR COLOR.

**CLASS 25—CLOTHING**

FOR CLOTHING, NAMELY, T-SHIRTS, SHORTS, SLEEPWEAR, SWIMWEAR, UNDERWEAR, FOOTWEAR, TOPS, BOTTOMS, SHIRTS, PANTS, DRESSES, COATS, JACKETS, SWEATSHIRTS, SWEATERS, JEANS, TROUSERS, AND BELTS; HEADWEAR, NAMELY, HATS, CAPS, MEN'S, WOMEN'S AND CHILDREN'S HEADWEAR IN THE NATURE OF BANDANAS AND BASEBALL CAPS (U.S. CLS. 22 AND 39).  
FIRST USE 10-11-2009; IN COMMERCE 10-11-2009.

**CLASS 41—EDUCATION AND ENTERTAINMENT**

FOR ENTERTAINMENT SERVICES, NAMELY, LIVE MUSIC CONCERTS AND CONCERT TOURS; MUSIC PUBLISHING SERVICES; MUSIC FAN CLUB SERVICES; ENTERTAINMENT SERVICES, NAMELY, PROVIDING AN ON-LINE COMPUTER DATABASE FEATURING NONDOWNLOADABLE PRERECORDED MUSIC, MUSICAL PERFORMANCES, MUSICAL VIDEOS, RELATED MUSIC VIDEO CLIPS AND MUSIC FILMS, AND MULTIMEDIA MATERIALS FEATURING MUSIC; PROVIDING AN ON-LINE COMPUTER DATABASE FEATURING INFORMATION REGARDING A MUSICAL GROUP, NAMELY, NONDOWNLOADABLE GRAPHICS, INFORMATION ABOUT THE MUSICAL PERFORMERS, NEWS, REVIEWS, PHOTOGRAPHS, SCHEDULES OF TOURS, SCHEDULES OF TRAVEL, SCHEDULES OF LIVE AND PRERECORDED MUSICAL PERFORMANCES, SCHEDULES OF RELEASES OF SOUND RECORDINGS, SCHEDULES OF RELEASES OF VIDEO RECORDINGS, SCHEDULES OF RELEASES OF DIGITAL RECORDINGS, SCHEDULES OF RELEASES OF MULTI-MEDIA SOFTWARE, SCHEDULES OF RELEASES OF COLLECTIBLE GOODS AND PRINTED MATTER MERCHANDISE (U.S. CLS. 100, 101 AND 107).

FIRST USE 10-11-2009; IN COMMERCE 10-11-2009.  
RONALD DELGIZZI, EXAMINING ATTORNEY

SN 85-089,066. GANART TECHNOLOGIES, CARROLLTON, TX. FILED 7-20-2010.

## TaaS

THE MARK CONSISTS OF THE LETTERS "TAAS" IN STYLIZED FORM, WITH THE LETTERS "T" AND "S" IN UPPER CASE AND WITH THE TWO LETTERS "A" IN LOWER CASE.

**CLASS 35—ADVERTISING AND BUSINESS**

FOR BUSINESS CONSULTING SERVICES, NAMELY, PROVIDING A TURNKEY BUSINESS SOLUTION FOR FACILITATING VALUE EXCHANGE BETWEEN THIRD PARTIES OVER A COMPUTER NETWORK OR A TELECOMMUNICATIONS NETWORK; BUSINESS CONSULTING SERVICES, NAMELY, PROVIDING A TURNKEY BUSINESS SOLUTION FOR PRICING, RENDERING, FULFILLING AND MONITORING ONLINE DATA EXCHANGES RELATING TO TRANSACTIONS FOR OTHERS; BUSINESS SERVICES IN THE NATURE OF PROVIDING DATA EXCHANGES RELATING TO BILLING AND PAYMENT ASSOCIATED WITH ONLINE TRANSACTIONS FOR OTHERS; BUSINESS ADMINISTRATION AND MANAGEMENT CONSULTATION IN THE FIELD OF ELECTRONIC TRANSFER AND DELIVERY OF FINANCIAL INSTRUMENTS, TICKETS, INFORMATION, SERVICES AND VALUE EXCHANGES OVER A COMPUTER NETWORK AND TELECOMMUNICATIONS NETWORK (U.S. CLS. 100, 101 AND 102).

**CLASS 36—INSURANCE AND FINANCIAL**

FOR FINANCIAL SERVICES, NAMELY, ELECTRONIC TRANSFER OF FINANCIAL INSTRUMENTS AND INFORMATION AND CONSULTING RELATING THERE TO (U.S. CLS. 100, 101 AND 102).

**CLASS 42—SCIENTIFIC AND COMPUTER SERVICES**

FOR COMPUTER SERVICES, NAMELY, ACTING AS AN APPLICATION SERVICE PROVIDER FEATURING SOFTWARE FOR PRICING, RENDERING, MONITORING, AND FULFILLING VALUE EXCHANGES BETWEEN THIRD PARTIES AND FOR PROVIDING COLLECTING, PAYING AND BILLING SERVICES RELATED TO AFORESAID VALUE EXCHANGES; DEVELOPING AND HOSTING SERVERS ON A COMPUTER NETWORK FOR THE PURPOSE OF PROVIDING E-COMMERCE APPLICATIONS FOR OTHERS VIA SUCH A SERVER (U.S. CLS. 100 AND 101).

JULIE WATSON, EXAMINING ATTORNEY

SN 85-089,894. AEG LIVE LLC, LOS ANGELES, CA. FILED 7-21-2010.

**THE VILLAGE OF HORRORS**

THE MARK CONSISTS OF STANDARD CHARACTERS WITHOUT CLAIM TO ANY PARTICULAR FONT, STYLE, SIZE, OR COLOR.

NO CLAIM IS MADE TO THE EXCLUSIVE RIGHT TO USE THE WORD "HORRORS," AS TO THE GOODS AND SERVICES IN CLASSES 16 AND 41 ONLY., APART FROM THE MARK AS SHOWN.

**CLASS 16—PAPER GOODS AND PRINTED MATTER**

FOR POSTERS; PAPER PRODUCTS, NAMELY, UNMOUNTED PHOTOGRAPHS; PENS (U.S. CLS. 2, 5, 22, 23, 29, 37, 38 AND 50).

**CLASS 25—CLOTHING**

FOR CLOTHING, NAMELY, T-SHIRTS AND SWEATSHIRTS; HEADWEAR (U.S. CLS. 22 AND 39).

**CLASS 26—FANCY GOODS**

FOR PINS, NAMELY, ORNAMENTAL NOVELTY PINS (U.S. CLS. 37, 39, 40, 42 AND 50).

**CLASS 41—EDUCATION AND ENTERTAINMENT**

FOR ENTERTAINMENT SERVICES IN THE NATURE OF AN ANNUAL HALLOWEEN EVENT (U.S. CLS. 100, 101 AND 107).

MARGERY A. TIERNEY, EXAMINING ATTORNEY

SN 85-091,603. ACCELERATED CARE PLUS CORP., RENO, NV. FILED 7-23-2010.

**ACCELERATED CARE PLUS**

THE MARK CONSISTS OF STANDARD CHARACTERS WITHOUT CLAIM TO ANY PARTICULAR FONT, STYLE, SIZE, OR COLOR.

SEC. 2(F).

**CLASS 9—ELECTRICAL AND SCIENTIFIC APPARATUS**

FOR COMPUTER-BASED PHYSICAL THERAPY AND REHABILITATION EQUIPMENT, NAMELY, A VIDEO GAME CONSOLE, CAMERA AND APPLICATION SOFTWARE THAT TRACKS THE MOVEMENTS OF A USER AND INTEGRATES SUCH MOVEMENTS INTO A VIDEO GAME DEPICTED ON A DISPLAY DEVICE, AND INSTRUCTION MANUALS SOLD AS A UNIT THEREWITH, FOR THE TREATMENT OF CHRONIC AND SUB ACUTE HEALTH CONDITIONS (U.S. CLS. 21, 23, 26, 36 AND 38).

FIRST USE 3-0-2010; IN COMMERCE 3-0-2010.

**CLASS 10—MEDICAL APPARATUS**

FOR THERAPEUTIC MACHINES AND EQUIPMENT, NAMELY, ELECTRICAL NEUROMUSCULAR STIMULATORS, ULTRASOUND EQUIPMENT, SHORTWAVE DIATHERMY EQUIPMENT, EXERCISE MACHINES, ELECTRICAL STIMULATORS, INFRARED STIMULATORS, ORTHOPEDIC DEVICES FOR THERAPEUTIC USE, PORTABLE ELECTRO-THERAPY STIMULATION DEVICES AND COMPONENTS THEREFOR AND ELECTRODES FOR MEDICAL USE, EXERCISE THERAPY BANDS, ALL FOR USE IN THE TREATMENT OF CHRONIC AND SUB ACUTE HEALTH CONDITIONS (U.S. CLS. 26, 39 AND 44).

FIRST USE 8-1-1999; IN COMMERCE 8-1-1999.

**CLASS 41—EDUCATION AND ENTERTAINMENT**

FOR EDUCATIONAL SERVICES, NAMELY, PROVIDING EDUCATIONAL MENTORING SERVICES AND PROGRAMS FOR THERAPISTS IN THE FIELD OF THE TREATMENT OF CHRONIC AND SUB ACUTE HEALTH CONDITIONS; PROVIDING CONTINUING PHYSICAL THERAPISTS EDUCATIONAL COURSES; TRAINING THERAPISTS IN THE USE AND OPERATION OF DEVICES USED FOR THE TREATMENT OF CHRONIC AND SUB ACUTE HEALTH CONDITIONS; TRAINING THERAPISTS IN THE FIELD OF BODYWORK THERAPY (U.S. CLS. 100, 101 AND 107).

FIRST USE 8-1-1999; IN COMMERCE 8-1-1999.

KELLEY WELLS, EXAMINING ATTORNEY

SN 85-091,952. JARED COOPER, JERICHO, NY. FILED 7-23-2010.



NO CLAIM IS MADE TO THE EXCLUSIVE RIGHT TO USE "SPORTS" AND "WEEKENDS", APART FROM THE MARK AS SHOWN.

THE MARK CONSISTS OF A MAP OF THE UNITED STATES WITH THE WORDS "SPORTS POWER WEEKENDS" INSIDE OF THE MAP. THE OUTLINE OF A FOOTBALL PLAYER IS WITHIN THE LETTER "O" IN SPORTS, THE OUTLINE OF A BASKETBALL PLAYER IS WITHIN THE LETTER "P" IN POWER, THE OUTLINE OF A BASEBALL PLAYER IS WITHIN THE LETTER "O" IN POWER, THE OUTLINE OF A HOCKEY PLAYER IS WITHIN THE LETTER "W" IN POWER, AND THE OUTLINE OF A SOCCER PLAYER IS WITHIN THE LETTER "R" IN POWER.

**CLASS 39—TRANSPORTATION AND STORAGE**

FOR PROVIDING A WEB SITE AND WEB SITE LINKS TO TRAVEL INFORMATION, GEOGRAPHIC INFORMATION, MAPS, MAP IMAGES AND TRIP ROUTING; ORGANIZING AND ARRANGING TRAVEL ACTIVITIES, NAMELY, FOR TOURS, TRAVEL TO SPORTING EVENTS AND TRAVEL ATTRACTIONS; PROVIDING INFORMATION ABOUT TRAVEL TO SPORTING EVENTS AND ATTRACTIONS AND TOURS; ORGANIZING SITE-SEEING TOURS; TRAVEL AGENCY SERVICES, NAMELY, MAKING RESERVATIONS AND BOOKINGS FOR TRANSPORTATION; TRAVEL AND TOUR TICKET RESERVATION SERVICES TO SPORTING EVENTS; PROVIDING NEWS IN THE FIELD OF SPORTS TRAVEL (U.S. CLS. 100 AND 105).

**CLASS 41—EDUCATION AND ENTERTAINMENT**

FOR COMPUTER SERVICES, NAMELY, PROVIDING ONLINE ARTICLES, BLOGS, AND AUDIO VISUAL PRESENTATIONS IN THE FIELDS OF SPORTS TRAVEL, TRAVEL PLANNING, BARS AND CLUBS, FOOD AND DRINK, NEIGHBORHOODS AND CULTURE, AND RESTAURANTS (U.S. CLS. 100, 101 AND 107).

H. M. FISHER, EXAMINING ATTORNEY

SN 85-092,723. MINDLESS DRIBBLE INC., REDWOOD CITY, CA. FILED 7-26-2010.

GROUPME

THE MARK CONSISTS OF STANDARD CHARACTERS WITHOUT CLAIM TO ANY PARTICULAR FONT, STYLE, SIZE, OR COLOR.

**CLASS 35—ADVERTISING AND BUSINESS**

FOR ADVERTISING SERVICES; ONLINE ADVERTISING ON AN ELECTRONIC OR OPTICAL COMMUNICATIONS NETWORK AND ON WIRELESS AND ELECTRONIC MOBILE DEVICES; PROMOTING THE GOODS AND SERVICES OF OTHERS BY PLACING ADVERTISEMENTS AND PROMOTIONAL DISPLAYS IN AN ELECTRONIC SITE ACCESSED THROUGH ELECTRONIC OR OPTICAL COMMUNICATIONS NETWORKS AND ON WIRELESS AND ELECTRONIC MOBILE DEVICES; ADVERTISING AND PROMOTION OF WEBSITES FOR OTHERS; PROVIDING ON-LINE DIRECTORY INFORMATION SERVICES FEATURING INFORMATION REGARDING THE WIRELESS COMMUNICATIONS AND SOCIAL NETWORKING SERVICES OF OTHERS; COMPUTERIZED DATABASE MANAGEMENT (U.S. CLS. 100, 101 AND 102).

**CLASS 36—INSURANCE AND FINANCIAL**

FOR PROVIDING ELECTRONIC PROCESSING OF ELECTRONIC FUNDS TRANSFER, ACH, CREDIT CARD, DEBIT CARD, ELECTRONIC CHECK AND ELECTRONIC PAYMENTS PROVIDED VIA AN ELECTRONIC OR OPTICAL COMMUNICATIONS NETWORK AND ON WIRELESS AND ELECTRONIC MOBILE DEVICES (U.S. CLS. 100, 101 AND 102).

**CLASS 38—COMMUNICATION**

FOR PROVIDING MULTIPLE-USER ACCESS TO COMPUTER NETWORKS FOR THE TRANSFER AND DISSEMINATION OF A WIDE RANGE OF INFORMATION; ELECTRONIC TRANSMISSION OF DATA, MESSAGES, IMAGES, AND DOCUMENTS; PROVIDING ON-LINE CHAT ROOMS AND ELECTRONIC BULLETIN BOARDS FOR TRANSMISSION OF MESSAGES AMONG USERS WITH OTHER ELECTRONIC OR OPTICAL COMMUNICATIONS NETWORK AND WIRELESS AND ELECTRONIC MOBILE DEVICE IN THE FIELD OF GENERAL INTEREST (U.S. CLS. 100, 101 AND 104).

**CLASS 42—SCIENTIFIC AND COMPUTER SERVICES**

FOR COMPUTER SERVICES, NAMELY, COMPUTER SOFTWARE DEVELOPMENT OF WEB APPLICATIONS FOR INTERNET AND WIRELESS AND ELECTRONIC MOBILE DEVICE USERS; PROVIDING TEMPORARY USE OF ON-LINE NON-DOWNLOADABLE SOFTWARE FOR ASSISTING IN WEBSITE DEVELOPMENT; PROVIDING TEMPORARY USE OF NON-DOWNLOADABLE SOFTWARE FOR USE IN SEARCH ENGINE OPTIMIZATION; PROVIDING TEMPORARY USE OF NON-DOWNLOADABLE SOFTWARE FOR USE IN ANALYZING ONLINE AND WIRELESS AND ELECTRONIC MOBILE DEVICE USER BEHAVIOR; SEARCHING AND RETRIEVING INFORMATION, SITES, AND OTHER RESOURCES AVAILABLE ON ELECTRONIC OR OPTICAL COMMUNICATIONS NETWORKS AND VIA WIRELESS AND ELECTRONIC MOBILE DEVICES FOR OTHERS; DESIGNING, CREATING, HOSTING, AND MAINTENANCE OF WEBSITES FOR OTHERS; PROVIDING TEMPORARY USE OF A WEB-BASED SOFTWARE FOR COMMUNICATIONS AMONG USERS VIA A PERSONALIZED WEBPAGE AND WIRELESS AND ELECTRONIC MOBILE DEVICE INTERFACE (U.S. CLS. 100 AND 101).

**CLASS 45—PERSONAL AND LEGAL SERVICES**

FOR ONLINE SOCIAL NETWORKING SERVICES (U.S. CLS. 100 AND 101).

MICHELE SWAIN, EXAMINING ATTORNEY

SN 85-092,731. INDUSTRIAS & CONFECIONES, S.A., 28045 MADRID, SPAIN, FILED 7-26-2010.



NO CLAIM IS MADE TO THE EXCLUSIVE RIGHT TO USE "EST 2010" AND "GENUINE BRAND", APART FROM THE MARK AS SHOWN.

THE MARK CONSISTS OF A BEAR WITH "EST. 2010" TO THE RIGHT, ABOVE "GALS & GUYS", ABOVE "GENUINE BRAND".

**CLASS 3—COSMETICS AND CLEANING PREPARATIONS**

FOR BLEACHING PREPARATIONS FOR LAUNDRY USE; PREPARATIONS FOR LAUNDRY USE, NAMELY, DETERGENT, SOAP AND STARCH; CLEANING, POLISHING SCOURING AND ABRASIVE PREPARATIONS; SOAPS, NAMELY, CREAM, DEODORANT, ALMOND AND ANTI-BACTERIAL SOAPS; PERFUMERY; ESSENTIAL OILS; COSMETICS; HAIR LOTIONS; AND DENTIFRICES (U.S. CLS. 1, 4, 6, 50, 51 AND 52).

SN 85-093,437. GOOD START GENETICS, INC., BOSTON, MA. FILED 7-27-2010.

**GOOD START GENETICS****CLASS 18—LEATHER GOODS**

FOR LEATHER AND IMITATION LEATHER; GOODS MADE OF LEATHER AND IMITATION LEATHER, NAMELY, KEY CASES, BRIEFCASES, CASES, POUCHES AND HANDBAGS; ANIMAL SKINS; TRUNKS AND TRAVELLING BAGS; UMBRELLAS, PARASOLS AND WALKING STICKS; WHIPS, HARNESS AND SADDLERY (U.S. CLS. 1, 2, 3, 22 AND 41).

THE MARK CONSISTS OF STANDARD CHARACTERS WITHOUT CLAIM TO ANY PARTICULAR FONT, STYLE, SIZE, OR COLOR.

NO CLAIM IS MADE TO THE EXCLUSIVE RIGHT TO USE "GENETICS", APART FROM THE MARK AS SHOWN.

**CLASS 25—CLOTHING**

FOR CLOTHING, NAMELY, SHIRTS, PANTS AND JACKETS; FOOTWEAR; HEADGEAR, NAMELY, HATS, CAPS AND VISORS (U.S. CLS. 22 AND 39).

TRICIA SONNEBORN, EXAMINING ATTORNEY

**CLASS 1—CHEMICALS**

FOR GENETIC SEQUENCING TEST KITS COMPRISING CHEMICAL TEST KITS FOR MEDICAL USE (U.S. CLS. 1, 5, 6, 10, 26 AND 46).

**CLASS 44—MEDICAL, BEAUTY AND AGRICULTURAL SERVICES**

FOR GENETIC TESTING FOR MEDICAL PURPOSES; PRENATAL TESTING FOR GENETIC DISORDERS; ISOLATING, TESTING, ANALYZING, AND EVALUATING NUCLEIC ACIDS FOR MEDICAL PURPOSES (U.S. CLS. 100 AND 101).

ANNE MADDEN, EXAMINING ATTORNEY

SN 85-092,759. THE BUREAU OF NATIONAL AFFAIRS, INC., ARLINGTON, VA. FILED 7-26-2010.

**CORPORATE ACCOUNTABILITY REPORT**

SN 85-093,948. CURRENT USA, INC., NORTH MANKATO, MN. FILED 7-27-2010.

THE MARK CONSISTS OF STANDARD CHARACTERS WITHOUT CLAIM TO ANY PARTICULAR FONT, STYLE, SIZE, OR COLOR.

OWNER OF U.S. REG. NO. 2,868,156.

NO CLAIM IS MADE TO THE EXCLUSIVE RIGHT TO USE "REPORT", APART FROM THE MARK AS SHOWN. SEC. 2(F).

**STAND OUT FROM THE CROWD.****CLASS 16—PAPER GOODS AND PRINTED MATTER**

FOR PERIODICALLY PUBLISHED REPORTS IN LOOSELEAF, PAMPHLET OR BOOKLET FORMAT FEATURING JUDICIAL OPINIONS, NEWS, INFORMATION AND ANALYSIS IN THE FIELD OF CORPORATE GOVERNANCE (U.S. CLS. 2, 5, 22, 23, 29, 37, 38 AND 50). FIRST USE 1-24-2003; IN COMMERCE 1-24-2003.

THE MARK CONSISTS OF STANDARD CHARACTERS WITHOUT CLAIM TO ANY PARTICULAR FONT, STYLE, SIZE, OR COLOR.

**CLASS 35—ADVERTISING AND BUSINESS**

FOR ON-LINE ORDERING AND MAIL ORDER CATALOG SERVICES FEATURING PAPER PRODUCTS, NAMELY, BROCHURES, BORDER PAPERS, CERTIFICATES, INVITATIONS, LETTERHEAD, POSTCARDS, BUSINESS CARDS, ENVELOPES, NOTE CARDS, NOTE PADS, MEMO PADS AND NEWSLETTERS; ON-LINE ORDERING AND MAIL ORDER CATALOG SERVICES FEATURING RECOGNITION PRODUCTS, NAMELY, AWARD TROPHIES, PLAQUES, PINS AND FOIL SEALS; ON-LINE ORDERING AND MAIL ORDER CATALOG SERVICES FEATURING PRESENTATION PRODUCTS, NAMELY, PRESENTATION FOLDERS, DISPLAY FRAMES, DISPLAY HOLDERS, AND BINDING SYSTEMS; ON-LINE ORDERING AND MAIL ORDER CATALOG SERVICES FEATURING POSTERS, VINYL BANNERS, AND EVENT ACCESSORIES, NAMELY, FAVOR BOXES, NAPKINS, PLACE CARDS AND EVENT TICKETS (U.S. CLS. 100, 101 AND 102).

FIRST USE 7-31-1994; IN COMMERCE 7-31-1994.

**CLASS 41—EDUCATION AND ENTERTAINMENT**

FOR PROVIDING ONLINE PUBLICATIONS IN THE NATURE OF REPORTS FEATURING JUDICIAL OPINIONS, NEWS, INFORMATION AND ANALYSIS IN THE FIELD OF CORPORATE GOVERNANCE; PROVIDING ONLINE PUBLICATIONS IN THE NATURE OF REPORTS FEATURING JUDICIAL OPINIONS, NEWS, INFORMATION AND ANALYSIS IN THE FIELD OF CORPORATE GOVERNANCE VIA E-MAIL (U.S. CLS. 100, 101 AND 107).

FIRST USE 5-12-2003; IN COMMERCE 4-5-2004.

RONALD MCMORROW, EXAMINING ATTORNEY

**CLASS 40—MATERIAL TREATMENT**

FOR CUSTOM PRINTING SERVICES, NAMELY, CUSTOM PRINTING OF PAPER PRODUCTS, NAMELY, BROCHURES, BORDER PAPERS, CERTIFICATES, INVITATIONS, LETTERHEAD, POSTCARDS, BUSINESS CARDS, ENVELOPES, NOTE CARDS, NOTE PADS, MEMO PADS AND NEWSLETTERS; CUSTOM IMPRINTING OF RECOGNITION PRODUCTS, NAMELY, AWARD TROPHIES, PLAQUES, PINS AND FOIL SEALS; CUSTOM IMPRINTING OF PRESENTATION PRODUCTS, NAMELY, PRESENTATION FOLDERS, DISPLAY FRAMES, DISPLAY HOLDERS, AND BINDING SYSTEMS; CUSTOM IMPRINTING OF POSTERS, VINYL BANNERS, AND EVENT ACCESSORIES, NAMELY, FAVOR BOXES, NAPKINS, PLACE CARDS AND EVENT TICKETS (U.S. CLS. 100, 103 AND 106).

FIRST USE 7-31-1994; IN COMMERCE 7-31-2004.  
DAVID COLLIER, EXAMINING ATTORNEY

---

SN 85-094,472. DAIMLER AG, STUTTGART, FED REP GERMANY, FILED 7-28-2010.

# R 63

THE MARK CONSISTS OF STANDARD CHARACTERS WITHOUT CLAIM TO ANY PARTICULAR FONT, STYLE, SIZE, OR COLOR.

OWNER OF FED REP GERMANY REG. NO. 30303255, DATED 2-21-2003, EXPIRES 1-31-2013.

NO CLAIM IS MADE TO THE EXCLUSIVE RIGHT TO USE "63", APART FROM THE MARK AS SHOWN.

**CLASS 12—VEHICLES**

FOR AUTOMOBILES AND THEIR STRUCTURAL PARTS (U.S. CLS. 19, 21, 23, 31, 35 AND 44).

**CLASS 28—TOYS AND SPORTING GOODS**

FOR TOY MODEL VEHICLES (U.S. CLS. 22, 23, 38 AND 50).

JAMES MACFARLANE, EXAMINING ATTORNEY

---

SN 85-094,773. HOECHST GMBH, FRANKFURT AM MAIN, FED REP GERMANY, FILED 7-28-2010.

# HOECHST

THE MARK CONSISTS OF STANDARD CHARACTERS WITHOUT CLAIM TO ANY PARTICULAR FONT, STYLE, SIZE, OR COLOR.

OWNER OF FED REP GERMANY REG. NO. 765192, DATED 9-10-1962, EXPIRES 6-30-2016.

OWNER OF U.S. REG. NOS. 894,852, 3,010,586 AND 3,593,897.

THE WORD(S) "HOECHST" HAS NO MEANING IN A FOREIGN LANGUAGE.

**CLASS 1—CHEMICALS**

FOR CHEMICALS FOR USE IN INDUSTRY AND SCIENCE; SPECIALTY CHEMICALS, NAMELY, CHEMICAL ADDITIVES FOR GENERAL INDUSTRIAL USE IN THE MANUFACTURE OF A WIDE VARIETY OF GOODS; SURFACE ACTIVE COMPOUNDS FOR GENERAL USE IN THE INDUSTRIAL ARTS, NAMELY, AS WETTING, SPREADING, EMULSIFYING, DISPERSING AND PENETRATING AGENTS; ADHESIVES FOR USE IN INDUSTRY; UNPROCESSED PLASTICS FOR INDUSTRIAL USE; SYNTHETIC RESINS; ARTIFICIAL SWEETENERS; FOOD PRESERVATIVE COMPOSITIONS; CHEMICALS AND TANNING AGENTS FOR USE IN THE MANUFACTURE OF LEATHER (U.S. CLS. 1, 5, 6, 10, 26 AND 46).

**CLASS 5—PHARMACEUTICALS**

FOR VACCINES, DIAGNOSTICS AND PHARMACEUTICAL PREPARATIONS FOR THE TREATMENT OF VIRAL, METABOLIC, ENDOCRINE, MUSCULOSKELETAL, CARDIOVASCULAR, CARDIOPULMONARY, GENITOURINARY, SEXUAL DYSFUNCTION, ONCOLOGICAL, HEPATOLOGICAL, OPHTHALMIC, RESPIRATORY, NEUROLOGICAL, GASTROINTESTINAL, HORMONAL, DERMATOLOGICAL, PSYCHIATRIC AND IMMUNE SYSTEM RELATED DISEASES AND DISORDERS (U.S. CLS. 6, 18, 44, 46, 51 AND 52).

DAWN FELDMAN, EXAMINING ATTORNEY

---

SN 85-094,965. EDGE COMPOSITES, LLC, OGDEN, UT. FILED 7-28-2010.

# ENVE

THE MARK CONSISTS OF STANDARD CHARACTERS WITHOUT CLAIM TO ANY PARTICULAR FONT, STYLE, SIZE, OR COLOR.

**CLASS 12—VEHICLES**

FOR BICYCLE PARTS, NAMELY, FORKS, STEMS, HANDLEBARS, SEAT POSTS AND WHEEL RIMS (U.S. CLS. 19, 21, 23, 31, 35 AND 44).

FIRST USE 1-23-2010; IN COMMERCE 1-23-2010.

**CLASS 35—ADVERTISING AND BUSINESS**

FOR ONLINE RETAIL STORE SERVICES FEATURING BICYCLE PARTS AND ACCESSORIES (U.S. CLS. 100, 101 AND 102).

FIRST USE 1-23-2010; IN COMMERCE 1-23-2010.

**CLASS 40—MATERIAL TREATMENT**

FOR CONTRACT MANUFACTURING IN THE FIELD OF BICYCLE PARTS AND ACCESSORIES (U.S. CLS. 100, 103 AND 106).

FIRST USE 1-23-2010; IN COMMERCE 1-23-2010.

ANDREA K. NADELMAN, EXAMINING ATTORNEY

SN 85-095,382. NEXT FITNESS EVOLUTION LLC, VALLEY STREAM, NY. FILED 7-28-2010.

## NEXT FITNESS EVOLUTION

THE MARK CONSISTS OF STANDARD CHARACTERS WITHOUT CLAIM TO ANY PARTICULAR FONT, STYLE, SIZE, OR COLOR.

NO CLAIM IS MADE TO THE EXCLUSIVE RIGHT TO USE "FITNESS", APART FROM THE MARK AS SHOWN.

### CLASS 35—ADVERTISING AND BUSINESS

FOR ONLINE RETAIL STORE SERVICES FEATURING FITNESS EQUIPMENT AND NUTRITIONAL SUPPLEMENTS; PROVIDING ONLINE REVIEWS OF THE CONSUMER PRODUCTS OF OTHERS, NAMELY, PHYSICAL FITNESS PRODUCTS, BOOKS AND VIDEOS (U.S. CLS. 100, 101 AND 102).

FIRST USE 4-30-2006; IN COMMERCE 4-30-2006.

### CLASS 41—EDUCATION AND ENTERTAINMENT

FOR PHYSICAL FITNESS CONSULTATION; PHYSICAL FITNESS TRAINING SERVICES; PROVIDING A WEBSITE FEATURING INFORMATION ON EXERCISE AND FITNESS; ON-LINE JOURNALS, NAMELY, BLOGS FEATURING INFORMATION ON PHYSICAL FITNESS AND EXERCISE (U.S. CLS. 100, 101 AND 107).

FIRST USE 4-30-2006; IN COMMERCE 4-30-2006.

### CLASS 44—MEDICAL, BEAUTY AND AGRICULTURAL SERVICES

FOR PROVIDING ASSISTANCE, FITNESS EVALUATION AND CONSULTATION TO INDIVIDUALS TO HELP THEM MAKE HEALTH, WELLNESS AND NUTRITIONAL CHANGES IN THEIR DAILY LIVING TO IMPROVE HEALTH; PROVIDING A WEBSITE FEATURING INFORMATION ABOUT HEALTH, WELLNESS AND NUTRITION PROVIDING A WEBSITE FEATURING INFORMATION ON HEALTH AND WELLNESS (U.S. CLS. 100 AND 101).

FIRST USE 4-30-2006; IN COMMERCE 4-30-2006.  
PATRICIA EVANKO, EXAMINING ATTORNEY

SN 85-095,652. EARLY ALERT, INC., TAMPA, FL. FILED 7-29-2010.

## BRIDGING THE GAP BETWEEN GOVERNMENT AND THE PRIVATE SECTOR

THE MARK CONSISTS OF STANDARD CHARACTERS WITHOUT CLAIM TO ANY PARTICULAR FONT, STYLE, SIZE, OR COLOR.

### CLASS 41—EDUCATION AND ENTERTAINMENT

FOR TRAINING SERVICES IN THE FIELD OF CRISIS AND DISASTER EVENTS, RESPONSE TO DISASTER EVENTS, AND DISASTER RECOVERY; CONDUCTING CLASSES AND WORKSHOPS IN THE FIELD OF EMERGENCY MANAGEMENT, NAMELY, HAZARD TRAINING AND EXERCISE PROGRAMS, INTEROPERABILITY ANALYSIS AND PLANNING, AND SITUATIONAL AWARENESS PROVIDING WEATHER AND DISASTER ALERTS FOR DECISION MAKING ASSISTANCE, ALL RELATING TO CRISIS DISASTER EVENTS (U.S. CLS. 100, 101 AND 107).

FIRST USE 2-1-1999; IN COMMERCE 2-1-1999.

### CLASS 45—PERSONAL AND LEGAL SERVICES

FOR CONSULTATION SERVICES CONCERNING EMERGENCY MANAGEMENT SERVICES; AND SECURITY SERVICES, NAMELY, THREAT SIMULATION VULNERABILITY ANALYSIS AND MITIGATION AND EMERGENCY AND CRISIS RESPONSE; SAFETY CONSULTING SERVICES IN THE FIELDS OF HAZARD ASSESSMENTS; AND SECURITY SERVICES, NAMELY, CBRN-CHEMICAL, BIOLOGICAL, RADIOLOGICAL AND NUCLEAR VULNERABILITY ASSESSMENT SERVICES (U.S. CLS. 100 AND 101).

FIRST USE 2-1-1999; IN COMMERCE 2-1-1999.  
STEVEN JACKSON, EXAMINING ATTORNEY

SN 85-095,981. WALLGATE LIMITED, WILTSHIRE, UNITED KINGDOM, FILED 7-29-2010.

## WALLGATE AMERICA

THE MARK CONSISTS OF STANDARD CHARACTERS WITHOUT CLAIM TO ANY PARTICULAR FONT, STYLE, SIZE, OR COLOR.

NO CLAIM IS MADE TO THE EXCLUSIVE RIGHT TO USE "AMERICA", APART FROM THE MARK AS SHOWN.

### CLASS 37—CONSTRUCTION AND REPAIR

FOR INSTALLATION, MAINTENANCE AND REPAIR OF WASHROOMS, WASHROOM AND SANITARY APPARATUS AND EQUIPMENT, ELECTRICAL EQUIPMENT AND ACCOMMODATION IN THE NATURE OF TOILETS, URINALS, TOILET SEATS, CISTERNS, WASHBASINS, SHOWERS, BATHS, BATH TUBS, DRINKING FOUNTAINS, BIDETS, ELECTRIC HOT AIR HAND DRIERS AND TAPS; RENOVATION IN THE FIELD OF WASHROOMS, WASHROOM AND SANITARY APPARATUS AND EQUIPMENT, ELECTRICAL EQUIPMENT AND ACCOMMODATION IN THE NATURE OF TOILETS, URINALS, TOILET SEATS, CISTERNS, WASHBASINS, SHOWERS, BATHS, BATH TUBS, DRINKING FOUNTAINS, BIDETS, ELECTRIC HOT AIR HAND DRIERS AND TAPS; RESTORATION IN THE FIELD OF WASHROOMS, WASHROOM AND SANITARY APPARATUS AND EQUIPMENT, ELECTRICAL EQUIPMENT AND ACCOMMODATION IN THE NATURE OF TOILETS, URINALS, TOILET SEATS, CISTERNS, WASHBASINS, SHOWERS, BATHS, BATH TUBS, DRINKING FOUNTAINS, BIDETS, ELECTRIC HOT AIR HAND DRIERS AND TAPS (U.S. CLS. 100, 103 AND 106).



**CLASS 42—SCIENTIFIC AND COMPUTER SERVICES**

FOR DESIGN FOR OTHERS IN THE FIELD OF WASHROOMS; INDUSTRIAL DESIGN; PRODUCT DEVELOPMENT CONSULTATION; TECHNICAL CONSULTATION IN THE FIELD OF DESIGN OF SANITARY, ELECTRICAL AND ELECTRONIC APPARATUS AND EQUIPMENT (U.S. CLS. 100 AND 101).  
ANDREA HACK, EXAMINING ATTORNEY

SN 85-097,170. MEDICAL ACTION INDUSTRIES INC., BRENTWOOD, NY. FILED 7-30-2010.

# MAI+PLUS

SN 85-096,378. GLOBAL FRANCHISE GROUP, LLC, NORCROSS, GA. FILED 7-29-2010.



NO CLAIM IS MADE TO THE EXCLUSIVE RIGHT TO USE "GLOBAL FRANCHISE GROUP", APART FROM THE MARK AS SHOWN.

**CLASS 35—ADVERTISING AND BUSINESS**

FOR FRANCHISING, NAMELY, CONSULTATION AND ASSISTANCE IN BUSINESS MANAGEMENT, ORGANIZATION AND PROMOTION; BUSINESS MARKETING SERVICES (U.S. CLS. 100, 101 AND 102).

**CLASS 45—PERSONAL AND LEGAL SERVICES**

FOR LICENSING OF INTELLECTUAL PROPERTY (U.S. CLS. 100 AND 101).  
DAVID TOOLEY, EXAMINING ATTORNEY

THE MARK CONSISTS OF STANDARD CHARACTERS WITHOUT CLAIM TO ANY PARTICULAR FONT, STYLE, SIZE, OR COLOR.

**CLASS 10—MEDICAL APPARATUS**

FOR MEDICAL APPARATUS, NAMELY, SINGLE PATIENT USE OR AUTOCLAVABLE PLASTIC PATIENT BEDSIDE VESSELS, NAMELY, BEDPANS, URINALS AND MEDICAL SPECIMEN CUPS (U.S. CLS. 26, 39 AND 44).

**CLASS 21—HOUSEWARES AND GLASS**

FOR PITCHERS, WASH BASINS, DRINKING GLASSES AND BOWLS (U.S. CLS. 2, 13, 23, 29, 30, 33, 40 AND 50).  
JACQUELINE A. LAVINE, EXAMINING ATTORNEY

SN 85-097,160. MEDICAL ACTION INDUSTRIES INC., BRENTWOOD, NY. FILED 7-30-2010.

# MAI+

THE MARK CONSISTS OF STANDARD CHARACTERS WITHOUT CLAIM TO ANY PARTICULAR FONT, STYLE, SIZE, OR COLOR.

**CLASS 10—MEDICAL APPARATUS**

FOR MEDICAL APPARATUS, NAMELY, SINGLE PATIENT USE OR AUTOCLAVABLE PLASTIC PATIENT BEDSIDE VESSELS, NAMELY, BEDPANS, URINALS AND MEDICAL SPECIMEN CUPS (U.S. CLS. 26, 39 AND 44).

**CLASS 21—HOUSEWARES AND GLASS**

FOR PITCHERS, WASH BASINS, DRINKING GLASSES AND BOWLS (U.S. CLS. 2, 13, 23, 29, 30, 33, 40 AND 50).  
JACQUELINE A. LAVINE, EXAMINING ATTORNEY

SN 85-097,307. DISCFARM CORPORATION, CORONA, CA. FILED 7-30-2010.

# DISCFARM

THE MARK CONSISTS OF STANDARD CHARACTERS WITHOUT CLAIM TO ANY PARTICULAR FONT, STYLE, SIZE, OR COLOR.

**CLASS 40—MATERIAL TREATMENT**

FOR DUPLICATION OF CDS, DVDS, FLASH MEMORY CARDS, AND OPTICAL DISCS CONTAINING DATA, DIGITAL CONTENT, SOFTWARE, MUSIC, TEXT, PHOTOGRAPHS, VIDEO; PRINTING; OFFSET PRINTING; AND SILK SCREEN PRINTING FOR OTHERS (U.S. CLS. 100, 103 AND 106).

**CLASS 42—SCIENTIFIC AND COMPUTER SERVICES**

FOR DUPLICATION OF DATA, DIGITAL CONTENT, SOFTWARE, MUSIC, TEXT, PHOTOGRAPHS, SLIDES, VIDEO, NAMELY, MEDIA DUPLICATION OF DATA AND DIGITAL INFORMATION; DUPLICATION OF DATA, DIGITAL CONTENT, SOFTWARE, MUSIC, TEXT, PHOTOGRAPHS, SLIDES, VIDEO, NAMELY, MEDIA DUPLICATION OF DATA AND DIGITAL INFORMATION ONTO OPTICAL DISCS AND FLASH MEMORY; DESIGN SERVICES FOR PACKAGING (U.S. CLS. 100 AND 101).  
BRIAN PINO, EXAMINING ATTORNEY

SN 85-097,605. ERICSSON FEDERAL INC., RESTON, VA.  
FILED 7-31-2010.



THE COLOR(S) WHITE, BLACK AND BLUE IS/ARE CLAIMED AS A FEATURE OF THE MARK.

THE MARK CONSISTS OF A STYLIZED THREE-BAND BLUE 3-D LIKE DESIGN WITH A WHITE CENTER AND THREE ENDS PARTIALLY COLORED IN BLACK.

#### CLASS 9—ELECTRICAL AND SCIENTIFIC APPARATUS

FOR TELECOMMUNICATIONS AND DATA NETWORKING HARDWARE, NAMELY, DEVICES FOR TRANSPORTING AND AGGREGATING VOICE, DATA, AND VIDEO COMMUNICATIONS ACROSS MULTIPLE NETWORK INFRASTRUCTURES AND COMMUNICATIONS PROTOCOLS; WIRELESS ADAPTERS USED TO LINK COMPUTERS TO A TELECOMMUNICATIONS NETWORK; COMPUTER HARDWARE EQUIPMENT USED IN COMMUNICATIONS TECHNOLOGY NETWORKS AND COMPUTER SOFTWARE FOR OPERATING COMMUNICATIONS TECHNOLOGY NETWORKS; BROADBAND POWER LINE COMMUNICATION SYSTEMS FOR TRANSFERRING BROADBAND DATA OVER ELECTRICAL POWER LINES, COMPRISED OF COMPUTER HARDWARE, SOFTWARE AND MODEMS; BROADBAND RADIOS; BROADBAND WIRELESS EQUIPMENT, NAMELY, TELECOMMUNICATIONS BASE STATION EQUIPMENT FOR CELLULAR AND FIXED NETWORKING AND COMMUNICATIONS APPLICATIONS; WIRELESS BROADBAND RADIOS (U.S. CLS. 21, 23, 26, 36 AND 38).

#### CLASS 35—ADVERTISING AND BUSINESS

FOR TELECOMMUNICATIONS NETWORK MANAGEMENT SERVICES, NAMELY, THE OPERATION AND ADMINISTRATION OF TELECOMMUNICATION SYSTEMS AND NETWORKS FOR OTHERS (U.S. CLS. 100, 101 AND 102).

#### CLASS 38—COMMUNICATION

FOR COMMUNICATION SERVICES, NAMELY, TRANSMISSION OF VOICE, AUDIO, VISUAL IMAGES AND DATA BY TELECOMMUNICATIONS NETWORKS, WIRELESS COMMUNICATION NETWORKS, THE INTERNET, INFORMATION SERVICES NETWORKS AND DATA NETWORKS; DIGITAL NETWORK TELECOMMUNICATIONS SERVICES; ELECTRONIC EXCHANGE OF DATA STORED IN DATABASES ACCESSIBLE VIA TELECOMMUNICATION NETWORKS; PROVIDING ACCESS TO TELECOMMUNICATION NETWORKS; PROVIDING TELECOMMUNICATIONS CONNECTIONS TO A GLOBAL COMPUTER NETWORK; TELECOMMUNICATION SERVICES, NAMELY, TRANSMISSION OF VOICE, DATA, GRAPHICS, SOUND AND VIDEO BY MEANS OF BROADBAND POWER LINE OR WIRELESS NETWORKS; TELECOMMUNICATION SERVICES, NAMELY, TRANSMISSION OF VOICE, DATA, GRAPHICS, IMAGES, AUDIO AND VIDEO BY MEANS OF TELECOMMUNICATIONS NETWORKS, WIRELESS COMMUNICATION NETWORKS, AND THE INTERNET; WIRELESS BROADBAND COMMUNICATION SERVICES; BROADBAND RADIO COMMUNICATION SERVICES (U.S. CLS. 100, 101 AND 104).

#### CLASS 42—SCIENTIFIC AND COMPUTER SERVICES

FOR COMPUTER PROJECT MANAGEMENT SERVICES IN THE FIELD OF TELECOMMUNICATION NETWORKS FOR OTHERS; DESIGNING ENHANCED COMPUTER HARDWARE FOR COMMUNICATIONS TECHNOLOGY NETWORKS; COMPUTER SERVICES, NAMELY, OPERATING COMMUNICATION COMPUTER NETWORKS FEATURING BROADBAND TRANSMISSION SOFTWARE FOR OTHERS; TECHNICAL SUPPORT SERVICES, NAMELY, TROUBLESHOOTING OF COMPUTER SOFTWARE PROBLEMS RELATING TO BROADBAND (U.S. CLS. 100 AND 101).

SIMON TENG, EXAMINING ATTORNEY

SN 85-097,606. ERICSSON FEDERAL INC., RESTON, VA.  
FILED 7-31-2010.



NO CLAIM IS MADE TO THE EXCLUSIVE RIGHT TO USE "NETWORKS", APART FROM THE MARK AS SHOWN.

THE COLOR(S) BLUE, BLACK AND WHITE IS/ARE CLAIMED AS A FEATURE OF THE MARK.

THE MARK CONSISTS THE WORDS "OCEUS" IN BLACK, BELOW THIS IS "NETWORKS" IN BLUE. TO THE LEFT IS A STYLIZED THREE-BAND BLUE 3-D LIKE DESIGN WITH A WHITE CENTER AND THREE ENDS PARTIALLY COLORED IN BLACK.

**CLASS 9—ELECTRICAL AND SCIENTIFIC APPARATUS**

FOR TELECOMMUNICATIONS AND DATA NETWORKING HARDWARE, NAMELY, DEVICES FOR TRANSPORTING AND AGGREGATING VOICE, DATA, AND VIDEO COMMUNICATIONS ACROSS MULTIPLE NETWORK INFRASTRUCTURES AND COMMUNICATIONS PROTOCOLS; WIRELESS ADAPTERS USED TO LINK COMPUTERS TO A TELECOMMUNICATIONS NETWORK; COMPUTER HARDWARE EQUIPMENT USED IN COMMUNICATIONS TECHNOLOGY NETWORKS AND COMPUTER SOFTWARE FOR OPERATING COMMUNICATIONS TECHNOLOGY NETWORKS; BROADBAND POWER LINE COMMUNICATION SYSTEMS FOR TRANSFERRING BROADBAND DATA OVER ELECTRICAL POWER LINES, COMPRISED OF COMPUTER HARDWARE, SOFTWARE AND MODEMS; BROADBAND RADIOS; BROADBAND WIRELESS EQUIPMENT, NAMELY, TELECOMMUNICATIONS BASE STATION EQUIPMENT FOR CELLULAR AND FIXED NETWORKING AND COMMUNICATIONS APPLICATIONS; WIRELESS BROADBAND RADIOS (U.S. CLS. 21, 23, 26, 36 AND 38).

**CLASS 35—ADVERTISING AND BUSINESS**

FOR TELECOMMUNICATIONS NETWORK MANAGEMENT SERVICES, NAMELY, THE OPERATION AND ADMINISTRATION OF TELECOMMUNICATION SYSTEMS AND NETWORKS FOR OTHERS (U.S. CLS. 100, 101 AND 102).

**CLASS 38—COMMUNICATION**

FOR COMMUNICATION SERVICES, NAMELY, TRANSMISSION OF VOICE, AUDIO, VISUAL IMAGES AND DATA BY TELECOMMUNICATIONS NETWORKS, WIRELESS COMMUNICATION NETWORKS, THE INTERNET, INFORMATION SERVICES NETWORKS AND DATA NETWORKS; DIGITAL NETWORK TELECOMMUNICATIONS SERVICES; ELECTRONIC EXCHANGE OF DATA STORED IN DATABASES ACCESSIBLE VIA TELECOMMUNICATION NETWORKS; PROVIDING ACCESS TO TELECOMMUNICATION NETWORKS; PROVIDING TELECOMMUNICATIONS CONNECTIONS TO A GLOBAL COMPUTER NETWORK; TELECOMMUNICATION SERVICES, NAMELY, TRANSMISSION OF VOICE, DATA, GRAPHICS, SOUND AND VIDEO BY MEANS OF BROADBAND POWER LINE OR WIRELESS NETWORKS; TELECOMMUNICATION SERVICES, NAMELY, TRANSMISSION OF VOICE, DATA, GRAPHICS, IMAGES, AUDIO AND VIDEO BY MEANS OF TELECOMMUNICATIONS NETWORKS, WIRELESS COMMUNICATION NETWORKS, AND THE INTERNET; WIRELESS BROADBAND COMMUNICATION SERVICES; BROADBAND RADIO COMMUNICATION SERVICES (U.S. CLS. 100, 101 AND 104).

**CLASS 42—SCIENTIFIC AND COMPUTER SERVICES**

FOR COMPUTER PROJECT MANAGEMENT SERVICES IN THE FIELD OF TELECOMMUNICATION NETWORKS FOR OTHERS; DESIGNING ENHANCED COMPUTER HARDWARE FOR COMMUNICATIONS TECHNOLOGY NETWORKS; COMPUTER SERVICES, NAMELY, OPERATING COMMUNICATION COMPUTER NETWORKS FEATURING BROADBAND TRANSMISSION SOFTWARE FOR OTHERS; TECHNICAL SUPPORT SERVICES, NAMELY, TROUBLESHOOTING OF COMPUTER SOFTWARE PROBLEMS RELATING TO BROADBAND (U.S. CLS. 100 AND 101).  
SIMON TENG, EXAMINING ATTORNEY

SN 85-097,607. ERICSSON FEDERAL INC., RESTON, VA.  
FILED 7-31-2010.



NO CLAIM IS MADE TO THE EXCLUSIVE RIGHT TO USE "NETWORKS", APART FROM THE MARK AS SHOWN.

THE COLOR(S) BLACK AND BLUE IS/ARE CLAIMED AS A FEATURE OF THE MARK.

THE MARK CONSISTS OF THE STYLIZED WORDS "OCEUS NETWORKS", WITH "OCEUS" IN BLACK AND "NETWORKS" IN BLUE.

**CLASS 9—ELECTRICAL AND SCIENTIFIC APPARATUS**

FOR TELECOMMUNICATIONS AND DATA NETWORKING HARDWARE, NAMELY, DEVICES FOR TRANSPORTING AND AGGREGATING VOICE, DATA, AND VIDEO COMMUNICATIONS ACROSS MULTIPLE NETWORK INFRASTRUCTURES AND COMMUNICATIONS PROTOCOLS; WIRELESS ADAPTERS USED TO LINK COMPUTERS TO A TELECOMMUNICATIONS NETWORK; COMPUTER HARDWARE EQUIPMENT USED IN COMMUNICATIONS TECHNOLOGY NETWORKS AND COMPUTER SOFTWARE FOR OPERATING COMMUNICATIONS TECHNOLOGY NETWORKS; BROADBAND POWER LINE COMMUNICATION SYSTEMS FOR TRANSFERRING BROADBAND DATA OVER ELECTRICAL POWER LINES, COMPRISED OF COMPUTER HARDWARE, SOFTWARE AND MODEMS; BROADBAND RADIOS; BROADBAND WIRELESS EQUIPMENT, NAMELY, TELECOMMUNICATIONS BASE STATION EQUIPMENT FOR CELLULAR AND FIXED NETWORKING AND COMMUNICATIONS APPLICATIONS; WIRELESS BROADBAND RADIOS (U.S. CLS. 21, 23, 26, 36 AND 38).

**CLASS 35—ADVERTISING AND BUSINESS**

FOR TELECOMMUNICATIONS NETWORK MANAGEMENT SERVICES, NAMELY, THE OPERATION AND ADMINISTRATION OF TELECOMMUNICATION SYSTEMS AND NETWORKS FOR OTHERS (U.S. CLS. 100, 101 AND 102).

**CLASS 38—COMMUNICATION**

FOR COMMUNICATION SERVICES, NAMELY, TRANSMISSION OF VOICE, AUDIO, VISUAL IMAGES AND DATA BY TELECOMMUNICATIONS NETWORKS, WIRELESS COMMUNICATION NETWORKS, THE INTERNET, INFORMATION SERVICES NETWORKS AND DATA NETWORKS; DIGITAL NETWORK TELECOMMUNICATIONS SERVICES; ELECTRONIC EXCHANGE OF DATA STORED IN DATABASES ACCESSIBLE VIA TELECOMMUNICATION NETWORKS; PROVIDING ACCESS TO TELECOMMUNICATION NETWORKS; PROVIDING TELECOMMUNICATIONS CONNECTIONS TO A GLOBAL COMPUTER NETWORK; TELECOMMUNICATION SERVICES, NAMELY, TRANSMISSION OF VOICE, DATA, GRAPHICS, SOUND AND VIDEO BY MEANS OF BROADBAND POWER LINE OR WIRELESS NETWORKS; TELECOMMUNICATION SERVICES, NAMELY, TRANSMISSION OF VOICE, DATA, GRAPHICS, IMAGES, AUDIO AND VIDEO BY MEANS OF TELECOMMUNICATIONS NETWORKS, WIRELESS COMMUNICATION NETWORKS, AND THE INTERNET; WIRELESS BROADBAND COMMUNICATION SERVICES; BROADBAND RADIO COMMUNICATION SERVICES (U.S. CLS. 100, 101 AND 104).

**CLASS 42—SCIENTIFIC AND COMPUTER SERVICES**

FOR COMPUTER PROJECT MANAGEMENT SERVICES IN THE FIELD OF TELECOMMUNICATION NETWORKS FOR OTHERS; DESIGNING ENHANCED COMPUTER HARDWARE FOR COMMUNICATIONS TECHNOLOGY NETWORKS; COMPUTER SERVICES, NAMELY, OPERATING COMMUNICATION COMPUTER NETWORKS FEATURING BROADBAND TRANSMISSION SOFTWARE FOR OTHERS; TECHNICAL SUPPORT SERVICES, NAMELY, TROUBLESHOOTING OF COMPUTER SOFTWARE PROBLEMS RELATING TO BROADBAND (U.S. CLS. 100 AND 101).

SIMON TENG, EXAMINING ATTORNEY

SN 85-097,608. ERICSSON FEDERAL INC., RESTON, VA. FILED 8-1-2010.



NO CLAIM IS MADE TO THE EXCLUSIVE RIGHT TO USE "NETWORKS", APART FROM THE MARK AS SHOWN.

THE COLOR(S) WHITE, GRAY, BLACK, AND BLUE IS/ARE CLAIMED AS A FEATURE OF THE MARK.

THE MARK CONSISTS THE WORDS "OCEUS" IN SHADED WHITE AND GRAY. BELOW THIS IS "NETWORKS" IN BLUE. TO THE LEFT IS A STYLIZED THREE-BAND BLUE 3-D LIKE DESIGN WITH A BLACK CENTER AND THREE ENDS PARTIALLY COLORED IN BLACK. THE BLACK BACKGROUND IS NOT PART OF THE MARK.

**CLASS 9—ELECTRICAL AND SCIENTIFIC APPARATUS**

FOR TELECOMMUNICATIONS AND DATA NETWORKING HARDWARE, NAMELY, DEVICES FOR TRANSPORTING AND AGGREGATING VOICE, DATA, AND VIDEO COMMUNICATIONS ACROSS MULTIPLE NETWORK INFRASTRUCTURES AND COMMUNICATIONS PROTOCOLS; WIRELESS ADAPTERS USED TO LINK COMPUTERS TO A TELECOMMUNICATIONS NETWORK; COMPUTER HARDWARE EQUIPMENT USED IN COMMUNICATIONS TECHNOLOGY NETWORKS AND COMPUTER SOFTWARE FOR OPERATING COMMUNICATIONS TECHNOLOGY NETWORKS; BROADBAND POWER LINE COMMUNICATION SYSTEMS FOR TRANSFERRING BROADBAND DATA OVER ELECTRICAL POWER LINES, COMPRISED OF COMPUTER HARDWARE, SOFTWARE AND MODEMS; BROADBAND RADIOS; BROADBAND WIRELESS EQUIPMENT, NAMELY, TELECOMMUNICATIONS BASE STATION EQUIPMENT FOR CELLULAR AND FIXED NETWORKING AND COMMUNICATIONS APPLICATIONS; WIRELESS BROADBAND RADIOS (U.S. CLS. 21, 23, 26, 36 AND 38).

**CLASS 35—ADVERTISING AND BUSINESS**

FOR TELECOMMUNICATIONS NETWORK MANAGEMENT SERVICES, NAMELY, THE OPERATION AND ADMINISTRATION OF TELECOMMUNICATION SYSTEMS AND NETWORKS FOR OTHERS (U.S. CLS. 100, 101 AND 102).

**CLASS 38—COMMUNICATION**

FOR COMMUNICATION SERVICES, NAMELY, TRANSMISSION OF VOICE, AUDIO, VISUAL IMAGES AND DATA BY TELECOMMUNICATIONS NETWORKS, WIRELESS COMMUNICATION NETWORKS, THE INTERNET, INFORMATION SERVICES NETWORKS AND DATA NETWORKS; DIGITAL NETWORK TELECOMMUNICATIONS SERVICES; ELECTRONIC EXCHANGE OF DATA STORED IN DATABASES ACCESSIBLE VIA TELECOMMUNICATION NETWORKS; PROVIDING ACCESS TO TELECOMMUNICATION NETWORKS; PROVIDING TELECOMMUNICATIONS CONNECTIONS TO A GLOBAL COMPUTER NETWORK; TELECOMMUNICATION SERVICES, NAMELY, TRANSMISSION OF VOICE, DATA, GRAPHICS, SOUND AND VIDEO BY MEANS OF BROADBAND POWER LINE OR WIRELESS NETWORKS; TELECOMMUNICATION SERVICES, NAMELY, TRANSMISSION OF VOICE, DATA, GRAPHICS, IMAGES, AUDIO AND VIDEO BY MEANS OF TELECOMMUNICATIONS NETWORKS, WIRELESS COMMUNICATION NETWORKS, AND THE INTERNET; WIRELESS BROADBAND COMMUNICATION SERVICES; BROADBAND RADIO COMMUNICATION SERVICES (U.S. CLS. 100, 101 AND 104).

**CLASS 42—SCIENTIFIC AND COMPUTER SERVICES**

FOR COMPUTER PROJECT MANAGEMENT SERVICES IN THE FIELD OF TELECOMMUNICATION NETWORKS FOR OTHERS; DESIGNING ENHANCED COMPUTER HARDWARE FOR COMMUNICATIONS TECHNOLOGY NETWORKS; COMPUTER SERVICES, NAMELY, OPERATING COMMUNICATION COMPUTER NETWORKS FEATURING BROADBAND TRANSMISSION SOFTWARE FOR OTHERS; TECHNICAL SUPPORT SERVICES, NAMELY, TROUBLESHOOTING OF COMPUTER SOFTWARE PROBLEMS RELATING TO BROADBAND (U.S. CLS. 100 AND 101).

SIMON TENG, EXAMINING ATTORNEY

SN 85-097,609. ERICSSON FEDERAL INC., RESTON, VA. FILED 8-1-2010.



NO CLAIM IS MADE TO THE EXCLUSIVE RIGHT TO USE "NETWORKS", APART FROM THE MARK AS SHOWN.

THE STIPPLING IS FOR SHADING PURPOSES ONLY.

**CLASS 9—ELECTRICAL AND SCIENTIFIC APPARATUS**

FOR TELECOMMUNICATIONS AND DATA NETWORKING HARDWARE, NAMELY, DEVICES FOR TRANSPORTING AND AGGREGATING VOICE, DATA, AND VIDEO COMMUNICATIONS ACROSS MULTIPLE NETWORK INFRASTRUCTURES AND COMMUNICATIONS PROTOCOLS; WIRELESS ADAPTERS USED TO LINK COMPUTERS TO A TELECOMMUNICATIONS NETWORK; COMPUTER HARDWARE EQUIPMENT USED IN COMMUNICATIONS TECHNOLOGY NETWORKS AND COMPUTER SOFTWARE FOR OPERATING COMMUNICATIONS TECHNOLOGY NETWORKS; BROADBAND POWER LINE COMMUNICATION SYSTEMS FOR TRANSFERRING BROADBAND DATA OVER ELECTRICAL POWER LINES, COMPRISED OF COMPUTER HARDWARE, SOFTWARE AND MODEMS; BROADBAND RADIOS; BROADBAND WIRELESS EQUIPMENT, NAMELY, TELECOMMUNICATIONS BASE STATION EQUIPMENT FOR CELLULAR AND FIXED NETWORKING AND COMMUNICATIONS APPLICATIONS; WIRELESS BROADBAND RADIOS (U.S. CLS. 21, 23, 26, 36 AND 38).

SN 85-097,783. CLEARBRIDGE HOLDINGS LIMITED, KOW-LON, HONG KONG, FILED 8-2-2010.

# Clearbridge

**CLASS 35—ADVERTISING AND BUSINESS**

FOR TELECOMMUNICATIONS NETWORK MANAGEMENT SERVICES, NAMELY, THE OPERATION AND ADMINISTRATION OF TELECOMMUNICATION SYSTEMS AND NETWORKS FOR OTHERS (U.S. CLS. 100, 101 AND 102).

THE MARK CONSISTS OF STANDARD CHARACTERS WITHOUT CLAIM TO ANY PARTICULAR FONT, STYLE, SIZE, OR COLOR.

PRIORITY CLAIMED UNDER SEC. 44(D) ON HONG KONG APPLICATION NO. 301547028, FILED 4-23-2010, REG. NO. 301547028, DATED 4-23-2010, EXPIRES 4-23-2020.

PRIORITY CLAIMED UNDER SEC. 44(D) ON HONG KONG APPLICATION NO. 301679068, FILED 8-2-2010, REG. NO. 301679068, DATED 8-2-2010, EXPIRES 8-2-2020.

**CLASS 38—COMMUNICATION**

FOR COMMUNICATION SERVICES, NAMELY, TRANSMISSION OF VOICE, AUDIO, VISUAL IMAGES AND DATA BY TELECOMMUNICATIONS NETWORKS, WIRELESS COMMUNICATION NETWORKS, THE INTERNET, INFORMATION SERVICES NETWORKS AND DATA NETWORKS; DIGITAL NETWORK TELECOMMUNICATIONS SERVICES; ELECTRONIC EXCHANGE OF DATA STORED IN DATABASES ACCESSIBLE VIA TELECOMMUNICATION NETWORKS; PROVIDING ACCESS TO TELECOMMUNICATION NETWORKS; PROVIDING TELECOMMUNICATIONS CONNECTIONS TO A GLOBAL COMPUTER NETWORK; TELECOMMUNICATION SERVICES, NAMELY, TRANSMISSION OF VOICE, DATA, GRAPHICS, SOUND AND VIDEO BY MEANS OF BROADBAND POWER LINE OR WIRELESS NETWORKS; TELECOMMUNICATION SERVICES, NAMELY, TRANSMISSION OF VOICE, DATA, GRAPHICS, IMAGES, AUDIO AND VIDEO BY MEANS OF TELECOMMUNICATIONS NETWORKS, WIRELESS COMMUNICATION NETWORKS, AND THE INTERNET; WIRELESS BROADBAND COMMUNICATION SERVICES; BROADBAND RADIO COMMUNICATION SERVICES (U.S. CLS. 100, 101 AND 104).

**CLASS 9—ELECTRICAL AND SCIENTIFIC APPARATUS**

FOR SURGICAL APPARATUS AND INSTRUMENTS FOR MEDICAL, DENTAL OR VETERINARY USE; ORTHOPEDIC ARTICLES NAMELY, ORTHOPEDIC APPARATUS AND INSTRUMENTS FOR DIAGNOSTIC AND THERAPEUTIC USE; MEDICAL MEMBRANES, NAMELY, ARTIFICIAL SKIN FOR SURGICAL PURPOSES; MEDICAL DEVICE, NAMELY, BLOOD PRESSURE MONITOR AND LASER DEVICES; DIAGNOSTIC DEVICE, NAMELY, FOR THE DIAGNOSIS OF CANCER, DIABETES AND CARDIOVASCULAR DISEASE; SYRINGES FOR MEDICAL PURPOSES AND FOR INJECTIONS; MEDICAL TUBING FOR DRAINAGE, TRANSFUSION AND ADMINISTERING DRUGS; DRUG DELIVERY APPARATUS, NAMELY, UNITS FOR DOSAGE, MEASURING AND MONITORING OF DRUG DELIVERY; MEDICAL APPARATUS, NAMELY, BLOOD MICRO PUMP SYSTEM FOR USE IN ARTIFICIAL ORGAN SUPPORT; BLOOD TESTING SYSTEM COMPRISED OF A BLOOD TESTING APPARATUS (U.S. CLS. 21, 23, 26, 36 AND 38).

**CLASS 42—SCIENTIFIC AND COMPUTER SERVICES**

FOR COMPUTER PROJECT MANAGEMENT SERVICES IN THE FIELD OF TELECOMMUNICATION NETWORKS FOR OTHERS; DESIGNING ENHANCED COMPUTER HARDWARE FOR COMMUNICATIONS TECHNOLOGY NETWORKS; COMPUTER SERVICES, NAMELY, OPERATING COMMUNICATION COMPUTER NETWORKS FEATURING BROADBAND TRANSMISSION SOFTWARE FOR OTHERS; TECHNICAL SUPPORT SERVICES, NAMELY, TROUBLESHOOTING OF COMPUTER SOFTWARE PROBLEMS RELATING TO BROADBAND (U.S. CLS. 100 AND 101).

SIMON TENG, EXAMINING ATTORNEY

**CLASS 10—MEDICAL APPARATUS**

FOR SURGICAL APPARATUS AND INSTRUMENTS FOR MEDICAL, DENTAL OR VETERINARY USE; ORTHOPEDIC ARTICLES NAMELY, ORTHOPEDIC APPARATUS AND INSTRUMENTS FOR DIAGNOSTIC AND THERAPEUTIC USE; MEDICAL MEMBRANES, NAMELY, ARTIFICIAL SKIN FOR SURGICAL PURPOSES; MEDICAL DEVICE, NAMELY, BLOOD PRESSURE MONITOR AND LASER DEVICES; DIAGNOSTIC DEVICE, NAMELY, FOR THE DIAGNOSIS OF CANCER, DIABETES AND CARDIOVASCULAR DISEASE; SYRINGES FOR MEDICAL PURPOSES AND FOR INJECTIONS; MEDICAL TUBING FOR DRAINAGE, TRANSFUSION AND ADMINISTERING DRUGS; DRUG DELIVERY APPARATUS, NAMELY, UNITS FOR DOSAGE, MEASURING AND MONITORING OF DRUG DELIVERY; MEDICAL APPARATUS, NAMELY, BLOOD MICRO PUMP SYSTEM FOR USE IN ARTIFICIAL ORGAN SUPPORT; BLOOD TESTING SYSTEM COMPRISED OF A BLOOD TESTING APPARATUS (U.S. CLS. 26, 39 AND 44).

**CLASS 42—SCIENTIFIC AND COMPUTER SERVICES**

FOR SCIENTIFIC AND TECHNOLOGICAL SERVICES, NAMELY, CONSULTING SERVICES IN THE FIELDS OF BIOTECHNOLOGY, PHARMACEUTICAL RESEARCH AND DEVELOPMENT AND GENETIC SCIENCE; SCIENTIFIC AND TECHNOLOGICAL RESEARCH IN THE BIOTECHNOLOGY AND PHARMACEUTICAL FIELDS; DESIGN OF DIAGNOSTIC EQUIPMENT IN THE FIELD OF GENE SCIENCE; MEDICAL RESEARCH IN THE FIELD OF GENETICS AND ONCOLOGY; DESIGN AND DEVELOPMENT OF COMPUTER HARDWARE AND SOFTWARE; DESIGN AND DEVELOPMENT OF SCIENTIFIC INSTRUMENTS AND DEVICES, NAMELY, MECHANICAL, ELECTROMECHANICAL AND OPTOELECTRONIC APPARATUS AND INSTRUMENTS; DATA ENCRYPTION SERVICES; DATA SECURITY SERVICES, NAMELY, DESIGN AND DEVELOPMENT OF ELECTRONIC DATA SECURITY SYSTEMS; GENETIC SERVICES, NAMELY, CONSULTING SERVICES IN THE FIELDS OF GENETIC SCIENCE (U.S. CLS. 100 AND 101).

GRETCHEN ULRICH, EXAMINING ATTORNEY

SN 85-098,042. THE OVADAFUT HOSIERY COMPANY, NEW YORK, NY. FILED 8-2-2010.

## V.K. NAGRANI

THE MARK CONSISTS OF STANDARD CHARACTERS WITHOUT CLAIM TO ANY PARTICULAR FONT, STYLE, SIZE, OR COLOR.

THE NAME(S), PORTRAIT(S), AND/OR SIGNATURE(S) SHOWN IN THE MARK IDENTIFIES "VIVEK KISHU NAGRANI", WHOSE CONSENT(S) TO REGISTER IS MADE OF RECORD.

**CLASS 25—CLOTHING**

FOR FOOTWEAR; LOUNGEWEAR; T-SHIRTS; TOPS; UNDERWEAR (U.S. CLS. 22 AND 39).

FIRST USE 1-1-2004; IN COMMERCE 1-1-2004.

**CLASS 35—ADVERTISING AND BUSINESS**

FOR RETAIL STORE SERVICES FEATURING CLOTHING, LOUNGEWEAR, UNDERWEAR, FOOTWEAR AND WATCHES (U.S. CLS. 100, 101 AND 102).

FIRST USE 5-27-2005; IN COMMERCE 5-27-2005.  
JENNIFER VASQUEZ, EXAMINING ATTORNEY

SN 85-099,147. HEIDECHE, MARK JOSEPH, DOWNERS GROVE, IL. FILED 8-3-2010.

## EVERYTHING UNDER

THE MARK CONSISTS OF STANDARD CHARACTERS WITHOUT CLAIM TO ANY PARTICULAR FONT, STYLE, SIZE, OR COLOR.

**CLASS 9—ELECTRICAL AND SCIENTIFIC APPARATUS**

FOR MUSICAL SOUND RECORDINGS (U.S. CLS. 21, 23, 26, 36 AND 38).

FIRST USE 8-31-2009; IN COMMERCE 8-31-2009.

**CLASS 41—EDUCATION AND ENTERTAINMENT**

FOR ENTERTAINMENT, NAMELY, LIVE MUSIC CONCERTS (U.S. CLS. 100, 101 AND 107).

FIRST USE 9-15-2009; IN COMMERCE 9-15-2009.  
BILL DAWE, EXAMINING ATTORNEY

SN 85-099,402. STRUTTA.COM MEDIA, INC., VANCOUVER, B.C., CANADA, FILED 8-3-2010.

# STRUTTA

THE MARK CONSISTS OF STANDARD CHARACTERS WITHOUT CLAIM TO ANY PARTICULAR FONT, STYLE, SIZE, OR COLOR.

**CLASS 35—ADVERTISING AND BUSINESS**

FOR VOTING SERVICES, NAMELY, SERVICES ALLOWING USERS TO CAST VOTES IN CONTESTS VIA THE INTERNET, TELEPHONES, MOBILE PHONES AND MOBILE DEVICES; PUBLIC OPINION POLLING; ADVERTISING AGENCIES, NAMELY, PROMOTING THE GOODS AND SERVICES OF OTHERS; DEVELOPING PROMOTIONAL CAMPAIGNS FOR BUSINESS; ONLINE ADVERTISING SERVICES FOR OTHERS; ADVERTISING AND PROMOTIONAL SERVICES (U.S. CLS. 100, 101 AND 102).

**CLASS 38—COMMUNICATION**

FOR AUDIO AND VIDEO BROADCASTING SERVICES OVER THE INTERNET; VIDEO BROADCASTING SERVICES OVER THE INTERNET OR OTHER COMMUNICATIONS NETWORK FEATURING THE UPLOADED, POSTED AND TAGGED VIDEOS OF OTHERS; ELECTRONIC TRANSMISSION OF DATA, PHOTOS, AUDIO AND VIDEO CLIPS VIA THE INTERNET; BROADCASTING OF VIDEO AND AUDIO PROGRAMMING OVER THE INTERNET (U.S. CLS. 100, 101 AND 104).

**CLASS 41—EDUCATION AND ENTERTAINMENT**

FOR ARRANGING OF CONTESTS (U.S. CLS. 100, 101 AND 107).

**CLASS 42—SCIENTIFIC AND COMPUTER SERVICES**

FOR PROVIDING A WEBSITE FEATURING TECHNOLOGY THAT ENABLES USERS TO CREATE A VOTING EVENT, VOTE ON THE ISSUE, CHANGE THEIR VOTE AT WILL AND TRACK THE INPUT AND DISPLAY IT IN A UNIQUE GRAPHICAL WAY; PROVIDING A WEBSITE FEATURING TEMPORARY USE OF NON-DOWNLOADABLE SOFTWARE ALLOWING USERS TO UPLOAD, POST AND DISPLAY ONLINE VIDEOS, PHOTOS, TEXT AND AUDIO FOR SHARING WITH OTHERS FOR ENTERTAINMENT PURPOSES; PROVIDING A WEBSITE ALLOWING USERS TO DOWNLOAD VIDEOS, PHOTOS, TEXT AND AUDIO FOR SHARING WITH OTHERS FOR ENTERTAINMENT PURPOSES (U.S. CLS. 100 AND 101).

KAREN BRACEY, EXAMINING ATTORNEY

SN 85-099,984. HUMANA INC., LOUISVILLE, KY. FILED 8-4-2010.

**MY ROAD AHEAD POWERED BY  
HUMANA**

THE MARK CONSISTS OF STANDARD CHARACTERS WITHOUT CLAIM TO ANY PARTICULAR FONT, STYLE, SIZE, OR COLOR.

OWNER OF U.S. REG. NOS. 3,497,184, 3,565,878 AND OTHERS.

**CLASS 16—PAPER GOODS AND PRINTED MATTER**

FOR PRINTED MATERIALS, NAMELY, BOOKS, NEWSLETTERS, PERIODICALS, BULLETINS, BROCHURES, PAMPHLETS, GUIDES, MAGAZINES, INFORMATION SHEETS AND POSTERS PROMOTING THE INTERESTS OF MATURE INDIVIDUALS AND IN THE FIELDS OF RETIREMENT, MATURE OR RETIRED LIFESTYLES, CARE GIVING, CHILDCARE, EDUCATION, ELDERCARE, ASSISTED CARE FACILITIES, LAW, ELDER LAW, LEGAL ASSISTANCE, BUSINESS, LOANS, MORTGAGES, BANKING, MONEY MANAGEMENT, INVESTMENTS, FINANCE, DISCOUNT AND SAVINGS PLANS, INSURANCE, REAL ESTATE, ELDER ASSISTANCE, HEALTH, HEALTH CARE, EXERCISE, FITNESS, ATHLETICS, SPORTS, MEDICAL PRODUCTS, PHARMACEUTICAL PRODUCTS AND SERVICES AND HEALTH PLANS, SENIOR CITIZENSHIP, LIVING WITH A CHRONIC MEDICAL CONDITION, VOTER EDUCATION, MEDICINE, TRAVEL, VOLUNTEER ACTIVITIES, AGING, BRAIN RESEARCH, FAMILY RELATIONSHIPS, CONSUMER ISSUES, ECONOMIC SECURITY, WORK AND INDEPENDENT LIVING (U.S. CLS. 2, 5, 22, 23, 29, 37, 38 AND 50).

**CLASS 35—ADVERTISING AND BUSINESS**

FOR PROMOTING THE INTERESTS OF MATURE INDIVIDUALS; PROMOTING PUBLIC AWARENESS AND ADVOCACY IN THE FIELDS OF RETIREMENT, MATURE OR RETIRED LIFESTYLES, CARE GIVING, CHILDCARE, EDUCATION, ELDERCARE, ASSISTED CARE FACILITIES, LAW, ELDER LAW, LEGAL ASSISTANCE, BUSINESS, LOANS, MORTGAGES, BANKING, MONEY MANAGEMENT, INVESTMENTS, FINANCE, DISCOUNT AND SAVINGS PLANS, INSURANCE, REAL ESTATE, ELDER ASSISTANCE, HEALTH, HEALTH CARE, EXERCISE, FITNESS, ATHLETICS, SPORTS, MEDICAL PRODUCTS, PHARMACEUTICAL PRODUCTS AND SERVICES AND HEALTH PLANS, SENIOR CITIZENSHIP, LIVING WITH A CHRONIC MEDICAL CONDITION, VOTER EDUCATION, MEDICINE, TRAVEL, VOLUNTEER ACTIVITIES, AGING, BRAIN RESEARCH, FAMILY RELATIONSHIPS, CONSUMER ISSUES, ECONOMIC SECURITY, WORK AND INDEPENDENT LIVING; PROVIDING CONSUMER INFORMATION IN THE FIELDS OF RETIREMENT, MATURE OR RETIRED LIFESTYLES, CARE GIVING, CHILDCARE, EDUCATION, ELDERCARE, ASSISTED CARE FACILITIES, LAW, ELDER LAW, LEGAL ASSISTANCE, BUSINESS, LOANS, MORTGAGES, BANKING, MONEY MANAGEMENT, INVESTMENTS, FINANCE, DISCOUNT AND SAVINGS PLANS, INSURANCE, REAL ESTATE, ELDER ASSISTANCE, HEALTH, HEALTH CARE, EXERCISE, FITNESS, ATHLETICS, SPORTS, MEDICAL PRODUCTS, PHARMACEUTICAL PRODUCTS AND SERVICES AND HEALTH PLANS, SENIOR CITIZENSHIP, LIVING WITH A CHRONIC MEDICAL CONDITION, VOTER EDUCATION, MEDICINE, TRAVEL, VOLUNTEER ACTIVITIES, AGING, BRAIN RESEARCH, FAMILY RELATIONSHIPS, CONSUMER ISSUES, ECONOMIC SECURITY, WORK AND INDE-

PENDENT LIVING; ONLINE ORDERING SERVICES FEATURING INSURANCE SERVICES, FINANCIAL PLANNING SERVICES, INVESTMENT SERVICES, CREDIT AND LOAN SERVICES, LEGAL SERVICES, PHARMACY SERVICES, TAX AND INCOME TAX CONSULTATION AND PREPARATION SERVICES, PHARMACEUTICAL, HEALTH AND MEDICAL PREPARATIONS AND PRODUCTS, BOOKS, MAGAZINES, PRE-RECORDED AUDIO AND VIDEOTAPES AND DISCS, COMPUTER SOFTWARE AND EDUCATIONAL MATERIAL; ONLINE RETAIL STORE SERVICES FEATURING INSURANCE SERVICES, PHARMACY SERVICES, ENTERTAINMENT SERVICES, TRAVEL SERVICES, HOBBY SERVICES, PHARMACEUTICAL, HEALTH AND MEDICAL PREPARATIONS; ARRANGING, CONDUCTING AND ORGANIZING TRADE SHOWS, CONVENTIONS AND EXPOSITIONS IN THE FIELD OF MATURE PERSONS AND PERSONS PREPARING FOR RETIREMENT, AND GOODS AND SERVICES INTENDED THEREFOR; ADMINISTRATION OF A DISCOUNT PROGRAM FOR ENABLING PARTICIPANTS TO OBTAIN DISCOUNTS ON GOODS AND SERVICES THROUGH USE OF A CREDIT CARD; ADMINISTRATION OF A DISCOUNT PROGRAM FOR ENABLING PARTICIPANTS TO OBTAIN DISCOUNTS ON GOODS AND SERVICES THROUGH USE OF A MEMBERSHIP CARD; PROMOTING THE GOODS AND SERVICES OF OTHERS BY AWARDED POINTS FOR CREDIT CARD USE; PROMOTING THE GOODS AND SERVICES OF OTHERS THROUGH INCENTIVE AWARD PROGRAMS; PROMOTING THE GOODS AND SERVICES OF OTHERS THROUGH THE DISTRIBUTION OF DISCOUNT CARDS AND PARTICIPATION IN MEMBERSHIP PROGRAMS; PROMOTING THE GOODS AND SERVICES OF OTHERS THROUGH PROMOTIONAL LOYALTY PROGRAMS AND REWARD INCENTIVE PROGRAMS IN THE NATURE OF PROVIDING CREDITS AND DISCOUNTS TO INDIVIDUAL MEMBERS OF A MEMBERSHIP GROUP FOR USE IN THIRD PARTY PURCHASES; COOPERATIVE MARKETING AND ADVERTISING SERVICES; CHARITABLE SERVICES, NAMELY, ORGANIZING AND CONDUCTING COMMUNITY VOLUNTEER PROGRAMS; BUSINESS SERVICES, NAMELY, PROMOTING THE GOODS AND SERVICES OF OTHERS BY PREPARING AND PLACING ADVERTISEMENTS IN NEWSLETTERS AND BULLETINS, ON GLOBAL COMPUTER NETWORKS AND AT TRADE SHOWS, CONVENTIONS AND EXPOSITIONS; PROVIDING A WEBSITE FEATURING CONSUMER INFORMATION CONCERNING AFFORDABLE HEALTHCARE; PROVIDING HEALTHCARE COST INFORMATION TO HEALTH PLAN PARTICIPANTS; COST MANAGEMENT FOR THE HEALTH BENEFIT PLANS FOR OTHERS; HEALTHCARE COST CONTAINMENT; HEALTHCARE COST REVIEW; HEALTHCARE UTILIZATION AND REVIEW SERVICES; PROVIDING INFORMATION IN THE FIELD OF HEALTHCARE UTILIZATION AND REVIEW SERVICES, NAMELY, INFORMATION CONCERNING THE EVALUATION OF HEALTHCARE FACILITIES AND PROVIDERS; MANAGED CARE SERVICES, NAMELY, ELECTRONIC PROCESSING OF HEALTHCARE INFORMATION; PHYSICIAN REFERRALS; CONSULTATION IN THE FIELD OF HEALTHCARE COST CONTAINMENT FOR HEALTH PLAN SPONSORS, NAMELY, PROVIDING INFORMATION TO CLIENTS AND PLAN PARTICIPANTS ON WAYS TO CONTAIN AND REDUCE COSTS OF HEALTHCARE; PROVIDING INFORMATION ABOUT THE COST OF HEALTH BENEFITS RELATED TO PATIENT CARE; PROVIDING CONSUMER INFORMATION IN THE FIELDS OF MEDICAL GOODS AND SERVICES; PROVIDING REBATES AND DISCOUNTS AT PARTICIPATING ESTABLISHMENTS OF OTHERS THROUGH THE USE OF MEMBERSHIP CARDS AND MEMBERSHIP PROGRAMS; PROVIDING DISCOUNT GROUP PURCHASING PROGRAM MEMBERSHIP INFORMATION VIA A GLOBAL COMPUTER NETWORK; PROVIDING AN ONLINE EDUCATIONAL DATABASE IN THE FIELDS OF RETAIL PHARMACY SERVICES, COST MANAGEMENT FOR HEALTH BENEFIT PLANS OF OTHERS; PROVIDING INFORMATION IN THE FIELD OF RETAIL PHARMACY SERVICES; TELEPHONE HOT LINE COUNSELING AND TELEPHONE INFORMATION SERVICES IN THE FIELD OF BUSINESS (U.S. CLS. 100, 101 AND 102).

**CLASS 36—INSURANCE AND FINANCIAL**

FOR PROVIDING INFORMATION, ADVICE AND CONSULTATION IN THE FIELDS OF LOANS, REAL ESTATE, MORTGAGE LENDING, BANKING, INSURANCE, MONEY MANAGEMENT, INVESTMENT, AND FINANCIAL MANAGEMENT; TELEPHONE HOT LINE COUNSELING AND TELEPHONE INFORMATION SERVICES IN THE FIELDS OF LOANS, REAL ESTATE, MORTGAGES, BANKING, INSURANCE, MONEY MANAGEMENT, INVESTMENTS, AND FINANCIAL MANAGEMENT; MONEY MANAGEMENT AND INVESTMENT ADVISORY SERVICES; PROVIDING INFORMATION AND CONSULTING SERVICES REGARDING, AND ADMINISTRATION OF, ANNUITIES, RETIREMENT FINANCIAL PLANNING, AND AUTOMOBILE, HOMEOWNER'S AND GROUP HEALTH INSURANCE PROGRAMS INCLUDING MEDI-GAP, LONG TERM CARE, HOSPITAL INDEMNITY, DENTAL AND OTHER HEALTH CARE RELATED SERVICES; PROVIDING FINANCIAL INFORMATION AND FINANCIAL CONSULTING SERVICES IN THE FIELD OF PREPAID PHARMACY PLANS; INSURANCE UNDERWRITING IN THE FIELD OF GROUP HEALTH INSURANCE; ADMINISTERING GROUP HEALTH INSURANCE PROGRAMS AND PROVIDING INFORMATION AND CONSULTING SERVICES WITH RESPECT TO ADMINISTERING GROUP HEALTH INSURANCE PROGRAMS; CREDIT CARD SERVICES; PROVIDING AN ONLINE EDUCATIONAL DATABASE ON GLOBAL COMPUTER NETWORKS IN THE FIELDS OF RETIREMENT FINANCIAL PLANNING, LOANS, MORTGAGE LENDING, BANKING, MONEY MANAGEMENT, INVESTMENTS, FINANCIAL PLANNING, SAVINGS PLANS, INSURANCE, REAL ESTATE, FINANCIAL ISSUES FOR CONSUMERS, AND PERSONAL ECONOMIC SECURITY (U.S. CLS. 100, 101 AND 102).

**CLASS 39—TRANSPORTATION AND STORAGE**

FOR TRAVEL SERVICES, NAMELY, ARRANGING TRAVEL PROGRAMS FOR MEMBERS OF APPLICANT THROUGH THIRD-PARTY PROVIDERS; AIRLINE, CAR RENTAL, CRUISE AND TOUR PACKAGE RESERVATIONS SERVICES VIA COMPUTER NETWORKS AND CALL CENTERS; PROVIDING AIRLINE, CAR RENTAL, CRUISE, TOUR PACKAGE, AND GENERAL TRAVEL INFORMATION VIA A GLOBAL COMPUTER NETWORK; PROVIDING AN ONLINE DATABASE IN THE FIELD OF TRAVEL (U.S. CLS. 100 AND 105).

**CLASS 44—MEDICAL, BEAUTY AND AGRICULTURAL SERVICES**

FOR PROVIDING MEDICAL INFORMATION VIA WEBSITES ON COMPUTER NETWORKS; PROVIDING AN ONLINE MEDICAL INFORMATION EDUCATIONAL DATABASE IN THE FIELDS OF MEDICAL ISSUES RELATED TO AGING, BRAIN RESEARCH FOR MEDICAL PURPOSES, LIVING WITH A CHRONIC MEDICAL CONDITION, MEDICINE, ELDER HEALTH, AND HEALTH CARE; PROVIDING MEDICAL INFORMATION, PROFESSIONAL MEDICAL COUNSELING AND MEDICAL CONSULTATION IN THE FIELDS OF MEDICAL CARE GIVING, ELDER HEALTH, HEALTHCARE; PROVIDING INTEGRATED ONLINE DATABASES THAT FEATURE INFORMATION ABOUT HEALTH AND WELLNESS ACTIVITIES FOR MATURE INDIVIDUALS; PROVIDING INTEGRATED ONLINE DATABASES THAT OFFER GUIDANCE ON PREVENTATIVE AND MAINTENANCE HEALTH ACTIVITIES FOR MATURE INDIVIDUALS; PROVIDING HEALTH INFORMATION IN THE FIELDS OF MEDICAL CARE, PATIENT CARE, AND CAREGIVER SUPPORT FOR MATURE INDIVIDUALS (U.S. CLS. 100 AND 101).

ANDREA HACK, EXAMINING ATTORNEY

SN 85-103,324. SILKROAD TECHNOLOGY, INC., WINSTON-SALEM, NC. FILED 8-9-2010.

# OPENHIRE

THE MARK CONSISTS OF STANDARD CHARACTERS WITHOUT CLAIM TO ANY PARTICULAR FONT, STYLE, SIZE, OR COLOR.

**CLASS 41—EDUCATION AND ENTERTAINMENT**

FOR BUSINESS TRAINING CONSULTANCY SERVICES (U.S. CLS. 100, 101 AND 107).

FIRST USE 8-0-1999; IN COMMERCE 8-0-1999.

**CLASS 42—SCIENTIFIC AND COMPUTER SERVICES**

FOR PROVIDING TEMPORARY USE OF ONLINE NON-DOWNLOADABLE SOFTWARE FOR USE IN THE FIELDS OF HUMAN RESOURCES AND RECRUITING MANAGEMENT AND APPLICANT TRACKING AND USER MANUALS, SOLD TOGETHER AS A UNIT; PROVIDING TEMPORARY USE OF ONLINE NON-DOWNLOADABLE SOFTWARE TO BUILD AND UPDATE INTRANETS AND PORTALS AND USER MANUALS, SOLD TOGETHER AS A UNIT; CONSULTING SERVICES IN THE FIELD OF HUMAN RESOURCES SOFTWARE IMPLEMENTATION (U.S. CLS. 100 AND 101).

FIRST USE 8-0-1999; IN COMMERCE 8-0-1999.

ALLISON SCHRODY, EXAMINING ATTORNEY

SN 85-104,004. L.S. HYDEN CONSULTING SERVICES, INC., SPRINGFIELD, OH. FILED 8-10-2010.

# LIFE DOESN'T WEIGHT

THE MARK CONSISTS OF STANDARD CHARACTERS WITHOUT CLAIM TO ANY PARTICULAR FONT, STYLE, SIZE, OR COLOR.

**CLASS 9—ELECTRICAL AND SCIENTIFIC APPARATUS**

FOR DOWNLOADABLE ELECTRONIC PUBLICATIONS IN THE NATURE OF WORKBOOKS, INSTRUCTOR COACHING MANUALS, JOURNALS AND BOOKLETS IN THE FIELDS OF LIFE COACHING, HEALTH, DIET AND NUTRITION, WEIGHT LOSS, IMPROVEMENT OF SELF IMAGE, STRESS MANAGEMENT AND STRESS REDUCTION, AND SPIRITUALITY; REFRIGERATOR MAGNETS (U.S. CLS. 21, 23, 26, 36 AND 38).



**CLASS 16—PAPER GOODS AND PRINTED MATTER**

FOR PUBLICATIONS, NAMELY, WORKBOOKS, INSTRUCTOR COACHING MANUALS, JOURNALS AND BOOKLETS IN THE FIELDS OF LIFE COACHING, HEALTH, DIET AND NUTRITION, WEIGHT LOSS, IMPROVEMENT OF SELF IMAGE, STRESS MANAGEMENT AND STRESS REDUCTION, AND SPIRITUALITY; PENS; BOOKMARKS (U.S. CLS. 2, 5, 22, 23, 29, 37, 38 AND 50).

**CLASS 41—EDUCATION AND ENTERTAINMENT**

FOR LIFE COACHING SERVICES IN THE FIELD OF IMPROVEMENT OF SELF IMAGE AND PERSONAL TRAINING IN CONNECTION WITH WEIGHT LOSS, PROVIDED IN PERSON AND VIA THE INTERNET (U.S. CLS. 100, 101 AND 107).

**CLASS 44—MEDICAL, BEAUTY AND AGRICULTURAL SERVICES**

FOR PROVIDING HEALTHY LIFESTYLE AND NUTRITION SERVICES, NAMELY, PERSONAL ASSESSMENTS, PERSONALIZED ROUTINES, MAINTENANCE SCHEDULES, AND COUNSELING, IN PERSON AND VIA THE INTERNET; ENERGY HEALING SERVICES, NAMELY, STRESS MANAGEMENT AND STRESS REDUCTION COUNSELING FOR INDIVIDUALS TO ENHANCE THEIR LIVES, PROVIDED IN PERSON AND VIA THE INTERNET; PROVIDING INFORMATION ON GOAL SETTING IN CONNECTION WITH MAINTAINING A HEALTHY LIFESTYLE AND LOSING WEIGHT, IN PERSON AND VIA THE INTERNET; PROVIDING A WEBSITE FEATURING INFORMATION AND ADVICE FOR GOAL SETTING AND DECISION MAKING IN THE FIELDS OF DIET, WEIGHT LOSS, HEALTHY BODY IMAGE, AND LIFESTYLE WELLNESS; PROVIDING COUNSELING SERVICES IN THE FIELDS OF HEALTH, NUTRITION AND LIFESTYLE WELLNESS, PROVIDED IN PERSON AND VIA THE INTERNET; WEIGHT REDUCTION DIET PLANNING AND SUPERVISION, PROVIDED IN PERSON AND VIA THE INTERNET (U.S. CLS. 100 AND 101).

**CLASS 45—PERSONAL AND LEGAL SERVICES**

FOR SPIRITUAL COUNSELING, PROVIDED IN PERSON AND VIA THE INTERNET; PROVIDING A WEBSITE FEATURING INFORMATION AND ADVICE IN THE FIELD OF SPIRITUAL COUNSELING IN CONNECTION TO SPIRITUAL AWARENESS AND LIFE PURPOSE (U.S. CLS. 100 AND 101).

SIMON TENG, EXAMINING ATTORNEY

SN 85-104,885. GENTLEMAN SCHOLAR STUDIOS, LLC, SANTA MONICA, CA. FILED 8-11-2010.

**GENTLEMAN SCHOLAR**

THE MARK CONSISTS OF STANDARD CHARACTERS WITHOUT CLAIM TO ANY PARTICULAR FONT, STYLE, SIZE, OR COLOR.

**CLASS 35—ADVERTISING AND BUSINESS**

FOR PRODUCTION OF TELEVISION COMMERCIALS; POST-PRODUCTION EDITING SERVICES FOR VIDEO AND AUDIO COMMERCIALS (U.S. CLS. 100, 101 AND 102).

**CLASS 41—EDUCATION AND ENTERTAINMENT**

FOR ENTERTAINMENT SERVICES IN THE NATURE OF CREATION, DEVELOPMENT, AND PRODUCTION OF TELEVISION PROGRAMMING; MULTIMEDIA ENTERTAINMENT SERVICES IN THE NATURE OF DEVELOPMENT, PRODUCTION AND POST-PRODUCTION SERVICES IN THE FIELDS OF VIDEO AND FILMS; ENTERTAINMENT SERVICES IN THE NATURE OF DEVELOPMENT, CREATION, PRODUCTION AND POST-PRODUCTION SERVICES OF MULTIMEDIA ENTERTAINMENT CONTENT; SPECIAL EFFECTS ANIMATION SERVICES FOR FILM AND VIDEO; ANIMATION PRODUCTION SERVICES; MUSIC VIDEO PRODUCTION; AUDIO PRODUCTION FOR ANIMATED FILMS, VIDEOS, AND TELEVISION SHOWS (U.S. CLS. 100, 101 AND 107).

**CLASS 42—SCIENTIFIC AND COMPUTER SERVICES**

FOR ANIMATION AND SPECIAL-EFFECTS DESIGN FOR OTHERS FOR FILMS, VIDEOS, AND TELEVISION SHOWS (U.S. CLS. 100 AND 101).

ELLEN B. AWRICH, EXAMINING ATTORNEY

SN 85-105,365. JULIE CLARK, PETOSKEY, MI. FILED 8-11-2010.

**CHEATERS SUCK**

THE MARK CONSISTS OF STANDARD CHARACTERS WITHOUT CLAIM TO ANY PARTICULAR FONT, STYLE, SIZE, OR COLOR.

**CLASS 16—PAPER GOODS AND PRINTED MATTER**

FOR GREETING CARDS; PAPER BANNERS; BUMPER STICKERS; STICKERS; STATIONERY (U.S. CLS. 2, 5, 22, 23, 29, 37, 38 AND 50).

**CLASS 21—HOUSEWARES AND GLASS**

FOR COFFEE CUPS (U.S. CLS. 2, 13, 23, 29, 30, 33, 40 AND 50).

**CLASS 25—CLOTHING**

FOR CLOTHING, NAMELY, SHIRTS AND CAPS (U.S. CLS. 22 AND 39).

TINA L. SNAPP, EXAMINING ATTORNEY

SN 85-105,480. FRANK, DANA, EL PASO, TX. FILED 8-11-2010.

**Dana Michelle**

THE MARK CONSISTS OF STANDARD CHARACTERS WITHOUT CLAIM TO ANY PARTICULAR FONT, STYLE, SIZE, OR COLOR.

THE NAME(S), PORTRAIT(S), AND/OR SIGNATURE(S) SHOWN IN THE MARK IDENTIFIES DANA MICHELLE FRANK, WHOSE CONSENT(S) TO REGISTER IS MADE OF RECORD.

#### CLASS 25—CLOTHING

FOR HEADBANDS (U.S. CLS. 22 AND 39).

#### CLASS 26—FANCY GOODS

FOR HAIR BANDS; HAIR BARRETTES; HAIR BOWS; HAIR CLIPS; HAIR ELASTICS; HAIR ORNAMENTS; NON-ELECTRIC HAIR CURLERS (U.S. CLS. 37, 39, 40, 42 AND 50).

CAROLINE WOOD, EXAMINING ATTORNEY

SN 85-106,750. WESTINGHOUSE ELECTRIC COMPANY LLC, CRANBERRY TOWNSHIP, PA. FILED 8-13-2010.

# WeSTE

THE MARK CONSISTS OF STANDARD CHARACTERS WITHOUT CLAIM TO ANY PARTICULAR FONT, STYLE, SIZE, OR COLOR.

THE WORDING "WESTE" HAS NO MEANING IN A FOREIGN LANGUAGE.

#### CLASS 11—ENVIRONMENTAL CONTROL APPARATUS

FOR NUCLEAR POWER PLANTS (U.S. CLS. 13, 21, 23, 31 AND 34).

#### CLASS 41—EDUCATION AND ENTERTAINMENT

FOR TRAINING SERVICES IN THE FIELD OF NUCLEAR POWER PLANT INDUSTRY (U.S. CLS. 100, 101 AND 107).

BILL DAWE, EXAMINING ATTORNEY

SN 85-107,095. PHASERX, INC., SEATTLE, WA. FILED 8-13-2010.

### UNLOCKING THE VALUE OF RNAi

THE MARK CONSISTS OF STANDARD CHARACTERS WITHOUT CLAIM TO ANY PARTICULAR FONT, STYLE, SIZE, OR COLOR.

NO CLAIM IS MADE TO THE EXCLUSIVE RIGHT TO USE "RNAI", APART FROM THE MARK AS SHOWN.

#### CLASS 5—PHARMACEUTICALS

FOR PHARMACEUTICAL PREPARATIONS, NAMELY, POLYMERIC DELIVERY TECHNOLOGIES IN THE FORM OF POWDERS OR LIQUID SOLUTIONS FOR THE TARGETED DELIVERY OF MACROMOLECULES AND PHARMACEUTICAL PREPARATIONS FOR MEDICAL PURPOSES (U.S. CLS. 6, 18, 44, 46, 51 AND 52).

#### CLASS 42—SCIENTIFIC AND COMPUTER SERVICES

FOR MEDICAL AND SCIENTIFIC RESEARCH IN THE FIELDS OF PHARMACEUTICALS, BIOLOGICS, DRUG DELIVERY AND MEDICAL THERAPEUTICS; PRODUCT RESEARCH AND DEVELOPMENT IN THE FIELDS OF PHARMACEUTICAL FORMULATIONS OF MACROMOLECULES, MACROMOLECULAR PHARMACEUTICAL PRODUCTS, MACROMOLECULAR THERAPEUTICS, AND DELIVERY OF MACROMOLECULAR THERAPEUTICS (U.S. CLS. 100 AND 101).

FONG HSU, EXAMINING ATTORNEY

SN 85-107,177. PHASERX, INC., SEATTLE, WA. FILED 8-13-2010.

### SMARTT POLYMER TECHNOLOGY

THE MARK CONSISTS OF STANDARD CHARACTERS WITHOUT CLAIM TO ANY PARTICULAR FONT, STYLE, SIZE, OR COLOR.

NO CLAIM IS MADE TO THE EXCLUSIVE RIGHT TO USE "POLYMER TECHNOLOGY", APART FROM THE MARK AS SHOWN.

#### CLASS 5—PHARMACEUTICALS

FOR PHARMACEUTICAL PREPARATIONS, NAMELY, POLYMERIC DELIVERY TECHNOLOGY AND FORMULATIONS IN THE FORM OF POWDERS OR LIQUID SOLUTIONS FOR DELIVERY OF MACROMOLECULAR THERAPEUTICS FOR USE IN HUMAN AND VETERINARY MEDICINE (U.S. CLS. 6, 18, 44, 46, 51 AND 52).

#### CLASS 42—SCIENTIFIC AND COMPUTER SERVICES

FOR MEDICAL AND SCIENTIFIC RESEARCH IN THE FIELDS OF PHARMACEUTICALS, BIOLOGICS, DRUG DELIVERY AND MEDICAL THERAPEUTICS; PRODUCT RESEARCH AND DEVELOPMENT IN THE FIELDS OF PHARMACEUTICAL FORMULATIONS OF MACROMOLECULES, MACROMOLECULAR PHARMACEUTICAL PRODUCTS, MACROMOLECULAR THERAPEUTICS, AND DELIVERY OF MACROMOLECULAR THERAPEUTICS (U.S. CLS. 100 AND 101).

FONG HSU, EXAMINING ATTORNEY

SN 85-107,296. PHASERX, INC., SEATTLE, WA. FILED 8-13-2010.



THE MARK CONSISTS OF A HORSESHOE SHAPE WITH A CIRCLE INSIDE WHERE THE HORSESHOE AND CIRCLE CONTAIN UNEVENLY SPACED HORIZONTAL LINES FOLLOWED BY THE WORD "PHASERX".

**CLASS 5—PHARMACEUTICALS**

FOR PHARMACEUTICAL PREPARATIONS, NAMELY, POLYMERIC DELIVERY TECHNOLOGIES IN THE FORM OF POWDERS OR LIQUID SOLUTIONS FOR THE TARGETED DELIVERY OF MACROMOLECULES AND PHARMACEUTICAL PREPARATIONS FOR MEDICAL PURPOSES (U.S. CLS. 6, 18, 44, 46, 51 AND 52).

**CLASS 42—SCIENTIFIC AND COMPUTER SERVICES**

FOR MEDICAL AND SCIENTIFIC RESEARCH IN THE FIELDS OF PHARMACEUTICALS, BIOLOGICS, DRUG DELIVERY AND MEDICAL THERAPEUTICS; PRODUCT RESEARCH AND DEVELOPMENT IN THE FIELDS OF PHARMACEUTICAL FORMULATIONS OF MACROMOLECULES, MACROMOLECULAR PHARMACEUTICAL PRODUCTS, MACROMOLECULAR THERAPEUTICS, AND DELIVERY OF MACROMOLECULAR THERAPEUTICS (U.S. CLS. 100 AND 101).

FONG HSU, EXAMINING ATTORNEY

SN 85-107,997. SODA-CLUB (CO2) ATLANTIC GMBH, ZUG, SWITZERLAND, FILED 8-16-2010.

 The logo for SodaStream features the word "soda" in a light blue, lowercase, sans-serif font, and the word "stream" in a light green, lowercase, sans-serif font. The letters are connected, and the "o" in "soda" has a small blue bubble above it.

THE COLOR(S) BLUE AND GREEN IS/ARE CLAIMED AS A FEATURE OF THE MARK.

THE MARK CONSISTS OF THE WORD "SODA" IN BLUE LETTERING WITH A BLUE BUBBLE ON TOP OF THE LETTER "D" AND THE WORD "STREAM" IN GREEN LETTERING.

SN 85-107,472. NATURAL DRINKS S/A, SAO PAULO, BRAZIL, FILED 8-13-2010.

# CAIPIONE

THE MARK CONSISTS OF STANDARD CHARACTERS WITHOUT CLAIM TO ANY PARTICULAR FONT, STYLE, SIZE, OR COLOR.

OWNER OF U.S. REG. NOS. 3,917,642 AND 3,917,643.

THE WORDING "CAIPIONE" HAS NO MEANING IN A FOREIGN LANGUAGE.

**CLASS 30—STAPLE FOODS**

FOR FROZEN DESSERT CONSISTING OF FRUIT AND CREAM OR CREAM SUBSTITUTES (U.S. CL. 46).

**CLASS 32—LIGHT BEVERAGES**

FOR CONCENTRATES, SYRUPS OR POWDERS USED IN THE PREPARATION OF SOFT DRINKS; FRUIT DRINKS AND FRUIT JUICES; NON-ALCOHOLIC BEVERAGES CONTAINING FRUIT JUICES; NON-ALCOHOLIC BEVERAGES, NAMELY, CARBONATED BEVERAGES; POWDERS USED IN THE PREPARATION OF FRUIT-BASED BEVERAGES; SYRUPS FOR BEVERAGES; SYRUPS FOR MAKING BEVERAGES; SYRUPS FOR MAKING FRUIT-FLAVORED DRINKS; SYRUPS FOR MAKING SOFT DRINKS (U.S. CLS. 45, 46 AND 48).

**CLASS 33—WINES AND SPIRITS**

FOR ALCOHOLIC BEVERAGES EXCEPT BEERS; DISTILLED SPIRITS (U.S. CLS. 47 AND 49).

CHRIS DONINGER, EXAMINING ATTORNEY

**CLASS 1—CHEMICALS**

FOR CHEMICALS FOR USE IN MANUFACTURE, DISPENSING AND CARBONATING OF BEVERAGES AND SODA WATER; CHEMICAL ADDITIVES FOR USE IN THE MANUFACTURE, DISPENSING AND CARBONATING OF BEVERAGES AND SODA WATER; CHEMICAL PREPARATIONS FOR USE IN THE BEVERAGE INDUSTRY, NAMELY, FOR MANUFACTURE, DISPENSING AND CARBONATING OF BEVERAGES AND SODA WATER. CHEMICAL GASES, NAMELY, CARBON DIOXIDE (CO2) FILLED CANISTERS FOR USE IN THE MANUFACTURE, DISPENSING AND CARBONATING OF BEVERAGES AND SODA WATER (U.S. CLS. 1, 5, 6, 10, 26 AND 46).

FIRST USE 1-0-2009; IN COMMERCE 1-0-2009.

**CLASS 6—METAL GOODS**

FOR METAL CONTAINERS FOR CARBON DIOXIDE MADE WHOLLY OR PRINCIPALLY OF COMMON METALS OR OF ALLOYS THEREOF; PARTS AND FITTINGS THEREOF, NAMELY, METAL LIDS AND METAL CAPS FOR BOTTLES (U.S. CLS. 2, 12, 13, 14, 23, 25 AND 50).

FIRST USE 1-0-2009; IN COMMERCE 1-0-2009.

**CLASS 7—MACHINERY**

FOR MACHINES FOR THE PRODUCTION OF SODA WATER AND SPARKLING BEVERAGES (U.S. CLS. 13, 19, 21, 23, 31, 34 AND 35).

FIRST USE 1-0-2009; IN COMMERCE 1-0-2009.

**CLASS 21—HOUSEWARES AND GLASS**

FOR PORTABLE PLASTIC CONTAINERS FOR BEVERAGES; HOUSEHOLD AND KITCHEN CONTAINERS FOR THE PREPARATION OF SPARKLING BEVERAGES, NOT OF PRECIOUS METAL OR COATED THEREWITH; PARTS AND FITTINGS FOR THE AFORESAID GOODS, NAMELY, PLASTIC LIDS (U.S. CLS. 2, 13, 23, 29, 30, 33, 40 AND 50).

FIRST USE 1-0-2009; IN COMMERCE 1-0-2009.

**CLASS 32—LIGHT BEVERAGES**

FOR MINERAL AND AERATED WATERS AND OTHER NON-ALCOHOLIC DRINKS, NAMELY, FRUIT DRINKS AND SOFT DRINKS, SYRUPS FOR MAKING BEVERAGES, NAMELY, SOFT DRINKS AND FRUIT DRINKS AND OTHER PREPARATIONS FOR MAKING BEVERAGES, NAMELY, CONCENTRATES USED IN THE PREPARATION OF SOFT DRINKS AND FRUIT DRINKS (U.S. CLS. 45, 46 AND 48).

FIRST USE 1-0-2009; IN COMMERCE 1-0-2009.

JANICE KIM, EXAMINING ATTORNEY

SN 85-108,003. VIRGINIA LAKE MANAGEMENT CO., INC., VIRGINIA BEACH, VA. FILED 8-16-2010.

SN 85-110,291. J.C. BROMAC CORPORATION, HAWTHORNE, CA. FILED 8-18-2010.

### VIRGINIA LAKE MANAGEMENT

THE MARK CONSISTS OF STANDARD CHARACTERS WITHOUT CLAIM TO ANY PARTICULAR FONT, STYLE, SIZE, OR COLOR.

NO CLAIM IS MADE TO THE EXCLUSIVE RIGHT TO USE "LAKE MANAGEMENT", APART FROM THE MARK AS SHOWN.  
SEC. 2(F).



#### CLASS 35—ADVERTISING AND BUSINESS

FOR FISHERIES MANAGEMENT (U.S. CLS. 100, 101 AND 102).

FIRST USE 4-16-1999; IN COMMERCE 4-16-1999.

#### CLASS 37—CONSTRUCTION AND REPAIR

FOR POND AND LAKE MAINTENANCE AND MANAGEMENT SERVICES (U.S. CLS. 100, 103 AND 106).

FIRST USE 4-16-1999; IN COMMERCE 4-16-1999.  
PAUL E. FAHRENKOPF, EXAMINING ATTORNEY

OWNER OF U.S. REG. NO. 1,957,849.

NO CLAIM IS MADE TO THE EXCLUSIVE RIGHT TO USE "MOTORCYCLES USA", APART FROM THE MARK AS SHOWN.

THE MARK CONSISTS OF THE SHAPE OF A SHIELD WITH AN EAGLE'S HEAD IN THE TOP SECTION AND THE WORD "EAGLERIDER" IN LARGE WRITING THROUGH THE UPPER MIDDLE SECTION OF THE SHIELD WITH THE WORD "MOTORCYCLES" WRITTEN IN SMALLER WRITING INSIDE A BANNER GOING THROUGH THE LOWER MIDDLE SECTION OF THE SHIELD AND THE LETTERS "USA" AT THE BOTTOM OF THE SHIELD.

SN 85-108,197. DAMERON ALLOY FOUNDRIES, COMP-  
TON, CA. FILED 8-16-2010.

### DAMERON

THE MARK CONSISTS OF STANDARD CHARACTERS WITHOUT CLAIM TO ANY PARTICULAR FONT, STYLE, SIZE, OR COLOR.

THE NAME(S), PORTRAIT(S), AND/OR SIGNATURE(S) SHOWN IN THE MARK IDENTIFIES "DAMERON", WHOSE CONSENT(S) TO REGISTER IS MADE OF RECORD.  
SEC. 2(F).

#### CLASS 40—MATERIAL TREATMENT

FOR METAL CASTING SERVICES; CUSTOM MANUFACTURE OF TOOLS (U.S. CLS. 100, 103 AND 106).  
FIRST USE 0-0-1946; IN COMMERCE 0-0-1946.

#### CLASS 42—SCIENTIFIC AND COMPUTER SERVICES

FOR METAL CASTING DESIGN AND ENGINEERING SERVICES; TOOL DESIGN AND ENGINEERING SERVICES (U.S. CLS. 100 AND 101).

FIRST USE 0-0-1946; IN COMMERCE 0-0-1946.  
REGINA DRUMMOND, EXAMINING ATTORNEY

#### CLASS 25—CLOTHING

FOR TOPS; T-SHIRTS, SHIRTS, JACKETS, HEADWEAR, HATS, BANDANAS, CAPS, GLOVES, BELTS (U.S. CLS. 22 AND 39).

FIRST USE 0-0-1995; IN COMMERCE 0-0-1995.

#### CLASS 35—ADVERTISING AND BUSINESS

FOR RETAIL STORES FEATURING MOTORCYCLES, MOTOR BIKES, AND SCOOTERS; FRANCHISE SERVICES, NAMELY, OFFERING BUSINESS MANAGEMENT ASSISTANCE IN THE ESTABLISHMENT AND OPERATION OF VEHICLE RENTAL, LEASING AND SALE BUSINESSES, FRANCHISE SERVICES, NAMELY OFFERING TECHNICAL ASSISTANCE IN THE ESTABLISHMENT AND/OR OPERATIONS OF RENTAL STORES AND SHOPS, ASSISTANCE IN THE ESTABLISHMENT, BUSINESS MANAGEMENT AND PRODUCT AND SERVICE COMMERCIALIZATION WITHIN THE FRAMEWORK OF A FRANCHISE CONTRACT; ONLINE RETAIL STORE SERVICES FEATURING MOTORCYCLES; PROVIDING A WEBSITE FEATURING INFORMATION FOR CONSUMERS IN THE FIELDS OF MOTORCYCLES, MOTORCYCLING AND MOTOR VEHICLES (U.S. CLS. 100, 101 AND 102).

FIRST USE 0-0-1995; IN COMMERCE 0-0-1995.

#### CLASS 39—TRANSPORTATION AND STORAGE

FOR LEASING AND RENTAL OF VEHICLES, LEASING AND RENTAL OF MOTORCYCLES, ARRANGING OF TRAVEL TOURS; PROVIDING INFORMATION IN THE FIELD OF THE VEHICLE AND MOTORCYCLE INDUSTRIES (U.S. CLS. 100 AND 105).

FIRST USE 0-0-1995; IN COMMERCE 0-0-1995.  
AISHA CLARKE, EXAMINING ATTORNEY

SN 85-110,624. EDGE COMPOSITES, LLC, OGDEN, UT.  
FILED 8-18-2010.



THE MARK CONSISTS OF THE STYLIZED LETTERS "ENVE".

#### CLASS 12—VEHICLES

FOR BICYCLE PARTS, NAMELY, FORKS, STEMS, HANDLEBARS, SEAT POSTS AND WHEEL RIMS (U.S. CLS. 19, 21, 23, 31, 35 AND 44).  
FIRST USE 1-23-2010; IN COMMERCE 1-23-2010.

#### CLASS 35—ADVERTISING AND BUSINESS

FOR ONLINE RETAIL STORE SERVICES FEATURING BICYCLE PARTS AND ACCESSORIES (U.S. CLS. 100, 101 AND 102).  
FIRST USE 1-23-2010; IN COMMERCE 1-23-2010.

#### CLASS 40—MATERIAL TREATMENT

FOR CONTRACT MANUFACTURING IN THE FIELD OF BICYCLE PARTS AND ACCESSORIES (U.S. CLS. 100, 103 AND 106).  
FIRST USE 1-23-2010; IN COMMERCE 1-23-2010.  
ANDREA K. NADELMAN, EXAMINING ATTORNEY

SN 85-110,834. DAISY DESIGN, LLC, MIAMI, FL. FILED 8-18-2010.

### DIVINE LINE ACTIVATION PROCESS

THE MARK CONSISTS OF STANDARD CHARACTERS WITHOUT CLAIM TO ANY PARTICULAR FONT, STYLE, SIZE, OR COLOR.

NO CLAIM IS MADE TO THE EXCLUSIVE RIGHT TO USE "ACTIVATION PROCESS", APART FROM THE MARK AS SHOWN.

#### CLASS 41—EDUCATION AND ENTERTAINMENT

FOR EDUCATIONAL SERVICES, NAMELY, CONDUCTING SEMINARS, LECTURES, TELESEMINARS, TELECLASSES AND WORKSHOPS, ALL IN THE FIELDS OF BODY CHAKRAS, ENERGY HEALING AND PERSONAL AWARENESS (U.S. CLS. 100, 101 AND 107).

#### CLASS 44—MEDICAL, BEAUTY AND AGRICULTURAL SERVICES

FOR PROVIDING BOTH IN-PERSON AND ON-LINE VIBRATIONAL ENERGY HEALING SERVICES, ALL THROUGH AWARENESS OF THE BODY'S MOVEMENT OF ITS VERTICAL ENERGY DELINEATED BY CHAKRAS; AND PROVIDING LONG-DISTANCE ENERGY HEALING SERVICES, ALL THROUGH AWARENESS OF THE BODY'S MOVEMENT OF VERTICAL ENERGY DELINEATED BY CHAKRAS (U.S. CLS. 100 AND 101).  
BERYL GARDNER, EXAMINING ATTORNEY

SN 85-112,539. PINNACLE VENTURES LIMITED, AUCKLAND, NEW ZEALAND, FILED 8-20-2010.

# VERTEX

THE MARK CONSISTS OF STANDARD CHARACTERS WITHOUT CLAIM TO ANY PARTICULAR FONT, STYLE, SIZE, OR COLOR.

#### CLASS 9—ELECTRICAL AND SCIENTIFIC APPARATUS

FOR BUOYANCY COMPENSATOR DEVICES FOR DIVERS; BUOYANCY CONTROL DEVICES FOR DIVERS; UNDERWATER BREATHING APPARATUS; REGULATORS FOR USE IN SCUBA DIVING; AIR TANKS AND AIR TANK VALVES FOR USE IN SCUBA DIVING; DIVING GLOVES; DIVING GOGGLES; DIVING BOOTS; DIVING SUITS; FACE MASKS FOR DIVING; SNORKELS; WEIGHT BELTS FOR DIVING; DIVING COMPUTERS; DIVING INSTRUMENTS, NAMELY, PRESSURE GAUGES, DEPTH GAUGES AND COMPASSES; SIGNALING AND SAFETY APPARATUS, NAMELY, SWIM AND DIVING MARKING AND SIGNALING BUOYS (U.S. CLS. 21, 23, 26, 36 AND 38).

#### CLASS 28—TOYS AND SPORTING GOODS

FOR SCUBA FINS AND SCUBA FLIPPERS; SCUBA EQUIPMENT, NAMELY, SPRING ACTIVATED SPEAR GUNS; SPEAR GUN BARRELS; SPEAR GUN SHAFTS; SPEAR GUN SLINGS; SPEAR GUN TIPS; SPEAR GUN POLE SPEARS; SPEAR GUN POLES; SPEAR GUN POLE HANDLES; SPEAR GUN GAFF HOOKS; SPEARS FOR USE IN FISHING (U.S. CLS. 22, 23, 38 AND 50).  
JOHN GARTNER, EXAMINING ATTORNEY

SN 85-112,617. FUJITSU LIMITED, KANAGAWA, 211-8588, JAPAN, FILED 8-20-2010.

# INTARFRM

THE MARK CONSISTS OF STANDARD CHARACTERS WITHOUT CLAIM TO ANY PARTICULAR FONT, STYLE, SIZE, OR COLOR.

#### CLASS 9—ELECTRICAL AND SCIENTIFIC APPARATUS

FOR COMPUTER SOFTWARE FOR DESIGNING, DEVELOPING, AND MAINTAINING SOFTWARE AND EXECUTING PROGRAMS THEREFOR; APPLICATION FRAMEWORK SOFTWARE FOR DEVELOPMENT OF SOFTWARE APPLICATIONS (U.S. CLS. 21, 23, 26, 36 AND 38).

#### CLASS 42—SCIENTIFIC AND COMPUTER SERVICES

FOR COMPUTER SERVICES FOR OTHERS, NAMELY, DESIGNING, DEVELOPING, AND MAINTAINING SOFTWARE AND EXECUTING PROGRAMS THEREFOR; PROVIDING NON-DOWNLOADABLE APPLICATION FRAMEWORK SOFTWARE FOR THE DEVELOPMENT OF SOFTWARE APPLICATIONS (U.S. CLS. 100 AND 101).

LEIGH CAROLINE CASE, EXAMINING ATTORNEY

SN 85-114,599. JOVOTO GMBH, BERLIN, FED REP GERMANY, FILED 8-24-2010.

jovoto

THE MARK CONSISTS OF STANDARD CHARACTERS WITHOUT CLAIM TO ANY PARTICULAR FONT, STYLE, SIZE, OR COLOR.

OWNER OF FED REP GERMANY REG. NO. 302010021479, DATED 6-15-2010, EXPIRES 4-30-2020.

THE WORDING "JOVOTO" HAS NO MEANING IN A FOREIGN LANGUAGE.

#### **CLASS 9—ELECTRICAL AND SCIENTIFIC APPARATUS**

FOR APPARATUS FOR RECORDING, TRANSMISSION OR REPRODUCTION OF SOUND OR IMAGES; BLANK MAGNETIC DATA CARRIERS; BLANK RECORD DISKS; COMPUTERS; COMPUTER PROGRAMS AND SOFTWARE, NAMELY, FOR PROGRAMS AND SOFTWARE MANAGING DATABASES IN THE FIELDS OF BUSINESS AND PRIVATE NETWORKS, AND ESTABLISHING AND ARRANGING OF BUSINESS AND PRIVATE CONTACTS; COMMUNICATIONS SOFTWARE FOR CONNECTING COMPUTER NETWORK USERS AND GLOBAL COMPUTER NETWORKS; COMPUTER SOFTWARE AND COMPUTER PROGRAMS IN THE FIELD OF CROWD SOURCING; COMPUTER SOFTWARE TO ENABLE UPLOADING, DOWNLOADING, ACCESSING, POSTING, DISPLAYING, TAGGING, BLOGGING, STREAMING, LINKING, SHARING OR OTHERWISE PROVIDING ELECTRONIC MEDIA OR INFORMATION VIA COMPUTER AND COMMUNICATION NETWORKS (U.S. CLS. 21, 23, 26, 36 AND 38).

#### **CLASS 35—ADVERTISING AND BUSINESS**

FOR CONCEPTION, DEVELOPMENT AND PRODUCTION OF ADVERTISING CONCEPTS FOR ALL MEDIA, WRITING OF PUBLICITY TEXTS, CONSULTING REGARDING BUSINESS COMMUNICATION PLANNING AND THE DEVELOPMENT OF BUSINESS COMMUNICATION STRATEGIES, NAMELY, ADVERTISING, MARKETING, PROMOTION AND PUBLIC RELATIONS SERVICES AND RELATED CONSULTING; ON-LINE ADVERTISING ON COMPUTER NETWORKS; RENTING OF ADVERTISING SPACES AND RENTAL OF ADVERTISING SPACE ON THE INTERNET; ARRANGING AND CONDUCTING MARKETING PROMOTIONAL EVENTS FOR OTHERS; ORGANIZATION OF EXHIBITIONS AND TRADE FAIRS FOR BUSINESS AND PROMOTIONAL PURPOSES; BUSINESS MANAGEMENT; BUSINESS ADMINISTRATION, IN PARTICULAR ARRANGING OF BUYING AND SELLING CONTRACTS FOR THIRD PARTIES, ARRANGING OF TRADING TRANSACTIONS AND COMMERCIAL CONTRACTS; PROVIDING OFFICE FUNCTIONS (U.S. CLS. 100, 101 AND 102).

#### **CLASS 38—COMMUNICATION**

FOR TELECOMMUNICATIONS IN THE NATURE OF PROVIDING INTERACTIVE AND ELECTRONIC PLATFORMS FOR COMMUNICATIONS AND FOR THE EXCHANGE OF DATA AND INFORMATION OF ALL KINDS, NAMELY, PROVIDING TELECOMMUNICATIONS CONNECTIONS TO A GLOBAL COMPUTER NETWORK, PROVIDING ON-LINE CHAT ROOMS FOR SOCIAL NETWORKING; COMMUNICATION SERVICES, NAMELY, TRANSMISSION OF VOICE, AUDIO, VISUAL IMAGES AND DATA BY TELECOMMUNICATIONS NETWORKS, WIRELESS COMMUNICATION NETWORKS, THE INTERNET, INFORMATION SERVICES

NETWORKS AND DATA NETWORKS; ONLINE SERVICES IN THE NATURE OF PROVIDING ACCESS TO INFORMATION AND MESSAGES VIA COMPUTER NETWORKS, NAMELY, PROVIDING E-MAIL SERVICES; PROVIDING ON-LINE CHAT ROOMS AND ELECTRONIC BULLETIN BOARDS FOR TRANSMISSION OF MESSAGES AMONG CREATIVE PROFESSIONALS AND AMONG USERS IN THE FIELD OF GENERAL INTEREST; PROVIDING ACCESS TO INFORMATION ON THE INTERNET, NAMELY, PROVIDING A CONTACT MANAGEMENT AND COMMUNICATIONS PLATFORM ON THE INTERNET FOR THE EXCHANGE OF INFORMATION, NAMELY, PROVIDING AN ON-LINE NETWORK ENVIRONMENT THAT FEATURES TECHNOLOGY THAT ENABLES USERS TO SHARE DATA; ELECTRONIC COLLECTION, SUPPLY AND FORWARDING OF MESSAGES OF ALL KINDS, NAMELY, PROVIDING E-MAIL SERVICES; PROVIDING ACCESS TO, DISTRIBUTION AND TRANSMISSION OF PHOTOGRAPHS, IMAGES AND OTHER INFORMATION VIA THE INTERNET AND PROVIDING ACCESS TO COMPUTER PROGRAMS ON DATA NETWORKS, NAMELY, PROVIDING TELECOMMUNICATION CONNECTIONS TO THE INTERNET OR DATABASES (U.S. CLS. 100, 101 AND 104).

#### **CLASS 41—EDUCATION AND ENTERTAINMENT**

FOR EDUCATION, NAMELY, COMPUTER EDUCATION TRAINING; CONTINUING EDUCATION SERVICES, NAMELY, PROVIDING LIVE AND ON-LINE CONTINUING PROFESSIONAL EDUCATION SEMINARS IN THE FIELDS OF DESIGN, ART, CREATION AND COMMUNICATION TECHNOLOGIES; PROVIDING OF TRAINING IN THE FIELD OF DESIGN, ADVERTISING AND COMMUNICATION TECHNOLOGIES; ENTERTAINMENT, NAMELY, CONDUCTING CONTESTS IN THE FIELDS OF DESIGN, ART, CREATION; ORGANIZING COMMUNITY SPORTING AND CULTURAL EVENTS; NON-DOWNLOADABLE ELECTRONIC PUBLICATIONS IN THE NATURE OF AN E-ZINE FEATURING NEWS, STORIES, REVIEWS, RECOMMENDATIONS AND COMMENTARY IN THE FIELDS OF DESIGN, ART, CREATION AND COMMUNICATION TECHNOLOGIES; DIGITAL IMAGING SERVICES (PHOTOGRAPHY); ELECTRONIC GAMES SERVICES PROVIDED BY MEANS OF THE INTERNET; PUBLISHING PRINTED MATTER, OTHER THAN FOR ADVERTISING PURPOSES, NAMELY, PUBLISHING OF BOOKS AND REVIEWS, WEB MAGAZINES, MUSIC; PUBLICATION OF BOOKS AND PERIODICALS AND ON-LINE ELECTRONIC PUBLISHING OF BOOKS AND PERIODICALS; ON-LINE PUBLISHING OF ELECTRONIC BOOKS AND MAGAZINES; ARRANGING AND CONDUCTING OF EDUCATIONAL CONFERENCES AND SYMPOSIA (U.S. CLS. 100, 101 AND 107).

#### **CLASS 42—SCIENTIFIC AND COMPUTER SERVICES**

FOR DESIGN AND DEVELOPMENT OF COMPUTER HARDWARE AND SOFTWARE; SERVICES OF DESIGN, NAMELY, INDUSTRIAL AND GRAPHIC ART DESIGN; INTERIOR DESIGN; PACKAGING DESIGN; ANIMATION AND SPECIAL-EFFECTS DESIGN FOR OTHERS; ARCHITECTURAL DESIGN; COMMERCIAL ART DESIGN; COMPUTER AIDED DESIGN FOR OTHERS; DESIGN OF TEXTILES; FASHION DESIGN; FOOTWEAR DESIGN SERVICES; COMPUTER SOFTWARE DESIGN FOR INFORMATION TECHNOLOGY PURPOSES IN THE FIELDS OF BUSINESS AND PRIVATE NETWORKS, AND THE ESTABLISHING AND ARRANGING OF BUSINESS AND PRIVATE CONTACTS; INSTALLATION AND MAINTENANCE OF COMPUTER SOFTWARE PROGRAMS, TECHNICAL CONSULTANCY AND SUPPORT WITH REGARD TO THE USE, APPLICATION AND MAINTENANCE OF COMPUTER SOFTWARE PROGRAMS OR PROGRAM-RELATED SOLUTIONS FOR INFORMATION TECHNOLOGY PURPOSES IN THE FIELDS OF BUSINESS AND PRIVATE NETWORKS AND THE ESTABLISHING AND ARRANGING OF BUSINESS AND PRIVATE CONTACTS, NAMELY, CONSULTING SERVICES IN THE FIELD OF IDENTIFICATION, SUPPORT, AND IMPLEMENTATION OF COMPUTER BASED INFORMATION SYSTEMS FOR BUSINESSES; UPDATING COMPUTER SOFTWARE

FOR OTHERS; UPDATING WEBSITES FOR OTHERS; DATA MANAGEMENT ON SERVERS, NAMELY, APPLICATION SERVICE PROVIDER FEATURING APPLICATION PROGRAMMING INTERFACE (API) SOFTWARE FOR ALLOWING DATA RETRIEVAL, UPLOAD, ACCESS AND MANAGEMENT; HOMEPAGE AND WEBPAGE DESIGN; CREATION OF WEB SITES FOR OTHERS; INSTALLATION OF COMPUTER SOFTWARE PROGRAMS; RENTAL AND MAINTENANCE OF MEMORY SPACE FOR WEBSITE APPLICATIONS, NAMELY, RENTAL OF WEB SERVERS AND HOSTING OF WEB SITES (U.S. CLS. 100 AND 101).

MATTHEW MCDOWELL, EXAMINING ATTORNEY

SN 85-116,125. DS LABORATORIES, INC., MIAMI BEACH, FL. FILED 8-26-2010.



THE MARK CONSISTS OF A CROWN.

### CLASS 3—COSMETICS AND CLEANING PREPARATIONS

FOR NON-MEDICATED SKIN CARE PREPARATIONS, NAMELY, CREAMS AND LOTIONS (U.S. CLS. 1, 4, 6, 50, 51 AND 52).

FIRST USE 1-1-2004; IN COMMERCE 1-1-2004.

### CLASS 5—PHARMACEUTICALS

FOR MEDICATED SKIN CARE PREPARATIONS, NAMELY, CREAMS AND LOTIONS (U.S. CLS. 6, 18, 44, 46, 51 AND 52).

FIRST USE 1-1-2004; IN COMMERCE 1-1-2004.  
MICHAEL SOUDERS, EXAMINING ATTORNEY

SN 85-118,207. KYE SYSTEMS CORP., TAIPEI HSIEN 241, TAIWAN, FILED 8-29-2010.

OWNER OF U.S. REG. NO. 3,804,276.

THE MARK CONSISTS OF A STYLIZED MARK OF "AGAMA".

THE ENGLISH TRANSLATION OF "AGAMA" IN THE MARK IS LIZARDS.

### CLASS 7—MACHINERY

FOR COMPRESSOR CLEANING MACHINES; DRY-CLEANING MACHINES; MACHINES FOR CLEANING SURFACES USING HIGH PRESSURE WATER; STEAM CLEANING MACHINES; POWER-DRIVEN CLEANING LANCES USING EXPLOSIVE MATERIALS; MACHINES FOR BLAST CLEANING A SURFACE; CLEANING DEVICES AND MACHINES, NAMELY, FLOOR CLEANING MACHINES, VACUUM CLEANERS, FLOOR WASHING MACHINES, ELECTRIC WASHING MACHINES, WAXING MACHINERY; FLOOR CLEANING MACHINES; VACUUM CLEANERS; FLOOR WASHING MACHINES; ELECTRIC WASHING MACHINES FOR HOUSEHOLD PURPOSES; HIGH PRESSURE PUMPS FOR WASHING APPLIANCES AND INSTALLATIONS; PRESSURE WASHING MACHINES; HOSES FOR VACUUM CLEANERS; ELECTRIC VACUUM CLEANERS AND THEIR COMPONENTS; DUST FILTERS AND BAGS FOR VACUUM CLEANERS; SUCTION NOZZLES FOR VACUUM CLEANERS; AUTOMATIC FLOOR SCRUBBERS; ROBOTIC VACUUM CLEANERS; FLOOR CLEANING ROBOTS WITH WIRELESS IP CAMERA FOR SECURITY MONITORING FUNCTION; ROBOT VACUUM CLEANERS WITH WIRELESS IP CAMERA FOR SECURITY MONITORING FUNCTION; MOTORS, EXCEPT FOR LAND VEHICLES, NAMELY, MOTORS FOR VACUUM CLEANERS, MOTORS FOR SMALL ELECTRIC HOUSEHOLD APPLIANCES; FILTERS AND PUMPS NOT INCLUDED IN OTHER CLASSES, NAMELY, VACUUM CLEANER FILTERS AND FILTERS FOR AIR-CLEANERS AND AIR PURIFIERS; ELECTRIC APPARATUS FOR DOMESTIC USE NOT INCLUDED IN OTHER CLASSES, NAMELY, VACUUM CLEANERS, ELECTRIC FLOOR POLISHERS, ELECTRIC CARPET SWEEPERS, ELECTRIC FOOD BLENDERS (U.S. CLS. 13, 19, 21, 23, 31, 34 AND 35).

### CLASS 11—ENVIRONMENTAL CONTROL APPARATUS

FOR LIGHTING TUBES; LIGHT BULBS; TABLE LAMPS; CEILING LIGHTS; DOWN LIGHTS; LASER LIGHT PROJECTORS; PROJECTOR LAMPS; LANDSCAPE LIGHTING INSTALLATIONS; STREET LAMPS; STRIP LIGHTS; WALL WASH LAMPS; ELECTRIC LIGHT BULBS; FLUORESCENT LIGHTING TUBES; ELECTRIC LIGHTING FIXTURES; ELECTRIC LANTERNS; LAMP SHADES; INCANDESCENT LAMPS AND THEIR FITTINGS; LAMP BASES; ELECTRIC TORCHES FOR LIGHTING; SPOT LIGHTS; CHANDELIERS; OVERHEAD LAMPS; SAFETY LAMPS FOR UNDERGROUND USE; LIGHT REFLECTORS; LANTERNS; ELECTRIC HOLIDAY LIGHTS; FLASHLIGHTS; HIGH INTENSITY SEARCH LIGHTS; POCKET SEARCH LIGHTS; FLAT PANEL LIGHTING APPARATUS; INFRARED LIGHTING FIXTURES; LED LIGHTING FIXTURES; LIGHTING APPARATUS, NAMELY, LIGHTING INSTALLATIONS; LIGHTING FIXTURES WITH MOTION DETECTION; ELECTRIC TRACK LIGHTING UNITS; INSTALLATIONS, DEVICES, APPARATUS, INSTRUMENTS AND ARTICLES FOR LIGHTING, NAMELY, ELECTRIC LAMPS, LAMP SHADES, LAMP ARMATURES, LIGHTING FIXTURES; ELECTRIC LAMPS, ELECTRIC LIGHTING FIXTURES AND ACCESSORIES FOR THE AFORESAID GOODS ALL SOLD AS A UNIT, NAMELY, STARTERS, BALLASTS, TRANSFORMERS, IGNITERS, SOCKETS AND STARTER HOLDERS (U.S. CLS. 13, 21, 23, 31 AND 34).

SUE LAWRENCE, EXAMINING ATTORNEY

SN 85-119,083. ENTONE, INC., CUPERTINO, CA. FILED 8-30-2010.

SN 85-119,851. GOVERNALE, PAMELA, EAST WILLISTON, NY. FILED 8-31-2010.

## FUSIONTV

THE MARK CONSISTS OF STANDARD CHARACTERS WITHOUT CLAIM TO ANY PARTICULAR FONT, STYLE, SIZE, OR COLOR.

### CLASS 9—ELECTRICAL AND SCIENTIFIC APPARATUS

FOR COMPUTER HARDWARE AND SOFTWARE FOR THE INTEGRATION OF TEXT, AUDIO, GRAPHICS, STILL IMAGES AND MOVING PICTURES INTO AN INTERACTIVE DELIVERY FOR MULTIMEDIA APPLICATIONS OVER DIGITAL BROADBAND NETWORKS FOR INTEGRATION WITH BROADCAST TELEVISION CHANNELS (U.S. CLS. 21, 23, 26, 36 AND 38).

### CLASS 38—COMMUNICATION

FOR PROVIDING TELECOMMUNICATIONS CONNECTIVITY SERVICES FOR THE TRANSFER OF MULTIMEDIA WORKS OVER DIGITAL BROADBAND NETWORKS FOR INTEGRATION WITH BROADCAST TELEVISION CHANNELS (U.S. CLS. 100, 101 AND 104).  
RUSS HERMAN, EXAMINING ATTORNEY

SN 85-119,505. GLOBALSTAR, INC., COVINGTON, LA. FILED 8-31-2010.

## SPOT HUG

THE MARK CONSISTS OF STANDARD CHARACTERS WITHOUT CLAIM TO ANY PARTICULAR FONT, STYLE, SIZE, OR COLOR.

### CLASS 9—ELECTRICAL AND SCIENTIFIC APPARATUS

FOR ELECTRONIC SYSTEMS FOR DETERMINING THE UNAUTHORIZED MOVEMENT AND TRACKING OF VEHICLES COMPRISED OF GPS LOCATORS, SATELLITE TRANSMITTERS AND PORTABLE RECEIVERS (U.S. CLS. 21, 23, 26, 36 AND 38).

### CLASS 38—COMMUNICATION

FOR ELECTRONIC TRANSMISSION OF DATA IN THE NATURE OF LOCATION BASED NOTIFICATIONS AND MESSAGES RELATING TO UNAUTHORIZED MOVEMENT AND TRACKING OF VEHICLES (U.S. CLS. 100, 101 AND 104).

### CLASS 45—PERSONAL AND LEGAL SERVICES

FOR TRACKING, LOCATING, AND MONITORING THE UNAUTHORIZED MOVEMENT OF VEHICLES (U.S. CLS. 100 AND 101).  
ELI HELLMAN, EXAMINING ATTORNEY

## PLUM DESIGN

THE MARK CONSISTS OF STANDARD CHARACTERS WITHOUT CLAIM TO ANY PARTICULAR FONT, STYLE, SIZE, OR COLOR.

NO CLAIM IS MADE TO THE EXCLUSIVE RIGHT TO USE "DESIGN", APART FROM THE MARK AS SHOWN.

### CLASS 4—LUBRICANTS AND FUELS

FOR CANDLES (U.S. CLS. 1, 6 AND 15).

### CLASS 20—FURNITURE AND ARTICLES NOT OTHERWISE CLASSIFIED

FOR PILLOWS (U.S. CLS. 2, 13, 22, 25, 32 AND 50).  
FIRST USE 7-29-2010; IN COMMERCE 7-29-2010.  
JOHN GARTNER, EXAMINING ATTORNEY

SN 85-120,365. OPENFEINT INC., MOUNTAIN VIEW, CA. FILED 8-31-2010.

## OPENFEINT PLAYTIME

THE MARK CONSISTS OF STANDARD CHARACTERS WITHOUT CLAIM TO ANY PARTICULAR FONT, STYLE, SIZE, OR COLOR.

NO CLAIM IS MADE TO THE EXCLUSIVE RIGHT TO USE "PLAYTIME", APART FROM THE MARK AS SHOWN.

### CLASS 9—ELECTRICAL AND SCIENTIFIC APPARATUS

FOR COMPUTER-SOFTWARE-DEVELOPMENT TOOLS (U.S. CLS. 21, 23, 26, 36 AND 38).

### CLASS 38—COMMUNICATION

FOR PROVIDING ONLINE CHAT ROOMS AND ELECTRONIC BULLETIN BOARDS; PROVIDING ONLINE FORUMS FOR COMMUNICATION IN THE FIELD OF ELECTRONIC GAMES (U.S. CLS. 100, 101 AND 104).

### CLASS 42—SCIENTIFIC AND COMPUTER SERVICES

FOR PROVIDING TEMPORARY USE OF ON-LINE NON-DOWNLOADABLE SOFTWARE-DEVELOPMENT-TOOLS IN THE FIELD OF ELECTRONIC GAMES; PROVIDING TEMPORARY USE OF NON-DOWNLOADABLE SOFTWARE APPLICATIONS FOR SOCIAL NETWORKING, CREATING A VIRTUAL COMMUNITY AND TRANSMISSION OF AUDIO, VIDEO, PHOTOGRAPHIC IMAGES, TEXT, GRAPHICS AND DATA IN THE FIELD OF ELECTRONIC GAMES (U.S. CLS. 100 AND 101).  
KELLEY WELLS, EXAMINING ATTORNEY



SN 85-120,596. URBANGREEN, INC., SAN FRANCISCO, CA.  
FILED 9-1-2010.

SN 85-122,455. GRANDMOTHER HEN, LLC, MEMPHIS, TN.  
FILED 9-3-2010.

## URBANGREEN

THE MARK CONSISTS OF STANDARD CHARACTERS WITHOUT CLAIM TO ANY PARTICULAR FONT, STYLE, SIZE, OR COLOR.

### CLASS 41—EDUCATION AND ENTERTAINMENT

FOR EDUCATIONAL SERVICES, NAMELY, PROVIDING TRAINING IN THE FIELD OF SUSTAINABLE LAND USE, GREEN REAL ESTATE DEVELOPMENT INCLUDING SUSTAINABLE BUILDINGS AND SUSTAINABLE COMMUNITIES (U.S. CLS. 100, 101 AND 107).

FIRST USE 4-1-2004; IN COMMERCE 4-1-2004.

### CLASS 42—SCIENTIFIC AND COMPUTER SERVICES

FOR CONSULTING AND ADVISORY SERVICES IN THE FIELD OF SUSTAINABLE LAND USE PLANNING, GREEN ARCHITECTURE AND SUSTAINABLE COMMUNITY PLANNING (U.S. CLS. 100 AND 101).

FIRST USE 4-1-2004; IN COMMERCE 4-1-2004.  
TARAH HARDY, EXAMINING ATTORNEY

---

SN 85-122,270. HUYSENTRUYT, CASSANDRA, LOS ANGELES, CA. FILED 9-2-2010.

## MADAME GREY

THE MARK CONSISTS OF STANDARD CHARACTERS WITHOUT CLAIM TO ANY PARTICULAR FONT, STYLE, SIZE, OR COLOR.

THE NAME "MADAME GREY" DOES NOT IDENTIFY A LIVING INDIVIDUAL.

### CLASS 3—COSMETICS AND CLEANING PREPARATIONS

FOR FRAGRANCES (U.S. CLS. 1, 4, 6, 50, 51 AND 52).

### CLASS 25—CLOTHING

FOR CLOTHING FOR WOMEN, NAMELY, DRESSES, EVENING DRESSES AND GOWNS, LINGERIE, ROBES, SLEEPWEAR, AND LOUNGEWEAR (U.S. CLS. 22 AND 39).

LINDA LAVACHE, EXAMINING ATTORNEY

## GRANDMOTHER HEN

THE MARK CONSISTS OF STANDARD CHARACTERS WITHOUT CLAIM TO ANY PARTICULAR FONT, STYLE, SIZE, OR COLOR.

### CLASS 35—ADVERTISING AND BUSINESS

FOR ONLINE ADVERTISING SERVICES FEATURING PRODUCTS, GOODS, SERVICES AND MERCHANDISE OF INTEREST TO GRANDPARENTS; RETAIL STORE SERVICES FEATURING CLOTHING FOR GRANDPARENTS AND THEIR GRANDCHILDREN, FOOD AND BEVERAGES FOR GRANDPARENTS AND THEIR GRANDCHILDREN, TOYS, SAFETY PRODUCTS AND GOODS FOR GRANDPARENTS AND THEIR GRANDCHILDREN, DIAPERS AND BABY PRODUCTS FOR GRANDPARENTS AND THEIR GRANDCHILDREN, FURNITURE AND FURNISHINGS FOR GRANDPARENTS AND THEIR GRANDCHILDREN, COSMETICS, AND BEAUTY PRODUCTS FOR GRANDPARENTS, JEWELRY FOR GRANDPARENTS AND THEIR GRANDCHILDREN, PAPER GOODS, PICTURE FRAMES AND HOUSEHOLD GOODS FOR GRANDPARENTS AND THEIR GRANDCHILDREN; PROVIDING ONLINE CONSUMER INFORMATION IN THE FIELD OF TRAVEL AND ACCOMMODATION DISCOUNTS FOR GRANDPARENTS AND THEIR GRANDCHILDREN (U.S. CLS. 100, 101 AND 102).

### CLASS 38—COMMUNICATION

FOR ONLINE CHAT ROOMS AND MESSAGE BOARDS FOR TRANSMISSION OF MESSAGES AMONG COMPUTER USERS IN FIELDS OF GENERAL INTEREST TO GRANDPARENTS (U.S. CLS. 100, 101 AND 104).

### CLASS 39—TRANSPORTATION AND STORAGE

FOR PROVIDING ONLINE TRAVEL INFORMATION AND RECOMMENDATIONS IN FIELDS OF GENERAL INTEREST TO GRANDPARENTS, NAMELY, INFORMATION AND RECOMMENDATIONS REGARDING AIR TRAVEL, AUTOMOBILE TRAVEL, TRAIN TRAVEL, AND RESERVATION SERVICES FOR TRAVEL ARRANGEMENTS (U.S. CLS. 100 AND 105).

### CLASS 41—EDUCATION AND ENTERTAINMENT

FOR EDUCATION SERVICES, NAMELY, PROVIDING ONLINE CLASSES, SEMINARS, WEBINARS, WORKSHOPS, TUTORIALS IN THE FIELD OF GENERAL INTEREST TO GRANDPARENTS AND DISTRIBUTION OF COURSE MATERIALS IN CONNECTION THEREWITH; PROVIDING ONLINE ENTERTAINMENT INFORMATION AND RECOMMENDATIONS FOR GRANDPARENTS; PROVIDING ONLINE EXERCISE AND PHYSICAL FITNESS INFORMATION OF GENERAL INTEREST TO GRANDPARENTS (U.S. CLS. 100, 101 AND 107).

**CLASS 43—HOTEL AND RESTAURANT SERVICES**

FOR PROVIDING ONLINE HOTEL, MOTEL, RESTAURANT AND ACCOMMODATION INFORMATION AND RECOMMENDATIONS IN FIELDS OF GENERAL INTEREST TO GRANDPARENTS, NAMELY, CHILD FRIENDLY RESTAURANTS, BUDGET FRIENDLY RESTAURANTS, CHILD FRIENDLY HOTELS, MOTELS, BED AND BREAKFAST FACILITIES AND OTHER TEMPORARY ACCOMMODATIONS, BUDGET FRIENDLY HOTELS, MOTELS, BED AND BREAKFAST FACILITIES AND OTHER TEMPORARY ACCOMMODATIONS; PROVIDING ONLINE INFORMATION AND RECOMMENDATIONS REGARDING HOTEL, MOTEL, RESTAURANT AND ACCOMMODATION RESERVATION SERVICES OF GENERAL INTEREST TO GRANDPARENTS (U.S. CLS. 100 AND 101).

**CLASS 44—MEDICAL, BEAUTY AND AGRICULTURAL SERVICES**

FOR PROVIDING ONLINE HEALTHCARE INFORMATION OF GENERAL INTEREST TO GRANDPARENTS, NAMELY, PROVIDING ONLINE DIETARY, HYGIENE AND BEAUTY CARE INFORMATION OF GENERAL INTEREST TO GRANDPARENTS; PROVIDING ONLINE WELLNESS INFORMATION OF GENERAL INTEREST TO GRANDPARENTS RELATED TO WELLNESS OF GRANDPARENTS AND THEIR GRANDCHILDREN; PROVIDING ONLINE INFORMATION REGARDING ILLNESSES, TREATMENTS AND ILLNESS PREVENTION OF GENERAL INTEREST TO GRANDPARENTS REGARDING ILLNESSES AND HEALTH PROBLEMS AND CONDITIONS OF GRANDPARENTS AND INFANTS AND CHILDREN (U.S. CLS. 100 AND 101).  
ANGELA DUONG, EXAMINING ATTORNEY

SN 85-122,762. WATER PIK, INC., FORT COLLINS, CO. FILED 9-3-2010.

**THE EVOLUTION OF FLOSS**

THE MARK CONSISTS OF STANDARD CHARACTERS WITHOUT CLAIM TO ANY PARTICULAR FONT, STYLE, SIZE, OR COLOR.

NO CLAIM IS MADE TO THE EXCLUSIVE RIGHT TO USE "FLOSS", APART FROM THE MARK AS SHOWN.

**CLASS 10—MEDICAL APPARATUS**

FOR DENTAL INSTRUMENTS, NAMELY, ORAL IRRIGATORS (U.S. CLS. 26, 39 AND 44).

**CLASS 21—HOUSEWARES AND GLASS**

FOR DENTAL FLOSSERS (U.S. CLS. 2, 13, 23, 29, 30, 33, 40 AND 50).  
SUNG IN, EXAMINING ATTORNEY

SN 85-123,132. ZIGI ENTERPRISES, INC., HUNTINGTON, DE. FILED 9-3-2010.

# ZLONDON

THE MARK CONSISTS OF STANDARD CHARACTERS WITHOUT CLAIM TO ANY PARTICULAR FONT, STYLE, SIZE, OR COLOR.

**CLASS 18—LEATHER GOODS**

FOR BAGS, NAMELY, HANDBAGS, PURSES, SPORT BAGS, ATHLETIC BAGS, BEACH BAGS, COSMETIC BAGS SOLD EMPTY, GARMENT BAGS FOR TRAVEL, OVERNIGHT BAGS, SCHOOL BAGS, SHOES BAGS FOR TRAVEL, TRAVEL BAGS; ALL OF THE FOREGOING DESIGNED IN LONDON, ENGLAND (U.S. CLS. 1, 2, 3, 22 AND 41).

**CLASS 25—CLOTHING**

FOR FOOTWEAR, NAMELY, SHOES, BOOTS, SLIPPERS, THONGS, SANDALS, ATHLETIC FOOTWEAR, BEACH FOOTWEAR, CASUAL FOOTWEAR, EVENING FOOTWEAR, EXERCISE FOOTWEAR; MEN'S, WOMEN'S AND CHILDREN'S CLOTHING, NAMELY, ANORAKS, APRONS, BELTS FOR CLOTHING, BATH WRAPS, CLOTH BIBS, BLOUSES, BODYSUITS, BATH ROBES, BLAZERS, BATHING SUITS, BASEBALL SHIRTS, BLOUSONS, BASEBALL UNIFORMS, BRIEFS, BRASSIERES, BRACES, CAPES, CARDIGANS, CULOTTES, CRAVATS, COATS, CAMISOLES, CHEMISES, COLLARS, COLLAR PROTECTORS, DICKIES, DRESSES, DRESSING GOWNS, EAR MUFFS; FORMAL WEAR, NAMELY, TUXEDOS, EVENING GOWNS, JACKETS, PANTS, SHIRTS, NECKTIES, CUMMERBUNDS, FOU-LARDS, FUR STOLETS, FUR MUFFS, FUR JACKETS, FUR HATS, FUR COATS, AND FUR JACKETS; GARTERS, GIRDLES, WINTER GLOVES, HOODS, HOSIERY, HOUSECOATS, JOGGING SUITS, JEANS, JACKETS, JUMPERS, JUMPSUITS, JERSEYS, LEG WARMERS, LEOTARDS, LINGERIE, LEGGINGS, LOUNGWEAR, MITTENS, MUFFS, MANTLES, MUFFLERS, NECKERCHIEFS, NECK WARMERS, NIGHTGOWNS, NIGHT SHIRTS, NIGHTIES, OVERALLS, OVERCOATS, PULL-OVERS, PANTYHOSE, PARKAS, PAJAMAS, PANTS, PETTICOATS, PONCHOS, CAR RACING SUITS, BOAT RACING SUITS, ROBES, RAINCOATS, SHORTS, SING-LETS, SWEAT SUITS, SHIRTS, SWEATERS, SOCKS, SWIMWEAR, STOCKINGS, SCARVES, SHAWLS, SKIRTS, SASHES, SWEAT PANTS, SWEAT SHIRTS, SWEAT TOPS, SUITS, SUSPENDERS, INFANT SLEEPERS, SLEEPWEAR, SUN SUITS, SWEAT JACKETS, SNOW SUITS, SWIMSUITS, TANK TOPS, TROUSERS, THONGS, T-SHIRTS, TOPS, TIGHTS, TIES, UNIFORMS, UNDERWEAR, UNDERPANTS, UNDERSHIRTS, UNITARDS, VESTS, VISORS, WAISTCOATS, WRISTBANDS, WARMUP PANTS, WARM-UP TOPS; HEADWEAR, NAMELY, CAPS, HATS, BERETS, TOQUES, SCARVES AND HEADBANDS; ALL OF THE FOREGOING DESIGNED IN LONDON, ENGLAND (U.S. CLS. 22 AND 39).  
REBECCA POVARCHUK, EXAMINING ATTORNEY

SN 85-123,246. POMPEI, LYNN M., NEW YORK, NY. FILED 9-3-2010.



THE COLOR(S) BLACK, GRAY, WHITE, TURQUOISE, YELLOW, AND PINK IS/ARE CLAIMED AS A FEATURE OF THE MARK.

THE MARK CONSISTS OF BLACK, WHITE AND GRAY FRENCH BULLDOG WITH PERKY PINK EARS WEARING A TURQUOISE DOG COLLAR FEATURING A SMALL YELLOW DOG BONE. THE BULLDOG HAS BLACK EYES WITH WHITE PUPILS. ITS MOUTH IS COLORED IN BLACK, GRAY, WHITE AND A SMALL AREA IS COLORED PINK.

#### CLASS 9—ELECTRICAL AND SCIENTIFIC APPARATUS

FOR AUDIO AND VIDEO RECORDINGS FEATURING ANIMATION, LIVE-ACTION, MUSIC, STORIES AND GAMES FOR CHILDREN; AUDIO AND VISUAL RECORDINGS IN ALL MEDIA FEATURING ANIMATION, LIVE-ACTION, MUSIC, STORIES AND GAMES FOR CHILDREN; AUDIO CASSETTE RECORDERS; AUDIO CASSETTE PLAYERS; PRE-RECORDED AUDIO CASSETTES, AUDIO DISCS, AND COMPACT DISCS FEATURING MUSIC, STORIES AND GAMES FOR CHILDREN; AUDIO SPEAKERS; BINOCULARS; CAMCORDERS; CAMERAS; PRERECORDED COMPACT DISCS AND MULTIMEDIA SOFTWARE RECORDED ON CD-ROMS FEATURING FICTIONAL CHARACTERS FROM A CHILDREN'S BOOK SERIES; PRE-RECORDED CD-ROMS FEATURING COMPUTER GAMES AND ACTIVITIES FOR CHILDREN; COMPUTER HARDWARE, NAMELY, CD-ROM DRIVES, CD-ROM WRITERS, AND COMPUTER MODEMS; PRERECORDED DVDS FEATURING DIGITAL FILES ABOUT FICTIONAL CHARACTERS FROM A CHILDREN'S BOOK SERIES; PRERECORDED AUDIO TAPES AND COMPACT DISCS FEATURING FICTIONAL CHARACTERS FROM A CHILDREN'S BOOK SERIES; PRERECORDED VIDEO TAPES FEATURING FICTIONAL CHARACTERS FROM A CHILDREN'S BOOK SERIES; ANIMATED DIGITAL STORYTELLING CARTRIDGES, ELECTRONIC GAME CARTRIDGES, ELECTRONIC GAME PROGRAMS, ELECTRONIC GAME SOFTWARE, VIDEO GAME CARTRIDGES, VIDEO GAME PROGRAMS; LIGHT SWITCH PLATES; CALCULATORS; CELLULAR TELEPHONES; CELLULAR TELEPHONE ACCESSORIES, NAMELY, HEADPHONES, HEAD SETS FOR CELLULAR PHONES, ADAPTERS AND BATTERIES FOR CELLULAR TELEPHONES; COMPUTER GAME SOFTWARE APPLICATIONS FOR USE ON CELLULAR TELEPHONES; CELLULAR TELEPHONE CASES; MICROCHIPS CONTAINING MUSICAL RECORDINGS; FACE PLATES FOR CELLULAR TELEPHONES; COMPACT DISC PLAYERS; COMPACT DISC RECORDERS; COMPUTER GAME PROGRAMS; COMPUTER GAME CARTRIDGES AND DISCS; COMPUTERS; COMPUTER HARDWARE; COMPUTER KEYBOARDS; COMPUTER MONITORS; COMPUTER MOUSE; COMPUTER DISC DRIVES; COMPUTER PROGRAMS, NAMELY, SOFTWARE LINKING DIGITIZED VIDEO AND AUDIO MEDIA TO A GLOBAL COMPUTER INFORMATION NETWORK; VIDEO GAME MACHINES FOR USE WITH TELEVISIONS FEATURING PARLOR-TYPE COMPUTER GAMES; VIDEO AND COMPUTER GAME PROGRAMS; VIDEO

GAME CARTRIDGES AND CASSETTES; COMPUTER GAME SOFTWARE; CHILDREN'S EDUCATIONAL SOFTWARE FEATURING LEARNING ACTIVITIES FOR CHILDREN; CORDLESS TELEPHONES; DECORATIVE REFRIGERATOR MAGNETS; DIGITAL CAMERAS; PRE-RECORDED DVDS, DIGITAL VERSATILE DISCS AND DIGITAL VIDEO DISCS FEATURING LIVE-ACTION AND ANIMATED ENTERTAINMENT FOR CHILDREN; PRE-RECORDED DVDS FEATURING MOTION PICTURE FILMS AND TELEVISION SHOWS ABOUT ANIMATED CARTOONS; DOWNLOADABLE MOTION PICTURES FEATURING CHILDREN'S ENTERTAINMENT; DOWNLOADABLE MUSIC, RINGTONES AND ELECTRONIC GAMES VIA THE INTERNET AND WIRELESS DEVICES; DVD PLAYERS; DVD RECORDERS; ELECTRONIC GAMES VIA THE INTERNET AND WIRELESS DEVICES; ELECTRONIC PERSONAL ORGANIZERS; EYEGLASS CASES; EYEGLASSES; HEADPHONES; KARAOKE MACHINES; MICROPHONES; MP3 PLAYERS; MP4 PLAYERS; MOUSE PADS; MOTION PICTURE FILMS FEATURING CHILDREN'S ENTERTAINMENT; MUSICAL SOUND RECORDINGS; PAGERS; PERSONAL STEREOS; PERSONAL VIDEO DISK PLAYERS; PERSONAL DIGITAL ASSISTANTS; PRINTERS; RADIOS; DOWNLOADABLE RING TONES VIA THE INTERNET AND WIRELESS DEVICES; SUNGLASSES; TELEPHONES; TELEVISION SETS; VIDEO CAMERAS; VIDEO CASSETTE RECORDERS; VIDEO CASSETTE PLAYERS; VIDEO GAME CARTRIDGES; VIDEO GAME DISCS; BLANK VIDEO CASSETTES; VIDEOPHONES; WALKIE-TALKIES; WRIST AND ARM RESTS FOR USE WITH COMPUTERS (U.S. CLS. 21, 23, 26, 36 AND 38).

#### CLASS 16—PAPER GOODS AND PRINTED MATTER

FOR PRINTED MATTER AND PAPER GOODS, NAMELY, A SERIES OF HARDCOVER AND PAPERBACK FICTIONAL BOOKS FOR CHILDREN AND ADULTS FEATURING CHARACTERS FROM ANIMATED, ACTION ADVENTURE, COMEDY AND/OR DRAMA FEATURES, COMIC BOOKS, CHILDREN'S BOOKS, MAGAZINES FEATURING CHARACTERS FROM ANIMATED, ACTION ADVENTURE, COMEDY AND/OR DRAMA FEATURES, COLORING BOOKS; BOOK COVERS; BOOKMARKS; CALENDARS; CHILDREN'S ACTIVITY BOOKS; CHILDREN'S ILLUSTRATED STORYBOOKS; CHILDREN'S POP-UP BOOKS AND NOVELTY CHILDREN'S BOOKS; CHILDREN'S DRAWING AND WRITING TABLETS; CHILDREN'S PLAY-ACTIVITY BOOKS, NAMELY, STICKER BOOKS, TRACING BOOKS, PAINTING BOOKS, CHILDREN'S WORKBOOKS IN THE FIELD OF READING FEATURING POSTERS AND BOOKMARKER; CHILDREN'S BOOKS COMBINED WITH ELECTRONIC, SOUND-EMITTING DEVICES CORRESPONDING TO THE CONTENTS OF THE SAID BOOKS AND SOLD TOGETHER AS UNITS; CHILDREN'S BOOKS COMBINED WITH STUFFED OR PLUSH DOLLS, MUSICAL TOYS, JEWELRY AND/OR PLASTIC FIGURINES CORRESPONDING TO THE CONTENTS OF THE SAID BOOKS AND SOLD TOGETHER AS UNITS; CHILDREN'S ARTS AND CRAFTS PAINT KITS, SOLD AS UNITS; COLORING BOOKS; COMIC MAGAZINES; DECALS; GIFT CARDS; HEAT TRANSFER PAPER; LITHOGRAPHS; MOUNTED AND/OR UNMOUNTED PHOTOGRAPHS; PAPER DOLL BOOKS; PAPER PARTY SUPPLIES, NAMELY, PAPER DECORATIONS, NAPKINS, PAPER TABLECLOTHS, INVITATION CARDS, PAPER PARTY FAVORS, DECORATIVE PAPER CENTERPIECES, PAPER PLACE MATS, PAPER TABLE CLOTHS, PAPER DOILIES, GIFT WRAPPING PAPER, PAPER BAGS FOR CHILDREN'S PRIZES, PLACE CARDS, CAKE DECORATIONS MADE OF PAPER, CREPE PAPER, PRINTED PAPER PARTY INVITATIONS; PAPER LUNCH BAGS; PAPER GIFT TAGS; PAPER GIFT BAGS; PAPER GOODS, NAMELY, STATIONERY, NOTEBOOKS, DIARIES; PERIODIC PUBLISHED COMIC STRIP; PICTURE BOOKS; PHOTO ALBUMS; PRINTED EMBROIDERY DESIGN PATTERNS; PRINTED PATTERNS FOR COSTUMES, PAJAMAS, SWEATSHIRTS AND T-SHIRTS; POSTERS; STICKERS; TEMPORARY PAPER TATTOOS; TISSUE PAPER; PRINTED MATTER, NAMELY, VINYL STATIC CLING SHEETS ON WHICH CHILDREN'S CARTOON CHARACTERS ARE PRINTED FOR AFFIXATION IN WINDOWS; WIRE BOUND NOTEBOOKS; WRITING

AND DRAWING MATERIALS, NAMELY, STATIONERY, WRITING PAPER, ENVELOPES, DIARIES, NOTE CARDS, GREETING CARDS, TRADING CARDS, ERASERS, CRAYONS, MARKERS, COLORED PENCILS, PAINTING SETS FOR CHILDREN, CHALK AND CHALKBOARDS FOR SCHOOL AND HOME USE, PENS, PENCILS, DECORATIVE PENCIL-TOP ORNAMENTS AND CASES FOR PENS (U.S. CLS. 2, 5, 22, 23, 29, 37, 38 AND 50).

#### CLASS 18—LEATHER GOODS

FOR DOG APPAREL, NAMELY, DOG CLOTHING; DOG COLLARS; DOG COATS; DOG LEASHES; DOG COLLARS AND LEADS; DOG PARKAS; NECKWEAR FOR DOGS; DOG SHOES; HANDBAGS; PURSES; TOTE BAGS (U.S. CLS. 1, 2, 3, 22 AND 41).

#### CLASS 25—CLOTHING

FOR MEN'S WOMEN'S AND CHILDREN'S CLOTHING ITEMS, NAMELY, T-SHIRTS; SHIRTS; SWEATSHIRTS; HALTER TOPS; SWEATPANTS; WARM-UP SUITS; TANK TOPS; UNDERWEAR; JERSEYS; VESTS; SHORTS; SKIRTS; JACKETS; COATS; RAINCOATS; ANORAKS; PARKAS; BLAZERS; CARDIGANS; BOLEROS; SPORT COATS; WIND RESISTANT JACKETS; SUITS; TUNICS; SOCKS; SLIPPERS; SWEATERS; DRESSES; GOWNS; JUMPERS; NECKTIES; HEAD WEAR; CAPS; HATS; HOODS; HEAD BANDS; SUN VISORS; GYM SHORTS; SLEEPWEAR; PAJAMAS; NIGHT SHIRTS; NIGHT GOWNS; PANTS; TROUSERS; JEANS; DUNGAREES; JUMPSUITS; OVERALLS; COVERALLS; FLIGHT SUITS; GYM SUITS; JOGGING SUITS; BODY SUITS; UNITARDS; CAMISOLES; CHEMISES; UNDERSHIRTS; SLIPS; FOUNDATION GARMENTS; BODY SHAPERS; BRASSIERES; BUSTIERS; GARTER BELTS; BRIEFS; BOXER SHORTS; BLOOMERS; UNDERPANTS; PANTIES; LINGERIE; LOUNGEWEAR; NIGHTGOWNS; NIGHT SHIRTS; NEGLIGEEES; ROBES; THERMAL UNDERWEAR; SKORTS; ROMPERS; CULOTTES; SHORTS; TURTLENECKS; UNDERCLOTHES; FOOTWEAR; BOOTS; ATHLETIC SHOES; ATHLETIC FOOTWEAR; GALOSHES; BEACH COVER-UPS; BEACHWEAR; SARONGS; BATHING TRUNKS; BATHING SUITS; SWIMWEAR; BIKINIS; BLAZERS; CLOTH BIBS FOR BABIES; GLOVES; SKI WEAR; SKI SUITS; SKI PANTS; SKI GLOVES; THERMAL SOCKS; PLAY SUITS; MITTENS; HALLOWEEN COSTUMES; HOSIERY; PANTYHOSE; TIGHTS; KNEE HIGHS; LEG WARMERS; LEGGINGS; INFANT WEAR; MITTENS; BELTS; SASHES; POLO SHIRTS; RAINWEAR; ROBES; SCARVES (U.S. CLS. 22 AND 39).

#### CLASS 28—TOYS AND SPORTING GOODS

FOR TOYS, GAMES, AND PLAYTHINGS, NAMELY, TOY ACTION FIGURES AND ACCESSORIES THEREOF; CHILDREN'S MULTIPLE ACTIVITY TOYS; PUPPETS; FINGER PUPPETS; BATH TOYS; RIDE-ON TOYS; ELECTRONIC HAND-HELD GAME UNITS OTHER THAN THOSE ADAPTED FOR USE WITH AN EXTERNAL DISPLAY SCREEN MONITOR; COLLECTIBLE TOY FIGURES; CRIB TOYS; DOLLS; DOLL CLOTHING; DOLL ACCESSORIES; DOLL PLAY SETS; ELECTRIC ACTION TOYS; MECHANICAL TOYS; MUSICAL TOYS; JIGSAW PUZZLES; LARGE JIGSAW PUZZLES FOR THE FLOOR; PLUSH TOYS; SNOW GLOBES; SQUEEZE TOYS; STUFFED TOYS; TALKING TOYS; TEDDY BEARS; TOY VEHICLES; TOY CARS; TOY FIGURES; TOY BANKS; TOY TRUCKS; WINDUP TOYS; TOY ANIMALS; FABRIC CLOTHING FOR DOLLS; INFLATABLE TOYS; DOG TOYS; PULL TOYS; BOARD GAMES; CARD GAMES; BALLOONS; PAPER FACE MASKS; CHRISTMAS TREE DECORATIONS EXCEPT CONFECTIONERY OR ILLUMINATION ARTICLES; CHRISTMAS TREE ORNAMENTS (U.S. CLS. 22, 23, 38 AND 50).

#### CLASS 41—EDUCATION AND ENTERTAINMENT

FOR ENTERTAINMENT SERVICES, IN THE NATURE OF AN ON-GOING TELEVISION PROGRAM IN THE FIELD OF ANIMATED CARTOONS FOR ENTERTAINMENT OF CHILDREN; ENTERTAINMENT SERVICES, IN THE NATURE OF AN ON-GOING LIVE ACTION TELEVISION PROGRAM FOR FAMILY ENTERTAINMENT; PRODUCTION, DISTRIBUTION, AND RENTAL OF MOTION PICTURE FILMS, NAMELY, SHORT FILMS, ANIMATED FILMS AND FULL LENGTH THEATRICAL FILMS; PRODUCTION OF TELEVISION AND RADIO PROGRAMS; DISTRIBUTION OF TELEVISION AND RADIO PROGRAMS FOR OTHERS; RENTAL OF TELEVISION AND RADIO PROGRAMS; PRODUCTION OF SOUND AND VIDEO RECORDINGS FOR OTHERS; PRODUCTION OF LIVE ENTERTAINMENT TELEVISION SHOWS AND INTERACTIVE TELEVISION PROGRAMS; DISTRIBUTION OF SHORT FILMS, ANIMATED FILMS AND FULL THEATRICAL LENGTH FILMS ALL IN THE FIELDS OF CHILDREN'S ENTERTAINMENT VIA MOBILE ELECTRONIC DEVICES, NAMELY, CELL PHONES, MOBILE PHONES, PERSONAL DIGITAL ASSISTANTS, COMPUTERS, AND WIRELESS HANDHELDS; PROVIDING A WEBSITE FEATURING NON-DOWNLOADABLE AUDIO-VISUAL CONTENT, NAMELY, MOTION PICTURES, ANIMATION, VIDEOS, AND FILM CLIPS ALL IN THE FIELD OF CHILDREN'S ENTERTAINMENT; PROVIDING ONLINE ENTERTAINMENT INFORMATION IN THE FIELDS OF ENTERTAINMENT, MOTION PICTURES, ANIMATION, FILMS, AND ENTERTAINMENT VIDEOS, VIA A GLOBAL COMPUTER NETWORK; PROVIDING BLOGS IN THE NATURE OF AN ONLINE JOURNAL VIA A GLOBAL COMPUTER NETWORK FEATURING ENTERTAINMENT, MOTION PICTURES, ANIMATION, FILMS, AND VIDEOS ALL IN THE FIELD OF ANIMATED CARTOONS; PROVIDING A WEBSITE FEATURING TEMPORARY USE OF NON-DOWNLOADABLE ONLINE INTERACTIVE VIDEO GAMES; PRESENTATION OF LIVE SHOW PERFORMANCES; ENTERTAINMENT IN THE NATURE OF THEATER PRODUCTIONS; ELECTRONIC PUBLISHING SERVICES, NAMELY, PUBLICATION OF TEXT AND GRAPHIC WORKS OF OTHERS ON INTERNET, ONLINE AND OTHER DIGITAL DELIVERY METHODS, FEATURING A WIDE VARIETY OF TOPICS (U.S. CLS. 100, 101 AND 107).

SIMON TENG, EXAMINING ATTORNEY

SN 85-123,684. FSI FONTSHOP INTERNATIONAL GMBH, BERLIN, FED REP GERMANY, FILED 9-7-2010.



OWNER OF U.S. REG. NO. 2,320,971.  
THE COLOR(S) BLACK AND WHITE IS/ARE CLAIMED AS A FEATURE OF THE MARK.  
THE MARK CONSISTS OF THE TWO STYLIZED LETTER "F"'S, ONE IN BLACK AND ONE IN WHITE.

**CLASS 9—ELECTRICAL AND SCIENTIFIC APPARATUS**

FOR COMPUTER SOFTWARE FOR COLLECTION, EDITING, ORGANIZING, MODIFYING, PRINTING, BOOK MARKING, TRANSMISSION, STORAGE, DISPLAYING, DIGITAL IMAGING, SHARING AND OUTPUT OF DATA AND INFORMATION IN THE FIELD OF ELECTRONIC PUBLISHING AND OF CREATION OF FONTS; TYPOGRAPHIC TYPEFACES, TYPOGRAPHIC FONTS, DIGITAL PICTURES, IMAGES, TYPE DESIGNS OF ALPHANUMERIC CHARACTERS, TYPOGRAPHICAL SYMBOLS AND/OR PRINTER'S FONTS, LETTERS, NUMERALS, FIGURATIVE SIGNS NAMELY CONVENTIONAL SIGNS, SYMBOLS AND SCIENTIFIC SIGNS AS WELL AS ORNAMENTS, FOR REPRODUCTION AND COPYING, NAMELY FOR THE CREATION OF TEXTS BY MEANS OF GRAPHIC TECHNIQUES ALL RECORDED ON COMPUTER MEDIA OR DOWNLOADABLE; CHARACTER STORAGE MEDIA, NAMELY, PRERECORDED MAGNETIC DATA CARRIERS, ELECTRONIC DATA CARRIERS, CD-ROM, DVD-ROM, MEMORY CARDS, AND FLASH DRIVES FEATURING THE FOREGOING (U.S. CLS. 21, 23, 26, 36 AND 38).

FIRST USE 11-0-1990; IN COMMERCE 4-0-1992.

**CLASS 16—PAPER GOODS AND PRINTED MATTER**

FOR TYPEFACES, TYPOGRAPHIC PRINTING FONTS AND PRINTER'S TYPE, IN PARTICULAR LETTERS AND ALPHABETS AND THEIR ACCESSORIES SUCH AS ACCENTS AND PUNCTUATION MARKS, NUMERALS AND OTHER FIGURATIVE SIGNS SUCH AS CONVENTIONAL SIGNS, SYMBOLS AND SCIENTIFIC SIGNS AS WELL AS ORNAMENTS, FOR REPRODUCTION AND COPYING, IN PARTICULAR FOR THE CREATION OF TEXTS BY MEANS OF GRAPHIC TECHNIQUES; PRINTED MATERIALS, IN PARTICULAR, HANDBOOKS, USER INSTRUCTION SHEETS AND MANUALS FOR USE WITH COMPUTER SOFTWARE; AND PRINTED SPECIALIST GRAPHICS IN THE NATURE OF DESIGN TYPEFACE FOR USE IN BOOKS, MAGAZINES, CATALOGUES AND POSTERS; POSTERS (U.S. CLS. 2, 5, 22, 23, 29, 37, 38 AND 50).

FIRST USE 11-0-1990; IN COMMERCE 4-0-1992.

ANDREA K. NADELMAN, EXAMINING ATTORNEY

SN 85-124,640. ALOK INTERNATIONAL INC., DALLAS, TX.  
FILED 9-8-2010.

**VASCO DA GAMA**

THE MARK CONSISTS OF STANDARD CHARACTERS WITHOUT CLAIM TO ANY PARTICULAR FONT, STYLE, SIZE, OR COLOR.

THE NAME(S), PORTRAIT(S), AND/OR SIGNATURE(S) SHOWN IN THE MARK DOES NOT IDENTIFY A PARTICULAR LIVING INDIVIDUAL.

**CLASS 11—ENVIRONMENTAL CONTROL APPARATUS**

FOR APPARATUS FOR ENVIRONMENTAL CONTROL, NAMELY, LAMPS, LANTERNS, LIGHTING FIXTURES (U.S. CLS. 13, 21, 23, 31 AND 34).

**CLASS 18—LEATHER GOODS**

FOR LEATHER PRODUCTS, NAMELY, BAGS, TOTE BAGS; ANIMAL CARRIERS; DOG APPAREL (U.S. CLS. 1, 2, 3, 22 AND 41).

**CLASS 20—FURNITURE AND ARTICLES NOT OTHERWISE CLASSIFIED**

FOR FURNITURE, NAMELY, BOOKCASES, COAT RACKS, CUSHIONS, FIREPLACE SCREENS, MAGAZINE RACKS, MIRRORS, PICTURE FRAMES, PILLOWS, PLANT STANDS, WINE RACKS, WOOD BOXES, WORKS OF ART MADE OF PLASTER OR WOOD, BAKER'S RACKS, BENCHES, HAMPERS, NON-METAL PLANT HANGERS, STEP STOOLS, FOLDING PARTITION SCREENS, UMBRELLA STANDS, WALL PLAQUES MADE OF PLASTER OR WOOD, BEDS FOR HOUSEHOLD PETS, NON-METAL PET TAGS (U.S. CLS. 2, 13, 22, 25, 32 AND 50).

**CLASS 21—HOUSEWARES AND GLASS**

FOR HOUSEHOLD CONTAINERS, NAMELY, BASKETS OF WICKER AND STRAW, CANDLE HOLDERS, CANDLE SNUFFERS, CONTAINERS FOR HOUSEHOLD USE, DRINKING VESSELS, BOWLS, PLATES, TOWEL BARS, CARVING BOARDS, NAPKIN RINGS, TRAYS FOR DOMESTIC PURPOSES, TRIVETS; SERVING UTENSILS NAMELY FORKS, TONGS, TURNERS (U.S. CLS. 2, 13, 23, 29, 30, 33, 40 AND 50).

**CLASS 24—FABRICS**

FOR TEXTILES AND FABRICS, NAMELY, BED BLANKETS, BED SHEETS, BEDSKIRTS, COMFORTERS, COVERLETS, QUILTS, THROWS, DUVETS, PILLOW CASES, MATTRESS PADS, MATTRESS COVERS, BATH LINENS, TOWELS, WASH CLOTHS, SHOWER CURTAINS, TOILET TANK COVERS, TABLE AND KITCHEN LINENS, TABLE RUNNERS, NAPKINS, PLACE MATS, COASTERS, DISH CLOTHS, POT HOLDERS, KITCHEN TOWELS, WINDOW COVERINGS AND TREATMENTS IN THE NATURE OF CURTAINS, DRAPERIES, SHEERS, SWAGS, AND VALANCES, CUSHION COVERS (U.S. CLS. 42 AND 50).

**CLASS 25—CLOTHING**

FOR CLOTHING, NAMELY, SHIRTS, PANTS, SWEATERS, COATS, JACKETS, SLEEPWEAR, DRESSES, SUITS, SHORTS, FOOTWEAR, CAPS, HATS, SWIMWEAR; ATHLETIC APPAREL, NAMELY, SHIRTS, SHORTS, PANTS, JACKETS, SWEATSHIRTS, SWEATPANTS, FOOTWEAR, HATS AND CAPS (U.S. CLS. 22 AND 39).

**CLASS 27—FLOOR COVERINGS**

FOR FLOOR COVERINGS, NAMELY, BATH MATS, FLOOR MATS, RUGS (U.S. CLS. 19, 20, 37, 42 AND 50).  
SUNG IN, EXAMINING ATTORNEY

SN 85-125,227. RYAN'S WELL FOUNDATION, KEMPTVILLE, ONTARIO, CANADA, FILED 9-8-2010.

**RYAN'S WELL FOUNDATION**

THE MARK CONSISTS OF STANDARD CHARACTERS WITHOUT CLAIM TO ANY PARTICULAR FONT, STYLE, SIZE, OR COLOR.

PRIORITY CLAIMED UNDER SEC. 44(D) ON CANADA APPLICATION NO. 1472255, FILED 3-8-2010, REG. NO. TMA786242, DATED 12-31-2010, EXPIRES 12-31-2025.

NO CLAIM IS MADE TO THE EXCLUSIVE RIGHT TO USE "WELL FOUNDATION", APART FROM THE MARK AS SHOWN.

**CLASS 36—INSURANCE AND FINANCIAL**

FOR CHARITABLE FUNDRAISING SERVICES (U.S. CLS. 100, 101 AND 102).

**CLASS 41—EDUCATION AND ENTERTAINMENT**

FOR EDUCATIONAL SERVICES, NAMELY, PROVIDING WORKSHOPS AND SEMINARS THAT SUPPORT ELEMENTARY AND SECONDARY CURRICULUM EXPECTATIONS, WITH SAID WORKSHOPS AND SEMINARS BEING ABOUT THE IMPORTANCE OF SAFE WATER AND ABOUT STUDENTS MAKING A DIFFERENCE IN THEIR COMMUNITIES BY BECOMING SOCIALLY ACTIVE, AND THE DISTRIBUTION OF COURSE AND EDUCATIONAL MATERIALS IN CONNECTION THEREWITH, NAMELY, LESSON PLANS AND PROGRAM MATERIALS (U.S. CLS. 100, 101 AND 107).

**CLASS 43—HOTEL AND RESTAURANT SERVICES**

FOR CHARITABLE SERVICES, NAMELY, PROVIDING SAFE DRINKING WATER TO THOSE IN DEVELOPING COUNTRIES (U.S. CLS. 100 AND 101).  
KEVIN CORWIN, EXAMINING ATTORNEY

---

SN 85-125,265. TURAATH MEDIA, L.L.C., DBA ARAB AMERICA, NORTHVILLE, MI. FILED 9-8-2010.



NO CLAIM IS MADE TO THE EXCLUSIVE RIGHT TO USE "ARAB AMERICA", APART FROM THE MARK AS SHOWN.

THE COLOR(S) GOLD, MAROON, AND GREEN IS/ARE CLAIMED AS A FEATURE OF THE MARK.

THE MARK CONSISTS OF THE WORD "ARAB" IN GOLD TEXT, THE WORD "AMERICA" BELOW THE WORD "ARAB" IN MAROON TEXT, AND A DESIGN, NAMELY, AN ILLUSTRATION OF A CITY IN GREEN WITH A SERIES OF 5 ISLAMIC DOMES IN FRONT OF THE CITY.

**CLASS 35—ADVERTISING AND BUSINESS**

FOR ASSOCIATION SERVICES, NAMELY, PROMOTING THE INTERESTS OF ARAB AMERICANS (U.S. CLS. 100, 101 AND 102).  
FIRST USE 9-3-2010; IN COMMERCE 9-7-2010.

**CLASS 41—EDUCATION AND ENTERTAINMENT**

FOR PROVIDING CURRENT EVENT NEWS AND INFORMATION VIA A GLOBAL COMPUTER NETWORK (U.S. CLS. 100, 101 AND 107).  
FIRST USE 6-2-2010; IN COMMERCE 8-24-2010.  
WANDA KAY PRICE, EXAMINING ATTORNEY

SN 85-125,517. EXACT SCIENCES CORPORATION, MADISON, WI. FILED 9-9-2010.

**COLOGUARD**

THE MARK CONSISTS OF STANDARD CHARACTERS WITHOUT CLAIM TO ANY PARTICULAR FONT, STYLE, SIZE, OR COLOR.

**CLASS 5—PHARMACEUTICALS**

FOR COLORECTAL CANCER SCREENING TEST KIT COMPRISED OF MOLECULAR DIAGNOSTIC REAGENTS FOR DETECTING ABNORMAL DNA IN STOOL FROM CANCER OR PRE-CANCEROUS COLON POLYPS (U.S. CLS. 6, 18, 44, 46, 51 AND 52).

**CLASS 10—MEDICAL APPARATUS**

FOR COLORECTAL CANCER SCREENING TEST KIT COMPRISED OF IMPLEMENTS AND CONTAINER FOR COLLECTING PATIENT STOOL SAMPLES FOR ANALYSIS (U.S. CLS. 26, 39 AND 44).  
ROBIN CHOSID, EXAMINING ATTORNEY

---

SN 85-126,054. WEBCBG, NEW ROCHELLE, NY. FILED 9-9-2010.

**CORETRANET**

THE MARK CONSISTS OF STANDARD CHARACTERS WITHOUT CLAIM TO ANY PARTICULAR FONT, STYLE, SIZE, OR COLOR.

**CLASS 9—ELECTRICAL AND SCIENTIFIC APPARATUS**

FOR COMPUTER SOFTWARE THAT PROVIDES WEB-BASED ACCESS TO APPLICATIONS AND SERVICES THROUGH A WEB OPERATING SYSTEM OR PORTAL INTERFACE (U.S. CLS. 21, 23, 26, 36 AND 38).

**CLASS 42—SCIENTIFIC AND COMPUTER SERVICES**

FOR APPLICATION SERVICE PROVIDER (ASP) FEATURING SOFTWARE FOR USE OF ONLINE COLLABORATION AND DOCUMENTS SHARING IN SOCIAL BUSINESS, ALSO KNOWN AS SOFTWARE FOR USE ENABLING USERS TO UPLOAD AND DOWNLOAD ELECTRONIC FILES (U.S. CLS. 100 AND 101).  
RONALD AIKENS, EXAMINING ATTORNEY

SN 85-126,084. THE CENTER FOR VICTIMS OF TORTURE,  
ST. PAUL, MN. FILED 9-9-2010.

KATHLEEN LORENZO, EXAMINING ATTORNEY

THE CENTER FOR VICTIMS OF  
TORTURE

THE MARK CONSISTS OF STANDARD CHARACTERS  
WITHOUT CLAIM TO ANY PARTICULAR FONT, STYLE,  
SIZE, OR COLOR.

OWNER OF U.S. REG. NO. 3,026,600.  
NO CLAIM IS MADE TO THE EXCLUSIVE RIGHT TO  
USE "CENTER", APART FROM THE MARK AS SHOWN.  
SEC. 2(F).

**CLASS 35—ADVERTISING AND BUSINESS**

FOR CHARITABLE SERVICES, NAMELY ORGANIZ-  
ING AND DEVELOPING PROJECTS THAT AIM TO  
PROMOTE GLOBAL AWARENESS ABOUT HOW TO  
HEAL TORTURE SURVIVORS AND PUT AN END TO  
THE PRACTICE OF TORTURE (U.S. CLS. 100, 101 AND  
102).

FIRST USE 5-5-1985; IN COMMERCE 5-5-1985.

**CLASS 44—MEDICAL, BEAUTY AND AGRICULTURAL SERVICES**

FOR PROVIDING MENTAL AND PHYSICAL REHA-  
BILITATIVE CARE TO SURVIVORS OF TORTURE AND  
MEMBERS OF THEIR FAMILIES (U.S. CLS. 100 AND  
101).

FIRST USE 5-5-1985; IN COMMERCE 5-5-1985.  
ANDREA HACK, EXAMINING ATTORNEY

SN 85-126,711. JERRY J. FIELDING, JR., BRIGHTON, MI.  
FILED 9-10-2010.

LOVE BUTTON

THE MARK CONSISTS OF STANDARD CHARACTERS  
WITHOUT CLAIM TO ANY PARTICULAR FONT, STYLE,  
SIZE, OR COLOR.

**CLASS 9—ELECTRICAL AND SCIENTIFIC APPARATUS**

FOR SHORT RANGE, WIRELESS DATA TRANSMIS-  
SION DEVICE FOR SOCIAL NETWORKING (U.S. CLS.  
21, 23, 26, 36 AND 38).

**CLASS 42—SCIENTIFIC AND COMPUTER SERVICES**

FOR COMPUTER SERVICES, NAMELY, HOSTING  
AND MAINTAINING AN ON-LINE WEB SITE FOR  
OTHERS TO ENGAGE IN ON-LINE DATING, SOCIAL  
INTRODUCTION AND SOCIAL NETWORKING (U.S.  
CLS. 100 AND 101).

**CLASS 45—PERSONAL AND LEGAL SERVICES**

FOR SOCIAL NETWORKING SITE, NAMELY, PRO-  
VIDING A SOCIAL NETWORKING WEBSITE FOR EN-  
TERTAINMENT PURPOSES (U.S. CLS. 100 AND 101).

SN 85-126,851. ELFENWORKS PRODUCTIONS LLC, BUR-  
LINGAME, CA. FILED 9-10-2010.

FAIR TRUTH

THE MARK CONSISTS OF STANDARD CHARACTERS  
WITHOUT CLAIM TO ANY PARTICULAR FONT, STYLE,  
SIZE, OR COLOR.

**CLASS 35—ADVERTISING AND BUSINESS**

FOR PROMOTING PUBLIC AWARENESS AND SUP-  
PORT OF FAIR TRADE AND LABOR STANDARDS,  
LAWS AND PRACTICES AS A MEANS TO ALLEVIATE  
POVERTY AND INEQUALITY; PROMOTING PUBLIC  
AWARENESS AND UNDERSTANDING OF FAIR  
TRADE STANDARDS CERTIFICATION AS A MAR-  
KET-BASED MODEL FOR FAIR TRADE AND LABOR  
PRACTICES AS A MEANS TO ALLEVIATE POVERTY  
AND INEQUALITY; PROVIDING ON-LINE BUSINESS  
INFORMATION IN THE FIELD OF FAIR TRADE  
PRACTICES; PROVIDING INTERACTIVE DATABASES  
OF BUSINESS INFORMATION IN THE FIELD OF FAIR  
TRADE PRACTICES; PROVIDING ON-LINE BUSINESS  
INFORMATION AND INTERACTIVE DATABASES OF  
BUSINESSES AND ORGANIZATIONS CONFORMING  
TO ESTABLISHED STANDARDS OF FAIR TRADE;  
ASSOCIATION SERVICES, NAMELY, PROMOTING  
THE PUBLIC INTEREST AND AWARENESS OF FAIR  
TRADE AND LABOR STANDARDS, LAWS AND PRAC-  
TICES (U.S. CLS. 100, 101 AND 102).

**CLASS 42—SCIENTIFIC AND COMPUTER SERVICES**

FOR EVALUATION OF THE BUSINESS PRACTICES,  
GOODS AND SERVICES OF OTHERS FOR THE PUR-  
POSE OF CERTIFICATION OF FAIR TRADE AND  
LABOR PRACTICES; ACCREDITATION SERVICES,  
NAMELY, SETTING AND PROVIDING STANDARDS  
FOR FAIR TRADE AND LABOR PRACTICE FOR THE  
PURPOSE OF ACCREDITATION; ACCREDITATION  
SERVICES, NAMELY, EVALUATING BUSINESSES  
AND ORGANIZATIONS TO DETERMINE WHETHER  
THE BUSINESSES AND ORGANIZATIONS CONFORM  
TO ESTABLISHED LAWS AND/OR STANDARDS OF  
FAIR TRADE AND LABOR PRACTICES (U.S. CLS. 100  
AND 101).

**CLASS 45—PERSONAL AND LEGAL SERVICES**

FOR LEGAL SERVICES, NAMELY, PROVIDING IN-  
FORMATION AND INTERACTIVE DATABASES FEAT-  
URING INFORMATION IN THE FIELD OF LABOR  
PRACTICES (U.S. CLS. 100 AND 101).

KIM SAITO, EXAMINING ATTORNEY

SN 85-127,066. GARMIN SWITZERLAND GMBH, SCHAFFHAUSEN, SWITZERLAND, FILED 9-10-2010.

# nüLink!

THE MARK CONSISTS OF STANDARD CHARACTERS WITHOUT CLAIM TO ANY PARTICULAR FONT, STYLE, SIZE, OR COLOR.

OWNER OF U.S. REG. NO. 3,801,098.

## CLASS 9—ELECTRICAL AND SCIENTIFIC APPARATUS

FOR CELLULAR TELEPHONES; TELEMATICS APPARATUS, NAMELY, WIRELESS COMMUNICATION NETWORK ACCESSIBLE DEVICES WHICH PROVIDE TELEMATIC SERVICES AND HAVE CELLULAR PHONE, SMARTPHONE AND GPS FUNCTIONS; GPS NAVIGATION DEVICE; GPS NAVIGATION DEVICE WITH ENHANCED SATELLITE ACQUISITION, GPS DEVICE THAT ALLOWS USERS TO CONNECT TO A WIRELESS COMMUNICATION NETWORK AND PROVIDES USERS WITH ONLINE LOCAL TRAFFIC INFORMATION, WEATHER INFORMATION, FUEL LOCATION AND PRICE INFORMATION, FLIGHT STATUS INFORMATION, TRAFFIC AND PARKING INFORMATION, TRAFFIC DIRECTIONS AND ROUTE ALTERNATIVES, RESTAURANT INFORMATION, MOVIE LISTINGS AND SCHEDULES, ENTERTAINMENT SCHEDULES AND OPTIONS, ACCESS TO AND THE ABILITY TO TRANSMIT VIA SOCIAL MEDIA, CURRENCY EXCHANGE RATE INFORMATION, TRAFFIC CAMERA PHOTOGRAPHS AND VIEWS, SAFETY CAMERAS PHOTOGRAPHS AND VIEWS, SATELLITE IMAGERY, PERSON LOCATOR, AND SEARCH CAPABILITY; GLOBAL POSITIONING SYSTEM DEVICE THAT ALLOWS USERS TO OBTAIN INFORMATION IN THE FIELDS OF MAPS, TELEPHONE LISTINGS AND ROUTE CALCULATION (U.S. CLS. 21, 23, 26, 36 AND 38).

## CLASS 35—ADVERTISING AND BUSINESS

FOR PROVIDING DATABASES IN THE FIELD TELEPHONE LISTINGS, IN THE NATURE OF TELEPHONE DIRECTORY INFORMATION (U.S. CLS. 100, 101 AND 102).

## CLASS 39—TRANSPORTATION AND STORAGE

FOR PROVIDING DATABASES IN THE FIELDS OF NAVIGATION INFORMATION, MAPS, AND ROUTE CALCULATION (U.S. CLS. 100 AND 105).

ASMAT KHAN, EXAMINING ATTORNEY

SN 85-127,282. GENABILITY INC., SAN FRANCISCO, CA. FILED 9-10-2010.

# GENABILITY

THE MARK CONSISTS OF STANDARD CHARACTERS WITHOUT CLAIM TO ANY PARTICULAR FONT, STYLE, SIZE, OR COLOR.

## CLASS 9—ELECTRICAL AND SCIENTIFIC APPARATUS

FOR DOWNLOADABLE INTERNET-BASED COMPUTER SOFTWARE FOR ENERGY PRICING, FORECASTING, MONITORING, MANAGEMENT AND OPTIMIZATION FOR INDIVIDUALS AND BUSINESS (U.S. CLS. 21, 23, 26, 36 AND 38).

## CLASS 35—ADVERTISING AND BUSINESS

FOR RETAIL ELECTRICITY PROVIDER SERVICES, NAMELY, PROVIDING A SERVICE THAT ALLOWS CUSTOMERS TO PURCHASE ENERGY, NAMELY, ELECTRICITY (U.S. CLS. 100, 101 AND 102).

## CLASS 36—INSURANCE AND FINANCIAL

FOR BROKERAGE OF ENERGY, NAMELY, ELECTRICITY (U.S. CLS. 100, 101 AND 102).

## CLASS 42—SCIENTIFIC AND COMPUTER SERVICES

FOR RESEARCH IN THE FIELD OF ENERGY; ELECTRICITY METERING SERVICES; CONSULTING SERVICES IN CONNECTION WITH SOFTWARE IMPLEMENTATION, INTEGRATION AND UTILIZATION (U.S. CLS. 100 AND 101).

MARGERY A. TIERNEY, EXAMINING ATTORNEY

SN 85-127,541. MATH MAVERICK, LLC, NAPLES, FL. FILED 9-11-2010.

# MATH MAVERICK

THE MARK CONSISTS OF STANDARD CHARACTERS WITHOUT CLAIM TO ANY PARTICULAR FONT, STYLE, SIZE, OR COLOR.

NO CLAIM IS MADE TO THE EXCLUSIVE RIGHT TO USE "MATH", APART FROM THE MARK AS SHOWN.

## CLASS 16—PAPER GOODS AND PRINTED MATTER

FOR WORKBOOKS, PRINTED COURSE MATERIALS, AND PRINTED LESSON PLANS IN THE FIELD OF MATHEMATICS (U.S. CLS. 2, 5, 22, 23, 29, 37, 38 AND 50).

FIRST USE 7-15-2010; IN COMMERCE 7-15-2010.

## CLASS 41—EDUCATION AND ENTERTAINMENT

FOR EDUCATION SERVICES, NAMELY, PROVIDING TUTORING SERVICES AND TUTORIAL SESSIONS IN THE FIELD OF MATHEMATICS (U.S. CLS. 100, 101 AND 107).

FIRST USE 7-15-2010; IN COMMERCE 7-15-2010.  
AMY ALFIERI, EXAMINING ATTORNEY



SN 85-127,807. MATH MAVERICK, LLC, NAPLES, FL.  
FILED 9-13-2010.

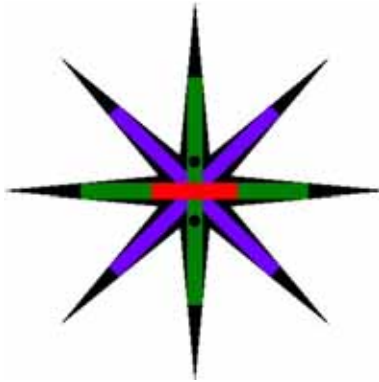

THE COLOR(S) BLACK, GREEN, PURPLE, RED IS/ARE CLAIMED AS A FEATURE OF THE MARK.

THE MARK CONSISTS OF AN EIGHT POINT STAR WITH A BLACK BACKGROUND WITH A GREEN BAR ON THE VERTICAL AXIS CONTAINING TWO BLACK DOTS, ONE ABOVE THE CENTER AND ONE BELOW, WITH A GREEN BAR ON THE HORIZONTAL AXIS WITH THE CENTER ONE-THIRD OF THE BAR IN RED, WITH A PURPLE X ON THE CROSS AXES.

#### CLASS 16—PAPER GOODS AND PRINTED MATTER

FOR WORKBOOKS, PRINTED COURSE MATERIALS, AND PRINTED LESSON PLANS IN THE FIELD OF MATHEMATICS (U.S. CLS. 2, 5, 22, 23, 29, 37, 38 AND 50).

FIRST USE 7-15-2010; IN COMMERCE 7-15-2010.

#### CLASS 41—EDUCATION AND ENTERTAINMENT

FOR EDUCATION SERVICES, NAMELY, PROVIDING TUTORING SERVICES AND TUTORIAL SESSIONS IN THE FIELD OF MATHEMATICS (U.S. CLS. 100, 101 AND 107).

FIRST USE 7-15-2010; IN COMMERCE 7-15-2010.  
AMY ALFIERI, EXAMINING ATTORNEY

SN 85-127,857. MIS QUALITY MANAGEMENT CORP., WILMINGTON, DE. FILED 9-13-2010.

# RISKORIGINS

THE MARK CONSISTS OF STANDARD CHARACTERS WITHOUT CLAIM TO ANY PARTICULAR FONT, STYLE, SIZE, OR COLOR.

#### CLASS 9—ELECTRICAL AND SCIENTIFIC APPARATUS

FOR SOFTWARE TO ASSIST FINANCIAL INSTITUTIONS WITH RISK ANALYSIS, COMPLIANCE AND REPORTING RELATING TO THE LOAN ORIGINATION PROCESS AND UNDERWRITTEN CREDIT REVIEW PROCESSES (U.S. CLS. 21, 23, 26, 36 AND 38).

#### CLASS 16—PAPER GOODS AND PRINTED MATTER

FOR PRINTED MATERIALS, NAMELY, PRODUCT GUIDES, USER GUIDES, INSTRUCTION MANUALS, INSTALLATION GUIDES, CONFIGURATION GUIDES, AND SOFTWARE DEVELOPING GUIDES, ALL FOR SOFTWARE RELATING TO FINANCIAL ANALYSIS AND RISK MANAGEMENT (U.S. CLS. 2, 5, 22, 23, 29, 37, 38 AND 50).

#### CLASS 42—SCIENTIFIC AND COMPUTER SERVICES

FOR PROVIDING TEMPORARY USE OF A WEB BASED SOFTWARE APPLICATION FOR ASSISTING FINANCIAL INSTITUTIONS WITH RISK ANALYSIS, COMPLIANCE AND REPORTING RELATING TO THE LOAN ORIGINATION PROCESS, AND UNDERWRITTEN CREDIT REVIEW PROCESSES; CUSTOMIZATION OF SOFTWARE TO ASSIST FINANCIAL INSTITUTIONS WITH RISK ANALYSIS, COMPLIANCE AND REPORTING RELATING TO THE LOAN ORIGINATION PROCESS, AND UNDERWRITTEN CREDIT REVIEW PROCESSES (U.S. CLS. 100 AND 101).

ADA HAN, EXAMINING ATTORNEY

SN 85-128,177. RADIAN GROUP INC., PHILADELPHIA, PA.  
FILED 9-13-2010.

## DISCOVER THE POWER OF R

THE MARK CONSISTS OF STANDARD CHARACTERS WITHOUT CLAIM TO ANY PARTICULAR FONT, STYLE, SIZE, OR COLOR.

#### CLASS 35—ADVERTISING AND BUSINESS

FOR MARKETING SERVICES, NAMELY, PROMOTING FINANCIAL GOODS AND SERVICES OF REAL ESTATE MORTGAGE LENDERS; AND SALES PROMOTION, NAMELY, PROMOTING REAL ESTATE LENDING SERVICES, TITLE INSURANCE, HAZARD PROTECTION AND FRAUD PROTECTION (U.S. CLS. 100, 101 AND 102).

#### CLASS 36—INSURANCE AND FINANCIAL

FOR REAL ESTATE MORTGAGE INSURANCE UNDERWRITING SERVICES (U.S. CLS. 100, 101 AND 102).  
RAMONA ORTIGA, EXAMINING ATTORNEY

SN 85-128,291. OXUS AMERICA, INC., ROCHESTER HILLS, MI. FILED 9-13-2010.

# OXUS

THE MARK CONSISTS OF STANDARD CHARACTERS WITHOUT CLAIM TO ANY PARTICULAR FONT, STYLE, SIZE, OR COLOR.

**CLASS 10—MEDICAL APPARATUS**

FOR OXYGEN CONCENTRATORS FOR MEDICAL APPLICATIONS, NAMELY, OXYGEN CONCENTRATORS FOR INCREASING OXYGEN CONTENT IN THE ATMOSPHERE OF AN ENCLOSURE; OXYGEN MASKS FOR MEDICAL USE, CANNULAE, OXYGEN INHALERS FOR MEDICAL PURPOSES SOLD EMPTY, AND OXYGEN MONITORS (U.S. CLS. 26, 39 AND 44).

FIRST USE 12-1-2000; IN COMMERCE 6-1-2005.

**CLASS 11—ENVIRONMENTAL CONTROL APPARATUS**

FOR OXYGEN CONCENTRATORS FOR USE WITH FUEL CELLS USED IN HEATING, VENTILATING, AIR CONDITIONING, LIGHTING AND POWER ASSISTANCE FOR BUILDING; OXYGEN CONCENTRATORS FOR PROCESSING WATER BY INCREASING OXYGEN CONTENT IN THE WATER (U.S. CLS. 13, 21, 23, 31 AND 34).

FIRST USE 12-1-2000; IN COMMERCE 6-1-2005.

KRISTIN DAHLING, EXAMINING ATTORNEY

SN 85-128,813. WESTINGHOUSE ELECTRIC COMPANY LLC, CRANBERRY TOWNSHIP, PA. FILED 9-14-2010.

**SIMPLY ELECTRIC**

THE MARK CONSISTS OF STANDARD CHARACTERS WITHOUT CLAIM TO ANY PARTICULAR FONT, STYLE, SIZE, OR COLOR.

NO CLAIM IS MADE TO THE EXCLUSIVE RIGHT TO USE "ELECTRIC", APART FROM THE MARK AS SHOWN.

**CLASS 11—ENVIRONMENTAL CONTROL APPARATUS**

FOR NUCLEAR POWER PLANTS (U.S. CLS. 13, 21, 23, 31 AND 34).

**CLASS 42—SCIENTIFIC AND COMPUTER SERVICES**

FOR DESIGNING PLANT COMPONENTS AND EQUIPMENT FOR NUCLEAR POWER PLANTS (U.S. CLS. 100 AND 101).

SUNG IN, EXAMINING ATTORNEY

SN 85-129,137. VALUE ADDED SCIENCE & TECHNOLOGIES, LLC, MASON CITY, IA. FILED 9-14-2010.

**NUTRIQUEST**

THE COLOR(S) GRAY AND GOLD IS/ARE CLAIMED AS A FEATURE OF THE MARK.

THE MARK CONSISTS OF LETTERING "NUTRI" IN GRAY AND LETTERING "QUEST" IN GOLD, WITH A GOLD ARROW EXTENDING TO THE RIGHT FROM THE BOTTOM OF THE "Q" AND UNDER THE LETTERING "QUEST".

**CLASS 5—PHARMACEUTICALS**

FOR NUTRITIONAL ADDITIVES FOR LIVESTOCK FEED (U.S. CLS. 6, 18, 44, 46, 51 AND 52).

FIRST USE 9-1-2010; IN COMMERCE 9-1-2010.

**CLASS 31—NATURAL AGRICULTURAL PRODUCTS**

FOR ANIMAL FEED (U.S. CLS. 1 AND 46).

FIRST USE 9-1-2010; IN COMMERCE 9-1-2010.

TARA PATE, EXAMINING ATTORNEY

SN 85-129,552. SMITH, PENNY RENEE, FRANKFORT, KY. AND COLLINS, WANDA LOTT, FINCHVILLE, KY. FILED 9-14-2010.

**Wikitiuning Education**

THE MARK CONSISTS OF STANDARD CHARACTERS WITHOUT CLAIM TO ANY PARTICULAR FONT, STYLE, SIZE, OR COLOR.

NO CLAIM IS MADE TO THE EXCLUSIVE RIGHT TO USE "EDUCATION", APART FROM THE MARK AS SHOWN.

**CLASS 41—EDUCATION AND ENTERTAINMENT**

FOR EDUCATION SERVICES, NAMELY, PROVIDING ON-LINE CONTINUING EDUCATION FOR LICENSED PROFESSIONALS IN THE FIELD OF COUNSELING, MARRIAGE AND FAMILY THERAPY, NURSING HOME ADMINISTRATION, PSYCHOLOGY, SOCIAL WORK, LAW ENFORCEMENT, AND DAY CARE ADMINISTRATION; EDUCATIONAL SERVICES, NAMELY, CONDUCTING ON-LINE EXHIBITIONS AND DISPLAYS AND INTERACTIVE EXHIBITS IN THE FIELD OF COUNSELING, MARRIAGE AND FAMILY THERAPY, NURSING HOME ADMINISTRATION, PSYCHOLOGY, SOCIAL WORK, LAW ENFORCEMENT, AND DAY CARE ADMINISTRATION; EDUCATIONAL SERVICES, NAMELY, PROVIDING ON-LINE CONTINUING EDUCATIONAL COURSES THAT UTILIZES WIKIS TO FACILITATE INTERACTIVE LEARNING IN THE FIELD OF COUNSELING, MARRIAGE AND FAMILY THERAPY, NURSING HOME ADMINISTRATION, PSYCHOLOGY, SOCIAL WORK, LAW ENFORCEMENT, AND DAY CARE ADMINISTRATION; PROVIDING COURSES OF INSTRUCTION AT THE LICENSED PROFESSIONAL CONTINUING EDUCATION LEVEL (U.S. CLS. 100, 101 AND 107).

FIRST USE 2-1-2009; IN COMMERCE 11-1-2009.

**CLASS 42—SCIENTIFIC AND COMPUTER SERVICES**

FOR PROVIDING AN ONLINE NETWORK SERVICE THAT ENABLES USERS TO EDIT AND SHARE CONTENT FOR CONTINUING EDUCATION PURPOSES IN THE FIELD OF COUNSELING, MARRIAGE AND FAMILY THERAPY, NURSING HOME ADMINISTRATION, PSYCHOLOGY, SOCIAL WORK, LAW ENFORCEMENT, AND DAY CARE ADMINISTRATION (U.S. CLS. 100 AND 101).

FIRST USE 2-1-2009; IN COMMERCE 11-1-2009.

JOHN KELLY, EXAMINING ATTORNEY

SN 85-129,758. THE SONICMIX COMPANY, INC., HAYWARD, CA. FILED 9-15-2010.

# SONICMIX

THE MARK CONSISTS OF STANDARD CHARACTERS WITHOUT CLAIM TO ANY PARTICULAR FONT, STYLE, SIZE, OR COLOR.

## CLASS 7—MACHINERY

FOR MACHINES FOR THE FOOD MANUFACTURING INDUSTRY FOR MIXING AND HEATING VARIOUS INGREDIENTS TO A SPECIFIED TEMPERATURE AND HOMOGENEOUS CONSISTENCY USING SOUND WAVES (U.S. CLS. 13, 19, 21, 23, 31, 34 AND 35).

## CLASS 9—ELECTRICAL AND SCIENTIFIC APPARATUS

FOR ENVIRONMENTAL CONTROLS FOR MACHINES FOR THE FOOD MANUFACTURING INDUSTRY FOR MIXING AND HEATING VARIOUS INGREDIENTS TO A SPECIFIED TEMPERATURE AND HOMOGENEOUS CONSISTENCY USING SOUND WAVES (U.S. CLS. 21, 23, 26, 36 AND 38).

STEVEN R. FINE, EXAMINING ATTORNEY

SN 85-130,386. IHOSPITAL, LLC, TAMPA, FL. FILED 9-15-2010.

# IHOSPITAL

THE MARK CONSISTS OF STANDARD CHARACTERS WITHOUT CLAIM TO ANY PARTICULAR FONT, STYLE, SIZE, OR COLOR.

## CLASS 35—ADVERTISING AND BUSINESS

FOR RETAIL AND ON-LINE STORE SERVICES FEATURING ACCESSORIES FOR PORTABLE AND HANDHELD DIGITAL ELECTRONIC DEVICES, CELL PHONES, PERSONAL DIGITAL ASSISTANTS, LAPTOPS, SET-TOP BOXES, AND PORTABLE MUSIC PLAYERS; PROCESSING WARRANTY REGISTRATION DOCUMENTS FOR OTHERS (U.S. CLS. 100, 101 AND 102).

## CLASS 36—INSURANCE AND FINANCIAL

FOR PROVIDING EXTENDED WARRANTIES ON PORTABLE AND HANDHELD DIGITAL ELECTRONIC DEVICES, CELL PHONES, PERSONAL DIGITAL ASSISTANTS, LAPTOPS, SET-TOP BOXES, AND PORTABLE MUSIC PLAYERS (U.S. CLS. 100, 101 AND 102).

## CLASS 37—CONSTRUCTION AND REPAIR

FOR INSTALLATION, MAINTENANCE AND REPAIR OF HARDWARE RELATED TO CELL PHONES, COMPUTERS AND COMPUTER PERIPHERALS, PORTABLE AND HANDHELD DIGITAL ELECTRONIC DEVICES, CELL PHONES, PERSONAL DIGITAL ASSISTANTS, LAPTOPS, SET-TOP BOXES, AND PORTABLE MUSIC PLAYERS (U.S. CLS. 100, 103 AND 106).

## CLASS 42—SCIENTIFIC AND COMPUTER SERVICES

FOR INSTALLATION, MAINTENANCE AND REPAIR OF SOFTWARE RELATED TO CELL PHONES, COMPUTERS AND COMPUTER PERIPHERALS, PORTABLE AND HANDHELD DIGITAL ELECTRONIC DEVICES, CELL PHONES, PERSONAL DIGITAL ASSISTANTS, LAPTOPS, SET-TOP BOXES, AND PORTABLE MUSIC PLAYERS (U.S. CLS. 100 AND 101).

ALLISON HOLTZ, EXAMINING ATTORNEY

SN 85-131,219. OLSON II, STEPHEN G., OMAHA, NE. AND OLSON, LISA, OMAHA, NE. AND ROBERT, BEN, OMAHA, NE. FILED 9-16-2010.

# Nebraska Winter Classic

THE MARK CONSISTS OF STANDARD CHARACTERS WITHOUT CLAIM TO ANY PARTICULAR FONT, STYLE, SIZE, OR COLOR.

NO CLAIM IS MADE TO THE EXCLUSIVE RIGHT TO USE "NEBRASKA", APART FROM THE MARK AS SHOWN.

## CLASS 16—PAPER GOODS AND PRINTED MATTER

FOR PRINTED GOODS AND PRINTED MATTER, NAMELY, PRESS RELEASES, BROCHURES AND SOUVENIR PROGRAMS FEATURING HOCKEY GAMES; PRINTED GOODS AND PRINTER MATTER, NAMELY, ENTRY TICKETS, PRICE TICKETS, PRINTED TICKETS, EVENT PROGRAMS, COLLECTOR'S PHOTOGRAPHS OF PLAYERS, TRADING CARDS, POSTERS (U.S. CLS. 2, 5, 22, 23, 29, 37, 38 AND 50).

## CLASS 25—CLOTHING

FOR CLOTHING AND GARMENTS, NAMELY, SPORTS JERSEYS, JACKETS, SWEATSHIRTS, T-SHIRTS, CAPS (U.S. CLS. 22 AND 39).

## CLASS 28—TOYS AND SPORTING GOODS

FOR SPORTING GOODS, NAMELY, HOCKEY GLOVES, HOCKEY STICKS, HOCKEY PUCKS (U.S. CLS. 22, 23, 38 AND 50).

## CLASS 41—EDUCATION AND ENTERTAINMENT

FOR ENTERTAINMENT IN THE NATURE OF HOCKEY GAMES (U.S. CLS. 100, 101 AND 107).

RENEE MCCRAY, EXAMINING ATTORNEY

SN 85-131,253. OLSON II, STEPHEN G., OMAHA, NE. AND OLSON, LISA, OMAHA, NE. AND ROBERT, BEN, OMAHA, NE. FILED 9-16-2010.

## Omaha Winter Classic

THE MARK CONSISTS OF STANDARD CHARACTERS WITHOUT CLAIM TO ANY PARTICULAR FONT, STYLE, SIZE, OR COLOR.

NO CLAIM IS MADE TO THE EXCLUSIVE RIGHT TO USE "OMAHA", APART FROM THE MARK AS SHOWN.

### CLASS 16—PAPER GOODS AND PRINTED MATTER

FOR PRINTED GOODS AND PRINTED MATTER, NAMELY, PRESS RELEASES, BROCHURES AND SOUVENIR PROGRAMS FEATURING HOCKEY GAMES; PRINTED GOODS AND PRINTER MATTER, NAMELY, ENTRY TICKETS, PRICE TICKETS, PRINTED TICKETS, EVENT PROGRAMS, COLLECTOR'S PHOTOGRAPHS OF PLAYERS, TRADING CARDS, POSTERS (U.S. CLS. 2, 5, 22, 23, 29, 37, 38 AND 50).

### CLASS 25—CLOTHING

FOR CLOTHING AND GARMENTS, NAMELY, SPORTS JERSEYS, JACKETS, SWEATSHIRTS, T-SHIRTS, CAPS (U.S. CLS. 22 AND 39).

### CLASS 28—TOYS AND SPORTING GOODS

FOR SPORTING GOODS, NAMELY, HOCKEY GLOVES, HOCKEY STICKS, HOCKEY PUCKS (U.S. CLS. 22, 23, 38 AND 50).

### CLASS 41—EDUCATION AND ENTERTAINMENT

FOR ENTERTAINMENT IN THE NATURE OF HOCKEY GAMES (U.S. CLS. 100, 101 AND 107).  
RENEE MCCRAY, EXAMINING ATTORNEY

SN 85-131,276. FRESH LIFELINES FOR YOUTH, INC., SAN JOSE, CA. FILED 9-16-2010.

# FLY

THE MARK CONSISTS OF STANDARD CHARACTERS WITHOUT CLAIM TO ANY PARTICULAR FONT, STYLE, SIZE, OR COLOR.

### CLASS 35—ADVERTISING AND BUSINESS

FOR CHARITABLE SERVICES, NAMELY, RECRUITING, ORGANIZING AND CONDUCTING VOLUNTEER PROGRAMS FOR YOUTH EDUCATION, SOCIAL SERVICES FOR YOUTH, LEGAL REPRESENTATION OF YOUTH, YOUTH MENTORSHIP, LEADERSHIP TRAINING, COMMUNITY SERVICE, POLITICAL ADVOCACY, AND SCHOOL DROP OUT PREVENTION (U.S. CLS. 100, 101 AND 102).

FIRST USE 11-25-2003; IN COMMERCE 11-25-2003.

### CLASS 36—INSURANCE AND FINANCIAL

FOR CHARITABLE FUNDRAISING SERVICES (U.S. CLS. 100, 101 AND 102).

FIRST USE 11-25-2003; IN COMMERCE 11-25-2003.  
STEVEN PEREZ, EXAMINING ATTORNEY

SN 85-132,185. REXNORD INDUSTRIES, LLC, GREENFIELD, WI. FILED 9-17-2010.

## FALK V-CLASS

THE MARK CONSISTS OF STANDARD CHARACTERS WITHOUT CLAIM TO ANY PARTICULAR FONT, STYLE, SIZE, OR COLOR.

OWNER OF U.S. REG. NOS. 666,570 AND 2,539,764.

### CLASS 7—MACHINERY

FOR MACHINE PARTS, NAMELY, FIXED AND VARIABLE SPEED REDUCERS AND INCREASESERS, TRANSMISSION GEARS, BACKSTOPS, CLUTCHES, PILLOW BLOCKS, OVERLOAD RELEASE MECHANISMS FOR TRANSMISSIONS NOT FOR LAND VEHICLES IN THE NATURE OF TORQUE LIMITERS, WELDED AND FABRICATED METAL HOUSINGS, CAST HOUSINGS, SHAFT COUPLINGS, ANTI-FRICTION BEARINGS, MECHANICAL CONTACT AND LABYRINTH SEALS, OIL COLLECTION PANS, OIL PUMPS FOR USE IN GEAR DRIVES, OIL ANTI-FOAMING DEVICES CONSISTING PRIMARILY OF PORTED STEEL BLOCKS AND PIPE PLUG FITTINGS, MECHANICAL OIL FLOW SWITCHES, BEDPLATES, BREATHER VENTS, TORQUE ARMS NOT FOR LAND VEHICLES, SWING BASES, SHAFT FANS FOR USE IN GEAR DRIVES, FOUNDATION PADS, AIR SHROUDS, OIL PUMP HOSES, OIL DIPSTICKS, MOTOR MOUNTS, TRANSITION BASES, CREEP DRIVES, MOTOR ADAPTERS, OIL EXCLUSION PANS, AND COOLING DEVICES, NAMELY, COOLING PLATES AND HEAT EXCHANGERS (U.S. CLS. 13, 19, 21, 23, 31, 34 AND 35).

### CLASS 9—ELECTRICAL AND SCIENTIFIC APPARATUS

FOR OIL LEVEL GAUGES; RESISTANCE TEMPERATURE DETECTORS; ACCELEROMETERS; TEMPERATURE SWITCHES; ELECTRIC OIL FLOW SWITCHES (U.S. CLS. 21, 23, 26, 36 AND 38).

SALLY SHIH, EXAMINING ATTORNEY

SN 85-132,262. AED ENTERPRISES, LLC, CINCINNATI, OH.  
FILED 9-17-2010.

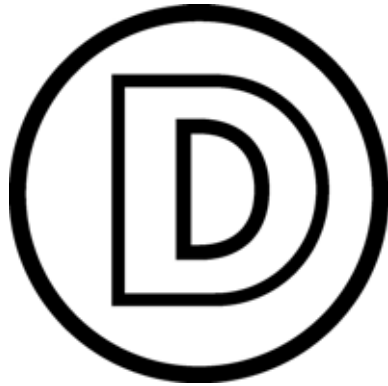

OWNER OF U.S. REG. NO. 2,996,770.  
THE MARK CONSISTS OF THE LETTER "D" WITHIN A  
CIRCLE.

#### CLASS 30—STAPLE FOODS

FOR PIZZA AND CALZONES (U.S. CL. 46).  
FIRST USE 2-10-2004; IN COMMERCE 2-10-2004.

#### CLASS 35—ADVERTISING AND BUSINESS

FOR RETAIL PIZZA STORE SERVICES SPECIALIZ-  
ING IN PIZZA FOR CONSUMPTION ON OR OFF THE  
PREMISES (U.S. CLS. 100, 101 AND 102).  
FIRST USE 2-10-2004; IN COMMERCE 2-10-2004.  
SETH A. RAPPAPORT, EXAMINING ATTORNEY

SN 85-132,338. WIGUP CORP., OTTAWA, CANADA, FILED  
9-17-2010.

THE MEDIA MENTOR FOR KIDS

THE MARK CONSISTS OF STANDARD CHARACTERS  
WITHOUT CLAIM TO ANY PARTICULAR FONT, STYLE,  
SIZE, OR COLOR.

NO CLAIM IS MADE TO THE EXCLUSIVE RIGHT TO  
USE "MEDIA" AND "FOR KIDS", APART FROM THE  
MARK AS SHOWN.

#### CLASS 35—ADVERTISING AND BUSINESS

FOR ON-LINE RETAIL STORES FEATURING MP3  
AND MUSIC DOWNLOADS; ON-LINE RETAIL STORES  
FEATURING PRE-RECORDED COMPACT DISCS FEAT-  
URING MUSICAL RECORDINGS AND MOTIVATION-  
AL TEXT READINGS AND BOOKS IN THE  
FIELDS OF SPORTS, CAREER, SPIRITUALITY, ENVIR-  
ONMENT, HEALTH, ARTS, ENTREPRENEURSHIP AND  
SOCIAL RESPONSIBILITY (U.S. CLS. 100, 101 AND 102).

#### CLASS 38—COMMUNICATION

FOR BROADCASTING OF LIVE OR PRE-RECORDED  
TELEVISION COVERAGE VIA THE INTERNET;  
BROADCASTING OF LIVE OR PRE-RECORDED INTER-  
VIEWS VIA THE INTERNET; BROADCASTING OF  
TELEVISION DOCUMENTARIES, TELEVISION SHOWS  
OR TELEVISION SHOW EXCERPTS, MOVIES AND LIVE  
OR PRE-RECORDED NEWS STORIES VIA THE INTER-  
NET; PROVIDING ON-LINE DISCUSSION FORUMS IN  
THE FIELDS OF SPORTS, CAREER, SPIRITUALITY,  
ENVIRONMENT, HEALTH, ARTS, ENTREPRENEUR-  
SHIP AND SOCIAL RESPONSIBILITY (U.S. CLS. 100,  
101 AND 104).

#### CLASS 41—EDUCATION AND ENTERTAIN- MENT

FOR PROVIDING A WEBSITE FEATURING NON-  
DOWNLOADABLE INTERACTIVE VIDEO GAME PRO-  
GRAMS, NON-DOWNLOADABLE INTERACTIVE VI-  
DEO GAMES, NON-DOWNLOADABLE MULTIMEDIA  
EDUCATIONAL DOCUMENTS OF OTHERS IN THE  
FIELDS OF SPORTS, CAREER, SPIRITUALITY, ENVIR-  
ONMENT, HEALTH, ARTS, ENTREPRENEURSHIP AND  
SOCIAL RESPONSIBILITY, NON-DOWNLOADABLE  
LIVE OR PRE-RECORDED TELEVISION COVERAGE,  
NON-DOWNLOADABLE LIVE OR PRE-RECORDED IN-  
TERRUENTS, NON-DOWNLOADABLE TELEVISION DOC-  
UMENTARIES, NON-DOWNLOADABLE TELEVISION  
SHOWS AND TELEVISION SHOW EXCERPTS, NON-  
DOWNLOADABLE MOVIES, AND NON-DOWNLOAD-  
ABLE LIVE OR PRE-RECORDED NEWS STORIES (U.S.  
CLS. 100, 101 AND 107).

SUZANNE BLANE, EXAMINING ATTORNEY

SN 85-132,628. ERICSSON FEDERAL INC., RESTON, VA.  
FILED 9-17-2010.

## Networking for a Better Tomorrow

THE MARK CONSISTS OF STANDARD CHARACTERS  
WITHOUT CLAIM TO ANY PARTICULAR FONT, STYLE,  
SIZE, OR COLOR.

NO CLAIM IS MADE TO THE EXCLUSIVE RIGHT TO  
USE "NETWORKING", APART FROM THE MARK AS  
SHOWN.

#### CLASS 9—ELECTRICAL AND SCIENTIFIC APPARATUS

FOR TELECOMMUNICATIONS AND DATA NET-  
WORKING HARDWARE, NAMELY, DEVICES FOR  
TRANSPORTING AND AGGREGATING VOICE, DATA,  
AND VIDEO COMMUNICATIONS ACROSS MULTIPLE  
NETWORK INFRASTRUCTURES AND COMMUNICA-  
TIONS PROTOCOLS; WIRELESS ADAPTERS USED TO  
LINK COMPUTERS TO A TELECOMMUNICATIONS  
NETWORK; COMPUTER HARDWARE EQUIPMENT  
USED IN COMMUNICATIONS TECHNOLOGY NET-  
WORKS AND COMPUTER SOFTWARE FOR OPERAT-  
ING COMMUNICATIONS TECHNOLOGY NETWORKS;  
BROADBAND POWER LINE COMMUNICATION SYS-  
TEMS FOR TRANSFERRING BROADBAND DATA  
OVER ELECTRICAL POWER LINES, COMPRISED OF  
COMPUTER HARDWARE, SOFTWARE AND MODEMS;  
BROADBAND RADIOS; BROADBAND WIRELESS  
EQUIPMENT, NAMELY, TELECOMMUNICATIONS  
BASE STATION EQUIPMENT FOR CELLULAR AND  
FIXED NETWORKING AND COMMUNICATIONS AP-  
PLICATIONS; WIRELESS BROADBAND RADIOS (U.S.  
CLS. 21, 23, 26, 36 AND 38).

**CLASS 35—ADVERTISING AND BUSINESS**

FOR TELECOMMUNICATIONS NETWORK MANAGEMENT SERVICES, NAMELY, THE OPERATION AND ADMINISTRATION OF TELECOMMUNICATION SYSTEMS AND NETWORKS FOR OTHERS (U.S. CLS. 100, 101 AND 102).

**CLASS 38—COMMUNICATION**

FOR COMMUNICATION SERVICES, NAMELY, TRANSMISSION OF VOICE, AUDIO, VISUAL IMAGES AND DATA BY TELECOMMUNICATIONS NETWORKS, WIRELESS COMMUNICATION NETWORKS, THE INTERNET, INFORMATION SERVICES NETWORKS AND DATA NETWORKS; DIGITAL NETWORK TELECOMMUNICATIONS SERVICES; ELECTRONIC EXCHANGE OF DATA STORED IN DATABASES ACCESSIBLE VIA TELECOMMUNICATION NETWORKS; PROVIDING ACCESS TO TELECOMMUNICATION NETWORKS; PROVIDING TELECOMMUNICATIONS CONNECTIONS TO A GLOBAL COMPUTER NETWORK; TELECOMMUNICATION SERVICES, NAMELY, TRANSMISSION OF VOICE, DATA, GRAPHICS, SOUND AND VIDEO BY MEANS OF BROADBAND POWER LINE OR WIRELESS NETWORKS; TELECOMMUNICATION SERVICES, NAMELY, TRANSMISSION OF VOICE, DATA, GRAPHICS, IMAGES, AUDIO AND VIDEO BY MEANS OF TELECOMMUNICATIONS NETWORKS, WIRELESS COMMUNICATION NETWORKS, AND THE INTERNET; WIRELESS BROADBAND COMMUNICATION SERVICES; BROADBAND RADIO COMMUNICATION SERVICES (U.S. CLS. 100, 101 AND 104).

**CLASS 42—SCIENTIFIC AND COMPUTER SERVICES**

FOR COMPUTER PROJECT MANAGEMENT SERVICES IN THE FIELD OF TELECOMMUNICATION NETWORKS FOR OTHERS; DESIGNING ENHANCED COMPUTER HARDWARE FOR COMMUNICATIONS TECHNOLOGY NETWORKS; COMPUTER SERVICES, NAMELY, OPERATING COMMUNICATION COMPUTER NETWORKS FEATURING BROADBAND TRANSMISSION SOFTWARE FOR OTHERS; TECHNICAL SUPPORT SERVICES, NAMELY, TROUBLESHOOTING OF COMPUTER SOFTWARE PROBLEMS RELATING TO BROADBAND (U.S. CLS. 100 AND 101).

SIMON TENG, EXAMINING ATTORNEY

SN 85-132,808. DOESN'T SUCK PRODUCTIONS, LLC, SAN FRANCISCO, CA. FILED 9-18-2010.



THE COLOR(S) YELLOW, WHITE, ORANGE AND BLUE IS/ARE CLAIMED AS A FEATURE OF THE MARK.

THE MARK CONSISTS OF THE DESIGN OF A SMILING YELLOW LEMON IN ORANGE, YELLOW AND WHITE COLORS. TO ITS RIGHT IS THE STYLIZED WORDING "LIFE DOESN'T SUCK" IN YELLOW AND ORANGE COLORS. THE BACKGROUND OF THE MARK IS BLUE.

**CLASS 25—CLOTHING**

FOR SHORT-SLEEVED OR LONG-SLEEVED T-SHIRTS (U.S. CLS. 22 AND 39).

FIRST USE 6-10-2010; IN COMMERCE 6-10-2010.

**CLASS 45—PERSONAL AND LEGAL SERVICES**

FOR INFORMATION SERVICES, NAMELY, PROVIDING A WEB SITE FEATURING PHOTOGRAPHIC, AUDIO, VIDEO AND PROSE PRESENTATIONS FEATURING ENTRIES POSTED BY USERS RELATED TO THEIR PERSONAL HISTORIES AND PERSONAL OBSERVATIONS OF LIFE IN GENERAL (U.S. CLS. 100 AND 101).

FIRST USE 6-9-2010; IN COMMERCE 6-9-2010.  
DAWN HAN, EXAMINING ATTORNEY

SN 85-133,260. N.V. ORGANON, OSS, NETHERLANDS, FILED 9-20-2010.

**IMPLANON QSERT**

THE MARK CONSISTS OF STANDARD CHARACTERS WITHOUT CLAIM TO ANY PARTICULAR FONT, STYLE, SIZE, OR COLOR.

OWNER OF U.S. REG. NO. 3,509,988.

**CLASS 5—PHARMACEUTICALS**

FOR CONTRACEPTIVE PHARMACEUTICAL PREPARATIONS CONTAINED IN AND RELEASED FROM IMPLANTS TO BE INSERTED UNDER THE SKIN FOR RELEASING HORMONES (U.S. CLS. 6, 18, 44, 46, 51 AND 52).

**CLASS 10—MEDICAL APPARATUS**

FOR NON-DEGRADABLE ARTIFICIAL IMPLANTS TO BE INSERTED UNDER THE SKIN FOR RELEASING HORMONES; MEDICAL DEVICE FOR ADMINISTERING NON-DEGRADABLE ARTIFICIAL IMPLANTS UNDER THE SKIN (U.S. CLS. 26, 39 AND 44).

RAMONA ORTIGA, EXAMINING ATTORNEY

SN 85-133,342. THE ARMOR GROUP, INC., MASON, OH. FILED 9-20-2010.

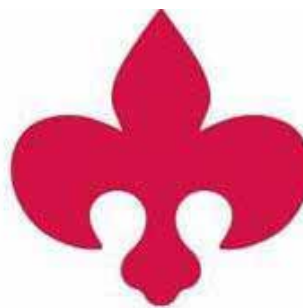

THE COLOR(S) RED IS/ARE CLAIMED AS A FEATURE OF THE MARK.

THE MARK CONSISTS OF A RED FLEUR-DE-LIS.

**CLASS 7—MACHINERY**

FOR WASHING MACHINES, NAMELY, CORNER LOAD WASHERS FOR INDUSTRIAL KITCHEN USE, PASS THROUGH WASHERS FOR INDUSTRIAL KITCHEN USE, GARBAGE CAN WASHERS IN THE NATURE OF PRESSURE WASHING MACHINES, CART AND RACK WASHERS, FRONT LOAD CLOTHES WASHERS, AND CONVEYOR WASHERS FOR COMMERCIAL AND RETAIL USE, AND STRUCTURAL REPLACEMENT PARTS THEREFOR (U.S. CLS. 13, 19, 21, 23, 31, 34 AND 35).

FIRST USE 6-1-1996; IN COMMERCE 6-1-1996.

**CLASS 12—VEHICLES**

FOR TRACTOR TRAILERS WITH MOBILE STORAGE TANKS, MOBILE FUEL TANKS, AND ENCLOSURES, AND STRUCTURAL PARTS THEREFOR; LAND VEHICLES FOR MEDICAL USE, AND STRUCTURAL PARTS THEREFOR (U.S. CLS. 19, 21, 23, 31, 35 AND 44).

FIRST USE 6-1-1996; IN COMMERCE 6-1-1996.

**CLASS 21—HOUSEWARES AND GLASS**

FOR TRASH CANS FOR PUBLIC, INDUSTRIAL, AND RETAIL USE; PLANTERS FOR FLOWERS AND PLANTS FOR PUBLIC, INDUSTRIAL, AND RETAIL USE (U.S. CLS. 2, 13, 23, 29, 30, 33, 40 AND 50).

FIRST USE 6-1-1996; IN COMMERCE 6-1-1996.

**CLASS 40—MATERIAL TREATMENT**

FOR CUSTOM FABRICATION OF METAL LOUVERS, DAMPERS, PIPING, SHIPPING CONTAINERS, STORAGE CONTAINERS, RACKS, COMMERCIAL WASHING MACHINES, STORAGE TANKS, MOBILE FUEL TANKS, ENCLOSURES, CLEANING AND FINISHING MACHINERY; METAL FINISHING SERVICES AND POWDER COATING OF METAL PRODUCTS (U.S. CLS. 100, 103 AND 106).

FIRST USE 6-1-1996; IN COMMERCE 6-1-1996.  
TINA L. SNAPP, EXAMINING ATTORNEY

---

SN 85-133,822. HIGGINBOTHAM, STEVEN K, DBA THE WHEEL WORKERS, HOUSTON, TX. FILED 9-20-2010.

The Wheel Workers

THE MARK CONSISTS OF STANDARD CHARACTERS WITHOUT CLAIM TO ANY PARTICULAR FONT, STYLE, SIZE, OR COLOR.

**CLASS 9—ELECTRICAL AND SCIENTIFIC APPARATUS**

FOR AUDIO AND VIDEO RECORDINGS FEATURING MUSIC AND ARTISTIC PERFORMANCES (U.S. CLS. 21, 23, 26, 36 AND 38).

FIRST USE 8-10-2010; IN COMMERCE 9-20-2010.

**CLASS 41—EDUCATION AND ENTERTAINMENT**

FOR ENTERTAINMENT, NAMELY, LIVE PERFORMANCES BY A MUSICAL BAND (U.S. CLS. 100, 101 AND 107).

FIRST USE 8-15-2010; IN COMMERCE 8-15-2010.  
TARA PATE, EXAMINING ATTORNEY

SN 85-134,296. WATERS TECHNOLOGIES CORPORATION, WILMINGTON, DE. FILED 9-21-2010.

VERTU

THE MARK CONSISTS OF STANDARD CHARACTERS WITHOUT CLAIM TO ANY PARTICULAR FONT, STYLE, SIZE, OR COLOR.

**CLASS 1—CHEMICALS**

FOR KITS COMPRISING CHEMICALLY-TREATED NON-MEDICAL TEST STRIPS, CHEMICAL AND BIO-CHEMICAL REAGENTS FOR NON-MEDICAL PURPOSES, AND ELECTRONIC DETECTORS FOR INDICATING THE PRESENCE OR ABSENCE OF TOXINS IN THE FIELDS OF AGRICULTURE AND FOOD PROCESSING (U.S. CLS. 1, 5, 6, 10, 26 AND 46).

**CLASS 9—ELECTRICAL AND SCIENTIFIC APPARATUS**

FOR ELECTRONIC DETECTORS FOR INDICATING THE PRESENCE OR ABSENCE OF TOXINS IN THE FIELDS OF AGRICULTURE AND FOOD PROCESSING (U.S. CLS. 21, 23, 26, 36 AND 38).

JULIE VEPPUMTHARA, EXAMINING ATTORNEY

---

SN 85-135,114. CORCEL IP LIMITED, HAMILTON, NEW ZEALAND, FILED 9-22-2010.

CORCEL

THE MARK CONSISTS OF STANDARD CHARACTERS WITHOUT CLAIM TO ANY PARTICULAR FONT, STYLE, SIZE, OR COLOR.

OWNER OF NEW ZEALAND REG. NO. 794104, DATED 8-8-2008, EXPIRES 8-8-2018.

**CLASS 7—MACHINERY**

FOR MACHINERY FOR MANUFACTURING CARDBOARD AND CORRUGATED CARDBOARD, PAPER AND CARDBOARD PACKAGING MATERIALS, PALLETS, CORNER PROTECTORS, EDGE PROTECTORS AND PACKAGING MATERIALS FOR PROTECTING GOODS DURING TRANSPORTATION (U.S. CLS. 13, 19, 21, 23, 31, 34 AND 35).

**CLASS 16—PAPER GOODS AND PRINTED MATTER**

FOR PACKING PAPER, CARDBOARD, CARDBOARD BOXES; CARDBOARD PACKAGING; CARDBOARD MATERIALS FOR USE IN PACKAGING, NAMELY, CARTONS, CONTAINERS AND BOXES FOR PACKAGING MADE OF PAPER AND CARDBOARD; PACKAGING MATERIALS OF PAPER AND CARDBOARD; CORRUGATED PACKAGING MATERIALS, NAMELY, CORRUGATED CONTAINERS; RIGID LINED PACKAGING MATERIALS OF PAPER AND CARDBOARD, NAMELY, BOXES; COLLAPSIBLE PACKAGING OF PAPER AND CARDBOARD, NAMELY, BOXES; CORNER PROTECTORS AND EDGE PROTECTORS FOR HOUSEHOLD APPLIANCES, MACHINERY, ELECTRONIC EQUIPMENT, CANNED GOODS, AND SHEET MATERIALS USED IN CONSTRUCTION MADE OF PAPER, CARD AND/OR CARDBOARD; PACKAGING MATERIALS MADE OF PAPER, CORRUGATED CARDBOARD FOR PROTECTING GOODS DURING TRANSPORTATION, NAMELY, BOXES, SHEETS OF PAPERBOARD AND EDGE PROTECTORS; SIGNBOARDS OF PAPER AND CARDBOARD; PAPERBOARD PAINT TRAYS; PAPERBOARD CAKE STANDS; PRINTED VISUALS IN THE NATURE OF PROMOTIONAL MATERIALS; PRINTED INSTRUCTIONAL AND TEACHING MATERIAL IN THE FIELD OF CARDBOARD PACKAGING AND PACKAGING FOR THE TRANSPORTATION OF GOODS (U.S. CLS. 2, 5, 22, 23, 29, 37, 38 AND 50).

**CLASS 20—FURNITURE AND ARTICLES NOT OTHERWISE CLASSIFIED**

FOR PALLETS MADE OF PAPER, CARD, CORRUGATED PAPER AND CARDBOARD FOR LOADING AND TRANSPORT (U.S. CLS. 2, 13, 22, 25, 32 AND 50).  
JASON TURNER, EXAMINING ATTORNEY

SN 85-135,468. EHRMANN AG OBERSCHÖNEGG IM ALLGÄU, OBERSCHÖNEGG, FED REP GERMANY, FILED 9-22-2010.

## Ehrmann Grand Dessert

THE MARK CONSISTS OF STANDARD CHARACTERS WITHOUT CLAIM TO ANY PARTICULAR FONT, STYLE, SIZE, OR COLOR.

OWNER OF U.S. REG. NOS. 3,158,855 AND 3,253,855.  
NO CLAIM IS MADE TO THE EXCLUSIVE RIGHT TO USE "DESSERT", APART FROM THE MARK AS SHOWN.

**CLASS 29—MEATS AND PROCESSED FOODS**

FOR MILK AND MILK PRODUCTS, NAMELY, SOUR MILK, YOGURT, KEFIR, BUTTERMILK, CREAM, WHEY, NON-ALCOHOLIC MILK BEVERAGES WITH A PREDOMINANT CONTENT OF MILK AND ALSO CONTAINING WHEY, MILK POWDER FOR NUTRITIONAL PURPOSES, CURD, HALF-FAT MILK, BUTTER, CHEESE, EDIBLE FATS; DAIRY-BASED SNACK FOODS EXCLUDING ICE CREAM, ICE MILK AND FROZEN YOGURT (U.S. CL. 46).

**CLASS 30—STAPLE FOODS**

FOR ICE MILK; ICE CREAM; DAIRY-BASED DESSERTS, NAMELY, DESSERT SOUFFLES, DESSERT MOUSSES, DESSERT PUDDINGS (U.S. CL. 46).

**CLASS 32—LIGHT BEVERAGES**

FOR NON-ALCOHOLIC BEVERAGES, NAMELY, FRUIT DRINKS, ENERGY DRINKS, VEGETABLE DRINKS, WHEY BEVERAGES, SOY BASED BEVERAGES NOT USED AS MILK SUBSTITUTES; HERBAL JUICES BEVERAGES (U.S. CLS. 45, 46 AND 48).  
KELLY CHOE, EXAMINING ATTORNEY

SN 85-136,024. I DO VENUES, OAKLAND, CA. FILED 9-22-2010.

## I Do Venues

THE MARK CONSISTS OF STANDARD CHARACTERS WITHOUT CLAIM TO ANY PARTICULAR FONT, STYLE, SIZE, OR COLOR.

**CLASS 35—ADVERTISING AND BUSINESS**

FOR PROVIDING INFORMATION ABOUT AND MAKING REFERRALS IN THE FIELD OF CONSUMER PRODUCTS AND SERVICES FOR RETAIL SERVICES CONCERNING PRODUCTS, SERVICES, EVENTS, ACTIVITIES, ATTRACTIONS AND FACILITIES IN PARTICULAR GEOGRAPHIC LOCATIONS (U.S. CLS. 100, 101 AND 102).  
FIRST USE 8-1-2010; IN COMMERCE 8-1-2010.

**CLASS 41—EDUCATION AND ENTERTAINMENT**

FOR PARTY AND WEDDING PLANNING AND COORDINATION SERVICES; PARTY AND WEDDING PLANNING CONSULTATION SERVICES; PARTY AND WEDDING PLANNING, COORDINATION AND CONSULTATION SERVICES; PROVIDING INFORMATION IN THE FIELD OF WEDDING PARTY PLANNING; PROVIDING INFORMATION REGARDING WEDDING PLANNING FOR WEDDING PARTIES; WEDDING PLANNING AND COORDINATION SERVICES (U.S. CLS. 100, 101 AND 107).

FIRST USE 1-9-2010; IN COMMERCE 1-9-2010.  
RONALD DELGIZZI, EXAMINING ATTORNEY

SN 85-136,240. DAON HOLDINGS LIMITED, GT, GRAND CAYMAN, CAYMAN ISLANDS, FILED 9-23-2010.

## Uniquely U

THE MARK CONSISTS OF STANDARD CHARACTERS WITHOUT CLAIM TO ANY PARTICULAR FONT, STYLE, SIZE, OR COLOR.

**CLASS 9—ELECTRICAL AND SCIENTIFIC APPARATUS**

FOR COMPUTER SOFTWARE FOR AUTHENTICATION OR IDENTIFICATION PURPOSES BY MEANS OF STORAGE OF BIOMETRIC FEATURES AND COMPARISON OF THE STORED FEATURES (U.S. CLS. 21, 23, 26, 36 AND 38).



**CLASS 42—SCIENTIFIC AND COMPUTER SERVICES**

FOR AUTHENTICATION TECHNOLOGY SERVICES, NAMELY, PROVIDING SECURE SERVER AND MOBILE DEVICE TECHNOLOGY SERVICES USING BIOMETRIC FEATURES STORED ON A COMPUTER NETWORK TO FACILITATE VALIDATING IDENTITIES (U.S. CLS. 100 AND 101).

**CLASS 45—PERSONAL AND LEGAL SERVICES**

FOR PROVIDING USER AUTHENTICATION SERVICES IN THE NATURE OF PROVIDING AUTHENTICATION OF INDIVIDUAL IDENTITY INFORMATION USING BIOMETRIC FEATURES STORED ON A COMPUTER NETWORK (U.S. CLS. 100 AND 101).  
STEVEN PEREZ, EXAMINING ATTORNEY

---

SN 85-136,291. AGUILA RECORDS, INC., WEST CHICAGO, IL. FILED 9-23-2010.

# Zona Cero

THE MARK CONSISTS OF STANDARD CHARACTERS WITHOUT CLAIM TO ANY PARTICULAR FONT, STYLE, SIZE, OR COLOR.

THE ENGLISH TRANSLATION OF "ZONA CERO" IN THE MARK IS "GROUND ZERO".

**CLASS 9—ELECTRICAL AND SCIENTIFIC APPARATUS**

FOR AUDIO AND VIDEO RECORDINGS FEATURING MUSIC AND ARTISTIC PERFORMANCES (U.S. CLS. 21, 23, 26, 36 AND 38).

**CLASS 41—EDUCATION AND ENTERTAINMENT**

FOR ENTERTAINMENT IN THE NATURE OF VISUAL AND AUDIO PERFORMANCES BY A MUSICAL GROUP; ENTERTAINMENT IN THE NATURE OF VISUAL AND AUDIO PERFORMANCES, NAMELY, MUSICAL BAND, ROCK GROUP, GYMNASTIC, DANCE, AND BALLET PERFORMANCES (U.S. CLS. 100, 101 AND 107).

KARANENDRA S. CHHINA, EXAMINING ATTORNEY

---

SN 85-136,294. DAON HOLDINGS LIMITED, GT, GRAND CAYMAN, CAYMAN ISLANDS, FILED 9-23-2010.

# Uniquely You

THE MARK CONSISTS OF STANDARD CHARACTERS WITHOUT CLAIM TO ANY PARTICULAR FONT, STYLE, SIZE, OR COLOR.

**CLASS 9—ELECTRICAL AND SCIENTIFIC APPARATUS**

FOR COMPUTER SOFTWARE FOR AUTHENTICATION OR IDENTIFICATION PURPOSES BY MEANS OF STORAGE OF BIOMETRIC FEATURES AND COMPARISON OF THE STORED FEATURES (U.S. CLS. 21, 23, 26, 36 AND 38).

**CLASS 42—SCIENTIFIC AND COMPUTER SERVICES**

FOR AUTHENTICATION TECHNOLOGY SERVICES, NAMELY, PROVIDING SECURE SERVER AND MOBILE DEVICE TECHNOLOGY SERVICES USING BIOMETRIC FEATURES STORED ON A COMPUTER NETWORK TO FACILITATE VALIDATING IDENTITIES (U.S. CLS. 100 AND 101).

**CLASS 45—PERSONAL AND LEGAL SERVICES**

FOR PROVIDING USER AUTHENTICATION SERVICES IN THE NATURE OF PROVIDING AUTHENTICATION OF INDIVIDUAL IDENTITY INFORMATION USING BIOMETRIC FEATURES STORED ON A COMPUTER NETWORK (U.S. CLS. 100 AND 101).  
STEVEN PEREZ, EXAMINING ATTORNEY

---

SN 85-138,513. MUM INDUSTRIES, LIMITED, MENTOR, OH. FILED 9-27-2010.

# MUM Industries

THE MARK CONSISTS OF STANDARD CHARACTERS WITHOUT CLAIM TO ANY PARTICULAR FONT, STYLE, SIZE, OR COLOR.

NO CLAIM IS MADE TO THE EXCLUSIVE RIGHT TO USE "INDUSTRIES", APART FROM THE MARK AS SHOWN.

**CLASS 35—ADVERTISING AND BUSINESS**

FOR CUSTOMER SERVICE SERVICES IN THE PLASTIC INJECTION MOLDING INDUSTRY; BUSINESS MANAGEMENT SERVICES, NAMELY, SUPPLY CHAIN LOGISTICS SERVICES; BUSINESS PROCESS ENGINEERING FOR OTHERS (U.S. CLS. 100, 101 AND 102).

FIRST USE 11-1-1996; IN COMMERCE 11-1-1996.

**CLASS 40—MATERIAL TREATMENT**

FOR CUSTOM MANUFACTURE OF PLASTIC INJECTION MOLDED PARTS TO THE ORDER AND SPECIFICATION OF OTHERS; CUSTOM TOOLING, STAMPING, AND MOLDING TO THE ORDER AND SPECIFICATION OF OTHERS FOR THE MANUFACTURE OF INJECTION MOLDING PLASTIC GOODS AND ASSEMBLIES; ASSEMBLY OF PCB GOODS AND INTEGRATED PLASTIC COMPONENTS FOR OTHERS; SALES SUPPORT SERVICES, NAMELY, PROVIDING INFORMATION ABOUT THE CONTRACT AND CUSTOM MANUFACTURING OF CONSUMER GOODS FOR OTHERS (U.S. CLS. 100, 101 AND 106).

FIRST USE 11-1-1996; IN COMMERCE 11-1-1996.

**CLASS 42—SCIENTIFIC AND COMPUTER SERVICES**

FOR NEW PRODUCT DESIGN FOR OTHERS; ENGINEERING AND PRODUCT ENGINEERING SERVICES IN PLASTIC INJECTION MOLDING INDUSTRY; PRODUCT TESTING (U.S. CLS. 100 AND 101).

FIRST USE 11-1-1996; IN COMMERCE 11-1-1996.  
KIMBERLY FRYE, EXAMINING ATTORNEY

---

SN 85-138,632. AUDI AG, INGOLSTADT, FED REP GERMANY, FILED 9-27-2010.

MMI

THE MARK CONSISTS OF STANDARD CHARACTERS WITHOUT CLAIM TO ANY PARTICULAR FONT, STYLE, SIZE, OR COLOR.

OWNER OF U.S. REG. NO. 2,902,541.

**CLASS 9—ELECTRICAL AND SCIENTIFIC APPARATUS**

FOR INTERACTIVE, COMPUTERIZED AUTOMOTIVE CONTROL SYSTEM FOR INTEGRATING, MANAGING AND PROVIDING DRIVER ACCESS TO FUNCTIONS OF AUTOMOBILE NAVIGATION SYSTEM, ENTERTAINMENT FEATURES, NAMELY, CD PLAYERS, DVD PLAYERS, MP3 PLAYERS, TAPE PLAYERS AND RADIO, COMMUNICATIONS EQUIPMENT, NAMELY, TELEPHONES, VEHICLE ENVIRONMENTAL INFORMATION AND CONTROLS REGARDING HEATING AND COOLING AND AUTOMOBILE CONTROL SYSTEMS, ALL INCORPORATED INTO A MOTOR VEHICLE (U.S. CLS. 21, 23, 26, 36 AND 38).

FIRST USE 5-1-2004; IN COMMERCE 5-1-2004.

**CLASS 12—VEHICLES**

FOR INTERNAL AUTOMOBILE CONTROLS, NAMELY, RECEIVERS, MONITORS AND INSTRUMENTS, LOCATED ON THE CENTER CONSOLE FOR MONITORING AND COORDINATING THE USE OF ENTERTAINMENT, COMMUNICATION AND NAVIGATION SYSTEMS AND TRANSMITTING VEHICLE INFORMATION WITHIN THE AUTOMOBILE AND SOLD AS AN INTEGRAL COMPONENT OF THE AUTOMOBILE (U.S. CLS. 19, 21, 23, 31, 35 AND 44).

FIRST USE 5-1-2004; IN COMMERCE 5-1-2004.  
LANA PHAM, EXAMINING ATTORNEY

---

SN 85-139,210. DINA KIMMEL, TARZANA, CA. FILED 9-27-2010.

WE ROCK THE SPECTRUM KID'S  
GYM

THE MARK CONSISTS OF STANDARD CHARACTERS WITHOUT CLAIM TO ANY PARTICULAR FONT, STYLE, SIZE, OR COLOR.

NO CLAIM IS MADE TO THE EXCLUSIVE RIGHT TO USE "KID'S GYM", APART FROM THE MARK AS SHOWN.

**CLASS 41—EDUCATION AND ENTERTAINMENT**

FOR PROVIDING PLAY FACILITIES FOR CHILDREN; PROVIDING CHILDREN'S PARTY CENTERS FOR THE PURPOSE OF ENTERTAINING CHILDREN AND CELEBRATING BIRTHDAYS; PROVIDING GYMNASIAC FACILITIES; PROVIDING FACILITIES FOR EDUCATIONAL, TRAINING AND EDUCATIONAL PURPOSES, NAMELY, PROVIDING INDOOR RECREATIONAL FACILITIES FOR GROUP RECREATION EVENTS; PROVIDING EXERCISE, FITNESS AND BALANCE CLASSES, BELLY DANCING CLASSES (U.S. CLS. 100, 101 AND 107).

**CLASS 43—HOTEL AND RESTAURANT SERVICES**

FOR PROVIDING MEETING FACILITIES FOR EDUCATIONAL AND THERAPEUTIC SERVICES IN THE NATURE OF SUPPORT GROUPS IN THE FIELD OF AUTISM (U.S. CLS. 100 AND 101).

**CLASS 44—MEDICAL, BEAUTY AND AGRICULTURAL SERVICES**

FOR PROVIDING FACILITIES FOR PHYSICAL THERAPY, OCCUPATIONAL THERAPY, BEHAVIORAL THERAPY AND SPEECH THERAPY (U.S. CLS. 100 AND 101).

ANDREA K. NADELMAN, EXAMINING ATTORNEY

---

SN 85-139,609. RAPID PATHOGEN SCREENING, INC., SARASOTA, FL. FILED 9-28-2010.

RPS INFLAMMADRY DETECTOR

THE MARK CONSISTS OF STANDARD CHARACTERS WITHOUT CLAIM TO ANY PARTICULAR FONT, STYLE, SIZE, OR COLOR.

OWNER OF U.S. REG. NO. 3,371,185.

NO CLAIM IS MADE TO THE EXCLUSIVE RIGHT TO USE "DETECTOR", APART FROM THE MARK AS SHOWN.

**CLASS 1—CHEMICALS**

FOR DIAGNOSTIC PREPARATIONS, REAGENTS, AND ASSAYS FOR DETECTING DRY EYES IN PATIENTS FOR MEDICAL RESEARCH USE; DIAGNOSTIC KITS CONSISTING PRIMARILY OF PREPARATIONS, REAGENTS, AND ASSAYS FOR DETECTING DRY EYES AND/OR OCULAR INFLAMMATION IN PATIENTS FOR MEDICAL RESEARCH USE (U.S. CLS. 1, 5, 6, 10, 26 AND 46).

**CLASS 5—PHARMACEUTICALS**

FOR MEDICAL DIAGNOSTIC PREPARATIONS, REAGENTS, AND ASSAYS FOR DETECTING DRY EYES IN PATIENTS; MEDICAL DIAGNOSTIC KITS CONSISTING PRIMARILY OF PREPARATIONS, REAGENTS, AND ASSAYS FOR DETECTING DRY EYES AND/OR OCULAR INFLAMMATION IN PATIENTS (U.S. CLS. 6, 18, 44, 46, 51 AND 52).

MARK SPARACINO, EXAMINING ATTORNEY

SN 85-139,947. CROWDSTAR INTERNATIONAL LIMITED, BLACKROCK, CO. DUBLIN, IRELAND, FILED 9-28-2010.

SN 85-140,402. ALBEROBELLO CAPITAL CORPORATION, CHARLOTTE, NC. FILED 9-28-2010.

# POP BOOM

THE MARK CONSISTS OF STANDARD CHARACTERS WITHOUT CLAIM TO ANY PARTICULAR FONT, STYLE, SIZE, OR COLOR.

## CLASS 9—ELECTRICAL AND SCIENTIFIC APPARATUS

FOR DOWNLOADABLE COMPUTER GAME SOFTWARE FOR USE ON WIRELESS DEVICES AND COMPUTERS; COMPUTER-GAME SOFTWARE, VIDEO GAME SOFTWARE, AND COMPUTER GAME APPLICATION SOFTWARE; INTERACTIVE-VIDEO-GAME PROGRAMS; ELECTRONIC GAME SOFTWARE AND ELECTRONIC GAME APPLICATION SOFTWARE THAT MAY BE ACCESSED VIA THE INTERNET, COMPUTERS AND WIRELESS DEVICES; COMPUTER SOFTWARE TO ENABLE UPLOADING, POSTING, SHOWING, DISPLAYING, TAGGING, BLOGGING, SHARING OR OTHERWISE PROVIDING ELECTRONIC MEDIA OR INFORMATION REGARDING THE FIELDS OF VIRTUAL COMMUNITIES, ELECTRONIC GAMING, ENTERTAINMENT AND GENERAL INTEREST VIA THE INTERNET OR OTHER COMMUNICATIONS NETWORKS WITH THIRD PARTIES (U.S. CLS. 21, 23, 26, 36 AND 38).

## CLASS 41—EDUCATION AND ENTERTAINMENT

FOR ENTERTAINMENT SERVICES, NAMELY, PROVIDING TEMPORARY USE OF NON-DOWNLOADABLE ELECTRONIC GAMES BY MEANS OF THE INTERNET OR OTHER WIRED OR WIRELESS NETWORKS (U.S. CLS. 100, 101 AND 107).

KEVIN DINALLO, EXAMINING ATTORNEY

SN 85-139,990. LAURA BLUMENFELD, WASHINGTON, DC. FILED 9-28-2010.

# NEWSIC

THE MARK CONSISTS OF STANDARD CHARACTERS WITHOUT CLAIM TO ANY PARTICULAR FONT, STYLE, SIZE, OR COLOR.

## CLASS 9—ELECTRICAL AND SCIENTIFIC APPARATUS

FOR COMPUTER SOFTWARE FOR WIRELESS TRANSMISSION OF MULTIMEDIA DATA, VIDEO, AUDIO, IMAGE AND TEXT-DATA AND FOR DELIVERING OF SOFTWARE APPLICATIONS TO MOBILE DEVICES (U.S. CLS. 21, 23, 26, 36 AND 38).

## CLASS 38—COMMUNICATION

FOR STREAMING OF AUDIO AND VIDEO MATERIAL OVER WIRELESS COMPUTER NETWORKS (U.S. CLS. 100, 101 AND 104).

JOHN DWYER, EXAMINING ATTORNEY

# ADSTERISK

THE MARK CONSISTS OF STANDARD CHARACTERS WITHOUT CLAIM TO ANY PARTICULAR FONT, STYLE, SIZE, OR COLOR.

## CLASS 9—ELECTRICAL AND SCIENTIFIC APPARATUS

FOR COMPUTER SOFTWARE FOR TRANSMITTING ONLINE CONTENT FOR RISK ANALYSIS AND VIEWING THE RESULTS OF SUCH ANALYSIS; COMPUTER SOFTWARE FOR SEARCHING, PLACING AND VIEWING AND RESPONDING TO ONLINE ADVERTISEMENTS (U.S. CLS. 21, 23, 26, 36 AND 38).

## CLASS 35—ADVERTISING AND BUSINESS

FOR PROVIDING ADVERTISING AND INFORMATION DISTRIBUTION SERVICES, NAMELY PROVIDING ONLINE ADVERTISING SPACE VIA GLOBAL INFORMATION NETWORKS, PROMOTING THE GOODS AND SERVICES OF OTHERS VIA A GLOBAL COMPUTER NETWORK, PROVIDING ONLINE COMPUTER DATABASES AND ONLINE SEARCHABLE DATABASES, ALL IN THE FIELD OF ONLINE ADVERTISING (U.S. CLS. 100, 101 AND 102).

## CLASS 42—SCIENTIFIC AND COMPUTER SERVICES

FOR COMPUTER SERVICES, NAMELY, PROVIDING TEMPORARY USE OF ONLINE, NON-DOWNLOADABLE SOFTWARE TO ALLOW USERS TO ANALYZE AND MITIGATE RISKS ASSOCIATED WITH ONLINE CONTENT AND TO SEARCH, PLACE AND VIEW AND RESPOND TO ONLINE ADVERTISEMENTS (U.S. CLS. 100 AND 101).

ANNE FARRELL, EXAMINING ATTORNEY

SN 85-141,027. CNY HEALING ARTS, LLC, SYRACUSE, NY. FILED 9-29-2010.

# THE FERTILE SECRET

THE MARK CONSISTS OF STANDARD CHARACTERS WITHOUT CLAIM TO ANY PARTICULAR FONT, STYLE, SIZE, OR COLOR.

**CLASS 9—ELECTRICAL AND SCIENTIFIC APPARATUS**

FOR DIGITAL MATERIALS, NAMELY, CDS, DVDS, AND DOWNLOADABLE AUDIO AND VIDEO FILES FEATURING INFORMATION REGARDING HUMAN FERTILITY AND REPRODUCTION, MASSAGE THERAPY, ACUPUNCTURE, YOGA, NUTRITIONAL COUNSELING, AND EASTERN THERAPIES; DOWNLOADABLE CONTENT, NAMELY, DOWNLOADABLE ELECTRONIC PUBLICATIONS IN THE NATURE OF MAGAZINES AND BOOKS FEATURING INFORMATION REGARDING HUMAN FERTILITY AND REPRODUCTION, MASSAGE THERAPY, ACUPUNCTURE, YOGA, NUTRITIONAL COUNSELING, AND EASTERN THERAPIES (U.S. CLS. 21, 23, 26, 36 AND 38).

**CLASS 16—PAPER GOODS AND PRINTED MATTER**

FOR PRINTED PUBLICATIONS, NAMELY, HAND-OUTS, WORKBOOKS, STORY BOOKS, FLASH CARDS, AND MAGAZINES, IN THE FIELD OF HUMAN FERTILITY AND REPRODUCTION; PRINTED PUBLICATIONS, NAMELY, MAGAZINES AND PROFESSIONAL JOURNALS IN FIELD OF MASSAGE THERAPY, ACUPUNCTURE, YOGA, NUTRITIONAL COUNSELING, AND EASTERN THERAPIES (U.S. CLS. 2, 5, 22, 23, 29, 37, 38 AND 50).

MARK SHINER, EXAMINING ATTORNEY

SN 85-141,786. FOR YOUR EASE ONLY, INC., CHICAGO, IL. FILED 9-30-2010.

**MAKE ME MILLIONS**

THE MARK CONSISTS OF STANDARD CHARACTERS WITHOUT CLAIM TO ANY PARTICULAR FONT, STYLE, SIZE, OR COLOR.

**CLASS 16—PAPER GOODS AND PRINTED MATTER**

FOR PUBLICATIONS, NAMELY, BOOKS, MAGAZINES AND NEWSLETTERS IN THE FIELD OF INVENTORS, ENTREPRENEURS AND PRODUCT DEVELOPMENT (U.S. CLS. 2, 5, 22, 23, 29, 37, 38 AND 50).

**CLASS 41—EDUCATION AND ENTERTAINMENT**

FOR ENTERTAINMENT SERVICES, NAMELY, A REALITY TELEVISION SERIES FEATURING INVENTORS, ENTREPRENEURS AND PRODUCT DEVELOPMENT (U.S. CLS. 100, 101 AND 107).

JOHN WILKE, EXAMINING ATTORNEY

SN 85-141,146. MARKEY'S AUDIO/VISUAL, INC., AKA MARKEY'S RENTAL & STAGING, INDIANAPOLIS, IN. FILED 9-29-2010.

SN 85-142,497. SENATOR INTERNATIONAL HOLDINGS LLC, MIAMI, FL. FILED 9-30-2010.

**DEFINING EXPERIENCES**

THE MARK CONSISTS OF STANDARD CHARACTERS WITHOUT CLAIM TO ANY PARTICULAR FONT, STYLE, SIZE, OR COLOR.

**CLASS 35—ADVERTISING AND BUSINESS**

FOR CORPORATE EVENT MANAGEMENT (U.S. CLS. 100, 101 AND 102).  
FIRST USE 11-0-2008; IN COMMERCE 11-0-2008.

**CLASS 41—EDUCATION AND ENTERTAINMENT**

FOR RENTAL OF AUDIO AND VIDEO EQUIPMENT, AND TECHNICAL SUPPORT ANCILLARY THERETO (U.S. CLS. 100, 101 AND 107).  
FIRST USE 11-0-2008; IN COMMERCE 11-0-2008.  
WILLIAM P. SHANAHAN, EXAMINING ATTORNEY

NO CLAIM IS MADE TO THE EXCLUSIVE RIGHT TO USE "INTERNATIONAL", APART FROM THE MARK AS SHOWN.

THE MARK CONSISTS OF THE BOLDED WORD "SENATOR" IN ALL CAPS ABOVE A DOUBLE HEADED ARROW BENEATH WHICH IS THE WORD "INTERNATIONAL" IN ALL CAPS.  
SEC. 2(F).

**CLASS 35—ADVERTISING AND BUSINESS**

FOR ARRANGING FOR PICKUP, DELIVERY, STORAGE AND TRANSPORTATION OF DOCUMENTS, PACKAGES, FREIGHT AND PARCELS VIA GROUND AND AIR CARRIERS; BUSINESS SERVICES, NAMELY, FREIGHT INFORMATION MANAGEMENT SERVICES, SHIPMENT PROCESSING, PREPARING SHIPPING DOCUMENTS AND INVOICES, TRACKING DOCUMENTS, PACKAGES AND FREIGHT OVER COMPUTER NETWORKS, INTRANETS AND INTERNETS; FREIGHT LOGISTICS MANAGEMENT (U.S. CLS. 100, 101 AND 102).  
FIRST USE 2-15-1984; IN COMMERCE 4-1-1988.

**CLASS 36—INSURANCE AND FINANCIAL**

FOR CUSTOMS BROKERAGE (U.S. CLS. 100, 101 AND 102).  
FIRST USE 2-15-1984; IN COMMERCE 4-1-1988.

**CLASS 39—TRANSPORTATION AND STORAGE**

FOR AIR FREIGHT SHIPPING SERVICES; FREIGHT AND TRANSPORT BROKERAGE; FREIGHT BROKERAGE; FREIGHT FORWARDING; FREIGHT FORWARDING SERVICES; FREIGHT TRAIN TRANSPORT; FREIGHT TRANSPORT BY SHIP; FREIGHT TRANSPORTATION BROKERAGE; FREIGHT TRANSPORTATION CONSULTATION IN THE FIELD OF FREIGHT TRANSPORTATION BY TRUCK, RAIL, AIR AND OCEAN; GLOBAL TRANSPORTATION OF FREIGHT FOR OTHERS BY ALL AVAILABLE MEANS; POSTAL, FREIGHT AND COURIER SERVICES; SUPPLY CHAIN LOGISTICS AND REVERSE LOGISTICS SERVICES, NAMELY, STORAGE, TRANSPORTATION AND DELIVERY OF DOCUMENTS, PACKAGES, RAW MATERIALS, AND OTHER FREIGHT FOR OTHERS BY AIR, RAIL, SHIP OR TRUCK; WAREHOUSING SERVICES, NAMELY, STORAGE, DISTRIBUTION, PICK-UP, AND PACKING FOR SHIPMENT OF DOCUMENTS, PACKAGES, RAW MATERIALS, AND OTHER FREIGHT FOR OTHERS (U.S. CLS. 100 AND 105).

FIRST USE 2-15-1984; IN COMMERCE 4-1-1988.  
GEORGE LORENZO, EXAMINING ATTORNEY

SN 85-143,243. CONTEXTV LLC, SCHAUMBURG, IL. FILED 10-1-2010.

# CONTEXTV

THE MARK CONSISTS OF STANDARD CHARACTERS WITHOUT CLAIM TO ANY PARTICULAR FONT, STYLE, SIZE, OR COLOR.

**CLASS 9—ELECTRICAL AND SCIENTIFIC APPARATUS**

FOR (BASED ON INTENT TO USE) COMPUTER HARDWARE AND SOFTWARE FOR PROCESSING OF VIDEO; COMPUTER SOFTWARE FOR INTEGRATING TEXT, AUDIO, AND GRAPHICS FOR VIDEOS; COMPUTER HARDWARE AND SOFTWARE FOR ADDING CONTENT TO VIDEO; COMPUTER HARDWARE AND SOFTWARE FOR ADDING CONTENT TO STREAMING VIDEO; COMPUTER HARDWARE AND SOFTWARE FOR ADDING CONTENT TO WEB BROADCASTED VIDEO; COMPUTER HARDWARE AND SOFTWARE FOR PROVIDING INTERACTIVE CONTENT TO VIDEO; COMPUTER HARDWARE AND SOFTWARE FOR PROVIDING VIEWER ACTUATED CONTENT TO VIDEO, INCLUDING WEB-BASED AND OTHER COMMUNICATIONS NETWORK CONTENT, PRIVATE DATABASE CONTENT, ADVERTISING CONTENT, INFORMATIONAL CONTENT, ENTERTAINMENT CONTENT, PROMOTION OF GOODS AND SERVICES OF OTHERS, MULTIMEDIA CONTENT, AND EDUCATIONAL CONTENT; COMPUTER HARDWARE AND SOFTWARE FOR PROCESSING OF VIDEO DATA, NAMELY, INTERPRETING VIDEO CONTENT AND IDENTIFYING SEGMENTS THAT CONTAIN KEY EVENTS AND LINKING ADDITIONAL CONTENT TO THE EVENTS; DOWNLOADABLE INTERACTIVE VIDEOS IN THE FIELD OF SPORTS ENTERTAINMENT FOR TELEVISIONS, VIDEO PLAYERS, VIDEO GAME SYSTEMS, MOBILE DEVICES, WIRELESS DEVICES, AND CELLULAR DEVICES (U.S. CLS. 21, 23, 26, 36 AND 38).

**CLASS 42—SCIENTIFIC AND COMPUTER SERVICES**

FOR (BASED ON USE IN COMMERCE) COMPUTER PROCESSING OF VIDEO DATA SERVICES, NAMELY, INTERPRETING VIDEO CONTENT AND IDENTIFYING SEGMENTS THAT CONTAIN PREDEFINED KEY EVENTS; PROVIDING A WEB SITE THAT GIVES COMPUTER USERS THE ABILITY TO UPLOAD VIDEOS; COMPUTER SERVICES, NAMELY, INTERACTIVE HOSTING SERVICES WHICH ALLOW THE USER TO PUBLISH AND SHARE THEIR OWN CONTENT FOR WEB-BASED AND OTHER COMMUNICATIONS ONLINE NETWORKS IN THE FIELD OF ADVERTISING CONTENT, ENTERTAINMENT CONTENT, AND EDUCATIONAL CONTENT; PROCESSING OF VIDEO DATA, NAMELY, INTERPRETING VIDEO CONTENT AND IDENTIFYING SEGMENTS THAT CONTAIN KEY EVENTS AND LINKING ADDITIONAL CONTENT TO THE EVENTS (U.S. CLS. 100 AND 101).

FIRST USE 3-0-2009; IN COMMERCE 3-0-2009.  
SIMON TENG, EXAMINING ATTORNEY

SN 85-143,278. CONTEXTV LLC, SCHAUMBURG, IL. FILED 10-1-2010.

# SPOTPLATFORM

THE MARK CONSISTS OF STANDARD CHARACTERS WITHOUT CLAIM TO ANY PARTICULAR FONT, STYLE, SIZE, OR COLOR.

**CLASS 9—ELECTRICAL AND SCIENTIFIC APPARATUS**

FOR COMPUTER HARDWARE AND SOFTWARE FOR PROCESSING OF VIDEO; COMPUTER SOFTWARE FOR INTEGRATING TEXT, AUDIO, AND GRAPHICS FOR VIDEOS; COMPUTER HARDWARE AND SOFTWARE FOR ADDING CONTENT TO VIDEO; COMPUTER HARDWARE AND SOFTWARE FOR ADDING CONTENT TO STREAMING VIDEO; COMPUTER HARDWARE AND SOFTWARE FOR ADDING CONTENT TO WEB BROADCASTED VIDEO; COMPUTER HARDWARE AND SOFTWARE FOR PROVIDING INTERACTIVE CONTENT TO VIDEO; COMPUTER HARDWARE AND SOFTWARE FOR PROCESSING OF VIDEO DATA, NAMELY, INTERPRETING VIDEO CONTENT AND IDENTIFYING SEGMENTS THAT CONTAIN KEY EVENTS AND LINKING ADDITIONAL CONTENT TO THE EVENTS; DOWNLOADABLE INTERACTIVE VIDEOS IN THE FIELD OF SPORTS ENTERTAINMENT FOR TELEVISIONS, VIDEO PLAYERS, VIDEO GAME SYSTEMS, MOBILE DEVICES, WIRELESS DEVICES, AND CELLULAR DEVICES (U.S. CLS. 21, 23, 26, 36 AND 38).

**CLASS 42—SCIENTIFIC AND COMPUTER SERVICES**

FOR COMPUTER PROCESSING OF VIDEO DATA SERVICES, NAMELY, INTERPRETING VIDEO CONTENT AND IDENTIFYING SEGMENTS THAT CONTAIN PREDEFINED KEY EVENTS; PROVIDING A WEB SITE THAT GIVES COMPUTER USERS THE ABILITY TO UPLOAD VIDEOS (U.S. CLS. 100 AND 101).

FIRST USE 3-0-2009; IN COMMERCE 3-0-2009.  
SIMON TENG, EXAMINING ATTORNEY

SN 85-144,936. SPECTRUM HEALTH INNOVATIONS, LLC,  
GRAND RAPIDS, MI. FILED 10-5-2010.

# CCAP

THE MARK CONSISTS OF STANDARD CHARACTERS WITHOUT CLAIM TO ANY PARTICULAR FONT, STYLE, SIZE, OR COLOR.

## CLASS 16—PAPER GOODS AND PRINTED MATTER

FOR PUBLICATIONS, NAMELY, PRINTED EDUCATIONAL MATERIALS, MANUALS, BOOKLETS, PRINTED REPORTS, CHARTS, AND PRINTED GUIDES IN THE FIELDS OF HEALTHCARE OPERATIONS MANAGEMENT, HOSPITAL OPERATIONS MANAGEMENT, AND HOSPITAL INPATIENT CLASSIFICATION FOR PAYMENT REIMBURSEMENT (U.S. CLS. 2, 5, 22, 23, 29, 37, 38 AND 50).

## CLASS 35—ADVERTISING AND BUSINESS

FOR CONSULTING IN THE FIELDS OF HEALTHCARE OPERATIONS MANAGEMENT AND HOSPITAL OPERATIONS MANAGEMENT; CONSULTING SERVICES IN THE FIELD OF HOSPITAL INPATIENT CLASSIFICATION FOR PAYMENT REIMBURSEMENT PURPOSES AND PROVIDING PATIENT PROFILES FOR HOSPITALS FOR PAYMENT REIMBURSEMENT PURPOSES (U.S. CLS. 100, 101 AND 102).

PAUL F. GAST, EXAMINING ATTORNEY

SN 85-145,643. DIESEL MACHINE WORKS, LOS ANGELES,  
CO. FILED 10-5-2010.



NO CLAIM IS MADE TO THE EXCLUSIVE RIGHT TO USE "DIESEL MACHINE WORKS", APART FROM THE MARK AS SHOWN.

THE COLOR(S) RED, WHITE, GRAY AND BLACK IS/ARE CLAIMED AS A FEATURE OF THE MARK.

THE MARK CONSISTS OF THE TERM "DIESEL MACHINE WORKS" IN RED SET AGAINST A WHITE BACKGROUND OVAL THAT IS OUTLINED IN BLACK AND GRAY. BEHIND APPEARS A STYLIZED SKULL AND CROSSBONES DESIGN WITH THE BONES DEPICTED AS ENGINE PISTONS AND CONNECTING RODS; THE SKULL IS WHITE WITH BLACK HIGHLIGHTS; THE CROSSBONES ARE GRAY WITH WHITE AND BLACK HIGHLIGHTS; TO EACH SIDE OF THE SKULL APPEARS A BLACK AND WHITE CHECKERED FLAG; THE ENTIRE MARK IS SET AGAINST A BLACK BACKGROUND.

## CLASS 35—ADVERTISING AND BUSINESS

FOR OPERATING AN ON-LINE SHOPPING SITE IN THE FIELD OF DIESEL, NATURAL GAS AND AUTOMOTIVE ENGINE PARTS (U.S. CLS. 100, 101 AND 102).  
FIRST USE 5-1-2010; IN COMMERCE 5-1-2010.

## CLASS 40—MATERIAL TREATMENT

FOR MACHINE SHOP SERVICES, NAMELY, MACHINING PARTS FOR OTHERS (U.S. CLS. 100, 103 AND 106).

FIRST USE 5-1-2010; IN COMMERCE 5-1-2010.  
JIM RINGLE, EXAMINING ATTORNEY

SN 85-146,420. PRYOR, CHARLENE, OVERLAND PARK, KS.  
FILED 10-6-2010.

# TRUMAN THE RED MULE

THE MARK CONSISTS OF STANDARD CHARACTERS WITHOUT CLAIM TO ANY PARTICULAR FONT, STYLE, SIZE, OR COLOR.

NO CLAIM IS MADE TO THE EXCLUSIVE RIGHT TO USE "RED MULE" IN CLASS 028, APART FROM THE MARK AS SHOWN.

## CLASS 16—PAPER GOODS AND PRINTED MATTER

FOR SERIES OF BOOKS FOR CHILDREN; DECALS, STICKERS, STICKER ALBUMS, POSTERS, COLORING BOOKS, ACTIVITY BOOKS, BOOKMARKS, AND GREETING CARDS (U.S. CLS. 2, 5, 22, 23, 29, 37, 38 AND 50).

## CLASS 25—CLOTHING

FOR CLOTHING NAMELY, SWEAT SHIRTS, T-SHIRTS, SHIRTS, SLEEPWEAR (U.S. CLS. 22 AND 39).

## CLASS 28—TOYS AND SPORTING GOODS

FOR PLUSH TOYS, STUFFED TOY ANIMALS, BOARD GAMES, TOY FIGURES; TOY ACTION FIGURES AND ACCESSORIES THEREFOR; SOFT SCULPTURE TOYS, AND STUFFED TOYS; TOY JEWELRY (U.S. CLS. 22, 23, 38 AND 50).

FONG HSU, EXAMINING ATTORNEY

SN 85-146,560. OUR CORPORATE LIFE LLC, MOUNTAIN-SIDE, NJ. FILED 10-6-2010.

# MAKING A LIVING AT WHAT YOU LOVE

THE MARK CONSISTS OF STANDARD CHARACTERS WITHOUT CLAIM TO ANY PARTICULAR FONT, STYLE, SIZE, OR COLOR.

**CLASS 9—ELECTRICAL AND SCIENTIFIC APPARATUS**

FOR DIGITAL MATERIALS, NAMELY, DVDS, CDS, DOWNLOADABLE PODCASTS, EZINES RECORDED ON COMPUTER MEDIA, DOWNLOADABLE WEBINARS, DOWNLOADABLE AUDIO BOOKS, EBOOKS RECORDED ON COMPUTER MEDIA AND DOWNLOADABLE MP3 AND AUDIO WAV FILES FEATURING INFORMATION ON HOW TO DETERMINE THE BENEFIT YOU BRING TO AN EMPLOYER THEREBY ELIMINATING OR REDUCING WORKPLACE FRICTION BETWEEN AND AMONG EMPLOYEES AND THEIR EMPLOYER; DIGITAL MEDIA, NAMELY, DVDS, CDS, DOWNLOADABLE PODCASTS, EZINES RECORDED ON COMPUTER MEDIA, DOWNLOADABLE WEBINARS, DOWNLOADABLE AUDIO BOOKS, EBOOKS RECORDED ON COMPUTER MEDIA AND DOWNLOADABLE MP3 AND AUDIO WAV FILES FEATURING INFORMATION ON HOW TO DETERMINE THE BENEFIT YOU BRING TO AN EMPLOYER THEREBY ELIMINATING OR REDUCING WORKPLACE FRICTION BETWEEN AND AMONG EMPLOYEES AND THEIR EMPLOYER (U.S. CLS. 21, 23, 26, 36 AND 38).

FIRST USE 5-13-2010; IN COMMERCE 5-13-2010.

**CLASS 35—ADVERTISING AND BUSINESS**

FOR CORPORATE CONSULTING SERVICE IN THE FIELD OF HUMAN RESOURCE DEVELOPMENT, NAMELY, FOR THE PROMOTION OF EMPLOYEE RETENTION, CAREER GROWTH, AND INCREASED PRODUCTIVITY FOR EMPLOYEES BY DETERMINING THE BENEFIT AN EMPLOYEE BRINGS TO AN EMPLOYER THEREBY ELIMINATING OR REDUCING WORKPLACE FRICTION BETWEEN AND AMONG EMPLOYEES AND THEIR EMPLOYER (U.S. CLS. 100, 101 AND 102).

FIRST USE 5-13-2010; IN COMMERCE 5-13-2010.

**CLASS 41—EDUCATION AND ENTERTAINMENT**

FOR BUSINESS EDUCATION AND TRAINING SERVICES, NAMELY, DEVELOPING, AND FACILITATING CUSTOMIZED IN-COMPANY LEADERSHIP AND EXECUTIVE DEVELOPMENT PROGRAMS, PROVIDING EXECUTIVE COACHING SERVICES, AND PROVIDING PUBLIC AND IN-COMPANY KEYNOTE PRESENTATIONS TO BUSINESS LEADERS; EDUCATIONAL SERVICES, NAMELY, CONDUCTING INDIVIDUAL AND GROUP PROFESSIONAL COACHING AND INDIVIDUAL AND GROUP CORPORATE PROFESSIONAL COACHING SERVICES IN THE FIELD OF DETERMINING THE BENEFIT YOU BRING TO AN EMPLOYER THEREBY ELIMINATING OR REDUCING WORKPLACE FRICTION BETWEEN AND AMONG EMPLOYEES AND THEIR EMPLOYER; COACHING SERVICES IN THE FIELD OF DETERMINING THE BENEFIT YOU BRING TO AN EMPLOYER THEREBY ELIMINATING OR REDUCING WORKPLACE FRICTION BETWEEN AND AMONG EMPLOYEES AND THEIR EMPLOYER; EDUCATIONAL SERVICES, NAMELY, CONDUCTING SEMINARS, WORKSHOPS, TELESEMINARS, WEBINARS AND CLASSES IN THE FIELDS OF DETERMINING THE BENEFIT YOU BRING TO AN EMPLOYER THEREBY ELIMINATING OR REDUCING WORKPLACE FRICTION BETWEEN AND AMONG EMPLOYEES AND THEIR EMPLOYER AND DISTRIBUTION OF TRAINING MATERIALS IN CONNECTION THEREWITH; EDUCATIONAL SERVICES, NAMELY, DEVELOPING AND CONDUCTING TRAINING COURSES AND DISTRIBUTION OF TRAINING MATERIALS IN CONNECTION THEREWITH FOR SUBJECT MATTERS AS REQUESTED BY CUSTOMERS (U.S. CLS. 100, 101 AND 107).

FIRST USE 5-13-2010; IN COMMERCE 5-13-2010.  
MAYUR VAGHANI, EXAMINING ATTORNEY

SN 85-146,585. PLANTRONICS, INC., SANTA CRUZ, CA.  
FILED 10-6-2010.

**VOCALYST**

THE MARK CONSISTS OF STANDARD CHARACTERS WITHOUT CLAIM TO ANY PARTICULAR FONT, STYLE, SIZE, OR COLOR.

**CLASS 38—COMMUNICATION**

FOR ELECTRONIC MAIL AND MESSAGING SERVICES, NAMELY, SENDING AND RECEIVING EMAILS, VOICEMAILS, TEXT MESSAGES AND OTHER DIGITAL MESSAGES; PROVIDING ACCESS TO THE INTERNET, ALL VIA HANDSFREE DEVICES, MOBILE HANDSETS AND COMPUTERS (U.S. CLS. 100, 101 AND 104).

**CLASS 42—SCIENTIFIC AND COMPUTER SERVICES**

FOR DATA CONVERSION OF ELECTRONIC INFORMATION, NAMELY, CONVERSION OF VOICE, TEXT AND OTHER DIGITAL MESSAGE DATA FROM VOICE TO TEXT AND TEXT TO VOICE (U.S. CLS. 100 AND 101).

DAVID ELTON, EXAMINING ATTORNEY

SN 85-147,159. MK ASSET, INC., WILMINGTON, DE. FILED  
10-7-2010.

**SHATTUCK HAMMOND PARTNERS**

THE MARK CONSISTS OF STANDARD CHARACTERS WITHOUT CLAIM TO ANY PARTICULAR FONT, STYLE, SIZE, OR COLOR.

NO CLAIM IS MADE TO THE EXCLUSIVE RIGHT TO USE "PARTNERS", APART FROM THE MARK AS SHOWN.

**CLASS 35—ADVERTISING AND BUSINESS**

FOR ACQUISITION AND MERGER CONSULTATION (U.S. CLS. 100, 101 AND 102).

FIRST USE 0-0-1993; IN COMMERCE 0-0-1993.

**CLASS 36—INSURANCE AND FINANCIAL**

FOR INVESTMENT BANKING SERVICES; STRATEGIC FINANCIAL ADVISORY SERVICES; REAL ESTATE CONSULTATION (U.S. CLS. 100, 101 AND 102).

FIRST USE 0-0-1993; IN COMMERCE 0-0-1993.  
ANDREA K. NADELMAN, EXAMINING ATTORNEY

SN 85-148,390. EXTRAFEET, INC., MARIETTA, GA. FILED 10-8-2010.



THE MARK CONSISTS OF THE WORD "EVILLE" WITH AN EXAGGERATED "V" BENEATH A SKULL WITH TWO PERPENDICULAR ORBITS BEHIND IT. THE LETTERS IN "EVILLE", THE SKULL, AND THE ORBITS ARE OUTLINED WITH A DARKER BORDER.

**CLASS 9—ELECTRICAL AND SCIENTIFIC APPARATUS**

FOR GAME SOFTWARE; COMPUTER APPLICATION SOFTWARE FOR MOBILE PHONES, NAMELY, FOR VIEWING COMIC BOOKS (U.S. CLS. 21, 23, 26, 36 AND 38).

**CLASS 25—CLOTHING**

FOR SHIRTS (U.S. CLS. 22 AND 39).

**CLASS 28—TOYS AND SPORTING GOODS**

FOR PROMOTIONAL GAME CARDS (U.S. CLS. 22, 23, 38 AND 50).

**CLASS 41—EDUCATION AND ENTERTAINMENT**

FOR PROVIDING A COMPUTER GAME FOR USE NETWORK-WIDE BY NETWORK USERS (U.S. CLS. 100, 101 AND 107).

KATHERINE M. DUBRAY, EXAMINING ATTORNEY

SN 85-148,644. VARSITY SPIRIT CORPORATION, MEMPHIS, TN. FILED 10-8-2010.

CHEERLEADING IS MY SPORT

THE MARK CONSISTS OF STANDARD CHARACTERS WITHOUT CLAIM TO ANY PARTICULAR FONT, STYLE, SIZE, OR COLOR.

OWNER OF U.S. REG. NOS. 1,576,926, 2,293,083 AND OTHERS.

NO CLAIM IS MADE TO THE EXCLUSIVE RIGHT TO USE "CHEERLEADING", APART FROM THE MARK AS SHOWN.

**CLASS 25—CLOTHING**

FOR ATHLETIC SHIRTS, ATHLETIC SHORTS, ATHLETIC TOPS, BODYSUITS, DRESSES, HATS, JACKETS, JERSEYS, JUMPERS, LEOTARDS, PANTS, SKIRTS, SWEATERS, SWEATPANTS, SWEATSHIRTS, T-SHIRTS, UNITARDS AND WARM-UP SUITS SOLD TO COLLEGES, HIGH SCHOOLS AND SCHOOL-AFFILIATED TEAMS, CLUBS, GROUPS AND INDIVIDUALS BY DIRECT SALES THROUGH SALES REPRESENTATIVES OR EMPLOYEES OF APPLICANT, THROUGH MAIL ORDER CATALOGUE SERVICES OR THROUGH CAMPUS BOOKSTORES OR OTHER RETAIL OUTLETS LOCATED AT COLLEGES AND HIGH SCHOOLS; UNIFORMS FOR CHEERLEADERS, DRILL TEAMS, POM POM SQUADS, PEP SQUADS, MASCOTS, BANDS AND BOOSTER CLUBS; FOOTWEAR, NAMELY, ATHLETIC SHOES, CHEERLEADER SHOES, DANCE SHOES, SLIPPERS, FLIP-FLOPS AND SANDALS (U.S. CLS. 22 AND 39).

**CLASS 41—EDUCATION AND ENTERTAINMENT**

FOR CONDUCTING CHEERLEADING COMPETITIONS AND PROVIDING INSTRUCTION AND TRAINING IN THE FIELDS OF SPORTS, CHEERLEADING AND DANCE; PROVIDING INSTRUCTIONAL PROGRAMMING AND DEMONSTRATION SERVICES FOR CHEERLEADERS, POMPON SQUADS, DANCE TEAMS, MASCOTS AND OTHER SCHOOL GROUPS (U.S. CLS. 100, 101 AND 107).

ALICE BENMAMAN, EXAMINING ATTORNEY

SN 85-148,811. SMISEK, WAYNE, COLORADO SPRINGS, CO. FILED 10-8-2010.

Fudgie

THE MARK CONSISTS OF STANDARD CHARACTERS WITHOUT CLAIM TO ANY PARTICULAR FONT, STYLE, SIZE, OR COLOR.

**CLASS 16—PAPER GOODS AND PRINTED MATTER**

FOR PUBLICATIONS AND PRINTED MATERIALS, NAMELY, CHILDREN'S BOOKS, ACTIVITY BOOKS, PICTURE BOOKS, PRINTED LESSON BOOKS IN THE FIELD OF EDUCATION AND CHARACTER DEVELOPMENT, COLORING BOOKS, POSTERS, CARTOON PRINTS, CARTOON STRIPS (U.S. CLS. 2, 5, 22, 23, 29, 37, 38 AND 50).

**CLASS 28—TOYS AND SPORTING GOODS**

FOR TOYS, NAMELY, BATH TOYS, PLASTIC ACTION FIGURES, STUFFED DOLLS AND ANIMALS, FANTASY CHARACTER TOYS, BOARD GAMES, PUZZLES (U.S. CLS. 22, 23, 38 AND 50).

BRIDGETT SMITH, EXAMINING ATTORNEY



SN 85-148,816. SMISEK, WAYNE, COLORADO SPRINGS, CO. FILED 10-8-2010.

SN 85-149,289. BEAUTY STAR TRADING COMPANY LTD., GUANGZHOU, CHINA, FILED 10-11-2010.

## Perfect Human Being

THE MARK CONSISTS OF STANDARD CHARACTERS WITHOUT CLAIM TO ANY PARTICULAR FONT, STYLE, SIZE, OR COLOR.

### CLASS 16—PAPER GOODS AND PRINTED MATTER

FOR PUBLICATIONS AND PRINTED MATERIALS, NAMELY, CHILDREN'S BOOKS, ACTIVITY BOOKS, PICTURE BOOKS, PRINTED LESSON BOOKS IN THE FIELD OF EDUCATION AND CHARACTER DEVELOPMENT, COLORING BOOKS, POSTERS, CARTOON PRINTS, CARTOON STRIPS (U.S. CLS. 2, 5, 22, 23, 29, 37, 38 AND 50).

### CLASS 25—CLOTHING

FOR CHILDREN'S AND BABY CLOTHING, NAMELY, SHIRTS, PANTS, SHORTS, ROMPERS, PAJAMAS, CLOTH BIBS, SOCKS, UNDERWEAR, JACKETS; SPORTSWEAR, NAMELY, T-SHIRTS, SWEATSHIRTS, SHIRTS, HATS, SOCKS, CAPS, PANTS, SHORTS, SHOES, BOOTS (U.S. CLS. 22 AND 39).

BRIDGETT SMITH, EXAMINING ATTORNEY

## GJARRAH

THE MARK CONSISTS OF STANDARD CHARACTERS WITHOUT CLAIM TO ANY PARTICULAR FONT, STYLE, SIZE, OR COLOR.

THE NAME SHOWN IN THE MARK DOES NOT IDENTIFY A PARTICULAR LIVING INDIVIDUAL.

### CLASS 3—COSMETICS AND CLEANING PREPARATIONS

FOR NON-MEDICATED KERATIN HAIR TREATMENT PREPARATIONS FOR COSMETIC PURPOSES; SHAMPOO (U.S. CLS. 1, 4, 6, 50, 51 AND 52).

FIRST USE 3-3-2009; IN COMMERCE 6-1-2009.

### CLASS 9—ELECTRICAL AND SCIENTIFIC APPARATUS

FOR ELECTRIC FLAT IRONS (U.S. CLS. 21, 23, 26, 36 AND 38).

FIRST USE 3-3-2009; IN COMMERCE 6-1-2009.

KRISTIN CARLSON, EXAMINING ATTORNEY

SN 85-149,128. TEAMREADINESS, INC., CHICAGO, IL. FILED 10-9-2010.

## Team Readiness

THE MARK CONSISTS OF STANDARD CHARACTERS WITHOUT CLAIM TO ANY PARTICULAR FONT, STYLE, SIZE, OR COLOR.

### CLASS 35—ADVERTISING AND BUSINESS

FOR PROVIDING ONLINE BUSINESS MANAGEMENT SERVICES, NAMELY, ONLINE DATABASE INFORMATION MANAGEMENT; PROVIDING BUSINESS KNOWLEDGE MANAGEMENT FOR THE PREPARATION OF DOCUMENTATION (U.S. CLS. 100, 101 AND 102).

FIRST USE 9-17-2007; IN COMMERCE 9-17-2007.

### CLASS 42—SCIENTIFIC AND COMPUTER SERVICES

FOR COMPUTER PROGRAMS AND SOFTWARE, NAMELY, ON-LINE NON-DOWNLOADABLE COMPUTER PROGRAMS FOR PROCESSING, TRANSMITTING, AND RECEIVING PERSONAL DATA AND FOR PROVIDING KNOWLEDGE MANAGEMENT SOLUTIONS (U.S. CLS. 100 AND 101).

FIRST USE 9-17-2007; IN COMMERCE 9-17-2007.

WILLIAM VERHOSEK, EXAMINING ATTORNEY

SN 85-149,608. CHETAN COMCORP FZC, DENVER, CO. FILED 10-11-2010.



NO CLAIM IS MADE TO THE EXCLUSIVE RIGHT TO USE "TV", APART FROM THE MARK AS SHOWN.

THE COLOR(S) GREEN, YELLOW, ORANGE, RED, PURPLE, BLUE, BLACK, AND WHITE IS/ARE CLAIMED AS A FEATURE OF THE MARK.

THE MARK CONSISTS OF THE WORD "KULTURE TV" FEATURING THE "K" IN GREEN, "U" IN YELLOW, "L" IN ORANGE, "T" IN RED, "U" IN PURPLE, "R" IN BLUE, "E" IN LIGHT BLUE, "TV" IN BLACK, WITH A DARK GREEN LEAF ON THE "K", AND SIX WHITE STARS IN THE WORD "KULTURE".

### CLASS 38—COMMUNICATION

FOR AUDIO AND VIDEO BROADCASTING SERVICES OVER THE INTERNET; BROADCAST OF CABLE TELEVISION PROGRAMMES; BROADCASTING OF TELEVISION PROGRAMMES; SATELLITE TELEVISION BROADCASTING; SUBSCRIPTION TELEVISION BROADCASTING; TELEVISION BROADCASTING; TELEVISION BROADCASTING CONSULTATION (U.S. CLS. 100, 101 AND 104).

**CLASS 41—EDUCATION AND ENTERTAINMENT**

FOR ENTERTAINMENT SERVICES IN THE NATURE OF CREATION, DEVELOPMENT, AND PRODUCTION OF TELEVISION PROGRAMMING; ENTERTAINMENT SERVICES IN THE NATURE OF DEVELOPMENT, CREATION, PRODUCTION AND POST-PRODUCTION SERVICES OF MULTIMEDIA ENTERTAINMENT CONTENT; ENTERTAINMENT SERVICES, NAMELY, MULTIMEDIA PRODUCTION SERVICES; FILM AND VIDEO FILM PRODUCTION; MOTION PICTURE AND VIDEO RENTAL SERVICES; PROVIDING A WEBSITE FEATURING ENTERTAINMENT INFORMATION; TELEVISION, VIDEO AND MOVIE FILMING SERVICES (U.S. CLS. 100, 101 AND 107).

DAVID C. REIHNER, EXAMINING ATTORNEY

SN 85-149,634. EVOLUTION AUTO SALES, LLC, OVIEDO, FL. FILED 10-11-2010.

**EVOLUTION AUTO**

THE MARK CONSISTS OF STANDARD CHARACTERS WITHOUT CLAIM TO ANY PARTICULAR FONT, STYLE, SIZE, OR COLOR.

NO CLAIM IS MADE TO THE EXCLUSIVE RIGHT TO USE "AUTO", APART FROM THE MARK AS SHOWN.

**CLASS 35—ADVERTISING AND BUSINESS**

FOR AUTOMOBILE DEALERSHIPS (U.S. CLS. 100, 101 AND 102).

**CLASS 37—CONSTRUCTION AND REPAIR**

FOR AUTOMOBILE REPAIR AND MAINTENANCE; AUTOMOBILE DETAILING (U.S. CLS. 100, 103 AND 106).

MICHAEL KEATING, EXAMINING ATTORNEY

SN 85-150,064. HASTA QUE SE AGOTEN, S.A. DE C.V., MEXICO, 11570, DISTRITO FEDERAL, MEXICO, FILED 10-11-2010.

THE NAME(S), PORTRAIT(S), AND/OR SIGNATURE(S) SHOWN IN THE MARK DOES NOT IDENTIFY A PARTICULAR LIVING INDIVIDUAL.

THE MARK CONSISTS OF THE STYLIZED TERMS "XIK BAL BAIA".

THE ENGLISH TRANSLATION OF "BAIA" IN THE MARK IS "BAY".

**CLASS 29—MEATS AND PROCESSED FOODS**

FOR OLIVE OIL (U.S. CL. 46).

**CLASS 33—WINES AND SPIRITS**

FOR WINE (U.S. CLS. 47 AND 49).  
YAT SYE, LEE, EXAMINING ATTORNEY

SN 85-150,235. 3DPLAN APS, DK-5000 ODENSE C, DENMARK, FILED 10-12-2010.



NO CLAIM IS MADE TO THE EXCLUSIVE RIGHT TO USE "SYSTEMS", APART FROM THE MARK AS SHOWN.

THE MARK CONSISTS OF THE LETTER "E" LOCATED IN THE MIDDLE OF A SOLID CIRCLE AND SURROUNDED BY FOUR DIVIDED QUADRANTS OF AN OUTLAYING CIRCLE AND FOUR ARROWS IN A CLOCKWISE DIRECTION; THE WORDS "ESOFT SYSTEMS" APPEARS BELOW THE BOTTOM TWO ARROWS.

**CLASS 35—ADVERTISING AND BUSINESS**

FOR MARKETING AND ADVERTISING REAL ESTATE SERVICES FOR OTHERS; DEVELOPING VISUAL MARKETING MATERIAL FOR ESTATE AGENTS; BUSINESS MANAGEMENT ASSISTANCE AND CONSULTANCY FOR ESTATE AGENTS AND PROVIDING ONLINE SEARCHABLE DATABASES FEATURING PHOTOS OF REAL ESTATE FOR MARKETING PURPOSES FOR REAL ESTATE AGENTS (U.S. CLS. 100, 101 AND 102).

FIRST USE 10-1-2010; IN COMMERCE 10-1-2010.

**CLASS 41—EDUCATION AND ENTERTAINMENT**

FOR PROFESSIONAL PHOTOGRAPHY SERVICES; TRAINING SERVICES IN THE FIELD OF PHOTOGRAPHY (U.S. CLS. 100, 101 AND 107).

FIRST USE 10-1-2010; IN COMMERCE 10-1-2010.

**CLASS 42—SCIENTIFIC AND COMPUTER SERVICES**

FOR DESIGN AND DEVELOPMENT OF SOFTWARE FOR VISUAL PRESENTATIONS OF REAL ESTATE; DESIGN AND DEVELOPMENT OF SOFTWARE FOR OFFICE SYSTEMS FOR REAL ESTATE AGENTS; DESIGN AND DEVELOPMENT OF WEBSITES FOR REAL ESTATE AGENTS (U.S. CLS. 100 AND 101).

FIRST USE 10-1-2010; IN COMMERCE 10-1-2010.  
RONALD MCMORROW, EXAMINING ATTORNEY

SN 85-151,435. PLATRE.COM LTD, LONDRES, UNITED KINGDOM, FILED 10-13-2010.

# STUC PIERRE

THE MARK CONSISTS OF STANDARD CHARACTERS WITHOUT CLAIM TO ANY PARTICULAR FONT, STYLE, SIZE, OR COLOR.

NO CLAIM IS MADE TO THE EXCLUSIVE RIGHT TO USE "STUC", APART FROM THE MARK AS SHOWN.

THE ENGLISH TRANSLATION OF "STUC" IN THE MARK IS STUCCO.

## CLASS 19—NON-METALLIC BUILDING MATERIALS

FOR NON METALLIC BUILDING MATERIALS, NAMELY, SOFFITS; NON-METALLIC RIGID PIPES FOR BUILDING; ASPHALT, PITCH AND BITUMEN; NON-METALLIC TRANSPORTABLE BUILDINGS; MONUMENTS, NOT OF METAL; NON-METALLIC BUILDING MATERIALS, NAMELY, CERAMIC TILES; NON-METAL SCAFFOLDING; GLASS FOR BUILDING; INSULATING GLASS FOR WINDOWS FOR BUILDING PURPOSES; CONCRETE; CEMENT MIXES; ROOFING CEMENT; WORKS OF ART OF STONE, CONCRETE OR MARBLE; STATUES OF STONE, CONCRETE OR MARBLE; FIGURINES OF STONE, CONCRETE OR MARBLE; NON-METAL STAINED-GLASS WINDOWS; BUILDING TIMBER; TOMBSTONES NOT OF METAL, NAMELY, TOMBSTONES OF STONE, CONCRETE OR MARBLE (U.S. CLS. 1, 12, 33 AND 50).

## CLASS 37—CONSTRUCTION AND REPAIR

FOR SERVICES RELATING TO THE CONSTRUCTION OF BUILDINGS, ROADS, BRIDGES, NAMELY, BUILDING CONSTRUCTION, ROAD CONSTRUCTION, CONSTRUCTION OF BUILDINGS; PROVIDING BUILDING CONSTRUCTION INFORMATION; BUILDING CONSTRUCTION SUPERVISION; MASONRY; PLASTERING; PLUMBING; ROOFING SERVICES; BUILDING SEALING SERVICES; BUILDING DEMOLITION; RENTAL OF CONSTRUCTION EQUIPMENT (U.S. CLS. 100, 103 AND 106).

## CLASS 42—SCIENTIFIC AND COMPUTER SERVICES

FOR ARCHITECTURAL CONSULTATION; CONSTRUCTION DRAFTING; ENGINEERING CONSULTANCY IN THE CONSTRUCTION FIELD (U.S. CLS. 100 AND 101).

EVELYN BRADLEY, EXAMINING ATTORNEY

SN 85-151,735. TWENTY FIRST CENTURY COMMUNICATIONS, INC., COLUMBUS, OH. FILED 10-13-2010.

# UNILITY

THE MARK CONSISTS OF STANDARD CHARACTERS WITHOUT CLAIM TO ANY PARTICULAR FONT, STYLE, SIZE, OR COLOR.

## CLASS 9—ELECTRICAL AND SCIENTIFIC APPARATUS

FOR DOWNLOADABLE SOFTWARE IN THE NATURE OF A MOBILE APPLICATION FOR MANAGEMENT AND MONITORING OF UTILITIES; DOWNLOADABLE SOFTWARE IN THE NATURE OF A MOBILE APPLICATION FOR MANAGEMENT AND MONITORING OF UTILITIES, NAMELY, GAS, WATER, CABLE, AND ELECTRIC UTILITIES; DOWNLOADABLE SOFTWARE IN THE NATURE OF A MOBILE APPLICATION FOR USE IN MONITORING OF ENERGY CONSUMPTION, RATE CHANGES AND COSTS, REPORTING UTILITY OUTAGES, CONDUCTING TRANSACTIONS INCLUDING PAYMENT AND MANAGEMENT OF UTILITY BILLS, CHANGING UTILITY SERVICE ADDRESSES, ADDING OR DISCONTINUING SERVICE, REQUESTING MAINTENANCE, REPORTING GAS LEAKS, AND RECEIVING BOIL WATER ALERTS (U.S. CLS. 21, 23, 26, 36 AND 38).

## CLASS 42—SCIENTIFIC AND COMPUTER SERVICES

FOR PROVIDING TEMPORARY USE OF NON-DOWNLOADABLE SOFTWARE IN THE NATURE OF A MOBILE APPLICATION FOR MANAGEMENT AND MONITORING OF UTILITIES; PROVIDING TEMPORARY USE OF NON-DOWNLOADABLE SOFTWARE IN THE NATURE OF A MOBILE APPLICATION FOR MANAGEMENT AND MONITORING OF UTILITIES, NAMELY, GAS, WATER, CABLE, AND ELECTRIC UTILITIES; PROVIDING TEMPORARY USE OF NON-DOWNLOADABLE SOFTWARE IN THE NATURE OF A MOBILE APPLICATION FOR USE IN MONITORING OF ENERGY CONSUMPTION AND COSTS, REPORTING UTILITY OUTAGES, CONDUCTING TRANSACTIONS INCLUDING PAYMENT AND MANAGEMENT OF UTILITY BILLS, CHANGING UTILITY SERVICE ADDRESSES, ADDING OR DISCONTINUING SERVICE, REQUESTING MAINTENANCE, REPORTING GAS LEAKS, AND RECEIVING UTILITY SERVICE ALERTS (U.S. CLS. 100 AND 101).

LINDSEY RUBIN, EXAMINING ATTORNEY

SN 85-151,744. GARMIN SWITZERLAND GMBH, SCHAFFHAUSEN, SWITZERLAND, FILED 10-13-2010.

# VIRB

THE MARK CONSISTS OF STANDARD CHARACTERS WITHOUT CLAIM TO ANY PARTICULAR FONT, STYLE, SIZE, OR COLOR.

**CLASS 9—ELECTRICAL AND SCIENTIFIC APPARATUS**

FOR ELECTRONIC EXERCISE MONITORS, NOT FOR MEDICAL PURPOSES, FOR THE MONITORING OF DISTANCES, NUMBER OF STEPS, CADENCE OF STEPS, NUMBER OF SWIMMING STROKES, TYPE OF SWIMMING STROKES, PACE, TIME DURATION OF EXERCISE SESSION, TIME ON PARTICULAR EXERCISE, AND CALORIES EXPENDED AND HEART RATE; ELECTRONIC DEVICE, NOT FOR MEDICAL PURPOSES, FOR RECORDING AND MONITORING EXERCISE SESSIONS, NAMELY, THE MONITORING OF DISTANCES, NUMBER OF STEPS, CADENCE OF STEPS, NUMBER OF SWIMMING STROKES, TYPE OF SWIMMING STROKES, PACE, TIME DURATION OF EXERCISE SESSION, TIME ON PARTICULAR EXERCISE, AND CALORIES EXPENDED AND HEART RATE; ELECTRONIC DEVICE THAT TRANSMITS DATA REGARDING EXERCISE SESSIONS, NAMELY, DISTANCES, NUMBER OF STEPS, CADENCE OF STEPS, NUMBER OF SWIMMING STROKES, TYPE OF SWIMMING STROKES, PACE, TIME DURATION OF EXERCISE SESSION, TIME ON PARTICULAR EXERCISE, CALORIES EXPENDED AND HEART RATE; ELECTRONIC DEVICE THAT RECEIVES DATA REGARDING EXERCISE SESSIONS, NAMELY, DISTANCES, NUMBER OF STEPS, CADENCE OF STEPS, NUMBER OF SWIMMING STROKES, TYPE OF SWIMMING STROKES, PACE, TIME DURATION OF EXERCISE SESSION, TIME ON PARTICULAR EXERCISE, CALORIES EXPENDED AND HEART RATE (U.S. CLS. 21, 23, 26, 36 AND 38).

**CLASS 10—MEDICAL APPARATUS**

FOR HEART RATE MONITORS FOR USE DURING EXERCISE SESSIONS (U.S. CLS. 26, 39 AND 44).

**CLASS 14—JEWELRY**

FOR WATCHES; CHRONOMETERS (U.S. CLS. 2, 27, 28 AND 50).

ASMAT KHAN, EXAMINING ATTORNEY

**CLASS 9—ELECTRICAL AND SCIENTIFIC APPARATUS**

FOR DOWNLOADABLE SOFTWARE IN THE NATURE OF A MOBILE APPLICATION FOR MANAGEMENT AND MONITORING OF UTILITIES; DOWNLOADABLE SOFTWARE IN THE NATURE OF A MOBILE APPLICATION FOR MANAGEMENT AND MONITORING OF UTILITIES, NAMELY, GAS, WATER, CABLE, AND ELECTRIC UTILITIES; DOWNLOADABLE SOFTWARE IN THE NATURE OF A MOBILE APPLICATION FOR USE IN MONITORING OF ENERGY CONSUMPTION, RATE CHANGES AND COSTS, REPORTING UTILITY OUTAGES, CONDUCTING TRANSACTIONS INCLUDING PAYMENT AND MANAGEMENT OF UTILITY BILLS, CHANGING UTILITY SERVICE ADDRESSES, ADDING OR DISCONTINUING SERVICE, REQUESTING MAINTENANCE, REPORTING GAS LEAKS, AND RECEIVING BOIL WATER ALERTS (U.S. CLS. 21, 23, 26, 36 AND 38).

**CLASS 42—SCIENTIFIC AND COMPUTER SERVICES**

FOR PROVIDING TEMPORARY USE OF NON-DOWNLOADABLE SOFTWARE IN THE NATURE OF A MOBILE APPLICATION FOR MANAGEMENT AND MONITORING OF UTILITIES; PROVIDING TEMPORARY USE OF NON-DOWNLOADABLE SOFTWARE IN THE NATURE OF A MOBILE APPLICATION FOR MANAGEMENT AND MONITORING OF UTILITIES, NAMELY, GAS, WATER, CABLE, AND ELECTRIC UTILITIES; PROVIDING TEMPORARY USE OF NON-DOWNLOADABLE SOFTWARE IN THE NATURE OF A MOBILE APPLICATION FOR USE IN MONITORING OF ENERGY CONSUMPTION AND COSTS, REPORTING UTILITY OUTAGES, CONDUCTING TRANSACTIONS INCLUDING PAYMENT AND MANAGEMENT OF UTILITY BILLS, CHANGING UTILITY SERVICE ADDRESSES, ADDING OR DISCONTINUING SERVICE, REQUESTING MAINTENANCE, REPORTING GAS LEAKS, AND RECEIVING UTILITY SERVICE ALERTS (U.S. CLS. 100 AND 101).

LINDSEY RUBIN, EXAMINING ATTORNEY

SN 85-151,750. TWENTY FIRST CENTURY COMMUNICATIONS, INC., COLUMBUS, OH. FILED 10-13-2010.

SN 85-152,784. APPLIED THERMOPLASTIC RESOURCES, LLC, CARTERSVILLE, GA. FILED 10-14-2010.



NO CLAIM IS MADE TO THE EXCLUSIVE RIGHT TO USE "THE UNIVERSAL UTILITY APP", APART FROM THE MARK AS SHOWN.

THE MARK CONSISTS OF THE LETTER "U" ON TOP OF A DIAMOND SHAPE INSIDE OF A ROUNDED SQUARE SHAPE WITH THE WORDING "UNILITY" AND "THE UNIVERSAL UTILITY APP" UNDERNEATH IT, WITH THE ENTIRE MARK BEING INSIDE OF A VERTICAL RECTANGULAR SHAPE.

# RESPIN

THE MARK CONSISTS OF STANDARD CHARACTERS WITHOUT CLAIM TO ANY PARTICULAR FONT, STYLE, SIZE, OR COLOR.

**CLASS 22—CORDAGE AND FIBERS**

FOR SYNTHETIC MATERIALS, NAMELY, SYNTHETIC FIBERS AND FILAMENTS FOR USE IN THE MANUFACTURE OF FABRICS, TEXTILES, YARNS AND CARPETS (U.S. CLS. 1, 2, 7, 19, 22, 42 AND 50).

**CLASS 40—MATERIAL TREATMENT**

FOR MATERIAL TREATMENT SERVICES IN CONNECTION WITH RECYCLING; RECYCLING OF RESINS, FIBERS AND CARPET (U.S. CLS. 100, 103 AND 106).

KIM MONINGHOFF, EXAMINING ATTORNEY

SN 85-153,080. MEDIASTORM, LLC, BROOKLYN, NY.  
FILED 10-14-2010.

SN 85-153,172. MELANIE REMBRANDT, DBA REMBRANDT COMMUNICATIONS, LLC, REDONDO BEACH, CA. FILED 10-14-2010.

## MEDIASTORM

THE MARK CONSISTS OF STANDARD CHARACTERS WITHOUT CLAIM TO ANY PARTICULAR FONT, STYLE, SIZE, OR COLOR.

### CLASS 9—ELECTRICAL AND SCIENTIFIC APPARATUS

FOR COMPUTER SOFTWARE FOR USE IN THE PRODUCTION OF VIDEO, VIDEO PRESENTATIONS, FLASH PRESENTATIONS; DOWNLOADABLE MULTIMEDIA FILES CONTAINING PHOTOGRAPHY, TEXT, AUDIO, MUSIC, VIDEO AND MAPS IN THE FIELD OF MULTIMEDIA PRODUCTION, FILM PRODUCTION, POST-PRODUCTION, PHOTOGRAPHY, VIDEOGRAPHY AND AUDIO PRODUCTION; DOWNLOADABLE ELECTRONIC PUBLICATIONS, NAMELY, PDF PAMPHLETS, BROCHURES, NEWSLETTERS, JOURNALS, MAGAZINES AND GUIDES IN THE FIELD OF MULTIMEDIA PRODUCTION, FILM PRODUCTION, FILM POST-PRODUCTION, PHOTOGRAPHY, VIDEOGRAPHY AND AUDIO PRODUCTION; DVDS FEATURING ORIGINAL PROGRAMMING (U.S. CLS. 21, 23, 26, 36 AND 38).  
FIRST USE 12-11-2007; IN COMMERCE 12-11-2007.

### CLASS 16—PAPER GOODS AND PRINTED MATTER

FOR PRINTED MATERIALS, NAMELY, MANUALS, PAMPHLETS, INSTRUCTIONAL BROCHURES, LEAFLETS AND GUIDES ON EDUCATION AND TRAINING IN THE FIELD OF MULTIMEDIA PRODUCTION, POST-PRODUCTION, RECORDING, VIDEO, FILM, AUDIO RECORDING AND PHOTOGRAPHY (U.S. CLS. 2, 5, 22, 23, 29, 37, 38 AND 50).  
FIRST USE 2-1-2005; IN COMMERCE 2-1-2005.

### CLASS 38—COMMUNICATION

FOR BROADCAST COMMUNICATION SERVICES, NAMELY, STREAMING VIDEO, PHOTO AND PHOTOGRAPHY, TEXT, AUDIO, MUSIC, VIDEO AND MAPS ON THE INTERNET AND MOBILE COMMUNICATIONS DEVICES (U.S. CLS. 100, 101 AND 104).  
FIRST USE 11-16-2005; IN COMMERCE 11-16-2005.

### CLASS 41—EDUCATION AND ENTERTAINMENT

FOR ENTERTAINMENT MEDIA PRODUCTION SERVICES, NAMELY, VIDEO AND FILM PRODUCTION, VIDEO AND AUDIO RECORDING SERVICES, FILM AND VIDEO POST-PRODUCTION EDITING SERVICES; EDUCATIONAL SERVICES, NAMELY, CONDUCTING WORKSHOPS AND SEMINARS THAT PROVIDE EDUCATION TO PROFESSIONALS IN THE FIELD OF MULTIMEDIA PRODUCTION, POST-PRODUCTION, RECORDING, VIDEO, FILM, AUDIO RECORDING AND PHOTOGRAPHY; DIGITAL VIDEO, AUDIO, AND MULTIMEDIA ONLINE PUBLISHING SERVICES (U.S. CLS. 100, 101 AND 107).  
FIRST USE 6-1-1994; IN COMMERCE 6-1-1994.  
ELIZABETH KAJUBI, EXAMINING ATTORNEY

## 1 Win Press

THE MARK CONSISTS OF STANDARD CHARACTERS WITHOUT CLAIM TO ANY PARTICULAR FONT, STYLE, SIZE, OR COLOR.

NO CLAIM IS MADE TO THE EXCLUSIVE RIGHT TO USE "PRESS", APART FROM THE MARK AS SHOWN.

### CLASS 9—ELECTRICAL AND SCIENTIFIC APPARATUS

FOR ELECTRONIC PUBLICATIONS, NAMELY, DOWNLOADABLE NEWSLETTERS, REPORTS AND ARTICLES IN THE FIELD OF SELF-HELP FOR ENTREPRENEURS (U.S. CLS. 21, 23, 26, 36 AND 38).  
FIRST USE 7-9-2010; IN COMMERCE 8-15-2010.

### CLASS 41—EDUCATION AND ENTERTAINMENT

FOR PUBLISHING OF SELF HELP INFORMATION FOR ENTREPRENEURS, NAMELY, BOOKS, NEWSLETTERS, REPORTS, WHITE PAPERS, AND BROCHURES; PROVIDING A WEBSITE FEATURING RESOURCES, NAMELY, NON-DOWNLOADABLE PUBLICATIONS IN THE NATURE OF BOOKS, REPORTS, AND NEWSLETTERS IN THE FIELD OF SELF-HELP FOR ENTREPRENEURS; AND ON-LINE JOURNALS, NAMELY, BLOGS, IN THE FIELD OF SELF-HELP FOR ENTREPRENEURS (U.S. CLS. 100, 101 AND 107).  
FIRST USE 7-9-2010; IN COMMERCE 8-15-2010.  
BILL DAWE, EXAMINING ATTORNEY

SN 85-153,827. PROFESSIONAL PHOTOGRAPHERS OF AMERICA, ATLANTA, GA. FILED 10-15-2010.



NO CLAIM IS MADE TO THE EXCLUSIVE RIGHT TO USE "EDUCATION", APART FROM THE MARK AS SHOWN.

THE MARK CONSISTS OF THE CAPITAL LETTERS "PPA" FOLLOWED BY THE LOWER CASE LETTERS "ED" FOLLOWED BY THE LOWER CASE LETTER "U" INSIDE A SUPERScript CIRCLE. THE SECOND LINE CONSISTS OF THE PHRASE "EDUCATION TO THE POWER OF U" IN LOWER CASE LETTERS.

### CLASS 16—PAPER GOODS AND PRINTED MATTER

FOR EDUCATIONAL PUBLICATIONS, NAMELY, HANDBOOKS, WRITTEN ARTICLES, CURRICULUM FOR WEBINARS, WORKSHOPS AND SEMINARS IN THE FIELDS OF PROFESSIONAL PHOTOGRAPHY (U.S. CLS. 2, 5, 22, 23, 29, 37, 38 AND 50).

**CLASS 41—EDUCATION AND ENTERTAINMENT**

FOR EDUCATIONAL SERVICES, NAMELY, CONDUCTING WEBINARS, SEMINARS AND WORKSHOPS IN THE FIELDS OF PROFESSIONAL PHOTOGRAPHY (U.S. CLS. 100, 101 AND 107).

JANICE KIM, EXAMINING ATTORNEY

SN 85-154,622. ARRHYTHMIA RESEARCH TECHNOLOGY, INC., FITCHBURG, MA. FILED 10-18-2010.

**WirelessDx**

NO CLAIM IS MADE TO THE EXCLUSIVE RIGHT TO USE "WIRELESS DX", APART FROM THE MARK AS SHOWN.

THE MARK CONSISTS OF THE WORDING "WIRELESS DX" WITH A WIRELESS SIGNAL CONSISTING OF A CIRCLE AND THREE SOUND WAVES EMANATING OVER THE "X", CREATING A STICK FIGURE DESIGN OF A PERSON.

**CLASS 10—MEDICAL APPARATUS**

FOR WIRELESS MEDICAL DEVICES FOR MONITORING VITAL SIGNS (U.S. CLS. 26, 39 AND 44).

**CLASS 44—MEDICAL, BEAUTY AND AGRICULTURAL SERVICES**

FOR PROVIDING MEDICAL SERVICES, NAMELY, MONITORING PATIENTS' VITALS USING DATA COLLECTED THROUGH WIRELESS MEDICAL MONITORING DEVICES (U.S. CLS. 100 AND 101).

KRISTIN CARLSON, EXAMINING ATTORNEY

SN 85-154,754. DB MUSIC PRODUCTIONS, INC, MIRAMAR, FL. FILED 10-18-2010.

**VELA**

THE MARK CONSISTS OF STANDARD CHARACTERS WITHOUT CLAIM TO ANY PARTICULAR FONT, STYLE, SIZE, OR COLOR.

THE NAME(S), PORTRAIT(S), AND/OR SIGNATURE(S) SHOWN IN THE MARK IDENTIFIES MARCELA VELASQUEZ, WHOSE CONSENT(S) TO REGISTER IS MADE OF RECORD.

**CLASS 9—ELECTRICAL AND SCIENTIFIC APPARATUS**

FOR AUDIO AND VIDEO RECORDINGS FEATURING MUSIC AND ARTISTIC PERFORMANCES; AUDIO RECORDINGS FEATURING MUSIC; COMPACT DISCS FEATURING MUSIC; DOWNLOADABLE MUSIC VIA THE INTERNET AND WIRELESS DEVICES; MUSICAL SOUND RECORDINGS; MUSICAL VIDEO RECORDINGS (U.S. CLS. 21, 23, 26, 36 AND 38).

FIRST USE 8-24-2010; IN COMMERCE 8-24-2010.

**CLASS 41—EDUCATION AND ENTERTAINMENT**

FOR ENTERTAINMENT IN THE NATURE OF VISUAL AND AUDIO PERFORMANCES, NAMELY, MUSICAL BAND, ROCK GROUP, GYMNASTIC, DANCE, AND BALLET PERFORMANCES; ENTERTAINMENT SERVICES IN THE NATURE OF LIVE MUSICAL PERFORMANCES (U.S. CLS. 100, 101 AND 107).

FIRST USE 8-24-2010; IN COMMERCE 8-24-2010.

DAWN HAN, EXAMINING ATTORNEY

SN 85-155,166. EDUCATIONDYNAMICS, LLC, HOBOKEN, NJ. FILED 10-18-2010.

**TEST DRIVE GRAD SCHOOL  
ONLINE**

THE MARK CONSISTS OF STANDARD CHARACTERS WITHOUT CLAIM TO ANY PARTICULAR FONT, STYLE, SIZE, OR COLOR.

**CLASS 38—COMMUNICATION**

FOR ELECTRONIC DELIVERY OF EDUCATIONAL CONTENT VIA A GLOBAL COMPUTER NETWORK; PROVIDING MULTIPLE USER ACCESS TO A GLOBAL COMPUTER NETWORK FEATURING COURSES OF INSTRUCTION AT THE GRADUATE LEVEL (U.S. CLS. 100, 101 AND 104).

**CLASS 41—EDUCATION AND ENTERTAINMENT**

FOR PROVIDING ONLINE COURSES OF INSTRUCTION AT THE GRADUATE SCHOOL LEVEL (U.S. CLS. 100, 101 AND 107).

JEFFREY LOOK, EXAMINING ATTORNEY

SN 85-155,171. UBS AG, STAMFORD BRANCH, STAMFORD, CT. FILED 10-18-2010.

**EXCELITAS TECHNOLOGIES**

THE MARK CONSISTS OF STANDARD CHARACTERS WITHOUT CLAIM TO ANY PARTICULAR FONT, STYLE, SIZE, OR COLOR.

NO CLAIM IS MADE TO THE EXCLUSIVE RIGHT TO USE "TECHNOLOGIES", APART FROM THE MARK AS SHOWN.

**CLASS 9—ELECTRICAL AND SCIENTIFIC APPARATUS**

FOR LABORATORY EQUIPMENT, NAMELY, PULSED LIGHT SOURCES, XENON LAMPS AND SUPPORTING ELECTRONIC CIRCUITS FOR USE IN THE FIELDS OF LIFE SCIENCE AND DEFENSE; INTEGRATED CIRCUITS AND SEMICONDUCTOR ARRAYS FOR LIGHT SENSING, MOLECULAR IMAGING, MEDICAL DIAGNOSTICS AND DEFENSE APPLICATIONS; OPTOELECTRONIC COMPONENTS, NAMELY, LIGHT EMITTING DIODES; PYROELECTRIC DETECTORS FOR DETECTING ELECTROMAGNETIC RADIATION; CHARGE COUPLED DEVICE CAMERAS FOR USE PRIMARILY IN THE FIELD OF BIOTECHNOLOGY; THERMOPILE SENSOR MODULES, EACH COMPRISING A THERMOPILE SENSOR AND SIGNAL PROCESSING CHIP WITHIN A HOUSING, FOR TEMPERATURE MEASUREMENT AND CONTROL IN A WIDE RANGE OF INDUSTRIAL, COMMERCIAL, RESIDENTIAL, APPLIANCE AND AUTOMOTIVE APPLICATIONS; SPECTROMETER COMPONENTS, NAMELY, ION DETECTORS; SAFETY SENSORS, NAMELY, SMOKE DETECTORS; X-RAY APPARATUS COMPONENTS, OTHER THAN FOR MEDICAL USE; ANTI-INTRUSION ALARMS; OCCUPANCY SENSORS, NAMELY, ELECTRONIC DEVICES WHICH DETECT THE PRESENCE OF OCCUPANTS AND CONTROL THE LIGHTING SYSTEM ACCORDINGLY; OPTOELECTRONIC EMITTERS AND DETECTORS FOR LASER RANGE FINDING, TARGET ACQUISITION DESIGNATION AND LASER WARNING SYSTEMS; ILLUMINATION SOURCES, NAMELY, REGULATORS FOR INFRARED COUNTERMEASURE SYSTEMS AND SPACE LIGHTING; RUBIDIUM TIME STANDARDS FOR GLOBAL POSITIONING SYSTEMS; POWER SUPPLIES FOR NAVIGATION AND COMMUNICATION; ENERGETIC INITIATION AND CONTROL DEVICES, NAMELY, ELECTRONIC CIRCUITS FOR USE IN FLIGHT TERMINATION, STAGE SEPARATION AND PAYLOAD INITIATION; LAMPS FOR USE IN VIDEO PROJECTORS AND OTHER VIDEO EQUIPMENT (U.S. CLS. 21, 23, 26, 36 AND 38).

**CLASS 11—ENVIRONMENTAL CONTROL APPARATUS**

FOR HIGH INTENSITY NARROW BEAM LAMPS, NAMELY, XENON LAMP ILLUMINATORS AND INFRARED ILLUMINATORS; LED LIGHT ENGINES (U.S. CLS. 13, 21, 23, 31 AND 34).

MATTHEW KLINE, EXAMINING ATTORNEY

SN 85-155,179. EDUCATIONDYNAMICS, LLC, HOBOKEN, NJ. FILED 10-18-2010.

TEST DRIVE GRAD SCHOOL  
ONLINE

THE MARK CONSISTS OF STANDARD CHARACTERS WITHOUT CLAIM TO ANY PARTICULAR FONT, STYLE, SIZE, OR COLOR.

**CLASS 35—ADVERTISING AND BUSINESS**

FOR ADMISSIONS SUPPORT SERVICES FOR EDUCATIONAL INSTITUTIONS, NAMELY, PROVIDING BUSINESS AND OFFICE SUPPORT SERVICES TO EDUCATIONAL INSTITUTIONS; PROVIDING ADVERTISING, MARKETING AND LEAD GENERATION SERVICES TO THIRD PARTIES; PROVIDING DATABASES FEATURING BUSINESS INFORMATION IN THE NATURE OF STUDENT CONTACT INFORMATION; DEVELOPMENT OF MARKETING PROGRAMS FOR EDUCATIONAL INSTITUTIONS, PARTICULARLY FOR ADMISSIONS ENROLLMENT MANAGEMENT SERVICES, RECRUITMENT AND RETENTION OF STUDENTS FOR EDUCATIONAL INSTITUTIONS; PROVIDING CONSUMER INFORMATION IN THE FIELD OF EDUCATION; CONSULTING SERVICES AND PROVIDING MARKETING, MANAGEMENT AND PROMOTIONAL PROGRAMS FOR INCREASING RECRUITMENT AND RETENTION RATES OF STUDENTS FOR EDUCATIONAL INSTITUTIONS (U.S. CLS. 100, 101 AND 102).

FIRST USE 7-1-2010; IN COMMERCE 7-1-2010.

**CLASS 41—EDUCATION AND ENTERTAINMENT**

FOR PROVIDING ONLINE SEARCHABLE DATABASES FEATURING INFORMATION ABOUT ONLINE COURSES OF STUDY; PROVIDING INFORMATION ONLINE RELATING TO EDUCATIONAL OPPORTUNITIES; EDUCATION SERVICES, NAMELY, PROVIDING OPPORTUNITIES FOR STUDENTS TO EXPERIENCE ONLINE COURSES OF INSTRUCTION AT THE POSTGRADUATE LEVEL; ADMISSIONS SCREENING FOR EDUCATIONAL INSTITUTIONS (U.S. CLS. 100, 101 AND 107).

FIRST USE 7-1-2010; IN COMMERCE 7-1-2010.

JEFFREY LOOK, EXAMINING ATTORNEY

SN 85-155,190. EDUCATIONDYNAMICS, LLC, HOBOKEN, NJ. FILED 10-18-2010.

TEST DRIVE COLLEGE ONLINE

THE MARK CONSISTS OF STANDARD CHARACTERS WITHOUT CLAIM TO ANY PARTICULAR FONT, STYLE, SIZE, OR COLOR.

**CLASS 35—ADVERTISING AND BUSINESS**

FOR ADMISSIONS SUPPORT SERVICES FOR EDUCATIONAL INSTITUTIONS, NAMELY, PROVIDING BUSINESS AND OFFICE SUPPORT SERVICES TO EDUCATIONAL INSTITUTIONS; PROVIDING ADVERTISING, MARKETING AND LEAD GENERATION SERVICES TO THIRD PARTIES; PROVIDING DATABASES FEATURING BUSINESS INFORMATION IN THE NATURE OF STUDENT CONTACT INFORMATION; DEVELOPMENT OF MARKETING PROGRAMS FOR EDUCATIONAL INSTITUTIONS, PARTICULARLY FOR ADMISSIONS ENROLLMENT MANAGEMENT SERVICES, RECRUITMENT AND RETENTION OF STUDENTS FOR EDUCATIONAL INSTITUTIONS; PROVIDING CONSUMER INFORMATION IN THE FIELD OF EDUCATION; CONSULTING SERVICES AND PROVIDING MARKETING, MANAGEMENT AND PROMOTIONAL PROGRAMS FOR INCREASING RECRUITMENT AND RETENTION RATES OF STUDENTS FOR EDUCATIONAL INSTITUTIONS (U.S. CLS. 100, 101 AND 102).

FIRST USE 3-0-2010; IN COMMERCE 3-0-2010.

**CLASS 38—COMMUNICATION**

FOR ELECTRONIC DELIVERY OF EDUCATIONAL CONTENT VIA A GLOBAL COMPUTER NETWORK; PROVIDING MULTIPLE USER ACCESS TO A GLOBAL COMPUTER NETWORK FEATURING COURSES OF INSTRUCTION AT THE COLLEGE LEVEL (U.S. CLS. 100, 101 AND 104).

FIRST USE 3-0-2010; IN COMMERCE 3-0-2010.

**CLASS 41—EDUCATION AND ENTERTAINMENT**

FOR PROVIDING ONLINE SEARCHABLE DATABASES FEATURING INFORMATION ABOUT ONLINE COURSES OF STUDY; PROVIDING INFORMATION ONLINE RELATING TO EDUCATIONAL OPPORTUNITIES; EDUCATION SERVICES, NAMELY, PROVIDING OPPORTUNITIES FOR STUDENTS TO EXPERIENCE ONLINE COURSES OF INSTRUCTION AT THE UNDERGRADUATE LEVEL; PROVIDING ONLINE COURSES OF INSTRUCTION AT THE UNDERGRADUATE LEVEL; ADMISSIONS SCREENING FOR EDUCATIONAL INSTITUTIONS (U.S. CLS. 100, 101 AND 107).

FIRST USE 3-0-2010; IN COMMERCE 3-0-2010.  
JEFFREY LOOK, EXAMINING ATTORNEY

SN 85-155,820. BAYER OY, 20210 TURKU, FINLAND, FILED 10-19-2010.

# ZIANTRA

THE MARK CONSISTS OF STANDARD CHARACTERS WITHOUT CLAIM TO ANY PARTICULAR FONT, STYLE, SIZE, OR COLOR.

PRIORITY CLAIMED UNDER SEC. 44(D) ON FINLAND APPLICATION NO. T201002401, FILED 9-3-2010, REG. NO. 250878, DATED 1-14-2011, EXPIRES 1-14-2021.

THE WORDING "ZIANTRA" HAS NO MEANING IN A FOREIGN LANGUAGE.

**CLASS 5—PHARMACEUTICALS**

FOR PHARMACEUTICAL PREPARATIONS, NAMELY, HORMONAL PREPARATIONS FOR MEDICAL USE (U.S. CLS. 6, 18, 44, 46, 51 AND 52).

**CLASS 10—MEDICAL APPARATUS**

FOR MEDICAL DEVICE, NAMELY, AN INTRAUTERINE DEVICE FOR CONTRACEPTION (U.S. CLS. 26, 39 AND 44).

ODESSA BIBBINS, EXAMINING ATTORNEY

SN 85-156,142. EYE LIGHTING INTERNATIONAL OF NORTH AMERICA, INC., MENTOR, OH. FILED 10-19-2010.

# HORTILUX

THE MARK CONSISTS OF STANDARD CHARACTERS WITHOUT CLAIM TO ANY PARTICULAR FONT, STYLE, SIZE, OR COLOR.

**CLASS 9—ELECTRICAL AND SCIENTIFIC APPARATUS**

FOR ELECTRIC LIGHTING BALLASTS (U.S. CLS. 21, 23, 26, 36 AND 38).

**CLASS 11—ENVIRONMENTAL CONTROL APPARATUS**

FOR ELECTRIC LIGHTING FIXTURES (U.S. CLS. 13, 21, 23, 31 AND 34).

DANNEAN HETZEL, EXAMINING ATTORNEY

SN 85-156,219. SHOPZILLA, INC., LOS ANGELES, CA. FILED 10-19-2010.



THE MARK CONSISTS OF THE WORD "TADA" INSIDE AN ENCLOSING GRAPHICAL ELEMENT.

**CLASS 9—ELECTRICAL AND SCIENTIFIC APPARATUS**

FOR DOWNLOADABLE ELECTRONIC NEWSLETTERS IN THE FIELD OF SHOPPING NEWS, NAMELY, SPECIAL DEALS AND DISCOUNTS FOR A WIDE VARIETY OF CONSUMER PRODUCTS OFFERED BY THIRD PARTIES; ON-LINE ELECTRONIC NEWSLETTERS DELIVERED BY E-MAIL IN THE FIELD OF CONSUMER SHOPPING NEWS, NAMELY, SPECIAL DEALS AND DISCOUNTS FOR A WIDE VARIETY OF CONSUMER PRODUCTS OFFERED BY THIRD PARTIES (U.S. CLS. 21, 23, 26, 36 AND 38).

FIRST USE 10-12-2010; IN COMMERCE 10-12-2010.

**CLASS 35—ADVERTISING AND BUSINESS**

FOR PROMOTING THE GOODS OF OTHERS THROUGH ONLINE ORDERING AND LISTING OF THOSE GOODS AND SERVICES; PROMOTING THE GOODS OF OTHERS BY MEANS OF OPERATING AN ON-LINE SHOPPING MALL WITH LINKS TO THE RETAIL WEB SITES OF OTHERS; PROVISION OF A WEB SITE FEATURING COMMERCIAL INFORMATION ON SHOPPING; PROMOTING THE GOODS OF OTHERS BY PROVIDING A WEB SITE FEATURING LINKS TO THE RETAIL WEB SITES OF OTHERS, AND DISCOUNT INFORMATION; PROMOTING THE SALE OF GOODS OF OTHERS THROUGH ELECTRONIC PROMOTIONS AND DISCOUNTS; PROMOTING THE GOODS OF OTHERS BY PROVIDING A COMMUNITY-DRIVEN WEB SITE FEATURING BUYING DEALS AND SPECIALS FOR THE GOODS OF OTHERS BASED ON A SPECIFIED LEVEL OF COMMUNITY PARTICIPATION (U.S. CLS. 100, 101 AND 102).

FIRST USE 10-12-2010; IN COMMERCE 10-12-2010.



**CLASS 41—EDUCATION AND ENTERTAINMENT**

FOR PROVIDING ON-LINE NEWSLETTERS IN THE FIELD OF CONSUMER SHOPPING NEWS, NAMELY, SPECIAL DEALS AND DISCOUNTS FOR A WIDE VARIETY OF CONSUMER PRODUCTS OFFERED BY THIRD PARTIES (U.S. CLS. 100, 101 AND 107).

FIRST USE 10-12-2010; IN COMMERCE 10-12-2010.  
ANGELA DUONG, EXAMINING ATTORNEY

SN 85-156,750. MCLENDON HARDWARE, INC., RENTON, WA. FILED 10-20-2010.

# MCLENDON

THE MARK CONSISTS OF STANDARD CHARACTERS WITHOUT CLAIM TO ANY PARTICULAR FONT, STYLE, SIZE, OR COLOR.

SEC. 2(F).

**CLASS 35—ADVERTISING AND BUSINESS**

FOR RETAIL STORE SERVICES FEATURING A WIDE VARIETY OF CONSUMER GOODS OF OTHERS (U.S. CLS. 100, 101 AND 102).

FIRST USE 0-0-1962; IN COMMERCE 0-0-1962.

SN 85-156,737. MCLENDON HARDWARE, INC., RENTON, WA. FILED 10-20-2010.

**CLASS 37—CONSTRUCTION AND REPAIR**

FOR INSTALLATION, MAINTENANCE AND REPAIR OF WINDOWS, DOORS, INSULATION, WATER HEATERS AND TANKLESS WATER HEATERS, FURNACES, PLUMBING FIXTURES, ELECTRICAL WIRING, HEAT PUMPS, AIR CONDITIONING, GENERATORS, DECKING AND RAILINGS, SIDING AND TRIM, GUTTERS AND CLOSET ORGANIZERS (U.S. CLS. 100, 103 AND 106).

FIRST USE 12-0-2007; IN COMMERCE 12-0-2007.  
JOHN KELLY, EXAMINING ATTORNEY



NO CLAIM IS MADE TO THE EXCLUSIVE RIGHT TO USE "COMPLETE HARDWARE", APART FROM THE MARK AS SHOWN.

THE MARK CONSISTS OF THE TERM "COMPLETE HARDWARE" IN A CIRCLE DESIGN BEHIND THE MARK "MCLENDON".

**CLASS 16—PAPER GOODS AND PRINTED MATTER**

FOR BALL POINT PENS; PAPER SHOPPING BAGS; PLASTIC SHOPPING BAGS (U.S. CLS. 2, 5, 22, 23, 29, 37, 38 AND 50).

FIRST USE 0-0-2000; IN COMMERCE 0-0-2000.

**CLASS 25—CLOTHING**

FOR HATS; SHIRTS; SWEATSHIRTS; VESTS (U.S. CLS. 22 AND 39).

FIRST USE 3-0-2003; IN COMMERCE 3-0-2003.

**CLASS 35—ADVERTISING AND BUSINESS**

FOR RETAIL STORE SERVICES FEATURING A WIDE VARIETY OF CONSUMER GOODS OF OTHERS (U.S. CLS. 100, 101 AND 102).

FIRST USE 12-0-1999; IN COMMERCE 12-0-1999.

**CLASS 37—CONSTRUCTION AND REPAIR**

FOR INSTALLATION, MAINTENANCE AND REPAIR OF WINDOWS, DOORS, INSULATION, WATER HEATERS AND TANKLESS WATER HEATERS, FURNACES, PLUMBING FIXTURES, ELECTRICAL WIRING, HEAT PUMPS, AIR CONDITIONING, GENERATORS, DECKING AND RAILINGS, SIDING AND TRIM, GUTTERS AND CLOSET ORGANIZERS (U.S. CLS. 100, 103 AND 106).

FIRST USE 12-0-2007; IN COMMERCE 12-0-2007.  
JOHN KELLY, EXAMINING ATTORNEY

SN 85-156,779. MCLENDON HARDWARE, INC., RENTON, WA. FILED 10-20-2010.



NO CLAIM IS MADE TO THE EXCLUSIVE RIGHT TO USE "COMPLETE HARDWARE", APART FROM THE MARK AS SHOWN.

THE MARK CONSISTS OF THE TERM "COMPLETE HARDWARE" IN A CIRCLE DESIGN BEHIND THE MARK "MCLENDON".

**CLASS 16—PAPER GOODS AND PRINTED MATTER**

FOR PUBLICATIONS, NAMELY, BROCHURES, BOOKLETS, NEWSLETTERS, ARTICLES AND HAND-OUTS IN THE FIELDS OF HOME IMPROVEMENT, CONSTRUCTION, DECORATING, GARDENING, LANDSCAPING AND RELATED ACTIVITIES (U.S. CLS. 2, 5, 22, 23, 29, 37, 38 AND 50).

**CLASS 18—LEATHER GOODS**

FOR REUSABLE SHOPPING BAGS (U.S. CLS. 1, 2, 3, 22 AND 41).

**CLASS 37—CONSTRUCTION AND REPAIR**

FOR RENTAL OF CONSTRUCTION AND BUILDING EQUIPMENT (U.S. CLS. 100, 103 AND 106).

JOHN KELLY, EXAMINING ATTORNEY

SN 85-158,899. AEVIDUM, LANCASTER, PA. FILED 10-22-2010.

# AEVIDUM

THE MARK CONSISTS OF STANDARD CHARACTERS WITHOUT CLAIM TO ANY PARTICULAR FONT, STYLE, SIZE, OR COLOR.

## CLASS 35—ADVERTISING AND BUSINESS

FOR (BASED ON USE IN COMMERCE) CHARITABLE SERVICES, NAMELY, PROMOTION OF PUBLIC AWARENESS IN THE AREA OF DEPRESSION, MENTAL HEALTH, AND SUICIDE PREVENTION (U.S. CLS. 100, 101 AND 102).

FIRST USE 12-15-2007; IN COMMERCE 12-15-2007.

## CLASS 41—EDUCATION AND ENTERTAINMENT

FOR (BASED ON INTENT TO USE) EDUCATION SERVICES, SPECIFICALLY CONDUCTING TRAINING AND SEMINARS IN THE AREA OF DEPRESSION, MENTAL HEALTH, AND SUICIDE PREVENTION; ENTERTAINMENT SERVICES IN THE NATURE OF ORGANIZING AND PRESENTING LIVE MUSICAL PERFORMANCES, DANCE PERFORMANCES, THEATER PRODUCTIONS (U.S. CLS. 100, 101 AND 107).

KELLY BOULTON, EXAMINING ATTORNEY

SN 85-159,406. ADVANCED ANALYTIXS, INC., PALO ALTO, CA. FILED 10-22-2010.

# VENUECUBE

THE MARK CONSISTS OF STANDARD CHARACTERS WITHOUT CLAIM TO ANY PARTICULAR FONT, STYLE, SIZE, OR COLOR.

## CLASS 35—ADVERTISING AND BUSINESS

FOR BUSINESS MANAGEMENT AND BUSINESS DATA MANAGEMENT SERVICES AS THEY RELATE TO LIVE EVENTS AND ASSEMBLIES, PROVIDING COLLECTION, VISUALIZATION, INTEGRATION, AND ANALYSIS OF DATA PERTAINING TO TICKETING, MARKETING, FINANCIAL, OPERATIONAL, AND FUNDRAISING DATA (U.S. CLS. 100, 101 AND 102).

## CLASS 42—SCIENTIFIC AND COMPUTER SERVICES

FOR PROVIDING USE OF ONLINE, NON-DOWNLOADABLE SOFTWARE FOR DATA MANAGEMENT SERVICES RELATED TO LIVE EVENTS OR ASSEMBLIES (U.S. CLS. 100 AND 101).

TOBY BULLOFF, EXAMINING ATTORNEY

SN 85-160,214. AMERICAN ADVERTISING FEDERATION, WASHINGTON, DC. FILED 10-25-2010.

# ADMERICA!

THE MARK CONSISTS OF STANDARD CHARACTERS WITHOUT CLAIM TO ANY PARTICULAR FONT, STYLE, SIZE, OR COLOR.

## CLASS 35—ADVERTISING AND BUSINESS

FOR SPONSORING AND ORGANIZING EXHIBITIONS AND TRADESHOWS FOR COMMERCIAL OR ADVERTISING PURPOSES TO PROMOTE NEW PRODUCTS AND SERVICES IN THE ADVERTISING INDUSTRY; BUSINESS NETWORKING (U.S. CLS. 100, 101 AND 102).

## CLASS 41—EDUCATION AND ENTERTAINMENT

FOR EDUCATIONAL SERVICES, NAMELY, SPONSORING AND ORGANIZING AN ANNUAL CONFERENCE FOR MEMBERS OF THE ADVERTISING INDUSTRY TO DISCUSS AND HOLD WORKSHOPS ON ADVERTISING INDUSTRY TRENDS AND IDEAS AND PROVIDING INCENTIVE AWARDS TO INDIVIDUALS AND COMPANIES THAT DEMONSTRATE EXCELLENCE IN THE ADVERTISING FIELD (U.S. CLS. 100, 101 AND 107).

ALICIA COLLINS, EXAMINING ATTORNEY

SN 85-161,065. BREAD POETS FRANCHISING, BISMARCK, ND. FILED 10-26-2010.



OWNER OF U.S. REG. NOS. 2,300,885 AND 3,797,244. NO CLAIM IS MADE TO THE EXCLUSIVE RIGHT TO USE "SANDWICH SHOP" OR "BREAD", APART FROM THE MARK AS SHOWN.

THE MARK CONSISTS OF A RISING SUN OVER TWO HILLS, ALL WITHIN A TRIANGLE CENTERED OVER THE WORDING "SONNETS SANDWICH SHOP BY BREAD POETS".

## CLASS 30—STAPLE FOODS

FOR BAKERY PRODUCTS (U.S. CL. 46).  
FIRST USE 9-30-2010; IN COMMERCE 9-30-2010.

## CLASS 43—HOTEL AND RESTAURANT SERVICES

FOR RESTAURANT SERVICES FEATURING SANDWICHES (U.S. CLS. 100 AND 101).  
FIRST USE 9-30-2010; IN COMMERCE 9-30-2010.  
IRA J. GOODSARD, EXAMINING ATTORNEY

SN 85-162,379. CULTIVE FRANCHISE, LLC, DAVIS, CA.  
FILED 10-27-2010.

SN 85-164,639. MUELLER SPORTS MEDICINE, INC., PRAIRIE DU SAC, WI. FILED 10-29-2010.



OWNER OF U.S. REG. NO. 3,745,197.  
NO CLAIM IS MADE TO THE EXCLUSIVE RIGHT TO USE "FROZEN YOGURT", APART FROM THE MARK AS SHOWN.

THE COLOR(S) GREEN AND ORANGE IS/ARE CLAIMED AS A FEATURE OF THE MARK.

THE MARK CONSISTS OF THE WORD "CULTIVÉ" IN GREEN WHEREIN THE DOT ABOVE THE "I" IN THE WORD "CULTIVE" IS REPLACED WITH AN ORANGE FLOWER SHAPE HAVING ONE GREEN DISPLACED PEDAL; THE WORDS "FROZEN YOGURT" IN ORANGE CAPITAL LETTERS APPEAR DIRECTLY UNDERNEATH THE WORD "CULTIVE".

THE ENGLISH TRANSLATION OF "CULTIVE" IS "CULTIVATED".

#### CLASS 30—STAPLE FOODS

FOR FROZEN YOGURT AND FROZEN YOGURT BASED DESSERTS (U.S. CL. 46).  
FIRST USE 6-17-2008; IN COMMERCE 6-17-2008.

#### CLASS 43—HOTEL AND RESTAURANT SERVICES

FOR RESTAURANT SERVICES FEATURING FROZEN YOGURT AND FROZEN YOGURT BASED DESSERTS FOR ON AND OFF PREMISES CONSUMPTION (U.S. CLS. 100 AND 101).  
FIRST USE 6-17-2008; IN COMMERCE 6-17-2008.  
ALEX KEAM, EXAMINING ATTORNEY

SN 85-164,448. HOECHST GMBH, FRANKFURT AM MAIN, FED REP GERMANY, FILED 10-29-2010.

# OPTIDIAL

THE MARK CONSISTS OF STANDARD CHARACTERS WITHOUT CLAIM TO ANY PARTICULAR FONT, STYLE, SIZE, OR COLOR.

OWNER OF ERPN CMNTY TM OFC REG. NO. 2064970, DATED 4-2-2002, EXPIRES 1-2-2021.  
OWNER OF U.S. REG. NO. 2,901,004.

#### CLASS 5—PHARMACEUTICALS

FOR INSULIN PREPARATIONS (U.S. CLS. 6, 18, 44, 46, 51 AND 52).

#### CLASS 10—MEDICAL APPARATUS

FOR MEDICAL DEVICES AND APPARATUS, NAMELY, DISPOSABLE PENS FOR INSULIN (U.S. CLS. 26, 39 AND 44).  
REBECCA GILBERT, EXAMINING ATTORNEY

## FITNESS CARE

THE MARK CONSISTS OF STANDARD CHARACTERS WITHOUT CLAIM TO ANY PARTICULAR FONT, STYLE, SIZE, OR COLOR.

NO CLAIM IS MADE TO THE EXCLUSIVE RIGHT TO USE "FITNESS", APART FROM THE MARK AS SHOWN.

#### CLASS 5—PHARMACEUTICALS

FOR TAPE AND TAPING SUPPLIES FOR MEDICAL PURPOSES, NAMELY, MEDICAL ADHESIVE TAPE, MEDICAL COHESIVE TAPE, MEDICAL PRETAPING FOAM UNDERWRAP, MEDICAL PRETAPING SPRAY ADHERENT; FIRST AID KITS; ATHLETIC TRAINERS' KITS COMPRISED PRIMARILY OF ADHESIVE BANDAGES, MEDICAL ADHESIVE TAPE, GAUZE PADS FOR DRESSINGS, MEDICAL COHESIVE TAPE, ANTI-BIOTIC OINTMENTS, ANTISEPTIC SPRAY, SPRAY-ON BANDAGES AND ICE BAGS FOR MEDICAL PURPOSES; ANALGESIC OINTMENTS AND BALMS; MEDICAL AND SURGICAL DRESSINGS, NAMELY, BLISTER PADS, WOUND DRESSINGS; NONMEDICATED TOPICAL GELS AND OINTMENTS FOR USE AS PERSONAL LUBRICANTS ON SKIN; ALL PURPOSE DISINFECTANTS AND ANTIBACTERIAL CLEANERS FOR SURFACES; SPRAY ON BANDAGES FOR SKIN WOUNDS; ANTISEPTIC SPRAYS AND OINTMENTS FOR MEDICAL USE; ADHESIVE BANDAGES (U.S. CLS. 6, 18, 44, 46, 51 AND 52).

#### CLASS 10—MEDICAL APPARATUS

FOR COHESIVE SUPPORT BANDAGES, COHESIVE COMPRESSION BANDAGES; COLD-HOT THERAPY PRODUCTS FOR MEDICAL PURPOSES, NAMELY, ICE BAGS, CHEMICALLY ACTIVATED COLD PACKS, CHEMICALLY ACTIVATED INSTANT COLD PACKS, COLD-HOT THERMAL PACKS FOR FIRST AID PURPOSES, SPRAY COOLANT FOR SKIN FOR MEDICAL PURPOSES, MEDICAL COLD-HOT WRAPS; ELASTIC BANDAGES, ELASTIC SUPPORT WRAPS FOR MEDICAL PURPOSES; MEDICAL AND ORTHOPEDIC PRODUCTS, NAMELY, ORTHOPEDIC BRACES, ANKLE BRACES, ANKLE SUPPORTS, ANKLE STABILIZERS, KNEE BRACES, KNEE SUPPORTS, KNEE STABILIZERS, KNEE SLEEVES, KNEE STRAPS, ELBOW SLEEVES, ELBOW SUPPORTS, WRIST BRACES, WRIST SUPPORTS, WRIST STABILIZERS, WRIST SLEEVES, COMPRESSION GLOVES, BACK BRACES, BACK SUPPORTS, BACK STABILIZERS, THUMB STABILIZERS, SHOULDER BRACES, THIGH SLEEVES, THIGH SUPPORTS, CALF/SHIN SUPPORTS, ARM SLINGS (U.S. CLS. 26, 39 AND 44).

#### CLASS 28—TOYS AND SPORTING GOODS

FOR TAPE AND TAPING SUPPLIES FOR ATHLETIC PURPOSES, NAMELY, ATHLETIC ADHESIVE TAPE, ATHLETIC COHESIVE TAPE AND BANDAGES, ATHLETIC PRETAPING FOAM UNDERWRAP, ATHLETIC PRETAPING SPRAY ADHERENT; GLARE REDUCING UNDER EYE STRIPS, EYE BLACK PASTE FOR REDUCING SUN GLARE FOR SPORTS ACTIVITIES; ATHLETIC SPORTING GOODS, NAMELY, ATHLETIC WRIST AND JOINT SUPPORTS, ANKLE BRACES, ANKLE SUPPORTS, ANKLE STABILIZERS, KNEE BRACES, KNEE SUPPORTS, KNEE STABILIZERS, KNEE PADS FOR ATHLETIC USE, KNEE SLEEVES, KNEE STRAPS, ELBOW SLEEVES, ELBOW SUPPORTS, ELBOW PADS FOR ATHLETIC USE, WRIST BRACES, WRIST SUPPORTS, WRIST STABILIZERS, WRIST SLEEVES, BACK BRACES, BACK SUPPORTS, BACK STABILIZERS, THUMB STABILIZERS, SHOULDER BRACES, THIGH SLEEVES, THIGH SUPPORTS, CALF/SHIN SUPPORTS, ARM SLINGS; COMPRESSION GLOVES FOR ATHLETIC

USE; MOUTH GUARDS FOR ATHLETIC USE; NOSE GUARDS FOR ATHLETIC USE; ATHLETIC SUPPORTERS, JOCK STRAPS, PROTECTIVE ATHLETIC CUPS, ATHLETIC SUPPORT BRIEFS; PROTECTIVE COLLARS FOR FASTENING TO FOOTBALL SHOULDER PADS; NONMEDICATED LUBRICATING OINTMENTS AND GELS FOR REDUCING SKIN FRICTION IN SPORTS ACTIVITIES AND RUNNING; GRIP ENHANCERS FOR USE IN ATHLETIC ACTIVITIES, NAMELY, CHALK, CRUSHED AND POWDERED ROSIN, WATER REPELLING SPRAY FOR HANDS, ADHESIVE POWDER FOR HANDS, AEROSOL ADHESIVE NON-SLIP RESIN SPRAY FOR HANDS, AND PINE TAR FOR ATHLETIC EQUIPMENT (U.S. CLS. 22, 23, 38 AND 50).

JAY BESCH, EXAMINING ATTORNEY

SN 85-165,323, SHELDON D. LIBER, SANTA MONICA, CA, FILED 10-29-2010.

## CHASING VALUE

THE MARK CONSISTS OF STANDARD CHARACTERS WITHOUT CLAIM TO ANY PARTICULAR FONT, STYLE, SIZE, OR COLOR.

NO CLAIM IS MADE TO THE EXCLUSIVE RIGHT TO USE "VALUE", APART FROM THE MARK AS SHOWN.

### CLASS 9—ELECTRICAL AND SCIENTIFIC APPARATUS

FOR DOWNLOADABLE ELECTRONIC NEWSLETTERS IN THE FIELD OF INVESTING AND FINANCIAL INVESTMENT SERVICES; COMPUTER SOFTWARE AND COMPUTER SOFTWARE APPLICATIONS, NAMELY, SOFTWARE FOR MANAGING FINANCES AND INVESTMENTS AND FUND MANAGEMENT AND FOR USE IN DELIVERING INFORMATION, ADVICE, QUOTATIONS, SAYINGS, FACTS, AND TIPS REGARDING FINANCE AND INVESTING (U.S. CLS. 21, 23, 26, 36 AND 38).

### CLASS 36—INSURANCE AND FINANCIAL

FOR FINANCIAL AND INVESTMENT SERVICES, NAMELY, HEDGE FUND, OPPORTUNITY FUND AND MUTUAL FUND INVESTMENT SERVICES; FINANCIAL MANAGEMENT; FINANCIAL MANAGEMENT SERVICES, NAMELY, FUNDS INVESTMENT, CLOSED END FUNDS, ALTERNATIVE INVESTMENT STRATEGY FUNDS, AND INVESTMENT OF FUNDS FOR OTHERS; CONSULTATION IN THE FIELD OF FINANCIAL AND INVESTMENT SERVICES, HEDGE FUNDS AND MUTUAL FUNDS; PRIVATE PLACEMENT OF FUNDS; FINANCIAL PLANNING; FINANCIAL INVESTMENT SERVICES; FINANCIAL ASSET MANAGEMENT SERVICES; INVESTMENT ADVISORY SERVICES; PROVIDING A WEBSITE FEATURING INFORMATION IN THE FIELD OF FINANCIAL INVESTMENT SERVICES, AND HEDGE FUNDS AND MUTUAL FUNDS; PROVIDING ONLINE NEWS IN THE FIELD OF FINANCE AND INVESTING (U.S. CLS. 100, 101 AND 102).

### CLASS 41—EDUCATION AND ENTERTAINMENT

FOR PROVIDING AN ONLINE COLUMN IN THE FIELD OF INVESTING, FINANCIAL AND INVESTMENT SERVICES; PROVIDING AN ONLINE BLOG AND NEWSLETTER ABOUT INVESTING AND FINANCIAL AND INVESTMENT SERVICES; EDUCATION SERVICES, NAMELY, PROVIDING LIVE AND ON-LINE CLASSES, EDUCATIONAL COURSES, SEMINARS AND WORKSHOPS IN THE FIELD OF FINANCE, INVESTING AND INVESTMENT SERVICES (U.S. CLS. 100, 101 AND 107).

WILLIAM BRECKENFELD, EXAMINING ATTORNEY

SN 85-165,406, TEMASEK HOLDINGS (PRIVATE) LIMITED, SINGAPORE, SINGAPORE, FILED 10-29-2010.

### TEMASEK INVESTMENT SERVICES

THE MARK CONSISTS OF STANDARD CHARACTERS WITHOUT CLAIM TO ANY PARTICULAR FONT, STYLE, SIZE, OR COLOR.

OWNER OF U.S. REG. NO. 3,187,580.

NO CLAIM IS MADE TO THE EXCLUSIVE RIGHT TO USE "INVESTMENT SERVICES", APART FROM THE MARK AS SHOWN.

### CLASS 35—ADVERTISING AND BUSINESS

FOR BUSINESS MANAGEMENT; BUSINESS ADMINISTRATION; PROFESSIONAL BUSINESS CONSULTANCY; BUSINESS MANAGEMENT AND ORGANIZATION CONSULTANCY; BUSINESS MANAGEMENT CONSULTANCY; ADVISORY SERVICES FOR BUSINESS MANAGEMENT (U.S. CLS. 100, 101 AND 102).

### CLASS 36—INSURANCE AND FINANCIAL

FOR FINANCIAL SERVICES, NAMELY, FINANCIAL PLANNING, FINANCIAL MANAGEMENT, FINANCIAL RESEARCH, FINANCIAL CONSULTATION; INVESTMENT SERVICES, NAMELY, MUTUAL FUND INVESTMENT; MUTUAL FUNDS, NAMELY, MUTUAL FUND DISTRIBUTION AND ESTABLISHING MUTUAL FUNDS FOR OTHERS; FINANCIAL CONSULTANCY SERVICES; FINANCIAL MANAGEMENT SERVICES; FUNDS INVESTMENT; CAPITAL INVESTMENTS (U.S. CLS. 100, 101 AND 102).

### CLASS 41—EDUCATION AND ENTERTAINMENT

FOR EDUCATIONAL SERVICES, NAMELY, CLASSES AND SEMINARS IN THE FIELD OF FINANCIAL AND BUSINESS MATTERS; TRAINING SERVICES IN THE FIELD OF FINANCIAL AND BUSINESS MATTERS; ARRANGING AND CONDUCTING OF EDUCATIONAL CONFERENCES, CONGRESSES, SEMINARS, SYMPOSIUMS AND TRAINING WORKSHOPS ALL IN THE FIELDS OF BUSINESS AND FINANCE (U.S. CLS. 100, 101 AND 107).

LINDA ESTRADA, EXAMINING ATTORNEY

SN 85-166,036, MICHAEL FOODS OF DELAWARE, INC., MINNETONKA, MN, FILED 11-1-2010.

## CHOOSE BETTER

THE MARK CONSISTS OF STANDARD CHARACTERS WITHOUT CLAIM TO ANY PARTICULAR FONT, STYLE, SIZE, OR COLOR.

**CLASS 29—MEATS AND PROCESSED FOODS**

FOR BUTTER, CHEESE; FROZEN PROCESSED POTATOES, EGGS, LIQUID EGGS, EGG SUBSTITUTES (U.S. CL. 46).

**CLASS 30—STAPLE FOODS**

FOR BAGELS; ENGLISH MUFFINS (U.S. CL. 46).  
JANICE KIM, EXAMINING ATTORNEY

SN 85-166,561. DECISION NUTRITION PLLC, GREAT NECK, NY. FILED 11-1-2010.

HD

THE MARK CONSISTS OF STANDARD CHARACTERS WITHOUT CLAIM TO ANY PARTICULAR FONT, STYLE, SIZE, OR COLOR.

SN 85-166,520. DECISION NUTRITION PLLC, GREAT NECK, NY. FILED 11-1-2010.

**CLASS 16—PAPER GOODS AND PRINTED MATTER**

FOR PUBLICATIONS, NAMELY, BOOKS, JOURNALS, PAMPHLETS, BROCHURES, AND NEWSLETTERS PERTAINING TO THE FIELDS OF NUTRITION, WEIGHT LOSS AND MAINTENANCE, HEALTH AND FITNESS (U.S. CLS. 2, 5, 22, 23, 29, 37, 38 AND 50).

**CLASS 44—MEDICAL, BEAUTY AND AGRICULTURAL SERVICES**

FOR DIETITIAN SERVICES AND NUTRITIONAL COUNSELING; SERVICES RENDERED BY A DIETITIAN, NAMELY, WEIGHT DIET PLANNING AND PROGRAMMING; PROVIDING WEIGHT LOSS PROGRAM SERVICES; NUTRITION COUNSELING SERVICES; WEIGHT REDUCTION DIET PLANNING AND SUPERVISION; FOOD NUTRITION CONSULTATION SERVICES; WEIGHT CONTROL EVALUATION SERVICES; WEIGHT CONTROL TREATMENT SERVICES; COUNSELING SERVICES IN THE FIELD OF WEIGHT LOSS, WEIGHT CONTROL, WEIGHT MAINTENANCE AND NUTRITION; PERSONAL SERVICES, NAMELY, DIET AND WELLNESS PLANNING AND SUPERVISION FOR WEIGHT LOSS, WEIGHT CONTROL AND WEIGHT MAINTENANCE; PROVIDING A WEB SITE FEATURING INFORMATION ABOUT WEIGHT LOSS, WEIGHT CONTROL AND MAINTENANCE, DIET AND EATING HABITS, NUTRITION, HEALTH AND LIFESTYLE WELLNESS (U.S. CLS. 100 AND 101).

RICHARD WHITE, EXAMINING ATTORNEY

DECISION NUTRITION

THE MARK CONSISTS OF STANDARD CHARACTERS WITHOUT CLAIM TO ANY PARTICULAR FONT, STYLE, SIZE, OR COLOR.

NO CLAIM IS MADE TO THE EXCLUSIVE RIGHT TO USE "NUTRITION", APART FROM THE MARK AS SHOWN.

**CLASS 16—PAPER GOODS AND PRINTED MATTER**

FOR PUBLICATIONS, NAMELY, BOOKS, JOURNALS, PAMPHLETS, BROCHURES, AND NEWSLETTERS PERTAINING TO THE FIELDS OF NUTRITION, WEIGHT LOSS AND MAINTENANCE, HEALTH AND FITNESS (U.S. CLS. 2, 5, 22, 23, 29, 37, 38 AND 50).

**CLASS 44—MEDICAL, BEAUTY AND AGRICULTURAL SERVICES**

FOR DIETITIAN SERVICES AND NUTRITIONAL COUNSELING; SERVICES RENDERED BY A DIETITIAN, NAMELY, WEIGHT DIET PLANNING AND PROGRAMMING; PROVIDING WEIGHT LOSS PROGRAM SERVICES; NUTRITION COUNSELING SERVICES; WEIGHT REDUCTION DIET PLANNING AND SUPERVISION; FOOD NUTRITION CONSULTATION SERVICES; WEIGHT CONTROL EVALUATION SERVICES; WEIGHT CONTROL TREATMENT SERVICES; COUNSELING SERVICES IN THE FIELD OF WEIGHT LOSS, WEIGHT CONTROL, WEIGHT MAINTENANCE AND NUTRITION; PERSONAL SERVICES, NAMELY, DIET AND WELLNESS PLANNING AND SUPERVISION FOR WEIGHT LOSS, WEIGHT CONTROL AND WEIGHT MAINTENANCE; PROVIDING A WEB SITE FEATURING INFORMATION ABOUT WEIGHT LOSS, WEIGHT CONTROL AND MAINTENANCE, DIET AND EATING HABITS, NUTRITION, HEALTH AND LIFESTYLE WELLNESS (U.S. CLS. 100 AND 101).

RICHARD WHITE, EXAMINING ATTORNEY

SN 85-166,597. CONSUMER INSIGHT, INC., SANTA MONICA, CA. FILED 11-1-2010.



NO CLAIM IS MADE TO THE EXCLUSIVE RIGHT TO USE "FOOD NEWS", APART FROM THE MARK AS SHOWN.

THE NAME "PHILIP LEMPERT" IDENTIFIES A LIVING INDIVIDUAL WHOSE CONSENT IS OF RECORD.

THE MARK CONSISTS OF THE NAME "PHIL LEMPERT'S", THE WORDS "FOOD NEWS TODAY", AND THREE STYLIZED DRAWINGS OF GROCERY BAGS, EACH OF WHICH BEARS ONE OF THE LETTERS "F N T".

**CLASS 38—COMMUNICATION**

FOR PROVIDING ON-LINE FACILITIES FOR REAL-TIME INTERACTION WITH OTHER COMPUTER USERS AND ELECTRONIC BULLETIN BOARDS FOR TRANSMISSION OF MESSAGES AMONG USERS IN THE FIELD OF THE RETAIL FOOD INDUSTRY, CONSUMER FOOD-BUYING HABITS AND TRENDS, AND NEW FOOD PRODUCTS (U.S. CLS. 100, 101 AND 104).

FIRST USE 10-27-2010; IN COMMERCE 10-27-2010.

**CLASS 41—EDUCATION AND ENTERTAINMENT**

FOR ENTERTAINMENT AND EDUCATION SERVICES, NAMELY, ONGOING AUDIO/VISUAL NEWS SEGMENTS PROVIDING INFORMATION CONCERNING THE RETAIL FOOD INDUSTRY, CONSUMER FOOD-BUYING HABITS AND TRENDS, AND NEW FOOD PRODUCTS (U.S. CLS. 100, 101 AND 107).

FIRST USE 10-27-2010; IN COMMERCE 10-27-2010.

KEVIN CORWIN, EXAMINING ATTORNEY

SN 85-167,428. RICHARD EMARD, ROSEVILLE, CA. FILED 11-2-2010.



THE COLOR(S) BLUE, WHITE, BLACK, ORANGE IS/ARE CLAIMED AS A FEATURE OF THE MARK.

THE MARK CONSISTS OF A SOLAR COLLECTOR IMAGE WITH A THICK BLUE BORDER ON MOST OF THE TOP AND LEFT SIDE, AND A THINNER BLACK OUTER BORDER AROUND THE ENTIRE IMAGE. BLACK LINES CREATE A GRID OF QUADRILATERALS ON THE INTERIOR PANEL IMAGE WHICH FADES FROM WHITE INTO BLUE. THE SOLAR COLLECTOR IMAGE IS POSITIONED TO THE LEFT OF AND PARTIALLY BEHIND THE ORANGE LETTERS "SWKS". SIX ORANGE SUN RAYS, WHICH ALTERNATE FROM LONG TO SHORT, EMANATE FROM THE UPPER RIGHT CORNER OF THE SOLAR COLLECTOR IMAGE.

THE WORDING "SWKS" HAS NO MEANING IN A FOREIGN LANGUAGE.

SN 85-167,392. RACK ROOM SHOES OF VIRGINIA, LLC, CHARLOTTE, NC. FILED 11-2-2010.



OWNER OF U.S. REG. NOS. 1,214,465, 1,915,708 AND 3,362,476.

NO CLAIM IS MADE TO THE EXCLUSIVE RIGHT TO USE "SHOES" AND "SHIP TO HOME", APART FROM THE MARK AS SHOWN.

THE MARK CONSISTS OF A STYLIZED TRUCK. "RACK ROOM SHOES," SURROUNDED BY A SQUARE-SHAPED OUTLINE MADE WITH DOTTED LINES, AND WITH THIN, DOTTED LINES BENEATH THE WORDS "RACK" AND "ROOM," APPEAR ON THE SIDE OF THE TRAILER OF THE TRUCK. BOTH THE OUTLINED SQUARE AND THE WORDS "RACK ROOM SHOES" ARE TILTED UP AT A 20-DEGREE ANGLE TO THE RIGHT. THE LETTER "S" APPEARS IN THE TIRE ON THE BACK AXLE; THE NUMBER "2" APPEARS IN THE TIRE ON THE CENTER AXLE; THE LETTER "H" APPEARS IN THE TIRE ON THE FRONT AXLE. BENEATH THE IMAGE OF THE TRUCK ARE THE LETTERS AND DIGITS "SHIP2HOME".

**CLASS 25—CLOTHING**

FOR FOOTWEAR (U.S. CLS. 22 AND 39).

**CLASS 35—ADVERTISING AND BUSINESS**

FOR RETAIL DEPARTMENT STORE SERVICES, DIRECT MAIL ORDER CATALOG SERVICES AND COMPUTERIZED ONLINE RETAIL DEPARTMENT STORE SERVICES FEATURING FOOTWEAR (U.S. CLS. 100, 101 AND 102).

NANCY CLARKE, EXAMINING ATTORNEY

**CLASS 35—ADVERTISING AND BUSINESS**

FOR FRANCHISE SERVICES, NAMELY, OFFERING BUSINESS MANAGEMENT ASSISTANCE IN THE ESTABLISHMENT AND OPERATION OF BUSINESSES THAT INSTALL AND MAINTAIN SOLAR PHOTOVOLTAIC SYSTEMS; FRANCHISING, NAMELY, OFFERING BUSINESS MANAGEMENT ASSISTANCE IN THE ESTABLISHMENT AND/OR OPERATION BUSINESSES THAT INSTALL AND MAINTAIN SOLAR PHOTOVOLTAIC SYSTEMS (U.S. CLS. 100, 101 AND 102).

**CLASS 37—CONSTRUCTION AND REPAIR**

FOR INSTALLATION AND MAINTENANCE OF PHOTOVOLTAIC/SOLAR THERMAL HYBRID INSTALLATIONS; INSTALLATION AND MAINTENANCE OF SOLAR THERMAL INSTALLATIONS; INSTALLATION OF SOLAR ENERGY SYSTEMS AND ALTERNATIVE ENERGY PRODUCTS FOR RESIDENTIAL AND COMMERCIAL USE; REPAIR AND INSTALLATION SERVICES, NAMELY, THE INSTALLATION OF HEATING, COOLING AND ENVIRONMENTAL CONTROL SYSTEMS PRIMARILY USING SOLAR ENERGY, RENEWABLE ENERGY RESOURCES AND RAINWATER (U.S. CLS. 100, 103 AND 106).

NELSON SNYDER, EXAMINING ATTORNEY

SN 85-167,438. NATIONAL ASSOCIATION OF PROFESSIONALLY ACCREDITED CONTRACTORS LLC, GREAT FALLS, VA. FILED 11-2-2010.

**NAPAC**

THE MARK CONSISTS OF STANDARD CHARACTERS WITHOUT CLAIM TO ANY PARTICULAR FONT, STYLE, SIZE, OR COLOR.

**CLASS 35—ADVERTISING AND BUSINESS**

FOR LOBBYING SERVICES, NAMELY, PROMOTING THE INTERESTS OF PROFESSIONAL CONTRACTORS IN THE HOME IMPROVEMENT AND REMODELING INDUSTRY IN THE FIELDS OF LEGISLATION AND REGULATION (U.S. CLS. 100, 101 AND 102).

FIRST USE 8-1-2010; IN COMMERCE 8-1-2010.

**CLASS 37—CONSTRUCTION AND REPAIR**

FOR PROVIDING ONLINE INFORMATION ABOUT HOME IMPROVEMENT AND REMODELING FOR PROFESSIONAL CONTRACTORS IN THE HOME IMPROVEMENT AND REMODELING INDUSTRY (U.S. CLS. 100, 103 AND 106).

FIRST USE 8-1-2010; IN COMMERCE 8-1-2010.

**CLASS 41—EDUCATION AND ENTERTAINMENT**

FOR CONDUCTING INSTRUCTIONAL AND TRAINING SEMINARS ABOUT THE LICENSING AND ACCREDITATION OF PROFESSIONAL CONTRACTORS IN THE HOME IMPROVEMENT AND REMODELING INDUSTRY AND DISTRIBUTION OF COURSE MATERIALS IN CONNECTION THEREWITH (U.S. CLS. 100, 101 AND 107).

FIRST USE 8-1-2010; IN COMMERCE 8-1-2010.

JOHN KELLY, EXAMINING ATTORNEY

---

SN 85-168,025. CUSTOM COUNTRY, LLC, CHARLESTON, SC. FILED 11-3-2010.

# YOUSA

THE MARK CONSISTS OF STANDARD CHARACTERS WITHOUT CLAIM TO ANY PARTICULAR FONT, STYLE, SIZE, OR COLOR.

THE WORDING "YOUSA" HAS NO MEANING IN A FOREIGN LANGUAGE.

**CLASS 24—FABRICS**

FOR BANNERS, FLAGS, AND TOWELS OF TEXTILES (U.S. CLS. 42 AND 50).

**CLASS 25—CLOTHING**

FOR APPAREL, NAMELY, T-SHIRTS, SPORT JERSEYS, SWEATSHIRTS, FLEECE PULLOVERS, FLEECE JACKETS, SPORTS BRAS, WORKOUT SHIRTS, SWIMSUITS, SHORTS, PANTS, POLO SHIRTS, AND BUTTON DOWN SHIRTS (U.S. CLS. 22 AND 39).

**CLASS 35—ADVERTISING AND BUSINESS**

FOR ON-LINE RETAIL STORE SERVICES IN THE FIELD OF CUSTOMIZED BANNERS, FLAGS, AND TOWELS OF TEXTILES, AND CUSTOMIZED APPAREL (U.S. CLS. 100, 101 AND 102).

WARREN L. OLANDRIA, EXAMINING ATTORNEY

SN 85-168,121. RMEL, CENTENNIAL, CO. FILED 11-3-2010.

# ELECTRIC ENERGY

THE MARK CONSISTS OF STANDARD CHARACTERS WITHOUT CLAIM TO ANY PARTICULAR FONT, STYLE, SIZE, OR COLOR.

SEC. 2(F).

**CLASS 9—ELECTRICAL AND SCIENTIFIC APPARATUS**

FOR DOWNLOADABLE MAGAZINES IN THE FIELD OF ENERGY (U.S. CLS. 21, 23, 26, 36 AND 38).

FIRST USE 8-0-2000; IN COMMERCE 8-0-2000.

**CLASS 16—PAPER GOODS AND PRINTED MATTER**

FOR MAGAZINES IN THE FIELD OF ENERGY (U.S. CLS. 2, 5, 22, 23, 29, 37, 38 AND 50).

FIRST USE 8-0-2000; IN COMMERCE 8-0-2000.

COLLEEN KEARNEY, EXAMINING ATTORNEY

---

SN 85-168,392. SANOFI-AVENTIS, 75013 PARIS, FRANCE, FILED 11-3-2010.

# GOAL STAR

THE MARK CONSISTS OF STANDARD CHARACTERS WITHOUT CLAIM TO ANY PARTICULAR FONT, STYLE, SIZE, OR COLOR.

PRIORITY CLAIMED UNDER SEC. 44(D) ON FRANCE APPLICATION NO. 10/3762797, FILED 8-30-2010, REG. NO. 10/3762797, DATED 8-30-2010, EXPIRES 8-30-2020.

OWNER OF U.S. REG. NOS. 3,787,454, 3,806,246 AND 3,806,247.

**CLASS 9—ELECTRICAL AND SCIENTIFIC APPARATUS**

FOR SOFTWARE DOWNLOADABLE VIA THE INTERNET OR MOBILE PHONE APPLICATIONS FOR MONITORING AND TRACKING BLOOD GLUCOSE LEVELS (U.S. CLS. 21, 23, 26, 36 AND 38).

**CLASS 10—MEDICAL APPARATUS**

FOR BLOOD GLUCOSE MONITORS SOLD AS A UNIT WITH BLOOD GLUCOSE MONITORING KITS COMPRISING STRIPS FOR MEASURING BLOOD GLUCOSE CONCENTRATIONS, LANCETS AND CONTROL SOLUTION (U.S. CLS. 26, 39 AND 44).

MICHAEL LITZAU, EXAMINING ATTORNEY

SN 85-169,010. B&M GLOBAL DISTRIBUTION, LLC, HOUSTON, TX. FILED 11-4-2010.



**CLASS 3—COSMETICS AND CLEANING PREPARATIONS**

FOR COSMETICS; HAIR CARE PREPARATIONS; NON-MEDICATED SKIN CARE PREPARATIONS (U.S. CLS. 1, 4, 6, 50, 51 AND 52).

**CLASS 25—CLOTHING**

FOR SLEEPWEAR; UNDERGARMENTS (U.S. CLS. 22 AND 39).

**CLASS 26—FANCY GOODS**

FOR HAIR EXTENSIONS (U.S. CLS. 37, 39, 40, 42 AND 50).  
GEORGE LORENZO, EXAMINING ATTORNEY

SN 85-169,088. NEW PENDULUM CORP., WILMINGTON, DE. FILED 11-4-2010.

DO GOOD THINGS

THE MARK CONSISTS OF STANDARD CHARACTERS WITHOUT CLAIM TO ANY PARTICULAR FONT, STYLE, SIZE, OR COLOR.

**CLASS 6—METAL GOODS**

FOR TOOL SETS, NAMELY, METAL SCREWS; METAL PIGGY BANKS (U.S. CLS. 2, 12, 13, 14, 23, 25 AND 50).

**CLASS 8—HAND TOOLS**

FOR TOOL SETS COMPRISED OF SCREWDRIVERS; HAND TOOLS, NAMELY, MULTI-FUNCTIONAL TOOLS COMPRISED OF A KNIFE, SCREWDRIVER, PLIERS, AND WIRE CUTTER (U.S. CLS. 23, 28 AND 44).

**CLASS 9—ELECTRICAL AND SCIENTIFIC APPARATUS**

FOR AUDIO RECORDINGS FEATURING MUSIC; BLANK USB FLASH DRIVES; EAR BUDS (U.S. CLS. 21, 23, 26, 36 AND 38).

**CLASS 11—ENVIRONMENTAL CONTROL APPARATUS**

FOR FLASHLIGHTS (U.S. CLS. 13, 21, 23, 31 AND 34).

**CLASS 16—PAPER GOODS AND PRINTED MATTER**

FOR STATIONERY SUPPLIES, NAMELY, WRITING INSTRUMENTS, PENS, NOTE PADS, AND ADHESIVE NOTE PADS; VINYL DECALS; ART PRINTS; POSTERS (U.S. CLS. 2, 5, 22, 23, 29, 37, 38 AND 50).

**CLASS 21—HOUSEWARES AND GLASS**

FOR TRAVEL MUGS; INSULATED DRINK CONTAINERS FOR FOOD OR BEVERAGES FOR COMMERCIAL USE; NON-METAL PIGGY BANKS; POSABLE CERAMIC, GLASS, CRYSTAL AND PORCELAIN FIGURINES; METAL WATER BOTTLES SOLD EMPTY; CANDY TINS (U.S. CLS. 2, 13, 23, 29, 30, 33, 40 AND 50).

**CLASS 24—FABRICS**

FOR BLANKETS, NAMELY, STADIUM BLANKETS (U.S. CLS. 42 AND 50).

**CLASS 28—TOYS AND SPORTING GOODS**

FOR ANIMAL CALLS, NAMELY, HOG CALLS; PLAYING CARDS; PUZZLES (U.S. CLS. 22, 23, 38 AND 50).

**CLASS 30—STAPLE FOODS**

FOR CANDY, NAMELY, MOLDED CANDY AND HARD CANDY; COOKIES (U.S. CL. 46).  
NAKIA HENRY, EXAMINING ATTORNEY

SN 85-169,344. NATIONAL ASSOCIATION OF PROFESSIONALLY ACCREDITED CONTRACTORS LLC, GREAT FALLS, VA. FILED 11-4-2010.



THE COLOR(S) SILVER IS/ARE CLAIMED AS A FEATURE OF THE MARK.

THE MARK CONSISTS OF A SILVER SQUARE WITH ROUNDED CORNERS WITHIN WHICH APPEAR THE SILVER HEADS OF TWO HAMMERS POSITIONED DIAGONALLY ACROSS FROM EACH OTHER, TO THE RIGHT OF WHICH APPEARS "NAPAC" IN UPPERCASE LETTERS WITH A DOT IN EACH SPACE BETWEEN THE LETTERS, WITH THE ENTIRE IMAGE DEPICTED IN SILVER OF VARYING SHADES; THE COLOR BLACK REPRESENTS BACKGROUND AND IS NOT PART OF THE MARK.

**CLASS 35—ADVERTISING AND BUSINESS**

FOR LOBBYING SERVICES, NAMELY, PROMOTING THE INTERESTS OF PROFESSIONAL CONTRACTORS IN THE HOME IMPROVEMENT AND REMODELING INDUSTRY IN THE FIELDS OF LEGISLATION AND REGULATION (U.S. CLS. 100, 101 AND 102).

FIRST USE 8-1-2010; IN COMMERCE 8-1-2010.



**CLASS 37—CONSTRUCTION AND REPAIR**

FOR PROVIDING ONLINE INFORMATION ABOUT HOME IMPROVEMENT AND REMODELING FOR PROFESSIONAL CONTRACTORS IN THE HOME IMPROVEMENT AND REMODELING INDUSTRY (U.S. CLS. 100, 103 AND 106).

FIRST USE 8-1-2010; IN COMMERCE 8-1-2010.

**CLASS 41—EDUCATION AND ENTERTAINMENT**

FOR CONDUCTING INSTRUCTIONAL AND TRAINING SEMINARS ABOUT THE LICENSING AND ACCREDITATION OF PROFESSIONAL CONTRACTORS IN THE HOME IMPROVEMENT AND REMODELING INDUSTRY AND DISTRIBUTION OF COURSE MATERIALS IN CONNECTION THEREWITH (U.S. CLS. 100, 101 AND 107).

FIRST USE 8-1-2010; IN COMMERCE 8-1-2010.  
JOHN KELLY, EXAMINING ATTORNEY

THE MARK CONSISTS OF THE LITERAL ELEMENTS "TIRR" WHEREIN THE LETTERS ARE IN BLACK WITH A SUPERIMPOSED TRANSLUCENT PARTIAL CIRCULAR ELEMENT OVER THE LETTERS.

**CLASS 41—EDUCATION AND ENTERTAINMENT**

FOR PROVIDING EDUCATION INFORMATION, RESIDENCY PROGRAMS IN THE NATURE OF MEDICAL TRAINING, FELLOWSHIPS IN THE NATURE OF MEDICAL TRAINING, AND EDUCATIONAL COURSES RELATING TO NEUROPSYCHOLOGY, SPINAL CORD INJURY MEDICINE AND BRAIN INJURY MEDICINE (U.S. CLS. 100, 101 AND 107).

**CLASS 42—SCIENTIFIC AND COMPUTER SERVICES**

FOR MEDICAL RESEARCH (U.S. CLS. 100 AND 101).  
APRIL ROACH, EXAMINING ATTORNEY

SN 85-169,697. THE UNSPOKEN, LLC, LAS VEGAS, NV.  
FILED 11-4-2010.

**BITCHIN' BIKES**

THE MARK CONSISTS OF STANDARD CHARACTERS WITHOUT CLAIM TO ANY PARTICULAR FONT, STYLE, SIZE, OR COLOR.

**CLASS 16—PAPER GOODS AND PRINTED MATTER**

FOR PRINTED MATTER AND PRINTED PUBLICATIONS, NAMELY, POSTERS (U.S. CLS. 2, 5, 22, 23, 29, 37, 38 AND 50).

**CLASS 21—HOUSEWARES AND GLASS**

FOR COFFEE MUGS AND CUPS (U.S. CLS. 2, 13, 23, 29, 30, 33, 40 AND 50).

**CLASS 25—CLOTHING**

FOR CLOTHING, NAMELY, LONG-SLEEVED AND SHORT-SLEEVED T-SHIRTS, TANK TOPS, JERSEYS, SHORTS, HATS, SWEATSHIRTS, JACKETS (U.S. CLS. 22 AND 39).

CHRIS WELLS, EXAMINING ATTORNEY

SN 85-170,061. THE INSTITUTE FOR REHABILITATION AND RESEARCH FOUNDATION, HOUSTON, TX. FILED 11-5-2010.

OWNER OF U.S. REG. NOS. 3,605,628, 3,671,951 AND 3,777,427.

SN 85-170,665. GENESIS CAREER SYSTEMS, LLC, SAN DIEGO, CA. FILED 11-5-2010.

**ARIES CAREER SYSTEMS**

THE MARK CONSISTS OF STANDARD CHARACTERS WITHOUT CLAIM TO ANY PARTICULAR FONT, STYLE, SIZE, OR COLOR.

NO CLAIM IS MADE TO THE EXCLUSIVE RIGHT TO USE "CAREER SYSTEMS", APART FROM THE MARK AS SHOWN.

**CLASS 9—ELECTRICAL AND SCIENTIFIC APPARATUS**

FOR AUDIO AND VIDEO RECORDINGS FEATURING CAREER COACHING, RESUME DRAFTING, INTERVIEWING SKILLS, AND JOB ATTAINMENT INFORMATION.; AUDIO DISCS FEATURING CAREER COACHING, RESUME DRAFTING, INTERVIEWING SKILLS, AND JOB ATTAINMENT INFORMATION.; AUDIO RECORDINGS FEATURING CAREER COACHING, RESUME DRAFTING, INTERVIEWING SKILLS, AND JOB ATTAINMENT INFORMATION.; COMPACT DISCS FEATURING CAREER COACHING, RESUME DRAFTING, INTERVIEWING SKILLS, AND JOB ATTAINMENT INFORMATION.; DIGITAL MATERIALS, NAMELY, AUDIO COMPACT DISCS, DIGITAL VIDEO DISCS, CD-ROMS, AND DOWNLOADABLE DIGITAL FILES FEATURING CAREER COACHING, RESUME DRAFTING, INTERVIEWING SKILLS, AND JOB ATTAINMENT INFORMATION.; DIGITAL MEDIA, NAMELY, AUDIO COMPACT DISCS, DIGITAL VIDEO DISCS, CD-ROMS, AND DOWNLOADABLE DIGITAL FILES FEATURING CAREER COACHING, RESUME DRAFTING, INTERVIEWING SKILLS, AND JOB ATTAINMENT INFORMATION.; DOWNLOADABLE MP3 FILES AND MP3 RECORDINGS FEATURING CAREER COACHING, RESUME DRAFTING, INTERVIEWING SKILLS, AND JOB ATTAINMENT INFORMATION.; DOWNLOADABLE MP3 FILES, MP3 RECORDINGS, ON-LINE DISCUSSION BOARDS, WEBCASTS, WEBINARS AND PODCASTS FEATURING MUSIC, AUDIO BOOKS IN THE FIELD OF CAREER COACHING, RESUME DRAFTING, INTERVIEWING SKILLS, AND JOB ATTAINMENT INFORMATION., AND NEWS BROADCASTS; DVDS FEATURING CAREER COACHING, RESUME DRAFTING, INTERVIEWING SKILLS, AND JOB ATTAINMENT INFORMATION.; MULTIMEDIA SOFTWARE RECORDED ON CD-ROM FEATURING CAREER COACHING, RESUME DRAFTING, INTERVIEWING SKILLS, AND JOB ATTAINMENT IN-

FORMATION.; PRE-RECORDED CDS FEATURING CAREER COACHING, RESUME DRAFTING, INTERVIEWING SKILLS, AND JOB ATTAINMENT INFORMATION.; PRE-RECORDED CDS, VIDEO TAPES, LASER DISKS AND DVDS FEATURING CAREER COACHING, RESUME DRAFTING, INTERVIEWING SKILLS, AND JOB ATTAINMENT INFORMATION.; PRE-RECORDED DIGITAL MEDIA FEATURING CAREER COACHING, RESUME DRAFTING, INTERVIEWING SKILLS, AND JOB ATTAINMENT INFORMATION.; PRE-RECORDED DIGITAL VIDEO DISCS FEATURING CAREER COACHING, RESUME DRAFTING, INTERVIEWING SKILLS, AND JOB ATTAINMENT INFORMATION.; PRE-RECORDED DVDS FEATURING CAREER COACHING, RESUME DRAFTING, INTERVIEWING SKILLS, AND JOB ATTAINMENT INFORMATION.; PRE-RECORDED ELECTRONIC AND DIGITAL MEDIA FEATURING CAREER COACHING, RESUME DRAFTING, INTERVIEWING SKILLS, AND JOB ATTAINMENT INFORMATION.; PRE-RECORDED ELECTRONIC MEDIA FEATURING CAREER COACHING, RESUME DRAFTING, INTERVIEWING SKILLS, AND JOB ATTAINMENT INFORMATION.; SOUND RECORDINGS FEATURING CAREER COACHING, RESUME DRAFTING, INTERVIEWING SKILLS, AND JOB ATTAINMENT INFORMATION.; VIDEO RECORDINGS FEATURING CAREER COACHING, RESUME DRAFTING, INTERVIEWING SKILLS, AND JOB ATTAINMENT INFORMATION.; VISUAL AND AUDIO RECORDINGS FEATURING CAREER COACHING, RESUME DRAFTING, INTERVIEWING SKILLS, AND JOB ATTAINMENT INFORMATION (U.S. CLS. 21, 23, 26, 36 AND 38).

FIRST USE 11-4-2010; IN COMMERCE 11-4-2010.

#### **CLASS 41—EDUCATION AND ENTERTAINMENT**

FOR CAREER COUNSELING; CHARITABLE SERVICES, NAMELY, PROVIDING TRAINING IN THE FIELD OF CAREER COACHING, RESUME DRAFTING, INTERVIEWING SKILLS, AND JOB ATTAINMENT.; CHARITABLE SERVICES, NAMELY, VOCATIONAL GUIDANCE AND CAREER COUNSELING TO INDIGENT PERSONS SEEKING EMPLOYMENT; CONDUCTING WORKSHOPS AND SEMINARS IN CAREER COACHING, RESUME DRAFTING, INTERVIEWING SKILLS, AND JOB ATTAINMENT.; EDUCATION IN THE FIELD OF CAREER COACHING, RESUME DRAFTING, INTERVIEWING SKILLS, AND JOB ATTAINMENT, RENDERED THROUGH CORRESPONDENCE COURSES; EDUCATION IN THE FIELD OF CAREER COACHING, RESUME DRAFTING, INTERVIEWING SKILLS, AND JOB ATTAINMENT, RENDERED THROUGH VIDEO CONFERENCE; EDUCATION SERVICES, NAMELY, MENTORING IN THE FIELD OF CAREER COACHING, RESUME DRAFTING, INTERVIEWING SKILLS, AND JOB ATTAINMENT.; EDUCATION SERVICES, NAMELY, ONE-ON-ONE MENTORING IN THE FIELD OF CAREER COACHING, RESUME DRAFTING, INTERVIEWING SKILLS, AND JOB ATTAINMENT.; EDUCATION SERVICES, NAMELY, PROVIDING MENTORING, TUTORING, CLASSES, SEMINARS AND WORKSHOPS IN THE FIELD OF CAREER COACHING, RESUME DRAFTING, INTERVIEWING SKILLS, AND JOB ATTAINMENT.; EDUCATION SERVICES, NAMELY, PROVIDING ON-LINE CLASSES, SEMINARS, WORKSHOPS IN THE FIELD OF CAREER COACHING, RESUME DRAFTING, INTERVIEWING SKILLS, AND JOB ATTAINMENT.; EDUCATION SERVICES, NAMELY, PROVIDING ON-LINE CLASSES, SEMINARS, WORKSHOPS IN THE FIELD OF CAREER COACHING, RESUME DRAFTING, INTERVIEWING SKILLS, AND JOB ATTAINMENT.; EDUCATION SERVICES, NAMELY, PROVIDING TUTORIAL SESSIONS IN THE FIELD(S) OF CAREER COACHING, RESUME DRAFTING, INTERVIEWING SKILLS, AND JOB ATTAINMENT.; EDUCATION SERVICES, NAMELY, PROVIDING TUTORIAL SESSIONS IN THE FIELDS OF

CAREER COACHING, RESUME DRAFTING, INTERVIEWING SKILLS, AND JOB ATTAINMENT.; EDUCATION SERVICES, NAMELY, PROVIDING TUTORING IN THE FIELD OF CAREER COACHING, RESUME DRAFTING, INTERVIEWING SKILLS, AND JOB ATTAINMENT.; EDUCATION SERVICES, NAMELY, PROVIDING TUTORING IN THE FIELDS OF CAREER COACHING, RESUME DRAFTING, INTERVIEWING SKILLS, AND JOB ATTAINMENT.; EDUCATION SERVICES, NAMELY, PROVIDING WORKSHOPS, PRESENTATIONS, AND SEMINARS IN THE FIELD OF CAREER COACHING, RESUME DRAFTING, INTERVIEWING SKILLS, AND JOB ATTAINMENT.; EDUCATION SERVICES, NAMELY, PROVIDING WORKSHOPS, PRESENTATIONS, AND SEMINARS IN THE FIELDS OF CAREER COACHING, RESUME DRAFTING, INTERVIEWING SKILLS, AND JOB ATTAINMENT.; EDUCATIONAL AND ENTERTAINMENT SERVICES, NAMELY, PROVIDING MOTIVATIONAL SPEAKING SERVICES IN THE FIELD OF CAREER COACHING, RESUME DRAFTING, INTERVIEWING SKILLS, AND JOB ATTAINMENT.; EDUCATIONAL SERVICES, NAMELY, CONDUCTING PROGRAMS IN THE FIELD OF CAREER COACHING, RESUME DRAFTING, INTERVIEWING SKILLS, AND JOB ATTAINMENT.; EDUCATIONAL SERVICES, NAMELY, CONDUCTING WORKSHOPS, PRESENTATIONS, AND SEMINARS IN THE FIELDS OF CAREER COACHING, RESUME DRAFTING, INTERVIEWING SKILLS, AND JOB ATTAINMENT, AND DISTRIBUTION OF TRAINING MATERIALS IN CONNECTION THEREWITH; EDUCATIONAL SERVICES, NAMELY, CONDUCTING WORKSHOPS, PRESENTATIONS, AND SEMINARS IN THE FIELD OF CAREER COACHING, RESUME DRAFTING, INTERVIEWING SKILLS, AND JOB ATTAINMENT, AND DISTRIBUTION OF PRINTED MATERIALS IN CONNECTION THEREWITH IN HARD COPY OR ELECTRONIC FORMAT ON THE SAME TOPICS; EDUCATIONAL SERVICES, NAMELY, CONDUCTING WORKSHOPS, PRESENTATIONS, AND SEMINARS IN THE FIELD OF CAREER COACHING, RESUME DRAFTING, INTERVIEWING SKILLS, AND JOB ATTAINMENT, AND DISTRIBUTION OF EDUCATIONAL MATERIALS IN CONNECTION THEREWITH; EDUCATIONAL SERVICES, NAMELY, PROVIDING EDUCATIONAL SPEAKERS IN THE FIELD OF CAREER COACHING, RESUME DRAFTING, INTERVIEWING SKILLS, AND JOB ATTAINMENT.; EDUCATIONAL SERVICES, NAMELY, PROVIDING ON-LINE WORKSHOPS, PRESENTATIONS, AND SEMINARS IN THE FIELDS OF CAREER COACHING, RESUME DRAFTING, INTERVIEWING SKILLS, AND JOB ATTAINMENT.; EDUCATIONAL SERVICES, NAMELY, PROVIDING WORKSHOPS, PRESENTATIONS, AND SEMINARS IN THE FIELDS OF CAREER COACHING, RESUME DRAFTING, INTERVIEWING SKILLS, AND JOB ATTAINMENT.; INSTRUCTION IN THE FIELD OF CAREER COACHING, RESUME DRAFTING, INTERVIEWING SKILLS, AND JOB ATTAINMENT.; PEER TO PEER COACHING SERVICES IN THE FIELD OF CAREER COACHING, RESUME DRAFTING, INTERVIEWING SKILLS, AND JOB ATTAINMENT.; PERSONAL COACHING SERVICES IN THE FIELD OF CAREER COACHING, RESUME DRAFTING, INTERVIEWING SKILLS, AND JOB ATTAINMENT.; PROFESSIONAL COACHING SERVICES IN THE FIELD OF CAREER COACHING, RESUME DRAFTING, INTERVIEWING SKILLS, AND JOB ATTAINMENT (U.S. CLS. 100, 101 AND 107).

FIRST USE 11-4-2010; IN COMMERCE 11-4-2010.  
SEAN CROWLEY, EXAMINING ATTORNEY

SN 85-170,884. U. S. VISION, INC., GLENDORA, NJ. FILED 11-6-2010.



THE COLOR(S) BLACK, WHITE, AND TEAL BLUE IS/ ARE CLAIMED AS A FEATURE OF THE MARK.

THE MARK CONSISTS OF A BALD HUMAN HEAD AND FACE IN WHITE AND OUTLINED IN BLACK WITH BLACK EYEBALLS AND BLACK SQUARE EYEGLASSES WITH TEAL BLUE LENSES.

#### CLASS 35—ADVERTISING AND BUSINESS

FOR RETAIL STORE AND ON-LINE RETAIL STORE SERVICES FEATURING OPTICAL GOODS AND SERVICES (U.S. CLS. 100, 101 AND 102).

FIRST USE 9-1-2010; IN COMMERCE 9-1-2010.

#### CLASS 44—MEDICAL, BEAUTY AND AGRICULTURAL SERVICES

FOR OPTICIAN SERVICES (U.S. CLS. 100 AND 101).

FIRST USE 9-1-2010; IN COMMERCE 9-1-2010.

REBECCA SMITH, EXAMINING ATTORNEY

SN 85-171,114. SANFORD, KEVIN, SANTA BARBARA, CA. FILED 11-8-2010.

MOBILE MINUTE

THE MARK CONSISTS OF STANDARD CHARACTERS WITHOUT CLAIM TO ANY PARTICULAR FONT, STYLE, SIZE, OR COLOR.

NO CLAIM IS MADE TO THE EXCLUSIVE RIGHT TO USE "MOBILE", APART FROM THE MARK AS SHOWN.

#### CLASS 9—ELECTRICAL AND SCIENTIFIC APPARATUS

FOR ELECTRICAL APPARATUS, NAMELY, SOUND RECORDING APPARATUS AND COMPUTER FOR EDITING, UPLOAD AND DOWNLOAD OF FIVE MINUTES OF CONTENT TO CELL PHONE OR COMPUTER VIA TEXT OR WEB (U.S. CLS. 21, 23, 26, 36 AND 38).

#### CLASS 38—COMMUNICATION

FOR COMMUNICATION SERVICES, NAMELY, ELECTRONIC TRANSMISSION AND STREAMING OF DIGITAL MEDIA CONTENT FOR OTHERS VIA GLOBAL AND LOCAL COMPUTER NETWORKS THAT CAN BE SENT TO A COMPUTER OR CELLULAR DEVICE; FAN INTERACTION VIA WEB, NAMELY, PROVIDING INTERNET CHAT ROOMS (U.S. CLS. 100, 101 AND 104).

#### CLASS 41—EDUCATION AND ENTERTAINMENT

FOR EDUCATION AND ENTERTAINMENT SERVICES, NAMELY, PRODUCTION OF SOUND AND MUSIC VIDEO RECORDINGS AND AUDIO AND VIDEO RECORDING SERVICES FEATURING CONCERT AND INTERVIEW FOOTAGE (U.S. CLS. 100, 101 AND 107).

ROBERT STRUCK, EXAMINING ATTORNEY

SN 85-171,534. CONTENT ORGANIZED INTERIORS, LLC, BOSTON, MA. FILED 11-8-2010.

content  
organized interiors

NO CLAIM IS MADE TO THE EXCLUSIVE RIGHT TO USE "ORGANIZED INTERIORS", APART FROM THE MARK AS SHOWN.

THE MARK CONSISTS OF THE WORD "CONTENT" SPELLED OUT IN LOWER CASE, WITH AN ASTERISK IN PLACE OF THE LETTER "O". THE WORDS "ORGANIZED" AND "INTERIORS" ARE LOCATED IN SMALLER FONT BELOW THE WORD "CONTENT".

#### CLASS 35—ADVERTISING AND BUSINESS

FOR RESELLER SERVICES, NAMELY, DISTRIBUTORSHIP SERVICES IN THE FIELD OF RESIDENTIAL FURNISHINGS (U.S. CLS. 100, 101 AND 102).

#### CLASS 42—SCIENTIFIC AND COMPUTER SERVICES

FOR INTERIOR DESIGN SERVICES; CONSULTATION IN THE FIELD OF INTERIOR DESIGN (U.S. CLS. 100 AND 101).

DARRYL SPRUILL, EXAMINING ATTORNEY

SN 85-171,550. GLOBAL WIRELESS SOLUTIONS, INC., DULLES, VA. FILED 11-8-2010.

THE STANDARD FOR  
BENCHMARKING

THE MARK CONSISTS OF STANDARD CHARACTERS WITHOUT CLAIM TO ANY PARTICULAR FONT, STYLE, SIZE, OR COLOR.

OWNER OF U.S. REG. NO. 2,745,946.

NO CLAIM IS MADE TO THE EXCLUSIVE RIGHT TO USE "BENCHMARKING", APART FROM THE MARK AS SHOWN.

**CLASS 9—ELECTRICAL AND SCIENTIFIC APPARATUS**

FOR MULTIMEDIA SOFTWARE RECORDED ON CD-ROM FEATURING WIRELESS ENGINEERING ELECTRONIC DATA; DOWNLOADABLE REPORTS FEATURING WIRELESS ENGINEERING ELECTRONIC DATA; PROVIDING DOWNLOADABLE COMPUTER SOFTWARE FOR ACCESSING AND REPORTING INFORMATION ON NETWORK PROBLEMS, NAMELY, NO WIRELESS NETWORK COVERAGE, DROPPED CALLS, FAILED CALL ATTEMPTS OR FAILED DATA SERVICES, AND WHICH ALLOWS USERS AND NETWORK PROVIDERS TO TRACK PERFORMANCE PROBLEMS ON VOICE AND DATA NETWORKS (U.S. CLS. 21, 23, 26, 36 AND 38).

FIRST USE 11-11-1996; IN COMMERCE 11-11-1996.

**CLASS 16—PAPER GOODS AND PRINTED MATTER**

FOR PRINTED REPORTS FEATURING WIRELESS ENGINEERING ELECTRONIC DATA (U.S. CLS. 2, 5, 22, 23, 29, 37, 38 AND 50).

FIRST USE 11-11-1996; IN COMMERCE 11-11-1996.

**CLASS 35—ADVERTISING AND BUSINESS**

FOR PROVIDING SERVICES FOR BUSINESSES IN THE WIRELESS COMMUNICATIONS INDUSTRY, NAMELY, DATA COMPILING AND ANALYZING IN THE FIELD OF BENCHMARKING AND NETWORK PERFORMANCE OF WIRELESS NETWORKS; PROVIDING AN ONLINE COMPUTER WEBSITE THAT PROVIDES DATA AND RELATED INFORMATION IN THE FIELD OF BENCHMARKING AND NETWORK PERFORMANCE OF WIRELESS NETWORKS (U.S. CLS. 100, 101 AND 102).

FIRST USE 11-11-1996; IN COMMERCE 11-11-1996.

**CLASS 42—SCIENTIFIC AND COMPUTER SERVICES**

FOR WIRELESS ENGINEERING CONSULTING SERVICES; ENGINEERING; PROVIDING AN INTERACTIVE WEB SITE THAT ENABLES USERS TO ENTER, ACCESS, TRACK, MANAGE, MONITOR, AND GENERATE INFORMATION AND REPORTS REGARDING WIRELESS ENGINEERING ELECTRONIC DATA (U.S. CLS. 100 AND 101).

FIRST USE 11-11-1996; IN COMMERCE 11-11-1996.  
KELLY TRUSILO, EXAMINING ATTORNEY

SN 85-172,506. ROLAND CORPORATION, SHIZUOKA, JAPAN, FILED 11-9-2010.



OWNER OF U.S. REG. NOS. 1,055,073, 1,150,998 AND OTHERS.

THE NAME SHOWN IN THE MARK DOES NOT IDENTIFY A PARTICULAR LIVING INDIVIDUAL.

THE MARK CONSISTS OF A SQUARE CONTAINING A TREE CENTERED IN THE MIDDLE WITH A MUSICAL NOTE POSITIONED ON THE TOP RIGHT CORNER, LEFT MIDDLE AND BOTTOM RIGHT CORNER OF THE TREE. THERE ARE FOUR SILHOUETTES OF BIRDS FLYING ON EACH TOP SIDE OF THE TREE. THE WORD "ROLAND" IS CENTERED BELOW THE TREE WITH THE WORD "FORESTA" CENTERED BELOW THE WORD "ROLAND".

THE ENGLISH TRANSLATION OF "FORESTA" IN THE MARK IS "FOREST".

**CLASS 9—ELECTRICAL AND SCIENTIFIC APPARATUS**

FOR SD AND CD RECORDERS; MUSIC PLAYERS, NAMELY, DIGITAL AUDIO PLAYERS; PERSONAL DRUM MONITORS, NAMELY, SPEAKER BOXES WITH AMPLIFIERS FOR MONITORING ELECTRONIC DRUM SOUNDS; SOFTWARE FOR DIGITAL AUDIO WORKSTATIONS FOR COMPOSING AND SYNTHESIZING AUDIO MUSIC TRACKS; USB MIDI INTERFACES; COMPUTER CONSOLES; USB AUDIO INTERFACES FOR COMPUTERS; KEYBOARD CONTROLLERS FOR COMPUTERS; METRONOMES (U.S. CLS. 21, 23, 26, 36 AND 38).

**CLASS 15—MUSICAL INSTRUMENTS**

FOR PIANOS; HARPSICHORDS; ORGANS; SYNTHESIZER KEYBOARD INSTRUMENTS; ACCORDIONS; DRUMS; TUNERS FOR MUSICAL INSTRUMENTS (U.S. CLS. 2, 21 AND 36).

TINA BROWN, EXAMINING ATTORNEY

SN 85-172,654. PIER PHARMACEUTICALS, INC., LOUISVILLE, CO. FILED 11-9-2010.

**PIER PHARMACEUTICALS**

THE MARK CONSISTS OF STANDARD CHARACTERS WITHOUT CLAIM TO ANY PARTICULAR FONT, STYLE, SIZE, OR COLOR.

NO CLAIM IS MADE TO THE EXCLUSIVE RIGHT TO USE "PHARMACEUTICALS", APART FROM THE MARK AS SHOWN.

**CLASS 5—PHARMACEUTICALS**

FOR PHARMACEUTICAL PRODUCTS AND PREPARATIONS TO TREAT SLEEP APNEA (U.S. CLS. 6, 18, 44, 46, 51 AND 52).

**CLASS 42—SCIENTIFIC AND COMPUTER SERVICES**

FOR PHARMACEUTICAL DRUG DEVELOPMENT SERVICES (U.S. CLS. 100 AND 101).

STEVEN PEREZ, EXAMINING ATTORNEY

SN 85-173,166. PHI DELTA THETA FRATERNITY, OXFORD, OH. FILED 11-10-2010.



OWNER OF U.S. REG. NOS. 224,978, 2,837,693 AND OTHERS.

THE MARK CONSISTS OF THE GREEK LETTER "PHI" WITH SIX STARS IN THE LETTER FOLLOWED BY THE WORDS "IRON PHI".

**CLASS 18—LEATHER GOODS**

FOR BAGS, NAMELY, DRAWSTRING BAGS AND DUFFEL BAGS (U.S. CLS. 1, 2, 3, 22 AND 41).  
FIRST USE 11-10-2010; IN COMMERCE 11-10-2010.

**CLASS 25—CLOTHING**

FOR CLOTHING AND APPAREL, NAMELY, TOPS, SHIRTS, T-SHIRTS, POLO SHIRTS, SWEATSHIRTS, BOTTOMS, PANTS, SHORTS; HEADWEAR (U.S. CLS. 22 AND 39).

FIRST USE 11-10-2010; IN COMMERCE 11-10-2010.  
CHERYL CLAYTON, EXAMINING ATTORNEY

SN 85-173,168. PHI DELTA THETA FRATERNITY, OXFORD, OH. FILED 11-10-2010.



OWNER OF U.S. REG. NOS. 224,978, 2,837,693 AND OTHERS.

NO CLAIM IS MADE TO THE EXCLUSIVE RIGHT TO USE "ATHLETES", APART FROM THE MARK AS SHOWN.

THE MARK CONSISTS OF A CIRCLE WITH THE WORDS "IRON PHI BROTHERHOOD OF ATHLETES" WRITTEN IN THE PERIMETER OF THE CIRCLE SURROUNDING THE GREEK LETTER PHI WITH SIX STARS IN THE LETTER.

**CLASS 18—LEATHER GOODS**

FOR BAGS, NAMELY, DRAWSTRING BAGS AND DUFFEL BAGS (U.S. CLS. 1, 2, 3, 22 AND 41).  
FIRST USE 11-10-2010; IN COMMERCE 11-10-2010.

**CLASS 25—CLOTHING**

FOR CLOTHING AND APPAREL, NAMELY, TOPS, SHIRTS, T-SHIRTS, SWEATSHIRTS, SINGLET, TRACK SUITS; HEADWEAR (U.S. CLS. 22 AND 39).

FIRST USE 11-10-2010; IN COMMERCE 11-10-2010.  
CHERYL CLAYTON, EXAMINING ATTORNEY

SN 85-173,169. PHI DELTA THETA FRATERNITY, OXFORD, OH. FILED 11-10-2010.



OWNER OF U.S. REG. NOS. 224,978, 2,837,693 AND OTHERS.

NO CLAIM IS MADE TO THE EXCLUSIVE RIGHT TO USE "ATHLETICS", APART FROM THE MARK AS SHOWN.

THE MARK CONSISTS OF THE GREEK LETTER PHI WITH SIX STARS IN THE LETTER FOLLOWED BY THE WORDS "IRON PHI ATHLETICS".

**CLASS 18—LEATHER GOODS**

FOR BAGS, NAMELY, DRAWSTRING BAGS AND DUFFEL BAGS (U.S. CLS. 1, 2, 3, 22 AND 41).

**CLASS 25—CLOTHING**

FOR CLOTHING AND APPAREL, NAMELY, TOPS, SHIRTS, T-SHIRTS, TANK TOPS, BOTTOMS, SHORTS; HEADWEAR (U.S. CLS. 22 AND 39).

FIRST USE 11-10-2010; IN COMMERCE 11-10-2010.  
CHERYL CLAYTON, EXAMINING ATTORNEY

SN 85-173,252. AKASHA, ANN ARBOR, MI. FILED 11-10-2010.



NO CLAIM IS MADE TO THE EXCLUSIVE RIGHT TO USE "THE LEADER IN DECORATIVE ACCENTS!", APART FROM THE MARK AS SHOWN.

THE COLOR(S) NAVY BLUE AND GOLD IS/ARE CLAIMED AS A FEATURE OF THE MARK.

THE MARK CONSISTS OF A CIRCULAR LOGO FOLLOWED BY THE WORD "AKASHA" IN ALL CAPITAL LETTERS ON ONE LINE. BELOW THAT, ON A SECOND LINE, THE FOLLOWING PHRASE IN UPPER/LOWER CASE: "THE LEADER IN DECORATIVE ACCENTS!" ALL WORDS AND LETTERS ARE COLORED IN NAVY BLUE. THE CIRCULAR LOGO INCLUDES A SPIRAL WITH EIGHT CURVED, TAPERED SPOKES, EACH SPOKE TERMINATING IN A POINT CONNECTED TO A SMALL CIRCLE, AND EACH CIRCLE ADJACENT A CONCENTRIC CIRCULAR BORDER. THE BACKGROUND OF THE LOGO IS THE SAME BLUE COLOR AS THE LETTERING. THE SPIRAL, SMALL CIRCLES AND CIRCULAR BORDER ARE GOLD.

THE ENGLISH TRANSLATION OF "AKASHA" IN THE MARK IS THE SANSKRIT WORD MEANING "AETHER" IN BOTH ITS ELEMENTAL AND MYTHOLOGICAL SENSES.

**CLASS 19—NON-METALLIC BUILDING MATERIALS**

FOR NATURAL STONE (U.S. CLS. 1, 12, 33 AND 50).  
FIRST USE 1-1-2009; IN COMMERCE 1-1-2009.

**CLASS 20—FURNITURE AND ARTICLES NOT OTHERWISE CLASSIFIED**

FOR SEA SHELLS (U.S. CLS. 2, 13, 22, 25, 32 AND 50).  
FIRST USE 1-1-2009; IN COMMERCE 1-1-2009.

**CLASS 21—HOUSEWARES AND GLASS**

FOR GLASS FOR DECORATIVE PURPOSES, NAMELY, GLASS MARBLES, GEMS AND SEA GLASS (U.S. CLS. 2, 13, 23, 29, 30, 33, 40 AND 50).  
FIRST USE 1-1-2009; IN COMMERCE 1-1-2009.

**CLASS 26—FANCY GOODS**

FOR ARTIFICIAL FRUIT (U.S. CLS. 37, 39, 40, 42 AND 50).  
FIRST USE 1-1-2009; IN COMMERCE 1-1-2009.  
TRACY FLETCHER, EXAMINING ATTORNEY

---

SN 85-173,817. ADVAYA HOSPITALITY LLC, ATLANTA, GA. FILED 11-10-2010.

ADVAYA

THE MARK CONSISTS OF STANDARD CHARACTERS WITHOUT CLAIM TO ANY PARTICULAR FONT, STYLE, SIZE, OR COLOR.

THE ENGLISH TRANSLATION OF "ADVAYA" IN THE MARK IS UNIQUE, ONENESS OR UNITY.

**CLASS 35—ADVERTISING AND BUSINESS**

FOR BUSINESS DEVELOPMENT SERVICES, NAMELY, PROVIDING START-UP SUPPORT FOR BUSINESSES OF OTHERS; FRANCHISE SERVICES, NAMELY, OFFERING BUSINESS MANAGEMENT ASSISTANCE IN THE ESTABLISHMENT AND OPERATION OF HOTELS AND RESTAURANTS; HOTEL MANAGEMENT FOR OTHERS; MANAGEMENT OF HOTEL INCENTIVE PROGRAMS OF OTHERS; RESTAURANT MANAGEMENT FOR OTHERS (U.S. CLS. 100, 101 AND 102).

**CLASS 36—INSURANCE AND FINANCIAL**

FOR REAL ESTATE INVESTMENT SERVICES (U.S. CLS. 100, 101 AND 102).

**CLASS 43—HOTEL AND RESTAURANT SERVICES**

FOR HOTEL SERVICES; RESTAURANT AND BAR SERVICES (U.S. CLS. 100 AND 101).  
GIANCARLO CASTRO, EXAMINING ATTORNEY

SN 85-174,088. MODE DESIGN GROUP, INC., NEW YORK, NY. FILED 11-10-2010.

Mode Design Group

THE MARK CONSISTS OF STANDARD CHARACTERS WITHOUT CLAIM TO ANY PARTICULAR FONT, STYLE, SIZE, OR COLOR.

NO CLAIM IS MADE TO THE EXCLUSIVE RIGHT TO USE "DESIGN GROUP", APART FROM THE MARK AS SHOWN.

**CLASS 35—ADVERTISING AND BUSINESS**

FOR ADVERTISING SERVICES, NAMELY, CREATING CORPORATE LOGOS FOR OTHERS; ADVERTISING, MARKETING AND PROMOTION SERVICES; DESIGN OF ADVERTISING MATERIALS FOR OTHERS; DEVELOPMENT OF MARKETING STRATEGIES AND CONCEPTS; MARKETING AND BRANDING SERVICES, NAMELY, PROVIDING CUSTOMIZED COMMUNICATION PROGRAMS TO OBTAIN CONSUMER INSIGHTS AND DEVELOP BRANDING STRATEGIES (U.S. CLS. 100, 101 AND 102).

FIRST USE 11-7-2008; IN COMMERCE 11-7-2008.

**CLASS 42—SCIENTIFIC AND COMPUTER SERVICES**

FOR DESIGN AND CREATING WEB SITES FOR OTHERS (U.S. CLS. 100 AND 101).

FIRST USE 11-7-2008; IN COMMERCE 11-7-2008.

NICHOLAS COLEMAN, EXAMINING ATTORNEY

---

SN 85-174,481. PERFECT WATER & ESSENTIALS LLC, LONDON, UT. FILED 11-11-2010.

PERFECT EMPOWERED DRINKING WATER

THE MARK CONSISTS OF STANDARD CHARACTERS WITHOUT CLAIM TO ANY PARTICULAR FONT, STYLE, SIZE, OR COLOR.

OWNER OF U.S. REG. NO. 3,581,705.

NO CLAIM IS MADE TO THE EXCLUSIVE RIGHT TO USE "DRINKING WATER", APART FROM THE MARK AS SHOWN.

**CLASS 5—PHARMACEUTICALS**

FOR NUTRITIONALLY FORTIFIED WATER (U.S. CLS. 6, 18, 44, 46, 51 AND 52).

**CLASS 32—LIGHT BEVERAGES**

FOR FLAVORED DRINKING WATER; FLAVORED ENHANCED DRINKING WATER (U.S. CLS. 45, 46 AND 48).

JOHN DALIER, EXAMINING ATTORNEY

SN 85-174,795. FIRST DATA CORPORATION, GREENWOOD VILLAGE, CO. FILED 11-11-2010.

## FIRST DATA SNAP

THE MARK CONSISTS OF STANDARD CHARACTERS WITHOUT CLAIM TO ANY PARTICULAR FONT, STYLE, SIZE, OR COLOR.

OWNER OF U.S. REG. NOS. 1,912,728, 2,705,109 AND OTHERS.

NO CLAIM IS MADE TO THE EXCLUSIVE RIGHT TO USE "DATA", APART FROM THE MARK AS SHOWN.

### CLASS 9—ELECTRICAL AND SCIENTIFIC APPARATUS

FOR COMPUTER SOFTWARE, NAMELY, A MOBILE OR BROWSER APPLICATION FOR USE IN BUSINESS-TO-BUSINESS PAYMENT SERVICES THAT ALLOWS CUSTOMERS TO UPDATE AND RECEIVE DATA STORED IN AN INDIVIDUAL'S AND/OR ENTERPRISE'S COMPUTER DATABASE IN REAL TIME WITH FULL TELEPHONY INTEGRATION OF THE TELEPHONE AND INTERNET BROWSER FEATURES OF THE MOBILE DEVICE (U.S. CLS. 21, 23, 26, 36 AND 38).

### CLASS 42—SCIENTIFIC AND COMPUTER SERVICES

FOR APPLICATION SERVICE PROVIDER IN THE FIELD OF MOBILE SALES FEATURING SOFTWARE FOR USE IN UPDATING AND RECEIVING DATA FOR THE SALE AND ON-BOARDING OF MERCHANT PAYMENT SERVICES INCLUDING CREDIT AND DEBIT CARD ACQUIRING, ELECTRONIC CHECK PROCESSING AND GIFT CARD ISSUING, THAT IS STORED IN AN INDIVIDUAL'S AND/OR ENTERPRISE'S COMPUTER DATABASE IN REAL TIME FOR USE WITH A MOBILE DEVICE AND WITH FULL TELEPHONY INTEGRATION OF THE TELEPHONE AND INTERNET BROWSER FEATURES OF THE MOBILE DEVICE (U.S. CLS. 100 AND 101).

KATHERINE M. DUBRAY, EXAMINING ATTORNEY

SN 85-174,821. TRILOGY DESIGNS, LLC, EL CAJON, CA. FILED 11-11-2010.



NO CLAIM IS MADE TO THE EXCLUSIVE RIGHT TO USE "DESIGNS", APART FROM THE MARK AS SHOWN.

THE MARK CONSISTS OF THE WORDS "TRILOGY DESIGNS" IN STYLIZED FONT WITH A STYLIZED CROSS WITH A HEART IN BETWEEN THE WORDS.

### CLASS 16—PAPER GOODS AND PRINTED MATTER

FOR PAINTINGS (U.S. CLS. 2, 5, 22, 23, 29, 37, 38 AND 50).

FIRST USE 9-3-2010; IN COMMERCE 9-3-2010.

### CLASS 21—HOUSEWARES AND GLASS

FOR MOSAIC ART TILES MADE OF GLASS AND CERAMIC; SCULPTURES OF CERAMIC (U.S. CLS. 2, 13, 23, 29, 30, 33, 40 AND 50).

FIRST USE 9-3-2010; IN COMMERCE 9-3-2010.

LESLEY LAMOTHE, EXAMINING ATTORNEY

SN 85-174,919. CSN STORES, LLC, BOSTON, MA. FILED 11-11-2010.

## JOSS & MAIN

THE MARK CONSISTS OF STANDARD CHARACTERS WITHOUT CLAIM TO ANY PARTICULAR FONT, STYLE, SIZE, OR COLOR.

### CLASS 35—ADVERTISING AND BUSINESS

FOR ON-LINE RETAIL STORE SERVICES FEATURING GENERAL CONSUMER MERCHANDISE AND SERVICES, NAMELY, HOUSEHOLD AND LIFESTYLE PRODUCTS, HOME FURNISHINGS, FURNITURE, BATH LINENS, BED LINENS, STATIONERY, WALL ORNAMENTS, APPLIANCES, TABLETOP ITEMS, COOKWARE, RUGS AND OTHER FLOOR COVERINGS, LUGGAGE, JUVENILE PRODUCTS, PET PRODUCTS, SOAPS, CANDLES AND EDIBLE GOODS, NAMELY, CHOCOLATES, SPICES AND SAUCES, CAKES AND JAMS, FASHION AND TREND-RELATED PRODUCTS, NAMELY, PERSONAL ACCESSORIES, NAMELY, HANDBAGS, TOTE BAGS, WALLETS, EYEGLASS CASES, LAPTOP BAGS, CELL PHONE CASES, AND KEYCHAINS (U.S. CLS. 100, 101 AND 102).

### CLASS 37—CONSTRUCTION AND REPAIR

FOR HOME MAINTENANCE SERVICES AND OTHER HOUSEHOLD SERVICES, NAMELY, REPAIR AND MAINTENANCE OF APPLIANCES, CARPETS, FURNITURE, PLUMBING, HVAC EQUIPMENT; HOME CLEANING SERVICES, PEST CONTROL SERVICES, INTERIOR PAINTING AND WALLPAPERING, AND EXTERIOR PAINTING (U.S. CLS. 100, 103 AND 106).

### CLASS 39—TRANSPORTATION AND STORAGE

FOR ARRANGING OF TOURS AND CRUISES; ARRANGING TRAVEL TOURS; RESERVATION AND BOOKING OF SEATS FOR TRAVEL; TRAVEL AND TOUR TICKET RESERVATION SERVICE; TRAVEL INFORMATION SERVICES; TRAVEL, EXCURSION AND CRUISE ARRANGEMENT (U.S. CLS. 100 AND 105).

### CLASS 41—EDUCATION AND ENTERTAINMENT

FOR TICKET RESERVATION AND BOOKING SERVICES FOR ENTERTAINMENT, SPORTING AND CULTURAL EVENTS (U.S. CLS. 100, 101 AND 107).

### CLASS 42—SCIENTIFIC AND COMPUTER SERVICES

FOR INTERIOR DESIGN CONSULTING SERVICE; HOME DESIGN SERVICES IN THE FIELD OF ARCHITECTURE, DESIGN OF INTERIOR DÉCOR, LANDSCAPE ARCHITECTURE, LIGHTING DESIGN, AND FURNITURE DESIGN (U.S. CLS. 100 AND 101).

**CLASS 43—HOTEL AND RESTAURANT SERVICES**

FOR RESERVATION OF HOTEL, MOTEL AND TEMPORARY LODGING ROOMS FOR TRAVELERS (U.S. CLS. 100 AND 101).

**CLASS 44—MEDICAL, BEAUTY AND AGRICULTURAL SERVICES**

FOR YARD AND LAWN CARE SERVICES, DESIGN SERVICES IN THE FIELD OF LANDSCAPE GARDENING DESIGN (U.S. CLS. 100 AND 101).  
JEFFREY LOOK, EXAMINING ATTORNEY

SN 85-175,193. GOLDEN PRIDE, INC., WEST PALM BEACH, FL. FILED 11-12-2010.

# RAWLEIGH

THE MARK CONSISTS OF STANDARD CHARACTERS WITHOUT CLAIM TO ANY PARTICULAR FONT, STYLE, SIZE, OR COLOR.  
SEC. 2(F).

**CLASS 3—COSMETICS AND CLEANING PREPARATIONS**

FOR SKIN CREAMS; LIP BALM; NON-MEDICATED AND HERBAL BODY CARE PRODUCTS, NAMELY, BODY OILS, SALVES AND LIP BALMS; ALL-PURPOSE CLEANERS, TOILET BOWL DETERGENTS (U.S. CLS. 1, 4, 6, 50, 51 AND 52).

FIRST USE 10-31-1960; IN COMMERCE 10-31-1960.

**CLASS 5—PHARMACEUTICALS**

FOR ANTI-ARTHRITIC COMPOSITIONS AND PREPARATIONS; HERBAL TOPICAL CREAMS, GELS, SALVES, SPRAYS, POWDER, BALMS, LINIMENT AND OINTMENTS FOR THE RELIEF OF ACHE AND PAIN; ANTISEPTIC PREPARATIONS; NASAL SPRAY PREPARATIONS; COUGH SYRUPS; MEDICATED THROAT SPRAYS; COLD SORE TREATMENT PREPARATIONS; AROMATHERAPY OILS FOR TREATING HEADACHES, RELIEVING STRESS, CURING INSOMNIA AND TREATING ANXIETY; VITAMIN AND MINERAL SUPPLEMENTS (U.S. CLS. 6, 18, 44, 46, 51 AND 52).

FIRST USE 10-31-1960; IN COMMERCE 10-31-1960.

**CLASS 29—MEATS AND PROCESSED FOODS**

FOR SOUP MIXES (U.S. CL. 46).  
FIRST USE 10-31-1960; IN COMMERCE 10-31-1960.

**CLASS 30—STAPLE FOODS**

FOR EXTRACTS USED AS FLAVORING; FLAVORINGS; FOOD ADDITIVES FOR NON-NUTRITIONAL PURPOSES FOR USE AS A FLAVORING; SEASONINGS; SEASONING MIXES; SPICES; CINNAMON; GRAVY MIXES; DESSERT PUDDINGS; CUSTARD-BASED FILLINGS FOR CAKES AND PIES; MEAT TENDERIZERS (U.S. CL. 46).

FIRST USE 10-31-1960; IN COMMERCE 10-31-1960.  
ROBIN CHOSID, EXAMINING ATTORNEY

SN 85-175,336. GUINNESS WORLD RECORDS LIMITED, LONDON, UNITED KINGDOM, FILED 11-12-2010.

# CHALLENGERS

THE MARK CONSISTS OF STANDARD CHARACTERS WITHOUT CLAIM TO ANY PARTICULAR FONT, STYLE, SIZE, OR COLOR.

**CLASS 38—COMMUNICATION**

FOR PROVIDING ACCESS TO A WEB SITE WHERE COMPUTER USERS CAN SEARCH FOR AND INTERACT WITH OTHER COMPUTER USERS CONCERNING TOPICS OF GENERAL INTEREST, AND CREATE AND PARTICIPATE IN ON-LINE COMMUNITIES AND SOCIAL NETWORKS FOR SETTING AND BREAKING RECORDS; ELECTRONIC TRANSMISSION OF AUDIO, VIDEO AND ELECTRONIC DATA, MESSAGES, VOICE, TEXT, SOUNDS, IMAGES AND PHOTOGRAPHS BY MEANS OF TELECOMMUNICATIONS DEVICES, NAMELY MOBILE TELEPHONES, COMPUTERS, PDAS, DIGITAL CAMERAS, CAMCORDERS, WEB CAMERAS AND TVS IN THE FIELDS OF EDUCATION, ENTERTAINMENT, COMPETITION AND RECORD-BREAKING ACTIVITIES; PROVISION OF INFORMATION AND ADVISORY SERVICES RELATING TO THE AFORESAID SERVICES; PROVIDING ON-LINE ELECTRONIC MESSAGE BOARDS FOR TRANSMISSION OF MESSAGES AMONG COMPUTER USERS CONCERNING ENTERTAINMENT, COMPETITION AND RECORD-BREAKING (U.S. CLS. 100, 101 AND 104).

**CLASS 41—EDUCATION AND ENTERTAINMENT**

FOR ENTERTAINMENT SERVICES, NAMELY, PROVIDING ONLINE COMPUTER GAMES; PROVIDING A WEBSITE FEATURING NON-DOWNLOADABLE AUDIO, VIDEO AND FILM CLIPS, PHOTOGRAPHS, AND OTHER MULTIMEDIA MATERIALS FEATURING RECORD-SETTING AND RECORD-BREAKING ACTIVITIES; BLOGS FEATURING INFORMATION REGARDING THE PRODUCTION, CREATION AND ON-LINE POSTING OF AUDIO, VIDEO AND FILM CLIPS, PHOTOGRAPHS, AND OTHER MULTIMEDIA MATERIALS (U.S. CLS. 100, 101 AND 107).

**CLASS 42—SCIENTIFIC AND COMPUTER SERVICES**

FOR HOSTING AN ONLINE WEB SITE WHERE COMPUTER USERS CAN SEARCH FOR OTHER COMPUTER USERS TO CREATE AND PARTICIPATE IN ONLINE COMMUNITIES, SOCIAL NETWORKS AND RECORD-SETTING AND RECORD-BREAKING ACTIVITIES (U.S. CLS. 100 AND 101).

ROBERT STRUCK, EXAMINING ATTORNEY

SN 85-175,340. GUINNESS WORLD RECORDS LIMITED, LONDON, UNITED KINGDOM, FILED 11-12-2010.



THE MARK CONSISTS OF THE WORD CHALLENGERS ON A BANNER.



**CLASS 38—COMMUNICATION**

FOR PROVIDING ACCESS TO A WEB SITE WHERE COMPUTER USERS CAN SEARCH FOR AND INTERACT WITH OTHER COMPUTER USERS CONCERNING TOPICS OF GENERAL INTEREST, AND CREATE AND PARTICIPATE IN ON-LINE COMMUNITIES AND SOCIAL NETWORKS FOR SETTING AND BREAKING RECORDS; ELECTRONIC TRANSMISSION OF AUDIO, VIDEO AND ELECTRONIC DATA, MESSAGES, VOICE, TEXT, SOUNDS, IMAGES AND PHOTOGRAPHS BY MEANS OF TELECOMMUNICATIONS DEVICES, NAMELY MOBILE TELEPHONES, COMPUTERS, PDAS, DIGITAL CAMERAS, CAMCORDERS, WEB CAMERAS AND TVS IN THE FIELDS OF EDUCATION, ENTERTAINMENT, COMPETITION AND RECORD-BREAKING ACTIVITIES; PROVISION OF INFORMATION AND ADVISORY SERVICES RELATING TO THE AFORESAID SERVICES; PROVIDING ON-LINE ELECTRONIC MESSAGE BOARDS FOR TRANSMISSION OF MESSAGES AMONG COMPUTER USERS CONCERNING ENTERTAINMENT, COMPETITION AND RECORD-BREAKING (U.S. CLS. 100, 101 AND 104).

**CLASS 41—EDUCATION AND ENTERTAINMENT**

FOR ENTERTAINMENT SERVICES, NAMELY, PROVIDING ONLINE COMPUTER GAMES; PROVIDING A WEBSITE FEATURING NON-DOWNLOADABLE AUDIO, VIDEO AND FILM CLIPS, PHOTOGRAPHS, AND OTHER MULTIMEDIA MATERIALS FEATURING RECORD-SETTING AND RECORD-BREAKING ACTIVITIES; BLOGS FEATURING INFORMATION REGARDING THE PRODUCTION, CREATION AND ON-LINE POSTING OF AUDIO, VIDEO AND FILM CLIPS, PHOTOGRAPHS, AND OTHER MULTIMEDIA MATERIALS (U.S. CLS. 100, 101 AND 107).

**CLASS 42—SCIENTIFIC AND COMPUTER SERVICES**

FOR HOSTING AN ONLINE WEB SITE WHERE COMPUTER USERS CAN SEARCH FOR OTHER COMPUTER USERS TO CREATE AND PARTICIPATE IN ONLINE COMMUNITIES, SOCIAL NETWORKS AND RECORD-SETTING AND RECORD-BREAKING ACTIVITIES (U.S. CLS. 100 AND 101).

ROBERT STRUCK, EXAMINING ATTORNEY

SN 85-175,344. BBK PICTURES, INC., PHILADELPHIA, PA. FILED 11-12-2010.

# ALYSIA'S

THE MARK CONSISTS OF STANDARD CHARACTERS WITHOUT CLAIM TO ANY PARTICULAR FONT, STYLE, SIZE, OR COLOR.

**CLASS 30—STAPLE FOODS**

FOR TEA-BASED BEVERAGES WITH FRUIT FLAVORING; TEA; AND TEA-BASED BEVERAGES (U.S. CL. 46).

**CLASS 32—LIGHT BEVERAGES**

FOR CONCENTRATED FRUIT JUICE; CONCENTRATES FOR MAKING FRUIT JUICES; FRUIT DRINKS AND FRUIT JUICES; FRUIT JUICES; FRUIT JUICE BASES; FRUIT JUICE CONCENTRATES; HERBAL JUICES; MIXED FRUIT JUICE; NON-ALCOHOLIC BEVERAGES CONTAINING FRUIT JUICES; NON-ALCOHOLIC FRUIT JUICE BEVERAGES; NON-ALCOHOLIC BEVERAGES WITH TEA FLAVOR (U.S. CLS. 45, 46 AND 48).

RICHARD WHITE, EXAMINING ATTORNEY

SN 85-175,347. HUMANA INC., LOUISVILLE, KY. FILED 11-12-2010.

# HUMANA GEAR

THE MARK CONSISTS OF STANDARD CHARACTERS WITHOUT CLAIM TO ANY PARTICULAR FONT, STYLE, SIZE, OR COLOR.

OWNER OF U.S. REG. NOS. 2,213,478, 3,497,184 AND OTHERS.

NO CLAIM IS MADE TO THE EXCLUSIVE RIGHT TO USE "GEAR" IN INTERNATIONAL CLASS 9, APART FROM THE MARK AS SHOWN.

**CLASS 9—ELECTRICAL AND SCIENTIFIC APPARATUS**

FOR MULTIFUNCTIONAL ELECTRONIC DEVICES FOR DISPLAYING, MEASURING, AND UPLOADING BIOMETRIC INFORMATION TO THE INTERNET FOR NON-MEDICAL PURPOSES (U.S. CLS. 21, 23, 26, 36 AND 38).

**CLASS 41—EDUCATION AND ENTERTAINMENT**

FOR PROVIDING A WEBSITE THROUGH WHICH USERS CAN LOCATE AND SHARE INFORMATION ABOUT FITNESS AND EXERCISE; ONLINE JOURNALS, NAMELY, BLOGS FEATURING FITNESS, EXERCISE, NUTRITION AND WEIGHT LOSS; PROVIDING INTERNET NEWS PORTALS FEATURING LINKS TO FITNESS AND EXERCISE STORIES AND EVENTS (U.S. CLS. 100, 101 AND 107).

**CLASS 42—SCIENTIFIC AND COMPUTER SERVICES**

FOR COMPUTER SERVICES, NAMELY, CREATING AND HOSTING AN ONLINE COMMUNITY WEBSITE FOR REGISTERED USERS TO UPLOAD, SHARE AND OTHERWISE PROVIDE FITNESS DATA TO TRACK, LOCATE, MONITOR AND LOG FITNESS, EXERCISE, NUTRITION AND WEIGHT LOSS GOALS AND PROGRESS, CALCULATE CALORIES, HEART RATE, AND BODY MASS INDEX; FITNESS ROUTINE ROUTING TECHNOLOGY, NAMELY, PROVIDING A WEB SITE THAT GIVES COMPUTER USERS THE ABILITY TO UPLOAD, EXCHANGE, AND SHARE FITNESS, EXERCISE, NUTRITION AND WEIGHT LOSS PHOTOS AND STORIES WITHIN A FITNESS COMMUNITY (U.S. CLS. 100 AND 101).

**CLASS 44—MEDICAL, BEAUTY AND AGRICULTURAL SERVICES**

FOR HEALTH AND WELLNESS PROGRAMS IN THE NATURE OF PROVIDING HEALTH AND WELLNESS INFORMATION; HEALTHCARE SERVICES, NAMELY, HEALTH AND WELLNESS PROGRAM TO EDUCATE PARTICIPANTS AND ENCOURAGE INCREASED PHYSICAL ACTIVITY; HEALTHCARE SERVICES, NAMELY, HEALTH AND WELLNESS PROGRAM TO ENCOURAGE PERMANENT, HEALTHY BEHAVIOR CHANGES BY PROVIDING THE OPPORTUNITY TO EARN REWARDS FOR PHYSICAL ACTIVITY; PROVIDING A WEBSITE FEATURING INFORMATION, NAMELY, PROVIDING HEALTH AND WELLNESS INFORMATION IN TEXT, AUDIO AND VIDEO-BASED ONLINE PROGRAMMING; PROVIDING A WEBSITE THROUGH WHICH USERS CAN LOCATE AND SHARE INFORMATION ABOUT NUTRITION AND WEIGHT LOSS; PROVIDING INTERNET NEWS PORTALS FEATURING LINKS TO NUTRITION AND WEIGHT LOSS STORIES AND EVENTS (U.S. CLS. 100 AND 101).

SARA BENJAMIN, EXAMINING ATTORNEY

---

SN 85-175,355. BBK PICTURES, INC., PHILADELPHIA, PA. FILED 11-12-2010.

# BOSTON

THE MARK CONSISTS OF STANDARD CHARACTERS WITHOUT CLAIM TO ANY PARTICULAR FONT, STYLE, SIZE, OR COLOR.

OWNER OF U.S. REG. NO. 1,994,407.

**CLASS 30—STAPLE FOODS**

FOR TEA-BASED BEVERAGES WITH FRUIT FLAVORING; TEA; AND TEA-BASED BEVERAGES (U.S. CL. 46).

**CLASS 32—LIGHT BEVERAGES**

FOR CONCENTRATED FRUIT JUICE; CONCENTRATES FOR MAKING FRUIT JUICES; FRUIT DRINKS AND FRUIT JUICES; FRUIT JUICES; FRUIT JUICE BASES; FRUIT JUICE CONCENTRATES; HERBAL JUICES; MIXED FRUIT JUICE; NON-ALCOHOLIC BEVERAGES CONTAINING FRUIT JUICES; NON-ALCOHOLIC FRUIT JUICE BEVERAGES; NON-ALCOHOLIC BEVERAGES WITH TEA FLAVOR (U.S. CLS. 45, 46 AND 48).

RICHARD WHITE, EXAMINING ATTORNEY

---

SN 85-175,893. SIGNATURE TRAVEL NETWORK COOPERATIVE INC., MARINA DEL REY, CA. FILED 11-12-2010.

# SIGNATURE

THE MARK CONSISTS OF STANDARD CHARACTERS WITHOUT CLAIM TO ANY PARTICULAR FONT, STYLE, SIZE, OR COLOR.

OWNER OF U.S. REG. NO. 3,052,215.

**CLASS 35—ADVERTISING AND BUSINESS**

FOR ADVERTISING AND ADVERTISEMENT SERVICES IN THE FIELD OF TRAVEL AND LODGING; ADVERTISING ON THE INTERNET FOR OTHERS IN THE FIELD OF TRAVEL AND LODGING; EMAIL MARKETING SERVICES; DIRECT MAIL ADVERTISING SERVICES; DISTRIBUTION OF ADVERTISING MATERIALS; PROMOTING, ADVERTISING AND MARKETING OF TRAVEL AND LODGING SERVICES OF OTHERS; ADVERTISING AND MARKETING FOR OTHERS, NAMELY, PROVIDING INFORMATION ABOUT THE GOODS AND SERVICES OF OTHERS IN THE TRAVEL INDUSTRY, INCLUDING INFORMATION REGARDING SPECIAL TERMS, AMENITIES AND DISCOUNTS; ADVERTISING AND MARKETING FOR OTHERS, NAMELY, PROVIDING INFORMATION REGARDING TRAVEL CONCIERGE SERVICES PROVIDED BY OTHERS (U.S. CLS. 100, 101 AND 102).

FIRST USE 1-0-2004; IN COMMERCE 1-0-2004.

**CLASS 39—TRANSPORTATION AND STORAGE**

FOR PROVIDING A WEBSITE FEATURING INFORMATION ON TRAVEL; PROVIDING AN ON-LINE COMPUTER DATABASE IN THE FIELD OF TRAVEL; PROVIDING LINKS TO WEB SITES OF OTHERS FEATURING TRAVEL; PROVISION OF TRAVEL INFORMATION (U.S. CLS. 100 AND 105).

FIRST USE 1-0-2004; IN COMMERCE 1-0-2004.

**CLASS 200—COLLECTIVE MEMBERSHIP**

FOR INDICATING MEMBERSHIP IN A COOPERATIVE ORGANIZATION OF TRAVEL AGENCIES.

FIRST USE 1-0-2004; IN COMMERCE 1-0-2004.

REBECCA POVARCHUK, EXAMINING ATTORNEY

---

SN 85-175,898. SIGNATURE TRAVEL NETWORK COOPERATIVE INC., MARINA DEL REY, CA. FILED 11-12-2010.

## SIGNATURE TRAVEL NETWORK

THE MARK CONSISTS OF STANDARD CHARACTERS WITHOUT CLAIM TO ANY PARTICULAR FONT, STYLE, SIZE, OR COLOR.

OWNER OF U.S. REG. NO. 3,052,215.

NO CLAIM IS MADE TO THE EXCLUSIVE RIGHT TO USE "TRAVEL NETWORK", APART FROM THE MARK AS SHOWN.

**CLASS 35—ADVERTISING AND BUSINESS**

FOR ADVERTISING AND ADVERTISEMENT SERVICES IN THE FIELD OF TRAVEL AND LODGING; ADVERTISING ON THE INTERNET FOR OTHERS IN THE FIELD OF TRAVEL AND LODGING; EMAIL MARKETING SERVICES; DIRECT MAIL ADVERTISING SERVICES; DISTRIBUTION OF ADVERTISING MATERIALS; PROMOTING, ADVERTISING AND MARKETING OF TRAVEL AND LODGING SERVICES OF OTHERS; ADVERTISING AND MARKETING FOR OTHERS, NAMELY, PROVIDING INFORMATION ABOUT THE GOODS AND SERVICES OF OTHERS IN THE TRAVEL INDUSTRY, INCLUDING INFORMATION REGARDING SPECIAL TERMS, AMENITIES AND DISCOUNTS; ADVERTISING AND MARKETING FOR OTHERS, NAMELY, PROVIDING INFORMATION REGARDING TRAVEL CONCIERGE SERVICES PROVIDED BY OTHERS (U.S. CLS. 100, 101 AND 102).

FIRST USE 1-0-2004; IN COMMERCE 1-0-2004.

**CLASS 39—TRANSPORTATION AND STORAGE**

FOR PROVIDING A WEBSITE FEATURING INFORMATION ON TRAVEL; PROVIDING AN ON-LINE COMPUTER DATABASE IN THE FIELD OF TRAVEL; PROVIDING LINKS TO WEB SITES OF OTHERS FEATURING TRAVEL; PROVISION OF TRAVEL INFORMATION (U.S. CLS. 100 AND 105).

FIRST USE 1-0-2004; IN COMMERCE 1-0-2004.

**CLASS 200—COLLECTIVE MEMBERSHIP**

FOR INDICATING MEMBERSHIP IN A COOPERATIVE ORGANIZATION OF TRAVEL AGENCIES.

FIRST USE 1-0-2004; IN COMMERCE 1-0-2004.

REBECCA POVARCHUK, EXAMINING ATTORNEY

SN 85-175,939. KENNETH J. BAGAN, NILES, IL. FILED 11-12-2010.

**MY GLOBAL BOX NETWORK**

THE MARK CONSISTS OF STANDARD CHARACTERS WITHOUT CLAIM TO ANY PARTICULAR FONT, STYLE, SIZE, OR COLOR.

NO CLAIM IS MADE TO THE EXCLUSIVE RIGHT TO USE "GLOBAL" "NETWORK", APART FROM THE MARK AS SHOWN.

**CLASS 9—ELECTRICAL AND SCIENTIFIC APPARATUS**

FOR INTERACTIVE COMPUTER KIOSKS COMPRISING COMPUTERS, COMPUTER HARDWARE, COMPUTER PERIPHERALS, AND COMPUTER OPERATING SOFTWARE, FOR USE IN MEASURING USERS' BLOOD PRESSURE, WEIGHT, BODY FAT, AND BLOOD-OXYGEN LEVELS (U.S. CLS. 21, 23, 26, 36 AND 38).

**CLASS 38—COMMUNICATION**

FOR COMMUNICATION SERVICES, NAMELY, TRANSMITTING RESULTS OF BLOOD PRESSURE, WEIGHT, BODY FAT, AND BLOOD-OXYGEN LEVEL TESTS TO OTHERS OVER THE INTERNET (U.S. CLS. 100, 101 AND 104).

ALLISON HOLTZ, EXAMINING ATTORNEY

SN 85-176,072. SITE BASED ENERGY, HAILEY, ID. FILED 11-12-2010.



NO CLAIM IS MADE TO THE EXCLUSIVE RIGHT TO USE "SITE BASED ENERGY", APART FROM THE MARK AS SHOWN.

THE COLOR(S) GREEN, LIGHT GREEN AND BLUE IS/ ARE CLAIMED AS A FEATURE OF THE MARK.

THE MARK CONSISTS OF A DESIGN OF A WIND TURBINE IN THE COLOR OF BLUE WITH A BORDER IN BACKGROUND COLOR. BEHIND THE LEFT PORTION OF THE WIND TURBINE IS A LINE THAT FORMS A HALF OF

A CIRCLE IN THE COLOR OF GREEN AND FADES TO LIGHT GREEN. DIRECTLY TO THE RIGHT OF THE WIND TURBINE DESIGN IS THE WORDING "SBE" IN LARGE STYLIZED FONT, WITH THE LETTERS "SB" IN THE COLOR OF BLUE AND THE LETTER "E" IN THE COLOR OF GREEN. DIRECTLY BELOW THE WORDING "SBE" IS THE WORDING "SITE BASED ENERGY" IN SMALL STYLIZED FONT, WITH THE WORDING "SITE BASED" IN THE COLOR OF BLUE AND THE WORD "ENERGY" IN THE COLOR OF GREEN.

**CLASS 7—MACHINERY**

FOR SOLAR-POWERED ELECTRICITY GENERATORS; WIND-POWERED ELECTRICITY GENERATORS (U.S. CLS. 13, 19, 21, 23, 31, 34 AND 35).

FIRST USE 6-26-2010; IN COMMERCE 6-26-2010.

**CLASS 37—CONSTRUCTION AND REPAIR**

FOR INSTALLATION OF RENEWABLE ENERGY GENERATION EQUIPMENT; INSTALLATION, MAINTENANCE AND REPAIR OF RENEWABLE ENERGY GENERATION EQUIPMENT (U.S. CLS. 100, 103 AND 106).

FIRST USE 6-26-2010; IN COMMERCE 6-26-2010.

ARETHA SOMERVILLE, EXAMINING ATTORNEY

SN 85-176,089. SMILERANK TECHNOLOGIES LLC, REDMOND, WA. FILED 11-13-2010.

# SmileRank

THE MARK CONSISTS OF STANDARD CHARACTERS WITHOUT CLAIM TO ANY PARTICULAR FONT, STYLE, SIZE, OR COLOR.

**CLASS 9—ELECTRICAL AND SCIENTIFIC APPARATUS**

FOR COMPUTER APPLICATION SOFTWARE FOR MOBILE PHONES, ELECTRONIC TABLETS AND PCS, NAMELY, SOFTWARE FOR USE IN PROVIDING DENTAL AND COSMETIC INFORMATION (U.S. CLS. 21, 23, 26, 36 AND 38).

**CLASS 44—MEDICAL, BEAUTY AND AGRICULTURAL SERVICES**

FOR PROVIDING A WEBSITE FEATURING INFORMATION FOR PATIENTS IN THE FIELD OF DENTAL HEALTH AND COSMETIC DENTISTRY (U.S. CLS. 100 AND 101).

EDWARD FENNESSY, EXAMINING ATTORNEY

SN 85-176,282. PETS A GO GO LLC, BRIARCLIFF MANOR, NY. FILED 11-14-2010.

## The Paw Squad

THE MARK CONSISTS OF STANDARD CHARACTERS WITHOUT CLAIM TO ANY PARTICULAR FONT, STYLE, SIZE, OR COLOR.

### CLASS 44—MEDICAL, BEAUTY AND AGRICULTURAL SERVICES

FOR PET CARE SERVICES, NAMELY, DOG WALKING, DOG BATHING, NON-MEDICATED PET GROOMING AND IN-HOME MEDICAL CARE (U.S. CLS. 100 AND 101).  
FIRST USE 8-28-2008; IN COMMERCE 10-1-2008.

### CLASS 45—PERSONAL AND LEGAL SERVICES

FOR PET SITTING (U.S. CLS. 100 AND 101).  
FIRST USE 8-28-2008; IN COMMERCE 10-1-2008.  
TRICIA SONNEBORN, EXAMINING ATTORNEY

SN 85-176,481. COURAGE UNLIMITED CORPORATION, REISTERSTOWN, MD. FILED 11-15-2010.



THE COLOR(S) RED, WHITE, BLACK, BLUE, GREY, TAWNY, YELLOW, AND GREEN IS/ARE CLAIMED AS A FEATURE OF THE MARK.

THE MARK CONSISTS OF THE STYLIZED WORDING "COURAGE UNLIMITED" IN WHITE LETTERING AGAINST A RED RECTANGULAR BACKGROUND ABOVE A HALF OVAL, BLACK-BORDERED FRAME INSIDE OF WHICH APPEARS A LEFT-PROFILE, TAWNY-COLORED LION HEAD, ABOVE AND TO THE LEFT OF THE LION HEAD APPEARS A BLUE AND WHITE DOVE IN FLIGHT WITH A BLACK EYE AND YELLOW BEAK, WITH BLUE SKY WITH WHITE CLOUDS AND GREY AND GREEN MOUNTAIN PEAK IN THE BACKGROUND OF THE HALF OVAL.

### CLASS 9—ELECTRICAL AND SCIENTIFIC APPARATUS

FOR COMPACT DISCS FEATURING MUSIC AND LYRICS (U.S. CLS. 21, 23, 26, 36 AND 38).  
FIRST USE 2-27-2006; IN COMMERCE 9-7-2006.

### CLASS 16—PAPER GOODS AND PRINTED MATTER

FOR STORY BOOKS (U.S. CLS. 2, 5, 22, 23, 29, 37, 38 AND 50).  
FIRST USE 2-27-2006; IN COMMERCE 9-7-2006.

### CLASS 28—TOYS AND SPORTING GOODS

FOR STUFFED TOY ANIMALS (U.S. CLS. 22, 23, 38 AND 50).  
FIRST USE 2-27-2006; IN COMMERCE 9-7-2006.  
ANDREW LEASER, EXAMINING ATTORNEY

SN 85-176,511. RYAN, FRANCES, HICKSVILLE, NY. FILED 11-15-2010.

## MADREPS

THE MARK CONSISTS OF STANDARD CHARACTERS WITHOUT CLAIM TO ANY PARTICULAR FONT, STYLE, SIZE, OR COLOR.

### CLASS 29—MEATS AND PROCESSED FOODS

FOR PROTEIN-BASED, NUTRIENT-DENSE SNACKS (U.S. CL. 46).

### CLASS 41—EDUCATION AND ENTERTAINMENT

FOR PROVIDING PHYSICAL FITNESS, EXERCISE, AND PERSONAL TRAINING FACILITIES, GROUP EXERCISE CLASSES, AND PHYSICAL FITNESS CONSULTATION (U.S. CLS. 100, 101 AND 107).  
JOHN WILKE, EXAMINING ATTORNEY

SN 85-176,653. THE STROLLO DESIGN COMPANY, DBA SMARTJARS, SAN DIEGO, CA. FILED 11-15-2010.

## SmartJars

THE MARK CONSISTS OF STANDARD CHARACTERS WITHOUT CLAIM TO ANY PARTICULAR FONT, STYLE, SIZE, OR COLOR.

### CLASS 20—FURNITURE AND ARTICLES NOT OTHERWISE CLASSIFIED

FOR CUSTOMIZABLE NON METAL CONTAINERS FOR COMMERCIAL AND INDUSTRIAL USE (U.S. CLS. 2, 13, 22, 25, 32 AND 50).

### CLASS 21—HOUSEWARES AND GLASS

FOR CUSTOMIZABLE NON METAL CONTAINERS FOR HOUSEHOLD USE (U.S. CLS. 2, 13, 23, 29, 30, 33, 40 AND 50).  
LAURA KOVALSKY, EXAMINING ATTORNEY

SN 85-177,022. KATZ, STEVEN L., POTOMAC, MD. FILED 11-15-2010.

SN 85-177,411. CASA DE TAMALES, LLC, FRESNO, CA. FILED 11-16-2010.

## MAN THE KITCHEN

THE MARK CONSISTS OF STANDARD CHARACTERS WITHOUT CLAIM TO ANY PARTICULAR FONT, STYLE, SIZE, OR COLOR.

NO CLAIM IS MADE TO THE EXCLUSIVE RIGHT TO USE "KITCHEN", APART FROM THE MARK AS SHOWN.

### CLASS 35—ADVERTISING AND BUSINESS

FOR RETAIL STORE AND ON-LINE RETAIL STORE SERVICES FEATURING FOODS, CUTLERY, KITCHEN GADGETS, KITCHEN UTENSILS, POTS AND PANS, BARBECUE AND GRILLING EQUIPMENT, DINNERWARE, TABLEWARE, GLASSWARE, FLATWARE, BARWARE, HOUSEWARES, TABLE LINENS, KITCHEN TOWELS, OVEN MITTS, STORAGE CONTAINERS, SOAPS AND CLEANING PRODUCTS, COOKBOOKS, AND HOUSEHOLD FURNISHINGS (U.S. CLS. 100, 101 AND 102).

### CLASS 41—EDUCATION AND ENTERTAINMENT

FOR EDUCATIONAL AND ENTERTAINMENT SERVICES, NAMELY, A CONTINUING PROGRAM ABOUT FOOD AND COOKING ACCESSIBLE BY RADIO, TELEVISION, SATELLITE, AUDIO, VIDEO AND COMPUTER NETWORKS (U.S. CLS. 100, 101 AND 107).

JEFFREY LOOK, EXAMINING ATTORNEY

SN 85-177,224. RETAIL BRAND ALLIANCE, INC., ENFIELD, CT. FILED 11-15-2010.

## DIGITAL TAILOR

THE MARK CONSISTS OF STANDARD CHARACTERS WITHOUT CLAIM TO ANY PARTICULAR FONT, STYLE, SIZE, OR COLOR.

OWNER OF U.S. REG. NO. 2,670,657.

NO CLAIM IS MADE TO THE EXCLUSIVE RIGHT TO USE "TAILOR", APART FROM THE MARK AS SHOWN.

### CLASS 25—CLOTHING

FOR CLOTHING, NAMELY, SHIRTS, TOPS, SWEATERS, JACKETS, PANTS, SUITS, BOTTOMS, SOCKS, HATS AND CAPS; SHOES; SHORTS, COATS, UNDERWEAR, VESTS, ROBES, HOSIERY, SKIRTS, DRESSES, LOUNGEWEAR, SCARVES, RAINWEAR, TROUSERS, TIES, POLO SHIRTS, PAJAMAS, GLOVES, BELTS, BOOTS, SLIPPERS, BEACH WEAR, SWIMWEAR (U.S. CLS. 22 AND 39).

### CLASS 35—ADVERTISING AND BUSINESS

FOR RETAIL STORE SERVICES, ONLINE RETAIL STORE SERVICES AND MAIL ORDER CATALOG SERVICES FEATURING CLOTHING (U.S. CLS. 100, 101 AND 102).

FRED CARL, EXAMINING ATTORNEY

## CASA DE TAMALES

THE MARK CONSISTS OF STANDARD CHARACTERS WITHOUT CLAIM TO ANY PARTICULAR FONT, STYLE, SIZE, OR COLOR.

OWNER OF U.S. REG. NO. 3,866,716.

NO CLAIM IS MADE TO THE EXCLUSIVE RIGHT TO USE "TAMALES", APART FROM THE MARK AS SHOWN.

THE ENGLISH TRANSLATION OF "CASA DE" IN THE MARK IS "HOUSE OF."

### CLASS 29—MEATS AND PROCESSED FOODS

FOR FROZEN AND PACKAGED ENTREES AND MEALS CONSISTING PRIMARILY OF MEAT, FISH, POULTRY, CHEESE AND/OR VEGETABLES (U.S. CL. 46).

FIRST USE 4-11-2010; IN COMMERCE 4-11-2010.

### CLASS 43—HOTEL AND RESTAURANT SERVICES

FOR RESTAURANT SERVICES, INCLUDING SIT-DOWN SERVICE OF FOOD AND TAKE-OUT RESTAURANT SERVICES; RESTAURANTS FEATURING HOME DELIVERY (U.S. CLS. 100 AND 101).

FIRST USE 4-11-2010; IN COMMERCE 4-11-2010.

SEAN CROWLEY, EXAMINING ATTORNEY

SN 85-177,488. G W PLASTICS, INC., BETHEL, VT. FILED 11-16-2010.

## GW PLASTICS

THE MARK CONSISTS OF STANDARD CHARACTERS WITHOUT CLAIM TO ANY PARTICULAR FONT, STYLE, SIZE, OR COLOR.

OWNER OF U.S. REG. NO. 2,020,099.

NO CLAIM IS MADE TO THE EXCLUSIVE RIGHT TO USE "PLASTICS", APART FROM THE MARK AS SHOWN.

### CLASS 40—MATERIAL TREATMENT

FOR PLASTIC AND SILICONE INJECTION MOLDING SERVICES FOR OTHERS, NAMELY, INJECTION MOLDING, CUSTOM MANUFACTURE OF MOLDS AND CONTRACT ASSEMBLY OF PLASTIC AND SILICONE PARTS (U.S. CLS. 100, 103 AND 106).

FIRST USE 4-26-1988; IN COMMERCE 4-26-1988.

### CLASS 42—SCIENTIFIC AND COMPUTER SERVICES

FOR PRODUCT RESEARCH; NEW PRODUCT DESIGN AND DEVELOPMENT SERVICES FOR OTHERS (U.S. CLS. 100 AND 101).

FIRST USE 4-26-1988; IN COMMERCE 4-26-1988.

MICHAEL KEATING, EXAMINING ATTORNEY

SN 85-177,641. MCMANUS II, WILSON, HUNTSVILLE, AL.  
FILED 11-16-2010.



OWNER OF U.S. REG. NO. 3,873,893.  
NO CLAIM IS MADE TO THE EXCLUSIVE RIGHT TO USE "VET AFFORDABLE PET CARE", APART FROM THE MARK AS SHOWN.

THE MARK CONSISTS OF THE STYLIZED WORDING "TRUSTY VET AFFORDABLE PET CARE" WITH THE DESIGN OF A HEART FOR THE LETTER "V" AND A PLUS SIGN FOR THE LETTER "T" IN "VET".

#### CLASS 43—HOTEL AND RESTAURANT SERVICES

FOR PET BOARDING SERVICES; PET DAYCARE SERVICES (U.S. CLS. 100 AND 101).

#### CLASS 44—MEDICAL, BEAUTY AND AGRICULTURAL SERVICES

FOR VETERINARY SERVICES; PET GROOMING SERVICES (U.S. CLS. 100 AND 101).  
AMY C. KEAN, EXAMINING ATTORNEY

SN 85-177,838. 3DELTA SYSTEMS, INC., CHANTILLY, VA.  
FILED 11-16-2010.

## Payment WorkSuite

THE MARK CONSISTS OF STANDARD CHARACTERS WITHOUT CLAIM TO ANY PARTICULAR FONT, STYLE, SIZE, OR COLOR.

NO CLAIM IS MADE TO THE EXCLUSIVE RIGHT TO USE "PAYMENT", APART FROM THE MARK AS SHOWN.

#### CLASS 36—INSURANCE AND FINANCIAL

FOR PROVIDING ELECTRONIC PROCESSING OF CREDIT CARD TRANSACTIONS AND ELECTRONIC PAYMENTS VIA A GLOBAL COMPUTER NETWORK (U.S. CLS. 100, 101 AND 102).  
FIRST USE 6-29-2010; IN COMMERCE 11-1-2010.

#### CLASS 38—COMMUNICATION

FOR PROVIDING ELECTRONIC TRANSMISSION OF CREDIT CARD TRANSACTION DATA AND ELECTRONIC PAYMENT DATA VIA A GLOBAL COMPUTER NETWORK (U.S. CLS. 100, 101 AND 104).  
FIRST USE 6-29-2010; IN COMMERCE 11-1-2010.

#### CLASS 42—SCIENTIFIC AND COMPUTER SERVICES

FOR DATA ENCRYPTION SERVICES (U.S. CLS. 100 AND 101).  
FIRST USE 6-29-2010; IN COMMERCE 11-1-2010.  
CHARLES L. JENKINS, EXAMINING ATTORNEY

SN 85-178,285. ROBERTO TREVINO AMADOR, SAN ANTONIO, TX. FILED 11-16-2010.



*Casa Cristo Rey*

OWNER OF MEXICO REG. NO. 878655, DATED 6-30-2004, EXPIRES 6-30-2014.

NO CLAIM IS MADE TO THE EXCLUSIVE RIGHT TO USE "CRISTO", APART FROM THE MARK AS SHOWN.

THE MARK CONSISTS OF WORDS "CASA CRISTO REY" IN STYLIZED FONT ABOVE A STRAIGHT LINE. TO THE LEFT OF THE WORDING, A CHRIST FIGURE WITH OUTSTRETCHED HANDS, BODY SHAPED LIKE A COLUMN AND TWO CHERUBS AT ITS FEET/BASE OF THE COLUMN.

THE ENGLISH TRANSLATION OF "CASA CRISTO REY" IN THE MARK IS HOUSE OF CHRIST THE KING.

#### CLASS 14—JEWELRY

FOR DECORATIVE BOXES MADE OF PRECIOUS METAL; JEWELRY BOXES; JEWELRY, NAMELY, CROSSES; MEDALS AND MEDALLIONS (U.S. CLS. 2, 27, 28 AND 50).

#### CLASS 16—PAPER GOODS AND PRINTED MATTER

FOR BIBLES; CALENDARS; CATALOGS IN THE FIELD OF RELIGIOUS ARTICLES; CHAPLETS (ROSARIES); LITHOGRAPHIC WORKS OF ART; PAINTINGS; RELIGIOUS BOOKS; ROSARIES; SEALING STAMPS; SEALING WAX; SEALS (U.S. CLS. 2, 5, 22, 23, 29, 37, 38 AND 50).

#### CLASS 20—FURNITURE AND ARTICLES NOT OTHERWISE CLASSIFIED

FOR POLYRESIN TABLETS WHICH LOOK LIKE STONE, AND HAVE QUOTATIONS, SAYINGS, AND BIBLE VERSES ENGRAVED ON THEM, PACKAGED WITH DISPLAY STAND; STATUES OF RELIGIOUS FIGURES, SAINTS, ANGELS MADE OF PLASTER, PLASTIC, WAX AND WOOD (U.S. CLS. 2, 13, 22, 25, 32 AND 50).

RUSS HERMAN, EXAMINING ATTORNEY

SN 85-178,424. GAZILLION, INC., SAN MATEO, CA. FILED 11-16-2010.

SN 85-178,767. OUT OF THE WOODS GRANITE, LLC, LAYTON, UT. FILED 11-17-2010.

## SECRET IDENTITY

THE MARK CONSISTS OF STANDARD CHARACTERS WITHOUT CLAIM TO ANY PARTICULAR FONT, STYLE, SIZE, OR COLOR.

### CLASS 9—ELECTRICAL AND SCIENTIFIC APPARATUS

FOR DOWNLOADABLE ELECTRONIC GAMES (U.S. CLS. 21, 23, 26, 36 AND 38).

### CLASS 41—EDUCATION AND ENTERTAINMENT

FOR ENTERTAINMENT SERVICES, NAMELY, PROVIDING THE TEMPORARY USE OF NON-DOWNLOADABLE ELECTRONIC GAMES (U.S. CLS. 100, 101 AND 107).

BRIAN NEVILLE, EXAMINING ATTORNEY

SN 85-178,573. CIPHEROPTICS, INC., RALEIGH, NC. FILED 11-17-2010.

## CERTES NETWORKS

THE MARK CONSISTS OF STANDARD CHARACTERS WITHOUT CLAIM TO ANY PARTICULAR FONT, STYLE, SIZE, OR COLOR.

NO CLAIM IS MADE TO THE EXCLUSIVE RIGHT TO USE "NETWORKS", APART FROM THE MARK AS SHOWN.

### CLASS 9—ELECTRICAL AND SCIENTIFIC APPARATUS

FOR COMPUTER HARDWARE AND SOFTWARE FOR SCALABLE SECURITY APPLICATIONS FOR HIGH PERFORMANCE NETWORKS (U.S. CLS. 21, 23, 26, 36 AND 38).

### CLASS 37—CONSTRUCTION AND REPAIR

FOR INSTALLATION OF COMPUTER HARDWARE USED IN CONNECTION WITH SCALABLE SECURITY APPLICATIONS FOR HIGH PERFORMANCE NETWORKS (U.S. CLS. 100, 103 AND 106).

### CLASS 42—SCIENTIFIC AND COMPUTER SERVICES

FOR TECHNICAL CONSULTING AND DESIGN SERVICES IN CONNECTION WITH COMPUTER HARDWARE AND SOFTWARE FOR SCALABLE SECURITY APPLICATIONS FOR HIGH PERFORMANCE NETWORKS; SOFTWARE INSTALLATION SERVICES IN CONNECTION WITH SCALABLE SECURITY APPLICATIONS FOR HIGH PERFORMANCE NETWORKS (U.S. CLS. 100 AND 101).

KAREN SEVERSON, EXAMINING ATTORNEY



NO CLAIM IS MADE TO THE EXCLUSIVE RIGHT TO USE "GRANITE", APART FROM THE MARK AS SHOWN.

THE MARK CONSISTS OF FOUR CONIFEROUS TREES WITH THE BLOCKED WORDING "OUT OF THE WOODS GRANITE" STACKED BELOW ON THREE LINES, WITH THE WORDING GRADUATING IN SIZE.

### CLASS 19—NON-METALLIC BUILDING MATERIALS

FOR BUILDING MATERIALS, NAMELY, NON-METAL COUNTERTOPS FOR FURTHER INSTALLATION; GRANITE; MANTELS FOR FIREPLACES OF STONE; NON-COMBUSTIBLE FIREPLACE SURROUNDS AND DECORATIVE FIREPLACE FACINGS MADE OF NON-METAL NON-COMBUSTIBLE MATERIALS; NON-STRUCTURAL BUILDING MATERIALS, NAMELY, GRANITE USED IN DECORATIVE SURFACE APPLICATIONS FOR COUNTERTOPS AND VANITY TOPS; PROTECTIVE SEALING COATINGS SOLD AS AN INTEGRAL COMPONENT OF GRANITE AND STONE; ROCK MATERIALS USED IN THE MANUFACTURE OF FLOORING, ROOFING, COUNTERTOPS, WALLS, CLADDING AND FIREPLACES (U.S. CLS. 1, 12, 33 AND 50).

FIRST USE 5-12-2010; IN COMMERCE 5-12-2010.

### CLASS 40—MATERIAL TREATMENT

FOR CUSTOM FABRICATION OF COUNTER TOPS (U.S. CLS. 100, 103 AND 106).

FIRST USE 5-12-2010; IN COMMERCE 5-12-2010.

CARYN GLASSER, EXAMINING ATTORNEY

SN 85-178,921. LAHR, LLC, DOYLESTOWN, PA. FILED 11-17-2010.

## ARCHETYPE

THE MARK CONSISTS OF STANDARD CHARACTERS WITHOUT CLAIM TO ANY PARTICULAR FONT, STYLE, SIZE, OR COLOR.

### CLASS 35—ADVERTISING AND BUSINESS

FOR TAX AND TAXATION PLANNING, ADVICE, INFORMATION AND CONSULTANCY SERVICES (U.S. CLS. 100, 101 AND 102).

**CLASS 36—INSURANCE AND FINANCIAL**

FOR FINANCIAL PLANNING AND INVESTMENT ADVISORY SERVICES; FINANCIAL SERVICES, NAMELY, WEALTH MANAGEMENT SERVICES; ESTATE PLANNING; INSURANCE INFORMATION AND CONSULTANCY; INSURANCE UNDERWRITING IN THE FIELD OF LIFE INSURANCE, ANNUITY, HEALTH INSURANCE, ERRORS AND OMISSION, MALPRACTICE, DISABILITY AND LONG TERM CARE; FINANCIAL PLANNING FOR RETIREMENT; CAPITAL INVESTMENT SERVICES; LENDING CONSULTANT SERVICES; CHARITABLE AND PHILANTHROPIC SERVICES, NAMELY, FINANCIAL ADVICE, STRATEGIES AND MANAGEMENT OF ASSETS (U.S. CLS. 100, 101 AND 102).

PRISCILLA MILTON, EXAMINING ATTORNEY

SN 85-178,996. CHARLESTON WOODWORKS, INC., CHARLESTON, SC. FILED 11-17-2010.



NO CLAIM IS MADE TO THE EXCLUSIVE RIGHT TO USE "CHARLESTON CHOPS", APART FROM THE MARK AS SHOWN.

THE MARK CONSISTS OF THE WORDS "CHARLESTON" AND "CHOPS" IN STYLIZED FONT NEXT TO A DESIGN OF AN OUTLINE OF A TREE RESEMBLING A PALM OR PALMETTO TREE.

SN 85-178,930. OFFI INTERNATIONAL BUYERS CORP., NEW YORK, NY. FILED 11-17-2010.

**JACOB**  
NEW YORK

NO CLAIM IS MADE TO THE EXCLUSIVE RIGHT TO USE "NEW YORK", APART FROM THE MARK AS SHOWN.

THE MARK CONSISTS OF THE WORDING "JACOB NEW YORK" IN WHICH "NEW YORK" APPEARS SMALLER AND CENTERED UNDERNEATH "JACOB", ALL IN UPPER CASE STYLIZED FONT.

**CLASS 9—ELECTRICAL AND SCIENTIFIC APPARATUS**

FOR CASES FOR EYEGLASSES AND SUNGLASSES; DECORATIVE CHARMS FOR CELLULAR TELEPHONES; SUNGLASSES (U.S. CLS. 21, 23, 26, 36 AND 38).

**CLASS 14—JEWELRY**

FOR CLOCKS AND WATCHES; COSTUME JEWELRY; JEWELRY (U.S. CLS. 2, 27, 28 AND 50).

**CLASS 18—LEATHER GOODS**

FOR BACKPACKS; BACKPACKS WITH ROLLING WHEELS; BACKPACKS, BOOK BAGS, SPORTS BAGS, BUM BAGS, WALLETS AND HANDBAGS; CHARM BAGS (OMAMORI-IRE); COIN PURSES; EVENING HANDBAGS; FASHION HANDBAGS; GENTLEMEN'S HANDBAGS; HANDBAGS; HANDBAGS FOR LADIES; HANDBAGS FOR MEN; HANDBAGS, PURSES AND WALLETS; LEATHER BAGS AND WALLETS; LEATHER BAGS, SUITCASES AND WALLETS; LEATHER CREDIT CARD WALLETS; LEATHER HANDBAGS; LUGGAGE; LUGGAGE AND TRUNKS; LUGGAGE TAGS; POCKET WALLETS; PURSE CHARMS; PURSES AND WALLETS; SCHOOLCHILDREN'S BACKPACKS; SMALL BACKPACKS; UMBRELLAS; WALLETS (U.S. CLS. 1, 2, 3, 22 AND 41).

ROBIN CHOSID, EXAMINING ATTORNEY

**CLASS 20—FURNITURE AND ARTICLES NOT OTHERWISE CLASSIFIED**

FOR WOOD CHOPPING BLOCK TABLES (U.S. CLS. 2, 13, 22, 25, 32 AND 50).

FIRST USE 3-5-2010; IN COMMERCE 3-5-2010.

**CLASS 21—HOUSEWARES AND GLASS**

FOR CHOPPING BOARDS FOR KITCHEN USE; CUTTING BOARDS; WOOD CHOPPING BLOCKS; WOOD CHOPPING BOARDS FOR KITCHEN USE (U.S. CLS. 2, 13, 23, 29, 30, 33, 40 AND 50).

FIRST USE 3-5-2010; IN COMMERCE 3-5-2010.

SARA BENJAMIN, EXAMINING ATTORNEY

SN 85-179,343. GENENTECH, INC., SOUTH SAN FRANCISCO, CA. FILED 11-17-2010.

**EVOLVING THE CARE OF ANEMIA**

THE MARK CONSISTS OF STANDARD CHARACTERS WITHOUT CLAIM TO ANY PARTICULAR FONT, STYLE, SIZE, OR COLOR.

**CLASS 41—EDUCATION AND ENTERTAINMENT**

FOR EDUCATION SERVICES, NAMELY, PROVIDING WORKSHOPS AND SYMPOSIA IN THE FIELD OF ANEMIA AND TREATMENT OPTIONS DIRECTED TO HEALTH CARE PROVIDERS AND CONSUMERS (U.S. CLS. 100, 101 AND 107).

**CLASS 44—MEDICAL, BEAUTY AND AGRICULTURAL SERVICES**

FOR PROVIDING MEDICAL INFORMATION REGARDING ANEMIA AND TREATMENT OPTIONS DIRECTED TO HEALTH CARE PROVIDERS AND CONSUMERS; PROVIDING MEDICAL INFORMATION VIA AN INTERNET WEBSITE REGARDING ANEMIA AND TREATMENT OPTIONS DIRECTED TO HEALTH CARE PROVIDERS AND CONSUMERS (U.S. CLS. 100 AND 101).

CHARLOTTE CORWIN, EXAMINING ATTORNEY



SN 85-179,995. ROCHE DIAGNOSTICS GMBH, 68305 MANNHEIM, FED REP GERMANY, FILED 11-18-2010.

# TAQMELT

THE MARK CONSISTS OF STANDARD CHARACTERS WITHOUT CLAIM TO ANY PARTICULAR FONT, STYLE, SIZE, OR COLOR.

PRIORITY CLAIMED UNDER SEC. 44(D) ON FED REP GERMANY APPLICATION NO. 302010049924, FILED 8-23-2010, REG. NO. 302010049924, DATED 10-19-2010, EXPIRES 8-31-2020.

## CLASS 1—CHEMICALS

FOR CHEMICAL, BIOCHEMICAL AND BIOLOGICAL PRODUCTS FOR INDUSTRIAL AND SCIENTIFIC PURPOSES, NAMELY, REAGENTS, BUFFERS AND CONTROLS; IN VITRO DIAGNOSTIC REAGENTS FOR SCIENTIFIC AND RESEARCH PURPOSES; KITS CONSISTING OF CHEMICAL, BIOCHEMICAL AND BIOLOGICAL PRODUCTS FOR INDUSTRIAL AND SCIENTIFIC PURPOSES, NAMELY, REAGENTS, BUFFERS AND CONTROLS (U.S. CLS. 1, 5, 6, 10, 26 AND 46).

## CLASS 5—PHARMACEUTICALS

FOR CHEMICAL, BIOCHEMICAL AND BIOLOGICAL REAGENTS FOR USE IN POLYMERASE CHAIN REACTION (PCR) APPLICATIONS FOR THE DETECTION OF DNA MUTATIONS FOR MEDICAL DIAGNOSTIC PURPOSES; KITS CONSISTING OF CHEMICAL, BIOCHEMICAL AND BIOLOGICAL PRODUCTS, NAMELY, REAGENTS, BUFFERS AND CONTROLS, FOR USE IN POLYMERASE CHAIN REACTION (PCR) APPLICATIONS FOR THE DETECTION OF DNA MUTATIONS FOR MEDICAL DIAGNOSTIC PURPOSES (U.S. CLS. 6, 18, 44, 46, 51 AND 52).

ANDREA HACK, EXAMINING ATTORNEY

SN 85-180,154. WORKRIGHT TRAINING LLC, CHICAGO, IL. FILED 11-18-2010.

# ADOPT THE GOLDEN EGG

THE MARK CONSISTS OF STANDARD CHARACTERS WITHOUT CLAIM TO ANY PARTICULAR FONT, STYLE, SIZE, OR COLOR.

OWNER OF U.S. REG. NO. 3,915,054.

## CLASS 16—PAPER GOODS AND PRINTED MATTER

FOR PUBLICATIONS, NAMELY, WORKBOOKS, OUTLINES, CATALOGS, NEWSLETTERS AND OTHER PRINTED TRAINING MATERIALS IN THE FIELD OF BUSINESS AND COMPLIANCE WITH WORKPLACE AND EMPLOYMENT LAWS, RULES AND REGULATIONS (U.S. CLS. 2, 5, 22, 23, 29, 37, 38 AND 50).

## CLASS 41—EDUCATION AND ENTERTAINMENT

FOR PROVIDING TRAINING SERVICES IN THE FIELD OF BUSINESS AND COMPLIANCE WITH WORKPLACE AND EMPLOYMENT LAWS, RULES AND REGULATIONS (U.S. CLS. 100, 101 AND 107).

BENJAMIN OKEKE, EXAMINING ATTORNEY

SN 85-180,209. CIRCUITCITY.COM INC, PORT WASHINGTON, NY. FILED 11-18-2010.

# CIRCUIT CITY

THE MARK CONSISTS OF STANDARD CHARACTERS WITHOUT CLAIM TO ANY PARTICULAR FONT, STYLE, SIZE, OR COLOR.

## CLASS 9—ELECTRICAL AND SCIENTIFIC APPARATUS

FOR AUDIO SPEAKERS; RADIOS; HEADPHONES; CD STORAGE RACKS; CD STORAGE WALLETS; CD CASES; ELECTRONIC MUSIC DOCKING STATIONS; ELECTRONIC TRAVEL ACCESSORIES, NAMELY, ADAPTERS, CONVERTERS, TRANSFORMERS AND BATTERY CHARGERS FOR ELECTRONIC DEVICES (U.S. CLS. 21, 23, 26, 36 AND 38).

## CLASS 11—ENVIRONMENTAL CONTROL APPARATUS

FOR AIR PURIFIERS (U.S. CLS. 13, 21, 23, 31 AND 34).

ANGELA M. MICHELI, EXAMINING ATTORNEY

SN 85-180,248. CARTOON VENTURES, INC., WOODLAND HILLS, CA. FILED 11-18-2010.

# TOONGOGGLES

THE MARK CONSISTS OF STANDARD CHARACTERS WITHOUT CLAIM TO ANY PARTICULAR FONT, STYLE, SIZE, OR COLOR.

## CLASS 35—ADVERTISING AND BUSINESS

FOR BUSINESS SERVICES, NAMELY, TRACKING AND MONITORING OF WEBSITE DATA OF OTHERS TO PROVIDE MARKETING, ADVERTISING AND COMMERCIAL ADMINISTRATION OF THE LICENSING OF ANIMATED CARTOON SHOWS OF OTHERS (U.S. CLS. 100, 101 AND 102).

## CLASS 41—EDUCATION AND ENTERTAINMENT

FOR ENTERTAINMENT SERVICES, NAMELY, PROVIDING A WEBSITE FEATURING NON-DOWNLOADABLE STREAMING ANIMATED CARTOON SHOWS AND CARTOON TRAILERS (U.S. CLS. 100, 101 AND 107).

MAYUR VAGHANI, EXAMINING ATTORNEY

SN 85-180,767. JANOME AMERICA, INC., MAHWAH, NJ.  
FILED 11-19-2010.



THE COLOR(S) RED IS/ARE CLAIMED AS A FEATURE OF THE MARK.

THE MARK CONSISTS OF THE WORD "ARTISTIC" IN RED LETTERS. THE LETTER "A" IS CURSIVE AND LARGER THAN THE OTHERS, WHICH ARE IN BLOCK FORM. THE DOT OF THE "I" IS A FLOWER.

#### CLASS 7—MACHINERY

FOR SEWING MACHINES (U.S. CLS. 13, 19, 21, 23, 31, 34 AND 35).

#### CLASS 9—ELECTRICAL AND SCIENTIFIC APPARATUS

FOR COMPUTER SOFTWARE FOR THE CREATION AND EDITING OF ORIGINAL EMBROIDERY DESIGNS, CREATION OF CUTTING FILES, MODIFICATION OF EXISTING DESIGNS, AND MANIPULATION OF STITCH DATA FOR USE IN SEWING AND QUILTING MACHINES (U.S. CLS. 21, 23, 26, 36 AND 38).

MICHAEL SOUDERS, EXAMINING ATTORNEY

SN 85-180,850. HEALTHY SWEET BEVERAGES, LLC, BRISTOL, CT. FILED 11-19-2010.

## A Sweet Way to Prevent Tooth Decay

THE MARK CONSISTS OF STANDARD CHARACTERS WITHOUT CLAIM TO ANY PARTICULAR FONT, STYLE, SIZE, OR COLOR.

#### CLASS 5—PHARMACEUTICALS

FOR DIETARY BEVERAGE SUPPLEMENTS FOR HUMAN CONSUMPTION IN LIQUID AND DRY MIX FORM FOR THERAPEUTIC PURPOSES; DIETARY SUPPLEMENTAL DRINKS IN THE NATURE OF VITAMIN AND MINERAL BEVERAGES; NUTRITIONALLY FORTIFIED BEVERAGES; VITAMIN FORTIFIED BEVERAGES; VITAMIN SUPPLEMENT IN TABLET FORM FOR USE IN MAKING AN EFFERVESCENT BEVERAGE WHEN ADDED TO WATER (U.S. CLS. 6, 18, 44, 46, 51 AND 52).

FIRST USE 10-1-2010; IN COMMERCE 3-3-2011.

#### CLASS 32—LIGHT BEVERAGES

FOR APPLE JUICE BEVERAGES; AROMATIZED BEVERAGES BASED ON FRUIT, PROTEIN, CORDIAL, SUGAR AND OTHER FLUID NUTRIENTS, NAMELY, CARBOHYDRATES DRINKS FOR USE AS A FOOD FILLERS; AROMATIZED BEVERAGES BASED ON FRUIT, PROTEIN, CORDIAL, SUGAR AND OTHER FLUID NUTRIENTS, NAMELY, PROTEIN DRINKS FOR USE AS A FOOD FILLERS AND NOT FOR USE AS A MEAL REPLACEMENT; BEAUTY BEVERAGES, NAMELY, FRUIT JUICES AND ENERGY DRINKS CONTAINING NUTRITIONAL SUPPLEMENTS; BREWED MALT-BASED ALCOHOLIC BEVERAGE IN THE NATURE OF A BEER; COCONUT-BASED BEV-

ERAGES; COCONUT-BASED NON-ALCOHOLIC BEVERAGES; CONCENTRATES, SYRUPS OR POWDERS FOR MAKING SOFT DRINKS OR TEA-FLAVORED BEVERAGES; CORN-BASED BEVERAGES NOT FOR FOOD PURPOSES (CHICHA MORADA); ESSENCES FOR MAKING NON-ALCOHOLIC BEVERAGES; FROZEN CARBONATED BEVERAGES; FROZEN FRUIT BEVERAGES; FROZEN FRUIT-BASED BEVERAGES; FRUIT BEVERAGES; FRUIT CONCENTRATES AND PUREES USED AS INGREDIENTS OF BEVERAGES; FRUIT-BASED BEVERAGES; FRUIT-FLAVORED BEVERAGES; GRAPE JUICE BEVERAGES; ICED FRUIT BEVERAGES; ISOTONIC BEVERAGES; KVASS; LEMON JUICE FOR USE IN THE PREPARATION OF BEVERAGES; MALT SYRUP FOR BEVERAGES; MILK OF ALMONDS FOR BEVERAGE; NON-ALCOHOLIC BEVERAGES CONTAINING FRUIT JUICES; NON-ALCOHOLIC BEVERAGES WITH TEA FLAVOR; NON-ALCOHOLIC BEVERAGES, NAMELY, CARBONATED BEVERAGES; NON-ALCOHOLIC FRUIT EXTRACTS USED IN THE PREPARATION OF BEVERAGES; NON-ALCOHOLIC FRUIT JUICE BEVERAGES; NON-ALCOHOLIC HONEY-BASED BEVERAGES; NON-ALCOHOLIC MALT BEVERAGE; NON-ALCOHOLIC RICE-BASED BEVERAGES NOT BEING MILK SUBSTITUTES; NON-CARBONATED, NON-ALCOHOLIC FROZEN FLAVORED BEVERAGES; OAT-BASED BEVERAGES WITH FRUIT JUICE NOT FOR FOOD PURPOSES; OAT-BASED BEVERAGES WITH MILK NOT FOR FOOD PURPOSES; ORANGE JUICE BEVERAGES; PINEAPPLE JUICE BEVERAGES; POWDERS USED IN THE PREPARATION OF FRUIT-BASED BEVERAGES; POWDERS USED IN THE PREPARATION OF ISOTONIC SPORTS DRINKS AND SPORTS BEVERAGES; PREPARATIONS FOR MAKING BEVERAGES, NAMELY, FRUIT FLAVORED SOFT DRINKS; FRUIT FLAVORED DRINKS; PREPARED ENTREES CONSISTING OF FRUIT DRINKS AND FRUIT JUICES, FRUIT-BASED BEVERAGES, NON-ALCOHOLIC BEVERAGES CONTAINING FRUIT JUICES, NON-ALCOHOLIC FRUIT EXTRACTS USED IN THE PREPARATION OF BEVERAGES, NON-ALCOHOLIC FRUIT JUICE BEVERAGES, VEGETABLE JUICES, VEGETABLE-FRUIT JUICES AND SMOOTHIES; SARSAPARILLA; SCENTED WATER FOR MAKING BEVERAGES; SHERBETS; SMOOTHIES; SORBETS IN THE FORM OF BEVERAGES; SORBETS IN THE NATURE OF BEVERAGES; SOY-BASED BEVERAGES NOT BEING MILK SUBSTITUTES; SYRUP SUBSTITUTES FOR MAKING BEVERAGES; SYRUPS FOR BEVERAGES; SYRUPS FOR MAKING BEVERAGES; SYRUPS FOR MAKING NON-ALCOHOLIC BEVERAGES; SYRUPS FOR MAKING WHEY-BASED BEVERAGES; TOMATO JUICE; TOMATO JUICE BEVERAGES; VEGETABLE JUICE; VEGETABLE JUICES; WATER BEVERAGES; WHEY BEVERAGES (U.S. CLS. 45, 46 AND 48).

FIRST USE 10-1-2010; IN COMMERCE 3-3-2011.  
REBECCA EISINGER, EXAMINING ATTORNEY

SN 85-180,870. GENENTECH, INC., SOUTH SAN FRANCISCO, CA. FILED 11-19-2010.

# HEPNET

THE MARK CONSISTS OF STANDARD CHARACTERS WITHOUT CLAIM TO ANY PARTICULAR FONT, STYLE, SIZE, OR COLOR.

#### CLASS 16—PAPER GOODS AND PRINTED MATTER

FOR PRINTED EDUCATIONAL MATERIALS RELATING TO VIRAL DISEASES (U.S. CLS. 2, 5, 22, 23, 29, 37, 38 AND 50).

**CLASS 41—EDUCATION AND ENTERTAINMENT**

FOR EDUCATIONAL SERVICES, NAMELY, PRESENTATIONS RELATING TO TREATMENT OF VIRAL DISEASES (U.S. CLS. 100, 101 AND 107).

CHARLOTTE CORWIN, EXAMINING ATTORNEY

SN 85-181,036. RENOVOCYTE, LLC, INDIANAPOLIS, IN. FILED 11-19-2010.

**WELLNESS BANKING**

THE MARK CONSISTS OF STANDARD CHARACTERS WITHOUT CLAIM TO ANY PARTICULAR FONT, STYLE, SIZE, OR COLOR.

NO CLAIM IS MADE TO THE EXCLUSIVE RIGHT TO USE "BANKING", APART FROM THE MARK AS SHOWN.

**CLASS 39—TRANSPORTATION AND STORAGE**

FOR STORAGE OF BIOLOGICAL CELLS AND TISSUES OF HUMANS AND ANIMALS FOR VETERINARY AND MEDICAL PURPOSES (U.S. CLS. 100 AND 105).

**CLASS 40—MATERIAL TREATMENT**

FOR PRESERVATION OF BIOLOGICAL CELLS AND TISSUES OF HUMANS AND ANIMALS FOR VETERINARY AND MEDICAL PURPOSES (U.S. CLS. 100, 103 AND 106).

BARBARA RUTLAND, EXAMINING ATTORNEY

SN 85-181,045. JEFFERSONLARSONSMITH, LLC, DBA CULTURESYN, LOS ANGELES, CA. FILED 11-19-2010.

**Tribal Leadership**

THE MARK CONSISTS OF STANDARD CHARACTERS WITHOUT CLAIM TO ANY PARTICULAR FONT, STYLE, SIZE, OR COLOR.

NO CLAIM IS MADE TO THE EXCLUSIVE RIGHT TO USE "LEADERSHIP", APART FROM THE MARK AS SHOWN.

**CLASS 9—ELECTRICAL AND SCIENTIFIC APPARATUS**

FOR AUDIO BOOKS IN THE FIELD OF LEADERSHIP, GROUP DYNAMICS AND MANAGEMENT (U.S. CLS. 21, 23, 26, 36 AND 38).

FIRST USE 1-22-2008; IN COMMERCE 1-22-2008.

**CLASS 16—PAPER GOODS AND PRINTED MATTER**

FOR A SERIES OF BOOKS AND WRITTEN ARTICLES IN THE FIELD OF LEADERSHIP, GROUP DYNAMICS AND MANAGEMENT; BOOKS IN THE FIELD OF LEADERSHIP, GROUP DYNAMICS AND MANAGEMENT; EDUCATIONAL PUBLICATIONS, NAMELY, TRAINING MANUALS IN THE FIELDS OF LEADERSHIP, GROUP DYNAMICS AND MANAGEMENT; PRINTED EDUCATIONAL MATERIALS IN THE FIELD OF LEADERSHIP, GROUP DYNAMICS AND MANAGEMENT; PRINTED TRAINING MATERIALS IN THE FIELD OF LEADERSHIP, GROUP DYNAMICS AND MANAGEMENT; SERIES OF NON-FICTION BOOKS IN THE FIELD OF LEADERSHIP, GROUP DYNAMICS AND MANAGEMENT (U.S. CLS. 2, 5, 22, 23, 29, 37, 38 AND 50).

FIRST USE 1-22-2008; IN COMMERCE 1-22-2008.

**CLASS 41—EDUCATION AND ENTERTAINMENT**

FOR ARRANGING PROFESSIONAL WORKSHOP AND TRAINING COURSES; BUSINESS EDUCATION AND TRAINING SERVICES, NAMELY, DEVELOPING, AND FACILITATING CUSTOMIZED IN-COMPANY LEADERSHIP AND EXECUTIVE DEVELOPMENT PROGRAMS, PROVIDING EXECUTIVE COACHING SERVICES, AND PROVIDING PUBLIC AND IN-COMPANY KEYNOTE PRESENTATIONS TO BUSINESS LEADERS; BUSINESS TRAINING CONSULTANCY SERVICES; DEVELOPING TRAINING SYSTEMS AND LEARNING METHODOLOGIES FOR OTHERS; EDUCATION SERVICES, NAMELY, PROVIDING CAREER RE-TRAINING COACHING, TRAINING, AND TELE-COURSES IN THE FIELDS OF LEADERSHIP, GROUP DYNAMICS AND MANAGEMENT; EDUCATIONAL SERVICES, NAMELY, CONDUCTING COACHING, TRAINING AND TELE-COURSES IN THE FIELD OF LEADERSHIP, GROUP DYNAMICS AND MANAGEMENT AND DISTRIBUTION OF TRAINING MATERIAL IN CONNECTION THEREWITH; PROFESSIONAL COACHING SERVICES IN THE FIELD OF LEADERSHIP, GROUP DYNAMICS, AND MANAGEMENT; PROVIDING GROUP COACHING AND LEARNING FORUMS IN THE FIELD OF LEADERSHIP DEVELOPMENT; WORKSHOPS AND SEMINARS IN THE FIELD OF LEADERSHIP, GROUP DYNAMICS AND MANAGEMENT (U.S. CLS. 100, 101 AND 107).

FIRST USE 1-22-2008; IN COMMERCE 1-22-2008.

ALEXANDER L. POWERS, EXAMINING ATTORNEY

SN 85-181,127. CMR & ASSOCIATES, INC., NEW YORK, NY. FILED 11-19-2010.



NO CLAIM IS MADE TO THE EXCLUSIVE RIGHT TO USE "POLICY", APART FROM THE MARK AS SHOWN.

THE MARK CONSISTS OF THE WORDS "POLICY SMART". "POLICY" IS ENCLOSED IN AN ROUNDED-EDGED RECTANGLE, AND "SMART" HAS A CHECK MARK OVER THE "M".

**CLASS 35—ADVERTISING AND BUSINESS**

FOR DATA COMPILING AND ANALYZING IN THE FIELD OF INSURANCE; INSURANCE LEAD COLLECTION AND MATCHING SERVICES, NAMELY, MATCHING CONSUMER REQUESTS FOR INSURANCE POLICY QUOTES COLLECTED OVER THE INTERNET TO PRE-QUALIFIED INSURANCE BROKERS, AGENTS AND AGENCIES INTERESTED IN THOSE REQUESTS; PROVIDING A PRICING PROGRAM IN THE FIELD OF PROPERTY AND CASUALTY INSURANCE THROUGH WHICH MEMBERS OF DESIGNATED ASSOCIATIONS, ORGANIZATIONS, AND GROUPS MAY BE OFFERED OR GRANTED DOWNWARD ADJUSTMENTS IN THE PREMIUMS FOR SUCH INSURANCE; PROVIDING INSURANCE AGENT REFERRALS (U.S. CLS. 100, 101 AND 102).

FIRST USE 6-4-2004; IN COMMERCE 6-4-2004.

**CLASS 36—INSURANCE AND FINANCIAL**

FOR ADMINISTRATION OF EMPLOYEE BENEFIT PLANS CONCERNING INSURANCE AND FINANCE; ADVISORY SERVICES IN THE FIELD OF EMPLOYEE BENEFITS FOR GROUP HEALTHCARE AND BUSINESS INSURANCE OFFERED TO EMPLOYEES IN ADDITION TO STANDARD BENEFITS SUCH AS MEDICAL, DENTAL, LIFE INSURANCE INCLUDING SHORT TERM DISABILITY, LONG TERM DISABILITY, CANCER INSURANCE, ACCIDENTAL DEATH AND DISMEMBERMENT; BROKERAGE IN THE FIELD OF ALL TYPES OF BUSINESS INSURANCE; CONSULTING AND INFORMATION CONCERNING INSURANCE; FINANCIAL CONSULTANCY AND INSURANCE CONSULTANCY; INSURANCE AGENCY AND BROKERAGE; INSURANCE AND FINANCIAL INFORMATION AND CONSULTANCY SERVICES; INSURANCE BROKERAGE; INSURANCE BROKERAGE SERVICES; INSURANCE CONSULTANCY; INSURANCE CONSULTANCY SERVICES, NAMELY, PROVIDING ADVICE IN THE FIELD OF PROPERTY AND CASUALTY INSURANCE; INSURANCE CONSULTATION; INSURANCE CONSULTING IN THE FIELD OF ALL TYPES OF BUSINESS INSURANCE; INSURANCE INFORMATION; INSURANCE INFORMATION AND CONSULTANCY; INSURANCE PREMIUM RATE COMPUTING; INSURANCE SERVICES, PROVIDING PREMIUM RATE QUOTES VIA ON-LINE, TELEPHONE AND MAIL MEANS; PROVIDING DETAILED INFORMATION REGARDING AVAILABLE INSURANCE PRODUCTS FOR COMMERCIAL PROPERTY AND CASUALTY, PROFESSIONAL AND PERSONAL LINES; PROVIDING INFORMATION IN INSURANCE MATTERS; PROVIDING INFORMATION REGARDING POLICY RATES FOR ALL TYPES OF INSURANCE AND ELECTRONIC PROCESSING OF INSURANCE CLAIMS AND PAYMENT DATA OVER A WEB BASED COMPUTER NETWORK (U.S. CLS. 100, 101 AND 102).

FIRST USE 6-4-2004; IN COMMERCE 6-4-2004.  
SUSAN STIGLITZ, EXAMINING ATTORNEY

**CLASS 40—MATERIAL TREATMENT**

FOR PRINTING SERVICES (U.S. CLS. 100, 103 AND 106).  
JEFFREY LOOK, EXAMINING ATTORNEY

SN 85-181,840. WEAVER, ROBERT J, MOREHEAD CITY, NC.  
FILED 11-20-2010.



SN 85-181,341. PAPER MART, INC., EAST HANOVER, NJ.  
FILED 11-19-2010.

**WE'RE PAPER SMART**

THE MARK CONSISTS OF STANDARD CHARACTERS WITHOUT CLAIM TO ANY PARTICULAR FONT, STYLE, SIZE, OR COLOR.

NO CLAIM IS MADE TO THE EXCLUSIVE RIGHT TO USE "PAPER", APART FROM THE MARK AS SHOWN.

**CLASS 35—ADVERTISING AND BUSINESS**

FOR DISTRIBUTORSHIP SERVICES IN THE FIELD OF STATIONERY (U.S. CLS. 100, 101 AND 102).

THE COLOR(S) LIGHT GREEN, DARK GREEN, DARK BLUE, LIGHT BLUE, BROWN, WHITE IS/ARE CLAIMED AS A FEATURE OF THE MARK.

THE MARK CONSISTS OF DARK GREEN WORDING "ENGINEERING FOR THE EARTH" AROUND A GLOBE WITH DARK GREEN LINES REPRESENTING THE LINES OF LATITUDE AND LONGITUDE. THE GLOBE IS DIVIDED IN A YIN-YANG STYLE CURVE WHERE THE RIGHT HALF SHOWS THE OUTLINE OF CONTINENTS IN DARK GREEN ON LIGHT GREEN BACKGROUND, AND THE LEFT HALF SHOWS THE LAND MASS OF CONTINENTS IN DARK GREEN AND BROWN. THE LEFT SIDE OF THE GLOBE SHOWS LIGHT BLUE AND DARK BLUE REPRESENTING WATER AT DIFFERING DEPTHS. THE COLOR WHITE IS SHOWN AS SNOW GLACIER ON THE TOP OF THE GLOBE.

**CLASS 36—INSURANCE AND FINANCIAL**

FOR PROVIDING COLLEGE SCHOLARSHIPS; PROVIDING EDUCATIONAL SCHOLARSHIPS; PROVIDING SCHOLARSHIPS FOR MUSICIANS, DANCERS, ARTISTS, AND SCIENTISTS (U.S. CLS. 100, 101 AND 102).

FIRST USE 6-7-2007; IN COMMERCE 7-1-2007.

**CLASS 42—SCIENTIFIC AND COMPUTER SERVICES**

SN 85-182,217. LEUNG, KAI, SAN FRANCISCO, CA. FILED 11-22-2010.

FOR CONSULTING SERVICES IN THE FIELD OF ENVIRONMENTAL ASSESSMENT AND PLANNING; CONSULTING SERVICES IN THE FIELDS OF ENERGY MEASUREMENT TO IMPROVE ENERGY EFFICIENCY; ENGINEERING SERVICES FOR BUILDING AND PROPERTY CONDITION ASSESSMENT, FACILITY MANAGEMENT, REPAIR AND RESTORATION, BUILDING INSTRUMENTATION AND MONITORING, AND ENVIRONMENTAL CONSULTING; ENVIRONMENTAL SERVICES, NAMELY, TECHNICAL CONSULTATION IN THE FIELD OF ENVIRONMENTAL SCIENCE, ENGINEERING SERVICES, DESIGN FOR OTHERS IN THE FIELD OF ENERGY ENGINEERING, DESIGNING AND TESTING OF ENERGY PRODUCTS FOR OTHERS; ENVIRONMENTAL SERVICES, NAMELY, TECHNICAL CONSULTATION IN THE FIELD OF ENVIRONMENTAL SCIENCE, ENGINEERING SERVICES, DESIGN FOR OTHERS IN THE FIELD OF ENVIRONMENTAL ENGINEERING, DESIGNING AND TESTING OF NEW ENVIRONMENTALLY FRIENDLY PRODUCTS FOR OTHERS; PROFESSIONAL CONSULTING SERVICES IN THE FIELDS OF ENGINEERING, LAND USE PLANNING, SURVEYING, LANDSCAPE ARCHITECTURE, AND ENVIRONMENTAL SCIENCES; SCIENTIFIC AND RESEARCH CONSULTATION IN THE FIELD OF FUELS, DIESEL FUEL, BIOFUEL AND BIODIESEL FUEL; TECHNICAL CONSULTANCY IN THE FIELD OF ENVIRONMENTAL SCIENCE; TECHNICAL CONSULTING IN THE FIELD OF ENVIRONMENTAL ENGINEERING; TECHNICAL CONSULTING IN THE FIELD OF POLLUTION DETECTION; TECHNOLOGICAL CONSULTING SERVICES IN THE FIELD OF ALTERNATIVE ENERGY GENERATION (U.S. CLS. 100 AND 101).

FIRST USE 6-7-2007; IN COMMERCE 7-1-2007.  
CHERYL CLAYTON, EXAMINING ATTORNEY

---

SN 85-182,043. SWH CORPORATION, IRVINE, CA. FILED 11-22-2010.

**MIMIS CAFE**

THE MARK CONSISTS OF STANDARD CHARACTERS WITHOUT CLAIM TO ANY PARTICULAR FONT, STYLE, SIZE, OR COLOR.

OWNER OF U.S. REG. NOS. 1,306,490, 3,052,780 AND OTHERS.

NO CLAIM IS MADE TO THE EXCLUSIVE RIGHT TO USE "CAFE", APART FROM THE MARK AS SHOWN.

**CLASS 29—MEATS AND PROCESSED FOODS**

FOR FROZEN, PREPARED OR PACKAGED ENTREES AND MEALS CONSISTING PRIMARILY OF MEAT, FISH, POULTRY, SEAFOOD, VEGETABLES, SOUPS, FRUIT SALADS OR VEGETABLE SALADS; FROZEN, PREPARED OR PACKAGED SIDE DISHES CONSISTING PRIMARILY OF MEAT, FISH, POULTRY, SEAFOOD, VEGETABLES, SOUPS, FRUIT SALADS OR VEGETABLE SALADS (U.S. CL. 46).

**CLASS 30—STAPLE FOODS**

FOR FROZEN, PREPARED OR PACKAGED ENTREES AND MEALS CONSISTING PRIMARILY OF PASTA, RICE, MACARONI, OR NOODLES; FROZEN, PREPARED OR PACKAGED SIDE DISHES CONSISTING PRIMARILY OF PASTA, RICE, MACARONI, OR NOODLES; BAKERY GOODS (U.S. CL. 46).

GEOFFREY FOSDICK, EXAMINING ATTORNEY



NO CLAIM IS MADE TO THE EXCLUSIVE RIGHT TO USE "TEA", APART FROM THE MARK AS SHOWN.

THE COLOR(S) BROWN AND GREEN IS/ARE CLAIMED AS A FEATURE OF THE MARK.

THE MARK CONSISTS OF A TEAPOT AND CUP IN BROWN NEXT TO A GREEN TEA LEAF. BELOW THE DESIGN IS THE WORDING "KAIZEN TEA" IN BROWN.

THE ENGLISH TRANSLATION OF THE WORD "KAIZEN" IN THE MARK IS CONTINUOUS IMPROVEMENT.

**CLASS 21—HOUSEWARES AND GLASS**

FOR TEA CANISTERS (U.S. CLS. 2, 13, 23, 29, 30, 33, 40 AND 50).

**CLASS 30—STAPLE FOODS**

FOR TEA; TEA BAGS; TEA EXTRACTS (U.S. CL. 46).  
JAMES GRIFFIN, EXAMINING ATTORNEY

---

SN 85-182,225. LEUNG, KAI, SAN FRANCISCO, CA. FILED 11-22-2010.

**SIMPLY KAIZEN.**

THE MARK CONSISTS OF STANDARD CHARACTERS WITHOUT CLAIM TO ANY PARTICULAR FONT, STYLE, SIZE, OR COLOR.

THE ENGLISH TRANSLATION OF THE WORD "KAIZEN" IN THE MARK IS "CONTINUOUS IMPROVEMENT".

**CLASS 21—HOUSEWARES AND GLASS**

FOR TEA CANISTERS (U.S. CLS. 2, 13, 23, 29, 30, 33, 40 AND 50).

**CLASS 30—STAPLE FOODS**

FOR TEA; TEA BAGS (U.S. CL. 46).  
JAMES GRIFFIN, EXAMINING ATTORNEY

SN 85-182,358. AMELIA'S DREAM, INC., NEW YORK, NY. FILED 11-22-2010.

## parent with angst

THE MARK CONSISTS OF STANDARD CHARACTERS WITHOUT CLAIM TO ANY PARTICULAR FONT, STYLE, SIZE, OR COLOR.

NO CLAIM IS MADE TO THE EXCLUSIVE RIGHT TO USE "PARENT" AS TO CLASS 41, APART FROM THE MARK AS SHOWN.

### CLASS 21—HOUSEWARES AND GLASS

FOR COFFEE CUPS, TEA CUPS AND MUGS (U.S. CLS. 2, 13, 23, 29, 30, 33, 40 AND 50).

### CLASS 28—TOYS AND SPORTING GOODS

FOR INFANT DEVELOPMENT TOYS (U.S. CLS. 22, 23, 38 AND 50).

### CLASS 41—EDUCATION AND ENTERTAINMENT

FOR ENTERTAINMENT IN THE NATURE OF LIVE COMEDIC, DRAMATIC AND/OR MUSICAL PERFORMANCES BY AN INDIVIDUAL; ENTERTAINMENT IN THE NATURE OF ON-GOING TELEVISION PROGRAMS IN THE FIELDS OF COMEDY AND VARIETY; ENTERTAINMENT, NAMELY, A CONTINUING COMEDY AND/OR VARIETY SHOW BROADCAST OVER THE INTERNET, TELEVISION, RADIO, SATELLITE, AUDIO AND VIDEO MEDIA (U.S. CLS. 100, 101 AND 107).

IRA J. GOODSAD, EXAMINING ATTORNEY

SN 85-182,401. STRATTON, ANN, EASTPOINT, KY. FILED 11-22-2010.

## ANN'S WEIGH USA

THE MARK CONSISTS OF STANDARD CHARACTERS WITHOUT CLAIM TO ANY PARTICULAR FONT, STYLE, SIZE, OR COLOR.

NO CLAIM IS MADE TO THE EXCLUSIVE RIGHT TO USE "USA", APART FROM THE MARK AS SHOWN.

THE NAME "ANN'S" IDENTIFIES A LIVING INDIVIDUAL WHOSE CONSENT IS OF RECORD.

### CLASS 5—PHARMACEUTICALS

FOR DIETETIC FOODS ADAPTED FOR MEDICAL PURPOSES; DIETETIC FOODS ADAPTED FOR MEDICAL USE; FOOD FOR MEDICALLY RESTRICTED DIETS (U.S. CLS. 6, 18, 44, 46, 51 AND 52).

### CLASS 44—MEDICAL, BEAUTY AND AGRICULTURAL SERVICES

FOR PROVIDING A WEBSITE FEATURING INFORMATION AND ADVICE IN THE FIELDS OF DIET, WEIGHT LOSS, DIET PLANNING AND LIFESTYLE WELLNESS; PROVIDING AN INTERACTIVE WEBSITE FEATURING INFORMATION AND LINKS RELATING TO HEALTHY LIVING AND WEIGHT LOSS; PROVIDING WEIGHT LOSS PROGRAM SERVICES; WEIGHT MANAGEMENT SERVICES, NAMELY, PROVIDING WEIGHT LOSS AND/OR WEIGHT MAINTENANCE PROGRAMS (U.S. CLS. 100 AND 101).

ALICIA COLLINS, EXAMINING ATTORNEY

SN 85-182,425. PULLMAN, JASON, ATLANTA, GA. FILED 11-22-2010.

## CAFFEINATED RADIO

THE MARK CONSISTS OF STANDARD CHARACTERS WITHOUT CLAIM TO ANY PARTICULAR FONT, STYLE, SIZE, OR COLOR.

### CLASS 25—CLOTHING

FOR CLOTHING AND APPAREL, NAMELY, HATS, HEADWEAR, UNDERWEAR, SHOES, PANTS, SHORTS, SWEATPANTS, OVERALLS, SHIRTS, TEE-SHIRTS, SWEATSHIRTS, BLOUSES, SKIRTS, DRESSES, JACKETS, VESTS, COATS, RAINWEAR, LINGERIE, SLEEPWEAR, LOUNGEWEAR, SWIMWEAR, GLOVES, SOCKS, HOSIERY, BELTS, SCARVES, TIES, SLIPPERS (U.S. CLS. 22 AND 39).

### CLASS 41—EDUCATION AND ENTERTAINMENT

FOR TELEVISION ENTERTAINMENT SERVICES, NAMELY, ON-GOING TELEVISION PROGRAMS FEATURING PERFORMANCES BY A TELEVISION PERSONALITY (U.S. CLS. 100, 101 AND 107).

FLORENTINA BLANDU, EXAMINING ATTORNEY

SN 85-182,614. TALKTO LLC, BOSTON, MA. FILED 11-22-2010.

## TALKTO

THE MARK CONSISTS OF STANDARD CHARACTERS WITHOUT CLAIM TO ANY PARTICULAR FONT, STYLE, SIZE, OR COLOR.

### CLASS 9—ELECTRICAL AND SCIENTIFIC APPARATUS

FOR COMPUTER APPLICATION SOFTWARE FOR MOBILE DEVICES, NAMELY, SOFTWARE FOR RECEIVING, SENDING AND RELAYING ELECTRONIC COMMUNICATIONS BETWEEN INDIVIDUALS AND BUSINESSES AND OTHER ORGANIZATIONS (U.S. CLS. 21, 23, 26, 36 AND 38).

**CLASS 38—COMMUNICATION**

FOR TELECOMMUNICATIONS TRANSMISSION AND RECEIVING SERVICES, NAMELY, MESSAGE SENDING, RECEIVING AND RELAYING; INTERNET-BASED MESSAGING SERVICES, NAMELY, PROVIDING A WEB SITE THROUGH WHICH USERS CAN SEND MESSAGES TO BUSINESSES AND OTHER ORGANIZATIONS (U.S. CLS. 100, 101 AND 104).

REBECCA POVARCHUK, EXAMINING ATTORNEY

SN 85-182,785. TRUSEVICH, DEBBIE, NEW BRAUNFELS, TX. FILED 11-22-2010.



SN 85-182,634. SOOTHIE SUCKERS LLC, PORTLAND, OR. FILED 11-22-2010.

**SOOTHIE SUCKERS**

THE MARK CONSISTS OF STANDARD CHARACTERS WITHOUT CLAIM TO ANY PARTICULAR FONT, STYLE, SIZE, OR COLOR.

**CLASS 5—PHARMACEUTICALS**

FOR MEDICINAL HERBAL PREPARATIONS; HERBAL AND FRUIT JUICE PREPARATIONS FOR THERAPEUTIC PURPOSES (U.S. CLS. 6, 18, 44, 46, 51 AND 52).

**CLASS 30—STAPLE FOODS**

FOR FREEZER POPS MADE PRIMARILY OF FRUIT JUICE; PACKAGED FRUIT JUICE FOR USE IN MAKING FRUIT ICES (U.S. CL. 46).

ANDREA BUTLER, EXAMINING ATTORNEY

NO CLAIM IS MADE TO THE EXCLUSIVE RIGHT TO USE "BEACH PRODUCT", APART FROM THE MARK AS SHOWN.

THE MARK CONSISTS OF A SUN WITH A HUMAN EYE IMPOSED OVER ITS LOWER HALF SURROUNDED BY A CIRCLE AND THE TEXT "SUN WATCH BEACH PRODUCT".

**CLASS 24—FABRICS**

FOR TOWELS; BLANKETS, NAMELY, BLANKET THROWS AND LAP BLANKETS (U.S. CLS. 42 AND 50).

**CLASS 25—CLOTHING**

FOR CLOTHING, NAMELY, SHIRTS (U.S. CLS. 22 AND 39).

SUSAN STIGLITZ, EXAMINING ATTORNEY

SN 85-182,781. TRUSEVICH, DEBBIE, NEW BRAUNFELS, TX. FILED 11-22-2010.

**SUN WATCH BEACH PRODUCT**

THE MARK CONSISTS OF STANDARD CHARACTERS WITHOUT CLAIM TO ANY PARTICULAR FONT, STYLE, SIZE, OR COLOR.

NO CLAIM IS MADE TO THE EXCLUSIVE RIGHT TO USE "BEACH PRODUCT", APART FROM THE MARK AS SHOWN.

**CLASS 24—FABRICS**

FOR TOWELS; BLANKETS, NAMELY, BLANKET THROWS AND LAP BLANKETS (U.S. CLS. 42 AND 50).

**CLASS 25—CLOTHING**

FOR CLOTHING, NAMELY, SHIRTS (U.S. CLS. 22 AND 39).

SUSAN STIGLITZ, EXAMINING ATTORNEY

SN 85-182,807. KIPROV, DOBRI D., SAN FRANCISCO, CA. FILED 11-22-2010.

**SILA**

THE MARK CONSISTS OF STANDARD CHARACTERS WITHOUT CLAIM TO ANY PARTICULAR FONT, STYLE, SIZE, OR COLOR.

**CLASS 29—MEATS AND PROCESSED FOODS**

FOR NUTRITIONAL FOOD, NAMELY, DIP AND VEGETABLE-BASED SPREAD (U.S. CL. 46).

FIRST USE 8-23-2010; IN COMMERCE 8-23-2010.

**CLASS 30—STAPLE FOODS**

FOR NUTRITIONAL FOOD, NAMELY, SAUCE (U.S. CL. 46).

FIRST USE 8-23-2010; IN COMMERCE 8-23-2010.

MELISSA VALLILLO, EXAMINING ATTORNEY

SN 85-182,895. UNDER THE BOW, PLANO, TX. FILED 11-22-2010.



NO CLAIM IS MADE TO THE EXCLUSIVE RIGHT TO USE "A GIFT AND WRAP SHOPPE", APART FROM THE MARK AS SHOWN.

THE MARK CONSISTS OF A BOW WITH THE STYLIZED TEXT "UNDER THE BOW A GIFT AND WRAP SHOPPE".

#### CLASS 35—ADVERTISING AND BUSINESS

FOR RETAIL STORE SERVICES FEATURING UNIQUE GIFT ITEMS, GLASSWARE, STATIONERY, SHOES, AND JEWELRY (U.S. CLS. 100, 101 AND 102).  
FIRST USE 2-5-2010; IN COMMERCE 2-5-2010.

#### CLASS 45—PERSONAL AND LEGAL SERVICES

FOR GIFT WRAPPING (U.S. CLS. 100 AND 101).  
FIRST USE 2-5-2010; IN COMMERCE 2-5-2010.  
DAVID HOFFMAN, EXAMINING ATTORNEY

SN 85-183,085. STROUMBOS, KIM, DENVER, CO. FILED 11-23-2010.

SOULI SKINSPA, LLC

THE MARK CONSISTS OF STANDARD CHARACTERS WITHOUT CLAIM TO ANY PARTICULAR FONT, STYLE, SIZE, OR COLOR.

NO CLAIM IS MADE TO THE EXCLUSIVE RIGHT TO USE "SKIN SPA LLC", APART FROM THE MARK AS SHOWN.

#### CLASS 35—ADVERTISING AND BUSINESS

FOR RETAIL STORE SERVICES FEATURING SKINCARE AND BEAUTY AND HEALTH PRODUCTS (U.S. CLS. 100, 101 AND 102).  
FIRST USE 11-1-2010; IN COMMERCE 11-1-2010.

#### CLASS 44—MEDICAL, BEAUTY AND AGRICULTURAL SERVICES

FOR PARAMEDICAL SKIN CARE SERVICES (U.S. CLS. 100 AND 101).  
FIRST USE 11-1-2010; IN COMMERCE 11-1-2010.  
GISELLE AGOSTO, EXAMINING ATTORNEY

SN 85-183,361. WYNDHAM TM CORP., LAS VEGAS, NV. FILED 11-23-2010.

WYNDHAM VACATION RENTALS

THE MARK CONSISTS OF STANDARD CHARACTERS WITHOUT CLAIM TO ANY PARTICULAR FONT, STYLE, SIZE, OR COLOR.

OWNER OF U.S. REG. NOS. 2,859,133, 3,851,635 AND OTHERS.

NO CLAIM IS MADE TO THE EXCLUSIVE RIGHT TO USE "VACATION RENTALS", APART FROM THE MARK AS SHOWN.

#### CLASS 36—INSURANCE AND FINANCIAL

FOR RENTAL OF VACATION PROPERTIES, HOMES, APARTMENTS, AND VILLAS (U.S. CLS. 100, 101 AND 102).

#### CLASS 43—HOTEL AND RESTAURANT SERVICES

FOR RESERVATION AND BOOKING FOR TEMPORARY ACCOMMODATION AND LODGING (U.S. CLS. 100 AND 101).

MARCIE MILONE, EXAMINING ATTORNEY

SN 85-183,415. A WORLD FIT FOR KIDS, LOS ANGELES, CA. FILED 11-23-2010.



NO CLAIM IS MADE TO THE EXCLUSIVE RIGHT TO USE "USA", APART FROM THE MARK AS SHOWN.

THE COLOR(S) RED, BLACK, GREY AND WHITE IS/ARE CLAIMED AS A FEATURE OF THE MARK.

THE MARK CONSISTS OF A GIRL AND A BOY STANDING NEXT TO ONE ANOTHER FACING FORWARD WITH THEIR ARMS TURNED TOWARD THE CENTER HOLDING A RED HEART ABOVE THEIR HEADS WITH EIGHT (8) BLACK SPARKS RADIATING FROM THE HEART ON A WHITE BACKGROUND; THE GIRL HAVING WHITE HAIR OUTLINED IN BLACK, RED HAIR BOWS OUTLINED IN BLACK, A GREY BODY AND FACE OUTLINED IN BLACK, A WHITE SHIRT OUTLINED IN BLACK, A RED SKIRT OUTLINED IN BLACK AND WHITE SHOES OUTLINED IN BLACK; THE BOY HAVING BLACK HAIR, A GREY BODY AND FACE OUTLINED IN BLACK, A RED SHIRT OUTLINED IN BLACK, WHITE SHORTS OUTLINED IN BLACK AND WHITE SHOES OUTLINED IN BLACK; THE LITERAL ELEMENT "A WORLD FIT FOR KIDS!" IN BLACK IN A SEMI-CIRCLE ABOVE THE GIRL AND BOY; THE LITERAL ELEMENT "USA" IN BLACK BELOW THE GIRL AND BOY; AND TWO (2) BLACK FILLED-IN CIRCLES ON EITHER SIDE OF THE GIRL AND BOY.



**CLASS 35—ADVERTISING AND BUSINESS**

FOR JOB PLACEMENT AND INTERNSHIP PLACEMENT SERVICES (U.S. CLS. 100, 101 AND 102).  
FIRST USE 9-1-2010; IN COMMERCE 9-1-2010.

**CLASS 41—EDUCATION AND ENTERTAINMENT**

FOR PROVIDING AFTER SCHOOL EDUCATION PROGRAMS FOR YOUTH IN THE FIELDS OF HEALTH, FITNESS AND GENERAL STUDIES; PROVIDING LEADERSHIP AND MENTORING TRAINING FOR TEENAGERS; AND PROVIDING JOB TRAINING (U.S. CLS. 100, 101 AND 107).  
FIRST USE 9-1-2010; IN COMMERCE 9-1-2010.

MARGERY A. TIERNEY, EXAMINING ATTORNEY

SN 85-183,879. DUNCAN, LLC, CHAGRIN FALLS, OH.  
FILED 11-23-2010.

THE GROUND CREW

THE MARK CONSISTS OF STANDARD CHARACTERS WITHOUT CLAIM TO ANY PARTICULAR FONT, STYLE, SIZE, OR COLOR.

**CLASS 41—EDUCATION AND ENTERTAINMENT**

FOR TRAINING SERVICES IN THE FIELD OF COMPUTERS (U.S. CLS. 100, 101 AND 107).

**CLASS 42—SCIENTIFIC AND COMPUTER SERVICES**

FOR DESIGN OF COMPUTER SOFTWARE AND COMPUTER NETWORKS; CONSULTATION SERVICES IN THE FIELD OF COMPUTERS (U.S. CLS. 100 AND 101).

DOMINIC J. FERRAIUOLO, EXAMINING ATTORNEY

SN 85-183,983. FACELUXE LICENSING I, LLC, FENTON, MO. FILED 11-23-2010.



THE MARK CONSISTS OF THE SILHOUETTE OF A WOMAN'S FACE.

**CLASS 35—ADVERTISING AND BUSINESS**

FOR RETAIL STORE AND ONLINE RETAIL STORE SERVICES IN THE FIELD OF SKIN CARE AND BEAUTY CARE PRODUCTS (U.S. CLS. 100, 101 AND 102).  
FIRST USE 11-22-2010; IN COMMERCE 11-22-2010.

**CLASS 44—MEDICAL, BEAUTY AND AGRICULTURAL SERVICES**

FOR HEALTH SPA SERVICES, NAMELY, PROVIDING SKIN CARE TREATMENTS, BEAUTY CARE TREATMENTS, FACIALS AND BODY WAXING SERVICES (U.S. CLS. 100 AND 101).

FIRST USE 11-22-2010; IN COMMERCE 11-22-2010.  
WANDA KAY PRICE, EXAMINING ATTORNEY

SN 85-184,000. FACELUXE LICENSING I, LLC, FENTON, MO. FILED 11-23-2010.

FACELUXE

THE MARK CONSISTS OF STANDARD CHARACTERS WITHOUT CLAIM TO ANY PARTICULAR FONT, STYLE, SIZE, OR COLOR.

**CLASS 35—ADVERTISING AND BUSINESS**

FOR RETAIL STORE AND ONLINE RETAIL STORE SERVICES IN THE FIELD OF SKIN CARE AND BEAUTY CARE PRODUCTS (U.S. CLS. 100, 101 AND 102).  
FIRST USE 11-22-2010; IN COMMERCE 11-22-2010.

**CLASS 44—MEDICAL, BEAUTY AND AGRICULTURAL SERVICES**

FOR HEALTH SPA SERVICES, NAMELY, PROVIDING SKIN CARE TREATMENTS, BEAUTY CARE TREATMENTS, FACIALS AND BODY WAXING SERVICES (U.S. CLS. 100 AND 101).

FIRST USE 11-22-2010; IN COMMERCE 11-22-2010.  
WANDA KAY PRICE, EXAMINING ATTORNEY

SN 85-184,424. TWIN EAGLE RESOURCE MANAGEMENT, LLC, HOUSTON, TX. FILED 11-24-2010.



NO CLAIM IS MADE TO THE EXCLUSIVE RIGHT TO USE "RESOURCE MANAGEMENT", APART FROM THE MARK AS SHOWN.

THE MARK CONSISTS OF AN IMAGE OF TWO SIDE BY SIDE EAGLE PROFILES CENTERED OVER THE WORDS "TWIN EAGLE" CENTERED OVER THE WORDS "RESOURCE MANAGEMENT".

**CLASS 35—ADVERTISING AND BUSINESS**

FOR BUSINESS MARKETING SERVICES IN THE FIELD OF VARIOUS PRODUCTS FOR ENERGY RELATED BUSINESSES (U.S. CLS. 100, 101 AND 102).

**CLASS 36—INSURANCE AND FINANCIAL**

FOR COMMODITY TRADING FOR OTHERS IN THE FIELD OF VARIOUS PRODUCTS FOR ENERGY RELATED BUSINESSES (U.S. CLS. 100, 101 AND 102).  
COURTNEY ALVAREZ, EXAMINING ATTORNEY

SN 85-184,547. GREATAMERICA LEASING CORPORATION, CEDAR RAPIDS, IA. FILED 11-24-2010.

**GREATAMERICA FINANCIAL  
SERVICES CORPORATION**

THE MARK CONSISTS OF STANDARD CHARACTERS WITHOUT CLAIM TO ANY PARTICULAR FONT, STYLE, SIZE, OR COLOR.

OWNER OF U.S. REG. NO. 1,864,894.  
NO CLAIM IS MADE TO THE EXCLUSIVE RIGHT TO USE "FINANCIAL SERVICES CORPORATION", APART FROM THE MARK AS SHOWN.

**CLASS 35—ADVERTISING AND BUSINESS**

FOR RENTAL AND LEASING OF PERSONAL PROPERTY AND EQUIPMENT, NAMELY, OFFICE EQUIPMENT (U.S. CLS. 100, 101 AND 102).

**CLASS 38—COMMUNICATION**

FOR RENTAL AND LEASING OF PERSONAL PROPERTY AND EQUIPMENT, NAMELY, INDUSTRIAL EQUIPMENT IN THE NATURE OF TELECOMMUNICATION EQUIPMENT (U.S. CLS. 100, 101 AND 104).

**CLASS 44—MEDICAL, BEAUTY AND AGRICULTURAL SERVICES**

FOR LEASING OF MEDICAL EQUIPMENT (U.S. CLS. 100 AND 101).  
TARAH HARDY, EXAMINING ATTORNEY

SN 85-184,709. SWAIN CORP., LOS ANGELES, CA. FILED 11-24-2010.

**ECOTOPIA**

THE MARK CONSISTS OF STANDARD CHARACTERS WITHOUT CLAIM TO ANY PARTICULAR FONT, STYLE, SIZE, OR COLOR.

**CLASS 9—ELECTRICAL AND SCIENTIFIC APPARATUS**

FOR DOWNLOADABLE COMPUTER GAME SOFTWARE VIA A GLOBAL COMPUTER NETWORK FOR USE ON WIRELESS DEVICES AND COMPUTERS (U.S. CLS. 21, 23, 26, 36 AND 38).

**CLASS 41—EDUCATION AND ENTERTAINMENT**

FOR ENTERTAINMENT SERVICES, NAMELY, PROVIDING ON-LINE COMPUTER GAMES (U.S. CLS. 100, 101 AND 107).

EDWARD NELSON, EXAMINING ATTORNEY

SN 85-184,739. DOWNEY, DANIEL, POMPANO BEACH, FL. FILED 11-24-2010.

**Edison Green LLC**

THE MARK CONSISTS OF STANDARD CHARACTERS WITHOUT CLAIM TO ANY PARTICULAR FONT, STYLE, SIZE, OR COLOR.

NO CLAIM IS MADE TO THE EXCLUSIVE RIGHT TO USE "GREEN LLC", APART FROM THE MARK AS SHOWN.

**CLASS 9—ELECTRICAL AND SCIENTIFIC APPARATUS**

FOR SOLAR PANELS FOR PRODUCTION OF ELECTRICITY (U.S. CLS. 21, 23, 26, 36 AND 38).

**CLASS 37—CONSTRUCTION AND REPAIR**

FOR INSTALLATION OF SOLAR ENERGY SYSTEMS AND ALTERNATIVE ENERGY PRODUCTS FOR RESIDENTIAL AND COMMERCIAL USE (U.S. CLS. 100, 103 AND 106).

KARANENDRA S. CHHINA, EXAMINING ATTORNEY

SN 85-184,978. INDUSTRIAL RIVET & FASTENER CO., NORTHVALE, NJ. FILED 11-24-2010.

**KINGSET**

THE MARK CONSISTS OF STANDARD CHARACTERS WITHOUT CLAIM TO ANY PARTICULAR FONT, STYLE, SIZE, OR COLOR.

OWNER OF U.S. REG. NOS. 2,189,026, 2,191,964 AND 3,507,857.

**CLASS 6—METAL GOODS**

FOR METAL FASTENERS, NAMELY, RIVETS AND SPECIALTY FASTENERS (U.S. CLS. 2, 12, 13, 14, 23, 25 AND 50).

**CLASS 7—MACHINERY**

FOR POWER-OPERATED FASTENER INSTALLATION TOOLS, NAMELY, FOR THE INSTALLATION OF RIVETS (U.S. CLS. 13, 19, 21, 23, 31, 34 AND 35).

**CLASS 8—HAND TOOLS**

FOR HAND-OPERATED FASTENER INSTALLATION TOOLS, NAMELY, FOR THE INSTALLATION OF RIVETS (U.S. CLS. 23, 28 AND 44).

AISHA CLARKE, EXAMINING ATTORNEY

SN 85-185,092. ANONYMIZER, INC., SAN DIEGO, CA.  
FILED 11-24-2010.



THE MARK CONSISTS OF A STYLIZED LETTER "A" INSIDE A CIRCLE.

**CLASS 9—ELECTRICAL AND SCIENTIFIC APPARATUS**

FOR COMPUTER SOFTWARE, NAMELY, COMPUTER SOFTWARE FOR REMOVING IDENTIFYING INFORMATION FROM GLOBAL COMMUNICATION NETWORK TRANSACTIONS, FOR PROVIDING UNIDENTIFIABLE TRANSMISSION OF INFORMATION OVER GLOBAL COMPUTER NETWORKS, AND FOR REMOVING SPYWARE AND OTHER MALICIOUS SOFTWARE (U.S. CLS. 21, 23, 26, 36 AND 38).

FIRST USE 12-1-2009; IN COMMERCE 2-23-2010.

**CLASS 38—COMMUNICATION**

FOR PROVIDING ANONYMOUS TRANSMISSION OF INFORMATION OVER GLOBAL COMPUTER NETWORKS (U.S. CLS. 100, 101 AND 104).

FIRST USE 2-23-2010; IN COMMERCE 2-23-2010.

**CLASS 42—SCIENTIFIC AND COMPUTER SERVICES**

FOR ONLINE SECURITY SERVICES, NAMELY, REMOVING IDENTIFYING INFORMATION FROM GLOBAL COMMUNICATION NETWORK TRANSACTIONS FOR OTHERS TO PROVIDE ANONYMITY AND PRIVACY (U.S. CLS. 100 AND 101).

FIRST USE 2-23-2010; IN COMMERCE 2-23-2010.  
LIEF MARTIN, EXAMINING ATTORNEY

SN 85-185,407. BENSY, LLC, WILMINGTON, DE. FILED 11-26-2010.

i-Wes

THE MARK CONSISTS OF STANDARD CHARACTERS WITHOUT CLAIM TO ANY PARTICULAR FONT, STYLE, SIZE, OR COLOR.

**CLASS 9—ELECTRICAL AND SCIENTIFIC APPARATUS**

FOR COMPUTER APPLICATION SOFTWARE FOR MOBILE PHONES, PORTABLE COMPUTERS, AND HANDHELD COMPUTERS, NAMELY, SOFTWARE FOR INTERFACING WITH EXERCISE EQUIPMENT; COMPUTER APPLICATION SOFTWARE FOR MOBILE PHONES, PORTABLE COMPUTERS, AND HANDHELD COMPUTERS, NAMELY, SOFTWARE FOR EXERCISE EQUIPMENT GAMING; DOWNLOADABLE SOFTWARE IN THE NATURE OF A MOBILE APPLICATION FOR USE IN COLLECTING EXERCISE MACHINE DATA; DOWNLOADABLE SOFTWARE IN THE NATURE OF A MOBILE APPLICATION FOR USE IN EXERCISE MACHINE GAMING; COMPUTER PERIPHERALS, NAMELY, INTERFACES FOR COMMUNICATION WITH EXERCISE EQUIPMENT; CHARGERS FOR BATTERIES; CELL PHONE BATTERY CHARGERS; TELEVISION AND VIDEO CONVERTERS; VIDEO MONITORS, VIDEO SCREENS; ELECTRONIC AND VIDEO GAME CONTROLLERS INCORPORATED INTO EXERCISE MACHINES; EXERCISE EQUIPMENT COMPUTER SOFTWARE FOR COLLECTING EXERCISE MACHINE DATA; EXERCISE EQUIPMENT COMPUTER HARDWARE FOR INTERFACING WITH EXERCISE MACHINE; COMPUTER PERIPHERALS FOR USE WITH EXERCISE EQUIPMENT FOR COLLECTING EXERCISE MACHINE DATA (U.S. CLS. 21, 23, 26, 36 AND 38).

**CLASS 28—TOYS AND SPORTING GOODS**

FOR EXERCISE MACHINES INCORPORATING ELECTRONIC AND VIDEO GAME CONTROLLERS (U.S. CLS. 22, 23, 38 AND 50).

MAYUR VAGHANI, EXAMINING ATTORNEY

SN 85-185,629. THE OAK INITIATIVE, INC., FORT MILL, SC.  
FILED 11-27-2010.

Oak Leaves Publishing

THE MARK CONSISTS OF STANDARD CHARACTERS WITHOUT CLAIM TO ANY PARTICULAR FONT, STYLE, SIZE, OR COLOR.

NO CLAIM IS MADE TO THE EXCLUSIVE RIGHT TO USE "PUBLISHING", APART FROM THE MARK AS SHOWN.

**CLASS 16—PAPER GOODS AND PRINTED MATTER**

FOR NON-FICTION BOOKS ON A VARIETY OF TOPICS (U.S. CLS. 2, 5, 22, 23, 29, 37, 38 AND 50).

**CLASS 41—EDUCATION AND ENTERTAINMENT**

FOR BOOK PUBLISHING (U.S. CLS. 100, 101 AND 107).  
PAUL F. GAST, EXAMINING ATTORNEY

SN 85-185,718. TANGORRA, ANTHONY, DBA LATITUDE TRANSPORT, WASHINGTON, DC. FILED 11-28-2010.

SN 85-185,992. COURTNEY ZAHNER, DBA KATIE'S COLORS, NORTH ATTLEBORO, MA. FILED 11-29-2010.

## Air Space Lounge

THE MARK CONSISTS OF STANDARD CHARACTERS WITHOUT CLAIM TO ANY PARTICULAR FONT, STYLE, SIZE, OR COLOR.

NO CLAIM IS MADE TO THE EXCLUSIVE RIGHT TO USE "LOUNGE", APART FROM THE MARK AS SHOWN.

### CLASS 39—TRANSPORTATION AND STORAGE

FOR AIRPORT SERVICES FEATURING TRANSIT LOUNGE FACILITIES FOR PASSENGER RELAXATION (U.S. CLS. 100 AND 105).

### CLASS 43—HOTEL AND RESTAURANT SERVICES

FOR CAFE AND RESTAURANT SERVICES (U.S. CLS. 100 AND 101).  
AMEEN IMAM, EXAMINING ATTORNEY

## Katie's Colors

THE MARK CONSISTS OF STANDARD CHARACTERS WITHOUT CLAIM TO ANY PARTICULAR FONT, STYLE, SIZE, OR COLOR.

NO CLAIM IS MADE TO THE EXCLUSIVE RIGHT TO USE "COLORS", APART FROM THE MARK AS SHOWN.

### CLASS 16—PAPER GOODS AND PRINTED MATTER

FOR CUSTOM PAINTINGS; MURALS (U.S. CLS. 2, 5, 22, 23, 29, 37, 38 AND 50).  
FIRST USE 6-19-2010; IN COMMERCE 6-19-2010.

### CLASS 40—MATERIAL TREATMENT

FOR CUSTOM FABRICATION AND PRODUCTION OF SETS FOR MUSICAL RECITALS (U.S. CLS. 100, 103 AND 106).  
EMILY CHUO, EXAMINING ATTORNEY

SN 85-185,904. ZAMBAITI PARATI S.P.A., ALBINO (BG), ITALY, FILED 11-29-2010.

SN 85-186,011. DAIMLER AG, STUTTGART, FED REP GERMANY, FILED 11-29-2010.

## MURELLA

THE MARK CONSISTS OF STANDARD CHARACTERS WITHOUT CLAIM TO ANY PARTICULAR FONT, STYLE, SIZE, OR COLOR.

THE WORDING "MURELLA" HAS NO MEANING IN A FOREIGN LANGUAGE.

### CLASS 24—FABRICS

FOR TEXTILE WALL HANGINGS COATED WITH POLYVINYL CHLORIDE (U.S. CLS. 42 AND 50).  
FIRST USE 0-0-1991; IN COMMERCE 0-0-1991.

### CLASS 27—FLOOR COVERINGS

FOR WALL COVERINGS OF TEXTILE COATED WITH POLYVINYL CHLORIDE; VINYL WALL COVERING WITH PAPER-BASED MEDIUM (U.S. CLS. 19, 20, 37, 42 AND 50).  
FIRST USE 0-0-1991; IN COMMERCE 0-0-1991.  
EMILY CHUO, EXAMINING ATTORNEY

## FORFOUR

THE MARK CONSISTS OF STANDARD CHARACTERS WITHOUT CLAIM TO ANY PARTICULAR FONT, STYLE, SIZE, OR COLOR.

OWNER OF FED REP GERMANY REG. NO. 30256119, DATED 1-17-2003, EXPIRES 11-30-2012.

### CLASS 12—VEHICLES

FOR AUTOMOBILES AND STRUCTURAL PARTS THEREFOR (U.S. CLS. 19, 21, 23, 31, 35 AND 44).

### CLASS 28—TOYS AND SPORTING GOODS

FOR TOY MODEL AUTOMOBILES (U.S. CLS. 22, 23, 38 AND 50).

### CLASS 37—CONSTRUCTION AND REPAIR

FOR REPAIR AND MAINTENANCE OF MOTOR VEHICLES (U.S. CLS. 100, 103 AND 106).  
SANJEEV VOHRA, EXAMINING ATTORNEY

SN 85-186,015. MODMEDIA LIMITED, BELIZE CITY, BELIZE, FILED 11-29-2010.

friendura

THE MARK CONSISTS OF STANDARD CHARACTERS WITHOUT CLAIM TO ANY PARTICULAR FONT, STYLE, SIZE, OR COLOR.

THE WORDING "FRIENDURA" HAS NO MEANING IN A FOREIGN LANGUAGE.

**CLASS 9—ELECTRICAL AND SCIENTIFIC APPARATUS**

FOR COMPUTER SOFTWARE PLATFORMS FOR ELECTRONIC TRANSMISSION OF MESSAGES, DIGITAL PICTURES AND OTHER DIGITAL DATA TYPES AMONG INTERNET USERS (U.S. CLS. 21, 23, 26, 36 AND 38).

**CLASS 38—COMMUNICATION**

FOR PROVIDING ON-LINE FORUMS FOR TRANSMISSION OF MESSAGES AMONG COMPUTER USERS CONCERNING TOPICS OF GENERAL INTEREST; TELECOMMUNICATION SERVICES, NAMELY, TRANSMISSION OF VOICE, DATA, GRAPHICS, IMAGES, AUDIO AND VIDEO BY MEANS OF TELECOMMUNICATIONS NETWORKS, WIRELESS COMMUNICATION NETWORKS, AND THE INTERNET (U.S. CLS. 100, 101 AND 104).

**CLASS 42—SCIENTIFIC AND COMPUTER SERVICES**

FOR COMPUTER SERVICES, NAMELY, CREATING AN ON-LINE COMMUNITY FOR REGISTERED USERS TO PARTICIPATE IN DISCUSSIONS, GET FEEDBACK FROM THEIR PEERS, FORM VIRTUAL COMMUNITIES, AND ENGAGE IN SOCIAL NETWORKING FEATURING THE SHARING OF MESSAGES, DIGITAL PICTURES AND OTHER DATA/INFORMATION (U.S. CLS. 100 AND 101).

EMILY CHUO, EXAMINING ATTORNEY

SN 85-186,183. SPRINGBOARD NON-PROFIT CONSUMER CREDIT MANAGEMENT, INC., RIVERSIDE, CA. FILED 11-29-2010.

SPRINGBOARD SOLUTIONS

THE MARK CONSISTS OF STANDARD CHARACTERS WITHOUT CLAIM TO ANY PARTICULAR FONT, STYLE, SIZE, OR COLOR.

OWNER OF U.S. REG. NOS. 2,577,739 AND 3,603,644.

NO CLAIM IS MADE TO THE EXCLUSIVE RIGHT TO USE "SOLUTIONS", APART FROM THE MARK AS SHOWN.

**CLASS 36—INSURANCE AND FINANCIAL**

FOR CREDIT AND DEBT COUNSELING; HOUSING COUNSELING, NAMELY, FINANCIAL COUNSELING RELATING TO HOME RENTAL, PURCHASE AND FORECLOSURE; DEBT MANAGEMENT SERVICES; CREDIT AND LOAN SERVICES, NAMELY, CREDIT CARD, MORTGAGE, AND STUDENT LOAN APPLICATION PROCESSING (U.S. CLS. 100, 101 AND 102).

**CLASS 41—EDUCATION AND ENTERTAINMENT**

FOR EDUCATIONAL SERVICES, NAMELY, CONDUCTING CLASSES, SEMINARS, AND WORKSHOPS IN THE FIELDS OF DEBT MANAGEMENT, HOME OWNERSHIP, BANKRUPTCY, CREDIT AND PERSONAL FINANCE (U.S. CLS. 100, 101 AND 107).

MARK PILARO, EXAMINING ATTORNEY

SN 85-186,225. CORPORATE DETOX, LLC, SCOTTSDALE, AZ. FILED 11-29-2010.

CORPORATE DETOX

THE MARK CONSISTS OF STANDARD CHARACTERS WITHOUT CLAIM TO ANY PARTICULAR FONT, STYLE, SIZE, OR COLOR.

NO CLAIM IS MADE TO THE EXCLUSIVE RIGHT TO USE "CORPORATE", APART FROM THE MARK AS SHOWN.

**CLASS 16—PAPER GOODS AND PRINTED MATTER**

FOR PRINTED MATTER, NAMELY, BOOKS, MANUALS, CURRICULUM, NEWSLETTERS AND BROCHURES IN THE FIELD OF COACHING AND CONSULTING WITH ORGANIZATIONS AND INDIVIDUALS REGARDING PRODUCTIVITY, COGNITION, AWARENESS AND CORPORATE CONSCIOUSNESS (U.S. CLS. 2, 5, 22, 23, 29, 37, 38 AND 50).

**CLASS 41—EDUCATION AND ENTERTAINMENT**

FOR PROVIDING GROUP AND PERSONAL COACHING SERVICES IN THE FIELD OF PRODUCTIVITY, AWARENESS AND COGNITION FOR ORGANIZATIONS AND INDIVIDUALS, AND CONSULTATION RELATED THERETO (U.S. CLS. 100, 101 AND 107).

TARAH HARDY, EXAMINING ATTORNEY

SN 85-186,282. LEATHERMAN TOOL GROUP, INC., PORTLAND, OR. FILED 11-29-2010.

LEAVE NOTHING UNDONE

THE MARK CONSISTS OF STANDARD CHARACTERS WITHOUT CLAIM TO ANY PARTICULAR FONT, STYLE, SIZE, OR COLOR.

**CLASS 8—HAND TOOLS**

FOR FOLDING KNIVES; HAND TOOLS, NAMELY, FOLDING MULTIPURPOSE HAND TOOL COMPRISED OF MULTIPLE BLADES AND ONE OR MORE OF THE FOLLOWING COMPONENTS: SCISSORS, PLIERS, WIRE CUTTERS, WIRE STRIPERS, SCREW DRIVERS, SAWS, FILES, CAN OPENERS, AND BOTTLE OPENER; KNIFE SHEATHS OF LEATHER; LEATHER SHEATHS FOR MULTIPURPOSE HAND TOOLS; LEATHER SWORD SCABBARDS (U.S. CLS. 23, 28 AND 44).

**CLASS 11—ENVIRONMENTAL CONTROL APPARATUS**

FOR FLASHLIGHTS (U.S. CLS. 13, 21, 23, 31 AND 34).

**CLASS 18—LEATHER GOODS**

FOR LEATHER GOODS, NAMELY, POUCHES (U.S. CLS. 1, 2, 3, 22 AND 41).  
BRIAN PINO, EXAMINING ATTORNEY

---

SN 85-186,325. PURPOSE JOURNEY, INC., NAPLES, FL. FILED 11-29-2010.

**PURPOSE JOURNEY**

THE MARK CONSISTS OF STANDARD CHARACTERS WITHOUT CLAIM TO ANY PARTICULAR FONT, STYLE, SIZE, OR COLOR.

**CLASS 16—PAPER GOODS AND PRINTED MATTER**

FOR BLANK JOURNALS; EDUCATIONAL PUBLICATIONS, NAMELY, BOOKS, HAND-OUTS, WORKBOOKS, JOURNALS, WORKSHEETS, AND CARDS IN THE FIELDS OF LIFE COACHING; JOURNALS CONCERNING LIFE COACHING; PRINTED EDUCATIONAL MATERIALS IN THE FIELD OF LIFE COACHING (U.S. CLS. 2, 5, 22, 23, 29, 37, 38 AND 50).

**CLASS 41—EDUCATION AND ENTERTAINMENT**

FOR LIFE COACHING SERVICES IN THE FIELD OF PERSONAL GROWTH AND PROFESSIONAL GROWTH; PERSONAL COACHING SERVICES IN THE FIELD OF PERSONAL GROWTH; PROVIDING GROUP COACHING AND LEARNING FORUMS IN THE FIELD OF LEADERSHIP DEVELOPMENT (U.S. CLS. 100, 101 AND 107).

**CLASS 42—SCIENTIFIC AND COMPUTER SERVICES**

FOR PROVIDING A WEBSITE THAT ENABLES USERS TO SUBSCRIBE TO LIFE COACHING SERVICES IN THE FIELD OF PERSONAL GROWTH AND PROFESSIONAL GROWTH; PROVIDING A WEBSITE THAT ENABLES USERS TO SUBSCRIBE TO GROUP COACHING AND LEARNING FORUMS IN THE FIELD OF LEADERSHIP DEVELOPMENT (U.S. CLS. 100 AND 101).  
JORDAN BAKER, EXAMINING ATTORNEY

SN 85-186,862. WIFS: WOMEN IN INSURANCE AND FINANCIAL SERVICES, INC., ALBANY, NY. FILED 11-30-2010.



THE MARK CONSISTS OF A BOX WITH A LEAF DESIGN AND THE WORDING "WIFS WOMEN IN INSURANCE & FINANCIAL SERVICES".

SEC. 2(F) AS TO "WOMEN IN INSURANCE AND FINANCIAL SERVICES".

**CLASS 35—ADVERTISING AND BUSINESS**

FOR ASSOCIATION SERVICES, NAMELY, PROMOTING THE INTERESTS OF WOMEN EMPLOYED IN OR ASSOCIATED WITH THE FIELD OF INSURANCE OR FINANCE (U.S. CLS. 100, 101 AND 102).  
FIRST USE 10-0-2008; IN COMMERCE 10-0-2008.

**CLASS 41—EDUCATION AND ENTERTAINMENT**

FOR EDUCATIONAL SERVICES, NAMELY, CONDUCTING WEBINARS, CONFERENCES AND WORKSHOPS IN THE FIELD OF INSURANCE AND FINANCE (U.S. CLS. 100, 101 AND 107).  
FIRST USE 10-0-2008; IN COMMERCE 10-0-2008.  
JILL PRATER, EXAMINING ATTORNEY

---

SN 85-186,893. SHINE! WHERE YOU STAND, LLC, MONROE TOWNSHIP, NJ. FILED 11-30-2010.

**SHINE! WHERE YOU STAND**

THE MARK CONSISTS OF STANDARD CHARACTERS WITHOUT CLAIM TO ANY PARTICULAR FONT, STYLE, SIZE, OR COLOR.

**CLASS 16—PAPER GOODS AND PRINTED MATTER**

FOR PRINTED MATERIALS, NAMELY, CALENDARS, NOTE CARDS AND ART PRINTS (U.S. CLS. 2, 5, 22, 23, 29, 37, 38 AND 50).

**CLASS 45—PERSONAL AND LEGAL SERVICES**

FOR PROVIDING ON-LINE INFORMATION IN THE FIELD OF SPIRITUALITY-BASED SELF HELP (U.S. CLS. 100 AND 101).  
ESTHER A. BORSUK, EXAMINING ATTORNEY

SN 85-187,081. IFILEGREEN, LLC, BRONX, NY. FILED 11-30-2010.

SN 85-187,159. MEETZI, LLC, WYLIE, TX. FILED 11-30-2010.



NO CLAIM IS MADE TO THE EXCLUSIVE RIGHT TO USE "GREEN RECORD STORAGE", APART FROM THE MARK AS SHOWN.

THE MARK CONSISTS OF THE LITERAL ELEMENT "IFILEGREEN" LOCATED ABOVE THE LITERAL ELEMENT "CLEAN, GREEN RECORD STORAGE" WITH A TREE DESIGN TO THE LEFT AND RIGHT OF "CLEAN, GREEN RECORD STORAGE".

**CLASS 16—PAPER GOODS AND PRINTED MATTER**

FOR FILE BOXES FOR STORAGE OF BUSINESS AND PERSONAL RECORD (U.S. CLS. 2, 5, 22, 23, 29, 37, 38 AND 50).

**CLASS 39—TRANSPORTATION AND STORAGE**

FOR ELECTRONIC STORAGE OF FILES AND DOCUMENTS (U.S. CLS. 100 AND 105).  
INGRID C. EULIN, EXAMINING ATTORNEY

SN 85-187,114. THE BEST OF ORGANIC LLC, WEST BLOOMFIELD, MI. FILED 11-30-2010.

RED LIGHT GREEN LIGHT FOODS

THE MARK CONSISTS OF STANDARD CHARACTERS WITHOUT CLAIM TO ANY PARTICULAR FONT, STYLE, SIZE, OR COLOR.

NO CLAIM IS MADE TO THE EXCLUSIVE RIGHT TO USE "FOODS", APART FROM THE MARK AS SHOWN.

**CLASS 16—PAPER GOODS AND PRINTED MATTER**

FOR BOOKS IN THE FIELD OF HEALTH, NUTRITION, AND LIFESTYLE (U.S. CLS. 2, 5, 22, 23, 29, 37, 38 AND 50).

**CLASS 41—EDUCATION AND ENTERTAINMENT**

FOR ENTERTAINMENT SERVICES IN THE NATURE OF ON-GOING TELEVISION PROGRAMS IN THE FIELD OF CHILDREN'S ENTERTAINMENT (U.S. CLS. 100, 101 AND 107).

TOBY BULLOFF, EXAMINING ATTORNEY

MEETZI

THE MARK CONSISTS OF STANDARD CHARACTERS WITHOUT CLAIM TO ANY PARTICULAR FONT, STYLE, SIZE, OR COLOR.

**CLASS 9—ELECTRICAL AND SCIENTIFIC APPARATUS**

FOR SOFTWARE FOR CREATING, OFFERING, HOSTING AND DELIVERING VIRTUAL MEETINGS, CONFERENCES AND PRESENTATIONS (U.S. CLS. 21, 23, 26, 36 AND 38).

**CLASS 38—COMMUNICATION**

FOR TELECOMMUNICATIONS SERVICES, NAMELY, BROADCASTING VIDEO AND AUDIO FROM VIRTUAL MEETINGS, CONFERENCES AND PRESENTATIONS OVER TELEPHONE AND COMPUTER NETWORKS (U.S. CLS. 100, 101 AND 104).

**CLASS 42—SCIENTIFIC AND COMPUTER SERVICES**

FOR COMPUTER SERVICES, NAMELY, HOSTING ON-LINE WEB FACILITIES FOR OTHERS FOR ORGANIZING AND CONDUCTING ONLINE MEETINGS, CONFERENCES, AND PRESENTATIONS (U.S. CLS. 100 AND 101).

SUNG IN, EXAMINING ATTORNEY

SN 85-187,485. CASSANITI, ALEXANDRA, SANTA MONICA, CA. FILED 11-30-2010.

SUMMER BUMMER

THE MARK CONSISTS OF STANDARD CHARACTERS WITHOUT CLAIM TO ANY PARTICULAR FONT, STYLE, SIZE, OR COLOR.

**CLASS 18—LEATHER GOODS**

FOR BEACH BAGS, CARRY ALL BAGS, SHOULDER BAGS, LEATHER AND IMITATION LEATHER BAGS AND TOTE BAGS (U.S. CLS. 1, 2, 3, 22 AND 41).

FIRST USE 1-15-2008; IN COMMERCE 1-15-2008.

**CLASS 25—CLOTHING**

FOR CLOTHING, NAMELY, T-SHIRTS, TOPS, BLOUSES, BATHING SUITS, BATHING TRUNKS, BEACH WEAR; FOOTWEAR; HATS AND CAPS (U.S. CLS. 22 AND 39).

FIRST USE 1-15-2008; IN COMMERCE 1-15-2008.

DAVID I, EXAMINING ATTORNEY

SN 85-187,505. CASSANITI, ALEXANDRA, SANTA MONICA, CA. FILED 11-30-2010.

## ALEXANDRA CASSANITI

THE MARK CONSISTS OF STANDARD CHARACTERS WITHOUT CLAIM TO ANY PARTICULAR FONT, STYLE, SIZE, OR COLOR.

THE NAME "ALEXANDRA CASSANITI" IDENTIFIES A LIVING INDIVIDUAL WHOSE CONSENT IS OF RECORD.

### CLASS 18—LEATHER GOODS

FOR BEACH BAGS, CARRY ALL BAGS, SHOULDER BAGS, LEATHER AND IMITATION LEATHER BAGS AND TOTE BAGS (U.S. CLS. 1, 2, 3, 22 AND 41).  
FIRST USE 1-15-2008; IN COMMERCE 1-15-2008.

### CLASS 25—CLOTHING

FOR CLOTHING, NAMELY, T-SHIRTS, TOPS, BLOUSES, BATHING SUITS, BATHING TRUNKS, BEACH WEAR; FOOTWEAR; HATS AND CAPS (U.S. CLS. 22 AND 39).  
FIRST USE 1-15-2008; IN COMMERCE 1-15-2008.  
DAVID I, EXAMINING ATTORNEY

SN 85-187,514. LUTHERAN HOMES SOCIETY, INC., TOLEDO, OH. FILED 11-30-2010.



NO CLAIM IS MADE TO THE EXCLUSIVE RIGHT TO USE "HOMES SOCIETY", APART FROM THE MARK AS SHOWN.

THE MARK CONSISTS OF A DESIGN OF A HOUSE WHICH HAS A HEART SHAPE CUT OUT OF THE CENTER OF IT, WITH THE LETTERS "LHS" WITHIN THE HEART, WHEREIN THE HORIZONTAL BAR OF A CROSS FORMS THE HORIZONTAL BAR OF THE "H" IN "LHS". ALL ABOVE THE WORDING "LUTHERAN HOMES SOCIETY".  
SEC. 2(F) AS TO "LUTHERAN HOMES SOCIETY".

### CLASS 43—HOTEL AND RESTAURANT SERVICES

FOR PROVIDING ASSISTED LIVING FACILITIES (U.S. CLS. 100 AND 101).  
FIRST USE 3-18-2001; IN COMMERCE 3-18-2001.

### CLASS 44—MEDICAL, BEAUTY AND AGRICULTURAL SERVICES

FOR NURSING HOMES (U.S. CLS. 100 AND 101).  
FIRST USE 3-18-2001; IN COMMERCE 3-18-2001.  
SARA BENJAMIN, EXAMINING ATTORNEY

SN 85-187,522. A.T.T.A.C.K. ATHLETICS, INC., CHICAGO, IL. FILED 11-30-2010.

## THIS AIN'T THAT

THE MARK CONSISTS OF STANDARD CHARACTERS WITHOUT CLAIM TO ANY PARTICULAR FONT, STYLE, SIZE, OR COLOR.

### CLASS 25—CLOTHING

FOR SHIRTS; SHORTS; HEADWEAR; PANTS; JACKETS (U.S. CLS. 22 AND 39).

### CLASS 41—EDUCATION AND ENTERTAINMENT

FOR ARRANGING AND CONDUCTING ATHLETIC TRAINING; PHYSICAL FITNESS, STRENGTH AND CONDITIONING CONSULTATION AND INSTRUCTION (U.S. CLS. 100, 101 AND 107).  
KAREN K. BUSH, EXAMINING ATTORNEY

SN 85-187,766. CGDL, LLC, TOLEDO, OH. FILED 11-30-2010.

## CleanLeads

THE MARK CONSISTS OF STANDARD CHARACTERS WITHOUT CLAIM TO ANY PARTICULAR FONT, STYLE, SIZE, OR COLOR.

### CLASS 35—ADVERTISING AND BUSINESS

FOR ADVERTISING, PROMOTION, AND MARKETING SERVICES IN THE NATURE OF CREATING TELEPHONE SCRIPTS, SALES LETTERS, SPECIAL REPORTS, POSTCARDS, AND FLYERS, AND PRODUCING AUDIO AND VIDEO PROGRAMS, ALL FOR BUSINESSES IN THE COMMERCIAL AND RESIDENTIAL CLEANING INDUSTRIES (U.S. CLS. 100, 101 AND 102).

### CLASS 41—EDUCATION AND ENTERTAINMENT

FOR COACHING SERVICES PROVIDED AS PART OF A BUSINESS AND MARKETING SYSTEM FOR THE COMMERCIAL AND RESIDENTIAL CLEANING INDUSTRIES, NAMELY, PROVIDING COACHING SERVICES TO CLIENT BUSINESSES IN THE COMMERCIAL AND RESIDENTIAL CLEANING INDUSTRIES WITH RESPECT TO MARKETING THEIR BUSINESS (U.S. CLS. 100, 101 AND 107).  
REBECCA EISINGER, EXAMINING ATTORNEY



SN 85-187,790. ZHOU MINGDONG, SAN DIEGO, CA. FILED 11-30-2010.

SN 85-188,017. AARP, WASHINGTON, DC. FILED 12-1-2010.

## AUREOLE

THE MARK CONSISTS OF STANDARD CHARACTERS WITHOUT CLAIM TO ANY PARTICULAR FONT, STYLE, SIZE, OR COLOR.

### CLASS 3—COSMETICS AND CLEANING PREPARATIONS

FOR CLEANSING CREAMS; CLEANSING MILK; COSMETIC PREPARATIONS; COSMETIC PREPARATIONS FOR BODY CARE; COSMETIC PREPARATIONS FOR SKIN CARE; COSMETIC PREPARATIONS FOR SKIN RENEWAL; COSMETIC SUN-PROTECTING PREPARATIONS; COSMETICS AND MAKE-UP (U.S. CLS. 1, 4, 6, 50, 51 AND 52).

### CLASS 21—HOUSEWARES AND GLASS

FOR POWER-OPERATED APPARATUS FOR SKIN CLEANSING AND EXFOLIATING USING A BRUSH; POWER-OPERATED BRUSH FOR SKIN SKIN CLEANSING AND EXFOLIATING; ELECTRIC TOOTHBRUSH; ELECTRIC HAIR COMB (U.S. CLS. 2, 13, 23, 29, 30, 33, 40 AND 50).

CHERYL CLAYTON, EXAMINING ATTORNEY

SN 85-187,911. MDISOFT, INC., VIENNA, VA. FILED 12-1-2010.

## SKYFER

THE MARK CONSISTS OF STANDARD CHARACTERS WITHOUT CLAIM TO ANY PARTICULAR FONT, STYLE, SIZE, OR COLOR.

### CLASS 9—ELECTRICAL AND SCIENTIFIC APPARATUS

FOR DOWNLOADABLE SOFTWARE IN THE NATURE OF A MOBILE APPLICATION FOR REAL TIME COLLABORATION AMONG USERS BASED ON THEIR GEOLOCATIONS FOR THE PURPOSE OF SEEKING AND OFFERING SKILLS AND SERVICES IN THE LOCAL COMMUNITY, AND EXCHANGING INFORMATION BETWEEN SERVICE SEEKERS AND SERVICE PROVIDERS (U.S. CLS. 21, 23, 26, 36 AND 38).

### CLASS 42—SCIENTIFIC AND COMPUTER SERVICES

FOR PROVIDING A WEBSITE FEATURING NON-DOWNLOADABLE SOFTWARE FOR REAL TIME COLLABORATION AMONG USERS BASED ON THEIR GEOLOCATIONS FOR THE PURPOSE OF SEEKING AND OFFERING SKILLS AND SERVICES IN THE LOCAL COMMUNITY, AND EXCHANGING INFORMATION BETWEEN SERVICE SEEKERS AND SERVICE PROVIDERS (U.S. CLS. 100 AND 101).

LINDA POWELL, EXAMINING ATTORNEY

## SEGUNDA JUVENTUD

THE MARK CONSISTS OF STANDARD CHARACTERS WITHOUT CLAIM TO ANY PARTICULAR FONT, STYLE, SIZE, OR COLOR.

OWNER OF U.S. REG. NO. 3,294,423.

THE ENGLISH TRANSLATION OF "SEGUNDA JUVENTUD" IN THE MARK IS "SECOND YOUTH".

### CLASS 16—PAPER GOODS AND PRINTED MATTER

FOR PRINTED MATERIALS, NAMELY, MAGAZINES AND NEWSLETTERS PROMOTING THE INTERESTS OF MATURE INDIVIDUALS AND IN THE FIELDS OF CAREGIVING, CHILDCARE, EDUCATION, MEDICAL SERVICES, ELDERCARE, EMPLOYMENT, ASSISTED CARE FACILITIES, LEGAL ASSISTANCE, BUSINESS, INSURANCE, REAL ESTATE, TRAVEL, ELDER ASSISTANCE, RETIREMENT, MATURE OR RETIRED LIFESTYLES, FINANCE, HEALTH, AGING, FAMILY RELATIONSHIPS, VOLUNTEER ACTIVITIES, CONSUMER ISSUES, ECONOMIC SECURITY, WORK, INDEPENDENT LIVING, AND FITNESS (U.S. CLS. 2, 5, 22, 23, 29, 37, 38 AND 50).

### CLASS 41—EDUCATION AND ENTERTAINMENT

FOR PROVIDING ONLINE MAGAZINES AND NEWSLETTERS PROMOTING THE INTERESTS OF MATURE INDIVIDUALS AND IN THE FIELDS OF CAREGIVING, CHILDCARE, EDUCATION, MEDICAL SERVICES, ELDERCARE, EMPLOYMENT, ASSISTED CARE FACILITIES, LEGAL ASSISTANCE, BUSINESS, INSURANCE, REAL ESTATE, TRAVEL, ELDER ASSISTANCE, RETIREMENT, MATURE OR RETIRED LIFESTYLES, FINANCE, HEALTH, AGING, FAMILY RELATIONSHIPS, VOLUNTEER ACTIVITIES, CONSUMER ISSUES, ECONOMIC SECURITY, WORK, INDEPENDENT LIVING, AND FITNESS (U.S. CLS. 100, 101 AND 107).

DOUGLAS LEE, EXAMINING ATTORNEY

SN 85-188,061. HARLEM GLOBETROTTERS INTERNATIONAL, INC., PHOENIX, AZ. FILED 12-1-2010.



OWNER OF U.S. REG. NOS. 542,474, 2,374,778 AND OTHERS.

NO CLAIM IS MADE TO THE EXCLUSIVE RIGHT TO USE "4 POINTS", APART FROM THE MARK AS SHOWN.

THE COLOR(S) RED, WHITE, BLUE, BLACK AND GOLD IS/ARE CLAIMED AS A FEATURE OF THE MARK.

THE MARK CONSISTS OF A BLUE CIRCLE WITH A BASKET BALL IN THE CENTER BEARING THE COLORS RED, WHITE AND BLUE, WITH AN OUTLINE OF BLACK. THE WORDS SURROUNDING THE BASKETBALL ARE "HARLEM" IN RED, "GLOBETROTTERS" IN BLUE AND "POINTS" IN GOLD WITH AN OUTLINE OF BLACK. THE NUMBER "4" APPEARS DIRECTLY IN THE CENTER OF THE BASKETBALL IN GOLD.

**CLASS 9—ELECTRICAL AND SCIENTIFIC APPARATUS**

FOR MOUSE PADS (U.S. CLS. 21, 23, 26, 36 AND 38).

**CLASS 16—PAPER GOODS AND PRINTED MATTER**

FOR REMOVABLE DECALS FOR PLACEMENT ON A BASKETBALL COURT (U.S. CLS. 2, 5, 22, 23, 29, 37, 38 AND 50).

**CLASS 28—TOYS AND SPORTING GOODS**

FOR FLYING DISCS AND BASKETBALLS (U.S. CLS. 22, 23, 38 AND 50).

**CLASS 41—EDUCATION AND ENTERTAINMENT**

FOR ENTERTAINMENT SERVICES IN THE NATURE OF BASKETBALL EXHIBITIONS (U.S. CLS. 100, 101 AND 107).

ALEXANDER L. POWERS, EXAMINING ATTORNEY

---

SN 85-188,146. SPRING LEAF CONCEPTS & DESIGN, INC., WACONIA, MN. FILED 12-1-2010.

**Spring Leaf Concepts & Design**

THE MARK CONSISTS OF STANDARD CHARACTERS WITHOUT CLAIM TO ANY PARTICULAR FONT, STYLE, SIZE, OR COLOR.

OWNER OF U.S. REG. NO. 2,653,913.

NO CLAIM IS MADE TO THE EXCLUSIVE RIGHT TO USE "DESIGN", APART FROM THE MARK AS SHOWN.

**CLASS 16—PAPER GOODS AND PRINTED MATTER**

FOR GREETING CARDS, STATIONERY, PAPER AND CARDBOARD PHOTOGRAPHIC MOUNTS (U.S. CLS. 2, 5, 22, 23, 29, 37, 38 AND 50).

FIRST USE 9-16-1996; IN COMMERCE 11-29-1997.

**CLASS 25—CLOTHING**

FOR WEARING APPAREL, NAMELY, HATS (U.S. CLS. 22 AND 39).

FIRST USE 9-16-1996; IN COMMERCE 11-29-1997.

MICHAEL GAAFAR, EXAMINING ATTORNEY

SN 85-188,172. TWIN EAGLE RESOURCE MANAGEMENT, LLC, HOUSTON, TX. FILED 12-1-2010.

**Twin Eagle Resource Management**

THE MARK CONSISTS OF STANDARD CHARACTERS WITHOUT CLAIM TO ANY PARTICULAR FONT, STYLE, SIZE, OR COLOR.

NO CLAIM IS MADE TO THE EXCLUSIVE RIGHT TO USE "RESOURCE MANAGEMENT", APART FROM THE MARK AS SHOWN.

**CLASS 35—ADVERTISING AND BUSINESS**

FOR BUSINESS MARKETING SERVICES OF VARIOUS PRODUCTS FOR ENERGY RELATED BUSINESSES (U.S. CLS. 100, 101 AND 102).

**CLASS 36—INSURANCE AND FINANCIAL**

FOR COMMODITY TRADING FOR OTHERS IN THE FIELD OF VARIOUS PRODUCTS FOR ENERGY RELATED BUSINESSES (U.S. CLS. 100, 101 AND 102).

COURTNEY ALVAREZ, EXAMINING ATTORNEY

---

SN 85-188,265. BUSH INDUSTRIES, INC., JAMESTOWN, NY. FILED 12-1-2010.

**INSTALL 360**

THE MARK CONSISTS OF STANDARD CHARACTERS WITHOUT CLAIM TO ANY PARTICULAR FONT, STYLE, SIZE, OR COLOR.

NO CLAIM IS MADE TO THE EXCLUSIVE RIGHT TO USE "INSTALL", APART FROM THE MARK AS SHOWN.

**CLASS 37—CONSTRUCTION AND REPAIR**

FOR FURNITURE INSTALLATION (U.S. CLS. 100, 103 AND 106).

**CLASS 39—TRANSPORTATION AND STORAGE**

FOR DELIVERY OF FURNITURE (U.S. CLS. 100 AND 105).

LINDA LAVACHE, EXAMINING ATTORNEY

---

SN 85-188,293. ROYAL ANIMALS LTD., NEW YORK, NY. FILED 12-1-2010.

**Royal Animals**

NO CLAIM IS MADE TO THE EXCLUSIVE RIGHT TO USE "ANIMALS", APART FROM THE MARK AS SHOWN.

THE MARK CONSISTS OF THE WORDS "ROYAL ANIMALS" IN STYLIZED WRITING.

SN 85-188,347. TINY PRINTS, INC., SUNNYVALE, CA. FILED 12-1-2010.

#### CLASS 18—LEATHER GOODS

FOR CLOTHING FOR DOMESTIC PETS; GARMENTS FOR PETS; PET CLOTHING; PET PRODUCTS, NAMELY, PET RESTRAINING DEVICES CONSISTING OF LEASHES, COLLARS, HARNESES, RESTRAINING STRAPS, AND LEASHES WITH LOCKING DEVICES (U.S. CLS. 1, 2, 3, 22 AND 41).

FIRST USE 11-1-2009; IN COMMERCE 11-1-2009.

#### CLASS 20—FURNITURE AND ARTICLES NOT OTHERWISE CLASSIFIED

FOR BEDS FOR HOUSEHOLD PETS; PET CUSHIONS; PORTABLE BEDS FOR PETS (U.S. CLS. 2, 13, 22, 25, 32 AND 50).

FIRST USE 11-1-2009; IN COMMERCE 11-1-2009.

#### CLASS 28—TOYS AND SPORTING GOODS

FOR PET TOYS; TOYS FOR DOMESTIC PETS (U.S. CLS. 22, 23, 38 AND 50).

FIRST USE 11-1-2009; IN COMMERCE 11-1-2009.  
WILLIAM ROSSMAN, EXAMINING ATTORNEY

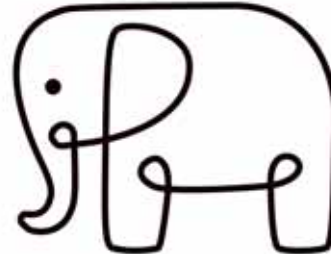

THE MARK CONSISTS OF A PROFILE VIEW OF AN ELEPHANT.

#### CLASS 16—PAPER GOODS AND PRINTED MATTER

FOR PAPER AND PRINTED MATTER, NAMELY, PRINTED ANNOUNCEMENTS, ANNOUNCEMENT CARDS, PRINTED INVITATIONS, INVITATION CARDS, THANK YOU CARDS, HOLIDAY CARDS, GREETING CARDS, CARDS WITH PHOTOGRAPHS, POSTCARDS, PAPER GIFT TAGS, ADDRESS LABELS, STICKERS, STATIONERY, AND ENVELOPES (U.S. CLS. 2, 5, 22, 23, 29, 37, 38 AND 50).

FIRST USE 9-8-2010; IN COMMERCE 9-8-2010.

#### CLASS 35—ADVERTISING AND BUSINESS

FOR ONLINE ORDERING SERVICES FEATURING PAPER AND PRINTED MATTER, NAMELY, ANNOUNCEMENTS, INVITATIONS, CARDS, THANK YOU CARDS, HOLIDAY CARDS, GREETING CARDS, CARDS WITH PHOTOGRAPHS, POSTCARDS, GIFT TAGS, ADDRESS LABELS, STICKERS, STATIONERY, ENVELOPES, SHOWER GIFTS, AND FAVORS (U.S. CLS. 100, 101 AND 102).

FIRST USE 9-8-2010; IN COMMERCE 9-8-2010.

#### CLASS 40—MATERIAL TREATMENT

FOR PRINTING; CUSTOM PRINTING SERVICES; PRINTING SERVICES, NAMELY, PRINTING OF ANNOUNCEMENTS, INVITATIONS, CARDS, THANK YOU CARDS, HOLIDAY CARDS, GREETING CARDS, CARDS WITH PHOTOGRAPHS, POSTCARDS, GIFT TAGS, ADDRESS LABELS, STICKERS, STATIONERY, AND ENVELOPES; PRINTING SERVICES IN THE FIELD OF PAPER AND PRINTED MATTER, ANNOUNCEMENTS, INVITATIONS, CARDS, THANK YOU CARDS, HOLIDAY CARDS, GREETING CARDS, CARDS WITH PHOTOGRAPHS, POSTCARDS, GIFT TAGS, ADDRESS LABELS, STICKERS, STATIONERY, ENVELOPES, SHOWER GIFTS, AND FAVORS; ONLINE PRINTING SERVICES (U.S. CLS. 100, 103 AND 106).

FIRST USE 9-8-2010; IN COMMERCE 9-8-2010.

#### CLASS 42—SCIENTIFIC AND COMPUTER SERVICES

FOR PROVIDING TEMPORARY USE OF ONLINE NON-DOWNLOADABLE SOFTWARE THAT ENABLES CUSTOMERS TO PERSONALIZE, DESIGN, UPLOAD CONTENT, AND CUSTOMIZE STATIONERY AND OTHER PRINTED ITEMS (U.S. CLS. 100 AND 101).

FIRST USE 9-8-2010; IN COMMERCE 9-8-2010.  
KATHY DE JONGE, EXAMINING ATTORNEY

SN 85-188,295. NEW BELGIUM BREWING COMPANY, INC., FORT COLLINS, CO. FILED 12-1-2010.

NEW BELGIUM BEER CONFIDENCE

THE MARK CONSISTS OF STANDARD CHARACTERS WITHOUT CLAIM TO ANY PARTICULAR FONT, STYLE, SIZE, OR COLOR.

OWNER OF U.S. REG. NOS. 2,817,123, 3,018,632 AND OTHERS.

NO CLAIM IS MADE TO THE EXCLUSIVE RIGHT TO USE "BELGIUM BEER", APART FROM THE MARK AS SHOWN.

#### CLASS 35—ADVERTISING AND BUSINESS

FOR ARRANGING AND CONDUCTING INCENTIVE REWARD PROGRAMS TO PROMOTE THE SALE OF BEER; PROVIDING INCENTIVE AWARD PROGRAMS FOR BEVERAGE DISTRIBUTORS FOR THE PURPOSE OF PROMOTING AND REWARDING LOYALTY (U.S. CLS. 100, 101 AND 102).

#### CLASS 41—EDUCATION AND ENTERTAINMENT

FOR PROVIDING RECOGNITION AND INCENTIVES BY THE WAY OF AWARDS AND CONTESTS TO DEMONSTRATE EXCELLENCE IN THE FIELD OF BEVERAGE DISTRIBUTION SERVICES (U.S. CLS. 100, 101 AND 107).

DAWN FELDMAN, EXAMINING ATTORNEY

SN 85-188,355. TINY PRINTS, INC., SUNNYVALE, CA. FILED 12-1-2010.

SN 85-188,407. INDITTOY, INC., COLUMBIA, MD. FILED 12-1-2010.

## BIG IMPRESSIONS

THE MARK CONSISTS OF STANDARD CHARACTERS WITHOUT CLAIM TO ANY PARTICULAR FONT, STYLE, SIZE, OR COLOR.

### CLASS 16—PAPER GOODS AND PRINTED MATTER

FOR PAPER AND PRINTED MATTER, NAMELY, PRINTED ANNOUNCEMENTS, ANNOUNCEMENT CARDS, PRINTED INVITATIONS, INVITATION CARDS, THANK YOU CARDS, HOLIDAY CARDS, GREETING CARDS, CARDS WITH PHOTOGRAPHS, POSTCARDS, PAPER GIFT TAGS, ADDRESS LABELS, STICKERS, STATIONERY, AND ENVELOPES (U.S. CLS. 2, 5, 22, 23, 29, 37, 38 AND 50).

FIRST USE 9-8-2010; IN COMMERCE 9-8-2010.

### CLASS 35—ADVERTISING AND BUSINESS

FOR ONLINE ORDERING SERVICES FEATURING PAPER AND PRINTED MATTER, NAMELY, ANNOUNCEMENTS, INVITATIONS, CARDS, THANK YOU CARDS, HOLIDAY CARDS, GREETING CARDS, CARDS WITH PHOTOGRAPHS, POSTCARDS, GIFT TAGS, ADDRESS LABELS, STICKERS, STATIONERY, ENVELOPES, SHOWER GIFTS, AND FAVORS (U.S. CLS. 100, 101 AND 102).

FIRST USE 9-8-2010; IN COMMERCE 9-8-2010.

### CLASS 40—MATERIAL TREATMENT

FOR PRINTING; CUSTOM PRINTING SERVICES; PRINTING SERVICES, NAMELY, PRINTING OF ANNOUNCEMENTS, INVITATIONS, CARDS, THANK YOU CARDS, HOLIDAY CARDS, GREETING CARDS, CARDS WITH PHOTOGRAPHS, POSTCARDS, GIFT TAGS, ADDRESS LABELS, STICKERS, STATIONERY, AND ENVELOPES; PRINTING SERVICES IN THE FIELD OF PAPER AND PRINTED MATTER, ANNOUNCEMENTS, INVITATIONS, CARDS, THANK YOU CARDS, HOLIDAY CARDS, GREETING CARDS, CARDS WITH PHOTOGRAPHS, POSTCARDS, GIFT TAGS, ADDRESS LABELS, STICKERS, STATIONERY, ENVELOPES, SHOWER GIFTS, AND FAVORS; ONLINE PRINTING SERVICES (U.S. CLS. 100, 103 AND 106).

FIRST USE 9-8-2010; IN COMMERCE 9-8-2010.

### CLASS 42—SCIENTIFIC AND COMPUTER SERVICES

FOR PROVIDING TEMPORARY USE OF ONLINE NON-DOWNLOADABLE SOFTWARE THAT ENABLES CUSTOMERS TO PERSONALIZE, DESIGN, UPLOAD CONTENT, AND CUSTOMIZE STATIONERY AND OTHER PRINTED ITEMS (U.S. CLS. 100 AND 101).

FIRST USE 9-8-2010; IN COMMERCE 9-8-2010.  
KATHY DE JONGE, EXAMINING ATTORNEY



NO CLAIM IS MADE TO THE EXCLUSIVE RIGHT TO USE "LANGUAGE", APART FROM THE MARK AS SHOWN.

THE COLOR(S) BLUE, WHITE, ORANGE-YELLOW IS/ARE CLAIMED AS A FEATURE OF THE MARK.

THE MARK CONSISTS OF THE WORDING "QUICK-N-EZ" IS IN BLUE AND PLACED ABOVE THE WORD "LANGUAGE". THE WORD "LANGUAGE" IS IN WHITE AND SUPERIMPOSED ON AN ORANGE-YELLOW RECTANGULAR BACKGROUND.

### CLASS 16—PAPER GOODS AND PRINTED MATTER

FOR PRINTED SPEECH AND LANGUAGE EDUCATION MATERIALS, NAMELY, FLASHCARDS, PRACTICE CHARTS, AND WORKBOOKS, TO ENHANCE FOREIGN SPEECH AND LANGUAGE SKILLS (U.S. CLS. 2, 5, 22, 23, 29, 37, 38 AND 50).

### CLASS 41—EDUCATION AND ENTERTAINMENT

FOR EDUCATIONAL SERVICES, NAMELY, CONDUCTING DISTANCE LEARNING INSTRUCTION VIA AN INTERACTIVE WEBSITE TO ENHANCE FOREIGN SPEECH AND LANGUAGE SKILLS (U.S. CLS. 100, 101 AND 107).

ANGELA DUONG, EXAMINING ATTORNEY

SN 85-188,468. DURO-LAST, INC., SAGINAW, MI. FILED 12-1-2010.

## DURO-FLEECE

THE MARK CONSISTS OF STANDARD CHARACTERS WITHOUT CLAIM TO ANY PARTICULAR FONT, STYLE, SIZE, OR COLOR.

OWNER OF U.S. REG. NOS. 1,798,975, 2,386,473 AND OTHERS.

### CLASS 1—CHEMICALS

FOR ROOFING ADHESIVE (U.S. CLS. 1, 5, 6, 10, 26 AND 46).

### CLASS 19—NON-METALLIC BUILDING MATERIALS

FOR ROOFING MEMBRANES (U.S. CLS. 1, 12, 33 AND 50).

DAVID COLLIER, EXAMINING ATTORNEY

SN 85-188,763. SUPRACOR, INC., SAN JOSE, CA. FILED 12-1-2010.

SN 85-188,813. RMP CAPITAL CORP, ISLANDIA, NY. FILED 12-1-2010.

# STIMULITE

THE MARK CONSISTS OF STANDARD CHARACTERS WITHOUT CLAIM TO ANY PARTICULAR FONT, STYLE, SIZE, OR COLOR.

OWNER OF U.S. REG. NOS. 1,873,040 AND 3,817,511.

## CLASS 20—FURNITURE AND ARTICLES NOT OTHERWISE CLASSIFIED

FOR LUMBAR CUSHIONS, NAMELY, BACK SUPPORT CUSHIONS NOT FOR MEDICAL PURPOSES; PET CUSHIONS; PLASTIC CUSHIONING SHEETS FOR LINING SHELVES (U.S. CLS. 2, 13, 22, 25, 32 AND 50).  
FIRST USE 0-0-2005; IN COMMERCE 0-0-2005.

## CLASS 24—FABRICS

FOR BATH GLOVES; BATH MITTS (U.S. CLS. 42 AND 50).  
FIRST USE 0-0-2005; IN COMMERCE 0-0-2005.

## CLASS 25—CLOTHING

FOR SLIPPERS; CAMISOLES (U.S. CLS. 22 AND 39).  
FIRST USE 0-0-2005; IN COMMERCE 0-0-2005.

## CLASS 28—TOYS AND SPORTING GOODS

FOR YOGA MATS; PERSONAL EXERCISE MATS; POOL MATS, NAMELY, POOL CUSHIONS (U.S. CLS. 22, 23, 38 AND 50).  
FIRST USE 0-0-2005; IN COMMERCE 0-0-2005.  
GEORGE LORENZO, EXAMINING ATTORNEY

SN 85-188,782. SYNDICATED PUZZLES, VICTORIA, CANADA, FILED 12-1-2010.

# LETTERLICIOUS

THE MARK CONSISTS OF STANDARD CHARACTERS WITHOUT CLAIM TO ANY PARTICULAR FONT, STYLE, SIZE, OR COLOR.

## CLASS 16—PAPER GOODS AND PRINTED MATTER

FOR SYNDICATED NEWSPAPER COLUMNS DEALING WITH GAMES AND PUZZLES (U.S. CLS. 2, 5, 22, 23, 29, 37, 38 AND 50).  
FIRST USE 11-9-2008; IN COMMERCE 11-9-2008.

## CLASS 41—EDUCATION AND ENTERTAINMENT

FOR ENTERTAINMENT SERVICES, NAMELY, PROVIDING A WEBSITE FEATURING GAMES AND PUZZLES (U.S. CLS. 100, 101 AND 107).  
FIRST USE 11-9-2008; IN COMMERCE 11-9-2008.  
JIM RINGLE, EXAMINING ATTORNEY

# RMP Capital Corp

THE MARK CONSISTS OF STANDARD CHARACTERS WITHOUT CLAIM TO ANY PARTICULAR FONT, STYLE, SIZE, OR COLOR.

NO CLAIM IS MADE TO THE EXCLUSIVE RIGHT TO USE "CAPITAL CORP", APART FROM THE MARK AS SHOWN.

## CLASS 35—ADVERTISING AND BUSINESS

FOR ACCOUNTS RECEIVABLE SERVICES; OUTSOURCING OF ACCOUNTS PAYABLE (U.S. CLS. 100, 101 AND 102).  
FIRST USE 0-0-2003; IN COMMERCE 0-0-2003.

## CLASS 36—INSURANCE AND FINANCIAL

FOR FINANCIAL AND FACTORING SERVICES, NAMELY, PURCHASING OF ACCOUNTS RECEIVABLE; FACTORING ACCOUNTS RECEIVABLE; TRADE FINANCING; PURCHASE ORDER FINANCING; AND ASSET BASED LENDING; FINANCIAL INTERMEDIARY SERVICES, NAMELY, DISBURSEMENT OF CONSTRUCTION FUNDS TO SUBCONTRACTORS, SUPPLIERS, AND EMPLOYEES OF A CONTRACTOR (U.S. CLS. 100, 101 AND 102).  
FIRST USE 0-0-2003; IN COMMERCE 0-0-2003.  
FLORENTINA BLANDU, EXAMINING ATTORNEY

SN 85-188,827. RMP CAPITAL CORP, ISLANDIA, NY. FILED 12-2-2010.



NO CLAIM IS MADE TO THE EXCLUSIVE RIGHT TO USE "CAPITAL CORP.", APART FROM THE MARK AS SHOWN.

THE COLOR(S) DARK GREEN (PANTONE PMS 3305C) AND WHITE IS/ARE CLAIMED AS A FEATURE OF THE MARK.

THE MARK CONSISTS OF A DEPICTION OF THE GREEK MYTHOLOGICAL FIGURE ATLAS LUNGING FORWARD WHILE SUPPORTING THE TERRESTRIAL GLOBE ON HIS BACK. ALL OF THE AFOREMENTIONED APPEARS OVER A BORDER THAT IS A COMBINATION OF A SQUARE AND AN EQUILATERAL TRIANGLE. THE WORDS "RMP CAPITAL CORP." APPEAR TO THE RIGHT OF THE SQUARE AND EQUILATERAL TRIANGLE BORDER. THE COLOR WHITE APPEARS ON THE FIGURE AND GLOBE DESIGN. A WHITE LINE ALSO APPEARS ON THE BOTTOM OF THE SQUARE AND EQUILATERAL TRIANGLE BORDER. THE COLOR DARK GREEN (PANTONE PMS 3305C) APPEARS ON THE SQUARE AND EQUILATERAL TRIANGLE BORDER AND ON THE WORDS "RMP CAPITAL CORP."

## CLASS 35—ADVERTISING AND BUSINESS

FOR ACCOUNTS RECEIVABLE SERVICES; OUTSOURCING OF ACCOUNTS PAYABLE (U.S. CLS. 100, 101 AND 102).  
FIRST USE 0-0-2003; IN COMMERCE 0-0-2003.

**CLASS 36—INSURANCE AND FINANCIAL**

FOR FINANCIAL AND FACTORING SERVICES, NAMELY, PURCHASING OF ACCOUNTS RECEIVABLE; FACTORING ACCOUNTS RECEIVABLE; TRADE FINANCING; PURCHASE ORDER FINANCING; AND ASSET BASED LENDING; FINANCIAL INTERMEDIARY SERVICES, NAMELY, DISBURSEMENT OF CONSTRUCTION FUNDS TO SUBCONTRACTORS, SUPPLIERS, AND EMPLOYEES OF A CONTRACTOR (U.S. CLS. 100, 101 AND 102).

FIRST USE 0-0-2003; IN COMMERCE 0-0-2003.  
FLORENTINA BLANDU, EXAMINING ATTORNEY

SN 85-188,837. RMP CAPITAL CORP, ISLANDIA, NY. FILED 12-2-2010.



NO CLAIM IS MADE TO THE EXCLUSIVE RIGHT TO USE "CAPITAL CORP.", APART FROM THE MARK AS SHOWN.

THE COLOR(S) DARK GREEN (PANTONE PMS 3305C), BLACK AND WHITE IS/ARE CLAIMED AS A FEATURE OF THE MARK.

THE MARK CONSISTS OF A DEPICTION OF THE GREEK MYTHOLOGICAL FIGURE ATLAS LUNGING FORWARD WHILE SUPPORTING THE TERRESTRIAL GLOBE ON HIS BACK. ALL OF THE AFOREMENTIONED APPEARS OVER A BORDER THAT IS A COMBINATION OF A SQUARE AND AN EQUILATERAL TRIANGLE. UNDERNEATH OF THE FIGURE ARE THE WORDS "WE MAKE FUNDING YOUR BUSINESS EASIER". THE WORDS "RMP CAPITAL CORP." APPEAR TO THE RIGHT OF THE SQUARE AND EQUILATERAL TRIANGLE BORDER. THE COLOR WHITE APPEARS ON THE FIGURE AND GLOBE DESIGN. A WHITE LINE ALSO APPEARS ON THE BOTTOM OF THE SQUARE AND EQUILATERAL TRIANGLE BORDER. THE COLOR DARK GREEN (PANTONE PMS 3305C) APPEARS ON THE SQUARE AND EQUILATERAL TRIANGLE BORDER AND ON THE WORDS "RMP CAPITAL CORP." THE COLOR BLACK APPEARS IN THE WORDING "WE MAKE FUNDING YOUR BUSINESS". THE WORD "EASIER" IS IN A STYLIZED FONT WITH A STYLIZED UNDERLINE IN THE COLOR DARK GREEN (PANTONE PMS 3305C).

**CLASS 35—ADVERTISING AND BUSINESS**

FOR ACCOUNTS RECEIVABLE SERVICES; OUTSOURCING OF ACCOUNTS PAYABLE (U.S. CLS. 100, 101 AND 102).

FIRST USE 0-0-2003; IN COMMERCE 0-0-2003.

**CLASS 36—INSURANCE AND FINANCIAL**

FOR FINANCIAL AND FACTORING SERVICES, NAMELY, PURCHASING OF ACCOUNTS RECEIVABLE; FACTORING ACCOUNTS RECEIVABLE; TRADE FINANCING; PURCHASE ORDER FINANCING; AND ASSET BASED LENDING; FINANCIAL INTERMEDIARY SERVICES, NAMELY, DISBURSEMENT OF CONSTRUCTION FUNDS TO SUBCONTRACTORS, SUPPLIERS, AND EMPLOYEES OF A CONTRACTOR (U.S. CLS. 100, 101 AND 102).

FIRST USE 0-0-2003; IN COMMERCE 0-0-2003.  
FLORENTINA BLANDU, EXAMINING ATTORNEY

SN 85-188,869. WIFS: WOMEN IN INSURANCE AND FINANCIAL SERVICES, INC., ALBANY, NY. FILED 12-2-2010.



THE MARK CONSISTS OF A BOX WITH A LEAF DESIGN AND THE WORDING "WIFS WOMEN IN INSURANCE & FINANCIAL SERVICES" AND THE WORDING "ATTRACT. DEVELOP. ADVANCE." APPEARING BELOW.

SEC. 2(F) AS TO "WOMEN IN INSURANCE AND FINANCIAL SERVICES".

**CLASS 35—ADVERTISING AND BUSINESS**

FOR ASSOCIATION SERVICES, NAMELY, PROMOTING THE INTERESTS OF WOMEN EMPLOYED IN OR ASSOCIATED WITH THE FIELD OF INSURANCE OR FINANCE (U.S. CLS. 100, 101 AND 102).

FIRST USE 10-0-2008; IN COMMERCE 10-0-2008.

**CLASS 41—EDUCATION AND ENTERTAINMENT**

FOR EDUCATIONAL SERVICES, NAMELY, CONDUCTING WEBINARS, CONFERENCES AND WORKSHOPS IN THE FIELD OF INSURANCE AND FINANCE (U.S. CLS. 100, 101 AND 107).

FIRST USE 10-0-2008; IN COMMERCE 10-0-2008.

JILL PRATER, EXAMINING ATTORNEY

SN 85-188,885. NURISE SALES & MARKETING LTD, OAKVILLE, ONTARIO, CANADA, FILED 12-2-2010.

# PURE RAIN

THE MARK CONSISTS OF STANDARD CHARACTERS WITHOUT CLAIM TO ANY PARTICULAR FONT, STYLE, SIZE, OR COLOR.

**CLASS 11—ENVIRONMENTAL CONTROL APPARATUS**

FOR FAUCET SPRAYERS; HAND HELD SHOWER HEADS; HAND SHOWERS, HAND HELD SHOWERS; IRRIGATION SPRAY NOZZLES; IRRIGATION SPRINKLERS; KITCHEN SINK SPRAYERS; OXYGEN GENERATOR FOR PROCESSING WATER BY INCREASING OXYGEN CONTENT IN THE WATER; PLUMBING FITTINGS, NAMELY, AERATORS FOR FAUCETS; PLUMBING FITTINGS, NAMELY, SHOWER CONTROL VALVES; PLUMBING FIXTURES, NAMELY SHOWER MIXERS; PLUMBING FIXTURES, NAMELY, SHOWER SPRAYERS; PLUMBING FIXTURES, NAMELY, SINK SPRAYERS; SHOWER FAUCET EXTENSIONS; SHOWER HEAD SPRAYERS; TAP WATER FAUCETS; VALVES BEING PARTS OF SPRINKLER SYSTEMS; WATER FAUCET SPOUT (U.S. CLS. 13, 21, 23, 31 AND 34).

**CLASS 21—HOUSEWARES AND GLASS**

FOR GARDEN HOSE SPRAYERS; GRASS SPRINKLERS; LAWN SPRINKLERS; PET GROOMING DEVICE COMPRISING A BUILT IN BRUSH HEAD AND AN ATTACHMENT THAT CONNECTS TO A WATER SOURCE; SHUT-OFF VALVES FOR WATER SPRINKLER NOZZLES; SPRAYER NOZZLES FOR GARDEN HOSES; SPRAYER WANDS FOR GARDEN HOSES; SPRAYERS ATTACHED TO GARDEN HOSES; STREAM DEFLECTOR NOZZLES FOR GARDEN HOSES (U.S. CLS. 2, 13, 23, 29, 30, 33, 40 AND 50).

SANI KHOURI, EXAMINING ATTORNEY

SN 85-188,972. MTL MOTORS, LLC, DEARBORN, MI. FILED 12-2-2010.



OWNER OF U.S. REG. NOS. 3,141,214, 3,415,913 AND 3,624,758.

THE MARK CONSISTS OF THE WORD "LAFONTAINE" IN A BANNER ACROSS AN ORB CONTAINING THE WORDING "THE FAMILY DEAL.COM" WITHIN THE ORB BENEATH THE BANNER.

THE ENGLISH TRANSLATION OF "LA FONTAINE" IS "THE FOUNTAIN."

**CLASS 35—ADVERTISING AND BUSINESS**

FOR MOTOR VEHICLE DEALERSHIP SERVICES IN THE FIELD OF NEW, USED AND PRE-OWNED CARS, LIGHT TRUCKS, VANS, SPORTS UTILITY VEHICLES AND MEDIUM DUTY TRUCKS; RETAIL STORE SERVICES FEATURING AUTOMOBILE PARTS AND ACCESSORIES; PROVIDING INFORMATION ABOUT AUTOMOBILE DEALERSHIPS AND ABOUT THE PURCHASE AND SALE OF AUTOMOBILES BY MEANS OF AN INTERNET WEBSITE (U.S. CLS. 100, 101 AND 102).

FIRST USE 1-1-2005; IN COMMERCE 1-1-2005.

**CLASS 36—INSURANCE AND FINANCIAL**

FOR FINANCING RELATED TO AUTOMOBILES (U.S. CLS. 100, 101 AND 102).

FIRST USE 1-1-2005; IN COMMERCE 1-1-2005.

**CLASS 37—CONSTRUCTION AND REPAIR**

FOR SERVICE, MAINTENANCE AND REPAIR OF MOTOR VEHICLES (U.S. CLS. 100, 103 AND 106).

FIRST USE 1-1-2005; IN COMMERCE 1-1-2005.

**CLASS 39—TRANSPORTATION AND STORAGE**

FOR RENTAL OF VEHICLES; LEASING OF VEHICLES; PROVIDING INFORMATION ABOUT LEASING AUTOMOBILES BY MEANS OF AN INTERNET WEBSITE (U.S. CLS. 100 AND 105).

FIRST USE 1-1-2005; IN COMMERCE 1-1-2005.  
MATTHEW PAPPAS, EXAMINING ATTORNEY

SN 85-188,985. BEACHBODY, LLC, SANTA MONICA, CA. FILED 12-2-2010.

**BEAUTY BY BEACHBODY**

THE MARK CONSISTS OF STANDARD CHARACTERS WITHOUT CLAIM TO ANY PARTICULAR FONT, STYLE, SIZE, OR COLOR.

OWNER OF U.S. REG. NOS. 2,862,904, 3,450,708 AND OTHERS.

NO CLAIM IS MADE TO THE EXCLUSIVE RIGHT TO USE "BEAUTY", APART FROM THE MARK AS SHOWN.

**CLASS 3—COSMETICS AND CLEANING PREPARATIONS**

FOR NON-MEDICATED SKIN CARE PREPARATIONS, NAMELY, SERUMS, LOTIONS, CREAMS, GELS, MASKS, SKIN EXFOLIANTS AND SPRAYS (U.S. CLS. 1, 4, 6, 50, 51 AND 52).

**CLASS 35—ADVERTISING AND BUSINESS**

FOR NETWORK MARKETING IN THE NATURE OF PROVIDING MARKETING INFORMATION VIA WEBSITES ON A GLOBAL COMPUTER NETWORK; ADVERTISING SERVICES; SALES PROMOTION SERVICES; MULTI-LEVEL MARKETING BUSINESS SERVICES; DIRECT MARKETING ADVERTISING FOR OTHERS; PREPARATION AND REALIZATION OF MEDIA AND ADVERTISING PLANS AND CONCEPTS; ADVERTISING VIA ELECTRONIC MEDIA AND SPECIFICALLY THE INTERNET; ORGANIZATION OF PROMOTIONS USING AUDIOVISUAL MEDIA; BUSINESS CONSULTING AND INFORMATION SERVICES; BUSINESS MANAGEMENT CONSULTING WITH RELATION TO STRATEGY, MARKETING, PRODUCTION, PERSONNEL AND RETAIL SALE MATTERS; BUSINESS MARKETING AND DIRECT MAIL CONSULTING SERVICES; CONSULTING SERVICES IN BUSINESS ORGANIZATION AND MANAGEMENT; CONSULTING SERVICES RELATING TO PUBLICITY; MARKETING CONSULTING; MEDIA BUYING AGENCY, NAMELY, SECURING AIRTIME ON ALL FORMS OF MEDIA COMMUNICATIONS STATIONS, SYSTEMS, NETWORKS, AND SERVICES FOR THE PURPOSE OF PROMOTING GOODS AND SERVICES OF OTHERS; ON-LINE RETAIL STORE SERVICES FEATURING SKIN CARE PREPARATIONS, MAKE-UP PRODUCTS FOR THE FACE AND BODY, PERFUME, COLOGNE, OILS, SOAPS AND HAIR CARE PREPARATIONS; BUSINESS CONSULTING SERVICES RELATING TO DISTRIBUTION, OPERATIONS MANAGEMENT SERVICES, LOGISTICS, REVERSE LOGISTICS, SUPPLY CHAIN, AND PRODUCTION SYSTEMS AND DISTRIBUTION SOLUTIONS; PRODUCTION AND DISTRIBUTION OF RADIO AND TELEVISION COMMERCIALS (U.S. CLS. 100, 101 AND 102).

WARREN L. OLANDRIA, EXAMINING ATTORNEY

SN 85-189,012. CASCADE FAMILY DENTAL, LLC, PAYSON, UT. FILED 12-2-2010.

**CASCADE FAMILY DENTAL**

THE MARK CONSISTS OF STANDARD CHARACTERS WITHOUT CLAIM TO ANY PARTICULAR FONT, STYLE, SIZE, OR COLOR.

NO CLAIM IS MADE TO THE EXCLUSIVE RIGHT TO USE "FAMILY DENTAL", APART FROM THE MARK AS SHOWN.

#### **CLASS 35—ADVERTISING AND BUSINESS**

FOR FRANCHISE SERVICES, NAMELY, OFFERING BUSINESS MANAGEMENT ASSISTANCE IN THE ESTABLISHMENT AND OPERATION OF DENTISTRY OFFICES (U.S. CLS. 100, 101 AND 102).

#### **CLASS 44—MEDICAL, BEAUTY AND AGRICULTURAL SERVICES**

FOR DENTIST SERVICES; DENTISTRY; ORTHODONTIC SERVICES (U.S. CLS. 100 AND 101).  
LAURA KOVALSKY, EXAMINING ATTORNEY

SN 85-189,074. BEACHBODY, LLC, SANTA MONICA, CA. FILED 12-2-2010.

### BEACHBODY BEAUTY

THE MARK CONSISTS OF STANDARD CHARACTERS WITHOUT CLAIM TO ANY PARTICULAR FONT, STYLE, SIZE, OR COLOR.

OWNER OF U.S. REG. NOS. 2,862,904, 3,450,708 AND OTHERS.

NO CLAIM IS MADE TO THE EXCLUSIVE RIGHT TO USE "BEAUTY", APART FROM THE MARK AS SHOWN.

#### **CLASS 3—COSMETICS AND CLEANING PREPARATIONS**

FOR NON-MEDICATED SKIN CARE PREPARATIONS, NAMELY, SERUMS, LOTIONS, CREAMS, GELS, MASKS, SKIN EXFOLIANTS AND SPRAYS (U.S. CLS. 1, 4, 6, 50, 51 AND 52).

#### **CLASS 35—ADVERTISING AND BUSINESS**

FOR NETWORK MARKETING IN THE NATURE OF PROVIDING MARKETING INFORMATION VIA WEBSITES ON A GLOBAL COMPUTER NETWORK; ADVERTISING SERVICES; SALES PROMOTION SERVICES; MULTI-LEVEL MARKETING BUSINESS SERVICES; DIRECT MARKETING ADVERTISING FOR OTHERS; PREPARATION AND REALIZATION OF MEDIA AND ADVERTISING PLANS AND CONCEPTS; ADVERTISING VIA ELECTRONIC MEDIA AND SPECIFICALLY THE INTERNET; ORGANIZATION OF PROMOTIONS USING AUDIOVISUAL MEDIA; BUSINESS CONSULTING AND INFORMATION SERVICES; BUSINESS MANAGEMENT CONSULTING WITH RELATION TO STRATEGY, MARKETING, PRODUCTION, PERSONNEL AND RETAIL SALE MATTERS; BUSINESS MARKETING AND DIRECT MAIL CONSULTING SERVICES; CONSULTING SERVICES IN BUSINESS ORGANIZATION AND MANAGEMENT; CONSULTING SERVICES RELATING TO PUBLICITY; MARKETING CONSULTING; MEDIA BUYING AGENCY, NAMELY, SECURING AIRTIME ON ALL FORMS OF MEDIA COMMUNICATIONS STATIONS, SYSTEMS, NETWORKS, AND SERVICES FOR THE PURPOSE OF PROMOTING GOODS AND SERVICES OF OTHERS; ON-LINE RETAIL STORE SERVICES FEATURING SKIN CARE PREPARATIONS, MAKE-UP PRODUCTS FOR THE FACE AND BODY, PERFUME, COLOGNE, OILS, SOAPS AND HAIR CARE PREPARATIONS; BUSINESS CONSULTING SERVICES RELATING TO DISTRIBUTION, OPERATIONS MANAGEMENT SERVICES, LOGISTICS, REVERSE LOGISTICS, SUPPLY CHAIN, AND PRODUCTION SYSTEMS AND DISTRIBUTION SOLUTIONS; PRODUCTION AND DISTRIBUTION OF RADIO AND TELEVISION COMMERCIALS (U.S. CLS. 100, 101 AND 102).

WARREN L. OLANDRIA, EXAMINING ATTORNEY

SN 85-189,171. FABRICATORS & MANUFACTURERS ASSOCIATION, INTERNATIONAL, ROCKFORD, IL. FILED 12-2-2010.



NO CLAIM IS MADE TO THE EXCLUSIVE RIGHT TO USE "LOG ON", "CALL IN" OR "INTERACT" AS TO CLASS 41, APART FROM THE MARK AS SHOWN.

THE MARK CONSISTS OF THE WORDS "FMA FABCAST" WITH "FMA" APPEARING VERTICALLY TO THE LEFT OF "FABCAST." BELOW APPEARS THE WORDING "[LOG ON] — [CALL IN] — [INTERACT]" ON A SHADED OBLONG CARRIER. THREE HORIZONTAL LINES THAT END IN CIRCLES APPEAR BEHIND THE WORDS "FMA FABCAST".

#### **CLASS 9—ELECTRICAL AND SCIENTIFIC APPARATUS**

FOR PRE-RECORDED CDS FEATURING EDUCATIONAL PRESENTATIONS IN THE FIELD OF METAL FABRICATION AND MANUFACTURING MANAGEMENT (U.S. CLS. 21, 23, 26, 36 AND 38).

FIRST USE 2-0-2006; IN COMMERCE 2-0-2006.

#### **CLASS 41—EDUCATION AND ENTERTAINMENT**

FOR EDUCATION SERVICES, NAMELY, PROVIDING ON-LINE, LIVE, INTERACTIVE TECHNICAL EDUCATION PROGRAMS IN THE FORM OF LIVE PRESENTATIONS AND WEBINARS IN THE FIELD OF METAL FABRICATION (U.S. CLS. 100, 101 AND 107).

FIRST USE 9-0-2005; IN COMMERCE 9-0-2005.

KATHERINE CONNOLLY, EXAMINING ATTORNEY



SN 85-189,195. COOKING UP ENGLISH, AUSTIN, TX. FILED 12-2-2010.



NO CLAIM IS MADE TO THE EXCLUSIVE RIGHT TO USE "ENGLISH" FOR INTERNATIONAL CLASS 041, APART FROM THE MARK AS SHOWN.

THE MARK CONSISTS OF THE FOLLOWING: A LARGE POT WITH TWO HANDLES ON EACH SIDE; FOUR CURVY LINES REPRESENTING STEAM RISING ABOVE THE LIQUID IN THE POT; THE WORDING "COOKING UP" IN ALL CAPS AND BOLD FACE FONT AND "ENGLISH" IN SCRIPT FONT BELOW THAT APPEARING ON THE FRONT OF THE POT.

#### CLASS 25—CLOTHING

FOR APRONS (U.S. CLS. 22 AND 39).  
FIRST USE 4-0-2010; IN COMMERCE 7-0-2010.

#### CLASS 41—EDUCATION AND ENTERTAINMENT

FOR EDUCATION SERVICES, NAMELY, PROVIDING MENTORING, TUTORING, CLASSES, SEMINARS AND WORKSHOPS IN THE FIELD OF LANGUAGE INSTRUCTION TAUGHT THROUGH COOKING CLASSES (U.S. CLS. 100, 101 AND 107).

FIRST USE 4-0-2010; IN COMMERCE 7-0-2010.  
SANDRA BUJA, EXAMINING ATTORNEY

SN 85-189,200. INUVO, INC., CLEARWATER, FL. FILED 12-2-2010.



THE MARK CONSISTS OF THE WORDS "BABY TO BEE" APPEARING IN LOWER CASE SCRIPT. A STYLIZED IMAGE OF A BABY SITTING IN A FLOWER APPEARS TO THE LEFT OF THE WORD "BABY" AND A STYLIZED IMAGE OF A BEE WITH A DOTTED LOOP INDICATING FLIGHT APPEARS ABOVE THE WORDS "BABY" AND "TO".

#### CLASS 35—ADVERTISING AND BUSINESS

FOR PROVIDING A SEARCHABLE ONLINE ADVERTISING WEBSITE AND INFORMATIONAL GUIDE FEATURING THE GOODS AND SERVICES OF OTHER VENDORS IN THE FIELD OF PREGNANCY, NEWBORN/INFANT PARENTING, PREGNANT WOMEN, PRE MATERNITY AND POST MATERNITY (U.S. CLS. 100, 101 AND 102).

FIRST USE 10-31-2010; IN COMMERCE 10-31-2010.

#### CLASS 41—EDUCATION AND ENTERTAINMENT

FOR PROVIDING ONLINE PUBLICATIONS IN THE NATURE OF RESOURCE GUIDES FOR PREGNANT WOMEN AND NEW MOMS IN THE FIELD OF PREGNANCY AND NEWBORN/INFANT PARENTING (U.S. CLS. 100, 101 AND 107).

FIRST USE 10-31-2010; IN COMMERCE 10-31-2010.  
JIM RINGLE, EXAMINING ATTORNEY

SN 85-189,324. BRODY, ADRIEN, LAS VEGAS, NV. FILED 12-2-2010.

## EVOL POWER

THE MARK CONSISTS OF STANDARD CHARACTERS WITHOUT CLAIM TO ANY PARTICULAR FONT, STYLE, SIZE, OR COLOR.

#### CLASS 5—PHARMACEUTICALS

FOR NUTRITIONAL ENERGY BARS FOR USE AS A MEAL SUBSTITUTE (U.S. CLS. 6, 18, 44, 46, 51 AND 52).

#### CLASS 30—STAPLE FOODS

FOR CHEWING GUMS; CHEWING GUMS WITH ENERGY BOOSTING NUTRIENTS, NOT FOR MEDICAL PURPOSES; CEREAL BASED ENERGY BOOSTING BARS, NOT FOR USE AS A MEAL SUBSTITUTE (U.S. CL. 46).

#### CLASS 32—LIGHT BEVERAGES

FOR ENERGY DRINKS; SPORTS DRINKS, NAMELY, ENERGY DRINKS; CONCENTRATES, SYRUPS, OR POWDERS USED IN THE PREPARATION OF SPORTS AND ENERGY DRINKS (U.S. CLS. 45, 46 AND 48).  
LINDSEY RUBIN, EXAMINING ATTORNEY

SN 85-189,326. LATIN BUSINESS TODAY, L.L.C., CORTLANDT MANOR, NY. FILED 12-2-2010.

LATIN BUSINESS TODAY  
THE BUSINESS MAGAZINE FOR THE NEXT GENERATION

THE MARK CONSISTS OF STANDARD CHARACTERS WITHOUT CLAIM TO ANY PARTICULAR FONT, STYLE, SIZE, OR COLOR.

NO CLAIM IS MADE TO THE EXCLUSIVE RIGHT TO USE "LATIN BUSINESS", APART FROM THE MARK AS SHOWN.

#### CLASS 16—PAPER GOODS AND PRINTED MATTER

FOR PRINT MAGAZINES IN THE FIELD OF BUSINESS AND FINANCE (U.S. CLS. 2, 5, 22, 23, 29, 37, 38 AND 50).

#### CLASS 41—EDUCATION AND ENTERTAINMENT

FOR PROVIDING ONLINE MAGAZINES IN THE FIELD OF BUSINESS AND FINANCE (U.S. CLS. 100, 101 AND 107).

ODESSA BIBBINS, EXAMINING ATTORNEY

JORDAN BAKER, EXAMINING ATTORNEY

---

 SN 85-189,418. JCW ENTERPRISES, INC., NEW YORK, NY.  
 FILED 12-2-2010.

# TREVOR

---

 SN 85-189,492. CHRISTMAS TREE SHOPS, INC., UNION, NJ.  
 FILED 12-2-2010.

THE MARK CONSISTS OF STANDARD CHARACTERS WITHOUT CLAIM TO ANY PARTICULAR FONT, STYLE, SIZE, OR COLOR.

## CLASS 9—ELECTRICAL AND SCIENTIFIC APPARATUS

FOR VIDEO AND COMPUTER GAME PROGRAMS, INTERACTIVE VIDEO GAME PROGRAMS, INTERACTIVE VIDEO GAMES OF VIRTUAL REALITY COMPRISED OF COMPUTER HARDWARE FOR USE WITH AN EXTERNAL MONITOR AND SOFTWARE, INTERACTIVE MULTIMEDIA COMPUTER GAME PROGRAM (U.S. CLS. 21, 23, 26, 36 AND 38).

## CLASS 41—EDUCATION AND ENTERTAINMENT

FOR PRODUCTION OF DVDS, VIDEOTAPES, TELEVISION PROGRAMS AND MULTIMEDIA PRODUCTION SERVICES ALL FEATURING CARTOON CHARACTERS; PRODUCTION AND DISTRIBUTION OF TELEVISION PROGRAMS FEATURING CARTOON CHARACTERS (U.S. CLS. 100, 101 AND 107).

## CLASS 45—PERSONAL AND LEGAL SERVICES

FOR CARTOON CHARACTER LICENSING (U.S. CLS. 100 AND 101).

CHRISTINA SOBRAL, EXAMINING ATTORNEY

---

 SN 85-189,431. YUMMYEARTH, INC., RIDGEWOOD, NJ.  
 FILED 12-2-2010.

# YUMEARTH

THE MARK CONSISTS OF STANDARD CHARACTERS WITHOUT CLAIM TO ANY PARTICULAR FONT, STYLE, SIZE, OR COLOR.

OWNER OF U.S. REG. NO. 3,206,008.

## CLASS 5—PHARMACEUTICALS

FOR VITAMIN PREPARATIONS; NUTRITIONAL AND DIETARY SUPPLEMENTS (U.S. CLS. 6, 18, 44, 46, 51 AND 52).

FIRST USE 12-2-2010; IN COMMERCE 12-2-2010.

## CLASS 30—STAPLE FOODS

FOR CANDY; VITAMIN-FORTIFIED CANDY; CHOCOLATE CANDIES (U.S. CL. 46).

FIRST USE 12-2-2010; IN COMMERCE 12-2-2010.

# NANTUCKET HOME

THE MARK CONSISTS OF STANDARD CHARACTERS WITHOUT CLAIM TO ANY PARTICULAR FONT, STYLE, SIZE, OR COLOR.

OWNER OF U.S. REG. NO. 2,902,512.

NO CLAIM IS MADE TO THE EXCLUSIVE RIGHT TO USE "HOME", APART FROM THE MARK AS SHOWN.

SEC. 2(F).

## CLASS 11—ENVIRONMENTAL CONTROL APPARATUS

FOR LAMPS (U.S. CLS. 13, 21, 23, 31 AND 34).

FIRST USE 11-1-2002; IN COMMERCE 11-1-2002.

## CLASS 16—PAPER GOODS AND PRINTED MATTER

FOR PHOTO ALBUMS (U.S. CLS. 2, 5, 22, 23, 29, 37, 38 AND 50).

FIRST USE 11-1-2002; IN COMMERCE 11-1-2002.

## CLASS 20—FURNITURE AND ARTICLES NOT OTHERWISE CLASSIFIED

FOR METAL FURNITURE, WOOD FURNITURE, FURNITURE FEATURING METAL AND GLASS, INDOOR FURNITURE, AND PICTURE FRAMES (U.S. CLS. 2, 13, 22, 25, 32 AND 50).

FIRST USE 11-1-2002; IN COMMERCE 11-1-2002.

## CLASS 21—HOUSEWARES AND GLASS

FOR BEVERAGE GLASSWARE, DISHWARE (U.S. CLS. 2, 13, 23, 29, 30, 33, 40 AND 50).

FIRST USE 11-1-2002; IN COMMERCE 11-1-2002.

## CLASS 24—FABRICS

FOR TOWELS (U.S. CLS. 42 AND 50).

FIRST USE 11-1-2002; IN COMMERCE 11-1-2002.

## CLASS 27—FLOOR COVERINGS

FOR RUGS, FLOOR MATS, SCATTER RUGS (U.S. CLS. 19, 20, 37, 42 AND 50).

FIRST USE 11-1-2002; IN COMMERCE 11-1-2002.

ALYSSA STEEL, EXAMINING ATTORNEY

SN 85-189,590. EDDY'S INTERNATIONAL TRADING INC.,  
CHINO, CA. FILED 12-2-2010.



THE MARK CONSISTS OF THE STYLIZED LETTERING "E" AND "S", OUTLINED, INSIDE OF AN OVAL WITH A 3 DIMENSIONAL APPEARANCE.

#### CLASS 4—LUBRICANTS AND FUELS

FOR BUTANE GAS CARTRIDGES SOLD FILLED (U.S. CLS. 1, 6 AND 15).  
FIRST USE 7-5-2007; IN COMMERCE 7-5-2007.

#### CLASS 11—ENVIRONMENTAL CONTROL APPARATUS

FOR ELECTRIC COOKING POTS, ELECTRIC WOKS, ELECTRIC RICE STEAMER, ELECTRIC FOOD STEAMER, ELECTRIC COOKING STOVES, ELECTRIC SLOW COOKERS, ELECTRIC HOT POTS IN THE NATURE OF ELECTRIC COOKING POTS (U.S. CLS. 13, 21, 23, 31 AND 34).

FIRST USE 7-5-2007; IN COMMERCE 7-5-2007.

#### CLASS 21—HOUSEWARES AND GLASS

FOR HOUSEHOLD UTENSILS, NAMELY, POTS AND PANS, POT AND PAN SCRAPERS, FRYING PANS, KITCHEN LADLE, ROLLING PINS, SPATULAS, TURNERS, WHISKS, CHOPSTICKS, CHOPSTICK CASES AND RESTS, BAKING DISHES, PLATES, BOWLS, NON-ELECTRIC WOKS, MIXING BOWLS, NON-ELECTRIC COOKING STEAMERS, CUTTING BOARDS, LUNCH-BOXES, SUSHI ROLLING MATS, TOOTHPICKS, CLEANING SPONGES, STEEL WOOL, STAINLESS STEEL SCRUBBING BRUSHES AND PADS, NYLON SCRUBBING PAD, KETTLES (U.S. CLS. 2, 13, 23, 29, 30, 33, 40 AND 50).

FIRST USE 7-5-2007; IN COMMERCE 7-5-2007.

ANDREA K. NADELMAN, EXAMINING ATTORNEY

SN 85-189,606. HOMECLICK LLC, EDISON, NJ. FILED 12-2-2010.

# Hechinger

THE MARK CONSISTS OF STANDARD CHARACTERS WITHOUT CLAIM TO ANY PARTICULAR FONT, STYLE, SIZE, OR COLOR.

OWNER OF U.S. REG. NO. 3,334,925.  
SEC. 2(F).

#### CLASS 7—MACHINERY

FOR POWER-OPERATED SAWS AND POWER SAW BLADES; HOUSEHOLD APPLIANCES, NAMELY, CLOTHES WASHING MACHINES, TRASH COMPACTORS AND DISH WASHING MACHINES (U.S. CLS. 13, 19, 21, 23, 31, 34 AND 35).

#### CLASS 11—ENVIRONMENTAL CONTROL APPARATUS

FOR ELECTRIC FANS AND VENTILATION FAN ACCESSORIES, NAMELY, GRILLES; BATHROOM AND SHOWER FIXTURES, ACCESSORIES AND CONTROLS, NAMELY, TOILETS, BATHTUBS, SHOWERS, SINKS, SINK PEDESTALS, SHOWER SPRAYERS, SHOWER MIXERS, TUB CONTROL VALVES, SHOWER CONTROL VALVES AND TOILET FLUSH CONTROL VALVES; SANITARY PIPES AND JOINTS FOR SANITARY PIPES, NAMELY, PIPES BEING PARTS OF SANITARY FACILITIES AND FLEXIBLE PIPES BEING PARTS OF BASIN, BATH, SHOWER AND SINK PLUMBING INSTALLATIONS; DRAIN SIPHONS; LIGHTING FIXTURES AND HOUSEHOLD APPLIANCES AND PARTS AND FITTINGS FOR THE AFORESAID APPLIANCES, NAMELY, REFRIGERATORS, FREEZERS, COOKING OVENS, MICROWAVE OVENS, GAS RANGES, ELECTRIC RANGES AND CLOTHES DRYERS (U.S. CLS. 13, 21, 23, 31 AND 34).

SAMUEL E. SHARPER JR., EXAMINING ATTORNEY

SN 85-189,644. HOMECLICK LLC, EDISON, NJ. FILED 12-2-2010.

# YARDSTAR

THE MARK CONSISTS OF STANDARD CHARACTERS WITHOUT CLAIM TO ANY PARTICULAR FONT, STYLE, SIZE, OR COLOR.

#### CLASS 7—MACHINERY

FOR ELECTRICAL WATER PUMPS FOR SWIMMING POOLS, SPAS, BATHS, AND WHIRLPOOLS; SWIMMING POOL SWEEPERS; LAWN AND GARDEN STRING TRIMMER SPOOLS; LAWN MOWERS, ELECTRIC LAWN TRIMMERS, POWER-OPERATED LAWN AND GARDEN STRING TRIMMERS; MECHANICAL SPREADERS FOR SEED AND DRY LAWN CHEMICALS; POWER BLOWERS FOR LAWN DEBRIS; POWER LAWN AND GARDEN TOOLS, NAMELY, CHIPPERS, SHREDDERS, CULTIVATORS, TILLERS, LAWN AND GARDEN EDGERS AND AERATORS (U.S. CLS. 13, 19, 21, 23, 31, 34 AND 35).

**CLASS 11—ENVIRONMENTAL CONTROL APPARATUS**

FOR REFRIGERATORS; SWIMMING POOL DRAIN COVERS; OUTDOOR ELECTRIC LIGHTING FIXTURES, LIGHTING ACCESSORIES, NAMELY, LANTERNS, REPLACEMENT ELECTRIC BULBS AND LIGHTING TUBES; LAWN SPRINKLER SYSTEMS COMPRISING PUMPS, VALVES AND FILTERS; DECORATIVE AND ORNAMENTAL WATER FOUNTAINS, DRINKING FOUNTAINS, FAUCETS; BARBECUES, BARBECUE SMOKERS AND BARBECUE GRILLS; CERAMIC BRIQUETTES AND LAVA ROCKS FOR USE IN BARBECUES, BARBECUE SMOKERS AND BARBECUE GRILLS; BARBECUE GRILL ACCESSORIES, NAMELY, COOKING GRATES, GRILL COVERS, WARMING TRAYS, LIGHTERS PRIMARILY FOR LIGHTING GRILLS AND TABLES DESIGNED TO HOLD GAS GRILLS; SPAS IN THE NATURE OF HEATED POOLS; SWIMMING POOL WATER CLEANING, FILTERING, HEATING AND CHLORINATING UNITS; ACCESSORIES FOR FIREPLACES, NAMELY, HOT AIR BLOWERS AND VENTILATION HOODS; DECORATIVE GRILLS MADE OF NON-METAL NON-COMBUSTIBLE MATERIALS FOR USE IN DECORATING EVACUATION DUCTS, AIR INLETS, AND HOT AIR OUTLETS OF FIREPLACES; FIREPLACE INSERTS IN THE NATURE OF HEAT EXCHANGERS, FIREPLACE HEARTHS, FIREPLACE DAMPERS, ANDIRONS, ARTIFICIAL LOGS AND ARTIFICIAL EMBERS POWERED BY GAS OR ELECTRICITY; FIREPLACES; ELECTRIC AND GAS PATIO HEATERS (U.S. CLS. 13, 21, 23, 31 AND 34).

SAMUEL E. SHARPER JR., EXAMINING ATTORNEY

SN 85-189,646. ARSA DISTRIBUTING, INC., EL PASO, TX. FILED 12-2-2010.

# Mamá Elvira

THE MARK CONSISTS OF STANDARD CHARACTERS WITHOUT CLAIM TO ANY PARTICULAR FONT, STYLE, SIZE, OR COLOR.

THE NAME "MAMÁ ELVIRA" DOES NOT IDENTIFY A LIVING INDIVIDUAL.

**CLASS 29—MEATS AND PROCESSED FOODS**

FOR CHILE CON QUESO; CHILE VERDE; GUACA-MOLE; REFRIED BEANS (U.S. CL. 46).

FIRST USE 10-1-2010; IN COMMERCE 12-1-2010.

**CLASS 30—STAPLE FOODS**

FOR CHILI SAUCE (U.S. CL. 46).

FIRST USE 10-1-2010; IN COMMERCE 12-1-2010.

SAMUEL E. SHARPER JR., EXAMINING ATTORNEY

SN 85-189,672. STONERIVER, INC., BROOKFIELD, WI. FILED 12-2-2010.

# P2P LINK

THE MARK CONSISTS OF STANDARD CHARACTERS WITHOUT CLAIM TO ANY PARTICULAR FONT, STYLE, SIZE, OR COLOR.

OWNER OF U.S. REG. NOS. 2,905,546 AND 3,017,764.

**CLASS 9—ELECTRICAL AND SCIENTIFIC APPARATUS**

FOR SOFTWARE FOR PROCESSING OF MEDICAL BILLS AND WORKERS' COMPENSATION CLAIMS (U.S. CLS. 21, 23, 26, 36 AND 38).

FIRST USE 3-15-2002; IN COMMERCE 3-15-2002.

**CLASS 35—ADVERTISING AND BUSINESS**

FOR BUSINESS CONSULTATION SERVICES (U.S. CLS. 100, 101 AND 102).

FIRST USE 3-15-2002; IN COMMERCE 3-15-2002.

**CLASS 42—SCIENTIFIC AND COMPUTER SERVICES**

FOR SOFTWARE AS A SERVICE (SAAS) SERVICES, NAMELY, HOSTING SOFTWARE FOR USE BY OTHERS FOR PROCESSING OF MEDICAL BILLS AND WORKERS' COMPENSATION CLAIMS (U.S. CLS. 100 AND 101).

FIRST USE 3-15-2002; IN COMMERCE 3-15-2002.

KAELIE KUNG, EXAMINING ATTORNEY

SN 85-189,708. STOCKPILE, INC., PALO ALTO, CA. FILED 12-2-2010.

# STOCKPILE

THE MARK CONSISTS OF STANDARD CHARACTERS WITHOUT CLAIM TO ANY PARTICULAR FONT, STYLE, SIZE, OR COLOR.

**CLASS 35—ADVERTISING AND BUSINESS**

FOR PROMOTIONAL SERVICES, NAMELY, PROMOTING THE GOODS AND SERVICES OF OTHERS BY MEANS OF PROVIDING STOCKS, BONDS, SECURITIES AND EQUITIES; ADMINISTRATION OF CUSTOMER LOYALTY AND REWARDS PROGRAMS TO PROMOTE GOODS AND SERVICES OF OTHERS; ADMINISTERING COUPONS, REBATES AND VOUCHERS PROMOTING THE GOODS AND SERVICES OF OTHERS; ADVERTISING SERVICES FOR PROMOTING THE BROKERAGE OF STOCKS, BONDS, SECURITIES AND EQUITIES; RECORDING AND REGISTERING THE TRANSFER OF STOCKS, BONDS, SECURITIES AND EQUITIES; COMPILING FINANCIAL, SECURITIES, STOCK EXCHANGE, TRADE AND QUOTE, INDEX VALUE AND OTHER FINANCIAL MARKET INFORMATION FOR BUSINESS PURPOSES; ISSUANCE AND MANAGEMENT OF GIFT CARDS AND GIFT CERTIFICATES EXCHANGEABLE FOR AND BACKED BY STOCKS, BONDS AND SECURITIES AND EQUITIES (U.S. CLS. 100, 101 AND 102).

**CLASS 36—INSURANCE AND FINANCIAL**

FOR BROKERAGE SERVICES FOR STOCKS, BONDS, SECURITIES AND EQUITIES; FINANCIAL SERVICES, NAMELY, ASSISTING OTHERS WITH THE COMPLETION OF FINANCIAL TRANSACTIONS FOR STOCKS, BONDS, SECURITIES AND EQUITIES; PROVIDING INFORMATION IN THE FIELD OF FINANCIAL STOCK AND EQUITY MARKETS (U.S. CLS. 100, 101 AND 102).

MARGERY A. TIERNEY, EXAMINING ATTORNEY

SN 85-189,712. TETRADIGM GROUP, LLC, ALEXANDRIA, VA. FILED 12-2-2010.

## TETRADIGM GROUP

THE MARK CONSISTS OF STANDARD CHARACTERS WITHOUT CLAIM TO ANY PARTICULAR FONT, STYLE, SIZE, OR COLOR.

NO CLAIM IS MADE TO THE EXCLUSIVE RIGHT TO USE "GROUP", APART FROM THE MARK AS SHOWN.

### CLASS 35—ADVERTISING AND BUSINESS

FOR BUSINESS DEVELOPMENT SERVICES, NAMELY, PROVIDING START-UP SUPPORT FOR BUSINESSES OF OTHERS; BUSINESS ORGANIZATION CONSULTANCY; BUSINESS CONSULTING AND INFORMATION SERVICES; PROMOTION OF BUSINESS OPPORTUNITIES; PROMOTION AND MARKETING SERVICES AND RELATED CONSULTANCY (U.S. CLS. 100, 101 AND 102).

FIRST USE 6-3-2010; IN COMMERCE 6-3-2010.

### CLASS 36—INSURANCE AND FINANCIAL

FOR VENTURE CAPITAL ADVISORY SERVICES TO EMERGING AND START-UP COMPANIES; VENTURE CAPITAL FUNDING FOR THE DEVELOPMENT OF INTELLECTUAL PROPERTY; VENTURE CAPITAL FUNDING FOR SALES AND LICENSING OF INTELLECTUAL PROPERTY, AND MANAGEMENT OF COMPANIES FUNDED BY VENTURE CAPITAL (U.S. CLS. 100, 101 AND 102).

FIRST USE 6-3-2010; IN COMMERCE 6-3-2010.  
LANA PHAM, EXAMINING ATTORNEY

SN 85-189,721. TETRADIGM GROUP, LLC, ALEXANDRIA, VA. FILED 12-2-2010.



NO CLAIM IS MADE TO THE EXCLUSIVE RIGHT TO USE "GROUP", APART FROM THE MARK AS SHOWN.

THE COLOR(S) BLUE AND GRAY IS/ARE CLAIMED AS A FEATURE OF THE MARK.

THE MARK CONSISTS OF THE FOLLOWING: 3 BLUE TRIANGLES AND 1 GRAY TRIANGLE FORMING THE APPEARANCE OF ONE SINGLE TRIANGLE FOLLOWED BY THE BLUE STYLIZED WORD, "TETRADIGM" AND THE GRAY STYLIZED WORD, "GROUP".

### CLASS 35—ADVERTISING AND BUSINESS

FOR BUSINESS DEVELOPMENT SERVICES, NAMELY, PROVIDING START-UP SUPPORT FOR BUSINESSES OF OTHERS; BUSINESS ORGANIZATION CONSULTANCY; BUSINESS CONSULTING AND INFORMATION SERVICES; PROMOTION OF BUSINESS OPPORTUNITIES; PROMOTION AND MARKETING SERVICES AND RELATED CONSULTANCY (U.S. CLS. 100, 101 AND 102).

FIRST USE 6-3-2010; IN COMMERCE 6-3-2010.

### CLASS 36—INSURANCE AND FINANCIAL

FOR VENTURE CAPITAL ADVISORY SERVICES TO EMERGING AND START-UP COMPANIES; VENTURE CAPITAL FUNDING FOR THE DEVELOPMENT OF INTELLECTUAL PROPERTY; VENTURE CAPITAL FUNDING FOR SALES AND LICENSING OF INTELLECTUAL PROPERTY, AND MANAGEMENT OF COMPANIES FUNDED BY VENTURE CAPITAL (U.S. CLS. 100, 101 AND 102).

FIRST USE 6-3-2010; IN COMMERCE 6-3-2010.  
LANA PHAM, EXAMINING ATTORNEY

SN 85-189,790. DAVIDSON OF DUNDEE, DUNDEE, FL. FILED 12-2-2010.



NO CLAIM IS MADE TO THE EXCLUSIVE RIGHT TO USE "DUNDEE" AND "DUNDEE, FLORIDA 33838", APART FROM THE MARK AS SHOWN.

THE MARK CONSISTS OF A CIRCULAR BACKGROUND WITH A FRUIT DESIGN AT THE CENTER, THE TEXT "DAVIDSON OF DUNDEE" ABOVE, AND "DUNDEE, FLORIDA 33838" BELOW THE DESIGN.

### CLASS 29—MEATS AND PROCESSED FOODS

FOR MARMALADES; JELLIES (U.S. CL. 46).  
FIRST USE 1-1-1967; IN COMMERCE 1-1-1967.

### CLASS 30—STAPLE FOODS

FOR CANDY; FRUIT JELLIES; CHOCOLATE (U.S. CL. 46).  
FIRST USE 1-1-1967; IN COMMERCE 1-1-1967.  
SANDRA BUJA, EXAMINING ATTORNEY

SN 85-189,846. SOCIETY OF ROSICRUCIANS AND SOCIETAS ROSICRUCIANA IN AMERICA, INC., ELFERS, FL. FILED 12-2-2010.

## SOCIETAS ROSICRUCIANA IN AMERICA

THE MARK CONSISTS OF STANDARD CHARACTERS WITHOUT CLAIM TO ANY PARTICULAR FONT, STYLE, SIZE, OR COLOR.

NO CLAIM IS MADE TO THE EXCLUSIVE RIGHT TO USE "SOCIETAS ROSICRUCIANA", APART FROM THE MARK AS SHOWN.

THE ENGLISH TRANSLATION OF "SOCIETAS ROSICRUCIANA" IN THE MARK IS SOCIETY OF ROSICRUCIANS.

SEC. 2(F).

**CLASS 16—PAPER GOODS AND PRINTED MATTER**

FOR PRINTED TEACHING MATERIALS IN THE FIELD OF ROSICRUCIAN PHILOSOPHY (U.S. CLS. 2, 5, 22, 23, 29, 37, 38 AND 50).  
FIRST USE 9-16-1912; IN COMMERCE 9-16-1912.

**CLASS 41—EDUCATION AND ENTERTAINMENT**

FOR EDUCATIONAL SERVICES, NAMELY, CONDUCTING CLASSES AND WORKSHOPS IN THE FIELD OF ROSICRUCIAN PHILOSOPHY AND DISTRIBUTION OF COURSE MATERIAL IN CONNECTION THEREWITH (U.S. CLS. 100, 101 AND 107).  
FIRST USE 9-16-1912; IN COMMERCE 9-16-1912.  
MAYUR VAGHANI, EXAMINING ATTORNEY

**CLASS 37—CONSTRUCTION AND REPAIR**

FOR INSTALLATION AND MAINTENANCE OF SOLAR PHOTOVOLTAIC INSTALLATIONS FOR RESIDENTIAL AND COMMERCIAL USE (U.S. CLS. 100, 103 AND 106).  
FIRST USE 10-31-2009; IN COMMERCE 10-31-2009.

**CLASS 42—SCIENTIFIC AND COMPUTER SERVICES**

FOR DESIGN OF SOLAR PHOTOVOLTAIC SYSTEMS; QUALITY EVALUATION FOR OTHERS IN THE FIELD OF MAINTENANCE, REPAIR AND INSTALLATION OF SOLAR AND PHOTOVOLTAIC INSTALLATIONS; TECHNICAL PLANNING OF SOLAR PHOTOVOLTAIC INSTALLATIONS (U.S. CLS. 100 AND 101).  
FIRST USE 10-31-2009; IN COMMERCE 10-31-2009.  
IRA J. GOODSaid, EXAMINING ATTORNEY

SN 85-189,898. HUSSAIN, IMRAN, LEEDS, UNITED KINGDOM, AND HUSSAIN, RIZWANA, LEEDS, UNITED KINGDOM, AND HUSSAIN, MAARIAH, LEEDS, UNITED KINGDOM, AND HUSSAIN, DANYAAL, LEEDS, UNITED KINGDOM, AND HUSSAIN, ZAHRA, LEEDS, UNITED KINGDOM, FILED 12-3-2010.

SN 85-190,031. MAIO CONSULTING, LLC, HOUSTON, TX. FILED 12-3-2010.



The logo for 'U-Stick' features a stylized 'U' inside a circle, followed by the word 'Stick' in a bold, sans-serif font.

MAIO CONSULTING

**CLASS 1—CHEMICALS**

FOR ADHESIVES AND GLUES FOR INDUSTRIAL AND COMMERCIAL USE (U.S. CLS. 1, 5, 6, 10, 26 AND 46).

**CLASS 16—PAPER GOODS AND PRINTED MATTER**

FOR GLUE FOR STATIONERY OR HOUSEHOLD PURPOSES (U.S. CLS. 2, 5, 22, 23, 29, 37, 38 AND 50).  
JIM RINGLE, EXAMINING ATTORNEY

THE MARK CONSISTS OF STANDARD CHARACTERS WITHOUT CLAIM TO ANY PARTICULAR FONT, STYLE, SIZE, OR COLOR.

OWNER OF U.S. REG. NO. 3,030,905.  
NO CLAIM IS MADE TO THE EXCLUSIVE RIGHT TO USE "CONSULTING", APART FROM THE MARK AS SHOWN.

SEC. 2(F).

**CLASS 35—ADVERTISING AND BUSINESS**

FOR BUSINESS CONSULTING SERVICES IN THE FIELD OF CONFIGURATION, DEVELOPMENT, DESIGN, SELECTION, IMPLEMENTATION, INTEGRATION, MAINTENANCE AND USE OF COMPUTER HARDWARE AND SOFTWARE SYSTEMS FOR OTHERS; BUSINESS CONSULTING SERVICES IN THE FIELD OF COMPUTER PROGRAMMING FOR OTHERS (U.S. CLS. 100, 101 AND 102).  
FIRST USE 1-1-2005; IN COMMERCE 1-1-2005.

**CLASS 42—SCIENTIFIC AND COMPUTER SERVICES**

FOR TECHNICAL CONSULTING SERVICES IN THE FIELD OF CONFIGURATION, DEVELOPMENT, DESIGN, SELECTION, IMPLEMENTATION, INTEGRATION, MAINTENANCE AND USE OF COMPUTER HARDWARE AND SOFTWARE SYSTEMS FOR OTHERS; TECHNICAL CONSULTING SERVICES IN THE FIELD OF COMPUTER PROGRAMMING FOR OTHERS (U.S. CLS. 100 AND 101).  
FIRST USE 1-1-2005; IN COMMERCE 1-1-2005.  
SALLY SHIH, EXAMINING ATTORNEY

SN 85-189,978. SYBAC SOLAR LLC, LAKELAND, FL, FL. FILED 12-3-2010.

SYBAC SOLAR

THE MARK CONSISTS OF STANDARD CHARACTERS WITHOUT CLAIM TO ANY PARTICULAR FONT, STYLE, SIZE, OR COLOR.

NO CLAIM IS MADE TO THE EXCLUSIVE RIGHT TO USE "SOLAR", APART FROM THE MARK AS SHOWN.

SN 85-190,179. TRAX TECHNOLOGIES, INC., SCOTTSDALE, AZ. FILED 12-3-2010.

SN 85-190,290. 217 ATLANTIC LLC, DELRAY BEACH, FL. FILED 12-3-2010.

## EMPOWER TRUST.

THE MARK CONSISTS OF STANDARD CHARACTERS WITHOUT CLAIM TO ANY PARTICULAR FONT, STYLE, SIZE, OR COLOR.

### CLASS 35—ADVERTISING AND BUSINESS

FOR ACCOUNT AUDITING; ACCOUNTS RECEIVABLE SERVICES (U.S. CLS. 100, 101 AND 102).  
FIRST USE 11-8-2010; IN COMMERCE 11-8-2010.

### CLASS 36—INSURANCE AND FINANCIAL

FOR ACCOUNTS RECEIVABLES FINANCING; BILL PAYMENT SERVICES (U.S. CLS. 100, 101 AND 102).  
FIRST USE 11-8-2010; IN COMMERCE 11-8-2010.

### CLASS 42—SCIENTIFIC AND COMPUTER SERVICES

FOR FILE SHARING SERVICES, NAMELY, PROVIDING A WEBSITE FEATURING TECHNOLOGY ENABLING USERS TO UPLOAD AND DOWNLOAD ELECTRONIC FILES; SOFTWARE AS A SERVICE (SAAS) SERVICES FEATURING SOFTWARE FOR FREIGHT AUDIT, PAYMENT, COST ALLOCATION, ACCOUNTS RECEIVABLE AND PAYABLE MANAGEMENT, AND TRANSPORTATION SPEND MANAGEMENT; SOFTWARE AS A SERVICE (SAAS) SERVICES, NAMELY, HOSTING SOFTWARE FOR USE BY OTHERS FOR FREIGHT AUDIT, PAYMENT, COST ALLOCATION, ACCOUNTS RECEIVABLE AND PAYABLE MANAGEMENT, AND TRANSPORTATION SPEND MANAGEMENT (U.S. CLS. 100 AND 101).

FIRST USE 11-8-2010; IN COMMERCE 11-8-2010.  
RONALD MCMORROW, EXAMINING ATTORNEY

SN 85-190,189. DIVILIO, JAMES, SAINT JAMES, NY. FILED 12-3-2010.

## CABO FRESH

THE MARK CONSISTS OF STANDARD CHARACTERS WITHOUT CLAIM TO ANY PARTICULAR FONT, STYLE, SIZE, OR COLOR.

NO CLAIM IS MADE TO THE EXCLUSIVE RIGHT TO USE "FRESH", APART FROM THE MARK AS SHOWN.

THE ENGLISH TRANSLATION OF "CABO" IN THE MARK IS CAPE.

### CLASS 30—STAPLE FOODS

FOR GUACAMOLE, SALSA (U.S. CL. 46).

### CLASS 43—HOTEL AND RESTAURANT SERVICES

FOR RESTAURANT AND BAR SERVICES; TAKE-OUT RESTAURANT SERVICES (U.S. CLS. 100 AND 101).  
JILL PRATER, EXAMINING ATTORNEY

## AMG Restaurants

THE MARK CONSISTS OF STANDARD CHARACTERS WITHOUT CLAIM TO ANY PARTICULAR FONT, STYLE, SIZE, OR COLOR.

NO CLAIM IS MADE TO THE EXCLUSIVE RIGHT TO USE "RESTAURANTS", APART FROM THE MARK AS SHOWN.

### CLASS 35—ADVERTISING AND BUSINESS

FOR OFFERING BUSINESS MANAGEMENT ASSISTANCE IN THE ESTABLISHMENT AND/OR OPERATION OF RESTAURANTS (U.S. CLS. 100, 101 AND 102).  
FIRST USE 11-1-2010; IN COMMERCE 11-1-2010.

### CLASS 43—HOTEL AND RESTAURANT SERVICES

FOR BAR AND RESTAURANT SERVICES (U.S. CLS. 100 AND 101).  
FIRST USE 11-1-2010; IN COMMERCE 11-1-2010.  
KIM MONINGHOFF, EXAMINING ATTORNEY

SN 85-190,305. WILSON, PAMELA D., GOLDEN, CO. FILED 12-3-2010.



**Precious Cargo**

*Transition specialists for  
your life • your treasures • your home*

NO CLAIM IS MADE TO THE EXCLUSIVE RIGHT TO USE "CARGO" FOR CLASS 35, APART FROM THE MARK AS SHOWN.

THE COLOR GRAY IS FOR SHADING PURPOSE ONLY.

THE MARK CONSISTS OF A HAND HOLDING THREE HEARTS ALL INSIDE A SQUARE. CENTERED BELOW THE DESIGN IS THE WORDING "PRECIOUS CARGO" AND CENTERED BELOW THAT WORDING IS "TRANSITION SPECIALISTS FOR YOUR LIFE YOUR TREASURES YOUR HOME" WITH A LEAF DESIGN FOLLOWING THE WORDS "LIFE" AND "TREASURES." THE COLOR GRAY IS ONLY USED FOR SHADING PURPOSES.

### CLASS 35—ADVERTISING AND BUSINESS

FOR MOVING AND RELOCATION SERVICES, NAMELY, PLANNING AND IMPLEMENTING MOVES OF HOMES FOR OTHERS (U.S. CLS. 100, 101 AND 102).  
FIRST USE 11-18-2010; IN COMMERCE 11-18-2010.

### CLASS 36—INSURANCE AND FINANCIAL

FOR REAL ESTATE LISTING (U.S. CLS. 100, 101 AND 102).  
FIRST USE 11-18-2010; IN COMMERCE 11-18-2010.

**CLASS 41—EDUCATION AND ENTERTAINMENT**

FOR EDUCATION SERVICES, NAMELY, PROVIDING CLASSES, SEMINARS, AND WORKSHOPS IN THE FIELDS OF MEDICAL, PSYCHOLOGICAL, LEGAL, AND FINANCIAL ISSUES FACING ADULT CHILDREN AND THEIR AGING PARENTS REGARDING PHYSICAL RELOCATION, AND DISTRIBUTING COURSE MATERIALS IN CONNECTION THEREWITH (U.S. CLS. 100, 101 AND 107).

FIRST USE 11-18-2010; IN COMMERCE 11-18-2010.  
DOMINICK J. SALEMI, EXAMINING ATTORNEY

SN 85-190,310. ADIDAS AG, HERZOGENAURACH 91074, FED REP GERMANY, FILED 12-3-2010.



SN 85-190,307. LA COCINA, INC., SAN FRANCISCO, CA. FILED 12-3-2010.



NO CLAIM IS MADE TO THE EXCLUSIVE RIGHT TO USE "STREET FOOD" FOR INTERNATIONAL CLASS 41, APART FROM THE MARK AS SHOWN.

THE MARK CONSISTS OF THE WORD "I", FOLLOWED BY A SIDE IMAGE OF A FOOD VENDING CART WITH A WHEEL IN THE REAR OF THE CART, A SUPPORT LEG IN THE FRONT OF THE CART AND AN OPEN UMBRELLA ON A LONG POLE RISING OUT OF THE FRONT SECTION OF THE CART, FOLLOWED BY THE WORDS "STREET FOOD".

**CLASS 25—CLOTHING**

FOR CLOTHING, NAMELY, SHIRTS, T-SHIRTS, HATS, JACKETS AND SWEATSHIRTS (U.S. CLS. 22 AND 39).

FIRST USE 8-22-2009; IN COMMERCE 8-22-2009.

**CLASS 41—EDUCATION AND ENTERTAINMENT**

FOR ENTERTAINMENT AND EDUCATION, NAMELY, FESTIVALS, CONFERENCES, PHOTO CONTESTS AND SCAVENGER HUNTS IN THE FIELDS OF FOOD AND COOKING (U.S. CLS. 100, 101 AND 107).

FIRST USE 8-22-2009; IN COMMERCE 8-22-2009.  
MARK PILARO, EXAMINING ATTORNEY

OWNER OF U.S. REG. NOS. 891,222, 1,253,013 AND 3,686,084.

THE MARK CONSISTS OF THE STYLIZED WORD "ADIDAS".

**CLASS 35—ADVERTISING AND BUSINESS**

FOR PROMOTIONAL SPONSORSHIP OF SPORTS AND ATHLETIC COMPETITIONS, TOURNAMENTS, EXHIBITIONS, EVENTS, ATHLETIC PROGRAMS AND ACTIVITIES (U.S. CLS. 100, 101 AND 102).

FIRST USE 4-19-1989; IN COMMERCE 4-19-1989.

**CLASS 41—EDUCATION AND ENTERTAINMENT**

FOR ORGANIZING AND CONDUCTING SPORTS AND ATHLETIC COMPETITIONS, TOURNAMENTS, EXHIBITIONS AND EVENTS; ATHLETIC TRAINING SERVICES (U.S. CLS. 100, 101 AND 107).

FIRST USE 4-19-1989; IN COMMERCE 4-19-1989.  
JULIE GUTTADAURO, EXAMINING ATTORNEY

SN 85-190,499. YOUNG ADULT INSTITUTE, INC., NEW YORK, NY. FILED 12-3-2010.

**REDEFINING ABILITIES**

THE MARK CONSISTS OF STANDARD CHARACTERS WITHOUT CLAIM TO ANY PARTICULAR FONT, STYLE, SIZE, OR COLOR.

**CLASS 35—ADVERTISING AND BUSINESS**

FOR EMPLOYMENT COUNSELING, EMPLOYMENT PLACEMENT, AND PERSONNEL MANAGEMENT, NAMELY, ON-SITE JOB COACHING AND SUPERVISION, ALL FOR DEVELOPMENTALLY DISABLED PERSONS (U.S. CLS. 100, 101 AND 102).



**CLASS 41—EDUCATION AND ENTERTAINMENT**

FOR EDUCATIONAL SERVICES, NAMELY, CONDUCTING CLASSES, SEMINARS, CONFERENCES AND WORKSHOPS IN THE FIELD OF INTERPERSONAL SKILLS AND PROPER WORKPLACE BEHAVIOR FOR DEVELOPMENTALLY DISABLED PERSONS; ARRANGING AND ORGANIZING EDUCATIONAL PROGRAMS AND ACTIVITIES IN THE FIELD OF CAMPING, ARTS AND CRAFTS, THEATER PARTIES AND SPORTING EVENTS FOR DEVELOPMENTALLY DISABLED INDIVIDUALS AND THEIR FAMILIES; CAREER COUNSELING FOR DEVELOPMENTALLY DISABLED INDIVIDUALS AND THEIR FAMILIES (U.S. CLS. 100, 101 AND 107).

**CLASS 44—MEDICAL, BEAUTY AND AGRICULTURAL SERVICES**

FOR MEDICAL AND PSYCHOLOGICAL COUNSELING FOR DEVELOPMENTALLY DISABLED INDIVIDUALS AND THEIR FAMILIES; MEDICAL SERVICES FOR DEVELOPMENTALLY DISABLED INDIVIDUALS (U.S. CLS. 100 AND 101).

AMEEN IMAM, EXAMINING ATTORNEY

SN 85-190,521. STELLAR BILLING, LLC, CHOKIO, MN. FILED 12-3-2010.

**SOURCEONE SOLUTIONS**

THE MARK CONSISTS OF STANDARD CHARACTERS WITHOUT CLAIM TO ANY PARTICULAR FONT, STYLE, SIZE, OR COLOR.

**CLASS 35—ADVERTISING AND BUSINESS**

FOR PROVIDING BILLING SERVICES FOR TELECOMMUNICATIONS COMPANIES (U.S. CLS. 100, 101 AND 102).

**CLASS 42—SCIENTIFIC AND COMPUTER SERVICES**

FOR PROVIDING ONLINE USE OF NON-DOWNLOADABLE SOFTWARE FOR USE IN BILLING FOR TELECOMMUNICATIONS SERVICES (U.S. CLS. 100 AND 101).

RONALD AIKENS, EXAMINING ATTORNEY

SN 85-190,532. KOLE, TED, WANTAGH, NY. FILED 12-3-2010.

**IRONWORKS**

THE MARK CONSISTS OF STANDARD CHARACTERS WITHOUT CLAIM TO ANY PARTICULAR FONT, STYLE, SIZE, OR COLOR.

**CLASS 22—CORDAGE AND FIBERS**

FOR CLOTH, NYLON AND/OR POLYESTER BAGS FOR STORAGE OF DAMP OR WET CLOTHING (U.S. CLS. 1, 2, 7, 19, 22, 42 AND 50).

FIRST USE 10-27-2010; IN COMMERCE 11-5-2010.

**CLASS 25—CLOTHING**

FOR CLOTHING, NAMELY, T-SHIRTS, SWEATSHIRTS, FOOTWEAR, HEADGEAR, NAMELY, HATS AND CAPS, SHORTS, CAPRI LEGGINGS, LEGGINGS, SWEAT PANTS, YOGA PANTS (U.S. CLS. 22 AND 39).

FIRST USE 10-27-2010; IN COMMERCE 11-5-2010.  
EDWARD FENNESSY, EXAMINING ATTORNEY

SN 85-190,906. PINSCHER LLC, MIAMI, FL. FILED 12-5-2010.



THE MARK CONSISTS OF A STYLIZED "N" INSIDE AN "O" ON A SOLID SQUARE BACKGROUND.

**CLASS 9—ELECTRICAL AND SCIENTIFIC APPARATUS**

FOR PRE-RECORDED CDS FEATURING MUSIC; PRE-RECORDED DIGITAL MEDIA FEATURING MUSIC (U.S. CLS. 21, 23, 26, 36 AND 38).

**CLASS 35—ADVERTISING AND BUSINESS**

FOR COMMERCIAL ADMINISTRATION OF THE LICENSING OF MUSICAL RECORDINGS OF OTHERS; ON-LINE RETAIL STORE SERVICES FEATURING DOWNLOADABLE PRE-RECORDED MUSIC AND VIDEO (U.S. CLS. 100, 101 AND 102).

**CLASS 41—EDUCATION AND ENTERTAINMENT**

FOR ENTERTAINMENT SERVICES IN THE NATURE OF RECORDING, PRODUCTION AND POST-PRODUCTION SERVICES IN THE FIELD OF MUSIC (U.S. CLS. 100, 101 AND 107).

SANDRA BUJA, EXAMINING ATTORNEY

SN 85-190,976. NORMAN LOVE CONFECTIONS, INC., FORT MYERS, FL. FILED 12-6-2010.

SN 85-191,287. PARRA, ANTHONY, WHITESTONE, NY. FILED 12-6-2010.



OWNER OF U.S. REG. NO. 3,081,905.  
THE COLOR(S) BROWN AND GREEN IS/ARE CLAIMED AS A FEATURE OF THE MARK.  
THE MARK CONSISTS OF A STYLIZED LETTER "N" IN THE COLOR BROWN, OVER A STYLIZED LETTER "L" IN THE COLOR GREEN.

#### CLASS 30—STAPLE FOODS

FOR CANDIES AND CHOCOLATES; HAND-CRAFTED CANDY AND CHOCOLATES; BAKERY DESSERTS; DESSERT MOUSSE; DESSERT PUDDINGS; PASTRIES; CAKES; BROWNIES; COOKIES; CANDY AND CHOCOLATES, NAMELY, CREAMS AND NOUGATS; BOXED CANDIES AND CHOCOLATES; INDIVIDUAL DESSERT AND SPECIALTY CAKES; CHOCOLATES, NAMELY, CHOCOLATE NOVELTIES; AND CANDY AND CHOCOLATE BARS; SPECIALTY COFFEES; CROISSANTS; MUFFINS; DANISHES; CAPPUCCINOS; BISCOTTI; HOT CHOCOLATE; HOT TEA; AND ICED TEA; CHOCOLATE CONFECTIONS, WEDDING CAKES AND CHOCOLATE COVERED ALMONDS; PARTY FAVORS AND WEDDING FAVORS CONSISTING PRIMARILY OF CHOCOLATE CONFECTIONS, PASTRIES, WEDDING CAKES, CAKES, CHOCOLATE COVERED ALMONDS, AND/OR BROWNIES (U.S. CL. 46).

FIRST USE 12-31-2003; IN COMMERCE 12-31-2003.

#### CLASS 35—ADVERTISING AND BUSINESS

FOR WHOLESALE AND RETAIL STORE AND ONLINE WHOLESALE AND RETAIL STORE SERVICES FEATURING CANDY, CHOCOLATES, CAKES, BAKERY DESSERTS, BROWNIES, COOKIES, BOXED CANDIES AND CHOCOLATES, PASTRIES, CHOCOLATE NOVELTIES, SMOOTHIES, SPECIALTY COFFEES, CROISSANTS, MUFFINS, DANISHES, CAPPUCCINOS, BISCOTTI, HOT CHOCOLATE, HOT TEA, ICED TEA AND GIFT BASKETS FILLED WITH SOME OR ALL OF THE FOREGOING (U.S. CLS. 100, 101 AND 102).

FIRST USE 12-31-2003; IN COMMERCE 12-31-2003.  
CHRISTINE MARTIN, EXAMINING ATTORNEY



"LUCAS FABLE" DOES NOT IDENTIFY A LIVING INDIVIDUAL.

THE MARK CONSISTS OF THE STYLIZED TEXT "LUCAS LF FABLE" WITH EARTHY VINES WRAPPED AROUND THE CENTERED LETTERS "L" AND "F".

#### CLASS 25—CLOTHING

FOR HATS; JACKETS; T-SHIRTS (U.S. CLS. 22 AND 39).

#### CLASS 41—EDUCATION AND ENTERTAINMENT

FOR AUDIO RECORDING AND PRODUCTION (U.S. CLS. 100, 101 AND 107).  
CAROL SPILS, EXAMINING ATTORNEY

SN 85-191,289. KICKDRUM, LLC, WEST HOLLYWOOD, CA. FILED 12-6-2010.

## KICK DRUM

THE MARK CONSISTS OF STANDARD CHARACTERS WITHOUT CLAIM TO ANY PARTICULAR FONT, STYLE, SIZE, OR COLOR.

#### CLASS 35—ADVERTISING AND BUSINESS

FOR RETAIL STORE SERVICES IN THE FIELD OF ENTERTAINMENT FEATURING PRE-RECORDED AUDIO AND AUDIOVISUAL RECORDINGS, PROVIDED VIA THE INTERNET AND OTHER COMPUTER AND ELECTRONIC COMMUNICATION NETWORKS; ADVERTISING, NAMELY, PROVIDING CLASSIFIED ADVERTISING SPACE VIA THE GLOBAL COMPUTER NETWORK; PROMOTING THE GOODS AND SERVICES OF OTHERS VIA THE INTERNET (U.S. CLS. 100, 101 AND 102).

#### CLASS 41—EDUCATION AND ENTERTAINMENT

FOR ENTERTAINMENT SERVICES, NAMELY, PROVIDING A WEB SITE FEATURING NON-DOWNLOADABLE MUSICAL PERFORMANCES, MUSICAL VIDEOS, RELATED FILM AND MUSICAL AUDIO CLIPS, ANIMATED FILMS, PHOTOGRAPHS, AND OTHER MULTIMEDIA MATERIALS FEATURING MUSIC (U.S. CLS. 100, 101 AND 107).

CAROL SPILS, EXAMINING ATTORNEY

SN 85-191,596. JIMMY JOHN'S ENTERPRISES, LLC, CHAMPAIGN, IL. FILED 12-6-2010.

SN 85-191,307. TRUSTMARK INSURANCE COMPANY, LAKE FOREST, IL. FILED 12-6-2010.

**FREAKY FAST DELIVERY!****LET'S TALK LIFE**

THE MARK CONSISTS OF STANDARD CHARACTERS WITHOUT CLAIM TO ANY PARTICULAR FONT, STYLE, SIZE, OR COLOR.

NO CLAIM IS MADE TO THE EXCLUSIVE RIGHT TO USE "LIFE", APART FROM THE MARK AS SHOWN.

**CLASS 36—INSURANCE AND FINANCIAL**

FOR UNDERWRITING, BROKERAGE, AND ADMINISTRATION OF INSURANCE AND BENEFIT PLANS IN THE FIELDS OF LIFE, HEALTH, ACCIDENT, MEDICAL, MENTAL HEALTH AND SUBSTANCE ABUSE, DISABILITY, PRESCRIPTION DRUG COVERAGE, DENTAL AND CRITICAL ILLNESS (U.S. CLS. 100, 101 AND 102).

**CLASS 44—MEDICAL, BEAUTY AND AGRICULTURAL SERVICES**

FOR WELLNESS AND HEALTH-RELATED CONSULTING SERVICES (U.S. CLS. 100 AND 101).  
RONALD DELGIZZI, EXAMINING ATTORNEY

THE MARK CONSISTS OF STANDARD CHARACTERS WITHOUT CLAIM TO ANY PARTICULAR FONT, STYLE, SIZE, OR COLOR.

OWNER OF U.S. REG. NOS. 2,593,631, 3,547,498 AND 3,698,424.

NO CLAIM IS MADE TO THE EXCLUSIVE RIGHT TO USE "FAST DELIVERY", APART FROM THE MARK AS SHOWN.

**CLASS 39—TRANSPORTATION AND STORAGE**

FOR DELIVERY OF FOOD BY RESTAURANTS (U.S. CLS. 100 AND 105).  
FIRST USE 1-0-2009; IN COMMERCE 1-0-2009.

**CLASS 43—HOTEL AND RESTAURANT SERVICES**

FOR RESTAURANT SERVICES (U.S. CLS. 100 AND 101).  
FIRST USE 1-0-2009; IN COMMERCE 1-0-2009.  
BARNEY CHARLON, EXAMINING ATTORNEY

SN 85-191,327. QUESTAR CORPORATION, SALT LAKE CITY, UT. FILED 12-6-2010.

SN 85-191,600. PREFERRED HOTEL GROUP, INC., CHICAGO, IL. FILED 12-6-2010.

**WEXPRO**

THE MARK CONSISTS OF STANDARD CHARACTERS WITHOUT CLAIM TO ANY PARTICULAR FONT, STYLE, SIZE, OR COLOR.

OWNER OF U.S. REG. NO. 3,635,890.

**CLASS 4—LUBRICANTS AND FUELS**

FOR NATURAL GAS, LIQUEFIED NATURAL GAS AND CRUDE OIL (U.S. CLS. 1, 6 AND 15).

**CLASS 35—ADVERTISING AND BUSINESS**

FOR OPERATING OIL AND GAS WELLS FOR OTHERS (U.S. CLS. 100, 101 AND 102).

**CLASS 37—CONSTRUCTION AND REPAIR**

FOR DRILLING AND COMPLETING OIL AND GAS WELLS; EQUIPPING OIL AND GAS WELLS, NAMELY, INSTALLING CASING, TUBING, AND PIPES INTO OIL AND GAS WELLS; OIL WELL DRILLING AND PUMPING (U.S. CLS. 100, 103 AND 106).

JUDITH HELFMAN, EXAMINING ATTORNEY

**PREFERRED SAFARIS & ADVENTURES**

THE MARK CONSISTS OF STANDARD CHARACTERS WITHOUT CLAIM TO ANY PARTICULAR FONT, STYLE, SIZE, OR COLOR.

OWNER OF U.S. REG. NOS. 1,419,160, 3,439,372 AND OTHERS.

NO CLAIM IS MADE TO THE EXCLUSIVE RIGHT TO USE "SAFARIS & ADVENTURES", APART FROM THE MARK AS SHOWN.

SEC. 2(F) AS TO "PREFERRED".

**CLASS 35—ADVERTISING AND BUSINESS**

FOR ADMINISTRATION OF A PARTNERSHIP PROGRAM FOR ENABLING PARTICIPANTS TO PROVIDE IMPROVED SERVICES THROUGH DISCOUNTS ON GOODS AND SERVICES AND EXCLUSIVE OFFERS AT HOTELS AND RESORTS; THE PROVISION AND ADMINISTRATION OF A PARTNERSHIP PROGRAM TO ALLOW PARTICIPANTS TO ACCESS EXCLUSIVE OR DISCOUNTED BENEFITS AND SERVICES (U.S. CLS. 100, 101 AND 102).

**CLASS 43—HOTEL AND RESTAURANT SERVICES**

FOR HOTEL SERVICES; RESORT HOTEL SERVICES; ACCOMMODATION RESERVATION SERVICES; PROVISION OF HOTEL ACCOMMODATION; PROVISION OF HOTEL VENUES FOR MEETINGS AND CONFERENCES; PROVIDING ADVICE AND INFORMATION TO TOURISTS AND TRAVELERS ON HOTEL DESTINATIONS; HOTEL RESERVATION AND BOOKING SERVICES (U.S. CLS. 100 AND 101).

KEVIN DINALLO, EXAMINING ATTORNEY

---

SN 85-191,692. HOLTORF, KENT, PALOS VERDES ESTATES, CA. FILED 12-6-2010.



OWNER OF U.S. REG. NO. 3,902,778.  
THE MARK CONSISTS OF A FRUIT TREE.

**CLASS 5—PHARMACEUTICALS**

FOR NUTRITIONAL SUPPLEMENTS (U.S. CLS. 6, 18, 44, 46, 51 AND 52).  
FIRST USE 3-0-2000; IN COMMERCE 3-0-2000.

**CLASS 44—MEDICAL, BEAUTY AND AGRICULTURAL SERVICES**

FOR PHYSICIAN SERVICES (U.S. CLS. 100 AND 101).  
FIRST USE 3-0-2000; IN COMMERCE 3-0-2000.  
HANNO RITTNER, EXAMINING ATTORNEY

---

SN 85-191,852. UPMC, PITTSBURGH, PA. FILED 12-7-2010.

**LIFECHANGINGMEDICINE**

THE COLOR(S) DARK PURPLE AND LIGHT PURPLE IS/ ARE CLAIMED AS A FEATURE OF THE MARK.

THE MARK CONSISTS OF THE TERM "LIFECHANGINGMEDICINE" WITH NO SPACES BETWEEN THE WORDS, WITH THE WORDS "LIFE" AND "MEDICINE" IN LIGHT PURPLE, AND THE WORD "CHANGING" IN DARK PURPLE. THE BACKGROUND OF THE MARK IS TRANSLUCENT.

**CLASS 35—ADVERTISING AND BUSINESS**

FOR BUSINESS MANAGEMENT AND CONSULTING SERVICES FOR THE HEALTHCARE INDUSTRY, NAMELY, PROVIDING INDUSTRY EXPERTISE AND SUPPLIER PARTNERSHIPS; HOSPITAL MANAGEMENT; NEW BUSINESS VENTURE DEVELOPMENT AND FORMATION CONSULTING SERVICES (U.S. CLS. 100, 101 AND 102).

**CLASS 36—INSURANCE AND FINANCIAL**

FOR ADMINISTRATION AND UNDERWRITING OF HEALTH, MEDICAL, PHARMACEUTICAL AND PRESCRIPTION DRUG INSURANCE PLANS (U.S. CLS. 100, 101 AND 102).

**CLASS 41—EDUCATION AND ENTERTAINMENT**

FOR EDUCATIONAL SERVICES, NAMELY, PROVIDING CLASSES, SEMINARS AND WORKSHOPS FOR THE GENERAL PUBLIC IN THE FIELD OF HEALTH AND DISSEMINATION OF RELATED EDUCATIONAL MATERIALS, AND PROVIDING CLASSES AND SEMINARS FOR MEDICAL STUDENTS AND HEALTH CARE PROFESSIONALS' CONTINUING MEDICAL EDUCATION IN THE FIELD OF HEALTH CARE AND CURRENT MEDICAL ISSUES (U.S. CLS. 100, 101 AND 107).

**CLASS 42—SCIENTIFIC AND COMPUTER SERVICES**

FOR MEDICAL RESEARCH (U.S. CLS. 100 AND 101).

**CLASS 44—MEDICAL, BEAUTY AND AGRICULTURAL SERVICES**

FOR HEALTHCARE; PHYSICIAN SERVICES; HOSPITALS; PROVIDING MEDICAL INFORMATION (U.S. CLS. 100 AND 101).

JIM RINGLE, EXAMINING ATTORNEY

---

SN 85-192,134. RHINOBACK, LLC, ORLANDO, FL. FILED 12-7-2010.

**RHINOBACK**

THE MARK CONSISTS OF STANDARD CHARACTERS WITHOUT CLAIM TO ANY PARTICULAR FONT, STYLE, SIZE, OR COLOR.

**CLASS 16—PAPER GOODS AND PRINTED MATTER**

FOR POSTERS (U.S. CLS. 2, 5, 22, 23, 29, 37, 38 AND 50).

**CLASS 21—HOUSEWARES AND GLASS**

FOR PORTABLE FOOD AND BEVERAGE COOLERS, INSULATING SLEEVE HOLDERS FOR BEVERAGE CANS OR BOTTLES (U.S. CLS. 2, 13, 23, 29, 30, 33, 40 AND 50).

**CLASS 25—CLOTHING**

FOR SPORTSWEAR, NAMELY, T-SHIRTS, SWEATSHIRTS, SWEATPANTS, SHORTS, CAPS, SKULL CAPS, JACKETS (U.S. CLS. 22 AND 39).

JUSTINE D. PARKER, EXAMINING ATTORNEY

SN 85-192,205. BEACHBODY, LLC, SANTA MONICA, CA.  
FILED 12-7-2010.

## THIN KITCHEN

THE MARK CONSISTS OF STANDARD CHARACTERS WITHOUT CLAIM TO ANY PARTICULAR FONT, STYLE, SIZE, OR COLOR.

OWNER OF U.S. REG. NOS. 3,415,276 AND 3,551,814.  
NO CLAIM IS MADE TO THE EXCLUSIVE RIGHT TO USE "KITCHEN", APART FROM THE MARK AS SHOWN.

### CLASS 5—PHARMACEUTICALS

FOR MEAL REPLACEMENT PROTEIN BARS, DIETARY SUPPLEMENTS AND DIET AIDS, NAMELY, VITAMINS AND MINERAL SUPPLEMENTS, FOOD FOR MEDICALLY RESTRICTED DIETS; FOOD SUPPLEMENTS; POWDERED NUTRITIONAL SUPPLEMENT DRINK AND SHAKE MIX, MEAL REPLACEMENT DRINKS AND SHAKES; BISCUITS, BREAD, BREAD ROLLS, CAKES, CEREAL PRODUCTS, CONFECTIONERY, CRACKERS, NOODLES, FISH SAUCE, RELISH, SAUCES, CEREAL-BASED SNACK-FOODS AND PREPARED DIETARY ITEMS TO ACCOMMODATE SPECIAL MEDICAL AND HEALTH CONDITIONS; DIETARY FIBER AS AN ADDITIVE FOR FOOD PRODUCTS; NUTRITIONAL ADDITIVES FOR MEDICAL PURPOSES FOR USE IN FOODS AND DIETARY SUPPLEMENTS FOR HUMAN CONSUMPTION; MEDICATED DIETETIC CANDY (U.S. CLS. 6, 18, 44, 46, 51 AND 52).

### CLASS 11—ENVIRONMENTAL CONTROL APPARATUS

FOR ELECTRIC GRILLS; ELECTRIC PANINI GRILLS; ELECTRIC SANDWICH MAKERS; ELECTRIC TOASTERS, ELECTRIC TOASTER OVENS; ELECTRIC FRYING PANS; BROILING PANS; WARMING PANS FOR BEDS; GRILL ACCESSORIES, NAMELY, WARMING TRAYS (U.S. CLS. 13, 21, 23, 31 AND 34).

### CLASS 21—HOUSEWARES AND GLASS

FOR COOKWARE, NAMELY, POTS, PANS, NON-ELECTRIC FRYING PANS, GLASS PANS, CAKE PANS, STEAMERS, METAL COOKING PANS; HOUSEHOLD UTENSILS, NAMELY, SPATULAS, WHISKS, TURNERS, KITCHEN TONGS, SERVING SPOONS AND FORKS, MIXING SPOONS, BASTING SPOONS, COOKING FORKS, AND STRAINERS; TEA STRAINERS; CHEESE BOARD AND KNIFE SET; SERVING TRAYS (U.S. CLS. 2, 13, 23, 29, 30, 33, 40 AND 50).

### CLASS 29—MEATS AND PROCESSED FOODS

FOR OLIVE OILS; FOODS, NAMELY, FROZEN, PREPARED AND PACKAGED MEAL COMBINATIONS CONSISTING PRIMARILY OF MEAT, POULTRY, SEAFOOD, FISH OR CHEESE; FROZEN VEGETABLES; PROCESSED FRUIT AND VEGETABLES; PROCESSED NUTS; PREPARED MEAT; FROZEN MEAT; HOTDOGS; HAMBURGER; DRIED MEAT; CHOW MEIN; CHEESE; CHEESE AND CRACKER COMBINATIONS; POULTRY; FISH; CANNED FRUIT; DRIED FRUIT; DRIED FRUIT MIXES; POTATO CHIPS; SOY CHIPS (U.S. CL. 46).

### CLASS 30—STAPLE FOODS

FOR COOKING SAUCES; DIPPING SAUCES; SALAD SAUCES; HOT SAUCE; SAUCES, NAMELY, BARBEQUE, CHEESE, CHICKEN WING, STEAK, CHILI, PEPPER, FISH, CURRY, PASTA, PICANTE, PIZZA, TERIYAKI AND SOY; FOODS, NAMELY, PROCESSED CEREALS; CEREAL BASED SNACK FOODS; POPCORN, PRETZELS; BAKERY DESSERTS; SNACK MIX CONSISTING PRIMARILY OF CRACKERS, PRETZELS, NUTS AND UNPOPPED POPCORN; RELISH; MUSTARD; KETCHUP; SAUCES FOR BARBECUED MEAT; SEASONINGS COATED FOR MEAT, FISH, POULTRY; MEAT PIES; PASTA; FROZEN, PREPARED AND PACKAGED MEALS CONSISTING PRIMARILY OF PASTA OR RICE; BISCUITS; BREAD; ROLLS, CAKES, RICE CAKES; BREAKFAST CEREALS; CORN CHIPS; PITA CHIPS; TORTILLA CHIPS; CRACKER AND CHEESE COMBINATIONS (U.S. CL. 46).

WARREN L. OLANDRIA, EXAMINING ATTORNEY

SN 85-192,273. SAGE WEDDING PROS, CORAL GABLES, FL. FILED 12-7-2010.

## Sage Wedding Pros

THE MARK CONSISTS OF STANDARD CHARACTERS WITHOUT CLAIM TO ANY PARTICULAR FONT, STYLE, SIZE, OR COLOR.

NO CLAIM IS MADE TO THE EXCLUSIVE RIGHT TO USE "WEDDING PROS", APART FROM THE MARK AS SHOWN.

### CLASS 35—ADVERTISING AND BUSINESS

FOR BUSINESS CONSULTATION; BUSINESS CONSULTATION AND MANAGEMENT REGARDING MARKETING ACTIVITIES AND LAUNCHING OF NEW PRODUCTS; BUSINESS CONSULTATION SERVICES; BUSINESS MANAGEMENT CONSULTING AND ADVISORY SERVICES; BUSINESS PLANNING; PROVIDING SPACE AT A WEB SITE FOR THE ADVERTISEMENT OF THE GOODS AND SERVICES OF OTHERS (U.S. CLS. 100, 101 AND 102).

FIRST USE 7-1-2009; IN COMMERCE 7-1-2009.

### CLASS 41—EDUCATION AND ENTERTAINMENT

FOR CONDUCTING WORKSHOPS AND SEMINARS IN THE WEDDING INDUSTRY (U.S. CLS. 100, 101 AND 107).

FIRST USE 7-1-2009; IN COMMERCE 7-1-2009.  
HEATHER BIDDULPH, EXAMINING ATTORNEY

SN 85-192,274. WOMEN BUSINESS LEADERS OF THE U.S. HEALTH CARE INDUSTRY FOUNDATION, WASHINGTON, DC. FILED 12-7-2010.



OWNER OF U.S. REG. NOS. 3,376,987, 3,513,058 AND 3,545,718.

THE MARK CONSISTS OF THE LETTERS "W", "B", "L" ABOVE THE TERM "WOMEN LEADING HEALTH CARE WWW.WBL.ORG" IN A SMALLER FONT, ALL OF WHICH APPEARS TO THE LEFT OF A STYLIZED DEPICTION OF TWO PEOPLE WITH RAISED ARMS THAT FORM THE LETTER "W" INSIDE TWO CONCENTRIC CIRCLES.

#### CLASS 35—ADVERTISING AND BUSINESS

FOR ASSOCIATION SERVICES, NAMELY, PROMOTING THE INTERESTS OF WOMEN IN THE FIELDS OF HEALTH CARE OR BUSINESS (U.S. CLS. 100, 101 AND 102).

#### CLASS 41—EDUCATION AND ENTERTAINMENT

FOR ARRANGING AND CONDUCTING OF CONFERENCES, WORKSHOPS, CLASSES, AND SEMINARS IN THE FIELD OF HEALTHCARE; ARRANGING AND CONDUCTING OF WORKSHOPS, CLASSES, SEMINARS, AND EDUCATIONAL CONFERENCES IN THE FIELD OF BUSINESS (U.S. CLS. 100, 101 AND 107).

HEATHER BIDDULPH, EXAMINING ATTORNEY

SN 85-192,408. PAPER MART, INC., EAST HANOVER, NJ. FILED 12-7-2010.



THE STIPLING IS FOR SHADING PURPOSES.  
THE MARK CONSISTS OF INTERLOCKING LETTERS "PM" SUPERIMPOSED OVER A STYLIZED GLOBE, WITH THREE EVERGREEN TREES TO THE LOWER RIGHT.

#### CLASS 16—PAPER GOODS AND PRINTED MATTER

FOR PAPER GOODS, NAMELY, XEROGRAPHIC, DUPLICATING, OFFSET PRINTING, PRINTING, MIMEOGRAPH, VELLUM AND BRISTOL BOARD (U.S. CLS. 2, 5, 22, 23, 29, 37, 38 AND 50).

#### CLASS 35—ADVERTISING AND BUSINESS

FOR DISTRIBUTORSHIP SERVICES IN THE FIELD OF STATIONERY (U.S. CLS. 100, 101 AND 102).

#### CLASS 40—MATERIAL TREATMENT

FOR PRINTING SERVICES (U.S. CLS. 100, 103 AND 106).

JEFFREY LOOK, EXAMINING ATTORNEY

SN 85-192,693. CONTINENTAL WESTERN CORPORATION, SAN LEANDRO, CA. FILED 12-7-2010.

CWC

THE MARK CONSISTS OF STANDARD CHARACTERS WITHOUT CLAIM TO ANY PARTICULAR FONT, STYLE, SIZE, OR COLOR.

OWNER OF U.S. REG. NO. 1,133,671.

#### CLASS 17—RUBBER GOODS

FOR STRAPPING TAPE OF SYNTHETIC SHEETING AND FIBERS; ADHESIVE PACKING TAPE FOR INDUSTRIAL OR COMMERCIAL USE; PLASTIC FILM FOR COMMERCIAL AND INDUSTRIAL USE; RUBBER BANDS FOR COMMERCIAL AND INDUSTRIAL USES; PLASTIC SHEETING FOR USE AS DROP CLOTHS (U.S. CLS. 1, 5, 12, 13, 35 AND 50).

FIRST USE 0-0-1977; IN COMMERCE 0-0-1977.

#### CLASS 22—CORDAGE AND FIBERS

FOR ROPE; TWINE OF SYNTHETIC AND NATURAL FIBERS; NON-METAL STRAPPING OR TIE DOWNS; NETTING; SISAL FIBER; SILAGE BAGS; TARPULINS (U.S. CLS. 1, 2, 7, 19, 22, 42 AND 50).

FIRST USE 0-0-1977; IN COMMERCE 0-0-1977.

#### CLASS 35—ADVERTISING AND BUSINESS

FOR DISTRIBUTORSHIP SERVICES IN THE FIELD OF ROPE, TWINE, STRAPPING, PACKING, TARPS, SAFETY, JANITORIAL, FOOD SERVICE AND PAPER PRODUCTS (U.S. CLS. 100, 101 AND 102).

FIRST USE 0-0-1977; IN COMMERCE 0-0-1977.

IRA J. GOODSaid, EXAMINING ATTORNEY

SN 85-192,700. MENON & ASSOCIATES, INC., SAN DIEGO, CA. FILED 12-7-2010.

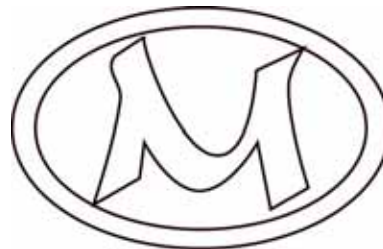

THE MARK CONSISTS OF A STYLIZED "M" INSIDE A HORIZONTAL OVAL.

**CLASS 4—LUBRICANTS AND FUELS**

FOR BIOFUEL (U.S. CLS. 1, 6 AND 15).

**CLASS 9—ELECTRICAL AND SCIENTIFIC APPARATUS**

FOR ELECTRONIC BIOTHREAT DETECTORS (U.S. CLS. 21, 23, 26, 36 AND 38).

**CLASS 31—NATURAL AGRICULTURAL PRODUCTS**FOR ANIMAL FEED (U.S. CLS. 1 AND 46).  
KELLY BOULTON, EXAMINING ATTORNEY**CLASS 31—NATURAL AGRICULTURAL PRODUCTS**FOR NUTS, NAMELY, RAW, FRESH AND UNPROCESSED NUTS (U.S. CLS. 1 AND 46).  
ALEXANDER L. POWERS, EXAMINING ATTORNEY

SN 85-193,150. SAFEXTOP, LLC, MIAMI, FL. FILED 12-8-2010.



THE MARK CONSISTS OF THE WORD "SAFEXTOP" IN STYLIZED LETTERS WITH THE "X" IN A LARGER FONT AND A CHECKERED FLAG LOCATED ABOVE THE LETTER "E".

**CLASS 1—CHEMICALS**

FOR BRAKE FLUID (U.S. CLS. 1, 5, 6, 10, 26 AND 46).

**CLASS 12—VEHICLES**

FOR BRAKE PADS FOR VEHICLES; BRAKE CYLINDERS; BRAKE CALIPERS FOR LAND VEHICLES; DISC BRAKES FOR VEHICLES; BRAKE DRUMS; BRAKE SHOES FOR VEHICLES; BRAKE LINES FOR VEHICLES; BRAKE CYLINDER REPAIR KITS SOLD AS A UNIT FOR LAND VEHICLES (U.S. CLS. 19, 21, 23, 31, 35 AND 44).

PATRICIA EVANKO, EXAMINING ATTORNEY

SN 85-193,164. HEALTH NUTZ, LLC, NORWALK, CT. FILED 12-8-2010.

LIFE'S SHORT . . . SAY YUM

THE MARK CONSISTS OF STANDARD CHARACTERS WITHOUT CLAIM TO ANY PARTICULAR FONT, STYLE, SIZE, OR COLOR.

OWNER OF U.S. REG. NOS. 3,779,461 AND 3,905,768.

**CLASS 29—MEATS AND PROCESSED FOODS**

FOR NUTS, NAMELY, PROCESSED, SHELLED, ROASTED AND PREPARED NUTS (U.S. CL. 46).

**CLASS 30—STAPLE FOODS**

FOR CHOCOLATE NUTS (U.S. CL. 46).

SN 85-193,244. EWIZE MARKETING 4U, LLC, HOLLYWOOD, FL. FILED 12-8-2010.



THE COLOR(S) GREEN, BLACK, AND WHITE IS/ARE CLAIMED AS A FEATURE OF THE MARK.

THE MARK CONSISTS OF THE WORDING "EWIZE" WITH AN OWL HEAD DESIGN WHERE THE "E" IS IN GREEN, "WIZE" IS IN WHITE SURROUNDED BY A GREEN ROUNDED RECTANGLE, AND THE OWL IS IN GREEN WITH WHITE ACCENTS AND BLACK AND WHITE EYES.

**CLASS 3—COSMETICS AND CLEANING PREPARATIONS**

FOR AFTER-SHAVE LOTIONS, AFTER-SHAVE, AGE SPOT REDUCING CREAMS, ANTI-AGING CREAMS, ANTI-WRINKLE CREAMS, AROMATIC BODY CARE PRODUCTS, NAMELY, BODY LOTION, SHOWER GEL, CUTICLE CREAM, SHAMPOO, CONDITIONER, NON-MEDICATED LIP BALM, SOAP, BODY POLISH, BODY AND FOOT SCRUB AND NON-MEDICATED FOOT CREAM, BATH CREAM, BATH LOTION, BEAUTY CREAMS, BEAUTY LOTIONS, BODY AND BEAUTY CARE COSMETICS, BODY CREAMS, BODY LOTIONS, BREATH FRESHENER, COLOGNES, PERFUMES, COSMETIC CREAMS, COSMETIC OILS, COSMETICS, FACE AND BODY LOTIONS, FACE CREAMS, HAIR STRAIGHTENING PREPARATIONS, LOTIONS FOR COSMETIC PURPOSES, NON-MEDICATED SKIN CARE PREPARATIONS, NAMELY, CREAMS, LOTIONS, GELS, TONERS, CLEANERS AND PEELS, PRE-SHAVE CREAMS, SHAVE CREAMS, SHAVING LOTIONS, SKIN CREAMS, SKIN LIGHTENERS (U.S. CLS. 1, 4, 6, 50, 51 AND 52).

**CLASS 5—PHARMACEUTICALS**

FOR MIXED VITAMIN PREPARATIONS, MULTI-VITAMIN PREPARATIONS, VITAMIN AND MINERAL SUPPLEMENTS, VITAMIN SUPPLEMENTS, VITAMIN TABLETS, VITAMINS (U.S. CLS. 6, 18, 44, 46, 51 AND 52).

**CLASS 34—SMOKERS' ARTICLES**

FOR ELECTRIC CIGARETTES, ELECTRONIC CIGARETTES FOR USE AS AN ALTERNATIVE TO TRADITIONAL CIGARETTES, ELECTRONIC CIGARETTES, SMOKELESS CIGARETTE VAPORIZER PIPE (U.S. CLS. 2, 8, 9 AND 17).

**CLASS 35—ADVERTISING AND BUSINESS**

FOR MARKETING SERVICES, NAMELY, PROVIDING INFORMATIONAL WEBPAGES DESIGNED TO GENERATE SALES TRAFFIC VIA HYPERLINKS TO OTHER WEBSITES, PROMOTING THE SALE OF GOODS AND SERVICES OF OTHERS THROUGH THE DISTRIBUTION OF PRINTED MATERIAL AND PROMOTIONAL CONTESTS, PROCURING OF CONTRACTS FOR THE PURCHASE AND SALE OF GOODS, BUSINESS ADMINISTRATION SERVICES FOR PROCESSING SALES MADE ON THE INTERNET, ADVERTISING SERVICES, FOR THIRD PARTIES, IN CONNECTION WITH COMMERCIALIZATION AND SALE OF PERFUMERY AND COSMETIC ARTICLES, PRODUCTS FOR HOUSEHOLD PURPOSES, OPTICAL PRODUCTS, CLOCKS AND TIMEPIECES, JEWELRY, FURNISHING ARTICLES, ADVERTISING, INCLUDING PROMOTION RELATING TO THE SALE OF ARTICLES AND SERVICES FOR THIRD PARTIES BY THE TRANSMISSION OF ADVERTISING MATERIAL AND THE DISSEMINATION OF ADVERTISING MESSAGES ON COMPUTER NETWORKS, SALES PROMOTION, PUBLICITY AND SALES PROMOTION SERVICES, THE BRINGING TOGETHER, FOR THE BENEFIT OF OTHERS, OF A VARIETY OF GOODS AND SERVICES, ENABLING CUSTOMERS TO CONVENIENTLY VIEW AND PURCHASE THOSE GOODS AND SERVICES FROM AN INTERNET WEBSITE PARTICULARLY SPECIALIZING IN THE MARKETING OF THE SALE OF GOODS AND SERVICES OF OTHERS (U.S. CLS. 100, 101 AND 102).

FIRST USE 10-25-2010; IN COMMERCE 10-25-2010.  
CHARLOTTE CORWIN, EXAMINING ATTORNEY

SN 85-193,549. CITY OF LONG BEACH, LONG BEACH, CA.  
FILED 12-8-2010.

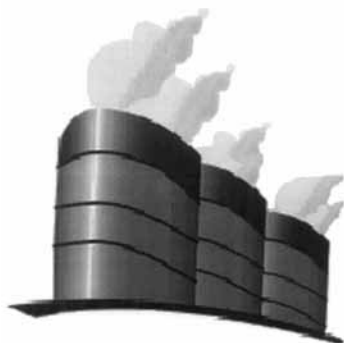

THE MARK CONSISTS OF THREE SMOKE STACKS DEPICTING SMOKE COMING FROM THE STACKS.

**CLASS 14—JEWELRY**

FOR JEWELRY, NAMELY, WATCHES, WATCHBANDS, RINGS, AND BRACELETS, CHARMS AND MEDALLIONS (U.S. CLS. 2, 27, 28 AND 50).

**CLASS 16—PAPER GOODS AND PRINTED MATTER**

FOR BOOKS PERTAINING TO THE SHIP QUEEN MARY, MONTHLY PERIODICALS, NAMELY, A NEWSLETTER PERTAINING TO THE SHIP QUEEN MARY, MOUNTED AND UNMOUNTED PHOTOGRAPHS, POSTERS, ENVELOPES, POST CARDS, AND GREETING CARDS (U.S. CLS. 2, 5, 22, 23, 29, 37, 38 AND 50).

**CLASS 18—LEATHER GOODS**

FOR LEATHER AND IMITATIONS OF LEATHER GOODS, NAMELY, PURSES, DRAWSTRING POUCHES, AND TRAVEL BAGS (U.S. CLS. 1, 2, 3, 22 AND 41).

**CLASS 21—HOUSEWARES AND GLASS**

FOR BEVERAGE GLASSWARE, NAMELY, WATER GLASSES, WINE GLASSES, SHOT GLASSES, COFFEE MUGS; DECANTERS, PITCHERS, PORCELAIN TEA POTS, PLATES, AND ICE BUCKETS (U.S. CLS. 2, 13, 23, 29, 30, 33, 40 AND 50).

**CLASS 25—CLOTHING**

FOR CLOTHING, NAMELY, TEE SHIRTS, TANK TOPS, SWEATSHIRTS, SHORTS, SWEATERS, TIES AND HATS (U.S. CLS. 22 AND 39).

**CLASS 28—TOYS AND SPORTING GOODS**

FOR TOYS, NAMELY, BOARD GAMES, PLAYING CARDS, SCALE MODEL SHIPS, TOY FIGURE PREMADE REPLICAS OF SHIPS (U.S. CLS. 22, 23, 38 AND 50).

H. M. FISHER, EXAMINING ATTORNEY

SN 85-193,605. BAKONYI-KISS, ATTILA, H-1037 BUDAPEST, HUNGARY, FILED 12-8-2010.



NO CLAIM IS MADE TO THE EXCLUSIVE RIGHT TO USE "DIET SYSTEM", APART FROM THE MARK AS SHOWN.

THE COLOR(S) YELLOW, RED, MAGENTA, PURPLE AND ORANGE IS/ARE CLAIMED AS A FEATURE OF THE MARK.

THE MARK CONSISTS OF THE WORD "GASTROYAL" IN THE COLOR YELLOW WITH A FORK SILHOUETTE IN THE COLOR YELLOW FORMING A PART OF THE LETTER "R", ALL ON A RED BACKGROUND WITH A YELLOW LINE BENEATH THE BACKGROUND, BELOW WHICH APPEARS THE LETTER "A" IN PURPLE, THE LETTER "B" IN ORANGE AND THE LETTER "C" IN MAGENTA, ALL THE LETTERS BEING CONTAINED IN SWIRLING ORANGE CIRCLES WITH A MAGENTA COLORED CRESCENT APPEARING ON THE LEFT SIDE OF EACH CIRCLE, AND THE WORDS "DIET SYSTEM" IN THE COLOR RED BELOW THE CIRCLES.

**CLASS 25—CLOTHING**

FOR CLOTHING, NAMELY, PANTS, SHORTS, SHIRTS, HATS, CAPS, SHIRTS, T-SHIRTS, CLOTH BIBS, CLOTH HEADBANDS AND VISORS, SWEATERS, JACKETS, RAINCOATS, COATS, WARM-UP SUITS, BATHING SUITS, ROBES, PAJAMAS, UNDERWEAR, SOCKS, SHOES, BOOTS, SLIPPERS, DRESSES, SKIRTS, UNITARDS, LEOTARDS, HOSIERY, SCARVES, VESTS, SPORT JACKETS, PARKAS, BELTS, TIES, SUITS, BLAZERS, GLOVES, SLEEPWEAR, NIGHTGOWNS, LINGERIE (U.S. CLS. 22 AND 39).

**CLASS 29—MEATS AND PROCESSED FOODS**

FOR MEAT, FISH, POULTRY AND GAME; MEAT EXTRACTS; PRESERVED, FROZEN, DRIED AND COOKED FRUITS AND VEGETABLES; JELLIES, JAMS, COMPOTES; EGGS, MILK; MILK PRODUCTS EXCLUDING ICE CREAM, ICE MILK AND FROZEN YOGURT; EDIBLE OILS AND FATS (U.S. CL. 46).



**CLASS 30—STAPLE FOODS**

FOR COFFEE, TEA, COCOA, SUGAR, RICE, TAPIOCA, SAGO, ARTIFICIAL COFFEE; FLOUR; CEREAL, BREAD, PASTRY AND CONFECTIONERY MADE OF SUGAR, EDIBLE ICES; HONEY, TREACLE; YEAST, BAKING-POWDER; SALT, MUSTARD; VINEGAR, SAUCES; SPICES; ICE (U.S. CL. 46).

**CLASS 32—LIGHT BEVERAGES**

FOR BEERS; MINERAL AND AERATED WATERS; NON-ALCOHOLIC DRINKS, NAMELY, SOFT DRINKS, COLAS, ENERGY DRINKS, ISOTONIC DRINKS, CIDER; FRUIT DRINKS AND FRUIT JUICES; SYRUPS FOR MAKING BEVERAGES; PREPARATIONS FOR MAKING BEVERAGES, NAMELY, SOFT DRINKS, COLAS, ENERGY DRINKS AND ISOTONIC DRINKS, FRUIT DRINKS AND FRUIT JUICES (U.S. CLS. 45, 46 AND 48).

**CLASS 35—ADVERTISING AND BUSINESS**

FOR ADVERTISING AND PUBLICITY SERVICES; RETAIL AND WHOLESALE STORE AND ONLINE RETAIL AND WHOLESALE STORE SERVICES FEATURING ALL KINDS OF FOODSTUFF, COSMETIC AND CLEANING PREPARATIONS, STATIONERY, HOUSEHOLD UTENSILS, CLOTHING, BEER, TABLE WATERS, NON-ALCOHOLIC BEVERAGES, ALCOHOLIC BEVERAGES AND TOBACCO PRODUCTS (U.S. CLS. 100, 101 AND 102).

**CLASS 43—HOTEL AND RESTAURANT SERVICES**

FOR SERVICES FOR PROVIDING FOOD AND DRINK, NAMELY, RESTAURANT, BARS, AND CAFE SERVICES; FOOD PREPARATION SERVICES FEATURING FRESH, PROPERLY PROPORTIONED, HEALTHY MEALS MADE TO ORDER FOR HOME DELIVERY; PROVIDING TEMPORARY ACCOMMODATION (U.S. CLS. 100 AND 101).

**CLASS 44—MEDICAL, BEAUTY AND AGRICULTURAL SERVICES**

FOR NUTRITION COUNSELING AND WEIGHT REDUCTION DIET PLANNING; PROVIDING INFORMATION IN THE FIELD OF NUTRITION, DIET, WEIGHT LOSS, WEIGHT MAINTENANCE (U.S. CLS. 100 AND 101).

TARAH HARDY, EXAMINING ATTORNEY



SN 85-193,686. AZAYA RANCH VINEYARD, LLC, SAN FRANCISCO, CA. FILED 12-8-2010.

**AZAYA RANCH VINEYARD**

THE MARK CONSISTS OF STANDARD CHARACTERS WITHOUT CLAIM TO ANY PARTICULAR FONT, STYLE, SIZE, OR COLOR.

NO CLAIM IS MADE TO THE EXCLUSIVE RIGHT TO USE "RANCH VINEYARD", APART FROM THE MARK AS SHOWN.

**CLASS 31—NATURAL AGRICULTURAL PRODUCTS**

FOR FRESH WINE GRAPES (U.S. CLS. 1 AND 46).

**CLASS 33—WINES AND SPIRITS**

FOR WINE (U.S. CLS. 47 AND 49).

**CLASS 44—MEDICAL, BEAUTY AND AGRICULTURAL SERVICES**

FOR VINEYARD AND WINERY SERVICES, NAMELY, THE GROWING AND CULTIVATION OF GRAPES FOR OTHERS (U.S. CLS. 100 AND 101).

TARAH HARDY, EXAMINING ATTORNEY



SN 85-193,757. HEALTHY BRANDS, INC., ORANGE, CA. FILED 12-8-2010.

**MEGA JUICE**

THE MARK CONSISTS OF STANDARD CHARACTERS WITHOUT CLAIM TO ANY PARTICULAR FONT, STYLE, SIZE, OR COLOR.

NO CLAIM IS MADE TO THE EXCLUSIVE RIGHT TO USE "JUICE", APART FROM THE MARK AS SHOWN.

**CLASS 5—PHARMACEUTICALS**

FOR VITAMIN ENRICHED WATER; VITAMIN FORTIFIED BEVERAGES (U.S. CLS. 6, 18, 44, 46, 51 AND 52).

**CLASS 32—LIGHT BEVERAGES**

FOR FRUIT-BASED BEVERAGES; FRUIT-FLAVORED BEVERAGES; NON-ALCOHOLIC BEVERAGES CONTAINING FRUIT JUICES (U.S. CLS. 45, 46 AND 48).

PAUL E. FAHRENKOPF, EXAMINING ATTORNEY



SN 85-193,784. CORTEZ, WILMA D., SANTA MONICA, CA. FILED 12-9-2010.

**PINK PAVEMENT**

THE MARK CONSISTS OF STANDARD CHARACTERS WITHOUT CLAIM TO ANY PARTICULAR FONT, STYLE, SIZE, OR COLOR.

**CLASS 16—PAPER GOODS AND PRINTED MATTER**

FOR GENERAL FEATURE MAGAZINE IN THE FIELD OF WOMEN'S CONCERNS, NAMELY, HEALTH AND FITNESS, BEAUTY, FASHION, EMPOWERMENT, SOCIAL LIFE, BOOKS AND BOOK CLUBS, NEW CONSUMER PRODUCTS, MONEY, CAREER, LEISURE ACTIVITIES, MOTHERHOOD AND PURSUING ONE'S PURPOSE; MAGAZINE PAPER; MAGAZINE SUPPLEMENTS TO NEWSPAPERS IN THE FIELD OF WOMEN'S CONCERNS, NAMELY, HEALTH AND FITNESS, BEAUTY, FASHION, EMPOWERMENT, SOCIAL LIFE, BOOKS AND BOOK CLUBS, NEW CONSUMER PRODUCTS, MONEY, CAREER, LEISURE ACTIVITIES, MOTHERHOOD AND PURSUING ONE'S PURPOSE; MAGAZINES IN THE FIELD OF WOMEN'S CONCERNS, NAMELY, HEALTH AND FITNESS, BEAUTY, FASHION, EMPOWERMENT, SOCIAL LIFE, BOOKS AND BOOK CLUBS, NEW CONSUMER PRODUCTS, MONEY, CAREER, LEISURE ACTIVITIES, MOTHERHOOD AND PURSUING ONE'S PURPOSE; PRINTED MATERIALS, NAMELY, JOURNALS FEATURING WOMEN'S CONCERNS, NAMELY, HEALTH AND FITNESS, BEAUTY, FASHION, EMPOWERMENT, SOCIAL LIFE, BOOKS AND BOOK CLUBS, NEW CONSUMER PRODUCTS, MONEY, CAREER, LEISURE ACTIVITIES, MOTHERHOOD AND PURSUING ONE'S PURPOSE; PRINTED MATTER, NAMELY, NEWSPAPERS, PHOTOGRAPHS, MAGAZINES, BOOKS, PRINTED PERIODICALS, NEWSLETTERS, AND BROCHURES ALL IN THE FIELDS OF SECURITIES, OPTIONS AND OTHER FINANCIAL INSTRUMENTS (U.S. CLS. 2, 5, 22, 23, 29, 37, 38 AND 50).

**CLASS 35—ADVERTISING AND BUSINESS**

FOR MAGAZINE SUBSCRIPTION AND FULFILLMENT SERVICES; PROMOTING THE GOODS AND SERVICES OF OTHERS BY PREPARING AND PLACING ADVERTISEMENTS IN AN ELECTRONIC MAGAZINE ACCESSED THROUGH A GLOBAL COMPUTER NETWORK; PROVIDING ADVERTISING SPACE IN PERIODICALS, NEWSPAPERS AND MAGAZINES (U.S. CLS. 100, 101 AND 102).

**CLASS 41—EDUCATION AND ENTERTAINMENT**

FOR MAGAZINE PUBLISHING; ON-LINE JOURNALS, NAMELY, BLOGS FEATURING INFORMATION FOR WOMEN CONCERNING HEALTH AND FITNESS, BEAUTY, FASHION, EMPOWERMENT, SOCIAL LIFE, BOOKS AND BOOK CLUBS, NEW CONSUMER PRODUCTS, MONEY, CAREER, LEISURE ACTIVITIES, MOTHERHOOD AND PURSUING ONE'S PURPOSE; PROVIDING ON-LINE MAGAZINES IN THE FIELD OF WOMEN'S CONCERNS, NAMELY, HEALTH AND FITNESS, BEAUTY, FASHION, EMPOWERMENT, SOCIAL LIFE, BOOKS AND BOOK CLUBS, NEW CONSUMER PRODUCTS, MONEY, CAREER, LEISURE ACTIVITIES, MOTHERHOOD AND PURSUING ONE'S PURPOSE; PROVIDING ON-LINE NON-DOWNLOADABLE GENERAL FEATURE MAGAZINES; PUBLICATION OF BOOKS, MAGAZINES, ALMANACS AND JOURNALS; PUBLICATION OF BOOKS, OF MAGAZINES, OF JOURNALS, OF NEWSPAPERS, OF PERIODICALS, OF CATALOGS, OF BROCHURES; PUBLICATION OF ELECTRONIC MAGAZINES; PUBLISHING OF WEB MAGAZINES (U.S. CLS. 100, 101 AND 107).

KATHERINE CHANG, EXAMINING ATTORNEY

SN 85-193,791. WINDOW WORLD INTERNATIONAL, LLC, NORTH WILKESBORO, NC. FILED 12-9-2010.



OWNER OF U.S. REG. NOS. 2,331,991, 3,016,669 AND 3,244,991.

NO CLAIM IS MADE TO THE EXCLUSIVE RIGHT TO USE "WINDOW", APART FROM THE MARK AS SHOWN.

THE MARK CONSISTS OF A LARGE CAPITAL LETTER "W", THE LETTERS "I-N-D-O-W" TO THE RIGHT OF THE TOP PORTION OF THE "W", AND THE LETTERS "O-R-L-D" UNDER THE LETTERS "I-N-D-O-W". THE CAPITAL LETTER "W" SERVES AS THE FIRST LETTER OF THE WORD "WINDOW" AND ALSO THE WORD "WORLD".

**CLASS 35—ADVERTISING AND BUSINESS**

FOR RETAIL STORE SERVICES FEATURING REPLACEMENT WINDOWS (U.S. CLS. 100, 101 AND 102).  
FIRST USE 2-19-1999; IN COMMERCE 2-19-1999.

**CLASS 37—CONSTRUCTION AND REPAIR**

FOR INSTALLATION OF REPLACEMENT WINDOWS (U.S. CLS. 100, 103 AND 106).  
FIRST USE 2-19-1999; IN COMMERCE 2-19-1999.  
KRISTIN CARLSON, EXAMINING ATTORNEY

SN 85-193,960. XCHANGEWITHME LLC, BRIGHTON, MI. FILED 12-9-2010.



THE MARK CONSISTS OF "XCHANGEWITHME" WITH THE LETTER "X" IN HIGHLY STYLIZED FORM.

**CLASS 9—ELECTRICAL AND SCIENTIFIC APPARATUS**

FOR COMPUTER APPLICATION SOFTWARE FOR MOBILE PHONES AND HANDHELD COMPUTERS, NAMELY, SOFTWARE FOR EXCHANGING, DISPLAYING AND MANAGING PERSONAL AND BUSINESS CONTACT INFORMATION (U.S. CLS. 21, 23, 26, 36 AND 38).

**CLASS 42—SCIENTIFIC AND COMPUTER SERVICES**

FOR PROVIDING TEMPORARY USE OF A WEB-BASED NON-DOWNLOADABLE SOFTWARE APPLICATION FOR EXCHANGING, DISPLAYING AND MANAGING BUSINESS AND PERSONAL CONTACT INFORMATION, NOT INCLUDING PROVIDING ON-LINE COMPUTER GAMES THAT ARE PLAYED ON-LINE (U.S. CLS. 100 AND 101).

CARYN GLASSER, EXAMINING ATTORNEY

SN 85-194,219. SEQUENCE, INC., BONITA SPRINGS, FL.  
FILED 12-9-2010.

## BRILLIANCE NEW YORK

THE MARK CONSISTS OF STANDARD CHARACTERS WITHOUT CLAIM TO ANY PARTICULAR FONT, STYLE, SIZE, OR COLOR.

NO CLAIM IS MADE TO THE EXCLUSIVE RIGHT TO USE "NEW YORK", APART FROM THE MARK AS SHOWN.

### CLASS 3—COSMETICS AND CLEANING PREPARATIONS

FOR COSMETICS; HAIR GEL AND HAIR MOUSSE; HAIR SHAMPOOS AND CONDITIONERS; SKIN CARE PRODUCTS, NAMELY, NON-MEDICATED SKIN SERUM (U.S. CLS. 1, 4, 6, 50, 51 AND 52).

### CLASS 9—ELECTRICAL AND SCIENTIFIC APPARATUS

FOR ELECTRIC HAIR CURLERS; ELECTRIC HAIR STRAIGHTENER (U.S. CLS. 21, 23, 26, 36 AND 38).

### CLASS 11—ENVIRONMENTAL CONTROL APPARATUS

FOR HAIR DRYERS (U.S. CLS. 13, 21, 23, 31 AND 34).  
DEIRDRE ROBERTSON, EXAMINING ATTORNEY

SN 85-194,313. ALTICOR INC., ADA, MI. FILED 12-9-2010.



THE COLOR(S) RED, GREEN, WHITE, NAVY BLUE, YELLOW, GREY IS/ARE CLAIMED AS A FEATURE OF THE MARK.

THE MARK CONSISTS OF CONCENTRIC HEARTS WITH A GREY HEART WITH A WHITE MIDDLE AT THE CENTER THEN RED HEART, THEN A WHITE HEART, THEN A GREEN HEART, THEN A WHITE HEART, ALL SURROUNDED BY A NAVY BLUE CIRCLE, THEN A YELLOW CIRCLE, ALL SURROUNDED BY A GREY WAVY CIRCLE WITH GREY SPOTS SURROUNDING THE EXTERIOR.

### CLASS 35—ADVERTISING AND BUSINESS

FOR PHILANTHROPIC SERVICES, NAMELY, ORGANIZING AND CONDUCTING VOLUNTEER PROGRAMS AND COMMUNITY SERVICE PROJECTS (U.S. CLS. 100, 101 AND 102).

### CLASS 36—INSURANCE AND FINANCIAL

FOR CHARITABLE FUNDRAISING (U.S. CLS. 100, 101 AND 102).  
RAUL CORDOVA, EXAMINING ATTORNEY

SN 85-194,392. ZOTOS INTERNATIONAL, INC., DARIEN, CT. FILED 12-9-2010.

## JOICO

THE MARK CONSISTS OF STANDARD CHARACTERS WITHOUT CLAIM TO ANY PARTICULAR FONT, STYLE, SIZE, OR COLOR.

OWNER OF U.S. REG. NO. 2,186,915.

### CLASS 3—COSMETICS AND CLEANING PREPARATIONS

FOR HAIR CARE PREPARATIONS; HAIR COLOR; HAIR SHAMPOOS AND CONDITIONERS; HAIR SPRAY; HAIR STYLING PREPARATIONS; PERMANENT WAVE PREPARATIONS (U.S. CLS. 1, 4, 6, 50, 51 AND 52).  
FIRST USE 11-15-1976; IN COMMERCE 11-15-1976.

### CLASS 41—EDUCATION AND ENTERTAINMENT

FOR EDUCATIONAL SERVICES, NAMELY, CONDUCTING WORKSHOPS, SEMINARS, AND EDUCATIONAL DEMONSTRATIONS IN THE FIELD OF HAIR CARE PRODUCTS, HAIR STYLING TECHNIQUES, AND HAIR CUTTING FOR SALON PROFESSIONALS (U.S. CLS. 100, 101 AND 107).

FIRST USE 5-7-1977; IN COMMERCE 5-7-1977.  
APRIL HESIK, EXAMINING ATTORNEY

SN 85-194,420. RUTHLESS ENTERTAINMENT PTE LTD, SINGAPORE, SINGAPORE, FILED 12-9-2010.



THE COLOR(S) RED, WHITE AND GREEN IS/ARE CLAIMED AS A FEATURE OF THE MARK.

THE MARK CONSISTS OF THE LETTER "D" TO RE-

SEMBLE A SPANISH GREEN OLIVE; THE "D" IS OLIVE GREEN AND IS ON A RED SQUARE BACKGROUND WITH ITS CORNERS ROUNDED AND CLIPPED; THE RED SQUARE BACKGROUND INCLUDES THE RED HOLE IN THE MIDDLE OF THE LETTER "D" TO RESEMBLE A PIMENTO PEPPER; AND THERE IS A WHITE CURVED LINE FROM LOWER LEFT CORNER TO UPPER RIGHT CORNER CREATING A SHADOW EFFECT, SO THAT THE RED BECOMES GRADUALLY LIGHTER AND THE GREEN BECOMES GRADUALLY LIGHTER.

#### **CLASS 9—ELECTRICAL AND SCIENTIFIC APPARATUS**

FOR COMPUTER APPLICATION SOFTWARE FOR MOBILE PHONES, NAMELY, SOFTWARE FOR DISPLAYING AND SHARING A USER'S LOCATION; FINDING, LOCATING, AND INTERACTING WITH OTHER USERS AND PLACES; AND FINDING NEARBY BARS, CLUBS AND RESTAURANTS TO BUY A DRINK OR OFFER TO BUY OTHER USERS A DRINK; DOWNLOADABLE SOFTWARE IN THE NATURE OF A MOBILE APPLICATION FOR DISPLAYING AND SHARING A USER'S LOCATION, FINDING, LOCATING, AND INTERACTING WITH OTHER USERS AND PLACES; AND FINDING NEARBY BARS, CLUBS AND RESTAURANTS TO BUY A DRINK OR OFFER TO BUY OTHER USERS A DRINK (U.S. CLS. 21, 23, 26, 36 AND 38).

#### **CLASS 35—ADVERTISING AND BUSINESS**

FOR ADVERTISEMENT VIA MOBILE PHONE NETWORKS; ADVERTISING AND MARKETING SERVICES PROVIDED BY MEANS OF INDIRECT METHODS OF MARKETING COMMUNICATIONS, NAMELY, SOCIAL MEDIA, SEARCH ENGINE MARKETING, INQUIRY MARKETING, INTERNET MARKETING, MOBILE MARKETING, BLOGGING AND OTHER FORMS OF PASSIVE, SHARABLE OR VIRAL COMMUNICATIONS CHANNELS; ADVERTISING, INCLUDING PROMOTION RELATING TO THE SALE OF ARTICLES AND SERVICES FOR THIRD PARTIES BY THE TRANSMISSION OF ADVERTISING MATERIAL AND THE DISSEMINATION OF ADVERTISING MESSAGES ON COMPUTER NETWORKS; ONLINE SERVICE FOR CONNECTING SOCIAL NETWORK USERS WITH RETAILERS FOR THE PURPOSE OF FACILITATING DISCOUNTED PURCHASES; PROMOTING THE SALE OF GOODS AND SERVICES OF OTHERS THROUGH ELECTRONIC COUPONING, PROMOTIONS AND DISCOUNTS (U.S. CLS. 100, 101 AND 102).

#### **CLASS 45—PERSONAL AND LEGAL SERVICES**

FOR ON-LINE SOCIAL NETWORKING SERVICES (U.S. CLS. 100 AND 101).  
JILL PRATER, EXAMINING ATTORNEY

SN 85-194,702. NEVER BORING DESIGN ASSOCIATES, INC., MODESTO, CA. FILED 12-9-2010.

### **NEVER BORING DESIGN**

THE MARK CONSISTS OF STANDARD CHARACTERS WITHOUT CLAIM TO ANY PARTICULAR FONT, STYLE, SIZE, OR COLOR.  
NO CLAIM IS MADE TO THE EXCLUSIVE RIGHT TO USE "DESIGN", APART FROM THE MARK AS SHOWN.

#### **CLASS 35—ADVERTISING AND BUSINESS**

FOR ADVERTISING SERVICES, PUBLIC RELATIONS AND MARKETING SERVICES, NAMELY, PROMOTING THE GOODS AND SERVICES OF OTHERS, THROUGH ALL PUBLIC COMMUNICATION MEANS (U.S. CLS. 100, 101 AND 102).

FIRST USE 2-1-1983; IN COMMERCE 1-1-1984.

#### **CLASS 42—SCIENTIFIC AND COMPUTER SERVICES**

FOR GRAPHIC DESIGN SERVICES, ALSO DESIGNING AND CREATING WEBSITES FOR OTHERS (U.S. CLS. 100 AND 101).

FIRST USE 2-1-1983; IN COMMERCE 1-1-1984.

JOHN GARTNER, EXAMINING ATTORNEY

SN 85-194,929. SOCIETY OF MANUFACTURING ENGINEERS, DEARBORN, MI. FILED 12-10-2010.

### **AERODEF MANUFACTURING**

THE MARK CONSISTS OF STANDARD CHARACTERS WITHOUT CLAIM TO ANY PARTICULAR FONT, STYLE, SIZE, OR COLOR.

NO CLAIM IS MADE TO THE EXCLUSIVE RIGHT TO USE "MANUFACTURING", APART FROM THE MARK AS SHOWN.

#### **CLASS 35—ADVERTISING AND BUSINESS**

FOR ARRANGING AND CONDUCTING BUSINESS CONFERENCES AND EXPOSITIONS IN THE FIELD OF AEROSPACE AND DEFENSE MANUFACTURING (U.S. CLS. 100, 101 AND 102).

FIRST USE 3-23-2010; IN COMMERCE 3-23-2010.

#### **CLASS 41—EDUCATION AND ENTERTAINMENT**

FOR EDUCATIONAL SERVICES, NAMELY, ARRANGING AND CONDUCTING CONFERENCES AND EXPOSITIONS IN THE FIELD OF AEROSPACE AND DEFENSE MANUFACTURING FOR NON-BUSINESS AND NON-COMMERCIAL PURPOSES (U.S. CLS. 100, 101 AND 107).

FIRST USE 3-23-2010; IN COMMERCE 3-23-2010.

CHRISTINE MARTIN, EXAMINING ATTORNEY

SN 85-194,946. WIZPERT, INC., NEW YORK, NY. FILED 12-10-2010.

### **WIZPERT**

THE MARK CONSISTS OF STANDARD CHARACTERS WITHOUT CLAIM TO ANY PARTICULAR FONT, STYLE, SIZE, OR COLOR.

**CLASS 9—ELECTRICAL AND SCIENTIFIC APPARATUS**

FOR COMPUTER APPLICATION SOFTWARE FOR MOBILE DEVICES ENABLING USERS TO BUY, SELL, PROVIDE, RECEIVE, AND EXCHANGE PERSONAL AND BUSINESS SERVICES (U.S. CLS. 21, 23, 26, 36 AND 38).

**CLASS 35—ADVERTISING AND BUSINESS**

FOR INFOMEDIARY SERVICES, NAMELY, FACILITATING TRANSACTIONS BETWEEN BUYERS AND SELLERS THROUGH PROVIDING BUYERS WITH INFORMATION ABOUT SELLERS AND SERVICES (U.S. CLS. 100, 101 AND 102).

**CLASS 42—SCIENTIFIC AND COMPUTER SERVICES**

FOR PROVIDING A WEB SITE FEATURING TEMPORARY USE OF NON-DOWNLOADABLE SOFTWARE THAT MATCHES BUYERS, SELLERS, PROVIDERS, AND RECIPIENTS OF PERSONAL AND BUSINESS SERVICES, AND WHICH ENABLES USERS TO BUY, SELL, PROVIDE, RECEIVE, AND EXCHANGE PERSONAL AND BUSINESS SERVICES (U.S. CLS. 100 AND 101).

VERNA BETH RIRIE, EXAMINING ATTORNEY

SN 85-195,096. JOHNSON & JOHNSON, NEW BRUNSWICK, NJ. FILED 12-10-2010.

**GREAT AMERICAN GROWBACK**

THE MARK CONSISTS OF STANDARD CHARACTERS WITHOUT CLAIM TO ANY PARTICULAR FONT, STYLE, SIZE, OR COLOR.

**CLASS 5—PHARMACEUTICALS**

FOR PHARMACEUTICAL PREPARATIONS FOR USE IN CONNECTION WITH HAIR LOSS (U.S. CLS. 6, 18, 44, 46, 51 AND 52).

**CLASS 44—MEDICAL, BEAUTY AND AGRICULTURAL SERVICES**

FOR PROVIDING INFORMATION IN THE FIELD OF HAIR LOSS (U.S. CLS. 100 AND 101).

KAREN K. BUSH, EXAMINING ATTORNEY

SN 85-195,057. L. SHUMAN AND SONS, LLC, ALEXANDRIA, VA. FILED 12-10-2010.



NO CLAIM IS MADE TO THE EXCLUSIVE RIGHT TO USE "ALEXANDRIA, VIRGINIA", "BAKERY" AND "EST. 1876", APART FROM THE MARK AS SHOWN.

THE MARK CONSISTS OF THE WORDING "SHUMAN'S BAKERY EST. 1876 ALEXANDRIA, VIRGINIA" WITH THE WORD "SHUMAN'S" IN STYLIZED LETTERING BELOW THE WORDS "ALEXANDRIA, VIRGINIA" AND ABOVE TWO HORIZONTAL LINES OF DIFFERENT WIDTHS AND ENDING WITH CURVES ON THE RIGHT ENDS BELOW WHICH APPEARS THE WORD "BAKERY" ABOVE "EST. 1876" WHICH, IN TURN, IS ABOVE TWO HORIZONTAL LINES OF DIFFERENT WIDTHS AND WITH CURVES ON BOTH ENDS AND ABOVE A DESIGN CONSISTING OF A CIRCLE, SEMICIRCLES, CURVING LINES AND A MODIFIED FLEUR-DE-LIS DESIGN.

**CLASS 30—STAPLE FOODS**

FOR BAKERY GOODS (U.S. CL. 46).  
FIRST USE 11-4-2010; IN COMMERCE 11-4-2010.

**CLASS 35—ADVERTISING AND BUSINESS**

FOR RETAIL BAKERY SHOPS (U.S. CLS. 100, 101 AND 102).

COLLEEN DOMBROW, EXAMINING ATTORNEY

SN 85-195,151. SOCIETY OF MANUFACTURING ENGINEERS, DEARBORN, MI. FILED 12-10-2010.



NO CLAIM IS MADE TO THE EXCLUSIVE RIGHT TO USE "MANUFACTURING", APART FROM THE MARK AS SHOWN.

THE MARK CONSISTS OF THE WORD "AERODEF" ABOVE THE WORD "MANUFACTURING" ALL TO THE LEFT OF A BROKEN ARROWHEAD.

**CLASS 35—ADVERTISING AND BUSINESS**

FOR ARRANGING AND CONDUCTING BUSINESS CONFERENCES AND EXPOSITIONS IN THE FIELD OF AEROSPACE AND DEFENSE MANUFACTURING (U.S. CLS. 100, 101 AND 102).

FIRST USE 3-23-2010; IN COMMERCE 3-23-2010.

**CLASS 41—EDUCATION AND ENTERTAINMENT**

FOR EDUCATIONAL SERVICES, NAMELY, ARRANGING AND CONDUCTING CONFERENCES AND EXPOSITIONS IN THE FIELD OF AEROSPACE AND DEFENSE MANUFACTURING FOR NON-BUSINESS AND NON-COMMERCIAL PURPOSES (U.S. CLS. 100, 101 AND 107).

FIRST USE 3-23-2010; IN COMMERCE 3-23-2010.  
CHRISTINE MARTIN, EXAMINING ATTORNEY

SN 85-195,165. SLICK RIDES, INC., DBA SEWFINE INTERIOR PRODUCTS, AMARILLO, TX. FILED 12-10-2010.



THE MARK CONSISTS OF THE WORD "SEWFINE" IN STYLIZED SCRIPT INSCRIBED INSIDE AN ELLIPSE WITH A SEWING NEEDLE SITUATED BENEATH THE WORD "SEWFINE".

#### CLASS 12—VEHICLES

FOR AUTOMOBILE PARTS AND ACCESSORIES, NAMELY, SEAT COVERS, DOOR PANELS, HEADLINERS, CONVERTIBLE TOPS, REPLACEMENT SEATS, WINDSHIELD SUN SHADES, TOP PADS FOR CONVERTIBLE TOPS COMPRISING FABRIC LINERS AND FOAM PADDING, FOR AUTOMOBILES AND PICK-UP TRUCKS, AND MOLDED DOOR PANELS FOR PICK-UP TRUCKS (U.S. CLS. 19, 21, 23, 31, 35 AND 44).  
FIRST USE 1-1-1980; IN COMMERCE 1-1-1980.

#### CLASS 27—FLOOR COVERINGS

FOR AUTOMOBILE CARPETING (U.S. CLS. 19, 20, 37, 42 AND 50).  
FIRST USE 1-1-1980; IN COMMERCE 1-1-1980.

#### CLASS 40—MATERIAL TREATMENT

FOR CUSTOM MANUFACTURE OF AUTOMOTIVE SEAT COVERS, REPLACEMENT FLOOR CARPETS, DOOR PANELS, HEADLINERS, CONVERTIBLE TOPS, REPLACEMENT SEATS, AND TOP PADS (U.S. CLS. 100, 103 AND 106).  
FIRST USE 1-1-1980; IN COMMERCE 1-1-1980.  
CHARLOTTE CORWIN, EXAMINING ATTORNEY

SN 85-195,167. ANDREW BETTIS AVIATION, MEMPHIS, TN. FILED 12-10-2010.

# AB AVIATION

THE MARK CONSISTS OF STANDARD CHARACTERS WITHOUT CLAIM TO ANY PARTICULAR FONT, STYLE, SIZE, OR COLOR.  
NO CLAIM IS MADE TO THE EXCLUSIVE RIGHT TO USE "AVIATION", APART FROM THE MARK AS SHOWN.

#### CLASS 35—ADVERTISING AND BUSINESS

FOR BUSINESS MANAGEMENT SERVICES, NAMELY, AIRCRAFT MANAGEMENT FOR OTHERS (U.S. CLS. 100, 101 AND 102).  
FIRST USE 7-1-2009; IN COMMERCE 7-1-2009.

#### CLASS 39—TRANSPORTATION AND STORAGE

FOR AIR TRANSPORTATION OF PASSENGERS AND FREIGHT (U.S. CLS. 100 AND 105).  
FIRST USE 7-1-2009; IN COMMERCE 7-1-2009.  
CHARLOTTE CORWIN, EXAMINING ATTORNEY

SN 85-195,302. STACY'S PITA CHIP COMPANY, INC., RANDOLF, MA. FILED 12-10-2010.

## STACY'S CRACKER CRISPS

THE MARK CONSISTS OF STANDARD CHARACTERS WITHOUT CLAIM TO ANY PARTICULAR FONT, STYLE, SIZE, OR COLOR.

OWNER OF U.S. REG. NOS. 3,162,759, 3,162,779 AND OTHERS.

NO CLAIM IS MADE TO THE EXCLUSIVE RIGHT TO USE "CRACKER CRISPS", APART FROM THE MARK AS SHOWN.

THE NAME "STACY" IDENTIFIES A LIVING INDIVIDUAL WHOSE CONSENT IS OF RECORD.

#### CLASS 29—MEATS AND PROCESSED FOODS

FOR NUT-BASED SNACK FOODS; NUT-BASED SNACK FOODS, NAMELY, NUT CRISPS (U.S. CL. 46).

#### CLASS 30—STAPLE FOODS

FOR BAGEL CHIPS; CRACKERS; EDIBLE WAFERS; FLOUR-BASED CHIPS; GRAIN-BASED CHIPS; PITA CHIPS; WHEAT-BASED SNACK FOODS (U.S. CL. 46).  
WENDY GOODMAN, EXAMINING ATTORNEY

SN 85-195,530. CENTRAL REGIONAL DENTAL TESTING SERVICE, INC., TOPEKA, KS. FILED 12-10-2010.

# crdts

THE MARK CONSISTS OF STANDARD CHARACTERS WITHOUT CLAIM TO ANY PARTICULAR FONT, STYLE, SIZE, OR COLOR.

#### CLASS 16—PAPER GOODS AND PRINTED MATTER

FOR PRINTED PAMPHLETS, BROCHURES, MANUALS, BOOKS, BOOKLETS, LEAFLETS, FLYERS, INFORMATIONAL SHEETS AND NEWSLETTERS, ADHESIVE BACKED STICKERS, AND KITS COMPRISING ONE OR MORE OF THE FOREGOING MATERIALS IN THE FIELD OF DENTISTRY AND DENTAL HYGIENE TESTING AND ACCREDITATION SERVICES (U.S. CLS. 2, 5, 22, 23, 29, 37, 38 AND 50).  
FIRST USE 6-1-1969; IN COMMERCE 2-1-1972.

#### CLASS 42—SCIENTIFIC AND COMPUTER SERVICES

FOR ACCREDITATION SERVICES, NAMELY, DEVELOPING AND ADMINISTERING STANDARDS AND PROCEDURES FOR CERTIFYING PROFESSIONALS IN THE FIELD OF DENTISTRY AND DENTAL HYGIENE (U.S. CLS. 100 AND 101).

FIRST USE 6-1-1969; IN COMMERCE 2-1-1972.  
EDWARD FENNESSY, EXAMINING ATTORNEY

SN 85-195,588. CORAMED TECHNOLOGIES, LLC, NILES, IL. FILED 12-10-2010.

# CORA

THE MARK CONSISTS OF STANDARD CHARACTERS WITHOUT CLAIM TO ANY PARTICULAR FONT, STYLE, SIZE, OR COLOR.

## CLASS 1—CHEMICALS

FOR REAGENTS AND CHEMICALS FOR SCIENTIFIC OR RESEARCH USE IN BLOOD TESTING TO DETERMINE PHYSICAL CHARACTERISTICS OF A BLOOD CLOT, PATIENT COAGULOPATHY OR PATIENT HEMOSTASIS (U.S. CLS. 1, 5, 6, 10, 26 AND 46).

## CLASS 5—PHARMACEUTICALS

FOR REAGENTS AND CHEMICALS FOR MEDICAL OR DIAGNOSTIC USE IN BLOOD TESTING TO DETERMINE PHYSICAL CHARACTERISTICS OF A BLOOD CLOT, PATIENT COAGULOPATHY OR PATIENT HEMOSTASIS (U.S. CLS. 6, 18, 44, 46, 51 AND 52).

## CLASS 10—MEDICAL APPARATUS

FOR COMPUTERIZED BLOOD TESTING APPARATUS AND DISPOSABLE TESTING DEVICES TO DETERMINE PHYSICAL CHARACTERISTICS OF A BLOOD CLOT, PATIENT COAGULOPATHY OR PATIENT HEMOSTASIS (U.S. CLS. 26, 39 AND 44).

## CLASS 42—SCIENTIFIC AND COMPUTER SERVICES

FOR DATA ANALYSIS AND COMPUTERIZED DIAGNOSTIC SERVICES PROVIDED AT POINT OF CARE OR REMOTELY FOR DETERMINING PHYSICAL CHARACTERISTICS OF A BLOOD CLOT, EVALUATING PATIENT COAGULOPATHY OR PATIENT HEMOSTASIS (U.S. CLS. 100 AND 101).

HEATHER SAPP, EXAMINING ATTORNEY

SN 85-195,856. NAS GLOBAL TRADE LTD., DBA GOLDEN HANDS, GRAND RAPIDS, MI. FILED 12-11-2010.



THE COLOR(S) BLACK AND YELLOW-GOLD IS/ARE CLAIMED AS A FEATURE OF THE MARK.

THE MARK CONSISTS OF A BLACK RECTANGLE WITH HORIZONTAL BLACK AND YELLOW-GOLD PANELS. THE UPPER PANEL BEARS THE WORD "GOLDEN" IN YELLOW-GOLD COLOR AND THE LOWER PANEL BEARS THE WORD "HANDS" IN BLACK COLOR.

## CLASS 18—LEATHER GOODS

FOR HANDBAGS, PURSES AND WALLETS (U.S. CLS. 1, 2, 3, 22 AND 41).

## CLASS 24—FABRICS

FOR BED LINEN AND TABLE LINEN; TEXTILE WALL HANGINGS (U.S. CLS. 42 AND 50).

## CLASS 25—CLOTHING

FOR WEARABLE GARMENTS AND CLOTHING, NAMELY, SHIRTS (U.S. CLS. 22 AND 39).

## CLASS 26—FANCY GOODS

FOR EMBROIDERY FOR GARMENTS (U.S. CLS. 37, 39, 40, 42 AND 50).

## CLASS 40—MATERIAL TREATMENT

FOR EMBROIDERY SERVICES (U.S. CLS. 100, 103 AND 106).

DAWN FELDMAN, EXAMINING ATTORNEY

SN 85-195,923. NEILSTEIN, ROSENBERG AND ASSOCIATES, LLC, DBA METALSUCKS, BROOKLYN, NY. FILED 12-11-2010.

# METAL SUCKS

THE MARK CONSISTS OF STANDARD CHARACTERS WITHOUT CLAIM TO ANY PARTICULAR FONT, STYLE, SIZE, OR COLOR.

NO CLAIM IS MADE TO THE EXCLUSIVE RIGHT TO USE "METAL", APART FROM THE MARK AS SHOWN.

SEC. 2(F).

## CLASS 25—CLOTHING

FOR A-SHIRTS; HOODED PULLOVERS; HOODED SWEAT SHIRTS; HOODED SWEATSHIRTS; LONG-SLEEVED SHIRTS; SHIRTS AND SHORT-SLEEVED SHIRTS; SHIRTS FOR INFANTS, BABIES, TODDLERS AND CHILDREN; SHORT-SLEEVED OR LONG-SLEEVED T-SHIRTS; SHORT-SLEEVED SHIRTS; SWEAT SHIRTS; SWEATSHIRTS; T-SHIRTS; TEE SHIRTS; WEARABLE GARMENTS AND CLOTHING, NAMELY, SHIRTS; SKIRTS AND DRESSES (U.S. CLS. 22 AND 39).

FIRST USE 12-26-2006; IN COMMERCE 12-26-2006.

**CLASS 41—EDUCATION AND ENTERTAINMENT**

FOR ENTERTAINMENT INFORMATION SERVICES, NAMELY, PROVIDING INFORMATION AND NEWS RELEASES ABOUT A MUSICAL ARTIST; ENTERTAINMENT SERVICES, NAMELY, PROVIDING A WEB SITE FEATURING NON-DOWNLOADABLE MUSICAL PERFORMANCES, MUSICAL VIDEOS, RELATED FILM CLIPS, PHOTOGRAPHS, AND OTHER MULTIMEDIA MATERIALS FEATURING HARD ROCK AND METAL MUSIC ARTISTS; ENTERTAINMENT SERVICES, NAMELY, PROVIDING A WEB SITE FEATURING PHOTOGRAPHIC AND PROSE PRESENTATIONS FEATURING HARD ROCK AND METAL MUSIC ARTISTS; ENTERTAINMENT SERVICES, NAMELY, PROVIDING A WEB SITE FEATURING PHOTOGRAPHIC, AUDIO, VIDEO AND PROSE PRESENTATIONS FEATURING HARD ROCK AND METAL MUSIC ARTISTS; ENTERTAINMENT SERVICES, NAMELY, PROVIDING A WEB SITE FEATURING PHOTOGRAPHIC, VIDEO AND PROSE PRESENTATIONS FEATURING HARD ROCK AND METAL MUSIC ARTISTS; ENTERTAINMENT SERVICES, NAMELY, PROVIDING NONDOWNLOADABLE PRERECORDED MUSIC, INFORMATION IN THE FIELD OF MUSIC, AND COMMENTARY AND ARTICLES ABOUT MUSIC, ALL ON-LINE VIA A GLOBAL COMPUTER NETWORK; ENTERTAINMENT SERVICES, NAMELY, PROVIDING ON-LINE REVIEWS OF HARD ROCK AND METAL MUSIC ARTISTS; PROVIDING A WEBSITE FEATURING ENTERTAINMENT INFORMATION; PROVIDING A WEBSITE FEATURING INFORMATION ABOUT ARTISTIC STYLES; PROVIDING A WEBSITE FEATURING INFORMATION IN THE FIELD OF MUSIC AND ENTERTAINMENT; PROVIDING AN EDUCATIONAL WEBSITE IN THE FIELDS OF MUSIC AND ENTERTAINMENT; PROVIDING AN INTERNET WEBSITE PORTAL FEATURING LINKS TO MUSICAL ARTIST WEBSITES AND MUSIC PERFORMANCE TICKET INFORMATION; PROVIDING AN INTERNET WEBSITE PORTAL IN THE FIELD OF MUSIC; PROVIDING ONLINE INTERVIEWS FEATURING MUSICIANS IN THE FIELD OF HARD ROCK AND METAL MUSIC ARTISTS FOR ENTERTAINMENT PURPOSES (U.S. CLS. 100, 101 AND 107).

FIRST USE 12-26-2006; IN COMMERCE 12-26-2006.  
SEAN CROWLEY, EXAMINING ATTORNEY

SN 85-195,939. EVERYDAY LEADERSHIP, LLC, SCHENECTADY, NY. FILED 12-11-2010.

**The Uncompromised**

THE MARK CONSISTS OF STANDARD CHARACTERS WITHOUT CLAIM TO ANY PARTICULAR FONT, STYLE, SIZE, OR COLOR.

**CLASS 16—PAPER GOODS AND PRINTED MATTER**

FOR A SERIES OF BOOKS AND WRITTEN ARTICLES IN THE FIELD OF BUSINESS, PERSONAL DEVELOPMENT, AND SELF-IMPROVEMENT (U.S. CLS. 2, 5, 22, 23, 29, 37, 38 AND 50).

**CLASS 41—EDUCATION AND ENTERTAINMENT**

FOR EDUCATIONAL SERVICES, NAMELY, COACHING, TRAINING, AND SPEAKING ENGAGEMENTS IN THE FIELD OF BUSINESS, PERSONAL DEVELOPMENT, AND SELF-IMPROVEMENT (U.S. CLS. 100, 101 AND 107).

FIRST USE 4-5-2010; IN COMMERCE 4-5-2010.  
ROBERT STRUCK, EXAMINING ATTORNEY

SN 85-196,029. 4WARD FINANCIAL MARKETING, HOUSTON, TX. FILED 12-12-2010.

**4WARD MARKETING**

THE MARK CONSISTS OF STANDARD CHARACTERS WITHOUT CLAIM TO ANY PARTICULAR FONT, STYLE, SIZE, OR COLOR.

NO CLAIM IS MADE TO THE EXCLUSIVE RIGHT TO USE "MARKETING", APART FROM THE MARK AS SHOWN.

**CLASS 16—PAPER GOODS AND PRINTED MATTER**

FOR PUBLICATIONS, NAMELY, MAGAZINES, NEWSLETTERS, AND PAMPHLETS IN THE FIELD OF FINANCIAL SERVICES (U.S. CLS. 2, 5, 22, 23, 29, 37, 38 AND 50).

**CLASS 35—ADVERTISING AND BUSINESS**

FOR PROFESSIONAL BUSINESS CONSULTING; BUSINESS MANAGEMENT CONSULTING AND ADVISORY SERVICES; BUSINESS MARKETING CONSULTING, ALL THE FORGOING IN THE FIELD OF FINANCIAL SERVICES (U.S. CLS. 100, 101 AND 102).

**CLASS 41—EDUCATION AND ENTERTAINMENT**

FOR EDUCATION, NAMELY, TRAINING AND MENTORING SERVICES IN THE FIELD OF FINANCIAL SERVICES FOR BROKER-DEALERS AND REGISTERED INVESTMENT ADVISERS; ON-LINE PUBLICATION OF INSTRUCTIONAL ARTICLES IN THE FIELD OF FINANCIAL SERVICES; PROVIDING NEWSLETTERS IN THE FIELD OF FINANCIAL SERVICES VIA E-MAIL; ORGANIZING SEMINARS AND INSTRUCTIONAL COURSES FOR FINANCIAL SERVICES PROVIDERS IN THE FIELDS OF ADVISING, PROMOTION, MARKETING AND BUSINESS DEVELOPMENT (U.S. CLS. 100, 101 AND 107).

CHRISTINA SOBRAL, EXAMINING ATTORNEY

SN 85-196,030. 4WARD FINANCIAL MARKETING, HOUSTON, TX. FILED 12-12-2010.

**4WARD NEWS**

THE MARK CONSISTS OF STANDARD CHARACTERS WITHOUT CLAIM TO ANY PARTICULAR FONT, STYLE, SIZE, OR COLOR.

NO CLAIM IS MADE TO THE EXCLUSIVE RIGHT TO USE "NEWS", APART FROM THE MARK AS SHOWN.

**CLASS 9—ELECTRICAL AND SCIENTIFIC APPARATUS**

FOR DOWNLOADABLE ELECTRONIC PUBLICATIONS IN THE NATURE OF NEWSLETTERS, PERIODICALS AND ONLINE ARTICLES, ALL IN THE FIELD OF FINANCIAL SERVICES (U.S. CLS. 21, 23, 26, 36 AND 38).



**CLASS 16—PAPER GOODS AND PRINTED MATTER**

FOR PUBLICATIONS, NAMELY, NEWSLETTERS, PERIODICALS, BROCHURES, PAMPHLETS, AND INFORMATION SHEETS IN THE FIELD OF FINANCIAL SERVICES (U.S. CLS. 2, 5, 22, 23, 29, 37, 38 AND 50).  
CHRISTINA SOBRAL, EXAMINING ATTORNEY

SN 85-196,651. THE JOHN POWERS MIDDLETON COMPANY LLC, WILMINGTON, DE. FILED 12-13-2010.

# B.R.A.S.H.

SN 85-196,114. THE JOHN POWERS MIDDLETON COMPANY LLC, WILMINGTON, DE. FILED 12-13-2010.

# CORE

THE MARK CONSISTS OF STANDARD CHARACTERS WITHOUT CLAIM TO ANY PARTICULAR FONT, STYLE, SIZE, OR COLOR.

**CLASS 35—ADVERTISING AND BUSINESS**

FOR POLITICAL PARTY SERVICES, NAMELY, PROMOTING THE INTERESTS OF A POLITICAL ORGANIZATION; PROMOTING PUBLIC AWARENESS OF POLITICAL ISSUES AND MATTERS (U.S. CLS. 100, 101 AND 102).

**CLASS 36—INSURANCE AND FINANCIAL**

FOR POLITICAL FUNDRAISING SERVICES (U.S. CLS. 100, 101 AND 102).  
TARA PATE, EXAMINING ATTORNEY

SN 85-196,116. THE JOHN POWERS MIDDLETON COMPANY LLC, WILMINGTON, DE. FILED 12-13-2010.

# THE CORE

THE MARK CONSISTS OF STANDARD CHARACTERS WITHOUT CLAIM TO ANY PARTICULAR FONT, STYLE, SIZE, OR COLOR.

**CLASS 35—ADVERTISING AND BUSINESS**

FOR POLITICAL PARTY SERVICES, NAMELY, PROMOTING THE INTERESTS OF A POLITICAL ORGANIZATION; PROMOTING PUBLIC AWARENESS OF POLITICAL ISSUES AND MATTERS (U.S. CLS. 100, 101 AND 102).

**CLASS 36—INSURANCE AND FINANCIAL**

FOR POLITICAL FUNDRAISING SERVICES (U.S. CLS. 100, 101 AND 102).  
TARA PATE, EXAMINING ATTORNEY

THE MARK CONSISTS OF STANDARD CHARACTERS WITHOUT CLAIM TO ANY PARTICULAR FONT, STYLE, SIZE, OR COLOR.

**CLASS 35—ADVERTISING AND BUSINESS**

FOR POLITICAL PARTY SERVICES, NAMELY, PROMOTING THE INTERESTS OF A POLITICAL ORGANIZATION; PROMOTING PUBLIC AWARENESS OF POLITICAL ISSUES AND MATTERS (U.S. CLS. 100, 101 AND 102).

**CLASS 36—INSURANCE AND FINANCIAL**

FOR POLITICAL FUNDRAISING SERVICES (U.S. CLS. 100, 101 AND 102).  
TARA PATE, EXAMINING ATTORNEY

SN 85-196,754. CONOLLY, BRIAN, BROADWAY, NSW, AUSTRALIA, FILED 12-13-2010.

# Xeflex

THE MARK CONSISTS OF STANDARD CHARACTERS WITHOUT CLAIM TO ANY PARTICULAR FONT, STYLE, SIZE, OR COLOR.

OWNER OF AUSTRALIA REG. NO. 1298324, DATED 12-18-2009, EXPIRES 5-10-2019.

**CLASS 24—FABRICS**

FOR TEXTILE FABRICS FOR THE MANUFACTURE OF CLOTHING (U.S. CLS. 42 AND 50).

**CLASS 25—CLOTHING**

FOR ATHLETIC APPAREL, NAMELY, SHIRTS, PANTS, JACKETS, FOOTWEAR, HATS AND CAPS, ATHLETIC UNIFORMS (U.S. CLS. 22 AND 39).  
WILLIAM VERHOSEK, EXAMINING ATTORNEY

SN 85-197,202. THE QUAKER OATS COMPANY, CHICAGO, IL. FILED 12-14-2010.

# MIXMANIA

THE MARK CONSISTS OF STANDARD CHARACTERS WITHOUT CLAIM TO ANY PARTICULAR FONT, STYLE, SIZE, OR COLOR.

**CLASS 29—MEATS AND PROCESSED FOODS**

FOR SNACK MIX CONSISTING PRIMARILY OF PROCESSED FRUITS, PROCESSED NUTS AND/OR RAISINS (U.S. CL. 46).

**CLASS 30—STAPLE FOODS**

FOR GRAIN-BASED SNACK FOODS (U.S. CL. 46).  
DAWN HAN, EXAMINING ATTORNEY

**CLASS 42—SCIENTIFIC AND COMPUTER SERVICES**

FOR SOFTWARE AS A SERVICE (SAAS) SERVICES FEATURING SOFTWARE FOR AN INTEGRATED TOOLSET FOR INTEGRATING THEATER AND GLOBAL DATA SOURCES (U.S. CLS. 100 AND 101).  
FIRST USE 11-0-2007; IN COMMERCE 11-0-2007.  
SOPHIA S. KIM, EXAMINING ATTORNEY

SN 85-197,368. DUNCAN, LLC, CHAGRIN FALLS, OH.  
FILED 12-14-2010.

SN 85-198,531. GOLINSKE, SUSAN, FARMINGTON HILLS, MI. FILED 12-15-2010.

STREAMING SOLUTIONS FOR  
MODERN BUSINESS

THE MARK CONSISTS OF STANDARD CHARACTERS WITHOUT CLAIM TO ANY PARTICULAR FONT, STYLE, SIZE, OR COLOR.

**CLASS 38—COMMUNICATION**

FOR RESELLING ACCESS TO COMPUTER OPERATING SYSTEMS, COMPUTER APPLICATIONS, COMPUTING ENVIRONMENTS, AND DATA STORAGE FACILITIES HOSTED BY OTHERS OVER COMPUTER NETWORKS AND INTERNETWORKS, INCLUDING THE INTERNET (U.S. CLS. 100, 101 AND 104).

**CLASS 42—SCIENTIFIC AND COMPUTER SERVICES**

FOR NETWORK-BASED CLOUD COMPUTING FEATURING SOFTWARE FOR USE IN FACILITATION OF TELECOMPUTING COLLABORATION, HUMAN RESOURCES SCHEDULING AND MANAGEMENT, AND MEDICAL CASE MANAGEMENT; CONSULTING SERVICES TO END USERS OF REMOTELY HOSTED, NON-DOWNLOADABLE COMPUTER SOFTWARE, NAMELY, COMPUTING ENVIRONMENTS, OPERATING SYSTEMS, APPLICATIONS, AND DATA MANAGEMENT SOFTWARE (U.S. CLS. 100 AND 101).

DOMINIC J. FERRAIUOLO, EXAMINING ATTORNEY

SN 85-197,370. INTELLIGENT SOFTWARE SOLUTIONS, INC., COLORADO SPRINGS, CO. FILED 12-14-2010.

SWIC

THE MARK CONSISTS OF STANDARD CHARACTERS WITHOUT CLAIM TO ANY PARTICULAR FONT, STYLE, SIZE, OR COLOR.

**CLASS 9—ELECTRICAL AND SCIENTIFIC APPARATUS**

FOR COMPUTER SOFTWARE FOR AN INTEGRATED TOOLSET FOR INTEGRATING THEATER AND GLOBAL DATA SOURCES (U.S. CLS. 21, 23, 26, 36 AND 38).  
FIRST USE 11-0-2007; IN COMMERCE 11-0-2007.

Surthriver girl

THE MARK CONSISTS OF STANDARD CHARACTERS WITHOUT CLAIM TO ANY PARTICULAR FONT, STYLE, SIZE, OR COLOR.

**CLASS 35—ADVERTISING AND BUSINESS**

FOR ON-LINE RETAIL STORE SERVICES FEATURING GREETING CARDS (U.S. CLS. 100, 101 AND 102).

**CLASS 40—MATERIAL TREATMENT**

FOR CUSTOM IMPRINTING OF APPAREL, MUGS AND PROMOTIONAL MERCHANDISE (U.S. CLS. 100, 103 AND 106).

RAUL CORDOVA, EXAMINING ATTORNEY

SN 85-198,828. ELANVEDA, DBA ELANVEDA, INC., CALABASAS, CA. FILED 12-15-2010.

ÉLANVEDA

OWNER OF U.S. REG. NO. 3,923,641.  
THE COLOR(S) DARK GREEN AND LIGHT GREEN IS/ARE CLAIMED AS A FEATURE OF THE MARK.  
THE MARK CONSISTS OF THE WORD "ELANVEDA" IN DARK GREEN STYLIZED FONT AND A STYLIZED LEAF DESIGN SHOWN IN DARK GREEN AND LIGHT GREEN.  
THE WORD "ELANVEDA" HAS NO MEANING IN A FOREIGN LANGUAGE.

**CLASS 5—PHARMACEUTICALS**

FOR AROMATIZED BEVERAGES BASED ON FRUIT, PROTEIN, CORDIAL, SUGAR AND OTHER FLUID NUTRIENTS, NAMELY, WEIGHT MANAGEMENT POWDERS FOR USE AS A FOOD FILLERS; DIETARY AND NUTRITIONAL SUPPLEMENTS; DIETARY AND NUTRITIONAL SUPPLEMENTS FOR ENDURANCE SPORTS; DIETARY AND NUTRITIONAL SUPPLEMENTS USED FOR WEIGHT LOSS; DIETARY SUPPLEMENTAL DRINKS IN THE NATURE OF VITAMIN AND MINERAL BEVERAGES; DIETARY SUPPLEMENTS FOR HUMAN CONSUMPTION; DIETARY SUPPLEMENTS IN THE NATURE OF WEIGHT LOSS POWDERS; FOOD SUPPLEMENTS, NAMELY, ANTI-OXIDANTS; HERB TEAS FOR MEDICINAL PURPOSES; HERBAL DRINKS USED TO AID IN SLEEP AND RELAXATION; HERBAL SUPPLEMENTS; HERBAL SUPPLEMENTS FOR SLEEPING PROBLEMS; MEDICINAL DRINKS; NUTRITIONAL SUPPLEMENTS IN LOTION FORM SOLD AS A COMPONENT OF NUTRITIONAL SKIN CARE PRODUCTS; NUTRITIONALLY FORTIFIED BEVERAGES; NUTRITIONALLY FORTIFIED WATER (U.S. CLS. 6, 18, 44, 46, 51 AND 52).

**CLASS 30—STAPLE FOODS**

FOR BEVERAGES MADE OF TEA; BEVERAGES WITH A TEA BASE (U.S. CL. 46).  
DAVID YONTEF, EXAMINING ATTORNEY

SN 85-199,331. SBV GROUP, WANCHAI, HONG KONG, FILED 12-16-2010.



THE STIPPLING IS FOR SHADING PURPOSES ONLY. THE MARK CONSISTS OF A STAR WITH THE STYLIZED TEXT "SPARK DOGZ". ON THE TOP RIGHT THERE IS A PAW PRINT.

**CLASS 28—TOYS AND SPORTING GOODS**

FOR PLUSH TOYS; TALKING TOYS (U.S. CLS. 22, 23, 38 AND 50).

**CLASS 41—EDUCATION AND ENTERTAINMENT**

FOR ENTERTAINMENT SERVICES IN THE NATURE OF ON-GOING TELEVISION PROGRAMS IN THE FIELD OF CHILDREN'S ENTERTAINMENT (U.S. CLS. 100, 101 AND 107).  
DOMINIC J. FERRAIUOLO, EXAMINING ATTORNEY

SN 85-199,473. KAY YOW CANCER FOUNDATION, INC., AKA KAY YOW CANCER FUND, CARY, NC. FILED 12-16-2010.

**KAY YOW CANCER FUND**

THE MARK CONSISTS OF STANDARD CHARACTERS WITHOUT CLAIM TO ANY PARTICULAR FONT, STYLE, SIZE, OR COLOR.

OWNER OF U.S. REG. NOS. 3,589,502 AND 3,635,696.  
NO CLAIM IS MADE TO THE EXCLUSIVE RIGHT TO USE "CANCER FUND", APART FROM THE MARK AS SHOWN.

THE NAME(S), PORTRAIT(S), AND/OR SIGNATURE(S) SHOWN IN THE MARK DOES NOT IDENTIFY A PARTICULAR LIVING INDIVIDUAL.

**CLASS 35—ADVERTISING AND BUSINESS**

FOR PROMOTING THE PUBLIC AWARENESS OF THE NEED FOR FINDING A CURE FOR CANCER, CANCER RESEARCH AND ASSISTING THE UNDER-SERVED (U.S. CLS. 100, 101 AND 102).  
FIRST USE 9-14-2010; IN COMMERCE 9-14-2010.

**CLASS 36—INSURANCE AND FINANCIAL**

FOR CHARITABLE FUND RAISING SERVICES (U.S. CLS. 100, 101 AND 102).  
FIRST USE 9-14-2010; IN COMMERCE 9-14-2010.  
ELLEN BURNS, EXAMINING ATTORNEY

SN 85-199,892. ROCKWELL AUTOMATION, INC., MILWAUKEE, WI. FILED 12-16-2010.

**TOTAL COST TO DESIGN,  
DEVELOP AND DELIVER**

THE MARK CONSISTS OF STANDARD CHARACTERS WITHOUT CLAIM TO ANY PARTICULAR FONT, STYLE, SIZE, OR COLOR.

**CLASS 35—ADVERTISING AND BUSINESS**

FOR BUSINESS CONSULTING SERVICES RELATED TO INDUSTRIAL AUTOMATION; ASSESSING COLLABORATIVE BUSINESS PROCESSES AND RESULTS TO ENHANCE COMPANY VALUE, NAMELY, BUSINESS MANAGEMENT CONSULTING IN RELATION TO STRATEGY, MARKETING, PRODUCTION, PERSONNEL, EQUIPMENT, AND SALE MATTERS FOR COMPANIES (U.S. CLS. 100, 101 AND 102).

**CLASS 41—EDUCATION AND ENTERTAINMENT**

FOR PROVIDING EDUCATION AND TRAINING TO THE CUSTOMERS, MEDIA AND EMPLOYEES, NAMELY, PROVIDING CLASSES, SEMINARS, WORKSHOPS, PRESENTATIONS AND MEETINGS IN THE FIELD OF INDUSTRIAL AUTOMATION (U.S. CLS. 100, 101 AND 107).  
JASON TURNER, EXAMINING ATTORNEY

SN 85-199,939. KAY YOW CANCER FOUNDATION, INC., AKA KAY YOW CANCER FUND, CARY, NC. FILED 12-16-2010.



OWNER OF U.S. REG. NOS. 3,589,502 AND 3,635,696. NO CLAIM IS MADE TO THE EXCLUSIVE RIGHT TO USE "CANCER FUND", APART FROM THE MARK AS SHOWN.

THE NAME(S), PORTRAIT(S), AND/OR SIGNATURE(S) SHOWN IN THE MARK DOES NOT IDENTIFY A PARTICULAR LIVING INDIVIDUAL.

THE COLOR(S) PINK AND BLACK IS/ARE CLAIMED AS A FEATURE OF THE MARK.

THE MARK CONSISTS OF THE WORDS "KAY YOW CANCER FUND" IN A STYLIZED BLACK FONT WITH THE LETTERS "O" AND "W" IN "YOW" OUTLINED IN PINK, THE LETTER "Y" CONSISTING OF A FANCIFUL PINK RIBBON AND THE WORDS "YOW" AND "FUND" OUTLINED IN BLACK.

#### CLASS 35—ADVERTISING AND BUSINESS

FOR PROMOTING THE PUBLIC AWARENESS OF THE NEED FOR FINDING A CURE FOR CANCER, CANCER RESEARCH AND ASSISTING THE UNDERSERVED (U.S. CLS. 100, 101 AND 102).

FIRST USE 9-14-2010; IN COMMERCE 9-14-2010.

#### CLASS 36—INSURANCE AND FINANCIAL

FOR CHARITABLE FUND RAISING SERVICES (U.S. CLS. 100, 101 AND 102).

FIRST USE 9-14-2010; IN COMMERCE 9-14-2010.  
ELLEN BURNS, EXAMINING ATTORNEY

SN 85-200,256. BLUE OX HOCKEY, LLC, DBA MUSKEGON LUMBERJACKS, MUSKEGON, MI. FILED 12-17-2010.

# Lumberjacks

THE MARK CONSISTS OF STANDARD CHARACTERS WITHOUT CLAIM TO ANY PARTICULAR FONT, STYLE, SIZE, OR COLOR.

#### CLASS 25—CLOTHING

FOR HOCKEY TEAM SPORTSWEAR, NAMELY, HATS, JACKETS, SHIRTS, AND SWEATSHIRTS, SOLD ONLY ON TEAM WEBSITES AND IN TEAM ARENAS (U.S. CLS. 22 AND 39).

FIRST USE 10-20-2010; IN COMMERCE 10-20-2010.

#### CLASS 41—EDUCATION AND ENTERTAINMENT

FOR ENTERTAINMENT IN THE NATURE OF HOCKEY GAMES (U.S. CLS. 100, 101 AND 107).

FIRST USE 10-2-2010; IN COMMERCE 10-2-2010.

ROBIN CHOSID, EXAMINING ATTORNEY

SN 85-200,265. FOCUSEDBUYER LLC, EASTON, PA. FILED 12-17-2010.

# FOCUSEDBUYER

THE MARK CONSISTS OF STANDARD CHARACTERS WITHOUT CLAIM TO ANY PARTICULAR FONT, STYLE, SIZE, OR COLOR.

#### CLASS 35—ADVERTISING AND BUSINESS

FOR OPERATING AN ONLINE MARKETPLACE FOR BUYERS AND SELLERS OF GOODS AND/OR SERVICES FOR FACILITATING TRANSACTIONS FOR PURCHASE OF GOODS AND SERVICES INCLUDING RETAIL AND POINT OF PURCHASE TRANSACTIONS AND PAYMENT SETTLEMENT (U.S. CLS. 100, 101 AND 102).

FIRST USE 1-29-2010; IN COMMERCE 1-29-2010.

#### CLASS 42—SCIENTIFIC AND COMPUTER SERVICES

FOR HOSTING WEB SITES ON A COMPUTER SERVER FOR A GLOBAL COMPUTER NETWORK WHICH FEATURE ELECTRONIC MARKETPLACES FOR FACILITATING TRANSACTIONS FOR PURCHASE OF GOODS AND SERVICES INCLUDING RETAIL AND POINT OF PURCHASE TRANSACTIONS AND PAYMENT SETTLEMENT (U.S. CLS. 100 AND 101).

FIRST USE 1-29-2010; IN COMMERCE 1-29-2010.

THOMAS MANOR, EXAMINING ATTORNEY

SN 85-200,280. NANO HOLDING GMBH, BAD WIESSEE, FED REP GERMANY, FILED 12-17-2010.



THE MARK CONSISTS OF THE DESIGN OF A SOCCER BALL WITH A STYLIZED LETTER N.

#### CLASS 5—PHARMACEUTICALS

FOR VITAMIN AND FOOD SUPPLEMENTS (U.S. CLS. 6, 18, 44, 46, 51 AND 52).

#### CLASS 35—ADVERTISING AND BUSINESS

FOR RETAIL AND ON-LINE STORE SERVICES FEATURING VITAMIN AND FOOD SUPPLEMENTS (U.S. CLS. 100, 101 AND 102).

THOMAS MANOR, EXAMINING ATTORNEY

SN 85-200,339. COVIDIEN AG, NEUHAUSEN AM RHEINFALL, SWITZERLAND, FILED 12-17-2010.

# COVIDIEN

THE MARK CONSISTS OF STANDARD CHARACTERS WITHOUT CLAIM TO ANY PARTICULAR FONT, STYLE, SIZE, OR COLOR.

OWNER OF SWITZERLAND REG. NO. 554876, DATED 1-30-2007, EXPIRES 10-20-2016.

OWNER OF U.S. REG. NOS. 3,361,986, 3,582,123 AND OTHERS.

## CLASS 3—COSMETICS AND CLEANING PREPARATIONS

FOR SKIN CARE PREPARATIONS, NAMELY, MOISTURE BARRIER CREAMS AND MOISTURIZING LOTIONS; SKIN CLEANSERS; HAIR SHAMPOO; NON-MEDICATED SOOTHING OINTMENTS (U.S. CLS. 1, 4, 6, 50, 51 AND 52).

## CLASS 5—PHARMACEUTICALS

FOR PHARMACEUTICALS, NAMELY, ANTI-INFLAMMATORY PREPARATIONS; MEDICAL PREPARATIONS FOR THE TREATMENT, RECONSTRUCTION, RE-CONTOURING AND REPAIR OF HUMAN TISSUE; MEDICAL PRODUCTS, NAMELY BIOLOGICAL PREPARATIONS FOR THE REPLACEMENT, REPAIR OR AUGMENTATION OF BONE; MEDICAL PREPARATIONS FOR THE TREATMENT OF CARDIOVASCULAR DISORDERS AND CONDITIONS, NAMELY, NON-ADHESIVE LIQUID EMBOLIC AGENTS; ANTIMICROBIAL BODY CLEANSERS; ANTIFUNGAL PREPARATIONS FOR MEDICAL AND SANITARY USE (U.S. CLS. 6, 18, 44, 46, 51 AND 52).

## CLASS 9—ELECTRICAL AND SCIENTIFIC APPARATUS

FOR COMPUTER SOFTWARE FOR USE IN MONITORING AND PROCESSING ELECTROENCEPHALOGRAPH SIGNALS; COMPUTER SOFTWARE FOR USE IN A MEDICAL IMAGING SYSTEM THAT ENABLES AND CONTROLS THE INJECTION OF CONTRAST MEDIA VIA MANIPULATION OF A TOUCH SCREEN DISPLAY; COMPUTER SOFTWARE FOR USE WITH MEDICAL PULSE OXIMETERS; COMPUTER SOFTWARE FOR MEDICAL VENTILATORS; MEDICAL DATA INTEGRATION SYSTEM COMPRISED OF COMPUTER HARDWARE AND SOFTWARE FOR MANAGEMENT OF MEDICAL AND PATIENT INFORMATION IN HOSPITALS AND MEDICAL PRACTICE (U.S. CLS. 21, 23, 26, 36 AND 38).

## CLASS 10—MEDICAL APPARATUS

FOR MEDICAL, SURGICAL AND VETERINARY APPARATUS, INSTRUMENTS AND DEVICES FOR USE IN GENERAL SURGERY; MEDICAL, SURGICAL AND VETERINARY APPARATUS, INSTRUMENTS AND DEVICES FOR USE IN ORTHOPEDIC SURGERY; MEDICAL, SURGICAL AND VETERINARY APPARATUS, INSTRUMENTS AND DEVICES FOR USE IN UROLOGICAL AND GYNECOLOGICAL SURGERY; MEDICAL, SURGICAL AND VETERINARY APPARATUS, INSTRUMENTS AND DEVICES FOR USE IN ABDOMINAL SURGERY; MEDICAL, SURGICAL AND VETERINARY APPARATUS, INSTRUMENTS AND DEVICES FOR USE IN VASCULAR AND CARDIAC SURGERY; MEDICAL, SURGICAL AND VETERINARY APPARATUS, INSTRUMENTS AND DEVICES FOR USE IN GASTRO-OESOPHAGAL SURGERY; MEDICAL, SURGICAL AND VETERINARY APPARATUS, INSTRUMENTS AND DEVICES FOR USE IN ANAL AND COLORECTAL SURGERY; MEDICAL, SURGICAL AND VETERINARY APPARATUS, INSTRUMENTS AND DEVICES FOR USE IN PLASTIC AND RECONSTRUCTIVE SURGERY; MEDICAL AND SURGICAL DEVICES, NAMELY, SHEATHS, EMBOLIC PROTECTION DEVICES, VASCULAR AND CORONARY OCCLUSION DEVICES, VASCULAR PROBES, FILTERS, SNARES AND MICRO SNARES, ENDOVASCULAR AND EMBOLIC COILS, WIRES AND CONNECTORS, IRRIGATION AND ASPIRATION DEVICES FOR EXCHANGE OF FLUIDS IN A BODY LUMEN, MOTOR DRIVE UNITS TO POWER VASCULAR CATHETERS; MEDICAL AND SURGICAL DEVICES FOR USE IN ENDOVASCULAR PROCEDURES, NAMELY, VASCULAR SEALINGS AND ACCESS DEVICES, SEPTAL OCCLUDERS, PFO DEVICES, THROMBECTOMY DEVICES; MEDICAL AND SURGICAL DRILLS FOR USE IN SOFT TISSUE REPAIR AND RECONSTRUCTION; MINIMALLY INVASIVE MEDICAL AND SURGICAL DEVICES FOR ENDOVASCULAR DIAGNOSIS AND THERAPY OF VASCULAR DISEASES; ARTIFICIAL VASCULAR GRAFTS FOR USE IN THE TREATMENT OF CEREBRAL ANEURYSMS; BONE IMPLANTS, BONE FILLERS AND BONE GRAFTING MATERIALS COMPRISING NON-LIVING MATERIALS (U.S. CLS. 26, 39 AND 44).

MENTS AND DEVICES FOR USE IN GASTRO-OESOPHAGAL SURGERY; MEDICAL, SURGICAL AND VETERINARY APPARATUS, INSTRUMENTS AND DEVICES FOR USE IN ANAL AND COLORECTAL SURGERY; MEDICAL, SURGICAL AND VETERINARY APPARATUS, INSTRUMENTS AND DEVICES FOR USE IN PLASTIC AND RECONSTRUCTIVE SURGERY; MEDICAL AND SURGICAL DEVICES, NAMELY, SHEATHS, EMBOLIC PROTECTION DEVICES, VASCULAR AND CORONARY OCCLUSION DEVICES, VASCULAR PROBES, FILTERS, SNARES AND MICRO SNARES, ENDOVASCULAR AND EMBOLIC COILS, WIRES AND CONNECTORS, IRRIGATION AND ASPIRATION DEVICES FOR EXCHANGE OF FLUIDS IN A BODY LUMEN, MOTOR DRIVE UNITS TO POWER VASCULAR CATHETERS; MEDICAL AND SURGICAL DEVICES FOR USE IN ENDOVASCULAR PROCEDURES, NAMELY, VASCULAR SEALINGS AND ACCESS DEVICES, SEPTAL OCCLUDERS, PFO DEVICES, THROMBECTOMY DEVICES; MEDICAL AND SURGICAL DRILLS FOR USE IN SOFT TISSUE REPAIR AND RECONSTRUCTION; MINIMALLY INVASIVE MEDICAL AND SURGICAL DEVICES FOR ENDOVASCULAR DIAGNOSIS AND THERAPY OF VASCULAR DISEASES; ARTIFICIAL VASCULAR GRAFTS FOR USE IN THE TREATMENT OF CEREBRAL ANEURYSMS; BONE IMPLANTS, BONE FILLERS AND BONE GRAFTING MATERIALS COMPRISING NON-LIVING MATERIALS (U.S. CLS. 26, 39 AND 44).

CHARLES L. JENKINS, EXAMINING ATTORNEY

SN 85-200,465. ECONOCORP, INC., RANDOLPH, MA. FILED 12-17-2010.

**ECONO-GREEN**  
CARTONS FOR A RESPONSIBLE FUTURE

NO CLAIM IS MADE TO THE EXCLUSIVE RIGHT TO USE "CARTONS", APART FROM THE MARK AS SHOWN.

THE MARK CONSISTS OF THE WORDS ECONO-GREEN ON A HORIZONTAL BACKGROUND SUGGESTING A PAINT STROKE, WITH THE WORDS CARTONS FOR A RESPONSIBLE FUTURE SHOWN BENEATH.

## CLASS 7—MACHINERY

FOR MACHINES FOR MAKING AND SEALING CARTONS IN AN ENVIRONMENTALLY SENSITIVE MANNER (U.S. CLS. 13, 19, 21, 23, 31, 34 AND 35).

## CLASS 16—PAPER GOODS AND PRINTED MATTER

FOR PAPER SOLD IN ROLL FORM FOR USE IN MACHINES FOR MAKING AND SEALING CARTONS IN AN ENVIRONMENTALLY SENSITIVE MANNER (U.S. CLS. 2, 5, 22, 23, 29, 37, 38 AND 50).

FONG HSU, EXAMINING ATTORNEY

SN 85-200,756. THE BLACK AND DECKER CORPORATION, TOWSON, MD. FILED 12-17-2010.



THE MARK CONSISTS OF "WEARABLE BACKING" IN ARIAL BLACK LETTERS WITH THE "WEARABLE" POSITIONED ON TOP OF THE "BACKING" AND WITH THE WORDS RELATIVELY POSITIONED TO START AND END TOGETHER AND A DESIGN WHICH SHOWS THE HALF OF A FLAP DISK GRINDING WHEEL TO THE LEFT OF A HORIZONTAL LINE THROUGH THE AXIS OF ROTATION OF THE WHEEL WHICH IS SLANTED FROM TOP LEFT TO BOTTOM RIGHT TO SHOW WEAR AND WITH THE "WEARABLE BACKING" ADJACENT AND TO THE RIGHT OF THE HORIZONTAL LINE AND WITH THE WHEEL EXTENDING ABOVE THE TOP OF THE "WEARABLE" AND WITH THE WHEEL EXTENDING TO THE BOTTOM OF THE "BACKING".

### CLASS 3—COSMETICS AND CLEANING PREPARATIONS

FOR COATED ABRASIVES AND SANDPAPER IN THE FORM OF DISCS; ABRASIVE PAPER (SANDPAPER) AND SANDPAPER (U.S. CLS. 1, 4, 6, 50, 51 AND 52).  
FIRST USE 6-1-2010; IN COMMERCE 6-1-2010.

### CLASS 7—MACHINERY

FOR POWER-OPERATED GRINDING WHEELS (U.S. CLS. 13, 19, 21, 23, 31, 34 AND 35).  
FIRST USE 6-1-2010; IN COMMERCE 6-1-2010.  
JANICE KIM, EXAMINING ATTORNEY

SN 85-200,949. RING CO., LTD., BANGKOK 10240, THAILAND, FILED 12-17-2010.



OWNER OF THAILAND REG. NO. KOR50330, DATED 10-28-1992, EXPIRES 10-27-2012.

THE MARK CONSISTS OF THE WORD "ELEGANZA" SURROUNDED BY A RING OF ROPE WITH FOUR KNOTS, AT THE TOP OF WHICH IS A CREST WITH A CROWN, THE CREST HAVING 2 DIAGONAL LINES IN THE UPPER LEFT, A STYLIZED CROSS IN THE UPPER RIGHT, AND IN THE BOTTOM A STAR-SHAPED DESIGN WITH 2 WINGS AND 2 FEET.

THE ENGLISH TRANSLATION OF THE ITALIAN WORD "ELEGANZA" IN THE MARK IS "ELEGANCE".

### CLASS 16—PAPER GOODS AND PRINTED MATTER

FOR PEN HOLDERS; PERSONAL ORGANIZERS (U.S. CLS. 2, 5, 22, 23, 29, 37, 38 AND 50).

### CLASS 18—LEATHER GOODS

FOR BAGS FOR PACKAGING OF LEATHER; CANVAS SHOPPING BAGS; CHAIN MESH PURSES; GROOMING ORGANIZERS FOR TRAVEL; HANDBAGS; HANDBAGS FOR LADIES; IMITATION LEATHER; JEWELRY ORGANIZERS FOR TRAVEL; KEY CASES; LEATHER SHOPPING BAGS; NAME CARD CASES; POCKET WALLETS; PURSES; REUSABLE SHOPPING BAGS; SHOPPING BAGS MADE OF SKIN; TEXTILE SHOPPING BAGS; TRAVELLING BAGS; WALLETS (U.S. CLS. 1, 2, 3, 22 AND 41).

### CLASS 25—CLOTHING

FOR BELTS; LEATHER BELTS (U.S. CLS. 22 AND 39).  
HEATHER SAPP, EXAMINING ATTORNEY

SN 85-201,720. FALLEN PINE LLC, MELBOURNE, AR. FILED 12-20-2010.



THE MARK CONSISTS OF THE STYLIZED TEXT "FALLEN PINE" WITH A DESIGN OF A TREE IN THE BACKGROUND OF THE WORD "PINE".

### CLASS 16—PAPER GOODS AND PRINTED MATTER

FOR PHOTOGRAPHS (U.S. CLS. 2, 5, 22, 23, 29, 37, 38 AND 50).  
FIRST USE 10-10-2009; IN COMMERCE 4-16-2010.

### CLASS 20—FURNITURE AND ARTICLES NOT OTHERWISE CLASSIFIED

FOR FURNITURE (U.S. CLS. 2, 13, 22, 25, 32 AND 50).  
FIRST USE 10-10-2009; IN COMMERCE 4-16-2010.

### CLASS 28—TOYS AND SPORTING GOODS

FOR CHRISTMAS TREE ORNAMENTS AND DECORATIONS (U.S. CLS. 22, 23, 38 AND 50).  
FIRST USE 10-10-2009; IN COMMERCE 4-16-2010.  
ROSELLE HERRERA, EXAMINING ATTORNEY

SN 85-201,885. 217 ATLANTIC LLC, DELRAY BEACH, FL. FILED 12-20-2010.

AFTER HOURS PRESENTED BY  
AMG RESTAURANTS

THE MARK CONSISTS OF STANDARD CHARACTERS WITHOUT CLAIM TO ANY PARTICULAR FONT, STYLE, SIZE, OR COLOR.

NO CLAIM IS MADE TO THE EXCLUSIVE RIGHT TO USE "PRESENTED BY" OR "RESTAURANTS", APART FROM THE MARK AS SHOWN.

**CLASS 35—ADVERTISING AND BUSINESS**

FOR OFFERING BUSINESS MANAGEMENT ASSISTANCE IN THE ESTABLISHMENT AND/OR OPERATION OF RESTAURANTS (U.S. CLS. 100, 101 AND 102).

**CLASS 41—EDUCATION AND ENTERTAINMENT**

FOR ARRANGING AND CONDUCTING NIGHTCLUB ENTERTAINMENT EVENTS (U.S. CLS. 100, 101 AND 107).

KIM MONINGHOFF, EXAMINING ATTORNEY

SN 85-202,292. PRECISION THERAPEUTICS, INC., PITTSBURGH, PA. FILED 12-20-2010.

# BIOSPECIFX

THE MARK CONSISTS OF STANDARD CHARACTERS WITHOUT CLAIM TO ANY PARTICULAR FONT, STYLE, SIZE, OR COLOR.

**CLASS 42—SCIENTIFIC AND COMPUTER SERVICES**

FOR MEDICAL LABORATORY SERVICES IN THE FIELD OF TUMOR CULTURE BIOLOGICAL ASSAYS INCLUDING TUMOR PROFILING (U.S. CLS. 100 AND 101).

**CLASS 44—MEDICAL, BEAUTY AND AGRICULTURAL SERVICES**

FOR MEDICAL TESTING IN THE NATURE OF PROVIDING TUMOR CULTURE BIOLOGICAL ASSAYS INCLUDING TUMOR PROFILING (U.S. CLS. 100 AND 101).

LAURA KOVALSKY, EXAMINING ATTORNEY

SN 85-201,896. ILLINOIS TOOL WORKS INC., GLENVIEW, IL. FILED 12-20-2010.



THE MARK CONSISTS OF THE WORDS "DOWN RIVER" NEXT TO A MILL WITH TREES.

**CLASS 17—RUBBER GOODS**

FOR RUBBER PADS USED FOR LOAD SECUREMENT AND DAMAGE PREVENTION OF FRAGILE ITEMS DURING SHIPMENT AND STORAGE (U.S. CLS. 1, 5, 12, 13, 35 AND 50).

**CLASS 20—FURNITURE AND ARTICLES NOT OTHERWISE CLASSIFIED**

FOR FULL LINE OF COMMERCIAL AND INDUSTRIAL PACKAGING MATERIALS MADE PRIMARILY OF CHIPBOARD, WOOD FIBER OR PLASTIC FOR USE DURING TRANSPORT TO HELP SECURE, STABILIZE, STACK, RESTRAIN AND PROTECT SHIPMENTS, NAMELY, CORRUGATED AND CHIPBOARD CAPS FOR PROTECTING PALLETIZED GOODS; CORRUGATED PALLETS; WOODCORE PALLETS; BULKHEAD PANELS; AND BRACE, SPACE AND VOID FILLERS IN THE FORMS OF SOLID INFLEXIBLE BOXES, SOLID BLOCKS, OR PANELS (U.S. CLS. 2, 13, 22, 25, 32 AND 50).

**CLASS 22—CORDAGE AND FIBERS**

FOR COMMERCIAL AND INDUSTRIAL PACKAGING MATERIALS, NAMELY, AIR-FILLED BAGS OF POLY-WOVEN TEXTILE MATERIAL FOR USE TO HELP SECURE, STABILIZE, STACK, RESTRAIN AND PROTECT SHIPMENTS DURING TRANSPORT; WOVEN, FABRIC, AND COMPOSITE STRAPS TO HELP SECURE, STABILIZE, STACK, RESTRAIN AND PROTECT SHIPMENTS; CORD TO HELP SECURE, STABILIZE, STACK, RESTRAIN AND PROTECT SHIPMENTS (U.S. CLS. 1, 2, 7, 19, 22, 42 AND 50).

LESLEY LAMOTHE, EXAMINING ATTORNEY

SN 85-202,300. FAMILIES IN THE LOOP, INC., CHICAGO, IL. FILED 12-20-2010.

# FAMILIES IN THE LOOP

THE MARK CONSISTS OF STANDARD CHARACTERS WITHOUT CLAIM TO ANY PARTICULAR FONT, STYLE, SIZE, OR COLOR.

**CLASS 35—ADVERTISING AND BUSINESS**

FOR BUSINESS NETWORKING (U.S. CLS. 100, 101 AND 102).

FIRST USE 11-4-2010; IN COMMERCE 11-4-2010.

**CLASS 41—EDUCATION AND ENTERTAINMENT**

FOR SOCIAL CLUB SERVICES, NAMELY, ARRANGING, ORGANIZING, AND HOSTING SOCIAL EVENTS, GET-TOGETHERS, AND PARTIES FOR CLUB MEMBERS (U.S. CLS. 100, 101 AND 107).

FIRST USE 11-4-2010; IN COMMERCE 11-4-2010.

ANNE MADDEN, EXAMINING ATTORNEY

SN 85-202,346. G-III LEATHER FASHIONS, INC., NEW YORK, NY. FILED 12-20-2010.

## GLOBAL TOUR

THE MARK CONSISTS OF STANDARD CHARACTERS WITHOUT CLAIM TO ANY PARTICULAR FONT, STYLE, SIZE, OR COLOR.

### CLASS 9—ELECTRICAL AND SCIENTIFIC APPARATUS

FOR COMPUTER BAGS, BRIEFCASES SPECIALLY ADAPTED FOR HOLDING LAPTOP COMPUTERS; AND HOLDERS FOR ELECTRONIC PRODUCTS, NAMELY, CASES FOR CELL PHONES, LAPTOPS AND PORTABLE MEDIA PLAYERS (U.S. CLS. 21, 23, 26, 36 AND 38).

### CLASS 16—PAPER GOODS AND PRINTED MATTER

FOR PASSPORT HOLDERS AND NOTEPAD COVERS (U.S. CLS. 2, 5, 22, 23, 29, 37, 38 AND 50).

### CLASS 18—LEATHER GOODS

FOR LUGGAGE, TOTE BAGS, BRIEFCASES, BRIEFCASE-TYPE PORTFOLIOS, LEATHER AGENDA CASES, WALLETS, CREDIT CARD CASES, BUSINESS CARD CASES, TOILETRY CASES SOLD EMPTY, MAKEUP CASES SOLD EMPTY, LUGGAGE TAGS, LEATHER KEY CHAINS, KEY CASES, JEWELRY ORGANIZERS FOR TRAVEL, SHOE BAGS FOR TRAVEL, AND TRAVEL KITS COMPRISING TRAVEL CASES (U.S. CLS. 1, 2, 3, 22 AND 41).

MARK SPARACINO, EXAMINING ATTORNEY

SN 85-202,416. VAPOR 4 LIFE, INC., NORTHBROOK, IL. FILED 12-21-2010.

## VAPORZEUS

THE MARK CONSISTS OF STANDARD CHARACTERS WITHOUT CLAIM TO ANY PARTICULAR FONT, STYLE, SIZE, OR COLOR.

### CLASS 5—PHARMACEUTICALS

FOR CAFFEINE PREPARATIONS FOR STIMULATIVE USE IN THE FORM OF CHEWING GUM; IMITATION CIGARETTES FOR QUITTING SMOKING; MEDICATED CHEWING GUM; MEDICATED CHEWING GUM FOR CIGARETTE SUBSTITUTE; MEDICATED GUM FOR CIGARETTE SUBSTITUTE; TOBACCO AND SMOKING CESSATION PREPARATIONS THAT TEMPORARILY REDUCE THE DESIRE TO SMOKE; TOBACCO-FREE CIGARETTES FOR MEDICAL PURPOSES (U.S. CLS. 6, 18, 44, 46, 51 AND 52).

### CLASS 34—SMOKERS' ARTICLES

FOR CIGARETTES CONTAINING TOBACCO SUBSTITUTES NOT FOR MEDICAL PURPOSES; ELECTRONIC CIGARETTE LIGHTERS; ELECTRONIC CIGARETTES; TOBACCO SUBSTITUTES; TOBACCO SUBSTITUTES NOT FOR MEDICAL PURPOSES (U.S. CLS. 2, 8, 9 AND 17).

LINDA ORNDORFF, EXAMINING ATTORNEY

SN 85-202,461. SYNTONICS LLC, COLUMBIA, MD. FILED 12-21-2010.



THE MARK CONSISTS OF A STYLIZED IMAGE OF A SOUND WAVE CONTAINING FOUR CURVED LINES FACING A DOWNWARD DIRECTION ABOVE FOUR ADDITIONAL CURVED LINES FACING AN UPWARD DIRECTION.

### CLASS 9—ELECTRICAL AND SCIENTIFIC APPARATUS

FOR DEVICES FOR WIRELESS RADIO TRANSMISSION INCLUDING OVER OPTICAL FIBER; APPARATUS FOR TRANSMISSION OF COMMUNICATIONS INCLUDING OVER OPTICAL FIBER; ANTENNAS; ANTENNAS FOR WIRELESS COMMUNICATION APPARATUS (U.S. CLS. 21, 23, 26, 36 AND 38).

FIRST USE 0-0-2000; IN COMMERCE 0-0-2005.

### CLASS 38—COMMUNICATION

FOR RADIO COMMUNICATION; MOBILE RADIO COMMUNICATION; RADIO COMMUNICATIONS VIA FIBER-OPTIC NETWORKS (U.S. CLS. 100, 101 AND 104).

FIRST USE 0-0-2000; IN COMMERCE 0-0-2000.

### CLASS 42—SCIENTIFIC AND COMPUTER SERVICES

FOR DESIGN AND DEVELOPMENT OF WIRELESS COMMUNICATION SYSTEMS FOR TRANSMISSION AND RECEPTION OF VOICE, DATA AND VIDEO, INCLUDING TRANSMISSION AND RECEPTION OVER OPTICAL FIBER (U.S. CLS. 100 AND 101).

FIRST USE 0-0-2000; IN COMMERCE 0-0-2005.

WILLIAM VERHOSEK, EXAMINING ATTORNEY



SN 85-202,489. AMERICAN COUNCIL OF TRUSTEES AND ALUMNI, WASHINGTON, DC. FILED 12-21-2010.

SN 85-202,657. MENARD, INC., EAU CLAIRE, WI. FILED 12-21-2010.

## What will they learn?

THE MARK CONSISTS OF STANDARD CHARACTERS WITHOUT CLAIM TO ANY PARTICULAR FONT, STYLE, SIZE, OR COLOR.

### **CLASS 16—PAPER GOODS AND PRINTED MATTER**

FOR PRINTED REPORTS FEATURING INFORMATION ON WHETHER COLLEGES REQUIRE THEIR STUDENTS TO LEARN CERTAIN SUBJECT MATTER, WHAT THEY EXPECT THEIR GRADUATES TO STUDY OUTSIDE THEIR MAJORS, HOW MUCH THEY ARE CHARGING, HOW MANY OF THEIR STUDENTS GRADUATE, AND WHAT THE COLLEGES SAY ABOUT THE EDUCATION THEY OFFER (U.S. CLS. 2, 5, 22, 23, 29, 37, 38 AND 50).

FIRST USE 8-31-2009; IN COMMERCE 8-31-2009.

### **CLASS 41—EDUCATION AND ENTERTAINMENT**

FOR PROVIDING A WEBSITE FEATURING INFORMATION ON WHETHER COLLEGES REQUIRE THEIR STUDENTS TO LEARN CERTAIN SUBJECT MATTER, WHAT THEY EXPECT THEIR GRADUATES TO STUDY OUTSIDE THEIR MAJORS, HOW MUCH THEY ARE CHARGING, HOW MANY OF THEIR STUDENTS GRADUATE, AND WHAT THE COLLEGES SAY ABOUT THE EDUCATION THEY OFFER (U.S. CLS. 100, 101 AND 107).

FIRST USE 8-19-2009; IN COMMERCE 8-19-2009.  
WILLIAM VERHOSEK, EXAMINING ATTORNEY

---

SN 85-202,518. PRECISION THERAPEUTICS, INC., PITTSBURGH, PA. FILED 12-21-2010.

## PROFILEFX

THE MARK CONSISTS OF STANDARD CHARACTERS WITHOUT CLAIM TO ANY PARTICULAR FONT, STYLE, SIZE, OR COLOR.

### **CLASS 42—SCIENTIFIC AND COMPUTER SERVICES**

FOR MEDICAL LABORATORY SERVICES IN THE FIELD OF TUMOR CULTURE BIOLOGICAL ASSAYS INCLUDING TUMOR PROFILING (U.S. CLS. 100 AND 101).

### **CLASS 44—MEDICAL, BEAUTY AND AGRICULTURAL SERVICES**

FOR MEDICAL TESTING IN THE NATURE OF PROVIDING TUMOR CULTURE BIOLOGICAL ASSAYS INCLUDING TUMOR PROFILING (U.S. CLS. 100 AND 101).

LAURA KOVALSKY, EXAMINING ATTORNEY

## SMART ELECTRICIAN

THE MARK CONSISTS OF STANDARD CHARACTERS WITHOUT CLAIM TO ANY PARTICULAR FONT, STYLE, SIZE, OR COLOR.

OWNER OF U.S. REG. NO. 3,836,929.

NO CLAIM IS MADE TO THE EXCLUSIVE RIGHT TO USE "ELECTRICIAN", APART FROM THE MARK AS SHOWN.

### **CLASS 9—ELECTRICAL AND SCIENTIFIC APPARATUS**

FOR ELECTRICAL OUTLETS (U.S. CLS. 21, 23, 26, 36 AND 38).

FIRST USE 10-1-2010; IN COMMERCE 10-1-2010.

### **CLASS 11—ENVIRONMENTAL CONTROL APPARATUS**

FOR PORTABLE LIGHTING EQUIPMENT, NAMELY, WORK LIGHTS (U.S. CLS. 13, 21, 23, 31 AND 34).

FIRST USE 11-1-2010; IN COMMERCE 11-1-2010.

### **CLASS 17—RUBBER GOODS**

FOR ELECTRICAL TAPE (U.S. CLS. 1, 5, 12, 13, 35 AND 50).

FIRST USE 6-1-2010; IN COMMERCE 6-1-2010.

WILLIAM BRECKENFELD, EXAMINING ATTORNEY

---

SN 85-202,683. MENARD, INC., EAU CLAIRE, WI. FILED 12-21-2010.

## DESIGNER'S IMAGE

THE MARK CONSISTS OF STANDARD CHARACTERS WITHOUT CLAIM TO ANY PARTICULAR FONT, STYLE, SIZE, OR COLOR.

OWNER OF U.S. REG. NOS. 3,120,159 AND 3,126,304.

### **CLASS 2—PAINTS**

FOR PAINTS (U.S. CLS. 6, 11 AND 16).

FIRST USE 10-1-2009; IN COMMERCE 10-1-2009.

### **CLASS 16—PAPER GOODS AND PRINTED MATTER**

FOR PAINT BRUSHES; PAINT ROLLER COVERS; PAINT ROLLER HANDLES (U.S. CLS. 2, 5, 22, 23, 29, 37, 38 AND 50).

WILLIAM BRECKENFELD, EXAMINING ATTORNEY

SN 85-202,695. BROWN, GARY, R. HUNTERVILLE, NC.  
FILED 12-21-2010.

# Doglovers.com

THE MARK CONSISTS OF STANDARD CHARACTERS WITHOUT CLAIM TO ANY PARTICULAR FONT, STYLE, SIZE, OR COLOR.

## CLASS 20—FURNITURE AND ARTICLES NOT OTHERWISE CLASSIFIED

FOR DOG BEDS (U.S. CLS. 2, 13, 22, 25, 32 AND 50).

## CLASS 31—NATURAL AGRICULTURAL PRODUCTS

FOR DOG FOOD (U.S. CLS. 1 AND 46).  
PAULA MAHONEY, EXAMINING ATTORNEY

SN 85-202,729. AUTOMATED HEALTHCARE SOLUTIONS LLC, MIRAMAR, FL. FILED 12-21-2010.

# Organic Intelligence

THE MARK CONSISTS OF STANDARD CHARACTERS WITHOUT CLAIM TO ANY PARTICULAR FONT, STYLE, SIZE, OR COLOR.

## CLASS 9—ELECTRICAL AND SCIENTIFIC APPARATUS

FOR COMPUTER SOFTWARE FOR USE IN MANAGING THE DISPENSING OF PRESCRIPTION MEDICATION (U.S. CLS. 21, 23, 26, 36 AND 38).

## CLASS 36—INSURANCE AND FINANCIAL

FOR CLAIMS ADMINISTRATION SERVICES IN THE FIELD OF HEALTH INSURANCE (U.S. CLS. 100, 101 AND 102).  
TINA L. SNAPP, EXAMINING ATTORNEY

SN 85-203,029. MCROSKEY MATTRESS COMPANY, SAN FRANCISCO, CA. FILED 12-21-2010.

# MCROSKEY

THE MARK CONSISTS OF STANDARD CHARACTERS WITHOUT CLAIM TO ANY PARTICULAR FONT, STYLE, SIZE, OR COLOR.

OWNER OF U.S. REG. NO. 226,624.

## CLASS 20—FURNITURE AND ARTICLES NOT OTHERWISE CLASSIFIED

FOR MATTRESS, BOX SPRINGS, AND PILLOWS (U.S. CLS. 2, 13, 22, 25, 32 AND 50).  
FIRST USE 10-25-1925; IN COMMERCE 10-25-1925.

## CLASS 35—ADVERTISING AND BUSINESS

FOR RETAIL STORE SERVICES FEATURING BEDDING (U.S. CLS. 100, 101 AND 102).  
FIRST USE 10-25-1925; IN COMMERCE 10-25-1925.  
CHARLES L. JENKINS, EXAMINING ATTORNEY

SN 85-203,206. RR INVESTMENTS, INC., DALLAS, TX.  
FILED 12-21-2010.



OWNER OF U.S. REG. NO. 1,985,250.  
THE MARK CONSISTS OF A DESIGN OF WINGS.

## CLASS 37—CONSTRUCTION AND REPAIR

FOR MAINTENANCE AND REPAIR SERVICES FOR AIRCRAFT (U.S. CLS. 100, 103 AND 106).  
FIRST USE 4-0-1984; IN COMMERCE 4-0-1984.

## CLASS 39—TRANSPORTATION AND STORAGE

FOR AIR TRANSPORTATION SERVICES AND AIR CHARTER SERVICES (U.S. CLS. 100 AND 105).  
FIRST USE 4-0-1984; IN COMMERCE 4-0-1984.  
C. DIONNE CLYBURN, EXAMINING ATTORNEY

SN 85-203,218. HENRY CALABRO, SMITHTOWN, NY.  
FILED 12-21-2010.

# OOH-FAH

THE MARK CONSISTS OF STANDARD CHARACTERS WITHOUT CLAIM TO ANY PARTICULAR FONT, STYLE, SIZE, OR COLOR.

## CLASS 18—LEATHER GOODS

FOR ATHLETIC BAGS; BACKPACKS; BEACH BAGS; HANDBAGS; SPORTS BAGS; TOTE BAGS (U.S. CLS. 1, 2, 3, 22 AND 41).

## CLASS 25—CLOTHING

FOR APRONS; BOXER SHORTS; HATS; HOODED SWEAT SHIRTS; NIGHT SHIRTS; PAJAMAS; PANTS; SHIRTS; SWEAT PANTS; SWEAT SHIRTS; SWEAT SUITS; T-SHIRTS (U.S. CLS. 22 AND 39).  
C. DIONNE CLYBURN, EXAMINING ATTORNEY

SN 85-203,635. HARRY N. ABRAMS, INC., NEW YORK, NY.  
FILED 12-22-2010.

## Abrams Appleseed

THE MARK CONSISTS OF STANDARD CHARACTERS WITHOUT CLAIM TO ANY PARTICULAR FONT, STYLE, SIZE, OR COLOR.

OWNER OF U.S. REG. NOS. 1,229,651, 2,184,766 AND 3,188,182.

### CLASS 16—PAPER GOODS AND PRINTED MATTER

FOR CHILDREN'S BOOKS (U.S. CLS. 2, 5, 22, 23, 29, 37, 38 AND 50).

### CLASS 41—EDUCATION AND ENTERTAINMENT

FOR BOOK PUBLISHING (U.S. CLS. 100, 101 AND 107).  
JOHN DALIER, EXAMINING ATTORNEY

SN 85-203,642. HARRY N. ABRAMS, INC., NEW YORK, NY.  
FILED 12-22-2010.

## Appleseed Books

THE MARK CONSISTS OF STANDARD CHARACTERS WITHOUT CLAIM TO ANY PARTICULAR FONT, STYLE, SIZE, OR COLOR.

NO CLAIM IS MADE TO THE EXCLUSIVE RIGHT TO USE "BOOKS", APART FROM THE MARK AS SHOWN.

### CLASS 16—PAPER GOODS AND PRINTED MATTER

FOR CHILDREN'S BOOKS (U.S. CLS. 2, 5, 22, 23, 29, 37, 38 AND 50).

### CLASS 41—EDUCATION AND ENTERTAINMENT

FOR BOOK PUBLISHING (U.S. CLS. 100, 101 AND 107).  
JOHN DALIER, EXAMINING ATTORNEY

SN 85-203,688. THE AES CORPORATION, ARLINGTON, VA.  
FILED 12-22-2010.

## sOS

THE MARK CONSISTS OF STANDARD CHARACTERS WITHOUT CLAIM TO ANY PARTICULAR FONT, STYLE, SIZE, OR COLOR.

### CLASS 9—ELECTRICAL AND SCIENTIFIC APPARATUS

FOR COMPUTER HARDWARE AND COMPUTER SOFTWARE FOR USE IN THE MANAGEMENT OF POWER PLANT SERVICES AND FOR USE IN THE MANAGEMENT OF ENERGY SERVICES, ENERGY STORAGE PLANTS, ENERGY STORAGE FACILITIES, ENERGY STORAGE FARMS, AND ENERGY STORAGE FLEETS (U.S. CLS. 21, 23, 26, 36 AND 38).

### CLASS 39—TRANSPORTATION AND STORAGE

FOR ELECTRICITY SUPPLY SERVICES, NAMELY, THE TRANSMISSION AND DISTRIBUTION OF ELECTRICITY AND TRANSMISSION OF STEAM FOR OTHERS (U.S. CLS. 100 AND 105).  
INGRID C. EULIN, EXAMINING ATTORNEY

SN 85-203,912. ARDSONS ENGINEERING INC., PASADENA, CA. FILED 12-22-2010.

## LOXTAR<sup>★</sup>

THE MARK CONSISTS OF ALL CAPITAL LETTERS "LOXTAR", ALL BOLD, AND A STAR IN THE SEMI CIRCLE OF THE LETTER "R".

### CLASS 1—CHEMICALS

FOR ADHESIVES FOR INDUSTRIAL USE (U.S. CLS. 1, 5, 6, 10, 26 AND 46).

### CLASS 4—LUBRICANTS AND FUELS

FOR INDUSTRIAL LUBRICANTS (U.S. CLS. 1, 6 AND 15).  
GEORGE LORENZO, EXAMINING ATTORNEY

SN 85-204,037. DOCUSIGN, INC., SEATTLE, WA. FILED 12-22-2010.

## SMARTNAV

THE MARK CONSISTS OF STANDARD CHARACTERS WITHOUT CLAIM TO ANY PARTICULAR FONT, STYLE, SIZE, OR COLOR.

**CLASS 42—SCIENTIFIC AND COMPUTER SERVICES**

FOR PROVIDING ON-LINE NON-DOWNLOADABLE SOFTWARE FOR USE WITH ELECTRONIC DATA VERIFICATION, NAMELY, TO FACILITATE ASSIGNMENT OF A LEGALLY BINDING ELECTRONIC SIGNATURE TO A DOCUMENT OR FILE FOR COMMUNICATION VIA A GLOBAL COMPUTER NETWORK; PROVIDING A WEBSITE THAT ALLOWS USERS TO UPLOAD AND ATTACH A LEGALLY BINDING ELECTRONIC SIGNATURE TO A DOCUMENT OR FILE FOR COMMUNICATION VIA A GLOBAL COMPUTER NETWORK (U.S. CLS. 100 AND 101).

**CLASS 45—PERSONAL AND LEGAL SERVICES**

FOR PROVIDING USER AUTHENTICATION SERVICES RELATED TO ELECTRONIC SIGNATURE IN E-COMMERCE TRANSACTIONS (U.S. CLS. 100 AND 101).  
RONALD AIKENS, EXAMINING ATTORNEY

---

SN 85-204,338. GOVERNMENTAL AND EDUCATIONAL ASSISTANCE CORP., HOPKINS, MN. FILED 12-22-2010.

**VISTA PRAIRIE COMMUNITIES**

THE MARK CONSISTS OF STANDARD CHARACTERS WITHOUT CLAIM TO ANY PARTICULAR FONT, STYLE, SIZE, OR COLOR.

NO CLAIM IS MADE TO THE EXCLUSIVE RIGHT TO USE "COMMUNITIES", APART FROM THE MARK AS SHOWN.

**CLASS 43—HOTEL AND RESTAURANT SERVICES**

FOR PROVIDING ASSISTANCE TO SENIOR CITIZENS SEEKING TO DETERMINE ASSISTED LIVING FACILITIES APPROPRIATE FOR THEIR NEEDS; PROVIDING ASSISTED LIVING FACILITIES; PROVIDING COMMUNITY CENTERS FOR SOCIAL GATHERINGS AND MEETINGS; RETIREMENT HOMES (U.S. CLS. 100 AND 101).

**CLASS 45—PERSONAL AND LEGAL SERVICES**

FOR PERSONAL CARE ASSISTANCE OF ACTIVITIES OF DAILY LIVING, SUCH AS BATHING, GROOMING AND PERSONAL MOBILITY FOR MENTALLY OR PHYSICALLY CHALLENGED PEOPLE; PROVIDING NON-MEDICAL ASSISTED LIVING SERVICES FOR PERSONAL PURPOSES IN THE NATURE OF SCHEDULING APPOINTMENTS, ANSWERING THE TELEPHONE, CHECKING MESSAGES, MAIL SORTING, MAIL HANDLING, MAIL RECEIVING AND SECRETARIAL AND CLERICAL SERVICES; PROVIDING NON-MEDICAL PERSONAL ASSISTANT SERVICES FOR OTHERS IN THE NATURE OF PLANNING, ORGANIZING, COORDINATING, ARRANGING AND ASSISTING INDIVIDUALS TO PERFORM DAILY TASKS (U.S. CLS. 100 AND 101).

DAVID I, EXAMINING ATTORNEY

SN 85-204,395. RACHEL WAGNER, INC., MIAMI BEACH, FL. FILED 12-22-2010.



THE MARK CONSISTS OF THE LETTERS "R" AND "K". AN IMAGE OF A SKULL THAT CONSISTS OF FLOWERS AND BUTTERFLIES IS PLACED IN BETWEEN THE LETTERS.

**CLASS 18—LEATHER GOODS**

FOR HANDBAGS, PURSES AND ACCESSORIES MADE OF LEATHER, NAMELY, LEATHER WALLETS, LEATHER KEY CHAINS, LEATHER BAGS, LEATHER HARNESES, LEATHER SHOULDER STRAPS, LEATHER SHOULDER BELTS (U.S. CLS. 1, 2, 3, 22 AND 41).

**CLASS 25—CLOTHING**

FOR ACCESSORIES MADE OF LEATHER, NAMELY, LEATHER BELTS, LEATHER CUFFS (U.S. CLS. 22 AND 39).

KRISTIN CARLSON, EXAMINING ATTORNEY

---

SN 85-204,500. PAPER-CHECK.COM, LLC, DBA PAPERCHECK, SAN FRANCISCO, CA. FILED 12-22-2010.

**PAPERCHECK**

THE MARK CONSISTS OF STANDARD CHARACTERS WITHOUT CLAIM TO ANY PARTICULAR FONT, STYLE, SIZE, OR COLOR.

OWNER OF U.S. REG. NO. 3,578,286.

SEC. 2(F).

**CLASS 35—ADVERTISING AND BUSINESS**

FOR PROJECT MANAGEMENT SERVICES FOR OTHERS IN THE FIELDS OF LANGUAGE TRANSLATION, CUSTOM WRITING, TEXT ADAPTATION, INTERPRETING AND PROOFREADING (U.S. CLS. 100, 101 AND 102).

FIRST USE 1-1-2005; IN COMMERCE 1-1-2005.

**CLASS 41—EDUCATION AND ENTERTAINMENT**

FOR PUBLICATION AND EDITING OF PRINTED MATTER; WRITTEN TEXT EDITING (U.S. CLS. 100, 101 AND 107).

FIRST USE 1-1-2005; IN COMMERCE 1-1-2005.

JOHN GARTNER, EXAMINING ATTORNEY

SN 85-204,648. GARZA, CARLOS, SPRINGFIELD, VA. AND O'MEARA, RICH, SILVER SPRING, MD. FILED 12-23-2010.

SN 85-204,665. WISDOM, PRODUCTIVE DECISION MAKING, LOVE AND MAGIC LLC, SAN JOSE, CA. FILED 12-23-2010.

## SILENT ORCHESTRA

THE MARK CONSISTS OF STANDARD CHARACTERS WITHOUT CLAIM TO ANY PARTICULAR FONT, STYLE, SIZE, OR COLOR.

### CLASS 9—ELECTRICAL AND SCIENTIFIC APPARATUS

FOR AUDIO RECORDINGS FEATURING MUSIC; DOWNLOADABLE AUDIO RECORDINGS FEATURING MUSIC; AUDIOVISUAL RECORDINGS FEATURING MUSIC; DOWNLOADABLE AUDIOVISUAL RECORDINGS FEATURING MUSIC; DIGITAL MATERIALS, NAMELY, PRE-RECORDED VIDEO TAPES, PRE-RECORDED VIDEO DISCS AND DIGITAL VIDEO DISCS (DVDS), AND DOWNLOADABLE AUDIO AND AUDIOVISUAL FILES FEATURING MUSIC (U.S. CLS. 21, 23, 26, 36 AND 38).

FIRST USE 10-31-2000; IN COMMERCE 10-31-2000.

### CLASS 41—EDUCATION AND ENTERTAINMENT

FOR ENTERTAINMENT SERVICES IN THE NATURE OF LIVE MUSICAL PERFORMANCES; MUSIC COMPOSITION FOR OTHERS (U.S. CLS. 100, 101 AND 107).

FIRST USE 0-0-1998; IN COMMERCE 0-0-1998.  
ANDREA BUTLER, EXAMINING ATTORNEY

SN 85-204,651. HORTON, RYAN C., PALM HARBOR, FL. FILED 12-23-2010.

## SLACK TIDE

THE MARK CONSISTS OF STANDARD CHARACTERS WITHOUT CLAIM TO ANY PARTICULAR FONT, STYLE, SIZE, OR COLOR.

### CLASS 35—ADVERTISING AND BUSINESS

FOR RETAIL STORE SERVICES FEATURING DIVING EQUIPMENT, FISHING EQUIPMENT, AND OUTDOOR SPORTING GOODS (U.S. CLS. 100, 101 AND 102).

### CLASS 43—HOTEL AND RESTAURANT SERVICES

FOR RESTAURANT SERVICES (U.S. CLS. 100 AND 101).  
ANDREA BUTLER, EXAMINING ATTORNEY

## WisdomWear

THE MARK CONSISTS OF STANDARD CHARACTERS WITHOUT CLAIM TO ANY PARTICULAR FONT, STYLE, SIZE, OR COLOR.

### CLASS 25—CLOTHING

FOR ATHLETIC APPAREL, NAMELY, SHIRTS, PANTS, JACKETS, FOOTWEAR, HATS AND CAPS, ATHLETIC UNIFORMS (U.S. CLS. 22 AND 39).

FIRST USE 9-1-2010; IN COMMERCE 12-18-2010.

### CLASS 42—SCIENTIFIC AND COMPUTER SERVICES

FOR CUSTOM DESIGN OF WEARABLE APPAREL BASED ON PERSONAL SELECTIONS MADE BY THE CUSTOMER (U.S. CLS. 100 AND 101).

FIRST USE 9-1-2010; IN COMMERCE 12-18-2010.  
JESSICA A. POWERS, EXAMINING ATTORNEY

SN 85-204,771. TASKSCRIBE LLC, MENDHAM, NJ. FILED 12-23-2010.

## KLOX

THE MARK CONSISTS OF STANDARD CHARACTERS WITHOUT CLAIM TO ANY PARTICULAR FONT, STYLE, SIZE, OR COLOR.

### CLASS 9—ELECTRICAL AND SCIENTIFIC APPARATUS

FOR COMPUTER SOFTWARE AND COMPUTER APPLICATION SOFTWARE FOR MOBILE PHONES AND WIRELESS COMMUNICATIONS DEVICES, NAMELY, BESPOKE BUSINESS SOFTWARE FOR INVENTORY MANAGEMENT, ORDER MANAGEMENT, PROCUREMENT MANAGEMENT, INVOICE MANAGEMENT, TIME AND EXPENSE REPORTING, CUSTOMER MANAGEMENT, EMPLOYEE MANAGEMENT, SALES FORCE MANAGEMENT, PURCHASING MANAGEMENT, PROJECT AND TASK MANAGEMENT AND MONITORING, INCLUDING TASK-THREADED HUMAN AND MATERIAL RESOURCE UTILIZATION; ENTERPRISE SOFTWARE IN THE NATURE OF A DATABASE FOR NON-TRANSACTIONAL DATA AND A SEARCH ENGINE FOR DATABASE CONTENT (U.S. CLS. 21, 23, 26, 36 AND 38).

**CLASS 42—SCIENTIFIC AND COMPUTER SERVICES**

FOR SOFTWARE AS A SERVICE (SAAS) SERVICES FEATURING BESPOKE BUSINESS SOFTWARE FOR INVENTORY MANAGEMENT, ORDER MANAGEMENT, PROCUREMENT MANAGEMENT, INVOICE MANAGEMENT, TIME AND EXPENSE REPORTING, CUSTOMER MANAGEMENT, EMPLOYEE MANAGEMENT, SALES FORCE MANAGEMENT, PURCHASING MANAGEMENT, PROJECT AND TASK MANAGEMENT AND MONITORING, INCLUDING TASK-THREADED HUMAN AND MATERIAL RESOURCE UTILIZATION (U.S. CLS. 100 AND 101).

LINDA MICKLEBURGH, EXAMINING ATTORNEY

SN 85-204,782. ADVANCED STATE OF NETWORKING, INC., YORK, PA. FILED 12-23-2010.

ASON

THE MARK CONSISTS OF STANDARD CHARACTERS WITHOUT CLAIM TO ANY PARTICULAR FONT, STYLE, SIZE, OR COLOR.

**CLASS 37—CONSTRUCTION AND REPAIR**

FOR MAINTENANCE AND REPAIR OF TELECOMMUNICATIONS NETWORKING HARDWARE, APPARATUS, AND INSTRUMENTS (U.S. CLS. 100, 103 AND 106).  
FIRST USE 2-25-2000; IN COMMERCE 3-0-2000.

**CLASS 42—SCIENTIFIC AND COMPUTER SERVICES**

FOR PLANNING, DESIGN AND MANAGEMENT OF INFORMATION TECHNOLOGY SYSTEMS (U.S. CLS. 100 AND 101).

FIRST USE 2-25-2000; IN COMMERCE 3-0-2000.  
AMY C. KEAN, EXAMINING ATTORNEY

SN 85-204,800. KBP HOLDINGS LLC, NEW YORK, NY. FILED 12-23-2010.

KBS+P

THE MARK CONSISTS OF STANDARD CHARACTERS WITHOUT CLAIM TO ANY PARTICULAR FONT, STYLE, SIZE, OR COLOR.

OWNER OF U.S. REG. NO. 2,524,839.

**CLASS 35—ADVERTISING AND BUSINESS**

FOR ADVERTISING AGENCY SERVICES; MARKETING COMMUNICATIONS SERVICES; PUBLIC RELATIONS AND PUBLICITY SERVICES; BUSINESS MARKETING CONSULTING IN THE FIELD OF BRAND CREATION, BRAND DEVELOPMENT, BRAND IDENTITY AND BRAND MARKETING; MARKET RESEARCH AND ANALYSIS; CONDUCTING MARKETING STUDIES; MONITORING AND EVALUATION OF ADVERTISING AND CUSTOMER COMMUNICATION CAMPAIGNS; BUSINESS RESEARCH AND STRATEGIC PLANNING SERVICES IN THE FIELD OF ADVERTISING, MARKETING COMMUNICATIONS, PROMOTIONS, AND PUBLIC RELATIONS; INTERACTIVE AND DIGITAL MEDIA ADVERTISING; DIRECT MARKETING ADVERTISING SERVICES; CUSTOMER RELATIONSHIP MANAGEMENT; EVENT MARKETING SERVICES; ARRANGING AND CONDUCTING MARKETING PROMOTIONAL EVENTS FOR OTHERS; SALES PROMOTION SERVICES; MEDIA CONSULTING SERVICES, NAMELY, PLANNING, BUYING AND NEGOTIATING ADVERTISING AND MEDIA SPACE AND TIME; RELATIONSHIP MARKETING SERVICES; ADVERTISING SERVICES, NAMELY, DEVELOPMENT OF BRANDED ENTERTAINMENT PROPERTIES AND PLATFORMS AND BRANDED CONTENT PROPERTIES AND PLATFORMS, NAMELY, INTEGRATING THE BRANDS OF OTHERS INTO THE CONTENT OF VARIOUS MEDIA PROGRAMMING AND DEVELOPING CONTENT BUILT AROUND BRANDS IN ALL MEDIA TECHNOLOGIES; DEVELOPMENT OF NEW TECHNOLOGY MARKETING PLATFORMS AND SOLUTIONS (U.S. CLS. 100, 101 AND 102).

FIRST USE 8-18-2009, THE MARK WAS FIRST USED ANYWHERE IN A DIFFERENT FORM OTHER THAN THAT SOUGHT TO BE REGISTERED AT LEAST AS EARLY AS 06/00/1996.; IN COMMERCE 8-18-2009, THE MARK WAS FIRST USED IN COMMERCE IN A DIFFERENT FORM OTHER THAN THAT SOUGHT TO BE REGISTERED AT LEAST AS EARLY AS 06/00/1996..

**CLASS 42—SCIENTIFIC AND COMPUTER SERVICES**

FOR GRAPHIC DESIGN SERVICES; DESIGN AND DEVELOPMENT OF INTERNET WEBSITES; CONSULTING SERVICES WITH REGARD TO THE DESIGN OF INTERNET WEBSITES; PRODUCT DESIGN; PACKAGING DESIGN; COMPUTER ANIMATION DESIGN SERVICES; INDUSTRIAL DESIGN SERVICES; CONSULTING SERVICES IN THE FIELD OF PRODUCT INNOVATIONS (U.S. CLS. 100 AND 101).

FIRST USE 8-18-2009, THE MARK WAS FIRST USED ANYWHERE IN A DIFFERENT FORM OTHER THAN THAT SOUGHT TO BE REGISTERED AT LEAST AS EARLY AS 06/00/1996; IN COMMERCE 8-18-2009, THE MARK WAS FIRST USED IN COMMERCE IN A DIFFERENT FORM OTHER THAN THAT SOUGHT TO BE REGISTERED AT LEAST AS EARLY AS 06/00/1996.

JUDITH HELFMAN, EXAMINING ATTORNEY

SN 85-204,838. WEALTH WATCHERS INTERNATIONAL, INC., NAPERVILLE, IL. FILED 12-23-2010.

BORN TO SAVE

THE MARK CONSISTS OF STANDARD CHARACTERS WITHOUT CLAIM TO ANY PARTICULAR FONT, STYLE, SIZE, OR COLOR.

**CLASS 25—CLOTHING**

FOR BASEBALL CAPS AND HATS; SWEATSHIRTS; T-SHIRTS (U.S. CLS. 22 AND 39).

**CLASS 35—ADVERTISING AND BUSINESS**

FOR PROMOTING PUBLIC AWARENESS OF FAITH-BASED CONSERVATION OF FINANCIAL AND ENVIRONMENTAL RESOURCES (U.S. CLS. 100, 101 AND 102).  
JUSTINE D. PARKER, EXAMINING ATTORNEY

SN 85-204,888. APPLGATE FARMS, LLC, BRIDGEWATER, NJ. FILED 12-23-2010.

**PROMISE TRACKER**

THE MARK CONSISTS OF STANDARD CHARACTERS WITHOUT CLAIM TO ANY PARTICULAR FONT, STYLE, SIZE, OR COLOR.

**CLASS 29—MEATS AND PROCESSED FOODS**

FOR DELI MEATS; ITALIAN SPECIALTY MEATS; HOT DOGS; BACON; SAUSAGE; BEEF; CHICKEN; TURKEY; PORK; FROZEN ENTREES CONSISTING PRIMARILY OF MEAT OR POULTRY; AND CHEESE (U.S. CL. 46).  
FIRST USE 9-1-2010; IN COMMERCE 9-1-2010.

**CLASS 35—ADVERTISING AND BUSINESS**

FOR PROVIDING A WEBSITE FEATURING INFORMATION FOR CONSUMERS ABOUT THE SOURCES OF APPLICANT'S FOOD PRODUCTS (U.S. CLS. 100, 101 AND 102).  
FIRST USE 9-1-2010; IN COMMERCE 9-1-2010.  
REBECCA EISINGER, EXAMINING ATTORNEY

SN 85-204,960. THE TRUSTEES OF THE STEVENS INSTITUTE OF TECHNOLOGY, HOBOKEN, NJ. FILED 12-23-2010.

**WATERBOTICS**

THE MARK CONSISTS OF STANDARD CHARACTERS WITHOUT CLAIM TO ANY PARTICULAR FONT, STYLE, SIZE, OR COLOR.

**CLASS 16—PAPER GOODS AND PRINTED MATTER**

FOR EDUCATION PUBLICATIONS, NAMELY, PRINTED EDUCATIONAL MATERIALS, GUIDES, BOOKS, BROCHURES, AND HAND-OUTS IN THE FIELDS OF SCIENCE, TECHNOLOGY, ENGINEERING, AND MATHEMATICS (U.S. CLS. 2, 5, 22, 23, 29, 37, 38 AND 50).

**CLASS 41—EDUCATION AND ENTERTAINMENT**

FOR EDUCATION SERVICES, NAMELY, PROVIDING CLASSES, SEMINARS, WORKSHOPS, AND CAMPS IN THE FIELDS OF SCIENCE, TECHNOLOGY, ENGINEERING, AND MATHEMATICS; EDUCATION SERVICES, NAMELY, PROVIDING HANDS-ON OPPORTUNITIES FOR CHILDREN IN THE FIELDS OF SCIENCE, TECHNOLOGY, ENGINEERING, AND MATHEMATICS THROUGH CLASSES, SEMINARS, WORKSHOPS, CAMPS, TRAINING AND CURRICULUM DEVELOPMENT FOR CHILDREN, PARENTS AND EDUCATORS; PROVIDING ONLINE PUBLICATIONS IN THE NATURE OF EDUCATIONAL MATERIALS, GUIDES, BOOKS, BROCHURES, AND HAND-OUTS IN THE FIELDS OF SCIENCE, TECHNOLOGY, ENGINEERING, AND MATHEMATICS (U.S. CLS. 100, 101 AND 107).  
JAMES GRIFFIN, EXAMINING ATTORNEY

SN 85-204,999. J'S RACING USA LLC, TORRANCE, CA. FILED 12-23-2010.

**J'S RACING**

THE MARK CONSISTS OF STANDARD CHARACTERS WITHOUT CLAIM TO ANY PARTICULAR FONT, STYLE, SIZE, OR COLOR.  
NO CLAIM IS MADE TO THE EXCLUSIVE RIGHT TO USE "RACING", APART FROM THE MARK AS SHOWN.

**CLASS 7—MACHINERY**

FOR AIR FILTERS FOR AUTOMOBILE ENGINES; AUTOMOTIVE INTAKE MANIFOLDS; ENGINE EXHAUST SYSTEMS COMPRISED OF PIPES, COLLECTOR AND MUFFLER; HEADERS AS PART OF VEHICLE EXHAUST SYSTEM; RADIATORS FOR VEHICLES (U.S. CLS. 13, 19, 21, 23, 31, 34 AND 35).  
FIRST USE 1-1-2008; IN COMMERCE 1-1-2008.

**CLASS 12—VEHICLES**

FOR AUTOMOBILE BUMPERS; AUTOMOBILE HOODS; AUTOMOTIVE CONVERSION KITS COMPRISED OF WINGS TO MAKE STRUCTURAL CHANGES TO AN AUTOMOBILE; BUMPERS FOR AUTOMOBILES; CLUTCHES FOR LAND VEHICLES; LUG NUTS FOR VEHICLE WHEELS; SUSPENSION SYSTEMS FOR AUTOMOBILES; VEHICLE ROLL BARS (U.S. CLS. 19, 21, 23, 31, 35 AND 44).  
FIRST USE 1-1-2008; IN COMMERCE 1-1-2008.  
PATRICIA EVANKO, EXAMINING ATTORNEY

SN 85-205,112. A&E TELEVISION NETWORKS, LLC, NEW YORK, NY. FILED 12-23-2010.

**CRIME: CROSSING THE LINE**

THE MARK CONSISTS OF STANDARD CHARACTERS WITHOUT CLAIM TO ANY PARTICULAR FONT, STYLE, SIZE, OR COLOR.  
NO CLAIM IS MADE TO THE EXCLUSIVE RIGHT TO USE "CRIME", APART FROM THE MARK AS SHOWN.

**CLASS 9—ELECTRICAL AND SCIENTIFIC APPARATUS**

FOR MULTIMEDIA GOODS, NAMELY, PRERECORDED DIGITAL VIDEO DISCS AND DVD FEATURING STORIES ABOUT CRIMINALS, CRIME STORIES, INTRIGUE AND MYSTERY; DIGITAL MEDIA, NAMELY, DOWNLOADABLE AUDIO AND VIDEO FILES FEATURING CRIMINALS, CRIME STORIES, INTRIGUE AND MYSTERY; DOWNLOADABLE ONLINE DISCUSSION BOARDS AND WEBCASTS FEATURING CRIMINALS, CRIME STORIES, INTRIGUE AND MYSTERY (U.S. CLS. 21, 23, 26, 36 AND 38).

SN 85-205,190. RICK FEDERMAN, LOS ANGELES, CA. FILED 12-23-2010.

**CLASS 41—EDUCATION AND ENTERTAINMENT**

FOR ENTERTAINMENT SERVICES, NAMELY, A MULTIMEDIA PROGRAM SERIES FEATURING CRIMINALS, CRIME STORIES, INTRIGUE AND MYSTERY DISTRIBUTED VIA VARIOUS PLATFORMS ACROSS MULTIPLE FORMS OF TRANSMISSION MEDIA; ENTERTAINMENT SERVICES, NAMELY, AN ONGOING TELEVISION PROGRAM FEATURING CRIMINALS, CRIME STORIES, INTRIGUE AND MYSTERY; PROVIDING A WEBSITE FEATURING CRIMINALS, CRIME STORIES, INTRIGUE AND MYSTERY, SUCH INFORMATION FOR ENTERTAINMENT PURPOSES ONLY (U.S. CLS. 100, 101 AND 107).

KAPIL BHANOT, EXAMINING ATTORNEY



THE MARK CONSISTS OF A CROWNED SMILEY FACE, CONSISTING OF A SMILE MADE OF A PARENTHESIS, EYES MADE OF A COLON, AND A CROWN MADE OF THE LETTER E.

**CLASS 18—LEATHER GOODS**

FOR ALL-PURPOSE REUSABLE CARRYING BAGS (U.S. CLS. 1, 2, 3, 22 AND 41).

FIRST USE 12-10-2010; IN COMMERCE 12-10-2010.

**CLASS 25—CLOTHING**

FOR HATS (U.S. CLS. 22 AND 39).

FIRST USE 9-1-2010; IN COMMERCE 9-1-2010.

RONALD MCMORROW, EXAMINING ATTORNEY

SN 85-205,180. BLUE-GRACE I.P. LLC, RIVERVIEW, FL. FILED 12-23-2010.

BLUEGRACE

THE MARK CONSISTS OF STANDARD CHARACTERS WITHOUT CLAIM TO ANY PARTICULAR FONT, STYLE, SIZE, OR COLOR.

OWNER OF U.S. REG. NO. 3,748,784.

**CLASS 35—ADVERTISING AND BUSINESS**

FOR FREIGHT LOGISTICS MANAGEMENT; TRANSPORTATION LOGISTICS SERVICES, NAMELY, ARRANGING THE TRANSPORTATION OF GOODS FOR OTHERS; TRANSPORTATION LOGISTICS SERVICES, NAMELY, PLANNING AND SCHEDULING SHIPMENTS FOR USERS OF TRANSPORTATION SERVICES (U.S. CLS. 100, 101 AND 102).

FIRST USE 9-1-2007; IN COMMERCE 12-1-2008.

**CLASS 39—TRANSPORTATION AND STORAGE**

FOR FREIGHT TRANSPORTATION BY ROAD, RAIL, AIR AND OCEAN; FREIGHT TRANSPORTATION CONSULTATION IN THE FIELD OF FREIGHT TRANSPORTATION BY TRUCK, RAIL, AIR AND OCEAN; SUPPLY CHAIN LOGISTICS AND REVERSE LOGISTICS SERVICES, NAMELY, STORAGE, TRANSPORTATION AND DELIVERY OF GOODS FOR OTHERS BY AIR, RAIL, SHIP OR TRUCK; TRANSPORTATION AND DELIVERY SERVICES BY AIR, ROAD, RAIL AND SEA (U.S. CLS. 100 AND 105).

FIRST USE 9-1-2007; IN COMMERCE 12-1-2008.

TRICIA SONNEBORN, EXAMINING ATTORNEY

SN 85-205,213. BUSH TURF INC., MILAN, IL. FILED 12-23-2010.

We've Got Game in the Skin

THE MARK CONSISTS OF STANDARD CHARACTERS WITHOUT CLAIM TO ANY PARTICULAR FONT, STYLE, SIZE, OR COLOR.

**CLASS 31—NATURAL AGRICULTURAL PRODUCTS**

FOR LAWN/TURF; TURF (U.S. CLS. 1 AND 46).

**CLASS 44—MEDICAL, BEAUTY AND AGRICULTURAL SERVICES**

FOR HORTICULTURAL PROCESSES AND TURF OR LAWN CARE SERVICES, NAMELY, PROVIDING PREPARATION AND DEVELOPMENT OF TURFGRASS AND/OR SOIL FOR PROVIDING AN ENVIRONMENT THAT ENCOURAGES IMPROVED GROWTH ATTRIBUTES (U.S. CLS. 100 AND 101).

LINDA ORNDORFF, EXAMINING ATTORNEY



SN 85-205,242. IT LIFELINE, INC., LIBERTY LAKE, WA.  
FILED 12-23-2010.

SN 85-205,290. LAURA MCKENZIE, INC., LOS ANGELES,  
CA. FILED 12-23-2010.



THE MARK CONSISTS OF THE WORDS BLACK AND CLOUD, WITH THE WORD BLACK OVER THE WORD CLOUD. THE WORD BLACK IS INSIDE OF A STYLIZED CLOUD, AND THE WORD CLOUD IS INSIDE OF A BLACK CIRCLE.

**CLASS 35—ADVERTISING AND BUSINESS**

FOR DISASTER RECOVERY SERVICES, NAMELY, BUSINESS PLANNING AND BUSINESS CONTINUITY CONSULTING (U.S. CLS. 100, 101 AND 102).  
FIRST USE 12-14-2010; IN COMMERCE 12-14-2010.

**CLASS 42—SCIENTIFIC AND COMPUTER SERVICES**

FOR COMPUTER SERVICES, NAMELY, DATA RECOVERY SERVICES (U.S. CLS. 100 AND 101).  
FIRST USE 12-14-2010; IN COMMERCE 12-14-2010.  
PAUL E. FAHRENKOPF, EXAMINING ATTORNEY

SN 85-205,247. S & D PRODUCTS, INC., BARTLETT, IL.  
FILED 12-23-2010.

**OUR BUSINESS HINGES ON  
YOUR BUSINESS**

THE MARK CONSISTS OF STANDARD CHARACTERS WITHOUT CLAIM TO ANY PARTICULAR FONT, STYLE, SIZE, OR COLOR.

**CLASS 6—METAL GOODS**

FOR METAL HINGES (U.S. CLS. 2, 12, 13, 14, 23, 25 AND 50).  
FIRST USE 10-1-2010; IN COMMERCE 10-1-2010.

**CLASS 35—ADVERTISING AND BUSINESS**

FOR RETAIL STORE SERVICES FEATURING METAL HINGES (U.S. CLS. 100, 101 AND 102).  
FIRST USE 10-1-2010; IN COMMERCE 10-1-2010.  
STEVEN JACKSON, EXAMINING ATTORNEY

**FREEDOM FOR THE CHILDREN**

THE MARK CONSISTS OF STANDARD CHARACTERS WITHOUT CLAIM TO ANY PARTICULAR FONT, STYLE, SIZE, OR COLOR.

NO CLAIM IS MADE TO THE EXCLUSIVE RIGHT TO USE "CHILDREN", APART FROM THE MARK AS SHOWN.

**CLASS 35—ADVERTISING AND BUSINESS**

FOR CHARITABLE SERVICES, NAMELY, ORGANIZING AND DEVELOPING PROJECTS THAT AIM TO PROMOTE GLOBAL AWARENESS ABOUT HUMAN TRAFFICKING AND COMMERCIAL SEX INDUSTRY (U.S. CLS. 100, 101 AND 102).

**CLASS 36—INSURANCE AND FINANCIAL**

FOR CHARITABLE FUNDRAISING SERVICES FOR PROMOTING RESEARCH, EDUCATION AND OTHER ACTIVITIES RELATING TO HUMAN TRAFFICKING AND COMMERCIAL SEX INDUSTRY (U.S. CLS. 100, 101 AND 102).  
TRACY CROSS, EXAMINING ATTORNEY

SN 85-205,350. YOUTH GUIDANCE, AKA YG, CHICAGO, IL.  
FILED 12-23-2010.

**B.A.M.**

THE MARK CONSISTS OF STANDARD CHARACTERS WITHOUT CLAIM TO ANY PARTICULAR FONT, STYLE, SIZE, OR COLOR.

**CLASS 41—EDUCATION AND ENTERTAINMENT**

FOR PROVIDING EDUCATIONAL MENTORING SERVICES AND PROGRAMS IN THE FIELD OF CHARACTER EDUCATION, GROUP COUNSELING, VIOLENCE PREVENTION, SOCIO-EMOTIONAL LEARNING, JUVENILE REHABILITATION, YOUTH DEVELOPMENT, AND TEAMBUILDING (U.S. CLS. 100, 101 AND 107).  
FIRST USE 9-1-2001; IN COMMERCE 9-1-2003.

**CLASS 45—PERSONAL AND LEGAL SERVICES**

FOR PROVIDING EMOTIONAL COUNSELING AND EMOTIONAL SUPPORT SERVICES FOR TROUBLED AND AT-RISK YOUTH AND THEIR FAMILIES (U.S. CLS. 100 AND 101).  
FIRST USE 9-1-2001; IN COMMERCE 9-1-2003.  
WILLIAM BRECKENFELD, EXAMINING ATTORNEY

SN 85-205,360. YOUTH GUIDANCE, AKA YG, CHICAGO, IL.  
FILED 12-23-2010.

SN 85-205,438. DOLKI KOREA LTD., WONJU-SI, GANG-  
WON-DO, REPUBLIC OF KOREA, FILED 12-23-2010.

## Becoming a Man

THE MARK CONSISTS OF STANDARD CHARACTERS WITHOUT CLAIM TO ANY PARTICULAR FONT, STYLE, SIZE, OR COLOR.

### CLASS 41—EDUCATION AND ENTERTAINMENT

FOR PROVIDING EDUCATIONAL MENTORING SERVICES AND PROGRAMS IN THE FIELD OF CHARACTER EDUCATION, GROUP COUNSELING, VIOLENCE PREVENTION, SOCIO-EMOTIONAL LEARNING, JUVENILE REHABILITATION, YOUTH DEVELOPMENT, AND TEAMBUILDING (U.S. CLS. 100, 101 AND 107).  
FIRST USE 9-1-2001; IN COMMERCE 9-1-2003.

### CLASS 45—PERSONAL AND LEGAL SERVICES

FOR PROVIDING EMOTIONAL COUNSELING AND EMOTIONAL SUPPORT SERVICES FOR TROUBLED AND AT-RISK YOUTH AND THEIR FAMILIES (U.S. CLS. 100 AND 101).  
FIRST USE 9-1-2001; IN COMMERCE 9-1-2003.

WILLIAM BRECKENFELD, EXAMINING ATTORNEY

SN 85-205,365. REARDON, BRIAN, SHERMAN OAKS, CA.  
FILED 12-23-2010.

## Synchrophonic

THE MARK CONSISTS OF STANDARD CHARACTERS WITHOUT CLAIM TO ANY PARTICULAR FONT, STYLE, SIZE, OR COLOR.

### CLASS 41—EDUCATION AND ENTERTAINMENT

FOR COMPOSITION OF MUSIC FOR OTHERS; CONSULTATION AND ADVICE REGARDING MUSICAL SELECTIONS AND ARRANGEMENTS FOR SOUND RECORDINGS AND LIVE PERFORMANCES; ENTERTAINMENT SERVICES BY A MUSICAL ARTIST AND PRODUCER, NAMELY, MUSICAL COMPOSITION FOR OTHERS AND PRODUCTION OF MUSICAL SOUND RECORDINGS; MUSIC PRODUCTION SERVICES; MUSIC PUBLISHING SERVICES; MUSIC TRANSCRIPTION FOR OTHERS; PRODUCTION OF MUSICAL SOUND RECORDING; PUBLICATION OF MUSICAL TEXTS (U.S. CLS. 100, 101 AND 107).  
FIRST USE 7-23-2002; IN COMMERCE 8-17-2006.

### CLASS 45—PERSONAL AND LEGAL SERVICES

FOR CONSULTING IN THE FIELD OF INTELLECTUAL PROPERTY LICENSING; LICENSING OF MUSIC (U.S. CLS. 100 AND 101).  
FIRST USE 7-23-2002; IN COMMERCE 8-17-2006.

ELIZABETH KAJUBI, EXAMINING ATTORNEY

## SALICID

THE MARK CONSISTS OF STANDARD CHARACTERS WITHOUT CLAIM TO ANY PARTICULAR FONT, STYLE, SIZE, OR COLOR.

### CLASS 5—PHARMACEUTICALS

FOR SANITARY STERILIZING PREPARATIONS FOR MEDICAL PURPOSE (U.S. CLS. 6, 18, 44, 46, 51 AND 52).

### CLASS 10—MEDICAL APPARATUS

FOR STEAM STERILIZER FOR MEDICAL PURPOSE, WATER STERILIZER FOR MEDICAL PURPOSE OR FOR USE BY DENTISTS AND ORAL HYGIENISTS, STERILIZED WATER SUPPLYING APPARATUS FOR USE BY DENTISTS AND ORAL HYGIENISTS OR FOR MEDICAL PURPOSE, STERILIZED WATER PRODUCING APPARATUS FOR USE BY DENTISTS AND ORAL HYGIENISTS OR FOR MEDICAL PURPOSE, ORAL CLEANING WATER PRODUCING APPARATUS FOR USE BY DENTISTS AND ORAL HYGIENISTS, CLEANING WATER PRODUCING APPARATUS FOR MEDICAL PURPOSE, NORMAL SALINE PRODUCING APPARATUS FOR MEDICAL PURPOSE OR FOR USE BY DENTISTS AND ORAL HYGIENISTS (U.S. CLS. 26, 39 AND 44).

### CLASS 11—ENVIRONMENTAL CONTROL APPARATUS

FOR STERILIZER FOR NON-MEDICAL PURPOSE, WATER STERILIZER FOR NON-MEDICAL PURPOSE, STERILIZED WATER SUPPLYING APPARATUS, STERILIZED WATER PURIFYING APPARATUS, APPARATUS FOR PRODUCING CLEAN WATER WHICH IS USED IN NON-MEDICAL ORAL APPLICATIONS, CLEANING WATER PRODUCING APPARATUS, BIDET STERILIZING APPARATUS, APPARATUS FOR WASHING BY USING STERILIZED WATER, APPARATUS FOR PRODUCING ISOTONIC SALINE SOLUTION, WATER PURIFIER, REFRIGERATION EQUIPMENT, NAMELY, MEATS STORING MACHINE, REFRIGERATION EQUIPMENT, NAMELY, SEAFOOD STORING MACHINE, REFRIGERATION EQUIPMENT, NAMELY, STERILIZING AND STORING MACHINE, WATER PURIFICATION UNITS FOR REMOVING RED TIDE, UNDERWATER STERILIZER USED TO STERILIZE WATER, UNDERWATER WATER PURIFICATION UNITS FOR REMOVING RED TIDE (U.S. CLS. 13, 21, 23, 31 AND 34).  
ANN E. SAPPENFIELD, EXAMINING ATTORNEY

SN 85-205,474. CHAD BORKOWSKI, YORBA LINDA, CA.  
FILED 12-23-2010.

## T2T

THE MARK CONSISTS OF STANDARD CHARACTERS WITHOUT CLAIM TO ANY PARTICULAR FONT, STYLE, SIZE, OR COLOR.

**CLASS 16—PAPER GOODS AND PRINTED MATTER**

FOR STICKERS (U.S. CLS. 2, 5, 22, 23, 29, 37, 38 AND 50).  
FIRST USE 2-1-2008; IN COMMERCE 2-1-2008.

**CLASS 25—CLOTHING**

FOR SHIRTS, SHORTS, HATS, TANK TOPS, SWEAT-SHIRTS, JACKETS, BEANIES, PANTS, UNDERWEAR, AND SOCKS (U.S. CLS. 22 AND 39).  
FIRST USE 2-1-2008; IN COMMERCE 2-1-2008.  
MARY BOAGNI, EXAMINING ATTORNEY

SN 85-205,548. ALLOSOURCE, CENTENNIAL, CO. FILED 12-24-2010.

**CLASS 9—ELECTRICAL AND SCIENTIFIC APPARATUS**

FOR BAGS AND CASES SPECIALLY ADAPTED FOR HOLDING OR CARRYING PORTABLE TELEPHONES AND TELEPHONE EQUIPMENT AND ACCESSORIES; EYEWEAR, NAMELY, SUNGLASSES, EYEGASSES AND OPHTHALMIC FRAMES AND CASES THEREFOR (U.S. CLS. 21, 23, 26, 36 AND 38).

**CLASS 25—CLOTHING**

FOR COLLARED SHIRTS; DRESS SHIRTS; HOODED SWEAT SHIRTS; KNIT SHIRTS; LONG-SLEEVED SHIRTS; OPEN-NECKED SHIRTS; POLO SHIRTS; SHIRTS AND SHORT-SLEEVED SHIRTS; SHORT-SLEEVED OR LONG-SLEEVED T-SHIRTS; SHORT-SLEEVED SHIRTS; SPORTS CAPS AND HATS; SWEAT SHIRTS; T-SHIRTS; WOMEN'S HATS AND HOODS (U.S. CLS. 22 AND 39).  
ELISSA GARBER KON, EXAMINING ATTORNEY

**DOING MORE WITH LIFE**

THE MARK CONSISTS OF STANDARD CHARACTERS WITHOUT CLAIM TO ANY PARTICULAR FONT, STYLE, SIZE, OR COLOR.

SN 85-205,654. BLACK STAR LINE S.A., CITY OF PANAMA, PANAMA, FILED 12-25-2010.

**CLASS 5—PHARMACEUTICALS**

FOR HUMAN ALLOGRAFT BONE, SKIN, AND TISSUE (U.S. CLS. 6, 18, 44, 46, 51 AND 52).

**CLASS 40—MATERIAL TREATMENT**

FOR CUSTOM FABRICATION OF HUMAN ALLOGRAFT BONE, SKIN, AND TISSUE TO THE ORDER AND SPECIFICATION OF OTHERS (U.S. CLS. 100, 103 AND 106).

**CLASS 44—MEDICAL, BEAUTY AND AGRICULTURAL SERVICES**

FOR BONE AND TISSUE BANK SERVICES; PROCESSING OF HUMAN ALLOGRAFT BONE, SKIN, AND TISSUE (U.S. CLS. 100 AND 101).  
KYLE PEETE, EXAMINING ATTORNEY

SN 85-205,627. MILTON, ANTHONY ROBERT, DUMFRIES, VA. FILED 12-25-2010.



THE MARK CONSISTS OF AN ABSTRACT PUZZLE PIECE CONTAINING 1 0 1 P WITHIN IT.



NO CLAIM IS MADE TO THE EXCLUSIVE RIGHT TO USE "AFRICAN" AND "CARD", APART FROM THE MARK AS SHOWN.

THE MARK CONSISTS OF THE WORDING "AFRICAN LIBERTY CARD" TO THE LEFT AND THE DESIGN OF TWO CURVY LINES CRISSCROSSING FROM THE LEFT TO THREE CURVY LINES ON THE RIGHT.

**CLASS 16—PAPER GOODS AND PRINTED MATTER**

FOR NON-MAGNETICALLY ENCODED PREPAID PURCHASE CARDS FOR PAYMENT OF GOODS AND SERVICES AND ALLOWING USERS TO TRANSFER FINANCIAL VALUE VIA WIRELESS COMMUNICATIONS (U.S. CLS. 2, 5, 22, 23, 29, 37, 38 AND 50).

**CLASS 36—INSURANCE AND FINANCIAL**

FOR ELECTRONIC FUNDS TRANSFER AND PAYMENT SERVICES USING A PREPAID CARD BY WIRELESS COMMUNICATIONS; PROVIDING ELECTRONIC PROCESSING OF FUNDS TRANSFER AND PAYMENTS BY WIRELESS COMMUNICATIONS (U.S. CLS. 100, 101 AND 102).  
SUE LAWRENCE, EXAMINING ATTORNEY

SN 85-205,680. MYBODY, L.L.C., PHOENIX, AZ. FILED 12-26-2010.

LOVE MY SKIN, LOVE MY BODY

THE MARK CONSISTS OF STANDARD CHARACTERS WITHOUT CLAIM TO ANY PARTICULAR FONT, STYLE, SIZE, OR COLOR.

**CLASS 3—COSMETICS AND CLEANING PREPARATIONS**

FOR ANTI-WRINKLE CREAM; BODY SCRUB; CLOTHS OR TISSUES IMPREGNATED WITH A SKIN CLEANSER; COSMETIC CREAMS; FEMININE DEODORANT SPRAYS; FEMININE DEODORANT SUPPOSITORIES; FEMININE HYGIENE CLEANSING TOWELETTES; HAIR SHAMPOOS AND CONDITIONERS; NON-MEDICATED ANTI-AGING SERUM; NON-MEDICATED FEMININE HYGIENE WASH; NON-MEDICATED LIP PROTECTORS; NON-MEDICATED SKIN CARE CREAMS AND LOTIONS; NON-MEDICATED SKIN CARE PREPARATIONS, NAMELY, CREAMS, LOTIONS, GELS, TONERS, CLEANERS AND PEELS; SKIN CARE PREPARATIONS, NAMELY, CHEMICAL PEELS FOR SKIN; SKIN LIGHTENING CREAMS; SKIN MASKS; SKIN MOISTURIZER; SKIN TONERS; SOAPS FOR BODY CARE; SUN SCREEN; WIPES IMPREGNATED WITH A SKIN CLEANSER; WRINKLE REMOVING SKIN CARE PREPARATIONS (U.S. CLS. 1, 4, 6, 50, 51 AND 52).

**CLASS 5—PHARMACEUTICALS**

FOR DIETARY AND NUTRITIONAL SUPPLEMENTS; MEDICATED SKIN CARE PREPARATIONS, NAMELY, CREAMS, LOTIONS, GELS, TONERS, CLEANERS AND PEELS; MEDICINAL CREAMS FOR SKIN CARE; NON-MEDICATED, THERAPEUTIC SKIN CREAMS FOR THE TREATMENT OF ACNE; NUTRACEUTICALS FOR USE AS A DIETARY SUPPLEMENT; NUTRITIONAL SUPPLEMENTS FOR PROMOTING HEALTHY SKIN; VAGINAL MOISTURIZERS; VAGINAL PREPARATIONS, NAMELY, ANTIFUNGALS; VAGINAL WASHES; VITAMINS AND VITAMIN PREPARATIONS (U.S. CLS. 6, 18, 44, 46, 51 AND 52).

**CLASS 35—ADVERTISING AND BUSINESS**

FOR ON-LINE RETAIL STORE SERVICES FEATURING SKIN CARE PRODUCTS, PERFUME, VITAMINS AND NUTRACEUTICALS; RETAIL STORE SERVICES FEATURING SKIN CARE PRODUCTS, PERFUME, VITAMINS AND NUTRACEUTICALS (U.S. CLS. 100, 101 AND 102).  
DANNEAN HETZEL, EXAMINING ATTORNEY

SN 85-205,684. MYBODY, L.L.C., PHOENIX, AZ. FILED 12-26-2010.

SAVE IT

THE MARK CONSISTS OF STANDARD CHARACTERS WITHOUT CLAIM TO ANY PARTICULAR FONT, STYLE, SIZE, OR COLOR.

**CLASS 3—COSMETICS AND CLEANING PREPARATIONS**

FOR ANTI-WRINKLE CREAM; BODY SCRUB; COSMETIC CREAMS; NON-MEDICATED ANTI-AGING SERUM; NON-MEDICATED SKIN CARE PREPARATIONS, NAMELY, CREAMS, LOTIONS, GELS, TONERS, CLEANERS AND PEELS; SKIN LIGHTENING CREAMS; SKIN MOISTURIZER; SOAPS FOR BODY CARE; SUN SCREEN (U.S. CLS. 1, 4, 6, 50, 51 AND 52).

**CLASS 5—PHARMACEUTICALS**

FOR DIETARY AND NUTRITIONAL SUPPLEMENTS; MEDICATED SKIN CARE PREPARATIONS, NAMELY, CREAMS, LOTIONS, GELS, TONERS, CLEANERS AND PEELS; MEDICINAL CREAMS FOR SKIN CARE; NON-MEDICATED, THERAPEUTIC SKIN CREAMS FOR THE TREATMENT OF ACNE; NUTRACEUTICALS FOR USE AS A DIETARY SUPPLEMENT; NUTRITIONAL SUPPLEMENTS FOR PROMOTING HEALTHY SKIN; VITAMINS AND VITAMIN PREPARATIONS (U.S. CLS. 6, 18, 44, 46, 51 AND 52).  
DANNEAN HETZEL, EXAMINING ATTORNEY

SN 85-205,686. MYBODY, L.L.C., PHOENIX, AZ. FILED 12-26-2010.

SECRET SERVICE

THE MARK CONSISTS OF STANDARD CHARACTERS WITHOUT CLAIM TO ANY PARTICULAR FONT, STYLE, SIZE, OR COLOR.

**CLASS 3—COSMETICS AND CLEANING PREPARATIONS**

FOR DISPOSABLE WIPES IMPREGNATED WITH CLEANSING CHEMICALS OR COMPOUNDS FOR PERSONAL HYGIENE; FEMININE DEODORANT SPRAYS; FEMININE DEODORANT SUPPOSITORIES; NON-MEDICATED FEMININE HYGIENE WASH (U.S. CLS. 1, 4, 6, 50, 51 AND 52).

**CLASS 5—PHARMACEUTICALS**

FOR FEMININE HYGIENE PADS; VAGINAL MOISTURIZERS; VAGINAL PREPARATIONS, NAMELY, ANTIFUNGALS; VAGINAL WASHES (U.S. CLS. 6, 18, 44, 46, 51 AND 52).  
DANNEAN HETZEL, EXAMINING ATTORNEY

SN 85-205,709. TEQUILA CUERVO LA ROJENA, S.A. DE C.V., CODIGO, MEXICO, FILED 12-26-2010.

VICENTE ROJAS

THE MARK CONSISTS OF STANDARD CHARACTERS WITHOUT CLAIM TO ANY PARTICULAR FONT, STYLE, SIZE, OR COLOR.

THE NAME(S), PORTRAIT(S), AND/OR SIGNATURE(S) SHOWN IN THE MARK DOES NOT IDENTIFY A PARTICULAR LIVING INDIVIDUAL.

**CLASS 32—LIGHT BEVERAGES**

FOR NON-ALCOHOLIC COCKTAIL MIXES (U.S. CLS. 45, 46 AND 48).

**CLASS 33—WINES AND SPIRITS**

FOR ALCOHOLIC BEVERAGES, NAMELY, DISTILLED SPIRITS, TEQUILA; PREPARED ALCOHOLIC COCKTAILS (U.S. CLS. 47 AND 49).

**CLASS 43—HOTEL AND RESTAURANT SERVICES**

FOR RESTAURANTS, BAR SERVICES; PROVIDING FOOD AND DRINKS FOR GUESTS (U.S. CLS. 100 AND 101).

ALICIA COLLINS, EXAMINING ATTORNEY

**CLASS 9—ELECTRICAL AND SCIENTIFIC APPARATUS**

FOR AUDIO AND VIDEO MEDIA, NAMELY, CDS AND DVDS CONTAINING INFORMATION ABOUT THE MENTAL SIDE OF RETIREMENT (U.S. CLS. 21, 23, 26, 36 AND 38).

FIRST USE 3-6-2008; IN COMMERCE 3-6-2008.

**CLASS 16—PAPER GOODS AND PRINTED MATTER**

FOR PRINTED MATTER, NAMELY, WORKBOOKS, CONTAINING INFORMATION ABOUT THE MENTAL SIDE OF RETIREMENT (U.S. CLS. 2, 5, 22, 23, 29, 37, 38 AND 50).

FIRST USE 9-0-1995; IN COMMERCE 9-0-1995.

DARRYL SPRUILL, EXAMINING ATTORNEY

SN 85-205,737. JOHN M. TAYMAN, SAN FRANCISCO, CA. FILED 12-26-2010.

SN 85-205,911. TAKING BEAUTY, LLC, PHILADELPHIA, PA. FILED 12-27-2010.

# Byliner

# AMERICAN MORTALS

THE MARK CONSISTS OF STANDARD CHARACTERS WITHOUT CLAIM TO ANY PARTICULAR FONT, STYLE, SIZE, OR COLOR.

THE MARK CONSISTS OF STANDARD CHARACTERS WITHOUT CLAIM TO ANY PARTICULAR FONT, STYLE, SIZE, OR COLOR.

**CLASS 41—EDUCATION AND ENTERTAINMENT**

FOR PROVIDING A DATABASE FEATURING INFORMATION ABOUT ARTISTS; PUBLISHING OF BOOKS, MAGAZINES; PUBLISHING OF ELECTRONIC PUBLICATIONS (U.S. CLS. 100, 101 AND 107).

FIRST USE 5-1-2000; IN COMMERCE 5-1-2000.

**CLASS 3—COSMETICS AND CLEANING PREPARATIONS**

FOR HAIR AND SKIN CARE PRODUCTS, NAMELY, SHAMPOOS, CONDITIONERS, BUBBLE BATHS, LIP BALMS AND BODY LOTIONS (U.S. CLS. 1, 4, 6, 50, 51 AND 52).

**CLASS 42—SCIENTIFIC AND COMPUTER SERVICES**

FOR PROVIDING A WEBSITE FEATURING A MEDIA AGGREGATOR AND SEARCH ENGINE FOR INTERNET CONTENT (U.S. CLS. 100 AND 101).

FIRST USE 5-1-2000; IN COMMERCE 5-1-2000.

CHERYL CLAYTON, EXAMINING ATTORNEY

**CLASS 35—ADVERTISING AND BUSINESS**

FOR RETAIL STORE AND ONLINE RETAIL STORE SERVICES FEATURING HAIR AND SKIN CARE PRODUCTS, NAMELY, SHAMPOOS, CONDITIONERS, BUBBLE BATHS, LIP BALMS AND BODY LOTIONS (U.S. CLS. 100, 101 AND 102).

MAYUR VAGHANI, EXAMINING ATTORNEY

SN 85-205,783. THE PACIFIC INSTITUTE INCORPORATED, SEATTLE, WA. FILED 12-27-2010.

SN 85-206,030. VIKI, INC., PALO ALTO, CA. FILED 12-27-2010.

# HOW TO MAKE RETIREMENT A NEW ADVENTURE

# VIKI

THE MARK CONSISTS OF STANDARD CHARACTERS WITHOUT CLAIM TO ANY PARTICULAR FONT, STYLE, SIZE, OR COLOR.

OWNER OF U.S. REG. NO. 2,030,742.

THE MARK CONSISTS OF STANDARD CHARACTERS WITHOUT CLAIM TO ANY PARTICULAR FONT, STYLE, SIZE, OR COLOR.

**CLASS 41—EDUCATION AND ENTERTAINMENT**

FOR ENTERTAINMENT SERVICES, NAMELY, PROVIDING A WEBSITE FEATURING NON-DOWNLOADABLE MUSIC, NON-DOWNLOADABLE VIDEOS, NON-DOWNLOADABLE TELEVISION PROGRAMS, NON-DOWNLOADABLE MOTION PICTURES, INFORMATION ON CURRENT EVENT AND ENTERTAINMENT NEWS, INFORMATION ON SPORTS, NON-DOWNLOADABLE GAMES, INFORMATION ON CULTURAL EVENTS AND INFORMATION ON ENTERTAINMENT-RELATED ON-LINE PROGRAMS VIA THE INTERNET (U.S. CLS. 100, 101 AND 107).

FIRST USE 12-2-2010; IN COMMERCE 12-2-2010.

**CLASS 42—SCIENTIFIC AND COMPUTER SERVICES**

FOR PROVIDING A WEBSITE THAT GIVES USERS THE ABILITY TO PURCHASE AND DOWNLOAD MUSIC, VIDEOS, TELEVISION PROGRAMS, MOTION PICTURES, RING TONES AND GRAPHICS; HOSTING OF DIGITAL CONTENT ON THE INTERNET (U.S. CLS. 100 AND 101).

TRACY FLETCHER, EXAMINING ATTORNEY

---

SN 85-206,058. BAILIDA INTERNATIONAL, INC., PRINCETON, NJ. FILED 12-27-2010.

mycool

THE MARK CONSISTS OF STANDARD CHARACTERS WITHOUT CLAIM TO ANY PARTICULAR FONT, STYLE, SIZE, OR COLOR.

**CLASS 9—ELECTRICAL AND SCIENTIFIC APPARATUS**

FOR 3D CAMERA SYSTEMS, NAMELY, ADAPTERS FOR ALLOWING 3D SHOOTING; AUDIO-VIDEO RECEIVERS; CALCULATING MACHINES, DATA-PROCESSING EQUIPMENT AND COMPUTERS; COMPUTER KEYBOARDS; DIGITAL CAMERAS; DVD PLAYERS; GPS NAVIGATION DEVICE; HOME THEATER PRODUCTS, NAMELY, LCD; KEYBOARDS; MOBILE PHONES; MP3 PLAYERS; MP4 PLAYERS; TELEVISIONS AND MONITORS; VIDEO GAME MACHINES FOR USE WITH TELEVISIONS; WIRELESS INDOOR AND OUTDOOR SPEAKERS (U.S. CLS. 21, 23, 26, 36 AND 38).

**CLASS 11—ENVIRONMENTAL CONTROL APPARATUS**

FOR AIR CLEANING UNITS; AIR CONDITIONERS; AIR PURIFIERS; COMBINATION MICROWAVE/CONVECTION OVEN; DEHUMIDIFIERS; ELECTRIC FANS; ELECTRIC RADIANT HEATERS; ELECTRIC RICE COOKER; FREEZERS; HOODS FOR RANGES; ICE MAKING MACHINES; INDUCTION OVENS; LED LIGHTING FIXTURES FOR INDOOR AND OUTDOOR LIGHTING APPLICATIONS; MICROWAVE OVENS; RANGE HOODS; REFRIGERATORS; SOLAR LIGHT FIXTURES, NAMELY, INDOOR AND OUTDOOR SOLAR POWERED LIGHTING UNITS AND FIXTURES; SOLAR WATER HEATERS; WINE COOLERS, NAMELY, REFRIGERATED CABINETS CONTAINING RACKS FOR WINE BOTTLES AND STORAGE SHELVES (U.S. CLS. 13, 21, 23, 31 AND 34).

MICHELLE DUBOIS, EXAMINING ATTORNEY

SN 85-206,066. BLUMBERG, JAY E., SOLANA BEACH, CA. FILED 12-27-2010.

FITTERATION

THE MARK CONSISTS OF STANDARD CHARACTERS WITHOUT CLAIM TO ANY PARTICULAR FONT, STYLE, SIZE, OR COLOR.

**CLASS 9—ELECTRICAL AND SCIENTIFIC APPARATUS**

FOR COMPUTER APPLICATION SOFTWARE FOR TRANSMISSION, ACCESS AND MANAGEMENT OF TEXT MESSAGING AND INTERNET COMMUNICATIONS, NAMELY, SOFTWARE FOR MOBILE PHONE SOCIAL NETWORKING IN THE HEALTH, FITNESS AND NUTRITION INDUSTRIES (U.S. CLS. 21, 23, 26, 36 AND 38).

**CLASS 42—SCIENTIFIC AND COMPUTER SERVICES**

FOR PROVIDING A WEB SITE FEATURING TECHNOLOGY THAT ENABLES INTERNET USERS TO CREATE, BOOKMARK, ANNOTATE, AND PUBLICLY SHARE FITNESS-RELATED DATA, AS WELL AS PROVIDING HEALTH AND FITNESS PROFESSIONALS WITH A SUBSCRIPTION-BASED CLIENT MANAGEMENT SYSTEM (U.S. CLS. 100 AND 101).

KEVON CHISOLM, EXAMINING ATTORNEY

---

SN 85-206,093. BLUMBERG, JAY E., SOLANA BEACH, CA. FILED 12-27-2010.

FITTER

THE MARK CONSISTS OF STANDARD CHARACTERS WITHOUT CLAIM TO ANY PARTICULAR FONT, STYLE, SIZE, OR COLOR.

**CLASS 9—ELECTRICAL AND SCIENTIFIC APPARATUS**

FOR COMPUTER APPLICATION SOFTWARE FOR TRANSMISSION, ACCESS AND MANAGEMENT OF TEXT MESSAGING AND INTERNET COMMUNICATIONS, NAMELY, SOFTWARE FOR MOBILE PHONE SOCIAL NETWORKING IN THE HEALTH, FITNESS AND NUTRITION INDUSTRIES (U.S. CLS. 21, 23, 26, 36 AND 38).

**CLASS 42—SCIENTIFIC AND COMPUTER SERVICES**

FOR PROVIDING A WEB SITE FEATURING TECHNOLOGY THAT ENABLES INTERNET USERS TO CREATE, BOOKMARK, ANNOTATE, AND PUBLICLY SHARE FITNESS-RELATED DATA, AS WELL AS PROVIDING HEALTH AND FITNESS PROFESSIONALS WITH A SUBSCRIPTION-BASED CLIENT MANAGEMENT SYSTEM (U.S. CLS. 100 AND 101).

KEVON CHISOLM, EXAMINING ATTORNEY

SN 85-206,101. ZINGA INVESTMENTS, LLC, HAYMARKET, VA. FILED 12-27-2010.

SN 85-206,174. JOB OPPORTUNITIES, INC., SAN DIEGO, CA. FILED 12-27-2010.

## ZINGA

THE MARK CONSISTS OF STANDARD CHARACTERS WITHOUT CLAIM TO ANY PARTICULAR FONT, STYLE, SIZE, OR COLOR.

### CLASS 30—STAPLE FOODS

FOR FROZEN YOGURT (U.S. CL. 46).

### CLASS 35—ADVERTISING AND BUSINESS

FOR RESTAURANT FRANCHISING, NAMELY, OFFERING BUSINESS MANAGEMENT ASSISTANCE IN THE ESTABLISHMENT AND/OR OPERATION OF RESTAURANTS (U.S. CLS. 100, 101 AND 102).

### CLASS 43—HOTEL AND RESTAURANT SERVICES

FOR RESTAURANT SERVICES (U.S. CLS. 100 AND 101).  
HEATHER BIDDULPH, EXAMINING ATTORNEY

---

SN 85-206,129. MAGLEV WIND TURBINE TECHNOLOGIES, INC., SIERRA VISTA, AZ. FILED 12-27-2010.

## REGENEDYNE

THE MARK CONSISTS OF STANDARD CHARACTERS WITHOUT CLAIM TO ANY PARTICULAR FONT, STYLE, SIZE, OR COLOR.

### CLASS 7—MACHINERY

FOR POWER GENERATORS, NAMELY, WIND ENERGY TURBINES (U.S. CLS. 13, 19, 21, 23, 31, 34 AND 35).

### CLASS 40—MATERIAL TREATMENT

FOR TECHNICAL CONSULTATION FOR OTHERS WITH REGARD TO POWER GENERATION, NAMELY, PRODUCING WIND ENERGY (U.S. CLS. 100, 103 AND 106).

### CLASS 42—SCIENTIFIC AND COMPUTER SERVICES

FOR RESEARCH, DEVELOPMENT, AND ENGINEERING SERVICES FOR OTHERS WITH REGARD TO POWER GENERATION, NAMELY, PRODUCING WIND ENERGY (U.S. CLS. 100 AND 101).  
MICHAEL WEBSTER, EXAMINING ATTORNEY

## SMART OPTIONS

THE MARK CONSISTS OF STANDARD CHARACTERS WITHOUT CLAIM TO ANY PARTICULAR FONT, STYLE, SIZE, OR COLOR.

### CLASS 35—ADVERTISING AND BUSINESS

FOR EMPLOYMENT STAFFING SERVICES, NAMELY, PLACING PEOPLE WITH AND WITHOUT DISABILITIES IN THE FIELD OF ADMINISTRATIVE AND CLERICAL, LANDSCAPING AND GROUNDS MAINTENANCE, JANITORIAL AND HOUSEKEEPING, COMMISSARY AND WAREHOUSING, FOOD SERVICE AND HOSPITALITY, LAUNDRY (U.S. CLS. 100, 101 AND 102).

### CLASS 37—CONSTRUCTION AND REPAIR

FOR LAUNDRY SERVICES (U.S. CLS. 100, 103 AND 106).  
MARK PILARO, EXAMINING ATTORNEY

---

SN 85-206,234. ALM MANAGEMENT SERVICES LLC, HONOLULU, HI. FILED 12-27-2010.

## ALA MOANA HOTEL

THE MARK CONSISTS OF STANDARD CHARACTERS WITHOUT CLAIM TO ANY PARTICULAR FONT, STYLE, SIZE, OR COLOR.

NO CLAIM IS MADE TO THE EXCLUSIVE RIGHT TO USE "HOTEL", APART FROM THE MARK AS SHOWN.

THE ENGLISH TRANSLATION OF "ALA MOANA" IN THE MARK IS OCEAN PATH.  
SEC. 2(F).

### CLASS 35—ADVERTISING AND BUSINESS

FOR ADMINISTRATIVE HOTEL MANAGEMENT; HOTEL MANAGEMENT FOR OTHERS (U.S. CLS. 100, 101 AND 102).  
FIRST USE 9-0-2005; IN COMMERCE 9-0-2005.

### CLASS 36—INSURANCE AND FINANCIAL

FOR MANAGEMENT OF VACATION CONDOMINIUMS AND VACATION APARTMENTS FOR OTHERS; LEASING AND MANAGEMENT FOR OTHERS OF VACATION CONDOMINIUMS LOCATED WITHIN HOTEL DEVELOPMENTS (U.S. CLS. 100, 101 AND 102).  
FIRST USE 9-0-2005; IN COMMERCE 9-0-2005.

**CLASS 43—HOTEL AND RESTAURANT SERVICES**

FOR PROVIDING TEMPORARY ACCOMMODATIONS; HOTEL SERVICES; RESORT LODGING SERVICES; RESERVATION SERVICES FOR TEMPORARY ACCOMMODATIONS; HOTEL AND TEMPORARY ACCOMMODATION INFORMATION SERVICES; RESTAURANT AND BAR SERVICES (U.S. CLS. 100 AND 101).

FIRST USE 8-0-1970; IN COMMERCE 8-0-1970.  
SIMON TENG, EXAMINING ATTORNEY

**CLASS 9—ELECTRICAL AND SCIENTIFIC APPARATUS**

FOR ELECTRONIC DEVICES, NAMELY, TRANSCEIVERS WORN BY INDIVIDUALS WITH PHYSICAL AND/OR COGNITIVE DISABILITIES OR IMPAIRMENTS SUCH AS ALZHEIMER'S DISEASE, AUTISM, AND DOWN SYNDROME, USED TO LOCATE SUCH INDIVIDUALS THROUGH CELLULAR TELEPHONE INFRASTRUCTURE AND NETWORK (U.S. CLS. 21, 23, 26, 36 AND 38).

**CLASS 45—PERSONAL AND LEGAL SERVICES**

FOR LOCATION SERVICES, NAMELY, PROVIDING REMOTE TRACKING, LOCATING AND MONITORING SERVICES OF INDIVIDUALS THROUGH CELLULAR TELEPHONE INFRASTRUCTURE AND NETWORK (U.S. CLS. 100 AND 101).

DAVID HOFFMAN, EXAMINING ATTORNEY

SN 85-206,354. SALTMAN, STEVEN, SOMERVILLE, MA. AND PICKER, CHRISTIAN, SOMERVILLE, MA. FILED 12-28-2010.

# LockerNotes

THE MARK CONSISTS OF STANDARD CHARACTERS WITHOUT CLAIM TO ANY PARTICULAR FONT, STYLE, SIZE, OR COLOR.

**CLASS 9—ELECTRICAL AND SCIENTIFIC APPARATUS**

FOR DECORATIVE MAGNETS; DECORATIVE REFRIGERATOR MAGNETS; ERASING MAGNETS; FRIDGE MAGNETS; MAGNETS; REFRIGERATOR MAGNETS (U.S. CLS. 21, 23, 26, 36 AND 38).

FIRST USE 11-24-2010; IN COMMERCE 11-24-2010.

**CLASS 16—PAPER GOODS AND PRINTED MATTER**

FOR DRY ERASE WRITING BOARDS AND WRITING SURFACES; MAGNETIC BOARDS; MAGNETIC BOARDS FOR SCHEDULING ACTIVITIES AND APPOINTMENTS; MAGNETIC BUMPER STICKERS; MAGNETIC PAPER; SCHOOL SUPPLY KITS CONTAINING VARIOUS COMBINATIONS OF SELECTED SCHOOL SUPPLIES, NAMELY, WRITING INSTRUMENTS, PENS, PENCILS, MECHANICAL PENCILS, ERASERS, MARKERS, CRAYONS, HIGHLIGHTER PENS, FOLDERS, NOTEBOOKS, PAPER, PROTRACTORS, PAPER CLIPS, PENCIL SHARPENERS, WRITING GRIPS, GLUE AND BOOK MARKS; STICK-ON WHITEBOARDS AND DRY-ERASE BOARDS; WHITEBOARD ERASERS (U.S. CLS. 2, 5, 22, 23, 29, 37, 38 AND 50).

FIRST USE 11-24-2010; IN COMMERCE 11-24-2010.  
DEZMONA MIZELLE, EXAMINING ATTORNEY

SN 85-206,395. JJCK LLC, FRISCO, TX. FILED 12-28-2010.

# TAKING THE SEARCH OUT OF SEARCH AND RESCUE

THE MARK CONSISTS OF STANDARD CHARACTERS WITHOUT CLAIM TO ANY PARTICULAR FONT, STYLE, SIZE, OR COLOR.

SN 85-206,466. MYBODY, L.L.C., PHOENIX, AZ. FILED 12-28-2010.

# MYTREATMENT

THE MARK CONSISTS OF STANDARD CHARACTERS WITHOUT CLAIM TO ANY PARTICULAR FONT, STYLE, SIZE, OR COLOR.

**CLASS 3—COSMETICS AND CLEANING PREPARATIONS**

FOR NON-MEDICATED ANTI-AGING SERUM; NON-MEDICATED SKIN CARE CREAMS AND LOTIONS; NON-MEDICATED SKIN CARE PREPARATIONS, NAMELY, CREAMS, LOTIONS, GELS, TONERS, CLEANSERS AND PEELS (U.S. CLS. 1, 4, 6, 50, 51 AND 52).

FIRST USE 1-28-2011; IN COMMERCE 1-28-2011.

**CLASS 5—PHARMACEUTICALS**

FOR MEDICATED SKIN CARE PREPARATIONS, NAMELY, CREAMS, LOTIONS, GELS, TONERS, CLEANSERS AND PEELS; MEDICINAL CREAMS FOR SKIN CARE (U.S. CLS. 6, 18, 44, 46, 51 AND 52).

FIRST USE 1-28-2011; IN COMMERCE 1-28-2011.  
MAYUR VAGHANI, EXAMINING ATTORNEY

SN 85-206,529. MARY FREE BED GUILD OF GRAND RAPIDS, MICHIGAN, GRAND RAPIDS, MI. FILED 12-28-2010.

# Mary Free Bed

THE MARK CONSISTS OF STANDARD CHARACTERS WITHOUT CLAIM TO ANY PARTICULAR FONT, STYLE, SIZE, OR COLOR.



**CLASS 36—INSURANCE AND FINANCIAL**

FOR CHARITABLE SERVICES, NAMELY PROVIDING FINANCIAL SUPPORT, DONATIONS, SPONSORSHIP AND SCHOLARSHIPS TO COMMUNITY AGENCIES, PROGRAMS, ORGANIZATIONS AND INDIVIDUALS SERVING THE PHYSICALLY DISABLED; LEASING OF REAL ESTATE; CHARITABLE FOUNDATION SERVICES, NAMELY PROVIDING FUNDRAISING ACTIVITIES AND INVESTMENT MANAGEMENT SERVICES TO SUPPORT MEDICAL EDUCATION AND RESEARCH AND ASSISTANCE FOR PROGRAMS AND SERVICES OF OTHERS (U.S. CLS. 100, 101 AND 102).

FIRST USE 3-21-1913; IN COMMERCE 3-21-1913.

**CLASS 41—EDUCATION AND ENTERTAINMENT**

FOR EDUCATIONAL SERVICES, NAMELY PROVIDING CLASSES, CLINICAL EXPERIENCES AND LECTURES IN THE FIELD OF HEALTH CARE; ART EXHIBITIONS; ORGANIZING, ARRANGING AND CONDUCTING SPORTING EVENTS, CLINICS AND PROGRAMS FOR INDIVIDUALS WITH DISABILITIES; VEHICLE DRIVING INSTRUCTION (U.S. CLS. 100, 101 AND 107).

FIRST USE 3-21-1913; IN COMMERCE 3-21-1913.

**CLASS 44—MEDICAL, BEAUTY AND AGRICULTURAL SERVICES**

FOR HOSPITALS; HEALTH CARE; PHYSICAL REHABILITATION; PHYSICAL THERAPY; OCCUPATIONAL THERAPY SERVICES; REHABILITATION PATIENT CARE SERVICES WHICH INCLUDES INPATIENT AND OUTPATIENT CARE; SPEECH AND HEARING THERAPY; PSYCHOLOGICAL CONSULTATION; FITTING OF PROSTHETICS (U.S. CLS. 100 AND 101).

FIRST USE 3-21-1913; IN COMMERCE 3-21-1913.

**CLASS 45—PERSONAL AND LEGAL SERVICES**

FOR ORGANIZING AND CONDUCTING SUPPORT GROUPS IN THE FIELDS OF STROKE, SPINAL CORD INJURY AND ADULT BRAIN INJURY (U.S. CLS. 100 AND 101).

FIRST USE 3-21-1913; IN COMMERCE 3-21-1913.  
ANNE MADDEN, EXAMINING ATTORNEY

---

SN 85-206,566. LAWSON, MICHAEL A., BEVERLY HILLS, CA. FILED 12-28-2010.

BLESSED BEYOND ALL REASON

THE MARK CONSISTS OF STANDARD CHARACTERS WITHOUT CLAIM TO ANY PARTICULAR FONT, STYLE, SIZE, OR COLOR.

**CLASS 12—VEHICLES**

FOR LICENSE PLATE FRAMES (U.S. CLS. 19, 21, 23, 31, 35 AND 44).

**CLASS 14—JEWELRY**

FOR ANKLE BRACELETS; BRACELETS; CHARMS FOR COLLAR JEWELRY AND BRACELET; JEWELRY, NAMELY, DOG TAGS FOR WEAR BY HUMANS FOR DECORATIVE PURPOSES; NECKLACES; RINGS; RUBBER OR SILICON WRISTBANDS IN THE NATURE OF A BRACELET (U.S. CLS. 2, 27, 28 AND 50).

**CLASS 16—PAPER GOODS AND PRINTED MATTER**

FOR GREETING CARDS; PAPERWEIGHTS; PENCILS; PENS; PUBLICATIONS, NAMELY, BROCHURES, BOOKLETS, AND TEACHING MATERIALS IN THE FIELD OF SUCCESSFUL RIGHTEOUS LIVING (U.S. CLS. 2, 5, 22, 23, 29, 37, 38 AND 50).

**CLASS 18—LEATHER GOODS**

FOR ALL PURPOSE SPORT BAGS; BACKPACKS, BOOK BAGS, SPORTS BAGS, BUM BAGS, WALLETS AND HANDBAGS; BAGS FOR CARRYING BABIES' ACCESSORIES; BRIEFCASE-TYPE PORTFOLIOS; BRIEFCASES; COLLARS FOR PETS; GARMENT BAGS FOR TRAVEL; GARMENTS FOR PETS; MESSENGER BAGS; PURSES; TOILETRY BAGS SOLD EMPTY (U.S. CLS. 1, 2, 3, 22 AND 41).

**CLASS 21—HOUSEWARES AND GLASS**

FOR BOWLS; COFFEE MUGS; DISHES AND PLATES; DRINKING CUPS FOR INFANTS AND PARTS AND FITTINGS THEREFOR, NAMELY, VALVES AND LIDS SOLD AS A UNIT; DRINKING GLASSES; GLASS MUGS; MUGS; TRAINING CUPS FOR BABIES AND CHILDREN (U.S. CLS. 2, 13, 23, 29, 30, 33, 40 AND 50).

**CLASS 25—CLOTHING**

FOR CAPS; CLOTHING FOR BABIES, TODDLERS AND CHILDREN, TREATED WITH FIRE AND HEAT RETARDANTS, NAMELY, PAJAMAS, JACKETS, SHIRTS, PANTS, JUMPERS; HATS FOR INFANTS, BABIES, TODDLERS AND CHILDREN; SHIRTS; SHIRTS FOR INFANTS, BABIES, TODDLERS AND CHILDREN; SWEATSHIRTS; T-SHIRTS (U.S. CLS. 22 AND 39).

**CLASS 28—TOYS AND SPORTING GOODS**

FOR BABY MULTIPLE ACTIVITY TOYS; CHRISTMAS TREE ORNAMENTS AND DECORATIONS; DOG TOYS (U.S. CLS. 22, 23, 38 AND 50).

**CLASS 41—EDUCATION AND ENTERTAINMENT**

FOR ENTERTAINMENT SERVICES, NAMELY, PROVIDING A WEB SITE FEATURING PHOTOGRAPHIC AND PROSE PRESENTATIONS FEATURING INFORMATION ON SUCCESSFUL RIGHTEOUS LIVING (U.S. CLS. 100, 101 AND 107).

KELLY CHOE, EXAMINING ATTORNEY

---

SN 85-206,640. SURFVIBE, LLC, LAS VEGAS, NV. FILED 12-28-2010.

**SURFVIBE**

THE MARK CONSISTS OF STANDARD CHARACTERS WITHOUT CLAIM TO ANY PARTICULAR FONT, STYLE, SIZE, OR COLOR.

**CLASS 16—PAPER GOODS AND PRINTED MATTER**

FOR PHOTOGRAPHS, PHOTOGRAPHIC PRINTS, PHOTO ALBUMS, AND POSTERS (U.S. CLS. 2, 5, 22, 23, 29, 37, 38 AND 50).

**CLASS 35—ADVERTISING AND BUSINESS**

FOR RETAIL STORE AND ON-LINE RETAIL STORE SERVICES FEATURING A WIDE VARIETY OF CONSUMER GOODS OF OTHERS (U.S. CLS. 100, 101 AND 102).

**CLASS 41—EDUCATION AND ENTERTAINMENT**

FOR PHOTOGRAPHY SERVICES (U.S. CLS. 100, 101 AND 107).  
BARBARA BROWN, EXAMINING ATTORNEY

**CLASS 36—INSURANCE AND FINANCIAL**

FOR INSURANCE SERVICES, NAMELY, UNDERWRITING EXTENDED COLLISION AND COMPREHENSIVE INSURANCE FOR ORGAN TRANSPORTER DEVICES, OFFERED AND CHARGED FOR SEPARATELY FROM THE GOODS (U.S. CLS. 100, 101 AND 102).

KATHERINE M. DUBRAY, EXAMINING ATTORNEY

SN 85-206,666. NATURAL SOURCING, LLC, OXFORD, CT. FILED 12-28-2010.

SN 85-206,652. LIFELINE SCIENTIFIC, INC., ITASCA, IL. FILED 12-28-2010.

**LIFESTATION**

THE MARK CONSISTS OF STANDARD CHARACTERS WITHOUT CLAIM TO ANY PARTICULAR FONT, STYLE, SIZE, OR COLOR.

**CLASS 5—PHARMACEUTICALS**

FOR SOLUTIONS FOR MEDICAL PURPOSES, NAMELY, SOLUTIONS FOR PERFUSION, PRESERVATION AND STORAGE OF ORGANS, TISSUES AND CELLS; SOLUTIONS FOR MEDICAL PURPOSES, NAMELY, SOLUTIONS FOR PERFUSION, PRESERVATION AND STORAGE OF ORGANS, TISSUES AND CELLS DURING TRANSPORT (U.S. CLS. 6, 18, 44, 46, 51 AND 52).

**CLASS 9—ELECTRICAL AND SCIENTIFIC APPARATUS**

FOR COMPUTER SOFTWARE FOR USE IN ORGAN TRANSPORT AND TRANSPLANTATION THAT INDICATES, MONITORS AND EVALUATES DATA FOR DIAGNOSTICS, ASSESSMENT AND TREATMENT (U.S. CLS. 21, 23, 26, 36 AND 38).

**CLASS 10—MEDICAL APPARATUS**

FOR CANNULAE, TUBING, AND COUPLERS FOR USE WITH CANNULAE; SURGICAL DRAPES; TRAYS SPECIALLY DESIGNED FOR HOLDING CONTAINERS FOR THE TRANSPORT AND STORAGE OF ORGANS, TISSUES AND CELLS; ORGAN MONITORS FOR USE IN ORGAN TRANSPLANTATION FOR USE BY ORGAN PROCUREMENT ORGANIZATIONS AND INSTITUTIONAL ORGAN PERFUSION PROGRAMS (U.S. CLS. 26, 39 AND 44).

**CLASS 20—FURNITURE AND ARTICLES NOT OTHERWISE CLASSIFIED**

FOR NONMETAL CONTAINERS FOR THE TRANSPORT AND STORAGE OF ORGANS, TISSUES AND CELLS FOR MEDICAL AND SCIENTIFIC PURPOSES; REPLACEMENT PARTS FOR NONMETAL CONTAINERS FOR THE TRANSPORT AND STORAGE OF ORGANS, TISSUES AND CELLS FOR MEDICAL AND SCIENTIFIC PURPOSES; PLASTIC CRATES FOR CONTAINERS FOR THE TRANSPORT AND STORAGE OF ORGANS, TISSUES AND CELLS (U.S. CLS. 2, 13, 22, 25, 32 AND 50).

**From Nature With Love**

THE MARK CONSISTS OF STANDARD CHARACTERS WITHOUT CLAIM TO ANY PARTICULAR FONT, STYLE, SIZE, OR COLOR.

**CLASS 3—COSMETICS AND CLEANING PREPARATIONS**

FOR ESSENTIAL OILS FOR USE IN THE MANUFACTURE OF SOAPS, CANDLES, AROMATHERAPY PRODUCTS, COSMETICS AND TOILETRIES ARTICLES SUCH AS SKIN CLEANSERS, BATH GELS, SALVES, SHAMPOOS, CONDITIONERS, LIP BALMS, BATH SALTS, MILK BATHS, BATH SPRITZERS, SKINCARE AND ESSENTIAL OIL BLEND PRODUCTS (U.S. CLS. 1, 4, 6, 50, 51 AND 52).

FIRST USE 10-20-1995; IN COMMERCE 10-20-1995.

**CLASS 4—LUBRICANTS AND FUELS**

FOR BEESWAX AND WICKS FOR USE IN THE MANUFACTURING OF CANDLES (U.S. CLS. 1, 6 AND 15).

FIRST USE 10-20-1995; IN COMMERCE 10-20-1995.

**CLASS 21—HOUSEWARES AND GLASS**

FOR GLASSWARE, NAMELY, BOTTLES AND JARS, HAIR COMBS, FACIAL SPONGES FOR APPLYING MAKE UP, AND COSMETIC BRUSHES FOR USE IN THE PACKAGING OF AROMATHERAPY PRODUCTS, COSMETICS, AND TOILETRY ARTICLES SUCH AS CLEANERS, BATH GELS, SALVES, SHAMPOOS, CONDITIONERS, LIP BALMS, BATH SALTS, MILK BATHS, BATH SPRITZERS, SKINCARE AND ESSENTIAL OIL BLEND PRODUCTS (U.S. CLS. 2, 13, 23, 29, 30, 33, 40 AND 50).

FIRST USE 10-20-1995; IN COMMERCE 10-20-1995.

SCOTT BIBB, EXAMINING ATTORNEY

SN 85-206,704. INVESTOR'S BUSINESS DAILY, INC., LOS ANGELES, CA. FILED 12-28-2010.

**CAN SLIM**

OWNER OF U.S. REG. NO. 3,081,940.

THE MARK CONSISTS OF THE WORDING "CAN SLIM" WITH A TRIANGLE APPEARING INSIDE OF THE LETTER "A" TO FORM A PART OF THE LETTER "A".

**CLASS 36—INSURANCE AND FINANCIAL**

FOR PROVIDING AN ON-LINE COMPUTER DATABASE IN THE FIELD OF FINANCIAL INFORMATION; FINANCIAL INFORMATION PROVIDED BY ELECTRONIC MEANS (U.S. CLS. 100, 101 AND 102).  
FIRST USE 6-30-2006; IN COMMERCE 6-30-2006.

**CLASS 41—EDUCATION AND ENTERTAINMENT**

FOR EDUCATIONAL SERVICES, NAMELY CONDUCTING WORKSHOPS, ON-LINE WORKSHOPS, SEMINARS, AND TRAINING IN THE FIELD OF FINANCIAL INVESTMENTS; PROVIDING ON-LINE NEWSLETTERS AND NEWSPAPERS IN THE FIELD OF FINANCIAL INFORMATION (U.S. CLS. 100, 101 AND 107).  
FIRST USE 6-30-2006; IN COMMERCE 6-30-2006.  
KHANH LE, EXAMINING ATTORNEY

SN 85-206,730. PER4MANCE TRAINING LLC, DBA TOTALCYCLIST LLC, CHARLOTTE, NC. FILED 12-28-2010.

**TOTALCYCLIST**

THE MARK CONSISTS OF STANDARD CHARACTERS WITHOUT CLAIM TO ANY PARTICULAR FONT, STYLE, SIZE, OR COLOR.

**CLASS 25—CLOTHING**

FOR CLOTHING, NAMELY, CYCLING JERSEYS AND SHORTS, SOCKS, T-SHIRTS (U.S. CLS. 22 AND 39).  
FIRST USE 1-30-2008; IN COMMERCE 1-30-2008.

**CLASS 41—EDUCATION AND ENTERTAINMENT**

FOR PHYSICAL FITNESS INSTRUCTION, NAMELY, ENDURANCE AND AEROBIC TRAINING FOR ELITE AND RECREATIONAL ATHLETES; PHYSICAL FITNESS CONSULTATION IN THE FIELD OF ENDURANCE AND AEROBIC TRAINING FOR ELITE AND RECREATIONAL ATHLETES (U.S. CLS. 100, 101 AND 107).  
FIRST USE 1-30-2008; IN COMMERCE 1-30-2008.  
NELSON SNYDER, EXAMINING ATTORNEY

SN 85-206,780. 9 TV PRODUCTIONS, LLC, SCOTTSDALE, AZ. FILED 12-28-2010.

**HOTTEST MOM IN AMERICA**

THE MARK CONSISTS OF STANDARD CHARACTERS WITHOUT CLAIM TO ANY PARTICULAR FONT, STYLE, SIZE, OR COLOR.

**CLASS 25—CLOTHING**

FOR CLOTHING FOR MEN, WOMEN AND CHILDREN, NAMELY, T-SHIRTS, TANK TOPS, SWEATSHIRTS, WIND RESISTANT JACKETS, JACKETS, SHORTS, SWEAT SUITS, AND SWEAT PANTS; FOOTWEAR; HEADWEAR (U.S. CLS. 22 AND 39).

**CLASS 35—ADVERTISING AND BUSINESS**

FOR PRODUCTION OF COMMERCIALS AND ADVERTISEMENTS DISTRIBUTED VIA PRINTED MEDIA, BROADCAST TELEVISION, THE GLOBAL COMPUTER NETWORK, MOBILE PHONE, SATELLITE, RADIO AND CABLE; MARKETING, ADVERTISING AND PROMOTIONAL SERVICES, AND RELATED CONSULTING SERVICES (U.S. CLS. 100, 101 AND 102).

**CLASS 41—EDUCATION AND ENTERTAINMENT**

FOR CONSULTING SERVICES RELATING TO ARRANGING AND CONDUCTING CONTESTS (U.S. CLS. 100, 101 AND 107).  
LINDA M. KING, EXAMINING ATTORNEY

SN 85-206,805. 9 TV PRODUCTIONS, LLC, SCOTTSDALE, AZ. FILED 12-28-2010.



THE MARK CONSISTS OF A SILHOUETTE OF A WOMAN WITH THE WORD "HOTTEST" IN STYLIZED FONT ABOVE THE DEPICTION OF A WOMAN, THE WORD "MOM" IN STYLIZED FONT GOING ACROSS THE MIDDLE OF THE DEPICTION OF A WOMAN, AND THE WORDS "IN AMERICA" IN STYLIZED FONT BELOW THE WORD "MOM".

**CLASS 25—CLOTHING**

FOR CLOTHING FOR MEN, WOMEN AND CHILDREN, NAMELY, T-SHIRTS, TANK TOPS, SWEATSHIRTS, WIND RESISTANT JACKETS, JACKETS, SHORTS, SWEAT SUITS, AND SWEAT PANTS; FOOTWEAR; HEADWEAR (U.S. CLS. 22 AND 39).

**CLASS 35—ADVERTISING AND BUSINESS**

FOR PRODUCTION OF COMMERCIALS AND ADVERTISEMENTS DISTRIBUTED VIA PRINTED MEDIA, BROADCAST TELEVISION, THE GLOBAL COMPUTER NETWORK, MOBILE PHONE, SATELLITE, RADIO AND CABLE; MARKETING, ADVERTISING AND PROMOTIONAL SERVICES, AND RELATED CONSULTING; PROVIDING REGISTRATION INFORMATION VIA THE GLOBAL COMPUTER NETWORK ABOUT ONGOING TELEVISION SERIES AND CONTESTS (U.S. CLS. 100, 101 AND 102).

**CLASS 36—INSURANCE AND FINANCIAL**

FOR FINANCIAL SPONSORSHIP OF TELEVISIONS SERIES AND CONTESTS PROMOTING MODERN DAY MOTHERHOOD (U.S. CLS. 100, 101 AND 102).

**CLASS 41—EDUCATION AND ENTERTAINMENT**

FOR ENTERTAINMENT SERVICES, NAMELY, ARRANGING AND CONDUCTING CONTESTS; PRODUCTION AND DISTRIBUTION OF ON-GOING TELEVISION SERIES AND ENTERTAINMENT PROGRAMS IN THE NATURE OF REALITY SHOWS AND CONTESTS, ALL DISTRIBUTED VIA BROADCAST TV, THE GLOBAL COMPUTER NETWORK, MOBILE PHONE, SATELLITE, RADIO OR CABLE; AND PROVIDING PROGRAMMING AND AUDITION INFORMATION VIA THE GLOBAL COMPUTER NETWORK RELATING TO ONGOING TELEVISION SERIES AND CONTESTS (U.S. CLS. 100, 101 AND 107).

LINDA M. KING, EXAMINING ATTORNEY

SN 85-207,119. BAIR PRODUCTS, INC., LOUISBURG, KS. FILED 12-29-2010.

# LUGGIE

THE MARK CONSISTS OF STANDARD CHARACTERS WITHOUT CLAIM TO ANY PARTICULAR FONT, STYLE, SIZE, OR COLOR.

**CLASS 7—MACHINERY**

FOR PARTS AND FITTINGS, NAMELY, NON-METAL DRIVE LUGS USED FOR TRACTION IN MACHINERY (U.S. CLS. 13, 19, 21, 23, 31, 34 AND 35).

**CLASS 12—VEHICLES**

FOR NON-METAL DRIVE LUGS USED FOR TRACTION IN VEHICLES (U.S. CLS. 19, 21, 23, 31, 35 AND 44).

MORGAN WYNNE, EXAMINING ATTORNEY

SN 85-207,124. BAIR PRODUCTS, INC., LOUISBURG, KS. FILED 12-29-2010.



THE MARK CONSISTS OF A CHARACTER WITH A SMILEY FACE, A LUG NUT FOR A BODY, SCREWS FOR LEGS, AND NUTS FOR FEET.

**CLASS 7—MACHINERY**

FOR PARTS AND FITTINGS, NAMELY, NON-METAL DRIVE LUGS USED FOR TRACTION IN MACHINERY (U.S. CLS. 13, 19, 21, 23, 31, 34 AND 35).

**CLASS 12—VEHICLES**

FOR NON-METAL DRIVE LUGS USED FOR TRACTION IN VEHICLES (U.S. CLS. 19, 21, 23, 31, 35 AND 44).

MORGAN WYNNE, EXAMINING ATTORNEY

SN 85-207,139. BLUE NOODLE INC., SAN FRANCISCO, CA. FILED 12-29-2010.

**WHAT THE HECK IS THAT?**

THE MARK CONSISTS OF STANDARD CHARACTERS WITHOUT CLAIM TO ANY PARTICULAR FONT, STYLE, SIZE, OR COLOR.

**CLASS 9—ELECTRICAL AND SCIENTIFIC APPARATUS**

FOR DOWNLOADABLE COMPUTER GAME SOFTWARE AND DOWNLOADABLE INTERACTIVE VIDEO GAMES VIA A GLOBAL COMPUTER NETWORK, WIRELESS DEVICES, MOBILE PHONES, SMART PHONES AND TABLET DEVICES; DOWNLOADABLE ELECTRONIC GAME SOFTWARE FOR WIRELESS DEVICES, MOBILE PHONES, SMART PHONES AND TABLET DEVICES (U.S. CLS. 21, 23, 26, 36 AND 38).

**CLASS 41—EDUCATION AND ENTERTAINMENT**

FOR ENTERTAINMENT SERVICES, NAMELY, PROVIDING ON-LINE COMPUTER GAMES AND NON-DOWNLOADABLE INTERACTIVE VIDEO GAMES VIA THE INTERNET; ENTERTAINMENT SERVICES, NAMELY, PROVIDING TEMPORARY ONLINE USE OF NON-DOWNLOADABLE ELECTRONIC GAMES, INTERACTIVE GAMES, COMPUTER GAMES AND VIDEO GAMES IN MOBILE WIRELESS FORM (U.S. CLS. 100, 101 AND 107).

JENNY PARK, EXAMINING ATTORNEY

SN 85-207,177. DEFENSELINE, LLC, MAUMEE, OH. FILED 12-29-2010.



THE MARK CONSISTS OF TWO CROSSED SWORDS SUPERIMPOSED ON A SHIELD, AND THE SHIELD IS TO THE LEFT OF THE WORD "DEFENSELINE".

**CLASS 41—EDUCATION AND ENTERTAINMENT**

FOR LANGUAGE TRANSLATION SERVICES (U.S. CLS. 100, 101 AND 107).

**CLASS 45—PERSONAL AND LEGAL SERVICES**

FOR CONSULTING SERVICES IN THE FIELD OF INTERNATIONAL SECURITY, NAMELY, SERVICES FOR INDIVIDUALS OR BUSINESSES TRAVELING OR OPENING OFFICES DOMESTICALLY OR OVERSEAS, IN THE NATURE OF DETAILED COUNTRY BRIEFINGS, VETTING OF LOCAL PERSONNEL, ESTABLISHING HOST COUNTRY GOVERNMENT CONTRACTS, PROVIDING INFORMATION ON SUITABLE SECURITY MEASURES, PROVIDING FOREIGN COUNTRY SECURITY BRIEFINGS, AND EMBASSY INFORMATION FOR SECURITY PURPOSES (U.S. CLS. 100 AND 101).  
LAURA HAMMEL, EXAMINING ATTORNEY

---

SN 85-207,184. FAYDA ENGINEERING & ENERGY SOLUTIONS, LLC, WILMINGTON, DE. FILED 12-29-2010.



THE MARK CONSISTS OF A DARK SHADED SUN WITH POINTED RAYS, AN UNSHADED RING JUST INSIDE THE PERIPHERY OF THE SUN, AND FOUR LIGHTLY SHADED CIRCLES CENTERED ON THE RING IN EACH OF TOP, BOTTOM, LEFT AND RIGHT POSITIONS. COLOR IS NOT A FEATURE OF THE MARK.

**CLASS 9—ELECTRICAL AND SCIENTIFIC APPARATUS**

FOR LIGHTING CONTROL SYSTEMS COMPRISING A CENTRAL CONTROLLER AND REMOTE CONTROL MODULES FOR CONTROLLING LIGHTING ARRAYS (U.S. CLS. 21, 23, 26, 36 AND 38).

**CLASS 42—SCIENTIFIC AND COMPUTER SERVICES**

FOR ENGINEERING SERVICES IN THE FIELD OF ENERGY EFFICIENCY; TECHNICAL CONSULTATION IN THE FIELD OF ENGINEERING SERVICES AND DESIGN FOR OTHERS IN THE FIELD OF ENERGY ENGINEERING (U.S. CLS. 100 AND 101).  
FIRST USE 10-6-2009; IN COMMERCE 10-6-2009.  
JAMES GRIFFIN, EXAMINING ATTORNEY

SN 85-207,233. YOTHER, CECIL L., PORT ANGELES, WA. FILED 12-29-2010.

**MELROSE MISSILE**

THE MARK CONSISTS OF STANDARD CHARACTERS WITHOUT CLAIM TO ANY PARTICULAR FONT, STYLE, SIZE, OR COLOR.

**CLASS 35—ADVERTISING AND BUSINESS**

FOR ADVERTISING SERVICES, NAMELY DISPLAY OF PRODUCT NAMES ON AUTOMOBILES ENTERED IN COMMERCIAL RACING EVENTS (U.S. CLS. 100, 101 AND 102).  
FIRST USE 3-0-1965; IN COMMERCE 3-0-1965.

**CLASS 41—EDUCATION AND ENTERTAINMENT**

FOR ENTERTAINMENT SERVICES, NAMELY COMPETITION AUTOMOBILE RACING (U.S. CLS. 100, 101 AND 107).  
FIRST USE 3-0-1965; IN COMMERCE 3-0-1965.  
MICHAEL WEBSTER, EXAMINING ATTORNEY

---

SN 85-207,398. SAFEWAY SAFETY STEP, LLC, FAIRFIELD, OH. FILED 12-29-2010.

**SAFEWAY TUB DOOR**

THE MARK CONSISTS OF STANDARD CHARACTERS WITHOUT CLAIM TO ANY PARTICULAR FONT, STYLE, SIZE, OR COLOR.

OWNER OF U.S. REG. NO. 2,836,567.  
NO CLAIM IS MADE TO THE EXCLUSIVE RIGHT TO USE "TUB DOOR", APART FROM THE MARK AS SHOWN.

**CLASS 11—ENVIRONMENTAL CONTROL APPARATUS**

FOR BATHTUB SIDEWALL INSERT AND DOOR TO PERMIT EASE OF ACCESS (U.S. CLS. 13, 21, 23, 31 AND 34).  
FIRST USE 12-1-2009; IN COMMERCE 12-1-2009.

**CLASS 37—CONSTRUCTION AND REPAIR**

FOR BATHTUB SIDEWALL INSERT AND DOOR INSTALLATION SERVICES (U.S. CLS. 100, 103 AND 106).  
FIRST USE 12-1-2009; IN COMMERCE 12-1-2009.  
TRACY WHITTAKER-BROWN, EXAMINING ATTORNEY

SN 85-207,489. RUSSELL LEONG DESIGN, CUPERTINO, CA. AND SHIN & LEE CORPORATION, SAN JOSE, CA. FILED 12-29-2010.



THE MARK CONSISTS OF AN ELONGATED PEACE SIGN WITH THE WORDS PEACE 2.0.

**CLASS 16—PAPER GOODS AND PRINTED MATTER**

FOR STICKERS (U.S. CLS. 2, 5, 22, 23, 29, 37, 38 AND 50).

**CLASS 18—LEATHER GOODS**

FOR ATHLETIC BAGS; TOTE BAGS; TRAVEL BAGS (U.S. CLS. 1, 2, 3, 22 AND 41).

**CLASS 21—HOUSEWARES AND GLASS**

FOR BOTTLES, SOLD EMPTY; CUPS; MUGS (U.S. CLS. 2, 13, 23, 29, 30, 33, 40 AND 50).

**CLASS 24—FABRICS**

FOR BEACH TOWELS (U.S. CLS. 42 AND 50).

**CLASS 25—CLOTHING**

FOR CAPS; DRESS SHIRTS; FLEECE PULLOVERS; HATS; HOODED SWEAT SHIRTS; SCARVES; SHIRTS; SOCKS; SWEAT PANTS; SWEAT SHIRTS; SWEATERS (U.S. CLS. 22 AND 39).

KELLY BOULTON, EXAMINING ATTORNEY

SN 85-207,695. QUANTUM MECHANIX, INC, COLLEGEVILLE, PA. FILED 12-30-2010.



THE MARK CONSISTS OF THE ALPHABET F WITHIN A CIRCLE AND THREE ROUND BRACKETS ON BOTH LEFT AND RIGHT SIDE OF THE CIRCLE AS SHOWN IN THE MARK.

**CLASS 25—CLOTHING**

FOR CLOTHING, NAMELY, T-SHIRTS, PANTS, SHOES, SWEATSHIRTS, HOODED SWEATSHIRTS, COATS AND HATS (U.S. CLS. 22 AND 39).

**CLASS 28—TOYS AND SPORTING GOODS**

FOR COLLECTIBLE SPECIALTY TOY FIGURINES (U.S. CLS. 22, 23, 38 AND 50).  
EUGENIA MARTIN, EXAMINING ATTORNEY

SN 85-207,696. KOBEL, BRYAN, RIDGEWOOD, NJ. FILED 12-30-2010.

**SORRY I'M NOT SORRY**

THE MARK CONSISTS OF STANDARD CHARACTERS WITHOUT CLAIM TO ANY PARTICULAR FONT, STYLE, SIZE, OR COLOR.

**CLASS 14—JEWELRY**

FOR PRECIOUS METALS, THEIR ALLOYS AND GOODS IN PRECIOUS METALS OR COATED THEREWITH, NAMELY, NECKLACES, PENDANTS; JEWELRY (U.S. CLS. 2, 27, 28 AND 50).

**CLASS 25—CLOTHING**

FOR CLOTHING, NAMELY, TOPS, BOTTOMS, T-SHIRTS, POLO SHIRTS, PANTS (U.S. CLS. 22 AND 39).  
INGA ERVIN, EXAMINING ATTORNEY

SN 85-207,749. PATEL, ANAND, DBA MYRIANN HOTEL MARKETING, DULUTH, GA. FILED 12-30-2010.

**RoomSailor**

THE MARK CONSISTS OF STANDARD CHARACTERS WITHOUT CLAIM TO ANY PARTICULAR FONT, STYLE, SIZE, OR COLOR.

**CLASS 9—ELECTRICAL AND SCIENTIFIC APPARATUS**

FOR DOWNLOADABLE SOFTWARE IN THE NATURE OF A MOBILE APPLICATION FOR LOCATING NEARBY HOTELS OFFERING COMPETITIVE PRICING (U.S. CLS. 21, 23, 26, 36 AND 38).

**CLASS 42—SCIENTIFIC AND COMPUTER SERVICES**

FOR PROVIDING TEMPORARY USE OF A WEB-BASED SOFTWARE APPLICATION FOR HOTELS TO OFFER COMPETITIVE ROOM PRICING TO USERS OF A CORRESPONDING MOBILE APPLICATION (U.S. CLS. 100 AND 101).  
SANDRA BUJA, EXAMINING ATTORNEY

SN 85-207,789. PRODUCTS ON THE GO, LLC, BOCA RATON, FL. FILED 12-30-2010.

## LOVE ON THE GO

THE MARK CONSISTS OF STANDARD CHARACTERS WITHOUT CLAIM TO ANY PARTICULAR FONT, STYLE, SIZE, OR COLOR.

### CLASS 5—PHARMACEUTICALS

FOR PERSONAL SEXUAL LUBRICANTS; SEXUAL STIMULANT GELS (U.S. CLS. 6, 18, 44, 46, 51 AND 52).

### CLASS 10—MEDICAL APPARATUS

FOR ADULT SEXUAL STIMULATION KIT COMPRISED PRIMARILY OF ADULT SEXUAL STIMULATION AIDS AND A WORKBOOK; CONDOMS (U.S. CLS. 26, 39 AND 44).

JENNIFER MARTIN, EXAMINING ATTORNEY

SN 85-207,818. HUNT REAL ESTATE CORPORATION, DEPEW, NY. FILED 12-30-2010.

## Buy Design

THE MARK CONSISTS OF STANDARD CHARACTERS WITHOUT CLAIM TO ANY PARTICULAR FONT, STYLE, SIZE, OR COLOR.

### CLASS 35—ADVERTISING AND BUSINESS

FOR ADVERTISING OF COMMERCIAL OR RESIDENTIAL REAL ESTATE; MATCHING CONSUMERS WITH REAL ESTATE PROFESSIONALS IN THE FIELD OF REAL ESTATE SERVICES VIA COMPUTER NETWORK; MEMBERSHIP CLUB SERVICES PROVIDING DISCOUNTS TO MEMBERS ON REAL ESTATE COMMISSIONS AND MORTGAGE FEES; NEGOTIATION AND RENEGOTIATION FOR OTHERS OF LEASES AND SUBLEASES AND REAL ESTATE PURCHASE AGREEMENTS; PROVIDING AN INTERACTIVE REAL ESTATE WEBSITE WHICH PROMOTES HOUSING AND APARTMENT PROPERTIES THROUGH OFFERING PROSPECTIVE TENANTS VIDEO WALK THROUGHS, PROPERTY DESCRIPTIONS, TEXT, PRICE, LOCATION, MAPS AND OTHER INFORMATION THAT WOULD BE INFLUENTIAL TO A PROSPECTIVE TENANT IN MAKING A RENTAL DECISION; REAL ESTATE TRANSACTION AUDITING SERVICES (U.S. CLS. 100, 101 AND 102).

FIRST USE 1-0-2009; IN COMMERCE 1-0-2009.

### CLASS 36—INSURANCE AND FINANCIAL

FOR ARRANGING OF LEASES AND RENTAL AGREEMENTS FOR REAL ESTATE; COMMERCIAL AND RESIDENTIAL REAL ESTATE AGENCY SERVICES; MEMBERSHIP CLUB SERVICES, NAMELY, PROVIDING INFORMATION TO MEMBERS IN THE FIELDS OF REAL ESTATE, MORTGAGES AND DEBT ELIMINATION; PROVIDING A DATABASE OF INFORMATION ABOUT RESIDENTIAL REAL ESTATE LISTINGS IN DIFFERENT NEIGHBORHOODS AND COMMUNITIES; PROVIDING A DATABASE OF RESIDENTIAL REAL ESTATE LISTINGS WITHIN NEIGHBORHOODS AND COMMUNITIES SPECIFICALLY IDENTIFIED BY USERS; PROVIDING AN INTERNET WEBSITE PORTAL OFFERING INFORMATION IN THE FIELDS OF REAL ESTATE CONCERNING THE PURCHASE AND SALE OF NEW AND RESALE HOMES AND CONDOS; PROVIDING INFORMATION IN THE FIELD OF REAL ESTATE BY MEANS OF LINKING THE WEB SITE TO OTHER WEB SITES FEATURING REAL ESTATE INFORMATION; PROVIDING REAL ESTATE LISTINGS VIA THE INTERNET; REAL ESTATE CONSULTATION; REAL ESTATE FINANCING SERVICES; REAL ESTATE INSURANCE UNDERWRITING SERVICES; REAL ESTATE SERVICES, NAMELY, PROVIDING ONLINE QUESTIONS TO HELP USERS DETERMINE THE BEST NEIGHBORHOODS AND COMMUNITIES SUITED TO THEIR INDIVIDUAL NEEDS AND PREFERENCES (U.S. CLS. 100, 101 AND 102).

FIRST USE 1-0-2009; IN COMMERCE 1-0-2009.

JAY BESCH, EXAMINING ATTORNEY

SN 85-207,828. STRATEGIC DIAGNOSTICS INC., NEWARK, DE. FILED 12-30-2010.

## XGAT

THE MARK CONSISTS OF STANDARD CHARACTERS WITHOUT CLAIM TO ANY PARTICULAR FONT, STYLE, SIZE, OR COLOR.

### CLASS 1—CHEMICALS

FOR ANTIBODIES FOR SCIENTIFIC OR RESEARCH USE (U.S. CLS. 1, 5, 6, 10, 26 AND 46).

### CLASS 40—MATERIAL TREATMENT

FOR ANTIBODY SERVICES, NAMELY, CUSTOM ANTIBODY PRODUCTION AND GENERATION; CUSTOM MANUFACTURE OF ANTIBODIES FOR OTHERS (U.S. CLS. 100, 103 AND 106).

### CLASS 42—SCIENTIFIC AND COMPUTER SERVICES

FOR SCIENTIFIC RESEARCH AND DEVELOPMENT, NAMELY, DEVELOPMENT OF ANTIBODIES FOR OTHERS (U.S. CLS. 100 AND 101).

PAM WILLIS, EXAMINING ATTORNEY

SN 85-207,879. PARTS TOWN, LLC, GLENVIEW, IL. FILED 12-30-2010.

# PartsTOWN

THE MARK CONSISTS OF STANDARD CHARACTERS WITHOUT CLAIM TO ANY PARTICULAR FONT, STYLE, SIZE, OR COLOR.

## CLASS 35—ADVERTISING AND BUSINESS

FOR COMPUTERIZED ON-LINE ORDERING SERVICES IN THE FIELD OF RESTAURANT EQUIPMENT PARTS; FACSIMILE ORDERING SERVICES IN THE FIELD OF RESTAURANT EQUIPMENT PARTS; PROVIDING A WEBSITE USED TO PLACE ON-LINE COMMERCIAL ORDERS IN THE FIELD OF RESTAURANT EQUIPMENT PARTS; RETAIL SERVICES THROUGH DIRECT SOLICITATION BY SALESPERSONS DIRECTED TO END-USERS FEATURING RESTAURANT EQUIPMENT PARTS; TELEPHONE ORDERING SERVICES IN THE FIELD OF RESTAURANT EQUIPMENT PARTS (U.S. CLS. 100, 101 AND 102).

FIRST USE 1-1-1987; IN COMMERCE 1-1-1987.

## CLASS 37—CONSTRUCTION AND REPAIR

FOR TECHNICAL SUPPORT SERVICES, NAMELY, TECHNICAL ADVICE RELATED TO THE INSTALLATION OF RESTAURANT EQUIPMENT PARTS; TECHNICAL SUPPORT SERVICES, NAMELY, TECHNICAL ADVICE RELATED TO THE REPAIR OF RESTAURANT EQUIPMENT PARTS (U.S. CLS. 100, 103 AND 106).

FIRST USE 1-1-1987; IN COMMERCE 1-1-1987.

## CLASS 39—TRANSPORTATION AND STORAGE

FOR DISTRIBUTION SERVICES, NAMELY, DELIVERY OF RESTAURANT EQUIPMENT PARTS; WAREHOUSING SERVICES, NAMELY, STORAGE, DISTRIBUTION, PICK-UP, PACKING, AND SHIPPING OF RESTAURANT EQUIPMENT PARTS (U.S. CLS. 100 AND 105).

FIRST USE 1-1-1987; IN COMMERCE 1-1-1987.  
CAROLYN CATALDO, EXAMINING ATTORNEY

SN 85-207,926. FEIGENBAUM, ZVIKA, REDONDO BEACH, CA. FILED 12-30-2010.

# 1756

THE MARK CONSISTS OF STANDARD CHARACTERS WITHOUT CLAIM TO ANY PARTICULAR FONT, STYLE, SIZE, OR COLOR.

## CLASS 32—LIGHT BEVERAGES

FOR BEER; ENERGY DRINKS; MALT LIQUOR; NON-ALCOHOLIC BEVERAGES CONTAINING FRUIT JUICES; NON-ALCOHOLIC BEVERAGES, NAMELY, CARBONATED BEVERAGES; NON-ALCOHOLIC COCKTAIL MIXES (U.S. CLS. 45, 46 AND 48).

## CLASS 33—WINES AND SPIRITS

FOR ALCOHOLIC COCKTAIL MIXES; CHAMPAGNE; HARD CIDER; LIQUOR; SPARKLING WINES; SPIRITS; WINE COOLERS; WINES (U.S. CLS. 47 AND 49).  
CAROLYN CATALDO, EXAMINING ATTORNEY

SN 85-207,928. PARTS TOWN, LLC, GLENVIEW, IL. FILED 12-30-2010.



THE MARK CONSISTS OF THE WORD MARK "PARTS-TOWN" WITH A PICTURE OF A HAND HOLDING A TRAY WITH AN OPEN BOX ON THE TRAY.

## CLASS 35—ADVERTISING AND BUSINESS

FOR COMPUTERIZED ON-LINE ORDERING SERVICES IN THE FIELD OF RESTAURANT EQUIPMENT PARTS; FACSIMILE ORDERING SERVICES IN THE FIELD OF RESTAURANT EQUIPMENT PARTS; PROVIDING A WEBSITE USED TO PLACE ON-LINE COMMERCIAL ORDERS IN THE FIELD OF RESTAURANT EQUIPMENT PARTS; RETAIL SERVICES THROUGH DIRECT SOLICITATION BY SALESPERSONS DIRECTED TO END-USERS FEATURING RESTAURANT EQUIPMENT PARTS; TELEPHONE ORDERING SERVICES IN THE FIELD OF RESTAURANT EQUIPMENT PARTS (U.S. CLS. 100, 101 AND 102).

FIRST USE 1-1-1987; IN COMMERCE 1-1-1987.

## CLASS 37—CONSTRUCTION AND REPAIR

FOR TECHNICAL SUPPORT SERVICES, NAMELY, TECHNICAL ADVICE RELATED TO THE INSTALLATION OF RESTAURANT EQUIPMENT PARTS; TECHNICAL SUPPORT SERVICES, NAMELY, TECHNICAL ADVICE RELATED TO THE REPAIR OF RESTAURANT EQUIPMENT PARTS (U.S. CLS. 100, 103 AND 106).

FIRST USE 1-1-1987; IN COMMERCE 1-1-1987.

## CLASS 39—TRANSPORTATION AND STORAGE

FOR DISTRIBUTION SERVICES, NAMELY, DELIVERY OF RESTAURANT EQUIPMENT PARTS; WAREHOUSING SERVICES, NAMELY, STORAGE, DISTRIBUTION, PICK-UP, PACKING, AND SHIPPING OF RESTAURANT EQUIPMENT PARTS (U.S. CLS. 100 AND 105).

FIRST USE 1-1-1987; IN COMMERCE 1-1-1987.  
CAROLYN CATALDO, EXAMINING ATTORNEY



SN 85-207,964. NEWSPAPERDIRECT INC., DBA NEWSPAPERDIRECT INC., RICHMOND, CANADA, FILED 12-30-2010.

SN 85-208,062. EDEN ESTHETIC, A PROFESSIONAL NURSING CORPORATION, TORRANCE, CA. FILED 12-30-2010.

# PressOn

THE MARK CONSISTS OF STANDARD CHARACTERS WITHOUT CLAIM TO ANY PARTICULAR FONT, STYLE, SIZE, OR COLOR.

## **CLASS 9—ELECTRICAL AND SCIENTIFIC APPARATUS**

FOR ELECTRONIC PUBLICATIONS, NAMELY, MAGAZINES AND NEWSPAPERS FEATURING NEWS, TRAVEL, ENTERTAINMENT, SPORTS, FASHION, RELIGION, POLITICS, COMMERCE, ART, HUMOR RECORDED ON COMPUTER MEDIA (U.S. CLS. 21, 23, 26, 36 AND 38).

## **CLASS 16—PAPER GOODS AND PRINTED MATTER**

FOR DAILY NEWSPAPER; GENERAL FEATURE MAGAZINES; MAGAZINES FEATURING NEWS, TRAVEL, ENTERTAINMENT, SPORTS, FASHION, RELIGION, POLITICS, COMMERCE, ART, HUMOR; MAGAZINES IN THE FIELD OF NEWS, TRAVEL, ENTERTAINMENT, SPORTS, FASHION, RELIGION, POLITICS, COMMERCE, ART, HUMOR; NEWSPAPERS; NEWSPAPERS FOR GENERAL CIRCULATION (U.S. CLS. 2, 5, 22, 23, 29, 37, 38 AND 50).

## **CLASS 35—ADVERTISING AND BUSINESS**

FOR ARRANGING NEWSPAPER SUBSCRIPTIONS FOR OTHERS; MAGAZINE SUBSCRIPTION AND FULFILLMENT SERVICES; NEWSPAPER SUBSCRIPTIONS; SUBSCRIPTIONS TO BOOKS, REVIEWS, NEWSPAPERS OR COMIC BOOKS (U.S. CLS. 100, 101 AND 102).

## **CLASS 41—EDUCATION AND ENTERTAINMENT**

FOR MAGAZINE PUBLISHING; MULTIMEDIA PUBLISHING OF BOOKS, MAGAZINES, JOURNALS, SOFTWARE, GAMES, MUSIC, AND ELECTRONIC PUBLICATIONS; NEWSPAPER PUBLICATION; NEWSPAPER PUBLISHING; ON-LINE LIBRARY SERVICES, NAMELY, PROVIDING ELECTRONIC LIBRARY SERVICES WHICH FEATURE NEWSPAPERS, MAGAZINES, PHOTOGRAPHS AND PICTURES VIA AN ON-LINE COMPUTER NETWORK; PROVIDING ON-LINE NON-DOWNLOADABLE GENERAL FEATURE MAGAZINES; PUBLICATION OF BOOKS, MAGAZINES, ALMANACS AND JOURNALS; PUBLICATION OF BOOKS, OF MAGAZINES, OF JOURNALS, OF NEWSPAPERS, OF PERIODICALS, OF CATALOGS, OF BROCHURES; PUBLICATION OF ELECTRONIC MAGAZINES; PUBLICATION OF ELECTRONIC NEWSPAPERS ACCESSIBLE VIA A GLOBAL COMPUTER NETWORK; PUBLICATION OF MAGAZINES; PUBLICATION OF MAGAZINES AND NEWSPAPERS; PUBLISHING OF BOOKS, MAGAZINES; PUBLISHING OF WEB MAGAZINES (U.S. CLS. 100, 101 AND 107).

JULIE VEPPUMTHARA, EXAMINING ATTORNEY

# ArqueDerma

THE MARK CONSISTS OF STANDARD CHARACTERS WITHOUT CLAIM TO ANY PARTICULAR FONT, STYLE, SIZE, OR COLOR.

## **CLASS 3—COSMETICS AND CLEANING PREPARATIONS**

FOR NON-MEDICATED SKIN CARE PREPARATIONS (U.S. CLS. 1, 4, 6, 50, 51 AND 52).

## **CLASS 41—EDUCATION AND ENTERTAINMENT**

FOR EDUCATIONAL SERVICES, NAMELY, CONDUCTING LIVE AND ON-LINE CLASSES, SEMINARS AND WORKSHOPS IN THE FIELD OF COSMETIC AND AESTHETIC PROCEDURES (U.S. CLS. 100, 101 AND 107).

## **CLASS 44—MEDICAL, BEAUTY AND AGRICULTURAL SERVICES**

FOR CONSULTING SERVICES IN THE FIELD OF MEDICAL CARE; NON-INVASIVE COSMETIC MEDICAL PROCEDURES (U.S. CLS. 100 AND 101).

JUDITH HELFMAN, EXAMINING ATTORNEY

SN 85-208,116. PORTALARIUM INC., AUSTIN, TX. FILED 12-30-2010.

# Ultimate Collector

THE MARK CONSISTS OF STANDARD CHARACTERS WITHOUT CLAIM TO ANY PARTICULAR FONT, STYLE, SIZE, OR COLOR.

## **CLASS 9—ELECTRICAL AND SCIENTIFIC APPARATUS**

FOR COMPUTER GAME PROGRAMMES; COMPUTER GAME PROGRAMMES DOWNLOADABLE VIA THE INTERNET; COMPUTER GAME SOFTWARE FOR USE ON MOBILE AND CELLULAR PHONES; COMPUTER GAME SOFTWARE FOR USE WITH PERSONAL COMPUTERS, HOME VIDEO GAME CONSOLES USED WITH TELEVISIONS AND ARCADE-BASED VIDEO GAME CONSOLES (U.S. CLS. 21, 23, 26, 36 AND 38).

## **CLASS 41—EDUCATION AND ENTERTAINMENT**

FOR ENTERTAINMENT SERVICES, NAMELY, PROVIDING ON-LINE COMPUTER GAMES (U.S. CLS. 100, 101 AND 107).

JUDITH HELFMAN, EXAMINING ATTORNEY

SN 85-208,348. SUMDEX, INC., CITY OF INDUSTRY, CA. FILED 12-30-2010.

SN 85-208,383. TPP ACQUISITION, INC., PLANO, TX. FILED 12-30-2010.

# SUMDEX

THE MARK CONSISTS OF STANDARD CHARACTERS WITHOUT CLAIM TO ANY PARTICULAR FONT, STYLE, SIZE, OR COLOR.

## CLASS 9—ELECTRICAL AND SCIENTIFIC APPARATUS

FOR CARRYING CASES AND CARRYING CONTAINERS, NAMELY, CARRYING CASES AND CARRYING CONTAINERS FOR NOTEBOOK PERSONAL COMPUTERS, SUBNOTE PERSONAL COMPUTERS, MINI-NOTEBOOK PERSONAL COMPUTERS, HANDHELD PALM TOP PERSONAL COMPUTERS, DIGITAL CAMERAS, HARD DISK DRIVERS, PORTABLE PRINTERS, DIGITAL VISUAL DISPLAYERS, MUSIC DISK PLAYERS, CAMERAS AND VIDEO CAMERAS (U.S. CLS. 21, 23, 26, 36 AND 38).

FIRST USE 7-1-1995; IN COMMERCE 7-1-1995.

## CLASS 18—LEATHER GOODS

FOR BRIEFCASES, BACKPACKS, LUGGAGE, AND RELATED ACCESSORIES, NAMELY, PURSES, HANDBAGS, TRAVEL BAGS, CARRY-ON BAGS, AND PASSPORT CASES (U.S. CLS. 1, 2, 3, 22 AND 41).

FIRST USE 7-1-1995; IN COMMERCE 7-1-1995.

SUSAN LESLIE DUBOIS, EXAMINING ATTORNEY

SN 85-208,380. EAGTAC, LLC, BLAINE, WA. FILED 12-30-2010.



THE MARK CONSISTS OF THE ARTISTIC RENDERING OF THE HEAD OF AN EAGLE.

## CLASS 9—ELECTRICAL AND SCIENTIFIC APPARATUS

FOR BATTERIES (U.S. CLS. 21, 23, 26, 36 AND 38).  
FIRST USE 11-0-2010; IN COMMERCE 11-0-2010.

## CLASS 11—ENVIRONMENTAL CONTROL APPARATUS

FOR FLASHLIGHTS; TACTICAL FLASHLIGHTS (U.S. CLS. 13, 21, 23, 31 AND 34).  
FIRST USE 11-0-2010; IN COMMERCE 11-0-2010.  
ROBIN CHOSID, EXAMINING ATTORNEY

OUR PICTURES. YOUR STORY.

THE MARK CONSISTS OF STANDARD CHARACTERS WITHOUT CLAIM TO ANY PARTICULAR FONT, STYLE, SIZE, OR COLOR.

## CLASS 35—ADVERTISING AND BUSINESS

FOR RETAIL STORE SERVICES FEATURING PHOTOGRAPHY RELATED PRODUCTS, FRAMES, GIFT CARDS, PHOTOGRAPHS, AND MERCHANDISE CUSTOMIZED WITH PHOTOGRAPHS (U.S. CLS. 100, 101 AND 102).

FIRST USE 11-1-2010; IN COMMERCE 11-1-2010.

## CLASS 41—EDUCATION AND ENTERTAINMENT

FOR PORTRAIT PHOTOGRAPHY (U.S. CLS. 100, 101 AND 107).

FIRST USE 11-1-2010; IN COMMERCE 11-1-2010.

WANDA KAY PRICE, EXAMINING ATTORNEY

SN 85-208,391. VENDMORE SYSTEMS, LLC, STAMFORD, CT. FILED 12-30-2010.

# QUICKSTORE24

THE MARK CONSISTS OF STANDARD CHARACTERS WITHOUT CLAIM TO ANY PARTICULAR FONT, STYLE, SIZE, OR COLOR.

## CLASS 9—ELECTRICAL AND SCIENTIFIC APPARATUS

FOR VENDING MACHINES (U.S. CLS. 21, 23, 26, 36 AND 38).

FIRST USE 6-17-2004; IN COMMERCE 6-17-2004.

## CLASS 35—ADVERTISING AND BUSINESS

FOR RENTAL OF VENDING MACHINES; VENDING MACHINE SERVICES (U.S. CLS. 100, 101 AND 102).

FIRST USE 6-17-2004; IN COMMERCE 6-17-2004.

ARETHA SOMERVILLE, EXAMINING ATTORNEY

SN 85-208,402. VENDMORE SYSTEMS, LLC, STAMFORD, CT. FILED 12-30-2010.



OWNER OF U.S. REG. NO. 3,548,290.  
THE COLOR(S) WHITE, DARK GREEN, LIGHT GREEN IS/ARE CLAIMED AS A FEATURE OF THE MARK.

THE MARK CONSISTS OF THE WORD "QUICKSTORE24". "QUICKSTORE24" OUTLINED IN DARK GREEN WITH "QUICK" CONSISTING OF WHITE-FILLED LETTERS, "STORE24" CONSISTING OF LIGHT GREEN-FILLED CHARACTERS, A DARK GREEN BANNER BEHIND "24", A DARK GREEN ARROW WITHIN THE LETTER "Q".

**CLASS 9—ELECTRICAL AND SCIENTIFIC APPARATUS**

FOR VENDING MACHINES (U.S. CLS. 21, 23, 26, 36 AND 38).  
FIRST USE 6-17-2004; IN COMMERCE 6-17-2004.

**CLASS 35—ADVERTISING AND BUSINESS**

FOR RENTAL OF VENDING MACHINES; VENDING MACHINE SERVICES (U.S. CLS. 100, 101 AND 102).  
FIRST USE 6-17-2004; IN COMMERCE 6-17-2004.  
ARETHA SOMERVILLE, EXAMINING ATTORNEY

SN 85-208,467. VENDMORE SYSTEMS, LLC, STAMFORD, CT. FILED 12-31-2010.

mDrink

THE MARK CONSISTS OF STANDARD CHARACTERS WITHOUT CLAIM TO ANY PARTICULAR FONT, STYLE, SIZE, OR COLOR.

**CLASS 9—ELECTRICAL AND SCIENTIFIC APPARATUS**

FOR COMPUTER APPLICATION SOFTWARE FOR MOBILE PHONES, NAMELY SOFTWARE FOR ORDERING FOOD AND BEVERAGE (U.S. CLS. 21, 23, 26, 36 AND 38).  
FIRST USE 10-12-2009; IN COMMERCE 10-12-2009.

**CLASS 35—ADVERTISING AND BUSINESS**

FOR ONLINE ORDERING SERVICES FOR VENDING MACHINES AND OTHER LOCATIONS WHERE FOOD AND BEVERAGE MAY BE PICKED UP (U.S. CLS. 100, 101 AND 102).  
FIRST USE 10-12-2009; IN COMMERCE 10-12-2009.  
ARETHA SOMERVILLE, EXAMINING ATTORNEY

SN 85-208,471. VENDMORE SYSTEMS, LLC, STAMFORD, CT. FILED 12-31-2010.

mdrink

THE COLOR(S) GREEN IS/ARE CLAIMED AS A FEATURE OF THE MARK.  
THE MARK CONSISTS OF STYLIZED "MDRINK" IN GREEN LETTERS.

**CLASS 9—ELECTRICAL AND SCIENTIFIC APPARATUS**

FOR COMPUTER APPLICATION SOFTWARE FOR MOBILE PHONES, NAMELY SOFTWARE FOR ORDERING FOOD AND BEVERAGE (U.S. CLS. 21, 23, 26, 36 AND 38).  
FIRST USE 10-12-2009; IN COMMERCE 10-12-2009.

**CLASS 35—ADVERTISING AND BUSINESS**

FOR ONLINE ORDERING SERVICES FOR VENDING MACHINES AND OTHER LOCATIONS WHERE FOOD AND BEVERAGE MAY BE PICKED UP (U.S. CLS. 100, 101 AND 102).  
FIRST USE 10-12-2009; IN COMMERCE 10-12-2009.  
ARETHA SOMERVILLE, EXAMINING ATTORNEY

SN 85-208,639. COMMONWEALTH PUBLIC BROADCASTING CORPORATION, RICHMOND, VA. FILED 12-31-2010.



THE MARK CONSISTS OF A STYLIZED VERSION OF THE LETTER "I" SUPERIMPOSED OVER A BACKGROUND OF A CIRCLE.

**CLASS 38—COMMUNICATION**

FOR TELEVISION BROADCASTING; RADIO BROADCASTING; AND PROVIDING INFORMATION RELATED TO PUBLIC BROADCASTING OF RADIO AND TELEVISION PROGRAMS VIA A GLOBAL COMPUTER INFORMATION NETWORK (U.S. CLS. 100, 101 AND 104).  
FIRST USE 1-1-2008; IN COMMERCE 1-1-2008.

**CLASS 41—EDUCATION AND ENTERTAINMENT**

FOR VIDEOTAPE AND RADIO PROGRAM PRODUCTION SERVICES; EDUCATIONAL SERVICES, NAMELY, DEVELOPING AND CONDUCTING TRAINING WORKSHOPS AND SEMINARS FOR PRE-SCHOOL TEACHERS AND PARENTS IN THE USE OF TELEVISION TO PROMOTE READING READINESS; PRODUCTION OF INSTRUCTIONAL TELEVISION PROGRAMS IN THE FIELD OF CURRICULUM GUIDES FOR TEACHERS IN ELEMENTARY AND SECONDARY LEVEL CLASSROOMS; DEVELOPING AND DISSEMINATING TEACHING MATERIALS OF OTHERS IN THE FIELD OF INSTRUCTIONAL TELEVISION PROGRAMS FOR STATE STANDARDS OF LEARNING FOR ELEMENTARY AND SECONDARY LEVEL CURRICULUM; ENTERTAINMENT SERVICES, NAMELY, PRODUCTION OF INSTRUCTIONAL TELEVISION PROGRAMS AND VIDEO PRODUCTION SERVICES FOR USE IN ELEMENTARY AND SECONDARY LEVEL CLASSROOMS; ENTERTAINMENT SERVICES, NAMELY, PRODUCING AND DISTRIBUTING INSTRUCTIONAL TELEVISION PROGRAMS AND VIDEOS FOR OTHERS FOR USE IN ELEMENTARY AND SECONDARY LEVEL CLASSROOMS (U.S. CLS. 100, 101 AND 107).  
FIRST USE 1-1-2008; IN COMMERCE 1-1-2008.

LAURIE KAUFMAN, EXAMINING ATTORNEY

**CLASS 41—EDUCATION AND ENTERTAINMENT**

FOR PRODUCTION OF TELEVISION PROGRAMS (U.S. CLS. 100, 101 AND 107).  
JESSICA FATHY, EXAMINING ATTORNEY

SN 85-208,697. HUNTIN' IS GOOD, INC., DBA HUNTIN' IS GOOD, INGLIS, FL. FILED 12-31-2010.

SN 85-208,700. JAMES MALINCHAK INTERNATIONAL, INC., HENDERSON, NV. FILED 12-31-2010.

**HUNTIN' IS GOOD!**

achieve a better, richer  
business & life...

THE MARK CONSISTS OF STANDARD CHARACTERS WITHOUT CLAIM TO ANY PARTICULAR FONT, STYLE, SIZE, OR COLOR.

OWNER OF U.S. REG. NO. 3,821,692.

THE MARK CONSISTS OF STANDARD CHARACTERS WITHOUT CLAIM TO ANY PARTICULAR FONT, STYLE, SIZE, OR COLOR.

**CLASS 12—VEHICLES**

FOR MUD FLAPS FOR VEHICLES (U.S. CLS. 19, 21, 23, 31, 35 AND 44).  
FIRST USE 6-1-2009; IN COMMERCE 6-1-2009.

**CLASS 9—ELECTRICAL AND SCIENTIFIC APPARATUS**

FOR DIGITAL MATERIALS, NAMELY, CDS, DVDS, DOWNLOADABLE PODCASTS AND DOWNLOADABLE AUDIO FILES ALL FEATURING PERSONAL AND PROFESSIONAL DEVELOPMENT INFORMATION; DOWNLOADABLE ELECTRONIC NEWSLETTERS IN THE FIELD OF PERSONAL AND PROFESSIONAL DEVELOPMENT (U.S. CLS. 21, 23, 26, 36 AND 38).

**CLASS 13—FIREARMS**

FOR PISTOL CASES (U.S. CLS. 2 AND 9).  
FIRST USE 6-1-2009; IN COMMERCE 6-1-2009.

**CLASS 16—PAPER GOODS AND PRINTED MATTER**

FOR PUBLICATIONS, NAMELY, BROCHURES, BOOKLETS, AND PRINTED TEACHING MATERIALS ALL IN THE FIELD OF PERSONAL AND PROFESSIONAL DEVELOPMENT (U.S. CLS. 2, 5, 22, 23, 29, 37, 38 AND 50).

**CLASS 14—JEWELRY**

FOR BRACELETS (U.S. CLS. 2, 27, 28 AND 50).  
FIRST USE 6-1-2009; IN COMMERCE 6-1-2009.

**CLASS 18—LEATHER GOODS**

FOR PURSES (U.S. CLS. 1, 2, 3, 22 AND 41).  
FIRST USE 6-1-2009; IN COMMERCE 6-1-2009.

**CLASS 25—CLOTHING**

FOR BASEBALL CAPS; SHIRTS AND SHORT-SLEEVED SHIRTS; SWEAT SHIRTS; T-SHIRTS (U.S. CLS. 22 AND 39).

**CLASS 20—FURNITURE AND ARTICLES NOT OTHERWISE CLASSIFIED**

FOR PLASTIC KEY CHAINS (U.S. CLS. 2, 13, 22, 25, 32 AND 50).  
FIRST USE 6-1-2009; IN COMMERCE 6-1-2009.

**CLASS 41—EDUCATION AND ENTERTAINMENT**

FOR EDUCATIONAL SERVICES, NAMELY, CONDUCTING SEMINARS, CONFERENCES AND WORKSHOPS ALL IN THE FIELD OF PERSONAL AND PROFESSIONAL DEVELOPMENT AND DISTRIBUTION OF COURSE MATERIAL IN CONNECTION THEREWITH (U.S. CLS. 100, 101 AND 107).  
JESSICA FATHY, EXAMINING ATTORNEY

**CLASS 21—HOUSEWARES AND GLASS**

FOR COFFEE CUPS (U.S. CLS. 2, 13, 23, 29, 30, 33, 40 AND 50).  
FIRST USE 6-1-2009; IN COMMERCE 6-1-2009.

**CLASS 22—CORDAGE AND FIBERS**

FOR MULTI-PURPOSE CLOTH BAGS (U.S. CLS. 1, 2, 7, 19, 22, 42 AND 50).  
FIRST USE 6-1-2009; IN COMMERCE 6-1-2009.

SN 85-208,729. BAKER PACIFIC, INC., DBA BAKER PACIFIC, SAN FRANCISCO, CA. FILED 12-31-2010.

**CLASS 28—TOYS AND SPORTING GOODS**

FOR ARCHERY BOW CASES (U.S. CLS. 22, 23, 38 AND 50).  
FIRST USE 6-1-2009; IN COMMERCE 6-1-2009.

**Baker Pacific****CLASS 35—ADVERTISING AND BUSINESS**

FOR ON-LINE RETAIL STORE SERVICES FEATURING CLOTHING AND ACCESSORIES (U.S. CLS. 100, 101 AND 102).  
FIRST USE 6-1-2009; IN COMMERCE 6-1-2009.

THE MARK CONSISTS OF STANDARD CHARACTERS WITHOUT CLAIM TO ANY PARTICULAR FONT, STYLE, SIZE, OR COLOR.

**CLASS 35—ADVERTISING AND BUSINESS**

FOR BUSINESS ACQUISITION AND MERGER CONSULTATION (U.S. CLS. 100, 101 AND 102).  
FIRST USE 7-9-2004; IN COMMERCE 7-9-2004.

**CLASS 36—INSURANCE AND FINANCIAL**

FOR FINANCIAL CONSULTING AND ADVISING IN THE FIELD OF MERGERS AND ACQUISITIONS (U.S. CLS. 100, 101 AND 102).  
FIRST USE 7-9-2004; IN COMMERCE 7-9-2004.  
TINA MAI, EXAMINING ATTORNEY

**CLASS 28—TOYS AND SPORTING GOODS**

FOR HOUSE MARK FOR A LINE OF SURFBOARDS AND SURFBOARD RELATED PRODUCTS, NAMELY, BOARDBAGS, FINS, LEASHES, SURFBOARD COVERS, SURFBOARD TRACTION PADS, TETHERS, BAGS SPECIALLY DESIGNED FOR CARRYING AND PROTECTING SURFBOARDS; SURFBOARDS, BODYBOARDS; SPORTING ACCESSORIES, NAMELY, LEG ROPES AND SECURITY LEASHES FOR SURFBOARDS, SURFBOARD DECK GRIPS AND WAX FOR SURFBOARDS (U.S. CLS. 22, 23, 38 AND 50).  
FIRST USE 8-13-2010; IN COMMERCE 10-17-2010.  
ALLISON HOLTZ, EXAMINING ATTORNEY

SN 85-208,814. SPECTRE GROUP INTERNATIONAL, LLC, ALEXANDRIA, VA. FILED 1-1-2011.



THE MARK CONSISTS OF THE WORD "SPECTRE" WITH A TRIANGULAR-SHAPED FLAG TO ITS LEFT CONSISTING OF SEVERAL HORIZONTAL STRIPES.

**CLASS 41—EDUCATION AND ENTERTAINMENT**

FOR TRAINING SERVICES IN THE FIELD OF LAW ENFORCEMENT, NATIONAL SECURITY, AND COUNTERNARCOTICS (U.S. CLS. 100, 101 AND 107).

**CLASS 45—PERSONAL AND LEGAL SERVICES**

FOR SECURITY CONSULTANCY; SECURITY INSPECTION SERVICES FOR OTHERS; SECURITY SERVICES, NAMELY, PROVIDING SECURITY ASSESSMENTS FOR BUSINESSES AND GOVERNMENTAL AGENCIES (U.S. CLS. 100 AND 101).  
HEATHER BIDDULPH, EXAMINING ATTORNEY

SN 85-208,821. FALKEN, ROBERT A., OCEANSIDE, CA. FILED 1-2-2011.

**BIPED**

THE MARK CONSISTS OF STANDARD CHARACTERS WITHOUT CLAIM TO ANY PARTICULAR FONT, STYLE, SIZE, OR COLOR.

**CLASS 25—CLOTHING**

FOR CLOTHING AND HEADWEAR, NAMELY T-SHIRTS, SHORTS, SWEAT PANTS, SWEAT SHIRTS, SWIMWEAR, JACKETS, WET SUITS, BELTS, JEANS, SLACKS, WOVEN SHIRTS, KNIT SHIRTS, TANK TOPS, SOCKS, SWEATERS, HATS, BEANIES, CAPS; FOOTWEAR (U.S. CLS. 22 AND 39).  
FIRST USE 12-6-2010; IN COMMERCE 12-15-2010.

SN 85-208,827. TIME TO KNOW LIMITED, ST. PETER PORT, GUERNSEY, FILED 1-2-2011.



THE MARK CONSISTS OF A TREE LOGO WITH AN HORIZONTAL LINE UNDERNEATH.

**CLASS 9—ELECTRICAL AND SCIENTIFIC APPARATUS**

FOR COMPUTERS; COMPUTER HARDWARE; COMPUTER SOFTWARE IN THE FIELD OF EDUCATIONAL SOFTWARE; COMPUTER PROGRAMS AND SOFTWARE FOR CREATING, PRODUCTION, EDITING AND TRANSMISSION OF AUDIO AND VIDEO, GRAPHICS AND IMAGES, ALL FOR CHILDREN'S AND ADULTS' EDUCATION; COMPUTER GAME SOFTWARE, INTERACTIVE MULTIMEDIA COMPUTER GAME SOFTWARE, ALL FOR CHILDREN'S AND ADULTS' EDUCATION (U.S. CLS. 21, 23, 26, 36 AND 38).  
FIRST USE 3-31-2009; IN COMMERCE 3-31-2009.

**CLASS 41—EDUCATION AND ENTERTAINMENT**

FOR MULTIMEDIA ENTERTAINMENT SOFTWARE PRODUCTION SERVICES; EDUCATIONAL SOFTWARE PRODUCTION SERVICES; EDUCATION SERVICES IN THE NATURE OF CLASSES, COURSES, SEMINARS, WORKSHOPS, CONFERENCES, ONLINE CLASSES AND ONLINE COURSES, AT THE KINDERGARTEN, PRESCHOOL, ELEMENTARY, JUNIOR HIGH SCHOOL, HIGH SCHOOL, AND COLLEGE LEVELS, IN AND OUT OF A CLASSROOM; TRAINING SERVICES IN THE FIELD OF EDUCATIONAL INSTRUCTION, NAMELY, TRAINING EDUCATIONAL INSTRUCTORS ON THE USE OF MULTIMEDIA TOOLS AND EDUCATIONAL SOFTWARE (U.S. CLS. 100, 101 AND 107).  
FIRST USE 3-31-2009; IN COMMERCE 3-31-2009.  
JILL PRATER, EXAMINING ATTORNEY

SN 85-208,847. LOVE MEGABYTES LLC, WOODSIDE, CA.  
FILED 1-2-2011.

## LOVE MEGABYTES

THE MARK CONSISTS OF STANDARD CHARACTERS WITHOUT CLAIM TO ANY PARTICULAR FONT, STYLE, SIZE, OR COLOR.

### CLASS 9—ELECTRICAL AND SCIENTIFIC APPARATUS

FOR DIGITAL MEDIA, NAMELY, PRE-RECORDED DVDS, DOWNLOADABLE AUDIO AND VIDEO RECORDINGS, AND CDS FEATURING AND PROMOTING MUSIC AND LIVE MUSICAL PRODUCTIONS (U.S. CLS. 21, 23, 26, 36 AND 38).

### CLASS 16—PAPER GOODS AND PRINTED MATTER

FOR EVENT PROGRAMS; POSTERS; SHEET MUSIC; SOUVENIR PROGRAMS CONCERNING LIVE MUSICAL PRODUCTIONS (U.S. CLS. 2, 5, 22, 23, 29, 37, 38 AND 50).

### CLASS 25—CLOTHING

FOR SCARVES; SWEATSHIRTS; T-SHIRTS (U.S. CLS. 22 AND 39).

### CLASS 41—EDUCATION AND ENTERTAINMENT

FOR ENTERTAINMENT IN THE NATURE OF THEATER PRODUCTIONS; ENTERTAINMENT SERVICES IN THE NATURE OF LIVE MUSICAL PERFORMANCES; ENTERTAINMENT SERVICES, NAMELY, NON-DOWNLOADABLE RINGTONES, PRE-RECORDED MUSIC, AND GRAPHICS PRESENTED TO MOBILE COMMUNICATIONS DEVICES VIA A GLOBAL COMPUTER NETWORK AND WIRELESS NETWORKS; ENTERTAINMENT SERVICES, NAMELY, PROVIDING A WEB SITE FEATURING NON-DOWNLOADABLE MUSICAL PERFORMANCES, MUSICAL VIDEOS, RELATED FILM CLIPS, PHOTOGRAPHS, AND OTHER MULTIMEDIA MATERIALS FEATURING MUSIC AND LIVE MUSICAL PRODUCTIONS; PROVIDING A WEBSITE FEATURING ENTERTAINMENT INFORMATION; PROVISION OF INFORMATION RELATING TO LIVE ENTERTAINMENT (U.S. CLS. 100, 101 AND 107).  
ROBIN MITTLER, EXAMINING ATTORNEY

SN 85-208,941. KAVOUKLIS, NIKKI, TARPON SPRINGS, FL.  
FILED 1-3-2011.

## ZENI SAYS

THE MARK CONSISTS OF STANDARD CHARACTERS WITHOUT CLAIM TO ANY PARTICULAR FONT, STYLE, SIZE, OR COLOR.

### CLASS 16—PAPER GOODS AND PRINTED MATTER

FOR PRINTED MATERIALS, NAMELY, SERIES OF CHILDREN'S BOOKS (U.S. CLS. 2, 5, 22, 23, 29, 37, 38 AND 50).

### CLASS 45—PERSONAL AND LEGAL SERVICES

FOR PROVIDING A WEBSITE FEATURING INSPIRATIONAL AND MOTIVATIONAL TOPICS AND INFORMATION AND THAT ENABLES USERS TO INTERACT AND SHARE INSPIRATIONAL AND MOTIVATIONAL INFORMATION (U.S. CLS. 100 AND 101).  
ERNEST SHOSHO, EXAMINING ATTORNEY

SN 85-208,942. KAVOUKLIS, NIKKI, TARPON SPRINGS, FL.  
FILED 1-3-2011.

## FINDING ZENI

THE MARK CONSISTS OF STANDARD CHARACTERS WITHOUT CLAIM TO ANY PARTICULAR FONT, STYLE, SIZE, OR COLOR.

### CLASS 16—PAPER GOODS AND PRINTED MATTER

FOR PRINTED MATERIALS, NAMELY, SERIES OF FICTION, MOTIVATIONAL, INSPIRATIONAL, AND CHILDREN'S BOOKS (U.S. CLS. 2, 5, 22, 23, 29, 37, 38 AND 50).

### CLASS 45—PERSONAL AND LEGAL SERVICES

FOR PROVIDING A WEBSITE FEATURING INSPIRATIONAL AND MOTIVATIONAL TOPICS AND INFORMATION AND THAT ENABLES USERS TO INTERACT AND SHARE INSPIRATIONAL AND MOTIVATIONAL INFORMATION (U.S. CLS. 100 AND 101).  
ERNEST SHOSHO, EXAMINING ATTORNEY

SN 85-208,951. IRUNURUN, LLC, ATLANTA, GA. FILED 1-3-2011.

## IRUNURUN

THE MARK CONSISTS OF STANDARD CHARACTERS WITHOUT CLAIM TO ANY PARTICULAR FONT, STYLE, SIZE, OR COLOR.

### CLASS 14—JEWELRY

FOR JEWELRY (U.S. CLS. 2, 27, 28 AND 50).

### CLASS 25—CLOTHING

FOR SHIRTS (U.S. CLS. 22 AND 39).  
JOHN DWYER, EXAMINING ATTORNEY

SN 85-209,012. GUERRILLAPPS, LLC, NEW YORK, NY.  
FILED 1-3-2011.

SN 85-209,141. DURO TEXTILES, LLC, FALL RIVER, MA.  
FILED 1-3-2011.

## TRASH TYCOON

THE MARK CONSISTS OF STANDARD CHARACTERS WITHOUT CLAIM TO ANY PARTICULAR FONT, STYLE, SIZE, OR COLOR.

### CLASS 9—ELECTRICAL AND SCIENTIFIC APPARATUS

FOR DOWNLOADABLE GAME SOFTWARE AND ELECTRONIC GAME SOFTWARE FOR WIRELESS DEVICES AND COMPUTERS; COMPUTER GAME SOFTWARE FOR USE ON PERSONAL COMPUTERS, LAPTOP COMPUTERS, AND HANDHELD DIGITAL ELECTRONIC DEVICES (U.S. CLS. 21, 23, 26, 36 AND 38).

### CLASS 41—EDUCATION AND ENTERTAINMENT

FOR ENTERTAINMENT SERVICES, NAMELY, PROVIDING ON-LINE ELECTRONIC GAMES (U.S. CLS. 100, 101 AND 107).  
SHAUNIA CARLYLE, EXAMINING ATTORNEY

SN 85-209,115. CALAND, PHILIPPE, VENICE, CA. FILED 1-3-2011.

## EARTHWE

THE MARK CONSISTS OF STANDARD CHARACTERS WITHOUT CLAIM TO ANY PARTICULAR FONT, STYLE, SIZE, OR COLOR.

### CLASS 25—CLOTHING

FOR SHIRTS (U.S. CLS. 22 AND 39).

### CLASS 42—SCIENTIFIC AND COMPUTER SERVICES

FOR HOSTING AN ON-LINE COMMUNITY WEB SITE FEATURING ENVIRONMENTAL SUSTAINABILITY AND COMMUNITY DEVELOPMENT (U.S. CLS. 100 AND 101).

### CLASS 43—HOTEL AND RESTAURANT SERVICES

FOR PROVIDING COMMUNITY CENTERS FOR SOCIAL GATHERINGS AND MEETINGS (U.S. CLS. 100 AND 101).  
JOHN DWYER, EXAMINING ATTORNEY

## tAkeCover

THE MARK CONSISTS OF THE WORD "TAKECOVER" WHERE THE "A" IS REPLACED WITH A LAMBDA AND THE LETTERS "T, K, E, O, V, E", AND "R" ARE IN LOWER CASE LETTERS AND THE "C" IS IN UPPER CASE.

### CLASS 20—FURNITURE AND ARTICLES NOT OTHERWISE CLASSIFIED

FOR PILLOWS, UPHOLSTERED FURNITURE (U.S. CLS. 2, 13, 22, 25, 32 AND 50).

### CLASS 22—CORDAGE AND FIBERS

FOR TENTS (U.S. CLS. 1, 2, 7, 19, 22, 42 AND 50).

### CLASS 24—FABRICS

FOR BLANKETS, QUILTS, COMFORTERS, BED SHEETS, PILLOW CASES, DRAPERY, TABLE LINEN (U.S. CLS. 42 AND 50).

### CLASS 27—FLOOR COVERINGS

FOR WALLPAPER (U.S. CLS. 19, 20, 37, 42 AND 50).  
ERNEST SHOSHO, EXAMINING ATTORNEY

SN 85-209,147. DURO TEXTILES, LLC, FALL RIVER, MA.  
FILED 1-3-2011.

## tAkeCover

THE MARK CONSISTS OF THE WORD "TAKECOVER" WHERE THE "A" IS REPLACED WITH A LAMBDA AND THE LETTERS "T, K, E, O, V, E", AND "R" ARE IN LOWER CASE LETTERS AND THE "C" IS IN UPPER CASE.

**CLASS 24—FABRICS**

FOR TEXTILES AND FABRICS FOR THE MANUFACTURE OF COMMERCIAL, HOUSEHOLD AND MILITARY PRODUCTS, FURNISHINGS AND APPAREL, NON-WOVEN TEXTILE FABRICS, WOVEN FABRICS AND KNITTED FABRICS (U.S. CLS. 42 AND 50).

**CLASS 40—MATERIAL TREATMENT**

FOR APPLYING FINISHES TO TEXTILES AND FABRICS, TEXTILE AND FABRIC PRINTING (U.S. CLS. 100, 103 AND 106).

ERNEST SHOSHO, EXAMINING ATTORNEY

**CLASS 44—MEDICAL, BEAUTY AND AGRICULTURAL SERVICES**

FOR TREE AND PLANT NURSERY (U.S. CLS. 100 AND 101).

STEPHANIE ALI, EXAMINING ATTORNEY

SN 85-209,148. PARTYLITE WORLDWIDE INC., PLYMOUTH, MA. FILED 1-3-2011.

SN 85-209,229. LEETTO, INC., JERICHO, NY. FILED 1-3-2011.

**DISCOVER THE GLOW WITHIN**

THE MARK CONSISTS OF STANDARD CHARACTERS WITHOUT CLAIM TO ANY PARTICULAR FONT, STYLE, SIZE, OR COLOR.

**CLASS 4—LUBRICANTS AND FUELS**

FOR CANDLES (U.S. CLS. 1, 6 AND 15).

**CLASS 35—ADVERTISING AND BUSINESS**

FOR SHOP-AT-HOME PARTIES FEATURING CANDLES (U.S. CLS. 100, 101 AND 102).

ALEXANDER L. POWERS, EXAMINING ATTORNEY

SN 85-209,191. SANCTUARY TIMBER & WILDLIFE, LLC, MONTGOMERY, AL. FILED 1-3-2011.

**Family Orchard**

THE MARK CONSISTS OF STANDARD CHARACTERS WITHOUT CLAIM TO ANY PARTICULAR FONT, STYLE, SIZE, OR COLOR.

NO CLAIM IS MADE TO THE EXCLUSIVE RIGHT TO USE "ORCHARD", APART FROM THE MARK AS SHOWN.

**CLASS 16—PAPER GOODS AND PRINTED MATTER**

FOR MAGAZINE IN THE FIELD OF AGRICULTURE AND WILDLIFE CONSERVATION AND MANAGEMENT (U.S. CLS. 2, 5, 22, 23, 29, 37, 38 AND 50).

**CLASS 35—ADVERTISING AND BUSINESS**

FOR MAIL ORDER CATALOG SERVICES FEATURING TREES, SHRUBS, ROOTSTOCK, AND BULBS; ONLINE CATALOG AND RETAIL SITE OFFERING TREES, SHRUBS, ROOTSTOCK AND BULBS (U.S. CLS. 100, 101 AND 102).

**LEETTO**

THE MARK CONSISTS OF STANDARD CHARACTERS WITHOUT CLAIM TO ANY PARTICULAR FONT, STYLE, SIZE, OR COLOR.

**CLASS 9—ELECTRICAL AND SCIENTIFIC APPARATUS**

FOR DOWNLOADABLE SOFTWARE FOR USE IN LOCATING, DISPLAYING AND SHARING A USER'S LOCATION AND FINDING, LOCATING, AND INTERACTING WITH OTHER USERS AND PLACES VIA GLOBAL POSITIONING AND OTHER LOCATION TECHNOLOGY; DOWNLOADABLE SOFTWARE FOR ELECTRONIC MAP DISPLAY, TRAVEL PLANNING AND EVENT PLANNING; DOWNLOADABLE SOFTWARE, NAMELY, SOFTWARE FOR DISPLAYING LOCATION AND PHYSICAL PRESENCE INFORMATION IN WIRELESS TELECOMMUNICATIONS DEVICES; DOWNLOADABLE SOFTWARE FOR USE IN OBTAINING COUPONS, REBATES, PRICE-COMPARISON INFORMATION AND PRODUCT REVIEWS, LINKS TO THE RETAIL WEBSITES OF OTHERS, AND DISCOUNT INFORMATION; DOWNLOADABLE COMPUTER SOFTWARE FOR USE IN THE RETRIEVAL OF DATA FROM THIRD-PARTY WEBSITES; DOWNLOADABLE COMPUTER SOFTWARE FOR USE IN GAINING ACCESS TO AND INTERFACING WITH THIRD-PARTY E-COMMERCE TOOLS; DOWNLOADABLE COMPUTER SOFTWARE FOR USE IN GAINING ACCESS TO AND INTERFACING WITH THIRD-PARTY RETAILERS (U.S. CLS. 21, 23, 26, 36 AND 38).



**CLASS 42—SCIENTIFIC AND COMPUTER SERVICES**

FOR PROVIDING TEMPORARY USE OF NONDOWNLOADABLE SOFTWARE FOR USE IN LOCATING, DISPLAYING AND SHARING A USER'S LOCATION AND FINDING, LOCATING, AND INTERACTING WITH OTHER USERS AND PLACES VIA GLOBAL POSITIONING AND OTHER LOCATION TECHNOLOGY; PROVIDING TEMPORARY USE OF NONDOWNLOADABLE SOFTWARE FOR ELECTRONIC MAP DISPLAY, TRAVEL PLANNING AND EVENT PLANNING; PROVIDING TEMPORARY USE OF NONDOWNLOADABLE SOFTWARE, NAMELY, SOFTWARE FOR DISPLAYING LOCATION AND PHYSICAL PRESENCE INFORMATION IN WIRELESS TELECOMMUNICATIONS DEVICES; PROVIDING TEMPORARY USE OF NONDOWNLOADABLE SOFTWARE FOR USE IN OBTAINING COUPONS, REBATES, PRICE-COMPARISON INFORMATION AND PRODUCT REVIEWS, LINKS TO THE RETAIL WEBSITES OF OTHERS, AND DISCOUNT INFORMATION; COMPUTER SERVICES, NAMELY, PROVIDING SEARCH ENGINES FOR LOCATING INFORMATION, RESOURCES, AND THE WEBSITES OF OTHERS VIA ELECTRONIC AND OPTICAL COMMUNICATIONS NETWORKS; PROVIDING A WIDE RANGE OF GENERAL INTEREST INFORMATION VIA ELECTRONIC AND OPTICAL COMMUNICATIONS NETWORKS; PROVIDING TEMPORARY USE OF NONDOWNLOADABLE SOFTWARE FOR USE IN THE RETRIEVAL OF DATA FROM THIRD-PARTY WEBSITES; PROVIDING TEMPORARY USE OF NONDOWNLOADABLE SOFTWARE FOR USE IN GAINING ACCESS TO AND INTERFACING WITH THIRD-PARTY E-COMMERCE TOOLS; PROVIDING TEMPORARY USE OF NONDOWNLOADABLE SOFTWARE FOR USE IN GAINING ACCESS TO AND INTERACTING WITH THIRD-PARTY RETAILERS (U.S. CLS. 100 AND 101).

**CLASS 45—PERSONAL AND LEGAL SERVICES**

FOR ONLINE SOCIAL NETWORKING SERVICES; ONLINE SOCIAL NETWORKING SERVICES CONDUCTED VIA WIRELESS TELECOMMUNICATIONS NETWORKS AND VIA ELECTRONIC AND OPTICAL COMMUNICATIONS NETWORKS (U.S. CLS. 100 AND 101).

JESSICA A. POWERS, EXAMINING ATTORNEY

SN 85-209,235. LEETTO, INC., JERICHO, NY. FILED 1-7-2011.



THE MARK CONSISTS OF A SQUARE COMPRISED OF 4 SQUARE-SHAPED TILES SURROUNDED BY A SQUARE WITHOUT TILES SUBSEQUENTLY SURROUNDED BY A SQUARE COMPRISED OF 20 SQUARE-SHAPED TILES WITH A STYLIZED LETTER "L" MADE UP OF 6 TILES IN THE UPPER RIGHT-HAND CORNER OF THE LARGER SQUARE.

**CLASS 9—ELECTRICAL AND SCIENTIFIC APPARATUS**

FOR DOWNLOADABLE SOFTWARE FOR USE IN LOCATING, DISPLAYING AND SHARING A USER'S LOCATION AND FINDING, LOCATING, AND INTERACTING WITH OTHER USERS AND PLACES VIA GLOBAL POSITIONING AND OTHER LOCATION TECHNOLOGY; DOWNLOADABLE SOFTWARE FOR ELECTRONIC MAP DISPLAY, TRAVEL PLANNING AND EVENT PLANNING; DOWNLOADABLE SOFTWARE, NAMELY, SOFTWARE FOR DISPLAYING LOCATION AND PHYSICAL PRESENCE INFORMATION IN WIRELESS TELECOMMUNICATIONS DEVICES; DOWNLOADABLE SOFTWARE FOR USE IN OBTAINING COUPONS, REBATES, PRICE-COMPARISON INFORMATION AND PRODUCT REVIEWS, LINKS TO THE RETAIL WEBSITES OF OTHERS, AND DISCOUNT INFORMATION; DOWNLOADABLE COMPUTER SOFTWARE FOR USE IN THE RETRIEVAL OF DATA FROM THIRD-PARTY WEBSITES; DOWNLOADABLE COMPUTER SOFTWARE FOR USE IN GAINING ACCESS TO AND INTERFACING WITH THIRD-PARTY E-COMMERCE TOOLS; DOWNLOADABLE COMPUTER SOFTWARE FOR USE IN GAINING ACCESS TO AND INTERFACING WITH THIRD-PARTY RETAILERS (U.S. CLS. 21, 23, 26, 36 AND 38).

**CLASS 42—SCIENTIFIC AND COMPUTER SERVICES**

FOR PROVIDING TEMPORARY USE OF NONDOWNLOADABLE SOFTWARE FOR USE IN LOCATING, DISPLAYING AND SHARING A USER'S LOCATION AND FINDING, LOCATING, AND INTERACTING WITH OTHER USERS AND PLACES VIA GLOBAL POSITIONING AND OTHER LOCATION TECHNOLOGY; PROVIDING TEMPORARY USE OF NONDOWNLOADABLE SOFTWARE FOR ELECTRONIC MAP DISPLAY, TRAVEL PLANNING AND EVENT PLANNING; PROVIDING TEMPORARY USE OF NONDOWNLOADABLE SOFTWARE, NAMELY, SOFTWARE FOR DISPLAYING LOCATION AND PHYSICAL PRESENCE INFORMATION IN WIRELESS TELECOMMUNICATIONS DEVICES; PROVIDING TEMPORARY USE OF NONDOWNLOADABLE SOFTWARE FOR USE IN OBTAINING COUPONS, REBATES, PRICE-COMPARISON INFORMATION AND PRODUCT REVIEWS, LINKS TO THE RETAIL WEBSITES OF OTHERS, AND DISCOUNT INFORMATION; COMPUTER SERVICES, NAMELY, PROVIDING SEARCH ENGINES FOR LOCATING INFORMATION, RESOURCES, AND THE WEBSITES OF OTHERS VIA ELECTRONIC AND OPTICAL COMMUNICATIONS NETWORKS; PROVIDING A WIDE RANGE OF GENERAL INTEREST INFORMATION VIA ELECTRONIC AND OPTICAL COMMUNICATIONS NETWORKS; PROVIDING TEMPORARY USE OF NONDOWNLOADABLE SOFTWARE FOR USE IN THE RETRIEVAL OF DATA FROM THIRD-PARTY WEBSITES; PROVIDING TEMPORARY USE OF NONDOWNLOADABLE SOFTWARE FOR USE IN GAINING ACCESS TO AND INTERFACING WITH THIRD-PARTY E-COMMERCE TOOLS; PROVIDING TEMPORARY USE OF NONDOWNLOADABLE SOFTWARE FOR USE IN GAINING ACCESS TO AND INTERACTING WITH THIRD-PARTY RETAILERS (U.S. CLS. 100 AND 101).

**CLASS 45—PERSONAL AND LEGAL SERVICES**

FOR ONLINE SOCIAL NETWORKING SERVICES; ONLINE SOCIAL NETWORKING SERVICES CONDUCTED VIA WIRELESS TELECOMMUNICATIONS NETWORKS AND VIA ELECTRONIC AND OPTICAL COMMUNICATIONS NETWORKS (U.S. CLS. 100 AND 101).

JESSICA A. POWERS, EXAMINING ATTORNEY

SN 85-209,321. RSVP, LLC, LOS ANGELES, CA. FILED 1-3-2011.

# RSVP

THE MARK CONSISTS OF STANDARD CHARACTERS WITHOUT CLAIM TO ANY PARTICULAR FONT, STYLE, SIZE, OR COLOR.

## CLASS 9—ELECTRICAL AND SCIENTIFIC APPARATUS

FOR PRE-RECORDED CDS, VIDEO TAPES, LASER DISKS AND DVDS FEATURING SEX EDUCATION (U.S. CLS. 21, 23, 26, 36 AND 38).

## CLASS 41—EDUCATION AND ENTERTAINMENT

FOR EDUCATIONAL SERVICES, NAMELY, CONDUCTING WORKSHOP SEMINARS IN THE FIELD OF SEX EDUCATION; EDUCATIONAL SERVICES, NAMELY, PROVIDING ON-LINE WORKSHOPS IN THE FIELD OF SEX EDUCATION (U.S. CLS. 100, 101 AND 107).

ROBIN CHOSID, EXAMINING ATTORNEY

SN 85-209,360. MERIDIAN INTERNATIONAL CO., LTD., CENTENNIAL, CO. FILED 1-3-2011.

# YARDSMITH

THE MARK CONSISTS OF STANDARD CHARACTERS WITHOUT CLAIM TO ANY PARTICULAR FONT, STYLE, SIZE, OR COLOR.

## CLASS 6—METAL GOODS

FOR LAWN AND GARDEN PRODUCTS MADE OF METAL, NAMELY, MALE AND FEMALE GARDEN HOSE CONNECTORS, GARDEN HOSE MENDERS, AND GARDEN HOSE COUPLINGS AND FITTINGS (U.S. CLS. 2, 12, 13, 14, 23, 25 AND 50).

## CLASS 8—HAND TOOLS

FOR LAWN AND GARDEN HAND TOOLS, NAMELY, PRUNING SAWS, PRUNING KNIVES, PRUNING SCISSORS, PRUNING SHEARS, RAKES, SPADES, HOES, POST HOLE DIGGERS, SHOVELS, SCRAPERS, AND FORKS (U.S. CLS. 23, 28 AND 44).

## CLASS 9—ELECTRICAL AND SCIENTIFIC APPARATUS

FOR MECHANICAL TIMERS FOR LAWN AND GARDEN SPRINKLERS (U.S. CLS. 21, 23, 26, 36 AND 38).

## CLASS 17—RUBBER GOODS

FOR LAWN AND GARDEN PRODUCTS MADE OF PLASTIC, NAMELY, MALE AND FEMALE GARDEN HOSE CONNECTORS, GARDEN HOSE MENDERS, AND GARDEN HOSE COUPLINGS AND FITTINGS (U.S. CLS. 1, 5, 12, 13, 35 AND 50).

## CLASS 21—HOUSEWARES AND GLASS

FOR LAWN AND GARDEN SPRINKLERS; SPRINKLER ACCESSORIES, NAMELY, MANUAL SHUT-OFF VALVES; LAWN AND GARDEN HOSE NOZZLES AND SPRAYERS (U.S. CLS. 2, 13, 23, 29, 30, 33, 40 AND 50).

JASON TURNER, EXAMINING ATTORNEY

SN 85-209,369. FOTOLIA LLC, NEW YORK, NY. FILED 1-3-2011.

# FOTOLIA

THE MARK CONSISTS OF STANDARD CHARACTERS WITHOUT CLAIM TO ANY PARTICULAR FONT, STYLE, SIZE, OR COLOR.

## CLASS 9—ELECTRICAL AND SCIENTIFIC APPARATUS

FOR DOWNLOADABLE PHOTOGRAPHS, ILLUSTRATIONS, IMAGES AND PICTORIAL AND GRAPHIC WORKS VIA THE INTERNET AND WIRELESS DEVICES (U.S. CLS. 21, 23, 26, 36 AND 38).

FIRST USE 0-0-2005; IN COMMERCE 0-0-2005.

## CLASS 35—ADVERTISING AND BUSINESS

FOR PROVIDING A WEB SITE AT WHICH USERS CAN OFFER GOODS FOR SALE AND BUY GOODS OFFERED BY OTHERS (U.S. CLS. 100, 101 AND 102).

FIRST USE 0-0-2005; IN COMMERCE 0-0-2005.

## CLASS 38—COMMUNICATION

FOR ELECTRONIC DELIVERY OF IMAGES AND PHOTOGRAPHS VIA A GLOBAL COMPUTER NETWORK (U.S. CLS. 100, 101 AND 104).

FIRST USE 0-0-2005; IN COMMERCE 0-0-2005.

## CLASS 42—SCIENTIFIC AND COMPUTER SERVICES

FOR PROVIDING A WEB SITE FEATURING TECHNOLOGY THAT ENABLES INTERNET USERS TO SHARE DOCUMENTS, IMAGES AND VIDEOS (U.S. CLS. 100 AND 101).

FIRST USE 0-0-2005; IN COMMERCE 0-0-2005.

## CLASS 45—PERSONAL AND LEGAL SERVICES

FOR STOCK PHOTOGRAPHY SERVICES, NAMELY, LEASING REPRODUCTION RIGHTS OF PHOTOGRAPHS, TRANSPARENCIES AND DIGITAL CONTENT TO OTHERS (U.S. CLS. 100 AND 101).

FIRST USE 0-0-2005; IN COMMERCE 0-0-2005.

KARANENDRA S. CHHINA, EXAMINING ATTORNEY

SN 85-209,372. TIG'S BACKYARD, LLC, OKLAHOMA CITY, OK. FILED 1-3-2011.

SN 85-209,435. FOTOLIA LLC, NEW YORK, NY. FILED 1-3-2011.

HOOT & DOODLE



THE MARK CONSISTS OF AN OBLONG SHAPED FIGURE WITH AN OVAL IN THE MIDDLE OF IT.

THE MARK CONSISTS OF STANDARD CHARACTERS WITHOUT CLAIM TO ANY PARTICULAR FONT, STYLE, SIZE, OR COLOR.

**CLASS 16—PAPER GOODS AND PRINTED MATTER**

FOR CHILDREN'S BOOKS (U.S. CLS. 2, 5, 22, 23, 29, 37, 38 AND 50).  
FIRST USE 12-13-2010; IN COMMERCE 12-13-2010.

**CLASS 25—CLOTHING**

FOR DRESSES (U.S. CLS. 22 AND 39).  
FIRST USE 12-13-2010; IN COMMERCE 12-13-2010.  
JOHN SCHUYLER YARD, EXAMINING ATTORNEY

**CLASS 9—ELECTRICAL AND SCIENTIFIC APPARATUS**

FOR DOWNLOADABLE PHOTOGRAPHS, ILLUSTRATIONS, IMAGES AND PICTORIAL AND GRAPHIC WORKS VIA THE INTERNET AND WIRELESS DEVICES (U.S. CLS. 21, 23, 26, 36 AND 38).  
FIRST USE 0-0-2005; IN COMMERCE 0-0-2005.

**CLASS 35—ADVERTISING AND BUSINESS**

FOR PROVIDING A WEB SITE AT WHICH USERS CAN OFFER GOODS FOR SALE AND BUY GOODS OFFERED BY OTHERS (U.S. CLS. 100, 101 AND 102).  
FIRST USE 0-0-2005; IN COMMERCE 0-0-2005.

**CLASS 38—COMMUNICATION**

FOR ELECTRONIC DELIVERY OF IMAGES AND PHOTOGRAPHS VIA A GLOBAL COMPUTER NETWORK (U.S. CLS. 100, 101 AND 104).  
FIRST USE 0-0-2005; IN COMMERCE 0-0-2005.

**CLASS 42—SCIENTIFIC AND COMPUTER SERVICES**

FOR PROVIDING A WEB SITE FEATURING TECHNOLOGY THAT ENABLES INTERNET USERS TO SHARE DOCUMENTS, IMAGES AND VIDEOS (U.S. CLS. 100 AND 101).  
FIRST USE 0-0-2005; IN COMMERCE 0-0-2005.

**CLASS 45—PERSONAL AND LEGAL SERVICES**

FOR STOCK PHOTOGRAPHY SERVICES, NAMELY, LEASING REPRODUCTION RIGHTS OF PHOTOGRAPHS, TRANSPARENCIES AND DIGITAL CONTENT TO OTHERS (U.S. CLS. 100 AND 101).  
FIRST USE 0-0-2005; IN COMMERCE 0-0-2005.  
KARANENDRA S. CHHINA, EXAMINING ATTORNEY

SN 85-209,417. SOLECTRA, BROOKLYN, NY. FILED 1-3-2011.

Aragas

THE MARK CONSISTS OF STANDARD CHARACTERS WITHOUT CLAIM TO ANY PARTICULAR FONT, STYLE, SIZE, OR COLOR.

**CLASS 4—LUBRICANTS AND FUELS**

FOR BIOFUELS (U.S. CLS. 1, 6 AND 15).  
FIRST USE 5-28-2007; IN COMMERCE 5-28-2007.

**CLASS 40—MATERIAL TREATMENT**

FOR WASTE-TO-ENERGY GENERATION SERVICES (U.S. CLS. 100, 103 AND 106).  
FIRST USE 5-28-2007; IN COMMERCE 5-28-2007.  
TINA BROWN, EXAMINING ATTORNEY

SN 85-209,450. FUZZY NATION, L.L.C., LAFAYETTE, NJ. FILED 1-3-2011.

OUT OF THE CAGE

THE MARK CONSISTS OF STANDARD CHARACTERS WITHOUT CLAIM TO ANY PARTICULAR FONT, STYLE, SIZE, OR COLOR.

**CLASS 18—LEATHER GOODS**

FOR CARD WALLETS; KIT BAGS; WALLETS (U.S. CLS. 1, 2, 3, 22 AND 41).

**CLASS 25—CLOTHING**

FOR BELTS FOR CLOTHING (U.S. CLS. 22 AND 39).  
CHRISTINE COOPER, EXAMINING ATTORNEY

SN 85-209,480. HOBBY LOBBY STORES, INC., OKLAHOMA CITY, OK. FILED 1-3-2011.

# FUNKY TOWN

THE MARK CONSISTS OF STANDARD CHARACTERS WITHOUT CLAIM TO ANY PARTICULAR FONT, STYLE, SIZE, OR COLOR.

**CLASS 6—METAL GOODS**

FOR BASKETS OF COMMON METALS (U.S. CLS. 2, 12, 13, 14, 23, 25 AND 50).

**CLASS 20—FURNITURE AND ARTICLES NOT OTHERWISE CLASSIFIED**

FOR FABRIC FIGURINES; FIGURINES OF WOOD (U.S. CLS. 2, 13, 22, 25, 32 AND 50).

**CLASS 21—HOUSEWARES AND GLASS**

FOR CANDLE HOLDERS; FIGURINES OF GLASS (U.S. CLS. 2, 13, 23, 29, 30, 33, 40 AND 50).

**CLASS 28—TOYS AND SPORTING GOODS**

FOR ARTIFICIAL CHRISTMAS TREES (U.S. CLS. 22, 23, 38 AND 50).  
JAMES A. RAUEN, EXAMINING ATTORNEY

SN 85-209,503. WEB X.0 MEDIA LLC, BAINBRIDGE ISLAND, WA. FILED 1-3-2011.

# DomainSherpa

THE MARK CONSISTS OF STANDARD CHARACTERS WITHOUT CLAIM TO ANY PARTICULAR FONT, STYLE, SIZE, OR COLOR.

**CLASS 35—ADVERTISING AND BUSINESS**

FOR PROVIDING ADVERTISING SPACE IN PERIODICALS, NEWSPAPERS AND MAGAZINES (U.S. CLS. 100, 101 AND 102).  
FIRST USE 1-1-2011; IN COMMERCE 1-1-2011.

**CLASS 41—EDUCATION AND ENTERTAINMENT**

FOR PROVIDING A WEBSITE FEATURING BLOGS AND NON-DOWNLOADABLE PUBLICATIONS IN THE NATURE OF ARTICLES IN THE FIELD(S) OF DOMAIN NAMES (U.S. CLS. 100, 101 AND 107).

FIRST USE 1-1-2011; IN COMMERCE 1-1-2011.  
SUSAN RICHARDS, EXAMINING ATTORNEY

SN 85-209,519. CORBO, VINCENT, JR., NORTH HOLLYWOOD, CA. FILED 1-3-2011.

# SPIT

THE MARK CONSISTS OF STANDARD CHARACTERS WITHOUT CLAIM TO ANY PARTICULAR FONT, STYLE, SIZE, OR COLOR.

OWNER OF U.S. REG. NO. 2,212,719.  
SEC. 2(F).

**CLASS 9—ELECTRICAL AND SCIENTIFIC APPARATUS**

FOR COMPACT DISCS FEATURING MUSIC; DIGITAL MUSIC DOWNLOADABLE FROM THE INTERNET (U.S. CLS. 21, 23, 26, 36 AND 38).

FIRST USE 1-1-1985; IN COMMERCE 1-1-1985.

**CLASS 41—EDUCATION AND ENTERTAINMENT**

FOR ENTERTAINMENT IN THE NATURE OF LIVE PERFORMANCES BY A MUSICAL GROUP (U.S. CLS. 100, 101 AND 107).

FIRST USE 1-1-1985; IN COMMERCE 1-1-1985.  
DOMINICK J. SALEMI, EXAMINING ATTORNEY

SN 85-209,542. TPP ACQUISITION, INC., PLANO, TX. FILED 1-3-2011.

# PICTURE PEOPLE

THE MARK CONSISTS OF STANDARD CHARACTERS WITHOUT CLAIM TO ANY PARTICULAR FONT, STYLE, SIZE, OR COLOR.

OWNER OF U.S. REG. NOS. 2,394,410 AND 2,412,495.  
SEC. 2(F).

**CLASS 35—ADVERTISING AND BUSINESS**

FOR RETAIL STORE SERVICES FEATURING PHOTOGRAPHY RELATED PRODUCTS, FRAMES, GIFT CARDS, PHOTOGRAPHS AND MERCHANDISE CUSTOMIZED WITH PHOTOGRAPHS (U.S. CLS. 100, 101 AND 102).

FIRST USE 1-31-2002, THE MARK WAS FIRST USED ANYWHERE IN A DIFFERENT FORM OTHER THAN THAT SOUGHT TO BE REGISTERED AT LEAST AS EARLY AS 11/09/1996.; IN COMMERCE 1-31-2002, THE MARK WAS FIRST USED IN COMMERCE IN A DIFFERENT FORM OTHER THAN THAT SOUGHT TO BE REGISTERED AT LEAST AS EARLY AS 11/09/1996..

**CLASS 41—EDUCATION AND ENTERTAINMENT**

FOR PORTRAIT PHOTOGRAPHY (U.S. CLS. 100, 101 AND 107).

FIRST USE 1-31-2002, THE MARK WAS FIRST USED ANYWHERE IN A DIFFERENT FORM OTHER THAN THAT SOUGHT TO BE REGISTERED AT LEAST AS EARLY AS 11/09/1996; IN COMMERCE 1-31-2002, THE MARK WAS FIRST USED IN COMMERCE IN A DIFFERENT FORM OTHER THAN THAT SOUGHT TO BE REGISTERED AT LEAST AS EARLY AS 11/09/1996.

WANDA KAY PRICE, EXAMINING ATTORNEY

SN 85-209,641. HO, CHI-JUI, SAN JOSE, CA. FILED 1-4-2011.

gleeyo

THE MARK CONSISTS OF STANDARD CHARACTERS WITHOUT CLAIM TO ANY PARTICULAR FONT, STYLE, SIZE, OR COLOR.

**CLASS 41—EDUCATION AND ENTERTAINMENT**

FOR ENTERTAINMENT MEDIA PRODUCTION SERVICES FOR MOTION PICTURES, TELEVISION AND INTERNET; ENTERTAINMENT SERVICES, NAMELY, NON-DOWNLOADABLE RINGTONES, PRE-RECORDED MUSIC, AND GRAPHICS PRESENTED TO MOBILE COMMUNICATIONS DEVICES VIA A GLOBAL COMPUTER NETWORK AND WIRELESS NETWORKS; ENTERTAINMENT SERVICES, NAMELY, PROVIDING TEMPORARY USE OF NON-DOWNLOADABLE COMPUTER GAMES; ENTERTAINMENT SERVICES, NAMELY, PROVIDING TEMPORARY USE OF NON-DOWNLOADABLE COMPUTER LEARNING GAMES; PROVIDING ADVICE AND INFORMATION TO ADULT FAMILY MEMBERS ON APPROPRIATE ENTERTAINMENT AND LEISURE ACTIVITIES FOR YOUNGER FAMILY MEMBERS; PROVIDING AN INTERNET WEBSITE PORTAL IN THE FIELD OF ENTERTAINMENT, CULTURAL AND SPORTING EVENTS (U.S. CLS. 100, 101 AND 107).

SN 85-209,565. ANTHEA GRAMMAS, ANAHEIM HILLS, CA. FILED 1-3-2011.

LOSE WEIGHT GAIN A SMILE

THE MARK CONSISTS OF STANDARD CHARACTERS WITHOUT CLAIM TO ANY PARTICULAR FONT, STYLE, SIZE, OR COLOR.

**CLASS 25—CLOTHING**

FOR CLOTHING FOR ATHLETIC USE, NAMELY, PADDED ELBOW COMPRESSION SLEEVES BEING PART OF AN ATHLETIC GARMENT; CLOTHING FOR ATHLETIC USE, NAMELY, PADDED PANTS; CLOTHING FOR ATHLETIC USE, NAMELY, PADDED SHIRTS; CLOTHING FOR ATHLETIC USE, NAMELY, PADDED SHORTS; CLOTHING ITEMS, NAMELY, ADHESIVE POCKETS THAT MAY BE AFFIXED DIRECTLY TO THE BODY AS A DECORATIVE PIECE OF CLOTHING WITH UTILITY; CLOTHING ITEMS, NAMELY, ADHESIVE POCKETS THAT MAY BE AFFIXED DIRECTLY TO THE INSIDE OF CLOTHING FOR STORAGE AND SAFEKEEPING OF PERSONAL ITEMS; CLOTHING SHIELDS, NAMELY, PADS APPLIED TO THE UNDERARMS OF SHIRTS, BLOUSES AND SWEATERS; CLOTHING, NAMELY, ARM WARMERS; CLOTHING, NAMELY, ATHLETIC SLEEVES; CLOTHING, NAMELY, BASE LAYERS; CLOTHING, NAMELY, FOLK COSTUMES; CLOTHING, NAMELY, HAND-WARMERS; CLOTHING, NAMELY, KHAKIS; CLOTHING, NAMELY, KNEE WARMERS; CLOTHING, NAMELY, NECK TUBES; HEADBANDS FOR CLOTHING; HOODS; JACKETS; JERSEYS; PARTS OF CLOTHING, NAMELY, GUSSETS FOR TIGHTS, GUSSETS FOR STOCKINGS, GUSSETS FOR BATHING SUITS, GUSSETS FOR UNDERWEAR, GUSSETS FOR LEOTARDS AND GUSSETS FOR FOOTLETS; PARTS OF CLOTHING, NAMELY, UNDERARM GUSSETS; TRAVEL CLOTHING CONTAINED IN A PACKAGE COMPRISING REVERSIBLE JACKETS, PANTS, SKIRTS, TOPS AND A BELT OR SCARF; TRIATHLON CLOTHING, NAMELY, TRIATHLON TIGHTS, TRIATHLON SHORTS, TRIATHLON SINGLETTS, TRIATHLON SHIRTS, TRIATHLON SUITS; UNDERARM CLOTHING SHIELDS; WEARABLE GARMENTS AND CLOTHING, NAMELY, SHIRTS (U.S. CLS. 22 AND 39).

**CLASS 45—PERSONAL AND LEGAL SERVICES**

FOR LICENSING OF ADVERTISING SLOGANS AND CARTOON CHARACTERS (U.S. CLS. 100 AND 101).  
JAMES GRIFFIN, EXAMINING ATTORNEY

**CLASS 42—SCIENTIFIC AND COMPUTER SERVICES**

FOR COMPUTER CONSULTATION; COMPUTER HARDWARE AND SOFTWARE CONSULTING SERVICES; COMPUTER NETWORK CONFIGURATION SERVICES; COMPUTER NETWORK DESIGN FOR OTHERS (U.S. CLS. 100 AND 101).

LANA PHAM, EXAMINING ATTORNEY

SN 85-209,685. WHG TM CORP., LAS VEGAS, NV. FILED 1-4-2011.

BAYMONT INN & SUITES

THE MARK CONSISTS OF STANDARD CHARACTERS WITHOUT CLAIM TO ANY PARTICULAR FONT, STYLE, SIZE, OR COLOR.

OWNER OF U.S. REG. NOS. 2,309,146, 3,232,172 AND OTHERS.

NO CLAIM IS MADE TO THE EXCLUSIVE RIGHT TO USE "INN & SUITES", APART FROM THE MARK AS SHOWN.

**CLASS 35—ADVERTISING AND BUSINESS**

FOR FRANCHISE SERVICES, NAMELY, OFFERING BUSINESS MANAGEMENT ASSISTANCE IN THE ESTABLISHMENT, OPERATION AND MARKETING OF HOTELS AND MOTELS (U.S. CLS. 100, 101 AND 102).

FIRST USE 6-22-1998; IN COMMERCE 6-22-1998.

**CLASS 43—HOTEL AND RESTAURANT SERVICES**

FOR HOTEL AND MOTEL SERVICES; AND MAKING LODGING RESERVATIONS FOR OTHERS (U.S. CLS. 100 AND 101).

FIRST USE 6-22-1998; IN COMMERCE 6-22-1998.  
EUGENIA MARTIN, EXAMINING ATTORNEY

SN 85-210,046. WILLIAMS, GRAHAM JOHN, ASHFORD, KENT, UNITED KINGDOM, FILED 1-4-2011.

SN 85-209,995. OLD LYME GOURMET COMPANY, DBA DEEP RIVER SNACKS, OLD LYME, CT. FILED 1-4-2011.

**Deep River Snacks**

THE MARK CONSISTS OF STANDARD CHARACTERS WITHOUT CLAIM TO ANY PARTICULAR FONT, STYLE, SIZE, OR COLOR.

NO CLAIM IS MADE TO THE EXCLUSIVE RIGHT TO USE "SNACKS", APART FROM THE MARK AS SHOWN.

**CLASS 29—MEATS AND PROCESSED FOODS**

FOR FRENCH FRIED POTATOES; FRIED POTATOES; POTATO CHIPS; POTATO CRISPS; POTATO CRISPS AND CHIPS; POTATO FRIES; POTATO STICKS; POTATO-BASED SNACK FOODS (U.S. CL. 46).

FIRST USE 9-1-2003; IN COMMERCE 9-1-2003.

**CLASS 30—STAPLE FOODS**

FOR POPCORN; POPPED POPCORN (U.S. CL. 46).  
FIRST USE 9-1-2003; IN COMMERCE 9-1-2003.  
ALICE BENMAMAN, EXAMINING ATTORNEY

SN 85-210,026. JOHNSON & JOHNSON, NEW BRUNSWICK, NJ. FILED 1-4-2011.

**KEEP ON MOMMIN'**

THE MARK CONSISTS OF STANDARD CHARACTERS WITHOUT CLAIM TO ANY PARTICULAR FONT, STYLE, SIZE, OR COLOR.

**CLASS 16—PAPER GOODS AND PRINTED MATTER**

FOR PRINTED MATERIAL, NAMELY, INFORMATIONAL FLYERS FEATURING OVER-THE-COUNTER PHARMACEUTICAL PREPARATIONS (U.S. CLS. 2, 5, 22, 23, 29, 37, 38 AND 50).

**CLASS 44—MEDICAL, BEAUTY AND AGRICULTURAL SERVICES**

FOR PROVIDING HEALTH AND WELLNESS INFORMATION ON OVER-THE-COUNTER PHARMACEUTICAL PREPARATIONS (U.S. CLS. 100 AND 101).  
CAROL SPILS, EXAMINING ATTORNEY



THE COLOR(S) BLUE IS/ARE CLAIMED AS A FEATURE OF THE MARK.

THE MARK CONSISTS OF AN ELONGATED, CURVED TRIANGULAR SHAPE WITH AN ARROW AT THE PEAK.

**CLASS 35—ADVERTISING AND BUSINESS**

FOR MANAGEMENT CONSULTING AND ADVISORY SERVICES IN THE AREAS OF CORPORATE GROWTH STRATEGY, INNOVATION AND GROWTH PROCESSES, ORGANIZATIONAL TRANSFORMATION, AND TALENT MANAGEMENT AND DEVELOPMENT STRATEGIES (U.S. CLS. 100, 101 AND 102).

**CLASS 41—EDUCATION AND ENTERTAINMENT**

FOR PERSONAL COACHING SERVICES IN THE FIELD OF PERSONAL DEVELOPMENT (U.S. CLS. 100, 101 AND 107).

LANA PHAM, EXAMINING ATTORNEY

SN 85-210,082. MGH HOLDINGS, LLC, HIGHLAND, UT. FILED 1-4-2011.

**MYOBIOLOGICS**

THE MARK CONSISTS OF STANDARD CHARACTERS WITHOUT CLAIM TO ANY PARTICULAR FONT, STYLE, SIZE, OR COLOR.

**CLASS 5—PHARMACEUTICALS**

FOR DIETARY SUPPLEMENTS; SPORTS CREAM FOR RELIEF OF PAIN; TOPICAL ANALGESIC CREAMS; TRANSDERMAL PATCHES FOR USE IN THE TREATMENT OF PAIN; ELECTROLYTE REPLACEMENT SOLUTIONS (U.S. CLS. 6, 18, 44, 46, 51 AND 52).

**CLASS 10—MEDICAL APPARATUS**

FOR CHEMICALLY ACTIVATED HOT AND/OR COLD COMPRESSES; THERAPEUTIC APPARATUS, NAMELY, CHEMICALLY ACTIVATED ANTI-CELLULITE WRAPS, ICE PACKS, COMPRESSES, AND COMPRESSION BANDAGES; THERAPEUTIC HOT AND COLD COMPRESSION WRAPS (U.S. CLS. 26, 39 AND 44).  
TINA BROWN, EXAMINING ATTORNEY

SN 85-210,084. ABRACO GROUP, LLC, CORAL GABLES, FL.  
FILED 1-4-2011.

# ASTURI

THE MARK CONSISTS OF STANDARD CHARACTERS WITHOUT CLAIM TO ANY PARTICULAR FONT, STYLE, SIZE, OR COLOR.

## CLASS 29—MEATS AND PROCESSED FOODS

FOR BOTTLED COOKED MEAT; CANNED COOKED MEAT; CHEESE; CHORIZO; DAIRY-BASED BEVERAGES; HAM; JAMS; MEAT JELLIES; MEAT PRESERVES; MEAT, FRUIT AND VEGETABLE JELLIES, JAMS; MEAT-BASED SNACK FOODS; MEAT-BASED SPREADS; YOGURT; YOGURT DRINKS (U.S. CL. 46).

## CLASS 30—STAPLE FOODS

FOR BREAD; BREAD STICKS; BRUSCHETTA-TOPPED BREAD; CHOCOLATE; COOKIES; CRACKERS; CRISP BREAD; DESSERT MOUSSE; DESSERT PUDDINGS; DESSERT SOUFFLES; FLAT BREAD; FROZEN CONFECTIONERY; FROZEN CONFECTIONS; FROZEN DESSERT CONSISTING OF FRUIT AND CREAM OR CREAM SUBSTITUTES; FROZEN YOGURT; FROZEN YOGURT CONFECTIONS; ICE CREAM DESSERTS; NON-DAIRY FROZEN CONFECTIONS; PASTRIES; RICE-BASED PUDDING DESSERT (U.S. CL. 46).

## CLASS 32—LIGHT BEVERAGES

FOR FRUIT BEVERAGES; FRUIT JUICES; FRUIT-BASED BEVERAGES; FRUIT-FLAVORED BEVERAGES; NON-ALCOHOLIC BEVERAGES CONTAINING FRUIT JUICES; NON-ALCOHOLIC BEVERAGES WITH TEA FLAVOR; NON-ALCOHOLIC BEVERAGES, NAMELY, CARBONATED BEVERAGES; NON-ALCOHOLIC FRUIT JUICE BEVERAGES; VEGETABLE JUICES (U.S. CLS. 45, 46 AND 48).

CHRISTINE MARTIN, EXAMINING ATTORNEY

SN 85-210,169. FINDINGS, INC., NEW YORK, NY. FILED 1-4-2011.

# FINDINGS

THE MARK CONSISTS OF STANDARD CHARACTERS WITHOUT CLAIM TO ANY PARTICULAR FONT, STYLE, SIZE, OR COLOR.

## CLASS 9—ELECTRICAL AND SCIENTIFIC APPARATUS

FOR COMPUTER APPLICATION SOFTWARE FOR MOBILE ELECTRONIC DEVICES FOR UPLOADING, DOWNLOADING, STREAMING, POSTING, DISPLAYING, EDITING, TAGGING, BLOGGING, LINKING, ORGANIZING, STORING, SHARING OR OTHERWISE PROVIDING ELECTRONIC MEDIA OR INFORMATION OVER COMMUNICATION NETWORKS; COMPUTER APPLICATION SOFTWARE FOR MOBILE ELECTRONIC DEVICES FOR CREATING INDEXES OF INFORMATION, SITES AND OTHER RESOURCES AVAILABLE ON COMPUTER NETWORKS; COMPUTER APPLICATION SOFTWARE FOR MOBILE ELECTRONIC DEVICES FOR SOCIAL NETWORKING AND TRANSMISSION OF ELECTRONIC MEDIA OR INFORMATION OVER COMMUNICATION NETWORKS (U.S. CLS. 21, 23, 26, 36 AND 38).

## CLASS 42—SCIENTIFIC AND COMPUTER SERVICES

FOR APPLICATION SERVICE PROVIDER (ASP) FEATURING SOFTWARE FOR UPLOADING, DOWNLOADING, STREAMING, POSTING, DISPLAYING, EDITING, TAGGING, BLOGGING, LINKING, ORGANIZING, STORING, SHARING OR OTHERWISE PROVIDING ELECTRONIC MEDIA OR INFORMATION OVER COMMUNICATION NETWORKS; APPLICATION SERVICE PROVIDER (ASP) FEATURING SOFTWARE FOR CREATING INDEXES OF INFORMATION, SITES AND OTHER RESOURCES AVAILABLE ON COMPUTER NETWORKS; APPLICATION SERVICE PROVIDER (ASP) FEATURING SOFTWARE FOR SOCIAL NETWORKING AND TRANSMISSION OF ELECTRONIC MEDIA OR INFORMATION OVER COMMUNICATION NETWORKS (U.S. CLS. 100 AND 101).

ANTHONY RINKER, EXAMINING ATTORNEY

SN 85-210,212. EYEFLY LLC, NEW YORK, NY. FILED 1-4-2011.

# EYEFLY

THE MARK CONSISTS OF STANDARD CHARACTERS WITHOUT CLAIM TO ANY PARTICULAR FONT, STYLE, SIZE, OR COLOR.

## CLASS 9—ELECTRICAL AND SCIENTIFIC APPARATUS

FOR EYE GLASSES, EYE GLASS FRAMES, EYE GLASS CORDS, EYE GLASS CHAINS, SUN GLASSES, SPORT GLASSES (U.S. CLS. 21, 23, 26, 36 AND 38).

## CLASS 35—ADVERTISING AND BUSINESS

FOR ONLINE RETAIL STORE SERVICES FEATURING EYE GLASSES, EYE GLASS FRAMES, EYE GLASS CORDS, EYE GLASS CHAINS, SUN GLASSES, AND SPORT GLASSES AND OTHER EYE GLASS ACCESSORIES (U.S. CLS. 100, 101 AND 102).

COLLEEN KEARNEY, EXAMINING ATTORNEY

SN 85-210,330. LONG JOHN SILVER'S INC., LOUISVILLE, KY. FILED 1-4-2011.

## WE SPEAK FISH

THE MARK CONSISTS OF STANDARD CHARACTERS WITHOUT CLAIM TO ANY PARTICULAR FONT, STYLE, SIZE, OR COLOR.

### CLASS 29—MEATS AND PROCESSED FOODS

FOR PREPARED ENTREES CONSISTING PRIMARILY OF SEAFOOD AND/OR CHICKEN FOR CONSUMPTION ON OR OFF PREMISES (U.S. CL. 46).

### CLASS 43—HOTEL AND RESTAURANT SERVICES

FOR RESTAURANT SERVICES (U.S. CLS. 100 AND 101).  
KARANENDRA S. CHHINA, EXAMINING ATTORNEY

SN 85-210,340. NOAH ELIAS, AKA NOAH ELIAS, COSTA MESA, CA. FILED 1-4-2011.

## American Artist

THE MARK CONSISTS OF STANDARD CHARACTERS WITHOUT CLAIM TO ANY PARTICULAR FONT, STYLE, SIZE, OR COLOR.

### CLASS 25—CLOTHING

FOR HATS; T-SHIRTS (U.S. CLS. 22 AND 39).

### CLASS 41—EDUCATION AND ENTERTAINMENT

FOR ENTERTAINMENT, NAMELY, A CONTINUING ART SHOW BROADCAST OVER INTERNET, SATELLITE, TELEVISION, CABLE TELEVISION (U.S. CLS. 100, 101 AND 107).

FIRST USE 6-1-2007; IN COMMERCE 6-1-2007.  
KARANENDRA S. CHHINA, EXAMINING ATTORNEY

SN 85-210,368. YOUNG MASTER MINDS, LLC, CINCINNATI, OH. FILED 1-4-2011.

## ?RIVY

THE MARK CONSISTS OF STANDARD CHARACTERS WITHOUT CLAIM TO ANY PARTICULAR FONT, STYLE, SIZE, OR COLOR.

### CLASS 35—ADVERTISING AND BUSINESS

FOR ADVERTISING THE SERVICES OF OTHERS VIA WEB PAGES OPTIMIZED FOR ONLINE SEARCH ENGINES; PROMOTING THE GOODS AND SERVICES OF OTHERS BY PROVIDING HYPERTEXT LINKS TO THE WEB SITES OF OTHERS (U.S. CLS. 100, 101 AND 102).

### CLASS 42—SCIENTIFIC AND COMPUTER SERVICES

FOR COMPUTER SERVICES, NAMELY, PROVIDING SEARCH ENGINES FOR OBTAINING DATA ON A GLOBAL COMPUTER NETWORK; PROVISION OF INTERNET SEARCH ENGINES (U.S. CLS. 100 AND 101).

GINA FINK, EXAMINING ATTORNEY

SN 85-210,414. CASCADIA GREEN BUILDING COUNCIL, PORTLAND, OR. FILED 1-4-2011.

## LIVING LIFE

THE MARK CONSISTS OF STANDARD CHARACTERS WITHOUT CLAIM TO ANY PARTICULAR FONT, STYLE, SIZE, OR COLOR.

OWNER OF U.S. REG. NO. 3,891,794.

### CLASS 35—ADVERTISING AND BUSINESS

FOR PROMOTING THE INTERESTS OF PEOPLE CONCERNED WITH ENVIRONMENTAL SUSTAINABILITY ISSUES; PROMOTING PUBLIC AWARENESS OF ENVIRONMENTAL ISSUES AND INITIATIVES; PROMOTING THE ENERGY EFFICIENT PRODUCTS AND SERVICES OF OTHERS (U.S. CLS. 100, 101 AND 102).

### CLASS 41—EDUCATION AND ENTERTAINMENT

FOR EDUCATIONAL SERVICES, NAMELY, CONFERENCES, CLASSES, SEMINARS, WORKSHOPS, LECTURES, AND FOCUS GROUPS ALL RELATING TO SUSTAINABLE DEVELOPMENT INCLUDING DESIGN, CONSTRUCTION, MAINTENANCE, AND OPERATIONS, ENERGY EFFICIENCY IN BUILDINGS, ENERGY CONSUMPTION AND ENERGY MANAGEMENT, ENVIRONMENTAL QUALITY OF BUILDINGS, NAMELY, ENVIRONMENTAL AND BUILDING ASSESSMENT, COMPLIANCE, AND PLANNING, ENGINEERING AND / OR ARCHITECTURAL DESIGN, AND THE RESEARCH AND DEVELOPMENT OF STANDARDS AND TECHNOLOGY THEREOF (U.S. CLS. 100, 101 AND 107).

### CLASS 42—SCIENTIFIC AND COMPUTER SERVICES

FOR CONSULTANCY IN THE FIELD OF ARCHITECTURAL DESIGN OF ENERGY EFFICIENT BUILDINGS; CONSULTING SERVICES IN THE FIELD OF ENVIRONMENTAL ASSESSMENT AND PLANNING; RESEARCH AND DEVELOPMENT AND CONSULTATION RELATED THERETO IN THE FIELD OF ARCHITECTURAL DESIGN OF ENERGY EFFICIENT BUILDINGS, ENVIRONMENTAL ASSESSMENT AND PLANNING, ARCHITECTURAL AND ENGINEERING SERVICES, AND THE DEVELOPMENT OF VOLUNTARY STANDARDS AND DEVELOPMENT OF TECHNOLOGY IN THE FOREGOING FIELDS; ENGINEERING SERVICES IN THE FIELD OF ENVIRONMENTAL COMPLIANCE (U.S. CLS. 100 AND 101).

JACQUELINE A. LAVINE, EXAMINING ATTORNEY



SN 85-210,422. V MANUFACTURING & LOGISTICS, INC.,  
WALNUT, CA. FILED 1-4-2011.



THE MARK CONSISTS OF AN OVERSIZED NUMBER 8 WITH THE LETTERS MP SUPERIMPOSED THEREUPON.

### CLASS 3—COSMETICS AND CLEANING PREPARATIONS

FOR AFTER SHAVE LOTIONS; AFTERSHAVE; AFTERSHAVE PREPARATIONS; ANTI-BACTERIAL SOAP; ANTIPERSPIRANTS AND DEODORANTS FOR PERSONAL USE; AROMATIC BODY CARE PRODUCTS, NAMELY, BODY LOTION, SHOWER GEL, CUTICLE CREAM, SHAMPOO, CONDITIONER, NON-MEDICATED LIP BALM, SOAP, BODY POLISH, BODY AND FOOT SCRUB AND NON-MEDICATED FOOT CREAM; BAR SOAP; BATH SOAPS IN LIQUID, SOLID OR GEL FORM; BODY CREAMS; BODY LOTIONS; BODY SPRAY USED AS A PERSONAL DEODORANT AND AS FRAGRANCE; COLOGNE; CREAM SOAPS; DEODORANT SOAP; FACE AND BODY CREAMS; FACE AND BODY LOTIONS; FACIAL CLEANSERS; FACIAL SCRUBS; FACIAL WASHES; FRAGRANCES; HAIR CLEANING PREPARATIONS; HAIR CONDITIONER; HAIR GELS; HAIR RINSES; HAIR SHAMPOO; HAIR SPRAYS; HAIR STYLING GEL; HAND CLEANING PREPARATIONS; HAND CREAMS; HAND LOTIONS; HAND SOAPS; MASSAGE OILS; MOISTURIZING PREPARATIONS FOR THE SKIN; PERFUMES; SHAVING CREAMS; SHAVING SOAPS; SHOWER GELS; SKIN CLEANSERS; SKIN MOISTURIZER; SOAPS FOR BODY CARE (U.S. CLS. 1, 4, 6, 50, 51 AND 52).

### CLASS 5—PHARMACEUTICALS

FOR ANTIBACTERIAL ALCOHOL SKIN SANITIZER GEL; DISPOSABLE SANITIZING WIPES; HAND-SANITIZING PREPARATIONS; ROOM DEODORANTS; SPORTS CREAM FOR RELIEF OF PAIN (U.S. CLS. 6, 18, 44, 46, 51 AND 52).

HEATHER BIDDULPH, EXAMINING ATTORNEY

SN 85-210,499. INSPORTS, INC., RESTON, VA. FILED 1-4-2011.

InSports

THE MARK CONSISTS OF STANDARD CHARACTERS WITHOUT CLAIM TO ANY PARTICULAR FONT, STYLE, SIZE, OR COLOR.

### CLASS 9—ELECTRICAL AND SCIENTIFIC APPARATUS

FOR COMPUTER APPLICATION SOFTWARE FOR MOBILE PHONES, NAMELY, SOFTWARE FOR SPORTS LEAGUE MANAGEMENT, TEAM MANAGEMENT, AND SCORING OF SPORTING EVENTS (U.S. CLS. 21, 23, 26, 36 AND 38).

FIRST USE 9-26-2010; IN COMMERCE 11-2-2010.

### CLASS 38—COMMUNICATION

FOR BROADCAST COMMUNICATION SERVICES, NAMELY, TRANSMITTING E-MAILS, FAXES, TEXT MESSAGES AND TELEPHONE VOICE MESSAGES TO DESIGNATED RECIPIENTS FOR OTHERS (U.S. CLS. 100, 101 AND 104).

FIRST USE 9-26-2010; IN COMMERCE 11-2-2010.

### CLASS 42—SCIENTIFIC AND COMPUTER SERVICES

FOR COMPUTER SERVICES, NAMELY, CREATING AN ON-LINE COMMUNITY FOR REGISTERED USERS TO PARTICIPATE IN DISCUSSIONS, GET FEEDBACK FROM THEIR PEERS, FORM VIRTUAL COMMUNITIES, AND ENGAGE IN SOCIAL NETWORKING; COMPUTER SERVICES, NAMELY, HOSTING AN INTERACTIVE WEB SITE THAT ALLOWS FAMILIES TO RECORD AND DISPLAY FAMILY PROFILES, RELATIONSHIPS, INTERESTS, AUDIO AND VIDEO CONTENT; COMPUTER SERVICES, NAMELY, HOSTING ON-LINE INTERACTIVE PUBLIC CALENDARS THAT ALLOW MULTIPLE PARTICIPANTS TO SHARE EVENT SCHEDULES, FACILITY RESERVATIONS, AND TRANSPORTATION REQUESTS; COMPUTER SERVICES, NAMELY, INTERACTIVE HOSTING SERVICES WHICH ALLOW THE USER TO PUBLISH AND SHARE THEIR OWN CONTENT AND IMAGES ON-LINE (U.S. CLS. 100 AND 101).

FIRST USE 9-26-2010; IN COMMERCE 11-2-2010.  
CHERYL CLAYTON, EXAMINING ATTORNEY

SN 85-210,510. AVANI HOLDINGS LLC, DBA AVANI,  
SANTA FE SPRINGS, CA. FILED 1-4-2011.



THE MARK CONSISTS OF A SHADED THIN BORDER ENCIRCLING A LARGER TRANSPARENT BORDER ENCIRCLING A SHADED CIRCLE CONTAINING TRANSPARENT OUTLINES OF A STEM OF A PLANT WITH FOUR TAPERED OVAL-SHAPED LEAVES PROTRUDING FROM FOUR OF THE SIX STEM ENDINGS.

### CLASS 18—LEATHER GOODS

FOR CANVAS SHOPPING BAGS; GENERAL PURPOSE BAGS FOR CARRYING YOGA EQUIPMENT; LEATHER SHOPPING BAGS; LUGGAGE; MESH SHOPPING BAGS; PURSES; REUSABLE SHOPPING BAGS; ROLL BAGS; SHOULDER BAGS; TOTE BAGS (U.S. CLS. 1, 2, 3, 22 AND 41).

**CLASS 21—HOUSEWARES AND GLASS**

FOR SPORTS BOTTLES SOLD EMPTY (U.S. CLS. 2, 13, 23, 29, 30, 33, 40 AND 50).

**CLASS 25—CLOTHING**

FOR (BASED ON USE IN COMMERCE) BOTTOMS; BRAS; CAMISOLES; JACKETS; TANK TOPS; TOPS; UNDERWEAR; YOGA PANTS; YOGA SHIRTS(BASED ON INTENT TO USE) FOOTWEAR; HATS; HEADBANDS; HEADWEAR; HOSIERY; LOUNGEWEAR; SCARVES; SLEEPWEAR; SOCKS (U.S. CLS. 22 AND 39).  
FIRST USE 10-1-2010; IN COMMERCE 10-1-2010.

**CLASS 26—FANCY GOODS**

FOR HAIR PINS; HAIR RIBBONS; RIBBONS (U.S. CLS. 37, 39, 40, 42 AND 50).

**CLASS 28—TOYS AND SPORTING GOODS**

FOR BAGS SPECIALLY ADAPTED TO CARRY YOGA EQUIPMENT; YOGA MATS (U.S. CLS. 22, 23, 38 AND 50).

**CLASS 35—ADVERTISING AND BUSINESS**

FOR ON-LINE RETAIL STORE SERVICES FEATURING CLOTHING (U.S. CLS. 100, 101 AND 102).  
FIRST USE 12-1-2010; IN COMMERCE 12-1-2010.  
AMEEN IMAM, EXAMINING ATTORNEY

---

SN 85-210,573. GOGNA KARAN, WELLINGTON, NEW ZEALAND, FILED 1-5-2011.

**CLASS 3—COSMETICS AND CLEANING PREPARATIONS**

FOR 3-IN-1 HAIR CONDITIONERS; 3-IN-1 HAIR SHAMPOOS; CONDITIONERS; HAIR BALSAM; HAIR BLEACH; HAIR BLEACHES; HAIR BLEACHING PREPARATIONS; HAIR CARE LOTIONS; HAIR CARE PRODUCTS, NAMELY, HEAT PROTECTION SPRAYS; HAIR COLOR; HAIR COLOR REMOVERS; HAIR COLORANTS; HAIR COLOURANTS; HAIR COLOURING; HAIR COLOURING AND DYES; HAIR COLOURING PREPARATIONS; HAIR CONDITIONER; HAIR CONDITIONERS; HAIR CONDITIONERS FOR BABIES; HAIR CREAMS; HAIR CURLING PREPARATIONS; HAIR DECOLORANTS; HAIR GEL; HAIR GEL AND HAIR MOUSSE; HAIR GELS; HAIR GLAZE; HAIR LACQUERS; HAIR LIGHTENERS; HAIR LOTION; HAIR LOTIONS; HAIR MASKS; HAIR MOUSSE; HAIR MOUSSES; HAIR NOURISHERS; HAIR POMADES; HAIR PRODUCTS, NAMELY, THICKENING CONTROL CREAMS; HAIR RELAXERS; HAIR RELAXING PREPARATIONS; HAIR RINSES; HAIR SHAMPOO; HAIR SHAMPOOS AND CONDITIONERS; HAIR SHEEN SPRAY; HAIR SPRAY; HAIR SPRAYS; HAIR SPRAYS AND HAIR GELS; HAIR STRAIGHTENING PREPARATIONS; HAIR STYLING FIXATIVE IN THE NATURE OF HAIR WAX; HAIR STYLING GEL; HAIR STYLING PREPARATIONS; HAIR STYLING SPRAY; HAIR WAVING PREPARATIONS; HAIR WAX; LOTIONS FOR HAIR; MOUSSE FOR HAIR; NON-MEDICATED BALMS FOR USE ON HAIR; NON-MEDICATED HAIR SERUMS; NON-MEDICATED HAIR TREATMENT PREPARATIONS FOR COSMETIC PURPOSES; NON-MEDICATED PREPARATIONS ALL FOR THE CARE OF SKIN, HAIR AND SCALP; NON-MEDICATED SERUMS FOR USE ON HAIR; OILS FOR HAIR CONDITIONING; POMADES FOR HAIR; PREPARATIONS FOR PERMANENT HAIR WAVES; PREPARATIONS FOR SETTING HAIR; STYLING CLAY FOR HAIR; STYLING FOAM FOR HAIR; STYLING PASTE FOR HAIR (U.S. CLS. 1, 4, 6, 50, 51 AND 52).

**CLASS 9—ELECTRICAL AND SCIENTIFIC APPARATUS**

FOR ELECTRIC HAIR CRIMPER; ELECTRIC HAIR CURLERS; ELECTRIC HAIR CURLING IRONS; ELECTRIC HAIR ROLLERS; ELECTRIC HAIR STRAIGHTENER; ELECTRIC HAIR STRAIGHTENING IRONS; ELECTRIC HAIR WAVING IMPLEMENTS; ELECTRIC HAIR-CURLERS; ELECTRIC HAND-HELD HAIR STYLING IRONS; ELECTRIC IRONS FOR STYLING HAIR; ELECTRIC ROTARY HAIR BRUSH FOR STYLING A USER'S HAIR; HAIR-CURLERS, ELECTRICALLY HEATED; HOT AIR HAIR BRUSHES (U.S. CLS. 21, 23, 26, 36 AND 38).  
JOHN KELLY, EXAMINING ATTORNEY

---

SN 85-210,614. MEDICUS RESOURCE MANAGEMENT, INC., WYOMISSING, PA. FILED 1-5-2011.

magicurl



NO CLAIM IS MADE TO THE EXCLUSIVE RIGHT TO USE "HEALTH & LIFESTYLE MANAGEMENT COMPANY", APART FROM THE MARK AS SHOWN.

THE COLOR(S) GREEN BLUE WHITE IS/ARE CLAIMED AS A FEATURE OF THE MARK.

THE MARK CONSISTS OF A CARTOON OF A HEART IN GREEN WITH WHITE HORIZONTAL BARS AND THE WORDS "MEDICUS A HEALTH & LIFESTYLE MANAGEMENT COMPANY" IN BLUE TO THE RIGHT OF THE CARTOON, WITH THE M OF "MEDICUS" OUTLINED IN GREEN.

THE MARK CONSISTS OF STANDARD CHARACTERS WITHOUT CLAIM TO ANY PARTICULAR FONT, STYLE, SIZE, OR COLOR.

**CLASS 35—ADVERTISING AND BUSINESS**

FOR MANAGED CARE SERVICES, NAMELY, HEALTHCARE UTILIZATION REVIEW AND PRE-CERTIFICATION SERVICES (U.S. CLS. 100, 101 AND 102).  
FIRST USE 5-1-2010; IN COMMERCE 5-1-2010.

**CLASS 44—MEDICAL, BEAUTY AND AGRICULTURAL SERVICES**

FOR HEALTH CARE SERVICES, NAMELY, DISEASE MANAGEMENT PROGRAMS AND WELLNESS PROGRAMS (U.S. CLS. 100 AND 101).  
FIRST USE 5-1-2010; IN COMMERCE 5-1-2010.

**CLASS 45—PERSONAL AND LEGAL SERVICES**

FOR CASE MANAGEMENT SERVICES, NAMELY, THE COORDINATION OF NECESSARY MEDICAL SERVICES FOR PATIENTS (U.S. CLS. 100 AND 101).  
FIRST USE 5-1-2010; IN COMMERCE 5-1-2010.  
HELENE LIWINSKI, EXAMINING ATTORNEY

---

SN 85-210,626. BERGAN, LLC, MONKEY ISLAND, OK. FILED 1-5-2011.

# PRUDENCE

THE MARK CONSISTS OF STANDARD CHARACTERS WITHOUT CLAIM TO ANY PARTICULAR FONT, STYLE, SIZE, OR COLOR.

**CLASS 5—PHARMACEUTICALS**

FOR MEDICATED SUPPLEMENTS FOR FOODSTUFFS FOR ANIMALS (U.S. CLS. 6, 18, 44, 46, 51 AND 52).

**CLASS 31—NATURAL AGRICULTURAL PRODUCTS**

FOR ANIMAL FOODSTUFFS, NAMELY, PET FOODS AND PET TREATS (U.S. CLS. 1 AND 46).  
DANNEAN HETZEL, EXAMINING ATTORNEY

---

SN 85-210,628. OPT IT, INC., CHICAGO, IL. FILED 1-5-2011.

# Local Graph

THE MARK CONSISTS OF STANDARD CHARACTERS WITHOUT CLAIM TO ANY PARTICULAR FONT, STYLE, SIZE, OR COLOR.

NO CLAIM IS MADE TO THE EXCLUSIVE RIGHT TO USE "LOCAL", APART FROM THE MARK AS SHOWN.

**CLASS 35—ADVERTISING AND BUSINESS**

FOR COMPILING OF INFORMATION INTO COMPUTER DATABASES; ADVERTISING SERVICES, PUBLIC RELATIONS AND MARKETING SERVICES, NAMELY, PROMOTING AND MARKETING THE GOODS AND SERVICES OF OTHERS VIA COMPUTER AND COMMUNICATION NETWORKS; ONLINE SERVICE FOR CONNECTING SOCIAL NETWORK USERS WITH RETAILERS FOR THE PURPOSES OF FACILITATING PATRONAGE; PROMOTING PUBLIC AWARENESS OF SHOPPING LOCALLY (U.S. CLS. 100, 101 AND 102).

**CLASS 38—COMMUNICATION**

FOR PROVIDING ACCESS TO COMPUTER AND ONLINE DATABASES; TELECOMMUNICATIONS SERVICES, NAMELY, ELECTRONIC TRANSMISSION OF DATA, MESSAGES AND INFORMATION; PROVIDING ON-LINE FORUMS FOR COMMUNICATION REGARDING LOCAL BUSINESSES AND SERVICE PROVIDERS; PROVIDING ON-LINE COMMUNICATIONS LINKS WHICH TRANSFER WEB SITE USERS TO OTHER LOCAL AND GLOBAL WEB PAGES (U.S. CLS. 100, 101 AND 104).

DANNEAN HETZEL, EXAMINING ATTORNEY

---

SN 85-210,659. AMERICAN AXLE & MANUFACTURING, INC., DETROIT, MI. FILED 1-5-2011.

# AAM

THE MARK CONSISTS OF STANDARD CHARACTERS WITHOUT CLAIM TO ANY PARTICULAR FONT, STYLE, SIZE, OR COLOR.

OWNER OF U.S. REG. NOS. 2,127,484, 2,615,863 AND OTHERS.

**CLASS 40—MATERIAL TREATMENT**

FOR CUSTOM MANUFACTURE OF AUTOMOBILE PARTS TO THE ORDER AND SPECIFICATION OF OTHERS (U.S. CLS. 100, 103 AND 106).

FIRST USE 5-0-1995; IN COMMERCE 5-0-1995.

**CLASS 42—SCIENTIFIC AND COMPUTER SERVICES**

FOR ENGINEERING SERVICES IN THE FIELD OF LAND VEHICLE PRODUCTION (U.S. CLS. 100 AND 101).  
FIRST USE 5-0-1995; IN COMMERCE 5-0-1995.

MARILYN IZZI, EXAMINING ATTORNEY

---

SN 85-210,668. THE NASDAQ OMX GROUP, INC, NEW YORK, NY. FILED 1-5-2011.

# ITCH

THE MARK CONSISTS OF STANDARD CHARACTERS WITHOUT CLAIM TO ANY PARTICULAR FONT, STYLE, SIZE, OR COLOR.

**CLASS 36—INSURANCE AND FINANCIAL**

FOR FINANCIAL SERVICES, NAMELY, PROVIDING FINANCIAL INFORMATION IN THE NATURE OF HISTORICAL SECURITIES TRADE ORDERS AND TRANSACTIONS VIA A GLOBAL COMPUTER NETWORK (U.S. CLS. 100, 101 AND 102).

**CLASS 38—COMMUNICATION**

FOR TELECOMMUNICATIONS SERVICES, NAMELY, PROVIDING ACCESS TO AN ONLINE DATABASE FEATURING FINANCIAL INFORMATION IN THE NATURE OF HISTORICAL SECURITIES TRADE ORDERS (U.S. CLS. 100, 101 AND 104).  
SUSAN LESLIE DUBOIS, EXAMINING ATTORNEY

**CLASS 5—PHARMACEUTICALS**

FOR KITS FOR DIAGNOSTIC CLINICAL MEDICAL LABORATORY IN THE FIELD OF CYTOLOGY PRIMARILY CONTAINING REAGENTS, AMPLIFIER MEDIA, AND CHEMICALS, AND KITS FOR DIAGNOSTIC CLINICAL MEDICAL LABORATORY IN THE FIELD OF FLOW CYTOMETRY PRIMARILY CONTAINING REAGENTS, AMPLIFIER MEDIA, AND CHEMICALS (U.S. CLS. 6, 18, 44, 46, 51 AND 52).  
WILLIAM ROSSMAN, EXAMINING ATTORNEY

SN 85-210,716. ZAPPONE, MARLENE, GREENSBURG, PA. FILED 1-5-2011.

SN 85-210,788. DOLCE & COMPANIES CORPORATION, PHOENIX, AZ. FILED 1-5-2011.

Remove PHONE from  
EAR-STICK it up your APS  
and DRIVE

THE MARK CONSISTS OF STANDARD CHARACTERS WITHOUT CLAIM TO ANY PARTICULAR FONT, STYLE, SIZE, OR COLOR.

**CLASS 16—PAPER GOODS AND PRINTED MATTER**

FOR BUMPER STICKERS (U.S. CLS. 2, 5, 22, 23, 29, 37, 38 AND 50).

**CLASS 25—CLOTHING**

FOR T-SHIRTS (U.S. CLS. 22 AND 39).  
SIMON TENG, EXAMINING ATTORNEY

SN 85-210,786. PATHFINDER BIOTECH LTD., PEPPER PIKE, OH. FILED 1-5-2011.

EAS

THE MARK CONSISTS OF STANDARD CHARACTERS WITHOUT CLAIM TO ANY PARTICULAR FONT, STYLE, SIZE, OR COLOR.

**CLASS 1—CHEMICALS**

FOR KITS FOR SCIENTIFIC OR MEDICAL RESEARCH IN THE FIELD OF CYTOLOGY PRIMARILY CONTAINING REAGENTS, AMPLIFIER MEDIA, AND CHEMICALS, AND KITS FOR SCIENTIFIC OR MEDICAL RESEARCH IN THE FIELD OF FLOW CYTOMETRY PRIMARILY CONTAINING REAGENTS, AMPLIFIER MEDIA, AND CHEMICALS (U.S. CLS. 1, 5, 6, 10, 26 AND 46).

Enjoy the sweet life!

THE MARK CONSISTS OF STANDARD CHARACTERS WITHOUT CLAIM TO ANY PARTICULAR FONT, STYLE, SIZE, OR COLOR.

**CLASS 3—COSMETICS AND CLEANING PREPARATIONS**

FOR AROMATIC BODY CARE PRODUCTS, NAMELY, BODY LOTION, SHOWER GEL, CUTICLE CREAM, SHAMPOO, CONDITIONER, NON-MEDICATED LIP BALM, SOAP, BODY POLISH, BODY AND FOOT SCRUB AND NON-MEDICATED FOOT CREAM; AROMATIC PREPARATIONS, NAMELY, BODY WASH AND LOTION; BEAUTY LOTIONS; BLUSH; BODY AND BEAUTY CARE COSMETICS; BODY LOTION; BODY LOTIONS; BODY WASH; COLORING PREPARATIONS FOR COSMETIC PURPOSES; COMPACTS CONTAINING MAKE-UP; CONCEALERS; COSMETICS; COSMETICS AND MAKE-UP; COSMETICS, NAMELY, COMPACTS; COSMETICS, NAMELY, LIP PRIMER; EYE MAKE-UP; EYEBROW COSMETICS; EYES MAKE-UP; FACIAL MAKE-UP; FOUNDATION MAKE-UP; FRAGRANCED BODY CARE PREPARATIONS, NAMELY, BODY WASH AND LOTION; LIP GLOSS; LIP LINER; LIPSTICK; LIPSTICK HOLDERS; LIPSTICKS; LOTIONS FOR COSMETIC PURPOSES; LOTIONS FOR FACE AND BODY CARE; LOTIONS FOR BODY; MAKE UP FOUNDATIONS; MAKE-UP; MAKE-UP FOR THE FACE AND BODY; MAKE-UP FOUNDATIONS; MAKE-UP KITS COMPRISED OF LIPSTICK, COMPACTS, LIP GLOSS AND EYE SHADOW; MAKE-UP POWDER; MAKE-UP PREPARATIONS; NON-MEDICATED CLEANSERS FOR PERSONAL USE, NAMELY, BODY WASH; NON-MEDICATED CLEANSERS, NAMELY, BODY WASH; NON-MEDICATED SKIN CARE CREAMS AND LOTIONS; NON-MEDICATED SKIN CARE PREPARATIONS, NAMELY, CREAMS, LOTIONS, GELS, TONERS, CLEANSERS AND PEELS; POWDER FOR MAKE-UP; SCENTED BODY LOTIONS AND CREAMS; SKIN CLEANSERS; SKIN LOTION; SKIN LOTIONS; SOAPS FOR BODY CARE; SOLID POWDER FOR COMPACTS (U.S. CLS. 1, 4, 6, 50, 51 AND 52).

**CLASS 44—MEDICAL, BEAUTY AND AGRICULTURAL SERVICES**

FOR BEAUTY SALON SERVICES; BEAUTY SPA SERVICES, NAMELY, COSMETIC BODY CARE; DAY SPA SERVICES, NAMELY, NAIL CARE, MANICURES, PEDICURES AND NAIL ENHANCEMENTS; HAIR COLOR SALON SERVICES; HAIR SALON SERVICES; HAIR SALON SERVICES, NAMELY, HAIR CUTTING, STYLING, COLORING, AND HAIR EXTENSION SERVICES; HAIR SALON SERVICES, NAMELY, TREATMENTS TO PROTECT HAIR FROM EFFECTS OF EXPOSURE TO SUNLIGHT, HEAT, HUMIDITY AND CHLORINATED WATER; NAIL CARE SALONS; SALON SERVICES, NAMELY, FACIALS, MANICURES AND MESSAGES THAT ARE PROVIDED IN A TRAILER OUTFITTED WITH CHAIR, TABLE AND SINK ACCESSORIES (U.S. CLS. 100 AND 101).

FIRST USE 6-7-2004; IN COMMERCE 6-7-2004.  
JUSTINE D. PARKER, EXAMINING ATTORNEY

SN 85-210,793. KALOGIANNI, ALEXANDER, HUNTINGTON, NY. FILED 1-5-2011.

# AutoKinesis

THE MARK CONSISTS OF STANDARD CHARACTERS WITHOUT CLAIM TO ANY PARTICULAR FONT, STYLE, SIZE, OR COLOR.

**CLASS 9—ELECTRICAL AND SCIENTIFIC APPARATUS**

FOR ELECTRONIC PUBLICATIONS, NAMELY, MAGAZINE FEATURING AUTOMOTIVE NEWS AND CULTURE RECORDED ON COMPUTER MEDIA (U.S. CLS. 21, 23, 26, 36 AND 38).

**CLASS 41—EDUCATION AND ENTERTAINMENT**

FOR PROVIDING ON-LINE MAGAZINES IN THE FIELD OF AUTOMOTIVE NEWS AND CULTURE (U.S. CLS. 100, 101 AND 107).

JUSTINE D. PARKER, EXAMINING ATTORNEY

SN 85-210,795. MOGULDOM MEDIA GROUP, LLC, NEW YORK, NY. FILED 1-5-2011.

# StyleBlazer

THE MARK CONSISTS OF STANDARD CHARACTERS WITHOUT CLAIM TO ANY PARTICULAR FONT, STYLE, SIZE, OR COLOR.

**CLASS 41—EDUCATION AND ENTERTAINMENT**

FOR ON-LINE JOURNALS, NAMELY, BLOGS FEATURING COMMENTARY AND OPINIONS ON FASHION, FOCUSED ON AFRICAN AMERICAN WOMEN (U.S. CLS. 100, 101 AND 107).

**CLASS 45—PERSONAL AND LEGAL SERVICES**

FOR PROVIDING NEWS AND INFORMATION IN THE FIELD OF FASHION; PROVISION OF A WEB SITE FEATURING INFORMATION ON FASHION; PROVISION OF A WEB SITE FEATURING INFORMATION ON LIFESTYLES (U.S. CLS. 100 AND 101).

KAREN K. BUSH, EXAMINING ATTORNEY

SN 85-210,967. HIDDEN VARIABLE STUDIOS, LLC, NORTH HOLLYWOOD, CA. FILED 1-5-2011.

# Hidden Variable

THE MARK CONSISTS OF STANDARD CHARACTERS WITHOUT CLAIM TO ANY PARTICULAR FONT, STYLE, SIZE, OR COLOR.

**CLASS 9—ELECTRICAL AND SCIENTIFIC APPARATUS**

FOR COMPUTER GAME SOFTWARE FOR PERSONAL COMPUTERS AND HOME VIDEO GAME CONSOLES; COMPUTER GAME SOFTWARE FOR USE ON MOBILE AND CELLULAR PHONES; COMPUTER SOFTWARE, NAMELY, GAME ENGINE SOFTWARE FOR VIDEO GAME DEVELOPMENT AND OPERATION; DOWNLOADABLE COMPUTER GAME PROGRAMS; VIDEO GAME SOFTWARE (U.S. CLS. 21, 23, 26, 36 AND 38).

**CLASS 42—SCIENTIFIC AND COMPUTER SERVICES**

FOR DESIGNING AND DEVELOPING COMPUTER GAME SOFTWARE AND VIDEO GAME SOFTWARE FOR USE WITH COMPUTERS, VIDEO GAME PROGRAM SYSTEMS AND COMPUTER NETWORKS; DESIGNING AND DEVELOPING WEBPAGES ON THE INTERNET; RESEARCH AND DEVELOPMENT FOR NEW PRODUCTS FOR OTHERS; SOFTWARE DEVELOPMENT AND PRODUCT DEVELOPMENT IN THE FIELD OF VIDEO GAMES AND COMPUTER GAMES; VIDEO GAME DEVELOPMENT SERVICES (U.S. CLS. 100 AND 101).

JEFFERY COWARD, EXAMINING ATTORNEY

SN 85-211,097. WENDR, LLC, NEW YORK, NY. FILED 1-5-2011.

# WENDR

THE MARK CONSISTS OF STANDARD CHARACTERS WITHOUT CLAIM TO ANY PARTICULAR FONT, STYLE, SIZE, OR COLOR.

**CLASS 9—ELECTRICAL AND SCIENTIFIC APPARATUS**

FOR COMPUTER APPLICATION SOFTWARE FOR MOBILE PHONES, PORTABLE MEDIA DEVICES, AND HANDHELD COMPUTERS, NAMELY, SOFTWARE FOR SOCIAL CALENDARING (U.S. CLS. 21, 23, 26, 36 AND 38).

**CLASS 42—SCIENTIFIC AND COMPUTER SERVICES**

FOR PROVIDING A WEB SITE FEATURING TEMPORARY USE OF NON-DOWNLOADABLE SOFTWARE FOR SOCIAL CALENDARING (U.S. CLS. 100 AND 101).  
MICHAEL WEBSTER, EXAMINING ATTORNEY

SN 85-211,212. FOREVER YOUNG INTERNATIONAL, INC., ESCONDIDO, CA. FILED 1-5-2011.

PERFECTSENSE

THE MARK CONSISTS OF STANDARD CHARACTERS WITHOUT CLAIM TO ANY PARTICULAR FONT, STYLE, SIZE, OR COLOR.  
OWNER OF U.S. REG. NO. 3,835,637.

**CLASS 3—COSMETICS AND CLEANING PREPARATIONS**

FOR AROMATHERAPY AND WAX TREATMENT PRODUCTS, NAMELY, PARAFFIN WAX-FILLED GLOVES FOR COSMETIC PURPOSES, COSMETIC PADS FOR APPLYING PARAFFIN WAX, PARAFFIN WAX-FILLED BOOTS FOR COSMETIC PURPOSES; SKIN LOTIONS, SKIN CREAMS, ESSENTIAL OILS, PARAFFIN WAX FOR COSMETIC PURPOSES, NON-MEDICATED COSMETIC OINTMENTS, AND ALOE VERA GEL FOR COSMETIC PURPOSES (U.S. CLS. 1, 4, 6, 50, 51 AND 52).

FIRST USE 11-8-2005; IN COMMERCE 11-8-2005.

**CLASS 10—MEDICAL APPARATUS**

FOR THERMAL SELF-HEATING APPLICATORS FOR HEATING AND APPLYING WAX, SKIN LOTIONS, SKIN CREAMS, NON-MEDICATED COSMETIC OINTMENTS, AND BEAUTY GELS FOR THERAPEUTIC PURPOSES (U.S. CLS. 26, 39 AND 44).

FIRST USE 11-8-2005; IN COMMERCE 11-8-2005.  
ADA HAN, EXAMINING ATTORNEY

SN 85-211,229. TAYMAC CORPORATION, GILBERT, AZ. FILED 1-5-2011.

TAYMAC

THE MARK CONSISTS OF STANDARD CHARACTERS WITHOUT CLAIM TO ANY PARTICULAR FONT, STYLE, SIZE, OR COLOR.

**CLASS 6—METAL GOODS**

FOR METAL PIPE CONNECTORS; METAL JUNCTIONS FOR PIPES; METAL PIPE CONNECTORS; METAL PIPE COLLARS; METAL PIPE FITTINGS; METAL CONNECTORS AND FITTINGS FOR CONNECTING PIPES TO ELECTRICAL BOXES AND ELECTRICAL JUNCTION BOXES (U.S. CLS. 2, 12, 13, 14, 23, 25 AND 50).

**CLASS 9—ELECTRICAL AND SCIENTIFIC APPARATUS**

FOR CABLE CONNECTORS; ELECTRICAL CONNECTORS; ELECTRICAL CONNECTOR HOUSINGS; ELECTRICAL POWER CONNECTORS; INSULATED ELECTRICAL CONNECTORS; THREADED CABLE CONNECTORS OF METAL (U.S. CLS. 21, 23, 26, 36 AND 38).

**CLASS 19—NON-METALLIC BUILDING MATERIALS**

FOR NON-METAL PIPE COLLARS; NON-METAL PIPE COUPLINGS AND JOINTS; NON-METAL PIPE FITTINGS; PIPE FITTINGS COMPRISED PRIMARILY OF PLASTIC; NON-METAL CONNECTORS AND FITTINGS FOR CONNECTING PIPES TO ELECTRICAL BOXES AND ELECTRICAL JUNCTION BOXES (U.S. CLS. 1, 12, 33 AND 50).

JILL PRATER, EXAMINING ATTORNEY

SN 85-211,241. MOGGLE, INC., PHILADELPHIA, PA. FILED 1-5-2011.



THE MARK CONSISTS OF THE LITERAL ELEMENT "PLAY" AND THE LITERAL ELEMENT "MOGGLE" WITH AN ARROW DESIGN AND A COG DESIGN.

**CLASS 9—ELECTRICAL AND SCIENTIFIC APPARATUS**

FOR INTERNET MONITORING AND SURVEILLANCE SOFTWARE, NAMELY, COMPUTER SOFTWARE FOR LIMITING ACCESS TO AND ACTIVITIES ON WEB SITES ON THE INTERNET, RECORDING AND TRACKING AND PROVIDING A RECORD OF A PERSON'S ACTIVITIES ON THE INTERNET, INCLUDING WEB SITES VISITED, E-MAIL CONTENT, CHAT/INSTANT MESSAGES CONTENT, KEYSTROKES AND SCREEN SHOTS, GENERATING COMPUTER USAGE REPORTS, AND SENDING E-MAIL ALERTS AND EVENT LOGS TO A PREDEFINED E-MAIL ADDRESS AND PASSWORD PROTECTED ONLINE PORTAL; COMPUTER APPLICATION SOFTWARE, NAMELY, SOFTWARE THAT VERIFIES A COMPUTER USER'S AGE (U.S. CLS. 21, 23, 26, 36 AND 38).

**CLASS 36—INSURANCE AND FINANCIAL**

FOR ELECTRONIC COMMERCE PAYMENT SERVICES, NAMELY, ESTABLISHING AND ADMINISTERING ONLINE SPENDING PROFILES THAT CONTROL, FACILITATE AND ADMINISTER APPROVED PAYMENTS USED TO PURCHASE GOODS AND SERVICES ON THE INTERNET; ON-LINE TRANSACTION AND PAYMENT MANAGEMENT SERVICES; DEBIT CARD SERVICES (U.S. CLS. 100, 101 AND 102).

**CLASS 42—SCIENTIFIC AND COMPUTER SERVICES**

FOR COMPUTER SERVICES, NAMELY, PROVIDING A WEB BASED SYSTEM AND ONLINE PORTAL FEATURING ONLINE NON-DOWNLOADABLE SOFTWARE THAT ENABLES CUSTOMERS (PARENTS /GUARDIANS) TO LIMIT CHILDREN'S ACCESS TO OR ACTIVITIES AND SPENDING ON CERTAIN TYPES OF WEBSITES, APPLICATIONS AND INTERNET CONTENT, RECORD AND TRACK A CHILD'S ACTIVITIES ON THE INTERNET, INCLUDING WEB SITES VISITED, E-MAIL CONTENT, CHAT/INSTANT MESSAGES CONTENT, KEYSTROKES AND SCREEN SHOTS, GENERATE COMPUTER USAGE REPORTS, AND SEND ALERTS AND EVENT LOGS TO A PREDEFINED E-MAIL ADDRESS AND PASSWORD PROTECTED ONLINE PORTAL; COMPUTER SERVICES, NAMELY, PROVIDING A WEB-BASED SYSTEM AND ONLINE PORTAL FEATURING ONLINE NON-DOWNLOADABLE SOFTWARE THAT VERIFIES A COMPUTER USER'S AGE (U.S. CLS. 100 AND 101).

JILL PRATER, EXAMINING ATTORNEY

SN 85-211,375. LEWIS, CAROLINE, DALLAS, TX. FILED 1-5-2011.



THE MARK CONSISTS OF THE STYLIZED TEXT "LEGALIZE LIFE" WITH A PAIR OF HANDS AND A BIRD.

**CLASS 16—PAPER GOODS AND PRINTED MATTER**

FOR BUMPER STICKERS; PAPER BANNERS (U.S. CLS. 2, 5, 22, 23, 29, 37, 38 AND 50).

SN 85-211,275. PENTON MEDIA, INC., NEW YORK, NY. FILED 1-5-2011.

**CLASS 25—CLOTHING**

FOR CAPS; JACKETS; SHORT-SLEEVED OR LONG-SLEEVED T-SHIRTS; SWEAT SHIRTS (U.S. CLS. 22 AND 39).

RENEE MCCRAY, EXAMINING ATTORNEY

**Nation's Restaurant News**

THE MARK CONSISTS OF STANDARD CHARACTERS WITHOUT CLAIM TO ANY PARTICULAR FONT, STYLE, SIZE, OR COLOR.

OWNER OF U.S. REG. NO. 2,503,806.

NO CLAIM IS MADE TO THE EXCLUSIVE RIGHT TO USE "NEWS", APART FROM THE MARK AS SHOWN.

SEC. 2(F).

SN 85-211,418. FARJAH, HIRBOD, DORTMUND, FED REP GERMANY, FILED 1-5-2011.

**CLASS 41—EDUCATION AND ENTERTAINMENT**

FOR PROVIDING ONLINE PUBLICATIONS IN THE NATURE OF MAGAZINES, GUIDES AND NEWSLETTERS FEATURING NEWS AND INFORMATION IN THE FIELD OF THE RESTAURANT AND FOOD SERVICE INDUSTRY; BLOGS FEATURING NEWS AND INFORMATION IN THE FIELD OF THE RESTAURANT AND FOOD SERVICE INDUSTRY; WEBCASTS IN THE FIELD OF THE RESTAURANT AND FOOD SERVICE INDUSTRY; PROVIDING NEWSLETTERS FEATURING NEWS AND INFORMATION IN THE FIELD OF THE RESTAURANT AND FOOD SERVICE INDUSTRY DELIVERED BY E-MAIL (U.S. CLS. 100, 101 AND 107).

FIRST USE 1-0-1999; IN COMMERCE 1-0-1999.

**CLASS 43—HOTEL AND RESTAURANT SERVICES**

FOR PROVIDING INFORMATION IN THE FIELD OF THE RESTAURANT AND FOOD SERVICE INDUSTRY; PROVIDING INFORMATION IN THE FIELD OF THE RESTAURANT AND FOOD SERVICE INDUSTRY VIA THE INTERNET (U.S. CLS. 100 AND 101).

FIRST USE 1-0-1999; IN COMMERCE 1-0-1999.

CHRISTINA SOBRAL, EXAMINING ATTORNEY

**Divadelic**

THE MARK CONSISTS OF STANDARD CHARACTERS WITHOUT CLAIM TO ANY PARTICULAR FONT, STYLE, SIZE, OR COLOR.

**CLASS 9—ELECTRICAL AND SCIENTIFIC APPARATUS**

FOR DIGITAL MEDIA, NAMELY, COMPACT DISCS, DOWNLOADABLE MP3 FILES, AND DOWNLOADABLE AUDIO FILES FEATURING MUSIC (U.S. CLS. 21, 23, 26, 36 AND 38).

FIRST USE 1-0-2005; IN COMMERCE 2-0-2008.

**CLASS 25—CLOTHING**

FOR JACKETS; PANTS; SHIRTS; SHOES (U.S. CLS. 22 AND 39).

FIRST USE 1-0-2005; IN COMMERCE 2-0-2008.

KAPIL BHANOT, EXAMINING ATTORNEY

SN 85-211,426. HOWSIMPLE, LLC, IDYLLWILD, CA. FILED 1-5-2011.

# howsimple

THE MARK CONSISTS OF STANDARD CHARACTERS WITHOUT CLAIM TO ANY PARTICULAR FONT, STYLE, SIZE, OR COLOR.

## CLASS 9—ELECTRICAL AND SCIENTIFIC APPARATUS

FOR COMPUTER PROGRAMS FOR ACCESSING AND DISPLAYING FILES ON BOTH THE INTERNET AND THE INTRANET ; NETWORK ACCESS SERVER OPERATING SOFTWARE FOR CONNECTING COMPUTERS TO THE INTERNET AND THE INTRANET (U.S. CLS. 21, 23, 26, 36 AND 38).

FIRST USE 4-15-2008; IN COMMERCE 3-1-2009.

## CLASS 42—SCIENTIFIC AND COMPUTER SERVICES

FOR COMPUTER SERVICES IN THE NATURE OF PROVIDING SEARCH ENGINES FOR OBTAINING, COMPILING AND SHARING DATA OVER COMPUTER NETWORKS, THE INTERNET AND WIRELESS NETWORKS (U.S. CLS. 100 AND 101).

FIRST USE 4-15-2008; IN COMMERCE 3-1-2009.  
PATRICIA EVANKO, EXAMINING ATTORNEY

---

SN 85-211,497. DAVIS VETERINARY MEDICAL CONSULTING, INC., DAVIS, CA. FILED 1-5-2011.

# Balance IT Original Blends

THE MARK CONSISTS OF STANDARD CHARACTERS WITHOUT CLAIM TO ANY PARTICULAR FONT, STYLE, SIZE, OR COLOR.

OWNER OF U.S. REG. NO. 3,094,401.

NO CLAIM IS MADE TO THE EXCLUSIVE RIGHT TO USE "ORIGINAL BLENDS", APART FROM THE MARK AS SHOWN.

## CLASS 5—PHARMACEUTICALS

FOR VITAMINS AND DIETARY FOOD SUPPLEMENTS FOR ANIMALS; DRY MIXTURE ANIMAL FEED ADDITIVE FOR USE AS A NUTRITIONAL SUPPLEMENT FOR MEDICINAL PURPOSES; FEED SUPPLEMENTS FOR CATS AND DOGS FOR MEDICINAL PURPOSES (U.S. CLS. 6, 18, 44, 46, 51 AND 52).

## CLASS 31—NATURAL AGRICULTURAL PRODUCTS

FOR PROTEIN NUTRIENT MIX FOR DOGS NOT FOR MEDICINAL PURPOSES, FOOD FOR ANIMALS, NON-MEDICAL ADDITIVES FOR DOG AND CAT FOOD (U.S. CLS. 1 AND 46).

MARTHA SANTOMARTINO, EXAMINING ATTORNEY

SN 85-211,512. ECOFRUITS INTERNATIONAL, INC., SOUTH JORDAN, UT. FILED 1-6-2011.

# ECOFRUITS

THE MARK CONSISTS OF STANDARD CHARACTERS WITHOUT CLAIM TO ANY PARTICULAR FONT, STYLE, SIZE, OR COLOR.

## CLASS 5—PHARMACEUTICALS

FOR DIETARY SUPPLEMENTAL DRINKS; NUTRACEUTICALS FOR USE AS A DIETARY SUPPLEMENT; NUTRITIONAL SUPPLEMENTS; POWDERED FRUIT-FLAVORED DIETARY SUPPLEMENT DRINK MIX; POWDERED NUTRITIONAL SUPPLEMENT DRINK MIX (U.S. CLS. 6, 18, 44, 46, 51 AND 52).

## CLASS 30—STAPLE FOODS

FOR EDIBLE FRUIT ICES; FROZEN CONFECTIONS; FROZEN YOGURT; FROZEN YOGURT MIXES; FRUIT ICE; FRUIT ICE BAR (U.S. CL. 46).

DEBRA LEE, EXAMINING ATTORNEY

---

SN 85-211,587. CHIH CHIEH HSU, TUCHENG CITY, TAIPEI, TAIWAN, FILED 1-6-2011.

# WOTANRAFT

THE MARK CONSISTS OF THE WORD WOTANRAFT IN A STYLIZED FONT IN WHICH THE VERTICAL LINE OF THE LETTER "T" IS DESIGNED IN A CURVED LINE, SIMILAR TO THE LETTER "C", AND THE LETTER "F" EXTENDS ITS VERTICAL LINE UNDER THE LINE OF OTHER LETTERS.

## CLASS 9—ELECTRICAL AND SCIENTIFIC APPARATUS

FOR COMPUTER BAGS; BACKPACKS ESPECIALLY ADAPTED FOR HOLDING LAPTOPS AND NOTEBOOK COMPUTERS; BAGS FOR CAMERAS AND PHOTOGRAPHIC EQUIPMENT; LEATHER PROTECTIVE COVERS SPECIALLY ADAPTED FOR PERSONAL ELECTRONIC DEVICES; DIGITAL PHOTO FRAMES FOR DISPLAYING DIGITAL PICTURES, VIDEO CLIPS AND MUSIC; EYEWEAR, NAMELY, SUNGLASSES, EYEGASSES AND OPHTHALMIC FRAMES AND CASES; FITTED PLASTIC FILMS KNOWN AS SKINS FOR COVERING AND PROVIDING A SCRATCH PROOF BARRIER OR PROTECTION FOR ELECTRONIC DEVICES, NAMELY, MP3 PLAYERS, MOBILE TELEPHONES, SMART TELEPHONES, DIGITAL CAMERAS, GLOBAL POSITIONING SYSTEMS AND PERSONAL DIGITAL ASSISTANTS (U.S. CLS. 21, 23, 26, 36 AND 38).

FIRST USE 9-30-2008; IN COMMERCE 1-31-2009.

## CLASS 18—LEATHER GOODS

FOR LEATHER PURSES; SCHOOL SATCHELS; TOOL BAGS SOLD EMPTY; BACKPACKS; BOOK BAGS; SPORTS BAGS; BUM BAGS; WALLETS AND HANDBAGS; LEATHER CASES; LEATHER STRAPS; COLLARS FOR ANIMALS; REINS (U.S. CLS. 1, 2, 3, 22 AND 41).

FIRST USE 9-30-2008; IN COMMERCE 1-31-2009.



JENNIFER MARTIN, EXAMINING ATTORNEY

SN 85-211,604. TOM TEPLEY, MOORHEAD, MN. FILED 1-6-2011.

# CONCRETE DEATH

THE MARK CONSISTS OF STANDARD CHARACTERS WITHOUT CLAIM TO ANY PARTICULAR FONT, STYLE, SIZE, OR COLOR.

## CLASS 25—CLOTHING

FOR CLOTHING, NAMELY T-SHIRTS AND HATS (U.S. CLS. 22 AND 39).

## CLASS 35—ADVERTISING AND BUSINESS

FOR RETAIL STORE SERVICES, FEATURING SPORTING GOODS AND EQUIPMENT AND APPAREL (U.S. CLS. 100, 101 AND 102).  
MARY ROSSMAN, EXAMINING ATTORNEY

SN 85-211,672. ENCOMPASS GROUP, LLC, MCDONOUGH, GA. FILED 1-6-2011.

# SPACE ADVENTURES

THE MARK CONSISTS OF STANDARD CHARACTERS WITHOUT CLAIM TO ANY PARTICULAR FONT, STYLE, SIZE, OR COLOR.

## CLASS 10—MEDICAL APPARATUS

FOR PATIENT EXAMINATION GOWNS (U.S. CLS. 26, 39 AND 44).

## CLASS 25—CLOTHING

FOR PAJAMA BOTTOMS; PAJAMAS (U.S. CLS. 22 AND 39).  
CHERYL CLAYTON, EXAMINING ATTORNEY

SN 85-211,676. NOVEM, INC., HOUSTON, TX. FILED 1-6-2011.

# THINKRELIABILITY

THE MARK CONSISTS OF STANDARD CHARACTERS WITHOUT CLAIM TO ANY PARTICULAR FONT, STYLE, SIZE, OR COLOR.

## CLASS 35—ADVERTISING AND BUSINESS

FOR BUSINESS MANAGEMENT AND CONSULTATION IN THE FIELD OF BUSINESS STRATEGY AND PROBLEM SOLVING (U.S. CLS. 100, 101 AND 102).  
FIRST USE 9-30-2000; IN COMMERCE 9-30-2000.

## CLASS 41—EDUCATION AND ENTERTAINMENT

FOR EDUCATIONAL SERVICES, NAMELY, PROVIDING CLASSES, SEMINARS, CONFERENCES AND WORKSHOPS IN THE FIELDS OF BUSINESS STRATEGY AND PROBLEM SOLVING AND DISTRIBUTING COURSE MATERIALS IN CONNECTION THEREWITH (U.S. CLS. 100, 101 AND 107).  
FIRST USE 9-30-2000; IN COMMERCE 9-30-2000.  
JOHN SCHUYLER YARD, EXAMINING ATTORNEY

SN 85-211,768. SEARS BRANDS, LLC, HOFFMAN ESTATES, IL. FILED 1-6-2011.

# FITSTUDIO

THE MARK CONSISTS OF STANDARD CHARACTERS WITHOUT CLAIM TO ANY PARTICULAR FONT, STYLE, SIZE, OR COLOR.

## CLASS 41—EDUCATION AND ENTERTAINMENT

FOR PROVIDING A WEBSITE FEATURING INFORMATION ON EXERCISE AND FITNESS; PROVIDING INFORMATION IN THE FIELD OF EXERCISE AND FITNESS (U.S. CLS. 100, 101 AND 107).

## CLASS 44—MEDICAL, BEAUTY AND AGRICULTURAL SERVICES

FOR PROVIDING A WEBSITE FEATURING INFORMATION ON HEALTH AND NUTRITION; PROVIDING INFORMATION IN THE FIELD OF HEALTH AND NUTRITION (U.S. CLS. 100 AND 101).  
STEVEN PEREZ, EXAMINING ATTORNEY

SN 85-211,803. SNOW JOE, LLC, BROOKLYN, NY. FILED 1-6-2011.

# ECOSHARP

THE MARK CONSISTS OF STANDARD CHARACTERS WITHOUT CLAIM TO ANY PARTICULAR FONT, STYLE, SIZE, OR COLOR.

**CLASS 7—MACHINERY**

FOR LAWN MOWERS; CHAIN SAWS; POWER-OPERATED HEDGE TRIMMERS; POWER-OPERATED BLOWERS; POWER-OPERATED LAWN AND GARDEN TILLERS; POWER-OPERATED GARDEN TOOLS, NAMELY, CHIPPERS, SHREDDERS, SHEARS, CULTIVATORS; GARDEN EDGERS; ELECTRIC WOOD CHIP-PERS AND LOG SPLITTERS; ELECTRIC YARD SWEEPERS; SNOW BLOWERS; SNOW BLOWER POWER EQUIPMENT, NAMELY, SNOW THROWERS AND POWER SHOVELS (U.S. CLS. 13, 19, 21, 23, 31, 34 AND 35).

**CLASS 8—HAND TOOLS**

FOR HAND TOOLS, NAMELY, PRUNERS AND RAKES; SNOW SHOVELS; HAND TOOLS, NAMELY, ICE CHOPPERS, SCRAPERS, AND WINDSHIELD SCRA-PERS; HAND OPERATED HEDGE TRIMMERS (U.S. CLS. 23, 28 AND 44).

THOMAS MANOR, EXAMINING ATTORNEY



SN 85-211,825. GIRALDO, NEIL, HANA, HI. FILED 1-6-2011.

**FISHBALLS**

THE MARK CONSISTS OF STANDARD CHARACTERS WITHOUT CLAIM TO ANY PARTICULAR FONT, STYLE, SIZE, OR COLOR.

**CLASS 25—CLOTHING**

FOR CAPS, T-SHIRTS, SHIRTS, SHORTS, SHOES, BRA TOPS, PANTS, SOCKS, BELTS, JACKETS, GOLF SHIRTS, LINGERIE, COATS, TIES, BANDANAS, SCARFS, UN-DER GARMENTS, PAJAMAS, AND SANDALS (U.S. CLS. 22 AND 39).

**CLASS 28—TOYS AND SPORTING GOODS**

FOR GOLF BALLS (U.S. CLS. 22, 23, 38 AND 50).  
ALEXANDER L. POWERS, EXAMINING ATTORNEY



SN 85-211,863. ORECK HOLDINGS, LLC, NASHVILLE, TN. FILED 1-6-2011.

**CLEANER. EASIER. SMARTER.**

THE MARK CONSISTS OF STANDARD CHARACTERS WITHOUT CLAIM TO ANY PARTICULAR FONT, STYLE, SIZE, OR COLOR.  
OWNER OF U.S. REG. NO. 3,363,090.

**CLASS 7—MACHINERY**

FOR FLOOR FINISHING MACHINES, ATTACH-MENTS AND ACCESSORIES SOLD THEREWITH; EX-TRACTOR MACHINES FOR USE IN CLEANING CARPETS, FABRICS AND UPHOLSTERY, ATTACH-MENTS AND ACCESSORIES SOLD THEREWITH; VA-CUUM CLEANERS, ATTACHMENTS AND ACCESSORIES SOLD THEREWITH; STEAM CLEANERS, ATTACHMENTS AND ACCESSORIES SOLD THERE-WITH (U.S. CLS. 13, 19, 21, 23, 31, 34 AND 35).

**CLASS 11—ENVIRONMENTAL CONTROL AP-  
PARATUS**

FOR AIR PURIFYING MACHINES FOR HOME, OF-FICE AND COMMERCIAL USE, ATTACHMENTS AND ACCESSORIES SOLD THEREWITH (U.S. CLS. 13, 21, 23, 31 AND 34).

DAVID TAYLOR, EXAMINING ATTORNEY



SN 85-211,907. STRATEGIC DIAGNOSTICS INC., NEWARK, DE. FILED 1-6-2011.

**GAT**

THE MARK CONSISTS OF STANDARD CHARACTERS WITHOUT CLAIM TO ANY PARTICULAR FONT, STYLE, SIZE, OR COLOR.

**CLASS 1—CHEMICALS**

FOR ANTIBODIES FOR SCIENTIFIC OR RESEARCH USE (U.S. CLS. 1, 5, 6, 10, 26 AND 46).

**CLASS 40—MATERIAL TREATMENT**

FOR ANTIBODY SERVICES, NAMELY, CUSTOM ANTIBODY PRODUCTION AND GENERATION; CUS-TOM MANUFACTURE OF ANTIBODIES FOR OTHERS (U.S. CLS. 100, 103 AND 106).

**CLASS 42—SCIENTIFIC AND COMPUTER SERVICES**

FOR SCIENTIFIC RESEARCH AND DEVELOPMENT, NAMELY, DEVELOPMENT OF ANTIBODIES FOR OTHERS (U.S. CLS. 100 AND 101).  
PAM WILLIS, EXAMINING ATTORNEY



SN 85-211,949. SIMPLIVT CORPORATION, WESTBOR-OUGH, MA. FILED 1-6-2011.

**SIMPLIWORKS**

THE MARK CONSISTS OF STANDARD CHARACTERS WITHOUT CLAIM TO ANY PARTICULAR FONT, STYLE, SIZE, OR COLOR.

**CLASS 9—ELECTRICAL AND SCIENTIFIC APPARATUS**

FOR COMPUTER HARDWARE AND SOFTWARE FOR COMPUTER SERVER AND DATA STORAGE VIRTUALIZATION (U.S. CLS. 21, 23, 26, 36 AND 38).

**CLASS 42—SCIENTIFIC AND COMPUTER SERVICES**

FOR COMPUTER SERVICES FOR COMPUTER SERVER AND DATA STORAGE VIRTUALIZATION; CONSULTING SERVICES IN THE FIELD OF DESIGN, SELECTION, IMPLEMENTATION AND USE OF COMPUTER HARDWARE AND SOFTWARE FOR OTHERS FOR COMPUTER SERVER AND DATA STORAGE VIRTUALIZATION (U.S. CLS. 100 AND 101).  
WENDY GOODMAN, EXAMINING ATTORNEY

SN 85-211,982. THE UNITED STATES SHOE CORPORATION, PORT WASHINGTON, NY. FILED 1-6-2011.

# FITSENSOR

THE MARK CONSISTS OF STANDARD CHARACTERS WITHOUT CLAIM TO ANY PARTICULAR FONT, STYLE, SIZE, OR COLOR.

**CLASS 35—ADVERTISING AND BUSINESS**

FOR RETAIL OPTICAL STORE SERVICES (U.S. CLS. 100, 101 AND 102).

**CLASS 44—MEDICAL, BEAUTY AND AGRICULTURAL SERVICES**

FOR OPTICAL AND OPTOMETRIC SERVICES, NAMELY THE FITTING OF OPTICAL LENSES USING AN OPTICAL MEASUREMENT DEVICE TO PLACE PRESCRIPTION LENSES IN EYEGLASS FRAMES (U.S. CLS. 100 AND 101).  
HOWARD B. LEVINE, EXAMINING ATTORNEY

SN 85-211,988. THE UNITED STATES SHOE CORPORATION, PORT WASHINGTON, NY. FILED 1-6-2011.

# ACCUFIT

THE MARK CONSISTS OF STANDARD CHARACTERS WITHOUT CLAIM TO ANY PARTICULAR FONT, STYLE, SIZE, OR COLOR.  
OWNER OF U.S. REG. NOS. 1,759,598 AND 1,841,049.

**CLASS 35—ADVERTISING AND BUSINESS**

FOR RETAIL OPTICAL STORE SERVICES (U.S. CLS. 100, 101 AND 102).

**CLASS 44—MEDICAL, BEAUTY AND AGRICULTURAL SERVICES**

FOR OPTICAL AND OPTOMETRIC SERVICES, NAMELY THE FITTING OF OPTICAL LENSES USING AN OPTICAL MEASUREMENT DEVICE TO PLACE PRESCRIPTION LENSES IN EYEGLASS FRAMES (U.S. CLS. 100 AND 101).  
HOWARD B. LEVINE, EXAMINING ATTORNEY

SN 85-211,996. FIFIELD, INC., HINGHAM, MA. FILED 1-6-2011.

# ALOR

THE MARK CONSISTS OF STANDARD CHARACTERS WITHOUT CLAIM TO ANY PARTICULAR FONT, STYLE, SIZE, OR COLOR.

THE WORDING "ALOR" HAS NO MEANING IN A FOREIGN LANGUAGE.

**CLASS 18—LEATHER GOODS**

FOR IMITATION LEATHER, NAMELY, IMITATION SUEDE (U.S. CLS. 1, 2, 3, 22 AND 41).

**CLASS 24—FABRICS**

FOR FABRIC OF IMITATION SUEDE (U.S. CLS. 42 AND 50).  
NANCY CLARKE, EXAMINING ATTORNEY

SN 85-212,017. AFFINERGY, INC., RESEARCH TRIANGLE PARK, NC. FILED 1-6-2011.

# ACTUATE

THE MARK CONSISTS OF STANDARD CHARACTERS WITHOUT CLAIM TO ANY PARTICULAR FONT, STYLE, SIZE, OR COLOR.

**CLASS 5—PHARMACEUTICALS**

FOR BIOLOGICAL BONE COMPOSITIONS COMPRISED MAINLY OF CALCIUM PHOSPHATE FOR USE IN REPAIRING BONES (U.S. CLS. 6, 18, 44, 46, 51 AND 52).

**CLASS 10—MEDICAL APPARATUS**

FOR SYNTHETIC BONE GRAFT IMPLANT MATERIAL FOR REPAIR OF BONES; SYNTHETIC BONE GRAFT IMPLANT FOR MEDICAL PURPOSES; SYNTHETIC BONE FOR MEDICAL PURPOSES; SYNTHETIC IMPLANTABLE SURGICAL MATERIAL FOR USE WITH BONE GRAFTS AND IMPLANTS; SYNTHETIC RESORBABLE BONE VOID FILLER (U.S. CLS. 26, 39 AND 44).  
SHAUNIA CARLYLE, EXAMINING ATTORNEY

SN 85-212,018. BOARD OF REGENTS OF THE UNIVERSITY SYSTEM OF GEORGIA, ATLANTA, GA. FILED 1-6-2011.

## BELIEVE BEGIN BECOME

THE MARK CONSISTS OF STANDARD CHARACTERS WITHOUT CLAIM TO ANY PARTICULAR FONT, STYLE, SIZE, OR COLOR.

### CLASS 16—PAPER GOODS AND PRINTED MATTER

FOR NOTEBOOKS; PENCILS; PENS; STATIONERY (U.S. CLS. 2, 5, 22, 23, 29, 37, 38 AND 50).  
FIRST USE 5-1-2007; IN COMMERCE 5-1-2007.

### CLASS 18—LEATHER GOODS

FOR BACKPACKS; BOOK BAGS; UMBRELLAS (U.S. CLS. 1, 2, 3, 22 AND 41).  
FIRST USE 5-1-2007; IN COMMERCE 5-1-2007.

### CLASS 25—CLOTHING

FOR HEADGEAR, NAMELY, HATS AND CAPS; HOODED SWEATSHIRTS; POLO SHIRTS; SHIRTS; SHORTS; T-SHIRTS (U.S. CLS. 22 AND 39).  
FIRST USE 4-17-2007; IN COMMERCE 4-17-2007.

### CLASS 41—EDUCATION AND ENTERTAINMENT

FOR EDUCATIONAL SERVICES, NAMELY, PROVIDING COURSES OF INSTRUCTION AT THE COLLEGE LEVEL AND DISTRIBUTION OF COURSE MATERIAL IN CONNECTION THEREWITH; ENTERTAINMENT IN THE NATURE OF COMPETITIONS IN THE FIELD OF ATHLETIC EVENTS (U.S. CLS. 100, 101 AND 107).  
FIRST USE 5-1-2007; IN COMMERCE 5-1-2007.  
SUSAN RICHARDS, EXAMINING ATTORNEY

SN 85-212,087. HILCO TRADING, LLC, NORTHBROOK, IL. FILED 1-6-2011.

# HILCO

THE MARK CONSISTS OF STANDARD CHARACTERS WITHOUT CLAIM TO ANY PARTICULAR FONT, STYLE, SIZE, OR COLOR.  
OWNER OF U.S. REG. NOS. 3,773,526, 3,807,057 AND OTHERS.

### CLASS 35—ADVERTISING AND BUSINESS

FOR ACQUISITION AND MERGER CONSULTATION; ANALYSES AND APPRAISALS OF ENTERPRISES; BUSINESS ACQUISITION AND MERGER CONSULTATION; BUSINESS APPRAISAL CONSULTATION; BUSINESS APPRAISALS; BUSINESS APPRAISALS AND EVALUATIONS IN BUSINESS MATTERS; BUSINESS INFORMATION SERVICES AND APPRAISALS; BUSINESS INVESTIGATIONS, EVALUATIONS, EXPERT APPRAISALS, INFORMATION AND RESEARCH; BUSINESS MERGER CONSULTATION; PROVIDING BUSINESS MANAGEMENT INFORMATION IN CONNECTION WITH CONSULTING AND ADVISORY SERVICES IN THE FIELD OF STRATEGIC PLANNING AND MERGERS AND ACQUISITIONS; ARRANGING AND CONDUCTING OF AUCTION SALES IN THE FIELDS OF INDUSTRIAL MACHINERY, INDUSTRIAL EQUIPMENT, INDUSTRIAL INVENTORY, INDUSTRIAL FURNITURE, INDUSTRIAL FIXTURES AND OTHER INDUSTRIAL ASSETS; LITIGATION SUPPORT SERVICES; RETAIL RESTRUCTURING AND CONSULTATION SERVICES; INTERIM RETAIL MANAGEMENT SERVICES; RETAIL OUTSOURCING SERVICES; FIXED ASSET RECOVERY SERVICES; ASSET PROTECTION SERVICES; BUSINESS AND MANAGEMENT CONSULTING SERVICES FOR THE RETAIL INDUSTRY (U.S. CLS. 100, 101 AND 102).

FIRST USE 7-0-1991; IN COMMERCE 7-0-1991.

### CLASS 36—INSURANCE AND FINANCIAL

FOR APPRAISAL AND EVALUATION OF REAL ESTATE; APPRAISAL OF REAL ESTATE; BUSINESS BROKERAGE SERVICES AND RELATED CONSULTING PERTAINING TO BUSINESS SALES, MERGERS, ACQUISITIONS AND BUSINESS VALUATIONS; CONSULTATION RELATING TO THE APPRAISAL OF GOODS; FINANCIAL CONSULTING AND ADVISING IN THE FIELD OF MERGERS AND ACQUISITIONS; REAL ESTATE APPRAISAL; REAL ESTATE APPRAISAL AND VALUATION; MANAGEMENT OF PRIVATE EQUITY FUNDS; PRIVATE EQUITY FUND INVESTMENT SERVICES; FINANCIAL SERVICES, NAMELY, COMMERCIAL LENDING, ASSET-BASED LENDING, MEZZANINE/SUBORDINATED DEBT LENDING, EQUITY INVESTMENT, INVESTMENT BANKING, PRIVATE PLACEMENT OF EQUITY AND DEBT INVESTMENTS, LEASE FINANCING, FACTORING SERVICES, INVESTMENT MANAGEMENT, FINANCIAL VALUATION AND BALANCE SHEET ADVISORY; BUSINESS LIQUIDATION SERVICES; BUSINESS LIQUIDATION SERVICES IN THE FIELDS OF INDUSTRIAL MACHINERY, INDUSTRIAL EQUIPMENT, INDUSTRIAL INVENTORY, INDUSTRIAL FURNITURE, INDUSTRIAL FIXTURES AND OTHER INDUSTRIAL ASSETS; BUSINESS LIQUIDATION SERVICES IN THE FIELD OF WHOLESALE CONSUMER INVENTORY; FINANCIAL INVESTMENT IN THE FIELD OF REAL ESTATE; FINANCIAL VALUATION OF PERSONAL PROPERTY AND REAL ESTATE; LEASING OF REAL ESTATE; REAL ESTATE ACQUISITION SERVICES; REAL ESTATE APPRAISAL; REAL ESTATE EQUITY SHARING, NAMELY, MANAGING AND ARRANGING FOR CO-OWNERSHIP OF REAL ESTATE; REAL ESTATE INVESTMENT; REAL ESTATE MANAGEMENT; REAL ESTATE PROCUREMENT FOR OTHERS; REAL ESTATE SYNDICATION; APPRAISAL AND VALUATION SERVICES; PROPERTY DISPOSITION SERVICES; LEASE TERMINATION SERVICES; LEASE RENEGOTIATION SERVICES; SALE AND LEASEBACK SERVICES; REAL ESTATE DEBT ADVISORY SERVICES; ASSET AND PROPERTY MANAGEMENT SERVICES; LOAN EVALUATION SERVICES; LOAN STRATEGY SERVICES; PROVIDING BUSINESS ADVICE AND INFORMATION REGARDING LOANS (U.S. CLS. 100, 101 AND 102).

FIRST USE 7-0-1991; IN COMMERCE 7-0-1991.  
HEATHER SAPP, EXAMINING ATTORNEY

SN 85-212,119. ERMIS LABS LLC, CROWNSVILLE, MD.  
FILED 1-6-2011.

## YOUR LAST 2 STEPS BEFORE SEEING A DERMATOLOGIST

THE MARK CONSISTS OF STANDARD CHARACTERS WITHOUT CLAIM TO ANY PARTICULAR FONT, STYLE, SIZE, OR COLOR.

### CLASS 3—COSMETICS AND CLEANING PREPARATIONS

FOR COSMETIC PREPARATIONS FOR SKIN CARE (U.S. CLS. 1, 4, 6, 50, 51 AND 52).

### CLASS 35—ADVERTISING AND BUSINESS

FOR ON-LINE RETAIL STORE SERVICES FEATURING SKIN CARE PRODUCTS (U.S. CLS. 100, 101 AND 102).

EUGENIA MARTIN, EXAMINING ATTORNEY

SN 85-212,132. HILCO TRADING, LLC, NORTHBROOK, IL.  
FILED 1-6-2011.

## MORE VALUE CREATED MORE WAYS

THE MARK CONSISTS OF STANDARD CHARACTERS WITHOUT CLAIM TO ANY PARTICULAR FONT, STYLE, SIZE, OR COLOR.

### CLASS 35—ADVERTISING AND BUSINESS

FOR ACQUISITION AND MERGER CONSULTATION; ANALYSES AND APPRAISALS OF ENTERPRISES; BUSINESS ACQUISITION AND MERGER CONSULTATION; BUSINESS APPRAISAL CONSULTATION; BUSINESS APPRAISALS; BUSINESS APPRAISALS AND EVALUATIONS IN BUSINESS MATTERS; BUSINESS INFORMATION SERVICES AND APPRAISALS; BUSINESS INVESTIGATIONS, EVALUATIONS, EXPERT APPRAISALS, INFORMATION AND RESEARCH; BUSINESS MERGER CONSULTATION; PROVIDING BUSINESS MANAGEMENT INFORMATION IN CONNECTION WITH CONSULTING AND ADVISORY SERVICES IN THE FIELD OF STRATEGIC PLANNING AND MERGERS AND ACQUISITIONS; ARRANGING AND CONDUCTING OF AUCTION SALES IN THE FIELDS OF INDUSTRIAL MACHINERY, INDUSTRIAL EQUIPMENT, INDUSTRIAL INVENTORY, INDUSTRIAL FURNITURE, INDUSTRIAL FIXTURES AND OTHER INDUSTRIAL ASSETS; LITIGATION SUPPORT SERVICES; RETAIL RESTRUCTURING AND CONSULTATION SERVICES; INTERIM RETAIL MANAGEMENT SERVICES; RETAIL OUTSOURCING SERVICES; FIXED ASSET RECOVERY SERVICES; ASSET PROTECTION SERVICES; BUSINESS AND MANAGEMENT CONSULTING SERVICES FOR THE RETAIL INDUSTRY (U.S. CLS. 100, 101 AND 102).

FIRST USE 12-31-2002; IN COMMERCE 12-31-2002.

### CLASS 36—INSURANCE AND FINANCIAL

FOR APPRAISAL AND EVALUATION OF REAL ESTATE; APPRAISAL OF REAL ESTATE; BUSINESS BROKERAGE SERVICES AND RELATED CONSULTING PERTAINING TO BUSINESS SALES, MERGERS, ACQUISITIONS AND BUSINESS VALUATIONS; CONSULTATION RELATING TO THE APPRAISAL OF GOODS; FINANCIAL CONSULTING AND ADVISING IN THE FIELD OF MERGERS AND ACQUISITIONS; REAL ESTATE APPRAISAL; REAL ESTATE APPRAISAL AND VALUATION; MANAGEMENT OF PRIVATE EQUITY FUNDS; PRIVATE EQUITY FUND INVESTMENT SERVICES; FINANCIAL SERVICES, NAMELY COMMERCIAL LENDING, ASSET-BASED LENDING, MEZZANINE/SUBORDINATED DEBT LENDING, EQUITY INVESTMENT, INVESTMENT BANKING, PRIVATE PLACEMENT OF EQUITY AND DEBT INVESTMENTS, LEASE FINANCING, FACTORING SERVICES, INVESTMENT MANAGEMENT, FINANCIAL VALUATION AND BALANCE SHEET ADVISORY; BUSINESS LIQUIDATION SERVICES; BUSINESS LIQUIDATION SERVICES IN THE FIELDS OF INDUSTRIAL MACHINERY, INDUSTRIAL EQUIPMENT, INDUSTRIAL INVENTORY, INDUSTRIAL FURNITURE, INDUSTRIAL FIXTURES AND OTHER INDUSTRIAL ASSETS; BUSINESS LIQUIDATION SERVICES IN THE FIELD OF WHOLESALE CONSUMER INVENTORY; FINANCIAL INVESTMENT IN THE FIELD OF REAL ESTATE; FINANCIAL VALUATION OF PERSONAL PROPERTY AND REAL ESTATE; LEASING OF REAL ESTATE; REAL ESTATE ACQUISITION SERVICES; REAL ESTATE APPRAISAL; REAL ESTATE EQUITY SHARING, NAMELY, MANAGING AND ARRANGING FOR CO-OWNERSHIP OF REAL ESTATE; REAL ESTATE INVESTMENT; REAL ESTATE MANAGEMENT; REAL ESTATE PROCUREMENT FOR OTHERS; REAL ESTATE SYNDICATION; APPRAISAL AND VALUATION SERVICES; PROPERTY DISPOSITION SERVICES; LEASE TERMINATION SERVICES; LEASE RENEGOTIATION SERVICES; SALE AND LEASEBACK SERVICES; REAL ESTATE DEBT ADVISORY SERVICES; ASSET AND PROPERTY MANAGEMENT SERVICES; LOAN EVALUATION SERVICES; LOAN STRATEGY SERVICES; PROVIDING BUSINESS ADVICE AND INFORMATION REGARDING LOANS (U.S. CLS. 100, 101 AND 102).

FIRST USE 12-31-2002; IN COMMERCE 12-31-2002.  
HEATHER SAPP, EXAMINING ATTORNEY

SN 85-212,293. PETSMART STORE SUPPORT GROUP, INC.,  
PHOENIX, AZ. FILED 1-6-2011.

## HAPPINESS IN STORE

THE MARK CONSISTS OF STANDARD CHARACTERS WITHOUT CLAIM TO ANY PARTICULAR FONT, STYLE, SIZE, OR COLOR.

### CLASS 35—ADVERTISING AND BUSINESS

FOR RETAIL STORE SERVICES AND ON-LINE RETAIL STORE SERVICES, FEATURING PET FOOD, PET SUPPLIES AND PET ACCESSORIES (U.S. CLS. 100, 101 AND 102).

### CLASS 43—HOTEL AND RESTAURANT SERVICES

FOR BOARDING FOR PETS; PET DAY CARE SERVICES; PROVIDING INFORMATION ABOUT PET BOARDING AND PET DAY CARE (U.S. CLS. 100 AND 101).

**CLASS 44—MEDICAL, BEAUTY AND AGRICULTURAL SERVICES**

FOR PET GROOMING SERVICES; PROVIDING INFORMATION ABOUT PET GROOMING SERVICES (U.S. CLS. 100 AND 101).

WILLIAM BRECKENFELD, EXAMINING ATTORNEY

---

SN 85-212,331. WE KNOW A PLACE, INC., SANTA FE SPRINGS, CA. FILED 1-6-2011.

**WE KNOW A PLACE**

THE MARK CONSISTS OF STANDARD CHARACTERS WITHOUT CLAIM TO ANY PARTICULAR FONT, STYLE, SIZE, OR COLOR.

**CLASS 35—ADVERTISING AND BUSINESS**

FOR REFERRAL SERVICES OF SOURCES OF ELDER CARE (U.S. CLS. 100, 101 AND 102).

**CLASS 43—HOTEL AND RESTAURANT SERVICES**

FOR CONSULTING SERVICES IN THE FIELD OF PROVIDING ASSISTED LIVING FACILITIES FOR THE ELDERLY (U.S. CLS. 100 AND 101).

**CLASS 44—MEDICAL, BEAUTY AND AGRICULTURAL SERVICES**

FOR CONSULTING SERVICES IN THE FIELD OF HEALTH CARE FOR THE ELDERLY (U.S. CLS. 100 AND 101).

KEVON CHISOLM, EXAMINING ATTORNEY

---

SN 85-212,356. WE KNOW A PLACE, INC., SANTA FE SPRINGS, CA. FILED 1-6-2011.



THE MARK CONSISTS OF THE DESIGN OF A HOUSE WITH A WINDOW, WHERE ONE OF THE ROOF LINES CONSISTS OF A HEART IN A MAGNIFYING GLASS.

**CLASS 35—ADVERTISING AND BUSINESS**

FOR REFERRAL SERVICES OF SOURCES OF ELDER CARE (U.S. CLS. 100, 101 AND 102).

**CLASS 43—HOTEL AND RESTAURANT SERVICES**

FOR CONSULTING SERVICES IN THE FIELD OF PROVIDING ASSISTED LIVING FACILITIES FOR THE ELDERLY (U.S. CLS. 100 AND 101).

**CLASS 44—MEDICAL, BEAUTY AND AGRICULTURAL SERVICES**

FOR CONSULTING SERVICES IN THE FIELD OF HEALTH CARE FOR THE ELDERLY (U.S. CLS. 100 AND 101).

KEVON CHISOLM, EXAMINING ATTORNEY

---

SN 85-212,399. FOG KIST OF SANTA CRUZ, LLC, SANTA CRUZ, CA. FILED 1-6-2011.

**FOG KIST**

THE MARK CONSISTS OF STANDARD CHARACTERS WITHOUT CLAIM TO ANY PARTICULAR FONT, STYLE, SIZE, OR COLOR.

**CLASS 30—STAPLE FOODS**

FOR SPICES (U.S. CL. 46).

**CLASS 31—NATURAL AGRICULTURAL PRODUCTS**

FOR FRESH FRUIT AND VEGETABLES (U.S. CLS. 1 AND 46).

**CLASS 43—HOTEL AND RESTAURANT SERVICES**

FOR RESTAURANT SERVICES (U.S. CLS. 100 AND 101).

STEVEN R. FINE, EXAMINING ATTORNEY

---

SN 85-212,490. CARNEGIE LEARNING, INC., PITTSBURGH, PA. FILED 1-7-2011.

**MATHia**

THE MARK CONSISTS OF STANDARD CHARACTERS WITHOUT CLAIM TO ANY PARTICULAR FONT, STYLE, SIZE, OR COLOR.

**CLASS 9—ELECTRICAL AND SCIENTIFIC APPARATUS**

FOR CHILDREN'S EDUCATIONAL SOFTWARE; EDUCATIONAL SOFTWARE FEATURING INSTRUCTION IN MATHEMATICS (U.S. CLS. 21, 23, 26, 36 AND 38).

**CLASS 16—PAPER GOODS AND PRINTED MATTER**

FOR CHILDREN'S INTERACTIVE EDUCATIONAL BOOKS (U.S. CLS. 2, 5, 22, 23, 29, 37, 38 AND 50).

**CLASS 38—COMMUNICATION**

FOR EDUCATIONAL TEXT MESSAGING SERVICES FOR TRANSMISSION OF EDUCATIONAL CONTENT VIA SMS (U.S. CLS. 100, 101 AND 104).

**CLASS 41—EDUCATION AND ENTERTAINMENT**

FOR CHILDREN'S EDUCATIONAL SERVICES, NAMELY, PROVIDING ACADEMIC PERFORMANCE EVALUATION, GUIDANCE AND MONITORING FOR CHILDREN PRE-KINDERGARTEN THROUGH GRADE 12 VIA THE INTERNET; PROVIDING AFTER SCHOOL EDUCATIONAL PROGRAMS FOR CHILDREN IN GRADES 6-8 (U.S. CLS. 100, 101 AND 107).  
DOMINICK J. SALEMI, EXAMINING ATTORNEY

SN 85-212,546. SIMPLIVT CORPORATION, WESTBOROUGH, MA. FILED 1-7-2011.

**SimpliVity**

**CLASS 9—ELECTRICAL AND SCIENTIFIC APPARATUS**

FOR COMPUTER HARDWARE AND SOFTWARE FOR COMPUTER SERVER AND DATA STORAGE VIRTUALIZATION; NONE OF THE AFOREMENTIONED GOODS FOR USE IN CONNECTION WITH ELECTRONIC DESIGN AUTOMATION OR COMPUTER AIDED ELECTRONIC CIRCUIT DESIGN, SIMULATION, AND VERIFICATION (U.S. CLS. 21, 23, 26, 36 AND 38).

**CLASS 42—SCIENTIFIC AND COMPUTER SERVICES**

FOR COMPUTER SERVICES FOR COMPUTER SERVER AND DATA STORAGE VIRTUALIZATION; CONSULTING SERVICES IN THE FIELD OF DESIGN, SELECTION, IMPLEMENTATION AND USE OF COMPUTER HARDWARE AND SOFTWARE FOR OTHERS FOR COMPUTER SERVER AND DATA STORAGE VIRTUALIZATION; NONE OF THE AFOREMENTIONED SERVICES IN THE FIELD OF ELECTRONIC DESIGN AUTOMATION OR COMPUTER AIDED ELECTRONIC CIRCUIT DESIGN, SIMULATION, AND VERIFICATION (U.S. CLS. 100 AND 101).  
WENDY GOODMAN, EXAMINING ATTORNEY

SN 85-212,525. RAMOS, TROY MICHAEL, NEWBURY PARK, CA. FILED 1-7-2011.

**H2A11**

SN 85-212,750. THOUGHTBOT, INC., NEW YORK, NY. FILED 1-7-2011.

**COPYCOPTER**

THE MARK CONSISTS OF STANDARD CHARACTERS WITHOUT CLAIM TO ANY PARTICULAR FONT, STYLE, SIZE, OR COLOR.

**CLASS 25—CLOTHING**

FOR ATHLETIC APPAREL, NAMELY, SHIRTS, PANTS, JACKETS, FOOTWEAR, HATS AND CAPS, ATHLETIC UNIFORMS (U.S. CLS. 22 AND 39).

**CLASS 32—LIGHT BEVERAGES**

FOR DRINKING WATER (U.S. CLS. 45, 46 AND 48).  
CHRISTOPHER BUONGIORNO, EXAMINING ATTORNEY

THE MARK CONSISTS OF STANDARD CHARACTERS WITHOUT CLAIM TO ANY PARTICULAR FONT, STYLE, SIZE, OR COLOR.

**CLASS 9—ELECTRICAL AND SCIENTIFIC APPARATUS**

FOR DOWNLOADABLE COMPUTER SOFTWARE, NAMELY, COMPUTER SOFTWARE DEVELOPMENT AND UTILITY TOOLS, DOWNLOADABLE SOFTWARE FOR CONTENT MANAGEMENT, CONTENT CREATION, CONTENT PUBLISHING, CONTENT FILTERING, CONTENT SELECTION, CONTENT AGGREGATION, CONTENT CATEGORIZATION, AND CONTENT SEARCHING (U.S. CLS. 21, 23, 26, 36 AND 38).

**CLASS 42—SCIENTIFIC AND COMPUTER SERVICES**

FOR SOFTWARE AS A SERVICE (SAAS) SERVICES, NAMELY, COMPUTER SOFTWARE DEVELOPMENT AND UTILITY TOOLS, PROVIDING A WEBSITE FEATURING NON-DOWNLOADABLE SOFTWARE FOR CONTENT MANAGEMENT, CONTENT CREATION, CONTENT PUBLISHING, CONTENT FILTERING, CONTENT SELECTION, CONTENT AGGREGATION, CONTENT CATEGORIZATION, AND CONTENT SEARCHING; SOFTWARE AS A SERVICE (SAAS) SERVICES FEATURING SOFTWARE IN THE FIELD OF CONTENT MANAGEMENT, CONTENT CREATION, CONTENT PUBLISHING, CONTENT FILTERING, CONTENT SELECTION, CONTENT AGGREGATION, CONTENT CATEGORIZATION, AND CONTENT SEARCHING (U.S. CLS. 100 AND 101).

HEATHER SAPP, EXAMINING ATTORNEY

SN 85-212,912. KOCH PRODUCTIONS, LLC, ATLANTA, GA. FILED 1-7-2011.

WHY WAG A LITTLE WHEN YOU  
CAN WAG-A-LOT

THE MARK CONSISTS OF STANDARD CHARACTERS WITHOUT CLAIM TO ANY PARTICULAR FONT, STYLE, SIZE, OR COLOR.

OWNER OF U.S. REG. NO. 2,591,589.

**CLASS 35—ADVERTISING AND BUSINESS**

FOR RETAIL PET STORES (U.S. CLS. 100, 101 AND 102).

FIRST USE 11-15-1999; IN COMMERCE 11-15-1999.

**CLASS 41—EDUCATION AND ENTERTAINMENT**

FOR KENNEL SERVICES, NAMELY, DOG TRAINING SERVICES (U.S. CLS. 100, 101 AND 107).

FIRST USE 11-15-1999; IN COMMERCE 11-15-1999.

**CLASS 43—HOTEL AND RESTAURANT SERVICES**

FOR KENNEL SERVICES, NAMELY, BOARDING FOR PETS (U.S. CLS. 100 AND 101).

FIRST USE 11-15-1999; IN COMMERCE 11-15-1999.

**CLASS 44—MEDICAL, BEAUTY AND AGRICULTURAL SERVICES**

FOR PET CARE SERVICES, NAMELY, DOG WALKING, DOG BATHING AND NON-MEDICATED PET GROOMING; PROVIDING SELF-SERVICE PET GROOMING FACILITIES (U.S. CLS. 100 AND 101).

FIRST USE 11-15-1999; IN COMMERCE 11-15-1999.

THEODORE MCBRIDE, EXAMINING ATTORNEY

SN 85-212,751. THOUGHTBOT, INC., NEW YORK, NY. FILED 1-7-2011.



THE MARK CONSISTS OF THE DESIGN OF A HELICOPTER.

**CLASS 9—ELECTRICAL AND SCIENTIFIC APPARATUS**

FOR DOWNLOADABLE COMPUTER SOFTWARE, NAMELY, COMPUTER SOFTWARE DEVELOPMENT AND UTILITY TOOLS, DOWNLOADABLE SOFTWARE FOR CONTENT MANAGEMENT, CONTENT CREATION, CONTENT PUBLISHING, CONTENT FILTERING, CONTENT SELECTION, CONTENT AGGREGATION, CONTENT CATEGORIZATION, AND CONTENT SEARCHING (U.S. CLS. 21, 23, 26, 36 AND 38).

**CLASS 42—SCIENTIFIC AND COMPUTER SERVICES**

FOR SOFTWARE AS A SERVICE (SAAS) SERVICES, NAMELY, COMPUTER SOFTWARE DEVELOPMENT AND UTILITY TOOLS, PROVIDING A WEBSITE FEATURING NON-DOWNLOADABLE SOFTWARE FOR CONTENT MANAGEMENT, CONTENT CREATION, CONTENT PUBLISHING, CONTENT FILTERING, CONTENT SELECTION, CONTENT AGGREGATION, CONTENT CATEGORIZATION, AND CONTENT SEARCHING; SOFTWARE AS A SERVICE (SAAS) SERVICES FEATURING SOFTWARE IN THE FIELD OF CONTENT MANAGEMENT, CONTENT CREATION, CONTENT PUBLISHING, CONTENT FILTERING, CONTENT SELECTION, CONTENT AGGREGATION, CONTENT CATEGORIZATION, AND CONTENT SEARCHING (U.S. CLS. 100 AND 101).

HEATHER SAPP, EXAMINING ATTORNEY

SN 85-212,932. INSPIRATION & MOTIVATION, INC., CHARLOTTE, NC. FILED 1-7-2011.

AMERICAN UNDERDOG

THE MARK CONSISTS OF STANDARD CHARACTERS WITHOUT CLAIM TO ANY PARTICULAR FONT, STYLE, SIZE, OR COLOR.

OWNER OF U.S. REG. NO. 3,878,063.

NO CLAIM IS MADE TO THE EXCLUSIVE RIGHT TO USE "AMERICAN", APART FROM THE MARK AS SHOWN.

**CLASS 16—PAPER GOODS AND PRINTED MATTER**

FOR MAGAZINES AND NEWSLETTERS IN THE FIELD OF BUSINESS SUCCESS STORIES (U.S. CLS. 2, 5, 22, 23, 29, 37, 38 AND 50).

FIRST USE 1-0-2010; IN COMMERCE 11-15-2010.



**CLASS 41—EDUCATION AND ENTERTAINMENT**

FOR ENTERTAINMENT IN THE NATURE OF ON-GOING TELEVISION PROGRAMS IN THE FIELD OF BUSINESS SUCCESS STORIES BROADCAST OVER TELEVISION, SATELLITE, AUDIO, AND VIDEO MEDIA; ENTERTAINMENT SERVICES, NAMELY, PROVIDING A WEBSITE FEATURING INFORMATION IN THE FIELD OF BUSINESS SUCCESS STORIES; ENTERTAINMENT SERVICES, NAMELY, PROVIDING RADIO PROGRAMS IN THE FIELD OF BUSINESS SUCCESS STORIES VIA A GLOBAL COMPUTER NETWORK; ENTERTAINMENT SERVICES, NAMELY, PROVIDING AN ON-GOING RADIO PROGRAM IN THE FIELD OF BUSINESS SUCCESS STORIES; ENTERTAINMENT SERVICES, NAMELY, PROVIDING WEBCASTS AND PODCASTS IN THE FIELD OF BUSINESS SUCCESS STORIES (U.S. CLS. 100, 101 AND 107).

FIRST USE 11-7-2009; IN COMMERCE 11-7-2009.  
MICHAEL ENGEL, EXAMINING ATTORNEY

---

SN 85-213,005. KAREEN Z. WALSH, VERONA, NJ. FILED 1-7-2011.

# AMPED

THE MARK CONSISTS OF STANDARD CHARACTERS WITHOUT CLAIM TO ANY PARTICULAR FONT, STYLE, SIZE, OR COLOR.

**CLASS 43—HOTEL AND RESTAURANT SERVICES**

FOR PROVIDING A WEBSITE FEATURING RECIPES AND MENU PLANNING TOOLS (U.S. CLS. 100 AND 101).

**CLASS 44—MEDICAL, BEAUTY AND AGRICULTURAL SERVICES**

FOR PROVIDING A WEBSITE FEATURING INFORMATION IN THE FIELDS OF WELLNESS, NUTRITION AND FOOD ALLERGIES (U.S. CLS. 100 AND 101).

JANICE KIM, EXAMINING ATTORNEY

---

SN 85-213,021. RPM INTERNATIONAL INC., MEDINA, OH. FILED 1-7-2011.

# THE VALUE OF 168

THE MARK CONSISTS OF STANDARD CHARACTERS WITHOUT CLAIM TO ANY PARTICULAR FONT, STYLE, SIZE, OR COLOR.

**CLASS 9—ELECTRICAL AND SCIENTIFIC APPARATUS**

FOR DOWNLOADABLE ELECTRONIC PUBLICATIONS IN THE NATURE OF FINANCIAL REPORTS OF INTEREST TO THE SHAREHOLDERS OF A HOLDING COMPANY, TO POTENTIAL INVESTORS IN THE HOLDING COMPANY, TO THE MEDIA, AND TO THE EMPLOYEES AND CUSTOMERS OF THE HOLDING COMPANY'S SUBSIDIARIES DOING BUSINESS IN THE FIELD OF SPECIALTY COATINGS AND SEALANTS (U.S. CLS. 21, 23, 26, 36 AND 38).

FIRST USE 2-7-2011; IN COMMERCE 2-7-2011.

**CLASS 16—PAPER GOODS AND PRINTED MATTER**

FOR PRINTED REPORTS FEATURING INFORMATION OF INTEREST TO THE SHAREHOLDERS OF A HOLDING COMPANY, TO POTENTIAL INVESTORS IN THE HOLDING COMPANY, TO THE MEDIA, AND TO THE EMPLOYEES AND CUSTOMERS OF THE HOLDING COMPANY'S SUBSIDIARIES DOING BUSINESS IN THE FIELD OF SPECIALTY COATINGS AND SEALANTS (U.S. CLS. 2, 5, 22, 23, 29, 37, 38 AND 50).

FIRST USE 2-7-2011; IN COMMERCE 2-7-2011.

LINDA MICKLEBURGH, EXAMINING ATTORNEY

---

SN 85-213,085. 3GEMS, CHATSWORTH, CA. FILED 1-7-2011.

# 3GEMS

THE MARK CONSISTS OF STANDARD CHARACTERS WITHOUT CLAIM TO ANY PARTICULAR FONT, STYLE, SIZE, OR COLOR.

**CLASS 10—MEDICAL APPARATUS**

FOR MEDICAL DIAGNOSTIC ANALYZER FOR ANALYZING HUMAN SAMPLES SUCH AS URINE, BLOOD AND BODY FLUIDS (U.S. CLS. 26, 39 AND 44).

**CLASS 44—MEDICAL, BEAUTY AND AGRICULTURAL SERVICES**

FOR MEDICAL TESTING SERVICES, NAMELY, ANALYZING HUMAN SAMPLES, SUCH AS URINE, BLOOD AND BODY FLUIDS (U.S. CLS. 100 AND 101).

THEODORE MCBRIDE, EXAMINING ATTORNEY

---

SN 85-213,280. PRAXIS INTERNATIONAL, INC., RANCHO SANTA FE, CA. FILED 1-7-2011.

# Innercise

THE MARK CONSISTS OF STANDARD CHARACTERS WITHOUT CLAIM TO ANY PARTICULAR FONT, STYLE, SIZE, OR COLOR.

**CLASS 41—EDUCATION AND ENTERTAINMENT**

FOR EDUCATION SERVICES, NAMELY, PROVIDING COACHING SESSIONS, LECTURES, CLASSES, SEMINARS, WORKSHOPS, ROUNDTABLE PROGRAMS, PANEL DISCUSSIONS, PRINTED MATERIALS, DVDS, CDS, MP3S, WEBINARS, ONGOING TELEVISION AND RADIO TALK SHOWS IN THE FIELDS OF PSYCHOLOGY AND NEUROLOGY, NAMELY BRAIN TRAINING AND THE SUBCONSCIOUS, AND HOW TO IDENTIFY AND REPROGRAM LIMITING BELIEFS; ENTERTAINMENT SERVICES, NAMELY, PROVIDING BRAIN TRAINING GAMES ON-LINE AND IN MOBILE WIRELESS FORM; ENTERTAINMENT SERVICES, NAMELY, PROVIDING ONLINE COMPUTER GAMES THAT HELP MAINTAIN AN ACTIVE BRAIN AND THUS IMPROVE MEMORY, SPEED OF PROCESSING, AND THAT PROVIDE A VARIETY OF COGNITIVE BENEFITS THAT POSITIVELY IMPACT QUALITY OF LIFE (U.S. CLS. 100, 101 AND 107).

**CLASS 42—SCIENTIFIC AND COMPUTER SERVICES**

FOR PROVIDING TEMPORARY USE OF NON-DOWNLOADABLE COGNITIVE STIMULATION COMPUTER PROGRAMS THAT HELP MAINTAIN AN ACTIVE BRAIN AND THUS IMPROVE MEMORY, SPEED OF PROCESSING, AND THAT PROVIDE A VARIETY OF COGNITIVE BENEFITS THAT POSITIVELY IMPACT QUALITY OF LIFE (U.S. CLS. 100 AND 101).

**CLASS 44—MEDICAL, BEAUTY AND AGRICULTURAL SERVICES**

FOR ENERGY HEALING SERVICES, NAMELY, QUANTUM TRANSFORMATION AND HEALING SERVICES TO ELIMINATE STRESS; ENERGY HEALING SERVICES, NAMELY, STRESS MANAGEMENT AND STRESS REDUCTION COUNSELING FOR INDIVIDUALS TO ENHANCE THEIR LIVES; PROVIDING A WEBSITE FEATURING INFORMATION CONCERNING ALTERNATIVE HEALTH AND HEALING (U.S. CLS. 100 AND 101).

LINDA MICKLEBURGH, EXAMINING ATTORNEY

---

SN 85-213,311. TERRA INDUSTRIES INC., DEERFIELD, IL. FILED 1-7-2011.



THE MARK CONSISTS OF A SQUARE ROTATED 90 DEGREES WITH THE STYLIZED LETTERS "TET" CENTERED ON A DARKENED BACKGROUND ABOVE A DESIGN OF FOUR DESCENDING CURVED LINES WITH THREE CURVED SUBSTANTIALLY HORIZONTAL LINES IN THE LOWER RIGHT QUADRANT.

**CLASS 1—CHEMICALS**

FOR NITROGEN AND FERTILIZERS; NITROGEN, CALCIUM PHOSPHATE AND SODIUM PHOSPHATE, ALL FOR USE IN THE FIELDS OF EXPLOSIVES, NITROGEN OXIDE ABATEMENT, PHARMACEUTICALS, ADHESIVES, AND ETHANOL FERMENTATION; UREA BASED DIESEL EXHAUST TREATMENT FLUID (U.S. CLS. 1, 5, 6, 10, 26 AND 46).

**CLASS 16—PAPER GOODS AND PRINTED MATTER**

FOR PRINTED REPORTS CONCERNING AGRICULTURE, FARM, INDUSTRIAL AND AUTOMOTIVE APPLICATIONS (U.S. CLS. 2, 5, 22, 23, 29, 37, 38 AND 50).  
MARK SHINER, EXAMINING ATTORNEY

---

SN 85-213,404. JOYA, BLANCA E, YAPHANK, NY. FILED 1-8-2011.

**NATURE'S POWER SCIENCE**

THE MARK CONSISTS OF STANDARD CHARACTERS WITHOUT CLAIM TO ANY PARTICULAR FONT, STYLE, SIZE, OR COLOR.

**CLASS 5—PHARMACEUTICALS**

FOR NATURAL HERBAL SUPPLEMENTS, VITAMINS (U.S. CLS. 6, 18, 44, 46, 51 AND 52).

**CLASS 35—ADVERTISING AND BUSINESS**

FOR RETAIL STORE SERVICES FEATURING HEALTH FOODS, DIETARY SUPPLEMENTS, NUTRITIONAL SUPPLEMENTS, HERBS, VITAMINS (U.S. CLS. 100, 101 AND 102).  
CHERYL CLAYTON, EXAMINING ATTORNEY

---

SN 85-213,419. CHANTICLAIR, LLC, ESTERO, FL. FILED 1-8-2011.

**ACQUAVIT**

THE MARK CONSISTS OF STANDARD CHARACTERS WITHOUT CLAIM TO ANY PARTICULAR FONT, STYLE, SIZE, OR COLOR.

**CLASS 14—JEWELRY**

FOR PRECIOUS METALS AND THEIR ALLOYS; JEWELRY (U.S. CLS. 2, 27, 28 AND 50).

**CLASS 25—CLOTHING**

FOR CLOTHING, NAMELY, SWIMWEAR, SWIMWEAR COVERUPS, JACKETS, PANTS, WARM UP SUITS, SHORTS, PULLOVERS, SWEATERS, DRESSES, SHIRTS, TANK TOPS, BRAS, UNDERWEAR, LINGERIE, ONE PIECE GARMENTS FOR WOMEN, FLEECE BOTTOMS, FLEECE SHORTS, FLEECE TOPS, FLEECE VESTS (U.S. CLS. 22 AND 39).

DANNEAN HETZEL, EXAMINING ATTORNEY

---

SN 85-213,433. FRANKLIN COVEY, CO., SALT LAKE CITY, UT. FILED 1-8-2011.

**THE DECISION IS YOURS**

THE MARK CONSISTS OF STANDARD CHARACTERS WITHOUT CLAIM TO ANY PARTICULAR FONT, STYLE, SIZE, OR COLOR.

**CLASS 16—PAPER GOODS AND PRINTED MATTER**

FOR EDUCATIONAL PUBLICATIONS, NAMELY, MANUALS, REFERENCE GUIDES AND PAMPHLETS IN THE FIELDS OF TIME MANAGEMENT, LEADERSHIP, COMMUNICATION AND PERSONAL DEVELOPMENT; PROJECT PLANNERS, TIME PLANNERS, CALENDARS, PERSONAL ORGANIZERS, BINDERS AND NOTEBOOKS (U.S. CLS. 2, 5, 22, 23, 29, 37, 38 AND 50).

FIRST USE 5-1-2008; IN COMMERCE 5-1-2008.

**CLASS 41—EDUCATION AND ENTERTAINMENT**

FOR EDUCATION SERVICES, NAMELY PROVIDING SEMINARS, WORKSHOPS, LECTURES AND CLASSES IN THE FIELD OF TIME MANAGEMENT, LEADERSHIP, COMMUNICATION, AND PERSONAL DEVELOPMENT, AND DISTRIBUTION OF COURSE MATERIALS IN CONNECTION THEREWITH (U.S. CLS. 100, 101 AND 107).

FIRST USE 5-1-2008; IN COMMERCE 5-1-2008.

REGINA DRUMMOND, EXAMINING ATTORNEY

---

SN 85-213,513. YAPP, INC., NEW YORK, NY. FILED 1-8-2011.

**YAPP**

THE MARK CONSISTS OF STANDARD CHARACTERS WITHOUT CLAIM TO ANY PARTICULAR FONT, STYLE, SIZE, OR COLOR.

**CLASS 9—ELECTRICAL AND SCIENTIFIC APPARATUS**

FOR COMPUTER SOFTWARE FOR CREATION AND PUBLICATION OF SOFTWARE APPLICATIONS AND INTERNET WEBSITES (U.S. CLS. 21, 23, 26, 36 AND 38).

**CLASS 42—SCIENTIFIC AND COMPUTER SERVICES**

FOR SOFTWARE AS A SERVICE FOR CREATION AND PUBLICATION OF SOFTWARE APPLICATIONS AND INTERNET WEBSITES; PROVIDING TEMPORARY USE OF NON-DOWNLOADABLE SOFTWARE FOR THE CREATION AND PUBLICATION OF SOFTWARE APPLICATIONS AND INTERNET WEBSITES; CONSULTING SERVICES RELATED TO THE CREATION, DESIGN, DEVELOPMENT, MANAGEMENT, MONETIZATION, PUBLICATION AND TRACKING OF SOFTWARE APPLICATIONS AND INTERNET WEBSITES (U.S. CLS. 100 AND 101).

ARETHA SOMERVILLE, EXAMINING ATTORNEY

---

SN 85-213,514. YAPP, INC., NEW YORK, NY. FILED 1-8-2011.

**YAPPIT**

THE MARK CONSISTS OF STANDARD CHARACTERS WITHOUT CLAIM TO ANY PARTICULAR FONT, STYLE, SIZE, OR COLOR.

**CLASS 9—ELECTRICAL AND SCIENTIFIC APPARATUS**

FOR COMPUTER SOFTWARE FOR CREATION AND PUBLICATION OF SOFTWARE APPLICATIONS AND INTERNET WEBSITES (U.S. CLS. 21, 23, 26, 36 AND 38).

**CLASS 42—SCIENTIFIC AND COMPUTER SERVICES**

FOR SOFTWARE AS A SERVICE FOR CREATION AND PUBLICATION OF SOFTWARE APPLICATIONS AND INTERNET WEBSITES; PROVIDING TEMPORARY USE OF NON-DOWNLOADABLE SOFTWARE FOR THE CREATION AND PUBLICATION OF SOFTWARE APPLICATIONS AND INTERNET WEBSITES; CONSULTING SERVICES RELATED TO THE CREATION, DESIGN, DEVELOPMENT, MANAGEMENT, MONETIZATION, PUBLICATION AND TRACKING OF SOFTWARE APPLICATIONS AND INTERNET WEBSITES (U.S. CLS. 100 AND 101).

ARETHA SOMERVILLE, EXAMINING ATTORNEY

---

SN 85-214,160. MENTAL IMAGES GMBH, BERLIN, GABON, FILED 1-10-2011.

**MENTAL GARDEN**

THE MARK CONSISTS OF STANDARD CHARACTERS WITHOUT CLAIM TO ANY PARTICULAR FONT, STYLE, SIZE, OR COLOR.

OWNER OF U.S. REG. NOS. 2,185,557, 2,185,558 AND 3,110,999.

**CLASS 41—EDUCATION AND ENTERTAINMENT**

FOR EDUCATIONAL SERVICES, NAMELY, PROVIDING ON-LINE TRAINING IN THE FORM OF COURSES, SEMINARS, AND WORKSHOPS IN THE FIELDS OF USING SOFTWARE FOR DESIGNING INNOVATIVE VIRTUAL REALITY ENVIRONMENTS, DESIGNING COMPUTER GAMES AND VIRTUAL REALITY SOFTWARE AND COMPUTER GRAPHICS OPERATIONS AND IMAGE RENDERING, DIGITAL ANIMATION AND SPECIAL EFFECTS OF IMAGES; ENTERTAINMENT SERVICES, NAMELY, PROVIDING ON-LINE INTERACTIVE COMPUTER GAMES, ON-LINE INTERACTIVE VIRTUAL REALITY GAMES, ON-LINE COMPUTER GAMES, ON-LINE VIRTUAL REALITY GAMES, AND ON-LINE MULTI-PLAYER ELECTRONIC COMPUTER GAMES; ENTERTAINMENT SERVICES, NAMELY, PROVIDING AN ON-LINE COMPUTER GAME (U.S. CLS. 100, 101 AND 107).

**CLASS 42—SCIENTIFIC AND COMPUTER SERVICES**

FOR COMPUTER SERVICES, NAMELY, PROVIDING TEMPORARY USE OF ON-LINE, NON-DOWNLOADABLE SOFTWARE FOR DESIGNING INNOVATIVE VIRTUAL REALITY ENVIRONMENTS; COMPUTER SERVICES, NAMELY, PROVIDING AN ON-LINE COMPUTER DATABASE FEATURING COMPUTER SOFTWARE DESIGN INFORMATION REGARDING DESIGNING INNOVATIVE VIRTUAL REALITY ENVIRONMENTS; COMPUTER SERVICES, NAMELY, PROVIDING AN ON-LINE COMPUTER DATABASE IN THE FIELD OF THE DESIGN OF DIGITAL ANIMATION AND SPECIAL EFFECTS OF IMAGES; COMPUTER SERVICES, NAMELY, CREATING AN ONLINE COMMUNITY FOR REGISTERED USERS TO PARTICIPATE IN VIRTUAL ENVIRONMENTS AND TO SHOWCASE THEIR COMPUTER GRAPHICS AND IMAGE RENDERING, DIGITAL ANIMATION, AND SPECIAL EFFECTS IMAGES; COMPUTER SERVICES, NAMELY, HOSTING ON-LINE WEB FACILITIES FOR OTHERS FOR ORGANIZING AND CONDUCTING ONLINE MEETINGS, GATHERINGS, AND INTERACTIVE DISCUSSIONS; COMPUTER SERVICES IN THE NATURE OF CUSTOMIZED WEB PAGES FEATURING USER-DEFINED INFORMATION, PERSONAL PROFILES AND INFORMATION; COMPUTER SERVICES, NAMELY, HOSTING THE WEB SITES OF OTHERS ON A COMPUTER SERVER FOR A GLOBAL COMPUTER NETWORK; COMPUTER SERVICES, NAMELY, CREATING AND MAINTAINING WEB SITES FOR OTHERS (U.S. CLS. 100 AND 101).

STEPHANIE ALI, EXAMINING ATTORNEY

**CLASS 41—EDUCATION AND ENTERTAINMENT**

FOR EDUCATIONAL SERVICES, NAMELY, PROVIDING ON-LINE TRAINING IN THE FORM OF COURSES, SEMINARS, AND WORKSHOPS IN THE FIELDS OF USING SOFTWARE FOR DESIGNING INNOVATIVE VIRTUAL REALITY ENVIRONMENTS, DESIGNING COMPUTER GAMES AND VIRTUAL REALITY SOFTWARE AND COMPUTER GRAPHICS OPERATIONS AND IMAGE RENDERING, DIGITAL ANIMATION AND SPECIAL EFFECTS OF IMAGES; ENTERTAINMENT SERVICES, NAMELY, PROVIDING ON-LINE INTERACTIVE COMPUTER GAMES, ON-LINE INTERACTIVE VIRTUAL REALITY GAMES, ON-LINE COMPUTER GAMES, ON-LINE VIRTUAL REALITY GAMES, AND ON-LINE MULTI-PLAYER ELECTRONIC COMPUTER GAMES; ENTERTAINMENT SERVICES, NAMELY, PROVIDING AN ON-LINE COMPUTER GAME (U.S. CLS. 100, 101 AND 107).

**CLASS 42—SCIENTIFIC AND COMPUTER SERVICES**

FOR COMPUTER SERVICES, NAMELY, PROVIDING TEMPORARY USE OF ON-LINE, NON-DOWNLOADABLE SOFTWARE FOR DESIGNING INNOVATIVE VIRTUAL REALITY ENVIRONMENTS; COMPUTER SERVICES, NAMELY, PROVIDING AN ON-LINE COMPUTER DATABASE FEATURING COMPUTER SOFTWARE DESIGN INFORMATION REGARDING DESIGNING INNOVATIVE VIRTUAL REALITY ENVIRONMENTS; COMPUTER SERVICES, NAMELY, PROVIDING AN ON-LINE COMPUTER DATABASE IN THE FIELD OF THE DESIGN OF DIGITAL ANIMATION AND SPECIAL EFFECTS OF IMAGES; COMPUTER SERVICES, NAMELY, CREATING AN ONLINE COMMUNITY FOR REGISTERED USERS TO PARTICIPATE IN VIRTUAL ENVIRONMENTS AND TO SHOWCASE THEIR COMPUTER GRAPHICS AND IMAGE RENDERING, DIGITAL ANIMATION, AND SPECIAL EFFECTS IMAGES; COMPUTER SERVICES, NAMELY, HOSTING ON-LINE WEB FACILITIES FOR OTHERS FOR ORGANIZING AND CONDUCTING ONLINE MEETINGS, GATHERINGS, AND INTERACTIVE DISCUSSIONS; COMPUTER SERVICES IN THE NATURE OF CUSTOMIZED WEB PAGES FEATURING USER-DEFINED INFORMATION, PERSONAL PROFILES AND INFORMATION; COMPUTER SERVICES, NAMELY, HOSTING THE WEB SITES OF OTHERS ON A COMPUTER SERVER FOR A GLOBAL COMPUTER NETWORK; COMPUTER SERVICES, NAMELY, CREATING AND MAINTAINING WEB SITES FOR OTHERS (U.S. CLS. 100 AND 101).

STEPHANIE ALI, EXAMINING ATTORNEY

---

SN 85-214,164. MENTAL IMAGES GMBH, BERLIN, GABON, FILED 1-10-2011.

---

SN 85-214,170. MENTAL IMAGES GMBH, BERLIN, GABON, FILED 1-10-2011.

**MENTAL MOON**

**MENTAL OCEAN**

THE MARK CONSISTS OF STANDARD CHARACTERS WITHOUT CLAIM TO ANY PARTICULAR FONT, STYLE, SIZE, OR COLOR.

OWNER OF U.S. REG. NOS. 2,185,557, 2,185,558 AND 3,110,999.

THE MARK CONSISTS OF STANDARD CHARACTERS WITHOUT CLAIM TO ANY PARTICULAR FONT, STYLE, SIZE, OR COLOR.

OWNER OF U.S. REG. NOS. 2,185,557, 2,185,558 AND 3,110,999.

**CLASS 41—EDUCATION AND ENTERTAINMENT**

FOR EDUCATIONAL SERVICES, NAMELY, PROVIDING ON-LINE TRAINING IN THE FORM OF COURSES, SEMINARS, AND WORKSHOPS IN THE FIELDS OF USING SOFTWARE FOR DESIGNING INNOVATIVE VIRTUAL REALITY ENVIRONMENTS, DESIGNING COMPUTER GAMES AND VIRTUAL REALITY SOFTWARE AND COMPUTER GRAPHICS OPERATIONS AND IMAGE RENDERING, DIGITAL ANIMATION AND SPECIAL EFFECTS OF IMAGES; ENTERTAINMENT SERVICES, NAMELY, PROVIDING ON-LINE INTERACTIVE COMPUTER GAMES, ON-LINE INTERACTIVE VIRTUAL REALITY GAMES, ON-LINE COMPUTER GAMES, ON-LINE VIRTUAL REALITY GAMES, AND ON-LINE MULTI-PLAYER ELECTRONIC COMPUTER GAMES; ENTERTAINMENT SERVICES, NAMELY, PROVIDING AN ON-LINE COMPUTER GAME (U.S. CLS. 100, 101 AND 107).

**CLASS 42—SCIENTIFIC AND COMPUTER SERVICES**

FOR COMPUTER SERVICES, NAMELY, PROVIDING TEMPORARY USE OF ON-LINE, NON-DOWNLOADABLE SOFTWARE FOR DESIGNING INNOVATIVE VIRTUAL REALITY ENVIRONMENTS; COMPUTER SERVICES, NAMELY, PROVIDING AN ON-LINE COMPUTER DATABASE FEATURING COMPUTER SOFTWARE DESIGN INFORMATION REGARDING DESIGNING INNOVATIVE VIRTUAL REALITY ENVIRONMENTS; COMPUTER SERVICES, NAMELY, PROVIDING AN ON-LINE COMPUTER DATABASE IN THE FIELD OF THE DESIGN OF DIGITAL ANIMATION AND SPECIAL EFFECTS OF IMAGES; COMPUTER SERVICES, NAMELY, CREATING AN ONLINE COMMUNITY FOR REGISTERED USERS TO PARTICIPATE IN VIRTUAL ENVIRONMENTS AND TO SHOWCASE THEIR COMPUTER GRAPHICS AND IMAGE RENDERING, DIGITAL ANIMATION, AND SPECIAL EFFECTS IMAGES; COMPUTER SERVICES, NAMELY, HOSTING ON-LINE WEB FACILITIES FOR OTHERS FOR ORGANIZING AND CONDUCTING ONLINE MEETINGS, GATHERINGS, AND INTERACTIVE DISCUSSIONS; COMPUTER SERVICES IN THE NATURE OF CUSTOMIZED WEB PAGES FEATURING USER-DEFINED INFORMATION, PERSONAL PROFILES AND INFORMATION; COMPUTER SERVICES, NAMELY, HOSTING THE WEB SITES OF OTHERS ON A COMPUTER SERVER FOR A GLOBAL COMPUTER NETWORK; COMPUTER SERVICES, NAMELY, CREATING AND MAINTAINING WEB SITES FOR OTHERS (U.S. CLS. 100 AND 101).

STEPHANIE ALI, EXAMINING ATTORNEY

**CLASS 41—EDUCATION AND ENTERTAINMENT**

FOR EDUCATIONAL SERVICES, NAMELY, PROVIDING ON-LINE TRAINING IN THE FORM OF COURSES, SEMINARS, AND WORKSHOPS IN THE FIELDS OF USING SOFTWARE FOR DESIGNING INNOVATIVE VIRTUAL REALITY ENVIRONMENTS, DESIGNING COMPUTER GAMES AND VIRTUAL REALITY SOFTWARE AND COMPUTER GRAPHICS OPERATIONS AND IMAGE RENDERING, DIGITAL ANIMATION AND SPECIAL EFFECTS OF IMAGES; ENTERTAINMENT SERVICES, NAMELY, PROVIDING ON-LINE INTERACTIVE COMPUTER GAMES, ON-LINE INTERACTIVE VIRTUAL REALITY GAMES, ON-LINE COMPUTER GAMES, ON-LINE VIRTUAL REALITY GAMES, AND ON-LINE MULTI-PLAYER ELECTRONIC COMPUTER GAMES; ENTERTAINMENT SERVICES, NAMELY, PROVIDING AN ON-LINE COMPUTER GAME (U.S. CLS. 100, 101 AND 107).

**CLASS 42—SCIENTIFIC AND COMPUTER SERVICES**

FOR COMPUTER SERVICES, NAMELY, PROVIDING TEMPORARY USE OF ON-LINE, NON-DOWNLOADABLE SOFTWARE FOR DESIGNING INNOVATIVE VIRTUAL REALITY ENVIRONMENTS; COMPUTER SERVICES, NAMELY, PROVIDING AN ON-LINE COMPUTER DATABASE FEATURING COMPUTER SOFTWARE DESIGN INFORMATION REGARDING DESIGNING INNOVATIVE VIRTUAL REALITY ENVIRONMENTS; COMPUTER SERVICES, NAMELY, PROVIDING AN ON-LINE COMPUTER DATABASE IN THE FIELD OF THE DESIGN OF DIGITAL ANIMATION AND SPECIAL EFFECTS OF IMAGES; COMPUTER SERVICES, NAMELY, CREATING AN ONLINE COMMUNITY FOR REGISTERED USERS TO PARTICIPATE IN VIRTUAL ENVIRONMENTS AND TO SHOWCASE THEIR COMPUTER GRAPHICS AND IMAGE RENDERING, DIGITAL ANIMATION, AND SPECIAL EFFECTS IMAGES; COMPUTER SERVICES, NAMELY, HOSTING ON-LINE WEB FACILITIES FOR OTHERS FOR ORGANIZING AND CONDUCTING ONLINE MEETINGS, GATHERINGS, AND INTERACTIVE DISCUSSIONS; COMPUTER SERVICES IN THE NATURE OF CUSTOMIZED WEB PAGES FEATURING USER-DEFINED INFORMATION, PERSONAL PROFILES AND INFORMATION; COMPUTER SERVICES, NAMELY, HOSTING THE WEB SITES OF OTHERS ON A COMPUTER SERVER FOR A GLOBAL COMPUTER NETWORK; COMPUTER SERVICES, NAMELY, CREATING AND MAINTAINING WEB SITES FOR OTHERS (U.S. CLS. 100 AND 101).

STEPHANIE ALI, EXAMINING ATTORNEY

SN 85-214,176. MENTAL IMAGES GMBH, BERLIN, GABON, FILED 1-10-2011.

SN 85-214,181. MENTAL IMAGES GMBH, BERLIN, GABON, FILED 1-10-2011.

**MENTAL PLANET**

**MENTAL UNIVERSE**

THE MARK CONSISTS OF STANDARD CHARACTERS WITHOUT CLAIM TO ANY PARTICULAR FONT, STYLE, SIZE, OR COLOR.

OWNER OF U.S. REG. NOS. 2,185,557, 2,185,558 AND 3,110,999.

THE MARK CONSISTS OF STANDARD CHARACTERS WITHOUT CLAIM TO ANY PARTICULAR FONT, STYLE, SIZE, OR COLOR.

OWNER OF U.S. REG. NOS. 2,185,557, 2,185,558 AND 3,110,999.

**CLASS 41—EDUCATION AND ENTERTAINMENT**

FOR EDUCATIONAL SERVICES, NAMELY, PROVIDING ON-LINE TRAINING IN THE FORM OF COURSES, SEMINARS, AND WORKSHOPS IN THE FIELDS OF USING SOFTWARE FOR DESIGNING INNOVATIVE VIRTUAL REALITY ENVIRONMENTS, DESIGNING COMPUTER GAMES AND VIRTUAL REALITY SOFTWARE AND COMPUTER GRAPHICS OPERATIONS AND IMAGE RENDERING, DIGITAL ANIMATION AND SPECIAL EFFECTS OF IMAGES; ENTERTAINMENT SERVICES, NAMELY, PROVIDING ON-LINE INTERACTIVE COMPUTER GAMES, ON-LINE INTERACTIVE VIRTUAL REALITY GAMES, ON-LINE COMPUTER GAMES, ON-LINE VIRTUAL REALITY GAMES, AND ON-LINE MULTI-PLAYER ELECTRONIC COMPUTER GAMES; ENTERTAINMENT SERVICES, NAMELY, PROVIDING AN ON-LINE COMPUTER GAME (U.S. CLS. 100, 101 AND 107).

**CLASS 42—SCIENTIFIC AND COMPUTER SERVICES**

FOR COMPUTER SERVICES, NAMELY, PROVIDING TEMPORARY USE OF ON-LINE, NON-DOWNLOADABLE SOFTWARE FOR DESIGNING INNOVATIVE VIRTUAL REALITY ENVIRONMENTS; COMPUTER SERVICES, NAMELY, PROVIDING AN ON-LINE COMPUTER DATABASE FEATURING COMPUTER SOFTWARE DESIGN INFORMATION REGARDING DESIGNING INNOVATIVE VIRTUAL REALITY ENVIRONMENTS; COMPUTER SERVICES, NAMELY, PROVIDING AN ON-LINE COMPUTER DATABASE IN THE FIELD OF THE DESIGN OF DIGITAL ANIMATION AND SPECIAL EFFECTS OF IMAGES; COMPUTER SERVICES, NAMELY, CREATING AN ONLINE COMMUNITY FOR REGISTERED USERS TO PARTICIPATE IN VIRTUAL ENVIRONMENTS AND TO SHOWCASE THEIR COMPUTER GRAPHICS AND IMAGE RENDERING, DIGITAL ANIMATION, AND SPECIAL EFFECTS IMAGES; COMPUTER SERVICES, NAMELY, HOSTING ON-LINE WEB FACILITIES FOR OTHERS FOR ORGANIZING AND CONDUCTING ONLINE MEETINGS, GATHERINGS, AND INTERACTIVE DISCUSSIONS; COMPUTER SERVICES IN THE NATURE OF CUSTOMIZED WEB PAGES FEATURING USER-DEFINED INFORMATION, PERSONAL PROFILES AND INFORMATION; COMPUTER SERVICES, NAMELY, HOSTING THE WEB SITES OF OTHERS ON A COMPUTER SERVER FOR A GLOBAL COMPUTER NETWORK; COMPUTER SERVICES, NAMELY, CREATING AND MAINTAINING WEB SITES FOR OTHERS (U.S. CLS. 100 AND 101).

STEPHANIE ALI, EXAMINING ATTORNEY

SN 85-214,208. MENTAL IMAGES GMBH, BERLIN, FED REP GERMANY, FILED 1-10-2011.

**MENTAL ZOO**

THE MARK CONSISTS OF STANDARD CHARACTERS WITHOUT CLAIM TO ANY PARTICULAR FONT, STYLE, SIZE, OR COLOR.

OWNER OF U.S. REG. NOS. 2,185,557, 2,185,558 AND 3,110,999.

**CLASS 41—EDUCATION AND ENTERTAINMENT**

FOR EDUCATIONAL SERVICES, NAMELY, PROVIDING ON-LINE TRAINING IN THE FORM OF COURSES, SEMINARS, AND WORKSHOPS IN THE FIELDS OF USING SOFTWARE FOR DESIGNING INNOVATIVE VIRTUAL REALITY ENVIRONMENTS, DESIGNING COMPUTER GAMES AND VIRTUAL REALITY SOFTWARE AND COMPUTER GRAPHICS OPERATIONS AND IMAGE RENDERING, DIGITAL ANIMATION AND SPECIAL EFFECTS OF IMAGES; ENTERTAINMENT SERVICES, NAMELY, PROVIDING ON-LINE INTERACTIVE COMPUTER GAMES, ON-LINE INTERACTIVE VIRTUAL REALITY GAMES, ON-LINE COMPUTER GAMES, ON-LINE VIRTUAL REALITY GAMES, AND ON-LINE MULTI-PLAYER ELECTRONIC COMPUTER GAMES; ENTERTAINMENT SERVICES, NAMELY, PROVIDING AN ON-LINE COMPUTER GAME (U.S. CLS. 100, 101 AND 107).

**CLASS 42—SCIENTIFIC AND COMPUTER SERVICES**

FOR COMPUTER SERVICES, NAMELY, PROVIDING TEMPORARY USE OF ON-LINE, NON-DOWNLOADABLE SOFTWARE FOR DESIGNING INNOVATIVE VIRTUAL REALITY ENVIRONMENTS; COMPUTER SERVICES, NAMELY, PROVIDING AN ON-LINE COMPUTER DATABASE FEATURING COMPUTER SOFTWARE DESIGN INFORMATION REGARDING DESIGNING INNOVATIVE VIRTUAL REALITY ENVIRONMENTS; COMPUTER SERVICES, NAMELY, PROVIDING AN ON-LINE COMPUTER DATABASE IN THE FIELD OF THE DESIGN OF DIGITAL ANIMATION AND SPECIAL EFFECTS OF IMAGES; COMPUTER SERVICES, NAMELY, CREATING AN ONLINE COMMUNITY FOR REGISTERED USERS TO PARTICIPATE IN VIRTUAL ENVIRONMENTS AND TO SHOWCASE THEIR COMPUTER GRAPHICS AND IMAGE RENDERING, DIGITAL ANIMATION, AND SPECIAL EFFECTS IMAGES; COMPUTER SERVICES, NAMELY, HOSTING ON-LINE WEB FACILITIES FOR OTHERS FOR ORGANIZING AND CONDUCTING ONLINE MEETINGS, GATHERINGS, AND INTERACTIVE DISCUSSIONS; COMPUTER SERVICES IN THE NATURE OF CUSTOMIZED WEB PAGES FEATURING USER-DEFINED INFORMATION, PERSONAL PROFILES AND INFORMATION; COMPUTER SERVICES, NAMELY, HOSTING THE WEB SITES OF OTHERS ON A COMPUTER SERVER FOR A GLOBAL COMPUTER NETWORK; COMPUTER SERVICES, NAMELY, CREATING AND MAINTAINING WEB SITES FOR OTHERS (U.S. CLS. 100 AND 101).

STEPHANIE ALI, EXAMINING ATTORNEY

SN 85-214,212. POPPT LLC, NEW YORK, NY. FILED 1-10-2011.

**poppt**

THE MARK CONSISTS OF STANDARD CHARACTERS WITHOUT CLAIM TO ANY PARTICULAR FONT, STYLE, SIZE, OR COLOR.

**CLASS 42—SCIENTIFIC AND COMPUTER SERVICES**

FOR COMPUTER SERVICES, NAMELY, CREATING AN ON-LINE COMMUNITY FOR REGISTERED USERS TO PARTICIPATE IN DISCUSSIONS, GET FEEDBACK FROM THEIR PEERS, FORM VIRTUAL COMMUNITIES, AND ENGAGE IN SOCIAL NETWORKING (U.S. CLS. 100 AND 101).

**CLASS 45—PERSONAL AND LEGAL SERVICES**

FOR ON-LINE SOCIAL NETWORKING SERVICES (U.S. CLS. 100 AND 101).  
CHERYL CLAYTON, EXAMINING ATTORNEY

---

SN 85-214,233. SANA PHARMA AS, OSLO, NORWAY, FILED 1-10-2011.

**AURA DERMA**

THE MARK CONSISTS OF STANDARD CHARACTERS WITHOUT CLAIM TO ANY PARTICULAR FONT, STYLE, SIZE, OR COLOR.

**CLASS 3—COSMETICS AND CLEANING PREPARATIONS**

FOR COSMETIC PRODUCTS, NAMELY CREAMS, LOTIONS AND GELS, ALL FOR MOISTURIZING, SOFTENING AND CLEANSING THE SKIN, AND FOR REDUCING FINE LINES AND WRINKLES (U.S. CLS. 1, 4, 6, 50, 51 AND 52).

**CLASS 5—PHARMACEUTICALS**

FOR DIETARY SUPPLEMENTS, NOT FOR MEDICAL USE (U.S. CLS. 6, 18, 44, 46, 51 AND 52).  
HELENE LIWINSKI, EXAMINING ATTORNEY

---

SN 85-214,234. MENTAL IMAGES GMBH, BERLIN, FED REP GERMANY, FILED 1-10-2011.

**MENTAL**

THE MARK CONSISTS OF STANDARD CHARACTERS WITHOUT CLAIM TO ANY PARTICULAR FONT, STYLE, SIZE, OR COLOR.

OWNER OF U.S. REG. NOS. 2,185,557, 2,185,558 AND 3,110,999.

**CLASS 9—ELECTRICAL AND SCIENTIFIC APPARATUS**

FOR COMPUTER GAME SOFTWARE; COMPUTER GAME PROGRAMS DOWNLOADABLE VIA THE INTERNET (U.S. CLS. 21, 23, 26, 36 AND 38).

**CLASS 41—EDUCATION AND ENTERTAINMENT**

FOR EDUCATIONAL SERVICES, NAMELY, PROVIDING ON-LINE TRAINING IN THE FORM OF COURSES, SEMINARS, AND WORKSHOPS IN THE FIELDS OF USING SOFTWARE FOR DESIGNING INNOVATIVE VIRTUAL REALITY ENVIRONMENTS, DESIGNING COMPUTER GAMES AND VIRTUAL REALITY SOFTWARE AND COMPUTER GRAPHICS OPERATIONS AND IMAGE RENDERING, DIGITAL ANIMATION AND SPECIAL EFFECTS OF IMAGES; ENTERTAINMENT SERVICES, NAMELY, PROVIDING ON-LINE INTERACTIVE COMPUTER GAMES, ON-LINE INTERACTIVE VIRTUAL REALITY GAMES, ON-LINE COMPUTER GAMES, ON-LINE VIRTUAL REALITY GAMES, AND ON-LINE MULTI-PLAYER ELECTRONIC COMPUTER GAMES; ENTERTAINMENT SERVICES, NAMELY, PROVIDING AN ON-LINE COMPUTER GAME (U.S. CLS. 100, 101 AND 107).

**CLASS 42—SCIENTIFIC AND COMPUTER SERVICES**

FOR COMPUTER SERVICES, NAMELY, PROVIDING TEMPORARY USE OF ON-LINE, NON-DOWNLOADABLE SOFTWARE FOR DESIGNING INNOVATIVE VIRTUAL REALITY ENVIRONMENTS; COMPUTER SERVICES, NAMELY, PROVIDING AN ON-LINE COMPUTER DATABASE FEATURING COMPUTER SOFTWARE DESIGN INFORMATION REGARDING DESIGNING INNOVATIVE VIRTUAL REALITY ENVIRONMENTS; COMPUTER SERVICES, NAMELY, PROVIDING AN ON-LINE COMPUTER DATABASE IN THE FIELD OF THE DESIGN OF DIGITAL ANIMATION AND SPECIAL EFFECTS OF IMAGES; COMPUTER SERVICES, NAMELY, CREATING AN ONLINE COMMUNITY FOR REGISTERED USERS TO PARTICIPATE IN VIRTUAL ENVIRONMENTS AND TO SHOWCASE THEIR COMPUTER GRAPHICS AND IMAGE RENDERING, DIGITAL ANIMATION, AND SPECIAL EFFECTS IMAGES; COMPUTER SERVICES, NAMELY, HOSTING ON-LINE WEB FACILITIES FOR OTHERS FOR ORGANIZING AND CONDUCTING ONLINE MEETINGS, GATHERINGS, AND INTERACTIVE DISCUSSIONS; COMPUTER SERVICES IN THE NATURE OF CUSTOMIZED WEB PAGES FEATURING USER-DEFINED INFORMATION, PERSONAL PROFILES AND INFORMATION; COMPUTER SERVICES, NAMELY, HOSTING THE WEB SITES OF OTHERS ON A COMPUTER SERVER FOR A GLOBAL COMPUTER NETWORK; COMPUTER SERVICES, NAMELY, CREATING AND MAINTAINING WEB SITES FOR OTHERS (U.S. CLS. 100 AND 101).

STEPHANIE ALI, EXAMINING ATTORNEY

---

SN 85-214,270. MARBLES LLC, CHICAGO, IL. FILED 1-10-2011.

**MARBLES**

THE MARK CONSISTS OF STANDARD CHARACTERS WITHOUT CLAIM TO ANY PARTICULAR FONT, STYLE, SIZE, OR COLOR.

**CLASS 35—ADVERTISING AND BUSINESS**

FOR RETAIL STORE AND ON-LINE RETAIL STORE SERVICES FEATURING MENTAL FITNESS PRODUCTS (U.S. CLS. 100, 101 AND 102).

FIRST USE 5-14-2008; IN COMMERCE 5-14-2008.

**CLASS 44—MEDICAL, BEAUTY AND AGRICULTURAL SERVICES**

FOR INTERNET-BASED HEALTH CARE INFORMATION SERVICES; PROVIDING HEALTH INFORMATION; PROVIDING ON-LINE INFORMATION, NEWS AND COMMENTARY IN THE FIELD OF HEALTH AND WELLNESS RELATING TO MENTAL FITNESS (U.S. CLS. 100 AND 101).

FIRST USE 11-11-2008; IN COMMERCE 11-11-2008.  
CHERYL CLAYTON, EXAMINING ATTORNEY

**CLASS 41—EDUCATION AND ENTERTAINMENT**

FOR PROVIDING INFORMATION AND NEWS IN THE FIELDS OF EDUCATION, READING, READING COMPREHENSION, AND LITERACY VIA THE INTERNET; EDUCATIONAL SERVICES, NAMELY DEVELOPING CURRICULUM FOR OTHERS IN THE FIELDS OF READING, READING COMPREHENSION, AND LITERACY; EDUCATIONAL SERVICES, NAMELY, PROVIDING LIVE AND ON-LINE CLASSES, SEMINARS, AND WORKSHOPS IN THE FIELDS OF READING, READING COMPREHENSION, AND LITERACY; EDUCATIONAL SERVICES, NAMELY, PROVIDING MENTORING, TUTORING, CLASSES, SEMINARS AND WORKSHOPS IN THE FIELDS OF READING, READING COMPREHENSION, AND LITERACY AND DISTRIBUTION OF PRINTED MATERIALS IN CONNECTION THEREWITH IN HARD COPY OR ELECTRONIC FORMAT ON THE SAME TOPICS (U.S. CLS. 100, 101 AND 107).

FIRST USE 8-31-2010; IN COMMERCE 9-2-2010.  
JACQUELINE A. LAVINE, EXAMINING ATTORNEY

SN 85-214,293. URBAN EDUCATION EXCHANGE, INC., NEW YORK, NY. FILED 1-10-2011.

SN 85-214,364. SEARS BRANDS, LLC, HOFFMAN ESTATES, IL. FILED 1-10-2011.

**READWORKS**

THE MARK CONSISTS OF STANDARD CHARACTERS WITHOUT CLAIM TO ANY PARTICULAR FONT, STYLE, SIZE, OR COLOR.

**CLASS 9—ELECTRICAL AND SCIENTIFIC APPARATUS**

FOR DOWNLOADABLE WEBINARS IN THE FIELDS OF LITERACY, READING, AND READING COMPREHENSION; DOWNLOADABLE VIDEO AND AUDIO RECORDINGS FEATURING CURRICULUM FOR OTHERS IN THE FIELDS OF READING, LITERACY, AND READING COMPREHENSION (U.S. CLS. 21, 23, 26, 36 AND 38).

FIRST USE 9-2-2010; IN COMMERCE 9-2-2010.

**CLASS 16—PAPER GOODS AND PRINTED MATTER**

FOR EDUCATIONAL PUBLICATIONS, NAMELY, LESSON PLANS, BOOKS, HAND-OUTS, AND WORKBOOKS IN THE FIELDS OF READING, READING COMPREHENSION, AND LITERACY; PRINTED INSTRUCTIONAL, EDUCATIONAL AND TEACHING MATERIALS IN THE FIELDS OF READING, READING COMPREHENSION, AND LITERACY (U.S. CLS. 2, 5, 22, 23, 29, 37, 38 AND 50).

FIRST USE 8-31-2010; IN COMMERCE 9-2-2010.

**CLASS 35—ADVERTISING AND BUSINESS**

FOR PUBLIC ADVOCACY TO PROMOTE AWARENESS OF THE IMPORTANCE OF READING AND LITERACY (U.S. CLS. 100, 101 AND 102).

FIRST USE 9-2-2010; IN COMMERCE 9-2-2010.

**GOLDEN ADORNMENTS**

THE MARK CONSISTS OF STANDARD CHARACTERS WITHOUT CLAIM TO ANY PARTICULAR FONT, STYLE, SIZE, OR COLOR.

NO CLAIM IS MADE TO THE EXCLUSIVE RIGHT TO USE "ADORNMENTS", APART FROM THE MARK AS SHOWN.

**CLASS 21—HOUSEWARES AND GLASS**

FOR CHRISTMAS, HOLIDAY OR SEASONAL DINNERWARE AND BEVERAGeware; CHRISTMAS, HOLIDAY OR SEASONAL SERVINGWARE FOR SERVING FOOD; CANDLE HOLDERS; BATH ACCESSORIES, NAMELY, LOTION DISPENSERS, SOAP DISPENSERS, CUP HOLDERS, SOAP DISHES (U.S. CLS. 2, 13, 23, 29, 30, 33, 40 AND 50).

**CLASS 28—TOYS AND SPORTING GOODS**

FOR ARTIFICIAL CHRISTMAS TREES; ARTIFICIAL CHRISTMAS GARLANDS; ARTIFICIAL CHRISTMAS WREATHS; PRE-LIT ARTIFICIAL CHRISTMAS TREES; PRE-LIT ARTIFICIAL CHRISTMAS GARLANDS; PRE-LIT ARTIFICIAL CHRISTMAS WREATHS; CHRISTMAS TREE ORNAMENTS; CHRISTMAS TREE ORNAMENTS, NAMELY, TREE TOPPERS; CHRISTMAS TREE DECORATIONS; CHRISTMAS TREE SKIRTS; CHRISTMAS STOCKINGS; TINSEL FOR CHRISTMAS TREES (U.S. CLS. 22, 23, 38 AND 50).

LINDA M. KING, EXAMINING ATTORNEY



SN 85-214,404. ENVIVA FOODS LLC, DENMARK, WI. FILED 1-10-2011.

## You'll Love OUR Healthy

THE MARK CONSISTS OF STANDARD CHARACTERS WITHOUT CLAIM TO ANY PARTICULAR FONT, STYLE, SIZE, OR COLOR.

### CLASS 29—MEATS AND PROCESSED FOODS

FOR ANIMAL OILS AND FATS; APPLE BUTTER; APPLESAUCE; ARRANGEMENTS OF CUT FRUIT; BAKED BEANS; BEAN CURD; BEAN DIP; BEEF; BEEF JERKY; BEEF PATTIES; BEEF SLICES; BEVERAGES CONSISTING PRINCIPALLY OF MILK; BEVERAGES HAVING A MILK BASE; BEVERAGES MADE FROM YOGHURT; BLANCHED NUTS; BLENDED CHEESE; BLENDED OIL; BOLOGNA; BONELESS SKINLESS CHICKEN TENDERLOIN; BOTTLED FRUITS; BROTH; BUTTER; BUTTER SUBSTITUTES; BUTTERMILK; CAESAR SALAD; CANDIED FRUIT; CANDIED FRUIT SNACKS; CANDIED NUTS; CANNED BEANS; CANNED FISH; CANNED FRUITS; CANNED FRUITS AND VEGETABLES; CANNED OR BOTTLED FRUITS; CANNED OR BOTTLED VEGETABLES; CANNED PEANUTS; CANNED PORK AND BEANS; CANNED PROCESSED OLIVES; CANNED TOMATOES; CANNED VEGETABLES; CANNED, COOKED OR OTHERWISE PROCESSED TOMATOES; CANOLA OIL; CHEESE; CHEESE AND CRACKER COMBINATIONS; CHEESE FOOD; CHEESE POWDER; CHEESE SPREADS; CHEESE SUBSTITUTES; CHICKEN; CHICKEN NUGGETS; CHICKEN STOCK; CHILI; CHOCOLATE MILK; CHOCOLATE NUT BUTTER; COCOA BUTTER FOR FOOD PURPOSES; COCONUT MEAL; COCONUT MILK POWDER; COCONUT OIL; COCONUT OIL AND FAT; COCONUT POWDER; COFFEE CREAMER; COFFEE WHITENERS CONSISTING PRINCIPALLY OF DAIRY PRODUCTS; COLE SLAW; CONDENSED MILK; COOKED FRUITS AND VEGETABLES; COOKED VEGETABLES; COOKING OIL; CORN OIL; CORNED BEEF; COTTAGE CHEESE; COWS' MILK; CRAB CAKES; CRANBERRY SAUCE; CREAM; CREAM CHEESE; CREAM, BEING DAIRY PRODUCTS; CREAMERS FOR BEVERAGES; CURD; DAIRY PRODUCTS EXCLUDING ICE CREAM, ICE MILK AND FROZEN YOGURT; DAIRY-BASED BEVERAGES; DAIRY-BASED CHOCOLATE FOOD BEVERAGES; DAIRY-BASED DIPS; DAIRY-BASED FOOD BEVERAGES; DAIRY-BASED FOOD BEVERAGES ALSO CONTAINING COCOA; DAIRY-BASED POWDERS FOR MAKING DAIRY-BASED FOOD BEVERAGES AND SHAKES; DAIRY-BASED SNACK FOODS EXCLUDING ICE CREAM, ICE MILK AND FROZEN YOGURT; DAIRY-BASED SPREADS; DIP MIXES; DIPS; DRIED EGGS; DRIED FRUITS; DRIED MILK FOR FOOD; DRIED MILK POWDER; DRIED VEGETABLES; DRINKING YOGURTS; DRINKS BASED ON YOGHURT; DRINKS BASED ON YOGURT; DRY WHEY; EDIBLE FATS; EDIBLE OIL; EDIBLE OILS; EDIBLE OILS AND EDIBLE FATS; EDIBLE OILS AND FATS; EDIBLE OILS AND FATS, FISH AND MEAT PRESERVES; EGG PRODUCT; EGG SUBSTITUTE; EGG WHITES; EGG YOLKS; EGGS; FISH; FISH CAKES; FISH FILLETS; FISH STOCK; FOOD ADDITIVES IN THE NATURE OF FAT ACIDS MADE FROM MEAT, FISH, FRUITS, VEGETABLES, EGGS, MILK AND EDIBLE OILS AND FATS; FRESH MEAT; FRESH POULTRY; FROZEN EGGS; FROZEN FRUITS; FROZEN PRE-PACKAGED ENTREES CONSISTING PRIMARILY OF SEAFOOD; FROZEN VEGETABLES; FRUIT AND SOY BASED SNACK FOOD; FRUIT AND VEGETABLE SALADS; FRUIT CHIPS; FRUIT CONCENTRATES AND PUREES USED AS INGREDIENTS OF FOODS; FRUIT CONSERVES; FRUIT JELLIES; FRUIT PRESERVES; FRUIT PULP; FRUIT PULPS; FRUIT PUREES; FRUIT SALADS; FRUIT SALADS AND VEGETABLE SALADS; FRUIT SPREADS; FRUIT TOPPING; FRUIT-BASED FOOD BEVERAGE; FRUIT-BASED ORGANIC FOOD BARS; FRUIT-BASED SNACK FOOD; FRUIT-BASED SPREADS; GOAT MILK; GRAPSEED OIL; HALF AND HALF; HAM; HAMBUR-

GER; HASH BROWN POTATOES; HAZELNUT SPREAD; HEN EGGS; HERRINGS; HOT DOGS; HUMMUS; INFUSED OILS FOR COOKING; JAMS; JAMS AND MARMALADES; JELLIES; JELLIES AND JAMS; JELLIES FOR FOOD; LOX; LUNCHEON MEATS; MAIZE OIL; MARGARINE; MARGARINE SUBSTITUTES; MARGARINE, EDIBLE OILS AND FATS; MEAT; MEAT, FISH, POULTRY AND GAME; MEAT, FROZEN; MILK; MILK BASED BEVERAGES CONTAINING FRUIT JUICE; MILK BEVERAGES CONTAINING FRUITS; MILK BEVERAGES WITH HIGH MILK CONTENT; MILK CURD; MILK DRINKS CONTAINING FRUITS; MILK POWDER; MILK POWDER FOR FOOD PURPOSES; MILK POWDER FOR NUTRITIONAL PURPOSES; MILK PRODUCTS EXCLUDING ICE CREAM, ICE MILK AND FROZEN YOGURT; MILK PROTEIN; MILK PROTEINS; MILK-BASED BEVERAGE CONTAINING COFFEE; MILK-BASED BEVERAGES CONTAINING MILK CONCENTRATES, VEGETABLE OIL AND ADDED NUTRIENTS; MILK-BASED BEVERAGES WITH CHOCOLATE; MILK-BASED BEVERAGES WITH HIGH MILK CONTENT; MILK-BASED ENERGY DRINKS; MOZZARELLA STICKS; NON-DAIRY CREAMER; NUT AND SEED-BASED SNACK BARS; NUT BUTTERS; NUT FLOURS; NUT TOPPING; NUT-BASED MILK; NUT-BASED SNACK FOODS; NUTRITIONAL OILS FOR FOOD PURPOSES; OIL-BASED COOKING SPRAY; OILS AND FATS FOR FOOD; OLIVE OIL; OLIVE OIL; OLIVE OILS; OMELETS; PALM OIL; PEANUT BUTTER; PEANUT BUTTER TOPPINGS; PEANUT OIL; PEANUT PASTE; PEANUT SPREAD; PEANUT-BASED FOOD BEVERAGES; PORK; POTATO CHIPS; POTATO SALAD; POULTRY; POULTRY SUBSTITUTES; POWDERED OILS AND FATS; PROCESSED EGGS; PROCESSED FISH; PROCESSED FRUIT- AND NUT-BASED FOOD BARS; PROCESSED OILS AND FATS; PROCESSED OLIVE PUREE; PROCESSED OLIVES; PROCESSED PEANUTS; PROCESSED VEGETABLES AND FRUITS; RAISINS; RAPE OIL; RICE BRAN OIL; RICE MILK FOR USE AS A MILK SUBSTITUTE; SALAD OIL; SALADS EXCEPT MACARONI, RICE, AND PASTA SALAD; SALMON; SARDINES; SEAFOOD; SESAME OIL; SHEEP CHEESE; SHEEP MILK; SHORTENING; SLICED MEAT; SNACK FOOD DIPS; SNACK MIX CONSISTING OF DEHYDRATED FRUIT AND PROCESSED NUTS; SNACK MIX CONSISTING OF PRIMARILY OF PROCESSED NUTS, SEEDS, DRIED FRUIT AND ALSO INCLUDING CHOCOLATE; SOFT CHEESE; SOFT WHITE CHEESE; SOFT-RIPENED CHEESE; SOUP CONCENTRATES; SOUPS; SOUPS AND PREPARATIONS FOR MAKING SOUPS; SOUR CREAM; SOUR CREAM SUBSTITUTES; SOY BEAN OIL; SOY BURGER PATTIES; SOY-BASED FOOD BARS; SOYA MILK; SOYBEAN MILK; SOYBEAN OIL; SOYBEAN OIL FOR COOKING; SUNFLOWER OIL; TOFU; TUNA FISH; TURKEY; TURKEY BURGER PATTIES; VEGETABLE OILS; VEGETABLE OILS AND FATS; VEGETABLE SALADS; VEGETABLE-BASED FOOD BEVERAGES; VEGETABLE-BASED MEAT SUBSTITUTES; VEGETABLE-BASED SNACK FOODS; VEGGIE BURGER PATTIES; WHIPPED CREAM; WHIPPING CREAM; WHITE CHEESE; YOGHURT; YOGHURT DRINKS; YOGHURTS; YOGURT; YOGURT DRINKS; YOGURT-BASED BEVERAGES; YOGURTS (U.S. CL. 46).

### CLASS 30—STAPLE FOODS

FOR BAKERY GOODS; BARBECUE SAUCE; BEVERAGES MADE OF COFFEE; BEVERAGES MADE OF TEA; BEVERAGES WITH A CHOCOLATE BASE; BEVERAGES WITH A COFFEE BASE; BEVERAGES WITH A TEA BASE; BREAD; BROWNIE MIXES; BROWNIES; CANDY BARS; CATSUP; CHEESE SAUCE; CHEESE-FLAVORED CORN SNACKS; CHOCOLATE; CHOCOLATE AND CHOCOLATES; CHOCOLATE BARS; CHOCOLATE CANDIES; CHOCOLATE CHIPS; CHOCOLATE COVERED COOKIES; CHOCOLATE COVERED FRUIT; CHOCOLATE COVERED NUTS; CHOCOLATE COVERED RAISINS; CHOCOLATE COVERED ROASTED COFFEE BEANS; CHOCOLATE SAUCE; CHOCOLATE SYRUP; CHOCOLATE TOPPING; CHOCOLATE-BASED BEVERAGES WITH MILK; COFFEE BASED BEVERAGES; COFFEE BEVERAGES WITH MILK; COLE SLAW DRESSING; COOKING SAUCES; DIPPING SAUCES; EDIBLE FRUIT ICES; EDIBLE ICES; FROZEN CUSTARDS; FROZEN DESSERT CONSISTING OF FRUIT AND CREAM OR CREAM SUBSTITUTES; FROZEN DESSERTS CONSISTING OF FLAVORED ICE BLOCKS WITH TOPPINGS; FROZEN JUICE BARS;

FROZEN SOY-BASED DESSERTS; FROZEN YOGHURT; FROZEN YOGURT; FRUIT ICE; FRUIT ICES; FRUIT SAUCES EXCLUDING CRANBERRY SAUCE AND APPLSAUCE; ICE CREAM; ICED COFFEE; ICED TEA; KETCHUP; MACARONI AND CHEESE; MAYONNAISE; MILK CHOCOLATE; MUSTARD; NATURAL SWEETENER; PESTO; PESTO SAUCE; PIZZA; PROCESSED CEREAL-BASED FOOD TO BE USED AS A BREAKFAST FOOD. SNACK FOOD OR INGREDIENT FOR MAKING OTHER FOODS; SALAD DRESSING; SALAD DRESSINGS; SALAD SAUCES; SALSA; SANDWICHES; SAUCE MIXES; SAUCES; SAUCES FOR BARBECUED MEAT; SHAKES; SHERBET; SOY BURGER SANDWICHES; SOY SAUCE; SOY-BASED ICE CREAM SUBSTITUTE; YOGURT-COVERED FRUIT (U.S. CL. 46).

HEATHER THOMPSON, EXAMINING ATTORNEY

JASON TURNER, EXAMINING ATTORNEY

SN 85-214,421. ARCHER MANUFACTURING, INC., DANVILLE, CA. FILED 1-10-2011.

SN 85-214,409. MVP GROUP INTERNATIONAL, INC., CHARLESTON, SC. FILED 1-10-2011.

## SAVANNAH SNOW

THE MARK CONSISTS OF STANDARD CHARACTERS WITHOUT CLAIM TO ANY PARTICULAR FONT, STYLE, SIZE, OR COLOR.

### CLASS 3—COSMETICS AND CLEANING PREPARATIONS

FOR SCENTED ROOM SPRAYS (U.S. CLS. 1, 4, 6, 50, 51 AND 52).

### CLASS 4—LUBRICANTS AND FUELS

FOR CANDLES; FRAGRANT WAX FOR USE IN POTPOURRI BURNERS; MELT TARTS, NAMELY, SCENTED WAX TO BE MELTED SLOWLY WITH A WARMER; SCENTED CANDLES; SCENTED WAX FOR USE IN CANDLE WARMERS (U.S. CLS. 1, 6 AND 15).

THEODORE MCBRIDE, EXAMINING ATTORNEY

SN 85-214,416. ARCHER MANUFACTURING, INC., DANVILLE, CA. FILED 1-10-2011.

## BLACK OPS

THE MARK CONSISTS OF STANDARD CHARACTERS WITHOUT CLAIM TO ANY PARTICULAR FONT, STYLE, SIZE, OR COLOR.

OWNER OF U.S. REG. NO. 2,495,513.

### CLASS 3—COSMETICS AND CLEANING PREPARATIONS

FOR ALL PURPOSE CLEANING PREPARATIONS (U.S. CLS. 1, 4, 6, 50, 51 AND 52).

### CLASS 5—PHARMACEUTICALS

FOR ALL PURPOSE DISINFECTING AND DEODORIZING PREPARATIONS (U.S. CLS. 6, 18, 44, 46, 51 AND 52).

## SPECIAL OPS

THE MARK CONSISTS OF STANDARD CHARACTERS WITHOUT CLAIM TO ANY PARTICULAR FONT, STYLE, SIZE, OR COLOR.

OWNER OF U.S. REG. NO. 2,495,513.

### CLASS 3—COSMETICS AND CLEANING PREPARATIONS

FOR ALL PURPOSE CLEANING PREPARATIONS (U.S. CLS. 1, 4, 6, 50, 51 AND 52).

### CLASS 5—PHARMACEUTICALS

FOR ALL PURPOSE DISINFECTING AND DEODORIZING PREPARATIONS (U.S. CLS. 6, 18, 44, 46, 51 AND 52).

JASON TURNER, EXAMINING ATTORNEY

SN 85-214,563. MCMENAMINS, INC., PORTLAND, OR. FILED 1-11-2011.

## ELKS TEMPLE

THE MARK CONSISTS OF STANDARD CHARACTERS WITHOUT CLAIM TO ANY PARTICULAR FONT, STYLE, SIZE, OR COLOR.

### CLASS 41—EDUCATION AND ENTERTAINMENT

FOR ENTERTAINMENT SERVICES IN THE NATURE OF LIVE MUSICAL PERFORMANCES (U.S. CLS. 100, 101 AND 107).

### CLASS 43—HOTEL AND RESTAURANT SERVICES

FOR HOTEL, RESTAURANT AND BAR SERVICES (U.S. CLS. 100 AND 101).

MATTHEW EINSTEIN, EXAMINING ATTORNEY

SN 85-214,726. U-GO STATIONS, INC., PHILADELPHIA, PA.  
FILED 1-11-2011.

WHEREVER U-GO, THERE'S U-GO

THE MARK CONSISTS OF STANDARD CHARACTERS WITHOUT CLAIM TO ANY PARTICULAR FONT, STYLE, SIZE, OR COLOR.

**CLASS 9—ELECTRICAL AND SCIENTIFIC APPARATUS**

FOR ELECTRICAL APPARATUS, NAMELY, CHARGING STATIONS FOR CHARGING ELECTRIC VEHICLES (U.S. CLS. 21, 23, 26, 36 AND 38).

**CLASS 37—CONSTRUCTION AND REPAIR**

FOR CHARGING STATION SERVICES FOR ELECTRIC VEHICLES (U.S. CLS. 100, 103 AND 106).  
DORITT L. CARROLL, EXAMINING ATTORNEY

SN 85-215,307. COVANTA ENERGY CORPORATION, MORRISTOWN, NJ. FILED 1-11-2011.



THE MARK CONSISTS OF THE OUTLINE OF A "CIRCLE" COMPRISED OF AN ARROW FORMING THE ARC ON ONE SIDE OF THE "CIRCLE" AND THE IMAGE OF AN ELECTRIC CABLE WITH A PLUG ON ONE END FORMING THE OTHER ARC OF THE "CIRCLE".

**CLASS 4—LUBRICANTS AND FUELS**

FOR BIOFUELS (U.S. CLS. 1, 6 AND 15).

**CLASS 35—ADVERTISING AND BUSINESS**

FOR OPERATION OF A BUSINESS FOR OTHERS, NAMELY, MUNICIPAL, INDUSTRIAL AND COMMERCIAL WATER AND WASTE WATER TREATMENT SYSTEMS, SLUDGE AND WASTE INCINERATION AND DISPOSAL FACILITIES, AND POWER PLANTS; PROCUREMENT SERVICES, NAMELY, PURCHASING OF MUNICIPAL, INDUSTRIAL AND COMMERCIAL WATER AND WASTE WATER TREATMENT SYSTEMS AND SLUDGE AND WASTE INCINERATION AND DISPOSAL FACILITIES FOR OTHERS; BUSINESS MANAGEMENT OF SEWERAGE SYSTEMS, TREATMENT SYSTEMS AND WATER BILLING SYSTEMS FOR OTHERS; AND CONSULTATION SERVICES RELATED TO THE FOREGOING (U.S. CLS. 100, 101 AND 102).

**CLASS 37—CONSTRUCTION AND REPAIR**

FOR WASTE DISPOSAL FOR OTHERS; MAINTENANCE OF MUNICIPAL, INDUSTRIAL, AND COMMERCIAL WATER AND WASTE WATER TREATMENT SYSTEMS, SLUDGE AND WASTE INCINERATION AND DISPOSAL FACILITIES, AND POWER PLANTS; CONSTRUCTION, OF MUNICIPAL, INDUSTRIAL AND COMMERCIAL WATER AND WASTE WATER TREATMENT SYSTEMS, SLUDGE AND WASTE INCINERATION AND WASTE DISPOSAL FACILITIES, AND POWER PLANTS AND CONSULTATION SERVICES RELATED TO THE FOREGOING (U.S. CLS. 100, 103 AND 106).

**CLASS 39—TRANSPORTATION AND STORAGE**

FOR PUBLIC UTILITIES IN THE NATURE OF SUPPLYING WATER AND WATER DISTRIBUTION AND DISTRIBUTION OF TREATED WATER, POWER, AND STEAM; OPERATION OF PIPELINES; UTILITY SERVICES IN THE NATURE OF ELECTRICITY DISTRIBUTION; UTILITY SERVICES, NAMELY, TRANSMISSION OF ELECTRICITY; UTILITY SERVICES IN THE NATURE OF SLUDGE AND WASTE INCINERATION AND WASTE DISPOSAL FACILITIES; AND CONSULTATION SERVICES RELATED TO THE FOREGOING AND RELATED TO PUBLIC UTILITIES IN THE NATURE OF SUPPLYING WATER AND WATER DISTRIBUTION AND DISTRIBUTION OF TREATED WATER, POWER AND STEAM (U.S. CLS. 100 AND 105).

**CLASS 40—MATERIAL TREATMENT**

FOR GENERATION OF ELECTRICITY; GENERATION OF POWER; TREATMENT OF MUNICIPAL, INDUSTRIAL AND COMMERCIAL WATER AND WASTE WATER; SLUDGE AND WASTE INCINERATION; WASTE-TO-FUEL GENERATION SERVICES; WASTE-TO-ENERGY GENERATION SERVICES; RECYCLING OF ELECTRONIC EQUIPMENT AND DEVICES; AND CONSULTATION SERVICES RELATING TO GENERATION OF ELECTRICITY, GENERATION OF POWER, AND MUNICIPAL, INDUSTRIAL AND COMMERCIAL WATER AND WASTE WATER TREATMENT SERVICES; PROVIDING MUNICIPAL, INDUSTRIAL AND COMMERCIAL WATER AND WASTE WATER TREATMENT SYSTEM SERVICES (U.S. CLS. 100, 103 AND 106).

**CLASS 42—SCIENTIFIC AND COMPUTER SERVICES**

FOR ARCHITECTURAL DESIGN OF MUNICIPAL, INDUSTRIAL AND COMMERCIAL WATER AND WASTE WATER TREATMENT SYSTEMS, SLUDGE AND WASTE INCINERATION AND DISPOSAL FACILITIES, AND POWER PLANTS; DESIGN, ENGINEERING, AND DEVELOPMENT OF POWER PLANTS; CONSULTATION RELATING TO ENGINEERING CONSTRUCTION SERVICES, NAMELY, DESIGN, ENGINEERING, AND DEVELOPMENT OF MUNICIPAL, INDUSTRIAL, AND COMMERCIAL WATER AND WASTE WATER TREATMENT SYSTEMS, SLUDGE AND WASTE INCINERATION AND DISPOSAL FACILITIES, AND POWER PLANTS; ENGINEERING SERVICES FOR THE CONSTRUCTION, DESIGN, AND DEVELOPMENT OF MUNICIPAL, INDUSTRIAL AND COMMERCIAL WATER AND WASTE WATER TREATMENT SYSTEMS, SLUDGE AND WASTE INCINERATION AND WASTE DISPOSAL FACILITIES, AND POWER PLANTS; AND CONSULTATION SERVICES RELATED TO THE FOREGOING (U.S. CLS. 100 AND 101).

BRIAN NEVILLE, EXAMINING ATTORNEY

SN 85-215,643. U.S. VENTURE, INC., APPLETON, WI. FILED 1-12-2011.

# THRIVE

THE MARK CONSISTS OF STANDARD CHARACTERS WITHOUT CLAIM TO ANY PARTICULAR FONT, STYLE, SIZE, OR COLOR.

## CLASS 1—CHEMICALS

FOR TRANSMISSION FLUIDS (U.S. CLS. 1, 5, 6, 10, 26 AND 46).

## CLASS 4—LUBRICANTS AND FUELS

FOR GEAR OILS; MOTOR OILS (U.S. CLS. 1, 6 AND 15).  
DOMINICK J. SALEMI, EXAMINING ATTORNEY

SN 85-216,054. WINDOW WORLD INTERNATIONAL, LLC, NORTH WILKESBORO, NC. FILED 1-12-2011.

# Window World

THE MARK CONSISTS OF STANDARD CHARACTERS WITHOUT CLAIM TO ANY PARTICULAR FONT, STYLE, SIZE, OR COLOR.

OWNER OF U.S. REG. NOS. 2,331,991, 3,016,669 AND 3,244,991.

NO CLAIM IS MADE TO THE EXCLUSIVE RIGHT TO USE "WINDOW", APART FROM THE MARK AS SHOWN.

## CLASS 35—ADVERTISING AND BUSINESS

FOR RETAIL STORE SERVICES FEATURING REPLACEMENT WINDOWS (U.S. CLS. 100, 101 AND 102).  
FIRST USE 10-1-1996; IN COMMERCE 10-1-1996.

## CLASS 37—CONSTRUCTION AND REPAIR

FOR INSTALLATION OF REPLACEMENT WINDOWS (U.S. CLS. 100, 103 AND 106).  
FIRST USE 10-1-1996; IN COMMERCE 10-1-1996.  
KRISTIN CARLSON, EXAMINING ATTORNEY

SN 85-216,226. EDUCATIONAL TESTING SERVICE, PRINCETON, NJ. FILED 1-12-2011.

# SPEAK

THE MARK CONSISTS OF STANDARD CHARACTERS WITHOUT CLAIM TO ANY PARTICULAR FONT, STYLE, SIZE, OR COLOR.

OWNER OF U.S. REG. NO. 1,297,432.

## CLASS 9—ELECTRICAL AND SCIENTIFIC APPARATUS

FOR AUDIO CASSETTES USED FOR PRACTICING SPOKEN ENGLISH AND FOR TESTING ENGLISH LANGUAGE PROFICIENCY (U.S. CLS. 21, 23, 26, 36 AND 38).

FIRST USE 9-30-1982; IN COMMERCE 9-30-1982.

## CLASS 16—PAPER GOODS AND PRINTED MATTER

FOR BOOKLETS USED FOR PRACTICING ENGLISH PROFICIENCY AND FOR TESTING ENGLISH LANGUAGE PROFICIENCY (U.S. CLS. 2, 5, 22, 23, 29, 37, 38 AND 50).

FIRST USE 9-30-1982; IN COMMERCE 9-30-1982.

CHRISTOPHER BUONGIORNO, EXAMINING ATTORNEY

SN 85-218,090. 4WARD FINANCIAL MARKETING, HOUSTON, TX. FILED 1-14-2011.



The logo for 4WARD MARKETING features the word "4WARD" in a bold, stylized font where the number "4" is significantly larger and more prominent than the letters "WARD". Below "4WARD" is the word "MARKETING" in a smaller, all-caps, sans-serif font.

NO CLAIM IS MADE TO THE EXCLUSIVE RIGHT TO USE "MARKETING", APART FROM THE MARK AS SHOWN.

THE MARK CONSISTS OF THE STYLIZED WORDS "4WARD MARKETING" WITH AN ARROW DESIGN THROUGH THE LETTERS.

## CLASS 16—PAPER GOODS AND PRINTED MATTER

FOR PUBLICATIONS, NAMELY, MAGAZINES, NEWSLETTERS, AND PAMPHLETS IN THE FIELD OF FINANCIAL SERVICES (U.S. CLS. 2, 5, 22, 23, 29, 37, 38 AND 50).

## CLASS 35—ADVERTISING AND BUSINESS

FOR PROFESSIONAL BUSINESS CONSULTING; BUSINESS MANAGEMENT CONSULTING AND ADVISORY SERVICES; BUSINESS MARKETING CONSULTING, ALL THE FORGOING IN THE FIELD OF FINANCIAL SERVICES (U.S. CLS. 100, 101 AND 102).

## CLASS 41—EDUCATION AND ENTERTAINMENT

FOR EDUCATION, NAMELY, TRAINING AND MENTORING SERVICES IN THE FIELD OF FINANCIAL SERVICES FOR BROKER-DEALERS AND REGISTERED INVESTMENT ADVISERS; ON-LINE PUBLICATION OF INSTRUCTIONAL ARTICLES IN THE FIELD OF FINANCIAL SERVICES; PROVIDING NEWSLETTERS IN THE FIELD OF FINANCIAL SERVICES VIA E-MAIL; ORGANIZING SEMINARS AND INSTRUCTIONAL COURSES FOR FINANCIAL SERVICES PROVIDERS IN THE FIELDS OF ADVISING, PROMOTION, MARKETING AND BUSINESS DEVELOPMENT (U.S. CLS. 100, 101 AND 107).

CHRISTINA SOBRAL, EXAMINING ATTORNEY

SN 85-219,687. FRANK RUSSELL COMPANY, SEATTLE, WA. FILED 1-18-2011.

**CLASS 42—SCIENTIFIC AND COMPUTER SERVICES**

FOR PROVIDING ONLINE NON-DOWNLOADABLE SOFTWARE FOR FINANCIAL ANALYSIS AND MEASUREMENT, AND FOR GRAPHICAL PRESENTATION, ALL IN THE FINANCIAL, INVESTMENT, AND RETIREMENT PLAN FIELDS (U.S. CLS. 100 AND 101).  
ALLISON HOLTZ, EXAMINING ATTORNEY

**RUSSELL MILESTONES**

THE MARK CONSISTS OF STANDARD CHARACTERS WITHOUT CLAIM TO ANY PARTICULAR FONT, STYLE, SIZE, OR COLOR.

**CLASS 9—ELECTRICAL AND SCIENTIFIC APPARATUS**

FOR DOWNLOADABLE ELECTRONIC FINANCIAL PUBLICATIONS, NAMELY, FACTSHEETS, FINANCIAL REPORTS, FINANCIAL BOOKLETS, FINANCIAL NEWSLETTERS, FINANCIAL BROCHURES, AND FINANCIAL BOOKS, ALL IN THE FINANCIAL, INVESTMENT AND RETIREMENT PLAN FIELDS; ELECTRONIC, MAGNETIC, OPTICAL AND OTHER MACHINE-READABLE MEDIA, NAMELY, COMPACT DISKS, MAGNETIC DISKS, AND COMPUTER MEMORIES CONTAINING/FEATURING FINANCIAL INFORMATION FOR USE IN THE FINANCIAL, INVESTMENT AND RETIREMENT PLAN FIELDS; DOWNLOADABLE VIDEO RECORDINGS IN THE FINANCIAL, INVESTMENT AND RETIREMENT PLAN FIELDS (U.S. CLS. 21, 23, 26, 36 AND 38).

**CLASS 16—PAPER GOODS AND PRINTED MATTER**

FOR PRINTED FINANCIAL PUBLICATIONS, NAMELY, PROSPECTUSES, FACTSHEETS, FINANCIAL REPORTS, FINANCIAL BOOKLETS, FINANCIAL NEWSLETTERS, FINANCIAL BROCHURES, AND FINANCIAL BOOKS, ALL IN THE FINANCIAL, INVESTMENT, AND RETIREMENT PLAN FIELDS (U.S. CLS. 2, 5, 22, 23, 29, 37, 38 AND 50).

**CLASS 36—INSURANCE AND FINANCIAL**

FOR FINANCIAL CONSULTING SERVICES; REAL ESTATE INVESTMENT CONSULTING SERVICES; INVESTMENT PORTFOLIO MANAGER EVALUATION SERVICES; INVESTMENT PORTFOLIO MONITORING SERVICES; INVESTMENT PORTFOLIO PERFORMANCE ANALYSIS SERVICES; SECURITIES, COMMODITIES AND REAL ESTATE INVESTMENT RESEARCH SERVICES; TRANSFER AGENCY SERVICES RENDERED TO ISSUERS OF INVESTMENT SECURITIES; CURRENCY BROKERAGE SERVICES; TRUST AND INVESTMENT MANAGEMENT SERVICES; COMMODITIES INVESTMENT MANAGEMENT SERVICES; SECURITIES UNDERWRITING SERVICES; SECURITIES BROKERAGE SERVICES; MUTUAL FUND ADMINISTRATION SERVICES; INVESTMENT BANKING SERVICES; PROVIDING FINANCIAL INFORMATION BY ELECTRONIC MEANS; FINANCIAL SERVICES IN THE NATURE OF AN INVESTMENT SECURITY, AND PROVIDING ONLINE FINANCIAL CALCULATORS (U.S. CLS. 100, 101 AND 102).

**CLASS 41—EDUCATION AND ENTERTAINMENT**

FOR EDUCATIONAL SERVICES, NAMELY, CONDUCTING CLASSES, CONFERENCES, TELECONFERENCES, SEMINARS, WORKSHOPS AND TUTORIALS, ALL IN THE FINANCIAL AND INVESTMENT FIELD (U.S. CLS. 100, 101 AND 107).

SN 85-219,887. SMARTBLOCK, INC., MANHASSET, NY. FILED 1-18-2011.

**SMART RESTORE**

THE MARK CONSISTS OF STANDARD CHARACTERS WITHOUT CLAIM TO ANY PARTICULAR FONT, STYLE, SIZE, OR COLOR.

**CLASS 5—PHARMACEUTICALS**

FOR NUTRITIONAL SUPPLEMENTS (U.S. CLS. 6, 18, 44, 46, 51 AND 52).

**CLASS 9—ELECTRICAL AND SCIENTIFIC APPARATUS**

FOR VIDEO AND AUDIO TAPES AND DOWNLOADABLE INFORMATION IN THE FORM OF NEWSLETTERS, BOOKLETS, INFORMATION SHEETS AND INFORMATIONAL BROCHURES IN THE FIELD OF DIET, EXERCISE, NUTRITION, WEIGHT MANAGEMENT, WEIGHT MAINTENANCE, APPETITE CONTROL, DIETARY SUPPLEMENTATION, WEIGHT LOSS, FAT CONTROL, COOKING AND LIFESTYLE (U.S. CLS. 21, 23, 26, 36 AND 38).

**CLASS 16—PAPER GOODS AND PRINTED MATTER**

FOR PRINTED NEWSLETTERS, BOOKLETS, INFORMATION SHEETS AND INFORMATIONAL BROCHURES IN THE FIELDS OF DIET, EXERCISE, NUTRITION, WEIGHT MANAGEMENT, WEIGHT MAINTENANCE, APPETITE CONTROL, DIETARY SUPPLEMENTATION, WEIGHT LOSS, FAT CONTROL, COOKING AND LIFESTYLE; PRINTED DIET, EXERCISE AND WEIGHT LOSS PLANS; DIARIES FOR TRACKING FOOD CONSUMPTION AND WEIGHT LOSS (U.S. CLS. 2, 5, 22, 23, 29, 37, 38 AND 50).

**CLASS 41—EDUCATION AND ENTERTAINMENT**

FOR PROVIDING A WEBSITE FEATURING NON-DOWNLOADABLE PUBLICATIONS IN THE NATURE OF NEWSLETTERS, BOOKLETS, INFORMATION SHEETS AND INFORMATIONAL BROCHURES IN THE FIELD OF DIET, EXERCISE, NUTRITION, WEIGHT MANAGEMENT, WEIGHT MAINTENANCE, APPETITE CONTROL, DIETARY SUPPLEMENTATION, WEIGHT LOSS, FAT CONTROL, COOKING AND LIFESTYLE (U.S. CLS. 100, 101 AND 107).

**CLASS 44—MEDICAL, BEAUTY AND AGRICULTURAL SERVICES**

FOR ALTERNATIVE MEDICINE SERVICES, NAMELY, DETOXIFICATION SERVICES; WEIGHT REDUCTION DIET PLANNING AND SUPERVISION; PROVIDING INFORMATION AND COUNSELING ABOUT DIETARY SUPPLEMENTS AND NUTRITION (U.S. CLS. 100 AND 101).

LINDA M. KING, EXAMINING ATTORNEY

SN 85-221,973. RUGBY PROPERTIES, LLC, VOORHEES, NJ. FILED 1-20-2011.



NO CLAIM IS MADE TO THE EXCLUSIVE RIGHT TO USE "CONNECTICUT", APART FROM THE MARK AS SHOWN.

THE COLOR(S) ORANGE, BLACK, AND WHITE IS/ARE CLAIMED AS A FEATURE OF THE MARK.

THE MARK CONSISTS OF AN ORANGE, BLACK AND WHITE PROFILE OF THE HEAD OF A WILDCAT, ABOVE THE BLACK WORD "WILDCATS", WHICH IS ABOVE THE ORANGE WORD "CONNECTICUT".

SN 85-220,854. CIPHEROPTICS, INC., RALEIGH, NC. FILED 1-19-2011.



NO CLAIM IS MADE TO THE EXCLUSIVE RIGHT TO USE "NETWORKS", APART FROM THE MARK AS SHOWN.

THE COLOR(S) BLUE AND BLACK IS/ARE CLAIMED AS A FEATURE OF THE MARK.

THE MARK CONSISTS OF "CERTES" IN BLUE LETTERS ABOVE "NETWORKS" IN BLACK LETTERS.

**CLASS 25—CLOTHING**

FOR BASEBALL CAPS AND HATS; RUGBY SHIRTS; RUGBY SHORTS; RUGBY TOPS; T-SHIRTS (U.S. CLS. 22 AND 39).

**CLASS 28—TOYS AND SPORTING GOODS**

FOR RUGBY BALLS (U.S. CLS. 22, 23, 38 AND 50).

**CLASS 41—EDUCATION AND ENTERTAINMENT**

FOR ENTERTAINMENT SERVICES, NAMELY, PARTICIPATION IN RUGBY MATCHES (U.S. CLS. 100, 101 AND 107).

AMY C. KEAN, EXAMINING ATTORNEY

**CLASS 9—ELECTRICAL AND SCIENTIFIC APPARATUS**

FOR COMPUTER HARDWARE AND SOFTWARE FOR SCALABLE SECURITY APPLICATIONS FOR HIGH PERFORMANCE NETWORKS (U.S. CLS. 21, 23, 26, 36 AND 38).

**CLASS 37—CONSTRUCTION AND REPAIR**

FOR INSTALLATION OF COMPUTER HARDWARE USED IN CONNECTION WITH SCALABLE SECURITY APPLICATIONS FOR HIGH PERFORMANCE NETWORKS (U.S. CLS. 100, 103 AND 106).

**CLASS 42—SCIENTIFIC AND COMPUTER SERVICES**

FOR TECHNICAL CONSULTING AND DESIGN SERVICES IN CONNECTION WITH COMPUTER HARDWARE AND SOFTWARE FOR SCALABLE SECURITY APPLICATIONS FOR HIGH PERFORMANCE NETWORKS; SOFTWARE INSTALLATION SERVICES IN CONNECTION WITH SCALABLE SECURITY APPLICATIONS FOR HIGH PERFORMANCE NETWORKS (U.S. CLS. 100 AND 101).

KAREN SEVERSON, EXAMINING ATTORNEY

SN 85-222,999. BECKER, PETER M, FAYETTEVILLE, NY. FILED 1-21-2011.

**'IN THE HOUSE' SPECIALTIES**

THE MARK CONSISTS OF STANDARD CHARACTERS WITHOUT CLAIM TO ANY PARTICULAR FONT, STYLE, SIZE, OR COLOR.

NO CLAIM IS MADE TO THE EXCLUSIVE RIGHT TO USE "SPECIALTIES", APART FROM THE MARK AS SHOWN.

**CLASS 24—FABRICS**

FOR FABRIC FLAGS (U.S. CLS. 42 AND 50).

**CLASS 27—FLOOR COVERINGS**

FOR FLOOR MATS (U.S. CLS. 19, 20, 37, 42 AND 50).  
JEFFERY COWARD, EXAMINING ATTORNEY

SN 85-223,272. BISSELL HOMECARE, INC., GRAND RAPIDS, MI. FILED 1-21-2011.

**PEE-EWW**

THE MARK CONSISTS OF STANDARD CHARACTERS WITHOUT CLAIM TO ANY PARTICULAR FONT, STYLE, SIZE, OR COLOR.

OWNER OF U.S. REG. NO. 3,729,839.

**CLASS 3—COSMETICS AND CLEANING PREPARATIONS**

FOR URINE STAIN REMOVERS (U.S. CLS. 1, 4, 6, 50, 51 AND 52).

**CLASS 5—PHARMACEUTICALS**

FOR URINE ODOR ELIMINATOR (U.S. CLS. 6, 18, 44, 46, 51 AND 52).

SANJEEV VOHRA, EXAMINING ATTORNEY

SN 85-223,839. MASALA DANCE & FITNESS, INC., IRVINE, CA. FILED 1-22-2011.

**MASALA BHANGRA**

THE MARK CONSISTS OF STANDARD CHARACTERS WITHOUT CLAIM TO ANY PARTICULAR FONT, STYLE, SIZE, OR COLOR.

CONCURRENT USE INFORMATION. NOT APPLICABLE OWNER OF U.S. REG. NO. 3,013,321.

NO CLAIM IS MADE TO THE EXCLUSIVE RIGHT TO USE "BHANGRA", APART FROM THE MARK AS SHOWN.

THE ENGLISH TRANSLATION OF "MASALA" IS "SPICY".

**CLASS 9—ELECTRICAL AND SCIENTIFIC APPARATUS**

FOR PRE-RECORDED CDS, VIDEO TAPES, LASER DISKS AND DVDS FEATURING PHYSICAL EXERCISE AND ORIGINALLY COMPOSED MUSIC (U.S. CLS. 21, 23, 26, 36 AND 38).

FIRST USE 1-31-2000; IN COMMERCE 1-31-2000.

**CLASS 18—LEATHER GOODS**

FOR BACKPACKS, BOOK BAGS, SPORTS BAGS, BUM BAGS, WALLETS AND HANDBAGS; CLUTCH BAGS; CLUTCH PURSES; FASHION HANDBAGS; HANDBAGS; HANDBAGS, PURSES AND WALLETS (U.S. CLS. 1, 2, 3, 22 AND 41).

FIRST USE 1-31-2000; IN COMMERCE 1-31-2000.

**CLASS 25—CLOTHING**

FOR APPAREL FOR DANCERS, NAMELY, TEE SHIRTS, SWEATSHIRTS, PANTS, LEGGINGS, SHORTS AND JACKETS; ATHLETIC APPAREL, NAMELY, SHIRTS, PANTS, JACKETS, FOOTWEAR, HATS AND CAPS, ATHLETIC UNIFORMS; CARGO PANTS; HEADBANDS AGAINST SWEATING; HOODED SWEAT SHIRTS; LONG-SLEEVED SHIRTS; PANTALOONS; SLEEVELESS JERSEYS; YOGA PANTS; YOGA SHIRTS (U.S. CLS. 22 AND 39).

FIRST USE 1-31-2000; IN COMMERCE 1-31-2000.

**CLASS 41—EDUCATION AND ENTERTAINMENT**

FOR DANCE INSTRUCTION; DANCE INSTRUCTION FOR CHILDREN; EDUCATION SERVICES, NAMELY, PROVIDING CLASSES AND INSTRUCTION IN THE FIELD OF DANCE; EDUCATIONAL SERVICES, NAMELY, CONDUCTING SEMINARS AND PROVIDING INSTRUCTION IN THE FIELD OF PHYSICAL EXERCISE, PHYSICAL FITNESS, STRENGTH CONDITIONING AND DISTRIBUTION OF COURSE MATERIAL IN CONNECTION THEREWITH; ENTERTAINMENT IN THE NATURE OF DANCE PERFORMANCES; ORGANIZING COMMUNITY FESTIVALS FEATURING A VARIETY OF ACTIVITIES, NAMELY, ART EXHIBITIONS, HERITAGE MARKETS, ETHNIC DANCES, AND THE LIKE; PROVIDING A WEB SITE FEATURING INFORMATION ON EXERCISE AND FITNESS (U.S. CLS. 100, 101 AND 107).

FIRST USE 1-31-2000; IN COMMERCE 1-31-2000. PRISCILLA MILTON, EXAMINING ATTORNEY

SN 85-224,247. STAR SCIENTIFIC, INC., GLEN ALLEN, VA. FILED 1-24-2011.

**STAR SCIENTIFIC**

THE MARK CONSISTS OF STANDARD CHARACTERS WITHOUT CLAIM TO ANY PARTICULAR FONT, STYLE, SIZE, OR COLOR.

**CLASS 5—PHARMACEUTICALS**

FOR PHARMACEUTICALS; NUTRACEUTICALS; DIETARY SUPPLEMENTS; AND TOBACCO AND SMOKING CESSATION PREPARATIONS THAT TEMPORARILY REDUCE THE DESIRE TO SMOKE (U.S. CLS. 6, 18, 44, 46, 51 AND 52).

**CLASS 34—SMOKERS' ARTICLES**

FOR SNUFF; COMPRESSED TOBACCO AND SMOKELESS TOBACCO (U.S. CLS. 2, 8, 9 AND 17).

AISHA CLARKE, EXAMINING ATTORNEY

SN 85-224,269. GOOGLE INC., MOUNTAIN VIEW, CA.  
FILED 1-24-2011.

## SAYNOW BROADCAST

THE MARK CONSISTS OF STANDARD CHARACTERS WITHOUT CLAIM TO ANY PARTICULAR FONT, STYLE, SIZE, OR COLOR.

NO CLAIM IS MADE TO THE EXCLUSIVE RIGHT TO USE "BROADCAST", APART FROM THE MARK AS SHOWN.

### CLASS 9—ELECTRICAL AND SCIENTIFIC APPARATUS

FOR COMPUTER APPLICATION SOFTWARE FOR MOBILE PHONES, NAMELY, SOFTWARE FOR USE IN TELEPHONY VOICE MESSAGING SERVICES AND TELECONFERENCING SERVICES; DOWNLOADABLE ELECTRONIC GAMES VIA THE INTERNET AND WIRELESS DEVICES (U.S. CLS. 21, 23, 26, 36 AND 38).

### CLASS 42—SCIENTIFIC AND COMPUTER SERVICES

FOR PROVIDING TEMPORARY USE OF WEB-BASED, NON-DOWNLOADABLE SOFTWARE APPLICATION FOR USE IN VOICE MESSAGING AND TELECONFERENCING (U.S. CLS. 100 AND 101).

RONALD AIKENS, EXAMINING ATTORNEY

---

SN 85-224,695. WIMPY KID, INC., PLAINVILLE, MA. FILED  
1-24-2011.

## DIARY OF A WIMPY KID

THE MARK CONSISTS OF STANDARD CHARACTERS WITHOUT CLAIM TO ANY PARTICULAR FONT, STYLE, SIZE, OR COLOR.

OWNER OF U.S. REG. NO. 3,601,775.

### CLASS 9—ELECTRICAL AND SCIENTIFIC APPARATUS

FOR DECORATIVE MAGNETS; GRADUATED RULERS (U.S. CLS. 21, 23, 26, 36 AND 38).

### CLASS 14—JEWELRY

FOR WRIST WATCHES; ORNAMENTAL PINS (U.S. CLS. 2, 27, 28 AND 50).

### CLASS 16—PAPER GOODS AND PRINTED MATTER

FOR POSTERS; TEMPORARY TATTOOS; PUBLICATIONS, NAMELY, POSTER BOOKS; NOTEBOOKS, NAMELY, BLANK NOTEBOOKS, AGENDA NOTEBOOKS, AND NOTEBOOKS FOR USE IN COMPLETING SCHOOL HOMEWORK ASSIGNMENTS; BOOKMARKS; PENCIL SHARPENERS; BLOTTING PADS; STICKERS; INK STAMPS; PENCILS; PENCIL POUCHES; FOLDERS; NOTEBOOK STORAGE BOXES; NOTEPADS, NAMELY, NOTEPADS CONTAINING ADHESIVE ON ONE SIDE OF THE SHEETS FOR ATTACHMENT TO SURFACES AND NOTEPADS NOT CONTAINING ADHESIVE; BINDERS; CUPS FOR STORAGE OF WRITING IMPLEMENTS SOLD EMPTY (U.S. CLS. 2, 5, 22, 23, 29, 37, 38 AND 50).

### CLASS 18—LEATHER GOODS

FOR WALLETS (U.S. CLS. 1, 2, 3, 22 AND 41).

### CLASS 21—HOUSEWARES AND GLASS

FOR DRINKING BOTTLES SOLD EMPTY; DRINKING MUGS; LUNCH BOXES; CUPS, NAMELY, DRINKING CUPS SOLD EMPTY; WASTE BASKETS (U.S. CLS. 2, 13, 23, 29, 30, 33, 40 AND 50).

### CLASS 22—CORDAGE AND FIBERS

FOR LANYARDS, NAMELY, LANYARDS FOR HOLDING BADGES AND LANYARDS FOR HOLDING KEYS (U.S. CLS. 1, 2, 7, 19, 22, 42 AND 50).

### CLASS 24—FABRICS

FOR BEACH TOWELS (U.S. CLS. 42 AND 50).

### CLASS 25—CLOTHING

FOR POLO SHIRTS; SWEATBANDS (U.S. CLS. 22 AND 39).

### CLASS 26—FANCY GOODS

FOR NOVELTY BUTTONS (U.S. CLS. 37, 39, 40, 42 AND 50).

MARK RADEMACHER, EXAMINING ATTORNEY

---

SN 85-225,372. RIBWORKS, LLC, NEWBURGH, NY. FILED  
1-25-2011.



THE MARK CONSISTS OF A STYLIZED GOAT'S HEAD WEARING SUNGLASSES.



**CLASS 29—MEATS AND PROCESSED FOODS**

FOR BARBEQUE, NAMELY, BABY BACK RIBS, PORK SPARE RIBS, BEEF RIBS, BEEF SHORT RIBS, LAMB RIBS, BEEF BRISKET, PULLED PORK, BARBEQUE CHICKEN, SMOKED CHICKEN WINGS, SMOKED ITALIAN SAUSAGE, SMOKED PORK SHANK AND SMOKED PRIME RIB (U.S. CL. 46).

**CLASS 43—HOTEL AND RESTAURANT SERVICES**

FOR RESTAURANT SERVICES (U.S. CLS. 100 AND 101).  
TINA MAI, EXAMINING ATTORNEY

SN 85-226,172. ALFONSO HERNANDEZ ESTRADA, AKA SAUL HERNANDEZ, MEXICO CITY, MEXICO, FILED 1-26-2011.

# Remando

THE MARK CONSISTS OF STANDARD CHARACTERS WITHOUT CLAIM TO ANY PARTICULAR FONT, STYLE, SIZE, OR COLOR.

THE ENGLISH TRANSLATION OF "REMANDO" IN THE MARK IS ROWING.

**CLASS 9—ELECTRICAL AND SCIENTIFIC APPARATUS**

FOR SERIES OF MUSICAL SOUND RECORDINGS, NAMELY, COMPACT DISCS, PRERECORDED AUDIO-CASSETTES, PRERECORDED VIDEOCASSETTES, RECORDS, AND DOWNLOADABLE MUSICAL SOUND RECORDINGS (U.S. CLS. 21, 23, 26, 36 AND 38).

**CLASS 41—EDUCATION AND ENTERTAINMENT**

FOR ENTERTAINMENT SERVICES IN THE NATURE OF LIVE MUSICAL PERFORMANCES (U.S. CLS. 100, 101 AND 107).

KIM SAITO, EXAMINING ATTORNEY

SN 85-226,342. THOMASVILLE HOME FURNISHINGS, INC., THOMASVILLE, NC. FILED 1-26-2011.

## SPECIAL ADDITIONS

THE MARK CONSISTS OF STANDARD CHARACTERS WITHOUT CLAIM TO ANY PARTICULAR FONT, STYLE, SIZE, OR COLOR.

**CLASS 20—FURNITURE AND ARTICLES NOT OTHERWISE CLASSIFIED**

FOR FURNITURE (U.S. CLS. 2, 13, 22, 25, 32 AND 50).

**CLASS 27—FLOOR COVERINGS**

FOR RUGS (U.S. CLS. 19, 20, 37, 42 AND 50).  
LINDA MICKLEBURGH, EXAMINING ATTORNEY

SN 85-226,567. THE CLEVELAND CLINIC FOUNDATION, CLEVELAND, OH. FILED 1-26-2011.

## GO! GET PHYSICAL

THE MARK CONSISTS OF STANDARD CHARACTERS WITHOUT CLAIM TO ANY PARTICULAR FONT, STYLE, SIZE, OR COLOR.

OWNER OF U.S. REG. NOS. 3,600,003 AND 3,906,133.

**CLASS 35—ADVERTISING AND BUSINESS**

FOR RETAIL STORE SERVICES FEATURING FITNESS AND HEALTH MONITORING EQUIPMENT, EXERCISE AND FITNESS EQUIPMENT AND SUPPLIES, INSTRUCTIONAL DVDS, AND APPAREL; ON-LINE RETAIL STORE SERVICES FEATURING FITNESS AND HEALTH MONITORING EQUIPMENT, EXERCISE AND FITNESS EQUIPMENT AND SUPPLIES, INSTRUCTIONAL DVDS, AND APPAREL (U.S. CLS. 100, 101 AND 102).

**CLASS 41—EDUCATION AND ENTERTAINMENT**

FOR PROVIDING INSTRUCTION IN THE FIELD OF PHYSICAL EXERCISE, HEALTH, NUTRITION, FITNESS, HEALTHY EATING AND HEALTHY LIFESTYLES; PROVIDING EQUIPMENT IN THE FIELD OF PHYSICAL EXERCISE; PROVIDING EXERCISE INSTRUCTION PROMOTING CARDIAC HEALTH; ON-LINE PROGRAMS ADVISING ON AND PROVIDING INFORMATION ABOUT FITNESS; ON-LINE EXERCISE PROGRAMS AND ONLINE EXERCISE PROGRAMS PROMOTING CARDIAC HEALTH, NAMELY, PROVIDING INFORMATION AND ADVICE REGARDING PHYSICAL EXERCISE (U.S. CLS. 100, 101 AND 107).

**CLASS 44—MEDICAL, BEAUTY AND AGRICULTURAL SERVICES**

FOR ON-LINE PROGRAMS ADVISING ON AND PROVIDING INFORMATION ABOUT HEALTH, NUTRITION, HEALTHY EATING, AND HEALTHY LIFESTYLES; ON-LINE PROGRAMS ADVISING ON AND PROVIDING INFORMATION ABOUT CARDIAC HEALTH (U.S. CLS. 100 AND 101).

MARK PILARO, EXAMINING ATTORNEY

SN 85-228,540. RMP CAPITAL CORP, ISLANDIA, NY. FILED 1-28-2011.

## FACTOR-IN-A-BOX

THE MARK CONSISTS OF STANDARD CHARACTERS WITHOUT CLAIM TO ANY PARTICULAR FONT, STYLE, SIZE, OR COLOR.

**CLASS 35—ADVERTISING AND BUSINESS**

FOR ACCOUNTS RECEIVABLE SERVICES; AND OUTSOURCING OF ACCOUNTS PAYABLE; PROVIDING BUSINESS CONSULTING SERVICES TO FACTORING COMPANIES (U.S. CLS. 100, 101 AND 102).

SN 85-230,124. STARBUCKS CORPORATION, DBA STARBUCKS COFFEE COMPANY, SEATTLE, WA. FILED 1-31-2011.

**CLASS 36—INSURANCE AND FINANCIAL**

FOR FINANCIAL AND FACTORING SERVICES, NAMELY, PURCHASING OF ACCOUNTS RECEIVABLE; FACTORING ACCOUNTS RECEIVABLE; TRADE FINANCING; PURCHASE ORDER FINANCING; ASSET BASED LENDING; AND PROVIDING FINANCIAL INFORMATION TO FACTORING COMPANIES WITHIN THE FUNCTIONS OF SALES, CREDIT, OPERATIONS, AND FINANCIAL MANAGEMENT (U.S. CLS. 100, 101 AND 102).

**STARBUCKS TRIBUTE BLEND**

THE MARK CONSISTS OF STANDARD CHARACTERS WITHOUT CLAIM TO ANY PARTICULAR FONT, STYLE, SIZE, OR COLOR.

NO CLAIM IS MADE TO THE EXCLUSIVE RIGHT TO USE "BLEND", APART FROM THE MARK AS SHOWN.

**CLASS 41—EDUCATION AND ENTERTAINMENT**

FOR EDUCATIONAL SERVICES, NAMELY, PROVIDING WORKSHOPS IN THE FIELD OF FACTORING INDUSTRY AND PROVIDING TRAINING MANUALS IN CONNECTION THEREWITH (U.S. CLS. 100, 101 AND 107).

FLORENTINA BLANDU, EXAMINING ATTORNEY

**CLASS 21—HOUSEWARES AND GLASS**

FOR INSULATED COFFEE AND BEVERAGE CUPS; COFFEE CUPS; TEA CUPS; MUGS; BEVERAGE GLASSWARE; DISHES; PLATES AND BOWLS; TRIVETS; STORAGE CANISTER SETS; NON-ELECTRIC DRIP COFFEE MAKERS; NON-ELECTRIC PLUNGER-STYLE COFFEE MAKERS (U.S. CLS. 2, 13, 23, 29, 30, 33, 40 AND 50).

**CLASS 30—STAPLE FOODS**

FOR GROUND AND WHOLE BEAN COFFEE; NON-ALCOHOLIC BEVERAGES MADE WITH A BASE OF COFFEE; NON-ALCOHOLIC BEVERAGES MADE WITH A BASE OF ESPRESSO; READY-TO-DRINK COFFEE (U.S. CL. 46).

TRACY FLETCHER, EXAMINING ATTORNEY

SN 85-228,617. IP HOLDINGS LLC, VANCOUVER, WA. FILED 1-28-2011.

SN 85-230,220. SPRINGBOARD NON-PROFIT CONSUMER CREDIT MANAGEMENT, INC., RIVERSIDE, CA. FILED 1-31-2011.

URBAN OCEAN



THE MARK CONSISTS OF A CURVED LINE.

THE MARK CONSISTS OF STANDARD CHARACTERS WITHOUT CLAIM TO ANY PARTICULAR FONT, STYLE, SIZE, OR COLOR.

**CLASS 11—ENVIRONMENTAL CONTROL APPARATUS**

FOR AQUARIUM FILTERS; AQUARIUM FILTRATION APPARATUS; AQUARIUM HEATERS; AQUARIUM LIGHTS; WATER FILTERING UNITS FOR AQUARIUMS (U.S. CLS. 13, 21, 23, 31 AND 34).

**CLASS 36—INSURANCE AND FINANCIAL**

FOR CREDIT COUNSELING; HOUSING COUNSELING, NAMELY, FINANCIAL COUNSELING RELATING TO HOME RENTAL, PURCHASE AND FORECLOSURE; FINANCIAL COUNSELING RELATING TO BANKRUPTCY; DEBT MANAGEMENT SERVICES; HOME OWNERSHIP SERVICES, NAMELY, FINANCIAL CONSULTING AND INFORMATION RELATED TO HOME RENTAL, PURCHASE AND FORECLOSURE; PROVIDING FINANCIAL INFORMATION ON DEBT MANAGEMENT, CONSUMER CREDIT, HOME OWNERSHIP, MONEY MANAGEMENT AND PERSONAL FINANCE, STUDENT LOANS AND BANKRUPTCY (U.S. CLS. 100, 101 AND 102).

FIRST USE 9-0-2007; IN COMMERCE 5-7-2008.

**CLASS 21—HOUSEWARES AND GLASS**

FOR AQUARIUM AIR STONES; AQUARIUM COVERS; AQUARIUM FISH NETS; AQUARIUM HOODS; AQUARIUM ORNAMENTS; AQUARIUMS; ARTIFICIAL AQUARIUM LANDSCAPES (U.S. CLS. 2, 13, 23, 29, 30, 33, 40 AND 50).

LAKEISHA LEWIS, EXAMINING ATTORNEY

**CLASS 41—EDUCATION AND ENTERTAINMENT**

FOR EDUCATIONAL SERVICES, NAMELY, CONDUCTING CLASSES, SEMINARS AND WORKSHOPS IN THE FIELDS OF DEBT MANAGEMENT, CONSUMER CREDIT, HOME OWNERSHIP, MONEY MANAGEMENT AND PERSONAL FINANCE, STUDENT LOANS AND BANKRUPTCY (U.S. CLS. 100, 101 AND 107).

FIRST USE 9-0-2007; IN COMMERCE 5-7-2008.

MARK PILARO, EXAMINING ATTORNEY

SN 85-234,103. AUTHENTIC SPECIALTY FOODS, INC.,  
CHINO, CA. FILED 2-4-2011.SN 85-233,578. VENDMORE SYSTEMS, LLC, STAMFORD,  
CT. FILED 2-3-2011.**EMBASA****MobileDrink**THE MARK CONSISTS OF STANDARD CHARACTERS  
WITHOUT CLAIM TO ANY PARTICULAR FONT, STYLE,  
SIZE, OR COLOR.

OWNER OF U.S. REG. NO. 3,191,123.

THE MARK CONSISTS OF STANDARD CHARACTERS  
WITHOUT CLAIM TO ANY PARTICULAR FONT, STYLE,  
SIZE, OR COLOR.**CLASS 9—ELECTRICAL AND SCIENTIFIC  
APPARATUS**FOR COMPUTER APPLICATION SOFTWARE FOR  
MOBILE PHONES, NAMELY SOFTWARE FOR ORDER-  
ING FOOD AND BEVERAGE (U.S. CLS. 21, 23, 26, 36  
AND 38).

FIRST USE 2-8-2008; IN COMMERCE 2-8-2008.

**CLASS 35—ADVERTISING AND BUSINESS**FOR ONLINE ORDERING SERVICES FOR VENDING  
MACHINES AND OTHER LOCATIONS WHERE FOOD  
AND BEVERAGE MAY BE PICKED UP (U.S. CLS. 100,  
101 AND 102).

FIRST USE 2-8-2008; IN COMMERCE 2-8-2008.

ARETHA SOMERVILLE, EXAMINING ATTORNEY

**CLASS 29—MEATS AND PROCESSED FOODS**FOR SPICED TOMATOES, MENUDO CON PATA  
(SOUP WITH BEEF), COOKING OIL, PROCESSED  
BEANS (U.S. CL. 46).**CLASS 30—STAPLE FOODS**FOR FLAN (CUSTARD MIX), SAUCES EXCLUDING  
APPLE SAUCE AND CRANBERRY SAUCE, CANDIES,  
CUSTARD, CORN SYRUP, CORNSTARCH, CHOCO-  
LATE AND SPICES, SWEETENED GELATINS (U.S. CL.  
46).

JAMES A. RAUEN, EXAMINING ATTORNEY

SN 85-234,798. COMMONWEALTH TRADING COMPANY,  
INC., SAN ANTONIO, TX. FILED 2-4-2011.SN 85-233,636. VENDMORE SYSTEMS, LLC, STAMFORD,  
CT. FILED 2-3-2011.**MobileDrink**THE COLOR(S) WHITE, LIGHT GREEN, DARK GREEN  
IS/ARE CLAIMED AS A FEATURE OF THE MARK.THE MARK CONSISTS OF THE LETTERS "MOBILE-  
DRINK" OUTLINED IN DARK GREEN AND CONSISTING  
OF THE WHITE-FILLED LETTERS "MOBILE" AND THE  
LIGHT GREEN-FILLED LETTERS "DRINK".THE MARK CONSISTS OF THE OVERLAPPING LET-  
TERS "CTC" INSIDE A WREATH DESIGN.**CLASS 9—ELECTRICAL AND SCIENTIFIC  
APPARATUS**FOR COMPUTER APPLICATION SOFTWARE FOR  
MOBILE PHONES, NAMELY SOFTWARE FOR ORDER-  
ING FOOD AND BEVERAGE (U.S. CLS. 21, 23, 26, 36  
AND 38).

FIRST USE 4-23-2008; IN COMMERCE 4-23-2008.

**CLASS 9—ELECTRICAL AND SCIENTIFIC  
APPARATUS**FOR COMPUTERS AND COMPUTER PERIPHERALS  
(U.S. CLS. 21, 23, 26, 36 AND 38).

FIRST USE 5-31-1996; IN COMMERCE 6-21-1996.

**CLASS 35—ADVERTISING AND BUSINESS**FOR ONLINE ORDERING SERVICES FOR VENDING  
MACHINES AND OTHER LOCATIONS WHERE FOOD  
AND BEVERAGE MAY BE PICKED UP (U.S. CLS. 100,  
101 AND 102).

FIRST USE 2-8-2008; IN COMMERCE 2-8-2008.

ARETHA SOMERVILLE, EXAMINING ATTORNEY

**CLASS 25—CLOTHING**FOR HEADWEAR, SHIRTS, AND JACKETS FOR MEN,  
WOMEN AND CHILDREN (U.S. CLS. 22 AND 39).

FIRST USE 5-31-1996; IN COMMERCE 6-21-1996.

**CLASS 35—ADVERTISING AND BUSINESS**FOR BUSINESS CONSULTATION AND BUSINESS  
MARKETING CONSULTING SERVICES (U.S. CLS. 100,  
101 AND 102).

FIRST USE 5-31-1996; IN COMMERCE 6-21-1996.

JAMES GRIFFIN, EXAMINING ATTORNEY

SN 85-235,560. MENTAL IMAGES GMBH, BERLIN, FED REP GERMANY, FILED 2-7-2011.

SN 85-238,321. XTRATEGY GROUP, LLC, MIAMI, FL. FILED 2-9-2011.

## MENTAL LIFE

THE MARK CONSISTS OF STANDARD CHARACTERS WITHOUT CLAIM TO ANY PARTICULAR FONT, STYLE, SIZE, OR COLOR.

OWNER OF U.S. REG. NOS. 2,185,557, 2,185,558 AND 3,110,999.

### CLASS 41—EDUCATION AND ENTERTAINMENT

FOR EDUCATIONAL SERVICES, NAMELY, PROVIDING ON-LINE TRAINING IN THE FORM OF COURSES, SEMINARS, AND WORKSHOPS IN THE FIELDS OF USING SOFTWARE FOR DESIGNING INNOVATIVE VIRTUAL REALITY ENVIRONMENTS, DESIGNING COMPUTER GAMES AND VIRTUAL REALITY SOFTWARE AND COMPUTER GRAPHICS OPERATIONS AND IMAGE RENDERING, DIGITAL ANIMATION AND SPECIAL EFFECTS OF IMAGES; ENTERTAINMENT SERVICES, NAMELY, PROVIDING ON-LINE INTERACTIVE COMPUTER GAMES, ON-LINE INTERACTIVE VIRTUAL REALITY GAMES, ON-LINE COMPUTER GAMES, ON-LINE VIRTUAL REALITY GAMES, AND ON-LINE MULTI-PLAYER ELECTRONIC COMPUTER GAMES; ENTERTAINMENT SERVICES, NAMELY, PROVIDING AN ON-LINE COMPUTER GAME (U.S. CLS. 100, 101 AND 107).

### CLASS 42—SCIENTIFIC AND COMPUTER SERVICES

FOR COMPUTER SERVICES, NAMELY, PROVIDING TEMPORARY USE OF ON-LINE, NON-DOWNLOADABLE SOFTWARE FOR DESIGNING INNOVATIVE VIRTUAL REALITY ENVIRONMENTS; COMPUTER SERVICES, NAMELY, PROVIDING AN ON-LINE COMPUTER DATABASE FEATURING COMPUTER SOFTWARE DESIGN INFORMATION REGARDING DESIGNING INNOVATIVE VIRTUAL REALITY ENVIRONMENTS; COMPUTER SERVICES, NAMELY, PROVIDING AN ON-LINE COMPUTER DATABASE IN THE FIELD OF THE DESIGN OF DIGITAL ANIMATION AND SPECIAL EFFECTS OF IMAGES; COMPUTER SERVICES, NAMELY, CREATING AN ONLINE COMMUNITY FOR REGISTERED USERS TO PARTICIPATE IN VIRTUAL ENVIRONMENTS AND TO SHOWCASE THEIR COMPUTER GRAPHICS AND IMAGE RENDERING, DIGITAL ANIMATION, AND SPECIAL EFFECTS IMAGES; COMPUTER SERVICES, NAMELY, HOSTING ON-LINE WEB FACILITIES FOR OTHERS FOR ORGANIZING AND CONDUCTING ONLINE MEETINGS, GATHERINGS, AND INTERACTIVE DISCUSSIONS; COMPUTER SERVICES IN THE NATURE OF CUSTOMIZED WEB PAGES FEATURING USER-DEFINED INFORMATION, PERSONAL PROFILES AND INFORMATION; COMPUTER SERVICES, NAMELY, HOSTING THE WEB SITES OF OTHERS ON A COMPUTER SERVER FOR A GLOBAL COMPUTER NETWORK; COMPUTER SERVICES, NAMELY, CREATING AND MAINTAINING WEB SITES FOR OTHERS (U.S. CLS. 100 AND 101).

STEPHANIE ALI, EXAMINING ATTORNEY



THE MARK CONSISTS OF THE TERM "BIOWORLD" IN STYLIZED SMALL CAP LETTERS WITH THE LETTER "L" BEING A DEPICTION A TREE.

### CLASS 8—HAND TOOLS

FOR BIODEGRADABLE CUTLERY, NAMELY, KNIVES, FORKS AND SPOONS; COMPOSTABLE AND BIODEGRADABLE CUTLERY, NAMELY, KNIVES, SPOONS, FORKS; DISPOSABLE TABLEWARE, NAMELY, KNIVES, FORKS AND SPOONS (U.S. CLS. 23, 28 AND 44).

### CLASS 16—PAPER GOODS AND PRINTED MATTER

FOR GROCERY BAGS; PACKAGING AND CONTAINERS COMPRISED OF STARCH-BASED MATERIALS IN THE NATURE OF A PAPER SUBSTITUTE FOR FOOD, BEVERAGES AND CONSUMER PRODUCTS; PAPER PACKAGING AND CONTAINERS FOR FOOD AND BEVERAGES COMPRISED OF MATERIALS DESIGNED TO LESSEN ADVERSE EFFECTS ON THE ENVIRONMENT; PLASTIC BAGS FOR PACKAGING; PLASTIC WRAP; SPECIALTY PAPERS, NAMELY, VEGETABLE PARCHMENT, FOR USE IN FOOD WRAPPING, PREPARATION, PROCESSING AND PACKAGING APPLICATIONS (U.S. CLS. 2, 5, 22, 23, 29, 37, 38 AND 50).

### CLASS 20—FURNITURE AND ARTICLES NOT OTHERWISE CLASSIFIED

FOR DRINKING STRAWS (U.S. CLS. 2, 13, 22, 25, 32 AND 50).

### CLASS 21—HOUSEWARES AND GLASS

FOR BIODEGRADABLE PAPER PULP-BASED PLATES, BOWLS AND CUPS; COMPOSTABLE AND BIODEGRADABLE PLATES, BOWLS, CUPS AND TRAYS; DISPOSABLE DINNERWARE, NAMELY, PLATES, BOWLS AND CUPS (U.S. CLS. 2, 13, 23, 29, 30, 33, 40 AND 50).

ESTHER A. BORSUK, EXAMINING ATTORNEY

SN 85-238,571. INDEPENDENCE VISITOR CENTER CORPORATION, PHILADELPHIA, PA. FILED 2-10-2011.



THE MARK CONSISTS OF A MAN STANDING NEXT TO A BICYCLE WEARING A NAME TAG NEXT TO A CITY SKYLINE WITH THE WORDING MR. PHILADELPHIA APPEARING BELOW.

#### CLASS 35—ADVERTISING AND BUSINESS

FOR CHAMBER OF COMMERCE SERVICES, NAMELY, PROMOTING BUSINESS AND TOURISM IN THE PHILADELPHIA AREA; PROVIDING COMMERCIAL INFORMATION IN THE FIELD OF ACCOMMODATIONS, ATTRACTIONS, DINING, SHOPPING, NIGHT LIFE, PARKS AND RECREATION, THEATER AND TRANSPORTATION IN THE PHILADELPHIA AREA (U.S. CLS. 100, 101 AND 102).  
FIRST USE 1-5-2011; IN COMMERCE 1-5-2011.

#### CLASS 39—TRANSPORTATION AND STORAGE

FOR PROVIDING TRAVEL INFORMATION RELATING TO ACCOMMODATIONS, ATTRACTIONS, DINING, SHOPPING, NIGHT LIFE, PARKS AND RECREATION, THEATER AND TRANSPORTATION IN THE PHILADELPHIA AREA (U.S. CLS. 100 AND 105).  
FIRST USE 1-5-2011; IN COMMERCE 1-5-2011.

#### CLASS 41—EDUCATION AND ENTERTAINMENT

FOR EDUCATIONAL SERVICES, NAMELY, PROVIDING HISTORICAL INFORMATION ON THE CITY OF PHILADELPHIA; ON-LINE JOURNALS, NAMELY, BLOGS FEATURING INFORMATION IN THE FIELD OF HISTORY, ACCOMMODATIONS, ATTRACTIONS, DINING, SHOPPING, NIGHT LIFE, PARKS AND RECREATION, THEATER AND TRANSPORTATION IN THE PHILADELPHIA AREA (U.S. CLS. 100, 101 AND 107).  
FIRST USE 1-5-2011; IN COMMERCE 1-5-2011.

SUNG IN, EXAMINING ATTORNEY

SN 85-238,902. SHORTRIDGE INSTRUMENTS, INC., SCOTTSDALE, AZ. FILED 2-10-2011.

#### SHORTRIDGE INSTRUMENTS

THE MARK CONSISTS OF STANDARD CHARACTERS WITHOUT CLAIM TO ANY PARTICULAR FONT, STYLE, SIZE, OR COLOR.

OWNER OF U.S. REG. NO. 2,980,380.

NO CLAIM IS MADE TO THE EXCLUSIVE RIGHT TO USE "INSTRUMENTS", APART FROM THE MARK AS SHOWN.

#### CLASS 37—CONSTRUCTION AND REPAIR

FOR REPAIR SERVICES, NAMELY, REPAIR OF FLUID FLOW MEASURING INSTRUMENTS (U.S. CLS. 100, 103 AND 106).

FIRST USE 0-0-1979; IN COMMERCE 0-0-1979.

#### CLASS 42—SCIENTIFIC AND COMPUTER SERVICES

FOR CALIBRATION SERVICES, NAMELY, CALIBRATION OF FLUID FLOW MEASURING EQUIPMENT (U.S. CLS. 100 AND 101).

FIRST USE 0-0-1979; IN COMMERCE 0-0-1979.

ROBIN MITTLER, EXAMINING ATTORNEY

SN 85-240,041. XAVIER UNIVERSITY CORPORATION, DBA XAVIER UNIVERSITY, CINCINNATI, OH. FILED 2-11-2011.



OWNER OF U.S. REG. NOS. 2,122,465, 2,122,467 AND 2,925,065.

THE MARK CONSISTS OF THE WORD "XAVIER" IN A BLOCK-STYLE FONT, THE ENTIRE WORD HAVING A SHADOW-LIKE EFFECT.

#### CLASS 16—PAPER GOODS AND PRINTED MATTER

FOR BUMPER STICKERS; MAGNETIC BUMPER STICKERS (U.S. CLS. 2, 5, 22, 23, 29, 37, 38 AND 50).

FIRST USE 10-1-2010; IN COMMERCE 10-1-2010.

#### CLASS 25—CLOTHING

FOR ATHLETIC APPAREL, NAMELY, SHIRTS, PANTS, JACKETS, FOOTWEAR, HATS AND CAPS, ATHLETIC UNIFORMS; SHIRTS (U.S. CLS. 22 AND 39).

FIRST USE 10-1-2010; IN COMMERCE 10-1-2010.

#### CLASS 41—EDUCATION AND ENTERTAINMENT

FOR ARRANGING AND CONDUCTING ATHLETIC COMPETITIONS; ENCOURAGING AMATEUR SPORTS AND PHYSICAL EDUCATION BY ORGANIZING, SANCTIONING, CONDUCTING, REGULATING AND GOVERNING AMATEUR ATHLETIC PROGRAMS AND ACTIVITIES (U.S. CLS. 100, 101 AND 107).

FIRST USE 10-1-2010; IN COMMERCE 10-1-2010.

ANGELA M. MICHELI, EXAMINING ATTORNEY

SN 85-241,259. THE NATIONAL COLLEGIATE ATHLETIC ASSOCIATION, INDIANAPOLIS, IN. FILED 2-14-2011.

**LIVE AT THE FINAL FOUR**

THE MARK CONSISTS OF STANDARD CHARACTERS WITHOUT CLAIM TO ANY PARTICULAR FONT, STYLE, SIZE, OR COLOR.

OWNER OF U.S. REG. NOS. 1,488,836, 2,964,266 AND OTHERS.

**CLASS 35—ADVERTISING AND BUSINESS**

FOR PROMOTING PUBLIC AWARENESS OF ATHLETIC CONTESTS, GAMES, TOURNAMENTS, EXHIBITIONS AND EVENTS (U.S. CLS. 100, 101 AND 102).

**CLASS 36—INSURANCE AND FINANCIAL**

FOR CHARITABLE FUNDRAISING SERVICES BY MEANS OF ORGANIZING AND CONDUCTING SPECIAL EVENTS (U.S. CLS. 100, 101 AND 102).

**CLASS 41—EDUCATION AND ENTERTAINMENT**

FOR ENTERTAINMENT SERVICES, NAMELY, ARRANGING AND CONDUCTING SPECIAL EVENTS FOR SOCIAL, CHARITABLE, AND ENTERTAINMENT PURPOSES; ARRANGING AND CONDUCTING ENTERTAINMENT IN THE NATURE OF CONCERTS, AWARD SHOWS, AND PRESENTATIONS IN THE FIELDS OF ATHLETICS, EDUCATION, AND CHARITABLE ENDEAVORS (U.S. CLS. 100, 101 AND 107).  
MARILYN IZZI, EXAMINING ATTORNEY

SN 85-241,265. THE NATIONAL COLLEGIATE ATHLETIC ASSOCIATION, INDIANAPOLIS, IN. FILED 2-14-2011.



OWNER OF U.S. REG. NOS. 1,488,836, 2,964,266 AND OTHERS.  
THE MARK CONSISTS OF THE BASKETBALL AND LINES.

**CLASS 35—ADVERTISING AND BUSINESS**

FOR PROMOTING PUBLIC AWARENESS OF ATHLETIC CONTESTS, GAMES, TOURNAMENTS, EXHIBITIONS AND EVENTS (U.S. CLS. 100, 101 AND 102).

**CLASS 36—INSURANCE AND FINANCIAL**

FOR CHARITABLE FUNDRAISING SERVICES BY MEANS OF ORGANIZING AND CONDUCTING SPECIAL EVENTS (U.S. CLS. 100, 101 AND 102).

**CLASS 41—EDUCATION AND ENTERTAINMENT**

FOR ENTERTAINMENT SERVICES, NAMELY, ARRANGING AND CONDUCTING SPECIAL EVENTS FOR SOCIAL, CHARITABLE, AND ENTERTAINMENT PURPOSES; ARRANGING AND CONDUCTING ENTERTAINMENT IN THE NATURE OF CONCERTS, AWARD SHOWS, AND PRESENTATIONS IN THE FIELDS OF ATHLETICS, EDUCATION, AND CHARITABLE ENDEAVORS (U.S. CLS. 100, 101 AND 107).  
MARILYN IZZI, EXAMINING ATTORNEY

SN 85-244,113. SEARS BRANDS, LLC, HOFFMAN ESTATES, IL. FILED 2-16-2011.

**SMART SENSE**

THE MARK CONSISTS OF STANDARD CHARACTERS WITHOUT CLAIM TO ANY PARTICULAR FONT, STYLE, SIZE, OR COLOR.

**CLASS 3—COSMETICS AND CLEANING PREPARATIONS**

FOR BABY WIPES; BABY POWDER; BABY LOTIONS; NON-MEDICATED DIAPER RASH OINTMENTS AND LOTIONS; BABY OIL; BABY SHAMPOO (U.S. CLS. 1, 4, 6, 50, 51 AND 52).

**CLASS 5—PHARMACEUTICALS**

FOR POWDERED INFANT FORMULA; ELECTROLYTE REPLACEMENT SOLUTIONS (U.S. CLS. 6, 18, 44, 46, 51 AND 52).

**CLASS 9—ELECTRICAL AND SCIENTIFIC APPARATUS**

FOR ALKALINE BATTERIES (U.S. CLS. 21, 23, 26, 36 AND 38).

**CLASS 16—PAPER GOODS AND PRINTED MATTER**

FOR DISPOSABLE DIAPERS (U.S. CLS. 2, 5, 22, 23, 29, 37, 38 AND 50).

**CLASS 32—LIGHT BEVERAGES**

FOR PURIFIED DRINKING WATER (U.S. CLS. 45, 46 AND 48).  
LINDA M. KING, EXAMINING ATTORNEY

SN 85-244,284, THOUGHTBOT, INC., NEW YORK, NY.  
FILED 2-16-2011.

SN 85-244,292, THOUGHTBOT, INC., NEW YORK, NY.  
FILED 2-16-2011.

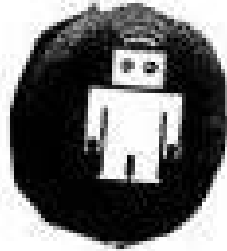

THE MARK CONSISTS OF THE DESIGN OF A ROBOT.

**CLASS 9—ELECTRICAL AND SCIENTIFIC APPARATUS**

FOR DOWNLOADABLE COMPUTER SOFTWARE, NAMELY, COMPUTER SOFTWARE DEVELOPMENT AND UTILITY TOOLS; DOWNLOADABLE SOFTWARE FOR CONTENT MANAGEMENT, CONTENT CREATION, CONTENT PUBLISHING, CONTENT FILTERING, CONTENT SELECTION, CONTENT AGGREGATION, CONTENT CATEGORIZATION, AND CONTENT SEARCHING (U.S. CLS. 21, 23, 26, 36 AND 38).  
FIRST USE 5-0-2007; IN COMMERCE 5-0-2007.

**CLASS 41—EDUCATION AND ENTERTAINMENT**

FOR EDUCATIONAL SERVICES, NAMELY, PROVIDING WORKSHOPS IN THE FIELD OF WEB SITE DESIGN AND DEVELOPMENT (U.S. CLS. 100, 101 AND 107).  
FIRST USE 5-0-2007; IN COMMERCE 9-0-2008.

**CLASS 42—SCIENTIFIC AND COMPUTER SERVICES**

FOR SOFTWARE AS A SERVICE (SAAS) SERVICES, NAMELY, COMPUTER SOFTWARE DEVELOPMENT AND UTILITY TOOLS; COMPUTER SERVICES, NAMELY, COMPUTER SOFTWARE DEVELOPMENT AND DEVELOPMENT OF UTILITY TOOLS FOR OTHERS; PROVIDING A WEBSITE FEATURING NON-DOWNLOADABLE SOFTWARE FOR CONTENT MANAGEMENT, CONTENT CREATION, CONTENT PUBLISHING, CONTENT FILTERING, CONTENT SELECTION, CONTENT AGGREGATION, CONTENT CATEGORIZATION, AND CONTENT SEARCHING; SOFTWARE AS A SERVICE (SAAS) SERVICES FEATURING SOFTWARE IN THE FIELD OF CONTENT MANAGEMENT, CONTENT CREATION, CONTENT PUBLISHING, CONTENT FILTERING, CONTENT SELECTION, CONTENT AGGREGATION, CONTENT CATEGORIZATION, AND CONTENT SEARCHING; CREATION, DESIGN, AND DEVELOPMENT OF WEB SITES FOR THIRD PARTIES (U.S. CLS. 100 AND 101).  
FIRST USE 5-0-2007; IN COMMERCE 5-0-2007.  
HEATHER SAPP, EXAMINING ATTORNEY

# THOUGHTBOT

THE MARK CONSISTS OF STANDARD CHARACTERS WITHOUT CLAIM TO ANY PARTICULAR FONT, STYLE, SIZE, OR COLOR.

**CLASS 9—ELECTRICAL AND SCIENTIFIC APPARATUS**

FOR DOWNLOADABLE COMPUTER SOFTWARE, NAMELY, COMPUTER SOFTWARE DEVELOPMENT AND UTILITY TOOLS; DOWNLOADABLE SOFTWARE FOR CONTENT MANAGEMENT, CONTENT CREATION, CONTENT PUBLISHING, CONTENT FILTERING, CONTENT SELECTION, CONTENT AGGREGATION, CONTENT CATEGORIZATION, AND CONTENT SEARCHING (U.S. CLS. 21, 23, 26, 36 AND 38).  
FIRST USE 6-0-2003; IN COMMERCE 6-0-2003.

**CLASS 41—EDUCATION AND ENTERTAINMENT**

FOR EDUCATIONAL SERVICES, NAMELY, PROVIDING WORKSHOPS IN THE FIELD OF WEB SITE DESIGN AND DEVELOPMENT (U.S. CLS. 100, 101 AND 107).  
FIRST USE 9-0-2008; IN COMMERCE 9-0-2008.

**CLASS 42—SCIENTIFIC AND COMPUTER SERVICES**

FOR SOFTWARE AS A SERVICE (SAAS) SERVICES, NAMELY, COMPUTER SOFTWARE DEVELOPMENT AND UTILITY TOOLS; COMPUTER SERVICES, NAMELY, COMPUTER SOFTWARE DEVELOPMENT AND DEVELOPMENT OF UTILITY TOOLS FOR OTHERS; PROVIDING A WEBSITE FEATURING NON-DOWNLOADABLE SOFTWARE FOR CONTENT MANAGEMENT, CONTENT CREATION, CONTENT PUBLISHING, CONTENT FILTERING, CONTENT SELECTION, CONTENT AGGREGATION, CONTENT CATEGORIZATION, AND CONTENT SEARCHING; SOFTWARE AS A SERVICE (SAAS) SERVICES FEATURING SOFTWARE IN THE FIELD OF CONTENT MANAGEMENT, CONTENT CREATION, CONTENT PUBLISHING, CONTENT FILTERING, CONTENT SELECTION, CONTENT AGGREGATION, CONTENT CATEGORIZATION, AND CONTENT SEARCHING; CREATION, DESIGN, AND DEVELOPMENT OF WEB SITES FOR THIRD PARTIES (U.S. CLS. 100 AND 101).  
FIRST USE 6-0-2003; IN COMMERCE 6-0-2003.  
HEATHER SAPP, EXAMINING ATTORNEY

SN 85-245,092, KALMBACH FEEDS, INC., UPPER SANDUSKY, OH. FILED 2-17-2011.

# RACK TAKER

THE MARK CONSISTS OF STANDARD CHARACTERS WITHOUT CLAIM TO ANY PARTICULAR FONT, STYLE, SIZE, OR COLOR.

**CLASS 5—PHARMACEUTICALS**

FOR DIETARY SUPPLEMENTS FOR DEER; FEED SUPPLEMENTS FOR DEER; MINERAL SUPPLEMENTS (U.S. CLS. 6, 18, 44, 46, 51 AND 52).

**CLASS 28—TOYS AND SPORTING GOODS**

FOR DEER ATTRACTANTS (U.S. CLS. 22, 23, 38 AND 50).

**CLASS 31—NATURAL AGRICULTURAL PRODUCTS**

FOR WILDLIFE SEED MIXTURES (U.S. CLS. 1 AND 46).  
ANDREA BUTLER, EXAMINING ATTORNEY

---

SN 85-245,950. TIMEX GROUP USA, INC., MIDDLEBURY, CT. FILED 2-18-2011.

# TRAIL MATE

THE MARK CONSISTS OF STANDARD CHARACTERS WITHOUT CLAIM TO ANY PARTICULAR FONT, STYLE, SIZE, OR COLOR.

**CLASS 9—ELECTRICAL AND SCIENTIFIC APPARATUS**

FOR ACCELEROMETERS (U.S. CLS. 21, 23, 26, 36 AND 38).  
FIRST USE 2-7-2011; IN COMMERCE 2-7-2011.

**CLASS 14—JEWELRY**

FOR WATCHES (U.S. CLS. 2, 27, 28 AND 50).  
FIRST USE 2-7-2011; IN COMMERCE 2-7-2011.  
CHARLES L. JENKINS, EXAMINING ATTORNEY

---

SN 85-246,476. THE PACIFIC INSTITUTE INCORPORATED, SEATTLE, WA. FILED 2-18-2011.

# ACHIEVING YOUR POTENTIAL

THE MARK CONSISTS OF STANDARD CHARACTERS WITHOUT CLAIM TO ANY PARTICULAR FONT, STYLE, SIZE, OR COLOR.  
OWNER OF U.S. REG. NOS. 1,962,244 AND 3,255,362.

**CLASS 9—ELECTRICAL AND SCIENTIFIC APPARATUS**

FOR AUDIO AND VIDEO MEDIA, NAMELY, CDS, DVDS, AND DOWNLOADABLE MEDIA FILES CONTAINING EDUCATIONAL AND MOTIVATIONAL MATERIAL IN THE FIELD OF DEVELOPING PERSONAL POTENTIAL; ELECTRONIC PUBLICATIONS IN THE NATURE OF BOOKS RECORDED ON COMPUTER MEDIA CONTAINING EDUCATIONAL AND MOTIVATIONAL MATERIAL IN THE FIELD OF DEVELOPING PERSONAL POTENTIAL; DOWNLOADABLE ELECTRONIC PUBLICATIONS IN THE NATURE OF BOOKS CONTAINING EDUCATIONAL AND MOTIVATIONAL MATERIAL IN THE FIELD OF DEVELOPING PERSONAL POTENTIAL (U.S. CLS. 21, 23, 26, 36 AND 38).  
FIRST USE 3-1-2006; IN COMMERCE 3-1-2006.

**CLASS 16—PAPER GOODS AND PRINTED MATTER**

FOR PRINTED MATTER, NAMELY, BOOKS, MANUALS, GUIDES, PAMPHLETS, AND BROCHURES CONTAINING EDUCATIONAL AND MOTIVATIONAL MATERIAL IN THE FIELD OF DEVELOPING PERSONAL POTENTIAL (U.S. CLS. 2, 5, 22, 23, 29, 37, 38 AND 50).  
FIRST USE 6-3-1976; IN COMMERCE 6-3-1976.

**CLASS 41—EDUCATION AND ENTERTAINMENT**

FOR PROVIDING EDUCATIONAL AND MOTIVATIONAL SEMINARS IN THE FIELD OF DEVELOPING PERSONAL POTENTIAL; EDUCATIONAL SERVICES, INCLUDING, PROVIDING LIVE AND ON-LINE CLASSES, SEMINARS, WORKSHOPS IN THE FIELD OF DEVELOPING PERSONAL POTENTIAL (U.S. CLS. 100, 101 AND 107).  
FIRST USE 6-3-1976; IN COMMERCE 6-3-1976.  
DARRYL SPRUILL, EXAMINING ATTORNEY

---

SN 85-251,808. JOHNSON & JOHNSON, NEW BRUNSWICK, NJ. FILED 2-25-2011.

# CAUSES & YOU

THE MARK CONSISTS OF STANDARD CHARACTERS WITHOUT CLAIM TO ANY PARTICULAR FONT, STYLE, SIZE, OR COLOR.

**CLASS 16—PAPER GOODS AND PRINTED MATTER**

FOR PRINTED MATERIALS, NAMELY, BROCHURES, PAMPHLETS, NEWSLETTERS, AND PRESS RELEASES IN THE FIELD OF SOCIAL RESPONSIBILITY (U.S. CLS. 2, 5, 22, 23, 29, 37, 38 AND 50).

**CLASS 35—ADVERTISING AND BUSINESS**

FOR PROMOTING PUBLIC AWARENESS OF SOCIAL RESPONSIBILITY; CHARITABLE SERVICES, NAMELY, PROVIDING A FREE ONLINE RESOURCE IN THE NATURE OF A WEBSITE FOR CONNECTING PEOPLE WHO HAVE SERVICE NEEDS WITH PEOPLE WHO ARE WILLING TO PROVIDE VOLUNTEER SERVICES TO PEOPLE AND ORGANIZATIONS ON THE SUBJECT OF SOCIAL RESPONSIBILITY (U.S. CLS. 100, 101 AND 102).



**CLASS 44—MEDICAL, BEAUTY AND AGRICULTURAL SERVICES**

FOR INFORMATION SERVICES, NAMELY, PROVIDING HEALTH INFORMATION TO PEOPLE AND ORGANIZATIONS ON THE SUBJECT OF SOCIAL RESPONSIBILITY THROUGH INTERACTIVE SOCIAL MEDIA WEBSITES (U.S. CLS. 100 AND 101).

CAROL SPILS, EXAMINING ATTORNEY

---

SN 85-251,810. JOHNSON & JOHNSON, NEW BRUNSWICK, NJ. FILED 2-25-2011.

**CARING & YOU**

THE MARK CONSISTS OF STANDARD CHARACTERS WITHOUT CLAIM TO ANY PARTICULAR FONT, STYLE, SIZE, OR COLOR.

**CLASS 16—PAPER GOODS AND PRINTED MATTER**

FOR PRINTED MATERIALS, NAMELY, BROCHURES, PAMPHLETS, NEWSLETTERS, AND PRESS RELEASES IN THE FIELD OF SOCIAL RESPONSIBILITY (U.S. CLS. 2, 5, 22, 23, 29, 37, 38 AND 50).

**CLASS 35—ADVERTISING AND BUSINESS**

FOR PROMOTING PUBLIC AWARENESS OF SOCIAL RESPONSIBILITY; CHARITABLE SERVICES, NAMELY, PROVIDING A FREE ONLINE RESOURCE IN THE NATURE OF A WEBSITE FOR CONNECTING PEOPLE WHO HAVE SERVICE NEEDS WITH PEOPLE WHO ARE WILLING TO PROVIDE VOLUNTEER SERVICES TO PEOPLE AND ORGANIZATIONS ON THE SUBJECT OF SOCIAL RESPONSIBILITY (U.S. CLS. 100, 101 AND 102).

**CLASS 44—MEDICAL, BEAUTY AND AGRICULTURAL SERVICES**

FOR INFORMATION SERVICES, NAMELY, PROVIDING HEALTH INFORMATION TO PEOPLE AND ORGANIZATIONS ON THE SUBJECT OF SOCIAL RESPONSIBILITY THROUGH INTERACTIVE SOCIAL MEDIA WEBSITES (U.S. CLS. 100 AND 101).

CAROL SPILS, EXAMINING ATTORNEY

---

SN 85-251,816. JOHNSON & JOHNSON, NEW BRUNSWICK, NJ. FILED 2-25-2011.

**CARING AND YOU**

THE MARK CONSISTS OF STANDARD CHARACTERS WITHOUT CLAIM TO ANY PARTICULAR FONT, STYLE, SIZE, OR COLOR.

**CLASS 16—PAPER GOODS AND PRINTED MATTER**

FOR PRINTED MATERIALS, NAMELY, BROCHURES, PAMPHLETS, NEWSLETTERS, AND PRESS RELEASES IN THE FIELD OF SOCIAL RESPONSIBILITY (U.S. CLS. 2, 5, 22, 23, 29, 37, 38 AND 50).

**CLASS 35—ADVERTISING AND BUSINESS**

FOR PROMOTING PUBLIC AWARENESS OF SOCIAL RESPONSIBILITY; CHARITABLE SERVICES, NAMELY, PROVIDING A FREE ONLINE RESOURCE IN THE NATURE OF A WEBSITE FOR CONNECTING PEOPLE WHO HAVE SERVICE NEEDS WITH PEOPLE WHO ARE WILLING TO PROVIDE VOLUNTEER SERVICES TO PEOPLE AND ORGANIZATIONS ON THE SUBJECT OF SOCIAL RESPONSIBILITY (U.S. CLS. 100, 101 AND 102).

**CLASS 44—MEDICAL, BEAUTY AND AGRICULTURAL SERVICES**

FOR INFORMATION SERVICES, NAMELY, PROVIDING HEALTH INFORMATION TO PEOPLE AND ORGANIZATIONS ON THE SUBJECT OF SOCIAL RESPONSIBILITY THROUGH INTERACTIVE SOCIAL MEDIA WEBSITES (U.S. CLS. 100 AND 101).

CAROL SPILS, EXAMINING ATTORNEY

---

SN 85-252,076. ROCHE DIAGNOSTICS GMBH, 68305 MANNHEIM, FED REP GERMANY, FILED 2-25-2011.

**ACCU-CHEK INFORM ME**

THE MARK CONSISTS OF STANDARD CHARACTERS WITHOUT CLAIM TO ANY PARTICULAR FONT, STYLE, SIZE, OR COLOR.

OWNER OF U.S. REG. NOS. 1,277,867, 2,732,629 AND OTHERS.

**CLASS 5—PHARMACEUTICALS**

FOR DIAGNOSTIC TEST STRIPS FOR DETERMINING THE LEVEL OF GLUCOSE IN BLOOD FOR MEDICAL AND CLINICAL USE; AND CONTROL SOLUTIONS USED FOR QUALITY CHECKS ON BLOOD GLUCOSE MONITORS AND DIAGNOSTIC TEST STRIPS FOR MEDICAL AND CLINICAL USE (U.S. CLS. 6, 18, 44, 46, 51 AND 52).

**CLASS 10—MEDICAL APPARATUS**

FOR BLOOD GLUCOSE MONITORS (U.S. CLS. 26, 39 AND 44).

CHARLOTTE CORWIN, EXAMINING ATTORNEY

SN 85-269,692. UNITED STATES POSTAL SERVICE, WASHINGTON, DC. FILED 3-17-2011.

**DELIVERING IN NEW WAYS**

THE MARK CONSISTS OF STANDARD CHARACTERS WITHOUT CLAIM TO ANY PARTICULAR FONT, STYLE, SIZE, OR COLOR.

**CLASS 35—ADVERTISING AND BUSINESS**

FOR SORTING, HANDLING AND RECEIVING PACKAGES AND LETTERS; DISSEMINATION OF ADVERTISEMENTS AND ADVERTISING MATERIALS; DISTRIBUTION AND DISSEMINATION OF ADVERTISING MATERIALS; DISTRIBUTION OF PUBLICITY MATERIALS (U.S. CLS. 100, 101 AND 102).

**CLASS 39—TRANSPORTATION AND STORAGE**

FOR PICKUP, TRANSPORTATION AND DELIVERY OF PACKAGES AND DOCUMENTS BY VARIOUS MODES OF TRANSPORTATION (U.S. CLS. 100 AND 105).

JEFFERY COWARD, EXAMINING ATTORNEY

\* \* \* \* \*

## SECTION 2.— INTERNATIONAL CLASSIFICATION

The short titles associated below with the international class numbers are terms designed merely for quick identification and are not an official part of the international classification. The full names of international classes are given in section 6.1 of the trademark rules of practice.

The designation "U.S. Cl." appearing in this section refers to the U.S. class in effect prior to Sep. 1, 1973 rather than the international class which applies to applications filed on or after that date. For adoption of international classification see notice in the OFFICIAL GAZETTE of Jun. 26, 1973 (911 O.G. TM 210).

### Application in one class

#### CLASS 1—CHEMICALS

SN 76-704,945. SHAMMAS, MILO, WINTERS, CA. FILED 10-18-2010.

## DOCTOR EARTH

THE MARK CONSISTS OF STANDARD CHARACTERS WITHOUT CLAIM TO ANY PARTICULAR FONT, STYLE, SIZE, OR COLOR.

OWNER OF U.S. REG. NOS. 3,731,095 AND 3,912,869. FOR PLANTING SOIL (U.S. CLS. 1, 5, 6, 10, 26 AND 46).

MICHAEL WIENER, EXAMINING ATTORNEY

---

SN 76-704,948. SHAMMAS, MILO, WINTERS, CA. FILED 10-18-2010.

## DR. EARTH

THE MARK CONSISTS OF STANDARD CHARACTERS WITHOUT CLAIM TO ANY PARTICULAR FONT, STYLE, SIZE, OR COLOR.

OWNER OF U.S. REG. NOS. 3,731,095 AND 3,912,869. FOR PLANTING SOIL (U.S. CLS. 1, 5, 6, 10, 26 AND 46).

MICHAEL WIENER, EXAMINING ATTORNEY

---

SN 76-705,819. DUMOND CHEMICALS, INC., MONROE TOWNSHIP, NJ. FILED 12-27-2010.

## CITRI-LIZE

THE MARK CONSISTS OF STANDARD CHARACTERS WITHOUT CLAIM TO ANY PARTICULAR FONT, STYLE, SIZE, OR COLOR.

FOR AN INDUSTRIAL CHEMICAL IN POWDER FORM (U.S. CLS. 1, 5, 6, 10, 26 AND 46).

RONALD AIKENS, EXAMINING ATTORNEY

#### CLASS 1—(Continued).

SN 77-877,614. SÜD-CHEMIE AG, MUNICH, FED REP GERMANY, FILED 11-20-2009.

## FIXAT

THE MARK CONSISTS OF STANDARD CHARACTERS WITHOUT CLAIM TO ANY PARTICULAR FONT, STYLE, SIZE, OR COLOR.

FOR CHEMICALS USED IN AGRICULTURE, NAMELY, CHEMICAL AGENTS FOR ANTICAKING AND PELLETIZING OF FOODSTUFFS FOR ANIMALS AND FOR BINDING TOXINS IN FOOD FOR ANIMALS AND HUMANS; CHEMICAL AGENTS FOR DETOXIFICATION AND DECONTAMINATION FOR FOODSTUFFS FOR ANIMALS (U.S. CLS. 1, 5, 6, 10, 26 AND 46).

NATALIE POLZER, EXAMINING ATTORNEY

---

SN 77-887,528. WESTERN APPLIED TECHNOLOGIES INC., GONZALES, CA. FILED 12-7-2009.

## HEALTHYSOIL

THE MARK CONSISTS OF STANDARD CHARACTERS WITHOUT CLAIM TO ANY PARTICULAR FONT, STYLE, SIZE, OR COLOR.

FOR HORTICULTURAL PRODUCTS, NAMELY, SOIL AMENDMENTS THAT ARE INCORPORATED INTO OR ONTO A TURF, LAWN OR SOIL PROFILE FOR CREATING A HEALTH MEDIUM FOR INCREASED ROOT GROWTH AND/OR A SMOOTHER TURF OR LAWN SURFACE CUT OR APPEARANCE (U.S. CLS. 1, 5, 6, 10, 26 AND 46).

FIRST USE 12-1-2002; IN COMMERCE 12-1-2002.

ALEXANDER L. POWERS, EXAMINING ATTORNEY

**CLASS 1—(Continued).**

SN 77-931,548. CERADYNE, INC., COSTA MESA, CA. FILED 2-9-2010.

**BOROBOND**

THE MARK CONSISTS OF STANDARD CHARACTERS WITHOUT CLAIM TO ANY PARTICULAR FONT, STYLE, SIZE, OR COLOR.

FOR CERAMIC ARTICLES HAVING PARTICLES RESISTANT TO PENETRATION BY NEUTRONS FOR USE AS A FILTERING MEDIA IN THE NUCLEAR INDUSTRY (U.S. CLS. 1, 5, 6, 10, 26 AND 46).

FIRST USE 11-27-2000; IN COMMERCE 11-27-2000.

JEAN IM, EXAMINING ATTORNEY

SN 79-077,427. ASHLAND-SÜDCHEMIE-KERNFEST GMBH, FED REP GERMANY, FILED 11-2-2009.

**INOBAKE**

THE MARK CONSISTS OF STANDARD CHARACTERS WITHOUT CLAIM TO ANY PARTICULAR FONT, STYLE, SIZE, OR COLOR.

PRIORITY DATE OF 6-10-2009 IS CLAIMED.

OWNER OF INTERNATIONAL REGISTRATION 1025203 DATED 11-2-2009, EXPIRES 11-2-2019.

THE WORDING "INOBAKE" HAS NO MEANING IN A FOREIGN LANGUAGE.

FOR CHEMICALS FOR USE IN INDUSTRY AND SCIENCE; UNPROCESSED ARTIFICIAL RESINS; UNPROCESSED SYNTHETIC RESINS; UNPROCESSED PLASTICS IN ALL FORMS; SOLDERING CHEMICALS AND TEMPERING CHEMICALS FOR USE IN METAL-WORKING OR SOLDERING; ADHESIVES FOR USE IN INDUSTRY; BINDING AGENTS, NAMELY, CHEMICAL PREPARATIONS IN LIQUID FORM AND POWDER FORM FOR USE AS A BINDING AGENT FOR FOUNDRY MOLDS AND IN FOUNDRY-MOLDED BODIES, IN PARTICULAR WITH AN INORGANIC BASE; FILTER MATERIAL, NAMELY, CHEMICAL PREPARATIONS FOR USE AS A FILTERING MEDIA FOR THE FILTRATION OF LIQUID METALS IN FOUNDRIES; CHEMICAL PREPARATIONS USED IN THE MANUFACTURE OF COATINGS FOR FOUNDRY MOULDS AND FOUNDRY CORES FORMED OF SAND, METAL, OR FOAM; CHEMICAL PREPARATIONS USED IN THE MANUFACTURE OF COATINGS WITH A BASE OF ALUMINUM SILICATES FOR FOUNDRY MOULDS AND FOUNDRY CORES OF SAND, METAL, OR FOAM; MOULD RELEASE PREPARATIONS; MOULD CARE AGENTS IN THE NATURE OF CHEMICAL ADDITIVES FOR USE IN THE MANUFACTURE OF FOUNDRY MOULDS AND INDUSTRIAL MOULD COATINGS, FOR USE IN THE INDUSTRY OF FOUNDRY ENGINEERING; UNPROCESSED POLYESTER RESINS BEING ARTIFICIAL RESINS OR SYNTHETIC RESINS IN LIQUID SOLUTIONS OR IN SOLID FORM, FOR THE MANUFACTURE OF LACQUERS, PAINTS, OR OTHER COATING MATERIALS (U.S. CLS. 1, 5, 6, 10, 26 AND 46).

CORY BOONE, EXAMINING ATTORNEY

**CLASS 1—(Continued).**

SN 79-088,569. SOCIETE LA BIOCHIMIE APPLIQUEE (SO-LA.BI.A), FRANCE, FILED 9-22-2010.

**FUCOGEL**

THE MARK CONSISTS OF STANDARD CHARACTERS WITHOUT CLAIM TO ANY PARTICULAR FONT, STYLE, SIZE, OR COLOR.

OWNER OF INTERNATIONAL REGISTRATION 0849540 DATED 1-21-2005, EXPIRES 1-21-2015.

FOR CHEMICAL AND BIOCHEMICAL PRODUCTS, NAMELY, BIOTECHNOLOGICAL POLYSACCHARIDES FOR USE IN THE FURTHER MANUFACTURE OF COSMETOLOGY AND DERMATOLOGY PRODUCTS; SEMI-FINISHED AND FINISHED BIOTECHNOLOGICAL PREPARATIONS BASED ON BIOTECHNOLOGICAL POLYSACCHARIDES, NAMELY, CHEMICALS USED IN THE FURTHER MANUFACTURE OF COSMETICS; SEMI-FINISHED AND FINISHED BIOTECHNOLOGICAL PREPARATIONS BASED ON BIOTECHNOLOGICAL POLYSACCHARIDES, NAMELY, CHEMICALS USED IN THE FURTHER MANUFACTURE OF PHARMACEUTICAL AND DERMATOLOGICAL PRODUCTS (U.S. CLS. 1, 5, 6, 10, 26 AND 46).

ELLEN PERKINS, EXAMINING ATTORNEY

SN 79-088,588. SOCIETE LA BIOCHIMIE APPLIQUEE (SO-LA.BI.A), FRANCE, FILED 9-22-2010.

**GLYCOLIFT**

THE MARK CONSISTS OF STANDARD CHARACTERS WITHOUT CLAIM TO ANY PARTICULAR FONT, STYLE, SIZE, OR COLOR.

OWNER OF INTERNATIONAL REGISTRATION 1054552 DATED 9-22-2010, EXPIRES 9-22-2020.

FOR BIOCHEMICAL AND BIOLOGICAL PRODUCTS FOR USE IN THE COSMETICS AND PHARMACEUTICALS INDUSTRIES, NAMELY, POLYSACCHARIDE-BASED PREPARATIONS AND PLANT EXTRACTS FOR USE IN THE FURTHER MANUFACTURE OF BODY CARE AND DERMATOLOGICAL PRODUCTS (U.S. CLS. 1, 5, 6, 10, 26 AND 46).

ELLEN PERKINS, EXAMINING ATTORNEY

SN 85-030,525. ENVIRONMENTAL MANUFACTURING SOLUTIONS, LLC, MELBOURNE, FL. FILED 5-5-2010.

**renovo**

THE MARK CONSISTS OF STANDARD CHARACTERS WITHOUT CLAIM TO ANY PARTICULAR FONT, STYLE, SIZE, OR COLOR.

FOR ANTI-STICK/RELEASE AGENT (U.S. CLS. 1, 5, 6, 10, 26 AND 46).

FIRST USE 9-1-2007; IN COMMERCE 9-1-2007.

ELISSA GARBER KON, EXAMINING ATTORNEY

**CLASS 1—(Continued).**

SN 85-031,846. CDI LABORATORIES, INC., MAYAGUEZ, PUERTO RICO, FILED 5-6-2010.



CUSTOM-DESIGNED  
Immunologics

NO CLAIM IS MADE TO THE EXCLUSIVE RIGHT TO USE "IMMUNOLOGICS", APART FROM THE MARK AS SHOWN.

THE COLOR(S) BEIGE, BLUE AND GREEN IS/ARE CLAIMED AS A FEATURE OF THE MARK.

THE MARK CONSISTS OF THE STYLIZED REPRESENTATION OF AN ANTIBODY IN BLUE AND GREEN OVER A BEIGE MATRIX OF DOTS. UNDERNEATH SUCH DESIGN, APPEAR THE WORDS "CUSTOM-DESIGNED IMMUNOLOGICS" IN BLUE.

FOR CHEMICAL AND BIOLOGICAL REAGENTS AND PREPARED LABORATORY MEDIA FOR SCIENTIFIC PURPOSES (U.S. CLS. 1, 5, 6, 10, 26 AND 46).

MIDGE BUTLER, EXAMINING ATTORNEY

**CLASS 1—(Continued).**

SN 85-032,842. ASHLAND LICENSING AND INTELLECTUAL PROPERTY LLC, DUBLIN, OH. FILED 5-7-2010.



OWNER OF U.S. REG. NOS. 3,146,757, 3,382,719 AND OTHERS.

NO CLAIM IS MADE TO THE EXCLUSIVE RIGHT TO USE "FUEL SYSTEM" OR "PROFESSIONAL SERIES", APART FROM THE MARK AS SHOWN.

THE MARK CONSISTS OF A CIRCLE BANDING A CENTER CIRCLE. THE BAND HAS THE WORDS "FUEL SYSTEM" IN IT. THE CENTER CIRCLE CONTAINS THE LETTERS "FS" WITH A "HOOK" IN BETWEEN THE "F" AND THE "S". A PARTIALLY DIVIDED RECTANGLE MISSING AN ENTIRE EDGE AND WITH ROUNDED CORNERS EXTENDS FROM THE SIDES OF THE BANDED CIRCLE AND CONTAINS THE WORDS "VALVOLINE PROFESSIONAL SERIES".

FOR AUTOMOTIVE CHEMICALS, NAMELY, CHEMICAL ADDITIVES FOR COMPLETE FUEL SYSTEM TREATMENT, FUEL INJECTOR CLEANER CHEMICAL ADDITIVES; BRAKE FLUIDS; ANTIFREEZE AND COOLANT ENHANCERS FOR VEHICLE ENGINES AND RADITORS, POWER STEERING FLUIDS, CHEMICAL ADDITIVES FOR ENGINE TREATMENT (U.S. CLS. 1, 5, 6, 10, 26 AND 46).

KRISTINA MORRIS, EXAMINING ATTORNEY

**CLASS 1—(Continued).**

SN 85-072,769. PETRONAS LUBRICANTS ITALY S.P.A., VILLASTELLONE, TORINO, ITALY, FILED 6-28-2010.

# PARAFULL

THE MARK CONSISTS OF STANDARD CHARACTERS WITHOUT CLAIM TO ANY PARTICULAR FONT, STYLE, SIZE, OR COLOR.

FOR CHEMICALS FOR USE IN INDUSTRY; ANTI-FREEZE AND ANTIFREEZING LIQUIDS; LIQUID CHEMICALS USED TO INHIBIT AND REMOVE LIMESCALE DEPOSITS; LIQUID STABILIZING CHEMICAL PREPARATIONS FOR COOLING CIRCUITS FOR INTERNAL COMBUSTION ENGINES FOR MOTOR VEHICLES, TRACTORS, EARTH-MOVING MACHINES, COMMERCIAL AND INDUSTRIAL VEHICLES, 2/4 TIME ENGINES FOR MOTOR VEHICLES, AND FIXED AND NAVAL ENGINES; ANAEROBIC ADHESIVES FOR INDUSTRIAL PURPOSES; DESCALING PREPARATIONS FOR INDUSTRIAL PURPOSES FOR USE IN CONNECTION WITH RADIATORS, INTERNAL COMBUSTION ENGINES AND COOLING CIRCUITS RELATED TO SAID EQUIPMENT; CHEMICAL PREPARATIONS, NAMELY, DEGREASING AND CLEANING SOLVENTS FOR USE IN CONNECTION WITH RADIATORS, INTERNAL COMBUSTION ENGINES AND COOLING CIRCUITS RELATED TO SAID EQUIPMENT; CHEMICAL ADDITIVES FOR MOTOR FUELS; BRAKE FLUIDS; AUTOMOBILE BRAKE SYSTEM LEAK SEALANTS; PROTECTIVE ANTIFREEZE FLUIDS FOR COMPRESSED-AIR BRAKING SYSTEMS OF INDUSTRIAL VEHICLES; POWER STEERING FLUID (U.S. CLS. 1, 5, 6, 10, 26 AND 46).

MARC LEIPZIG, EXAMINING ATTORNEY

SN 85-105,051. PQ CORPORATION, VALLEY FORGE, PA. FILED 8-11-2010.

# PREXSIL

THE MARK CONSISTS OF STANDARD CHARACTERS WITHOUT CLAIM TO ANY PARTICULAR FONT, STYLE, SIZE, OR COLOR.

FOR SODIUM SILICATE USED AS AN EXTENDER FOR PHENOLIC RESIN ADHESIVES (U.S. CLS. 1, 5, 6, 10, 26 AND 46).

LESLEY LAMOTHE, EXAMINING ATTORNEY

**CLASS 1—(Continued).**

SN 85-130,859. DELTA WATER TECHNOLOGIES, DBA DELTA WATER LABORATORIES, INC., LUBBOCK, TX. FILED 9-16-2010.

# KleerTrace

THE MARK CONSISTS OF STANDARD CHARACTERS WITHOUT CLAIM TO ANY PARTICULAR FONT, STYLE, SIZE, OR COLOR.

FOR CHEMICALS FOR THE TREATMENT OF COOLING WATER SYSTEMS; CHEMICALS FOR THE TREATMENT OF WATER AND WASTEWATER (U.S. CLS. 1, 5, 6, 10, 26 AND 46).

MARY ROSSMAN, EXAMINING ATTORNEY

SN 85-134,267. WATERS TECHNOLOGIES CORPORATION, WILMINGTON, DE. FILED 9-21-2010.

# DON-V

THE MARK CONSISTS OF STANDARD CHARACTERS WITHOUT CLAIM TO ANY PARTICULAR FONT, STYLE, SIZE, OR COLOR.

FOR CHEMICAL TEST KITS FOR INDICATING THE PRESENCE OR ABSENCE OF TOXINS FOR LABORATORY OR RESEARCH USE; CHEMICAL AND BIOCHEMICAL REAGENTS FOR NON-MEDICAL PURPOSES FOR INDICATING THE PRESENCE OR ABSENCE OF TOXINS; CHEMICALLY TREATED NON-MEDICAL TEST STRIPS FOR INDICATING THE PRESENCE OR ABSENCE OF TOXINS (U.S. CLS. 1, 5, 6, 10, 26 AND 46).

JULIE VEPPUMTHARA, EXAMINING ATTORNEY

SN 85-134,282. WATERS TECHNOLOGIES CORPORATION, WILMINGTON, DE. FILED 9-21-2010.

# AFLA-V

THE MARK CONSISTS OF STANDARD CHARACTERS WITHOUT CLAIM TO ANY PARTICULAR FONT, STYLE, SIZE, OR COLOR.

FOR CHEMICAL TEST KITS FOR INDICATING THE PRESENCE OR ABSENCE OF TOXINS FOR LABORATORY OR RESEARCH USE; CHEMICAL AND BIOCHEMICAL REAGENTS FOR NON-MEDICAL PURPOSES FOR INDICATING THE PRESENCE OR ABSENCE OF TOXINS; CHEMICALLY TREATED NON-MEDICAL TEST STRIPS FOR INDICATING THE PRESENCE OR ABSENCE OF TOXINS (U.S. CLS. 1, 5, 6, 10, 26 AND 46).

JULIE VEPPUMTHARA, EXAMINING ATTORNEY

**CLASS 1—(Continued).**

SN 85-135,098. RIZOBACTER ARGENTINA S.A., PERGAMINO, ARGENTINA, FILED 9-21-2010.

**Signum**  
Bio-inducer

NO CLAIM IS MADE TO THE EXCLUSIVE RIGHT TO USE "BIO-INDUCER", APART FROM THE MARK AS SHOWN.

THE COLOR(S) BLUE, PALE BLUE AND GRAY IS/ARE CLAIMED AS A FEATURE OF THE MARK.

THE MARK CONSISTS OF THE WORD "SIGNUM" WITH THE ROOT "SIG" IN BLUE COLOR, AND THE PORTION "NUM" IN PALE BLUE COLOR; OVER THE EXPRESSION "BIO-INDUCER" IN GREY COLOR AND SMALLER LETTERS.

FOR INOCULANTS, NAMELY, BIOLOGICAL MICRO-ORGANISMS USED IN FERMENTATION OF SILAGE; NATURAL FERTILIZERS; NON-CHEMICAL BIO-FERTILIZERS (U.S. CLS. 1, 5, 6, 10, 26 AND 46).

JOHN SCHUYLER YARD, EXAMINING ATTORNEY

SN 85-153,721. NORTHWEST AGRICULTURAL PRODUCTS, INC., PASCO, WA. FILED 10-15-2010.

## ChelAmine Granular

THE MARK CONSISTS OF STANDARD CHARACTERS WITHOUT CLAIM TO ANY PARTICULAR FONT, STYLE, SIZE, OR COLOR.

NO CLAIM IS MADE TO THE EXCLUSIVE RIGHT TO USE "GRANULAR", APART FROM THE MARK AS SHOWN.

FOR FERTILIZERS FOR AGRICULTURAL USE (U.S. CLS. 1, 5, 6, 10, 26 AND 46).

ANN E. SAPPENFIELD, EXAMINING ATTORNEY

SN 85-161,303. ECOSYSTEM PRODUCTS LLC, TROUP, TX. FILED 10-26-2010.

**TBM<sup>o</sup>1**

THE MARK CONSISTS OF THE STYLIZED TEXT "TBM 1" WITH A TARGET IN THE MIDDLE.

FOR SOIL CONDITIONING PREPARATIONS; BACTERIA FOR WASTE WATER TREATMENT; BACILLUS AND OTHER MICROBES SUSPENDED IN POWDERED OR LIQUID FORM FOR SANITATION, ODOR CONTROL, AND WASTE WATER TREATMENT APPLICATIONS; BIOLOGICALLY ACTIVE ENZYMES AND MICROORGANISMS THAT ARE AIMED AT SANITIZING WATER ENVIRONMENTS AND TO TREAT THE ACTIVATION AND OPTIMIZATION OF BIOLOGICAL FILTER SYSTEMS (U.S. CLS. 1, 5, 6, 10, 26 AND 46).

H. M. FISHER, EXAMINING ATTORNEY

**CLASS 1—(Continued).**

SN 85-164,677. GREENLINE "THE SOIL COMPANY" GMBH, OHRDRUF, FED REP GERMANY, FILED 10-29-2010.

## CLAVIS-5

THE MARK CONSISTS OF STANDARD CHARACTERS WITHOUT CLAIM TO ANY PARTICULAR FONT, STYLE, SIZE, OR COLOR.

OWNER OF ERPN CMNTY TM OFC REG. NO. 009083676, DATED 9-27-2010, EXPIRES 5-6-2020.

FOR MANURES; MANURE FOR AGRICULTURE; SOIL CONDITIONERS FOR AGRICULTURAL USE (U.S. CLS. 1, 5, 6, 10, 26 AND 46).

SANJEEV VOHRA, EXAMINING ATTORNEY

SN 85-168,128. ALEX MILNE ASSOCIATES LTD., ETOBICOKE, ONTARIO, CANADA, FILED 11-3-2010.



OWNER OF CANADA REG. NO. TMA768755, DATED 6-4-2010, EXPIRES 6-4-2025.

NO CLAIM IS MADE TO THE EXCLUSIVE RIGHT TO USE "HORSES", APART FROM THE MARK AS SHOWN.

THE MARK CONSISTS OF THE TERMS "JUST ADD HORSES" SET FORTH ABOVE A STYLIZED HORSE DESIGN.

FOR CHEMICAL PREPARATION FOR STABILIZING SOIL AND DUST; WATERPROOFING CHEMICAL COMPOSITIONS; EPOXY RESINS; CHEMICAL PREPARATIONS, NAMELY, DEGREASING CLEANERS (U.S. CLS. 1, 5, 6, 10, 26 AND 46).

FIRST USE 9-7-2010; IN COMMERCE 9-7-2010.

DORITT L. CARROLL, EXAMINING ATTORNEY

**CLASS 1—(Continued).**

SN 85-170,392. ECOSYSTEM PRODUCTS LLC, TROUP, TX. FILED 11-5-2010.



The logo consists of the letters 'TBM' in a bold, sans-serif font, followed by a degree symbol (°) and the number '2'. The degree symbol is positioned between the 'M' and the '2'.

THE MARK CONSISTS OF THE STYLIZED TEXT "TBM 2" WITH A BULLSEYE TARGET.

FOR PLANT GROWTH REGULATORS FOR AGRICULTURAL USE; PLANT GROWTH REGULATING PREPARATIONS; SOIL CONDITIONING PREPARATIONS; BACTERIA FOR WASTE WATER TREATMENT; BACILLUS AND OTHER MICROBES SUSPENDED IN POWDERED OR LIQUID FORM FOR SANITATION, ODOR CONTROL AND WASTE WATER TREATMENT APPLICATIONS; BIOLOGICALLY ACTIVE ENZYMES AND MICROORGANISMS THAT ARE AIMED AT SANITIZING WATER ENVIRONMENTS AND TO TREAT THE ACTIVATION AND OPTIMIZATION OF BIOLOGICAL FILTER SYSTEMS; ENZYMES TO AID IN DIGESTION FOR USE IN MANUFACTURING ANIMAL FEEDS (U.S. CLS. 1, 5, 6, 10, 26 AND 46).

H. M. FISHER, EXAMINING ATTORNEY

---

SN 85-171,559. ROTAM AGROCHEM INTERNATIONAL CO. LTD., CHAI WAN, HONG KONG, FILED 11-8-2010.



The logo consists of the letters 'R', 'R', and 'L' in a bold, sans-serif font, separated by small triangles. A thick, black, downward-pointing triangle is positioned beneath the letters.

THE MARK CONSISTS OF THE LETTERS "R R L" SEPARATED BY TRIANGLE DESIGNS WITH A GRADUALLY INCREASING SLOPE APPEARING BENEATH THE LETTERS.

FOR CHEMICAL PRODUCTS FOR USE IN HORTICULTURE, AGRICULTURE AND FORESTRY, NAMELY, CHEMICAL PREPARATIONS FOR THE TREATMENT OF SEEDS; CHEMICAL SOIL CONDITIONERS; SOIL FERTILIZERS; CHEMICAL PREPARATIONS FOR PRESERVING SEEDS; PLANT GROWTH REGULATORS FOR AGRICULTURAL USE; CHEMICAL PREPARATIONS USED FOR DIAGNOSTIC PURPOSES IN CONNECTION WITH AGRICULTURAL APPLICATIONS (U.S. CLS. 1, 5, 6, 10, 26 AND 46).

RUSS HERMAN, EXAMINING ATTORNEY

**CLASS 1—(Continued).**

SN 85-172,849. SCI PROTEK, INC., VISALIA, CA. FILED 11-9-2010.

# LIFT OFF

THE MARK CONSISTS OF STANDARD CHARACTERS WITHOUT CLAIM TO ANY PARTICULAR FONT, STYLE, SIZE, OR COLOR.

FOR FERTILIZERS AND PLANT GROWTH NUTRIENTS FOR USE IN AGRICULTURE (U.S. CLS. 1, 5, 6, 10, 26 AND 46).

MARILYN IZZI, EXAMINING ATTORNEY

---

SN 85-173,917. RED LINE SYNTHETIC OIL CORP., BENICIA, CA. FILED 11-10-2010.

# OPTIMOL

THE MARK CONSISTS OF STANDARD CHARACTERS WITHOUT CLAIM TO ANY PARTICULAR FONT, STYLE, SIZE, OR COLOR.

FOR CHEMICALS, NAMELY, DAMPING FLUID USED TO DISSIPATE ENERGY IN AUTOMOTIVE, MOTORCYCLE, BICYCLE AND INDUSTRIAL SUSPENSIONS (U.S. CLS. 1, 5, 6, 10, 26 AND 46).

PRISCILLA MILTON, EXAMINING ATTORNEY

---

SN 85-176,756. MICROBIOLOGICS, INC, ST. CLOUD, MN. FILED 11-15-2010.

# KWIK-STIK

THE MARK CONSISTS OF STANDARD CHARACTERS WITHOUT CLAIM TO ANY PARTICULAR FONT, STYLE, SIZE, OR COLOR.

FOR PRESERVED MICROORGANISM PREPARATIONS FOR CLINICAL OR INDUSTRIAL LABORATORY QUALITY CONTROL USE (U.S. CLS. 1, 5, 6, 10, 26 AND 46).

FIRST USE 0-0-1999; IN COMMERCE 0-0-1999.

C. DIONNE CLYBURN, EXAMINING ATTORNEY



**CLASS 1—(Continued).**

SN 85-181,811. BARISH, LONNIE MERRITT, NEWTOWN, PA. FILED 11-20-2010.



THE MARK CONSISTS OF THE LETTERS "M P R" WITH A DESIGN OF A STYLIZED "M P" AND A BACKWARDS "R".

FOR MEN'S, WOMEN'S, AND CHILDREN'S CLOTHING, NAMELY, SWEATSHIRTS, SHIRTS, JEANS, JACKETS, COATS, SWEATPANTS, SLACKS, SUITS, HATS, HEADBANDS, VISORS, CAPS, DRESSES, SHOES, SNEAKERS, BOOTS, WRISTBANDS, SOCKS, T-SHIRTS, BELTS, UNDERGARMENTS, NECKTIES, DRESS SHIRTS, COLLARED SHIRTS, RUGBY SHIRTS, KNIT SHIRTS, SHORTS, AND SANDALS (U.S. CLS. 1, 5, 6, 10, 26 AND 46).

FIRST USE 1-1-2001; IN COMMERCE 4-1-2007.  
MORGAN WYNNE, EXAMINING ATTORNEY

SN 85-182,574. OREGON RESOURCES CORPORATION, PORTLAND, OR. FILED 11-22-2010.



THE MARK CONSISTS OF THE WORD "SPHERICHROME" APPEARING OVER THE TOP OF A CIRCLE, WITH A STAR DESIGN APPEARING AS THE DOT ON THE LETTER "I".

FOR FOUNDRY SAND (U.S. CLS. 1, 5, 6, 10, 26 AND 46).

WILLIAM BRECKENFELD, EXAMINING ATTORNEY

**CLASS 1—(Continued).**

SN 85-184,770. THE W.W. HENRY COMPANY L.P., ALIQUIPPA, PA. FILED 11-24-2010.

## HENRY LIQUID TAPE

THE MARK CONSISTS OF STANDARD CHARACTERS WITHOUT CLAIM TO ANY PARTICULAR FONT, STYLE, SIZE, OR COLOR.

OWNER OF U.S. REG. NOS. 1,064,754, 2,726,870 AND OTHERS.

NO CLAIM IS MADE TO THE EXCLUSIVE RIGHT TO USE "LIQUID TAPE", APART FROM THE MARK AS SHOWN.

FOR ADHESIVES FOR FLOOR COVERINGS (U.S. CLS. 1, 5, 6, 10, 26 AND 46).

MARY ROSSMAN, EXAMINING ATTORNEY

SN 85-188,651. FREEPORT-MCMORAN COPPER & GOLD INC., PHOENIX, AZ. FILED 12-1-2010.



OWNER OF U.S. REG. NO. 381,097.

NO CLAIM IS MADE TO THE EXCLUSIVE RIGHT TO USE "BRAND", APART FROM THE MARK AS SHOWN.

THE MARK CONSISTS OF AN IMAGE OF A HOLLOW TRIANGLE SURROUNDED BY A SOLID TRIANGLE. THE WORDS "TRIANGLE BRAND" APPEAR OUTSIDE AND ON TOP OF THE LEFT AND RIGHT EDGES OF THE TRIANGLE IMAGE.

FOR COPPER SULPHATE (U.S. CLS. 1, 5, 6, 10, 26 AND 46).

FIRST USE 12-31-2000, THE MARK WAS FIRST USED ANYWHERE IN A DIFFERENT FORM OTHER THAN THAT SOUGHT TO BE REGISTERED AT LEAST AS EARLY AS 09/20/1939; IN COMMERCE 12-31-2000, THE MARK WAS FIRST USED IN COMMERCE IN A DIFFERENT FORM OTHER THAN THAT SOUGHT TO BE REGISTERED AT LEAST AS EARLY AS 09/20/1939.

JANET LEE, EXAMINING ATTORNEY

**CLASS 1—(Continued).**

SN 85-190,070. GK WORLD HOLDING LLC, FORT LAUDERDALE, FL. FILED 12-3-2010.

# TRIOXXY

THE MARK CONSISTS OF STANDARD CHARACTERS WITHOUT CLAIM TO ANY PARTICULAR FONT, STYLE, SIZE, OR COLOR.

FOR POLYMERS AND POLYMERIC ADDITIVES FOR USE IN THE MANUFACTURE OF PHARMACEUTICAL PREPARATIONS, MEDICAL DEVICES, PLASTICS, COSMETICS, PERSONAL CARE PRODUCTS, COATINGS, ADHESIVES, AND LUBRICANTS (U.S. CLS. 1, 5, 6, 10, 26 AND 46).

SUE LAWRENCE, EXAMINING ATTORNEY

SN 85-190,430. OUTSIDEPRIDE.COM, INC., DBA OUTSIDE-PRIDE.COM, INDEPENDENCE, OR. FILED 12-3-2010.

# LazyMan Soil MD

THE MARK CONSISTS OF STANDARD CHARACTERS WITHOUT CLAIM TO ANY PARTICULAR FONT, STYLE, SIZE, OR COLOR.

OWNER OF U.S. REG. NOS. 3,093,135 AND 3,577,613. NO CLAIM IS MADE TO THE EXCLUSIVE RIGHT TO USE "SOIL", APART FROM THE MARK AS SHOWN. FOR FERTILIZERS (U.S. CLS. 1, 5, 6, 10, 26 AND 46).

VIVIAN MICZNIK FIRST, EXAMINING ATTORNEY

SN 85-191,291. AH WATER, INC., TEMECULA, CA. FILED 12-6-2010.

# TriOxyn

THE MARK CONSISTS OF STANDARD CHARACTERS WITHOUT CLAIM TO ANY PARTICULAR FONT, STYLE, SIZE, OR COLOR.

FOR ENHANCED NITRATE PRODUCTS, NAMELY, CALCIUM NITRATE USED FOR ODOR CONTROL IN THE WASTE WATER INDUSTRY (U.S. CLS. 1, 5, 6, 10, 26 AND 46).

RUDY R. SINGLETON, EXAMINING ATTORNEY

**CLASS 1—(Continued).**

SN 85-192,181. CAW INDUSTRIES, INC., RAPID CITY, SD. FILED 12-7-2010.



The logo for Dr. Willard's features the word "Dr." in a serif font above the word "Willard's" in a larger, bold serif font. Both words are enclosed within a thin, arched line that follows the curve of the letters.

OWNER OF U.S. REG. NOS. 1,785,082, 3,881,458 AND OTHERS.

THE NAME "DR. WILLARD" DOES NOT IDENTIFY A LIVING INDIVIDUAL.

THE MARK CONSISTS OF THE WORD "DR." APPEARING BENEATH A LINE AND ABOVE THE WORD "WILLARD'S" WHICH IS ITSELF BENEATH AND ABOVE SEPARATE LINES, THE WORDS ARRANGED IN AN ARCHING MANNER.

FOR CHEMICALS, NAMELY, AQUEOUS CATALYST-CONTAINING COMPOSITIONS FOR USE IN ALTERING THE PROPERTIES OF LIQUID WATER, AND FOR GENERAL USE IN AGRICULTURE AND HORTICULTURE, FOR USE IN WASHING, CLEANING, DISINFECTING AND SANITIZING IN HOUSEHOLD, INDUSTRIAL, AND INSTITUTIONAL APPLICATIONS, FOR USE IN PERSONAL CARE, SKIN CARE AND COSMETIC APPLICATIONS, SHAMPOOING AND HAIR TREATING, FOR USE IN PHARMACEUTICAL, MEDICINAL AND VETERINARY APPLICATIONS, IN HOLISTIC AND HOMEOPATHIC MEDICINE APPLICATIONS, IN DIETARY SUPPLEMENT AND NUTRITIONAL SUPPLEMENTS, AND FOR USE IN TREATING CARBONACEOUS FOSSIL FUELS AND BITUMINOUS MATERIALS (U.S. CLS. 1, 5, 6, 10, 26 AND 46).

FIRST USE 11-0-2010; IN COMMERCE 11-0-2010.  
ROSELLE HERRERA, EXAMINING ATTORNEY

SN 85-193,207. LEBANON SEABOARD CORPORATION, LEBANON, PA. FILED 12-8-2010.

A NATURAL SYSTEMS APPROACH

THE MARK CONSISTS OF STANDARD CHARACTERS WITHOUT CLAIM TO ANY PARTICULAR FONT, STYLE, SIZE, OR COLOR.

NO CLAIM IS MADE TO THE EXCLUSIVE RIGHT TO USE "NATURAL SYSTEMS", APART FROM THE MARK AS SHOWN.

SEC. 2(F).

FOR BIOLOGICAL FERTILIZERS AND SOIL CONDITIONERS FOR DOMESTIC, AGRICULTURAL, COMMERCIAL AND HORTICULTURAL USE (U.S. CLS. 1, 5, 6, 10, 26 AND 46).

FIRST USE 1-31-2001; IN COMMERCE 1-31-2001.

MARC LEIPZIG, EXAMINING ATTORNEY

**CLASS 1—(Continued).**

SN 85-193,881. PROP SUPPLY & SERVICE, LLC, AKA RAINBOW CERAMICS, HOUSTON, TX. FILED 12-9-2010.

# ReaLite

THE MARK CONSISTS OF STANDARD CHARACTERS WITHOUT CLAIM TO ANY PARTICULAR FONT, STYLE, SIZE, OR COLOR.

THE WORDING "REALITE" HAS NO MEANING IN ENGLISH.

FOR PROPPANT FOR USE IN OIL WELL AND GAS WELL HYDRAULIC FRACTURING OPERATIONS (U.S. CLS. 1, 5, 6, 10, 26 AND 46).

FIRST USE 11-15-2008; IN COMMERCE 12-15-2008.

PAUL MORENO, EXAMINING ATTORNEY

SN 85-197,483. SCHAEFFER MFG. CO., ST. LOUIS, MO. FILED 12-14-2010.

# SOYSHIELD

THE MARK CONSISTS OF STANDARD CHARACTERS WITHOUT CLAIM TO ANY PARTICULAR FONT, STYLE, SIZE, OR COLOR.

FOR CHEMICAL ADDITIVES FOR FUEL TREATMENT CONTAINING METHYL SOYATE BIO-DIESEL DERIVED FROM SOYBEAN OIL (U.S. CLS. 1, 5, 6, 10, 26 AND 46).

FIRST USE 2-1-1998; IN COMMERCE 2-1-1998.

EMILY CHUO, EXAMINING ATTORNEY

SN 85-202,787. INTERNATIONAL FLORA TECHNOLOGIES LTD., CHANDLER, AZ. FILED 12-21-2010.



THE MARK CONSISTS OF A DROPLET DESIGN WITH "L22" FEATURED WITHIN THE DROPLET.

FOR BOTANICAL AND BOTANICALLY-DERIVED EXTRACTS FOR USE IN THE MANUFACTURE OF PERSONAL CARE PRODUCTS, PHARMACEUTICALS, AND COSMETICS (U.S. CLS. 1, 5, 6, 10, 26 AND 46).

AISHA SALEM, EXAMINING ATTORNEY

**CLASS 1—(Continued).**

SN 85-202,833. CRC INDUSTRIES, INC., WARMINSTER, PA. FILED 12-21-2010.

# FiberLock

THE MARK CONSISTS OF STANDARD CHARACTERS WITHOUT CLAIM TO ANY PARTICULAR FONT, STYLE, SIZE, OR COLOR.

FOR CHEMICAL COMPOSITIONS FOR SEALING LEAKS IN THE FLUID SYSTEM OF INTERNAL COMBUSTION ENGINES (U.S. CLS. 1, 5, 6, 10, 26 AND 46).

FIRST USE 2-24-2011; IN COMMERCE 2-24-2011.

DOMINICK J. SALEMI, EXAMINING ATTORNEY

SN 85-203,715. ARDEN CORPORATION, BINGHAM FARMS, MI. FILED 12-22-2010.

# EVERBLOC

THE MARK CONSISTS OF STANDARD CHARACTERS WITHOUT CLAIM TO ANY PARTICULAR FONT, STYLE, SIZE, OR COLOR.

FOR CHEMICAL TREATMENT APPLIED TO FABRIC FOR WATER RESISTANCE AND STAIN RESISTANCE (U.S. CLS. 1, 5, 6, 10, 26 AND 46).

ROSELLE HERRERA, EXAMINING ATTORNEY

SN 85-203,781. ALBERMARLE CORPORATION, BATON ROUGE, LA. FILED 12-22-2010.

# GOBIO

THE MARK CONSISTS OF STANDARD CHARACTERS WITHOUT CLAIM TO ANY PARTICULAR FONT, STYLE, SIZE, OR COLOR.

FOR CATALYSTS USED IN THE MANUFACTURE AND TREATMENT OF BIOFUELS AND BIOMASS (U.S. CLS. 1, 5, 6, 10, 26 AND 46).

NANCY CLARKE, EXAMINING ATTORNEY

**CLASS 1—(Continued).**

SN 85-204,168. INNOVATIVE PLASTICS TECHNOLOGY, LLC, WILMINGTON, DE. FILED 12-22-2010.

# VERSACRYL

THE MARK CONSISTS OF STANDARD CHARACTERS WITHOUT CLAIM TO ANY PARTICULAR FONT, STYLE, SIZE, OR COLOR.

FOR ULTRAVIOLET CURABLE COATING COMPOSITION, NAMELY, A URETHANE-ACRYLIC COATING COMPOSITION FOR EXTERIOR BUILDING PRODUCTS, NAMELY, SIDING, ROOFING, DECKING, FRAMING, RAILING AND FENCING (U.S. CLS. 1, 5, 6, 10, 26 AND 46).

LINDA MICKLEBURGH, EXAMINING ATTORNEY

**CLASS 1—(Continued).**

SN 85-205,916. SCI PROTEK, INC., VISALIA, CA. FILED 12-27-2010.

# T-MATE

THE MARK CONSISTS OF STANDARD CHARACTERS WITHOUT CLAIM TO ANY PARTICULAR FONT, STYLE, SIZE, OR COLOR.

FOR AGRICULTURAL SOIL WETTERS AND ADJUVANTS FOR USE WITH AGRICULTURAL CHEMICALS; DISPERSING AGENTS USED WITH SOIL APPLIED PESTICIDES (U.S. CLS. 1, 5, 6, 10, 26 AND 46).

MARILYN IZZI, EXAMINING ATTORNEY

---

SN 85-205,631. NEW SEED, INC., WILMINGTON, DE. FILED 12-25-2010.

# BOSTON DANDY

THE MARK CONSISTS OF STANDARD CHARACTERS WITHOUT CLAIM TO ANY PARTICULAR FONT, STYLE, SIZE, OR COLOR.

NO CLAIM IS MADE TO THE EXCLUSIVE RIGHT TO USE "BOSTON", APART FROM THE MARK AS SHOWN.

FOR ACTIVE CHEMICAL INGREDIENTS FOR USE IN THE MANUFACTURE OF ANTI-CANCER DRUGS; ACTIVE CHEMICAL INGREDIENTS FOR USE IN THE MANUFACTURE OF PHARMACEUTICALS FOR TREATING INFLAMMATORY, KIDNEY, VIRAL, METABOLIC, ENDOCRINE, MUSCULOSKELETAL, CARDIOVASCULAR, CARDIOPULMONARY, RESPIRATORY, NEUROLOGICAL, GASTROINTESTINAL, HORMONAL, DERMATOLOGICAL, GENITOURINARY, SEXUAL DYSFUNCTION, HEPATOLOGICAL, OPHTHALMIC, PSYCHIATRIC AND IMMUNE SYSTEM RELATED DISEASES AND DISORDERS; ANTIOXIDANTS AND PROTEINS USED IN THE MANUFACTURE OF COSMETICS, BEVERAGES, FOOD PRODUCTS AND FOOD SUPPLEMENTS; BIOCHEMICALS FOR IN VITRO AND IN VIVO SCIENTIFIC USE; BIOCHEMICALS, NAMELY, POLYPEPTIDES FOR IN VITRO RESEARCH USE (U.S. CLS. 1, 5, 6, 10, 26 AND 46).

ALICIA COLLINS, EXAMINING ATTORNEY

---

SN 85-206,611. JOHN A. THOMSON FOR THOMSON FAMILY PARTNERSHIP, DBA VITAMIN INSTITUTE, NORTH HOLLYWOOD, CA. FILED 12-28-2010.



THE MARK CONSISTS OF THE NUMBER ONE AND INSIDE OF IT THE NUMBER. THE WORDING 50 IN ONE. FOR PLANT HORMONES (PHYTOHORMONES); PREPARATIONS FOR FORTIFYING PLANTS (U.S. CLS. 1, 5, 6, 10, 26 AND 46).

FIRST USE 8-27-1951; IN COMMERCE 8-27-1951.

ERNEST SHOSHO, EXAMINING ATTORNEY

**CLASS 1—(Continued).**

SN 85-206,815. BIO SOIL ENHANCERS, INC., HATTIESBURG, MS. FILED 12-28-2010.



THE COLOR(S) DARK GREEN AND LIGHT GREEN IS/ ARE CLAIMED AS A FEATURE OF THE MARK.

THE MARK CONSISTS OF "SUMA" IN DARK GREEN AND "GROW" IN LIGHT GREEN. A WATER DROP ABOVE AND CENTERED OVER THE WORD IN DARK GREEN. THE STYLIZED LINE BELOW "SUMA" IS IN LIGHT GREEN AND THE STYLIZED LINE UNDER "GROW" IS IN DARK GREEN. BETWEEN THE STYLIZED LINES IS A LIGHT GREEN LEAF.

FOR NUTRITIVE ADDITIVE TO ENHANCE THE BIOLOGICAL ACTIVITY OF WATER, SOIL, SEEDS AND PLANTS FOR PURPOSES OF FERTILIZATION AND BIOREMEDIATION OF POLLUTANTS (U.S. CLS. 1, 5, 6, 10, 26 AND 46).

FIRST USE 6-11-2010; IN COMMERCE 6-11-2010.  
LINDA M. KING, EXAMINING ATTORNEY

---

SN 85-207,318. ACTIVE MINERALS INTERNATIONAL, LLC, HUNT VALLEY, MD. FILED 12-29-2010.

## ACTI-POZZ

THE MARK CONSISTS OF STANDARD CHARACTERS WITHOUT CLAIM TO ANY PARTICULAR FONT, STYLE, SIZE, OR COLOR.

FOR PARTIALLY CALCINED META KAOLIN USED AS AN ADDITIVE FOR CEMENT AND CONCRETE (U.S. CLS. 1, 5, 6, 10, 26 AND 46).

HOWARD SMIGA, EXAMINING ATTORNEY

---

SN 85-209,491. AMERICAN AGRITECH, L.L.C., CHANDLER, AZ. FILED 1-3-2011.

## ELEMENTS

THE MARK CONSISTS OF STANDARD CHARACTERS WITHOUT CLAIM TO ANY PARTICULAR FONT, STYLE, SIZE, OR COLOR.

FOR HYDROPONIC, HORTICULTURAL, AGRICULTURAL PLANT GROWTH NUTRIENT AND PLANT FOOD SUPPLEMENT (U.S. CLS. 1, 5, 6, 10, 26 AND 46).

KELLY BOULTON, EXAMINING ATTORNEY

**CLASS 1—(Continued).**

SN 85-209,856. FINE AGROCHEMICALS LIMITED, WHITTINGTON, WORCESTER, UNITED KINGDOM, FILED 1-4-2011.

## EXILIS PLUS

THE MARK CONSISTS OF STANDARD CHARACTERS WITHOUT CLAIM TO ANY PARTICULAR FONT, STYLE, SIZE, OR COLOR.

OWNER OF U.S. REG. NO. 2,449,797.

FOR PLANT GROWTH REGULATORS FOR AGRICULTURAL, HORTICULTURAL, AND FLORICULTURAL USE (U.S. CLS. 1, 5, 6, 10, 26 AND 46).

FIRST USE 4-1-2001; IN COMMERCE 4-1-2001.

ALLISON SCHRODY, EXAMINING ATTORNEY

---

SN 85-212,664. STONEXPRESS, INC., KENNESAW, GA. FILED 1-7-2011.



NO CLAIM IS MADE TO THE EXCLUSIVE RIGHT TO USE "SPRAY" OR "STICK", APART FROM THE MARK AS SHOWN.

THE MARK CONSISTS OF THE WORDS "SPRAY 'N STICK" IN WHICH THE APOSTROPHE FORMS A SPRAY CAN, SPRAYING ONTO A TILE SURFACE.

FOR ADHESIVES, OTHER THAN FOR STATIONERY OR HOUSEHOLD PURPOSES; CONSTRUCTION INDUSTRY ADHESIVES (U.S. CLS. 1, 5, 6, 10, 26 AND 46).

FIRST USE 1-7-2011; IN COMMERCE 1-7-2011.

JENNIFER MARTIN, EXAMINING ATTORNEY

**CLASS 1—(Continued).**

SN 85-231,370. NATIONAL PETROCHEMICAL INDUSTRIAL COMPANY, JEDDAH, SAUDI ARABIA, FILED 2-1-2011.



OWNER OF SAUDI ARABIA REG. NO. 917/96, DATED 5-14-2007, EXPIRES 6-8-2016.

THE COLOR(S) BLUE, BLACK AND WHITE IS/ARE CLAIMED AS A FEATURE OF THE MARK.

THE MARK CONSISTS OF THE STYLIZED WORD "TELDENE" IN THE COLOR BLACK, WITH A CIRCULAR SWIRL DESIGN IN THE COLORS BLUE AND WHITE ABOVE THE WORD "TELDENE".

FOR CHEMICALS USED IN INDUSTRY, NAMELY, POLYPROPYLENE RESINS (U.S. CLS. 1, 5, 6, 10, 26 AND 46).

KELLEY WELLS, EXAMINING ATTORNEY

SN 85-234,503. ARDEN CORPORATION, BINGHAM FARMS, MI. FILED 2-4-2011.

## EVERSHIELD

THE MARK CONSISTS OF STANDARD CHARACTERS WITHOUT CLAIM TO ANY PARTICULAR FONT, STYLE, SIZE, OR COLOR.

FOR CHEMICAL TREATMENT APPLIED TO FABRIC FOR WATER RESISTANCE AND STAIN RESISTANCE (U.S. CLS. 1, 5, 6, 10, 26 AND 46).

ROSELLE HERRERA, EXAMINING ATTORNEY

SN 85-238,863. SMOOTH-ON, INC., EASTON, PA. FILED 2-10-2011.

## ACROBAT

THE MARK CONSISTS OF STANDARD CHARACTERS WITHOUT CLAIM TO ANY PARTICULAR FONT, STYLE, SIZE, OR COLOR.

FOR FIBER-REINFORCED CASTING ALGINATE (U.S. CLS. 1, 5, 6, 10, 26 AND 46).

FIRST USE 9-0-2010; IN COMMERCE 9-0-2010.

DAVID TAYLOR, EXAMINING ATTORNEY

**CLASS 2—PAINTS**

SN 79-085,737. BASF COATINGS AG, FED REP GERMANY, FILED 4-27-2010.

# IGLOSS

THE MARK CONSISTS OF STANDARD CHARACTERS WITHOUT CLAIM TO ANY PARTICULAR FONT, STYLE, SIZE, OR COLOR.

PRIORITY DATE OF 10-27-2009 IS CLAIMED.

OWNER OF INTERNATIONAL REGISTRATION 1046726 DATED 4-27-2010, EXPIRES 4-27-2020.

FOR PAINTS, VARNISHES, PRIMING COATS, NAMELY, PRIMERS, COATINGS IN THE NATURE OF AUTOMOBILE FINISHING FILLER COATS, ALL FOR THE USE IN THE AUTOMOTIVE INDUSTRY (U.S. CLS. 6, 11 AND 16).

AISHA SALEM, EXAMINING ATTORNEY

SN 85-010,538. HI-TEMP COATINGS TECHNOLOGY COMPANY, INC., BOXBOROUGH, MA. FILED 4-9-2010.

## Hi-Temp 1027

THE MARK CONSISTS OF STANDARD CHARACTERS WITHOUT CLAIM TO ANY PARTICULAR FONT, STYLE, SIZE, OR COLOR.

NO CLAIM IS MADE TO THE EXCLUSIVE RIGHT TO USE "HIGH TEMP", APART FROM THE MARK AS SHOWN.

FOR COATING COMPOSITIONS IN THE NATURE OF HIGH-BUILD, SINGLE COMPONENT PAINT FORMULATED TO PREVENT CORROSION UNDER INSULATION OF CARBON STEEL FOR INDUSTRIAL APPLICATIONS (U.S. CLS. 6, 11 AND 16).

FIRST USE 6-1-2006; IN COMMERCE 6-1-2006.

H. M. FISHER, EXAMINING ATTORNEY

SN 85-010,547. HI-TEMP COATINGS TECHNOLOGY COMPANY, INC., BOXBOROUGH, MA. FILED 4-9-2010.

## Hi-Temp 707

THE MARK CONSISTS OF STANDARD CHARACTERS WITHOUT CLAIM TO ANY PARTICULAR FONT, STYLE, SIZE, OR COLOR.

NO CLAIM IS MADE TO THE EXCLUSIVE RIGHT TO USE "HIGH TEMP", APART FROM THE MARK AS SHOWN.

FOR COATING COMPOSITIONS IN THE NATURE OF WATERBORNE THERMAL INTERFACE PAINT FOR INSULATION AND ANTI-CONDENSATION SUBSTRATES FOR BOTH CARBON AND STAINLESS STEEL SUBSTRATES FOR INDUSTRIAL APPLICATIONS (U.S. CLS. 6, 11 AND 16).

FIRST USE 9-1-2008; IN COMMERCE 9-1-2008.

H. M. FISHER, EXAMINING ATTORNEY

**CLASS 2—(Continued).**

SN 85-045,077. RHINO LININGS CORPORATION, SAN DIEGO, CA. FILED 5-21-2010.

**RHINO ECO-COAT**

THE MARK CONSISTS OF STANDARD CHARACTERS WITHOUT CLAIM TO ANY PARTICULAR FONT, STYLE, SIZE, OR COLOR.

OWNER OF U.S. REG. NOS. 1,910,469, 2,752,078 AND OTHERS.

FOR SPRAYABLE HYBRID POLYURETHANE/POLYUREA COATING FOR APPLICATION ON A WIDE RANGE OF COMMERCIAL AND INDUSTRIAL PRODUCTS, NAMELY, ROOFS (U.S. CLS. 6, 11 AND 16).

FIRST USE 2-26-2010; IN COMMERCE 2-26-2010.  
PRISCILLA MILTON, EXAMINING ATTORNEY

**CLASS 2—(Continued).**

SN 85-196,596. TURBON INTERNATIONAL INC., CINNAMINSON, NJ. FILED 12-13-2010.

**EVERGREEN**

THE MARK CONSISTS OF STANDARD CHARACTERS WITHOUT CLAIM TO ANY PARTICULAR FONT, STYLE, SIZE, OR COLOR.

OWNER OF U.S. REG. NOS. 3,282,309 AND 3,282,572.  
FOR TONER; PHOTOCOPIER TONER; PHOTOCOPIER TONER IN CARTRIDGES; TONER CARTRIDGES; FILLED INK CARTRIDGES (U.S. CLS. 6, 11 AND 16).

FIRST USE 11-25-1996; IN COMMERCE 11-25-1996.  
NAKIA HENRY, EXAMINING ATTORNEY

SN 85-093,476. VALSPAR SOURCING, INC., MINNEAPOLIS, MN. FILED 7-27-2010.

**KOSMIC SPARKS**

THE MARK CONSISTS OF STANDARD CHARACTERS WITHOUT CLAIM TO ANY PARTICULAR FONT, STYLE, SIZE, OR COLOR.

OWNER OF U.S. REG. NO. 3,131,081.  
FOR AUTOMOTIVE PAINT (U.S. CLS. 6, 11 AND 16).  
MATTHEW EINSTEIN, EXAMINING ATTORNEY

SN 85-196,611. TURBON INTERNATIONAL INC., CINNAMINSON, NJ. FILED 12-13-2010.



OWNER OF U.S. REG. NOS. 3,282,309 AND 3,282,572.  
THE MARK CONSISTS OF THE VERBIAGE "EVERGREEN" WITH A FANCIFUL DEPICTION OF A GLOBE APPEARING ABOVE "EVERGREEN".

FOR TONER; PHOTOCOPIER TONER; PHOTOCOPIER TONER IN CARTRIDGES; TONER CARTRIDGES; FILLED INK CARTRIDGES (U.S. CLS. 6, 11 AND 16).

FIRST USE 11-25-1996; IN COMMERCE 11-25-1996.  
NAKIA HENRY, EXAMINING ATTORNEY

SN 85-190,608. WYETT, ANNE J., LAGUNA BEACH, CA. FILED 12-3-2010.

**jane glo**

THE MARK CONSISTS OF STANDARD CHARACTERS WITHOUT CLAIM TO ANY PARTICULAR FONT, STYLE, SIZE, OR COLOR.

THE NAME "JANE GLO" DOES NOT IDENTIFY A LIVING INDIVIDUAL.

FOR PAINTS, LACQUERS, VARNISHES (U.S. CLS. 6, 11 AND 16).

DOUGLAS LEE, EXAMINING ATTORNEY

SN 85-198,172. TITAN COATINGS, INC., BESSEMER, AL. FILED 12-15-2010.

**ULTRABRITE**

THE MARK CONSISTS OF STANDARD CHARACTERS WITHOUT CLAIM TO ANY PARTICULAR FONT, STYLE, SIZE, OR COLOR.

FOR POLYESTER COATING FOR USE WITH LIGHTING FIXTURES (U.S. CLS. 6, 11 AND 16).

FIRST USE 11-30-2010; IN COMMERCE 11-30-2010.  
PRISCILLA MILTON, EXAMINING ATTORNEY

**CLASS 2—(Continued).**

SN 85-198,512. HONTEK CORPORATION, SOUTH WINDSOR, CT. FILED 12-15-2010.

# HONTEK

THE MARK CONSISTS OF STANDARD CHARACTERS WITHOUT CLAIM TO ANY PARTICULAR FONT, STYLE, SIZE, OR COLOR.

FOR ABRASION-RESISTANT COATING COMPOSITIONS FOR POLYMERIC AND OTHER SUBSTRATES FOR USE ON HELICOPTER ROTOR BLADES, AIRCRAFT PROPELLER BLADES, RADOMES, ANTENNAS, NOSE CONES, PROPELLER BLADES ON BOATS AND SHIPS, TURBINE BLADES IN HYDRO-POWER GENERATION PLANTS, PERSONAL WATERCRAFT, LIFT FAN BLADES AND PROPULSION BLADES FOR AIR CUSHIONED VEHICLES, WIND MILL BLADES, EARTH MOVING EQUIPMENT FAN BLADES AND MARINE POWER CONNECTORS (U.S. CLS. 6, 11 AND 16).

FIRST USE 3-26-2004; IN COMMERCE 3-26-2004.  
MORGAN WYNNE, EXAMINING ATTORNEY

SN 85-202,613. NEPTUNE COATINGS CORPORATION, GRASS VALLEY, CA. FILED 12-21-2010.



NO CLAIM IS MADE TO THE EXCLUSIVE RIGHT TO USE "MEMBRANE", APART FROM THE MARK AS SHOWN.

THE COLOR(S) BLUE, WHITE, BLACK IS/ARE CLAIMED AS A FEATURE OF THE MARK.

THE MARK CONSISTS OF A BROKEN BLUE OVAL DESIGN CONTAINING THE WORD "REFLEX" IN LARGE CAPITAL WHITE LETTERS OVERTOP THE WORD "MEMBRANE" IN LOWERCASE BLACK LETTERS, WHEREIN THE "R" AND "E" OF THE WORD "REFLEX" ARE CONNECTED.

FOR ELASTOMERIC-BASED COATINGS FOR USE ON ROOFS, WALLS AND BUILDING FOUNDATIONS (U.S. CLS. 6, 11 AND 16).

BARBARA BROWN, EXAMINING ATTORNEY

**CLASS 2—(Continued).**

SN 85-214,609. BEHR PROCESS CORPORATION, SANTA ANA, CA. FILED 1-11-2011.

## PREMIUM PLUS ULTRA

THE MARK CONSISTS OF STANDARD CHARACTERS WITHOUT CLAIM TO ANY PARTICULAR FONT, STYLE, SIZE, OR COLOR.

OWNER OF U.S. REG. NOS. 3,538,801, 3,541,958 AND 3,758,949.

NO CLAIM IS MADE TO THE EXCLUSIVE RIGHT TO USE "PREMIUM", APART FROM THE MARK AS SHOWN. FOR INTERIOR PAINT (U.S. CLS. 6, 11 AND 16).

FIRST USE 4-1-2009; IN COMMERCE 4-1-2009.  
JAY FLOWERS, EXAMINING ATTORNEY

**CLASS 3—COSMETICS AND CLEANING PREPARATIONS**

SN 77-538,006. DELICIOUS BRANDS LLC, DALLAS, TX. FILED 8-4-2008.

# C.BOOTH

THE MARK CONSISTS OF STANDARD CHARACTERS WITHOUT CLAIM TO ANY PARTICULAR FONT, STYLE, SIZE, OR COLOR.

THE NAME(S), PORTRAIT(S), AND/OR SIGNATURE(S) SHOWN IN THE MARK IDENTIFIES "C.BOOTH", WHOSE CONSENT(S) TO REGISTER IS MADE OF RECORD.

FOR BODY WASH; BODY BUTTER; DRY OIL SPRAY; WHIPPED BODY CREAM; BUBBLE BATH; HAND SOAP; BODY LOTION; BODY CLEANSER; BODY MOISTURIZER; BODY SCRUB; BODY CREAM; BODY MIST; FACIAL CLEANSER; TONER PADS; FACE MOISTURIZER; FACE CREAM; EYE CREAM; HAND AND NAIL TREATMENTS, NAMELY, NON-MEDICATED HAND AND NAIL CARE PREPARATIONS; FACE MASK; NON-MEDICATED ACNE TREATMENT PREPARATIONS; STAIN REMOVING PREPARATIONS; SKIN WHITENING CREAMS; BRIGHTENING FLUID; NIGHT CREAM; FACE SCRUB; HAND CREAM; LIP BUTTER; LIP GLOSS; PRE-MOISTENED COSMETIC TOWELETTES; NAIL POLISH REMOVER; MAKE UP REMOVER; HYDRATING BODY LOTION; SCREEN CLEANSER; DEODORANT FOR WOMEN; FEMININE HYGIENE TOWELETTES; EYE MAKEUP AND LIPSTICK REMOVER; EYEWEAR CLEANING FLUID; SUNSCREEN; NON-MEDICATED FOOT CREAM; SHOWER CLEANSER; BATH OIL; NON-MEDICATED BATH SOAK; CREAM BATH; FACE TONER; FACE LOTION; WRINKLE CREAM; SKIN CARE PRODUCTS, NAMELY, NON-MEDICATED SKIN SERUM; FACE GEL (U.S. CLS. 1, 4, 6, 50, 51 AND 52).

FIRST USE 9-0-2007; IN COMMERCE 9-0-2007.

MARIA-VICTORIA SUAREZ, EXAMINING ATTORNEY



**CLASS 3—(Continued).**

SN 77-727,688. NU SCENTS TRADING INC, RIDGEFIELD, NJ. FILED S.R. 5-2-2009; AM. P.R. 8-11-2010.

**COPA&CABANA**

THE MARK CONSISTS OF STANDARD CHARACTERS WITHOUT CLAIM TO ANY PARTICULAR FONT, STYLE, SIZE, OR COLOR.

FOR COGNES, PERFUMES AND COSMETICS; COSMETICS IN GENERAL, INCLUDING PERFUMES; DISINFECTING PERFUMED SOAPS; EAU DE PERFUME; ESSENTIAL OILS AS PERFUME FOR LAUNDRY PURPOSES; LIQUID PERFUMES; OILS FOR PERFUMES AND SCENTS; PERFUME; PERFUME OILS; PERFUME OILS FOR THE MANUFACTURE OF COSMETIC PREPARATIONS; PERFUMED CREAMS; PERFUMED EXTRACTS FOR TISSUES AND PERFUMES; PERFUMED PASTE; PERFUMED POWDER; PERFUMED POWDERS; PERFUMED SOAP; PERFUMED SOAPS; PERFUMED TALCUM POWDER; PERFUMES; PERFUMES AND COGNES; PERFUMES AND TOILET WATERS; PERFUMES FOR INDUSTRIAL PURPOSES; PERFUMES, AFTERSHAVES AND COGNES; PERFUMES, EAU DE COGNES AND AFTERSHAVES; PERFUMES, EAUX DE COLOGNE AND AFTERSHAVES; PERFUMING SACHETS (U.S. CLS. 1, 4, 6, 50, 51 AND 52).

PAUL MORENO, EXAMINING ATTORNEY

---

SN 77-861,722. AMOREPACIFIC CORPORATION, SEOUL, REPUBLIC OF KOREA, FILED 10-30-2009.

**탄력 (彈力) 크림**  
**FIRMING CREAM**

NO CLAIM IS MADE TO THE EXCLUSIVE RIGHT TO USE "FIRMING CREAM", APART FROM THE MARK AS SHOWN.

THE MARK CONSISTS OF TWO-SYLLABLE KOREAN LETTERS FOLLOWED BY TWO-SYLLABLE CHINESE LETTERS IN PARENTHESIS AND TWO SYLLABLE KOREAN LETTERS IN FIRST LINE, AND "FIRMING CREAM" IN SECOND LINE.

THE NON-LATIN CHARACTERS IN THE MARK TRANSLITERATE TO TAHN-RYOK KUH-RIM AND THIS MEANS ELASTIC FORCE CREAM IN ENGLISH.

FOR COSMETIC CREAMS; COSMETICS; FACIAL CREAMS; LIQUID SOAPS; NON-MEDICATED SKIN CREAMS (U.S. CLS. 1, 4, 6, 50, 51 AND 52).

ELIZABETH KAJUBI, EXAMINING ATTORNEY

**CLASS 3—(Continued).**

SN 77-885,198. HI-TRON USA, LLC, POWAY, CA. FILED 12-3-2009.

**REVO**

THE MARK CONSISTS OF STANDARD CHARACTERS WITHOUT CLAIM TO ANY PARTICULAR FONT, STYLE, SIZE, OR COLOR.

FOR COSMETICS, MAKEUP AND BEAUTY CARE IN THE NATURE OF NON-MEDICATED SKIN CARE PREPARATIONS, NAMELY, FOUNDATION, PRIMER, LOOSE AND PRESSED POWDER, BLUSH, HIGHLIGHTER, BRONZER, EYE SHADOW, COLORED EYE CREAM, EYE LINER, EYE PENCILS, MASCARA, EYEBROW PENCILS, LIP COLOR, LIPSTICK, LIP GLOSS, LIP BASE, LIP PENCILS, AND LIP BALM, MAKEUP REMOVERS, NAMELY, SOAPS, LOTIONS, LIQUIDS, AND CREAMS, AND FACIAL LOTIONS; NAIL CARE PREPARATIONS, NAMELY, ARTIFICIAL NAILS AND NAIL TIPS, ACRYLIC POWDER, NAIL GLUE, ACRYLIC LIQUID, NAIL COLOR, NAIL BASE COAT, NAIL STRENGTHENER, NAIL TOP COAT, NAIL SAVING PREPARATIONS, CUTICLE OIL, AND CUTICLE LOTIONS; NON-MEDICATED TOILETRIES, NAMELY, LOTIONS, CREAMS, DEODORANT, MEDICATED AND NON-MEDICATED SOAPS FOR FACE AND BODY, FACIAL MASSAGING WASHES AND CLEANSERS; BATH PRODUCTS, NAMELY, BATH OIL, BATH AND SHOWER GEL, BUBBLE BATH, BATH CRYSTALS, BATH SALT, BODY EXFOLIANT, BODY BUTTER, AND FRAGRANCE SPRAYS FOR THE BODY, FOOT DEODORANT SPRAYS, NON-MEDICATED FOOT SOAKS AND EXFOLIANTS (U.S. CLS. 1, 4, 6, 50, 51 AND 52).

NICHOLAS ALTREE, EXAMINING ATTORNEY

---

SN 77-905,350. S2 SYNERGY LLC, DBA POO-POURRI, DALLAS, TX. FILED 1-5-2010.

**Aroma To Go**

THE MARK CONSISTS OF STANDARD CHARACTERS WITHOUT CLAIM TO ANY PARTICULAR FONT, STYLE, SIZE, OR COLOR.

NO CLAIM IS MADE TO THE EXCLUSIVE RIGHT TO USE "AROMA", APART FROM THE MARK AS SHOWN.

FOR FRAGRANCES; FRAGRANCES AND PERFUMERY; FRAGRANCES FOR PERSONAL USE (U.S. CLS. 1, 4, 6, 50, 51 AND 52).

HEATHER THOMPSON, EXAMINING ATTORNEY

**CLASS 3—(Continued).**

SN 77-955,492. AUSTRALIAN GOLD, LLC, INDIANAPOLIS, IN. FILED 3-10-2010.

# HD FÂTALE

THE MARK CONSISTS OF STANDARD CHARACTERS WITHOUT CLAIM TO ANY PARTICULAR FONT, STYLE, SIZE, OR COLOR.

OWNER OF U.S. REG. NO. 3,842,695.

THE ENGLISH TRANSLATION OF THE WORD "FÂTALE" IN THE MARK IS FATAL.

FOR NON-MEDICATED INDOOR AND OUTDOOR SKIN TANNING PREPARATIONS (U.S. CLS. 1, 4, 6, 50, 51 AND 52).

ANGELA M. MICHELI, EXAMINING ATTORNEY

SN 78-981,430. RECKITT BENCKISER S.A.R.L, G.D. DE LUXEMBOURG, LUXEMBOURG, FILED 6-5-2006.

# TREES FOR CHANGE

THE MARK CONSISTS OF STANDARD CHARACTERS WITHOUT CLAIM TO ANY PARTICULAR FONT, STYLE, SIZE, OR COLOR.

OWNER OF ERPN CMNTY TM OFC REG. NO. 5115688, DATED 1-14-2008, EXPIRES 6-5-2016.

FOR DETERGENT SOAP; DETERGENTS FOR MACHINE DISHWASHERS; DISHWASHING DETERGENT; SOAPS AND DETERGENTS; DECALCIFYING AND DESCALING PREPARATIONS FOR CLEANING HOUSEHOLD PRODUCTS (U.S. CLS. 1, 4, 6, 50, 51 AND 52).

FIRST USE 7-2-2009; IN COMMERCE 7-2-2009.

SETH A. RAPPAPORT, EXAMINING ATTORNEY

SN 79-077,160. MONTBLANC-SIMPLO GMBH, FED REP GERMANY, FILED 2-9-2009.

# PIX

OWNER OF INTERNATIONAL REGISTRATION 0681438 DATED 8-22-1997, EXPIRES 8-22-2017.

THE MARK CONSISTS OF THE WORD "PIX" IN STYLIZED FONT.

FOR TOILET SOAPS; PERFUMERY; ESSENTIAL OILS; COSMETICS; HAIR LOTIONS; DENTIFRICES (U.S. CLS. 1, 4, 6, 50, 51 AND 52).

TINA BROWN, EXAMINING ATTORNEY

**CLASS 3—(Continued).**

SN 79-078,719. ANDREAS TAUER, SWITZERLAND, FILED 11-30-2009.

# Tauer

THE MARK CONSISTS OF STANDARD CHARACTERS WITHOUT CLAIM TO ANY PARTICULAR FONT, STYLE, SIZE, OR COLOR.

PRIORITY DATE OF 11-30-2009 IS CLAIMED.

OWNER OF INTERNATIONAL REGISTRATION 1028303 DATED 11-30-2009, EXPIRES 11-30-2019.

SEC. 2(F).

FOR PERFUMERY (U.S. CLS. 1, 4, 6, 50, 51 AND 52).

REBECCA SMITH, EXAMINING ATTORNEY

SN 79-082,542. CONTAINER PTY LTD, AUSTRALIA, FILED 4-16-2010.

# LEIF

THE MARK CONSISTS OF STANDARD CHARACTERS WITHOUT CLAIM TO ANY PARTICULAR FONT, STYLE, SIZE, OR COLOR.

PRIORITY DATE OF 10-28-2009 IS CLAIMED.

OWNER OF INTERNATIONAL REGISTRATION 1038630 DATED 4-16-2010, EXPIRES 4-16-2020.

THE NAME SHOWN IN THE MARK DOES NOT IDENTIFY A PARTICULAR LIVING INDIVIDUAL.

FOR NON-MEDICATED HAIR CARE PREPARATIONS, NAMELY, COLORANTS, CONDITIONERS, CREAMS, DYES, GELS, LOTIONS, RINSES, SHAMPOOS AND SPRAY; NON-MEDICATED SKIN CARE PREPARATIONS, NAMELY, SKIN BALSAMS, CLARIFIERS, CLEANERS, CREAMS, GELS, LOTIONS, OILS, TONERS AND PEELS; NON-MEDICATED POWDERS, NAMELY, BODY POWDER AND FACE POWDER; COSMETIC SUNTAN PREPARATIONS, NAMELY, SUNTAN CREAMS, LOTIONS AND OILS (U.S. CLS. 1, 4, 6, 50, 51 AND 52).

TINA BROWN, EXAMINING ATTORNEY

**CLASS 3—(Continued).**

SN 79-082,595. PIGEON CORPORATION, BUPYEONG-GU, INCHEON, REPUBLIC OF KOREA, FILED 4-13-2010.

# OLIFE

THE MARK CONSISTS OF STANDARD CHARACTERS WITHOUT CLAIM TO ANY PARTICULAR FONT, STYLE, SIZE, OR COLOR.

PRIORITY DATE OF 4-1-2010 IS CLAIMED.

OWNER OF INTERNATIONAL REGISTRATION 1038838 DATED 4-13-2010, EXPIRES 4-13-2020.

FOR LAUNDRY PREPARATIONS, NAMELY, LAUNDRY DETERGENT; BLEACHING PREPARATIONS FOR LAUNDRY; FABRIC SOFTENERS FOR LAUNDRY USE; ANTISTATIC PREPARATIONS FOR HOUSEHOLD PURPOSES; BLEACHING SALTS; LAUNDRY STARCH; ADHESIVES FOR COSMETIC PURPOSES; SOAPS NOT FOR PERSONAL USE, NAMELY, FOR LAUNDRY; SOAP FOR PERSONAL USE; LAUNDRY DETERGENTS; DETERGENTS PREPARED FROM PETROLEUM FOR HOUSEHOLD CLEANING USE; LAUNDRY SOAPS; CLEANING PREPARATIONS FOR HOUSEHOLD PURPOSES; DISINFECTANT SOAP; DISH DETERGENTS; RINSE AIDING PREPARATION FOR CLOTHING; DETERGENTS FOR AUTOMOBILES; GLASS CLEANSERS; TOILET BOWL DETERGENTS; SHAMPOOS; HAND CLEANERS AS HAND CLEANING PREPARATIONS; BABY SHAMPOO; DEODORANT SOAP; LAUNDRY DETERGENT FOR WASHING BABIES' CLOTHES; FABRIC SOFTENERS FOR USE IN WASHING BABIES' CLOTHES; BABY SOAP; DRY-CLEANING FLUIDS; COLOR-BRIGHTENING CHEMICALS FOR HOUSEHOLD PURPOSES LAUNDRY; TOILET DETERGENT; DETERGENTS OTHER THAN FOR USE IN MANUFACTURING OPERATIONS AND FOR MEDICAL PURPOSES; RUST REMOVING PREPARATIONS; PREPARATIONS FOR CLEANING WASTE PIPES; COSMETICS; COTTON STICKS FOR COSMETIC PURPOSES; SHINING PREPARATIONS OR POLISH; AUTOMOBILE POLISHES; ABRASIVES, NAMELY, ABRASIVE PASTE; DENTIFRICES; POTPOURRI FRAGRANCES; COSMETICS FOR ANIMALS; AROMATIC PREPARATIONS, NAMELY, CREAM, LOTION OR BODY SPRAY FOR HOUSEHOLD PURPOSES; PERFUMERY (U.S. CLS. 1, 4, 6, 50, 51 AND 52).

MARIAM MAHMOUDI, EXAMINING ATTORNEY

**CLASS 3—(Continued).**

SN 79-084,151. PARFUMS CHRISTIAN DIOR, FRANCE, FILED 6-4-2010.



PRIORITY DATE OF 12-9-2009 IS CLAIMED. OWNER OF INTERNATIONAL REGISTRATION 1043015 DATED 6-4-2010, EXPIRES 6-4-2020.

OWNER OF U.S. REG. NOS. 573,430, 2,027,820 AND OTHERS.

NO CLAIM IS MADE TO THE EXCLUSIVE RIGHT TO USE "COLOGNE" OR "PARIS", APART FROM THE MARK AS SHOWN.

THE NAME "CHRISTIAN DIOR" DOES NOT IDENTIFY A LIVING INDIVIDUAL.

THE MARK CONSISTS OF THE WORD "COLOGNE" ABOVE "ROYALE", ALL ABOVE "CHRISTIAN DIOR" IN SMALLER LETTERS, WHICH IS ABOVE "PARIS" IN EVEN SMALLER LETTERS, ALL OF WHICH IS CENTERED IN A RECTANGLE MADE UP OF A THICK LINE IN BETWEEN TWO THIN LINES.

THE ENGLISH TRANSLATION OF THE WORDS "COLOGNE ROYALE" IN THE MARK IS ROYAL COLOGNE.

FOR PERFUMES (U.S. CLS. 1, 4, 6, 50, 51 AND 52).

EVELYN BRADLEY, EXAMINING ATTORNEY

SN 79-084,830. MORRIS PROFUMI S.P.A., ITALY, FILED 6-4-2010.



PRIORITY DATE OF 5-10-2010 IS CLAIMED.

OWNER OF INTERNATIONAL REGISTRATION 1044583 DATED 6-4-2010, EXPIRES 6-4-2020.

NO CLAIM IS MADE TO THE EXCLUSIVE RIGHT TO USE "PERFUME HOLDING", APART FROM THE MARK AS SHOWN.

THE COLOR(S) WHITE AND VIOLET IS/ARE CLAIMED AS A FEATURE OF THE MARK.

THE MARK CONSISTS OF THE ACRONYM "PH" PLACED ABOVE THE WORDS "PERFUME HOLDING" WRITTEN IN VIOLET.

FOR SOAPS; PERFUMES; ESSENTIAL OILS, COSMETICS, EAU-DE-COLOGNE, EAU-DE-TOILETTE, PERFUME SPRAYS FOR BODY; COSMETIC OILS, CREAMS, BEAUTY GELS AND LOTIONS FOR SKIN; COSMETIC PREPARATIONS FOR SHAVING, NAMELY, SHAVING BALM, SHAVING LOTION, SHAVING CREAM; TALCUM POWDERS FOR COSMETIC USE; COSMETIC PREPARATIONS FOR BATHING AND SHOWER, NAMELY, SHOWER AND BATH GEL, SHOWER AND BATH FOAM, SHOWER CREAMS; HAIR LOTIONS; DENTIFRICES; NON-MEDICATED MOUTHWASHES; DEODORANTS FOR PERSONAL USE; NON-MEDICATED TOILETRIES (U.S. CLS. 1, 4, 6, 50, 51 AND 52).

BENJAMIN OKEKE, EXAMINING ATTORNEY

**CLASS 3—(Continued).**

SN 79-085,421. L'OREAL, FRANCE, FILED 4-2-2010.

**BIOTIFUL**

OWNER OF INTERNATIONAL REGISTRATION 0768248A DATED 9-21-2001, EXPIRES 9-21-2011.

FOR SOAPS, PERFUMERY, ESSENTIAL OILS, COSMETICS, HAIR LOTIONS, DENTIFRICES (U.S. CLS. 1, 4, 6, 50, 51 AND 52).

HEATHER THOMPSON, EXAMINING ATTORNEY

SN 79-085,823. DREUMEX B.V., NETHERLANDS, FILED 6-2-2010.

**DREUMEX**

OWNER OF INTERNATIONAL REGISTRATION 0373770 DATED 11-25-1970, EXPIRES 11-25-2020.

FOR WASHING, CLEANING AND POLISHING PREPARATIONS FOR INDUSTRIAL AND HOUSEHOLD USE, NAMELY PROTECTIVE HAND CREAMS, RECONDITIONING SKIN CREAMS, CREAM SOAPS, ANTIBACTERIAL SOAPS, SHOWER AND HAIR SOAPS, HAND CLEANSING PASTES AND GELS, NON-MEDICATED HAND WASH PREPARATIONS, AND WIPES IMPREGNATED WITH A SKIN CLEANSER; DISINFECTANT SOAPS FOR CLEANING AND DISINFECTING OF SURFACES, EQUIPMENT AND MATERIALS; SHAMPOO AND CLEANERS FOR VEHICLES (U.S. CLS. 1, 4, 6, 50, 51 AND 52).

KAREN BRACEY, EXAMINING ATTORNEY

SN 79-089,020. IDEA INTERNATIONAL CO., LTD., MINATO-KU, TOKYO, JAPAN, FILED 8-3-2010.

**Terracuore**

OWNER OF INTERNATIONAL REGISTRATION 1055768 DATED 8-3-2010, EXPIRES 8-3-2020.

THE ENGLISH TRANSLATION OF "TERRACUORE" IN THE MARK IS "EARTH HEART".

FOR ANTI-STATIC PREPARATIONS FOR HOUSEHOLD PURPOSES; DE-GREASING PREPARATIONS FOR HOUSEHOLD PURPOSES; RUST REMOVING PREPARATIONS; STAIN REMOVING BENZINE; FABRIC SOFTENERS FOR LAUNDRY USE; LAUNDRY BLEACH; ADHESIVES FOR AFFIXING FALSE HAIR; ADHESIVES FOR AFFIXING FALSE EYELASHES; LAUNDRY STARCH; FUNORI, NAMELY, SEAWEED GELATINE FOR LAUNDRY USE; PAINT STRIPPING PREPARATIONS; SHOE AND BOOT CREAM; SHOE BLACK, NAMELY, SHOE POLISH; POLISHING PREPARATIONS; SOAPS AND DETERGENTS; SHAMPOOS FOR PETS; DENTIFRICES; COSMETICS AND NON-MEDICATED TOILETRIES; COSMETICS FOR ANIMALS; NATURAL PERFUMERY MADE FROM PLANTS; NATURAL PERFUMERY PREPARED FROM ANIMAL EXTRACTS; SYNTHETIC PERFUMERY; COMPOUND PERFUMERY; FOOD FLAVORINGS PREPARED FROM ESSENTIAL OILS; INCENSES AND FRAGRANCES; ABRASIVE PAPER, NAMELY, SANDPAPER; ABRASIVE CLOTH; ABRASIVE SAND; ARTIFICIAL PUMICE STONE; POLISHING PAPER; FALSE NAILS; FALSE EYELASHES (U.S. CLS. 1, 4, 6, 50, 51 AND 52).

MICHAEL TANNER, EXAMINING ATTORNEY

**CLASS 3—(Continued).**

SN 79-090,558. CGBS INTERNATIONAL S.A., SWITZERLAND, FILED 9-22-2010.

**FATAL  
BEAUTY**PRIORITY DATE OF 5-11-2010 IS CLAIMED.  
OWNER OF INTERNATIONAL REGISTRATION 1059991 DATED 9-22-2010, EXPIRES 9-22-2020.

NO CLAIM IS MADE TO THE EXCLUSIVE RIGHT TO USE "BEAUTY", APART FROM THE MARK AS SHOWN.

THE MARK CONSISTS OF THE STYLIZED WORDING "FATAL BEAUTY" WITH A STYLIZED UPSIDE-DOWN COMMA.

FOR CREAMS, POMADES, GELS AND LOTIONS FOR COSMETIC PURPOSES, COSMETIC PREPARATIONS FOR SKIN CARE, CLEANSING MILK FOR TOILET PURPOSES, MAKE-UP REMOVING PREPARATIONS, OILS FOR COSMETIC PURPOSES, SUN-TANNING PREPARATIONS, COSMETIC SUNSCREEN PREPARATIONS, BATH SALTS NOT FOR MEDICAL PURPOSES, DEODORANTS FOR PERSONAL USE, DEODORANT SOAPS, SOAPS, PERFUMES, TOILET WATERS, MAKE-UP PREPARATIONS (U.S. CLS. 1, 4, 6, 50, 51 AND 52).

BERYL GARDNER, EXAMINING ATTORNEY

SN 79-092,861. BANDO CHEMICAL INDUSTRIES, LTD., JAPAN, FILED 12-27-2010.

**TOPX**

THE MARK CONSISTS OF STANDARD CHARACTERS WITHOUT CLAIM TO ANY PARTICULAR FONT, STYLE, SIZE, OR COLOR.

PRIORITY DATE OF 6-30-2010 IS CLAIMED.  
OWNER OF INTERNATIONAL REGISTRATION 1065902 DATED 12-27-2010, EXPIRES 12-27-2020.

FOR ABRASIVE SHEETS, ABRASIVE TAPES, ABRASIVE SLURRIES, ABRASIVE GRAINS (U.S. CLS. 1, 4, 6, 50, 51 AND 52).

RONALD AIKENS, EXAMINING ATTORNEY

**CLASS 3—(Continued).**

SN 85-001,849. COSMETIC SOLUTIONS, INC, POMPANO BEACH, FL. FILED 3-30-2010.

**DR BECKER SKINCARE**

THE MARK CONSISTS OF STANDARD CHARACTERS WITHOUT CLAIM TO ANY PARTICULAR FONT, STYLE, SIZE, OR COLOR.

NO CLAIM IS MADE TO THE EXCLUSIVE RIGHT TO USE "SKINCARE", APART FROM THE MARK AS SHOWN. THE NAME(S), PORTRAIT(S), AND/OR SIGNATURE(S) SHOWN IN THE MARK IDENTIFIES WARREN BECKER, WHOSE CONSENT(S) TO REGISTER IS MADE OF RECORD.

FOR SKIN CARE PRODUCTS, NAMELY, CLEANSERS, EXFOLIATORS, MOISTURIZERS, CREAMS, AND SERUMS (U.S. CLS. 1, 4, 6, 50, 51 AND 52).

FIRST USE 1-7-2000; IN COMMERCE 1-7-2000.  
THOMAS MANOR, EXAMINING ATTORNEY

SN 85-005,618. TOM PEI-YEN ,DREW, JHONGHE CITY, TAIWAN, FILED 4-3-2010.



NO CLAIM IS MADE TO THE EXCLUSIVE RIGHT TO USE "NEW YORK", APART FROM THE MARK AS SHOWN. THE COLOR(S) GOLDEN YELLOW IS/ARE CLAIMED AS A FEATURE OF THE MARK.

THE MARK CONSISTS OF A DESIGN ELEMENT COMPRISED OF A SILHOUETTE OF A WOMAN HOLDING A GLOBE, WITH THREE CURVED BANDS PLACED BELOW THE WOMAN, ALL SET INSIDE AN OVAL, WITH THE STYLIZED WORDING "DAZZLING JENNY NEW YORK" SET BELOW THE OVAL. THE COLOR GOLDEN YELLOW APPEARS IN THE WORDING "DAZZLING JENNY NEW YORK", IN THE BORDER OF THE OVAL, IN THE THREE CURVED BANDS, IN THE SILHOUETTE OF THE WOMAN, AND IN THE SHADED AREAS OF THE GLOBE.

FOR COSMETIC PRODUCTS IN THE FORM OF AEROSOLS FOR SKINCARE (U.S. CLS. 1, 4, 6, 50, 51 AND 52).

FIRST USE 6-1-2006; IN COMMERCE 7-1-2006.  
MICHAEL GAAFAR, EXAMINING ATTORNEY

**CLASS 3—(Continued).**

SN 85-008,004. MAKE MONEY LIMITED, LONDON, UNITED KINGDOM, FILED 4-7-2010.

**Eyeko**

THE MARK CONSISTS OF STANDARD CHARACTERS WITHOUT CLAIM TO ANY PARTICULAR FONT, STYLE, SIZE, OR COLOR.

FOR COSMETICS; PERFUMES (U.S. CLS. 1, 4, 6, 50, 51 AND 52).

FIRST USE 8-1-2001; IN COMMERCE 8-1-2001.  
JOSETTE BEVERLY, EXAMINING ATTORNEY

SN 85-022,843. KARISMATIC, INC., AKA KARISMATIC MAKEUP, PARK RIDGE, IL. FILED 4-26-2010.

**K KARISMATIC**

THE MARK CONSISTS OF STANDARD CHARACTERS WITHOUT CLAIM TO ANY PARTICULAR FONT, STYLE, SIZE, OR COLOR.

FOR EYE LINER; EYE MAKE-UP; EYE PENCILS; EYE SHADOW; EYE SHADOWS; EYE-SHADOW; EYES MAKE-UP; EYES PENCILS; EYESHADOW; EYESHADOWS; FACE POWDER; FOUNDATION; FOUNDATION MAKE-UP; FOUNDATIONS; LIP GLOSS; LIP LINER; LIPSTICK; LIPSTICKS; MAKE UP FOUNDATIONS; MAKE-UP FOUNDATIONS; MAKE-UP KITS COMPRISED OF LIP LINER, EYE SHADOW, BRONZER, LIP GLOSS, LIP STICK, BLUSH, FOUNDATION AND POWDERS; SKIN BRONZER (U.S. CLS. 1, 4, 6, 50, 51 AND 52).

FIRST USE 1-1-2008; IN COMMERCE 1-1-2009.  
ANGELA M. MICHELI, EXAMINING ATTORNEY

SN 85-022,898. DAFU LICENSING, INC., LOS ANGELES, CA. FILED 4-26-2010.

**DAISY FUENTES MYSTERIO**

THE MARK CONSISTS OF STANDARD CHARACTERS WITHOUT CLAIM TO ANY PARTICULAR FONT, STYLE, SIZE, OR COLOR.

OWNER OF U.S. REG. NO. 3,230,497.

THE NAME(S), PORTRAIT(S), AND/OR SIGNATURE(S) SHOWN IN THE MARK IDENTIFIES "DAISY FUENTES", WHOSE CONSENT(S) TO REGISTER IS MADE OF RECORD.

FOR FRAGRANCES; NON-MEDICATED SKIN CARE PREPARATIONS; NON-MEDICATED TOILETRIES (U.S. CLS. 1, 4, 6, 50, 51 AND 52).

RAUL CORDOVA, EXAMINING ATTORNEY

**CLASS 3—(Continued).**

SN 85-024,624. THE SUN PRODUCTS CORPORATION, WILTON, CT. FILED 4-27-2010.

## THE SCIENCE OF STAIN FIGHTING

THE MARK CONSISTS OF STANDARD CHARACTERS WITHOUT CLAIM TO ANY PARTICULAR FONT, STYLE, SIZE, OR COLOR.

FOR LAUNDRY DETERGENT; STAIN REMOVING PREPARATIONS IN THE NATURE OF STAIN PRE-TREATERS AND STAIN TREATERS (U.S. CLS. 1, 4, 6, 50, 51 AND 52).

WILLIAM P. SHANAHAN, EXAMINING ATTORNEY

SN 85-029,379. FERGUSON ENTERPRISES, INC., NEWPORT NEWS, VA. FILED 5-4-2010.

## PROSELECT

THE MARK CONSISTS OF STANDARD CHARACTERS WITHOUT CLAIM TO ANY PARTICULAR FONT, STYLE, SIZE, OR COLOR.

OWNER OF U.S. REG. NOS. 3,065,212, 3,764,410 AND OTHERS.

FOR ABRASIVE PAPER, NAMELY, SANDPAPER (U.S. CLS. 1, 4, 6, 50, 51 AND 52).

FIRST USE 9-1-2009; IN COMMERCE 9-1-2009.  
SANI KHOURI, EXAMINING ATTORNEY

SN 85-029,386. SPARITUAL, LLC, VAN NUYS, CA. FILED 5-4-2010.

## SLOW

THE MARK CONSISTS OF STANDARD CHARACTERS WITHOUT CLAIM TO ANY PARTICULAR FONT, STYLE, SIZE, OR COLOR.

FOR PERFUME (U.S. CLS. 1, 4, 6, 50, 51 AND 52).  
BRIAN PINO, EXAMINING ATTORNEY

**CLASS 3—(Continued).**

SN 85-032,488. SILVERMAN, SELENA, HILLSBOROUGH, CA. FILED 5-7-2010.

## SELENA ROSE

THE MARK CONSISTS OF STANDARD CHARACTERS WITHOUT CLAIM TO ANY PARTICULAR FONT, STYLE, SIZE, OR COLOR.

THE NAME(S), PORTRAIT(S), AND/OR SIGNATURE(S) SHOWN IN THE MARK IDENTIFIES "SELENA ROSE" SILVERMAN, WHOSE CONSENT(S) TO REGISTER IS MADE OF RECORD.

FOR COSMETICS, HAIR CARE PREPARATIONS, PERFUMES, FRAGRANCES, BODY WASH, BODY LOTIONS, NAIL POLISHES AND NON-MEDICATED SKIN CARE PREPARATIONS (U.S. CLS. 1, 4, 6, 50, 51 AND 52).  
COLLEEN KEARNEY, EXAMINING ATTORNEY

SN 85-036,847. FIJI BLEND LLC, CALABASAS, CA. FILED 5-12-2010.

## FIJIBLEND

THE MARK CONSISTS OF STANDARD CHARACTERS WITHOUT CLAIM TO ANY PARTICULAR FONT, STYLE, SIZE, OR COLOR.

FOR SUN TANNING AND SKIN CARE LOTIONS, GELS, OILS, MISTS, AND CREAMS (U.S. CLS. 1, 4, 6, 50, 51 AND 52).

RONALD AIKENS, EXAMINING ATTORNEY

SN 85-039,109. ABERCROMBIE & FITCH TRADING CO., NEW ALBANY, OH. FILED 5-14-2010.



OWNER OF U.S. REG. NOS. 3,588,412, 3,745,498 AND OTHERS.

THE COLOR(S) BURGUNDY-RED AND WHITE IS/ARE CLAIMED AS A FEATURE OF THE MARK.

THE MARK CONSISTS OF A BURGUNDY-RED BIRD DESIGN SILHOUETTE WITH A WHITE PERIMETER.

FOR AFTER-SHAVE; BODY CREAMS; BODY LOTIONS; BODY SPRAY USED AS A PERSONAL DEODORANT AND AS FRAGRANCE; BODY SPRAYS; BODY WASH; COLOGNE; DEODORANTS AND ANTIPERSPIRANTS FOR PERSONAL USE; FRAGRANCES FOR PERSONAL USE; HAIR SHAMPOOS AND CONDITIONERS; HAIR STYLING PREPARATIONS; HAND CREAMS; HAND LOTIONS; LIP BALM; LIP GLOSS; MAKE-UP; PERFUME; SHAVING PREPARATIONS (U.S. CLS. 1, 4, 6, 50, 51 AND 52).

ROBERT C. CLARK JR., EXAMINING ATTORNEY

**CLASS 3—(Continued).**

SN 85-041,510. GUERRIERO, GLENN, GANSEVOORT, NY. AND GUERRIERO, MARYANN, GANSEVOORT, NY. FILED 5-18-2010.

# Brooklyn Attitude

THE MARK CONSISTS OF STANDARD CHARACTERS WITHOUT CLAIM TO ANY PARTICULAR FONT, STYLE, SIZE, OR COLOR.

FOR HAIR BLEACH; HAIR BLEACHES; HAIR CARE CREAMS; HAIR CARE LOTIONS; HAIR CARE PREPARATIONS; HAIR CLEANING PREPARATIONS; HAIR COLOR; HAIR COLOR REMOVERS; HAIR COLORANTS; HAIR COLORING PREPARATIONS; HAIR COLORING; HAIR CONDITIONERS; HAIR CONDITIONERS FOR BABIES; HAIR CURLING PREPARATIONS; HAIR GEL AND HAIR MOUSSE; HAIR GELS; HAIR GLAZE; HAIR MOUSSES; HAIR OILS; HAIR POMADES; HAIR RINSES; HAIR SHAMPOO; HAIR SHAMPOOS AND CONDITIONERS; HAIR SPRAYS AND HAIR GELS; HAIR STRAIGHTENING PREPARATIONS; HAIR STYLING FIXATIVE IN THE NATURE OF HAIR WAX; HAIR STYLING PREPARATIONS; HAIR TONICS; HAIR WAX; HAIR-WASHING POWDER; STYLING CLAY FOR HAIR; STYLING FOAM FOR HAIR; STYLING PASTE FOR HAIR; WAX FOR REMOVING BODY HAIR (U.S. CLS. 1, 4, 6, 50, 51 AND 52).

FIRST USE 7-3-2003; IN COMMERCE 7-3-2003.  
BILL DAWE, EXAMINING ATTORNEY

**CLASS 3—(Continued).**

SN 85-044,536. BOWER JACQUELINE RAE, BELFAST, ME. FILED 5-21-2010.

# SKINBOT

THE MARK CONSISTS OF STANDARD CHARACTERS WITHOUT CLAIM TO ANY PARTICULAR FONT, STYLE, SIZE, OR COLOR.

FOR COSMETICS AND CLEANING PRODUCTS, NAMELY, COSMETIC CREAMS FOR SKINCARE, NON-MEDICATED SKIN CARE PREPARATIONS, WRINKLE REMOVING SKIN CARE PREPARATIONS, PERFUMERY, ESSENTIAL OILS, COSMETICS, HAIR LOTIONS, FACIAL CREAMS, TOILET WATERS, BATH GELS, BATH SALTS, BEAUTY MASKS, MASSAGE OILS FOR CONSUMERS OF ALL AGES (U.S. CLS. 1, 4, 6, 50, 51 AND 52).

AMY C. KEAN, EXAMINING ATTORNEY

SN 85-046,860. SWEDISH SKIN CARE, INC., BEVERLY HILLS, CA. FILED 5-25-2010.

SN 85-042,086. LOUDERMILK, INC., LOS ANGELES, CA. FILED 5-18-2010.

# LUXURY ECO

THE MARK CONSISTS OF STANDARD CHARACTERS WITHOUT CLAIM TO ANY PARTICULAR FONT, STYLE, SIZE, OR COLOR.

OWNER OF U.S. REG. NOS. 3,169,886, 3,270,381 AND 3,420,791.

FOR HAIR CARE PRODUCTS, NAMELY, CONDITIONERS, HAIR CARE CREAMS, HAIR CARE LOTIONS, HAIR CARE PREPARATIONS, AND SHAMPOO; COSMETICS; MAKE-UP; PERFUME; FRAGRANCE; COLOGNE, SKIN CLEANSERS (U.S. CLS. 1, 4, 6, 50, 51 AND 52).

ROBERT STRUCK, EXAMINING ATTORNEY

# REJUVEN-A

THE MARK CONSISTS OF STANDARD CHARACTERS WITHOUT CLAIM TO ANY PARTICULAR FONT, STYLE, SIZE, OR COLOR.

FOR NON-MEDICATED SKIN CARE AND BODY CARE PRODUCTS, NAMELY, SKIN CREAMS, ANTI-WRINKLE AND FIRING CREAMS, NIGHT CREAMS AND DAY CREAMS; SKIN LOTIONS, NAMELY, MOISTURIZERS; NON-MEDICATED SKIN SERUMS, NAMELY, EYE ANTI-WRINKLE PREPARATIONS; NON-MEDICATED SKIN SPRAYS, NAMELY, SUN CARE PREPARATIONS AND TANNING PREPARATIONS; SKIN GELS; SKIN POWDERS, CLEANSERS AND TONERS (U.S. CLS. 1, 4, 6, 50, 51 AND 52).

BARBARA GAYNOR, EXAMINING ATTORNEY

**CLASS 3—(Continued).**

SN 85-046,861. SWEDISH SKIN CARE, INC., BEVERLY HILLS, CA. FILED 5-25-2010.

**RAZOR BURN FREEDOM**

THE MARK CONSISTS OF STANDARD CHARACTERS WITHOUT CLAIM TO ANY PARTICULAR FONT, STYLE, SIZE, OR COLOR.

NO CLAIM IS MADE TO THE EXCLUSIVE RIGHT TO USE "RAZOR BURN", APART FROM THE MARK AS SHOWN.

FOR NON-MEDICATED SKIN CARE AND BODY CARE PRODUCTS, NAMELY, SKIN CARE PREPARATIONS, TOPICAL SKIN SPRAYS FOR COSMETIC PURPOSES, EXFOLIATING CREAM, SKIN CLEANSER, FACIAL SCRUB, BODY SCRUB, SKIN LOTION, SKIN GELS, SKIN MOISTURIZER, SOAP, TONER, SKIN CLEANSER, SKIN CONDITIONER AND NON-MEDICATED SKIN ASTRINGENT (U.S. CLS. 1, 4, 6, 50, 51 AND 52).

BARBARA GAYNOR, EXAMINING ATTORNEY

SN 85-051,500. NUTEK DISPOSABLES, INC., GREAT NECK, NY. FILED 6-1-2010.

**TRI-FORM**

THE MARK CONSISTS OF STANDARD CHARACTERS WITHOUT CLAIM TO ANY PARTICULAR FONT, STYLE, SIZE, OR COLOR.

FOR BABY WIPES; ADULT AND FEMININE WIPES, NAMELY, DISPOSABLE WIPES IMPREGNATED WITH CLEANSING CHEMICALS OR COMPOUNDS FOR PERSONAL HYGIENE USE (U.S. CLS. 1, 4, 6, 50, 51 AND 52).  
JEAN IM, EXAMINING ATTORNEY

SN 85-051,842. JOHNSON PRODUCTS COMPANY, INC., DALLAS, TX. FILED 6-1-2010.

**FIBERCARE**

THE MARK CONSISTS OF STANDARD CHARACTERS WITHOUT CLAIM TO ANY PARTICULAR FONT, STYLE, SIZE, OR COLOR.

FOR HAIR CARE PREPARATIONS (U.S. CLS. 1, 4, 6, 50, 51 AND 52).  
MATTHEW KLINE, EXAMINING ATTORNEY

**CLASS 3—(Continued).**

SN 85-055,641. LITTLEFIELD, TREVOR T, DBA SUN KISSED NATURALS INC (S CORPORATION OF HAWAII), LA-HAINA, HI. FILED 6-5-2010.

**Sun Kissed Naturals**

THE MARK CONSISTS OF STANDARD CHARACTERS WITHOUT CLAIM TO ANY PARTICULAR FONT, STYLE, SIZE, OR COLOR.

NO CLAIM IS MADE TO THE EXCLUSIVE RIGHT TO USE "NATURALS", APART FROM THE MARK AS SHOWN.

FOR BODY LOTIONS (U.S. CLS. 1, 4, 6, 50, 51 AND 52).  
FIRST USE 9-1-2009; IN COMMERCE 2-1-2010.

LINDA ORNDORFF, EXAMINING ATTORNEY

SN 85-056,110. AUSTRALIAN GOLD, LLC, INDIANAPOLIS, IN. FILED 6-7-2010.

**HOMEGROWN HIPPIE**

THE MARK CONSISTS OF STANDARD CHARACTERS WITHOUT CLAIM TO ANY PARTICULAR FONT, STYLE, SIZE, OR COLOR.

FOR NON-MEDICATED INDOOR AND OUTDOOR SKIN TANNING PREPARATIONS (U.S. CLS. 1, 4, 6, 50, 51 AND 52).

MICHELLE DUBOIS, EXAMINING ATTORNEY

SN 85-058,706. KATE SPADE LLC, NEW YORK, NY. FILED 6-9-2010.

**KATE SPADE NEW YORK**

THE MARK CONSISTS OF STANDARD CHARACTERS WITHOUT CLAIM TO ANY PARTICULAR FONT, STYLE, SIZE, OR COLOR.

OWNER OF U.S. REG. NOS. 2,446,491, 3,095,754 AND OTHERS.

NO CLAIM IS MADE TO THE EXCLUSIVE RIGHT TO USE "NEW YORK", APART FROM THE MARK AS SHOWN.

THE NAME(S), PORTRAIT(S), AND/OR SIGNATURE(S) SHOWN IN THE MARK IDENTIFIES "KATE SPADE", WHOSE CONSENT(S) TO REGISTER IS MADE OF RECORD.

FOR COSMETICS; LIPSTICK; NAIL POLISH (U.S. CLS. 1, 4, 6, 50, 51 AND 52).

JERI J. FICKES, EXAMINING ATTORNEY



**CLASS 3—(Continued).**

SN 85-058,896. KIRK, BRIDGETTE, CENTENNIAL PARK, AUSTRALIA, FILED 6-9-2010.

# SPILT MILK

THE MARK CONSISTS OF STANDARD CHARACTERS WITHOUT CLAIM TO ANY PARTICULAR FONT, STYLE, SIZE, OR COLOR.

OWNER OF AUSTRALIA REG. NO. 1291569, DATED 3-26-2009, EXPIRES 3-26-2019.

FOR PERFUMED HAIR POWDER, HAIR STYLING POWDER, HAIR SHAMPOO, HAIR CONDITIONER, HAIR TREATMENT, NAMELY, NON-MEDICATED HAIR TREATMENT PREPARATIONS FOR COSMETIC PURPOSES AND SKIN TANNING PRODUCTS, NAMELY, SUN-TANNING OILS AND LOTIONS, TANNING CREAMS (U.S. CLS. 1, 4, 6, 50, 51 AND 52).

MARLENE BELL, EXAMINING ATTORNEY

---

SN 85-065,246. UNILEVER SUPPLY CHAIN, INC., CLINTON, CT. FILED 6-17-2010.



OWNER OF U.S. REG. NOS. 2,700,941 AND 3,648,858. THE COLOR(S) GREY, BLACK AND WHITE IS/ARE CLAIMED AS A FEATURE OF THE MARK.

THE MARK CONSISTS OF A STYLIZED "X" DESIGN IN GREY WITH THE WORD "AXE" INSIDE IN BLACK OUTLINED IN WHITE.

FOR SOAPS; PERFUMERY, ESSENTIAL OILS, COSMETICS; COLOGNES, EAU DE TOILETTE, PERFUME BODY SPRAYS; NON-MEDICATED OILS, CREAMS AND LOTIONS FOR THE SKIN; SHAVING FOAM, SHAVING GEL, PRE-SHAVING AND AFTER-SHAVING LOTIONS; TALCUM POWDER; NON-MEDICATED PREPARATIONS FOR THE BATH AND SHOWER; HAIR LOTIONS; DENTIFRICES; NON-MEDICATED MOUTHWASHES; DEODORANTS; ANTI-PERSPIRANTS FOR PERSONAL USE (U.S. CLS. 1, 4, 6, 50, 51 AND 52).

JANICE L. MCMORROW, EXAMINING ATTORNEY

**CLASS 3—(Continued).**

SN 85-065,251. UNILEVER SUPPLY CHAIN, INC., CLINTON, CT. FILED 6-17-2010.



OWNER OF U.S. REG. NOS. 2,700,941 AND 3,648,858. THE COLOR(S) BLACK, WHITE AND GREY IS/ARE CLAIMED AS A FEATURE OF THE MARK.

THE MARK CONSISTS OF A STYLIZED "X" DESIGN IN BLACK WITH THE WORD "AXE" INSIDE IN GREY OUTLINED IN WHITE.

FOR SOAPS; PERFUMERY, ESSENTIAL OILS, COSMETICS; COLOGNES, EAU DE TOILETTE, PERFUME BODY SPRAYS; NON-MEDICATED OILS, CREAMS AND LOTIONS FOR THE SKIN; SHAVING FOAM, SHAVING GEL, PRE-SHAVING AND AFTER-SHAVING LOTIONS; TALCUM POWDER; NON-MEDICATED PREPARATIONS FOR THE BATH AND SHOWER; HAIR LOTIONS; DENTIFRICES; NON-MEDICATED MOUTHWASHES; DEODORANTS; ANTI-PERSPIRANTS FOR PERSONAL USE (U.S. CLS. 1, 4, 6, 50, 51 AND 52).

JANICE L. MCMORROW, EXAMINING ATTORNEY

---

SN 85-066,690. NUVO RESIDENTIAL, LLC, SALT LAKE CITY, UT. FILED 6-18-2010.

# CITRACHARGE

THE MARK CONSISTS OF STANDARD CHARACTERS WITHOUT CLAIM TO ANY PARTICULAR FONT, STYLE, SIZE, OR COLOR.

FOR WATER CONDITIONING ADDITIVE FOR CLEANING AND PREVENTING BUILD UP OF HARD WATER SCALE IN WATER-USING APPLIANCES, AROUND WATER SOURCES, AND IN LIQUID-CARRYING CONTAINERS (U.S. CLS. 1, 4, 6, 50, 51 AND 52).

JOSETTE BEVERLY, EXAMINING ATTORNEY

**CLASS 3—(Continued).**

SN 85-069,375. UNILEVER SUPPLY CHAIN, INC., CLINTON, CT. FILED 6-23-2010.

**FAIRY BERRY STRAWBERRY**

THE MARK CONSISTS OF STANDARD CHARACTERS WITHOUT CLAIM TO ANY PARTICULAR FONT, STYLE, SIZE, OR COLOR.

NO CLAIM IS MADE TO THE EXCLUSIVE RIGHT TO USE "BERRY STRAWBERRY", APART FROM THE MARK AS SHOWN.

FOR SOAPS; PERFUMERY; ESSENTIAL OILS; DEODORANTS AND ANTIPERSPIRANTS; HAIR CARE STYLING PREPARATIONS; HAIR COLORANTS, HAIR DYES, HAIR LOTIONS, HAIR WAVING PREPARATIONS, SHAMPOOS, CONDITIONERS, HAIR SPRAYS, HAIR DRESSINGS, HAIR LACQUERS, HAIR MOUSSES, HAIR GLAZES, HAIR GELS, HAIR MOISTURIZERS, HAIR LIQUID MOISTURIZING TREATMENTS FOR HAIR, NON-MEDICATED HAIR PRESERVATION TREATMENTS, HAIR OILS, HAIR TONIC, HAIR CREAMS, NON-MEDICATED PREPARATIONS FOR THE BATH AND/OR SHOWER; NON-MEDICATED SKIN CARE PREPARATIONS; COSMETICS (U.S. CLS. 1, 4, 6, 50, 51 AND 52).

JANICE L. MCMORROW, EXAMINING ATTORNEY

---

SN 85-071,198. DRAKE, WILHELMINA, SANTA CLARA, CA. AND PACIFICO, CHRISTINE, SANTA CLARA, CA. FILED 6-24-2010.

**Anya Mati**

THE MARK CONSISTS OF STANDARD CHARACTERS WITHOUT CLAIM TO ANY PARTICULAR FONT, STYLE, SIZE, OR COLOR.

THE NAME(S), PORTRAIT(S), AND/OR SIGNATURE(S) SHOWN IN THE MARK DOES NOT IDENTIFY A PARTICULAR LIVING INDIVIDUAL.

THE ENGLISH TRANSLATION OF "ANYA MATI" IN THE MARK IS MOTHER.

FOR NATURAL COCOA BUTTER BASED PERSONAL CARE PRODUCTS, NAMELY, BODY LOTION, SHOWER GEL, SOAP, BODY POLISH, BODY AND FOOT SCRUB AND NON-MEDICATED SKIN CREAMS; NATURAL MINERAL MAKE-UP; NON-MEDICATED SERUMS FOR USE ON SKIN AND HAIR (U.S. CLS. 1, 4, 6, 50, 51 AND 52).

MICHAEL WEBSTER, EXAMINING ATTORNEY

**CLASS 3—(Continued).**

SN 85-071,410. L'OREAL, PARIS, FRANCE, FILED 6-25-2010.

**OXYGÉNISTE**

THE MARK CONSISTS OF STANDARD CHARACTERS WITHOUT CLAIM TO ANY PARTICULAR FONT, STYLE, SIZE, OR COLOR.

PRIORITY CLAIMED UNDER SEC. 44(D) ON FRANCE APPLICATION NO. 103737067, FILED 5-10-2010, REG. NO. 103737067, DATED 5-10-2010, EXPIRES 5-10-2020.

THE WORDING "OXYGÉNISTE" HAS NO MEANING IN A FOREIGN LANGUAGE.

FOR PERFUME, TOILET WATER, BATH AND SHOWER GELS AND SALTS NOT FOR MEDICAL PURPOSE; TOILET SOAPS, BODY DEODORANTS; COSMETICS, NAMELY, CREAMS, MILKS, LOTIONS, GELS AND POWDERS FOR THE FACE, THE BODY AND THE HANDS; NON-MEDICATED SUN CARE PREPARATIONS; MAKEUP PREPARATIONS; SHAMPOOS; PRODUCTS FOR HAIR STYLING AND HAIR CARE, NAMELY, GELS, SPRAYS, MOUSSES, BALMS, CREAM, SERUMS, WAX AND LOTIONS; HAIR LACQUERS; HAIR COLORING AND HAIR DECOLORANT PREPARATIONS; PROTECTIVE COLORING PREPARATIONS FOR TREATED HAIR; PERMANENT WAVING AND CURLING PREPARATIONS; ESSENTIAL OILS FOR PERSONAL USE (U.S. CLS. 1, 4, 6, 50, 51 AND 52).

HEATHER THOMPSON, EXAMINING ATTORNEY

---

SN 85-072,447. UNIMED INTERNATIONAL, INC., EDISON, NJ. FILED 6-27-2010.

**CHAMONIX**

THE MARK CONSISTS OF STANDARD CHARACTERS WITHOUT CLAIM TO ANY PARTICULAR FONT, STYLE, SIZE, OR COLOR.

OWNER OF U.S. REG. NO. 3,022,428.

FOR ANTI-AGING CREAMS; ANTI-WRINKLE CREAMS; BEAUTY CREAMS; CLEANSING CREAMS; COSMETIC CREAMS; COSMETIC CREAMS FOR SKIN CARE; COSMETIC PREPARATIONS, NAMELY, FIRING CREAMS; EYE CREAM; FACE CREAMS; LIP CREAM; SKIN CREAMS; WRINKLE RESISTANT CREAM (U.S. CLS. 1, 4, 6, 50, 51 AND 52).

FIRST USE 4-15-1999; IN COMMERCE 4-15-1999.

KATHERINE CHANG, EXAMINING ATTORNEY

**CLASS 3—(Continued).**

SN 85-074,232. RDPR LIMITED, BRIGHTON, ENGLAND, FILED 6-29-2010.

# ROJA

THE MARK CONSISTS OF STANDARD CHARACTERS WITHOUT CLAIM TO ANY PARTICULAR FONT, STYLE, SIZE, OR COLOR.

PRIORITY CLAIMED UNDER SEC. 44(D) ON ERPN CMNTY TM OFC APPLICATION NO. 008823437, FILED 1-20-2010, REG. NO. 008823437, DATED 8-2-2010, EXPIRES 1-20-2020.

FOR SOAPS; PERFUMERY, ESSENTIAL OILS, COSMETICS, HAIR LOTIONS; DENTIFRICES; PERFUMES AND PERFUMERY PRODUCTS, NAMELY, COLOGNE AND AFTERSHAVE; AROMATIC SUBSTANCES, NAMELY, AROMATIC OILS AND AROMATIC ESSENTIAL OILS, FOR USE IN THE MANUFACTURE OF PERFUMES; FINE FRAGRANCES; PERFUMED BATH FOAM PREPARATIONS, NAMELY, PERFUMED BATH FOAM AND FOAM CLEANSERS FOR PERSONAL USE; PERFUMED BATH SALTS; PERFUMED BEAUTY MILKS, BATH MILKS AND CLEANSING MILKS; PERFUMED SKIN AND BODY LOTIONS; PERFUMED BODY SPRAYS; PERFUMED BODY CREAMS; PERFUMED SOAPS (U.S. CLS. 1, 4, 6, 50, 51 AND 52).

JANICE KIM, EXAMINING ATTORNEY

---

SN 85-079,339. L'OREAL, PARIS, FRANCE, FILED 7-7-2010.

# CHROMA CARE

THE MARK CONSISTS OF STANDARD CHARACTERS WITHOUT CLAIM TO ANY PARTICULAR FONT, STYLE, SIZE, OR COLOR.

PRIORITY CLAIMED UNDER SEC. 44(D) ON FRANCE APPLICATION NO. 103739176, FILED 5-19-2010, REG. NO. 103739176, DATED 5-19-2010, EXPIRES 5-19-2020.

OWNER OF U.S. REG. NOS. 3,025,362, 3,125,361 AND OTHERS.

NO CLAIM IS MADE TO THE EXCLUSIVE RIGHT TO USE "CHROMA", APART FROM THE MARK AS SHOWN.

FOR SHAMPOOS; PRODUCTS FOR HAIR STYLING AND HAIR CARE, NAMELY, GELS, MOUSSES, BALMS, CREAM, WAX SERUMS, LOTIONS AND MASKS; HAIR LACQUERS; HAIR COLORING AND HAIR DECOLORANT PREPARATIONS; PROTECTIVE COLORING PREPARATIONS FOR TREATED HAIR; PERMANENT WAVING AND CURLING PREPARATIONS; ESSENTIAL OILS FOR PERSONAL USE (U.S. CLS. 1, 4, 6, 50, 51 AND 52).

HEATHER THOMPSON, EXAMINING ATTORNEY

**CLASS 3—(Continued).**

SN 85-082,070. SWEDISH SKIN CARE, INC., BEVERLY HILLS, CA. FILED 7-11-2010.

# Heritage. Research. Results.

THE MARK CONSISTS OF STANDARD CHARACTERS WITHOUT CLAIM TO ANY PARTICULAR FONT, STYLE, SIZE, OR COLOR.

FOR NON-MEDICATED SKIN CARE PREPARATIONS; NON-MEDICATED BODY CARE PREPARATIONS, NAMELY, TOPICAL SKIN SPRAYS FOR COSMETIC PURPOSES, EXFOLIATING CREAM, SKIN CLEANSER, FACIAL SCRUB, BODY SCRUB, SKIN LOTION, SKIN GELS, SKIN MOISTURIZER, SOAP, TONER, SKIN CLEANSER, SKIN CONDITIONER AND NON-MEDICATED SKIN ASTRINGENT (U.S. CLS. 1, 4, 6, 50, 51 AND 52).

BARBARA GAYNOR, EXAMINING ATTORNEY

---

SN 85-088,409. L'OREAL, PARIS, FRANCE, FILED 7-20-2010.



PRIORITY CLAIMED UNDER SEC. 44(D) ON FRANCE APPLICATION NO. 103742449, FILED 6-1-2010, REG. NO. 103742449, DATED 6-1-2010, EXPIRES 6-1-2020.

THE MARK CONSISTS OF THE STYLIZED TERM "MICROLOGIC" WITH THE SMALLEST OF THREE RINGS SERVING AS THE SECOND LETTER "O" IN "MICROLOGIC", AND TWO SUCCESSIVELY LARGER RINGS STACKED ABOVE THE SMALLEST RING.

FOR SHAMPOOS; PRODUCTS FOR HAIR STYLING AND HAIR CARE, NAMELY, GELS, MOUSSES, BALMS, CREAM, WAX, SERUMS, LOTIONS AND MASKS; HAIR LACQUERS; HAIR COLORING AND HAIR DECOLORANT PREPARATIONS; PROTECTIVE COLORING PREPARATIONS FOR TREATED HAIR; PERMANENT WAVING AND CURLING PREPARATIONS; ESSENTIAL OILS FOR PERSONAL USE (U.S. CLS. 1, 4, 6, 50, 51 AND 52).

HEATHER THOMPSON, EXAMINING ATTORNEY

**CLASS 3—(Continued).**

SN 85-088,415. L'OREAL, PARIS, FRANCE, FILED 7-20-2010.

**COLORCHANGE**

PRIORITY CLAIMED UNDER SEC. 44(D) ON FRANCE APPLICATION NO. 103734174, FILED 4-29-2010, REG. NO. 10/3734174, DATED 4-29-2010, EXPIRES 4-29-2020.

THE MARK CONSISTS OF "COLORCHANGE" IN STYLIZED FORM.

FOR SHAMPOOS; PRODUCTS FOR HAIR STYLING AND HAIR CARE, NAMELY, GELS, MOUSSES, BALMS, CREAM, WAX, SERUMS, LOTIONS AND MASKS; HAIR COLORING AND HAIR DECOLORANT PREPARATIONS; PROTECTIVE COLORING PREPARATIONS FOR TREATED HAIR; PERMANENT WAVING AND CURLING PREPARATIONS; ESSENTIAL OILS FOR PERSONAL USE (U.S. CLS. 1, 4, 6, 50, 51 AND 52).

HEATHER THOMPSON, EXAMINING ATTORNEY

---

SN 85-092,701. FAROUK SYSTEMS, INC., HOUSTON, TX, FILED 7-26-2010.

# EQUICHI

**HIGH PERFORMANCE HORSE**

NO CLAIM IS MADE TO THE EXCLUSIVE RIGHT TO USE "HIGH PERFORMANCE HORSE", APART FROM THE MARK AS SHOWN.

THE MARK CONSISTS OF THE WORDS "EQUICHI" AND "HIGH PERFORMANCE HORSE".

FOR NON-MEDICATED GROOMING PREPARATIONS FOR HORSES, NAMELY, SOAPS, HORSE WASHES, SHAMPOOS, MOISTURIZERS, CONDITIONERS, DETANGLERS, GLOSSERS, AND SHINERS (U.S. CLS. 1, 4, 6, 50, 51 AND 52).

JAMES A. RAUEN, EXAMINING ATTORNEY

---

SN 85-114,828. HEALTH IS WITHIN, INC., MONTAUK, NY, FILED 8-24-2010.

**ESSENTIAL 3 WISHES**

THE MARK CONSISTS OF STANDARD CHARACTERS WITHOUT CLAIM TO ANY PARTICULAR FONT, STYLE, SIZE, OR COLOR.

FOR HAND CLEANING PREPARATIONS (U.S. CLS. 1, 4, 6, 50, 51 AND 52).

SAIMA MAKHDOM, EXAMINING ATTORNEY

**CLASS 3—(Continued).**

SN 85-120,071. KATE SPADE LLC, NEW YORK, NY, FILED 8-31-2010.



OWNER OF U.S. REG. NOS. 3,092,920, 3,271,494 AND OTHERS.

NO CLAIM IS MADE TO THE EXCLUSIVE RIGHT TO USE "NEW YORK", APART FROM THE MARK AS SHOWN. THE NAME(S), PORTRAIT(S), AND/OR SIGNATURE(S) SHOWN IN THE MARK IDENTIFIES "KATE SPADE", WHOSE CONSENT(S) TO REGISTER IS MADE OF RECORD.

THE MARK CONSISTS OF A SPADE DESIGN WITH THE WORDS "KATE SPADE NEW YORK" UNDERNEATH.

FOR AFTER SHAVE LOTIONS; BODY LOTION; BODY MILK; BODY OIL; BODY POWDER; BODY SCRUB; BODY SPRAYS; BUBBLE BATH; COSMETICS; ESSENTIAL OILS; FACE AND BODY CREAMS; FACE POWDER; FRAGRANCES; HAIR SHAMPOOS AND CONDITIONERS; HAIR STYLING PREPARATIONS; PERFUMES AND COLOGNES; PERSONAL DEODORANTS; POTPOURRI; SKIN CLEANSERS; SOAPS FOR PERSONAL USE; SUN-TANNING OILS AND LOTIONS; TOILET SOAP (U.S. CLS. 1, 4, 6, 50, 51 AND 52).

JERI J. FICKES, EXAMINING ATTORNEY

---

SN 85-122,421. JIM KAI YING, DBA Y2 INTERNATIONAL TRADING COMPANY, TUEN MUN, HONG KONG, FILED 9-3-2010.

**BEAUTIES FACTORY**

OWNER OF HONG KONG REG. NO. 301445959, DATED 10-9-2009, EXPIRES 10-8-2019.

THE MARK CONSISTS OF BACKGROUND IS BLACK IN COLOR. ALL LETTERS ARE WHITE IN COLOR.

FOR BEAUTY CARE PRODUCT, NAMELY, MAKE-UP REMOVER, FACE POWDER; NAIL CARE PRODUCT, NAMELY, NAIL GEL, NAIL POLISH REMOVER, FALSE NAILS, NAIL POLISH, NAIL POLISH BASE COAT, NAIL POLISH TOP COAT; NAIL GROOMING PRODUCTS, NAMELY, TIPS, GLUE, LACQUER AND GLITTER; EYE GROOMING PRODUCTS, NAMELY, EYESHADOW, BLUSHES, LIP GLOSS, EYELINER, EYE MAKE-UP REMOVER, FALSE EYELASHES, MASCARA, GLITTER (U.S. CLS. 1, 4, 6, 50, 51 AND 52).

FIRST USE 1-1-2007; IN COMMERCE 1-1-2007.

JILL PRATER, EXAMINING ATTORNEY

**CLASS 3—(Continued).**

SN 85-138,492. NAPPORGANICS, INC, STOUGHTON, MA. FILED 9-27-2010.

**NOURISHEA**

THE MARK CONSISTS OF STANDARD CHARACTERS WITHOUT CLAIM TO ANY PARTICULAR FONT, STYLE, SIZE, OR COLOR.

FOR BODY SOAPS FOR CLEANING USE; SHEA BUTTER SHOWER GELS; SHAMPOOS; HAIR CONDITIONERS; SHEA BUTTER FOR COSMETIC PURPOSE; BODY CARE CRÈMES (U.S. CLS. 1, 4, 6, 50, 51 AND 52).  
THOMAS MANOR, EXAMINING ATTORNEY

---

SN 85-151,365. ORLY INTERNATIONAL, INC., VAN NUYS, CA. FILED 10-13-2010.

**GEL FX**

THE MARK CONSISTS OF STANDARD CHARACTERS WITHOUT CLAIM TO ANY PARTICULAR FONT, STYLE, SIZE, OR COLOR.

NO CLAIM IS MADE TO THE EXCLUSIVE RIGHT TO USE "GEL", APART FROM THE MARK AS SHOWN.

FOR NAIL CARE PREPARATIONS (U.S. CLS. 1, 4, 6, 50, 51 AND 52).  
BRIAN CALLAGHAN, EXAMINING ATTORNEY

---

SN 85-161,341. THE STEPHAN CO., FORT LAUDERDALE, FL. FILED 10-26-2010.

**MASSIMO FAUST**

THE MARK CONSISTS OF STANDARD CHARACTERS WITHOUT CLAIM TO ANY PARTICULAR FONT, STYLE, SIZE, OR COLOR.

OWNER OF U.S. REG. NO. 1,580,972.  
THE NAME "MASSIMO FAUST" DOES NOT IDENTIFY A LIVING INDIVIDUAL.

FOR HAIR CARE PRODUCTS; NAMELY, DAILY RINSE, CONDITIONER, SHAMPOO, STYLING GEL, HAIR SPRITZ IN THE NATURE OF A MOISTURIZING SOLUTION FOR HAIR, AND HAIR SPRAY (U.S. CLS. 1, 4, 6, 50, 51 AND 52).

FIRST USE 2-6-1990; IN COMMERCE 2-6-1990.  
MAYUR VAGHANI, EXAMINING ATTORNEY

**CLASS 3—(Continued).**

SN 85-164,591. CLINE, RODNEY, BUFORD, GA. FILED 10-29-2010.

**Green Options**

THE MARK CONSISTS OF STANDARD CHARACTERS WITHOUT CLAIM TO ANY PARTICULAR FONT, STYLE, SIZE, OR COLOR.

NO CLAIM IS MADE TO THE EXCLUSIVE RIGHT TO USE "GREEN", APART FROM THE MARK AS SHOWN.

FOR ALL-PURPOSE CLEANERS (U.S. CLS. 1, 4, 6, 50, 51 AND 52).

FIRST USE 3-2-2002; IN COMMERCE 3-2-2002.

GIANCARLO CASTRO, EXAMINING ATTORNEY

---

SN 85-166,031. SIERRA SAGE HERBS LLC, BOISE, ID. FILED 11-1-2010.

**SOUTHERN BUTTER**

THE MARK CONSISTS OF STANDARD CHARACTERS WITHOUT CLAIM TO ANY PARTICULAR FONT, STYLE, SIZE, OR COLOR.

NO CLAIM IS MADE TO THE EXCLUSIVE RIGHT TO USE "BUTTER", APART FROM THE MARK AS SHOWN.

FOR NON-MEDICATED HERBAL BODY CARE PRODUCTS, NAMELY, SALVES (U.S. CLS. 1, 4, 6, 50, 51 AND 52).

JANICE KIM, EXAMINING ATTORNEY

**CLASS 3—(Continued).**

SN 85-166,369. COSMOS CORPORATION, WENTZVILLE, MO. FILED 11-1-2010.

**CLASS 3—(Continued).**

SN 85-167,798. MBL/TONI&GUY PRODUCTS L.P., CARROLLTON, TX. FILED 11-3-2010.

## TONI & GUY

THE MARK CONSISTS OF STANDARD CHARACTERS WITHOUT CLAIM TO ANY PARTICULAR FONT, STYLE, SIZE, OR COLOR.

FOR BREATH FRESHENERS; COSMETICS, NAMELY, COSMETIC MAKEUP REMOVERS, COMPACTS, EYE MAKEUP, LIP GLOSS, BLUSH, LIPSTICK, MASCARA, NAIL POLISH, NAIL GLITTER, FACE POWDER; DEODORANTS, NAMELY, PERSONAL DEODORANTS, BODY DEODORANTS; DEODORANT SOAPS; SOAPS FOR HANDS, FACE AND BODY; FRAGRANCES FOR PERSONAL USE, NAMELY, EAU DE TOILETTE, PERFUME AND ESSENTIAL OILS; FRAGRANCES FOR ROOMS AND AUTOMOBILES; HAIR CARE PRODUCTS, NAMELY, HAIR SHAMPOO, HAIR LOTIONS, HAIR CONDITIONERS, HAIR CREAMS, HAIR WAXES, HAIR SPRAYS, HAIR GELS, HAIR COLOR GELS AND CONDITIONERS, HAIR POMADES, HAIR MOUSSES AND HAIR CARE PREPARATIONS; SKIN CARE PRODUCTS, NAMELY, NON-MEDICATED SKIN CARE PREPARATIONS, COLD CREAMS, FACIAL CREAMS, EXFOLIANTS, BEAUTY, FACIAL AND BODY MASKS, FACIAL AND SKIN CLEANSERS; AFTER-SHAVE LOTION; NON-MEDICATED BATH CARE PREPARATIONS IN THE NATURE OF BATH GELS, BATH POWDER, BATH SOAPS, BUBBLE BATH, LOTIONS, OILS, FOAMS, BEADS, MILKS AND CRYSTALS; PERSONAL CARE PREPARATIONS, NAMELY, BATH, HAND AND BODY LOTIONS, BODY POWDER, BABY POWDER; SHAVING GEL; SHAVING PREPARATIONS; SUN SCREEN PREPARATIONS; SACHETS; TOOTHPASTE; AND FACE PAINTING KITS (U.S. CLS. 1, 4, 6, 50, 51 AND 52).  
ROBERT C. CLARK JR., EXAMINING ATTORNEY



SN 85-170,918. SDY HAIR SOLUTIONS, LLC, MINNEAPOLIS, MN. FILED 11-6-2010.

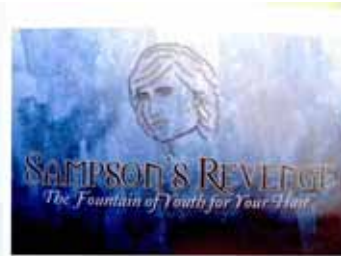

OWNER OF U.S. REG. NOS. 2,959,292 AND 3,834,669.  
NO CLAIM IS MADE TO THE EXCLUSIVE RIGHT TO USE "NATURALLY GREEN" "STAIN" "ODOR", APART FROM THE MARK AS SHOWN.

THE MARK CONSISTS OF THE WORDS "NATURALLY GREEN TROPICLEAN STOP IT STOPS THE STAIN STOPS THE ODOR STOPS THE HABIT", WITH A PALM TREE REPRESENTING THE LETTER "T" IN "TROPICLEAN", ALL OF WHICH IS WITHIN A STOP SIGN.

FOR CARPET CLEANING PREPARATIONS; CARPET CLEANING PREPARATIONS WITH DEODORIZERS; STAIN REMOVING PREPARATIONS; STAIN REMOVING PREPARATIONS WITH DEODORIZERS; PET STAIN REMOVERS (U.S. CLS. 1, 4, 6, 50, 51 AND 52).  
FONG HSU, EXAMINING ATTORNEY

THE COLOR(S) YELLOW, BLACK AND NUMEROUS SHADES OF BLUE IS/ARE CLAIMED AS A FEATURE OF THE MARK.

THE MARK CONSISTS OF THE BACKGROUND IS NUMEROUS SHADES OF BLUE IN A RUSTIC, WATER COLOR TYPE STYLE, GRADIATING FROM LIGHTER ON TOP TO DARKER ON THE BOTTOM. THE IMAGE LAIN OVER TOP IS OF A MAN'S HEAD OUTLINED IN A DARK

**CLASS 3—(Continued).**

BLUE, CUT OFF AT THE NECK. HIS HEAD IS AT A 3/4 TURN WITH LONGER HAIR AT A LENGTH JUST BELOW THE CHIN. UNDERNEATH THE MAN'S HEAD IS THE NAME OF THE PRODUCT WRITTEN IN A STYLIZED TEXT: "SAMPSON'S REVENGE"; IT IS WRITTEN IN DARK, NAVY BLUE HIGHLIGHTED WITH YELLOW. UNDERNEATH THE NAME IS THE TAGLINE: "THE FOUNTAIN OF YOUTH FOR YOUR HAIR" ALSO WRITTEN IN A STYLIZED TEXT BUT IN A LIGHTER BLUE HIGHLIGHTED IN BLACK.

FOR HAIR SHAMPOOS AND CONDITIONERS (U.S. CLS. 1, 4, 6, 50, 51 AND 52).

FIRST USE 12-4-2009; IN COMMERCE 3-3-2010.  
JAMES A. RAUEN, EXAMINING ATTORNEY

**CLASS 3—(Continued).**

SN 85-172,532. CARA MAE NATURALS, LLC, ASHEVILLE, NC. FILED 11-9-2010.

# Cara Mae

SN 85-170,919. SDY HAIR SOLUTIONS, LLC, MINNEAPOLIS, MN. FILED 11-6-2010.



THE COLOR(S) YELLOW, GREEN, BLACK AND NUMEROUS SHADES OF MAROON IS/ARE CLAIMED AS A FEATURE OF THE MARK.

THE MARK CONSISTS OF THE BACKGROUND IS NUMEROUS SHADES OF MAROON IN A RUSTIC, WATER-COLOR TYPE STYLE, GRADIATING FROM LIGHTER ON TOP TO DARKER ON THE BOTTOM. THE IMAGE LAIN OVER TOP IS OF A WOMAN'S HEAD OUTLINED IN A DARK MAROON, CUT OFF AT THE NECK. HER HAIR IS LONG WITH A SIDE-SWEPT BANG. UNDERNEATH THE WOMAN'S HEAD IS THE NAME OF THE PRODUCT WRITTEN IN A STYLIZED TEXT: "DELLAH'S REWARD"; IT IS WRITTEN IN DARK, MAROON HIGHLIGHTED WITH YELLOW AND GREEN. UNDERNEATH THE NAME IS THE TAGLINE: "THE FOUNTAIN OF YOUTH FOR YOUR HAIR" ALSO WRITTEN IN A STYLIZED TEXT BUT IN A LIGHTER MAROON HIGHLIGHTED IN BLACK.

FOR HAIR SHAMPOOS AND CONDITIONERS (U.S. CLS. 1, 4, 6, 50, 51 AND 52).

FIRST USE 12-4-2009; IN COMMERCE 3-3-2010.  
JAMES A. RAUEN, EXAMINING ATTORNEY

THE MARK CONSISTS OF STANDARD CHARACTERS WITHOUT CLAIM TO ANY PARTICULAR FONT, STYLE, SIZE, OR COLOR.

THE NAME(S), PORTRAIT(S), AND/OR SIGNATURE(S) SHOWN IN THE MARK DOES NOT IDENTIFY A PARTICULAR LIVING INDIVIDUAL.

FOR AROMATIC BODY CARE PRODUCTS, NAMELY, BODY LOTION, SHOWER GEL, CUTICLE CREAM, SHAMPOO, CONDITIONER, NON-MEDICATED LIP BALM, SOAP, BODY POLISH, BODY AND FOOT SCRUB AND NON-MEDICATED FOOT CREAM; AROMATIC PREPARATIONS, NAMELY, CREAM, LOTION, BODY SPRAY; BABY BUBBLE BATH; BABY HAND SOAP; BABY LOTION; BAR SOAP; BATH AND SHOWER GELS AND SALTS NOT FOR MEDICAL PURPOSES; BATH FIZZIES; BATH GEL; BATH GELS; BATH LOTION; BATH SALTS; BATH SALTS; BATH SOAPS; BATH SOAPS IN LIQUID, SOLID OR GEL FORM; BATHING LOTIONS; BEAUTY GELS; BEAUTY LOTIONS; BODY LOTION; BODY LOTIONS; BODY SPRAY USED AS A PERSONAL DEODORANT AND AS FRAGRANCE; BODY SPRAYS; BREATH FRESHENING SPRAYS; COSMETIC SOAPS; COSMETIC SUNTAN LOTIONS; EYE LOTIONS; FACE AND BODY LOTIONS; FACIAL LOTION; FOOT DEODORANT SPRAY; HAND LOTIONS; HAND SOAPS; HANDMADE SOAP BARS; LIP BALM; LIP GLOSS; LIQUID BATH SOAPS; LIQUID SOAP; LIQUID SOAPS; LIQUID SOAPS FOR HANDS AND FACE; LIQUID SOAPS FOR HANDS, FACE AND BODY; LOTIONS FOR COSMETIC PURPOSES; LOTIONS FOR FACE AND BODY CARE; MASSAGE LOTIONS; MINERAL SALT IN THE NATURE OF BATH SALTS NOT FOR MEDICAL PURPOSES; NATURAL COCOA BUTTER BASED PERSONAL CARE PRODUCTS, NAMELY, BODY LOTION, SHOWER GEL, SOAP, BODY POLISH, BODY AND FOOT SCRUB AND NON-MEDICATED SKIN CREAMS; NATURAL SOAP BARS; NATURALLY HANDMADE SOAP BARS; NON-MEDICATED BATH SALTS; NON-MEDICATED DIAPER RASH OINTMENTS AND LOTIONS; NON-MEDICATED FOOT LOTIONS; NON-MEDICATED HERBAL BODY CARE PRODUCTS, NAMELY, BODY OILS, SALVES, AND LIP BALMS; NON-MEDICATED LIP BALM THAT DOES NOT CONTAIN BEESWAX; NON-MEDICATED LIP CARE PREPARATIONS; NON-MEDICATED LIP PROTECTORS; NON-MEDICATED SKIN CARE CREAMS AND LOTIONS; NON-MEDICATED SKIN CARE PREPARATIONS, NAMELY, CREAMS, LOTIONS, GELS, TONERS, CLEANERS AND PEELS; ORGANIC SOAP BARS; SCENTED BODY LOTIONS AND CREAMS; SCENTED BODY SPRAY; SHAVING BALM; SHAVING LOTION; SHAVING LOTIONS; SHAVING SOAP; SHAVING SOAPS; SKIN AND BODY TOPICAL LOTIONS, CREAMS AND OILS FOR COSMETIC USE; SKIN CARE PREPARATIONS, NAMELY, BODY BALM; SKIN CLEANSING LOTION; SKIN LOTION; SKIN LOTIONS; SKIN SOAP; SKIN TONERS; SOAPS FOR BODY CARE; SOAPS FOR HOUSEHOLD USE; SOAPS FOR PERSONAL USE; SOAPS FOR TOILET PURPOSES; SUN CARE LOTIONS; SUN TAN LOTION; SUN-BLOCK LOTIONS; SUN-TANNING OILS AND LOTIONS; TOILET SOAP; TOILET SOAPS; TONING LOTION, FOR THE FACE, BODY AND HANDS (U.S. CLS. 1, 4, 6, 50, 51 AND 52).

RUSS HERMAN, EXAMINING ATTORNEY

**CLASS 3—(Continued).**

SN 85-177,310. WONG, MIRIAM M., STAFFORD, TX. FILED 11-15-2010.

**WRINKLEFREE DHEA**

THE MARK CONSISTS OF STANDARD CHARACTERS WITHOUT CLAIM TO ANY PARTICULAR FONT, STYLE, SIZE, OR COLOR.

NO CLAIM IS MADE TO THE EXCLUSIVE RIGHT TO USE "DHEA", APART FROM THE MARK AS SHOWN.

FOR ANTI-WRINKLE CREAMS, BEAUTY CREAMS, BEAUTY CREAMS FOR BODY CARE, BODY CREAM, COSMETIC CREAMS FOR SKIN CARE, COSMETIC NOURISHING CREAMS, COSMETIC PREPARATIONS FOR SKIN CARE, COSMETIC PREPARATIONS FOR SKIN RENEWAL AND FACE CREAMS, ALL CONTAINING DHEA (DEHYDROEPIANDROSTERONE) (U.S. CLS. 1, 4, 6, 50, 51 AND 52).

FIRST USE 3-5-1997; IN COMMERCE 3-5-1997.

JOHN GARTNER, EXAMINING ATTORNEY

**CLASS 3—(Continued).**

SN 85-178,873. ERNO LASZLO, INC., NEW YORK, NY. FILED 11-17-2010.

**ERNO LASZLO**

THE MARK CONSISTS OF STANDARD CHARACTERS WITHOUT CLAIM TO ANY PARTICULAR FONT, STYLE, SIZE, OR COLOR.

THE NAME(S), PORTRAIT(S), AND/OR SIGNATURE(S) SHOWN IN THE MARK DOES NOT IDENTIFY A PARTICULAR LIVING INDIVIDUAL.

FOR NON-MEDICATED SKIN CARE PREPARATIONS (U.S. CLS. 1, 4, 6, 50, 51 AND 52).

FIRST USE 0-0-1941; IN COMMERCE 0-0-1941.

EDWARD FENNESSY, EXAMINING ATTORNEY

SN 85-177,561. GABRIELLE STUDIO, INC., NEW YORK, NY. FILED 11-16-2010.

**DONNA KARAN CASHMERE BEAUTY**

THE MARK CONSISTS OF STANDARD CHARACTERS WITHOUT CLAIM TO ANY PARTICULAR FONT, STYLE, SIZE, OR COLOR.

OWNER OF U.S. REG. NOS. 2,375,843, 3,011,483 AND OTHERS.

NO CLAIM IS MADE TO THE EXCLUSIVE RIGHT TO USE "BEAUTY", APART FROM THE MARK AS SHOWN.

THE NAME(S), PORTRAIT(S), AND/OR SIGNATURE(S) SHOWN IN THE MARK IDENTIFIES "DONNA KARAN", WHOSE CONSENT(S) TO REGISTER IS MADE OF RECORD.

FOR COSMETICS; FRAGRANCES FOR PERSONAL USE; NON-MEDICATED BATH PREPARATIONS; NON-MEDICATED SKIN CARE PREPARATIONS; NON-MEDICATED TOILETRIES (U.S. CLS. 1, 4, 6, 50, 51 AND 52).

CORY BOONE, EXAMINING ATTORNEY

SN 85-178,911. BISSELL HOMECARE, INC., GRAND RAPIDS, MI. FILED 11-17-2010.

**STOMP 'N GO**

THE MARK CONSISTS OF STANDARD CHARACTERS WITHOUT CLAIM TO ANY PARTICULAR FONT, STYLE, SIZE, OR COLOR.

FOR IMPREGNATED CLEANING PADS FOR TREATING CARPET AND UPHOLSTERY SPOTS AND STAINS IMPREGNATED WITH CLEANSING CHEMICALS OR COMPOUNDS FOR HOUSEHOLD USE (U.S. CLS. 1, 4, 6, 50, 51 AND 52).

SANJEEV VOHRA, EXAMINING ATTORNEY



**CLASS 3—(Continued).**

SN 85-180,181. SALON COMMODITIES, INC., MELROSE PARK, IL. FILED 11-18-2010.



THE MARK CONSISTS OF THE LITERAL TERM "JOY" AND THE BUST AND ARM OF A WOMEN WEARING A HOOP EARRINGS AND A BRACELET, WITH SPARKLE ACCENTS ON THE HOOP EARRINGS, BRACELET, AND THE LETTER "J".

FOR HAIR CARE PRODUCTS, NAMELY, HAIR CLEANSERS, CONDITIONERS, EMOLLIENT HAIR SPRAYS, STYLING GELS, STYLING CREAMS AND SHINE, MOISTURIZING CREAMS, LOTIONS, OILS, SCALP CLEANSERS AND CONDITIONERS, AND ORGANIC HAIR COLOR ENHANCERS (U.S. CLS. 1, 4, 6, 50, 51 AND 52).

WILLIAM P. SHANAHAN, EXAMINING ATTORNEY

---

SN 85-181,512. MAL'AK NATURAL, LLC, SUGAR LAND, TX. FILED 11-19-2010.

## MAL'AK NATURAL

THE MARK CONSISTS OF STANDARD CHARACTERS WITHOUT CLAIM TO ANY PARTICULAR FONT, STYLE, SIZE, OR COLOR.

NO CLAIM IS MADE TO THE EXCLUSIVE RIGHT TO USE "NATURAL", APART FROM THE MARK AS SHOWN.

THE ENGLISH TRANSLATION OF THE WORD "MAL'AK" IN THE MARK IS MESSENGER.

FOR FACIAL CLEANSERS; FACIAL MOISTURIZER WITH SPF; LIP BALM; SKIN MOISTURIZER (U.S. CLS. 1, 4, 6, 50, 51 AND 52).

FIRST USE 10-1-2009; IN COMMERCE 10-1-2009.

LOURDES AYALA, EXAMINING ATTORNEY

**CLASS 3—(Continued).**

SN 85-184,989. THIRD MAN, INC., NEW YORK, NY. FILED 11-24-2010.

## EAU MODERNE

THE MARK CONSISTS OF STANDARD CHARACTERS WITHOUT CLAIM TO ANY PARTICULAR FONT, STYLE, SIZE, OR COLOR.

THE ENGLISH TRANSLATION OF "EAU" IN THE MARK IS "WATER".

FOR AFTERSHAVE; BATHING LOTIONS; BEAUTY LOTIONS; BODY LOTIONS; COLOGNE; COSMETIC PREPARATIONS FOR BODY CARE; SOAPS FOR PERSONAL USE; COSMETIC SOAPS; COSMETICS AND COSMETIC PREPARATIONS; EAU DE TOILETTE; EAU DE COLOGNE; FRAGRANCES FOR PERSONAL USE; NON-MEDICATED TOILETRIES; PERFUMES; POT-POURRI; ROOM FRAGRANCES; SKIN AND BODY TOPICAL LOTIONS, CREAMS, OILS AND GELS; TOILET WATER (U.S. CLS. 1, 4, 6, 50, 51 AND 52).

AISHA CLARKE, EXAMINING ATTORNEY

---

SN 85-186,463. HABER, SANDRA L, GLENWOOD SPRINGS, CO. FILED 11-29-2010.

## SOPHISTICATED SYRUP

THE MARK CONSISTS OF STANDARD CHARACTERS WITHOUT CLAIM TO ANY PARTICULAR FONT, STYLE, SIZE, OR COLOR.

NO CLAIM IS MADE TO THE EXCLUSIVE RIGHT TO USE "SYRUP", APART FROM THE MARK AS SHOWN.

FOR FOOD FLAVORINGS PREPARED FROM ESSENTIAL OILS (U.S. CLS. 1, 4, 6, 50, 51 AND 52).

FIRST USE 3-12-2010; IN COMMERCE 6-3-2010.

ANNE E. GUSTASON, EXAMINING ATTORNEY

---

SN 85-187,115. FARIAS VILLARREAL, MARTIN JESUS GERARDO, HOUSTON, TX. FILED 11-30-2010.

## Vidarela

THE MARK CONSISTS OF STANDARD CHARACTERS WITHOUT CLAIM TO ANY PARTICULAR FONT, STYLE, SIZE, OR COLOR.

THE WORDING "VIDARELA" HAS NO MEANING IN A FOREIGN LANGUAGE.

FOR BODY CREAM; BODY CREAMS; COLD CREAM; COLD CREAMS; COSMETIC CREAMS; COSMETIC CREAMS FOR SKIN CARE (U.S. CLS. 1, 4, 6, 50, 51 AND 52).

SUNG IN, EXAMINING ATTORNEY

**CLASS 3—(Continued).**

SN 85-187,180. HARRINGTON MULTI MEDIA MARKET-  
ING LLC, CLEARWATER, FL. FILED 11-30-2010.

# PURE PACK

THE MARK CONSISTS OF STANDARD CHARACTERS  
WITHOUT CLAIM TO ANY PARTICULAR FONT, STYLE,  
SIZE, OR COLOR.

NO CLAIM IS MADE TO THE EXCLUSIVE RIGHT TO  
USE "PACK", APART FROM THE MARK AS SHOWN.

FOR BODY AND BEAUTY CARE COSMETICS; COS-  
METIC CREAMS; COSMETIC PREPARATIONS; COS-  
METIC PREPARATIONS FOR BODY CARE; COSMETIC  
PREPARATIONS FOR EYE LASHES; COSMETIC PRE-  
PARATIONS FOR PROTECTING THE SKIN FROM THE  
SUN'S RAYS; COSMETIC PREPARATIONS FOR SKIN  
CARE; COSMETIC PREPARATIONS FOR SKIN RENEW-  
AL; COSMETIC PREPARATIONS FOR THE HAIR AND  
SCALP; COSMETIC SUN-PROTECTING PREPARA-  
TIONS; COSMETICS AND MAKE-UP; LOTIONS FOR  
COSMETIC PURPOSES; MAKE-UP KITS COMPRISED  
OF SKINS CREAMS, LOTIONS AND GELS; PRIVATE  
LABEL COSMETICS; SKIN AND BODY TOPICAL LO-  
TIONS, CREAMS AND OILS FOR COSMETIC USE; SKIN  
FRESHENERS; TANNING AND AFTER-SUN MILKS,  
GELS AND OILS; TEETH WHITENING STRIPS IM-  
PREGNATED WITH TEETH WHITENING PREPARA-  
TIONS; TOOTH WHITENERS FOR COSMETIC  
PURPOSES COMPRISED OF NEUTRAL SODIUM  
FLUORIDE SUSTAINED RELEASE GEL; WRINKLE-  
MINIMIZING COSMETIC PREPARATIONS FOR TOPI-  
CAL FACIAL USE (U.S. CLS. 1, 4, 6, 50, 51 AND 52).

MARGERY A. TIERNEY, EXAMINING ATTORNEY

SN 85-187,402. CORTEC CORPORATION, ST. PAUL, MN.  
FILED 11-30-2010.

# STAINLESS WIZARD

THE MARK CONSISTS OF STANDARD CHARACTERS  
WITHOUT CLAIM TO ANY PARTICULAR FONT, STYLE,  
SIZE, OR COLOR.

NO CLAIM IS MADE TO THE EXCLUSIVE RIGHT TO  
USE "STAINLESS", APART FROM THE MARK AS SHOWN.

FOR CLEANING SOLUTIONS FOR CLEANING  
STAINLESS STEEL SURFACES (U.S. CLS. 1, 4, 6, 50, 51  
AND 52).

ANTHONY RINKER, EXAMINING ATTORNEY

**CLASS 3—(Continued).**

SN 85-187,422. HUBER PARFUMS, LTD., NEW YORK, NY.  
FILED 11-30-2010.

# H

THE MARK CONSISTS OF UPPERCASE "H".  
FOR PERFUMES (U.S. CLS. 1, 4, 6, 50, 51 AND 52).  
ELISSA GARBER KON, EXAMINING ATTORNEY

SN 85-188,240. CHEN, CANDACE, LOS ANGELES, CA.  
FILED 12-1-2010.

# Macho Man

THE MARK CONSISTS OF STANDARD CHARACTERS  
WITHOUT CLAIM TO ANY PARTICULAR FONT, STYLE,  
SIZE, OR COLOR.

NO CLAIM IS MADE TO THE EXCLUSIVE RIGHT TO  
USE "MAN", APART FROM THE MARK AS SHOWN.

FOR NON-MEDICATED SKIN CARE PREPARATIONS;  
SKIN CLEANSERS; SUN BLOCK (U.S. CLS. 1, 4, 6, 50, 51  
AND 52).

SCOTT BIBB, EXAMINING ATTORNEY

SN 85-188,250. CLINICAL HEALTH SERVICES, INC., TAM-  
PA, FL. FILED 12-1-2010.

# Therapist's Choice

THE MARK CONSISTS OF STANDARD CHARACTERS  
WITHOUT CLAIM TO ANY PARTICULAR FONT, STYLE,  
SIZE, OR COLOR.

NO CLAIM IS MADE TO THE EXCLUSIVE RIGHT TO  
USE "THERAPIST'S", APART FROM THE MARK AS  
SHOWN.

FOR MASSAGE CREAMS; MASSAGE LOTIONS; MAS-  
SAGE OILS (U.S. CLS. 1, 4, 6, 50, 51 AND 52).

FIRST USE 9-6-2007; IN COMMERCE 9-6-2007.

WILLIAM ROSSMAN, EXAMINING ATTORNEY

**CLASS 3—(Continued).**

SN 85-188,587. DEUG GON MOON, SEOUL, REPUBLIC OF KOREA, FILED 12-1-2010.

# ILOMYS

THE MARK CONSISTS OF STANDARD CHARACTERS WITHOUT CLAIM TO ANY PARTICULAR FONT, STYLE, SIZE, OR COLOR.

THE WORDING "ILOMYS" HAS NO MEANING IN A FOREIGN LANGUAGE.

FOR COSMETICS; COSMETICS AND MAKE-UP; BODY LOTIONS; COSMETIC PREPARATIONS FOR SKIN CARE; SKIN CLEANSERS; COSMETIC SUN-PROTECTING PREPARATIONS; COSMETIC PREPARATIONS FOR SLIMMING PURPOSES; FOUNDATIONS; FACE AND BODY CREAMS; MASK PACK FOR COSMETIC PURPOSES; BEAUTY MASKS; BEAUTY SOAP (U.S. CLS. 1, 4, 6, 50, 51 AND 52).

JOHN WILKE, EXAMINING ATTORNEY

SN 85-188,983. FARIAS VILLARREAL, MARTIN JESUS GERARDO, HOUSTON, TX. FILED 12-2-2010.

## Mr. Look T Transforma

THE MARK CONSISTS OF STANDARD CHARACTERS WITHOUT CLAIM TO ANY PARTICULAR FONT, STYLE, SIZE, OR COLOR.

THE ENGLISH TRANSLATION OF THE WORD "TRANSFORMA" IN THE MARK IS TO TRANSFORM.

FOR HAIR CARE CREAMS; HAIR CARE LOTIONS; HAIR CARE PREPARATIONS; HAIR COLOR; HAIR COLORANTS; HAIR CONDITIONER; HAIR CONDITIONERS; HAIR CREAMS; HAIR GEL; HAIR GEL AND HAIR MOUSSE; HAIR GELS; HAIR LOTIONS; HAIR MOUSSE; HAIR MOUSSES; HAIR POMADES; HAIR SHAMPOO; HAIR SHAMPOOS AND CONDITIONERS; HAIR SHEEN SPRAY; HAIR SPRAYS AND HAIR GELS; HAIR STYLING GEL; HAIR STYLING PREPARATIONS; HAIR TONIC; HAIR WAX (U.S. CLS. 1, 4, 6, 50, 51 AND 52).

SUNG IN, EXAMINING ATTORNEY

**CLASS 3—(Continued).**

SN 85-189,036. FARIAS VILLARREAL, MARTIN JESUS GERARDO, HOUSTON, TX. FILED 12-2-2010.

## Placenta Vidarela

THE MARK CONSISTS OF STANDARD CHARACTERS WITHOUT CLAIM TO ANY PARTICULAR FONT, STYLE, SIZE, OR COLOR.

NO CLAIM IS MADE TO THE EXCLUSIVE RIGHT TO USE "PLACENTA", APART FROM THE MARK AS SHOWN.

THE WORDING "VIDARELA" HAS NO MEANING IN A FOREIGN LANGUAGE.

FOR HAIR RINSES; HAIR SHAMPOO; HAIR SHAMPOOS AND CONDITIONERS; SHAMPOO-CONDITIONERS; SHAMPOOS; ALL OF THE FOREGOING CONTAINING PLACENTA AS A COMPONENT (U.S. CLS. 1, 4, 6, 50, 51 AND 52).

SUNG IN, EXAMINING ATTORNEY

SN 85-189,087. WILKIE, MARTHA, KINGWOOD, TX. FILED 12-2-2010.



THE MARK CONSISTS OF THE STYLIZED TEXT "BATHOLOGY THE SCIENCE OF RELAXATION" AND A VINE DESIGN.

FOR AFTER-SHAVE; ALL-PURPOSE CLEANERS; ANTIBACTERIAL SOAP; AROMATIC BODY CARE PRODUCTS, NAMELY, BODY LOTION, SHOWER GEL, CUTICLE CREAM, SHAMPOO, CONDITIONER, NON-MEDICATED LIP BALM, SOAP, BODY POLISH, BODY AND FOOT SCRUB AND NON-MEDICATED FOOT CREAM; AROMATIC EVAPORATING BATH AND SHOWER BALLS IN THE NATURE OF SCENTED BATH FIZZIES; BATH AND SHOWER GELS AND SALTS NOT FOR MEDICAL PURPOSES; BATH OILS AND BATH SALTS; BATH SOAPS IN LIQUID, SOLID OR GEL FORM; BODY BUTTER; HAND AND BODY CREAM; GLITTER FOR COSMETIC PURPOSES; LOTIONS FOR SKIN, FACE, BODY; BODY SPRAY USED AS A PERSONAL DEODORANT AND AS FRAGRANCE; BUBBLE BATH; COLOGNES, PERFUMES AND COSMETICS; DETERGENTS FOR HOUSEHOLD USE; FOOT DEODORANT SPRAY; FOOT POWDER; FOOT SCRUBS; FOOT SMOOTHING STONES; GIFT BASKETS CONTAINING NON-MEDICATED BATH PREPARATIONS AND COSMETIC PREPARATIONS; LIQUID SOAPS FOR HANDS, FACE AND BODY; PET CARE KITS COMPRISING SHAMPOO, CONDITIONER, BODY SPRAY; ROOM FRAGRANCES (U.S. CLS. 1, 4, 6, 50, 51 AND 52).

HOWARD B. LEVINE, EXAMINING ATTORNEY

**CLASS 3—(Continued).**

SN 85-189,430. SHIPMAN ASSOCIATES, INC., SAN FRANCISCO, CA. FILED 12-2-2010.

**Meet Matte**

THE MARK CONSISTS OF STANDARD CHARACTERS WITHOUT CLAIM TO ANY PARTICULAR FONT, STYLE, SIZE, OR COLOR.

NO CLAIM IS MADE TO THE EXCLUSIVE RIGHT TO USE "MATTE", APART FROM THE MARK AS SHOWN.

FOR COSMETICS (U.S. CLS. 1, 4, 6, 50, 51 AND 52).  
BRIAN CALLAGHAN, EXAMINING ATTORNEY

**CLASS 3—(Continued).**

SN 85-191,031. PROMESA DISTRIBUTORS, WINSTON SALEM, NC. FILED 12-6-2010.

**CRECE-MAX**

THE MARK CONSISTS OF STANDARD CHARACTERS WITHOUT CLAIM TO ANY PARTICULAR FONT, STYLE, SIZE, OR COLOR.

THE ENGLISH TRANSLATION OF THE WORD "CRECE" IN THE MARK IS "GROW".

FOR BABY SHAMPOO; HAIR SHAMPOO; HAIR SHAMPOOS AND CONDITIONERS; SHAMPOO-CONDITIONERS; SHAMPOOS (U.S. CLS. 1, 4, 6, 50, 51 AND 52).  
MICHAEL WEBSTER, EXAMINING ATTORNEY

SN 85-190,130. UNION SUPPLY COMPANY, RANCHO DOMINGUEZ, CA. FILED 12-3-2010.

**LEVEL 10**

THE MARK CONSISTS OF STANDARD CHARACTERS WITHOUT CLAIM TO ANY PARTICULAR FONT, STYLE, SIZE, OR COLOR.

FOR PERSONAL CARE PRODUCTS, NAMELY, SHAMPOOS, HAIR CONDITIONERS, SOAPS, BODY LOTIONS, DEODORANTS FOR PERSONAL USE, AND SHAVING PREPARATIONS (U.S. CLS. 1, 4, 6, 50, 51 AND 52).

KAREN K. BUSH, EXAMINING ATTORNEY

SN 85-191,196. DR PRODUCTS, LLC, TUCSON, AZ. FILED 12-6-2010.

**Tooth Juice**

THE MARK CONSISTS OF STANDARD CHARACTERS WITHOUT CLAIM TO ANY PARTICULAR FONT, STYLE, SIZE, OR COLOR.

NO CLAIM IS MADE TO THE EXCLUSIVE RIGHT TO USE "TOOTH", APART FROM THE MARK AS SHOWN.

FOR TOOTH CLEANING PREPARATIONS (U.S. CLS. 1, 4, 6, 50, 51 AND 52).

ANTHONY RINKER, EXAMINING ATTORNEY

SN 85-190,452. SHISEIDO COMPANY, LIMITED, TOKYO, JAPAN, FILED 12-3-2010.

**YUTAKA CLUB**

THE MARK CONSISTS OF STANDARD CHARACTERS WITHOUT CLAIM TO ANY PARTICULAR FONT, STYLE, SIZE, OR COLOR.

FOR SOAPS, PERFUMERIES, AND COSMETICS; MAKE-UP AND SKIN CARE PRODUCTS, NAMELY, NON-MEDICATED SKIN CARE PREPARATIONS FOR THE FACE (U.S. CLS. 1, 4, 6, 50, 51 AND 52).

MATTHEW KLINE, EXAMINING ATTORNEY

SN 85-192,194. LABORATOIRES D'ARPHIN S.A.S., PARIS, FRANCE, FILED 12-7-2010.

**SELECTIV MELA SYSTEM**

THE MARK CONSISTS OF STANDARD CHARACTERS WITHOUT CLAIM TO ANY PARTICULAR FONT, STYLE, SIZE, OR COLOR.

NO CLAIM IS MADE TO THE EXCLUSIVE RIGHT TO USE "SYSTEM", APART FROM THE MARK AS SHOWN.

FOR COSMETICS; NON-MEDICATED SKIN CARE PREPARATIONS (U.S. CLS. 1, 4, 6, 50, 51 AND 52).

EDWARD FENNESSY, EXAMINING ATTORNEY

**CLASS 3—(Continued).**

SN 85-193,054. SIERRA SAGE HERBS LLC, BOISE, ID. FILED 12-8-2010.

**GREEN GOO**

THE MARK CONSISTS OF STANDARD CHARACTERS WITHOUT CLAIM TO ANY PARTICULAR FONT, STYLE, SIZE, OR COLOR.

NO CLAIM IS MADE TO THE EXCLUSIVE RIGHT TO USE "GREEN", APART FROM THE MARK AS SHOWN.

FOR NON-MEDICATED HERBAL BODY CARE PRODUCTS, NAMELY, SALVES (U.S. CLS. 1, 4, 6, 50, 51 AND 52).

FIRST USE 6-0-2008; IN COMMERCE 6-0-2008.  
JANICE KIM, EXAMINING ATTORNEY

---

SN 85-193,485. FACEGAMES, INC., BAYSIDE, NY. FILED 12-8-2010.

**BEAUTYGAMES**

THE MARK CONSISTS OF STANDARD CHARACTERS WITHOUT CLAIM TO ANY PARTICULAR FONT, STYLE, SIZE, OR COLOR.

OWNER OF U.S. REG. NOS. 2,518,315, 3,914,250 AND OTHERS.

FOR BEAUTY AND SKIN CARE PRODUCTS, NAMELY, FACE MOISTURIZERS, FACE CLEANSERS, FACE TONERS, FACE CREAMS, SKIN CREAMS, BODY LOTIONS, BODY MOISTURIZERS, BODY SCRUBS AND BODY EXFOLIANTS (U.S. CLS. 1, 4, 6, 50, 51 AND 52).

FIRST USE 6-19-1999; IN COMMERCE 1-0-2000.  
ALLISON SCHRODY, EXAMINING ATTORNEY

---

SN 85-193,524. DRY, INC., PORTLAND, OR. FILED 12-8-2010.

**WRINKLE REDUCER PLUS**

THE MARK CONSISTS OF STANDARD CHARACTERS WITHOUT CLAIM TO ANY PARTICULAR FONT, STYLE, SIZE, OR COLOR.

NO CLAIM IS MADE TO THE EXCLUSIVE RIGHT TO USE "WRINKLE REDUCER", APART FROM THE MARK AS SHOWN.

FOR SPRAYS FOR THE CARE AND DE-WRINKLING OF CLOTHING, FABRICS, AND CURTAINS; SCENTED FABRIC REFRESHING SPRAY FOR USE ON CLOTHING, FABRICS, AND CURTAINS; ANTI-STATIC SPRAYS FOR CLOTHING, FABRICS, AND CURTAINS (U.S. CLS. 1, 4, 6, 50, 51 AND 52).

ROBIN CHOSID, EXAMINING ATTORNEY

**CLASS 3—(Continued).**

SN 85-194,874. COMPTOIR NOUVEAU DE LA PARFUMERIE, 75008 PARIS, FRANCE, FILED 12-10-2010.

**UN JARDIN SUR LE TOIT**

THE MARK CONSISTS OF STANDARD CHARACTERS WITHOUT CLAIM TO ANY PARTICULAR FONT, STYLE, SIZE, OR COLOR.

PRIORITY CLAIMED UNDER SEC. 44(D) ON FRANCE APPLICATION NO. 103756657, FILED 7-27-2010, REG. NO. 103756657, DATED 7-27-2010, EXPIRES 7-27-2020.

THE ENGLISH TRANSLATION OF "UN JARDIN SUR LE TOIT" IN THE MARK IS A ROOFTOP GARDEN.

FOR PERFUMES, NAMELY, PERFUMERY, TOILET WATER, PERFUME WATER, ESSENTIAL OILS FOR PERSONAL USE, COSMETICS, HAIR LOTIONS, BODY LOTIONS, SOAPS, DENTIFRICES, DEODORANTS FOR PERSONAL USE, BATH AND SHOWER GELS, SHAMPOOS, BEAUTY CREAMS FOR THE BODY (U.S. CLS. 1, 4, 6, 50, 51 AND 52).

ELIZABETH KAJUBI, EXAMINING ATTORNEY

---

SN 85-195,101. AWESOME PRODUCTS, INC., BUENA PARK, CA. FILED 12-10-2010.

**LA'S TOTALLY AWESOME**

THE MARK CONSISTS OF STANDARD CHARACTERS WITHOUT CLAIM TO ANY PARTICULAR FONT, STYLE, SIZE, OR COLOR.

OWNER OF U.S. REG. NO. 2,859,642.  
FOR LAUNDRY DETERGENT (U.S. CLS. 1, 4, 6, 50, 51 AND 52).

FIRST USE 7-1-1990; IN COMMERCE 7-1-1990.  
ELIZABETH KAJUBI, EXAMINING ATTORNEY

---

SN 85-195,888. MEDIDERM LABORATORIES, LLC, SANTA FE SPRINGS, CA. FILED 12-11-2010.

**NANOVERA**

THE MARK CONSISTS OF STANDARD CHARACTERS WITHOUT CLAIM TO ANY PARTICULAR FONT, STYLE, SIZE, OR COLOR.

FOR ANTI-WRINKLE CREAMS; BEAUTY CREAMS (U.S. CLS. 1, 4, 6, 50, 51 AND 52).

FIRST USE 11-7-2006; IN COMMERCE 11-7-2006.  
DAWN HAN, EXAMINING ATTORNEY

**CLASS 3—(Continued).**

SN 85-195,889. MEDIDERM LABORATORIES, LLC, SANTA FE SPRINGS, CA. FILED 12-11-2010.

# NANOALOE

THE MARK CONSISTS OF STANDARD CHARACTERS WITHOUT CLAIM TO ANY PARTICULAR FONT, STYLE, SIZE, OR COLOR.

FOR ANTI-AGING CREAM; ANTI-WRINKLE CREAM; BEAUTY CREAMS (U.S. CLS. 1, 4, 6, 50, 51 AND 52).  
DAWN HAN, EXAMINING ATTORNEY

SN 85-196,981. THE QUEST GROUP, IRVINE, CA. FILED 12-14-2010.

# CLARITY BY CABLETRUTH

THE MARK CONSISTS OF STANDARD CHARACTERS WITHOUT CLAIM TO ANY PARTICULAR FONT, STYLE, SIZE, OR COLOR.

OWNER OF U.S. REG. NO. 3,514,167.  
FOR CLEANING PREPARATIONS FOR AUDIO AND VIDEO EQUIPMENT (U.S. CLS. 1, 4, 6, 50, 51 AND 52).  
ALICIA COLLINS, EXAMINING ATTORNEY

SN 85-197,276. SHIPMAN ASSOCIATES, INC., SAN FRANCISCO, CA. FILED 12-14-2010.

# Nude Tude

THE MARK CONSISTS OF STANDARD CHARACTERS WITHOUT CLAIM TO ANY PARTICULAR FONT, STYLE, SIZE, OR COLOR.

NO CLAIM IS MADE TO THE EXCLUSIVE RIGHT TO USE "NUDE", APART FROM THE MARK AS SHOWN.  
FOR COSMETICS (U.S. CLS. 1, 4, 6, 50, 51 AND 52).  
BRIAN CALLAGHAN, EXAMINING ATTORNEY

**CLASS 3—(Continued).**

SN 85-197,508. PERFORMANCE BRANDS, INC., SUNRISE, FL. FILED 12-14-2010.

# WONDER TAN

THE MARK CONSISTS OF STANDARD CHARACTERS WITHOUT CLAIM TO ANY PARTICULAR FONT, STYLE, SIZE, OR COLOR.

NO CLAIM IS MADE TO THE EXCLUSIVE RIGHT TO USE "TAN", APART FROM THE MARK AS SHOWN.

FOR SELF-TANNING PREPARATIONS (U.S. CLS. 1, 4, 6, 50, 51 AND 52).

KATHERINE CHANG, EXAMINING ATTORNEY

SN 85-198,939. AMERICAN INTERNATIONAL INDUSTRIES, COMMERCE, CA. FILED 12-15-2010.

# SO EASY

THE MARK CONSISTS OF STANDARD CHARACTERS WITHOUT CLAIM TO ANY PARTICULAR FONT, STYLE, SIZE, OR COLOR.

FOR ADHESIVES FOR AFFIXING FALSE HAIR; ADHESIVES FOR ARTIFICIAL NAILS; ADHESIVES FOR FALSE EYELASHES, HAIR AND NAILS; AFTER-SUN GELS; AFTER-SUN OILS; ALOE VERA GEL FOR COSMETIC PURPOSES; ASTRINGENTS FOR COSMETIC PURPOSES; BABY HAIR CONDITIONER; BABY SHAMPOO; BATH OILS FOR COSMETIC PURPOSES; BATH POWDER; BLEACHING PREPARATIONS FOR COSMETIC PURPOSES; BLEACHING PREPARATIONS FOR THE HAIR; BODY AND BEAUTY CARE COSMETICS; CLEANER FOR COSMETIC BRUSHES; CLEANSING CREAMS; COCOA BUTTER FOR COSMETIC PURPOSES; COSMETIC CREAMS; COSMETIC CREAMS FOR SKIN CARE; COSMETIC HAIR DRESSING PREPARATIONS; COSMETIC HAND CREAMS; COSMETIC MASKS; COSMETIC MASSAGE CREAMS; COSMETIC PENCILS; COSMETIC PREPARATIONS; COSMETIC PREPARATIONS FOR BODY CARE; COSMETIC PREPARATIONS FOR EYE LASHES; COSMETIC PREPARATIONS FOR SKIN CARE; COSMETIC PREPARATIONS FOR SKIN RENEWAL; COSMETIC PREPARATIONS FOR THE CARE OF MOUTH AND TEETH; COSMETIC PREPARATIONS FOR THE HAIR AND SCALP; COSMETIC PREPARATIONS, NAMELY, FIRMLING CREAMS; COSMETIC SKIN FRESHENERS; COSMETIC SOAPS; COSMETIC SUN-PROTECTING PREPARATIONS; COSMETICS; COSMETICS AND COSMETIC PREPARATIONS; COSMETICS AND MAKE-UP; COTTON WOOL BALLS FOR COSMETIC USE; CUTICLE CONDITIONERS; EYE GELS; EYE MAKE-UP; EYE PENCILS; EYE SHADOW; EYE SHADOWS; EYEBROW COSMETICS; EYES PENCILS; FACE AND BODY MILK; FACE CREAMS; FACE CREAMS FOR COSMETIC USE; FACE GLITTER; FACE POWDER; FALSE NAILS; FOOT POWDER; FOOT SCRUBS; GAUZE FOR COSMETIC PURPOSES; GLITTER FOR COSMETIC PURPOSES; HAIR CONDITIONER; HAIR SHAMPOO; HAIR SHAMPOOS AND CONDITIONERS; HENNA FOR COSMETIC PURPOSES; LIQUID SOAPS FOR HANDS AND FACE; LOTIONS FOR COSMETIC PURPOSES; MOISTURIZING SOLUTIONS FOR THE SKIN; NAIL BUFFING PREPARATIONS; NAIL CARE PREPARATIONS, NAMELY, NAIL SOFTENERS; NAIL CREAM; NAIL ENAMEL; NAIL ENAMEL REMOVERS; NAIL GEL; NAIL HARDENERS; NAIL POLISH; NAIL POLISH BASE COAT; NAIL POLISH

**CLASS 3—(Continued).**

REMOVER; NAIL POLISH TOP COAT; NAIL TIPS; NAIL VARNISH; NAIL VARNISH FOR COSMETIC PURPOSES; NON-MEDICATED FOOT CREAM; NON-MEDICATED HAIR TREATMENT PREPARATIONS FOR COSMETIC PURPOSES; NON-MEDICATED SKIN CARE CREAMS AND LOTIONS; NON-MEDICATED SKIN CARE PREPARATIONS; NON-MEDICATED SKIN CREAMS; OILS FOR COSMETIC PURPOSES; PARAFFIN WAX FOR COSMETIC PURPOSES; PERFUME; PERFUME OILS; PERFUME OILS FOR THE MANUFACTURE OF COSMETIC PREPARATIONS; PERFUMED POWDER; PERFUMED SOAP; PETROLEUM JELLY FOR COSMETIC PURPOSES; PRE-MOISTENED COSMETIC TISSUES; SELF-TANNING PREPARATIONS; SHAMPOO-CONDITIONERS; SHAMPOOS FOR BABIES; SHEA BUTTER FOR COSMETIC PURPOSES; SKIN AND BODY TOPICAL LOTIONS, CREAMS AND OILS FOR COSMETIC USE; SKIN CONDITIONERS; SKIN CREAMS; SKIN EMOLLIENTS; SKIN LOTION; SKIN MASKS; SKIN MOISTURIZER; SKIN SOAP; SKIN TONERS; TANNING GELS; TANNING OILS; TEETH WHITENING STRIPS IMPREGNATED WITH TEETH WHITENING PREPARATIONS; TOOTHPASTE; TOOTHPASTE AND MOUTHWASHES; WRINKLE-MINIMIZING COSMETIC PREPARATIONS FOR TOPICAL FACIAL USE (U.S. CLS. 1, 4, 6, 50, 51 AND 52).

MARY ROSSMAN, EXAMINING ATTORNEY

SN 85-199,323. BRAUN, MANFRED, HATTERSHEIM, FED REP GERMANY, FILED 12-16-2010.

**SEA SAILING**

THE MARK CONSISTS OF STANDARD CHARACTERS WITHOUT CLAIM TO ANY PARTICULAR FONT, STYLE, SIZE, OR COLOR.

FOR BODY AND SKIN SOAP, PRE-SHAVE LOTION, AFTER-SHAVE LOTION, BODY LOTION, BODY CREAM, BODY POWDER, PERSONAL DEODORANT SPRAY, PERSONAL DEODORANT STICKS, PERSONAL ROLL-ON DEODORANTS, PERFUMES, COLOGNE, TOILET WATER AND SHOWER GEL (U.S. CLS. 1, 4, 6, 50, 51 AND 52).

MICHAEL WIENER, EXAMINING ATTORNEY

SN 85-199,526. HIP INNOVATIONS, LLC, WILLISTON, VT. FILED 12-16-2010.

**CELEBRATE**

THE MARK CONSISTS OF STANDARD CHARACTERS WITHOUT CLAIM TO ANY PARTICULAR FONT, STYLE, SIZE, OR COLOR.

FOR HOUSEHOLD CLEANING PREPARATIONS (U.S. CLS. 1, 4, 6, 50, 51 AND 52).

CAROLINE WOOD, EXAMINING ATTORNEY

**CLASS 3—(Continued).**

SN 85-201,244. JOHN PAUL MITCHELL SYSTEMS, SANTA CLARITA, CA. FILED 12-18-2010.

**BARBER'S CLASSIC**

THE MARK CONSISTS OF STANDARD CHARACTERS WITHOUT CLAIM TO ANY PARTICULAR FONT, STYLE, SIZE, OR COLOR.

NO CLAIM IS MADE TO THE EXCLUSIVE RIGHT TO USE "CLASSIC", APART FROM THE MARK AS SHOWN.

FOR HAIR STYLING PREPARATIONS (U.S. CLS. 1, 4, 6, 50, 51 AND 52).

ALEXANDER L. POWERS, EXAMINING ATTORNEY

SN 85-201,246. JOHN PAUL MITCHELL SYSTEMS, SANTA CLARITA, CA. FILED 12-18-2010.

**CLEAN CUT**

THE MARK CONSISTS OF STANDARD CHARACTERS WITHOUT CLAIM TO ANY PARTICULAR FONT, STYLE, SIZE, OR COLOR.

FOR HAIR STYLING PREPARATIONS (U.S. CLS. 1, 4, 6, 50, 51 AND 52).

ALEXANDER L. POWERS, EXAMINING ATTORNEY

SN 85-201,247. JOHN PAUL MITCHELL SYSTEMS, SANTA CLARITA, CA. FILED 12-18-2010.

**CONSTRUCTION PASTE**

THE MARK CONSISTS OF STANDARD CHARACTERS WITHOUT CLAIM TO ANY PARTICULAR FONT, STYLE, SIZE, OR COLOR.

NO CLAIM IS MADE TO THE EXCLUSIVE RIGHT TO USE "PASTE", APART FROM THE MARK AS SHOWN.

FOR HAIR STYLING PREPARATIONS (U.S. CLS. 1, 4, 6, 50, 51 AND 52).

ALEXANDER L. POWERS, EXAMINING ATTORNEY

**CLASS 3—(Continued).**

SN 85-201,854. GILCHRIST & SOAMES, INC., INDIANAPOLIS, IN. FILED 12-20-2010.

**ECOLUTION**

THE MARK CONSISTS OF STANDARD CHARACTERS WITHOUT CLAIM TO ANY PARTICULAR FONT, STYLE, SIZE, OR COLOR.

FOR SOAPS, BATH AND SHOWER GELS, BODY LOTION, BATH CRYSTALS AND SALTS, SHAMPOO AND CONDITIONER; FRAGRANCE, NAMELY, PERFUME (U.S. CLS. 1, 4, 6, 50, 51 AND 52).

MICHELE SWAIN, EXAMINING ATTORNEY

SN 85-201,927. OSWIN LABORATORIES PTY. LTD., MULGRAVE VIC 3170, AUSTRALIA, FILED 12-20-2010.



NO CLAIM IS MADE TO THE EXCLUSIVE RIGHT TO USE "SINCE 1977", APART FROM THE MARK AS SHOWN.

THE MARK CONSISTS OF THE WORD "LE TAN" STYLIZED WITH DESIGNS OF SUN WITH RAYS, WAVES AND DIVIDED DISCS AND ABOVE THE IMAGE THE WORDS "LOVING SUMMER SINCE 1977".

THE ENGLISH TRANSLATION OF THE WORDS "LE TAN" IN THE MARK IS THE TAN.

FOR NON MEDICATED SUN BLOCK PREPARATIONS, SUN TAN LOTIONS AND PREPARATIONS, SKIN MOISTURIZERS, NON MEDICATED PREPARATIONS FOR RELIEF OF SUN BURN (U.S. CLS. 1, 4, 6, 50, 51 AND 52).

DORITT L. CARROLL, EXAMINING ATTORNEY

**CLASS 3—(Continued).**

SN 85-202,011. VICTORIA'S SECRET STORES BRAND MANAGEMENT, INC., REYNOLDSBURG, OH. FILED 12-20-2010.

**BIG VOLUME**

THE MARK CONSISTS OF STANDARD CHARACTERS WITHOUT CLAIM TO ANY PARTICULAR FONT, STYLE, SIZE, OR COLOR.

NO CLAIM IS MADE TO THE EXCLUSIVE RIGHT TO USE "VOLUME", APART FROM THE MARK AS SHOWN.

FOR MASCARA (U.S. CLS. 1, 4, 6, 50, 51 AND 52).

CAROLINE WOOD, EXAMINING ATTORNEY

SN 85-202,570. MIRIAM T. BELL, ATLANTA, GA. FILED 12-21-2010.



THE NAME(S), PORTRAIT(S), AND/OR SIGNATURE(S) SHOWN IN THE MARK IDENTIFIES MIRIAM TSHOMBE BELL, WHOSE CONSENT(S) TO REGISTER IS MADE OF RECORD.

THE MARK CONSISTS OF THE STYLIZED TEXT TSHOMBE WRITTEN ABOVE A STYLIZED TREE BRANCH WITH A STYLIZED NUT IMAGE TO THE RIGHT OF THE BRANCH.

THE WORDING TSHOMBE HAS NO MEANING IN A FOREIGN LANGUAGE.

FOR BEAUTY CREAMS; BODY CREAM; HAIR CREAMS (U.S. CLS. 1, 4, 6, 50, 51 AND 52).

FIRST USE 10-10-2010; IN COMMERCE 10-10-2010.

TRACY CROSS, EXAMINING ATTORNEY

SN 85-202,610. ELENA SHUMSKY, OVIEDO, FL. FILED 12-21-2010.

**Clearoll**

THE MARK CONSISTS OF STANDARD CHARACTERS WITHOUT CLAIM TO ANY PARTICULAR FONT, STYLE, SIZE, OR COLOR.

FOR PRIVATE LABEL COSMETICS (U.S. CLS. 1, 4, 6, 50, 51 AND 52).

THEODORE MCBRIDE, EXAMINING ATTORNEY



**CLASS 3—(Continued).**

SN 85-203,620. VO, THANH THUY DAO, LAS VEGAS, NV.  
FILED 12-22-2010.



NO CLAIM IS MADE TO THE EXCLUSIVE RIGHT TO USE "TEETH WHITENING", APART FROM THE MARK AS SHOWN.

THE MARK CONSISTS OF SMALL HEART ABOVE A LARGER, STYLIZED HEART; LOVELYSMILE APPEARS IN STYLIZED LETTERS BEGINNING WITHIN THE LARGER HEART; TEETH WHITENING APPEARS IN STYLIZED LETTERS BELOW LOVELYSMILE.

FOR COSMETIC PREPARATIONS FOR THE CARE OF MOUTH AND TEETH; DENTAL BLEACHING GELS; NON-MEDICATED DENTAL RINSE; TEETH CLEANING LOTIONS; TEETH WHITENING KIT; TEETH WHITENING STRIPS IMPREGNATED WITH TEETH WHITENING PREPARATIONS; TOOTH WHITENING CREAMS; TOOTH WHITENING GELS; TOOTH WHITENING PASTES; TOOTH WHITENING PREPARATIONS (U.S. CLS. 1, 4, 6, 50, 51 AND 52).

KATINA MISTER, EXAMINING ATTORNEY

SN 85-203,689. TUPPERWARE PRODUCTS S.A., FRIBOURG,  
SWITZERLAND, FILED 12-22-2010.

**PRETTY MODEL**

THE MARK CONSISTS OF STANDARD CHARACTERS WITHOUT CLAIM TO ANY PARTICULAR FONT, STYLE, SIZE, OR COLOR.

FOR PERFUMERY; DEODORANTS AND ANTIPERSPIRANTS FOR PERSONAL USE; TALCUM POWDER; AND NON-MEDICATED SKIN CARE PREPARATIONS (U.S. CLS. 1, 4, 6, 50, 51 AND 52).

DAVID ELTON, EXAMINING ATTORNEY

SN 85-203,695. TUPPERWARE PRODUCTS S.A., FRIBOURG,  
SWITZERLAND, FILED 12-22-2010.

**TRENDY DESIGN**

THE MARK CONSISTS OF STANDARD CHARACTERS WITHOUT CLAIM TO ANY PARTICULAR FONT, STYLE, SIZE, OR COLOR.

FOR PERFUMERY; DEODORANTS AND ANTIPERSPIRANTS FOR PERSONAL USE; TALCUM POWDER; AND NON-MEDICATED SKIN CARE PREPARATIONS (U.S. CLS. 1, 4, 6, 50, 51 AND 52).

DAVID ELTON, EXAMINING ATTORNEY

**CLASS 3—(Continued).**

SN 85-203,743. VO, THANH THUY DAO, LAS VEGAS, NV.  
FILED 12-22-2010.



NO CLAIM IS MADE TO THE EXCLUSIVE RIGHT TO USE "TEETH WHITENING", APART FROM THE MARK AS SHOWN.

THE MARK CONSISTS OF SMALL HEART WITH A LARGER STYLIZED HEART BELOW IT; LOVELYSMILES IN STYLIZED LETTERS WITH TEETH WHITENING IN STYLIZED LETTERS BELOW IT.

FOR DENTAL BLEACHING GELS; NON-MEDICATED DENTAL RINSE; TEETH CLEANING LOTIONS; TEETH WHITENING KIT; TEETH WHITENING STRIPS IMPREGNATED WITH TEETH WHITENING PREPARATIONS; TOOTH WHITENING CREAMS; TOOTH WHITENING GELS; TOOTH WHITENING PASTES; TOOTH WHITENING PREPARATIONS (U.S. CLS. 1, 4, 6, 50, 51 AND 52).

KATINA MISTER, EXAMINING ATTORNEY

SN 85-203,762. ATLANTIC COAST MEDIA GROUP, LLC,  
JERSEY CITY, NJ. FILED 12-22-2010.

**INSTAYOUNG**

THE MARK CONSISTS OF STANDARD CHARACTERS WITHOUT CLAIM TO ANY PARTICULAR FONT, STYLE, SIZE, OR COLOR.

FOR ANTI-AGING MOISTURIZERS, SKIN GELS, SKIN SERUMS, SKIN CREAMS, SKIN LOTIONS, NON-MEDICATED SKIN CARE PREPARATIONS (U.S. CLS. 1, 4, 6, 50, 51 AND 52).

KIM MONINGHOFF, EXAMINING ATTORNEY

SN 85-203,801. JE'ANE, LLC, LEESVILLE, LA. FILED 12-22-  
2010.

**Lipsavvy! By Je' Ane**

THE MARK CONSISTS OF STANDARD CHARACTERS WITHOUT CLAIM TO ANY PARTICULAR FONT, STYLE, SIZE, OR COLOR.

FOR COSMETICS, NAMELY, COMPACTS; COSMETICS, NAMELY, LIP PRIMER; COSMETICS, NAMELY, LIP REPAIRERS (U.S. CLS. 1, 4, 6, 50, 51 AND 52).

CHRISTOPHER BUONGIORNO, EXAMINING ATTORNEY

**CLASS 3—(Continued).**

SN 85-203,918. LEADING EDGE MARKETING, INC., NASSAU, NEW PROVIDENCE, BAHAMAS, FILED 12-22-2010.

# Skinception

THE MARK CONSISTS OF STANDARD CHARACTERS WITHOUT CLAIM TO ANY PARTICULAR FONT, STYLE, SIZE, OR COLOR.

FOR SKIN CREAM (U.S. CLS. 1, 4, 6, 50, 51 AND 52).  
JILL PRATER, EXAMINING ATTORNEY

**CLASS 3—(Continued).**

SN 85-204,278. FMN DISTRIBUTION LTD, VANCOUVER, CANADA, FILED 12-22-2010.

# BUSY BODIES

THE MARK CONSISTS OF STANDARD CHARACTERS WITHOUT CLAIM TO ANY PARTICULAR FONT, STYLE, SIZE, OR COLOR.

FOR AFTER-SHAVE LOTIONS; BATH SOAPS IN LIQUID, SOLID OR GEL FORM; FACE AND BODY LOTIONS; HAIR CARE CREAMS; HAIR CARE LOTIONS; HAIR CONDITIONERS; HAIR GEL; HAIR LOTIONS; HAIR RINSES; HAIR SHAMPOOS AND CONDITIONERS; HAND CREAMS; SHOWER GELS (U.S. CLS. 1, 4, 6, 50, 51 AND 52).

BRIAN NEVILLE, EXAMINING ATTORNEY

SN 85-203,988. CHAPMAN PRODUCTS CO., INC., FOUNTAIN INN, SC. FILED 12-22-2010.

# HAIROBI

THE MARK CONSISTS OF STANDARD CHARACTERS WITHOUT CLAIM TO ANY PARTICULAR FONT, STYLE, SIZE, OR COLOR.

FOR HAIR CARE PRODUCTS, NAMELY, SHAMPOO, CONDITIONER, WRAP LOTION AND GREASE (U.S. CLS. 1, 4, 6, 50, 51 AND 52).

FIRST USE 3-17-2010; IN COMMERCE 3-23-2010.  
NICHOLAS COLEMAN, EXAMINING ATTORNEY

SN 85-204,340. COLBERT, SHEILA, OAKLAND, CA. FILED 12-22-2010.

# FRESHLY PURE

SN 85-204,019. COTY US LLC, NEW YORK, NY. FILED 12-22-2010.

# PRINCESS BRIDE

THE MARK CONSISTS OF STANDARD CHARACTERS WITHOUT CLAIM TO ANY PARTICULAR FONT, STYLE, SIZE, OR COLOR.

FOR PERFUMERY, COSMETICS, ESSENTIAL OILS, SOAPS, HAIR LOTIONS (U.S. CLS. 1, 4, 6, 50, 51 AND 52).  
CHERYL CLAYTON, EXAMINING ATTORNEY

THE MARK CONSISTS OF STANDARD CHARACTERS WITHOUT CLAIM TO ANY PARTICULAR FONT, STYLE, SIZE, OR COLOR.

FOR BODY POWDER; DEODORANT FOR PERSONAL USE; DEODORANTS FOR BODY CARE (U.S. CLS. 1, 4, 50, 51 AND 52).

DAVID I, EXAMINING ATTORNEY

**CLASS 3—(Continued).**

SN 85-204,461. MARC ATLAN DESIGN, INC., VENICE, CA.  
FILED 12-22-2010.

**PETITE MORT**

THE MARK CONSISTS OF STANDARD CHARACTERS WITHOUT CLAIM TO ANY PARTICULAR FONT, STYLE, SIZE, OR COLOR.

THE ENGLISH TRANSLATION OF "PETITE MORT" IN THE MARK IS SMALL DEATH.

FOR PERFUMES, EAU DE PARFUM, TOILET WATER, EAU-DE-COLOGNE, ESSENTIAL OILS, COSMETIC CREAMS, NON MEDICATED COSMETIC PREPARATIONS FOR USE IN THE BATH OR SHOWER, NAMELY, BATH AND SHOWER MILK, BATH AND SHOWER GEL, BATH OIL, BATH SALTS, SKIN MOISTURIZING CREAMS, ANTI-WRINKLE CREAMS, SKIN CLEANSING GELS, NON MEDICATED EXFOLIATING CREAMS AND GELS FOR THE SKIN, BEAUTY MASKS, COSMETIC PREPARATIONS FOR SKIN RENEWAL, COSMETIC SUN TANNING PREPARATIONS, NAMELY, MILKS, GELS, LOTIONS AND OILS, HAIR LOTIONS, HAIR SPRAYS, COSMETIC PREPARATIONS, NAMELY, MASCARA, LIPSTICK, MAKE-UP, FACIAL FOUNDATION, EYE-LINER, MAKE-UP POWDER, NAIL VARNISH FOR COSMETIC PURPOSES, COSMETIC PREPARATIONS FOR SLIMMING PURPOSES, NAMELY, SCULPTING GELS, CREAMS AND LOTIONS FOR CELLULITE REDUCTION, MAKE-UP REMOVING PREPARATIONS, NAMELY, MILKS, GELS, LOTIONS AND CREAMS, DEODORANTS FOR PERSONAL USE, ANTI-PERSPIRANTS, SOAPS, OILS FOR COSMETIC PURPOSES, COSMETIC MILK, BODY CREAM, MOISTURIZING LOTION FOR THE BODY, TALCUM POWDER FOR TOILETRY USE, AFTER-SHAVE LOTION, AFTER-SHAVE BALM, ALUM STONE FOR PERSONAL USE, SHAVING FOAM, SHAVING PREPARATIONS, POTPOURRI, TISSUES IMPREGNATED WITH COSMETIC LOTIONS, COSMETIC PREPARATIONS FOR MOUTH CARE, DENTIFRICES (U.S. CLS. 1, 4, 6, 50, 51 AND 52).  
FIRST USE 11-5-2007; IN COMMERCE 12-15-2010.

THEODORE MCBRIDE, EXAMINING ATTORNEY

SN 85-204,787. BISSELL, PAMELA, EWING, NJ. FILED 12-23-2010.

**CALLURID**

THE MARK CONSISTS OF STANDARD CHARACTERS WITHOUT CLAIM TO ANY PARTICULAR FONT, STYLE, SIZE, OR COLOR.

FOR NON-MEDICATED FOOT CREAM (U.S. CLS. 1, 4, 6, 50, 51 AND 52).

FLORENTINA BLANDU, EXAMINING ATTORNEY

**CLASS 3—(Continued).**

SN 85-204,987. TANYA ZUCKERBROT, BAY HARBOR, FL.  
FILED 12-23-2010.



OWNER OF U.S. REG. NO. 3,841,360.  
THE MARK CONSISTS OF A STYLIZED LETTER "F".  
FOR COSMETICS (U.S. CLS. 1, 4, 6, 50, 51 AND 52).  
ALYSSA STEEL, EXAMINING ATTORNEY

SN 85-205,149. GOSMILE, INC., BERKELEY, CA. FILED 12-23-2010.

**SMILE ON THE GO**

THE MARK CONSISTS OF STANDARD CHARACTERS WITHOUT CLAIM TO ANY PARTICULAR FONT, STYLE, SIZE, OR COLOR.

OWNER OF U.S. REG. NOS. 2,914,821, 3,016,610 AND 3,325,107.

FOR KITS COMPRISED PRIMARILY OF TEETH WHITENING PREPARATIONS; TEETH WHITENING PREPARATIONS (U.S. CLS. 1, 4, 6, 50, 51 AND 52).

LINDA ORNDORFF, EXAMINING ATTORNEY

**CLASS 3—(Continued).**

SN 85-205,494. PURESTPETS, LLC, GAINESVILLE, FL. FILED 12-24-2010.



THE MARK CONSISTS OF A SILHOUETTE OF A DOG LEAPING TO CATCH A BALL.

FOR PET GROOMING PRODUCTS, NAMELY, PET SHAMPOOS, PET CONDITIONERS, PET TINCTURES, PET SPRAYS, PET CREAMS, PET TONICS, PET OINTMENTS, PET APOTHECARY, PET DEODORIZERS, PET POMADES, PET DETANGLER, PET COLOGNE, PET EAR CLEANER, PET HEALTH REMEDIES (U.S. CLS. 1, 4, 6, 50, 51 AND 52).

FIRST USE 6-2-2010; IN COMMERCE 7-3-2010.  
HEATHER SAPP, EXAMINING ATTORNEY

SN 85-205,678. MYBODY, L.L.C., PHOENIX, AZ. FILED 12-26-2010.

**BRIGHTAMIN-C**

THE MARK CONSISTS OF STANDARD CHARACTERS WITHOUT CLAIM TO ANY PARTICULAR FONT, STYLE, SIZE, OR COLOR.

FOR NON-MEDICATED ANTI-AGING SERUM (U.S. CLS. 1, 4, 6, 50, 51 AND 52).

FIRST USE 1-28-2011; IN COMMERCE 1-28-2011.  
DANNEAN HETZEL, EXAMINING ATTORNEY

SN 85-205,681. MYBODY, L.L.C., PHOENIX, AZ. FILED 12-26-2010.

**MITT WITS**

THE MARK CONSISTS OF STANDARD CHARACTERS WITHOUT CLAIM TO ANY PARTICULAR FONT, STYLE, SIZE, OR COLOR.

FOR CLOTHS OR TISSUES IMPREGNATED WITH A SKIN CLEANSER (U.S. CLS. 1, 4, 6, 50, 51 AND 52).

DANNEAN HETZEL, EXAMINING ATTORNEY

**CLASS 3—(Continued).**

SN 85-205,691. MYBODY, L.L.C., PHOENIX, AZ. FILED 12-26-2010.

**CALM AFTER THE STORM**

THE MARK CONSISTS OF STANDARD CHARACTERS WITHOUT CLAIM TO ANY PARTICULAR FONT, STYLE, SIZE, OR COLOR.

FOR NON-MEDICATED SKIN CARE CREAMS AND LOTIONS (U.S. CLS. 1, 4, 6, 50, 51 AND 52).

FIRST USE 1-28-2011; IN COMMERCE 1-28-2011.  
SHAUNIA CARLYLE, EXAMINING ATTORNEY

SN 85-205,736. BEFORE AND AFTER CANDY, LLC, SANTA BARBARA, CA. FILED 12-26-2010.

**BAAM**

THE MARK CONSISTS OF STANDARD CHARACTERS WITHOUT CLAIM TO ANY PARTICULAR FONT, STYLE, SIZE, OR COLOR.

OWNER OF U.S. REG. NO. 3,763,675.

FOR BREATH FRESHENER; BREATH MINTS FOR USE AS A BREATH FRESHENER; LIP BALM; LIP GLOSS; SKIN MOISTURIZER (U.S. CLS. 1, 4, 6, 50, 51 AND 52).

FIRST USE 9-15-2009; IN COMMERCE 9-15-2009.  
CHERYL CLAYTON, EXAMINING ATTORNEY

SN 85-206,322. DESIGNER SKIN, LLC, INDIANAPOLIS, IN. FILED 12-28-2010.

**MODERN BOMBSHELL**

THE MARK CONSISTS OF STANDARD CHARACTERS WITHOUT CLAIM TO ANY PARTICULAR FONT, STYLE, SIZE, OR COLOR.

FOR INDOOR AND OUTDOOR NON-MEDICATED SKIN TANNING PREPARATION (U.S. CLS. 1, 4, 6, 50, 51 AND 52).

BENJAMIN OKEKE, EXAMINING ATTORNEY

**CLASS 3—(Continued).**

SN 85-206,424. MYBODY, L.L.C., PHOENIX, AZ. FILED 12-28-2010.

**YOUTH OVERNIGHT**

THE MARK CONSISTS OF STANDARD CHARACTERS WITHOUT CLAIM TO ANY PARTICULAR FONT, STYLE, SIZE, OR COLOR.

FOR NON-MEDICATED SKIN CARE CREAMS AND LOTIONS (U.S. CLS. 1, 4, 6, 50, 51 AND 52).  
FIRST USE 1-28-2011; IN COMMERCE 1-28-2011.  
SHAUNIA CARLYLE, EXAMINING ATTORNEY

SN 85-206,445. MYBODY, L.L.C., PHOENIX, AZ. FILED 12-28-2010.

**POSTPONE IT**

THE MARK CONSISTS OF STANDARD CHARACTERS WITHOUT CLAIM TO ANY PARTICULAR FONT, STYLE, SIZE, OR COLOR.

FOR FACIAL CLEANSERS; NON-MEDICATED ANTI-AGING SERUM; SKIN MOISTURIZER; SUN SCREEN (U.S. CLS. 1, 4, 6, 50, 51 AND 52).  
SHAUNIA CARLYLE, EXAMINING ATTORNEY

SN 85-206,462. MYBODY, L.L.C., PHOENIX, AZ. FILED 12-28-2010.

**MYSUNPROTECTOR**

THE MARK CONSISTS OF STANDARD CHARACTERS WITHOUT CLAIM TO ANY PARTICULAR FONT, STYLE, SIZE, OR COLOR.

FOR SUN BLOCK; SUN SCREEN (U.S. CLS. 1, 4, 6, 50, 51 AND 52).  
FIRST USE 1-28-2011; IN COMMERCE 1-28-2011.  
MAYUR VAGHANI, EXAMINING ATTORNEY

**CLASS 3—(Continued).**

SN 85-206,468. MYBODY, L.L.C., PHOENIX, AZ. FILED 12-28-2010.

**MYHYDRATOR**

THE MARK CONSISTS OF STANDARD CHARACTERS WITHOUT CLAIM TO ANY PARTICULAR FONT, STYLE, SIZE, OR COLOR.

FOR ANTI-AGING MOISTURIZER; MOISTURIZING CREAMS; MOISTURIZING PREPARATIONS FOR THE SKIN; MOISTURIZING SOLUTIONS FOR THE SKIN; SKIN MOISTURIZER (U.S. CLS. 1, 4, 6, 50, 51 AND 52).  
FIRST USE 1-28-2011; IN COMMERCE 1-28-2011.  
MAYUR VAGHANI, EXAMINING ATTORNEY

SN 85-206,484. MYBODY, L.L.C., PHOENIX, AZ. FILED 12-28-2010.

**MYCLEANSER**

THE MARK CONSISTS OF STANDARD CHARACTERS WITHOUT CLAIM TO ANY PARTICULAR FONT, STYLE, SIZE, OR COLOR.

FOR FACIAL CLEANSERS (U.S. CLS. 1, 4, 6, 50, 51 AND 52).  
FIRST USE 1-28-2011; IN COMMERCE 1-28-2011.  
MAYUR VAGHANI, EXAMINING ATTORNEY

SN 85-206,499. BLUEBEARDS INC, DBA BLUEBEARDS ORIGINAL, EXTON, PA. FILED 12-28-2010.



OWNER OF U.S. REG. NO. 3,229,315.

THE MARK CONSISTS OF A SKULL AND CROSSBONES WITH THE WORDS "THE BLUEBEARDS REVENGE".

FOR AFTER-SHAVE LOTIONS; PRE-SHAVE CREAMS; SHAVE CREAMS; SHAVING BALM; SHAVING GELS; SHAVING LOTIONS; SHAVING PREPARATIONS; SHAVING SOAPS (U.S. CLS. 1, 4, 6, 50, 51 AND 52).  
FIRST USE 8-1-2010; IN COMMERCE 11-1-2010.

ALLISON SCHRODY, EXAMINING ATTORNEY

**CLASS 3—(Continued).**

SN 85-206,706. DAVIS, ELIZABETH, LODI, CA. FILED 12-28-2010.

# EpiMD

THE MARK CONSISTS OF STANDARD CHARACTERS WITHOUT CLAIM TO ANY PARTICULAR FONT, STYLE, SIZE, OR COLOR.

FOR COSMETIC SUNSCREEN PREPARATIONS; EXFOLIANTS FOR SKIN; SKIN CLEANSERS; SKIN MOISTURIZER (U.S. CLS. 1, 4, 6, 50, 51 AND 52).

BARNEY CHARLON, EXAMINING ATTORNEY

---

SN 85-206,868. JC 23 ENTERTAINMENT, INC., BEVERLY HILLS, CA. FILED 12-28-2010.



THE MARK CONSISTS OF STYLIZED CHARACTER SITTING IN YOGA STYLE.

FOR LAUNDRY DETERGENT, LAUNDRY FABRIC CONDITIONER, LAUNDRY PRE-SOAK, LAUNDRY SOAP, SOAPS AND DETERGENTS, SOAPS FOR BODY CARE, SOAPS FOR HOUSEHOLD USE, SOAPS FOR PERSONAL USE, PERFUMERY, ESSENTIAL OILS, COSMETICS, HAIR LOTIONS, DENTIFRICES (U.S. CLS. 1, 4, 6, 50, 51 AND 52).

CYNTHIA SLOAN, EXAMINING ATTORNEY

---

SN 85-206,879. ENZATURAL, LLC, LAS VEGAS, NV. FILED 12-28-2010.

# Enzatural

THE MARK CONSISTS OF STANDARD CHARACTERS WITHOUT CLAIM TO ANY PARTICULAR FONT, STYLE, SIZE, OR COLOR.

FOR COSMETICS; CREAMS FOR CELLULITE REDUCTION; HAIR GEL; HAIR SPRAY; PERFUMES (U.S. CLS. 1, 4, 6, 50, 51 AND 52).

ROBIN CHOSID, EXAMINING ATTORNEY

**CLASS 3—(Continued).**

SN 85-207,004. CREATIVE CALLING SOLUTIONS (B.V.I.) LIMITED, ROAD TOWN, TORTOLA, BR.VIRGIN ISLANDS, FILED 12-29-2010.

# HAPPINESS IS

THE MARK CONSISTS OF STANDARD CHARACTERS WITHOUT CLAIM TO ANY PARTICULAR FONT, STYLE, SIZE, OR COLOR.

FOR BODY AND BATH PRODUCTS, NAMELY, SKIN LOTION, BODY BUTTER, BODY SCRUBS, SHOWER AND BATH GEL, BATH BEADS, BARS OF SOAP FOR PERSONAL USE, NON-MEDICATED MINERAL BATH CRYSTALS, POWDERS AND SALTS, FOAM BATH, BODY WASH, NON-MEDICATED BODY MIST, FRAGRANCES FOR PERSONAL USE; COSMETICS; HAIR PRODUCTS, NAMELY, HAIR SHAMPOO, HAIR CONDITIONER AND HAIR STYLING PREPARATIONS; SKIN CARE PRODUCTS, NAMELY, NON-MEDICATED SKIN CARE PREPARATIONS; COSMETIC OILS; ESSENTIAL OILS; BABY OILS, BODY OILS, BATH OILS FOR COSMETIC PURPOSES; FRAGRANCE OILS FOR PERSONAL USE AND ACCESSORIES FOR ALL OF THE ABOVE, NAMELY, COSMETIC BALLS (U.S. CLS. 1, 4, 6, 50, 51 AND 52).

JEFFERY COWARD, EXAMINING ATTORNEY

---

SN 85-207,006. TRACIE MARTYN, INC., NEW YORK, NY. FILED 12-29-2010.

# RESCULPTING BODY CREAM

THE MARK CONSISTS OF STANDARD CHARACTERS WITHOUT CLAIM TO ANY PARTICULAR FONT, STYLE, SIZE, OR COLOR.

OWNER OF U.S. REG. NOS. 2,718,598, 3,538,500 AND OTHERS.

NO CLAIM IS MADE TO THE EXCLUSIVE RIGHT TO USE "BODY CREAM", APART FROM THE MARK AS SHOWN.

FOR NON-MEDICATED SKIN CARE PREPARATIONS (U.S. CLS. 1, 4, 6, 50, 51 AND 52).

FIRST USE 7-2-2007; IN COMMERCE 7-2-2007.

KRISTIN CARLSON, EXAMINING ATTORNEY

**CLASS 3—(Continued).**

SN 85-207,147. MOMOTANI JUNTENKAN LTD., OSAKA 552-0012, JAPAN, FILED 12-29-2010.



THE MARK CONSISTS OF THE WORDING RF28 WITH A TEAR OR DROPLET DESIGN TO THE RIGHT.

FOR SOAPS AND DETERGENTS; COSMETICS AND NON-MEDITATED TOILETRIES; PERFUMES USED AS COSMETICS OR TOILETRIES; HAIR CARE PREPARATIONS; COSMETIC SOAPS; HAND SOAPS; MEDICATED SOAPS; BATH SOAPS, LIQUID SOAPS; CLEANSING CREAMS; COSMETIC CREAMS; TOILET WATER; MAKE-UP POWDER; FACE-POWDER PASTE; SUNSCREEN CREAMS (U.S. CLS. 1, 4, 6, 50, 51 AND 52).

ALICIA COLLINS, EXAMINING ATTORNEY

SN 85-207,165. SHISEIDO COMPANY, LIMITED, TOKYO, JAPAN, FILED 12-29-2010.

## SuperVeil-UV 360

THE MARK CONSISTS OF STANDARD CHARACTERS WITHOUT CLAIM TO ANY PARTICULAR FONT, STYLE, SIZE, OR COLOR.

FOR SOAPS, PERFUMERIES, COSMETICS AND BODY CARE PRODUCTS, NAMELY, SUN PROTECTION CREAM (U.S. CLS. 1, 4, 6, 50, 51 AND 52).

MATTHEW KLINE, EXAMINING ATTORNEY

SN 85-207,288. BAY CONVERTING INC., GREEN BAY, WI, FILED 12-29-2010.

## EARTH DELICATE

THE MARK CONSISTS OF STANDARD CHARACTERS WITHOUT CLAIM TO ANY PARTICULAR FONT, STYLE, SIZE, OR COLOR.

FOR AUTOMATIC DISH WASHING DETERGENT (U.S. CLS. 1, 4, 6, 50, 51 AND 52).

ZHALEH DELANEY, EXAMINING ATTORNEY

**CLASS 3—(Continued).**

SN 85-207,377. MYBODY, L.L.C., PHOENIX, AZ. FILED 12-29-2010.

## MYBODY

THE MARK CONSISTS OF STANDARD CHARACTERS WITHOUT CLAIM TO ANY PARTICULAR FONT, STYLE, SIZE, OR COLOR.

FOR ANTI-WRINKLE CREAMS; CLOTHS OR TISSUES IMPREGNATED WITH A SKIN CLEANSER; FEMININE DEODORANT SPRAYS; FEMININE DEODORANT SUPPOSITORIES; FEMININE HYGIENE CLEANSING TOWELLES; NON-MEDICATED ANTI-AGING SERUM; NON-MEDICATED FEMININE HYGIENE WASH; NON-MEDICATED SKIN CARE PREPARATIONS, NAMELY, CREAMS, LOTIONS, GELS, TONERS, CLEANERS AND PEELS; NON-MEDICATED SKIN CREAMS; SKIN LIGHTENING CREAMS; SKIN MASKS; SKIN MOISTURIZER; SUN SCREEN; WRINKLE REMOVING SKIN CARE PREPARATIONS (U.S. CLS. 1, 4, 6, 50, 51 AND 52).

MAYUR VAGHANI, EXAMINING ATTORNEY

SN 85-208,328. DR FRESH INC, BUENA PARK, CA. FILED 12-30-2010.

## Sensijel

THE MARK CONSISTS OF STANDARD CHARACTERS WITHOUT CLAIM TO ANY PARTICULAR FONT, STYLE, SIZE, OR COLOR.

FOR ANTI-CAVITY MOUTHWASHES; BREATH FRESHENER; BREATH FRESHENER, NAMELY, BETEL NUT POWDER; BREATH FRESHENER, NAMELY, KATHA; BREATH FRESHENER, NAMELY, MUKHWAS; BREATH FRESHENER, NAMELY, PAN MASALA; BREATH FRESHENER, NAMELY, SCENTED SUPARI; BREATH FRESHENING CONFECTIONARY, NAMELY, DISSOLVABLE BREATH STRIPS, BREATH MINTS, CANDY AND GUM; BREATH FRESHENING SPRAYS; BREATH FRESHENING STRIPS; BREATH MINTS FOR USE AS A BREATH FRESHENER; DENTIFRICES AND MOUTHWASHES; HOME DENTAL CARE PRODUCTS FOR DOGS AND CATS, NAMELY, TOOTHPASTE; MOUTHWASH; MOUTHWASHES; NON-MEDICATED BREATH FRESHENING STRIPS; NON-MEDICATED MOUTHWASH AND GARGLE; NON-MEDICATED MOUTHWASHES; TEETH WHITENING KIT; TEETH WHITENING STRIPS IMPREGNATED WITH TEETH WHITENING PREPARATIONS; TOOTH WHITENERS FOR COSMETIC PURPOSES COMPRISED OF NEUTRAL SODIUM FLUORIDE SUSTAINED RELEASE GEL; TOOTH WHITENING CREAMS; TOOTH WHITENING GELS; TOOTH WHITENING PASTES; TOOTH WHITENING PREPARATIONS; TOOTHPASTE; TOOTHPASTE AND MOUTHWASHES; TOOTHPASTES (U.S. CLS. 1, 4, 6, 50, 51 AND 52).

FIRST USE 8-28-2009; IN COMMERCE 8-28-2009.

STEVEN JACKSON, EXAMINING ATTORNEY

**CLASS 3—(Continued).**

SN 85-208,407. BEYOND DENTAL & HEALTH, INC., STAFFORD, TX. FILED 12-30-2010.

**SOLO**

THE MARK CONSISTS OF STANDARD CHARACTERS WITHOUT CLAIM TO ANY PARTICULAR FONT, STYLE, SIZE, OR COLOR.

FOR TEETH WHITENING KITS (U.S. CLS. 1, 4, 6, 50, 51 AND 52).

KARANENDRA S. CHHINA, EXAMINING ATTORNEY

SN 85-208,824. PARFUMS DE COEUR, LTD., DARIEN, CT. FILED 1-2-2011.

**2 HOT**

THE MARK CONSISTS OF STANDARD CHARACTERS WITHOUT CLAIM TO ANY PARTICULAR FONT, STYLE, SIZE, OR COLOR.

FOR WOMEN'S FRAGRANCES, NAMELY EAU DE COLOGNE, SCENTED BODY SPRAYS, PERSONAL DEODORANTS, SHOWER GELS, BODY LOTIONS, BODY POWDERS AND SOAPS (U.S. CLS. 1, 4, 6, 50, 51 AND 52).

FIRST USE 1-1-2010; IN COMMERCE 1-1-2010.  
KRISTINA MORRIS, EXAMINING ATTORNEY

SN 85-208,895. SNYDER, CARRINGTON J, MALIBU, CA. FILED 1-2-2011.

**Saint Raphael**

THE MARK CONSISTS OF STANDARD CHARACTERS WITHOUT CLAIM TO ANY PARTICULAR FONT, STYLE, SIZE, OR COLOR.

FOR BODY AND BEAUTY CARE COSMETICS; CLEANSING CREAMS; COLOGNES, PERFUMES AND COSMETICS; COSMETIC HAND CREAMS; COSMETIC NOURISHING CREAMS; COSMETIC PREPARATIONS, NAMELY, FIRING CREAMS; COSMETIC PREPARATIONS, NAMELY, FIRING LOTIONS; COSMETICS; COSMETICS AND MAKE-UP; COSMETICS IN GENERAL, INCLUDING PERFUMES; NAIL VARNISH FOR COSMETIC PURPOSES (U.S. CLS. 1, 4, 6, 50, 51 AND 52).

JANICE KIM, EXAMINING ATTORNEY

**CLASS 3—(Continued).**

SN 85-209,055. PARFUMS DE COEUR, LTD., DARIEN, CT. FILED 1-3-2011.

**FIREWORKS**

THE MARK CONSISTS OF STANDARD CHARACTERS WITHOUT CLAIM TO ANY PARTICULAR FONT, STYLE, SIZE, OR COLOR.

FOR WOMEN'S AND MEN'S FRAGRANCES, NAMELY, PERFUME, COLOGNE, EAU DE TOILETTE, AFTERSHAVE, SCENTED BODY SPRAYS AND PERSONAL DEODORANTS; SHOWER GELS; BODY LOTIONS; BODY POWDERS; SOAPS (U.S. CLS. 1, 4, 6, 50, 51 AND 52).

KRISTINA MORRIS, EXAMINING ATTORNEY

SN 85-209,063. PARFUMS DE COEUR, LTD., DARIEN, CT. FILED 1-3-2011.

**SLOW DANCE**

THE MARK CONSISTS OF STANDARD CHARACTERS WITHOUT CLAIM TO ANY PARTICULAR FONT, STYLE, SIZE, OR COLOR.

FOR BODY POWDER; BODY SPRAY USED AS A PERSONAL DEODORANT AND AS A FRAGRANCE; PERFUMES, EAU DE COLOGNES AND AFTERSHAVES; SHOWER GELS; SOAPS FOR BODY CARE; TOILET WATERS (U.S. CLS. 1, 4, 6, 50, 51 AND 52).

KRISTINA MORRIS, EXAMINING ATTORNEY

SN 85-209,323. ACTIVEION CLEANING SOLUTIONS LLC, MINNEAPOLIS, MN. FILED 1-3-2011.

**ACTIVEION EXP**

THE MARK CONSISTS OF STANDARD CHARACTERS WITHOUT CLAIM TO ANY PARTICULAR FONT, STYLE, SIZE, OR COLOR.

OWNER OF U.S. REG. NOS. 3,842,362 AND 3,863,086.  
FOR CLEANSERS FOR PERSONAL HYGIENIC USE; CLEANERS FOR MEDICAL USE ON SUPPLIES, EQUIPMENT, AND MEDICAL FACILITY SURFACES (U.S. CLS. 1, 4, 6, 50, 51 AND 52).

DAVID TAYLOR, EXAMINING ATTORNEY



**CLASS 3—(Continued).**

SN 85-209,346. COMBE INCORPORATED, WHITE PLAINS, NY. FILED 1-3-2011.

## JUST FOR MEN

THE MARK CONSISTS OF STANDARD CHARACTERS WITHOUT CLAIM TO ANY PARTICULAR FONT, STYLE, SIZE, OR COLOR.

OWNER OF U.S. REG. NOS. 1,508,758, 3,870,671 AND OTHERS.

SEC. 2(F).  
FOR SHAMPOOS THAT BOTH CLEANSE AND COLOR HAIR (U.S. CLS. 1, 4, 6, 50, 51 AND 52).

TRACY CROSS, EXAMINING ATTORNEY

SN 85-209,724. MYBODY, L.L.C., PHOENIX, AZ. FILED 1-4-2011.



THE COLOR(S) WHITE, PINK AND GRAY IS/ARE CLAIMED AS A FEATURE OF THE MARK.

THE MARK CONSISTS OF A WHITE DESIGN HEART WITHIN A PINK DESIGN HEART WITH THE WORD "MYBODY" IN GRAY.

FOR ANTI-WRINKLE CREAMS; NONMEDICATED ANTI-AGING SERUM; NONMEDICATED SKIN CARE REPARATIONS, NAMELY, CREAMS, LOTIONS, GELS, TONERS, CLEANERS AND PEELS; NON-MEDICATED SKIN CREAMS; SKIN LIGHTENING CREAMS; SKIN MOISTURIZER; SUN SCREEN; WRINKLE REMOVING SKIN CARE PREPARATIONS (U.S. CLS. 1, 4, 6, 50, 51 AND 52).

FIRST USE 1-28-2011; IN COMMERCE 1-28-2011.  
MAYUR VAGHANI, EXAMINING ATTORNEY

SN 85-209,740. MYBODY, L.L.C., PHOENIX, AZ. FILED 1-4-2011.



THE COLOR(S) WHITE, GREEN AND GRAY IS/ARE CLAIMED AS A FEATURE OF THE MARK.

THE MARK CONSISTS OF A WHITE DESIGN HEART WITHIN A GREEN DESIGN HEART WITH THE WORD "MYBODY" IN GRAY.

FOR ANTI-WRINKLE CREAMS; NONMEDICATED ANTI-AGING SERUM; NONMEDICATED SKIN CARE REPARATIONS, NAMELY, CREAMS, LOTIONS, GELS, TONERS, CLEANERS AND PEELS; NON-MEDICATED SKIN CREAMS; SKIN LIGHTENING CREAMS; SKIN MOISTURIZER; SUN SCREEN; WRINKLE REMOVING SKIN CARE PREPARATIONS (U.S. CLS. 1, 4, 6, 50, 51 AND 52).

FIRST USE 1-28-2011; IN COMMERCE 1-28-2011.  
MAYUR VAGHANI, EXAMINING ATTORNEY

**CLASS 3—(Continued).**

SN 85-209,743. MYBODY, L.L.C., PHOENIX, AZ. FILED 1-4-2011.



THE COLOR(S) WHITE, BLUE AND GRAY IS/ARE CLAIMED AS A FEATURE OF THE MARK.

THE MARK CONSISTS OF A WHITE DESIGN HEART WITHIN A BLUE DESIGN HEART WITH THE WORD "MYBODY" IN GRAY.

FOR ANTI-WRINKLE CREAMS; NONMEDICATED ANTI-AGING SERUM; NONMEDICATED SKIN CARE REPARATIONS, NAMELY, CREAMS, LOTIONS, GELS, TONERS, CLEANERS AND PEELS; NON-MEDICATED SKIN CREAMS; SKIN LIGHTENING CREAMS; SKIN MOISTURIZER; SUN SCREEN; WRINKLE REMOVING SKIN CARE PREPARATIONS (U.S. CLS. 1, 4, 6, 50, 51 AND 52).

FIRST USE 1-28-2011; IN COMMERCE 1-28-2011.  
MAYUR VAGHANI, EXAMINING ATTORNEY

SN 85-210,163. SALON PROFESSIONAL SERVICES, INC., BELMAR, NJ. FILED 1-4-2011.

## THIS IS IT!

THE MARK CONSISTS OF STANDARD CHARACTERS WITHOUT CLAIM TO ANY PARTICULAR FONT, STYLE, SIZE, OR COLOR.

FOR AFTER-SHAVE LOTIONS; AFTER-SUN LOTIONS; BAR SOAP; BATH OIL; BATH SOAPS; BODY LOTION; COSMETICS; DEODORANT FOR PERSONAL USE; EYEBROW PENCILS; EYELINER; FACIAL LOTION; HAIR CARE PREPARATIONS; HAIR CONDITIONER; HAIR GEL; HAIR MOUSSE; HAIR SHAMPOO; HAIRSPRAY; HAND LOTIONS; LIP BALM; LIP GLOSS; LIPSTICK; MASCARA; MASSAGE OIL; NAIL POLISH; NON-MEDICATED BODY SOAKS; NON-MEDICATED FOOT CREAM; NON-MEDICATED LIP CARE PREPARATIONS; NON-MEDICATED SKIN CARE PREPARATIONS; PERFUME; SHAVING LOTION; SKIN CLEANSERS; SOAPS AND DETERGENTS (U.S. CLS. 1, 4, 6, 50, 51 AND 52).

MATTHEW MCDOWELL, EXAMINING ATTORNEY

**CLASS 3—(Continued).**

SN 85-210,283. COMFORT CREAMS, INC., KAMUELA, HI. FILED 1-4-2011.

**LOTION + AID**

THE MARK CONSISTS OF STANDARD CHARACTERS WITHOUT CLAIM TO ANY PARTICULAR FONT, STYLE, SIZE, OR COLOR.

NO CLAIM IS MADE TO THE EXCLUSIVE RIGHT TO USE "LOTION", APART FROM THE MARK AS SHOWN.

FOR MASSAGE CREAMS (U.S. CLS. 1, 4, 6, 50, 51 AND 52).

FIRST USE 1-13-2003; IN COMMERCE 1-13-2003.  
BARBARA BROWN, EXAMINING ATTORNEY

SN 85-210,364. ELKARIM, NAZAR, MASON, OH. FILED 1-4-2011.

**DERMATIVA**

THE MARK CONSISTS OF STANDARD CHARACTERS WITHOUT CLAIM TO ANY PARTICULAR FONT, STYLE, SIZE, OR COLOR.

FOR BEAUTY GELS; FOAM CLEANSERS FOR PERSONAL USE; MOISTURIZING SOLUTIONS FOR THE SKIN; NON-MEDICATED SKIN CREAMS; SKIN LOTION (U.S. CLS. 1, 4, 6, 50, 51 AND 52).

JOHN KELLY, EXAMINING ATTORNEY

SN 85-210,489. STEPHEN GREGORY MASTEY, SANTA CLARITA, CA. FILED 1-4-2011.

**Fruitaria**

THE MARK CONSISTS OF STANDARD CHARACTERS WITHOUT CLAIM TO ANY PARTICULAR FONT, STYLE, SIZE, OR COLOR.

FOR HAIR CARE PREPARATIONS (U.S. CLS. 1, 4, 6, 50, 51 AND 52).

MARGARET POWER, EXAMINING ATTORNEY

**CLASS 3—(Continued).**

SN 85-210,592. MANA PRODUCTS, INC., LONG ISLAND CITY, NY. FILED 1-5-2011.

**MANE BOOST**

THE MARK CONSISTS OF STANDARD CHARACTERS WITHOUT CLAIM TO ANY PARTICULAR FONT, STYLE, SIZE, OR COLOR.

FOR HAIR CARE PREPARATIONS (U.S. CLS. 1, 4, 6, 50, 51 AND 52).

JULIE VEPPUMTHARA, EXAMINING ATTORNEY

SN 85-210,595. COTY B.V., 2031 CC HAARLEM, NETHERLANDS, FILED 1-5-2011.

**MISS BEHAVE**

THE MARK CONSISTS OF STANDARD CHARACTERS WITHOUT CLAIM TO ANY PARTICULAR FONT, STYLE, SIZE, OR COLOR.

FOR PERFUMERY (U.S. CLS. 1, 4, 6, 50, 51 AND 52).

LINDA MICKLEBURGH, EXAMINING ATTORNEY

SN 85-210,784. MYBODY, L.L.C., PHOENIX, AZ. FILED 1-5-2011.



THE COLOR(S) WHITE, RED AND GRAY IS/ARE CLAIMED AS A FEATURE OF THE MARK.

THE MARK CONSISTS OF A WHITE DESIGN HEART WITHIN A RED DESIGN HEART WITH THE WORD "MYBODY" IN GRAY.

FOR ANTI-WRINKLE CREAMS; CLOTHS OR TISSUES IMPREGNATED WITH A SKIN CLEANSER; FEMININE DEODORANT SPRAYS; FEMININE DEODORANT SUPPOSITORIES; FEMININE HYGIENE CLEANSING TOWELETTES; NON-MEDICATED ANTI-AGING SERUM; NON-MEDICATED FEMININE HYGIENE WASH; NON-MEDICATED SKIN CREAMS; SKIN LIGHTENING CREAMS; SKIN MASKS; SKIN MOISTURIZER; SUN SCREEN; WRINKLE REMOVING SKIN CARE PREPARATIONS (U.S. CLS. 1, 4, 6, 50, 51 AND 52).

MAYUR VAGHANI, EXAMINING ATTORNEY

**CLASS 3—(Continued).**

SN 85-210,925. UNILEVER SUPPLY CHAIN, INC., CLINTON, CT. FILED 1-5-2011.

### EXPERIENCE THE THRILL OF ADVENTURE

THE MARK CONSISTS OF STANDARD CHARACTERS WITHOUT CLAIM TO ANY PARTICULAR FONT, STYLE, SIZE, OR COLOR.

FOR DEODORANTS, ANTIPERSPIRANTS AND BODY SPRAYS (U.S. CLS. 1, 4, 6, 50, 51 AND 52).  
ANNE MADDEN, EXAMINING ATTORNEY

---

SN 85-211,809. BE GREEN BATH AND BODY, NORTH EASTON, MA. FILED 1-6-2011.

### Be Green Bath and Body

THE MARK CONSISTS OF STANDARD CHARACTERS WITHOUT CLAIM TO ANY PARTICULAR FONT, STYLE, SIZE, OR COLOR.

NO CLAIM IS MADE TO THE EXCLUSIVE RIGHT TO USE "BATH AND BODY", APART FROM THE MARK AS SHOWN.

FOR BABY POWDER; BATH HERBS; BODY LOTIONS; BODY OILS; BODY POWDER; BODY SCRUB; FACE AND BODY CREAMS; FACIAL CLEANSERS; FACIAL CLEANSING GRAINS; LIP BALM; LIQUID SOAPS FOR HANDS, FACE AND BODY; LOTIONS FOR FACE AND BODY CARE; MAKE-UP REMOVER; NON-MEDICATED DIAPER RASH OINTMENTS AND LOTIONS; SKIN TONERS (U.S. CLS. 1, 4, 6, 50, 51 AND 52).

FIRST USE 4-15-2009; IN COMMERCE 4-21-2009.  
THOMAS MANOR, EXAMINING ATTORNEY

---

SN 85-211,870. THREE POND INVESTMENTS, LLC, STOKESDALE, NC. FILED 1-6-2011.

### Blue Armor

THE MARK CONSISTS OF STANDARD CHARACTERS WITHOUT CLAIM TO ANY PARTICULAR FONT, STYLE, SIZE, OR COLOR.

FOR AUTOMOBILE AND CAR WAX PREPARATIONS; DETERGENTS FOR AUTOMOBILES (U.S. CLS. 1, 4, 6, 50, 51 AND 52).

DAVID TAYLOR, EXAMINING ATTORNEY

**CLASS 3—(Continued).**

SN 85-211,894. THE JOCK SOAP COMPANY, INC., NEWARK, DE. FILED 1-6-2011.

### TALL DRINK

THE MARK CONSISTS OF STANDARD CHARACTERS WITHOUT CLAIM TO ANY PARTICULAR FONT, STYLE, SIZE, OR COLOR.

FOR BODY AND BEAUTY CARE PRODUCTS, NAMELY, COSMETICS, PERFUME, COLOGNE, EAU DE TOILETTE, EAU DE PERFUME, EAU DE COLOGNE AND TOILET WATER, FACIAL, HAND, SKIN AND BODY CREAMS, LOTIONS, CONDITIONERS, MOISTURIZERS AND CLEANSERS, MASSAGE OILS, ESSENTIAL OILS FOR PERSONAL USE, TALCUM POWDER, BATH BEADS, BATH CRYSTALS, BATH FOAM, BATH GELS, BATH OILS, BATH POWDERS, BATH SALTS, BODY SCRUBS, BODY FRAGRANCES, BODY GELS, BODY SPRAYS, SHOWER GELS, BODY OILS, BODY POWDERS, SUNLESS TANNING MISTS AND LOTIONS; COSMETICS SOLD AS A UNIT WITH PERFUME, COLOGNE, EAU DE TOILETTE, EAU DE PERFUME, EAU DE COLOGNE AND/OR TOILET WATER (U.S. CLS. 1, 4, 6, 50, 51 AND 52).

FIRST USE 9-1-2008; IN COMMERCE 9-1-2008.  
EDWARD FENNESSY, EXAMINING ATTORNEY

---

SN 85-211,983. THE JOCK SOAP COMPANY, INC., NEWARK, DE. FILED 1-6-2011.

### Revivify-C

THE MARK CONSISTS OF STANDARD CHARACTERS WITHOUT CLAIM TO ANY PARTICULAR FONT, STYLE, SIZE, OR COLOR.

FOR BODY AND BEAUTY CARE COSMETICS, PERFUME, COLOGNE, EAU DE TOILETTE, EAU DE PERFUME, EAU DE COLOGNE AND TOILET WATER; COSMETICS SOLD AS A UNIT WITH PERFUME, COLOGNE, EAU DE TOILETTE, EAU DE PERFUME, EAU DE COLOGNE AND/OR TOILET WATER; FACIAL, HAND, SKIN AND BODY CREAMS, LOTIONS, CONDITIONERS, MOISTURIZERS AND CLEANSERS; MASSAGE OILS, ESSENTIAL OILS FOR PERSONAL USE; TALCUM POWDER, BATH BEADS, BATH CRYSTALS, BATH FOAM, BATH GELS, BATH OILS, BATH POWDERS, BATH SALTS, BODY SCRUBS, BODY FRAGRANCES, BODY GELS, BODY SPRAYS, SHOWER GELS, BODY OILS, BODY POWDERS, SUNLESS TANNING MISTS AND LOTIONS (U.S. CLS. 1, 4, 6, 50, 51 AND 52).

FIRST USE 1-1-2009; IN COMMERCE 1-1-2009.  
EDWARD FENNESSY, EXAMINING ATTORNEY

**CLASS 3—(Continued).**

SN 85-212,350. BIOPRO GROUP INC., LA GRANGE, IL.  
FILED 1-6-2011.

# CurePomade

THE MARK CONSISTS OF STANDARD CHARACTERS WITHOUT CLAIM TO ANY PARTICULAR FONT, STYLE, SIZE, OR COLOR.

FOR FACIAL CREAMS (U.S. CLS. 1, 4, 6, 50, 51 AND 52).

SHAUNIA CARLYLE, EXAMINING ATTORNEY

SN 85-212,651. VALUE MARKETING, INC., CEDARHURST, NY. FILED 1-7-2011.

# LÉBRILLÉNCĪ

SKIN BRIGHTENING TREATMENT

NO CLAIM IS MADE TO THE EXCLUSIVE RIGHT TO USE "SKIN BRIGHTENING TREATMENT", APART FROM THE MARK AS SHOWN.

THE MARK CONSISTS OF A MADE UP WORD CONSISTING OF THE LETTERS "LEBRILLENC", WITH EACH "E" HAVING AN ACCENT MARK ABOVE, AND THE LETTER "C" WITH A LINE ABOVE, WITH A LINE BENEATH THE ENTIRE WORD, AND THE WORDS "SKIN BRIGHTENING TREATMENT" POSITIONED FLUSH RIGHT.

FOR AGE SPOT REDUCING CREAMS; SKIN LIGHTENERS; SKIN LIGHTENING CREAMS; SKIN WHITENING CREAMS; SKIN WHITENING PREPARATIONS; VANISHING CREAM (U.S. CLS. 1, 4, 6, 50, 51 AND 52).

HELENE LIWINSKI, EXAMINING ATTORNEY

SN 85-212,796. TRISTAR PRODUCTS, INC., FAIRFIELD, NJ. FILED 1-7-2011.

# STARBRITE

THE MARK CONSISTS OF STANDARD CHARACTERS WITHOUT CLAIM TO ANY PARTICULAR FONT, STYLE, SIZE, OR COLOR.

FOR TOOTHPASTE (U.S. CLS. 1, 4, 6, 50, 51 AND 52).  
CHRISTINE COOPER, EXAMINING ATTORNEY

**CLASS 3—(Continued).**

SN 85-212,978. NOGUEIRA, RICARDO, MORRIS PLAINS, NJ. FILED 1-7-2011.

# Pochissimo

FOR PET FRAGRANCES; PET SHAMPOO (U.S. CLS. 1, 4, 6, 50, 51 AND 52).

MARIA-VICTORIA SUAREZ, EXAMINING ATTORNEY

SN 85-213,571. CONOVER, GEORGE L., SOMERSET, NJ. FILED 1-9-2011.

# FREZAZ

THE MARK CONSISTS OF STANDARD CHARACTERS WITHOUT CLAIM TO ANY PARTICULAR FONT, STYLE, SIZE, OR COLOR.

FOR DISPOSABLE WIPES IMPREGNATED WITH CLEANSING CHEMICALS OR COMPOUNDS FOR PERSONAL HYGIENE (U.S. CLS. 1, 4, 6, 50, 51 AND 52).

JASON TURNER, EXAMINING ATTORNEY

SN 85-213,760. ABERCROMBIE & FITCH TRADING CO., NEW ALBANY, OH. FILED 1-10-2011.

# A & F NOW

THE MARK CONSISTS OF STANDARD CHARACTERS WITHOUT CLAIM TO ANY PARTICULAR FONT, STYLE, SIZE, OR COLOR.

OWNER OF U.S. REG. NOS. 1,169,714, 3,349,895 AND OTHERS.

FOR AFTER-SHAVE; BATH OILS; BEAUTY CREAMS; BEAUTY LOTIONS; BODY AND BEAUTY CARE COSMETICS; BODY CREAMS; BODY LOTIONS; BODY OILS; BODY SCRUB; BODY SPRAY USED AS A PERSONAL DEODORANT AND AS FRAGRANCE; BODY SPRAYS; BODY WASH; COLOGNE; DEODORANTS AND ANTIPERSPIRANTS FOR PERSONAL USE; FACIAL SCRUBS; FRAGRANCES FOR PERSONAL USE; HAIR CARE PREPARATIONS; HAIR STYLING PREPARATIONS; HAND CREAMS; HAND LOTIONS; LIP BALM; LIP GLOSS; MAKE-UP; NON-MEDICATED BATH PREPARATIONS; PERFUME; SHAVING PREPARATIONS; SOAPS FOR PERSONAL USE (U.S. CLS. 1, 4, 6, 50, 51 AND 52).

JOHN DALIER, EXAMINING ATTORNEY

**CLASS 3—(Continued).**

SN 85-214,285. NICOLAS JURNJACK, NEW YORK, NY. FILED 1-10-2011.

## NICOLAS JURNJACK

THE MARK CONSISTS OF STANDARD CHARACTERS WITHOUT CLAIM TO ANY PARTICULAR FONT, STYLE, SIZE, OR COLOR.

THE NAME "NICOLAS JURNJACK" IDENTIFIES A LIVING INDIVIDUAL WHOSE CONSENT IS OF RECORD. FOR HAIR CONDITIONERS (U.S. CLS. 1, 4, 6, 50, 51 AND 52).

CHARLOTTE CORWIN, EXAMINING ATTORNEY

**CLASS 3—(Continued).**

SN 85-217,357. FARIAS VILLARREAL, MARTIN JESUS GERARDO, HOUSTON, TX. FILED 1-13-2011.

## Mr. Look Cerveza

THE MARK CONSISTS OF STANDARD CHARACTERS WITHOUT CLAIM TO ANY PARTICULAR FONT, STYLE, SIZE, OR COLOR.

NO CLAIM IS MADE TO THE EXCLUSIVE RIGHT TO USE "CERVEZA", APART FROM THE MARK AS SHOWN.

THE ENGLISH TRANSLATION OF THE WORD "CERVEZA" IN THE MARK IS "BEER".

FOR HAIR SHAMPOO; HAIR SHAMPOOS AND CONDITIONERS; SHAMPOO-CONDITIONERS; SHAMPOOS; ALL OF THE FOREGOING CONTAINING THE MAIN INGREDIENT OF BEER AS A COMPONENT (U.S. CLS. 1, 4, 6, 50, 51 AND 52).

SUNG IN, EXAMINING ATTORNEY

SN 85-214,460. KAMMULA, INC., GLENDALE, CA. FILED 1-10-2011.

## PRANAYUMS

THE MARK CONSISTS OF STANDARD CHARACTERS WITHOUT CLAIM TO ANY PARTICULAR FONT, STYLE, SIZE, OR COLOR.

FOR BREATH FRESHENER, NAMELY, MUKHWAS (U.S. CLS. 1, 4, 6, 50, 51 AND 52).

WILLIAM BRECKENFELD, EXAMINING ATTORNEY

SN 85-217,375. FARIAS VILLARREAL, MARTIN JESUS GERARDO, HOUSTON, TX. FILED 1-13-2011.

## Mr. Look Beer

THE MARK CONSISTS OF STANDARD CHARACTERS WITHOUT CLAIM TO ANY PARTICULAR FONT, STYLE, SIZE, OR COLOR.

NO CLAIM IS MADE TO THE EXCLUSIVE RIGHT TO USE "BEER", APART FROM THE MARK AS SHOWN.

FOR HAIR GEL; HAIR GEL AND HAIR MOUSSE; HAIR SHAMPOO; HAIR SHAMPOOS AND CONDITIONERS; SHAMPOO-CONDITIONERS; SHAMPOOS; ALL OF THE FOREGOING CONTAINING THE MAIN INGREDIENT OF BEER AS A COMPONENT (U.S. CLS. 1, 4, 6, 50, 51 AND 52).

SUNG IN, EXAMINING ATTORNEY

SN 85-216,382. GOSMILE, INC., BERKELEY, CA. FILED 1-12-2011.

## JET SET

THE MARK CONSISTS OF STANDARD CHARACTERS WITHOUT CLAIM TO ANY PARTICULAR FONT, STYLE, SIZE, OR COLOR.

FOR TOOTH MAINTENANCE KITS COMPRISED PRIMARILY OF TOOTHPASTES AND TOOTHBRUSHES (U.S. CLS. 1, 4, 6, 50, 51 AND 52).

FIRST USE 9-0-2009; IN COMMERCE 9-0-2009. LINDA ORNDORFF, EXAMINING ATTORNEY

SN 85-217,951. L'OREAL USA CREATIVE, INC., NEW YORK, NY. FILED 1-14-2011.

## GREENCUTS

THE MARK CONSISTS OF STANDARD CHARACTERS WITHOUT CLAIM TO ANY PARTICULAR FONT, STYLE, SIZE, OR COLOR.

FOR HAIR CARE PREPARATIONS AND HAIR STYLING PREPARATIONS (U.S. CLS. 1, 4, 6, 50, 51 AND 52).

ELISSA GARBER KON, EXAMINING ATTORNEY

**CLASS 3—(Continued).**

SN 85-221,133. MAKARI SIMMONS LLC, NEW YORK, NY. FILED 1-19-2011.

**PORE IT OUT**

THE MARK CONSISTS OF STANDARD CHARACTERS WITHOUT CLAIM TO ANY PARTICULAR FONT, STYLE, SIZE, OR COLOR.

NO CLAIM IS MADE TO THE EXCLUSIVE RIGHT TO USE "PORE", APART FROM THE MARK AS SHOWN.

FOR AGE SPOT REDUCING CREAMS; ANTI-AGING CLEANSER; ANTI-AGING MOISTURIZER; ANTI-WRINKLE CREAMS; ANTIBACTERIAL SKIN SOAPS; ASTRINGENTS FOR COSMETIC PURPOSES; BEAUTY SERUMS; BODY AND BEAUTY CARE COSMETICS; BODY MILKS; CLOTHS OR TISSUES IMPREGNATED WITH A SKIN CLEANSER; COSMETIC CREAMS FOR SKIN CARE; COSMETIC FACIAL BLOTTING PAPERS; COSMETIC PREPARATIONS FOR SKIN RENEWAL; COSMETIC SUNSCREEN PREPARATIONS; COSMETICS; COSMETICS AND MAKE-UP; CREAMS FOR CELLULITE REDUCTION; EXFOLIANT CREAMS; FACIAL BEAUTY MASKS; FACIAL CLEANSERS; FACIAL CLEANSING MILK; FACIAL CONCEALER; FACIAL LOTION; FACIAL MOISTURIZER WITH SPF; FACIAL SCRUBS; FACIAL WASHES; FOAM CLEANSERS FOR PERSONAL USE; LOTIONS FOR CELLULITE REDUCTION; MOISTURIZING CREAMS; MOISTURIZING MILKS; MOISTURIZING PREPARATIONS FOR THE SKIN; SKIN AND BODY TOPICAL LOTIONS, CREAMS AND OILS FOR COSMETIC USE; SKIN CLARIFIERS; SKIN CLEANSERS; SKIN LIGHTENERS; SKIN MASKS; SKIN MOISTURIZER; SKIN SOAP; SUNSCREEN CREAM; WIPES IMPREGNATED WITH A SKIN CLEANSER (U.S. CLS. 1, 4, 6, 50, 51 AND 52).

JEFFERY COWARD, EXAMINING ATTORNEY

**CLASS 3—(Continued).**

SN 85-222,364. COTY US LLC, NEW YORK, NY. FILED 1-20-2011.

**SEX APPEAL**

THE MARK CONSISTS OF STANDARD CHARACTERS WITHOUT CLAIM TO ANY PARTICULAR FONT, STYLE, SIZE, OR COLOR.

FOR PERFUMERY (U.S. CLS. 1, 4, 6, 50, 51 AND 52). FIRST USE 6-15-1975; IN COMMERCE 6-15-1975. CHERYL CLAYTON, EXAMINING ATTORNEY

SN 85-224,185. COTY US LLC, NEW YORK, NY. FILED 1-24-2011.

**PREPPY PRINCESS**

THE MARK CONSISTS OF STANDARD CHARACTERS WITHOUT CLAIM TO ANY PARTICULAR FONT, STYLE, SIZE, OR COLOR.

FOR PERFUMERY (U.S. CLS. 1, 4, 6, 50, 51 AND 52). FIRST USE 1-1-2011; IN COMMERCE 1-1-2011. CHERYL CLAYTON, EXAMINING ATTORNEY

SN 85-221,965. COTY US LLC, NEW YORK, NY. FILED 1-20-2011.

**DUET**

THE MARK CONSISTS OF STANDARD CHARACTERS WITHOUT CLAIM TO ANY PARTICULAR FONT, STYLE, SIZE, OR COLOR.

FOR PERFUMERY, ESSENTIAL OILS, COSMETICS, SOAPS AND HAIR LOTIONS (U.S. CLS. 1, 4, 6, 50, 51 AND 52).

CHERYL CLAYTON, EXAMINING ATTORNEY

SN 85-225,646. HARDY WAY LLC, NEW YORK, NY. FILED 1-25-2011.

**VILLAIN**

THE MARK CONSISTS OF STANDARD CHARACTERS WITHOUT CLAIM TO ANY PARTICULAR FONT, STYLE, SIZE, OR COLOR.

FOR BATH SOAPS; BODY CREAM; BODY LOTION; COSMETICS; DEODORANT FOR PERSONAL USE; EAU DE PARFUM; EAU DE TOILETTE; FRAGRANCES; SHAMPOOS; SHOWER AND BATH GEL (U.S. CLS. 1, 4, 6, 50, 51 AND 52).

AISHA CLARKE, EXAMINING ATTORNEY

**CLASS 3—(Continued).**

SN 85-227,398. TUPPERWARE PRODUCTS S.A., FRIBOURG, SWITZERLAND, FILED 1-27-2011.

# UNIRE

THE MARK CONSISTS OF STANDARD CHARACTERS WITHOUT CLAIM TO ANY PARTICULAR FONT, STYLE, SIZE, OR COLOR.

THE ENGLISH TRANSLATION OF "UNIRE" IN THE MARK IS TO JOIN.

FOR PERFUMERY; DEODORANTS AND ANTIPERSPIRANTS FOR PERSONAL USE; TALCUM POWDER; AND NON-MEDICATED SKIN CARE PREPARATIONS (U.S. CLS. 1, 4, 6, 50, 51 AND 52).

DAVID ELTON, EXAMINING ATTORNEY

**CLASS 3—(Continued).**

SN 85-232,910. TUPPERWARE PRODUCTS S.A., FRIBOURG, SWITZERLAND, FILED 2-3-2011.

# EXOTIC CHARM

THE MARK CONSISTS OF STANDARD CHARACTERS WITHOUT CLAIM TO ANY PARTICULAR FONT, STYLE, SIZE, OR COLOR.

OWNER OF U.S. REG. NO. 3,880,845.

FOR PERFUMERY; DEODORANTS AND ANTIPERSPIRANTS FOR PERSONAL USE; TALCUM POWDER; AND NON-MEDICATED SKIN CARE PREPARATIONS (U.S. CLS. 1, 4, 6, 50, 51 AND 52).

DAVID ELTON, EXAMINING ATTORNEY

SN 85-228,822. CARTER, SHAWN, NEW YORK, NY. FILED 1-28-2011.

# AKA SHAWN CARTER

THE MARK CONSISTS OF STANDARD CHARACTERS WITHOUT CLAIM TO ANY PARTICULAR FONT, STYLE, SIZE, OR COLOR.

THE NAME(S), PORTRAIT(S), AND/OR SIGNATURE(S) SHOWN IN THE MARK IDENTIFIES SHAWN CARTER, WHOSE CONSENT(S) TO REGISTER IS MADE OF RECORD.

FOR FRAGRANCES, NAMELY, PERFUME, COLOGNE, EAU DE COLOGNE, EAU DE TOILETTE, SHAVING GEL, AFTER SHAVE, SOAP, BODY LOTION, BATH GEL, FACE CREAM AND COSMETICS (U.S. CLS. 1, 4, 6, 50, 51 AND 52).

MATTHEW EINSTEIN, EXAMINING ATTORNEY

SN 85-232,912. TUPPERWARE PRODUCTS S.A., FRIBOURG, SWITZERLAND, FILED 2-3-2011.

# MODERN LOOK

THE MARK CONSISTS OF STANDARD CHARACTERS WITHOUT CLAIM TO ANY PARTICULAR FONT, STYLE, SIZE, OR COLOR.

FOR PERFUMERY; DEODORANTS AND ANTIPERSPIRANTS FOR PERSONAL USE; TALCUM POWDER; AND NON-MEDICATED SKIN CARE PREPARATIONS (U.S. CLS. 1, 4, 6, 50, 51 AND 52).

DAVID ELTON, EXAMINING ATTORNEY

SN 85-229,122. MISSION PRODUCT HOLDINGS, INC., NEW YORK, NY. FILED 1-28-2011.

# CONTINUOUS PLAY

THE MARK CONSISTS OF STANDARD CHARACTERS WITHOUT CLAIM TO ANY PARTICULAR FONT, STYLE, SIZE, OR COLOR.

FOR SUN SCREEN PREPARATIONS; SUN BLOCK PREPARATIONS (U.S. CLS. 1, 4, 6, 50, 51 AND 52).

DAVID I, EXAMINING ATTORNEY

SN 85-234,225. BELLA SOAP COMPANY, INC., LOOMIS, CA. FILED 2-4-2011.

# Bella Kiss-the-Itch-Goodbye Formula

THE MARK CONSISTS OF STANDARD CHARACTERS WITHOUT CLAIM TO ANY PARTICULAR FONT, STYLE, SIZE, OR COLOR.

NO CLAIM IS MADE TO THE EXCLUSIVE RIGHT TO USE "FORMULA", APART FROM THE MARK AS SHOWN. THE ENGLISH TRANSLATION OF "BELLA" IN THE MARK IS "BEAUTIFUL".

FOR LIP BALM (U.S. CLS. 1, 4, 6, 50, 51 AND 52).

EMILY CHUO, EXAMINING ATTORNEY

**CLASS 3—(Continued).**

SN 85-244,597. STANLEY LOGISTICS, L.L.C., NEW BRITAIN, CT. FILED 2-17-2011.

# FATMAX

THE MARK CONSISTS OF STANDARD CHARACTERS WITHOUT CLAIM TO ANY PARTICULAR FONT, STYLE, SIZE, OR COLOR.

OWNER OF U.S. REG. NOS. 2,579,681, 3,163,439 AND 3,823,252.

FOR ABRASIVE ACCESSORIES FOR SANDERS, NAMELY, SANDPAPER, AND ABRASIVE PADS FOR SANDING (U.S. CLS. 1, 4, 6, 50, 51 AND 52).

KAPIL BHANOT, EXAMINING ATTORNEY

SN 85-245,661. COTY US LLC, NEW YORK, NY. FILED 2-18-2011.

# GREIGE

THE MARK CONSISTS OF STANDARD CHARACTERS WITHOUT CLAIM TO ANY PARTICULAR FONT, STYLE, SIZE, OR COLOR.

THE WORDING "GREIGE" HAS NO MEANING IN A FOREIGN LANGUAGE.

FOR COSMETICS, SPECIFICALLY NAIL POLISH, NAIL TREATMENT PRODUCTS, NAMELY, CLEAR AND COLOR NAIL POLISHES, NAIL POLISH REMOVER, NAIL CLEANSERS AND NAIL POLISH BASE COATS (U.S. CLS. 1, 4, 6, 50, 51 AND 52).

CHERYL CLAYTON, EXAMINING ATTORNEY

SN 85-248,790. MANA PRODUCTS, INC., LONG ISLAND CITY, NY. FILED 2-22-2011.

# DO GOOD BE BEAUTIFUL

THE MARK CONSISTS OF STANDARD CHARACTERS WITHOUT CLAIM TO ANY PARTICULAR FONT, STYLE, SIZE, OR COLOR.

FOR COSMETICS, NON-MEDICATED SKIN CARE PREPARATIONS, HAIR CARE PREPARATIONS (U.S. CLS. 1, 4, 6, 50, 51 AND 52).

JULIE VEPPUMTHARA, EXAMINING ATTORNEY

**CLASS 3—(Continued).**

SN 85-248,795. MANA PRODUCTS, INC., LONG ISLAND CITY, NY. FILED 2-22-2011.

# DO GOOD BE HAPPY

THE MARK CONSISTS OF STANDARD CHARACTERS WITHOUT CLAIM TO ANY PARTICULAR FONT, STYLE, SIZE, OR COLOR.

FOR COSMETICS, NON-MEDICATED SKIN CARE PREPARATIONS, HAIR CARE PREPARATIONS (U.S. CLS. 1, 4, 6, 50, 51 AND 52).

JULIE VEPPUMTHARA, EXAMINING ATTORNEY

SN 85-269,242. HARD CANDY, LLC, HOLLYWOOD, FL. FILED 3-17-2011.

# HARD CANDY BLING

THE MARK CONSISTS OF STANDARD CHARACTERS WITHOUT CLAIM TO ANY PARTICULAR FONT, STYLE, SIZE, OR COLOR.

OWNER OF U.S. REG. NOS. 2,552,029, 3,695,602 AND OTHERS.

FOR FRAGRANCES AND PERFUMERY (U.S. CLS. 1, 4, 6, 50, 51 AND 52).

SUSAN RICHARDS, EXAMINING ATTORNEY

**CLASS 4—LUBRICANTS AND FUELS**

SN 85-054,624. AMERICAN DENTAL SUPPLY, INC., AKA ADS, INC., ALLENTOWN, PA. FILED 6-4-2010.

# LIQUI-FOIL

THE MARK CONSISTS OF STANDARD CHARACTERS WITHOUT CLAIM TO ANY PARTICULAR FONT, STYLE, SIZE, OR COLOR.

FOR LUBRICANTS FOR DENTAL INSTRUMENTS (U.S. CLS. 1, 6 AND 15).

FIRST USE 3-11-1982; IN COMMERCE 3-11-1982.

MORGAN WYNNE, EXAMINING ATTORNEY



**CLASS 4—(Continued).**

SN 85-115,680. CANDLE ARTISANS, INC., WASHINGTON, NJ. FILED 8-25-2010.

# EVENT PACK

THE MARK CONSISTS OF STANDARD CHARACTERS WITHOUT CLAIM TO ANY PARTICULAR FONT, STYLE, SIZE, OR COLOR.

OWNER OF U.S. REG. NO. 3,794,678.  
NO CLAIM IS MADE TO THE EXCLUSIVE RIGHT TO USE "PACK", APART FROM THE MARK AS SHOWN.  
FOR CANDLES (U.S. CLS. 1, 6 AND 15).  
FIRST USE 7-24-2009; IN COMMERCE 7-24-2009.  
REBECCA SMITH, EXAMINING ATTORNEY

**CLASS 4—(Continued).**

SN 85-172,488. VISION CANDLES INC., MIAMI, FL. FILED 11-9-2010.



THE MARK CONSISTS OF STARS GROUPED IN A SEMICIRCLE ABOVE TRIANGLE WITH LIGHTED CANDLE CUTOUT IN THE CENTER. THE WORDS "TU VISION" APPEAR DIRECTLY UNDERNEATH THE DESIGN.

THE ENGLISH TRANSLATION OF "TU" IN THE MARK IS YOUR.  
FOR CANDLES (U.S. CLS. 1, 6 AND 15).  
FIRST USE 10-31-2004; IN COMMERCE 10-31-2004.  
ANDREA BUTLER, EXAMINING ATTORNEY

SN 85-182,240. PENNYWICK CANDLES LLC, AKA PENNYWICK CANDLES, VIENNA, VA. FILED 11-22-2010.



NO CLAIM IS MADE TO THE EXCLUSIVE RIGHT TO USE "CANDLES", APART FROM THE MARK AS SHOWN.  
THE MARK CONSISTS OF THE WORDS "PENNYWICK CANDLES" WITH A FLAME COMING FROM THE LETTER "I" IN "PENNYWICK".

FOR CANDLES; SCENTED CANDLES (U.S. CLS. 1, 6 AND 15).  
FIRST USE 10-4-2009; IN COMMERCE 11-9-2009.  
JAMES GRIFFIN, EXAMINING ATTORNEY

SN 85-142,246. LAMPLIGHT FARMS INCORPORATED, MENOMONEE FALLS, WI. FILED 9-30-2010.

# Double Wick

NO CLAIM IS MADE TO THE EXCLUSIVE RIGHT TO USE "DOUBLE WICK", APART FROM THE MARK AS SHOWN.

THE MARK CONSISTS OF THE STYLIZED WORDING "DOUBLE" ABOVE THE STYLIZED WORDING "WICK" WITH THE REPRESENTATION OF TWO FLAME ELEMENTS APPEARING OVER THE LOWER CASE "I".

FOR PATIO TORCHES FEATURING FLAME ENHANCING TECHNOLOGY (U.S. CLS. 1, 6 AND 15).  
TASNEEM HUSSAIN, EXAMINING ATTORNEY

SN 85-183,654. CHS INC., INVER GROVE HEIGHTS, MN. FILED 11-23-2010.

# INDOL

THE MARK CONSISTS OF STANDARD CHARACTERS WITHOUT CLAIM TO ANY PARTICULAR FONT, STYLE, SIZE, OR COLOR.

FOR HYDRAULIC OILS (U.S. CLS. 1, 6 AND 15).  
FIRST USE 0-0-1998; IN COMMERCE 0-0-1998.  
SUE LAWRENCE, EXAMINING ATTORNEY

**CLASS 4—(Continued).**

SN 85-187,779. KRONBICHLER, ELISABETH, BARDONIA, NY. FILED 11-30-2010.

**LiebeStricken**

THE MARK CONSISTS OF STANDARD CHARACTERS WITHOUT CLAIM TO ANY PARTICULAR FONT, STYLE, SIZE, OR COLOR.

THE ENGLISH TRANSLATION OF "LIEBESTRICKEN" IN THE MARK IS "LOVE TO KNIT".

FOR CANDLES (U.S. CLS. 1, 6 AND 15).

FIRST USE 5-20-2009; IN COMMERCE 5-20-2009.

REBECCA EISINGER, EXAMINING ATTORNEY

**CLASS 4—(Continued).**

SN 85-205,727. TAQSEEM, INC., SACRAMENTO, CA. FILED 12-26-2010.

**Tonic Before Sex**

THE MARK CONSISTS OF STANDARD CHARACTERS WITHOUT CLAIM TO ANY PARTICULAR FONT, STYLE, SIZE, OR COLOR.

OWNER OF U.S. REG. NOS. 3,728,369 AND 3,731,428. FOR CANDLES; SCENTED CANDLES (U.S. CLS. 1, 6 AND 15).

SARA BENJAMIN, EXAMINING ATTORNEY

SN 85-204,586. SIEGEL OIL COMPANY, DENVER, CO. FILED 12-23-2010.

**SKY**

THE MARK CONSISTS OF STANDARD CHARACTERS WITHOUT CLAIM TO ANY PARTICULAR FONT, STYLE, SIZE, OR COLOR.

OWNER OF U.S. REG. NO. 3,846,183.

FOR MOTOR OILS; LUBRICANTS FOR MOTOR VEHICLES (U.S. CLS. 1, 6 AND 15).

FIRST USE 7-0-2009; IN COMMERCE 7-0-2009.

HANNO RITTNER, EXAMINING ATTORNEY

SN 85-207,581. SKYLER STEWART, DBA BEE LASSO, REDDING, CA. FILED 12-29-2010.

**BEE LASSO**

THE MARK CONSISTS OF STANDARD CHARACTERS WITHOUT CLAIM TO ANY PARTICULAR FONT, STYLE, SIZE, OR COLOR.

NO CLAIM IS MADE TO THE EXCLUSIVE RIGHT TO USE "BEE", APART FROM THE MARK AS SHOWN.

FOR WICKS FOR CANDLES FOR LIGHTING (U.S. CLS. 1, 6 AND 15).

FIRST USE 7-13-2010; IN COMMERCE 7-13-2010.

INGA ERVIN, EXAMINING ATTORNEY

SN 85-205,723. TAQSEEM, INC., SACRAMENTO, CA. FILED 12-26-2010.

**Tonic After Sex**

THE MARK CONSISTS OF STANDARD CHARACTERS WITHOUT CLAIM TO ANY PARTICULAR FONT, STYLE, SIZE, OR COLOR.

OWNER OF U.S. REG. NOS. 3,728,369 AND 3,731,428.

FOR CANDLES; SCENTED CANDLES (U.S. CLS. 1, 6 AND 15).

SARA BENJAMIN, EXAMINING ATTORNEY

SN 85-208,626. D-GENERATION, INC, DAYTONA BEACH, FL. FILED 12-31-2010.

**LIVE LOVE LAUGH**

THE MARK CONSISTS OF STANDARD CHARACTERS WITHOUT CLAIM TO ANY PARTICULAR FONT, STYLE, SIZE, OR COLOR.

OWNER OF U.S. REG. NOS. 3,440,470 AND 3,877,139. FOR CANDLES; SCENTED CANDLES (U.S. CLS. 1, 6 AND 15).

FIRST USE 3-5-1999; IN COMMERCE 3-5-1999.

JUSTINE D. PARKER, EXAMINING ATTORNEY

**CLASS 4—(Continued).**

SN 85-211,914. MVP GROUP INTERNATIONAL, INC., CHARLESTON, SC. FILED 1-6-2011.

**HOT NUTS**

THE MARK CONSISTS OF STANDARD CHARACTERS WITHOUT CLAIM TO ANY PARTICULAR FONT, STYLE, SIZE, OR COLOR.

FOR CHARCOAL BRIQUETTES; COMBUSTIBLE BRIQUETTES (U.S. CLS. 1, 6 AND 15).

THEODORE MCBRIDE, EXAMINING ATTORNEY

SN 85-213,094. FSHS OF SOUTH FLORIDA, INC., HOLLYWOOD, FL. FILED 1-7-2011.

**MOC**

THE MARK CONSISTS OF STANDARD CHARACTERS WITHOUT CLAIM TO ANY PARTICULAR FONT, STYLE, SIZE, OR COLOR.

FOR CANDLES (U.S. CLS. 1, 6 AND 15).

FIRST USE 12-15-2010; IN COMMERCE 12-15-2010.

BILL DAWE, EXAMINING ATTORNEY

SN 85-241,222. PARTYLITE WORLDWIDE INC., PLYMOUTH, MA. FILED 2-14-2011.

**GLOLITE BY PARTYLITE**

THE MARK CONSISTS OF STANDARD CHARACTERS WITHOUT CLAIM TO ANY PARTICULAR FONT, STYLE, SIZE, OR COLOR.

OWNER OF U.S. REG. NOS. 1,735,998, 2,762,405 AND 3,261,962.

FOR CANDLES (U.S. CLS. 1, 6 AND 15).

ALEXANDER L. POWERS, EXAMINING ATTORNEY

**CLASS 5—PHARMACEUTICALS**

SN 76-705,467. BENEHEALTH LTD., RED BANK, NJ. FILED 11-24-2010.

**BENEHEALTH**

THE MARK CONSISTS OF STANDARD CHARACTERS WITHOUT CLAIM TO ANY PARTICULAR FONT, STYLE, SIZE, OR COLOR.

FOR MICROFIBER TOWELS ATTACHED TO A HANDLE, FOR USE IN WASHING AND DRYING THE FEET AND TOES, AND IMPREGNATED WITH A PROPRIETARY ANTIMICROBIAL TREATMENT TO PREVENT BACTERIA AND FUNGUS; AND MEDICATED OINTMENT FOR TREATING DERMATOLOGICAL CONDITIONS OF THE FEET (U.S. CLS. 6, 18, 44, 46, 51 AND 52).

MARC LEIPZIG, EXAMINING ATTORNEY

SN 76-705,723. PLAIA, GERALDINE, SEA GIRT, NJ. FILED 12-20-2010.



THE COLOR(S) BLUE, GOLD, GRAY, BLACK AND WHITE IS/ARE CLAIMED AS A FEATURE OF THE MARK.

THE MARK CONSISTS OF THE WORDS "ESCAPE TO SLEEP" IN A STYLIZED BLACK FONT ON A GRAY OVOID BANNER WITHIN A BLUE CRESCENT MOON CONTAINING WHITE WATER DROPS AND TRIMMED WITH A DECORATIVE GOLD BORDER. IN THE BACKGROUND AND TO THE RIGHT ARE ADDITIONAL SETS OF GRAYISH CURVED LINES TERMINATING IN SMALLER BLUE AND WHITE CRESCENT MOONS.

FOR HOMEOPATHIC NUTRITIONAL SUPPLEMENT DRINKS (U.S. CLS. 6, 18, 44, 46, 51 AND 52).

FIRST USE 0-0-1998; IN COMMERCE 0-0-1998.

JOHN WILKE, EXAMINING ATTORNEY

SN 76-706,274. USA MILLENNIUM, L.P., BEAUMONT, TX. FILED 2-4-2011.

**SPEED DETOX**

THE MARK CONSISTS OF STANDARD CHARACTERS WITHOUT CLAIM TO ANY PARTICULAR FONT, STYLE, SIZE, OR COLOR.

OWNER OF U.S. REG. NOS. 2,965,239 AND 3,020,062.

NO CLAIM IS MADE TO THE EXCLUSIVE RIGHT TO USE "DETOX", APART FROM THE MARK AS SHOWN.

FOR DIETARY SUPPLEMENTAL DRINKS (U.S. CLS. 6, 18, 44, 46, 51 AND 52).

SAMUEL E. SHARPER JR., EXAMINING ATTORNEY

**CLASS 5—(Continued).**

SN 77-703,257. REGENOVATE ENDOGEN INC., WATER-  
LOO, ONTARIO, CANADA, FILED 3-31-2009.

**CONTINUOUS STIMULUS**

THE MARK CONSISTS OF STANDARD CHARACTERS  
WITHOUT CLAIM TO ANY PARTICULAR FONT, STYLE,  
SIZE, OR COLOR.

PRIORITY CLAIMED UNDER SEC. 44(D) ON CANADA  
APPLICATION NO. 1430771, FILED 3-12-2009, REG. NO.  
TMA782,414, DATED 11-15-2010, EXPIRES 11-15-2025.

FOR DIETARY AND NUTRITIONAL SUPPLEMENTS  
FOR MUSCLE BUILDING, STRENGTH AND PERFORM-  
ANCE ENHANCEMENT, AND WEIGHT LOSS IN THE  
FORM OF POWDERED DRINK MIXES, LIQUID  
DRINKS, AND CAPSULES (U.S. CLS. 6, 18, 44, 46, 51  
AND 52).

KIM SAITO, EXAMINING ATTORNEY

SN 77-703,312. REGENOVATE ENDOGEN INC., WATER-  
LOO, ONTARIO, CANADA, FILED 3-31-2009.

**K.I.S.S.**

THE MARK CONSISTS OF STANDARD CHARACTERS  
WITHOUT CLAIM TO ANY PARTICULAR FONT, STYLE,  
SIZE, OR COLOR.

PRIORITY CLAIMED UNDER SEC. 44(D) ON CANADA  
APPLICATION NO. 1430770, FILED 3-12-2009, REG. NO.  
TMA782,415, DATED 11-15-2010, EXPIRES 11-15-2025.

FOR DIETARY AND NUTRITIONAL SUPPLEMENTS  
FOR MUSCLE BUILDING, STRENGTH AND PERFORM-  
ANCE ENHANCEMENT, AND WEIGHT LOSS IN THE  
FORM OF POWDERED DRINK MIXES, LIQUID  
DRINKS, AND CAPSULES (U.S. CLS. 6, 18, 44, 46, 51  
AND 52).

KIM SAITO, EXAMINING ATTORNEY

SN 77-837,590. INNOVACTIV INC., RIMOUSKI, QUEBEC,  
CANADA, FILED 9-29-2009.

*InSea<sup>2</sup>*

THE MARK CONSISTS OF TERM "INSEA" WITH THE  
NUMBER "2" AS A SUPERScript.

FOR RAW MATERIAL INGREDIENT DERIVED  
FROM A MIXTURE OF NATURAL ALGAE, NAMELY,  
KELP AND BLADDERWRACK, AND CONCENTRATED  
IN POLYPHENOLS FOR USE AS AN ADDITIVE TO  
HELP SUPPORT A HEALTHY BLOOD GLUCOSE LEVEL  
AFTER A MEAL (U.S. CLS. 6, 18, 44, 46, 51 AND 52).

FIRST USE 10-0-2008; IN COMMERCE 10-0-2008.

LAURIE MAYES, EXAMINING ATTORNEY

**CLASS 5—(Continued).**

SN 77-843,542. DRINKWEL, LLC, IRVINE, CA. FILED 10-7-  
2009.

**DRINKWEL**

THE MARK CONSISTS OF STANDARD CHARACTERS  
WITHOUT CLAIM TO ANY PARTICULAR FONT, STYLE,  
SIZE, OR COLOR.

FOR NUTRITIONAL SUPPLEMENTS, NAMELY, A  
MULTIVITAMIN SPECIALLY FORMULATED FOR PEO-  
PLE THAT DRINK ALCOHOL (U.S. CLS. 6, 18, 44, 46, 51  
AND 52).

FIRST USE 5-11-2010; IN COMMERCE 5-11-2010.

RAUL CORDOVA, EXAMINING ATTORNEY

SN 77-860,669. NATURE'S SHIELD, INC., PALM, PA. FILED  
10-29-2009.

**NATURE'S SHIELD**

THE MARK CONSISTS OF STANDARD CHARACTERS  
WITHOUT CLAIM TO ANY PARTICULAR FONT, STYLE,  
SIZE, OR COLOR.

FOR DIETARY SUPPLEMENTS, FOOD SUPPLE-  
MENTS, HERBAL SUPPLEMENTS, HOMEOPATHIC  
SUPPLEMENTS, MINERAL SUPPLEMENTS, NATURO-  
PATHIC DIETARY SUPPLEMENTS, NUTRACEUTICAL  
DIETARY SUPPLEMENTS, NUTRITIONAL SUPPLE-  
MENTS, AND VITAMIN SUPPLEMENTS; HERBAL PRE-  
PARATIONS FOR MEDICINAL USE, HOMEOPATHIC  
PREPARATIONS, NAMELY, HOMEOPATHIC SUPPLE-  
MENTS FOR MEDICINAL USE, AND MINERAL PRE-  
PARATIONS FOR MEDICINAL USE (U.S. CLS. 6, 18, 44,  
46, 51 AND 52).

BARBARA BROWN, EXAMINING ATTORNEY

SN 77-863,027. 4LIFE TRADEMARKS, LLC, SANDY, UT.  
FILED 11-2-2009.



OWNER OF U.S. REG. NOS. 2,475,300, 2,486,970 AND  
2,659,033.

THE MARK CONSISTS OF THE DESIGN OF A LABEL  
WITH AN OVERALL RECTANGLE SHAPE WITH CURVED  
CORNERS. IT IS SHADED FROM DARK TO LIGHT  
MOVING FROM LEFT TO RIGHT. IN THE CENTER  
APPEARS A SMALLER LIGHTLY SHADED HORIZONTAL  
RECTANGLE THAT INTERSECTS WITH A VERTICAL  
RECTANGLE, SHADED FROM LIGHT TO DARK, ON  
THE LEFT SIDE OF THE HORIZONTAL RECTANGLE.  
WHERE THESE TWO RECTANGLE INTERSECT A SMALL-  
ER RECTANGLE APPEARS, DARKLY SHADED WITH  
THE TERM "4LIFE" APPEARING INSIDE OF IT. THE DOT  
OF THE LETTER "I" IN "4LIFE" IS FORMED BY A DESIGN

**CLASS 5—(Continued).**

OF THE SUN, BENEATH AND TO THE RIGHT OF THE HORIZONTAL RECTANGLE ARE TWO INTERSECTING PERPENDICULAR LINES FLANKING THE RECTANGLE. STARTING AT THE TOP-RIGHT OF THE VERTICAL RECTANGLE APPEARS A WIDE HORIZONTAL BAND THAT IS SHADED FROM DARK TO LIGHT MOVING FROM LEFT TO RIGHT. AT THE BOTTOM OF THE VERTICAL RECTANGLE A WIDE HORIZONTAL BAND APPEARS THAT IS SHADED FROM LIGHT TO DARK. AT THE RIGHT END OF THE LABEL, A VERTICAL UNSHADED RECTANGLE APPEARS. THE OVERALL RECTANGULAR SHAPE OF THE LABEL IS DEPICTED IN DOTTED LINES AND IS NOT CLAIMED AS A FEATURE OF THE MARK.

FOR DIETARY AND NUTRITIONAL SUPPLEMENTS; VITAMIN, MINERAL AND HERBAL SUPPLEMENTS (U.S. CLS. 6, 18, 44, 46, 51 AND 52).

FIRST USE 10-31-2001; IN COMMERCE 10-31-2001.  
MARILYN IZZI, EXAMINING ATTORNEY

SN 77-867,057. 4LIFE TRADEMARKS, LLC, SANDY, UT.  
FILED 11-6-2009.



OWNER OF U.S. REG. NOS. 2,475,300, 2,486,970 AND 2,659,033.

THE MARK CONSISTS OF THE DESIGN OF A PRODUCT LABEL WITH AN OVERALL RECTANGLE SHAPE WITH CURVED CORNERS. THE TOP OF THE RECTANGLE IS BORDERED WITH A WIDE HORIZONTAL BAND THAT IS SHADED DARKER AT THE ENDS AND LIGHTER IN THE CENTER. THE BOTTOM OF THE LABEL IS SHADED WITH A DARK HORIZONTAL BAND WITH A LIGHT HORIZONTAL BAND ABOVE IT. IN THE DARK, BOTTOM BAND, THE TERM "4LIFE" APPEARS WITH THE DESIGN OF THE SUN APPEARING AS THE DOT OF THE LETTER "I". IN THE CENTER OF THE LABEL ARE THREE SINGLE LINED CONCENTRIC CIRCLES. IN THE FOREGROUND OF THE CIRCLES, A RECTANGLE APPEARS WITH A DARK HORIZONTAL BAND AT THE TOP OF IT. TO THE BOTTOM AND RIGHT OF THE CENTER RECTANGLE APPEARS TWO INTERSECTING LINES THAT FLANK THE BOTTOM AND RIGHT OF THE RECTANGLE. THE OVERALL RECTANGULAR SHAPE OF THE LABEL IS DEPICTED IN DOTTED LINES AND IS NOT CLAIMED AS A FEATURE OF THE MARK.

FOR DIETARY AND NUTRITIONAL SUPPLEMENTS; VITAMIN, MINERAL AND HERBAL SUPPLEMENTS (U.S. CLS. 6, 18, 44, 46, 51 AND 52).

FIRST USE 8-31-2002; IN COMMERCE 8-31-2002.  
MARILYN IZZI, EXAMINING ATTORNEY

**CLASS 5—(Continued).**

SN 77-868,556. ANAGALLIS HERBS LLC, COS COB, CT.  
FILED 11-9-2009.

**LIP LIBATIONS HERBAL BALM**

THE MARK CONSISTS OF STANDARD CHARACTERS WITHOUT CLAIM TO ANY PARTICULAR FONT, STYLE, SIZE, OR COLOR.

NO CLAIM IS MADE TO THE EXCLUSIVE RIGHT TO USE "LIP" AND "HERBAL BALM", APART FROM THE MARK AS SHOWN.

FOR HERBAL TOPICAL CREAMS, GELS, SALVES, SPRAYS, POWDER, BALMS, LINIMENT AND OINTMENTS FOR THE RELIEF OF ACHES AND PAIN (U.S. CLS. 6, 18, 44, 46, 51 AND 52).

FIRST USE 6-29-2009; IN COMMERCE 6-29-2009.  
COLLEEN DOMBROW, EXAMINING ATTORNEY

SN 77-880,260. MELALEUCA, INC., IDAHO FALLS, ID.  
FILED 11-24-2009.

**OLIGO**

THE MARK CONSISTS OF STANDARD CHARACTERS WITHOUT CLAIM TO ANY PARTICULAR FONT, STYLE, SIZE, OR COLOR.

FOR BLENDED INGREDIENTS CONSISTING OF MINERALS, FIBER, AND AMINO ACIDS FOR USE IN DIETARY SUPPLEMENTATION, INCORPORATED AS A COMPONENT OF DIETARY AND NUTRITIONAL SUPPLEMENTS (U.S. CLS. 6, 18, 44, 46, 51 AND 52).

HENRY S. ZAK, EXAMINING ATTORNEY

SN 77-882,120. JOHNSON & JOHNSON, NEW BRUNSWICK, NJ. FILED 11-30-2009.

**TOUGH PADS**

THE MARK CONSISTS OF STANDARD CHARACTERS WITHOUT CLAIM TO ANY PARTICULAR FONT, STYLE, SIZE, OR COLOR.

OWNER OF U.S. REG. NO. 2,789,569.  
NO CLAIM IS MADE TO THE EXCLUSIVE RIGHT TO USE "PADS", APART FROM THE MARK AS SHOWN.

FOR WOUND DRESSINGS, NAMELY, ADHESIVE PADS (U.S. CLS. 6, 18, 44, 46, 51 AND 52).

JAMES A. RAUEN, EXAMINING ATTORNEY

**CLASS 5—(Continued).**

SN 78-595,971. TRUE VALUE COMPANY, CHICAGO, IL. FILED 3-28-2005.

**GREEN THUMB**

THE MARK CONSISTS OF STANDARD CHARACTERS WITHOUT CLAIM TO ANY PARTICULAR FONT, STYLE, SIZE, OR COLOR.

OWNER OF U.S. REG. NOS. 581,301, 3,075,371 AND OTHERS.

FOR INSECTICIDE AND HERBICIDE (U.S. CLS. 6, 18, 44, 46, 51 AND 52).

FIRST USE 11-1-1986; IN COMMERCE 11-1-1986.  
DOMINIC FATHY, EXAMINING ATTORNEY

**CLASS 5—(Continued).**

SN 79-080,950. FIRST SCIENTIFIC DENTAL GMBH, FED REP GERMANY, FILED 2-11-2010.

**Go! Easy**

THE MARK CONSISTS OF STANDARD CHARACTERS WITHOUT CLAIM TO ANY PARTICULAR FONT, STYLE, SIZE, OR COLOR.

OWNER OF INTERNATIONAL REGISTRATION 1034348 DATED 2-11-2010, EXPIRES 2-11-2020.

FOR DENTAL MEDICINAL PRODUCTS, NAMELY, FILLING MATERIALS, LINING MATERIALS, ADHESIVES, DENTAL RESTORATION COMPOUNDS BEING DUAL CEMENT FOR USE IN BUILD-UP, COMPOUNDS USED IN ENDODONTIC PROCEDURES, CEMENTS, SEALANTS, CROWN AND BRIDGE MATERIALS, IMPRESSION MATERIALS, IMPLANTS COMPRISING LIVING TISSUES, RELINING MATERIALS, AND ORTHODONTIC ALGINATE FOR DENTAL IMPRESSIONS, USED FOR PROSTHETIC, RESTORATIVE AND PREVENTIVE DENTISTRY (U.S. CLS. 6, 18, 44, 46, 51 AND 52).

LAURA HAMMEL, EXAMINING ATTORNEY

SN 78-780,818. SMITH & NEPHEW (OVERSEAS) LIMITED, LONDON, UNITED KINGDOM, FILED 12-27-2005.

**PHARMACRYST**

THE MARK CONSISTS OF STANDARD CHARACTERS WITHOUT CLAIM TO ANY PARTICULAR FONT, STYLE, SIZE, OR COLOR.

PRIORITY CLAIMED UNDER SEC. 44(D) ON CANADA APPLICATION NO. 1264417, FILED 7-6-2005.

FOR DERMATOLOGICAL CREAMS, GELS, FOAMS, OINTMENTS AND/OR SOLUTIONS; RESPIRATORY PRODUCTS, NAMELY, NEBULIZER SOLUTIONS, DRY POWDER FOR INHALERS AND METERED DOSE INHALERS; GASTROINTESTINAL PRODUCTS, NAMELY, ENEMAS, SUPPOSITORIES, AND ORAL MEDICATION (U.S. CLS. 6, 18, 44, 46, 51 AND 52).

CHRISTINE COOPER, EXAMINING ATTORNEY

SN 79-086,236. MICRO MEGA INTERNATIONAL MANUFACTURES, F-25000 BESANCON, FRANCE, FILED 7-22-2010.

**HOPE**

THE MARK CONSISTS OF STANDARD CHARACTERS WITHOUT CLAIM TO ANY PARTICULAR FONT, STYLE, SIZE, OR COLOR.

OWNER OF INTERNATIONAL REGISTRATION 1048105 DATED 7-22-2010, EXPIRES 7-22-2020.

FOR DENTAL CEMENTS; DENTAL CEMENTS INTENDED FOR TREATING PERFORATIONS AND FILLINGS OF DENTAL ROOTS AND DENTAL PULP CAPPING (U.S. CLS. 6, 18, 44, 46, 51 AND 52).

JESSICA FATHY, EXAMINING ATTORNEY

**CLASS 5—(Continued).**

SN 79-090,913. MURTAZA LIAKATALI DATOO PARDAN,  
UNITED KINGDOM, FILED 9-9-2010.

# FamiPRO

THE MARK CONSISTS OF STANDARD CHARACTERS WITHOUT CLAIM TO ANY PARTICULAR FONT, STYLE, SIZE, OR COLOR.

OWNER OF INTERNATIONAL REGISTRATION 1060843  
DATED 9-9-2010, EXPIRES 9-9-2020.

FOR ABSORBENT ARTICLES FOR CLEANSING THE BODY FOR MEDICAL USE, NAMELY, SKIN PADS, PADS FOR USE IN MENSTRUATION, MEDICAL ABSORBENT CONTAINMENT PADS FOR WOUNDS; ABSORBENT COTTON GAUZE FOR MEDICAL USE; ABSORBENT WOUND DRESSINGS; ABSORBENT MATERIALS FOR BANDAGING SKIN WOUNDS; ABSORBENT SANITARY ARTICLES, NAMELY, PADS; ABSORBENT SANITARY ARTICLES FOR USE DURING MENSTRUATION; ABSORBENT SANITARY UNDERCLOTHING; ABSORBENT WADDING FOR MEDICAL CLEANING; PHARMACEUTICAL PREPARATIONS, NAMELY, ACNE CLEANSERS, ACNE CREAMS; ADHESIVE BANDAGES; ADHESIVE BANDAGES CONTAINING PHARMACEUTICALS FOR TREATING ACNE AND SKIN WOUNDS FOR TRANSDERMAL APPLICATION; ADHESIVE BANDAGES FOR TRANSDERMAL ADMINISTERING OF PHARMACEUTICAL PRODUCTS FOR TREATING ACNE AND SKIN WOUNDS; AIR DEODORANTS; AIR FRESHENERS; AIR FRESHENING PREPARATIONS; AIR PURIFYING PREPARATIONS; BABIES' ADHESIVE BANDAGES; MEDICATED BABIES' SKIN CREAMS; MEDICATED BABY CARE PRODUCTS, NAMELY, MEDICATED BALMS; BALMS FOR MEDICAL PURPOSES; HYGIENIC BANDAGES, NAMELY, MENSTRUATION BANDAGES; WOUND DRESSING BANDAGES FOR ANIMALS; WOUND DRESSING BANDAGES FOR VETERINARY USE; BANDAGES FOR DRESSINGS; ADHESIVE BANDAGES PRODUCED FROM SYNTHETIC MATERIALS; ADHESIVE BANDAGES FOR DRESSINGS; GAUZE BANDAGES FOR MAKING CASTS; GAUZE BANDAGES FOR MAKING SPLINTS; ADHESIVE BANDAGES FOR PROTECTING THE SKIN; WOUND DRESSING BANDAGES FOR THE ORAL CAVITY; ADHESIVE BANDAGES FOR THE PREVENTION OF BLISTERS; ADHESIVE BANDAGES HAVING ADSORBENT PROPERTIES; MEDICATED SKIN AND BODY CREAMS CREAMS AND LOTIONS; TISSUES IMPREGNATED WITH DISINFECTANT FOR HYGIENE PURPOSES; TISSUES IMPREGNATED WITH DISINFECTANTS; COTTON GAUZE FOR DENTAL PURPOSES; COTTON GAUZE FOR MEDICAL PURPOSES; MEDICATED CREAMS FOR APPLICATION AFTER EXPOSURE TO THE SUN. MEDICATED CREAMS FOR BODY SCRUBS; MEDICATED CREAMS FOR CLEANING THE SKIN; MEDICATED CREAMS FOR HYDRATING THE SKIN; MEDICATED CREAMS FOR MOISTURIZING THE SKIN; MEDICATED SKIN CREAMS FOR PERSONAL CARE; MEDICATED CREAMS FOR PROTECTION AGAINST THE SUN; MEDICATED CREAMS FOR PROTECTION OF THE SKIN; MEDICATED CREAMS FOR SOFTENING THE SKIN; MEDICATED CREAMS FOR SOOTHING THE SKIN; MEDICATED CREAMS FOR SOOTHING THE SKIN; MEDICATED CREAMS FOR THE BODY; MEDICATED CREAMS FOR THE CARE OF THE BODY; MEDICATED CREAMS FOR THE CARE OF THE FACE; MEDICATED CREAMS FOR THE CARE OF THE FEET; MEDICATED CREAMS FOR THE CARE OF THE HANDS; MEDICATED CREAMS FOR THE CARE OF THE SKIN; MEDICATED CREAMS FOR THE EYES; MEDICATED CREAMS FOR THE FACE; MEDICATED CREAMS FOR THE FEET; MEDICATED CREAMS FOR THE LIPS; MEDICATED CREAMS FOR THE SKIN; MEDICATED CREAMS FOR USE IN THE CLEANSING OF SENSITIVE SKINS; MEDICATED CREAMS EXCLUDING SOAP FOR USE IN WASHING THE FACE AND BODY; MEDICATED CREAMS FOR THE SKIN; DEODORANT, DEODORANT STICKS AND DEODORANT CREAMS FOR HOUSEHOLD USE; TOPICAL ANTISEPTIC PREPARATIONS FOR MEDICAL USE; PESTICIDAL FUMIGATING PREPARATIONS FOR DESTROYING

**CLASS 5—(Continued).**

HARMFUL ORGANISMS IN THE SOIL; INSECT REPELLENTS; INSECT CATCHING ADHESIVE PAPERS; INSECT CATCHING ADHESIVE STRIPS; INSECT CATCHING ADHESIVES; INSECT GROWTH REGULATORS FOR AGRICULTURAL USE; INSECT MATING DISRUPTANTS IN THE NATURE OF PHEROMONES; INSECT REPELLENT INCENSE; INSECT REPELLENT PREPARATIONS; INSECT REPELLENTS; INSECT REPELLENTS FOR USE IN AGRICULTURE. INSECT REPELLENTS FOR USE ON THE PERSON; INSECT REPELLENTS FOR USE WITH ANIMALS; INSECT REPELLING ANKLE BANDS; INSECT REPELLING COLLARS; INSECT REPELLING NECK BANDS; INSECT REPELLING PREPARATIONS; INSECT REPELLING TAGS; INSECT REPELLING WRIST BANDS; INSECTICIDAL PREPARATIONS FOR ANIMALS; INSECTICIDAL STRIPS; INSECTICIDES FOR AGRICULTURAL AND DOMESTIC USE; INSECTICIDES FOR AGRICULTURAL USE ON ARABLE LAND; INSECTICIDES FOR AGRICULTURAL USE ON CROPS; INSECTICIDES FOR DOMESTIC USE; INSECTICIDES FOR KILLING MOSQUITOS; INSECTICIDES FOR USE AS SEED DRESSINGS; INSECTICIDES FOR VETERINARY USE; MEDICAL MOUTHWASHES; MEDICAL PLASTERS; MEDICATED SKIN BALMS; MEDICATED CLEANSING PREPARATIONS FOR THE SKIN (OTHER THAN SOAP); MEDICATED CREAMS FOR APPLICATION TO THE SKIN; MEDICATED CREAMS FOR THE CARE OF THE FEET; MEDICATED CREAMS FOR THE TREATMENT OF THE BODY; MEDICATED CREAMS FOR THE TREATMENT OF THE FACE; MEDICATED MOUTH SPRAY; MEDICATED MOUTH WASHES; MEDICATED MOUTH WASHES FOR PREVENTING PLAQUE; MEDICATED MOUTH WASHES FOR THE PREVENTION OF TARTAR; MEDICATED MOUTH WASHES FOR THE REMOVAL OF PLAQUE; MEDICATED MOUTH WASHES FOR THE REMOVAL OF TARTAR; MEDICATED MOUTH WASHES FOR THE TREATMENT OF PLAQUE; MEDICATED MOUTH WASHES FOR THE TREATMENT OF TARTAR; MEDICATED TALCUM POWDER; MEDICINAL ALCOHOL; MEDICINAL BEVERAGES; MEDICINAL CREAMS FOR THE PROTECTION OF THE SKIN; MOSQUITO REPELLENTS; MEDICINAL SKIN CREAMS CONTAINING IRISH MOSS FOR MEDICAL PURPOSES; MOSS KILLERS; MOSS KILLING SUBSTANCES; MOTH REPELLENTS; MOTH-BALLS; MOTHPROOFING PAPER; MOTHPROOFING PREPARATIONS; MOULDING WAX FOR DENTISTS; BREATH AND MOUTH FRESHENERS FOR MEDICAL USE; MOUTH RINSES FOR MEDICAL USE; MOUTH SPRAYS FOR MEDICAL USE. MOUTH RINSES FOR MEDICAL USE; MEDICATED MOUTHWASH PREPARATIONS FOR ORAL HYGIENE PURPOSES; MOUTHWASHES (GARGLES) FOR MEDICAL PURPOSES; MOUTHWASHES FOR MEDICAL PURPOSES; NASAL DECONGESTANTS; NASAL DROPS FOR THE TREATMENT OF ALLERGIES; NASAL SPRAY FOR THE TREATMENT OF ALLERGIES; NASAL WASHES; MEDICATED NATURAL BODY CARE CREAMS, BALMS, AND WASHES FOR THE FACE; OILS ADAPTED FOR MEDICAL USE; ORAL DISINFECTANTS; PAIN RELIEVING CREAMS; PAIN RELIEVING PREPARATIONS; PAIN RELIEVING SUBSTANCES; PAPER ADHESIVE TAPE FOR MEDICAL PURPOSES; PAPER TISSUES IMPREGNATED WITH ANTIMICROBIAL PREPARATIONS FOR MEDICAL USE; PAPER TOWELS IMPREGNATED WITH ANTIMICROBIAL PREPARATIONS; PAPER WIPES IMPREGNATED WITH ANTIMICROBIAL PREPARATIONS; PRE-MOISTENED MEDICATED WIPES; PARASITICIDES; PARASITICIDES FOR LIVESTOCK; POWDERS FOR KILLING FLEAS; POWDERS FOR KILLING FLEAS ON ANIMALS; MEDICATED POWDERS FOR SKIN CARE; FEMININE HYGIENE PADS; VETERINARY PREPARATIONS FOR THE CONTROL OF MASTITIS IN ANIMALS; INSECT REPELLENTS; REPELLENTS FOR ANIMALS; REPELLENTS FOR CATS; REPELLENTS FOR DOGS; ROOM DEODOR-

**CLASS 5—(Continued).**

ANTS; ROOM DEODORIZING PREPARATIONS; SANITARY NAPKINS; SANITARY PADS; SANITARY PADS FOR USE IN FEMININE HYGIENE; WIPES AND TISSUES IMPREGNATED WITH PHARMACEUTICAL LOTIONS FOR THE TREATMENT OF SKIN CONDITIONS; ANTISEPTIC AND SANITIZING WIPES FOR HYGIENIC PURPOSES; ANTISEPTIC WIPES FOR MEDICAL USE; WIPES FOR MEDICAL USE IMPREGNATED WITH SANITIZING PREPARATIONS; MEDICATED WIPES FOR SURGICAL USE; WIPES MADE OF TISSUE IMPREGNATED WITH SANITIZING PREPARATIONS (U.S. CLS. 6, 18, 44, 46, 51 AND 52).

JOHN E. MICHOS, EXAMINING ATTORNEY

SN 79-092,966. ASTELLAS PHARMA INC., JAPAN, FILED 1-4-2011.

# CAXADE

PRIORITY DATE OF 7-15-2010 IS CLAIMED.  
OWNER OF INTERNATIONAL REGISTRATION 1066209 DATED 1-4-2011, EXPIRES 1-4-2021.  
FOR PHARMACEUTICAL PREPARATIONS FOR THE TREATMENT OF DIABETES (U.S. CLS. 6, 18, 44, 46, 51 AND 52).  
STEPHANIE ALI, EXAMINING ATTORNEY

SN 79-092,967. ASTELLAS PHARMA INC., JAPAN, FILED 1-4-2011.

# ETOGLER

PRIORITY DATE OF 7-15-2010 IS CLAIMED.  
OWNER OF INTERNATIONAL REGISTRATION 1066210 DATED 1-4-2011, EXPIRES 1-4-2021.  
FOR PHARMACEUTICAL PREPARATIONS FOR THE TREATMENT OF DIABETES (U.S. CLS. 6, 18, 44, 46, 51 AND 52).  
STEPHANIE ALI, EXAMINING ATTORNEY

SN 79-092,968. ASTELLAS PHARMA INC., JAPAN, FILED 1-4-2011.

# GREMOVI

PRIORITY DATE OF 7-15-2010 IS CLAIMED.  
OWNER OF INTERNATIONAL REGISTRATION 1066211 DATED 1-4-2011, EXPIRES 1-4-2021.  
FOR PHARMACEUTICAL PREPARATIONS FOR THE TREATMENT OF DIABETES (U.S. CLS. 6, 18, 44, 46, 51 AND 52).  
STEPHANIE ALI, EXAMINING ATTORNEY

**CLASS 5—(Continued).**

SN 79-092,969. ASTELLAS PHARMA INC., JAPAN, FILED 1-4-2011.

# MEVONI

PRIORITY DATE OF 7-15-2010 IS CLAIMED.  
OWNER OF INTERNATIONAL REGISTRATION 1066212 DATED 1-4-2011, EXPIRES 1-4-2021.  
FOR PHARMACEUTICAL PREPARATIONS FOR THE TREATMENT OF DIABETES (U.S. CLS. 6, 18, 44, 46, 51 AND 52).  
STEPHANIE ALI, EXAMINING ATTORNEY

SN 79-092,970. ASTELLAS PHARMA INC., JAPAN, FILED 1-4-2011.

# SUGLAT

PRIORITY DATE OF 7-15-2010 IS CLAIMED.  
OWNER OF INTERNATIONAL REGISTRATION 1066213 DATED 1-4-2011, EXPIRES 1-4-2021.  
FOR PHARMACEUTICAL PREPARATIONS FOR THE TREATMENT OF DIABETES (U.S. CLS. 6, 18, 44, 46, 51 AND 52).  
STEPHANIE ALI, EXAMINING ATTORNEY

SN 79-092,977. WELLNESS COACHING PTY LTD, AUSTRALIA, FILED 1-4-2011.

# ThyroSynergy

THE MARK CONSISTS OF STANDARD CHARACTERS WITHOUT CLAIM TO ANY PARTICULAR FONT, STYLE, SIZE, OR COLOR.  
OWNER OF INTERNATIONAL REGISTRATION 1066243 DATED 1-4-2011, EXPIRES 1-4-2021.  
FOR NUTRITIONAL SUPPLEMENTS (U.S. CLS. 6, 18, 44, 46, 51 AND 52).  
STEPHANIE ALI, EXAMINING ATTORNEY

SN 79-093,929. VOCO GMBH, FED REP GERMANY, FILED 12-22-2010.

# Cimara

THE MARK CONSISTS OF STANDARD CHARACTERS WITHOUT CLAIM TO ANY PARTICULAR FONT, STYLE, SIZE, OR COLOR.  
OWNER OF INTERNATIONAL REGISTRATION 1068114 DATED 12-22-2010, EXPIRES 12-22-2020.  
FOR PHARMACEUTICAL PRODUCTS AND MATERIALS FOR DENTAL MEDICINE, NAMELY DENTAL FILLING MATERIALS AND DENTAL CEMENTS (U.S. CLS. 6, 18, 44, 46, 51 AND 52).  
SUZANNE BLANE, EXAMINING ATTORNEY



**CLASS 5—(Continued).**

SN 79-094,051. BOEHRINGER INGELHEIM INTERNATIONAL GMBH, FED REP GERMANY, FILED 12-20-2010.

# LEBAURO

THE MARK CONSISTS OF STANDARD CHARACTERS WITHOUT CLAIM TO ANY PARTICULAR FONT, STYLE, SIZE, OR COLOR.

OWNER OF INTERNATIONAL REGISTRATION 1068333 DATED 12-20-2010, EXPIRES 12-20-2020.

FOR PHARMACEUTICAL PREPARATIONS, NAMELY, PHARMACEUTICAL PREPARATIONS FOR THE TREATMENT OF DISEASES AND DISORDERS OF THE ALIMENTARY TRACT AND METABOLISM, AND BLOOD AND BLOOD FORMING ORGANS; PHARMACEUTICAL PREPARATIONS FOR THE TREATMENT OF DISEASES AND DISORDERS OF CARDIOVASCULAR SYSTEM, MUSCULOSKELETAL SYSTEM, CENTRAL NERVOUS SYSTEM, PERIPHERAL NERVOUS SYSTEM, GENITOURINARY SYSTEM AND RESPIRATORY SYSTEM; PHARMACEUTICAL PREPARATIONS FOR THE TREATMENT OF DERMATOLOGICAL, HORMONAL, INFECTIOUS, VIRAL AND ONCOLOGICAL DISEASES AND DISORDERS (U.S. CLS. 6, 18, 44, 46, 51 AND 52).

ALICE BENMAMAN, EXAMINING ATTORNEY

**CLASS 5—(Continued).**

SN 79-094,493. FRESENIUS KABI AG, FED REP GERMANY, FILED 12-16-2010.

# Reconvan

THE MARK CONSISTS OF STANDARD CHARACTERS WITHOUT CLAIM TO ANY PARTICULAR FONT, STYLE, SIZE, OR COLOR.

OWNER OF INTERNATIONAL REGISTRATION 0893865 DATED 6-8-2006, EXPIRES 6-8-2016.

FOR PHARMACEUTICAL PREPARATIONS, NAMELY TUBE FEEDINGS FOR ENTERAL NUTRITION FOR INTENSIVE CARE PATIENTS (U.S. CLS. 6, 18, 44, 46, 51 AND 52).

SUZANNE BLANE, EXAMINING ATTORNEY

SN 85-009,642. HONIG, ISAAC, BROOKLYN, NY. FILED 4-8-2010.

## Sprouts Healing with Green

THE MARK CONSISTS OF STANDARD CHARACTERS WITHOUT CLAIM TO ANY PARTICULAR FONT, STYLE, SIZE, OR COLOR.

NO CLAIM IS MADE TO THE EXCLUSIVE RIGHT TO USE "SPROUTS" AND "GREEN", APART FROM THE MARK AS SHOWN.

FOR DIETARY SUPPLEMENTS MADE FROM HERBS (U.S. CLS. 6, 18, 44, 46, 51 AND 52).

RONALD AIKENS, EXAMINING ATTORNEY

SN 79-094,221. NOVARTIS AG, SWITZERLAND, FILED 1-31-2011.

# FARIDAK

THE MARK CONSISTS OF STANDARD CHARACTERS WITHOUT CLAIM TO ANY PARTICULAR FONT, STYLE, SIZE, OR COLOR.

PRIORITY DATE OF 1-21-2011 IS CLAIMED.

OWNER OF INTERNATIONAL REGISTRATION 1068820 DATED 1-31-2011, EXPIRES 1-31-2021.

FOR PHARMACEUTICAL PREPARATIONS FOR THE PREVENTION AND TREATMENT OF DISORDERS OF THE NERVOUS SYSTEM, THE IMMUNE SYSTEM, THE CARDIO-VASCULAR SYSTEM, THE METABOLIC SYSTEM, THE RESPIRATORY SYSTEM, THE MUSCULOSKELETAL SYSTEM, THE GENITOURINARY SYSTEM; PHARMACEUTICAL PREPARATIONS FOR USE IN DERMATOLOGY, ONCOLOGY, NEPHROLOGY, HEMATOLOGY AND IN TISSUE AND ORGAN TRANSPLANTATION, IN OPHTHALMOLOGY, AND FOR GASTROENTEROLOGICAL DISORDERS; PHARMACEUTICAL PREPARATIONS FOR THE PREVENTION AND TREATMENT OF OCULAR DISORDERS OR DISEASES; PHARMACEUTICAL PREPARATIONS FOR THE TREATMENT OF BACTERIA-BASED DISEASES; PHARMACEUTICAL PREPARATIONS FOR THE TREATMENT OF DIABETES, ANTI-INFECTIVE PREPARATIONS, ANTIVIRAL PREPARATIONS, ANTIBIOTICS, ANTI-FUNGAL PREPARATIONS (U.S. CLS. 6, 18, 44, 46, 51 AND 52).

JUSTINE D. PARKER, EXAMINING ATTORNEY

SN 85-020,113. DR. CATHERINE WILBERT, MANDEVILLE, LA. FILED 4-21-2010.



Wellness  
Innovations

THE MARK CONSISTS OF THE WORDING WELLNESS INNOVATIONS WRITTEN IN A STYLIZED FONT WITH AN IMAGE OF A LOTUS APPEARING TO THE RIGHT OF THE TERM WELLNESS AND OVER THE WORD INNOVATIONS.

FOR DIETARY AND NUTRITIONAL SUPPLEMENTS (U.S. CLS. 6, 18, 44, 46, 51 AND 52).

FIRST USE 1-1-2010; IN COMMERCE 1-1-2010.

RICHARD WHITE, EXAMINING ATTORNEY

**CLASS 5—(Continued).**

SN 85-021,910. AQTIS I.P. B.V., UTRECHT, NETHERLANDS, FILED 4-23-2010.

# ELLANSÉ

THE MARK CONSISTS OF STANDARD CHARACTERS WITHOUT CLAIM TO ANY PARTICULAR FONT, STYLE, SIZE, OR COLOR.

PRIORITY CLAIMED UNDER SEC. 44(D) ON BENELUX APPLICATION NO. 1198204, FILED 2-26-2010, REG. NO. 0879382, DATED 4-9-2010, EXPIRES 2-26-2020.

THE WORDING "ELLANSÉ" HAS NO MEANING IN A FOREIGN LANGUAGE.

FOR MEDICAL DERMATOLOGICAL PREPARATIONS, NAMELY, INJECTABLE DERMAL FILLER IN THE FORM OF PRE-FILLED SYRINGES FOR USE IN FILLING OUT WRINKLES, FOLDS, SCARS, LIPS, FOR FACE AND BODY CONTOURING AND FOR REJUVENATING THE SKIN; MEDICAL TREATMENT PREPARATIONS FOR COSMETIC RESTORATION AND AUGMENTATION, NAMELY, INJECTABLE DERMAL FILLER IN THE FORM OF PRE-FILLED SYRINGES FOR USE AS A TREATMENT ALTERNATIVE TO PLASTIC SURGERY AND INTERNAL TISSUE AUGMENTATION, ALL THE AFOREMENTIONED GOODS EXCLUDING BODY SLIMMING PRODUCTS (U.S. CLS. 6, 18, 44, 46, 51 AND 52).

STEVEN PEREZ, EXAMINING ATTORNEY

SN 85-025,948. CALLIDUS BIOPHARMA, INC., BENSALEM, PA. FILED 4-29-2010.



NO CLAIM IS MADE TO THE EXCLUSIVE RIGHT TO USE "BIOPHARMA", APART FROM THE MARK AS SHOWN.

THE MARK CONSISTS OF A DESIGN OF THREE STACKED DIAGONAL BARS WITH A FAINT MIRROR IMAGE IN THE BACKGROUND. TO THE RIGHT OF THE DESIGN IS THE WORDING "CALLIDUS" WITH A LINE UNDERNEATH THE "CALL" LETTERING AND THE WORD "BIOPHARMA" TO THE RIGHT OF THE UNDERLINE.

FOR PHARMACEUTICALS USED IN ENZYME REPLACEMENT THERAPIES (U.S. CLS. 6, 18, 44, 46, 51 AND 52).

JENNIFER VASQUEZ, EXAMINING ATTORNEY

**CLASS 5—(Continued).**

SN 85-029,748. AMERICAN BOTANICAL PHARMACY, MARINA DEL REY, CA. FILED 5-4-2010.

## DR. SCHULZE'S ENERGY "SHOT"

THE MARK CONSISTS OF STANDARD CHARACTERS WITHOUT CLAIM TO ANY PARTICULAR FONT, STYLE, SIZE, OR COLOR.

OWNER OF U.S. REG. NOS. 3,253,227, 3,549,136 AND OTHERS.

NO CLAIM IS MADE TO THE EXCLUSIVE RIGHT TO USE "ENERGY SHOT", APART FROM THE MARK AS SHOWN.

THE NAME(S), PORTRAIT(S), AND/OR SIGNATURE(S) SHOWN IN THE MARK IDENTIFIES DR. RICHARD "SCHULZE", WHOSE CONSENT(S) TO REGISTER IS MADE OF RECORD.

FOR HERBAL SUPPLEMENTS (U.S. CLS. 6, 18, 44, 46, 51 AND 52).

FIRST USE 12-0-2009; IN COMMERCE 1-0-2010.

MORGAN WYNNE, EXAMINING ATTORNEY

SN 85-037,155. A BETTER WEIGH, INC., CHICAGO, IL. FILED 5-12-2010.

# LIPO-IGNITE

THE MARK CONSISTS OF STANDARD CHARACTERS WITHOUT CLAIM TO ANY PARTICULAR FONT, STYLE, SIZE, OR COLOR.

FOR PHARMACEUTICAL PREPARATION IN THE NATURE OF A CUSTOM BLEND INJECTION FOR PURPOSES OF WEIGHT LOSS (U.S. CLS. 6, 18, 44, 46, 51 AND 52).

FIRST USE 7-1-2009; IN COMMERCE 7-1-2009.

DOMINIC FATHY, EXAMINING ATTORNEY

SN 85-038,355. MCGIBBONS, STEVE, SAN DIEGO, CA. FILED 5-13-2010.

# 4-Change

THE MARK CONSISTS OF STANDARD CHARACTERS WITHOUT CLAIM TO ANY PARTICULAR FONT, STYLE, SIZE, OR COLOR.

FOR DIETARY SUPPLEMENTS (U.S. CLS. 6, 18, 44, 46, 51 AND 52).

DANNEAN HETZEL, EXAMINING ATTORNEY

**CLASS 5—(Continued).**

SN 85-041,393. MANUEL ISRAEL MALACARA ESPERÓN, MEXICO, D.F., MEXICO, FILED 5-18-2010.



THE COLOR(S) SILVER AND MAROON IS/ARE CLAIMED AS A FEATURE OF THE MARK.

THE MARK CONSISTS OF THE WORDING "MOINSAGE" IN SILVER ON A RECTANGLE WITH A MAROON BACKGROUND.

THE WORDING "MOINSAGE" HAS NO MEANING IN A FOREIGN LANGUAGE.

FOR PHARMACEUTICAL PRODUCTS, NAMELY, ANTI-OXIDANTS FOR RETARDING THE AGING PROCESS (U.S. CLS. 6, 18, 44, 46, 51 AND 52).

BILL DAWE, EXAMINING ATTORNEY

SN 85-051,423. GEBAUER COMPANY, CLEVELAND, OH. FILED 6-1-2010.

**ACCU-STREAM 360**

THE MARK CONSISTS OF STANDARD CHARACTERS WITHOUT CLAIM TO ANY PARTICULAR FONT, STYLE, SIZE, OR COLOR.

FOR PHARMACEUTICAL PREPARATIONS, NAMELY, TOPICAL ANESTHETICS, ANALGESICS, SKIN REFRIGERANTS, DISPENSABLE VAPOCOOLANTS, AND DISPENSABLE VAPOCOOLANTS IN THE NATURE OF ETHYL CHLORIDE (U.S. CLS. 6, 18, 44, 46, 51 AND 52).

WILLIAM P. SHANAHAN, EXAMINING ATTORNEY

SN 85-051,510. GEBAUER COMPANY, CLEVELAND, OH. FILED 6-1-2010.

**ACCU-STREAM 360 WITH SURE LOCK TECHNOLOGY**

THE MARK CONSISTS OF STANDARD CHARACTERS WITHOUT CLAIM TO ANY PARTICULAR FONT, STYLE, SIZE, OR COLOR.

NO CLAIM IS MADE TO THE EXCLUSIVE RIGHT TO USE "TECHNOLOGY", APART FROM THE MARK AS SHOWN.

FOR PHARMACEUTICAL PREPARATIONS, NAMELY, TOPICAL ANESTHETICS, ANALGESICS, SKIN REFRIGERANTS, DISPENSABLE VAPOCOOLANTS, AND DISPENSABLE VAPOCOOLANTS IN THE NATURE OF ETHYL CHLORIDE (U.S. CLS. 6, 18, 44, 46, 51 AND 52).

WILLIAM P. SHANAHAN, EXAMINING ATTORNEY

**CLASS 5—(Continued).**

SN 85-052,374. TIBOTEC PHARMACEUTICALS, LITTLE ISLAND CO. CORK, IRELAND, FILED 6-2-2010.

**ROSPERO**

THE MARK CONSISTS OF STANDARD CHARACTERS WITHOUT CLAIM TO ANY PARTICULAR FONT, STYLE, SIZE, OR COLOR.

FOR HUMAN PHARMACEUTICAL PREPARATIONS FOR THE TREATMENT OF ANTI-VIRAL DISEASES, AUTO-IMMUNE AND INFLAMMATORY DISEASES, CARDIOVASCULAR DISEASES, CENTRAL NERVOUS SYSTEM DISEASES, PAIN, DERMATOLOGIC DISORDERS, INFECTIOUS-RELATED DISEASES, METABOLIC DISEASES, GASTROINTESTINAL DISEASES, MUSCLE DYSTONIAS, WRINKLES AND SMOOTH MUSCLE DISORDERS, ONCOLOGIC DISEASES, OPHTHALMIC DISEASES, RESPIRATORY DISEASES; VACCINES; AND HEMOSTATIC AGENTS (U.S. CLS. 6, 18, 44, 46, 51 AND 52).

KAPIL BHANOT, EXAMINING ATTORNEY

SN 85-052,375. TIBOTEC PHARMACEUTICALS, LITTLE ISLAND CO. CORK, IRELAND, FILED 6-2-2010.

**INTHUSA**

THE MARK CONSISTS OF STANDARD CHARACTERS WITHOUT CLAIM TO ANY PARTICULAR FONT, STYLE, SIZE, OR COLOR.

FOR HUMAN PHARMACEUTICAL PREPARATIONS FOR THE TREATMENT OF ANTI-VIRAL DISEASES, AUTO-IMMUNE AND INFLAMMATORY DISEASES, CARDIOVASCULAR DISEASES, CENTRAL NERVOUS SYSTEM DISEASES, PAIN, DERMATOLOGIC DISORDERS, INFECTIOUS-RELATED DISEASES, METABOLIC DISEASES, GASTROINTESTINAL DISEASES, MUSCLE DYSTONIAS, WRINKLES AND SMOOTH MUSCLE DISORDERS, ONCOLOGIC DISEASES, OPHTHALMIC DISEASES, RESPIRATORY DISEASES; VACCINES; AND HEMOSTATIC AGENTS (U.S. CLS. 6, 18, 44, 46, 51 AND 52).

KAPIL BHANOT, EXAMINING ATTORNEY

**CLASS 5—(Continued).**

SN 85-052,376. TIBOTEC PHARMACEUTICALS, LITTLE ISLAND CO. CORK, IRELAND, FILED 6-2-2010.

# COURENA

THE MARK CONSISTS OF STANDARD CHARACTERS WITHOUT CLAIM TO ANY PARTICULAR FONT, STYLE, SIZE, OR COLOR.

FOR HUMAN PHARMACEUTICAL PREPARATIONS FOR THE TREATMENT OF ANTI-VIRAL DISEASES, AUTO-IMMUNE AND INFLAMMATORY DISEASES, CARDIOVASCULAR DISEASES, CENTRAL NERVOUS SYSTEM DISEASES, PAIN, DERMATOLOGIC DISORDERS, INFECTIOUS-RELATED DISEASES, METABOLIC DISEASES, GASTROINTESTINAL DISEASES, MUSCLE DYSTONIAS, WRINKLES AND SMOOTH MUSCLE DISORDERS, ONCOLOGIC DISEASES, OPHTHALMIC DISEASES, RESPIRATORY DISEASES; VACCINES; AND HEMOSTATIC AGENTS (U.S. CLS. 6, 18, 44, 46, 51 AND 52).

KAPIL BHANOT, EXAMINING ATTORNEY

**CLASS 5—(Continued).**

SN 85-052,378. TIBOTEC PHARMACEUTICALS, LITTLE ISLAND CO. CORK, IRELAND, FILED 6-2-2010.

# RIVANTA

THE MARK CONSISTS OF STANDARD CHARACTERS WITHOUT CLAIM TO ANY PARTICULAR FONT, STYLE, SIZE, OR COLOR.

FOR HUMAN PHARMACEUTICAL PREPARATIONS FOR THE TREATMENT OF ANTI-VIRAL DISEASES, AUTO-IMMUNE AND INFLAMMATORY DISEASES, CARDIOVASCULAR DISEASES, CENTRAL NERVOUS SYSTEM DISEASES, PAIN, DERMATOLOGIC DISORDERS, INFECTIOUS-RELATED DISEASES, METABOLIC DISEASES, GASTROINTESTINAL DISEASES, MUSCLE DYSTONIAS, WRINKLES AND SMOOTH MUSCLE DISORDERS, ONCOLOGIC DISEASES, OPHTHALMIC DISEASES, RESPIRATORY DISEASES; VACCINES; AND HEMOSTATIC AGENTS (U.S. CLS. 6, 18, 44, 46, 51 AND 52).

KAPIL BHANOT, EXAMINING ATTORNEY

---

SN 85-052,377. TIBOTEC PHARMACEUTICALS, LITTLE ISLAND CO. CORK, IRELAND, FILED 6-2-2010.

# VENJOIA

THE MARK CONSISTS OF STANDARD CHARACTERS WITHOUT CLAIM TO ANY PARTICULAR FONT, STYLE, SIZE, OR COLOR.

FOR HUMAN PHARMACEUTICAL PREPARATIONS FOR THE TREATMENT OF ANTI-VIRAL DISEASES, AUTO-IMMUNE AND INFLAMMATORY DISEASES, CARDIOVASCULAR DISEASES, CENTRAL NERVOUS SYSTEM DISEASES, PAIN, DERMATOLOGIC DISORDERS, INFECTIOUS-RELATED DISEASES, METABOLIC DISEASES, GASTROINTESTINAL DISEASES, MUSCLE DYSTONIAS, WRINKLES AND SMOOTH MUSCLE DISORDERS, ONCOLOGIC DISEASES, OPHTHALMIC DISEASES, RESPIRATORY DISEASES; VACCINES; AND HEMOSTATIC AGENTS (U.S. CLS. 6, 18, 44, 46, 51 AND 52).

KAPIL BHANOT, EXAMINING ATTORNEY

---

SN 85-052,379. TIBOTEC PHARMACEUTICALS, LITTLE ISLAND CO. CORK, IRELAND, FILED 6-2-2010.

# MANIFIQ

THE MARK CONSISTS OF STANDARD CHARACTERS WITHOUT CLAIM TO ANY PARTICULAR FONT, STYLE, SIZE, OR COLOR.

FOR HUMAN PHARMACEUTICAL PREPARATIONS FOR THE TREATMENT OF ANTI-VIRAL DISEASES, AUTO-IMMUNE AND INFLAMMATORY DISEASES, CARDIOVASCULAR DISEASES, CENTRAL NERVOUS SYSTEM DISEASES, PAIN, DERMATOLOGIC DISORDERS, INFECTIOUS-RELATED DISEASES, METABOLIC DISEASES, GASTROINTESTINAL DISEASES, MUSCLE DYSTONIAS, WRINKLES AND SMOOTH MUSCLE DISORDERS, ONCOLOGIC DISEASES, OPHTHALMIC DISEASES, RESPIRATORY DISEASES; VACCINES; AND HEMOSTATIC AGENTS (U.S. CLS. 6, 18, 44, 46, 51 AND 52).

KAPIL BHANOT, EXAMINING ATTORNEY

**CLASS 5—(Continued).**

SN 85-052,380. TIBOTEC PHARMACEUTICALS, LITTLE ISLAND CO. CORK, IRELAND, FILED 6-2-2010.

# EVOTION

THE MARK CONSISTS OF STANDARD CHARACTERS WITHOUT CLAIM TO ANY PARTICULAR FONT, STYLE, SIZE, OR COLOR.

FOR HUMAN PHARMACEUTICAL PREPARATIONS FOR THE TREATMENT OF ANTI-VIRAL DISEASES, AUTO-IMMUNE AND INFLAMMATORY DISEASES, CARDIOVASCULAR DISEASES, CENTRAL NERVOUS SYSTEM DISEASES, PAIN, DERMATOLOGIC DISORDERS, INFECTIOUS-RELATED DISEASES, METABOLIC DISEASES, GASTROINTESTINAL DISEASES, MUSCLE DYSTONIAS, WRINKLES AND SMOOTH MUSCLE DISORDERS, ONCOLOGIC DISEASES, OPHTHALMIC DISEASES, RESPIRATORY DISEASES; VACCINES; AND HEMOSTATIC AGENTS (U.S. CLS. 6, 18, 44, 46, 51 AND 52).

KAPIL BHANOT, EXAMINING ATTORNEY

SN 85-060,405. TIBOTEC PHARMACEUTICALS, LITTLE ISLAND CO. CORK, IRELAND, FILED 6-11-2010.

# BRILIA

THE MARK CONSISTS OF STANDARD CHARACTERS WITHOUT CLAIM TO ANY PARTICULAR FONT, STYLE, SIZE, OR COLOR.

FOR HUMAN PHARMACEUTICAL PREPARATIONS FOR THE TREATMENT OF ANTI-VIRAL DISEASES, AUTO-IMMUNE AND INFLAMMATORY DISEASES, CARDIOVASCULAR DISEASES, CENTRAL NERVOUS SYSTEM DISEASES, PAIN, DERMATOLOGIC DISORDERS, INFECTIOUS-RELATED DISEASES, METABOLIC DISEASES, GASTROINTESTINAL DISEASES, MUSCLE DYSTONIAS, WRINKLES AND SMOOTH MUSCLE DISORDERS, ONCOLOGIC DISEASES, OPHTHALMIC DISEASES, RESPIRATORY DISEASES; VACCINES; AND HEMOSTATIC AGENTS (U.S. CLS. 6, 18, 44, 46, 51 AND 52).

KAPIL BHANOT, EXAMINING ATTORNEY

**CLASS 5—(Continued).**

SN 85-060,407. TIBOTEC PHARMACEUTICALS, LITTLE ISLAND CO. CORK, IRELAND, FILED 6-11-2010.

# NUPREMIS

THE MARK CONSISTS OF STANDARD CHARACTERS WITHOUT CLAIM TO ANY PARTICULAR FONT, STYLE, SIZE, OR COLOR.

FOR HUMAN PHARMACEUTICAL PREPARATIONS FOR THE TREATMENT OF ANTI-VIRAL DISEASES, AUTO-IMMUNE AND INFLAMMATORY DISEASES, CARDIOVASCULAR DISEASES, CENTRAL NERVOUS SYSTEM DISEASES, PAIN, DERMATOLOGIC DISORDERS, INFECTIOUS-RELATED DISEASES, METABOLIC DISEASES, GASTROINTESTINAL DISEASES, MUSCLE DYSTONIAS, WRINKLES AND SMOOTH MUSCLE DISORDERS, ONCOLOGIC DISEASES, OPHTHALMIC DISEASES, RESPIRATORY DISEASES; VACCINES; AND HEMOSTATIC AGENTS (U.S. CLS. 6, 18, 44, 46, 51 AND 52).

KAPIL BHANOT, EXAMINING ATTORNEY

SN 85-063,424. HDM TRADEMARKS LTD., OAKVILLE, ONTARIO, CANADA, FILED 6-15-2010.

# DIET-TECH

THE MARK CONSISTS OF STANDARD CHARACTERS WITHOUT CLAIM TO ANY PARTICULAR FONT, STYLE, SIZE, OR COLOR.

FOR INGREDIENT BLEND SOLD AS AN INTEGRAL COMPONENT IN DIETARY AND NUTRITIONAL SUPPLEMENTS (U.S. CLS. 6, 18, 44, 46, 51 AND 52).

JAMES STEIN, EXAMINING ATTORNEY

SN 85-071,552. PROTHERICS INC., BRENTWOOD, TN, FILED 6-25-2010.

# CROFAB

OWNER OF U.S. REG. NO. 2,737,584.

THE MARK CONSISTS OF THE TERM "CROFAB" IN A STYLIZED FONT, WITH THE LETTERS "A" AND "B" IN UPPER CASE.

FOR CHEMICAL REAGENTS FOR MEDICAL OR VETERINARY PURPOSES FOR THE TREATMENT OF ENVENOMATION BY SNAKES; CHEMICAL REAGENTS FOR THERAPEUTIC AND DIAGNOSTIC PURPOSES FOR THE TREATMENT OF ENVENOMATION BY SNAKES; CHEMICO-PHARMACEUTICAL PREPARATIONS FOR THE TREATMENT OF ENVENOMATION BY SNAKES; CHEMICAL PREPARATIONS FOR MEDICAL OR PHARMACEUTICAL PURPOSES FOR THE TREATMENT OF ENVENOMATION BY SNAKES; MEDICINES FOR THE TREATMENT OF ENVENOMATION BY SNAKES; PHARMACEUTICAL AND VETERINARY PREPARATIONS FOR THE TREATMENT OF ENVENOMATION BY SNAKES (U.S. CLS. 6, 18, 44, 46, 51 AND 52).

JOSETTE BEVERLY, EXAMINING ATTORNEY

**CLASS 5—(Continued).**

SN 85-072,449. UNIMED INTERNATIONAL, INC., EDISON, NJ. FILED 6-27-2010.

CHAMONIX NUTRACEUTICALS

THE MARK CONSISTS OF STANDARD CHARACTERS WITHOUT CLAIM TO ANY PARTICULAR FONT, STYLE, SIZE, OR COLOR.

OWNER OF U.S. REG. NO. 3,022,428.

NO CLAIM IS MADE TO THE EXCLUSIVE RIGHT TO USE "NUTRACEUTICALS", APART FROM THE MARK AS SHOWN.

FOR DIETARY AND NUTRITIONAL SUPPLEMENTS; MIXED VITAMIN PREPARATIONS; VITAMIN SUPPLEMENTS (U.S. CLS. 6, 18, 44, 46, 51 AND 52).

FIRST USE 10-1-2007; IN COMMERCE 10-1-2007.

KATHERINE CHANG, EXAMINING ATTORNEY

SN 85-072,572. JOHNSON & JOHNSON, NEW BRUNSWICK, NJ. FILED 6-28-2010.

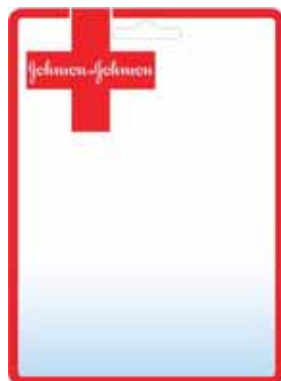

OWNER OF U.S. REG. NOS. 54,308, 1,889,576 AND OTHERS.

THE COLOR(S) RED, WHITE, BLUE IS/ARE CLAIMED AS A FEATURE OF THE MARK.

THE MARK CONSISTS OF A RECTANGLE SHAPE IN RED WITH THE STYLIZED WORDS "JOHNSON & JOHNSON" IN WHITE IN A RED CROSS ON THE UPPER LEFT SIDE OF THE RECTANGLE WITH THE BOTTOM IN LIGHT BLUE COLOR CHANGING TO WHITE.

FOR MEDICAL ADHESIVE TAPE, NAMELY, FIRST AID TAPES; AND WOUND DRESSINGS, NAMELY, WRAPS FOR SECURING DRESSINGS TO WOUNDS (U.S. CLS. 6, 18, 44, 46, 51 AND 52).

BENJAMIN OKEKE, EXAMINING ATTORNEY

**CLASS 5—(Continued).**

SN 85-083,031. TIBOTEC PHARMACEUTICALS, LITTLE ISLAND CO. CORK, IRELAND, FILED 7-13-2010.

BRILYA

THE MARK CONSISTS OF STANDARD CHARACTERS WITHOUT CLAIM TO ANY PARTICULAR FONT, STYLE, SIZE, OR COLOR.

FOR HUMAN PHARMACEUTICAL PREPARATIONS FOR THE TREATMENT OF ANTI-VIRAL DISEASES, AUTO-IMMUNE AND INFLAMMATORY DISEASES, CARDIOVASCULAR DISEASES, CENTRAL NERVOUS SYSTEM DISEASES, PAIN, DERMATOLOGIC DISORDERS, INFECTIOUS-RELATED DISEASES, METABOLIC DISEASES, GASTROINTESTINAL DISEASES, MUSCLE DYSTONIAS, WRINKLES AND SMOOTH MUSCLE DISORDERS, ONCOLOGIC DISEASES, OPHTHALMIC DISEASES, RESPIRATORY DISEASES; VACCINES; AND HEMOSTATIC AGENTS (U.S. CLS. 6, 18, 44, 46, 51 AND 52).

KAPIL BHANOT, EXAMINING ATTORNEY

SN 85-083,033. TIBOTEC PHARMACEUTICALS, LITTLE ISLAND CO. CORK, IRELAND, FILED 7-13-2010.

BRYLYA

THE MARK CONSISTS OF STANDARD CHARACTERS WITHOUT CLAIM TO ANY PARTICULAR FONT, STYLE, SIZE, OR COLOR.

FOR HUMAN PHARMACEUTICAL PREPARATIONS FOR THE TREATMENT OF ANTI-VIRAL DISEASES, AUTO-IMMUNE AND INFLAMMATORY DISEASES, CARDIOVASCULAR DISEASES, CENTRAL NERVOUS SYSTEM DISEASES, PAIN, DERMATOLOGIC DISORDERS, INFECTIOUS-RELATED DISEASES, METABOLIC DISEASES, GASTROINTESTINAL DISEASES, MUSCLE DYSTONIAS, WRINKLES AND SMOOTH MUSCLE DISORDERS, ONCOLOGIC DISEASES, OPHTHALMIC DISEASES, RESPIRATORY DISEASES; VACCINES; AND HEMOSTATIC AGENTS (U.S. CLS. 6, 18, 44, 46, 51 AND 52).

KAPIL BHANOT, EXAMINING ATTORNEY

**CLASS 5—(Continued).**

SN 85-084,059. PFIZER INC., NEW YORK, NY. FILED 7-14-2010.

# GLIMPZ

THE MARK CONSISTS OF STANDARD CHARACTERS WITHOUT CLAIM TO ANY PARTICULAR FONT, STYLE, SIZE, OR COLOR.

FOR PHARMACEUTICAL PREPARATIONS FOR THE TREATMENT OF CARDIOVASCULAR, CENTRAL NERVOUS SYSTEM, ENDOCRINE, GASTROINTESTINAL, HEMATOLOGIC, IMMUNOLOGICAL, INFECTIOUS, INFLAMMATORY, MENOPAUSAL, METABOLIC, MUSCULOSKELETAL, NEUROLOGICAL, ONCOLOGICAL, OPHTHALMOLOGICAL, PSYCHIATRIC, RESPIRATORY, UROGENITAL, UROLOGICAL AND VIRAL DISEASES AND DISORDERS; PHARMACEUTICAL PREPARATIONS FOR THE TREATMENT OF ERECTILE DYSFUNCTION, SEXUAL DYSFUNCTION AND PAIN; PHARMACEUTICAL PREPARATIONS, NAMELY, ANTI-FUNGAL PREPARATIONS, SMOKING CESSATION PREPARATIONS; VACCINES FOR HUMAN USE (U.S. CLS. 6, 18, 44, 46, 51 AND 52).

RAMONA ORTIGA, EXAMINING ATTORNEY

**CLASS 5—(Continued).**

SN 85-087,782. MYLAN INC., CANONSBURG, PA. FILED 7-19-2010.

## MYLAN INSTITUTIONAL

THE MARK CONSISTS OF STANDARD CHARACTERS WITHOUT CLAIM TO ANY PARTICULAR FONT, STYLE, SIZE, OR COLOR.

OWNER OF U.S. REG. NOS. 1,726,950, 3,343,114 AND OTHERS.

NO CLAIM IS MADE TO THE EXCLUSIVE RIGHT TO USE "INSTITUTIONAL", APART FROM THE MARK AS SHOWN.

FOR ANALGESICS; GENERAL ANESTHETICS; INHALANT ANESTHETICS; LOCAL ANESTHETICS; ANESTHETICS FOR SURGICAL AND NON-SURGICAL USE; ANTIBIOTICS; ANTIHISTAMINES; ANTI-INFECTIVE AGENTS; ANTI-INFLAMMATORY AGENTS; CONTRACEPTIVES; NEUROMUSCULAR REVERSAL AGENTS; MUSCLE RELAXANTS; PAIN RELIEVERS; PHARMACEUTICAL PREPARATIONS FOR THE TREATMENT OF CANCER, HYPERURICEMIA, CARDIOVASCULAR DISEASES AND DISORDERS, DERMATOLOGICAL DISEASES AND DISORDERS, UROLOGICAL DISEASES AND DISORDERS, GASTROINTESTINAL CONDITIONS, NEUROLOGICAL CONDITIONS, RESPIRATORY CONDITIONS, PSYCHIATRIC CONDITIONS, ALLERGIC CONDITIONS, METABOLIC CONDITIONS; WOUND DRESSINGS; VITAMINS (U.S. CLS. 6, 18, 44, 46, 51 AND 52).

RENEE SERVANCE, EXAMINING ATTORNEY

SN 85-097,051. ALTUCCELL INC., DIX HILLS, NY. FILED 7-30-2010.

# ALTuCELL

THE MARK CONSISTS OF STANDARD CHARACTERS WITHOUT CLAIM TO ANY PARTICULAR FONT, STYLE, SIZE, OR COLOR.

FOR PHARMACEUTICAL PREPARATIONS AND SUBSTANCES FOR CELL AND MOLECULAR THERAPY AND THE PREVENTION AND TREATMENT OF AUTO-IMMUNE DISORDERS, DIABETES AND DEGENERATIVE DISEASES; CELL PREPARATIONS, NAMELY, CELL GROWTH MEDIA FOR GROWING CELLS FOR MEDICAL PURPOSES AND STEM CELLS FOR USE IN FOR CELL AND MOLECULAR THERAPY AND THE TREATMENT OF AUTO-IMMUNE DISORDERS, DIABETES AND DEGENERATIVE DISEASES; LIVING TISSUE FOR MEDICAL PURPOSES, NAMELY, HUMAN ALLOGRAFT TISSUE, SURGICAL TISSUE, VASCULAR GRAFT, FOR USE IN RECONSTRUCTIVE SURGERY, BONE IMPLANTS COMPRISING LIVING TISSUE, IMPLANTABLE LIVING TISSUE, ENCAPSULATING CELLS, AND FOR IMPLANTING INTO HUMANS AND ANIMALS (U.S. CLS. 6, 18, 44, 46, 51 AND 52).

AMY C. KEAN, EXAMINING ATTORNEY

SN 85-086,648. TARO PHARMACEUTICAL INDUSTRIES LTD., HAIFA BAY, ISRAEL, FILED 7-16-2010.

# TERIL

THE MARK CONSISTS OF STANDARD CHARACTERS WITHOUT CLAIM TO ANY PARTICULAR FONT, STYLE, SIZE, OR COLOR.

FOR PHARMACEUTICAL PREPARATIONS FOR THE TREATMENT OF EPILEPSY AND NEURALGY, PHARMACEUTICAL PREPARATIONS, NAMELY, CARBAMAZEPINE (U.S. CLS. 6, 18, 44, 46, 51 AND 52).

DEBRA LEE, EXAMINING ATTORNEY

**CLASS 5—(Continued).**

SN 85-097,093. ALTUCCELL, INC., DIX HILLS, NY. FILED 7-30-2010.

# ALTSuLIN

THE MARK CONSISTS OF STANDARD CHARACTERS WITHOUT CLAIM TO ANY PARTICULAR FONT, STYLE, SIZE, OR COLOR.

FOR PHARMACEUTICAL PREPARATIONS AND SUBSTANCES FOR CELL AND MOLECULAR THERAPY AND THE PREVENTION AND TREATMENT OF AUTO-IMMUNE DISORDERS, DIABETES AND DEGENERATIVE DISEASES; CELL PREPARATIONS FOR CELL AND MOLECULAR THERAPY AND THE TREATMENT OF AUTO-IMMUNE DISORDERS, DIABETES AND DEGENERATIVE DISEASES; LIVING TISSUE FOR MEDICAL PURPOSES, NAMELY, HUMAN ALLOGRAFT TISSUE, SURGICAL TISSUE, VASCULAR GRAFT, FOR USE IN RECONSTRUCTIVE SURGERY, BONE IMPLANTS COMPRISING LIVING TISSUE, IMPLANTABLE LIVING TISSUE, ENCAPSULATING CELLS, AND FOR IMPLANTING INTO HUMANS AND ANIMALS (U.S. CLS. 6, 18, 44, 46, 51 AND 52).

MICHAEL ENGEL, EXAMINING ATTORNEY

SN 85-098,678. PROTHERICS INC., BRENTWOOD, TN. FILED 8-3-2010.

# CROFab

OWNER OF U.S. REG. NO. 2,737,584.

THE MARK CONSISTS OF THE TERM "CROFAB" IN A STYLIZED FONT, WITH THE LETTERS A AND B IN LOWER CASE.

FOR CHEMICAL REAGENTS FOR MEDICAL OR VETERINARY PURPOSES FOR THE TREATMENT OF ENVENOMATION BY SNAKES; CHEMICAL REAGENTS FOR THERAPEUTIC AND DIAGNOSTIC PURPOSES FOR THE TREATMENT OF ENVENOMATION BY SNAKES; CHEMICO-PHARMACEUTICAL PREPARATIONS FOR THE TREATMENT OF ENVENOMATION BY SNAKES; CHEMICAL PREPARATIONS FOR MEDICAL OR PHARMACEUTICAL PURPOSES FOR THE TREATMENT OF ENVENOMATION BY SNAKES; MEDICINES FOR THE TREATMENT OF ENVENOMATION BY SNAKES; PHARMACEUTICAL AND VETERINARY PREPARATIONS FOR THE TREATMENT OF ENVENOMATION BY SNAKES (U.S. CLS. 6, 18, 44, 46, 51 AND 52).

JOSETTE BEVERLY, EXAMINING ATTORNEY

**CLASS 5—(Continued).**

SN 85-111,144. SINOCEM CORPORATION, BEIJING, CHINA, FILED 8-19-2010.



OWNER OF U.S. REG. NOS. 3,120,986, 3,570,150 AND OTHERS.

THE MARK CONSISTS OF A HALF-FILLED BEAKER WITH AN ARCHED BOARDER ALONG THE BOTTOM SIDE OF THE BEAKER CONTAINING "SINOCEM".

FOR HERBICIDES FOR AGRICULTURAL USE; PREPARATIONS FOR DESTROYING NOXIOUS PLANTS; PREPARATIONS FOR DESTROYING NOXIOUS ANIMALS; INSECTICIDES; PESTICIDES; GERMICIDES FOR AGRICULTURE PURPOSES; FUNGICIDES FOR AGRICULTURE PURPOSES; PLANT GROWTH REGULATING PREPARATIONS; DIETARY SUPPLEMENTS ADAPTED FOR MEDICAL USE; SURGICAL TISSUES; MEDICATED SUPPLEMENTS FOR FOODSTUFFS FOR ANIMALS; MEDICINAL HERBAL PREPARATIONS; MEDICINAL PREPARATIONS FOR THE TREATMENT OF INFECTIOUS DISEASES AND FOR USE IN ONCOLOGY; MIXED VITAMIN PREPARATIONS; NATURAL HERBAL SUPPLEMENTS; BIOLOGICAL PREPARATIONS FOR THE TREATMENT OF CANCER; AGRICULTURAL BIOPESTICIDES; CHEMICAL PREPARATIONS FOR SANITARY USE; CHEMICAL PREPARATIONS TO TREAT WHEAT SMUT; CHEMICAL REAGENTS FOR MEDICAL OR VETERINARY PURPOSES; CHEMICAL PREPARATIONS FOR TREATING PHYLLXERA (U.S. CLS. 6, 18, 44, 46, 51 AND 52).

ALICIA COLLINS, EXAMINING ATTORNEY

SN 85-112,602. NTH DEGREE INNOVATIONS, INC., MILLTOWN, NJ. FILED 8-20-2010.

## PROTEIN TO THE NTH DEGREE

THE MARK CONSISTS OF STANDARD CHARACTERS WITHOUT CLAIM TO ANY PARTICULAR FONT, STYLE, SIZE, OR COLOR.

NO CLAIM IS MADE TO THE EXCLUSIVE RIGHT TO USE "PROTEIN", APART FROM THE MARK AS SHOWN.

FOR DIETARY SUPPLEMENTS CONTAINING PROTEIN; NUTRITIONAL DRINK MIX FOR USE AS A MEAL REPLACEMENT CONTAINING PROTEIN; NUTRITIONAL SHAKES FOR USE AS A MEAL SUBSTITUTE CONTAINING PROTEIN; NUTRITIONAL SUPPLEMENT IN THE NATURE OF A NUTRIENT-DENSE, PROTEIN-BASED DRINK MIX; NUTRITIONAL SUPPLEMENTS CONTAINING PROTEIN; POWDERED NUTRITIONAL SUPPLEMENT DRINK MIX CONTAINING PROTEIN; PROTEIN SUPPLEMENTS (U.S. CLS. 6, 18, 44, 46, 51 AND 52).

LAURIE MAYES, EXAMINING ATTORNEY



**CLASS 5—(Continued).**

SN 85-117,240. JOHNSON & JOHNSON, NEW BRUNSWICK, NJ. FILED 8-27-2010.

# HURT-FREE

THE MARK CONSISTS OF STANDARD CHARACTERS WITHOUT CLAIM TO ANY PARTICULAR FONT, STYLE, SIZE, OR COLOR.

OWNER OF U.S. REG. NOS. 2,667,434, 2,872,900 AND 3,898,815.

SEC. 2(F).

FOR ANTISEPTIC WASH, SELF-ADHERING TAPE FOR USE IN FIRST AID (U.S. CLS. 6, 18, 44, 46, 51 AND 52).

FIRST USE 1-19-2001; IN COMMERCE 1-19-2001.  
VERNA BETH RIRIE, EXAMINING ATTORNEY

**CLASS 5—(Continued).**

SN 85-127,667. PROSYNTHESIS LABORATORIES, INC., STERLING, VA. FILED 9-12-2010.



NO CLAIM IS MADE TO THE EXCLUSIVE RIGHT TO USE "THE CHOCOLATE MILK DIET", APART FROM THE MARK AS SHOWN.

THE COLOR(S) LIGHT CHOCOLATE BROWN; DARK CHOCOLATE BROWN; TAN; BEIGE IS/ARE CLAIMED AS A FEATURE OF THE MARK.

THE MARK CONSISTS OF THE STYLIZED WORDS "THE IDEAL CHOCOLATE MILK DIET" PLUS TWO HORIZONTAL LINES APPEARING BETWEEN THE WORD "DIET". THE WORDING "THE" AND "IDEAL" APPEAR IN THE COLOR LIGHT CHOCOLATE BROWN. THE WORDING "CHOCOLATE MILK" APPEARS IN THE COLOR DARK CHOCOLATE BROWN SURROUNDED BY A TAN OUTLINE. THE TWO HORIZONTAL LINES APPEAR IN THE COLOR TAN. THE BACKGROUND APPEARS IN THE COLOR BEIGE.

FOR DIETARY SUPPLEMENTS IN THE NATURE OF WEIGHT LOSS POWDERS WHICH CONTAIN CHOCOLATE MILK DERIVATIVES (U.S. CLS. 6, 18, 44, 46, 51 AND 52).

CIMMERIAN COLEMAN, EXAMINING ATTORNEY

SN 85-119,071. ARNSTON, CATHARINE V., DBA THE NAUGHTY NUTRITIONIST, BOSTON, MA. FILED 8-30-2010.

# naughtybits

THE MARK CONSISTS OF STANDARD CHARACTERS WITHOUT CLAIM TO ANY PARTICULAR FONT, STYLE, SIZE, OR COLOR.

FOR DIETARY AND NUTRITIONAL SUPPLEMENTS; DIETARY FOOD SUPPLEMENTS (U.S. CLS. 6, 18, 44, 46, 51 AND 52).

FIRST USE 6-1-2010; IN COMMERCE 6-2-2010.

KARANENDRA S. CHHINA, EXAMINING ATTORNEY

SN 85-130,230. EXCELIMMUNE, INC, SOMERVILLE, MA. FILED 9-15-2010.

# EXCELIMMUNE

THE MARK CONSISTS OF STANDARD CHARACTERS WITHOUT CLAIM TO ANY PARTICULAR FONT, STYLE, SIZE, OR COLOR.

FOR PHARMACEUTICAL PREPARATIONS FOR THE PREVENTION AND TREATMENT OF VIRAL, INFECTIOUS, BACTERIAL, ONCOLOGICAL AND PROTEIN DISEASES IN HUMANS POTENTIALLY TREATED WITH ANTIBODIES; HUMAN RECOMBINANT POLYCLONAL ANTIBODIES FOR THE PREVENTION AND TREATMENT OF VIRAL, INFECTIOUS, BACTERIAL, ONCOLOGICAL AND PROTEIN DISEASES (U.S. CLS. 6, 18, 44, 46, 51 AND 52).

NICHOLAS COLEMAN, EXAMINING ATTORNEY

**CLASS 5—(Continued).**

SN 85-137,211. ARCH CHEMICALS, INC., NORWALK, CT. FILED 9-24-2010.

**RESTORE**<sub>S.M.A.R.T</sub>  
SELECTIVE MANAGEMENT AQUATIC RESTORATION TOOL

NO CLAIM IS MADE TO THE EXCLUSIVE RIGHT TO USE "RESTORE" OR "SELECTIVE MANAGEMENT AQUATIC RESTORATION TOOL", APART FROM THE MARK AS SHOWN.

THE COLOR(S) MAROON AND WHITE IS/ARE CLAIMED AS A FEATURE OF THE MARK.

THE MARK CONSISTS OF THE STYLIZED WORDING "RESTORE S.M.A.R.T." IN MAROON, AND THE STYLIZED WORDING "SELECTIVE MANAGEMENT AQUATIC RESTORATION TOOL" APPEARING BELOW THIS WORDING IN WHITE AGAINST A MAROON RECTANGULAR BACKGROUND. THE COLOR WHITE APPEARING IN THE REST OF THE MARK REPRESENTS BACKGROUND AND/OR TRANSPARENT AREA AND IS NOT PART OF THE MARK.

FOR AQUATIC HERBICIDES (U.S. CLS. 6, 18, 44, 46, 51 AND 52).

ANDREW LEASER, EXAMINING ATTORNEY

SN 85-139,420. AGROINDUSTRIAS FLORIS SOCIEDAD ANONIMA CERRADA, LIMA, LIMA, PERU, FILED 9-27-2010.

**SANTA NATURA**

THE MARK CONSISTS OF STANDARD CHARACTERS WITHOUT CLAIM TO ANY PARTICULAR FONT, STYLE, SIZE, OR COLOR.

OWNER OF PERU REG. NO. P00048770, DATED 9-15-1998, EXPIRES 9-15-2018.

NO CLAIM IS MADE TO THE EXCLUSIVE RIGHT TO USE "NATURA", APART FROM THE MARK AS SHOWN.

THE ENGLISH TRANSLATION OF "SANTA NATURA" IN THE MARK IS "SAINT" OR "HOLY NATURE".

FOR DIETARY AND NUTRITIONAL SUPPLEMENTS CONTAINING MEDICINAL HERBS AND ROOTS; DIETARY AND NUTRITIONALLY FORTIFIED FOOD PRODUCTS ADAPTED FOR MEDICAL USE; DIETARY FOOD SUPPLEMENTS; DIETARY SUPPLEMENTS FOR CHILDREN AND SICK PEOPLE; DIETETIC BEVERAGES ADAPTED FOR MEDICAL PURPOSES; DIETETIC FOODS ADAPTED FOR MEDICAL PURPOSES; DIETETIC FOODS ADAPTED FOR MEDICAL USE; MEDICAL AND SURGICAL DRESSINGS; MEDICAL AND SURGICAL PLASTERS; SANITARY PREPARATIONS FOR MEDICAL USE; SANITARY STERILIZING PREPARATIONS; VITAMINS (U.S. CLS. 6, 18, 44, 46, 51 AND 52).

RONALD DELGIZZI, EXAMINING ATTORNEY

**CLASS 5—(Continued).**

SN 85-139,654. ATRIUM INNOVATIONS INC., QUEBEC CITY, QUEBEC, CANADA, FILED 9-28-2010.

**GLUTEN FREEZE**

THE MARK CONSISTS OF STANDARD CHARACTERS WITHOUT CLAIM TO ANY PARTICULAR FONT, STYLE, SIZE, OR COLOR.

NO CLAIM IS MADE TO THE EXCLUSIVE RIGHT TO USE "GLUTEN", APART FROM THE MARK AS SHOWN.

FOR DIETARY AND NUTRITIONAL SUPPLEMENTS, NOT CONTAINING GLUTEN (U.S. CLS. 6, 18, 44, 46, 51 AND 52).

FIRST USE 8-12-2010; IN COMMERCE 8-12-2010.

KATHLEEN LORENZO, EXAMINING ATTORNEY

SN 85-139,819. ATRIUM INNOVATIONS INC., QUEBEC CITY, QUEBEC, CANADA, FILED 9-28-2010.

**YEAST FREEZE**

THE MARK CONSISTS OF STANDARD CHARACTERS WITHOUT CLAIM TO ANY PARTICULAR FONT, STYLE, SIZE, OR COLOR.

NO CLAIM IS MADE TO THE EXCLUSIVE RIGHT TO USE "YEAST", APART FROM THE MARK AS SHOWN.

FOR DIETARY AND NUTRITIONAL SUPPLEMENTS, NOT CONTAINING YEAST (U.S. CLS. 6, 18, 44, 46, 51 AND 52).

FIRST USE 8-12-2010; IN COMMERCE 8-12-2010.

KATHLEEN LORENZO, EXAMINING ATTORNEY

SN 85-145,755. PREMIER NUTRITION, INC., CARLSBAD, CA. FILED 10-5-2010.

**PREMIER PROTEIN**

THE MARK CONSISTS OF STANDARD CHARACTERS WITHOUT CLAIM TO ANY PARTICULAR FONT, STYLE, SIZE, OR COLOR.

OWNER OF U.S. REG. NO. 2,444,257.

NO CLAIM IS MADE TO THE EXCLUSIVE RIGHT TO USE "PROTEIN", APART FROM THE MARK AS SHOWN.

FOR MEAL REPLACEMENT POWDERS CONTAINING PROTEIN; MEAL REPLACEMENT SHAKES CONTAINING PROTEIN (U.S. CLS. 6, 18, 44, 46, 51 AND 52).

FIRST USE 1-16-2007; IN COMMERCE 1-16-2007.

JUSTINE D. PARKER, EXAMINING ATTORNEY

**CLASS 5—(Continued).**

SN 85-149,539. JOHNSON & JOHNSON, NEW BRUNSWICK, NJ. FILED 10-11-2010.



OWNER OF U.S. REG. NO. 3,851,000.  
THE MARK CONSISTS OF THE WORD "HYDROBLEND" UNDERNEATH A DESIGN OF A WATER DROPLET.  
FOR OPHTHALMIC PREPARATIONS (U.S. CLS. 6, 18, 44, 46, 51 AND 52).  
LAKEISHA LEWIS, EXAMINING ATTORNEY

SN 85-150,746. CELGENE CORPORATION, SUMMIT, NJ. FILED 10-12-2010.

# ZONLYST

THE MARK CONSISTS OF STANDARD CHARACTERS WITHOUT CLAIM TO ANY PARTICULAR FONT, STYLE, SIZE, OR COLOR.

OWNER OF SWITZERLAND REG. NO. 606507, DATED 10-6-2010, EXPIRES 10-6-2020.

FOR PHARMACEUTICAL PREPARATIONS, NAMELY, CYTOKINE INHIBITORY DRUGS; PHARMACEUTICAL PREPARATIONS THAT MODULATE THE IMMUNE SYSTEM; PHARMACEUTICAL PREPARATIONS FOR THE TREATMENT OF CERTAIN CANCERS AND BLOOD DISEASES AND PRINTED DOSAGE INSTRUCTIONAL MANUALS SOLD TOGETHER AS A UNIT (U.S. CLS. 6, 18, 44, 46, 51 AND 52).

WANDA KAY PRICE, EXAMINING ATTORNEY

SN 85-152,077. BIG APPLE SUPPLEMENTS, WHITE PLAINS, NY. FILED 10-13-2010.

# ZENERECT

THE MARK CONSISTS OF STANDARD CHARACTERS WITHOUT CLAIM TO ANY PARTICULAR FONT, STYLE, SIZE, OR COLOR.

FOR NATURAL SUPPLEMENTS FOR TREATING ERECTILE DYSFUNCTION (U.S. CLS. 6, 18, 44, 46, 51 AND 52).

FIRST USE 9-30-2008; IN COMMERCE 9-30-2008.  
JESSICA A. POWERS, EXAMINING ATTORNEY

**CLASS 5—(Continued).**

SN 85-157,785. SARTA, RICHARD, LAKE WORTH, FL. FILED 10-21-2010.

# chlorellina

THE MARK CONSISTS OF STANDARD CHARACTERS WITHOUT CLAIM TO ANY PARTICULAR FONT, STYLE, SIZE, OR COLOR.

FOR HEALTH FOOD SUPPLEMENTS (U.S. CLS. 6, 18, 44, 46, 51 AND 52).

FIRST USE 10-1-2010; IN COMMERCE 10-1-2010.  
DORITT L. CARROLL, EXAMINING ATTORNEY

SN 85-157,905. MANUEL ISRAEL MALACARA ESPERÓN, MEXICO, D.F., MEXICO, FILED 10-21-2010.



NO CLAIM IS MADE TO THE EXCLUSIVE RIGHT TO USE "FEMME" AND "HOMME", APART FROM THE MARK AS SHOWN.

THE COLOR(S) SILVER, RED AND BLACK IS/ARE CLAIMED AS A FEATURE OF THE MARK.

THE MARK CONSISTS OF THE WORD "PUASSANCE" IN SILVER LETTERS, THE WORDS "FEMME & HOMME" IN RED LETTERS AND A PARTIAL RED OVAL ON A BLACK BACKGROUND.

"PUASSANCE" DOES NOT HAVE ANY TRANSLATION. THE WORDING "FEMME & HOMME" TRANSLATE TO "WOMAN AND MAN" IN ENGLISH.

FOR PHARMACEUTICAL PRODUCTS TO BE USED TO INCREASE LIBIDO AND ENERGY (U.S. CLS. 6, 18, 44, 46, 51 AND 52).

JOHN E. MICHOS, EXAMINING ATTORNEY

SN 85-158,953. SANOFI-AVENTIS, PARIS, FRANCE, FILED 10-22-2010.

# DYSRUX

THE MARK CONSISTS OF STANDARD CHARACTERS WITHOUT CLAIM TO ANY PARTICULAR FONT, STYLE, SIZE, OR COLOR.

PRIORITY CLAIMED UNDER SEC. 44(D) ON FRANCE APPLICATION NO. 10/3763357, FILED 9-1-2010, REG. NO. 10/3763357, DATED 9-1-2010, EXPIRES 9-1-2020.

FOR PHARMACEUTICAL PREPARATIONS FOR THE PREVENTION AND TREATMENT OF CANCER (U.S. CLS. 6, 18, 44, 46, 51 AND 52).

JUDITH HELFMAN, EXAMINING ATTORNEY

**CLASS 5—(Continued).**

SN 85-158,960. SANOFI-AVENTIS, PARIS, FRANCE, FILED 10-22-2010.

**TIVOLZA**

THE MARK CONSISTS OF STANDARD CHARACTERS WITHOUT CLAIM TO ANY PARTICULAR FONT, STYLE, SIZE, OR COLOR.

PRIORITY CLAIMED UNDER SEC. 44(D) ON FRANCE APPLICATION NO. 10/3759252, FILED 8-6-2010, REG. NO. 10/3759252, DATED 8-6-2010, EXPIRES 8-6-2020.

FOR PHARMACEUTICAL PREPARATIONS FOR THE PREVENTION AND TREATMENT OF CANCER (U.S. CLS. 6, 18, 44, 46, 51 AND 52).

JUDITH HELFMAN, EXAMINING ATTORNEY

SN 85-158,968. SANOFI-AVENTIS, PARIS, FRANCE, FILED 10-22-2010.

**TURSEGE**

THE MARK CONSISTS OF STANDARD CHARACTERS WITHOUT CLAIM TO ANY PARTICULAR FONT, STYLE, SIZE, OR COLOR.

PRIORITY CLAIMED UNDER SEC. 44(D) ON FRANCE APPLICATION NO. 10/3763542, FILED 9-2-2010, REG. NO. 10/3763542, DATED 9-2-2010, EXPIRES 9-2-2020.

FOR PHARMACEUTICAL PREPARATIONS FOR THE PREVENTION AND TREATMENT OF CANCER (U.S. CLS. 6, 18, 44, 46, 51 AND 52).

JUDITH HELFMAN, EXAMINING ATTORNEY

SN 85-159,956. MEDI-PURE PRODUCTS INC., TA MEDI-PURE PRODUCTS INC, SARATOGA SPRINGS, UT, FILED 10-25-2010.

**M.P.H. Drops**

THE MARK CONSISTS OF STANDARD CHARACTERS WITHOUT CLAIM TO ANY PARTICULAR FONT, STYLE, SIZE, OR COLOR.

NO CLAIM IS MADE TO THE EXCLUSIVE RIGHT TO USE "DROPS", APART FROM THE MARK AS SHOWN.

FOR DIETARY AND NUTRITIONAL SUPPLEMENTS USED FOR WEIGHT LOSS (U.S. CLS. 6, 18, 44, 46, 51 AND 52).

FIRST USE 6-1-2010; IN COMMERCE 6-2-2010.

ANNE FARRELL, EXAMINING ATTORNEY

**CLASS 5—(Continued).**

SN 85-160,452. COUNTRY LIFE, LLC, HAUPPAUGE, NY, FILED 10-25-2010.

**TRI PROTEIN PLUS**

THE MARK CONSISTS OF STANDARD CHARACTERS WITHOUT CLAIM TO ANY PARTICULAR FONT, STYLE, SIZE, OR COLOR.

NO CLAIM IS MADE TO THE EXCLUSIVE RIGHT TO USE "TRI PROTEIN", APART FROM THE MARK AS SHOWN.

FOR DIETARY AND NUTRITIONAL SUPPLEMENTS CONTAINING PROTEIN (U.S. CLS. 6, 18, 44, 46, 51 AND 52).

FIRST USE 1-13-1998; IN COMMERCE 1-13-1998.

CAROLYN CATALDO, EXAMINING ATTORNEY

SN 85-161,139. DR. JAMES ZINREICH, OWENS MILLS, MD, FILED 10-26-2010.

**BREATHEZEN**

THE MARK CONSISTS OF STANDARD CHARACTERS WITHOUT CLAIM TO ANY PARTICULAR FONT, STYLE, SIZE, OR COLOR.

FOR NASAL SPRAY PREPARATIONS FOR NASAL AND PARANASAL SINUSES FOR THE PURPOSE OF IMPROVING AIRFLOW; NASAL RINSE PREPARATIONS FOR NASAL AND PARANASAL SINUSES FOR THE PURPOSE OF IMPROVING AIRFLOW (U.S. CLS. 6, 18, 44, 46, 51 AND 52).

MICHAEL SOUDERS, EXAMINING ATTORNEY

SN 85-162,795. HAMUI, LEON J., WESLEY CHAPEL, FL, FILED 10-27-2010.

**RARAMURI**

THE MARK CONSISTS OF STANDARD CHARACTERS WITHOUT CLAIM TO ANY PARTICULAR FONT, STYLE, SIZE, OR COLOR.

THE ENGLISH TRANSLATION OF THE WORD "RARAMURI" IN THE MARK IS RUNNERS ON FOOT OR THOSE WHO RUN FAST.

FOR DIETARY AND NUTRITIONAL SUPPLEMENTS (U.S. CLS. 6, 18, 44, 46, 51 AND 52).

ELLEN PERKINS, EXAMINING ATTORNEY

**CLASS 5—(Continued).**

SN 85-164,659. NUTRITION DISCOUNTERS, INC, VILLA PARK, IL. FILED 10-29-2010.

**ISO FORT**

THE MARK CONSISTS OF STANDARD CHARACTERS WITHOUT CLAIM TO ANY PARTICULAR FONT, STYLE, SIZE, OR COLOR.

NO CLAIM IS MADE TO THE EXCLUSIVE RIGHT TO USE "ISO", APART FROM THE MARK AS SHOWN.

FOR DIETARY AND NUTRITIONAL SUPPLEMENTS; DIETARY SUPPLEMENTS (U.S. CLS. 6, 18, 44, 46, 51 AND 52).

FIRST USE 6-1-2010; IN COMMERCE 6-1-2010.  
TARA PATE, EXAMINING ATTORNEY

**CLASS 5—(Continued).**

SN 85-172,848. KARREMAN, HUBERT J., NARVON, PA. FILED 11-9-2010.

**PHYTO-MAST**

THE MARK CONSISTS OF STANDARD CHARACTERS WITHOUT CLAIM TO ANY PARTICULAR FONT, STYLE, SIZE, OR COLOR.

FOR A NON-FEED BOTANICAL FORMULATION FOR BOVINE UDDER HEALTH, NAMELY, PLANT EXTRACTS FOR VETERINARY PURPOSES; A NON-FEED BOTANICAL FORMULATION FOR BOVINE UDDER HEALTH, NAMELY, NON-FEED SUPPLEMENTS FOR LIVESTOCK (U.S. CLS. 6, 18, 44, 46, 51 AND 52).

FIRST USE 1-5-2005; IN COMMERCE 1-5-2005.  
AISHA SALEM, EXAMINING ATTORNEY

SN 85-166,012. MERCK SHARP & DOHME CORP., WHITEHOUSE STATION, NJ. FILED 11-1-2010.

**CORDAPTIVE**

THE MARK CONSISTS OF STANDARD CHARACTERS WITHOUT CLAIM TO ANY PARTICULAR FONT, STYLE, SIZE, OR COLOR.

FOR PHARMACEUTICAL PREPARATIONS FOR THE TREATMENT OF CARDIOVASCULAR DISEASES AND DISORDERS (U.S. CLS. 6, 18, 44, 46, 51 AND 52).

ROBERT C. CLARK JR., EXAMINING ATTORNEY

SN 85-174,989. PARRY, CLARISSA, DBA PARRY'S GLUTEN-FREE BAKERY, SIMI VALLEY, CA. FILED 11-11-2010.

**SafeBread**

THE MARK CONSISTS OF STANDARD CHARACTERS WITHOUT CLAIM TO ANY PARTICULAR FONT, STYLE, SIZE, OR COLOR.

FOR WHEAT- AND GLUTEN-FREE BREAD MIXES TO ACCOMMODATE SPECIAL MEDICAL AND HEALTH CONDITIONS (U.S. CLS. 6, 18, 44, 46, 51 AND 52).

FIRST USE 5-7-2008; IN COMMERCE 4-25-2010.  
REBECCA SMITH, EXAMINING ATTORNEY

SN 85-171,480. KRAUSE, FREDRIC J, CORONA, CA. FILED 11-8-2010.

**GUN POWDER**

THE MARK CONSISTS OF STANDARD CHARACTERS WITHOUT CLAIM TO ANY PARTICULAR FONT, STYLE, SIZE, OR COLOR.

FOR DIETARY AND NUTRITIONAL SUPPLEMENTS (U.S. CLS. 6, 18, 44, 46, 51 AND 52).

FIRST USE 1-4-2003; IN COMMERCE 3-24-2003.  
JENNY PARK, EXAMINING ATTORNEY

SN 85-175,598. RUTH A. MCCARTY, DBA TCM BIOTHERAPEUTICS, LLC, SAN CLEMENTE, CA. FILED 11-12-2010.

**Eternal Spring of Life  
Herbs**

THE MARK CONSISTS OF STANDARD CHARACTERS WITHOUT CLAIM TO ANY PARTICULAR FONT, STYLE, SIZE, OR COLOR.

NO CLAIM IS MADE TO THE EXCLUSIVE RIGHT TO USE "HERBS", APART FROM THE MARK AS SHOWN.

FOR HERBS FOR MEDICINAL PURPOSES (U.S. CLS. 6, 18, 44, 46, 51 AND 52).

FIRST USE 2-28-2007; IN COMMERCE 2-28-2007.  
SUNG IN, EXAMINING ATTORNEY

**CLASS 5—(Continued).**

SN 85-175,725. THE RENU PROJECT COMPANY, DBA RENU TEA, UNIVERSITY PLACE, WA. FILED 11-12-2010.

# Renutea

THE MARK CONSISTS OF STANDARD CHARACTERS WITHOUT CLAIM TO ANY PARTICULAR FONT, STYLE, SIZE, OR COLOR.

FOR NUTRITIONALLY FORTIFIED BEVERAGES, NAMELY, TEAS (U.S. CLS. 6, 18, 44, 46, 51 AND 52).  
JEFF DEFORD, EXAMINING ATTORNEY

**CLASS 5—(Continued).**

SN 85-178,845. CRYOLIFE, INC., KENNESAW, GA. FILED 11-17-2010.

## THE IDEAL HEMOSTAT

THE MARK CONSISTS OF STANDARD CHARACTERS WITHOUT CLAIM TO ANY PARTICULAR FONT, STYLE, SIZE, OR COLOR.

NO CLAIM IS MADE TO THE EXCLUSIVE RIGHT TO USE "HEMOSTAT", APART FROM THE MARK AS SHOWN. FOR SURGICAL DRESSINGS, NAMELY, ABSORBABLE SURGICAL HEMOSTATS USED TO CONTROL BLEEDING (U.S. CLS. 6, 18, 44, 46, 51 AND 52).  
NAAKWAMA ANKRAH, EXAMINING ATTORNEY

SN 85-179,174. TJL ENTERPRISES, INC., LONG BEACH, CA. FILED 11-17-2010.

## TUMMY CALM

THE MARK CONSISTS OF STANDARD CHARACTERS WITHOUT CLAIM TO ANY PARTICULAR FONT, STYLE, SIZE, OR COLOR.

NO CLAIM IS MADE TO THE EXCLUSIVE RIGHT TO USE "TUMMY", APART FROM THE MARK AS SHOWN. FOR HOMEOPATHIC MEDICINE FOR DIGESTIVE UPSET (U.S. CLS. 6, 18, 44, 46, 51 AND 52).  
CAROLINE WOOD, EXAMINING ATTORNEY

SN 85-177,848. SOAKED UP, INC., NEW YORK, NY. FILED 11-16-2010.

## UNDO YOUR HANGOVER

THE MARK CONSISTS OF STANDARD CHARACTERS WITHOUT CLAIM TO ANY PARTICULAR FONT, STYLE, SIZE, OR COLOR.

NO CLAIM IS MADE TO THE EXCLUSIVE RIGHT TO USE "HANGOVER", APART FROM THE MARK AS SHOWN.

FOR DIETARY AND NUTRITIONAL SUPPLEMENTS; DIETARY BEVERAGE SUPPLEMENTS FOR HUMAN CONSUMPTION IN LIQUID AND DRY MIX FORM FOR THERAPEUTIC PURPOSES; DIETARY SUPPLEMENT BEVERAGE FOR REHYDRATION; DIETARY SUPPLEMENTAL DRINKS; DIETARY SUPPLEMENTAL DRINKS IN THE NATURE OF VITAMIN AND MINERAL BEVERAGES; DIETARY SUPPLEMENTS; DIETARY SUPPLEMENTS FOR HUMAN CONSUMPTION; DIETARY SUPPLEMENTS FOR HANGOVERS AND REHYDRATION; NUTRITIONAL ADDITIVES FOR MEDICAL PURPOSES FOR USE IN FOODS AND DIETARY SUPPLEMENTS FOR HUMAN CONSUMPTION; NUTRITIONAL ADDITIVES FOR MEDICAL PURPOSES USED IN FOODS AND DIETARY SUPPLEMENTS FOR HUMAN CONSUMPTION; POWDERED FRUIT-FLAVORED DIETARY SUPPLEMENT DRINK MIX (U.S. CLS. 6, 18, 44, 46, 51 AND 52).  
TINA BROWN, EXAMINING ATTORNEY

SN 85-179,650. CRYOLIFE, INC., KENNESAW, GA. FILED 11-18-2010.

## THE NEXT GENERATION HEMOSTAT

THE MARK CONSISTS OF STANDARD CHARACTERS WITHOUT CLAIM TO ANY PARTICULAR FONT, STYLE, SIZE, OR COLOR.

NO CLAIM IS MADE TO THE EXCLUSIVE RIGHT TO USE "HEMOSTAT", APART FROM THE MARK AS SHOWN. FOR SURGICAL DRESSINGS, NAMELY, ABSORBABLE SURGICAL HEMOSTATS USED TO CONTROL BLEEDING (U.S. CLS. 6, 18, 44, 46, 51 AND 52).  
NAAKWAMA ANKRAH, EXAMINING ATTORNEY

**CLASS 5—(Continued).**

SN 85-179,997. VORWALLER, JOHN A., KELLER, TX. FILED 11-18-2010.

**GLUCOVERA**

THE MARK CONSISTS OF STANDARD CHARACTERS WITHOUT CLAIM TO ANY PARTICULAR FONT, STYLE, SIZE, OR COLOR.

FOR DIETARY AND NUTRITIONAL SUPPLEMENTS CONTAINING ALOE VERA DERIVED POLYSACCHARIDES FOR MANAGING DIETARY GLUCOSE (U.S. CLS. 6, 18, 44, 46, 51 AND 52).

FIRST USE 4-26-2010; IN COMMERCE 6-21-2010.  
HOWARD B. LEVINE, EXAMINING ATTORNEY

SN 85-182,585. TEVA ANIMAL HEALTH, INC., ST. JOSEPH, MO. FILED 11-22-2010.



OWNER OF U.S. REG. NOS. 2,149,925, 2,847,926 AND OTHERS.

THE MARK CONSISTS OF THE OVERLAPPING IMAGES OF HORSE, DOG AND A CAT. THE IMAGES APPEAR IN A SQUARE FRAME. THE ACRONYM "DVM" IS WRITTEN BELOW THE SQUARE FRAME DESCRIBED BEFORE.

FOR VETERINARY PHARMACEUTICAL PREPARATIONS FOR THE TREATMENT OF INTESTINAL DISEASES, DERMATOLOGICAL CONDITIONS, DIABETES, PAIN, VIRAL INFECTIONS, BACTERIAL INFECTIONS, RESPIRATORY DISORDERS, ANXIETY, METABOLIC DISORDERS, DEPRESSION, PSYCHOSIS, ASTHMA, AND ALLERGIES (U.S. CLS. 6, 18, 44, 46, 51 AND 52).

ANDREA BUTLER, EXAMINING ATTORNEY

**CLASS 5—(Continued).**

SN 85-182,603. DOCTOR'S SIGNATURE SALES & MARKETING INTERNATIONAL CORP., POWAY, CA. FILED 11-22-2010.

**VITALI-C PLUS**

THE MARK CONSISTS OF STANDARD CHARACTERS WITHOUT CLAIM TO ANY PARTICULAR FONT, STYLE, SIZE, OR COLOR.

FOR DIETARY AND NUTRITIONAL SUPPLEMENTS CONTAINING VITAMIN C; VITAMINS CONTAINING VITAMIN C (U.S. CLS. 6, 18, 44, 46, 51 AND 52).

FIRST USE 8-14-2010; IN COMMERCE 8-14-2010.  
SALLY SHIH, EXAMINING ATTORNEY

SN 85-182,831. DEER DEFEAT LLC, GERMANTOWN, NY. FILED 11-22-2010.

**DEER DEFEAT**

THE MARK CONSISTS OF STANDARD CHARACTERS WITHOUT CLAIM TO ANY PARTICULAR FONT, STYLE, SIZE, OR COLOR.

NO CLAIM IS MADE TO THE EXCLUSIVE RIGHT TO USE "DEER", APART FROM THE MARK AS SHOWN.

FOR ANIMAL REPELLANTS, NAMELY, FOR DEER, RABBITS AND OTHER BROWSING ANIMALS (U.S. CLS. 6, 18, 44, 46, 51 AND 52).

FIRST USE 3-7-2009; IN COMMERCE 4-10-2010.  
LESLIE RICHARDS, EXAMINING ATTORNEY

SN 85-183,175. FISHER, GARTH, BEVERLY HILLS, CA. FILED 11-23-2010.

**AGING RESPONSE**

THE MARK CONSISTS OF STANDARD CHARACTERS WITHOUT CLAIM TO ANY PARTICULAR FONT, STYLE, SIZE, OR COLOR.

NO CLAIM IS MADE TO THE EXCLUSIVE RIGHT TO USE "AGING", APART FROM THE MARK AS SHOWN.

FOR NUTRITIONAL AND DIETARY SUPPLEMENTS FOR HUMANS, NAMELY, PILLS, TABLETS, CAPSULES, CAPLETS, POWDERS AND LIQUID DROPS; VITAMINS; HORMONE REPLACEMENT THERAPY PREPARATIONS (U.S. CLS. 6, 18, 44, 46, 51 AND 52).

TAMARA FRAZIER, EXAMINING ATTORNEY

**CLASS 5—(Continued).**

SN 85-183,872. ULTIMATE NUTRITION, INC., FARMINGTON, CT. FILED 11-23-2010.

**ANABOLIC RELOAD**

THE MARK CONSISTS OF STANDARD CHARACTERS WITHOUT CLAIM TO ANY PARTICULAR FONT, STYLE, SIZE, OR COLOR.

NO CLAIM IS MADE TO THE EXCLUSIVE RIGHT TO USE "ANABOLIC", APART FROM THE MARK AS SHOWN. FOR DIETARY SUPPLEMENTS; FOOD SUPPLEMENTS (U.S. CLS. 6, 18, 44, 46, 51 AND 52).

SHAUNIA CARLYLE, EXAMINING ATTORNEY

**CLASS 5—(Continued).**

SN 85-186,955. BIG BUCKS ENTERPRISES, INC., DBA MESSINA WILDLIFE MANAGEMENT, WASHINGTON, NJ. FILED 11-30-2010.

**GOOSE STOPPER**

THE MARK CONSISTS OF STANDARD CHARACTERS WITHOUT CLAIM TO ANY PARTICULAR FONT, STYLE, SIZE, OR COLOR.

OWNER OF U.S. REG. NOS. 3,639,095, 3,714,283 AND OTHERS.

NO CLAIM IS MADE TO THE EXCLUSIVE RIGHT TO USE "GOOSE", APART FROM THE MARK AS SHOWN.

FOR ANIMAL AND INSECT REPELLANTS (U.S. CLS. 6, 18, 44, 46, 51 AND 52).

FIRST USE 2-1-2001; IN COMMERCE 2-1-2001.

TRICIA SONNEBORN, EXAMINING ATTORNEY

SN 85-185,926. HI-VIDOMIN LABORATORIES, INC., PITTSBURGH, PA. FILED 11-29-2010.



NO CLAIM IS MADE TO THE EXCLUSIVE RIGHT TO USE "EASY SWALLOW TECHNOLOGY", APART FROM THE MARK AS SHOWN.

THE COLOR(S) BLUE AND BLACK IS/ARE CLAIMED AS A FEATURE OF THE MARK.

THE MARK CONSISTS OF THE LETTERS "E" AND "Z" IN BLUE TO THE LEFT OF THE WORDS "EASY SWALLOW TECHNOLOGY" IN BLACK.

FOR DIETARY SUPPLEMENTS (U.S. CLS. 6, 18, 44, 46, 51 AND 52).

MICHAEL ENGEL, EXAMINING ATTORNEY

SN 85-187,214. PROMESA DISTRIBUTORS, WINSTON SALEM, NC. FILED 11-30-2010.

**XL-ULTRA GRIPAL**

THE MARK CONSISTS OF STANDARD CHARACTERS WITHOUT CLAIM TO ANY PARTICULAR FONT, STYLE, SIZE, OR COLOR.

NO CLAIM IS MADE TO THE EXCLUSIVE RIGHT TO USE "GRIPAL", APART FROM THE MARK AS SHOWN.

THE ENGLISH TRANSLATION OF THE WORD "GRIPAL" IN THE MARK IS "FLU".

FOR ANTI-COUGH DROPS; COUGH DROPS; COUGH EXPECTORANTS; COUGH LOZENGES; COUGH SYRUPS; COUGH TREATMENT PREPARATIONS (U.S. CLS. 6, 18, 44, 46, 51 AND 52).

MICHAEL WEBSTER, EXAMINING ATTORNEY

SN 85-186,010. SYNOVIS LIFE TECHNOLOGIES, INC., ST. PAUL, MN. FILED 11-29-2010.

**SIMPLE. STERILE. SECURE.**

THE MARK CONSISTS OF STANDARD CHARACTERS WITHOUT CLAIM TO ANY PARTICULAR FONT, STYLE, SIZE, OR COLOR.

NO CLAIM IS MADE TO THE EXCLUSIVE RIGHT TO USE "STERILE", APART FROM THE MARK AS SHOWN.

FOR RE-MODELABLE STERILE ANIMAL TISSUES FOR USE AS SURGICAL IMPLANTS (U.S. CLS. 6, 18, 44, 46, 51 AND 52).

EMILY CHUO, EXAMINING ATTORNEY

SN 85-187,650. AMGEN INC., THOUSAND OAKS, CA. FILED 11-30-2010.

**FITRA**

THE MARK CONSISTS OF STANDARD CHARACTERS WITHOUT CLAIM TO ANY PARTICULAR FONT, STYLE, SIZE, OR COLOR.

THE WORDING "FITRA" HAS NO MEANING OTHER THAN TRADEMARK SIGNIFICANCE.

FOR PHARMACEUTICAL PREPARATIONS FOR USE IN THE TREATMENT OF ONCOLOGICAL AND METABOLIC DISEASES AND DISORDERS, AND COMPLICATIONS ASSOCIATED THEREWITH (U.S. CLS. 6, 18, 44, 46, 51 AND 52).

KEVON CHISOLM, EXAMINING ATTORNEY



**CLASS 5—(Continued).**

SN 85-187,737. FORCES OF NATURE, INC., SAN FRANCISCO, CA. FILED 11-30-2010.

## FORCES OF NATURE

THE MARK CONSISTS OF STANDARD CHARACTERS WITHOUT CLAIM TO ANY PARTICULAR FONT, STYLE, SIZE, OR COLOR.

OWNER OF U.S. REG. NO. 3,227,535.  
FOR HOMEOPATHIC PHARMACEUTICALS FOR USE IN THE TREATMENT OF ACNE, WARTS, NAIL FUNGUS, PAIN, HERPES, HEMORRHOIDS, SHINGLES, PHN, ECZEMA, DERMATITIS, ERECTILE DYSFUNCTION, YEAST INFECTION, FISSURE, PMS, ATHLETE'S FOOT, MENOPAUSE, RINGWORM, IMPETIGO, CHICKEN POX, JOCK ITCH, STRETCH MARKS, MOLES, MOLLUSCUM, SCARS, COLD, FLU, AND SORENESS (U.S. CLS. 6, 18, 44, 46, 51 AND 52).  
KIMBERLY PERRY, EXAMINING ATTORNEY

SN 85-187,908. SEACRA ENTERPRISES, INC., DBA DTC HEALTH, CARY, NC. FILED 12-1-2010.

## FlexicosePlus

THE MARK CONSISTS OF STANDARD CHARACTERS WITHOUT CLAIM TO ANY PARTICULAR FONT, STYLE, SIZE, OR COLOR.

OWNER OF U.S. REG. NO. 2,931,964.  
FOR DIETARY AND NUTRITIONAL SUPPLEMENTS; DIETARY FOOD SUPPLEMENTS; DIETARY SUPPLEMENTAL DRINKS; DIETARY SUPPLEMENTAL DRINKS IN THE NATURE OF VITAMIN AND MINERAL BEVERAGES; DIETARY SUPPLEMENTS FOR ANIMALS; DIETARY SUPPLEMENTS FOR HUMAN CONSUMPTION; DIETARY SUPPLEMENTS FOR PETS; DIETARY SUPPLEMENTS, NAMELY, A LIQUID GLUCOSAMINE FORMULA FOR HUMANS AND ANIMALS USED FOR ARTHRITIS CARE; LIQUID NUTRITIONAL SUPPLEMENT; LIQUID VITAMIN SUPPLEMENTS; NATURAL HERBAL SUPPLEMENTS; NUTRITIONAL SUPPLEMENTS; VITAMIN AND MINERAL SUPPLEMENTS; VITAMIN SUPPLEMENTS (U.S. CLS. 6, 18, 44, 46, 51 AND 52).  
FIRST USE 12-1-2010; IN COMMERCE 12-1-2010.  
LINDA POWELL, EXAMINING ATTORNEY

**CLASS 5—(Continued).**

SN 85-188,243. THE HAMILTON GROUP, INC, DBA HAMILTON LABS, RANCHO SANTA MARGARITA, CA. FILED 12-1-2010.

## Pain Guard

THE MARK CONSISTS OF STANDARD CHARACTERS WITHOUT CLAIM TO ANY PARTICULAR FONT, STYLE, SIZE, OR COLOR.

NO CLAIM IS MADE TO THE EXCLUSIVE RIGHT TO USE "PAIN", APART FROM THE MARK AS SHOWN.  
FOR HERBAL TOPICAL CREAMS, GELS, SALVES, SPRAYS, POWDER, BALMS, LINIMENT AND OINTMENTS FOR THE RELIEF OF ACHEs AND PAIN (U.S. CLS. 6, 18, 44, 46, 51 AND 52).  
FIRST USE 9-10-1999; IN COMMERCE 9-10-1999.  
MARK RADEMACHER, EXAMINING ATTORNEY

SN 85-188,258. MILLER & STONE GROUP, INC., PROSPECT, CT. FILED 12-1-2010.

## SLEEP NOW

THE MARK CONSISTS OF STANDARD CHARACTERS WITHOUT CLAIM TO ANY PARTICULAR FONT, STYLE, SIZE, OR COLOR.

NO CLAIM IS MADE TO THE EXCLUSIVE RIGHT TO USE "SLEEP", APART FROM THE MARK AS SHOWN.  
FOR DIETARY AND NUTRITIONAL SUPPLEMENTS (U.S. CLS. 6, 18, 44, 46, 51 AND 52).  
CHRISTINE MARTIN, EXAMINING ATTORNEY

SN 85-188,487. JOINT JUICE, INC., SAN FRANCISCO, CA. FILED 12-1-2010.

## EASY SHOT

THE MARK CONSISTS OF STANDARD CHARACTERS WITHOUT CLAIM TO ANY PARTICULAR FONT, STYLE, SIZE, OR COLOR.

NO CLAIM IS MADE TO THE EXCLUSIVE RIGHT TO USE "SHOT", APART FROM THE MARK AS SHOWN.  
FOR DIETARY AND NUTRITIONAL SUPPLEMENTS; DIETARY BEVERAGES SUPPLEMENTS FOR HUMAN CONSUMPTION IN LIQUID FORM FOR NUTRITIONAL PURPOSES (U.S. CLS. 6, 18, 44, 46, 51 AND 52).  
FIRST USE 12-1-2010; IN COMMERCE 12-1-2010.  
ALYSSA STEEL, EXAMINING ATTORNEY

**CLASS 5—(Continued).**

SN 85-188,954. URBANUS VICTUS, L.L.C., KANSAS CITY, MO. FILED 12-2-2010.

# LIFE EQUALS

THE MARK CONSISTS OF STANDARD CHARACTERS WITHOUT CLAIM TO ANY PARTICULAR FONT, STYLE, SIZE, OR COLOR.

FOR BEE POLLEN FOR USE AS A DIETARY FOOD SUPPLEMENT; BEVERAGES CONTAINING CHLOROPHYLL FOR USE AS A NUTRITIONAL SUPPLEMENT; CALCIUM MONTMORILLONITE CLAY FOR THERAPEUTIC PURPOSES USED TO ENHANCE THE PRODUCTION OF ENZYMES IN LIVING BEINGS OR AS A MINERAL SUPPLEMENT; CALCIUM SUPPLEMENTS; DIETARY AND NUTRITIONAL SUPPLEMENTS; DIETARY AND NUTRITIONAL SUPPLEMENTS CONTAINING, NAMELY, SODIUM ASCORBATE, CALCIUM ASCORBATE, FISH OIL, HERBS, MEDICINAL ROOTS, AND BERRIES; DIETARY AND NUTRITIONAL SUPPLEMENTS FOR ENDURANCE SPORTS; DIETARY AND NUTRITIONAL SUPPLEMENTS USED FOR WEIGHT LOSS; DIETARY BEVERAGE SUPPLEMENTS FOR HUMAN CONSUMPTION IN LIQUID AND DRY MIX FORM FOR THERAPEUTIC PURPOSES; DIETARY FOOD SUPPLEMENTS; DIETARY SUPPLEMENT BEVERAGE FOR ENERGY, FOCUS, SLEEPING AID, IMMUNE SYSTEM HEALTH, LONGEVITY, HERBAL BLEND, DAILY MULTIVITAMIN REQUIREMENTS, RECOVERY, PRE-WORKOUT, ENDURANCE TRAINING, STRENGTH TRAINING, REPLENISHMENT, DETOXIFICATION; DIETARY SUPPLEMENT FOR ELIMINATING TOXINS FROM THE INTESTINAL TRACT; DIETARY SUPPLEMENTS; DIETARY SUPPLEMENTS FOR HUMAN CONSUMPTION; DIETARY SUPPLEMENTS FOR CONTROLLING CHOLESTEROL; DIETARY SUPPLEMENTS FOR TREATMENT OF CLAUSTROPHOBIA; DIETARY SUPPLEMENTS FOR URINARY HEALTH; DIETARY SUPPLEMENTS IN THE NATURE OF WEIGHT LOSS POWDERS; DIETARY SUPPLEMENTS ALSO CONTAINING ELDERBERRY, MAGNESIUM STEARATE, ACAI BERRY, GUARANA, FISH OIL; DIETARY SUPPLEMENTS FOR HUMANS, CHILDREN, TEENAGERS, ADULTS, PREGNANT WOMEN, TREATING NAUSEA, TREATING FATIGUE, TREATING COLD SYMPTOMS, TREATING LACK OF FOCUS, TREATING UNDERNUTRITION; ENZYME FOOD SUPPLEMENTS; FOOD SUPPLEMENTS; FOOD SUPPLEMENTS FOR HUMANS, CHILDREN, TEENAGERS, ADULTS, PREGNANT WOMEN, TREATING NAUSEA, TREATING FATIGUE, TREATING COLD SYMPTOMS, TREATING LACK OF FOCUS, TREATING UNDERNUTRITION; FOOD SUPPLEMENTS, NAMELY, ANTI-OXIDANTS; GROUND FLAXSEED FIBER FOR USE AS A DIETARY SUPPLEMENT; HEALTH FOOD SUPPLEMENTS; HERBAL SUPPLEMENTS; HERBAL SUPPLEMENTS FOR SLEEPING PROBLEMS; HOMEOPATHIC SUPPLEMENTS; LECITHIN FOR USE AS A DIETARY SUPPLEMENT; LIQUID NUTRITIONAL SUPPLEMENT; LIQUID VITAMIN SUPPLEMENTS; MEAL REPLACEMENT AND DIETARY SUPPLEMENT DRINK MIXES; MEDICATED SUPPLEMENTS FOR FOODSTUFFS FOR BABIES; MINERAL FOOD SUPPLEMENTS; MINERAL NUTRITIONAL SUPPLEMENTS; MINERAL SUPPLEMENTS; NATURAL DIETARY SUPPLEMENTS FOR TREATMENT OF CLAUSTROPHOBIA; NATURAL HERBAL SUPPLEMENTS; NATURAL SUPPLEMENTS FOR TREATING ERECTILE DYSFUNCTION; NATURAL SUPPLEMENTS FOR TREATING DEPRESSION AND ANXIETY; NATURAL SUPPLEMENTS FOR TREATING CANDIDA; NUTRACEUTICALS FOR USE AS A DIETARY SUPPLEMENT; NUTRACEUTICALS FOR USE AS A DIETARY SUPPLEMENT FOR ENERGY, FOCUS, SLEEPING AID, IMMUNE SYSTEM HEALTH, LONGEVITY, HERBAL BLEND, DAILY MULTIVITAMIN REQUIREMENTS, RECOVERY, PRE-WORKOUT, ENDURANCE TRAINING, STRENGTH TRAINING, REPLENISHMENT, DETOXIFICATION; NUTRITIONAL ADDITIVES FOR MEDICAL PURPOSES FOR USE IN

**CLASS 5—(Continued).**

FOODS AND DIETARY SUPPLEMENTS FOR HUMAN CONSUMPTION; NUTRITIONAL ADDITIVES FOR MEDICAL PURPOSES USED IN FOODS AND DIETARY SUPPLEMENTS FOR HUMAN CONSUMPTION; NUTRITIONAL AND DIETARY SUPPLEMENTS FORMED AND PACKAGED AS BARS; NUTRITIONAL SUPPLEMENTS; NUTRITIONAL SUPPLEMENTS IN LOTION FORM SOLD AS A COMPONENT OF NUTRITIONAL SKIN CARE PRODUCTS; NUTRITIONAL SUPPLEMENT IN THE NATURE OF A NUTRIENT-DENSE, PROTEIN-BASED DRINK MIX; NUTRITIONAL SUPPLEMENT FOR ELIMINATING TOXINS FROM THE INTESTINAL TRACT; NUTRITIONAL SUPPLEMENT FOR ELIMINATING TOXINS FROM THE BODY; NUTRITIONAL SUPPLEMENTS IN CAPSULE FORM FOR DOGS; NUTRITIONAL SUPPLEMENTS, NAMELY, PROBIOTIC COMPOSITIONS; NUTRITIONAL SUPPLEMENTS FOR BOOSTING ENERGY, INCREASING FOCUS, SLEEPING AID, IMMUNE SYSTEM HEALTH, LONGEVITY, HERBAL BLEND, DAILY MULTIVITAMIN REQUIREMENTS, RECOVERY, PRE-WORKOUT, ENDURANCE TRAINING, STRENGTH TRAINING, REPLENISHMENT, DETOXIFICATION; POWDERED FRUIT-FLAVORED DIETARY SUPPLEMENT DRINK MIX; POWDERED NUTRITIONAL SUPPLEMENT DRINK MIX; PROTEIN SUPPLEMENTS; SOY PROTEIN FOR USE AS A NUTRITIONAL SUPPLEMENT IN VARIOUS POWDERED AND READY-TO-DRINK BEVERAGES; VITAMIN AND MINERAL SUPPLEMENTS; VITAMIN SUPPLEMENT IN TABLET FORM FOR USE IN MAKING AN EFFERESCENT BEVERAGE WHEN ADDED TO WATER; VITAMIN SUPPLEMENTS; WEIGHT MANAGEMENT SUPPLEMENTS; WHEAT FOR USE AS A DIETARY SUPPLEMENT; WHEY PROTEIN SUPPLEMENTS; ZINC SUPPLEMENT LOZENGES (U.S. CLS. 6, 18, 44, 46, 51 AND 52).

MICHAEL KEATING, EXAMINING ATTORNEY

SN 85-189,186. ANE UNIVERSAL INC, MIAMI, FL. FILED 12-2-2010.



THE MARK CONSISTS OF THE WORD "VIALITY", WHEREIN THE FIRST LETTER "I" DOT CASTS A REVERSE IMAGE SHADOW OVER THE LETTER "V" AND THE FIRST LETTER "I".

FOR NATURAL SUPPLEMENTS FOR TREATING ERECTILE DYSFUNCTION (U.S. CLS. 6, 18, 44, 46, 51 AND 52).

MATTHEW PAPPAS, EXAMINING ATTORNEY

**CLASS 5—(Continued).**

SN 85-189,544. MIKOLAJCZYK, WILLIAM, ANTHEM, AZ. FILED 12-2-2010.



OWNER OF U.S. REG. NO. 3,920,438.  
THE COLOR(S) RED, WHITE, BLUE, BLACK IS/ARE CLAIMED AS A FEATURE OF THE MARK.  
THE MARK CONSISTS OF THE WORDS "BIKERS DEFENSE" APPEARING IN RED AND OUTLINED IN BLACK ABOVE A STYLIZED FLAMING MOTORCYCLE APPEARING IN WHITE AND OUTLINED IN BLUE, THE GRAY IN THE MARK IS INTENDED AS SHADOWING AND IS NOT PART OF THE MARK.  
FOR VITAMINS (U.S. CLS. 6, 18, 44, 46, 51 AND 52).  
FIRST USE 11-27-2010; IN COMMERCE 11-27-2010.  
SCOTT BIBB, EXAMINING ATTORNEY

SN 85-189,621. BARRY D. SEARS, PH.D., MARBLEHEAD, MA. FILED 12-2-2010.

# OMEGA RX

THE MARK CONSISTS OF STANDARD CHARACTERS WITHOUT CLAIM TO ANY PARTICULAR FONT, STYLE, SIZE, OR COLOR.  
OWNER OF U.S. REG. NO. 2,962,705.  
NO CLAIM IS MADE TO THE EXCLUSIVE RIGHT TO USE "OMEGA", APART FROM THE MARK AS SHOWN.  
FOR DIETARY SUPPLEMENTS CONTAINING FISH OIL (U.S. CLS. 6, 18, 44, 46, 51 AND 52).  
FIRST USE 3-0-2002; IN COMMERCE 3-0-2002.  
ALYSSA STEEL, EXAMINING ATTORNEY

SN 85-189,936. INTERVET INTERNATIONAL B.V., BOXMEER, NETHERLANDS, FILED 12-3-2010.

# MILDVAC-MA5

THE MARK CONSISTS OF STANDARD CHARACTERS WITHOUT CLAIM TO ANY PARTICULAR FONT, STYLE, SIZE, OR COLOR.  
OWNER OF U.S. REG. NOS. 1,785,174, 3,367,173 AND OTHERS.  
FOR AVIAN PRODUCTS FOR VETERINARY USE, NAMELY, BRONCHITIS VACCINES (U.S. CLS. 6, 18, 44, 46, 51 AND 52).  
TRACY FLETCHER, EXAMINING ATTORNEY

**CLASS 5—(Continued).**

SN 85-190,107. AMERISCIENCES, LP, HOUSTON, TX. FILED 12-3-2010.

# OS<sup>2</sup>

THE MARK CONSISTS OF "OS<sup>2</sup>" THE "2" IS A SUPERSCRIPT.  
FOR VITAMIN AND MINERAL SUPPLEMENTS, NUTRITIONAL SUPPLEMENTS, AND DIETARY SUPPLEMENTS (U.S. CLS. 6, 18, 44, 46, 51 AND 52).  
FIRST USE 12-1-2010; IN COMMERCE 12-1-2010.  
SANI KHOURI, EXAMINING ATTORNEY

SN 85-190,657. RAINBOW LIGHT NUTRITIONAL SYSTEMS, INC., SANTA CRUZ, CA. FILED 12-3-2010.

# LIVER LONGEVITY

THE MARK CONSISTS OF STANDARD CHARACTERS WITHOUT CLAIM TO ANY PARTICULAR FONT, STYLE, SIZE, OR COLOR.  
NO CLAIM IS MADE TO THE EXCLUSIVE RIGHT TO USE "LIVER", APART FROM THE MARK AS SHOWN.  
FOR DIETARY AND NUTRITIONAL SUPPLEMENTS; VITAMINS (U.S. CLS. 6, 18, 44, 46, 51 AND 52).  
IRA J. GOODSaid, EXAMINING ATTORNEY

SN 85-192,450. GENERAL SUPPLY IMPORT & EXPORT LLC, MIAMI, FL. FILED 12-7-2010.



THE COLOR(S) WHITE, YELLOW AND PURPLE IS/ARE CLAIMED AS A FEATURE OF THE MARK.  
THE MARK CONSISTS OF THE WORDS "SANI PROTECTOR" APPEARING IN WHITE, UNDERNEATH A YELLOW ARCH WHICH SURROUNDS THE WORDS, ALL AGAINST A PURPLE BACKGROUND. THE RECTANGULAR SHAPE OF THE BACKGROUND IS NOT PART OF THE MARK.  
FOR SANITARY NAPKINS (U.S. CLS. 6, 18, 44, 46, 51 AND 52).  
LINDA LAVACHE, EXAMINING ATTORNEY

**CLASS 5—(Continued).**

SN 85-192,833. BIOGEN IDEC MA INC., CAMBRIDGE, MA. FILED 12-8-2010.

**STRATIS JCV**

THE MARK CONSISTS OF STANDARD CHARACTERS WITHOUT CLAIM TO ANY PARTICULAR FONT, STYLE, SIZE, OR COLOR.

NO CLAIM IS MADE TO THE EXCLUSIVE RIGHT TO USE "JCV", APART FROM THE MARK AS SHOWN.

FOR MEDICAL DIAGNOSTIC REAGENTS AND ASSAYS FOR TESTING OF BODY FLUIDS (U.S. CLS. 6, 18, 44, 46, 51 AND 52).

JOHN E. MICHOS, EXAMINING ATTORNEY

**CLASS 5—(Continued).**

SN 85-195,506. MEDIPURE PRODUCTS INC., SARATOGA SPRINGS, UT. FILED 12-10-2010.

**MediPure Products**

THE MARK CONSISTS OF STANDARD CHARACTERS WITHOUT CLAIM TO ANY PARTICULAR FONT, STYLE, SIZE, OR COLOR.

NO CLAIM IS MADE TO THE EXCLUSIVE RIGHT TO USE "PRODUCTS", APART FROM THE MARK AS SHOWN.

FOR DIETARY AND NUTRITIONAL SUPPLEMENTS (U.S. CLS. 6, 18, 44, 46, 51 AND 52).

FIRST USE 8-1-2009; IN COMMERCE 8-15-2009.

ANNE FARRELL, EXAMINING ATTORNEY

SN 85-194,151. NUTRI-FUSION SYSTEMS, LLC, DBA HCG FUSION, SANDY, UT. FILED 12-9-2010.

**HCG FUSION**

THE MARK CONSISTS OF STANDARD CHARACTERS WITHOUT CLAIM TO ANY PARTICULAR FONT, STYLE, SIZE, OR COLOR.

NO CLAIM IS MADE TO THE EXCLUSIVE RIGHT TO USE "HCG", APART FROM THE MARK AS SHOWN.

FOR DIETARY AND NUTRITIONAL SUPPLEMENTS CONTAINING HUMAN CHORIONIC GONADOTROPIN (U.S. CLS. 6, 18, 44, 46, 51 AND 52).

FIRST USE 4-30-2010; IN COMMERCE 4-30-2010.

MICHAEL KEATING, EXAMINING ATTORNEY

SN 85-195,896. RAMBOD, HANY, LOS GATOS, CA. FILED 12-11-2010.

**GLYCOJECT**

THE MARK CONSISTS OF STANDARD CHARACTERS WITHOUT CLAIM TO ANY PARTICULAR FONT, STYLE, SIZE, OR COLOR.

FOR DIETARY AND NUTRITIONAL SUPPLEMENTS; NUTRITIONAL SUPPLEMENTS, NAMELY, CARBOHYDRATES IN POWDERED FORM (U.S. CLS. 6, 18, 44, 46, 51 AND 52).

DAWN HAN, EXAMINING ATTORNEY

SN 85-195,170. CASSEL GROUP, LLC, VENICE, CA. FILED 12-10-2010.

**DR. ZEN'S LIQUID CALM**

THE MARK CONSISTS OF STANDARD CHARACTERS WITHOUT CLAIM TO ANY PARTICULAR FONT, STYLE, SIZE, OR COLOR.

NO CLAIM IS MADE TO THE EXCLUSIVE RIGHT TO USE "LIQUID", APART FROM THE MARK AS SHOWN.

FOR DIETARY SUPPLEMENT BEVERAGE FOR RELAXATION (U.S. CLS. 6, 18, 44, 46, 51 AND 52).

FIRST USE 11-1-2009; IN COMMERCE 1-6-2010.

JOHN WILKE, EXAMINING ATTORNEY

SN 85-197,726. WINSTON LABORATORIES, INC., VERNON HILLS, IL. FILED 12-14-2010.

**Zuacta**

THE MARK CONSISTS OF STANDARD CHARACTERS WITHOUT CLAIM TO ANY PARTICULAR FONT, STYLE, SIZE, OR COLOR.

FOR MEDICATED CREAMS, OINTMENTS, LOTIONS AND GELS FOR TOPICAL APPLICATION FOR TREATMENT OF ARTHRITIS (U.S. CLS. 6, 18, 44, 46, 51 AND 52).

JAY FLOWERS, EXAMINING ATTORNEY

**CLASS 5—(Continued).**

SN 85-199,432. CHERVINSKY, ALEX, BROOKLYN, NY.  
FILED 12-16-2010.

# ARIZONA

THE MARK CONSISTS OF STANDARD CHARACTERS  
WITHOUT CLAIM TO ANY PARTICULAR FONT, STYLE,  
SIZE, OR COLOR.  
FOR PREPARATION FOR THE RELIEF OF PAIN (U.S.  
CLS. 6, 18, 44, 46, 51 AND 52).  
ANNE MADDEN, EXAMINING ATTORNEY

SN 85-200,092. SMM DISTRIBUTORS LLC, LOS ANGELES,  
CA. FILED 12-16-2010.

# RoomShocker

THE MARK CONSISTS OF STANDARD CHARACTERS  
WITHOUT CLAIM TO ANY PARTICULAR FONT, STYLE,  
SIZE, OR COLOR.  
FOR HOUSEHOLD DEODORIZER (U.S. CLS. 6, 18, 44,  
46, 51 AND 52).  
FIRST USE 1-1-2008; IN COMMERCE 1-1-2008.  
DAWN HAN, EXAMINING ATTORNEY

SN 85-200,247. NUTRITION & FITNESS, INC., FAYETTE-  
VILLE, NC. FILED 12-17-2010.

# LEVARIS

THE MARK CONSISTS OF STANDARD CHARACTERS  
WITHOUT CLAIM TO ANY PARTICULAR FONT, STYLE,  
SIZE, OR COLOR.  
FOR DIETARY SUPPLEMENTS (U.S. CLS. 6, 18, 44, 46,  
51 AND 52).  
SUSAN RICHARDS, EXAMINING ATTORNEY

**CLASS 5—(Continued).**

SN 85-201,201. ALLMAX NUTRITION, INC., ONTARIO, M2N  
6N4, CANADA, FILED 12-18-2010.

# CYTOGREENS

THE MARK CONSISTS OF STANDARD CHARACTERS  
WITHOUT CLAIM TO ANY PARTICULAR FONT, STYLE,  
SIZE, OR COLOR.  
FOR DIETARY SUPPLEMENTS; NUTRITIONAL SUP-  
PLEMENTS (U.S. CLS. 6, 18, 44, 46, 51 AND 52).  
KEVIN CORWIN, EXAMINING ATTORNEY

SN 85-201,344. ELI LILLY AND COMPANY, INDIANAPOLIS,  
IN. FILED 12-19-2010.

# HABEREX

THE MARK CONSISTS OF STANDARD CHARACTERS  
WITHOUT CLAIM TO ANY PARTICULAR FONT, STYLE,  
SIZE, OR COLOR.  
THE WORDING "HABEREX" HAS NO MEANING IN A  
FOREIGN LANGUAGE.  
FOR PREPARATIONS FOR DESTROYING VERMIN,  
NAMELY, INSECTICIDES FOR USE WITH LIVESTOCK  
AND LIVESTOCK PREMISES; VETERINARY PREPARA-  
TIONS FOR THE TREATMENT, CONTROL AND SYMP-  
TOMATIC RELIEF OF INFECTIOUS AND METABOLIC  
DISEASES OF LIVESTOCK; DIETARY FOOD SUPPLE-  
MENTS FOR ANIMALS; ANTIBACTERIAL PHARMA-  
CEUTICALS FOR VETERINARY USE; PRODUCTION  
ENHANCEMENT FOR LIVESTOCK, NAMELY, MEDI-  
CATED FEED AND MEDICATED WATER ADDITIVES;  
MEDICATED FEED ADDITIVES AND MEDICATED  
WATER ADDITIVES FOR ANIMALS; DIAGNOSTIC  
AGENTS, PREPARATIONS AND SUBSTANCES TO  
IDENTIFY PATHOGENS OR RESIDUES OF BIOLOGI-  
CAL INTEREST FOR VETERINARY USE; PRE-FILED  
VETERINARY PREPARATIONS FOR THE PREVEN-  
TION OF IMMUNOLOGICAL, BACTERIAL, AND IN-  
FECTIOUS DISEASES (U.S. CLS. 6, 18, 44, 46, 51 AND 52).  
BRIAN PINO, EXAMINING ATTORNEY

SN 85-201,651. CERTIS U.S.A. L.L.C., COLUMBIA, MD.  
FILED 12-20-2010.

# BACILO-X

THE MARK CONSISTS OF STANDARD CHARACTERS  
WITHOUT CLAIM TO ANY PARTICULAR FONT, STYLE,  
SIZE, OR COLOR.  
FOR FUNGICIDES (U.S. CLS. 6, 18, 44, 46, 51 AND 52).  
SANJEEV VOHRA, EXAMINING ATTORNEY

**CLASS 5—(Continued).**

SN 85-201,656. CERTIS U.S.A. L.L.C., COLUMBIA, MD. FILED 12-20-2010.

# AMYLO-X

THE MARK CONSISTS OF STANDARD CHARACTERS WITHOUT CLAIM TO ANY PARTICULAR FONT, STYLE, SIZE, OR COLOR.

FOR FUNGICIDES (U.S. CLS. 6, 18, 44, 46, 51 AND 52).  
SANJEEV VOHRA, EXAMINING ATTORNEY

SN 85-202,322. ANA ELOISE DEL CARMEN ALFARO DE MARON, SAN MARCOS, EL SALVADOR, FILED 12-20-2010.

# GLOTOLIN

THE MARK CONSISTS OF STANDARD CHARACTERS WITHOUT CLAIM TO ANY PARTICULAR FONT, STYLE, SIZE, OR COLOR.

FOR DIETARY SUPPLEMENTS (U.S. CLS. 6, 18, 44, 46, 51 AND 52).  
LAURA KOVALSKY, EXAMINING ATTORNEY

SN 85-202,427. PFIZER INC., NEW YORK, NY. FILED 12-21-2010.

# EPTIBRA

THE MARK CONSISTS OF STANDARD CHARACTERS WITHOUT CLAIM TO ANY PARTICULAR FONT, STYLE, SIZE, OR COLOR.

FOR PHARMACEUTICAL PREPARATIONS FOR THE TREATMENT OF CARDIOVASCULAR, CENTRAL NERVOUS SYSTEM, ENDOCRINE, GASTROINTESTINAL, HEMATOLOGIC, IMMUNOLOGICAL, INFECTIOUS, INFLAMMATORY, MENOPAUSAL, METABOLIC, MUSCULOSKELETAL, NEUROLOGICAL, ONCOLOGICAL, OPHTHALMOLOGICAL, PSYCHIATRIC, RESPIRATORY, UROGENITAL, UROLOGICAL AND VIRAL DISEASES AND DISORDERS; PHARMACEUTICAL PREPARATIONS FOR THE TREATMENT OF ERECTILE DYSFUNCTION, SEXUAL DYSFUNCTION AND PAIN; PHARMACEUTICAL PREPARATIONS, NAMELY, ANTI-FUNGAL PREPARATIONS, DERMATOLOGICAL PREPARATIONS, SMOKING CESSATION PREPARATIONS; VACCINES FOR HUMAN USE (U.S. CLS. 6, 18, 44, 46, 51 AND 52).  
SKYE YOUNG, EXAMINING ATTORNEY

**CLASS 5—(Continued).**

SN 85-202,428. PFIZER INC., NEW YORK, NY. FILED 12-21-2010.

# EPULZ

THE MARK CONSISTS OF STANDARD CHARACTERS WITHOUT CLAIM TO ANY PARTICULAR FONT, STYLE, SIZE, OR COLOR.

FOR PHARMACEUTICAL PREPARATIONS FOR THE TREATMENT OF CARDIOVASCULAR, CENTRAL NERVOUS SYSTEM, ENDOCRINE, GASTROINTESTINAL, HEMATOLOGIC, IMMUNOLOGICAL, INFECTIOUS, INFLAMMATORY, MENOPAUSAL, METABOLIC, MUSCULOSKELETAL, NEUROLOGICAL, ONCOLOGICAL, OPHTHALMOLOGICAL, PSYCHIATRIC, RESPIRATORY, UROGENITAL, UROLOGICAL AND VIRAL DISEASES AND DISORDERS; PHARMACEUTICAL PREPARATIONS FOR THE TREATMENT OF ERECTILE DYSFUNCTION, SEXUAL DYSFUNCTION AND PAIN; PHARMACEUTICAL PREPARATIONS, NAMELY, ANTI-FUNGAL PREPARATIONS, DERMATOLOGICAL PREPARATIONS, SMOKING CESSATION PREPARATIONS; VACCINES FOR HUMAN USE (U.S. CLS. 6, 18, 44, 46, 51 AND 52).  
SKYE YOUNG, EXAMINING ATTORNEY

SN 85-202,598. ANTISENSE PHARMA GMBH, D-93053 REGENSBURG, FED REP GERMANY, FILED 12-21-2010.

# ONCOMUN

THE MARK CONSISTS OF STANDARD CHARACTERS WITHOUT CLAIM TO ANY PARTICULAR FONT, STYLE, SIZE, OR COLOR.

OWNER OF FED REP GERMANY REG. NO. 39950898, DATED 12-8-1999, EXPIRES 8-31-2019.

OWNER OF U.S. REG. NO. 2,859,250.  
FOR PHARMACEUTICAL PREPARATIONS FOR USE IN THE TREATMENT OF NEOPLASMS (U.S. CLS. 6, 18, 44, 46, 51 AND 52).  
ARETHA SOMERVILLE, EXAMINING ATTORNEY

SN 85-202,689. RAINFOREST NUTRITIONALS, INC., RALEIGH, NC. FILED 12-21-2010.

# VINICOL

THE MARK CONSISTS OF STANDARD CHARACTERS WITHOUT CLAIM TO ANY PARTICULAR FONT, STYLE, SIZE, OR COLOR.

FOR NUTRITIONAL SUPPLEMENTS (U.S. CLS. 6, 18, 44, 46, 51 AND 52).  
SUNG IN, EXAMINING ATTORNEY

**CLASS 5—(Continued).**

SN 85-202,744. AMARIN PHARMA INC., MYSTIC, CT. FILED 12-21-2010.

# VASCEPA

THE MARK CONSISTS OF STANDARD CHARACTERS WITHOUT CLAIM TO ANY PARTICULAR FONT, STYLE, SIZE, OR COLOR.

FOR PHARMACEUTICAL PREPARATIONS FOR THE TREATMENT OF CARDIOVASCULAR CONDITIONS (U.S. CLS. 6, 18, 44, 46, 51 AND 52).

MATTHEW PAPPAS, EXAMINING ATTORNEY

**CLASS 5—(Continued).**

SN 85-204,781. BISSELL, PAMELA, EWING, NJ. FILED 12-23-2010.

# NEURORID

THE MARK CONSISTS OF STANDARD CHARACTERS WITHOUT CLAIM TO ANY PARTICULAR FONT, STYLE, SIZE, OR COLOR.

FOR PREPARATION FOR THE RELIEF OF PAIN (U.S. CLS. 6, 18, 44, 46, 51 AND 52).

FLORENTINA BLANDU, EXAMINING ATTORNEY

SN 85-204,289. WELLEMENTS, LLC, SCOTTSDALE, AZ. FILED 12-22-2010.

# TEEM

THE MARK CONSISTS OF STANDARD CHARACTERS WITHOUT CLAIM TO ANY PARTICULAR FONT, STYLE, SIZE, OR COLOR.

FOR DIETARY AND NUTRITIONAL SUPPLEMENTS, PROTEIN SUPPLEMENTS, VITAMIN SUPPLEMENTS, AMINO ACID SUPPLEMENTS (U.S. CLS. 6, 18, 44, 46, 51 AND 52).

REBECCA SMITH, EXAMINING ATTORNEY

SN 85-204,791. BISSELL, PAMELA, EWING, NJ. FILED 12-23-2010.

# FUNGIRID

THE MARK CONSISTS OF STANDARD CHARACTERS WITHOUT CLAIM TO ANY PARTICULAR FONT, STYLE, SIZE, OR COLOR.

FOR NAIL FUNGUS TREATMENT PREPARATIONS (U.S. CLS. 6, 18, 44, 46, 51 AND 52).

FLORENTINA BLANDU, EXAMINING ATTORNEY

SN 85-204,649. PFIZER INC., NEW YORK, NY. FILED 12-23-2010.

# DEVRIAZ

THE MARK CONSISTS OF STANDARD CHARACTERS WITHOUT CLAIM TO ANY PARTICULAR FONT, STYLE, SIZE, OR COLOR.

FOR PHARMACEUTICAL PREPARATIONS FOR THE TREATMENT OF CARDIOVASCULAR, CENTRAL NERVOUS SYSTEM, ENDOCRINE, GASTROINTESTINAL, HEMATOLOGIC, IMMUNOLOGICAL, INFECTIOUS, INFLAMMATORY, MENOPAUSAL, METABOLIC, MUSCULOSKELETAL, NEUROLOGICAL, ONCOLOGICAL, OPHTHALMOLOGICAL, RESPIRATORY, UROGENITAL, UROLOGICAL AND VIRAL DISEASES AND DISORDERS; PHARMACEUTICAL PREPARATIONS FOR THE TREATMENT OF ERECTILE DYSFUNCTION, SEXUAL DYSFUNCTION AND PAIN; PHARMACEUTICAL PREPARATIONS, NAMELY, ANTIFUNGAL PREPARATIONS, DERMATOLOGICAL PREPARATIONS, SMOKING CESSATION PREPARATIONS; VACCINES FOR HUMAN USE (U.S. CLS. 6, 18, 44, 46, 51 AND 52).

SKYE YOUNG, EXAMINING ATTORNEY

SN 85-205,000. TANYA ZUCKERBROT, BAY HARBOR, FL. FILED 12-23-2010.



OWNER OF U.S. REG. NO. 3,841,360.

THE MARK CONSISTS OF A STYLIZED LETTER "F". FOR DRINK POWDERS, NAMELY, POWDERED NUTRITIONAL SUPPLEMENT DRINK MIX (U.S. CLS. 6, 18, 44, 46, 51 AND 52).

ALYSSA STEEL, EXAMINING ATTORNEY

**CLASS 5—(Continued).**

SN 85-205,064. PRINCE OF PEACE ENTERPRISES, INC., HAYWARD, CA. FILED 12-23-2010.

## PAIN RELIEF WITHOUT THE PILLS

THE MARK CONSISTS OF STANDARD CHARACTERS WITHOUT CLAIM TO ANY PARTICULAR FONT, STYLE, SIZE, OR COLOR.

FOR ANALGESICS (U.S. CLS. 6, 18, 44, 46, 51 AND 52). FIRST USE 7-12-2010; IN COMMERCE 7-12-2010. MORGAN WYNNE, EXAMINING ATTORNEY

SN 85-205,268. AXLEY, GARY, ROLAND, OK. FILED 12-23-2010.

## Rodrastin

THE MARK CONSISTS OF STANDARD CHARACTERS WITHOUT CLAIM TO ANY PARTICULAR FONT, STYLE, SIZE, OR COLOR.

FOR HERBAL SUPPLEMENTS (U.S. CLS. 6, 18, 44, 46, 51 AND 52). FIRST USE 2-15-2004; IN COMMERCE 2-15-2004. REGINA DRUMMOND, EXAMINING ATTORNEY

SN 85-205,611. GILAD GAD M, RESEDA, CA. AND GILAD VARDA, RESEDA, CA. FILED 12-24-2010.

## Agmaset

THE MARK CONSISTS OF STANDARD CHARACTERS WITHOUT CLAIM TO ANY PARTICULAR FONT, STYLE, SIZE, OR COLOR.

FOR ANIMAL FEED ADDITIVE FOR USE AS A NUTRITIONAL SUPPLEMENT FOR MEDICAL PURPOSES; ANIMAL FEED SUPPLEMENTS; ANTI-DIABETIC PHARMACEUTICALS; ANTI-DIABETIC PREPARATIONS; ANTIDIABETIC PREPARATIONS; DIETARY AND NUTRITIONAL SUPPLEMENTS; DIETARY AND NUTRITIONAL SUPPLEMENTS FOR ENDURANCE SPORTS; DIETARY AND NUTRITIONALLY FORTIFIED FOOD PRODUCTS ADAPTED FOR MEDICAL USE; DIETARY BEVERAGE SUPPLEMENTS FOR HUMAN CONSUMPTION IN LIQUID AND DRY MIX FORM FOR THERAPEUTIC PURPOSES; DIETARY DRINK MIX FOR USE AS A MEAL REPLACEMENT; DIETARY FOOD SUPPLEMENTS; DIETARY PET SUPPLEMENTS IN THE FORM OF PET TREATS; DIETARY SUPPLEMENT BEVERAGE FOR AIDING NERVE HEALTH; DIETARY SUPPLEMENTAL DRINKS; DIETARY SUPPLEMENTAL DRINKS IN THE NATURE OF VITAMIN AND MINERAL BEVERAGES; DIETARY SUPPLEMENTS; DIETARY SUPPLEMENTS FOR ANIMALS; DIETARY SUPPLEMENTS FOR HUMAN CONSUMPTION; DIETARY SUPPLEMENTS FOR PETS; DIETARY SUPPLEMENTS FOR PETS IN THE NATURE

**CLASS 5—(Continued).**

OF A POWDERED DRINK MIX; DIETARY SUPPLEMENTS FOR AIDING NERVE HEALTH; FEED SUPPLEMENTS FOR PETS, LIVESTOCK; FOOD SUPPLEMENTS; FOOD SUPPLEMENTS FOR AIDING NERVE HEALTH; FOODS FOR INDIVIDUALS WITH SPECIAL DIETARY REQUIREMENTS NECESSITATED BY MEDICAL TREATMENTS; HEALTH FOOD SUPPLEMENTS; HOMEOPATHIC SUPPLEMENTS; LIQUID NUTRITIONAL SUPPLEMENT; MEAL REPLACEMENT AND DIETARY SUPPLEMENT DRINK MIXES; MEDICATED SUPPLEMENTS FOR FOODSTUFFS FOR ANIMALS; NATURAL SUPPLEMENTS FOR TREATING DEPRESSION AND ANXIETY; NON-MEDICATED ADDITIVES FOR ANIMAL FEED FOR USE AS NUTRITIONAL SUPPLEMENTS; NUTRACEUTICALS FOR USE AS A DIETARY SUPPLEMENT; NUTRACEUTICALS FOR USE AS A DIETARY SUPPLEMENT FOR AIDING NERVE HEALTH; NUTRITIONAL ADDITIVES FOR MEDICAL PURPOSES FOR USE IN FOODS AND DIETARY SUPPLEMENTS FOR HUMAN CONSUMPTION; NUTRITIONAL ADDITIVES FOR MEDICAL PURPOSES USED IN FOODS AND DIETARY SUPPLEMENTS FOR HUMAN CONSUMPTION; NUTRITIONAL AND DIETARY SUPPLEMENTS FORMED AND PACKAGED AS BARS; NUTRITIONAL SUPPLEMENTS; NUTRITIONAL SUPPLEMENTS FOR AIDING NERVE HEALTH; NUTRITIONAL SUPPLEMENTS IN CAPSULE FORM FOR DOGS; NUTRITIONAL SUPPLEMENTS IN LOTION FORM SOLD AS A COMPONENT OF NUTRITIONAL SKIN CARE PRODUCTS; OPHTHALMIC PREPARATIONS; OPHTHALMOLOGIC PREPARATIONS; OPHTHALMOLOGICAL PREPARATIONS; PHARMACEUTICAL PREPARATIONS ACTING ON THE CENTRAL NERVOUS SYSTEM; PHARMACEUTICAL PREPARATIONS AND SUBSTANCES FOR THE TREATMENT OF DAMAGED SKIN AND TISSUE; PHARMACEUTICAL PREPARATIONS AND SUBSTANCES FOR THE TREATMENT OF INFECTIOUS DISEASES, BLOOD DISORDERS, PAIN, INFLAMMATION, SEPSIS, ALOPECIA, OBESITY AND COGNITIVE DISORDERS; PHARMACEUTICAL PREPARATIONS AND SUBSTANCES FOR THE TREATMENT OF PSYCHIATRIC DISEASES AND DISORDERS; PHARMACEUTICAL PREPARATIONS FOR THE PREVENTION AND TREATMENT OF DISORDERS OF THE NERVOUS SYSTEM, THE IMMUNE SYSTEM, THE CARDIO-VASCULAR SYSTEM, THE METABOLIC SYSTEM, THE RESPIRATORY SYSTEM, THE MUSCULO-SKELETAL SYSTEM, THE GENITOURINARY SYSTEM; FOR THE TREATMENT OF INFLAMMATORY DISORDERS; FOR USE IN DERMATOLOGY, ONCOLOGY, HEMATOLOGY AND IN TISSUE AND ORGAN TRANSPLANTATION, IN OPHTHALMOLOGY AND FOR GASTROENTEROLOGICAL DISORDERS; PHARMACEUTICAL PREPARATIONS FOR THE PREVENTION AND TREATMENT OF OCULAR DISORDERS OR DISEASES, BACTERIA-BASED DISEASES OR DISORDERS, AUTOIMMUNE DISEASES OR DISORDERS, KIDNEY DISEASES OR DISORDERS, AND DIABETES; PHARMACEUTICAL PREPARATIONS FOR THE PREVENTION OF NERVOUS SYSTEM DAMAGE; PHARMACEUTICAL PREPARATIONS FOR THE TREATMENT AND PREVENTION OF NERVOUS SYSTEM DAMAGE; PHARMACEUTICAL PREPARATIONS FOR THE TREATMENT OF EYE DISEASES AND CONDITIONS; PHARMACEUTICAL PREPARATIONS FOR THE TREATMENT OF KIDNEY DISEASES; PHARMACEUTICAL PREPARATIONS FOR THE TREATMENT OF NERVOUS SYSTEM DAMAGE; PHARMACEUTICAL PREPARATIONS FOR TREATING DIABETES; PHARMACEUTICAL PREPARATIONS FOR TREATING SKIN DISORDERS; PHARMACEUTICAL PREPARATIONS FOR USE IN CHEMOTHERAPY; PHARMACEUTICAL PREPARATIONS FOR NERVOUS SYSTEM DAMAGE; PHARMACEUTICAL PREPARATIONS, NAMELY, A TOPICAL PREPARATION FOR THE TREATMENT OF OCULAR DISORDERS PRESCRIBED BY OPHTHALMOLOGISTS, EYE SURGEONS, AND OPTOMETRISTS; PHARMACEUTICAL PREPARATIONS, NAMELY, ANTI-



**CLASS 5—(Continued).**

DEPRESSANTS; PHARMACEUTICAL PRODUCTS FOR OPHTHALMOLOGICAL USE; PHARMACEUTICAL PRODUCTS FOR THE PREVENTION AND TREATMENT OF CANCER; POWDERED NUTRITIONAL SUPPLEMENT DRINK MIX; PREPARATION FOR THE RELIEF OF PAIN; THERAPEUTIC PHARMACEUTICAL FOR THE TREATMENT OF NERVOUS SYSTEM DAMAGE; VETERINARY PREPARATIONS FOR NERVOUS SYSTEM DAMAGE; VETERINARY PREPARATIONS, NAMELY, PAIN RELIEF MEDICATION; VITAMINS AND DIETARY FOOD SUPPLEMENTS FOR ANIMALS (U.S. CLS. 6, 18, 44, 46, 51 AND 52).

FIRST USE 12-1-2010; IN COMMERCE 12-1-2010.

REBECCA POVARCHUK, EXAMINING ATTORNEY

---

SN 85-205,688. MYBODY, L.L.C., PHOENIX, AZ. FILED 12-26-2010.

**LET ME CLARIFY**

THE MARK CONSISTS OF STANDARD CHARACTERS WITHOUT CLAIM TO ANY PARTICULAR FONT, STYLE, SIZE, OR COLOR.

FOR MEDICINAL CREAMS FOR SKIN CARE (U.S. CLS. 6, 18, 44, 46, 51 AND 52).

FIRST USE 1-28-2011; IN COMMERCE 1-28-2011.

SHAUNIA CARLYLE, EXAMINING ATTORNEY

---

SN 85-205,690. MYBODY, L.L.C., PHOENIX, AZ. FILED 12-26-2010.

**LIGHT THE WAY**

THE MARK CONSISTS OF STANDARD CHARACTERS WITHOUT CLAIM TO ANY PARTICULAR FONT, STYLE, SIZE, OR COLOR.

FOR MEDICINAL CREAMS FOR SKIN CARE (U.S. CLS. 6, 18, 44, 46, 51 AND 52).

FIRST USE 1-28-2011; IN COMMERCE 1-28-2011.

SHAUNIA CARLYLE, EXAMINING ATTORNEY

**CLASS 5—(Continued).**

SN 85-206,123. NEEL ALAN ENTERPRISES, BATON ROUGE, LA. FILED 12-27-2010.

**Eastern Zen Western Energy**

THE MARK CONSISTS OF STANDARD CHARACTERS WITHOUT CLAIM TO ANY PARTICULAR FONT, STYLE, SIZE, OR COLOR.

FOR DIETARY SUPPLEMENTAL DRINKS; DIETARY SUPPLEMENTAL DRINKS IN THE NATURE OF VITAMIN AND MINERAL BEVERAGES (U.S. CLS. 6, 18, 44, 46, 51 AND 52).

FIRST USE 11-1-2009; IN COMMERCE 9-1-2010.

ELIZABETH HUGHITT, EXAMINING ATTORNEY

---

SN 85-206,269. SUSTAINA BEVERAGE GROUP LLC, CARMEL, CA. FILED 12-27-2010.

THE MARK CONSISTS OF THE STYLIZED MARK "SUSTAINA" WITH A LEAF IMAGE OVER THE "I".

FOR VITAMIN SUPPLEMENTS (U.S. CLS. 6, 18, 44, 46, 51 AND 52).

DEIRDRE ROBERTSON, EXAMINING ATTORNEY

---

SN 85-206,388. MYBODY, L.L.C., PHOENIX, AZ. FILED 12-28-2010.

THE MARK CONSISTS OF STANDARD CHARACTERS WITHOUT CLAIM TO ANY PARTICULAR FONT, STYLE, SIZE, OR COLOR.

FOR MEDICATED SKIN CARE PREPARATIONS; MEDICATED SKIN CARE PREPARATIONS, NAMELY, CREAMS, LOTIONS, GELS, TONERS, CLEANERS AND PEELS; MEDICINAL CREAMS FOR SKIN CARE; NON-MEDICATED, THERAPEUTIC SKIN CREAMS FOR THE TREATMENT OF ACNE; NUTRITIONAL SUPPLEMENTS FOR PROMOTING HEALTHY SKIN; NUTRITIONAL SUPPLEMENTS IN LOTION FORM SOLD AS A COMPONENT OF NUTRITIONAL SKIN CARE PRODUCTS; VAGINAL MOISTURIZERS; VAGINAL PREPARATIONS, NAMELY, ANTIFUNGALS; VAGINAL WASHES (U.S. CLS. 6, 18, 44, 46, 51 AND 52).

SHAUNIA CARLYLE, EXAMINING ATTORNEY

**CLASS 5—(Continued).**

SN 85-206,579. HARRY J. BOSWORTH COMPANY, SKOKIE, IL. FILED 12-28-2010.

**PHARMACAINE**

THE MARK CONSISTS OF STANDARD CHARACTERS WITHOUT CLAIM TO ANY PARTICULAR FONT, STYLE, SIZE, OR COLOR.

FOR TOPICAL ANESTHETICS (U.S. CLS. 6, 18, 44, 46, 51 AND 52).

ANNE MADDEN, EXAMINING ATTORNEY

SN 85-206,623. INFINITY ENTERPRISES INCORPORATED, TOKYO, JAPAN, FILED 12-28-2010.

**OmniCare**

THE MARK CONSISTS OF STANDARD CHARACTERS WITHOUT CLAIM TO ANY PARTICULAR FONT, STYLE, SIZE, OR COLOR.

FOR DIETARY AND NUTRITIONAL SUPPLEMENTS (U.S. CLS. 6, 18, 44, 46, 51 AND 52).

STEVEN PEREZ, EXAMINING ATTORNEY

SN 85-206,901. WEINZIMMER, RUSS, MILFORD, NH. FILED 12-28-2010.

**ORACROM**

THE MARK CONSISTS OF STANDARD CHARACTERS WITHOUT CLAIM TO ANY PARTICULAR FONT, STYLE, SIZE, OR COLOR.

FOR PHARMACEUTICAL PREPARATIONS FOR TREATING ORAL ALLERGIC SYMPTOMS DUE TO ORAL CONTACT WITH FRUITS AND/OR VEGETABLES (U.S. CLS. 6, 18, 44, 46, 51 AND 52).

JOSETTE BEVERLY, EXAMINING ATTORNEY

**CLASS 5—(Continued).**

SN 85-206,902. WEINZIMMER, RUSS, MILFORD, NH. FILED 12-28-2010.

**FRUITACROM**

THE MARK CONSISTS OF STANDARD CHARACTERS WITHOUT CLAIM TO ANY PARTICULAR FONT, STYLE, SIZE, OR COLOR.

FOR PHARMACEUTICAL PREPARATIONS FOR TREATING ORAL ALLERGIC SYMPTOMS DUE TO ORAL CONTACT WITH FRUITS AND/OR VEGETABLES (U.S. CLS. 6, 18, 44, 46, 51 AND 52).

JOSETTE BEVERLY, EXAMINING ATTORNEY

SN 85-207,017. DH NUTRACEUTICALS LLC, DBA DH NUTRACEUTICALS LLC, EDISON, NJ. FILED 12-29-2010.

**TESSENCEA**

THE MARK CONSISTS OF STANDARD CHARACTERS WITHOUT CLAIM TO ANY PARTICULAR FONT, STYLE, SIZE, OR COLOR.

FOR DIETARY AND NUTRITIONAL SUPPLEMENTS (U.S. CLS. 6, 18, 44, 46, 51 AND 52).

MATTHEW PAPPAS, EXAMINING ATTORNEY

SN 85-207,036. AGOURON PHARMACEUTICALS, INC., SAN DIEGO, CA. FILED 12-29-2010.

**AXITILIENT**

THE MARK CONSISTS OF STANDARD CHARACTERS WITHOUT CLAIM TO ANY PARTICULAR FONT, STYLE, SIZE, OR COLOR.

FOR PHARMACEUTICAL PREPARATIONS FOR THE TREATMENT OF CARDIOVASCULAR, CENTRAL NERVOUS SYSTEM, ENDOCRINE, GASTROINTESTINAL, HEMATOLOGIC, IMMUNOLOGICAL, INFECTIOUS, INFLAMMATORY, MENOPAUSAL, METABOLIC, MUSCULOSKELETAL, NEUROLOGICAL, ONCOLOGICAL, OPHTHALMOLOGICAL, PSYCHIATRIC, RESPIRATORY, UROGENITAL, UROLOGICAL AND VIRAL DISEASES AND DISORDERS; PHARMACEUTICAL PREPARATIONS FOR THE TREATMENT OF ERECTILE DYSFUNCTION, SEXUAL DYSFUNCTION AND PAIN; PHARMACEUTICAL PREPARATIONS, NAMELY, ANTI-FUNGAL PREPARATIONS, DERMATOLOGICAL PREPARATIONS, SMOKING CESSATION PREPARATIONS; VACCINES FOR HUMAN USE (U.S. CLS. 6, 18, 44, 46, 51 AND 52).

MATTHEW PAPPAS, EXAMINING ATTORNEY

**CLASS 5—(Continued).**

SN 85-207,583. LEADERLANDS, LLC, CARSON CITY, NV. FILED 12-29-2010.

## LEADERLANDS

THE MARK CONSISTS OF STANDARD CHARACTERS WITHOUT CLAIM TO ANY PARTICULAR FONT, STYLE, SIZE, OR COLOR.

FOR DIETARY SUPPLEMENTS (U.S. CLS. 6, 18, 44, 46, 51 AND 52).

LINDSEY RUBIN, EXAMINING ATTORNEY

SN 85-207,875. THE WORDS BEST SUPERFRUIT, DBA YOUJUVE, FAIRFAX, VA. FILED 12-30-2010.

## YouJuve

THE MARK CONSISTS OF STANDARD CHARACTERS WITHOUT CLAIM TO ANY PARTICULAR FONT, STYLE, SIZE, OR COLOR.

FOR MEAL REPLACEMENT POWDERS; NUTRITIONAL SUPPLEMENTS; POWDERED NUTRITIONAL SUPPLEMENT DRINK MIX (U.S. CLS. 6, 18, 44, 46, 51 AND 52).

FIRST USE 7-1-2010; IN COMMERCE 10-1-2010.

GEORGE LORENZO, EXAMINING ATTORNEY

SN 85-207,993. PFIZER INC., NEW YORK, NY. FILED 12-30-2010.

## POMACIN

THE MARK CONSISTS OF STANDARD CHARACTERS WITHOUT CLAIM TO ANY PARTICULAR FONT, STYLE, SIZE, OR COLOR.

FOR VETERINARY PREPARATIONS FOR THE PREVENTION OR TREATMENT OF OCULAR DISORDERS; ORAL DISEASES; CENTRAL NERVOUS SYSTEM DISEASES AND DISORDERS, NAMELY CENTRAL NERVOUS SYSTEM INFECTIONS, BRAIN DISEASES, CENTRAL NERVOUS SYSTEM MOVEMENT DISORDERS, OCULAR MOTILITY DISORDERS, SPINAL CORD DISEASES, ENCEPHALITIS, EPILEPSY, ALZHEIMER'S, CEREBRAL PALSY, INSOMNIA, SEIZURE DISORDERS; CIRCULATORY SYSTEM DISEASES AND DISORDERS, NAMELY DISORDERS IN BLOOD CIRCULATION, HYPERTENSION, PORTAL HYPERTENSION, PULMONARY DISEASES, PULMONARY HYPERTENSION AND HEART FAILURE; IMMUNOLOGICAL DISEASES AND DISORDERS, NAMELY AUTOIMMUNE DISEASES, IMMUNOLOGIC DEFICIENCY SYNDROMES; THE CARDIO-VASCULAR SYSTEM; THE RESPIRATORY SYSTEM; MUSCULOSKELETAL DISEASES AND DISORDERS, NAMELY CONNECTIVE TISSUE DISEASES, BONE DISEASES, OSTEOPOROSIS, SPINAL DISEASES, BACK PAIN, FRACTURES,

**CLASS 5—(Continued).**

SPRAINS, CARTILAGE INJURIES; THE DIGESTIVE SYSTEM; GENITOURINARY DISEASES, NAMELY UROLOGICAL DISEASES, INFERTILITY, SEXUALLY TRANSMITTED DISEASES, INFLAMMATORY PELVIC DISEASES; AND REPRODUCTIVE HEALTH DISEASES AND DISORDERS, NAMELY, MALE AND FEMALE INFERTILITY, OVULATION DISORDERS, HORMONE REPLACEMENT THERAPY INDICATED FOR THE RELIEF OF MENOPAUSE SYMPTOMS AND THE PREVENTION OF OSTEOPOROSIS; VETERINARY PREPARATIONS FOR THE TREATMENT OR PREVENTION OF INFECTIOUS DISEASES, OBESITY, BEHAVIORAL DISORDERS AND INFLAMMATORY DISORDERS; VETERINARY PREPARATIONS FOR USE IN DERMATOLOGY, ONCOLOGY, HEMATOLOGY, OPHTHALMOLOGY, AND GASTROENTEROLOGY; VETERINARY PREPARATIONS, NAMELY, DENTAL PREPARATIONS, NAMELY A PHARMACEUTICAL DRUG OR VACCINE FOR THE TREATMENT OR PREVENTION OF TOOTH DECAY, TOOTH SENSITIVITY, GINGIVITIS, HALITOSIS AND PERIODONTAL DISEASE; VETERINARY PREPARATIONS, NAMELY, NUTRITIONAL ADDITIVES TO FOODSTUFFS FOR ANIMALS FOR MEDICAL PURPOSES AND FOOD SUPPLEMENTS; VETERINARY PREPARATIONS, NAMELY, PHARMACEUTICAL PREPARATIONS FOR RELIEVING TEETHING PAINS AND TOOTHACHES IN COMPANION ANIMALS; VETERINARY PARASITICIDES; VETERINARY ANALGESIC PREPARATIONS; VETERINARY ANTI-ALLERGEN PREPARATIONS, NAMELY, ALLERGY MEDICATIONS; VETERINARY PREPARATIONS, NAMELY, ANTI-INFECTIVES, ANTI-BACTERIALS, ANTI-VIRALS, ANTIBIOTICS, ANTIFUNGALS, ANTHELMINTICS, ALL OF THE FOREGOING FOR TREATING FELINES, CANINES, BOVINES, PORCINES, EQUINES, RABBITS, POULTRY, GOATS AND SHEEP (U.S. CLS. 6, 18, 44, 46, 51 AND 52).

SKYE YOUNG, EXAMINING ATTORNEY

SN 85-207,998. PFIZER INC., NEW YORK, NY. FILED 12-30-2010.

## PREVADE

THE MARK CONSISTS OF STANDARD CHARACTERS WITHOUT CLAIM TO ANY PARTICULAR FONT, STYLE, SIZE, OR COLOR.

FOR VETERINARY PREPARATIONS FOR THE PREVENTION OR TREATMENT OF OCULAR DISORDERS; ORAL DISEASES; CENTRAL NERVOUS SYSTEM DISEASES AND DISORDERS, NAMELY CENTRAL NERVOUS SYSTEM INFECTIONS, BRAIN DISEASES, CENTRAL NERVOUS SYSTEM MOVEMENT DISORDERS, OCULAR MOTILITY DISORDERS, SPINAL CORD DISEASES, ENCEPHALITIS, EPILEPSY, ALZHEIMER'S, CEREBRAL PALSY, INSOMNIA, SEIZURE DISORDERS; CIRCULATORY SYSTEM DISEASES AND DISORDERS, NAMELY DISORDERS IN BLOOD CIRCULATION, HYPERTENSION, PORTAL HYPERTENSION, PULMONARY DISEASES, PULMONARY HYPERTENSION AND HEART FAILURE; IMMUNOLOGICAL DISEASES AND DISORDERS, NAMELY AUTOIMMUNE DISEASES, IMMUNOLOGIC DEFICIENCY SYNDROMES; THE CARDIO-VASCULAR SYSTEM; THE RESPIRATORY SYSTEM; MUSCULOSKELETAL DISEASES AND DISORDERS, NAMELY CONNECTIVE TISSUE DISEASES, BONE DISEASES, OSTEOPOROSIS, SPINAL DISEASES, BACK PAIN, FRACTURES, SPRAINS, CARTILAGE INJURIES; THE DIGESTIVE SYSTEM; GENITOURINARY DISEASES, NAMELY UROLOGICAL DISEASES, INFERTILITY, SEXUALLY TRANSMITTED DISEASES, INFLAMMATORY PELVIC DISEASES; AND REPRODUCTIVE HEALTH DISEASES AND DISORDERS, NAMELY, MALE AND FEMALE INFERTILITY, OVULATION DISORDERS, HORMONE

**CLASS 5—(Continued).**

REPLACEMENT THERAPY INDICATED FOR THE RELIEF OF MENOPAUSE SYMPTOMS AND THE PREVENTION OF OSTEOPOROSIS; VETERINARY PREPARATIONS FOR THE TREATMENT OR PREVENTION OF INFECTIOUS DISEASES, OBESITY, BEHAVIORAL DISORDERS AND INFLAMMATORY DISORDERS; VETERINARY PREPARATIONS FOR USE IN DERMATOLOGY, ONCOLOGY, HEMATOLOGY, OPHTHALMOLOGY, AND GASTROENTEROLOGY; VETERINARY PREPARATIONS, NAMELY, DENTAL PREPARATIONS, NAMELY A PHARMACEUTICAL DRUG OR VACCINE FOR THE TREATMENT OR PREVENTION OF TOOTH DECAY, TOOTH SENSITIVITY, GINGIVITIS, HALITOSIS AND PERIODONTAL DISEASE; VETERINARY PREPARATIONS, NAMELY, NUTRITIONAL ADDITIVES TO FOODSTUFFS FOR ANIMALS FOR MEDICAL PURPOSES AND FOOD SUPPLEMENTS; VETERINARY PREPARATIONS, NAMELY, PHARMACEUTICAL PREPARATIONS FOR RELIEVING TEETHING PAINS AND TOOTHACHES IN COMPANION ANIMALS; VETERINARY PARASITICIDES; VETERINARY ANALGESIC PREPARATIONS; VETERINARY ANTI-ALLERGEN PREPARATIONS, NAMELY, ALLERGY MEDICATIONS; VETERINARY PREPARATIONS, NAMELY, ANTI-INFECTIVES, ANTI-BACTERIALS, ANTI-VIRALS, ANTIBIOTICS, ANTIFUNGALS, ANTHELMINTICS, ALL OF THE FOREGOING FOR TREATING FELINES, CANINES, BOVINES, PORCINES, EQUINES, RABBITS, POULTRY, GOATS AND SHEEP (U.S. CLS. 6, 18, 44, 46, 51 AND 52).

SKYE YOUNG, EXAMINING ATTORNEY

SN 85-208,211. PARADOCS ALL NATURAL INC, PLANTATION, FL. FILED 12-30-2010.

## Just Stop

THE MARK CONSISTS OF STANDARD CHARACTERS WITHOUT CLAIM TO ANY PARTICULAR FONT, STYLE, SIZE, OR COLOR.

FOR HERBAL SUPPLEMENTS; SMOKING CESSATION PREPARATIONS (U.S. CLS. 6, 18, 44, 46, 51 AND 52).

FIRST USE 2-1-2010; IN COMMERCE 6-1-2010.  
ANGELA M. MICHELL, EXAMINING ATTORNEY

SN 85-208,263. JARROW FORMULAS, INC., LOS ANGELES, CA. FILED 12-30-2010.

## RESISTIMMUNE

THE MARK CONSISTS OF STANDARD CHARACTERS WITHOUT CLAIM TO ANY PARTICULAR FONT, STYLE, SIZE, OR COLOR.

FOR DIETARY AND NUTRITIONAL SUPPLEMENTS (U.S. CLS. 6, 18, 44, 46, 51 AND 52).

PAUL E. FAHRENKOPF, EXAMINING ATTORNEY

**CLASS 5—(Continued).**

SN 85-208,368. MAXIMUM LIVING, INC., SOULSBYVILLE, CA. FILED 12-30-2010.

## MOODASSURE

THE MARK CONSISTS OF STANDARD CHARACTERS WITHOUT CLAIM TO ANY PARTICULAR FONT, STYLE, SIZE, OR COLOR.

FOR DIETARY AND NUTRITIONAL SUPPLEMENTS CONTAINING ST. JOHN'S WORT (U.S. CLS. 6, 18, 44, 46, 51 AND 52).

FIRST USE 5-24-1999; IN COMMERCE 5-24-1999.  
ALICIA COLLINS, EXAMINING ATTORNEY

SN 85-208,673. VETOQUINOL S.A., CEDEX, FRANCE, FILED 12-31-2010.

## MARBOCYL

THE MARK CONSISTS OF STANDARD CHARACTERS WITHOUT CLAIM TO ANY PARTICULAR FONT, STYLE, SIZE, OR COLOR.

FOR ANTI-INFECTIVE PRODUCTS FOR VETERINARY USE (U.S. CLS. 6, 18, 44, 46, 51 AND 52).

JILL PRATER, EXAMINING ATTORNEY

SN 85-208,713. RMK DIVERSIFIED, LLC, CHANDLER, AZ. FILED 12-31-2010.

## AFTER BURNER

THE MARK CONSISTS OF STANDARD CHARACTERS WITHOUT CLAIM TO ANY PARTICULAR FONT, STYLE, SIZE, OR COLOR.

FOR TRANSDERMAL PATCHES FOR USE IN THE TREATMENT OF HANGOVERS (U.S. CLS. 6, 18, 44, 46, 51 AND 52).

FIRST USE 12-31-2010; IN COMMERCE 12-31-2010.  
ANDREA HACK, EXAMINING ATTORNEY

**CLASS 5—(Continued).**

SN 85-208,738. ADVANCED DERMATOLOGIC SOLUTIONS, LLC, MARIETTA, GA. FILED 12-31-2010.



THE COLOR(S) RED AND BLUE IS/ARE CLAIMED AS A FEATURE OF THE MARK.

THE MARK CONSISTS OF THE STYLIZED LETTERS "RO" IN RED WITH THE LINE ABOVE THE LETTER "O" IN BLUE AND THE STYLIZED LETTERS "CLEARA" IN BLUE. FOR DERMATOLOGICAL PHARMACEUTICAL PRODUCTS (U.S. CLS. 6, 18, 44, 46, 51 AND 52).

HELENE LIWINSKI, EXAMINING ATTORNEY

SN 85-208,778. CRYSTAL VISION LTD, NEWPORT BEACH, CA. FILED 1-1-2011.

## SKINNY LIFE

THE MARK CONSISTS OF STANDARD CHARACTERS WITHOUT CLAIM TO ANY PARTICULAR FONT, STYLE, SIZE, OR COLOR.

FOR DIETARY AND NUTRITIONAL SUPPLEMENTS, VITAMIN AND MINERAL SUPPLEMENTS, NUTRACEUTICALS FOR HEALTHY LEAN WEIGHT SUPPORT, MEAL REPLACEMENT POWDERED SUPPLEMENT, HERBAL METABOLISM BOOSTER SUPPLEMENT, ESSENTIAL FATTY ACID SUPPLEMENTS FOR OPTIMUM HEALTH AND WEIGHT CONTROL (U.S. CLS. 6, 18, 44, 46, 51 AND 52).

APRIL ROACH, EXAMINING ATTORNEY

SN 85-208,931. DOW AGROSCIENCES LLC, INDIANAPOLIS, IN. FILED 1-3-2011.

## DEFENDOR

THE MARK CONSISTS OF STANDARD CHARACTERS WITHOUT CLAIM TO ANY PARTICULAR FONT, STYLE, SIZE, OR COLOR.

FOR PESTICIDES AND PREPARATIONS FOR DESTROYING VERMIN, NAMELY, HERBICIDES, INSECTICIDES AND FUNGICIDES FOR AGRICULTURE, HORTICULTURE, FORESTRY, TURF AND ORNAMENTAL, COMMERCIAL, INDUSTRIAL AND DOMESTIC USE (U.S. CLS. 6, 18, 44, 46, 51 AND 52).

ANNE E. GUSTASON, EXAMINING ATTORNEY

**CLASS 5—(Continued).**

SN 85-208,932. DOW AGROSCIENCES LLC, INDIANAPOLIS, IN. FILED 1-3-2011.

## CHALLENGER

THE MARK CONSISTS OF STANDARD CHARACTERS WITHOUT CLAIM TO ANY PARTICULAR FONT, STYLE, SIZE, OR COLOR.

FOR PESTICIDES AND PREPARATIONS FOR DESTROYING VERMIN, NAMELY, HERBICIDES, INSECTICIDES AND FUNGICIDES FOR AGRICULTURE, HORTICULTURE, FORESTRY, TURF AND ORNAMENTAL, COMMERCIAL, INDUSTRIAL AND DOMESTIC USE (U.S. CLS. 6, 18, 44, 46, 51 AND 52).

ANNE E. GUSTASON, EXAMINING ATTORNEY

SN 85-208,969. RESERVE LIFE ORGANICS, LLC, GAINESVILLE, FL. FILED 1-3-2011.

## COCOAWELL

THE MARK CONSISTS OF STANDARD CHARACTERS WITHOUT CLAIM TO ANY PARTICULAR FONT, STYLE, SIZE, OR COLOR.

FOR DIETARY AND NUTRITIONAL SUPPLEMENTS CONTAINING COCOA (U.S. CLS. 6, 18, 44, 46, 51 AND 52).

CHERYL CLAYTON, EXAMINING ATTORNEY

SN 85-209,242. PERFECT WORLD SOLUTIONS, INC., PHOENIX, AZ. FILED 1-3-2011.

## BIONICEDGE

THE MARK CONSISTS OF STANDARD CHARACTERS WITHOUT CLAIM TO ANY PARTICULAR FONT, STYLE, SIZE, OR COLOR.

FOR BRACELETS AND BANDS FOR MEDICAL PURPOSES CONTAINING IMPRINTED METAL OR SILICON FOR PROTON ALIGNMENT (U.S. CLS. 6, 18, 44, 46, 51 AND 52).

GISELLE AGOSTO, EXAMINING ATTORNEY

**CLASS 5—(Continued).**

SN 85-209,333. ACTIVEION CLEANING SOLUTIONS LLC, MINNEAPOLIS, MN. FILED 1-3-2011.

**ACTIVEION EXP**

THE MARK CONSISTS OF STANDARD CHARACTERS WITHOUT CLAIM TO ANY PARTICULAR FONT, STYLE, SIZE, OR COLOR.

OWNER OF U.S. REG. NOS. 3,842,362 AND 3,863,086. FOR SANITIZING PREPARATIONS AND DISINFECTANTS FOR PERSONAL HYGIENIC USE; SANITIZING PREPARATIONS AND DISINFECTANTS FOR MEDICAL USE ON SUPPLIES, EQUIPMENT, AND MEDICAL FACILITY SURFACES (U.S. CLS. 6, 18, 44, 46, 51 AND 52).

DAVID TAYLOR, EXAMINING ATTORNEY

**CLASS 5—(Continued).**

SN 85-209,733. MYBODY, L.L.C., PHOENIX, AZ. FILED 1-4-2011.



THE COLOR(S) WHITE, GREEN AND GRAY IS/ARE CLAIMED AS A FEATURE OF THE MARK.

THE MARK CONSISTS OF A WHITE DESIGN HEART WITHIN A GREEN DESIGN HEART WITH THE WORD "MYBODY" IN GRAY.

FOR DIETARY AND NUTRITIONAL SUPPLEMENTS; MEDICATED SKIN CARE PREPARATIONS; MEDICATED SKIN CARE PREPARATIONS, NAMELY, CREAMS, LOTIONS, GELS, TONERS, CLEANERS AND PEELS; MEDICINAL CREAMS FOR SKIN CARE; NON-MEDICATED, THERAPEUTIC SKIN CREAMS FOR THE TREATMENT OF ACNE; NUTRACEUTICALS FOR USE AS A DIETARY SUPPLEMENT; NUTRITIONAL SUPPLEMENTS FOR PROMOTING HEALTHY SKIN; NUTRITIONAL SUPPLEMENTS IN LOTION FORM SOLD AS A COMPONENT OF NUTRITIONAL SKIN CARE PRODUCTS; VAGINAL MOISTURIZERS; VAGINAL PREPARATIONS, NAMELY, ANTIFUNGALS; VAGINAL WASHES; VITAMINS AND VITAMIN PREPARATIONS (U.S. CLS. 6, 18, 44, 46, 51 AND 52).

MAYUR VAGHANI, EXAMINING ATTORNEY

SN 85-209,732. MYBODY, L.L.C., PHOENIX, AZ. FILED 1-4-2011.



THE COLOR(S) WHITE, PINK AND GRAY IS/ARE CLAIMED AS A FEATURE OF THE MARK.

THE MARK CONSISTS OF A WHITE DESIGN HEART WITHIN A PINK DESIGN HEART WITH THE WORD "MYBODY" IN GRAY.

FOR DIETARY AND NUTRITIONAL SUPPLEMENTS; MEDICATED SKIN CARE PREPARATIONS; MEDICATED SKIN CARE PREPARATIONS, NAMELY, CREAMS, LOTIONS, GELS, TONERS, CLEANERS AND PEELS; MEDICINAL CREAMS FOR SKIN CARE; NON-MEDICATED, THERAPEUTIC SKIN CREAMS FOR THE TREATMENT OF ACNE; NUTRACEUTICALS FOR USE AS A DIETARY SUPPLEMENT; NUTRITIONAL SUPPLEMENTS FOR PROMOTING HEALTHY SKIN; NUTRITIONAL SUPPLEMENTS IN LOTION FORM SOLD AS A COMPONENT OF NUTRITIONAL SKIN CARE PRODUCTS; VAGINAL MOISTURIZERS; VAGINAL PREPARATIONS, NAMELY, ANTIFUNGALS; VAGINAL WASHES; VITAMINS AND VITAMIN PREPARATIONS (U.S. CLS. 6, 18, 44, 46, 51 AND 52).

MAYUR VAGHANI, EXAMINING ATTORNEY

SN 85-209,738. MYBODY, L.L.C., PHOENIX, AZ. FILED 1-4-2011.



THE COLOR(S) WHITE, BLUE AND GRAY IS/ARE CLAIMED AS A FEATURE OF THE MARK.

THE MARK CONSISTS OF A WHITE DESIGN HEART WITHIN A BLUE DESIGN HEART WITH THE WORD "MYBODY" IN GRAY.

FOR DIETARY AND NUTRITIONAL SUPPLEMENTS; MEDICATED SKIN CARE PREPARATIONS; MEDICATED SKIN CARE PREPARATIONS, NAMELY, CREAMS, LOTIONS, GELS, TONERS, CLEANERS AND PEELS; MEDICINAL CREAMS FOR SKIN CARE; NON-MEDICATED, THERAPEUTIC SKIN CREAMS FOR THE TREATMENT OF ACNE; NUTRACEUTICALS FOR USE AS A DIETARY SUPPLEMENT; NUTRITIONAL SUPPLEMENTS FOR PROMOTING HEALTHY SKIN; NUTRITIONAL SUPPLEMENTS IN LOTION FORM SOLD AS A COMPONENT OF NUTRITIONAL SKIN CARE PRODUCTS; VAGINAL MOISTURIZERS; VAGINAL PREPARATIONS, NAMELY, ANTIFUNGALS; VAGINAL WASHES; VITAMINS AND VITAMIN PREPARATIONS (U.S. CLS. 6, 18, 44, 46, 51 AND 52).

MAYUR VAGHANI, EXAMINING ATTORNEY

**CLASS 5—(Continued).**

SN 85-209,749. TOPAZ PHARMACEUTICALS, INC., HORSHAM, PA. FILED 1-4-2011.

ONE KID, ONE TUBE, ONE TIME

THE MARK CONSISTS OF STANDARD CHARACTERS WITHOUT CLAIM TO ANY PARTICULAR FONT, STYLE, SIZE, OR COLOR.

FOR PREPARATIONS FOR THE TREATMENT OF LICE AND SCABIES (U.S. CLS. 6, 18, 44, 46, 51 AND 52).  
DARRYL SPRUILL, EXAMINING ATTORNEY

SN 85-209,906. GLAXO GROUP LIMITED, GREENFORD, MIDDLESEX, UNITED KINGDOM, FILED 1-4-2011.

**DUOJEX**

THE MARK CONSISTS OF STANDARD CHARACTERS WITHOUT CLAIM TO ANY PARTICULAR FONT, STYLE, SIZE, OR COLOR.

FOR PHARMACEUTICAL PREPARATIONS AND SUBSTANCES FOR THE TREATMENT OF DAMAGED SKIN AND TISSUE; PHARMACEUTICAL PREPARATIONS AND SUBSTANCES FOR THE TREATMENT OF INFECTIOUS DISEASES, BLOOD DISORDERS, PAIN, INFLAMMATION, SEPSIS, ALOPECIA, OBESITY AND COGNITIVE DISORDERS; PHARMACEUTICAL PREPARATIONS AND SUBSTANCES FOR THE TREATMENT OF VIRAL, METABOLIC, ENDOCRINE, MUSCULOSKELETAL, CARDIOVASCULAR, CARDIO-PULMONARY, GENITOURINARY, SEXUAL DYSFUNCTION, ONCOLOGICAL, HEPATOLOGICAL, OPHTHALMIC, RESPIRATORY, NEUROLOGICAL, GASTROINTESTINAL, HORMONAL, DERMATOLOGICAL, PSYCHIATRIC AND IMMUNE SYSTEM RELATED DISEASES AND DISORDERS; VACCINES (U.S. CLS. 6, 18, 44, 46, 51 AND 52).

CAROLYN CATALDO, EXAMINING ATTORNEY

**CLASS 5—(Continued).**

SN 85-209,917. REGENERON PHARMACEUTICALS, INC., TARRYTOWN, NY. FILED 1-4-2011.



THE COLOR(S) DARK BLUE, LIGHT BLUE, AND YELLOW IS/ARE CLAIMED AS A FEATURE OF THE MARK.

THE MARK CONSISTS OF AN EYE DESIGN. THERE ARE TWO THICK CRESCENT SHAPES FACING EACH OTHER ON THE LEFT AND THE RIGHT. THE CRESCENT SHAPE ON THE LEFT IS THE COLOR DARK BLUE. THE CRESCENT SHAPE ON THE RIGHT IS THE COLOR YELLOW. IN BETWEEN THE TWO CRESCENT SHAPES ARE A SERIES OF LIGHT BLUE SQUARES WITH A DARK BLUE CIRCLE IN THE MIDDLE.

FOR PHARMACEUTICAL PREPARATIONS, NAMELY, OPHTHALMICS; PHARMACEUTICAL PREPARATIONS FOR THE TREATMENT OF OPHTHALMIC DISEASES AND CONDITIONS (U.S. CLS. 6, 18, 44, 46, 51 AND 52).

GEORGE LORENZO, EXAMINING ATTORNEY

SN 85-209,921. REGENERON PHARMACEUTICALS, INC., TARRYTOWN, NY. FILED 1-4-2011.



THE COLOR(S) DARK BLUE, LIGHT BLUE, AND YELLOW IS/ARE CLAIMED AS A FEATURE OF THE MARK.

THE MARK CONSISTS OF THE WORD "EYLEA" AND AN EYE DESIGN TO THE LEFT OF THE WORD "EYLEA". THE WORD "EYLEA" IS IN THE COLOR DARK BLUE. WITH RESPECT TO THE EYE DESIGN, THERE ARE TWO THICK CRESCENT SHAPES FACING EACH OTHER ON THE LEFT AND THE RIGHT. THE CRESCENT SHAPE ON THE LEFT IS THE COLOR DARK BLUE. THE CRESCENT SHAPE ON THE RIGHT IS THE COLOR YELLOW. IN BETWEEN THE TWO CRESCENT SHAPES ARE A SERIES OF LIGHT BLUE SQUARES WITH A DARK BLUE CIRCLE IN THE MIDDLE.

FOR PHARMACEUTICAL PREPARATIONS, NAMELY, OPHTHALMICS; PHARMACEUTICAL PREPARATIONS FOR THE TREATMENT OF OPHTHALMIC DISEASES AND CONDITIONS (U.S. CLS. 6, 18, 44, 46, 51 AND 52).

GEORGE LORENZO, EXAMINING ATTORNEY

**CLASS 5—(Continued).**

SN 85-209,927. YUMALITE INCORPORATED, COLLINGWOOD, ONTARIO, CANADA, FILED 1-4-2011.

# YumaVite

THE MARK CONSISTS OF STANDARD CHARACTERS WITHOUT CLAIM TO ANY PARTICULAR FONT, STYLE, SIZE, OR COLOR.  
FOR VITAMIN SUPPLEMENTS (U.S. CLS. 6, 18, 44, 46, 51 AND 52).  
JENNIFER VASQUEZ, EXAMINING ATTORNEY

**CLASS 5—(Continued).**

SN 85-210,237. INDUS BIOTECH PRIVATE LIMITED, PUNE, MAHARASHTRA, INDIA, FILED 1-4-2011.

# BIOCREAT

THE MARK CONSISTS OF STANDARD CHARACTERS WITHOUT CLAIM TO ANY PARTICULAR FONT, STYLE, SIZE, OR COLOR.  
FOR NUTRITIONAL AND DIETARY SUPPLEMENTS (U.S. CLS. 6, 18, 44, 46, 51 AND 52).  
SAIMA MAKHDOOM, EXAMINING ATTORNEY

SN 85-210,192. PESKIN, BRIAN, HOUSTON, TX. FILED 1-4-2011.

# THE POWER OF THE PARENTS

THE MARK CONSISTS OF STANDARD CHARACTERS WITHOUT CLAIM TO ANY PARTICULAR FONT, STYLE, SIZE, OR COLOR.  
FOR DIETARY AND NUTRITIONAL SUPPLEMENTS (U.S. CLS. 6, 18, 44, 46, 51 AND 52).  
FIRST USE 1-2-2011; IN COMMERCE 1-2-2011.  
DAVID TAYLOR, EXAMINING ATTORNEY

SN 85-210,245. INDUS BIOTECH PRIVATE LIMITED, PUNE, MAHARASHTRA, INDIA, FILED 1-4-2011.

# TORABOLIC

THE MARK CONSISTS OF STANDARD CHARACTERS WITHOUT CLAIM TO ANY PARTICULAR FONT, STYLE, SIZE, OR COLOR.  
FOR NUTRITIONAL AND DIETARY SUPPLEMENTS (U.S. CLS. 6, 18, 44, 46, 51 AND 52).  
FIRST USE 1-1-2009; IN COMMERCE 1-1-2009.  
SAIMA MAKHDOOM, EXAMINING ATTORNEY

SN 85-210,199. INDUS BIOTECH PRIVATE LIMITED, PUNE, MAHARASHTRA, INDIA, FILED 1-4-2011.

# HYPEROX

THE MARK CONSISTS OF STANDARD CHARACTERS WITHOUT CLAIM TO ANY PARTICULAR FONT, STYLE, SIZE, OR COLOR.  
FOR NUTRITIONAL AND DIETARY SUPPLEMENTS (U.S. CLS. 6, 18, 44, 46, 51 AND 52).  
FIRST USE 4-24-2009; IN COMMERCE 4-24-2009.  
SAIMA MAKHDOOM, EXAMINING ATTORNEY

SN 85-210,253. INDUS BIOTECH PRIVATE LIMITED, PUNE, MAHARASHTRA, INDIA, FILED 1-4-2011.

# TESTOSURGE

THE MARK CONSISTS OF STANDARD CHARACTERS WITHOUT CLAIM TO ANY PARTICULAR FONT, STYLE, SIZE, OR COLOR.  
FOR NUTRITIONAL AND DIETARY SUPPLEMENTS (U.S. CLS. 6, 18, 44, 46, 51 AND 52).  
FIRST USE 1-1-2009; IN COMMERCE 1-1-2009.  
SAIMA MAKHDOOM, EXAMINING ATTORNEY



**CLASS 5—(Continued).**

SN 85-210,313. NOVEN PHARMACEUTICALS, INC., MIAMI, FL. FILED 1-4-2011.

# E-DOT

THE MARK CONSISTS OF STANDARD CHARACTERS WITHOUT CLAIM TO ANY PARTICULAR FONT, STYLE, SIZE, OR COLOR.

FOR PHARMACEUTICAL PREPARATIONS, NAMELY THERAPEUTIC SYSTEMS IN THE FORM OF A BANDAGE OR PATCH TO BE ATTACHED TO SKIN OR MUCOSAL MEMBRANES FOR TREATMENT OF STEROIDAL OR HORMONAL DEFICIENCIES AND IMBALANCES (U.S. CLS. 6, 18, 44, 46, 51 AND 52).  
RAMONA ORTIGA, EXAMINING ATTORNEY

---

SN 85-210,651. HS TM, LLC, NEWARK, DE. FILED 1-5-2011.

# DRI-GARD

THE MARK CONSISTS OF STANDARD CHARACTERS WITHOUT CLAIM TO ANY PARTICULAR FONT, STYLE, SIZE, OR COLOR.

OWNER OF U.S. REG. NO. 2,218,904.  
FOR COTTON ROLL SUBSTITUTES FOR DENTAL USE (U.S. CLS. 6, 18, 44, 46, 51 AND 52).  
WILLIAM P. SHANAHAN, EXAMINING ATTORNEY

---

SN 85-210,685. ROCHE DIAGNOSTICS GMBH, 68305 MANNHEIM, FED REP GERMANY, FILED 1-5-2011.

# ACCU-CHEK SMARTVIEW

THE MARK CONSISTS OF STANDARD CHARACTERS WITHOUT CLAIM TO ANY PARTICULAR FONT, STYLE, SIZE, OR COLOR.

OWNER OF U.S. REG. NOS. 1,277,867, 3,411,797 AND OTHERS.

FOR DIAGNOSTIC TEST STRIPS FOR DETERMINING THE LEVEL OF GLUCOSE IN BLOOD FOR MEDICAL AND CLINICAL USE; AND CONTROL SOLUTIONS USED FOR QUALITY CHECKS ON BLOOD GLUCOSE MONITORS AND DIAGNOSTIC TEST STRIPS FOR MEDICAL AND CLINICAL USE (U.S. CLS. 6, 18, 44, 46, 51 AND 52).  
CHARLOTTE CORWIN, EXAMINING ATTORNEY

**CLASS 5—(Continued).**

SN 85-210,785. MYBODY, L.L.C., PHOENIX, AZ. FILED 1-5-2011.



THE COLOR(S) WHITE, RED AND GRAY IS/ARE CLAIMED AS A FEATURE OF THE MARK.

THE MARK CONSISTS OF A WHITE DESIGN HEART WITHIN A RED DESIGN HEART WITH THE WORD "MYBODY" IN GRAY.

FOR MEDICATED SKIN CARE PREPARATIONS; MEDICATED SKIN CARE PREPARATIONS, NAMELY, CREAMS, LOTIONS, GELS, TONERS, CLEANERS AND PEELS; MEDICINAL CREAMS FOR SKIN CARE; NON-MEDICATED, THERAPEUTIC SKIN CREAMS FOR THE TREATMENT OF ACNE; NUTRITIONAL SUPPLEMENTS FOR PROMOTING HEALTHY SKIN; NUTRITIONAL SUPPLEMENTS IN LOTION FORM SOLD AS A COMPONENT OF NUTRITIONAL SKIN CARE PRODUCTS; VAGINAL MOISTURIZERS; VAGINAL PREPARATIONS, NAMELY, ANTIFUNGALS; VAGINAL WASHES (U.S. CLS. 6, 18, 44, 46, 51 AND 52).  
MAYUR VAGHANI, EXAMINING ATTORNEY

---

SN 85-210,880. VIBRATIONAL NUTRITION RESEARCH, LLC, BEVERLY HILLS, CA. FILED 1-5-2011.

# VibraMins

THE MARK CONSISTS OF STANDARD CHARACTERS WITHOUT CLAIM TO ANY PARTICULAR FONT, STYLE, SIZE, OR COLOR.

FOR NUTRITIONAL SUPPLEMENTS (U.S. CLS. 6, 18, 44, 46, 51 AND 52).

FIRST USE 6-0-2010; IN COMMERCE 6-0-2010.  
TINA BROWN, EXAMINING ATTORNEY

**CLASS 5—(Continued).**

SN 85-210,915. GLAXO GROUP LIMITED, GREENFORD, MIDDLESEX, UNITED KINGDOM, FILED 1-5-2011.

# NUJOUR

THE MARK CONSISTS OF STANDARD CHARACTERS WITHOUT CLAIM TO ANY PARTICULAR FONT, STYLE, SIZE, OR COLOR.

FOR PHARMACEUTICAL PREPARATIONS AND SUBSTANCES FOR THE TREATMENT OF DAMAGED SKIN AND TISSUE; PHARMACEUTICAL PREPARATIONS AND SUBSTANCES FOR THE TREATMENT OF INFECTIOUS DISEASES, BLOOD DISORDERS, PAIN, INFLAMMATION, SEPSIS, ALOPECIA, OBESITY AND COGNITIVE DISORDERS; PHARMACEUTICAL PREPARATIONS AND SUBSTANCES FOR THE TREATMENT OF VIRAL, METABOLIC, ENDOCRINE, MUSCULOSKELETAL, CARDIOVASCULAR, CARDIOPULMONARY, GENITOURINARY, SEXUAL DYSFUNCTION, ONCOLOGICAL, HEPATOLOGICAL, OPHTHALMIC, RESPIRATORY, NEUROLOGICAL, GASTROINTESTINAL, HORMONAL, DERMATOLOGICAL, PSYCHIATRIC AND IMMUNE SYSTEM RELATED DISEASES AND DISORDERS; VACCINES (U.S. CLS. 6, 18, 44, 46, 51 AND 52).

CAROLYN CATALDO, EXAMINING ATTORNEY

**CLASS 5—(Continued).**

SN 85-210,922. GLAXO GROUP LIMITED, GREENFORD, MIDDLESEX, UNITED KINGDOM, FILED 1-5-2011.

# JERCEME

THE MARK CONSISTS OF STANDARD CHARACTERS WITHOUT CLAIM TO ANY PARTICULAR FONT, STYLE, SIZE, OR COLOR.

FOR PHARMACEUTICAL PREPARATIONS AND SUBSTANCES FOR THE TREATMENT OF DAMAGED SKIN AND TISSUE; PHARMACEUTICAL PREPARATIONS AND SUBSTANCES FOR THE TREATMENT OF INFECTIOUS DISEASES, BLOOD DISORDERS, PAIN, INFLAMMATION, SEPSIS, ALOPECIA, OBESITY AND COGNITIVE DISORDERS; PHARMACEUTICAL PREPARATIONS AND SUBSTANCES FOR THE TREATMENT OF VIRAL, METABOLIC, ENDOCRINE, MUSCULOSKELETAL, CARDIOVASCULAR, CARDIOPULMONARY, GENITOURINARY, SEXUAL DYSFUNCTION, ONCOLOGICAL, HEPATOLOGICAL, OPHTHALMIC, RESPIRATORY, NEUROLOGICAL, GASTROINTESTINAL, HORMONAL, DERMATOLOGICAL, PSYCHIATRIC AND IMMUNE SYSTEM RELATED DISEASES AND DISORDERS; VACCINES (U.S. CLS. 6, 18, 44, 46, 51 AND 52).

CAROLYN CATALDO, EXAMINING ATTORNEY

---

SN 85-210,919. GLAXO GROUP LIMITED, GREENFORD, MIDDLESEX, UNITED KINGDOM, FILED 1-5-2011.

# ENOGIVA

THE MARK CONSISTS OF STANDARD CHARACTERS WITHOUT CLAIM TO ANY PARTICULAR FONT, STYLE, SIZE, OR COLOR.

FOR PHARMACEUTICAL PREPARATIONS AND SUBSTANCES FOR THE TREATMENT OF DAMAGED SKIN AND TISSUE; PHARMACEUTICAL PREPARATIONS AND SUBSTANCES FOR THE TREATMENT OF INFECTIOUS DISEASES, BLOOD DISORDERS, PAIN, INFLAMMATION, SEPSIS, ALOPECIA, OBESITY AND COGNITIVE DISORDERS; PHARMACEUTICAL PREPARATIONS AND SUBSTANCES FOR THE TREATMENT OF VIRAL, METABOLIC, ENDOCRINE, MUSCULOSKELETAL, CARDIOVASCULAR, CARDIOPULMONARY, GENITOURINARY, SEXUAL DYSFUNCTION, ONCOLOGICAL, HEPATOLOGICAL, OPHTHALMIC, RESPIRATORY, NEUROLOGICAL, GASTROINTESTINAL, HORMONAL, DERMATOLOGICAL, PSYCHIATRIC AND IMMUNE SYSTEM RELATED DISEASES AND DISORDERS; VACCINES (U.S. CLS. 6, 18, 44, 46, 51 AND 52).

CAROLYN CATALDO, EXAMINING ATTORNEY

---

SN 85-210,928. GLAXO GROUP LIMITED, GREENFORD, MIDDLESEX, UNITED KINGDOM, FILED 1-5-2011.

# ESSOVA

THE MARK CONSISTS OF STANDARD CHARACTERS WITHOUT CLAIM TO ANY PARTICULAR FONT, STYLE, SIZE, OR COLOR.

FOR PHARMACEUTICAL PREPARATIONS AND SUBSTANCES FOR THE TREATMENT OF DAMAGED SKIN AND TISSUE; PHARMACEUTICAL PREPARATIONS AND SUBSTANCES FOR THE TREATMENT OF INFECTIOUS DISEASES, BLOOD DISORDERS, PAIN, INFLAMMATION, SEPSIS, ALOPECIA, OBESITY AND COGNITIVE DISORDERS; PHARMACEUTICAL PREPARATIONS AND SUBSTANCES FOR THE TREATMENT OF VIRAL, METABOLIC, ENDOCRINE, MUSCULOSKELETAL, CARDIOVASCULAR, CARDIOPULMONARY, GENITOURINARY, SEXUAL DYSFUNCTION, ONCOLOGICAL, HEPATOLOGICAL, OPHTHALMIC, RESPIRATORY, NEUROLOGICAL, GASTROINTESTINAL, HORMONAL, DERMATOLOGICAL, PSYCHIATRIC AND IMMUNE SYSTEM RELATED DISEASES AND DISORDERS; VACCINES (U.S. CLS. 6, 18, 44, 46, 51 AND 52).

CAROLYN CATALDO, EXAMINING ATTORNEY

**CLASS 5—(Continued).**

SN 85-210,929. GLAXO GROUP LIMITED, GREENFORD, MIDDLESEX, UNITED KINGDOM, FILED 1-5-2011.

# BEPLORA

THE MARK CONSISTS OF STANDARD CHARACTERS WITHOUT CLAIM TO ANY PARTICULAR FONT, STYLE, SIZE, OR COLOR.

FOR PHARMACEUTICAL PREPARATIONS AND SUBSTANCES FOR THE TREATMENT OF DAMAGED SKIN AND TISSUE; PHARMACEUTICAL PREPARATIONS AND SUBSTANCES FOR THE TREATMENT OF INFECTIOUS DISEASES, BLOOD DISORDERS, PAIN, INFLAMMATION, SEPSIS, ALOPECIA, OBESITY AND COGNITIVE DISORDERS; PHARMACEUTICAL PREPARATIONS AND SUBSTANCES FOR THE TREATMENT OF VIRAL, METABOLIC, ENDOCRINE, MUSCULOSKELETAL, CARDIOVASCULAR, CARDIOPULMONARY, GENITOURINARY, SEXUAL DYSFUNCTION, ONCOLOGICAL, HEPATOLOGICAL, OPHTHALMIC, RESPIRATORY, NEUROLOGICAL, GASTROINTESTINAL, HORMONAL, DERMATOLOGICAL, PSYCHIATRIC AND IMMUNE SYSTEM RELATED DISEASES AND DISORDERS; VACCINES (U.S. CLS. 6, 18, 44, 46, 51 AND 52).

CAROLYN CATALDO, EXAMINING ATTORNEY

**CLASS 5—(Continued).**

SN 85-210,934. GLAXO GROUP LIMITED, GREENFORD, MIDDLESEX, UNITED KINGDOM, FILED 1-5-2011.

# AUROLLIS

THE MARK CONSISTS OF STANDARD CHARACTERS WITHOUT CLAIM TO ANY PARTICULAR FONT, STYLE, SIZE, OR COLOR.

FOR PHARMACEUTICAL PREPARATIONS AND SUBSTANCES FOR THE TREATMENT OF DAMAGED SKIN AND TISSUE; PHARMACEUTICAL PREPARATIONS AND SUBSTANCES FOR THE TREATMENT OF INFECTIOUS DISEASES, BLOOD DISORDERS, PAIN, INFLAMMATION, SEPSIS, ALOPECIA, OBESITY AND COGNITIVE DISORDERS; PHARMACEUTICAL PREPARATIONS AND SUBSTANCES FOR THE TREATMENT OF VIRAL, METABOLIC, ENDOCRINE, MUSCULOSKELETAL, CARDIOVASCULAR, CARDIOPULMONARY, GENITOURINARY, SEXUAL DYSFUNCTION, ONCOLOGICAL, HEPATOLOGICAL, OPHTHALMIC, RESPIRATORY, NEUROLOGICAL, GASTROINTESTINAL, HORMONAL, DERMATOLOGICAL, PSYCHIATRIC AND IMMUNE SYSTEM RELATED DISEASES AND DISORDERS; VACCINES (U.S. CLS. 6, 18, 44, 46, 51 AND 52).

CAROLYN CATALDO, EXAMINING ATTORNEY

SN 85-210,931. GLAXO GROUP LIMITED, GREENFORD, MIDDLESEX, UNITED KINGDOM, FILED 1-5-2011.

# ELICERE

THE MARK CONSISTS OF STANDARD CHARACTERS WITHOUT CLAIM TO ANY PARTICULAR FONT, STYLE, SIZE, OR COLOR.

FOR PHARMACEUTICAL PREPARATIONS AND SUBSTANCES FOR THE TREATMENT OF DAMAGED SKIN AND TISSUE; PHARMACEUTICAL PREPARATIONS AND SUBSTANCES FOR THE TREATMENT OF INFECTIOUS DISEASES, BLOOD DISORDERS, PAIN, INFLAMMATION, SEPSIS, ALOPECIA, OBESITY AND COGNITIVE DISORDERS; PHARMACEUTICAL PREPARATIONS AND SUBSTANCES FOR THE TREATMENT OF VIRAL, METABOLIC, ENDOCRINE, MUSCULOSKELETAL, CARDIOVASCULAR, CARDIOPULMONARY, GENITOURINARY, SEXUAL DYSFUNCTION, ONCOLOGICAL, HEPATOLOGICAL, OPHTHALMIC, RESPIRATORY, NEUROLOGICAL, GASTROINTESTINAL, HORMONAL, DERMATOLOGICAL, PSYCHIATRIC AND IMMUNE SYSTEM RELATED DISEASES AND DISORDERS; VACCINES (U.S. CLS. 6, 18, 44, 46, 51 AND 52).

CAROLYN CATALDO, EXAMINING ATTORNEY

SN 85-210,940. GLAXO GROUP LIMITED, GREENFORD, MIDDLESEX, UNITED KINGDOM, FILED 1-5-2011.

# SECOVEN

THE MARK CONSISTS OF STANDARD CHARACTERS WITHOUT CLAIM TO ANY PARTICULAR FONT, STYLE, SIZE, OR COLOR.

FOR PHARMACEUTICAL PREPARATIONS AND SUBSTANCES FOR THE TREATMENT OF DAMAGED SKIN AND TISSUE; PHARMACEUTICAL PREPARATIONS AND SUBSTANCES FOR THE TREATMENT OF INFECTIOUS DISEASES, BLOOD DISORDERS, PAIN, INFLAMMATION, SEPSIS, ALOPECIA, OBESITY AND COGNITIVE DISORDERS; PHARMACEUTICAL PREPARATIONS AND SUBSTANCES FOR THE TREATMENT OF VIRAL, METABOLIC, ENDOCRINE, MUSCULOSKELETAL, CARDIOVASCULAR, CARDIOPULMONARY, GENITOURINARY, SEXUAL DYSFUNCTION, ONCOLOGICAL, HEPATOLOGICAL, OPHTHALMIC, RESPIRATORY, NEUROLOGICAL, GASTROINTESTINAL, HORMONAL, DERMATOLOGICAL, PSYCHIATRIC AND IMMUNE SYSTEM RELATED DISEASES AND DISORDERS; VACCINES (U.S. CLS. 6, 18, 44, 46, 51 AND 52).

CAROLYN CATALDO, EXAMINING ATTORNEY

**CLASS 5—(Continued).**

SN 85-210,943. GLAXO GROUP LIMITED, GREENFORD, MIDDLESEX, UNITED KINGDOM, FILED 1-5-2011.

# LUSEVE

THE MARK CONSISTS OF STANDARD CHARACTERS WITHOUT CLAIM TO ANY PARTICULAR FONT, STYLE, SIZE, OR COLOR.

FOR PHARMACEUTICAL PREPARATIONS AND SUBSTANCES FOR THE TREATMENT OF DAMAGED SKIN AND TISSUE; PHARMACEUTICAL PREPARATIONS AND SUBSTANCES FOR THE TREATMENT OF INFECTIOUS DISEASES, BLOOD DISORDERS, PAIN, INFLAMMATION, SEPSIS, ALOPECIA, OBESITY AND COGNITIVE DISORDERS; PHARMACEUTICAL PREPARATIONS AND SUBSTANCES FOR THE TREATMENT OF VIRAL, METABOLIC, ENDOCRINE, MUSCULOSKELETAL, CARDIOVASCULAR, CARDIOPULMONARY, GENITOURINARY, SEXUAL DYSFUNCTION, ONCOLOGICAL, HEPATOLOGICAL, OPHTHALMIC, RESPIRATORY, NEUROLOGICAL, GASTROINTESTINAL, HORMONAL, DERMATOLOGICAL, PSYCHIATRIC AND IMMUNE SYSTEM RELATED DISEASES AND DISORDERS; VACCINES (U.S. CLS. 6, 18, 44, 46, 51 AND 52).

CAROLYN CATALDO, EXAMINING ATTORNEY

SN 85-210,947. GLAXO GROUP LIMITED, GREENFORD, MIDDLESEX, UNITED KINGDOM, FILED 1-5-2011.

# FOTOPREL

THE MARK CONSISTS OF STANDARD CHARACTERS WITHOUT CLAIM TO ANY PARTICULAR FONT, STYLE, SIZE, OR COLOR.

FOR PHARMACEUTICAL PREPARATIONS AND SUBSTANCES FOR THE TREATMENT OF DAMAGED SKIN AND TISSUE; PHARMACEUTICAL PREPARATIONS AND SUBSTANCES FOR THE TREATMENT OF INFECTIOUS DISEASES, BLOOD DISORDERS, PAIN, INFLAMMATION, SEPSIS, ALOPECIA, OBESITY AND COGNITIVE DISORDERS; PHARMACEUTICAL PREPARATIONS AND SUBSTANCES FOR THE TREATMENT OF VIRAL, METABOLIC, ENDOCRINE, MUSCULOSKELETAL, CARDIOVASCULAR, CARDIOPULMONARY, GENITOURINARY, SEXUAL DYSFUNCTION, ONCOLOGICAL, HEPATOLOGICAL, OPHTHALMIC, RESPIRATORY, NEUROLOGICAL, GASTROINTESTINAL, HORMONAL, DERMATOLOGICAL, PSYCHIATRIC AND IMMUNE SYSTEM RELATED DISEASES AND DISORDERS; VACCINES (U.S. CLS. 6, 18, 44, 46, 51 AND 52).

GEORGE LORENZO, EXAMINING ATTORNEY

**CLASS 5—(Continued).**

SN 85-210,951. GLAXO GROUP LIMITED, GREENFORD, MIDDLESEX, UNITED KINGDOM, FILED 1-5-2011.

# FABIOR

THE MARK CONSISTS OF STANDARD CHARACTERS WITHOUT CLAIM TO ANY PARTICULAR FONT, STYLE, SIZE, OR COLOR.

FOR PHARMACEUTICAL PREPARATIONS AND SUBSTANCES FOR THE TREATMENT OF DAMAGED SKIN AND TISSUE; PHARMACEUTICAL PREPARATIONS AND SUBSTANCES FOR THE TREATMENT OF INFECTIOUS DISEASES, BLOOD DISORDERS, PAIN, INFLAMMATION, SEPSIS, ALOPECIA, OBESITY AND COGNITIVE DISORDERS; PHARMACEUTICAL PREPARATIONS AND SUBSTANCES FOR THE TREATMENT OF VIRAL, METABOLIC, ENDOCRINE, MUSCULOSKELETAL, CARDIOVASCULAR, CARDIOPULMONARY, GENITOURINARY, SEXUAL DYSFUNCTION, ONCOLOGICAL, HEPATOLOGICAL, OPHTHALMIC, RESPIRATORY, NEUROLOGICAL, GASTROINTESTINAL, HORMONAL, DERMATOLOGICAL, PSYCHIATRIC AND IMMUNE SYSTEM RELATED DISEASES AND DISORDERS; VACCINES (U.S. CLS. 6, 18, 44, 46, 51 AND 52).

GEORGE LORENZO, EXAMINING ATTORNEY

SN 85-210,989. DIPEXIIUM PHARMACEUTICALS, LLC, WHITE PLAINS, NY. FILED 1-5-2011.

# LOCILEX

THE MARK CONSISTS OF STANDARD CHARACTERS WITHOUT CLAIM TO ANY PARTICULAR FONT, STYLE, SIZE, OR COLOR.

FOR ANTIBIOTIC CREAMS (U.S. CLS. 6, 18, 44, 46, 51 AND 52).

JACQUELINE A. LAVINE, EXAMINING ATTORNEY

SN 85-211,012. PREMIER ONLINE, INC., TAMPA, FL. FILED 1-5-2011.

# CORE CUTTER PLUS

THE MARK CONSISTS OF STANDARD CHARACTERS WITHOUT CLAIM TO ANY PARTICULAR FONT, STYLE, SIZE, OR COLOR.

FOR DIETARY AND NUTRITIONAL SUPPLEMENTS (U.S. CLS. 6, 18, 44, 46, 51 AND 52).

HELENE LIWINSKI, EXAMINING ATTORNEY

**CLASS 5—(Continued).**

SN 85-211,077. MAKHTESHIM CHEMICAL WORKS LTD., BEER SHEVA, ISRAEL, FILED 1-5-2011.

# PIVOT

THE MARK CONSISTS OF STANDARD CHARACTERS WITHOUT CLAIM TO ANY PARTICULAR FONT, STYLE, SIZE, OR COLOR.  
FOR INSECT GROWTH REGULATORS FOR PROFESSIONAL AND DOMESTIC USE (U.S. CLS. 6, 18, 44, 46, 51 AND 52).  
MICHAEL WEBSTER, EXAMINING ATTORNEY

SN 85-211,084. MAKHTESHIM CHEMICAL WORKS LTD., BEER SHEVA, ISRAEL, FILED 1-5-2011.

# NOVAPRO

THE MARK CONSISTS OF STANDARD CHARACTERS WITHOUT CLAIM TO ANY PARTICULAR FONT, STYLE, SIZE, OR COLOR.  
FOR INSECT GROWTH REGULATORS FOR PROFESSIONAL AND DOMESTIC USE (U.S. CLS. 6, 18, 44, 46, 51 AND 52).  
MICHAEL WEBSTER, EXAMINING ATTORNEY

SN 85-211,195. IML US TRADEMARK LTD., OAKVILLE, ONTARIO, CANADA, FILED 1-5-2011.

# AVEGA SMART

THE MARK CONSISTS OF STANDARD CHARACTERS WITHOUT CLAIM TO ANY PARTICULAR FONT, STYLE, SIZE, OR COLOR.  
FOR NUTRITIONAL AND DIETARY SUPPLEMENTS (U.S. CLS. 6, 18, 44, 46, 51 AND 52).  
ADA HAN, EXAMINING ATTORNEY

**CLASS 5—(Continued).**

SN 85-211,198. IML US TRADEMARK LTD., OAKVILLE, ONTARIO, CANADA, FILED 1-5-2011.

# NATURE SMART

THE MARK CONSISTS OF STANDARD CHARACTERS WITHOUT CLAIM TO ANY PARTICULAR FONT, STYLE, SIZE, OR COLOR.  
FOR NUTRITIONAL AND DIETARY SUPPLEMENTS (U.S. CLS. 6, 18, 44, 46, 51 AND 52).  
ADA HAN, EXAMINING ATTORNEY

SN 85-211,240. SCHIFF NUTRITION INTERNATIONAL, INC., SALT LAKE CITY, UT, FILED 1-5-2011.

# MIGHTY FLEX

THE MARK CONSISTS OF STANDARD CHARACTERS WITHOUT CLAIM TO ANY PARTICULAR FONT, STYLE, SIZE, OR COLOR.  
OWNER OF U.S. REG. NOS. 3,043,818, 3,635,376 AND OTHERS.  
FOR DIETARY AND NUTRITIONAL SUPPLEMENTS; DIETARY BEVERAGE SUPPLEMENTS FOR HUMAN CONSUMPTION IN LIQUID AND DRY MIX FORM FOR THERAPEUTIC PURPOSES; DIETARY FOOD SUPPLEMENTS; DIETARY SUPPLEMENTAL DRINKS; DIETARY SUPPLEMENTS; NUTRITIONAL AND DIETARY SUPPLEMENTS FORMED AND PACKAGED AS BARS (U.S. CLS. 6, 18, 44, 46, 51 AND 52).  
JILL PRATER, EXAMINING ATTORNEY

SN 85-211,428. MEDIPURE PRODUCTS INC, DRAPER, UT, FILED 1-5-2011.

# Aqua Lift

THE MARK CONSISTS OF STANDARD CHARACTERS WITHOUT CLAIM TO ANY PARTICULAR FONT, STYLE, SIZE, OR COLOR.  
FOR HOMEOPATHIC SUPPLEMENTS (U.S. CLS. 6, 18, 44, 46, 51 AND 52).  
FIRST USE 1-15-2008; IN COMMERCE 1-15-2008.  
PATRICIA EVANKO, EXAMINING ATTORNEY

**CLASS 5—(Continued).**

SN 85-211,552. MINNTECH CORPORATION, MINNEAPOLIS, NY. FILED 1-6-2011.

**FEAR NO GEAR**

THE MARK CONSISTS OF STANDARD CHARACTERS WITHOUT CLAIM TO ANY PARTICULAR FONT, STYLE, SIZE, OR COLOR.

FOR ANITMICROBIAL DEODORIZING SPRAY FOR USE ON FABRIC, SPORTS EQUIPMENT AND GYM EQUIPMENT (U.S. CLS. 6, 18, 44, 46, 51 AND 52).  
NICHOLAS COLEMAN, EXAMINING ATTORNEY

**CLASS 5—(Continued).**

SN 85-211,828. NANOMEDEX PHARMACEUTICALS, INC., FITCHBURG, WI. FILED 1-6-2011.

**MICROFOL**

THE MARK CONSISTS OF STANDARD CHARACTERS WITHOUT CLAIM TO ANY PARTICULAR FONT, STYLE, SIZE, OR COLOR.

FOR PHARMACEUTICAL PREPARATIONS FOR INTRAVENOUS ANESTHETIC USE (U.S. CLS. 6, 18, 44, 46, 51 AND 52).  
ALEXANDER L. POWERS, EXAMINING ATTORNEY

SN 85-211,685. CHURCH & DWIGHT CO., INC., PRINCETON, NJ. FILED 1-6-2011.

**FIRE & ICE**

THE MARK CONSISTS OF STANDARD CHARACTERS WITHOUT CLAIM TO ANY PARTICULAR FONT, STYLE, SIZE, OR COLOR.

OWNER OF U.S. REG. NO. 3,779,143.  
FOR PERSONAL SEXUAL LUBRICANTS; SILICONE-BASED PERSONAL LUBRICANTS (U.S. CLS. 6, 18, 44, 46, 51 AND 52).  
EUGENIA MARTIN, EXAMINING ATTORNEY

SN 85-211,690. DOUGLAS BIO RESEARCH, SAINT LOUIS, MO. FILED 1-6-2011.

**SKIN RESCUE**

THE MARK CONSISTS OF STANDARD CHARACTERS WITHOUT CLAIM TO ANY PARTICULAR FONT, STYLE, SIZE, OR COLOR.

NO CLAIM IS MADE TO THE EXCLUSIVE RIGHT TO USE "SKIN", APART FROM THE MARK AS SHOWN.  
FOR MEDICATED SOLUTION, NAMELY, TOPICAL FIRST-AID SPRAY FOR TREATING SKIN CUTS, ABRASIONS AND BURNS (U.S. CLS. 6, 18, 44, 46, 51 AND 52).  
MAYUR VAGHANI, EXAMINING ATTORNEY

SN 85-211,829. VITAMIN SHOPPE INDUSTRIES INC., NORTH BERGEN, NJ. FILED 1-6-2011.

**PRIMALPRO**

THE MARK CONSISTS OF STANDARD CHARACTERS WITHOUT CLAIM TO ANY PARTICULAR FONT, STYLE, SIZE, OR COLOR.

FOR VITAMINS AND VITAMIN, MINERAL, DIETARY AND NUTRITIONAL SUPPLEMENTS (U.S. CLS. 6, 18, 44, 46, 51 AND 52).  
ALEXANDER L. POWERS, EXAMINING ATTORNEY

SN 85-211,978. HEALTHY DIRECTIONS, LLC, POTOMAC, MD. FILED 1-6-2011.

**CogniBoost**

THE MARK CONSISTS OF STANDARD CHARACTERS WITHOUT CLAIM TO ANY PARTICULAR FONT, STYLE, SIZE, OR COLOR.

FOR NUTRITIONAL SUPPLEMENTS (U.S. CLS. 6, 18, 44, 46, 51 AND 52).  
JOHN KELLY, EXAMINING ATTORNEY

**CLASS 5—(Continued).**

SN 85-212,070. INTERCHEM CORPORATION, PARAMUS, NJ. FILED 1-6-2011.



THE MARK CONSISTS OF THE WORD "STERIPHARMA", WITH THE LETTERS "STERI" IN BLACK LOWERCASE LETTERS AND THE LETTERS "PHARMA" IN WHITE LOWERCASE LETTERS INSIDE A BLACK OVAL BACKGROUND.

FOR ANTIBIOTICS (U.S. CLS. 6, 18, 44, 46, 51 AND 52).  
JACQUELINE A. LAVINE, EXAMINING ATTORNEY

---

SN 85-212,178. TRANSCRYPT PHARMACEUTICALS, INC., PT. RICHMOND, CA. FILED 1-6-2011.

## SETRODON

THE MARK CONSISTS OF STANDARD CHARACTERS WITHOUT CLAIM TO ANY PARTICULAR FONT, STYLE, SIZE, OR COLOR.

FOR PHARMACEUTICAL PREPARATIONS FOR THE PREVENTION AND TREATMENT OF OBSESSIVE COMPULSIVE DISORDER AND OTHER RELATED DISORDERS (U.S. CLS. 6, 18, 44, 46, 51 AND 52).

TINA BROWN, EXAMINING ATTORNEY

---

SN 85-212,465. ORO AGRICULTURE INC, TROPHY CLUB, TX. FILED 1-7-2011.

## APPEAL

THE MARK CONSISTS OF STANDARD CHARACTERS WITHOUT CLAIM TO ANY PARTICULAR FONT, STYLE, SIZE, OR COLOR.

FOR AGRICULTURAL PESTICIDES; BIOCIDES, GERMICIDES, BACTERICIDES, VIRUCIDES, FUNGICIDES, INSECTICIDES, PESTICIDES AND HERBICIDES (U.S. CLS. 6, 18, 44, 46, 51 AND 52).

MICHAEL SOUDERS, EXAMINING ATTORNEY

**CLASS 5—(Continued).**

SN 85-212,495. WINFIELD SOLUTIONS, LLC., SHOREVIEW, MN. FILED 1-7-2011.

## CONFINE

THE MARK CONSISTS OF STANDARD CHARACTERS WITHOUT CLAIM TO ANY PARTICULAR FONT, STYLE, SIZE, OR COLOR.

OWNER OF U.S. REG. NO. 2,936,446.

FOR FUNGICIDES FOR AGRICULTURAL USE (U.S. CLS. 6, 18, 44, 46, 51 AND 52).

DOMINICK J. SALEMI, EXAMINING ATTORNEY

---

SN 85-212,582. PERFECT WORLD SOLUTIONS, INC., PHOENIX, AZ. FILED 1-7-2011.

## BIONICSPORT

THE MARK CONSISTS OF STANDARD CHARACTERS WITHOUT CLAIM TO ANY PARTICULAR FONT, STYLE, SIZE, OR COLOR.

FOR BRACELETS AND BANDS FOR MEDICAL PURPOSES CONTAINING IMPRINTED METAL OR SILICON FOR PROTON ALIGNMENT (U.S. CLS. 6, 18, 44, 46, 51 AND 52).

GISELLE AGOSTO, EXAMINING ATTORNEY

---

SN 85-212,626. VITAL PHARMACEUTICALS, INC., WESTON, FL. FILED 1-7-2011.

## TEST JACK

THE MARK CONSISTS OF STANDARD CHARACTERS WITHOUT CLAIM TO ANY PARTICULAR FONT, STYLE, SIZE, OR COLOR.

FOR DIETARY AND NUTRITIONAL SUPPLEMENTS (U.S. CLS. 6, 18, 44, 46, 51 AND 52).

ANNE MADDEN, EXAMINING ATTORNEY

**CLASS 5—(Continued).**

SN 85-212,841. THIN CENTERS, LLC, DALLAS, TX. FILED 1-7-2011.

**THINCenters MD**



THE MARK CONSISTS OF THE WORDS "THIN CENTERS MD" IN STYLIZED LETTERING WITH A STYLIZED REPRESENTATION OF A CADUCEUS PLACED BETWEEN THE LETTERS "M" AND "D".

FOR VITAMINS; DIETARY AND NUTRITIONAL SUPPLEMENTS; DIETARY AND NUTRITIONAL SUPPLEMENTS USED FOR WEIGHT LOSS; FOOD FOR MEDICALLY RESTRICTED DIETS; DIETARY SUPPLEMENTAL DRINKS (U.S. CLS. 6, 18, 44, 46, 51 AND 52).  
FIRST USE 12-4-2010; IN COMMERCE 12-4-2010.

ALEXANDER L. POWERS, EXAMINING ATTORNEY

**CLASS 5—(Continued).**

SN 85-214,296. ORIONS THREE KINGS, UNION, NJ. FILED 1-10-2011.



THE MARK CONSISTS OF THREE KINGS HOLDING HERBS IN THEIR HANDS. THERE IS ALSO A CROWN WITH THE STYLIZED TEXT "JOLLY 3 KINGS".

FOR HERBAL SUPPLEMENTS (U.S. CLS. 6, 18, 44, 46, 51 AND 52).

SUNG IN, EXAMINING ATTORNEY

SN 85-212,957. NOVARTIS AG, BASEL, SWITZERLAND, FILED 1-7-2011.

HAPPINESS IS A DAY WITHOUT  
HEARTBURN

THE MARK CONSISTS OF STANDARD CHARACTERS WITHOUT CLAIM TO ANY PARTICULAR FONT, STYLE, SIZE, OR COLOR.

FOR PHARMACEUTICAL PREPARATIONS FOR THE TREATMENT OF GASTROINTESTINAL DISORDERS (U.S. CLS. 6, 18, 44, 46, 51 AND 52).

JUSTINE D. PARKER, EXAMINING ATTORNEY

SN 85-214,733. GLAXO GROUP LIMITED, GREENFORD, MIDDLESEX, UNITED KINGDOM, FILED 1-11-2011.

**ATEZON**

SN 85-213,536. FORTIER, CARLOS R., MIDLOTHIAN, VA. FILED 1-8-2011.

**MASFLEX**

THE MARK CONSISTS OF STANDARD CHARACTERS WITHOUT CLAIM TO ANY PARTICULAR FONT, STYLE, SIZE, OR COLOR.

FOR ANALGESIC AND MUSCLE RELAXANT PHARMACEUTICAL PREPARATIONS; ANALGESIC BALM; ANALGESICS; HERBAL TOPICAL CREAMS, GELS, SALVES, SPRAYS, POWDER, BALMS, LINIMENT AND OINTMENTS FOR THE RELIEF OF ACHES AND PAIN; TOPICAL ANALGESIC CREAMS (U.S. CLS. 6, 18, 44, 46, 51 AND 52).

FIRST USE 2-2-2001; IN COMMERCE 2-2-2001.

BRIAN NEVILLE, EXAMINING ATTORNEY

THE MARK CONSISTS OF STANDARD CHARACTERS WITHOUT CLAIM TO ANY PARTICULAR FONT, STYLE, SIZE, OR COLOR.

FOR PHARMACEUTICAL PREPARATIONS AND SUBSTANCES FOR THE TREATMENT OF DAMAGED SKIN AND TISSUE; PHARMACEUTICAL PREPARATIONS AND SUBSTANCES FOR THE TREATMENT OF INFECTIOUS DISEASES, BLOOD DISORDERS, PAIN, INFLAMMATION, SEPSIS, ALOPECIA, OBESITY AND COGNITIVE DISORDERS; PHARMACEUTICAL PREPARATIONS AND SUBSTANCES FOR THE TREATMENT OF VIRAL, METABOLIC, ENDOCRINE, MUSCULOSKELETAL, CARDIOVASCULAR, CARDIO-PULMONARY, GENITOURINARY, SEXUAL DYSFUNCTION, ONCOLOGICAL, HEPATOLOGICAL, OPHTHALMIC, RESPIRATORY, NEUROLOGICAL, GASTROINTESTINAL, HORMONAL, DERMATOLOGICAL, PSYCHIATRIC AND IMMUNE SYSTEM RELATED DISEASES AND DISORDERS; VACCINES (U.S. CLS. 6, 18, 44, 46, 51 AND 52).

GEORGE LORENZO, EXAMINING ATTORNEY



**CLASS 5—(Continued).**

SN 85-214,734. GLAXO GROUP LIMITED, GREENFORD, MIDDLESEX, UNITED KINGDOM, FILED 1-11-2011.

# DAIRIN

THE MARK CONSISTS OF STANDARD CHARACTERS WITHOUT CLAIM TO ANY PARTICULAR FONT, STYLE, SIZE, OR COLOR.

FOR PHARMACEUTICAL PREPARATIONS AND SUBSTANCES FOR THE TREATMENT OF DAMAGED SKIN AND TISSUE; PHARMACEUTICAL PREPARATIONS AND SUBSTANCES FOR THE TREATMENT OF INFECTIOUS DISEASES, BLOOD DISORDERS, PAIN, INFLAMMATION, SEPSIS, ALOPECIA, OBESITY AND COGNITIVE DISORDERS; PHARMACEUTICAL PREPARATIONS AND SUBSTANCES FOR THE TREATMENT OF VIRAL, METABOLIC, ENDOCRINE, MUSCULOSKELETAL, CARDIOVASCULAR, CARDIOPULMONARY, GENITOURINARY, SEXUAL DYSFUNCTION, ONCOLOGICAL, HEPATOLOGICAL, OPHTHALMIC, RESPIRATORY, NEUROLOGICAL, GASTROINTESTINAL, HORMONAL, DERMATOLOGICAL, PSYCHIATRIC AND IMMUNE SYSTEM RELATED DISEASES AND DISORDERS; VACCINES (U.S. CLS. 6, 18, 44, 46, 51 AND 52).

GEORGE LORENZO, EXAMINING ATTORNEY

**CLASS 5—(Continued).**

SN 85-214,737. GLAXO GROUP LIMITED, GREENFORD, MIDDLESEX, UNITED KINGDOM, FILED 1-11-2011.

# NARAZA

THE MARK CONSISTS OF STANDARD CHARACTERS WITHOUT CLAIM TO ANY PARTICULAR FONT, STYLE, SIZE, OR COLOR.

FOR PHARMACEUTICAL PREPARATIONS AND SUBSTANCES FOR THE TREATMENT OF DAMAGED SKIN AND TISSUE; PHARMACEUTICAL PREPARATIONS AND SUBSTANCES FOR THE TREATMENT OF INFECTIOUS DISEASES, BLOOD DISORDERS, PAIN, INFLAMMATION, SEPSIS, ALOPECIA, OBESITY AND COGNITIVE DISORDERS; PHARMACEUTICAL PREPARATIONS AND SUBSTANCES FOR THE TREATMENT OF VIRAL, METABOLIC, ENDOCRINE, MUSCULOSKELETAL, CARDIOVASCULAR, CARDIOPULMONARY, GENITOURINARY, SEXUAL DYSFUNCTION, ONCOLOGICAL, HEPATOLOGICAL, OPHTHALMIC, RESPIRATORY, NEUROLOGICAL, GASTROINTESTINAL, HORMONAL, DERMATOLOGICAL, PSYCHIATRIC AND IMMUNE SYSTEM RELATED DISEASES AND DISORDERS; VACCINES (U.S. CLS. 6, 18, 44, 46, 51 AND 52).

GEORGE LORENZO, EXAMINING ATTORNEY

SN 85-214,735. GLAXO GROUP LIMITED, GREENFORD, MIDDLESEX, UNITED KINGDOM, FILED 1-11-2011.

# CILITAL

THE MARK CONSISTS OF STANDARD CHARACTERS WITHOUT CLAIM TO ANY PARTICULAR FONT, STYLE, SIZE, OR COLOR.

FOR PHARMACEUTICAL PREPARATIONS AND SUBSTANCES FOR THE TREATMENT OF DAMAGED SKIN AND TISSUE; PHARMACEUTICAL PREPARATIONS AND SUBSTANCES FOR THE TREATMENT OF INFECTIOUS DISEASES, BLOOD DISORDERS, PAIN, INFLAMMATION, SEPSIS, ALOPECIA, OBESITY AND COGNITIVE DISORDERS; PHARMACEUTICAL PREPARATIONS AND SUBSTANCES FOR THE TREATMENT OF VIRAL, METABOLIC, ENDOCRINE, MUSCULOSKELETAL, CARDIOVASCULAR, CARDIOPULMONARY, GENITOURINARY, SEXUAL DYSFUNCTION, ONCOLOGICAL, HEPATOLOGICAL, OPHTHALMIC, RESPIRATORY, NEUROLOGICAL, GASTROINTESTINAL, HORMONAL, DERMATOLOGICAL, PSYCHIATRIC AND IMMUNE SYSTEM RELATED DISEASES AND DISORDERS; VACCINES (U.S. CLS. 6, 18, 44, 46, 51 AND 52).

GEORGE LORENZO, EXAMINING ATTORNEY

SN 85-214,740. GLAXO GROUP LIMITED, GREENFORD, MIDDLESEX, UNITED KINGDOM, FILED 1-11-2011.

# ZALIMAR

THE MARK CONSISTS OF STANDARD CHARACTERS WITHOUT CLAIM TO ANY PARTICULAR FONT, STYLE, SIZE, OR COLOR.

FOR PHARMACEUTICAL PREPARATIONS AND SUBSTANCES FOR THE TREATMENT OF DAMAGED SKIN AND TISSUE; PHARMACEUTICAL PREPARATIONS AND SUBSTANCES FOR THE TREATMENT OF INFECTIOUS DISEASES, BLOOD DISORDERS, PAIN, INFLAMMATION, SEPSIS, ALOPECIA, OBESITY AND COGNITIVE DISORDERS; PHARMACEUTICAL PREPARATIONS AND SUBSTANCES FOR THE TREATMENT OF VIRAL, METABOLIC, ENDOCRINE, MUSCULOSKELETAL, CARDIOVASCULAR, CARDIOPULMONARY, GENITOURINARY, SEXUAL DYSFUNCTION, ONCOLOGICAL, HEPATOLOGICAL, OPHTHALMIC, RESPIRATORY, NEUROLOGICAL, GASTROINTESTINAL, HORMONAL, DERMATOLOGICAL, PSYCHIATRIC AND IMMUNE SYSTEM RELATED DISEASES AND DISORDERS; VACCINES (U.S. CLS. 6, 18, 44, 46, 51 AND 52).

GEORGE LORENZO, EXAMINING ATTORNEY

**CLASS 5—(Continued).**

SN 85-214,743. GLAXO GROUP LIMITED, GREENFORD, MIDDLESEX, UNITED KINGDOM, FILED 1-11-2011.

# ARELIVON

THE MARK CONSISTS OF STANDARD CHARACTERS WITHOUT CLAIM TO ANY PARTICULAR FONT, STYLE, SIZE, OR COLOR.

FOR PHARMACEUTICAL PREPARATIONS AND SUBSTANCES FOR THE TREATMENT OF DAMAGED SKIN AND TISSUE; PHARMACEUTICAL PREPARATIONS AND SUBSTANCES FOR THE TREATMENT OF INFECTIOUS DISEASES, BLOOD DISORDERS, PAIN, INFLAMMATION, SEPSIS, ALOPECIA, OBESITY AND COGNITIVE DISORDERS; PHARMACEUTICAL PREPARATIONS AND SUBSTANCES FOR THE TREATMENT OF VIRAL, METABOLIC, ENDOCRINE, MUSCULOSKELETAL, CARDIOVASCULAR, CARDIO-PULMONARY, GENITOURINARY, SEXUAL DYSFUNCTION, ONCOLOGICAL, HEPATOLOGICAL, OPHTHALMIC, RESPIRATORY, NEUROLOGICAL, GAS-TROINTESTINAL, HORMONAL, DERMATOLOGICAL, PSYCHIATRIC AND IMMUNE SYSTEM RELATED DISEASES AND DISORDERS; VACCINES (U.S. CLS. 6, 18, 44, 46, 51 AND 52).

GEORGE LORENZO, EXAMINING ATTORNEY

**CLASS 5—(Continued).**

SN 85-220,628. BRISTOL-MYERS SQUIBB COMPANY, NEW YORK, NY. FILED 1-19-2011.

# COMFICLICK

THE MARK CONSISTS OF STANDARD CHARACTERS WITHOUT CLAIM TO ANY PARTICULAR FONT, STYLE, SIZE, OR COLOR.

FOR A SYRINGE PRE-FILLED WITH PHARMACEUTICAL PREPARATIONS FOR TREATING AUTO-IMMUNE DISEASES FOR HUMAN USE (U.S. CLS. 6, 18, 44, 46, 51 AND 52).

WENDY GOODMAN, EXAMINING ATTORNEY

SN 85-220,631. BRISTOL-MYERS SQUIBB COMPANY, NEW YORK, NY. FILED 1-19-2011.

# COMFICLIQ

THE MARK CONSISTS OF STANDARD CHARACTERS WITHOUT CLAIM TO ANY PARTICULAR FONT, STYLE, SIZE, OR COLOR.

FOR A SYRINGE PRE-FILLED WITH PHARMACEUTICAL PREPARATIONS FOR TREATING AUTO-IMMUNE DISEASES FOR HUMAN USE (U.S. CLS. 6, 18, 44, 46, 51 AND 52).

WENDY GOODMAN, EXAMINING ATTORNEY

SN 85-220,634. BRISTOL-MYERS SQUIBB COMPANY, NEW YORK, NY. FILED 1-19-2011.

# GENCLICK

THE MARK CONSISTS OF STANDARD CHARACTERS WITHOUT CLAIM TO ANY PARTICULAR FONT, STYLE, SIZE, OR COLOR.

FOR A SYRINGE PRE-FILLED WITH PHARMACEUTICAL PREPARATIONS FOR TREATING AUTO-IMMUNE DISEASES FOR HUMAN USE (U.S. CLS. 6, 18, 44, 46, 51 AND 52).

WENDY GOODMAN, EXAMINING ATTORNEY

SN 85-220,623. BRISTOL-MYERS SQUIBB COMPANY, NEW YORK, NY. FILED 1-19-2011.

# ACTIVJEX

THE MARK CONSISTS OF STANDARD CHARACTERS WITHOUT CLAIM TO ANY PARTICULAR FONT, STYLE, SIZE, OR COLOR.

FOR A SYRINGE PRE-FILLED WITH PHARMACEUTICAL PREPARATIONS FOR TREATING AUTO-IMMUNE DISEASES FOR HUMAN USE (U.S. CLS. 6, 18, 44, 46, 51 AND 52).

WENDY GOODMAN, EXAMINING ATTORNEY

SN 85-220,624. BRISTOL-MYERS SQUIBB COMPANY, NEW YORK, NY. FILED 1-19-2011.

# FULLCLICK

THE MARK CONSISTS OF STANDARD CHARACTERS WITHOUT CLAIM TO ANY PARTICULAR FONT, STYLE, SIZE, OR COLOR.

FOR A SYRINGE PRE-FILLED WITH PHARMACEUTICAL PREPARATIONS FOR TREATING AUTO-IMMUNE DISEASES FOR HUMAN USE (U.S. CLS. 6, 18, 44, 46, 51 AND 52).

WENDY GOODMAN, EXAMINING ATTORNEY

**CLASS 5—(Continued).**

SN 85-220,636. BRISTOL-MYERS SQUIBB COMPANY, NEW YORK, NY. FILED 1-19-2011.

**JUSTCLICK**

THE MARK CONSISTS OF STANDARD CHARACTERS WITHOUT CLAIM TO ANY PARTICULAR FONT, STYLE, SIZE, OR COLOR.

FOR A SYRINGE PRE-FILLED WITH PHARMACEUTICAL PREPARATIONS FOR TREATING AUTO-IMMUNE DISEASES FOR HUMAN USE (U.S. CLS. 6, 18, 44, 46, 51 AND 52).

WENDY GOODMAN, EXAMINING ATTORNEY

**CLASS 5—(Continued).**

SN 85-220,642. BRISTOL-MYERS SQUIBB COMPANY, NEW YORK, NY. FILED 1-19-2011.

**QUTOUCH**

THE MARK CONSISTS OF STANDARD CHARACTERS WITHOUT CLAIM TO ANY PARTICULAR FONT, STYLE, SIZE, OR COLOR.

FOR A SYRINGE PRE-FILLED WITH PHARMACEUTICAL PREPARATIONS FOR TREATING AUTO-IMMUNE DISEASES FOR HUMAN USE (U.S. CLS. 6, 18, 44, 46, 51 AND 52).

WENDY GOODMAN, EXAMINING ATTORNEY

SN 85-220,638. BRISTOL-MYERS SQUIBB COMPANY, NEW YORK, NY. FILED 1-19-2011.

**Q-TOUCH**

THE MARK CONSISTS OF STANDARD CHARACTERS WITHOUT CLAIM TO ANY PARTICULAR FONT, STYLE, SIZE, OR COLOR.

FOR A SYRINGE PRE-FILLED WITH PHARMACEUTICAL PREPARATIONS FOR TREATING AUTO-IMMUNE DISEASES FOR HUMAN USE (U.S. CLS. 6, 18, 44, 46, 51 AND 52).

WENDY GOODMAN, EXAMINING ATTORNEY

SN 85-220,645. BRISTOL-MYERS SQUIBB COMPANY, NEW YORK, NY. FILED 1-19-2011.

**SQ-COMFORT**

THE MARK CONSISTS OF STANDARD CHARACTERS WITHOUT CLAIM TO ANY PARTICULAR FONT, STYLE, SIZE, OR COLOR.

FOR A SYRINGE PRE-FILLED WITH PHARMACEUTICAL PREPARATIONS FOR TREATING AUTO-IMMUNE DISEASES FOR HUMAN USE (U.S. CLS. 6, 18, 44, 46, 51 AND 52).

WENDY GOODMAN, EXAMINING ATTORNEY

SN 85-220,641. BRISTOL-MYERS SQUIBB COMPANY, NEW YORK, NY. FILED 1-19-2011.

**QUETOUCH**

THE MARK CONSISTS OF STANDARD CHARACTERS WITHOUT CLAIM TO ANY PARTICULAR FONT, STYLE, SIZE, OR COLOR.

FOR A SYRINGE PRE-FILLED WITH PHARMACEUTICAL PREPARATIONS FOR TREATING AUTO-IMMUNE DISEASES FOR HUMAN USE (U.S. CLS. 6, 18, 44, 46, 51 AND 52).

WENDY GOODMAN, EXAMINING ATTORNEY

SN 85-220,646. BRISTOL-MYERS SQUIBB COMPANY, NEW YORK, NY. FILED 1-19-2011.

**SQ-TOUCH**

THE MARK CONSISTS OF STANDARD CHARACTERS WITHOUT CLAIM TO ANY PARTICULAR FONT, STYLE, SIZE, OR COLOR.

FOR A SYRINGE PRE-FILLED WITH PHARMACEUTICAL PREPARATIONS FOR TREATING AUTO-IMMUNE DISEASES FOR HUMAN USE (U.S. CLS. 6, 18, 44, 46, 51 AND 52).

WENDY GOODMAN, EXAMINING ATTORNEY

**CLASS 5—(Continued).**

SN 85-220,649. BRISTOL-MYERS SQUIBB COMPANY, NEW YORK, NY. FILED 1-19-2011.

# SUREQ

THE MARK CONSISTS OF STANDARD CHARACTERS WITHOUT CLAIM TO ANY PARTICULAR FONT, STYLE, SIZE, OR COLOR.

FOR A SYRINGE PRE-FILLED WITH PHARMACEUTICAL PREPARATIONS FOR TREATING AUTO-IMMUNE DISEASES FOR HUMAN USE (U.S. CLS. 6, 18, 44, 46, 51 AND 52).

WENDY GOODMAN, EXAMINING ATTORNEY



SN 85-220,653. BRISTOL-MYERS SQUIBB COMPANY, NEW YORK, NY. FILED 1-19-2011.

# VALIDOSE

THE MARK CONSISTS OF STANDARD CHARACTERS WITHOUT CLAIM TO ANY PARTICULAR FONT, STYLE, SIZE, OR COLOR.

FOR A SYRINGE PRE-FILLED WITH PHARMACEUTICAL PREPARATIONS FOR TREATING AUTO-IMMUNE DISEASES FOR HUMAN USE (U.S. CLS. 6, 18, 44, 46, 51 AND 52).

WENDY GOODMAN, EXAMINING ATTORNEY



SN 85-224,115. WHEAT, JARED R., NORCROSS, GA. FILED 1-24-2011.

# N.O. OVERLOAD

THE MARK CONSISTS OF STANDARD CHARACTERS WITHOUT CLAIM TO ANY PARTICULAR FONT, STYLE, SIZE, OR COLOR.

NO CLAIM IS MADE TO THE EXCLUSIVE RIGHT TO USE "N.O.", APART FROM THE MARK AS SHOWN.

FOR DIETARY SUPPLEMENTS (U.S. CLS. 6, 18, 44, 46, 51 AND 52).

LINDSEY RUBIN, EXAMINING ATTORNEY

**CLASS 5—(Continued).**

SN 85-224,154. WHEAT, JARED R., NORCROSS, GA. FILED 1-24-2011.

# SUSTANON 250

THE MARK CONSISTS OF STANDARD CHARACTERS WITHOUT CLAIM TO ANY PARTICULAR FONT, STYLE, SIZE, OR COLOR.

NO CLAIM IS MADE TO THE EXCLUSIVE RIGHT TO USE "250", APART FROM THE MARK AS SHOWN.

FOR DIETARY SUPPLEMENTS (U.S. CLS. 6, 18, 44, 46, 51 AND 52).

LINDSEY RUBIN, EXAMINING ATTORNEY



SN 85-224,321. PFIZER INC., NEW YORK, NY. FILED 1-24-2011.

# VMEERA

THE MARK CONSISTS OF STANDARD CHARACTERS WITHOUT CLAIM TO ANY PARTICULAR FONT, STYLE, SIZE, OR COLOR.

FOR PHARMACEUTICAL PREPARATIONS FOR THE TREATMENT OF CARDIOVASCULAR, CENTRAL NERVOUS SYSTEM, ENDOCRINE, GASTROINTESTINAL, HEMATOLOGIC, IMMUNOLOGICAL, INFECTIOUS, INFLAMMATORY, MENOPAUSAL, METABOLIC, MUSCULOSKELETAL, NEUROLOGICAL, ONCOLOGICAL, OPHTHALMOLOGICAL, PSYCHIATRIC, RESPIRATORY, UROGENITAL, UROLOGICAL AND VIRAL DISEASES AND DISORDERS; PHARMACEUTICAL PREPARATIONS FOR THE TREATMENT OF ERECTILE DYSFUNCTION, SEXUAL DYSFUNCTION AND PAIN; PHARMACEUTICAL PREPARATIONS, NAMELY, ANTI-FUNGAL PREPARATIONS, DERMATOLOGICAL PREPARATIONS, SMOKING CESSATION PREPARATIONS; VACCINES FOR HUMAN USE; ALL IN INTERNATIONAL CLASS 5 (U.S. CLS. 6, 18, 44, 46, 51 AND 52).

SKYE YOUNG, EXAMINING ATTORNEY

**CLASS 5—(Continued).**

SN 85-226,679. PFIZER INC., NEW YORK, NY. FILED 1-26-2011.

# ZUITION

THE MARK CONSISTS OF STANDARD CHARACTERS WITHOUT CLAIM TO ANY PARTICULAR FONT, STYLE, SIZE, OR COLOR.

FOR PHARMACEUTICAL PREPARATIONS FOR THE TREATMENT OF CARDIOVASCULAR, CENTRAL NERVOUS SYSTEM, ENDOCRINE, GASTROINTESTINAL, HEMATOLOGIC, IMMUNOLOGICAL, INFECTIOUS, INFLAMMATORY, MENOPAUSAL, METABOLIC, MUSCULOSKELETAL, NEUROLOGICAL, ONCOLOGICAL, OPHTHALMOLOGICAL, PSYCHIATRIC, RESPIRATORY, UROGENITAL, UROLOGICAL AND VIRAL DISEASES AND DISORDERS; PHARMACEUTICAL PREPARATIONS FOR THE TREATMENT OF ERECTILE DYSFUNCTION, SEXUAL DYSFUNCTION AND PAIN; PHARMACEUTICAL PREPARATIONS, NAMELY, ANTI-FUNGAL PREPARATIONS, DERMATOLOGICAL PREPARATIONS, SMOKING CESSATION PREPARATIONS; VACCINES FOR HUMAN USE (U.S. CLS. 6, 18, 44, 46, 51 AND 52).

SKYE YOUNG, EXAMINING ATTORNEY

**CLASS 5—(Continued).**

SN 85-228,926. WESTERN HOLDINGS, LLC, CARSON CITY, NV. FILED 1-28-2011.

# VENITONE

THE MARK CONSISTS OF STANDARD CHARACTERS WITHOUT CLAIM TO ANY PARTICULAR FONT, STYLE, SIZE, OR COLOR.

FOR DIETARY SUPPLEMENTS (U.S. CLS. 6, 18, 44, 46, 51 AND 52).

KATHERINE M. DUBRAY, EXAMINING ATTORNEY

SN 85-227,355. NUTRITION & FITNESS, INC., FAYETTEVILLE, NC. FILED 1-27-2011.

# MAX T

THE MARK CONSISTS OF STANDARD CHARACTERS WITHOUT CLAIM TO ANY PARTICULAR FONT, STYLE, SIZE, OR COLOR.

FOR DIETARY SUPPLEMENTS (U.S. CLS. 6, 18, 44, 46, 51 AND 52).

SUSAN RICHARDS, EXAMINING ATTORNEY

SN 85-229,741. BRISTOL-MYERS SQUIBB COMPANY, NEW YORK, NY. FILED 1-31-2011.

# A-CLICK

THE MARK CONSISTS OF STANDARD CHARACTERS WITHOUT CLAIM TO ANY PARTICULAR FONT, STYLE, SIZE, OR COLOR.

FOR A SYRINGE PRE-FILLED WITH PHARMACEUTICAL PREPARATIONS FOR TREATING AUTO-IMMUNE DISEASES FOR HUMAN USE (U.S. CLS. 6, 18, 44, 46, 51 AND 52).

WENDY GOODMAN, EXAMINING ATTORNEY

SN 85-227,651. BRISTOL-MYERS SQUIBB COMPANY, NEW YORK, NY. FILED 1-27-2011.

# ORENCIA DIRECTJECT

THE MARK CONSISTS OF STANDARD CHARACTERS WITHOUT CLAIM TO ANY PARTICULAR FONT, STYLE, SIZE, OR COLOR.

OWNER OF U.S. REG. NOS. 2,948,497, 3,184,992 AND OTHERS.

FOR A SYRINGE PRE-FILLED WITH PHARMACEUTICAL PREPARATIONS FOR TREATING AUTO-IMMUNE DISEASES FOR HUMAN USE (U.S. CLS. 6, 18, 44, 46, 51 AND 52).

WENDY GOODMAN, EXAMINING ATTORNEY

SN 85-229,743. BRISTOL-MYERS SQUIBB COMPANY, NEW YORK, NY. FILED 1-31-2011.

# A-CLIQ

THE MARK CONSISTS OF STANDARD CHARACTERS WITHOUT CLAIM TO ANY PARTICULAR FONT, STYLE, SIZE, OR COLOR.

FOR A SYRINGE PRE-FILLED WITH PHARMACEUTICAL PREPARATIONS FOR TREATING AUTO-IMMUNE DISEASES FOR HUMAN USE (U.S. CLS. 6, 18, 44, 46, 51 AND 52).

WENDY GOODMAN, EXAMINING ATTORNEY

**CLASS 5—(Continued).**

SN 85-229,744. BRISTOL-MYERS SQUIBB COMPANY, NEW YORK, NY. FILED 1-31-2011.

# BECLICK

THE MARK CONSISTS OF STANDARD CHARACTERS WITHOUT CLAIM TO ANY PARTICULAR FONT, STYLE, SIZE, OR COLOR.

FOR A SYRINGE PRE-FILLED WITH PHARMACEUTICAL PREPARATIONS FOR TREATING AUTO-IMMUNE DISEASES FOR HUMAN USE (U.S. CLS. 6, 18, 44, 46, 51 AND 52).

WENDY GOODMAN, EXAMINING ATTORNEY

---

SN 85-229,745. BRISTOL-MYERS SQUIBB COMPANY, NEW YORK, NY. FILED 1-31-2011.

# CLICKJECT

THE MARK CONSISTS OF STANDARD CHARACTERS WITHOUT CLAIM TO ANY PARTICULAR FONT, STYLE, SIZE, OR COLOR.

FOR A SYRINGE PRE-FILLED WITH PHARMACEUTICAL PREPARATIONS FOR TREATING AUTO-IMMUNE DISEASES FOR HUMAN USE (U.S. CLS. 6, 18, 44, 46, 51 AND 52).

WENDY GOODMAN, EXAMINING ATTORNEY

---

SN 85-229,746. BRISTOL-MYERS SQUIBB COMPANY, NEW YORK, NY. FILED 1-31-2011.

# QLICK DOSE

THE MARK CONSISTS OF STANDARD CHARACTERS WITHOUT CLAIM TO ANY PARTICULAR FONT, STYLE, SIZE, OR COLOR.

NO CLAIM IS MADE TO THE EXCLUSIVE RIGHT TO USE "DOSE", APART FROM THE MARK AS SHOWN.

FOR A SYRINGE PRE-FILLED WITH PHARMACEUTICAL PREPARATIONS FOR TREATING AUTO-IMMUNE DISEASES FOR HUMAN USE (U.S. CLS. 6, 18, 44, 46, 51 AND 52).

WENDY GOODMAN, EXAMINING ATTORNEY

**CLASS 5—(Continued).**

SN 85-229,779. WELLEMENTS, LLC, SCOTTSDALE, AZ. FILED 1-31-2011.

# Output PWR-X

THE MARK CONSISTS OF STANDARD CHARACTERS WITHOUT CLAIM TO ANY PARTICULAR FONT, STYLE, SIZE, OR COLOR.

FOR ELECTROLYTE, AMINO ACID AND CARBOHYDRATE DIETARY AND NUTRITIONAL SUPPLEMENT FOR HUMAN CONSUMPTION IN DRY MIX AND POWDERED FORMS (U.S. CLS. 6, 18, 44, 46, 51 AND 52).

REBECCA SMITH, EXAMINING ATTORNEY

---

SN 85-229,784. WELLEMENTS, LLC, SCOTTSDALE, AZ. FILED 1-31-2011.

# Output PWR

THE MARK CONSISTS OF STANDARD CHARACTERS WITHOUT CLAIM TO ANY PARTICULAR FONT, STYLE, SIZE, OR COLOR.

FOR ELECTROLYTE, AMINO ACID AND CARBOHYDRATE DIETARY AND NUTRITIONAL SUPPLEMENT FOR HUMAN CONSUMPTION IN DRY MIX AND POWDERED FORMS (U.S. CLS. 6, 18, 44, 46, 51 AND 52).

REBECCA SMITH, EXAMINING ATTORNEY

---

SN 85-229,789. WELLEMENTS, LLC, SCOTTSDALE, AZ. FILED 1-31-2011.

# Output NDR

THE MARK CONSISTS OF STANDARD CHARACTERS WITHOUT CLAIM TO ANY PARTICULAR FONT, STYLE, SIZE, OR COLOR.

FOR ELECTROLYTE, AMINO ACID AND CARBOHYDRATE DIETARY AND NUTRITIONAL SUPPLEMENT FOR HUMAN CONSUMPTION IN DRY MIX AND POWDERED FORMS (U.S. CLS. 6, 18, 44, 46, 51 AND 52).

REBECCA SMITH, EXAMINING ATTORNEY

**CLASS 5—(Continued).**

SN 85-229,795. WELLEMENTS, LLC, SCOTTSDALE, AZ. FILED 1-31-2011.

# Output NDR-X

THE MARK CONSISTS OF STANDARD CHARACTERS WITHOUT CLAIM TO ANY PARTICULAR FONT, STYLE, SIZE, OR COLOR.

FOR ELECTROLYTE, AMINO ACID AND CARBOHYDRATE DIETARY AND NUTRITIONAL SUPPLEMENT FOR HUMAN CONSUMPTION IN DRY MIX AND POWDERED FORMS (U.S. CLS. 6, 18, 44, 46, 51 AND 52).  
REBECCA SMITH, EXAMINING ATTORNEY

**CLASS 5—(Continued).**

SN 85-232,899. INFINITY ENTERPRISES INCORPORATED, TOKYO, JAPAN, FILED 2-3-2011.

# Origination

THE MARK CONSISTS OF STANDARD CHARACTERS WITHOUT CLAIM TO ANY PARTICULAR FONT, STYLE, SIZE, OR COLOR.

FOR DIETARY AND NUTRITIONAL SUPPLEMENTS (U.S. CLS. 6, 18, 44, 46, 51 AND 52).  
STEVEN PEREZ, EXAMINING ATTORNEY

SN 85-231,100. WESTERN HOLDINGS, LLC, CARSON CITY, NV. FILED 2-1-2011.

# THEAZAMIN

THE MARK CONSISTS OF STANDARD CHARACTERS WITHOUT CLAIM TO ANY PARTICULAR FONT, STYLE, SIZE, OR COLOR.

FOR DIETARY SUPPLEMENTS (U.S. CLS. 6, 18, 44, 46, 51 AND 52).  
KATHERINE M. DUBRAY, EXAMINING ATTORNEY

SN 85-233,012. PFIZER INC., NEW YORK, NY. FILED 2-3-2011.

# PREXIVA

THE MARK CONSISTS OF STANDARD CHARACTERS WITHOUT CLAIM TO ANY PARTICULAR FONT, STYLE, SIZE, OR COLOR.

FOR VETERINARY PREPARATIONS FOR THE PREVENTION OR TREATMENT OF OCULAR DISORDERS; ORAL DISEASES; CENTRAL NERVOUS SYSTEM DISEASES AND DISORDERS, NAMELY CENTRAL NERVOUS SYSTEM INFECTIONS, BRAIN DISEASES, CENTRAL NERVOUS SYSTEM MOVEMENT DISORDERS, OCULAR MOTILITY DISORDERS, SPINAL CORD DISEASES, ENCEPHALITIS, EPILEPSY, ALZHEIMER'S, CEREBRAL PALSY, INSOMNIA, SEIZURE DISORDERS; CIRCULATORY SYSTEM DISEASES AND DISORDERS, NAMELY DISORDERS IN BLOOD CIRCULATION, HYPERTENSION, PORTAL HYPERTENSION, PULMONARY DISEASES, PULMONARY HYPERTENSION AND HEART FAILURE; IMMUNOLOGICAL DISEASES AND DISORDERS, NAMELY AUTOIMMUNE DISEASES, IMMUNOLOGIC DEFICIENCY SYNDROMES; THE CARDIO-VASCULAR SYSTEM; THE RESPIRATORY SYSTEM; MUSCULOSKELETAL DISEASES AND DISORDERS, NAMELY CONNECTIVE TISSUE DISEASES, BONE DISEASES, OSTEOPOROSIS, SPINAL DISEASES, BACK PAIN, FRACTURES, SPRAINS, CARTILAGE INJURIES; THE DIGESTIVE SYSTEM; GENITOURINARY DISEASES, NAMELY UROLOGICAL DISEASES, INFERTILITY, SEXUALLY TRANSMITTED DISEASES, INFLAMMATORY PELVIC DISEASES; AND REPRODUCTIVE HEALTH DISEASES AND DISORDERS, NAMELY, MALE AND FEMALE INFERTILITY, OVULATION DISORDERS, HORMONE REPLACEMENT THERAPY INDICATED FOR THE RELIEF OF MENOPAUSE SYMPTOMS AND THE PREVENTION OF OSTEOPOROSIS; VETERINARY PREPARATIONS FOR THE TREATMENT OR PREVENTION OF INFECTIOUS DISEASES, OBESITY, BEHAVIORAL DISORDERS AND INFLAMMATORY

SN 85-231,555. IML US TRADEMARK LTD., OAKVILLE, ONTARIO, CANADA, FILED 2-1-2011.

# TRIMSMART

THE MARK CONSISTS OF STANDARD CHARACTERS WITHOUT CLAIM TO ANY PARTICULAR FONT, STYLE, SIZE, OR COLOR.

FOR PROPRIETARY INGREDIENT BLEND SOLD AS AN INTEGRAL PART OF NUTRITIONAL SUPPLEMENTS FOR PERFORMANCE AND STRENGTH ENHANCEMENT, BODY COMPOSITION ENHANCEMENT AND MUSCLE BUILDING ENHANCEMENT (U.S. CLS. 6, 18, 44, 46, 51 AND 52).  
ADA HAN, EXAMINING ATTORNEY

**CLASS 5—(Continued).**

DISORDERS; VETERINARY PREPARATIONS FOR USE IN DERMATOLOGY, ONCOLOGY, HEMATOLOGY, OPHTHALMOLOGY, AND GASTROENTEROLOGY; VETERINARY PREPARATIONS, NAMELY, DENTAL PREPARATIONS, NAMELY A PHARMACEUTICAL DRUG OR VACCINE FOR THE TREATMENT OR PREVENTION OF TOOTH DECAY, TOOTH SENSITIVITY, GINGIVITIS, HALITOSIS AND PERIODONTAL DISEASE; VETERINARY PREPARATIONS, NAMELY, NUTRITIONAL ADITIVES TO FOODSTUFFS FOR ANIMALS FOR MEDICAL PURPOSES AND FOOD SUPPLEMENTS; VETERINARY PREPARATIONS, NAMELY, PHARMACEUTICAL PREPARATIONS FOR RELIEVING TEETHING PAINS AND TOOTHACHES IN COMPANION ANIMALS; VETERINARY PARASITICIDES; VETERINARY ANALGESIC PREPARATIONS; VETERINARY ANTI-ALLERGEN PREPARATIONS, NAMELY, ALLERGY MEDICATIONS; VETERINARY PREPARATIONS, NAMELY, ANTI-INFECTIVES, ANTI-BACTERIALS, ANTI-VIRALS, ANTIBIOTICS, ANTIFUNGALS (U.S. CLS. 6, 18, 44, 46, 51 AND 52).

SKYE YOUNG, EXAMINING ATTORNEY

---

SN 85-238,707. NEW CHAPTER, INC., BRATTLEBORO, VT. FILED 2-10-2011.

**TARGETCAL**

THE MARK CONSISTS OF STANDARD CHARACTERS WITHOUT CLAIM TO ANY PARTICULAR FONT, STYLE, SIZE, OR COLOR.

FOR VITAMINS; NUTRITIONAL AND DIETARY SUPPLEMENTS; VITAMIN AND HERBAL FORMULATIONS FOR USE AS AN INGREDIENT IN NUTRITIONAL AND DIETARY SUPPLEMENTS (U.S. CLS. 6, 18, 44, 46, 51 AND 52).

DAVID TOOLEY, EXAMINING ATTORNEY

---

SN 85-242,787. MGH HOLDINGS, LLC, HIGHLAND, UT. FILED 2-15-2011.



THE MARK CONSISTS OF A STYLIZED NUMBER "6" WITH A STYLIZED LOWER-CASE LETTER "N" TO THE RIGHT OF IT, AND A DEGREE SYMBOL ABOVE THE LETTER "N".

FOR DIETARY SUPPLEMENTS; ELECTROLYTE REPLACEMENT SOLUTIONS (U.S. CLS. 6, 18, 44, 46, 51 AND 52).

TINA BROWN, EXAMINING ATTORNEY

**CLASS 5—(Continued).**

SN 85-246,595. VITAL PHARMACEUTICALS, INC., WESTON, FL. FILED 2-18-2011.

**LIQUIMINS**

THE MARK CONSISTS OF STANDARD CHARACTERS WITHOUT CLAIM TO ANY PARTICULAR FONT, STYLE, SIZE, OR COLOR.

FOR DIETARY AND NUTRITIONAL SUPPLEMENTS (U.S. CLS. 6, 18, 44, 46, 51 AND 52).

ANNE MADDEN, EXAMINING ATTORNEY

---

SN 85-247,358. VITAL PHARMACEUTICALS, INC., WESTON, FL. FILED 2-21-2011.

**I-II-III**

THE MARK CONSISTS OF STANDARD CHARACTERS WITHOUT CLAIM TO ANY PARTICULAR FONT, STYLE, SIZE, OR COLOR.

FOR DIETARY AND NUTRITIONAL SUPPLEMENTS (U.S. CLS. 6, 18, 44, 46, 51 AND 52).

ANNE MADDEN, EXAMINING ATTORNEY

---

SN 85-251,243. SCHIFF NUTRITION INTERNATIONAL, INC., SALT LAKE CITY, UT. FILED 2-24-2011.

**STAY STRONG**

THE MARK CONSISTS OF STANDARD CHARACTERS WITHOUT CLAIM TO ANY PARTICULAR FONT, STYLE, SIZE, OR COLOR.

FOR DIETARY AND NUTRITIONAL SUPPLEMENTS (U.S. CLS. 6, 18, 44, 46, 51 AND 52).

JILL PRATER, EXAMINING ATTORNEY



**CLASS 6—METAL GOODS**

SN 76-704,590. MAGNETEK, INC., MENOMONEE FALLS, WI. FILED 9-21-2010.



THE MARK CONSISTS OF THE TERM "E-HOUSE" TO THE RIGHT OF A STYLIZED REPRESENTATION OF THE RAYS OF THE SUN WHICH CONSISTS OF THREE CONVERGENT LINES.

FOR METAL SHELTER STRUCTURES (U.S. CLS. 2, 12, 13, 14, 23, 25 AND 50).  
LINDA MICKLEBURGH, EXAMINING ATTORNEY

SN 76-704,784. NCI GROUP, INC., HOUSTON, TX. FILED 10-5-2010.

**CUBIX**

THE MARK CONSISTS OF STANDARD CHARACTERS WITHOUT CLAIM TO ANY PARTICULAR FONT, STYLE, SIZE, OR COLOR.

FOR GENERAL PURPOSE METAL STORAGE UNITS (U.S. CLS. 2, 12, 13, 14, 23, 25 AND 50).  
NANCY CLARKE, EXAMINING ATTORNEY

SN 79-078,350. BLANC AERO INDUSTRIES; (SOCIÉTÉ PAR ACTIONS SIMPLIFIÉE), FRANCE, FILED 7-30-2009.

**TAPER-HI-LITE**

THE MARK CONSISTS OF STANDARD CHARACTERS WITHOUT CLAIM TO ANY PARTICULAR FONT, STYLE, SIZE, OR COLOR.

OWNER OF INTERNATIONAL REGISTRATION 0789020 DATED 8-20-2002, EXPIRES 8-20-2012.

FOR HARDWARE OF METAL, NAMELY, SCREWS, NUTS AND BOLTS, RIVETS, WASHERS, SPRINGS, CLAMPS (U.S. CLS. 2, 12, 13, 14, 23, 25 AND 50).

ANDREW RHIM, EXAMINING ATTORNEY

**CLASS 6—(Continued).**

SN 79-083,494. LAMPRE INTERNATIONAL B.V., NL-1014 BA AMSTERDAM, NETHERLANDS, FILED 5-4-2010.

**sanisteel** 

PRIORITY DATE OF 11-26-2009 IS CLAIMED.  
OWNER OF INTERNATIONAL REGISTRATION 1035407 DATED 12-2-2009, EXPIRES 12-2-2019.

THE MARK CONSISTS OF THE STYLIZED WORDING "SANISTEEL" TO THE LEFT OF A DESIGN OF A U-SHAPED MAGNET WITH A TEARDROP DESIGN IN THE CENTER.

FOR METALS, NAMELY, SHEETS, STRIPS AND COILS FORMED OF STEEL, ALUMINUM AND COMMON METAL; NON-COATED AND COATED METALS FOR FURTHER MANUFACTURING (U.S. CLS. 2, 12, 13, 14, 23, 25 AND 50).

TASNEEM HUSSAIN, EXAMINING ATTORNEY

SN 79-089,670. MIYAGAWA CORPORATION, OSAKA, JAPAN, FILED 10-15-2010.

**MRX**

THE MARK CONSISTS OF STANDARD CHARACTERS WITHOUT CLAIM TO ANY PARTICULAR FONT, STYLE, SIZE, OR COLOR.

OWNER OF INTERNATIONAL REGISTRATION 1057414 DATED 10-15-2010, EXPIRES 10-15-2020.

FOR METAL RIVETS; NAILS; METAL SCREWS AND METAL DRILLING SCREWS; METAL SCREW NAILS; BOLTS OF METAL; NUTS OF METAL; METAL HARDWARE, NAMELY, WASHERS (U.S. CLS. 2, 12, 13, 14, 23, 25 AND 50).

INGRID C. EULIN, EXAMINING ATTORNEY

SN 79-092,146. JIANGYIN NANFANG PIPE FITTING MAKING CO., LTD., CHINA, FILED 1-4-2011.

**NFF**

OWNER OF INTERNATIONAL REGISTRATION 1063967 DATED 1-4-2011, EXPIRES 1-4-2021.

FOR NOZZLES OF METAL; ELBOWS OF METAL FOR PIPES; GREASE NIPPLES; JUNCTIONS OF METAL FOR PIPES; VALVES OF METAL, OTHER THAN PARTS OF MACHINE; PIPEWORK OF METAL; MANIFOLDS OF METAL FOR PIPELINES; STEEL PIPES; PIPES OF METAL; DUCTS OF METAL FOR VENTILATING AND AIR CONDITIONING INSTALLATIONS (U.S. CLS. 2, 12, 13, 14, 23, 25 AND 50).

CHERYL CLAYTON, EXAMINING ATTORNEY

**CLASS 6—(Continued).**

SN 85-042,653. ALCAN RHENALU, COURBEVOIE, FRANCE, FILED 5-19-2010.

**SELFBRAZE**

THE MARK CONSISTS OF STANDARD CHARACTERS WITHOUT CLAIM TO ANY PARTICULAR FONT, STYLE, SIZE, OR COLOR.

OWNER OF ERPN CMNTY TM OFC REG. NO. 008795023, DATED 6-28-2010, EXPIRES 1-6-2020.

FOR COMMON METALS AND THEIR ALLOYS; ALUMINUM ALLOYS; SHEETS OF COMMON METALS FOR USE IN THE MOTOR INDUSTRY; LAMINATES FOR USE IN THE MANUFACTURE OF PRINTED CIRCUIT BOARDS FOR THE MOTOR INDUSTRY; BRAZING SHEETS IN THE NATURE OF SHEETS OF ALUMINUM ALLOY FOR BRAZING; SHEETS OF ALUMINUM ALLOY FOR BRAZING; BRAZING ALLOYS CONTAINING ALUMINUM, ALUMINUM ALLOYS FOR HEAT EXCHANGERS FOR USE IN VEHICLE RADIATORS (U.S. CLS. 2, 12, 13, 14, 23, 25 AND 50).

SEAN CROWLEY, EXAMINING ATTORNEY

SN 85-044,963. BELLCOMB TECHNOLOGIES INCORPORATED., NEW HOPE, MN. FILED 5-21-2010.

**NAUTICAL LITE**

THE MARK CONSISTS OF STANDARD CHARACTERS WITHOUT CLAIM TO ANY PARTICULAR FONT, STYLE, SIZE, OR COLOR.

NO CLAIM IS MADE TO THE EXCLUSIVE RIGHT TO USE "NAUTICAL", APART FROM THE MARK AS SHOWN.

FOR STRUCTURAL AND DECORATIVE PANELS MADE OF ALUMINUM FOR USE IN THE MANUFACTURING AND REPAIR OF MARINE VESSELS (U.S. CLS. 2, 12, 13, 14, 23, 25 AND 50).

ELISSA GARBER KON, EXAMINING ATTORNEY

SN 85-051,429. WÜRTH INDUSTRIE SERVICE GMBH & CO.KG, BAD MERGENTHEIM, FED REP GERMANY, FILED 6-1-2010.

**WÜPLAST**

THE MARK CONSISTS OF STANDARD CHARACTERS WITHOUT CLAIM TO ANY PARTICULAR FONT, STYLE, SIZE, OR COLOR.

OWNER OF FED REP GERMANY REG. NO. 302008048663, DATED 10-28-2008, EXPIRES 7-31-2018.

THE WORDING "WÜPLAST" HAS NO MEANING IN A FOREIGN LANGUAGE.

FOR SCREWS MADE OF METAL (U.S. CLS. 2, 12, 13, 14, 23, 25 AND 50).

PAM WILLIS, EXAMINING ATTORNEY

**CLASS 6—(Continued).**

SN 85-052,641. FREEPORT-MCMORAN COPPER & GOLD INC., PHOENIX, AZ. FILED 6-2-2010.

**PD-135**

THE MARK CONSISTS OF STANDARD CHARACTERS WITHOUT CLAIM TO ANY PARTICULAR FONT, STYLE, SIZE, OR COLOR.

FOR HIGH PERFORMANCE COPPER ALLOY PROVIDED IN THE FORM OF RODS AND WIRE FOR GENERAL INDUSTRIAL USE (U.S. CLS. 2, 12, 13, 14, 23, 25 AND 50).

FIRST USE 0-0-1965; IN COMMERCE 0-0-1965.

IRA J. GOODSaid, EXAMINING ATTORNEY

SN 85-052,649. FREEPORT-MCMORAN COPPER & GOLD INC., PHOENIX, AZ. FILED 6-2-2010.

**PD-35EF**

THE MARK CONSISTS OF STANDARD CHARACTERS WITHOUT CLAIM TO ANY PARTICULAR FONT, STYLE, SIZE, OR COLOR.

FOR HIGH PERFORMANCE COPPER ALLOY PROVIDED IN THE FORM OF RODS AND WIRE FOR GENERAL INDUSTRIAL USE (U.S. CLS. 2, 12, 13, 14, 23, 25 AND 50).

FIRST USE 0-0-2005; IN COMMERCE 0-0-2005.

IRA J. GOODSaid, EXAMINING ATTORNEY

SN 85-052,654. FREEPORT-MCMORAN COPPER & GOLD INC., PHOENIX, AZ. FILED 6-2-2010.

**PD-80EF**

THE MARK CONSISTS OF STANDARD CHARACTERS WITHOUT CLAIM TO ANY PARTICULAR FONT, STYLE, SIZE, OR COLOR.

FOR COPPER ALLOY PROVIDED IN THE FORM OF RODS AND WIRE FOR GENERAL INDUSTRIAL USE (U.S. CLS. 2, 12, 13, 14, 23, 25 AND 50).

FIRST USE 0-0-2005; IN COMMERCE 0-0-2005.

IRA J. GOODSaid, EXAMINING ATTORNEY

**CLASS 6—(Continued).**

SN 85-080,084. DRAHTZUG STEIN WIRE & WELDING GMBH & CO. KG, ALTLEININGEN, FED REP GERMANY, FILED 7-8-2010.

**STEIN-MEGAFIL**

THE MARK CONSISTS OF STANDARD CHARACTERS WITHOUT CLAIM TO ANY PARTICULAR FONT, STYLE, SIZE, OR COLOR.

FOR WELDING WIRES OF METAL (U.S. CLS. 2, 12, 13, 14, 23, 25 AND 50).

FIRST USE 3-0-2007; IN COMMERCE 3-0-2007.  
BENJAMIN OKEKE, EXAMINING ATTORNEY

SN 85-168,291. WITTRIG, RICK, DBA FIREPIT ART, LEBA-NON, TN. FILED 11-3-2010.



NO CLAIM IS MADE TO THE EXCLUSIVE RIGHT TO USE "ART", APART FROM THE MARK AS SHOWN.

THE COLOR(S) ORANGE AND BLACK IS/ARE CLAIMED AS A FEATURE OF THE MARK.

THE MARK CONSISTS OF A BLACK FIRE BOWL ON AN ORANGE BASE WITH ORANGE FLAMES, TO THE LEFT OF THE WORDS "FIRE PIT ART" IN BLACK OVER "A GATHERING PLACE FOR FAMILY & FRIENDS" IN ORANGE.

FOR WORKS OF ART OF COMMON METAL (U.S. CLS. 2, 12, 13, 14, 23, 25 AND 50).

JAMES GRIFFIN, EXAMINING ATTORNEY

SN 85-173,834. THE TRUSTEE OF THE KUVET FAMILY TRUSTS OF 1987, AUSTIN, TX. FILED 11-10-2010.

**CRUSADE FOR PETS**

THE MARK CONSISTS OF STANDARD CHARACTERS WITHOUT CLAIM TO ANY PARTICULAR FONT, STYLE, SIZE, OR COLOR.

NO CLAIM IS MADE TO THE EXCLUSIVE RIGHT TO USE "PETS", APART FROM THE MARK AS SHOWN.

FOR METAL PET IDENTIFICATION TAGS (U.S. CLS. 2, 12, 13, 14, 23, 25 AND 50).

CAROLYN CATALDO, EXAMINING ATTORNEY

**CLASS 6—(Continued).**

SN 85-173,961. TOTO U.S.A., INC., MORROW, GA. FILED 11-10-2010.

**MERCER**

THE MARK CONSISTS OF STANDARD CHARACTERS WITHOUT CLAIM TO ANY PARTICULAR FONT, STYLE, SIZE, OR COLOR.

OWNER OF U.S. REG. NOS. 3,074,824 AND 3,074,825.  
SEC. 2(F).

FOR METAL GARMENT HOOKS (U.S. CLS. 2, 12, 13, 14, 23, 25 AND 50).

FIRST USE 9-10-2004; IN COMMERCE 9-10-2004.  
ELLEN B. AWRICH, EXAMINING ATTORNEY

SN 85-174,432. AWNEX, INC., BALL GROUND, GA. FILED 11-11-2010.

**AWNGUARD**

THE MARK CONSISTS OF STANDARD CHARACTERS WITHOUT CLAIM TO ANY PARTICULAR FONT, STYLE, SIZE, OR COLOR.

FOR ARCHITECTURAL CANOPY SYSTEM, NAMELY, METAL CANOPIES AND METAL AWNINGS (U.S. CLS. 2, 12, 13, 14, 23, 25 AND 50).

MARGERY A. TIERNEY, EXAMINING ATTORNEY

SN 85-178,330. UNISON HARDWARE, INC., SACRAMENTO, CA. FILED 11-16-2010.

**Oslo**

THE MARK CONSISTS OF STANDARD CHARACTERS WITHOUT CLAIM TO ANY PARTICULAR FONT, STYLE, SIZE, OR COLOR.

FOR METAL HANDLES FOR DOOR (U.S. CLS. 2, 12, 13, 14, 23, 25 AND 50).

FIRST USE 7-1-2005; IN COMMERCE 7-1-2005.  
AMEEN IMAM, EXAMINING ATTORNEY

**CLASS 6—(Continued).**

SN 85-181,901. SALT LIFE HOLDINGS, LLC, JACKSONVILLE, FL. FILED 11-21-2010.

**SALT LIFE**

THE MARK CONSISTS OF STANDARD CHARACTERS WITHOUT CLAIM TO ANY PARTICULAR FONT, STYLE, SIZE, OR COLOR.

OWNER OF U.S. REG. NOS. 3,001,343, 3,843,123 AND OTHERS.

FOR METAL DOG TAGS; METAL LICENSE PLATES; METAL KEY RINGS; METAL KEY HOLDERS (U.S. CLS. 2, 12, 13, 14, 23, 25 AND 50).

APRIL HESIK, EXAMINING ATTORNEY

**CLASS 6—(Continued).**

SN 85-186,227. SECURITY BOSS MANUFACTURING, LLC, BROWNSVILLE, MN. FILED 11-29-2010.

**Kennel Clad**

THE MARK CONSISTS OF STANDARD CHARACTERS WITHOUT CLAIM TO ANY PARTICULAR FONT, STYLE, SIZE, OR COLOR.

NO CLAIM IS MADE TO THE EXCLUSIVE RIGHT TO USE "KENNEL", APART FROM THE MARK AS SHOWN.

FOR ANIMAL DOORS, PRIMARILY OF METAL, AND PARTS THEREFOR (U.S. CLS. 2, 12, 13, 14, 23, 25 AND 50).

TARAH HARDY, EXAMINING ATTORNEY

SN 85-182,380. GOAD COMPANY, ELLISVILLE, MO. FILED 11-22-2010.

**DUOBEAR**

THE MARK CONSISTS OF STANDARD CHARACTERS WITHOUT CLAIM TO ANY PARTICULAR FONT, STYLE, SIZE, OR COLOR.

FOR FITTED LINERS FOR METAL PROCESS TANKS COMPRISED OF A DOUBLE BARRIER OF CHEMICALLY RESISTANT MATERIALS, USED FOR LINING TANKS (U.S. CLS. 2, 12, 13, 14, 23, 25 AND 50).

FIRST USE 8-10-2010; IN COMMERCE 9-24-2010.

CARYN GLASSER, EXAMINING ATTORNEY

SN 85-189,856. LIONS MARKETING & PROMOTIONS, LLC, BAY SHORE, NY. FILED 12-3-2010.

**TANK TOGA**

THE MARK CONSISTS OF STANDARD CHARACTERS WITHOUT CLAIM TO ANY PARTICULAR FONT, STYLE, SIZE, OR COLOR.

NO CLAIM IS MADE TO THE EXCLUSIVE RIGHT TO USE "TANK", APART FROM THE MARK AS SHOWN.

FOR DECORATIVE COVERING FOR METAL TANKS THAT STORE FLUIDS (U.S. CLS. 2, 12, 13, 14, 23, 25 AND 50).

JAMES A. RAUEN, EXAMINING ATTORNEY

SN 85-186,120. JEAN G SAINT GERMAIN, DBA SPEEDOPED SIDECYCLE, LLC, BROOKLYN, NY. FILED 11-29-2010.

*SpeedOPed SideCycle*

SN 85-191,240. CHAMPION FIBERGLASS, INC., HOUSTON, TX. FILED 12-6-2010.

**CHAMPION TRAY**

NO CLAIM IS MADE TO THE EXCLUSIVE RIGHT TO USE "LLC", APART FROM THE MARK AS SHOWN.

THE MARK CONSISTS OF THE STYLIZED WORDING, "SPEEDOPED SIDECYCLE LLC", WITH THE STYLIZED DESIGN OF AN RV STABILIZATION SYSTEM INSIDE THE LETTER "O".

FOR RECREATIONAL VEHICLE STABILIZATION SYSTEM COMPRISED OF A PAIR OF ADJUSTABLE METAL TUBING BRACES THAT ARE PLACED AGAINST EACH SIDE OF THE VEHICLE FRAME AND ARE CONNECTED WITH A CHAIN AND ARE TENSIONED WITH A CHAIN TENSIONER (U.S. CLS. 2, 12, 13, 14, 23, 25 AND 50).

IRA J. GOODSaid, EXAMINING ATTORNEY

THE MARK CONSISTS OF STANDARD CHARACTERS WITHOUT CLAIM TO ANY PARTICULAR FONT, STYLE, SIZE, OR COLOR.

OWNER OF U.S. REG. NOS. 2,630,742, 2,642,187 AND 3,532,056.

NO CLAIM IS MADE TO THE EXCLUSIVE RIGHT TO USE "TRAY", APART FROM THE MARK AS SHOWN.

FOR CABLE TRAY (U.S. CLS. 2, 12, 13, 14, 23, 25 AND 50).

DOMINICK J. SALEMI, EXAMINING ATTORNEY

**CLASS 6—(Continued).**

SN 85-191,258. CHAMPION FIBERGLASS, INC., SPRING, TX. FILED 12-6-2010.

**CHAMPION CABLE TRAY**

THE MARK CONSISTS OF STANDARD CHARACTERS WITHOUT CLAIM TO ANY PARTICULAR FONT, STYLE, SIZE, OR COLOR.

OWNER OF U.S. REG. NOS. 2,630,742, 2,642,187 AND 3,532,056.

NO CLAIM IS MADE TO THE EXCLUSIVE RIGHT TO USE "CABLE TRAY", APART FROM THE MARK AS SHOWN.

FOR CABLE TRAY (U.S. CLS. 2, 12, 13, 14, 23, 25 AND 50).

DOMINICK J. SALEMI, EXAMINING ATTORNEY

**CLASS 6—(Continued).**

SN 85-203,270. CONDUIT SA DE CV, ECATEPEC 55400, MEXICO, FILED 12-21-2010.

**RYMCO**

THE MARK CONSISTS OF STANDARD CHARACTERS WITHOUT CLAIM TO ANY PARTICULAR FONT, STYLE, SIZE, OR COLOR.

OWNER OF U.S. REG. NO. 3,202,967.

FOR METAL FENCE POSTS, SQUARE METAL TUBING AND SHAPES, GALVANIZED STEEL TUBES (U.S. CLS. 2, 12, 13, 14, 23, 25 AND 50).

CAROLYN CATALDO, EXAMINING ATTORNEY

SN 85-198,216. VALMONT INDUSTRIES, INC., OMAHA, NE. FILED 12-15-2010.

**ULTRA-LOW PROFILE**

THE MARK CONSISTS OF STANDARD CHARACTERS WITHOUT CLAIM TO ANY PARTICULAR FONT, STYLE, SIZE, OR COLOR.

FOR METAL PLATFORMS TO ATTACH TO MONO-POLES (U.S. CLS. 2, 12, 13, 14, 23, 25 AND 50).

JACLYN KIDWELL WALKER, EXAMINING ATTORNEY

SN 85-204,982. BATTLEWAGON MOUNTS, LLC, CLEVELAND, OH. FILED 12-23-2010.

**BATTLEWAGON**

THE MARK CONSISTS OF STANDARD CHARACTERS WITHOUT CLAIM TO ANY PARTICULAR FONT, STYLE, SIZE, OR COLOR.

FOR RADAR AND ANTENNAE MOUNTS MADE OF METAL, NAMELY, STAINLESS STEEL (U.S. CLS. 2, 12, 13, 14, 23, 25 AND 50).

FIRST USE 11-0-2009; IN COMMERCE 11-0-2009. PAM WILLIS, EXAMINING ATTORNEY

SN 85-202,592. STOUT STUFF, LLC, BENTONVILLE, AR. FILED 12-21-2010.

**STOUTSTUFF**

THE MARK CONSISTS OF STANDARD CHARACTERS WITHOUT CLAIM TO ANY PARTICULAR FONT, STYLE, SIZE, OR COLOR.

FOR ADJUSTABLE METAL HANGER SYSTEM COMPRISED OF WALL-MOUNTED RAILS, RAIL-HUNG HOOKS AND BRACKETS FOR USE IN HOMES AND GARAGES (U.S. CLS. 2, 12, 13, 14, 23, 25 AND 50).

TRACY CROSS, EXAMINING ATTORNEY

SN 85-205,842. GRANITE SECURITY PRODUCTS, INC., IRVING, TX. FILED 12-27-2010.

**DEPUTY**

THE MARK CONSISTS OF STANDARD CHARACTERS WITHOUT CLAIM TO ANY PARTICULAR FONT, STYLE, SIZE, OR COLOR.

FOR METAL SAFES (U.S. CLS. 2, 12, 13, 14, 23, 25 AND 50).

ALICIA COLLINS, EXAMINING ATTORNEY

**CLASS 6—(Continued).**

SN 85-205,981. GRANITE SECURITY PRODUCTS, INC., IRVING, TX. FILED 12-27-2010.

# PONY

THE MARK CONSISTS OF STANDARD CHARACTERS WITHOUT CLAIM TO ANY PARTICULAR FONT, STYLE, SIZE, OR COLOR.

FOR METAL SAFES (U.S. CLS. 2, 12, 13, 14, 23, 25 AND 50).

FIRST USE 6-6-2001; IN COMMERCE 6-6-2001.  
ALICIA COLLINS, EXAMINING ATTORNEY

**CLASS 6—(Continued).**

SN 85-206,662. I KANG ENTERPRISE CO., LTD., KAOHSIUNG COUNTY, TAIWAN, FILED 12-28-2010.

# IK

THE MARK CONSISTS OF STANDARD CHARACTERS WITHOUT CLAIM TO ANY PARTICULAR FONT, STYLE, SIZE, OR COLOR.

FOR METAL FASTENERS, NAMELY, BOLTS, NAILS, RIVETS, SCREWS; METAL NUTS; METAL SCREWS; SCREW RINGS OF METAL; SCREWS OF METAL (U.S. CLS. 2, 12, 13, 14, 23, 25 AND 50).

FIRST USE 10-1-2007; IN COMMERCE 10-1-2007.  
GEORGE LORENZO, EXAMINING ATTORNEY

SN 85-206,457. GRANITE SECURITY PRODUCTS, INC., IRVING, TX. FILED 12-28-2010.

# SILVERADO

THE MARK CONSISTS OF STANDARD CHARACTERS WITHOUT CLAIM TO ANY PARTICULAR FONT, STYLE, SIZE, OR COLOR.

FOR METAL SAFES (U.S. CLS. 2, 12, 13, 14, 23, 25 AND 50).

FIRST USE 4-6-2001; IN COMMERCE 4-6-2001.  
ALICIA COLLINS, EXAMINING ATTORNEY

SN 85-209,827. J.T. EATON & COMPANY, INC., TWINSBURG, OH. FILED 1-4-2011.

# SPEEDY CLEAN

THE MARK CONSISTS OF STANDARD CHARACTERS WITHOUT CLAIM TO ANY PARTICULAR FONT, STYLE, SIZE, OR COLOR.

FOR ANIMAL TRAPS (U.S. CLS. 2, 12, 13, 14, 23, 25 AND 50).

GEORGE LORENZO, EXAMINING ATTORNEY

SN 85-206,516. GRANITE SECURITY PRODUCTS, INC., IRVING, TX. FILED 12-28-2010.

# TRADITION

THE MARK CONSISTS OF STANDARD CHARACTERS WITHOUT CLAIM TO ANY PARTICULAR FONT, STYLE, SIZE, OR COLOR.

FOR METAL SAFES (U.S. CLS. 2, 12, 13, 14, 23, 25 AND 50).

FIRST USE 4-16-2001; IN COMMERCE 4-16-2001.  
ALICIA COLLINS, EXAMINING ATTORNEY

SN 85-211,591. THE DELANEY CO., CUMMING, GA. FILED 1-6-2011.

# TULUM

THE MARK CONSISTS OF STANDARD CHARACTERS WITHOUT CLAIM TO ANY PARTICULAR FONT, STYLE, SIZE, OR COLOR.

FOR DOOR HANDLE SETS MADE PRINCIPALLY OF METAL (U.S. CLS. 2, 12, 13, 14, 23, 25 AND 50).

BRIAN NEVILLE, EXAMINING ATTORNEY

**CLASS 6—(Continued).**

SN 85-211,964. ROLL N RACK LLC, MUKWONAGO, WI.  
FILED 1-6-2011.

# FASTBACK

THE MARK CONSISTS OF STANDARD CHARACTERS  
WITHOUT CLAIM TO ANY PARTICULAR FONT, STYLE,  
SIZE, OR COLOR.

FOR HAND OPERATED METAL FIRE HOSE REELS  
(U.S. CLS. 2, 12, 13, 14, 23, 25 AND 50).  
SUSAN RICHARDS, EXAMINING ATTORNEY

**CLASS 6—(Continued).**

SN 85-212,513. GUMM INTERNATIONAL L.L.C., BURNS-  
VILLE, MN. FILED 1-7-2011.

# EAGLE EYES

THE MARK CONSISTS OF STANDARD CHARACTERS  
WITHOUT CLAIM TO ANY PARTICULAR FONT, STYLE,  
SIZE, OR COLOR.

FOR METAL TENT PEGS; METAL TENT POLES;  
METAL TENT STAKES (U.S. CLS. 2, 12, 13, 14, 23, 25  
AND 50).  
WILLIAM P. SHANAHAN, EXAMINING ATTORNEY

SN 85-212,156. THE DELANEY CO., CUMMING, GA. FILED  
1-6-2011.

# CIRA

THE MARK CONSISTS OF STANDARD CHARACTERS  
WITHOUT CLAIM TO ANY PARTICULAR FONT, STYLE,  
SIZE, OR COLOR.

FOR DOOR HANDLE SETS MADE PRINCIPALLY OF  
METAL (U.S. CLS. 2, 12, 13, 14, 23, 25 AND 50).  
FIRST USE 5-18-2010; IN COMMERCE 5-18-2010.  
BRIAN NEVILLE, EXAMINING ATTORNEY

SN 85-212,603. UNISON HARDWARE, INC., SACRAMENTO,  
CA. FILED 1-7-2011.

SN 85-212,500. CENTURIA STEEL BUILDINGS CORP.,  
PHILADELPHIA, PA. FILED 1-7-2011.

# Munich

## THE BEST VALUE IN SPACE

THE MARK CONSISTS OF STANDARD CHARACTERS  
WITHOUT CLAIM TO ANY PARTICULAR FONT, STYLE,  
SIZE, OR COLOR.

FOR PRE-FABRICATED AND PRE-ENGINEERED  
STEEL BUILDINGS (U.S. CLS. 2, 12, 13, 14, 23, 25 AND  
50).  
FIRST USE 1-6-2011; IN COMMERCE 1-6-2011.  
KIM SAITO, EXAMINING ATTORNEY

THE MARK CONSISTS OF STANDARD CHARACTERS  
WITHOUT CLAIM TO ANY PARTICULAR FONT, STYLE,  
SIZE, OR COLOR.

FOR METAL HANDLES FOR DOORS, NAMELY,  
DOOR HANDLES (U.S. CLS. 2, 12, 13, 14, 23, 25 AND 50).  
FIRST USE 7-1-2005; IN COMMERCE 7-1-2005.  
AMEEN IMAM, EXAMINING ATTORNEY

**CLASS 6—(Continued).**

SN 85-212,889. TARGET BRANDS, INC., MINNEAPOLIS, MN. FILED 1-7-2011.

**CANTERBOROUGH**

THE MARK CONSISTS OF STANDARD CHARACTERS WITHOUT CLAIM TO ANY PARTICULAR FONT, STYLE, SIZE, OR COLOR.

FOR METAL LAWN AND GARDEN STRUCTURES, NAMELY, ARCHES, ARBORS, GAZEBOS, TRELISES, FENCING, TRELISES IN THE NATURE OF TUTEURS, GATES AND LANDSCAPE EDGING; METAL TUBS; METAL GREENHOUSE FRAMES; METAL WEATHER VANES; BASKETS OF COMMON METALS; DECORATIVE BOXES MADE OF NON-PRECIOUS METAL; DESKTOP STATUARY MADE OF NON-PRECIOUS METAL; METAL DOOR HARDWARE, NAMELY, KEYS, KEY CYLINDERS, CLASPS AND CHAIN DOOR GUARDS; DOOR STOPS OF METAL; FIREPLACE GRATES; METAL BATHROOM AND KITCHEN HARDWARE, NAMELY, PULLS AND KNOBS; METAL HOOKS; METAL KEY HOOKS; PIGGY BANKS OF METAL; WROUGHT IRON DECORATIVE ARTWORK; DECORATIVE HARDWARE AND FIXTURES MADE OF METAL, NAMELY, MAILBOXES, HOUSE NUMBERS, METAL ADDRESS PLATES, DOORKNOBS, CLOTHING HOOKS, DRAWER PULLS, DRAWER KNOBS, DRAWER HANDLES, CABINET PULLS, CABINET KNOBS AND CABINET HANDLES; METAL PLANT HANGERS; HOSE HANGERS OF METAL; METAL STORAGE CONTAINERS, NAMELY, HOSE POTS; METAL GARDEN STAKES (U.S. CLS. 2, 12, 13, 14, 23, 25 AND 50).

TRACY CROSS, EXAMINING ATTORNEY

**CLASS 6—(Continued).**

SN 85-218,010. TARGET BRANDS, INC., MINNEAPOLIS, MN. FILED 1-14-2011.

**EDEN PARK**

THE MARK CONSISTS OF STANDARD CHARACTERS WITHOUT CLAIM TO ANY PARTICULAR FONT, STYLE, SIZE, OR COLOR.

OWNER OF U.S. REG. NO. 2,866,654.

FOR METAL LAWN AND GARDEN STRUCTURES, NAMELY, ARCHES, ARBORS, GAZEBOS, TRELISES, FENCING, TRELISES IN THE NATURE OF TUTEURS, GATES AND LANDSCAPE EDGING; METAL TUBS; METAL GREENHOUSE FRAMES; METAL WEATHER VANES; BASKETS OF COMMON METALS; DECORATIVE BOXES MADE OF NON-PRECIOUS METAL; DESKTOP STATUARY MADE OF NON-PRECIOUS METAL; METAL DOOR HARDWARE, NAMELY, KEYS, KEY CYLINDERS, CLASPS AND CHAIN DOOR GUARDS; DOOR STOPS OF METAL; FIREPLACE GRATES; METAL BATHROOM AND KITCHEN HARDWARE, NAMELY, PULLS AND KNOBS; METAL HOOKS; METAL KEY HOOKS; PIGGY BANKS OF METAL; WROUGHT IRON DECORATIVE ARTWORK; DECORATIVE HARDWARE AND FIXTURES MADE OF METAL, NAMELY, MAILBOXES, HOUSE NUMBERS, METAL ADDRESS PLATES, DOORKNOBS, CLOTHING HOOKS, DRAWER PULLS, DRAWER KNOBS, DRAWER HANDLES, CABINET PULLS, CABINET KNOBS AND CABINET HANDLES; METAL PLANT HANGERS; HOSE HANGERS OF METAL; METAL STORAGE CONTAINERS, NAMELY, HOSE POTS; METAL GARDEN STAKES; METAL PLANT CONTAINERS (U.S. CLS. 2, 12, 13, 14, 23, 25 AND 50).

TRACY CROSS, EXAMINING ATTORNEY

SN 85-213,853. UNISON HARDWARE, INC., SACRAMENTO, CA. FILED 1-10-2011.

**Stuttgart**

THE MARK CONSISTS OF STANDARD CHARACTERS WITHOUT CLAIM TO ANY PARTICULAR FONT, STYLE, SIZE, OR COLOR.

FOR METAL DOOR HANDLES (U.S. CLS. 2, 12, 13, 14, 23, 25 AND 50).

FIRST USE 1-1-2007; IN COMMERCE 1-1-2007.  
AMEEN IMAM, EXAMINING ATTORNEY

SN 85-218,037. THE DELANEY CO., CUMMING, GA. FILED 1-14-2011.

**KERRY**

THE MARK CONSISTS OF STANDARD CHARACTERS WITHOUT CLAIM TO ANY PARTICULAR FONT, STYLE, SIZE, OR COLOR.

FOR DOOR HANDLE SETS MADE PRINCIPALLY OF METAL (U.S. CLS. 2, 12, 13, 14, 23, 25 AND 50).

BRIAN NEVILLE, EXAMINING ATTORNEY



**CLASS 6—(Continued).**

SN 85-218,042. THE DELANEY CO., CUMMING, GA. FILED 1-14-2011.

# ARTINO

THE MARK CONSISTS OF STANDARD CHARACTERS WITHOUT CLAIM TO ANY PARTICULAR FONT, STYLE, SIZE, OR COLOR.

FOR DOOR HANDLE SETS MADE PRINCIPALLY OF METAL (U.S. CLS. 2, 12, 13, 14, 23, 25 AND 50).  
BRIAN NEVILLE, EXAMINING ATTORNEY

---

SN 85-232,914. TEKNOR APEX COMPANY, PAWTUCKET, RI. FILED 2-3-2011.

# SEALFAST

THE MARK CONSISTS OF STANDARD CHARACTERS WITHOUT CLAIM TO ANY PARTICULAR FONT, STYLE, SIZE, OR COLOR.

FOR METAL COUPLINGS FOR USE WITH GARDEN HOSES OR WATERING HOSES (U.S. CLS. 2, 12, 13, 14, 23, 25 AND 50).  
PAM WILLIS, EXAMINING ATTORNEY

---

SN 85-238,081. L&P PROPERTY MANAGEMENT COMPANY, SOUTHGATE, CA. FILED 2-9-2011.

# BARRICAGE

THE MARK CONSISTS OF STANDARD CHARACTERS WITHOUT CLAIM TO ANY PARTICULAR FONT, STYLE, SIZE, OR COLOR.

FOR WELDED-WIRE GABIONS CONSISTING PRIMARILY OF METAL FOR EARTH RETENTION AND STABILIZATION, EROSION AND FLOOD CONTROL, AND ARCHITECTURAL APPLICATIONS; CAGE STRUCTURES AND MULTI-COMPARTMENTAL CAGE STRUCTURES CONSISTING PRIMARILY OF METAL FOR FORMING GABIONS; METALLIC FASTENERS FOR INTERCONNECTING COMPONENT PARTS OF GABION STRUCTURES; CONTAINERIZED GABIONS CONSISTING PRIMARILY OF METAL; METAL COMPONENT PARTS OF ALL THE AFORESAID GOODS (U.S. CLS. 2, 12, 13, 14, 23, 25 AND 50).  
SUSAN RICHARDS, EXAMINING ATTORNEY

**CLASS 7—MACHINERY**

SN 76-702,425. TSUBAKIMOTO CHAIN CO., OSAKA 5300005, JAPAN, FILED 5-19-2008.

# ZIP CHAIN

THE MARK CONSISTS OF STANDARD CHARACTERS WITHOUT CLAIM TO ANY PARTICULAR FONT, STYLE, SIZE, OR COLOR.

PRIORITY CLAIMED UNDER SEC. 44(D) ON JAPAN APPLICATION NO. 2008-025411, FILED 4-2-2008.  
OWNER OF U.S. REG. NO. 3,658,311.

NO CLAIM IS MADE TO THE EXCLUSIVE RIGHT TO USE "CHAIN", APART FROM THE MARK AS SHOWN.

FOR LOADING-UNLOADING MACHINES AND APPARATUS, NAMELY, CHAIN CONVEYORS, BUCKET ELEVATORS, LIFTERS, NAMELY, INDUSTRIAL LIFT TABLES, MACHINE ELEMENTS NOT FOR LAND VEHICLES, NAMELY, CHAINS, CABLE DRAG CHAINS, BELTS, SPROCKETS, GEARS, GEARBOXES, PULLEYS, COUPLINGS, CLUTCHES, TORQUE LIMITERS, REDUCTION GEARS FOR ELECTROMOTIVE MOTORS, SPEED CHANGE GEARS, POWER TRANSMISSION DEVICES FOR INDUSTRIES, SHOCK ABSORBERS, CYLINDERS, AND BEARINGS (U.S. CLS. 13, 19, 21, 23, 31, 34 AND 35).  
ANDREW RHIM, EXAMINING ATTORNEY

---

SN 76-702,993. IMPCO TECHNOLOGIES, INC., SANTA ANA, CA. FILED 5-17-2010.



OWNER OF U.S. REG. NOS. 1,418,216, 2,360,064 AND OTHERS.

THE MARK CONSISTS OF THE STYLIZED WORDING "IMPCO" WITH THREE BISECTED BARS ON EITHER SIDE OF THE WORDING TOP AND BOTTOM BARS BEING LARGER THAN THE MIDDLE BAR.

FOR CARBURETION DEVICES AND ASSOCIATED EQUIPMENT FOR AN INTERNAL COMBUSTION ENGINES, NAMELY, FUEL CONVERTERS, CARBURETORS, AIR/FUEL MIXERS, NAMELY, VALVES BEING ENGINE PARTS FOR INTRODUCING FUEL-AIR MIXTURES INTO THE COMBUSTION CHAMBERS OF INTERNAL COMBUSTION ENGINES, AND ADAPTIVE PARTS TO COUPLE FUEL INJECTION SYSTEMS TO ENGINES, NAMELY, COUPLINGS FOR ENGINES; ELECTRONIC AND MECHANICAL SAFETY SHUT-OFF VALVES FOR USE WITH FUEL INJECTION SYSTEMS BEING PARTS OF ENGINES (U.S. CLS. 13, 19, 21, 23, 31, 34 AND 35).

FIRST USE 12-31-1986; IN COMMERCE 12-31-1986.  
TASNEEM HUSSAIN, EXAMINING ATTORNEY

**CLASS 7—(Continued).**

SN 76-703,005. BETEK BERGBAU- UND HARTMETALL-TECHNIK KARL-HEINZ SIMON GMBH &, DE- 78733 AICHHALDEN, FED REP GERMANY, FILED 5-18-2010.

# BETEK Tools

THE MARK CONSISTS OF STANDARD CHARACTERS WITHOUT CLAIM TO ANY PARTICULAR FONT, STYLE, SIZE, OR COLOR.

OWNER OF U.S. REG. NO. 2,845,766.

NO CLAIM IS MADE TO THE EXCLUSIVE RIGHT TO USE "TOOLS", APART FROM THE MARK AS SHOWN.

FOR PARTS OF POWER OPERATED MACHINES, NAMELY, CUTTING BITS AND WEARING WASHERS FOR ROAD MILLING MACHINES; CUTTING BITS AND WEARING WASHERS FOR SURFACE MINING MACHINES; CUTTING BITS AND WEARING WASHERS FOR SOIL STABILIZING MACHINES AND COLD RECYCLING MACHINES; ROUND SHANK BITS, WELDING BARS, QUICK CHANGE BARS AND HOLDERS, WELD-ON CASING CROWNS, STOP WEDGES AND SCREW CONNECTIONS FOR FOUNDATION DRILLING MACHINES; ROUND SHANK BITS, BIT HOLDERS AND WELD-ON TEETH FOR HORIZONTAL DIRECTIONAL DRILLING MACHINES; CUTTING TEETH AND TEETH HOLDERS FOR DIAPHRAGM WALL CUTTING MACHINES; ROUND SHANK BITS AND BIT HOLDERS FOR TRENCHING MACHINES; ROUND SHANK BITS AND CUTTING TEETH FOR MINING AND TUNNELING MACHINES; ROUND SHANK BITS AND BIT HOLDERS FOR HYDRAULIC MILLING CUTTERS; AND CUTTING TEETH FOR TREE STUMP GRINDING MACHINES, MULCHING MACHINES, WOOD SHREDDING MACHINES, STONE CRUSHING MACHINES AND PAPER ROLL CORE SHREDDING MACHINES (U.S. CLS. 13, 19, 21, 23, 31, 34 AND 35).

FLORENTINA BLANDU, EXAMINING ATTORNEY

SN 76-705,766. STAR ASIA, U.S.A., LLC, RENTON, WA. FILED 12-23-2010.

# VAPER

THE MARK CONSISTS OF STANDARD CHARACTERS WITHOUT CLAIM TO ANY PARTICULAR FONT, STYLE, SIZE, OR COLOR.

OWNER OF U.S. REG. NOS. 3,149,252, 3,261,628 AND 3,870,741.

FOR BENCH GRINDERS (U.S. CLS. 13, 19, 21, 23, 31, 34 AND 35).

DAVID HOFFMAN, EXAMINING ATTORNEY

**CLASS 7—(Continued).**

SN 77-636,325. MUDMASTER, INC, ESCONDIDO, CA. FILED 12-18-2008.

## MUDMASTER WASHMASTER

THE MARK CONSISTS OF STANDARD CHARACTERS WITHOUT CLAIM TO ANY PARTICULAR FONT, STYLE, SIZE, OR COLOR.

FOR ELECTRIC WASHING MACHINES FOR INDUSTRIAL PURPOSES (U.S. CLS. 13, 19, 21, 23, 31, 34 AND 35).

NATALIE POLZER, EXAMINING ATTORNEY

SN 77-871,663. WAGSTAFF INC., SPOKANE, WA. FILED 11-12-2009.

# EVERCAST

THE MARK CONSISTS OF STANDARD CHARACTERS WITHOUT CLAIM TO ANY PARTICULAR FONT, STYLE, SIZE, OR COLOR.

FOR METAL CASTING MACHINES AND COMPONENTS THEREFORE, NAMELY, METAL CASTING MOLDS, MOLD TABLES, GRAPHITE MOLD RINGS, REFRACTORY MOLD LINERS, AND MOLTEN METAL DISTRIBUTION TROUGHS FOR MOLD TABLES, METAL CASTING MACHINES, METAL CASTING MOLD TABLE CONTROL MACHINES, METAL CASTING VERTICAL LIFT MACHINES (U.S. CLS. 13, 19, 21, 23, 31, 34 AND 35).

LOURDES AYALA, EXAMINING ATTORNEY

SN 77-897,741. SPEECO, INCORPORATED, GOLDEN, CO. FILED 12-20-2009.

## Solutions for Country Living

THE MARK CONSISTS OF STANDARD CHARACTERS WITHOUT CLAIM TO ANY PARTICULAR FONT, STYLE, SIZE, OR COLOR.

FOR AGRICULTURAL MACHINERY, NAMELY, LOG SPLITTERS, POSTHOLE DIGGERS AND HITCHES (U.S. CLS. 13, 19, 21, 23, 31, 34 AND 35).

FIRST USE 4-1-2007; IN COMMERCE 4-1-2007.

BARBARA BROWN, EXAMINING ATTORNEY

**CLASS 7—(Continued).**

SN 79-082,952. JIANGYIN LONG-BRIGHT DRILL PIPE; MANUFACTURE CO., LTD., CHINA, FILED 5-7-2010.

# LBT

OWNER OF INTERNATIONAL REGISTRATION 1039840 DATED 5-7-2010, EXPIRES 5-7-2020.

FOR MINE BORERS; APPARATUS FOR MACHINING, NAMELY, CUTTING MACHINES; DRILLING MACHINES; MINE WORKING MACHINES, NAMELY, EARTH DRILLING MACHINES; MACHINERY AND EQUIPMENT FOR GEOLOGICAL EXPLORATION, MINING, AND MINERAL SEPARATION, NAMELY, EARTH MOVING MACHINES; DRILLING RIGS FLOATING OR NON-FLOATING; MACHINES AND EQUIPMENT FOR OIL DEVELOPMENT AND REFINEMENT, NAMELY, OIL SEPARATORS; PETROCHEMICAL PLANTS, NAMELY, MACHINES IN THE NATURE OF EXTRACTING MACHINES AND SEPARATING MACHINES USED IN THE MANUFACTURE OF PETROCHEMICALS; OIL DRILLING MACHINES; DRIFTING MACHINES, NAMELY, FOR SEPARATING OIL (U.S. CLS. 13, 19, 21, 23, 31, 34 AND 35).

DOMINIC FATHY, EXAMINING ATTORNEY

**CLASS 7—(Continued).**

SN 79-084,454. KABUSHIKI KAISHA NPC (ALSO TRADING AS NPC INCORPORATED), JAPAN, FILED 6-1-2010.



OWNER OF INTERNATIONAL REGISTRATION 1043670 DATED 6-1-2010, EXPIRES 6-1-2020.

THE COLOR(S) BLUE AND RED IS/ARE CLAIMED AS A FEATURE OF THE MARK.

THE MARK CONSISTS OF THE WORDING "NPC" IN RED WITHIN TWO RECTANGLES WITH THE INNER RECTANGLE IN LIGHT BLUE AND THE OUTER RECTANGLE ROTATED TO LOOK DIAMOND-SHAPED IN DARK BLUE.

FOR MACHINES FOR MANUFACTURING PHOTO-VOLTAIC MODULES; VACUUM PACKAGING MACHINES (U.S. CLS. 13, 19, 21, 23, 31, 34 AND 35).

WILLIAM VERHOSEK, EXAMINING ATTORNEY

SN 79-085,165. CAPELLO S.R.L., ITALY, FILED 7-2-2010.



SN 79-083,512. PHILIPPE STARCK, PARIS, FRANCE, FILED 5-11-2010.

**DEMOCRATIC ECOLOGY BY STARCK**

THE MARK CONSISTS OF STANDARD CHARACTERS WITHOUT CLAIM TO ANY PARTICULAR FONT, STYLE, SIZE, OR COLOR.

OWNER OF INTERNATIONAL REGISTRATION 1041338 DATED 5-11-2010, EXPIRES 5-11-2020.

NO CLAIM IS MADE TO THE EXCLUSIVE RIGHT TO USE "ECOLOGY", APART FROM THE MARK AS SHOWN.

FOR WIND TURBINES (U.S. CLS. 13, 19, 21, 23, 31, 34 AND 35).

JAMES STEIN, EXAMINING ATTORNEY

OWNER OF INTERNATIONAL REGISTRATION 0871481 DATED 9-28-2005, EXPIRES 9-28-2015.

THE MARK CONSIST OF THE WORD "CAPELLO" IN FANCY LOWERCASE CHARACTERS; ABOVE IT THERE IS AN AGRICULTURAL MACHINE, A CORN EAR AND A WHEAT HEAD, ALL STYLIZED AND DEPICTED WITHIN A SQUARE FRAME.

THE WORDING "CAPELLO" HAS NO MEANING IN A FOREIGN LANGUAGE.

FOR CUTTING HEADS AND PLATFORMS FOR COMBINED REAPERS AND THRESHERS, AND THEIR PARTS AND ACCESSORIES, NAMELY, TRANSMISSION GEARS, TRANSMISSION SHAFTS, AND TRANSMISSION SETS COMPRISED OF HYDRAULIC PUMPS AND CLUTCHES (U.S. CLS. 13, 19, 21, 23, 31, 34 AND 35).

DOUGLAS LEE, EXAMINING ATTORNEY

**CLASS 7—(Continued).**

SN 79-085,917. CALLIDUS INVESTMENTS B.V., NETHERLANDS, FILED 3-12-2010.

# CALLIDUS

THE MARK CONSISTS OF STANDARD CHARACTERS WITHOUT CLAIM TO ANY PARTICULAR FONT, STYLE, SIZE, OR COLOR.

OWNER OF INTERNATIONAL REGISTRATION 1047246 DATED 3-12-2010, EXPIRES 3-12-2020.

FOR ELEVATORS AND PARTS OF ELEVATORS; HANDLING SYSTEMS, NAMELY, MECHANICAL AND PNEUMATIC HOISTING APPARATUS; HYDRAULIC PUMPS MOVING STAIRCASES, NAMELY, ESCALATORS; INDUSTRIAL MACHINES, NAMELY, DRILLING MACHINES USED IN THE OIL AND GAS FIELDS; OFFSHORE INDUSTRIAL OIL ELECTRIC WELDING MACHINES AND GAS WELDING MACHINES; FUEL INJECTORS, HYDRAULIC TORQUE CONVERTERS; MACHINES, NAMELY, HYDRAULIC POWER GENERATORS; OIL FIELD EQUIPMENT, NAMELY, DRILLING RIG MECHANICAL HANDLING MACHINES AND DEVICES; CLEANING MACHINES FOR MACHINES FOR CREATING CHEMICAL PREPARATIONS (U.S. CLS. 13, 19, 21, 23, 31, 34 AND 35).

ANDRÉA K. NADELMAN, EXAMINING ATTORNEY

**CLASS 7—(Continued).**

SN 79-088,446. J.C.BAMFORD EXCAVATORS LIMITED, UNITED KINGDOM, FILED 9-22-2010.



PRIORITY DATE OF 4-1-2010 IS CLAIMED.  
OWNER OF INTERNATIONAL REGISTRATION 1054224 DATED 9-22-2010, EXPIRES 9-22-2020.

THE MARK CONSISTS OF THE STYLIZED WORDING "ECOROAD" INSIDE A SHADED RECTANGLE.

FOR POWER OPERATED MACHINES AND APPARATUS FOR DIGGING, EXCAVATING, MECHANICAL HANDLING, LIFTING, LOADING AND TRANSPORTING OF EARTH, MINERALS, SOIL, CROPS AND OF LIKE MATERIALS, NAMELY, AGRICULTURAL MACHINES, NAMELY, TELESCOPIC HANDLERS AND WHEELED LOADERS; EARTHMOVING MACHINES, NAMELY, LOADERS, BACKHOES, AND EXCAVATORS; POWER-OPERATED LIFTING AND MOVING EQUIPMENT, NAMELY, FORKLIFTS AND TELEHANDLERS; FRONT END LOADERS; SKID-STEER LOADERS; ASPHALT PAVING MACHINES, NAMELY, ASPHALT ROLLERS; COMPACTING AND VIBRATING MACHINES AND EQUIPMENT, NAMELY, EARTH-COMPACTING MACHINES, INCLUDING VIBRATORY PLATE COMPACTORS; ROAD ROLLERS USED WITH ASPHALT PAVING; ASPHALT AND CONCRETE CUTTING MACHINES; PARTS AND FITTINGS INCLUDED IN THIS CLASS FOR ALL THE AFORESAID GOODS (U.S. CLS. 13, 19, 21, 23, 31, 34 AND 35).

SCOTT BIBB, EXAMINING ATTORNEY

SN 79-088,165. PIAB AB, SWEDEN, FILED 9-9-2010.

# piGRIP

THE MARK CONSISTS OF STANDARD CHARACTERS WITHOUT CLAIM TO ANY PARTICULAR FONT, STYLE, SIZE, OR COLOR.

PRIORITY DATE OF 3-11-2010 IS CLAIMED.  
OWNER OF INTERNATIONAL REGISTRATION 1053392 DATED 9-9-2010, EXPIRES 9-9-2020.

FOR MACHINE PARTS, NAMELY, SUCTION CUPS FOR LIFTING DEVICES (U.S. CLS. 13, 19, 21, 23, 31, 34 AND 35).

JILL C. ALT, EXAMINING ATTORNEY

SN 79-089,560. EPU PTY LTD, AUSTRALIA, FILED 10-13-2010.

# ENABLER

THE MARK CONSISTS OF STANDARD CHARACTERS WITHOUT CLAIM TO ANY PARTICULAR FONT, STYLE, SIZE, OR COLOR.

PRIORITY DATE OF 4-13-2010 IS CLAIMED.  
OWNER OF INTERNATIONAL REGISTRATION 1057145 DATED 10-13-2010, EXPIRES 10-13-2020.

FOR ENGINE EXHAUST SYSTEM COMPONENTS, NAMELY, AUTOMOTIVE EXHAUST PIPE, EXHAUST PIPES FOR LAND VEHICLES, EXHAUST MUFFLERS FOR MOTORS, AND ENGINE EXHAUST SYSTEMS COMPRISED OF PIPES, COLLECTOR AND MUFFLER (U.S. CLS. 13, 19, 21, 23, 31, 34 AND 35).

LINDA MICKLEBURGH, EXAMINING ATTORNEY

**CLASS 7—(Continued).**

SN 85-036,520. STANLEY FILTER COMPANY, LLC, TULSA, OK. FILED 5-12-2010.



OWNER OF U.S. REG. NO. 1,659,433.

NO CLAIM IS MADE TO THE EXCLUSIVE RIGHT TO USE "FILTER" AND "OILMEN", APART FROM THE MARK AS SHOWN.

THE MARK CONSISTS OF A GLOBE IMAGE ENCLOSED IN A DOUBLE CIRCLE WITH "BY OILMEN" ON TOP AND "FOR OILMEN" ON BOTTOM WITH "STANLEY FILTER" INSIDE AN ARROW AFFIXED ON TOP ACROSS THE CENTER.

FOR FIBERGLASS FILTERS FOR DOWNHOLE SAND FILTRATION AND GAS SEPARATION MACHINES FOR USE IN THE OIL AND GAS INDUSTRY (U.S. CLS. 13, 19, 21, 23, 31, 34 AND 35).

FIRST USE 7-0-2005; IN COMMERCE 7-0-2005.  
ALYSSA STEEL, EXAMINING ATTORNEY

SN 85-041,268. AMCOL INTERNATIONAL CORPORATION, HOFFMAN ESTATES, IL. FILED 5-18-2010.

# MANTA

THE MARK CONSISTS OF STANDARD CHARACTERS WITHOUT CLAIM TO ANY PARTICULAR FONT, STYLE, SIZE, OR COLOR.

FOR EQUIPMENT USED IN WATER TREATMENT, NAMELY, MACHINES IN THE NATURE OF INDUSTRIAL MIXERS USED FOR MIXING OF CHEMICALS IN THE INITIAL STAGES OF A WATER TREATMENT PROCESS (U.S. CLS. 13, 19, 21, 23, 31, 34 AND 35).

CHARLES L. JENKINS, EXAMINING ATTORNEY

SN 85-060,661. MIN, WEIXING, KALEEN ACT 2618, AUSTRALIA, FILED 6-11-2010.

# P'TRACK

THE MARK CONSISTS OF STANDARD CHARACTERS WITHOUT CLAIM TO ANY PARTICULAR FONT, STYLE, SIZE, OR COLOR.

FOR MACHINE PARTS, NAMELY, RUBBER TRACKS BEING PARTS FOR EXCAVATORS AND TRACK DRIVEN LOADERS (U.S. CLS. 13, 19, 21, 23, 31, 34 AND 35).

FIRST USE 2-1-2011; IN COMMERCE 2-1-2011.  
MARLENE BELL, EXAMINING ATTORNEY

**CLASS 7—(Continued).**

SN 85-077,279. GREAT TOP TECHNOLOGY CO., LTD., KAOHSIUNG COUNTY, TAIWAN, FILED 7-2-2010.

THE MARK CONSISTS OF TWO JAPANESE CHARACTERS OVER THE WORD "LAKUMA".

THE ENGLISH TRANSLATION OF "LAKUMA" IN THE MARK IS "HAPPY HORSE".

THE NON-LATIN CHARACTERS IN THE MARK TRANSLITERATE TO "LAKUMA" AND THIS MEANS HAPPY HORSE IN ENGLISH.

FOR AGRICULTURAL MACHINES, NAMELY, CULTIVATORS, SEEDERS, RICE CUTTING MACHINES, SOWERS, HAULING MACHINES FOR FARMING, FERTILIZER SPREADERS; WOOD CHIPPING MACHINES; WOOD DRILLING MACHINES; WOOD SAWING MACHINES; FRUIT CLASSIFICATION MACHINES; MOTORS FOR VEHICLE ELECTRIC WINDOW CONTROL; DIRECT CURRENT GENERATORS; ELECTRIC GENERATORS; ELECTRIC MOTORS FOR MACHINES (U.S. CLS. 13, 19, 21, 23, 31, 34 AND 35).

LAURIE KAUFMAN, EXAMINING ATTORNEY

SN 85-079,398. MOTO TASSINARI, INC., WEST LEBANON, NH. FILED 7-7-2010.



THE MARK CONSISTS OF TWO STRAIGHT BARS THAT ARE NEARLY VERTICAL WITH THE BOTTOM ENDS OF THE BARS CLOSER TO EACH OTHER THAN THE TOP ENDS AND A THIRD BAR NEARLY HORIZONTAL, WITH A BEND IN THE MIDDLE SO THAT THE MIDDLE IS HIGHER THAN THE ENDS, PLACED ABOVE THE TWO NEARLY VERTICAL BARS.

FOR MOTORCYCLE PARTS, NAMELY, PARTS THAT MAKE THE MOTOR RUN MORE EFFICIENTLY IN THE NATURE OF REED VALVES AND INTAKE BOOTS WITH INTERCHANGEABLE VELOCITY STACKS FOR MOTORS (U.S. CLS. 13, 19, 21, 23, 31, 34 AND 35).

PRISCILLA MILTON, EXAMINING ATTORNEY

**CLASS 7—(Continued).**

SN 85-081,075. MITSUBISHI PAPER MILLS LIMITED, TOKYO, JAPAN, FILED 7-9-2010.

# IDP

THE MARK CONSISTS OF STANDARD CHARACTERS WITHOUT CLAIM TO ANY PARTICULAR FONT, STYLE, SIZE, OR COLOR.

OWNER OF JAPAN REG. NO. 5377428, DATED 12-17-2010, EXPIRES 12-17-2020.

FOR PRINTING PLATEMAKING MACHINES AND PARTS THEREFOR; PRINTING PLATES (U.S. CLS. 13, 19, 21, 23, 31, 34 AND 35).

JOSETTE BEVERLY, EXAMINING ATTORNEY

**CLASS 7—(Continued).**

SN 85-096,475. HORIZON INTERNATIONAL INC., SHIGA, JAPAN, FILED 7-30-2010.

# StitchLiner

THE MARK CONSISTS OF STANDARD CHARACTERS WITHOUT CLAIM TO ANY PARTICULAR FONT, STYLE, SIZE, OR COLOR.

SEC. 2(F).

FOR APPARATUS, MACHINES AND MACHINE TOOLS FOR USE IN THE PRINTING AND PUBLISHING INDUSTRY, ALL FOR HANDLING AND BINDING PAPER SHEETS TO FORM BOOKS AND BOOKLETS, NAMELY, MACHINES FOR GATHERING, BINDING AND JOGGING, COLLATING, SCORING, FOLDING, STAPLING, AND TRIMMING PAPER SHEETS, AND FOR CONVEYING BOOKS AND BOOKLETS, AND REPLACEMENT PARTS FOR THE AFOREMENTIONED APPARATUS, MACHINES, AND MACHINE TOOLS (U.S. CLS. 13, 19, 21, 23, 31, 34 AND 35).

FIRST USE 4-30-2002; IN COMMERCE 3-8-2004.

YAT SYE, LEE, EXAMINING ATTORNEY

SN 85-098,337. EATON CORPORATION, CLEVELAND, OH, FILED 8-2-2010.

# DURAFORCE

THE MARK CONSISTS OF STANDARD CHARACTERS WITHOUT CLAIM TO ANY PARTICULAR FONT, STYLE, SIZE, OR COLOR.

FOR HYDRAULIC PUMPS AND HYDRAULIC MOTORS FOR MACHINES (U.S. CLS. 13, 19, 21, 23, 31, 34 AND 35).

LINDSEY RUBIN, EXAMINING ATTORNEY

SN 85-099,012. BSH BOSCH UND SIEMENS HAUSGERAETE GMBH, MUNICH, FED REP GERMANY, FILED 8-3-2010.

# SilencePlus

THE MARK CONSISTS OF STANDARD CHARACTERS WITHOUT CLAIM TO ANY PARTICULAR FONT, STYLE, SIZE, OR COLOR.

PRIORITY CLAIMED UNDER SEC. 44(D) ON ERPNTY TM OFC APPLICATION NO. 008874778, FILED 2-11-2010, REG. NO. 008874778, DATED 8-2-2010, EXPIRES 2-11-2020.

OWNER OF U.S. REG. NO. 3,180,180.

FOR HOUSEHOLD AND KITCHEN MACHINES AND EQUIPMENT, NAMELY, DISHWASHERS; STRUCTURAL PARTS OF ALL AFOREMENTIONED GOODS (U.S. CLS. 13, 19, 21, 23, 31, 34 AND 35).

THOMAS MANOR, EXAMINING ATTORNEY

SN 85-090,864. I & J FISNAR, INC., WAYNE, NJ, FILED 7-22-2010.

# QUANTX

THE MARK CONSISTS OF STANDARD CHARACTERS WITHOUT CLAIM TO ANY PARTICULAR FONT, STYLE, SIZE, OR COLOR.

FOR AUTOMATIC LIQUID DISPENSING MACHINES FOR USE IN INDUSTRIAL APPLICATIONS SUCH AS ADHESIVE, GLUE, CYANOACRYLATES, SILICONE, RTV, ANAEROBIC RESIN, EPOXY, UV CURE FORMULATIONS AND MANY MORE FLUIDS, COMPRISING AUTOMATIC DISPENSING MACHINES, ARTICULATED ARM GUIDES, VACUUM PICK-UP PENS, STORAGE STRANDS, ADAPTERS, DISPENSING TIPS, CARTRIDGES, BARREL LOADERS, BARREL STORAGE CAPS, BARREL ADAPTERS, BARREL PISTONS, BARREL TIP CAPS, BARREL FINGER SWITCHES, CLEAN ROOM FILTERS AND MUFFLERS; DISPENSING PUMP CONTROL VALVES; INDUSTRIAL ROBOTS; PERISTALTIC PUMPS FOR MACHINES; MACHINE PARTS, NAMELY, NOZZLES WHICH ARE PARTS OF POWER-OPERATED SPRAYERS; SYRINGES SPECIALLY DESIGNED FOR USE WITH AUTOMATED LIQUID DISPENSING MACHINES; AND INDUSTRIAL ROBOTS COMPRISED OF 4 AXES TABLETOP, GANTRY AND SCARA ASSEMBLY; TWO PART METER AND MIXING MACHINES; INDUSTRIAL HOT MELT GLUE GUNS (U.S. CLS. 13, 19, 21, 23, 31, 34 AND 35).

LINDA M. KING, EXAMINING ATTORNEY

**CLASS 7—(Continued).**

SN 85-118,782. WILLIAM P. NUGENT CO., INC., PLYMOUTH, MN. FILED 8-30-2010.

# POSI-LINK

THE MARK CONSISTS OF STANDARD CHARACTERS WITHOUT CLAIM TO ANY PARTICULAR FONT, STYLE, SIZE, OR COLOR.

FOR MACHINE PARTS, NAMELY, COMPONENTS FOR USE IN FLUID CONTROL SYSTEMS, NAMELY, PLUG AND SOCKET CONNECTORS (U.S. CLS. 13, 19, 21, 23, 31, 34 AND 35).

PAUL MORENO, EXAMINING ATTORNEY

SN 85-126,958. H. BARBER & SONS, INC., NAUGATUCK, CT. FILED 9-10-2010.

# SAND MAN

THE MARK CONSISTS OF STANDARD CHARACTERS WITHOUT CLAIM TO ANY PARTICULAR FONT, STYLE, SIZE, OR COLOR.

NO CLAIM IS MADE TO THE EXCLUSIVE RIGHT TO USE "SAND", APART FROM THE MARK AS SHOWN.

FOR A SELF-PROPELLED, WALK-BEHIND SAND CLEANER THAT REMOVES STONES AND OTHER DEBRIS FROM SANDY SURFACES (U.S. CLS. 13, 19, 21, 23, 31, 34 AND 35).

FIRST USE 1-1-1998; IN COMMERCE 1-1-1998.

JEFF DEFORD, EXAMINING ATTORNEY

SN 85-134,737. ISTART PARTNERS, LTD., GRANBURY, TX. FILED 9-21-2010.

# iStart

THE MARK CONSISTS OF STANDARD CHARACTERS WITHOUT CLAIM TO ANY PARTICULAR FONT, STYLE, SIZE, OR COLOR.

FOR STARTERS FOR MOTORS AND ENGINES USED IN AIRCRAFT (U.S. CLS. 13, 19, 21, 23, 31, 34 AND 35).

FIRST USE 7-26-2010; IN COMMERCE 7-26-2010.

GINA FINK, EXAMINING ATTORNEY

**CLASS 7—(Continued).**

SN 85-149,904. ADANCED RAIL CONCEPTS, LLC, SNOHOMISH, WA. FILED 10-11-2010.



THE MARK CONSISTS OF STYLIZED LETTERS "ARC" OVER A STYLIZED REPRESENTATION OF A CURVED TRAIN TRACK.

FOR MACHINES AND APPARATUS FOR USE IN THE CONSTRUCTION, LOGGING, ROAD AND RAIL INDUSTRIES, NAMELY, TRACK MOUNTED RAIL EXCAVATORS AND STRUCTURAL PARTS AND FITTINGS THEREOF (U.S. CLS. 13, 19, 21, 23, 31, 34 AND 35).

FIRST USE 6-26-2009; IN COMMERCE 4-26-2010.

WILLIAM ROSSMAN, EXAMINING ATTORNEY

SN 85-151,240. MATERIAL HANDLING TECHNOLOGIES, INC., MORRISVILLE, NC. FILED 10-13-2010.

# STEALTHZONE

THE MARK CONSISTS OF STANDARD CHARACTERS WITHOUT CLAIM TO ANY PARTICULAR FONT, STYLE, SIZE, OR COLOR.

FOR CONVEYOR SYSTEMS, NAMELY, DC ZONED CONVEYORS THAT EACH HAVE A 24 VOLT DC POWERED ROLLER, A CONTROL CARD, AND A PHOTO EYE (U.S. CLS. 13, 19, 21, 23, 31, 34 AND 35).

FIRST USE 1-0-2005; IN COMMERCE 1-0-2005.

KAREN K. BUSH, EXAMINING ATTORNEY

SN 85-153,393. ELECTROLUX HOME PRODUCTS, INC., CHARLOTTE, NC. FILED 10-15-2010.

# IMMERSIONCARE

THE MARK CONSISTS OF STANDARD CHARACTERS WITHOUT CLAIM TO ANY PARTICULAR FONT, STYLE, SIZE, OR COLOR.

FOR WASH SYSTEM, NAMELY, VARIABLE SPEED WASH SYSTEM COMPRISED OF A VARIABLE SPEED MOTOR, PULLEY AND FLYWHEEL DRIVE SYSTEM AND SOLD AS AN INTEGRAL COMPONENT OF CLOTHES WASHERS (U.S. CLS. 13, 19, 21, 23, 31, 34 AND 35).

BRENDAN MCCAULEY, EXAMINING ATTORNEY

**CLASS 7—(Continued).**

SN 85-159,498. RME, INC, TIJERAS, NM. FILED 10-22-2010.

**Personal Power Plant**

THE MARK CONSISTS OF STANDARD CHARACTERS WITHOUT CLAIM TO ANY PARTICULAR FONT, STYLE, SIZE, OR COLOR.

NO CLAIM IS MADE TO THE EXCLUSIVE RIGHT TO USE "POWER", APART FROM THE MARK AS SHOWN.

FOR A MULTI SOURCE RENEWABLE ENERGY GENERATOR (U.S. CLS. 13, 19, 21, 23, 31, 34 AND 35).

HEATHER SAPP, EXAMINING ATTORNEY

**CLASS 7—(Continued).**

SN 85-186,336. TECH RIM STANDARDS LLC, AUBURN HILLS, MI. FILED 11-29-2010.

**TECH-PIVOT 80**

THE MARK CONSISTS OF STANDARD CHARACTERS WITHOUT CLAIM TO ANY PARTICULAR FONT, STYLE, SIZE, OR COLOR.

NO CLAIM IS MADE TO THE EXCLUSIVE RIGHT TO USE "80", APART FROM THE MARK AS SHOWN.

FOR AIR-OPERATED POWER TOOLS, NAMELY, STRUCTURAL COMPONENTS OF COMPRESSED AIR MACHINES FOR DUMPING MACHINE TOOLS INTO AUTOMATED ASSEMBLY LINES (U.S. CLS. 13, 19, 21, 23, 31, 34 AND 35).

DAVID YONTEF, EXAMINING ATTORNEY

SN 85-171,623. PLASTIFLEX CANADA INC., ORANGEVILLE, ONTARIO, CANADA, FILED 11-8-2010.

**VACSOC**

THE MARK CONSISTS OF STANDARD CHARACTERS WITHOUT CLAIM TO ANY PARTICULAR FONT, STYLE, SIZE, OR COLOR.

FOR FABRIC SLEEVES SPECIALLY FITTED FOR USE WITH VACUUM CLEANER HOSES (U.S. CLS. 13, 19, 21, 23, 31, 34 AND 35).

FIRST USE 3-0-2004; IN COMMERCE 3-0-2004.

ELISSA GARBER KON, EXAMINING ATTORNEY

SN 85-188,434. ACCUSTREAM, INC., NEW BRIGHTON, MN. FILED 12-1-2010.

SN 85-178,719. MICRO JIG, WINTER SPRINGS, FL. FILED 11-17-2010.

**3D Pushblock**

THE MARK CONSISTS OF STANDARD CHARACTERS WITHOUT CLAIM TO ANY PARTICULAR FONT, STYLE, SIZE, OR COLOR.

NO CLAIM IS MADE TO THE EXCLUSIVE RIGHT TO USE "PUSHBLOCK", APART FROM THE MARK AS SHOWN.

FOR SAFETY DEVICES FOR WOODWORKING TOOLS, NAMELY, PUSHING DEVICE FOR FEEDING MATERIAL ON TABLE SAWS AND JIGS SPECIALLY ADAPTED FOR USE WITH POWER WOODWORKING TOOLS SUCH AS TABLE SAWS, JOINTERS, BAND SAWS, AND ROUTER TABLES (U.S. CLS. 13, 19, 21, 23, 31, 34 AND 35).

FIRST USE 9-1-2010; IN COMMERCE 10-1-2010.

JEFFREY LOOK, EXAMINING ATTORNEY

**DIALINE**

THE MARK CONSISTS OF STANDARD CHARACTERS WITHOUT CLAIM TO ANY PARTICULAR FONT, STYLE, SIZE, OR COLOR.

FOR MACHINE TOOL PARTS, NAMELY, CUTTING HEADS FOR FLUID JET CUTTING MACHINE TOOLS AND STRUCTURAL PARTS OF SUCH CUTTING HEADS (U.S. CLS. 13, 19, 21, 23, 31, 34 AND 35).

FIRST USE 1-1-2009; IN COMMERCE 1-1-2009.

LINDA LAVACHE, EXAMINING ATTORNEY



**CLASS 7—(Continued).**

SN 85-192,201. LARRYJ. RIGGS, PLACENTIA, CA. FILED 12-7-2010.



NO CLAIM IS MADE TO THE EXCLUSIVE RIGHT TO USE "EXHAUST SYSTEMS", APART FROM THE MARK AS SHOWN.

THE MARK CONSISTS OF THE STYLIZED WORDS "BIG GUN EXHAUST SYSTEMS" APPEARING ON A RECTANGULAR BACKGROUND.

FOR ENGINE EXHAUST SYSTEMS COMPRISED OF PIPES, COLLECTOR AND MUFFLER (U.S. CLS. 13, 19, 21, 23, 31, 34 AND 35).

FIRST USE 11-28-1997; IN COMMERCE 11-28-1997.  
KATHERINE CONNOLLY, EXAMINING ATTORNEY

SN 85-194,719. THE POMO GROUP, LLC, NEW YORK, NY. FILED 12-9-2010.

# Pomo Qui

THE MARK CONSISTS OF STANDARD CHARACTERS WITHOUT CLAIM TO ANY PARTICULAR FONT, STYLE, SIZE, OR COLOR.

THE ENGLISH TRANSLATION OF "QUI" IN THE MARK IS "HERE".

FOR ELECTRIC MACHINES FOR MAKING PASTA (U.S. CLS. 13, 19, 21, 23, 31, 34 AND 35).

CHARLES L. JENKINS, EXAMINING ATTORNEY

SN 85-195,050. PETTER INVESTMENTS, INC., SOUTH HAVEN, MI. FILED 12-10-2010.

# TAWS

THE MARK CONSISTS OF STANDARD CHARACTERS WITHOUT CLAIM TO ANY PARTICULAR FONT, STYLE, SIZE, OR COLOR.

FOR SELF CONTAINED HIGH PRESSURE WASHING SYSTEM FOR USE ON AIRCRAFT (U.S. CLS. 13, 19, 21, 23, 31, 34 AND 35).

FIRST USE 8-0-2010; IN COMMERCE 8-0-2010.  
RAUL CORDOVA, EXAMINING ATTORNEY

**CLASS 7—(Continued).**

SN 85-199,459. UMAGINATION LABS, LLC, NEWTON, MA. FILED 12-16-2010.

# GUTTER RAT

THE MARK CONSISTS OF STANDARD CHARACTERS WITHOUT CLAIM TO ANY PARTICULAR FONT, STYLE, SIZE, OR COLOR.

NO CLAIM IS MADE TO THE EXCLUSIVE RIGHT TO USE "GUTTER", APART FROM THE MARK AS SHOWN.

FOR POWER TOOLS, NAMELY, AUTOMATED DEVICES FOR CLEARING DEBRIS AND DIRT FROM DRAINAGE CHANNELS FOUND ON BUILDINGS AND WALKWAYS (U.S. CLS. 13, 19, 21, 23, 31, 34 AND 35).

GENE MACIOL, EXAMINING ATTORNEY

SN 85-201,936. GENERAL ELECTRIC COMPANY, SCHECTADY, NY. FILED 12-20-2010.

# FLEXEFFICIENT

THE MARK CONSISTS OF STANDARD CHARACTERS WITHOUT CLAIM TO ANY PARTICULAR FONT, STYLE, SIZE, OR COLOR.

FOR GAS TURBINES NOT FOR LAND VEHICLES (U.S. CLS. 13, 19, 21, 23, 31, 34 AND 35).

PAUL F. GAST, EXAMINING ATTORNEY

SN 85-203,507. ENVISION ENERGY (JIANGYIN) CO., LTD., JIANGSU PROVINCE, CHINA, FILED 12-22-2010.



THE MARK CONSISTS OF THE WORD "ENVISION" AND THREE WAVY BANDS FORMING A BALL-SHAPED DEVICE ON THE LEFT.

FOR AC GENERATORS; ELECTRIC GENERATORS; ELECTRIC GENERATORS AND RELATED EQUIPMENT, NAMELY, AUTOMATIC STANDBY ELECTRIC GENERATOR SETS; GENERATORS FOR WIND TURBINES; HIGH-VOLTAGE GENERATORS; PARTS OF WIND TURBINE MOTORS, NAMELY, COMPACT DRIVE SYSTEMS; PORTABLE ELECTRIC POWER GENERATORS; PROPELLERS FOR WIND-POWERED ELECTRICITY GENERATORS; WIND TURBINES; WIND-POWERED ELECTRICITY GENERATORS (U.S. CLS. 13, 19, 21, 23, 31, 34 AND 35).

FIRST USE 7-13-2008; IN COMMERCE 8-1-2008.  
TIMOTHY FINNEGAN, EXAMINING ATTORNEY

**CLASS 7—(Continued).**

SN 85-203,654. K-TEC, INC., OREM, UT. FILED 12-22-2010.



THE MARK CONSISTS OF A SWIRL DESIGN.  
FOR ELECTRIC FOOD BLENDERS FOR USE IN THE  
FIELD OF FOOD AND DRINK PREPARATION (U.S.  
CLS. 13, 19, 21, 23, 31, 34 AND 35).  
ELI HELLMAN, EXAMINING ATTORNEY

**CLASS 7—(Continued).**

SN 85-203,837. PSK INC., GYEONGGI-DO, REPUBLIC OF KOREA, FILED 12-22-2010.

# EVOSYS

THE MARK CONSISTS OF STANDARD CHARACTERS  
WITHOUT CLAIM TO ANY PARTICULAR FONT, STYLE,  
SIZE, OR COLOR.

PRIORITY CLAIMED UNDER SEC. 44(D) ON REPUBLIC  
OF KOREA APPLICATION NO. 40-2010-0060, FILED 11-25-  
2010.

FOR SEMICONDUCTOR WAFER PROCESSING MA-  
CHINES; ETCHING MACHINES USED FOR MANUFAC-  
TURING SEMICONDUCTOR WAFERS; ASHING  
MACHINES USED FOR MANUFACTURING SEMICON-  
DUCTOR WAFERS; CLEANING MACHINES USED FOR  
MANUFACTURING SEMICONDUCTOR WAFERS (U.S.  
CLS. 13, 19, 21, 23, 31, 34 AND 35).

CARYN GLASSER, EXAMINING ATTORNEY

---

SN 85-203,829. PSK INC., GYEONGGI-DO, REPUBLIC OF  
KOREA, FILED 12-22-2010.

---

SN 85-204,044. WANG, FRANCES, TAICHUNG CITY, TAI-  
WAN, FILED 12-22-2010.

# EVOLITE

# InnoServ

THE MARK CONSISTS OF STANDARD CHARACTERS  
WITHOUT CLAIM TO ANY PARTICULAR FONT, STYLE,  
SIZE, OR COLOR.

PRIORITY CLAIMED UNDER SEC. 44(D) ON REPUBLIC  
OF KOREA APPLICATION NO. 40-2010-0060, FILED 11-25-  
2010.

FOR SEMICONDUCTOR WAFER PROCESSING MA-  
CHINES; ETCHING MACHINES USED FOR MANUFAC-  
TURING SEMICONDUCTOR WAFERS; ASHING  
MACHINES USED FOR MANUFACTURING SEMICON-  
DUCTOR WAFERS; CLEANING MACHINES USED FOR  
MANUFACTURING SEMICONDUCTOR WAFERS (U.S.  
CLS. 13, 19, 21, 23, 31, 34 AND 35).

CARYN GLASSER, EXAMINING ATTORNEY

THE MARK CONSISTS OF STANDARD CHARACTERS  
WITHOUT CLAIM TO ANY PARTICULAR FONT, STYLE,  
SIZE, OR COLOR.

FOR AUTOMATIC PART REMOVING MACHINES  
FOR OPTICAL AND ELECTRONIC PARTS, AUTO-  
MATIC PART INSERTERS FOR OPTICAL AND ELEC-  
TRONIC PARTS, AUTOMATIC FILLING MACHINES  
FOR OPTICAL AND ELECTRONIC PARTS, FILM COAT-  
ING MACHINES FOR OPTICAL AND ELECTRONIC  
PARTS, OPTICAL LENS CUTTING MACHINES, OPTI-  
CAL PARTS ASSEMBLY MACHINES, ALIGNING AND  
STEERING MACHINES FOR OPTICAL AND ELECTRO-  
NIC PARTS, TERMINAL CRIMPING MACHINES, OR-  
IENTATING MACHINES FOR OPTICAL AND  
ELECTRONIC PARTS, LIGHT GUIDE PLATE CUTTING  
MACHINES, PRINTED CIRCUIT BOARD DRILLING  
MACHINES, ROBOTIC ARMS FOR INDUSTRIAL PUR-  
POSES (U.S. CLS. 13, 19, 21, 23, 31, 34 AND 35).

RONALD AIKENS, EXAMINING ATTORNEY

**CLASS 7—(Continued).**

SN 85-205,046. SHUN CHUAN MACHINERY IND. CO., LTD., MAOLI COUNTY 358, TAIWAN, FILED 12-23-2010.



THE MARK CONSISTS OF THE LETTER "V" IN A TRIANGLE, THE WORDS "SUN MASTER" WITH A DOT IN THE "U", THE "U" AND "N" ARE CONNECTED, AND THE "T" STRETCHED OVER THE LETTERS "SUN MAS" AND "ER".

FOR LATHES; METAL WORKING MACHINES; MILLING MACHINES; DRILLING MACHINES; GRINDING MACHINES; METAL EXTRUSION PRESSES; MILLING CUTTERS; CUTTING MACHINES; WOODWORKING MACHINES, NAMELY, LATHES (U.S. CLS. 13, 19, 21, 23, 31, 34 AND 35).

FIRST USE 4-15-2008; IN COMMERCE 4-15-2008.  
SUSAN STIGLITZ, EXAMINING ATTORNEY

SN 85-205,417. BALBOA WATER GROUP, INC., TUSTIN, CA. FILED 12-23-2010.

WOW

THE MARK CONSISTS OF STANDARD CHARACTERS WITHOUT CLAIM TO ANY PARTICULAR FONT, STYLE, SIZE, OR COLOR.

FOR ELECTRICAL WATER PUMPS FOR SPAS AND WHIRLPOOLS (U.S. CLS. 13, 19, 21, 23, 31, 34 AND 35).

FIRST USE 12-0-1998; IN COMMERCE 12-0-1998.  
AISHA SALEM, EXAMINING ATTORNEY

SN 85-205,924. HERRAMIENTAS PREZISS, S.A., MONTGAT, BARCELONA, SPAIN, FILED 12-27-2010.

DYNAX

THE MARK CONSISTS OF STANDARD CHARACTERS WITHOUT CLAIM TO ANY PARTICULAR FONT, STYLE, SIZE, OR COLOR.

OWNER OF U.S. REG. NO. 2,993,753.  
FOR ROUTER BITS (U.S. CLS. 13, 19, 21, 23, 31, 34 AND 35).

FIRST USE 2-1-1994; IN COMMERCE 7-4-1997.  
ELLEN PERKINS, EXAMINING ATTORNEY

**CLASS 7—(Continued).**

SN 85-206,099. YUNN CHAANG HAULAGE MECHANICAL CO. LTD., KAOHSIUNG CITY, TAIWAN, FILED 12-27-2010.

CPW

THE MARK CONSISTS OF STANDARD CHARACTERS WITHOUT CLAIM TO ANY PARTICULAR FONT, STYLE, SIZE, OR COLOR.

FOR HYDRAULIC PUMPS; WATER PUMPS FOR LAND VEHICLES (U.S. CLS. 13, 19, 21, 23, 31, 34 AND 35).

FIRST USE 6-15-2006; IN COMMERCE 6-15-2006.  
KEVON CHISOLM, EXAMINING ATTORNEY

SN 85-207,426. EDGE CRAFT CORPORATION, AVONDALE, PA. FILED 12-29-2010.

SHARP STEEL-N-STROP

THE MARK CONSISTS OF STANDARD CHARACTERS WITHOUT CLAIM TO ANY PARTICULAR FONT, STYLE, SIZE, OR COLOR.

OWNER OF U.S. REG. NO. 2,984,370.  
SEC. 2(F).

FOR ELECTRIC SHARPENERS (U.S. CLS. 13, 19, 21, 23, 31, 34 AND 35).

FIRST USE 5-17-2005; IN COMMERCE 5-17-2005.  
KRISTIN CARLSON, EXAMINING ATTORNEY

SN 85-207,794. GREENE ENVIRONMENTAL CORPORATION, BOSTON, MA. FILED 12-30-2010.

GREEN YOUR RIDE

THE MARK CONSISTS OF STANDARD CHARACTERS WITHOUT CLAIM TO ANY PARTICULAR FONT, STYLE, SIZE, OR COLOR.

FOR EXHAUST FILTERS FOR MOTORS AND ENGINES (U.S. CLS. 13, 19, 21, 23, 31, 34 AND 35).

BRIAN NEVILLE, EXAMINING ATTORNEY

**CLASS 7—(Continued).**

SN 85-207,799. GREENE ENVIRONMENTAL CORPORATION, BOSTON, MA. FILED 12-30-2010.

**GREEN YOUR CAR**

THE MARK CONSISTS OF STANDARD CHARACTERS WITHOUT CLAIM TO ANY PARTICULAR FONT, STYLE, SIZE, OR COLOR.

FOR EXHAUST FILTERS FOR MOTORS AND ENGINES (U.S. CLS. 13, 19, 21, 23, 31, 34 AND 35).  
BRIAN NEVILLE, EXAMINING ATTORNEY

SN 85-207,997. HARMAR SUMMIT, LLC, LAKE WINNEBAGO, MO. FILED 12-30-2010.

**SIERRA**

THE MARK CONSISTS OF STANDARD CHARACTERS WITHOUT CLAIM TO ANY PARTICULAR FONT, STYLE, SIZE, OR COLOR.

FOR MATERIAL LIFTS, NAMELY LIFTS FOR TRANSPORTING GROCERIES AND OTHER MATERIALS BETWEEN FLOORS OR LEVELS OF A BUILDING (U.S. CLS. 13, 19, 21, 23, 31, 34 AND 35).

KATHERINE M. DUBRAY, EXAMINING ATTORNEY

SN 85-208,003. HARMAR SUMMIT, LLC, LAKE WINNEBAGO, MO. FILED 12-30-2010.

**HIGHLANDER**

THE MARK CONSISTS OF STANDARD CHARACTERS WITHOUT CLAIM TO ANY PARTICULAR FONT, STYLE, SIZE, OR COLOR.

FOR VERTICAL PLATFORM LIFTS (U.S. CLS. 13, 19, 21, 23, 31, 34 AND 35).

FIRST USE 8-1-2009; IN COMMERCE 8-1-2009.

KATHERINE M. DUBRAY, EXAMINING ATTORNEY

**CLASS 7—(Continued).**

SN 85-209,343. ACTIVEION CLEANING SOLUTIONS LLC, MINNEAPOLIS, MN. FILED 1-3-2011.

**ACTIVEION EXP**

THE MARK CONSISTS OF STANDARD CHARACTERS WITHOUT CLAIM TO ANY PARTICULAR FONT, STYLE, SIZE, OR COLOR.

OWNER OF U.S. REG. NOS. 3,842,362 AND 3,863,086.  
FOR MACHINES FOR CLEANING, SANITIZING, AND/OR DISINFECTING SURFACES USING WATER (U.S. CLS. 13, 19, 21, 23, 31, 34 AND 35).

DAVID TAYLOR, EXAMINING ATTORNEY

SN 85-209,626. KAMAK DYNAMICS USA GROUP, WEST COVINA, CA. FILED 1-4-2011.



THE MARK CONSISTS OF A CIRCLE OF SIX CURVE LINES FORMED A VORTEX.

FOR AUTOMOTIVE PARTS, NAMELY, TURBO CHARGER SYSTEMS (U.S. CLS. 13, 19, 21, 23, 31, 34 AND 35).

FIRST USE 6-1-2008; IN COMMERCE 11-1-2008.

JOHN SCHUYLER YARD, EXAMINING ATTORNEY

SN 85-209,979. PARSLAW, HAROLD W., WASHINGTON, MI. FILED 1-4-2011.

**POWER TOWER**

THE MARK CONSISTS OF STANDARD CHARACTERS WITHOUT CLAIM TO ANY PARTICULAR FONT, STYLE, SIZE, OR COLOR.

FOR AGRICULTURAL MACHINERY, NAMELY, POWER TOOL USED TO MOVE AGRICULTURAL STORAGE CONTAINERS (U.S. CLS. 13, 19, 21, 23, 31, 34 AND 35).

FIRST USE 12-20-2010; IN COMMERCE 12-20-2010.

MARIA-VICTORIA SUAREZ, EXAMINING ATTORNEY

**CLASS 7—(Continued).**

SN 85-210,533. COLORADO HOT ROD PARTS, FORT COLLINS, CO. FILED 1-5-2011.

**Real Street Ram**

THE MARK CONSISTS OF STANDARD CHARACTERS WITHOUT CLAIM TO ANY PARTICULAR FONT, STYLE, SIZE, OR COLOR.  
FOR AUTOMOTIVE INTAKE MANIFOLDS (U.S. CLS. 13, 19, 21, 23, 31, 34 AND 35).  
FLORENTINA BLANDU, EXAMINING ATTORNEY

**CLASS 7—(Continued).**

SN 85-211,132. VALLEY ROLLER COMPANY, INC., MANSFIELD, TX. FILED 1-5-2011.

**Valthane**

THE MARK CONSISTS OF STANDARD CHARACTERS WITHOUT CLAIM TO ANY PARTICULAR FONT, STYLE, SIZE, OR COLOR.  
FOR MACHINE PARTS, NAMELY, ROLLERS COATED WITH SYNTHETIC MATERIAL (U.S. CLS. 13, 19, 21, 23, 31, 34 AND 35).  
FIRST USE 1-1-1994; IN COMMERCE 1-1-1994.  
TINA L. SNAPP, EXAMINING ATTORNEY

SN 85-210,577. MANN, SAMUEL J., ENGLEWOOD, NJ. FILED 1-5-2011.

**SAILING WITH POWERBOAT  
CONVENIENCE**

THE MARK CONSISTS OF STANDARD CHARACTERS WITHOUT CLAIM TO ANY PARTICULAR FONT, STYLE, SIZE, OR COLOR.  
FOR WINCHES (U.S. CLS. 13, 19, 21, 23, 31, 34 AND 35).  
DANNEAN HETZEL, EXAMINING ATTORNEY

SN 85-211,152. VALLEY ROLLER COMPANY, INC., MANSFIELD, TX. FILED 1-5-2011.

**Val-Coat**

THE MARK CONSISTS OF STANDARD CHARACTERS WITHOUT CLAIM TO ANY PARTICULAR FONT, STYLE, SIZE, OR COLOR.  
FOR MACHINE PARTS, NAMELY, ROLLERS COATED WITH SYNTHETIC MATERIAL (U.S. CLS. 13, 19, 21, 23, 31, 34 AND 35).  
FIRST USE 1-1-1995; IN COMMERCE 1-1-1995.  
TINA L. SNAPP, EXAMINING ATTORNEY

SN 85-211,073. VALLEY ROLLER COMPANY, INC., MANSFIELD, TX. FILED 1-5-2011.

**Dura-Release**

THE MARK CONSISTS OF STANDARD CHARACTERS WITHOUT CLAIM TO ANY PARTICULAR FONT, STYLE, SIZE, OR COLOR.  
FOR MACHINE PARTS, NAMELY, ROLLERS COATED WITH SYNTHETIC MATERIAL (U.S. CLS. 13, 19, 21, 23, 31, 34 AND 35).  
FIRST USE 9-1-1999; IN COMMERCE 9-1-1999.  
TINA L. SNAPP, EXAMINING ATTORNEY

SN 85-211,165. VALLEY ROLLER COMPANY, INC., MANSFIELD, TX. FILED 1-5-2011.

**Ultimate Val-Coat**

THE MARK CONSISTS OF STANDARD CHARACTERS WITHOUT CLAIM TO ANY PARTICULAR FONT, STYLE, SIZE, OR COLOR.  
FOR MACHINE PARTS, NAMELY, ROLLERS COATED WITH SYNTHETIC MATERIAL (U.S. CLS. 13, 19, 21, 23, 31, 34 AND 35).  
FIRST USE 1-1-1995; IN COMMERCE 1-1-1995.  
TINA L. SNAPP, EXAMINING ATTORNEY

**CLASS 7—(Continued).**

SN 85-211,704. BISSELL HOMCARE, INC., GRAND RAPIDS, MI. FILED 1-6-2011.

**LIFT-OFF**

THE MARK CONSISTS OF STANDARD CHARACTERS WITHOUT CLAIM TO ANY PARTICULAR FONT, STYLE, SIZE, OR COLOR.

OWNER OF U.S. REG. NOS. 2,267,713 AND 3,206,993.  
FOR ELECTRICAL CLEANING DEVICES, NAMELY, CARPET, BARE FLOOR, AND UPHOLSTERY DEEP CLEANING EXTRACTORS, STEAM CLEANERS, AND VACUUM CLEANERS AND ACCESSORIES (U.S. CLS. 13, 19, 21, 23, 31, 34 AND 35).  
ELLEN BURNS, EXAMINING ATTORNEY

**CLASS 7—(Continued).**

SN 85-239,593. COLORADO HOT ROD PARTS, FORT COLLINS, CO. FILED 2-11-2011.

**Street Ram**

THE MARK CONSISTS OF STANDARD CHARACTERS WITHOUT CLAIM TO ANY PARTICULAR FONT, STYLE, SIZE, OR COLOR.

FOR AUTOMOTIVE INTAKE MANIFOLDS (U.S. CLS. 13, 19, 21, 23, 31, 34 AND 35).  
FLORENTINA BLANDU, EXAMINING ATTORNEY

SN 85-212,303. NOVELLUS SYSTEMS, INC., SAN JOSE, CA. FILED 1-6-2011.

**TELOS**

THE MARK CONSISTS OF STANDARD CHARACTERS WITHOUT CLAIM TO ANY PARTICULAR FONT, STYLE, SIZE, OR COLOR.

FOR MACHINES FOR MANUFACTURING SEMICONDUCTORS AND PARTS FOR SUCH MACHINES; CHEMICAL VAPOR DEPOSITION REACTORS FOR USE IN MANUFACTURING SEMICONDUCTORS (U.S. CLS. 13, 19, 21, 23, 31, 34 AND 35).  
H. M. FISHER, EXAMINING ATTORNEY

SN 85-242,982. ORECK HOLDINGS, LLC, NASHVILLE, TN. FILED 2-15-2011.

**AVIATOR**

THE MARK CONSISTS OF STANDARD CHARACTERS WITHOUT CLAIM TO ANY PARTICULAR FONT, STYLE, SIZE, OR COLOR.

FOR VACUUM CLEANERS (U.S. CLS. 13, 19, 21, 23, 31, 34 AND 35).  
DAVID TAYLOR, EXAMINING ATTORNEY

SN 85-216,964. SAFEWORKS, LLC, TUKWILA, WA. FILED 1-13-2011.



OWNER OF U.S. REG. NO. 2,406,766.  
THE MARK CONSISTS OF AN IMAGE OF A SPIDER HANGING FROM A SINGLE STRAND.  
FOR POWER DRIVEN SUSPENDED STAGING AND SCAFFOLDING, AND COMPONENT PARTS THEREOF (U.S. CLS. 13, 19, 21, 23, 31, 34 AND 35).  
FIRST USE 0-0-1947; IN COMMERCE 7-6-1948.  
ANDREA K. NADELMAN, EXAMINING ATTORNEY

**CLASS 8—HAND TOOLS**

SN 77-915,229. INDUSTRIAL DE ESPUMAS PLASTICAS, S.A. DE C.V. MEXICO CITY, MEXICO, FILED 1-19-2010.

**ALMOND FOODSERVICE**

THE MARK CONSISTS OF STANDARD CHARACTERS WITHOUT CLAIM TO ANY PARTICULAR FONT, STYLE, SIZE, OR COLOR.

NO CLAIM IS MADE TO THE EXCLUSIVE RIGHT TO USE "FOODSERVICE", APART FROM THE MARK AS SHOWN.  
FOR CUTLERY, NAMELY, FORKS, SPOONS AND KNIVES (U.S. CLS. 23, 28 AND 44).  
KATHERINE M. DUBRAY, EXAMINING ATTORNEY

**CLASS 8—(Continued).**

SN 79-087,754. PROMED GMBH MEDIZINISCHE GERÄTE UND KOSMETISCHE ERZEUGNISSE, 82490 FARCHANT, FED REP GERMANY, FILED 5-14-2010.

*Pedibelle*

OWNER OF INTERNATIONAL REGISTRATION 0610319 DATED 10-13-1993, EXPIRES 10-13-2013.

FOR ELECTRIC NAIL BUFFERS FOR MANICURE AND PEDICURE AND PARTS THEREFOR, NAMELY, POLISHING AND BUFFING PADS (U.S. CLS. 23, 28 AND 44).

KAREN BRACEY, EXAMINING ATTORNEY

SN 85-041,190. MAG-LOK TOOLS, INC., CARROLLTON, TX. FILED 5-18-2010.



THE MARK CONSISTS OF THE WORDING "BE GREEN!" ADJACENT AN ILLUSTRATION OF A BEE AND A SERIES OF DASHES.

FOR HAND-HELD GARDENING TOOLS, NAMELY, SHOVELS, RAKES, AERATORS, PLANTERS, HOES, SPADES, TROWELS AND CULTIVATORS (U.S. CLS. 23, 28 AND 44).

TRACY CROSS, EXAMINING ATTORNEY

SN 85-063,432. INNOVATIVE COSMETICS LTD., JERUSALEM 93123, ISRAEL, FILED 6-15-2010.

*Slique*

PRIORITY CLAIMED UNDER SEC. 44(D) ON ISRAEL APPLICATION NO. 226863, FILED 1-26-2010, REG. NO. 226863, DATED 3-7-2011, EXPIRES 1-26-2020.

THE MARK CONSISTS OF THE WORD "SLIQUE" IN A STYLIZED MANNER WITH A DESIGN OVER THE LETTER "I" AND AN ACCENT MARK OVER THE LETTER "I".

FOR APPLIANCES FOR BODY AND FACIAL HAIR REMOVAL, NAMELY, NON-ELECTRIC DEPILATORY APPLIANCES (U.S. CLS. 23, 28 AND 44).

LINDA ORNDORFF, EXAMINING ATTORNEY

**CLASS 8—(Continued).**

SN 85-074,023. FROST, JAMES A., DBA FROST CUTLERY, OOLTEWAH, TN. FILED 6-29-2010.

TROPHY STAG

THE MARK CONSISTS OF STANDARD CHARACTERS WITHOUT CLAIM TO ANY PARTICULAR FONT, STYLE, SIZE, OR COLOR.

FOR CUTLERY, NAMELY, FIXED BLADE KNIVES (U.S. CLS. 23, 28 AND 44).

FIRST USE 3-31-2006; IN COMMERCE 3-31-2006.

LEIGH CAROLINE CASE, EXAMINING ATTORNEY

SN 85-131,378. SUNBEAM PRODUCTS, INC., BOCA RATON, FL. FILED 9-16-2010.

NAIL JUNKIE

THE MARK CONSISTS OF STANDARD CHARACTERS WITHOUT CLAIM TO ANY PARTICULAR FONT, STYLE, SIZE, OR COLOR.

NO CLAIM IS MADE TO THE EXCLUSIVE RIGHT TO USE "NAIL", APART FROM THE MARK AS SHOWN.

FOR ELECTRIC NAIL TRIMMER AND GRINDER FOR ANIMALS (U.S. CLS. 23, 28 AND 44).

MICHAEL WEBSTER, EXAMINING ATTORNEY

SN 85-132,896. BATTERY EASY PRODUCTS, INC., WILMINGTON, NC. FILED 9-18-2010.

Battery Easy

THE MARK CONSISTS OF STANDARD CHARACTERS WITHOUT CLAIM TO ANY PARTICULAR FONT, STYLE, SIZE, OR COLOR.

NO CLAIM IS MADE TO THE EXCLUSIVE RIGHT TO USE "BATTERY", APART FROM THE MARK AS SHOWN.

FOR HAND TOOL FOR REMOVING HEARING AID BATTERIES (U.S. CLS. 23, 28 AND 44).

MARCIE MILONE, EXAMINING ATTORNEY

**CLASS 8—(Continued).**

SN 85-136,606. REVLON CONSUMER PRODUCTS CORPORATION, NEW YORK, NY. FILED 9-23-2010.



THE MARK CONSISTS OF A DESIGN OF 4 DIAMONDS ARRANGED IN A DIAMOND PATTERN.  
FOR EYELASH CURLERS; NAIL FILES; TWEEZERS (U.S. CLS. 23, 28 AND 44).  
JOHN SCHUYLER YARD, EXAMINING ATTORNEY

SN 85-148,081. TRAN, NGHE, BOTHELL, WA. FILED 10-8-2010.

**MY NIPPERS**

THE MARK CONSISTS OF STANDARD CHARACTERS WITHOUT CLAIM TO ANY PARTICULAR FONT, STYLE, SIZE, OR COLOR.

NO CLAIM IS MADE TO THE EXCLUSIVE RIGHT TO USE "NIPPERS", APART FROM THE MARK AS SHOWN.

FOR HAND TOOLS, NAMELY, CUTICLE SCISSORS; MANICURE IMPLEMENTS, NAMELY, NAIL FILES, NAIL CLIPPERS, CUTICLE PUSHERS, TWEEZERS; PEDICURE IMPLEMENTS, NAMELY, NAIL AND CUTICLE NIPPERS (U.S. CLS. 23, 28 AND 44).

BRIAN NEVILLE, EXAMINING ATTORNEY

SN 85-171,836. BERRY, JOHN A., DBA JOHN A. BERRY SR., AIKEN, SC. FILED 11-8-2010.

**HAMMER HELPER**

THE MARK CONSISTS OF STANDARD CHARACTERS WITHOUT CLAIM TO ANY PARTICULAR FONT, STYLE, SIZE, OR COLOR.

NO CLAIM IS MADE TO THE EXCLUSIVE RIGHT TO USE "HAMMER", APART FROM THE MARK AS SHOWN.

FOR HAMMERS (U.S. CLS. 23, 28 AND 44).  
KELLY TRUSILO, EXAMINING ATTORNEY

**CLASS 8—(Continued).**

SN 85-179,214. DEXTER-RUSSELL, INC., SOUTHBRIDGE, MA. FILED 11-17-2010.

**DEXSTEEL**

THE MARK CONSISTS OF STANDARD CHARACTERS WITHOUT CLAIM TO ANY PARTICULAR FONT, STYLE, SIZE, OR COLOR.

OWNER OF U.S. REG. NOS. 1,937,870, 2,426,473 AND 3,547,765.

FOR BONING KNIVES, SLITTING KNIVES, ANGLED KNIVES, POULTRY KNIVES, SKINNING KNIVES, PARING KNIVES, STEAK KNIVES, FILLETING KNIVES, COOK'S KNIVES, BREAD KNIVES, SANDWICH KNIVES, BUTCHER KNIVES, FISH SPLITTERS, CHUCK KNIVES, CHEESE KNIVES, CLAM KNIVES, OYSTER KNIVES, SCALLOP KNIVES, MANUALLY-OPERATED SLICING KNIVES, PIZZA SLICERS AND CHEESE SLICERS, UTILITY KNIVES, PIE KNIVES, VEGETABLE AND PRODUCE KNIVES, RIBBING KNIVES, TRIMMING KNIVES, HEADING KNIVES, SANDWICH SPREADERS WITH A SERRATED CUTTING EDGE AND SLICER KNIVES, ALL OF THE FOREGOING BEING MADE WHOLLY OR IN SUBSTANTIAL PART OF STEEL (U.S. CLS. 23, 28 AND 44).

FIRST USE 1-1-2011; IN COMMERCE 1-1-2011.

BRENDAN REGAN, EXAMINING ATTORNEY

SN 85-187,332. LOFLEY, ROBERT SR., TAMPA, FL. AND LOFLEY, ROBERT JR., TAMPA, FL. FILED 11-30-2010.

**TOMAHAWK CHIEF**

THE MARK CONSISTS OF STANDARD CHARACTERS WITHOUT CLAIM TO ANY PARTICULAR FONT, STYLE, SIZE, OR COLOR.

OWNER OF U.S. REG. NO. 3,920,815.

FOR HAND TOOL FOR ROTATING A WHEEL HAND BRAKE AND PIVOTING A KNUCKLE COUPLER ON A RAILROAD CAR (U.S. CLS. 23, 28 AND 44).

NANCY CLARKE, EXAMINING ATTORNEY

SN 85-187,639. LEATHERMAN TOOL GROUP, INC., PORTLAND, OR. FILED 11-30-2010.

**WINGMAN**

THE MARK CONSISTS OF STANDARD CHARACTERS WITHOUT CLAIM TO ANY PARTICULAR FONT, STYLE, SIZE, OR COLOR.

FOR MULTIFUNCTION HAND TOOL INCLUDING TWO OR MORE OF THE FOLLOWING ELEMENTS: PLIERS, SCREWDRIVERS, WIRE CUTTER, WIRE STRIPPER, SCISSORS, FILE, AND CAN OPENER (U.S. CLS. 23, 28 AND 44).

BRIAN PINO, EXAMINING ATTORNEY



**CLASS 8—(Continued).**

SN 85-188,049. MEREDITH CORPORATION, DES MOINES, IA. FILED 12-1-2010.

BETTER HOMES AND GARDENS

THE MARK CONSISTS OF STANDARD CHARACTERS WITHOUT CLAIM TO ANY PARTICULAR FONT, STYLE, SIZE, OR COLOR.  
OWNER OF U.S. REG. NOS. 2,921,794, 3,091,547 AND OTHERS.  
FOR FLATWARE, NAMELY, KNIVES, FORKS AND SPOONS (U.S. CLS. 23, 28 AND 44).  
FIRST USE 2-8-2010; IN COMMERCE 2-8-2010.  
JENNIFER DIXON, EXAMINING ATTORNEY

SN 85-188,316. BURNELL, STANLEY JOSEPH, JR., PORTSMOUTH, VA. FILED 12-1-2010.

STRAINER BUDDIES

THE MARK CONSISTS OF STANDARD CHARACTERS WITHOUT CLAIM TO ANY PARTICULAR FONT, STYLE, SIZE, OR COLOR.  
NO CLAIM IS MADE TO THE EXCLUSIVE RIGHT TO USE "STRAINER", APART FROM THE MARK AS SHOWN.  
FOR HAND TOOLS SPECIALLY DESIGNED FOR INSTALLING STRAINERS IN KITCHEN SINKS OR IN ANY OTHER SINKS THAT REQUIRE STRAINERS (U.S. CLS. 23, 28 AND 44).  
DAWN FELDMAN, EXAMINING ATTORNEY

SN 85-197,383. QUEEN CUTLERY COMPANY, TITUSVILLE, PA. FILED 12-14-2010.

RCC

THE MARK CONSISTS OF STANDARD CHARACTERS WITHOUT CLAIM TO ANY PARTICULAR FONT, STYLE, SIZE, OR COLOR.  
FOR POCKET KNIVES (U.S. CLS. 23, 28 AND 44).  
FIRST USE 12-0-1940; IN COMMERCE 12-0-1940.  
MEGHAN REINHART, EXAMINING ATTORNEY

**CLASS 8—(Continued).**

SN 85-197,400. QUEEN CUTLERY COMPANY, TITUSVILLE, PA. FILED 12-14-2010.

RC

THE MARK CONSISTS OF STANDARD CHARACTERS WITHOUT CLAIM TO ANY PARTICULAR FONT, STYLE, SIZE, OR COLOR.  
FOR POCKET KNIVES (U.S. CLS. 23, 28 AND 44).  
MEGHAN REINHART, EXAMINING ATTORNEY

SN 85-197,806. MENTOR GROUP, L.L.C., OREGON CITY, OR. FILED 12-14-2010.

T-ROD

THE MARK CONSISTS OF STANDARD CHARACTERS WITHOUT CLAIM TO ANY PARTICULAR FONT, STYLE, SIZE, OR COLOR.  
FOR KNIVES, NAMELY, ADJUSTABLE FIXED BLADE KNIVES (U.S. CLS. 23, 28 AND 44).  
LESLEY LAMOTHE, EXAMINING ATTORNEY

SN 85-201,072. ALL AMERICAN PRODUCTS GROUP, INC., SAN FERNANDO, CA. FILED 12-17-2010.



NO CLAIM IS MADE TO THE EXCLUSIVE RIGHT TO USE "DRILL CLAMP", APART FROM THE MARK AS SHOWN.

THE MARK CONSISTS OF THE STYLIZED TEXT "BOMB SIGHT DRILL CLAMP" WITH A TARGET IN THE MIDDLE.  
FOR CLAMPING BUSHINGS (U.S. CLS. 23, 28 AND 44).  
FIRST USE 4-6-2008; IN COMMERCE 4-6-2008.  
COLLEEN KEARNEY, EXAMINING ATTORNEY

**CLASS 8—(Continued).**

SN 85-208,916. VIGOR, LLC, NEW YORK, NY. FILED 1-3-2011.



NO CLAIM IS MADE TO THE EXCLUSIVE RIGHT TO USE "BLADES", APART FROM THE MARK AS SHOWN.

THE MARK CONSISTS OF THE TERM "FEIMSTER BLADES", WITH A DEPICTION OF A KNIFE BETWEEN TWO SEMI CIRCLES APPEARING TO THE LEFT OF THE WORD PORTION OF THE MARK.

FOR CHEF KNIVES; CUTLERY, NAMELY, KNIVES; HOUSEHOLD KNIVES; KNIFE BAGS; KNIFE SHARPENERS; KNIFE SHEATHS (U.S. CLS. 23, 28 AND 44).  
KEVON CHISOLM, EXAMINING ATTORNEY

SN 85-209,233. 4THOUGHT HOLDINGS L.L.C., SEATTLE, WA. FILED 1-3-2011.

## SpeedSet

THE MARK CONSISTS OF STANDARD CHARACTERS WITHOUT CLAIM TO ANY PARTICULAR FONT, STYLE, SIZE, OR COLOR.

FOR TOOL BELTS (U.S. CLS. 23, 28 AND 44).  
STEVEN PEREZ, EXAMINING ATTORNEY

SN 85-209,824. CONAIR CORPORATION, STAMFORD, CT. FILED 1-4-2011.

## i-stubble

THE MARK CONSISTS OF STANDARD CHARACTERS WITHOUT CLAIM TO ANY PARTICULAR FONT, STYLE, SIZE, OR COLOR.

FOR ELECTRIC AND BATTERY-POWERED HAIR CLIPPERS; ELECTRIC RAZORS AND ELECTRIC HAIR CLIPPERS (U.S. CLS. 23, 28 AND 44).

GISELLE AGOSTO, EXAMINING ATTORNEY

**CLASS 8—(Continued).**

SN 85-210,408. KAI U.S.A., LTD., DBA KERSHAW KNIVES, TUALATIN, OR. FILED 1-4-2011.

## BRAWLER

THE MARK CONSISTS OF STANDARD CHARACTERS WITHOUT CLAIM TO ANY PARTICULAR FONT, STYLE, SIZE, OR COLOR.

FOR KNIVES (U.S. CLS. 23, 28 AND 44).  
GILBERT SWIFT, EXAMINING ATTORNEY

SN 85-210,410. KAI U.S.A., LTD., DBA KERSHAW KNIVES, TUALATIN, OR. FILED 1-4-2011.

## ECHELON

THE MARK CONSISTS OF STANDARD CHARACTERS WITHOUT CLAIM TO ANY PARTICULAR FONT, STYLE, SIZE, OR COLOR.

FOR KNIVES (U.S. CLS. 23, 28 AND 44).  
GILBERT SWIFT, EXAMINING ATTORNEY

SN 85-212,324. ROBERTS CONSOLIDATED INDUSTRIES, INC., BOCA RATON, FL. FILED 1-6-2011.

## TIGER TOOTH

THE MARK CONSISTS OF STANDARD CHARACTERS WITHOUT CLAIM TO ANY PARTICULAR FONT, STYLE, SIZE, OR COLOR.

FOR TROWELS (U.S. CLS. 23, 28 AND 44).  
JEFFERY COWARD, EXAMINING ATTORNEY

MAY 3, 2011

U.S. PATENT AND TRADEMARK OFFICE

TM 579

**CLASS 8—(Continued).**

SN 85-231,387. PACIFIC WORLD CORPORATION, LAKE FOREST, CA. FILED 2-1-2011.



THE MARK CONSISTS OF A STYLIZED LOWER CASE "G" FOLLOWED BY A STYLIZED UPPER CASE "G".

FOR MANICURE IMPLEMENTS, NAMELY, NAIL FILES; PEDICURE IMPLEMENTS, NAMELY, NAIL FILES (U.S. CLS. 23, 28 AND 44).

HOWARD SMIGA, EXAMINING ATTORNEY

**CLASS 9—ELECTRICAL AND SCIENTIFIC APPARATUS**

SN 76-704,536. TROY GROUP, INC., COSTA MESA, CA. FILED 9-17-2010.

TROY SECURE CHECKFLOW

THE MARK CONSISTS OF STANDARD CHARACTERS WITHOUT CLAIM TO ANY PARTICULAR FONT, STYLE, SIZE, OR COLOR.

OWNER OF U.S. REG. NOS. 1,322,989, 3,142,637 AND OTHERS.

NO CLAIM IS MADE TO THE EXCLUSIVE RIGHT TO USE "SECURE", APART FROM THE MARK AS SHOWN.

FOR SOFTWARE FOR ALLOWING ONE OR MORE USERS TO REQUEST, APPROVE AND PRINT CHECKS (U.S. CLS. 21, 23, 26, 36 AND 38).

WILLIAM ROSSMAN, EXAMINING ATTORNEY

SN 85-245,984. STANLEY LOGISTICS, L.L.C., NEW BRITAIN, CT. FILED 2-18-2011.

FATMAX XTREME

THE MARK CONSISTS OF STANDARD CHARACTERS WITHOUT CLAIM TO ANY PARTICULAR FONT, STYLE, SIZE, OR COLOR.

OWNER OF U.S. REG. NOS. 3,738,219, 3,786,344 AND 3,851,751.

FOR HAND TOOLS, NAMELY, RATCHET WRENCHES, HANDS SAWS, HAMMERS, HAMMER TACKERS, SCREWDRIVERS, DEMOLITION DRIVERS, TRIGGER CLAMPS AND CHALK LINE REELS (U.S. CLS. 23, 28 AND 44).

FIRST USE 6-1-2009; IN COMMERCE 6-1-2009.

KAPIL BHANOT, EXAMINING ATTORNEY

SN 77-078,782. GLOBESTAR SYSTEMS INC., TORONTO, ONTARIO, CANADA, FILED 1-9-2007.

ConnexASSIST

THE MARK CONSISTS OF STANDARD CHARACTERS WITHOUT CLAIM TO ANY PARTICULAR FONT, STYLE, SIZE, OR COLOR.

PRIORITY CLAIMED UNDER SEC. 44(D) ON CANADA APPLICATION NO. 1330511, FILED 12-21-2006, REG. NO. TMA749431, DATED 10-5-2009, EXPIRES 10-5-2024.

OWNER OF U.S. REG. NO. 3,028,749.

FOR TELEPHONE APPARATUS, NAMELY, WIRELESS INTERCOMS FOR USE IN TELEPHONE SYSTEMS INCORPORATING WIRELESS HANDSETS (U.S. CLS. 21, 23, 26, 36 AND 38).

TRICIA SONNEBORN, EXAMINING ATTORNEY

**CLASS 9—(Continued).**

SN 77-303,036. SONY COMPUTER ENTERTAINMENT EUROPE LIMITED, LONDON, UNITED KINGDOM, FILED 10-12-2007.

## OPERATION CREATURE FEATURE

THE MARK CONSISTS OF STANDARD CHARACTERS WITHOUT CLAIM TO ANY PARTICULAR FONT, STYLE, SIZE, OR COLOR.

PRIORITY CLAIMED UNDER SEC. 44(D) ON UNITED KINGDOM APPLICATION NO. 2452514, FILED 4-13-2007, REG. NO. 2452514, DATED 4-13-2007, EXPIRES 4-13-2017.

FOR ELECTRONIC DEVICES, NAMELY, WIRELESS ROUTERS FOR THE WIRELESS RECEIPT, STORAGE AND/OR TRANSMISSION OF DATA AND MESSAGES; COMPUTER SOFTWARE FOR PHOTO AND/OR VIDEO MANIPULATION; SOUND AND/OR VIDEO RECORDINGS FEATURING MUSIC AND ENTERTAINMENT, TELEVISION PROGRAMS, MOTION PICTURES, NEWS, SPORTS, CULTURAL EVENTS, AND ENTERTAINMENT-RELATED PROGRAMS OF ALL KINDS; DOWNLOADABLE DIGITAL SOUND AND/OR VIDEO RECORDINGS FEATURING MUSIC AND ENTERTAINMENT, TELEVISION PROGRAMS, MOTION PICTURES, NEWS, SPORTS, CULTURAL EVENTS, AND ENTERTAINMENT-RELATED PROGRAMS OF ALL KINDS; AND COMPUTER SOFTWARE TO ALLOW USERS TO PERFORM ELECTRONIC BUSINESS TRANSACTIONS VIA THE INTERNET (U.S. CLS. 21, 23, 26, 36 AND 38).

JOHN E. MICHOŠ, EXAMINING ATTORNEY

SN 77-435,793. KENNETH COLE PRODUCTIONS (LIC), LLC, NEW YORK, NY. FILED 3-31-2008.

## LE TIGRE

THE MARK CONSISTS OF STANDARD CHARACTERS WITHOUT CLAIM TO ANY PARTICULAR FONT, STYLE, SIZE, OR COLOR.

OWNER OF U.S. REG. NO. 1,186,863.

THE FOREIGN WORDING IN THE MARK TRANSLATES INTO ENGLISH AS THE TIGER.

FOR EYEGLASSES; SUNGLASSES; MAGNIFYING GLASSES; MAGNIFYING LENSES; EYEGLASS FRAMES; EYEGLASS LENSES; CAMERA AND PHONE CASES; EYEWEAR ACCESSORIES, NAMELY, STRAPS, NECK CORDS AND HEAD STRAPS WHICH RESTRAIN EYEWEAR FROM MOVEMENT ON A WEARER; EYEGLASS CASES AND EYEGLASS CHAINS (U.S. CLS. 21, 23, 26, 36 AND 38).

TINA L. SNAPP, EXAMINING ATTORNEY

**CLASS 9—(Continued).**

SN 77-486,706. TAGENT CORPORATION, MOUNTAIN VIEW, CA. FILED 5-29-2008.

## GPS FOR THE LAB

THE MARK CONSISTS OF STANDARD CHARACTERS WITHOUT CLAIM TO ANY PARTICULAR FONT, STYLE, SIZE, OR COLOR.

NO CLAIM IS MADE TO THE EXCLUSIVE RIGHT TO USE "LAB", APART FROM THE MARK AS SHOWN.

FOR A MEDICAL TRACKING SYSTEM, NAMELY, AN ELECTRONIC TAG READER AND RADIO FREQUENCY TAGS THAT PERMIT REAL TIME LOCATION AND SAMPLE IDENTIFICATION FOR MEDICAL LABORATORY SAMPLES (U.S. CLS. 21, 23, 26, 36 AND 38).

KELLY BOULTON, EXAMINING ATTORNEY

SN 77-525,657. DIVERSITECH CORPORATION, DULUTH, GA. FILED 7-18-2008.



THE COLOR(S) BLUE IS/ARE CLAIMED AS A FEATURE OF THE MARK.

THE MARK CONSISTS OF A THREE DIMENSIONAL CONFIGURATION OF THE GOODS CONSISTING OF ONE PIECE MEASURING 2-5/8" IN DIAMETER ON THE TOP AND BOTTOM, AND MEASURING 1-1/8" IN HEIGHT. THE TOP AND BOTTOM OF THE GOODS ARE ROUND AND TRANSLUCENT BLUE IN COLOR. THE GOODS HAVE A LIGHT TRANSLUCENT BLUE OUTLINE AND A DARK TRANSLUCENT BLUE INNER STRIPE.

SEC. 2(F).

FOR DEVICE TO DETECT THE PRESENCE OF CONDENSATE OVERFLOW WHICH WILL INTERRUPT THE CONTROL CIRCUIT OF AN AIR CONDITIONER, REFRIGERATION UNIT OR WATER COOLING SYSTEM (U.S. CLS. 21, 23, 26, 36 AND 38).

FIRST USE 6-0-2003; IN COMMERCE 6-0-2003.

PAM WILLIS, EXAMINING ATTORNEY

**CLASS 9—(Continued).**

SN 77-583,805. NINTENDO OF AMERICA INC., REDMOND, WA. FILED 10-2-2008.

((••))  
nintendo zone

PRIORITY CLAIMED UNDER SEC. 44(D) ON JAPAN APPLICATION NO. 2008-079566, FILED 9-30-2008, REG. NO. 5324017, DATED 5-21-2010, EXPIRES 5-21-2020.

OWNER OF U.S. REG. NOS. 1,213,822, 1,628,966 AND OTHERS.

THE MARK CONSISTS OF THE WORDS "NINTENDO ZONE"; WITH TRANSMISSION WAVES EMANATING FROM THE DOT ABOVE THE LETTER "I".

FOR VIDEO GAME DISCS; VIDEO GAME CARTRIDGES; PROGRAMS FOR VIDEO GAMES; OPTICAL DISCS, ROM CARDS, ROM CARTRIDGES, CD-ROMS, DVD-ROMS AND OTHER STORAGE MEDIA, NAMELY, FLASH MEMORY ALL STORING PROGRAMS FOR VIDEO GAME MACHINES; CONTROLLERS, JOYSTICKS AND MEMORY CARDS FOR VIDEO GAME MACHINES; MICROPHONES FOR VIDEO GAME MACHINES; SOUND RECEIVERS FOR VIDEO GAME MACHINES; PARTS AND FITTINGS FOR VIDEO GAME MACHINES, NAMELY, POWER SUPPLIES, TRANSFORMERS, CABLES AND MODEMS; PROGRAMS FOR HANDHELD GAMES WITH LIQUID CRYSTAL DISPLAYS; OPTICAL DISCS, ROM CARDS, ROM CARTRIDGES, CD-ROMS, DVD-ROMS AND OTHER STORAGE MEDIA STORING PROGRAMS, NAMELY, FLASH MEMORY, ALL FOR HANDHELD GAMES WITH LIQUID CRYSTAL DISPLAYS; PROGRAMS FOR ARCADE VIDEO GAME MACHINES; OPTICAL DISCS, ROM CARDS, ROM CARTRIDGES, CD-ROMS, DVD-ROMS AND OTHER STORAGE MEDIA, NAMELY, FLASH MEMORY ALL STORING PROGRAMS FOR ARCADE VIDEO GAME MACHINES; VIDEO GAME COMPUTERS; OPTICAL DISCS, ROM CARDS, ROM CARTRIDGES, CD-ROMS, DVD-ROMS AND OTHER STORAGE MEDIA, NAMELY, FLASH MEMORY ALL STORING PROGRAMS FOR VIDEO GAME COMPUTERS; DOWNLOADABLE PROGRAMS FOR VIDEO GAME COMPUTERS; PROGRAMS FOR VIDEO GAME COMPUTERS; GAME PROGRAMS FOR CELLULAR PHONES; OTHER ELECTRONIC MACHINES, APPARATUS AND THEIR PARTS, NAMELY, ELECTRONIC GAME SOFTWARE, ELECTRONIC VIDEO GAME MACHINES FOR USE WITH COMPUTER MONITOR OR TELEVISION; MICROPHONES; HEADSETS WITH MICROPHONES; PARTS AND FITTINGS FOR CELLULAR PHONES, NAMELY, STRAPS FOR CELLULAR PHONES, DISPLAY SCREEN PROTECTORS, SLEEVES, CASES, SKINS, STANDS, EAR PHONES, POWER SUPPLIES AND TRANSFORMERS; PRE-RECORDED COMPACT DISCS FEATURING ENTERTAINMENT CONTENT, NAMELY, MUSIC, STORIES, GAMES AND GAME HINTS; PHONOGRAPHIC RECORDS FEATURING CHILDREN'S ENTERTAINMENT CONTENT, NAMELY, STORIES AND MUSIC; ELECTRONIC CIRCUITS AND CD-ROMS WITH RECORDED AUTOMATIC PERFORMANCE PROGRAMS FOR ELECTRONIC MUSICAL INSTRUMENTS; DOWNLOADABLE MUSIC FILES; CINEMATOGRAPHIC FILMS FEATURING CHILDREN'S ENTERTAINMENT CONTENT, NAMELY, STORIES, MUSIC AND GAMES; DOWNLOADABLE IMAGE FILES FEATURING PHOTOGRAPHS, ART, VIDEO GAME CHARACTERS, VIDEO GAME SCENES AND VIDEO GAME IMAGES; RECORDED VIDEO DISCS AND VIDEO TAPES FEATURING CHILDREN'S ENTERTAINMENT CONTENT, NAMELY, STORIES, MUSIC AND GAMES; DOWNLOADABLE ELECTRONIC PUBLICATIONS, NAMELY, COMMENTARY ARTICLES, GAME STRATEGY GUIDES AND STORIES FEATURING ENTERTAINMENT CONTENT, NAMELY, GAMES AND PUZZLES; CARTRIDGES, COMPACT DISCS, OPTICAL DISCS AND MEMORY CARDS FEATURING ENTERTAINMENT, INFORMATIONAL AND EDUCATIONAL CONTENT, NAMELY, GAMES AND PUZZLES; EDUCATIONAL AND ENTERTAINMENT SOFTWARE FEATURING

**CLASS 9—(Continued).**

TURING INSTRUCTION IN GAMES, PUZZLES, PHYSICAL FITNESS, DIET, NUTRITION, SPORTS AND EXERCISE; COMPUTER GAME CARTRIDGES; COMPUTER GAME DISCS, COMPUTER GAME MEMORY CARDS; COMPUTER GAME PROGRAMS; COMPUTER GAME SOFTWARE; ELECTRONIC GAME CARTRIDGES; ELECTRONIC GAME DISCS; ELECTRONIC GAME MEMORY CARDS; ELECTRONIC GAME PROGRAMS; ELECTRONIC GAME SOFTWARE; ELECTRONIC INTERACTIVE BOARD GAMES FOR USE WITH EXTERNAL MONITORS; INTERACTIVE GAME CARTRIDGES; INTERACTIVE GAME DISCS; INTERACTIVE GAME MEMORY CARDS; INTERACTIVE GAME PROGRAMS; INTERACTIVE GAME SOFTWARE; MAGNETIC CODED TRADING CARDS AND DISCS FEATURING GAME PROGRAM AND DATA CONTENT; MUSICAL SOUND RECORDINGS; VIDEO GAME CARTRIDGES; VIDEO GAME DISCS; VIDEO GAME MEMORY CARDS; VIDEO GAME PROGRAMS; VIDEO GAME SOFTWARE; MAGNETIC TRADING CARDS AND DISCS FEATURING GAME PROGRAM AND DATA CONTENT (U.S. CLS. 21, 23, 26, 36 AND 38).

MATTHEW MCDOWELL, EXAMINING ATTORNEY

SN 77-716,563. IPX INTERNATIONAL INC., FARMINGDALE, NJ. FILED 4-17-2009.



THE COLOR(S) BLUE, WHITE, AND GRAY IS/ARE CLAIMED AS A FEATURE OF THE MARK.

THE MARK CONSISTS OF BLUE SQUARE CONTAINING LETTERS "IPX" WHERE THE "I" AND "P" ARE WHITE AND THE "X" IS GRAY.

FOR SECURITY CAMERAS; COMPUTER SECURITY CAMERAS; DIGITAL SECURITY CAMERAS; ENVIRONMENTAL ENCLOSURES, NAMELY, STRUCTURES SPECIALLY ADAPTED TO HOLD AND PROTECT CAMERAS FROM OUTDOOR ELEMENTS AND TAMPERING; VIDEO SECURITY CAMERAS (U.S. CLS. 21, 23, 26, 36 AND 38).

FIRST USE 8-23-2005; IN COMMERCE 8-23-2005.

NICHOLAS COLEMAN, EXAMINING ATTORNEY

**CLASS 9—(Continued).**

SN 77-754,538. LG ELECTRONICS INC., SEOUL, REPUBLIC OF KOREA, FILED 6-8-2009.

# EcoSmart

THE MARK CONSISTS OF STANDARD CHARACTERS WITHOUT CLAIM TO ANY PARTICULAR FONT, STYLE, SIZE, OR COLOR.

PRIORITY CLAIMED UNDER SEC. 44(D) ON REPUBLIC OF KOREA APPLICATION NO. 40-2009-0025, FILED 6-2-2009, REG. NO. 0844030, DATED 11-23-2010, EXPIRES 11-23-2020.

FOR TELEVISION RECEIVERS (U.S. CLS. 21, 23, 26, 36 AND 38).

HELENE LIWINSKI, EXAMINING ATTORNEY

---

SN 77-766,584. CHILIAD PUBLISHING INCORPORATED, HENDRON, VA. FILED 6-23-2009.

## CONNECTING ALL THE DOTS

THE MARK CONSISTS OF STANDARD CHARACTERS WITHOUT CLAIM TO ANY PARTICULAR FONT, STYLE, SIZE, OR COLOR.

FOR COMMUNICATIONS SOFTWARE FOR CONNECTING COMPUTER NETWORK USERS, LOCAL COMPUTER NETWORKS AND GLOBAL COMPUTER NETWORKS; SOFTWARE FOR SEARCHING THE CONTENTS OF COMPUTERS AND COMPUTER NETWORKS; SOFTWARE FOR ENSURING THE SECURITY OF ELECTRONIC TRANSMISSIONS ACROSS COMPUTER NETWORKS; SOFTWARE FOR COMPUTER AND NETWORK DATABASE MANAGEMENT AND INTEGRATION (U.S. CLS. 21, 23, 26, 36 AND 38).

ALYSSA STEEL, EXAMINING ATTORNEY

---

SN 77-787,973. AUGER, ALBERT, NAPLES, FL. FILED 7-23-2009.

## IN SEARCH OF A PROFITABLE LIFE

THE MARK CONSISTS OF STANDARD CHARACTERS WITHOUT CLAIM TO ANY PARTICULAR FONT, STYLE, SIZE, OR COLOR.

FOR AUDIO TAPES, VIDEO TAPES, DVDS, DOWNLOADABLE AUDIO FILES, DOWNLOADABLE DVDS, AND DOWNLOADABLE ELECTRONIC PUBLICATIONS IN THE NATURE OF BOOKS, WORKBOOKS, MAGAZINES, JOURNALS AND PAMPHLETS ALL IN THE FIELD OF SELF-IMPROVEMENT, SPIRITUALITY, BUSINESS MANAGEMENT, FINANCE AND PERSONAL GROWTH (U.S. CLS. 21, 23, 26, 36 AND 38).

ROBERT STRUCK, EXAMINING ATTORNEY

**CLASS 9—(Continued).**

SN 77-826,637. SHINING UNION LIMITED, TSUEN WAN, NT, HONG KONG, FILED 9-15-2009.

# SecuKeyboard

THE MARK CONSISTS OF STANDARD CHARACTERS WITHOUT CLAIM TO ANY PARTICULAR FONT, STYLE, SIZE, OR COLOR.

PRIORITY CLAIMED UNDER SEC. 44(D) ON HONG KONG APPLICATION NO. 301422396, FILED 9-8-2009, REG. NO. 301422396, DATED 9-8-2009, EXPIRES 9-8-2019.

FOR CALCULATING MACHINES; DATA PROCESSING APPARATUS; NAMELY, DATA PROCESSORS; COMPUTERS; LAPTOP COMPUTERS; COMPUTER KEYBOARDS; READ-ONLY MEMORY COMPACT DISCS, NAMELY, RECORDED COMPACT DISCS AND BLANK RECORDABLE COMPACT DISCS FOR STORING APPLICATION SOFTWARE FOR INTERFACING OR CONTROLLING COMPUTER PERIPHERAL; COMPUTER PERIPHERAL DEVICES; RECORDED COMPUTER SOFTWARE, NAMELY, COMPUTER APPLICATION SOFTWARE FOR INTERFACING OR CONTROLLING COMPUTER PERIPHERAL; DATA PROCESSING EQUIPMENT, NAMELY, COMPUTER MOUSE; NOTEBOOK COMPUTERS; DOWNLOADABLE COMPUTER SOFTWARE FOR USE IN THE IDENTIFICATION AND AUTHENTICATION OF INDIVIDUALS BASED ON THEIR UNIQUE CHARACTERISTICS, NAMELY, FINGERPRINTS, IN INTERNATIONAL CLASS 9 (U.S. CLS. 21, 23, 26, 36 AND 38).

MARLENE BELL, EXAMINING ATTORNEY

---

SN 77-857,051. STAR GROUP COMMUNICATIONS, INC., VOORHEES, NJ. FILED 10-26-2009.

# chill

THE MARK CONSISTS OF STANDARD CHARACTERS WITHOUT CLAIM TO ANY PARTICULAR FONT, STYLE, SIZE, OR COLOR.

FOR DIGITAL AUDIO PLAYERS; DIGITAL MATERIAL, NAMELY, PACKAGED RECORDED CDS, DOWNLOADABLE AUDIO FILES, AND DOWNLOADABLE SOUND CARDS AS PART OF AN AUDIO THERAPY PROGRAM FEATURING DEEP RELAXATION AND DAILY STRESS RELIEF (U.S. CLS. 21, 23, 26, 36 AND 38).

FIRST USE 9-17-2009; IN COMMERCE 9-17-2009.

LINDA ESTRADA, EXAMINING ATTORNEY

**CLASS 9—(Continued).**

SN 77-863,017. CATALETTO, BARBARA, DBA CASECODER LLC, MINEOLA, NY. FILED 11-2-2009.



OWNER OF U.S. REG. NO. 3,549,244.  
THE COLOR(S) DARK BLUE, LIGHT BLUE AND GREY IS/ARE CLAIMED AS A FEATURE OF THE MARK.  
THE MARK CONSISTS OF THE WORD "CASE" IN DARK BLUE, THE WORD "CODER" IN LIGHT BLUE, COMBINED AS ONE WORD WITH NO SPACE BETWEEN THE TWO; TO THE RIGHT OF "CASECODER" ARE TWO INTERSECTING, GRAY HALF-ELLIPSES WHICH PARTIALLY WRAP AROUND THE WORDING. BENEATH THE TERM "CASECODER" IS THE WORDING "CONFIDENT CODING ... AT YOUR FINGERTIPS" IN THE COLOR GRAY.  
SEC. 2(F) AS TO "CASECODER".  
FOR COMPUTER SOFTWARE FOR WEB-BASED ON-LINE MEDICAL CODING MANAGEMENT SYSTEM (U.S. CLS. 21, 23, 26, 36 AND 38).  
FIRST USE 10-15-2009; IN COMMERCE 10-15-2009.  
RUSS HERMAN, EXAMINING ATTORNEY

SN 77-865,513. SONY CORPORATION, TOKYO, JAPAN, FILED 11-5-2009.



THE MARK CONSISTS OF THE LETTERS "PHIQ" IN A HIGHLY STYLIZED FORM WHEREIN THE "Q" SITS IN THE CROOK OF THE "P" AND THE TAIL OF THE "Q" COMES TO A TRIANGULAR POINT. THE INSIDE, OPEN PORTION OF THE "P" AND "Q" ARE HORIZONTAL RECTANGULAR BARS THAT FORM EACH LETTER "I".  
THE WORD(S) "PHIQ" OR "PQ" HAS NO MEANING IN A FOREIGN LANGUAGE.  
FOR HEADPHONES; EARPHONES; MOBILE PHONES; MP3 PLAYERS; MP4 PLAYERS (U.S. CLS. 21, 23, 26, 36 AND 38).  
KRISTIN DAHLING, EXAMINING ATTORNEY

**CLASS 9—(Continued).**

SN 77-868,582. AGENCYPORT INSURANCE SERVICES, INC., BOSTON, MA. FILED 11-9-2009.

**AGENCYPORTAL**

THE MARK CONSISTS OF STANDARD CHARACTERS WITHOUT CLAIM TO ANY PARTICULAR FONT, STYLE, SIZE, OR COLOR.  
SEC. 2(F).  
FOR COMPUTER SOFTWARE, NAMELY, AN APPLICATION THAT PROVIDES WORKFLOW, RULES, AND A DATA SCHEMA THAT ENABLES PROPERTY AND CASUALTY INSURERS TO TRANSACT BUSINESS WITH THEIR AGENTS OVER THE WEB (U.S. CLS. 21, 23, 26, 36 AND 38).  
FIRST USE 12-0-2003; IN COMMERCE 12-0-2003.  
RAMONA ORTIGA, EXAMINING ATTORNEY

SN 77-871,468. VILLAGE PROFILE.COM, INC., ELGIN, IL. FILED 11-12-2009.

**FUNCTION SEQUENCE**

THE MARK CONSISTS OF STANDARD CHARACTERS WITHOUT CLAIM TO ANY PARTICULAR FONT, STYLE, SIZE, OR COLOR.  
FOR ELECTRONIC BOOK READER COVER; ELECTRONIC BOOK READERS WITH FLEXIBLE SCREEN (U.S. CLS. 21, 23, 26, 36 AND 38).  
MAYUR VAGHANI, EXAMINING ATTORNEY

SN 77-885,146. DELAWARE CAPITAL FORMATION, INC., WILMINGTON, DE. FILED 12-3-2009.

**PHOENIX SQL**

THE MARK CONSISTS OF STANDARD CHARACTERS WITHOUT CLAIM TO ANY PARTICULAR FONT, STYLE, SIZE, OR COLOR.  
NO CLAIM IS MADE TO THE EXCLUSIVE RIGHT TO USE "SQL", APART FROM THE MARK AS SHOWN.  
FOR COMPUTER SOFTWARE DOWNLOADED FROM AN EXTERNAL MEMORY SOURCE, FOR EXAMPLE, FROM A CD, THAT PROVIDES ON-LINE MANAGEMENT OF THE FUELING OPERATIONS OF AT LEAST ONE FUELING SITE, NAMELY, VERIFYING AUTHORIZED USERS, POLLING TRANSACTIONS, REPORTING ACTIVITIES BY AUTHORIZED USERS, RECONCILIATION OF ACCOUNTS, AND REPORTING FUEL INVENTORY; COMPUTER SOFTWARE DOWNLOADED FROM AN EXTERNAL MEMORY SOURCE, FOR EXAMPLE, FROM A CD, THAT PROVIDES ON-LINE COMMUNICATIONS FOR CONNECTING TO AND MANAGING AT LEAST ONE FUELING SITE (U.S. CLS. 21, 23, 26, 36 AND 38).  
MEGHAN REINHART, EXAMINING ATTORNEY

**CLASS 9—(Continued).**

SN 77-897,830. QUANMAX INC., TAIPEI 11493, TAIWAN,  
FILED 12-21-2009.



THE MARK CONSISTS OF TWO CROSS LIKE CONTOURS FORMED AT AN ANGLE TO EACH OTHER WITH EACH FORMED BY THREE VERTICAL DOTS AND FOUR HORIZONTAL DOTS ALL NEXT TO THE LETTERS "QUANMAX".

FOR COMPUTER KEYBOARDS; PRERECORDED MAGNETIC TAPES CONTAINING COMPUTER SOFTWARE FOR USE IN DATABASE MANAGEMENT AND WORD PROCESSING; COMPUTER BACKUP AND STORAGE SYSTEMS WITH MULTIPLE REMOVABLE RAID CARTRIDGES; COMPUTER STORAGE DEVICES, NAMELY, BLANK FLASH DRIVES; COMPUTER STORAGE DEVICES, NAMELY, HIGH-SPEED STORAGE SUBSYSTEMS FOR STORAGE AND BACKUP OF ELECTRONIC DATA EITHER LOCALLY OR VIA A TELECOMMUNICATIONS NETWORK; VIDEO RECORDING DEVICES; COMPUTER HARDWARE, NAMELY, COMPUTER NETWORK ATTACHED DATA STORAGE DEVICES; COMPUTER HARDWARE, NAMELY, FIREWALLS; COMPUTER SOFTWARE FOR CREATION OF FIREWALLS; BACKUP DRIVES FOR COMPUTERS; COMPUTER HARD DRIVES ENCLOSURES; AND EXTERNAL COMPUTER HARD DRIVES; BLANK MAGNETIC OPTICAL DISCS; PRINTED CIRCUIT BOARDS; COMPUTER HARDWARE IN THE FIELD OF FORENSICS, NAMELY, COMPUTER MODULES; COMPUTER TOUCH-SENSITIVE INPUT DEVICES; DIGITAL INPUT AND OUTPUT SCANNERS; COMPUTER MICE; COMPUTER APPLICATION SOFTWARE, NAMELY, SOFTWARE FOR USE IN DATABASE MANAGEMENT, ELECTRONIC STORAGE OF DATA MANAGEMENT, ELECTRONIC STORAGE DATA FOR USE IN MOBILE PHONES, PORTABLE MEDIA PLAYERS, AND HANDHELD COMPUTERS; COMPUTER FIRMWARE FOR USE IN DATABASE MANAGEMENT, WORD PROCESSING; COMPUTER MIDDLE WARE IS A SOFTWARE THAT PROVIDES A LINK BETWEEN SEPARATE SOFTWARE APPLICATIONS AND FOR USE IN DATABASE MANAGEMENT AND WORD PROCESSING; ADAPTER CARDS; COMPUTER MOTHERBOARDS; SLOT-STYLE COMPUTER MOTHERBOARDS; EMBEDDED COMPUTER MOTHERBOARDS; SINGLE BOARD COMPUTER MOTHERBOARDS; MAINFRAMES; COMPUTERS; ELECTRONIC DATA PROCESSORS; COMPUTER PRINTERS; DATA STORAGE MACHINES; DATA PROCESSORS; MICRO PROCESSORS; MICROCOMPUTERS; DVD BURNERS; PASSIVE BACKPLANES; PERSONAL COMPUTERS WITH LIQUID CRYSTAL DISPLAY (LCD) MONITORS; HIGH-DENSITY PLUG-IN PC MOTHERBOARDS; SIGNAL CONVERTERS; MEMORIES FOR USE WITH COMPUTERS; NOTEBOOK COMPUTERS; COMPUTER SERVERS; TABLET PCS; PROGRAMMA-

**CLASS 9—(Continued).**

BLE DATA ACCESS PROCESSORS; CENTRAL PROCESSING UNITS; PROCESS CONTROL COMPUTERS; BARCODE READERS; MAGNETIC TAPES, ENCODED WITH COMPUTER PROGRAMS FOR ENCRYPTING OR DECRYPTING INFORMATION DATA; DRUMS UNITS FOR PRINTERS, FACSIMILE MACHINES, SCANNERS, COPYING MACHINES AND MULTIFUNCTION ELECTRONIC DEVICES FOR USE IN COPYING, PRINTING, SCANNING, VIDEO CAPTURE AND/OR TRANSMITTING DOCUMENTS AND IMAGES; BLANK COMPUTER DISKS AND MAGNETIC CARDS, AND PRE-RECORDED COMPUTER DISKS AND MAGNETIC CARDS FEATURING START-UP COMPUTER OPERATION SOFTWARE; BLANK ELECTRONIC DATA CARRIERS, NAMELY, OPTICAL COMPUTER DATA STORAGE DISKS; COIN SORTING AND CALCULATION MACHINES; GEIGER COUNTERS; CASH REGISTERS; AUTOMATED BILLING MACHINES FOR PROCESSING ACCOUNTING INFORMATION; COMPUTERS FOR USE IN ACCOUNTING, INVOICING AND BOOK-KEEPING (U.S. CLS. 21, 23, 26, 36 AND 38).

MARIA-VICTORIA SUAREZ, EXAMINING ATTORNEY

SN 77-901,404. IBASE TECHNOLOGY INC., TAIPEI 115,  
TAIWAN, FILED 12-28-2009.

# iBASE

THE MARK CONSISTS OF STANDARD CHARACTERS WITHOUT CLAIM TO ANY PARTICULAR FONT, STYLE, SIZE, OR COLOR.

FOR COMPUTER INTERFACE BOARDS; MOTHERBOARDS; COMPUTERS; COMPUTER SERVERS; NETWORKING FIREWALLS; DIGITAL SURVEILLANCE SYSTEMS (DSS) COMPRISED OF DIGITAL VIDEO RECORDER AND VIDEO CAMERAS; DIGITAL SIGNAGE MONITORS; INTERACTIVE COMPUTER KIOSKS COMPRISING COMPUTERS, COMPUTER HARDWARE, COMPUTER PERIPHERALS, AND ATM KIOSKS, INFORMATION KIOSKS, CASH DEPOSITORY KIOSKS, LOBBY BANKING KIOSKS, PAYMENT KIOSKS, TICKETING KIOSKS, COIN VENDING KIOSKS AND DUAL-DISPLAY KIOSKS (U.S. CLS. 21, 23, 26, 36 AND 38).

FIRST USE 2-28-2000; IN COMMERCE 1-31-2005.

CAROLINE WOOD, EXAMINING ATTORNEY



**CLASS 9—(Continued).**

SN 77-902,908. DISTRIBUTION MANAGEMENT CONSOLIDATORS WORLDWIDE, LLC, AKA DMC WORLDWIDE, NEW YORK, NY. FILED 12-30-2009.

# Ripple

THE MARK CONSISTS OF STANDARD CHARACTERS WITHOUT CLAIM TO ANY PARTICULAR FONT, STYLE, SIZE, OR COLOR.

FOR PORTABLE AND HANDHELD ELECTRONIC DEVICES FOR RECEIVING TEXT, IMAGES, VIDEO AND SOUND THROUGH WIRELESS COMMUNICATION AND FOR REPRODUCING TEXT, IMAGES, VIDEO AND SOUNDS; PORTABLE AND HANDHELD ELECTRONIC DEVICES FOR DISPLAYING ELECTRONIC PUBLICATIONS, NAMELY, BOOKS, MAGAZINES, NEWSPAPERS, PERIODICALS, VIDEO AND MULTIMEDIA PRESENTATIONS (U.S. CLS. 21, 23, 26, 36 AND 38).  
HOWARD B. LEVINE, EXAMINING ATTORNEY

---

SN 77-903,528. MONSTER CABLE PRODUCTS, INC., BRISBANE, CA. FILED 12-31-2009.

# ENZO

THE MARK CONSISTS OF STANDARD CHARACTERS WITHOUT CLAIM TO ANY PARTICULAR FONT, STYLE, SIZE, OR COLOR.

FOR ELECTRICAL AND ELECTROMAGNETIC SIGNAL TRANSMITTING, AMPLIFYING, RECEIVING, AND CONVERTING DEVICES, NAMELY, CABLES, WIRES, CONNECTORS FOR USE WITH ELECTRICAL, ELECTRONIC, AND COMPUTER DEVICES (U.S. CLS. 21, 23, 26, 36 AND 38).  
DOMINIC FATHY, EXAMINING ATTORNEY

**CLASS 9—(Continued).**

SN 77-903,781. NAPIER, KEIKO MASE, TOLUCA LAKE, CA. FILED 12-31-2009.

# easy-glide tab

THE MARK CONSISTS OF STANDARD CHARACTERS WITHOUT CLAIM TO ANY PARTICULAR FONT, STYLE, SIZE, OR COLOR.

NO CLAIM IS MADE TO THE EXCLUSIVE RIGHT TO USE "TAB", APART FROM THE MARK AS SHOWN.

FOR CASES FOR WORD PROCESSING TAPES; SILICONE CASES FOR MP3 PLAYERS, MOBILE TELEPHONES, SMART TELEPHONES, DIGITAL CAMERAS, GLOBAL POSITIONING SYSTEMS AND PERSONAL DIGITAL ASSISTANTS, LAPTOPS AND PORTABLE MEDIA PLAYERS, PORTABLE VIDEO PLAYERS, PORTABLE MUSIC PLAYERS AND GLOBAL POSITIONING SYSTEMS; CARRYING CASES FOR MP3 PLAYERS, MOBILE TELEPHONES, SMART TELEPHONES, DIGITAL CAMERAS, GLOBAL POSITIONING SYSTEMS AND PERSONAL DIGITAL ASSISTANTS, LAPTOPS AND PORTABLE MEDIA PLAYERS, PORTABLE VIDEO PLAYERS, PORTABLE MUSIC PLAYERS AND GLOBAL POSITIONING SYSTEMS; PROTECTIVE CASES FOR MP3 PLAYERS, MOBILE TELEPHONES, SMART TELEPHONES, DIGITAL CAMERAS, GLOBAL POSITIONING SYSTEMS AND PERSONAL DIGITAL ASSISTANTS, LAPTOPS AND PORTABLE MEDIA PLAYERS, PORTABLE VIDEO PLAYERS, PORTABLE MUSIC PLAYERS AND GLOBAL POSITIONING SYSTEMS; SCREEN PROTECTORS FOR MP3 PLAYERS, MOBILE TELEPHONES, SMART TELEPHONES, DIGITAL CAMERAS, GLOBAL POSITIONING SYSTEMS AND PERSONAL DIGITAL ASSISTANTS, LAPTOPS AND PORTABLE MEDIA PLAYERS, PORTABLE VIDEO PLAYERS, PORTABLE MUSIC PLAYERS AND GLOBAL POSITIONING SYSTEMS; COMPUTER STANDS SPECIALLY DESIGNED FOR TILTING WHILE HOLDING A COMPUTER; COMPUTER DOCKING STATIONS; WRIST RESTS FOR USE WITH COMPUTERS AND COMPUTER MICE; HEADSETS FOR MP3 PLAYERS, MOBILE TELEPHONES, SMART TELEPHONES, DIGITAL CAMERAS, GLOBAL POSITIONING SYSTEMS AND PERSONAL DIGITAL ASSISTANTS, LAPTOPS AND PORTABLE MEDIA PLAYERS, PORTABLE VIDEO PLAYERS, PORTABLE MUSIC PLAYERS AND GLOBAL POSITIONING SYSTEMS; MOUSE PADS; COMPUTER KEYBOARDS ALL FOR PORTABLE COMPUTERS, PORTABLE AUDIO PLAYERS, CELLULAR TELEPHONES, DIGITAL CAMERAS, PERSONAL DIGITAL ASSISTANTS, PORTABLE TELEPHONES, AND ELECTRONIC PERSONAL ORGANIZERS; PROTECTIVE FILMS, NAMELY, FITTED PLASTIC FILMS KNOWN AS SKINS FOR COVERING AND PROVIDING A SCRATCH PROOF BARRIER OR PROTECTION FOR ELECTRIC DEVICES, NAMELY, MP3 PLAYERS, MOBILE TELEPHONES, SMART TELEPHONES, DIGITAL CAMERAS, GLOBAL POSITIONING SYSTEMS AND PERSONAL DIGITAL ASSISTANTS, LAPTOPS AND PORTABLE MEDIA PLAYERS, PORTABLE VIDEO PLAYERS, PORTABLE MUSIC PLAYERS AND GLOBAL POSITIONING SYSTEMS; STRAPS, NAMELY, MOBILE PHONE STRAPS; INTERNAL COOLING FANS FOR NOTEBOOK COMPUTERS; PROTECTIVE SHEETS OF FILM FOR ELECTRIC DEVICES, NAMELY, MP3 PLAYERS, MOBILE TELEPHONES, SMART TELEPHONES, DIGITAL CAMERAS, GLOBAL POSITIONING SYSTEMS AND PERSONAL DIGITAL ASSISTANTS, LAPTOPS AND PORTABLE MEDIA PLAYERS, PORTABLE VIDEO PLAYERS, PORTABLE MUSIC PLAYERS AND GLOBAL POSITIONING SYSTEMS; PROTECTIVE FILMS AND CLEANING CLOTHS FOR PROTECTIVE FILMS SOLD AS A UNIT, NAMELY, FITTED PLASTIC FILMS KNOWN AS SKINS FOR COVERING AND PROVIDING A SCRATCH PROOF BARRIER OR PROTECTION FOR ELECTRIC DEVICES, FOR USE WITH MP3 PLAYERS, MOBILE TELEPHONES, SMART TELEPHONES, DIGITAL CAMERAS, GLOBAL POSITIONING SYSTEMS AND PERSONAL DIGITAL ASSISTANTS, LAPTOPS AND PORTABLE MEDIA

**CLASS 9—(Continued).**

PLAYERS, PORTABLE VIDEO PLAYERS, PORTABLE MUSIC PLAYERS AND GLOBAL POSITIONING SYSTEMS; PROTECTIVE SHEETS OF FILM FOR ELECTRIC DEVICES AND CLEANING CLOTHS FOR PROTECTIVE SHEETS OF FILM SOLD AS A UNIT, FOR USE WITH MP3 PLAYERS, MOBILE TELEPHONES, SMART TELEPHONES, DIGITAL CAMERAS, GLOBAL POSITIONING SYSTEMS AND PERSONAL DIGITAL ASSISTANTS, LAPTOPS AND PORTABLE MEDIA PLAYERS, PORTABLE VIDEO PLAYERS, PORTABLE MUSIC PLAYERS AND GLOBAL POSITIONING SYSTEMS; COMPUTER PERIPHERALS; BAGS AND CASES FOR COMPUTERS; BAGS AND CASES SPECIALLY ADAPTED FOR HOLDING OR CARRYING PORTABLE TELEPHONES AND TELEPHONE EQUIPMENT AND ACCESSORIES; COMPUTER BAGS (U.S. CLS. 21, 23, 26, 36 AND 38).

KATHLEEN LORENZO, EXAMINING ATTORNEY

SN 77-939,484. GUNVISION SYSTEMS, LLC, AUSTIN, TX. FILED 2-18-2010.

## GUNVISION

THE MARK CONSISTS OF STANDARD CHARACTERS WITHOUT CLAIM TO ANY PARTICULAR FONT, STYLE, SIZE, OR COLOR.

FOR HEAD-MOUNTED VIDEO DISPLAY AND A FIREARM MOUNT FOR ATTACHING A VIDEO CAMERA TO A FIREARM, SOLD TOGETHER AS A UNIT (U.S. CLS. 21, 23, 26, 36 AND 38).

KIMBERLY FRYE, EXAMINING ATTORNEY

SN 77-948,707. AURIGA MEASUREMENT SYSTEMS, LLC, LOWELL, MA. FILED 3-2-2010.



NO CLAIM IS MADE TO THE EXCLUSIVE RIGHT TO USE "MICROWAVE", APART FROM THE MARK AS SHOWN.

THE MARK CONSISTS OF A PENTAGON COMPRISED OF POLYGONS TO THE LEFT OF THE WORDS "AURIGA MICROWAVE" STACKED ONE ON TOP OF THE OTHER.

FOR RADIO FREQUENCY (RF) DEVICES, CIRCUITS AND SYSTEMS, NAMELY, AUTOMATED TEST EQUIPMENT (ATE) TO TEST THE FUNCTIONALITY OF RF CIRCUITS, PULSED CURRENT-VOLTAGE/RADIO FREQUENCY (IV/RF) MEASUREMENT SYSTEMS, RF BIAS TEES, RF SWITCHES, RF TRANSMITTERS, RF RECEIVERS AND AMPLIFIERS (U.S. CLS. 21, 23, 26, 36 AND 38).

BRIAN PINO, EXAMINING ATTORNEY

**CLASS 9—(Continued).**

SN 77-950,519. GETAC TECHNOLOGY CORPORATION, HSINCHU, TAIWAN, FILED 3-4-2010.

## QUADRACLEAR

THE MARK CONSISTS OF STANDARD CHARACTERS WITHOUT CLAIM TO ANY PARTICULAR FONT, STYLE, SIZE, OR COLOR.

PRIORITY CLAIMED UNDER SEC. 44(D) ON TAIWAN APPLICATION NO. 098050097, FILED 11-10-2009.

FOR BAR CODE READERS; CALCULATING MACHINES; CAMCORDERS; CINEMATOGRAPHIC CAMERAS; PHOTOGRAPHIC CAMERAS; TIME RECORDING DEVICES, NAMELY, TIME CLOCKS; AUTOMATIC VENDING MACHINES AND MECHANISMS FOR COIN-OPERATED APPARATUS; AUTOMOTIVE MEASURING INSTRUMENTS, NAMELY, WATER TEMPERATURE GAUGES, AIR FUEL/RATIO GAUGES, BOOST GAUGES, VACUUM GAUGES AND EXHAUST GAS TEMPERATURE GAUGES; ELECTRONIC-BASED INSTRUMENTS FOR MEASURING ENVIRONMENTAL PARAMETERS INCLUDING HUMIDITY, MOLD, BACTERIA, AIR QUALITY AND WATER QUALITY; COMPUTER HARDWARE AND COMPUTER PERIPHERAL DEVICES; COMPUTERS; PRINTERS FOR USE WITH COMPUTERS; ELECTRIC CONTROL PANELS; APPARATUS FOR RECORDING, TRANSMISSION, PROCESSING AND REPRODUCTION OF SOUND, IMAGES OR DATA; METAL DETECTORS; DVD PLAYERS; ELECTRONIC NOTICE BOARDS; FACSIMILE MACHINES; FLUORESCENT SCREENS; AMUSEMENT APPARATUS ADAPTED FOR USE WITH AN EXTERNAL DISPLAY SCREEN OR MONITOR; HYGROMETERS; TELEPHONE APPARATUS, NAMELY, INTERCOMS; INTEROPERABLE COMMUNICATION SYSTEM DESIGNED TO PROVIDE RADIO, STREAMING VIDEO, WIRELESS INTERNET, AND VOIP PHONE; NOTEBOOK AND LAPTOP COMPUTERS; MEASURING INSTRUMENTATION AND APPARATUS, NAMELY, DIGITIZERS; COMPUTER MONITORS; ON-BOARD COMPUTERS, NAMELY, NAVIGATION APPARATUS FOR VEHICLES; PERSONAL STEREOS; POCKET CALCULATORS; PORTABLE TELEPHONES; SLIDE OR PHOTOGRAPH PROJECTION APPARATUS; PROJECTION SCREENS; REMOTE CONTROL TELEMETERING MACHINES AND APPARATUS; SATELLITE NAVIGATIONAL SYSTEM, NAMELY, A GLOBAL POSITIONING SYSTEM (GPS); SURVEYING INSTRUMENTS; TELEPHONE APPARATUS; TEMPERATURE INDICATORS; VENDING MACHINES; VIDEO SCREENS; WALKIE-TALKIES; ELECTRIC METERS; ELECTRONIC DEVICES, NAMELY, HANDHELDS FOR EXCHANGING DATA IN ENERGY METERS OR SUBMETERS; ENVIRONMENTAL MONITORING SYSTEM COMPRISED OF METERS AND SENSORS THAT MEASURE PRESSURE, HUMIDITY, TEMPERATURE AND INCLUDES ALARM AND REPORTING FUNCTIONS; FLOW METERS; GAS METERS; PANEL METERS, NAMELY, AN ELECTRONIC INSTRUMENT THAT DISPLAYS AN INPUT SIGNAL IN EITHER A DIGITAL OR ANALOG FORM; PARKING METERS; SCIENTIFIC MEASURING INSTRUMENTS, NAMELY, CONDUCTIVITY METERS; TEMPERATURE METERS NOT FOR MEDICAL USE; VIBRATION METERS; WATER METERS; ELECTRONIC MONITORS AND MONITOR MODULES FOR MONITORING ELECTRIC CURRENT AND ELECTRICAL SIGNALS; ACCESS CONTROL AND ALARM MONITORING SYSTEMS; ALARM MONITORING SYSTEMS; COMPUTER HARDWARE AND SOFTWARE, FOR USE WITH MEDICAL PATIENT MONITORING EQUIPMENT, FOR RECEIVING, PROCESSING, TRANSMITTING AND DISPLAYING DATA; COMPUTER HARDWARE AND SOFTWARE SYSTEM FOR REMOTELY MONITORING ENVIRONMENTAL CONDITIONS AND CONTROLLING DEVICES WITHIN A BUILDING, FACILITY, GROUNDS, OR DESIGNATED SPATIAL AREA; WATER TESTING INSTRUMENTATION FOR MONITORING AND DETECTING CONTAMINATION; SIGNALING BUOYS; SIGNALING DEVICES, NAMELY, TRAFFIC-LIGHT AP-

**CLASS 9—(Continued).**

PARATUS; VEHICLE TRAFFIC SIGNALS; RADAR; RADAR DETECTORS; RADAR OBJECT DETECTORS FOR USE ON VEHICLES; AMUSEMENT MACHINES, NAMELY, HAND-HELD ELECTRONIC GAME UNITS ADAPTED FOR USE WITH AN EXTERNAL DISPLAY SCREEN OR MONITOR; COMPUTER SCREENS; ELECTRONIC APPARATUS, NAMELY, ELECTRONIC DISPLAY BOARDS, PLASMA DISPLAY BOARDS, ELECTRONIC DISPLAY SCREENS; ENTERTAINMENT SYSTEM COMPRISING A COMPUTER, MULTIPLE IMAGE DISPLAY SCREEN, MULTIPLE INPUT DEVICES AND A PRINTER; FLAT PANEL DISPLAY SCREENS; LCD LARGE-SCREEN DISPLAYS; TELEPHONE SETS WITH SCREEN AND KEYBOARD; TELEVISION APPARATUS FOR PROJECTION PURPOSES; CAR TELEVISIONS; LIQUID CRYSTAL DISPLAY (LCD) TELEVISIONS; PLASMA TELEVISIONS; PORTABLE TELEVISIONS; TELEVISION CAMERAS; TELEVISION MONITORS; TELEVISION SETS; TELEVISIONS AND MONITORS; TELEVISIONS AND VIDEO RECORDERS; WIRELESS TELEVISION SET FOR PROVIDING VIDEO CONFERENCING AND TELEPHONE SERVICE OVER THE INTERNET (U.S. CLS. 21, 23, 26, 36 AND 38).

FIRST USE 9-29-2009; IN COMMERCE 9-30-2009.  
SHAUNIA CARLYLE, EXAMINING ATTORNEY

SN 77-967,605. JAWA HOLDINGS, LLC, SCOTTSDALE, AZ.  
FILED 3-24-2010.

**TEXT NOW**

THE MARK CONSISTS OF STANDARD CHARACTERS WITHOUT CLAIM TO ANY PARTICULAR FONT, STYLE, SIZE, OR COLOR.

NO CLAIM IS MADE TO THE EXCLUSIVE RIGHT TO USE "TEXT", APART FROM THE MARK AS SHOWN.

FOR SOFTWARE FOR COMPUTERS AND PORTABLE ELECTRONIC DEVICES THAT ENABLE USERS TO PRIVATELY SHARE AND ACCESS RELEVANT REAL-TIME INFORMATION WITH RESPECT TO A CENTRAL SERVER IN RESPONSE TO USER QUERY (U.S. CLS. 21, 23, 26, 36 AND 38).

MARK SPARACINO, EXAMINING ATTORNEY

SN 79-083,056. NIPPON CHEMI-CON CORPORATION, JAPAN, FILED 4-30-2010.

**D L C A P**

OWNER OF INTERNATIONAL REGISTRATION 1040089 DATED 4-30-2010, EXPIRES 4-30-2020.

FOR CAPACITORS FOR TELECOMMUNICATION MACHINES AND APPARATUS (U.S. CLS. 21, 23, 26, 36 AND 38).

INGRID C. EULIN, EXAMINING ATTORNEY

**CLASS 9—(Continued).**

SN 79-083,496. CYTOO, FRANCE, FILED 4-30-2010.



PRIORITY DATE OF 11-23-2009 IS CLAIMED.  
OWNER OF INTERNATIONAL REGISTRATION 1041269 DATED 4-30-2010, EXPIRES 4-30-2020.

THE COLOR(S) GREEN, WHITE AND BLACK IS/ARE CLAIMED AS A FEATURE OF THE MARK.

THE MARK CONSISTS OF A BLACK SQUARE WITH A GREEN CROSSBOW DESIGN ABOVE THE WORDING "CYTOO" IN WHITE.

FOR LABORATORY EQUIPMENT AND INSTRUMENTS, NAMELY, CELL CULTURE VESSELS FOR CELL ANALYSIS, HIGH CONTENT ANALYSIS AND CELL SCREENING, FOR THE LIFE SCIENCES RESEARCH MARKET AND THE PHARMACEUTICAL INDUSTRY MARKET; COMPUTER SOFTWARE FOR CELL AND MOLECULAR ANALYSIS, HIGH CONTENT ANALYSIS AND CELL SCREENING, OTHER THAN FOR MEDICAL USE (U.S. CLS. 21, 23, 26, 36 AND 38).

MATTHEW EINSTEIN, EXAMINING ATTORNEY

SN 79-083,753. SPM INSTRUMENT AB, SWEDEN, FILED 5-10-2010.

**SPM HD**

PRIORITY DATE OF 4-15-2010 IS CLAIMED.  
OWNER OF INTERNATIONAL REGISTRATION 1042025 DATED 5-10-2010, EXPIRES 5-10-2020.

FOR APPARATUS AND INSTRUMENTS TO MEASURE THE OPERATING CONDITION OF MACHINES WITH ROTATING ELEMENTS, NAMELY, SHOCK PULSE METERS, ELECTRONIC STETHOSCOPES, LEAK DETECTORS, BEARING CONDITION MONITORS AND VIBRATION MONITORS; DATA PROCESSING EQUIPMENT FOR MEASURING THE OPERATING CONDITION OF MACHINES WITH ROTATING ELEMENTS (U.S. CLS. 21, 23, 26, 36 AND 38).

MICHAEL LITZAU, EXAMINING ATTORNEY

**CLASS 9—(Continued).**

SN 79-084,690. INOVADIS, FRANCE, FILED 6-4-2010.

**CLASS 9—(Continued).**

SN 79-086,321. ZHEJIANG ZHENLONG BATTERY CO., LTD., CHINA, FILED 8-3-2010.



OWNER OF INTERNATIONAL REGISTRATION 1044229  
DATED 6-4-2010, EXPIRES 6-4-2020.

THE MARK CONSISTS OF A DESIGN OF A CIRCLE WITHIN ANOTHER LARGER CIRCLE WITH THE TERM "ELIPSON" IN STYLIZED FONT BENEATH THE DESIGN.

FOR APPARATUS FOR RECORDING, TRANSMITTING, REPRODUCING OR PROCESSING SOUND; APPARATUS, INSTRUMENTS, DEVICES, UNITS AND EQUIPMENT FOR PUBLIC ADDRESS, BROADCASTING, PICK-UP AND TRANSMISSION OF SOUND, NAMELY, LOUDSPEAKER CABINETS AND COMPONENT PARTS THEREOF, ACOUSTIC CONDUITS, NAMELY, ACOUSTIC REFLECTORS AND DAMPERS; SOUND PROJECTORS AND AMPLIFIERS, NAMELY, SOUND VIBRATION GENERATORS; LOUDSPEAKERS AND COMPONENT PARTS THEREOF; LOUDSPEAKERS FITTED WITH INTEGRATED AMPLIFIERS AND COMPONENT PARTS THEREOF; AMPLIFIERS AND COMPONENT PARTS THEREOF; LOUDSPEAKER CABINETS AND COMPONENT PARTS THEREOF; OMNIDIRECTIONAL LOUDSPEAKER CABINETS AND COMPONENT PARTS THEREOF; AUTOMOBILE RADIOS AND COMPONENT PARTS THEREOF, CD-ROM, MINIDISK AND MP3 READERS AND WRITERS, COMPACT DISK PLAYERS, DVD PLAYERS; HEADPHONES AND COMPONENT PARTS THEREOF; AUDIO CABLES (U.S. CLS. 21, 23, 26, 36 AND 38).

BENJAMIN OKEKE, EXAMINING ATTORNEY

OWNER OF INTERNATIONAL REGISTRATION 1048337  
DATED 8-3-2010, EXPIRES 8-3-2020.

THE MARK CONSISTS OF THE WORD "GENELONG" IN STYLIZED FONT, BENEATH A DESIGN OF THREE OVERLAPPING ANGLED LINES IN AN OVAL.

THE WORDING "GENELONG" HAS NO MEANING IN A FOREIGN LANGUAGE.

FOR ACCUMULATORS, ELECTRIC; PLATES FOR BATTERIES; GALVANIC CELLS; BATTERY CHARGERS; ACCUMULATORS, ELECTRIC, FOR VEHICLES (U.S. CLS. 21, 23, 26, 36 AND 38).

LIEF MARTIN, EXAMINING ATTORNEY

**CLASS 9—(Continued).**

SN 79-087,852. KIM, DAE IL, REPUBLIC OF KOREA, FILED 8-18-2010.



OWNER OF INTERNATIONAL REGISTRATION 1052504 DATED 8-18-2010, EXPIRES 8-18-2020.

THE MARK CONSISTS OF ASIAN CHARACTERS ABOVE AND BELOW THE WORD "SAGAWAFUJII" IN STYLIZED FONT.

THE WORDING "SAGAWAFUJII" HAS NO MEANING IN A FOREIGN LANGUAGE.

THE NON-LATIN CHARACTERS IN THE MARK TRANSLITERATE TO "SAGAWAFUJII" AND THIS HAS NO MEANING IN A FOREIGN LANGUAGE.

FOR THEATRE GLASSES; SPECTACLE FRAMES MADE OF METAL AND OF SYNTHETIC MATERIAL; MONOCULAR FRAMES; READING EYEGLASSES; DUSTPROOF GLASSES; ANTI-GLARE GLASSES; EYE-SHADES; CORRECTIVE GLASSES; EYEGLASSES; PROTECTIVE EYEGLASSES; PROTECTIVE EYE PIECES; SUNGLASSES; LENSES FOR SUNGLASSES; GOGGLES FOR SPORTS; SPECTACLES; CASES FOR SPECTACLES AND SUNGLASSES; SPECTACLE GLASSES; EYEGLASS CHAINS; SIDE GUARDS FOR EYEGLASSES; EYEGLASS CORDS; EYEGLASS FRAMES; FRAMES FOR SPECTACLES AND SUNGLASSES; FRAMES FOR EYEGLASSES AND PINCE-NEZ; SPECTACLE HOLDERS; GLACIER EYEGLASSES; OPERA GLASSES; MONOCLES; PINCE-NEZ; PINCE-NEZ CHAINS; PINCE-NEZ CORDS; PINCE-NEZ MOUNTINGS; CONTACT LENSES (U.S. CLS. 21, 23, 26, 36 AND 38).

ERNEST SHOSHO, EXAMINING ATTORNEY

**CLASS 9—(Continued).**

SN 79-088,023. DANIEL NESTOR SOLENTHALER, CH-3072 OSTERMUNDIGEN, SWITZERLAND, FILED 9-9-2010.



SN 79-087,918. HYUN JIN, AHN, REPUBLIC OF KOREA, FILED 8-23-2010.

# NETCURY

OWNER OF INTERNATIONAL REGISTRATION 1052657 DATED 8-23-2010, EXPIRES 8-23-2020.

FOR INTERNET PROTOCOL CAMERAS; SECURITY ALARMS; ANTI-THEFT WARNING APPARATUS, NAMELY, THEFT ALARMS; ELECTRICAL AND ELECTRONIC BURGLAR ALARMS; ELECTRIC THEFT PREVENTION INSTALLATIONS, NAMELY, THEFT ALARMS (U.S. CLS. 21, 23, 26, 36 AND 38).

DEIRDRE ROBERTSON, EXAMINING ATTORNEY

OWNER OF INTERNATIONAL REGISTRATION 1052955 DATED 9-9-2010, EXPIRES 9-9-2020.

THE MARK CONSISTS OF THE ROUND, SHADED FACE OF A TIMEPIECE TILTED SLIGHTLY TO THE RIGHT. THE OUTER RIM APPEARS TO BE OF METAL. THE TOP HALF IN THE LIGHT, THE LOWER HALF IN THE SHADOW. THE HOURS ARE MARKED BY ROMAN NUMERALS AND THE TIME IS SHOWN WITH HOUR HAND POINTING BETWEEN SEVEN AND EIGHT AND THE MINUTE HAND BETWEEN FIFTEEN AND TWENTY MINUTES PAST THE HOUR. AT THE TOP, TO THE RIGHT, IS THE WORD "TIMESENSOR" IN LIGHT, STYLIZED LETTERING.

FOR COMPUTER SOFTWARE FOR USE IN CUSTOMER RELATIONSHIP MANAGEMENT; DATABASE MANAGEMENT SOFTWARE FOR SERVICE PROVIDERS (U.S. CLS. 21, 23, 26, 36 AND 38).

JILL C. ALT, EXAMINING ATTORNEY

**CLASS 9—(Continued).**

SN 79-089,426. DEMIRER KABLO TESISLERI SANAYI VE TICARET ANONIM SIRKETI, TURKEY, FILED 5-18-2010.



OWNER OF INTERNATIONAL REGISTRATION 1032070 DATED 9-11-2009, EXPIRES 9-11-2019.

NO CLAIM IS MADE TO THE EXCLUSIVE RIGHT TO USE "KABLO", APART FROM THE MARK AS SHOWN.

THE COLOR(S) ORANGE IS/ARE CLAIMED AS A FEATURE OF THE MARK.

THE MARK CONSISTS OF THE STYLIZED WORDING "DK DEMIRER KABLO" IN ORANGE.

THE ENGLISH TRANSLATION OF "KABLO" IN THE MARK IS CABLE. THE TERM "DEMIRER" HAS NO MEANING IN A FOREIGN LANGUAGE.

FOR ELECTRIC ENERGY TRANSMISSION, TRANSFORMATION, STORAGE, CONTROL APPARATUS AND DEVICES, NAMELY, ELECTRICAL CABLES, ELECTRONIC CABLES, ELECTRICAL INTERCONNECT CABLES, AND POWER SUPPLIES; ALL TYPES OF LOW VOLTAGE, MEDIUM VOLTAGE, HIGH VOLTAGE, AND EXTRA HIGH VOLTAGE ENERGY ELECTRICAL CABLES; HIGH AND EXTRA HIGH VOLTAGE CABLE CONNECTORS; HIGH AND EXTRA HIGH VOLTAGE GIS (GAS INSULATED SUBSTATION), NAMELY, ELECTRICAL SWITCHGEAR IN THE NATURE OF VOLTAGE BOOSTING DEVICES FOR ELECTRIC POWER LINES; TRANSFORMERS; CONNECTION FITTINGS FOR ELECTRIC CABLES AND WIRES IN THE NATURE OF OUTDOOR SEALING-ENDS; CABLE SCREEN EARTHING, NAMELY, METAL GROUNDING BUSHINGS AND METAL GROUNDING CLAMPS, BOTH FOR USE ONLY AS PARTS AND FITTINGS FOR COAXIAL CABLE, AND NOT FOR NON-ELECTRIC CABLE OR MACHINERY OR MACHINERY PARTS; CROSS-BONDING LINK BOXES, NAMELY, ELECTRIC JUNCTION BOXES; INSTALLATION AND CONTROL CABLES, NAMELY, COMPUTER CABLES AND CONNECTION CABLES; ALL SORTS OF SPECIAL TYPE CABLES, NAMELY, ETHERNET CABLES AND HIGH DEFINITION MULTIMEDIA CABLES; ALL SORTS OF TELECOMMUNICATION CABLES, NAMELY, COAXIAL CABLES AND CABLES FOR OPTICAL SIGNAL TRANSMISSION; FIBEROPTIC CABLES (U.S. CLS. 21, 23, 26, 36 AND 38).

NELSON SNYDER, EXAMINING ATTORNEY

SN 79-091,175. NATIVE INSTRUMENTS GMBH, FED REP GERMANY, FILED 10-7-2010.

# iMASCHINE

THE MARK CONSISTS OF STANDARD CHARACTERS WITHOUT CLAIM TO ANY PARTICULAR FONT, STYLE, SIZE, OR COLOR.

PRIORITY DATE OF 9-9-2010 IS CLAIMED.

OWNER OF INTERNATIONAL REGISTRATION 1061433 DATED 10-7-2010, EXPIRES 10-7-2020.

FOR COMPUTER SOFTWARE FOR GENERATING MUSIC AND SOUND; COMPUTER SOFTWARE FOR THE CONTROL AND REMOTE CONTROL OF COMPUTER HARDWARE, COMPUTER SOFTWARE AND DATA PROCESSING SYSTEMS; COMPUTER HARDWARE FOR GENERATING MUSIC AND SOUND (U.S. CLS. 21, 23, 26, 36 AND 38).

SAMUEL E. SHARPER JR., EXAMINING ATTORNEY

**CLASS 9—(Continued).**

SN 79-092,451. BEIJING NUFRONT MOBILE MULTIMEDIA TECHNOLOGY CO., LTD, CHINA, FILED 1-4-2011.



PRIORITY DATE OF 9-9-2010 IS CLAIMED.

OWNER OF INTERNATIONAL REGISTRATION 1064805 DATED 1-4-2011, EXPIRES 1-4-2021.

FOR APPARATUS FOR RECORDING, TRANSMISSION, PROCESSING AND REPRODUCTION OF SOUND, IMAGES OR DATA; COMPUTERS; DATA PROCESSORS; DIGITAL SIGNAL PROCESSORS; SEMICONDUCTORS; INTEGRATED CIRCUITS; ELECTRONIC CHIPS FOR THE MANUFACTURE OF INTEGRATED CIRCUITS; INTEGRATED CIRCUIT CHIPS FOR DIGITAL VIDEO COMPRESSION AND DECOMPRESSION; BLANK SMART CARDS (U.S. CLS. 21, 23, 26, 36 AND 38).

BARBARA RUTLAND, EXAMINING ATTORNEY

SN 79-093,728. GLOBAL BEST WAY CO., LTD., CHINA, FILED 1-4-2011.



OWNER OF INTERNATIONAL REGISTRATION 1067541 DATED 1-4-2011, EXPIRES 1-4-2021.

THIS TRADEMARK CONSISTS OF A STYLIZED CAPITAL LATIN WORD "RIWA".

FOR HAIR-CURLERS, ELECTRICALLY HEATED; EYEGASSES; SUNGLASSES; CAMERAS; BATTERIES; FLAT IRONS, ELECTRIC; COMPUTERS; CIGAR LIGHTERS FOR AUTOMOBILES; PORTABLE TELEPHONES (U.S. CLS. 21, 23, 26, 36 AND 38).

LANA PHAM, EXAMINING ATTORNEY

SN 79-094,038. SHAMIR OPTICAL INDUSTRY LTD., ISRAEL, FILED 1-3-2011.

# GLACIER PLUS

THE MARK CONSISTS OF STANDARD CHARACTERS WITHOUT CLAIM TO ANY PARTICULAR FONT, STYLE, SIZE, OR COLOR.

PRIORITY DATE OF 8-10-2010 IS CLAIMED.

OWNER OF INTERNATIONAL REGISTRATION 1068315 DATED 1-3-2011, EXPIRES 1-3-2021.

FOR OPTICAL LENSES FOR SPECTACLES; SPECTACLES; CONTAINERS FOR OPTICAL LENSES AND SPECTACLES; CASES, HOLDERS, PARTS AND FITTINGS FOR THE AFOREMENTIONED GOODS; COMPUTER SOFTWARE FOR PRODUCTION OF OPTICAL LENSES (U.S. CLS. 21, 23, 26, 36 AND 38).

JENNIFER MARTIN, EXAMINING ATTORNEY

**CLASS 9—(Continued).**

SN 79-094,133. C.E.I.A. - COSTRUZIONI ELETTRONICHE INDUSTRIALI AUTOMATISMI S.P.A., ITALY, FILED 12-16-2010.

# CMD

THE MARK CONSISTS OF STANDARD CHARACTERS WITHOUT CLAIM TO ANY PARTICULAR FONT, STYLE, SIZE, OR COLOR.

PRIORITY DATE OF 6-16-2010 IS CLAIMED.  
OWNER OF INTERNATIONAL REGISTRATION 1068627 DATED 12-16-2010, EXPIRES 12-16-2020.  
FOR METAL DETECTORS (U.S. CLS. 21, 23, 26, 36 AND 38).

APRIL ROACH, EXAMINING ATTORNEY

SN 79-094,273. BEIJING NUFRONT MOBILE MULTIMEDIA TECHNOLOGY CO., LTD, CHINA, FILED 1-4-2011.

# NUSMART

PRIORITY DATE OF 9-9-2010 IS CLAIMED.  
OWNER OF INTERNATIONAL REGISTRATION 1068918 DATED 1-4-2011, EXPIRES 1-4-2021.

FOR APPARATUS FOR RECORDING, TRANSMISSION, PROCESSING AND REPRODUCTION OF SOUND, IMAGES OR DATA; COMPUTERS; DATA PROCESSORS; DIGITAL SIGNAL PROCESSORS; SEMICONDUCTORS; INTEGRATED CIRCUITS; ELECTRONIC CHIPS FOR THE MANUFACTURE OF INTEGRATED CIRCUITS; INTEGRATED CIRCUIT CHIPS FOR DIGITAL VIDEO COMPRESSION AND DECOMPRESSION; BLANK SMART CARDS (U.S. CLS. 21, 23, 26, 36 AND 38).

BARBARA RUTLAND, EXAMINING ATTORNEY

SN 79-094,295. BEIJING NUFRONT MOBILE MULTIMEDIA TECHNOLOGY CO., LTD, CHINA, FILED 2-11-2011.

# NuStar

PRIORITY DATE OF 10-11-2010 IS CLAIMED.  
OWNER OF INTERNATIONAL REGISTRATION 1068962 DATED 2-11-2011, EXPIRES 2-11-2021.

FOR APPARATUS, FOR RECORDING, TRANSMISSION, PROCESSING AND REPRODUCTION OF DATA; COMPUTERS; DATA PROCESSORS; DIGITAL SIGNAL PROCESSORS; SEMICONDUCTORS; INTEGRATED CIRCUITS; ELECTRONIC CHIPS FOR THE MANUFACTURE OF INTEGRATED CIRCUITS; INTEGRATED CIRCUIT CHIPS FOR DIGITAL VIDEO COMPRESSION AND DECOMPRESSION; BLANK SMART CARDS (U.S. CLS. 21, 23, 26, 36 AND 38).

BARBARA RUTLAND, EXAMINING ATTORNEY

**CLASS 9—(Continued).**

SN 79-975,170. GIANNI VERSACE S.P.A., I-20121 MILANO, ITALY, FILED 9-3-2009.

# VERSACE

THE MARK CONSISTS OF STANDARD CHARACTERS WITHOUT CLAIM TO ANY PARTICULAR FONT, STYLE, SIZE, OR COLOR.

PRIORITY DATE OF 5-25-2009 IS CLAIMED.  
OWNER OF INTERNATIONAL REGISTRATION 1018595 DATED 9-3-2009, EXPIRES 9-3-2019.  
OWNER OF U.S. REG. NOS. 1,123,748, 1,641,270 AND OTHERS.  
SEC. 2(F).  
FOR MOBILE PHONES (U.S. CLS. 21, 23, 26, 36 AND 38).

APRIL ROACH, EXAMINING ATTORNEY

SN 85-001,436. IDEA OVEN LLC, WILMINGTON, NC. FILED 3-29-2010.

# MediForms

THE MARK CONSISTS OF STANDARD CHARACTERS WITHOUT CLAIM TO ANY PARTICULAR FONT, STYLE, SIZE, OR COLOR.

SEC. 2(F).  
FOR COMPUTER SOFTWARE FOR CONTROLLING AND MANAGING PATIENT MEDICAL INFORMATION (U.S. CLS. 21, 23, 26, 36 AND 38).  
FIRST USE 12-15-2006; IN COMMERCE 2-17-2007.

SKYE YOUNG, EXAMINING ATTORNEY

SN 85-004,214. ANAND PAG INC, IRVING, TX. FILED 4-1-2010.

# Collaboration On-the-Go

THE MARK CONSISTS OF STANDARD CHARACTERS WITHOUT CLAIM TO ANY PARTICULAR FONT, STYLE, SIZE, OR COLOR.

FOR COMPUTER APPLICATION SOFTWARE FOR USE WITH USER INTERFACES AND WORKFLOW FOR BUSINESS APPLICATIONS ASSOCIATED WITH ERP SYSTEMS ON LAPTOPS, DESKTOPS AND MOBILE DEVICES, NAMELY, MOBILE PHONES, PDAS, HANDHELD COMPUTERS, TABLETS AND SMART PHONES; COMPUTER SOFTWARE FOR ENABLING BUSINESS PROCESSES ON MOBILE DEVICES, NAMELY, MOBILE PHONES, PDAS, HANDHELD COMPUTERS AND SMART PHONES BY COMMUNICATING TO BACK END DATABASE SYSTEMS USING WEB SERVICES OR HTTP SERVICE CALLS (U.S. CLS. 21, 23, 26, 36 AND 38).

REGINA DRUMMOND, EXAMINING ATTORNEY

**CLASS 9—(Continued).**

SN 85-015,131. VTECH COMMUNICATIONS, INC., BEAVERTON, OR. FILED 4-15-2010.

**AUDIO ASSIST**

THE MARK CONSISTS OF STANDARD CHARACTERS WITHOUT CLAIM TO ANY PARTICULAR FONT, STYLE, SIZE, OR COLOR.

NO CLAIM IS MADE TO THE EXCLUSIVE RIGHT TO USE "AUDIO", APART FROM THE MARK AS SHOWN.

FOR AN AUDIO SYSTEM SOLD AS AN INTEGRAL COMPONENT OF CORDED TELEPHONES AND CORDLESS TELEPHONES (U.S. CLS. 21, 23, 26, 36 AND 38).

FIRST USE 1-31-2009; IN COMMERCE 1-31-2009.  
LINDA LAVACHE, EXAMINING ATTORNEY

---

SN 85-015,140. VTECH COMMUNICATIONS, INC., BEAVERTON, OR. FILED 4-15-2010.

**MESSAGE GUARD**

THE MARK CONSISTS OF STANDARD CHARACTERS WITHOUT CLAIM TO ANY PARTICULAR FONT, STYLE, SIZE, OR COLOR.

NO CLAIM IS MADE TO THE EXCLUSIVE RIGHT TO USE "MESSAGE", APART FROM THE MARK AS SHOWN.

FOR MEMORY SYSTEM SOLD AS AN INTEGRAL COMPONENT OF TELEPHONES AND TELEPHONE ANSWERING DEVICES (U.S. CLS. 21, 23, 26, 36 AND 38).

FIRST USE 1-1-1998; IN COMMERCE 1-1-1998.  
LINDA LAVACHE, EXAMINING ATTORNEY

---

SN 85-016,341. ACCESSORYONE, SHERMAN OAKS, CA. FILED 4-16-2010.

**AccessoryOne**

THE MARK CONSISTS OF STANDARD CHARACTERS WITHOUT CLAIM TO ANY PARTICULAR FONT, STYLE, SIZE, OR COLOR.

FOR ELECTRONICS AND CELL PHONE ACCESSORIES, NAMELY, CELL PHONE BATTERIES, BATTERY CASES; LAP TOP ACCESSORIES, NAMELY, CARRYING CASES, BAGS, AND BATTERIES (U.S. CLS. 21, 23, 26, 36 AND 38).

FIRST USE 2-1-2002; IN COMMERCE 2-1-2002.  
DOMINIC FATHY, EXAMINING ATTORNEY

**CLASS 9—(Continued).**

SN 85-016,370. BETTER PLACE, INC., PALO ALTO, CA. FILED 4-16-2010.

**FORAY**

THE MARK CONSISTS OF STANDARD CHARACTERS WITHOUT CLAIM TO ANY PARTICULAR FONT, STYLE, SIZE, OR COLOR.

FOR COMPUTER HARDWARE; SOFTWARE FOR USE IN AUTOMOBILES, TRUCKS AND LAND VEHICLES TO MONITOR AVAILABILITY AND USAGE OF ELECTRIC AND OTHER SOURCES OF POWER, AND FOR CONTROL OF AUDIO, VIDEO AND MULTIMEDIA CONTENT FEATURES OF THE AUTOMOBILES, TRUCKS AND LAND VEHICLES; VEHICLE OPERATING SYSTEM SOFTWARE; SOFTWARE FOR USE IN AUTOMOBILES, TRUCKS AND LAND VEHICLES FOR NAVIGATION, AND FOR OPERATION OF SAFETY AND OTHER FEATURES; SOFTWARE TO MANAGE AND FACILITATE THE DISTRIBUTION OF INFORMATIONAL, EDUCATIONAL AND ENTERTAINMENT AUDIO, VISUAL AND MULTIMEDIA CONTENT TO AUTOMOBILES, TRUCKS AND LAND VEHICLES; SOFTWARE FOR USE IN MANAGING ELECTRICITY, BATTERY REPLACEMENT AND BATTERY RECHARGING NETWORKS FOR AUTOMOBILES, TRUCKS AND LAND VEHICLES; SOFTWARE FOR USE IN OPERATING, MONITORING AND MAINTAINING BATTERIES FOR AUTOMOBILES, TRUCKS AND LAND VEHICLES; SOFTWARE FOR USE IN ENERGY MANAGEMENT SERVICES FOR AUTOMOBILES, TRUCKS AND LAND VEHICLES TO CALCULATE MILEAGE, RANGE, MONITOR BATTERY LIFE AND MAINTAIN RECORDS REGARDING ENERGY USAGE, TO MANAGE COMMUNICATIONS REGARDING VEHICLE ENERGY USAGE BETWEEN THE VEHICLE AND A NETWORK OF FACILITIES FOR THE DISTRIBUTION OF ELECTRICITY FOR LAND VEHICLES, AND TO COMMUNICATE BETWEEN VEHICLE CONTROL CENTERS AND VEHICLE OPERATING SYSTEMS; DIGITAL MATERIALS, NAMELY, DOWNLOADABLE AUDIO FILES AND CDS, FEATURING, MUSIC, SOUNDS FOR USE IN ELECTRIC VEHICLES, NAVIGATION INFORMATION AND INFORMATION REGARDING A WIDE VARIETY OF TOPICS OF INTEREST (U.S. CLS. 21, 23, 26, 36 AND 38).

AMY ALFIERI, EXAMINING ATTORNEY

---

SN 85-018,027. THIRD RAIL DEVICES, LLC, WESTLAKE, OH. FILED 4-20-2010.

**Third Rail Devices**

THE MARK CONSISTS OF STANDARD CHARACTERS WITHOUT CLAIM TO ANY PARTICULAR FONT, STYLE, SIZE, OR COLOR.

NO CLAIM IS MADE TO THE EXCLUSIVE RIGHT TO USE "DEVICES", APART FROM THE MARK AS SHOWN.

FOR COMPUTER HARDWARE AND TELECOMMUNICATIONS HARDWARE FOR USE IN THE TELECOMMUNICATIONS INDUSTRY, NAMELY, TELEPHONY SUPPORT DEVICES, SPECIFICALLY, SWITCHING DEVICES, ALSO KNOWN AS ETHERNET SWITCHES, ROUTERS, MODEMS AND GATEWAY ROUTERS (U.S. CLS. 21, 23, 26, 36 AND 38).

FIRST USE 4-14-2010; IN COMMERCE 4-14-2010.  
RONALD AIKENS, EXAMINING ATTORNEY



**CLASS 9—(Continued).**

SN 85-019,067. CROPS CO., LTD., TOKYO, JAPAN, FILED 4-21-2010.



OWNER OF U.S. REG. NO. 2,965,690.  
THE MARK CONSISTS OF A STYLIZED AND CARICATURE DESIGN OF A SCORPION.

FOR BICYCLE METERS, NAMELY, ODOMETERS AND SPEEDOMETERS; APPARATUS FOR RECORDING, TRANSMISSION OR REPRODUCTION OF SOUNDS OF IMAGES FOR USE ON BICYCLES; PRE-RECORDED MAGNETIC DATA CARRIERS WITH AUDIO, VIDEO, PHOTOGRAPHS, GRAPHICS, TEXTS, FEATURING SOUND RECORDINGS AND IMAGES; DATA PROCESSING EQUIPMENT AND COMPUTERS AND PARTS AND FITTINGS THEREOF; ERGOMETERS NOT FOR MEDICAL PURPOSES (U.S. CLS. 21, 23, 26, 36 AND 38).

FIRST USE 2-9-2007; IN COMMERCE 2-9-2007.  
TRACY WHITTAKER-BROWN, EXAMINING ATTORNEY

**CLASS 9—(Continued).**

SN 85-026,071. APLUS FLASH TECHNOLOGY, INC., DBA APLUS FLASH TECHNOLOGY, INC., SAN JOSE, CA. FILED 4-29-2010.

HiNOR<sup>Std</sup>

THE MARK CONSISTS OF THE LETTERS "HINORSTD" WITH THE "I" IN LOWER CASE AND "H" AND "NOR" IN UPPER CASE AND THE LETTERS "STD" IN SUPERSCRIP.

FOR COMPUTER CHIPS; COMPUTER MEMORIES; COMPUTER MEMORY HARDWARE; ELECTRONIC CHIPS FOR THE MANUFACTURE OF INTEGRATED CIRCUITS; ELECTRONIC MEMORIES; MEMORIES FOR DATA PROCESSING EQUIPMENT; MEMORIES FOR USE WITH COMPUTERS; SEMI-CONDUCTOR MEMORIES; SEMI-CONDUCTOR MEMORY UNITS (U.S. CLS. 21, 23, 26, 36 AND 38).

ANNE FARRELL, EXAMINING ATTORNEY

SN 85-025,292. EXPRESS TELLER SERVICES, INC., PHOENIX, AZ. FILED 4-28-2010.



NO CLAIM IS MADE TO THE EXCLUSIVE RIGHT TO USE "EXPRESS TELLER SERVICES", "ATM", AND "SALES AND SERVICE", APART FROM THE MARK AS SHOWN.

THE COLOR(S) GREEN, WHITE AND BLACK IS/ARE CLAIMED AS A FEATURE OF THE MARK.

THE MARK CONSISTS OF A CIRCULAR LOGO WITH WORDING. THE MIDDLE RING OF THE LOGO IS A THICK CIRCLE OUTLINED IN GREEN AND WHITE WITH THE WORDS "EXPRESS TELLER SERVICES" ON THE TOP AND "SALES AND SERVICE", ALL WORDS IN WHITE. THE INNER CIRCLE OF THE LOGO IS WHITE AND OUTLINED WITH GREEN AND WHITE. THE TERM "ATM" APPEARS IN THE MIDDLE OF THE LOGO IN BLACK LETTERING.

FOR AUTOMATED TELLER MACHINES (ATM) (U.S. CLS. 21, 23, 26, 36 AND 38).

FIRST USE 1-1-2002; IN COMMERCE 1-1-2002.  
JAMES STEIN, EXAMINING ATTORNEY

SN 85-026,080. APLUS FLASH TECHNOLOGY, INC., DBA APLUS FLASH TECHNOLOGY, INC., SAN JOSE, CA. FILED 4-29-2010.

HiNOR<sup>Emb</sup>

THE MARK CONSISTS OF THE LETTERS "HINOREMB" WITH THE "I" IN LOWER CASE AND "H" AND "NOR" IN UPPERCASE AND THE "EMB" IN SUPERSCRIP.

FOR COMPUTER CHIPS; COMPUTER MEMORIES; COMPUTER MEMORY HARDWARE; ELECTRONIC CHIPS FOR THE MANUFACTURE OF INTEGRATED CIRCUITS; ELECTRONIC MEMORIES; MEMORIES FOR DATA PROCESSING EQUIPMENT; MEMORIES FOR USE WITH COMPUTERS; SEMI-CONDUCTOR MEMORIES; SEMI-CONDUCTOR MEMORY UNITS (U.S. CLS. 21, 23, 26, 36 AND 38).

ANNE FARRELL, EXAMINING ATTORNEY

**CLASS 9—(Continued).**

SN 85-026,090. APLUS FLASH TECHNOLOGY, INC., SAN JOSE, CA. FILED 4-29-2010.

# HiNOR<sup>NAND</sup>

THE MARK CONSISTS OF THE LETTERS "HINOR-NAND" WITH THE "I" IN LOWER CASE AND "H" AND "NOR" IN UPPER CASE AND THE LETTERS "NAND" IN SUPERSCRIPIT.

FOR COMPUTER CHIPS; COMPUTER MEMORIES; COMPUTER MEMORY HARDWARE; ELECTRONIC CHIPS FOR THE MANUFACTURE OF INTEGRATED CIRCUITS; ELECTRONIC MEMORIES; MEMORIES FOR DATA PROCESSING EQUIPMENT; MEMORIES FOR USE WITH COMPUTERS; SEMI-CONDUCTOR MEMORIES; SEMI-CONDUCTOR MEMORY UNITS (U.S. CLS. 21, 23, 26, 36 AND 38).

ANNE FARRELL, EXAMINING ATTORNEY

SN 85-026,359. DIVENTION DESIGN, LLC, SAN JOSE, CA. FILED 4-29-2010.

# BANANATOOTH

THE MARK CONSISTS OF STANDARD CHARACTERS WITHOUT CLAIM TO ANY PARTICULAR FONT, STYLE, SIZE, OR COLOR.

FOR DIGITAL PORTABLE EQUIPMENT, NAMELY, PORTABLE DIGITAL ELECTRONIC DEVICES FOR RECORDING, ORGANIZING, TRANSMITTING, MANIPULATING, OR REVIEWING TEXT, DATA, IMAGE, VIDEO FILES, OR AUDIO FILES; AUDIO HEADSETS AND MULTIMEDIA SPEAKER SYSTEMS, INCLUDING PORTABLE OR WIRELESS HEADSETS OR MULTIMEDIA SPEAKER SYSTEMS FOR PDA, CELLULAR PHONES, PCS, MP3 PLAYERS OR OTHER PERSONAL ELECTRONIC ENTERTAINMENT APPLICATIONS; WIRELESS EQUIPMENT, NAMELY, DEVICES FOR WIRELESS RADIO TRANSMISSION; USB HARDWARE IN THE NATURE OF WIRELESS ADAPTERS FOR COMPUTERS; WIRELESS CELLULAR PHONE HEADSETS; WIRELESS APPARATUS, NAMELY, WIRELESS TELEPHONY APPARATUS, WIRELESS ADAPTERS FOR COMPUTERS, WIRELESS COMPUTER PERIPHERALS, WIRELESS BROADBAND RADIOS, WIRELESS NARROWBAND RADIOS, WIRELESS COMMUNICATION DEVICES FOR VOICE, DATA OR IMAGE TRANSMISSION; WIRELESS RECEIVERS; WIRELESS HANDHELD TRANSMITTERS OR RECEIVERS; WIRELESS TRANSMITTERS; WIRELESS AUDIO SPEAKERS; WIRELESS PORTABLE RECEIVERS OR TRANSMITTERS; REMOTE CONTROL APPARATUS, NAMELY, REMOTE CONTROL TRANSMITTER FOR RADIO-CONTROLLED DEVICES; SOUNDING APPARATUS, NAMELY, ECHO SOUNDING DEVICES (U.S. CLS. 21, 23, 26, 36 AND 38).  
FIRST USE 6-10-2009; IN COMMERCE 6-10-2009.  
FRED CARL, EXAMINING ATTORNEY

**CLASS 9—(Continued).**

SN 85-027,916. COTENDO INC., SUNNYVALE, CA. FILED 4-30-2010.

# CLOUDLET

THE MARK CONSISTS OF STANDARD CHARACTERS WITHOUT CLAIM TO ANY PARTICULAR FONT, STYLE, SIZE, OR COLOR.

FOR SOFTWARE FOR ENABLING, FACILITATING, IMPROVING AND ACCELERATING CONTENT DELIVERY AND COMPUTER NETWORK TRAFFIC MANAGEMENT IN A CONTENT DELIVERY NETWORK (U.S. CLS. 21, 23, 26, 36 AND 38).

BARBARA BROWN, EXAMINING ATTORNEY

SN 85-029,409. FERGUSON ENTERPRISES, INC., NEWPORT NEWS, VA. FILED 5-4-2010.

# PROSELECT

THE MARK CONSISTS OF STANDARD CHARACTERS WITHOUT CLAIM TO ANY PARTICULAR FONT, STYLE, SIZE, OR COLOR.

FOR BATTERIES, BATTERIES AND BATTERY CHARGERS, BATTERIES FOR POCKETLAMPS (U.S. CLS. 21, 23, 26, 36 AND 38).

SANI KHOURI, EXAMINING ATTORNEY

SN 85-030,123. ROSE COLORED GLASSES LLC, SANTA MONICA, CA. FILED 5-4-2010.

# MELODIES BY MJB

THE MARK CONSISTS OF STANDARD CHARACTERS WITHOUT CLAIM TO ANY PARTICULAR FONT, STYLE, SIZE, OR COLOR.

THE NAME(S), PORTRAIT(S), AND/OR SIGNATURE(S) SHOWN IN THE MARK IDENTIFIES MARY J. BLIGE, WHOSE CONSENT(S) TO REGISTER IS MADE OF RECORD.

FOR EYEWEAR AND SUNGLASSES (U.S. CLS. 21, 23, 26, 36 AND 38).

FRED CARL, EXAMINING ATTORNEY

**CLASS 9—(Continued).**

SN 85-030,265. SYSTEM I/O, INC., DBA INFINIBAND TRADE ASSOCIATION, BEAVERTON, OR. FILED 5-4-2010.

# INFINIBAND

THE MARK CONSISTS OF STANDARD CHARACTERS WITHOUT CLAIM TO ANY PARTICULAR FONT, STYLE, SIZE, OR COLOR.

OWNER OF U.S. REG. NOS. 2,493,390 AND 2,673,920.  
FOR COMPUTER HARDWARE; COMPUTER SOFTWARE FOR COMMUNICATING OVER BOTH LOCAL AND GLOBAL NETWORKS FOR THE INTEROPERATION AND MANAGEMENT OF COMPUTER SYSTEMS AND DEVICES (U.S. CLS. 21, 23, 26, 36 AND 38).  
MAUREEN DALL, EXAMINING ATTORNEY

SN 85-031,160. NUMA TACTICAL, LLC, NEW YORK, NY. FILED 5-5-2010.

# NUMA

THE MARK CONSISTS OF STANDARD CHARACTERS WITHOUT CLAIM TO ANY PARTICULAR FONT, STYLE, SIZE, OR COLOR.

FOR PROTECTIVE EYEWEAR; SUNGLASSES (U.S. CLS. 21, 23, 26, 36 AND 38).  
FIRST USE 11-19-2005; IN COMMERCE 11-19-2005.  
GRETTA YAO, EXAMINING ATTORNEY

SN 85-032,158. ALMAX MANUFACTURING CO., DBA MAXTECH CIRCUIT, KIRKLAND, WA. FILED 5-6-2010.



THE MARK CONSISTS OF A SOLID SQUARE WITH ROUNDED CORNERS THAT CONTAINS AN "S"-SHAPE SYMBOL WITH AN ARROW AT ITS HEAD AND A CIRCLE AT ITS TAIL. THE WORD "SENSTOUCH" APPEARS TO THE RIGHT OF THE DESIGN.

FOR ELECTRONIC TOUCH SENSITIVE SWITCHES (U.S. CLS. 21, 23, 26, 36 AND 38).  
REBECCA EISINGER, EXAMINING ATTORNEY

**CLASS 9—(Continued).**

SN 85-034,540. WORLDQUANT, LLC, OLD GREENWICH, CT. FILED 5-10-2010.

# WQHYDRA

THE MARK CONSISTS OF STANDARD CHARACTERS WITHOUT CLAIM TO ANY PARTICULAR FONT, STYLE, SIZE, OR COLOR.

FOR COMPUTER PROGRAMS FOR USE IN CONNECTION WITH ELECTRONIC TRADING OF VARIOUS FINANCIAL INSTRUMENTS, NAMELY, SOFTWARE FOR ELECTRONICALLY TRADING SECURITIES (U.S. CLS. 21, 23, 26, 36 AND 38).  
CHRISTINE COOPER, EXAMINING ATTORNEY

SN 85-036,028. TENREHTE TECHNOLOGIES, INC., ROCHESTER, NY. FILED 5-12-2010.

# PICOWATT

THE MARK CONSISTS OF STANDARD CHARACTERS WITHOUT CLAIM TO ANY PARTICULAR FONT, STYLE, SIZE, OR COLOR.

FOR SCIENTIFIC, MEASURING, SIGNALING, CHECKING, SUPERVISION, TEACHING APPARATUS AND INSTRUMENTS, NAMELY, WIRELESS OUTLET PLUG ADAPTERS (U.S. CLS. 21, 23, 26, 36 AND 38).  
FIRST USE 4-1-2009; IN COMMERCE 9-1-2009.  
KIM SAITO, EXAMINING ATTORNEY

SN 85-036,310. HPI INTERNATIONAL INC., BROOKLYN, NY. FILED 5-12-2010.

# ECKO-CLIPZ

THE MARK CONSISTS OF STANDARD CHARACTERS WITHOUT CLAIM TO ANY PARTICULAR FONT, STYLE, SIZE, OR COLOR.

FOR HEADPHONES (U.S. CLS. 21, 23, 26, 36 AND 38).  
FIRST USE 4-15-2010; IN COMMERCE 4-15-2010.  
CHARLES L. JENKINS, EXAMINING ATTORNEY

**CLASS 9—(Continued).**

SN 85-038,509. RELATIVITY MEDIA, LLC, LOS ANGELES, CA. FILED 5-14-2010.

## IMMORTALS

THE MARK CONSISTS OF STANDARD CHARACTERS WITHOUT CLAIM TO ANY PARTICULAR FONT, STYLE, SIZE, OR COLOR.

FOR COVERS FOR CELL PHONES; DIGITAL MUSIC PLAYERS; LAPTOP COMPUTERS; AMUSEMENT MACHINES, NAMELY, HAND-HELD ELECTRONIC GAME UNITS ADAPTED FOR USE WITH AN EXTERNAL DISPLAY SCREEN OR MONITOR; HAND-HELD ELECTRONIC GAMES ADAPTED FOR USE WITH TELEVISION RECEIVERS ONLY; HAND-HELD UNITS FOR PLAYING ELECTRONIC GAMES FOR USE WITH EXTERNAL DISPLAY SCREEN OR MONITOR; PERSONAL DIGITAL ASSISTANTS (PDAS); MAGNETS AND MAGNET SHEETS; COMPUTER STORAGE DEVICES, NAMELY, BLANK FLASH DRIVES; VIDEO GAME SOFTWARE AND INTERACTIVE VIDEO GAME PROGRAMS; BACKPACKS ADAPTED FOR HOLDING COMPUTERS; CAMERA CASES; CASES FOR MOBILE PHONES; CASES FOR PDAS; CELL PHONES; DECORATIVE CHARMS FOR CELL PHONES; LAPTOP CARRYING CASES; MOUSEPADS; NEON SIGNS (U.S. CLS. 21, 23, 26, 36 AND 38).

EDWARD FENNESSY, EXAMINING ATTORNEY

SN 85-039,711. BUDD, TERENCE DARIAN, LOS ANGELES, CA. FILED 5-16-2010.

## Old School

THE MARK CONSISTS OF STANDARD CHARACTERS WITHOUT CLAIM TO ANY PARTICULAR FONT, STYLE, SIZE, OR COLOR.

FOR EDUCATIONAL SOFTWARE FEATURING INSTRUCTION IN MATH, ENGLISH, HISTORY, MUSIC, AND SCIENCE (U.S. CLS. 21, 23, 26, 36 AND 38).

LINDA ESTRADA, EXAMINING ATTORNEY

SN 85-039,732. YEXA.COM PTY LTD, BRISBANE, QUEENSLAND, AUSTRALIA, FILED 5-16-2010.



THE MARK CONSISTS OF A STYLIZED WORD "YEXA". FOR DOWNLOADABLE COMPUTER SOFTWARE PROGRAM FOR USE IN DESIGNING AND MANAGING CONTENT ON A WEB SITE, AND TO ASSIST PROGRAMMERS IN DEVELOPING WEB-BASED SOFTWARE APPLICATIONS (U.S. CLS. 21, 23, 26, 36 AND 38).

JILL C. ALT, EXAMINING ATTORNEY

**CLASS 9—(Continued).**

SN 85-040,133. PERFECT SOURCE TECHNOLOGY CORP., TAOYUAN COUNTY, TAIWAN, FILED 5-17-2010.



THE COLOR(S) GREEN, WHITE, BLACK AND BLUE IS/ ARE CLAIMED AS A FEATURE OF THE MARK.

THE MARK CONSISTS OF THE COLOR GREEN APPLIED TO "PST", THE COLOR WHITE APPLIED TO SIX HORIZONTAL STRIPES ON "PST", THE COLOR BLACK APPLIED TO "PERFECT SOURCE", AND THE COLOR BLUE APPLIED TO THE STYLIZED, HORIZONTAL DESIGN.

FOR ACCUMULATORS AND BATTERIES; BUILDING-INTEGRATED PHOTOVOLTAICS (BIPV); CRYSTALLINE SILICON CHIPS; INVERTERS FOR SOLAR POWER SYSTEM; SOLAR CELLS; SOLAR CELL MODULES; SILICON WAFER SUBSTRATES; SOLAR POWER SYSTEM COMPRISING SOLAR MODULES, ACCUMULATORS, CONTROLLERS, CONVERTERS FOR ELECTRICITY GENERATION; SOLAR POWER SYSTEM CONTROLLERS; SOLAR WIND POWER SYSTEM COMPRISED OF MACHINE FOUNDATION, MAIN SHAFT, GEAR BOX, ELECTRIC GENERATOR, CONTROL UNIT, TOWER, IMPELLER HUB, AND BLADES; SOLAR CHARGERS; SOLAR CHARGING STATION; SOLAR CELL FOR MOBILE PHONES; SILICON CHIPS; SOLAR WAFERS (U.S. CLS. 21, 23, 26, 36 AND 38).

ANNE MADDEN, EXAMINING ATTORNEY

SN 85-041,088. 745 LLC, DBA SEVEN45 STUDIOS, BOSTON, MA. FILED 5-18-2010.

## AIRSTRIKE

THE MARK CONSISTS OF STANDARD CHARACTERS WITHOUT CLAIM TO ANY PARTICULAR FONT, STYLE, SIZE, OR COLOR.

FOR SIMULATED DRUM CONTROLLERS FOR USE WITH COMPUTER GAME SOFTWARE, VIDEO GAME SOFTWARE, INTERACTIVE VIDEO GAMES, AND INTERACTIVE COMPUTER GAMES (U.S. CLS. 21, 23, 26, 36 AND 38).

LOURDES AYALA, EXAMINING ATTORNEY

**CLASS 9—(Continued).**

SN 85-041,161. PROCONGPS, INC., KNOXVILLE, TN. FILED 5-18-2010.



NO CLAIM IS MADE TO THE EXCLUSIVE RIGHT TO USE "LOAN", APART FROM THE MARK AS SHOWN.

THE COLOR(S) BLUE, GRAY, AND GREEN IS/ARE CLAIMED AS A FEATURE OF THE MARK.

THE MARK CONSISTS OF THE WORD "LOAN" IN BLUE BLOCK LETTERS, EACH SURROUNDED BY A GRAY BORDER, AND A GREEN PLUS SYMBOL WITH A GRAY BORDER DISPOSED TO THE UPPER RIGHT OF THE LETTER "N" IN THE WORD "LOAN"; AND A BLUE SWOOSH CURVE HAVING ITS LEFTMOST END DISPOSED BELOW THE LETTER "O" IN THE WORD "LOAN" AND EXTENDING BEHIND THE WORD "LOAN" AND HAVING A POINT AT ITS RIGHTMOST END WHICH IS DISPOSED IN FRONT OF THE GREEN PLUS SYMBOL.

FOR WIRELESS DEVICES FOR NAVIGATION, COMMUNICATION AND TRACKING, NAMELY, PORTABLE TRACKING UNITS THAT COMBINE GPS AND CELLULAR TECHNOLOGIES FOR DETERMINING LOCATION INFORMATION AND COMMUNICATING THE LOCATION INFORMATION (U.S. CLS. 21, 23, 26, 36 AND 38).

FIRST USE 12-30-2009; IN COMMERCE 12-30-2009.  
APRIL HESIK, EXAMINING ATTORNEY

---

SN 85-042,248. UNCOMMON, LLC, CHICAGO, IL. FILED 5-19-2010.

# YOUNIQUE

THE MARK CONSISTS OF STANDARD CHARACTERS WITHOUT CLAIM TO ANY PARTICULAR FONT, STYLE, SIZE, OR COLOR.

FOR CARRYING CASES OR BAGS DESIGNED FOR STORAGE AND TRANSPORTATION OF CONSUMER ELECTRONICS, CELLULAR PHONES, MEDIA PLAYERS, AND LAPTOP COMPUTERS (U.S. CLS. 21, 23, 26, 36 AND 38).

TASNEEM HUSSAIN, EXAMINING ATTORNEY

**CLASS 9—(Continued).**

SN 85-043,033. LEISURE ELECTRONICS TECHNOLOGY CO., LTD., TOKYO, JAPAN, FILED 5-19-2010.

# G-RANG

THE MARK CONSISTS OF STANDARD CHARACTERS WITHOUT CLAIM TO ANY PARTICULAR FONT, STYLE, SIZE, OR COLOR.

FOR RANDOM NUMBER GENERATION DEVICE, NAMELY, COMPUTER CHIPS, PERIPHERAL COMPONENT INTERFACE (PCI) CARDS AND INTEGRATED CIRCUITS; ANTI-FREEZE MICROCOMPUTERS (U.S. CLS. 21, 23, 26, 36 AND 38).

CAROLINE WOOD, EXAMINING ATTORNEY

---

SN 85-043,046. NEUROSCRIPT, LLC, TEMPE, AZ. FILED 5-19-2010.

# NEUROSCRIPT

THE MARK CONSISTS OF STANDARD CHARACTERS WITHOUT CLAIM TO ANY PARTICULAR FONT, STYLE, SIZE, OR COLOR.

FOR DOWNLOADABLE COMPUTER SOFTWARE FOR ANALYSIS OF FINE MOTOR CONTROL AND IMPAIRMENT, IN PARTICULAR, HANDWRITING OR DRAWING OR POINTING TASKS USING TABLET COMPUTER, ELECTRONIC PENS, TOUCH SCREEN, MOUSE, OR SCANNED IMAGES (U.S. CLS. 21, 23, 26, 36 AND 38).

FIRST USE 4-13-1993; IN COMMERCE 6-2-2004.  
SIMON TENG, EXAMINING ATTORNEY

---

SN 85-043,202. JONATHAN H. BASSAN, SANTA BARBARA, CA. FILED 5-19-2010.

# SWAMICITY

THE MARK CONSISTS OF STANDARD CHARACTERS WITHOUT CLAIM TO ANY PARTICULAR FONT, STYLE, SIZE, OR COLOR.

FOR SOFTWARE SYSTEMS FOR MOBILE COMPUTING DEVICES, NAMELY, AN INTEGRATED SUITE OF COMPUTER SOFTWARE PROGRAMS FOR DELIVERING TRAVEL INFORMATION (U.S. CLS. 21, 23, 26, 36 AND 38).

FIRST USE 3-1-2010; IN COMMERCE 3-1-2010.  
FRED CARL, EXAMINING ATTORNEY

**CLASS 9—(Continued).**

SN 85-043,856. AMAZON TECHNOLOGIES, INC., RENO, NV. FILED 5-20-2010.

**AMAZONCROSSING**

THE MARK CONSISTS OF STANDARD CHARACTERS WITHOUT CLAIM TO ANY PARTICULAR FONT, STYLE, SIZE, OR COLOR.

OWNER OF U.S. REG. NOS. 2,649,373, 3,709,331 AND OTHERS.

FOR DOWNLOADABLE AUDIO WORKS IN THE NATURE OF SOUND RECORDINGS, VISUAL WORKS IN THE NATURE OF IMAGES AND PHOTOGRAPHS, AUDIOVISUAL WORKS IN THE NATURE OF MULTIMEDIA PRESENTATIONS, LITERARY WORKS IN THE NATURE OF BOOKS, MAGAZINES, PERIODICALS AND JOURNALS, FICTION AND NONFICTION AUDIOBOOKS ON A VARIETY OF TOPICS, FICTION AND NONFICTION ELECTRONIC BOOKS ON A VARIETY OF TOPICS; ELECTRONIC PUBLICATIONS IN THE NATURE OF MAGAZINES, NEWSPAPERS, PERIODICALS, NEWSLETTERS, AND JOURNALS, ALL ON A VARIETY OF TOPICS (U.S. CLS. 21, 23, 26, 36 AND 38).

ANDREA HACK, EXAMINING ATTORNEY

SN 85-044,282. JETSON CREATIVE LLC, OAKLAND, CA. FILED 5-20-2010.

**Magic Window**

THE MARK CONSISTS OF STANDARD CHARACTERS WITHOUT CLAIM TO ANY PARTICULAR FONT, STYLE, SIZE, OR COLOR.

FOR COMPUTER SOFTWARE FOR ORGANIZING AND VIEWING DIGITAL IMAGES AND PHOTOGRAPHS (U.S. CLS. 21, 23, 26, 36 AND 38).

FIRST USE 4-22-2010; IN COMMERCE 4-22-2010.

DEBRA LEE, EXAMINING ATTORNEY

SN 85-044,681. REMOTE TECHNOLOGIES INCORPORATED, SHAKOPEE, MN. FILED 5-21-2010.

**PRO CONTROL**

THE MARK CONSISTS OF STANDARD CHARACTERS WITHOUT CLAIM TO ANY PARTICULAR FONT, STYLE, SIZE, OR COLOR.

NO CLAIM IS MADE TO THE EXCLUSIVE RIGHT TO USE "CONTROL", APART FROM THE MARK AS SHOWN.

FOR HOME AUTOMATION SYSTEMS COMPRISING WIRELESS AND WIRED CONTROLLERS, CONTROL PROCESSORS, CONTROLLED DEVICES, AND SOFTWARE FOR LIGHTING, HVAC, SECURITY, SAFETY, AUDIO, VISUAL, AND OTHER HOME CONTROL APPLICATIONS (U.S. CLS. 21, 23, 26, 36 AND 38).

NAPOLEON SHARMA, EXAMINING ATTORNEY

**CLASS 9—(Continued).**

SN 85-044,719. REMOTE TECHNOLOGIES INCORPORATED, SHAKOPEE, MN. FILED 5-21-2010.

THE MARK CONSISTS OF THE TERM "PRO" IN STYLIZED LETTERS.

FOR HOME AUTOMATION SYSTEMS COMPRISING WIRELESS AND WIRED CONTROLLERS, CONTROL PROCESSORS, CONTROLLED DEVICES, AND SOFTWARE FOR LIGHTING, HVAC, SECURITY, SAFETY, AUDIO, VISUAL, AND OTHER HOME CONTROL APPLICATIONS (U.S. CLS. 21, 23, 26, 36 AND 38).

NAPOLEON SHARMA, EXAMINING ATTORNEY

SN 85-044,977. C SPEED, LLC, LIVERPOOL, NY. FILED 5-21-2010.

**REARVIEW**

THE MARK CONSISTS OF STANDARD CHARACTERS WITHOUT CLAIM TO ANY PARTICULAR FONT, STYLE, SIZE, OR COLOR.

FOR DATA VISUALIZATION PRODUCTS IN THE NATURE OF COMPUTER SOFTWARE DESIGNED FOR INTEROPERATION WITH EQUIPMENT INCLUDING LOGIC ANALYZERS, OSCILLOSCOPES, RADARS, MEDICAL DEVICES AND COMPUTERS, NAMELY, COMPUTER SOFTWARE FOR THE PURPOSE OF OPERATING, CONTROLLING, AND/OR DISPLAY OF DATA COLLECTED FROM AFOREMENTIONED EQUIPMENT, AND FOR STORING, ORGANIZING, AND RETRIEVING VARIOUS TYPES OF SIGNAL DATA ASSOCIATED WITH ELECTRONICS, RADAR, MEDICAL, SCIENTIFIC AND INDUSTRIAL APPLICATIONS (U.S. CLS. 21, 23, 26, 36 AND 38).

KEVIN CORWIN, EXAMINING ATTORNEY

SN 85-045,123. APOKALYYIS, INC., DENVER, CO. FILED 5-21-2010.

**APOKALYYIS**

THE MARK CONSISTS OF STANDARD CHARACTERS WITHOUT CLAIM TO ANY PARTICULAR FONT, STYLE, SIZE, OR COLOR.

THE ENGLISH TRANSLATION OF THE GREEK TERM "APOKALYYIS" IN THE MARK IS "REVELATION".

FOR COMPUTER SOFTWARE FOR RECOGNIZING PATTERNS AND RELATIONSHIPS IN DATA; COMPUTER HARDWARE AND ACCESSORIES, NAMELY PERIPHERALS FOR USE WITH SOFTWARE FOR RECOGNIZING PATTERNS AND RELATIONSHIPS IN DATA (U.S. CLS. 21, 23, 26, 36 AND 38).

AISHA SALEM, EXAMINING ATTORNEY

**CLASS 9—(Continued).**

SN 85-045,158. APOKALYYIS, INC., DENVER, CO. FILED 5-21-2010.

# RDDR

THE MARK CONSISTS OF STANDARD CHARACTERS WITHOUT CLAIM TO ANY PARTICULAR FONT, STYLE, SIZE, OR COLOR.

FOR COMPUTER SOFTWARE FOR RECOGNIZING PATTERNS AND RELATIONSHIPS IN DATA; COMPUTER HARDWARE AND ACCESSORIES, NAMELY PERIPHERALS FOR USE WITH SOFTWARE FOR RECOGNIZING PATTERNS AND RELATIONSHIPS IN DATA (U.S. CLS. 21, 23, 26, 36 AND 38).

AISHA SALEM, EXAMINING ATTORNEY

**CLASS 9—(Continued).**

SN 85-046,134. CRAMER PRODUCTS, INC., GARDNER, KS. FILED 5-24-2010.

# THE FIRST AIDER

THE MARK CONSISTS OF STANDARD CHARACTERS WITHOUT CLAIM TO ANY PARTICULAR FONT, STYLE, SIZE, OR COLOR.

OWNER OF U.S. REG. NO. 535,897.

SEC. 2(F).

FOR DOWNLOADABLE ELECTRONIC NEWSLETTERS DELIVERED BY EMAIL IN THE FIELD OF SPORTS MEDICINE AND ATHLETIC TRAINING; DOWNLOADABLE ELECTRONIC NEWSLETTERS IN THE FIELD OF SPORTS MEDICINE AND ATHLETIC TRAINING (U.S. CLS. 21, 23, 26, 36 AND 38).

FIRST USE 0-0-2002; IN COMMERCE 0-0-2002.

RICHARD WHITE, EXAMINING ATTORNEY

SN 85-045,416. UNIVERSAL CITY STUDIOS LLLP, UNIVERSAL CITY, CA. FILED 5-21-2010.

# UNIVERSAL MUSIC GROUP

THE MARK CONSISTS OF STANDARD CHARACTERS WITHOUT CLAIM TO ANY PARTICULAR FONT, STYLE, SIZE, OR COLOR.

OWNER OF U.S. REG. NOS. 1,144,545 AND 1,637,487.

NO CLAIM IS MADE TO THE EXCLUSIVE RIGHT TO USE "MUSIC GROUP", APART FROM THE MARK AS SHOWN.

FOR PRE-RECORDED AUDIO TAPES, DISCS AND CASSETTES, VIDEO TAPES, DISCS AND CASSETTES, DIGITAL AUDIO AND AUDIO VIDEO TAPES AND DISCS, CDS, DVDS, LASER DISCS, AND PHONOGRAPH RECORDS FEATURING MUSIC, SOUNDS AND ENTERTAINMENT; MUSICAL SOUND AND VIDEO RECORDINGS; DOWN LOADABLE RING TONES, MUSIC, SOUNDS, MP3 FILES, GRAPHICS, ELECTRONIC GAMES, IMAGES AND VIDEOS FOR WIRELESS COMMUNICATION DEVICES; DOWNLOADABLE VIDEOS FEATURING MUSIC AND ENTERTAINMENT, MUSIC, SOUNDS, MP3 FILES, GRAPHICS, COMPUTER GAME PROGRAMS AND IMAGES (U.S. CLS. 21, 23, 26, 36 AND 38).

FIRST USE 0-0-1999; IN COMMERCE 0-0-1999.

MORGAN WYNNE, EXAMINING ATTORNEY

SN 85-046,196. FOLEY, PATRICK, AMES, IA. FILED 5-24-2010.

# vPowerHouse

THE MARK CONSISTS OF STANDARD CHARACTERS WITHOUT CLAIM TO ANY PARTICULAR FONT, STYLE, SIZE, OR COLOR.

FOR COMPUTER SIMULATION SOFTWARE THAT ALLOWS COMMUNICATION BETWEEN A TEACHER AND A STUDENT FOR TEACHING AND ASSESSMENT, NAMELY, SOFTWARE SIMULATING THE CONTROLS OF POWER PLANTS FOR THE INTERACTIVE INSTRUCTION AND TRAINING OF POWER PLANT STAFF (U.S. CLS. 21, 23, 26, 36 AND 38).

FIRST USE 11-20-1997; IN COMMERCE 11-20-1997.

JILL C. ALT, EXAMINING ATTORNEY

**CLASS 9—(Continued).**

SN 85-046,657. ANTON PAAR USA, INC., ASHLAND, VA. FILED 5-24-2010.



THE MARK CONSISTS OF A GLOBE.  
FOR SCIENTIFIC INSTRUMENTS, NAMELY, ALCOHOL METERS, BEVERAGE METERS FOR MEASURING AND ANALYZING THE SUGAR, CO<sub>2</sub>, ALCOHOL, AND EXTRACT CONTENT OF BEVERAGES, CO<sub>2</sub> METERS, DENSITY METERS, CONCENTRATION METERS, DYNAMIC-MECHANICAL THERMAL ANALYSIS (DMTA) INSTRUMENTS, HIGH-PRESSURE DIGESTION SYSTEMS COMPRISED OF VESSELS FOR THE HEATING AND MINERALIZATION OF SAMPLES, MICROWAVE DIGESTION SYSTEMS, NAMELY, MICROWAVE REACTORS FOR LABORATORY USE, INCLUDING FOR PERFORMING DRYING, EVAPORATION, EXTRACTION, UV DIGESTION, AND/OR OXYGEN COMBUSTION, MICROWAVE SYNTHESIS SYSTEMS, OXYGEN METERS, POLARIMETERS, REFRACTOMETERS, RHEOMETERS FOR INVESTIGATING THE DEFORMATION AND FLOW BEHAVIOR OF LIQUID AND/OR SOLID SAMPLES, SUGAR ANALYZERS, SURFACE ANALYZERS FOR PERFORMING SOLID SURFACE ANALYSIS AND ANALYZING SURFACE CHEMISTRY AND PROPERTIES OF MACROSCOPIC SOLIDS, THERMOMETERS, TRIBOMETERS, TURBIDITY METERS, VISCOMETERS FOR MEASURING FLOW RESISTANCE, X-RAY STRUCTURE ANALYZERS, SMALL-ANGLE X-RAY SCATTERING (SAXS) SYSTEMS, X-RAY DIFFRACTION (XRD) SYSTEMS, CO<sub>2</sub> SENSORS, DENSITY AND SOUND VELOCITY SENSORS, DENSITY SENSORS, EVALUATION UNITS FOR MEASURING THE DENSITY AND CONCENTRATION OF LIQUIDS AND GASES, AND SOUND VELOCITY SENSORS; AND ACCOMPANYING COMPUTER SOFTWARE, NAMELY, COMPUTER OPERATING SOFTWARE SOLD AS A UNIT WITH EACH OF THE INSTRUMENTS LISTED ABOVE FOR USE IN SCIENTIFIC LABORATORY OPERATIONS (U.S. CLS. 21, 23, 26, 36 AND 38).

FIRST USE 12-31-1986; IN COMMERCE 12-31-1986.  
KATHERINE M. DUBRAY, EXAMINING ATTORNEY

**CLASS 9—(Continued).**

SN 85-046,958. BENCOMP COMMUNICATIONS, INC., VICTOR, NY. FILED 5-25-2010.

## PerkWorks

THE MARK CONSISTS OF STANDARD CHARACTERS WITHOUT CLAIM TO ANY PARTICULAR FONT, STYLE, SIZE, OR COLOR.

FOR SOFTWARE FOR CREATING EMPLOYEE BENEFIT INFORMATION REPORTS IN THE FIELD OF EMPLOYMENT RECRUITING AND RETENTION SERVICES; SOFTWARE FOR ARITHMETIC PROCESSING AND CALCULATING COMPENSATION DATA AND BENEFIT DATA TO GENERATE BENEFIT STATEMENTS FOR CURRENT AND PROSPECTIVE EMPLOYEES (U.S. CLS. 21, 23, 26, 36 AND 38).

KEVIN CORWIN, EXAMINING ATTORNEY

---

SN 85-047,441. COLLISIONAVERT, LLC, IRWIN, PA. FILED 5-25-2010.

## CollisionAvert

THE MARK CONSISTS OF STANDARD CHARACTERS WITHOUT CLAIM TO ANY PARTICULAR FONT, STYLE, SIZE, OR COLOR.

FOR AUDIO AND VISUAL ALERT SYSTEMS, NAMELY, ELECTROMAGNETIC OR RADIO WAVE PROXIMITY DETECTION EQUIPMENT FOR ALERTING PEOPLE OF THE PROXIMITY OF VEHICLES, EQUIPMENT, PERSONNEL OR PASSERSBY (U.S. CLS. 21, 23, 26, 36 AND 38).

COURTNEY ALVAREZ, EXAMINING ATTORNEY

---

SN 85-048,885. POWERMAX USA, INC, RANCHO CUCAMONGA, CA. FILED 5-27-2010.

## ULTRA MAX

THE MARK CONSISTS OF STANDARD CHARACTERS WITHOUT CLAIM TO ANY PARTICULAR FONT, STYLE, SIZE, OR COLOR.

FOR ELECTRICAL AND SCIENTIFIC PRODUCTS, NAMELY, ELECTRIC AND SOLAR BATTERIES FOR TOY VEHICLES (U.S. CLS. 21, 23, 26, 36 AND 38).

FIRST USE 1-1-2008; IN COMMERCE 3-1-2008.  
DAVID TOOLEY, EXAMINING ATTORNEY



**CLASS 9—(Continued).**

SN 85-049,257. DENTON, JAMES S., TELLURIDE, CO. FILED 5-27-2010.

These were our people.  
And this is how we began.

THE MARK CONSISTS OF STANDARD CHARACTERS WITHOUT CLAIM TO ANY PARTICULAR FONT, STYLE, SIZE, OR COLOR.

FOR MOTION PICTURE FILMS ABOUT STORIES IN THE FIELDS OF HISTORY, HISTORICAL SUBJECTS AND INDIVIDUALS (U.S. CLS. 21, 23, 26, 36 AND 38).  
KRISTIN DAHLING, EXAMINING ATTORNEY

**CLASS 9—(Continued).**

SN 85-051,373. MARKETING DISPLAYS INC., FARMINGTON HILLS, MI. FILED 6-1-2010.

**MENU BOARD IN-A-BOX**

THE MARK CONSISTS OF STANDARD CHARACTERS WITHOUT CLAIM TO ANY PARTICULAR FONT, STYLE, SIZE, OR COLOR.

NO CLAIM IS MADE TO THE EXCLUSIVE RIGHT TO USE "MENU BOARD", APART FROM THE MARK AS SHOWN.

FOR INFORMATION DISPLAY SYSTEMS FOR RETAIL GOODS, NAMELY, LCD AND PLASMA DISPLAY MONITORS, CENTRAL PROCESSING UNITS (CPU'S) TO DECODE AND TRANSMIT CONTENT TO THE MONITORS, SOFTWARE TO DEVELOP, MANAGE, SCHEDULE, AND DISTRIBUTE CONTENT OVER THE INTERNET TO THE CPU'S, SOLD TOGETHER WITH MOUNTING BRACKETS AND CABLES (U.S. CLS. 21, 23, 26, 36 AND 38).

FIRST USE 5-22-2010; IN COMMERCE 5-22-2010.  
THOMAS MANOR, EXAMINING ATTORNEY

SN 85-051,693. KINOVA INC., SAINT-HYACINTHE, QC, CANADA, FILED 6-1-2010.

**KINOVA**

THE MARK CONSISTS OF STANDARD CHARACTERS WITHOUT CLAIM TO ANY PARTICULAR FONT, STYLE, SIZE, OR COLOR.

THE WORDING "KINOVA" HAS NO MEANING IN A FOREIGN LANGUAGE.

FOR ROBOTIC ARM DESIGNED TO ASSIST THOSE WITH MOBILITY LIMITATIONS (U.S. CLS. 21, 23, 26, 36 AND 38).

Alice BENMAMAN, EXAMINING ATTORNEY

SN 85-052,512. MARKETING EVOLUTION, INC., EL DORADO HILLS, CA. FILED 6-2-2010.

**VOOM**

THE MARK CONSISTS OF STANDARD CHARACTERS WITHOUT CLAIM TO ANY PARTICULAR FONT, STYLE, SIZE, OR COLOR.

FOR COMPUTER SEARCH ENGINE SOFTWARE USED FOR MARKETING RESEARCH; ELECTRONIC MARKETING TOOLS, NAMELY, COMPUTER SOFTWARE FOR MEASURING, ANALYZING, AND EVALUATING CONSUMER RESPONSES FOR MARKETING PURPOSES (U.S. CLS. 21, 23, 26, 36 AND 38).

BERYL GARDNER, EXAMINING ATTORNEY

SN 85-050,621. APOKALYYIS, INC., DENVER, CO. FILED 5-28-2010.

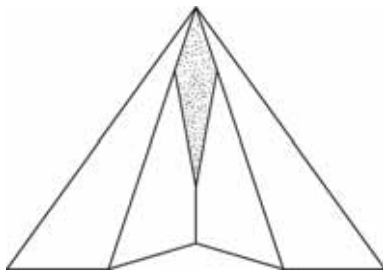

THE MARK CONSISTS OF A PARTIAL PYRAMID DESIGN, MADE UP OF FOUR TRIANGLE SHAPES AND A DIAMOND SHAPE.

FOR COMPUTER SOFTWARE FOR RECOGNIZING PATTERNS AND RELATIONSHIPS IN DATA; COMPUTER HARDWARE AND ACCESSORIES, NAMELY, PERIPHERALS FOR USE WITH SOFTWARE FOR RECOGNIZING PATTERNS AND RELATIONSHIPS IN DATA (U.S. CLS. 21, 23, 26, 36 AND 38).

AISHA SALEM, EXAMINING ATTORNEY

**CLASS 9—(Continued).**

SN 85-052,816. SHOTZOOM, LLC., SCOTTSDALE, AZ. FILED 6-2-2010.

# SHOTZOOM

THE MARK CONSISTS OF STANDARD CHARACTERS WITHOUT CLAIM TO ANY PARTICULAR FONT, STYLE, SIZE, OR COLOR.

FOR DOWNLOADABLE SPORTS APPLICATION SOFTWARE USING ELECTRONIC SATELLITE TRACKING FOR MEASURING, DISPLAYING, AND RECORDING DISTANCES, STATISTICS, AND SCORE CARDS, AND ALLOWING COMPARISON, WAGERING, AND COMMUNICATION REGARDING LIVE ACTION SPORT ACTIVITIES VIA THE INTERNET AND WIRELESS DEVICES (U.S. CLS. 21, 23, 26, 36 AND 38).

FIRST USE 10-15-2008; IN COMMERCE 10-15-2008.  
BARBARA BROWN, EXAMINING ATTORNEY

---

SN 85-052,822. TRANSMITIVE, LLC, NEW YORK, NY. FILED 6-2-2010.

# TRANSMITIVE

THE MARK CONSISTS OF STANDARD CHARACTERS WITHOUT CLAIM TO ANY PARTICULAR FONT, STYLE, SIZE, OR COLOR.

FOR IR/RF TRANSCEIVER FOR WIRELESS CONTROL OF INFRARED-RECEIVING DEVICES FROM SMARTPHONES, TABLETS, LAPTOPS (U.S. CLS. 21, 23, 26, 36 AND 38).

PAUL F. GAST, EXAMINING ATTORNEY

---

SN 85-053,118. W2007 STRATOSPHERE PROPCO., L.P., LAS VEGAS, NV. FILED 6-2-2010.

# SKYJUMP

THE MARK CONSISTS OF STANDARD CHARACTERS WITHOUT CLAIM TO ANY PARTICULAR FONT, STYLE, SIZE, OR COLOR.

FOR DIGITAL MEDIA, NAMELY, CDS AND DVDS FEATURING SOUVENIR PICTURES AND VIDEOS; MAGNETIC CODED GIFT CARDS; MAGNETIC IDENTIFYING CARDS; MAGNETS; MOUSEPADS; SLOT MACHINES; SUNGLASSES (U.S. CLS. 21, 23, 26, 36 AND 38).

EMILY CHUO, EXAMINING ATTORNEY

**CLASS 9—(Continued).**

SN 85-053,124. W2007 STRATOSPHERE PROPCO., L.P., LAS VEGAS, NV. FILED 6-2-2010.

# SKYJUMP LAS VEGAS

THE MARK CONSISTS OF STANDARD CHARACTERS WITHOUT CLAIM TO ANY PARTICULAR FONT, STYLE, SIZE, OR COLOR.

NO CLAIM IS MADE TO THE EXCLUSIVE RIGHT TO USE "LAS VEGAS", APART FROM THE MARK AS SHOWN.

FOR DIGITAL MEDIA, NAMELY, CDS AND DVDS FEATURING SOUVENIR PICTURES AND VIDEOS; MAGNETIC CODED GIFT CARDS; MAGNETIC IDENTIFYING CARDS; MAGNETS; MOUSEPADS; SLOT MACHINES; SUNGLASSES (U.S. CLS. 21, 23, 26, 36 AND 38).

EMILY CHUO, EXAMINING ATTORNEY

---

SN 85-053,130. W2007 STRATOSPHERE PROPCO., L.P., LAS VEGAS, NV. FILED 6-2-2010.



NO CLAIM IS MADE TO THE EXCLUSIVE RIGHT TO USE "LAS VEGAS", APART FROM THE MARK AS SHOWN.

THE MARK CONSISTS OF THE WORDS "SKY JUMP" STAGGERED AND HORIZONTALLY POSITIONED OVER A TARGET AND THE WORDS "LAS VEGAS".

FOR DIGITAL MEDIA, NAMELY, CDS AND DVDS FEATURING SOUVENIR PICTURES AND VIDEOS; MAGNETIC CODED GIFT CARDS; MAGNETIC IDENTIFYING CARDS; MAGNETS; MOUSEPADS; SLOT MACHINES; SUNGLASSES (U.S. CLS. 21, 23, 26, 36 AND 38).

EMILY CHUO, EXAMINING ATTORNEY

**CLASS 9—(Continued).**

SN 85-053,479. LEISURE ELECTRONICS TECHNOLOGY CO., LTD., TOKYO, JAPAN, FILED 6-3-2010.



THE MARK CONSISTS OF THE CAPITAL LETTERS "LET" FOLLOWED BY THE LOWERCASE LETTERS "ECH". THE LETTER "L" HAS A STRAIGHT LINE THROUGH THE FRONT PART OF THE "L" AND THE LETTER "E" HAS A STRAIGHT LINE THROUGH THE TOP PART OF THE "E".

FOR RANDOM NUMBER GENERATION DEVICE, NAMELY, COMPUTER CHIPS, PERIPHERAL COMPONENT INTERFACE (PCI) CARDS AND INTEGRATED CIRCUITS; ANTI-FREEZE MICROCOMPUTERS (U.S. CLS. 21, 23, 26, 36 AND 38).

CAROLINE WOOD, EXAMINING ATTORNEY

**CLASS 9—(Continued).**

SN 85-054,493. MANNING, JAMES, FARMINGDALE, NY. FILED 6-4-2010.

## Entertainment Minute

THE MARK CONSISTS OF STANDARD CHARACTERS WITHOUT CLAIM TO ANY PARTICULAR FONT, STYLE, SIZE, OR COLOR.

NO CLAIM IS MADE TO THE EXCLUSIVE RIGHT TO USE "ENTERTAINMENT", APART FROM THE MARK AS SHOWN.

FOR DIGITAL MEDIA, NAMELY, PRE-RECORDED VIDEO CASSETTES, DIGITAL VIDEO DISCS, DIGITAL VERSATILE DISCS, DOWNLOADABLE AUDIO AND VIDEO RECORDINGS, DVDS, AND HIGH DEFINITION DIGITAL DISCS FEATURING BEHIND THE SCENES MOVIE MAKING SUBJECT MATTER (U.S. CLS. 21, 23, 26, 36 AND 38).

FIRST USE 1-7-2005; IN COMMERCE 3-5-2007.

CORY BOONE, EXAMINING ATTORNEY

SN 85-055,520. COORDINATED SYSTEMS INTERNATIONAL, INC., NASHUA, NH. FILED 6-5-2010.

## ENERGY AVENGER

THE MARK CONSISTS OF STANDARD CHARACTERS WITHOUT CLAIM TO ANY PARTICULAR FONT, STYLE, SIZE, OR COLOR.

NO CLAIM IS MADE TO THE EXCLUSIVE RIGHT TO USE "ENERGY", APART FROM THE MARK AS SHOWN.

FOR ELECTRIC CONTROL DEVICES FOR HEATING AND ENERGY MANAGEMENT; ELECTRONIC CONTROLLERS USED TO REDUCE POWER CONSUMPTION (U.S. CLS. 21, 23, 26, 36 AND 38).

JEAN IM, EXAMINING ATTORNEY

SN 85-054,318. BURNS COMPUTER SERVICES, LLC, ANN ARBOR, MI. FILED 6-3-2010.



THE MARK CONSISTS OF STANDARD CHARACTERS WITHOUT CLAIM TO ANY PARTICULAR FONT, STYLE, SIZE, OR COLOR.

FOR SYSTEMS COMPRISING COMPUTER HARDWARE AND COMPUTER SOFTWARE SOLD AS A UNIT AND CONFIGURED FOR THE COLLECTION AND ANALYSIS OF DATA DURING A DISASTER TRAINING DRILL, EMERGENCY TRAINING DRILL, AND/OR MEDICAL TRAINING DRILL; COMPUTER SOFTWARE CONFIGURED FOR THE COLLECTION AND ANALYSIS OF DATA DURING A DISASTER TRAINING DRILL, EMERGENCY TRAINING DRILL, AND/OR MEDICAL TRAINING DRILL; COMPUTER HARDWARE CONFIGURED FOR THE COLLECTION AND ANALYSIS OF DATA DURING A DISASTER TRAINING DRILL, EMERGENCY TRAINING DRILL, AND/OR MEDICAL TRAINING DRILL (U.S. CLS. 21, 23, 26, 36 AND 38).

TRACY CROSS, EXAMINING ATTORNEY

SN 85-056,948. CMPMR, LLC, NORTH DARTMOUTH, MA. FILED 6-8-2010.

## EMERALD EMR

THE MARK CONSISTS OF STANDARD CHARACTERS WITHOUT CLAIM TO ANY PARTICULAR FONT, STYLE, SIZE, OR COLOR.

NO CLAIM IS MADE TO THE EXCLUSIVE RIGHT TO USE "EMR", APART FROM THE MARK AS SHOWN.

FOR COMPUTER SOFTWARE FOR MAINTAINING PATIENT RECORDS, GENERATING ELECTRONIC PRESCRIPTIONS, AND MAINTAINING PROCEDURE AND DIAGNOSTIC CODES IN THE FIELD OF MEDICAL PRACTICE MANAGEMENT, AND NOT FOR USE IN CONNECTION WITH AN ACCOUNTS RECEIVABLE DATABASE (U.S. CLS. 21, 23, 26, 36 AND 38).

JENNIFER VASQUEZ, EXAMINING ATTORNEY

**CLASS 9—(Continued).**

SN 85-057,964. JONES, FRANCESCO, CASTRO VALLEY, CA. FILED 6-9-2010.

**RAP IS A JOKE**

THE MARK CONSISTS OF STANDARD CHARACTERS WITHOUT CLAIM TO ANY PARTICULAR FONT, STYLE, SIZE, OR COLOR.

NO CLAIM IS MADE TO THE EXCLUSIVE RIGHT TO USE "RAP", APART FROM THE MARK AS SHOWN.

FOR SOUND AND VIDEO RECORDINGS FEATURING RAP MUSIC AND COMEDY (U.S. CLS. 21, 23, 26, 36 AND 38).

FIRST USE 1-1-2009; IN COMMERCE 1-1-2009.  
NICHOLAS COLEMAN, EXAMINING ATTORNEY

**CLASS 9—(Continued).**

SN 85-059,575. AMYLIN PHARMACEUTICALS, INC., SAN DIEGO, CA. FILED 6-10-2010.

**DIABETES LIFE HARMONIZED  
T2D HEALTH**

THE MARK CONSISTS OF STANDARD CHARACTERS WITHOUT CLAIM TO ANY PARTICULAR FONT, STYLE, SIZE, OR COLOR.

NO CLAIM IS MADE TO THE EXCLUSIVE RIGHT TO USE "DIABETES" AND "T2D HEALTH", APART FROM THE MARK AS SHOWN.

FOR COMPUTER SOFTWARE THAT PROVIDES WEB-BASED ACCESS TO EDUCATIONAL AND INFORMATION SERVICES IN THE FIELDS OF DIABETES, OBESITY, AND CARDIOVASCULAR DISEASE THROUGH A WEB OPERATING SYSTEM PORTAL (U.S. CLS. 21, 23, 26, 36 AND 38).  
SCOTT BIBB, EXAMINING ATTORNEY

SN 85-058,477. CRYTEK GMBH, FRANKFURT AM MAIN, FED REP GERMANY, FILED 6-9-2010.

**WORLD OF ATLANTIS**

THE MARK CONSISTS OF STANDARD CHARACTERS WITHOUT CLAIM TO ANY PARTICULAR FONT, STYLE, SIZE, OR COLOR.

OWNER OF ERPN CMNTY TM OFC REG. NO. 009162579, DATED 2-17-2011, EXPIRES 6-9-2020.

FOR COMPUTER SOFTWARE FOR THE MANAGEMENT, TRANSMISSION, STORAGE AND SHARED USE OF COMPUTER GAME PROGRAMS AND OF ELECTRONICALLY STORED INFORMATION VIA COMPUTER NETWORKS FOR USERS; DOWNLOADABLE COMPUTER GAMES; COMPUTER GAMES; GAMES FOR COMPUTER GAMING CONSOLES; SOFTWARE FOR GRAPHIC DATA PROCESSING; COMPUTER GRAPHICS SOFTWARE; VIRTUAL REALITY GAME SOFTWARE; VIRTUAL REALITY SOFTWARE; MAGNETIC AND OPTICAL DATA CARRIERS CONTAINING RECORDED GAME SOFTWARE FOR COMPUTERS, GAMING CONSOLES, MOBILE PHONES OR MOBILE DATA TERMINALS AND COMPUTER GAMES AND VIDEO GAMES; COMPUTER GAMES, VIDEO GAMES AND GAMES ON GAMING CONSOLES, HANDHELDS AND MOBILE PHONES SUPPLIED ONLINE BY MEANS OF ELECTRONIC MULTIMEDIA ELECTRONIC BROADCAST OR NETWORK TRANSMISSIONS; VIDEO GAMES CASSETTES; VIDEO GAME TAPE CASSETTES; VIDEO TAPES FEATURING COMEDY, DRAMA, ACTION, ADVENTURE AND/OR ANIMATION; INTEGRATED CIRCUITS CONTAINING RECORDED SOFTWARE FOR USE WITH COMPUTER GAMING CONSOLES AND VIDEO GAME CONSOLES FOR USE WITH AN EXTERNAL DISPLAY SCREEN OR MONITOR; AND MANUALS SOLD TOGETHER AS A UNIT OR PROVIDED VIA DOWNLOAD OR ONLINE WITH AND RELATING TO ANY OF THE FOREGOING (U.S. CLS. 21, 23, 26, 36 AND 38).

JOHN DALIER, EXAMINING ATTORNEY

SN 85-059,579. AMYLIN PHARMACEUTICALS, INC., SAN DIEGO, CA. FILED 6-10-2010.

**DIABETES LIFE HARMONIZED**

THE MARK CONSISTS OF STANDARD CHARACTERS WITHOUT CLAIM TO ANY PARTICULAR FONT, STYLE, SIZE, OR COLOR.

NO CLAIM IS MADE TO THE EXCLUSIVE RIGHT TO USE "DIABETES", APART FROM THE MARK AS SHOWN.

FOR COMPUTER SOFTWARE THAT PROVIDES WEB-BASED ACCESS TO EDUCATIONAL AND INFORMATION SERVICES IN THE FIELDS OF DIABETES, OBESITY, AND CARDIOVASCULAR DISEASE THROUGH A WEB OPERATING SYSTEM PORTAL (U.S. CLS. 21, 23, 26, 36 AND 38).  
SCOTT BIBB, EXAMINING ATTORNEY

SN 85-060,749. SENSORMATIC ELECTRONICS, LLC, BOCA RATON, FL. FILED 6-11-2010.

**IPIPHANY**

THE MARK CONSISTS OF STANDARD CHARACTERS WITHOUT CLAIM TO ANY PARTICULAR FONT, STYLE, SIZE, OR COLOR.

FOR CAMERAS (U.S. CLS. 21, 23, 26, 36 AND 38).  
PAULA MAHONEY, EXAMINING ATTORNEY

**CLASS 9—(Continued).**

SN 85-061,815. U.S. VISION, INC., GLENDORA, NJ. FILED 6-14-2010.

**EYES & TIES**

THE MARK CONSISTS OF STANDARD CHARACTERS WITHOUT CLAIM TO ANY PARTICULAR FONT, STYLE, SIZE, OR COLOR.

NO CLAIM IS MADE TO THE EXCLUSIVE RIGHT TO USE "EYES", APART FROM THE MARK AS SHOWN.

FOR EYEWEAR, NAMELY, SUNGLASSES, EYEGLASSES AND OPHTHALMIC FRAMES AND CASES THEREFOR; SUNGLASSES (U.S. CLS. 21, 23, 26, 36 AND 38).

CAROLYN CATALDO, EXAMINING ATTORNEY

SN 85-065,142. HOVIND, CHAD, CINCINNATI, OH. FILED 6-17-2010.



NO CLAIM IS MADE TO THE EXCLUSIVE RIGHT TO USE THE SYMBOL OF THE DOLLAR SIGN, APART FROM THE MARK AS SHOWN.

THE MARK CONSISTS OF THE WORD "GODONOMICS" WITH THE "S" CREATED FROM A DOLLAR SIGN.

FOR PRE-RECORDED DVDS FEATURING INFORMATION IN THE FIELD OF RELIGION AND ECONOMICS (U.S. CLS. 21, 23, 26, 36 AND 38).

FIRST USE 10-4-2009; IN COMMERCE 10-4-2009.  
NAPOLEON SHARMA, EXAMINING ATTORNEY

SN 85-065,399. GREENLEE TEXTRON INC., ROCKFORD, IL. FILED 6-17-2010.

**FISHFINDER**

THE MARK CONSISTS OF STANDARD CHARACTERS WITHOUT CLAIM TO ANY PARTICULAR FONT, STYLE, SIZE, OR COLOR.

FOR VIDEO CAMERAS FOR INSPECTION OF AREAS TO ENABLE A USER TO ROUTE, REPLACE, TROUBLESHOOT AND SERVICE ELECTRICAL AND COMMUNICATION CABLING AND WIRING (U.S. CLS. 21, 23, 26, 36 AND 38).

KELLY BOULTON, EXAMINING ATTORNEY

**CLASS 9—(Continued).**

SN 85-066,797. DATAWAVE TECHNOLOGIES CORPORATION, LOVELAND, CO. FILED 6-18-2010.

**DATAWAVE TECHNOLOGIES**

THE MARK CONSISTS OF STANDARD CHARACTERS WITHOUT CLAIM TO ANY PARTICULAR FONT, STYLE, SIZE, OR COLOR.

OWNER OF U.S. REG. NOS. 2,339,556 AND 2,437,791.

NO CLAIM IS MADE TO THE EXCLUSIVE RIGHT TO USE "TECHNOLOGIES", APART FROM THE MARK AS SHOWN.

FOR COMPUTER SOFTWARE FOR USE IN DATA ACQUISITION AND ANALYSIS, USED IN SCIENTIFIC RESEARCH (U.S. CLS. 21, 23, 26, 36 AND 38).

FIRST USE 10-1-1993; IN COMMERCE 10-1-1993.

SAIMA MAKHDOOM, EXAMINING ATTORNEY

SN 85-069,748. AAMP OF FLORIDA, INC., CLEARWATER, FL. FILED 6-23-2010.

**ISIMPLE**

THE MARK CONSISTS OF STANDARD CHARACTERS WITHOUT CLAIM TO ANY PARTICULAR FONT, STYLE, SIZE, OR COLOR.

OWNER OF U.S. REG. NO. 3,386,693.

FOR AUDIO DEVICES, NAMELY, AMPLIFIER INTEGRATION INTERFACES, AUDIO CABLES, AUDIO EQUALIZERS, AUDIO INTERFACES, AUDIO SIGNAL AMPLIFIERS, AUDIO SIGNAL SWITCHERS, AUXILIARY INPUT DEVICES FOR AUTOMOTIVE RADIOS, BAND-PASS FILTERS FOR USE WITH AUDIO CIRCUITS AND SPEAKER ENCLOSURES, BASS BLOCKERS IN THE NATURE OF A HIGH PASS FILTER THAT ATTENUATES LOWER FREQUENCIES; CD CHANGER INTERFACES, FLOATING GROUND ADAPTERS, FM MODULATED AUDIO RECEIVERS, FM MODULATED AUDIO TRANSMITTERS, HIGH-PASS FILTERS; LINE OUTPUT CONVERTERS, LOWPASS FILTERS, POWER RESISTORS, RADIO FREQUENCY AUDIO RECEIVERS, RADIO FREQUENCY AUDIO TRANSMITTERS, RADIO INSTALLATION INTERFACES, RCA LEVEL ATTENUATORS, RCA LEVEL CONTROLLER, RCA SWITCHER SATELLITE, RADIO INTERFACES, VOLUME CONTROLS; NOISE CONTROL, NAMELY, ANTENNA GROUND LOOP ISOLATORS, CHOKE FILTERS, FILTERING CAPACITORS, POWER LEAD FILTERS; CELL PHONE DEVICES, NAMELY, CELL PHONE INTERFACES, CHARGE CORDS, DOORLOCK INTERFACES; PORTABLE ELECTRONIC INTERFACES, NAMELY, PDA INTERFACES, PORTABLE VIDEO PLAYER INTERFACES; DVD CHANGER INTERFACES, DVD INTERFACES, GAME SYSTEM INTERFACES, IN-CAR ENTERTAINMENT SYSTEM INTERFACES, LCD VIDEO MONITORING INTERFACES, NAVIGATION AUDIO AND RADIO INTERFACES, NAVIGATION SYSTEM INTERFACES, RADIO FREQUENCY AUDIO/VIDEO RECEIVERS, RADIO FREQUENCY AUDIO/VIDEO TRANSMITTERS, RADIO FREQUENCY VIDEO RECEIVERS, RADIO FREQUENCY TRANSMITTERS, VIDEO CABLES, VIDEO SIGNAL AMPLIFIERS, VIDEO SIGNAL SWITCHERS; TIMERS; AUDIO SIGNAL DISTRIBUTION PRODUCTS NAMELY, SIGNAL PROCESSORS, CABLES FOR AUDIO SIGNAL TRANSMISSION; DIGITAL SIGNAL PROCESSORS, AUDIO DEVICES, NAMELY, LINE DRIVERS; SECURITY DEVICES, NAMELY, INDUS-

**CLASS 9—(Continued).**

TRIAL AUTOMATION AND PROCESS CONTROL SIGNAL TRANSMISSION CABLE DOORLOCK INTERFACES, KEYLESS ENTRY SYSTEMS, NAMELY, ELECTRONIC PROGRAMMABLE KEYLESS ACTIVATION UNLOCKING SYSTEM COMPRISED OF A MICROPROCESSOR, SIGNAL DETECTOR AND SIGNAL EMITTER; SHORT RANGE RADIO INTERFACES FOR MOBILE DEVICES; MP3 PLAYER ACCESSORIES AND MP3 PLAYER INTERFACE KITS COMPRISING PLAYER ELECTRICAL POWER CORD AND PLAYER TRANSMITTERS; AUDIOVISUAL DEVICES, NAMELY, VIDEO PROCESSORS; VIDEO SIGNAL DISTRIBUTION PRODUCTS, NAMELY, VIDEO TRANSMISSION APPARATUS; COMPUTER OPERATING SYSTEMS, LOUDSPEAKER SYSTEMS; INTERFACES FOR INDUSTRIAL AUTOMATION AND PROCESS CONTROL SIGNAL TRANSMISSION CABLES; INFRARED CAMERA REPEATERS; INFRARED CAMERA TRANSMITTERS; PULSE GENERATORS FOR TESTING ELECTRIC CURRENT; AND DEVICES FOR HANDS-FREE USE OF MOBILE PHONES (U.S. CLS. 21, 23, 26, 36 AND 38).

KELLY BOULTON, EXAMINING ATTORNEY

**CLASS 9—(Continued).**

TRIAL AUTOMATION AND PROCESS CONTROL SIGNAL TRANSMISSION CABLE DOORLOCK INTERFACES, KEYLESS ENTRY SYSTEMS, NAMELY, ELECTRONIC PROGRAMMABLE KEYLESS ACTIVATION UNLOCKING SYSTEM COMPRISED OF A MICROPROCESSOR, SIGNAL DETECTOR AND SIGNAL EMITTER; SHORT RANGE RADIO INTERFACES FOR MOBILE DEVICES; MP3 PLAYER ACCESSORIES AND MP3 PLAYER INTERFACE KITS COMPRISING PLAYER ELECTRICAL POWER CORD AND PLAYER TRANSMITTERS; AUDIOVISUAL DEVICES, NAMELY, VIDEO PROCESSORS; VIDEO SIGNAL DISTRIBUTION PRODUCTS, NAMELY, VIDEO TRANSMISSION APPARATUS; COMPUTER OPERATING SYSTEMS, LOUDSPEAKER SYSTEMS; INTERFACES FOR INDUSTRIAL AUTOMATION AND PROCESS CONTROL SIGNAL TRANSMISSION CABLES; INFRARED CAMERA REPEATERS; INFRARED CAMERA TRANSMITTERS; PULSE GENERATORS FOR TESTING ELECTRIC CURRENT; AND DEVICES FOR HANDS-FREE USE OF MOBILE PHONES (U.S. CLS. 21, 23, 26, 36 AND 38).

KELLY BOULTON, EXAMINING ATTORNEY

---

SN 85-069,750. AAMP OF FLORIDA, INC., CLEARWATER, FL. FILED 6-23-2010.

**ISIMPLE GET CONNECTED**

THE MARK CONSISTS OF STANDARD CHARACTERS WITHOUT CLAIM TO ANY PARTICULAR FONT, STYLE, SIZE, OR COLOR.

OWNER OF U.S. REG. NO. 3,386,693.

FOR AUDIO DEVICES, NAMELY, AMPLIFIER INTEGRATION INTERFACES, AUDIO CABLES, AUDIO EQUALIZERS, AUDIO INTERFACES, AUDIO SIGNAL AMPLIFIERS, AUDIO SIGNAL SWITCHERS, AUXILIARY INPUT DEVICES FOR AUTOMOTIVE RADIOS, BAND-PASS FILTERS FOR USE WITH AUDIO CIRCUITS AND SPEAKER ENCLOSURES, BASS BLOCKERS IN THE NATURE OF A HIGH PASS FILTER THAT ATTENUATES LOWER FREQUENCIES; CD CHANGER INTERFACES, FLOATING GROUND ADAPTERS, FM MODULATED AUDIO RECEIVERS, FM MODULATED AUDIO TRANSMITTERS, HIGH-PASS FILTERS; LINE OUTPUT CONVERTERS, LOWPASS FILTERS, POWER RESISTORS, RADIO FREQUENCY AUDIO RECEIVERS, RADIO FREQUENCY AUDIO TRANSMITTERS, RADIO INSTALLATION INTERFACES, RCA LEVEL ATTENUATORS, RCA LEVEL CONTROLLER, RCA SWITCHER SATELLITE, RADIO INTERFACES, VOLUME CONTROLS; NOISE CONTROL, NAMELY, ANTENNA GROUND LOOP ISOLATORS, CHOKE FILTERS, FILTERING CAPACITORS, POWER LEAD FILTERS; CELL PHONE DEVICES, NAMELY, CELL PHONE INTERFACES, CHARGE CORDS, DOORLOCK INTERFACES; PORTABLE ELECTRONIC INTERFACES, NAMELY, PDA INTERFACES, PORTABLE VIDEO PLAYER INTERFACES; DVD CHANGER INTERFACES, DVD INTERFACES, GAME SYSTEM INTERFACES, IN-CAR ENTERTAINMENT SYSTEM INTERFACES, LCD VIDEO MONITORING INTERFACES, NAVIGATION AUDIO AND RADIO INTERFACES, NAVIGATION SYSTEM INTERFACES, RADIO FREQUENCY AUDIO/VIDEO RECEIVERS, RADIO FREQUENCY AUDIO/VIDEO TRANSMITTERS, RADIO FREQUENCY VIDEO RECEIVERS, RADIO FREQUENCY TRANSMITTERS, VIDEO CABLES, VIDEO SIGNAL AMPLIFIERS, VIDEO SIGNAL SWITCHERS; TIMERS; AUDIO SIGNAL DISTRIBUTION PRODUCTS NAMELY, SIGNAL PROCESSORS, CABLES FOR AUDIO SIGNAL TRANSMISSION; DIGITAL SIGNAL PROCESSORS, AUDIO DEVICES, NAMELY, LINE DRIVERS; SECURITY DEVICES, NAMELY, INDUS-

---

SN 85-070,165. ARISE HEALTH SOLUTIONS, LLC, KIRKLAND, WA. FILED 6-23-2010.

**ARISE HEALTH SOLUTIONS**

THE MARK CONSISTS OF STANDARD CHARACTERS WITHOUT CLAIM TO ANY PARTICULAR FONT, STYLE, SIZE, OR COLOR.

NO CLAIM IS MADE TO THE EXCLUSIVE RIGHT TO USE "HEALTH SOLUTIONS", APART FROM THE MARK AS SHOWN.

FOR COMPUTER SOFTWARE FOR USE IN ACCESSING ELECTRONIC MEDICAL RECORDS USING AN INTERNET INTERFACE (U.S. CLS. 21, 23, 26, 36 AND 38).

MARTHA FROMM, EXAMINING ATTORNEY

**CLASS 9—(Continued).**

SN 85-073,407. SAMIL POWER CO., LTD., JIANGSU PROVINCE, CHINA, FILED 6-28-2010.



THE MARK CONSISTS OF THE WORD "SAMILPOWER", WITH THREE BANDS TAPERING TO A POINT AND FORMING A SEMICIRCLE ABOVE IT AND ANOTHER THREE BANDS TAPERING TO A POINT AND FORMING A SEMICIRCLE BELOW IT.

THE WORDING "SAMILPOWER" HAS NO MEANING IN A FOREIGN LANGUAGE.

FOR ACOUSTIC COUPLERS; CENTRAL PROCESSING UNITS (CPU); COMPUTER NETWORK INTERFACE DEVICES; DISTRIBUTION BOXES FOR ELECTRICAL POWER; DOWNLOADABLE COMPUTER GAME PROGRAMS; ELECTRIC CABLES, WIRES, CONDUCTORS AND CONNECTION FITTINGS THEREFOR; INVERTERS; JUNCTION BOXES; RESISTANCE MEASURING INSTRUMENTS; VOLTAGE STABILIZING POWER SUPPLY (U.S. CLS. 21, 23, 26, 36 AND 38).

TARA PATE, EXAMINING ATTORNEY

**CLASS 9—(Continued).**

SN 85-076,626. OPEN SOFTWARE SOLUTIONS, L.L.C., AKA OSS OPEN SOFTWARE SOLUTIONS, DAVENPORT, IA, FILED 7-1-2010.



OPEN SOFTWARE SOLUTIONS

NO CLAIM IS MADE TO THE EXCLUSIVE RIGHT TO USE "OPEN SOFTWARE SOLUTIONS", APART FROM THE MARK AS SHOWN.

THE MARK CONSISTS OF LETTERS "OSS" POSITIONED INSIDE OVAL WITH WORDS "OPEN SOFTWARE SOLUTIONS" UNDERNEATH OVAL.

FOR COMPUTER SOFTWARE FOR MEDICAL OFFICE MANAGEMENT FOR ACCOUNTING FUNCTIONS, PATIENT APPOINTMENT MANAGEMENT AND PATIENT ELECTRONIC RECORDS MANAGEMENT (U.S. CLS. 21, 23, 26, 36 AND 38).

DAWN FELDMAN, EXAMINING ATTORNEY

SN 85-076,944. LIVEYEARBOOK, INC., NEENAH, WI. FILED 7-2-2010.

SN 85-073,926. TURNER BROADCASTING SYSTEM ASIA PACIFIC, INC., ATLANTA, GA. FILED 6-29-2010.

**TUZKI**

THE MARK CONSISTS OF STANDARD CHARACTERS WITHOUT CLAIM TO ANY PARTICULAR FONT, STYLE, SIZE, OR COLOR.

FOR VIDEO GAME SOFTWARE; DOWNLOADABLE MUSICAL SOUND RECORDINGS; DOWNLOADABLE VIDEO RECORDINGS FEATURING ANIMATED CHARACTERS (U.S. CLS. 21, 23, 26, 36 AND 38).

SEAN CROWLEY, EXAMINING ATTORNEY

**LIVEYEARBOOK**

THE MARK CONSISTS OF STANDARD CHARACTERS WITHOUT CLAIM TO ANY PARTICULAR FONT, STYLE, SIZE, OR COLOR.

OWNER OF U.S. REG. NO. 2,985,066.

FOR DOWNLOADABLE MULTIMEDIA FILES, AUDIO FILES, VIDEO FILES, PICTURE FILES, GRAPHIC FILES AND TEXT FILES FEATURING CONTENT FROM OR FOR SCHOOL YEARBOOKS, CHURCH DIRECTORIES, ACTIVITY BOOKS, MEMORY BOOKS (U.S. CLS. 21, 23, 26, 36 AND 38).

RUSS HERMAN, EXAMINING ATTORNEY

**CLASS 9—(Continued).**

SN 85-077,828. APLUS FLASH TECHNOLOGY, INC., DBA APLUS FLASH TECHNOLOGY, INC., SAN JOSE, CA. FILED 7-4-2010.

# HiEE

THE MARK CONSISTS OF THE LETTERS "HiEE" WITH THE "i" IN LOWER CASE AND THE "H" AND "EE" IN UPPER CASE.

FOR COMPUTER CHIPS; COMPUTER MEMORIES; COMPUTER MEMORY HARDWARE; ELECTRONIC CHIPS FOR THE MANUFACTURER OF INTEGRATED CIRCUITS; ELECTRONIC MEMORIES; MEMORIES FOR DATA PROCESSING EQUIPMENT; MEMORIES FOR USE WITH COMPUTERS; SEMI-CONDUCTOR MEMORIES; SEMI-CONDUCTOR MEMORY UNITS (U.S. CLS. 21, 23, 26, 36 AND 38).

ANNE FARRELL, EXAMINING ATTORNEY

**CLASS 9—(Continued).**

SN 85-082,917. GUERCIO, JAMES W., BOULDER, CO. FILED 7-12-2010.



NO CLAIM IS MADE TO THE EXCLUSIVE RIGHT TO USE "RECORDS", APART FROM THE MARK AS SHOWN.

THE MARK CONSISTS OF THE WORDS "CARIBOU RECORDS" IN STYLIZED SCRIPT LETTERING UNDERNEATH A FANCIFUL DESIGN OF A CARIBOU DEER WALKING IN A FIELD WITH TREES AND A MOUNTAIN IN THE BACKGROUND.

FOR MUSICAL SOUND RECORDINGS, PHONOGRAPH RECORDS FEATURING MUSIC, PRE-RECORDED COMPACT DISCS FEATURING MUSIC, DOWNLOADABLE MUSICAL SOUND RECORDINGS (U.S. CLS. 21, 23, 26, 36 AND 38).

FIRST USE 0-0-1977; IN COMMERCE 0-0-1977.

TASNEEM HUSSAIN, EXAMINING ATTORNEY

SN 85-079,013. GUERCIO, JAMES W., BOULDER, CO. FILED 7-6-2010.

## CARIBOU RECORDS

THE MARK CONSISTS OF STANDARD CHARACTERS WITHOUT CLAIM TO ANY PARTICULAR FONT, STYLE, SIZE, OR COLOR.

NO CLAIM IS MADE TO THE EXCLUSIVE RIGHT TO USE "RECORDS", APART FROM THE MARK AS SHOWN.

FOR MUSICAL SOUND RECORDINGS, PHONOGRAPH RECORDS FEATURING MUSIC, PRE-RECORDED COMPACT DISCS FEATURING MUSIC, DOWNLOADABLE MUSICAL SOUND RECORDINGS (U.S. CLS. 21, 23, 26, 36 AND 38).

FIRST USE 0-0-1977; IN COMMERCE 0-0-1977.

TASNEEM HUSSAIN, EXAMINING ATTORNEY

SN 85-083,163. NEW CONCEPTS DEVELOPMENT CORPORATION, WOODSTOCK, IL. FILED 7-13-2010.

## MERCURY EXTREME

THE MARK CONSISTS OF STANDARD CHARACTERS WITHOUT CLAIM TO ANY PARTICULAR FONT, STYLE, SIZE, OR COLOR.

FOR DATA STORAGE DEVICES, NAMELY, SOLID STATE DRIVES (U.S. CLS. 21, 23, 26, 36 AND 38).

FIRST USE 1-26-2010; IN COMMERCE 1-7-2011.

DAVID C. REIHNER, EXAMINING ATTORNEY



**CLASS 9—(Continued).**

SN 85-083,830. ABRAM, PHILLIP ALFRED, MIDDLETOWN, CT. FILED 7-13-2010.

## Combign Desine

THE MARK CONSISTS OF STANDARD CHARACTERS WITHOUT CLAIM TO ANY PARTICULAR FONT, STYLE, SIZE, OR COLOR.

NO CLAIM IS MADE TO THE EXCLUSIVE RIGHT TO USE "DESIGN", APART FROM THE MARK AS SHOWN.

FOR COMPUTER GAME SOFTWARE; COMPUTER GAME SOFTWARE FOR USE ON MOBILE AND CELLULAR PHONES; COMPUTER GAME SOFTWARE FOR USE WITH PERSONAL COMPUTERS, HOME VIDEO GAME CONSOLES USED WITH TELEVISIONS, AND FOR ARCADE-BASED VIDEO GAME CONSOLES; ELECTRONIC GAME SOFTWARE FOR WIRELESS DEVICES (U.S. CLS. 21, 23, 26, 36 AND 38).

JACLYN KIDWELL WALKER, EXAMINING ATTORNEY

---

SN 85-085,706. DVW, LLC, NASHVILLE, TN. FILED 7-15-2010.

## Red Land Records

THE MARK CONSISTS OF STANDARD CHARACTERS WITHOUT CLAIM TO ANY PARTICULAR FONT, STYLE, SIZE, OR COLOR.

NO CLAIM IS MADE TO THE EXCLUSIVE RIGHT TO USE "RECORDS", APART FROM THE MARK AS SHOWN.

FOR PRERECORDED AUDIO DISCS, TAPES AND PHONOGRAPH RECORDS FEATURING MUSIC AND MUSICAL PERFORMANCES; PRERECORDED VIDEO DISCS AND TAPES FEATURING MUSIC AND MUSICAL PERFORMANCES; DOWNLOADABLE AUDIO AND VIDEO RECORDINGS FEATURING MUSIC AND MUSICAL PERFORMANCES VIA A GLOBAL COMPUTER NETWORK (U.S. CLS. 21, 23, 26, 36 AND 38).

NATALIE POLZER, EXAMINING ATTORNEY

**CLASS 9—(Continued).**

SN 85-089,217. BAE SYSTEMS INFORMATION AND ELECTRONIC SYSTEMS INTEGRATION INC., NASHUA, NH. FILED 7-21-2010.



THE MARK CONSISTS OF THE TERM "BARRACUDA" AND THE DESIGN OF A FIGHTER JET FIRING MISSILES AT A BARRACUDA; ABOVE THE LETTER "B" IS A STYLIZED ARROW.

FOR ELECTRONIC WARFARE SYSTEMS AND DEVICES, NAMELY, A FULLY INTEGRATED ELECTRONIC WARFARE SUITE OF COMPUTER SOFTWARE AND COMPUTER HARDWARE FOR USE ON A MILITARY AIRCRAFT, SUCH SYSTEMS AND DEVICES BEING CAPABLE OF WORKING WITH THE AIRCRAFT'S MISSIONS SYSTEMS TO PROVIDE AN INTEGRATED SUITE INCLUDING A BROADBAND 360 DEGREE SITUATIONAL AWARENESS SUITE FOR RADAR WARNING, PRECISION DIRECTION FINDING, PRECISION GEOLOCATION OF THREAT EMITTERS, AND A MULTI-SPECTRAL COUNTERMEASURE SYSTEM AND RESPONSE MANAGER, ALL CONSISTING OF LOW OBSERVABLE APERTURES, APERTURE ELECTRONICS, AN ELECTRONIC WARFARE RACK, ELECTRONICS MODULES, A COUNTERMEASURE CONTROLLER, MULTI-SPECTRAL COUNTERMEASURES AND DISPENSERS (U.S. CLS. 21, 23, 26, 36 AND 38).

WILLIAM P. SHANAHAN, EXAMINING ATTORNEY

---

SN 85-095,575. WMS GAMING INC., WAUKEGAN, IL. FILED 7-29-2010.

## MASTROS

THE MARK CONSISTS OF STANDARD CHARACTERS WITHOUT CLAIM TO ANY PARTICULAR FONT, STYLE, SIZE, OR COLOR.

THE NAME(S), PORTRAIT(S), AND/OR SIGNATURE(S) SHOWN IN THE MARK IDENTIFIES MICHAEL MASTROPIETRO, WHOSE CONSENT(S) TO REGISTER IS MADE OF RECORD.

FOR COMPONENTS FOR GAMING MACHINES THAT GENERATE OR DISPLAY WAGER OUTCOMES, NAMELY, CONTROLLERS, DISPLAYS, BUTTON PANELS, BOLSTERS, ELECTRICAL WIRING, AND COMPUTER HARDWARE AND SOFTWARE ASSOCIATED THEREWITH; GAMING MACHINES, NAMELY, DEVICES WHICH ACCEPT A WAGER; GAMING SOFTWARE THAT GENERATES OR DISPLAYS WAGER OUTCOMES OF GAMING MACHINES (U.S. CLS. 21, 23, 26, 36 AND 38).

JASON BLAIR, EXAMINING ATTORNEY

**CLASS 9—(Continued).**

SN 85-097,845. KAPLAN, JONATHAN, BATON ROUGE, LA.  
FILED 8-2-2010.

# BuildMyBod

THE MARK CONSISTS OF STANDARD CHARACTERS WITHOUT CLAIM TO ANY PARTICULAR FONT, STYLE, SIZE, OR COLOR.

FOR COMPUTER APPLICATION SOFTWARE FOR MOBILE PHONES AND HANDHELD COMPUTERS, NAMELY, SOFTWARE FOR USE BY PATIENTS AND PROSPECTIVE PATIENTS OF HEALTHCARE PROVIDERS FOR ACCESSING PROVIDER-SPECIFIC PRICING INFORMATION FOR HEALTHCARE SERVICES (U.S. CLS. 21, 23, 26, 36 AND 38).

KATHLEEN M. VANSTON, EXAMINING ATTORNEY

**CLASS 9—(Continued).**

SN 85-097,984. IKONIX GROUP, INC., LAKE FOREST, IL.  
FILED 8-2-2010.

# smartCONFIG

THE MARK CONSISTS OF STANDARD CHARACTERS WITHOUT CLAIM TO ANY PARTICULAR FONT, STYLE, SIZE, OR COLOR.

FOR AC ELECTRICAL POWER SUPPLIES; ELECTRICAL POWER SUPPLIES; AND AC ELECTRICAL POWER SUPPLIES WHICH MAY BE INTERCONNECTED AND ARE PROVIDED WITH CHANGES TO THE AVAILABLE OPTIONS DEPENDING ON THE NUMBER OF AC ELECTRICAL POWER SUPPLIES THAT ARE INTERCONNECTED (U.S. CLS. 21, 23, 26, 36 AND 38).

JOHN DALIER, EXAMINING ATTORNEY

SN 85-097,988. IKONIX GROUP, INC., LAKE FOREST, IL.  
FILED 8-2-2010.

# smartDETECT

THE MARK CONSISTS OF STANDARD CHARACTERS WITHOUT CLAIM TO ANY PARTICULAR FONT, STYLE, SIZE, OR COLOR.

FOR AC ELECTRICAL POWER SUPPLIES; ELECTRICAL POWER SUPPLIES; AND AC ELECTRICAL POWER SUPPLIES WHICH MAY BE INTERCONNECTED AND ARE PROVIDED WITH CHANGES TO THE AVAILABLE OPTIONS DEPENDING ON THE NUMBER OF AC ELECTRICAL POWER SUPPLIES THAT ARE INTERCONNECTED (U.S. CLS. 21, 23, 26, 36 AND 38).

JOHN DALIER, EXAMINING ATTORNEY

SN 85-097,991. IKONIX GROUP, INC., LAKE FOREST, IL.  
FILED 8-2-2010.

# smartVOLT

THE MARK CONSISTS OF STANDARD CHARACTERS WITHOUT CLAIM TO ANY PARTICULAR FONT, STYLE, SIZE, OR COLOR.

FOR ELECTRICAL AND ELECTRONIC MEASURING AND TESTING DEVICES PROVIDED WITH USER ADJUSTABLE SETTINGS FOR POWERING UP FOR USE IN MEASURING AND TESTING ELECTRICAL POWER FLUCTUATIONS; ELECTRICAL AND ELECTRONIC MEASURING AND TESTING DEVICES, NAMELY, AC ELECTRICAL POWER SUPPLIES, ELECTRICAL POWER SUPPLY FREQUENCY CONVERTERS, AC ELECTRICAL POWER SUPPLIES, DC POWER SUPPLIES, DC ELECTRONIC LOAD MEASURERS AND TESTERS, AC ELECTRONIC LOAD MEASURERS AND TESTERS, AC ELECTRICAL POWER SUPPLY MEASURERS AND TESTERS, AND DC POWER SUPPLY MEASURERS AND TESTERS (U.S. CLS. 21, 23, 26, 36 AND 38).

JOHN DALIER, EXAMINING ATTORNEY

# variPLUS

THE MARK CONSISTS OF STANDARD CHARACTERS WITHOUT CLAIM TO ANY PARTICULAR FONT, STYLE, SIZE, OR COLOR.

FOR AC ELECTRICAL POWER SUPPLIES AND ELECTRICAL POWER SUPPLIES (U.S. CLS. 21, 23, 26, 36 AND 38).

FIRST USE 1-11-2011; IN COMMERCE 1-11-2011.

JOHN DALIER, EXAMINING ATTORNEY

**CLASS 9—(Continued).**

SN 85-098,522. SEX CULT RECORDS, NEW YORK CITY, NY. FILED 8-2-2010.

**Sex Cult Records**

THE MARK CONSISTS OF STANDARD CHARACTERS WITHOUT CLAIM TO ANY PARTICULAR FONT, STYLE, SIZE, OR COLOR.

NO CLAIM IS MADE TO THE EXCLUSIVE RIGHT TO USE "RECORDS", APART FROM THE MARK AS SHOWN.

FOR AUDIO AND VIDEO RECORDINGS FEATURING MUSIC AND ARTISTIC PERFORMANCES; AUDIO RECORDINGS FEATURING MUSIC; AUDIO TAPES FEATURING MUSIC; COMPACT DISCS FEATURING MUSIC; COMPACT DISCS FEATURING MUSIC AND SPOKEN WORD IN THE FORM OF POETRY; DIGITAL MUSIC DOWNLOADABLE FROM THE INTERNET; DOWNLOADABLE MP3 FILES, MP3 RECORDINGS, ON-LINE DISCUSSION BOARDS, WEBCASTS, WEBINARS AND PODCASTS FEATURING MUSIC, AUDIO BOOKS IN THE FIELD OF MUSIC, AND NEWS BROADCASTS; DOWNLOADABLE MUSICAL SOUND RECORDINGS; DOWNLOADABLE RING TONES, GRAPHICS AND MUSIC VIA A GLOBAL COMPUTER NETWORK AND WIRELESS DEVICES; DOWNLOADABLE VIDEO RECORDINGS FEATURING MUSIC; DOWNLOADABLE MUSIC VIA THE INTERNET AND WIRELESS DEVICES; MUSICAL SOUND RECORDINGS; MUSICAL VIDEO RECORDINGS; PHONOGRAPH RECORDS FEATURING MUSIC; PRERECORDED AUDIO TAPES FEATURING MUSIC; PRERECORDED VIDEO CASSETTES FEATURING MUSIC; PRERECORDED VIDEO TAPES FEATURING MUSIC; SERIES OF MUSICAL SOUND RECORDINGS; SOUND RECORDINGS FEATURING MUSIC; VIDEO RECORDINGS FEATURING MUSIC; VISUAL RECORDINGS AND AUDIOVISUAL RECORDINGS FEATURING MUSIC AND ANIMATION (U.S. CLS. 21, 23, 26, 36 AND 38).

JULIE VEPPIUMTHARA, EXAMINING ATTORNEY

SN 85-111,126. WESTINGHOUSE ELECTRIC COMPANY LLC, CRANBERRY TOWNSHIP, PA. FILED 8-19-2010.

**ALS**

THE MARK CONSISTS OF STANDARD CHARACTERS WITHOUT CLAIM TO ANY PARTICULAR FONT, STYLE, SIZE, OR COLOR.

FOR AUTOMATED PROCESS CONTROL SYSTEM COMPRISED OF LOGIC BASED HARDWARE USED TO MONITOR THE STATUS OF INDUSTRIAL MACHINERY, NAMELY, TURBINES, GENERATORS AND COMPRESSORS (U.S. CLS. 21, 23, 26, 36 AND 38).

BILL DAWE, EXAMINING ATTORNEY

**CLASS 9—(Continued).**

SN 85-114,110. MOLEX INCORPORATED, LISLE, IL. FILED 8-23-2010.

**SOLARSPEC**

THE MARK CONSISTS OF STANDARD CHARACTERS WITHOUT CLAIM TO ANY PARTICULAR FONT, STYLE, SIZE, OR COLOR.

FOR ELECTRICAL CONNECTORS, ELECTRICAL JUNCTION BOXES, ELECTRICAL CABLES AND CORDSETS, AND CABLE ASSEMBLIES, ALL THE FOREGOING DESIGNED FOR USE WITH SOLAR PANELS FOR PRODUCTION OF ELECTRICITY (U.S. CLS. 21, 23, 26, 36 AND 38).

C. DIONNE CLYBURN, EXAMINING ATTORNEY

SN 85-114,195. AMA PARTNERS LLC, NEW ORLEANS, LA. FILED 8-24-2010.

**JEANTHERAPY**

THE MARK CONSISTS OF STANDARD CHARACTERS WITHOUT CLAIM TO ANY PARTICULAR FONT, STYLE, SIZE, OR COLOR.

FOR COMPUTER APPLICATION SOFTWARE FOR MOBILE PHONES, NAMELY, SOFTWARE FOR USE IN DOWNLOADING OR COMPLETING TRANSACTIONS FOR PURCHASING GOODS ENTERTAINMENT, SHOPPING AND INFORMATION SERVICES (U.S. CLS. 21, 23, 26, 36 AND 38).

ANNE E. GUSTASON, EXAMINING ATTORNEY

SN 85-116,576. LEVID MEDIA, LLC, RANCHO SANTA MARGARITA, CA. FILED 8-26-2010.

**CueScore Billiards System**

THE MARK CONSISTS OF STANDARD CHARACTERS WITHOUT CLAIM TO ANY PARTICULAR FONT, STYLE, SIZE, OR COLOR.

NO CLAIM IS MADE TO THE EXCLUSIVE RIGHT TO USE "BILLIARDS SYSTEM", APART FROM THE MARK AS SHOWN.

FOR DOWNLOADABLE SOFTWARE IN THE NATURE OF A MOBILE APPLICATION FOR SCORING BILLIARDS GAMES (U.S. CLS. 21, 23, 26, 36 AND 38).

NATALIE POLZER, EXAMINING ATTORNEY

**CLASS 9—(Continued).**

SN 85-117,947. GHC SPECIALTY BRANDS, LLC, JANESVILLE, WI. FILED 8-27-2010.



OWNER OF U.S. REG. NO. 3,160,164.  
NO CLAIM IS MADE TO THE EXCLUSIVE RIGHT TO USE "SIGHT", APART FROM THE MARK AS SHOWN.  
THE MARK CONSISTS OF THE WORDS "SIGHT" AND "DEFENSE" WITH THE "S" IN THE WORD "SIGHT" OVERLAPPING A DEPICTION OF A STAR.

FOR SAFETY EYEWEAR, NAMELY, SAFETY GOGGLES, SAFETY EYEGLASSES, SAFETY EYE AND FACE SHIELDS; EYE PROTECTION ACCESSORIES, NAMELY, SAFETY NECK AND HEAD STRAPS WHICH RESTRAIN SAFETY EYEWEAR FROM MOVEMENT ON A WEARER, CASES AND DISPENSERS FOR PROTECTIVE EYEWEAR (U.S. CLS. 21, 23, 26, 36 AND 38).

FIRST USE 12-22-2005; IN COMMERCE 12-22-2005.  
SALLY SHIH, EXAMINING ATTORNEY

**CLASS 9—(Continued).**

SN 85-121,491. ORBIS TECHNOLOGIES, INC., ANNAPOLIS, MD. FILED 9-2-2010.



THE COLOR(S) GREEN AND RED IS/ARE CLAIMED AS A FEATURE OF THE MARK.

THE MARK CONSISTS OF THE WORD "TACTIPEDIA" AND THE LETTER "T" IS A GREEN CAMOUFLAGE PATTERN THAT IS ENCLOSED IN A STYLIZED REPRESENTATION OF A COMPUTER SELECTION KEY THAT IS RED AND THE REMAINING LETTERS "ACTIPEDIA" ARE GREEN.

FOR COMPUTER SOFTWARE FOR ACCESSING AN INTERACTIVE ENCYCLOPEDIA AND KNOWLEDGE REPOSITORY IN THE FIELD OF MILITARY INTELLIGENCE (U.S. CLS. 21, 23, 26, 36 AND 38).

FIRST USE 2-0-2009; IN COMMERCE 2-0-2009.  
KAELIE KUNG, EXAMINING ATTORNEY

SN 85-118,759. DIRECTORY WIZARDS, INC., TOWNSEND, DE. FILED 8-30-2010.

## UNITYSYNC

THE MARK CONSISTS OF STANDARD CHARACTERS WITHOUT CLAIM TO ANY PARTICULAR FONT, STYLE, SIZE, OR COLOR.

FOR COMPUTER SOFTWARE FOR SYNCHRONIZATION OF USER IDENTITY DATA BETWEEN ANY COMBINATION OF EMAIL, DIRECTORY AND DATABASE-RELATED SERVICES (U.S. CLS. 21, 23, 26, 36 AND 38).

RUSS HERMAN, EXAMINING ATTORNEY

SN 85-121,496. ORBIS TECHNOLOGIES, INC., ANNAPOLIS, MD. FILED 9-2-2010.

## TACTIPEDIA

THE MARK CONSISTS OF STANDARD CHARACTERS WITHOUT CLAIM TO ANY PARTICULAR FONT, STYLE, SIZE, OR COLOR.

FOR COMPUTER SOFTWARE FOR ACCESSING AN INTERACTIVE ENCYCLOPEDIA AND KNOWLEDGE REPOSITORY IN THE FIELD OF MILITARY INTELLIGENCE (U.S. CLS. 21, 23, 26, 36 AND 38).

FIRST USE 2-0-2009; IN COMMERCE 2-0-2009.  
KAELIE KUNG, EXAMINING ATTORNEY

SN 85-119,784. ARISTOCRAT TECHNOLOGIES AUSTRALIA PTY LTD, NORTH RYDE, NSW, AUSTRALIA, FILED 8-31-2010.



PRIORITY CLAIMED UNDER SEC. 44(D) ON AUSTRALIA APPLICATION NO. 1353115, FILED 3-26-2010, REG. NO. 1353115, DATED 3-26-2010, EXPIRES 3-26-2020.

OWNER OF U.S. REG. NOS. 2,573,028, 2,890,663 AND 3,132,499.

THE MARK CONSISTS OF COIN CARTOON WITH TOPHAT AND GLOVE BETWEEN THE WORDS "CASHMAN" AND "FEVER", BOTH OF WHICH APPEAR IN A STYLIZED FONT.

FOR ELECTRONIC GAMING MACHINES, NAMELY, DEVICES WHICH ACCEPT A WAGER (U.S. CLS. 21, 23, 26, 36 AND 38).

APRIL HESIK, EXAMINING ATTORNEY

SN 85-122,247. APPDNA, INC., LAS VEGAS, NV. FILED 9-2-2010.

## APTITUDE

THE MARK CONSISTS OF STANDARD CHARACTERS WITHOUT CLAIM TO ANY PARTICULAR FONT, STYLE, SIZE, OR COLOR.

FOR DOWNLOADABLE COMPUTER SOFTWARE FOR USE IN APPLICATION MANAGEMENT, TESTING, MIGRATION, IMPLEMENTATION, AND EVALUATION (U.S. CLS. 21, 23, 26, 36 AND 38).

FIRST USE 10-1-2007; IN COMMERCE 10-1-2007.  
JANET LEE, EXAMINING ATTORNEY

**CLASS 9—(Continued).**

SN 85-124,263. CROWDSTAR INTERNATIONAL LIMITED, BLACKROCK, CO. DUBLIN, IRELAND, FILED 9-7-2010.

**CROWDSTAR'S MIGHTY PIRATES**

THE MARK CONSISTS OF STANDARD CHARACTERS WITHOUT CLAIM TO ANY PARTICULAR FONT, STYLE, SIZE, OR COLOR.

OWNER OF U.S. REG. NOS. 3,800,884 AND 3,885,298.

FOR DOWNLOADABLE COMPUTER GAME SOFTWARE FOR USE ON WIRELESS DEVICES AND COMPUTERS; COMPUTER-GAME SOFTWARE, VIDEO GAME SOFTWARE, AND COMPUTER GAME APPLICATION SOFTWARE; INTERACTIVE-VIDEO-GAME PROGRAMS; ELECTRONIC GAME SOFTWARE AND ELECTRONIC GAME APPLICATION SOFTWARE THAT MAY BE ACCESSED VIA THE INTERNET, COMPUTERS AND WIRELESS DEVICES; COMPUTER SOFTWARE TO ENABLE UPLOADING, POSTING, SHOWING, DISPLAYING, TAGGING, BLOGGING, SHARING OR OTHERWISE PROVIDING ELECTRONIC MEDIA OR INFORMATION REGARDING THE FIELDS OF VIRTUAL COMMUNITIES, ELECTRONIC GAMING, ENTERTAINMENT AND GENERAL INTEREST VIA THE INTERNET OR OTHER COMMUNICATIONS NETWORKS WITH THIRD PARTIES (U.S. CLS. 21, 23, 26, 36 AND 38).

KEVIN DINALLO, EXAMINING ATTORNEY

---

SN 85-125,519. ALPHAVISTA SERVICES, INC., SUNNYVALE, CA. FILED 9-9-2010.

**CAREK12**

THE MARK CONSISTS OF STANDARD CHARACTERS WITHOUT CLAIM TO ANY PARTICULAR FONT, STYLE, SIZE, OR COLOR.

FOR EDUCATIONAL SOFTWARE FOR CHILDREN (U.S. CLS. 21, 23, 26, 36 AND 38).

FIRST USE 7-1-2010; IN COMMERCE 7-1-2010.

PAUL E. FAHRENKOPF, EXAMINING ATTORNEY

**CLASS 9—(Continued).**

SN 85-126,165. SMULE, INC., PALO ALTO, CA. FILED 9-9-2010.

**MAGIC PIANO**

THE MARK CONSISTS OF STANDARD CHARACTERS WITHOUT CLAIM TO ANY PARTICULAR FONT, STYLE, SIZE, OR COLOR.

NO CLAIM IS MADE TO THE EXCLUSIVE RIGHT TO USE "PIANO", APART FROM THE MARK AS SHOWN.

FOR GAME SOFTWARE; COMPUTER APPLICATION SOFTWARE FOR MOBILE COMPUTERS, NAMELY, SOFTWARE THAT ALLOWS A MOBILE DEVICE TO BE USED AS A MUSICAL INSTRUMENT AND ALLOWS USERS TO PLAY MUSIC ALONE OR VIRTUALLY WITH OTHERS; COMPUTER GRAPHICS SOFTWARE; COMPUTER SOFTWARE PROGRAMS FOR THE INTEGRATION OF TEXT, AUDIO, GRAPHICS, STILL IMAGES AND MOVING PICTURES INTO AN INTERACTIVE DELIVERY FOR MULTIMEDIA APPLICATIONS; SOFTWARE FOR PROCESSING DIGITAL MUSIC FILES; COMPUTER SOFTWARE FEATURING MUSICAL SOUND RECORDINGS AND MUSICAL VIDEO RECORDINGS; COMPUTER SOFTWARE FOR COMMUNICATING WITH USERS OF HAND-HELD COMPUTERS; COMPUTER SOFTWARE FOR MANIPULATING DIGITAL AUDIO INFORMATION FOR USE IN AUDIO MEDIA APPLICATIONS; COMPUTER SOFTWARE FOR PROCESSING DIGITAL MUSIC FILES; COMPUTER SOFTWARE FOR USE IN RELATION TO DIGITAL ANIMATION AND SPECIAL EFFECTS OF IMAGES; COMPUTER SOFTWARE FOR WIRELESS CONTENT DELIVERY; COMPUTER SOFTWARE PLATFORMS FOR DEVELOPMENT OF INTERACTIVE AUDIO APPLICATIONS FOR USE WITH MOBILE AUDIO PLATFORMS; COMPUTER SOFTWARE TO CONTROL AND IMPROVE COMPUTER AND AUDIO EQUIPMENT SOUND QUALITY; COMPUTER SOFTWARE EXECUTABLE TO CAUSE MOBILE DEVICES TO FUNCTION AS MUSICAL INSTRUMENTS; DOWNLOADABLE COMPUTER SOFTWARE FOR MOBILE DEVICES THAT ENABLES USERS TO TRANSFORM AND ENHANCE THE VIDEO AND AUDIO CAPABILITIES OF THEIR MOBILE DEVICES; DOWNLOADABLE COMPUTER SOFTWARE EXECUTABLE TO COMMUNICATE AMONGST MOBILE DEVICES USING AUDIO ENCODINGS OF INFORMATION; DOWNLOADABLE COMPUTER SOFTWARE EXECUTABLE TO PROVIDE MOBILE DEVICES WITH SIGNAL PROCESSING CAPABILITIES; DOWNLOADABLE COMPUTER SOFTWARE FOR MOBILE DEVICES THAT ENABLES USERS TO INTERACTIVELY PERFORM INDIVIDUALIZED AUDIO AND VIDEO APPLICATIONS; DOWNLOADABLE COMPUTER SOFTWARE FOR MOBILE DEVICES THAT ENABLES USERS TO SEND MUSIC, TEXT, AUDIO, VIDEO, AND GRAPHICS INFORMATION TO OTHER USERS OF MOBILE DEVICES; DOWNLOADABLE COMPUTER SOFTWARE FOR MOBILE DEVICES FOR ENABLING USERS TO DOWNLOAD AND SHARE INTERACTIVE AUDIO AND MUSIC USING MOBILE PHONES; DOWNLOADABLE COMPUTER SOFTWARE FOR MOBILE DEVICES FOR ENHANCING AUDIO AND VIDEO CAPABILITIES FOR ENTERTAINMENT PURPOSES; DOWNLOADABLE COMPUTER SOFTWARE FOR MOBILE DEVICES FOR PERSONALIZING AUDIO PERFORMANCES ON A MOBILE DEVICE BASED ON USER INTERACTION (U.S. CLS. 21, 23, 26, 36 AND 38).

FIRST USE 4-3-2010; IN COMMERCE 4-3-2010.

BRENDAN MCCAULEY, EXAMINING ATTORNEY

**CLASS 9—(Continued).**

SN 85-127,119. SARAB, SINGH, CANOGA PARK, CA. FILED 9-10-2010.

# SABUNO

THE MARK CONSISTS OF STANDARD CHARACTERS WITHOUT CLAIM TO ANY PARTICULAR FONT, STYLE, SIZE, OR COLOR.

THE WORDING "SABUNO" HAS NO MEANING IN A FOREIGN LANGUAGE.

FOR COMMUNICATION SOFTWARE FOR PROVIDING ACCESS TO THE INTERNET; COMPUTER NETWORK INTERFACE DEVICES; COMPUTER PROGRAMS FOR SEARCHING REMOTELY FOR CONTENT ON COMPUTERS AND COMPUTER NETWORKS; COMPUTER PROGRAMS FOR SEARCHING THE CONTENTS OF COMPUTERS AND COMPUTER NETWORKS BY REMOTE CONTROL; COMPUTER PROGRAMS FOR USING THE INTERNET AND THE WORLD WIDE WEB; COMPUTER SEARCH ENGINE SOFTWARE; COMPUTER SOFTWARE THAT PROVIDES REAL-TIME, INTEGRATED BUSINESS MANAGEMENT INTELLIGENCE BY COMBINING INFORMATION FROM VARIOUS DATABASES AND PRESENTING IT IN AN EASY-TO-UNDERSTAND USER INTERFACE; COMPUTER SOFTWARE THAT PROVIDES WEB-BASED ACCESS TO APPLICATIONS AND SERVICES THROUGH A WEB OPERATING SYSTEM OR PORTAL INTERFACE; ELECTRONIC DISPLAY INTERFACES; MULTIFUNCTION KEYBOARDS (U.S. CLS. 21, 23, 26, 36 AND 38).

JACQUELINE A. LAVINE, EXAMINING ATTORNEY

**CLASS 9—(Continued).**

SN 85-128,427. RICHMEG INDUSTRY CO., LTD., PEI TUN DIST. TAICHUNG, TAIWAN, FILED 9-13-2010.



OWNER OF TAIWAN REG. NO. 01274572, DATED 8-16-2007, EXPIRES 8-15-2017.

THE MARK CONSISTS OF A STYLIZED LETTER "S" WITHIN A STYLIZED LETTER "C".

FOR ELECTROMAGNETIC SOLENOIDS, ELECTROMAGNETIC VALVES, ELECTROMAGNETIC CONTROL VALVES, ELECTROMAGNETIC ROTARY VALVES, CASES OF ELECTROMAGNETIC VALVES, VENDING MACHINES, ELECTRIC LOCKS, ELECTRONIC LOCKS, ELECTRIC ANTI-THEFT LOCKS, MAGNETIC CARD LOCKS, ELECTRONIC COMBINATION LOCKS, ANTI-THEFT WARNING APPARATUS NOT FOR VEHICLES, NAMELY, BURGLAR ALARMS, MAIN CONTROLLER FOR ANTI-THEFT SYSTEM, ANTI-THEFT WARNING APPARATUS, NAMELY, THEFT ALARMS, ELECTROMAGNETIC SWITCHES, COMMUTATORS, TRANSFORMERS, SWITCHBOARDS, CAPACITORS, CONDENSERS (U.S. CLS. 21, 23, 26, 36 AND 38).

SUZANNE BLANE, EXAMINING ATTORNEY

SN 85-127,535. SENTER, RANDALL HALL, LOS ANGELES, CA. FILED 9-11-2010.



THE COLOR(S) RED, ORANGE, YELLOW, GREEN, BLUE, INDIGO, AND VIOLET AS A RAINBOW GRADIENT IS/ARE CLAIMED AS A FEATURE OF THE MARK.

THE MARK CONSISTS OF THE STYLIZED WORDING "SUPERPLAYER" IN THE COLORS RED, ORANGE, YELLOW, GREEN, BLUE, INDIGO AND VIOLET SUPERIMPOSED OVER A RAINBOW MUSICAL STAFF IN THE COLORS GREEN, VIOLET, ORANGE, RED AND YELLOW WITH A TUNING FORK BEHIND IT IN THE COLORS GREEN AND BLUE. THE "S" OF THE WORDING "SUPERPLAYER" IS A REVERSED TREBLE CLEF.

FOR MOTION PICTURE FILMS ABOUT A SINGULAR MUSICAL SUPERHERO CALLED SUPERPLAYER (U.S. CLS. 21, 23, 26, 36 AND 38).

STEPHANIE ALI, EXAMINING ATTORNEY

SN 85-129,428. KOLLSMAN, INC, MERRIMACK, NH. FILED 9-14-2010.

# EFVS-XP

THE MARK CONSISTS OF STANDARD CHARACTERS WITHOUT CLAIM TO ANY PARTICULAR FONT, STYLE, SIZE, OR COLOR.

FOR AN AIRCRAFT INSTRUMENTATION SYSTEM CONSISTING OF A HEAD UP DISPLAY MONITOR AND COMPUTER FOR PROVIDING FLIGHT GUIDANCE SYMBOLOLOGY THAT PROVIDES FLIGHT INFORMATION, COMBINED WITH INFRARED OPTICAL SENSORS AND IMAGING SOFTWARE ALGORITHMS THAT PROVIDE AN ENHANCED IMAGE THAT IS TRANSMITTED TO VARIOUS MONITORS IN THE COCKPIT, ALL OF WHICH ARE FOR USE IN AIRCRAFT COCKPIT, CABIN AND RADOME IN ORDER TO ENABLE OPERATION OF THE AIRCRAFT DURING TAKE OFF, TAXI, AND LANDING IN LOW VISIBILITY CONDITIONS (U.S. CLS. 21, 23, 26, 36 AND 38).

APRIL ROACH, EXAMINING ATTORNEY

**CLASS 9—(Continued).**

SN 85-130,239. PALMERSTON LIMITED, DOUGLAS, UNITED KINGDOM, FILED 9-15-2010.



OWNER OF UNITED KINGDOM REG. NO. 2284309B, DATED 10-15-2001, EXPIRES 10-15-2011.

OWNER OF U.S. REG. NOS. 2,918,742 AND 3,495,940. THE MARK CONSISTS OF A STYLIZED "3".

FOR TELEMATICS APPARATUS AND INSTRUMENTS, NAMELY, WEB CONSOLES, ELECTRIC DISTRIBUTION CONSOLES; WIRELESS NETWORK ENABLED APPLIANCES, NAMELY, TVS, DVD MACHINES, RADIOS, PERSONAL MONITORS, WIRELESS VIDEO GATEWAY SYSTEMS, NAMELY, APPARATUS AND EQUIPMENT COMBINING HARDWARE AND SOFTWARE TO ENABLE DECODING OF BINARY INFORMATION TO TRANSMIT OVER A NETWORK STANDARD FOR DISTANT RECEPTION, APPARATUS AND EQUIPMENT FOR VIDEO CALLING, VIDEO MESSAGING, STREAMING AND DOWNLOADING OF DATA FROM INTERNET BROWSERS IN THE FIELDS OF SPORTS AND ENTERTAINMENT; TELEVISION ANTENNAS; TELEVISION SETS; TELEVISION SET TOP BOXES TO FACILITATE COMMUNICATION BETWEEN TELEVISION SETS AND MOBILE TELEPHONES OR MOBILE ELECTRONIC DEVICES; TELECOMMUNICATIONS EQUIPMENT MAKING USE OF A SHORT-RANGE NETWORK PROTOCOL FOR CONNECTING DIFFERENT TYPES OF ELECTRONIC DEVICES, NAMELY, TELEPHONES, MOBILE TELEPHONES, MOBILE ELECTRONIC DEVICES, FACSIMILE MACHINES, MOBILE TELEPHONES AND MOBILE ELECTRONIC DEVICES USED TO ACCESS ENTERPRISE APPLICATIONS, TELEGRAM MACHINES AND MODEMS FOR ACCESSING THE INTERNET AND DATABASES ON THE INTERNET; ELECTRONIC DEVICES FOR RECEIVING TELEVISION, LOCAL, SATELLITE, WIRELESS, PERSONAL NETWORK, MESHED NETWORK, IEEE 802.11 STANDARD NETWORK, DEDICATED WIRELESS DATA NETWORK FOR PROFESSIONAL USERS, OFDM (ORTHOGONAL FREQUENCY DIVISION MULTIPLEXING), ULTRAWIDEBAND NETWORK AND GLOBAL COMMUNICATION NETWORK TRANSMISSIONS AND TRANSMITTING THEM TO A TELEVISION OR OTHER DISPLAY DEVICE AND COMPUTER PROGRAMS FOR USE THEREWITH; OPTICAL DISC PLAYERS AND COMPUTER PROGRAMS THEREFOR; BLANK MAGNETIC DATA CARRIERS; PRE-RECORDED MAGNETIC DATA CARRIERS AND COMPACT DISCS FEATURING COMPUTER SOFTWARE TO ENABLE AUDIO AND VISUAL MONITORING IN THE NATURE OF A WEBCAM, AND COMPUTER SOFTWARE FOR DEVICE LOCATION, FOR DETERMINING THE POSITION OF VEHICLES AND FOR TRACKING OF VEHICLES OR MOVABLE EQUIPMENT OR APPARATUS; PRE-RECORDED MAGNETIC DATA CARRIERS AND COMPACT DISCS FEATURING MUSICAL RECORDINGS, TEXT, GRAPHICS, SOUND RECORDINGS, VISUAL IMAGES, AUDIO-VISUAL RECORDINGS, ELECTRONIC DATABASES, MULTIMEDIA INFORMATION AND MATERIALS ALL IN THE FIELDS OF ENTERTAINMENT, EDUCATION, AND INFORMATION ON NEWS, SPORT, MUSIC, GAMES, BUSINESS, FINANCE, LIFESTYLE AND WEATHER; BLANK SMART CARDS; ENCODED SMART CARDS CONTAINING PROGRAMMING USED TO AUTHENTICATE, ACCESS, ENABLE, OPERATE,

**CLASS 9—(Continued).**

ENHANCE AND ACTIVATE WIRELESS PRODUCTS AND SERVICES; MEMORY CARDS, BLANK ELECTRONIC STORAGE MEDIA, IEEE 802.11 STANDARD CARDS, PCMCIA (PERSONAL COMPUTER MEMORY CARD INTERNATIONAL ASSOCIATION) CARDS; USB MEMORY DEVICES, NAMELY, A DEVICE WHICH PROVIDES CAPACITY FOR STORING DATA, AND WHICH IS DESIGNED FOR USE WITH THE USB STANDARD; LAPTOP PC CARDS, ENCODED ELECTRONIC CHIP CARDS CONTAINING PROGRAMMING USED TO AUTHENTICATE, ACCESS, ENABLE, OPERATE, ENHANCE AND ACTIVATE WIRELESS PRODUCTS AND SERVICES; DATA CARDS, NAMELY, EXTERNAL MASS STORAGE DEVICES; BLANK RECORDING COMPACT DISCS; ELECTRONIC EQUIPMENT MAKING USE OF A SHORT-RANGE NETWORK PROTOCOL FOR CONNECTING DIFFERENT TYPES OF ELECTRONIC DEVICES FOR RECORDING, TRANSMISSION, SENDING, RECEIVING, REPRODUCING, FACILITATING AND ENABLING TRANSMISSION OF SOUND, IMAGES, DATA, TEXTUAL MATERIAL, VOICES, AUDIO, VIDEO, AUDIO-VIDEO AND MULTI-MEDIA, NAMELY, VIDEO RECORDERS, DVD MACHINES, TAPE RECORDERS, STEREOS, MP3 PLAYERS, PERSONAL STEREOS, CALCULATORS; TELEPRINTERS, TELEGRAM MACHINES, TELEPHONES, MOBILE TELEPHONES, MOBILE ELECTRONIC DEVICES, NAMELY, BAR CODE READERS, BAR CODE SCANNERS, AND BAR CODE READERS AND SCANNERS FOR STOCK-TAKING, STOCK CONTROL PURPOSES, AND FOR USE IN THE READING OF MEDICAL PRESCRIPTIONS; BAR CODE READERS AND SCANNERS WITH WIRELESS DATA TRANSFER CAPABILITIES; PDAS, PAGERS, COMPUTERS, HANDHELD COMPUTERS, POCKET PCS, TABLET PCS, KEYBOARDS, JOYSTICKS, PORTABLE WEB CONSOLES, PORTABLE ELECTRIC DISTRIBUTION CONSOLES, COMPUTER HARDWARE USED FOR GENERATING A VIRTUAL KEYBOARD, COMPUTER CAMERAS, DIGITAL CAMERAS, 35MM CAMERAS, VIDEO CAMERAS, CAMERAS BEING MOBILE PHONE ACCESSORIES, RADIOS, AM/FM RADIOS, COMPUTER TERMINALS, LAPTOPS, CELL PHONES, WLAN (WIRELESS LAN) PHONES; DOWNLOADABLE SOFTWARE, NAMELY, COMPUTER SOFTWARE AND PROGRAMS FOR DATABASE MANAGEMENT FOR USE IN ACCOUNTING AND FOR DOWNLOADING ELECTRONIC PUBLICATIONS FROM THE INTERNET, SEARCHING DATA ON THE INTERNET, SEARCHING OF DATA AND DATABASES, MANAGING COMMUNICATIONS AND DATA EXCHANGE BETWEEN COMPUTERS, FACILITATING INTERACTIVE MULTIMEDIA COMMUNICATIONS, CREATING, EDITING AND DELIVERING TEXTUAL AND GRAPHIC INFORMATION VIA COMPUTER COMMUNICATION NETWORKS AND WIRELESS NETWORKS, TRANSMITTING AND RECEIVING ELECTRONIC MAIL AND FACSIMILES OVER WIRELESS OR FIXED WIRELESS TELECOMMUNICATIONS NETWORKS ALONE OR IN COMBINATION WITH THE INTERNET, DIGITAL PUBLISHING, PRINTING AND IMAGING, WORD PROCESSING, ELECTRONIC DOCUMENT STORAGE, MANIPULATION, TRANSFER AND RETRIEVAL, AND ENTERPRISE APPLICATIONS FOR TRANSPORTATION AND ASSET TRACKING; DOWNLOADABLE SOFTWARE FOR USE IN THE UTILITIES INDUSTRIES, NAMELY, REMOTE METER READING SOFTWARE; DOWNLOADABLE SOFTWARE FOR INVENTORY TRACKING AND MANAGEMENT, FOR THE RETAIL INDUSTRY AND POINT OF SALE AND IEEE 802.11 STANDARD BASED RETAIL WLAN (WIRELESS LAN), FOR THE WHOLESALE TRADE INDUSTRY AND FOR HANDHELD SCANNERS FOR INVENTORY APPLICATIONS, FOR THE FINANCIAL, INSURANCE AND REAL ESTATE INDUSTRIES, FOR SALE TEAMS, FOR REMOTE SALE FORCE AUTOMATION, FOR THE HEALTHCARE INDUSTRY AND FOR WIRELESS PERSONAL MONITORS LINKED TO HOSPITALS AND FOR WIRELESS PERSONAL MONITORS LINKED TO EMERGENCY DATABASES, FOR SECURITY AND FOR WIRELESS SECURITY SYSTEMS FOR BUILDINGS, FOR PROFESSIONAL BUSINESS SERVICES, FOR DURABLE MANUFACTURING AND PRODUCTION TRACKING SYSTEMS; COMPUTER OPERATING SYSTEM PROGRAMS; COMPUTER NETWORK OPERATING SYSTEM PROGRAMS; DOWNLOADABLE DATA AND COMPUTER SOFTWARE AND PROGRAMS FOR USE IN WIRELESS OR FIXED WIRELESS TELECOMMUNICATIONS,

**CLASS 9—(Continued).**

NAMELY, DIGITAL PUBLISHING, PRINTING, IMAGING, AND ELECTRONIC DOCUMENT STORAGE, MANIPULATION, TRANSFER, RETRIEVAL, PROCESSING, LOGGING, STORING, TRANSMISSION, DELIVERING, RECEPTION, INPUT, OUTPUT AND PRINTING OF NON-PICTORIAL, TEXTUAL AND GRAPHICAL DATA; SOFTWARE FOR PRODUCTION, FULFILLMENT, DISTRIBUTION AND PUBLISHING OF MULTIMEDIA CONTENT OVER FIXED LINE AND WIRELESS NETWORKS; DOWNLOADABLE SOFTWARE AND COMPUTER SOFTWARE FOR MOBILE TELEPHONES, MOBILE ELECTRONIC DEVICES AND NETWORKING HARDWARE FOR THE FACILITATION OF INTERACTIVE MULTIMEDIA COMMUNICATIONS, SMS (SIMPLE MESSAGING SERVICE) AND MMS (MULTIMEDIA MESSAGING SERVICE) OVER WIRELESS OR FIXED WIRELESS TELECOMMUNICATIONS NETWORKS; DOWNLOADABLE PROGRAMS AND COMPUTER PROGRAMS FOR MANAGING COMMUNICATIONS AND DATA EXCHANGE BETWEEN HANDHELD COMPUTERS AND DESKTOP COMPUTERS; COMPUTER PRINTERS; PHOTOCOPIERS; COMPUTER PRINTING HARDWARE, NAMELY, IMAGE SETTERS, PROOFERS, PLATEMAKERS AND ELECTRONIC SCREEN DISPLAYS; WIRELESS TELECOMMUNICATIONS HARDWARE AND SOFTWARE, NAMELY, WIRELESS COMMUNICATION ANTENNAS, ROUTERS, SWITCHES, TOWERS, HANDSETS AND WIRELESS DEVICES TO ENABLE OR FACILITATE TRANSMISSION OF TEXTUAL MATERIAL, DATA, VOICE, AUDIO, VIDEO, AUDIO-VIDEO AND MULTIMEDIA SERVICES TO WIRELESS DEVICES; DOWNLOADABLE ELECTRONIC PUBLICATIONS IN THE NATURE OF MAGAZINES, BOOKS, NEWSPAPERS, BROCHURES AND LEAFLETS SUPPLIED ON-LINE FROM DATABASES OR FROM FACILITIES PROVIDED ON THE INTERNET ALL IN THE FIELD OF ENTERTAINMENT, SPORT, LIFESTYLE, MUSIC, GAMES, NEWS AND WEATHER; ELECTRONIC AND COMPUTER GAME SOFTWARE, COMPUTER GAMES PROGRAMS, COMPUTER GAME CARTRIDGES; ELECTRIC DISTRIBUTION CONSOLES FOR VIDEO GAME MACHINES FOR USE WITH TELEVISIONS (U.S. CLS. 21, 23, 26, 36 AND 38).

JULIE VEPPUMTHARA, EXAMINING ATTORNEY

**CLASS 9—(Continued).**

SN 85-133,493. FITNESS DE CUISINE, LLC, FORT MILL, SC. FILED 9-20-2010.

**BETTER NOT PERFECT**

THE MARK CONSISTS OF STANDARD CHARACTERS WITHOUT CLAIM TO ANY PARTICULAR FONT, STYLE, SIZE, OR COLOR.

FOR PRE-RECORDED DVDS FEATURING CULINARY INSTRUCTION (U.S. CLS. 21, 23, 26, 36 AND 38).  
STEVEN JACKSON, EXAMINING ATTORNEY

SN 85-133,653. UNIVERSITY CORPORATION FOR ATMOSPHERIC RESEARCH, BOULDER, CO. FILED 9-20-2010.

SN 85-132,325. POKER 123, LLC, LAS VEGAS, NV. FILED 9-17-2010.

**POKER 1-2-3**

THE MARK CONSISTS OF STANDARD CHARACTERS WITHOUT CLAIM TO ANY PARTICULAR FONT, STYLE, SIZE, OR COLOR.

NO CLAIM IS MADE TO THE EXCLUSIVE RIGHT TO USE "POKER", APART FROM THE MARK AS SHOWN.

FOR COMPUTERIZED VIDEO TABLE GAMES FOR GAMING PURPOSES; COMPUTER GAME SOFTWARE FOR GAMING MACHINES, NAMELY, DEVICES WHICH ACCEPT A WAGER (U.S. CLS. 21, 23, 26, 36 AND 38).

SETH A. RAPPAPORT, EXAMINING ATTORNEY

**Checktime**

THE MARK CONSISTS OF STANDARD CHARACTERS WITHOUT CLAIM TO ANY PARTICULAR FONT, STYLE, SIZE, OR COLOR.

FOR SOFTWARE PROGRAM THAT GIVES CRITICAL INFORMATION TO AIRCRAFT OPERATIONS AND PILOTS REGARDING HOW LONG DE-ICING FLUID WILL REMAIN EFFECTIVE FOR THE GIVEN AIRCRAFT, TAKING INTO ACCOUNT ALL PRECIPITATION AND WEATHER CONDITIONS (U.S. CLS. 21, 23, 26, 36 AND 38).

FIRST USE 5-0-2004; IN COMMERCE 10-0-2004.

TOBY BULLOFF, EXAMINING ATTORNEY



**CLASS 9—(Continued).**

SN 85-133,783. RED.COM, INC., LAKE FOREST, CA. FILED 9-20-2010.

# HDRX

THE MARK CONSISTS OF STANDARD CHARACTERS WITHOUT CLAIM TO ANY PARTICULAR FONT, STYLE, SIZE, OR COLOR.

FOR DIGITAL CINEMA CAMERA SYSTEMS AND COMPONENTS THEREOF, SOLD INDIVIDUALLY OR AS A UNIT, COMPRISED OF CAMERAS, OPTICAL DIGITAL IMAGE SENSORS, CAMERA LENSES, FLASH MEMORY CARDS, ELECTRONIC MEMORIES, HARD DRIVES FOR VIDEO RECORDERS, VIDEO MONITORS AND FLAT PANEL DISPLAY SCREENS, ALL FOR USE IN THE CREATION, STORAGE, DELIVERY, MANIPULATION, RECORDING, PLAYBACK OR VIEWING OF VIDEO AND PHOTOS WITH A RANGE OF INTENSITY LEVELS OF LUMINANCE AND CONTRAST BETWEEN THE LIGHTEST AND DARKEST AREAS OF AN IMAGE; DIGITAL CINEMA CAMERA SYSTEMS COMPRISING CAMERAS AND OPERATIONAL SOFTWARE THEREFOR FOR MERGING MULTIPLE IMAGES TO CREATE A FINAL STILL OR MOTION IMAGE CONTAINING A RANGE OF INTENSITY LEVELS OF LUMINANCE AND CONTRAST BETWEEN THE LIGHTEST AND DARKEST AREAS OF THE IMAGE; SOFTWARE FOR DIGITAL CAMERA SYSTEMS WHICH ENABLES THE MERGING OF MULTIPLE IMAGES TO CREATE A FINAL STILL OR MOTION IMAGE CONTAINING A RANGE OF INTENSITY LEVELS OF LUMINANCE AND CONTRAST BETWEEN THE LIGHTEST AND DARKEST AREAS OF THE IMAGE; COMPUTER SOFTWARE FOR THE EDITING, MANIPULATION, AND INTEGRATION OF MULTIPLE DIGITAL STILL OR MOTION IMAGES TO CREATE A FINAL STILL OR MOTION IMAGE CONTAINING A RANGE OF INTENSITY LEVELS OF LUMINANCE AND CONTRAST BETWEEN THE LIGHTEST AND DARKEST AREAS OF THE IMAGE (U.S. CLS. 21, 23, 26, 36 AND 38).

STEVEN PEREZ, EXAMINING ATTORNEY

SN 85-134,114. TIANZEXIN INDUSTRIAL INVESTMENT CO., LTD., TANGXIA, DONGGUAN CITY, CHINA, FILED 9-20-2010.



THE COLOR(S) WHITE AND BLUE IS/ARE CLAIMED AS A FEATURE OF THE MARK.

THE MARK CONSISTS OF A BLUE TRAPEZOID HAVING ROUNDED CORNERS AND PARALLEL RIGHT AND LEFT SIDES WITH THE LEFT SIDE RISING SLIGHTLY HIGHER, AND CONTAINING THE WHITE LITERAL ELEMENT "NETIS".

THE WORDING "NETIS" HAS NO MEANING IN A FOREIGN LANGUAGE.

FOR COMPUTER NETWORK ADAPTERS, SWITCHES, ROUTERS AND HUBS (U.S. CLS. 21, 23, 26, 36 AND 38).  
TINA BROWN, EXAMINING ATTORNEY

**CLASS 9—(Continued).**

SN 85-135,052. PETERS, JAMES, NEWBURY PARK, CA. FILED 9-21-2010.

# TIET

THE MARK CONSISTS OF STANDARD CHARACTERS WITHOUT CLAIM TO ANY PARTICULAR FONT, STYLE, SIZE, OR COLOR.

THE WORDING "TIET" HAS NO MEANING IN A FOREIGN LANGUAGE.

FOR FAUX SUEDE AND HOOK AND LOOP FASTENER STRAP, NAMELY, A DEVICE FOR ATTACHING A TABLET COMPUTER TO THE LEG (U.S. CLS. 21, 23, 26, 36 AND 38).

RICHARD WHITE, EXAMINING ATTORNEY

SN 85-137,553. H & B VENTURE, LLC, FORT LAUDERDALE, FL. FILED 9-24-2010.



NO CLAIM IS MADE TO THE EXCLUSIVE RIGHT TO USE "NATIONAL FISHING REPORT", APART FROM THE MARK AS SHOWN.

THE COLOR(S) NAVY BLUE, BLUE, LIGHT BLUE, MEDIUM BLUE, GREY, LIGHT GREY, WHITE, BLACK IS/ARE CLAIMED AS A FEATURE OF THE MARK.

THE MARK CONSISTS OF THE WORDING "NATIONAL" IN INITIAL CAPITAL LETTER APPEARING IN NAVY BLUE WITH LIGHT BLUE BORDER AND UNDERLINED BY THE POINTED NOSE OF A SAILFISH IN NAVY BLUE WITH THE SAIL FISH FACING LEFT AND APPEARING TO THE RIGHT OF THE WORDING WITH THE BODY AND TAIL APPEARING IN THE NAVY BLUE, WHITE, MEDIUM BLUE AND LIGHT BLUE, THE MOUTH APPEARING IN GREY AND LIGHT GREY, THE EYEBROW AND EYEBALL IN BLACK AND THE EYE IN WHITE, AND BELOW THE SAILFISH'S POINTED NOSE IS THE WORDING "FISHING REPORT" IN INITIAL CAPITAL LETTERS APPEARING IN NAVY BLUE.

FOR DOWNLOADABLE SOFTWARE IN THE NATURE OF A MOBILE APPLICATION FOR PROVIDING UP-TO-DATE NATIONAL FISHING REPORTS IN THE UNITED STATES TO MOBILE DEVICES (U.S. CLS. 21, 23, 26, 36 AND 38).

FIRST USE 5-31-2010; IN COMMERCE 9-1-2010.  
BARBARA BROWN, EXAMINING ATTORNEY

**CLASS 9—(Continued).**

SN 85-139,095. ST4 LEARNING, INC., DOVER, NH. FILED 9-27-2010.

goQ

THE MARK CONSISTS OF STANDARD CHARACTERS WITHOUT CLAIM TO ANY PARTICULAR FONT, STYLE, SIZE, OR COLOR.

FOR COMPUTER SOFTWARE, NAMELY, SOFTWARE TO ASSIST IN READING, WRITING, AND COMPOSITION (U.S. CLS. 21, 23, 26, 36 AND 38).

DOUGLAS LEE, EXAMINING ATTORNEY

SN 85-140,720. KOLLSMAN, INC, MERRIMACK, NH. FILED 9-29-2010.

EFVS-NG

THE MARK CONSISTS OF STANDARD CHARACTERS WITHOUT CLAIM TO ANY PARTICULAR FONT, STYLE, SIZE, OR COLOR.

FOR AN AIRCRAFT INSTRUMENTATION SYSTEM CONSISTING OF A HEAD UP DISPLAY MONITOR AND COMPUTER FOR PROVIDING FLIGHT GUIDANCE SYMBOLOGY THAT PROVIDES FLIGHT INFORMATION, COMBINED WITH INFRARED OPTICAL SENSORS AND IMAGING SOFTWARE ALGORITHMS THAT PROVIDE AN ENHANCED IMAGE THAT IS TRANSMITTED TO VARIOUS MONITORS IN THE COCKPIT, ALL OF WHICH ARE FOR USE IN AIRCRAFT COCKPIT, CABIN AND RADOME IN ORDER TO ENABLE OPERATION OF THE AIRCRAFT DURING TAKE OFF, TAXI, AND LANDING IN LOW VISIBILITY CONDITIONS (U.S. CLS. 21, 23, 26, 36 AND 38).

APRIL ROACH, EXAMINING ATTORNEY

SN 85-144,190. ATHEROS COMMUNICATIONS, INC., SAN JOSE, CA. FILED 10-4-2010.

MUSIC

THE MARK CONSISTS OF STANDARD CHARACTERS WITHOUT CLAIM TO ANY PARTICULAR FONT, STYLE, SIZE, OR COLOR.

FOR ETHERNET SWITCHES (U.S. CLS. 21, 23, 26, 36 AND 38).

RAUL CORDOVA, EXAMINING ATTORNEY

**CLASS 9—(Continued).**

SN 85-144,660. KAPER II, INC., KELSO, WA. FILED 10-4-2010.

Glows When It Blows

THE MARK CONSISTS OF STANDARD CHARACTERS WITHOUT CLAIM TO ANY PARTICULAR FONT, STYLE, SIZE, OR COLOR.

FOR ELECTRICAL FUSES (U.S. CLS. 21, 23, 26, 36 AND 38).

FIRST USE 8-16-2010; IN COMMERCE 8-16-2010.

MARK SHINER, EXAMINING ATTORNEY

SN 85-145,462. DYNAMIC GLOBAL PRODUCTS, LLC, MIAMI, FL. FILED 10-5-2010.

SOL  
Bright Idea. Brilliant Solution.

THE COLOR(S) GREEN, ORANGE, AND YELLOW IS/ ARE CLAIMED AS A FEATURE OF THE MARK.

THE MARK CONSISTS OF THE WORDING "SOL BRIGHT IDEA. BRILLIANT SOLUTION" AND A DESIGN ELEMENT COMPRISING THE IMAGE OF A SUN INSIDE OF THE LOWERCASE "O" IN "SOL" AND A STRAIGHT LINE OR MACRON ABOVE THE LOWERCASE LETTER "O" IN THE WORD "SOL". THE COLOR GREEN APPEARS IN THE TEXT "SOL BRIGHT IDEA. BRILLIANT SOLUTION" AND IN THE STRAIGHT LINE OR MACRON ABOVE THE LOWERCASE LETTER "O". THE COLORS ORANGE AND YELLOW APPEAR IN THE SUN. THE COLOR WHITE REPRESENTS BACKGROUND, OUTLINING, SHADING AND/OR TRANSPARENT AREAS AND IS NOT PART OF THE MARK.

THE ENGLISH TRANSLATION OF THE WORD "SOL" IN THE MARK IS SUN.

FOR CARRYING CASES FOR CELL PHONES; CARRYING CASES FOR MOBILE COMPUTERS; CARRYING CASES SPECIALLY ADAPTED FOR POCKET CALCULATORS AND CELL PHONES; CASES FOR MOBILE PHONES; CELL PHONE BATTERY CHARGERS; CELL PHONE BATTERY CHARGERS FOR USE IN VEHICLES; CELL PHONE CASES; CELL PHONE COVERS; CELL PHONE FACEPLATES; COMPUTER CARRYING CASES; DEVICES FOR HANDS-FREE USE OF MOBILE PHONES; HANDS FREE DEVICES FOR MOBILE-PHONES; LAPTOP CARRYING CASES; NOTEBOOK COMPUTER CARRYING CASES; PROTECTIVE COVERS AND CASES FOR CELL PHONES, LAPTOPS AND PORTABLE MEDIA PLAYERS (U.S. CLS. 21, 23, 26, 36 AND 38).

Laurie Kaufman, EXAMINING ATTORNEY

**CLASS 9—(Continued).**

SN 85-145,640. HARRINGTON, STEPHEN, DBA ESERVICES INC., HOLLYWOOD, FL. FILED 10-5-2010.

## Varan Monitor

THE MARK CONSISTS OF STANDARD CHARACTERS WITHOUT CLAIM TO ANY PARTICULAR FONT, STYLE, SIZE, OR COLOR.

NO CLAIM IS MADE TO THE EXCLUSIVE RIGHT TO USE "MONITOR", APART FROM THE MARK AS SHOWN. FOR COMPUTER SOFTWARE AND HARDWARE FOR REMOTE MONITORING OF THIRD PARTY HARDWARE INSTALLED WITHIN A CONTROL SYSTEM PROJECT (U.S. CLS. 21, 23, 26, 36 AND 38).

FIRST USE 4-1-2010; IN COMMERCE 5-3-2010.  
ANDREA K. NADELMAN, EXAMINING ATTORNEY

SN 85-146,595. BAXTER INTERNATIONAL INC., DEERFIELD, IL. FILED 10-6-2010.

## HOMECHOICE SMARTCARE

THE MARK CONSISTS OF STANDARD CHARACTERS WITHOUT CLAIM TO ANY PARTICULAR FONT, STYLE, SIZE, OR COLOR.

OWNER OF U.S. REG. NO. 1,942,523.  
FOR IMBEDDED OPERATING SOFTWARE FOR A PERITONEAL DIALYSIS MACHINE THAT PROVIDES FOR USER INTRODUCTION OF A PRESCRIBED PERITONEAL DIALYSIS THERAPY AND EXECUTES THE PRESCRIBED THERAPY (U.S. CLS. 21, 23, 26, 36 AND 38).

CHRISTINE MARTIN, EXAMINING ATTORNEY

SN 85-147,067. ORCA MD LLC, PARK CITY, UT. FILED 10-7-2010.

## ORCA MD

THE MARK CONSISTS OF STANDARD CHARACTERS WITHOUT CLAIM TO ANY PARTICULAR FONT, STYLE, SIZE, OR COLOR.

NO CLAIM IS MADE TO THE EXCLUSIVE RIGHT TO USE "MD", APART FROM THE MARK AS SHOWN.

FOR DOWNLOADABLE SOFTWARE FOR PROVIDING HEALTH INFORMATION (U.S. CLS. 21, 23, 26, 36 AND 38).

FIRST USE 9-1-2010; IN COMMERCE 9-1-2010.  
ALLISON HOLTZ, EXAMINING ATTORNEY

**CLASS 9—(Continued).**

SN 85-147,119. KOVCOM, INC, AUSTINTOWN, OH. FILED 10-7-2010.

## Youngstown Shakedown

THE MARK CONSISTS OF STANDARD CHARACTERS WITHOUT CLAIM TO ANY PARTICULAR FONT, STYLE, SIZE, OR COLOR.

NO CLAIM IS MADE TO THE EXCLUSIVE RIGHT TO USE "YOUNGSTOWN", APART FROM THE MARK AS SHOWN.

FOR MOTION PICTURE FILMS FEATURING CRIME AND GANGSTER SUBJECT MATTER (U.S. CLS. 21, 23, 26, 36 AND 38).

LESLEY LAMOTHE, EXAMINING ATTORNEY

SN 85-149,984. ENDLESSBEAUTY.COM, LLC, AUSTIN, TX. FILED 10-11-2010.

## BEAUTY CALLS

THE MARK CONSISTS OF STANDARD CHARACTERS WITHOUT CLAIM TO ANY PARTICULAR FONT, STYLE, SIZE, OR COLOR.

NO CLAIM IS MADE TO THE EXCLUSIVE RIGHT TO USE "BEAUTY", APART FROM THE MARK AS SHOWN.

FOR DOWNLOADABLE SOFTWARE IN THE NATURE OF A MOBILE APPLICATION FOR PROVIDING HEALTH AND BEAUTY TIPS, SAVER MOBILE COUPONS, AND VIRTUAL BEAUTY CONSULTATIONS (U.S. CLS. 21, 23, 26, 36 AND 38).

FIRST USE 3-1-2010; IN COMMERCE 3-1-2010.  
SETH A. RAPPAPORT, EXAMINING ATTORNEY

SN 85-150,518. THE TALBOT GROUP INC., BEDFORD, TX. FILED 10-12-2010.



## webAV

OWNER OF U.S. REG. NO. 3,793,046.

THE MARK CONSISTS OF THREE QUADRILATERALS TO THE LEFT OF THE WORD "WEBAV" WHERE "WEB" IS IN LOWER CASE AND "AV" IS IN UPPER CASE.

FOR COMPUTER SOFTWARE FOR CONFIRMATION OF AGE AND MEMBERSHIP INFORMATION FROM DRIVER'S LICENSES AND OTHER GOVERNMENT-ISSUED DOCUMENTS (U.S. CLS. 21, 23, 26, 36 AND 38).

FIRST USE 4-14-2010; IN COMMERCE 4-14-2010.  
WILLIAM BRECKENFELD, EXAMINING ATTORNEY

**CLASS 9—(Continued).**

SN 85-152,418. HERMAN, BONNIE, CHICAGO, IL. AND SHELTON, DON R., LA QUINTA, CA. AND PUERLING, HELEN, SAN ANSELMO, CA. AND DRESSLAR, DOROTHY, PALM SPRINGS, CA. FILED 10-14-2010.

**THE SINGERS UNLIMITED**

THE MARK CONSISTS OF STANDARD CHARACTERS WITHOUT CLAIM TO ANY PARTICULAR FONT, STYLE, SIZE, OR COLOR.

SEC. 2(F).  
FOR SERIES OF MUSICAL SOUND RECORDINGS (U.S. CLS. 21, 23, 26, 36 AND 38).  
FIRST USE 7-0-1967; IN COMMERCE 7-0-1967.  
DAVID C. REIHNER, EXAMINING ATTORNEY

---

SN 85-152,944. NBS-KASTLE, INC., DBA NBS AUDIO CABLES, ST. LOUIS PARK, MN. FILED 10-14-2010.



THE MARK CONSISTS OF THE LETTERS "NBS" DEPICTED IN STYLIZED FORM.

FOR AUDIO EQUIPMENT, NAMELY, AMPLIFIERS, PRE-AMPLIFIERS, POWER LINE CONDITIONERS, MEDIA PLAYERS, AUDIO SPEAKERS; AUDIO CABLES (U.S. CLS. 21, 23, 26, 36 AND 38).

FIRST USE 10-15-1990; IN COMMERCE 10-15-1990.  
CHARLOTTE CORWIN, EXAMINING ATTORNEY

---

SN 85-153,204. V-MODA CORPORATION, LOS ANGELES, CA. FILED 10-14-2010.

**ROCKSTAR**

THE MARK CONSISTS OF STANDARD CHARACTERS WITHOUT CLAIM TO ANY PARTICULAR FONT, STYLE, SIZE, OR COLOR.

FOR EARPHONES AND HEADPHONES FOR PERSONAL USE (U.S. CLS. 21, 23, 26, 36 AND 38).  
JOHN GARTNER, EXAMINING ATTORNEY

**CLASS 9—(Continued).**

SN 85-154,624. LONG, SHUNYOU, LUTHERVILLE, MD. FILED 10-18-2010.

**MyBattery Platform**

THE MARK CONSISTS OF STANDARD CHARACTERS WITHOUT CLAIM TO ANY PARTICULAR FONT, STYLE, SIZE, OR COLOR.

NO CLAIM IS MADE TO THE EXCLUSIVE RIGHT TO USE "PLATFORM", APART FROM THE MARK AS SHOWN.

FOR COMPUTER SOFTWARE FOR THE DATABASING, VISUALIZATION, MANIPULATION, VIRTUAL REALITY IMMERSION AND INTEGRATION OF GEOGRAPHIC INFORMATION WITH ON-LINE MEMBER COMMUNITIES; COMPUTER SOFTWARE THAT PROVIDES REAL-TIME, INTEGRATED BUSINESS MANAGEMENT INTELLIGENCE BY COMBINING INFORMATION FROM VARIOUS DATABASES AND PRESENTING IT IN AN EASY-TO-UNDERSTAND USER INTERFACE (U.S. CLS. 21, 23, 26, 36 AND 38).

FIRST USE 4-27-2008; IN COMMERCE 4-27-2008.  
BRENDAN MCCAULEY, EXAMINING ATTORNEY

---

SN 85-154,689. CROWDSTAR INTERNATIONAL LIMITED, BLACKROCK, CO. DUBLIN, IRELAND, FILED 10-18-2010.

**CROWDSTAR'S IT GIRL**

THE MARK CONSISTS OF STANDARD CHARACTERS WITHOUT CLAIM TO ANY PARTICULAR FONT, STYLE, SIZE, OR COLOR.

OWNER OF U.S. REG. NOS. 3,800,884 AND 3,885,298.  
FOR DOWNLOADABLE COMPUTER GAME SOFTWARE FOR USE ON WIRELESS DEVICES AND COMPUTERS; COMPUTER-GAME SOFTWARE, VIDEO GAME SOFTWARE, AND COMPUTER GAME APPLICATION SOFTWARE; INTERACTIVE-VIDEO-GAME PROGRAMS; ELECTRONIC GAME SOFTWARE AND ELECTRONIC GAME APPLICATION SOFTWARE THAT MAY BE ACCESSED VIA THE INTERNET, COMPUTERS AND WIRELESS DEVICES (U.S. CLS. 21, 23, 26, 36 AND 38).

KEVIN DINALLO, EXAMINING ATTORNEY

**CLASS 9—(Continued).**

SN 85-155,867. PC-TEL, INC., BLOOMINGDALE, IL. FILED 10-19-2010.

# SEEHAWK

THE MARK CONSISTS OF STANDARD CHARACTERS WITHOUT CLAIM TO ANY PARTICULAR FONT, STYLE, SIZE, OR COLOR.

FOR COMPUTER SOFTWARE FOR LAPTOPS FOR USE IN MULTI-SOURCE DATA COLLECTION, MEASUREMENT AND REPORTING AND FOR IDENTIFYING SOURCES OF CO-CHANNEL INTERFERENCE AND MEASURING GEOGRAPHIC REACH OF CELLULAR COMMUNICATIONS, FOR PURPOSES OF OPTIMIZING OR REDUCING INTERFERENCE IN CELLULAR TELEPHONE SITES, ALL IN THE FIELD OF CELLULAR COMMUNICATIONS NETWORK MAINTENANCE; COMPUTER SOFTWARE PROGRAM FOR SIGNAL PROPAGATION MEASUREMENT AND SIGNAL INTERFERENCE MEASUREMENT IN WIRELESS COMMUNICATION NETWORKS (U.S. CLS. 21, 23, 26, 36 AND 38).

COLLEEN KEARNEY, EXAMINING ATTORNEY

**CLASS 9—(Continued).**

SN 85-157,356. 3702537 CANADA INC., DOLLARD-DES-ORMEAUX., CANADA, FILED 10-20-2010.

SACHI MIZYAKE JAPAN EYEWEAR

THE MARK CONSISTS OF STANDARD CHARACTERS WITHOUT CLAIM TO ANY PARTICULAR FONT, STYLE, SIZE, OR COLOR.

OWNER OF CANADA REG. NO. TMA662,929, DATED 4-20-2006, EXPIRES 4-20-2021.

NO CLAIM IS MADE TO THE EXCLUSIVE RIGHT TO USE "JAPAN EYEWEAR", APART FROM THE MARK AS SHOWN.

THE NAME "SACHI MIZYAKE" DOES NOT IDENTIFY A LIVING INDIVIDUAL.

THE WORDING "SACHI MIZYAKE" HAS NO MEANING IN A FOREIGN LANGUAGE.

FOR EYEWEAR, NAMELY, EYEGLASSES, SUNGLASSES, READING GLASSES, SPECTACLES FOR SPORTS; EYEGLASS BAGS AND CASES, EYEGLASS CHAINS AND CORDS, OPTICAL FRAMES, CLIP-ON LENSES, CLIP-ON SUNGLASSES, FLIP-UP LENSES, FLIP-UP SUNGLASSES, CONTACT LENSES; CONTAINERS FOR CONTACT LENSES (U.S. CLS. 21, 23, 26, 36 AND 38).

MICHAEL WIENER, EXAMINING ATTORNEY

SN 85-159,057. CAPITAL TECHNOLOGY INFORMATION SERVICES, INC., ROCKVILLE, MD. FILED 10-22-2010.

# MPHR

THE MARK CONSISTS OF STANDARD CHARACTERS WITHOUT CLAIM TO ANY PARTICULAR FONT, STYLE, SIZE, OR COLOR.

FOR COMPUTER SOFTWARE FOR USE IN STORING A USER'S HEALTHCARE RECORDS, FOR ALLOWING USERS TO ACCESS THEIR HEALTHCARE RECORDS IN REAL-TIME AND SHARE THEM WITH DOCTORS AND OTHER HEALTHCARE PROVIDERS, FOR TRACKING AND MONITORING A USER'S HEALTH STATUS, MEDICAL CONDITIONS, AND MEDICAL CONTACT INFORMATION, FOR TRACKING A USER'S PAST MEDICAL PROCEDURES, FOR PROVIDING THE RESULTS OF MEDICAL TESTS, FOR MANAGING THE DOSAGE, STRENGTH, AND FREQUENCY OF A USER'S PRESCRIPTION AND OVER-THE-COUNTER MEDICATIONS, FOR SCHEDULING AND MANAGING A USER'S MEDICAL APPOINTMENTS, FOR STORING A USER'S IMMUNIZATION RECORDS, FOR TRACKING A USER'S ALLERGIES, AND FOR MONITORING A USER'S DIET, CALORIC INTAKE, AND EXERCISE PROGRAMS, FOR PROVIDING USERS WITH PICTORIAL AND GRAPHIC REPRESENTATIONS OF MEDICAL CONDITIONS, MEDICATIONS, AND PRESCRIPTIONS, TEST RESULTS, AND MEDICAL CONTACTS, FOR PROVIDING MAPS TO HEALTHCARE PROVIDERS AND INSTITUTIONS, FOR PROVIDING USERS ACCESS TO RSS FEEDS, AND FOR PROVIDING USERS WITH HEALTH RELATED ALERTS, REMINDERS, AND NOTIFICATIONS (U.S. CLS. 21, 23, 26, 36 AND 38).

BILL DAWE, EXAMINING ATTORNEY

SN 85-156,020. TURNING EDGE SOLUTIONS, LLC, WEXFORD, PA. FILED 10-19-2010.

# SMI SAFETY MAINTENANCE INSPECTION

THE MARK CONSISTS OF STANDARD CHARACTERS WITHOUT CLAIM TO ANY PARTICULAR FONT, STYLE, SIZE, OR COLOR.

NO CLAIM IS MADE TO THE EXCLUSIVE RIGHT TO USE "SAFETY MAINTENANCE INSPECTION", APART FROM THE MARK AS SHOWN.

FOR COMPUTER SOFTWARE AND HARDWARE FOR MANAGEMENT OF AUTOMOBILE MAINTENANCE SERVICES (U.S. CLS. 21, 23, 26, 36 AND 38).

RON FAIRBANKS, EXAMINING ATTORNEY

**CLASS 9—(Continued).**

SN 85-160,128. EXPLOTRAIN, LLC, FORT WALTON BEACH, FL. FILED 10-25-2010.



THE MARK CONSISTS OF STYLIZED REPRESENTATION OF THE LETTERS "E", "X" AND "P".

FOR LIFESAVING TEACHING AND DEMONSTRATION SIMULATOR FOR TRAINING PURPOSES AND FOR THE SAFE SIMULATION OF THE DETONATION OF COMMERCIAL AND MILITARY EXPLOSIVES, NAMELY, CHEMICAL, HEAT, PRESSURE, ELECTRICAL AND IMPACT EXPLOSIVES FROM CLASS 1 EXPLOSIVE MATERIALS, MILITARY ARTILLERY SHELLS, MISSILES, ROCKETS, BAZOOKAS, IEDS, GUNS, BOMBS, LAND MINES, GRENADES, TNT, BLASTING AGENTS, NITROGLYCERIN, EXPLOSIVE BOOBY TRAPS, AND RELATED COMMERCIAL BLASTING AND MILITARY ORDINANCE AND AMMUNITION, AS WELL AS DIRECT AND INDIRECT EXPLOSIVE MATERIALS, AND ASSOCIATED INSTRUCTIONAL MATERIALS, STRUCTURAL AND REPLACEMENT ACCESSORIES SOLD THEREWITH (U.S. CLS. 21, 23, 26, 36 AND 38).

FIRST USE 11-13-2006; IN COMMERCE 11-13-2006.  
GISELLE AGOSTO, EXAMINING ATTORNEY

SN 85-160,684. EXPLOTRAIN, LLC, FORT WALTON BEACH, FL. FILED 10-25-2010.

# EXPLOTRAIN

THE MARK CONSISTS OF STANDARD CHARACTERS WITHOUT CLAIM TO ANY PARTICULAR FONT, STYLE, SIZE, OR COLOR.

FOR LIFESAVING TEACHING AND DEMONSTRATION SIMULATOR FOR TRAINING PURPOSES AND FOR THE SAFE SIMULATION OF THE DETONATION OF COMMERCIAL AND MILITARY EXPLOSIVES, NAMELY, CHEMICAL, HEAT, PRESSURE, ELECTRICAL AND IMPACT EXPLOSIVES FROM CLASS 1 EXPLOSIVE MATERIALS, MILITARY ARTILLERY SHELLS, MISSILES, ROCKETS, BAZOOKAS, IEDS, GUNS, BOMBS, LAND MINES, GRENADES, TNT, BLASTING AGENTS, NITROGLYCERIN, EXPLOSIVE BOOBY TRAPS, AND RELATED COMMERCIAL BLASTING AND MILITARY ORDINANCE AND AMMUNITION, AS WELL AS DIRECT AND INDIRECT EXPLOSIVE MATERIALS, AND ASSOCIATED INSTRUCTIONAL MATERIALS, STRUCTURAL AND REPLACEMENT ACCESSORIES SOLD THEREWITH (U.S. CLS. 21, 23, 26, 36 AND 38).

FIRST USE 5-11-2000; IN COMMERCE 5-11-2000.  
GISELLE AGOSTO, EXAMINING ATTORNEY

**CLASS 9—(Continued).**

SN 85-160,695. KNIGHT, JASON, DBA XTREME KNIGHT, SAN ANTONIO, TX. FILED 10-25-2010.



THE MARK CONSISTS OF A CAPITAL "X" AND A CAPITAL "K"; THE LETTER "X" MERGES ALONG THE BACKBONE OF THE LETTER "K" FORMING A SINGLE SHAPE; THE "X" HAS EXTENSIONS ON THE LEFT SIDE OF THE LETTER, ON TOP AND BOTTOM FORMING 90 DEGREE ANGLES, THE LETTER "K" HAS THE SAME EXTENSIONS ON THE UPPER RIGHT SIDE OF THE LETTER AND LOWER RIGHT SIDE OF THE LETTER TO CREATE THE ILLUSION OF ROMAN NUMERALS. EMANATING FROM THE BOTTOMS OF THESE LETTERS ARE THE OUTLINES OF THE TOP PORTION OF AN "X" AND "K". ALSO BELOW THE JOINED "XK" SHAPE APPEARS THE WORDING "XTREME KNIGHT", BELOW WHICH APPEARS THE WORDING "XTREME KNIGHT = LIFE" AND ON THE LOWEST LINE APPEARS THE WORDING "WWW.XTREMEKNIGHT.COM".

FOR REFLECTIVE AND ILLUMINATED CLOTHING FOR SAFETY PURPOSES; SAFETY PRODUCTS, NAMELY, EMBROIDERED REFLECTIVE PATCHES TO BE WORN ON CLOTHING; SAFETY PRODUCTS, NAMELY, REFLECTIVE SAFETY BANDS TO BE WORN ON THE BODY (U.S. CLS. 21, 23, 26, 36 AND 38).

FIRST USE 10-3-2010; IN COMMERCE 10-25-2010.  
SUSAN STIGLITZ, EXAMINING ATTORNEY

SN 85-161,753. SUPERIOR COMMUNICATIONS, INC., IRVINDALE, CA. FILED 10-26-2010.

## Smart. Simple. Sensible.

THE MARK CONSISTS OF STANDARD CHARACTERS WITHOUT CLAIM TO ANY PARTICULAR FONT, STYLE, SIZE, OR COLOR.

NO CLAIM IS MADE TO THE EXCLUSIVE RIGHT TO USE "SMART", APART FROM THE MARK AS SHOWN.

FOR WIRELESS PHONE ACCESSORIES, NAMELY, CARRYING BAGS SPECIFICALLY ADAPTED FOR WIRELESS PHONES, WIRELESS PHONE CASES AND SPECIALTY HOLSTERS FOR CARRYING WIRELESS PHONES, BATTERY CHARGERS, HEADSETS, AND SCREEN PROTECTORS (U.S. CLS. 21, 23, 26, 36 AND 38).

FIRST USE 1-6-2011; IN COMMERCE 1-6-2011.

RUDY R. SINGLETON, EXAMINING ATTORNEY

**CLASS 9—(Continued).**

SN 85-162,345. SKECHERS U.S.A., INC. II, MANHATTAN BEACH, CA. FILED 10-27-2010.

**KEWL BREEZE**

THE MARK CONSISTS OF STANDARD CHARACTERS WITHOUT CLAIM TO ANY PARTICULAR FONT, STYLE, SIZE, OR COLOR.

FOR EYEWEAR, NAMELY, EYEGLASSES, SUNGLASSES AND OPTICAL FRAMES, EXCLUDING SAFETY SPECTACLES; EYEWEAR ACCESSORIES, NAMELY, EYEWEAR CASES, NECK CORDS AND NECK CHAINS (U.S. CLS. 21, 23, 26, 36 AND 38).

KAREN BRACEY, EXAMINING ATTORNEY

**CLASS 9—(Continued).**

SN 85-164,503. SATORIUS AG, GOETTINGEN, FED REP GERMANY, FILED 10-29-2010.

**M-pact**

THE MARK CONSISTS OF STANDARD CHARACTERS WITHOUT CLAIM TO ANY PARTICULAR FONT, STYLE, SIZE, OR COLOR.

PRIORITY CLAIMED UNDER SEC. 44(D) ON FED REP GERMANY APPLICATION NO. 302010032486, FILED 5-28-2010, REG. NO. 302010032486, DATED 7-26-2010, EXPIRES 5-31-2020.

FOR SCALES, WEIGHING APPARATUS AND WEIGHING SYSTEMS, NAMELY, LOAD CELLS, DIGITAL READOUT DEVICES, NAMELY, LCD READOUT DISPLAYS, WEIGHING PLATFORMS, LOAD PLATES AND WIND SHIELDS AS A STRUCTURAL PART, AND STRUCTURAL PARTS THEREOF (U.S. CLS. 21, 23, 26, 36 AND 38).

HENRY S. ZAK, EXAMINING ATTORNEY

SN 85-165,014. WASTE MANAGEMENT, INC., HOUSTON, TX. FILED 10-29-2010.

SN 85-163,039. YAN, KELVIN, DBA APOGEE INC., BREA, CA. FILED 10-27-2010.



OWNER OF U.S. REG. NO. 3,703,050.  
THE COLOR(S) YELLOW (PANTONE 123C), GRAY (PANTONE COOL GRAY 10C), PURE WHITE IS/ARE CLAIMED AS A FEATURE OF THE MARK.

THE MARK CONSISTS OF YELLOW (PANTONE 123C) WHICH APPEARS IN THE HONEYCOMB AND BAR THAT CONNECTS THE "N" AND THE "E" OF THE "KANEX" MARK, AND GRAY (PANTONE COOL GRAY 10C) APPEARS IN THE OUTLINE OF THE HONEYCOMB AND IN EACH LETTER OF THE "KANEX" MARK.

FOR AUDIO CABLES; COMPONENT VIDEO CABLES; COMPUTER CABLES; CONNECTION CABLES; TRANSMITTERS AND RECEIVERS FOR AUDIO AND VIDEO SIGNALS FOR TRANSMISSION OVER TWISTED PAIR CABLES; VIDEO CABLES (U.S. CLS. 21, 23, 26, 36 AND 38).

BENJAMIN OKEKE, EXAMINING ATTORNEY



OWNER OF U.S. REG. NOS. 3,677,065 AND 3,830,774.  
NO CLAIM IS MADE TO THE EXCLUSIVE RIGHT TO USE "0 85952 99999 2", APART FROM THE MARK AS SHOWN.

THE MARK CONSISTS OF AN OVERALL CIRCULAR DESIGN FORMED BY TWO ARROWS POINTING CLOCKWISE AND INTERSECTED BY A CAN AND A BOTTLE AT ONE POINT AND INTERSECTED AT ANOTHER POINT BY A GENERALLY RECTANGULAR DESIGN FORMED BY TWO ARROWS WITH "GREENOPOLIS" AND A RANDOM BARCODE NUMBER APPEARING BELOW A PLURALITY OF VERTICAL LINES.

FOR REVERSE VENDING MACHINES THAT AUTOMATE CONTAINER RECYCLING BY ACCEPTING EMPTY CONTAINERS FOR VALUE (U.S. CLS. 21, 23, 26, 36 AND 38).

MATTHEW EINSTEIN, EXAMINING ATTORNEY

**CLASS 9—(Continued).**

SN 85-166,330. HILLERICH & BRADSBY CO., LOUISVILLE, KY. FILED 11-1-2010.

**LOUISVILLE SLUGGER**

THE MARK CONSISTS OF STANDARD CHARACTERS WITHOUT CLAIM TO ANY PARTICULAR FONT, STYLE, SIZE, OR COLOR.

OWNER OF U.S. REG. NOS. 1,328,693, 2,414,509 AND OTHERS.

SEC. 2(F) AS TO "LOUISVILLE".

FOR EYEWEAR; EYEWEAR CASES (U.S. CLS. 21, 23, 26, 36 AND 38).

FONG HSU, EXAMINING ATTORNEY

---

SN 85-166,708. ALPHAVISTA SERVICES, INC., SUNNYVALE, CA. FILED 11-2-2010.

**CEEK 12**

THE MARK CONSISTS OF STANDARD CHARACTERS WITHOUT CLAIM TO ANY PARTICULAR FONT, STYLE, SIZE, OR COLOR.

FOR EDUCATIONAL SOFTWARE FOR CHILDREN (U.S. CLS. 21, 23, 26, 36 AND 38).

PAUL E. FAHRENKOPF, EXAMINING ATTORNEY

---

SN 85-166,848. CRF, INC., DBA CRF HEALTH, PLYMOUTH MEETING, PA. FILED 11-2-2010.

**TRIALMAX MOBILE**

THE MARK CONSISTS OF STANDARD CHARACTERS WITHOUT CLAIM TO ANY PARTICULAR FONT, STYLE, SIZE, OR COLOR.

OWNER OF U.S. REG. NOS. 3,114,603 AND 3,421,470.

NO CLAIM IS MADE TO THE EXCLUSIVE RIGHT TO USE "MOBILE", APART FROM THE MARK AS SHOWN.

FOR COMPUTER SOFTWARE FOR THE COLLECTION, EDITING, ORGANIZING, MODIFYING, BOOK MARKING, TRANSMISSION, STORAGE AND SHARING OF PATIENT REPORTED OUTCOMES ON WEB BASED, SHORT MESSAGE SERVICE, AND MOBILE DEVICES; DOWNLOADABLE COMPUTER SOFTWARE FOR THE COLLECTION, EDITING, ORGANIZING, MODIFYING, BOOK MARKING, TRANSMISSION, STORAGE AND SHARING OF PATIENT REPORTED OUTCOMES ON WEB BASED, SHORT MESSAGE SERVICE, AND MOBILE DEVICES (U.S. CLS. 21, 23, 26, 36 AND 38).

JOSETTE BEVERLY, EXAMINING ATTORNEY

**CLASS 9—(Continued).**

SN 85-166,850. CRF, INC., DBA CRF HEALTH, PLYMOUTH MEETING, PA. FILED 11-2-2010.

**TRIALMAX WEB**

THE MARK CONSISTS OF STANDARD CHARACTERS WITHOUT CLAIM TO ANY PARTICULAR FONT, STYLE, SIZE, OR COLOR.

OWNER OF U.S. REG. NOS. 3,114,603 AND 3,421,470.

NO CLAIM IS MADE TO THE EXCLUSIVE RIGHT TO USE "WEB", APART FROM THE MARK AS SHOWN.

FOR COMPUTER SOFTWARE FOR THE COLLECTION, EDITING, ORGANIZING, MODIFYING, BOOK MARKING, TRANSMISSION, STORAGE AND SHARING OF PATIENT REPORTED OUTCOMES ON WEB BASED, SHORT MESSAGE SERVICE, AND MOBILE DEVICES; DOWNLOADABLE COMPUTER SOFTWARE FOR THE COLLECTION, EDITING, ORGANIZING, MODIFYING, BOOK MARKING, TRANSMISSION, STORAGE AND SHARING OF PATIENT REPORTED OUTCOMES ON WEB BASED, SHORT MESSAGE SERVICE, AND MOBILE DEVICES (U.S. CLS. 21, 23, 26, 36 AND 38).

JOSETTE BEVERLY, EXAMINING ATTORNEY

---

SN 85-166,851. CRF, INC., DBA CRF HEALTH, PLYMOUTH MEETING, PA. FILED 11-2-2010.

**TRIALMAX SITE**

THE MARK CONSISTS OF STANDARD CHARACTERS WITHOUT CLAIM TO ANY PARTICULAR FONT, STYLE, SIZE, OR COLOR.

OWNER OF U.S. REG. NOS. 3,114,603 AND 3,421,470.

NO CLAIM IS MADE TO THE EXCLUSIVE RIGHT TO USE "SITE", APART FROM THE MARK AS SHOWN.

FOR COMPUTER SOFTWARE FOR THE COLLECTION, EDITING, ORGANIZING, MODIFYING, BOOK MARKING, TRANSMISSION, STORAGE AND SHARING OF PATIENT REPORTED OUTCOMES; DOWNLOADABLE COMPUTER SOFTWARE FOR THE COLLECTION, EDITING, ORGANIZING, MODIFYING, BOOK MARKING, TRANSMISSION, STORAGE AND SHARING OF PATIENT REPORTED OUTCOMES (U.S. CLS. 21, 23, 26, 36 AND 38).

JOSETTE BEVERLY, EXAMINING ATTORNEY



**CLASS 9—(Continued).**

SN 85-166,854. CRF, INC., DBA CRF HEALTH, PLYMOUTH MEETING, PA. FILED 11-2-2010.

**TRIALMAX VOICE**

THE MARK CONSISTS OF STANDARD CHARACTERS WITHOUT CLAIM TO ANY PARTICULAR FONT, STYLE, SIZE, OR COLOR.

OWNER OF U.S. REG. NOS. 3,114,603 AND 3,421,470. NO CLAIM IS MADE TO THE EXCLUSIVE RIGHT TO USE "VOICE", APART FROM THE MARK AS SHOWN.

FOR COMPUTER SOFTWARE FOR THE COLLECTION, EDITING, ORGANIZING, MODIFYING, BOOK MARKING, TRANSMISSION, STORAGE AND SHARING OF PATIENT REPORTED OUTCOMES; DOWNLOADABLE COMPUTER SOFTWARE FOR THE COLLECTION, EDITING, ORGANIZING, MODIFYING, BOOK MARKING, TRANSMISSION, STORAGE AND SHARING OF PATIENT REPORTED OUTCOMES (U.S. CLS. 21, 23, 26, 36 AND 38).

JOSETTE BEVERLY, EXAMINING ATTORNEY

**CLASS 9—(Continued).**

SN 85-166,866. CRF, INC., DBA CRF HEALTH, PLYMOUTH MEETING, PA. FILED 11-2-2010.

**TRIALMAX TOUCH**

THE MARK CONSISTS OF STANDARD CHARACTERS WITHOUT CLAIM TO ANY PARTICULAR FONT, STYLE, SIZE, OR COLOR.

OWNER OF U.S. REG. NOS. 3,114,603 AND 3,421,470. FOR COMPUTER SOFTWARE FOR THE COLLECTION, EDITING, ORGANIZING, MODIFYING, BOOK MARKING, TRANSMISSION, STORAGE AND SHARING OF PATIENT REPORTED OUTCOMES ON HANDHELDS AND PDAS; DOWNLOADABLE COMPUTER SOFTWARE FOR THE COLLECTION, EDITING, ORGANIZING, MODIFYING, BOOK MARKING, TRANSMISSION, STORAGE AND SHARING OF PATIENT REPORTED OUTCOMES ON HANDHELDS AND PDAS (U.S. CLS. 21, 23, 26, 36 AND 38).

JOSETTE BEVERLY, EXAMINING ATTORNEY

SN 85-166,856. CRF, INC., DBA CRF HEALTH, PLYMOUTH MEETING, PA. FILED 11-2-2010.

**TRIALMAX SLATE**

THE MARK CONSISTS OF STANDARD CHARACTERS WITHOUT CLAIM TO ANY PARTICULAR FONT, STYLE, SIZE, OR COLOR.

OWNER OF U.S. REG. NOS. 3,114,603 AND 3,421,470. NO CLAIM IS MADE TO THE EXCLUSIVE RIGHT TO USE "SLATE", APART FROM THE MARK AS SHOWN.

FOR COMPUTER SOFTWARE FOR THE COLLECTION, EDITING, ORGANIZING, MODIFYING, BOOK MARKING, TRANSMISSION, STORAGE AND SHARING OF PATIENT REPORTED OUTCOMES; DOWNLOADABLE COMPUTER SOFTWARE FOR THE COLLECTION, EDITING, ORGANIZING, MODIFYING, BOOK MARKING, TRANSMISSION, STORAGE AND SHARING OF PATIENT REPORTED OUTCOMES (U.S. CLS. 21, 23, 26, 36 AND 38).

JOSETTE BEVERLY, EXAMINING ATTORNEY

SN 85-167,094. HARMAN INTERNATIONAL INDUSTRIES, INCORPORATED, NORTHRIDGE, CA. FILED 11-2-2010.



OWNER OF U.S. REG. NOS. 1,130,709, 1,385,112 AND OTHERS.

THE MARK CONSISTS OF THE WORDING "INFINITY" IN STYLIZED FONT WITH A STYLIZED INFINITY SYMBOL TO THE LEFT OF THE WORDING.

FOR TELEVISIONS, LIQUID CRYSTAL DISPLAY TELEVISIONS, PLASMA TELEVISIONS, TELEVISION MONITORS, RE-MOTE CONTROL UNITS FOR TELEVISIONS (U.S. CLS. 21, 23, 26, 36 AND 38).

JULIE WATSON, EXAMINING ATTORNEY

**CLASS 9—(Continued).**

SN 85-167,711. VOXBOX INC., LOS GATOS, CA. FILED 11-3-2010.

# PERSONIXX

THE MARK CONSISTS OF STANDARD CHARACTERS WITHOUT CLAIM TO ANY PARTICULAR FONT, STYLE, SIZE, OR COLOR.

FOR COMPUTER SOFTWARE ENABLING THE PRODUCTION OF PERSONALIZED AUDIO RECORDINGS FEATURING CONCATENATED PHRASES FOR MESSAGES, GREETINGS, ALERTS, ALARMS, RINGTONES AND RINGBACK TONES; COMPUTER APPLICATION SOFTWARE FOR WIRELESS DEVICES TO FACILITATE THE CREATION AND DISTRIBUTION OF PERSONALIZED AUDIO RECORDINGS; COMPUTER DATABASE MANAGEMENT SOFTWARE FOR USE IN PERSONALIZING AUDIO AND VIDEO CONTENT AND MAKING IT AVAILABLE TO CLIENT DEVICES AND INTERFACES; COMPUTER HARDWARE AND COMPUTER SOFTWARE PROGRAMS FOR THE INTEGRATION OF TEXT, AUDIO, GRAPHICS, STILL IMAGES AND MOVING PICTURES INTO AN INTERACTIVE DELIVERY FOR MULTIMEDIA APPLICATIONS; COMPUTER HARDWARE AND SOFTWARE FOR PROCESSING DIGITAL MUSIC FILES; COMPUTER SOFTWARE FOR MANIPULATING DIGITAL AUDIO INFORMATION FOR USE IN AUDIO MEDIA APPLICATIONS; COMPUTER SOFTWARE PLATFORMS FOR CUSTOMIZING MULTIMEDIA ENTERTAINMENT CONTENT THAT WILL BE DISTRIBUTED VIA THE INTERNET AND WIRELESS DEVICES FOR THE PURPOSES OF MARKETING, ADVERTISING AND PROMOTION (U.S. CLS. 21, 23, 26, 36 AND 38).

LINDA E. BLOHM, EXAMINING ATTORNEY

SN 85-167,872. WET LABS, INC., PHILOMATH, OR. FILED 11-3-2010.

# WET LABS

THE MARK CONSISTS OF STANDARD CHARACTERS WITHOUT CLAIM TO ANY PARTICULAR FONT, STYLE, SIZE, OR COLOR.

NO CLAIM IS MADE TO THE EXCLUSIVE RIGHT TO USE "LABS", APART FROM THE MARK AS SHOWN.

FOR SCIENTIFIC AND TECHNICAL APPARATUS, NAMELY, FLUOROMETERS; SCATTERING METERS, NAMELY, SINGLE-CHANNEL BACKSCATTERING METERS, NINE-WAVELENGTH BACKSCATTERING METERS, VOLUME SCATTERING FUNCTION METERS, THREEANGLE VOLUME SCATTERING FUNCTION METERS, AND TURBIDITY METERS; ENVIRONMENTAL CHARACTERIZATION OPTICS (ECO) METERS; ABSORPTION AND OR ATTENUATION METERS; WATER QUALITY METERS; PHOSPHATE SENSORS; TRANSMISSOMETERS; BATTERIES AND BATTERY PACKS; AND ELECTRONIC COMMUNICATIONS SYSTEMS COMPRISED OF COMPUTER HARDWARE AND SOFTWARE FOR THE TRANSMISSION OF DATA BETWEEN TWO POINTS (U.S. CLS. 21, 23, 26, 36 AND 38).

ZACHARY BELLO, EXAMINING ATTORNEY

**CLASS 9—(Continued).**

SN 85-168,744. ESCAPE APPS. LLC, LOS ANGELES, CA. FILED 11-4-2010.

# Know What

THE MARK CONSISTS OF STANDARD CHARACTERS WITHOUT CLAIM TO ANY PARTICULAR FONT, STYLE, SIZE, OR COLOR.

FOR COMPUTER SOFTWARE FOR MOBILE PHONES AND HANDHELD COMPUTERS, NAMELY, SOFTWARE FOR USE IN SEARCHING DATABASES OF GEOLOCATED INFORMATION (U.S. CLS. 21, 23, 26, 36 AND 38).

FIRST USE 6-21-2010; IN COMMERCE 11-1-2010.

KATHERINE M. DUBRAY, EXAMINING ATTORNEY

SN 85-168,800. PARAMETRIC TECHNOLOGY CORPORATION, NEEDHAM, MA. FILED 11-4-2010.

# Unlock Potential

THE MARK CONSISTS OF STANDARD CHARACTERS WITHOUT CLAIM TO ANY PARTICULAR FONT, STYLE, SIZE, OR COLOR.

FOR COMPUTER SOFTWARE FOR COMPUTER AIDED DESIGN (CAD), COMPUTER AIDED MANUFACTURING (CAM), AND COMPUTER AIDED ENGINEERING (CAE); SOFTWARE FOR VISUALIZATION AND DIGITAL MOCKUP, NAMELY, SOFTWARE FOR PROVIDING TWO-DIMENSIONAL AND THREE-DIMENSIONAL VISUALIZATION AND GRAPHICAL CAPABILITIES FOR COMPUTER CREATED DRAWINGS, DESIGNS, MODELS AND RENDERINGS; SOFTWARE FOR THE MANAGEMENT OF THE PRODUCT DEVELOPMENT PROCESS, NAMELY, SOFTWARE FOR COMPUTER AIDED DESIGN (CAD) DATA MANAGEMENT, PRODUCT DATA MANAGEMENT (PDM), PRODUCT PROCESS AND PRODUCTION AUTOMATION; SOFTWARE FOR WORKFLOWS, AND SHARED WORKSPACES FOR THE PURPOSES OF PRODUCT LIFECYCLE MANAGEMENT (PLM), COLLABORATION, CONFIGURATION AND CHANGE MANAGEMENT, REQUIREMENTS MANAGEMENT, AND MANUFACTURING PLANNING; COMPUTER AND SOFTWARE DEVELOPMENT TOOLKITS, HAVING APPLICATION PROGRAMMING INTERFACES, DEVELOPMENT UTILITIES, AND SAMPLE CODE, ALLOWING FOR THE CREATION OF COMPATIBLE APPLICATIONS; AND ACCOMPANYING USER GUIDES SOLD WITH ALL THE FOREGOING COMPUTER SOFTWARE AS A UNIT (U.S. CLS. 21, 23, 26, 36 AND 38).

STEVEN JACKSON, EXAMINING ATTORNEY

**CLASS 9—(Continued).**

SN 85-169,154. COMPUFLEX CORPORATION, SPRINGFIELD, NJ. FILED 11-4-2010.

# CashView

THE MARK CONSISTS OF STANDARD CHARACTERS WITHOUT CLAIM TO ANY PARTICULAR FONT, STYLE, SIZE, OR COLOR.

FOR COMPUTER SOFTWARE AND HARDWARE FOR USE IN THE FINANCIAL INDUSTRIES ACCOUNTING OF FUNDS (U.S. CLS. 21, 23, 26, 36 AND 38).

FIRST USE 9-1-2009; IN COMMERCE 9-1-2009.  
APRIL ROACH, EXAMINING ATTORNEY

---

SN 85-171,558. DREAM2DESIGN, LLC, FORT LAUDERALE, FL. FILED 11-8-2010.

# childprotect online

NO CLAIM IS MADE TO THE EXCLUSIVE RIGHT TO USE "ONLINE", APART FROM THE MARK AS SHOWN.

THE MARK CONSISTS OF THE STYLIZED TEXT "CHILDPROTECT ONLINE".

FOR COMPUTER APPLICATION SOFTWARE FOR MOBILE PHONES, NAMELY, SOFTWARE FOR ALLOWING PARENTS TO MONITOR THEIR CHILDREN'S MOBILE PHONE ACTIVITY (U.S. CLS. 21, 23, 26, 36 AND 38).

FIRST USE 3-31-2009; IN COMMERCE 3-31-2009.  
RUSS HERMAN, EXAMINING ATTORNEY

---

SN 85-173,639. MANIPELLA DESIGN, LLC, TULSA, OK. FILED 11-10-2010.

## GAME'TIME FANTASY BASEBALL

THE MARK CONSISTS OF STANDARD CHARACTERS WITHOUT CLAIM TO ANY PARTICULAR FONT, STYLE, SIZE, OR COLOR.

NO CLAIM IS MADE TO THE EXCLUSIVE RIGHT TO USE "FANTASY BASEBALL", APART FROM THE MARK AS SHOWN.

FOR DOWNLOADABLE SOFTWARE IN THE NATURE OF A MOBILE APPLICATION FOR PLAYING FANTASY BASEBALL IN A SINGLE GAME FORMAT (U.S. CLS. 21, 23, 26, 36 AND 38).

SUNG IN, EXAMINING ATTORNEY

**CLASS 9—(Continued).**

SN 85-174,084. GREENBERG, ANDREW B, DBA ECO-GREENZ TOTE, SPRING, TX. FILED 11-10-2010.

# Eco-Greenz Tote

THE MARK CONSISTS OF STANDARD CHARACTERS WITHOUT CLAIM TO ANY PARTICULAR FONT, STYLE, SIZE, OR COLOR.

NO CLAIM IS MADE TO THE EXCLUSIVE RIGHT TO USE "TOTE", APART FROM THE MARK AS SHOWN.

FOR COMPUTER BAGS (U.S. CLS. 21, 23, 26, 36 AND 38).

KAREN SEVERSON, EXAMINING ATTORNEY

---

SN 85-174,119. CREATIVE MOBILE SOLUTION DESIGN, INC., NEWPORT BEACH, CA. FILED 11-10-2010.

# You've Got Power

THE MARK CONSISTS OF STANDARD CHARACTERS WITHOUT CLAIM TO ANY PARTICULAR FONT, STYLE, SIZE, OR COLOR.

NO CLAIM IS MADE TO THE EXCLUSIVE RIGHT TO USE "POWER", APART FROM THE MARK AS SHOWN.

FOR BATTERIES AND BATTERY CHARGERS; BATTERY CHARGE DEVICES; BATTERY CHARGERS; CELL PHONE BATTERY CHARGERS; CHARGERS FOR BATTERIES; CHARGERS FOR ELECTRIC BATTERIES; CHARGING APPLIANCES FOR RECHARGEABLE EQUIPMENT; DISTRIBUTION BOXES FOR ELECTRICAL POWER; ELECTRICAL POWER DISTRIBUTION UNITS; POWER DISTRIBUTING BOXES; POWER SUPPLIES; POWER SUPPLY CONNECTORS AND ADAPTORS FOR USE WITH PORTABLE ELECTRONIC DEVICES; RECHARGEABLE ELECTRIC BATTERIES; RENEWABLE BATTERY SYSTEM TO PROVIDE BACK-UP POWER (U.S. CLS. 21, 23, 26, 36 AND 38).

AMY C. KEAN, EXAMINING ATTORNEY

**CLASS 9—(Continued).**

SN 85-175,145. SHENZHEN FUTURE TECHNOLOGY COMPANY LIMITED, BAO'AN, SHENZHEN, CHINA, FILED 11-12-2010.



THE MARK CONSISTS OF THE STYLIZED WORDING "IDEACASE" WITH THE DOT OVER THE LETTER "I" SHOWN AS A CIRCLE WITH LINES RADIATING OUT FROM IT AND WITH THE NUMBER "1" INSIDE A CIRCLE TO THE LEFT OF THE WORDING "IDEACASE".

FOR AD SERVER, NAMELY, A COMPUTER SERVER FOR STORING ADVERTISEMENTS AND DELIVERING ADVERTISEMENTS TO WEBSITES; BAGS AND CASES SPECIALLY ADAPTED FOR HOLDING OR CARRYING PORTABLE TELEPHONES AND TELEPHONE EQUIPMENT AND ACCESSORIES; BATTERIES AND BATTERY CHARGERS; CARRYING CASES FOR MOBILE COMPUTERS; CARRYING CASES, HOLDERS, PROTECTIVE CASES AND STANDS FEATURING POWER SUPPLY CONNECTORS, ADAPTORS, SPEAKERS AND BATTERY CHARGING DEVICES, SPECIALLY ADAPTED FOR USE WITH HANDHELD DIGITAL ELECTRONIC DEVICES; CELL PHONE CASES; CELL PHONE COVERS; CELLULAR PHONES; NEOPRENE LAPTOP COVERS; NOTEBOOK COMPUTER CARRYING CASES (U.S. CLS. 21, 23, 26, 36 AND 38).

FIRST USE 5-28-2010; IN COMMERCE 5-28-2010.  
KELLEY WELLS, EXAMINING ATTORNEY

SN 85-175,310. MECHOSHADE SYSTEMS, INC., LONG ISLAND CITY, NY. FILED 11-12-2010.

# MECHOLUX

THE MARK CONSISTS OF STANDARD CHARACTERS WITHOUT CLAIM TO ANY PARTICULAR FONT, STYLE, SIZE, OR COLOR.

FOR LIGHTING CONTROL SYSTEMS COMPRISED OF AUTOMATED WINDOW SHADE CONTROLS AND AUTOMATED LIGHTING CONTROLS (U.S. CLS. 21, 23, 26, 36 AND 38).

FIRST USE 11-1-2010; IN COMMERCE 11-1-2010.  
TARAH HARDY, EXAMINING ATTORNEY

**CLASS 9—(Continued).**

SN 85-176,578. METIS SECURE SOLUTIONS, LLC, OAKMONT, PA. FILED 11-15-2010.

**METIS SECURE SOLUTIONS**

THE MARK CONSISTS OF STANDARD CHARACTERS WITHOUT CLAIM TO ANY PARTICULAR FONT, STYLE, SIZE, OR COLOR.

NO CLAIM IS MADE TO THE EXCLUSIVE RIGHT TO USE "SECURE SOLUTIONS", APART FROM THE MARK AS SHOWN.

FOR EMERGENCY NOTIFICATION SYSTEM COMPRISED OF HARDWARE IN THE NATURE OF SECURITY ALARMS MOUNTED TO WALLS THAT PROVIDE VOICE, TEXT, FLASHING LIGHTS AND SIRENS TO PROVIDE AN ALERT WHEN ACTIVATED BY A USER OR SECURITY PERSONNEL; AND INTERFACE SOFTWARE FOR OPERATION OF THE SECURITY ALARMS WHICH UTILIZES MULTIPLE COMMUNICATION PROTOCOL TYPES IN THE NATURE OF ETHERNET, FM-RBDS AND WIRELESS MESH, DEPENDING UPON AVAILABILITY OF THESE NETWORKS (U.S. CLS. 21, 23, 26, 36 AND 38).

FIRST USE 4-1-2009; IN COMMERCE 4-1-2009.

LEIGH CAROLINE CASE, EXAMINING ATTORNEY

SN 85-176,603. METIS SECURE SOLUTIONS, LLC, OAKMONT, PA. FILED 11-15-2010.



NO CLAIM IS MADE TO THE EXCLUSIVE RIGHT TO USE "SECURE SOLUTIONS", APART FROM THE MARK AS SHOWN.

THE MARK CONSISTS OF A CIRCLE WITH A BISECTING SOLID DIAGONAL BAR MOVING DOWNWARD FROM LEFT TO RIGHT WITH A SECOND SHORTER DIAGONAL BAR MOVING DOWNWARD FROM LEFT TO RIGHT, BOTH OF WHICH BARS GO THROUGH AND OVERLAY THE CIRCLE AND THE WORDS "METIS SECURE SOLUTIONS" APPEARING TO THE RIGHT OF THE CIRCLE.

FOR EMERGENCY NOTIFICATION SYSTEM COMPRISED OF HARDWARE IN THE NATURE OF SECURITY ALARMS MOUNTED TO WALLS THAT PROVIDE VOICE, TEXT, FLASHING LIGHTS AND SIRENS TO PROVIDE AN ALERT WHEN ACTIVATED BY A USER OR SECURITY PERSONNEL; AND INTERFACE SOFTWARE FOR OPERATION OF THE SECURITY ALARMS WHICH UTILIZES MULTIPLE COMMUNICATION PROTOCOL TYPES IN THE NATURE OF ETHERNET, FM-RBDS AND WIRELESS MESH, DEPENDING UPON AVAILABILITY OF THESE NETWORKS (U.S. CLS. 21, 23, 26, 36 AND 38).

FIRST USE 4-1-2009; IN COMMERCE 4-1-2009.

LEIGH CAROLINE CASE, EXAMINING ATTORNEY

**CLASS 9—(Continued).**

SN 85-176,719. STYX MEDIA, INC., DBA GOLEM GEAR, INC., PLANT CITY, FL. FILED 11-15-2010.

**Armadillo Sidemount**

THE MARK CONSISTS OF STANDARD CHARACTERS WITHOUT CLAIM TO ANY PARTICULAR FONT, STYLE, SIZE, OR COLOR.

NO CLAIM IS MADE TO THE EXCLUSIVE RIGHT TO USE "SIDEMOUNT", APART FROM THE MARK AS SHOWN.

FOR BUOYANCY COMPENSATOR JACKET FOR USE IN SCUBA DIVING (U.S. CLS. 21, 23, 26, 36 AND 38).

FIRST USE 5-1-2006; IN COMMERCE 5-1-2006.

C. DIONNE CLYBURN, EXAMINING ATTORNEY

SN 85-177,173. SDL ATLAS, L.L.C., CHICAGO, IL. FILED 11-15-2010.

**TEXTILE TESTING SOLUTIONS**

THE MARK CONSISTS OF STANDARD CHARACTERS WITHOUT CLAIM TO ANY PARTICULAR FONT, STYLE, SIZE, OR COLOR.

OWNER OF U.S. REG. NO. 2,984,317.

SEC. 2(F).

FOR TEXTILE LABORATORY TESTING MACHINES FOR TESTING OF TEXTILE FABRICS (U.S. CLS. 21, 23, 26, 36 AND 38).

FIRST USE 10-0-2003; IN COMMERCE 10-0-2003.

TOBY BULLOFF, EXAMINING ATTORNEY

SN 85-177,665. CINEMA PC, LLC, ALBUQUERQUE, NM. FILED 11-16-2010.

**CINEMA PC**

NO CLAIM IS MADE TO THE EXCLUSIVE RIGHT TO USE "CINEMA PC", APART FROM THE MARK AS SHOWN. THE MARK CONSISTS OF THE STYLIZED WORDS "CINEMA PC". AN IMAGE OF A STYLIZED OVAL AND HALF CIRCLE ABOVE THE TEXT.

FOR HOME THEATER PERSONAL COMPUTERS (U.S. CLS. 21, 23, 26, 36 AND 38).

AMY C. KEAN, EXAMINING ATTORNEY

**CLASS 9—(Continued).**

SN 85-177,935. CARTOON NETWORK, INC., THE, ATLANTA, GA. FILED 11-16-2010.

**GUY SUAVÉ: HOMICIDAL SPY**

THE MARK CONSISTS OF STANDARD CHARACTERS WITHOUT CLAIM TO ANY PARTICULAR FONT, STYLE, SIZE, OR COLOR.

THE NAME "GUY SUAVE" DOES NOT IDENTIFY A LIVING INDIVIDUAL.

FOR DVDS FEATURING ENTERTAINMENT, NAMELY, ANIMATION, COMEDY, ACTION AND ADVENTURE FOR YOUNG ADULTS AND ADULTS; DOWNLOADABLE PRE-RECORDED VIDEO RECORDING FEATURING ANIMATION, COMEDY, ACTION AND ADVENTURE; DOWNLOADABLE MULTIMEDIA FILES CONTAINING TEXT AND GRAPHICS FEATURING ANIMATION, COMEDY, ACTION AND ADVENTURE (U.S. CLS. 21, 23, 26, 36 AND 38).

FRED CARL, EXAMINING ATTORNEY

SN 85-178,625. ORANGE ELECTRONIC NORTH AMERICA, LLC, MAINEVILLE, OH. FILED 11-17-2010.



NO CLAIM IS MADE TO THE EXCLUSIVE RIGHT TO USE "SENSOR", APART FROM THE MARK AS SHOWN.

THE COLOR(S) ORANGE IS/ARE CLAIMED AS A FEATURE OF THE MARK.

THE MARK CONSISTS OF TWO WORDS, "SIMPLE SENSOR", WHERE ALL TEXT IS CAPITALIZED AND ALL TEXT IS THE COLOR ORANGE.

FOR AUTOMATIC INDICATORS OF LOW PRESSURE IN TIRES; PRESSURE SENSORS; VEHICLE SAFETY EQUIPMENT, NAMELY, ELECTRONIC TIRE PRESSURE MONITORS (U.S. CLS. 21, 23, 26, 36 AND 38).

FIRST USE 10-1-2010; IN COMMERCE 11-1-2010.

FRED CARL, EXAMINING ATTORNEY

SN 85-178,781. SOFTWARE FX, INC., BOCA RATON, FL. FILED 11-17-2010.



THE MARK CONSISTS OF THE NUMBER "2" WITH AN ARROW POINTING TO THE RIGHT AT THE BOTTOM HORIZONTAL PORTION OF THE NUMBER, FOLLOWED BY THE LETTER "W" WITH AN ARROW POINTING TO THE LEFT ON THE UPPER RIGHT END OF THE LETTER, FOLLOWED BY THE WORD "BUILDER", WITH THE NUMBER AND LETTERS LEANING TO THE RIGHT.

FOR COMPUTER SOFTWARE FOR DEVELOPMENT, DEPLOYMENT AND DELIVERY OF RICH DATA APPLICATIONS FOR TWO-WAY RADIOS (U.S. CLS. 21, 23, 26, 36 AND 38).

KATHERINE STOIDES, EXAMINING ATTORNEY

**CLASS 9—(Continued).**

SN 85-178,810. SOUTH DAKOTA NETWORK, LLC, SIOUX FALLS, SD. FILED 11-17-2010.

## SDN Session

THE MARK CONSISTS OF STANDARD CHARACTERS WITHOUT CLAIM TO ANY PARTICULAR FONT, STYLE, SIZE, OR COLOR.

OWNER OF U.S. REG. NOS. 3,471,797, 3,475,729 AND OTHERS.

NO CLAIM IS MADE TO THE EXCLUSIVE RIGHT TO USE "SESSION", APART FROM THE MARK AS SHOWN.

FOR COMPUTER SOFTWARE FOR SIMULTANEOUS, MULTIPLE MODES OF COMMUNICATION OVER LOCAL AREA NETWORKS AND THE INTERNET VIA INSTANT MESSAGING, VOICE OVER INTERNET PROTOCOL (VOIP), VIDEO CONFERENCING, AUDIO CONFERENCING, APPLICATION SHARING, COMPUTER DESKTOP SHARING, FILE TRANSFER, SENSING AND PROVIDING USER PRESENCE INFORMATION, AND TELEPHONY (U.S. CLS. 21, 23, 26, 36 AND 38).

CAROLYN CATALDO, EXAMINING ATTORNEY

**CLASS 9—(Continued).**

SN 85-178,860. BITS LIMITED, NORTHPORT, NY. FILED 11-17-2010.

## True Surge

THE MARK CONSISTS OF STANDARD CHARACTERS WITHOUT CLAIM TO ANY PARTICULAR FONT, STYLE, SIZE, OR COLOR.

NO CLAIM IS MADE TO THE EXCLUSIVE RIGHT TO USE "SURGE", APART FROM THE MARK AS SHOWN.

FOR DISTRIBUTION BOXES FOR ELECTRICAL POWER; ELECTRICAL DISTRIBUTION SYSTEMS, NAMELY, POWER DISTRIBUTION PANELS; ELECTRICAL PLUG DEVICE ENABLING CONNECTION AND DISCONNECTION OF POWER AND/OR CONTROL CABLES; ELECTRICAL POWER CONNECTORS; ELECTRICAL POWER DEVICES, NAMELY, MULTIMEDIA OUTLETS; ELECTRICAL POWER DEVICES, NAMELY, TAPS; ELECTRICAL POWER DISTRIBUTION BLOCKS; ELECTRICAL POWER DISTRIBUTION UNITS; ELECTRICAL POWER EXTENSION CORDS; ELECTRONIC CONTROLLERS USED TO REDUCE POWER CONSUMPTION; MICROPROCESSOR-BASED HARDWARE SYSTEMS USED TO REDUCE POWER CONSUMPTION; POWER ADAPTERS; POWER ADAPTERS FOR COMPUTERS; POWER DISTRIBUTING BOXES; UNINTERRUPTIBLE ELECTRICAL POWER SUPPLIES; VOLTAGE SURGE PROTECTORS; VOLTAGE SURGE SUPPRESSORS (U.S. CLS. 21, 23, 26, 36 AND 38).

CHERYL CLAYTON, EXAMINING ATTORNEY

SN 85-178,848. THERMO GAMMA-METRICS, LLC, SAN DIEGO, CA. FILED 11-17-2010.

## CB Omni

THE MARK CONSISTS OF STANDARD CHARACTERS WITHOUT CLAIM TO ANY PARTICULAR FONT, STYLE, SIZE, OR COLOR.

NO CLAIM IS MADE TO THE EXCLUSIVE RIGHT TO USE "CB", APART FROM THE MARK AS SHOWN.

FOR CROSS BELT ELEMENTAL ANALYZER FOR BULK MATERIALS FLOWING ON A CONVEYOR BELT, NAMELY, BULK MATERIAL ANALYZERS FOR ANALYZING THE MATERIAL COMPOSITION OF THE BULK MATERIALS AND COMPUTING PERCENTAGES OF THE ELEMENTS THEREIN (U.S. CLS. 21, 23, 26, 36 AND 38).

FIRST USE 1-0-2007; IN COMMERCE 1-0-2007.

MATTHEW MCDOWELL, EXAMINING ATTORNEY

SN 85-179,910. CHATA BIOSYSTEMS, INC., FORT COLLINS, CO. FILED 11-18-2010.

## CHEM+MIX Pro

OWNER OF U.S. REG. NOS. 2,877,530, 3,723,403 AND OTHERS.

NO CLAIM IS MADE TO THE EXCLUSIVE RIGHT TO USE "PRO", APART FROM THE MARK AS SHOWN.

THE MARK CONSISTS OF THE TEXT STRINGS "CHEM" AND "MIX" IN-BETWEEN WHICH IS A "+" CHARACTER OF A LIGHTER SHADE, ALL FOLLOWED BY THE TEXT STRING "PRO".

FOR INSTRUMENTS AND COMPONENTS FOR AUTOMATED CHEMICAL SOLUTION PREPARATION, NAMELY, ELECTRONIC DEVICES AND ASSOCIATED COMPUTER PROGRAMS FOR AUTOMATIC PREPARATION OF MIXTURES OF CONSTITUENT INGREDIENTS/CHEMISTRIES, BY DOSING/MEASURING THE INGREDIENTS ACCORDING TO INPUT RECEIVED (U.S. CLS. 21, 23, 26, 36 AND 38).

FIRST USE 3-1-2010, THE MARK WAS FIRST USED ANYWHERE IN A DIFFERENT FORM OTHER THAN THAT SOUGHT TO BE REGISTERED AT LEAST AS EARLY AS 03/13/2006; IN COMMERCE 3-1-2010, THE MARK WAS FIRST USED IN COMMERCE IN A DIFFERENT FORM OTHER THAN THAT SOUGHT TO BE REGISTERED AT LEAST AS EARLY AS 03/13/2006.

KELLY TRUSILO, EXAMINING ATTORNEY

**CLASS 9—(Continued).**

SN 85-180,602. SCAN3D, GLENDALE, CA. FILED 11-18-2010.



THE MARK CONSISTS OF FIVE DIAGONAL LINES FROM A POINT SOURCE DEPICTING SCANNING RAYS, THE WORD "SCAN3D" APPEARS AT THE BOTTOM OF THE RAYS WRITTEN IN STYLIZED AND IN MIRRORED TEXT.

FOR MOBILE MAPPING SYSTEM COMPRISED OF HIGH ACCURACY GPS, CAMERA THAT TAKES VIDEO AND PICTURES, AND LASER DISTANCE MEASURING SCANNERS, FOR CAPTURING GEOREFERENCED POINT CLOUD DATA AND 360 DEGREE IMAGERY FROM A VEHICLE AT HIGHWAY SPEEDS (U.S. CLS. 21, 23, 26, 36 AND 38).

FIRST USE 9-22-2010; IN COMMERCE 10-26-2010.  
KATHERINE M. DUBRAY, EXAMINING ATTORNEY

---

SN 85-180,661. TEXTRONIC, INC, MIAMI, FL. FILED 11-19-2010.



NO CLAIM IS MADE TO THE EXCLUSIVE RIGHT TO USE "USA", APART FROM THE MARK AS SHOWN.

THE COLOR(S) YELLOW AND BLACK IS/ARE CLAIMED AS A FEATURE OF THE MARK.

THE MARK CONSISTS OF WORD "TEXUSA" WHEREIN THE LETTER "X" OF WORD "TEXUSA" IS IN YELLOW COLOR AND THE LETTERS "TEUSA" IS IN BLACK COLOR AS SHOWN IN THE MARK.

FOR AUTOMOTIVE MEASURING INSTRUMENTS, NAMELY, WATER TEMPERATURE GAUGES, AIR FUEL/RATIO GAUGES, BOOST GAUGES, VACUUM GAUGES AND EXHAUST GAS TEMPERATURE GAUGES; LIGHT SWITCHES (U.S. CLS. 21, 23, 26, 36 AND 38).

FIRST USE 1-1-2005; IN COMMERCE 1-1-2005.  
TEJBIR SINGH, EXAMINING ATTORNEY

**CLASS 9—(Continued).**

SN 85-180,734. NAPCO SECURITY TECHNOLOGIES, INC., AMITYVILLE, NY. FILED 11-19-2010.

# IBRIDGE

THE MARK CONSISTS OF STANDARD CHARACTERS WITHOUT CLAIM TO ANY PARTICULAR FONT, STYLE, SIZE, OR COLOR.

FOR FIRE ALARMS, ALARM CENTRAL UNITS, ANTI-INTRUSION ALARMS, BURGLAR ALARMS, PERSONAL SECURITY ALARMS, SMOKE ALARMS, AND GAS ALARMS; SPRINKLER SYSTEMS FOR FIRE PROTECTION; RADIO, VIDEO AND DIGITAL SIGNAL TRANSMITTERS, RECEIVERS AND SWITCHES, ANTENNAS, ELECTRONIC LOCKS, TELEPHONE COMMUNICATION BASE STATIONS, AND VOICE AND VIDEO COMMUNICATION HUBS; ENVIRONMENTAL SENSORS AND DETECTORS FOR DETECTING HEAT, TEMPERATURE, WATER, SMOKE, GAS, PRESSURE AND MOVEMENT; REMOTE CONTROL UNITS, KEYPADS AND CONTROL PANELS FOR SECURITY SYSTEMS, FIRE ALARMS, ALARM CENTRAL UNITS, ANTI-INTRUSION ALARMS, BURGLAR ALARMS, PERSONAL HEALTH AND SECURITY ALARMS, SMOKE AND GAS ALARMS, HOME SURVEILLANCE SYSTEMS, LIGHTING CONTROLS, HOME AUTOMATION DEVICES AND SPRINKLER SYSTEMS FOR FIRE PROTECTION; COMPUTER SOFTWARE USED TO OPERATE, MANAGE AND MONITOR SECURITY SYSTEMS, FIRE ALARMS, ALARM CENTRAL UNITS, ANTI-INTRUSION ALARMS, BURGLAR ALARMS, PERSONAL HEALTH AND SECURITY ALARMS, SMOKE AND GAS ALARMS, HOME SURVEILLANCE SYSTEMS, LIGHTING CONTROLS AND HOME AUTOMATION DEVICES; HOME AND OFFICE AUTOMATION SYSTEMS COMPRISING WIRELESS AND WIRED CONTROLLERS, CONTROLLED DEVICES, AND SOFTWARE FOR OPERATING LIGHTING, HVAC, SECURITY, SAFETY AND OTHER HOME AND OFFICE MONITORING AND CONTROL APPLICATIONS; ELECTRICAL CONTROLLERS AND SWITCHES FOR USE WITH WATER FLOW AND SPRINKLER SYSTEMS, HOME AUTOMATION AND LIGHTING; LIGHTING CONTROL PANELS; MOTION SENSITIVE SECURITY LIGHTS; ELECTRIC AND ELECTRONIC VIDEO SURVEILLANCE INSTALLATIONS; CAMERAS, NAMELY, VIDEO, TELEVISION AND SURVEILLANCE CAMERAS; VIDEO AND TELEVISION MONITORS; LOCATOR SYSTEMS, NAMELY, SATELLITE AND RADIO TRANSMITTERS AND RECEIVERS, AND ANTENNAS (U.S. CLS. 21, 23, 26, 36 AND 38).

KEVON CHISOLM, EXAMINING ATTORNEY

**CLASS 9—(Continued).**

SN 85-180,914. TWO BROTHERS RACING, INC., SANTA ANA, CA. FILED 11-19-2010.

# ROKFORM

THE MARK CONSISTS OF STANDARD CHARACTERS WITHOUT CLAIM TO ANY PARTICULAR FONT, STYLE, SIZE, OR COLOR.

FOR EARPHONES AND HEADPHONES; AUDIO SPEAKERS; BATTERY CHARGERS AND POWER ACCESSORIES, NAMELY, ADAPTORS, CAPACITORS, CONVERTERS, CELLS, AND COUPLERS, FOR ELECTRONIC DEVICES; PROTECTIVE COVERS FOR ELECTRONIC DEVICES, NAMELY, CELL PHONES, MP3 PLAYERS, TABLET COMPUTERS, PERSONAL MUSIC PLAYERS, HANDHELD COMPUTERS, HANDHELD GAMING DEVICES, LAPTOPS, AND MEDIA PLAYERS; PROTECTIVE CASES FOR ELECTRONIC DEVICES, NAMELY, CELL PHONES, MP3 PLAYERS, TABLET COMPUTERS, PERSONAL MUSIC PLAYERS, HANDHELD COMPUTERS, HANDHELD GAMING DEVICES, LAPTOPS, AND MEDIA PLAYERS; CLEAR PROTECTIVE COVER FILM FOR ELECTRONIC DEVICES, NAMELY, CELL PHONES, MP3 PLAYERS, TABLET COMPUTERS, PERSONAL MUSIC PLAYERS, HANDHELD COMPUTERS, HANDHELD GAMING DEVICES, LAPTOPS, AND MEDIA PLAYERS; CLEAR PROTECTIVE COVER FILM FOR ELECTRONIC SCREENS; BAGS AND POUCHES SPECIFICALLY ADAPTED FOR HOLDING OR CARRYING ELECTRONIC DEVICES, NAMELY, CELL PHONES, MP3 PLAYERS, TABLET COMPUTERS, PERSONAL MUSIC PLAYERS, HANDHELD COMPUTERS, HANDHELD GAMING DEVICES, LAPTOPS, AND MEDIA PLAYERS; CASES AND CONTAINERS SPECIFICALLY ADAPTED FOR HOLDING OR CARRYING ELECTRONIC DEVICES, NAMELY, CELL PHONES, MP3 PLAYERS, TABLET COMPUTERS, PERSONAL MUSIC PLAYERS, HANDHELD COMPUTERS, HANDHELD GAMING DEVICES, LAPTOPS, AND MEDIA PLAYERS; PROTECTIVE SLEEVES AND ARMBANDS FOR ELECTRONIC DEVICES, NAMELY, CELL PHONES, MP3 PLAYERS, TABLET COMPUTERS, PERSONAL MUSIC PLAYERS, HANDHELD COMPUTERS, HANDHELD GAMING DEVICES, LAPTOPS, AND MEDIA PLAYERS; MEDIA PLAYERS; ELECTRIC CABLES; DIGITAL AUDIO COMPONENTS AND TUNERS; ELECTRICAL AND ELECTRONIC CONNECTORS; MOBILE MEDIA DEVICE SOFTWARE AND APPLICATIONS FOR CREATING AND BUYING PROTECTIVE CASES FOR ELECTRONIC DEVICES (U.S. CLS. 21, 23, 26, 36 AND 38).

GIANCARLO CASTRO, EXAMINING ATTORNEY

SN 85-180,952. PINPOINT PROFIT RECOVERY SERVICES, INC., STAMFORD, CT. FILED 11-19-2010.

# PINPOINTER

THE MARK CONSISTS OF STANDARD CHARACTERS WITHOUT CLAIM TO ANY PARTICULAR FONT, STYLE, SIZE, OR COLOR.

FOR COMPUTER AUDITING SOFTWARE FOR IDENTIFYING OVERPAYMENTS WHEN CONDUCTING HISTORIC PAYABLES DISBURSEMENT AUDITS (U.S. CLS. 21, 23, 26, 36 AND 38).

FIRST USE 6-1-2004; IN COMMERCE 6-1-2004.  
ANNE FARRELL, EXAMINING ATTORNEY

**CLASS 9—(Continued).**

SN 85-181,150. APPSOLUTE MEDIA LLC, VALLEY STREAM, NY. FILED 11-19-2010.

# EM3

THE MARK CONSISTS OF STANDARD CHARACTERS WITHOUT CLAIM TO ANY PARTICULAR FONT, STYLE, SIZE, OR COLOR.

FOR DOWNLOADABLE AUDIO FILES, MP3 AND MP4 FILES, MP3 AND MP4 RECORDINGS, MULTIMEDIA FILES, TEXT FILES, AUDIO MATERIAL, VIDEO MATERIAL, GAMES, ON-LINE DISCUSSION BOARDS, WEBCASTS, WEBINARS AND PODCASTS FEATURING MUSIC, AND NEWS BROADCASTS FOR MOBILE APPLICATIONS, MOBILE PHONES AND WIRELESS DEVICES AND THE LIKE (U.S. CLS. 21, 23, 26, 36 AND 38).

STEVEN JACKSON, EXAMINING ATTORNEY

SN 85-181,536. PERFECT PROMOTIONS, PLEASANT HILL, MO. FILED 11-19-2010.

# EKG MEDRULER

THE MARK CONSISTS OF STANDARD CHARACTERS WITHOUT CLAIM TO ANY PARTICULAR FONT, STYLE, SIZE, OR COLOR.

NO CLAIM IS MADE TO THE EXCLUSIVE RIGHT TO USE "EKG", APART FROM THE MARK AS SHOWN.

FOR LABORATORY APPARATUS, NAMELY, A MULTIFACETED MEASURING AND CALCULATING DEVICE DESIGNED TO FACILITATE ELECTROCARDIOGRAM INTERPRETATION (U.S. CLS. 21, 23, 26, 36 AND 38).

ALYSSA STEEL, EXAMINING ATTORNEY



**CLASS 9—(Continued).**

SN 85-181,902. SALT LIFE HOLDINGS, LLC, JACKSONVILLE, FL. FILED 11-21-2010.

# SALT LIFE

THE MARK CONSISTS OF STANDARD CHARACTERS WITHOUT CLAIM TO ANY PARTICULAR FONT, STYLE, SIZE, OR COLOR.

OWNER OF U.S. REG. NOS. 3,001,343, 3,843,123 AND OTHERS.

FOR SUNGLASSES; EYEWEAR; CHAINS, CORDS AND CASES FOR SUNGLASSES AND EYEGLASSES; ELECTRONIC NAVIGATIONAL AND POSITIONING APPARATUS AND INSTRUMENTS; DIVING INSTRUMENTS, NAMELY, DEPTH GAUGES AND AIR GAUGES; FISHING INSTRUMENTS, NAMELY, MARINE DEPTH FINDERS, FISH FINDERS BEING SONAR EQUIPMENT, DOWNLOADABLE ELECTRONIC MAPS AND SONAR CHART PLOTTERS; DIVING GLOVES; DIVING SUITS; PROTECTIVE DIVING SHOES; DIVING BOOTIES BEING PROTECTIVE DIVING SHOES (U.S. CLS. 21, 23, 26, 36 AND 38).

APRIL HESIK, EXAMINING ATTORNEY

---

SN 85-181,965. DIEBOLD, INCORPORATED, NORTH CANTON, OH. FILED 11-21-2010.

# OPTEVIEW RESOLVE

THE MARK CONSISTS OF STANDARD CHARACTERS WITHOUT CLAIM TO ANY PARTICULAR FONT, STYLE, SIZE, OR COLOR.

OWNER OF U.S. REG. NO. 3,295,594.

FOR COMPUTER SOFTWARE FOR MONITORING AUTOMATED BANKING MACHINES (U.S. CLS. 21, 23, 26, 36 AND 38).

DAVID TOOLEY, EXAMINING ATTORNEY

---

SN 85-182,720. GE INFRASTRUCTURE SENSING, INC., BILLERICA, MA. FILED 11-22-2010.

# TIMBERMINI

THE MARK CONSISTS OF STANDARD CHARACTERS WITHOUT CLAIM TO ANY PARTICULAR FONT, STYLE, SIZE, OR COLOR.

FOR MOISTURE METERS FOR CONTROLLING, TESTING AND DETECTING MOISTURE IN WOOD AND STRUCTURAL PARTS AND FITTINGS THEREOF (U.S. CLS. 21, 23, 26, 36 AND 38).

JEFFREY LOOK, EXAMINING ATTORNEY

**CLASS 9—(Continued).**

SN 85-182,949. THE HAPPIEST BABY, INC., LOS ANGELES, CA. FILED 11-22-2010.

# THE HAPPIEST BABY GUIDE

THE MARK CONSISTS OF STANDARD CHARACTERS WITHOUT CLAIM TO ANY PARTICULAR FONT, STYLE, SIZE, OR COLOR.

OWNER OF U.S. REG. NOS. 3,318,991, 3,434,465 AND 3,851,032.

NO CLAIM IS MADE TO THE EXCLUSIVE RIGHT TO USE "GUIDE", APART FROM THE MARK AS SHOWN.

FOR PRE-RECORDED VIDEOS, VIDEODISCS, LASER DISCS, VIDEOTAPES, VIDEOCASSETTES, DVDS, AUDIOCASSETTES, CD-ROM'S, AND CDS FEATURING INFORMATION ON INFANT DEVELOPMENT, TODDLER DEVELOPMENT, AND/OR PARENTING SKILLS; BABY MONITORS (U.S. CLS. 21, 23, 26, 36 AND 38).

DAVID ELTON, EXAMINING ATTORNEY

---

SN 85-183,610. GAIAM AMERICAS, INC., LOUISVILLE, CO. FILED S.R. 11-23-2010; AM. P.R. 11-23-2010.

# The FIRM

OWNER OF U.S. REG. NOS. 1,522,134, 1,928,088 AND 2,117,719.

THE MARK CONSISTS OF THE WORDS "THE FIRM" IN STYLIZED LETTERING.

FOR DIGITAL MEDIA, NAMELY, PRE-RECORDED DVDS, ALL IN THE FIELD OF EXERCISE AND FITNESS (U.S. CLS. 21, 23, 26, 36 AND 38).

FIRST USE 4-9-2002; IN COMMERCE 4-9-2002.

JANET LEE, EXAMINING ATTORNEY

**CLASS 9—(Continued).**

SN 85-184,531. HOME BOX OFFICE, INC., NEW YORK, NJ. FILED 11-24-2010.



OWNER OF U.S. REG. NOS. 1,020,101, 1,132,132 AND OTHERS.

THE MARK CONSISTS OF "HBO" LETTERS WITH BULLET "O".

FOR PRE-RECORDED VIDEO DISCS, DVDS, HIGH DEFINITION DIGITAL DISCS, AND VIDEOTAPES, ALL IN THE FIELDS OF DRAMA, COMEDY, DOCUMENTARY, SPORTS, MUSIC AND VARIETY; COMPACT DISCS AND DIGITAL AUDIO DISCS FEATURING CONTENT FROM OR RELATED TO TELEVISION PROGRAMMING OR TELEVISION SERIES; PRE-RECORDED COMPACT DISCS AND DIGITAL AUDIO DISCS FEATURING SOUNDTRACKS FROM OR RELATED TO TELEVISION PROGRAMMING OR TELEVISION SERIES (U.S. CLS. 21, 23, 26, 36 AND 38).

FIRST USE 1-10-1999; IN COMMERCE 1-10-1999.  
STEVEN R. FINE, EXAMINING ATTORNEY

SN 85-184,926. BIZLINK TECHNOLOGY, INC., FREMONT, CA. FILED 11-24-2010.



THE MARK CONSISTS OF STANDARD CHARACTERS WITHOUT CLAIM TO ANY PARTICULAR FONT, STYLE, SIZE, OR COLOR.

FOR ELECTRONIC COMPONENTS, NAMELY, CABLES, POWER CORDS AND WIRE HARNESSSES THAT PROVIDE CONNECTIVITY TO ELECTRONIC APPLIANCES AND SYSTEMS FOR USE IN THE DATA COMMUNICATIONS, MEDICAL EQUIPMENT, CONSUMER ELECTRONICS, AUTOMOTIVE, HOME APPLIANCE, AND TESTING INDUSTRIES (U.S. CLS. 21, 23, 26, 36 AND 38).

FIRST USE 8-1-1997; IN COMMERCE 8-1-1997.  
JEFF DEFORD, EXAMINING ATTORNEY

**CLASS 9—(Continued).**

SN 85-185,575. ALBERT, AMANDA A, DBA CONCRETE SAFARI, SOUTH HOLLAND, IL. FILED 11-26-2010.



THE MARK CONSISTS OF "CONCRETE SAFARI" ARE IN A FONT CALLED KRAVITZ. ALL THE LETTERS WILL BE THE SAME COLOR, BUT THE COLOR WILL CHANGE EVERY TIME PRINTED.

FOR ELECTRONIC PUBLICATIONS, NAMELY, MAGAZINES, BOOKS, MANUALS AND GUIDES FEATURING INFORMATION ABOUT ISSUES AND CONFLICTS CONFRONTED BY PEOPLE OF DIFFERENT ETHNICITIES AND SOLUTIONS TO THE CONFLICTS, RECORDED ON COMPUTER MEDIA; VIDEO MAGAZINE RECORDED ON ELECTRONIC MEDIA FEATURING INFORMATION ABOUT ISSUES AND CONFLICTS CONFRONTED BY PEOPLE OF DIFFERENT ETHNICITIES AND SOLUTIONS TO THE CONFLICTS (U.S. CLS. 21, 23, 26, 36 AND 38).

WENDY GOODMAN, EXAMINING ATTORNEY

SN 85-185,834. TALPHA TECHNOLOGIES, INC, WASHINGTON, DC. FILED 11-29-2010.



THE MARK CONSISTS OF STANDARD CHARACTERS WITHOUT CLAIM TO ANY PARTICULAR FONT, STYLE, SIZE, OR COLOR.

FOR ELECTRONIC TRANSMITTERS FOR JAMMING SIGNALS (U.S. CLS. 21, 23, 26, 36 AND 38).

KATHERINE M. DUBRAY, EXAMINING ATTORNEY

SN 85-186,139. CRITICALKEY, LLC, CHICAGO, IL. FILED 11-29-2010.



THE MARK CONSISTS OF STANDARD CHARACTERS WITHOUT CLAIM TO ANY PARTICULAR FONT, STYLE, SIZE, OR COLOR.

FOR COMPUTER SOFTWARE FOR LINKING HEALTH CARE SYSTEMS (U.S. CLS. 21, 23, 26, 36 AND 38).

BENJAMIN OKEKE, EXAMINING ATTORNEY

**CLASS 9—(Continued).**

SN 85-187,018. THERMO GAMMA-METRICS, LLC, SAN DIEGO, CA. FILED 11-30-2010.

**Blast-Hole Xpert**

THE MARK CONSISTS OF STANDARD CHARACTERS WITHOUT CLAIM TO ANY PARTICULAR FONT, STYLE, SIZE, OR COLOR.

NO CLAIM IS MADE TO THE EXCLUSIVE RIGHT TO USE "BLAST-HOLE", APART FROM THE MARK AS SHOWN.

FOR BLAST-HOLE ANALYZER FOR USE ON DRILL RIGS IN THE NATURE OF A LASER SPECTROSCOPE (U.S. CLS. 21, 23, 26, 36 AND 38).

FIRST USE 5-0-2009; IN COMMERCE 5-0-2009.

MATTHEW MCDOWELL, EXAMINING ATTORNEY

SN 85-187,556. ABBOTT DIABETES CARE INC., ALAMEDA, CA. FILED 11-30-2010.

**FREESTYLE AUTO-ASSIST**

THE MARK CONSISTS OF STANDARD CHARACTERS WITHOUT CLAIM TO ANY PARTICULAR FONT, STYLE, SIZE, OR COLOR.

OWNER OF U.S. REG. NOS. 2,670,744, 3,111,863 AND OTHERS.

FOR COMPUTER SOFTWARE APPLICATION USED FOR THE MANAGEMENT OF DIABETES (U.S. CLS. 21, 23, 26, 36 AND 38).

ROBIN MITTLER, EXAMINING ATTORNEY

SN 85-187,619. PURE PC, DALLAS, TX. FILED 11-30-2010.



THE MARK CONSISTS OF THE STYLIZED WORDING "PUREPC" SET TO THE RIGHT OF AN ABSTRACT DESIGN ELEMENT COMPRISED OF TWO CURVED BANDS.

FOR PERSONAL COMPUTERS (U.S. CLS. 21, 23, 26, 36 AND 38).

FIRST USE 10-9-2010; IN COMMERCE 10-9-2010.

MICHAEL GAAFAR, EXAMINING ATTORNEY

**CLASS 9—(Continued).**

SN 85-187,867. YOUNG, GARY GEORGE, NEWPORT BEACH, CA. FILED 12-1-2010.

**KoolShades**

THE MARK CONSISTS OF STANDARD CHARACTERS WITHOUT CLAIM TO ANY PARTICULAR FONT, STYLE, SIZE, OR COLOR.

FOR EYEWEAR, NAMELY, SUNGLASSES, EYEGLASSES AND OPHTHALMIC FRAMES AND CASES THEREFOR (U.S. CLS. 21, 23, 26, 36 AND 38).

FIRST USE 6-1-1998; IN COMMERCE 6-1-1998.

CURTIS FRENCH, EXAMINING ATTORNEY

SN 85-188,276. HOME BOX OFFICE, INC., NEW YORK, NY. FILED 12-1-2010.

**SEX AND THE CITY**

THE MARK CONSISTS OF STANDARD CHARACTERS WITHOUT CLAIM TO ANY PARTICULAR FONT, STYLE, SIZE, OR COLOR.

OWNER OF U.S. REG. NOS. 2,513,906, 3,667,868 AND OTHERS.

FOR PRE-RECORDED AUDIO-VIDEO CASSETTES AND DISCS, VIDEO DISCS, DVDS AND HIGH DEFINITION DIGITAL DISCS FEATURING A TELEVISION SERIES; AUDIO DISCS AND COMPACT DISCS FEATURING CONTENT FROM OR RELATED TO A TELEVISION SERIES; PRE-RECORDED AUDIO DISCS AND COMPACT DISCS FEATURING SOUNDTRACKS FROM OR RELATED TO A TELEVISION SERIES (U.S. CLS. 21, 23, 26, 36 AND 38).

FIRST USE 5-23-2000; IN COMMERCE 5-23-2000.

STEVEN R. FINE, EXAMINING ATTORNEY

SN 85-188,447. AERIUS INTERNATIONAL, INC., LAS VEGAS, NV. FILED 12-1-2010.

**AERIUS GREEN TECHNOLOGY**

THE MARK CONSISTS OF STANDARD CHARACTERS WITHOUT CLAIM TO ANY PARTICULAR FONT, STYLE, SIZE, OR COLOR.

NO CLAIM IS MADE TO THE EXCLUSIVE RIGHT TO USE "GREEN TECHNOLOGY", APART FROM THE MARK AS SHOWN.

FOR ANTENNAS FOR WIRELESS COMMUNICATIONS APPARATUS AND CELLULAR TELEPHONES (U.S. CLS. 21, 23, 26, 36 AND 38).

RONALD AIKENS, EXAMINING ATTORNEY

**CLASS 9—(Continued).**

SN 85-188,579. APPLIED FIRE TECHNOLOGIES, LLC, COPPELL, TX. FILED 12-1-2010.



THE COLOR(S) BLUE, WHITE AND GREEN IS/ARE CLAIMED AS A FEATURE OF THE MARK.

THE MARK CONSISTS OF A STYLIZED VIEW OF THREE BLUE AND WHITE HOUSES OVER GREEN LANDSCAPING WITH A GREEN TREE.

FOR SMOKE ALARMS (U.S. CLS. 21, 23, 26, 36 AND 38).

DAVID COLLIER, EXAMINING ATTORNEY

SN 85-188,812. SCOTT SCHAFER, DBA ANTIGRAVITY BATTERIES, LOS ANGELES, CA. FILED 12-1-2010.



NO CLAIM IS MADE TO THE EXCLUSIVE RIGHT TO USE "ANTIGRAVITY BATTERIES", APART FROM THE MARK AS SHOWN.

THE COLOR(S) RED, WHITE, BLACK IS/ARE CLAIMED AS A FEATURE OF THE MARK.

THE MARK CONSISTS OF AN OVAL SHAPE WITH A STYLIZED "S" RUNNING THROUGH IT WITH THE COMPANY NAME "ANTIGRAVITY BATTERIES", IN WHITE ON OR AROUND THE DESIGN. THE COLOR OF THE OVAL SHAPE (RED) IS ALWAYS A CONTRASTING COLOR FROM THE STYLIZED S (BLACK). THE TIPS OF THE STYLIZED "S" CHANGE TO THE CONTRASTING COLOR RED ONCE THEY EXIT THE PERIMETER OF THE OVAL. THE BLACK BACKGROUND IS NOT CLAIMED AS A FEATURE OF THE MARK.

FOR BATTERIES; BATTERIES AND BATTERY CHARGERS; BATTERIES FOR VEHICLES; BATTERIES, ELECTRIC; BATTERIES, ELECTRIC, FOR VEHICLES; BATTERY BOXES; BATTERY CABLES; BATTERY CASES; BATTERY CHARGERS; BATTERY JUMP STARTERS; BATTERY MONITORING DEVICES THAT MAY BE ATTACHED TO A BATTERY TO MONITOR THE PERFORMANCE OF THE BATTERY AND OPERATING SOFTWARE FOR USE THEREWITH, SOLD AS A UNIT; BATTERY PACKS; BATTERY PERFORMANCE MONITORS; BATTERY TERMINAL CONNECTOR CLAMPS; LITHIUM IRON PHOSPHATE BATTERIES (U.S. CLS. 21, 23, 26, 36 AND 38).

FIRST USE 7-7-2010; IN COMMERCE 8-28-2010.

FLORENTINA BLANDU, EXAMINING ATTORNEY

**CLASS 9—(Continued).**

SN 85-188,864. CREAGH COMPUTER SYSTEMS, INC., SAN DIEGO, CA. FILED 12-2-2010.

**REACONNECT**

THE MARK CONSISTS OF STANDARD CHARACTERS WITHOUT CLAIM TO ANY PARTICULAR FONT, STYLE, SIZE, OR COLOR.

FOR COMPUTER SOFTWARE, NAMELY, SOFTWARE FOR COMMERCIAL REAL ESTATE AGENTS TO PROVIDE LOGIN INFORMATION FOR PHONE CALLS AND MEETINGS FROM PROSPECTIVE BUYERS AND TENANTS (U.S. CLS. 21, 23, 26, 36 AND 38).

KATHLEEN LORENZO, EXAMINING ATTORNEY

SN 85-189,145. FOSSIL SOFTWARE, ROCKWALL, TX. FILED 12-2-2010.

**Appzilla**

THE MARK CONSISTS OF STANDARD CHARACTERS WITHOUT CLAIM TO ANY PARTICULAR FONT, STYLE, SIZE, OR COLOR.

FOR DOWNLOADABLE COMPUTER APPLICATION SOFTWARE FOR MOBILE PHONES, PORTABLE MEDIA PLAYERS AND HANDHELD COMPUTERS, NAMELY, SOFTWARE FOR PROVIDING MATHEMATICAL CALCULATIONS, ENTERTAINMENT COMPUTER GAMES, ENTERTAINMENT DIGITAL IMAGE MANIPULATION, CALENDARS, DAY PLANNERS, JOURNALS, NOTE TAKING, AND CUSTOMIZABLE FLASHCARDS (U.S. CLS. 21, 23, 26, 36 AND 38).

FIRST USE 11-1-2009; IN COMMERCE 3-1-2010.

SIMON TENG, EXAMINING ATTORNEY

SN 85-189,166. APPLIED VISION CORPORATION, CUYA-HOGA FALLS, OH. FILED 12-2-2010.

**CYCLOPS**

THE MARK CONSISTS OF STANDARD CHARACTERS WITHOUT CLAIM TO ANY PARTICULAR FONT, STYLE, SIZE, OR COLOR.

FOR MACHINE VISION SYSTEMS AND PARTS THEREOF COMPRISED OF CAMERAS, LIGHTS, COMPUTER HARDWARE AND SOFTWARE, FOR MONITORING, LOCATING, GUIDING, IDENTIFYING, MEASURING AND INSPECTING WHETHER OBJECTS ARE DAMAGED OR DEFECTIVE (U.S. CLS. 21, 23, 26, 36 AND 38).

SIMON TENG, EXAMINING ATTORNEY

**CLASS 9—(Continued).**

SN 85-189,361. GEORGIA TECH RESEARCH CORPORATION, ATLANTA, GA. FILED 12-2-2010.

**CLASS 9—(Continued).**

SN 85-189,487. NLU PRODUCTS, LLC, DRAPER, UT. FILED 12-2-2010.

# FALCONVIEW



THE MARK CONSISTS OF STANDARD CHARACTERS WITHOUT CLAIM TO ANY PARTICULAR FONT, STYLE, SIZE, OR COLOR.

FOR COMPUTER SOFTWARE APPLICATION FOR USE IN MAPPING; MAPPING SOFTWARE (U.S. CLS. 21, 23, 26, 36 AND 38).

FIRST USE 6-0-1994; IN COMMERCE 6-0-1994.  
JENNY PARK, EXAMINING ATTORNEY

THE MARK CONSISTS OF THE LETTERS "DO" INSIDE A BOX.

FOR ACCESSORIES FOR ELECTRONIC DEVICES, NAMELY, STYLUSES, CASES, BATTERIES, SCREEN PROTECTORS, BODYWRAPS, COVERS, OVERLAYS AND BATTERY CHARGERS, ALL OF THE FOREGOING FOR USE IN CONNECTION WITH PERSONAL DIGITAL ASSISTANTS, CELL PHONES, PORTABLE MEDIA PLAYERS, CAMERAS, GAMING CONSOLES, LAPTOP COMPUTERS AND NOTEBOOK COMPUTERS (U.S. CLS. 21, 23, 26, 36 AND 38).

FIRST USE 7-6-2006; IN COMMERCE 7-6-2006.  
REBECCA GILBERT, EXAMINING ATTORNEY

SN 85-189,440. ESTEREL TECHNOLOGIES, INC., MOUNTAIN VIEW, CA. FILED 12-2-2010.

SN 85-189,507. NLU PRODUCTS, LLC, DRAPER, UT. FILED 12-2-2010.

# SCADE SYSTEM

# GOT IT COVERED

THE MARK CONSISTS OF STANDARD CHARACTERS WITHOUT CLAIM TO ANY PARTICULAR FONT, STYLE, SIZE, OR COLOR.

OWNER OF U.S. REG. NOS. 3,020,031, 3,575,709 AND OTHERS.

NO CLAIM IS MADE TO THE EXCLUSIVE RIGHT TO USE "SYSTEM", APART FROM THE MARK AS SHOWN.

FOR COMPUTER SOFTWARE DEVELOPMENT TOOLS; COMPUTER SOFTWARE PLATFORMS FOR CREATING EMBEDDED SOFTWARE USED FOR CRITICAL FUNCTIONS AND TO CREATE EXECUTABLE SPECIFICATIONS, FORMAL TESTS, AND AUTOMATICALLY GENERATED CODE (U.S. CLS. 21, 23, 26, 36 AND 38).

CHRISTINE COOPER, EXAMINING ATTORNEY

THE MARK CONSISTS OF STANDARD CHARACTERS WITHOUT CLAIM TO ANY PARTICULAR FONT, STYLE, SIZE, OR COLOR.

FOR ACCESSORIES FOR ELECTRONIC DEVICES, NAMELY, STYLUSES, CASES, BATTERIES, SCREEN PROTECTORS, BODY WRAPS, COVERS, OVERLAYS AND BATTERY CHARGERS, ALL OF THE FOREGOING FOR USE IN CONNECTION WITH PERSONAL DIGITAL ASSISTANTS, CELL PHONES, PORTABLE MEDIA PLAYERS, CAMERAS, GAMING CONSOLES, LAPTOP COMPUTERS AND NOTEBOOK COMPUTERS (U.S. CLS. 21, 23, 26, 36 AND 38).

FIRST USE 10-1-2006; IN COMMERCE 10-1-2006.  
REBECCA GILBERT, EXAMINING ATTORNEY

**CLASS 9—(Continued).**

SN 85-189,580. VOCARE, INC., LEBANON, IN. FILED 12-2-2010.

# VOCARE

THE MARK CONSISTS OF STANDARD CHARACTERS WITHOUT CLAIM TO ANY PARTICULAR FONT, STYLE, SIZE, OR COLOR.

THE WORDING "VOCARE" HAS NO MEANING IN A FOREIGN LANGUAGE.

FOR WIRELESS TRANSCIVERS FOR SAFETY MONITORING AND EMERGENCY COMMUNICATIONS (U.S. CLS. 21, 23, 26, 36 AND 38).

ANDREA K. NADELMAN, EXAMINING ATTORNEY

SN 85-190,082. ASTRO APE STUDIOS, NEW YORK, NY. FILED 12-3-2010.



NO CLAIM IS MADE TO THE EXCLUSIVE RIGHT TO USE "SOCIAL" AND "MOBILE" AND "GAMING", APART FROM THE MARK AS SHOWN.

THE MARK CONSISTS OF THE STYLIZED TEXT "ASTROAPESTUDIOS SOCIAL.MOBILE.GAMING" WITH A DESIGN OF A FUTURISTIC APE ASTRONAUT WITH EYES AS STARS WEARING A HELMET WITH A SINGLE ANTENNA.

FOR COMPUTER APPLICATION SOFTWARE FOR MOBILE PHONES, NAMELY, SOFTWARE FOR SOCIAL GAMES WHICH ALLOWS INTERACTIVE GAME PLAY ON A SMART PHONE AND CONNECT FRIENDS THROUGH VARIOUS SOCIAL NETWORKS AND THE DEVICE ITSELF (U.S. CLS. 21, 23, 26, 36 AND 38).

FIRST USE 7-1-2010; IN COMMERCE 7-1-2010.

JAY FLOWERS, EXAMINING ATTORNEY

**CLASS 9—(Continued).**

SN 85-190,112. LONG PAN, CORONA, NY. FILED 12-3-2010.

# AOKO

THE MARK CONSISTS OF "AOKO" IN STYLIZED FORM. FOR CARRYING CASES FOR CELL PHONES; CARRYING CASES SPECIALLY ADAPTED FOR POCKET CALCULATORS AND CELLPHONES; CASES FOR MOBILE PHONES; CELL PHONE BACKPLATES; CELL PHONE BATTERY CHARGERS; CELL PHONE BATTERY CHARGERS FOR USE IN VEHICLES; CELL PHONE CASES; CELL PHONE COVERS; CELL PHONE FACEPLATES; CELL PHONE HAVING LARGE KEYS AND NUMBERS THAT ASSIST USERS HAVING IMPAIRED VISION OR DEXTERITY; CELL PHONES; CELLULAR PHONE ACCESSORY CHARMS; CELLULAR PHONE USAGE DETECTION SYSTEM COMPRISING A CAMERA AND A MOBILE PHONE SIGNAL RECEIVING DEVICE; CELLULAR PHONES; COMPUTER GAME SOFTWARE FOR USE ON MOBILE AND CELLULAR PHONES; COMPUTER SOFTWARE, NAMELY, ELECTRONIC FINANCIAL PLATFORM THAT ACCOMMODATES MULTIPLE TYPES OF PAYMENT AND DEBT TRANSACTIONS IN AN INTEGRATED MOBILE PHONE, PDA, AND WEB BASED ENVIRONMENT; COMPUTER-CONTROLLED ELECTRONIC APPARATUS FOR ELECTROPHYSIOLOGICAL MEASUREMENT AND TESTING OF CELLS; CONTINGENCY RESPONSE COMMUNICATION SYSTEM DESIGNED TO PROVIDE RADIO INTEROPERABILITY, STREAMING VIDEO, WIRELESS INTERNET, AND VOIP PHONE; DEVICES FOR HANDS-FREE USE OF MOBILE PHONES; DIGITAL CELLULAR PHONES; DIGITAL PHONES; DISPOSABLE PLASTIC BIOREACTORS FOR CELL CULTURING; DOWNLOADABLE GRAPHICS FOR MOBILE PHONES; DOWNLOADABLE RING TONES AND GRAPHICS FOR MOBILE PHONES; DOWNLOADABLE RING TONES FOR MOBILE PHONES; DRY CELLS; DRY CELLS AND BATTERIES; EAR PHONES; ELECTRICAL CELLS AND BATTERIES; ELECTRICAL EQUIPMENT FOR THE GENETIC MODIFICATION OF CELLS FOR RESEARCH PURPOSES; ELECTROLYSERS; ELECTRONIC APPARATUS FOR ELECTROPHYSIOLOGICAL MEASUREMENT AND TESTING OF CELLS; ELECTRONIC EQUIPMENT, NAMELY, ELECTROLYSIS CELL FOR USE IN THE MANUFACTURE OF VARIOUS IONIC SOLUTIONS; FLOW CYTOMETERS AND FLOW-BASED ANALYZERS PROVIDING CELL AND PARTICLE ANALYSIS, DETECTION, OR COUNTING FOR SCIENTIFIC, LABORATORY, AND GENERAL RESEARCH USES; FUEL CELLS; HANDS FREE DEVICES FOR MOBILE-PHONES; HANDS FREE KITS FOR PHONES; HEAD-CLIP CELL PHONE HOLDERS; HEADSETS FOR CELLULAR OR MOBILE PHONES; INTERNET PHONES; INTEROPERABLE COMMUNICATION SYSTEM DESIGNED TO PROVIDE RADIO, STREAMING VIDEO, WIRELESS INTERNET, AND VOIP PHONE; KEYBOARDS FOR MOBILE PHONES; MOBILE PHONE STRAPS; MOBILE PHONES; PHOTOELECTRIC CELLS; PHOTOVOLTAIC CELLS; PHOTOVOLTAIC CELLS ALSO INCLUDING A SOLAR THERMAL COLLECTOR SOLD AS A UNIT; PHOTOVOLTAIC CELLS AND MODULES; PROTECTIVE COVERS AND CASES FOR CELL PHONES, LAPTOPS AND PORTABLE MEDIA PLAYERS; SILICON SOLAR CELL MATERIAL FOR ELECTRICITY GENERATION INCORPORATED INTO PAVEMENT MATERIALS; SOLAR CELLS; STRAPS FOR MOBILE PHONES; TELEMATICS APPARATUS, NAMELY, WIRELESS INTERNET DEVICES WHICH PROVIDE TELEMATIC SERVICES AND HAVE A CELLULAR PHONE FUNCTION; TELEPHONE CALL ROUTER, FOR HOME AND OFFICE TOUCHTONE PHONES, FOR INTERNATIONAL AND LONG DISTANCE CALLS MADE FROM VARIOUS TELEPHONY PLATFORMS INCLUDING VOIP PLATFORM WITHOUT THE REQUIREMENT FOR INTER-

**CLASS 9—(Continued).**

NET; TELEPHONE CALL ROUTERS FOR LONG DISTANCE CALLS MADE THROUGH PSTN AND VOIP PLATFORMS FROM ANY TOUCHTONE PHONE WITHOUT A REQUIREMENT FOR INTERNET ACCESS; VIDEO PHONES; VINYL COVERS SPECIALLY ADAPTED FOR CELL PHONES, MP3 PLAYERS, LAPTOPS, COMPUTERS, PORTABLE SATELLITE RADIOS, PERSONAL DIGITAL ASSISTANTS, REMOTE CONTROLS, AND TELEVISION SATELLITE RECORDERS; WET CELL BATTERIES; WET CELLS; WIRELESS CELLULAR PHONE HEADSETS (U.S. CLS. 21, 23, 26, 36 AND 38).

FIRST USE 3-15-2010; IN COMMERCE 3-15-2010.  
MARC LEIPZIG, EXAMINING ATTORNEY

**CLASS 9—(Continued).**

SN 85-190,487. CRYPTGO TECHNOLOGIES INC., NEW YORK, NY. FILED 12-3-2010.

# CryptGo

SN 85-190,160. STORY ORNAMENTS, LLC, OCOEE, FL. FILED 12-3-2010.



FOR DIGITAL PHOTO FRAMES FOR DISPLAYING DIGITAL PICTURES, VIDEO CLIPS AND MUSIC (U.S. CLS. 21, 23, 26, 36 AND 38).

RONALD MCMORROW, EXAMINING ATTORNEY

THE MARK CONSISTS OF STANDARD CHARACTERS WITHOUT CLAIM TO ANY PARTICULAR FONT, STYLE, SIZE, OR COLOR.

FOR COMPUTER HARDWARE; COMPUTER PERIPHERALS; COMPUTER SECURITY DEVICES CONNECTED VIA USB PORTS, NAMELY, USB COMPUTER SECURITY KEY; USB HARDWARE; USB OPERATING SOFTWARE, NAMELY, COMPUTER OPERATING SYSTEM SOFTWARE CONTAINED ON A USB KEY; COMPUTER SOFTWARE FOR USE IN DATA BACKUP, RECOVERY AND RESTORATION; COMPUTER SECURITY SOFTWARE FOR USE IN SECURING DATA, NETWORKS, COMPUTERS AND ONLINE TRANSACTIONS (U.S. CLS. 21, 23, 26, 36 AND 38).

FIRST USE 11-18-2010; IN COMMERCE 11-22-2010.  
MATTHEW MCDOWELL, EXAMINING ATTORNEY

SN 85-190,730. THOMAS SULLIVAN, CINCINNATI, OH. FILED 12-4-2010.

# KNUCKLE BUCKLE

SN 85-190,197. POLYCONCEPT HONG KONG LIMITED, HUNG HOM, KOWLOON, HONG KONG, FILED 12-3-2010.

# iGrandphone

THE MARK CONSISTS OF STANDARD CHARACTERS WITHOUT CLAIM TO ANY PARTICULAR FONT, STYLE, SIZE, OR COLOR.

FOR ELECTRONIC MOBILE PHONE DOCKING STATIONS, TELEPHONES (U.S. CLS. 21, 23, 26, 36 AND 38).  
TRICIA SONNEBORN, EXAMINING ATTORNEY

THE MARK CONSISTS OF STANDARD CHARACTERS WITHOUT CLAIM TO ANY PARTICULAR FONT, STYLE, SIZE, OR COLOR.

FOR SPECIALTY HOLDERS FOR USE IN ATTACHING PORTABLE ELECTRONIC DEVICES TO THE HAND, NAMELY, PERSONAL DIGITAL ASSISTANTS (PDA), MOBILE TELEPHONES, TABLET COMPUTERS, AND DEVICES FOR RECEIVING, RECORDING, ORGANIZING AND REVIEWING TEXT, IMAGES AND SOUND THROUGH WIRELESS INTERNET ACCESS AND FOR DISPLAYING ELECTRONICALLY PUBLISHED MATERIALS, NAMELY, BOOKS, JOURNALS, NEWSPAPERS, MAGAZINES AND MULTIMEDIA PRESENTATIONS (U.S. CLS. 21, 23, 26, 36 AND 38).

ELLEN B. AWRICH, EXAMINING ATTORNEY

**CLASS 9—(Continued).**

SN 85-190,811. HONEST LABEL FOODS, LLC, SAN LUIS OBISPO, CA. FILED 12-4-2010.

**HONEST LABEL FOODS**

THE MARK CONSISTS OF STANDARD CHARACTERS WITHOUT CLAIM TO ANY PARTICULAR FONT, STYLE, SIZE, OR COLOR.

NO CLAIM IS MADE TO THE EXCLUSIVE RIGHT TO USE "FOODS", APART FROM THE MARK AS SHOWN.

FOR AD SERVER, NAMELY, A COMPUTER SERVER FOR STORING ADVERTISEMENTS AND DELIVERING ADVERTISEMENTS TO WEBSITES; COMPUTER APPLICATION SOFTWARE FOR MOBILE COMPUTING DEVICES, MOBILE PHONES, COMPUTERS, NAMELY, SOFTWARE FOR ALLOWING USERS TO LOOK UP, SUBMIT, AND INTERACT WITH DATA ABOUT CONSUMER PRODUCTS AND SERVICES; COMPUTER SOFTWARE FOR ACCESSING INFORMATION DIRECTORIES THAT MAY BE DOWNLOADED FROM THE GLOBAL COMPUTER NETWORK; COMPUTER SOFTWARE FOR PROCESSING DIGITAL IMAGES (U.S. CLS. 21, 23, 26, 36 AND 38).

NATALIE POLZER, EXAMINING ATTORNEY

SN 85-190,887. NEW CHARITY ERA, L3C, GAINESVILLE, FL. FILED 12-5-2010.

**Raise the Village**

THE MARK CONSISTS OF STANDARD CHARACTERS WITHOUT CLAIM TO ANY PARTICULAR FONT, STYLE, SIZE, OR COLOR.

NO CLAIM IS MADE TO THE EXCLUSIVE RIGHT TO USE "VILLAGE", APART FROM THE MARK AS SHOWN.

FOR COMPUTER APPLICATION SOFTWARE FOR MOBILE PHONES, PORTABLE MEDIA PLAYERS AND HANDHELD COMPUTERS, NAMELY, ENTERTAINMENT SOFTWARE FOR PROVIDING SIMULATION OF A CURRENT VILLAGE THAT THE USER SPONSORS BY PLEDGING AND TRANSFERRING MONEY TO ADDRESS THE SPECIFIC NEEDS OF THE VILLAGE (U.S. CLS. 21, 23, 26, 36 AND 38).

FIRST USE 12-1-2010; IN COMMERCE 12-1-2010.  
KATHERINE STOIDES, EXAMINING ATTORNEY

**CLASS 9—(Continued).**

SN 85-191,299. ACCOUNTING NERD, LLC, EL PASO, TX. FILED 12-6-2010.

**Accounting Nerd, LLC**

THE MARK CONSISTS OF STANDARD CHARACTERS WITHOUT CLAIM TO ANY PARTICULAR FONT, STYLE, SIZE, OR COLOR.

NO CLAIM IS MADE TO THE EXCLUSIVE RIGHT TO USE "ACCOUNTING" AND "LLC", APART FROM THE MARK AS SHOWN.

FOR COMPUTER SOFTWARE FOR ACCOUNTING AND FINANCIAL ANALYSIS OF REAL ESTATE ACQUISITIONS AND DISPOSITIONS (U.S. CLS. 21, 23, 26, 36 AND 38).

GRETTA YAO, EXAMINING ATTORNEY

SN 85-191,348. HOYA CORPORATION, TOKYO, JAPAN. FILED 12-6-2010.

**NULUX**

THE MARK CONSISTS OF STANDARD CHARACTERS WITHOUT CLAIM TO ANY PARTICULAR FONT, STYLE, SIZE, OR COLOR.

OWNER OF U.S. REG. NO. 2,392,743.

FOR EYEGLASS LENSES (U.S. CLS. 21, 23, 26, 36 AND 38).

FIRST USE 1-0-1988; IN COMMERCE 1-0-1988.

GINA FINK, EXAMINING ATTORNEY

SN 85-191,698. COREGUARD LLC, ROSWELL, GA. FILED 12-6-2010.

**WINDTALKER**

THE MARK CONSISTS OF STANDARD CHARACTERS WITHOUT CLAIM TO ANY PARTICULAR FONT, STYLE, SIZE, OR COLOR.

FOR COMPUTER SOFTWARE FOR ENCRYPTION; COMPUTER SOFTWARE FOR ENABLING SECURE STORAGE AND TRANSMISSION OF DOCUMENT, FILE, AND DATA, AND FOR EDITING DOCUMENTS INTO PORTABLE DOCUMENT FORMAT, TAGGED IMAGE FILE FORMAT, CSF FILE FORMAT, DRAWING WEB FORMAT, THREE-DIMENSIONAL FILE FORMAT, STEREO LITHOGRAPHY FORMAT, AND ISF FILE FORMAT (U.S. CLS. 21, 23, 26, 36 AND 38).

HANNO RITTNER, EXAMINING ATTORNEY



**CLASS 9—(Continued).**

SN 85-191,699. INDUSTRIAL SENSOR VISION INTERNATIONAL CORPORATION, CHESHIRE, IL. FILED 12-6-2010.

# TRUSCAM

THE MARK CONSISTS OF STANDARD CHARACTERS WITHOUT CLAIM TO ANY PARTICULAR FONT, STYLE, SIZE, OR COLOR.

FOR DIGITAL CAMERAS FOR INDUSTRIAL USE (U.S. CLS. 21, 23, 26, 36 AND 38).

FIRST USE 10-20-2010; IN COMMERCE 10-20-2010.  
HANNO RITTNER, EXAMINING ATTORNEY

---

SN 85-191,712. JOE BLOW USA, INC., QUINCY, IL. FILED 12-6-2010.

# Joe Blow USA

NO CLAIM IS MADE TO THE EXCLUSIVE RIGHT TO USE "USA", APART FROM THE MARK AS SHOWN.

THE MARK CONSISTS OF THE STYLIZED TEXT "JOE BLOW USA" WITH THE "O"'S REPLACED BY CIRCULAR ARROWS.

FOR FAN RECIRCULATING CONTROLLER FOR AIR CONDITIONING AND HEATING SYSTEMS (U.S. CLS. 21, 23, 26, 36 AND 38).

JOHN WILKE, EXAMINING ATTORNEY

---

SN 85-191,778. HEGONOMY MEDIA, INC., LOS ANGELES, CA. FILED 12-6-2010.

# Hegemony Media

THE MARK CONSISTS OF STANDARD CHARACTERS WITHOUT CLAIM TO ANY PARTICULAR FONT, STYLE, SIZE, OR COLOR.

NO CLAIM IS MADE TO THE EXCLUSIVE RIGHT TO USE "MEDIA", APART FROM THE MARK AS SHOWN.

FOR MUSICAL SOUND RECORDINGS FEATURING POPULAR MUSIC PERFORMANCES THAT ARE DIGITALLY DOWNLOADABLE AND EMBODIED ON CDS AND OTHER MEDIUM (U.S. CLS. 21, 23, 26, 36 AND 38).

B. PARADEWELAI, EXAMINING ATTORNEY

**CLASS 9—(Continued).**

SN 85-191,949. ADVANCE MAGAZINE PUBLISHERS INC., NEW YORK, NY. FILED 12-7-2010.

# DETAILS FINDER

THE MARK CONSISTS OF STANDARD CHARACTERS WITHOUT CLAIM TO ANY PARTICULAR FONT, STYLE, SIZE, OR COLOR.

NO CLAIM IS MADE TO THE EXCLUSIVE RIGHT TO USE "FINDER", APART FROM THE MARK AS SHOWN.

FOR SOFTWARE APPLICATIONS FOR USE IN CONNECTION WITH SMARTPHONES, PDA DEVICES, TABLE COMPUTERS AND OTHER PORTABLE AND HANDHELD DIGITAL ELECTRONIC DEVICES, NAMELY, SOFTWARE FOR ACCESSING, VIEWING, INTERACTING WITH AND DOWNLOADING CONTENT FROM MAGAZINES AND WEBSITES AND TRAVEL GUIDES FOR RESTAURANTS, BARS, CLUBS, RETAIL STORES, HEALTH CLUBS, SPAS AND LOCATING PEOPLE (U.S. CLS. 21, 23, 26, 36 AND 38).

DAWN FELDMAN, EXAMINING ATTORNEY

---

SN 85-192,613. RODRIGUEZ, TYMOTHI, STOCKTON, CA. FILED 12-7-2010.

# Cognitive Assistance for Independent Living

THE MARK CONSISTS OF STANDARD CHARACTERS WITHOUT CLAIM TO ANY PARTICULAR FONT, STYLE, SIZE, OR COLOR.

FOR COMPUTER SOFTWARE FOR REMINDING USERS TO TAKE MEDICATION, SCHEDULE APPOINTMENTS, GROCERY SHOPPING, PAYING BILLS AND OVERALL DAILY PLANNING (U.S. CLS. 21, 23, 26, 36 AND 38).

FIRST USE 11-25-2010; IN COMMERCE 11-25-2010.  
PAUL MORENO, EXAMINING ATTORNEY

---

SN 85-192,718. K. DONALDSON LLC, BOSTON, MA. FILED 12-7-2010.

# scitecmed

THE MARK CONSISTS OF STANDARD CHARACTERS WITHOUT CLAIM TO ANY PARTICULAR FONT, STYLE, SIZE, OR COLOR.

FOR DOWNLOADABLE COMPUTER SOFTWARE FOR COLLECTING, ANALYZING, AND SHARING OF RESEARCH AND SCHOLARLY DATA (U.S. CLS. 21, 23, 26, 36 AND 38).

FIRST USE 2-10-2010; IN COMMERCE 2-10-2010.  
KELLY BOULTON, EXAMINING ATTORNEY

**CLASS 9—(Continued).**

SN 85-192,885. BRIGHT ANGLE, NEW YORK, NY. FILED 12-8-2010.



THE COLOR(S) WHITE, BLACK, RED, YELLOW, BLUE IS/ARE CLAIMED AS A FEATURE OF THE MARK.

THE MARK CONSISTS OF THE NAME "TELLMEWARE" IN BLACK ON A WHITE BACKGROUND. THE LETTER "T" AND THE LETTER "R" EXTEND WITH ARROWS. THERE ARE 3 DOTS AT THE END OF THE NAME - ONE BLUE AT THE TOP RIGHT OF THE LETTER "M", ONE RED AT THE END OF THE WORD "WARE", AND ONE YELLOW DOT AT THE END OF THE "ME".

FOR INTERACTIVE MULTIMEDIA COMPUTER PROGRAM FOR PROVIDING INTERACTIVE FLOOR PLANS AND DIRECTION ROUTES THROUGH PUBLIC VENUES FOR USE ON WEBSITES AND HANDHELD ELECTRONIC DEVICES (U.S. CLS. 21, 23, 26, 36 AND 38).  
SKYE YOUNG, EXAMINING ATTORNEY

SN 85-193,220. AM GROUP PLUS SPÓLKA Z O.O., BY-DGOSZCZ, POLAND, FILED 12-8-2010.

# SOLANO

THE MARK CONSISTS OF STANDARD CHARACTERS WITHOUT CLAIM TO ANY PARTICULAR FONT, STYLE, SIZE, OR COLOR.

THE WORDING "SOLANO" HAS NO MEANING IN A FOREIGN LANGUAGE.

FOR EYEGLASS FRAMES; SUNGLASSES (U.S. CLS. 21, 23, 26, 36 AND 38).

FIRST USE 8-31-2003; IN COMMERCE 1-0-2011.

RENEE MCCRAY, EXAMINING ATTORNEY

**CLASS 9—(Continued).**

SN 85-193,615. UNIVERSAL INTERNATIONAL MUSIC B.V., BAARN, NETHERLANDS, FILED 12-8-2010.

# DREAMBOATS

THE MARK CONSISTS OF STANDARD CHARACTERS WITHOUT CLAIM TO ANY PARTICULAR FONT, STYLE, SIZE, OR COLOR.

FOR PRE-RECORDED AUDIO TAPES, DISCS AND CASSETTES, VIDEO TAPES, DISCS AND CASSETTES, DIGITAL AUDIO AND AUDIO VIDEO TAPES AND DISCS, CDS, DVDS, LASER DISCS, AND PHONOGRAPH RECORDS FEATURING MUSIC AND MUSIC-RELATED ENTERTAINMENT; THEATRICAL AND MUSICAL SOUND AND VIDEO RECORDINGS; VIRTUAL REALITY GAME SOFTWARE; DOWNLOADABLE RING TONES, MUSIC, MP3 FILES FEATURING MUSIC, GRAPHICS, GAMES, IMAGES AND VIDEOS FEATURING MUSIC AND MUSIC-RELATED ENTERTAINMENT FOR WIRELESS COMMUNICATION DEVICES; DOWNLOADABLE MUSIC, MP3 FILES FEATURING MUSIC, GRAPHICS, COMPUTER GAMES, IMAGES AND VIDEOS FEATURING MUSIC AND MUSIC-RELATED ENTERTAINMENT; COMPUTER GAME SOFTWARE, TAPES, CARTRIDGES AND CASSETTES; VIDEO GAME SOFTWARE, TAPES, CARTRIDGES AND CASSETTES; AND MOUSE PADS (U.S. CLS. 21, 23, 26, 36 AND 38).  
TINA BROWN, EXAMINING ATTORNEY

SN 85-193,693. WYATT TECHNOLOGY CORPORATION, GOLETA, CA. FILED 12-8-2010.

# Möbiuξ

THE MARK CONSISTS OF THE WORD "MÖBIUS" WITH THE LETTER "S" REPLACED BY A GREEK LETTER ZETA. FOR ELECTROPHORESIS MOBILITY MEASURING INSTRUMENTS (U.S. CLS. 21, 23, 26, 36 AND 38).

MARGARET POWER, EXAMINING ATTORNEY

SN 85-193,889. ZAHARAKIS, STEVE, HELLERTOWN, PA. FILED 12-9-2010.

# dzdock

THE MARK CONSISTS OF STANDARD CHARACTERS WITHOUT CLAIM TO ANY PARTICULAR FONT, STYLE, SIZE, OR COLOR.

FOR STAND FOR SUPPORTING PORTABLE ELECTRONIC DEVICES SUCH AS LAPTOPS, E-READERS, CELLULAR PHONES (U.S. CLS. 21, 23, 26, 36 AND 38).

FIRST USE 9-1-2010; IN COMMERCE 10-10-2010.

ELLEN B. AWRICH, EXAMINING ATTORNEY

**CLASS 9—(Continued).**

SN 85-194,092. COMPUTERS AND STRUCTURES, INC., BERKELEY, CA. FILED 12-9-2010.

# CSIBRIDGE

THE MARK CONSISTS OF STANDARD CHARACTERS WITHOUT CLAIM TO ANY PARTICULAR FONT, STYLE, SIZE, OR COLOR.

OWNER OF U.S. REG. NO. 3,727,166.  
FOR COMPUTER PROGRAMS FOR STRUCTURAL AND EARTHQUAKE ENGINEERING APPLICATIONS AND USER AND INSTRUCTION MANUALS SOLD THEREWITH (U.S. CLS. 21, 23, 26, 36 AND 38).

FIRST USE 11-19-2009; IN COMMERCE 11-19-2009.  
JAMES GRIFFIN, EXAMINING ATTORNEY

**CLASS 9—(Continued).**

SN 85-194,372. REDGEAR TECHNOLOGIES, INC., KANSAS CITY, MO. FILED 12-9-2010.



OWNER OF U.S. REG. NOS. 2,700,202 AND 3,838,299.  
THE MARK CONSISTS OF A SYMBOL IN THE SHAPE OF A GEAR NEXT TO THE WORD "TAXWORKS".

FOR COMPUTER SOFTWARE AND SOFTWARE UPGRADES FOR USE IN TAX RETURN PREPARATION FOR OTHERS, CALCULATION, ELECTRONIC FILING OF TAX RETURNS, TAX PLANNING, PROCESSING APPLICATIONS FOR AND ISSUING TAX-RELATED BAND PRODUCTS, FINANCIAL ANALYSIS, ACCOUNTING AND FINANCIAL DOCUMENT PROCESSING, MAINTAINING TAX CLIENT DATABASES, IMPORTATION OF CLIENT FINANCIAL DATA, AND BUSINESS PRACTICE MANAGEMENT BY TAX SERVICE PROVIDERS AND ACCOUNTANTS (U.S. CLS. 21, 23, 26, 36 AND 38).

FIRST USE 8-0-2007; IN COMMERCE 8-0-2007.  
INGRID C. EULIN, EXAMINING ATTORNEY

SN 85-194,248. NOVARTIS AG, BASEL, SWITZERLAND, FILED 12-9-2010.

# DAILIES AIR140

THE MARK CONSISTS OF STANDARD CHARACTERS WITHOUT CLAIM TO ANY PARTICULAR FONT, STYLE, SIZE, OR COLOR.

OWNER OF U.S. REG. NOS. 2,167,845 AND 3,555,421.  
FOR CONTACT LENSES (U.S. CLS. 21, 23, 26, 36 AND 38).

IRA J. GOODSAD, EXAMINING ATTORNEY

SN 85-194,834. DAPPER GENTLEMEN, LLC, GILBERT, AZ. FILED 12-10-2010.

# Wordicus

SN 85-194,280. FUHU, INC., EL SEGUNDO, CA. FILED 12-9-2010.

# FETCH IT

THE MARK CONSISTS OF STANDARD CHARACTERS WITHOUT CLAIM TO ANY PARTICULAR FONT, STYLE, SIZE, OR COLOR.

FOR DOWNLOADABLE SOFTWARE THAT ALLOWS FOR PERSONALIZED INTERACTION OVER NETWORKED MEDIA BY ENABLING THE USER ONE-STOP ACCESS TO A USER'S FAVORITE NEWS, INFORMATION, INTERNET APPLICATIONS AND MULTIMEDIA CONTENT (U.S. CLS. 21, 23, 26, 36 AND 38).

PAUL F. GAST, EXAMINING ATTORNEY

THE MARK CONSISTS OF STANDARD CHARACTERS WITHOUT CLAIM TO ANY PARTICULAR FONT, STYLE, SIZE, OR COLOR.

FOR COMPUTER APPLICATION SOFTWARE FOR MOBILE PHONES AND COMPUTERS, NAMELY, VIDEO GAME SOFTWARE (U.S. CLS. 21, 23, 26, 36 AND 38).

FIRST USE 1-1-2010; IN COMMERCE 12-1-2010.  
DORITT L. CARROLL, EXAMINING ATTORNEY

**CLASS 9—(Continued).**

SN 85-195,634. CALSYS, INC., SANTA CLARA, CA. FILED 12-10-2010.

# VClear

THE MARK CONSISTS OF STANDARD CHARACTERS WITHOUT CLAIM TO ANY PARTICULAR FONT, STYLE, SIZE, OR COLOR.

FOR PROGRAMMABLE INTEGRATED CIRCUITS AND INTEGRATED CIRCUITS FOR VIDEO PRE-PROCESSING AND PROCESSING, ADAPTIVE NOISE REDUCTION, MOTION-AWARE DE-INTERLACING, AND ADVANCED SCALING TECHNOLOGY TO IMPROVE THE IMAGE QUALITY AND LOWER THE ENCODING BIT RATE (U.S. CLS. 21, 23, 26, 36 AND 38).

FIRST USE 10-0-2009; IN COMMERCE 10-0-2009.  
ANTHONY RINKER, EXAMINING ATTORNEY

**CLASS 9—(Continued).**

SN 85-195,696. ALTICAST CORPORATION, SEOUL, REPUBLIC OF KOREA, FILED 12-10-2010.

# AltiSynchro

THE MARK CONSISTS OF STANDARD CHARACTERS WITHOUT CLAIM TO ANY PARTICULAR FONT, STYLE, SIZE, OR COLOR.

OWNER OF REPUBLIC OF KOREA REG. NO. KR40-0521865, DATED 5-31-2002, EXPIRES 5-31-2012.

FOR COMPUTER SERVERS, COMPUTER SOFTWARE FOR FETCHING, STORING, ENCODING, SCHEDULING, AND TRANSMITTING INTERACTIVE DATA AND APPLICATIONS OVER FIXED AND WIRELESS MEDIUM; COMPUTER SOFTWARE FOR MANAGING RESOURCES UTILIZED FOR BROADCASTING DATA AND APPLICATIONS OVER FIXED AND WIRELESS MEDIUM; COMPUTER SOFTWARE FOR COLLECTING AND MANAGING INTERACTIVE RESPONSES BROADCAST OVER FIXED AND WIRELESS MEDIUM (U.S. CLS. 21, 23, 26, 36 AND 38).

KRISTIN DAHLING, EXAMINING ATTORNEY

SN 85-196,219. ARJON, LUIS, THOUSAND OAKS, CA. FILED 12-13-2010.

# Kush House

THE MARK CONSISTS OF STANDARD CHARACTERS WITHOUT CLAIM TO ANY PARTICULAR FONT, STYLE, SIZE, OR COLOR.

FOR AUDIO AND VIDEO RECORDINGS FEATURING MUSIC AND ARTISTIC PERFORMANCES (U.S. CLS. 21, 23, 26, 36 AND 38).

MEGHAN REINHART, EXAMINING ATTORNEY

SN 85-195,648. CALSYS, INC., SANTA CLARA, CA. FILED 12-10-2010.

# VSafer

THE MARK CONSISTS OF STANDARD CHARACTERS WITHOUT CLAIM TO ANY PARTICULAR FONT, STYLE, SIZE, OR COLOR.

FOR PROGRAMMABLE INTEGRATED CIRCUITS AND INTEGRATED CIRCUITS FOR DIGITAL VIDEO ANALYSIS, NAMELY, OBJECT RECOGNITION AND EXTRACTION, MOTION DETECTION, OBJECT TRACKING AND ADVANCED VIDEO ANALYTICS (U.S. CLS. 21, 23, 26, 36 AND 38).

FIRST USE 10-0-2009; IN COMMERCE 10-0-2009.  
ANTHONY RINKER, EXAMINING ATTORNEY

SN 85-196,435. PHOENIX CONTACT DEVELOPMENT AND MANUFACTURING, INC., MIDDLETOWN, PA. FILED 12-13-2010.

# VALUELINE

THE MARK CONSISTS OF STANDARD CHARACTERS WITHOUT CLAIM TO ANY PARTICULAR FONT, STYLE, SIZE, OR COLOR.

FOR RUGGIDIZED COMPUTERS CAPABLE OF WITHSTANDING SHOCKS, VIBRATIONS AND HIGH TEMPERATURES FOR USE IN INDUSTRIAL SITES (U.S. CLS. 21, 23, 26, 36 AND 38).

FIRST USE 2-28-2009; IN COMMERCE 2-28-2009.  
CHARLOTTE CORWIN, EXAMINING ATTORNEY

**CLASS 9—(Continued).**

SN 85-196,447. APOGEE INC., BREA, CA. FILED 12-13-2010.

# Drive-In

THE MARK CONSISTS OF STANDARD CHARACTERS WITHOUT CLAIM TO ANY PARTICULAR FONT, STYLE, SIZE, OR COLOR.

FOR MOUNTING DEVICES FOR MONITORS (U.S. CLS. 21, 23, 26, 36 AND 38).

NAAKWAMA ANKRAH, EXAMINING ATTORNEY

SN 85-196,768. DURA ENGRAVING CORP., DBA DURA ARCHITECTURAL SIGNAGE, LONG ISLAND CITY, NY. FILED 12-13-2010.

# DURA GLOW

THE MARK CONSISTS OF STANDARD CHARACTERS WITHOUT CLAIM TO ANY PARTICULAR FONT, STYLE, SIZE, OR COLOR.

NO CLAIM IS MADE TO THE EXCLUSIVE RIGHT TO USE "GLOW", APART FROM THE MARK AS SHOWN.

FOR NON-ELECTRIC, SELF-LUMINOUS, GLOW-IN-THE-DARK PHOTO LUMINESCENT SAFETY SIGN AGE FOR BUILDING EVACUATION GUIDANCE (U.S. CLS. 21, 23, 26, 36 AND 38).

RICHARD WHITE, EXAMINING ATTORNEY

SN 85-197,369. SENSOR PRODUCTS INC., MADISON, NJ. FILED 12-14-2010.

# TOPAQ

THE MARK CONSISTS OF STANDARD CHARACTERS WITHOUT CLAIM TO ANY PARTICULAR FONT, STYLE, SIZE, OR COLOR.

FOR INDUSTRIAL MANUFACTURING PRESSURE AND MEASUREMENT AND IMAGING SYSTEMS COMPRISING HIGH RESOLUTION DESKTOP OPTICAL AND CHARGE COUPLED DEVICES; DENSITOMETERS AND INTERPRETATIVE SOFTWARE FOR THE ANALYSIS, COLORIZATION AND REVIEW OF STATISTICAL DATA (U.S. CLS. 21, 23, 26, 36 AND 38).

FIRST USE 6-1-1997; IN COMMERCE 6-1-1997.

PRISCILLA MILTON, EXAMINING ATTORNEY

**CLASS 9—(Continued).**

SN 85-197,707. AGILE BRANDS, LLC, STUDIO CITY, CA. FILED 12-14-2010.

## Computer Clothing Company

THE MARK CONSISTS OF STANDARD CHARACTERS WITHOUT CLAIM TO ANY PARTICULAR FONT, STYLE, SIZE, OR COLOR.

NO CLAIM IS MADE TO THE EXCLUSIVE RIGHT TO USE "COMPUTER" AND "COMPANY", APART FROM THE MARK AS SHOWN.

FOR BACKPACKS ESPECIALLY ADAPTED FOR HOLDING LAPTOPS; BACKPACKS ESPECIALLY ADAPTED FOR HOLDING LAPTOPS AND NOTEBOOK COMPUTERS; BAGS AND CASES SPECIALLY ADAPTED FOR HOLDING OR CARRYING PORTABLE TELEPHONES AND TELEPHONE EQUIPMENT AND ACCESSORIES; BRIEFCASES SPECIALLY ADAPTED FOR HOLDING LAPTOP COMPUTERS; CAMERA CASES; CARRYING CASES FOR CELL PHONES; CARRYING CASES FOR MOBILE COMPUTERS; CARRYING CASES SPECIALLY ADAPTED FOR POCKET CALCULATORS AND CELLPHONES; CARRYING CASES, HOLDERS, PROTECTIVE CASES AND STANDS FEATURING POWER SUPPLY CONNECTORS, ADAPTORS, SPEAKERS AND BATTERY CHARGING DEVICES, SPECIALLY ADAPTED FOR USE WITH HANDHELD DIGITAL ELECTRONIC DEVICES; CASES FOR ELECTRONIC DIARIES; CASES FOR MOBILE PHONES; CASES FOR PHOTOGRAPHIC APPARATUS; CELL PHONE CASES; COMPUTER CARRYING CASES; CUSHIONED SUPPORT BASE SPECIALLY ADAPTED TO PROP UP LAPTOP COMPUTERS; EARPHONE ACCESSORIES, NAMELY, EARPHONE CUSHIONS, EARPHONE PADS, CORD MANAGEMENT SYSTEMS, EARPHONE CASES, AND EARPHONE EXTENSION CORDS; LAPTOP CARRYING CASES; MESSENGER BAGS ESPECIALLY ADAPTED FOR HOLDING LAPTOPS; NEOPRENE LAPTOP COVERS; NOTEBOOK AND LAPTOP COMPUTERS; PLASTIC CASES SPECIALLY ADAPTED FOR HOLDING COMPACT DISCS, DVDS AND OTHER ELECTRONIC MEDIA; PROTECTIVE CARRYING CASES FOR PORTABLE MUSIC PLAYERS, NAMELY, MP3 PLAYERS; PROTECTIVE CARRYING CASES SPECIALLY ADAPTED FOR GLOBAL POSITIONING SYSTEM (GPS) APPARATUS; PROTECTIVE CARRYING CASES SPECIALLY ADAPTED FOR PERSONAL DIGITAL ASSISTANTS (PDA); PROTECTIVE CARRYING CASES SPECIALLY ADAPTED FOR VIDEO GAME CONSOLES FOR USE WITH AN EXTERNAL DISPLAY SCREEN OR MONITOR; PROTECTIVE COVERS AND CASES FOR CELL PHONES, LAPTOPS AND PORTABLE MEDIA PLAYERS; PROTECTIVE SLEEVES FOR LAPTOP COMPUTERS; ROLLING CASES ESPECIALLY ADAPTED FOR HOLDING LAPTOPS AND NOTEBOOK COMPUTERS; VINYL COVERS SPECIALLY ADAPTED FOR CELL PHONES, MP3 PLAYERS, LAPTOPS, COMPUTERS, PORTABLE SATELLITE RADIOS, PERSONAL DIGITAL ASSISTANTS, REMOTE CONTROLS, AND TELEVISION SATELLITE RECORDERS; WHEELED BACKPACKS ESPECIALLY ADAPTED FOR HOLDING LAPTOPS; WHEELED MESSENGER BAGS ESPECIALLY ADAPTED FOR HOLDING LAPTOPS (U.S. CLS. 21, 23, 26, 36 AND 38).

MARK SHINER, EXAMINING ATTORNEY

**CLASS 9—(Continued).**

SN 85-197,735. AGILE BRANDS, LLC, STUDIO CITY, CA. FILED 12-14-2010.

## Computer Apparel

THE MARK CONSISTS OF STANDARD CHARACTERS WITHOUT CLAIM TO ANY PARTICULAR FONT, STYLE, SIZE, OR COLOR.

NO CLAIM IS MADE TO THE EXCLUSIVE RIGHT TO USE "COMPUTER", APART FROM THE MARK AS SHOWN.

FOR BACKPACKS ESPECIALLY ADAPTED FOR HOLDING LAPTOPS; BACKPACKS ESPECIALLY ADAPTED FOR HOLDING LAPTOPS AND NOTEBOOK COMPUTERS; BAGS AND CASES ESPECIALLY ADAPTED FOR HOLDING OR CARRYING PORTABLE TELEPHONES AND TELEPHONE EQUIPMENT AND ACCESSORIES; BRIEFCASES ESPECIALLY ADAPTED FOR HOLDING LAPTOP COMPUTERS; CAMERA CASES; CARRYING CASES FOR CELL PHONES; CARRYING CASES FOR MOBILE COMPUTERS; CARRYING CASES ESPECIALLY ADAPTED FOR POCKET CALCULATORS AND CELLPHONES; CARRYING CASES, HOLDERS, PROTECTIVE CASES AND STANDS FEATURING POWER SUPPLY CONNECTORS, ADAPTORS, SPEAKERS AND BATTERY CHARGING DEVICES, ESPECIALLY ADAPTED FOR USE WITH HANDHELD DIGITAL ELECTRONIC DEVICES; CASES FOR MOBILE PHONES; CASES FOR PHOTOGRAPHIC APPARATUS; CASES FOR POCKET CALCULATORS; CASES FOR TELEPHONES; CELL PHONE CASES; COMPUTER CARRYING CASES; CUSHIONED SUPPORT BASE ESPECIALLY ADAPTED TO PROP UP LAPTOP COMPUTERS; EARPHONE ACCESSORIES, NAMELY, EARPHONE CUSHIONS, EARPHONE PADS, CORD MANAGEMENT SYSTEMS, EARPHONE CASES, AND EARPHONE EXTENSION CORDS; LAPTOP CARRYING CASES; MESSENGER BAGS ESPECIALLY ADAPTED FOR HOLDING LAPTOPS; NEOPRENE LAPTOP COVERS; NOTEBOOK AND LAPTOP COMPUTERS; NOTEBOOK COMPUTER CARRYING CASES; PROTECTIVE CARRYING CASES FOR PORTABLE MUSIC PLAYERS, NAMELY, MP3 PLAYERS; PROTECTIVE CARRYING CASES ESPECIALLY ADAPTED FOR GLOBAL POSITIONING SYSTEM (GPS) APPARATUS; PROTECTIVE CARRYING CASES ESPECIALLY ADAPTED FOR PERSONAL DIGITAL ASSISTANTS (PDA); PROTECTIVE CARRYING CASES ESPECIALLY ADAPTED FOR VIDEO GAME CONSOLES FOR USE WITH AN EXTERNAL DISPLAY SCREEN OR MONITOR; PROTECTIVE COVERS AND CASES FOR CELL PHONES, LAPTOPS AND PORTABLE MEDIA PLAYERS; PROTECTIVE SLEEVES FOR LAPTOP COMPUTERS; ROLLING CASES ESPECIALLY ADAPTED FOR HOLDING LAPTOPS AND NOTEBOOK COMPUTERS; VINYL COVERS ESPECIALLY ADAPTED FOR CELL PHONES, MP3 PLAYERS, LAPTOPS, COMPUTERS, PORTABLE SATELLITE RADIOS, PERSONAL DIGITAL ASSISTANTS, REMOTE CONTROLS, AND TELEVISION SATELLITE RECORDERS; WHEELED BACKPACKS ESPECIALLY ADAPTED FOR HOLDING LAPTOPS; WHEELED MESSENGER BAGS ESPECIALLY ADAPTED FOR HOLDING LAPTOPS (U.S. CLS. 21, 23, 26, 36 AND 38).

MARK SHINER, EXAMINING ATTORNEY

**CLASS 9—(Continued).**

SN 85-198,541. KOGER, INC., PARAMUS, NJ. FILED 12-15-2010.

## PTAS

THE MARK CONSISTS OF STANDARD CHARACTERS WITHOUT CLAIM TO ANY PARTICULAR FONT, STYLE, SIZE, OR COLOR.

FOR COMPUTER SOFTWARE TO TRACK CONTRIBUTIONS TO RETIREMENT INVESTMENTS AND FUNDS, TO MONITOR BENEFITS AND DISTRIBUTIONS, TO TRACK BENEFICIARIES, AND TO PROVIDE ALLOCATIONS OF ASSETS AMONG VARIOUS INVESTMENTS AND FUNDS (U.S. CLS. 21, 23, 26, 36 AND 38).

FIRST USE 5-0-1998; IN COMMERCE 5-0-1998.

ANNE MADDEN, EXAMINING ATTORNEY

SN 85-198,547. HARMONY BALL COMPANY, COLUMBUS, OH. FILED 12-15-2010.

## CUBEBOT

THE MARK CONSISTS OF STANDARD CHARACTERS WITHOUT CLAIM TO ANY PARTICULAR FONT, STYLE, SIZE, OR COLOR.

FOR COMPUTER PROGRAMS, NAMELY, COMPUTER GAME PROGRAMS (U.S. CLS. 21, 23, 26, 36 AND 38).

ANDREW RHIM, EXAMINING ATTORNEY

SN 85-198,554. KOGER, INC., PARAMUS, NJ. FILED 12-15-2010.

## NTAS

THE MARK CONSISTS OF STANDARD CHARACTERS WITHOUT CLAIM TO ANY PARTICULAR FONT, STYLE, SIZE, OR COLOR.

FOR COMPUTER SOFTWARE FOR USE IN THE FINANCIAL AND INVESTMENT FIELDS TO ADMINISTER INVESTMENT FUNDS, TO RECORD INVESTMENT TRANSACTIONS, TO MONITOR INVESTMENT FUND RULES, TO CALCULATE PERFORMANCE AND MANAGEMENT FEES AND TO CREATE REPORTS TO INVESTORS (U.S. CLS. 21, 23, 26, 36 AND 38).

FIRST USE 4-0-1995; IN COMMERCE 4-0-1995.

ANNE MADDEN, EXAMINING ATTORNEY

**CLASS 9—(Continued).**

SN 85-198,857. ACTIONTEC ELECTRONICS, INC., SUNNYVALE, CA. FILED 12-15-2010.

**MYWIRELESSTV**

THE MARK CONSISTS OF STANDARD CHARACTERS WITHOUT CLAIM TO ANY PARTICULAR FONT, STYLE, SIZE, OR COLOR.

FOR COMPUTER HARDWARE, COMPUTER SOFTWARE, TRANSMITTERS AND RECEIVERS ALL TO FACILITATE THE TRANSMISSION OF HIGH DEFINITION CONTENT FROM ONE DEVICE TO ANOTHER DEVICE IN THE HOME (U.S. CLS. 21, 23, 26, 36 AND 38).  
JERI J. FICKES, EXAMINING ATTORNEY

---

SN 85-199,049. CELESTRON ACQUISITION, LLC, DBA CELESTRON, TORRANCE, CA. FILED 12-15-2010.

**CELESTRON LUMINOS EYEPIECES**

THE MARK CONSISTS OF STANDARD CHARACTERS WITHOUT CLAIM TO ANY PARTICULAR FONT, STYLE, SIZE, OR COLOR.

OWNER OF U.S. REG. NOS. 1,139,857 AND 3,005,393.  
NO CLAIM IS MADE TO THE EXCLUSIVE RIGHT TO USE "EYEPIECES", APART FROM THE MARK AS SHOWN.  
THE ENGLISH TRANSLATION OF THE WORD "LUMINOS" IN THE MARK IS BRIGHT.  
FOR EYEPIECES FOR TELESCOPES (U.S. CLS. 21, 23, 26, 36 AND 38).  
ODESSA BIBBINS, EXAMINING ATTORNEY

---

SN 85-199,569. JOE BAKHSHI, MIAMI, FL. FILED 12-16-2010.

**Ready To Swipe**

THE MARK CONSISTS OF STANDARD CHARACTERS WITHOUT CLAIM TO ANY PARTICULAR FONT, STYLE, SIZE, OR COLOR.

FOR CARD READERS FOR CREDIT CARDS; CARD READERS FOR MAGNETICALLY ENCODED CARDS; CARD READING EQUIPMENT; COMPUTER EQUIPMENT, NAMELY, WIRELESS CARDS; COMPUTER PROGRAM FOR THE COMPILATION OF CREDIT REPORTING DATA; CREDIT CARD ENCODING MACHINES; ELECTRONIC COMPUTERIZED CREDIT CARD IMPRINTERS; ELECTRONIC MACHINES FOR READING CREDIT CARDS AND RECORDING FINANCIAL OPERATIONS; MAGNETICALLY ENCODED CREDIT CARDS (U.S. CLS. 21, 23, 26, 36 AND 38).  
LINDA M. KING, EXAMINING ATTORNEY

**CLASS 9—(Continued).**

SN 85-199,640. BLANK, HARRY, LAGUNA NIGUEL, CA. AND BLANK, JOY, LAGUNA NIGUEL, CA. FILED 12-16-2010.

**WHAT'S IN A WORD**

THE MARK CONSISTS OF STANDARD CHARACTERS WITHOUT CLAIM TO ANY PARTICULAR FONT, STYLE, SIZE, OR COLOR.

OWNER OF U.S. REG. NO. 3,187,754.  
FOR COMPUTER GAME CARTRIDGES; COMPUTER GAME CARTRIDGES AND DISCS; COMPUTER GAME CASSETTES; COMPUTER GAME DISCS; COMPUTER GAME EQUIPMENT, NAMELY, DISCS; COMPUTER GAME PROGRAMS DOWNLOADABLE VIA THE INTERNET; COMPUTER GAME PROGRAMS; COMPUTER GAME PROGRAMS, CARTRIDGES, AND CASSETTES; COMPUTER GAME SOFTWARE; COMPUTER GAME TAPES; INTERACTIVE AUDIO GAME DISCS CONTAINING AN EDUCATIONAL GAME; INTERACTIVE GAME PROGRAMS; INTERACTIVE GAME SOFTWARE; INTERACTIVE MULTIMEDIA COMPUTER GAME PROGRAM; INTERACTIVE VIDEO GAME PROGRAMS; VIDEO GAME CARTRIDGES; VIDEO GAME CARTRIDGES AND CASSETTES; VIDEO GAME CARTRIDGES AND DISCS; VIDEO GAME DISCS; VIDEO GAME INTERACTIVE HAND HELD REMOTE CONTROLS FOR PLAYING ELECTRONIC GAMES; VIDEO GAME INTERACTIVE REMOTE CONTROL UNITS; VIDEO GAME JOYSTICKS; VIDEO GAME MACHINES FOR USE WITH TELEVISIONS; VIDEO GAME SOFTWARE; VIDEO GAME TAPE CASSETTES (U.S. CLS. 21, 23, 26, 36 AND 38).

FIRST USE 12-1-2010; IN COMMERCE 12-1-2010.  
BRIAN PINO, EXAMINING ATTORNEY

---

SN 85-200,224. KOGER, INC., PARAMUS, NJ. FILED 12-17-2010.

**IKAS**

THE MARK CONSISTS OF STANDARD CHARACTERS WITHOUT CLAIM TO ANY PARTICULAR FONT, STYLE, SIZE, OR COLOR.

FOR COMPUTER SOFTWARE FOR INVESTMENT FUND PORTFOLIO VALUATIONS AND INVESTMENT FUND ADMINISTRATION AND ACCOUNTING (U.S. CLS. 21, 23, 26, 36 AND 38).  
FIRST USE 3-0-2008; IN COMMERCE 3-0-2008.  
ANNE MADDEN, EXAMINING ATTORNEY

**CLASS 9—(Continued).**

SN 85-200,226. KOGER, INC., PARAMUS, NJ. FILED 12-17-2010.

**GRID**

THE MARK CONSISTS OF STANDARD CHARACTERS WITHOUT CLAIM TO ANY PARTICULAR FONT, STYLE, SIZE, OR COLOR.

FOR COMPUTER SOFTWARE TO PROCESS AND TRANSFER FINANCIAL INVESTMENT DATA (U.S. CLS. 21, 23, 26, 36 AND 38).

FIRST USE 1-0-2001; IN COMMERCE 1-0-2001.  
ANNE MADDEN, EXAMINING ATTORNEY

**CLASS 9—(Continued).**

SN 85-201,223. DIGITAT CONCEPTS LLC, WEST PALM BEACH, FL. FILED 12-18-2010.

**Hear Your Brand**

THE MARK CONSISTS OF STANDARD CHARACTERS WITHOUT CLAIM TO ANY PARTICULAR FONT, STYLE, SIZE, OR COLOR.

FOR ELECTRONIC PRODUCTS, NAMELY, BOOM BOXES, AUDIO SPEAKERS, RADIOS, HEADPHONES, EARPHONES, CD PLAYERS, DVD PLAYERS, MP3 PLAYERS AND PORTABLE MEDIA PLAYERS (U.S. CLS. 21, 23, 26, 36 AND 38).

LESLEY LAMOTHE, EXAMINING ATTORNEY

SN 85-201,119. ORBOTIX, INC., BOULDER, CO. FILED 12-17-2010.

**SPHERO**

THE MARK CONSISTS OF STANDARD CHARACTERS WITHOUT CLAIM TO ANY PARTICULAR FONT, STYLE, SIZE, OR COLOR.

FOR ROBOTS FOR PERSONAL OR HOBBY USE; TRANSMITTERS AND RECEIVERS FOR REMOTELY CONTROLLING DEVICES; COMPUTER GAME SOFTWARE; INTERACTIVE VIDEO GAME PROGRAMS; DOWNLOADABLE COMPUTER AND VIDEO GAME SOFTWARE; COMPUTER PROGRAMS, NAMELY, GAME SOFTWARE FOR USE ON COMPUTERS AND VIDEO GAME PLAYERS; VIDEO GAME CONTROLLERS (U.S. CLS. 21, 23, 26, 36 AND 38).

DOMINIC FATHY, EXAMINING ATTORNEY

SN 85-201,402. GUITAR CENTER, INC., WESTLAKE VILLAGE, CA. FILED 12-19-2010.

**FAT WIRE**

THE MARK CONSISTS OF STANDARD CHARACTERS WITHOUT CLAIM TO ANY PARTICULAR FONT, STYLE, SIZE, OR COLOR.

NO CLAIM IS MADE TO THE EXCLUSIVE RIGHT TO USE "WIRE", APART FROM THE MARK AS SHOWN.

FOR ELECTRIC CABLES FOR USE WITH GUITARS, MIXERS, PROAUDIO APPLICATIONS, RECORDING APPLICATIONS AND OTHER MUSICAL APPLICATIONS REQUIRING THE USE OF CABLES (U.S. CLS. 21, 23, 26, 36 AND 38).

RON FAIRBANKS, EXAMINING ATTORNEY

SN 85-201,218. TOLBERT, NYESUADAH, LOUISVILLE, KY. FILED 12-18-2010.

**Nyesuadah**

THE MARK CONSISTS OF STANDARD CHARACTERS WITHOUT CLAIM TO ANY PARTICULAR FONT, STYLE, SIZE, OR COLOR.

FOR AUDIO AND VIDEO RECORDINGS FEATURING MUSIC AND ARTISTIC PERFORMANCES (U.S. CLS. 21, 23, 26, 36 AND 38).

JOHN DWYER, EXAMINING ATTORNEY

SN 85-202,079. DEEMO, LLC, SAN JOSE, CA. FILED 12-20-2010.

**KidZone**

THE MARK CONSISTS OF STANDARD CHARACTERS WITHOUT CLAIM TO ANY PARTICULAR FONT, STYLE, SIZE, OR COLOR.

FOR COMPUTER APPLICATION SOFTWARE FOR MOBILE PHONES, TABLET COMPUTERS, HAND HELD COMPUTERS, PORTABLE MEDIA PLAYERS AND GAMING DEVICES, NAMELY, SOFTWARE FOR CREATING A RESTRICTED ZONE WITH PROTECTIVE FUNCTIONALITY WITHIN AN OPERATING SYSTEM (U.S. CLS. 21, 23, 26, 36 AND 38).

FIRST USE 12-20-2010; IN COMMERCE 12-20-2010.  
ANGELA M. MICHELI, EXAMINING ATTORNEY



**CLASS 9—(Continued).**

SN 85-202,141. SILICON IMAGE, INC., SUNNYVALE, CA.  
FILED 12-20-2010.

**INSTAPREVUE**

THE MARK CONSISTS OF STANDARD CHARACTERS WITHOUT CLAIM TO ANY PARTICULAR FONT, STYLE, SIZE, OR COLOR.

FOR COMPUTER CHIPS, INTEGRATED CIRCUITS, SEMICONDUCTORS AND MICROPROCESSORS; ELECTRICAL, ELECTRONIC AND DIGITAL CONNECTORS, CABLES, AND COMPONENTS THEREOF; COMPUTER HARDWARE; COMPUTER HARDWARE COMPONENTS NAMELY COMPUTER MONITORS, COMPUTER PERIPHERALS, VIDEO SCALERS AND VIDEO INPUT PROCESSORS; CONSUMER ELECTRONICS DEVICES, NAMELY CABLE, SATELLITE AND TERRESTRIAL DIGITAL SET-TOP BOXES, DVD PLAYERS AND RECORDERS, DIGITAL VHS PLAYERS AND RECORDERS, PERSONAL VIDEO RECORDERS, CABLE BOXES, AUDIO/VIDEO RECEIVERS, LIQUID CRYSTAL DISPLAY (LCD) PROJECTORS, MULTIMEDIA PROJECTORS, TELEVISIONS, INTEGRATED TELEVISIONS, TELEVISION MONITORS AND VIDEO MONITORS, CAMERAS, PERSONAL DIGITAL ASSISTANTS, PHOTOGRAPHIC PROJECTORS, SLIDE PROJECTORS, VIDEO MONITORS, LASER DISC RECORDERS AND PLAYERS, MP3 RECORDERS AND PLAYERS, GAMING MACHINES, VIDEO GAME MACHINES FOR USE WITH TELEVISIONS AND EXTERNAL DISPLAYS; TUNERS, NAMELY TELEVISION TUNERS, CAR BROADCASTING TUNERS, AND STEREO TUNERS; DIGITAL VIDEO CASSETTE PLAYERS AND RECORDERS; CABLE SET-TOP BOXES; TELEVISION MONITORS; INTERNET TELEVISION HARDWARE, NAMELY CONVERTERS, TRANSMITTERS, RECEIVERS, AND MONITORS; TELEVISION PROCESSORS, NAMELY, VIDEO PROCESSORS, DIGITAL SIGNAL PROCESSORS, AND SATELLITE PROCESSORS; VIDEO DE-INTERLACE PROCESSORS; FULLY-INTEGRATED VIDEO PROCESSORS; DIGITAL INTERFACE EXTENDER DEVICE FOR CONNECTING COMPUTER AND COMMUNICATIONS HARDWARE, CONSUMER ELECTRONICS DEVICES, COMPONENTS, AND PERIPHERALS; VIDEO/AUDIO INPUT AND OUTPUT PROCESSORS WITH SWITCHING CAPABILITIES; VIDEO/AUDIO INPUT AND OUTPUT PROCESSORS WHICH INCORPORATE ELECTRONIC SWITCHES; COMPUTER SOFTWARE, NAMELY, COMPUTER SOFTWARE FOR SETTING UP AND CONFIGURING ELECTRONIC DEVICES (U.S. CLS. 21, 23, 26, 36 AND 38).

DAVID TAYLOR, EXAMINING ATTORNEY

**CLASS 9—(Continued).**

SN 85-202,486. RANDOM HOUSE, INC., NEW YORK, NY.  
FILED 12-21-2010.

**THE EBOOK INSIDER**

THE MARK CONSISTS OF STANDARD CHARACTERS WITHOUT CLAIM TO ANY PARTICULAR FONT, STYLE, SIZE, OR COLOR.

NO CLAIM IS MADE TO THE EXCLUSIVE RIGHT TO USE "EBOOK", APART FROM THE MARK AS SHOWN.

FOR DOWNLOADABLE ELECTRONIC PUBLICATIONS IN THE NATURE OF ELECTRONIC BOOKS IN THE FIELD OF READERS' GUIDES FEATURING INFORMATION ON EBOOKS, AUTHORS, BOOKS EXCERPTS, AND OTHER PUBLISHING INFORMATION (U.S. CLS. 21, 23, 26, 36 AND 38).

FIRST USE 12-21-2010; IN COMMERCE 12-21-2010.

KALIE KUNG, EXAMINING ATTORNEY

SN 85-202,490. ZOLL MEDICAL CORPORATION, CHELMSFORD, MA. FILED 12-21-2010.

**SENSE 'N SYNC**

THE MARK CONSISTS OF STANDARD CHARACTERS WITHOUT CLAIM TO ANY PARTICULAR FONT, STYLE, SIZE, OR COLOR.

FOR SOFTWARE COMPONENT FOR COLLECTING DATA FROM EXTERNAL EMERGENCY RESPONSE SYSTEM DEVICES (U.S. CLS. 21, 23, 26, 36 AND 38).

CHERYL CLAYTON, EXAMINING ATTORNEY

SN 85-202,509. LIVING BASEBALL CARD, LLC, MUSKOGON, MI. FILED 12-21-2010.

**THE LIVING BASEBALL CARD**

THE MARK CONSISTS OF STANDARD CHARACTERS WITHOUT CLAIM TO ANY PARTICULAR FONT, STYLE, SIZE, OR COLOR.

NO CLAIM IS MADE TO THE EXCLUSIVE RIGHT TO USE "BASEBALL", APART FROM THE MARK AS SHOWN.

FOR VIDEO DISKS FEATURING BASEBALL PLAYERS (U.S. CLS. 21, 23, 26, 36 AND 38).

FLORENTINA BLANDU, EXAMINING ATTORNEY

**CLASS 9—(Continued).**

SN 85-202,535. SCHOLASTIC INC., NEW YORK, NY. FILED 12-21-2010.

**TOUCH & TILT**

THE MARK CONSISTS OF STANDARD CHARACTERS WITHOUT CLAIM TO ANY PARTICULAR FONT, STYLE, SIZE, OR COLOR.

FOR ELECTRONIC PUBLICATIONS, NAMELY, BOOKS FOR CHILDREN IN THE FIELD OF READING IMPROVEMENT RECORDED ON COMPUTER MEDIA (U.S. CLS. 21, 23, 26, 36 AND 38).

TRACY CROSS, EXAMINING ATTORNEY

SN 85-202,543. SCHOLASTIC INC., NEW YORK, NY. FILED 12-21-2010.



THE MARK CONSISTS OF THE WORD "TOUCH" IN STYLIZED LETTERING, UNDERNEATH WHICH IS A STYLIZED "&" WITHIN A CIRCLE, BOTH OF WHICH ARE WITHIN A ROUNDED SHAPE, AND BELOW WHICH IS THE WORD "TILT" IN STYLIZED LETTERING, LOCATED WITHIN A DESIGN OF A SIGN.

FOR ELECTRONIC PUBLICATIONS, NAMELY, BOOKS FOR CHILDREN IN THE FIELD OF READING IMPROVEMENT RECORDED ON COMPUTER MEDIA (U.S. CLS. 21, 23, 26, 36 AND 38).

TRACY CROSS, EXAMINING ATTORNEY

SN 85-202,552. APLICA JOHN, CHICAGO, IL. FILED 12-21-2010.

**blurex**

THE MARK CONSISTS OF STANDARD CHARACTERS WITHOUT CLAIM TO ANY PARTICULAR FONT, STYLE, SIZE, OR COLOR.

FOR CARRYING CASES FOR MOBILE COMPUTERS (U.S. CLS. 21, 23, 26, 36 AND 38).

FIRST USE 11-2-2010; IN COMMERCE 11-2-2010.

MARY ROSSMAN, EXAMINING ATTORNEY

**CLASS 9—(Continued).**

SN 85-202,668. PROMEGA CORPORATION, MADISON, WI. FILED 12-21-2010.

**MAXWELL**

THE MARK CONSISTS OF STANDARD CHARACTERS WITHOUT CLAIM TO ANY PARTICULAR FONT, STYLE, SIZE, OR COLOR.

OWNER OF U.S. REG. NO. 3,125,120.

SEC. 2(F).

FOR LABORATORY APPARATUS, NAMELY, MAGNETIC SEPARATION INSTRUMENT FOR USE IN BIOSEPARATIONS (U.S. CLS. 21, 23, 26, 36 AND 38).

FIRST USE 10-31-2005; IN COMMERCE 10-31-2005.

MATTHEW PAPPAS, EXAMINING ATTORNEY

SN 85-202,721. ANNECHIARICO, MIKE, HARRISON, NY. FILED 12-21-2010.

**PigFish**

THE MARK CONSISTS OF STANDARD CHARACTERS WITHOUT CLAIM TO ANY PARTICULAR FONT, STYLE, SIZE, OR COLOR.

FOR COMPUTER GAME SOFTWARE (U.S. CLS. 21, 23, 26, 36 AND 38).

SUNG IN, EXAMINING ATTORNEY

SN 85-202,765. NEXT LIMIT S.L., MADRID, SPAIN, FILED 12-21-2010.

**EARTHFLOW**

THE MARK CONSISTS OF STANDARD CHARACTERS WITHOUT CLAIM TO ANY PARTICULAR FONT, STYLE, SIZE, OR COLOR.

FOR COMPUTER SOFTWARE FOR CALCULATING, MODELING AND DISPLAYING THE MOTION OF FLUIDS IN A THREE-DIMENSIONAL ENVIRONMENT; COMPUTER SOFTWARE FOR CALCULATING, MODELING AND DISPLAYING THE MOTION OF FLUIDS IN A THREE-DIMENSIONAL ENVIRONMENT THAT MAY BE DOWNLOADED FROM A GLOBAL COMPUTER NETWORK (U.S. CLS. 21, 23, 26, 36 AND 38).

ZHALEH DELANEY, EXAMINING ATTORNEY

**CLASS 9—(Continued).**

SN 85-203,214. BURKHART, BRANDON, RIVERSIDE, CA. FILED 12-21-2010.

# Genesis

THE MARK CONSISTS OF STANDARD CHARACTERS WITHOUT CLAIM TO ANY PARTICULAR FONT, STYLE, SIZE, OR COLOR.

FOR BALLASTS FOR HALOGEN LIGHTS (U.S. CLS. 21, 23, 26, 36 AND 38).

C. DIONNE CLYBURN, EXAMINING ATTORNEY

**CLASS 9—(Continued).**

SN 85-203,273. EPCSOLUTIONS, INC., GREAT FALLS, VA. FILED 12-21-2010.

# SCAVE

THE MARK CONSISTS OF STANDARD CHARACTERS WITHOUT CLAIM TO ANY PARTICULAR FONT, STYLE, SIZE, OR COLOR.

FOR SOFTWARE PROGRAM FOR WIRELESS CONSUMER ACCESS TO MANUFACTURER DATA (U.S. CLS. 21, 23, 26, 36 AND 38).

CAROLYN CATALDO, EXAMINING ATTORNEY

SN 85-203,219. MARGARITAVILLE ENTERPRISES, LLC, PALM BEACH, FL. FILED 12-21-2010.

## MARGARITAVILLE POLARIZED TECHNOLOGY

THE MARK CONSISTS OF STANDARD CHARACTERS WITHOUT CLAIM TO ANY PARTICULAR FONT, STYLE, SIZE, OR COLOR.

OWNER OF U.S. REG. NOS. 1,831,949, 3,002,009 AND OTHERS.

NO CLAIM IS MADE TO THE EXCLUSIVE RIGHT TO USE "POLARIZED TECHNOLOGY", APART FROM THE MARK AS SHOWN.

FOR EYEWEAR, SUNGLASSES, EYEGLASSES, GOGGLES FOR SPORTS, CASES FOR EYEGLASSES AND SUNGLASSES, EYEWEAR ACCESSORIES, NAMELY, STRAPS, NECK CORDS AND HEAD STRAPS WHICH RESTRAIN EYEWEAR FROM MOVEMENT ON A WEARER (U.S. CLS. 21, 23, 26, 36 AND 38).

C. DIONNE CLYBURN, EXAMINING ATTORNEY

SN 85-203,292. VIBRACODE, LLC, NASHVILLE, TN. FILED 12-21-2010.

# SIDETACTS

THE MARK CONSISTS OF STANDARD CHARACTERS WITHOUT CLAIM TO ANY PARTICULAR FONT, STYLE, SIZE, OR COLOR.

FOR COMPUTER APPLICATION SOFTWARE FOR MOBILE PHONES, NAMELY, CONTACTS MANAGEMENT SOFTWARE (U.S. CLS. 21, 23, 26, 36 AND 38).

KAREN K. BUSH, EXAMINING ATTORNEY

SN 85-203,272. VIBRACODE, LLC, NASHVILLE, TN. FILED 12-21-2010.

# SIDEFLYER

THE MARK CONSISTS OF STANDARD CHARACTERS WITHOUT CLAIM TO ANY PARTICULAR FONT, STYLE, SIZE, OR COLOR.

FOR DOWNLOADABLE ELECTRONIC DATA FILES CONTAINING PERSONAL CONTACT INFORMATION FOR USE WITH COMPUTER APPLICATION SOFTWARE (U.S. CLS. 21, 23, 26, 36 AND 38).

KAREN K. BUSH, EXAMINING ATTORNEY



THE MARK CONSISTS OF THE WORD "OUKU" WITH STYLIZED DESIGN AND THREE WATER-DROPLET-SHAPED DEVICES ABOVE THE LETTER "O".

THE WORDING OUKU HAS NO MEANING IN A FOREIGN LANGUAGE.

FOR MOBILE PHONES; RADIOTELEPHONY SETS; SATELLITE NAVIGATIONAL SYSTEM, NAMELY, A GLOBAL POSITIONING SYSTEM (GPS); TELEPHONE APPARATUS; TELEPHONE TRANSMITTERS; TRANSMITTERS OF ELECTRONIC SIGNALS; VIDEO TELEPHONES (U.S. CLS. 21, 23, 26, 36 AND 38).

HEATHER BIDDULPH, EXAMINING ATTORNEY

**CLASS 9—(Continued).**

SN 85-203,586. PROMEGA CORPORATION, MADISON, WI. FILED 12-22-2010.

# JETSTREAM

THE MARK CONSISTS OF STANDARD CHARACTERS WITHOUT CLAIM TO ANY PARTICULAR FONT, STYLE, SIZE, OR COLOR.

FOR SOFTWARE FOR RECEIVING, MANAGING AND CONTROLLING RADIO FREQUENCY IDENTIFICATION DEVICES AND SENSORS (U.S. CLS. 21, 23, 26, 36 AND 38).

MATTHEW PAPPAS, EXAMINING ATTORNEY

**CLASS 9—(Continued).**

SN 85-203,942. DIGITAC, INC., NEW YORK, NY. FILED 12-22-2010.

# DIGITAC

THE MARK CONSISTS OF STANDARD CHARACTERS WITHOUT CLAIM TO ANY PARTICULAR FONT, STYLE, SIZE, OR COLOR.

FOR DIGITAL CAMERAS; DIGITAL VIDEO CAMERAS; DISPOSABLE CAMERAS (U.S. CLS. 21, 23, 26, 36 AND 38).

HENRY S. ZAK, EXAMINING ATTORNEY

SN 85-203,631. YU KAI CHEUNG CREEVY, 139 PIK WAN RD., KLN, HONG KONG, FILED 12-22-2010.

# Black Gate

THE MARK CONSISTS OF STANDARD CHARACTERS WITHOUT CLAIM TO ANY PARTICULAR FONT, STYLE, SIZE, OR COLOR.

FOR ELECTRIC CAPACITORS (U.S. CLS. 21, 23, 26, 36 AND 38).

KEVIN DINALLO, EXAMINING ATTORNEY

SN 85-203,947. AMERICAN LASER ENTERPRISES, LLC, WIXOM, MI. FILED 12-22-2010.

# R-Las

THE MARK CONSISTS OF STANDARD CHARACTERS WITHOUT CLAIM TO ANY PARTICULAR FONT, STYLE, SIZE, OR COLOR.

FOR LASER EQUIPMENT FOR NON-MEDICAL PURPOSES (U.S. CLS. 21, 23, 26, 36 AND 38).

HENRY S. ZAK, EXAMINING ATTORNEY

SN 85-203,671. TYCO ELECTRONICS CORPORATION, BERYN, PA. FILED 12-22-2010.

# QUADRA

THE MARK CONSISTS OF STANDARD CHARACTERS WITHOUT CLAIM TO ANY PARTICULAR FONT, STYLE, SIZE, OR COLOR.

FOR CONNECTORS FOR COMMUNICATIONS AND DATA CENTER EQUIPMENT (U.S. CLS. 21, 23, 26, 36 AND 38).

DOUGLAS LEE, EXAMINING ATTORNEY

SN 85-204,028. F3M3 COMPANIES, INC., MIRAMAR, FL. FILED 12-22-2010.

# P235

THE MARK CONSISTS OF STANDARD CHARACTERS WITHOUT CLAIM TO ANY PARTICULAR FONT, STYLE, SIZE, OR COLOR.

FOR WIRELESS COMMUNICATIONS TRACKING SYSTEM USING GPS TO LOCATE INDIVIDUALS, OBJECTS, AND PETS; GPS TRACKING DEVICE AND APPARATUS (U.S. CLS. 21, 23, 26, 36 AND 38).

FIRST USE 10-31-2008; IN COMMERCE 10-31-2008.

RONALD AIKENS, EXAMINING ATTORNEY

**CLASS 9—(Continued).**

SN 85-204,052. KIVLOVITZ, DOV, SEABROOK, TX. FILED 12-22-2010.

**Data Postman**

THE MARK CONSISTS OF STANDARD CHARACTERS WITHOUT CLAIM TO ANY PARTICULAR FONT, STYLE, SIZE, OR COLOR.

NO CLAIM IS MADE TO THE EXCLUSIVE RIGHT TO USE "DATA", APART FROM THE MARK AS SHOWN.

FOR COMPUTER SOFTWARE USED FOR MANAGING TRANSACTIONAL DATA, PROVIDING STATISTICAL ANALYSIS, AND PRODUCING NOTIFICATIONS AND REPORTS IN THE FIELD OF WAREHOUSING AND DISTRIBUTION (U.S. CLS. 21, 23, 26, 36 AND 38).

FIRST USE 4-11-2010; IN COMMERCE 10-1-2010.  
KEVON CHISOLM, EXAMINING ATTORNEY

**CLASS 9—(Continued).**

SN 85-204,285. MAVIZON TECHNOLOGIES LLC, NEW ALBANY, IN. FILED 12-22-2010.

**MAVIA**

THE MARK CONSISTS OF STANDARD CHARACTERS WITHOUT CLAIM TO ANY PARTICULAR FONT, STYLE, SIZE, OR COLOR.

FOR COMPUTER HARDWARE AND SOFTWARE INTERFACE USED FOR CONTROLLING VEHICLE FEATURES BY MEANS OF ANY DEVICE CONNECTED TO THE INTERNET OR A CELL NETWORK (U.S. CLS. 21, 23, 26, 36 AND 38).

ANNE MADDEN, EXAMINING ATTORNEY

SN 85-204,078. TENNVAC INC., TAIPEI HSIEN, TAIWAN, FILED 12-22-2010.

**PFCAN**

THE MARK CONSISTS OF STANDARD CHARACTERS WITHOUT CLAIM TO ANY PARTICULAR FONT, STYLE, SIZE, OR COLOR.

FOR ELECTRONIC CIRCUIT BOARD COMPONENT PARTS PROVIDING ELECTROMAGNETIC INTERFERENCE SHIELDING (U.S. CLS. 21, 23, 26, 36 AND 38).

FIRST USE 7-0-2007; IN COMMERCE 7-0-2007.  
KAREN K. BUSH, EXAMINING ATTORNEY

SN 85-204,364. GANNETT CO., INC., MCLEAN, VA. FILED 12-22-2010.

**IT'S ALL WITHIN REACH**

THE MARK CONSISTS OF STANDARD CHARACTERS WITHOUT CLAIM TO ANY PARTICULAR FONT, STYLE, SIZE, OR COLOR.

FOR COIN ACTUATED NEWSPAPER VENDING MACHINES (U.S. CLS. 21, 23, 26, 36 AND 38).

SOPHIA S. KIM, EXAMINING ATTORNEY

SN 85-204,211. FEE TECHNOLOGY INC., TULSA, OK. FILED 12-22-2010.

**PROFIT SOLVER**

THE MARK CONSISTS OF STANDARD CHARACTERS WITHOUT CLAIM TO ANY PARTICULAR FONT, STYLE, SIZE, OR COLOR.

FOR COMPUTER SOFTWARE FOR CALCULATING SERVICE FEES TO BE CHARGED BASED UPON THE DESIRED LEVEL OF PROFITABILITY (U.S. CLS. 21, 23, 26, 36 AND 38).

FIRST USE 11-22-2007; IN COMMERCE 11-22-2007.  
SCOTT BIBB, EXAMINING ATTORNEY

SN 85-204,411. BLACKLINE GPS INC., CALGARY, ALBERTA, CANADA, FILED 12-22-2010.

**VUE DPS**

THE MARK CONSISTS OF STANDARD CHARACTERS WITHOUT CLAIM TO ANY PARTICULAR FONT, STYLE, SIZE, OR COLOR.

FOR ELECTRONIC DEVICES PROGRAMMED TO USE GLOBAL POSITIONING SYSTEMS (GPS) FOR USE IN LOCATING AND TRACKING PEOPLE AND VEHICLES (U.S. CLS. 21, 23, 26, 36 AND 38).

PAUL F. GAST, EXAMINING ATTORNEY

**CLASS 9—(Continued).**

SN 85-204,435. BALLY GAMING, INC., DBA BALLY TECHNOLOGIES, LAS VEGAS, NV. FILED 12-22-2010.

**SEA GODDESS**

THE MARK CONSISTS OF STANDARD CHARACTERS WITHOUT CLAIM TO ANY PARTICULAR FONT, STYLE, SIZE, OR COLOR.

FOR COMPUTER GAMING SOFTWARE, GAMING SOFTWARE THAT GENERATES OR DISPLAYS WAGER OUTCOMES OF GAMING MACHINES, DOWNLOADABLE COMPUTER GAME SOFTWARE FOR GAMING, GAMING MACHINES, NAMELY, DEVICES THAT ACCEPT A WAGER; SLOT MACHINES (U.S. CLS. 21, 23, 26, 36 AND 38).

THEODORE MCBRIDE, EXAMINING ATTORNEY

**CLASS 9—(Continued).**

SN 85-204,442. BALLY GAMING, INC., DBA BALLY TECHNOLOGIES, LAS VEGAS, NV. FILED 12-22-2010.

**ALOHA ISLAND**

THE MARK CONSISTS OF STANDARD CHARACTERS WITHOUT CLAIM TO ANY PARTICULAR FONT, STYLE, SIZE, OR COLOR.

FOR COMPUTER GAMING SOFTWARE, GAMING SOFTWARE THAT GENERATES OR DISPLAYS WAGER OUTCOMES OF GAMING MACHINES, DOWNLOADABLE COMPUTER GAME SOFTWARE FOR GAMING, GAMING MACHINES, NAMELY, DEVICES THAT ACCEPT A WAGER; SLOT MACHINES (U.S. CLS. 21, 23, 26, 36 AND 38).

THEODORE MCBRIDE, EXAMINING ATTORNEY

SN 85-204,439. BALLY GAMING, INC., DBA BALLY TECHNOLOGIES, LAS VEGAS, NV. FILED 12-22-2010.

**ALOHA BEACH**

THE MARK CONSISTS OF STANDARD CHARACTERS WITHOUT CLAIM TO ANY PARTICULAR FONT, STYLE, SIZE, OR COLOR.

FOR COMPUTER GAMING SOFTWARE, GAMING SOFTWARE THAT GENERATES OR DISPLAYS WAGER OUTCOMES OF GAMING MACHINES, DOWNLOADABLE COMPUTER GAME SOFTWARE FOR GAMING, GAMING MACHINES, NAMELY, DEVICES THAT ACCEPT A WAGER; SLOT MACHINES (U.S. CLS. 21, 23, 26, 36 AND 38).

THEODORE MCBRIDE, EXAMINING ATTORNEY

SN 85-204,445. BALLY GAMING, INC., DBA BALLY TECHNOLOGIES, LAS VEGAS, NV. FILED 12-22-2010.

**ALOHA LUAU**

THE MARK CONSISTS OF STANDARD CHARACTERS WITHOUT CLAIM TO ANY PARTICULAR FONT, STYLE, SIZE, OR COLOR.

FOR COMPUTER GAMING SOFTWARE, GAMING SOFTWARE THAT GENERATES OR DISPLAYS WAGER OUTCOMES OF GAMING MACHINES, DOWNLOADABLE COMPUTER GAME SOFTWARE FOR GAMING, GAMING MACHINES, NAMELY, DEVICES THAT ACCEPT A WAGER; SLOT MACHINES (U.S. CLS. 21, 23, 26, 36 AND 38).

THEODORE MCBRIDE, EXAMINING ATTORNEY

SN 85-204,441. BALLY GAMING, INC., DBA BALLY TECHNOLOGIES, LAS VEGAS, NV. FILED 12-22-2010.

**ALOHA DELIGHT**

THE MARK CONSISTS OF STANDARD CHARACTERS WITHOUT CLAIM TO ANY PARTICULAR FONT, STYLE, SIZE, OR COLOR.

FOR COMPUTER GAMING SOFTWARE, GAMING SOFTWARE THAT GENERATES OR DISPLAYS WAGER OUTCOMES OF GAMING MACHINES, DOWNLOADABLE COMPUTER GAME SOFTWARE FOR GAMING, GAMING MACHINES, NAMELY, DEVICES THAT ACCEPT A WAGER; SLOT MACHINES (U.S. CLS. 21, 23, 26, 36 AND 38).

THEODORE MCBRIDE, EXAMINING ATTORNEY

SN 85-204,448. BALLY GAMING, INC., DBA BALLY TECHNOLOGIES, LAS VEGAS, NV. FILED 12-22-2010.

**HEART OF THE JUNGLE**

THE MARK CONSISTS OF STANDARD CHARACTERS WITHOUT CLAIM TO ANY PARTICULAR FONT, STYLE, SIZE, OR COLOR.

FOR COMPUTER GAMING SOFTWARE, GAMING SOFTWARE THAT GENERATES OR DISPLAYS WAGER OUTCOMES OF GAMING MACHINES, DOWNLOADABLE COMPUTER GAME SOFTWARE FOR GAMING, GAMING MACHINES, NAMELY, DEVICES THAT ACCEPT A WAGER; SLOT MACHINES (U.S. CLS. 21, 23, 26, 36 AND 38).

THEODORE MCBRIDE, EXAMINING ATTORNEY

**CLASS 9—(Continued).**

SN 85-204,452. BALLY GAMING, INC., DBA BALLY TECHNOLOGIES, LAS VEGAS, NV. FILED 12-22-2010.

# TEXAS TREASURE

THE MARK CONSISTS OF STANDARD CHARACTERS WITHOUT CLAIM TO ANY PARTICULAR FONT, STYLE, SIZE, OR COLOR.

FOR COMPUTER GAMING SOFTWARE, GAMING SOFTWARE THAT GENERATES OR DISPLAYS WAGER OUTCOMES OF GAMING MACHINES, DOWNLOADABLE COMPUTER GAME SOFTWARE FOR GAMING, GAMING MACHINES, NAMELY, DEVICES THAT ACCEPT A WAGER; SLOT MACHINES (U.S. CLS. 21, 23, 26, 36 AND 38).

THEODORE MCBRIDE, EXAMINING ATTORNEY

SN 85-204,454. BALLY GAMING, INC., DBA BALLY TECHNOLOGIES, LAS VEGAS, NV. FILED 12-22-2010.

# TEXAS TYCOON

THE MARK CONSISTS OF STANDARD CHARACTERS WITHOUT CLAIM TO ANY PARTICULAR FONT, STYLE, SIZE, OR COLOR.

FOR COMPUTER GAMING SOFTWARE, GAMING SOFTWARE THAT GENERATES OR DISPLAYS WAGER OUTCOMES OF GAMING MACHINES, DOWNLOADABLE COMPUTER GAME SOFTWARE FOR GAMING, GAMING MACHINES, NAMELY, DEVICES THAT ACCEPT A WAGER; SLOT MACHINES (U.S. CLS. 21, 23, 26, 36 AND 38).

THEODORE MCBRIDE, EXAMINING ATTORNEY

SN 85-204,457. INNOVA ELECTRONICS CORP., FOUNTAIN VALLEY, CA. FILED 12-22-2010.

# FIXASSIST

THE MARK CONSISTS OF STANDARD CHARACTERS WITHOUT CLAIM TO ANY PARTICULAR FONT, STYLE, SIZE, OR COLOR.

FOR SOFTWARE FOR THE OPERATION OF THE ELECTRONIC AUTOMOTIVE DIAGNOSTIC PRODUCTS, NAMELY, SCANNERS FOR USE IN DIAGNOSTIC TESTING AND LIVE DATA RETRIEVAL FOR COMPUTERIZED AUTOMOBILE SYSTEMS (U.S. CLS. 21, 23, 26, 36 AND 38).

ADA HAN, EXAMINING ATTORNEY

**CLASS 9—(Continued).**

SN 85-204,660. PERMIK, INC., BOCA RATON, FL. FILED 12-23-2010.

# MyPocketDrive

THE MARK CONSISTS OF STANDARD CHARACTERS WITHOUT CLAIM TO ANY PARTICULAR FONT, STYLE, SIZE, OR COLOR.

FOR BACKUP DRIVES FOR COMPUTERS (U.S. CLS. 21, 23, 26, 36 AND 38).

KATHERINE M. DUBRAY, EXAMINING ATTORNEY

SN 85-204,672. ROSS HEMINGWAY, KINGSTON, CANADA, FILED 12-23-2010.

# V-PLANNER

THE MARK CONSISTS OF STANDARD CHARACTERS WITHOUT CLAIM TO ANY PARTICULAR FONT, STYLE, SIZE, OR COLOR.

FOR COMPUTER SOFTWARE AND HARDWARE FOR PLANNING, MANAGING, AND CALCULATING OF DECOMPRESSION ASCENT TIME SCHEDULES AND BREATHING GAS; DIVE COMPUTERS FOR UNDERWATER USE (U.S. CLS. 21, 23, 26, 36 AND 38).

FIRST USE 8-13-2001; IN COMMERCE 8-13-2001.

KHANH LE, EXAMINING ATTORNEY

SN 85-204,681. ROSS HEMINGWAY, KINGSTON, CANADA, FILED 12-23-2010.

# MULTIDECO

THE MARK CONSISTS OF STANDARD CHARACTERS WITHOUT CLAIM TO ANY PARTICULAR FONT, STYLE, SIZE, OR COLOR.

FOR COMPUTER SOFTWARE AND HARDWARE FOR PLANNING, MANAGING, AND CALCULATING OF DECOMPRESSION ASCENT TIME SCHEDULES AND BREATHING GAS; DIVE COMPUTERS FOR UNDERWATER USE (U.S. CLS. 21, 23, 26, 36 AND 38).

FIRST USE 12-7-2009; IN COMMERCE 12-7-2009.

KHANH LE, EXAMINING ATTORNEY

**CLASS 9—(Continued).**

SN 85-204,684. WIRELESS GRIDS CORPORATION, AUSTIN, TX. FILED 12-23-2010.

# KOMACI

THE MARK CONSISTS OF STANDARD CHARACTERS WITHOUT CLAIM TO ANY PARTICULAR FONT, STYLE, SIZE, OR COLOR.

FOR NETWORK INFRASTRUCTURE SOFTWARE FOR GAMING, ENTERTAINMENT, EDUCATION AND BUSINESS APPLICATIONS (U.S. CLS. 21, 23, 26, 36 AND 38).

CHARLOTTE CORWIN, EXAMINING ATTORNEY

**CLASS 9—(Continued).**

SN 85-204,703. THE LAMAR COMPANY, L.L.C., BATON ROUGE, LA. FILED 12-23-2010.

# ROAD NINJA

THE MARK CONSISTS OF STANDARD CHARACTERS WITHOUT CLAIM TO ANY PARTICULAR FONT, STYLE, SIZE, OR COLOR.

FOR DOWNLOADABLE SOFTWARE FOR MOBILE DEVICES SUCH AS CELL PHONES AND SMART PHONES, NAMELY, SOFTWARE FOR USE IN PROVIDING TRAVELERS INFORMATION REGARDING SERVICES OFFERED AT HIGHWAY LOCATIONS (U.S. CLS. 21, 23, 26, 36 AND 38).

ANNE MADDEN, EXAMINING ATTORNEY

SN 85-204,809. RICHPORT MEDIA INC., NEW YORK, NY. FILED 12-23-2010.

# FRATERNAL ORDER

THE MARK CONSISTS OF STANDARD CHARACTERS WITHOUT CLAIM TO ANY PARTICULAR FONT, STYLE, SIZE, OR COLOR.

FOR VIDEO GAME SOFTWARE (U.S. CLS. 21, 23, 26, 36 AND 38).

JENNIFER DIXON, EXAMINING ATTORNEY

SN 85-204,697. ELITE SPIDERS, LLC, ROBBINSVILLE, NJ. FILED 12-23-2010.

# MoDA

THE MARK CONSISTS OF STANDARD CHARACTERS WITHOUT CLAIM TO ANY PARTICULAR FONT, STYLE, SIZE, OR COLOR.

THE ENGLISH TRANSLATION OF "MODA" IN THE MARK IS "FASHION".

FOR BAGS AND CASES SPECIALLY ADAPTED FOR HOLDING OR CARRYING PORTABLE TELEPHONES AND TELEPHONE EQUIPMENT AND ACCESSORIES; BATTERY CHARGE DEVICES; CARRYING CASES, HOLDERS, PROTECTIVE CASES AND STANDS FEATURING POWER SUPPLY CONNECTORS, ADAPTORS, SPEAKERS AND BATTERY CHARGING DEVICES, SPECIALLY ADAPTED FOR USE WITH HANDHELD DIGITAL ELECTRONIC DEVICES; CASES FOR MOBILE PHONES; DEVICES FOR HANDS-FREE USE OF MOBILE PHONES; EARPHONE ACCESSORIES, NAMELY, EARPHONE CUSHIONS, EARPHONE PADS, CORD MANAGEMENT SYSTEMS, EARPHONE CASES, AND EARPHONE EXTENSION CORDS; ELECTRONIC DEVICE TO CHARGE AND SECURE TABLET PCS; HANDS FREE DEVICES FOR MOBILE-PHONES; HEADSETS FOR CELLULAR OR MOBILE PHONES; POWER SUPPLY CONNECTORS AND ADAPTORS FOR USE WITH PORTABLE ELECTRONIC DEVICES (U.S. CLS. 21, 23, 26, 36 AND 38).

FIRST USE 12-12-2010; IN COMMERCE 12-12-2010.  
CIMMERIAN COLEMAN, EXAMINING ATTORNEY

SN 85-205,226. BALLY GAMING, INC., DBA BALLY TECHNOLOGIES, LAS VEGAS, NV. FILED 12-23-2010.

# TOTAL BLAST

THE MARK CONSISTS OF STANDARD CHARACTERS WITHOUT CLAIM TO ANY PARTICULAR FONT, STYLE, SIZE, OR COLOR.

FOR COMPUTER GAMING SOFTWARE, GAMING SOFTWARE THAT GENERATES OR DISPLAYS WAGER OUTCOMES OF GAMING MACHINES, DOWNLOADABLE COMPUTER GAME SOFTWARE FOR GAMING, GAMING MACHINES, NAMELY, DEVICES THAT ACCEPT A WAGER; SLOT MACHINES (U.S. CLS. 21, 23, 26, 36 AND 38).

THEODORE MCBRIDE, EXAMINING ATTORNEY



**CLASS 9—(Continued).**

SN 85-205,236. STRETCH COMPUTING, INC., WESTERN SPRINGS, IL. FILED 12-23-2010.

# rTeam

THE MARK CONSISTS OF STANDARD CHARACTERS WITHOUT CLAIM TO ANY PARTICULAR FONT, STYLE, SIZE, OR COLOR.

FOR COMPUTER APPLICATION SOFTWARE FOR MOBILE PHONES, NAMELY, SOFTWARE FOR COMMUNICATION AND COORDINATION OF SPORT TEAMS (U.S. CLS. 21, 23, 26, 36 AND 38).

FIRST USE 8-1-2010; IN COMMERCE 12-16-2010.  
KEVIN CORWIN, EXAMINING ATTORNEY

---

SN 85-205,332. SCHWARTZ, JUSTIN, BROOKLYN, NY. FILED 12-23-2010.

# Privatext

THE MARK CONSISTS OF STANDARD CHARACTERS WITHOUT CLAIM TO ANY PARTICULAR FONT, STYLE, SIZE, OR COLOR.

FOR COMPUTER APPLICATION SOFTWARE FOR MOBILE PHONES, NAMELY, SOFTWARE FOR TEXT MESSAGING, PICTURE MESSAGING, AND VIDEO MESSAGING (U.S. CLS. 21, 23, 26, 36 AND 38).

KATINA MISTER, EXAMINING ATTORNEY

---

SN 85-205,639. ALNEMER ALLEN Y, PLANO, TX. FILED 12-25-2010.

# ARABYTE

THE MARK CONSISTS OF STANDARD CHARACTERS WITHOUT CLAIM TO ANY PARTICULAR FONT, STYLE, SIZE, OR COLOR.

FOR COMMUNICATIONS SOFTWARE FOR CONNECTING RADIOS AND TELEPHONES; COMPUTER APPLICATION SOFTWARE FOR MOBILE PHONES, NAMELY, SOFTWARE FOR DISPATCH AND RADIO INTEROPERABILITY; CONTINGENCY RESPONSE COMMUNICATION SYSTEM DESIGNED TO PROVIDE RADIO INTEROPERABILITY, STREAMING VIDEO, WIRELESS INTERNET, AND VOIP PHONE; RADIOS AND TELEPHONES; TELECOMMUNICATIONS AND DATA NETWORKING HARDWARE, NAMELY, DEVICES FOR TRANSPORTING AND AGGREGATING VOICE, DATA, AND VIDEO COMMUNICATIONS ACROSS MULTIPLE NETWORK INFRASTRUCTURES AND COMMUNICATIONS PROTOCOLS; TWO-WAY RADIOS (U.S. CLS. 21, 23, 26, 36 AND 38).

JAMES MACFARLANE, EXAMINING ATTORNEY

**CLASS 9—(Continued).**

SN 85-205,661. WOLF, AXEL, BUROW, FED REP GERMANY, FILED 12-26-2010.

# Cosmic

THE MARK CONSISTS OF STANDARD CHARACTERS WITHOUT CLAIM TO ANY PARTICULAR FONT, STYLE, SIZE, OR COLOR.

FOR COMPUTER APPLICATION SOFTWARE FOR MOBILE PHONES AND TABLET COMPUTERS, NAMELY, SOFTWARE FOR THE SIMULATION OF CELESTIAL EVENTS (U.S. CLS. 21, 23, 26, 36 AND 38).

JENNIFER MARTIN, EXAMINING ATTORNEY

---

SN 85-205,669. HTC CORPORATION, TAOYUAN, TAIWAN, FILED 12-26-2010.

# SCRIBE

THE MARK CONSISTS OF STANDARD CHARACTERS WITHOUT CLAIM TO ANY PARTICULAR FONT, STYLE, SIZE, OR COLOR.

FOR HANDHELD WIRELESS DEVICE, NAMELY, A TABLET COMPUTER (U.S. CLS. 21, 23, 26, 36 AND 38).

DANNEAN HETZEL, EXAMINING ATTORNEY

---

SN 85-205,755. ALPINE HOLDING B.V., 3789 AL SOESTERBERG, NETHERLANDS, FILED 12-27-2010.

# MOTOSAFE

THE MARK CONSISTS OF STANDARD CHARACTERS WITHOUT CLAIM TO ANY PARTICULAR FONT, STYLE, SIZE, OR COLOR.

FOR EAR PLUGS FOR SOUNDPROOFING; EAR PLUGS NOT FOR MEDICAL PURPOSES (U.S. CLS. 21, 23, 26, 36 AND 38).

FIRST USE 7-0-2000; IN COMMERCE 7-0-2006.  
WENDY GOODMAN, EXAMINING ATTORNEY

**CLASS 9—(Continued).**

SN 85-205,756. ALPINE HOLDING B.V., 3789 AL SOESTERBERG, NETHERLANDS, FILED 12-27-2010.

# MUSICSAFE

THE MARK CONSISTS OF STANDARD CHARACTERS WITHOUT CLAIM TO ANY PARTICULAR FONT, STYLE, SIZE, OR COLOR.

FOR EAR PLUGS FOR SOUNDPROOFING; EAR PLUGS NOT FOR MEDICAL PURPOSES (U.S. CLS. 21, 23, 26, 36 AND 38).

FIRST USE 7-0-2000; IN COMMERCE 7-0-2006.  
WENDY GOODMAN, EXAMINING ATTORNEY

SN 85-205,780. JAIR ELECTRONICS CORPORATION, DORAL, FL. FILED 12-27-2010.

# XENTI

THE MARK CONSISTS OF STANDARD CHARACTERS WITHOUT CLAIM TO ANY PARTICULAR FONT, STYLE, SIZE, OR COLOR.

FOR CELLULAR TELEPHONES; TABLET COMPUTERS (U.S. CLS. 21, 23, 26, 36 AND 38).

DARRYL SPRUILL, EXAMINING ATTORNEY

SN 85-205,800. NAVAJO MANUFACTURING COMPANY, DENVER, CO. FILED 12-27-2010.

# ENVY EYEWEAR

THE MARK CONSISTS OF STANDARD CHARACTERS WITHOUT CLAIM TO ANY PARTICULAR FONT, STYLE, SIZE, OR COLOR.

OWNER OF U.S. REG. NOS. 3,165,245 AND 3,227,146.  
NO CLAIM IS MADE TO THE EXCLUSIVE RIGHT TO USE "EYEWEAR", APART FROM THE MARK AS SHOWN.  
FOR SUNGLASSES (U.S. CLS. 21, 23, 26, 36 AND 38).

FIRST USE 7-0-2009; IN COMMERCE 7-0-2009.  
JENNIFER MARTIN, EXAMINING ATTORNEY

**CLASS 9—(Continued).**

SN 85-205,858. BASEONELABS LLC, TEMPLETON, MA. FILED 12-27-2010.

# impactband

THE MARK CONSISTS OF STANDARD CHARACTERS WITHOUT CLAIM TO ANY PARTICULAR FONT, STYLE, SIZE, OR COLOR.

FOR CELL PHONE AND HANDHELD COMPUTING DEVICE COVERS (U.S. CLS. 21, 23, 26, 36 AND 38).

FIRST USE 6-10-2010; IN COMMERCE 9-10-2010.  
ROBIN MITTLER, EXAMINING ATTORNEY

SN 85-206,163. INFINEON TECHNOLOGIES AG, NEUBERG, FED REP GERMANY, FILED 12-27-2010.

# PrimeSTACK

THE MARK CONSISTS OF STANDARD CHARACTERS WITHOUT CLAIM TO ANY PARTICULAR FONT, STYLE, SIZE, OR COLOR.

PRIORITY CLAIMED UNDER SEC. 44(D) ON ERPNTM CMNTY TM OFC APPLICATION NO. 9399031, FILED 9-24-2010, REG. NO. 9399031, DATED 2-24-2011, EXPIRES 9-24-2020.

FOR SEMICONDUCTOR DEVICES (U.S. CLS. 21, 23, 26, 36 AND 38).

JEFFERY COWARD, EXAMINING ATTORNEY

SN 85-206,255. POWER INTEGRATIONS, INC., SAN JOSE, CA. FILED 12-27-2010.

# EESIP

THE MARK CONSISTS OF STANDARD CHARACTERS WITHOUT CLAIM TO ANY PARTICULAR FONT, STYLE, SIZE, OR COLOR.

FOR INTEGRATED CIRCUITS HAVING LOW POWER CONSUMPTION OR LOW POWER LOSS FOR USE IN ELECTRONIC DEVICES; AC/DC POWER CONVERTERS HAVING LOW POWER CONSUMPTION OR POWER LOSS; SEMICONDUCTOR DEVICES FOR SMART POWER APPLICATIONS; AND INTEGRATED CIRCUITS FOR SWITCHED-MODE POWER CONVERSIONS (U.S. CLS. 21, 23, 26, 36 AND 38).

MARK T. MULLEN, EXAMINING ATTORNEY

**CLASS 9—(Continued).**

SN 85-206,361. KOKOPELLI'S EARTH, INC., MEDIA, PA. FILED 12-28-2010.

# GoodChat

THE MARK CONSISTS OF STANDARD CHARACTERS WITHOUT CLAIM TO ANY PARTICULAR FONT, STYLE, SIZE, OR COLOR.

FOR COMPUTER APPLICATION SOFTWARE FOR MOBILE PHONES, NAMELY, SOFTWARE FOR FACILITATING AUDIO GROUP COMMUNICATION (U.S. CLS. 21, 23, 26, 36 AND 38).

GISELLE AGOSTO, EXAMINING ATTORNEY

**CLASS 9—(Continued).**

SN 85-206,384. 60MO, INC., WOOSTER, OH. FILED 12-28-2010.

# 60mo

THE MARK CONSISTS OF STANDARD CHARACTERS WITHOUT CLAIM TO ANY PARTICULAR FONT, STYLE, SIZE, OR COLOR.

FOR COMPUTER OPERATING SOFTWARE; COMPUTER PROGRAM FOR THE COMPILATION OF CREDIT REPORTING DATA; COMPUTER PROGRAMS AND COMPUTER SOFTWARE FOR ELECTRONICALLY TRADING SECURITIES; COMPUTER PROGRAMS FOR CONNECTING REMOTELY TO COMPUTERS OR COMPUTER NETWORKS; COMPUTER PROGRAMS FOR SEARCHING REMOTELY FOR CONTENT ON COMPUTERS AND COMPUTER NETWORKS; COMPUTER PROGRAMS FOR SEARCHING THE CONTENTS OF COMPUTERS AND COMPUTER NETWORKS BY REMOTE CONTROL; COMPUTER PROGRAMS FOR THE ENABLING OF ACCESS OR ENTRANCE CONTROL; COMPUTER PROGRAMS FOR USING THE INTERNET AND THE WORLD WIDE WEB; COMPUTER PROGRAMS FOR USING THE INTERNET AND THE WORLDWIDE WEB; COMPUTER PROGRAMS USED FOR ELECTRONIC CASH REGISTER SYSTEMS; COMPUTER SOFTWARE DEVELOPMENT TOOLS; COMPUTER SOFTWARE FOR APPLICATION AND DATABASE INTEGRATION; COMPUTER SOFTWARE FOR CREATING SEARCHABLE DATABASES OF INFORMATION AND DATA; COMPUTER SOFTWARE FOR PROVIDING AN ON-LINE DATABASE IN THE FIELD OF TRANSACTION PROCESSING TO UPLOAD TRANSACTIONAL DATA, PROVIDE STATISTICAL ANALYSIS, AND PRODUCE NOTIFICATIONS AND REPORTS; COMPUTER SOFTWARE FOR THE COLLECTION, EDITING, ORGANIZING, MODIFYING, BOOK MARKING, TRANSMISSION, STORAGE AND SHARING OF DATA AND INFORMATION; COMPUTER SOFTWARE FOR THE FIELD OF WAREHOUSING AND DISTRIBUTION, TO MANAGE TRANSACTIONAL DATA, PROVIDE STATISTICAL ANALYSIS, AND PRODUCE NOTIFICATIONS AND REPORTS; COMPUTER SOFTWARE FOR WIRELESS CONTENT DELIVERY; COMPUTER SOFTWARE THAT PROVIDES REAL-TIME, INTEGRATED BUSINESS MANAGEMENT INTELLIGENCE BY COMBINING INFORMATION FROM VARIOUS DATABASES AND PRESENTING IT IN AN EASY-TO-UNDERSTAND USER INTERFACE; COMPUTER SOFTWARE THAT PROVIDES WEB-BASED ACCESS TO APPLICATIONS AND SERVICES THROUGH A WEB OPERATING SYSTEM OR PORTAL INTERFACE; COMPUTER SOFTWARE, NAMELY, ELECTRONIC FINANCIAL PLATFORM THAT ACCOMMODATES MULTIPLE TYPES OF PAYMENT AND DEBT TRANSACTIONS IN AN INTEGRATED MOBILE PHONE, PDA, AND WEB BASED ENVIRONMENT; COMPUTER SOFTWARE, NAMELY, SOFTWARE DEVELOPMENT TOOLS FOR THE CREATION OF MOBILE INTERNET APPLICATIONS AND CLIENT INTERFACES; COMPUTERS FOR USE IN DATA MANAGEMENT; ENTERPRISE SOFTWARE IN THE NATURE OF A DATABASE FOR NON-TRANSACTIONAL DATA AND A SEARCH ENGINE FOR DATABASE CONTENT (U.S. CLS. 21, 23, 26, 36 AND 38).

FIRST USE 11-9-2010; IN COMMERCE 11-9-2010.

MARK PILARO, EXAMINING ATTORNEY

SN 85-206,374. RIPPLE MOBILE LLC, DUBLIN, OH. FILED 12-28-2010.



THE MARK CONSISTS OF A DESIGN FEATURING A STYLIZED CLOCK FACE ENCIRCLED BY A MARKER HAVING A DOWNWARD ORIENTED TRIANGULAR TAIL INDICATING A LOCATION ON A MAP.

FOR COMPUTER SOFTWARE FOR TIME AND LOCATION MANAGEMENT. MOBILE PRODUCTIVITY APPLICATIONS. SOFTWARE FOR MOBILE PHONES AND OTHER MOBILE DEVICES, NAMELY, SOFTWARE FOR TIME AND LOCATION MANAGEMENT. DOWNLOADABLE SOFTWARE IN THE NATURE OF A MOBILE APPLICATION FOR TIME AND LOCATION MANAGEMENT (U.S. CLS. 21, 23, 26, 36 AND 38).

ALLISON HOLTZ, EXAMINING ATTORNEY

**CLASS 9—(Continued).**

SN 85-206,431. FLEXWARE INTERNATIONAL LLC, LOS ANGELES, CA. FILED 12-28-2010.

# FLEXWARE

THE MARK CONSISTS OF STANDARD CHARACTERS WITHOUT CLAIM TO ANY PARTICULAR FONT, STYLE, SIZE, OR COLOR.

FOR COMPUTER SOFTWARE FOR USE IN THE FIELD OF BUSINESS MANAGEMENT, ACCOUNTING, COST ANALYSIS AND ECONOMIC AND MONETARY CALCULATIONS (U.S. CLS. 21, 23, 26, 36 AND 38).

FIRST USE 0-0-1981; IN COMMERCE 0-0-1981.  
AISHA CLARKE, EXAMINING ATTORNEY

**CLASS 9—(Continued).**

SN 85-206,551. LIQUIDUS MARKETING, INC., CHICAGO, IL. FILED 12-28-2010.



 couchbuyer

SN 85-206,509. KEYLANE, LLC, PEARLAND, TX. FILED 12-28-2010.

# HIRE YOUR MONEY

THE MARK CONSISTS OF STANDARD CHARACTERS WITHOUT CLAIM TO ANY PARTICULAR FONT, STYLE, SIZE, OR COLOR.

FOR DIGITAL MATERIALS, NAMELY, CDS AND DVDS FEATURING EDUCATIONAL RESOURCES AND MATERIALS IN THE FIELD OF FINANCE (U.S. CLS. 21, 23, 26, 36 AND 38).

DEIRDRE ROBERTSON, EXAMINING ATTORNEY

THE MARK CONSISTS OF A SQUARE BAR CODE FLOATING ABOVE THE SEAT OF A COUCH IMAGE, ALL OF WHICH IS ABOVE ANOTHER SMALLER SQUARE BAR CODE ADJACENT TO THE TERM "COUCHBUYER".

FOR DOWNLOADABLE SOFTWARE FOR SMARTPHONES AND OTHER WIRELESS HANDHELD DEVICES TO ALLOW USERS TO IDENTIFY AND PURCHASE RETAIL GOODS VIA DIGITAL SCANNING (U.S. CLS. 21, 23, 26, 36 AND 38).

FIRST USE 12-1-2010; IN COMMERCE 12-1-2010.  
KAPIL BHANOT, EXAMINING ATTORNEY

SN 85-206,515. KEYLANE, LLC, PEARLAND, TX. FILED 12-28-2010.

# YOUR PERSONAL GUIDE TO PLENTEOUSNESS

THE MARK CONSISTS OF STANDARD CHARACTERS WITHOUT CLAIM TO ANY PARTICULAR FONT, STYLE, SIZE, OR COLOR.

FOR DIGITAL MATERIALS, NAMELY, CDS AND DVDS FEATURING EDUCATIONAL RESOURCES AND MATERIALS IN THE FIELD OF FINANCE (U.S. CLS. 21, 23, 26, 36 AND 38).

DEIRDRE ROBERTSON, EXAMINING ATTORNEY

SN 85-206,658. ADVANCED DATA SYSTEMS CORPORATION, AKA ADS, PARAMUS, NJ. FILED 12-28-2010.

# Get in on The Act...The Stimulus Act!

THE MARK CONSISTS OF STANDARD CHARACTERS WITHOUT CLAIM TO ANY PARTICULAR FONT, STYLE, SIZE, OR COLOR.

FOR MEDICAL SOFTWARE FOR ELECTRONIC HEALTH RECORDS (U.S. CLS. 21, 23, 26, 36 AND 38).

MARK SHINER, EXAMINING ATTORNEY

**CLASS 9—(Continued).**

SN 85-206,714. BREWER SCIENCE, INC., ROLLA, MO.  
FILED 12-28-2010.



OWNER OF U.S. REG. NO. 2,699,395.  
THE MARK CONSISTS OF A CARICATURE OF A HAWK  
IN FLIGHT.

FOR SEMICONDUCTOR WAFER PROCESSING  
EQUIPMENT, NAMELY ELECTRONIC DEBONDING  
EQUIPMENT, FOR USE IN THE SEMICONDUCTOR  
INDUSTRY (U.S. CLS. 21, 23, 26, 36 AND 38).  
PAUL MORENO, EXAMINING ATTORNEY

---

SN 85-206,735. HUNTER INDUSTRIES, INC., SAN MARCOS,  
CA. FILED 12-28-2010.

## FLOW-SYNC

THE MARK CONSISTS OF STANDARD CHARACTERS  
WITHOUT CLAIM TO ANY PARTICULAR FONT, STYLE,  
SIZE, OR COLOR.

FOR ELECTRONIC SENSORS CONNECTABLE TO  
ELECTRONIC IRRIGATION CONTROLLERS USED IN  
RESIDENTIAL AND COMMERCIAL IRRIGATION SYS-  
TEMS TO DETECT WATER FLOW RATES (U.S. CLS. 21,  
23, 26, 36 AND 38).  
HENRY S. ZAK, EXAMINING ATTORNEY

---

SN 85-206,862. SNORKEL BOB BRAND, INC., KIHEI, HI.  
FILED 12-28-2010.

## MOFLO<sub>2</sub>

OWNER OF U.S. REG. NO. 2,520,617.  
THE MARK CONSISTS OF THE WORD "MOFLO" WITH  
A SUBSCRIPT NUMERAL "2" ON THE END OF THE  
WORD.

FOR SCUBA SNORKELS; SNORKELS (U.S. CLS. 21, 23,  
26, 36 AND 38).  
MARGARET POWER, EXAMINING ATTORNEY

**CLASS 9—(Continued).**

SN 85-206,965. SMITH, DOUGLAS, SAN ANTONIO, TX.  
FILED 12-29-2010.

## PACS-LITE

THE MARK CONSISTS OF STANDARD CHARACTERS  
WITHOUT CLAIM TO ANY PARTICULAR FONT, STYLE,  
SIZE, OR COLOR.

FOR COMPUTER SOFTWARE, NAMELY, SOFTWARE  
FOR VIEWING RADIOLOGY IMAGING STUDIES OVER  
SECURE INTERNET CONNECTION USING MINIMIZED  
BANDWIDTH REQUIREMENTS WITH CAPABILITIES  
FOR INITIATING ONLINE WEB CONFERENCING  
AND SECURE EMAIL COMMUNICATION WITH  
OTHER MEDICAL PERSONNEL (U.S. CLS. 21, 23, 26,  
36 AND 38).  
JAMES LOVELACE, EXAMINING ATTORNEY

---

SN 85-206,975. TREEPODIA, HERZLIYA PITUACH, ISRAEL,  
FILED 12-29-2010.

## wishclip

THE MARK CONSISTS OF STANDARD CHARACTERS  
WITHOUT CLAIM TO ANY PARTICULAR FONT, STYLE,  
SIZE, OR COLOR.

FOR AUDIO AND VIDEO RECORDINGS FEATURING  
CUSTOM SELECTED PICTURES AND PRODUCT CHO-  
SEN BY THE USER, WHICH WOULD THEN BE FEAT-  
URED IN THE AUTOMATICALLY PRODUCED VIDEO  
(U.S. CLS. 21, 23, 26, 36 AND 38).

FIRST USE 12-5-2010; IN COMMERCE 12-24-2010.  
CHERYL CLAYTON, EXAMINING ATTORNEY

**CLASS 9—(Continued).**

SN 85-207,112. ORBOTIX, INC., BOULDER, CO. FILED 12-29-2010.



THE MARK CONSISTS OF THE STYLIZED WORD "SPHERO" WITH THE DESIGN OF A CIRCLE LOCATED ABOVE THE STYLIZED WORD THAT CONTAINS A TAIL-LIKE FEATURE AT THE TOP OF THE CIRCLE WITH THE DESIGN OF TWO DIFFERENT SIZE OVALS WITHIN THE CIRCLE.

FOR ROBOTS FOR PERSONAL OR HOBBY USE; TRANSMITTERS AND RECEIVERS FOR REMOTELY CONTROLLING DEVICES; COMPUTER GAME SOFTWARE; INTERACTIVE VIDEO GAME PROGRAMS; DOWNLOADABLE COMPUTER AND VIDEO GAME SOFTWARE; COMPUTER PROGRAMS, NAMELY, GAME SOFTWARE FOR USE ON COMPUTERS AND VIDEO GAME PLAYERS; VIDEO GAME CONTROLLERS (U.S. CLS. 21, 23, 26, 36 AND 38).

DOMINIC FATHY, EXAMINING ATTORNEY

SN 85-207,117. ORBOTIX, INC., BOULDER, CO. FILED 12-29-2010.



THE MARK CONSISTS OF THE STYLIZED WORD "SPHERO" WITH THE DESIGN OF A CIRCLE LOCATED TO THE LEFT OF THE STYLIZED WORD THAT CONTAINS A TAIL-LIKE FEATURE AT THE TOP OF THE CIRCLE WITH THE DESIGN OF TWO DIFFERENT SIZE OVALS WITHIN THE CIRCLE.

FOR ROBOTS FOR PERSONAL OR HOBBY USE; TRANSMITTERS AND RECEIVERS FOR REMOTELY CONTROLLING DEVICES; COMPUTER GAME SOFTWARE; INTERACTIVE VIDEO GAME PROGRAMS; DOWNLOADABLE COMPUTER AND VIDEO GAME SOFTWARE; COMPUTER PROGRAMS, NAMELY, GAME SOFTWARE FOR USE ON COMPUTERS AND VIDEO GAME PLAYERS; VIDEO GAME CONTROLLERS (U.S. CLS. 21, 23, 26, 36 AND 38).

DOMINIC FATHY, EXAMINING ATTORNEY

**CLASS 9—(Continued).**

SN 85-207,140. FAYDA ENGINEERING & ENERGY SOLUTIONS, LLC, WILMINGTON, DE. FILED 12-29-2010.

**WATT CLIPPER**

THE MARK CONSISTS OF STANDARD CHARACTERS WITHOUT CLAIM TO ANY PARTICULAR FONT, STYLE, SIZE, OR COLOR.

FOR LIGHTING CONTROL SYSTEMS COMPRISING A CENTRAL CONTROLLER AND REMOTE CONTROL MODULES FOR CONTROLLING LIGHTING ARRAYS (U.S. CLS. 21, 23, 26, 36 AND 38).

JAMES GRIFFIN, EXAMINING ATTORNEY

SN 85-207,153. PRESTAN PRODUCTS LLC, MAYFIELD VILLAGE, OH. FILED 12-29-2010.

**PRESTAN**

THE MARK CONSISTS OF STANDARD CHARACTERS WITHOUT CLAIM TO ANY PARTICULAR FONT, STYLE, SIZE, OR COLOR.

FOR APPARATUS AND INSTRUMENTS FOR EDUCATION AND TRAINING OF EMERGENCY LIFE-SAVING SKILLS, NAMELY DEFIBRILLATION AND RESUSCITATION MANIKINS (U.S. CLS. 21, 23, 26, 36 AND 38).

FIRST USE 12-1-2005; IN COMMERCE 12-1-2005.  
ALICIA COLLINS, EXAMINING ATTORNEY

SN 85-207,168. CLIFF CHISM, VALLEJO, CA. FILED 12-29-2010.

**THE EX-HUZZ**

THE MARK CONSISTS OF STANDARD CHARACTERS WITHOUT CLAIM TO ANY PARTICULAR FONT, STYLE, SIZE, OR COLOR.

FOR MUSICAL SOUND RECORDINGS; MUSICAL VIDEO RECORDINGS; PRE-RECORDED ELECTRONIC AND DIGITAL MEDIA FEATURING MUSIC; SERIES OF MUSICAL SOUND RECORDINGS (U.S. CLS. 21, 23, 26, 36 AND 38).

KATHERINE M. DUBRAY, EXAMINING ATTORNEY

**CLASS 9—(Continued).**

SN 85-207,200. PIXELWORKS, INC., PORTLAND, OR. FILED 12-29-2010.

# SNAP2FIT

THE MARK CONSISTS OF STANDARD CHARACTERS WITHOUT CLAIM TO ANY PARTICULAR FONT, STYLE, SIZE, OR COLOR.

FOR INTEGRATED CIRCUITS; INTEGRATED CIRCUIT MODULES; COMPUTER SOFTWARE FOR THE PROCESSING, PERFORMANCE ENHANCEMENT, AND OPTIMIZATION OF VIDEO, COMPUTER GRAPHICS, AND WEB INFORMATION ON A WIDE VARIETY OF DISPLAY MEDIA; COMPUTER SOFTWARE TO AID IN THE DESIGN OF GRAPHICAL USER INTERFACES FOR USE WITH FLAT-PANEL MONITORS, PROJECTORS, DIGITAL TELEVISIONS, AND OTHER ADVANCED DISPLAY PRODUCTS; COMPUTER SOFTWARE PROGRAMS AND COMPUTER SOFTWARE OBJECT LIBRARIES TO ASSIST ENGINEERS TO DESIGN AND DEVELOP PROTOTYPES FOR ADVANCED DISPLAY APPLICATIONS, AND TO DEBUG AND CONFIGURE ADVANCED DISPLAY APPLICATIONS; COMPUTER SOFTWARE TO ASSIST ENGINEERS IN THE DESIGN OF PRODUCTION DISPLAY PRODUCTS THAT USE LIQUID CRYSTAL DISPLAY (LCD), LIQUID CRYSTAL ON SILICON (LCOS), POLYSILICON, PLASMA, CATHODE RAY TUBE (CRT), AND DIGITAL LIGHT PROCESSING TECHNOLOGIES; COMPUTER SOFTWARE FOR USE AS DEVICE DRIVERS IN THE FORMATS OF HIGH DEFINITION TELEVISION (HDTV), STANDARD DEFINITION TELEVISION (SDTV), DIGITAL RED-GREEN-BLUE (RGB), ANALOG RED-GREEN-BLUE (RGB), AND VIDEO TV (U.S. CLS. 21, 23, 26, 36 AND 38).

JAMES GRIFFIN, EXAMINING ATTORNEY

SN 85-207,218. DREAMHAMMER, INC., SANTA MONICA, CA. FILED 12-29-2010.



THE MARK CONSISTS OF THE TERM "OMNI" IN A STYLIZED FORM.

FOR COMPUTER SOFTWARE TO MANAGE, ANALYZE, RETRIEVE, MONITOR, MAINTAIN, REPORT ON, STRUCTURE, MODEL, FORECAST, PRESENT AND DISPLAY DATA AND INFORMATION FROM COMPUTER DATABASES AND THE INTERNET, AND FOR THE DEVELOPMENT, ANALYSIS, MANAGEMENT, INTEGRATION, DEPLOYMENT AND MAINTENANCE OF COMPUTER SOFTWARE; CONTENT MANAGEMENT SOFTWARE, DATABASE MANAGEMENT SOFTWARE; APPLICATION SERVER SOFTWARE, NAMELY, COMPUTER SOFTWARE TO USED TO OPERATE INTERNET-BASED OR INTRANET-BASED COMPUTER SERVERS ON WHICH A VARIOUS COMPUTER LANGUAGES AND COMPUTER APPLICATIONS OPERATE SIMULTANEOUSLY (U.S. CLS. 21, 23, 26, 36 AND 38).

WILLIAM BRECKENFELD, EXAMINING ATTORNEY

**CLASS 9—(Continued).**

SN 85-207,228. DREAMHAMMER, INC., SANTA MONICA, CA. FILED 12-29-2010.

# POWERED BY OMNI

THE MARK CONSISTS OF STANDARD CHARACTERS WITHOUT CLAIM TO ANY PARTICULAR FONT, STYLE, SIZE, OR COLOR.

FOR COMPUTER SOFTWARE TO MANAGE, ANALYZE, RETRIEVE, MONITOR, MAINTAIN, REPORT ON, STRUCTURE, MODEL, FORECAST, PRESENT AND DISPLAY DATA AND INFORMATION FROM COMPUTER DATABASES AND THE INTERNET, AND FOR THE DEVELOPMENT, ANALYSIS, MANAGEMENT, INTEGRATION, DEPLOYMENT AND MAINTENANCE OF COMPUTER SOFTWARE; CONTENT MANAGEMENT SOFTWARE, DATABASE MANAGEMENT SOFTWARE; APPLICATION SERVER SOFTWARE, NAMELY, COMPUTER SOFTWARE TO USED TO OPERATE INTERNET-BASED OR INTRANET-BASED COMPUTER SERVERS ON WHICH A VARIOUS COMPUTER LANGUAGES AND COMPUTER APPLICATIONS OPERATE SIMULTANEOUSLY (U.S. CLS. 21, 23, 26, 36 AND 38).

WILLIAM BRECKENFELD, EXAMINING ATTORNEY

SN 85-207,234. COMREX CORPORATION, DEVENS, MA. FILED 12-29-2010.

# Liveshot

THE MARK CONSISTS OF STANDARD CHARACTERS WITHOUT CLAIM TO ANY PARTICULAR FONT, STYLE, SIZE, OR COLOR.

FOR VIDEO TRANSMISSION EQUIPMENT FOR USE IN PROFESSIONAL VIDEO SETTINGS SUCH AS BROADCASTING, NAMELY MULTI-FORMAT DIGITAL VIDEO CODER/DECODERS, ALSO KNOWN AS CODECS, TO PROVIDE NETWORK TRANSMISSION CAPABILITIES TO EXISTING CAMERAS (U.S. CLS. 21, 23, 26, 36 AND 38).

KATINA MISTER, EXAMINING ATTORNEY

SN 85-207,237. DREAMHAMMER, INC., SANTA MONICA, CA. FILED 12-29-2010.

# BALLISTA

THE MARK CONSISTS OF STANDARD CHARACTERS WITHOUT CLAIM TO ANY PARTICULAR FONT, STYLE, SIZE, OR COLOR.

FOR COMPUTER SOFTWARE FOR MANAGING UNMANNED VEHICLES (U.S. CLS. 21, 23, 26, 36 AND 38).

WILLIAM BRECKENFELD, EXAMINING ATTORNEY

**CLASS 9—(Continued).**

SN 85-207,286. SWITCH PLUS PLUS, LLC, SANTA CLARA, CA. FILED 12-29-2010.

# SimSwitch

THE MARK CONSISTS OF STANDARD CHARACTERS WITHOUT CLAIM TO ANY PARTICULAR FONT, STYLE, SIZE, OR COLOR.

FOR COMPUTER SOFTWARE FOR NETWORKING OPTIMIZATION (U.S. CLS. 21, 23, 26, 36 AND 38).  
KARANENDRA S. CHHINA, EXAMINING ATTORNEY

**CLASS 9—(Continued).**

SN 85-207,460. HANNSTAR DISPLAY CORPORATION, TAIPEI 248, TAIWAN, FILED 12-29-2010.

# HS-IPS

SN 85-207,316. RADIODETECTION LIMITED, BRISTOL, UNITED KINGDOM, FILED 12-29-2010.

# RD5000

THE MARK CONSISTS OF STANDARD CHARACTERS WITHOUT CLAIM TO ANY PARTICULAR FONT, STYLE, SIZE, OR COLOR.

FOR GEOPHYSICAL SURVEYING MACHINES AND INSTRUMENTS FOR USE IN LOCATING, TRACING, IDENTIFYING AND FAULT-FINDING IN RELATION TO UNDERGROUND CABLES, PIPES AND DRAINS; ELECTROMAGNETIC FIELD DETECTORS; PARTS AND FITTINGS FOR ALL THE AFORESAID GOODS (U.S. CLS. 21, 23, 26, 36 AND 38).  
KARANENDRA S. CHHINA, EXAMINING ATTORNEY

FOR GLOBAL POSITIONING SYSTEM (GPS); PERSONAL DIGITAL ASSISTANTS (PDA); CAR NAVIGATION COMPUTERS ; COMPUTERS; HANDHELD PERSONAL COMPUTERS; LIQUID CRYSTAL DISPLAY (LCD) TELEVISIONS; LCD PANELS; MOBILE PHONES; PORTABLE DVD PLAYERS; PORTABLE MEDIA PLAYERS; NOTEBOOK COMPUTERS; DIGITAL PHOTO FRAMES FOR DISPLAYING DIGITAL PICTURES, VIDEO CLIPS AND MUSIC; GPS NAVIGATION DEVICE; ELECTRONIC BILLBOARDS; COMPUTER CURSOR CONTROL DEVICES, NAMELY, TOUCH PADS; TOUCH PANELS; TABLET COMPUTERS; CLOSED-CIRCUIT TELEVISION (CCTV); FLAT PANEL DISPLAY SCREENS; ELECTRONIC BOOK READER; COMPUTER HARDWARE; LIQUID CRYSTAL DISPLAY (LCD) MONITORS (U.S. CLS. 21, 23, 26, 36 AND 38).

KATHRYN COWARD, EXAMINING ATTORNEY

SN 85-207,446. HANNSTAR DISPLAY CORPORATION, TAIPEI 248, TAIWAN, FILED 12-29-2010.

# HS-IPS

THE MARK CONSISTS OF STANDARD CHARACTERS WITHOUT CLAIM TO ANY PARTICULAR FONT, STYLE, SIZE, OR COLOR.

FOR GLOBAL POSITIONING SYSTEM (GPS); PERSONAL DIGITAL ASSISTANTS (PDA); CAR NAVIGATION COMPUTERS ; COMPUTERS; HANDHELD PERSONAL COMPUTERS; LIQUID CRYSTAL DISPLAY (LCD) TELEVISIONS; LCD PANELS; MOBILE PHONES; PORTABLE DVD PLAYERS; PORTABLE MEDIA PLAYERS; NOTEBOOK COMPUTERS; DIGITAL PHOTO FRAMES FOR DISPLAYING DIGITAL PICTURES, VIDEO CLIPS AND MUSIC; GPS NAVIGATION DEVICE; ELECTRONIC BILLBOARDS; COMPUTER CURSOR CONTROL DEVICES, NAMELY, TOUCH PADS; TOUCH PANELS; TABLET COMPUTERS; CLOSED-CIRCUIT TELEVISION (CCTV); FLAT PANEL DISPLAY SCREENS; ELECTRONIC BOOK READER; COMPUTER HARDWARE; LIQUID CRYSTAL DISPLAY (LCD) MONITORS (U.S. CLS. 21, 23, 26, 36 AND 38).  
KATHRYN COWARD, EXAMINING ATTORNEY

SN 85-207,588. TOM, RAYMOND, SUNNYVALE, CA. FILED 12-29-2010.

# Vuetopia

THE MARK CONSISTS OF STANDARD CHARACTERS WITHOUT CLAIM TO ANY PARTICULAR FONT, STYLE, SIZE, OR COLOR.

FOR COMPUTER SOFTWARE IN THE FIELD OF AUDIO VISUALIZATION THAT ALLOWS USERS TO CREATE, ORGANIZE, MANIPULATE AND INTEGRATE VIDEO, AUDIO, GRAPHIC, TEXT, MULTIMEDIA CONTENT, AND OTHER DATA FILES WHILE PLAYING MUSIC OR OTHER AUDIO FILES (U.S. CLS. 21, 23, 26, 36 AND 38).  
MARK SHINER, EXAMINING ATTORNEY



**CLASS 9—(Continued).**

SN 85-207,694. STOYLE, CHERYL, FRANKLIN, NJ. FILED 12-30-2010.

# GET USED TO IT

THE MARK CONSISTS OF STANDARD CHARACTERS WITHOUT CLAIM TO ANY PARTICULAR FONT, STYLE, SIZE, OR COLOR.

FOR TELECOMMUNICATIONS AND DATA NETWORKING HARDWARE, NAMELY, DEVICES FOR TRANSPORTING AND AGGREGATING VOICE, DATA, AND VIDEO COMMUNICATIONS ACROSS MULTIPLE NETWORK INFRASTRUCTURES AND COMMUNICATIONS PROTOCOLS (U.S. CLS. 21, 23, 26, 36 AND 38).

EUGENIA MARTIN, EXAMINING ATTORNEY

**CLASS 9—(Continued).**

SN 85-207,779. NEXT LIMIT S.L., MADRID, SPAIN, FILED 12-30-2010.

# ANYVERSE

THE MARK CONSISTS OF STANDARD CHARACTERS WITHOUT CLAIM TO ANY PARTICULAR FONT, STYLE, SIZE, OR COLOR.

FOR COMPUTER APPLICATION SOFTWARE FOR MOBILE TELEPHONES, HANDHELD COMPUTERS AND PORTABLE COMPUTERS, NAMELY, SOFTWARE FOR THREE-DIMENSIONAL GRAPHICS DESIGN AND MODELING; DOWNLOADABLE COMPUTER SOFTWARE FOR THREE-DIMENSIONAL GRAPHICS DESIGN AND MODELING (U.S. CLS. 21, 23, 26, 36 AND 38).

ZHALEH DELANEY, EXAMINING ATTORNEY

SN 85-207,759. ASTRO-MED, INC., WEST WARWICK, RI. FILED 12-30-2010.



THE MARK CONSISTS OF THE WORD "PLEXO" WITH AN EXCLAMATION MARK THEREAFTER.

FOR COLOUR PRINTERS (U.S. CLS. 21, 23, 26, 36 AND 38).

BRIAN NEVILLE, EXAMINING ATTORNEY

SN 85-207,815. AG LEADER TECHNOLOGY, INC., AMES, IA. FILED 12-30-2010.

# AGFINITI

THE MARK CONSISTS OF STANDARD CHARACTERS WITHOUT CLAIM TO ANY PARTICULAR FONT, STYLE, SIZE, OR COLOR.

FOR COMPUTER SOFTWARE FOR PROCESSING, MANAGING, STORING, DISPLAYING, DISTRIBUTING, AND ANALYZING DATA IN THE FIELD OF AGRICULTURE (U.S. CLS. 21, 23, 26, 36 AND 38).

RUDY R. SINGLETON, EXAMINING ATTORNEY

SN 85-207,764. PLURIBUS NETWORKS INC., LOS ALTOS, CA. FILED 12-30-2010.

# VRENDER

THE MARK CONSISTS OF STANDARD CHARACTERS WITHOUT CLAIM TO ANY PARTICULAR FONT, STYLE, SIZE, OR COLOR.

FOR COMPUTER SOFTWARE, NAMELY, SOFTWARE THAT PROVIDES A UNIFIED, NEAR-REAL TIME VIEW OF THE TOPOLOGY AND UTILIZATION OF ONE OR MORE NETWORKS; GRAPHICAL USER INTERFACE SOFTWARE FOR USE IN GRAPHICALLY DISPLAYING BOTH NETWORK TOPOLOGY AND UTILIZATION (U.S. CLS. 21, 23, 26, 36 AND 38).

LINDA MICKLEBURGH, EXAMINING ATTORNEY

SN 85-207,829. MWM MOBILE PRODUCTS, LLC, INDIANAPOLIS, IN. FILED 12-30-2010.

# BE GOOD TO YOUR EARS

THE MARK CONSISTS OF STANDARD CHARACTERS WITHOUT CLAIM TO ANY PARTICULAR FONT, STYLE, SIZE, OR COLOR.

FOR ACOUSTIC COMPONENTS, NAMELY, HEADPHONES, EARPHONES, SOUND PRESSURE LIMITERS AND SOUND PRESSURE LEVEL METERS (U.S. CLS. 21, 23, 26, 36 AND 38).

RUDY R. SINGLETON, EXAMINING ATTORNEY

**CLASS 9—(Continued).**

SN 85-207,840. AG LEADER TECHNOLOGY, INC., AMES, IA. FILED 12-30-2010.



THE MARK CONSISTS OF THE TERM "AGFINITI" ABOVE A MODIFIED INFINITY SYMBOL WITHIN ONE LOOP OF WHICH IS A FANCIFUL DEPICTION OF A FARM FIELD.

FOR COMPUTER SOFTWARE FOR PROCESSING, MANAGING, STORING, DISPLAYING, DISTRIBUTING, AND ANALYZING DATA IN THE FIELD OF AGRICULTURE (U.S. CLS. 21, 23, 26, 36 AND 38).

RUDY R. SINGLETON, EXAMINING ATTORNEY

SN 85-207,889. FIFIELD, INC., HINGHAM, MA. FILED 12-30-2010.

## FIRE AWAY!

THE MARK CONSISTS OF STANDARD CHARACTERS WITHOUT CLAIM TO ANY PARTICULAR FONT, STYLE, SIZE, OR COLOR.

FOR FIRE BLANKETS (U.S. CLS. 21, 23, 26, 36 AND 38).

NANCY CLARKE, EXAMINING ATTORNEY

SN 85-207,932. GSL BIOTECH, CHICAGO, IL. FILED 12-30-2010.

## SnapGene

THE MARK CONSISTS OF STANDARD CHARACTERS WITHOUT CLAIM TO ANY PARTICULAR FONT, STYLE, SIZE, OR COLOR.

FOR COMPUTER SOFTWARE FOR FACILITATING MOLECULAR BIOLOGY PROCEDURES (U.S. CLS. 21, 23, 26, 36 AND 38).

CAROLYN CATALDO, EXAMINING ATTORNEY

**CLASS 9—(Continued).**

SN 85-207,996. THE TALK MARKET, INC., NEW YORK, NY. FILED 12-30-2010.

## Videolucious

THE MARK CONSISTS OF STANDARD CHARACTERS WITHOUT CLAIM TO ANY PARTICULAR FONT, STYLE, SIZE, OR COLOR.

FOR COMPUTER PROGRAMS FOR EDITING IMAGES, SOUND AND VIDEO (U.S. CLS. 21, 23, 26, 36 AND 38).

FIRST USE 12-30-2010; IN COMMERCE 12-30-2010.

DANIEL CAPSHAW, EXAMINING ATTORNEY

SN 85-208,037. OKTA, INC., SAN FRANCISCO, CA. FILED 12-30-2010.

## OKTA YOUR CLOUD, COVERED

THE MARK CONSISTS OF STANDARD CHARACTERS WITHOUT CLAIM TO ANY PARTICULAR FONT, STYLE, SIZE, OR COLOR.

FOR COMPUTER SOFTWARE FOR THE UNIFICATION, MANAGEMENT, OPTIMIZATION AND INTEGRATION OF COMPUTER SYSTEMS AND NETWORKS, ENTERPRISE SOFTWARE APPLICATIONS, USERS, AND INTERNET RESOURCES; COMPUTER SOFTWARE FOR COMPUTER SYSTEMS AND NETWORK ACCESS CONTROL, FEATURING DIGITAL IDENTITY AUTHENTICATION, SECURITY MANAGEMENT AND SECURITY APPLICATION AUDITING; COMPUTER SOFTWARE FOR THE MONITORING, ANALYZING, AND REPORTING ON THE PERFORMANCE OF COMPUTER SYSTEMS, NETWORKS, AND ENTERPRISE SOFTWARE APPLICATIONS (U.S. CLS. 21, 23, 26, 36 AND 38).

KIM SAITO, EXAMINING ATTORNEY

SN 85-208,121. DESAI, HIMANSHU, AUSTIN, TX. FILED 12-30-2010.

## PHR @ HOME

THE MARK CONSISTS OF STANDARD CHARACTERS WITHOUT CLAIM TO ANY PARTICULAR FONT, STYLE, SIZE, OR COLOR.

FOR COMPUTER SOFTWARE FOR THE COLLECTION, EDITING, ORGANIZING, MODIFYING, BOOK MARKING, TRACKING, TRANSMISSION, STORAGE AND SHARING OF HEALTH DATA, INFORMATION, RECORDS, AND INDICIA (U.S. CLS. 21, 23, 26, 36 AND 38).

FIRST USE 12-22-2010; IN COMMERCE 12-22-2010.

CAROL SPILLS, EXAMINING ATTORNEY

**CLASS 9—(Continued).**

SN 85-208,314. DECHNIA, LLC, DBA OSCIUM, OKLAHOMA CITY, OK. FILED 12-30-2010.

## Innovation for Inventors

THE MARK CONSISTS OF STANDARD CHARACTERS WITHOUT CLAIM TO ANY PARTICULAR FONT, STYLE, SIZE, OR COLOR.

FOR ELECTRONIC INSTRUMENTS, NAMELY, LOGIC ANALYZERS; OSCILLOSCOPES (U.S. CLS. 21, 23, 26, 36 AND 38).

SAMUEL E. SHARPER JR., EXAMINING ATTORNEY

SN 85-208,322. DECHNIA, LLC, DBA OSCIUM, OKLAHOMA CITY, OK. FILED 12-30-2010.

## iMSO

THE MARK CONSISTS OF STANDARD CHARACTERS WITHOUT CLAIM TO ANY PARTICULAR FONT, STYLE, SIZE, OR COLOR.

FOR ELECTRONIC INSTRUMENTS, NAMELY, LOGIC ANALYZERS; OSCILLOSCOPES (U.S. CLS. 21, 23, 26, 36 AND 38).

SAMUEL E. SHARPER JR., EXAMINING ATTORNEY

SN 85-208,351. HELMER, STEPHEN ANTHONY, DBA HAZARD MOUTH, EL CAJON, CA. FILED 12-30-2010.

## Hazard Mouth

THE MARK CONSISTS OF STANDARD CHARACTERS WITHOUT CLAIM TO ANY PARTICULAR FONT, STYLE, SIZE, OR COLOR.

FOR AUDIO AND VIDEO RECORDINGS FEATURING MUSIC AND ARTISTIC PERFORMANCES (U.S. CLS. 21, 23, 26, 36 AND 38).

SUSAN STIGLITZ, EXAMINING ATTORNEY

**CLASS 9—(Continued).**

SN 85-208,373. INNEX, INC., CITY OF INDUSTRY, CA. FILED 12-30-2010.



THE MARK CONSISTS OF A STYLIZED "KMD" TO THE RIGHT OF A KOMODO DRAGON HEAD, BELOW A SERIES OF SLANTED LINES.

FOR ADAPTERS; BATTERY CHARGERS; CARRYING CASES, HOLDERS, PROTECTIVE CASES AND STANDS FEATURING POWER SUPPLY CONNECTORS, ADAPTORS, SPEAKERS AND BATTERY CHARGING DEVICES, SPECIALLY ADAPTED FOR USE WITH HANDHELD DIGITAL ELECTRONIC DEVICES; EAR PHONES; GAME CONTROLLERS FOR COMPUTER GAMES; PROTECTIVE CARRYING CASES SPECIALLY ADAPTED FOR VIDEO GAME CONSOLES FOR USE WITH AN EXTERNAL DISPLAY SCREEN OR MONITOR; VIDEO GAME INTERACTIVE HAND HELD REMOTE CONTROLS FOR PLAYING ELECTRONIC GAMES; VIDEO GAME INTERACTIVE REMOTE CONTROL UNITS; VIDEO GAME JOYSTICKS (U.S. CLS. 21, 23, 26, 36 AND 38).

FIRST USE 12-21-2010; IN COMMERCE 12-21-2010.  
ROBIN CHOSID, EXAMINING ATTORNEY

SN 85-208,408. VENDMORE SYSTEMS, LLC, STAMFORD, CT. FILED 12-30-2010.

## Quickstore

THE MARK CONSISTS OF STANDARD CHARACTERS WITHOUT CLAIM TO ANY PARTICULAR FONT, STYLE, SIZE, OR COLOR.

OWNER OF U.S. REG. NO. 3,548,290.  
FOR VENDING MACHINES (U.S. CLS. 21, 23, 26, 36 AND 38).

FIRST USE 6-17-2004; IN COMMERCE 6-17-2004.  
ARETHA SOMERVILLE, EXAMINING ATTORNEY

SN 85-208,439. WHEELER, BRETT, EVERGREEN, CO. FILED 12-31-2010.

## ICONNECT

THE MARK CONSISTS OF STANDARD CHARACTERS WITHOUT CLAIM TO ANY PARTICULAR FONT, STYLE, SIZE, OR COLOR.

FOR COMPUTER SOFTWARE, NAMELY, SOFTWARE FOR MOBILE PHONES AND WIRELESS DEVICES FOR ACCESSING PROMOTIONAL AND ADVERTISING GAMING INFORMATION THEREBY CONNECTING GAMING ESTABLISHMENTS WITH PLAYERS (U.S. CLS. 21, 23, 26, 36 AND 38).

KATINA MISTER, EXAMINING ATTORNEY

**CLASS 9—(Continued).**

SN 85-208,681. CONFIDENT GOVERNANCE, AKA ENCRISP LLC, RESTON, VA. FILED 12-31-2010.

## Governance as a Service

THE MARK CONSISTS OF STANDARD CHARACTERS WITHOUT CLAIM TO ANY PARTICULAR FONT, STYLE, SIZE, OR COLOR.

OWNER OF U.S. REG. NOS. 3,897,065 AND 3,897,071.

NO CLAIM IS MADE TO THE EXCLUSIVE RIGHT TO USE "GOVERNANCE", APART FROM THE MARK AS SHOWN.

FOR DOWNLOADABLE SOFTWARE FOR USE IN APPLICATIONS TO STORE, MANAGE, TRACK, ANALYZE AND REPORT DATA THROUGH DEVELOPMENT OF SOLUTIONS USABLE IN ENTERPRISE GOVERNANCE, RISK ASSESSMENT, BUSINESS RULES DESIGN FOR COMPLIANCE AND INTERNAL CONTROLS, INFORMATION SECURITY, BUSINESS ANALYSIS, EXECUTIVE BOARD AND AUDIT COMMITTEE PLANNING; FOR USE IN BUSINESS GOVERNANCE ANALYTICS IN THE FIELDS OF ENTERPRISE RISK MANAGEMENT, CORPORATE AND ENVIRONMENTAL SUSTAINABILITY, GOVERNANCE RISK AND COMPLIANCE MANAGEMENT AND OPERATIONAL EFFICIENCY; FOR USE IN FACILITATING COLLABORATION AND COMMUNICATING AMONG PEER PROFESSIONALS IN THE SECURITY, GOVERNANCE RISK COMPLIANCE AND CORPORATE SUSTAINABILITY MARKETS FOR PRIVATE AND PUBLIC BUSINESSES ENTITIES.; DOWNLOADABLE SOFTWARE IN THE NATURE OF A MOBILE APPLICATION FOR USE IN COMPUTER E-COMMERCE WHICH ALLOWS USERS TO PERFORM ELECTRONIC BUSINESS TRANSACTIONS, COMMUNICATE WITH OTHER USERS, AND ACCESS AND EXCHANGE INFORMATION VIA A GLOBAL COMPUTER NETWORK; DOWNLOADABLE COMPUTER SOFTWARE FOR USE IN CUSTOMIZING COMPUTER APPLICATION USER INTERFACES (U.S. CLS. 21, 23, 26, 36 AND 38).

FIRST USE 3-1-2010; IN COMMERCE 3-1-2010.

JILL PRATER, EXAMINING ATTORNEY

SN 85-208,703. SCHULER, SERGIO, AUSTIN, TX. FILED 12-31-2010.

## EventGenie

THE MARK CONSISTS OF STANDARD CHARACTERS WITHOUT CLAIM TO ANY PARTICULAR FONT, STYLE, SIZE, OR COLOR.

FOR COMPUTER APPLICATION SOFTWARE FOR MOBILE PHONES, NAMELY, SOFTWARE FOR TRACKING THE AGE AND OTHER PROPERTIES OF EVENTS (U.S. CLS. 21, 23, 26, 36 AND 38).

FIRST USE 6-25-2009; IN COMMERCE 8-31-2009.

MARK T. MULLEN, EXAMINING ATTORNEY

**CLASS 9—(Continued).**

SN 85-208,708. PRAGMATICA INNOVATIONS, LLC, VIRGINIA BEACH, VA. FILED 12-31-2010.

# DE<sub>2</sub>

THE MARK CONSISTS OF THE LETTERS "DE" FOLLOWED BY A SLIGHTLY SMALLER NUMBER "2".

FOR COMPUTER SOFTWARE FOR APPLICATION AND DATABASE INTEGRATION; COMPUTER SOFTWARE FOR PROVIDING AN ON-LINE DATABASE IN THE FIELD OF TRANSACTION PROCESSING TO UPLOAD TRANSACTIONAL DATA, PROVIDE STATISTICAL ANALYSIS, AND PRODUCE NOTIFICATIONS AND REPORTS; COMPUTER SOFTWARE FOR THE COLLECTION, EDITING, ORGANIZING, MODIFYING, BOOK MARKING, TRANSMISSION, STORAGE AND SHARING OF DATA AND INFORMATION; COMPUTER SOFTWARE THAT PROVIDES REAL-TIME, INTEGRATED BUSINESS MANAGEMENT INTELLIGENCE BY COMBINING INFORMATION FROM VARIOUS DATABASES AND PRESENTING IT IN AN EASY-TO-UNDERSTAND USER INTERFACE; COMPUTER SOFTWARE THAT PROVIDES WEB-BASED ACCESS TO APPLICATIONS AND SERVICES THROUGH A WEB OPERATING SYSTEM OR PORTAL INTERFACE; ENTERPRISE SOFTWARE IN THE NATURE OF A DATABASE FOR NON-TRANSACTIONAL DATA AND A SEARCH ENGINE FOR DATABASE CONTENT (U.S. CLS. 21, 23, 26, 36 AND 38).

FIRST USE 4-24-2009; IN COMMERCE 4-24-2009.

MARK SHINER, EXAMINING ATTORNEY

SN 85-208,769. GNL ENTERTAINMENT, INC., WASHINGTON, DC. FILED 1-1-2011.

## Painted On Water

THE MARK CONSISTS OF STANDARD CHARACTERS WITHOUT CLAIM TO ANY PARTICULAR FONT, STYLE, SIZE, OR COLOR.

FOR AUDIO AND VIDEO RECORDINGS FEATURING MUSIC AND ARTISTIC PERFORMANCES; COMPACT DISCS FEATURING MUSIC; DIGITAL MUSIC DOWNLOADABLE FROM THE INTERNET; DOWNLOADABLE MUSICAL SOUND RECORDINGS; MUSICAL SOUND RECORDINGS; MUSICAL VIDEO RECORDINGS; SERIES OF MUSICAL SOUND RECORDINGS (U.S. CLS. 21, 23, 26, 36 AND 38).

FIRST USE 6-9-2009; IN COMMERCE 6-9-2009.

ANDREA HACK, EXAMINING ATTORNEY

**CLASS 9—(Continued).**

SN 85-208,911. BIZY ME, DBA BIZY ME, MURRIETA, CA. FILED 1-2-2011.

**Bizy.me**

THE MARK CONSISTS OF STANDARD CHARACTERS WITHOUT CLAIM TO ANY PARTICULAR FONT, STYLE, SIZE, OR COLOR.  
FOR WEB SITE DEVELOPMENT SOFTWARE (U.S. CLS. 21, 23, 26, 36 AND 38).  
JANICE KIM, EXAMINING ATTORNEY

---

SN 85-208,917. ABDEL FAHMY, OAKBROOK TERRACE, IL. FILED 1-3-2011.

**DrugTrail**

THE MARK CONSISTS OF STANDARD CHARACTERS WITHOUT CLAIM TO ANY PARTICULAR FONT, STYLE, SIZE, OR COLOR.  
FOR COMPUTER SOFTWARE FOR INTERPRETATION OF DRUG TEST RESULTS IN LABORATORIES (U.S. CLS. 21, 23, 26, 36 AND 38).  
FIRST USE 12-30-2010; IN COMMERCE 12-30-2010.  
KAELIE KUNG, EXAMINING ATTORNEY

---

SN 85-209,093. QUDEC, INC., CUPERTINO, CA. FILED 1-3-2011.

**Make Wiser Choices**

THE MARK CONSISTS OF STANDARD CHARACTERS WITHOUT CLAIM TO ANY PARTICULAR FONT, STYLE, SIZE, OR COLOR.  
FOR COMPUTER SOFTWARE FOR USE IN ANALYTIC AND STATISTICAL MODELS FOR THE UNDERSTANDING AND PREDICTING OF CONSUMERS, BUSINESSES, AND MARKET TRENDS AND ACTIONS, AND SCIENTIFIC PROCESSES ALL TO ASSIST IN DECISION MAKING IN THE CONTEXT OF BUSINESS, SCIENTIFIC AND RESEARCH APPLICATIONS (U.S. CLS. 21, 23, 26, 36 AND 38).  
JANET LEE, EXAMINING ATTORNEY

**CLASS 9—(Continued).**

SN 85-209,153. ESCORT INC., WEST CHESTER, OH. FILED 1-3-2011.

**S3**

THE MARK CONSISTS OF STANDARD CHARACTERS WITHOUT CLAIM TO ANY PARTICULAR FONT, STYLE, SIZE, OR COLOR.  
FOR POLICE RADAR AND LASER SPEED DETECTORS WITH AUDIBLE AND/OR VISIBLE WARNING ANNUCIATORS (U.S. CLS. 21, 23, 26, 36 AND 38).  
FIRST USE 11-0-2010; IN COMMERCE 11-0-2010.  
ALEXANDER L. POWERS, EXAMINING ATTORNEY

---

SN 85-209,240. BANOM, INC., WAYNE, PA. FILED 1-3-2011.

**ViziLite**

THE MARK CONSISTS OF STANDARD CHARACTERS WITHOUT CLAIM TO ANY PARTICULAR FONT, STYLE, SIZE, OR COLOR.  
FOR CUT-RESISTANT GLOVES FOR INDUSTRIAL USE (U.S. CLS. 21, 23, 26, 36 AND 38).  
MICHAEL WEBSTER, EXAMINING ATTORNEY

---

SN 85-209,310. FISHER HAMILTON L.L.C., TWO RIVERS, WI. FILED 1-3-2011.

**ACCENT**

THE MARK CONSISTS OF STANDARD CHARACTERS WITHOUT CLAIM TO ANY PARTICULAR FONT, STYLE, SIZE, OR COLOR.  
FOR LABORATORY FURNITURE (U.S. CLS. 21, 23, 26, 36 AND 38).  
FIRST USE 0-0-2000; IN COMMERCE 0-0-2000.  
STEVEN PEREZ, EXAMINING ATTORNEY

**CLASS 9—(Continued).**

SN 85-209,354. MOBEGIC, INCORPORATED, DBA UN-  
BOUND COMMERCE, NEWTON, MA. FILED 1-3-2011.

**Mobile Presence**

THE MARK CONSISTS OF STANDARD CHARACTERS  
WITHOUT CLAIM TO ANY PARTICULAR FONT, STYLE,  
SIZE, OR COLOR.

FOR COMPUTER SOFTWARE FOR WIRELESS CON-  
TENT DELIVERY (U.S. CLS. 21, 23, 26, 36 AND 38).  
FIRST USE 9-1-2008; IN COMMERCE 12-10-2008.  
JACQUELINE A. LAVINE, EXAMINING ATTORNEY

---

SN 85-209,375. G.A.E.M.S., INC., BOTHELL, WA. FILED 1-3-  
2011.

**G155**

THE MARK CONSISTS OF STANDARD CHARACTERS  
WITHOUT CLAIM TO ANY PARTICULAR FONT, STYLE,  
SIZE, OR COLOR.

FOR CHASSIS FOR CONTAINING A VIDEO GAME  
CONSOLE AND INCLUDING AN INTEGRATED DIS-  
PLAY SCREEN (U.S. CLS. 21, 23, 26, 36 AND 38).  
KRISTINA MORRIS, EXAMINING ATTORNEY

---

SN 85-209,399. G.A.E.M.S., INC., BOTHELL, WA. FILED 1-3-  
2011.

**G170**

THE MARK CONSISTS OF STANDARD CHARACTERS  
WITHOUT CLAIM TO ANY PARTICULAR FONT, STYLE,  
SIZE, OR COLOR.

FOR CHASSIS FOR CONTAINING A VIDEO GAME  
CONSOLE AND INCLUDING AN INTEGRATED DIS-  
PLAY SCREEN (U.S. CLS. 21, 23, 26, 36 AND 38).  
KRISTINA MORRIS, EXAMINING ATTORNEY

**CLASS 9—(Continued).**

SN 85-209,404. MOORECO, INC., TEMPLE, TX. FILED 1-3-  
2011.

**OneBoard**

THE MARK CONSISTS OF STANDARD CHARACTERS  
WITHOUT CLAIM TO ANY PARTICULAR FONT, STYLE,  
SIZE, OR COLOR.

FOR COMPUTER WHITEBOARDS; COMPUTER  
HARDWARE, NAMELY, AN INTERACTIVE ELECTRO-  
NIC WHITEBOARD DESIGNED TO INCORPORATE A  
COMPUTER AND A PROJECTOR IN ORDER TO AL-  
LOW THE USER TO ACCESS AND CONTROL ANY  
COMPUTER APPLICATION PROJECTED ON THE  
WHITEBOARD BY PRESSING ON THE WHITEBOARD'S  
TOUCH-SENSITIVE SURFACE OR BY USING PENS TO  
TAKE NOTES, EDIT, AND HIGHLIGHT INFORMATION  
ON THE WHITEBOARD ITSELF (U.S. CLS. 21, 23, 26, 36  
AND 38).

JOSETTE BEVERLY, EXAMINING ATTORNEY

---

SN 85-209,405. MOORECO, INC., TEMPLE, TX. FILED 1-3-  
2011.

**iTeach**

THE MARK CONSISTS OF STANDARD CHARACTERS  
WITHOUT CLAIM TO ANY PARTICULAR FONT, STYLE,  
SIZE, OR COLOR.

FOR STANDS SPECIALLY DESIGNED FOR HOLDING  
COMPUTER WHITEBOARDS, LAPTOP COMPUTERS,  
AND MULTIMEDIA PROJECTORS (U.S. CLS. 21, 23, 26,  
36 AND 38).

FIRST USE 8-31-2010; IN COMMERCE 8-31-2010.  
JOSETTE BEVERLY, EXAMINING ATTORNEY

---

SN 85-209,425. G.A.E.M.S., INC., BOTHELL, WA. FILED 1-3-  
2011.

**G220**

THE MARK CONSISTS OF STANDARD CHARACTERS  
WITHOUT CLAIM TO ANY PARTICULAR FONT, STYLE,  
SIZE, OR COLOR.

FOR CHASSIS FOR CONTAINING A VIDEO GAME  
CONSOLE AND INCLUDING AN INTEGRATED DIS-  
PLAY SCREEN (U.S. CLS. 21, 23, 26, 36 AND 38).  
KRISTINA MORRIS, EXAMINING ATTORNEY

**CLASS 9—(Continued).**

SN 85-209,496. G.A.E.M.S., INC., BOTHELL, WA. FILED 1-3-2011.



THE MARK CONSISTS OF THE LETTER "G" STYLIZED AND SHOWN WITHIN A CIRCLE.

FOR CHASSIS FOR CONTAINING A VIDEO GAME CONSOLE AND INCLUDING AN INTEGRATED DISPLAY SCREEN (U.S. CLS. 21, 23, 26, 36 AND 38).

KRISTINA MORRIS, EXAMINING ATTORNEY

SN 85-209,512. FONT DINER, INC., EAU CLAIRE, WI. FILED 1-3-2011.

**RETROGRAPHER**

THE MARK CONSISTS OF STANDARD CHARACTERS WITHOUT CLAIM TO ANY PARTICULAR FONT, STYLE, SIZE, OR COLOR.

FOR COMPUTER APPLICATION SOFTWARE FOR MOBILE COMPUTING DEVICES AND PERSONAL COMPUTERS, NAMELY, SOFTWARE FOR REVIEWING, MANIPULATING AND AMENDING DIGITAL PHOTOGRAPHS (U.S. CLS. 21, 23, 26, 36 AND 38).

DOMINICK J. SALEMI, EXAMINING ATTORNEY

**CLASS 9—(Continued).**

SN 85-209,516. VILLAIN LLC, CARY, NC. FILED 1-3-2011.

**VILLAIN**

THE MARK CONSISTS OF STANDARD CHARACTERS WITHOUT CLAIM TO ANY PARTICULAR FONT, STYLE, SIZE, OR COLOR.

FOR COMPUTER GAME SOFTWARE; COMPUTER GAME SOFTWARE DOWNLOADABLE FROM A GLOBAL COMPUTER NETWORK; COMPUTER GAME SOFTWARE FOR USE ON MOBILE AND CELLULAR PHONES; COMPUTER GAME SOFTWARE FOR USE WITH PERSONAL COMPUTERS, HOME VIDEO GAME CONSOLES USED WITH TELEVISIONS AND ARCADE-BASED VIDEO GAME CONSOLES; DOWNLOADABLE COMPUTER GAME SOFTWARE VIA A GLOBAL COMPUTER NETWORK AND WIRELESS DEVICES (U.S. CLS. 21, 23, 26, 36 AND 38).

FIRST USE 5-31-2009; IN COMMERCE 5-31-2009.

DOMINICK J. SALEMI, EXAMINING ATTORNEY

SN 85-209,562. VELVET ARCHITECTS, LLC, SAN JOSE, CA. FILED 1-3-2011.

**Avengees**

THE MARK CONSISTS OF STANDARD CHARACTERS WITHOUT CLAIM TO ANY PARTICULAR FONT, STYLE, SIZE, OR COLOR.

FOR COMPUTER APPLICATION SOFTWARE FOR MOBILE PHONES, NAMELY, SOFTWARE FOR PLAYING GAMES (U.S. CLS. 21, 23, 26, 36 AND 38).

JAMES GRIFFIN, EXAMINING ATTORNEY

SN 85-209,576. PAIRSHARE, LLC, SANTA ROSA, CA. FILED 1-3-2011.

**PairShare**

THE MARK CONSISTS OF STANDARD CHARACTERS WITHOUT CLAIM TO ANY PARTICULAR FONT, STYLE, SIZE, OR COLOR.

FOR COMPUTER APPLICATION SOFTWARE FOR MOBILE PHONES, NAMELY, SOFTWARE FOR ALLOWING USERS TO BROADCAST A SONG TO OTHER USERS SO THEY CAN LISTEN IN (U.S. CLS. 21, 23, 26, 36 AND 38).

FIRST USE 8-15-2007; IN COMMERCE 12-15-2010.

JAMES GRIFFIN, EXAMINING ATTORNEY

**CLASS 9—(Continued).**

SN 85-209,734. GLOBAL SENSORS, LLC, BELMONT, NC. FILED 1-4-2011.

# DataMark

THE MARK CONSISTS OF STANDARD CHARACTERS WITHOUT CLAIM TO ANY PARTICULAR FONT, STYLE, SIZE, OR COLOR.

FOR TEMPERATURE INDICATORS (U.S. CLS. 21, 23, 26, 36 AND 38).

JEAN IM, EXAMINING ATTORNEY

---

SN 85-209,798. DATABUILDER, INC., GRIMES, IA. FILED 1-4-2011.

# E-PCS

THE MARK CONSISTS OF STANDARD CHARACTERS WITHOUT CLAIM TO ANY PARTICULAR FONT, STYLE, SIZE, OR COLOR.

OWNER OF U.S. REG. NO. 2,924,580.

SEC. 2(F).

FOR SOFTWARE COLLABORATION SYSTEM TO ENABLE CONSTRUCTION CONTRACTORS, ARCHITECTS AND PROJECT OWNERS TO SHARE INFORMATION ON PROJECT STATUS (U.S. CLS. 21, 23, 26, 36 AND 38).

FIRST USE 4-14-2004; IN COMMERCE 4-14-2004.

NAKIA HENRY, EXAMINING ATTORNEY

---

SN 85-209,809. CLARK, JOHN R., GROSSE POINTE, MI. FILED 1-4-2011.

# CONTRACK

THE MARK CONSISTS OF STANDARD CHARACTERS WITHOUT CLAIM TO ANY PARTICULAR FONT, STYLE, SIZE, OR COLOR.

FOR COMPUTER SOFTWARE USED IN DRAFTING, TRACKING AND MANAGEMENT OF CONTRACTS AND CONTRACT DATABASES AND GENERATING REPORTS (U.S. CLS. 21, 23, 26, 36 AND 38).

MATTHEW MCDOWELL, EXAMINING ATTORNEY

**CLASS 9—(Continued).**

SN 85-209,873. CAPITAL TECHNOLOGY INFORMATION SERVICES, INC., ROCKVILLE, MD. FILED 1-4-2011.

# MWARRIOR

THE MARK CONSISTS OF STANDARD CHARACTERS WITHOUT CLAIM TO ANY PARTICULAR FONT, STYLE, SIZE, OR COLOR.

FOR COMPUTER SOFTWARE FOR USE IN STORING A USER'S HEALTHCARE RECORDS, ALLOWING USERS TO ACCESS THEIR HEALTHCARE RECORDS IN REAL-TIME AND SHARE THEM WITH DOCTORS AND OTHER HEALTHCARE PROVIDERS, TRACKING AND MONITORING A USER'S HEALTH STATUS, MEDICAL CONDITIONS, AND MEDICAL CONTACT INFORMATION, TRACKING A USER'S PAST MEDICAL PROCEDURES, PROVIDING THE RESULTS OF MEDICAL TESTS, MANAGING THE DOSAGE, STRENGTH, AND FREQUENCY OF A USER'S PRESCRIPTION AND OVER-THE-COUNTER MEDICATIONS, REPORTING DRUG INTERACTIONS, SCHEDULING AND MANAGING A USER'S MEDICAL APPOINTMENTS, STORING A USER'S IMMUNIZATION RECORDS, TRACKING A USER'S ALLERGIES, AND MONITORING A USER'S DIET, CALORIC INTAKE, AND EXERCISE PROGRAMS, PROVIDING USERS WITH PICTORIAL AND GRAPHIC REPRESENTATIONS OF MEDICAL CONDITIONS, MEDICATIONS, AND PRESCRIPTIONS, TEST RESULTS, AND MEDICAL CONTACTS, PROVIDING MAPS TO HEALTHCARE PROVIDERS AND INSTITUTIONS, PROVIDING USERS ACCESS TO RSS FEEDS, AND PROVIDING USERS WITH HEALTH RELATED ALERTS, REMINDERS, AND NOTIFICATIONS (U.S. CLS. 21, 23, 26, 36 AND 38).

COLLEEN KEARNEY, EXAMINING ATTORNEY

---

SN 85-209,888. MYERS-HOLUM, INC., NEW YORK, NY. FILED 1-4-2011.

# ChartGen

THE MARK CONSISTS OF STANDARD CHARACTERS WITHOUT CLAIM TO ANY PARTICULAR FONT, STYLE, SIZE, OR COLOR.

FOR COMPUTER APPLICATION SOFTWARE FOR PERSONAL COMPUTERS AND ENTERPRISE SYSTEMS, NAMELY, SOFTWARE FOR EXTRACTING DATA FROM PROFESSIONAL NETWORK DATABASES, EXPORTING TO CONTACT MANAGEMENT AND CUSTOMER RELATIONSHIP MANAGEMENT (CRM) SYSTEMS, AND CHARTING THE RESULTS; COMPUTER SOFTWARE FOR USE IN CUSTOMER RELATIONSHIP MANAGEMENT (CRM) (U.S. CLS. 21, 23, 26, 36 AND 38).

FIRST USE 1-1-1999; IN COMMERCE 1-1-1999.

BARBARA BROWN, EXAMINING ATTORNEY



**CLASS 9—(Continued).**

SN 85-209,982. ECLINICALWORKS, LLC, WESTBOROUGH, MA. FILED 1-4-2011.

IMPROVING HEALTHCARE  
TOGETHER

THE MARK CONSISTS OF STANDARD CHARACTERS WITHOUT CLAIM TO ANY PARTICULAR FONT, STYLE, SIZE, OR COLOR.  
FOR COMPUTER SOFTWARE FOR CONTROLLING AND MANAGING PATIENT MEDICAL INFORMATION (U.S. CLS. 21, 23, 26, 36 AND 38).  
MARIA-VICTORIA SUAREZ, EXAMINING ATTORNEY

SN 85-209,993. TRIMBLE NAVIGATION LIMITED, SUNNYVALE, CA. FILED 1-4-2011.

SiteFID

THE MARK CONSISTS OF STANDARD CHARACTERS WITHOUT CLAIM TO ANY PARTICULAR FONT, STYLE, SIZE, OR COLOR.  
FOR FLAME IONIZATION DETECTORS USED TO DETECT AND MONITOR GREENHOUSE GAS EMISSIONS FROM LANDFILLS (U.S. CLS. 21, 23, 26, 36 AND 38).  
CARYN GLASSER, EXAMINING ATTORNEY

**CLASS 9—(Continued).**

SN 85-210,041. JVC KENWOOD HOLDINGS, INC., KANAGAWA, JAPAN, FILED 1-4-2011.

*Ryomax*

PRIORITY CLAIMED UNDER SEC. 44(D) ON JAPAN APPLICATION NO. 201059579, FILED 7-29-2010, REG. NO. 5393168, DATED 2-25-2011, EXPIRES 2-25-2021.  
THE MARK CONSISTS OF THE WORD "RYOMAX" IN STYLIZED LETTERS.  
THE WORDING "RYOMAX" HAS NO MEANING IN A FOREIGN LANGUAGE.

FOR COMPACT DISC PLAYERS FOR AUTOMOBILES; COMPACT DISC PLAYERS; DIGITAL AUDIO PLAYERS; RECORD PLAYERS; PERSONAL STEREOS; TAPE CASSETTE PLAYERS FOR AUTOMOBILES; TAPE CASSETTE PLAYERS; MINI DISC PLAYERS FOR AUTOMOBILES, NAMELY, AUDIO DISC PLAYERS FOR AUTOMOBILES; MINI DISC PLAYERS, NAMELY, AUDIO DISC PLAYERS; TAPE RECORDERS; SOUND RECORDING APPARATUS, NAMELY, AUDIO-FREQUENCY APPARATUS, NAMELY, FREQUENCY METERS, AUDIO MIXERS; ANTENNAS; AMPLIFIERS FOR AUTOMOBILES; AMPLIFIERS; EARPHONES; HEADPHONES; LOUDSPEAKERS FOR AUTOMOBILES; LOUDSPEAKERS; HORNS FOR LOUDSPEAKERS; MICROPHONES; CAR BROADCASTING TUNERS; STEREO TUNERS; RADIO TUNERS; AUDIO EQUIPMENT FOR VEHICLES, NAMELY, EQUALIZERS; AUDIO EQUIPMENT, NAMELY, AUDIO EQUALIZERS; CABINETS FOR LOUDSPEAKERS; PRERECORDED MAGNETIC DATA CARRIERS FEATURING SOUND RECORDINGS; ELECTRONIC STILL CAMERAS; VIDEO CAMERAS; CAMCORDERS; VIDEODISC PLAYERS; VIDEO TAPE RECORDERS AND PLAYERS; VIDEO DISC RECORDERS AND PLAYERS; DVD-PLAYERS; DVD RECORDING APPARATUS; HIGH DEFINITION DISC PLAYERS; HIGH DEFINITION DISC RECORDING APPARATUS; HARD DISC AUDIO PLAYERS; HARD DISC AUDIO RECORDERS; HARD DISC VIDEO PLAYERS; HARD DISC VIDEO RECORDERS; VIDEO PROJECTION APPARATUS, NAMELY, VIDEO PROJECTORS; VIDEO PROJECTORS FOR MOVIES; VIDEO SCREENS; AUDIO AND VIDEO RECEIVERS; TELEVISION RECEIVERS, NAMELY, TV SETS FOR AUTOMOBILES; TELEVISION RECEIVERS, NAMELY, TV SETS; LIQUID CRYSTAL DISPLAYS; REMOTE CONTROLS FOR RADIOS, TELEVISIONS AND STEREOS; VEHICLE RADIOS; RADIO RECEIVERS; TELEPHONE SETS; PORTABLE TELEPHONES; RADIOTELEPHONES; RADIOTELEPHONY SETS, NAMELY, RADIO RECEIVERS, RADIO TRANSMITTERS, AND REPEATERS FOR RADIO STATIONS; FACSIMILE MACHINES; VIDEO TELEPHONES; REPEATERS FOR RADIO STATIONS; WIRELESS COMMUNICATIONS EQUIPMENT, NAMELY, TRANSCEIVERS, MOBILE TRANSCEIVERS, HANDHELD TRANSCEIVERS AND PARTS AND ACCESSORIES THEREOF, NAMELY, MICROPHONES AND EXTERNAL SPEAKERS FOR REPEATERS FOR RADIO STATIONS, BATTERIES, ANTENNAS AND MICROPHONES FOR MOBILE TRANSCEIVERS AND HANDHELD TRANSCEIVERS, AND CHARGERS FOR HANDHELD TRANSCEIVERS; NAVIGATION APPARATUS FOR VEHICLES, NAMELY, ON-BOARD COMPUTERS; SATELLITE NAVIGATIONAL APPARATUS, NAMELY, A GLOBAL POSITIONING SYSTEM; RECEIVERS FOR SATELLITES; SATELLITE DISHES FOR SATELLITE TRANSMISSIONS;

**CLASS 9—(Continued).**

COMPUTERS; LAPTOP COMPUTERS; COMPUTER MONITORS; COMPUTER MOUSE; MOUSE PADS; PRINTERS FOR USE WITH COMPUTERS; SCANNERS; COMPUTER PROGRAMS FOR EDITING IMAGES, SOUND AND VIDEO; SOFTWARE TO CONTROL AND IMPROVE AUDIO EQUIPMENT SOUND QUALITY; BLANK VIDEO TAPES; PRERECORDED VIDEO TAPES FEATURING MOVIES AND MUSIC VIDEOS; BLANK AUDIO TAPES; PRERECORDED AUDIO TAPES FEATURING MUSIC AND POETRY; BLANK VIDEO DISCS; PRERECORDED VIDEO DISCS FEATURING MOVIES AND MUSIC VIDEOS; BLANK AUDIO DISCS; PRERECORDED AUDIO DISCS FEATURING MUSIC AND POETRY; CENTRAL PROCESSING UNITS; COMPUTER MEMORIES; SEMICONDUCTORS; INTEGRATED CIRCUITS; AC ADAPTERS FOR AUDIO AND VISUAL APPARATUS; PERSONAL DIGITAL ASSISTANTS PDA (U.S. CLS. 21, 23, 26, 36 AND 38).

ANGELA DUONG, EXAMINING ATTORNEY

SN 85-210,382. SENSORTECH SYSTEMS, INC., MOORPARK, CA. FILED 1-4-2011.

# MoistTech

THE MARK CONSISTS OF STANDARD CHARACTERS WITHOUT CLAIM TO ANY PARTICULAR FONT, STYLE, SIZE, OR COLOR.

FOR LABORATORY INSTRUMENTATION FOR MEASURING MOISTURE USING NIR (NEAR INFRARED) AND RF (RADIO FREQUENCY) TECHNOLOGIES (U.S. CLS. 21, 23, 26, 36 AND 38).

FIRST USE 1-1-2003; IN COMMERCE 1-1-2003.  
GINA FINK, EXAMINING ATTORNEY

SN 85-210,544. XENEXX CORP. LIMITED, HONG KONE, HONG KONG, FILED 1-5-2011.

# xenexx

THE MARK CONSISTS OF WORD "XENEXX".  
FOR TELEPHONE APPARATUS; TELEPHONE HEADSETS; TELEPHONE HEADSETS, INCLUDING TELEPHONE HEADSETS FOR CALL CENTERS; AMPLIFIERS; USB CABLES; AUDIO CABLES; CABLE CONNECTORS; COMPUTER CABLES; ELECTRIC CORDS; VOIP TELEPHONES; TELEPHONES FOR MAKING CALLS OVER THE INTERNET WITH THE HELP OF COMPUTERS; TELEPHONES FOR MAKING CALLS OVER THE INTERNET; COMMUNICATION DEVICES, NAMELY, USB HARDWARE AND/OR OPERATING SOFTWARE FOR VOICE COMMUNICATION VIA THE INTERNET (U.S. CLS. 21, 23, 26, 36 AND 38).

FIRST USE 1-31-2007; IN COMMERCE 1-31-2007.  
PAM WILLIS, EXAMINING ATTORNEY

**CLASS 9—(Continued).**

SN 85-210,610. RGIS, LLC, AUBURN HILLS, MI. FILED 1-5-2011.

# EXACTCOUNT

THE MARK CONSISTS OF STANDARD CHARACTERS WITHOUT CLAIM TO ANY PARTICULAR FONT, STYLE, SIZE, OR COLOR.

FOR INVENTORY MANAGEMENT SOFTWARE; INVENTORY OPERATIONS MANAGEMENT SOFTWARE (U.S. CLS. 21, 23, 26, 36 AND 38).

FLORENTINA BLANDU, EXAMINING ATTORNEY

SN 85-210,650. GREENVITY COMMUNICATIONS, INC., MILPITAS, CA. FILED 1-5-2011.

# GREENVITY

THE MARK CONSISTS OF STANDARD CHARACTERS WITHOUT CLAIM TO ANY PARTICULAR FONT, STYLE, SIZE, OR COLOR.

FOR SEMICONDUCTOR CHIPS, CIRCUIT BOARDS (U.S. CLS. 21, 23, 26, 36 AND 38).

THEODORE MCBRIDE, EXAMINING ATTORNEY

SN 85-210,696. CHAO-WEN LIANG, TAICHUNG CITY, TAIWAN, FILED 1-5-2011.

# Lens2scope

THE MARK CONSISTS OF STANDARD CHARACTERS WITHOUT CLAIM TO ANY PARTICULAR FONT, STYLE, SIZE, OR COLOR.

FOR OCULARS (U.S. CLS. 21, 23, 26, 36 AND 38).

FIRST USE 9-21-2010; IN COMMERCE 12-26-2010.

WILLIAM P. SHANAHAN, EXAMINING ATTORNEY

**CLASS 9—(Continued).**

SN 85-210,811. COCKOS INCORPORATED, SAN FRANCISCO, CA. FILED 1-5-2011.

**REAPER**

THE MARK CONSISTS OF STANDARD CHARACTERS WITHOUT CLAIM TO ANY PARTICULAR FONT, STYLE, SIZE, OR COLOR.

FOR COMPUTER HARDWARE AND SOFTWARE FOR AUDIO AND VIDEO PRODUCTION, NAMELY, FOR THE RECORDING, EDITING, AND PLAYBACK OF AUDIO AND VIDEO (U.S. CLS. 21, 23, 26, 36 AND 38).

FIRST USE 12-18-2005; IN COMMERCE 8-22-2006.  
 ASMAT KHAN, EXAMINING ATTORNEY

---

SN 85-210,832. INSIGHT EQUITY A.P.X., LP, SOUTHLAKE, TX. FILED 1-5-2011.

**NOVEL**

THE MARK CONSISTS OF STANDARD CHARACTERS WITHOUT CLAIM TO ANY PARTICULAR FONT, STYLE, SIZE, OR COLOR.

OWNER OF U.S. REG. NO. 3,881,077.  
 FOR OPHTHALMIC LENSES FOR EYEGLASSES (U.S. CLS. 21, 23, 26, 36 AND 38).

TIMOTHY FINNEGAN, EXAMINING ATTORNEY

---

SN 85-210,840. LIGHTVANTAGE, GARDNERVILLE, NV. FILED 1-5-2011.

**Foodcaching**

THE MARK CONSISTS OF STANDARD CHARACTERS WITHOUT CLAIM TO ANY PARTICULAR FONT, STYLE, SIZE, OR COLOR.

FOR COMPUTER APPLICATION SOFTWARE FOR SMARTPHONES AND PERSONAL ELECTRONIC DEVICES, NAMELY, SOFTWARE FOR LOCATING RESTAURANTS (U.S. CLS. 21, 23, 26, 36 AND 38).

FIRST USE 9-15-2010; IN COMMERCE 10-10-2010.  
 ASMAT KHAN, EXAMINING ATTORNEY

**CLASS 9—(Continued).**

SN 85-210,846. MOFTWARE INC, SUGAR LAND, TX. FILED 1-5-2011.

**FOLDO**

THE MARK CONSISTS OF STANDARD CHARACTERS WITHOUT CLAIM TO ANY PARTICULAR FONT, STYLE, SIZE, OR COLOR.

FOR CARRYING CASES, HOLDERS, PROTECTIVE CASES AND STANDS FEATURING POWER SUPPLY CONNECTORS, ADAPTORS, SPEAKERS AND BATTERY CHARGING DEVICES, SPECIALLY ADAPTED FOR USE WITH HANDHELD DIGITAL ELECTRONIC DEVICES; COMPUTER STANDS SPECIALLY DESIGNED FOR HOLDING A COMPUTER, PRINTER AND ACCESSORIES; STANDS FOR HANDHELD DIGITAL ELECTRONIC DEVICES; STANDS FOR PERSONAL DIGITAL ELECTRONIC DEVICES; STANDS FOR PHOTOGRAPHIC APPARATUS; STANDS SPECIALLY ADAPTED FOR STEREOs AND AUDIO SPEAKERS (U.S. CLS. 21, 23, 26, 36 AND 38).

FIRST USE 11-2-2010; IN COMMERCE 11-2-2010.  
 JOHN KELLY, EXAMINING ATTORNEY

---

SN 85-211,029. NEXSAN TECHNOLOGIES, THOUSAND OAKS, CA. FILED 1-5-2011.

**E-CENTRE**

THE MARK CONSISTS OF STANDARD CHARACTERS WITHOUT CLAIM TO ANY PARTICULAR FONT, STYLE, SIZE, OR COLOR.

FOR A COMPUTER HARDWARE AND SOFTWARE SOLUTION WHICH PERFORMS MANAGEMENT FOR DATA STORAGE (U.S. CLS. 21, 23, 26, 36 AND 38).

KATHRYN COWARD, EXAMINING ATTORNEY

**CLASS 9—(Continued).**

SN 85-211,053. RICOH COMPANY, LTD., TOKYO 143-8555, JAPAN, FILED 1-5-2011.



THE COLOR(S) BLUE IS/ARE CLAIMED AS A FEATURE OF THE MARK.

THE MARK CONSISTS OF A STYLIZED LETTER "Q" IN THE COLOR BLUE. THE OPENING IN THE LETTER "Q" IS TRANSPARENT AND IS NOT PART OF THE MARK.

FOR MULTI FUNCTIONAL DEVICES WHICH INCORPORATE COPIER, FACSIMILE, SCANNER AND/OR PRINTER FUNCTIONS; PARTS, FITTINGS AND ACCESSORIES FOR THE AFORESAID GOODS; SOFTWARE, COMPUTER PROGRAMS AND COMPUTER SOFTWARE FOR THE OPERATION AND NETWORKING OF THE AFORESAID GOODS; INTERACTIVE DIGITAL PHOTO FRAMES FOR SENDING AND RECEIVING DIGITAL PHOTOS OVER A COMPUTER NETWORK (U.S. CLS. 21, 23, 26, 36 AND 38).

JOHN E. MICHOS, EXAMINING ATTORNEY

SN 85-211,196. TAYMAC CORPORATION, GILBERT, AZ. FILED 1-5-2011.

# TAYMAC

THE MARK CONSISTS OF STANDARD CHARACTERS WITHOUT CLAIM TO ANY PARTICULAR FONT, STYLE, SIZE, OR COLOR.

FOR ELECTRIC LIGHT SWITCHES; ELECTRIC SOCKETS; ELECTRIC SWITCHES; ELECTRICAL OUTLETS; ELECTRICAL RECEPTACLES (U.S. CLS. 21, 23, 26, 36 AND 38).

JILL PRATER, EXAMINING ATTORNEY

**CLASS 9—(Continued).**

SN 85-211,202. CHRISTOPHER M. ERNST, CLEVELAND, OH. FILED 1-5-2011.

# Solardis

THE MARK CONSISTS OF STANDARD CHARACTERS WITHOUT CLAIM TO ANY PARTICULAR FONT, STYLE, SIZE, OR COLOR.

FOR PHOTOVOLTAIC CELLS AND MODULES; PHOTOVOLTAIC INSTALLATION APPARATUS, NAMELY, SOLAR MODULES FOR PRODUCTION OF ELECTRICITY, SOLAR THERMAL AND ELECTRIC RECEIVERS, TRACKING MECHANISMS AND CONCENTRATING OPTICS, AND CONTROL ALGORITHMS; PHOTOVOLTAIC INVERTERS; PHOTOVOLTAIC SYSTEMS THAT CONVERT SUNLIGHT INTO ELECTRIC AND THERMAL ENERGY (U.S. CLS. 21, 23, 26, 36 AND 38).

TINA L. SNAPP, EXAMINING ATTORNEY

SN 85-211,235. ROCKWELL, JUSTIN H., LONGS, SC. FILED 1-5-2011.

# TextBoard

THE MARK CONSISTS OF STANDARD CHARACTERS WITHOUT CLAIM TO ANY PARTICULAR FONT, STYLE, SIZE, OR COLOR.

FOR AD SERVER, NAMELY, A COMPUTER SERVER FOR STORING ADVERTISEMENTS AND DELIVERING ADVERTISEMENTS TO WEBSITES; COMPUTER APPLICATION SOFTWARE FOR MOBILE MARKETING SERVICES, NAMELY, SOFTWARE FOR TEXT MESSAGE MARKETING, SMS MARKETING, MMS MARKETING; COMPUTER SOFTWARE FOR THE COLLECTION, EDITING, ORGANIZING, MODIFYING, BOOK MARKING, TRANSMISSION, STORAGE AND SHARING OF DATA AND INFORMATION (U.S. CLS. 21, 23, 26, 36 AND 38).

FIRST USE 8-8-2010; IN COMMERCE 8-8-2010.  
JILL PRATER, EXAMINING ATTORNEY

SN 85-211,315. AYOUB, ABEER, WAYNE, NJ. FILED 1-5-2011.

# Ic-HD

THE MARK CONSISTS OF STANDARD CHARACTERS WITHOUT CLAIM TO ANY PARTICULAR FONT, STYLE, SIZE, OR COLOR.

FOR EYEWEAR (U.S. CLS. 21, 23, 26, 36 AND 38).  
KATHERINE STOIDES, EXAMINING ATTORNEY

**CLASS 9—(Continued).**

SN 85-211,471. KEYWORD ROCKSTAR, INC., FLOWERY BRANCH, GA. FILED 1-5-2011.



THE MARK CONSISTS OF THE DESIGN OF A STAR WITHIN A BORDERED SQUARE.

FOR COMPUTER SOFTWARE WHICH PROVIDES AUTOMATION TOOLS FOR THE PURPOSE OF BUILDING WEB BANNERS, PERFORMING RESEARCH REGARDING PAID INTERNET TRAFFIC TARGETING, AND BUILDING PAY-PER-CLICK CAMPAIGNS (U.S. CLS. 21, 23, 26, 36 AND 38).

FIRST USE 1-5-2011; IN COMMERCE 1-5-2011.  
PAUL F. GAST, EXAMINING ATTORNEY

---

SN 85-211,486. RED LANTERN GAME STUDIOS LLC, UNION, NJ. FILED 1-5-2011.

# Ironbound

THE MARK CONSISTS OF STANDARD CHARACTERS WITHOUT CLAIM TO ANY PARTICULAR FONT, STYLE, SIZE, OR COLOR.

FOR COMPUTER GAME CARTRIDGES; COMPUTER GAME CARTRIDGES AND DISCS; COMPUTER GAME DISCS; COMPUTER GAME EQUIPMENT, NAMELY, DISCS; COMPUTER GAME PROGRAMMES; COMPUTER GAME PROGRAMMES DOWNLOADABLE VIA THE INTERNET; COMPUTER GAME PROGRAMS; COMPUTER GAME SOFTWARE; COMPUTER GAME SOFTWARE DOWNLOADABLE FROM A GLOBAL COMPUTER NETWORK; COMPUTER GAME SOFTWARE FOR PERSONAL COMPUTERS AND HOME VIDEO GAME CONSOLES; COMPUTER GAME SOFTWARE FOR USE ON MOBILE AND CELLULAR PHONES; COMPUTER GAME SOFTWARE FOR USE WITH PERSONAL COMPUTERS, HOME VIDEO GAME CONSOLES USED WITH TELEVISIONS AND ARCADE-BASED VIDEO GAME CONSOLES; DOWNLOADABLE COMPUTER GAME PROGRAMS; DOWNLOADABLE COMPUTER GAME SOFTWARE VIA A GLOBAL COMPUTER NETWORK AND WIRELESS DEVICES; DOWNLOADABLE ELECTRONIC GAME PROGRAMS; GAME SOFTWARE; INTERACTIVE GAME PROGRAMS; INTERACTIVE GAME SOFTWARE; VIDEO AND COMPUTER GAME PROGRAMS; VIDEO GAME CARTRIDGES AND DISCS; VIDEO GAME DISCS; VIDEO GAME SOFTWARE (U.S. CLS. 21, 23, 26, 36 AND 38).

CHERYL CLAYTON, EXAMINING ATTORNEY

**CLASS 9—(Continued).**

SN 85-211,491. VIDAPPE INC, FORMERLY STAR LI INC, SAINT PETERSBURG, FL. FILED 1-5-2011.

THE COLOR(S) PURPLE AND ORANGE IS/ARE CLAIMED AS A FEATURE OF THE MARK.

THE MARK CONSISTS OF A STYLIZED CAPITAL LETTER "V" WITH THE RIGHT DIAGONAL LINE OF THE "V" EXTENDED UPWARDS AND BESET BY TWO SMALL CIRCLES, SUCH THAT THE RIGHT SIDE OF THE "V" RESEMBLES A PERCENTAGE SYMBOL. THE STYLIZED "V" IS IMMEDIATELY FOLLOWED BY THE LOWER CASE LETTERS "IDA", SUCH THAT THE RIGHT CIRCLE OF THE PERCENTAGE SYMBOL APPEARS AS THE DOT ON THE LOWER CASE "I". "VIDA" IS PURPLE AND IS IMMEDIATELY FOLLOWED BY THE LOWER CASE LETTERS "PPE", WHICH ARE ORANGE.

FOR DOWNLOADABLE SOFTWARE IN THE NATURE OF A MOBILE APPLICATION FOR ALERTING USERS OF NEARBY RETAIL STORES AND RESTAURANTS OFFERING DISCOUNTS THAT CORRESPOND TO THE PARTICULAR DISCOUNT CARDS EACH USER OWNS (U.S. CLS. 21, 23, 26, 36 AND 38).

CHERYL CLAYTON, EXAMINING ATTORNEY

---

SN 85-211,493. FUTURE MASTER INTERNATIONAL LTD, NORTH POINT, HONG KONG, FILED 1-5-2011.

# Kata

THE MARK CONSISTS OF STANDARD CHARACTERS WITHOUT CLAIM TO ANY PARTICULAR FONT, STYLE, SIZE, OR COLOR.

FOR CELLULAR PHONES (U.S. CLS. 21, 23, 26, 36 AND 38).

FIRST USE 11-15-2010; IN COMMERCE 11-15-2010.

CHERYL CLAYTON, EXAMINING ATTORNEY

**CLASS 9—(Continued).**

SN 85-211,544. EMOTIV LIMITED, KWUN TONG, HONG KONG, FILED 1-6-2011.

# EMOTIV

THE MARK CONSISTS OF STANDARD CHARACTERS WITHOUT CLAIM TO ANY PARTICULAR FONT, STYLE, SIZE, OR COLOR.

FOR COMPUTER SOFTWARE FOR INTERPRETATION OF NEURO AND BRAIN SCANS PROVIDED BY DIAGNOSTIC IMAGING EQUIPMENT FOR USE IN THE COMPUTER GAMING FIELD; COMPUTER SOFTWARE FOR INTERPRETATION OF NEURO AND BRAIN SCANS PROVIDED BY DIAGNOSTIC IMAGING EQUIPMENT FOR USE IN THE MEDICAL FIELD (U.S. CLS. 21, 23, 26, 36 AND 38).

FIRST USE 4-1-2010; IN COMMERCE 9-1-2010.  
MICHAEL GAFFAR, EXAMINING ATTORNEY

SN 85-211,694. HEIM, GARY, KERRVILLE, TX. FILED 1-6-2011.

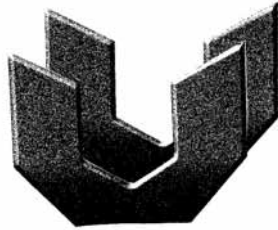

THE STIPPLING IS FOR SHADING PURPOSES ONLY. THE MARK CONSISTS OF THE STYLIZED TEXT "UU". FOR SUNGLASSES (U.S. CLS. 21, 23, 26, 36 AND 38). HELENE LIWINSKI, EXAMINING ATTORNEY

SN 85-211,723. SYSARC INFOMATIX PVT. LTD., RICHARDSON, TX. FILED 1-6-2011.

# LENDperfect

THE MARK CONSISTS OF STANDARD CHARACTERS WITHOUT CLAIM TO ANY PARTICULAR FONT, STYLE, SIZE, OR COLOR.

FOR COMPUTER SOFTWARE TO AUTOMATE COMMERCIAL, CONSTRUCTION, REAL ESTATE AND CONSUMER LOAN APPLICATION PROCESSING FROM INCEPTION TO CLOSING AND LOAN SERVICING (U.S. CLS. 21, 23, 26, 36 AND 38).

MAYUR VAGHANI, EXAMINING ATTORNEY

**CLASS 9—(Continued).**

SN 85-211,756. THE FONT BUREAU, INC., BOSTON, MA. FILED 1-6-2011.

# FB ALIX

THE MARK CONSISTS OF STANDARD CHARACTERS WITHOUT CLAIM TO ANY PARTICULAR FONT, STYLE, SIZE, OR COLOR.

FOR PRINTING FONTS THAT CAN BE DOWNLOADED PROVIDED BY MEANS OF ELECTRONIC TRANSMISSION; TYPEFACE FONTS RECORDED ON MAGNETIC MEDIA (U.S. CLS. 21, 23, 26, 36 AND 38).

FIRST USE 1-5-2011; IN COMMERCE 1-5-2011.  
KARANENDRA S. CHHINA, EXAMINING ATTORNEY

SN 85-211,777. MAGID MINA, DBA INVISICORP, INC., LOS ANGELES, CA. FILED 1-6-2011.

# InvisiPay

THE MARK CONSISTS OF STANDARD CHARACTERS WITHOUT CLAIM TO ANY PARTICULAR FONT, STYLE, SIZE, OR COLOR.

FOR COMPUTER SOFTWARE, NAMELY, ELECTRONIC FINANCIAL PLATFORM THAT ACCOMMODATES MULTIPLE TYPES OF PAYMENT AND DEBT TRANSACTIONS IN AN INTEGRATED MOBILE PHONE, PDA, AND WEB BASED ENVIRONMENT (U.S. CLS. 21, 23, 26, 36 AND 38).

FIRST USE 9-1-2010; IN COMMERCE 9-1-2010.  
ANNE MADDEN, EXAMINING ATTORNEY

SN 85-211,787. MAGID MINA, DBA INVISICORP, INC., LOS ANGELES, CA. FILED 1-6-2011.

# InvisiCode

THE MARK CONSISTS OF STANDARD CHARACTERS WITHOUT CLAIM TO ANY PARTICULAR FONT, STYLE, SIZE, OR COLOR.

FOR COMPUTER SOFTWARE, NAMELY, ELECTRONIC FINANCIAL PLATFORM THAT ACCOMMODATES MULTIPLE TYPES OF PAYMENT AND DEBT TRANSACTIONS IN AN INTEGRATED MOBILE PHONE, PDA, AND WEB BASED ENVIRONMENT (U.S. CLS. 21, 23, 26, 36 AND 38).

FIRST USE 9-1-2010; IN COMMERCE 9-1-2010.  
ANNE MADDEN, EXAMINING ATTORNEY

**CLASS 9—(Continued).**

SN 85-211,900. EQUITRAC CORPORATION, PLANTATION, FL. FILED 1-6-2011.

WE'RE HELPING PEOPLE PRINT  
SMARTER

THE MARK CONSISTS OF STANDARD CHARACTERS WITHOUT CLAIM TO ANY PARTICULAR FONT, STYLE, SIZE, OR COLOR.

FOR COMPUTER HARDWARE IN THE NATURE OF DATA RECORDERS FOR CONTROLLING, MONITORING, RECORDING AND REPORTING THE USE MADE OF OFFICE EQUIPMENT; COMPUTER SOFTWARE FOR CONTROLLING, MONITORING, RECORDING AND REPORTING THE USE MADE OF OFFICE EQUIPMENT; COMPUTER SOFTWARE FOR TRACKING, ALLOCATING AND REPORTING COSTS ASSOCIATED WITH THE USE OF OFFICE EQUIPMENT (U.S. CLS. 21, 23, 26, 36 AND 38).

FIRST USE 2-0-2010; IN COMMERCE 2-0-2010.  
KIM SAITO, EXAMINING ATTORNEY

SN 85-211,933. NEWPORT CORPORATION, IRVINE, CA. FILED 1-6-2011.

NSTRUCT

THE MARK CONSISTS OF STANDARD CHARACTERS WITHOUT CLAIM TO ANY PARTICULAR FONT, STYLE, SIZE, OR COLOR.

FOR SOFTWARE USED TO CONTROL PHOTONIC INSTRUMENTS (U.S. CLS. 21, 23, 26, 36 AND 38).  
ROBIN CHOSID, EXAMINING ATTORNEY

SN 85-211,989. REPUBLIC ALTERNATIVE TECHNOLOGIES, STRONGSVILLE, OH. FILED 1-6-2011.

RGT

THE MARK CONSISTS OF STANDARD CHARACTERS WITHOUT CLAIM TO ANY PARTICULAR FONT, STYLE, SIZE, OR COLOR.

FOR ANODES FOR USE IN ELECTROLYTIC PROCESSES AND APPARATUSES (U.S. CLS. 21, 23, 26, 36 AND 38).  
MAUREEN DALL, EXAMINING ATTORNEY

**CLASS 9—(Continued).**

SN 85-212,012. HUNTER INDUSTRIES, INC., SAN MARCOS, CA. FILED 1-6-2011.

Flow-Clik

THE MARK CONSISTS OF STANDARD CHARACTERS WITHOUT CLAIM TO ANY PARTICULAR FONT, STYLE, SIZE, OR COLOR.

OWNER OF U.S. REG. NOS. 1,846,661, 1,901,597 AND 2,294,090.

FOR ELECTRONIC WATER VOLUME SENSORS FOR CONNECTION TO ELECTRONIC IRRIGATION CONTROLLERS USED IN RESIDENTIAL AND COMMERCIAL IRRIGATION (U.S. CLS. 21, 23, 26, 36 AND 38).

FIRST USE 5-31-2003; IN COMMERCE 5-31-2003.  
HENRY S. ZAK, EXAMINING ATTORNEY

SN 85-212,121. COIN ACCEPTORS, INC., ST. LOUIS, MO. FILED 1-6-2011.

ARROW

THE MARK CONSISTS OF STANDARD CHARACTERS WITHOUT CLAIM TO ANY PARTICULAR FONT, STYLE, SIZE, OR COLOR.

FOR ELECTRONIC DEVICES FOR WIRELESS COLLECTION OF DATA FROM A VENDING MACHINE; BILL VALIDATORS; VENDING MACHINES (U.S. CLS. 21, 23, 26, 36 AND 38).

HEATHER SAPP, EXAMINING ATTORNEY

SN 85-212,299. POCKET GEMS, INC., SAN FRANCISCO, CA. FILED 1-6-2011.

PocketGems

THE MARK CONSISTS OF THE WORD "POCKETGEMS" IN STYLIZED LETTERING WITH A STYLIZED GEM STONE FORMING THE LETTER "G" WITH THREE LINES RADIATING FROM THE TOP OF THE GEM STONE.

FOR COMPUTER GAME SOFTWARE FOR USE ON MOBILE AND CELLULAR PHONES; DOWNLOADABLE COMPUTER GAME SOFTWARE VIA A GLOBAL COMPUTER NETWORK AND WIRELESS DEVICES (U.S. CLS. 21, 23, 26, 36 AND 38).

FIRST USE 12-15-2010; IN COMMERCE 12-15-2010.  
LAURIE KAUFMAN, EXAMINING ATTORNEY

**CLASS 9—(Continued).**

SN 85-212,307. POCKET GEMS, INC., SAN FRANCISCO, CA. FILED 1-6-2011.

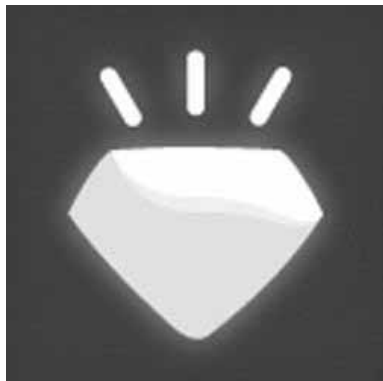

THE MARK CONSISTS OF A STYLIZED GEM STONE WITH THREE LINES RADIATING FROM THE TOP OF THE GEM STONE.

FOR COMPUTER GAME SOFTWARE FOR USE ON MOBILE AND CELLULAR PHONES; DOWNLOADABLE COMPUTER GAME SOFTWARE VIA A GLOBAL COMPUTER NETWORK AND WIRELESS DEVICES (U.S. CLS. 21, 23, 26, 36 AND 38).

LAURIE KAUFMAN, EXAMINING ATTORNEY

**CLASS 9—(Continued).**

SN 85-212,421. YULONG COMPUTER TELECOMMUNICATION SCIENTIFIC (SHENZHEN) CO., LTD, SHENZHEN, CHINA, FILED 1-6-2011.

**Coolpad**

OWNER OF U.S. REG. NO. 3,527,661.

THE MARK CONSISTS OF THE WORD "COOLPAD" IN STYLIZED LETTERS.

FOR AERIALS; ALARM INSTALLATIONS AND ALARMS; AUTOMATIC TURNSTILES; AUTOMATIC VENDING MACHINES; BATTERIES AND BATTERY CHARGERS; CAMCORDERS; CAMERAS; CHARGERS FOR ELECTRIC BATTERIES; COMPUTER APPLICATION SOFTWARE FOR MOBILE PHONES AND HANDHELD COMPUTERS, NAMELY, SOFTWARE FOR USE IN DATABASE MANAGEMENT; COMPUTER HARDWARE AND PERIPHERAL DEVICES; COMPUTER HARDWARE AND SOFTWARE SYSTEM FOR REMOTELY MONITORING ENVIRONMENTAL CONDITIONS AND CONTROLLING DEVICES WITHIN A BUILDING, FACILITY, GROUNDS, OR DESIGNATED SPATIAL AREA; COUNTERFEIT MONEY DETECTION LIGHT TO BE USED IN RETAIL STORES AND BANKS; DIGITAL SIGNAL PROCESSORS; ELECTROLYSIS APPARATUS FOR ELECTROPLATING PURPOSES; ELECTRONIC AGENDAS; ELECTRONIC NAVIGATIONAL AND POSITIONING APPARATUS AND INSTRUMENTS; ELECTRONIC NOTICE BOARDS; ELECTRONIC POCKET TRANSLATORS; ELECTRONIC TAGS FOR GOODS; FAX MACHINES; HAIR-CURLERS, ELECTRICALLY HEATED; HAND-HELD ELECTRONIC DICTIONARIES; INTEGRATED CIRCUITS; MAGNIFYING GLASSES; MOBILE TELEPHONES; NOTEBOOK AND LAPTOP COMPUTERS; PHOTOGRAPHIC SLIDE TRANSPARENCIES; PORTABLE AND HANDHELD DIGITAL ELECTRONIC DEVICES FOR RECORDING, ORGANIZING, TRANSMITTING, MANIPULATING, AND REVIEWING TEXT, DATA, IMAGE, AND AUDIO FILES; PORTABLE TELEPHONES; RADIOTELEPHONY SETS; SPECTACLES; VIDEO RECORDERS; WEIGHING APPARATUS AND INSTRUMENTS (U.S. CLS. 21, 23, 26, 36 AND 38).

DAWN FELDMAN, EXAMINING ATTORNEY

SN 85-212,323. TRIDENT SPACE AND DEFENSE, LLC, TORRANCE, CA. FILED 1-6-2011.

**PROTEUS**

THE MARK CONSISTS OF STANDARD CHARACTERS WITHOUT CLAIM TO ANY PARTICULAR FONT, STYLE, SIZE, OR COLOR.

FOR SOLID STATE HARD DRIVES FOR USE IN RECORDING DIGITAL AND VIDEO INFORMATION IN INDUSTRIAL, MILITARY AND SPACE APPLICATIONS (U.S. CLS. 21, 23, 26, 36 AND 38).

FIRST USE 6-17-2010; IN COMMERCE 6-17-2010.

ODESSA BIBBINS, EXAMINING ATTORNEY

SN 85-212,359. LEAPFROG SYSTEMS LLC, LAS VEGAS, NV. FILED 1-6-2011.

**FROG**

THE MARK CONSISTS OF STANDARD CHARACTERS WITHOUT CLAIM TO ANY PARTICULAR FONT, STYLE, SIZE, OR COLOR.

FOR ELECTRICAL CONTROLS FOR IRRIGATION SPRINKLER SYSTEMS (U.S. CLS. 21, 23, 26, 36 AND 38).

KEVON CHISOLM, EXAMINING ATTORNEY



**CLASS 9—(Continued).**

SN 85-212,477. EMOTIV LIMITED, KWUN TONG, HONG KONG, FILED 1-7-2011.



THE COLOR(S) ORANGE AND WHITE IS/ARE CLAIMED AS A FEATURE OF THE MARK.

THE MARK CONSISTS OF A PAINT BOARD SHAPED OBJECT IN ORANGE COLOR, WHEREIN THE INSIDE CONTAINS A CUT OUT IN THE SHAPE OF THE LETTER "E" IN WHITE COLOR.

FOR COMPUTER SOFTWARE FOR INTERPRETATION OF NEURO AND BRAIN SCANS PROVIDED BY DIAGNOSTIC IMAGING EQUIPMENT FOR USE IN THE COMPUTER GAMING FIELD; COMPUTER SOFTWARE FOR INTERPRETATION OF NEURO AND BRAIN SCANS PROVIDED BY DIAGNOSTIC IMAGING EQUIPMENT FOR USE IN THE MEDICAL FIELD (U.S. CLS. 21, 23, 26, 36 AND 38).

FIRST USE 4-1-2010; IN COMMERCE 9-1-2010.  
MICHAEL GAAFAR, EXAMINING ATTORNEY

SN 85-212,697. APOGEE INC., BREA, CA. FILED 1-7-2011.

kanexpro

THE MARK CONSISTS OF STANDARD CHARACTERS WITHOUT CLAIM TO ANY PARTICULAR FONT, STYLE, SIZE, OR COLOR.

OWNER OF U.S. REG. NO. 3,703,050.  
FOR DISTRIBUTION AMPLIFIERS FOR AUDIO AND VIDEO SIGNALS; MATRIX SWITCHERS FOR AUDIO AND VIDEO SIGNALS; TRANSMITTERS AND RECEIVERS FOR AUDIO AND VIDEO SIGNALS FOR TRANSMISSION OVER TWISTED PAIR CABLES (U.S. CLS. 21, 23, 26, 36 AND 38).

NAAKWAMA ANKRAH, EXAMINING ATTORNEY

**CLASS 9—(Continued).**

SN 85-212,799. WOLO MANUFACTURING CORP., DEER PARK, NY. FILED 1-7-2011.

EMERGENCY 1

THE MARK CONSISTS OF STANDARD CHARACTERS WITHOUT CLAIM TO ANY PARTICULAR FONT, STYLE, SIZE, OR COLOR.

NO CLAIM IS MADE TO THE EXCLUSIVE RIGHT TO USE "EMERGENCY", APART FROM THE MARK AS SHOWN.

FOR AUTOMOTIVE SAFETY WARNING LIGHTS, NAMELY, ROTATING LIGHTS (U.S. CLS. 21, 23, 26, 36 AND 38).

FIRST USE 2-1-2002; IN COMMERCE 2-1-2002.  
KELLY BOULTON, EXAMINING ATTORNEY

SN 85-212,926. LINEAR LLC, CARLSBAD, CA. FILED 1-7-2011.

DMC1 IPLAY

THE MARK CONSISTS OF STANDARD CHARACTERS WITHOUT CLAIM TO ANY PARTICULAR FONT, STYLE, SIZE, OR COLOR.

FOR CENTRAL INTERCOM SYSTEMS AND CENTRAL STEREO MUSIC SYSTEMS COMPRISED OF CD PLAYERS, SPEAKERS, RECEIVERS, TRANSMITTERS, ELECTRONIC DOCKING STATIONS SPECIALLY DESIGNED FOR HOLDING PORTABLE AND HANDHELD DIGITAL ELECTRONIC DEVICES, WIRE AND MASTER CONTROL PANELS FOR DISTRIBUTION OF SOUND; AUDIO SPEAKERS; PARTS AND ACCESSORIES THEREOF, NAMELY VOLUME CONTROLS, SUBWOOFERS, REMOTE CONTROLS, CHARGERS (U.S. CLS. 21, 23, 26, 36 AND 38).

HELENE LIWINSKI, EXAMINING ATTORNEY

**CLASS 9—(Continued).**

SN 85-212,992. CREE, INC., DURHAM, NC. FILED 1-7-2011.



OWNER OF U.S. REG. NOS. 2,452,761, 3,327,299 AND OTHERS.

THE MARK CONSISTS OF DIAMOND-SHAPED DESIGN WITH HORIZONTAL STRIPES.

FOR DIODES; TRANSISTORS; SEMICONDUCTOR DEVICES; SEMICONDUCTOR CHIPS; SEMICONDUCTOR WAFERS (U.S. CLS. 21, 23, 26, 36 AND 38).

FIRST USE 7-0-1990; IN COMMERCE 7-0-1990.

STEVEN PEREZ, EXAMINING ATTORNEY

SN 85-213,011. VITAL SOFTWARE CORPORATION, FORT LAUDERDALE, FL. FILED 1-7-2011.

RELIEF IS A HEARTBEAT AWAY

THE MARK CONSISTS OF STANDARD CHARACTERS WITHOUT CLAIM TO ANY PARTICULAR FONT, STYLE, SIZE, OR COLOR.

FOR COMPUTER SOFTWARE FOR APPLICATION AND DATABASE INTEGRATION; COMPUTER SOFTWARE FOR PROVIDING AN ON-LINE DATABASE IN THE FIELD OF TRANSACTION PROCESSING TO UPLOAD TRANSACTIONAL DATA, PROVIDE STATISTICAL ANALYSIS, AND PRODUCE NOTIFICATIONS AND REPORTS (U.S. CLS. 21, 23, 26, 36 AND 38).

MATTHEW MCDOWELL, EXAMINING ATTORNEY

**CLASS 9—(Continued).**

SN 85-213,052. VITAL SOFTWARE CORPORATION, FORT LAUDERDALE, FL. FILED 1-7-2011.

BECAUSE YOU ARE VITAL

THE MARK CONSISTS OF STANDARD CHARACTERS WITHOUT CLAIM TO ANY PARTICULAR FONT, STYLE, SIZE, OR COLOR.

FOR COMPUTER SOFTWARE FOR APPLICATION AND DATABASE INTEGRATION; COMPUTER SOFTWARE FOR PROVIDING AN ON-LINE DATABASE IN THE FIELD OF TRANSACTION PROCESSING TO UPLOAD TRANSACTIONAL DATA, PROVIDE STATISTICAL ANALYSIS, AND PRODUCE NOTIFICATIONS AND REPORTS (U.S. CLS. 21, 23, 26, 36 AND 38).

MATTHEW MCDOWELL, EXAMINING ATTORNEY

SN 85-213,097. VITAL SOFTWARE CORPORATION, FORT LAUDERDALE, FL. FILED 1-7-2011.

BECAUSE U R VITAL

THE MARK CONSISTS OF STANDARD CHARACTERS WITHOUT CLAIM TO ANY PARTICULAR FONT, STYLE, SIZE, OR COLOR.

FOR COMPUTER SOFTWARE FOR APPLICATION AND DATABASE INTEGRATION; COMPUTER SOFTWARE FOR PROVIDING AN ON-LINE DATABASE IN THE FIELD OF TRANSACTION PROCESSING TO UPLOAD TRANSACTIONAL DATA, PROVIDE STATISTICAL ANALYSIS, AND PRODUCE NOTIFICATIONS AND REPORTS (U.S. CLS. 21, 23, 26, 36 AND 38).

MATTHEW MCDOWELL, EXAMINING ATTORNEY

SN 85-213,180. PISTOLSTAR, INC., AMHERST, NH. FILED 1-7-2011.

PortalGuard

THE MARK CONSISTS OF STANDARD CHARACTERS WITHOUT CLAIM TO ANY PARTICULAR FONT, STYLE, SIZE, OR COLOR.

FOR DOWNLOADABLE COMPUTER SOFTWARE FOR PROVIDING SELF-SERVICE PASSWORD MANAGEMENT AND OTHER USER AUTHENTICATION MANAGEMENT (U.S. CLS. 21, 23, 26, 36 AND 38).

FIRST USE 7-14-2009; IN COMMERCE 7-14-2009.

JOHN KELLY, EXAMINING ATTORNEY

**CLASS 9—(Continued).**

SN 85-213,236. NAPOLEON HILL FOUNDATION, WISE, VA. FILED 1-7-2011.

**THE SIX GHOSTS OF FEAR**

THE MARK CONSISTS OF STANDARD CHARACTERS WITHOUT CLAIM TO ANY PARTICULAR FONT, STYLE, SIZE, OR COLOR.

FOR PRE-RECORDED CDS, DVDS, AUDIO AND VIDEO CASSETTES, ELECTRONIC AND DIGITAL MEDIA, NAMELY, DOWNLOADABLE AUDIO FILES IN THE FIELDS OF SELF-DEVELOPMENT, SELF-IMPROVEMENT, AND PERSONAL ACHIEVEMENT (U.S. CLS. 21, 23, 26, 36 AND 38).

DOMINIC J. FERRAIUOLO, EXAMINING ATTORNEY

**CLASS 9—(Continued).**

SN 85-213,664. AMERICAN WATERWELL INTERNATIONAL CORPORATION, WILMINGTON, NEW CASTLE, DE. FILED 1-9-2011.

**WATERWELL**

THE MARK CONSISTS OF STYLIZED WORD "WATERWELL".

FOR AIR ANALYSIS APPARATUS; AMMETERS; DIAGNOSTIC APPARATUS FOR TESTING FOOD; FLOW METERS; GLASSWARE FOR SCIENTIFIC EXPERIMENTS IN LABORATORIES; LENGTH MEASURING GAUGES; LEVEL GAUGES; MANOMETERS; MICRO-METER GAUGES; OZONISERS; PROBES FOR TESTING INTEGRATED CIRCUITS; RESIDUAL GAS ANALYZERS; RESISTANCE MEASURING INSTRUMENTS; RHEOMETERS FOR MEASURING THE VISCOSITY AND VISCOELASTICITY OF FLUIDS; SCIENTIFIC MEASURING INSTRUMENTS, NAMELY, CONDUCTIVITY METERS; SURVEYING MACHINES AND INSTRUMENTS; THERMOMETERS; VOLTMETERS (U.S. CLS. 21, 23, 26, 36 AND 38).

FIRST USE 6-12-2009; IN COMMERCE 6-12-2009.  
HELENE LIWINSKI, EXAMINING ATTORNEY

SN 85-213,369. INFLUENCE, MENOMONEE FALLS, WI. FILED 1-7-2011.

**SalesPal**

THE MARK CONSISTS OF STANDARD CHARACTERS WITHOUT CLAIM TO ANY PARTICULAR FONT, STYLE, SIZE, OR COLOR.

FOR COMPUTER APPLICATION SOFTWARE FOR SMARTPHONES, PORTABLE COMPUTERS AND PERSONAL ELECTRONIC DEVICES, NAMELY, SOFTWARE FOR THE PURPOSE OF MONITORING SALES ACTIVITY AND SALES PIPELINE IN A USER FRIENDLY GRAPHICAL USER INTERFACE; COMPUTER SOFTWARE FOR THE PURPOSE OF MONITORING SALES ACTIVITY AND SALES PIPELINE IN A USER FRIENDLY GRAPHICAL USER INTERFACE (U.S. CLS. 21, 23, 26, 36 AND 38).

FIRST USE 1-15-2010; IN COMMERCE 12-15-2010.  
TINA BROWN, EXAMINING ATTORNEY

SN 85-214,213. NEURALOG, INC., STAFFORD, TX. FILED 1-10-2011.

**NeuraJet17**

SN 85-213,587. TONGIER, NATHAN A., ALBUQUERQUE, NM. FILED 1-9-2011.

**Torment Faktory**

THE MARK CONSISTS OF STANDARD CHARACTERS WITHOUT CLAIM TO ANY PARTICULAR FONT, STYLE, SIZE, OR COLOR.

FOR AUDIO AND VIDEO RECORDINGS FEATURING MUSIC AND ARTISTIC PERFORMANCES (U.S. CLS. 21, 23, 26, 36 AND 38).

DAVID TAYLOR, EXAMINING ATTORNEY

THE MARK CONSISTS OF STANDARD CHARACTERS WITHOUT CLAIM TO ANY PARTICULAR FONT, STYLE, SIZE, OR COLOR.

FOR INK-JET COLOR PRINTERS (U.S. CLS. 21, 23, 26, 36 AND 38).

FIRST USE 12-8-2009; IN COMMERCE 12-8-2009.  
CHERYL CLAYTON, EXAMINING ATTORNEY

**CLASS 9—(Continued).**

SN 85-214,219. SAINT LOUIS UNIVERSITY, ST. LOUIS, MO.  
FILED 1-10-2011.



THE MARK CONSISTS OF A STYLIZED DEPICTION OF THE HEAD OF A CHARM DOLL (A "BILLIKEN") WITH TWO POINTED EARS AND A TUFT OF HAIR ON THE TOP OF ITS HEAD. THE MOUTH IS CURVED AND THE RIGHT EYE IS CLOSED

FOR MOUSEPADS (U.S. CLS. 21, 23, 26, 36 AND 38).  
FIRST USE 0-0-2000; IN COMMERCE 0-0-2000.  
KARANENDRA S. CHHINA, EXAMINING ATTORNEY

SN 85-214,287. UNCLE SAM'S FIREWORKS CITY, INC.,  
BIXBY, OK. FILED 1-10-2011.

## Talon

THE MARK CONSISTS OF STANDARD CHARACTERS WITHOUT CLAIM TO ANY PARTICULAR FONT, STYLE, SIZE, OR COLOR.

FOR ELECTRIC IGNITER FOR FIREWORKS/PYRO-TECHNICS (U.S. CLS. 21, 23, 26, 36 AND 38).  
FIRST USE 4-20-2009; IN COMMERCE 4-20-2009.  
JACQUELINE A. LAVINE, EXAMINING ATTORNEY

SN 85-214,326. FEHRMANN KSCHUK SERVICES LLC,  
MIDLOTHIAN, VA. FILED 1-10-2011.

## FINALYSER

THE MARK CONSISTS OF STANDARD CHARACTERS WITHOUT CLAIM TO ANY PARTICULAR FONT, STYLE, SIZE, OR COLOR.

FOR DESKTOP PUBLISHING SOFTWARE (U.S. CLS. 21, 23, 26, 36 AND 38).  
FIRST USE 11-14-2010; IN COMMERCE 11-14-2010.  
SUNG IN, EXAMINING ATTORNEY

**CLASS 9—(Continued).**

SN 85-214,403. COACTIV, LLC, RIDGEFIELD, CT. FILED 1-10-2011.

## EXAM-PAD

THE MARK CONSISTS OF STANDARD CHARACTERS WITHOUT CLAIM TO ANY PARTICULAR FONT, STYLE, SIZE, OR COLOR.

OWNER OF U.S. REG. NOS. 2,913,278, 2,916,420 AND OTHERS.

FOR TABLET COMPUTER (U.S. CLS. 21, 23, 26, 36 AND 38).

FIRST USE 1-10-2011; IN COMMERCE 1-10-2011.  
HEATHER THOMPSON, EXAMINING ATTORNEY

SN 85-214,407. COACTIV, LLC, RIDGEFIELD, CT. FILED 1-10-2011.

## EXAM-JACKET

THE MARK CONSISTS OF STANDARD CHARACTERS WITHOUT CLAIM TO ANY PARTICULAR FONT, STYLE, SIZE, OR COLOR.

OWNER OF U.S. REG. NOS. 2,913,278, 2,916,420 AND OTHERS.

FOR MEDICAL SOFTWARE FOR INDEXING, ASSOCIATING, AND VIEWING MULTIPLE MEDICAL IMAGE STUDIES OF A PATIENT (U.S. CLS. 21, 23, 26, 36 AND 38).

HEATHER THOMPSON, EXAMINING ATTORNEY

SN 85-214,952. ARISTOCRAT TECHNOLOGIES AUSTRALIA PTY LTD, NORTH RYDE, NSW, AUSTRALIA, FILED 1-11-2011.

## THE AMAZING DAVE

THE MARK CONSISTS OF STANDARD CHARACTERS WITHOUT CLAIM TO ANY PARTICULAR FONT, STYLE, SIZE, OR COLOR.

THE NAME(S), PORTRAIT(S), AND/OR SIGNATURE(S) SHOWN IN THE MARK DOES NOT IDENTIFY A PARTICULAR LIVING INDIVIDUAL.

FOR ELECTRONIC GAMING MACHINES, NAMELY, DEVICES WHICH ACCEPT A WAGER (U.S. CLS. 21, 23, 26, 36 AND 38).

MEGHAN REINHART, EXAMINING ATTORNEY

**CLASS 9—(Continued).**

SN 85-214,986. ARISTOCRAT TECHNOLOGIES AUSTRALIA PTY LTD, NORTH RYDE, NSW, AUSTRALIA, FILED 1-11-2011.

**CLASS 9—(Continued).**

SN 85-218,411. HTC CORPORATION, TAOYUAN CITY, TAIWAN, FILED 1-14-2011.

# MORE PEARLS

THE MARK CONSISTS OF STANDARD CHARACTERS WITHOUT CLAIM TO ANY PARTICULAR FONT, STYLE, SIZE, OR COLOR.

FOR ELECTRONIC GAMING MACHINES, NAMELY, DEVICES WHICH ACCEPT A WAGER (U.S. CLS. 21, 23, 26, 36 AND 38).

MEGHAN REINHART, EXAMINING ATTORNEY

# HTC PASSION

THE MARK CONSISTS OF STANDARD CHARACTERS WITHOUT CLAIM TO ANY PARTICULAR FONT, STYLE, SIZE, OR COLOR.

OWNER OF U.S. REG. NOS. 3,584,880, 3,890,684 AND OTHERS.

FOR MOBILE PHONES, SMARTPHONES, CELLULAR PHONES, PORTABLE COMPUTERS, AND PERSONAL DIGITAL ASSISTANTS AND WIRELESS HANDHELD DIGITAL ELECTRONIC DEVICES FOR COMMUNICATING, RECORDING, ORGANIZING, TRANSMITTING, MANIPULATING, STORING, AND REVIEWING TEXT, DATA, IMAGE, AND AUDIO FILES (U.S. CLS. 21, 23, 26, 36 AND 38).

DANNEAN HETZEL, EXAMINING ATTORNEY

SN 85-216,290. THE FONT BUREAU, INC., BOSTON, MA. FILED 1-12-2011.

# CANTO

THE MARK CONSISTS OF STANDARD CHARACTERS WITHOUT CLAIM TO ANY PARTICULAR FONT, STYLE, SIZE, OR COLOR.

THE ENGLISH TRANSLATION OF "CANTO" IN THE MARK IS "SONG".

FOR PRINTING FONTS THAT CAN BE DOWNLOADED PROVIDED BY MEANS OF ELECTRONIC TRANSMISSION; TYPEFACE FONTS RECORDED ON MAGNETIC MEDIA (U.S. CLS. 21, 23, 26, 36 AND 38).

FIRST USE 1-11-2011; IN COMMERCE 1-11-2011.  
KARANENDRA S. CHHINA, EXAMINING ATTORNEY

SN 85-218,417. NAMCO BANDAI GAMES INC., SHINAGAWA-KU TOKYO, JAPAN, FILED 1-14-2011.

# DUALPENSPO RTS

SN 85-217,963. TECMO KOEI GAMES CO., LTD., YOKOHAMA, KANAGAWA, JAPAN, FILED 1-14-2011.

## WARRIORS; LEGENDS OF TROY

THE MARK CONSISTS OF STANDARD CHARACTERS WITHOUT CLAIM TO ANY PARTICULAR FONT, STYLE, SIZE, OR COLOR.

FOR COMPUTER GAME DISCS; COMPUTER GAME PROGRAMS; COMPUTER GAME SOFTWARE; VIDEO GAME DISCS; VIDEO GAME PROGRAMS; VIDEO GAME SOFTWARE; DOWNLOADABLE COMPUTER GAME SOFTWARE; DOWNLOADABLE VIDEO GAME SOFTWARE (U.S. CLS. 21, 23, 26, 36 AND 38).

ANTHONY RINKER, EXAMINING ATTORNEY

THE MARK CONSISTS OF STANDARD CHARACTERS WITHOUT CLAIM TO ANY PARTICULAR FONT, STYLE, SIZE, OR COLOR.

FOR COMPUTER GAME PROGRAMS; COMPUTER GAME PROGRAMS, CARTRIDGES, AND CASSETTES; COMPUTER GAME SOFTWARE; DOWNLOADABLE COMPUTER GAME PROGRAMS; DOWNLOADABLE COMPUTER GAME SOFTWARE VIA A GLOBAL COMPUTER NETWORK AND WIRELESS DEVICES; VIDEO GAME CARTRIDGES; VIDEO GAME DISCS; VIDEO GAME SOFTWARE (U.S. CLS. 21, 23, 26, 36 AND 38).

PRISCILLA MILTON, EXAMINING ATTORNEY

**CLASS 9—(Continued).**

SN 85-218,477. HTC CORPORATION, SEATTLE, WA. FILED 1-14-2011.

**HTC PASSION**

THE MARK CONSISTS OF STANDARD CHARACTERS WITHOUT CLAIM TO ANY PARTICULAR FONT, STYLE, SIZE, OR COLOR.

OWNER OF U.S. REG. NOS. 3,584,880, 3,890,684 AND OTHERS.

FOR COMPUTER HARDWARE AND SOFTWARE FOR ENABLING, OPERATING, ENHANCING, CUSTOMIZING, UPDATING AND MANAGING MOBILE, PORTABLE, SMART, VOICE-OVER-INTERNET-PROTOCOL, AND WIRELESS DEVICES; USER INTERFACE SOFTWARE; COMPUTER HARDWARE AND SOFTWARE FOR DELIVERING, ENABLING, CREATING, ENHANCING, CUSTOMIZING, UPDATING, AND MANAGING USER INTERFACING, TELECOMMUNICATIONS AND TELECOMMUNICATIONS SERVICES; COMPUTER HARDWARE AND SOFTWARE FOR TRANSMITTING AND RECEIVING VOICE, IMAGE, DATA, AUDIO, VIDEO AND MULTIMEDIA CONTENT; WIRELESS MODEMS; ACCESSORIES FOR THE ABOVE GOODS, NAMELY, HEADSETS, HEADSETS WITH WIRELESS TRANSMISSION FUNCTION, CONNECTION CABLES, IN-CAR TELEPHONE HANDSET CRADLES, IN-CAR MOUNTS AND FACE PLATES FOR MOBILE PHONES, SMARTPHONES, CELLULAR PHONES, PORTABLE COMPUTERS AND PERSONAL DIGITAL ASSISTANTS, REPLACEMENT PARTS THEREFOR, BATTERIES, BATTERY CHARGER ADAPTORS, BATTERY CHARGERS, CASES, POUCHES SPECIFICALLY ADAPTED FOR CARRYING MOBILE PHONES, SMARTPHONES, CELLULAR PHONES AND PERSONAL DIGITAL ASSISTANTS, IN-VEHICLE BATTERY CHARGERS, IN-VEHICLE HOLDERS, REMOTE CONTROLS, KEYBOARDS; MICROPHONES; AND LOUDSPEAKERS (U.S. CLS. 21, 23, 26, 36 AND 38).

DANNEAN HETZEL, EXAMINING ATTORNEY

SN 85-218,570. HTC CORPORATION, TAOYUAN CITY, TAIWAN, FILED 1-14-2011.

**PASSION**

THE MARK CONSISTS OF STANDARD CHARACTERS WITHOUT CLAIM TO ANY PARTICULAR FONT, STYLE, SIZE, OR COLOR.

FOR MOBILE PHONES, SMARTPHONES, CELLULAR PHONES, PORTABLE COMPUTERS, AND PERSONAL DIGITAL ASSISTANTS AND WIRELESS HANDHELD DIGITAL ELECTRONIC DEVICES FOR COMMUNICATING, RECORDING, ORGANIZING, TRANSMITTING, MANIPULATING, STORING, AND REVIEWING TEXT, DATA, IMAGE, AND AUDIO FILES (U.S. CLS. 21, 23, 26, 36 AND 38).

DANNEAN HETZEL, EXAMINING ATTORNEY

**CLASS 9—(Continued).**

SN 85-218,572. HTC CORPORATION, TAOYUAN CITY, TAIWAN, FILED 1-14-2011.

**PASSION**

THE MARK CONSISTS OF STANDARD CHARACTERS WITHOUT CLAIM TO ANY PARTICULAR FONT, STYLE, SIZE, OR COLOR.

FOR COMPUTER HARDWARE AND SOFTWARE FOR ENABLING, OPERATING, ENHANCING, CUSTOMIZING, UPDATING AND MANAGING MOBILE, PORTABLE, SMART, VOICE-OVER-INTERNET-PROTOCOL, AND WIRELESS DEVICES; USER INTERFACE SOFTWARE; COMPUTER HARDWARE AND SOFTWARE FOR DELIVERING, ENABLING, CREATING, ENHANCING, CUSTOMIZING, UPDATING, AND MANAGING USER INTERFACING, TELECOMMUNICATIONS AND TELECOMMUNICATIONS SERVICES; COMPUTER HARDWARE AND SOFTWARE FOR TRANSMITTING AND RECEIVING VOICE, IMAGE, DATA, AUDIO, VIDEO AND MULTIMEDIA CONTENT; WIRELESS MODEMS; ACCESSORIES FOR THE ABOVE GOODS, NAMELY, HEADSETS, HEADSETS WITH WIRELESS TRANSMISSION FUNCTION, CONNECTION CABLES, IN-CAR TELEPHONE HANDSET CRADLES, IN-CAR MOUNTS AND FACE PLATES FOR MOBILE PHONES, SMARTPHONES, CELLULAR PHONES, PORTABLE COMPUTERS AND PERSONAL DIGITAL ASSISTANTS, REPLACEMENT PARTS THEREFOR, BATTERIES, BATTERY CHARGER ADAPTORS, BATTERY CHARGERS, CASES, POUCHES SPECIFICALLY ADAPTED FOR CARRYING MOBILE PHONES, SMARTPHONES, CELLULAR PHONES AND PERSONAL DIGITAL ASSISTANTS, IN-VEHICLE BATTERY CHARGERS, IN-VEHICLE HOLDERS, REMOTE CONTROLS, KEYBOARDS; MICROPHONES; AND LOUDSPEAKERS (U.S. CLS. 21, 23, 26, 36 AND 38).

DANNEAN HETZEL, EXAMINING ATTORNEY

SN 85-220,242. HTC CORPORATION, TAOYUAN CITY, TAIWAN, FILED 1-18-2011.

**HTC ARRIVE**

THE MARK CONSISTS OF STANDARD CHARACTERS WITHOUT CLAIM TO ANY PARTICULAR FONT, STYLE, SIZE, OR COLOR.

OWNER OF U.S. REG. NOS. 3,584,880, 3,819,603 AND 3,890,684.

FOR MOBILE PHONES, SMARTPHONES, CELLULAR PHONES, PORTABLE COMPUTERS, AND PERSONAL DIGITAL ASSISTANTS AND WIRELESS HANDHELD DIGITAL ELECTRONIC DEVICES FOR COMMUNICATING, RECORDING, ORGANIZING, TRANSMITTING, MANIPULATING, STORING, AND REVIEWING TEXT, DATA, IMAGE, AND AUDIO FILES (U.S. CLS. 21, 23, 26, 36 AND 38).

DANNEAN HETZEL, EXAMINING ATTORNEY

**CLASS 9—(Continued).**

SN 85-220,297. HTC CORPORATION, TAOYUAN CITY, TAIWAN, FILED 1-18-2011.

**CLASS 9—(Continued).**

SN 85-220,495. FREMANTLEMEDIA NORTH AMERICA, INC., BURBANK, CA. AND SOCIAL GAME UNIVERSE, INC., TORONTO, CANADA, FILED 1-18-2011.

# HTC ARRIVE

# GROW OPS

THE MARK CONSISTS OF STANDARD CHARACTERS WITHOUT CLAIM TO ANY PARTICULAR FONT, STYLE, SIZE, OR COLOR.

OWNER OF U.S. REG. NOS. 3,584,880, 3,819,603 AND 3,890,684.

FOR COMPUTER HARDWARE AND SOFTWARE FOR ENABLING, OPERATING, ENHANCING, CUSTOMIZING, UPDATING AND MANAGING MOBILE, PORTABLE, SMART, VOICE-OVER-INTERNET-PROTOCOL, AND WIRELESS DEVICES; USER INTERFACE SOFTWARE; COMPUTER HARDWARE AND SOFTWARE FOR DELIVERING, ENABLING, CREATING, ENHANCING, CUSTOMIZING, UPDATING, AND MANAGING USER INTERFACING, TELECOMMUNICATIONS AND TELECOMMUNICATIONS SERVICES; COMPUTER HARDWARE AND SOFTWARE FOR TRANSMITTING AND RECEIVING VOICE, IMAGE, DATA, AUDIO, VIDEO AND MULTIMEDIA CONTENT; WIRELESS MODEMS; ACCESSORIES FOR THE ABOVE GOODS, NAMELY, HEADSETS, HEADSETS WITH WIRELESS TRANSMISSION FUNCTION, CONNECTION CABLES, IN-CAR TELEPHONE HANDSET CRADLES, IN-CAR MOUNTS AND FACE PLATES FOR MOBILE PHONES, SMARTPHONES, CELLULAR PHONES, PORTABLE COMPUTERS AND PERSONAL DIGITAL ASSISTANTS, REPLACEMENT PARTS THEREFOR, BATTERIES, BATTERY CHARGER ADAPTORS, BATTERY CHARGERS, CASES, POUCHES SPECIFICALLY ADAPTED FOR CARRYING MOBILE PHONES, SMARTPHONES, CELLULAR PHONES AND PERSONAL DIGITAL ASSISTANTS, IN-VEHICLE BATTERY CHARGERS, IN-VEHICLE HOLDERS, REMOTE CONTROLS, KEYBOARDS; MICROPHONES; AND LOUDSPEAKERS (U.S. CLS. 21, 23, 26, 36 AND 38).

DANNEAN HETZEL, EXAMINING ATTORNEY

THE MARK CONSISTS OF STANDARD CHARACTERS WITHOUT CLAIM TO ANY PARTICULAR FONT, STYLE, SIZE, OR COLOR.

FOR COMPUTER GAME SOFTWARE; VIDEO GAME PROGRAMS; AND COMPUTER SOFTWARE PLATFORMS FOR SOCIAL NETWORKING; INTERACTIVE VIDEO GAME PROGRAMS; DOWNLOADABLE ELECTRONIC GAME PROGRAMS AND COMPUTER SOFTWARE PLATFORMS FOR SOCIAL NETWORKING THAT MAY BE ACCESSED VIA THE INTERNET, COMPUTERS AND WIRELESS DEVICES; COMPUTER SOFTWARE TO ENABLE UPLOADING, POSTING, SHOWING, DISPLAYING, TAGGING, BLOGGING, SHARING OR OTHERWISE PROVIDING ELECTRONIC MEDIA OR INFORMATION IN THE FIELDS OF VIRTUAL COMMUNITIES, ELECTRONIC GAMING, ENTERTAINMENT, AND GENERAL INTEREST VIA THE INTERNET OR OTHER COMMUNICATIONS NETWORKS WITH THIRD PARTIES (U.S. CLS. 21, 23, 26, 36 AND 38).

TAMARA FRAZIER, EXAMINING ATTORNEY

**CLASS 9—(Continued).**

SN 85-221,275. HTC CORPORATION, TAOYUAN CITY, TAIWAN, FILED 1-19-2011.

**HTC SENSATION**

THE MARK CONSISTS OF STANDARD CHARACTERS WITHOUT CLAIM TO ANY PARTICULAR FONT, STYLE, SIZE, OR COLOR.

OWNER OF U.S. REG. NOS. 3,584,880, 3,819,603 AND 3,890,684.

FOR COMPUTER HARDWARE AND SOFTWARE FOR ENABLING, OPERATING, ENHANCING, CUSTOMIZING, UPDATING AND MANAGING MOBILE, PORTABLE, SMART, VOICE-OVER-INTERNET-PROTOCOL, AND WIRELESS DEVICES; USER INTERFACE SOFTWARE; COMPUTER HARDWARE AND SOFTWARE FOR DELIVERING, ENABLING, CREATING, ENHANCING, CUSTOMIZING, UPDATING, AND MANAGING USER INTERFACING, TELECOMMUNICATIONS AND TELECOMMUNICATIONS SERVICES; COMPUTER HARDWARE AND SOFTWARE FOR TRANSMITTING AND RECEIVING VOICE, IMAGE, DATA, AUDIO, VIDEO AND MULTIMEDIA CONTENT; WIRELESS MODEMS; ACCESSORIES FOR THE ABOVE GOODS, NAMELY, HEADSETS, HEADSETS WITH WIRELESS TRANSMISSION FUNCTION, CONNECTION CABLES, IN-CAR TELEPHONE HANDSET CRADLES, IN-CAR MOUNTS AND FACE PLATES FOR MOBILE PHONES, SMARTPHONES, CELLULAR PHONES, PORTABLE COMPUTERS AND PERSONAL DIGITAL ASSISTANTS, REPLACEMENT PARTS THEREFOR, BATTERIES, BATTERY CHARGER ADAPTORS, BATTERY CHARGERS, CASES, POUCHES SPECIFICALLY ADAPTED FOR CARRYING MOBILE PHONES, SMARTPHONES, CELLULAR PHONES AND PERSONAL DIGITAL ASSISTANTS, IN-VEHICLE BATTERY CHARGERS, IN-VEHICLE HOLDERS, REMOTE CONTROLS, KEYBOARDS; MICROPHONES; AND LOUDSPEAKERS (U.S. CLS. 21, 23, 26, 36 AND 38).

DANNEAN HETZEL, EXAMINING ATTORNEY

SN 85-221,280. HTC CORPORATION, TAOYUAN CITY, TAIWAN, FILED 1-19-2011.

**HTC SENSATION**

THE MARK CONSISTS OF STANDARD CHARACTERS WITHOUT CLAIM TO ANY PARTICULAR FONT, STYLE, SIZE, OR COLOR.

OWNER OF U.S. REG. NOS. 3,584,880, 3,819,603 AND 3,890,684.

FOR MOBILE PHONES, SMARTPHONES, CELLULAR PHONES, PORTABLE COMPUTERS, AND PERSONAL DIGITAL ASSISTANTS AND WIRELESS HANDHELD DIGITAL ELECTRONIC DEVICES FOR COMMUNICATING, RECORDING, ORGANIZING, TRANSMITTING, MANIPULATING, STORING, AND REVIEWING TEXT, DATA, IMAGE, AND AUDIO FILES (U.S. CLS. 21, 23, 26, 36 AND 38).

DANNEAN HETZEL, EXAMINING ATTORNEY

**CLASS 9—(Continued).**

SN 85-221,567. BALLY GAMING, INC., DBA BALLY TECHNOLOGIES, LAS VEGAS, NV. FILED 1-19-2011.

**BREAKTHROUGH BONUS**

THE MARK CONSISTS OF STANDARD CHARACTERS WITHOUT CLAIM TO ANY PARTICULAR FONT, STYLE, SIZE, OR COLOR.

FOR COMPUTER GAMING SOFTWARE, GAMING SOFTWARE THAT GENERATES OR DISPLAYS WAGER OUTCOMES OF GAMING MACHINES, DOWNLOADABLE COMPUTER GAME SOFTWARE FOR GAMING, GAMING MACHINES, NAMELY, DEVICES THAT ACCEPT A WAGER; SLOT MACHINES (U.S. CLS. 21, 23, 26, 36 AND 38).

THEODORE MCBRIDE, EXAMINING ATTORNEY

SN 85-221,570. BALLY GAMING, INC., DBA BALLY TECHNOLOGIES, LAS VEGAS, NV. FILED 1-19-2011.

**HOT SPIN**

THE MARK CONSISTS OF STANDARD CHARACTERS WITHOUT CLAIM TO ANY PARTICULAR FONT, STYLE, SIZE, OR COLOR.

FOR COMPUTER GAMING SOFTWARE, GAMING SOFTWARE THAT GENERATES OR DISPLAYS WAGER OUTCOMES OF GAMING MACHINES, DOWNLOADABLE COMPUTER GAME SOFTWARE FOR GAMING, GAMING MACHINES, NAMELY, DEVICES THAT ACCEPT A WAGER; SLOT MACHINES (U.S. CLS. 21, 23, 26, 36 AND 38).

THEODORE MCBRIDE, EXAMINING ATTORNEY

SN 85-221,784. RADWARE LTD., TEL AVIV, ISRAEL, FILED 1-20-2011.

**VDIRECT**

THE MARK CONSISTS OF STANDARD CHARACTERS WITHOUT CLAIM TO ANY PARTICULAR FONT, STYLE, SIZE, OR COLOR.

FOR COMPUTER SOFTWARE FOR THE MANAGEMENT OF APPLICATION DELIVERY CONTROLLERS THROUGH COMPUTER NETWORK PROVISIONING SYSTEMS (U.S. CLS. 21, 23, 26, 36 AND 38).

KATHERINE CHANG, EXAMINING ATTORNEY



**CLASS 9—(Continued).**

SN 85-222,996. FONT DINER, INC., EAU CLAIRE, WI. FILED 1-21-2011.

**KIDDIE COCKTAILS**

THE MARK CONSISTS OF STANDARD CHARACTERS WITHOUT CLAIM TO ANY PARTICULAR FONT, STYLE, SIZE, OR COLOR.

FOR PRINTING FONTS THAT CAN BE DOWN-LOADED PROVIDED BY MEANS OF ELECTRONIC TRANSMISSION; TYPEFACE FONTS RECORDED ON MAGNETIC MEDIA (U.S. CLS. 21, 23, 26, 36 AND 38).

FIRST USE 5-15-2003; IN COMMERCE 5-15-2003.  
DOMINICK J. SALEMI, EXAMINING ATTORNEY

**CLASS 9—(Continued).**

SN 85-224,199. SMITHS DETECTION INC., DANBURY, CT. FILED 1-24-2011.

**RADSEEKER**

THE MARK CONSISTS OF STANDARD CHARACTERS WITHOUT CLAIM TO ANY PARTICULAR FONT, STYLE, SIZE, OR COLOR.

FOR APPARATUS AND INSTRUMENTS FOR DETECTING AND ANALYZING CHEMICAL NUCLEAR MATERIALS (U.S. CLS. 21, 23, 26, 36 AND 38).

FIRST USE 11-19-2010; IN COMMERCE 11-19-2010.  
JASON TURNER, EXAMINING ATTORNEY

SN 85-223,091. FONT DINER, INC., EAU CLAIRE, WI. FILED 1-21-2011.

**MOSQUITO FIESTA**

THE MARK CONSISTS OF STANDARD CHARACTERS WITHOUT CLAIM TO ANY PARTICULAR FONT, STYLE, SIZE, OR COLOR.

FOR PRINTING FONTS THAT CAN BE DOWN-LOADED PROVIDED BY MEANS OF ELECTRONIC TRANSMISSION; TYPEFACE FONTS RECORDED ON MAGNETIC MEDIA (U.S. CLS. 21, 23, 26, 36 AND 38).

FIRST USE 5-15-2003; IN COMMERCE 5-15-2003.  
DOMINICK J. SALEMI, EXAMINING ATTORNEY

SN 85-224,538. ALPINE HOLDING B.V., 3789 AL SOESTERBERG, NETHERLANDS, FILED 1-24-2011.

**SLEEP SOFT**

THE MARK CONSISTS OF STANDARD CHARACTERS WITHOUT CLAIM TO ANY PARTICULAR FONT, STYLE, SIZE, OR COLOR.

FOR EAR PLUGS FOR SLEEPING; EAR PLUGS FOR SOUNDPROOFING; EAR PLUGS NOT FOR MEDICAL PURPOSES (U.S. CLS. 21, 23, 26, 36 AND 38).

FIRST USE 7-0-2000; IN COMMERCE 7-0-2006.  
WENDY GOODMAN, EXAMINING ATTORNEY

SN 85-223,115. FONT DINER, INC., EAU CLAIRE, WI. FILED 1-21-2011.

**VOLCANO KING**

THE MARK CONSISTS OF STANDARD CHARACTERS WITHOUT CLAIM TO ANY PARTICULAR FONT, STYLE, SIZE, OR COLOR.

FOR PRINTING FONTS THAT CAN BE DOWN-LOADED PROVIDED BY MEANS OF ELECTRONIC TRANSMISSION; TYPEFACE FONTS RECORDED ON MAGNETIC MEDIA (U.S. CLS. 21, 23, 26, 36 AND 38).

FIRST USE 5-15-2003; IN COMMERCE 5-15-2003.  
DOMINICK J. SALEMI, EXAMINING ATTORNEY

SN 85-224,768. EDUCATIONAL TESTING SERVICE, PRINCETON, NJ. FILED 1-24-2011.

**ETS**

THE MARK CONSISTS OF STANDARD CHARACTERS WITHOUT CLAIM TO ANY PARTICULAR FONT, STYLE, SIZE, OR COLOR.

OWNER OF U.S. REG. NOS. 1,166,461, 2,363,333 AND OTHERS.

FOR INTERACTIVE MULTIMEDIA SOFTWARE PROGRAMS FOR MOBILE PLATFORMS FOR ENGLISH LANGUAGE LEARNING (U.S. CLS. 21, 23, 26, 36 AND 38).

CHRISTOPHER BUONGIORNO, EXAMINING ATTORNEY

**CLASS 9—(Continued).**

SN 85-224,794. EDUCATIONAL TESTING SERVICE, PRINCETON, NJ. FILED 1-24-2011.



OWNER OF U.S. REG. NOS. 1,592,803, 3,792,129 AND OTHERS.

THE COLOR(S) BLUE AND MAROON IS/ARE CLAIMED AS A FEATURE OF THE MARK.

THE MARK CONSISTS OF THE LETTERS "ETS" IN BLUE STYLIZED LETTERS WITHIN TWO INTERLOCKING SEMI-CIRCULAR DESIGNS. THE CIRCULAR DESIGN ON THE BOTTOM LEFT IS BLUE AND THE ONE ON THE TOP RIGHT IS MAROON.

FOR INTERACTIVE MULTIMEDIA SOFTWARE PROGRAMS FOR MOBILE PLATFORMS FOR ENGLISH LANGUAGE LEARNING (U.S. CLS. 21, 23, 26, 36 AND 38).

CHRISTOPHER BUONGIORNO, EXAMINING ATTORNEY

---

SN 85-224,834. BROCADE COMMUNICATIONS SYSTEMS, INC., SAN JOSE, CA. FILED 1-24-2011.

## VDX

THE MARK CONSISTS OF STANDARD CHARACTERS WITHOUT CLAIM TO ANY PARTICULAR FONT, STYLE, SIZE, OR COLOR.

FOR COMPUTER NETWORKING HARDWARE (U.S. CLS. 21, 23, 26, 36 AND 38).

DORITT L. CARROLL, EXAMINING ATTORNEY

---

SN 85-225,190. BANOM, INC., WAYNE, PA. FILED 1-25-2011.

## LEVEL 4

THE MARK CONSISTS OF STANDARD CHARACTERS WITHOUT CLAIM TO ANY PARTICULAR FONT, STYLE, SIZE, OR COLOR.

FOR CUT-RESISTANT GLOVES AND PROTECTIVE SLEEVES FOR INDUSTRIAL USE (U.S. CLS. 21, 23, 26, 36 AND 38).

MICHAEL WEBSTER, EXAMINING ATTORNEY

**CLASS 9—(Continued).**

SN 85-225,207. BANOM, INC., WAYNE, PA. FILED 1-25-2011.

## TAPERFIT

THE MARK CONSISTS OF STANDARD CHARACTERS WITHOUT CLAIM TO ANY PARTICULAR FONT, STYLE, SIZE, OR COLOR.

FOR AN ELASTICISED KNIT WRIST INCORPORATED IN PROTECTIVE GLOVES FOR INDUSTRIAL USE (U.S. CLS. 21, 23, 26, 36 AND 38).

MICHAEL WEBSTER, EXAMINING ATTORNEY

---

SN 85-225,932. BALLY GAMING, INC., DBA BALLY TECHNOLOGIES, LAS VEGAS, NV. FILED 1-25-2011.

## PIRATE'S TROVE

THE MARK CONSISTS OF STANDARD CHARACTERS WITHOUT CLAIM TO ANY PARTICULAR FONT, STYLE, SIZE, OR COLOR.

FOR COMPUTER-GAMING SOFTWARE; GAMING SOFTWARE THAT GENERATES OR DISPLAYS WAGER OUTCOMES OF GAMING MACHINES; DOWNLOADABLE COMPUTER GAME SOFTWARE FOR GAMING; GAMING MACHINES, NAMELY, DEVICES THAT ACCEPT A WAGER; SLOT MACHINES (U.S. CLS. 21, 23, 26, 36 AND 38).

THEODORE MCBRIDE, EXAMINING ATTORNEY

---

SN 85-225,940. BALLY GAMING, INC., DBA BALLY TECHNOLOGIES, LAS VEGAS, NV. FILED 1-25-2011.

## PERSIAN EMPIRE

THE MARK CONSISTS OF STANDARD CHARACTERS WITHOUT CLAIM TO ANY PARTICULAR FONT, STYLE, SIZE, OR COLOR.

FOR COMPUTER-GAMING SOFTWARE; GAMING SOFTWARE THAT GENERATES OR DISPLAYS WAGER OUTCOMES OF GAMING MACHINES; DOWNLOADABLE COMPUTER GAME SOFTWARE FOR GAMING; GAMING MACHINES, NAMELY, DEVICES THAT ACCEPT A WAGER; SLOT MACHINES (U.S. CLS. 21, 23, 26, 36 AND 38).

FIRST USE 2-10-2010; IN COMMERCE 2-10-2010.

THEODORE MCBRIDE, EXAMINING ATTORNEY

**CLASS 9—(Continued).**

SN 85-225,951. BALLY GAMING, INC., DBA BALLY TECHNOLOGIES, LAS VEGAS, NV. FILED 1-25-2011.

**ISLAND WINS**

THE MARK CONSISTS OF STANDARD CHARACTERS WITHOUT CLAIM TO ANY PARTICULAR FONT, STYLE, SIZE, OR COLOR.

FOR COMPUTER-GAMING SOFTWARE; GAMING SOFTWARE THAT GENERATES OR DISPLAYS WAGER OUTCOMES OF GAMING MACHINES; DOWNLOADABLE COMPUTER GAME SOFTWARE FOR GAMING; GAMING MACHINES, NAMELY, DEVICES THAT ACCEPT A WAGER; SLOT MACHINES (U.S. CLS. 21, 23, 26, 36 AND 38).

FIRST USE 2-10-2010; IN COMMERCE 2-10-2010.  
THEODORE MCBRIDE, EXAMINING ATTORNEY

---

SN 85-225,971. BALLY GAMING, INC., DBA BALLY TECHNOLOGIES, LAS VEGAS, NV. FILED 1-25-2011.

**ASIAN TREASURES**

THE MARK CONSISTS OF STANDARD CHARACTERS WITHOUT CLAIM TO ANY PARTICULAR FONT, STYLE, SIZE, OR COLOR.

FOR COMPUTER-GAMING SOFTWARE; GAMING SOFTWARE THAT GENERATES OR DISPLAYS WAGER OUTCOMES OF GAMING MACHINES; DOWNLOADABLE COMPUTER GAME SOFTWARE FOR GAMING; GAMING MACHINES, NAMELY, DEVICES THAT ACCEPT A WAGER; SLOT MACHINES (U.S. CLS. 21, 23, 26, 36 AND 38).

FIRST USE 2-10-2010; IN COMMERCE 2-10-2010.  
THEODORE MCBRIDE, EXAMINING ATTORNEY

---

SN 85-225,977. BALLY GAMING, INC., DBA BALLY TECHNOLOGIES, LAS VEGAS, NV. FILED 1-25-2011.

**MAYAN TREASURES**

THE MARK CONSISTS OF STANDARD CHARACTERS WITHOUT CLAIM TO ANY PARTICULAR FONT, STYLE, SIZE, OR COLOR.

FOR COMPUTER-GAMING SOFTWARE; GAMING SOFTWARE THAT GENERATES OR DISPLAYS WAGER OUTCOMES OF GAMING MACHINES; DOWNLOADABLE COMPUTER GAME SOFTWARE FOR GAMING; GAMING MACHINES, NAMELY, DEVICES THAT ACCEPT A WAGER; SLOT MACHINES (U.S. CLS. 21, 23, 26, 36 AND 38).

FIRST USE 8-13-2008; IN COMMERCE 8-13-2008.  
THEODORE MCBRIDE, EXAMINING ATTORNEY

**CLASS 9—(Continued).**

SN 85-225,992. BALLY GAMING, INC., DBA BALLY TECHNOLOGIES, LAS VEGAS, NV. FILED 1-25-2011.

**FORT WILD**

THE MARK CONSISTS OF STANDARD CHARACTERS WITHOUT CLAIM TO ANY PARTICULAR FONT, STYLE, SIZE, OR COLOR.

FOR COMPUTER-GAMING SOFTWARE; GAMING SOFTWARE THAT GENERATES OR DISPLAYS WAGER OUTCOMES OF GAMING MACHINES; DOWNLOADABLE COMPUTER GAME SOFTWARE FOR GAMING; GAMING MACHINES, NAMELY, DEVICES THAT ACCEPT A WAGER; SLOT MACHINES (U.S. CLS. 21, 23, 26, 36 AND 38).

THEODORE MCBRIDE, EXAMINING ATTORNEY

---

SN 85-226,580. KABBALAH CENTRE INTERNATIONAL, INC., LOS ANGELES, CA. FILED 1-26-2011.



OWNER OF U.S. REG. NOS. 2,416,725, 2,487,893 AND OTHERS.

THE MARK CONSISTS OF BLACK AND WHITE LION DESIGN IN BOX. THE LINING AND STIPPLING IS A FEATURE OF THE MARK AND DOES NOT INDICATE COLOR.

FOR DIGITAL MATERIALS, NAMELY, CD'S, DVD'S, DOWNLOADABLE AUDIO FILES FEATURING RELIGION AND SPIRITUALITY; DIGITAL MEDIA, NAMELY, PRE-RECORDED DVDS, DOWNLOADABLE AUDIO AND VIDEO RECORDINGS, AND CDS FEATURING AND PROMOTING RELIGION AND SPIRITUALITY (U.S. CLS. 21, 23, 26, 36 AND 38).

FIRST USE 5-1-2001; IN COMMERCE 5-1-2001.  
ROBIN CHOSID, EXAMINING ATTORNEY

**CLASS 9—(Continued).**

SN 85-226,836. OLYMPUS CORPORATION, TOKYO, JAPAN, FILED 1-26-2011.

**OLYMPUS STREAM**

THE MARK CONSISTS OF STANDARD CHARACTERS WITHOUT CLAIM TO ANY PARTICULAR FONT, STYLE, SIZE, OR COLOR.

OWNER OF U.S. REG. NOS. 647,456, 3,225,365 AND 3,726,228.

FOR MICROSCOPIC SOFTWARE TO CONTROL MICROSCOPES, CAPTURE IMAGES, AND PROCESS AND ANALYZE IMAGES CAPTURED BY DIGITAL IMAGING DEVICES FOR INDUSTRIAL USE (U.S. CLS. 21, 23, 26, 36 AND 38).

LEIGH CAROLINE CASE, EXAMINING ATTORNEY

SN 85-230,118. WETLAND STUDIES AND SOLUTIONS, INC., GAINESVILLE, VA. FILED 1-31-2011.

**SmartDraft**

THE MARK CONSISTS OF STANDARD CHARACTERS WITHOUT CLAIM TO ANY PARTICULAR FONT, STYLE, SIZE, OR COLOR.

FOR COMPUTER SOFTWARE THAT ENHANCES THE PRODUCTIVITY OF AUTOCAD SOFTWARE PRODUCTS WHEN USED IN CIVIL ENGINEERING, SURVEYING AND DESIGN APPLICATIONS (U.S. CLS. 21, 23, 26, 36 AND 38).

FIRST USE 6-27-2005; IN COMMERCE 7-2-2005.  
DAVID TAYLOR, EXAMINING ATTORNEY

SN 85-230,747. ENVERV, INC., SAN JOSE, CA. FILED 1-31-2011.

**TurboPLC**

THE MARK CONSISTS OF THE LETTERS "TURBOPLC" UNDERScoreD BY A LINE.

FOR SEMICONDUCTORS FOR COMMUNICATIONS AND CONTROL SYSTEMS, NAMELY POWER LINE COMMUNICATIONS (U.S. CLS. 21, 23, 26, 36 AND 38).

LINDA POWELL, EXAMINING ATTORNEY

**CLASS 9—(Continued).**

SN 85-230,827. SHAMIR OPTICAL INDUSTRY LTD., UPPER GALILEE 12135, ISRAEL, FILED 2-1-2011.

**RELAX PROPRIOCEPTION**

THE MARK CONSISTS OF STANDARD CHARACTERS WITHOUT CLAIM TO ANY PARTICULAR FONT, STYLE, SIZE, OR COLOR.

FOR OPTICAL LENSES FOR SPECTACLES AND OPTICAL INSTRUMENTS; SPECTACLES; CONTACT LENSES ; CONTAINERS FOR OPTICAL LENSES, CONTACT LENSES AND SPECTACLES; CASES, HOLDERS, PARTS AND FITTINGS FOR THE AFOREMENTIONED GOODS; COMPUTER SOFTWARE FOR PRODUCTION OF OPTICAL LENSES (U.S. CLS. 21, 23, 26, 36 AND 38).

JENNIFER MARTIN, EXAMINING ATTORNEY

SN 85-230,829. SHAMIR OPTICAL INDUSTRY LTD., UPPER GALILEE 12135, ISRAEL, FILED 2-1-2011.

**OFFICE PROPRIOCEPTION**

THE MARK CONSISTS OF STANDARD CHARACTERS WITHOUT CLAIM TO ANY PARTICULAR FONT, STYLE, SIZE, OR COLOR.

FOR OPTICAL LENSES FOR SPECTACLES AND OPTICAL INSTRUMENTS; SPECTACLES; CONTACT LENSES ; CONTAINERS FOR OPTICAL LENSES, CONTACT LENSES AND SPECTACLES; CASES, HOLDERS, PARTS AND FITTINGS FOR THE AFOREMENTIONED GOODS; COMPUTER SOFTWARE FOR PRODUCTION OF OPTICAL LENSES (U.S. CLS. 21, 23, 26, 36 AND 38).

JENNIFER MARTIN, EXAMINING ATTORNEY

SN 85-231,390. PACIFIC WORLD CORPORATION, LAKE FOREST, CA. FILED 2-1-2011.

**gG**

THE MARK CONSISTS OF A STYLIZED LOWER CASE "G" FOLLOWED BY A STYLIZED UPPER CASE "G".

FOR DIGITAL MUSIC DOWNLOADABLE FROM THE INTERNET; MOTION PICTURE FILMS FEATURING CHILDREN'S ENTERTAINMENT; PRE-RECORDED CDS FEATURING MUSIC; PRE-RECORDED DVDS FEATURING MUSIC, MOVIES AND THEATRICAL PRODUCTIONS; SUNGLASSES; VIDEO GAME SOFTWARE (U.S. CLS. 21, 23, 26, 36 AND 38).

HOWARD SMIGA, EXAMINING ATTORNEY

**CLASS 9—(Continued).**

SN 85-232,113. MOCON, INC., MINNEAPOLIS, MN. FILED 2-2-2011.

**MULTICHECK**

THE MARK CONSISTS OF STANDARD CHARACTERS WITHOUT CLAIM TO ANY PARTICULAR FONT, STYLE, SIZE, OR COLOR.

FOR APPARATUS FOR MEASURING LEAKS AND BURST PRESSURE IN PACKAGING MATERIALS AND MEASURING CONCENTRATIONS OF GASES IN FLEXIBLE PACKAGES (U.S. CLS. 21, 23, 26, 36 AND 38).

DAVID ELTON, EXAMINING ATTORNEY

**CLASS 9—(Continued).**

SN 85-235,940. POWER INTEGRATIONS, INC., SAN JOSE, CA. FILED 2-7-2011.

**INNOVATION IN POWER  
CONVERSION**

THE MARK CONSISTS OF STANDARD CHARACTERS WITHOUT CLAIM TO ANY PARTICULAR FONT, STYLE, SIZE, OR COLOR.

FOR SEMICONDUCTOR DEVICES AND INTEGRATED CIRCUITS FOR SMART POWER OPERATIONS AND POWER CONVERSION (U.S. CLS. 21, 23, 26, 36 AND 38).

MARK T. MULLEN, EXAMINING ATTORNEY

SN 85-233,478. SCHOLASTIC INC., NEW YORK, NY. FILED 2-3-2011.

**Building Language for Literacy**

OWNER OF U.S. REG. NO. 2,516,655.  
THE MARK CONSISTS OF THE WORDS "BUILDING LANGUAGE FOR LITERACY" IN STYLIZED LETTERING.

FOR PRE-RECORDED CD'S FEATURING SONGS AND POEMS FOR CHILDREN AND HAND PUPPETS PROVIDED THEREWITH AS A UNIT (U.S. CLS. 21, 23, 26, 36 AND 38).

FIRST USE 8-1-2005; IN COMMERCE 8-1-2005.

TRACY CROSS, EXAMINING ATTORNEY

SN 85-237,488. AKER WADE POWER TECHNOLOGIES, LLC, CHARLOTTESVILLE, VA. FILED 2-9-2011.

**SARGE**

THE MARK CONSISTS OF STANDARD CHARACTERS WITHOUT CLAIM TO ANY PARTICULAR FONT, STYLE, SIZE, OR COLOR.

FOR BATTERY CHARGERS; FAST CHARGERS FOR ELECTRIC VEHICLE BATTERIES (U.S. CLS. 21, 23, 26, 36 AND 38).

KIM SAITO, EXAMINING ATTORNEY

SN 85-235,930. POWER INTEGRATIONS, INC., SAN JOSE, CA. FILED 2-7-2011.

**FILTERFUSE**

THE MARK CONSISTS OF STANDARD CHARACTERS WITHOUT CLAIM TO ANY PARTICULAR FONT, STYLE, SIZE, OR COLOR.

FOR SEMICONDUCTOR DEVICES AND INTEGRATED CIRCUITS FOR SMART POWER OPERATIONS AND POWER CONVERSION (U.S. CLS. 21, 23, 26, 36 AND 38).

MARK T. MULLEN, EXAMINING ATTORNEY

SN 85-239,124. TRIMBLE NAVIGATION LIMITED, SUNNYVALE, CA. FILED 2-10-2011.

**CORRIDOR ANALYST**

THE MARK CONSISTS OF STANDARD CHARACTERS WITHOUT CLAIM TO ANY PARTICULAR FONT, STYLE, SIZE, OR COLOR.

NO CLAIM IS MADE TO THE EXCLUSIVE RIGHT TO USE "CORRIDOR", APART FROM THE MARK AS SHOWN. FOR SOFTWARE FOR USE IN PLANNING AND OPTIMIZING ROUTES FOR POWER LINES AND TRANSMISSION LINES (U.S. CLS. 21, 23, 26, 36 AND 38).

CARYN GLASSER, EXAMINING ATTORNEY

**CLASS 9—(Continued).**

SN 85-239,225. MARGARITAVILLE ENTERPRISES, LLC, PALM BEACH, FL. FILED 2-10-2011.



OWNER OF U.S. REG. NOS. 1,831,949, 2,995,765 AND 3,759,336.

THE MARK CONSISTS OF THE WORDS "MARGARITAVILLE" WITH THE WORDS "SHADES OF THE TROPICS" UNDERNEATH AND A PALM TREE IN PLACE OF THE LETTER "I" IN THE WORD "MARGARITAVILLE".

FOR EYEWEAR, SUNGLASSES, EYEGLASSES, GOGGLES FOR SPORTS, CASES FOR EYEGLASSES AND SUNGLASSES, EYEWEAR ACCESSORIES, NAMELY, STRAPS, NECK CORDS AND HEAD STRAPS WHICH RESTRAIN EYEWEAR FROM MOVEMENT ON A WEARER (U.S. CLS. 21, 23, 26, 36 AND 38).

C. DIONNE CLYBURN, EXAMINING ATTORNEY

SN 85-239,280. ALPINE HOLDING B.V., 3789 AL SOESTERBERG, NETHERLANDS, FILED 2-10-2011.

# FLYFIT

THE MARK CONSISTS OF STANDARD CHARACTERS WITHOUT CLAIM TO ANY PARTICULAR FONT, STYLE, SIZE, OR COLOR.

FOR EAR PLUGS FOR SOUNDPROOFING; EAR PLUGS NOT FOR MEDICAL PURPOSES (U.S. CLS. 21, 23, 26, 36 AND 38).

FIRST USE 2-0-2005; IN COMMERCE 2-0-2010.

WENDY GOODMAN, EXAMINING ATTORNEY

SN 85-239,357. APOGEE INC., BREA, CA. FILED 2-10-2011.

# KanexPro

OWNER OF U.S. REG. NO. 3,703,050.

THE COLOR(S) BLUE, GREY AND ORANGE IS/ARE CLAIMED AS A FEATURE OF THE MARK.

THE MARK CONSISTS OF BLUE WHICH APPEARS IN THE "KANEX" PART OF THE MARK, GREY WHICH APPEARS IN THE "PRO" PART OF THE MARK, AND ORANGE WHICH APPEARS IN SQUARES CONNECTING THE SEMI CIRCLES OF THE "O" PART OF THE MARK, FONT STYLE IS SF GRANDEZZA.

FOR AUDIO CABLES; AUDIO-RECEIVERS AND VIDEO-RECEIVERS; AUDIO-VIDEO RECEIVERS; DISTRIBUTION AMPLIFIERS FOR AUDIO AND VIDEO SIGNALS; TRANSMITTERS AND RECEIVERS FOR AUDIO AND VIDEO SIGNALS FOR TRANSMISSION OVER TWISTED PAIR CABLES (U.S. CLS. 21, 23, 26, 36 AND 38).

NAKWAMA ANKRAH, EXAMINING ATTORNEY

**CLASS 9—(Continued).**

SN 85-239,401. MONAVIE LLC, SOUTH JORDAN, UT. FILED 2-10-2011.

# MONA·VIE

THE MARK CONSISTS OF STANDARD CHARACTERS WITHOUT CLAIM TO ANY PARTICULAR FONT, STYLE, SIZE, OR COLOR.

OWNER OF U.S. REG. NOS. 3,106,146, 3,111,333 AND OTHERS.

FOR AUDIO AND VIDEO RECORDINGS FEATURING INFORMATION ON NUTRITIONAL SUPPLEMENTS AND DIETARY SUPPLEMENTS, AND ON HOW TO MARKET NUTRITIONAL AND DIETARY SUPPLEMENTS TO OTHERS USING DIRECT SELLING; DIGITAL MEDIA, NAMELY, PRE-RECORDED DVDS, DOWNLOADABLE AUDIO AND VIDEO RECORDINGS, AND CDS FEATURING AND PROMOTING INFORMATION ON NUTRITIONAL SUPPLEMENTS AND DIETARY SUPPLEMENTS, AND ON HOW TO MARKET NUTRITIONAL AND DIETARY SUPPLEMENTS TO OTHERS USING DIRECT SELLING; DIGITAL MEDIA, NAMELY, CDS, DVDS, DOWNLOADABLE AUDIO FILES, AND DOWNLOADABLE VIDEO FILES FEATURING INFORMATION ON NUTRITIONAL SUPPLEMENTS AND DIETARY SUPPLEMENTS, AND ON HOW TO MARKET NUTRITIONAL AND DIETARY SUPPLEMENTS TO OTHERS USING DIRECT SELLING; VIDEO RECORDINGS FEATURING INFORMATION ON NUTRITIONAL SUPPLEMENTS AND DIETARY SUPPLEMENTS, AND ON HOW TO MARKET NUTRITIONAL AND DIETARY SUPPLEMENTS TO OTHERS USING DIRECT SELLING (U.S. CLS. 21, 23, 26, 36 AND 38).

FIRST USE 1-7-2005; IN COMMERCE 1-7-2005.

JANET LEE, EXAMINING ATTORNEY

SN 85-239,721. TEXAS TECH UNIVERSITY SYSTEM, LUBBOCK, TX. FILED 2-11-2011.

THE COLOR(S) PURPLE, GRAY, AND GREEN IS/ARE CLAIMED AS A FEATURE OF THE MARK.

THE MARK CONSISTS OF "MOMMY MED" IN PURPLE WITH AN OUTLINE OF A PERSON IN GRAY FOLLOWED BY A GREEN CHECK MARK.

FOR MEDICAL SOFTWARE FOR STORING DRUG INFORMATION (U.S. CLS. 21, 23, 26, 36 AND 38).

TOBY BULLOFF, EXAMINING ATTORNEY

**CLASS 9—(Continued).**

SN 85-239,734. TEXAS TECH UNIVERSITY SYSTEM, LUBBOCK, TX. FILED 2-11-2011.

**Mommy Med**

THE MARK CONSISTS OF STANDARD CHARACTERS WITHOUT CLAIM TO ANY PARTICULAR FONT, STYLE, SIZE, OR COLOR.  
FOR MEDICAL SOFTWARE FOR STORING DRUG INFORMATION (U.S. CLS. 21, 23, 26, 36 AND 38).  
TOBY BULLOFF, EXAMINING ATTORNEY

SN 85-243,245. ARLINGTON INDUSTRIES, INC., MIAMI, FL. FILED 2-15-2011.

**GARD-N-POST**

THE MARK CONSISTS OF STANDARD CHARACTERS WITHOUT CLAIM TO ANY PARTICULAR FONT, STYLE, SIZE, OR COLOR.  
FOR ELECTRIC JUNCTION BOXES (U.S. CLS. 21, 23, 26, 36 AND 38).  
FIRST USE 2-1-2001; IN COMMERCE 2-1-2001.  
ROSELLE HERRERA, EXAMINING ATTORNEY

SN 85-244,631. STANLEY LOGISTICS, L.L.C., NEW BRITAIN, CT. FILED 2-17-2011.

**FATMAX**

THE MARK CONSISTS OF STANDARD CHARACTERS WITHOUT CLAIM TO ANY PARTICULAR FONT, STYLE, SIZE, OR COLOR.  
OWNER OF U.S. REG. NOS. 2,579,681, 3,163,439 AND 3,823,252.  
FOR BATTERIES AND BATTERY CHARGERS (U.S. CLS. 21, 23, 26, 36 AND 38).  
KAPIL BHANOT, EXAMINING ATTORNEY

**CLASS 9—(Continued).**

SN 85-244,983. RADWARE LTD., TEL AVIV, ISRAEL, FILED 2-17-2011.

**CID**

THE MARK CONSISTS OF STANDARD CHARACTERS WITHOUT CLAIM TO ANY PARTICULAR FONT, STYLE, SIZE, OR COLOR.  
OWNER OF U.S. REG. NO. 2,936,888.  
FOR COMPUTER HARDWARE AND COMPUTER SOFTWARE FOR PROVISION OF HIGH AVAILABILITY AND LOAD BALANCING FOR CONTENT SCREENERS, NAMELY, ANTI-VIRUS GATEWAY SOFTWARE AND URL CONTENT FILTER SOFTWARE OPERATING IN COMPUTER NETWORKS (U.S. CLS. 21, 23, 26, 36 AND 38).  
FIRST USE 4-30-2009; IN COMMERCE 4-30-2009.  
KATHERINE CHANG, EXAMINING ATTORNEY

SN 85-251,143. ZL TECHNOLOGIES, INC., SAN JOSE, CA. FILED 2-24-2011.

**DirectExtract**

THE MARK CONSISTS OF STANDARD CHARACTERS WITHOUT CLAIM TO ANY PARTICULAR FONT, STYLE, SIZE, OR COLOR.  
FOR COMPUTER SOFTWARE FOR CREATING SEARCHABLE DATABASES OF INFORMATION AND DATA (U.S. CLS. 21, 23, 26, 36 AND 38).  
FIRST USE 1-10-2011; IN COMMERCE 1-10-2011.  
CAROLYN CATALDO, EXAMINING ATTORNEY

SN 85-252,579. THE FONT BUREAU INC., BOSTON, MA. FILED 2-26-2011.

**HERON**

THE MARK CONSISTS OF STANDARD CHARACTERS WITHOUT CLAIM TO ANY PARTICULAR FONT, STYLE, SIZE, OR COLOR.  
FOR PRINTING FONTS THAT CAN BE DOWNLOADED PROVIDED BY MEANS OF ELECTRONIC TRANSMISSION; TYPEFACE FONTS RECORDED ON MAGNETIC MEDIA (U.S. CLS. 21, 23, 26, 36 AND 38).  
FIRST USE 5-15-2006; IN COMMERCE 5-15-2006.  
KARANENDRA S. CHHINA, EXAMINING ATTORNEY

**CLASS 9—(Continued).**

SN 85-253,090. THE FONT BUREAU INC., BOSTON, MA. AND CARTER & CONE TYPE INC., CAMBRIDGE, MA. FILED 2-28-2011.

**BIG FIGGINS**

THE MARK CONSISTS OF STANDARD CHARACTERS WITHOUT CLAIM TO ANY PARTICULAR FONT, STYLE, SIZE, OR COLOR.

FOR PRINTING FONTS THAT CAN BE DOWN-LOADED PROVIDED BY MEANS OF ELECTRONIC TRANSMISSION; TYPEFACE FONTS RECORDED ON MAGNETIC MEDIA (U.S. CLS. 21, 23, 26, 36 AND 38).

FIRST USE 2-25-2011; IN COMMERCE 2-25-2011.  
KARANENDRA S. CHHINA, EXAMINING ATTORNEY

SN 85-265,157. MIAMI TRIBE OF OKLAHOMA BUSINESS DEVELOPMENT AUTHORITY, A TRIBAL ENTERPRISE OF THE MIAMI TRIBE OF OKLAHOMA, MIAMI, OK. FILED 3-11-2011.

**WHEELIN' N' DEALIN'**

THE MARK CONSISTS OF STANDARD CHARACTERS WITHOUT CLAIM TO ANY PARTICULAR FONT, STYLE, SIZE, OR COLOR.

FOR GAMING MACHINES, NAMELY, BINGO-RELATED GAMES AND SLOT MACHINES (U.S. CLS. 21, 23, 26, 36 AND 38).

KATHY DE JONGE, EXAMINING ATTORNEY

SN 85-268,551. DREAMHAMMER INCORPORATED, SANTA MONICA, CA. FILED 3-16-2011.



THE MARK CONSISTS OF A STYLIZED BOX WITH A STYLIZED HAMMER WITHIN THE BOX AND ABOVE THE WORD "BALLISTA".

FOR COMPUTER SOFTWARE FOR MANAGING UNMANNED VEHICLES (U.S. CLS. 21, 23, 26, 36 AND 38).  
WILLIAM BRECKENFELD, EXAMINING ATTORNEY

**CLASS 10—MEDICAL APPARATUS**

SN 77-415,323. BAINS ULTRA INC., ST. NICOLAS, QUEBEC, CANADA, FILED 3-6-2008.

**YOUR SOURCE FOR WELLNESS**

THE MARK CONSISTS OF STANDARD CHARACTERS WITHOUT CLAIM TO ANY PARTICULAR FONT, STYLE, SIZE, OR COLOR.

PRIORITY CLAIMED UNDER SEC. 44(D) ON CANADA APPLICATION NO. 1385596, FILED 2-29-2008, REG. NO. TMA792403, DATED 3-9-2011, EXPIRES 3-9-2026.

FOR THERAPEUTIC APPARATUS, NAMELY, A HEALTH CARE UNIT BUILT INTO A SHOWER FOR HEAT THERAPY, SOUND THERAPY, AROMATHERAPY, LIGHT THERAPY AND CHROMOTHERAPY (U.S. CLS. 26, 39 AND 44).

MARIAM MAHMOUDI, EXAMINING ATTORNEY

SN 77-746,890. 3D IMAGING & SIMULATIONS CORP., DAEJEON, REPUBLIC OF KOREA, FILED 5-28-2009.

**FIREDCR**

THE MARK CONSISTS OF STANDARD CHARACTERS WITHOUT CLAIM TO ANY PARTICULAR FONT, STYLE, SIZE, OR COLOR.

PRIORITY CLAIMED UNDER SEC. 44(D) ON REPUBLIC OF KOREA APPLICATION NO. 20090019660, FILED 4-28-2009, REG. NO. 40-0818324, DATED 3-29-2010, EXPIRES 3-29-2020.

FOR MEDICAL DEVICES AND APPARATUS, NAMELY, RADIOLOGY SCREENS, X-RAY PROTECTION TOOLS, X-RAY SCANNERS, X-RAY IMAGE SCANNERS, X-RAY MOBILE MONITORING SCANNERS, RADIOLOGICAL BEAM SCANNERS, X-RAY CT SCANNERS, X-RAY FILM, X-RAY PHOTOGRAPHS, MAGNETIC RESONANCE IMAGERS, POSITRON EMISSION TOMOGRAPHY IMAGING TOOLS, ELECTROMAGNETIC DIAGNOSTIC IMAGING TOOLS; CT SCANNER COMPONENTS, NAMELY, INTEGRAL COMPONENTS OF THE IMAGE CHANGE OF A CT SCANNER FOR CAPTURING X-RAYS AND CONVERTING THE X-RAYS INTO IMAGE INFORMATION; X-RAY PROTECTION DEVICES FOR MEDICAL PURPOSES; MEDICAL X-RAY APPARATUSES; AND RADIOLOGICAL APPARATUS FOR MEDICAL PURPOSES (U.S. CLS. 26, 39 AND 44).

SHAILA SETTLES, EXAMINING ATTORNEY



**CLASS 10—(Continued).**

SN 77-789,519. MICRO DENTAL LABORATORIES, DUBLIN, CA. FILED 7-24-2009.

# P2Z

THE MARK CONSISTS OF STANDARD CHARACTERS WITHOUT CLAIM TO ANY PARTICULAR FONT, STYLE, SIZE, OR COLOR.

FOR DENTAL PROSTHETIC APPARATUSES, NAMELY, VENEERS, INLAYS AND ONLAYS (U.S. CLS. 26, 39 AND 44).

KATINA MISTER, EXAMINING ATTORNEY

SN 77-840,431. LES INDUSTRIES HOLMONT LTÉE, ST-HYACINTHE, QUEBEC, CANADA, FILED 10-2-2009.

# VINCI MED-X CARE

THE MARK CONSISTS OF STANDARD CHARACTERS WITHOUT CLAIM TO ANY PARTICULAR FONT, STYLE, SIZE, OR COLOR.

PRIORITY CLAIMED UNDER SEC. 44(D) ON CANADA APPLICATION NO. 1450891, FILED 9-8-2009, REG. NO. 787608, DATED 1-18-2011, EXPIRES 1-18-2026.

NO CLAIM IS MADE TO THE EXCLUSIVE RIGHT TO USE "CARE", APART FROM THE MARK AS SHOWN.

FOR GENITAL SUPPORTS, LUMBAR SUPPORTS, WRIST SUPPORTS, KNEE SUPPORTS AND ANKLE SUPPORTS FACILITATING RECOVERY FOLLOWING INJURY; SPLINTS FOR MEDICAL PURPOSES, ATHLETIC SUPPORTERS FOR MEDICAL USE (U.S. CLS. 26, 39 AND 44).

TRACY CROSS, EXAMINING ATTORNEY

SN 77-916,236. PSORIA-SHIELD, INC., ORMOND BEACH, FL. FILED 1-20-2010.

# PSORIA-LIGHT

THE MARK CONSISTS OF STANDARD CHARACTERS WITHOUT CLAIM TO ANY PARTICULAR FONT, STYLE, SIZE, OR COLOR.

FOR MEDICAL DEVICES, NAMELY, PHOTOTHERAPEUTIC APPARATUS FOR MEDICAL PURPOSES IN THE NATURE OF AN ULTRAVIOLET (UV) LIGHT SOURCE FOR MEDICAL AND AESTHETIC SKIN TREATMENTS (U.S. CLS. 26, 39 AND 44).

FIRST USE 4-19-2009; IN COMMERCE 5-2-2009.

LAURIE KAUFMAN, EXAMINING ATTORNEY

**CLASS 10—(Continued).**

SN 79-085,080. MANGAR INTERNATIONAL LIMITED, PRE-STEIGNE, POWYS LD8 2UF, UNITED KINGDOM, FILED 6-18-2010.

# AIRSTACK

THE MARK CONSISTS OF STANDARD CHARACTERS WITHOUT CLAIM TO ANY PARTICULAR FONT, STYLE, SIZE, OR COLOR.

PRIORITY DATE OF 2-26-2010 IS CLAIMED.

OWNER OF INTERNATIONAL REGISTRATION 1045254 DATED 6-18-2010, EXPIRES 6-18-2020.

FOR MEDICAL APPARATUS, FOR HEAD, NECK, LEG, BACK, ARM, AND BODY SUPPORTING PURPOSES; MEDICAL APPARATUS AND DEVICES FOR LIFTING, LOWERING, MOVING, TRANSFERRING AND SUPPORTING DISABLED, INFIRM, HANDICAP, SICK OR DECEASED PERSONS; MEDICAL APPARATUS FOR RAISING, LOWERING AND TRANSFERRING PERSONS TO AND FROM A SEAT; COLLAPSIBLE BRIDGING DEVICES FOR TRANSFERRING PEOPLE BETWEEN TWO SEATS FOR MEDICAL, ORTHOPEDIC OR SURGICAL PURPOSES; PNEUMATICALLY OPERATED OR INFLATED APPARATUS AND DEVICES, NAMELY, LIFTS AND HEAD, NECK, LEG, BACK, ARM AND BODY SUPPORT ALL FOR MEDICAL, ORTHOPEDIC OR SURGICAL PURPOSES OR HANDLING DECEASED PERSONS; MULTIPLE PURPOSE MEDICAL SUPPORTS, NAMELY, CUSHIONS, INFLATABLE BAGS, PILLOWS; TRANSFER BOARDS, STRETCHERS, PLATFORMS, SUPPORT STANDS, MATTRESSES, BEDS, SEATS, CHAIRS AND SUPPORTS, ALL FOR MEDICAL, ORTHOPEDIC OR SURGICAL PURPOSES; FRAMES AND FRAMEWORKS FOR LIFTING, MOVING, TRANSFERRING AND SUPPORTING THE INFIRM, HANDICAPPED, DISABLED, SICK OR DECEASED PERSONS; LIFT APPARATUS FOR RAISING AND LOWERING PERSONS CONFINED TO BED; BEDS FOR MEDICAL PURPOSES; REPOSITIONING AIDS FOR THE SICK AND THE ELDERLY; PARTS AND FITTINGS FOR ALL THE AFORESAID GOODS (U.S. CLS. 26, 39 AND 44).

JOHN E. MICHOS, EXAMINING ATTORNEY

SN 79-085,233. KIBODAN A/S, DK-2820 GENTOFTE, DENMARK, FILED 3-2-2010.

# KIBODAN

THE MARK CONSISTS OF STANDARD CHARACTERS WITHOUT CLAIM TO ANY PARTICULAR FONT, STYLE, SIZE, OR COLOR.

PRIORITY DATE OF 11-10-2009 IS CLAIMED.

OWNER OF INTERNATIONAL REGISTRATION 1045507 DATED 3-2-2010, EXPIRES 3-2-2020.

THE WORDING "KIBODAN" HAS NO MEANING IN A FOREIGN LANGUAGE.

FOR MEDICINE DOSING BOXES, NAMELY, BOXES FOR USE BY MEDICINE TAKERS DIVIDED INTO COMPARTMENTS FOR PILLS OR OTHER MEDICATION TO BE TAKEN AT SPECIFIC INTERVALS DURING THE DAY, WEEK OR MONTH (U.S. CLS. 26, 39 AND 44).

FRED CARL, EXAMINING ATTORNEY

**CLASS 10—(Continued).**

SN 79-087,048. RICHARD WOLF GMBH, 75438 KNITTLINGEN, FED REP GERMANY, FILED 6-12-2010.

# VictOR HD

THE MARK CONSISTS OF STANDARD CHARACTERS WITHOUT CLAIM TO ANY PARTICULAR FONT, STYLE, SIZE, OR COLOR.

OWNER OF INTERNATIONAL REGISTRATION 1050311 DATED 6-12-2010, EXPIRES 6-12-2020.

NO CLAIM IS MADE TO THE EXCLUSIVE RIGHT TO USE "HD", APART FROM THE MARK AS SHOWN.

FOR COMPUTERIZED MEDICAL RECORDING AND DOCUMENTATION APPARATUS FOR USE IN ENDOSCOPIC APPLICATIONS (U.S. CLS. 26, 39 AND 44).

ANNE E. GUSTASON, EXAMINING ATTORNEY

SN 79-089,983. YORAMOS LTD., ISRAEL, FILED 10-12-2010.

# MASTER CAUTION

THE MARK CONSISTS OF STANDARD CHARACTERS WITHOUT CLAIM TO ANY PARTICULAR FONT, STYLE, SIZE, OR COLOR.

PRIORITY DATE OF 4-14-2010 IS CLAIMED.

OWNER OF INTERNATIONAL REGISTRATION 1058270 DATED 10-12-2010, EXPIRES 10-12-2020.

FOR MEDICAL TOOLS AND INSTRUMENTS, NAMELY, TOOLS FOR DIAGNOSING, MONITORING, AND WARNING OF ISSUES RELATED TO THE CARDIO-VASCULAR, BLOOD, RESPIRATORY OR INTERNAL ORGANS OF A PERSON (U.S. CLS. 26, 39 AND 44).

JOHN WILKE, EXAMINING ATTORNEY

SN 79-094,087. KONINKLIJKE PHILIPS ELECTRONICS N.V., NETHERLANDS, FILED 12-10-2010.

# VasoCT

THE MARK CONSISTS OF STANDARD CHARACTERS WITHOUT CLAIM TO ANY PARTICULAR FONT, STYLE, SIZE, OR COLOR.

PRIORITY DATE OF 6-11-2010 IS CLAIMED.

OWNER OF INTERNATIONAL REGISTRATION 1068463 DATED 12-10-2010, EXPIRES 12-10-2020.

FOR MEDICAL SCANNERS AND X-RAY APPARATUS PRE-INSTALLED WITH MEDICAL IMAGING SOFTWARE (U.S. CLS. 26, 39 AND 44).

KAREN SEVERSON, EXAMINING ATTORNEY

**CLASS 10—(Continued).**

SN 85-004,690. VITAPATH GENETICS, INC., FOSTER CITY, CA. FILED 4-1-2010.

# VITAPATH

THE MARK CONSISTS OF STANDARD CHARACTERS WITHOUT CLAIM TO ANY PARTICULAR FONT, STYLE, SIZE, OR COLOR.

FOR MEDICAL TEST KITS USED TO PERFORM DNA TESTS WHICH INDICATE PREDISPOSITION FOR MEDICAL DISEASE FOR PROFESSIONAL USE, COMPRISED OF DEVICES USED TO COLLECT DNA (U.S. CLS. 26, 39 AND 44).

COLLEEN KEARNEY, EXAMINING ATTORNEY

SN 85-017,029. BEDROCK INVENTIONS, LLC, MENLO PARK, CA. FILED 4-19-2010.

# THE FIRST PASS SYSTEM

THE MARK CONSISTS OF STANDARD CHARACTERS WITHOUT CLAIM TO ANY PARTICULAR FONT, STYLE, SIZE, OR COLOR.

NO CLAIM IS MADE TO THE EXCLUSIVE RIGHT TO USE "SYSTEM", APART FROM THE MARK AS SHOWN.

FOR SURGICAL DEVICES AND INSTRUMENTS, NAMELY, NEUROSURGICAL DEVICES AND INSTRUMENTS CONSISTING OF A COMPLEX SYSTEM USED IN NEUROSURGERY TO PERFORM ULTRASOUND-ALIGNED PLACEMENT OF VENTRICULAR DRAINS OR OTHER DEVICES TARGETED TO INTRACRANIAL TARGETS, NOT FOR USE IN ORTHOPEDIC OR OTHER NON-NEUROSURGICAL PROCEDURES (U.S. CLS. 26, 39 AND 44).

RENEE MCCRAY, EXAMINING ATTORNEY

SN 85-032,203. INCREDIBLE THREADS LLC, ELGIN, IL. FILED 5-6-2010.



THE MARK CONSISTS OF THE WORD "THERMAVAST" INCLUDING A STYLIZED LETTER "V" WITH A RAINBOW EXTENDING FROM THE LETTER "V".

FOR CARDIOVASCULAR COMPRESSION HOSIERY; SOCKS FOR MEDICAL OR THERAPEUTIC USE; MEDICAL TREATMENT APPAREL; BLANKETS FOR MEDICAL PURPOSES; AND MEDICAL GOWNS (U.S. CLS. 26, 39 AND 44).

EDWARD NELSON, EXAMINING ATTORNEY

**CLASS 10—(Continued).**

SN 85-036,766. L.A.D. GLOBAL ENTERPRISES, INC.,  
OLATHE, KS. FILED 5-12-2010.

**MORLUV**

THE MARK CONSISTS OF STANDARD CHARACTERS  
WITHOUT CLAIM TO ANY PARTICULAR FONT, STYLE,  
SIZE, OR COLOR.

FOR APPAREL FOR PROFESSIONALS IN HOSPITAL  
AND HEALTHCARE INDUSTRIES IN THE NATURE OF  
MEDICAL WEARING APPAREL, NAMELY, SCRUB  
TOPS AND SCRUB PANTS (U.S. CLS. 26, 39 AND 44).  
NAPOLEON SHARMA, EXAMINING ATTORNEY

SN 85-041,709. MASIMO CORPORATION, IRVINE, CA.  
FILED 5-18-2010.

**GREEN DESIGNED IN**

THE MARK CONSISTS OF STANDARD CHARACTERS  
WITHOUT CLAIM TO ANY PARTICULAR FONT, STYLE,  
SIZE, OR COLOR.

NO CLAIM IS MADE TO THE EXCLUSIVE RIGHT TO  
USE "GREEN", APART FROM THE MARK AS SHOWN.

FOR MEDICAL DEVICES, NAMELY, PATIENT MONI-  
TORS AND PATIENT SENSORS (U.S. CLS. 26, 39 AND  
44).

CHARLES L. JENKINS, EXAMINING ATTORNEY

SN 85-047,101. MASIMO CORPORATION, IRVINE, CA.  
FILED 5-25-2010.

**RAINBOW ACOUSTIC MONITORING**

THE MARK CONSISTS OF STANDARD CHARACTERS  
WITHOUT CLAIM TO ANY PARTICULAR FONT, STYLE,  
SIZE, OR COLOR.

OWNER OF U.S. REG. NO. 3,124,475.

NO CLAIM IS MADE TO THE EXCLUSIVE RIGHT TO  
USE "ACOUSTIC MONITORING", APART FROM THE  
MARK AS SHOWN.

FOR MEDICAL DEVICES, NAMELY, PATIENT MONI-  
TORS AND PATIENT SENSORS (U.S. CLS. 26, 39 AND  
44).

CHARLES L. JENKINS, EXAMINING ATTORNEY

**CLASS 10—(Continued).**

SN 85-050,726. TENSEGRITY TECHNOLOGIES, INC., MILL  
VALLEY, CA. FILED 5-28-2010.

**MILLIMETERS MATTER**

THE MARK CONSISTS OF STANDARD CHARACTERS  
WITHOUT CLAIM TO ANY PARTICULAR FONT, STYLE,  
SIZE, OR COLOR.

NO CLAIM IS MADE TO THE EXCLUSIVE RIGHT TO  
USE "MILLIMETERS", APART FROM THE MARK AS  
SHOWN.

FOR MEDICAL DEVICES AND APPARATUS TO  
MEASURE, DIAGNOSE AND TREAT BIOMECHANICAL  
FOOT DISORDERS; ORTHOTIC INSERTS FOR FOOT-  
WEAR; ORTHOPEDIC DEVICE TO STRETCH AND  
EXERCISE THE TOES AND FEET (U.S. CLS. 26, 39  
AND 44).

ANNE FARRELL, EXAMINING ATTORNEY

SN 85-069,669. MASIMO CORPORATION, IRVINE, CA.  
FILED 6-23-2010.

**DAS**

THE MARK CONSISTS OF STANDARD CHARACTERS  
WITHOUT CLAIM TO ANY PARTICULAR FONT, STYLE,  
SIZE, OR COLOR.

FOR MEDICAL DEVICES, NAMELY, PATIENT MONI-  
TORS AND PATIENT SENSORS (U.S. CLS. 26, 39 AND  
44).

CHARLES L. JENKINS, EXAMINING ATTORNEY

SN 85-082,454. GAYMAR INDUSTRIES, INC., ORCHARD  
PARK, NY. FILED 7-12-2010.

**PATIENT ACCESS ZONE**

THE MARK CONSISTS OF STANDARD CHARACTERS  
WITHOUT CLAIM TO ANY PARTICULAR FONT, STYLE,  
SIZE, OR COLOR.

NO CLAIM IS MADE TO THE EXCLUSIVE RIGHT TO  
USE "PATIENT", APART FROM THE MARK AS SHOWN.

FOR MEDICAL EQUIPMENT, NAMELY, MAT-  
TRESSES, MATTRESS OVERLAYS, AND AIR CONTROL  
UNITS THEREFOR, ALL FOR THE PREVENTION AND  
TREATMENT OF PRESSURE ULCERS (U.S. CLS. 26, 39  
AND 44).

FIRST USE 5-16-2009; IN COMMERCE 9-10-2009.

KIMBERLY PERRY, EXAMINING ATTORNEY

**CLASS 10—(Continued).**

SN 85-091,750. OLIVER-TOLAS HEALTHCARE PACKAGING, LLC, GRAND RAPIDS, MI. FILED 7-23-2010.

**DISPOS-A-VENT**

THE MARK CONSISTS OF STANDARD CHARACTERS WITHOUT CLAIM TO ANY PARTICULAR FONT, STYLE, SIZE, OR COLOR.

FOR DISPOSABLE MEDICAL STERILIZATION POUCHES MADE OF ONE OR MORE OF PAPER, NON-WOVEN SHEET MATERIAL CONSISTING OF MAN-MADE FIBERS, METAL FOIL, AND POLYMER FILM (U.S. CLS. 26, 39 AND 44).

FIRST USE 9-1-2003; IN COMMERCE 9-1-2003.  
TRACY CROSS, EXAMINING ATTORNEY

---

SN 85-093,930. CORPAK MEDSYSTEMS, INC., WHEELING, IL. FILED 7-27-2010.

TELLS YOU WHERE YOU ARE  
...NO MATTER WHERE YOU'RE  
AT

THE MARK CONSISTS OF STANDARD CHARACTERS WITHOUT CLAIM TO ANY PARTICULAR FONT, STYLE, SIZE, OR COLOR.

FOR MEDICAL APPARATUS, NAMELY, AN EXTRACORPOREAL ELECTRONIC APPARATUS FOR LOCATING THE POSITION OF A CATHETER DISPOSED WITHIN A PATIENT'S BODY (U.S. CLS. 26, 39 AND 44).

FIRST USE 7-0-2006; IN COMMERCE 7-0-2006.  
AMY ALFIERI, EXAMINING ATTORNEY

---

SN 85-108,930. NANOVIBRONIX, INC., CEDARHURST, NY. FILED 8-17-2010.

**PAINSHIELD**

THE MARK CONSISTS OF STANDARD CHARACTERS WITHOUT CLAIM TO ANY PARTICULAR FONT, STYLE, SIZE, OR COLOR.

FOR LOW FREQUENCY ULTRASOUND DEVICE FOR APPLICATION OF ACOUSTIC ENERGY TO THE HUMAN BODY FOR PURPOSES OF HEALING SOFT TISSUE AND WOUNDS, NERVE REGENERATION AND REDUCING PAIN (U.S. CLS. 26, 39 AND 44).

FIRST USE 4-8-2010; IN COMMERCE 4-8-2010.  
MARK RADEMACHER, EXAMINING ATTORNEY

**CLASS 10—(Continued).**

SN 85-114,303. SUNCOAST DENTAL, INC., CLEARWATER, FL. FILED 8-24-2010.

**TATUM INTEGRITY IMPLANT**

THE MARK CONSISTS OF STANDARD CHARACTERS WITHOUT CLAIM TO ANY PARTICULAR FONT, STYLE, SIZE, OR COLOR.

NO CLAIM IS MADE TO THE EXCLUSIVE RIGHT TO USE "IMPLANT", APART FROM THE MARK AS SHOWN.

FOR DENTAL IMPLANTS; CONNECTED ABUTMENTS, NAMELY, DENTAL IMPLANT ABUTMENTS THAT CONNECT DENTAL IMPLANTS AND CROWNS (U.S. CLS. 26, 39 AND 44).

KATHERINE CHANG, EXAMINING ATTORNEY

---

SN 85-116,797. ALTIMATE MEDICAL, INC., MORTON, MN. FILED 8-26-2010.

**MAGICIAN**

THE MARK CONSISTS OF STANDARD CHARACTERS WITHOUT CLAIM TO ANY PARTICULAR FONT, STYLE, SIZE, OR COLOR.

FOR MEDICAL APPARATUS IN THE NATURE OF STATIONARY AND WHEELED STANDING AIDS, POSTURE SUPPORTS AND ACCESSORIES USEABLE THEREWITH, NAMELY, SEATS, ARMRESTS, SUPPORT CUSHIONS, WHEELS AND TABLES; WITH ALL OF THE FOREGOING FOR MEDICAL PURPOSES (U.S. CLS. 26, 39 AND 44).

FIRST USE 9-1-1996; IN COMMERCE 9-1-1996.  
ELIZABETH HUGHITT, EXAMINING ATTORNEY

**CLASS 10—(Continued).**

SN 85-122,449. BEIJING HONKON TECHNOLOGY CO., LTD., BEIJING, CHINA, FILED 9-3-2010.

 The logo for "Aeslight" features the word "Aeslight" in a sans-serif font. The letter "A" is stylized with a wavy line extending from its top left corner across the middle of the word.

THE MARK CONSISTS OF THE WORDING "AESLIGHT" WITH A WAVY LINE ACROSS THE MIDDLE OF THE LETTER "A" AND A WAVY LINE ABOVE THE LETTER "I".

FOR APPARATUS FOR PHYSICAL TRAINING FOR MEDICAL USE; DENTAL APPARATUS, NAMELY, INTRA-ORAL LIGHT SYSTEMS; ELECTRIC MASSAGE APPARATUS FOR HOUSEHOLD USE; GLOVES FOR MASSAGE; GLOVES FOR MEDICAL PURPOSES; GLOVES FOR MEDICAL USE; LASERS FOR MEDICAL PURPOSES; MASSAGE APPARATUS; MASSAGE APPARATUS; MASSAGE APPARATUS; MASSAGE APPARATUS AND INSTRUMENTS; MASSAGE CHAIRS; MASSAGE CHAIRS WITH BUILT-IN MASSAGE APPARATUS; MASSAGERS IN THE NATURE OF ELECTROMECHANICAL MASSAGE MECHANISM FOR CHAIRS; MASSAGING APPARATUS FOR PERSONAL USE; MEDICAL APPARATUS AND INSTRUMENTS FOR DIAGNOSTIC RADIOPHARMACEUTICAL USE; MEDICAL APPARATUS AND INSTRUMENTS FOR MONITORING VITAL SIGNS, BLOOD PROPERTIES AND RESPIRATORY EVENTS; MEDICAL APPARATUS, NAMELY, ELECTRIC VAPORIZER FOR UPPER RESPIRATORY CONDITIONS; MEDICAL APPARATUS, NAMELY, ELECTRIC VAPORIZER THAT EMITS MENTHOL FOR TREATMENT OF UPPER RESPIRATORY CONDITIONS; PHYSICAL EXERCISE APPARATUS, FOR MEDICAL PURPOSES; SURGICAL INSTRUMENTS AND APPARATUS; SURGICAL INSTRUMENTS FOR USE IN OPHTHALMIC SURGERY; SURGICAL INSTRUMENTS FOR USE IN ORTHOPEDIC AND SPINAL SURGERY; THERAPEUTIC HOT AND COLD COMPRESSION WRAPS; THERAPEUTIC SAUNAS (U.S. CLS. 26, 39 AND 44).

FIRST USE 5-25-2002; IN COMMERCE 1-18-2010.  
RAMONA ORTIGA, EXAMINING ATTORNEY

SN 85-133,103. BIOMET 3I, LLC, PALM BEACH GARDENS, FL. FILED 9-20-2010.

 The logo for "PSD" consists of the letters "PSD" in a bold, serif font.

THE MARK CONSISTS OF STANDARD CHARACTERS WITHOUT CLAIM TO ANY PARTICULAR FONT, STYLE, SIZE, OR COLOR.

FOR DENTAL IMPLANTS (U.S. CLS. 26, 39 AND 44).  
BILL DAWE, EXAMINING ATTORNEY

**CLASS 10—(Continued).**

SN 85-151,143. GALDERMA S.A., CHAM, SWITZERLAND, FILED 10-12-2010.

 The logo for "EMERVEL" features the word "EMERVEL" in a bold, serif font.

THE MARK CONSISTS OF STANDARD CHARACTERS WITHOUT CLAIM TO ANY PARTICULAR FONT, STYLE, SIZE, OR COLOR.

OWNER OF U.S. REG. NO. 3,875,260.

FOR MEDICAL DEVICES, NAMELY, HYPODERMIC, MEDICAL AND INJECTION SYRINGES, AUTOMATIC MEDICAL FLUID INJECTORS AND MEDICAL NEEDLES TO BE USED IN THE FIELD OF DERMATOLOGY (U.S. CLS. 26, 39 AND 44).

DAWN HAN, EXAMINING ATTORNEY

SN 85-154,382. FIKES, RAYMOND, MESA, AZ. FILED 10-16-2010.



NO CLAIM IS MADE TO THE EXCLUSIVE RIGHT TO USE "DOFF" AND "DONNER", APART FROM THE MARK AS SHOWN.

THE MARK CONSISTS OF A CIRCLE CONTAINING TWO STYLIZED DOLPHINS WITHIN THE TWO PARTS OF A YIN-YANG SYMBOL. THE YIN-YANG SYMBOL IS SURROUNDED BY FOUR CONCENTRIC RINGS, ONE OF WHICH CONTAINS THE TEXT "DOFF N' DONNER" AND TWO DOTS; THE OUTERMOST RING HAS A SCALLOPED BORDER.

FOR MEDICAL APPARATUS, NAMELY, ASSISTIVE PERSONAL AID DEVICE FOR DONNING AND REMOVING COMPRESSION TIGHTS AND SOCKS (U.S. CLS. 26, 39 AND 44).

REBECCA EISINGER, EXAMINING ATTORNEY

**CLASS 10—(Continued).**

SN 85-155,860. ONTIUM, LLC, SANDY, UT. FILED 10-19-2010.

ONTIUM MEDICAL

THE MARK CONSISTS OF STANDARD CHARACTERS WITHOUT CLAIM TO ANY PARTICULAR FONT, STYLE, SIZE, OR COLOR.

NO CLAIM IS MADE TO THE EXCLUSIVE RIGHT TO USE "MEDICAL", APART FROM THE MARK AS SHOWN. THE WORDING "ONTIUM" HAS NO MEANING IN A FOREIGN LANGUAGE.

FOR CLEARERS IN THE NATURE OF A DEFLAGGER APPARATUS FOR SURGICAL SUCTION TIPS (U.S. CLS. 26, 39 AND 44).

KRISTINA MORRIS, EXAMINING ATTORNEY

**CLASS 10—(Continued).**

SN 85-163,597. DENTOLOGY SCIENCES COMPANY, LLC, HOUSTON, TX. FILED 10-28-2010.



THE COLOR(S) LIGHT BLUE, DARK BLUE IS/ARE CLAIMED AS A FEATURE OF THE MARK.

THE MARK CONSISTS OF A STYLIZED CIRCULAR FACE COMPRISED OF A LIGHT BLUE "C" WITH AN EYE ON THE LEFT SIDE AND A DARK BLUE "D" WITH A PORTION OF A SMILE ON THE RIGHT. THE LITERAL ELEMENT IS LIGHT AND DARK BLUE, WITH "CONFI" IN DARK BLUE AND "DENTURES" IN LIGHT BLUE. THE WHITE IN THE MARK REPRESENTS BACKGROUND OR TRANSPARENCY AND IS NOT CLAIMED AS A FEATURE OF THE MARK.

FOR DENTURES (U.S. CLS. 26, 39 AND 44).  
FIRST USE 9-13-2010; IN COMMERCE 9-13-2010.  
KIMBERLY FRYE, EXAMINING ATTORNEY

SN 85-156,875. BACON, BRETT, E., DBA SONIC SAFE, EPSOM, NH. FILED 10-20-2010.

SONIC SAFE

THE MARK CONSISTS OF STANDARD CHARACTERS WITHOUT CLAIM TO ANY PARTICULAR FONT, STYLE, SIZE, OR COLOR.

NO CLAIM IS MADE TO THE EXCLUSIVE RIGHT TO USE "SONIC", APART FROM THE MARK AS SHOWN.

FOR ASSISTIVE LISTENING DEVICE FOR THE HEARING IMPAIRED (U.S. CLS. 26, 39 AND 44).

FIRST USE 8-10-2010; IN COMMERCE 9-5-2010.  
APRIL ROACH, EXAMINING ATTORNEY

SN 85-170,440. ALTIMATE MEDICAL, INC., MORTON, MN. FILED 11-5-2010.

GLIDER

THE MARK CONSISTS OF STANDARD CHARACTERS WITHOUT CLAIM TO ANY PARTICULAR FONT, STYLE, SIZE, OR COLOR.

FOR MEDICAL APPARATUS IN THE NATURE OF STATIONARY POSTURE SUPPORTS FOR THOSE OF REDUCED MOBILITY DUE TO AGE, INJURY OR DISABILITY; WITH THE FOREGOING BEING FOR MEDICAL PURPOSES (U.S. CLS. 26, 39 AND 44).

FIRST USE 11-0-1998; IN COMMERCE 11-0-1998.  
ELIZABETH HUGHITT, EXAMINING ATTORNEY

**CLASS 10—(Continued).**

SN 85-175,762. HK SURGICAL, INC., SAN JUAN CAPISTRANO, CA. FILED 11-12-2010.

**HK SURGICAL**

THE MARK CONSISTS OF STANDARD CHARACTERS WITHOUT CLAIM TO ANY PARTICULAR FONT, STYLE, SIZE, OR COLOR.

OWNER OF U.S. REG. NOS. 3,257,086 AND 3,349,684.

NO CLAIM IS MADE TO THE EXCLUSIVE RIGHT TO USE "SURGICAL", APART FROM THE MARK AS SHOWN.

FOR MEDICAL TABLE SHEETS FOR OPERATING TABLES; MEDICAL PRODUCTS, NAMELY, LIPOSUCTION CANNULA HANDLES, TEMPERATURE CONTROLLED WATER BATH FOR IV SOLUTIONS, ULTRASONIC CANNULA CLEANING MACHINES, MEDICAL ASPIRATORS AND ASPIRATION TUBING (U.S. CLS. 26, 39 AND 44).

STEVEN JACKSON, EXAMINING ATTORNEY

---

SN 85-186,075. MOTION CONTROL, INC., SALT LAKE CITY, UT. FILED 11-29-2010.

**MOTION ARM**

THE MARK CONSISTS OF STANDARD CHARACTERS WITHOUT CLAIM TO ANY PARTICULAR FONT, STYLE, SIZE, OR COLOR.

NO CLAIM IS MADE TO THE EXCLUSIVE RIGHT TO USE "ARM", APART FROM THE MARK AS SHOWN.

FOR A NON-IMPLANTABLE, EXTERNAL, ELBOW PROSTHESIS (U.S. CLS. 26, 39 AND 44).

CAROLINE WOOD, EXAMINING ATTORNEY

---

SN 85-186,196. BEAM ASSOCIATES LLC, LYNDHURST, NJ. FILED 11-29-2010.

**Isin Robotics**

THE MARK CONSISTS OF STANDARD CHARACTERS WITHOUT CLAIM TO ANY PARTICULAR FONT, STYLE, SIZE, OR COLOR.

NO CLAIM IS MADE TO THE EXCLUSIVE RIGHT TO USE "ROBOTICS", APART FROM THE MARK AS SHOWN.

FOR EXTERNAL FIXATION DEVICE FOR USE IN ORTHOPEDIC CORRECTIVE PROCEDURES (U.S. CLS. 26, 39 AND 44).

RAUL CORDOVA, EXAMINING ATTORNEY

**CLASS 10—(Continued).**

SN 85-186,813. WONG, KIN C., CLOSTER, NJ. FILED 11-30-2010.



THE MARK CONSISTS OF "ULMUKA" COMBINED WITH A DESIGN OF A MOTHER OWL AND A BABY OWL ON BRANCHES WITH LEAVES.

THE ENGLISH TRANSLATION OF THE WORD "ULMUKA" IN THE MARK IS "OWL".

FOR BABY BOTTLE NIPPLES; BABY BOTTLES; FEEDING BOTTLES; PACIFIERS FOR BABIES; TEETHING RINGS INCORPORATING BABY RATTLES (U.S. CLS. 26, 39 AND 44).

KIM MONINGHOFF, EXAMINING ATTORNEY

---

SN 85-187,469. LITTLE RAPIDS CORPORATION, GREEN BAY, WI. FILED 11-30-2010.

**COVER MATE**

THE MARK CONSISTS OF STANDARD CHARACTERS WITHOUT CLAIM TO ANY PARTICULAR FONT, STYLE, SIZE, OR COLOR.

NO CLAIM IS MADE TO THE EXCLUSIVE RIGHT TO USE "COVER", APART FROM THE MARK AS SHOWN.

FOR DISPOSABLE COVERS FOR MEDICAL EQUIPMENT (U.S. CLS. 26, 39 AND 44).

WILLIAM VERHOSEK, EXAMINING ATTORNEY

---

SN 85-187,906. NOVA IMAGING, INC., LEXINGTON, MA. FILED 12-1-2010.

**MaRIUS**

THE MARK CONSISTS OF STANDARD CHARACTERS WITHOUT CLAIM TO ANY PARTICULAR FONT, STYLE, SIZE, OR COLOR.

FOR MEDICAL SCANNING DEVICES FOR IMAGING, USED FOR IDENTIFYING NON-INVASIVE TISSUE CHARACTERIZATION OF THE ATHEROSCLEROTIC PLAQUE (U.S. CLS. 26, 39 AND 44).

LINDA POWELL, EXAMINING ATTORNEY

**CLASS 10—(Continued).**

SN 85-187,918. NORDSON CORPORATION, WESTLAKE, OH. FILED 12-1-2010.

# ARTISTE

THE MARK CONSISTS OF STANDARD CHARACTERS WITHOUT CLAIM TO ANY PARTICULAR FONT, STYLE, SIZE, OR COLOR.

FOR MEDICAL DEVICE FOR USE IN THE ADMINISTRATION OF STERILE MATERIALS INTO PATIENT SKIN UNDER ASEPTIC CONDITIONS (U.S. CLS. 26, 39 AND 44).

LINDA POWELL, EXAMINING ATTORNEY

**CLASS 10—(Continued).**

SN 85-190,191. ADVANCED IMAGING RESEARCH, INC., CLEVELAND, OH. FILED 12-3-2010.

## SREE MEDICAL SYSTEMS

THE MARK CONSISTS OF STANDARD CHARACTERS WITHOUT CLAIM TO ANY PARTICULAR FONT, STYLE, SIZE, OR COLOR.

NO CLAIM IS MADE TO THE EXCLUSIVE RIGHT TO USE "MEDICAL SYSTEMS", APART FROM THE MARK AS SHOWN.

THE ENGLISH TRANSLATION OF THE WORD "SREE" IN THE MARK IS A MASCULINE TITLE OF VENERATION, NAMELY, MISTER.

FOR MEDICAL EQUIPMENT FOR USE IN MAGNETIC RESONANCE IMAGING, NAMELY, RF COILS AND ACCESSORIES THEREFOR, NAMELY, INCUBATORS FOR BABIES, RESPIRATORS FOR ARTIFICIAL RESPIRATION, VENTILATORS FOR SUPPLYING OXYGEN/AIR TO A PATIENT'S LUNGS, ELECTROCARDIOGRAM LEADS AND MONITOR FOR MEASURING A PATIENT'S HEART RATE AND PULSE, SATURATED PARTIAL PRESSURE OXYGEN MONITOR FOR MEASURING A PATIENT'S BLOOD OXYGENATION LEVEL, THERMOMETERS FOR MEASURING A PATIENT'S TEMPERATURE AT THE AUXILIARY NODES/ARMPITS, NAVEL, PALM AND FEET, OXYGEN AND AIR CYLINDERS FOR SUPPLYING OXYGEN/AIR TO A PATIENT, PRESSURE REDUCER FOR RELIEVING OXYGEN/AIR PRESSURE BEFORE REACHING A PATIENT, FLOW TUBE FOR MEASURING OXYGEN/AIR FLOW VOLUME AND RATE TO A PATIENT, AND INJECTOR FOR INJECTING IMAGE CONTRAST DYES INTO A PATIENT (U.S. CLS. 26, 39 AND 44).

FIRST USE 7-29-2010; IN COMMERCE 7-29-2010.

JILL PRATER, EXAMINING ATTORNEY

SN 85-189,588. APIRA SCIENCE INC., NEWPORT BEACH, CA. FILED 12-2-2010.

# iGrow

THE MARK CONSISTS OF STANDARD CHARACTERS WITHOUT CLAIM TO ANY PARTICULAR FONT, STYLE, SIZE, OR COLOR.

OWNER OF U.S. REG. NO. 3,857,453.  
FOR LASERS FOR THE COSMETIC TREATMENT OF THE FACE AND SKIN (U.S. CLS. 26, 39 AND 44).

FIRST USE 10-7-2008; IN COMMERCE 8-1-2010.

DEBRA LEE, EXAMINING ATTORNEY

SN 85-191,458. KOWA COMPANY, LTD., NAGOYA, JAPAN, FILED 12-6-2010.

PRIORITY CLAIMED UNDER SEC. 44(D) ON JAPAN APPLICATION NO. 2010093291, FILED 12-1-2010.

THE MARK CONSISTS OF THE LETTERS "A","P" IN STYLIZED FORM.

FOR PERIMETER, NAMELY, OPHTHALMIC DEVICE INTENDED TO DETERMINE THE EXTENT OF THE PERIPHERAL VISUAL FIELD OF A PATIENT (U.S. CLS. 26, 39 AND 44).

MATTHEW KLINE, EXAMINING ATTORNEY



**CLASS 10—(Continued).**

SN 85-193,219. SECURISYN MEDICAL, LLC, LITTLETON, CO. FILED 12-8-2010.



NO CLAIM IS MADE TO THE EXCLUSIVE RIGHT TO USE "MEDICAL", APART FROM THE MARK AS SHOWN. THE COLOR(S) GREEN, ORANGE, WHITE AND GREY IS/ARE CLAIMED AS A FEATURE OF THE MARK.

THE MARK CONSISTS OF THE WORDS "SECURISYN MEDICAL" IN ALL CAPS, COMPRISED OF THE LETTERS "SECURISYN" IN GREEN AND THE LETTERS "MEDICAL" IN WHITE. THE WORD "SECURISYN" APPEARS IN A CIRCULAR ARC EXTENDING FROM 9 O'CLOCK TO 3 O'CLOCK TO FORM THE TOP HALF OF A CIRCLE. THE LETTER R IN "SECURISYN" FORMS THE TOP OF THE ARC AT 12 O'CLOCK. AN ORANGE BANNER-LIKE RIBBON WITH INWARD NOTCHED ENDS FORMS THE BOTTOM HALF OF THE CIRCLE, EXTENDING FROM 3 O'CLOCK TO 9 O'CLOCK, WITH THE WORD "MEDICAL" SUPERIMPOSED ON THE ORANGE BANNER IN WHITE EXTENDING FROM 8 O'CLOCK TO 4 O'CLOCK. IN THE CENTER OF THE CIRCLE FORMED BY THE WORD "SECURISYN" AND THE ORANGE BANNER-LIKE RIBBON IS A PALE GREY GEOMETRIC CROSS WITH ARMS OF EQUAL LENGTH AND WIDTH. SUPERIMPOSED ON THE GREY CROSS IS A SIMPLE GREEN GRAPHIC FIGURE REPRESENTING A PERSON OF EITHER GENDER WITH ARMS STRETCHED UPWARD. THERE ARE NINETEEN GREEN LEAVES OF VARIOUS SIZES EXTENDING AWAY FROM THIS FIGURE AT VARIOUS ANGLES, AS IF THE FIGURE REPRESENTS THE TRUNK OF A TREE AND THE LEAVES REPRESENT THE BRANCHES OF THE TREE.

FOR MEDICAL ENDOTRACHEAL TUBE WITH SECURING DEVICE (U.S. CLS. 26, 39 AND 44).

DORITT L. CARROLL, EXAMINING ATTORNEY

SN 85-195,056. LETHAN CORPORATION, HAMILTON, OH. FILED 12-10-2010.

# Metaform

THE MARK CONSISTS OF STANDARD CHARACTERS WITHOUT CLAIM TO ANY PARTICULAR FONT, STYLE, SIZE, OR COLOR.

FOR APPARATUS FOR VIBRATIONAL THERAPY, NAMELY, TUNING FORKS (U.S. CLS. 26, 39 AND 44).

FIRST USE 11-14-2005; IN COMMERCE 3-17-2006.

RAUL CORDOVA, EXAMINING ATTORNEY

**CLASS 10—(Continued).**

SN 85-195,566. DUANE READE INTERNATIONAL, LLC, NEW YORK, NY. FILED 12-10-2010.

# POP HEAT

THE MARK CONSISTS OF STANDARD CHARACTERS WITHOUT CLAIM TO ANY PARTICULAR FONT, STYLE, SIZE, OR COLOR.

NO CLAIM IS MADE TO THE EXCLUSIVE RIGHT TO USE "HEAT", APART FROM THE MARK AS SHOWN.

FOR CHEMICALLY ACTIVATED HEATING PADS FOR MEDICAL PURPOSES (U.S. CLS. 26, 39 AND 44).

ALEXANDER L. POWERS, EXAMINING ATTORNEY

SN 85-196,899. MEDELA HOLDING AG, BAAR, SWITZERLAND, FILED 12-13-2010.

# ME TIME IS WE TIME

THE MARK CONSISTS OF STANDARD CHARACTERS WITHOUT CLAIM TO ANY PARTICULAR FONT, STYLE, SIZE, OR COLOR.

FOR ARTIFICIAL LIMBS, EYES AND TEETH; SUTURE MATERIALS; PHOTOTHERAPEUTIC APPARATUS FOR MEDICAL PURPOSES; VACUUM PUMPS FOR MEDICAL PURPOSES; MEDICAL SPECIMEN COLLECTING CONTAINERS AND MEDICAL POUCHES AND CONTAINERS FOR MEDICAL SPECIMENS AS WELL AS FOR THE COLLECTION, DISPOSAL, AND TRANSPORT OF BODY FLUIDS; FORCEPS FOR MEDICAL USE; INCUBATORS FOR NEWBORNS; LAMPS, NAMELY, MEDICAL EXAMINATION LAMPS, SURGICAL LAMPS, ULTRAVIOLET RAY LAMPS FOR MEDICAL PURPOSES AND PHOTOTHERAPY LAMPS FOR MEDICAL PURPOSES; BREAST PUMPS; BREAST SHIELDS; FEEDING BOTTLES; MEDICAL POUCHES AND CONTAINERS SPECIALLY DESIGNED FOR THE COLLECTION, DEEP-FREEZING, STORING, TRANSPORT, AND REHEATING BREAST MILK FOR MEDICAL PURPOSES; FEEDING BOTTLES FOR MEDICAL PURPOSES; BREAST NIPPLE SHIELDS FOR MEDICAL PURPOSES; NIPPLE FORMERS FOR BREASTFEEDING, NAMELY, MEDICAL DEVICE WHICH APPLIES PRESSURE ON THE NIPPLE MUSCLE AND HELPS IT TO EXTEND OR PREPARE FLAT OR INVERTED NIPPLES FOR BREASTFEEDING; BAGS AND CONTAINERS SPECIALLY ADAPTED FOR USE HOLDING STERILIZER UNITS FOR MEDICAL PURPOSES; COOLING BAGS FOR MEDICAL PURPOSES, NAMELY, FOR COOLING APPARATUS USED FOR MEDICAL AND SURGICAL EQUIPMENT USED DURING MEDICAL AND SURGICAL PROCEDURES; ELASTIC STOCKINGS, MEDICAL COMPRESSION STOCKINGS FOR VARICOSE VEINS; BAGS AND CONTAINERS SPECIALLY ADAPTED FOR HOLDING MEDICAL STEAM CLEANERS AND STERILIZERS FOR MEDICAL PURPOSES; VENTOUSES, NAMELY, MEDICAL VACUUM PUMPS DESIGNED TO ACCELERATE CHILDBIRTH; DUMMIES OR TEATS FOR BABIES, NAMELY, PACIFIERS AND BABY BOTTLE NIPPLES (U.S. CLS. 26, 39 AND 44).

DAVID TAYLOR, EXAMINING ATTORNEY

**CLASS 10—(Continued).**

SN 85-196,925. MIHIN, WILLIAM, SANDPOINT, ID. FILED 12-13-2010.

**HEADACHE HAMMOCK**

THE MARK CONSISTS OF STANDARD CHARACTERS WITHOUT CLAIM TO ANY PARTICULAR FONT, STYLE, SIZE, OR COLOR.

NO CLAIM IS MADE TO THE EXCLUSIVE RIGHT TO USE "HEADACHE", APART FROM THE MARK AS SHOWN.

FOR ORTHOPEDIC DEVICES FOR THERAPEUTIC USE (U.S. CLS. 26, 39 AND 44).

SANDRA BUJA, EXAMINING ATTORNEY

SN 85-200,804. NOVAMED-USA INC., ELMSFORD, NY. FILED 12-17-2010.



THE MARK CONSISTS OF THE WORD "KOALA" WITH THE COMBINED DELTA TRIANGLE SYMBOL AND LETTER "T" TO THE UPPER RIGHT OF THE WORD "KOALA". THE DESIGN OF A KOALA BEAR'S HEAD IS DEPICTED INSIDE THE LETTER "O" IN THE WORD "KOALA".

FOR PATIENT WARMING SYSTEMS COMPRISED OF A WARMING MATTRESS, WARMING BLANKET, AND TEMPERATURE CONTROLLER THEREFORE (U.S. CLS. 26, 39 AND 44).

FIRST USE 1-0-2008; IN COMMERCE 1-0-2008.

ALLISON SCHRODY, EXAMINING ATTORNEY

SN 85-202,690. EXTREMITY MEDICAL, LLC, PARSIPPANY, NJ. FILED 12-21-2010.



OWNER OF U.S. REG. NOS. 3,652,074, 3,756,648 AND OTHERS.

THE MARK CONSISTS OF LETTERS, "XMCP", WITH THE "X" REPRESENTED BY THE DESIGN OF A PERSON WITH A SOLID CIRCLE FOR A HEAD AND A THIN LINE CURVED DOWNWARD AND RUNNING FROM THE LEFT HAND TO THE RIGHT HAND OF THE PERSON.

FOR MEDICAL DEVICES, NAMELY, INTRAMEDULLARY FUSION DEVICES (U.S. CLS. 26, 39 AND 44).

WILLIAM BRECKENFELD, EXAMINING ATTORNEY

**CLASS 10—(Continued).**

SN 85-202,859. ALLEN MEDICAL SYSTEMS, INC., BATESVILLE, IN. FILED 12-21-2010.

**C-FLEX**

THE MARK CONSISTS OF STANDARD CHARACTERS WITHOUT CLAIM TO ANY PARTICULAR FONT, STYLE, SIZE, OR COLOR.

FOR MEDICAL AND SURGICAL APPARATUS AND INSTRUMENTS, NAMELY, DEVICES USED TO POSITION SURGICAL PATIENTS (U.S. CLS. 26, 39 AND 44).

FIRST USE 8-23-2007; IN COMMERCE 8-23-2007.

TIMOTHY FINNEGAN, EXAMINING ATTORNEY

SN 85-203,571. WOUND CARE 360, INC., BOCA GRANDE, HI. FILED 12-22-2010.

**Site Seal**

THE MARK CONSISTS OF STANDARD CHARACTERS WITHOUT CLAIM TO ANY PARTICULAR FONT, STYLE, SIZE, OR COLOR.

FOR MEDICAL APPARATUS AND INSTRUMENTS FOR USE IN SURGERY (U.S. CLS. 26, 39 AND 44).

JOHN DALIER, EXAMINING ATTORNEY

SN 85-203,770. PRETIKA CORPORATION, LAGUNA NIGUEL, CA. FILED 12-22-2010.

**DermaLife**

THE MARK CONSISTS OF STANDARD CHARACTERS WITHOUT CLAIM TO ANY PARTICULAR FONT, STYLE, SIZE, OR COLOR.

OWNER OF U.S. REG. NO. 3,840,417.

FOR PERSONAL AND SKIN CARE PRODUCTS, NAMELY, SKIN REJUVENATION TOOLS, NAMELY, ELECTRIC FACIAL MASSAGE APPARATUS (U.S. CLS. 26, 39 AND 44).

FIRST USE 1-1-2010; IN COMMERCE 1-1-2010.

LINDSEY RUBIN, EXAMINING ATTORNEY

**CLASS 10—(Continued).**

SN 85-203,856. RIVERA-PABON, WILFREDO, CAGUAS, PUERTO RICO, FILED 12-22-2010.



NO CLAIM IS MADE TO THE EXCLUSIVE RIGHT TO USE "EAR", APART FROM THE MARK AS SHOWN.

THE COLOR(S) RED, BLACK AND BLUE IS/ARE CLAIMED AS A FEATURE OF THE MARK.

THE MARK CONSISTS OF A RED CURSIVE LETTER "M" FINISHING AS A HEARING AID IN THE EXTERNAL AUDITORY CANAL. NEXT TO THE LETTER "M" APPEAR A BLACK SILHOUETTE OF AN EAR. THE RED LETTER "M" AND THE BLACK EAR SILHOUETTE APPEAR OVER A DIMENSIONAL SQUARE WITH ROUNDED EDGES WHICH BACKGROUND APPEAR AS A COLOR BLUE DEGRADATION FROM LIGHTER BLUE ON TOP TO A DARKER ONE AT THE BOTTOM. BELOW THE LETTER "M" AND THE EAR SILHOUETTE APPEARS THE WORD "MASTER'S" IN RED COLOR AND THE WORD "EAR" IN BLACK COLOR, ALL IN BLOCK STYLE LETTER.

FOR HEARING AIDS (U.S. CLS. 26, 39 AND 44).  
MARK SPARACINO, EXAMINING ATTORNEY

SN 85-204,236. ASCEND EAGLE INC., AMERICAN CANYON, CA. FILED 12-22-2010.

## NuComfort

THE MARK CONSISTS OF STANDARD CHARACTERS WITHOUT CLAIM TO ANY PARTICULAR FONT, STYLE, SIZE, OR COLOR.

NO CLAIM IS MADE TO THE EXCLUSIVE RIGHT TO USE "COMFORT", APART FROM THE MARK AS SHOWN.

FOR DENTAL GLOVES (U.S. CLS. 26, 39 AND 44).  
FIRST USE 1-1-2009; IN COMMERCE 1-1-2009.  
EUGENIA MARTIN, EXAMINING ATTORNEY

**CLASS 10—(Continued).**

SN 85-204,427. ARTIVENT CORPORATION, SAN FRANCISCO, CA. FILED 12-22-2010.

## ARTIVENT

THE MARK CONSISTS OF STANDARD CHARACTERS WITHOUT CLAIM TO ANY PARTICULAR FONT, STYLE, SIZE, OR COLOR.

FOR MEDICAL DEVICES, NAMELY RESUSCITATION APPARATUS, MANUAL VENTILATORS, MANUAL EMERGENCY VENTILATORS, TRANSPORT VENTILATORS, POWERED VENTILATORS, POWERED EMERGENCY VENTILATORS, POSITIVE END EXPIRATORY VALVES, OXYGEN MASKS, OXYGEN TUBING, OXYGEN FILTERS, ENDOTRACHEAL TUBES, NASOPHARYNGEAL AIRWAY TUBING, LARYNGEAL MASKS, AIRWAY MANOMETERS, MANUAL RESUSCITATORS, RESUSCITATORS, VENTILATORS, FACE MASKS ALL FOR USE DURING ARTIFICIAL VENTILATION AND RESUSCITATION (U.S. CLS. 26, 39 AND 44).

THEODORE MCBRIDE, EXAMINING ATTORNEY

SN 85-204,899. SDS DENTAL INC., AKA SUMMIT DENTAL SYSTEMS, FORT LAUDERDALE, FL. FILED 12-23-2010.

## ZIPCLAVE

THE MARK CONSISTS OF STANDARD CHARACTERS WITHOUT CLAIM TO ANY PARTICULAR FONT, STYLE, SIZE, OR COLOR.

FOR AUTOCLAVES FOR MEDICAL USE (U.S. CLS. 26, 39 AND 44).

ROBIN CHOSID, EXAMINING ATTORNEY

SN 85-206,285. NATALIE LEVY-SARRAF, WOODLAND HILLS, CA. FILED 12-28-2010.

## DO IT SAFE

THE MARK CONSISTS OF STANDARD CHARACTERS WITHOUT CLAIM TO ANY PARTICULAR FONT, STYLE, SIZE, OR COLOR.

FOR MEDICAL DEVICES FOR SALE OVER THE COUNTER IN PHARMACIES AND DRUGSTORES, NAMELY, DOSING MEDICATION DISPENSERS IN THE FORM OF AN ORAL SYRINGE AND A SELF RESEALING BOTTLE CLOSURE PERFORMABLE BY THE ORAL SYRINGE, SOLD AS A KIT (U.S. CLS. 26, 39 AND 44).

ALICIA COLLINS, EXAMINING ATTORNEY

**CLASS 10—(Continued).**

SN 85-207,452. 3-POINT PRODUCTS, INC., STEVENSVILLE, MD. FILED 12-29-2010.

# 3pp

THE MARK CONSISTS OF STANDARD CHARACTERS WITHOUT CLAIM TO ANY PARTICULAR FONT, STYLE, SIZE, OR COLOR.

FOR MEDICAL BRACES FOR FINGERS, THUMBS, WRISTS, ANKLES, AND ELBOWS; SPLINTS FOR FINGERS, THUMBS, WRISTS, ANKLES, AND ELBOWS (U.S. CLS. 26, 39 AND 44).

FIRST USE 12-23-2004; IN COMMERCE 12-31-2004.  
MARY ROSSMAN, EXAMINING ATTORNEY

SN 85-207,619. GRUNFELD, NURIT, LOS ANGELES, CA. AND HANDELMAN, JULIE, LOS ANGELES, CA. FILED 12-29-2010.

# City of Sleep

THE MARK CONSISTS OF STANDARD CHARACTERS WITHOUT CLAIM TO ANY PARTICULAR FONT, STYLE, SIZE, OR COLOR.

FOR HUMIDIFICATION APPARATUS FOR MEDICAL PURPOSES; MEDICAL APPARATUS, NAMELY, BI-LEVEL POSITIVE AIRWAY PRESSURE (BPAP) DEVICES; MEDICAL APPARATUS, NAMELY, CONTINUOUS POSITIVE AIRWAY PRESSURE (CPAP) DEVICES; MEDICAL APPARATUS, NAMELY, VARIABLE POSITIVE AIRWAY PRESSURE DEVICES (VPAP) (U.S. CLS. 26, 39 AND 44).

LINDSEY RUBIN, EXAMINING ATTORNEY

SN 85-207,731. 3-POINT PRODUCTS, INC., STEVENSVILLE, MD. FILED 12-30-2010.

# SKINSATIONAL

THE MARK CONSISTS OF STANDARD CHARACTERS WITHOUT CLAIM TO ANY PARTICULAR FONT, STYLE, SIZE, OR COLOR.

FOR MASSAGE APPARATUS (U.S. CLS. 26, 39 AND 44).

FIRST USE 12-31-2006; IN COMMERCE 12-31-2006.  
MARY ROSSMAN, EXAMINING ATTORNEY

**CLASS 10—(Continued).**

SN 85-207,983. AUDIO EVOLUTION DIAGNOSTICS, INC., ALBANY, NY. FILED 12-30-2010.

# VITALSCOPE

THE MARK CONSISTS OF STANDARD CHARACTERS WITHOUT CLAIM TO ANY PARTICULAR FONT, STYLE, SIZE, OR COLOR.

FOR STETHOSCOPES (U.S. CLS. 26, 39 AND 44).  
ALICE BENMAMAN, EXAMINING ATTORNEY

SN 85-208,137. ACTIVECARE, INC., SALT LAKE CITY, UT. FILED 12-30-2010.

# ActiveHome

THE MARK CONSISTS OF STANDARD CHARACTERS WITHOUT CLAIM TO ANY PARTICULAR FONT, STYLE, SIZE, OR COLOR.

FOR PERSONAL TRANSMITTING AND RECEIVING UNITS FOR REMOTELY MONITORING THE HEALTH OR CONDITION OF AN INDIVIDUAL OR GROUP OF INDIVIDUALS AND FOR PROVIDING REMOTE ACCESS TO EMERGENCY, SAFETY AND CONVENIENCE SERVICES, NAMELY, ELECTRONIC PERSONAL MONITORS TO REMOTELY MONITOR PHYSIOLOGICAL DATA AND HAVING CELLULAR OR RADIO FREQUENCY COMMUNICATION CAPABILITIES (U.S. CLS. 26, 39 AND 44).

HENRY S. ZAK, EXAMINING ATTORNEY

SN 85-208,144. SENSORY AUGMENTATION CORPORATION, LONG BEACH, CA. FILED 12-30-2010.

# WALKJOY

THE MARK CONSISTS OF STANDARD CHARACTERS WITHOUT CLAIM TO ANY PARTICULAR FONT, STYLE, SIZE, OR COLOR.

FOR MEDICAL DEVICE TO RESTORE BALANCE AND GAIT (U.S. CLS. 26, 39 AND 44).

MATTHEW EINSTEIN, EXAMINING ATTORNEY

**CLASS 10—(Continued).**

SN 85-208,384. RONALD D. OLDRING, BELLEVUE, WA.  
FILED 12-30-2010.

## THE SPANKY HANKY

THE MARK CONSISTS OF STANDARD CHARACTERS  
WITHOUT CLAIM TO ANY PARTICULAR FONT, STYLE,  
SIZE, OR COLOR.

FOR ADULT SEXUAL STIMULATION AIDS,  
NAMELY, A MASTURBATION CLOTH (U.S. CLS. 26, 39  
AND 44).

WANDA KAY PRICE, EXAMINING ATTORNEY

**CLASS 10—(Continued).**

SN 85-208,761. WALSH, BRIAN V, TRABUCO CANYON, CA.  
FILED 1-1-2011.

## Toe-ease

THE MARK CONSISTS OF STANDARD CHARACTERS  
WITHOUT CLAIM TO ANY PARTICULAR FONT, STYLE,  
SIZE, OR COLOR.

FOR ORTHOTIC INSERTS FOR FOOTWEAR (U.S.  
CLS. 26, 39 AND 44).

KEVON CHISOLM, EXAMINING ATTORNEY

SN 85-208,757. WALSH, BRIAN V, TRABUCO CANYON, CA.  
FILED 1-1-2011.

## Achillease

THE MARK CONSISTS OF STANDARD CHARACTERS  
WITHOUT CLAIM TO ANY PARTICULAR FONT, STYLE,  
SIZE, OR COLOR.

FOR ORTHOTIC INSERTS FOR FOOTWEAR (U.S.  
CLS. 26, 39 AND 44).

KEVON CHISOLM, EXAMINING ATTORNEY

SN 85-208,763. WALSH, BRIAN V, TRABUCO CANYON, CA.  
FILED 1-1-2011.

## Strapease

THE MARK CONSISTS OF STANDARD CHARACTERS  
WITHOUT CLAIM TO ANY PARTICULAR FONT, STYLE,  
SIZE, OR COLOR.

FOR ORTHOTIC INSERTS FOR FOOTWEAR (U.S.  
CLS. 26, 39 AND 44).

KEVON CHISOLM, EXAMINING ATTORNEY

SN 85-208,758. WALSH, BRIAN V, TRABUCO CANYON, CA.  
FILED 1-1-2011.

## Archease

THE MARK CONSISTS OF STANDARD CHARACTERS  
WITHOUT CLAIM TO ANY PARTICULAR FONT, STYLE,  
SIZE, OR COLOR.

FOR ORTHOTIC INSERTS FOR FOOTWEAR (U.S.  
CLS. 26, 39 AND 44).

KEVON CHISOLM, EXAMINING ATTORNEY

SN 85-209,045. JOM PERSONAL PRODUCTS CORP., WILL-  
IMINGTON, DE. FILED 1-3-2011.

## JOM

THE MARK CONSISTS OF STANDARD CHARACTERS  
WITHOUT CLAIM TO ANY PARTICULAR FONT, STYLE,  
SIZE, OR COLOR.

FOR ADULT SEXUAL STIMULATION KIT COM-  
PRISED PRIMARILY OF ADULT SEXUAL STIMULA-  
TION AIDS AND A WORKBOOK (U.S. CLS. 26, 39 AND  
44).

ALICIA COLLINS, EXAMINING ATTORNEY

**CLASS 10—(Continued).**

SN 85-209,102. CIRRUS HEALTHCARE PRODUCTS, L.L.C.,  
COLD SPRING HARBOR, NY. FILED 1-3-2011.

**EARSOOTHE**

THE MARK CONSISTS OF STANDARD CHARACTERS  
WITHOUT CLAIM TO ANY PARTICULAR FONT, STYLE,  
SIZE, OR COLOR.

FOR EAR PLUGS FOR MEDICAL PURPOSES (U.S.  
CLS. 26, 39 AND 44).

JENNIFER MARTIN, EXAMINING ATTORNEY

**CLASS 10—(Continued).**

SN 85-209,514. COLLEN, JESS M, OSSINING, NY. FILED 1-3-  
2011.

**ORAL SOX**

THE MARK CONSISTS OF STANDARD CHARACTERS  
WITHOUT CLAIM TO ANY PARTICULAR FONT, STYLE,  
SIZE, OR COLOR.

FOR PERSONAL HYGIENE PRODUCTS, NAMELY,  
DENTAL DAMS (U.S. CLS. 26, 39 AND 44).

DOMINICK J. SALEMI, EXAMINING ATTORNEY

SN 85-209,214. CORELINK, LLC, ST. LOUIS, MO. FILED 1-3-  
2011.

**CORELINK**

THE MARK CONSISTS OF STANDARD CHARACTERS  
WITHOUT CLAIM TO ANY PARTICULAR FONT, STYLE,  
SIZE, OR COLOR.

FOR MEDICAL DEVICES, NAMELY, DEVICES FOR  
SPINAL DISC REPAIR IN THE NATURE OF AN  
APPARATUS USED IN SPINAL DISC REPAIR PROCE-  
DURES (U.S. CLS. 26, 39 AND 44).

FIRST USE 1-16-2007; IN COMMERCE 1-1-2010.

ANNE E. GUSTASON, EXAMINING ATTORNEY

SN 85-210,280. ESAOTE S.P.A., MILANO, ITALY, FILED 1-4-  
2011.

**MYLABTOUCH**

THE MARK CONSISTS OF STANDARD CHARACTERS  
WITHOUT CLAIM TO ANY PARTICULAR FONT, STYLE,  
SIZE, OR COLOR.

OWNER OF ERP N CMNTY TM OFC REG. NO. 009245135,  
DATED 12-6-2010, EXPIRES 12-6-2020.

FOR MEDICAL DIAGNOSTIC APPARATUS,  
NAMELY, ULTRASOUND IMAGING MACHINES (U.S.  
CLS. 26, 39 AND 44).

BARBARA BROWN, EXAMINING ATTORNEY

SN 85-209,345. ACTIVEION CLEANING SOLUTIONS LLC,  
MINNEAPOLIS, MN. FILED 1-3-2011.

**ACTIVEION EXP**

THE MARK CONSISTS OF STANDARD CHARACTERS  
WITHOUT CLAIM TO ANY PARTICULAR FONT, STYLE,  
SIZE, OR COLOR.

OWNER OF U.S. REG. NOS. 3,842,362 AND 3,863,086.

FOR MACHINE USED FOR SANITIZING AND DISIN-  
FECTING HUMAN SKIN AND MEDICAL AND SURGI-  
CAL EQUIPMENT FOR USE IN HOSPITALS AND  
OTHER MEDICAL SETTINGS, SOLD AS A UNIT WITH  
SANITIZING AND DISINFECTING SOLUTIONS AND  
EMPTY CONTAINERS THEREFOR (U.S. CLS. 26, 39  
AND 44).

DAVID TAYLOR, EXAMINING ATTORNEY

SN 85-210,375. MBIO DIAGNOSTICS, INC., BOULDER, CO.  
FILED 1-4-2011.

**LIGHTDECK**

THE MARK CONSISTS OF STANDARD CHARACTERS  
WITHOUT CLAIM TO ANY PARTICULAR FONT, STYLE,  
SIZE, OR COLOR.

FOR MEDICAL TESTING DEVICES FOR MEASUR-  
ING DISEASE MARKERS, NAMELY, APPARATUS FOR  
MEDICAL DIAGNOSTIC TESTING, AND, INTEGRA-  
TION OF BIOLOGICAL SAMPLE PREPARATION WITH  
DETECTION, IN THE FIELDS OF IMMUNOASSAYS,  
MICROSCOPY, WHOLE CELL ENUMERATION, AND  
MOLECULAR DIAGNOSTICS (U.S. CLS. 26, 39 AND 44).

GINA FINK, EXAMINING ATTORNEY

**CLASS 10—(Continued).**

SN 85-210,558. MARVAO MEDICAL DEVICES LTD, GALWAY, IRELAND, FILED 1-5-2011.

**NexSite**

THE MARK CONSISTS OF STANDARD CHARACTERS WITHOUT CLAIM TO ANY PARTICULAR FONT, STYLE, SIZE, OR COLOR.  
FOR CATHETERS AND PARTS AND FITTINGS THEREFOR (U.S. CLS. 26, 39 AND 44).  
APRIL HESIK, EXAMINING ATTORNEY

SN 85-210,707. MECTRA LABS, INC., BLOOMFIELD, IN. FILED 1-5-2011.

**ALIEN**

THE MARK CONSISTS OF STANDARD CHARACTERS WITHOUT CLAIM TO ANY PARTICULAR FONT, STYLE, SIZE, OR COLOR.  
FOR MEDICAL DEVICES, NAMELY, ENDOSCOPIC NEEDLES (U.S. CLS. 26, 39 AND 44).  
REBECCA POVARCHUK, EXAMINING ATTORNEY

SN 85-211,035. DEPUY, INC., WARSAW, IN. FILED 1-5-2011.

**TRUEBOND**

THE MARK CONSISTS OF STANDARD CHARACTERS WITHOUT CLAIM TO ANY PARTICULAR FONT, STYLE, SIZE, OR COLOR.  
FOR SCREWS MADE OF ARTIFICIAL MATERIALS FOR USE WITH ORTHOPAEDIC HIP IMPLANTS; BONE SCREWS (U.S. CLS. 26, 39 AND 44).  
KEVIN DINALLO, EXAMINING ATTORNEY

**CLASS 10—(Continued).**

SN 85-211,089. AUDINA HEARING INSTRUMENTS, INC., LONGWOOD, FL. FILED 1-5-2011.

**SoftTouch**

THE MARK CONSISTS OF STANDARD CHARACTERS WITHOUT CLAIM TO ANY PARTICULAR FONT, STYLE, SIZE, OR COLOR.  
OWNER OF U.S. REG. NO. 3,800,096.  
FOR MEDICAL HEARING INSTRUMENTS AND PARTS OF SUCH DEVICES (U.S. CLS. 26, 39 AND 44).  
MICHAEL WEBSTER, EXAMINING ATTORNEY

SN 85-212,199. CHURCH & DWIGHT CO., INC., PRINCETON, NJ. FILED 1-6-2011.

**TROJAN MAGNUM ECSTASY**

THE MARK CONSISTS OF STANDARD CHARACTERS WITHOUT CLAIM TO ANY PARTICULAR FONT, STYLE, SIZE, OR COLOR.  
OWNER OF U.S. REG. NOS. 3,716,786, 3,897,486 AND OTHERS.  
FOR CONDOMS (U.S. CLS. 26, 39 AND 44).  
FIRST USE 1-27-2009; IN COMMERCE 1-27-2009.  
EUGENIA MARTIN, EXAMINING ATTORNEY

SN 85-212,509. AMERICAN SCIENTIFIC RESOURCES, INC., NEW PALTZ, NY. FILED 1-7-2011.

**KIDZ-MED**

THE MARK CONSISTS OF STANDARD CHARACTERS WITHOUT CLAIM TO ANY PARTICULAR FONT, STYLE, SIZE, OR COLOR.  
OWNER OF U.S. REG. NOS. 2,994,070, 3,010,297 AND 3,175,408.  
FOR CLINICAL THERMOMETERS; FEVER THERMOMETERS; THERMOMETERS FOR MEDICAL PURPOSES (U.S. CLS. 26, 39 AND 44).  
FIRST USE 9-0-2007; IN COMMERCE 9-0-2007.  
APRIL HESIK, EXAMINING ATTORNEY

**CLASS 10—(Continued).**

SN 85-212,712. BOSTON SCIENTIFIC SCIMED, INC., MAPLE GROVE, MN. FILED 1-7-2011.

# GLADIATOR

THE MARK CONSISTS OF STANDARD CHARACTERS WITHOUT CLAIM TO ANY PARTICULAR FONT, STYLE, SIZE, OR COLOR.  
FOR MEDICAL CATHETERS AND MEDICAL BALLOON CATHETERS (U.S. CLS. 26, 39 AND 44).  
MAYUR VAGHANI, EXAMINING ATTORNEY

SN 85-212,736. BOSTON SCIENTIFIC SCIMED, INC., MAPLE GROVE, MN. FILED 1-7-2011.

# EMERGE

THE MARK CONSISTS OF STANDARD CHARACTERS WITHOUT CLAIM TO ANY PARTICULAR FONT, STYLE, SIZE, OR COLOR.  
FOR MEDICAL CATHETERS AND MEDICAL BALLOON CATHETERS (U.S. CLS. 26, 39 AND 44).  
MAYUR VAGHANI, EXAMINING ATTORNEY

SN 85-213,161. DOMAIN SURGICAL, INC., SALT LAKE CITY, UT. FILED 1-7-2011.

# FMWAND

THE MARK CONSISTS OF STANDARD CHARACTERS WITHOUT CLAIM TO ANY PARTICULAR FONT, STYLE, SIZE, OR COLOR.  
FOR MEDICAL DEVICES, NAMELY, SURGICAL DEVICES THAT FACILITATE THE IDENTIFICATION, SEPARATION OR ABLATION OF BIOLOGIC TISSUES; SURGICAL AND MEDICAL APPARATUS AND INSTRUMENTS FOR USE IN GENERAL SURGERY; SURGICAL INSTRUMENTS, NAMELY, SURGICAL HANDPIECES (U.S. CLS. 26, 39 AND 44).  
SUSAN LESLIE DUBOIS, EXAMINING ATTORNEY

**CLASS 10—(Continued).**

SN 85-214,068. BOSTON SCIENTIFIC SCIMED, INC., MAPLE GROVE, MN. FILED 1-10-2011.

# NYBAX

THE MARK CONSISTS OF STANDARD CHARACTERS WITHOUT CLAIM TO ANY PARTICULAR FONT, STYLE, SIZE, OR COLOR.  
FOR BALLOON CATHETERS AND BALLOON MATERIAL SOLD AS A COMPONENT OF BALLOON CATHETERS (U.S. CLS. 26, 39 AND 44).  
MAYUR VAGHANI, EXAMINING ATTORNEY

SN 85-222,535. PIONEER SURGICAL TECHNOLOGY, INC., MARQUETTE, MI. FILED 1-20-2011.

# ASPECT

THE MARK CONSISTS OF STANDARD CHARACTERS WITHOUT CLAIM TO ANY PARTICULAR FONT, STYLE, SIZE, OR COLOR.  
FOR IMPLANTABLE ORTHOPEDIC DEVICES, NAMELY, SURGICAL IMPLANTS AND BONE IMPLANTS COMPOSED OF ARTIFICIAL MATERIALS; SPINAL FIXATION AND STABILIZATION DEVICES; SURGICAL INSTRUMENTS FOR USE IN ORTHOPEDIC AND SPINAL SURGERY (U.S. CLS. 26, 39 AND 44).  
HAI-LY LAM, EXAMINING ATTORNEY

SN 85-231,493. DEPUY, INC., WARSAW, IN. FILED 2-1-2011.

# STEPTECH

THE MARK CONSISTS OF STANDARD CHARACTERS WITHOUT CLAIM TO ANY PARTICULAR FONT, STYLE, SIZE, OR COLOR.  
FOR ORTHOPAEDIC IMPLANTS MADE OF ARTIFICIAL MATERIALS (U.S. CLS. 26, 39 AND 44).  
FIRST USE 3-0-2010; IN COMMERCE 3-0-2010.  
KEVIN DINALLO, EXAMINING ATTORNEY



**CLASS 10—(Continued).**

SN 85-234,087. BOSTON SCIENTIFIC SCIMED, INC., MAPLE GROVE, MN. FILED 2-4-2011.

# LOTUS

THE MARK CONSISTS OF STANDARD CHARACTERS WITHOUT CLAIM TO ANY PARTICULAR FONT, STYLE, SIZE, OR COLOR.

FOR MEDICAL DEVICES AND INSTRUMENTS FOR USE IN THE TREATMENT OF CARDIAC, CARDIOVASCULAR, AND HEART VALVE DISEASE AND DISORDERS, NAMELY, IMPLANTABLE HEART VALVES, AND IMPLANTABLE HEART VALVE DELIVERY SYSTEMS FOR USE IN HEART VALVE REPLACEMENTS (U.S. CLS. 26, 39 AND 44).

MAYUR VAGHANI, EXAMINING ATTORNEY

**CLASS 10—(Continued).**

SN 85-259,717. JOM PERSONAL PRODUCTS CORP., WILLINGTON, DE. FILED 3-7-2011.

# It's all about you

THE MARK CONSISTS OF STANDARD CHARACTERS WITHOUT CLAIM TO ANY PARTICULAR FONT, STYLE, SIZE, OR COLOR.

FOR ADULT SEXUAL STIMULATION KIT COMPRISED PRIMARILY OF ADULT SEXUAL STIMULATION AIDS AND A WORKBOOK (U.S. CLS. 26, 39 AND 44).

ALICIA COLLINS, EXAMINING ATTORNEY

SN 85-242,688. POLYMEDICA CORPORATION, WOBURN, MA. FILED 2-15-2011.



The logo for Liberty Link features the word "Liberty" in a stylized, cursive font, followed by the word "Link" in a bold, sans-serif font. A curved line arches over the word "Link", connecting it to "Liberty".

OWNER OF U.S. REG. NOS. 3,040,046, 3,618,554 AND OTHERS.

THE MARK CONSISTS OF THE WORDS "LIBERTY LINK" IN TWO SEPARATE STYLIZED FONTS. SEPARATE BRUSH-STROKE GRAPHICS APPEAR BELOW THE WORD "LIBERTY" AND ABOVE THE WORD "LINK".

FOR LANCING DEVICES (U.S. CLS. 26, 39 AND 44).

KAREN SEVERSON, EXAMINING ATTORNEY

**CLASS 11—ENVIRONMENTAL CONTROL APPARATUS**

SN 76-705,671. FAN FI INTERNATIONAL, INC., SPARKS, NV. FILED 12-13-2010.

# BELLA LUCE

THE MARK CONSISTS OF STANDARD CHARACTERS WITHOUT CLAIM TO ANY PARTICULAR FONT, STYLE, SIZE, OR COLOR.

NO CLAIM IS MADE TO THE EXCLUSIVE RIGHT TO USE "LUCE", APART FROM THE MARK AS SHOWN.

THE ENGLISH TRANSLATION OF "BELLA LUCE" IS "BEAUTIFUL LIGHT".

FOR LAMPS, NAMELY, ELECTRIC LAMPS (U.S. CLS. 13, 21, 23, 31 AND 34).

REBECCA GILBERT, EXAMINING ATTORNEY

SN 85-254,253. SCHERING-PLOUGH HEALTHCARE PRODUCTS, INC., MEMPHIS, TN. FILED 3-1-2011.

# ACUTREAT

THE MARK CONSISTS OF STANDARD CHARACTERS WITHOUT CLAIM TO ANY PARTICULAR FONT, STYLE, SIZE, OR COLOR.

FOR MEDICAL DEVICE FOR THE REMOVAL OF WARTS, CORNS, AND CALLUSES (U.S. CLS. 26, 39 AND 44).

AISHA CLARKE, EXAMINING ATTORNEY

SN 77-728,241. TRIPLEX MANUFACTURING L.P., CHICAGO, IL. FILED 5-4-2009.

# BT SERIES

THE MARK CONSISTS OF STANDARD CHARACTERS WITHOUT CLAIM TO ANY PARTICULAR FONT, STYLE, SIZE, OR COLOR.

NO CLAIM IS MADE TO THE EXCLUSIVE RIGHT TO USE "SERIES", APART FROM THE MARK AS SHOWN.

FOR LIGHTS AND LIGHTING APPARATUS FOR VEHICLES (U.S. CLS. 13, 21, 23, 31 AND 34).

JACLYN KIDWELL WALKER, EXAMINING ATTORNEY

**CLASS 11—(Continued).**

SN 77-729,052. RECKITT BENCKISER LLC, PARSIPPANY, NJ. FILED 5-5-2009.

**CHERRY & BERRY BLOSSOM**

THE MARK CONSISTS OF STANDARD CHARACTERS WITHOUT CLAIM TO ANY PARTICULAR FONT, STYLE, SIZE, OR COLOR.

FOR ELECTRIC AND BATTERY POWERED DISPENSERS FOR ROOM FRAGRANCES, AIR FRESHENERS AND ROOM DEODORANTS FOR SCENTING, PURIFYING OR FRESHENING THE ATMOSPHERE; PARTS AND FITTINGS FOR ALL THE AFORESAID GOODS SOLD AS A UNIT THEREWITH (U.S. CLS. 13, 21, 23, 31 AND 34).

LEIGH LOWRY, EXAMINING ATTORNEY

SN 77-959,487. M BABY, L.L.C., PHOENIX, AZ. FILED 3-15-2010.

**bum-burrs**

THE MARK CONSISTS OF STANDARD CHARACTERS WITHOUT CLAIM TO ANY PARTICULAR FONT, STYLE, SIZE, OR COLOR.

FOR REMOVABLE SEAT COOLING DEVICES PLACED ONTO THE PADDING OF INFANT, TODDLER, AND CHILDREN'S CAR SEATS (U.S. CLS. 13, 21, 23, 31 AND 34).

PAM WILLIS, EXAMINING ATTORNEY

SN 77-967,043. M BABY, PHOENIX, AZ. FILED 3-24-2010.



THE MARK CONSISTS OF THE STYLIZED TEXT "M BABY" WITH THE "M" INSIDE A CIRCLE.

FOR REMOVABLE SEAT COOLING DEVICES PLACED ONTO THE PADDING OF INFANT, TODDLER, AND CHILDREN'S CAR SEATS (U.S. CLS. 13, 21, 23, 31 AND 34).

PAM WILLIS, EXAMINING ATTORNEY

**CLASS 11—(Continued).**

SN 79-085,124. OILON INTERNATIONAL OY, FINLAND, FILED 6-17-2010.



PRIORITY DATE OF 2-12-2010 IS CLAIMED. OWNER OF INTERNATIONAL REGISTRATION 1045373 DATED 6-17-2010, EXPIRES 6-17-2020.

FOR OIL AND GAS BURNERS FOR USE IN RESIDENTIAL, COMMERCIAL AND INDUSTRIAL BUILDINGS AS WELL AS POWER PLANTS; HEAT PUMPS (U.S. CLS. 13, 21, 23, 31 AND 34).

ANNÉ E. GUSTASON, EXAMINING ATTORNEY

SN 79-085,163. SAFED SUISSE SA, SWITZERLAND, FILED 3-22-2010.



THE MARK CONSISTS OF STANDARD CHARACTERS WITHOUT CLAIM TO ANY PARTICULAR FONT, STYLE, SIZE, OR COLOR.

OWNER OF INTERNATIONAL REGISTRATION 0845233 DATED 3-3-2005, EXPIRES 3-3-2015.

FOR HEAT TREATMENT FURNACES (U.S. CLS. 13, 21, 23, 31 AND 34).

MARTHA FROMM, EXAMINING ATTORNEY

SN 79-086,120. HERBERT WALDMANN GMBH & CO. KG., FED REP GERMANY, FILED 7-28-2010.

**Waldmann PRESS + PROOF**

THE MARK CONSISTS OF STANDARD CHARACTERS WITHOUT CLAIM TO ANY PARTICULAR FONT, STYLE, SIZE, OR COLOR.

PRIORITY DATE OF 3-26-2010 IS CLAIMED. OWNER OF INTERNATIONAL REGISTRATION 1047784 DATED 7-28-2010, EXPIRES 7-28-2020.

OWNER OF U.S. REG. NO. 2,334,581.

THE WORDS "PRESS + PROOF" APPEARING IN THE MARK HAS NO SIGNIFICANCE NOR IS IT A TERM OF ART IN THE RELEVANT TRADE OR INDUSTRY OR AS APPLIED TO THE GOODS/SERVICES LISTED IN THE APPLICATION, OR ANY GEOGRAPHICAL SIGNIFICANCE.

FOR FLUORESCENT ELECTRIC LIGHT BULBS, FLUORESCENT LAMP TUBES AND FLUORESCENT LAMPS (U.S. CLS. 13, 21, 23, 31 AND 34).

ALICE BENMAMAN, EXAMINING ATTORNEY

**CLASS 11—(Continued).**

SN 79-086,270. DAIKIN INDUSTRIES, LTD., OSAKA-SHI;  
 OSAKA, JAPAN, FILED 3-10-2010.



PRIORITY DATE OF 1-12-2010 IS CLAIMED.  
 OWNER OF INTERNATIONAL REGISTRATION 1048192  
 DATED 3-10-2010, EXPIRES 3-10-2020.

THE MARK CONSISTS OF THE WORD "STREAMER"  
 WITH A DESIGN OF TWO VERTICAL WAVY LINES THAT  
 ARE CONNECTED.

FOR SET UNITS OF TOILET BOWL AND SEAT;  
 BATHROOM SETS COMPRISED OF TOILETS, SINKS,  
 BATHROOM WALL PANELS OF METAL OR NOT OF  
 METAL, AND BATHROOM FLOORING OF METAL,  
 BAMBOO, LAMINATE, RUBBER, WOOD, OR TILE,  
 SOLD AS A UNIT; EVAPORATORS FOR CHEMICAL  
 PROCESSING; DISTILLERS FOR CHEMICAL PROCES-  
 SING; HEAT EXCHANGERS FOR CHEMICAL PROCES-  
 SING; INDUSTRIAL BOILERS; AIR-CONDITIONING  
 APPARATUS FOR INDUSTRIAL PURPOSES; AIR-CON-  
 DITIONING APPARATUS FOR INDUSTRIAL PUR-  
 POSSES AND THEIR REPLACEMENT AND  
 COMPONENT PARTS AND FITTINGS; INDUSTRIAL  
 HUMIDIFIERS; INDUSTRIAL DEHUMIDIFIERS; IN-  
 DUSTRIAL AIR PURIFIERS; INDUSTRIAL AIR PURI-  
 FIERS AND THEIR REPLACEMENT AND COMPONENT  
 PARTS AND FITTINGS; BATHROOM VENTILATION  
 INSTALLATIONS FOR INDUSTRIAL PURPOSES; AIR  
 BLAST TYPE AIR-CONDITIONING APPARATUS FOR  
 BATHROOM FOR INDUSTRIAL PURPOSES; AIR-CON-  
 DITIONING APPARATUS FOR BATHROOM FOR IN-  
 DUSTRIAL PURPOSES; ELECTRIC LAVATORY AIR  
 DEODORIZING APPARATUS FOR INDUSTRIAL PUR-  
 POSSES; ELECTRIC AIR DEODORIZING APPARATUS  
 FOR INDUSTRIAL PURPOSES; ELECTRIC AIR DEO-  
 DORIZING APPARATUS FOR INDUSTRIAL PURPOSES  
 AND THEIR REPLACEMENT AND COMPONENT  
 PARTS AND FITTINGS; VENTILATION INSTALLA-  
 TIONS FOR INDUSTRIAL PURPOSES AND THEIR  
 REPLACEMENT AND COMPONENT PARTS AND FIT-  
 TINGS; AIR CONDITIONING APPARATUS IN THE  
 NATURE OF FAN-COIL UNIT; AIR CONDITIONING  
 APPARATUS FOR VEHICLES; AIR CONDITIONING  
 APPARATUS FOR LAND VEHICLES; AIR CONDITIO-  
 NING APPARATUS FOR AIR VEHICLES; AIR CONDITIO-  
 NING APPARATUS FOR SHIPS; AIR PURIFIERS  
 FOR SMOKING ROOM; FREEZING MACHINES AND  
 APPARATUS, NAMELY, FREEZERS AND REFRIGERA-  
 TORS; ELECTRIC REFRIGERATORS FOR INDUSTRIAL  
 PURPOSES; ELECTRIC LAUNDRY CLOTHES DRYERS  
 FOR INDUSTRIAL PURPOSES; MACHINES AND APPA-  
 RATUS FOR USE IN BEAUTY SALONS AND BARBERS'  
 SHOPS, NAMELY, HAIR DRYING MACHINES, HAIR  
 STEAMERS, NAIL DRYING MACHINES, TANNING  
 BEDS AND TANNING LAMPS; COOKING EQUIPMENT  
 FOR INDUSTRIAL PURPOSES, NAMELY, COOKING  
 RANGES, ELECTRIC COOKING OVENS, MICROWAVE  
 OVENS, ELECTRIC RICE COOKERS, ELECTRIC TOAST-  
 ERS, AND ELECTRIC ROASTERS; INDUSTRIAL ELEC-  
 TRIC DISH DRYING APPARATUS AND  
 INSTALLATIONS; DISH DISINFECTANT APPARATUS  
 FOR INDUSTRIAL PURPOSES; HOUSEHOLD ELEC-  
 TROTHERMIC APPLIANCES, NAMELY, PORTABLE  
 ELECTRIC WARM AIR DRIERS, AIR STERILISERS,  
 HAIR DRIERS, ELECTRIC FANS, AND FUTON DRIERS  
 FOR HOUSEHOLD PURPOSES; AIR-CONDITIONING  
 APPARATUS FOR HOUSEHOLD PURPOSES; AIR-CON-

**CLASS 11—(Continued).**

DITIONING APPARATUS FOR HOUSEHOLD PUR-  
 POSSES AND THEIR REPLACEMENT AND COMPONENT  
 PARTS AND FITTINGS; ELECTRIC DISH DRYING  
 APPARATUS AND INSTALLATIONS FOR HOUSEHOLD  
 PURPOSES; COOKING EQUIPMENT FOR HOUSEHOLD  
 PURPOSES, NAMELY, COOKING OVENS, MICROWAVE  
 OVENS, ELECTRIC RICE COOKERS, ELECTRIC TOAST-  
 ERS, AND ELECTRIC ROASTERS; BATHROOM VENTI-  
 LATION INSTALLATIONS FOR HOUSEHOLD  
 PURPOSES; AIR BLAST TYPE AIR-CONDITIONING  
 APPARATUS FOR BATHROOM FOR HOUSEHOLD  
 PURPOSES; AIR-CONDITIONING APPARATUS FOR  
 BATHROOM FOR HOUSEHOLD PURPOSES; ELECTRIC  
 LAVATORY AIR DEODORIZING APPARATUS FOR  
 HOUSEHOLD PURPOSES; ELECTRIC AIR DEODORIZ-  
 ING APPARATUS FOR HOUSEHOLD PURPOSES; ELEC-  
 TRIC AIR DEODORIZING APPARATUS FOR  
 HOUSEHOLD PURPOSES AND THEIR REPLACEMENT  
 AND COMPONENT PARTS AND FITTINGS; VENTILA-  
 TION INSTALLATIONS FOR HOUSEHOLD PURPOSES  
 FOR USE IN BATHROOMS, LOUNGES, KITCHENS, OR  
 ENTRANCES; VENTILATION INSTALLATIONS FOR  
 HOUSEHOLD PURPOSES FOR USE IN BATHROOMS,  
 LOUNGES, KITCHENS, OR ENTRANCES, AND THEIR  
 REPLACEMENT AND COMPONENT PARTS AND FIT-  
 TINGS; AIR PURIFIERS FOR HOUSEHOLD PURPOSES;  
 AIR PURIFIERS FOR HOUSEHOLD PURPOSES AND  
 THEIR COMPONENT AND REPLACEMENT PARTS  
 AND FITTINGS; GAS WATER HEATERS FOR HOUSE-  
 HOLD USE; NON-ELECTRIC COOKING HEATERS FOR  
 HOUSEHOLD PURPOSES, NAMELY, GAS COOKING  
 OVENS FOR HOUSEHOLD PURPOSES, JAPANESE  
 KITCHEN FURNACES ALSO KNOWN AS KAMADO,  
 JAPANESE CHARCOAL COOKING STOVES FOR  
 HOUSEHOLD PURPOSES ALSO KNOWN AS SHICHIR-  
 IN, OIL COOKING STOVES FOR HOUSEHOLD PUR-  
 POSSES, BAKING OVENS FOR HOUSEHOLD PURPOSES,  
 BARBECUE GRILLS; KITCHEN WORKTOPS; KITCHEN  
 SINKS; INTEGRATED KITCHEN SYSTEM COMPRISED  
 OF ELECTRIC COOKING STOVES AND OVENS, GAS  
 OR ELECTRIC COOKING STOVES, SINKS, STORAGE  
 RACKS, AND KITCHEN WORKTOPS; BATHTUB UNITS  
 INTEGRAL WITH A BATHROOM FLOOR; BATH TUBS  
 FOR USE IN MAKING BUBBLES; SHOWERS; BATHTUB  
 UNITS INTEGRAL WITH A BATHROOM FLOOR AND A  
 SINK; BATH TUBS; BATH BOILERS; BATHTUB UNITS  
 HAVING ASSISTANCE FUNCTIONS FOR TAKING A  
 BATH; TOILET STOOL UNITS WITH A WASHING  
 WATER SQUIRTER; DISINFECTANT DISPENSERS  
 FOR TOILETS; TOILET BOWLS; TOILET SEATS FOR  
 USE WITH JAPANESE STYLE TOILET BOWLS; JAPA-  
 NESE CHARCOAL HEATERS FOR HOUSEHOLD PUR-  
 POSSES USE ALSO KNOWN AS HIBACHI; GAS STOVES  
 BEING SPACE-HEATERS FOR HOUSEHOLD USE; JAPA-  
 NESE ELECTRIC LEG-WARMING APPARATUS FOR  
 HOUSEHOLD PURPOSES ALSO KNOWN AS ELECTRIC  
 KOTATSU; COAL STOVES BEING SPACE HEATERS  
 FOR HOUSEHOLD USE; OIL STOVES BEING SPACE  
 HEATERS FOR HOUSEHOLD USE; SLOW-BURNING  
 STOVES BEING WOOD STOVES FOR HOUSEHOLD  
 USE; GAS STOVES BEING HEATERS EQUIPPED WITH  
 FANS (U.S. CLS. 13, 21, 23, 31 AND 34).

LAURA HAMMEL, EXAMINING ATTORNEY

**CLASS 11—(Continued).**

SN 79-089,217. OSRAM GESELLSCHAFT MIT BESCHRÄNKTER HAFTUNG, 81543 MÜNCHEN, FED REP GERMANY, FILED 9-22-2010.

# EMH

THE MARK CONSISTS OF STANDARD CHARACTERS WITHOUT CLAIM TO ANY PARTICULAR FONT, STYLE, SIZE, OR COLOR.

PRIORITY DATE OF 4-28-2010 IS CLAIMED.  
OWNER OF INTERNATIONAL REGISTRATION 1056321 DATED 9-22-2010, EXPIRES 9-22-2020.

FOR LIGHTING APPARATUS, NAMELY, ELECTRIC LAMPS, SINGLE-ENDED LIGHT BULBS, DOUBLE-ENDED LIGHT BULBS, AND LUMINAIRES; STRUCTURAL PARTS FOR THE AFORESAID GOODS (U.S. CLS. 13, 21, 23, 31 AND 34).  
DAWN HAN, EXAMINING ATTORNEY

SN 79-093,763. RATIONAL AG, FED REP GERMANY, FILED 12-20-2010.

# whiteefficiency

THE MARK CONSISTS OF STANDARD CHARACTERS WITHOUT CLAIM TO ANY PARTICULAR FONT, STYLE, SIZE, OR COLOR.

PRIORITY DATE OF 11-4-2010 IS CLAIMED.  
OWNER OF INTERNATIONAL REGISTRATION 1067661 DATED 12-20-2010, EXPIRES 12-20-2020.

FOR COOKING AND STEAM GENERATING APPARATUS FOR THE TREATMENT AND PREPARATION OF FOOD IN COMMERCIAL KITCHENS, NAMELY, ELECTRIC FOOD COOKERS, ELECTRIC FOOD STEAMERS, AND COOKING OVENS, ALL FOR COMMERCIAL USE AND SOLD AS A UNIT; GAS FOOD COOKERS, GAS FOOD STEAMERS AND COOKING OVENS, ALL FOR COMMERCIAL USE AND SOLD AS A UNIT; AND STRUCTURAL PARTS AND ACCESSORIES THEREFOR (U.S. CLS. 13, 21, 23, 31 AND 34).  
ROBERT STRUCK, EXAMINING ATTORNEY

SN 85-007,384. GEOENERGY ENTERPRISES, LLC, PUTNUM VALLEY, NY. FILED 4-6-2010.

# GeoColumn

THE MARK CONSISTS OF STANDARD CHARACTERS WITHOUT CLAIM TO ANY PARTICULAR FONT, STYLE, SIZE, OR COLOR.

FOR GEOTHERMAL-BASED HVAC UNITS (U.S. CLS. 13, 21, 23, 31 AND 34).  
FIRST USE 1-1-2003; IN COMMERCE 11-24-2010.  
TARA PATE, EXAMINING ATTORNEY

**CLASS 11—(Continued).**

SN 85-026,759. ALSTOM POWER INC., WINDSOR, CT. FILED 4-29-2010.

# FLOWPAC

THE MARK CONSISTS OF STANDARD CHARACTERS WITHOUT CLAIM TO ANY PARTICULAR FONT, STYLE, SIZE, OR COLOR.

FOR FLUE GAS EMISSIONS CONTROL EQUIPMENT, NAMELY, FLUE GAS SCRUBBERS AND GAS SCRUBBER COMPONENTS, NAMELY, AIR LIFTS, SIEVE TRAYS, QUENCHING SYSTEMS, MIST ELIMINATORS, REACTION TANKS AND AIR SPARGERS, USED FOR WET FLUE GAS DESULFURIZATION (U.S. CLS. 13, 21, 23, 31 AND 34).

FIRST USE 4-23-2010; IN COMMERCE 4-23-2010.  
DAVID TAYLOR, EXAMINING ATTORNEY

SN 85-027,432. THE VOLLRATH COMPANY L.L.C., SHEBOYGAN, WI. FILED 4-30-2010.

# SOMERSET

THE MARK CONSISTS OF STANDARD CHARACTERS WITHOUT CLAIM TO ANY PARTICULAR FONT, STYLE, SIZE, OR COLOR.

FOR CHAFING DISHES (U.S. CLS. 13, 21, 23, 31 AND 34).  
ALYSSA STEEL, EXAMINING ATTORNEY

SN 85-028,511. HYDRO INTERNATIONAL PLC, CLEVEDON, AVON, UNITED KINGDOM, FILED 5-3-2010.

# HYDRO-SLUDGE

THE MARK CONSISTS OF STANDARD CHARACTERS WITHOUT CLAIM TO ANY PARTICULAR FONT, STYLE, SIZE, OR COLOR.

OWNER OF U.S. REG. NOS. 2,720,973, 3,006,908 AND OTHERS.

FOR SEPARATORS FOR THE TREATMENT OF WATER AND WASTE WATER, NAMELY, FOR SEPARATING SOLID MATERIAL FROM WATER AND WASTE WATER; AND REPLACEMENT PARTS AND FITTING THEREFOR, NAMELY, FILTERS AND SCREENS (U.S. CLS. 13, 21, 23, 31 AND 34).

RAUL CORDOVA, EXAMINING ATTORNEY

**CLASS 11—(Continued).**

SN 85-037,417. DFT, INC., EXTON, PA. FILED 5-13-2010.

**ULTRA-TROL**

THE MARK CONSISTS OF STANDARD CHARACTERS WITHOUT CLAIM TO ANY PARTICULAR FONT, STYLE, SIZE, OR COLOR.

FOR CONTROL VALVES FOR PLUMBING AND HEATING AND COOLING INSTALLATIONS (U.S. CLS. 13, 21, 23, 31 AND 34).

FIRST USE 2-22-1983; IN COMMERCE 2-22-1983.  
LEIGH LOWRY, EXAMINING ATTORNEY

SN 85-037,514. DFT, INC., EXTON, PA. FILED 5-13-2010.

**UNIFLO**

THE MARK CONSISTS OF STANDARD CHARACTERS WITHOUT CLAIM TO ANY PARTICULAR FONT, STYLE, SIZE, OR COLOR.

FOR CONTROL VALVES FOR PLUMBING AND HEATING AND COOLING INSTALLATIONS (U.S. CLS. 13, 21, 23, 31 AND 34).

FIRST USE 12-31-1994; IN COMMERCE 12-31-1994.  
LEIGH LOWRY, EXAMINING ATTORNEY

SN 85-042,691. SMC CORPORATION, TOKYO, JAPAN, FILED 5-19-2010.

**SMC THERMO DRYER**

THE MARK CONSISTS OF STANDARD CHARACTERS WITHOUT CLAIM TO ANY PARTICULAR FONT, STYLE, SIZE, OR COLOR.

OWNER OF U.S. REG. NOS. 1,591,693 AND 2,651,173.  
NO CLAIM IS MADE TO THE EXCLUSIVE RIGHT TO USE "DRYER", APART FROM THE MARK AS SHOWN.

FOR INDUSTRIAL APPARATUS, NAMELY, INDUSTRIAL DRYER FOR PROVIDING TEMPERATURE-REGULATED DEHUMIDIFIED AIR (U.S. CLS. 13, 21, 23, 31 AND 34).  
JAY BESCH, EXAMINING ATTORNEY

**CLASS 11—(Continued).**

SN 85-044,232. TECH 4 KIDS INC., MISSISSAUGA, ONTARIO, CANADA, FILED 5-20-2010.

**SWITCH LITE**

THE MARK CONSISTS OF STANDARD CHARACTERS WITHOUT CLAIM TO ANY PARTICULAR FONT, STYLE, SIZE, OR COLOR.

NO CLAIM IS MADE TO THE EXCLUSIVE RIGHT TO USE "LITE", APART FROM THE MARK AS SHOWN.

FOR FLASHLIGHTS AND CLIP-ON LIGHTS, NAMELY, LIGHTS TO BE TEMPORARILY ATTACHED TO A CHILD'S CLOTHING (U.S. CLS. 13, 21, 23, 31 AND 34).

JEFFREY LOOK, EXAMINING ATTORNEY

SN 85-056,702. VERTEX INDUSTRIALS, INC., MONTCLAIR, CA. FILED 6-7-2010.

**Vertex**

THE MARK CONSISTS OF STANDARD CHARACTERS WITHOUT CLAIM TO ANY PARTICULAR FONT, STYLE, SIZE, OR COLOR.

OWNER OF U.S. REG. NO. 3,611,821.

FOR WATER PURIFICATION AND FILTRATION APPARATUS (U.S. CLS. 13, 21, 23, 31 AND 34).

FIRST USE 6-1-1998; IN COMMERCE 6-1-1998.  
MARY CRAWFORD, EXAMINING ATTORNEY

SN 85-065,971. GROWOP TECHNOLOGY, LTD, IRVINE, CA. FILED 6-17-2010.



NO CLAIM IS MADE TO THE EXCLUSIVE RIGHT TO USE "GROW OP TECHNOLOGY", APART FROM THE MARK AS SHOWN.

THE COLOR(S) GREEN AND BLACK IS/ARE CLAIMED AS A FEATURE OF THE MARK.

THE MARK CONSISTS OF A GREEN LEAF IN A GREEN CIRCLE, WITH THE BACKGROUND WITHIN THE CIRCLE PARTIALLY GREEN; AND TO THE RIGHT ARE THE WORDS "GROWOP TECHNOLOGY", WITH "GROW" IN GREEN LETTERING, AND "OP TECHNOLOGY" IN BLACK LETTERING. THE COLOR WHITE REPRESENTS TRANSPARENT AREAS AND IS NOT PART OF THE MARK.

FOR HYDROPONIC PLANT GROWING SYSTEM CONSISTING OF LIGHTING FIXTURES, IRRIGATION SYSTEMS, CARBON DIOXIDE GENERATORS, AIR CONDITIONING AND DEHUMIDIFIER UNITS, WATER STORAGE UNITS, CARBON AIR SCRUBBERS, NUTRIENT PROVISIONS SYSTEMS, REMOTE VIDEO CAMERA SYSTEM, GROW AND DRAIN TRAYS, PLANT TRIMMERS, SOLAR PANELS, AND REFLECTIVE WALL COVERINGS SOLD TOGETHER AS A UNIT (U.S. CLS. 13, 21, 23, 31 AND 34).

FIRST USE 2-15-2010; IN COMMERCE 2-15-2010.  
JEFFERY COWARD, EXAMINING ATTORNEY

**CLASS 11—(Continued).**

SN 85-076,092. AMISTCO SEPARATION PRODUCTS, INC., ALVIN, TX. FILED 7-1-2010.

# MISTFIX

THE MARK CONSISTS OF STANDARD CHARACTERS WITHOUT CLAIM TO ANY PARTICULAR FONT, STYLE, SIZE, OR COLOR.

FOR SEPARATORS FOR THE CLEANING AND PURIFICATION OF AIR AND LIQUIDS, FOR USE IN REFINERIES AND CHEMICAL PLANTS; MIST ELIMINATORS FOR COLLECTING LIQUID DROPLETS FROM GAS STREAMS, FOR USE IN REFINERIES AND CHEMICAL PLANTS (U.S. CLS. 13, 21, 23, 31 AND 34).  
FIRST USE 0-0-2005; IN COMMERCE 0-0-2005.  
TEJBIR SINGH, EXAMINING ATTORNEY

SN 85-089,922. FOREFRONT LLC, KIRKLAND, WA. FILED 7-21-2010.

# RA ENERGY

THE MARK CONSISTS OF STANDARD CHARACTERS WITHOUT CLAIM TO ANY PARTICULAR FONT, STYLE, SIZE, OR COLOR.

NO CLAIM IS MADE TO THE EXCLUSIVE RIGHT TO USE "ENERGY", APART FROM THE MARK AS SHOWN.  
FOR SOLAR POWERED COOKING STOVES FOR OUTDOOR USE (U.S. CLS. 13, 21, 23, 31 AND 34).  
FIRST USE 3-8-2010; IN COMMERCE 3-8-2010.  
INGRID C. EULIN, EXAMINING ATTORNEY

SN 85-091,199. MERCHANT ONE GROUP LLC., AUSTIN, TX. FILED 7-23-2010.

# SUNSTONE

THE MARK CONSISTS OF STANDARD CHARACTERS WITHOUT CLAIM TO ANY PARTICULAR FONT, STYLE, SIZE, OR COLOR.

FOR STAINLESS STEEL GAS GRILLS FOR CONSUMERS (U.S. CLS. 13, 21, 23, 31 AND 34).  
ALICE BENMAMAN, EXAMINING ATTORNEY

**CLASS 11—(Continued).**

SN 85-091,737. CONAIR CORPORATION, STAMFORD, CT. FILED 7-23-2010.

# VOLARE

THE MARK CONSISTS OF STANDARD CHARACTERS WITHOUT CLAIM TO ANY PARTICULAR FONT, STYLE, SIZE, OR COLOR.

THE ENGLISH TRANSLATION OF "VOLARE" IN THE MARK IS "TO FLY".

FOR HAND-HELD ELECTRIC HAIR DRYERS (U.S. CLS. 13, 21, 23, 31 AND 34).  
C. DIONNE CLYBURN, EXAMINING ATTORNEY

SN 85-093,758. ULTRATECH SYSTEMS, INC., CARMEL, NY. FILED 7-27-2010.

# UltraTech

OWNER OF U.S. REG. NO. 3,224,537.

THE MARK CONSISTS OF THE TWO WORDS "ULTRA" AND "TECH", WHICH ARE NOT SEPARATED BY A SPACE ARE PRESENTED IN A DIGITAL FONT STYLE.

FOR AIR PURIFICATION APPARATUS FOR REMOVING AIRBORNE CONTAMINANTS IN BUILDING INSTALLATIONS THROUGH AIR STERILIZATION BY ULTRAVIOLET RADIATION (U.S. CLS. 13, 21, 23, 31 AND 34).

RUSS HERMAN, EXAMINING ATTORNEY

SN 85-093,789. ULTRATECH SYSTEMS, INC., CARMEL, NY. FILED 7-27-2010.

# UltraTech

THE MARK CONSISTS OF STANDARD CHARACTERS WITHOUT CLAIM TO ANY PARTICULAR FONT, STYLE, SIZE, OR COLOR.

OWNER OF U.S. REG. NO. 3,224,537.

FOR AIR PURIFICATION APPARATUS FOR REMOVING AIRBORNE CONTAMINANTS IN BUILDING INSTALLATIONS THROUGH AIR STERILIZATION BY ULTRAVIOLET RADIATION (U.S. CLS. 13, 21, 23, 31 AND 34).

RUSS HERMAN, EXAMINING ATTORNEY

**CLASS 11—(Continued).**

SN 85-101,282. HANGZHOU GREAT STAR INDUSTRIAL CO., LTD., HANGZHOU, ZHEJIANG, CHINA, FILED 8-5-2010.

# ValueMax

THE MARK CONSISTS OF "VALUEMAX" IN STYLIZED LETTERING.

FOR ACETYLENE BURNERS; CHANDELIERS; ELECTRIC LIGHTS FOR CHRISTMAS TREES; FLASHLIGHTS; PROJECTOR LAMPS; SEARCHLIGHTS; SPOTLIGHTS (U.S. CLS. 13, 21, 23, 31 AND 34).  
FIRST USE 5-0-2002; IN COMMERCE 5-0-2002.  
MATTHEW MCDOWELL, EXAMINING ATTORNEY

SN 85-108,206. ROSS INDUSTRIES, INCORPORATED, MIDLAND, VA. FILED 8-16-2010.

**INTEGRAL INTERVENTION**

THE MARK CONSISTS OF STANDARD CHARACTERS WITHOUT CLAIM TO ANY PARTICULAR FONT, STYLE, SIZE, OR COLOR.

FOR SANITATION DEVICE, NAMELY, AN ASSEMBLY COMPRISED OF A RESERVOIR TANK, DISPLACEMENT PUMP, TUBING, PIPING, SPRAY BARS AND AN OVERSPRAY COLLECTION SYSTEM USED TO APPLY ANTI-MICROBIAL SOLUTION TREATMENT TO FOOD PRODUCTS (U.S. CLS. 13, 21, 23, 31 AND 34).  
JENNIFER DIXON, EXAMINING ATTORNEY

SN 85-133,166. KOHLER CO., KOHLER, WI. FILED 9-20-2010.

# LITHOCAST

THE MARK CONSISTS OF STANDARD CHARACTERS WITHOUT CLAIM TO ANY PARTICULAR FONT, STYLE, SIZE, OR COLOR.

FOR BATHTUBS (U.S. CLS. 13, 21, 23, 31 AND 34).  
REBECCA EISINGER, EXAMINING ATTORNEY

**CLASS 11—(Continued).**

SN 85-134,466. JAMES L SCHUPPE, DBA INDUCTION SYSTEMS, INC., WAUKESHA, WI. FILED 9-21-2010.

# PowerFlex

THE COLOR(S) RED AND BLACK IS/ARE CLAIMED AS A FEATURE OF THE MARK.

THE MARK CONSISTS OF THE WORD "POWERFLEX" WITH THE WORD "POWER" APPEARING IN BLACK AND THE WORD "FLEX" APPEARING IN RED.

FOR ELECTRICAL INDUCTION HEATING APPARATUS FOR HEATING METAL WORKPIECES (U.S. CLS. 13, 21, 23, 31 AND 34).

FIRST USE 5-21-2005; IN COMMERCE 1-16-2006.  
KELLY TRUSILO, EXAMINING ATTORNEY

SN 85-172,541. FEELUX CO., LTD., YANGJU-SI, GYEONGGI-DO, REPUBLIC OF KOREA, FILED 11-9-2010.

# FEELLED

THE MARK CONSISTS OF STANDARD CHARACTERS WITHOUT CLAIM TO ANY PARTICULAR FONT, STYLE, SIZE, OR COLOR.

FOR AQUARIUM LIGHTS; LIGHTING APPARATUS FOR THEATRES, CLUBS AND DISCOTHEQUES; LIGHTING APPARATUS FOR SPORTS ARENAS; BICYCLE LAMPS; BICYCLE LIGHTS; CEILING LIGHTS; CHANDELIERS; DECORATION LAMPS; DIVING LIGHTS; DYNAMO LAMPS; ELECTRIC LAMPS; ELECTRIC LIGHTS FOR CHRISTMAS TREES; ELECTRIC POCKET TORCHES; FAIRY LIGHTS FOR FESTIVE DECORATION, NAMELY, LIGHTED PARTY-THEMED DECORATIONS, ELECTRIC LIGHT DECORATIVE STRINGS; FISH GATHERING LAMP; FLASHLIGHTS; FLOODLIGHTS; FLUORESCENT LAMP TUBES; FLUORESCENT LAMPS; GERMICIDAL LAMPS FOR PURIFYING AIR; GERMICIDAL LAMPS; HEADLIGHTS FOR VEHICLES; LAMPS; LAMPS FOR DIRECTIONAL SIGNALS OF VEHICLES; LAMPS FOR OUTDOOR USE; LANTERNS FOR LIGHTING; LANTERNS; LED (LIGHT EMITTING DIODES) LIGHTING FIXTURES FOR USE IN DISPLAY, COMMERCIAL, INDUSTRIAL, RESIDENTIAL, AND ARCHITECTURAL ACCENT LIGHTING APPLICATIONS; LED (LIGHT EMITTING DIODE) LIGHTING FIXTURES; LED LIGHT ASSEMBLIES FOR STREET LIGHTS, SIGNS, COMMERCIAL LIGHTING, AUTOMOBILES, BUILDINGS, AND OTHER ARCHITECTURAL USES; LED LIGHT BULBS; LED LIGHTING FIXTURES FOR INDOOR AND OUTDOOR LIGHTING APPLICATIONS; LIGHT BULBS; LIGHTS FOR VEHICLES; LIGHTING APPARATUS FOR BICYCLES; LIGHTING APPARATUS FOR VEHICLES; ELECTRIC LIGHTING FIXTURES; LIGHTING APPARATUS, NAMELY, LIGHTING INSTALLATIONS; LIGHTING DEVICES FOR SHOWCASES; LIGHTING TUBES; MERCURY LAMPS; MINER'S LAMPS; MINIATURE LIGHT BULBS; NEON LAMPS; OVERHEAD LAMPS; PROJECTOR LAMPS; SAFETY LAMPS FOR UNDERGROUND USE; SAFETY LAMPS; SPOTLIGHTS; STANDARD LAMPS, SEARCHLIGHTS; STREET LAMPS; ELECTRIC TORCHES FOR LIGHTING; ULTRAVIOLET RAY LAMPS, NOT FOR MEDICAL PURPOSES; WATER SURFACE LAMPS (U.S. CLS. 13, 21, 23, 31 AND 34).  
LESLIE RICHARDS, EXAMINING ATTORNEY

**CLASS 11—(Continued).**

SN 85-173,544. HIGH TECH LIGHTING AND AUDIO INC., DBA DJ STAGE SHOP CO., LOS ANGELES, CA. FILED 11-10-2010.

HTL  
High Tech Lighting

THE MARK CONSISTS OF STANDARD CHARACTERS WITHOUT CLAIM TO ANY PARTICULAR FONT, STYLE, SIZE, OR COLOR.

NO CLAIM IS MADE TO THE EXCLUSIVE RIGHT TO USE "HIGH TECH LIGHTING", APART FROM THE MARK AS SHOWN.

FOR LIGHTING APPARATUS FOR DISCOTHEQUES AND NIGHTCLUBS, NAMELY, LIGHTS THAT PROJECT VARIOUS PATTERNS, DIMENSIONS, AND COLORS (U.S. CLS. 13, 21, 23, 31 AND 34).

FIRST USE 1-1-2005; IN COMMERCE 10-1-2007.  
MAUREEN DALL, EXAMINING ATTORNEY

SN 85-179,704. GAMETIME LIGHTS, LLC, POWELL, TN. FILED 11-18-2010.



NO CLAIM IS MADE TO THE EXCLUSIVE RIGHT TO USE "LIGHTS", APART FROM THE MARK AS SHOWN.

THE MARK CONSISTS OF THE WORD "CAMPUS" INSIDE OF A FLASH LIGHT BODY AND THE WORD "LIGHTS" APPEARING AS THE LIGHT EMITTED FROM THE FLASH LIGHT BODY.

FOR FLASHLIGHTS; LED LIGHTS FOR LIGHTING PURPOSES INCORPORATED INTO KEY CHAINS, SMALL TOYS OR OTHER SIMILAR PERSONAL ITEMS (U.S. CLS. 13, 21, 23, 31 AND 34).

FIRST USE 3-2-2010; IN COMMERCE 10-12-2010.  
JAMES MACFARLANE, EXAMINING ATTORNEY

**CLASS 11—(Continued).**

SN 85-180,923. EVO, INC., BEAVERTON, OR. FILED 11-19-2010.

fresh to plate

THE MARK CONSISTS OF STANDARD CHARACTERS WITHOUT CLAIM TO ANY PARTICULAR FONT, STYLE, SIZE, OR COLOR.

FOR MULTI-PURPOSE, GAS AND ELECTRIC COUNTERTOP FOOD PREPARATION APPARATUS FOR COOKING, BAKING, BROILING, ROASTING, TOASTING, SEARING, BROWNING, BARBECUING AND GRILLING FOOD (U.S. CLS. 13, 21, 23, 31 AND 34).

FIRST USE 9-25-2009; IN COMMERCE 9-25-2009.  
MARGERY A. TIERNEY, EXAMINING ATTORNEY

SN 85-183,816. VILLA OLYMPIC INC., BRANTFORD, ONTARIO, CANADA, FILED 11-23-2010.

SMOKERIN

FOR BARBECUE SMOKERS (U.S. CLS. 13, 21, 23, 31 AND 34).

FIRST USE 9-1-2010; IN COMMERCE 10-1-2010.  
TAMARA FRAZIER, EXAMINING ATTORNEY

SN 85-184,379. BAHNSON, INC., WINSTON-SALEM, NC. FILED 11-24-2010.

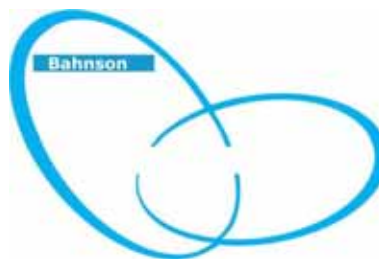

THE COLOR(S) BLUE AND WHITE IS/ARE CLAIMED AS A FEATURE OF THE MARK.

THE MARK CONSISTS OF THE TERM "BAHNSON" IN WHITE LETTERING INSIDE A BLUE RECTANGLE. THE RECTANGLE IS INSIDE AN INCOMPLETE OVAL, WHICH INTERSECTS WITH ANOTHER INCOMPLETE OVAL, BOTH SHOWN IN BLUE.

FOR INDUSTRIAL ELECTRIC OSCILLATING FANS FOR AUTOMATIC CLEANING OF CEILINGS, LIGHT FIXTURES, DUCTS AND OTHER OVERHEAD STRUCTURES EXPOSED TO FIBROUS AIRBORNE CONTAMINANTS (U.S. CLS. 13, 21, 23, 31 AND 34).

FIRST USE 1-1-2009; IN COMMERCE 1-1-2009.  
SUSAN LESLIE DUBOIS, EXAMINING ATTORNEY



**CLASS 11—(Continued).**

SN 85-184,982. OPTRONICS INTERNATIONAL, LLC, TULSA, OK. FILED 11-24-2010.



NO CLAIM IS MADE TO THE EXCLUSIVE RIGHT TO USE "SERIES", APART FROM THE MARK AS SHOWN.

THE MARK CONSISTS OF THE WORDS "MILLENNIUM SERIES" IN STYLIZED FONT.

FOR LIGHT PANELS FOR VEHICLES, NAMELY, TRUCKS (U.S. CLS. 13, 21, 23, 31 AND 34).

FIRST USE 7-1-2010, THE MARK WAS FIRST USED ANYWHERE IN A DIFFERENT FORM OTHER THAN THAT SOUGHT TO BE REGISTERED AT LEAST AS EARLY AS 07/00/1999 ; IN COMMERCE 7-1-2010, THE MARK WAS FIRST USED IN COMMERCE IN A DIFFERENT FORM OTHER THAN THAT SOUGHT TO BE REGISTERED AT LEAST AS EARLY AS 07/00/1999.

AISHA CLARKE, EXAMINING ATTORNEY

---

SN 85-186,350. MTI WHIRLPOOLS, INC., SUGAR HILL, GA. FILED 11-29-2010.

**E-Z TILE BASE**

THE MARK CONSISTS OF STANDARD CHARACTERS WITHOUT CLAIM TO ANY PARTICULAR FONT, STYLE, SIZE, OR COLOR.

NO CLAIM IS MADE TO THE EXCLUSIVE RIGHT TO USE "TILE BASE", APART FROM THE MARK AS SHOWN.

FOR SHOWER BASES; SHOWER PLATFORMS; SHOWER STANDS; SHOWER TRAYS (U.S. CLS. 13, 21, 23, 31 AND 34).

DAVID YONTEF, EXAMINING ATTORNEY

---

SN 85-186,741. BEACH 'N OUTBACK LIMITED, MACAU, MACAO, FILED 11-29-2010.

**BEACH 'N OUTBACK**

THE MARK CONSISTS OF STANDARD CHARACTERS WITHOUT CLAIM TO ANY PARTICULAR FONT, STYLE, SIZE, OR COLOR.

FOR ELECTRIC AND/OR FUEL OPERATED COOKING APPARATUS, NAMELY, BARBECUES, GRILLS, AND HIBACHIS (U.S. CLS. 13, 21, 23, 31 AND 34).

TINA MAI, EXAMINING ATTORNEY

**CLASS 11—(Continued).**

SN 85-187,645. GO GALLEY LLC, COLUMBIA, TN. FILED 11-30-2010.



NO CLAIM IS MADE TO THE EXCLUSIVE RIGHT TO USE "GRILL, SMOKE, FRY, BOIL.", APART FROM THE MARK AS SHOWN.

THE MARK CONSISTS OF TWO OUTER RINGS WITH THE STYLIZED TEXT "WWW.GOGALLEY.COM" CENTERED IN THE UPPER ARCH WITHIN THE OUTER RINGS. THE FOREGROUND CONTAINS A SILHOUETTE OF TWO MOUNTAINS LOCATED INSIDE THE OUTER RINGS. THE STYLIZED TEXT "GOGALLEY" APPEARS HORIZONTALLY ACROSS THE MOUNTAIN SILHOUETTE AND THE OUTER RINGS. THE BOTTOM PORTION OF LOGO'S OUTER RINGS FEATURES A RECTANGULAR DESIGN ELEMENT CONTAINING THE STYLIZED TEXT "GRILL, SMOKE, FRY, BOIL. COOK ANYTHING ANYWHERE" BENEATH THE WORDING "GOGALLEY".

FOR PORTABLE OUTDOOR COMBINATION GAS GRILL, BARBECUE SMOKER, GAS COOKER, GAS BURNER AND ROTISSERIE COOKING APPLIANCE (U.S. CLS. 13, 21, 23, 31 AND 34).

FIRST USE 7-3-2008; IN COMMERCE 1-16-2009.

NAPOLEON SHARMA, EXAMINING ATTORNEY

---

SN 85-192,753. BRASS LIGHT GALLERY, INC., MILWAUKEE, WI. FILED 12-7-2010.

**TOUCHMARK LIGHTING**

THE MARK CONSISTS OF STANDARD CHARACTERS WITHOUT CLAIM TO ANY PARTICULAR FONT, STYLE, SIZE, OR COLOR.

NO CLAIM IS MADE TO THE EXCLUSIVE RIGHT TO USE "LIGHTING", APART FROM THE MARK AS SHOWN.

FOR ELECTRIC LIGHTING FIXTURES (U.S. CLS. 13, 21, 23, 31 AND 34).

MARK SHINER, EXAMINING ATTORNEY

**CLASS 11—(Continued).**

SN 85-194,877. MASTER BRANDS HK LIMITED, MARLBOROUGH, MA. FILED 12-10-2010.



THE MARK CONSISTS OF THE WORD "AXIUM" INSIDE AN ELLIPTICAL OVAL DESIGN, THE LETTER "I" BEING INSIDE A HELIX.

FOR ELECTRIC FANS (U.S. CLS. 13, 21, 23, 31 AND 34).

FIRST USE 6-15-2008; IN COMMERCE 3-15-2009.  
JESSICA A. POWERS, EXAMINING ATTORNEY

---

SN 85-194,906. MASTER BRANDS HK LIMITED, MARLBOROUGH, MA. FILED 12-10-2010.

**AXIUM**

THE MARK CONSISTS OF STANDARD CHARACTERS WITHOUT CLAIM TO ANY PARTICULAR FONT, STYLE, SIZE, OR COLOR.

FOR ELECTRIC FANS (U.S. CLS. 13, 21, 23, 31 AND 34).

FIRST USE 6-15-2008; IN COMMERCE 3-15-2009.  
JESSICA A. POWERS, EXAMINING ATTORNEY

---

SN 85-194,928. MASTER BRANDS HK LIMITED, MARLBOROUGH, MA. FILED 12-10-2010.

**EXTREME TURBULENCE**

THE MARK CONSISTS OF STANDARD CHARACTERS WITHOUT CLAIM TO ANY PARTICULAR FONT, STYLE, SIZE, OR COLOR.

FOR ELECTRIC FANS (U.S. CLS. 13, 21, 23, 31 AND 34).

FIRST USE 6-15-2008; IN COMMERCE 3-15-2009.  
JESSICA A. POWERS, EXAMINING ATTORNEY

**CLASS 11—(Continued).**

SN 85-198,140. SOFFAR,RANDALL JAY, SUGAR LAND, TX. FILED 12-15-2010.

**BUMPER DUMPER**

THE MARK CONSISTS OF STANDARD CHARACTERS WITHOUT CLAIM TO ANY PARTICULAR FONT, STYLE, SIZE, OR COLOR.

FOR PORTABLE TOILETS (U.S. CLS. 13, 21, 23, 31 AND 34).

FIRST USE 1-1-1998; IN COMMERCE 1-1-1998.  
KELLY CHOE, EXAMINING ATTORNEY

---

SN 85-198,528. FOOD EQUIPMENT TECHNOLOGIES COMPANY, INC., DBA FETCO, LAKE ZURICH, IL. FILED 12-15-2010.

**AMPRESSO**

THE MARK CONSISTS OF STANDARD CHARACTERS WITHOUT CLAIM TO ANY PARTICULAR FONT, STYLE, SIZE, OR COLOR.

FOR ELECTRIC COFFEE MAKERS AND ELECTRIC TEA MAKERS (U.S. CLS. 13, 21, 23, 31 AND 34).

RAUL CORDOVA, EXAMINING ATTORNEY

**CLASS 11—(Continued).**

SN 85-199,734. LOTSTAR LIMITED, KOWLOON, HONG KONG, FILED 12-16-2010.



NO CLAIM IS MADE TO THE EXCLUSIVE RIGHT TO USE "ECO LIGHTING SOLUTION", APART FROM THE MARK AS SHOWN.

THE COLOR(S) BLACK, WHITE, DARK GREEN AND LIGHT GREEN IS/ARE CLAIMED AS A FEATURE OF THE MARK.

THE MARK CONSISTS OF A DESIGN WHICH INCLUDES A WHITE SUN SHINING ON THREE VERTICAL 3D BLOCKS COLORED WHITE, LIGHT GREEN AND DARK GREEN, ALL INSIDE OF A LIGHT GREEN ROUNDED RECTANGLE. THE WORDING "ECOCITYLED" IS BELOW THE DESIGN IN LIGHT GREEN. THE WORDING "YOUR ECO LIGHTING SOLUTION" FOLLOWS BELOW IN BLACK.

FOR LAMPS; LAMP BULBS; LIGHTING FIXTURES; LED LIGHTING FIXTURES FOR INDOOR AND OUTDOOR LIGHTING APPLICATIONS; LED LAMPS; LED LIGHT BULBS; LED LUMINARIES; LIGHTING APPARATUS, NAMELY, LIGHTING INSTALLATIONS (U.S. CLS. 13, 21, 23, 31 AND 34).

MATTHEW EINSTEIN, EXAMINING ATTORNEY

SN 85-203,600. UNILUX ADVANCED MANUFACTURING, LLC, SCHENECTADY, NY. FILED 12-22-2010.



THE MARK CONSISTS OF A FLAME DESIGN WITH THE WORD "EVOLV" BELOW THE FLAME.

FOR COMMERCIAL BOILERS (U.S. CLS. 13, 21, 23, 31 AND 34).

HEATHER SAPP, EXAMINING ATTORNEY

**CLASS 11—(Continued).**

SN 85-203,616. UNILUX ADVANCED MANUFACTURING, LLC, SCHENECTADY, NY. FILED 12-22-2010.

# EVOLV

THE MARK CONSISTS OF STANDARD CHARACTERS WITHOUT CLAIM TO ANY PARTICULAR FONT, STYLE, SIZE, OR COLOR.

FOR COMMERCIAL BOILERS (U.S. CLS. 13, 21, 23, 31 AND 34).

HEATHER SAPP, EXAMINING ATTORNEY

SN 85-205,314. VUE TECHNOLOGY LLC, SLIDELL, LA. FILED 12-23-2010.

# GROWVUE

THE MARK CONSISTS OF STANDARD CHARACTERS WITHOUT CLAIM TO ANY PARTICULAR FONT, STYLE, SIZE, OR COLOR.

OWNER OF U.S. REG. NO. 3,479,556.

FOR ELECTRIC LIGHTING FIXTURES; LED (LIGHT EMITTING DIODE) LIGHTING FIXTURES; LIGHT EMITTING DIODE (LED) PLANT GROW LIGHT; LIGHTING FIXTURES; LIGHTS FOR USE IN GROWING PLANTS (U.S. CLS. 13, 21, 23, 31 AND 34).

TRACY CROSS, EXAMINING ATTORNEY

SN 85-206,344. WHIRLPOOL PROPERTIES, INC., ST. JOSEPH, MI. FILED 12-28-2010.



OWNER OF U.S. REG. NOS. 1,137,316, 2,799,094 AND OTHERS.

THE MARK CONSISTS OF A SWIRL.

FOR AIR PURIFIERS; AIR-CONDITIONING APPARATUS; APPARATUS FOR COOKING, NAMELY, COOK-TOPS; BAKING OVENS; CLOTHES DRYERS; DEHUMIDIFIERS FOR HOUSEHOLD USE; ELECTRIC RANGES; ELECTRIC REFRIGERATORS; EXHAUST HOODS FOR KITCHENS; FREEZERS; GAS RANGES; GAS REFRIGERATORS; ICE CHESTS; ICE CUBE MAKING MACHINES; MICROWAVE OVENS; RANGE HOODS; REFRIGERATED BEVERAGE DISPENSING UNITS; WINE COOLERS, NAMELY, REFRIGERATED CABINETS CONTAINING RACKS FOR WINE BOTTLES AND STORAGE SHELVES (U.S. CLS. 13, 21, 23, 31 AND 34).

DEZMONA MIZELLE, EXAMINING ATTORNEY

**CLASS 11—(Continued).**

SN 85-206,348. WHIRLPOOL PROPERTIES, INC., ST. JOSEPH, MI. FILED 12-28-2010.



OWNER OF U.S. REG. NOS. 1,137,316, 2,799,094 AND OTHERS.

THE MARK CONSISTS OF A SWIRL.  
FOR ELECTRICALLY OPERATED HOT WATER DISPENSERS, WATER PURIFICATION AND DELIVERY SYSTEMS COMPRISING STAND ALONE WATER CABINETS, BUILT-IN BOTTLED WATER DISPENSING APPARATUS FOR HOT OR CHILLED WATER, DOMESTIC WATER FILTRATION UNITS, REVERSE OSMOSIS UNITS FOR PURIFICATION OF WATER; WATER DELIVERY PUMPS, WATER DISTILLATION UNITS (U.S. CLS. 13, 21, 23, 31 AND 34).

DEZMONA MIZELLE, EXAMINING ATTORNEY

SN 85-206,351. WHIRLPOOL PROPERTIES, INC., ST. JOSEPH, MI. FILED 12-28-2010.



OWNER OF U.S. REG. NOS. 1,137,316, 2,799,094 AND OTHERS.

THE MARK CONSISTS OF A SWIRL.  
FOR GAS WATER HEATERS; WATER HEATERS (U.S. CLS. 13, 21, 23, 31 AND 34).

DEZMONA MIZELLE, EXAMINING ATTORNEY

SN 85-206,353. WHIRLPOOL PROPERTIES, INC., ST. JOSEPH, MI. FILED 12-28-2010.



OWNER OF U.S. REG. NOS. 1,137,316, 2,799,094 AND OTHERS.

THE MARK CONSISTS OF A SWIRL.  
FOR WATER CONDITIONING UNITS, WATER SOFTENERS, WATER COOLERS, WATER CHILLERS, COUNTERTOP WATER FILTRATION DEVICES, HOME WATER FILTRATION DEVICES AND WATER FAUCET FILTERS (U.S. CLS. 13, 21, 23, 31 AND 34).

DEZMONA MIZELLE, EXAMINING ATTORNEY

**CLASS 11—(Continued).**

SN 85-207,259. GENERAL-FITTING(S) CO., LTD., TAIPEI CITY 11560, TAIWAN, FILED 12-29-2010.



THE MARK CONSISTS OF A DESIGN OF A DOTTED "L" PATTERN IN A CIRCLE FOLLOWED BY WORDING "LUXTOP" IN STYLIZED FONT.

FOR AUTOMOTIVE LIGHTING HEADLIGHTS FOR VEHICLES; BACKUP LIGHTS FOR LAND VEHICLES; CEILING LIGHTS; CHANDELIERS; ELECTRIC DISCHARGE TUBES FOR LIGHTING; ELECTRIC LIGHT BULBS; ELECTRIC LIGHTING FIXTURES; FLUORESCENT LIGHTING TUBES; HALOGEN LIGHT BULBS; HEADLIGHTS FOR VEHICLES; INCANDESCENT LAMPS AND THEIR FITTINGS; LAMP SHADES; LED LIGHTING FIXTURES FOR INDOOR AND OUTDOOR LIGHTING APPLICATIONS; LIGHT BULBS; LIGHTING APPARATUS FOR VEHICLES; LIGHTING APPARATUS FOR THEATRES, CLUBS AND DISCOTHEQUES; LIGHTING DEVICES FOR THEATRICAL PRODUCTIONS; LIGHTING FIXTURES; LIGHTING FIXTURES WITH MOTION DETECTION; ORNAMENTAL DECORATIONS SPECIALLY ADAPTED FOR AFFIXATION TO CHANDELIERS; PROJECTOR LAMPS; REAR LIGHTS FOR VEHICLES; RUNNING LIGHTS FOR LAND VEHICLES; SOLAR LIGHT FIXTURES, NAMELY, INDOOR AND OUTDOOR SOLAR POWERED LIGHTING UNITS AND FIXTURES; SOLAR-POWERED ALL-WEATHER LIGHTS; SPOT LIGHTS; STREET LAMPS; TABLE LAMPS; TAIL LIGHTS FOR LAND VEHICLES; VEHICLE REFLECTORS; VEHICLE TURN-SIGNAL LIGHT BULBS (U.S. CLS. 13, 21, 23, 31 AND 34).

NATALIE POLZER, EXAMINING ATTORNEY

SN 85-207,361. ALLSOP, INC., BELLINGHAM, WA. FILED 12-29-2010.

**SOJI**

THE MARK CONSISTS OF STANDARD CHARACTERS WITHOUT CLAIM TO ANY PARTICULAR FONT, STYLE, SIZE, OR COLOR.

FOR LANDSCAPE LIGHTING INSTALLATIONS; LANTERNS FOR LIGHTING; LED LIGHTING FIXTURES FOR INDOOR AND OUTDOOR LIGHTING APPLICATIONS; SOLAR LIGHT FIXTURES, NAMELY, INDOOR AND OUTDOOR SOLAR POWERED LIGHTING UNITS AND FIXTURES; SOLAR-POWERED ALL-WEATHER LIGHTS (U.S. CLS. 13, 21, 23, 31 AND 34).

FIRST USE 2-0-2007; IN COMMERCE 2-0-2007.  
ROSELLE HERRERA, EXAMINING ATTORNEY

**CLASS 11—(Continued).**

SN 85-207,518. RESTAURANT TECHNOLOGIES, INC., MEN-  
DOTA HEIGHTS, MN. FILED 12-29-2010.



THE MARK CONSISTS OF THE LETTERS "RTI", EN-  
CIRCLED BY TWO CURVES FORMING AN ELLIPSE THAT  
OPENS TO THE RIGHT OF THE LETTER "I".

FOR FILTERS, PUMPS, AND TANKS SOLD IN COM-  
BINATION FOR USE IN RESTAURANT COOKING OIL  
HANDLING SYSTEMS (U.S. CLS. 13, 21, 23, 31 AND 34).  
ANNE MADDEN, EXAMINING ATTORNEY

---

SN 85-207,532. RESTAURANT TECHNOLOGIES, INC., MEN-  
DOTA HEIGHTS, MN. FILED 12-29-2010.

**RTI**

THE MARK CONSISTS OF STANDARD CHARACTERS  
WITHOUT CLAIM TO ANY PARTICULAR FONT, STYLE,  
SIZE, OR COLOR.

FOR FILTERS, PUMPS, AND TANKS SOLD IN COM-  
BINATION FOR USE IN RESTAURANT COOKING OIL  
HANDLING SYSTEMS (U.S. CLS. 13, 21, 23, 31 AND 34).  
ANNE MADDEN, EXAMINING ATTORNEY

---

SN 85-207,575. CYCLOPTICS TECHNOLOGIES, LLC, DAY-  
TON, OH. FILED 12-29-2010.

**PARGROW**

THE MARK CONSISTS OF STANDARD CHARACTERS  
WITHOUT CLAIM TO ANY PARTICULAR FONT, STYLE,  
SIZE, OR COLOR.

FOR ELECTRIC LUMINAIRES; LAMPS; LIGHTING  
FIXTURES (U.S. CLS. 13, 21, 23, 31 AND 34).  
SCOTT BIBB, EXAMINING ATTORNEY

**CLASS 11—(Continued).**

SN 85-208,426. KNOWLES, ART, ANDALUSIA, AL. FILED  
12-31-2010.

**AIRGORILLA**

THE MARK CONSISTS OF STANDARD CHARACTERS  
WITHOUT CLAIM TO ANY PARTICULAR FONT, STYLE,  
SIZE, OR COLOR.

FOR AIR CLEANING UNITS; AIR CLEANING UNITS  
CONTAINING AN AIR FILTER, ULTRAVIOLET  
LIGHTS AND A PHOTOCATALYTIC FILTER; AIR  
PURIFICATION UNITS; AIR PURIFIERS (U.S. CLS. 13,  
21, 23, 31 AND 34).

EUGENIA MARTIN, EXAMINING ATTORNEY

---

SN 85-208,627. ALPHA/OMEGA ENVIRONMENTAL, INC.,  
COLORADO SPRINGS, CO. FILED 12-31-2010.

**ION-SEP**

THE MARK CONSISTS OF STANDARD CHARACTERS  
WITHOUT CLAIM TO ANY PARTICULAR FONT, STYLE,  
SIZE, OR COLOR.

FOR WATER PURIFICATION FILTER CARTRIDGES  
(U.S. CLS. 13, 21, 23, 31 AND 34).

CARYN GLASSER, EXAMINING ATTORNEY

---

SN 85-208,772. CYCLOPTICS TECHNOLOGIES, LLC, DAY-  
TON, OH. FILED 1-1-2011.

**ALL-BRIGHT**

THE MARK CONSISTS OF STANDARD CHARACTERS  
WITHOUT CLAIM TO ANY PARTICULAR FONT, STYLE,  
SIZE, OR COLOR.

FOR ELECTRIC LUMINAIRES; LAMP REFLECTORS;  
LAMPS; LIGHT REFLECTORS; LIGHTING FIXTURES  
(U.S. CLS. 13, 21, 23, 31 AND 34).

SCOTT BIBB, EXAMINING ATTORNEY

**CLASS 11—(Continued).**

SN 85-209,308. TECHTRONIC FLOOR CARE TECHNOLOGY LIMITED, ROAD TOWN, TORTOLA, BR.VIRGIN ISLANDS, FILED 1-3-2011.



OWNER OF U.S. REG. NOS. 652,995, 2,008,110 AND OTHERS.  
 THE MARK CONSISTS OF THE WORD "HOOVER" INSIDE A CIRCLE.  
 FOR AIR PURIFIERS (U.S. CLS. 13, 21, 23, 31 AND 34).  
 FIRST USE 12-7-2010; IN COMMERCE 12-7-2010.  
 PRISCILLA MILTON, EXAMINING ATTORNEY

SN 85-209,980. CANDLE LAMP COMPANY, LLC., RIVERSIDE, CA. FILED 1-4-2011.

**EZ TOUCH**

THE MARK CONSISTS OF STANDARD CHARACTERS WITHOUT CLAIM TO ANY PARTICULAR FONT, STYLE, SIZE, OR COLOR.  
 FOR ELECTRIC CANDLES (U.S. CLS. 13, 21, 23, 31 AND 34).  
 MARIA-VICTORIA SUAREZ, EXAMINING ATTORNEY

SN 85-210,534. WON, HAION, BASKING RIDGE, NJ. FILED 1-5-2011.

**G-Midifier**

THE MARK CONSISTS OF STANDARD CHARACTERS WITHOUT CLAIM TO ANY PARTICULAR FONT, STYLE, SIZE, OR COLOR.  
 FOR HUMIDIFIERS (U.S. CLS. 13, 21, 23, 31 AND 34).  
 FIRST USE 11-1-2010; IN COMMERCE 11-1-2010.  
 BRENDAN MCCAULEY, EXAMINING ATTORNEY

**CLASS 11—(Continued).**

SN 85-210,909. TURBO AIR, INC., CARSON, CA. FILED 1-5-2011.

**TEXAKING**

THE MARK CONSISTS OF STANDARD CHARACTERS WITHOUT CLAIM TO ANY PARTICULAR FONT, STYLE, SIZE, OR COLOR.  
 FOR AIR CONDITIONERS; REFRIGERATORS (U.S. CLS. 13, 21, 23, 31 AND 34).  
 MAUREEN DALL, EXAMINING ATTORNEY

SN 85-211,570. BEVERAGE-AIR CORPORATION, WINSTON-SALEM, NC. FILED 1-6-2011.

**MarketMax**

THE MARK CONSISTS OF STANDARD CHARACTERS WITHOUT CLAIM TO ANY PARTICULAR FONT, STYLE, SIZE, OR COLOR.  
 FOR FREEZERS; REFRIGERATORS (U.S. CLS. 13, 21, 23, 31 AND 34).  
 JERI J. FICKES, EXAMINING ATTORNEY

SN 85-211,776. GOLIGHT, INC, CULBERTSON, NE. FILED 1-6-2011.

**PROWLER**

THE MARK CONSISTS OF STANDARD CHARACTERS WITHOUT CLAIM TO ANY PARTICULAR FONT, STYLE, SIZE, OR COLOR.  
 FOR SEARCHLIGHTS (U.S. CLS. 13, 21, 23, 31 AND 34).  
 TINA MAI, EXAMINING ATTORNEY

**CLASS 11—(Continued).**

SN 85-212,085. GREENSUN ENERGY LTD., HAR HOTZVIM, JERUSALEM, ISRAEL, FILED 1-6-2011.



OWNER OF ISRAEL REG. NO. 207112, DATED 6-3-2009, EXPIRES 12-25-2017.

THE MARK CONSISTS OF THE STYLIZED LETTERS "GSE".

FOR SOLAR PANEL SYSTEMS FOR THE PRODUCTION OF ENERGY AND ELECTRIC POWER COMPRISING PRIMARILY PHOTOVOLTAIC-BASED POWER PLANTS; SOLAR PANEL SYSTEMS FOR THE PRODUCTION OF ENERGY AND ELECTRIC POWER COMPRISING PRIMARILY SOLAR THERMAL-BASED POWER PLANTS; SOLAR POWER STATIONS AND FARMS, NAMELY, PHOTOVOLTAIC-BASED AND SOLAR THERMAL-BASED POWER PLANTS; SOLAR PANELS, NAMELY, SOLAR COLLECTORS (U.S. CLS. 13, 21, 23, 31 AND 34).

EUGENIA MARTIN, EXAMINING ATTORNEY

---

SN 85-212,994. CREE, INC., DURHAM, NC. FILED 1-7-2011.



OWNER OF U.S. REG. NOS. 2,452,761, 3,327,299 AND OTHERS.

THE MARK CONSISTS OF A DIAMOND-SHAPED DESIGN WITH HORIZONTAL STRIPES.

FOR FLASHLIGHTS; LED (LIGHT EMITTING DIODE) LIGHTING FIXTURES; LIGHT BULBS; LIGHTING FIXTURES; SPOTLIGHTS (U.S. CLS. 13, 21, 23, 31 AND 34).

FIRST USE 5-31-2008; IN COMMERCE 5-31-2008.

STEVEN PEREZ, EXAMINING ATTORNEY

**CLASS 11—(Continued).**

SN 85-213,009. JOAN LUNDEN PRODUCTIONS, INC., ARMONK, NY. FILED 1-7-2011.

JOAN LUNDEN HOME

THE MARK CONSISTS OF STANDARD CHARACTERS WITHOUT CLAIM TO ANY PARTICULAR FONT, STYLE, SIZE, OR COLOR.

NO CLAIM IS MADE TO THE EXCLUSIVE RIGHT TO USE "HOME", APART FROM THE MARK AS SHOWN.

THE NAME(S), PORTRAIT(S), AND/OR SIGNATURE(S) SHOWN IN THE MARK IDENTIFIES "JOAN LUNDEN", WHOSE CONSENT(S) TO REGISTER IS MADE OF RECORD.

FOR DISINFECTING AND SANITIZING APPARATUS USING ULTRAVIOLET LIGHT FOR HOUSEHOLD USE (U.S. CLS. 13, 21, 23, 31 AND 34).

THEODORE MCBRIDE, EXAMINING ATTORNEY

---

SN 85-213,204. SOUTHERN PRIDE DISTRIBUTING, LLC, MARION, IL. FILED 1-7-2011.

ROLLTISSERIE

THE MARK CONSISTS OF STANDARD CHARACTERS WITHOUT CLAIM TO ANY PARTICULAR FONT, STYLE, SIZE, OR COLOR.

FOR BARBECUE OVENS AND SMOKERS (U.S. CLS. 13, 21, 23, 31 AND 34).

LINDA LAVACHE, EXAMINING ATTORNEY

---

SN 85-213,416. SUNWAY PRODUCTS LIMITED, HONG KONG, HONG KONG, FILED 1-8-2011.

BLOCKLITE

THE MARK CONSISTS OF STANDARD CHARACTERS WITHOUT CLAIM TO ANY PARTICULAR FONT, STYLE, SIZE, OR COLOR.

FOR FLASHLIGHTS (U.S. CLS. 13, 21, 23, 31 AND 34).

DANNEAN HETZEL, EXAMINING ATTORNEY

**CLASS 11—(Continued).**

SN 85-214,356. COMMONPATH, LLC, VENTURA, CA. FILED 1-10-2011.



The logo for "Kandle by Ozeri" features the word "Kandle" in a stylized font where the letter "K" is light blue and the remaining letters "andle" are black. Below "Kandle" is the text "by Ozeri" in a smaller, black, sans-serif font.

THE COLOR(S) BLACK, BLUE, AND GRAY IS/ARE CLAIMED AS A FEATURE OF THE MARK.

THE MARK CONSISTS OF THE WORDS "BY OZERI" IN BLACK STYLIZED TYPEFACE ARRAYED BELOW THE WORD "KANDLE" IN STYLIZED TYPEFACE. THE LETTER "K" AND "E" IN "KANDLE" APPEAR IN BLUE TYPEFACE WHEREAS THE REMAINING LETTERS, "ANDL" APPEAR IN BLACK TYPEFACE. THERE ARE THREE GRAY BARS OR RAYS THAT APPEAR BELOW THE CROSS BAR IN THE LETTER "E" IN "KANDLE".

FOR CLIP-ON LIGHTS TO AID IN THE VIEWING AND READING OF PORTABLE ELECTRONIC DEVICES USED FOR RECEIVING AND READING TEXT AND IMAGES AND SOUND AND USED FOR DISPLAYING ELECTRONICALLY PUBLISHED MATERIALS, NAMELY, BOOKS, JOURNALS, NEWSPAPERS, MAGAZINES, AND MULTIMEDIA PRESENTATIONS; CLIP-ON LIGHTS TO AID IN THE VIEWING AND READING OF PRINTED MATERIALS, NAMELY, BOOKS, NOTEPADS, JOURNALS, MAGAZINES, PERIODICALS, MANUSCRIPTS AND NEWSPAPERS; ALL OF THE AFOREMENTIONED GOODS NOT BEING CANDLE SHAPED OR ELECTRONIC CANDLES (U.S. CLS. 13, 21, 23, 31 AND 34).

FIRST USE 12-31-2010; IN COMMERCE 12-31-2010.  
AISHA CLARKE, EXAMINING ATTORNEY

SN 85-220,453. BEACH 'N OUTBACK LIMITED, MACAU, MACAO, FILED 1-18-2011.

## THE CALIFORNIAN

THE MARK CONSISTS OF STANDARD CHARACTERS WITHOUT CLAIM TO ANY PARTICULAR FONT, STYLE, SIZE, OR COLOR.

FOR ELECTRIC AND/OR FUEL OPERATED COOKING APPARATUS, NAMELY, BARBECUES, GRILLS, AND HIBACHIS (U.S. CLS. 13, 21, 23, 31 AND 34).

TINA MAI, EXAMINING ATTORNEY

**CLASS 11—(Continued).**

SN 85-223,297. ORECK HOLDINGS, LLC, NASHVILLE, TN. FILED 1-21-2011.

## DUALMAX

THE MARK CONSISTS OF STANDARD CHARACTERS WITHOUT CLAIM TO ANY PARTICULAR FONT, STYLE, SIZE, OR COLOR.

FOR AIR PURIFIERS (U.S. CLS. 13, 21, 23, 31 AND 34).  
DAVID TAYLOR, EXAMINING ATTORNEY

SN 85-227,747. CYCLOPTICS TECHNOLOGIES, LLC, DAYTON, OH. FILED 1-27-2011.

## LIGHTSTALK

THE MARK CONSISTS OF STANDARD CHARACTERS WITHOUT CLAIM TO ANY PARTICULAR FONT, STYLE, SIZE, OR COLOR.

FOR ELECTRIC LUMINAIRES; LAMPS; LIGHTING FIXTURES (U.S. CLS. 13, 21, 23, 31 AND 34).

SCOTT BIBB, EXAMINING ATTORNEY

SN 85-232,413. SOUTHERN PRIDE DISTRIBUTING, LLC, MARION, IL. FILED 2-2-2011.

## WE'VE COME A LONG WAY FROM THE CAVE

THE MARK CONSISTS OF STANDARD CHARACTERS WITHOUT CLAIM TO ANY PARTICULAR FONT, STYLE, SIZE, OR COLOR.

FOR BARBECUE OVENS AND SMOKERS (U.S. CLS. 13, 21, 23, 31 AND 34).

LINDA LAVACHE, EXAMINING ATTORNEY

SN 85-237,039. KOHLER CO., KOHLER, WI. FILED 2-8-2011.

## LAWNFIELD

THE MARK CONSISTS OF STANDARD CHARACTERS WITHOUT CLAIM TO ANY PARTICULAR FONT, STYLE, SIZE, OR COLOR.

FOR SINKS (U.S. CLS. 13, 21, 23, 31 AND 34).

ANNE FARRELL, EXAMINING ATTORNEY



**CLASS 11—(Continued).**

SN 85-237,154. KOHLER CO., KOHLER, WI. FILED 2-8-2011.

**WHEATLAND**

THE MARK CONSISTS OF STANDARD CHARACTERS WITHOUT CLAIM TO ANY PARTICULAR FONT, STYLE, SIZE, OR COLOR.

FOR SINKS (U.S. CLS. 13, 21, 23, 31 AND 34).  
ANNE FARRELL, EXAMINING ATTORNEY

---

SN 85-244,595. STANLEY LOGISTICS, L.L.C., NEW BRITAIN, CT. FILED 2-17-2011.

**FATMAX**

THE MARK CONSISTS OF STANDARD CHARACTERS WITHOUT CLAIM TO ANY PARTICULAR FONT, STYLE, SIZE, OR COLOR.

OWNER OF U.S. REG. NOS. 2,579,681, 3,163,439 AND 3,823,252.

FOR FLASHLIGHTS; HEAT GUNS (U.S. CLS. 13, 21, 23, 31 AND 34).

KAPIL BHANOT, EXAMINING ATTORNEY

---

SN 85-255,797. FOOD EQUIPMENT TECHNOLOGIES COMPANY, INC., DBA FETCO, LAKE ZURICH, IL. FILED 3-2-2011.

**AM PRESSO**

THE MARK CONSISTS OF STANDARD CHARACTERS WITHOUT CLAIM TO ANY PARTICULAR FONT, STYLE, SIZE, OR COLOR.

FOR ELECTRICAL COFFEE MAKERS AND ELECTRICAL TEA MAKERS AND ELECTRICAL, COMBINATION COFFEE AND TEA MAKERS (U.S. CLS. 13, 21, 23, 31 AND 34).

RAUL CORDOVA, EXAMINING ATTORNEY

**CLASS 12—VEHICLES**

SN 77-754,252. FIAT AUTO S.P.A., TORINO, ITALY, FILED 6-8-2009.

**DUETTO**

THE MARK CONSISTS OF STANDARD CHARACTERS WITHOUT CLAIM TO ANY PARTICULAR FONT, STYLE, SIZE, OR COLOR.

OWNER OF ITALY REG. NO. 817636, DATED 6-12-2000, RENEWED AS REG. NO. 001304205, DATED 10-27-2008, EXPIRES 10-27-2018.

THE ENGLISH TRANSLATION OF THE WORD "DUETTO" IN THE MARK IS "DUET".

FOR MOTOR VEHICLES, NAMELY, AUTOMOBILES AND SPORT UTILITY VEHICLES (U.S. CLS. 19, 21, 23, 31, 35 AND 44).

TARA PATE, EXAMINING ATTORNEY

---

SN 77-789,276. WELD, BROCK, TUSTIN, CA. FILED 7-24-2009.

OWNER OF U.S. REG. NO. 3,400,041.

THE COLOR(S) BLACK, WHITE AND RED IS/ARE CLAIMED AS A FEATURE OF THE MARK.

THE MARK CONSISTS OF THE WORDING "BMF" IN BLACK, OUTLINED IN WHITE AND RED.

FOR LAND VEHICLE PARTS AND ACCESSORIES, NAMELY, TIRES (U.S. CLS. 19, 21, 23, 31, 35 AND 44).

SUE LAWRENCE, EXAMINING ATTORNEY

---

SN 77-919,393. TOMBERLIN AUTOMOTIVE GROUP, INC. AUGUSTA, GA. FILED 1-25-2010.

**TOMBERLIN ANVIL**

THE MARK CONSISTS OF STANDARD CHARACTERS WITHOUT CLAIM TO ANY PARTICULAR FONT, STYLE, SIZE, OR COLOR.

OWNER OF U.S. REG. NOS. 3,172,271 AND 3,175,239.

FOR ELECTRIC MOTOR VEHICLES, NAMELY, LOW SPEED LAND VEHICLES FOR ROAD USE (U.S. CLS. 19, 21, 23, 31, 35 AND 44).

STEVEN PEREZ, EXAMINING ATTORNEY

**CLASS 12—(Continued).**

SN 79-084,541. SVEFLYTT AKTIEBOLAG, SWEDEN, FILED 6-9-2010.

PRIORITY DATE OF 12-22-2009 IS CLAIMED.  
OWNER OF INTERNATIONAL REGISTRATION 1043903 DATED 6-9-2010, EXPIRES 6-9-2020.

THE MARK CONSISTS OF THE WORDING "MULTI TROLLEY" WHERE THE LETTER "L" IN "MULTI" AND THE FIRST LETTER "L" IN "TROLLEY" ARE CONNECTED BY A TROLLEY DESIGN.

FOR APPARATUS IN THE NATURE OF TROLLEYS FOR TRANSPORTING GOODS; HAND PROPELLED TROLLEYS (U.S. CLS. 19, 21, 23, 31, 35 AND 44).  
MARTHA FROMM, EXAMINING ATTORNEY

**CLASS 12—(Continued).**

SN 79-089,797. AKEBONO BRAKE INDUSTRY CO., LTD., TOKYO, JAPAN, FILED 8-30-2010.

PRIORITY DATE OF 6-28-2010 IS CLAIMED.  
OWNER OF INTERNATIONAL REGISTRATION 1057803 DATED 8-30-2010, EXPIRES 8-30-2020.

OWNER OF U.S. REG. NOS. 1,256,025 AND 3,761,443.  
NO CLAIM IS MADE TO THE EXCLUSIVE RIGHT TO USE "BRAKE EXPERTS", APART FROM THE MARK AS SHOWN.

THE ENGLISH TRANSLATION OF THE FOREIGN WORD(S) IN THE MARK IS: "DAWN".

FOR NON-ELECTRIC PRIME MOVERS FOR LAND VEHICLES, BUT NOT INCLUDING THEIR PARTS; STRUCTURAL PARTS AND FITTINGS FOR LAND VEHICLES, NAMELY, CLUTCH FACINGS, DISC BRAKES, DRUM BRAKES, DISC PADS, BRAKE DISC ROTORS, BRAKE DRUMS, BRAKE LININGS, BRAKE SHOES, BRAKE SHOE PART KITS COMPRISED OF PAD CLIPS, PAD SPRINGS AND SHIMS, BRAKE CALIPER PART KITS COMPRISED OF ANTI-RATTLE SPRINGS, BLEEDER SCREWS, WASHERS AND SPRINGS, HUBS FOR VEHICLE WHEELS, BEARINGS FOR VEHICLE WHEELS, STEERING KNUCKLES FOR VEHICLE WHEELS; AC MOTORS OR DC MOTORS FOR LAND VEHICLES, BUT NOT INCLUDING THEIR PARTS; RAILWAY ROLLING STOCK AND THEIR PARTS AND FITTINGS; AUTOMOBILES AND THEIR PARTS AND FITTINGS, NAMELY, CLUTCH FACINGS, DISC BRAKES, DRUM BRAKES, DISC PADS, BRAKE DISC ROTORS, BRAKE DRUMS, BRAKE LININGS, BRAKE SHOES, BRAKE SHOE PART KITS COMPRISED OF PAD CLIPS, PAD SPRINGS AND SHIMS, BRAKE CALIPER PART KITS COMPRISED OF ANTI-RATTLE SPRINGS, BLEEDER SCREWS, WASHERS AND SPRINGS, HUBS FOR VEHICLE WHEELS, BEARINGS FOR VEHICLE WHEELS, STEERING KNUCKLES FOR VEHICLE WHEELS; TWO-WHEELED MOTOR VEHICLES, BICYCLES AND THEIR PARTS AND FITTINGS, NAMELY, CLUTCH FACINGS, DISC BRAKES, DRUM BRAKES, DISC PADS, BRAKE DISC ROTORS, BRAKE DRUMS, BRAKE LININGS, BRAKE SHOES, BRAKE SHOE PART KITS COMPRISED OF PAD CLIPS, PAD SPRINGS AND SHIMS, BRAKE CALIPER PART KITS COMPRISED OF ANTI-RATTLE SPRINGS, BLEEDER SCREWS, WASHERS AND SPRINGS, HUBS FOR VEHICLE WHEELS, BEARINGS FOR VEHICLE WHEELS, STEERING KNUCKLES FOR VEHICLE WHEELS (U.S. CLS. 19, 21, 23, 31, 35 AND 44).  
CYNTHIA SLOAN, EXAMINING ATTORNEY

SN 79-087,609. DR. MORITZ FRIEBEL & DR. JOACHIM PAPROTH GBR (VERTRETUNGSBERECHTIGTE GESELLSCHAFTER: DR. JOACHIM PAPROTH, 14513 TELTOW; DR. MORITZ FRIEBEL, 14193 BERLIN), FED REP GERMANY, FILED 8-9-2010.

THE MARK CONSISTS OF STANDARD CHARACTERS WITHOUT CLAIM TO ANY PARTICULAR FONT, STYLE, SIZE, OR COLOR.

PRIORITY DATE OF 2-11-2010 IS CLAIMED.  
OWNER OF INTERNATIONAL REGISTRATION 1051855 DATED 8-9-2010, EXPIRES 8-9-2020.

FOR BICYCLES; BICYCLE PARTS, NAMELY, BRAKES, BICYCLE WHEELS, FENDERS, NIPPLES; RIMS FOR BICYCLE WHEELS; BICYCLE WHEEL HUBS; BICYCLE PEDALS; BICYCLE SADDLES; BICYCLE FRAMES; BICYCLE TIRES; SPOKES FOR BICYCLE WHEELS; BICYCLE CHAINS; HANDLEBARS; WHEEL SETS COMPOSED OF VEHICLE WHEELS AND STRUCTURAL PARTS THEREFOR; TRICYCLES; BICYCLE TRAILERS (U.S. CLS. 19, 21, 23, 31, 35 AND 44).  
ROBIN MITTLER, EXAMINING ATTORNEY

**CLASS 12—(Continued).**

SN 79-092,450. SAAB AUTOMOBILE AB, SWEDEN, FILED 12-22-2010.

# eXWD

THE MARK CONSISTS OF STANDARD CHARACTERS WITHOUT CLAIM TO ANY PARTICULAR FONT, STYLE, SIZE, OR COLOR.

PRIORITY DATE OF 12-13-2010 IS CLAIMED.

OWNER OF INTERNATIONAL REGISTRATION 1064804 DATED 12-22-2010, EXPIRES 12-22-2020.

FOR MOTOR VEHICLES, NAMELY, AUTOMOBILES, SPORT UTILITY VEHICLES, TRUCKS, VANS, ENGINES THEREFOR AND STRUCTURAL PARTS THEREOF (U.S. CLS. 19, 21, 23, 31, 35 AND 44).

ASMAT KHAN, EXAMINING ATTORNEY

---

SN 79-094,192. GUSTAV MAGENWIRTH GMBH & CO. KG, FED REP GERMANY, FILED 10-8-2010.

# Storm

THE MARK CONSISTS OF STANDARD CHARACTERS WITHOUT CLAIM TO ANY PARTICULAR FONT, STYLE, SIZE, OR COLOR.

PRIORITY DATE OF 4-8-2010 IS CLAIMED.

OWNER OF INTERNATIONAL REGISTRATION 1068776 DATED 10-8-2010, EXPIRES 10-8-2020.

FOR BRAKE DISCS, IN PARTICULAR FOR HYDRAULIC DISC BRAKES FOR BICYCLES; HYDRAULIC DISC BRAKES FOR BICYCLES (U.S. CLS. 19, 21, 23, 31, 35 AND 44).

JEFFREY LOOK, EXAMINING ATTORNEY

---

SN 85-021,083. TELEDYNE BENTHOS, INC., DBA TELEDYNE WEBB RESEARCH, NORTH FALMOUTH, MA, FILED 4-22-2010.

# SLOCUM

THE MARK CONSISTS OF STANDARD CHARACTERS WITHOUT CLAIM TO ANY PARTICULAR FONT, STYLE, SIZE, OR COLOR.

SEC. 2(F).

FOR AUTONOMOUS UNDERWATER VEHICLES (AUVS), NAMELY, SUBMARINES; UNMANNED UNDERWATER VEHICLES (UUVS), NAMELY, SUBMARINES (U.S. CLS. 19, 21, 23, 31, 35 AND 44).

FIRST USE 4-0-1996; IN COMMERCE 12-27-2002.

JOSETTE BEVERLY, EXAMINING ATTORNEY

**CLASS 12—(Continued).**

SN 85-049,522. NUNA INTERNATIONAL B.V., BJ AMSTERDAM ZUIDOOST, NETHERLANDS, FILED 5-27-2010.

# PEPP

THE MARK CONSISTS OF STANDARD CHARACTERS WITHOUT CLAIM TO ANY PARTICULAR FONT, STYLE, SIZE, OR COLOR.

FOR STROLLERS, SAFETY CAR SEATS FOR CHILDREN (U.S. CLS. 19, 21, 23, 31, 35 AND 44).

DAVID MURRAY, EXAMINING ATTORNEY

---

SN 85-050,898. HU, JIAN, RUI'AN, CHINA, FILED 5-29-2010.



NO CLAIM IS MADE TO THE EXCLUSIVE RIGHT TO USE "AUTO", APART FROM THE MARK AS SHOWN.

THE COLOR(S) BROWN, BLACK, SILVER AND GRAY IS/ARE CLAIMED AS A FEATURE OF THE MARK.

THE MARK CONSISTS OF A SILVER AND GRAY BULL OVER A BROWN GLOBE CENTERED ON EUROPE AND AFRICA WITH LANDMASSES IN A LIGHTER BROWN. AROUND THE GLOBE IS A SILVER AND GRAY RING WITH "BOMETEC" IN BLACK WRITTEN AT THE TOP, "AUTO" IN BLACK WRITTEN AT THE BOTTOM AND STYLIZED IMAGES OF WHEAT IN GRAY ON EITHER SIDE.

THE WORDING "BOMETEC" HAS NO MEANING IN A FOREIGN LANGUAGE.

FOR LAND VEHICLE PARTS IN THE NATURE OF WIRE HARNESSSES, NAMELY, WIRES, TERMINALS AND CONNECTORS BUNDLED TOGETHER TO TRANSMIT ELECTRIC POWER AND SIGNALS TO ELECTRIC OR ELECTRONIC EQUIPMENT MOUNTED ON THE BODY PARTS OF AUTOMOBILES (U.S. CLS. 19, 21, 23, 31, 35 AND 44).

FIRST USE 7-7-2009; IN COMMERCE 7-7-2009.

DAVID TAYLOR, EXAMINING ATTORNEY

**CLASS 12—(Continued).**

SN 85-052,502. TSM CO. LTD., TOKYO, JAPAN, FILED 6-2-2010.



THE MARK CONSISTS OF STYLIZED LETTERS "ST" FOLLOWED BY A CHECKED FLAG DESIGN.

FOR LAND VEHICLE PARTS, NAMELY, WHEELS; VEHICLE WHEEL RIMS; VEHICLE WHEEL RIMS AND STRUCTURAL PARTS THEREFOR; VEHICLE WHEELS; WHEEL RIMS; WHEEL RIMS FOR MOTOR CARS (U.S. CLS. 19, 21, 23, 31, 35 AND 44).

KAREN BRACEY, EXAMINING ATTORNEY

SN 85-060,495. RAYTHEON COMPANY, TA RTN, WALTHAM, MA. FILED 6-11-2010.

# AirLOB

THE MARK CONSISTS OF STANDARD CHARACTERS WITHOUT CLAIM TO ANY PARTICULAR FONT, STYLE, SIZE, OR COLOR.

FOR ROCKET-POWERED APPARATUS FOR LOCOMOTION, NAMELY, PRECISION ORBITAL SOLID ROCKET BOOSTERS IN THE NATURE OF TRANSPORT LAUNCHERS FOR MILITARY AND CIVILIAN USE (U.S. CLS. 19, 21, 23, 31, 35 AND 44).

GINA FINK, EXAMINING ATTORNEY

SN 85-060,680. RAYTHEON COMPANY, TA RTN, WALTHAM, MA. FILED 6-11-2010.



THE COLOR(S) RED, WHITE, AND LIGHT SKY BLUE IS/ARE CLAIMED AS A FEATURE OF THE MARK.

THE MARK CONSISTS OF A SOLID LIGHT SKY BLUE SPHERE IN THE BACKGROUND WITH A LIGHT SKY BLUE LINE DEPICTING AN OBLONG SHAPE DRAWN

**CLASS 12—(Continued).**

DIAGONALLY AROUND THE SPHERE FROM JUST BELOW THE SPHERE TO THE UPPER RIGHT HAND CORNER OF THE MARK AND THEN BACK DOWN BEHIND THE SPHERE AND DOWN TO THE LOWER LEFT HAND CORNER OF THE MARK AND BACK UP THROUGH THE MIDDLE OF THE SPHERE. THE WORD "AIRLOB" APPEARS IN RED LETTERING IN THE FOREGROUND CENTERED ON THE SPHERE. THERE IS A SMALL WHITE ISOSCELES BULLET-SHAPED TRIANGLE ABOVE THE "L" IN THE WORD MARK AND A SMALL DOWNWARD-POINTING RED PLUME SHAPE UNDERNEATH THE "L" IN THE WORD MARK WHICH EXTENDS UP OUT OF THE LOWER PORTION OF THE DIAGONAL OBLONG LINE SO THAT THE "L" AND THE FEATURES IMMEDIATELY ABOVE AND BELOW THE "L" FIGURATIVELY SUGGEST A ROCKET.

FOR ROCKET-POWERED APPARATUS FOR LOCOMOTION, NAMELY, PRECISION ORBITAL SOLID ROCKET BOOSTERS IN THE NATURE OF TRANSPORT LAUNCHERS FOR MILITARY AND CIVILIAN USE (U.S. CLS. 19, 21, 23, 31, 35 AND 44).

GINA FINK, EXAMINING ATTORNEY

SN 85-063,125. BIKEFORCE INTERNATIONAL CO.,LTD., TAICHUNG CITY, TAIWAN, FILED 6-15-2010.

# MORTOP

THE MARK CONSISTS OF THE STYLIZED WORDING "MORTOP" WITH THE FIRST LETTER "O" ATTACHED TO THE LETTER "T" AND THE SECOND LETTER "O" ATTACHED TO THE LETTER "P".

FOR BICYCLE BELLS; BICYCLE BRAKES; BICYCLE FRAMES; BICYCLE HANDLEBAR GRIPS; BICYCLE SADDLES; BICYCLE SEAT POSTS; BICYCLE STANDS; BICYCLE WHEELS, RIMS AND STRUCTURAL PARTS THEREFOR; HANDLEBARS; INNER TUBES FOR BICYCLES; RIMS FOR BICYCLE WHEELS; SPOKES FOR BICYCLE WHEELS; TIRES (U.S. CLS. 19, 21, 23, 31, 35 AND 44).

FIRST USE 8-1-2008; IN COMMERCE 12-20-2009.

GENE MACIOL, EXAMINING ATTORNEY

**CLASS 12—(Continued).**

SN 85-067,801. SANGSIN BRAKE CO.,LTD., DAEGU, REPUBLIC OF KOREA, FILED 6-21-2010.

# HARDRON

THE MARK CONSISTS OF STANDARD CHARACTERS WITHOUT CLAIM TO ANY PARTICULAR FONT, STYLE, SIZE, OR COLOR.

FOR CARTS; BICYCLES; SPORTING CARS; BUS; TRUCKS; PASSENGER CARS (AUTOMOBILES); ELECTRIC LOCOMOTIVES; AEROPLANES; FISHING BOATS; BRAKE LININGS FOR VEHICLES; BRAKE PADS FOR VEHICLES; BRAKE SHOES ASSEMBLY FOR VEHICLES; HAND BRAKE SHOES ASSEMBLY FOR VEHICLES; BRAKE BRACKET ASSEMBLY FOR VEHICLES; BRAKES FOR AUTOMOBILES; PLASTIC PARTS FOR VEHICLES, NAMELY, EXTERIOR DECORATIVE SIDE TRIM FOR LAND VEHICLES; BLOCK BRAKES FOR VEHICLES; CONICAL BRAKES FOR VEHICLES; BRAKE FORKS FOR VEHICLES; DISK BRAKES FOR LAND VEHICLES; BAND BRAKES FOR VEHICLES; RUBBER TRANSMISSION BELTS FOR LAND VEHICLES; DRIVING CHAINS FOR LAND VEHICLES; ROLLER CHAINS FOR LAND VEHICLES; CLUTCHES FOR LAND VEHICLES; LEATHER SEAT BELTS FOR LAND VEHICLES; WINDSHIELD WIPERS FOR LAND VEHICLES; POWER TRANSMISSION BELT FOR AUTOMOBILE; SEAT COVERS FOR AUTOMOBILES; SAFETY SEATS FOR CHILDREN (FOR AUTOMOBILE); SEATS FOR AUTOMOBILE (U.S. CLS. 19, 21, 23, 31, 35 AND 44).

KHANH LE, EXAMINING ATTORNEY

SN 85-075,052. DONOVAN MARINE, INC., HARAHAN, LA. FILED 6-30-2010.

## TOUGH GUY PREMIER

THE MARK CONSISTS OF STANDARD CHARACTERS WITHOUT CLAIM TO ANY PARTICULAR FONT, STYLE, SIZE, OR COLOR.

NO CLAIM IS MADE TO THE EXCLUSIVE RIGHT TO USE "PREMIER", APART FROM THE MARK AS SHOWN. FOR TRAILER PARTS (U.S. CLS. 19, 21, 23, 31, 35 AND 44).

FIRST USE 11-1-2007; IN COMMERCE 11-1-2007. FRANK LATTUCA, EXAMINING ATTORNEY

**CLASS 12—(Continued).**

SN 85-075,983. FLAMING RIVER INDUSTRIES, INC., BE-REA, OH. FILED 7-1-2010.

## STEERING YOU IN THE RIGHT DIRECTION

THE MARK CONSISTS OF STANDARD CHARACTERS WITHOUT CLAIM TO ANY PARTICULAR FONT, STYLE, SIZE, OR COLOR.

FOR AUTOMOTIVE COMPONENTS AND PARTS, NAMELY, UNIVERSAL JOINTS, RACK AND PINION STEERING ASSEMBLIES, STEERING COLUMNS, AND STEERING WHEELS (U.S. CLS. 19, 21, 23, 31, 35 AND 44).

JEFF DEFORD, EXAMINING ATTORNEY

SN 85-080,732. INNOVATIVE VEHICLE SOLUTIONS, LLC, MADISON HEIGHTS, MI. FILED 7-8-2010.

# Havoc

THE MARK CONSISTS OF STANDARD CHARACTERS WITHOUT CLAIM TO ANY PARTICULAR FONT, STYLE, SIZE, OR COLOR.

FOR PLASTIC PARTS FOR VEHICLES, NAMELY, AUTOMOTIVE EXTERIOR AND INTERIOR PLASTIC EXTRUDED DECORATIVE AND PROTECTIVE TRIM (U.S. CLS. 19, 21, 23, 31, 35 AND 44).

FIRST USE 11-2-2009; IN COMMERCE 11-2-2009. MARK PILARO, EXAMINING ATTORNEY

SN 85-083,252. SOLIS, RODOLFO, PHARR, TX. FILED 7-13-2010.



THE NAME SHOWN IN THE MARK DOES NOT IDENTIFY A PARTICULAR LIVING INDIVIDUAL.

THE MARK CONSISTS OF AN OVAL OUTLINED IN BLACK WITH THE STYLIZED WORD "STHEBSON" IN BLACK IN THE CENTER OF OVAL.

THE WORDING "STHEBSON" HAS NO MEANING IN A FOREIGN LANGUAGE.

FOR STEERING AND SUSPENSION SYSTEMS AND PARTS FOR STEERING AND SUSPENSION SYSTEMS FOR VEHICLES, NAMELY, BUSHING KITS, INNER TIE ROD ENDS, OUTER TIE ROD ENDS, SLEEVES; AUTOMOTIVE ENGINE MOUNTS (U.S. CLS. 19, 21, 23, 31, 35 AND 44).

FIRST USE 1-23-2007; IN COMMERCE 1-23-2007. JIM RINGLE, EXAMINING ATTORNEY

**CLASS 12—(Continued).**

SN 85-101,273. PT INSERASENA, SIDOARJO, INDONESIA,  
FILED 8-5-2010.

**POLYGON**

THE MARK CONSISTS OF A STYLIZED BOLD-FACED FONT WITH AN OUTLINE AROUND EACH LETTER TO FORM THE WORD "POLYGON".

FOR RACING BICYCLES; BICYCLES WITHOUT MOTORS; ELECTRIC MOTOR BICYCLES; AND BICYCLES PARTS AND COMPONENTS, NAMELY, FRAMES, FORKS AND SUSPENSIONS, HANDLEBARS, HANDLE STEMS, SADDLES AND SEAT POSTS (U.S. CLS. 19, 21, 23, 31, 35 AND 44).

STEPHANIE ALI, EXAMINING ATTORNEY

**CLASS 12—(Continued).**

SN 85-106,887. DAGOSTINO, GIOVANNI, WESTON, FL.  
FILED 8-13-2010.

**AG BICYCLES**

THE MARK CONSISTS OF STANDARD CHARACTERS WITHOUT CLAIM TO ANY PARTICULAR FONT, STYLE, SIZE, OR COLOR.

OWNER OF U.S. REG. NOS. 3,607,325 AND 3,613,578.

NO CLAIM IS MADE TO THE EXCLUSIVE RIGHT TO USE "BICYCLES", APART FROM THE MARK AS SHOWN.

FOR BICYCLE RACKS FOR VEHICLES; BICYCLE SADDLE COVERS; BICYCLE SADDLES; BICYCLE SEAT POSTS; BICYCLE STANDS; BICYCLE TAGS; BICYCLE TRAINING HARNESSSES; BICYCLE TRAINING WHEELS; BICYCLE WATER BOTTLE CAGES; BICYCLE WHEELS; BICYCLE WHEELS, RIMS AND STRUCTURAL PARTS THEREFOR; BICYCLE-MOUNTED PET SEAT; BICYCLES; CELL PHONE CASES ADAPTED FOR BICYCLES; COMPONENTS FOR BICYCLES, NAMELY, HEADSETS WHICH PROVIDE A ROTATABLE INTERFACE BETWEEN THE BICYCLE FORK AND THE BICYCLE FRAME; DELIVERY BICYCLES; ELASTOMERIC APPLIQUES FOR PLACEMENT ONTO MOTORCYCLES, ALL-TERRAIN VEHICLES, AND BICYCLES TO PREVENT RIDERS FROM SLIPPING; FITTED BICYCLE COVERS; FRAMES FOR BICYCLES; FRAMES, FOR LUGGAGE CARRIERS, FOR BICYCLES; FRONT AND REAR BICYCLE RACK PACKS; HANDLEBARS FOR BICYCLES; INNER TUBES FOR BICYCLES; MECHANICAL SOUND-MAKING DEVICES THAT ARE MOUNTED ON THE FORKS OF A BICYCLE TO PRODUCE MOTORCYCLE-LIKE SOUNDS AS THE BICYCLE MOVES; MOTORS FOR BICYCLES; MOUNTAIN BICYCLES; MUDGUARDS FOR BICYCLES; PANNIER BAGS FOR BICYCLES; RACING BICYCLES; RIMS FOR BICYCLE WHEELS; ROAD RACING BICYCLES; SADDLE COVERS FOR BICYCLES; SADDLEBAGS FOR BICYCLES; SADDLES FOR BICYCLES; SAFETY PADS FOR BICYCLES; SPOKE CLIPS FOR BICYCLE WHEELS; SPOKES FOR BICYCLE WHEELS; STRUCTURAL PARTS OF BICYCLES; TANDEM BICYCLES; TIRE INFLATORS FOR BICYCLES; TIRES FOR CHILDREN'S BICYCLES; TOURING BICYCLES; VELOMOBILE BODIES, NAMELY, SPECIALLY ADAPTED FOR WEATHER PROTECTION SHELLS FOR USE ON BICYCLES AND ADULT TRICYCLES; WATER BOTTLE CAGES FOR BICYCLES; WATER BOTTLE HOLDERS FOR BICYCLES; WHEEL HUBS FOR BICYCLES; WHEEL RIMS FOR BICYCLES; WHEELS FOR BICYCLES (U.S. CLS. 19, 21, 23, 31, 35 AND 44).

TARA PATE, EXAMINING ATTORNEY

SN 85-102,759. HUGE RAINBOW INTERNATIONAL INC.,  
TAIPEI COUNTY, TAIWAN, FILED 8-9-2010.

**KILIN**

THE MARK CONSISTS OF STANDARD CHARACTERS WITHOUT CLAIM TO ANY PARTICULAR FONT, STYLE, SIZE, OR COLOR.

THE WORD "KILIN" IN THE MARK HAS NO PARTICULAR ENGLISH TRANSLATION BUT INSTEAD IDENTIFIES A LEGENDARY CREATURE FROM CHINESE MYTHOLOGY.

FOR TIRES FOR VEHICLES (U.S. CLS. 19, 21, 23, 31, 35 AND 44).

FIRST USE 8-9-2010; IN COMMERCE 8-9-2010.  
STEVEN PEREZ, EXAMINING ATTORNEY

**CLASS 12—(Continued).**

SN 85-106,907. DAGOSTINO, GIOVANNI, WESTON, FL.  
FILED 8-13-2010.



OWNER OF U.S. REG. NOS. 3,607,325 AND 3,613,578.  
THE COLOR(S) GREEN, BLACK AND WHITE IS/ARE  
CLAIMED AS A FEATURE OF THE MARK.

THE MARK CONSISTS OF A BLACK CIRCLE WITH  
WHITE OUTLINES CONTAINING A GREEN CIRCLE WITH  
A WHITE BAR ACROSS THE MIDDLE, CONTAINING THE  
LETTERS "A" AND "G" IN BLACK WITH A WHITE OUT-  
LINE AND WITH THE LETTER "A" INSIDE THE LETTER  
"G".

FOR AIR PUMPS OF TWO-WHEELED MOTOR VEHI-  
CLES OR BICYCLES; BASKETS ADAPTED FOR BI-  
CYCLES; BICYCLE BELLS; BICYCLE BRAKES;  
BICYCLE CHAINS; BICYCLE FRAMES; BICYCLE  
FRAMES AND BICYCLE HANDLEBAR GRIPS; BI-  
CYCLE GEARS; BICYCLE GRIP TAPE; BICYCLE HAN-  
DLEBAR GRIPS; BICYCLE HORNS; BICYCLE  
KICKSTANDS; BICYCLE PARTS, NAMELY, BRAKE  
SHOES; BICYCLE PARTS, NAMELY, CHANGE-SPEED  
GEARS; BICYCLE PARTS, NAMELY, DISK WHEELS;  
BICYCLE PARTS, NAMELY, DRIVE CHAINS; BICYCLE  
PARTS, NAMELY, DRIVE TRAINS; BICYCLE PARTS,  
NAMELY, FORK CROWN COVERS; BICYCLE PARTS,  
NAMELY, FORKS; BICYCLE PARTS, NAMELY, FRONT  
FORK JOINTS; BICYCLE PARTS, NAMELY, GEAR  
WHEELS; BICYCLE PARTS, NAMELY, HANDLE BAR  
ENDS; BICYCLE PARTS, NAMELY, HANDLE BAR  
STEMS; BICYCLE PARTS, NAMELY, SPROCKETS; BI-  
CYCLE PARTS, NAMELY, TUBES AND CONNECTORS  
FOR BICYCLE FRAMES; BICYCLE PEDALS; BICYCLE  
PUMPS; BICYCLE RACKS FOR VEHICLES; BICYCLE  
SADDLE COVERS; BICYCLE SADDLES; BICYCLE SEAT  
POSTS; BICYCLE STANDS; BICYCLE TAGS; BICYCLE  
TRAINING HARNESES; BICYCLE TRAINING  
WHEELS; BICYCLE WATER BOTTLE CAGES; BICYCLE  
WHEELS; BICYCLE WHEELS, RIMS AND STRUCTUR-  
AL PARTS THEREFOR; BICYCLE-MOUNTED PET  
SEAT; BICYCLES; CELL PHONE CASES ADAPTED  
FOR BICYCLES; COMPONENTS FOR BICYCLES,  
NAMELY, HEADSETS WHICH PROVIDE A ROTATA-  
BLE INTERFACE BETWEEN THE BICYCLE FORK AND  
THE BICYCLE FRAME; DELIVERY BICYCLES; ELAS-  
TOMERIC APPLIQUES FOR PLACEMENT ONTO MO-  
TORCYCLES, ALL-TERRAIN VEHICLES, AND  
BICYCLES TO PREVENT RIDERS FROM SLIPPING;  
FITTED BICYCLE COVERS; FRAMES FOR BICYCLES;  
FRAMES, FOR LUGGAGE CARRIERS, FOR BICYCLES;  
FRONT AND REAR BICYCLE RACK PACKS; GEAR  
LEVERS FOR BICYCLE WHEELS; HANDLEBARS; IN-

**CLASS 12—(Continued).**

NER TUBES; INNER TUBES FOR BICYCLES; MECHAN-  
ICAL SOUND-MAKING DEVICES THAT ARE  
MOUNTED ON THE FORKS OF A BICYCLE TO PRO-  
DUCE MOTORCYCLE-LIKE SOUNDS AS THE BICYCLE  
MOVES; MOTORS FOR BICYCLES; MOUNTAIN BI-  
CYCLES; MUDGUARDS; PANNIER BAGS FOR BI-  
CYCLES; RACING BICYCLES; RIMS FOR BICYCLE  
WHEELS; ROAD RACING BICYCLES; SADDLE COVERS  
FOR BICYCLES; SADDLEBAGS FOR BICYCLES; SAD-  
DLES FOR BICYCLES; SAFETY PADS FOR BICYCLES;  
SPOKE CLIPS FOR BICYCLE WHEELS; SPOKES FOR  
BICYCLE WHEELS; STRUCTURAL PARTS OF BI-  
CYCLES; TANDEM BICYCLES; TIRE INFLATORS;  
TIRES; TIRES FOR CHILDREN'S BICYCLES; TOURING  
BICYCLES; VELOMOBILE BODIES, NAMELY, SPE-  
CIALLY ADAPTED FOR WEATHER PROTECTION  
SHELLS FOR USE ON BICYCLES AND ADULT TRI-  
CYCLES; WATER BOTTLE CAGES FOR BICYCLES;  
WATER BOTTLE HOLDERS FOR BICYCLES; WHEEL  
HUBS; WHEEL RIMS; WHEELS FOR BICYCLES, CY-  
CLES (U.S. CLS. 19, 21, 23, 31, 35 AND 44).

TARA PATE, EXAMINING ATTORNEY

SN 85-139,831. WATARU KATO, OWARIASAH, JAPAN,  
FILED 9-28-2010.



THE MARK CONSISTS OF THE LETTERS "LB" ENCASED  
IN A DIAMOND POSITIONED ABOVE THE PHRASE "LB  
PERFORMANCE", WITH A STAR REPLACING THE "O" IN  
"PERFORMANCE".

FOR AUTOMOBILE AERO PARTS, NAMELY, FRONT  
BUMPER SPOILERS, REAR BUMPER SPOILERS, REAR  
WINGS, AND SIDE SKIRTS (U.S. CLS. 19, 21, 23, 31, 35  
AND 44).

FIRST USE 2-1-2008; IN COMMERCE 2-1-2008.

KATHLEEN LORENZO, EXAMINING ATTORNEY

SN 85-163,632. FISHER AUTOMOTIVE, INC., IRVINE, CA.  
FILED 10-28-2010.

**EVER**

THE MARK CONSISTS OF STANDARD CHARACTERS  
WITHOUT CLAIM TO ANY PARTICULAR FONT, STYLE,  
SIZE, OR COLOR.

FOR ELECTRIC VEHICLES, NAMELY, CARS (U.S.  
CLS. 19, 21, 23, 31, 35 AND 44).

TRACY CROSS, EXAMINING ATTORNEY

**CLASS 12—(Continued).**

SN 85-170,221. YUGEN KAISHA N AND N, SUITA-SHI, OSAKA-FU, JAPAN, FILED 11-5-2010.



NO CLAIM IS MADE TO THE EXCLUSIVE RIGHT TO USE "RACING", APART FROM THE MARK AS SHOWN.

THE MARK CONSISTS OF SEVEN SOLID DOTS ARRANGED IN A CIRCLE ABOVE THE STYLIZED WORDING "HOKUTO" WHICH IS ABOVE THE STYLIZED WORDING "RACING".

THE ENGLISH TRANSLATION OF THE WORD "HOKUTO" IN THE MARK IS "THE GREAT DIPPER".

FOR AUTOMOBILE PARTS, NAMELY, WHEELS, AERODYNAMIC SPOILERS, STEERING WHEELS, SEATS, SEAT COVERS, SEAT BELTS, GEAR STICK KNOBS, REARVIEW MIRRORS, AND PEDAL COVERS (U.S. CLS. 19, 21, 23, 31, 35 AND 44).

LAKEISHA LEWIS, EXAMINING ATTORNEY

SN 85-174,206. ARON & ASSOCIATES, DEERFIELD BEACH, FL. FILED 11-11-2010.

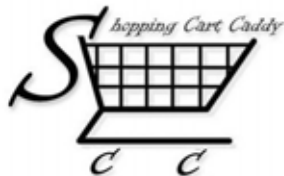

NO CLAIM IS MADE TO THE EXCLUSIVE RIGHT TO USE "SHOPPING CART CADDY", APART FROM THE MARK AS SHOWN.

THE MARK CONSISTS OF A DEPICTION OF A SIDE VIEW OF A SHOPPING CART WITH AN OVER-SIZED STYLIZED "S" IN FRONT OF THE CART FOLLOWED BY THE TEXT "SHOPPING CART CADDY" ABOVE THE CART, AND A PAIR OF STYLIZED "C"'S REPRESENTING THE TWO WHEELS ALONG THE BOTTOM OF THE CART.

FOR SHOPPING CART TRAY FOR ATTACHMENT TO A SHOPPING CART FOR HOLDING PERSONAL EFFECTS WHILE SHOPPING (U.S. CLS. 19, 21, 23, 31, 35 AND 44).

LESLEY LAMOTHE, EXAMINING ATTORNEY

**CLASS 12—(Continued).**

SN 85-184,800. ALL AMERICAN GROUP, INC., ELKHART, IN. FILED 11-24-2010.



THE MARK CONSISTS OF A CIRCLE WITH A TRIANGULAR DESIGN.

FOR RECREATIONAL VEHICLES, NAMELY, MOTOR HOMES, MINI-MOTOR HOMES, TOWABLE TRAILERS, FIFTH WHEELS, FOLDING TOWABLE TRAILERS, TRAVEL TRAILERS AND TRUCK CAMPERS (U.S. CLS. 19, 21, 23, 31, 35 AND 44).

JASON TURNER, EXAMINING ATTORNEY

SN 85-185,480. LEVIN, CAROLYN B., DBA BACKSEAT GENERATION LLC, BOUND BROOK, NJ. FILED 11-26-2010.



NO CLAIM IS MADE TO THE EXCLUSIVE RIGHT TO USE "TUSHIE", APART FROM THE MARK AS SHOWN.

THE COLOR(S) ORANGE, BROWN, TAN, LIGHT BLUE, WHITE AND BLACK IS/ARE CLAIMED AS A FEATURE OF THE MARK.

THE MARK CONSISTS OF A DESIGN OF A TURTLE WITH A PLAID PATTERNED SHELL CONSISTING OF FOUR LIGHT BLUE DIAMOND SHAPES, FOUR TAN DIAMOND SHAPES, AND THE REMAINING DIAMOND SHAPES ARE IN BROWN AND ALL OF WHICH ARE OUTLINED IN WHITE. THE SAME TURTLE HAS ORANGE LEGS, AN ORANGE TAIL AND AN ORANGE NECK AND HEAD WITH WHITE AND BLACK EYES. UNDERNEATH OF THE TURTLE DESIGN IS THE WORDING "TUSHIE TURTLE" IN BROWN FOLLOWED IMMEDIATELY UNDERNEATH BY THE WORDING "GOT IT COVERED" IN BROWN.

FOR COVERS FOR BABY STROLLERS; COVERS FOR CHILDREN'S CAR SEATS; WHEELCHAIR PADS (U.S. CLS. 19, 21, 23, 31, 35 AND 44).

HAI-LY LAM, EXAMINING ATTORNEY



**CLASS 12—(Continued).**

SN 85-185,622. CHL AUTO PARTS CO., LTD., HSINCHU COUNTY, TAIWAN, FILED 11-27-2010.



THE MARK CONSISTS OF A FIRST UPPER CASE LETTER "P" PARTIALLY OVERLAPPING A SECOND UPPER CASE LETTER "P" WITH THE LETTERS "URE" ADJACENT A LEG OF THE FIRST UPPER CASE LETTER "P" AND THE LETTERS "OLY" ADJACENT A LEG OF THE SECOND UPPER CASE LETTER "P".

FOR LAND VEHICLES AND PARTS THEREOF, NAMELY, PLASTIC BUMPER, PLASTIC GRILLE, PLASTIC STEP PAD, BODIES FOR VEHICLES AND BUMPER STRIP, SPOILER/VALANCE/AIR DEFLECTOR, FOG LAMP COVER, FENDER TRIM MOLDING/WHEEL OPENING MOLDING, BUMPER BRACKET, BUMPER SKID PLATE, LICENSE PLATE BRACKET, BUMPER GRILLE, FENDER TRIM FLARE/WHEEL OPENING FLARE, TOW HOOK OPENING COVER, GRILLE MOUNTING PANEL, FAN SHROUD, PLASTIC FENDER, INNER FENDER, PLASTIC HOODS FOR VEHICLES, RADIATOR SUPPORT, HEADLAMP MOUNTING BRACKET; PLASTIC PARTS FOR VEHICLES, NAMELY, AUTOMOTIVE EXTERIOR AND INTERIOR PLASTIC EXTRUDED DECORATIVE AND PROTECTIVE TRIM (U.S. CLS. 19, 21, 23, 31, 35 AND 44).

FIRST USE 3-1-2010; IN COMMERCE 4-1-2010.  
ALEXANDER L. POWERS, EXAMINING ATTORNEY

SN 85-185,635. HUANG, STEPHEN, TAICHUNG COUNTY, TAIWAN, FILED 11-27-2010.



NO CLAIM IS MADE TO THE EXCLUSIVE RIGHT TO USE "CYCLING", APART FROM THE MARK AS SHOWN. THE MARK CONSISTS OF THE STYLIZED LETTER "S" OVERLYING AN OVAL CONTOUR ABOVE THE STYLIZED WORD "CYCLING", ALL ABOVE THE STYLIZED WORD "STEP".

FOR BICYCLE AND BICYCLE PARTS AND ACCESSORIES, NAMELY, BICYCLE FRAME, FOLDING BIKE, BICYCLE FORK, BICYCLE SEATPOST, BICYCLE STEM, BICYCLE RIM, BICYCLE WHEEL, BICYCLE HUB, BICYCLE CRANK; MOTORCYCLE PARTS AND ACCESSORIES, NAMELY, MOTORCYCLE BRAKES, MOTORCYCLE WHEEL, MOTORCYCLE HUB, MOTORCYCLE SHOCK ABSORBERS, MOTORCYCLE CLUTCH BRAKE LEVER, MOTORCYCLE RIM LOCKING NUTS (U.S. CLS. 19, 21, 23, 31, 35 AND 44).

FIRST USE 8-13-2009; IN COMMERCE 8-13-2009.  
BRIAN CALLAGHAN, EXAMINING ATTORNEY

**CLASS 12—(Continued).**

SN 85-186,589. WATSON PRODUCTIONS, HAUPPAUGE, NY, FILED 11-29-2010.



OWNER OF U.S. REG. NO. 3,876,721.  
THE MARK CONSISTS OF A FEW PARALLEL LINES NEXT TO AN "A" SHOWN IN A PIECE OF LUGGAGE NEXT TO "LAGATECARTE".

FOR MOBILE CART OR KIOSK FOR THE SALE OF ITEMS INCLUDING DUTY-FREE GOODS AND NON-DUTY FREE GOODS (U.S. CLS. 19, 21, 23, 31, 35 AND 44).  
FIRST USE 2-15-2010; IN COMMERCE 2-15-2010.  
WENDY GOODMAN, EXAMINING ATTORNEY

SN 85-186,700. POWERSPORTS GROUP, INC., DBA JP MARINE, CHULA VISTA, CA. AND PALMER, JOSHUA, CHULA VISTA, CA. FILED 11-29-2010.



NO CLAIM IS MADE TO THE EXCLUSIVE RIGHT TO USE "MARINE", APART FROM THE MARK AS SHOWN. THE MARK CONSISTS OF THE LETTERS "JP" CONTAINING THE WORD "MARINE".

FOR INFLATABLE BOATS (U.S. CLS. 19, 21, 23, 31, 35 AND 44).  
FIRST USE 8-1-2010; IN COMMERCE 8-1-2010.  
ROBIN CHOSID, EXAMINING ATTORNEY

SN 85-187,995. STOMPERTECH INDUSTRIES, INC., CLEARWATER, MN. FILED 12-1-2010.

# Stompertech

THE MARK CONSISTS OF STANDARD CHARACTERS WITHOUT CLAIM TO ANY PARTICULAR FONT, STYLE, SIZE, OR COLOR.

FOR ALL-TERRAIN VEHICLES, CAMPERS, RECREATIONAL WATERCRAFT, NAMELY, MOTORIZED VESSELS EQUIPPED TO PROVIDE ICE FISHING HOUSING, LAND VEHICLES SPECIFICALLY AFFIXED WITH DEER STANDS, OFF ROAD CAMPERS, TRAILERS, LAND VEHICLES FOR HUNTING, ATV TRAILERS, AND RECREATIONAL VEHICLE PARTS AND ACCESSORIES, NAMELY, SCISSOR LIFTS THAT ARE SPECIFICALLY MOUNTED TO LAND VEHICLES TO LIFT OUTDOOR EQUIPMENT, TRAILER FRAMES THAT ARE SPECIFICALLY DESIGNED TO MOUNT TO LAND VEHICLES TO HAUL EQUIPMENT, AND PULL OUT CANOPIES SPECIFICALLY DESIGNED TO AFFIX TO LAND VEHICLES (U.S. CLS. 19, 21, 23, 31, 35 AND 44).

JUDITH HELFMAN, EXAMINING ATTORNEY

**CLASS 12—(Continued).**

SN 85-188,319. DE POEL JR., HAIKO, JAMAICA ESTATES, NY. FILED 12-1-2010.

# ÜBERPLÄTE

THE ENGLISH TRANSLATION OF "UBER" IN THE MARK IS TRANSLATES INTO ENGLISH AS "OVER", "ABOVE" OR "SUPER".

FOR LICENSE PLATE FRAMES; LICENSE PLATE HOLDERS (U.S. CLS. 19, 21, 23, 31, 35 AND 44).  
KATHERINE CHANG, EXAMINING ATTORNEY

SN 85-189,070. BLENCH, ROBIN, OCEANSIDE, CA. FILED 12-2-2010.

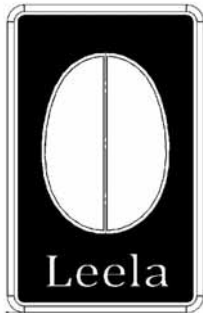

THE MARK CONSISTS OF THE STYLIZED WORD "LEELA" AND A BISECTED OVAL INSIDE A RECTANGLE WITH ROUNDED CORNERS.

FOR AUTOMOBILES (U.S. CLS. 19, 21, 23, 31, 35 AND 44).  
ADA HAN, EXAMINING ATTORNEY

SN 85-189,383. RYCA MOTORS, WHITTIER, CA. FILED 12-2-2010.

# RYCA

THE MARK CONSISTS OF THE WORD "RYCA" PRINTED IN A STYLIZED FONT AND HAVING THE LETTER R'S RIGHT LEG ATTACHED TO THE LETTER A'S RIGHT LEG.

FOR MOTORCYCLES; MOTORCYCLES AND STRUCTURAL PARTS THEREFOR (U.S. CLS. 19, 21, 23, 31, 35 AND 44).

FIRST USE 2-1-2009; IN COMMERCE 9-1-2009.  
SUSAN STIGLITZ, EXAMINING ATTORNEY

**CLASS 12—(Continued).**

SN 85-189,720. DIAMOND E ENTERPRISES, LLC, NEW PLYMOUTH, ID. FILED 12-2-2010.

# PaxRite

THE MARK CONSISTS OF STANDARD CHARACTERS WITHOUT CLAIM TO ANY PARTICULAR FONT, STYLE, SIZE, OR COLOR.

FOR STEEL CARGO CARRIER FOR UTILITY TERRAIN VEHICLE (U.S. CLS. 19, 21, 23, 31, 35 AND 44).  
SUNG IN, EXAMINING ATTORNEY

SN 85-189,779. CARSTACHE LLC, DBA CARSTACHE, SAN FRANCISCO, CA. FILED 12-2-2010.

# BIKESTACHE

THE MARK CONSISTS OF STANDARD CHARACTERS WITHOUT CLAIM TO ANY PARTICULAR FONT, STYLE, SIZE, OR COLOR.

OWNER OF U.S. REG. NOS. 3,860,260 AND 3,863,358.  
FOR ORNAMENTAL NOVELTY ITEMS SPECIALLY ADAPTED FOR BICYCLES AND MOTORCYCLES, NAMELY, PLUSH FABRIC MUSTACHES THAT ATTACH TO THE HANDLEBARS OF BICYCLES AND MOTORCYCLES (U.S. CLS. 19, 21, 23, 31, 35 AND 44).  
FIRST USE 11-7-2009; IN COMMERCE 12-1-2010.  
RUSS HERMAN, EXAMINING ATTORNEY

SN 85-192,030. ROCKYMOUNTS, INC., BOULDER, CO. FILED 12-7-2010.

# rockymounts

THE MARK CONSISTS OF THE WORDS "ROCKY-MOUNTS" IN STYLIZED FORM.

FOR RACKS FOR VEHICLES FOR BICYCLES (U.S. CLS. 19, 21, 23, 31, 35 AND 44).

FIRST USE 1-1-1993; IN COMMERCE 1-1-1993.

MARGERY A. TIERNEY, EXAMINING ATTORNEY

**CLASS 12—(Continued).**

SN 85-192,771. GLOBAL HOUSE OF TRIMS, DBA RETRO-SPEC CYCLING CLUB, LOS ANGELES, CA. FILED S.R. 12-8-2010; AM. P.R. 3-14-2011.

# RETROSPEC

THE MARK CONSISTS OF STANDARD CHARACTERS WITHOUT CLAIM TO ANY PARTICULAR FONT, STYLE, SIZE, OR COLOR.

FOR BICYCLE FRAMES AND BICYCLE HANDLEBAR GRIPS; BICYCLE PARTS, NAMELY, SADDLES, RIM TAPE, HANDLEBAR TAPE, BICYCLE STEM, CASSETTES, FREEWHEELS, BOTTOM BRACKETS, CRANKSETS, FENDERS, SPOKES, BRAKES, TIRES AND INNER TUBES THEREFORE, TOE CLIPS, CHAIN STAYS, HANDLE BARS, FORKS, AND SUSPENSIONS; BICYCLE WHEELS, RIMS AND STRUCTURAL PARTS THEREFOR; BICYCLES (U.S. CLS. 19, 21, 23, 31, 35 AND 44).

FIRST USE 8-10-2009; IN COMMERCE 12-10-2009.  
KATHLEEN M. VANSTON, EXAMINING ATTORNEY

**CLASS 12—(Continued).**

SN 85-197,793. SD WHEELS LLC, IRVINE, CA. FILED 12-14-2010.



THE COLOR(S) WHITE, BLACK, BROWN AND RED IS/ ARE CLAIMED AS A FEATURE OF THE MARK.

THE MARK CONSISTS OF A BLACK BACKGROUND WITH BROWN PAINT SPLOTCHES AROUND THE ENTIRE EDGE OF THE MARK. IN THE MIDDLE APPEARS THE WORDING "DIRT" IN STYLIZED RED FONT WITH WHITE OUTLINES. THE LETTERS IN THE "DIRT" WORDING APPEAR AS ALL CAPITAL LETTERS.

FOR CUSTOMIZED WHEELS FOR CARS AND TRUCKS (U.S. CLS. 19, 21, 23, 31, 35 AND 44).

DEIRDRE ROBERTSON, EXAMINING ATTORNEY

SN 85-199,927. WATERLOO INDUSTRIES INC., OAK CREEK, WI. FILED 12-16-2010.

# UNI-CART

THE MARK CONSISTS OF STANDARD CHARACTERS WITHOUT CLAIM TO ANY PARTICULAR FONT, STYLE, SIZE, OR COLOR.

OWNER OF U.S. REG. NO. 1,142,446.

FOR HOSPITAL CARTS (U.S. CLS. 19, 21, 23, 31, 35 AND 44).

DAWN HAN, EXAMINING ATTORNEY

SN 85-203,023. REX BIONICS LIMITED, AUCKLAND, NEW ZEALAND, FILED 12-21-2010.

# PREMIER

THE MARK CONSISTS OF STANDARD CHARACTERS WITHOUT CLAIM TO ANY PARTICULAR FONT, STYLE, SIZE, OR COLOR.

OWNER OF U.S. REG. NO. 3,732,084.

FOR FUNERAL VEHICLES, NAMELY, FUNERAL CARS, FUNERAL COACHES, FUNERAL TRUCKS, HEARSES AND FLOWER CARS (U.S. CLS. 19, 21, 23, 31, 35 AND 44).

FIRST USE 6-30-2008; IN COMMERCE 6-30-2008.

JERI J. FICKES, EXAMINING ATTORNEY

# REX

THE MARK CONSISTS OF STANDARD CHARACTERS WITHOUT CLAIM TO ANY PARTICULAR FONT, STYLE, SIZE, OR COLOR.

OWNER OF U.S. REG. NO. 3,727,476.

FOR MOTORIZED, ROBOTIC, SELF-PROPELLED, PERSONAL MOBILITY TRANSPORTATION DEVICES PROVIDING MULTIPLE FUNCTIONS FOR INDIVIDUALS WITH MOBILITY-RELATED NEEDS (U.S. CLS. 19, 21, 23, 31, 35 AND 44).

JESSICA FATHY, EXAMINING ATTORNEY

**CLASS 12—(Continued).**

SN 85-203,639. KODIAK INNOVATIONS, LLC, ROCK HILL, SC. FILED 12-22-2010.

# AIRFLOW

THE MARK CONSISTS OF STANDARD CHARACTERS WITHOUT CLAIM TO ANY PARTICULAR FONT, STYLE, SIZE, OR COLOR.

FOR AERO-DYNAMIC FAIRINGS FOR VEHICLES (U.S. CLS. 19, 21, 23, 31, 35 AND 44).

FIRST USE 6-3-2010; IN COMMERCE 8-15-2010.  
LAKEISHA LEWIS, EXAMINING ATTORNEY

SN 85-204,790. SUMMER INFANT (USA), INC., WOONSOCKET, RI. FILED 12-23-2010.

# UPSTART

THE MARK CONSISTS OF STANDARD CHARACTERS WITHOUT CLAIM TO ANY PARTICULAR FONT, STYLE, SIZE, OR COLOR.

FOR STROLLERS (U.S. CLS. 19, 21, 23, 31, 35 AND 44).  
JUDITH HELFMAN, EXAMINING ATTORNEY

SN 85-206,603. NESTEK MARIN A.S., ISTANBUL, TURKEY, FILED 12-28-2010.



THE MARK CONSISTS OF A PROPELLER WITH THE WORD "DYNOPROP" ACROSS AND TO THE RIGHT OF IT. FOR SHIP PROPELLERS (U.S. CLS. 19, 21, 23, 31, 35 AND 44).

LINDSEY RUBIN, EXAMINING ATTORNEY

**CLASS 12—(Continued).**

SN 85-207,001. POLARIS INDUSTRIES INC., MEDINA, MN. FILED 12-29-2010.

# PROSTAR

THE MARK CONSISTS OF STANDARD CHARACTERS WITHOUT CLAIM TO ANY PARTICULAR FONT, STYLE, SIZE, OR COLOR.

FOR ENGINES FOR RECREATIONAL VEHICLES (U.S. CLS. 19, 21, 23, 31, 35 AND 44).

VIVIAN MICZNIK FIRST, EXAMINING ATTORNEY

SN 85-208,592. MAJERIK, MATTHEW M., WARRIOR, AL. FILED 12-31-2010.



THE COLOR(S) RED IS/ARE CLAIMED AS A FEATURE OF THE MARK.

THE MARK CONSISTS OF A STYLIZED CAPITAL LETTER "E" IN BOLD RED, FOLLOWED BY A STYLIZED CAPITAL LETTER "D" IN BOLD RED, FOLLOWED BY A STYLIZED CAPITAL LETTER "V" IN BOLD RED.

FOR ALL-TERRAIN VEHICLES; BODIES FOR VEHICLES; CARGO CARRIERS FOR VEHICLES; LAND VEHICLES AND STRUCTURAL PARTS THEREFOR; TRUCKS AND STRUCTURAL PARTS THEREFOR; UTVS (UTILITY TERRAIN VEHICLES); VEHICLE BODIES (U.S. CLS. 19, 21, 23, 31, 35 AND 44).

FIRST USE 12-29-2010; IN COMMERCE 12-29-2010.  
RONALD DELGIZZI, EXAMINING ATTORNEY

SN 85-208,644. AJEWOLE, OLUWASHOLA A, SANTA MONICA, CA. FILED 12-31-2010.

# SWAG TAG

THE MARK CONSISTS OF STANDARD CHARACTERS WITHOUT CLAIM TO ANY PARTICULAR FONT, STYLE, SIZE, OR COLOR.

FOR AUTO ACCESSORIES, NAMELY, SIDE MIRROR PROTECTIVE AND VANITY COVERS (U.S. CLS. 19, 21, 23, 31, 35 AND 44).

Laurie Kaufman, Examining Attorney

**CLASS 12—(Continued).**

SN 85-209,152. SUPER SONIC WHEELS (USA) INC., SOUTH EL MONTE, CA. FILED 1-3-2011.

# ARMANO

THE MARK CONSISTS OF STANDARD CHARACTERS WITHOUT CLAIM TO ANY PARTICULAR FONT, STYLE, SIZE, OR COLOR.

OWNER OF U.S. REG. NO. 3,436,995.  
FOR LAND VEHICLE PARTS, NAMELY, WHEELS, WHEEL RIMS, AND WHEEL RIMS FOR MOTORCARS (U.S. CLS. 19, 21, 23, 31, 35 AND 44).  
FIRST USE 10-1-2002; IN COMMERCE 10-1-2002.  
ALEXANDER L. POWERS, EXAMINING ATTORNEY

---

SN 85-210,944. MORPHEUS CYCLES LLC, BRONX, NY. FILED 1-5-2011.

# MORPHEUS

THE MARK CONSISTS OF STANDARD CHARACTERS WITHOUT CLAIM TO ANY PARTICULAR FONT, STYLE, SIZE, OR COLOR.

FOR BICYCLE PARTS, NAMELY, BICYCLE FRAMES, BICYCLE SUSPENSIONS, BICYCLE PUMPS, INNER TUBES, BICYCLE SADDLES, GRIPS, HANDLEBAR PADS, HANDLEBAR TAPE, BRAKE LEVERS, SEAT POSTS, BREAKS AND WATER BOTTLE CAGES (U.S. CLS. 19, 21, 23, 31, 35 AND 44).  
FIRST USE 2-15-2008; IN COMMERCE 1-1-2009.  
GISELLE AGOSTO, EXAMINING ATTORNEY

---

SN 85-211,385. WISSWELL, ROBERT L., POWAY, CA. FILED 1-5-2011.

# TECMATIC

THE MARK CONSISTS OF STANDARD CHARACTERS WITHOUT CLAIM TO ANY PARTICULAR FONT, STYLE, SIZE, OR COLOR.

FOR BICYCLE PARTS, NAMELY, BEARINGS AND BOTTOM BRACKETS (U.S. CLS. 19, 21, 23, 31, 35 AND 44).  
FIRST USE 1-3-2011; IN COMMERCE 1-3-2011.  
BARBARA BROWN, EXAMINING ATTORNEY

**CLASS 12—(Continued).**

SN 85-211,944. FOX FACTORY, INC., WATSONVILLE, CA. FILED 1-6-2011.

# FLOAT Ti

THE MARK CONSISTS OF STANDARD CHARACTERS WITHOUT CLAIM TO ANY PARTICULAR FONT, STYLE, SIZE, OR COLOR.

OWNER OF U.S. REG. NO. 2,464,300.  
NO CLAIM IS MADE TO THE EXCLUSIVE RIGHT TO USE "Ti", APART FROM THE MARK AS SHOWN.  
FOR BICYCLE PARTS, NAMELY, SHOCK ABSORBERS; SUSPENSION SYSTEMS FOR VEHICLES, NAMELY, BICYCLES AND MOTOR VEHICLES; VEHICLE PARTS, NAMELY, SHOCK ABSORBERS; ALL OF THE GOODS LISTED HEREIN BEING COMPRISED IN PART OF TITANIUM (U.S. CLS. 19, 21, 23, 31, 35 AND 44).

BARBARA RUTLAND, EXAMINING ATTORNEY

---

SN 85-216,048. POLARIS INDUSTRIES INC., MEDINA, MN. FILED 1-12-2011.

# PRO-STEEL

THE MARK CONSISTS OF STANDARD CHARACTERS WITHOUT CLAIM TO ANY PARTICULAR FONT, STYLE, SIZE, OR COLOR.

FOR CABS FOR ALL-TERRAIN UTILITY VEHICLES (U.S. CLS. 19, 21, 23, 31, 35 AND 44).  
VIVIAN MICZNIK FIRST, EXAMINING ATTORNEY

---

SN 85-222,921. RADIO FLYER, INC., CHICAGO, IL. FILED 1-21-2011.

# STYLE 'N RIDE

THE MARK CONSISTS OF STANDARD CHARACTERS WITHOUT CLAIM TO ANY PARTICULAR FONT, STYLE, SIZE, OR COLOR.

FOR NON-MOTORIZED SCOOTERS (U.S. CLS. 19, 21, 23, 31, 35 AND 44).  
JOHN DWYER, EXAMINING ATTORNEY

**CLASS 12—(Continued).**

SN 85-228,422. FORD MOTOR COMPANY, DEARBORN, MI.  
FILED 1-28-2011.



NO CLAIM IS MADE TO THE EXCLUSIVE RIGHT TO USE "ELECTRIC", APART FROM THE MARK AS SHOWN. THE COLOR(S) WHITE, GRAY AND GREEN IS/ARE CLAIMED AS A FEATURE OF THE MARK.

THE MARK CONSISTS OF THE WORD "ELECTRIC" IN A GRAY STYLIZED FORMAT THAT INCLUDES WHITE SHADING AS IF LIGHT WERE BEING SHONE ON THE WORD. THE LETTER "E" IS GREEN AND THE OUTLINE OF THE LETTER IS IN THE SHAPE OF A OUTLET PLUG. FOR AUTOMOBILES (U.S. CLS. 19, 21, 23, 31, 35 AND 44).

KEVON CHISOLM, EXAMINING ATTORNEY

SN 85-238,292. RADIO FLYER, INC., CHICAGO, IL. FILED 2-9-2011.

# RFX

THE MARK CONSISTS OF STANDARD CHARACTERS WITHOUT CLAIM TO ANY PARTICULAR FONT, STYLE, SIZE, OR COLOR.

FOR NON-MOTORIZED SCOOTER (U.S. CLS. 19, 21, 23, 31, 35 AND 44).

JOHN DWYER, EXAMINING ATTORNEY

**CLASS 13—FIREARMS**

SN 79-084,367. EURENCO, FRANCE, FILED 5-31-2010.

# HEXOSHEET

OWNER OF INTERNATIONAL REGISTRATION 1043446  
DATED 5-31-2010, EXPIRES 5-31-2020.

FOR SHEET EXPLOSIVES (U.S. CLS. 2 AND 9).  
SEAN CROWLEY, EXAMINING ATTORNEY

SN 79-084,982. EURENCO, FRANCE, FILED 5-31-2010.

# Flexicut

OWNER OF INTERNATIONAL REGISTRATION 1044931  
DATED 5-31-2010, EXPIRES 5-31-2020.

FOR FLEXIBLE CUTTING CORDS, NAMELY, FLEXIBLE, LINEAR EXPLOSIVE CHARGE FOR USE IN CUTTING (U.S. CLS. 2 AND 9).

SEAN CROWLEY, EXAMINING ATTORNEY

**CLASS 13—(Continued).**

SN 79-084,983. EURENCO, FRANCE, FILED 5-31-2010.

# Hexotube

OWNER OF INTERNATIONAL REGISTRATION 1044932  
DATED 5-31-2010, EXPIRES 5-31-2020.

FOR PLASTIC EXPLOSIVES PACKED IN A CARTRIDGE WITH CAULKING GUN (U.S. CLS. 2 AND 9).  
SEAN CROWLEY, EXAMINING ATTORNEY

SN 79-085,249. EURENCO, FRANCE, FILED 5-31-2010.

# Hexomax

OWNER OF INTERNATIONAL REGISTRATION 1045542  
DATED 5-31-2010, EXPIRES 5-31-2020.

FOR RDX-BASED PLASTIC EXPLOSIVE BLOCKS (U.S. CLS. 2 AND 9).

SEAN CROWLEY, EXAMINING ATTORNEY

SN 79-085,250. EURENCO, FRANCE, FILED 5-31-2010.

# HEXOTAPE

OWNER OF INTERNATIONAL REGISTRATION 1045543  
DATED 5-31-2010, EXPIRES 5-31-2020.

FOR FLEXIBLE ADHESIVE EXPLOSIVE TAPE (U.S. CLS. 2 AND 9).

SEAN CROWLEY, EXAMINING ATTORNEY

SN 85-100,872. HORNADY MANUFACTURING COMPANY,  
GRAND ISLAND, NE. FILED 8-5-2010.

# STEEL MATCH

THE MARK CONSISTS OF STANDARD CHARACTERS WITHOUT CLAIM TO ANY PARTICULAR FONT, STYLE, SIZE, OR COLOR.

NO CLAIM IS MADE TO THE EXCLUSIVE RIGHT TO USE "STEEL", APART FROM THE MARK AS SHOWN.

FOR AMMUNITION; BULLETS (U.S. CLS. 2 AND 9).

SALLY SHIH, EXAMINING ATTORNEY

**CLASS 13—(Continued).**

SN 85-183,426. SMITH, BRENT, BURLESON, TX. FILED 11-23-2010.



NO CLAIM IS MADE TO THE EXCLUSIVE RIGHT TO USE "LEATHER CO", APART FROM THE MARK AS SHOWN.

THE MARK CONSISTS OF AN OVAL BORDER WITH THE TEXT "SMITH CREEK LEATHER CO" AROUND THE OUTER EDGE AND A TREE BETWEEN "SMITH" AND "CREEK", AND A 3 INITIAL NOMENCLATURE "SCL" IN THE MIDDLE.

FOR GUN BELTS, GUN SCABBARDS AND GUN HOLSTERS MADE PREDOMINANTLY OF LEATHER (U.S. CLS. 2 AND 9).

FIRST USE 10-21-2010; IN COMMERCE 10-29-2010.  
HOWARD SMIGA, EXAMINING ATTORNEY

SN 85-204,480. CENTRAL HOLDING CORPORATION, LAKE OZARK, MO. FILED 12-22-2010.

## DoubleTap

THE MARK CONSISTS OF STANDARD CHARACTERS WITHOUT CLAIM TO ANY PARTICULAR FONT, STYLE, SIZE, OR COLOR.

FOR PISTOLS (U.S. CLS. 2 AND 9).  
THEODORE MCBRIDE, EXAMINING ATTORNEY

SN 85-204,882. GRIZZLY CARTRIDGE CO., RAINIER, OR. FILED 12-23-2010.

## GRIZZLY

THE MARK CONSISTS OF STANDARD CHARACTERS WITHOUT CLAIM TO ANY PARTICULAR FONT, STYLE, SIZE, OR COLOR.

OWNER OF U.S. REG. NO. 2,955,957.  
FOR CARTRIDGES AND AMMUNITION, NAMELY METALLIC CARTRIDGE AMMUNITION FOR MULTIPLE USES, INCLUDING TARGET-SHOOTING AND HUNTING (U.S. CLS. 2 AND 9).

FIRST USE 4-1-2003; IN COMMERCE 4-1-2003.  
NICHOLAS COLEMAN, EXAMINING ATTORNEY

**CLASS 13—(Continued).**

SN 85-211,597. AUTO BOLT, LLC, CRAWFORDSVILLE, IN. FILED 1-6-2011.

## DREADNOUGHT

THE MARK CONSISTS OF STANDARD CHARACTERS WITHOUT CLAIM TO ANY PARTICULAR FONT, STYLE, SIZE, OR COLOR.

FOR COMPONENT PARTS FOR RIFLES; RIFLE BARRELS (U.S. CLS. 2 AND 9).

MARY ROSSMAN, EXAMINING ATTORNEY

SN 85-212,246. CROMMETT, RICHARD V, BEVERLY HILLS, CA. FILED 1-6-2011.

## ICE-15

THE MARK CONSISTS OF STANDARD CHARACTERS WITHOUT CLAIM TO ANY PARTICULAR FONT, STYLE, SIZE, OR COLOR.

FOR AUTOMATIC RIFLES; COMBINATION PISTOLS AND RIFLES; COMPONENT PARTS FOR RIFLES; FIREARMS; HUNTING RIFLES; MILITARY RIFLES; RIFLES; RIFLES AND PARTS THEREOF; SPORTING RIFLES (U.S. CLS. 2 AND 9).

ANGELA M. MICHELI, EXAMINING ATTORNEY

SN 85-222,937. RA BRANDS, L.L.C., MADISON, NC. FILED 1-21-2011.

## SPORTSMAN

THE MARK CONSISTS OF STANDARD CHARACTERS WITHOUT CLAIM TO ANY PARTICULAR FONT, STYLE, SIZE, OR COLOR.

OWNER OF U.S. REG. NOS. 279,904 AND 3,365,500.  
FOR SHOTGUNS (U.S. CLS. 2 AND 9).

FIRST USE 9-5-1930; IN COMMERCE 9-5-1930.  
JUDITH HELFMAN, EXAMINING ATTORNEY

**CLASS 14—JEWELRY**

SN 77-803,647. HEATHER B. MOORE, INC., CLEVELAND HEIGHTS, OH. FILED 8-13-2009.



THE NAME(S), PORTRAIT(S), AND/OR SIGNATURE(S) SHOWN IN THE MARK IDENTIFIES "HEATHER B. MOORE", WHOSE CONSENT(S) TO REGISTER IS MADE OF RECORD.

THE COLOR(S) CHERRY WOOD IS/ARE CLAIMED AS A FEATURE OF THE MARK.

THE MARK CONSISTS OF THE DESIGN OF A THREE-DIMENSIONAL WOODEN BLOCK DISPLAY FOR JEWELRY IN THE COLOR CHERRY WOOD WITH THE PHRASES "CHERISH WHO YOU ARE" AND "HEATHER B. MOORE" INSCRIBED THEREON, ALSO IN THE COLOR CHERRY WOOD. THE WORDING IS ENGRAVED INTO THE WOODEN BLOCK. THE BROKEN LINES SHOW THE PLACEMENT OF THE WORDING IN THE MARK, BUT NO CLAIM IS MADE TO THE SHAPE OF THE WOODEN BLOCK. IN ADDITION, THE BROKEN LINES WITHIN THE BLOCK INDICATE WOOD GRAIN, AND ARE NOT CLAIMED AS PART OF THE MARK.

FOR JEWELRY (U.S. CLS. 2, 27, 28 AND 50).  
FIRST USE 6-30-2009; IN COMMERCE 6-30-2009.  
DAVID HOFFMAN, EXAMINING ATTORNEY

SN 77-873,754. VINTAJ NATURAL BRASS CO., GALENA, IL. FILED 11-16-2009.

**DECORIVET**

THE MARK CONSISTS OF STANDARD CHARACTERS WITHOUT CLAIM TO ANY PARTICULAR FONT, STYLE, SIZE, OR COLOR.

FOR JEWELRY FINDINGS; BEADING ACCESSORIES, NAMELY, BEADS FOR MAKING JEWELRY; EMBELLISHMENTS, NAMELY, METAL CHARMS FOR MAKING JEWELRY; EMBELLISHMENTS, NAMELY, METAL JEWELRY CHARMS FOR USE IN CRAFTING (U.S. CLS. 2, 27, 28 AND 50).

MARK SPARACINO, EXAMINING ATTORNEY

**CLASS 14—(Continued).**

SN 77-873,756. VINTAJ NATURAL BRASS CO., GALENA, IL. FILED 11-16-2009.

**ALTERED BLANK**

THE MARK CONSISTS OF STANDARD CHARACTERS WITHOUT CLAIM TO ANY PARTICULAR FONT, STYLE, SIZE, OR COLOR.

NO CLAIM IS MADE TO THE EXCLUSIVE RIGHT TO USE "BLANK", APART FROM THE MARK AS SHOWN.

FOR JEWELRY FINDINGS; BEADING ACCESSORIES, NAMELY, BEADS FOR MAKING JEWELRY; EMBELLISHMENTS, NAMELY, METAL CHARMS FOR MAKING JEWELRY; EMBELLISHMENTS, NAMELY, METAL JEWELRY CHARMS FOR USE IN CRAFTING; NON-DECORATIVE JEWELRY, NAMELY, METAL JEWELRY BLANKS FOR USE CRAFTING AND MAKING DECORATIVE JEWELRY (U.S. CLS. 2, 27, 28 AND 50).

MARK SPARACINO, EXAMINING ATTORNEY

SN 77-882,246. CALLAWAY CONSOLIDATED, INC., TUCKER, GA. FILED 11-30-2009.

**ECOAU**

THE MARK CONSISTS OF STANDARD CHARACTERS WITHOUT CLAIM TO ANY PARTICULAR FONT, STYLE, SIZE, OR COLOR.

THE WORDING "ECOAU" HAS NO MEANING IN A FOREIGN LANGUAGE.

FOR ANKLETS, BRACELETS, JEWELRY CHAINS, CHARMS, WATCH CLASPS, EARRINGS, JEWELRY BOXES MADE OF PRECIOUS METAL, JEWELRY CLASPS, NECKLACES, PENDANT MOUNTINGS, PENDANTS, RING MOUNTINGS, AND RINGS (U.S. CLS. 2, 27, 28 AND 50).

FIRST USE 9-7-2010; IN COMMERCE 9-7-2010.

MARLENE BELL, EXAMINING ATTORNEY



**CLASS 14—(Continued).**

SN 77-954,302. FORMULA ONE LICENSING BV, AMSTERDAM, NETHERLANDS, FILED 3-9-2010.

## UNITED STATES GRAND PRIX

THE MARK CONSISTS OF STANDARD CHARACTERS WITHOUT CLAIM TO ANY PARTICULAR FONT, STYLE, SIZE, OR COLOR.

OWNER OF U.S. REG. NO. 3,752,597.

NO CLAIM IS MADE TO THE EXCLUSIVE RIGHT TO USE "UNITED STATES", APART FROM THE MARK AS SHOWN.

FOR ALARM CLOCKS, AMULETS, BADGES OF PRECIOUS METAL, BOXES OF PRECIOUS METAL, BRACELETS, BROOCHES, CASES FOR CLOCK AND WATCH MAKING, CASES FOR WATCHES AND CLOCKS, WATCH CHAINS, JEWELLERY CHAINS, PERSONAL JEWELRY CHARMS, CHRONOGRAPHS FOR USE AS WATCHES, CHRONOMETERS, CHRONOSCOPES, CLOCKS, CLOCKS AND WATCHES, COMMEMORATIVE COINS, DIALS FOR CLOCK-AND-WATCH-MAKING, DIAMONDS, EARRINGS, WALL CLOCKS, FIGURINES OF PRECIOUS METAL, GOLD, HAT ORNAMENTS OF PRECIOUS METAL, HOROLOGICAL INSTRUMENTS, INGOTS OF PRECIOUS METALS, JEWELLERY CASES, MEDALLIONS, MEDALS, NECKLACES, ORNAMENTAL PINS, PASTE JEWELLERY, PEARLS, PENDANTS, PLATINUM, PRECIOUS METALS AND THEIR ALLOYS, PRECIOUS STONES, RINGS, SILVER, STATUES OF PRECIOUS METAL, STOPWATCHES, STRAPS FOR WRISTWATCHES, APPARATUS FOR TIMING SPORTS EVENTS; TROPHIES OF PRECIOUS METALS; WATCH BANDS, WATCH CASES, WATCHES, WRISTWATCHES (U.S. CLS. 2, 27, 28 AND 50).

KAREN SEVERSON, EXAMINING ATTORNEY

SN 78-706,690. DIVERSIFIED GLOBAL TECHNOLOGIES, LLC, WOONSOCKET, RI. FILED 9-3-2005.

# PLUSH

THE MARK CONSISTS OF STANDARD CHARACTERS WITHOUT CLAIM TO ANY PARTICULAR FONT, STYLE, SIZE, OR COLOR.

FOR BRACELETS; COSTUME JEWELRY; JEWELRY; LAPEL PINS; PINS BEING JEWELRY (U.S. CLS. 2, 27, 28 AND 50).

ANN E. SAPPENFIELD, EXAMINING ATTORNEY

**CLASS 14—(Continued).**

SN 79-083,631. MONTRES TUDOR SA, SWITZERLAND, FILED 5-27-2010.

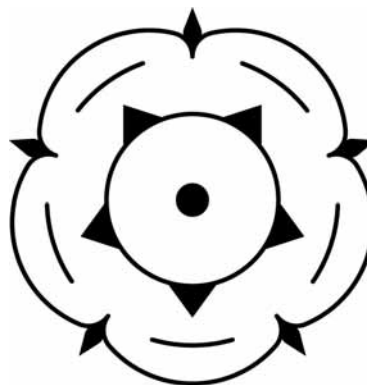

PRIORITY DATE OF 12-16-2009 IS CLAIMED.

OWNER OF INTERNATIONAL REGISTRATION 1041609 DATED 5-27-2010, EXPIRES 5-27-2020.

THE MARK CONSISTS OF A STYLIZED CIRCLE-LIKE DESIGN THAT IS EVENLY SEGMENTED AND INDENTED BY FIVE (5) DIAMOND SHAPED OBJECTS, THAT ENCASES FIVE (5) EVENLY SPACED LINES, THAT ENCASES A CIRCLE WITH FIVE (5) EVENLY SPACED TRIANGLES TOUCHING THE CIRCLE'S PERIMETER, THAT ENCASES A SMALLER FILLED IN CIRCLE.

FOR JEWELRY, TIMEPIECES, NAMELY, WATCHES, WRISTWATCHES, WATCH PARTS, CLOCKS AND OTHER CHRONOMETRIC INSTRUMENTS, CHRONOMETERS, CHRONOGRAPHS FOR USE AS WATCHES AND TIMEPIECES, APPARATUS FOR TIMING SPORTS EVENTS, DIALS FOR CLOCKS AND WATCHMAKING, BOXES AND PRESENTATION CASES FOR TIMEPIECES AND JEWELRY (U.S. CLS. 2, 27, 28 AND 50).

LANA PHAM, EXAMINING ATTORNEY

SN 79-085,459. MONTRES TUDOR SA, SWITZERLAND, FILED 7-13-2010.

# TUDOR HERITAGE

THE MARK CONSISTS OF STANDARD CHARACTERS WITHOUT CLAIM TO ANY PARTICULAR FONT, STYLE, SIZE, OR COLOR.

PRIORITY DATE OF 2-5-2010 IS CLAIMED.

OWNER OF INTERNATIONAL REGISTRATION 1046048 DATED 7-13-2010, EXPIRES 7-13-2020.

OWNER OF U.S. REG. NOS. 646,485, 1,002,030 AND OTHERS.

FOR JEWELRY, TIMEPIECES, NAMELY, WATCHES, WRISTWATCHES, WATCH PARTS, CLOCKS AND OTHER CHRONOMETRIC INSTRUMENTS, CHRONOMETERS, CHRONOGRAPHS FOR USE AS WATCHES AND TIMEPIECES, APPARATUS FOR TIMING SPORTS EVENTS, DIALS FOR CLOCKS AND WATCHMAKING, BOXES AND PRESENTATION CASES FOR TIMEPIECES AND JEWELRY (U.S. CLS. 2, 27, 28 AND 50).

LANA PHAM, EXAMINING ATTORNEY

**CLASS 14—(Continued).**

SN 79-090,431. GIOVANNI BALESTRA & FIGLI S.P.A., ITALY, FILED 6-12-2009.

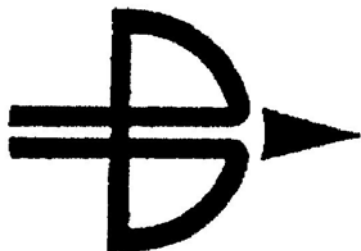

OWNER OF INTERNATIONAL REGISTRATION 0357850 DATED 6-13-1969, EXPIRES 6-13-2019.

THE MARK CONSISTS OF A DECORATIVE DESIGN OF AN ARROW CONTAINING TWO CIRCULAR TRIANGLES WITH TWO LINES EXTENDING THERE FROM.

FOR SMALL JEWELRY CHAINS AND BRACELETS MADE OF GOLD AND SILVER AND OTHER JEWELRY, GOLD AND SILVER JEWELRY (U.S. CLS. 2, 27, 28 AND 50).

JENNIFER VASQUEZ, EXAMINING ATTORNEY

SN 79-090,559. FORMISANO LAURENT, SPAIN, FILED 10-13-2010.



PRIORITY DATE OF 4-15-2010 IS CLAIMED.

OWNER OF INTERNATIONAL REGISTRATION 1059995 DATED 10-13-2010, EXPIRES 10-13-2020.

THE MARK CONSISTS OF A STYLIZED REPRESENTATION OF AN EYE WITH A HEART AROUND THE PUPIL.

FOR PRECIOUS METALS AND THEIR ALLOYS, AND GOODS FORMED THEREFROM OR COATED THEREWITH AND NOT INCLUDED IN OTHER CLASSES, NAMELY, FIGURINES AND BOXES; JEWELRY, NAMELY, RINGS, EARRINGS, CUFF LINKS, BRACELETS, CHARMS, BROOCHES, JEWELRY CHAINS, NECKLACES, MEDALS AND MEDALLIONS, JEWELRY ORNAMENTS, JEWELRY PEARLS, PRECIOUS STONES, ORNAMENTAL PRECIOUS AND SEMI- PRECIOUS STONES, PASTE JEWELRY, JEWELRY CASES, TIMEPIECES AND WATCHES (U.S. CLS. 2, 27, 28 AND 50).

TINA BROWN, EXAMINING ATTORNEY

**CLASS 14—(Continued).**

SN 85-027,208. BONGIOVANNI, MICHELE ANDREA, SOMERVILLE, NJ. FILED 4-30-2010.



NO CLAIM IS MADE TO THE EXCLUSIVE RIGHT TO USE "DESIGNS", APART FROM THE MARK AS SHOWN.

THE COLOR(S) MAROON, RED, YELLOW, BLUE, WHITE AND ORANGE IS/ARE CLAIMED AS A FEATURE OF THE MARK.

THE MARK CONSISTS OF THE STYLIZED WORDING "SUN & EARTH DESIGNS" IN MAROON, AND A SUN WITH YELLOW RAYS. THE SUN IS MAROON AROUND THE EDGE WITH RED INSIDE THE MAROON. SMALL WHITE CIRCLES SURROUND THE EDGE OF THE SUN, AND INSIDE THOSE CIRCLES ARE DIAMONDS OUTLINED IN ORANGE. INSIDE THE RED IS A BLUE CIRCLE CONTAINING A STAR OUTLINED IN WHITE, AND INSIDE THE STAR IS A YELLOW RING AND THEN A WHITE RING.

FOR RELIGIOUS JEWELRY (U.S. CLS. 2, 27, 28 AND 50).

ROBIN MITTLER, EXAMINING ATTORNEY

SN 85-033,073. FASHION WORLD, INC., DBA BIJAN, BEVERLY HILLS, CA. FILED 5-7-2010.

# BIJAN

THE MARK CONSISTS OF STANDARD CHARACTERS WITHOUT CLAIM TO ANY PARTICULAR FONT, STYLE, SIZE, OR COLOR.

THE NAME "BIJAN" IDENTIFIES A LIVING INDIVIDUAL WHOSE CONSENT IS OF RECORD.

FOR BODY JEWELRY; BRACELETS; BROACHES; CHARMS; CHARMS FOR COLLAR JEWELRY AND BRACELET; DIAMOND JEWELRY; GEMSTONE JEWELRY; IDENTIFICATION BRACELETS; JEWELRY; JEWELRY BOXES; JEWELRY BOXES OF PRECIOUS METAL; JEWELRY CASES; JEWELRY CASES OF PRECIOUS METAL; JEWELRY CHAINS; JEWELRY WATCHES; JEWELRY, NAMELY, ARM CUFFS; JEWELRY, NAMELY, DOG TAGS FOR WEAR BY HUMANS FOR DECORATIVE PURPOSES; LAPEL PINS; RINGS; RINGS BEING JEWELRY; WATCHES AND JEWELRY; WATCHES, CLOCKS, JEWELRY AND IMITATION JEWELRY (U.S. CLS. 2, 27, 28 AND 50).

FIRST USE 5-10-1984; IN COMMERCE 5-10-1984.

TOBY BULLOFF, EXAMINING ATTORNEY

**CLASS 14—(Continued).**

SN 85-033,614. BEN HAKMAN & COMPANY LLC, NEW YORK, NY. FILED 5-8-2010.

# SUN FIRE

THE MARK CONSISTS OF STANDARD CHARACTERS WITHOUT CLAIM TO ANY PARTICULAR FONT, STYLE, SIZE, OR COLOR.

FOR DIAMONDS (U.S. CLS. 2, 27, 28 AND 50).  
FIRST USE 3-10-2009; IN COMMERCE 3-10-2009.  
MICHAEL WIENER, EXAMINING ATTORNEY

SN 85-047,926. SWISS WATCH INTERNATIONAL, INC., HOLLYWOOD, FL. FILED 5-26-2010.



The logo consists of the words "red line" in a lowercase, bold, sans-serif font. The word "red" is in red and "line" is in black.

THE COLOR(S) RED IS/ARE CLAIMED AS A FEATURE OF THE MARK.

THE MARK CONSISTS OF THE STYLIZED TERM "RED-LINE" IN THE COLOR RED.

FOR WATCHES, NAMELY, HOROLOGICAL AND CHRONOMETRIC INSTRUMENTS, NAMELY, MEN'S AND WOMEN'S WRIST WATCHES AND CHRONOMETERS (U.S. CLS. 2, 27, 28 AND 50).

FIRST USE 1-21-2011; IN COMMERCE 1-21-2011.  
DANIEL CAPSHAW, EXAMINING ATTORNEY

SN 85-048,361. LA PIERRE, JILL, ELMHURST, PA. FILED 5-26-2010.

# GLAMOROUS GOLFER

THE MARK CONSISTS OF STANDARD CHARACTERS WITHOUT CLAIM TO ANY PARTICULAR FONT, STYLE, SIZE, OR COLOR.

OWNER OF U.S. REG. NO. 3,766,806.  
NO CLAIM IS MADE TO THE EXCLUSIVE RIGHT TO USE "GOLFER", APART FROM THE MARK AS SHOWN.  
FOR JEWELRY (U.S. CLS. 2, 27, 28 AND 50).  
FIRST USE 7-0-2009; IN COMMERCE 7-0-2009.  
KELLY BOULTON, EXAMINING ATTORNEY

**CLASS 14—(Continued).**

SN 85-050,794. CHEEKY COUTURE, CICERO, IN. FILED 5-28-2010.

# Cheeky Couture

THE MARK CONSISTS OF STANDARD CHARACTERS WITHOUT CLAIM TO ANY PARTICULAR FONT, STYLE, SIZE, OR COLOR.

NO CLAIM IS MADE TO THE EXCLUSIVE RIGHT TO USE "COUTURE", APART FROM THE MARK AS SHOWN.  
FOR JEWELRY AND IMITATION JEWELRY (U.S. CLS. 2, 27, 28 AND 50).

FIRST USE 8-25-2004; IN COMMERCE 11-0-2004.  
WILLIAM P. SHANAHAN, EXAMINING ATTORNEY

SN 85-054,262. HEISENPORT, INC., CIUDAD DE PANAMA, PANAMA, FILED 6-3-2010.

# SANTIAGO GONZALEZ

THE MARK CONSISTS OF STANDARD CHARACTERS WITHOUT CLAIM TO ANY PARTICULAR FONT, STYLE, SIZE, OR COLOR.

THE NAME(S), PORTRAIT(S), AND/OR SIGNATURE(S) SHOWN IN THE MARK IDENTIFIES SANTIAGO BARBERI GONZALEZ, WHOSE CONSENT(S) TO REGISTER IS MADE OF RECORD.

FOR BOXES FOR TIMEPIECES, WATCH CASES, CUFF-LINK CASES, JEWELRY CASES, JEWELRY ORGANIZERS, LEATHER JEWELRY AND ACCESSORY BOXES, WATCHBANDS (U.S. CLS. 2, 27, 28 AND 50).

JENNIFER MARTIN, EXAMINING ATTORNEY

SN 85-059,539. HEISENPORT, INC., CIUDAD DE PANAMA, PANAMA, FILED 6-10-2010.

# SANTIAGO GONZALEZ



THE NAME(S), PORTRAIT(S), AND/OR SIGNATURE(S) SHOWN IN THE MARK IDENTIFIES SANTIAGO BARBERI GONZALEZ, WHOSE CONSENT(S) TO REGISTER IS MADE OF RECORD.

THE MARK CONSISTS OF THE WORDS "SANTIAGO GONZALEZ" CENTERED OVER A STARBURST DESIGN.  
FOR BOXES FOR TIMEPIECES, WATCH CASES, CUFF-LINK CASES, JEWELRY CASES, JEWELRY ORGANIZERS, LEATHER JEWELRY AND ACCESSORY BOXES, WATCHBANDS (U.S. CLS. 2, 27, 28 AND 50).

JENNIFER MARTIN, EXAMINING ATTORNEY

**CLASS 14—(Continued).**

SN 85-069,409. IMJEWELLEE, LLC, WARRIOR, AL. FILED 6-23-2010.



THE MARK CONSISTS OF THE LETTER "J" FOLLOWED BY THE LETTER "X" WITH THE LETTER "O" PLACED OVER IT FOLLOWED BY THE LETTER "K".

FOR BODY JEWELRY; BROACHES; CHARMS; COSTUME JEWELRY; GEMSTONE JEWELRY; JEWELRY; JEWELRY AND IMITATION JEWELRY; JEWELRY RING HOLDERS (U.S. CLS. 2, 27, 28 AND 50).

FIRST USE 7-29-2009; IN COMMERCE 7-29-2009.  
JACLYN KIDWELL WALKER, EXAMINING ATTORNEY

SN 85-083,736. ANCIENT MODERN ART, LLC, NEW YORK, NY. FILED 7-13-2010.



OWNER OF U.S. REG. NO. 3,839,037.  
THE MARK CONSISTS OF SANSKRIT LETTERS FOR "JIVASUKHA" INSIDE AN OVAL HAVING A CIRCLE NEAR ITS RIGHTMOST EDGE.

THE NON-LATIN CHARACTERS IN THE MARK TRANSLITERATE TO "JIVASUKHA" AND THIS HAS NO MEANING IN A FOREIGN LANGUAGE.

FOR JEWELRY MADE WHOLLY OR IN PART OF PRECIOUS METALS, NAMELY, RINGS, EARRINGS, NECKLACES, EARRINGS, CUFF BRACELETS, PENDANTS, BANGLES, BROOCHES, CUFF LINKS AND WATCHES (U.S. CLS. 2, 27, 28 AND 50).

FIRST USE 9-1-2009; IN COMMERCE 9-1-2009.  
BRENDAN REGAN, EXAMINING ATTORNEY

**CLASS 14—(Continued).**

SN 85-100,449. GALILI, BENYAMIN, FLUSHING, NY. FILED 8-4-2010.



THE NAME(S), PORTRAIT(S), AND/OR SIGNATURE(S) SHOWN IN THE MARK DOES NOT IDENTIFY A PARTICULAR LIVING INDIVIDUAL.

THE MARK CONSISTS OF A CAPITAL LETTER "V". INSIDE THE LETTER "V", LOCATED IN THE MIDDLE, THERE IS A CAPITAL LETTER "B". ON BOTH SIDES AND BELOW THE LETTER "B" WITHIN THE "V", ARE THREE SWIRLING FLORAL PATTERNS. ON THE LEFT UPPER SIDE OF THE LETTER "V", THERE IS A SIGNATURE OF THE FIRST NAME, THE WORD "VERA", AND ON THE RIGHT BOTTOM SIDE OF THE LETTER "V", THERE IS A SIGNATURE OF THE LAST NAME, THE WORD "BROWN".

FOR JEWELRY, NAMELY, BRACELETS, NECKLACE, RINGS, EAR RINGS, PENDANTS, CUFF LINKS, PINS; DIAMOND JEWELRY; JEWELRY AND PRECIOUS METALS; WATCHES; KEY CHAINS AS JEWELRY; KEY CHAINS OF PRECIOUS METAL (U.S. CLS. 2, 27, 28 AND 50).

NICHOLAS COLEMAN, EXAMINING ATTORNEY

SN 85-150,390. CHANDRU LAKHATI, DBA A1 WATCHES INC, NEW YORK, NY. FILED 10-12-2010.

# Techno Pave

THE MARK CONSISTS OF STANDARD CHARACTERS WITHOUT CLAIM TO ANY PARTICULAR FONT, STYLE, SIZE, OR COLOR.

NO CLAIM IS MADE TO THE EXCLUSIVE RIGHT TO USE "PAVE", APART FROM THE MARK AS SHOWN.

FOR FASHION WATCHES AND ACCESSORIES, NAMELY, JEWELRY CHAINS, CHARMS, RINGS, BRACELETS, NECKLACES, WATCH BANDS (U.S. CLS. 2, 27, 28 AND 50).

FIRST USE 8-0-2010; IN COMMERCE 8-0-2010.  
GRETTA YAO, EXAMINING ATTORNEY

**CLASS 14—(Continued).**

SN 85-150,861. DHOLAKIYA, HASMUKH, NEW YORK, NY.  
FILED 10-12-2010.

**THE DIAMOND STORY**

THE MARK CONSISTS OF STANDARD CHARACTERS WITHOUT CLAIM TO ANY PARTICULAR FONT, STYLE, SIZE, OR COLOR.

NO CLAIM IS MADE TO THE EXCLUSIVE RIGHT TO USE "DIAMOND", APART FROM THE MARK AS SHOWN.

FOR CUT DIAMONDS; DIAMOND JEWELRY; DIAMONDS; GEMSTONE JEWELRY; GEMSTONES; JEWELRY; PRECIOUS GEMSTONES; SEMI-PRECIOUS GEMSTONES (U.S. CLS. 2, 27, 28 AND 50).

KATHY DE JONGE, EXAMINING ATTORNEY

SN 85-150,869. DHOLAKIYA, HASMUKH, NEW YORK, NY.  
FILED 10-12-2010.

**MY DIAMOND STORY**

THE MARK CONSISTS OF STANDARD CHARACTERS WITHOUT CLAIM TO ANY PARTICULAR FONT, STYLE, SIZE, OR COLOR.

NO CLAIM IS MADE TO THE EXCLUSIVE RIGHT TO USE "DIAMOND", APART FROM THE MARK AS SHOWN.

FOR CUT DIAMONDS; DIAMOND JEWELRY; DIAMONDS; GEMSTONE JEWELRY; GEMSTONES; JEWELRY; PRECIOUS GEMSTONES; SEMI-PRECIOUS GEMSTONES (U.S. CLS. 2, 27, 28 AND 50).

KATHY DE JONGE, EXAMINING ATTORNEY

SN 85-167,033. BECCA LOCKHART, DBA B DEZIGNED,  
BELMONT, CA. FILED 11-2-2010.



THE NAME "BECCA LOCKHART" IDENTIFIES A LIVING INDIVIDUAL WHOSE CONSENT IS OF RECORD.

THE MARK CONSISTS OF THE STYLIZED WORDING "BECCA LOCKHART" WITH "B DEZIGNED" UNDERNEATH IT IN ALL CAPITAL LETTERS. BETWEEN THE CAPITAL LETTERS "B" AND "D" IS A SMALL STYLIZED LETTER "B".

FOR EARRINGS, NECKLACES, BRACELETS, ANKLETS THAT ARE LONGER THAN NORMAL AND HANG OVER THE BACK OF YOUR SHOES (U.S. CLS. 2, 27, 28 AND 50).

FIRST USE 1-4-2008; IN COMMERCE 3-5-2008.

AISHA CLARKE, EXAMINING ATTORNEY

**CLASS 14—(Continued).**

SN 85-169,434. MOBILEEYES MARKETING LLC, DBA  
SKANBANDZ, RYE BROOK, NY. FILED 11-4-2010.



NO CLAIM IS MADE TO THE EXCLUSIVE RIGHT TO USE "SCAN BANDS" AND ".COM", APART FROM THE MARK AS SHOWN.

THE MARK CONSISTS OF A DESIGN BARCODE ON THE LEFT SIDE OF THE WORDING "SKANBANDZ" AND ".COM" ABOVE THE WORD "SKANBANDZ". THE SECOND LETTER "A" AND "N" ARE SHAPED TO FORM EYES AND A NOSE WITH A SMILING MOUTH BELOW THE LETTERS AND EYEBROWS ABOVE THE LETTERS "A" AND "N".

FOR RUBBER OR SILICONE JEWELRY AS A FASHION ACCESSORY THAT CONTAINS A QR CODE OR 2-DIMENSIONAL BAR CODE PRINTED ON IT THAT WHEN SCANNED WILL REDIRECT TO A USER DEFINED FUNCTION ON THE INTERNET (U.S. CLS. 2, 27, 28 AND 50).

FIRST USE 11-15-2010; IN COMMERCE 11-15-2010.

COURTNEY ALVAREZ, EXAMINING ATTORNEY

SN 85-173,136. HETAL DIAMONDS INC, NEW YORK, NY.  
FILED 11-10-2010.

**RST**

THE MARK CONSISTS OF STANDARD CHARACTERS WITHOUT CLAIM TO ANY PARTICULAR FONT, STYLE, SIZE, OR COLOR.

FOR FASHION AND DIAMOND JEWELRY PRODUCTS, NAMELY, PENDANTS, RINGS, EARRINGS, BRACELETS, WATCHES, NECKLACES, CHARMS, SOLITAIRE STUDS, BANGLES, NOSE RINGS, ANKLETS, TOE RINGS (U.S. CLS. 2, 27, 28 AND 50).

FIRST USE 6-1-2009; IN COMMERCE 6-1-2009.

GINA HAYES, EXAMINING ATTORNEY

**CLASS 14—(Continued).**

SN 85-176,912. SALT LIFE HOLDINGS, LLC, JACKSONVILLE, FL. FILED 11-15-2010.

# SALT LIFE

THE MARK CONSISTS OF STANDARD CHARACTERS WITHOUT CLAIM TO ANY PARTICULAR FONT, STYLE, SIZE, OR COLOR.

OWNER OF U.S. REG. NOS. 3,001,343, 3,843,123 AND OTHERS.

FOR JEWELRY BOXES; JEWELRY HOLDERS, NAMELY, HOLDERS FOR NECKLACES, BRACELETS, EARRINGS, AND RINGS; WATCHES; CLOCKS; COINS, NAMELY, COLLECTIBLE COINS, COMMEMORATIVE COINS, NON-MONETARY COINS, AND SOUVENIR PRESSED COINS; CUFF LINKS; TIE BARS; TIE TACKS; TUXEDO STUDS BEING JEWELRY; KEY RINGS OF PRECIOUS METAL; KEY HOLDERS OF PRECIOUS METAL (U.S. CLS. 2, 27, 28 AND 50).

APRIL HESIK, EXAMINING ATTORNEY

**CLASS 14—(Continued).**

SN 85-181,882. ANDMORE PRODUCTS, INC., POWAY, CA. FILED 11-20-2010.

# BELLA DONNA FASHION

THE MARK CONSISTS OF STANDARD CHARACTERS WITHOUT CLAIM TO ANY PARTICULAR FONT, STYLE, SIZE, OR COLOR.

NO CLAIM IS MADE TO THE EXCLUSIVE RIGHT TO USE "FASHION", APART FROM THE MARK AS SHOWN.

THE ENGLISH TRANSLATION OF "BELLA DONNA" IN THE MARK IS BEAUTIFUL LADY.

FOR BROOCHES; JEWELRY BROOCHES (U.S. CLS. 2, 27, 28 AND 50).

LAKEISHA LEWIS, EXAMINING ATTORNEY

SN 85-179,824. RAND & PASEKA MFG. CO., INC., FREEPORT, NY. FILED 11-18-2010.



THE MARK CONSISTS OF THE STYLIZED CAPITAL LETTER "R" SUPERIMPOSED OVER THE STYLIZED CAPITAL LETTER "P".

FOR ARTICLES OF JEWELRY, NAMELY, CROSSES, STARS OF DAVID, LOCKETS AND EARRINGS (U.S. CLS. 2, 27, 28 AND 50).

FIRST USE 7-13-1956; IN COMMERCE 6-21-1957.

SEAN CROWLEY, EXAMINING ATTORNEY

SN 85-182,847. KABBALAH CENTRE INTERNATIONAL, INC., LOS ANGELES, CA. FILED 11-22-2010.

# KABBALAH RED STRING

THE MARK CONSISTS OF STANDARD CHARACTERS WITHOUT CLAIM TO ANY PARTICULAR FONT, STYLE, SIZE, OR COLOR.

OWNER OF U.S. REG. NOS. 3,411,334, 3,547,328 AND OTHERS.

NO CLAIM IS MADE TO THE EXCLUSIVE RIGHT TO USE "RED STRING", APART FROM THE MARK AS SHOWN.

FOR JEWELRY, NAMELY, STRING THAT IS TIED AROUND THE WRIST OF THE USER TO FORM A BRACELET (U.S. CLS. 2, 27, 28 AND 50).

FIRST USE 3-19-2004; IN COMMERCE 3-19-2004.

ROBIN CHOSID, EXAMINING ATTORNEY

**CLASS 14—(Continued).**

SN 85-183,241. BLACKWATER MERCANTILE, LLC, MILTON, FL. FILED 11-23-2010.

## Adora Belle Jewelry

THE MARK CONSISTS OF STANDARD CHARACTERS WITHOUT CLAIM TO ANY PARTICULAR FONT, STYLE, SIZE, OR COLOR.

NO CLAIM IS MADE TO THE EXCLUSIVE RIGHT TO USE "JEWELRY", APART FROM THE MARK AS SHOWN.

THE ENGLISH TRANSLATION OF THE WORD "ADORE BELLE" IN THE MARK IS "ADORE BEAUTIFUL".

FOR BEADS FOR USE IN THE MANUFACTURE OF JEWELRY; BODY JEWELRY; BRACELETS; BROOCHES; BRONZE JEWELRY; BROOCHES; CHARMS; CHARMS FOR COLLAR JEWELRY AND BRACELET; COSTUME JEWELRY; DIAMOND JEWELRY; GEMSTONE JEWELRY; IDENTIFICATION BRACELETS; INEXPENSIVE NON-JEWELRY WATCHES; JEWELRY; JEWELRY AND IMITATION JEWELRY; JEWELRY ARMOIRES; JEWELRY BOXES; JEWELRY BOXES NOT OF METAL; JEWELRY BOXES OF METAL; JEWELRY BROOCHES; JEWELRY CASES; JEWELRY CASES NOT OF PRECIOUS METAL; JEWELRY CHAINS; JEWELRY FINDINGS; JEWELRY FOR ATTACHMENT TO CLOTHING; JEWELRY FOR THE HEAD; JEWELRY IN THE NATURE OF ARMBANDS; JEWELRY ORGANIZERS; JEWELRY PINS FOR USE ON HATS; JEWELRY RING HOLDERS; JEWELRY STICKPINS; JEWELRY WATCHES; JEWELRY, NAMELY, AMULETS; JEWELRY, NAMELY, ANKLETS; JEWELRY, NAMELY, ARM CUFFS; JEWELRY, NAMELY, CROSSES; JEWELRY, NAMELY, STONE PENDANTS; LAPEL PINS; LEATHER JEWELRY AND ACCESSORY BOXES; PET JEWELRY; PINS BEING JEWELRY; PLASTIC BRACELETS IN THE NATURE OF JEWELRY; PRECIOUS AND SEMI-PRECIOUS CRYSTAL STONES AND BEADS FOR USE IN JEWELRY; RINGS; RINGS BEING JEWELRY; STAINLESS STEEL JEWELRY BRACELETS; WATCHES AND JEWELRY; WATCHES, CLOCKS, JEWELRY AND IMITATION JEWELRY; WOMEN'S JEWELRY (U.S. CLS. 2, 27, 28 AND 50).

DEIRDRE ROBERTSON, EXAMINING ATTORNEY

SN 85-187,464. GLAM GLOBAL, LLC, SPARKS, MD. FILED 11-30-2010.

## GLAM GLOBES

THE MARK CONSISTS OF STANDARD CHARACTERS WITHOUT CLAIM TO ANY PARTICULAR FONT, STYLE, SIZE, OR COLOR.

NO CLAIM IS MADE TO THE EXCLUSIVE RIGHT TO USE "GLOBES", APART FROM THE MARK AS SHOWN.

FOR JEWELRY (U.S. CLS. 2, 27, 28 AND 50).

FIRST USE 9-30-2010; IN COMMERCE 11-1-2010.

LINDA LAVACHE, EXAMINING ATTORNEY

**CLASS 14—(Continued).**

SN 85-187,788. SAM, ELIZABETH, BROOKLYN, NY. FILED 11-30-2010.



THE MARK CONSISTS OF THE STYLIZED TEXT "EVALARE" WITH A CIRCLE OF STARS AND A STAR AT THE END.

FOR BANGLES; BRACELETS; BROOCHES; CHARMS; EARRINGS; NECKLACES; PENDANTS; RINGS; WATCHES (U.S. CLS. 2, 27, 28 AND 50).

MICHAEL KEATING, EXAMINING ATTORNEY

SN 85-189,273. TRIBANDZ LLC, COCKEYSVILLE, MD. FILED 12-2-2010.

## TRIBANDZ

THE MARK CONSISTS OF STANDARD CHARACTERS WITHOUT CLAIM TO ANY PARTICULAR FONT, STYLE, SIZE, OR COLOR.

FOR SILICONE WRISTBANDS IN THE NATURE OF DECORATIVE BRACELETS WHICH CONTAIN COMPARTMENTS THAT HOUSE STYLIZED INSERTS, NOT FOR HOSPITAL OR MEDICAL USE (U.S. CLS. 2, 27, 28 AND 50).

FIRST USE 8-18-2010; IN COMMERCE 8-18-2010.

DAVID ELTON, EXAMINING ATTORNEY

SN 85-189,294. TRIBANDZ LLC, COCKEYSVILLE, MD. FILED 12-2-2010.

## TIBBZ

THE MARK CONSISTS OF STANDARD CHARACTERS WITHOUT CLAIM TO ANY PARTICULAR FONT, STYLE, SIZE, OR COLOR.

FOR SMALL STYLIZED PLASTIC DISC INSERTS IN THE NATURE OF CHARMS WHICH ARE PLACED INTO SILICONE WRISTBANDS IN THE NATURE OF DECORATIVE BRACELETS (U.S. CLS. 2, 27, 28 AND 50).

FIRST USE 8-18-2010; IN COMMERCE 8-18-2010.

DAVID ELTON, EXAMINING ATTORNEY

**CLASS 14—(Continued).**

SN 85-190,059. PERFECTCUT LTD., NEW YORK, NY. FILED 12-3-2010.

**JUSTPERFECT MACHINE SET  
PRODUCT**

THE MARK CONSISTS OF STANDARD CHARACTERS WITHOUT CLAIM TO ANY PARTICULAR FONT, STYLE, SIZE, OR COLOR.

NO CLAIM IS MADE TO THE EXCLUSIVE RIGHT TO USE "MACHINE SET PRODUCT", APART FROM THE MARK AS SHOWN.

FOR JEWELRY (U.S. CLS. 2, 27, 28 AND 50).  
KATHERINE CHANG, EXAMINING ATTORNEY

SN 85-190,601. DANDIYA, MEGHAN, PLANO, TX. FILED 12-3-2010.

**COLORINTHEROUGH**

THE MARK CONSISTS OF STANDARD CHARACTERS WITHOUT CLAIM TO ANY PARTICULAR FONT, STYLE, SIZE, OR COLOR.

FOR JEWELRY (U.S. CLS. 2, 27, 28 AND 50).  
EVELYN BRADLEY, EXAMINING ATTORNEY

SN 85-191,108. INDUSTRIAL STRENGTH CORPORATION, SACRAMENTO, CA. FILED 12-6-2010.

*The Original*  
*Inspire-Ring*

NO CLAIM IS MADE TO THE EXCLUSIVE RIGHT TO USE "ORIGINAL", APART FROM THE MARK AS SHOWN. THE MARK CONSISTS OF THE WORDS "THE ORIGINAL INSPIRE-RING" IN SCRIPT FORMAT.

FOR RINGS BEING JEWELRY (U.S. CLS. 2, 27, 28 AND 50).  
FLORENTINA BLANDU, EXAMINING ATTORNEY

**CLASS 14—(Continued).**

SN 85-191,221. WEAR YOUR MUSIC, LLC, WOONSOCKET, RI. FILED 12-6-2010.



THE COLOR(S) BLACK AND WHITE IS/ARE CLAIMED AS A FEATURE OF THE MARK.

THE MARK CONSISTS OF THE WORDS "ROCKRECYCLED" ARCHED IN BLACK ABOVE A BLACK TRIANGLE WITH ARROWS POINTING CLOCKWISE AT THE EDGES OF THE TRIANGLE WITH A WHITE CIRCLE IN THE CENTER OF THE TRIANGLE.

FOR JEWELRY (U.S. CLS. 2, 27, 28 AND 50).  
FIRST USE 11-1-2010; IN COMMERCE 11-1-2010.  
JENNIFER MARTIN, EXAMINING ATTORNEY

SN 85-192,027. HENNES, MELINDA, BEVERLY HILLS, CA. FILED 12-7-2010.

**hautey**

THE MARK CONSISTS OF STANDARD CHARACTERS WITHOUT CLAIM TO ANY PARTICULAR FONT, STYLE, SIZE, OR COLOR.

FOR BODY JEWELRY; BRACELETS; PERSONAL JEWELRY CHARMS; COSTUME JEWELRY; GEMSTONE JEWELRY; HAIR JEWELRY IN THE NATURE OF JEWELRY FOR USE IN THE HAIR; JEWELRY; JEWELRY AND IMITATION JEWELRY; JEWELRY CHAINS; JEWELRY FOR ATTACHMENT TO CLOTHING; JEWELRY FOR THE HEAD; JEWELRY, NAMELY, ANKLETS; PINS BEING JEWELRY; RINGS; RINGS BEING JEWELRY; WOMEN'S JEWELRY (U.S. CLS. 2, 27, 28 AND 50).

MARGERIE A. TIERNEY, EXAMINING ATTORNEY



**CLASS 14—(Continued).**

SN 85-192,567. BRAVADO INTERNATIONAL GROUP LIMITED, LONDON, UNITED KINGDOM, FILED 12-7-2010.

# BRAVADO

THE MARK CONSISTS OF STANDARD CHARACTERS WITHOUT CLAIM TO ANY PARTICULAR FONT, STYLE, SIZE, OR COLOR.

FOR JEWELRY CASES; ORNAMENTS, TIE CLIPS AND FIGURINES ALL MADE OF PRECIOUS METAL; CLOCKS; JEWELRY; PINS BEING JEWELRY; AND WATCHES (U.S. CLS. 2, 27, 28 AND 50).

FIRST USE 12-0-1994; IN COMMERCE 12-0-1994.  
SUE LAWRENCE, EXAMINING ATTORNEY

SN 85-192,683. ZIMMERLEY, LEE, CHARLOTTE, NC. FILED 12-7-2010.

# Chinacat Creations

THE MARK CONSISTS OF STANDARD CHARACTERS WITHOUT CLAIM TO ANY PARTICULAR FONT, STYLE, SIZE, OR COLOR.

NO CLAIM IS MADE TO THE EXCLUSIVE RIGHT TO USE "CREATIONS", APART FROM THE MARK AS SHOWN.

FOR JEWELRY (U.S. CLS. 2, 27, 28 AND 50).  
FIRST USE 8-1-2005; IN COMMERCE 8-1-2005.  
JAMES LOVELACE, EXAMINING ATTORNEY

SN 85-199,247. 1400446 ALBERTA LTD., EDMONTON, ALBERTA, CANADA, FILED 12-16-2010.



NO CLAIM IS MADE TO THE EXCLUSIVE RIGHT TO USE "925", APART FROM THE MARK AS SHOWN.

THE MARK CONSISTS OF A SHIELD DESIGN WITH THE LETTER "M" IN THE SHAPE OF A CROWN AND DOUBLE LINES UNDERNEATH THE CROWN, AND A CIRCLE DESIGN WITH THE NUMBERS "925" INSIDE THE CIRCLE.

FOR JEWELRY, NAMELY, STERLING SILVER JEWELRY IN THE NATURE OF RINGS, EARRINGS, CHARMS, BRACELETS, BANGLES, RING BANDS, NECKLACES, PENDANTS, PINS, BROOCHES, AND BODY JEWELRY, WITH OR WITHOUT BEADS, PEARLS, AND PRECIOUS AND SEMI-PRECIOUS GEMSTONES; WATCHES (U.S. CLS. 2, 27, 28 AND 50).

FIRST USE 2-1-2010; IN COMMERCE 2-1-2010.  
RONALD DELGIZZI, EXAMINING ATTORNEY

**CLASS 14—(Continued).**

SN 85-200,784. BROUN, WAYNE H., WARRIEWOOD BEACH NSW, AUSTRALIA, FILED 12-17-2010.



THE MARK CONSISTS OF A COAT OF ARMS FEATURING A LION HOLDING A FLEUR-DE-LIS AND STANDING ATOP AN ARMOUR HELMET THAT IS ABOVE A SHIELD FEATURING A CHEVRON AND THREE FLEUR-DE-LIS, ALL SURROUNDED BY LEAVES. ABOVE THE LION IS A BANNER FEATURING THE WORDING "FLOREAT MAJESTAS".

THE ENGLISH TRANSLATION OF "FLOREAT MAJESTAS" IN THE MARK IS LET MAJESTY FLOURISH.

FOR JEWELRY; IMITATION JEWELRY; COSTUME JEWELRY; JEWELRY OF PRECIOUS AND SEMI-PRECIOUS STONES AND METALS; PEARLS; JEWELRY OF NON-PRECIOUS STONES, METALS, PEARLS, PEWTER, CRYSTAL, GLASS, BEADS, PLASTIC AND NATURAL AND SYNTHETIC STONES; JEWELRY BOXES AND CASES; DECORATIVE BOXES MADE OF PRECIOUS METALS; WATCHES AND CLOCKS; BADGES OF PRECIOUS METAL AND BUCKLES FOR WATCH STRAPS; BROOCHES; MEDALLIONS; PINS BEING JEWELRY; BRACELETS; JEWELRY CHAINS; CHARMS; NON-MONETARY COINS OF PRECIOUS METAL; CUFF LINKS; EARRINGS AND EAR ORNAMENTS IN THE NATURE OF EAR CLIPS AND EAR STUDS; HAT ORNAMENTS OF PRECIOUS METAL; IDENTIFICATION BRACELETS; NECKLACES; PENDANTS; LAPEL PINS; RINGS; RING BANDS BEING JEWELRY; TIE CLIPS, FASTENERS, PINS, AND TACKS; AND WRIST-WATCHES (U.S. CLS. 2, 27, 28 AND 50).

LINDA LAVACHE, EXAMINING ATTORNEY

SN 85-205,077. FANTASY DIAMOND CORPORATION, CHICAGO, IL. FILED 12-23-2010.

# HONOR

THE MARK CONSISTS OF STANDARD CHARACTERS WITHOUT CLAIM TO ANY PARTICULAR FONT, STYLE, SIZE, OR COLOR.

OWNER OF U.S. REG. NO. 535,394.

FOR FINGER RINGS (U.S. CLS. 2, 27, 28 AND 50).

FIRST USE 12-17-1948; IN COMMERCE 2-22-1949.

MORGAN WYNNE, EXAMINING ATTORNEY

**CLASS 14—(Continued).**

SN 85-205,303. MCCULLOUGH, KATHLEEN, FORT WORTH, TX. FILED 12-23-2010.



THE MARK CONSISTS OF TWO FIGURES THAT ARE IN A TANDEM PARACHUTING POSITION. THERE IS A PARACHUTE ATTACHED TO BOTH FIGURES. THEIR FEET ARE CENTERED ABOVE THE LETTER "C" IN PARACHUTE. THE LETTER "C" IS DESIGNED WITH CIRCLES, SLOWLY GETTING SMALLER AS THEY MOVE INWARD TO REPRESENT A BULLS-EYE. THIS IS USED TO REPRESENT A LANDING SPOT FOR THE TWO PEOPLE ATTACHED TO THE PARACHUTE. THERE IS A SUN BEHIND THE PARACHUTE. BELOW THERE IS THE STYLIZED TEXT "PARACHUTE PROMISE".

FOR JEWELRY (U.S. CLS. 2, 27, 28 AND 50).  
FIRST USE 9-30-2007; IN COMMERCE 6-13-2008.  
TRACY CROSS, EXAMINING ATTORNEY

SN 85-205,935. AGAS & TAMAR, TEL AVIV, ISRAEL, FILED 12-27-2010.

THE MARK CONSISTS OF THE WORDS "AGAS & TAMAR" WITH THE DESIGN OF A RING APPEARING TO THE LEFT OF THE WORDS.

THE ENGLISH TRANSLATION OF THE WORD "AGAS" IN THE MARK IS "PEAR", AND THE ENGLISH TRANSLATION OF THE WORD "TAMAR" IN THE MARK IS "DATE FRUIT".

FOR JEWELRY (U.S. CLS. 2, 27, 28 AND 50).  
LINDA M. KING, EXAMINING ATTORNEY

**CLASS 14—(Continued).**

SN 85-206,188. MARCELLO, CHRISTINE, THOUSAND OAKS, CA. FILED 12-27-2010.



TALIA M. SANTINO

THE NAME(S), PORTRAIT(S), AND/OR SIGNATURE(S) SHOWN IN THE MARK DOES NOT IDENTIFY A PARTICULAR LIVING INDIVIDUAL.

THE MARK CONSISTS OF THREE LOOPS CONNECTING IN UNISON. TO THE RIGHT THERE IS THE STYLIZED TEXT "TALIA M. SANTINO".

FOR JEWELRY; PET JEWELRY (U.S. CLS. 2, 27, 28 AND 50).

FIRST USE 6-1-2010; IN COMMERCE 10-29-2010.  
CHRISTOPHER BUONGIORNO, EXAMINING ATTORNEY

SN 85-206,380. JAMES M. FORTESCUE, WASHINGTON, NC. FILED 12-28-2010.

**INVEST IN LOVE**

THE MARK CONSISTS OF STANDARD CHARACTERS WITHOUT CLAIM TO ANY PARTICULAR FONT, STYLE, SIZE, OR COLOR.

FOR JEWELRY (U.S. CLS. 2, 27, 28 AND 50).  
FIRST USE 12-1-2010; IN COMMERCE 12-1-2010.  
GISELLE AGOSTO, EXAMINING ATTORNEY

SN 85-206,544. MICHELLE HARDING, WEST MILFORD, NJ. FILED 12-28-2010.

**CELEBIPAWS**

THE MARK CONSISTS OF STANDARD CHARACTERS WITHOUT CLAIM TO ANY PARTICULAR FONT, STYLE, SIZE, OR COLOR.

FOR PET JEWELRY (U.S. CLS. 2, 27, 28 AND 50).  
SANJEEV VOHRA, EXAMINING ATTORNEY

**CLASS 14—(Continued).**

SN 85-206,739. INNOVATION JEWELRY, INC., LOS ANGELES, CA. FILED 12-28-2010.



FOR DIAMOND JEWELRY; DIAMONDS; JEWELRY (U.S. CLS. 2, 27, 28 AND 50).  
FIRST USE 2-15-2010; IN COMMERCE 2-15-2010.  
APRIL ROACH, EXAMINING ATTORNEY

**CLASS 14—(Continued).**

SN 85-207,235. BAMBOOPINK, IRVINE, CA. FILED 12-29-2010.

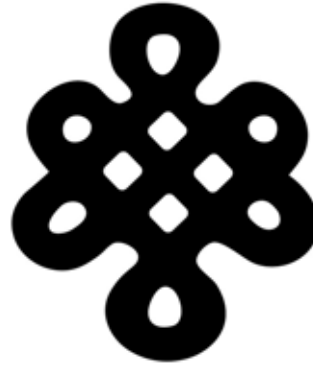

THE MARK CONSISTS OF A LOVE KNOT.  
FOR JEWELRY (U.S. CLS. 2, 27, 28 AND 50).  
MICHAEL WEBSTER, EXAMINING ATTORNEY

SN 85-207,825. ROBBINS BROS. JEWELRY, INC., AZUSA, CA. FILED 12-30-2010.

**BELLA LUNA**

THE MARK CONSISTS OF STANDARD CHARACTERS WITHOUT CLAIM TO ANY PARTICULAR FONT, STYLE, SIZE, OR COLOR.  
THE ENGLISH TRANSLATION OF "BELLA LUNA" IN THE MARK IS "BEAUTIFUL MOON".  
FOR CUT DIAMONDS (U.S. CLS. 2, 27, 28 AND 50).  
JAY BESCH, EXAMINING ATTORNEY

SN 85-206,842. JC 23 ENTERTAINMENT, INC., BEVERLY HILLS, CA. FILED 12-28-2010.



THE MARK CONSISTS OF STYLIZED CHARACTER SITTING IN YOGA STYLE.  
FOR JEWELRY; WATCHES; PET JEWELRY (U.S. CLS. 2, 27, 28 AND 50).  
CYNTHIA SLOAN, EXAMINING ATTORNEY

SN 85-208,000. BISHOP, RICHARD, NORMAN, HORNCAS- TLE LINCOLNSHIR, UNITED KINGDOM, FILED 12-30-2010.

**MERLIN**

THE MARK CONSISTS OF STANDARD CHARACTERS WITHOUT CLAIM TO ANY PARTICULAR FONT, STYLE, SIZE, OR COLOR.  
FOR CLOCKS AND WATCHES (U.S. CLS. 2, 27, 28 AND 50).  
KELLEY WELLS, EXAMINING ATTORNEY

**CLASS 14—(Continued).**

SN 85-208,379. LI SHERRY HAIXIA, MIAMI, FL. FILED 12-30-2010.



THE MARK CONSISTS OF STYLIZED WORD "FURISS" AND DESIGN. THE DESIGN IS A WOLF STANDING IN RIGHTWARD AND THE WORD "FURISS" IS UNDER OF THE WOLF DESIGN.

FOR BOXES OF PRECIOUS METAL; CHARMS; CLOCKS; JEWELRY; PRECIOUS METAL ALLOYS; WATCH BANDS; WATCH CHAINS; WATCHES; WORKS OF ART OF PRECIOUS METAL; WRISTWATCHES (U.S. CLS. 2, 27, 28 AND 50).

FIRST USE 3-17-2009; IN COMMERCE 3-17-2009.  
ROBIN CHOSID, EXAMINING ATTORNEY

SN 85-209,004. TIMEX GROUP USA, INC., MIDDLEBURY, CT. FILED 1-3-2011.



THE MARK CONSISTS OF A BOLD "V" WITH FOUR CURVED LINES ON EITHER SIDE THAT GET PROGRESSIVELY THINNER AS THEY MOVE AWAY FROM THE "V".  
FOR WATCHES (U.S. CLS. 2, 27, 28 AND 50).  
CHARLES L. JENKINS, EXAMINING ATTORNEY

SN 85-209,577. ST. BRENDAN'S RULE, MCLEAN, VA. FILED 1-3-2011.

## Add-a-Pet

THE MARK CONSISTS OF STANDARD CHARACTERS WITHOUT CLAIM TO ANY PARTICULAR FONT, STYLE, SIZE, OR COLOR.

FOR BEADS FOR USE IN THE MANUFACTURE OF JEWELRY; BRACELETS; CHARMS FOR COLLAR JEWELRY AND BRACELET; JEWELRY; NECKLACES (U.S. CLS. 2, 27, 28 AND 50).

FIRST USE 10-2-2010; IN COMMERCE 11-21-2010.  
JAMES GRIFFIN, EXAMINING ATTORNEY

**CLASS 14—(Continued).**

SN 85-209,857. RICHLINE GROUP, INC., MOUNT VERNON, NY. FILED 1-4-2011.

## 100 MIL

THE MARK CONSISTS OF STANDARD CHARACTERS WITHOUT CLAIM TO ANY PARTICULAR FONT, STYLE, SIZE, OR COLOR.

FOR JEWELRY (U.S. CLS. 2, 27, 28 AND 50).  
PAUL E. FAHRENKOPF, EXAMINING ATTORNEY

SN 85-210,064. WILLIAMS, YAISA P., BOWIE, MD. FILED 1-4-2011.

## SWEET CHIC

THE MARK CONSISTS OF STANDARD CHARACTERS WITHOUT CLAIM TO ANY PARTICULAR FONT, STYLE, SIZE, OR COLOR.

FOR JEWELRY (U.S. CLS. 2, 27, 28 AND 50).  
HELENE LIWINSKI, EXAMINING ATTORNEY

SN 85-210,279. BALLSIES, L.L.C., MESA, AZ. FILED 1-4-2011.

## BALLSIES

THE MARK CONSISTS OF STANDARD CHARACTERS WITHOUT CLAIM TO ANY PARTICULAR FONT, STYLE, SIZE, OR COLOR.

FOR JEWELRY (U.S. CLS. 2, 27, 28 AND 50).  
FIRST USE 9-8-2010; IN COMMERCE 9-8-2010.  
BARBARA BROWN, EXAMINING ATTORNEY

SN 85-211,973. JASON A. VILLATICO, WEBSTER, MA. AND JOSEPH A. VILLATICO, WEBSTER, MA. FILED 1-6-2011.

## Balancepoint

THE MARK CONSISTS OF STANDARD CHARACTERS WITHOUT CLAIM TO ANY PARTICULAR FONT, STYLE, SIZE, OR COLOR.

FOR BRACELETS; NECKLACES; RUBBER OR SILICON WRISTBANDS IN THE NATURE OF A BRACELET (U.S. CLS. 2, 27, 28 AND 50).

TINA MAI, EXAMINING ATTORNEY

**CLASS 14—(Continued).**

SN 85-212,103. USA DISCOUNTERS, LTD., VIRGINIA BEACH, VA. FILED 1-6-2011.

**CARBINE**

THE MARK CONSISTS OF STANDARD CHARACTERS WITHOUT CLAIM TO ANY PARTICULAR FONT, STYLE, SIZE, OR COLOR.  
FOR WATCHES (U.S. CLS. 2, 27, 28 AND 50).  
MARK SHINER, EXAMINING ATTORNEY

SN 85-212,207. USA DISCOUNTERS, LTD., VIRGINIA BEACH, VA. FILED 1-6-2011.

**SENTINEL**

THE MARK CONSISTS OF STANDARD CHARACTERS WITHOUT CLAIM TO ANY PARTICULAR FONT, STYLE, SIZE, OR COLOR.  
FOR WATCHES (U.S. CLS. 2, 27, 28 AND 50).  
MARK SHINER, EXAMINING ATTORNEY

SN 85-212,981. SAMUEL AARON, INC., LONG ISLAND CITY, NY. FILED 1-7-2011.

**ROCK N' ICE**

THE MARK CONSISTS OF STANDARD CHARACTERS WITHOUT CLAIM TO ANY PARTICULAR FONT, STYLE, SIZE, OR COLOR.  
FOR JEWELRY (U.S. CLS. 2, 27, 28 AND 50).  
MICHAEL SOUDERS, EXAMINING ATTORNEY

**CLASS 14—(Continued).**

SN 85-214,201. SAINT LOUIS UNIVERSITY, ST. LOUIS, MO. FILED 1-10-2011.



THE MARK CONSISTS OF A STYLIZED DEPICTION OF THE HEAD OF A CHARM DOLL (A "BILLIKEN") WITH TWO POINTED EARS AND A TUFT OF HAIR ON THE TOP OF ITS HEAD. THE MOUTH IS CURVED AND THE RIGHT EYE IS CLOSED.

FOR JEWELRY, NAMELY, EARRINGS, PENDANTS, NECKLACES, BEADS AND LAPEL PINS; CLOCKS (U.S. CLS. 2, 27, 28 AND 50).  
FIRST USE 0-0-2000; IN COMMERCE 0-0-2000.  
KARANENDRA S. CHHINA, EXAMINING ATTORNEY

SN 85-214,327. CONFETTI CONCEPTS, INC., DBA FEMINGLES, SCOTTSDALE, AZ. FILED 1-10-2011.

**FEMINGLES**

THE MARK CONSISTS OF STANDARD CHARACTERS WITHOUT CLAIM TO ANY PARTICULAR FONT, STYLE, SIZE, OR COLOR.

FOR LAPEL PINS; NECKLACES; ORNAMENTAL LAPEL PINS; ORNAMENTAL PINS; ORNAMENTAL PINS MADE OF PRECIOUS METAL; PINS BEING JEWELRY; RINGS; RINGS; RINGS BEING JEWELRY; TIE PINS; TIE-PINS OF PRECIOUS METAL (U.S. CLS. 2, 27, 28 AND 50).

THOMAS MANOR, EXAMINING ATTORNEY

**CLASS 14—(Continued).**

SN 85-217,653. SEARS BRANDS, LLC, HOFFMAN ESTATES, IL. FILED 1-14-2011.



THE MARK CONSISTS OF THE CAPITAL LETTER "T" NEXT TO A SMALLER CAPITAL "D".  
FOR JEWELRY (U.S. CLS. 2, 27, 28 AND 50).  
STEVEN PEREZ, EXAMINING ATTORNEY

SN 85-231,395. PACIFIC WORLD CORPORATION, LAKE FOREST, CA. FILED 2-1-2011.



THE MARK CONSISTS OF A STYLIZED LOWER CASE "G" FOLLOWED BY A STYLIZED UPPER CASE "G".  
FOR COSTUME JEWELRY; WATCHES (U.S. CLS. 2, 27, 28 AND 50).  
HOWARD SMIGA, EXAMINING ATTORNEY

SN 85-235,126. FREDERICK GOLDMAN, INC., NEW YORK, NY. FILED 2-6-2011.

**YOUR SIGNATURE**

THE MARK CONSISTS OF STANDARD CHARACTERS WITHOUT CLAIM TO ANY PARTICULAR FONT, STYLE, SIZE, OR COLOR.  
FOR JEWELRY (U.S. CLS. 2, 27, 28 AND 50).  
SHAUNIA CARLYLE, EXAMINING ATTORNEY

**CLASS 14—(Continued).**

SN 85-246,952. D-GENERATION, INC, DAYTONA BEACH, FL. FILED 2-19-2011.



THE MARK CONSISTS OF STANDARD CHARACTERS WITHOUT CLAIM TO ANY PARTICULAR FONT, STYLE, SIZE, OR COLOR.

FOR JEWELRY (U.S. CLS. 2, 27, 28 AND 50).  
FIRST USE 11-13-2008; IN COMMERCE 11-13-2008.  
JUSTINE D. PARKER, EXAMINING ATTORNEY

**CLASS 15—MUSICAL INSTRUMENTS**

SN 76-704,713. YAMAHA CORPORATION, HAMAMATSU-SHI, SHIZUOKA, JAPAN, FILED 9-28-2010.



THE MARK CONSISTS OF STANDARD CHARACTERS WITHOUT CLAIM TO ANY PARTICULAR FONT, STYLE, SIZE, OR COLOR.

NO CLAIM IS MADE TO THE EXCLUSIVE RIGHT TO USE "SERIES", APART FROM THE MARK AS SHOWN.  
FOR ELECTRIC GUITARS, GUITARS, PICKS FOR STRINGED INSTRUMENTS, STRINGS FOR MUSICAL INSTRUMENTS (U.S. CLS. 2, 21 AND 36).  
RAMONA ORTIGA, EXAMINING ATTORNEY

SN 77-951,401. DALE ROBERTSON, PIERREFONDS, CANADA, FILED 3-5-2010.



THE MARK CONSISTS OF STANDARD CHARACTERS WITHOUT CLAIM TO ANY PARTICULAR FONT, STYLE, SIZE, OR COLOR.

SEC. 2(F).  
FOR WOODWIND INSTRUMENTS (U.S. CLS. 2, 21 AND 36).  
FIRST USE 10-1-2004; IN COMMERCE 10-1-2004.  
MARY ROSSMAN, EXAMINING ATTORNEY

**CLASS 15—(Continued).**

SN 79-091,493. MIRAPHONE GRASLITZER MUSIKINSTRUMENTENERZEUGER E.G., FED REP GERMANY, FILED 10-21-2010.



OWNER OF INTERNATIONAL REGISTRATION 0470438 DATED 7-6-1982, EXPIRES 7-6-2012.  
OWNER OF U.S. REG. NO. 1,133,089.  
FOR MUSICAL INSTRUMENTS EXCLUDING TALKING MACHINES, WIRELESS TELEGRAPH AND TELEPHONE APPARATUS, NAMELY, TUBAS, FRENCH HORNS, BARITONES, EUPHONIUMS, TROMBONES, TRUMPETS, ALTO HORNS, FLEUGELHORNS, COACH HORNS (U.S. CLS. 2, 21 AND 36).  
SEAN CROWLEY, EXAMINING ATTORNEY

SN 85-170,892. BML, INC, CHATTANOOGA, TN. FILED 11-6-2010.

**J.BACKLUND DESIGN**

THE MARK CONSISTS OF STANDARD CHARACTERS WITHOUT CLAIM TO ANY PARTICULAR FONT, STYLE, SIZE, OR COLOR.  
NO CLAIM IS MADE TO THE EXCLUSIVE RIGHT TO USE "DESIGN", APART FROM THE MARK AS SHOWN.  
THE NAME(S), PORTRAIT(S), AND/OR SIGNATURE(S) SHOWN IN THE MARK IDENTIFIES "JOHN BACKLUND", WHOSE CONSENT(S) TO REGISTER IS MADE OF RECORD.  
FOR ELECTRIC GUITARS (U.S. CLS. 2, 21 AND 36).  
FIRST USE 1-17-2008; IN COMMERCE 1-17-2008.  
YAT SYE, LEE, EXAMINING ATTORNEY

SN 85-187,606. FERRIN, ANDREW, LEBANON, TN. FILED 11-30-2010.



THE MARK CONSISTS OF THE STYLIZED TEXT "THE LEDGE" WITH A SILHOUETTE OF A MAN ON THE TOP OF THE "L" AND ROCK CRAGS ON THE "T" "L" AND "G".  
FOR METAL RACKS SPECIALLY ADAPTED FOR GUITARS AND MUSICAL INSTRUMENTS (U.S. CLS. 2, 21 AND 36).  
NATALIE POLZER, EXAMINING ATTORNEY

**CLASS 15—(Continued).**

SN 85-189,791. AUSTIN BAZAAR INC, AUSTIN, TX. FILED 12-2-2010.



THE MARK CONSISTS OF THE STYLIZED TEXT "BARCELONA" WITH LINES ABOVE AND BELOW.  
FOR MUSICAL INSTRUMENTS (U.S. CLS. 2, 21 AND 36).  
FIRST USE 7-13-2009; IN COMMERCE 7-13-2009.  
TRACY FLETCHER, EXAMINING ATTORNEY

SN 85-199,824. GRAHAM, JAN G., SHELBY TOWNSHIP, MI. FILED 12-16-2010.

**G BONE**

THE MARK CONSISTS OF STANDARD CHARACTERS WITHOUT CLAIM TO ANY PARTICULAR FONT, STYLE, SIZE, OR COLOR.  
FOR GUITARS (U.S. CLS. 2, 21 AND 36).  
FIRST USE 12-16-2010; IN COMMERCE 12-16-2010.  
REGINA DRUMMOND, EXAMINING ATTORNEY

SN 85-204,607. GOOD, JOHN, THOUSAND OAKS, CA. FILED 12-23-2010.

**JOHN GOOD**

THE MARK CONSISTS OF STANDARD CHARACTERS WITHOUT CLAIM TO ANY PARTICULAR FONT, STYLE, SIZE, OR COLOR.  
FOR MUSICAL INSTRUMENTS, NAMELY, DRUMS (U.S. CLS. 2, 21 AND 36).  
DEZMONA MIZELLE, EXAMINING ATTORNEY

**CLASS 15—(Continued).**

SN 85-208,892. PADILLA, DANIEL M., CHICAGO, IL. FILED 1-2-2011.



THE MARK CONSISTS OF THE NAME "GRYDER" SUPERIMPOSED OVER THE IMAGE OF A LIGHTENING BOLT. ONLY THE LETTER "G" IS CAPITALIZED WITH THE UPPER MOST SEGMENT EXTENDED TO REACH THE LOCATION JUST ABOVE THE LETTER "Y". THE BOTTOM OF THE LOWER CASE "Y" EXTENDS TO REACH THE LOCATION JUST BELOW THE LETTER "G". THE LIGHTENING BOLT EXTENDS FROM THE UPPER LEFT TO THE LOWER RIGHT.

FOR GUITAR PICKS (U.S. CLS. 2, 21 AND 36).  
JANICE KIM, EXAMINING ATTORNEY

SN 85-209,042. DRUM RÖHL, LLC, NORTH EAST, PA. FILED 1-3-2011.

# DRUM RÖHL

THE MARK CONSISTS OF STANDARD CHARACTERS WITHOUT CLAIM TO ANY PARTICULAR FONT, STYLE, SIZE, OR COLOR.

NO CLAIM IS MADE TO THE EXCLUSIVE RIGHT TO USE "DRUM", APART FROM THE MARK AS SHOWN.

FOR DRUMS (U.S. CLS. 2, 21 AND 36).  
FIRST USE 11-22-2010; IN COMMERCE 11-22-2010.  
LAURA KOVALSKY, EXAMINING ATTORNEY

SN 85-212,344. MEYER MUSIC COMPANY, BLUE SPRINGS, MO. FILED 1-6-2011.



THE MARK CONSISTS OF A CROWN WITH THE STYLIZED TEXT "GIUSEPPE".

FOR CELLOS; MUSICAL INSTRUMENTS, NAMELY, STRING BASSES; VIOLAS; VIOLINS (U.S. CLS. 2, 21 AND 36).

FIRST USE 4-7-2009; IN COMMERCE 4-8-2009.  
TIMOTHY FINNEGAN, EXAMINING ATTORNEY

**CLASS 15—(Continued).**

SN 85-228,172. FREMANTLEMEDIA NORTH AMERICA, INC., BURBANK, CA. AND SIMCO LIMITED, LONDON, UNITED KINGDOM, FILED 1-27-2011.

# THE X FACTOR

THE MARK CONSISTS OF STANDARD CHARACTERS WITHOUT CLAIM TO ANY PARTICULAR FONT, STYLE, SIZE, OR COLOR.

FOR MUSICAL INSTRUMENTS, NAMELY GUITARS; MUSICAL INSTRUMENT ACCESSORIES, NAMELY, STANDS, CASES, CARRYING BAGS AND STORAGE BAGS (U.S. CLS. 2, 21 AND 36).

TAMARA FRAZIER, EXAMINING ATTORNEY

**CLASS 16—PAPER GOODS AND PRINTED MATTER**

SN 76-703,916. AMERICAN WOODMARK CORPORATION, WINCHESTER, VA. FILED 7-26-2010.

## CONNECT COLLABORATE CELEBRATE WAYPOINT LIVING SPACES

THE MARK CONSISTS OF STANDARD CHARACTERS WITHOUT CLAIM TO ANY PARTICULAR FONT, STYLE, SIZE, OR COLOR.

FOR PRINTED PUBLICATIONS, NAMELY, A MAGAZINE AND ARTICLES FEATURING INFORMATION IN THE FIELD OF CABINETRY (U.S. CLS. 2, 5, 22, 23, 29, 37, 38 AND 50).

FIRST USE 4-0-2010; IN COMMERCE 4-0-2010.  
PAUL MORENO, EXAMINING ATTORNEY

SN 76-703,917. AMERICAN WOODMARK CORPORATION, WINCHESTER, VA. FILED 7-26-2010.



THE MARK CONSISTS OF THE DESIGN OF THREE ARROWS FORMING A CIRCLE. EACH ARROW CON-



**CLASS 16—(Continued).**

TAINS WORDING. THE ARROW AT THE TOP CONTAINS THE WORDING "CONNECT". THE TOP ARROW LEADS INTO THE ARROW ON THE RIGHT. THE ARROW ON THE RIGHT CONTAINS THE WORDING "COLLABORATE". THE ARROW ON THE RIGHT LEADS INTO THE ARROW ON THE LEFT. THE ARROW ON THE LEFT CONTAINS THE WORDING "CELEBRATE". THE ARROW ON THE LEFT LEADS INTO THE ARROW AT THE TOP. THE WORDING "WAYPOINT LIVING SPACES" APPEARS INSIDE THE CIRCLE.

FOR PRINTED PUBLICATIONS, NAMELY, A MAGAZINE AND ARTICLES FEATURING INFORMATION IN THE FIELD OF CABINETRY (U.S. CLS. 2, 5, 22, 23, 29, 37, 38 AND 50).

FIRST USE 4-0-2010; IN COMMERCE 4-0-2010.  
PAUL MORENO, EXAMINING ATTORNEY

**CLASS 16—(Continued).**

SN 77-583,806. NINTENDO OF AMERICA INC., REDMOND, WA. FILED 10-2-2008.



SN 76-705,894. FLOORTEX EUROPE LIMITED, GLOUCESTERSHIRE, UNITED KINGDOM, FILED 1-4-2011.

# DESKTEX

THE MARK CONSISTS OF STANDARD CHARACTERS WITHOUT CLAIM TO ANY PARTICULAR FONT, STYLE, SIZE, OR COLOR.

FOR DESK PROTECTION, NAMELY, DESK PADS (U.S. CLS. 2, 5, 22, 23, 29, 37, 38 AND 50).

FIRST USE 11-10-2010; IN COMMERCE 11-10-2010.  
JENNIFER VASQUEZ, EXAMINING ATTORNEY

OWNER OF JAPAN REG. NO. 5324017, DATED 5-21-2010, EXPIRES 5-21-2020.

OWNER OF U.S. REG. NOS. 1,213,822, 1,628,966 AND OTHERS.

THE MARK CONSISTS OF THE WORDS "NINTENDO ZONE"; WITH TRANSMISSION WAVES EMANATING FROM THE DOT ABOVE THE LETTER "I".

FOR NOTEBOOKS; MECHANICAL PENCILS; PENCIL CASES; STATIONERY; STUDY MATERIALS, NAMELY, FLASH CARDS; TRADING CARDS; MAGAZINES FEATURING VIDEO GAMES, VIDEO GAMES SYSTEMS AND ACCESSORIES; CATALOGUES FEATURING VIDEO GAMES, VIDEO GAMES SYSTEMS AND ACCESSORIES; PAMPHLETS FEATURING VIDEO GAMES, VIDEO GAMES SYSTEMS AND ACCESSORIES; OTHER PRINTED MATTER, NAMELY, POSTERS; BANNERS OF PAPER; FLAGS OF PAPER; ELECTRIC PENCIL SHARPENERS; DECORATORS' PAINTBRUSHES; INDUSTRIAL PACKAGING CONTAINERS OF PAPER; FOOD WRAPPING PLASTIC FILM FOR HOUSEHOLD USE; GARBAGE BAGS OF PAPER FOR HOUSEHOLD USE; GARBAGE BAGS OF PLASTICS FOR HOUSEHOLD USE; PAPER PATTERNS FOR MAKING CLOTHES; HYGIENIC HAND TOWELS OF PAPER; TOWELS OF PAPER; TABLE NAPKINS OF PAPER; HAND TOWELS OF PAPER; HANDKERCHIEFS OF PAPER; TABLE CLOTHS OF PAPER; PAPER AND CARDBOARD; PAINTINGS AND CALLIGRAPHIC WORKS; PRINTED MATTER AND PUBLICATIONS, NAMELY, ADDRESS BOOKS; ARTISTS' BRUSHES; ARTISTS' PASTELS; ARTS AND CRAFTS PAINT KITS; BOOK COVERS; BOOKMARKS; BOOKPLATES; CARDBOARD GIFT BOXES; CHILDREN'S BOOKS; COLORING BOOKS; CHILDREN'S ACTIVITY BOOKS; COMIC BOOKS; CRAYONS; DECORATIVE FIGURES ATTACHABLE TO PENCILS; DRAWING RULERS; DRY ERASE WRITING BOARDS; ERASERS; FELT-TIP MARKERS; GIFT WRAPPING PAPER; GREETING CARDS; INVITATION CARDS; IRON-ON TRANSFERS; MAGAZINES, BOOKS, BOOKLETS AND MANUALS REGARDING VIDEO GAMES; MAGNETIC SLATE BOARDS FOR WRITING; MEMO BOARDS; MEMO PADS; NEWSPAPER CARTOONS; NOTEPADS; PAINTING SETS FOR CHILDREN; PAPER BANNERS; PAPER DECORATIONS MOUNTABLE ON DOORS; PAPER NAPKINS; PAPER PARTY FAVORS; PAPER PLACEMATS; PAPER STAPLERS; PAPER TABLE COVERS; PAPERBACK BOOKS FOR CHILDREN; PENCIL BOXES WITH MAGNETIC CLOSURES; PENCIL SHARPENERS; PENCILS; PENS; PICTURE STORYBOOKS; POSTCARDS; POSTERS; RING BINDERS; RUBBER STAMPS; SCORE BOOKS; SCRAPBOOKS AND STAMP COLLECTOR BOOKS; SCRATCH PADS; STAPLERS IN THE NATURE OF OFFICE REQUISITES; STATIONERY-TYPE PORTFOLIOS; STICKER ALBUMS; STICKERS; STORYBOOK AND AUDIO CASSETTES PACKAGED AS A UNIT (U.S. CLS. 2, 5, 22, 23, 29, 37, 38 AND 50).

MATTHEW MCDOWELL, EXAMINING ATTORNEY

SN 77-439,388. LASER SUBSTRATES, INC., BOCA RATON, FL. FILED 4-3-2008.

# TRANSFORM

THE MARK CONSISTS OF STANDARD CHARACTERS WITHOUT CLAIM TO ANY PARTICULAR FONT, STYLE, SIZE, OR COLOR.

FOR BLANK BUSINESS FORMS, NAMELY, BLANK SELF-MAILERS FOR INVOICES, STATEMENTS, CHECKS AND NOTICES (U.S. CLS. 2, 5, 22, 23, 29, 37, 38 AND 50).

FIRST USE 8-27-2004; IN COMMERCE 9-20-2004.  
STEVEN R. FINE, EXAMINING ATTORNEY

**CLASS 16—(Continued).**

SN 77-769,974. VRKLJAN, DUNJA, VANCOUVER, CANADA, FILED 6-29-2009.

## Mia de Fleur

THE MARK CONSISTS OF STANDARD CHARACTERS WITHOUT CLAIM TO ANY PARTICULAR FONT, STYLE, SIZE, OR COLOR.

THE NAME(S), PORTRAIT(S), AND/OR SIGNATURE(S) SHOWN IN THE MARK DOES NOT IDENTIFY A PARTICULAR LIVING INDIVIDUAL.

THE ENGLISH TRANSLATION OF "DE FLEUR" IN THE MARK IS "OF FLOWER".

FOR ORIGINAL WORKS OF ART, NAMELY, BLACK AND WHITE INK AND WASH ILLUSTRATIONS AND PICTURES, LINE DRAWINGS, WATER COLOR ILLUSTRATIONS, PICTURES, PASTEL ILLUSTRATIONS, ACRYLIC PAINTINGS, OIL PAINTINGS; PHOTOGRAPHS; PHOTOGRAPHS THAT HAVE BEEN COMPUTER MANIPULATED AND ENHANCED TO LOOK LIKE PAINTINGS; PRINTED ART REPRODUCTIONS; GRAPHIC ART REPRODUCTIONS; CALENDARS; POSTERS; POSTCARDS; GREETING CARDS; BOOKS FEATURING WORKS OF ART (U.S. CLS. 2, 5, 22, 23, 29, 37, 38 AND 50).

BARBARA GAYNOR, EXAMINING ATTORNEY

SN 77-868,323. THE PROCTER & GAMBLE COMPANY, CINCINNATI, OH. FILED 11-9-2009.

## BOUNTY EXTRA SOFT

THE MARK CONSISTS OF STANDARD CHARACTERS WITHOUT CLAIM TO ANY PARTICULAR FONT, STYLE, SIZE, OR COLOR.

OWNER OF U.S. REG. NO. 793,371. SEC. 2(F) AS TO "EXTRA SOFT". FOR PAPER TOWELS (U.S. CLS. 2, 5, 22, 23, 29, 37, 38 AND 50).

FIRST USE 2-4-2008; IN COMMERCE 2-4-2008. MICHELE SWAIN, EXAMINING ATTORNEY

**CLASS 16—(Continued).**

SN 77-880,779. MADSTONE COMPANY, INC., NEW YORK, NY. FILED 11-25-2009.



THE MARK CONSISTS OF THE WORD "MADSTONE" BELOW THE DESIGN ELEMENT OF A MAN SITTING ON A ROCK.

FOR SERIES OF BOOKS FEATURING CHILDREN, TEENS AND ADULT FICTION; SERIES OF NON-FICTION BOOKS IN THE FIELD OF BIOGRAPHIES AND POLITICS (U.S. CLS. 2, 5, 22, 23, 29, 37, 38 AND 50).

TEJBIR SINGH, EXAMINING ATTORNEY

SN 77-940,830. RIVAS-MINTZ, MARIA A, PHILADELPHIA, PA. AND MELENDEZ, DAYANA, NARBERTH, PA. AND MINTZ, GARY, PHILADELPHIA, PA. FILED 2-21-2010.

## RAMÓN CAMALEÓN

THE MARK CONSISTS OF STANDARD CHARACTERS WITHOUT CLAIM TO ANY PARTICULAR FONT, STYLE, SIZE, OR COLOR.

THE NAME(S), PORTRAIT(S), AND/OR SIGNATURE(S) SHOWN IN THE MARK DOES NOT IDENTIFY A PARTICULAR LIVING INDIVIDUAL.

THE ENGLISH TRANSLATION OF "RAMÓN CAMALEÓN" IN THE MARK IS RAMON CHAMELEON.

FOR A SERIES OF BOOKS AND WRITTEN ARTICLES IN THE FIELD OF LEARNING A FOREIGN LANGUAGE; A SERIES OF BOOKS, WRITTEN ARTICLES, HANDOUTS AND WORKSHEETS IN THE FIELD OF LEARNING A FOREIGN LANGUAGE; CHILDREN'S ACTIVITY BOOKS; CHILDREN'S BOOKS; CHILDREN'S INTERACTIVE EDUCATIONAL BOOKS; CHILDREN'S STORYBOOKS; COLORING BOOKS; EDUCATIONAL BOOKS FEATURING FOREIGN LANGUAGE LEARNING; EDUCATIONAL KITS SOLD AS A UNIT IN THE FIELD OF LEARNING A FOREIGN LANGUAGE CONSISTING PRIMARILY OF EDUCATIONAL BOOKS, FLASH CARDS AND WORKSHEETS; EDUCATIONAL PUBLICATIONS, NAMELY, EDUCATIONAL LEARNING CARDS, FLASH CARDS, ACTIVITY CARDS, WORKBOOKS, TEXTBOOKS, ACTIVITY BOOKS, STORY BOOKS, PUZZLE BOOKS, PRINTED PUZZLES, TEACHER GUIDES, MANUALS, POSTERS AND EDUCATIONAL BOOKLETS IN THE FIELD OF LEARNING A FOREIGN LANGUAGE; EDUCATIONAL PUBLICATIONS, NAMELY, BOOKS, FLASH CARDS, POSTERS, WORKSHEETS IN THE FIELDS OF LEARNING A FOREIGN LANGUAGE; PICTURE BOOKS; TALKING CHILDREN'S BOOKS (U.S. CLS. 2, 5, 22, 23, 29, 37, 38 AND 50).

TRACY CROSS, EXAMINING ATTORNEY

**CLASS 16—(Continued).**

SN 79-086,782. ALBERT HORN SÖHNE GMBH & CO. KG,  
FED REP GERMANY, FILED 8-9-2010.



OWNER OF INTERNATIONAL REGISTRATION 0452802  
DATED 5-29-1980, EXPIRES 5-29-2020.

OWNER OF U.S. REG. NO. 731,873.

THE MARK CONSISTS OF A HORN WITH THE WORD-  
ING "HORN" WITHIN THE ARC.

FOR PRINTED MATTER, NAMELY, PICTURE POST-  
CARDS, PHOTOGRAPHIC POSTCARDS, GREETING  
CARDS, BEREAVEMENT CARDS AND PLACE CARDS  
(U.S. CLS. 2, 5, 22, 23, 29, 37, 38 AND 50).

MARTHA FROMM, EXAMINING ATTORNEY

SN 85-000,140. NCD ACQUISITION INC., SANTA FE  
SPRINGS, CA. FILED 3-27-2010.

**CENTURY BUSINESS SOLUTIONS**

THE MARK CONSISTS OF STANDARD CHARACTERS  
WITHOUT CLAIM TO ANY PARTICULAR FONT, STYLE,  
SIZE, OR COLOR.

FOR PLASTIC SLEEVES FOR HOLDING AND DIS-  
PLAYING PHOTOGRAPHS, DOCUMENTS, ART  
PRINTS, DRAWINGS AND PAINTINGS, COINS, MAGA-  
ZINES, NEWSPAPERS, PHOTOGRAPHS, PRINTED  
AWARDS AND CERTIFICATES, STAMPS, TRADING  
CARDS AND ADDRESS BOOKS, BOOKS, MAGAZINES,  
MANUSCRIPTS, AND NEWSPAPERS; BOOKS AND AR-  
CHIVAL SUPPLIES, NAMELY, SCRAPBOOKS; SCRAP-  
BOOK ALBUMS; PHOTOGRAPH ALBUMS (U.S. CLS. 2,  
5, 22, 23, 29, 37, 38 AND 50).

FIRST USE 2-0-2000; IN COMMERCE 2-0-2000.

NICHOLAS COLEMAN, EXAMINING ATTORNEY

**CLASS 16—(Continued).**

SN 85-013,108. WILSON, EBONY S., DBA E. MOORE, TULSA,  
OK. FILED 4-13-2010.



THE COLOR(S) RED, WHITE, BROWN, BLACK IS/ARE  
CLAIMED AS A FEATURE OF THE MARK.

THE MARK CONSISTS OF LITTLE AFRICAN AMERI-  
CAN BROWN GIRL WHO HAS BLACK AFRO PUFFS  
WEARING A RED AND WHITE POLKA DOT DRESS, THE  
POLKADOTS BEING WHITE WITH RED CIRCLE SHOES.

FOR (BASED ON USE IN COMMERCE) A SERIES OF  
BOOKS AND WRITTEN ARTICLES IN THE FIELD OF  
PRESCHOOL AND ELEMENTARY MATH, READING,  
SCIENCE, LIFE SKILLS, AND SOCIAL STUDIES.; A  
SERIES OF BOOKS, WRITTEN ARTICLES, HANDOUTS  
AND WORKSHEETS IN THE FIELD OF PRESCHOOL  
AND ELEMENTARY MATH, READING, SCIENCE, LIFE  
SKILLS, CHARACTER EDUCATION AND SOCIAL STU-  
DIES; BABY BOOKS; BIRTHDAY BOOKS; BOOKS IN  
THE FIELD OF PRESCHOOL AND ELEMENTARY  
MATH, READING, SCIENCE, LIFE SKILLS AND SO-  
CIAL STUDIES; CHILDREN'S BOOKS; EDUCATIONAL  
BOOKS FEATURING PRESCHOOL AND ELEMENTARY  
MATH, READING, SCIENCE, LIFE SKILLS, CHAR-  
ACTER EDUCATION, SOCIAL STUDIES; PICTURE BOOKS;  
PRINTED MATTER, NAMELY, NEWSPAPERS, PHOTO-  
GRAPHS, MAGAZINES, BOOKS, PRINTED PERIOD-  
ICALS, NEWSLETTERS, AND BROCHURES ALL IN  
THE FIELDS OF SECURITIES, OPTIONS AND OTHER  
FINANCIAL INSTRUMENTS; RESOURCE BOOKS IN  
THE FIELD OF MATH, SCIENCE, READING, SOCIAL  
STUDIES, LIFE SKILLS, CHARACTER EDUCATION  
FOR CHILDREN; SERIES OF FICTION BOOKS; SERIES  
OF NON-FICTION BOOKS IN THE FIELD OF MATH,  
SCIENCE, READING, HUMANITIES, SOCIAL STUDIES,  
LIFE SKILLS, CHARACTER EDUCATION; STORY  
BOOKS (BASED ON INTENT TO USE) ADDRESS  
BOOKS; APPOINTMENT BOOKS; BOOK MARKERS;  
BOOK MARKERS OF PRECIOUS METAL; BOOK  
MARKS; BOOK PLATES; BOOK-COVER PAPER; BOOKS  
IN THE FIELD OF MEMORY TRAINING ACTIVITIES  
SOLD AS A UNIT WITH TWO AND THREE DIMEN-  
SIONAL POSITIONABLE FIGURES; CARDBOARD  
BACKING FOR BINDING BOOKS; CHILDREN'S ACTI-  
VITY BOOKS; CHILDREN'S INTERACTIVE EDU-  
CATIONAL BOOKS; COLORING BOOKS; COMIC BOOKS;  
EDUCATIONAL KITS SOLD AS A UNIT IN THE FIELD  
OF PRESCHOOL AND ELEMENTARY MATH, SCIENCE,  
READING, LIFE SKILLS, CHARACTER EDUCATION  
AND SOCIAL STUDIES CONSISTING PRIMARILY OF  
EDUCATIONAL BOOKS, FLASH CARDS AND WORK-  
SHEETS, AND ALSO INCLUDING AN EDUCATIONAL  
DVD; EDUCATIONAL PUBLICATIONS, NAMELY, EDU-  
CATIONAL LEARNING CARDS, FLASH CARDS, ACTI-  
VITY CARDS, WORKBOOKS, TEXTBOOKS,  
ACTIVITY BOOKS, STORY BOOKS IN THE FIELDS OF  
MATH, SCIENCE, READING, SOCIAL STUDIES, LIFE  
SKILLS AND CHARACTER EDUCATION; FLIP BOOKS;  
GIFT SETS CONSISTING OF A BOOK IN THE FIELD OF  
MATH, SCIENCE, READING, CHARACTER EDU-  
CATION, LIFE SKILLS AND SOCIAL STUDIES AND ALSO  
INCLUDING A BLANKET; NOTE BOOKS; PRINTED  
MATERIALS, NAMELY, NOVELS AND SERIES OF  
FICTION BOOKS AND SHORT STORIES FEATURING  
SCENES AND CHARACTERS BASED ON VIDEO  
GAMES; PRINTED MUSIC BOOKS; PROTECTIVE COV-

**CLASS 16—(Continued).**

ERS FOR BOOKS; PROTECTIVE COVERS FOR SHEETS OR PAPER AND PAGES OF BOOKS AND THE LIKE; PUBLICATIONS, NAMELY, EDUCATIONAL LEARNING CARDS, FLASH CARDS, ACTIVITY CARDS, WORKBOOKS, TEXTBOOKS, PUZZLES, TEACHER GUIDES, MANUALS, POSTERS AND EDUCATIONAL BOOKLETS IN THE FIELDS OF MATH, SCIENCE, READING, ENGLISH, SOCIAL STUDIES AND HUMANITIES, CHARACTER EDUCATION AND LIFE SKILLS; SCHOOL SUPPLY KITS CONTAINING VARIOUS COMBINATIONS OF SELECTED SCHOOL SUPPLIES, NAMELY, WRITING INSTRUMENTS, PENS, PENCILS, MECHANICAL PENCILS, ERASERS, MARKERS, CRAYONS, HIGHLIGHTER PENS, FOLDERS, NOTEBOOKS, PAPER, PROTRACTORS, PAPER CLIPS, PENCIL SHARPENERS, WRITING GRIPS, GLUE AND BOOK MARKS; SERIES OF FICTION WORKS, NAMELY, NOVELS AND BOOKS; SONG BOOKS; TALKING CHILDREN'S BOOKS (U.S. CLS. 2, 5, 22, 23, 29, 37, 38 AND 50).  
FIRST USE 9-10-2006; IN COMMERCE 7-30-2007.  
BARBARA RUTLAND, EXAMINING ATTORNEY

SN 85-025,897. CULTURAME!, LLC, DOBBS FERRY, NY. FILED 4-29-2010.



THE MARK CONSISTS OF A LARGE OPEN SEMI CIRCLE SURROUNDING THE WORD "CULTÚRAME" WITH AN OPENING AT THE TOP RIGHT CORNER OF THE CIRCLE.

FOR PAPER, CARDBOARD AND GOODS MADE FROM THESE MATERIALS, NAMELY, GREETING CARDS; BOOKBINDING MATERIAL; PHOTOGRAPHS; STATIONERY; ADHESIVES FOR STATIONERY OR HOUSEHOLD PURPOSES; PRINTED INSTRUCTIONAL AND TEACHING MATERIAL IN THE FIELD OF LANGUAGE AND CULTURE (U.S. CLS. 2, 5, 22, 23, 29, 37, 38 AND 50).

FIRST USE 4-27-2010; IN COMMERCE 4-27-2010.  
VIVIAN MICZNIK FIRST, EXAMINING ATTORNEY

SN 85-030,791. OFFBEAT, INC., NEW ORLEANS, LA. FILED 5-5-2010.

## OffBeat

THE MARK CONSISTS OF STANDARD CHARACTERS WITHOUT CLAIM TO ANY PARTICULAR FONT, STYLE, SIZE, OR COLOR.

FOR PUBLICATIONS, NAMELY, MAGAZINES IN THE FIELDS OF LOUISIANA MUSIC AND CULTURE (U.S. CLS. 2, 5, 22, 23, 29, 37, 38 AND 50).

FIRST USE 6-1-1988; IN COMMERCE 6-1-1988.  
KATHLEEN M. VANSTON, EXAMINING ATTORNEY

**CLASS 16—(Continued).**

SN 85-032,489. POMODORO LLC, SAN DIEGO, CA. FILED 5-7-2010.

## MIMOSA

THE MARK CONSISTS OF STANDARD CHARACTERS WITHOUT CLAIM TO ANY PARTICULAR FONT, STYLE, SIZE, OR COLOR.

FOR PAPER GOODS AND PRINTED MATTER, NAMELY, TOILET PAPER, PAPER BABY DIAPERS AND CELLULOSE WIPES FOR BABIES AND ADULTS (U.S. CLS. 2, 5, 22, 23, 29, 37, 38 AND 50).

COLLEEN KEARNEY, EXAMINING ATTORNEY

SN 85-033,830. JASPER STATE BRAND, INC., BEVERLY HILLS, CA. FILED 5-10-2010.

## JASPER STATE

THE MARK CONSISTS OF STANDARD CHARACTERS WITHOUT CLAIM TO ANY PARTICULAR FONT, STYLE, SIZE, OR COLOR.

FOR CHILDREN'S BOOKS (U.S. CLS. 2, 5, 22, 23, 29, 37, 38 AND 50).

JENNIFER VASQUEZ, EXAMINING ATTORNEY

SN 85-034,162. JASPER STATE BRAND, INC., BEVERLY HILLS, CA. FILED 5-10-2010.



THE COLOR(S) BROWN, DARK BROWN, LIGHT BROWN, PINK, RED, GOLD, GRAY, BLACK, BLUE AND WHITE IS/ARE CLAIMED AS A FEATURE OF THE MARK.

THE MARK CONSISTS OF A BROWN MINIATURE POODLE HAVING A PINK NOSE AND TONGUE, LIGHT BROWN EYES WITH DARK BROWN PUPILS AND WHITE EYE BALLS, BLACK CLAWS AND BLACK OUTLINING.

**CLASS 16—(Continued).**

THE POODLE IS WEARING A BLUE DENIM JACKET THAT IS OUTLINED IN BLACK, RED GOGGLES OUTLINED IN BLACK WITH GRAY AND WHITE STREAKED LENS, A RED COLLAR WITH BLACK OUTLINING, THE COLLAR HAVING A GOLD DOG TAG OUTLINED IN BLACK WITH THE WORDS "JASPER STATE JOHNSON" AND NUMBERS "555-1015" IN BLACK, THERE IS A BLACK LINE BENEATH THE NUMBERS AND ABOVE THE WORD "JASPER". THE POODLE HAS WHITE SHADOWING ALL OVER.

FOR CHILDREN'S BOOKS (U.S. CLS. 2, 5, 22, 23, 29, 37, 38 AND 50).  
JENNIFER VASQUEZ, EXAMINING ATTORNEY

**CLASS 16—(Continued).**

SN 85-036,554. RAINER WERNER FASSBINDER FOUNDATION GEMEINNUTZIGE GESELLSCHAFT MBH, NEW YORK, NY. FILED 5-12-2010.

SN 85-035,364. GREEN BAY PACKAGING, INC., GREEN BAY, WI. FILED 5-11-2010.

SMART PARTNERS...SMARTER  
SOLUTIONS

THE MARK CONSISTS OF STANDARD CHARACTERS WITHOUT CLAIM TO ANY PARTICULAR FONT, STYLE, SIZE, OR COLOR.

FOR CORRUGATED AND PAPERBOARD PACKAGING, NAMELY, BOXES, CARTONS, AND SHIPPING CONTAINERS (U.S. CLS. 2, 5, 22, 23, 29, 37, 38 AND 50).  
FIRST USE 12-31-2009; IN COMMERCE 12-31-2009.  
DARRYL SPRUILL, EXAMINING ATTORNEY

RAINER WERNER FASSBINDER

SN 85-036,089. CITY OF AUSTIN, AUSTIN, TX. FILED 5-12-2010.



NO CLAIM IS MADE TO THE EXCLUSIVE RIGHT TO USE "GREEN", APART FROM THE MARK AS SHOWN.

THE COLOR(S) GREEN, BLACK, RED AND BLUE IS/ARE CLAIMED AS A FEATURE OF THE MARK.

THE MARK CONSISTS OF THE WORDING "GROW GREEN" AND A DESIGN ELEMENT FEATURING A LADYBUG ON A SINGLE LEAF WITH A SINGLE WATER DROPLET. THE COLOR BLACK APPEARS IN THE WORDING "GROW GREEN". THE COLOR GREEN APPEARS IN THE LEAF. THE COLOR BLACK APPEARS IN THE LADYBUG AND OUTLINES THE LEAF, LADYBUG, AND THE WATER DROPLET. THE COLOR RED APPEARS IN THE LADYBUG. THE COLOR BLUE APPEARS IN THE WATER DROPLET. THE COLOR WHITE REPRESENTS BACKGROUND, OUTLINING, SHADING AND/OR TRANSPARENT AREAS AND IS NOT PART OF THE MARK.

FOR EDUCATIONAL PUBLICATIONS, NAMELY, FACT SHEETS, BOOKLETS, AND PRINTED DESIGN TEMPLATES IN THE FIELDS OF EARTH-WISE LANDSCAPING (U.S. CLS. 2, 5, 22, 23, 29, 37, 38 AND 50).

FIRST USE 5-1-2000; IN COMMERCE 5-1-2000.  
LAURIE KAUFMAN, EXAMINING ATTORNEY

THE MARK CONSISTS OF STANDARD CHARACTERS WITHOUT CLAIM TO ANY PARTICULAR FONT, STYLE, SIZE, OR COLOR.

THE NAME "RAINER WERNER FASSBINDER" DOES NOT IDENTIFY A PARTICULAR LIVING INDIVIDUAL.

FOR PRINTED MATTER, NAMELY, BOOKS, MAGAZINES, JOURNALS, NEWSLETTERS, LEAFLETS, FOLIOS, BOOKLETS, PAMPHLETS AND BROCHURES IN THE FIELD OF FILMS, TELEVISION PROGRAMS, THEATRE, MUSICAL AND OPERA PRODUCTIONS AND ART EXHIBITIONS; PUBLICATIONS, NAMELY, BOOKS, MAGAZINES, JOURNALS, NEWSLETTERS, LEAFLETS, FOLIOS, BOOKLETS, PAMPHLETS AND BROCHURES IN THE FIELD OF FILMS, TELEVISION PROGRAMS, THEATRE, MUSICAL AND OPERA PRODUCTIONS AND ART EXHIBITIONS; PROMOTIONAL TYPE MATTER, NAMELY, POSTERS, CALENDARS, STICKERS, DECALS, BUMPER STICKERS, GIFT AND GREETING CARDS, MOTIVATIONAL CARDS, OCCASION AND NOTE CARDS, PLACE, RECORD, SCORE AND TRADING CARDS, POSTCARDS, SCRAPBOOKS, STATIONERY, NOTE PADS, NOTE BOOKS, FOLDERS, BOOKMARKS, PAPER PENNANTS, BINDERS, WRITING PAPER, ENVELOPES, ADDRESS AND APPOINTMENT BOOKS, DESK PADS, PAPER TAGS, PASSPORT CASES, HOLDERS, AND COVERS, DESK TOP AND PERSONAL ORGANIZERS, ORGANIZERS FOR STATIONERY USE, STATIONERY-TYPE PORTFOLIOS, PAPER FLAGS, STAMP ALBUMS, PAPER BANNERS, BOOK COVERS AND HOLDERS, CHECKBOOK COVERS, COIN AND PHOTOGRAPH ALBUMS, PHOTOGRAPHIC OR ART MOUNTS, PAPER OR CARDBOARD PICTURE MOUNTS, PICTURE BOOKS, PRINTED PAPER SIGNS, PAPER PARTY FAVORS, PAPER EMBLEMS, PRINTED EMBLEMS, PAPER IDENTIFICATION TAGS, PAPER NAME BADGES, PAPER ILLUSTRATION BOARDS, TOUR BOOKS, AND PHOTOGRAPHS (U.S. CLS. 2, 5, 22, 23, 29, 37, 38 AND 50).

SARA BENJAMIN, EXAMINING ATTORNEY

**CLASS 16—(Continued).**

SN 85-041,170. ALLEN, KATHY O., SIOUX FALLS, SD.  
FILED 5-18-2010.



gebut  
OFFICIALLY OUT.

THE MARK CONSISTS OF THE MARK IS THE WORD "GEBUT" IN SCRIPTED LETTERS WITH "OFFICIALLY OUT." UNDERNEATH IN BLOCK LETTERS.

FOR 3D DECALS FOR USE ON ANY SURFACE; A SERIES OF BOOKS AND WRITTEN ARTICLES IN THE FIELD OF COMING OUT AS IT RELATES TO ONE'S SEXUAL ORIENTATION, AND A DEBUT INTO SOCIETY; A SERIES OF BOOKS, WRITTEN ARTICLES, HANDOUTS AND WORKSHEETS IN THE FIELD OF COMING OUT AS IT RELATES TO ONE'S SEXUAL ORIENTATION, AND A DEBUT INTO SOCIETY; ADDRESS BOOKS; ADDRESS BOOKS AND DIARIES; ADDRESS LABELS; ADDRESS LISTS; ADDRESS PLATES; ADDRESS STAMPS; ADHESIVE CORNERS FOR PHOTOGRAPHS; ADHESIVE FOILS STATIONERY; ADHESIVE LABELS; ADHESIVE NOTE PADS; ADHESIVE NOTE PAPER; ADHESIVE TAPE DISPENSERS; ADHESIVE TAPE DISPENSERS FOR HOUSEHOLD OR STATIONERY USE; ADHESIVE TAPES FOR STATIONERY PURPOSES; ADHESIVE-BACKED PHOTOGRAPHS; ADHESIVES FOR DO-IT-YOURSELF PURPOSES; ADHESIVES FOR STATIONERY OR HOUSEHOLD PURPOSES; ADHESIVES IN THE FORM OF TAPE FOR STATIONERY; ADVERTISING SIGNS OF PAPER OR CARDBOARD; AGENDAS; ALBUMS FOR STICKERS; ANNIVERSARY BOOKS; ANNOUNCEMENT CARDS; APPOINTMENT BOOKS; ART PADS; ART PAPER; ART PRINTS; ART PRINTS COMPRISED OF DIGITAL ILLUSTRATIONS ORIGINATING FROM PHOTOGRAPHS; ART PRINTS ON CANVAS; ARTISTS' BRUSHES; ARTISTS' PASTELS; ARTISTS' PENCILS; ARTISTS' PENS; ARTS AND CRAFT CLAY KITS; AUTOGRAPH BOOKS; BAGS FOR MICROWAVE COOKING; BALL PENS; BALL POINT PENS; BALL-POINT PENS; BALLPOINT PENS; BANK CHECKS; BANNERS OF PAPER; BASEBALL CARDS; BATHROOM TISSUE; BIBLES; BILLBOOKS; BINDERS; BINDERS (OFFICE SUPPLIES); BINDERS FOR OFFICE USE; BIRTHDAY BOOKS; BLACKBOARD ERASERS; BLACKBOARDS; BLACKBOARDS AND SCRAP BOOKS; BLANK CARDS; BLANK FORMS; BLANK JOURNAL BOOKS; BLANK JOURNALS; BLANK NOTE CARDS; BLANK OR PARTIALLY PRINTED PAPER LABELS; BLANK OR PARTIALLY PRINTED POSTCARDS; BLANK PAPER NOTEBOOKS; BLANK WRITING JOURNALS; BLOTTER; BLOTTERS; BLOT-TING PAPER; BLUEPRINTS; BOOK COVERS; BOOK ENDS; BOOK HOLDERS; BOOK MARKERS; BOOK MARKERS OF PRECIOUS METAL; BOOK MARKS; BOOK PLATES; BOOK-COVER PAPER; BOOKENDS; BOOKLETS IN THE FIELD OF COMING OUT AS IT RELATES TO ONE'S SEXUAL ORIENTATION, AND A DEBUT INTO SOCIETY; BOOKMARKERS; BOOK-MARKS; BOOKS IN THE FIELD OF COMING OUT AS IT RELATES TO ONE'S SEXUAL ORIENTATION, AND A DEBUT INTO SOCIETY; BOTTLE WRAPPERS OF CARDBOARD OR PAPER; BOXES OF CARDBOARD OR PAPER; BOXES OF PAPER; BOXES OF PAPER OR CARDBOARD; BRAG BOOKS; BROCHURES ABOUT COMING OUT AS IT RELATES TO ONE'S SEXUAL ORIENTATION, AND A DEBUT INTO SOCIETY; CANVAS FOR PAINTING; CANVAS FOR PRINTING; CANVAS PANELS FOR ARTISTS; CARBON PAPER; CARBON PAPER; CARBONLESS PAPER; CARD FILES; CARDBOARD; CARDBOARD BOXES; CARDBOARD CAKE BOXES; CARDBOARD CARRIERS FOR FOOD AND BEVERAGES; CARDBOARD CARTONS; CARDBOARD CONTAINERS; CARDBOARD HANG TAGS; CARD-

**CLASS 16—(Continued).**

BOARD MAILING TUBES; CARDBOARD PACKAGING; CARDBOARD PACKAGING BOXES IN COLLAPSIBLE FORM; CARDBOARD PACKAGING BOXES IN MADE-UP FORM; CARDBOARD SIGNBOARDS; CARDBOARD TUBES; CARDS BEARING UNIVERSAL GREETINGS; CARDS NOT MAGNETICALLY CODED FOR USE IN BUSINESS TRANSACTIONS; CARDS, NAMELY, GREETING CARDS, NOTE CARDS AND BUSINESS CARDS; CARICATURES; CARTOON PRINTS; CARTOON STRIPS; CASES FOR CHECKS; CASH RECEIPT BOOKS; CAT BOX LINERS IN THE FORM OF PLASTIC BAGS; CATALOGS IN THE FIELD OF COMING OUT AS IT RELATES ONE'S SEXUAL ORIENTATION, AND A DEBUT INTO SOCIETY; CELLOPHANE PAPER; CHALK; CHALK AND BLACKBOARDS; CHALK AND CHALKBOARDS; CHALK BOARDS FOR SCHOOL AND HOME USE; CHALK ERASERS; CHALK STICKS; CHALKS; CHARCOAL PENCILS; CHARTS IN THE FIELD OF COMING OUT AS IT RELATES TO ONE'S SEXUAL ORIENTATION, AND A DEBUT INTO SOCIETY; CHECK BOOKS; CHECKBOOK AND PASSBOOK WALLETS; CHECKBOOK COVERS; CHECKBOOK HOLDERS; CHECK-QUE BOOKS; CHILDREN'S ACTIVITY BOOKS; CHILDREN'S BOOKS; CHILDREN'S INTERACTIVE EDUCATIONAL BOOKS; CHILDREN'S STORYBOOKS; CHILDREN'S WALL STICKERS AND MURALS; CHILDREN'S ARTS AND CRAFTS PAPER KITS; CHRISTMAS CARDS; CIGAR BANDS; CIRCULARS IN THE FIELD OF COMING OUT AS IT RELATES TO ONE'S SEXUAL ORIENTATION, AND A DEBUT INTO SOCIETY; CITY DIRECTORIES; CLASSIFIED DIRECTORIES; CLIP BOARDS; COARSE TISSUE; COASTERS MADE OF PAPER; COASTERS OF PAPER; COFFEE TABLE BOOKS FEATURING COMING OUT AS IT RELATES TO ONE'S SEXUAL ORIENTATION, AND A DEBUT INTO SOCIETY; COIN ALBUMS; COIN HOLDERS; COIN MATS. COIN WRAPPERS; COLLAPSIBLE BOXES OF PAPER; COLLAPSIBLE CARDBOARD BOXES; COLLECTIBLE PAPER MONEY; COLLECTOR'S PHOTOGRAPHS OF PLAYERS; COLOR PENCILS; COLOR PRINTS; COLORBOARD; COLORED CRAFT AND ART SAND; COLORING BOOKS; COLOUR PENCILS; COLOURED PENS; COLUMNS ON THE SUBJECT OF COMING OUT AS IT RELATES TO ONE'S SEXUAL ORIENTATION, AND A DEBUT INTO SOCIETY; COMIC BOOKS; COMIC MAGAZINES; COMIC STRIPS; COMIC STRIPS APPEARING IN ONE'S SEXUAL ORIENTATION, AND A DEBUT INTO SOCIETY; COMIC STRIPS' COMIC FEATURES; COMICS; COMMEMORATIVE BOOKS FEATURING COMING OUT AS IT RELATES TO ONE'S SEXUAL ORIENTATION, AND A DEBUT INTO SOCIETY; COMMEMORATIVE STAMP SHEETS; COMPOSITION BOOKS; COMPOSTABLE AND BIODEGRADABLE PAPER PULP-BASED TO-GO CONTAINERS FOR FOOD; COMPUTER GAME INSTRUCTION MANUALS; COMPUTER MANUALS FOR AS IT RELATES TO ONE'S SEXUAL ORIENTATION, AND A DEBUT INTO SOCIETY; COMPUTER PAPER; COMPUTER PRINTER INK RIBBONS; COMPUTER PRINTER RIBBONS; COMPUTER PROGRAM MANUALS FOR COMING OUT AS IT RELATES TO ONE'S SEXUAL ORIENTATION, AND A DEBUT INTO SOCIETY; COMPUTER RIBBONS; CONSTRUCTION PAPER; CONTAINERS FOR ICE MADE OF PAPER OR CARDBOARD; CONTAINERS FOR STORAGE OR TRANSPORT MADE OF PAPER OR CARDBOARD; COOK BOOKS; COOKBOOK HOLDERS; COPIER PAPER; COPY BOOKS; COPY PAPER; COPY-BOOKS; COPYHOLDERS; COPYING PAPER; CORRECTING FLUID FOR TYPE; CORRECTING INK; CORRECTING PENCILS; CORRECTION FLUIDS FOR DOCUMENTS; CORRESPONDENCE CARDS; CORRESPONDENCE HOLDERS; CORRESPONDENCE RACKS; CORRUGATED BOARD; CORRUGATED BOARD AND PAPER CONTAINERS; CORRUGATED BOXES; CORRUGATED CARDBOARD; CORRUGATED CARDBOARD BOXES; CORRUGATED CONTAINERS; CORRUGATED PAPER; CORRUGATED PAPER PANELS LAMINATED WITH BLEACHED WHITE PAPER PRIMARILY FOR APPLICATION OF PRINTED MEDIA FOR FURTHER USE IN SIGNAGE APPLICATIONS; CORRUGATED PAPER PANELS LAMINATED WITH KRAFT LINERBOARD PRIMARILY FOR LAMINATION WITH DECORATIVE OVERLAYS FOR FURTHER USE IN THE CONSTRUCTION OF WALL PARTITIONS, ROOM DIVIDERS, DESKTOPS AND TABLETOPS; CORRUGATED RECORD STORAGE BOXES; COSMETIC REMOVING PAPER; COUPON BOOKS; COUPONS; COVERS OF

**CLASS 16—(Continued).**

PAPER FOR FLOWER POTS; CRAFT PAPER; CRAYONS; CREDIT CARDS WITHOUT MAGNETIC CODING; CREPE PAPER. CREPE PAPER FOR MEDICAL, SANITARY OR DOMESTIC USE; CROSSWORD PUZZLES; CUSTOM PAINTINGS; CUSTOMIZABLE JOURNAL BOOKS; DAILY NEWSPAPER; DAILY PLANNERS; DATA BOOKS; DATE BOOKS; DATE STAMPS; DATE STAMPS; DAY PLANNERS; DEBIT CARDS WITHOUT MAGNETIC CODING; DECALCOMANIAS; DECALS; DECORATIONS FOR PENCILS; DECORATIVE DECALS FOR VEHICLE WINDOWS; DECORATIVE PAPER BOWS FOR WRAPPING; DECORATIVE PAPER CENTERPIECES; DECORATIVE PENCIL-TOP ORNAMENTS; DECORATIVE STICKERS FOR HELMETS; DECORATORS' PAINTBRUSHES; DESK BASKETS FOR DESK ACCESSORIES; DESK BLOTTERS; DESK CALENDARS; DESK FILE TRAYS; DESK MOUNT BOARDS FOR READING AND WRITING; DESK MOUNTED STATIONERY CABINETS; DESK PADS; DESK SETS; DESK STANDS AND HOLDERS FOR PENS, PENCILS, AND INK; DESKTOP BUSINESS CARD HOLDERS; DESKTOP DOCUMENT RACKS; DESKTOP DOCUMENT STANDS; DESKTOP ORGANIZERS; DESKTOP PLANNERS; DESKTOP REVOLVING ROTARY CARD FILES; DESKTOP STATIONERY CABINETS; DIARIES; DICTIONARIES; DIGITAL PRINTING PAPER; DIRECTORIES OF BUSINESSES FEATURING GOODS AND SERVICES IN THE FIELD OF COMING OUT AS IT RELATES TO ONE'S SEXUAL ORIENTATION, AND A DEBUT INTO SOCIETY; DIRECTORY BOARDS; DISPOSABLE DIAPERS; DISPOSABLE ENVELOPES CONFIGURED TO RECEIVE ONE OR MORE PIECES OF USED CHEWING GUM; DISPOSABLE HOUSEBREAKING PADS FOR PETS; DISPOSABLE HOUSEBREAKING PADS FOR USE IN TRAINING PUPPIES; DISPOSABLE NAPKINS; DISPOSABLE NAPPIES; DISPOSABLE TRAINING PANTS; DISPOSABLE WIPES NOT IMPREGNATED WITH CHEMICALS OR COMPOUNDS; DOCUMENT COVERS; DOCUMENT FILE RACKS; DOCUMENT FILE TRAYS; DOCUMENT FILES; DOCUMENT FOLDERS IN THE FORM OF WALLETS; DOCUMENT HOLDERS; DRAWER LINERS; DRAWING BOARDS; DRAWING BRUSHES; DRAWING PADS; DRAWING PAPER; DRAWING PENCILS; DRAWINGS; DRIVER'S LICENSE CASES; DRIVER'S LICENSE HOLDERS; EASEL PADS; EASELS; EDUCATIONAL BOOKS FEATURING COMING OUT AS IT RELATES TO ONE'S SEXUAL ORIENTATION, AND A DEBUT INTO SOCIETY; EDUCATIONAL KITS SOLD AS A UNIT IN THE FIELD OF COMING OUT AS IT RELATES TO ONE'S SEXUAL ORIENTATION, AND A DEBUT INTO SOCIETY; CONSISTING PRIMARILY OF EDUCATIONAL BOOKS, FLASH CARDS AND WORKSHEETS, AND ALSO INCLUDING AN EDUCATIONAL DVD; EDUCATIONAL PUBLICATIONS, NAMELY, BOOKS, HAND-OUTS, WORKBOOKS, JOURNALS, PLAYBOOKS, WORKSHEETS AND CARDS IN THE FIELD OF RIGHT-BRAIN FITNESS; EDUCATIONAL PUBLICATIONS, NAMELY, EDUCATIONAL LEARNING CARDS, FLASH CARDS, ACTIVITY CARDS, WORKBOOKS, TEXTBOOKS, ACTIVITY BOOKS, STORY BOOKS, PUZZLE BOOKS, PRINTED PUZZLES, TEACHER GUIDES, MANUALS, POSTERS AND EDUCATIONAL BOOKLETS IN THE FIELD OF COMING OUT AS IT RELATES TO ONE'S SEXUAL ORIENTATION, AND A DEBUT INTO SOCIETY; EDUCATIONAL PUBLICATIONS, NAMELY, TRAINING MANUALS IN THE FIELD OF COMING OUT AS IT RELATES TO ONE'S SEXUAL ORIENTATION, AND A DEBUT INTO SOCIETY; EDUCATIONAL PUBLICATIONS, NAMELY, BOOKS AND MAGAZINES IN THE FIELDS OF COMING OUT AS IT RELATES TO ONE'S SEXUAL ORIENTATION, AND A DEBUT INTO SOCIETY; ELECTRIC PENCIL SHARPENERS; EMBROIDERY DESIGN PATTERNS; ENCYCLOPEDIAS; ENGAGEMENT BOOKS; ENGRAVING PLATES; ENGRAVINGS AND THEIR REPRODUCTIONS; ENTRY TICKETS; ENVELOPE PAPER; ENVELOPE PAPERS; ENVELOPES; ENVELOPES FOR STATIONERY USE; ERASERS; ETCHING NEEDLES; ETCHINGS; EVENT ALBUMS; EVENT PROGRAMS; EVENTS ALBUMS; EVENTS PROGRAMMES; EXERCISE BOOKS; EXERCISE-BOOK COVERS; EXPENSE BOOKS; EXTENSIONS AND ATTACHMENTS FOR PENCILS; FABRIC GIFT BAGS; FABRICS FOR BOOKBINDING; FACE TOWELS OF PAPER; FACIAL TISSUE; FACSIMILE TRANSMISSION PAPER; FELT MARKING PENS; FELT PENS; FELT TIP MARKERS; FELT WRITING PENS; FELT-TIP PENS;

**CLASS 16—(Continued).**

FIGURES MADE OF PAPER; FILE BOXES FOR STORAGE OF BUSINESS AND PERSONAL RECORD; FILE BOXES FOR STORAGE OF MAGAZINES; FILE CARDS; FILE TRAYS; FILING CARDS; FILING FOLDERS, PAPER LABELS AND PRINTED INSTRUCTIONAL MATERIALS FOR ORGANIZING PERSONAL FILES; FILLER PAPER; FINGERPRINT KITS; FLASH CARDS; FLUORESCENT PAPER; FOLDERS FOR LETTERS; FOOD BAG TAPE FOR FREEZER USE; FOOD WRAPPERS; FOOD WRAPPING PLASTIC FILM FOR HOUSEHOLD USE; FOUNTAIN PEN INK CARTRIDGES; FOUNTAIN PENS; FRAMED ART PRINTS; FRAMED PAINTINGS; FREE-STANDING AND WALL-MOUNTED PAPER AND CARDBOARD BOXES FOR DEPOSITING A WRITTEN MESSAGE OR PRAYER WISHING A LOVED ONE WELL, FOR USE IN HOSPITALS, ELDER CARE RESIDENCES, SCHOOLS, AND INSTITUTIONS FOR CHILDREN WITH SPECIAL NEEDS; FREEZER BAGS; GARBAGE BAGS OF PAPER; GARBAGE BAGS OF PAPER; GARBAGE BAGS OF PLASTIC; GARBAGE BAGS OF PLASTICS; GAZETTEERS; GENERAL FEATURE MAGAZINE IN THE FIELD OF COMING OUT AS IT RELATES TO ONE'S SEXUAL ORIENTATION, AND A DEBUT INTO SOCIETY; GENERAL FEATURE MAGAZINES; GENERAL PURPOSE PLASTIC BAGS; GIFT BAGS; GIFT BOOKS FEATURING COMING OUT AS IT RELATES TO ONE'S SEXUAL ORIENTATION, AND A DEBUT INTO SOCIETY; GIFT BOXES; GIFT BOXES MADE OF CARDBOARD; GIFT CARDS; GIFT SETS CONSISTING OF A BOOK IN THE FIELD OF COMING OUT AS IT RELATES TO ONE'S SEXUAL ORIENTATION, AND A DEBUT INTO SOCIETY; AND ALSO INCLUDING A BLANKET; GIFT SETS CONSISTING PRIMARILY OF PRINTED MESSAGES CONTAINED IN A BOTTLE, GIFT CARDS AND ALSO INCLUDING STONES AND CHOCOLATES; GIFT WRAP PAPER; GIFT WRAP PAPER EMBEDDED WITH WILDFLOWER SEEDS; GIFT WRAPPING PAPER; GIFT-WRAPPING PAPER; GLITTER GLUE FOR STATIONERY PURPOSES; GLITTER PENS FOR STATIONERY PURPOSES; GLOBES; GLUE FOR STATIONERY OR HOUSEHOLD PURPOSES; GREETING CARDS; GREETINGS CARDS AND POSTCARDS; GROCERY BAGS; GROCERY PAPER; GUEST BOOKS; GUIDE BOOKS FEATURING COMING OUT AS IT RELATES TO ONE'S SEXUAL ORIENTATION, AND A DEBUT INTO SOCIETY; GUMMED PAPER; GUMMED TAPE FOR STATIONERY OR HOUSEHOLD USE; HALLOWEEN GOODIE BAGS OF PAPER OR PLASTIC; HAND TOWELS OF PAPER; HANDKERCHIEFS OF PAPER; HANDPAINTED PAPER WINE BOTTLE LABELS; HANGING FOLDERS; HAT BOXES OF CARDBOARD; HAT BOXES OF PAPER; HEAT TRANSFER PAPER; HIGHLIGHTER PENS; HIGHLIGHTING MARKERS; HIGHLIGHTING PENS; HOLDERS FOR ADHESIVE TAPES; HOLDERS FOR DESK ACCESSORIES; HOLDERS FOR NOTEPADS; HOLDERS FOR SUCH STICKY TAPES; HOLDERS SPECIALLY ADAPTED FOR HOLDING GREETING CARDS; HOLIDAY CARDS; HOTEL DIRECTORIES; ILLUSTRATED NOTEPADS; ILLUSTRATION BOARDS; ILLUSTRATIONS; IMITATION LEATHER PAPER; IMPRESSION STAMPS; INDEX BOOKS; INDEX CARDS; INDIA INK; INDIA PAPER; INDUSTRIAL MARKING PRODUCTS, NAMELY, SOAPSTONE; INDUSTRIAL PACKAGING CONTAINERS OF PAPER; INFLIGHT MAGAZINES; INFORMATIONAL FLYERS FEATURING COMING OUT AS IT RELATES TO ONE'S SEXUAL ORIENTATION, AND A DEBUT INTO SOCIETY; INFORMATIONAL LETTERS CONCERNING COMING OUT AS IT RELATES TO ONE'S SEXUAL ORIENTATION, AND A DEBUT INTO SOCIETY; INFORMATIONAL SHEETS ABOUT COMING OUT AS IT RELATES TO ONE'S SEXUAL ORIENTATION, AND A DEBUT INTO SOCIETY; INK ERASERS; INK PADS; INK PENS; INK STAMPS; INK STICKS; INKING PADS; INKING RIBBONS; INKWELLS; INSTRUCTION SHEETS; JAPANESE CEREMONIAL PAPER STRINGS (MIZUHIKI); JAPANESE HANDICRAFT PAPER; JAPANESE PAPER; KRAFT PAPER; LABEL PAPER; LABEL PRINTING MACHINE RIBBONS; LABEL PRINTING MACHINES; LAMINATED PAPER; LAP DESKS; LASER PRINT PAPER; LASER PRINTING PAPER; LAWN AND LEAF DISPOSAL BAGS; LAWN AND LEAF DISPOSAL SYSTEM COMPRISING A BAG, A BAG SUPPORT, AND A HANDLE FOR ATTACHING TO THE BAG, SOLD AS A KIT; LEAF DISPOSAL BAGS; LEAFLETS ABOUT COMING OUT AS IT RELATES TO ONE'S SEXUAL

**CLASS 16—(Continued).**

ORIENTATION, AND A DEBUT INTO SOCIETY; LEATHER APPOINTMENT BOOK COVERS; LEATHER BOOK COVERS; LEDGER BOOKS; LETTER FILES; LETTER HOLDERS; LETTER OPENERS; LETTER OPENERS OF PRECIOUS METAL; LETTER PAPER; LETTER TRAYS; LETTER-OPENERS; LETTERHEAD PAPER; LINING PAPER; LOG BOOKS; LOOSE LEAF PAPER; LUMINOUS PAPER; LUNCH BAGS; LUNCH BAGS MADE OF TEXTILE; MAGAZINE COLUMNS ABOUT COMING OUT AS IT RELATES TO ONE'S SEXUAL ORIENTATION, AND A DEBUT INTO SOCIETY; MAGAZINE DEPARTMENTS IN THE FIELD OF COMING OUT AS IT RELATES TO ONE'S SEXUAL ORIENTATION, AND A DEBUT INTO SOCIETY; MAGAZINE SECTIONS IN THE FIELD OF COMING OUT AS IT RELATES TO ONE'S SEXUAL ORIENTATION, AND A DEBUT INTO SOCIETY; MAGAZINE SUPPLEMENTS TO NEWSPAPERS IN THE FIELD OF COMING OUT AS IT RELATES TO ONE'S SEXUAL ORIENTATION, AND A DEBUT INTO SOCIETY; MAGNETIC BOARDS; MANUALS IN THE FIELD OF COMING OUT AS IT RELATES TO ONE'S SEXUAL ORIENTATION, AND A DEBUT INTO SOCIETY; MANUSCRIPT BOOKS; MAPS; MARKERS; MARKING CHALK; MASKING PAPER; MEMO PADS; MEMORY BOOKS; MERCHANDISE BAGS; METALLIC GIFT WRAP; METALLIC GIFT WRAPPING PAPER; METALLIC PAPER PARTY DECORATIONS; MICROWAVE COOKING BAGS; MINI PHOTO ALBUMS; MODELING CLAY; MODELLING CLAY; MOISTENERS IN THE NATURE OF HAND HELD DEVICES FOR WETTING STAMPS, ENVELOPES AND GUMMED PAPER SURFACES; MONEY CLIPS; MOTIVATIONAL CARDS; MOUNTED POSTERS; MOUNTING BOARDS; MURALS; MUSIC SHEETS; MUSICAL GREETING CARDS; NAPKIN PAPER; NAPKINS OF PAPER FOR REMOVING MAKE-UP; NEWS BULLETINS; NEWSLETTERS IN THE FIELD OF COMING OUT AS IT RELATES TO ONE'S SEXUAL ORIENTATION, AND A DEBUT INTO SOCIETY; NEWSPAPER CARTOONS; NEWSPAPER COMIC STRIPS; NEWSPAPERS; NEWSPAPERS FOR GENERAL CIRCULATION; NEWSPAPERS IN THE FIELD OF COMING OUT AS IT RELATES TO ONE'S SEXUAL ORIENTATION, AND A DEBUT INTO SOCIETY; NEWSPRINT PAPER; NON-FICTION BOOKS ON A VARIETY OF TOPICS; NON-FICTION BOOKS ON A VARIETY OF TOPICS; NON-MAGNETICALLY ENCODED FIDELITY CARDS; NON-MAGNETICALLY ENCODED PREPAID PURCHASE CARDS FOR PURCHASING GIFTS; NON-MAGNETICALLY ENCODED VOLUNTEER IDENTITY CARDS; NOTE BOOKS; NOTE CARDS; NOTE CARDS FEATURING CALLIGRAPHY, PRESSED FLOWERS AND/OR IMAGES OF PRESSED FLOWERS; NOTE CARDS THAT UNFOLD TO ACT AS WORKSHEETS FOR DAILY/MONTHLY PLANNERS, ORGANIZERS, CALENDARS, TO DO LISTS THAT RE-FOLD TO MAKE A CREDIT CARD SIZED ITEM THAT FITS NEATLY IN YOUR WALLET OR POCKET; NOTE PAD HOLDERS; NOTE PADS; NOTE PAPER; NOTE PAPERS; NOTE-BOARDS; NOTEBOOK DIVIDERS; NOTEBOOK PAPER; NOTEBOOKS; NOTELETS; NOTEPADS; NOVELS; NOVELTY IDENTIFICATION CARDS; NOVELTY IDENTIFICATION DOCUMENTS IN THE NATURE OF IMITATION PASSPORTS; OCCASION CARDS; OFFICE STATIONERY; ONION SKIN PAPER; OPAQUE PAPER; ORDER FORMS; ORGANIZERS FOR STATIONERY USE; PACKAGING CONTAINERS OF PAPER; PACKAGING MATERIALS MADE OF RECYCLED PAPER; PACKING CARDBOARD; PACKING CARDBOARD CONTAINERS; PACKING PAPER; PAINT APPLICATOR ROLLERS; PAINT APPLICATORS; PAINT BOXES AND BRUSHES; PAINT BRUSHES; PAINT ROLLERS; PAINT STIRRERS; PAINT STIRRERS AND PADDLES; PAINT TRAY LINERS OF PAPER OR PLASTIC; PAMPHLETS IN THE FIELD OF COMING OUT AS IT RELATES TO ONE'S SEXUAL ORIENTATION, AND A DEBUT INTO SOCIETY; PAPER; PAPER AND CARDBOARD; PAPER BABY BIBS; PAPER BADGES; PAPER BAGS; PAPER BAGS AND SACKS; PAPER BAGS FOR PACKAGING; PAPER BANNERS; PAPER BOARD; PAPER BOARDS; PAPER BOWS FOR GIFT WRAP; PAPER BOXES; PAPER BOXES FOR STORING GREETING CARDS; PAPER

**CLASS 16—(Continued).**

CAKE DECORATIONS; PAPER CARTON SEALING TAPE; PAPER CLIPS; PAPER CONTAINERS; PAPER COVERS FOR TELEPHONE RECEIVERS; PAPER CUTTERS; PAPER DECORATIVE GARLANDS FOR PARTIES; PAPER DISPLAY BOXES; PAPER DOILIES; PAPER DROP CLOTHS; PAPER EGG CARTONS; PAPER EMBLEMS; PAPER ENVELOPES FOR PACKAGING; PAPER FLOOR MATS; PAPER FLOWER POT COVERS; PAPER FOLDERS; PAPER FOOD WRAP. PAPER FOR BAGS AND SACKS; PAPER FOR USE IN MAKING SIGNS; PAPER FOR WRAPPING AND PACKAGING; PAPER GARBAGE BAGS; PAPER GIFT BAGS; PAPER GIFT BAGS FOR WINE; PAPER GIFT TAGS; PAPER GIFT WRAP; PAPER GIFT WRAP BOWS; PAPER GIFT WRAPPING RIBBONS; PAPER HAND-TOWELS; PAPER HANDKERCHIEFS; PAPER HANDTOWELS; PAPER HANG TAGS; PAPER IDENTIFICATION TAGS; PAPER KNIVES; PAPER LABELS; PAPER LACE; PAPER MATS; PAPER NAME BADGES; PAPER NAPKINS; PAPER NOTE TABLETS; PAPER NOTEBOOKS; PAPER PACKAGING AND CONTAINERS FOR FOOD AND BEVERAGES COMPRISED OF MATERIALS DESIGNED TO LESSEN ADVERSE EFFECTS ON THE ENVIRONMENT; PAPER PADDING; PAPER PARTY BAGS; PAPER PARTY DECORATIONS; PAPER PARTY FAVORS; PAPER PATCHES FOR CLOTHING; PAPER PET CRATE MATS; PAPER PLACE MATS; PAPER PRODUCTS, NAMELY, PAPER TUBES; PAPER PRODUCTS, NAMELY, PAPER TUBES AND PAPER CORES; PAPER RACKS; PAPER RIBBONS; PAPER SERVIETTES; PAPER SHEETS FOR NOTE TAKING; PAPER SHOPPING BAGS; PAPER SIGN HOLDERS; PAPER SIGNBOARDS; PAPER STATIONERY; PAPER STATIONERY WITH INSPIRATIONAL MESSAGES IMPRINTED THEREON; PAPER TABLE CLOTHS; PAPER TABLE LINENS; PAPER TABLECLOTHS; PAPER TAGS; PAPER TAKE-OUT CARTONS FOR FOOD; PAPER TISSUES; PAPER TISSUES FOR COSMETIC USE; PAPER TOWELS; PAPER WASH-CLOTHS; PAPER WEIGHTS; PAPER WINE GIFT BAGS; PAPERBOARD; PAPERWEIGHTS; PARAFFINED PAPER; PARCHMENT PAPER; PARTY GOODIE BAGS OF PAPER OR PLASTIC; PARTY ORNAMENTS OF PAPER; PASSBOOK COVERS; PASSENGER TICKETS; PASSPORT CASES; PASSPORT COVERS; PASSPORT HOLDERS; PASTEL CRAYONS; PASTELS; PATTERNS FOR DRESS-MAKING; PATTERNS FOR MAKING CLOTHES; PEN AND PENCIL CASES; PEN AND PENCIL CASES AND BOXES; PEN AND PENCIL HOLDERS; PEN AND PENCIL TRAYS; PEN CASES; PEN CLIPS; PEN HOLDERS; PEN INK CARTRIDGES; PEN INK REFILLS; PEN OR PENCIL HOLDERS; PEN RESTS; PEN STANDS; PENCIL BOXES; PENCIL CASES; PENCIL LEAD HOLDERS; PENCIL LEADS; PENCIL OR PEN BOXES; PENCIL ORNAMENTS; PENCIL POINT PROTECTORS; PENCIL SHARPENERS; PENCIL SHARPENING MACHINES; PENCILS; PENCILS FOR PAINTING AND DRAWING; PENHOLDERS; PENNANTS OF PAPER; PENS; PERSONAL ORGANIZERS; PERSONALIZED PAPER PLACE MATS; PERSONALIZED WRITTEN OR PRINTED MESSAGES IN DECORATIVE MINIATURE ENVELOPES CONTAINED IN A JAR; PHOTO MATS; PHOTO STANDS; PHOTO STORAGE BOXES; PHOTO-ENGRAVINGS; PHOTOCOPY PAPERS; PHOTOGRAPH ALBUM PAGES; PHOTOGRAPH ALBUMS; PHOTOGRAPH MOUNTS; PHOTOGRAPH STANDS; PHOTOGRAPHIC ALBUMS; PHOTOGRAPHS; PICTORIAL PRINTS; PICTURE BOOKS; PICTURE FRAMING MAT BOARDS; PICTURE POSTCARDS; PICTURES; PLACARDS OF PAPER OR CARDBOARD; PLACE CARDS; PLACE MATS OF PAPER; PLASTIC ADHESIVES FOR HOUSEHOLD OR DOMESTIC USE; PLASTIC BAGS FOR DISPOSABLE DIAPERS; PLASTIC BAGS FOR DISPOSING OF PET WASTE; PLASTIC BAGS FOR PACKAGING; PLASTIC BAGS FOR PACKAGING ICE; PLASTIC BAGS FOR PACKING; PLASTIC BAGS IN THE SHAPE OF TUBES FOR THE DISPOSAL OF PET-WASTE; PLASTIC BAGS IN THE SHAPE OF TUBES FOR THE STORAGE AND DISPOSAL OF WASTE, INCLUDING SANITARY WASTE SUCH AS DIAPERS AND NAPPIES, FEMININE HYGIENE PRODUCTS AND INCONTINENCE PRODUCTS; PLASTIC BASEBALL CARD HOLDERS; PLASTIC BUBBLE PACKS FOR WRAPPING OR PACKAGING; PLASTIC CARDS IMPRINTED WITH NUMBERS USED TO TRACK USE OF THE CARD; PLASTIC FOILS; PLASTIC FOOD STORAGE BAGS FOR HOUSEHOLD USE; PLASTIC GARBAGE BAGS; PLASTIC GIFT WRAP; PLASTIC OR PAPER BAGS FOR HOUSEHOLD USE;



**CLASS 16—(Continued).**

PLASTIC OR PAPER BAGS FOR MERCHANDISE PACKAGING; PLASTIC OVEN COOKING BAGS; PLASTIC SANDWICH BAGS; PLASTIC SHEETS FOR WRITING, PRINTING, AND MARKING; PLASTIC SHOPPING BAGS; PLASTIC WRAP; POCKET CALENDARS; POCKET MEMORANDUM BOOKS; POCKET SECRETARIES; POLYPROPYLENE FOIL FOR PACKING; POST CARDS; POSTCARD PAPER; POSTCARDS; POSTCARDS AND GREETING CARDS; POSTCARDS AND PICTURE POSTCARDS; POSTER BOARD; POSTERS; POSTERS MADE OF PAPER; PRE-PAID TELEPHONE CALLING CARDS, NOT MAGNETICALLY ENCODED; PRESCRIPTION REMINDER PADS; PRESENTATION FOLDERS; PRESSURE SENSITIVE ADHESIVE IMAGES IN THE NATURE OF DOUBLE-SIDED TAPE THAT CAN ADHERE TO A SURFACE ON ONE SIDE AND RECEIVE AND RETAIN DECORATIVE MATERIALS ON AN OPPOSING SIDE FOR DECORATIVE HOUSEHOLD PURPOSES; PRESSURE SENSITIVE GRAPHICS FOR APPLICATION TO AUTOMOBILES; PRICE TAGS; PRICE TICKETS; PRINTED ADVERTISING BOARDS OF PAPER OR CARDBOARD; PRINTED ART REPRODUCTIONS; PRINTED AWARD CERTIFICATES; PRINTED AWARDS; PRINTED CALENDARS; PRINTED CERTIFICATES; PRINTED CERTIFICATES FOR SPORTS AND/OR ENTERTAINMENT FANS; PRINTED CERTIFICATES IN THE FIELD OF SPORTS AND/OR ENTERTAINMENT; PRINTED CHARTS; PRINTED CONSUMER REPORTS FEATURING INFORMATION ON COMING OUT AS IT RELATES TO ONE'S SEXUAL ORIENTATION, AND A DEBUT INTO SOCIETY; PRINTED CORRESPONDENCE COURSE MATERIALS IN THE FIELD OF COMING OUT AS IT RELATES TO ONE'S SEXUAL ORIENTATION, AND A DEBUT INTO SOCIETY; PRINTED EDUCATIONAL MATERIALS IN THE FIELD OF COMING OUT AS IT RELATES TO ONE'S SEXUAL ORIENTATION, AND A DEBUT INTO SOCIETY; PRINTED EMBLEMS; PRINTED FORMS; PRINTED GRAPHS; PRINTED GREETING CARDS WITH ELECTRONIC INFORMATION STORED THEREIN; PRINTED GUIDES FOR COMING OUT AS IT RELATES TO ONE'S SEXUAL ORIENTATION, AND A DEBUT INTO SOCIETY; PRINTED HOLOGRAMS; PRINTED HOROSCOPES; PRINTED INFORMATIONAL CARDS IN THE FIELD OF COMING OUT AS IT RELATES TO ONE'S SEXUAL ORIENTATION, AND A DEBUT INTO SOCIETY; PRINTED INFORMATIONAL FOLDERS IN THE FIELD OF COMING OUT AS IT RELATES TO ONE'S SEXUAL ORIENTATION, AND A DEBUT INTO SOCIETY; PRINTED INSTRUCTIONAL MATERIAL ON TELECOMMUNICATIONS; PRINTED INSTRUCTIONAL, EDUCATIONAL, AND TEACHING MATERIALS IN THE FIELD OF COMING OUT AS IT RELATES TO ONE'S SEXUAL ORIENTATION, AND A DEBUT INTO SOCIETY; PRINTED INVITATIONS; PRINTED LECTURES; PRINTED LESSONS ON COMING OUT AS IT RELATES TO ONE'S SEXUAL ORIENTATION, AND A DEBUT INTO SOCIETY; PRINTED MAIL RESPONSE CARDS RELATING TO COMING OUT AS IT RELATES TO ONE'S SEXUAL ORIENTATION, AND A DEBUT INTO SOCIETY; PRINTED MATERIAL IN THE NATURE OF COLOR SAMPLES; PRINTED MATERIAL IN THE NATURE OF DECALS FOR MAINTENANCE SERVICE AND APPOINTMENT REMINDERS; PRINTED MATERIAL, NAMELY, SURVEYS AND ASSESSMENTS IN THE FIELD OF EDUCATOR TRAINING AND PERFORMANCE; PRINTED MATERIALS, NAMELY, CURRICULA IN THE FIELD OF COMING OUT AS IT RELATES TO ONE'S SEXUAL ORIENTATION, AND A DEBUT INTO SOCIETY; PRINTED MATERIALS, NAMELY, NOVELS AND SERIES OF FICTION BOOKS AND SHORT STORIES FEATURING SCENES AND CHARACTERS BASED ON VIDEO GAMES; PRINTED MATERIALS, NAMELY, PRESS RELEASES FEATURING COMING OUT AS IT RELATES TO ONE'S SEXUAL ORIENTATION, AND A DEBUT INTO SOCIETY; PRINTED MATTER, NAMELY, NEWSPAPERS, PHOTOGRAPHS, MAGAZINES, BOOKS, PRINTED PERIODICALS, NEWSLETTERS, AND BROCHURES ALL IN THE FIELDS OF SECURITIES, OPTIONS AND OTHER FINANCIAL INSTRUMENTS; PRINTED MATTER, NAMELY, VINYL STATIC CLING SHEETS ON WHICH PRAYERS ARE PRINTED FOR AFFIXATION IN WINDOWS AND WINDSHIELDS; PRINTED MENUS; PRINTED MUSIC BOOKS; PRINTED NEWS RELEASES IN THE FIELD OF COMING OUT AS IT RELATES TO ONE'S SEXUAL ORIENTATION, AND A DEBUT INTO

**CLASS 16—(Continued).**

SOCIETY; PRINTED NOVELTY WINE LABELS; PRINTED PAPER LABELS; PRINTED PAPER SIGNS; PRINTED PAPER SIGNS, NAMELY, TABLE TENTS; PRINTED PATTERNS; PRINTED PERIODICALS IN THE FIELD OF DANCE; PRINTED PERIODICALS IN THE FIELD OF FIGURATIVE ARTS; PRINTED PERIODICALS IN THE FIELD OF MOVIES; PRINTED PERIODICALS IN THE FIELD OF MUSIC; PRINTED PERIODICALS IN THE FIELD OF PLAYS; PRINTED PERIODICALS IN THE FIELD OF TOURISM; PRINTED PERIODICALS IN THE FIELD OF COMING OUT AS IT RELATES TO ONE'S SEXUAL ORIENTATION, AND A DEBUT INTO SOCIETY; PRINTED PHARMACEUTICAL INFORMATION SLIDE CARD; PRINTED PLANS; PRINTED PRODUCTS, NAMELY, LISTS FEATURING COMING OUT AS IT RELATES TO ONE'S SEXUAL ORIENTATION, AND A DEBUT INTO SOCIETY; PRINTED PRODUCTS, NAMELY, MENU BOARDS; PRINTED PRODUCTS, NAMELY, PRODUCT GUIDES FEATURING COMING OUT AS IT RELATES TO ONE'S SEXUAL ORIENTATION, AND A DEBUT INTO SOCIETY; PRINTED REBUS PUZZLES; PRINTED RECIPE CARDS; PRINTED RECIPES SOLD AS A COMPONENT OF FOOD PACKAGING; PRINTED REPORTS FEATURING COMING OUT AS IT RELATES TO ONE'S SEXUAL ORIENTATION, AND A DEBUT INTO SOCIETY; PRINTED ROTARY WHEELS COMING OUT AS IT RELATES TO ONE'S SEXUAL ORIENTATION, AND A DEBUT INTO SOCIETY; PRINTED ROTATING WHEELS FOR COMING OUT AS IT RELATES TO ONE'S SEXUAL ORIENTATION, AND A DEBUT INTO SOCIETY; PRINTED SEMINAR NOTES; PRINTED SPEECH AND LANGUAGE THERAPY CARDS TO ENHANCE SPEECH AND LANGUAGE SKILLS; PRINTED TABLES OF COMING OUT AS IT RELATES TO ONE'S SEXUAL ORIENTATION, AND A DEBUT INTO SOCIETY; PRINTED TEACHING ACTIVITY GUIDES IN THE FIELD OF COMING OUT AS IT RELATES TO ONE'S SEXUAL ORIENTATION, AND A DEBUT INTO SOCIETY; TEACHING MATERIALS IN THE FIELD OF COMING OUT AS IT RELATES TO ONE'S SEXUAL ORIENTATION, AND A DEBUT INTO SOCIETY; PRINTED TEACHING MATERIALS IN THE FIELD OF COMING OUT AS IT RELATES TO ONE'S SEXUAL ORIENTATION, AND A DEBUT INTO SOCIETY; PRINTED TICKETS; PRINTED WINE AND BEER BOTTLE LABELS INCORPORATING A FEATURE THAT CHANGES COLOR IN RESPONSE TO FLUCTUATION IN TEMPERATURE OF THE CONTENTS OF THE BOTTLE TO WHICH THE LABEL IS AFFIXED; PRINTING FONTS; PRINTING PAPER; PRINTING PAPERS; PRINTS; PROOFING PAPER; PROTECTIVE COVERS FOR BOOKS; PUBLICATIONS, NAMELY, BROCHURES, BOOKLETS, AND TEACHING MATERIALS IN THE FIELD OF COMING OUT AS IT RELATES TO ONE'S SEXUAL ORIENTATION, AND A DEBUT INTO SOCIETY; PUBLICATIONS, NAMELY, BOOKS, MAGAZINES IN THE FIELDS OF COMING OUT AS IT RELATES TO ONE'S SEXUAL ORIENTATION, AND A DEBUT INTO SOCIETY; PUSH PINS; QUESTIONNAIRES ON COMING OUT AS IT RELATES TO ONE'S SEXUAL ORIENTATION, AND A DEBUT INTO SOCIETY; QUICK REFERENCE POCKET GUIDES IN THE FIELD OF COMING OUT AS IT RELATES TO ONE'S SEXUAL ORIENTATION, AND A DEBUT INTO SOCIETY; READING EASELS; RECIPE BOOKS; RECIPE BOOKS; RECORD CARDS; RECYCLABLE HOLOGRAPHIC AND NON-HOLOGRAPHIC PAPERBOARD HAVING A METALLIC COATING; RECYCLED BOND PAPER; RECYCLED PAPER; RED ALGAE GELATINE GLUE, FOR STATIONERY OR HOUSEHOLD PURPOSES (FUNORI); REFERENCE BOOKS IN THE FIELD OF COMING OUT AS IT RELATES TO ONE'S SEXUAL ORIENTATION, AND A DEBUT INTO SOCIETY; REFILLS FOR BALLPOINT PENS; REINFORCED STATIONERY TABS; RELIGIOUS BOOKS; RELIGIOUS CIRCULAR LETTERS; REMOVABLE TATTOOS; REPLICATIONS OF HUMAN AND ANIMAL SKELETONS, OR PARTS OF SKELETONS, AND FOSSILS FOR EDUCATIONAL PURPOSES; REPORTERS' NOTEBOOKS; REPRODUCTION PAPER; RESEARCH REPORTS FEATURING COMING OUT AS IT RELATES TO ONE'S SEXUAL ORIENTATION, AND A DEBUT INTO SOCIETY; RESOURCE BOOKS IN THE FIELD OF COMING OUT AS IT RELATES TO ONE'S SEXUAL ORIENTATION, AND A DEBUT INTO SOCIETY; RETRACTABLE PENCILS; RIBBONS AND BANDS MADE OF PAPER AND CARDBOARD FOR

**CLASS 16—(Continued).**

USE ON FLORAL CONTAINERS; RICE PAPER; ROAD MAPS; ROLE PLAYING GAME EQUIPMENT IN THE NATURE OF GAME BOOK MANUALS; ROLLER BALL PENS; ROMANCE NOVELS; ROSARIES; RUBBER BANDS; RUBBER DOCUMENT STAMPS; RUBBER ERASERS; RUBBER FINGER TIPS; RUBBER STAMP; RUBBER STAMPS; RUBBISH BAGS (MADE OF PAPER OR PLASTIC MATERIALS); RULED PAPER; SAFETY PAPER; SANDPAPER FOR SHARPENING DRAWING PENCILS; SANDWICH BAGS; SCENTED DRAWER LINERS; SCENTED PAPER DRAWER LINERS; SCHOLARLY BOOKS ON VARIOUS TOPICS, NAMELY, COMING OUT AS IT RELATES TO ONE'S SEXUAL ORIENTATION, AND A DEBUT INTO SOCIETY; SCHOOL SUPPLY KITS CONTAINING VARIOUS COMBINATIONS OF SELECTED SCHOOL SUPPLIES, NAMELY, WRITING INSTRUMENTS, PENS, PENCILS, MECHANICAL PENCILS, ERASERS, MARKERS, CRAYONS, HIGHLIGHTER PENS, FOLDERS, NOTEBOOKS, PAPER, PROTRACTORS, PAPER CLIPS, PENCIL SHARPENERS, WRITING GRIPS, GLUE AND BOOK MARKS; SCHOOL WRITING BOOKS; SCHOOL YEARBOOKS; SCORE BOOKS; SCORE CARDS; SCORE CHARTS; SCORE PADS; SCORE SHEETS; SCORE-BOOKS; SCORE-CARDS; SCRAP BOOKS; SCRAPBOOK ALBUMS; SCRAPBOOK PAGES; SCRAPBOOKS; SCRATCH CARDS; SCRATCH PADS; SCRIBBLE PADS; SEAL INK PADS; SEALING STAMPS; SEALING WAX; SEALS; SEALS FOR OFFICES; SEALS FOR THE OFFICE; SELF-ADHESIVE PLASTIC SHEETS FOR LINING SHELVES; SELF-ADHESIVE TAPES FOR STATIONERY AND HOUSEHOLD PURPOSES; SEMI-PROCESSED PAPER; SERIES OF COMPUTER GAME HINT BOOKS; SERIES OF FICTION AND NON-FICTION BOOKS ON A VARIETY OF TOPICS; SERIES OF FICTION AND NON-FICTION BOOKS ON A VARIETY OF TOPICS; SERIES OF FICTION BOOKS; SERIES OF FICTION WORKS, NAMELY, NOVELS AND BOOKS; SERIES OF NON-FICTION BOOKS IN THE FIELD OF COMING OUT AS IT RELATES TO ONE'S SEXUAL ORIENTATION, AND A DEBUT INTO SOCIETY; SHEET MUSIC; SHELF PAPER; SHIPPING LABELS; SKETCH BOOKS; SKETCH PADS; SKETCHBOOKS; SKETCHES; SLATE BOARDS FOR WRITING; SLATE PENCILS; SLEEVES FOR HOLDING AND PROTECTING STAMPS; SMALL BLACKBOARDS; SOCIAL NOTE CARDS; SOFTWARE PROGRAMMES AND DATA PROCESSING PROGRAMMES IN PRINTED FORM; SONG BOOKS; SOUVENIR PROGRAMS CONCERNING COMING OUT AS IT RELATES TO ONE'S SEXUAL ORIENTATION, AND A DEBUT INTO SOCIETY; SPECIALTY PAPERS, NAMELY, VEGETABLE PARCHMENT, FOR USE IN FOOD WRAPPING, PREPARATION, PROCESSING AND PACKAGING APPLICATIONS; SPIRAL BINDING MACHINES FOR OFFICE USE; SPIRIT MASTERS; SPORTS TRADING CARDS; STAMP ALBUMS; STAMP CASES; STAMP INKS; STAMP PAD INKS; STAMP PADS; STAMP STANDS; STAMPING INKS; STANDS FOR PEN AND PENCIL; STANDS FOR PENS; STANDS FOR WRITING IMPLEMENTS; STAPLE REMOVERS; STAPLER HOLDERS; STAPLERS; STAPLES; STAPLING PRESSES; STATIONERY; STATIONERY BOXES; STATIONERY CASES; STATIONERY FOLDERS; STATIONERY WRITING PAPER AND ENVELOPES; STATIONERY-TYPE PORTFOLIOS; STEEL PENS; STENCIL CASES; STENCIL PAPER; STENCIL PAPER; STENCIL PLATES; STENCILING MACHINES; STENCILS; STENCILS AND PATTERNS, BEING OF PAPER AND PLASTIC, FOR THE TRANSFERRING OF GRAPHIC DESIGNS TO PUMPKINS, MINI-PUMPKINS, GOURDS, AND OTHER FRUITS AND VEGETABLES; STENCILS USED IN THE PRODUCTION OF ELECTRONIC CIRCUIT BOARDS AND OTHER ELECTRONIC COMPONENTS; STENCILS USED TO APPLY DESIGNS ONTO TENNIS RACKETS; STENOGRAPHERS' NOTEBOOKS; STICK MARKERS; STICKER ALBUMS; STICKERS; STICKERS; STICKERS AND DECALCOMANIAS; STICKERS AND STICKER ALBUMS; STICKERS AND TRANSFERS; STORAGE ALBUMS FOR TYPEWRITER PRINTWHEELS AND TYPEBALLS; STORAGE CONTAINERS MADE OF PAPER; STORIES IN ILLUSTRATED FORM; STORY BOOKS; STRAIGHT EDGES; STRIPS OF FANCY PAPER (TANZAKU); STUDY GUIDES; SYNDICATED COLUMNS DEALING WITH COMING OUT AS IT RELATES TO ONE'S SEXUAL ORIENTATION, AND A DEBUT INTO SOCIETY; SYNDICATED MAGAZINE SECTIONS DEALING WITH COMING OUT AS IT RELATES TO ONE'S SEXUAL

**CLASS 16—(Continued).**

ORIENTATION, AND A DEBUT INTO SOCIETY; SYNDICATED NEWSPAPER COLUMNS DEALING WITH COMING OUT AS IT RELATES TO ONE'S SEXUAL ORIENTATION, AND A DEBUT INTO SOCIETY; SYNTHETIC BOND PAPER; SYNTHETIC PAPER; TABLE CLOTHS OF PAPER; TABLE LINENS OF PAPER; TABLE MATS OF PAPER; TABLE NAPKINS OF PAPER; TAGS FOR INDEX CARDS; TAILORS' CHALK; TALKING CHILDREN'S BOOKS; TAPE CARTRIDGES AND TAPES FOR LABEL PRINTING MACHINES; TAROT CARDS; TEAR-OFF CALENDARS; TELEPHONE CALLING CARDS, NOT MAGNETICALLY ENCODED; TELEPHONE DIRECTORIES; TELEPHONE INDEXES; TELEPHONE NUMBER BOOKS; TEMPORARY TATTOOS; TERRESTRIAL GLOBES; TEXTBOOKS IN THE FIELD OF COMING OUT AS IT RELATES TO ONE'S SEXUAL ORIENTATION, AND A DEBUT INTO SOCIETY; TEXTILE GIFT BAGS FOR WINE; TEXTILE WINE GIFT BAGS; THERMOSENSITIVE PAPER; THICK JAPANESE PAPER; THREE DIMENSIONAL MODELS FOR EDUCATIONAL PURPOSES; THREE-RING BINDERS; THUMB-TACKS; TICK IDENTIFICATION AND REMOVAL KIT COMPOSED PRIMARILY OF PRINTED EDUCATIONAL/ INFORMATION INSERTS IN THE NATURE OF A TICK IDENTIFICATION CHART, REMOVAL INSTRUCTIONS AND A SYMPTOM RECORD WITH LISTS OF INFORMATIONAL WEB SITES AND ALSO INCLUDING TWEEZERS, MAGNIFYING GLASS, ANTISEPTIC WIPE, MOIST WRAP, PLASTIC BAG AND PENCIL; TICKET STOCK; TIPS FOR BALLPOINT PENS; TISSUE PAPER; TISSUE PAPER FOR USE AS MATERIAL OF STENCIL PAPER (GANPISHI); TISSUES OF PAPER FOR REMOVING MAKE-UP; TOILET PAPER; TOILET SEAT COVER PAPER; TOILET TISSUE; TOILET TRAINING TARGETS MADE OF PAPER; TRACING NEEDLES FOR DRAWING PURPOSES; TRACING PAPER; TRADE JOURNALS IN THE FIELD OF COMING OUT AS IT RELATES TO ONE'S SEXUAL ORIENTATION, AND A DEBUT INTO SOCIETY; TRADING CARD DISCS OF PAPER OR CARDBOARD; TRADING CARD MILK BOTTLE CAPS; TRADING CARDS; TRASH BAGS; TRASH CAN LINERS; TRAVEL BOOKS; TREATED PAPER FOR WRAPPING FLOWERS AND FLORAL DISPLAYS; TRIVIA CARDS; TYPEFACE; TYPEWRITER KEYS; TYPEWRITER PAPER; TYPEWRITER PRINTWHEELS; TYPEWRITER RIBBONS; TYPEWRITER TYPEBALLS; TYPEWRITER TYPING ELEMENTS; TYPEWRITERS; UNMOUNTED AND MOUNTED PHOTOGRAPHS; UNMOUNTED POSTERS; VINYL LETTERS AND NUMBERS FOR USE IN MAKING POSTERS IN THE FIELD OF COMING OUT AS IT RELATES TO ONE'S SEXUAL ORIENTATION, AND A DEBUT INTO SOCIETY; VISITING CARDS; VOUCHER BOOKS; WALL CALENDARS; WALL COVERING SAMPLE BOOKS; WALLPAPER STENCILS; WATERCOLOR PICTURES; WATERCOLOURS; WATER-PROOF PAPER; WAX BOND PAPER; WAX PAPER; WEDDING ALBUMS; WEDDING BOOKS; WHITE PAPERBOARD; WIRE-BOUND NOTEBOOKS; WIREBOUND BOOKS; WORKBOOKS DIRECTED TO COMING OUT AS IT RELATES TO ONE'S SEXUAL ORIENTATION, AND A DEBUT INTO SOCIETY; WRAPPING PAPER; WRISTBANDS FOR THE RETENTION OF WRITING INSTRUMENTS; WRITING BRUSHES; WRITING GRIPS; WRITING IMPLEMENTS; WRITING IMPLEMENTS; WRITING INK; WRITING INSTRUMENTS; WRITING JOURNAL SHEETS; WRITING PADS; WRITING PAPER; WRITING PAPER HOLDERS; WRITING PAPER PADS; WRITING PEN KITS COMPRISING PARTS FOR MAKING WRITING PENS; WRITING PENS THAT MAY ALSO BE USED TO PERFORM PEN SPINNING TRICKS; WRITING SLATES; WRITING TABLETS; WRITING UTENSILS; WRITING UTENSILS MADE OF FIBRES; XEROGRAPHIC PAPER; YEARBOOKS IN THE FIELD OF COMING OUT AS IT RELATES TO ONE'S SEXUAL ORIENTATION, AND A DEBUT INTO SOCIETY; COMING OUT IRON ON TRANSFERS AND PLASTIC TRANSFERS (U.S. CLS. 2, 5, 22, 23, 29, 37, 38 AND 50).  
PRISCILLA MILTON, EXAMINING ATTORNEY

**CLASS 16—(Continued).**

SN 85-044,427. GREEN STREET ADVISORS, INC., NEWPORT BEACH, CA. FILED 5-20-2010.

**HEARD ON THE BEACH**

THE MARK CONSISTS OF STANDARD CHARACTERS WITHOUT CLAIM TO ANY PARTICULAR FONT, STYLE, SIZE, OR COLOR.

FOR PUBLICATIONS, NAMELY, NEWSLETTERS AND RESEARCH REPORTS FEATURING REAL ESTATE, FINANCE AND INVESTMENT (U.S. CLS. 2, 5, 22, 23, 29, 37, 38 AND 50).

FIRST USE 3-28-1999; IN COMMERCE 3-28-1999.  
GRETTA YAO, EXAMINING ATTORNEY

**CLASS 16—(Continued).**

SN 85-046,740. DISNEY ENTERPRISES, INC., BURBANK, CA. FILED 5-24-2010.

**DISNEY IT'S A SMALL WORLD**

SN 85-045,541. READY, SET, READ, INC., ALISO VIEJO, CA. FILED 5-21-2010.



THE MARK CONSISTS OF A DOG HOLDING A BOOK IN ITS MOUTH, ALL INSIDE A CIRCLE WITH ITS PAWS RESTING ON THE OUTER EDGE OF THE CIRCLE.

FOR EDUCATIONAL MATERIALS, NAMELY, A SERIES OF BOOKS FEATURING A COMPREHENSIVE READING PROGRAM, WITH EACH BOOK FEATURING ONE OR MORE LITERARY CHARACTERS, FOR ENABLING THE READER TO STRENGTHEN PHONICS SKILLS, UNDERSTAND THE MEANING OF WORDS, AND BUILD VOCABULARY THROUGH INDIVIDUAL LESSONS (U.S. CLS. 2, 5, 22, 23, 29, 37, 38 AND 50).

KATHERINE M. DUBRAY, EXAMINING ATTORNEY

THE MARK CONSISTS OF STANDARD CHARACTERS WITHOUT CLAIM TO ANY PARTICULAR FONT, STYLE, SIZE, OR COLOR.

OWNER OF U.S. REG. NOS. 1,162,727, 3,328,006 AND OTHERS.

FOR ADDRESS BOOKS; ALMANACS; APPLIQUES IN THE FORM OF DECALS; APPOINTMENT BOOKS; ART PRINTS; ARTS AND CRAFT PAINT KITS; AUTOGRAPH BOOKS; BABY BOOKS; BALL POINT PENS; BASEBALL CARDS; BINDERS; BOOKENDS; BOOKMARKS; A SERIES OF FICTION BOOKS; BOOKS, MAGAZINES, NEWSLETTERS AND PRINTED PERIODICALS FEATURING INFORMATION ABOUT THEME PARK ATTRACTIONS AND STORIES, GAMES AND ACTIVITIES FOR CHILDREN; BUMPER STICKERS; CALENDARS; CARTOON STRIPS; CHRISTMAS CARDS; CHALK; CHILDREN'S ACTIVITY BOOKS; COASTERS MADE OF PAPER; COIN ALBUMS; COLORING BOOKS; COLOR PENCILS; COMIC BOOKS; COMIC STRIPS; COUPON BOOKS; DECALS; DECORATIVE PAPER CENTERPIECES; DIARIES; DISPOSABLE DIAPERS FOR BABIES; DRAWING RULERS; ENVELOPES; ERASERS; FELT PENS; FLASH CARDS; GIFT CARDS; GIFT WRAPPING PAPER; GREETING CARDS; GUEST BOOKS; MEMO PADS; MODELING CLAY; NEWSPAPERS; NOTE PAPER; NOTEBOOKS; NOTEBOOK PAPER; PAINTINGS; PAPER FLAGS; PAPER PARTY FAVORS; PAPER CAKE DECORATIONS; PAPER PARTY DECORATIONS; PAPER NAPKINS; PAPER PARTY BAGS; PAPERWEIGHTS; PAPER GIFT WRAP BOWS; PAPER PENNANTS; PAPER PLACE MATS; PAPER TABLE CLOTHS; PEN AND PENCIL HOLDERS; PENCILS; PENCIL SHARPENERS; PEN AND PENCIL CASES AND BOXES; PENS; PHOTOGRAPH ALBUMS; PHOTOGRAPHS; PHOTO-ENGRAVINGS; PICTORIAL PRINTS; PICTURE BOOKS; PORTRAITS; POSTCARDS; POSTERS; PRINTED AWARDS; PRINTED CERTIFICATES; PRINTED INVITATIONS; PRINTED MENUS; RECIPE BOOKS; RUBBER STAMPS; SCORE CARDS; STAMP ALBUMS; STATIONERY; STAPLERS; STICKERS; TRADING CARDS; UNGRADUATED RULERS; WRITING PAPER; WRITING IMPLEMENTS (U.S. CLS. 2, 5, 22, 23, 29, 37, 38 AND 50).

MICHAEL GAFFAR, EXAMINING ATTORNEY

**CLASS 16—(Continued).**

SN 85-047,207. KOTSCHENREUTHER, PHILIP, BEL AIR, MD. FILED 5-25-2010.



NO CLAIM IS MADE TO THE EXCLUSIVE RIGHT TO USE "FAITH-BASED FINANCIAL MANAGEMENT", APART FROM THE MARK AS SHOWN.

THE MARK CONSISTS OF A TREE SITTING AT THE TOP OF A HILL WITH A PATH LEADING UP TO IT. THE WORDS "FAITH-BASED FINANCIAL MANAGEMENT" ARE SITUATED BELOW THE TREE LOGO.

FOR EDUCATIONAL PUBLICATIONS, NAMELY, HAND-OUTS AND WORKBOOKS IN THE FIELDS OF PERSONAL FINANCIAL MANAGEMENT AND FINANCIAL PLANNING (U.S. CLS. 2, 5, 22, 23, 29, 37, 38 AND 50).

JULIE VEPPUMTHARA, EXAMINING ATTORNEY

**CLASS 16—(Continued).**

SN 85-052,957. W2007 STRATOSPHERE PROPCO., L.P., LAS VEGAS, NV. FILED 6-2-2010.

**SKYJUMP LAS VEGAS**

THE MARK CONSISTS OF STANDARD CHARACTERS WITHOUT CLAIM TO ANY PARTICULAR FONT, STYLE, SIZE, OR COLOR.

NO CLAIM IS MADE TO THE EXCLUSIVE RIGHT TO USE "LAS VEGAS", APART FROM THE MARK AS SHOWN.

FOR BOOKMARKS; CALENDARS; CHILDREN'S ACTIVITY BOOKS; COUPONS; GIFT CARDS; GREETING CARDS; PHOTOGRAPHS; PICTURES; POSTCARDS; POSTERS; PRINTED TICKETS; STATIONERY; STICKERS; WRITING INSTRUMENTS (U.S. CLS. 2, 5, 22, 23, 29, 37, 38 AND 50).

EMILY CHUO, EXAMINING ATTORNEY

SN 85-052,909. W2007 STRATOSPHERE PROPCO., L.P., LAS VEGAS, NV. FILED 6-2-2010.

**SKYJUMP**

THE MARK CONSISTS OF STANDARD CHARACTERS WITHOUT CLAIM TO ANY PARTICULAR FONT, STYLE, SIZE, OR COLOR.

FOR BOOKMARKS; CALENDARS; CHILDREN'S ACTIVITY BOOKS; COUPONS; GIFT CARDS; GREETING CARDS; PHOTOGRAPHS; PICTURES; POSTCARDS; POSTERS; PRINTED TICKETS; STATIONERY; STICKERS; WRITING INSTRUMENTS (U.S. CLS. 2, 5, 22, 23, 29, 37, 38 AND 50).

EMILY CHUO, EXAMINING ATTORNEY



NO CLAIM IS MADE TO THE EXCLUSIVE RIGHT TO USE "LAS VEGAS", APART FROM THE MARK AS SHOWN.

THE MARK CONSISTS OF THE WORDS "SKY JUMP" STAGGERED AND HORIZONTALLY POSITIONED OVER A TARGET AND THE WORDS "LAS VEGAS".

FOR BOOKMARKS; CALENDARS; CHILDREN'S ACTIVITY BOOKS; COUPONS; GIFT CARDS; GREETING CARDS; PHOTOGRAPHS; PICTURES; POSTCARDS; POSTERS; PRINTED TICKETS; STATIONERY; STICKERS; WRITING INSTRUMENTS (U.S. CLS. 2, 5, 22, 23, 29, 37, 38 AND 50).

EMILY CHUO, EXAMINING ATTORNEY

**CLASS 16—(Continued).**

SN 85-054,270. HEISENPORT, INC., CIUDAD DE PANAMA, PANAMA, FILED 6-3-2010.

SANTIAGO GONZALEZ

THE MARK CONSISTS OF STANDARD CHARACTERS WITHOUT CLAIM TO ANY PARTICULAR FONT, STYLE, SIZE, OR COLOR.

THE NAME(S), PORTRAIT(S), AND/OR SIGNATURE(S) SHOWN IN THE MARK IDENTIFIES SANTIAGO BARBERI GONZALEZ, WHOSE CONSENT(S) TO REGISTER IS MADE OF RECORD.

FOR BLOTTERS, LETTER TRAYS AND HOLDERS, LETTER OPENERS, PEN AND PENCIL CASES, AGENDA COVERS, AGENDAS, APPOINTMENT BOOKS, ADDRESS BOOKS AND DIARIES, BLANK JOURNALS, BOOKMARKS, PASSPORT COVERS, BOOK COVERS AND NOTE PAD COVERS, CHECKBOOK COVERS, DESKTOP BUSINESS CARD HOLDERS, DESKTOP ORGANIZERS, HOLDERS FOR DESK ACCESSORIES, DESK FILE TRAYS, DESK PADS, DESK SETS (U.S. CLS. 2, 5, 22, 23, 29, 37, 38 AND 50).

JENNIFER MARTIN, EXAMINING ATTORNEY

---

SN 85-059,555. HEISENPORT, INC., CIUDAD DE PANAMA, PANAMA, FILED 6-10-2010.

SANTIAGO GONZALEZ  
✦

THE NAME(S), PORTRAIT(S), AND/OR SIGNATURE(S) SHOWN IN THE MARK IDENTIFIES SANTIAGO BARBERI GONZALEZ, WHOSE CONSENT(S) TO REGISTER IS MADE OF RECORD.

THE MARK CONSISTS OF THE WORDS "SANTIAGO GONZALEZ" CENTERED OVER A STARBURST DESIGN.

FOR BLOTTERS, LETTER TRAYS AND HOLDERS, LETTER OPENERS, PEN AND PENCIL CASES, AGENDA COVERS, AGENDAS, APPOINTMENT BOOKS, ADDRESS BOOKS AND DIARIES, BLANK JOURNALS, BOOKMARKS, PASSPORT COVERS, BOOK COVERS AND NOTE PAD COVERS, CHECKBOOK COVERS, DESKTOP BUSINESS CARD HOLDERS, DESKTOP ORGANIZERS, HOLDERS FOR DESK ACCESSORIES, DESK FILE TRAYS, DESK PADS, DESK SETS (U.S. CLS. 2, 5, 22, 23, 29, 37, 38 AND 50).

JENNIFER MARTIN, EXAMINING ATTORNEY

**CLASS 16—(Continued).**

SN 85-059,751. GAME BITES INC., LIDO BEACH, NY. FILED 6-10-2010.



THE MARK CONSISTS OF THE TERM "PLAYPEN" APPEARING IN ALL CAPITAL LETTERS. ABOVE THE TERM "PLAYPEN" APPEARS AN OPAQUE CIRCLE WITH A CURVED LINE ON EITHER SIDE OF THE CIRCLE, EXTENDING ABOVE THE CIRCLE ON THE LEFT SIDE, AND BELOW THE CIRCLE ON THE RIGHT SIDE.

FOR BROCHURES, MANUALS, PAMPHLETS, MAGAZINES AND NEWSLETTERS IN THE FIELDS OF TECHNOLOGY, NIGHTLIFE, INTERACTIVE GAMING, FASHION AND ENTERTAINMENT; BUMPER STICKERS; BUSINESS CARDS; CALENDARS; GIFT CARDS, GIFT WRAPPING PAPER; GREETING CARDS; PAPER BAGS FOR PACKAGING; PAPER BAGS; PAPER DISPLAY BOXES; PAPER GIFT BAGS; PAPER GIFT WRAP; GIFT BOXES; GIFT TISSUE PAPER; PAPER GIFT BOWS; PAPER GIFT WRAPPING RIBBONS; PAPER IDENTIFICATION TAGS; PAPER NAME BADGES; PICTURE BOOKS; PICTURES; PLASTIC BAGS FOR PACKAGING; PRINTED AWARD CERTIFICATES; PRINTED CALENDARS; PRINTED PAPER BANNERS; PAPER BANNERS; PRINTED PAPER SIGNS; TRADING CARDS; TRIVIA CARDS; WALL CALENDARS (U.S. CLS. 2, 5, 22, 23, 29, 37, 38 AND 50).

GISELLE AGOSTO, EXAMINING ATTORNEY

---

SN 85-074,735. MEREDITH CORPORATION, DES MOINES, IA. FILED 6-30-2010.

QUILTING CHANGES EVERYTHING

THE MARK CONSISTS OF STANDARD CHARACTERS WITHOUT CLAIM TO ANY PARTICULAR FONT, STYLE, SIZE, OR COLOR.

NO CLAIM IS MADE TO THE EXCLUSIVE RIGHT TO USE "QUILTING", APART FROM THE MARK AS SHOWN.

FOR PERIODIC PUBLICATION, NAMELY, A MAGAZINE FEATURING PATTERNS, DESIGNS, TECHNIQUES AND ARTICLES REGARDING PROJECTS MADE FROM CLOTH; A GENERAL INTEREST MAGAZINE COLUMN PROVIDING INFORMATION ON PROJECTS MADE FROM CLOTH (U.S. CLS. 2, 5, 22, 23, 29, 37, 38 AND 50).

FIRST USE 1-15-2009; IN COMMERCE 1-15-2009.  
CARRIE GENOVESE, EXAMINING ATTORNEY

**CLASS 16—(Continued).**

SN 85-076,948. LIVEYEARBOOK, INC., NEENAH, WI. FILED 7-2-2010.

**LIVEYEARBOOK**

THE MARK CONSISTS OF STANDARD CHARACTERS WITHOUT CLAIM TO ANY PARTICULAR FONT, STYLE, SIZE, OR COLOR.

OWNER OF U.S. REG. NO. 2,985,066.

FOR EDUCATIONAL ACTIVITY BOOKS; SCHOOL YEARBOOKS; SCHOOL AND PROFESSIONAL ATHLETIC YEARBOOKS; CHURCH DIRECTORIES AND PHOTO ALBUM MEMORY BOOKS (U.S. CLS. 2, 5, 22, 23, 29, 37, 38 AND 50).

RUSS HERMAN, EXAMINING ATTORNEY

SN 85-079,008. COLOMBINI, RICHARD V, SAINT LOUIS PARK, MN. FILED 7-6-2010.

**Preschool University**

THE MARK CONSISTS OF STANDARD CHARACTERS WITHOUT CLAIM TO ANY PARTICULAR FONT, STYLE, SIZE, OR COLOR.

FOR A SERIES OF BOOKS, WRITTEN ARTICLES, HANDOUTS AND WORKSHEETS IN THE FIELD OF EARLY CHILDHOOD EDUCATION; CHILDREN'S ACTIVITY BOOKS; CHILDREN'S BOOKS; CHILDREN'S INTERACTIVE EDUCATIONAL BOOKS; EDUCATIONAL AND LEARNING PUBLICATIONS, NAMELY, BOOKLETS AND FLASH CARDS ON A VARIETY OF EDUCATIONAL DISCIPLINES IN PRE-SCHOOL THROUGH EIGHTH GRADE; EDUCATIONAL KITS SOLD AS A UNIT IN THE FIELD OF EARLY CHILDHOOD EDUCATION CONSISTING PRIMARILY OF EDUCATIONAL BOOKS, FLASH CARDS AND WORKSHEETS, AND ALSO INCLUDING AN EDUCATIONAL DVD; EDUCATIONAL PUBLICATIONS, NAMELY, BOOKS, HAND-OUTS, WORKBOOKS, JOURNALS, PLAYBOOKS, WORKSHEETS AND CARDS IN THE FIELD OF RIGHT-BRAIN FITNESS; EDUCATIONAL PUBLICATIONS, NAMELY, EDUCATIONAL LEARNING CARDS, FLASH CARDS, ACTIVITY CARDS, WORKBOOKS, TEXTBOOKS, ACTIVITY BOOKS, STORY BOOKS, PUZZLE BOOKS, PRINTED PUZZLES, TEACHER GUIDES, MANUALS, POSTERS AND EDUCATIONAL BOOKLETS IN THE FIELD OF EARLY CHILDHOOD EDUCATION; PICTURE BOOKS (U.S. CLS. 2, 5, 22, 23, 29, 37, 38 AND 50).

FIRST USE 7-28-2010; IN COMMERCE 7-28-2010.

STEVEN JACKSON, EXAMINING ATTORNEY

**CLASS 16—(Continued).**

SN 85-080,386. GRAPECITY INCORPORATED, AKA GRAPECITY, SENDAI, JAPAN, FILED 7-8-2010.



THE MARK CONSISTS OF A NEARLY COMPLETE CIRCLE FORMING AN ARCH OVER A CIRCLE WITH TWO PRONGS AT THE BOTTOM.

FOR PRINTED EDUCATIONAL MATERIALS IN THE FIELD OF INSTRUCTION IN CONNECTION WITH ENGLISH LANGUAGE AND CULTURE (U.S. CLS. 2, 5, 22, 23, 29, 37, 38 AND 50).

AMY KERTGATE, EXAMINING ATTORNEY

SN 85-080,403. EBNER, DEBBIE, ASHEVILLE, NC. FILED 7-8-2010.

**A YEAR OF COUPONS**

THE MARK CONSISTS OF STANDARD CHARACTERS WITHOUT CLAIM TO ANY PARTICULAR FONT, STYLE, SIZE, OR COLOR.

NO CLAIM IS MADE TO THE EXCLUSIVE RIGHT TO USE "COUPONS", APART FROM THE MARK AS SHOWN.

FOR PRINTED THIRD PARTY PROMOTIONAL MEDIA, NAMELY, COUPONS, SHEETS AND PAMPHLETS CONTAINING PRINTED OFFERS FOR PRICE DISCOUNTS OR OTHER VALUE, PRINTED PROMOTIONAL CARRIER MEDIA, NAMELY, PAMPHLETS, BROCHURES, FLYERS AND PAGES OF COUPONS, DISPLAYING BUSINESS NAMES, PRODUCT BRAND NAMES AND PRODUCT INFORMATION OF OTHERS; PRINTED PROMOTIONAL CARRIER MEDIA FOR USE BY OTHERS, NAMELY, PAMPHLETS, BROCHURES, FLYERS AND PAGES OF COUPONS, CONTAINING MULTIPLE COUPONS, USED TO INFORM PARTICIPANTS AND CUSTOMERS ABOUT FUND RAISING ACTIVITIES AND SHARED REVENUE ACTIVITIES INVOLVING SALE OF PRINTED CARRIER MEDIA HAVING MULTIPLE COUPONS PROMOTING THE SALE OF GOODS OR SERVICES OF OTHERS (U.S. CLS. 2, 5, 22, 23, 29, 37, 38 AND 50).

HENRY S. ZAK, EXAMINING ATTORNEY

**CLASS 16—(Continued).**

SN 85-083,295. GUIDEPOSTS A CHURCH CORPORATION,  
CARMEL, NY. FILED 7-13-2010.

**CLASS 16—(Continued).**

SN 85-089,034. WARNER BROS. ENTERTAINMENT INC.,  
BURBANK, CA. FILED 7-20-2010.

## HOPE SPRINGS

THE MARK CONSISTS OF STANDARD CHARACTERS WITHOUT CLAIM TO ANY PARTICULAR FONT, STYLE, SIZE, OR COLOR.

FOR BOOKS IN THE FIELD OF FAITH AND SCRIPTURE BASED CONCEPTS; MAGAZINES IN THE FIELD OF FAITH AND SCRIPTURE BASED CONCEPTS; PRINTED PERIODICALS IN THE FIELD OF FAITH AND SCRIPTURE BASED CONCEPTS; NEWSLETTERS IN THE FIELD OF FAITH AND SCRIPTURE BASED CONCEPTS; CALENDARS; BUMPER STICKERS; NOTEBOOKS; BLANK JOURNALS; GREETING CARDS; DAILY PLANNERS; MONTHLY PLANNERS; YEARLY PLANNERS; BANK CHECKS; CHECK BOOK COVERS; POSTERS; PICTURES FOR HANGING (U.S. CLS. 2, 5, 22, 23, 29, 37, 38 AND 50).

BILL DAWE, EXAMINING ATTORNEY

## HUFFLEPUFF

SN 85-083,720. GRAPECITY INCORPORATED, AKA  
GRAPECITY, SENDAI, JAPAN, FILED 7-13-2010.



THE MARK CONSISTS OF THE STYLIZED WORD "GRAPESEED" AND A VINE WITH LEAVES ON THE END RUNNING THROUGH THE LETTERS "E", "E" AND "D" IN "SEED".

FOR PRINTED EDUCATIONAL MATERIALS IN THE FIELD OF INSTRUCTION IN CONNECTION WITH ENGLISH LANGUAGE AND CULTURE (U.S. CLS. 2, 5, 22, 23, 29, 37, 38 AND 50).

AMY KERTGATE, EXAMINING ATTORNEY

THE MARK CONSISTS OF STANDARD CHARACTERS WITHOUT CLAIM TO ANY PARTICULAR FONT, STYLE, SIZE, OR COLOR.

OWNER OF U.S. REG. NO. 2,505,434.

FOR PRINTED MATTER AND PAPER GOODS, NAMELY, BOOKS FEATURING CHARACTERS FROM ANIMATED, ACTION ADVENTURE, COMEDY AND/OR DRAMA FEATURES, COMIC BOOKS, CHILDREN'S BOOKS, MAGAZINES FEATURING CHARACTERS FROM ANIMATED, ACTION ADVENTURE, COMEDY AND/OR DRAMA FEATURES, COLORING BOOKS, CHILDREN'S ACTIVITY BOOKS; STATIONERY, WRITING PAPER, ENVELOPES, NOTEBOOKS, DIARIES, NOTE CARDS, GREETING CARDS, TRADING CARDS; LITHOGRAPHS; PENS, PENCILS, CASES THEREFOR, ERASERS, CRAYONS, MARKERS, COLORED PENCILS, PAINTING SETS FOR CHILDREN, CHALK AND CHALKBOARDS; DECALS, HEAT TRANSFERS; POSTERS; MOUNTED AND/OR UNMOUNTED PHOTOGRAPHS; BOOK COVERS, BOOK MARKS; CALENDARS, GIFT WRAPPING PAPER; PAPER PARTY FAVORS AND PAPER PARTY DECORATIONS, NAMELY, PAPER NAPKINS, PAPER PLACE MATS, CREPE PAPER, INVITATIONS, PAPER TABLE CLOTHS, PAPER CAKE DECORATIONS; PRINTED TRANSFERS FOR EMBROIDERY OR FABRIC APPLIQUÉS; PRINTED PATTERNS FOR COSTUMES, PAJAMAS, SWEATSHIRTS AND T-SHIRTS (U.S. CLS. 2, 5, 22, 23, 29, 37, 38 AND 50).

LINDA MICKLEBURGH, EXAMINING ATTORNEY

**CLASS 16—(Continued).**

SN 85-090,035. LESNICK, MARTHA MCCANN, NASHVILLE, TN. FILED 7-21-2010.

**FIRE ENGINE FRED**

THE MARK CONSISTS OF STANDARD CHARACTERS WITHOUT CLAIM TO ANY PARTICULAR FONT, STYLE, SIZE, OR COLOR.

FOR CHILDREN'S BOOKS, CHILDREN'S ACTIVITY BOOKS, CHILDREN'S WORKBOOKS, CHILDREN'S MAGAZINES, COLORING BOOKS, COMIC BOOKS, POP-UP BOOKS, TRADING CARDS, TRADING CARD ALBUMS, BOOKMARKS, COLOR PRINTS, POSTERS, CALENDARS, MAPS, GREETING CARDS, POSTCARDS, RUBBER STAMPS, PAPER PENNANTS, JOURNALS, STICKER ALBUMS, STICKERS, DECALS, BUMPER STICKERS, STATIONERY, NOTEBOOKS, BINDERS, NOTE PADS, WRITING PADS, ARTS AND CRAFTS PAPER, PENCILS, PENS, PEN AND PENCIL CASES, RULERS, CHECK BOOK COVERS, ADDRESS BOOKS, COMPOSITION BOOKS, PAPER BOOK COVERS, ART PRINTS, PICTURES, PHOTOGRAPHS, PHOTOGRAPH ALBUMS, ART MOUNTS, PAPER SHOPPING BAGS, LUNCH BAGS, WRAPPING PAPER, PLASTIC DECALS FOR USE AS TEMPORARY TATTOOS; PAPER SIGNS AND BANNERS FOR DECORATIVE PURPOSES; PAPER PARTY GOODS, NAMELY, INVITATIONS, HATS, NAPKINS, TABLE CLOTHS, PLACE MATS, PARTY BAGS, PARTY FAVORS AND PARTY DECORATIONS; PAPER CAKE DECORATIONS, PAPER BAGS AND MERCHANDISE BAGS, PAPER GIFT BAGS, PAPER HOLIDAY DECORATIONS; PRINTED INSTRUCTIONAL, EDUCATIONAL AND TEACHING MATERIAL, NAMELY, BOOKS, WORKBOOKS, TEACHING AIDS, PRINTS, PICTURES, POSTERS AND PAMPHLETS FOR USE IN THE FIELDS OF LANGUAGE EDUCATION, SAFETY EDUCATION, RACIAL TOLERANCE EDUCATION, FIRE-FIGHTING EDUCATION, MULTICULTURAL AWARENESS EDUCATION AND PERSONAL DEVELOPMENT (U.S. CLS. 2, 5, 22, 23, 29, 37, 38 AND 50).

JOHN DALIER, EXAMINING ATTORNEY

SN 85-090,981. THE PIERPONT MORGAN LIBRARY, NEW YORK, NY. FILED 7-22-2010.

**THE MORGAN LIBRARY & MUSEUM**

THE MARK CONSISTS OF STANDARD CHARACTERS WITHOUT CLAIM TO ANY PARTICULAR FONT, STYLE, SIZE, OR COLOR.

OWNER OF U.S. REG. NOS. 1,191,681, 1,192,656 AND 2,859,409.

NO CLAIM IS MADE TO THE EXCLUSIVE RIGHT TO USE "LIBRARY & MUSEUM", APART FROM THE MARK AS SHOWN.

FOR POSTCARDS, EXHIBIT CATALOGS DEALING WITH ART, ARTISTIC PRINTS, GREETING CARDS, POSTERS, BOOKMARKERS, BOOKS CONCERNING ART, AND PAINTINGS AND PRINTED ART REPRODUCTIONS OF WORKS DISPLAYED IN MUSEUMS (U.S. CLS. 2, 5, 22, 23, 29, 37, 38 AND 50).

FIRST USE 4-29-2006; IN COMMERCE 4-29-2006.  
DAVID C. REIHNER, EXAMINING ATTORNEY

**CLASS 16—(Continued).**

SN 85-091,957. PGI/PHOENIX GRAPHIX, INC., CHANDLER, AZ. FILED 7-23-2010.



OWNER OF U.S. REG. NO. 2,042,932.

THE MARK CONSISTS OF THE LETTERS "PGI" BELOW A PHOENIX ALL INSIDE OF A SHADED SHIELD WITH A BORDER.

FOR PRESSURE SENSITIVE GRAPHIC DECALS FOR LAND VEHICLES (U.S. CLS. 2, 5, 22, 23, 29, 37, 38 AND 50).

FIRST USE 6-1-2010; IN COMMERCE 6-1-2010.  
RAMONA ORTIGA, EXAMINING ATTORNEY

SN 85-091,998. PGI/PHOENIX GRAPHIX, INC., CHANDLER, AZ. FILED 7-23-2010.

**PHOENIX GRAPHIX**

THE MARK CONSISTS OF STANDARD CHARACTERS WITHOUT CLAIM TO ANY PARTICULAR FONT, STYLE, SIZE, OR COLOR.

OWNER OF U.S. REG. NO. 2,042,932.

NO CLAIM IS MADE TO THE EXCLUSIVE RIGHT TO USE "GRAPHIX", APART FROM THE MARK AS SHOWN. SEC. 2(F).

FOR PRINTER MATTER AND ADHESIVE MATERIALS, NAMELY, AUTOMOBILE DETAIL DECAL KITS (U.S. CLS. 2, 5, 22, 23, 29, 37, 38 AND 50).

FIRST USE 1-1-1986; IN COMMERCE 1-1-1986.  
RAMONA ORTIGA, EXAMINING ATTORNEY



**CLASS 16—(Continued).**

SN 85-099,466. PGI/PHOENIX GRAPHIX, INC., CHANDLER, AZ. FILED 8-3-2010.



OWNER OF U.S. REG. NO. 2,042,932.  
NO CLAIM IS MADE TO THE EXCLUSIVE RIGHT TO USE "GRAPHIX", APART FROM THE MARK AS SHOWN. THE MARK CONSISTS OF THE LETTERS "PGI" BELOW A "PHOENIX" ALL INSIDE OF A SHADED SHIELD WITH A BORDER, THE WORD "PHOENIX" TO THE RIGHT OF THE SHIELD, THE WORD "GRAPHIX" BELOW IT, AND THE WORDS "ANY DECAL, ANY CAR, ANY YEAR!" IN QUOTATIONS BELOW THE WORD "GRAPHIX".  
SEC. 2(F) AS TO "PHOENIX".

FOR PRINTED MATTERS AND ADHESIVE MATERIALS, NAMELY, AUTOMOBILE DETAIL DECAL KITS (U.S. CLS. 2, 5, 22, 23, 29, 37, 38 AND 50).

FIRST USE 6-1-2010; IN COMMERCE 6-1-2010.  
RAMONA ORTIGA, EXAMINING ATTORNEY

**CLASS 16—(Continued).**

SN 85-102,862. JAMES TULLY, WEST SIMSBURY, CT. FILED 8-9-2010.

**SEASONS MEDIA**

THE MARK CONSISTS OF STANDARD CHARACTERS WITHOUT CLAIM TO ANY PARTICULAR FONT, STYLE, SIZE, OR COLOR.

NO CLAIM IS MADE TO THE EXCLUSIVE RIGHT TO USE "MEDIA", APART FROM THE MARK AS SHOWN.

FOR QUARTERLY DIRECT MAIL PUBLICATION IN THE NATURE OF A MAGAZINE FEATURING LOCAL CONTENT, NAMELY LOCAL ADVERTISEMENTS AND ORIGINAL PHOTOGRAPHS AND GENERAL FEATURE ARTICLES (U.S. CLS. 2, 5, 22, 23, 29, 37, 38 AND 50).

JULIE WATSON, EXAMINING ATTORNEY

SN 85-102,278. WARNER BROS. ENTERTAINMENT INC., BURBANK, CA. FILED 8-6-2010.

**HARRY POTTER AND THE PRISONER OF AZKABAN**

THE MARK CONSISTS OF STANDARD CHARACTERS WITHOUT CLAIM TO ANY PARTICULAR FONT, STYLE, SIZE, OR COLOR.

OWNER OF U.S. REG. NOS. 2,924,262, 2,973,235 AND OTHERS.

FOR PRINTED MATTER AND PAPER GOODS, NAMELY, BOOKS FEATURING CHARACTERS FROM ANIMATED, ACTION ADVENTURE, COMEDY AND/OR DRAMA FEATURES, COMIC BOOKS, CHILDREN'S BOOKS, MAGAZINES FEATURING CHARACTERS FROM ANIMATED, ACTION ADVENTURE, COMEDY AND/OR DRAMA FEATURES, COLORING BOOKS, CHILDREN'S ACTIVITY BOOKS; STATIONERY, WRITING PAPER, ENVELOPES, NOTEBOOKS, DIARIES, NOTE CARDS, GREETING CARDS, TRADING CARDS; LITHOGRAPHS; PENS, PENCILS, CASES THEREFOR, ERASERS, CRAYONS, MARKERS, COLORED PENCILS, PAINTING SETS FOR CHILDREN, CHALK AND CHALKBOARDS; DECALS, HEAT TRANSFERS; POSTERS; MOUNTED AND/OR UNMOUNTED PHOTOGRAPHS; BOOK COVERS, BOOK MARKS, CALENDARS, GIFT WRAPPING PAPER; PAPER PARTY FAVORS AND PAPER PARTY DECORATIONS, NAMELY, PAPER NAPKINS, PAPER PLACE MATS, CREPE PAPER, INVITATIONS, PAPER TABLE CLOTHS, PAPER CAKE DECORATIONS; PRINTED TRANSFERS FOR EMBROIDERY OR FABRIC APPLIQUES; PRINTED PATTERNS FOR COSTUMES, PAJAMAS, SWEATSHIRTS AND T-SHIRTS (U.S. CLS. 2, 5, 22, 23, 29, 37, 38 AND 50).

LINDA MICKLEBURGH, EXAMINING ATTORNEY

SN 85-107,678. SHRI KRISHNA NIDHI FOUNDATION, AKA SKN FOUNDATION, HILLSBOROUGH, NJ. FILED 8-14-2010.

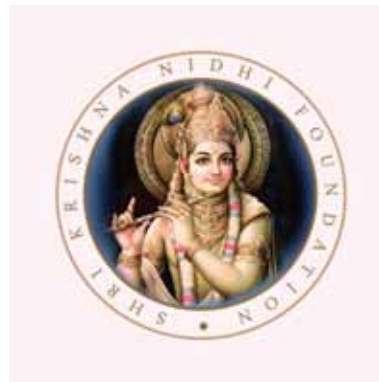

NO CLAIM IS MADE TO THE EXCLUSIVE RIGHT TO USE "FOUNDATION", APART FROM THE MARK AS SHOWN.

THE NAME AND PORTRAIT SHOWN IN THE MARK DOES NOT IDENTIFY A PARTICULAR LIVING INDIVIDUAL.

THE COLOR(S) BLACK, WHITE, LIGHT BLUE, DARK BLUE, PINK, GOLD, RED, BEIGE, BROWN, AND LIGHT PURPLE IS/ARE CLAIMED AS A FEATURE OF THE MARK.

THE MARK CONSISTS OF AN EMBLEM OF A HUMAN FIGURE IN THE COLORS BEIGE, GOLD, RED, PINK, BLACK, AND WHITE; HOLDING A FLUTE IN THE

**CLASS 16—(Continued).**

COLORS GOLD AND BLACK; WEARING A GARLAND IN THE COLORS BEIGE, PINK, AND LIGHT BLUE; WEARING JEWELRY IN THE COLORS GOLD, PINK, LIGHT BLUE, AND DARK BLUE; WITH A BACKGROUND IN THE COLORS DARK BLUE AND LIGHT BLUE; EMBLEM ENCLOSED IN FIRST CIRCLE WITH A BORDER IN THE COLOR BROWN; THE SECOND CIRCLE WITH A BORDER IN THE COLOR LIGHT PURPLE; BETWEEN THE FIRST AND SECOND CIRCLE THE WORDS "SHRI KRISHNA NIDHI FOUNDATION" WHICH APPEAR IN BROWN.

THE ENGLISH TRANSLATION OF "SHRI KRISHNA NIDHI" IN THE MARK IS "LORD KRISHNA'S TREASURE".

FOR EDUCATIONAL AND LEARNING PUBLICATIONS, NAMELY, BOOKLETS AND FLASH CARDS ON A VARIETY OF EDUCATIONAL DISCIPLINES IN PRE-SCHOOL THROUGH EIGHTH GRADE; EDUCATIONAL PUBLICATIONS, NAMELY, TRAINING MANUALS IN THE FIELD OF DRIVING; EDUCATIONAL PUBLICATIONS, NAMELY, BOOKS IN THE FIELD OF HEALTH EDUCATION; PRINTED EDUCATIONAL MATERIALS IN THE FIELD OF INDIAN CULTURE; PRINTED INSTRUCTIONAL, EDUCATIONAL, AND TEACHING MATERIALS IN THE FIELD OF HEALTH EDUCATION (U.S. CLS. 2, 5, 22, 23, 29, 37, 38 AND 50).

FIRST USE 8-1-2009; IN COMMERCE 8-1-2009.

ROBERT C. CLARK JR., EXAMINING ATTORNEY

**CLASS 16—(Continued).**

SN 85-124,085. SAAL - BROWN, INC., DBA PACIFIC LICENSING, SANTA ROSA, CA. FILED 9-7-2010.

PIN-UP NOIR



SN 85-116,162. JBZ&A, INC., WILLMINGTON, DE. FILED 8-26-2010.

INSPIRING BUSINESS  
PERFORMANCE

THE MARK CONSISTS OF STANDARD CHARACTERS WITHOUT CLAIM TO ANY PARTICULAR FONT, STYLE, SIZE, OR COLOR.

NO CLAIM IS MADE TO THE EXCLUSIVE RIGHT TO USE "BUSINESS PERFORMANCE", APART FROM THE MARK AS SHOWN.

FOR NEWSLETTER IN THE FIELDS OF LIFESTYLE, TRAVEL, FINANCE, HEALTH, FAMILY, EMPLOYEE TRAINING, EMPLOYEE BENEFITS, EMPLOYEE LEASING, PROFESSIONAL EMPLOYER ORGANIZATION SERVICES AND RELATED PERSONNEL ISSUES, EMPLOYEE SERVICES, HUMAN RESOURCES, AND BUSINESS; PRE-PRINTED BUSINESS HUMAN RESOURCES FORMS (U.S. CLS. 2, 5, 22, 23, 29, 37, 38 AND 50).

JENNIFER DIXON, EXAMINING ATTORNEY

THE COLOR(S) BLACK, WHITE, AND RED (PMS 032) IS/ARE CLAIMED AS A FEATURE OF THE MARK.

THE MARK CONSISTS OF A WOMAN'S SILHOUETTE IN BLACK SITTING ON A WINE GLASS THAT IS SHADED IN BLACK WITH A WHITE FADE-AWAY BACKGROUND AND RED (PMS 032) SHADED OVAL BEHIND THE WOMAN'S SILHOUETTE.

THE ENGLISH TRANSLATION OF "NOIR" IN THE MARK IS "BLACK".

FOR PRINTED NOVELTY WINE LABELS (U.S. CLS. 2, 5, 22, 23, 29, 37, 38 AND 50).

DAVID C. REIHNER, EXAMINING ATTORNEY

**CLASS 16—(Continued).**

SN 85-147,354. DENA DESIGNS, INC., LAFAYETTE, CA.  
FILED 10-7-2010.

**HAUTE GIRL**

THE MARK CONSISTS OF STANDARD CHARACTERS WITHOUT CLAIM TO ANY PARTICULAR FONT, STYLE, SIZE, OR COLOR.

NO CLAIM IS MADE TO THE EXCLUSIVE RIGHT TO USE "GIRL", APART FROM THE MARK AS SHOWN.

THE ENGLISH TRANSLATION OF THE WORD "HAUTE" IN THE MARK IS HIGH.

FOR ACTIVITY BOOKS FOR CHILDREN, ADDRESS BOOKS, ADHESIVE BACKED NOTE PAPER, ADHESIVES FOR STATIONERY OR HOUSEHOLD USE, APPOINTMENT BOOKS, ART PAPER, ARTS AND CRAFT PAINT KITS, AUTOGRAPH BOOKS, BABY BOOKS, BALL POINT PENS, BINDERS, BOOK COVERS, BOOK MARKERS, BOOKENDS, BOOKMARKS, BOOKS, PAPER BOWS FOR GIFT PAPER, BUMPER STICKERS, CALENDARS, CHALK, COLORED PENCILS, COLORING BOOKS, CONSTRUCTION PAPER, COPYBOOKS, CRAYONS, DECALS, DECORATIVE PAPER CENTERPIECES, DECORATIVE PAPER HOLDERS, DIARIES, DRAWING RULERS, ENVELOPES, ERASERS, FOLDERS, GIFT CARDS, GIFT WRAPPING PAPER, GREETING CARDS, IRON-ON TRANSFER, LITHOGRAPHS, MAGAZINES, MARKERS, MEMO PADS, MODELING CLAY, MUSIC SHEETS, NEWSPAPER CARTOONS, NEWSPAPERS, GAMES AND ACTIVITIES, NOTEBOOKS, NOTEPADS, PAINT BOOKS, PAPER BAGS FOR PARTIES, PAPER CAKE DECORATIONS, PAPER COASTERS, PAPER DECORATIONS FOR CAKES, PAPER NAPKINS, PAPER PARTY BAGS, PAPER PARTY DECORATIONS, PAPER PLACE MATS, PAPER TABLE CLOTHS, PAPER WEIGHTS, PASTES FOR STATIONERY OR HOUSEHOLD PURPOSES, PEN AND PENCIL BOXES, PEN AND PENCIL CASES, PENCIL SHARPENERS, PENCILS, PENS, PRINTED INVITATIONS, PRINTED PERIODICALS, PHOTOGRAPHS, PHOTOGRAPH ALBUMS, PICTURE BOOKS, POSTCARDS, POSTER PAINTS, POSTERS, RUBBER STAMPS, ART RUBBING BOARDS, STAPLERS, STATIONERY, STENCILS, STICKERS, TEMPORARY TATTOOS, TRADING CARDS, WRITING PAPER, BANK CHECKS AND CHECK BOOKS (U.S. CLS. 2, 5, 22, 23, 29, 37, 38 AND 50).

NAAKWAMA ANKRAH, EXAMINING ATTORNEY

SN 85-153,979. VISION PHONE CARD DISTRIBUTORS, INC.,  
BRONX, NY. FILED 10-15-2010.

**SEÑORA**

THE MARK CONSISTS OF STANDARD CHARACTERS WITHOUT CLAIM TO ANY PARTICULAR FONT, STYLE, SIZE, OR COLOR.

THE ENGLISH TRANSLATION OF "SEÑORA" IN THE MARK IS "LADY".

FOR TELEPHONE CALLING CARDS, NOT MAGNETICALLY ENCODED (U.S. CLS. 2, 5, 22, 23, 29, 37, 38 AND 50).

MARIA-VICTORIA SUAREZ, EXAMINING ATTORNEY

**CLASS 16—(Continued).**

SN 85-163,651. HALLMARK LICENSING, INC., KANSAS CITY, MO. FILED 10-28-2010.

**CONVERSATIONS TO KEEP**

THE MARK CONSISTS OF STANDARD CHARACTERS WITHOUT CLAIM TO ANY PARTICULAR FONT, STYLE, SIZE, OR COLOR.

FOR PRINTED CHILDREN'S BOOKS AND PRINTED CHILDREN'S STORYBOOKS WITH A RECORDABLE FEATURE THAT ALLOWS THE USER TO READ PASSAGES FROM THE BOOK AND STORYBOOK AND RECORD THEIR VOICE IN THE BOOK, THEREBY ALLOWING OTHERS TO READ ALONG LATER WHILE LISTENING TO THE RECORDED VOICE; MEMORY-KEEPING ALBUMS IN THE NATURE OF PHOTO ALBUMS AND SCRAPBOOKS WITH A RECORDABLE FEATURE THAT ALLOWS THE USER TO RECORD PERSONAL MESSAGES ON THE ALBUM (U.S. CLS. 2, 5, 22, 23, 29, 37, 38 AND 50).

ROSELLE HERRERA, EXAMINING ATTORNEY

SN 85-170,603. DAYSPRING CARDS, INC., SILOAM SPRINGS, AR. FILED 11-5-2010.

**SIMPLY MARVELOUS**

THE MARK CONSISTS OF STANDARD CHARACTERS WITHOUT CLAIM TO ANY PARTICULAR FONT, STYLE, SIZE, OR COLOR.

FOR GREETING CARDS; GIFT BAGS; CALENDARS; BLANK JOURNALS FOR PERSONAL USE (U.S. CLS. 2, 5, 22, 23, 29, 37, 38 AND 50).

DANNEAN HETZEL, EXAMINING ATTORNEY

SN 85-170,616. DAYSPRING CARDS, INC., SILOAM SPRINGS, AR. FILED 11-5-2010.

**BEAUTY & GRACE**

THE MARK CONSISTS OF STANDARD CHARACTERS WITHOUT CLAIM TO ANY PARTICULAR FONT, STYLE, SIZE, OR COLOR.

FOR GREETING CARDS; GIFT BAGS; CALENDARS; BLANK JOURNALS FOR PERSONAL USE (U.S. CLS. 2, 5, 22, 23, 29, 37, 38 AND 50).

DANNEAN HETZEL, EXAMINING ATTORNEY

**CLASS 16—(Continued).**

SN 85-171,290. LMW PUBLISHING LLC, BALTIMORE, MD, MD. FILED 11-8-2010.

**ASTUTE MAGAZINE**

THE MARK CONSISTS OF STANDARD CHARACTERS WITHOUT CLAIM TO ANY PARTICULAR FONT, STYLE, SIZE, OR COLOR.

NO CLAIM IS MADE TO THE EXCLUSIVE RIGHT TO USE "MAGAZINE", APART FROM THE MARK AS SHOWN.

FOR GENERAL FEATURE MAGAZINE IN THE FIELD OF ENTERTAINMENT, LIFESTYLE, HEALTH AND WELLNESS, PHOTOGRAPHY, POLITICS, ACADEMIA, EMPLOYMENT, ENTREPRENEURSHIP, AND ATHLETICS (U.S. CLS. 2, 5, 22, 23, 29, 37, 38 AND 50).

ANDREA HACK, EXAMINING ATTORNEY

---

SN 85-171,385. MORGAN, PAULA A., CLINTON, NY. FILED 11-8-2010.

**My Country Kitties Series**

THE MARK CONSISTS OF STANDARD CHARACTERS WITHOUT CLAIM TO ANY PARTICULAR FONT, STYLE, SIZE, OR COLOR.

NO CLAIM IS MADE TO THE EXCLUSIVE RIGHT TO USE "KITTIES SERIES", APART FROM THE MARK AS SHOWN.

FOR SERIES OF FICTION BOOKS (U.S. CLS. 2, 5, 22, 23, 29, 37, 38 AND 50).

MICHELE SWAIN, EXAMINING ATTORNEY

---

SN 85-172,004. JASPER & BLACK LLC, MINNEAPOLIS, MN. FILED 11-8-2010.

**Lulalu**

THE MARK CONSISTS OF STANDARD CHARACTERS WITHOUT CLAIM TO ANY PARTICULAR FONT, STYLE, SIZE, OR COLOR.

FOR ADHESIVE NOTE PADS; ADHESIVE NOTE PAPER; ADHESIVE-BACKED LETTERS AND NUMBERS FOR USE IN MAKING SIGNS, POSTERS, AND MAGNETS; BULLDOG CLIPS; ILLUSTRATED NOTEPADS; MAGNETIC BOARDS; MAGNETIC PAPER; MEMO PADS; NOTE PADS; NOTE PAPER; NOTE PAPERS; NOTEBOARDS; PAPER LETTERS AND NUMBER FOR USE IN MAKING SIGNS, POSTERS, AND MAGNETS; PAPER PICTURE MOUNTS; PAPER STATIONERY; PAPERBOARD; PHOTOGRAPH MOUNTS; PHOTOGRAPHIC ALBUMS; PICTURE FRAMING MAT BOARDS; PICTURE MOUNTS OF CARDBOARD; PICTURE MOUNTS OF PAPER; SELF-ADHESIVE TAPES FOR STATIONERY AND HOUSEHOLD PURPOSES (U.S. CLS. 2, 5, 22, 23, 29, 37, 38 AND 50).

ROBERT C. CLARK JR., EXAMINING ATTORNEY

**CLASS 16—(Continued).**

SN 85-174,250. CAMPASANO, STEPHANIE, HOLMDEL, NJ. FILED 11-11-2010.

**SHEET INNOVATIONS**

THE MARK CONSISTS OF STANDARD CHARACTERS WITHOUT CLAIM TO ANY PARTICULAR FONT, STYLE, SIZE, OR COLOR.

NO CLAIM IS MADE TO THE EXCLUSIVE RIGHT TO USE "SHEET", APART FROM THE MARK AS SHOWN.

FOR DECALS IN THE FORM OF APPLIQUES THAT CAN BE IRON ON OR SEW ON FOR PLACEMENT ONTO A BED SHEET FOR AIDING A USER IN PROPERLY ORIENTING THE BED SHEET ON A BED (U.S. CLS. 2, 5, 22, 23, 29, 37, 38 AND 50).

RUSS HERMAN, EXAMINING ATTORNEY

---

SN 85-174,805. D AND S CORLEY LIMITED, DBA DSC LABORATORIES, MISSISSAUGA, ONTARIO, CANADA, FILED 11-11-2010.

**SlateMate**

THE MARK CONSISTS OF STANDARD CHARACTERS WITHOUT CLAIM TO ANY PARTICULAR FONT, STYLE, SIZE, OR COLOR.

FOR PRINTED BLACK, WHITE, GRAY AND MULTI-COLORED PATTERNS DESIGNED TO GENERATE PRE-DETERMINED RESPONSES ON ELECTRONIC MEASURING EQUIPMENT USED WITH DIGITAL CAMERAS (U.S. CLS. 2, 5, 22, 23, 29, 37, 38 AND 50).

FIRST USE 3-1-2007; IN COMMERCE 4-1-2010.

TAMARA FRAZIER, EXAMINING ATTORNEY

---

SN 85-174,944. D AND S CORLEY LIMITED, DBA DSC LABORATORIES, MISSISSAUGA, ONTARIO, CANADA, FILED 11-11-2010.

**CamBook**

THE MARK CONSISTS OF STANDARD CHARACTERS WITHOUT CLAIM TO ANY PARTICULAR FONT, STYLE, SIZE, OR COLOR.

FOR CHARTS IN THE FIELD OF DIGITAL CINEMA DESIGNED TO GENERATE PRE-DETERMINED RESPONSES ON ELECTRONIC MEASURING EQUIPMENT USED WITH DIGITAL CAMERAS (U.S. CLS. 2, 5, 22, 23, 29, 37, 38 AND 50).

FIRST USE 3-1-2003; IN COMMERCE 3-1-2003.

TAMARA FRAZIER, EXAMINING ATTORNEY

**CLASS 16—(Continued).**

SN 85-175,827. PWXYZ, LLC, NEW YORK, NY. FILED 11-12-2010.



OWNER OF U.S. REG. NOS. 393,903 AND 3,325,635.  
THE COLOR(S) RED, BLACK AND WHITE IS/ARE CLAIMED AS A FEATURE OF THE MARK.

THE MARK CONSISTS OF THE LETTERS "PW" IN WHITE WITH BLACK OUTLINES WITH THE WORDING "PUBLISHERS WEEKLY" UNDERNEATH IN WHITE, ALL INSIDE A RED BOX, AND THE WORDING "SHOW DAILY" TO THE RIGHT OF THE BOX IN BLACK LETTERS.

SEC. 2(F) AS TO "PUBLISHERS WEEKLY".

FOR MAGAZINES FEATURING BOOK PUBLISHING AND BOOK SELLING; MAGAZINES IN THE FIELD OF BOOK PUBLISHING AND BOOK SELLING (U.S. CLS. 2, 5, 22, 23, 29, 37, 38 AND 50).

FIRST USE 5-1-1987; IN COMMERCE 5-1-1987.

JANET LEE, EXAMINING ATTORNEY

**CLASS 16—(Continued).**

SN 85-179,472. O'ROURKE, KAREN, ZEPHYRHILLS, FL. FILED 11-17-2010.

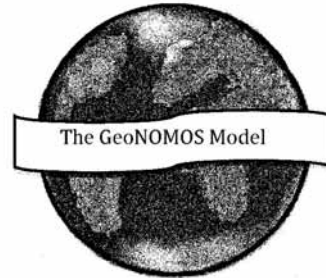

NO CLAIM IS MADE TO THE EXCLUSIVE RIGHT TO USE "MODEL", APART FROM THE MARK AS SHOWN.

THE STIPPLING IS FOR SHADING PURPOSES ONLY.  
FOR PRINTED EDUCATIONAL MATERIALS IN THE FIELD OF LAW, ECONOMICS, AND HUMAN RIGHTS; THREE DIMENSIONAL MODELS FOR EDUCATIONAL PURPOSES (U.S. CLS. 2, 5, 22, 23, 29, 37, 38 AND 50).

DAVID TOOLEY, EXAMINING ATTORNEY

SN 85-182,068. SALT LIFE HOLDINGS, LLC, JACKSONVILLE, FL. FILED 11-22-2010.

# SALT LIFE

THE MARK CONSISTS OF STANDARD CHARACTERS WITHOUT CLAIM TO ANY PARTICULAR FONT, STYLE, SIZE, OR COLOR.

OWNER OF U.S. REG. NOS. 3,001,343, 3,843,123 AND OTHERS.

FOR DECALS; COIN HOLDERS; MONEY CLIPS; PAPER BANNERS; PAPER NAPKINS; PAPER TABLE CLOTHS; PAPER COASTERS; POSTERS; CALENDARS; STATIONERY; MAGAZINES IN THE FIELD OF SPORTS AND OUTDOOR LIFE (U.S. CLS. 2, 5, 22, 23, 29, 37, 38 AND 50).

APRIL HESIK, EXAMINING ATTORNEY

SN 85-182,250. HELP WE'VE GOT KIDS INC., TORONTO, ON, CANADA, FILED 11-22-2010.

# HELP!...WE'VE GOT KIDS

NO CLAIM IS MADE TO THE EXCLUSIVE RIGHT TO USE "PITTSBURGH", APART FROM THE MARK AS SHOWN.

THE MARK CONSISTS OF THE WORDING "CUE PITTSBURGH" IN STYLIZED LETTERS ON A DARK CIRCLE BACKGROUND.

FOR MAGAZINES IN THE FIELD OF LESBIAN, GAY, BISEXUAL AND TRANSGENDERED CULTURE AND REGIONAL COMMUNITY EVENTS (U.S. CLS. 2, 5, 22, 23, 29, 37, 38 AND 50).

FIRST USE 1-1-2009; IN COMMERCE 1-1-2009.

FRED CARL, EXAMINING ATTORNEY

THE MARK CONSISTS OF STANDARD CHARACTERS WITHOUT CLAIM TO ANY PARTICULAR FONT, STYLE, SIZE, OR COLOR.

NO CLAIM IS MADE TO THE EXCLUSIVE RIGHT TO USE "KIDS", APART FROM THE MARK AS SHOWN.

FOR INFORMATIONAL DIRECTORY, NAMELY, CLASSIFIED, DIRECTORIES OF CHILDREN'S PRODUCTS AND SOURCE SERVICES (U.S. CLS. 2, 5, 22, 23, 29, 37, 38 AND 50).

MATTHEW KLINE, EXAMINING ATTORNEY

**CLASS 16—(Continued).**

SN 85-182,953. THE HAPPIEST BABY, INC., LOS ANGELES, CA. FILED 11-22-2010.

**THE HAPPIEST BABY GUIDE**

THE MARK CONSISTS OF STANDARD CHARACTERS WITHOUT CLAIM TO ANY PARTICULAR FONT, STYLE, SIZE, OR COLOR.

OWNER OF U.S. REG. NOS. 3,318,991, 3,434,465 AND 3,851,032.

NO CLAIM IS MADE TO THE EXCLUSIVE RIGHT TO USE "GUIDE", APART FROM THE MARK AS SHOWN.

FOR BOOKS, MAGAZINES, PAMPHLETS, BROCHURES, HANDOUTS, CIRCULARS, NEWSPAPERS, NEWSLETTERS, BOOKLETS, PERIODICALS, TEXTBOOKS, TREATISES, COLUMNS, ARTICLES, HANDBOOKS, PRIMERS, FLYERS, AND TEXTS FEATURING INFORMATION ON INFANT DEVELOPMENT, TODDLER DEVELOPMENT, AND/OR PARENTING SKILLS; PENCILS; BINDERS; PAPER PRODUCTS, NAMELY, STATIONERY, NOTE PADS AND POSTCARDS; NOTE CARDS; POSTERS; ADDRESS BOOKS, BLANK JOURNAL BOOKS, PENS, PRINTED EDUCATIONAL CARDS (U.S. CLS. 2, 5, 22, 23, 29, 37, 38 AND 50).

DAVID ELTON, EXAMINING ATTORNEY

**CLASS 16—(Continued).**

SN 85-185,271. SARA REINKE, DBA BLOODHORSE PRESS, LOUISVILLE, KY. FILED 11-25-2010.



NO CLAIM IS MADE TO THE EXCLUSIVE RIGHT TO USE "PRESS" AND "INDEPENDENT" AND "WOMAN-OWNED", APART FROM THE MARK AS SHOWN.

THE COLOR(S) BLACK, YELLOW, RED, AND WHITE IS/ARE CLAIMED AS A FEATURE OF THE MARK.

THE MARK CONSISTS OF A BLACK HORSE HEAD AND NECK DESIGN WITH A YELLOW MANE, EYE AND NOSTRIL AGAINST A RED SEMI-CIRCULAR BACKGROUND AND WHITE FRAME, WITH BLACK BORDER. TO THE RIGHT OF THE HORSE DESIGN IS A BLACK RECTANGULAR FIELD ON WHICH APPEARS THE WORDING "BLOODHORSE PRESS" IN YELLOW WITH THE WORDING "INDEPENDENT, WOMAN-OWNED, AND DAMN PROUD OF IT" APPEARING BELOW IN RED. FOR SERIES OF FICTION WORKS, NAMELY, NOVELS AND BOOKS (U.S. CLS. 2, 5, 22, 23, 29, 37, 38 AND 50).

MICHAEL SOUDERS, EXAMINING ATTORNEY

SN 85-186,041. WRITE SOLUTIONS, GRAND RAPIDS, MI. FILED 11-29-2010.

**BE THE HERO OF YOUR OWN STORY**

THE MARK CONSISTS OF STANDARD CHARACTERS WITHOUT CLAIM TO ANY PARTICULAR FONT, STYLE, SIZE, OR COLOR.

FOR PRINTED INSPIRATIONAL AND INFORMATIONAL BOOKLETS (U.S. CLS. 2, 5, 22, 23, 29, 37, 38 AND 50).

CAROLINE WOOD, EXAMINING ATTORNEY

SN 85-184,441. POWER LITERACY, L.L.C., OVERLAND PARK, KS. FILED 11-24-2010.

**POWER LITERACY CLASSROOM TEACHING FRAMEWORK (CTF)**

THE MARK CONSISTS OF STANDARD CHARACTERS WITHOUT CLAIM TO ANY PARTICULAR FONT, STYLE, SIZE, OR COLOR.

OWNER OF U.S. REG. NOS. 2,452,531 AND 2,454,604.

NO CLAIM IS MADE TO THE EXCLUSIVE RIGHT TO USE "LITERACY CLASSROOM TEACHING FRAMEWORK", APART FROM THE MARK AS SHOWN.

FOR PRINTED MATTER, NAMELY, INSTRUCTIONAL BOOKS AND BOOKLETS FOR TEACHING STUDENTS LITERACY AND READING SKILLS AT ALL LEVELS AND IN TRAINING TEACHERS WHO WILL TEACH STUDENTS LITERACY AND READING AT ALL LEVELS (U.S. CLS. 2, 5, 22, 23, 29, 37, 38 AND 50).

FIRST USE 12-31-2003; IN COMMERCE 12-31-2003.

JULIE WATSON, EXAMINING ATTORNEY

SN 85-186,056. WRITE SOLUTIONS, GRAND RAPIDS, MI. FILED 11-29-2010.

**PAM'S POCKETBOOKS**

THE MARK CONSISTS OF STANDARD CHARACTERS WITHOUT CLAIM TO ANY PARTICULAR FONT, STYLE, SIZE, OR COLOR.

NO CLAIM IS MADE TO THE EXCLUSIVE RIGHT TO USE "POCKETBOOKS", APART FROM THE MARK AS SHOWN.

FOR PRINTED INSPIRATIONAL AND INFORMATIONAL BOOKLETS (U.S. CLS. 2, 5, 22, 23, 29, 37, 38 AND 50).

CAROLINE WOOD, EXAMINING ATTORNEY

**CLASS 16—(Continued).**

SN 85-186,140. BROWN, NATHAN OWEN, ISSAQUAH, WA.  
FILED 11-29-2010.

## Rulon Brown

THE MARK CONSISTS OF STANDARD CHARACTERS WITHOUT CLAIM TO ANY PARTICULAR FONT, STYLE, SIZE, OR COLOR.

THE NAME "RULON BROWN" IDENTIFIES THE STAGE NAME OF NATHAN OWEN BROWN, A LIVING INDIVIDUAL WHOSE CONSENT IS OF RECORD.

FOR PAPER GOODS AND PRINTED MATTER, NAMELY, SHEET MUSIC, STICKERS, POSTERS AND POSTCARDS IN THE FIELD OF MUSICAL ENTERTAINMENT (U.S. CLS. 2, 5, 22, 23, 29, 37, 38 AND 50).

FIRST USE 10-18-2010; IN COMMERCE 10-24-2010.

REBECCA POVARCHUK, EXAMINING ATTORNEY

---

SN 85-186,228. DUDZINSKI, LYNDA A., MONEE, IL. FILED  
11-29-2010.

## DUZCO - a tiny little division of Lynda's mind

THE MARK CONSISTS OF STANDARD CHARACTERS WITHOUT CLAIM TO ANY PARTICULAR FONT, STYLE, SIZE, OR COLOR.

FOR STATIONERY, NAMELY, GREETING CARDS, PRINTED MEMORIAL CARDS, INVITATION CARDS, LETTERHEAD PAPER, PRINTED NOTEPADS, AND ENVELOPES (U.S. CLS. 2, 5, 22, 23, 29, 37, 38 AND 50).

TARAH HARDY, EXAMINING ATTORNEY

---

SN 85-186,355. THE MILLENNIAL GROUP, LLC, AKRON,  
OH. FILED 11-29-2010.

## SIGNIFICANT TOMORROWS

THE MARK CONSISTS OF STANDARD CHARACTERS WITHOUT CLAIM TO ANY PARTICULAR FONT, STYLE, SIZE, OR COLOR.

FOR FOLDERS AND BINDERS PREPARED PRIOR TO A LIFE CHANGING EVENT CONTAINING IMPORTANT PAPERWORK AND OTHER USEFUL INFORMATION INCLUDING PROFESSIONAL CONTACT NAMES, FINANCIAL DOCUMENTS, AND ESTATE PLANNING DOCUMENTS (U.S. CLS. 2, 5, 22, 23, 29, 37, 38 AND 50).

TAMARA FRAZIER, EXAMINING ATTORNEY

**CLASS 16—(Continued).**

SN 85-186,923. ANN SCOTT DESIGN, MORRISTOWN, NJ.  
FILED 11-30-2010.

## AnnScott

THE MARK CONSISTS OF STANDARD CHARACTERS WITHOUT CLAIM TO ANY PARTICULAR FONT, STYLE, SIZE, OR COLOR.

THE NAME(S), PORTRAIT(S), AND/OR SIGNATURE(S) SHOWN IN THE MARK DOES NOT IDENTIFY A PARTICULAR LIVING INDIVIDUAL.

FOR CARDS, NAMELY, GIFT CARDS, NOTE CARDS, GREETING CARDS AND INVITATION CARDS; NOTELETS (U.S. CLS. 2, 5, 22, 23, 29, 37, 38 AND 50).

FIRST USE 6-0-2009; IN COMMERCE 6-0-2009.

KIMBERLY FRYE, EXAMINING ATTORNEY

---

SN 85-187,176. BOOMERATION GREETINGS LLC., COL-  
LINGSWOOD, NJ. FILED 11-30-2010.

## BOOMERATION GREETINGS

THE MARK CONSISTS OF STANDARD CHARACTERS WITHOUT CLAIM TO ANY PARTICULAR FONT, STYLE, SIZE, OR COLOR.

NO CLAIM IS MADE TO THE EXCLUSIVE RIGHT TO USE "GREETINGS", APART FROM THE MARK AS SHOWN.

FOR CARDS, NAMELY, GREETING CARDS, NOTE CARDS, AND BUSINESS CARDS (U.S. CLS. 2, 5, 22, 23, 29, 37, 38 AND 50).

MARK RADEMACHER, EXAMINING ATTORNEY

**CLASS 16—(Continued).**

SN 85-187,394. SMART FORTUNE INTERNATIONAL LIMITED, TAICHUNG CITY, TAIWAN, FILED 11-30-2010.



THE COLOR(S) BLUE, ORANGE AND WHITE IS/ARE CLAIMED AS A FEATURE OF THE MARK.

THE MARK CONSISTS OF THE TERM "SMART" IN WHITE, STYLIZED FONT ON A BLUE RECTANGULAR BACKGROUND POSITIONED DIRECTLY TO THE LEFT OF THE TERM "FORTUNE" HAVING A LETTER "O" IN THE SHAPE OF AN ORANGE BALL AND THE REMAINING LETTERS IN BLUE, STYLIZED FONT ON A WHITE RECTANGULAR BACKGROUND THAT IS BORDERED IN BLUE. A BLUE RECTANGLE CREATES A BORDER FOR THE ENTIRE MARK.

FOR FOLDERS, PAPER REPORT COVERS, DOCUMENT FILES, DOCUMENT HOLDERS, BINDERS, PAPER EXPANDING FILES, SLEEVES FOR HOLDING AND PROTECTING DOCUMENTS (U.S. CLS. 2, 5, 22, 23, 29, 37, 38 AND 50).

MARTHA FROMM, EXAMINING ATTORNEY

**CLASS 16—(Continued).**

SN 85-187,847. LEAHMAN, BRANDT K., WILLIAMSBURG, VA. AND DOW, JOHN, WILLIAMSBURG, VA. FILED 12-1-2010.



THE COLOR(S) RED IS/ARE CLAIMED AS A FEATURE OF THE MARK.

THE MARK CONSISTS OF A FACE THAT IS RED, WITH RED EYES AND A RED MOUTH; DRIPS COMING FROM THE EYES, MOUTH AND FACE ARE ALSO RED.

FOR STICKERS (U.S. CLS. 2, 5, 22, 23, 29, 37, 38 AND 50).

CHRISTOPHER BUONGIORNO, EXAMINING ATTORNEY

SN 85-187,461. TERESA THOMAS, PELHAM, AL. AND SAM JONES, PELHAM, AL. FILED 11-30-2010.

## Scripture Tree

THE MARK CONSISTS OF STANDARD CHARACTERS WITHOUT CLAIM TO ANY PARTICULAR FONT, STYLE, SIZE, OR COLOR.

NO CLAIM IS MADE TO THE EXCLUSIVE RIGHT TO USE "SCRIPTURE", APART FROM THE MARK AS SHOWN.

FOR PERSONALIZED WRITTEN OR PRINTED BIBLE SCRIPTURES, ON PAPER STATIONERY WITH INSPIRATIONAL OR CHRISTIAN MESSAGES IMPRINTED THEREON INCLUDED IN DECORATIVE FLOWER ARRANGEMENTS; PERSONALIZED WRITTEN OR PRINTED BIBLE SCRIPTURES, ON PAPER STATIONERY WITH INSPIRATIONAL OR CHRISTIAN MESSAGES ARRANGED AND HELD IN DECORATIVE WOODEN, METAL, OR PLASTIC HOLDERS (U.S. CLS. 2, 5, 22, 23, 29, 37, 38 AND 50).

ANNE E. GUSTASON, EXAMINING ATTORNEY

SN 85-188,052. LUNCH BOX QUILTS, LLC, SCOTTSDALE, AZ. FILED 12-1-2010.



NO CLAIM IS MADE TO THE EXCLUSIVE RIGHT TO USE "QUILTS", APART FROM THE MARK AS SHOWN.

THE MARK CONSISTS OF A STYLIZED "LUNCH BOX" WITH A "QUILT" DESIGN ON ITS SIDE, NEXT TO THE WORDING "LUNCH BOX QUILTS".

FOR EMBROIDERY DESIGN PATTERNS (U.S. CLS. 2, 5, 22, 23, 29, 37, 38 AND 50).

FIRST USE 11-1-2007; IN COMMERCE 11-1-2007.

IRA J. GOODSaid, EXAMINING ATTORNEY



**CLASS 16—(Continued).**

SN 85-188,306. REIGER, MARY ANN, CLEVELAND, OH. FILED 12-1-2010.



The logo for "Infinite Stream" features the word "Infinite" in a cursive script and "Stream" in a similar script, with a wavy line above "Stream" that extends from the end of "Infinite".

THE MARK CONSISTS OF THE WORDS "INFINITE STREAM" WITH TWO WAVY LINES IN BETWEEN THE WORD "INFINITE" AND "STREAM".

FOR INFORMATIONAL FLYERS FEATURING SPIRITUAL ENERGY TEACHINGS.; INFORMATIONAL LETTERS CONCERNING SPIRITUAL ENERGY TEACHINGS.; INFORMATIONAL SHEETS ABOUT SPIRITUAL ENERGY TEACHINGS.; PAPER TEACHING MATERIALS IN THE FIELD OF SPIRITUAL ENERGY TEACHINGS.; PRINTED MATTER, NAMELY, PAPER SIGNS, BOOKS, MANUALS, CURRICULUM, NEWSLETTERS, INFORMATIONAL CARDS AND BROCHURES IN THE FIELD OF SPIRITUAL ENERGY TEACHINGS.; PRINTED TEACHING ACTIVITY GUIDES IN THE FIELD OF SPIRITUAL ENERGY TEACHINGS.; PUBLICATIONS, NAMELY, BROCHURES, BOOKLETS, AND TEACHING MATERIALS IN THE FIELD OF SPIRITUAL ENERGY TEACHINGS (U.S. CLS. 2, 5, 22, 23, 29, 37, 38 AND 50).

DAWN FELDMAN, EXAMINING ATTORNEY

SN 85-188,411. DOWRICK, PETER W., KANEOHE, HI. FILED 12-1-2010.



The logo for "TeenACE" features the word "Teen" in a serif font and "ACE" in a larger, bold, serif font.

THE MARK CONSISTS OF STANDARD CHARACTERS WITHOUT CLAIM TO ANY PARTICULAR FONT, STYLE, SIZE, OR COLOR.

OWNER OF U.S. REG. NO. 3,126,880.

FOR PRINTED EDUCATIONAL MATERIALS IN THE FIELD OF LITERACY AND OTHER EDUCATION TO ADOLESCENTS AND THEIR FAMILIES (U.S. CLS. 2, 5, 22, 23, 29, 37, 38 AND 50).

FIRST USE 12-2-2003; IN COMMERCE 5-31-2004.  
JENNIFER DIXON, EXAMINING ATTORNEY

SN 85-188,729. B&D LITHO OF ARIZONA, INC., DBA B&D LITHO, PHOENIX, AZ. FILED 12-1-2010.



The logo for "ACR" features the letters "ACR" in a bold, serif font.

THE MARK CONSISTS OF STANDARD CHARACTERS WITHOUT CLAIM TO ANY PARTICULAR FONT, STYLE, SIZE, OR COLOR.

FOR PRINTED FORMS (U.S. CLS. 2, 5, 22, 23, 29, 37, 38 AND 50).

FIRST USE 1-6-2005; IN COMMERCE 1-6-2005.  
KATHLEEN M. VANSTON, EXAMINING ATTORNEY

**CLASS 16—(Continued).**

SN 85-188,784. CABIN CREEK, LLC, PLEASANT GROVE, UT. FILED 12-1-2010.



The logo for "QUICK PIC" features the words "QUICK PIC" in a bold, serif font.

THE MARK CONSISTS OF STANDARD CHARACTERS WITHOUT CLAIM TO ANY PARTICULAR FONT, STYLE, SIZE, OR COLOR.

NO CLAIM IS MADE TO THE EXCLUSIVE RIGHT TO USE "PIC", APART FROM THE MARK AS SHOWN.

FOR SCRAPBOOK ALBUMS (U.S. CLS. 2, 5, 22, 23, 29, 37, 38 AND 50).

TINA BROWN, EXAMINING ATTORNEY

SN 85-189,354. AMOS PRESS, INC., SIDNEY, OH. FILED 12-2-2010.



The logo for "AMOS AUTO ENTHUSIAST" features the words "AMOS AUTO ENTHUSIAST" in a bold, serif font.

THE MARK CONSISTS OF STANDARD CHARACTERS WITHOUT CLAIM TO ANY PARTICULAR FONT, STYLE, SIZE, OR COLOR.

OWNER OF U.S. REG. NOS. 2,859,074, 3,425,026 AND 3,810,424.

NO CLAIM IS MADE TO THE EXCLUSIVE RIGHT TO USE "AUTO ENTHUSIAST", APART FROM THE MARK AS SHOWN.

FOR MAGAZINES FEATURING CARS (U.S. CLS. 2, 5, 22, 23, 29, 37, 38 AND 50).

FIRST USE 11-16-2010; IN COMMERCE 11-16-2010.  
JAY FLOWERS, EXAMINING ATTORNEY

SN 85-189,560. COMMAND PACKAGING, LOS ANGELES, CA. FILED 12-2-2010.



OWNER OF U.S. REG. NOS. 3,073,376, 3,461,026 AND 3,885,380.

NO CLAIM IS MADE TO THE EXCLUSIVE RIGHT TO USE "STONE", APART FROM THE MARK AS SHOWN.

THE MARKS CONSISTS OF THE WORDING "ENCORE STONE" WITH A DESIGN OF A SEASHELL.

FOR GENERAL PURPOSE PLASTIC BAGS (U.S. CLS. 2, 5, 22, 23, 29, 37, 38 AND 50).

FIRST USE 11-15-2010; IN COMMERCE 11-15-2010.  
EVELYN BRADLEY, EXAMINING ATTORNEY

**CLASS 16—(Continued).**

SN 85-189,903. HUSSAIN, IMRAN, LEEDS, UNITED KINGDOM, AND HUSSAIN, RIZWANA, LEEDS, UNITED KINGDOM, AND HUSSAIN, MAARIAH, LEEDS, UNITED KINGDOM, AND HUSSAIN, DANYAAL, LEEDS, UNITED KINGDOM, AND HUSSAIN, ZAHRA, LEEDS, UNITED KINGDOM, FILED 12-3-2010.



FOR ADHESIVES FOR STATIONERY AND HOUSEHOLD USE; ADHESIVES FOR STATIONERY OR HOUSEHOLD PURPOSES; ADHESIVES FOR STATIONERY PURPOSES (U.S. CLS. 2, 5, 22, 23, 29, 37, 38 AND 50).  
JIM RINGLE, EXAMINING ATTORNEY

SN 85-191,181. HIS BREATH NOW PUBLICATIONS, LLC, WHITE, GA. FILED 12-6-2010.

## The First-Ever Shape-Changing Book

THE MARK CONSISTS OF STANDARD CHARACTERS WITHOUT CLAIM TO ANY PARTICULAR FONT, STYLE, SIZE, OR COLOR.

NO CLAIM IS MADE TO THE EXCLUSIVE RIGHT TO USE "BOOK", APART FROM THE MARK AS SHOWN.

FOR GIFT SETS CONSISTING PRIMARILY OF PRINTED MESSAGES CONTAINED IN A BOTTLE (U.S. CLS. 2, 5, 22, 23, 29, 37, 38 AND 50).

FIRST USE 8-23-2010; IN COMMERCE 8-23-2010.  
VIVIAN MICZNIK FIRST, EXAMINING ATTORNEY

SN 85-192,654. KRIZMAN, LISA, CHERRY HILL, NJ. FILED 12-7-2010.

## SPECIAL COUNSEL PRODUCTIONS

THE MARK CONSISTS OF STANDARD CHARACTERS WITHOUT CLAIM TO ANY PARTICULAR FONT, STYLE, SIZE, OR COLOR.

NO CLAIM IS MADE TO THE EXCLUSIVE RIGHT TO USE "PRODUCTIONS", APART FROM THE MARK AS SHOWN.

FOR PRINTED MATERIALS, NAMELY, WRITTEN SCRIPTS FOR COURTROOM DRAMA PRESENTATIONS TO STUDENTS FOR EDUCATIONAL PURPOSES; WRITTEN GUIDEBOOKS ON THE TOPIC OF SPECIAL EDUCATION; WRITTEN SCRIPTS FOR LIVE PROGRAM PRESENTATIONS ON THE TOPIC OF SELF ADVOCACY FOR SPECIAL EDUCATION (U.S. CLS. 2, 5, 22, 23, 29, 37, 38 AND 50).

ALEXANDER L. POWERS, EXAMINING ATTORNEY

**CLASS 16—(Continued).**

SN 85-193,711. COMEAU, ELAINE, MAPLE RIDGE, BC, CANADA, FILED 12-8-2010.

## Easy Daysies

THE MARK CONSISTS OF STANDARD CHARACTERS WITHOUT CLAIM TO ANY PARTICULAR FONT, STYLE, SIZE, OR COLOR.

FOR MAGNETIC AND ADHESIVE BOARDS FOR SCHEDULING AND ORGANIZING ACTIVITIES AND APPOINTMENTS FOR CHILDREN (U.S. CLS. 2, 5, 22, 23, 29, 37, 38 AND 50).

FIRST USE 4-8-2008; IN COMMERCE 9-14-2008.  
LINDSEY RUBIN, EXAMINING ATTORNEY

SN 85-194,878. ASOCIACION DE EMPRESARIOS MEXICANOS, SAN ANTONIO, TX. FILED 12-10-2010.

## EMPRESARIOS AEM

THE MARK CONSISTS OF STANDARD CHARACTERS WITHOUT CLAIM TO ANY PARTICULAR FONT, STYLE, SIZE, OR COLOR.

NO CLAIM IS MADE TO THE EXCLUSIVE RIGHT TO USE "EMPRESARIOS", APART FROM THE MARK AS SHOWN.

THE ENGLISH TRANSLATION OF THE WORD "EMPRESARIOS" IN THE MARK IS "BUSINESSMEN".

FOR GENERAL FEATURE MAGAZINE IN THE FIELDS OF BUSINESS IN THE UNITED STATES AND MEXICO (U.S. CLS. 2, 5, 22, 23, 29, 37, 38 AND 50).

FIRST USE 10-30-2010; IN COMMERCE 10-30-2010.  
MARK PILARO, EXAMINING ATTORNEY

SN 85-196,903. PUMA PRESS, LLC, FLAGSTAFF, AZ. FILED 12-13-2010.



## Puma Press

NO CLAIM IS MADE TO THE EXCLUSIVE RIGHT TO USE "PRESS", APART FROM THE MARK AS SHOWN.

THE MARK CONSISTS OF A PALEO-INDIAN PETROGLYPH OF AN ADULT FEMALE PUMA IN SIDE VIEW AND THE STYLIZED WORDING "PUMA PRESS".

FOR SERIES OF FICTION AND NON-FICTION BOOKS ON A VARIETY OF TOPICS (U.S. CLS. 2, 5, 22, 23, 29, 37, 38 AND 50).

FIRST USE 5-1-2001; IN COMMERCE 5-1-2001.  
KIM SAITO, EXAMINING ATTORNEY

**CLASS 16—(Continued).**

SN 85-198,116. SIMPLICITY PATTERN CO., INC., NEW YORK, NY. FILED 12-15-2010.

**CLASS 16—(Continued).**

SN 85-199,129. ZIA PROJECTS, INC., BEECH MOUNTAIN, NC. FILED 12-16-2010.

**MORE THAN A BOSS... AN ADVENTURE!**

**SEW SIMPLE**

THE MARK CONSISTS OF STANDARD CHARACTERS WITHOUT CLAIM TO ANY PARTICULAR FONT, STYLE, SIZE, OR COLOR.

FOR PRINTED PATTERNS (U.S. CLS. 2, 5, 22, 23, 29, 37, 38 AND 50).

PAULA MAHONEY, EXAMINING ATTORNEY

THE MARK CONSISTS OF STANDARD CHARACTERS WITHOUT CLAIM TO ANY PARTICULAR FONT, STYLE, SIZE, OR COLOR.

FOR ADHESIVE NOTE PADS; ADHESIVE NOTE PAPER; ANNOUNCEMENT CARDS; BLANK NOTE CARDS; BLANK PAPER NOTEBOOKS; BUMPER STICKERS; BUSINESS CARDS; CARDS, NAMELY, GREETING, NOTE; COASTERS MADE OF PAPER; COPIER PAPER; DESKTOP BUSINESS CARD HOLDERS; ENVELOPE PAPER; GIFT WRAP PAPER; GREETINGS CARDS AND POSTCARDS; LETTERHEAD PAPER; NOTE CARDS; NOTE CARDS THAT UNFOLD TO ACT AS WORKSHEETS FOR DAILY/MONTHLY PLANNERS, ORGANIZERS, CALENDARS, TO DO LISTS THAT REFOLD TO MAKE A CREDIT CARD SIZED ITEM THAT FITS NEATLY IN YOUR WALLET OR POCKET; NOTE PADS; NOTE PAPER; NOTEBOOK PAPER; NOVELTY IDENTIFICATION CARDS; OCCASION CARDS; OFFICE STATIONERY; PAPER FOR PHOTOCOPYING; PAPER GIFT WRAP; PAPER NOTE TABLETS; PAPER NOTEBOOKS; PAPER PARTY BAGS; PAPER PARTY DECORATIONS; PAPER PARTY FAVORS; PAPER PICTURE MOUNTS; PAPER PLACE MATS; PAPER STATIONERY; PICTURE MOUNTS OF PAPER; PLACE CARDS; POST CARDS; POSTCARDS AND GREETING CARDS; SCRATCH PADS; SOCIAL NOTE CARDS; STATIONERY WRITING PAPER AND ENVELOPES; TOILET PAPER; TOILET SEAT COVER PAPER; TOILET TRAINING TARGETS MADE OF PAPER; WRITING PADS (U.S. CLS. 2, 5, 22, 23, 29, 37, 38 AND 50).

JUSTINE D. PARKER, EXAMINING ATTORNEY

SN 85-198,247. UNIVERSITY OF SOUTH CAROLINA, COLUMBIA, SC. FILED 12-15-2010.

SN 85-199,661. MWR, LLC, BARRINGTON, RI. FILED 12-16-2010.

**USCAN**

**BOOKFLIP**

THE MARK CONSISTS OF STANDARD CHARACTERS WITHOUT CLAIM TO ANY PARTICULAR FONT, STYLE, SIZE, OR COLOR.

FOR ANATOMICAL MODELS FOR SCIENTIFIC, INSTRUCTIONAL, AND EDUCATIONAL USE, NAMELY, ULTRASOUND TRAINING MODELS (U.S. CLS. 2, 5, 22, 23, 29, 37, 38 AND 50).

MARK PILARO, EXAMINING ATTORNEY

THE MARK CONSISTS OF STANDARD CHARACTERS WITHOUT CLAIM TO ANY PARTICULAR FONT, STYLE, SIZE, OR COLOR.

FOR BOOKMARKS (U.S. CLS. 2, 5, 22, 23, 29, 37, 38 AND 50).

FIRST USE 5-15-1993; IN COMMERCE 5-15-1993. BRIAN PINO, EXAMINING ATTORNEY

**CLASS 16—(Continued).**

SN 85-200,820. BROUN, WAYNE H., WARRIEWOOD BEACH NSW, AUSTRALIA, FILED 12-17-2010.



THE MARK CONSISTS OF A COAT OF ARMS FEATURING A LION HOLDING A FLEUR-DE-LIS AND STANDING ATOP AN ARMOUR HELMET THAT IS ABOVE A SHIELD FEATURING A CHEVRON AND THREE FLEUR-DE-LIS, ALL SURROUNDED BY LEAVES. ABOVE THE LION IS A BANNER FEATURING THE WORDING "FLOREAT MAJESTAS".

THE ENGLISH TRANSLATION OF "FLOREAT MAJESTAS" IN THE MARK IS LET MAJESTY FLOURISH.

FOR ADDRESS BOOKS, AUTOGRAPH BOOKS, BIRTHDAY BOOKS, APPOINTMENT BOOKS, ANNIVERSARY BOOKS, GUEST BOOKS, TRAVEL BOOKS, VISITOR BOOKS, NOTE BOOKS, PICTURE BOOKS, SONG BOOKS, PRINTED MUSIC BOOKS, SHEET MUSIC, CHILDREN'S ACTIVITY AND COLORING BOOKS, CHILDREN'S BIBLE STORIES BOOKS, COOK BOOKS, PHOTO ALBUMS, SCRAPBOOK ALBUMS, STAMP ALBUMS, STICKER ALBUMS, STICKERS, BOOK COVERS, NOTE CARDS, POSTCARDS, MEMO PADS; STATIONERY, INCLUDING WRITING PAPER AND ENVELOPES; BOOKMARKS, CALENDARS, GREETING CARDS, PAPER EMBLEMS, FLAGS AND BANNERS OF PAPER, ILLUSTRATED PRINTS AND POSTERS, PRINTED ART REPRODUCTIONS AND ILLUSTRATIONS OF COATS OF ARMS FRAMED OR UNFRAMED, PRINTED CERTIFICATES OF CLAN MEMBERSHIP FRAMED OR UNFRAMED, CLAN HISTORY BOOKS WITH OR WITHOUT ILLUSTRATIONS (U.S. CLS. 2, 5, 22, 23, 29, 37, 38 AND 50).

LINDA LAVACHE, EXAMINING ATTORNEY

SN 85-201,155. WILDWIESESWOOFWERKS, SHINGLE SPRINGS, CA. FILED 12-17-2010.

# ReTOX

THE MARK CONSISTS OF STANDARD CHARACTERS WITHOUT CLAIM TO ANY PARTICULAR FONT, STYLE, SIZE, OR COLOR.

FOR BUMPER STICKERS; STICKERS (U.S. CLS. 2, 5, 22, 23, 29, 37, 38 AND 50).

JUSTINE D. PARKER, EXAMINING ATTORNEY

**CLASS 16—(Continued).**

SN 85-201,311. NYSTROM, MATTHEW P., DBA GUZZLE-D.ORG, NEW ORLEANS, LA. FILED 12-18-2010.



THE MARK CONSISTS OF THE MARK IS A CHARACTERIZED FUEL TANK WITH DEVIL HORNS. THE STYLIZATION OF THE MARK RESEMBLES A FUEL SYMBOL THAT SUGGESTS THAT FUEL/GASOLINE IS THE DEVIL. COLOR IS NOT NECESSARY ALTHOUGH THE MARK CAN BE FOUND IN DIFFERENT COLORS. THE DEVIL HORNS ARE PLACED AT THE TOP OF THE FUEL TANK. THE STYLIZED FUEL PUMP HANDLE RESEMBLES A DEVIL LIKE TAIL ON THE RIGHT SIDE OF THE TANK.

FOR ALUMINUM FOIL LAMINATED PAPER FOR PRINTING PURPOSES; ART PRINTS; ART PRINTS COMPRISED OF DIGITAL ILLUSTRATIONS ORIGINATING FROM PHOTOGRAPHS; ART PRINTS ON CANVAS; CANVAS FOR PRINTING; CARTOON PRINTS; COLOR PRINTS; COMIC STRIPS APPEARING IN MAJOR PUBLICATIONS; FRAMED ART PRINTS; GRAPHIC FINE ART PRINTS; GRAPHIC PRINTS AND REPRESENTATIONS; LITHOGRAPHIC PRINTS; MERCHANDISE BAGS; MOUNTED POSTERS; PARTIALLY PRINTED FORMS; PHOTOGRAPHIC PRINTS; PICTORIAL PRINTS; PLASTIC OR PAPER BAGS FOR MERCHANDISE PACKAGING; POSTER BOARD; POSTERS; POSTERS MADE OF PAPER; PRINTED ART REPRODUCTIONS; PRINTED AWARD CERTIFICATES; PRINTED AWARDS; PRINTED CALENDARS; PRINTED CERTIFICATES; PRINTED CERTIFICATES FOR SPORTS AND/OR ENTERTAINMENT FANS; PRINTED CHARTS; PRINTED COLLECTOR CARDS MADE PRIMARILY OF PAPER AND ALSO INCLUDING METAL; PRINTED COLLECTOR CARDS MADE PRIMARILY OF PAPER BUT ALSO INCLUDING METAL; PRINTED EMBLEMS; PRINTED FORMS; PRINTED GRAPHS; PRINTED GREETING CARDS WITH ELECTRONIC INFORMATION STORED THEREIN; PRINTED HOLOGRAMS; PRINTED INVITATIONS; PRINTED MATERIAL IN THE NATURE OF COLOR SAMPLES; PRINTED MUSIC BOOKS; PRINTED NOVELTY WINE LABELS; PRINTED PAPER LABELS; PRINTED PAPER SIGNS; PRINTED PATTERNS; PRINTED STORIES IN ILLUSTRATED FORM; PRINTED TICKETS; PRINTS; SILK SCREEN PRINTS; UNMOUNTED POSTERS (U.S. CLS. 2, 5, 22, 23, 29, 37, 38 AND 50).

FIRST USE 2-3-2008; IN COMMERCE 6-12-2009.

ARETHA SOMERVILLE, EXAMINING ATTORNEY

**CLASS 16—(Continued).**

SN 85-203,226. LIFE PLUS STYLE LTD., NEW YORK, NY.  
FILED 12-21-2010.

**THE ART OF MY LIFE**

THE MARK CONSISTS OF STANDARD CHARACTERS WITHOUT CLAIM TO ANY PARTICULAR FONT, STYLE, SIZE, OR COLOR.

FOR BLANK JOURNALS; MEMO PADS; NOTE CARDS; PEN AND PENCIL CASES; STATIONERY (U.S. CLS. 2, 5, 22, 23, 29, 37, 38 AND 50).

FIRST USE 12-9-2010; IN COMMERCE 12-9-2010.  
MICHAEL TANNER, EXAMINING ATTORNEY

SN 85-203,532. KUKLA, FRANK, JEFFERSON CITY, MO.  
FILED 12-22-2010.

**SUPPORT THE TRUTH**

THE MARK CONSISTS OF STANDARD CHARACTERS WITHOUT CLAIM TO ANY PARTICULAR FONT, STYLE, SIZE, OR COLOR.

FOR STICKERS (U.S. CLS. 2, 5, 22, 23, 29, 37, 38 AND 50).

DARRYL SPRUILL, EXAMINING ATTORNEY

SN 85-203,579. GANNETT CO., INC., MCLEAN, VA. FILED  
12-22-2010.

**IT'S ALL WITHIN REACH**

THE MARK CONSISTS OF STANDARD CHARACTERS WITHOUT CLAIM TO ANY PARTICULAR FONT, STYLE, SIZE, OR COLOR.

FOR NEWSPAPERS CONTAINING NEWS ON TOPICS OF GENERAL INTEREST (U.S. CLS. 2, 5, 22, 23, 29, 37, 38 AND 50).

SOPHIA S. KIM, EXAMINING ATTORNEY

**CLASS 16—(Continued).**

SN 85-204,023. DMC COMMUNICATIONS, LLC, BRAYBURG, NJ. FILED 12-22-2010.

**EXPERT VIEWS**

THE MARK CONSISTS OF STANDARD CHARACTERS WITHOUT CLAIM TO ANY PARTICULAR FONT, STYLE, SIZE, OR COLOR.

FOR PUBLICATIONS, NAMELY, NEWSLETTERS IN THE FIELDS OF GASTROINTESTINAL HEALTH AND WELLNESS (U.S. CLS. 2, 5, 22, 23, 29, 37, 38 AND 50).

KATHERINE CHANG, EXAMINING ATTORNEY

SN 85-204,468. SANCHEZ, JOSHUA, NORTH SALT LAKE, UT. FILED 12-22-2010.



NO CLAIM IS MADE TO THE EXCLUSIVE RIGHT TO USE "REAL ESTATE", APART FROM THE MARK AS SHOWN.

THE MARK CONSISTS OF A PERSON AT THE START OF A PATH LEADING TO RESIDENTIAL AND COMMERCIAL BUILDINGS. THE PATH IS IN THE SHAPE OF AN "R" AND A "G". TO THE RIGHT THERE IS THE STYLIZED TEXT "REAL ESTATE GENESIS".

FOR BOOKS IN THE FIELD OF REAL ESTATE INVESTMENT; NEWSLETTERS IN THE FIELD OF REAL ESTATE INVESTMENT (U.S. CLS. 2, 5, 22, 23, 29, 37, 38 AND 50).

KHANH LE, EXAMINING ATTORNEY

SN 85-204,508. JEANIE MORGAN, FORT THOMAS, KY.  
FILED 12-22-2010.

**EsScents**

THE MARK CONSISTS OF STANDARD CHARACTERS WITHOUT CLAIM TO ANY PARTICULAR FONT, STYLE, SIZE, OR COLOR.

FOR DECALS (U.S. CLS. 2, 5, 22, 23, 29, 37, 38 AND 50).

EMILY CHUO, EXAMINING ATTORNEY

**CLASS 16—(Continued).**

SN 85-204,587. FRENCH, MICHAEL, LANCASTER, CA. AND FRENCH, GAIL, LANCASTER, CA. FILED 12-23-2010.

# THE ROSE

THE MARK CONSISTS OF STANDARD CHARACTERS WITHOUT CLAIM TO ANY PARTICULAR FONT, STYLE, SIZE, OR COLOR.

FOR ARTIST PALETTES FOR PAINTING (U.S. CLS. 2, 5, 22, 23, 29, 37, 38 AND 50).

HANNO RITTNER, EXAMINING ATTORNEY

---

SN 85-205,261. RICK FEDERMAN, LOS ANGELES, CA. FILED 12-23-2010.



THE MARK CONSISTS OF A CROWNED SMILEY FACE, CONSISTING OF A SMILE MADE OF A PARENTHESIS, EYES MADE OF A COLON, AND A CROWN MADE OF THE LETTER E, WITHIN A WAX IMPRESSION AS IF MADE BY A STAMP.

FOR CHILDREN'S BOOKS; STICKERS (U.S. CLS. 2, 5, 22, 23, 29, 37, 38 AND 50).

FIRST USE 12-10-2010; IN COMMERCE 12-10-2010.

RONALD MCMORROW, EXAMINING ATTORNEY

---

SN 85-205,472. STEWART TAGGART, ESSEX, CT. FILED 12-23-2010.

# Grenatec

THE MARK CONSISTS OF STANDARD CHARACTERS WITHOUT CLAIM TO ANY PARTICULAR FONT, STYLE, SIZE, OR COLOR.

FOR RESEARCH REPORTS FEATURING RENEWABLE ENERGY (U.S. CLS. 2, 5, 22, 23, 29, 37, 38 AND 50).

BARBARA BROWN, EXAMINING ATTORNEY

**CLASS 16—(Continued).**

SN 85-205,959. STEPHENS MEDIA LLC, DBA ELY TIMES, LAS VEGAS, NV. FILED 12-27-2010.

# The Ely Times

THE MARK CONSISTS OF STANDARD CHARACTERS WITHOUT CLAIM TO ANY PARTICULAR FONT, STYLE, SIZE, OR COLOR.

NO CLAIM IS MADE TO THE EXCLUSIVE RIGHT TO USE "ELY", APART FROM THE MARK AS SHOWN.

FOR NEWSPAPERS (U.S. CLS. 2, 5, 22, 23, 29, 37, 38 AND 50).

FIRST USE 9-1-2000; IN COMMERCE 9-1-2000.

EDWARD FENNESSY, EXAMINING ATTORNEY

---

SN 85-206,005. SCOFAMCO INC, HASTINGS, MN. FILED 12-27-2010.

# Personia

THE MARK CONSISTS OF STANDARD CHARACTERS WITHOUT CLAIM TO ANY PARTICULAR FONT, STYLE, SIZE, OR COLOR.

FOR PERSONAL SECURITY PRODUCT, NAMELY, A PROTECTIVE FABRIC SLEEVE USED TO HOLD CREDIT CARDS (U.S. CLS. 2, 5, 22, 23, 29, 37, 38 AND 50).

HELENE LIWINSKI, EXAMINING ATTORNEY

---

SN 85-206,206. AL SOWAYEGH, FAISAL, PARKVILLE, MO. FILED 12-27-2010.

# The Protectorate

THE MARK CONSISTS OF STANDARD CHARACTERS WITHOUT CLAIM TO ANY PARTICULAR FONT, STYLE, SIZE, OR COLOR.

FOR CARTOON PRINTS; COMIC BOOKS (U.S. CLS. 2, 5, 22, 23, 29, 37, 38 AND 50).

BARNEY CHARLON, EXAMINING ATTORNEY

**CLASS 16—(Continued).**

SN 85-206,259. FLIZANES, JJ, BEVERLY HILLS, CA. FILED 12-27-2010.

## Fit 2 Love

THE MARK CONSISTS OF STANDARD CHARACTERS WITHOUT CLAIM TO ANY PARTICULAR FONT, STYLE, SIZE, OR COLOR.

FOR A SERIES OF BOOKS AND WRITTEN ARTICLES IN THE FIELD OF FITNESS (U.S. CLS. 2, 5, 22, 23, 29, 37, 38 AND 50).

DAVID TOOLEY, EXAMINING ATTORNEY

**CLASS 16—(Continued).**

SN 85-206,926. CURTIS, NEIL, A., FREEPORT, NY. FILED 12-29-2010.

## No God? Know God!

THE MARK CONSISTS OF STANDARD CHARACTERS WITHOUT CLAIM TO ANY PARTICULAR FONT, STYLE, SIZE, OR COLOR.

FOR BOOKS IN THE FIELD OF SELF-HELP; PRAYER BOOKS; RELIGIOUS BOOKS (U.S. CLS. 2, 5, 22, 23, 29, 37, 38 AND 50).

RUDY R. SINGLETON, EXAMINING ATTORNEY

SN 85-206,846. JC 23 ENTERTAINMENT, INC., BEVERLY HILLS, CA. FILED 12-28-2010.



THE MARK CONSISTS OF STYLIZED CHARACTER SITTING IN YOGA STYLE.

FOR PRINTED MATTER AND PAPER GOODS, NAMELY, BOOKS FEATURING CHARACTERS FROM ANIMATED, ACTION ADVENTURE, COMEDY AND/OR DRAMA FEATURES, COMIC BOOKS, CHILDREN'S BOOKS, MAGAZINES FEATURING CHARACTERS FROM ANIMATED, ACTION ADVENTURE, COMEDY AND/OR DRAMA FEATURES, COLORING BOOKS, CHILDREN'S ACTIVITY BOOKS; STATIONERY, WRITING PAPER, ENVELOPES, NOTEBOOKS, DIARIES, NOTE CARDS, GREETING CARDS, TRADING CARDS; LITHOGRAPHS; PENS, PENCILS, PEN CASES, PENCIL CASES, ERASERS, CRAYONS, MARKERS, COLORED PENCILS, PAINTING SETS FOR CHILDREN, CHALK AND CHALKBOARDS; DECALS, HEAT TRANSFER PAPER, POSTERS; MOUNTED AND/OR UN-MOUNTED PHOTOGRAPHS; BOOKS COVERS, BOOK MARKS, CALENDARS, GIFT WRAPPING PAPER; PAPER PARTY FAVORS AND PAPER PARTY DECORATIONS—NAMELY, PAPER NAPKINS, PAPER DOILIES, PAPER PLACE MATS, CREPE PAPER, PRINTED INVITATIONS, PAPER TABLE CLOTHS, PAPER CAKE DECORATIONS; PRINTED TRANSFERS FOR EMBROIDERY OR FABRIC APPLIQUÉS; PRINTED PATTERNS FOR COSTUMES, PAJAMAS, SWEATSHIRTS AND T-SHIRTS, PAPER WEIGHTS, PAPER COASTERS, PAPER MATS (U.S. CLS. 2, 5, 22, 23, 29, 37, 38 AND 50).

CYNTHIA SLOAN, EXAMINING ATTORNEY

SN 85-207,270. ASSOCIATES IN MEDICAL MARKETING CO., INC., NEWTOWN, PA. FILED 12-29-2010.

## CONTEMPORARY GUIDE TO SURGICAL INFECTIONS

THE MARK CONSISTS OF STANDARD CHARACTERS WITHOUT CLAIM TO ANY PARTICULAR FONT, STYLE, SIZE, OR COLOR.

NO CLAIM IS MADE TO THE EXCLUSIVE RIGHT TO USE "GUIDE TO SURGICAL INFECTIONS", APART FROM THE MARK AS SHOWN.

FOR A SERIES OF PERIODICALLY REVISED MEDICAL REFERENCE BOOKS (U.S. CLS. 2, 5, 22, 23, 29, 37, 38 AND 50).

BRENDAN MCCAULEY, EXAMINING ATTORNEY

SN 85-207,275. BAY CONVERTING INC., GREEN BAY, WI. FILED 12-29-2010.

## EARTH DELICATE

THE MARK CONSISTS OF STANDARD CHARACTERS WITHOUT CLAIM TO ANY PARTICULAR FONT, STYLE, SIZE, OR COLOR.

FOR PARCHMENT PAPER (U.S. CLS. 2, 5, 22, 23, 29, 37, 38 AND 50).

FIRST USE 8-12-2009; IN COMMERCE 8-12-2009.  
ZHALEH DELANEY, EXAMINING ATTORNEY

**CLASS 16—(Continued).**

SN 85-207,429. DASHBOARD DOODLES, HAPPY VALLEY, OR. FILED 12-29-2010.

**DASHBOARD DOODLES**

THE MARK CONSISTS OF STANDARD CHARACTERS WITHOUT CLAIM TO ANY PARTICULAR FONT, STYLE, SIZE, OR COLOR.

FOR BANNERS OF PAPER; BUMPER STICKERS; DECALS; DECORATIVE DECALS FOR VEHICLE WINDOWS; MAGNETIC BUMPER STICKERS; POSTERS (U.S. CLS. 2, 5, 22, 23, 29, 37, 38 AND 50).

FIRST USE 8-30-2010; IN COMMERCE 8-30-2010.  
MARK SHINER, EXAMINING ATTORNEY

SN 85-207,472. CBS STUDIOS INC., STUDIO CITY, CA. FILED 12-29-2010.

**CRIMINAL MINDS**

THE MARK CONSISTS OF STANDARD CHARACTERS WITHOUT CLAIM TO ANY PARTICULAR FONT, STYLE, SIZE, OR COLOR.

OWNER OF U.S. REG. NOS. 3,162,620 AND 3,568,706.  
FOR SERIES OF FICTIONAL BOOKS (U.S. CLS. 2, 5, 22, 23, 29, 37, 38 AND 50).

FIRST USE 11-6-2007; IN COMMERCE 11-6-2007.  
ANNE E. GUSTASON, EXAMINING ATTORNEY

SN 85-207,564. SHELLEY METTEN, LOS ANGELES, CA. FILED 12-29-2010.

**SPECIAL ME**

THE MARK CONSISTS OF STANDARD CHARACTERS WITHOUT CLAIM TO ANY PARTICULAR FONT, STYLE, SIZE, OR COLOR.

FOR EDUCATIONAL BOOKS FEATURING ANATOMY AND PHYSIOLOGY (U.S. CLS. 2, 5, 22, 23, 29, 37, 38 AND 50).

CHARLOTTE CORWIN, EXAMINING ATTORNEY

**CLASS 16—(Continued).**

SN 85-208,024. BIPOLAR BEACON OF HOPE, VANCOUVER, WA. FILED 12-30-2010.

**Bipolar Beacon of Hope**

THE MARK CONSISTS OF STANDARD CHARACTERS WITHOUT CLAIM TO ANY PARTICULAR FONT, STYLE, SIZE, OR COLOR.

NO CLAIM IS MADE TO THE EXCLUSIVE RIGHT TO USE "BIPOLAR", APART FROM THE MARK AS SHOWN.

FOR BOOKS IN THE FIELD OF BIPOLAR DISORDER (U.S. CLS. 2, 5, 22, 23, 29, 37, 38 AND 50).

FIRST USE 10-12-2010; IN COMMERCE 10-12-2010.  
ROSELLE HERRERA, EXAMINING ATTORNEY

SN 85-208,183. INSTITUTE FOR THE STUDY OF HUMAN KNOWLEDGE, LOS ALTOS, CA. FILED 12-30-2010.



THE MARK CONSISTS OF IMAGE OF A BIRD WITH EIGHT FEATHERS FORMING A CROWN ON THE TOP OF ITS HEAD, AN ELONGATED BEAK POINTING FORWARD, A WING AND TAIL POINTING BACKWARD IN THE FORM OF A REVERSED LETTER "C", AND ONE EYE SHOWING AT THE VIEWER. THE BIRD SITS OVER THE WORD "HOOPOE" WRITTEN WITH THE TWO LETTER "O"'S INTERLINKED.

FOR CHILDREN'S BOOKS; EDUCATIONAL BOOKS FEATURING TEACHING STORIES; EDUCATIONAL PUBLICATIONS, NAMELY, BOOKS, HAND-OUTS, WORKBOOKS, JOURNALS, PLAYBOOKS, WORKSHEETS AND CARDS IN THE FIELD OF RIGHT-BRAIN FITNESS; EDUCATIONAL PUBLICATIONS, NAMELY, EDUCATIONAL LEARNING CARDS, FLASH CARDS, ACTIVITY CARDS, WORKBOOKS, TEXTBOOKS, ACTIVITY BOOKS, STORY BOOKS, PUZZLE BOOKS, PRINTED PUZZLES, TEACHER GUIDES, MANUALS, POSTERS AND EDUCATIONAL BOOKLETS IN THE FIELD OF CHILDREN'S LITERACY; EDUCATIONAL PUBLICATIONS, NAMELY, TEACHING STORIES AND USER GUIDES IN THE FIELDS OF CHILDREN'S LITERACY; PRINTED EDUCATIONAL MATERIALS IN THE FIELD OF CHILDREN'S LITERACY; PRINTED INSTRUCTIONAL, EDUCATIONAL, AND TEACHING MATERIALS IN THE FIELD OF CHILDREN'S LITERACY; SERIES OF FICTION AND NON-FICTION BOOKS ON A VARIETY OF TOPICS (U.S. CLS. 2, 5, 22, 23, 29, 37, 38 AND 50).

FIRST USE 2-28-1996; IN COMMERCE 2-28-1998.  
HENRY S. ZAK, EXAMINING ATTORNEY



**CLASS 16—(Continued).**

SN 85-208,742. ALLPAK CONTAINER, INC, RENTON, WA.  
FILED 12-31-2010.

**ALLPAKTROJAN**

THE MARK CONSISTS OF STANDARD CHARACTERS WITHOUT CLAIM TO ANY PARTICULAR FONT, STYLE, SIZE, OR COLOR.

FOR PAPER BOXES, CARDBOARD BOXES, CORRUGATED BOXES, PAPER DISPLAY BOXES, PAPER-BASED POINT-OF-PURCHASE DISPLAYS, PAPERBOARD BOXES FOR INDUSTRIAL PACKAGING, CARDBOARD CONTAINERS, INDUSTRIAL PACKAGING CONTAINERS OF PAPER, CORRUGATED CONTAINERS, PAPER CARTONS FOR DELIVERING GOODS, CARDBOARD CARTONS, PAPERBOARD PACKING (U.S. CLS. 2, 5, 22, 23, 29, 37, 38 AND 50).  
SANDRA BUJA, EXAMINING ATTORNEY

SN 85-208,773. GNL ENTERTAINMENT, INC., WASHINGTON, DC. FILED 1-1-2011.

**Painted On Water**

THE MARK CONSISTS OF STANDARD CHARACTERS WITHOUT CLAIM TO ANY PARTICULAR FONT, STYLE, SIZE, OR COLOR.

FOR PRINTED MUSIC BOOKS; SHEET MUSIC (U.S. CLS. 2, 5, 22, 23, 29, 37, 38 AND 50).  
ANDREA HACK, EXAMINING ATTORNEY

SN 85-208,842. VOIP CARDS, LLC, LAWRENCEVILLE, GA.  
FILED 1-2-2011.

**MI BANDERA**

THE MARK CONSISTS OF STANDARD CHARACTERS WITHOUT CLAIM TO ANY PARTICULAR FONT, STYLE, SIZE, OR COLOR.

THE ENGLISH TRANSLATION OF "MI BANDERA" IN THE MARK IS MY FLAG.

FOR PRE-PAID TELEPHONE CALLING CARDS, NOT MAGNETICALLY ENCODED (U.S. CLS. 2, 5, 22, 23, 29, 37, 38 AND 50).

FIRST USE 12-1-2010; IN COMMERCE 12-1-2010.  
KATHERINE M. DUBRAY, EXAMINING ATTORNEY

**CLASS 16—(Continued).**

SN 85-208,940. KAVOUKLIS, NIKKI, TARPON SPRINGS, FL.  
FILED 1-3-2011.

**ZENI**

THE MARK CONSISTS OF STANDARD CHARACTERS WITHOUT CLAIM TO ANY PARTICULAR FONT, STYLE, SIZE, OR COLOR.

FOR PRINTED MATERIALS, NAMELY, SERIES OF FICTION, MOTIVATIONAL, INSPIRATIONAL, AND CHILDREN'S BOOKS (U.S. CLS. 2, 5, 22, 23, 29, 37, 38 AND 50).

ERNEST SHOSHO, EXAMINING ATTORNEY

SN 85-208,974. COCHREN, LESLIE JAMES, DBA RIVERCAT, SPANISH LAKE, MO. FILED 1-3-2011.

**RIVERCAT**

THE MARK CONSISTS OF STANDARD CHARACTERS WITHOUT CLAIM TO ANY PARTICULAR FONT, STYLE, SIZE, OR COLOR.

FOR OFFSET PAPER; OFFSET PRINTING PAPER FOR PAMPHLETS; OILPROOF PAPER; ONION SKIN PAPER; OPAQUE PAPER; PACKAGING CONTAINERS OF PAPER; PACKING PAPER; PAPER; PAPER AND CARDBOARD; PAPER BABY BIBS; PAPER BADGES; PAPER BAGS; PAPER BAGS AND SACKS; PAPER BAGS FOR PACKAGING; PAPER EMBLEMS; PAPER ENVELOPES FOR PACKAGING; PAPER FLAGS; PAPER FOOD WRAP; PAPER NAPKINS; PAPER NOTE TABLETS; PAPER NOTEBOOKS; PAPER PARTY BAGS; PAPER PARTY FAVORS; PAPER PENNANTS; PAPER POUCHES FOR PACKAGING; PAPER POUCHES SOLD EMPTY FOR HOLDING CONDIMENTS; PAPER PRODUCTS, NAMELY, PAPER TUBES; PAPER PRODUCTS, NAMELY, PAPER TUBES AND PAPER CORES; PAPER RACKS; PAPER SHOPPING BAGS; PAPER STATIONERY; PAPER TAKE-OUT CARTONS FOR FOOD (U.S. CLS. 2, 5, 22, 23, 29, 37, 38 AND 50).

FIRST USE 6-1-2000; IN COMMERCE 6-1-2000.  
CHERYL CLAYTON, EXAMINING ATTORNEY

SN 85-208,981. PERRY DOG, LLP, SKOKIE, IL. FILED 1-3-2011.

**PERRY DOG**

THE MARK CONSISTS OF STANDARD CHARACTERS WITHOUT CLAIM TO ANY PARTICULAR FONT, STYLE, SIZE, OR COLOR.

FOR GREETING CARDS (U.S. CLS. 2, 5, 22, 23, 29, 37, 38 AND 50).

WILLIAM ROSSMAN, EXAMINING ATTORNEY

**CLASS 16—(Continued).**

SN 85-209,072. BLUE LINK VENTURES, LLC, NEW YORK, NY. FILED 1-3-2011.

# Thankster

THE MARK CONSISTS OF STANDARD CHARACTERS WITHOUT CLAIM TO ANY PARTICULAR FONT, STYLE, SIZE, OR COLOR.

FOR ANNOUNCEMENT CARDS; ENVELOPES; GREETING CARDS; NOTE CARDS; PLACE CARDS (U.S. CLS. 2, 5, 22, 23, 29, 37, 38 AND 50).

TINA L. SNAPP, EXAMINING ATTORNEY

SN 85-209,184. FIRST RISE, LLC, WINOOSKI, VT. FILED 1-3-2011.



THE COLOR(S) DARK GREEN, LIGHT GREEN AND WHITE IS/ARE CLAIMED AS A FEATURE OF THE MARK.

THE MARK CONSISTS OF THE LETTERS "F" AND "R" AND THE WORDS "FIRST RISE. FIRST" IS IN DARK GREEN ON A TRANSPARENT BACKGROUND. "RISE" IS IN LIGHT GREEN ON A TRANSPARENT BACKGROUND. LETTER "F" IS ABOVE "FIRST", IN DARK GREEN ON NEUTRAL BACKGROUND. LETTER "R" IS CENTERED ABOVE "FIRST RISE", IS SLIGHTLY ABOVE AND TOUCHING LETTER "F", AND IS IN WHITE OVER A LIGHT AND DARK GREEN BACKGROUND FIGURE. THE BACKGROUND FIGURE DEPICTS A LEAF HAVING SERRATED EDGES AND ITS TIP DOUBLED OVER. THE MAIN PART OF THE LEAF IS LIGHT GREEN, AND THE DOUBLED-OVER TIP IS DARK GREEN. A LIGHT-GREEN FIGURE OF THE LOWER END OF A FOUNTAIN PEN EXTENDS LEFT AND DOWN FROM THE LOWER LEFT CORNER OF LETTER "R". THE POINT OF THE PEN TOUCHES THE LOWER RIGHT CORNER OF LETTER "F", WHICH EXTENDS DOWN AND TO THE RIGHT TO MEET IT.

FOR SERIES OF FICTION AND NON-FICTION BOOKS ON A VARIETY OF TOPICS (U.S. CLS. 2, 5, 22, 23, 29, 37, 38 AND 50).

FIRST USE 12-29-2010; IN COMMERCE 12-29-2010.  
NICHOLAS COLEMAN, EXAMINING ATTORNEY

**CLASS 16—(Continued).**

SN 85-209,356. TINY PRINTS, INC., SUNNYVALE, CA. FILED 1-3-2011.

# MAGNOLIA PRESS

THE MARK CONSISTS OF STANDARD CHARACTERS WITHOUT CLAIM TO ANY PARTICULAR FONT, STYLE, SIZE, OR COLOR.

NO CLAIM IS MADE TO THE EXCLUSIVE RIGHT TO USE "PRESS", APART FROM THE MARK AS SHOWN.

FOR PAPER AND PRINTED MATTER, NAMELY, ANNOUNCEMENT CARDS, PRINTED INVITATIONS, INVITATION CARDS, THANK YOU CARDS, HOLIDAY CARDS, GREETING CARDS, CARDS WITH PHOTOGRAPHS, POSTCARDS, GIFT TAGS, ADDRESS LABELS, STICKERS, STATIONERY, AND ENVELOPES (U.S. CLS. 2, 5, 22, 23, 29, 37, 38 AND 50).

FIRST USE 6-4-2009; IN COMMERCE 6-5-2009.  
KATHY DE JONGE, EXAMINING ATTORNEY

SN 85-209,483. HUDDLE, SANDY, DBA BE YOUR OWN REASON!, ASTON, PA. FILED 1-3-2011.

# Be Your Own Reason!

THE MARK CONSISTS OF THE WORDS "BE YOUR OWN REASON!" IN STYLIZED FONT.

FOR ART PRINTS; BOOKMARKS; CALENDARS; CARDS, NAMELY, GREETING CARDS, NOTE CARDS, POST CARDS; PRINTS IN THE NATURE OF MOTIVATIONAL AND INSPIRATIONAL IMAGES AND MESSAGES; STICKERS (U.S. CLS. 2, 5, 22, 23, 29, 37, 38 AND 50).

FIRST USE 11-0-2010; IN COMMERCE 11-0-2010.  
ADA HAN, EXAMINING ATTORNEY

SN 85-209,494. HUDDLE, SANDY, DBA BE YOUR OWN REASON!, ASTON, PA. FILED 1-3-2011.

# be the light, be the change, Be Your Own Reason!

THE MARK CONSISTS OF THE WORDS "BE THE LIGHT, BE THE CHANGE, BE YOUR OWN REASON!" IN STYLIZED FONT.

FOR ART PRINTS; BOOKMARKS; CALENDARS; CARDS, NAMELY, GREETING CARDS, NOTE CARDS, POST CARDS; PRINTS IN THE NATURE OF MOTIVATIONAL AND INSPIRATIONAL IMAGES AND MESSAGES; STICKERS (U.S. CLS. 2, 5, 22, 23, 29, 37, 38 AND 50).

FIRST USE 11-0-2010; IN COMMERCE 11-0-2010.  
ADA HAN, EXAMINING ATTORNEY

**CLASS 16—(Continued).**

SN 85-209,506. BRAVE BULL LLC, CHERRY HILL, NJ.  
FILED 1-3-2011.

**Bulls Before Breakfast**

THE MARK CONSISTS OF STANDARD CHARACTERS  
WITHOUT CLAIM TO ANY PARTICULAR FONT, STYLE,  
SIZE, OR COLOR.  
FOR GUIDE BOOKS FEATURING PAMPLONA (U.S.  
CLS. 2, 5, 22, 23, 29, 37, 38 AND 50).  
SUSAN RICHARDS, EXAMINING ATTORNEY

SN 85-209,588. HUNTER, JASON ALBERT, LANSDALE, PA.  
FILED 1-3-2011.

**RECRAYON**

THE MARK CONSISTS OF STANDARD CHARACTERS  
WITHOUT CLAIM TO ANY PARTICULAR FONT, STYLE,  
SIZE, OR COLOR.  
FOR CRAYONS (U.S. CLS. 2, 5, 22, 23, 29, 37, 38 AND  
50).  
SCOTT BIBB, EXAMINING ATTORNEY

SN 85-209,841. BOOKNER, BECCI, MURFREESBORO, TN.  
FILED 1-4-2011.

**Violet Ink**

THE MARK CONSISTS OF STANDARD CHARACTERS  
WITHOUT CLAIM TO ANY PARTICULAR FONT, STYLE,  
SIZE, OR COLOR.  
FOR SERIES OF FICTION AND NON-FICTION  
BOOKS ON A VARIETY OF TOPICS (U.S. CLS. 2, 5, 22,  
23, 29, 37, 38 AND 50).  
MARTHA SANTOMARTINO, EXAMINING ATTORNEY

**CLASS 16—(Continued).**

SN 85-210,023. TOUZET & HEMEL, LLC, NEW ORLEANS,  
LA. FILED 1-4-2011.

**FLEURDELEE**

THE MARK CONSISTS OF STANDARD CHARACTERS  
WITHOUT CLAIM TO ANY PARTICULAR FONT, STYLE,  
SIZE, OR COLOR.  
FOR CHILDREN'S STORYBOOKS (U.S. CLS. 2, 5, 22,  
23, 29, 37, 38 AND 50).  
HEATHER THOMPSON, EXAMINING ATTORNEY

SN 85-210,068. TOUZET & HEMEL, LLC, NEW ORLEANS,  
LA. FILED 1-4-2011.



THE MARK CONSISTS OF A DRAWING OF A LITTLE  
BOY.  
FOR CHILDREN'S STORYBOOKS (U.S. CLS. 2, 5, 22,  
23, 29, 37, 38 AND 50).  
HEATHER THOMPSON, EXAMINING ATTORNEY

SN 85-210,282. MELODRAMA PUBLISHING, LLC, PATCH-  
OGUE, NY. FILED 1-4-2011.

**WIFEY**

THE MARK CONSISTS OF STANDARD CHARACTERS  
WITHOUT CLAIM TO ANY PARTICULAR FONT, STYLE,  
SIZE, OR COLOR.  
FOR SERIES OF FICTION BOOKS; SERIES OF FICTION  
WORKS, NAMELY, NOVELS AND BOOKS (U.S.  
CLS. 2, 5, 22, 23, 29, 37, 38 AND 50).  
BARBARA BROWN, EXAMINING ATTORNEY

**CLASS 16—(Continued).**

SN 85-210,401. COLONIAL PATTERNS, INC., KANSAS CITY, MO. FILED 1-4-2011.



*Aunt Martha's*

THE MARK CONSISTS OF THE STYLIZED WORDING "AUNT MARTHA'S" AND DESIGN. THE DESIGN CONSISTS OF A WOMAN OR "GRANNY" SITTING IN A CHAIR HOLDING AN EMBROIDERY HOOP, A CAT SITS TO THE LEFT SIDE OF THE CHAIR, AND A BASKET SITS TO THE RIGHT SIDE OF THE CHAIR.

FOR EMBROIDERY DESIGN PATTERNS (U.S. CLS. 2, 5, 22, 23, 29, 37, 38 AND 50).  
FIRST USE 12-1-1930; IN COMMERCE 12-1-1930.  
REGINA DRUMMOND, EXAMINING ATTORNEY

SN 85-210,402. GMT PUBLISHING SARL, GENEVA, SWITZERLAND, FILED 1-4-2011.

GMT

THE MARK CONSISTS OF STANDARD CHARACTERS WITHOUT CLAIM TO ANY PARTICULAR FONT, STYLE, SIZE, OR COLOR.

FOR MAGAZINES IN THE FIELD OF WATCHES (U.S. CLS. 2, 5, 22, 23, 29, 37, 38 AND 50).  
FIRST USE 0-0-2004; IN COMMERCE 0-0-2004.  
GILBERT SWIFT, EXAMINING ATTORNEY

SN 85-210,594. SYNDICATED PUZZLES, VICTORIA, CANADA, FILED 1-5-2011.

letterlicious

THE MARK CONSISTS OF STANDARD CHARACTERS WITHOUT CLAIM TO ANY PARTICULAR FONT, STYLE, SIZE, OR COLOR.

FOR CROSSWORD PUZZLES (U.S. CLS. 2, 5, 22, 23, 29, 37, 38 AND 50).  
FIRST USE 11-9-2008; IN COMMERCE 12-23-2010.  
JIM RINGLE, EXAMINING ATTORNEY

**CLASS 16—(Continued).**

SN 85-210,894. GODWIN III, ROYCE, KENNETH, AKA KEN GODWIN, SAINT AUGUSTINE, FL. AND GODWIN, PATRICIA, EILEEN, AKA EILEEN GODWIN, SAINT AUGUSTINE, FL. FILED 1-5-2011.

Nauti Boy

THE MARK CONSISTS OF STANDARD CHARACTERS WITHOUT CLAIM TO ANY PARTICULAR FONT, STYLE, SIZE, OR COLOR.

FOR GENERAL FEATURE MAGAZINE IN THE FIELD OF ADULT ENTERTAINMENT; MAGAZINE PAPER; MAGAZINES FEATURING ADULT ENTERTAINMENT; MAGAZINES IN THE FIELD OF ADULT ENTERTAINMENT (U.S. CLS. 2, 5, 22, 23, 29, 37, 38 AND 50).

JUSTINE D. PARKER, EXAMINING ATTORNEY

SN 85-210,950. TELEFONICA, S.A., MADRID, SPAIN, FILED 1-5-2011.

MOVISTAR

THE MARK CONSISTS OF STANDARD CHARACTERS WITHOUT CLAIM TO ANY PARTICULAR FONT, STYLE, SIZE, OR COLOR.

OWNER OF U.S. REG. NOS. 2,930,460, 3,381,838 AND OTHERS.

FOR PRINTED MATTER, NAMELY, VISITOR'S CARDS, LEAFLETS, MAGAZINES, AND CATALOGS IN THE FIELD OF TELECOMMUNICATIONS AND TELECOMMUNICATION PRODUCTS (U.S. CLS. 2, 5, 22, 23, 29, 37, 38 AND 50).

TINA MAI, EXAMINING ATTORNEY

SN 85-211,091. KITARU INNOVATIONS INC., LASCELLES, BARBADOS, FILED 1-5-2011.

ONE ARM BANDIT

THE MARK CONSISTS OF STANDARD CHARACTERS WITHOUT CLAIM TO ANY PARTICULAR FONT, STYLE, SIZE, OR COLOR.

FOR ADHESIVE TAPES AND TAPE DISPENSERS FOR STATIONERY OR HOUSEHOLD PURPOSES (U.S. CLS. 2, 5, 22, 23, 29, 37, 38 AND 50).

FIRST USE 7-31-2006; IN COMMERCE 7-31-2006.  
MICHAEL WEBSTER, EXAMINING ATTORNEY

**CLASS 16—(Continued).**

SN 85-211,398. EDWARDS, SALLY, DBA HEART ZONES, SACRAMENTO, CA. FILED 1-5-2011.

**ZONING**

THE MARK CONSISTS OF STANDARD CHARACTERS WITHOUT CLAIM TO ANY PARTICULAR FONT, STYLE, SIZE, OR COLOR.

FOR PRINTED INFORMATIONAL CARDS IN THE FIELD OF EXERCISE AND PHYSICAL FITNESS (U.S. CLS. 2, 5, 22, 23, 29, 37, 38 AND 50).

FIRST USE 1-3-2011; IN COMMERCE 1-3-2011.  
EDWARD NELSON, EXAMINING ATTORNEY

**CLASS 16—(Continued).**

SN 85-212,989. TRISHA HARDING, BROOKLYN, NY. FILED 1-7-2011.

**Emo Creatures**

THE MARK CONSISTS OF STANDARD CHARACTERS WITHOUT CLAIM TO ANY PARTICULAR FONT, STYLE, SIZE, OR COLOR.

FOR STICKER TRADING CARDS (U.S. CLS. 2, 5, 22, 23, 29, 37, 38 AND 50).

JUSTINE D. PARKER, EXAMINING ATTORNEY

SN 85-212,172. MOMMY MOO MOO, LLC, GLEN ALLEN, VA. FILED 1-6-2011.

**UDDERLY RIDICULOUS**

THE MARK CONSISTS OF STANDARD CHARACTERS WITHOUT CLAIM TO ANY PARTICULAR FONT, STYLE, SIZE, OR COLOR.

FOR CHILDREN'S BOOKS (U.S. CLS. 2, 5, 22, 23, 29, 37, 38 AND 50).

INGA ERVIN, EXAMINING ATTORNEY

SN 85-213,132. LIFE PLUS STYLE LTD., NEW YORK, NY. FILED 1-7-2011.

**THE LIFE I LIVE**

THE MARK CONSISTS OF STANDARD CHARACTERS WITHOUT CLAIM TO ANY PARTICULAR FONT, STYLE, SIZE, OR COLOR.

FOR BLANK JOURNALS; MEMO PADS; NOTE CARDS; PEN AND PENCIL CASES; STATIONERY (U.S. CLS. 2, 5, 22, 23, 29, 37, 38 AND 50).

FIRST USE 12-9-2010; IN COMMERCE 12-9-2010.  
MICHAEL TANNER, EXAMINING ATTORNEY

SN 85-212,411. SHERLOCK'S GUIDES, INC., HOUSTON, TX. FILED 1-6-2011.

**Sherlock's**

THE MARK CONSISTS OF STANDARD CHARACTERS WITHOUT CLAIM TO ANY PARTICULAR FONT, STYLE, SIZE, OR COLOR.

FOR PUBLICATIONS, NAMELY, NON-FICTION BOOKS IN THE FIELDS OF TRAVEL (U.S. CLS. 2, 5, 22, 23, 29, 37, 38 AND 50).

DAWN FELDMAN, EXAMINING ATTORNEY

SN 85-213,185. LIFE PLUS STYLE LTD., NEW YORK, NY. FILED 1-7-2011.

**CHICKEN SCRATCH**

THE MARK CONSISTS OF STANDARD CHARACTERS WITHOUT CLAIM TO ANY PARTICULAR FONT, STYLE, SIZE, OR COLOR.

FOR BLANK JOURNALS; MEMO PADS; NOTE CARDS; PEN AND PENCIL CASES; STATIONERY (U.S. CLS. 2, 5, 22, 23, 29, 37, 38 AND 50).

FIRST USE 12-9-2010; IN COMMERCE 12-9-2010.  
MICHAEL TANNER, EXAMINING ATTORNEY

**CLASS 16—(Continued).**

SN 85-213,343. RINCON, SERGIO, DALLAS, TX. FILED 1-7-2011.

**striking thoughts**

THE MARK CONSISTS OF STANDARD CHARACTERS WITHOUT CLAIM TO ANY PARTICULAR FONT, STYLE, SIZE, OR COLOR.

FOR GREETING CARDS (U.S. CLS. 2, 5, 22, 23, 29, 37, 38 AND 50).

RONALD DELGIZZI, EXAMINING ATTORNEY

SN 85-213,520. BENNETT, SUSANNE DR., SANTA MONICA, CA. FILED 1-8-2011.

**Clean Skin Healthy Body**

THE MARK CONSISTS OF STANDARD CHARACTERS WITHOUT CLAIM TO ANY PARTICULAR FONT, STYLE, SIZE, OR COLOR.

FOR EDUCATIONAL BOOKS FEATURING PROMOTING OPTIMAL HEALTH THROUGH PROPER SKIN CARE (U.S. CLS. 2, 5, 22, 23, 29, 37, 38 AND 50).

BRENDAN MCCAULEY, EXAMINING ATTORNEY

SN 85-214,246. SAINT LOUIS UNIVERSITY, ST. LOUIS, MO. FILED 1-10-2011.



THE MARK CONSISTS OF A STYLIZED DEPICTION OF THE HEAD OF A CHARM DOLL (A "BILLIKEN") WITH TWO POINTED EARS AND A TUFT OF HAIR ON THE TOP OF ITS HEAD. THE MOUTH IS CURVED AND THE RIGHT EYE IS CLOSED.

FOR PAPER GOODS, NAMELY, PAPER FOLDERS, DECALS, STICKERS, NOTEBOOKS, DRY ERASE WRITING BOARD, BINDERS, POSTERS, BROCHURES IN THE FIELD OF ATHLETICS AND ADMISSIONS INFORMATION, SPORTS MEDIA GUIDES AND EVENT PROGRAMS, AND TEMPORARY TATTOOS (U.S. CLS. 2, 5, 22, 23, 29, 37, 38 AND 50).

FIRST USE 0-0-2000; IN COMMERCE 0-0-2000.

KARANENDRA S. CHHINA, EXAMINING ATTORNEY

**CLASS 16—(Continued).**

SN 85-214,301. DPE LABEL HOLDING CORP., BROOKLYN, NY. FILED 1-10-2011.

**El Capo**

THE MARK CONSISTS OF STANDARD CHARACTERS WITHOUT CLAIM TO ANY PARTICULAR FONT, STYLE, SIZE, OR COLOR.

THE ENGLISH TRANSLATION OF "EL CAPO" IN THE MARK IS "THE BOSS".

FOR PRE-PAID TELEPHONE CALLING CARDS, NOT MAGNETICALLY ENCODED (U.S. CLS. 2, 5, 22, 23, 29, 37, 38 AND 50).

SUNG IN, EXAMINING ATTORNEY

SN 85-214,482. CURIODYSEY, SAN MATEO, CA. FILED 1-10-2011.

**CURIODYSEY**

THE MARK CONSISTS OF STANDARD CHARACTERS WITHOUT CLAIM TO ANY PARTICULAR FONT, STYLE, SIZE, OR COLOR.

FOR PRINTED MATERIALS, NAMELY, INSTRUCTIONAL, EDUCATIONAL AND TEACHING MATERIALS ON THE SUBJECTS OF PLANTS, ANIMALS AND THE ENVIRONMENT; PRINTED MATERIALS, NAMELY, POSTERS, STICKERS, DECALS, POSTCARDS, BROCHURES, AND IDENTIFICATION AND FIELD GUIDES ON THE SUBJECTS OF PLANTS, ANIMALS AND THE ENVIRONMENT (U.S. CLS. 2, 5, 22, 23, 29, 37, 38 AND 50).

WILLIAM BRECKENFELD, EXAMINING ATTORNEY

SN 85-215,935. LIFE PLUS STYLE LTD., NEW YORK, NY. FILED 1-12-2011.

**A LITTLE BIRD TOLD ME**

THE MARK CONSISTS OF STANDARD CHARACTERS WITHOUT CLAIM TO ANY PARTICULAR FONT, STYLE, SIZE, OR COLOR.

FOR BLANK JOURNALS; MEMO PADS; NOTE CARDS; PEN AND PENCIL CASES; STATIONERY (U.S. CLS. 2, 5, 22, 23, 29, 37, 38 AND 50).

FIRST USE 12-9-2010; IN COMMERCE 12-9-2010.

MICHAEL TANNER, EXAMINING ATTORNEY

**CLASS 16—(Continued).**

SN 85-216,046. LIFE PLUS STYLE LTD., NEW YORK, NY. FILED 1-12-2011.

**RANDOM THOUGHTS**

THE MARK CONSISTS OF STANDARD CHARACTERS WITHOUT CLAIM TO ANY PARTICULAR FONT, STYLE, SIZE, OR COLOR.

FOR BLANK JOURNALS; MEMO PADS; NOTE CARDS; PEN AND PENCIL CASES; STATIONERY (U.S. CLS. 2, 5, 22, 23, 29, 37, 38 AND 50).

FIRST USE 12-9-2010; IN COMMERCE 12-9-2010.  
MICHAEL TANNER, EXAMINING ATTORNEY

---

SN 85-221,037. LOTTA LUV, LLC, NEW YORK, NY. FILED 1-19-2011.

**MOODEEZ INK**

THE MARK CONSISTS OF STANDARD CHARACTERS WITHOUT CLAIM TO ANY PARTICULAR FONT, STYLE, SIZE, OR COLOR.

NO CLAIM IS MADE TO THE EXCLUSIVE RIGHT TO USE "INK", APART FROM THE MARK AS SHOWN.

FOR REMOVABLE TATTOOS; TEMPORARY TATTOOS (U.S. CLS. 2, 5, 22, 23, 29, 37, 38 AND 50).  
MAYUR VAGHANI, EXAMINING ATTORNEY

---

SN 85-228,490. EDIBLE COMMUNITIES, INC., MISSOULA, MT. FILED 1-28-2011.

**EDIBLE DC**

THE MARK CONSISTS OF STANDARD CHARACTERS WITHOUT CLAIM TO ANY PARTICULAR FONT, STYLE, SIZE, OR COLOR.

OWNER OF U.S. REG. NOS. 3,281,408, 3,440,817 AND OTHERS.

NO CLAIM IS MADE TO THE EXCLUSIVE RIGHT TO USE "DC", APART FROM THE MARK AS SHOWN.

FOR MAGAZINES FEATURING TOURISM, CULINARY AND AGRICULTURE INDUSTRIES AND PUBLICATIONS, NAMELY, MAGAZINES AND NEWSLETTERS DEALING WITH CONNECTING CONSUMERS WITH LOCAL GROWERS, FOOD RETAILERS, CHEFS AND FOOD ARTISANS (U.S. CLS. 2, 5, 22, 23, 29, 37, 38 AND 50).  
DAVID HOFFMAN, EXAMINING ATTORNEY

**CLASS 16—(Continued).**

SN 85-228,722. D-GENERATION, INC, DAYTONA BEACH, FL. FILED 1-28-2011.

**LIVE LOVE LAUGH**

THE MARK CONSISTS OF STANDARD CHARACTERS WITHOUT CLAIM TO ANY PARTICULAR FONT, STYLE, SIZE, OR COLOR.

OWNER OF U.S. REG. NOS. 3,877,139 AND 3,877,141.  
FOR 3D DECALS FOR USE ON ANY SURFACE; DECALS; GREETING CARDS; PAPER BAGS; PAPER NOTE TABLETS; PAPER STATIONERY; PHOTOGRAPHIC ALBUMS; POSTERS; STICKERS (U.S. CLS. 2, 5, 22, 23, 29, 37, 38 AND 50).

FIRST USE 8-5-1999; IN COMMERCE 8-5-1999.  
JUSTINE D. PARKER, EXAMINING ATTORNEY

---

SN 85-231,408. PACIFIC WORLD CORPORATION, LAKE FOREST, CA. FILED 2-1-2011.



THE MARK CONSISTS OF A STYLIZED LOWER CASE "G" FOLLOWED BY A STYLIZED UPPER CASE "G".

FOR BINDERS; BLANK JOURNALS; CALENDARS; DAY PLANNERS; DRAWING PAPER; ERASERS; FILE FOLDERS; GLUE STICKS FOR STATIONERY OR HOUSEHOLD USE; MEMO PADS; NOTE PADS; NOTEBOOKS; PENCILS; PENS; SKETCH PADS; STATIONERY (U.S. CLS. 2, 5, 22, 23, 29, 37, 38 AND 50).

HOWARD SMIGA, EXAMINING ATTORNEY

---

SN 85-238,660. SIMPLICITY PATTERN CO., INC., NEW YORK, NY. FILED 2-10-2011.

**WORKROOM**

THE MARK CONSISTS OF STANDARD CHARACTERS WITHOUT CLAIM TO ANY PARTICULAR FONT, STYLE, SIZE, OR COLOR.

FOR PATTERNS FOR MAKING CLOTHING AND CRAFTS (U.S. CLS. 2, 5, 22, 23, 29, 37, 38 AND 50).

PAULA MAHONEY, EXAMINING ATTORNEY

**CLASS 16—(Continued).**

SN 85-239,181. STAPLES THE OFFICE SUPERSTORE, LLC., FRAMINGHAM, MA. FILED 2-10-2011.

**STAPLES NIKO**

THE MARK CONSISTS OF STANDARD CHARACTERS WITHOUT CLAIM TO ANY PARTICULAR FONT, STYLE, SIZE, OR COLOR.

OWNER OF U.S. REG. NOS. 1,438,390, 3,385,468 AND OTHERS.

NO CLAIM IS MADE TO THE EXCLUSIVE RIGHT TO USE "NIKO", APART FROM THE MARK AS SHOWN.

FOR WRITING INSTRUMENTS, NAMELY, PENS (U.S. CLS. 2, 5, 22, 23, 29, 37, 38 AND 50).

KAELIE KUNG, EXAMINING ATTORNEY

SN 85-244,119. SEARS BRANDS, LLC, HOFFMAN ESTATES, IL. FILED 2-16-2011.

**TEAR-A-SIZE**

THE MARK CONSISTS OF STANDARD CHARACTERS WITHOUT CLAIM TO ANY PARTICULAR FONT, STYLE, SIZE, OR COLOR.

FOR PAPER TOWELS (U.S. CLS. 2, 5, 22, 23, 29, 37, 38 AND 50).

STEVEN PEREZ, EXAMINING ATTORNEY

SN 85-255,946. SEARS BRANDS, LLC, HOFFMAN ESTATES, IL. FILED 3-2-2011.

**SMART SENSE**

THE MARK CONSISTS OF STANDARD CHARACTERS WITHOUT CLAIM TO ANY PARTICULAR FONT, STYLE, SIZE, OR COLOR.

FOR STATIONERY AND SCHOOL SUPPLIES, NAMELY, WRITING INSTRUMENTS, PENS, PENCILS, MECHANICAL PENCILS, ERASERS, MARKERS, CRAYONS, HIGHLIGHTER PENS, FOLDERS, NOTEBOOKS, PAPER, PROTRACTORS, PAPER CLIPS, PENCIL SHARPENERS, WRITING GRIPS, GLUE AND BOOK MARKS (U.S. CLS. 2, 5, 22, 23, 29, 37, 38 AND 50).

LINDA M. KING, EXAMINING ATTORNEY

**CLASS 16—(Continued).**

SN 85-256,580. SEARS BRANDS, LLC, HOFFMAN ESTATES, IL. FILED 3-3-2011.



THE MARK CONSISTS OF THE WORDING "SMART SENSE" APPEARING INSIDE A CLOUD. THE BROKEN LINES ARE NOT A PART OF THE MARK AND ARE INTENDED SIMPLY TO SHOW THE POSITION OF THE MARK.

FOR STATIONERY AND SCHOOL SUPPLIES, NAMELY, WRITING INSTRUMENTS, PENS, PENCILS, MECHANICAL PENCILS, ERASERS, MARKERS, CRAYONS, HIGHLIGHTER PENS, FOLDERS, NOTEBOOKS, PAPER, PROTRACTORS, PAPER CLIPS, PENCIL SHARPENERS, WRITING GRIPS, GLUE AND BOOK MARKS (U.S. CLS. 2, 5, 22, 23, 29, 37, 38 AND 50).

LINDA M. KING, EXAMINING ATTORNEY

SN 85-975,071. JOHN B. SANFILIPPO & SON, INC., ELGIN, IL. FILED S.R. 10-20-2010; AM. P.R. 2-16-2011.

**ENERGY SNX**

THE MARK CONSISTS OF STANDARD CHARACTERS WITHOUT CLAIM TO ANY PARTICULAR FONT, STYLE, SIZE, OR COLOR.

FOR STICKERS AND DECALCOMANIAS (U.S. CLS. 2, 5, 22, 23, 29, 37, 38 AND 50).

FIRST USE 7-28-2010; IN COMMERCE 7-28-2010.

MORGAN WYNNE, EXAMINING ATTORNEY

**CLASS 17—RUBBER GOODS**

SN 79-091,295. SIKA AG, SWITZERLAND, FILED 10-15-2010.

**SIKAPROOF**

THE MARK CONSISTS OF STANDARD CHARACTERS WITHOUT CLAIM TO ANY PARTICULAR FONT, STYLE, SIZE, OR COLOR.

PRIORITY DATE OF 7-5-2010 IS CLAIMED.

OWNER OF INTERNATIONAL REGISTRATION 1061817 DATED 10-15-2010, EXPIRES 10-15-2020.

OWNER OF U.S. REG. NOS. 1,405,403, 3,184,084 AND OTHERS.

FOR PLASTIC SEALING SHEETS, IN PARTICULAR FOR CONSTRUCTION PURPOSES (U.S. CLS. 1, 5, 12, 13, 35 AND 50).

BRIDGETT SMITH, EXAMINING ATTORNEY



**CLASS 17—(Continued).**

SN 85-055,000. B GREEN INNOVATIONS, INC., MATAWAN, NJ. FILED 6-4-2010.

**ECOGRIP**

THE MARK CONSISTS OF STANDARD CHARACTERS WITHOUT CLAIM TO ANY PARTICULAR FONT, STYLE, SIZE, OR COLOR.

FOR HAND TOOLS, NAMELY, RUBBER GRIPPING TOOLS FOR USE IN RAISING, SUPPORTING AND STABILIZING WOODCRAFT PROJECTS WHILE WOODWORKING, ALL WITHOUT LEAVING MARKS ON THE WOOD (U.S. CLS. 1, 5, 12, 13, 35 AND 50).

RENEE SERVANCE, EXAMINING ATTORNEY

SN 85-117,935. GHC SPECIALTY BRANDS, LLC, JANESVILLE, WI. FILED 8-27-2010.



OWNER OF U.S. REG. NO. 1,765,881.

THE MARK CONSISTS OF THE WORD "ENVIRO" ABOVE THE WORD "SORB", BOTH OVERLAPPING A DEPICTION OF A GLOBE WITH CONTOURS OF THE CONTINENTS AND AN ORBIT WITH AN ARROW AROUND THE GLOBE.

FOR ABSORBENT PADS, NAMELY, PILLOW-LIKE, SOCK-LIKE AND BLANKET-LIKE PADS FOR CLEANING UP CHEMICAL, OIL OR SOLVENT LIQUID SPILLS (U.S. CLS. 1, 5, 12, 13, 35 AND 50).

FIRST USE 9-0-1991; IN COMMERCE 9-0-1991.  
SALLY SHIH, EXAMINING ATTORNEY

SN 85-179,890. INTERMARK CORPORATION, DBA INTERMARK (USA), INC., SAN JOSE, CA. FILED 11-18-2010.

**EZ-Foam**

THE MARK CONSISTS OF STANDARD CHARACTERS WITHOUT CLAIM TO ANY PARTICULAR FONT, STYLE, SIZE, OR COLOR.

FOR HIGH CONDUCTIVITY AND EMI SHIELDING FOAM MATERIAL (U.S. CLS. 1, 5, 12, 13, 35 AND 50).  
MARIA-VICTORIA SUAREZ, EXAMINING ATTORNEY

**CLASS 17—(Continued).**

SN 85-186,580. KRAY, JAMES, WHEATON, IL. AND KRAY, JANE, WHEATON, IL. FILED 11-29-2010.

**THE POST BOOT**

THE MARK CONSISTS OF STANDARD CHARACTERS WITHOUT CLAIM TO ANY PARTICULAR FONT, STYLE, SIZE, OR COLOR.

NO CLAIM IS MADE TO THE EXCLUSIVE RIGHT TO USE "POST", APART FROM THE MARK AS SHOWN.

FOR CIRCULAR RUBBER PAD DESIGNED TO ELIMINATE THE NEED FOR TRIMMING GRASS AND WEED GROWTH AROUND FENCE POSTS, MAIL BOX POSTS, AND STREET SIGNS (U.S. CLS. 1, 5, 12, 13, 35 AND 50).  
SUNG IN, EXAMINING ATTORNEY

SN 85-193,269. TB PHILLY, INC, DBA TBP CONVERTING, PHOENIXVILLE, PA. FILED 12-8-2010.



THE COLOR(S) GREEN (PANTONE 369) AND WHITE IS/ ARE CLAIMED AS A FEATURE OF THE MARK.

THE MARK CONSISTS OF THE STYLIZED GREEN AND WHITE WORDING "ZIALOC" ROTATED 90 DEGREES TO THE RIGHT; THE MARK FURTHER CONSISTS OF TWO STRAIGHT, GREEN LINES, WITH ONE APPEARING TO THE LEFT OF THE ROTATED WORDING AND ONE TO THE RIGHT OF THE ROTATED WORDING.

FOR ADHESIVE PACKING TAPE FOR INDUSTRIAL OR COMMERCIAL USE; ADHESIVE PLASTIC FILM FOR INDUSTRIAL AND COMMERCIAL USE; ADHESIVE SEALANT AND CAULKING COMPOUND; ADHESIVE SEALANTS FOR GENERAL USE; ADHESIVE TAPE FOR INDUSTRIAL AND COMMERCIAL USE; FOAM RUBBER; OPEN CELL FOAM IN ROLL FORM; THERMOPLASTIC AND FOAMED PLASTIC SECTIONS FOR USE IN THE MANUFACTURE OF WINDOWS, DOORS, FACADE GLAZINGS, AND PARTITION WALLS FOR USE AS BUILDING MATERIALS FOR HEAT-INSULATING APPLICATIONS (U.S. CLS. 1, 5, 12, 13, 35 AND 50).

FIRST USE 12-8-2010; IN COMMERCE 12-8-2010.  
KEVIN CORWIN, EXAMINING ATTORNEY

**CLASS 17—(Continued).**

SN 85-201,926. RAVEN INDUSTRIES, INC., SIOUX FALLS, SD. FILED 12-20-2010.

**ABSOLUTE BARRIER**

THE MARK CONSISTS OF STANDARD CHARACTERS WITHOUT CLAIM TO ANY PARTICULAR FONT, STYLE, SIZE, OR COLOR.

NO CLAIM IS MADE TO THE EXCLUSIVE RIGHT TO USE "BARRIER", APART FROM THE MARK AS SHOWN. FOR PLASTIC TARP-LIKE SHEETING USED IN THE CONSTRUCTION INDUSTRY AS A VAPOR BARRIER FOR CONTAINMENT AND RESTRICTION OF NATURALLY OCCURRING GASES (U.S. CLS. 1, 5, 12, 13, 35 AND 50).

MICHAEL TANNER, EXAMINING ATTORNEY

SN 85-205,995. PAIGE PRODUCTS INC., DENVER, NC. FILED 12-27-2010.

**FoodNotations**

THE MARK CONSISTS OF STANDARD CHARACTERS WITHOUT CLAIM TO ANY PARTICULAR FONT, STYLE, SIZE, OR COLOR.

FOR PLASTIC, FOAM AND CORRUGATED PVC FLUTED SUBSTRATES FOR USE IN THE MANUFACTURE OF SIGNS (U.S. CLS. 1, 5, 12, 13, 35 AND 50).

SANJEEV VOHRA, EXAMINING ATTORNEY

SN 85-207,408. DAVID LEVY COMPANY, INC., CERRITOS, CA. FILED 12-29-2010.

**CYGUSA**

THE MARK CONSISTS OF STANDARD CHARACTERS WITHOUT CLAIM TO ANY PARTICULAR FONT, STYLE, SIZE, OR COLOR.

FOR HEAT SHRINK NYLON TUBING FOR COVERING ELECTRICAL WIRE AND NYLON GROMMETS (U.S. CLS. 1, 5, 12, 13, 35 AND 50).

PAM WILLIS, EXAMINING ATTORNEY

**CLASS 17—(Continued).**

SN 85-207,431. VON ROLL USA, INC., SCHENECTADY, NY. FILED 12-29-2010.

**PYROMID**

THE MARK CONSISTS OF STANDARD CHARACTERS WITHOUT CLAIM TO ANY PARTICULAR FONT, STYLE, SIZE, OR COLOR.

FOR FLEXIBLE INSULATING MATERIAL FOR ELECTRICAL APPLICATIONS (U.S. CLS. 1, 5, 12, 13, 35 AND 50).

FIRST USE 10-4-2004; IN COMMERCE 10-4-2004.  
JEAN IM, EXAMINING ATTORNEY

SN 85-208,276. BRIDJIT INC., KENT, WA. FILED 12-30-2010.

**BRIDJIT**

THE MARK CONSISTS OF STANDARD CHARACTERS WITHOUT CLAIM TO ANY PARTICULAR FONT, STYLE, SIZE, OR COLOR.

FOR RUBBER RAMPS THAT FITS INTO A RESIDENTIAL CURB AND GUTTER, ALLOWING VEHICLES TO DRIVE DIRECTLY OVER THE CURB (U.S. CLS. 1, 5, 12, 13, 35 AND 50).

FIRST USE 1-2-2008; IN COMMERCE 1-2-2008.  
SEAN CROWLEY, EXAMINING ATTORNEY

SN 85-210,843. SAINT-GOBAIN PERFORMANCE PLASTICS CORPORATION, AURORA, OH. FILED 1-5-2011.

**CORETECH**

THE MARK CONSISTS OF STANDARD CHARACTERS WITHOUT CLAIM TO ANY PARTICULAR FONT, STYLE, SIZE, OR COLOR.

FOR NON-METAL LAMINATE FOR CHEMICAL AND BIOLOGICAL BARRIER PROTECTION (U.S. CLS. 1, 5, 12, 13, 35 AND 50).

FIRST USE 9-0-2008; IN COMMERCE 5-0-2009.  
REGINA DRUMMOND, EXAMINING ATTORNEY

**CLASS 17—(Continued).**

SN 85-213,000. ROBERN INC., BRISTOL, PA. FILED 1-7-2011.

**SAFESEAL**

THE MARK CONSISTS OF STANDARD CHARACTERS WITHOUT CLAIM TO ANY PARTICULAR FONT, STYLE, SIZE, OR COLOR.

FOR NON-METAL GASKETS FOR USE WITH BATHROOM CABINETS (U.S. CLS. 1, 5, 12, 13, 35 AND 50).

FIRST USE 10-10-1994; IN COMMERCE 10-10-1994.

ODESSA BIBBINS, EXAMINING ATTORNEY

---

SN 85-213,393. NOVEL IDEAS, INC., RIVERVIEW, FL. FILED 1-8-2011.

**EarthCurb**

THE MARK CONSISTS OF STANDARD CHARACTERS WITHOUT CLAIM TO ANY PARTICULAR FONT, STYLE, SIZE, OR COLOR.

FOR RUBBER PRODUCTS, NAMELY, MULCH MADE OF RECYCLED RUBBER FOR USE IN LANDSCAPING AND HORTICULTURE APPLICATIONS (U.S. CLS. 1, 5, 12, 13, 35 AND 50).

FIRST USE 12-27-2010; IN COMMERCE 1-6-2011.

CORY BOONE, EXAMINING ATTORNEY

---

SN 85-229,214. CHEMICAL BROTHERS INTERNATIONAL, LLC, MCKINNEY, TX. FILED 1-28-2011.

**QuadFoam**

THE MARK CONSISTS OF STANDARD CHARACTERS WITHOUT CLAIM TO ANY PARTICULAR FONT, STYLE, SIZE, OR COLOR.

FOR POLYURETHANE SPRAY FOAM FOR USE IN THE RESIDENTIAL AND COMMERCIAL INSULATION MARKETS (U.S. CLS. 1, 5, 12, 13, 35 AND 50).

FIRST USE 1-31-2010; IN COMMERCE 1-31-2010.

RAMONA ORTIGA, EXAMINING ATTORNEY

**CLASS 17—(Continued).**

SN 85-245,408. CHEMICAL BROTHERS INTERNATIONAL, LLC, MCKINNEY, TX. FILED 2-17-2011.

**RetroSeal**

THE MARK CONSISTS OF STANDARD CHARACTERS WITHOUT CLAIM TO ANY PARTICULAR FONT, STYLE, SIZE, OR COLOR.

FOR COMMERCIAL AND RESIDENTIAL BUILDING INSULATION MADE IN WHOLE OR IN PART OF FOAM, CASTOR OIL, POLYURETHANE, RECYCLED OILS, SOYBEAN OIL AND OTHER ORGANIC, RENEWABLE AND OR RE-PURPOSED MATERIALS (U.S. CLS. 1, 5, 12, 13, 35 AND 50).

FIRST USE 2-15-2011; IN COMMERCE 2-15-2011.

RAMONA ORTIGA, EXAMINING ATTORNEY

---

SN 85-245,419. CHEMICAL BROTHERS INTERNATIONAL, LLC, MCKINNEY, TX. FILED 2-17-2011.

**RetroSpray**

THE MARK CONSISTS OF STANDARD CHARACTERS WITHOUT CLAIM TO ANY PARTICULAR FONT, STYLE, SIZE, OR COLOR.

FOR COMMERCIAL AND RESIDENTIAL BUILDING INSULATION MADE IN WHOLE OR IN PART OF FOAM, CASTOR OIL, POLYURETHANE, RECYCLED OILS, SOYBEAN OIL AND OTHER ORGANIC, RENEWABLE AND OR RE-PURPOSED MATERIALS (U.S. CLS. 1, 5, 12, 13, 35 AND 50).

FIRST USE 2-15-2011; IN COMMERCE 2-15-2011.

RAMONA ORTIGA, EXAMINING ATTORNEY

---

SN 85-251,389. GREENOVO RESEARCH, INC., TAIPEI CITY, TAIWAN, FILED 2-25-2011.

**ECOPAIR**

THE MARK CONSISTS OF STANDARD CHARACTERS WITHOUT CLAIM TO ANY PARTICULAR FONT, STYLE, SIZE, OR COLOR.

FOR AGRI-BASED POLYURETHANE FOAM FOR USE IN COMPOSITES; BIODEGRADABLE FILM FOR USE IN LINING GARDENS AND FLOWERBEDS; BIODEGRADABLE NON-PAPER PACKAGING AND SHIPPING BUFFERS FOR PHYSICAL AND THERMAL PROTECTION OF ITEMS DURING SHIPPING; PADDING MATERIALS OF RUBBER OR PLASTIC; PLASTIC FILMS USED AS PACKAGING FOR FOOD; EXPANDED PLASTIC PELLETS FOR PACKAGING; PACKAGING MATERIALS MADE FROM STONE-BASED PLASTIC SUBSTITUTES; CARBON FIBERS NOT FOR TEXTILE USE; CHEMICAL FIBER THREAD AND YARN NOT FOR TEXTILE USE; RUBBER DERIVATIVES; FOAM RUBBER; ELECTRIC, THERMAL AND ACOUSTIC INSULATORS; HIGH HEAT

**CLASS 17—(Continued).**

THERMOPLASTIC RESIN IN PELLET FORM FOR USE IN MANUFACTURING; NANOCOMPOSITE POLYMER COMPOUNDS IN PELLET FORM FOR USE IN FURTHER MANUFACTURE; PLASTIC COMPOSITE MATERIAL IN THE FORM OF PROFILES, BOARDS, SHEETS, BLOCKS, RODS, POWDER, AND PELLETS FOR USE IN MANUFACTURING; PLASTIC FILM FOR COMMERCIAL AND INDUSTRIAL USE; EXTRUDED SEMI-FINISHED GOODS MADE OF SYNTHETIC MATERIALS IN THE FORM OF PLATES, BARS, PIPES AND FLEXIBLE HOSES FOR INDUSTRIAL, CONSTRUCTION AND AGRICULTURAL USE; FOAM FOR USE IN THE MANUFACTURE OF FOOTWEAR; MYCOLOGICAL BIOMATERIAL IN THE NATURE OF A PLASTIC FOAM SUBSTITUTE FOR USE IN THE MANUFACTURE OF BOAT HULLS, THE INSIDE OF WIND TURBINE BLADES, LIGHT WEIGHT VEHICLE PANELS AND THE LIKE; MOISTURE MANAGEMENT CUSHIONING URETHANE FOAMS, FOR USE IN FOOTWEAR AND APPAREL APPLICATIONS; MICA; OPEN CELL FOAM IN ROLL FORM; PLASTIC FOAM USED FOR ARTS AND CRAFTS; PLASTIC IN BARS, BLOCKS, PELLETS, RODS, SHEETS AND TUBES FOR GENERAL INDUSTRIAL USE; PLASTIC IN EXTRUDED FORM FOR GENERAL INDUSTRIAL USE; PLASTIC IN POWDERED FORM; PLASTIC SOLDERING THREADS; POLYPROPYLENE RESINS IN PELLET FORM FOR USE IN FURTHER MANUFACTURE; RESINS IN BARS, BLOCKS, PELLETS, RODS, SHEETS AND TUBES FOR GENERAL INDUSTRIAL USE; RESINS IN EXTRUDED FORM FOR GENERAL INDUSTRIAL USE; SEMI-FINISHED INJECTION MOLDED PRODUCTS OF PLASTIC FOR USE IN A VARIETY OF INDUSTRIES; SEMI-PROCESSED CELLULOSE ACETATE FOR USE IN FURTHER MANUFACTURING; SEMI-PROCESSED PLASTICS; SEMI-WORKED SYNTHETIC PLASTIC AND SYNTHETIC RESINS AS SEMI-FINISHED PRODUCTS IN FORM OF PELLETS, RODS, FOILS, FOAMS, FIBERS, FILMS AND SHEETS; SILICONE RUBBER; SYNTHETIC ELASTOMER RESIN BLENDED WITH ADDITIVES AND COLORANTS SOLD IN A PELLET FORM; SYNTHETIC RUBBER; THERMOPLASTIC COMPOSITE SHEETS CONTAINING GLASS FIBER FOR USE IN THE MANUFACTURE OF OTHER GOODS; THERMOPLASTIC COMPOUNDS, THERMOPLASTIC ELASTOMER RESINS AND THERMOPLASTIC CONCENTRATES IN PELLET FORM FOR USE IN MANUFACTURING IN A WIDE VARIETY OF INDUSTRIES; VISCOUS GEL POLYMER MATERIAL IN SHEET FORM AND CAST SHAPES FOR USE IN THE MANUFACTURE OF CUSTOM CUSHIONED PRODUCTS FOR USE IN THE FIELDS OF MEDICAL, THERAPEUTIC, SAFETY, APPAREL, FOOTWEAR AND SPORTING GOODS (U.S. CLS. 1, 5, 12, 13, 35 AND 50).  
DEBRA LEE, EXAMINING ATTORNEY

**CLASS 18—LEATHER GOODS**

SN 77-790,081. BJ TOY COMPANY, INC., PEN ARGYL, PA. FILED 7-27-2009.



NO CLAIM IS MADE TO THE EXCLUSIVE RIGHT TO USE "UMBRELLA", APART FROM THE MARK AS SHOWN.

THE MARK CONSISTS OF THE STYLIZED TEXT "BLUE MOUNTAIN UMBRELLA" WITH UMBRELLAS ON THE BACKGROUND.

FOR UMBRELLAS (U.S. CLS. 1, 2, 3, 22 AND 41).  
FIRST USE 11-0-2008; IN COMMERCE 11-0-2008.  
ELLEN PERKINS, EXAMINING ATTORNEY

**CLASS 18—(Continued).**

SN 77-932,866. MASTROPAOLO, STEVEN M., HUNTINGTON BEACH, CA. FILED 2-10-2010.

# MASTRO

THE MARK CONSISTS OF STANDARD CHARACTERS WITHOUT CLAIM TO ANY PARTICULAR FONT, STYLE, SIZE, OR COLOR.

THE ENGLISH TRANSLATION OF "MASTRO" IN THE MARK IS LEDGER.

FOR BACKPACKS, TOTE BAGS, COIN PURSES, SPORT BAGS, DUFFEL BAGS, WHEELED BAGS, WALLETS (U.S. CLS. 1, 2, 3, 22 AND 41).

MARY BOAGNI, EXAMINING ATTORNEY

SN 79-080,908. SENZ TECHNOLOGIES B.V., DELFT, NETHERLANDS, FILED 3-10-2010.



PRIORITY DATE OF 9-11-2009 IS CLAIMED.

OWNER OF INTERNATIONAL REGISTRATION 1034182 DATED 3-10-2010, EXPIRES 3-10-2020.

THE MARK CONSISTS OF A STYLIZED SUN DESIGN WITH TEN SUN RAYS EMANATING THEREFROM, A RAINBOW DESIGN COMPRISING THREE CURVED LINES, A STYLIZED CLOUD, AND FOUR LINES COMPRISING DOTTED LINES REPRESENTING RAIN.

FOR UMBRELLAS AND PARASOLS; BAGS, NAMELY, HANDBAGS, PURSES, ALL-PURPOSE CARRYING BAGS, ALL-PURPOSE ATHLETIC BAGS AND CARRY-ALL BAGS; BRIEFCASES; TRUNKS; VALISES; LEATHER AND IMITATION LEATHER AND GOODS MADE OF THESE ARTICLES AND NOT INCLUDED IN OTHER CLASSES, NAMELY, LEATHER BRIEFCASES, LEATHER HANDBAGS, LEATHER BAGS FOR MERCHANDISE PACKAGING, LEATHER CASES, LEATHER SUITCASES, TRAVELLING CASES OF LEATHER, LEATHER PURSES, LEATHER SHOPPING BAGS, POUCHES OF LEATHER, LEATHER WALLETS, LEATHER BOXES FOR STORING GREETING CARDS, LEATHER KEY-CASES, LEATHER CASES FOR KEYS, LEATHER KEY CHAINS, LEATHER FOR FURNITURE, LEATHER FOR HARNESSSES, LEATHER FOR SHOES, LEATHER SOLD IN BULK, LEATHER STRAPS AND LEATHER THREAD (U.S. CLS. 1, 2, 3, 22 AND 41).

DAVID YONTEF, EXAMINING ATTORNEY

**CLASS 18—(Continued).**

SN 79-084,485. SHANGHAI CONWOOD INTERNATIONAL CO., LTD., CHINA, FILED 6-3-2010.



OWNER OF INTERNATIONAL REGISTRATION 1043753 DATED 6-3-2010, EXPIRES 6-3-2020.

OWNER OF U.S. REG. NO. 1,298,814.

THE MARK CONSISTS OF A SHADED INCOMPLETE CIRCLE WITH THE LETTER "E" IN THE CENTER NEXT TO THE WORD "ECHOLAC".

FOR PURSES; BACKPACKS; LEATHERWARE, NAMELY, TRAVELLING SETS COMPRISED OF VANITY CASES SOLD EMPTY; TRAVELLING BAGS; AT-TACHÉ CASES; TRAVELING CASES; LUGGAGE, NAMELY, TRUNKS; HANDBAGS; SCHOOL BAGS; ALL PURPOSE SPORTS BAGS (U.S. CLS. 1, 2, 3, 22 AND 41).  
DAYNA BROWNE, EXAMINING ATTORNEY

SN 79-089,076. AGRESSOR CORPORATION PTY LTD, AUSTRALIA, FILED 9-8-2010.

# AGRESA

THE MARK CONSISTS OF STANDARD CHARACTERS WITHOUT CLAIM TO ANY PARTICULAR FONT, STYLE, SIZE, OR COLOR.

PRIORITY DATE OF 3-12-2010 IS CLAIMED.

OWNER OF INTERNATIONAL REGISTRATION 1055972 DATED 9-8-2010, EXPIRES 9-8-2020.

THE WORDING "AGRESA" HAS NO MEANING IN A FOREIGN LANGUAGE.

FOR MONEY BAGS OF LEATHER AND IMITATION LEATHER; TRAVEL BAGS; POUCHES OF LEATHER AND IMITATION LEATHER (U.S. CLS. 1, 2, 3, 22 AND 41).

DAVID HOFFMAN, EXAMINING ATTORNEY

SN 85-036,265. ETHAN K PTE LTD., BRADDELL HEIGHTS ESTAT, SINGAPORE, FILED 5-12-2010.

# ETHAN K

THE MARK CONSISTS OF STANDARD CHARACTERS WITHOUT CLAIM TO ANY PARTICULAR FONT, STYLE, SIZE, OR COLOR.

THE NAME "ETHAN K.", A.K.A. KOI WEI JIE, IDENTIFIES A LIVING INDIVIDUAL WHOSE CONSENT IS OF RECORD.

FOR BAGS, HANDBAGS, CLUTCH BAGS, PURSES, WALLETS, BRIEFCASES, TRAVEL BAGS, CREDIT CARD AND BUSINESS CARD HOLDERS, TOILETRY BAGS SOLD EMPTY, SHOULDER BELTS, ALL MADE OF LEATHER OR IMITATION LEATHER (U.S. CLS. 1, 2, 3, 22 AND 41).

TOBY BULLOFF, EXAMINING ATTORNEY

**CLASS 18—(Continued).**

SN 85-037,069. STRIVERS ROW, LLC, ATLANTA, GA. FILED 5-12-2010.



OWNER OF U.S. REG. NO. 3,717,736.

THE MARK CONSISTS OF THE WORD "STRIVERS" CENTERED ABOVE A KEY IN THE MIDDLE WITH THE WORD "ROW" CENTERED BELOW THE KEY.

FOR BACKPACKS, BOOKBAGS, SPORTS BAGS, HANDBAGS, WALLETS, GARMENT BAGS, TOTE BAGS AND SHOULDER BAGS (U.S. CLS. 1, 2, 3, 22 AND 41).  
INGRID C. EULIN, EXAMINING ATTORNEY

SN 85-037,435. PAWS ABOARD, LLC, TAMPA, FL. FILED 5-13-2010.

# FREEDOM LEASH

THE MARK CONSISTS OF STANDARD CHARACTERS WITHOUT CLAIM TO ANY PARTICULAR FONT, STYLE, SIZE, OR COLOR.

NO CLAIM IS MADE TO THE EXCLUSIVE RIGHT TO USE "LEASH", APART FROM THE MARK AS SHOWN.

FOR RETRACTABLE LEASHES FOR DOGS (U.S. CLS. 1, 2, 3, 22 AND 41).

JOSETTE BEVERLY, EXAMINING ATTORNEY

SN 85-043,035. TORREGROSSA, LTD., BROOKLYN, NY. FILED 5-19-2010.

# TORREGROSSA

THE MARK CONSISTS OF STANDARD CHARACTERS WITHOUT CLAIM TO ANY PARTICULAR FONT, STYLE, SIZE, OR COLOR.

FOR ACCESSORIES FOR PETS, NAMELY, CARRIERS, LEASHES AND COLLARS, ANIMAL CLOTHING, BEACH BAGS, DIAPER BAGS, BRIEFCASES AND AT-TACHÉ CASES, LUGGAGE, BUSINESS CARD CASES, WALLETS, HANDBAGS, PURSES, UMBRELLAS, AND DUFFEL BAGS (U.S. CLS. 1, 2, 3, 22 AND 41).

CAROLINE WOOD, EXAMINING ATTORNEY

**CLASS 18—(Continued).**

SN 85-044,856. TORREGROSSA, LTD., BROOKLYN, NY.  
FILED 5-21-2010.



THE MARK CONSISTS OF AN OVAL, INSIDE OF WHICH IS THE SHADOW DESIGN OF A BIRD ATOP THE SHADOW DESIGN OF A CASTLE AND FLANKED BY THREE STARS ON EITHER SIDE, AND ON THE OUTSIDE OF WHICH APPEARS A SHADOW VINE DESIGN ON EITHER SIDE OF THE OVAL.

FOR ACCESSORIES FOR PETS, NAMELY, CARRIERS, LEASHES AND COLLARS, ANIMAL CLOTHING, BEACH BAGS, DIAPER BAGS, BRIEFCASES AND ATTACHE CASES, LUGGAGE, BUSINESS CARD CASES, WALLETS, HANDBAGS, PURSES, UMBRELLAS, AND DUFFEL BAGS (U.S. CLS. 1, 2, 3, 22 AND 41).  
CAROLINE WOOD, EXAMINING ATTORNEY

SN 85-048,910. MST, REDONDO BEACH, CA. FILED 5-27-2010.

**JUNGLE KIDDY**

THE MARK CONSISTS OF STANDARD CHARACTERS WITHOUT CLAIM TO ANY PARTICULAR FONT, STYLE, SIZE, OR COLOR.

FOR CLOTHING FOR PETS; PET ACCESSORIES IN THE NATURE OF COLLARS AND LEASHES (U.S. CLS. 1, 2, 3, 22 AND 41).

NICHOLAS COLEMAN, EXAMINING ATTORNEY

**CLASS 18—(Continued).**

SN 85-052,145. GIORRY LIMITED, SLOUGH, UNITED KINGDOM, FILED 6-1-2010.



OWNER OF UNITED KINGDOM REG. NO. 2533983, DATED 12-9-2009, EXPIRES 12-9-2034.

THE COLOR(S) THE DARK RED AND DARK GREY IS/ARE CLAIMED AS A FEATURE OF THE MARK.

THE MARK CONSISTS OF A STYLIZED "G" IN DARK GREY AND DARK RED, NEXT TO THE WORD "GIORRY" IN DARK GREY.

FOR BEACH BAGS; BELT BAGS; BELT BAGS AND HIP BAGS; BOOK BAGS; BOSTON BAGS; BRIEFCASE-TYPE LEATHER BUSINESS FOLDERS; BRIEFCASES; BUM BAGS; CANTLE BAGS; CANVAS SHOPPING BAGS; CARRY-ALL BAGS; CARRY-ON BAGS; CASES OF IMITATION LEATHER; CHALK BAGS; CHARM BAGS (OMAMORI-IRE); CLUTCH BAGS; COSMETIC BAGS SOLD EMPTY; DIAPER BAGS; DRAWSTRING BAGS; DRY BAGS; LEATHER AND IMITATION LEATHER; LEATHER AND IMITATION LEATHER BAGS; LEATHER AND IMITATION LEATHER SPORT BAGS AND GENERAL PURPOSE TROLLEY BAGS; LEATHER BAGS AND WALLETS; LEATHER BAGS FOR MERCHANDISE PACKAGING; LEATHER BAGS, SUITCASES AND WALLETS; LEATHER BINDERS FOR TRAVEL PURPOSES; LEATHER BOXES FOR STORING GREETING CARDS; LEATHER BRIEFCASES; LEATHER CASES; LEATHER CASES FOR KEYS; LEATHER CREDIT CARD CASES; LEATHER CREDIT CARD HOLDER; LEATHER CREDIT CARD WALLETS; LEATHER HANDBAGS; LEATHER KEY CHAINS; LEATHER PURSES; LEATHER SHOPPING BAGS; LEATHER SHOULDER BELTS; MAKE-UP BAGS SOLD EMPTY; MEN'S CLUTCH BAGS; MESSENGER BAGS; POUCHES OF LEATHER (U.S. CLS. 1, 2, 3, 22 AND 41).  
REBECCA EISINGER, EXAMINING ATTORNEY

SN 85-054,274. HEISENPORT, INC., CIUDAD DE PANAMA, PANAMA, FILED 6-3-2010.

**SANTIAGO GONZALEZ**

THE MARK CONSISTS OF STANDARD CHARACTERS WITHOUT CLAIM TO ANY PARTICULAR FONT, STYLE, SIZE, OR COLOR.

THE NAME(S), PORTRAIT(S), AND/OR SIGNATURE(S) SHOWN IN THE MARK IDENTIFIES SANTIAGO BARBERI GONZALEZ, WHOSE CONSENT(S) TO REGISTER IS MADE OF RECORD.

FOR LEATHER AND IMITATION LEATHER GOODS, NAMELY, HANDBAGS, WALLETS, COSMETIC CASES SOLD EMPTY, KEY CASES, COIN PURSES, BRIEF CASES, DOCUMENT CASES, ATTACHE CASES, LUGGAGE AND TRUNKS, ANIMAL LEASHES, DUFFEL BAGS, BUSINESS CARD CASES, CREDIT CARD CASES AND HOLDERS, ALL PURPOSE CARRYING BAGS, BACKPACKS, BEACH BAGS, GENTLEMEN'S HANDBAGS, GYM BAGS, LEATHER KEY CHAINS, MESSENGER BAGS, OVERNIGHT BAGS, TRAVEL BAGS, UMBRELLAS (U.S. CLS. 1, 2, 3, 22 AND 41).

JENNIFER MARTIN, EXAMINING ATTORNEY

**CLASS 18—(Continued).**

SN 85-059,572. HEISENPORT, INC., CIUDAD DE PANAMA, PANAMA, FILED 6-10-2010.

SANTIAGO GONZALEZ  
✦

THE NAME(S), PORTRAIT(S), AND/OR SIGNATURE(S) SHOWN IN THE MARK IDENTIFIES SANTIAGO BARBERI GONZALEZ, WHOSE CONSENT(S) TO REGISTER IS MADE OF RECORD.

THE MARK CONSISTS OF THE WORDS "SANTIAGO GONZALEZ" CENTERED OVER A STAR BURST DESIGN.

FOR LEATHER AND IMITATION LEATHER GOODS, NAMELY, HANDBAGS, WALLETS, COSMETIC CASES SOLD EMPTY, KEY CASES, COIN PURSES, BRIEF CASES, DOCUMENT CASES, ATTACHE CASES, LUGGAGE AND TRUNKS, ANIMAL LEASHES, DUFFEL BAGS, BUSINESS CARD CASES, CREDIT CARD CASES AND HOLDERS, ALL PURPOSE CARRYING BAGS, BACKPACKS, BEACH BAGS, GENTLEMEN'S HANDBAGS, GYM BAGS, LEATHER KEY CHAINS, MESSENGER BAGS, OVERNIGHT BAGS, TRAVEL BAGS, UMBRELLAS (U.S. CLS. 1, 2, 3, 22 AND 41).

JENNIFER MARTIN, EXAMINING ATTORNEY

**CLASS 18—(Continued).**

SN 85-070,558. GALAXY WEB DESIGNS, LLC, DBA BABYOSO.COM, COLLEYVILLE, TX. FILED 6-24-2010.

BABYOSO

THE MARK CONSISTS OF STANDARD CHARACTERS WITHOUT CLAIM TO ANY PARTICULAR FONT, STYLE, SIZE, OR COLOR.

FOR EMBROIDERED GARMENT BAGS FOR TRAVEL AND BACKPACKS FOR BABIES (U.S. CLS. 1, 2, 3, 22 AND 41).

FIRST USE 10-31-2009; IN COMMERCE 10-31-2009.

DAVID TAYLOR, EXAMINING ATTORNEY

SN 85-088,833. KATE SPADE LLC, NEW YORK, NY. FILED 7-20-2010.

KATE SPADE SATURDAY

CADENCE

THE MARK CONSISTS OF STANDARD CHARACTERS WITHOUT CLAIM TO ANY PARTICULAR FONT, STYLE, SIZE, OR COLOR.

FOR ALL PURPOSE SPORT BAGS; ATHLETIC BAGS; BABY BACKPACKS; BACKPACKS; BEACH BAGS; BOOK BAGS; CALLING CARD CASES; CHANGE PURSES; COIN PURSES; DIAPER BAGS; DUFFEL BAGS; FANNY PACKS; GYM BAGS; HANDBAGS; KNAPSACKS; KEY CASES; LEATHER KEY CHAINS; LUGGAGE; LUGGAGE TAGS; OVERNIGHT BAGS; PURSES; SATCHELS; LEATHER AND MESH SHOPPING BAGS; TOTE BAGS; UMBRELLAS; WAIST PACKS; WALLETS (U.S. CLS. 1, 2, 3, 22 AND 41).

ELIZABETH KAJUBI, EXAMINING ATTORNEY

THE MARK CONSISTS OF STANDARD CHARACTERS WITHOUT CLAIM TO ANY PARTICULAR FONT, STYLE, SIZE, OR COLOR.

OWNER OF U.S. REG. NOS. 2,578,942, 2,905,861 AND OTHERS.

THE NAME "KATE SPADE" IDENTIFIES A LIVING INDIVIDUAL WHOSE CONSENT IS OF RECORD.

FOR BACKPACKS; BEACH BAGS; CARD WALLETS; CLUTCH BAGS; CLUTCH PURSES; COSMETIC BAGS SOLD EMPTY; COSMETIC CASES SOLD EMPTY; CREDIT CARD CASES; HANDBAGS; KEY BAGS; KEY CASES; KEY WALLETS; LUGGAGE; PURSES; SPORT BAGS; TOTE BAGS; TRAVEL BAGS; TRAVEL CASES; UMBRELLAS; WALLETS (U.S. CLS. 1, 2, 3, 22 AND 41).

JERI J. FICKES, EXAMINING ATTORNEY

SN 85-069,634. DISNEY ONLINE STUDIOS CANADA INC., VANCOUVER, CANADA, FILED 6-23-2010.

**CLASS 18—(Continued).**

SN 85-102,364. SPRAYGROUND LLC, ELBERON, NJ. FILED 8-6-2010.

HELLO MY NAME IS

THE MARK CONSISTS OF STANDARD CHARACTERS WITHOUT CLAIM TO ANY PARTICULAR FONT, STYLE, SIZE, OR COLOR.

FOR BABY BACKPACKS; BACKPACKS; BACKPACKS; BACKPACKS WITH ROLLING WHEELS; BACKPACKS, BOOK BAGS, SPORTS BAGS, BUM BAGS, WALLETS AND HANDBAGS; MILITARY DUFFLE BAGS, GARMENT BAGS FOR TRAVEL, TOTE BAGS, SHOULDER BAGS AND BACKPACKS; POUCHES AND BAGS SOLD EMPTY FOR ATTACHMENT TO BACKPACKS; PROTECTIVE FITTED LINERS FOR BACKPACKS AND LUGGAGE; SACK PACKS, NAMELY, DRAWSTRING BAGS USED AS BACKPACKS; SCHOOLCHILDREN'S BACKPACKS; SMALL BACKPACKS (U.S. CLS. 1, 2, 3, 22 AND 41).

FIRST USE 7-1-2010; IN COMMERCE 7-1-2010.  
ANNE MADDEN, EXAMINING ATTORNEY

SN 85-116,552. MOYNIHAN, JOHN, WESTERLY, RI. FILED 8-26-2010.

QUICK HALTER

THE MARK CONSISTS OF STANDARD CHARACTERS WITHOUT CLAIM TO ANY PARTICULAR FONT, STYLE, SIZE, OR COLOR.

NO CLAIM IS MADE TO THE EXCLUSIVE RIGHT TO USE "HALTER", APART FROM THE MARK AS SHOWN.

FOR DOG COLLARS; ANIMAL HARNESSSES, NAMELY, DOG HALTERS; ANIMAL HARNESSSES, NAMELY, DOG HALTERS CONTAINING DOG COLLARS AS AN INTEGRAL COMPONENT AND SOLD AS A UNIT (U.S. CLS. 1, 2, 3, 22 AND 41).

JIM RINGLE, EXAMINING ATTORNEY

**CLASS 18—(Continued).**

SN 85-130,664. D.CLAIRE, SODDY DAISY, TN. FILED 9-15-2010.



THE NAME SHOWN IN THE MARK DOES NOT IDENTIFY A PARTICULAR LIVING INDIVIDUAL.

THE MARK CONSISTS OF AN OVAL ROUNDEL, "D.CLAIRE" WITH FLOWER ACCENTS IN THE CENTER, AND TAGLINE "STYLE AS UNIQUE AS YOU" BELOW.

FOR ALL-PURPOSE CARRYING BAGS; BACKPACKS; CLUTCH BAGS; HANDBAGS; PURSES; TOTE BAGS; WALLETS (U.S. CLS. 1, 2, 3, 22 AND 41).

FIRST USE 1-1-2010; IN COMMERCE 3-1-2010.  
LAURIE KAUFMAN, EXAMINING ATTORNEY

SN 85-147,324. DENA DESIGNS, INC., LAFAYETTE, CA. FILED 10-7-2010.

HAUTE GIRL

THE MARK CONSISTS OF STANDARD CHARACTERS WITHOUT CLAIM TO ANY PARTICULAR FONT, STYLE, SIZE, OR COLOR.

NO CLAIM IS MADE TO THE EXCLUSIVE RIGHT TO USE "GIRL", APART FROM THE MARK AS SHOWN.

THE ENGLISH TRANSLATION OF THE WORD "HAUTE" IN THE MARK IS HIGH.

FOR ALL PURPOSE CARRYING BAGS; PURSES; COSMETIC BAGS SOLD EMPTY; GYM BAGS; BACKPACKS, BOOK BAGS, SPORTS BAGS, BUM BAGS, WALLETS AND HANDBAGS (U.S. CLS. 1, 2, 3, 22 AND 41).

NAKWAMA ANKRAH, EXAMINING ATTORNEY



**CLASS 18—(Continued).**

SN 85-150,954. GONZALEZ, PATRICIA, PLANT CITY, FL.  
FILED 10-12-2010.

**BAGS · 4 · BAGS**

THE MARK CONSISTS OF STANDARD CHARACTERS WITHOUT CLAIM TO ANY PARTICULAR FONT, STYLE, SIZE, OR COLOR.

NO CLAIM IS MADE TO THE EXCLUSIVE RIGHT TO USE "BAGS", APART FROM THE MARK AS SHOWN.

FOR ALL PURPOSE SPORT BAGS; ALL-PURPOSE ATHLETIC BAGS; ALL-PURPOSE CARRYING BAGS; ALL-PURPOSE REUSABLE CARRYING BAGS; BACKPACKS, BOOK BAGS, SPORTS BAGS, BUM BAGS, WALLETS AND HANDBAGS; BAGS FOR SPORTS; BEACH BAGS; BELT BAGS; BELT BAGS AND HIP BAGS; BOOK BAGS; CANVAS SHOPPING BAGS; CARRY-ALL BAGS; CHANGE PURSES; CHARM BAGS (OMAMORI-IRE); CLUTCH BAGS; CLUTCH PURSES; COIN PURSES; DRAWSTRING BAGS; DUFFEL BAGS; FLEXIBLE BAGS FOR GARMENTS; GYM BAGS; HANDBAGS, PURSES AND WALLETS; HOBO BAGS; KNITTED BAGS, NOT OF PRECIOUS METALS; LEATHER BAGS AND WALLETS; LEATHER BAGS, SUITCASES AND WALLETS; LUGGAGE; MEN'S CLUTCH BAGS; MESH SHOPPING BAGS; MESSENGER BAGS; POUCHES AND BAGS SOLD EMPTY FOR ATTACHMENT TO BACKPACKS; PROTECTIVE FITTED LINERS FOR BACKPACKS AND LUGGAGE; PURSES; PURSES; PURSES AND WALLETS; REUSABLE SHOPPING BAGS; ROLL BAGS; SADDLE HORN BAGS; SCHOOL BAGS; SCHOOL BOOK BAGS; SHOULDER BAGS; SLING BAGS; SMALL BAGS FOR MEN; SOUVENIR BAGS; STRING BAGS FOR SHOPPING; TOTE BAGS; TRAVEL BAGS; WAIST BAGS (U.S. CLS. 1, 2, 3, 22 AND 41).

MICHAEL WIENER, EXAMINING ATTORNEY

SN 85-176,487. K & A PRODUCTS, LLC, SCOTTSDALE, AZ.  
FILED 11-15-2010.

**THE WORLD IS YOUR PARK**

THE MARK CONSISTS OF STANDARD CHARACTERS WITHOUT CLAIM TO ANY PARTICULAR FONT, STYLE, SIZE, OR COLOR.

FOR HARNESES, DOG CLOTHING, PET PRODUCTS, NAMELY, PET RESTRAINING DEVICES CONSISTING OF LEASHES, COLLARS, PET LEASHES WITH LOCKING DEVICES, HARNESES, RESTRAINING STRAPS; PET COLLARS, PET LEASHES, PET LEASHES WITH LOCKING DEVICES; PET TAGS SPECIALLY ADAPTED FOR ATTACHING TO PET LEASHES OR COLLARS; PET ACCESSORIES, NAMELY, CANVAS, VINYL AND LEATHER POUCHES FOR HOLDING DISPOSABLE BAGS TO PLACE PET WASTE IN (U.S. CLS. 1, 2, 3, 22 AND 41).

JOHN DALIER, EXAMINING ATTORNEY

**CLASS 18—(Continued).**

SN 85-180,609. LEVEL BODYBOARDING CLOTHING COMPANY SA, VALENCIA, VENEZUELA, FILED 11-18-2010.

**LEVEL BODYBOARDING**

THE MARK CONSISTS OF STANDARD CHARACTERS WITHOUT CLAIM TO ANY PARTICULAR FONT, STYLE, SIZE, OR COLOR.

NO CLAIM IS MADE TO THE EXCLUSIVE RIGHT TO USE "BODYBOARDING", APART FROM THE MARK AS SHOWN.

FOR BACKPACKS; BILLFOLDS; DUFFLE BAGS; FANNY PACKS; HANDBAGS; SPORTS BAGS; SUITCASES (U.S. CLS. 1, 2, 3, 22 AND 41).

HOWARD SMIGA, EXAMINING ATTORNEY

SN 85-183,707. LU, LYNN, COVINA, CA. AND WU, TIF-FANY, COVINA, CA. FILED 11-23-2010.

**HEIRLOOM**

THE MARK CONSISTS OF STANDARD CHARACTERS WITHOUT CLAIM TO ANY PARTICULAR FONT, STYLE, SIZE, OR COLOR.

OWNER OF U.S. REG. NO. 3,815,155.  
FOR HAND BAGS, PURSES, LUGGAGE, COIN PURSES, WALLETS, JEWELRY ORGANIZERS FOR TRAVEL, COSMETIC CASES SOLD EMPTY, AND BUSINESS CARD CASES MADE OF LEATHER (U.S. CLS. 1, 2, 3, 22 AND 41).

FIRST USE 9-1-2006; IN COMMERCE 9-1-2006.

LAKEISHA LEWIS, EXAMINING ATTORNEY

**CLASS 18—(Continued).**

SN 85-188,546. SNOW, NACHE, UPPER MARLBORO, MD. FILED 12-1-2010.



THE MARK CONSISTS OF THE STYLIZED WORD "TAL-LOOK".  
 FOR MAKE-UP BAGS SOLD EMPTY; PURSES; SHOE BAGS FOR TRAVEL; WALLETS (U.S. CLS. 1, 2, 3, 22 AND 41).  
 FIRST USE 2-1-2010; IN COMMERCE 2-2-2010.  
 DAVID COLLIER, EXAMINING ATTORNEY

SN 85-189,272. SRY IMPORTS LLC, PORT WASHINGTON, NY. FILED 12-2-2010.



NO CLAIM IS MADE TO THE EXCLUSIVE RIGHT TO USE "PACK", APART FROM THE MARK AS SHOWN.  
 THE MARK CONSISTS OF A RECTANGULAR PLAQUE WITH THE WORD "VIP" IN THE UPPER PORTION AND THE WORD "PAQ" IN THE LOWER PORTION AND A GEOMETRIC TRIANGLE DESIGN WITHIN.  
 FOR LUGGAGE (U.S. CLS. 1, 2, 3, 22 AND 41).  
 CARYN GLASSER, EXAMINING ATTORNEY

**CLASS 18—(Continued).**

SN 85-189,339. SRY IMPORTS LLC, PORT WASHINGTON, NY. FILED 12-2-2010.



NO CLAIM IS MADE TO THE EXCLUSIVE RIGHT TO USE "PACK", APART FROM THE MARK AS SHOWN.  
 THE MARK CONSISTS OF A RECTANGULAR PLAQUE WITH THE WORD "THE" IN THE UPPER PORTION AND THE WORD "PAQ" IN THE LOWER PORTION AND A GEOMETRIC TRIANGLE DESIGN WITHIN.  
 FOR CARRY-ON BAGS; LUGGAGE; TRAVEL BAGS (U.S. CLS. 1, 2, 3, 22 AND 41).  
 CARYN GLASSER, EXAMINING ATTORNEY

SN 85-189,404. SEVERO, SARAH, NAPLES, FL. FILED 12-2-2010.



THE NAME "PAUL BEYOND" DOES NOT IDENTIFY A LIVING INDIVIDUAL.  
 THE MARK CONSISTS OF THE STYLIZED LETTERS "P" AND "B", A DOUBLE VERTICAL LINE BELOW AND THE STYLIZED WORDS "PAUL BEYOND" BELOW THE DOUBLE LINE.  
 FOR BELT BAGS; BELT BAGS AND HIP BAGS; HANDBAGS; LEATHER AND IMITATION LEATHER; LEATHER SHOULDER BELTS; WALLETS (U.S. CLS. 1, 2, 3, 22 AND 41).  
 MARGERY A. TIERNEY, EXAMINING ATTORNEY

**CLASS 18—(Continued).**

SN 85-193,560. ME TOO LLC, NEW YORK, NY. FILED 12-8-2010.

**SOHO by Me Too**

THE MARK CONSISTS OF STANDARD CHARACTERS WITHOUT CLAIM TO ANY PARTICULAR FONT, STYLE, SIZE, OR COLOR.

OWNER OF U.S. REG. NO. 3,757,658.

NO CLAIM IS MADE TO THE EXCLUSIVE RIGHT TO USE "SOHO", APART FROM THE MARK AS SHOWN.

FOR BAGS, NAMELY, HANDBAGS, PURSES, CLUTCHES, AND WALLETS (U.S. CLS. 1, 2, 3, 22 AND 41).

JULIE GUTTADAURO, EXAMINING ATTORNEY

SN 85-193,588. ME TOO LLC, NEW YORK, NY. FILED 12-8-2010.

**Me Too SOHO**

THE MARK CONSISTS OF STANDARD CHARACTERS WITHOUT CLAIM TO ANY PARTICULAR FONT, STYLE, SIZE, OR COLOR.

OWNER OF U.S. REG. NO. 3,757,658.

NO CLAIM IS MADE TO THE EXCLUSIVE RIGHT TO USE "SOHO", APART FROM THE MARK AS SHOWN.

FOR BAGS, NAMELY, HANDBAGS, PURSES, CLUTCHES, AND WALLETS (U.S. CLS. 1, 2, 3, 22 AND 41).

JULIE GUTTADAURO, EXAMINING ATTORNEY

SN 85-196,183. ESTEE LAUDER COSMETICS LTD, AGINCOURT, ONTARIO, CANADA, FILED 12-13-2010.

**CLEARLY MAC**

THE MARK CONSISTS OF STANDARD CHARACTERS WITHOUT CLAIM TO ANY PARTICULAR FONT, STYLE, SIZE, OR COLOR.

OWNER OF U.S. REG. NOS. 1,642,532, 3,237,448 AND OTHERS.

FOR COSMETIC BAGS SOLD EMPTY (U.S. CLS. 1, 2, 3, 22 AND 41).

MEGHAN REINHART, EXAMINING ATTORNEY

**CLASS 18—(Continued).**

SN 85-196,589. BRAITHWAITE MARY M, NORTH PORT, FL. FILED 12-13-2010.

**PALMBRELLA**

THE MARK CONSISTS OF STANDARD CHARACTERS WITHOUT CLAIM TO ANY PARTICULAR FONT, STYLE, SIZE, OR COLOR.

FOR BEACH UMBRELLAS; GOLF UMBRELLAS; PATIO UMBRELLAS; UMBRELLAS (U.S. CLS. 1, 2, 3, 22 AND 41).

FIRST USE 6-1-2002; IN COMMERCE 6-1-2002.

JULIE VEPPUMTHARA, EXAMINING ATTORNEY

SN 85-197,577. GREEN, GEORGE M., ARGYLE, TX. FILED 12-14-2010.

**HIS**

THE MARK CONSISTS OF STANDARD CHARACTERS WITHOUT CLAIM TO ANY PARTICULAR FONT, STYLE, SIZE, OR COLOR.

FOR HANDBAGS, PURSES AND WALLETS; LEATHER BAGS AND WALLETS; LEATHER CREDIT CARD WALLETS; POCKET WALLETS; PURSES AND WALLETS; WALLETS; WALLETS INCLUDING CARD HOLDERS; WALLETS MADE OF LEATHER OR OTHER MATERIALS; WALLETS WITH CARD COMPARTMENTS (U.S. CLS. 1, 2, 3, 22 AND 41).

AMY C. KEAN, EXAMINING ATTORNEY

SN 85-200,528. PANIZZI, BRIAN, LAFAYETTE, IN. FILED 12-17-2010.



THE MARK CONSISTS OF THE TEXT "OLEBALLNCHAIN" WITH A "FLYING BEAGLE" ATTACHED BY LEASH TO THE FIRST LETTER, "O".

FOR DOG RESTRAINT PRODUCT, NAMELY, A HOLLOW PLASTIC BALL THAT IS ATTACHED TO A DOG BY WAY OF A TUBE COVERED CHAIN, WHICH IS AFFIXED TO A DOG COLLAR OR HARNESS; PET CLOTHING; ANIMAL HARNESSES (U.S. CLS. 1, 2, 3, 22 AND 41).

ALLISON SCHRODY, EXAMINING ATTORNEY

**CLASS 18—(Continued).**

SN 85-200,840. NICOLE MARROW, NEW YORK, NY. FILED 12-17-2010.

# COCOLICIOUS

THE MARK CONSISTS OF STANDARD CHARACTERS WITHOUT CLAIM TO ANY PARTICULAR FONT, STYLE, SIZE, OR COLOR.  
FOR HANDBAGS (U.S. CLS. 1, 2, 3, 22 AND 41).  
DEBRA LEE, EXAMINING ATTORNEY

SN 85-200,880. NICOLE MARROW, NEW YORK, NY. FILED 12-17-2010.

# LICIOUS

THE MARK CONSISTS OF STANDARD CHARACTERS WITHOUT CLAIM TO ANY PARTICULAR FONT, STYLE, SIZE, OR COLOR.  
FOR HANDBAGS (U.S. CLS. 1, 2, 3, 22 AND 41).  
DEBRA LEE, EXAMINING ATTORNEY

SN 85-202,754. PROENZA SCHOULER, LLC, NEW YORK, NY. FILED 12-21-2010.



OWNER OF U.S. REG. NO. 3,477,291.  
THE MARK CONSISTS OF A HIGHLY STYLIZED DESIGN BASED ON THE LETTERS "P" AND "S".  
FOR HANDBAGS; WALLETS (U.S. CLS. 1, 2, 3, 22 AND 41).  
FIRST USE 0-0-2008; IN COMMERCE 0-0-2008.  
BENJAMIN OKEKE, EXAMINING ATTORNEY

**CLASS 18—(Continued).**

SN 85-203,519. ARITZIA LP, VANCOUVER, BC, CANADA, FILED 12-22-2010.



THE MARK CONSISTS OF TWO DOGS FACING EACH OTHER, STANDING ON HIND LEGS WITH FRONT LEGS TOUCHING.  
FOR LEATHER AND IMITATION LEATHER BAGS; PURSES; WALLETS (U.S. CLS. 1, 2, 3, 22 AND 41).  
FIRST USE 3-19-2010; IN COMMERCE 3-19-2010.  
PAUL E. FAHRENKOPF, EXAMINING ATTORNEY

SN 85-203,665. FTI CORPORATION LIMITED, HUNG HOM KL, HONG KONG, FILED 12-22-2010.



THE MARK CONSISTS OF THE OUTLINE OF AN AIRPLANE SUPERIMPOSED ON A STYLIZED GLOBE.  
FOR BACKPACKS; TRAVEL BAGS; BEACH BAGS; BRIEFCASES; LEATHER SHOULDER BELTS; GARMENT BAGS FOR TRAVEL; HANDBAGS; STRING BAGS FOR SHOPPING; LUGGAGE AND TRUNKS; PURSES; UNFITTED VANITY CASES; PARASOLS; UMBRELLAS; NAME CARD CASES; HUNTERS' GAME BAGS; TRAVELLING TRUNKS; POCKET WALLETS (U.S. CLS. 1, 2, 3, 22 AND 41).  
FIRST USE 4-20-2010; IN COMMERCE 5-30-2010.  
GEORGE LORENZO, EXAMINING ATTORNEY

**CLASS 18—(Continued).**

SN 85-204,544. STARLIGHT ACCESSORIES, INC., NEW YORK, NY. FILED 12-22-2010.

# DEB+DAVE

THE MARK CONSISTS OF STANDARD CHARACTERS WITHOUT CLAIM TO ANY PARTICULAR FONT, STYLE, SIZE, OR COLOR.

FOR BEACH BAGS; BOOK BAGS; COSMETIC BAGS SOLD EMPTY; CREDIT CARD CASES AND HOLDERS; PURSES; SHOULDER BAGS; TOTE BAGS; WALLET (U.S. CLS. 1, 2, 3, 22 AND 41).

YAT SYE, LEE, EXAMINING ATTORNEY

---

SN 85-205,403. PG INVESTMENTS OF VIRGINIA, LLC, WILMINGTON, DE. FILED 12-23-2010.

# BLACKWATER

THE MARK CONSISTS OF STANDARD CHARACTERS WITHOUT CLAIM TO ANY PARTICULAR FONT, STYLE, SIZE, OR COLOR.

FOR BACKPACKS, BOOK BAGS, SPORTS BAGS, ATHLETIC BAGS, GYM BAGS; HUNTING BAGS; ALL PURPOSE CARRYING BAGS; TRAVEL BAGS; MESSENGER BAGS; MILITARY DUFFLE BAGS, GARMENT BAGS FOR TRAVEL, TOTE BAGS, SHOULDER BAGS, WALLET AND HANDBAGS (U.S. CLS. 1, 2, 3, 22 AND 41).

ANGELA M. MICHELI, EXAMINING ATTORNEY

---

SN 85-205,944. HARD CANDY, LLC, HOLLYWOOD, FL. FILED 12-27-2010.

# HARD CANDY

THE MARK CONSISTS OF STANDARD CHARACTERS WITHOUT CLAIM TO ANY PARTICULAR FONT, STYLE, SIZE, OR COLOR.

OWNER OF U.S. REG. NOS. 2,552,029, 3,695,602 AND OTHERS.

FOR COSMETIC BAGS SOLD EMPTY; COSMETIC CASES SOLD EMPTY (U.S. CLS. 1, 2, 3, 22 AND 41).

SUSAN RICHARDS, EXAMINING ATTORNEY

**CLASS 18—(Continued).**

SN 85-205,945. HARD CANDY, LLC, HOLLYWOOD, FL. FILED 12-27-2010.



OWNER OF U.S. REG. NOS. 2,552,029, 3,695,602 AND OTHERS.

THE COLOR(S) BLACK, WHITE, PINK AND LIGHT PINK IS/ARE CLAIMED AS A FEATURE OF THE MARK.

THE MARK CONSISTS OF A PINK HEART WITH LIGHT PINK SCROLLING, A WHITE BANNER OUTLINED IN BLACK, WRAPPING AROUND THE HEART, AND THE WORDING "HARD CANDY" IN BLACK ON THE BANNER.

FOR COSMETIC BAGS SOLD EMPTY; COSMETIC CASES SOLD EMPTY (U.S. CLS. 1, 2, 3, 22 AND 41).

SUSAN RICHARDS, EXAMINING ATTORNEY

---

SN 85-206,556. MICHELLE HARDING, WEST MILFORD, NJ. FILED 12-28-2010.

# CELEBIPAWS

THE MARK CONSISTS OF STANDARD CHARACTERS WITHOUT CLAIM TO ANY PARTICULAR FONT, STYLE, SIZE, OR COLOR.

FOR PET CLOTHING (U.S. CLS. 1, 2, 3, 22 AND 41).

SANJEEV VOHRA, EXAMINING ATTORNEY

---

SN 85-206,864. FUTAI, INC. (USA), EDISON, NJ. FILED 12-28-2010.

# Leighton

THE MARK CONSISTS OF STANDARD CHARACTERS WITHOUT CLAIM TO ANY PARTICULAR FONT, STYLE, SIZE, OR COLOR.

OWNER OF U.S. REG. NO. 1,924,888.

SEC. 2(F).

FOR GOLF UMBRELLAS; UMBRELLAS (U.S. CLS. 1, 2, 3, 22 AND 41).

FIRST USE 1-14-1993; IN COMMERCE 1-14-1993.

SANJEEV VOHRA, EXAMINING ATTORNEY

**CLASS 18—(Continued).**

SN 85-207,180. KATIE KALSI, LLC, GERMANTOWN, TN.  
FILED 12-29-2010.



THE MARK CONSISTS OF MIRROR IMAGE LETTER "K".

FOR HANDBAGS; STRAPS FOR HANDBAGS; WALLETS (U.S. CLS. 1, 2, 3, 22 AND 41).

FIRST USE 12-17-2010; IN COMMERCE 12-17-2010.  
SUZANNE BLANE, EXAMINING ATTORNEY

---

SN 85-207,777. J. MITTON & ASSOCIATES, INC., DBA  
INTREPID INTERNATIONAL, NEW HOLLAND, PA.  
FILED 12-30-2010.

## BEST FRIEND

THE MARK CONSISTS OF STANDARD CHARACTERS WITHOUT CLAIM TO ANY PARTICULAR FONT, STYLE, SIZE, OR COLOR.

FOR EQUINE MUZZLES AND BAREBACK RIDING PRODUCTS, NAMELY, BAREBACK PADS AND BAREBACK MOUNTING DEVICES, NAMELY, A COTTON STRAP WHICH ENCIRCLES THE HORSE WITH A STIRRUP ATTACHED (U.S. CLS. 1, 2, 3, 22 AND 41).

FIRST USE 1-1-2001; IN COMMERCE 1-1-2001.  
ADA HAN, EXAMINING ATTORNEY

---

SN 85-207,912. LUCKENBACH, LISA J., OJAI, CA. FILED 12-30-2010.

## WiggleLess

THE MARK CONSISTS OF STANDARD CHARACTERS WITHOUT CLAIM TO ANY PARTICULAR FONT, STYLE, SIZE, OR COLOR.

FOR DOG CLOTHING (U.S. CLS. 1, 2, 3, 22 AND 41).  
GEORGE LORENZO, EXAMINING ATTORNEY

**CLASS 18—(Continued).**

SN 85-209,121. DURO TEXTILES, LLC, FALL RIVER, MA.  
FILED 1-3-2011.

## tAkeCover

THE MARK CONSISTS OF THE WORD "TAKECOVER" WHERE THE "A" IS REPLACED WITH A LAMBDA AND THE LETTERS "T", "K", "E", "O", "V", "E", AND "R" ARE IN LOWER CASE LETTERS AND THE "C" IS IN UPPER CASE.

FOR LUGGAGE, BACKPACKS, ALL-PURPOSE CARRYING BAGS, SPORTS BAGS, CARRY-ON BAGS, DUFFEL BAGS, SLING BAGS, WHEELED BAGS (U.S. CLS. 1, 2, 3, 22 AND 41).

ERNEST SHOSHO, EXAMINING ATTORNEY

---

SN 85-210,878. CREME BRULEE DESIGN, AHWATUKEE, AZ. FILED 1-5-2011.



THE MARK CONSISTS OF A FLAME WITH TWO PEAKS AND A HOLE IN THE CENTER OF THE FLAME COMBINED WITH THE TEXT "CRÈME BRÛLÉE".

FOR HANDBAGS (U.S. CLS. 1, 2, 3, 22 AND 41).  
GISELLE AGOSTO, EXAMINING ATTORNEY

---

SN 85-212,476. LEIBOLD, MARY, SOUTH RUSSELL, OH.  
FILED 1-7-2011.

## EQUIFLEXSLEEVE

THE MARK CONSISTS OF STANDARD CHARACTERS WITHOUT CLAIM TO ANY PARTICULAR FONT, STYLE, SIZE, OR COLOR.

FOR PET CLOTHING, NAMELY, WOVEN CLOTH SLEEVE FITTED FOR A HORSE'S LEG (U.S. CLS. 1, 2, 3, 22 AND 41).

KAPIL BHANOT, EXAMINING ATTORNEY

**CLASS 18—(Continued).**

SN 85-213,140. GJM,LLC, CHICAGO, IL. FILED 1-7-2011.

**Kumfy Tailz**

THE MARK CONSISTS OF STANDARD CHARACTERS WITHOUT CLAIM TO ANY PARTICULAR FONT, STYLE, SIZE, OR COLOR.

FOR ANIMAL CARRIERS; ANIMAL HARNESSSES; ANIMAL LEASHES; ANIMAL TRAINING DEVICE IN THE NATURE OF A METAL CAN CONTAINING COIN-SIZED PIECES OF METAL; ANIMAL WRAPS AND COVERS; CELLULOSE FOR USE AS ANIMAL BEDDING; CLIPS THAT ARE APPLIED TO THE SCRUFF OF AN ANIMAL'S NECK TO PINCH-INDUCE A BEHAVIORAL INHIBITION RESPONSE; CLOTHING FOR ANIMALS; CLOTHING FOR DOMESTIC PETS; COLLARS FOR ANIMALS; COLLARS OF ANIMALS; DOG CLOTHING; FEED BAGS FOR ANIMALS; LEASHES FOR ANIMALS; LEGGINGS FOR ANIMALS; MATS AND PADS MADE OF FABRIC FOR USE WITH ANIMAL TRAINING; PAPER FOR USE AS ANIMAL BEDDING; PET ACCESSORIES, NAMELY, SPECIALLY DESIGNED CANVAS, VINYL OR LEATHER BAGS ATTACHED TO ANIMAL LEASHES FOR HOLDING SMALL ITEMS SUCH AS KEYS, CREDIT CARDS, MONEY OR DISPOSABLE BAGS FOR DISPOSING OF PET WASTE; PET CLOTHING; SMALL ANIMAL BEDDING MADE OF RECYCLED PAPER (U.S. CLS. 1, 2, 3, 22 AND 41).

JENNIFER MARTIN, EXAMINING ATTORNEY

---

SN 85-213,150. LUCKY BRAND DUGAREES, INC., VERNON, CA. FILED 1-7-2011.

**LUCKY BRAND**

THE MARK CONSISTS OF STANDARD CHARACTERS WITHOUT CLAIM TO ANY PARTICULAR FONT, STYLE, SIZE, OR COLOR.

OWNER OF U.S. REG. NOS. 2,936,774 AND 3,107,591. NO CLAIM IS MADE TO THE EXCLUSIVE RIGHT TO USE "BRAND", APART FROM THE MARK AS SHOWN. FOR CLUTCHES; COSMETIC BAGS SOLD EMPTY; HANDBAGS; MESSENGER BAGS; TOTE BAGS; WALLET (U.S. CLS. 1, 2, 3, 22 AND 41).

FIRST USE 7-15-2003; IN COMMERCE 7-15-2003. MICHAEL SOUDERS, EXAMINING ATTORNEY

**CLASS 18—(Continued).**

SN 85-213,187. SOFTOUCH CONCEPTS, INC., UNION CITY, CA. FILED 1-7-2011.

**SENSE-IBLE**

THE MARK CONSISTS OF STANDARD CHARACTERS WITHOUT CLAIM TO ANY PARTICULAR FONT, STYLE, SIZE, OR COLOR.

FOR PET RESTRAINING DEVICES CONSISTING OF HARNESSSES FOR USE IN DOG WALKING (U.S. CLS. 1, 2, 3, 22 AND 41).

FIRST USE 10-31-2004; IN COMMERCE 10-31-2004. APRIL ROACH, EXAMINING ATTORNEY

---

SN 85-213,200. SOFTOUCH CONCEPTS, INC., UNION CITY, CA. FILED 1-7-2011.

**SOF-LOOP**

THE MARK CONSISTS OF STANDARD CHARACTERS WITHOUT CLAIM TO ANY PARTICULAR FONT, STYLE, SIZE, OR COLOR.

FOR DOG LEASHES (U.S. CLS. 1, 2, 3, 22 AND 41).

FIRST USE 2-28-2007; IN COMMERCE 2-28-2007. APRIL ROACH, EXAMINING ATTORNEY

---

SN 85-216,252. JE'ANE, LLC, LEESVILLE, LA. FILED 1-12-2011.

**LipSavvy!**

THE MARK CONSISTS OF STANDARD CHARACTERS WITHOUT CLAIM TO ANY PARTICULAR FONT, STYLE, SIZE, OR COLOR.

FOR COSMETIC BAGS SOLD EMPTY; COSMETIC CARRYING CASES SOLD EMPTY; COSMETIC CASES SOLD EMPTY (U.S. CLS. 1, 2, 3, 22 AND 41).

CHRISTOPHER BUONGIORNO, EXAMINING ATTORNEY

**CLASS 18—(Continued).**

SN 85-228,183. FREMANTLE MEDIA NORTH AMERICA, INC., BURBANK, CA. AND SIMCO LIMITED, LONDON, UNITED KINGDOM, FILED 1-27-2011.

**THE X FACTOR**

THE MARK CONSISTS OF STANDARD CHARACTERS WITHOUT CLAIM TO ANY PARTICULAR FONT, STYLE, SIZE, OR COLOR.

FOR BACK PACKS; BAGS FOR SPORTS; BUM BAGS; DUFFEL BAGS; HANDBAGS; HOLDALLS; LEATHER BAGS, SUITCASES AND WALLETS; UMBRELLAS (U.S. CLS. 1, 2, 3, 22 AND 41).

TAMARA FRAZIER, EXAMINING ATTORNEY

---

SN 85-228,841. CARTER, SHAWN, NEW YORK, NY. FILED 1-28-2011.

**AKA SHAWN CARTER**

THE MARK CONSISTS OF STANDARD CHARACTERS WITHOUT CLAIM TO ANY PARTICULAR FONT, STYLE, SIZE, OR COLOR.

THE NAME(S), PORTRAIT(S), AND/OR SIGNATURE(S) SHOWN IN THE MARK IDENTIFIES SHAWN CARTER, WHOSE CONSENT(S) TO REGISTER IS MADE OF RECORD.

FOR BAGS, NAMELY, WALLETS, BOOK BAGS, MESSENGER BAGS, HANDBAGS, SHOULDER BAGS, CLUTCHES, LUGGAGE AND UMBRELLA (U.S. CLS. 1, 2, 3, 22 AND 41).

MATTHEW EINSTEIN, EXAMINING ATTORNEY

---

SN 85-231,419. PACIFIC WORLD CORPORATION, LAKE FOREST, CA. FILED 2-1-2011.



THE MARK CONSISTS OF A STYLIZED LOWER CASE "G" FOLLOWED BY A STYLIZED UPPER CASE "G".

FOR BACK PACKS; PURSES; WALLETS (U.S. CLS. 1, 2, 3, 22 AND 41).

HOWARD SMIGA, EXAMINING ATTORNEY

**CLASS 18—(Continued).**

SN 85-247,619. IM READY-MADE, LLC, NEW YORK, NY. FILED 2-21-2011.



OWNER OF U.S. REG. NOS. 3,293,901, 3,354,162 AND OTHERS.

THE MARK CONSISTS OF A STYLIZED DAISY CONSISTING OF 8 PETALS AROUND A ROUND CENTER.

FOR (BASED ON USE IN COMMERCE) HANDBAGS, PURSES AND WALLETS (BASED ON INTENT TO USE) LUGGAGE; TOTE BAGS (U.S. CLS. 1, 2, 3, 22 AND 41).

FIRST USE 1-0-2010; IN COMMERCE 1-0-2010.  
DEBRA LEE, EXAMINING ATTORNEY

---

SN 85-260,040. COLLECTIVE BRANDS COOPERATIEF U.A., AMSTERDAM, NETHERLANDS, FILED 3-7-2011.

**COURT MAX**

THE MARK CONSISTS OF STANDARD CHARACTERS WITHOUT CLAIM TO ANY PARTICULAR FONT, STYLE, SIZE, OR COLOR.

FOR LEATHER AND IMITATIONS OF LEATHER, AND GOODS MADE OF THESE MATERIALS AND NOT INCLUDED IN OTHER CLASSES, NAMELY, ALL PURPOSE ATHLETIC AND SPORTS BAGS, DUFFEL BAGS, BACKPACKS, HANDBAGS, SCHOOL BAGS, LUGGAGE, FANNY PACKS, TRAVEL BAGS, GYM BAGS, SHOULDER BAGS, BOOK BAGS, MESSENGER BAGS, ATTACHÉ CASES, PURSES, AND WALLETS (U.S. CLS. 1, 2, 3, 22 AND 41).

DAVID ELTON, EXAMINING ATTORNEY



**CLASS 19—NON-METALLIC BUILDING MATERIALS**

**CLASS 19—(Continued).**

SN 76-705,836. JAMES M. PRATT, NEEDHAM, MA. FILED 12-29-2010.

SN 85-055,390. DYNAMIC SHELTERS INC., CALGARY, CANADA, FILED 6-4-2010.

**BASEMENTMATE**

**DYNAMIC SHELTERS**

THE MARK CONSISTS OF STANDARD CHARACTERS WITHOUT CLAIM TO ANY PARTICULAR FONT, STYLE, SIZE, OR COLOR.

FOR BUILDING MATERIALS, NAMELY, COMPOSITE PANELS COMPOSED PRIMARILY OF NONMETAL MATERIALS (U.S. CLS. 1, 12, 33 AND 50).

JILL PRATER, EXAMINING ATTORNEY

THE MARK CONSISTS OF STANDARD CHARACTERS WITHOUT CLAIM TO ANY PARTICULAR FONT, STYLE, SIZE, OR COLOR.

NO CLAIM IS MADE TO THE EXCLUSIVE RIGHT TO USE "SHELTER", APART FROM THE MARK AS SHOWN.

FOR NON-METAL SHELTER STRUCTURES, NAMELY, AIR INFLATED SHELTERS CONSISTING OF PRESSURIZED AIR BEAMS COVERED BY WATER-PROOF FABRIC AND NOT FOR USE AS HOMES (U.S. CLS. 1, 12, 33 AND 50).

FIRST USE 1-1-2005; IN COMMERCE 1-1-2005.  
MATTHEW EINSTEIN, EXAMINING ATTORNEY

SN 79-086,780. DIDIER-WERKE AG, FED REP GERMANY, FILED 4-29-2010.

**RESISTAL**

SN 85-062,096. TEXSA, S.A., BARCELONA, SPAIN, FILED 6-14-2010.

OWNER OF INTERNATIONAL REGISTRATION 0336389 DATED 5-5-1967, EXPIRES 5-5-2017.

OWNER OF U.S. REG. NO. 1,080,357.

FOR REFRACTORY BRICKS; REFRACTORY MASSES, NAMELY, MONOLITHICS; REFRACTORY MORTARS, ALL GOODS NOT OF METAL (U.S. CLS. 1, 12, 33 AND 50).

MARY I. SPARROW, EXAMINING ATTORNEY

SN 85-045,302. SILPRO, LLC, AYER, MA. FILED 5-21-2010.

**MOPLY**

**FASCO**

THE MARK CONSISTS OF STANDARD CHARACTERS WITHOUT CLAIM TO ANY PARTICULAR FONT, STYLE, SIZE, OR COLOR.

FOR PATCHING COMPOUND MADE OF A CEMENT BASE FOR USE ON FLOORS (U.S. CLS. 1, 12, 33 AND 50).  
FIRST USE 0-0-2006; IN COMMERCE 0-0-2006.

APRIL ROACH, EXAMINING ATTORNEY

THE MARK CONSISTS OF STANDARD CHARACTERS WITHOUT CLAIM TO ANY PARTICULAR FONT, STYLE, SIZE, OR COLOR.

OWNER OF ERPN CMNTY TM OFC REG. NO. 001199355, DATED 7-11-2000, EXPIRES 6-8-2019.

FOR BUILDING MATERIALS, NAMELY, ASPHALT BASED ROOFING MASTICS (U.S. CLS. 1, 12, 33 AND 50).

SOPHIA S. KIM, EXAMINING ATTORNEY

**CLASS 19—(Continued).**

SN 85-070,979. INDUSTRIAS AUXILIARES FAUS S.L., VALENCIA, SPAIN, FILED 6-24-2010.



NO CLAIM IS MADE TO THE EXCLUSIVE RIGHT TO USE "LONGSTRIP", APART FROM THE MARK AS SHOWN.

THE COLOR(S) BLACK AND RED IS/ARE CLAIMED AS A FEATURE OF THE MARK.

THE MARK CONSISTS OF THE WORDS "LONG" AND "STRIP" IN STYLIZED LETTERS IN BLACK. THE LETTERS FOR THE WORD "LONG" ARE IN BOLD FONT AND THE LETTERS FOR THE WORD "STRIP" ARE IN A THINNER FONT. DIRECTLY BELOW THESE TWO WORDS ARE THREE HORIZONTAL LINES. THE FIRST LINE IS IN BLACK, THE SECOND LINE IS IN RED, AND THE THIRD LINE IS IN BLACK.

FOR LAMINATE FLOORING (U.S. CLS. 1, 12, 33 AND 50).

DEIRDRE ROBERTSON, EXAMINING ATTORNEY

---

SN 85-140,281. SOUTHERN STAR CONCRETE INC, HOUSTON, TX. FILED 9-28-2010.



OWNER OF U.S. REG. NO. 2,900,839.  
THE COLOR(S) RED AND BLUE IS/ARE CLAIMED AS A FEATURE OF THE MARK.

THE MARK CONSISTS OF THE WORDING "SOUTHERN STAR" IN BLUE LETTERING, ABOVE WHICH IS A RED SEVEN-POINTED STAR.

FOR NON-METALLIC BUILDING MATERIALS, NAMELY, READY-MIX CONCRETE; NON-METALLIC RIGID PIPES FOR BUILDING; ASPHALT, PITCH AND BITUMEN; NON-METALLIC TRANSPORTABLE BUILDINGS; MONUMENTS, NOT OF METAL (U.S. CLS. 1, 12, 33 AND 50).

AISHA SALEM, EXAMINING ATTORNEY

**CLASS 19—(Continued).**

SN 85-141,751. TEXAS CEMENT PRODUCTS, INC., HOUSTON, TX. FILED 9-30-2010.

## EPOXYPLUS

THE MARK CONSISTS OF STANDARD CHARACTERS WITHOUT CLAIM TO ANY PARTICULAR FONT, STYLE, SIZE, OR COLOR.

FOR EPOXY GROUT FOR CERAMIC TILE AND NATURAL STONE (U.S. CLS. 1, 12, 33 AND 50).

FIRST USE 10-11-1999; IN COMMERCE 10-11-1999.

ROSELLE HERRERA, EXAMINING ATTORNEY

---

SN 85-141,951. TEXAS CEMENT PRODUCTS, INC., HOUSTON, TX. FILED 9-30-2010.

## Porcelain TS

THE MARK CONSISTS OF STANDARD CHARACTERS WITHOUT CLAIM TO ANY PARTICULAR FONT, STYLE, SIZE, OR COLOR.

NO CLAIM IS MADE TO THE EXCLUSIVE RIGHT TO USE "PORCELAIN", APART FROM THE MARK AS SHOWN.

THE WORD(S) "TS" HAS NO MEANING IN A FOREIGN LANGUAGE.

FOR DRYSET MORTAR FOR BONDING PORCELAIN TILE, CERAMIC TILE AND NATURAL STONE (U.S. CLS. 1, 12, 33 AND 50).

FIRST USE 6-1-2006; IN COMMERCE 6-1-2006.

ROSELLE HERRERA, EXAMINING ATTORNEY

---

SN 85-168,190. THREE RIVERS MARINE & RAIL TERMINALS, L.P., CHARLEROI, PA. FILED 11-3-2010.

## PENNSYLVANIA PINK

THE MARK CONSISTS OF STANDARD CHARACTERS WITHOUT CLAIM TO ANY PARTICULAR FONT, STYLE, SIZE, OR COLOR.

NO CLAIM IS MADE TO THE EXCLUSIVE RIGHT TO USE "PENNSYLVANIA", APART FROM THE MARK AS SHOWN.

SEC. 2(F).

FOR DECORATIVE STONE (U.S. CLS. 1, 12, 33 AND 50).

FIRST USE 4-30-2004; IN COMMERCE 4-30-2004.

C. DIONNE CLYBURN, EXAMINING ATTORNEY

**CLASS 19—(Continued).**

SN 85-175,543. NAGLE III, WILLIAM J., DBA NEW ENGLAND WOODWORKING COMPANY, MIDDLETOWN, RI. FILED 11-12-2010.



NO CLAIM IS MADE TO THE EXCLUSIVE RIGHT TO USE "SASH WWW.NEWOODWORKING.COM", APART FROM THE MARK AS SHOWN.

THE COLOR(S) LIGHT GREEN, BLACK, BEIGE, BROWN IS/ARE CLAIMED AS A FEATURE OF THE MARK.

THE MARK CONSISTS OF THE MARK IS LIGHT GREEN AND OVAL IN SHAPE WITH A RECTANGLE BEIGE AND BROWN BORDER. THE WORDS "NEWPORT SASH WWW.NEWOODWORKING.COM" IN BLACK APPEAR IN THE MIDDLE OF THE OVAL, WHICH IS OUTLINED IN BLACK.

FOR NON-METAL STORM WINDOWS; NON-METAL WINDOWS; NON-METAL WINDOWS AND DOORS (U.S. CLS. 1, 12, 33 AND 50).

SOPHIA S. KIM, EXAMINING ATTORNEY

SN 85-177,055. THORWORKS INDUSTRIES, INC., SANDUSKY, OH. FILED 11-15-2010.

**BULL CRETE**

THE MARK CONSISTS OF STANDARD CHARACTERS WITHOUT CLAIM TO ANY PARTICULAR FONT, STYLE, SIZE, OR COLOR.

FOR POLYMER BASED PATCHING COMPOUND USED TO PATCH AND SEAL CONCRETE AND ASPHALT SURFACES (U.S. CLS. 1, 12, 33 AND 50).

FIRST USE 11-10-2010; IN COMMERCE 11-10-2010.

VERNA BETH RIRIE, EXAMINING ATTORNEY

**CLASS 19—(Continued).**

SN 85-183,425. FUNDER AMERICA, INC., MOCKSVILLE, NC. FILED 11-23-2010.

**SURFACE SYNERGIES**

THE MARK CONSISTS OF STANDARD CHARACTERS WITHOUT CLAIM TO ANY PARTICULAR FONT, STYLE, SIZE, OR COLOR.

NO CLAIM IS MADE TO THE EXCLUSIVE RIGHT TO USE "SURFACE", APART FROM THE MARK AS SHOWN.

FOR DECORATIVE NON-METALLIC RESIN IMPREGNATED LAMINATED PANELS IN THE NATURE OF RESIN VENEERS FOR USE IN COUNTERTOPS AND TABLETOPS, PANELS, DOORS, AND MOULDINGS TO PROVIDE A FINISHED SURFACE FOR A BASE MATERIAL (U.S. CLS. 1, 12, 33 AND 50).

BRIAN PINO, EXAMINING ATTORNEY

SN 85-183,443. FUNDER AMERICA, INC., MOCKSVILLE, NC. FILED 11-23-2010.

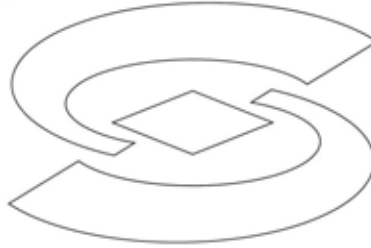

THE MARK CONSISTS OF A STYLIZED LETTER "S".

FOR DECORATIVE NON-METALLIC RESIN IMPREGNATED LAMINATED PANELS IN THE NATURE OF RESIN VENEERS FOR USE IN COUNTERTOPS AND TABLETOPS, PANELS, DOORS, AND MOULDINGS TO PROVIDE A FINISHED SURFACE FOR A BASE MATERIAL (U.S. CLS. 1, 12, 33 AND 50).

BRIAN PINO, EXAMINING ATTORNEY

SN 85-183,965. KEYSTONE RETAINING WALL SYSTEMS, INC., MINNEAPOLIS, MN. FILED 11-23-2010.

**KEYSTONE GARDEN WALL**

THE MARK CONSISTS OF STANDARD CHARACTERS WITHOUT CLAIM TO ANY PARTICULAR FONT, STYLE, SIZE, OR COLOR.

OWNER OF U.S. REG. NOS. 2,468,614, 3,144,403 AND OTHERS.

NO CLAIM IS MADE TO THE EXCLUSIVE RIGHT TO USE "GARDEN WALL", APART FROM THE MARK AS SHOWN.

FOR MODULAR CONCRETE BLOCKS USED TO CONSTRUCT EARTH RETAINING WALLS; MODULAR CONCRETE BLOCKS USED IN LANDSCAPING APPLICATIONS (U.S. CLS. 1, 12, 33 AND 50).

KAELIE KUNG, EXAMINING ATTORNEY

**CLASS 19—(Continued).**

SN 85-188,318. TANDUS US, LLC, DALTON, GA. FILED 12-1-2010.

**power(shield)**

THE MARK CONSISTS OF STANDARD CHARACTERS WITHOUT CLAIM TO ANY PARTICULAR FONT, STYLE, SIZE, OR COLOR.

OWNER OF U.S. REG. NO. 3,924,059.  
FOR FLOORING UNDERLAYMENTS (U.S. CLS. 1, 12, 33 AND 50).  
FIRST USE 1-31-2010; IN COMMERCE 1-31-2010.  
DAWN FELDMAN, EXAMINING ATTORNEY

**CLASS 19—(Continued).**

SN 85-189,919. YUAN, SHUAI, RALEIGH, NC. FILED 12-3-2010.

**MOKK**

THE MARK CONSISTS OF STANDARD CHARACTERS WITHOUT CLAIM TO ANY PARTICULAR FONT, STYLE, SIZE, OR COLOR.

THE WORDING "MOKK" HAS NO MEANING IN A FOREIGN LANGUAGE.  
FOR RUBBER FLOORING (U.S. CLS. 1, 12, 33 AND 50).  
FIRST USE 12-0-2009; IN COMMERCE 12-0-2009.  
BARNEY CHARLON, EXAMINING ATTORNEY

SN 85-188,838. WINDOW PRODUCTS, INC., DBA CASCADE WINDOWS, SPOKANE VALLEY, WA. FILED 12-2-2010.

**SOLAMENTE**

THE MARK CONSISTS OF STANDARD CHARACTERS WITHOUT CLAIM TO ANY PARTICULAR FONT, STYLE, SIZE, OR COLOR.

THE ENGLISH TRANSLATION OF THE WORD "SOLAMENTE" IN THE MARK IS "ONLY".  
FOR NON-METAL DOORS; VINYL DOORS; VINYL WINDOWS (U.S. CLS. 1, 12, 33 AND 50).  
RICHARD WHITE, EXAMINING ATTORNEY

SN 85-194,507. BORAL COMPOSITES INC., ROSWELL, GA. FILED 12-9-2010.

**BORAL TRUExTERIOR**

THE MARK CONSISTS OF STANDARD CHARACTERS WITHOUT CLAIM TO ANY PARTICULAR FONT, STYLE, SIZE, OR COLOR.

FOR NON-METAL BUILDING PRODUCTS, NAMELY, TRIM, SIDING, SOFFIT, MOLDING, AND MILLWORK EXCLUSIVE OF CABINETS (U.S. CLS. 1, 12, 33 AND 50).  
LINDA E. BLOHM, EXAMINING ATTORNEY

SN 85-188,877. DURO-LAST, INC., SAGINAW, MI. FILED 12-2-2010.

**DURO-BLUE**

THE MARK CONSISTS OF STANDARD CHARACTERS WITHOUT CLAIM TO ANY PARTICULAR FONT, STYLE, SIZE, OR COLOR.

OWNER OF U.S. REG. NOS. 1,798,975, 2,386,473 AND OTHERS.  
FOR ROOFING UNDERLAYMENT (U.S. CLS. 1, 12, 33 AND 50).  
DAVID COLLIER, EXAMINING ATTORNEY

SN 85-195,469. AZEK BUILDING PRODUCTS, INC., SCRANTON, PA. FILED 12-10-2010.

**MODENA**

THE MARK CONSISTS OF STANDARD CHARACTERS WITHOUT CLAIM TO ANY PARTICULAR FONT, STYLE, SIZE, OR COLOR.

FOR BUILDING MATERIALS, NAMELY, NON-METAL DECKING BOARDS (U.S. CLS. 1, 12, 33 AND 50).  
FIRST USE 12-10-2010; IN COMMERCE 12-10-2010.  
KRISTIN CARLSON, EXAMINING ATTORNEY

**CLASS 19—(Continued).**

SN 85-196,302. TAMKO BUILDING PRODUCTS, INC., JOPLIN, MO. FILED 12-13-2010.

LAMARITE ESTATESLATE

THE MARK CONSISTS OF STANDARD CHARACTERS WITHOUT CLAIM TO ANY PARTICULAR FONT, STYLE, SIZE, OR COLOR.

OWNER OF U.S. REG. NO. 2,809,190.

FOR NONMETAL BUILDING MATERIALS, NAMELY, NONMETAL COMPOSITE ROOFING MATERIALS, NAMELY, SIMULATED ROOFING SHINGLES, ROOFING SLATE, ROOFING WOOD SHAKES, ROOFING TILES, SOLD AS A UNIT TOGETHER WITH COMPOSITE ROOFING MATERIALS SUITABLE FOR ROOF HIP AND RIDGE APPLICATIONS WITH EACH TYPE OF MATERIAL (U.S. CLS. 1, 12, 33 AND 50).

DEIRDRE ROBERTSON, EXAMINING ATTORNEY

**CLASS 19—(Continued).**

SN 85-204,594. ZHEJIANG XINYUAN BAMBOO PRODUCTS CO., LTD., ZHEJIANG PROVINCE, CHINA, FILED 12-23-2010.



THE MARK CONSISTS OF THE STYLIZED LETTERS XY BETWEEN TWO CHINESE CHARACTERS.

THE NON-LATIN CHARACTERS IN THE MARK TRANSLITERATE TO XIN; YUAN AND THIS MEANS GLAD; FAR IN ENGLISH.

FOR BAMBOO FLOORING; CONSTRUCTION MATERIALS, NAMELY, NON-METAL FLOORING MATERIALS; FLOOR PANELS NOT OF METAL; NON-METAL FLOORS; RAW AND COATED CHIP BOARDS FOR THE BUILDING INDUSTRY, FURNITURE AND INTERIOR DECORATING; VENEER FOR FLOORS (U.S. CLS. 1, 12, 33 AND 50).

DEZMONA MIZELLE, EXAMINING ATTORNEY

SN 85-197,612. SAN ANTONIO FEDERAL CREDIT UNION, DBA CU2CU, SAN ANTONIO, TX. FILED 12-14-2010.



THE COLOR(S) RED AND BLUE IS/ARE CLAIMED AS A FEATURE OF THE MARK.

THE MARK CONSISTS OF THE LETTERS "CU", IN THE COLOR RED, ON THE LEFT SIDE OF THE NUMBER "2", WHICH IS IN BLUE, AND THE LETTERS "CU", IN THE COLOR RED, ON THE RIGHT SIDE OF THE NUMBER "2".

FOR MANUFACTURED HOUSING, NAMELY, MOBILE HOMES (U.S. CLS. 1, 12, 33 AND 50).

KEVIN DINALLO, EXAMINING ATTORNEY

SN 85-205,825. HYDROHOIST MARINE GROUP, INC., CLAREMORE, OK. FILED 12-27-2010.

HP2

THE MARK CONSISTS OF STANDARD CHARACTERS WITHOUT CLAIM TO ANY PARTICULAR FONT, STYLE, SIZE, OR COLOR.

OWNER OF U.S. REG. NO. 3,116,710.

FOR NON-METAL FLOATING DOCKS (U.S. CLS. 1, 12, 33 AND 50).

FIRST USE 2-1-2004; IN COMMERCE 2-1-2004.

CHARLOTTE CORWIN, EXAMINING ATTORNEY

**CLASS 19—(Continued).**

SN 85-208,667. D-GENERATION, INC, DAYTONA BEACH, FL. FILED 12-31-2010.

**LIVE LOVE LAUGH**

THE MARK CONSISTS OF STANDARD CHARACTERS WITHOUT CLAIM TO ANY PARTICULAR FONT, STYLE, SIZE, OR COLOR.

OWNER OF U.S. REG. NOS. 3,440,470 AND 3,877,139. FOR CAST STONE GARDEN AND HOUSEHOLD ORNAMENTS; FIGURINES OF STONE, CONCRETE OR MARBLE; NON-LUMINOUS, NON-MECHANICAL SIGNS NOT OF METAL; STATUETTES OF STONE, CONCRETE OR MARBLE; WALL PLAQUES MADE OF STONE, CONCRETE OR MARBLE; WORKS OF ART OF STONE, CONCRETE OR MARBLE (U.S. CLS. 1, 12, 33 AND 50).

FIRST USE 10-1-1999; IN COMMERCE 10-1-1999. JUSTINE D. PARKER, EXAMINING ATTORNEY

SN 85-209,170. LRM INDUSTRIES INTERNATIONAL, INC., ROCKLEDGE, FL. FILED 1-3-2011.

**VALUSTAIR**

THE MARK CONSISTS OF STANDARD CHARACTERS WITHOUT CLAIM TO ANY PARTICULAR FONT, STYLE, SIZE, OR COLOR.

FOR COMPOSITE MODULAR STAIRCASES MADE OF PLASTIC (U.S. CLS. 1, 12, 33 AND 50). KIMBERLY FRYE, EXAMINING ATTORNEY

SN 85-211,167. H.B. FULLER CONSTRUCTION PRODUCTS INC., SAINT PAUL, MN. FILED 1-5-2011.

**POWER GROUT**

THE MARK CONSISTS OF STANDARD CHARACTERS WITHOUT CLAIM TO ANY PARTICULAR FONT, STYLE, SIZE, OR COLOR.

OWNER OF U.S. REG. NOS. 2,684,677, 3,840,397 AND OTHERS.

NO CLAIM IS MADE TO THE EXCLUSIVE RIGHT TO USE "GROUT", APART FROM THE MARK AS SHOWN.

FOR ANTIMICROBIAL, STAIN, ULTRAVIOLET AND EFFLORESCENCE RESISTANT GROUT (U.S. CLS. 1, 12, 33 AND 50).

SUSAN STIGLITZ, EXAMINING ATTORNEY

**CLASS 19—(Continued).**

SN 85-211,340. CARDINAL IG COMPANY, EDEN PRAIRIE, MN. FILED 1-5-2011.

**ENDUR-IG**

THE MARK CONSISTS OF STANDARD CHARACTERS WITHOUT CLAIM TO ANY PARTICULAR FONT, STYLE, SIZE, OR COLOR.

FOR INSULATING GLASS UNITS (U.S. CLS. 1, 12, 33 AND 50).

KIM MONINGHOFF, EXAMINING ATTORNEY

SN 85-212,755. MARVIN LUMBER AND CEDAR COMPANY, WARROAD, MN. FILED 1-7-2011.

**BUILT FOR LIFE**

THE MARK CONSISTS OF STANDARD CHARACTERS WITHOUT CLAIM TO ANY PARTICULAR FONT, STYLE, SIZE, OR COLOR.

FOR NON-METAL WINDOWS AND DOORS (U.S. CLS. 1, 12, 33 AND 50).

JULIE VEPPUMTHARA, EXAMINING ATTORNEY

SN 85-224,141. L&P PROPERTY MANAGEMENT COMPANY, SOUTHGATE, CA. FILED 1-24-2011.

**SCOURSTOP**

THE MARK CONSISTS OF STANDARD CHARACTERS WITHOUT CLAIM TO ANY PARTICULAR FONT, STYLE, SIZE, OR COLOR.

FOR EROSION CONTROL MATS (U.S. CLS. 1, 12, 33 AND 50).

FIRST USE 0-0-2004; IN COMMERCE 0-0-2005.

SUSAN RICHARDS, EXAMINING ATTORNEY

**CLASS 19—(Continued).**

SN 85-227,224. ROBERTS CONSOLIDATED INDUSTRIES, INC., BOCA RATON, FL. FILED 1-26-2011.

FIRST PIECE OF THE  
PUZZLE...IS ACTUALLY UNDER  
THE FLOOR

THE MARK CONSISTS OF STANDARD CHARACTERS WITHOUT CLAIM TO ANY PARTICULAR FONT, STYLE, SIZE, OR COLOR.

FOR FLOORING UNDERLAYMENTS (U.S. CLS. 1, 12, 33 AND 50).

JEFFERY COWARD, EXAMINING ATTORNEY

SN 85-227,228. ROBERTS CONSOLIDATED INDUSTRIES, INC., BOCA RATON, FL. FILED 1-26-2011.

ROBERTS COMPLETE

THE MARK CONSISTS OF STANDARD CHARACTERS WITHOUT CLAIM TO ANY PARTICULAR FONT, STYLE, SIZE, OR COLOR.

OWNER OF U.S. REG. NOS. 664,947 AND 1,728,752. FOR FLOORING UNDERLAYMENTS (U.S. CLS. 1, 12, 33 AND 50).

JEFFERY COWARD, EXAMINING ATTORNEY

SN 85-233,068. SAINT-GOBAIN PERFORMANCE PLASTICS CORPORATION, AURORA, OH. FILED 2-3-2011.

SOLARLOC

THE MARK CONSISTS OF STANDARD CHARACTERS WITHOUT CLAIM TO ANY PARTICULAR FONT, STYLE, SIZE, OR COLOR.

FOR ROOFING ATTACHMENT SYSTEM COMPRISED OF ADHESIVES AND NON-METAL HOOK AND FASTENERS FOR USE IN ATTACHING PHOTOVOLTAIC MODULES TO A FLUOROPOLYMER MEMBRANE STRUCTURE (U.S. CLS. 1, 12, 33 AND 50).

REGINA DRUMMOND, EXAMINING ATTORNEY

**CLASS 20—FURNITURE AND ARTICLES NOT OTHERWISE CLASSIFIED**

SN 76-702,855. SANKEI KOGYO CO., LTD, SUZUKI-SHI, MIE-KEN, JAPAN, FILED 5-7-2010.

HECMEEC

OWNER OF JAPAN REG. NO. 5292882, DATED 1-8-2010, EXPIRES 1-8-2020.

THE MARK CONSISTS OF THE WORDING "HECMEEC" IN STYLIZED LETTERING, WITH PIPE SEGMENTS FORMING THE TWO LETTER "C"'S.

FOR CHAIRS, DESKS, TABLES, STOOLS INCLUDING COUNTER STOOLS, RACKS FOR STORAGE, SHELVES, CUSHIONS, JAPANESE FLOOR CUSHIONS, PILLOWS, MATTRESSES, TOY BOXES, HANGERBOARDS IN THE NATURE OF PLASTIC PEG BOARDS, SCREENS, FOLDING FLOOR SCREENS AND BENCHES (U.S. CLS. 2, 13, 22, 25, 32 AND 50).

JULIE VEPPUMTHARA, EXAMINING ATTORNEY

SN 76-703,914. AMERICAN WOODMARK CORPORATION, WINCHESTER, VA. FILED 7-26-2010.



THE MARK CONSISTS OF THE DESIGN OF THREE ARROWS FORMING A CIRCLE. EACH ARROW CONTAINS WORDING. THE ARROW AT THE TOP CONTAINS THE WORDING "CONNECT". THE TOP ARROW LEADS INTO THE ARROW ON THE RIGHT. THE ARROW ON THE RIGHT CONTAINS THE WORDING "COLLABORATE". THE ARROW ON THE RIGHT LEADS INTO THE ARROW ON THE LEFT. THE ARROW ON THE LEFT CONTAINS THE WORDING "CELEBRATE". THE ARROW ON THE LEFT LEADS INTO THE ARROW AT THE TOP. THE WORDING "WAYPOINT LIVING SPACES" APPEARS INSIDE THE CIRCLE.

FOR KITCHEN CABINETS AND BATHROOM VANITIES (U.S. CLS. 2, 13, 22, 25, 32 AND 50).

PAUL MORENO, EXAMINING ATTORNEY

**CLASS 20—(Continued).**

SN 76-704,071. AMERICAN WOODMARK CORPORATION,  
WINCHESTER, VA. FILED 8-10-2010.

**LAUSANNE**

THE MARK CONSISTS OF STANDARD CHARACTERS  
WITHOUT CLAIM TO ANY PARTICULAR FONT, STYLE,  
SIZE, OR COLOR.  
FOR KITCHEN CABINETS AND BATHROOM VA-  
NITIES (U.S. CLS. 2, 13, 22, 25, 32 AND 50).  
PAUL MORENO, EXAMINING ATTORNEY

SN 76-704,072. AMERICAN WOODMARK CORPORATION,  
WINCHESTER, VA. FILED 8-10-2010.

**NEW HAVEN**

THE MARK CONSISTS OF STANDARD CHARACTERS  
WITHOUT CLAIM TO ANY PARTICULAR FONT, STYLE,  
SIZE, OR COLOR.  
FOR KITCHEN CABINETS AND BATHROOM VA-  
NITIES (U.S. CLS. 2, 13, 22, 25, 32 AND 50).  
PAUL MORENO, EXAMINING ATTORNEY

SN 76-705,936. POUNDEX ASSOCIATES CORPORATION,  
CITY OF INDUSTRY, CA. FILED 1-7-2011.

**VERACOW**

THE MARK CONSISTS OF STANDARD CHARACTERS  
WITHOUT CLAIM TO ANY PARTICULAR FONT, STYLE,  
SIZE, OR COLOR.  
FOR FURNITURE (U.S. CLS. 2, 13, 22, 25, 32 AND 50).  
TINA BROWN, EXAMINING ATTORNEY

**CLASS 20—(Continued).**

SN 77-653,480. STEELE, MARK A., NEW PRAGUE, MN.  
FILED 1-21-2009.

**PRESSURE-LOK**

THE MARK CONSISTS OF STANDARD CHARACTERS  
WITHOUT CLAIM TO ANY PARTICULAR FONT, STYLE,  
SIZE, OR COLOR.  
FOR NONMETAL CONTAINERS HAVING A FLUID  
ACTUATED CLOSURE, IN THE FORM OF A POUCH  
FOR STORAGE OF LIQUIDS, SOLIDS OR COMBINA-  
TIONS THEREOF (U.S. CLS. 2, 13, 22, 25, 32 AND 50).  
FIRST USE 12-9-2008; IN COMMERCE 12-16-2008.  
CHARLES L. JENKINS, EXAMINING ATTORNEY

SN 77-845,661. Y-TEX CORPORATION, CODY, WY. FILED  
10-9-2009.

**LONE STAR**

THE MARK CONSISTS OF STANDARD CHARACTERS  
WITHOUT CLAIM TO ANY PARTICULAR FONT, STYLE,  
SIZE, OR COLOR.  
FOR PLASTIC EAR TAGS FOR LIVESTOCK (U.S. CLS.  
2, 13, 22, 25, 32 AND 50).  
FIRST USE 0-0-1968; IN COMMERCE 1-0-2010.  
RAMONA ORTIGA, EXAMINING ATTORNEY

SN 77-945,532. REBAR GROUP, INC., SAN FRANCISCO, CA.  
FILED 2-26-2010.

**Walklet**

THE MARK CONSISTS OF STANDARD CHARACTERS  
WITHOUT CLAIM TO ANY PARTICULAR FONT, STYLE,  
SIZE, OR COLOR.  
FOR MODULAR SIDEWALK EXTENSION AND AUG-  
MENTATION SYSTEM PRIMARILY FOR SEATING  
PURPOSES AND ALSO FOR SOCIAL GATHERING  
PURPOSES CONSISTING OF SEATING FURNITURE  
MADE OF WOOD OR SYNTHETIC PANELS, AND ALSO  
FEATURING ATTACHED DECKS, PLATFORMS,  
HANDRAILS, AND PLANTERS (U.S. CLS. 2, 13, 22, 25,  
32 AND 50).  
FIRST USE 8-1-2010; IN COMMERCE 9-1-2010.  
LESLIE RICHARDS, EXAMINING ATTORNEY



**CLASS 20—(Continued).**

SN 79-082,700. STRING DESIGN AKTIEBOLAG, SWEDEN, FILED 4-28-2010.

# STRING

THE MARK CONSISTS OF STANDARD CHARACTERS WITHOUT CLAIM TO ANY PARTICULAR FONT, STYLE, SIZE, OR COLOR.

OWNER OF INTERNATIONAL REGISTRATION 1039086 DATED 4-28-2010, EXPIRES 4-28-2020.

OWNER OF U.S. REG. NO. 633,619.

FOR FURNITURE, TABLES, WRITING DESKS, BOOKCASES, MAGAZINE RACKS, WALL SHELVES, CORNER SHELVES; CHESTS OF DRAWERS, WALL CUPBOARDS, UNDER WINDOW CUPBOARDS, KITCHEN RACKS AND SHELVES, STORAGE CABINETS; SHELVES; SECTIONAL WALL FURNITURE, NAMELY, COMBINATIONS OF SHELVING, BOOKCASES, MAGAZINE RACKS, FOLDING TABLES, AND WRITING DESKS (U.S. CLS. 2, 13, 22, 25, 32 AND 50).

ALICE BENMAMAN, EXAMINING ATTORNEY

**CLASS 20—(Continued).**

SN 79-092,641. DBI PLASTICS A/S, DENMARK, FILED 1-7-2011.

# DBI

THE MARK CONSISTS OF STANDARD CHARACTERS WITHOUT CLAIM TO ANY PARTICULAR FONT, STYLE, SIZE, OR COLOR.

OWNER OF INTERNATIONAL REGISTRATION 1065336 DATED 1-7-2011, EXPIRES 1-7-2021.

FOR PROTECTIVE CAPS AND PLUGS OF PLASTIC FOR THREADS AND FOR COVERING OPENINGS, IN FOR EXAMPLE, MACHINERY, TUBES AND PIPES, AND ELECTRIC AND HYDRAULIC APPARATUS (U.S. CLS. 2, 13, 22, 25, 32 AND 50).

NICHOLAS COLEMAN, EXAMINING ATTORNEY

SN 79-083,183. ARPER S.P.A., ITALY, FILED 5-6-2010.

# CLIP IT EASY

THE MARK CONSISTS OF STANDARD CHARACTERS WITHOUT CLAIM TO ANY PARTICULAR FONT, STYLE, SIZE, OR COLOR.

PRIORITY DATE OF 4-1-2010 IS CLAIMED.

OWNER OF INTERNATIONAL REGISTRATION 1040463 DATED 5-6-2010, EXPIRES 5-6-2020.

NO CLAIM IS MADE TO THE EXCLUSIVE RIGHT TO USE "CLIP", APART FROM THE MARK AS SHOWN.

FOR FURNITURE, EXCLUDING MIRRORS OR FURNITURE INCORPORATING MIRRORS (U.S. CLS. 2, 13, 22, 25, 32 AND 50).

ANDREA HACK, EXAMINING ATTORNEY

SN 85-026,699. PARAGON FURNITURE, L.P., ARLINGTON, TX, FILED 4-29-2010.

# INTUITIVE

THE MARK CONSISTS OF STANDARD CHARACTERS WITHOUT CLAIM TO ANY PARTICULAR FONT, STYLE, SIZE, OR COLOR.

FOR FURNITURE FOR THE OFFICE, CLASSROOM AND LIBRARY (U.S. CLS. 2, 13, 22, 25, 32 AND 50).

FIRST USE 10-0-2009; IN COMMERCE 10-0-2009.

KAREN K. BUSH, EXAMINING ATTORNEY

SN 79-083,184. ARPER S.P.A., ITALY, FILED 5-6-2010.

# √clip.it.easy

PRIORITY DATE OF 4-1-2010 IS CLAIMED.

OWNER OF INTERNATIONAL REGISTRATION 1040464 DATED 5-6-2010, EXPIRES 5-6-2020.

THE MARK CONSISTS OF THE STYLIZED WORDING "CLIP—IT—EASY" WITH SMALL DASH MARKS BETWEEN THE WORDS, AND A CURVED LINE RESEMBLING A TYPE OF CLIP OR HOOK APPEARING NEXT TO AND ABOVE THE WORD "CLIP".

FOR FURNITURE, EXCLUDING MIRRORS OR FURNITURE INCORPORATING MIRRORS (U.S. CLS. 2, 13, 22, 25, 32 AND 50).

ANDREA HACK, EXAMINING ATTORNEY

SN 85-027,741. WS PACKAGING GROUP, INC., GREEN BAY, WI, FILED 4-30-2010.

# FLEXWRAP

THE MARK CONSISTS OF STANDARD CHARACTERS WITHOUT CLAIM TO ANY PARTICULAR FONT, STYLE, SIZE, OR COLOR.

FOR MULTILAYER PLASTIC LABELS FOR USE WITH PRIMARY LABEL PACKAGING (U.S. CLS. 2, 13, 22, 25, 32 AND 50).

FIRST USE 9-27-2009; IN COMMERCE 9-27-2009.

MICHAEL LITZAU, EXAMINING ATTORNEY

**CLASS 20—(Continued).**

SN 85-027,780. BOGART, LLC, PASADENA, CA. FILED 4-30-2010.

# Bogart

THE MARK CONSISTS OF STANDARD CHARACTERS WITHOUT CLAIM TO ANY PARTICULAR FONT, STYLE, SIZE, OR COLOR.

SEC. 2(F).  
FOR BEDROOM FURNITURE; CABINETS; ENTERTAINMENT CENTERS; FURNITURE; FURNITURE CHESTS; FURNITURE FOR HOUSE, OFFICE AND GARDEN; FURNITURE MADE FROM WOOD OR SUBSTITUTES FOR WOOD; FURNITURE, MIRRORS, PICTURE FRAMES; FURNITURE, NAMELY, DRESSERS; FURNITURE, NAMELY, WARDROBES; LIBRARY FURNITURE; LIVING ROOM FURNITURE; MIRRORS; OFFICE FURNITURE; RESIDENTIAL AND COMMERCIAL FURNITURE; TABLES; UPHOLSTERED FURNITURE (U.S. CLS. 2, 13, 22, 25, 32 AND 50).

FIRST USE 10-16-2002; IN COMMERCE 10-16-2002.  
HENRY S. ZAK, EXAMINING ATTORNEY

SN 85-048,209. ANIMALS MATTER, INC., TORRANCE, CA. FILED 5-26-2010.

# Katie Puff

THE MARK CONSISTS OF STANDARD CHARACTERS WITHOUT CLAIM TO ANY PARTICULAR FONT, STYLE, SIZE, OR COLOR.

"KATIE PUFF" DOES NOT IDENTIFY A LIVING INDIVIDUAL.

FOR BEDS FOR HOUSEHOLD PETS; DOG BEDS; PET CUSHIONS (U.S. CLS. 2, 13, 22, 25, 32 AND 50).  
FIRST USE 11-15-2003; IN COMMERCE 8-12-2004.  
ELIZABETH HUGHITT, EXAMINING ATTORNEY

SN 85-052,763. BLUE SKY INNOVATION GROUP, INC., CLEVELAND, OH. FILED 6-2-2010.

# EXPANDIA

THE MARK CONSISTS OF STANDARD CHARACTERS WITHOUT CLAIM TO ANY PARTICULAR FONT, STYLE, SIZE, OR COLOR.

FOR FURNITURE, NAMELY, TABLES, EXPANDABLE TABLES, COFFEE TABLES, END TABLES AND SIDE TABLES (U.S. CLS. 2, 13, 22, 25, 32 AND 50).

SANI KHOURI, EXAMINING ATTORNEY

**CLASS 20—(Continued).**

SN 85-052,775. BLUE SKY INNOVATION GROUP, INC., CLEVELAND, OH. FILED 6-2-2010.

## EXPAND YOUR ENTERTAINING

THE MARK CONSISTS OF STANDARD CHARACTERS WITHOUT CLAIM TO ANY PARTICULAR FONT, STYLE, SIZE, OR COLOR.

FOR FURNITURE, NAMELY, TABLES, EXPANDABLE TABLES, COFFEE TABLES, END TABLES AND SIDE TABLES (U.S. CLS. 2, 13, 22, 25, 32 AND 50).

SANI KHOURI, EXAMINING ATTORNEY

SN 85-054,939. STYGIAN, LLC, BEVERLY HILLS, CA. FILED 6-4-2010.

## DOUBLE DARE YOU

THE MARK CONSISTS OF STANDARD CHARACTERS WITHOUT CLAIM TO ANY PARTICULAR FONT, STYLE, SIZE, OR COLOR.

FOR FURNITURE; NON-METAL AND NON-LEATHER KEY CHAINS, KEY FOBS AND KEY RINGS; PICTURE FRAMES, PLASTIC NOVELTY LICENSE PLATES, PLASTIC PILLBOXES FOR COMMERCIAL PURPOSES, PILLOWS, BATH PILLOWS, SLEEPING BAGS AND SEAT CUSHIONS AND UMBRELLA STANDS; OUTDOOR FURNITURE, FURNITURE CUSHIONS; CHAIR PADS, WINDOW BLINDS, WINDOW SHADES, CURTAIN RODS, NON-METAL CURTAIN RINGS, CURTAIN TIE-BACKS IN THE NATURE OF DRAPERY HOOKS; AND BEACH CHAIRS (U.S. CLS. 2, 13, 22, 25, 32 AND 50).

ODESSA BIBBINS, EXAMINING ATTORNEY

SN 85-069,142. DISNEY ONLINE STUDIOS CANADA INC., VANCOUVER, CANADA, FILED 6-22-2010.

## CLUB PENGUIN

THE MARK CONSISTS OF STANDARD CHARACTERS WITHOUT CLAIM TO ANY PARTICULAR FONT, STYLE, SIZE, OR COLOR.

FOR FURNITURE; DECORATIVE GLITTER; FIGURINES AND STATUETTES MADE OF PLASTER, PLASTIC, WAX, OR WOOD; HAND FANS; PICTURE FRAMES; SLEEPING BAGS; MIRRORS; PLASTIC NAME BADGES; PILLOWS; WIND CHIMES; WINDOW BLINDS (U.S. CLS. 2, 13, 22, 25, 32 AND 50).

ELIZABETH KAJUBI, EXAMINING ATTORNEY

**CLASS 20—(Continued).**

SN 85-083,732. WERNER MEDIA PARTNERS, LLC, DBA NATURE'S SLEEP, LLC, DAVIE, FL. FILED 7-13-2010.

# Viscolite

THE MARK CONSISTS OF STANDARD CHARACTERS WITHOUT CLAIM TO ANY PARTICULAR FONT, STYLE, SIZE, OR COLOR.

FOR SLEEP PRODUCTS, NAMELY, PILLOWS (U.S. CLS. 2, 13, 22, 25, 32 AND 50).

FIRST USE 8-31-2009; IN COMMERCE 8-31-2009.  
MARCIE MILONE, EXAMINING ATTORNEY

**CLASS 20—(Continued).**

SN 85-094,161. ADVANCED FINISHING USA, DBA A TEX LLC, FAIRVIEW, PA. FILED 7-27-2010.



THE COLOR(S) GREEN, YELLOW AND WHITE IS/ARE CLAIMED AS A FEATURE OF THE MARK.

THE MARK CONSISTS OF THE WORDING "GREEN" WRITTEN IN WHITE AND OUTLINED IN GREEN, SKEWED TO THE LEFT ABOVE THE WORDING "PARROT" WRITTEN IN WHITE AND OUTLINED IN GREEN AND A GREEN PARROT SITTING ATOP THE LETTER "T", AND THE PARROT HAVING A WHITE CHEST, A WHITE BEAK OUTLINED IN GREEN, AND WHITE FACE WITH GREEN EYE, THE ENTIRE MARK HAVING A YELLOW SHADING OR OUTLINE.

FOR OUTDOOR FURNITURE (U.S. CLS. 2, 13, 22, 25, 32 AND 50).

JENNY PARK, EXAMINING ATTORNEY

SN 85-119,743. PAMELA GOVERNALE, EAST WILLISTON, NY. FILED 8-31-2010.

# VANITY PILLOW

THE MARK CONSISTS OF STANDARD CHARACTERS WITHOUT CLAIM TO ANY PARTICULAR FONT, STYLE, SIZE, OR COLOR.

NO CLAIM IS MADE TO THE EXCLUSIVE RIGHT TO USE "PILLOW", APART FROM THE MARK AS SHOWN.

FOR PILLOWS (U.S. CLS. 2, 13, 22, 25, 32 AND 50).

FIRST USE 7-29-2010; IN COMMERCE 7-29-2010.

BERYL GARDNER, EXAMINING ATTORNEY

SN 85-084,751. TRUCK ACCESSORIES GROUP, LLC, EL-KHART, IN. FILED 7-14-2010.

# STOR-MATE

THE MARK CONSISTS OF STANDARD CHARACTERS WITHOUT CLAIM TO ANY PARTICULAR FONT, STYLE, SIZE, OR COLOR.

FOR FIBERGLASS CONTAINERS FOR STORAGE OF HOUSEHOLD SUPPLIES, PERSONAL ITEMS, BOATING SUPPLIES, DOMESTICATED ANIMAL FEED, HOME GARDENING SUPPLIES, AND PATIO ITEMS (U.S. CLS. 2, 13, 22, 25, 32 AND 50).

FIRST USE 12-0-2008; IN COMMERCE 12-0-2008.  
MICHELE SWAIN, EXAMINING ATTORNEY

SN 85-171,582. RICHARD C. PETEK, MEDINA, OH. FILED 11-8-2010.

# ELEV8

THE MARK CONSISTS OF STANDARD CHARACTERS WITHOUT CLAIM TO ANY PARTICULAR FONT, STYLE, SIZE, OR COLOR.

FOR NON-METAL STRAP-ON LEG HEIGHT EXTENSION PLATFORMS TO BE ATTACHED TO SHOES FOR EXTENDING THE VERTICAL REACH OF WORKMEN (U.S. CLS. 2, 13, 22, 25, 32 AND 50).

NAPOLEON SHARMA, EXAMINING ATTORNEY

**CLASS 20—(Continued).**

SN 85-171,621. RICHARD C. PETEK, MEDINA, OH. FILED 11-8-2010.

**WORKBOOST**

THE MARK CONSISTS OF STANDARD CHARACTERS WITHOUT CLAIM TO ANY PARTICULAR FONT, STYLE, SIZE, OR COLOR.

FOR NON-METAL STRAP-ON LEG HEIGHT EXTENSION PLATFORMS TO BE ATTACHED TO SHOES FOR EXTENDING THE VERTICAL REACH OF WORKMEN (U.S. CLS. 2, 13, 22, 25, 32 AND 50).

NAPOLEON SHARMA, EXAMINING ATTORNEY

**CLASS 20—(Continued).**

SN 85-184,554. PATTI J. MORAN, PINNACLE, NC. FILED 11-24-2010.

**MINI SNOOZE**

THE MARK CONSISTS OF STANDARD CHARACTERS WITHOUT CLAIM TO ANY PARTICULAR FONT, STYLE, SIZE, OR COLOR.

FOR HEAD RESTS IN THE NATURE OF A CUSHIONED STAND FOR SUPPORTING THE FOREHEAD FOR USE ON A TABLE, TRAY, DESK OR OTHER FLAT SURFACE (U.S. CLS. 2, 13, 22, 25, 32 AND 50).

TARAH HARDY, EXAMINING ATTORNEY

SN 85-178,717. MAGNUSSEN INTERNATIONAL CORP., NEW HAMBURG ONTARIO, CANADA, FILED 11-17-2010.

**OLD POST TRADING**

THE MARK CONSISTS OF STANDARD CHARACTERS WITHOUT CLAIM TO ANY PARTICULAR FONT, STYLE, SIZE, OR COLOR.

NO CLAIM IS MADE TO THE EXCLUSIVE RIGHT TO USE "TRADING", APART FROM THE MARK AS SHOWN, FOR FURNITURE AND MIRRORS (U.S. CLS. 2, 13, 22, 25, 32 AND 50).

FIRST USE 8-31-2009; IN COMMERCE 8-31-2009.  
JEFFREY LOOK, EXAMINING ATTORNEY

SN 85-186,958. HOOVER MATERIALS HANDLING GROUP, INC., HOUSTON, TX. FILED 11-30-2010.

**EZtote**

THE MARK CONSISTS OF STANDARD CHARACTERS WITHOUT CLAIM TO ANY PARTICULAR FONT, STYLE, SIZE, OR COLOR.

FOR SHIPPING AND STORAGE CONTAINERS AND TANKS PRIMARILY COMPRISED OF MOLDED PLASTIC, WITH A STEEL FRAME, FOR LIQUIDS; PLASTIC INTERMEDIATE BULK CONTAINERS FOR INDUSTRIAL AND COMMERCIAL USE (U.S. CLS. 2, 13, 22, 25, 32 AND 50).

FIRST USE 11-10-2010; IN COMMERCE 11-20-2010.  
TRICIA SONNEBORN, EXAMINING ATTORNEY

SN 85-182,312. SALT LIFE HOLDINGS, LLC, JACKSONVILLE, FL. FILED 11-22-2010.

**SALT LIFE**

THE MARK CONSISTS OF STANDARD CHARACTERS WITHOUT CLAIM TO ANY PARTICULAR FONT, STYLE, SIZE, OR COLOR.

OWNER OF U.S. REG. NOS. 3,001,343, 3,843,123 AND OTHERS.

FOR PLASTIC NOVELTY LICENSE PLATES; FURNITURE; BEACH CHAIRS; PICTURE FRAMES; PLASTIC BANNERS; VINYL BANNERS; SLEEPING BAGS; NON-METAL KEY RINGS; NON-METAL KEY HOLDERS (U.S. CLS. 2, 13, 22, 25, 32 AND 50).

APRIL HESIK, EXAMINING ATTORNEY

SN 85-187,347. FIRST LINK PRODUCTS CORP, WAUCONDA, IL. FILED 11-30-2010.

**Get Out Gear**

THE MARK CONSISTS OF STANDARD CHARACTERS WITHOUT CLAIM TO ANY PARTICULAR FONT, STYLE, SIZE, OR COLOR.

NO CLAIM IS MADE TO THE EXCLUSIVE RIGHT TO USE "GEAR", APART FROM THE MARK AS SHOWN.

FOR FURNITURE FOR CAMPING (U.S. CLS. 2, 13, 22, 25, 32 AND 50).

SHAUNIA CARLYLE, EXAMINING ATTORNEY

**CLASS 20—(Continued).**

SN 85-189,599. SUNSET PUBLISHING CORPORATION, MENLO PARK, CA. FILED 12-2-2010.

**HOME BY SUNSET**

THE MARK CONSISTS OF STANDARD CHARACTERS WITHOUT CLAIM TO ANY PARTICULAR FONT, STYLE, SIZE, OR COLOR.

OWNER OF U.S. REG. NOS. 511,453, 2,087,856 AND OTHERS.

NO CLAIM IS MADE TO THE EXCLUSIVE RIGHT TO USE "HOME", APART FROM THE MARK AS SHOWN.

FOR BEDS; CHAIRS; COUCHES; DECORATIVE BEAD CURTAINS; OTTOMANS; PILLOWS; SOFAS; TABLES (U.S. CLS. 2, 13, 22, 25, 32 AND 50).

MARIA-VICTORIA SUAREZ, EXAMINING ATTORNEY

**CLASS 20—(Continued).**

SN 85-196,836. GOODWIN, ROBERT W., BELLINGHAM, WA. FILED 12-13-2010.

**DAVE'S DONUTS**

THE MARK CONSISTS OF STANDARD CHARACTERS WITHOUT CLAIM TO ANY PARTICULAR FONT, STYLE, SIZE, OR COLOR.

OWNER OF U.S. REG. NO. 3,415,570.

NO CLAIM IS MADE TO THE EXCLUSIVE RIGHT TO USE "DONUTS", APART FROM THE MARK AS SHOWN.

FOR SEAT CUSHIONS (U.S. CLS. 2, 13, 22, 25, 32 AND 50).

FIRST USE 12-14-2007; IN COMMERCE 12-14-2007.

ELLEN PERKINS, EXAMINING ATTORNEY

SN 85-191,147. JEFFREY G. SPENCE, SPARKS, NV. FILED 12-6-2010.

**BLUETONE CHIMES**

THE MARK CONSISTS OF STANDARD CHARACTERS WITHOUT CLAIM TO ANY PARTICULAR FONT, STYLE, SIZE, OR COLOR.

NO CLAIM IS MADE TO THE EXCLUSIVE RIGHT TO USE "CHIMES", APART FROM THE MARK AS SHOWN.

FOR WIND CHIMES (U.S. CLS. 2, 13, 22, 25, 32 AND 50).

ROBIN CHOSID, EXAMINING ATTORNEY

SN 85-198,110. ALLSEATING CORPORATION, MISSISSAUGA, CANADA, FILED 12-15-2010.

**VITA**

THE MARK CONSISTS OF STANDARD CHARACTERS WITHOUT CLAIM TO ANY PARTICULAR FONT, STYLE, SIZE, OR COLOR.

FOR FURNITURE, NAMELY, CHAIRS (U.S. CLS. 2, 13, 22, 25, 32 AND 50).

LESLIE RICHARDS, EXAMINING ATTORNEY

SN 85-193,180. SGRISK, LYNDHURST, NJ. FILED 12-8-2010.

**Hug an Actuary with  
Increasing Frequency**

THE MARK CONSISTS OF STANDARD CHARACTERS WITHOUT CLAIM TO ANY PARTICULAR FONT, STYLE, SIZE, OR COLOR.

OWNER OF U.S. REG. NO. 3,924,339.

NO CLAIM IS MADE TO THE EXCLUSIVE RIGHT TO USE "ACTUARY", APART FROM THE MARK AS SHOWN.

FOR PLASTIC KEY CHAIN TAGS; PLASTIC KEY RINGS (U.S. CLS. 2, 13, 22, 25, 32 AND 50).

FIRST USE 10-1-2009; IN COMMERCE 10-1-2009.

TRACY FLETCHER, EXAMINING ATTORNEY

SN 85-199,245. BEDFORD INDUSTRIES, INC., WORTHINGTON, MN. FILED 12-16-2010.

**POLYTWIST**

THE MARK CONSISTS OF STANDARD CHARACTERS WITHOUT CLAIM TO ANY PARTICULAR FONT, STYLE, SIZE, OR COLOR.

OWNER OF U.S. REG. NOS. 2,306,305 AND 2,730,128.

FOR POLYMERIC TWIST TIE CLOSURES FOR USE WITH PACKAGING (U.S. CLS. 2, 13, 22, 25, 32 AND 50).

MARTHA FROMM, EXAMINING ATTORNEY

**CLASS 20—(Continued).**

SN 85-200,246. L&P PROPERTY MANAGEMENT COMPANY, SOUTHGATE, CA. FILED 12-17-2010.

**COMFORTILT**

THE MARK CONSISTS OF STANDARD CHARACTERS WITHOUT CLAIM TO ANY PARTICULAR FONT, STYLE, SIZE, OR COLOR.

OWNER OF U.S. REG. NO. 1,139,962.  
FOR FURNITURE COMPONENTS, NAMELY, RECLINING CHAIR MECHANISMS (U.S. CLS. 2, 13, 22, 25, 32 AND 50).

FIRST USE 11-1-1978; IN COMMERCE 11-1-1978.  
SUSAN RICHARDS, EXAMINING ATTORNEY

---

SN 85-200,651. WINPAK PORTION PACKAGING, INC., NEWTOWN, PA. FILED 12-17-2010.

**REVOH**

THE MARK CONSISTS OF STANDARD CHARACTERS WITHOUT CLAIM TO ANY PARTICULAR FONT, STYLE, SIZE, OR COLOR.

FOR PLASTIC CONTAINERS AND COVERS FOR THE FOOD INDUSTRY (U.S. CLS. 2, 13, 22, 25, 32 AND 50).  
RAMONA ORTIGA, EXAMINING ATTORNEY

---

SN 85-202,200. ZINUS INC., HAYWARD, CA. FILED 12-20-2010.

**spa massage**

THE MARK CONSISTS OF STANDARD CHARACTERS WITHOUT CLAIM TO ANY PARTICULAR FONT, STYLE, SIZE, OR COLOR.

NO CLAIM IS MADE TO THE EXCLUSIVE RIGHT TO USE "MASSAGE", APART FROM THE MARK AS SHOWN.  
FOR BEDS, MATTRESSES, PILLOWS AND BOLSTERS; CUSHIONS (U.S. CLS. 2, 13, 22, 25, 32 AND 50).  
ALICIA COLLINS, EXAMINING ATTORNEY

**CLASS 20—(Continued).**

SN 85-203,261. NORRIS, TROY J., SHAWNEE, KS. FILED 12-21-2010.

**GLOBE-WERNICKE**

THE MARK CONSISTS OF STANDARD CHARACTERS WITHOUT CLAIM TO ANY PARTICULAR FONT, STYLE, SIZE, OR COLOR.

FOR BOOKCASES; CABINET DOORS FOR FURNITURE CABINETS; CABINETS; CABINETS FOR DISPLAY PURPOSES; FILING CABINETS (U.S. CLS. 2, 13, 22, 25, 32 AND 50).

DEZMONA MIZELLE, EXAMINING ATTORNEY

---

SN 85-204,595. ZHEJIANG XINYUAN BAMBOO PRODUCTS CO., LTD., ZHEJIANG PROVINCE, CHINA, FILED 12-23-2010.



THE MARK CONSISTS OF THE STYLIZED LETTERS IA BETWEEN TWO CHINESE CHARACTERS. THE TWO LETTERS ARE ABOVE A LINE AND IN FRONT OF AN ELLIPTIC DEVICE WITH A DOT.

THE NON-LATIN CHARACTERS IN THE MARK TRANSLITERATE TO XIN; YUAN AND THIS MEANS GLAD; FAR IN ENGLISH.

FOR BAMBOO CURTAINS; FURNITURE; OUTDOOR FURNITURE; WORKS OF ART MADE OF WOOD (U.S. CLS. 2, 13, 22, 25, 32 AND 50).

DEZMONA MIZELLE, EXAMINING ATTORNEY

**CLASS 20—(Continued).**

SN 85-204,993. LAFAYETTE VENETIAN BLIND, INC., WEST LAFAYETTE, IN. FILED 12-23-2010.



NO CLAIM IS MADE TO THE EXCLUSIVE RIGHT TO USE "ROMAN SHADE LIFTING SYSTEMS", APART FROM THE MARK AS SHOWN.

THE MARK CONSISTS OF THREE SEPARATE BLOCKS CONTAINING "T", "L", AND "C" WITH THE TAG PHRASE "ROMAN SHADE LIFTING SYSTEMS" UNDERNEATH.

FOR WINDOW BLINDS, WINDOW SHADES, AND VENETIAN BLINDS; LIFT SYSTEM FOR WINDOW BLINDS AND WINDOW SHADES CONSISTING OF CORD SHIELD, CABLE TIES, AND TUBING ADAPTER (U.S. CLS. 2, 13, 22, 25, 32 AND 50).

JEFFERY COWARD, EXAMINING ATTORNEY

**CLASS 20—(Continued).**

SN 85-206,863. JC 23 ENTERTAINMENT, INC., BEVERLY HILLS, CA. FILED 12-28-2010.



THE MARK CONSISTS OF STYLIZED CHARACTER SITTING IN YOGA STYLE.

FOR HOUSEHOLD FURNITURE, NAMELY, ADULT AND JUVENILE BEDROOM FURNITURE, LIVING ROOM FURNITURE, DINING ROOM FURNITURE, BATHROOM FURNITURE, KITCHEN FURNITURE, OUTDOOR FURNITURE, MIRRORS, PICTURE FRAMES (U.S. CLS. 2, 13, 22, 25, 32 AND 50).

CYNTHIA SLOAN, EXAMINING ATTORNEY

SN 85-208,675. HANG A BUNCH, LLC, AKA HANG A BUNCH, LLC, BLOOMFIELD HILLS, MI. FILED 12-31-2010.

## Hang A Bunch

THE MARK CONSISTS OF STANDARD CHARACTERS WITHOUT CLAIM TO ANY PARTICULAR FONT, STYLE, SIZE, OR COLOR.

FOR HANGERS FOR CLOTHES (U.S. CLS. 2, 13, 22, 25, 32 AND 50).

JILL PRATER, EXAMINING ATTORNEY

SN 85-205,013. LAFAYETTE VENETIAN BLIND, INC., WEST LAFAYETTE, IN. FILED 12-23-2010.

## TLC Roman Shade Lifting Systems

THE MARK CONSISTS OF STANDARD CHARACTERS WITHOUT CLAIM TO ANY PARTICULAR FONT, STYLE, SIZE, OR COLOR.

NO CLAIM IS MADE TO THE EXCLUSIVE RIGHT TO USE "ROMAN SHADE LIFTING SYSTEMS", APART FROM THE MARK AS SHOWN.

FOR WINDOW BLINDS, WINDOW SHADES, AND VENETIAN BLINDS; LIFT SYSTEM FOR WINDOW BLINDS AND WINDOW SHADES CONSISTING OF CORD SHIELD, CABLE TIES, AND TUBING ADAPTER (U.S. CLS. 2, 13, 22, 25, 32 AND 50).

JEFFERY COWARD, EXAMINING ATTORNEY

SN 85-209,024. ROBERTS & SONS, SANTA ROSA, CA. FILED 1-3-2011.

## ROBERTS & SONS

THE MARK CONSISTS OF STANDARD CHARACTERS WITHOUT CLAIM TO ANY PARTICULAR FONT, STYLE, SIZE, OR COLOR.

OWNER OF U.S. REG. NO. 3,720,350.

SEC. 2(F).

FOR WOOD BARRELS (U.S. CLS. 2, 13, 22, 25, 32 AND 50).

FIRST USE 0-0-2005; IN COMMERCE 0-0-2005.

SANDRA BUJA, EXAMINING ATTORNEY

**CLASS 20—(Continued).**

SN 85-209,207. BETTER METAL, LLC, LA VERGNE, TN. FILED 1-3-2011.

# SLB

THE MARK CONSISTS OF STANDARD CHARACTERS WITHOUT CLAIM TO ANY PARTICULAR FONT, STYLE, SIZE, OR COLOR.

FOR NON-METAL HARDWARE, NAMELY, PLASTIC BLOCK HANGERS FOR THE PURPOSE OF SUPPORTING COAXIAL CABLE (U.S. CLS. 2, 13, 22, 25, 32 AND 50).

KIMBERLY FRYE, EXAMINING ATTORNEY

---

SN 85-209,403. MOORECO, INC., TEMPLE, TX. FILED 1-3-2011.

# iFlex

THE MARK CONSISTS OF STANDARD CHARACTERS WITHOUT CLAIM TO ANY PARTICULAR FONT, STYLE, SIZE, OR COLOR.

FOR FURNITURE; MODULAR FURNITURE; DESKS; OFFICE TABLES; MODULAR AND CONFIGURABLE DESKS AND OFFICE TABLES (U.S. CLS. 2, 13, 22, 25, 32 AND 50).

FIRST USE 10-31-2010; IN COMMERCE 10-31-2010.  
JOSETTE BEVERLY, EXAMINING ATTORNEY

---

SN 85-210,839. CLAYTON-MARCUS COMPANY, INC., MCLEAN, VA. FILED 1-5-2011.

# KENSINGTON BY CLAYTON MARCUS

THE MARK CONSISTS OF STANDARD CHARACTERS WITHOUT CLAIM TO ANY PARTICULAR FONT, STYLE, SIZE, OR COLOR.

OWNER OF U.S. REG. NOS. 1,150,447 AND 1,627,170.

THE NAME(S), PORTRAIT(S), AND/OR SIGNATURE(S) SHOWN IN THE MARK DOES NOT IDENTIFY A PARTICULAR LIVING INDIVIDUAL.

FOR UPHOLSTERED FURNITURE (U.S. CLS. 2, 13, 22, 25, 32 AND 50).

KELLEY WELLS, EXAMINING ATTORNEY

**CLASS 20—(Continued).**

SN 85-210,856. SMART SOLUTIONS RECREATIONAL PRODUCTS, INC., CHAMPAIGN, IL. FILED 1-5-2011.

# ADD-A-DRAWER

THE MARK CONSISTS OF STANDARD CHARACTERS WITHOUT CLAIM TO ANY PARTICULAR FONT, STYLE, SIZE, OR COLOR.

FOR DRAWERS (U.S. CLS. 2, 13, 22, 25, 32 AND 50).

FIRST USE 6-0-2007; IN COMMERCE 4-30-2008.

HEATHER SAPP, EXAMINING ATTORNEY

---

SN 85-211,913. THE CELL-O-CORE COMPANY, SHARON CENTER, OH. FILED 1-6-2011.

# CELLO-GREEN

THE MARK CONSISTS OF STANDARD CHARACTERS WITHOUT CLAIM TO ANY PARTICULAR FONT, STYLE, SIZE, OR COLOR.

FOR BIODEGRADABLE DRINKING STRAWS (U.S. CLS. 2, 13, 22, 25, 32 AND 50).

FIRST USE 8-20-2008; IN COMMERCE 8-20-2008.

MARTHA SANTOMARTINO, EXAMINING ATTORNEY

---

SN 85-212,338. LINUS & LOLITA, ATLANTA, GA. FILED 1-6-2011.

# Linus & Lolita

THE MARK CONSISTS OF STANDARD CHARACTERS WITHOUT CLAIM TO ANY PARTICULAR FONT, STYLE, SIZE, OR COLOR.

FOR WARDROBES (U.S. CLS. 2, 13, 22, 25, 32 AND 50).

TIMOTHY FINNEGAN, EXAMINING ATTORNEY



**CLASS 20—(Continued).**

SN 85-213,210. SOBEL WESTEX, LAS VEGAS, NV. FILED 1-7-2011.

**SAHARA NIGHTS**

THE MARK CONSISTS OF STANDARD CHARACTERS WITHOUT CLAIM TO ANY PARTICULAR FONT, STYLE, SIZE, OR COLOR.

OWNER OF U.S. REG. NOS. 3,514,363 AND 3,851,085.  
FOR PILLOWS (U.S. CLS. 2, 13, 22, 25, 32 AND 50).  
FIRST USE 2-3-2009; IN COMMERCE 2-3-2009.  
JENNIFER MARTIN, EXAMINING ATTORNEY

SN 85-214,350. KNOPF SYSTEMS LLC, WILMINGTON, DE.  
FILED 1-10-2011.

**AGREE**

THE MARK CONSISTS OF STANDARD CHARACTERS WITHOUT CLAIM TO ANY PARTICULAR FONT, STYLE, SIZE, OR COLOR.

FOR MATTRESSES; SLEEP PRODUCTS, NAMELY, MATTRESSES, SPRING MATTRESSES, BOX SPRINGS AND MATTRESS FOUNDATIONS (U.S. CLS. 2, 13, 22, 25, 32 AND 50).

SUNG IN, EXAMINING ATTORNEY

SN 85-214,796. FOUR PAWS PRODUCTS, LTD., HAUP-PAUGE, NY. FILED 1-11-2011.

**KEEPER SLEEPER**

THE MARK CONSISTS OF STANDARD CHARACTERS WITHOUT CLAIM TO ANY PARTICULAR FONT, STYLE, SIZE, OR COLOR.

OWNER OF U.S. REG. NOS. 2,718,770 AND 2,722,170.  
NO CLAIM IS MADE TO THE EXCLUSIVE RIGHT TO USE "SLEEPER", APART FROM THE MARK AS SHOWN.  
FOR PET BEDS (U.S. CLS. 2, 13, 22, 25, 32 AND 50).  
SCOTT BIBB, EXAMINING ATTORNEY

**CLASS 20—(Continued).**

SN 85-217,169. ZINUS INC., HAYWARD, CA. FILED 1-13-2011.

**Massage Inside**

THE MARK CONSISTS OF STANDARD CHARACTERS WITHOUT CLAIM TO ANY PARTICULAR FONT, STYLE, SIZE, OR COLOR.

NO CLAIM IS MADE TO THE EXCLUSIVE RIGHT TO USE "MASSAGE", APART FROM THE MARK AS SHOWN, FOR BEDS, MATTRESSES, PILLOWS AND BOLSTERS (U.S. CLS. 2, 13, 22, 25, 32 AND 50).

ALICIA COLLINS, EXAMINING ATTORNEY

SN 85-219,897. SEALY TECHNOLOGY LLC, TRINITY, NC.  
FILED 1-18-2011.

**THE MOST SUPPORTIVE  
MATTRESS FOR ALL YOU DO IN  
BED**

THE MARK CONSISTS OF STANDARD CHARACTERS WITHOUT CLAIM TO ANY PARTICULAR FONT, STYLE, SIZE, OR COLOR.

FOR BOX SPRINGS; MATTRESSES (U.S. CLS. 2, 13, 22, 25, 32 AND 50).

KIM MONINGHOFF, EXAMINING ATTORNEY

SN 85-221,756. RENO, RONALD L, MACOMB, MI. FILED 1-20-2011.

**EZ Scoop Clip**

THE MARK CONSISTS OF STANDARD CHARACTERS WITHOUT CLAIM TO ANY PARTICULAR FONT, STYLE, SIZE, OR COLOR.

NO CLAIM IS MADE TO THE EXCLUSIVE RIGHT TO USE "SCOOP CLIP", APART FROM THE MARK AS SHOWN.

FOR NON-METAL CLIPS FOR PET PRODUCTS, NAMELY, A UNIVERSAL MULTI-PURPOSE CLIP WHICH CAN BE CLIPPED TO THE FRONT AND/OR BACK AND/OR EITHER OR BOTH SIDES OF MOST SPRING ACTION PET POOP SCOOPERS AND ALSO CLIP ONTO THE STANDARD SHOVEL AND/OR RAKE POOP SCOOPER. ATTACHING CLIP ONTO A DOG LEASH TO FASTEN ONE OR MORE EMPTY AND/OR FULL PET WASTE BAGS FOR WALKING A DOG. USING THE CLIP TO CLIP THE DOG LEASH ONTO A BELT, POCKET OR OTHER PIECE OF CLOTHING TO REDUCE STRESS IN HOLDING THE LEASH AND TO HELP TRAIN THE DOG FOR LIMITED PULLING AND/OR TUGGING BEHAVIOR (U.S. CLS. 2, 13, 22, 25, 32 AND 50).

MARK SHINER, EXAMINING ATTORNEY

**CLASS 20—(Continued).**

SN 85-222,537. OATEY CO., CLEVELAND, OH. FILED 1-20-2011.

# DUOFIT

THE MARK CONSISTS OF STANDARD CHARACTERS WITHOUT CLAIM TO ANY PARTICULAR FONT, STYLE, SIZE, OR COLOR.

FOR NON-METAL CLAMPS (U.S. CLS. 2, 13, 22, 25, 32 AND 50).

DAVID TAYLOR, EXAMINING ATTORNEY

---

SN 85-231,424. PACIFIC WORLD CORPORATION, LAKE FOREST, CA. FILED 2-1-2011.



THE MARK CONSISTS OF A STYLIZED LOWER CASE "G" FOLLOWED BY A STYLIZED UPPER CASE "G".

FOR FOAM TOE SEPARATORS FOR USE IN PEDICURES (U.S. CLS. 2, 13, 22, 25, 32 AND 50).

HOWARD SMIGA, EXAMINING ATTORNEY

---

SN 85-231,822. JACKSON, DEAN, D. TORONTO, ONTARIO, CANADA, FILED 2-1-2011.

# AEROPOD

THE MARK CONSISTS OF STANDARD CHARACTERS WITHOUT CLAIM TO ANY PARTICULAR FONT, STYLE, SIZE, OR COLOR.

FOR CABINETS FOR DISPLAY PURPOSES (U.S. CLS. 2, 13, 22, 25, 32 AND 50).

FIRST USE 7-15-2003; IN COMMERCE 1-24-2004.

HEATHER BIDDULPH, EXAMINING ATTORNEY

**CLASS 21—HOUSEWARES AND GLASS**

SN 77-937,625. BRAZOS INTERNATIONAL, INC., MIAMI, FL. FILED 2-17-2010.

# Sapo de Papel

THE MARK CONSISTS OF STANDARD CHARACTERS WITHOUT CLAIM TO ANY PARTICULAR FONT, STYLE, SIZE, OR COLOR.

OWNER OF U.S. REG. NO. 2,085,951.

THE ENGLISH TRANSLATION OF "SAPO DE PAPEL" IN THE MARK IS "PAPER TOAD".

SEC. 2(F).

FOR INSECT TRAPS (U.S. CLS. 2, 13, 23, 29, 30, 33, 40 AND 50).

FIRST USE 8-8-2005; IN COMMERCE 8-8-2005.

MARC LEIPZIG, EXAMINING ATTORNEY

---

SN 85-043,091. VILLA OLYMPIC INC., BRANTFORD, ONTARIO, CANADA, FILED 5-19-2010.

# QTENSILS

THE MARK CONSISTS OF STANDARD CHARACTERS WITHOUT CLAIM TO ANY PARTICULAR FONT, STYLE, SIZE, OR COLOR.

FOR BARBECUE AND GRILL COVERS; HOUSEHOLD STORAGE CONTAINERS FOR FOOD; UTENSILS FOR COOKING, OUTDOOR COOKING, AND GRILLING, NAMELY, SPATULAS, COOKING FORKS, TONGS, BASTING BRUSHES, TURNERS, NON-ELECTRIC GRIDDLES, ALL PURPOSE PORTABLE HOUSEHOLD CONTAINERS FOR SAUCES, SALT AND PEPPER SHAKERS, WIRE GRILLING BASKETS, VEGETABLE STEAMING BASKETS, BARBECUE SKEWERS, CORN COB HOLDERS; PIZZA STONES; POULTRY ROASTING PANS, GRILL PANS; KEBAB RACKS; ROASTING RACKS; TOPPERS, NAMELY, PERFORATED PLATES THAT ARE PLACED ON TOP OF A GRILL FOR PURPOSES OF COOKING FOOD AT A REDUCED HEAT; WOOD COOKING PLANKS FOR USE IN GRILLING; GRILLING GRIDS; GRILL PANS; SEASONING INJECTORS FOR FLAVORING FOODS, GRILL LIFTERS FOR LIFTING HOT GRILL RACKS OR GRIDS; GRILL TOP PIZZA RACKS; GRILL TOP SMOKER BOXES; BARBECUE SCRAPING BRUSHES; WIRE AND NYLON CLEANING BRUSHES FOR HOUSEHOLD USE (U.S. CLS. 2, 13, 23, 29, 30, 33, 40 AND 50).

KAREN BRACEY, EXAMINING ATTORNEY

**CLASS 21—(Continued).**

SN 85-046,712. W2007 STRATOSPHERE PROPCO., L.P., LAS VEGAS, NV. FILED 5-24-2010.



NO CLAIM IS MADE TO THE EXCLUSIVE RIGHT TO USE "LAS VEGAS", APART FROM THE MARK AS SHOWN. THE MARK CONSISTS OF THE WORDS "SKY JUMP" STAGGERED AND HORIZONTALLY POSITIONED OVER A TARGET AND THE WORDS "LAS VEGAS".

FOR BEVERAGEWARE; BOTTLE OPENERS; COASTERS NOT OF PAPER AND NOT BEING TABLE LINEN; CONTAINERS FOR HOUSEHOLD OR KITCHEN USE; FIGURINES OF GLASS AND CERAMIC; FLASKS; PLASTIC WATER BOTTLES SOLD EMPTY; PLATES; SHOT GLASSES (U.S. CLS. 2, 13, 23, 29, 30, 33, 40 AND 50).

EMILY CHUO, EXAMINING ATTORNEY

SN 85-046,716. W2007 STRATOSPHERE PROPCO., L.P., LAS VEGAS, NV. FILED 5-24-2010.

## SKYJUMP LAS VEGAS

THE MARK CONSISTS OF STANDARD CHARACTERS WITHOUT CLAIM TO ANY PARTICULAR FONT, STYLE, SIZE, OR COLOR.

NO CLAIM IS MADE TO THE EXCLUSIVE RIGHT TO USE "LAS VEGAS", APART FROM THE MARK AS SHOWN.

FOR BEVERAGEWARE; BOTTLE OPENERS; COASTERS NOT OF PAPER AND NOT BEING TABLE LINEN; CONTAINERS FOR HOUSEHOLD OR KITCHEN USE; FIGURINES OF GLASS AND CERAMIC; FLASKS; PLASTIC WATER BOTTLES SOLD EMPTY; PLATES; SHOT GLASSES (U.S. CLS. 2, 13, 23, 29, 30, 33, 40 AND 50).

EMILY CHUO, EXAMINING ATTORNEY

**CLASS 21—(Continued).**

SN 85-046,721. W2007 STRATOSPHERE PROPCO., L.P., LAS VEGAS, NV. FILED 5-24-2010.

## SKYJUMP

THE MARK CONSISTS OF STANDARD CHARACTERS WITHOUT CLAIM TO ANY PARTICULAR FONT, STYLE, SIZE, OR COLOR.

FOR BEVERAGEWARE; BOTTLE OPENERS; COASTERS NOT OF PAPER AND NOT BEING TABLE LINEN; CONTAINERS FOR HOUSEHOLD OR KITCHEN USE; FIGURINES OF GLASS AND CERAMIC; FLASKS; PLASTIC WATER BOTTLES SOLD EMPTY; PLATES; SHOT GLASSES (U.S. CLS. 2, 13, 23, 29, 30, 33, 40 AND 50).

LOURDES AYALA, EXAMINING ATTORNEY

SN 85-047,347. CALIFORNIA INNOVATIONS INC., TORONTO, ONTARIO, CANADA, FILED 5-25-2010.

## GREATEST PRODUCTS UNDER THE SUN

THE MARK CONSISTS OF STANDARD CHARACTERS WITHOUT CLAIM TO ANY PARTICULAR FONT, STYLE, SIZE, OR COLOR.

PRIORITY CLAIMED UNDER SEC. 44(D) ON CANADA APPLICATION NO. 1479392, FILED 5-3-2010, REG. NO. TMA791426, DATED 2-23-2011, EXPIRES 2-23-2027.

FOR INSULATED PORTABLE COOLERS FOR FOOD AND BEVERAGES (U.S. CLS. 2, 13, 23, 29, 30, 33, 40 AND 50).

FIRST USE 12-31-1987; IN COMMERCE 12-31-1987.  
NICHOLAS COLEMAN, EXAMINING ATTORNEY

SN 85-056,666. LEPARC INTERNATIONAL CO., LTD., SONJIANG, SHANGHAI, CHINA, FILED 6-7-2010.



THE COLOR(S) DARK TEAL, LIGHT TEAL, GREEN AND WHITE IS/ARE CLAIMED AS A FEATURE OF THE MARK.

THE MARK CONSISTS OF THE WORDS "LEPARC GREEN SCENE" WITH A LEAF DESIGN ATTACHED TO THE LAST "E" IN "SCENE." THE COLOR DARK TEAL APPEARS IN THE WORD "LEPARC" AND IN THE WORD "GREEN." THE COLOR LIGHT TEAL APPEARS IN THE OUTLINE OF THE WORD "GREEN." THE COLOR GREEN APPEARS IN THE WORD "SCENE" AND THE LEAF DESIGN, AND THE COLOR WHITE APPEARS IN THE VEINING OF THE LEAF DESIGN.

FOR GARDEN HOSE SPRAYERS; GARDEN HOSE SPRAYER NOZZLES; GARDEN HOSE SPRINKLERS (U.S. CLS. 2, 13, 23, 29, 30, 33, 40 AND 50).

FIRST USE 1-12-2006; IN COMMERCE 1-12-2006.  
CARYN GLASSER, EXAMINING ATTORNEY

**CLASS 21—(Continued).**

SN 85-059,654. LAURA MESSANO, MASSAPEQUA, NY.  
FILED 6-10-2010.

**FLOWER TOPPERS**

THE MARK CONSISTS OF STANDARD CHARACTERS WITHOUT CLAIM TO ANY PARTICULAR FONT, STYLE, SIZE, OR COLOR.

NO CLAIM IS MADE TO THE EXCLUSIVE RIGHT TO USE "FLOWER", APART FROM THE MARK AS SHOWN.

FOR PLANTER TRAYS (U.S. CLS. 2, 13, 23, 29, 30, 33, 40 AND 50).

NAKIA HENRY, EXAMINING ATTORNEY

SN 85-062,399. TARGET BRANDS, INC., MINNEAPOLIS, MN. FILED 6-14-2010.



OWNER OF U.S. REG. NOS. 1,384,035, 2,757,366 AND 2,799,815.

THE COLOR(S) GREEN IS/ARE CLAIMED AS A FEATURE OF THE MARK.

THE MARK CONSISTS OF A GREEN OVAL WITH THE TEXT "SMITH & HAWKEN" CENTERED IN THE MIDDLE.

FOR CONTAINERS FOR PLANTS; STATUES OF CHINA, CRYSTAL, EARTHENWARE, GLASS, TERRA COTTA, PORCELAIN; VASES AND FLOWER POTS ALL BEING OF GLASS, CERAMIC, EARTHENWARE, TERRA-COTTA, CONCRETE, MARBLE, PLASTER, STONE AND PORCELAIN; GARDEN HOSE POTS NOT OF METAL; GARDENING GLOVES; TOWEL RAILS; WATERING CANS; BIRD BATHS; BIRD FEEDERS; BIRD HOUSES; BIRD CAGES; LAWN AND GARDEN PLASTIC STORAGE CONTAINERS FOR DOMESTIC USE; PLANT CONTAINERS AND POTS; LAWN AND GARDEN ORNAMENTS OF CHINA, CRYSTAL, GLASS, PORCELAIN; HANGING BASKETS OF WICKER, STRAW, WOOD, CLOTH; WATERING EQUIPMENT, NAMELY, WATERING CANS AND POTS; LAWN AND GARDEN SPRINKLERS; GARDEN HOSE SPRAYERS; BROOMS; BUCKETS AND SIEVES; CANDLE HOLDERS; URNS; ORNAMENTS OF CHINA, CRYSTAL, GLASS, PORCELAIN, NOT INCLUDING CHRISTMAS TREE ORNAMENTS; HOUSEHOLD FOOD AND BEVERAGE CONTAINERS; DINNERWARE; BEVERAGE WARE; SERVING DISHES; DECORATIVE CHARMS FOR ATTACHMENT TO BEVERAGE GLASSWARE; PORTABLE ICE CHESTS AND BEVERAGE COOLERS; WOOD COOKING PLANKS FOR USE IN GRILLING (U.S. CLS. 2, 13, 23, 29, 30, 33, 40 AND 50).

ALEXANDER L. POWERS, EXAMINING ATTORNEY

**CLASS 21—(Continued).**

SN 85-103,675. INNO-LABS LP, WINFIELD, KS. FILED 8-9-2010.

**Marinating Made Easy**

THE MARK CONSISTS OF STANDARD CHARACTERS WITHOUT CLAIM TO ANY PARTICULAR FONT, STYLE, SIZE, OR COLOR.

NO CLAIM IS MADE TO THE EXCLUSIVE RIGHT TO USE "MARINATING", APART FROM THE MARK AS SHOWN.

FOR COOKING SKEWERS; COOKING UTENSILS, NAMELY, WIRE BASKETS; HOUSEHOLD UTENSILS, NAMELY, TURNERS; UTENSILS FOR BARBECUES, NAMELY, FORKS, TONGS, TURNERS (U.S. CLS. 2, 13, 23, 29, 30, 33, 40 AND 50).

FIRST USE 1-1-2008; IN COMMERCE 4-15-2008.

HOWARD B. LEVINE, EXAMINING ATTORNEY

SN 85-114,906. TERVIS TUMBLER COMPANY, NORTH VENICE, FL. FILED 8-24-2010.

**ALWAYS FULL OF FUN**

THE MARK CONSISTS OF STANDARD CHARACTERS WITHOUT CLAIM TO ANY PARTICULAR FONT, STYLE, SIZE, OR COLOR.

FOR BEVERAGEWARE; DINNERWARE; DISHWARE; ICE BUCKETS; PITCHERS (U.S. CLS. 2, 13, 23, 29, 30, 33, 40 AND 50).

FIRST USE 1-1-2011; IN COMMERCE 1-1-2011.

GRETTA YAO, EXAMINING ATTORNEY

SN 85-134,028. P/N TECHNOLOGY AND DESIGN, LAFAYETTE, IN. FILED 9-20-2010.

**KLIK-N-KLENZ THE CLEAN HANDS PRODUCT**

THE MARK CONSISTS OF STANDARD CHARACTERS WITHOUT CLAIM TO ANY PARTICULAR FONT, STYLE, SIZE, OR COLOR.

NO CLAIM IS MADE TO THE EXCLUSIVE RIGHT TO USE "PRODUCT", APART FROM THE MARK AS SHOWN.

FOR PORTABLE DISPENSERS FOR PAPER TOWELS IN THE NATURE OF MOIST TOWELETTES (U.S. CLS. 2, 13, 23, 29, 30, 33, 40 AND 50).

SAIMA MAKHDOOM, EXAMINING ATTORNEY

**CLASS 21—(Continued).**

SN 85-137,635. KITCHEN & COOKWARE, INC., BELL, CA.  
FILED 9-24-2010.



NO CLAIM IS MADE TO THE EXCLUSIVE RIGHT TO USE THE NON-LATIN CHARACTERS THAT TRANSLITERATE TO SAE RO UN AND HOUSE & COOKWARE, APART FROM THE MARK AS SHOWN.

THE MARK CONSISTS OF NON-LATIN CHARACTERS THAT TRANSLITERATE TO SAE RO UN, GA JOK, GONG GAN, AND NO VEL AND THIS MEANS "NEW", "FAMILY", "SPACE", AND "NOVEL" IN ENGLISH. BELOW THE NON-LATIN CHARACTERS APPEARS THE WORD "NOVEL" AND "HOUSE & COOKWARE" DIRECTLY UNDERNEATH.

THE NON-LATIN CHARACTERS IN THE MARK TRANSLITERATE TO SAE RO UN, GA JOK, GONG GAN, AND NO VEL AND THIS MEANS "NEW", "FAMILY", "SPACE", AND "NOVEL" IN ENGLISH.

FOR (BASED ON USE IN COMMERCE) CONTAINERS FOR HOUSEHOLD OR KITCHEN USE; HOUSEHOLD UTENSILS, NAMELY, KITCHEN TONGS (BASED ON INTENT TO USE) LADLES, FOR KITCHEN USE; NON-ELECTRIC KITCHEN CONTAINERS NOT MADE OF PRECIOUS METAL; PORTABLE PLASTIC CONTAINERS FOR STORING HOUSEHOLD AND KITCHEN GOODS; WOOD CHOPPING BOARDS FOR KITCHEN USE (U.S. CLS. 2, 13, 23, 29, 30, 33, 40 AND 50).

FIRST USE 3-1-2010; IN COMMERCE 3-1-2010.

JACLYN KIDWELL WALKER, EXAMINING ATTORNEY

SN 85-172,862. TERVIS TUMBLER COMPANY, NORTH VENICE, FL. FILED 11-9-2010.

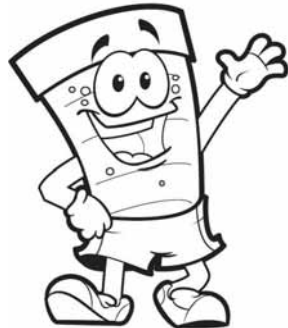

THE MARK CONSISTS OF A FANCIFUL CARICATURE OF A TUMBLER WITH FOUR HORIZONTAL LINES WEARING SHORTS AT THE BOTTOM OF THE TUMBLER WITH TWO ARMS WITH GLOVED HANDS ON THE SIDES OF THE TUMBLER, THE CHARACTER'S LEFT HAND IS WAIVING UPWARDS AND THE RIGHT HAND IS RESTING DOWNWARDS ON THE HIP, AND TWO LEGS WITH SHOES AT THE BOTTOM OF THE TUMBLER, AND ON THE FRONT OF THE TUMBLER IS A FRECKLED SMILING FACE WHICH CONSISTS OF TWO EYEBROWS OVER TWO OPEN EYES OVER AN OPENED SMILING MOUTH.

FOR BEVERAGeware; DINNERWARE; DISHWARE; ICE BUCKETS; PITCHERS (U.S. CLS. 2, 13, 23, 29, 30, 33, 40 AND 50).

FIRST USE 8-14-2010; IN COMMERCE 8-14-2010.

MARK PILARO, EXAMINING ATTORNEY

**CLASS 21—(Continued).**

SN 85-174,094. EUROPEAN MARBLE CO., INC., DENVER, CO. FILED 11-10-2010.



NO CLAIM IS MADE TO THE EXCLUSIVE RIGHT TO USE "COOKING STONE", APART FROM THE MARK AS SHOWN.

THE COLOR(S) BLACK, RED AND YELLOW IS/ARE CLAIMED AS A FEATURE OF THE MARK.

THE MARK CONSISTS OF THE STYLIZED WORDING "TUSCANO" IN YELLOW AND "COOKING STONE" IN BLACK. THE WORDING IS SET AGAINST A CIRCLE WITH YELLOW AND GOLD ON TOP HALF WITH A BLACK LINE DESIGN, AND WITH "TUSCANO" SET AGAINST THE SOLID BLACK ON BOTTOM HALF WITH YELLOW LETTERS AND RED FIRE SYMBOL, WITH "COOKING STONE" SET BELOW THE CIRCLE DESIGN UNDERLINED BY TWO BLACK LINES.

FOR PIZZA STONES (U.S. CLS. 2, 13, 23, 29, 30, 33, 40 AND 50).

FIRST USE 8-9-2010; IN COMMERCE 8-9-2010.

TIMOTHY FINNEGAN, EXAMINING ATTORNEY

SN 85-188,489. WILTON INDUSTRIES, INC., WOODRIDGE, IL. FILED 12-1-2010.

INDULGENCE PROFESSIONAL  
STONEWARE

THE MARK CONSISTS OF STANDARD CHARACTERS WITHOUT CLAIM TO ANY PARTICULAR FONT, STYLE, SIZE, OR COLOR.

OWNER OF U.S. REG. NO. 2,757,290.

NO CLAIM IS MADE TO THE EXCLUSIVE RIGHT TO USE "PROFESSIONAL STONEWARE", APART FROM THE MARK AS SHOWN.

FOR BAKEWARE (U.S. CLS. 2, 13, 23, 29, 30, 33, 40 AND 50).

LINDA MICKLEBURGH, EXAMINING ATTORNEY

**CLASS 21—(Continued).**

SN 85-189,545. ELECTROLUX HOME PRODUCTS, INC., CHARLOTTE, NC. FILED 12-2-2010.

**FRIGIDAIRE**

OWNER OF U.S. REG. NOS. 364,709, 616,196 AND 2,712,131.

THE MARK CONSISTS OF THE WORD "FRIGIDAIRE" WITH A STYLIZED VERSION OF THE LETTER "A".

FOR PORTABLE SOFT AND HARD SIDED COOLERS FOR FOOD AND BEVERAGES; THERMALLY INSULATED CONTAINERS FOR FOOD AND BEVERAGES, CONTAINERS FOR HOUSEHOLD OR KITCHEN USE (U.S. CLS. 2, 13, 23, 29, 30, 33, 40 AND 50).

TEJBIR SINGH, EXAMINING ATTORNEY

SN 85-189,982. EXCELLENCE THROUGH LIGHTWEIGHT, INC., HIALEAH, FL. FILED 12-3-2010.

**THE PERFECT GRIP**

THE MARK CONSISTS OF STANDARD CHARACTERS WITHOUT CLAIM TO ANY PARTICULAR FONT, STYLE, SIZE, OR COLOR.

FOR BEVERAGE CONTAINERS FOR HOUSEHOLD USE (U.S. CLS. 2, 13, 23, 29, 30, 33, 40 AND 50).

IRA J. GOODSARD, EXAMINING ATTORNEY

SN 85-190,970. OLD BLUE LLC, LAKE GENEVA, WI. FILED 12-6-2010.

**BRICK & MORTAR**

THE MARK CONSISTS OF STANDARD CHARACTERS WITHOUT CLAIM TO ANY PARTICULAR FONT, STYLE, SIZE, OR COLOR.

FOR BAKEWARE; BEVERAGE GLASSWARE; CANISTER SETS; DINNERWARE; HOUSEHOLD UTENSILS, NAMELY, SCRAPERS, ROLLING PINS, SPATULAS, WHISKS; LADLES, FOR KITCHEN USE; MUGS; PANS; POTS; SERVING SPOONS; SOAP DISPENSERS; SPICE RACKS; TRAYS; VASES (U.S. CLS. 2, 13, 23, 29, 30, 33, 40 AND 50).

CHRISTINE MARTIN, EXAMINING ATTORNEY

**CLASS 21—(Continued).**

SN 85-195,067. HANNON GROUP LTD., BURLINGTON, WI. FILED 12-10-2010.

**LUNCHIN' LADIES**

THE MARK CONSISTS OF STANDARD CHARACTERS WITHOUT CLAIM TO ANY PARTICULAR FONT, STYLE, SIZE, OR COLOR.

FOR INSULATED BAGS FOR FOOD OR BEVERAGE FOR DOMESTIC USE; INSULATED CONTAINERS FOR BEVERAGE CANS FOR DOMESTIC USE; INSULATED CONTAINERS FOR FOOD OR BEVERAGE FOR DOMESTIC USE; THERMAL INSULATED BAGS FOR FOOD OR BEVERAGES; THERMAL INSULATED CONTAINERS FOR FOOD OR BEVERAGES (U.S. CLS. 2, 13, 23, 29, 30, 33, 40 AND 50).

FIRST USE 5-22-2009; IN COMMERCE 5-22-2009.  
VERNA BETH RIRIE, EXAMINING ATTORNEY

SN 85-198,971. VIVINT, INC., PROVO, UT. FILED 12-15-2010.

**LIVE INTELLIGENTLY**

THE MARK CONSISTS OF STANDARD CHARACTERS WITHOUT CLAIM TO ANY PARTICULAR FONT, STYLE, SIZE, OR COLOR.

FOR BEVERAGEWARE (U.S. CLS. 2, 13, 23, 29, 30, 33, 40 AND 50).

TARA PATE, EXAMINING ATTORNEY

SN 85-201,304. AQUATICA GALLERY LLC, SANTA FE SPRINGS, CA. FILED 12-18-2010.



THE COLOR(S) BEIGE, BLUE, YELLOW, GRAY, WHITE, TAN IS/ARE CLAIMED AS A FEATURE OF THE MARK.

THE MARK CONSISTS OF A STYLIZED FISH WITH A GRAY HEAD WITH BLUE EYE AND BLUE BUBBLES WITH WHITE HIGHLIGHT IN INCREASING SIZE COMING FROM FISH HEAD, GOING UP, BODY OF FISH ALTER-

**CLASS 21—(Continued).**

NATING BLUE, YELLOW, BLUE, YELLOW SECTIONS WITH LAST SECTION OUTLINED IN BLUE WITH THE OUTLINE CONTINUING UNDER GRAY FIN WHICH IS UNDER A LIGHT TAN, WITH JAGGED WHITE STRIP IN MIDDLE, PART OF A SPIRAL SHELL FROM WHICH THE FISH APPEARS TO BE COMING, THE SHELL SPIRAL SEGMENTS BEING DARKER BEIGE FADING TO LIGHT TAN, ALL OF THE ABOVE UNDER TWO BLUE STRIPES, THE LARGER ON TOP SEPARATED FROM SMALL BOTTOM STRIPE BY WHITE STRIPE.

FOR AQUARIUMS (U.S. CLS. 2, 13, 23, 29, 30, 33, 40 AND 50).

FIRST USE 11-22-2010; IN COMMERCE 11-22-2010.  
ARETHA SOMERVILLE, EXAMINING ATTORNEY

---

SN 85-201,938. WOOLLY POCKET CORPORATION, INC.,  
LOS ANGELES, CA. FILED 12-20-2010.

The Good Life Grows in  
Pockets

THE MARK CONSISTS OF STANDARD CHARACTERS WITHOUT CLAIM TO ANY PARTICULAR FONT, STYLE, SIZE, OR COLOR.

FOR FLEXIBLE, BREATHABLE, AND MODULAR GARDENING CONTAINERS WITH BUILT-IN MOISTURE BARRIERS FOR BOTH INDOORS AND OUTDOORS THAT ARE DESIGNED TO BE PLACED ON HORIZONTAL SURFACES AND ON WALLS FOR VERTICAL GARDENING (U.S. CLS. 2, 13, 23, 29, 30, 33, 40 AND 50).

FIRST USE 12-22-2009; IN COMMERCE 12-22-2009.  
ALLISON SCHRODY, EXAMINING ATTORNEY

---

SN 85-201,969. WOOLLY POCKET CORPORATION, INC.,  
LOS ANGELES, CA. FILED 12-20-2010.

Woolly Pocket

THE MARK CONSISTS OF STANDARD CHARACTERS WITHOUT CLAIM TO ANY PARTICULAR FONT, STYLE, SIZE, OR COLOR.

FOR FLEXIBLE, BREATHABLE, AND MODULAR GARDENING CONTAINERS WITH BUILT-IN MOISTURE BARRIERS FOR BOTH INDOORS AND OUTDOORS THAT ARE DESIGNED TO BE PLACED ON HORIZONTAL SURFACES AND ON WALLS FOR VERTICAL GARDENING (U.S. CLS. 2, 13, 23, 29, 30, 33, 40 AND 50).

FIRST USE 12-22-2009; IN COMMERCE 12-22-2009.  
ALLISON SCHRODY, EXAMINING ATTORNEY

**CLASS 21—(Continued).**

SN 85-203,905. TIGER MAZE, INC., ORMOND BEACH, FL.  
FILED 12-22-2010.

tigermaze

THE MARK CONSISTS OF STANDARD CHARACTERS WITHOUT CLAIM TO ANY PARTICULAR FONT, STYLE, SIZE, OR COLOR.

FOR INSECT TRAPS (U.S. CLS. 2, 13, 23, 29, 30, 33, 40 AND 50).

JILL PRATER, EXAMINING ATTORNEY

---

SN 85-206,117. ECO VESSEL LLC, BOULDER, CO. FILED 12-27-2010.

Gobble n Go

THE MARK CONSISTS OF STANDARD CHARACTERS WITHOUT CLAIM TO ANY PARTICULAR FONT, STYLE, SIZE, OR COLOR.

FOR COLLAPSIBLE STORAGE CONTAINERS FOR DOMESTIC USE; LUNCH BOXES (U.S. CLS. 2, 13, 23, 29, 30, 33, 40 AND 50).

TRACY FLETCHER, EXAMINING ATTORNEY

---

SN 85-206,479. EVRIHOLDER PRODUCTS LLC, ANAHEIM,  
CA. FILED 12-28-2010.

SNAP 'N SNACK

THE MARK CONSISTS OF STANDARD CHARACTERS WITHOUT CLAIM TO ANY PARTICULAR FONT, STYLE, SIZE, OR COLOR.

FOR PLASTIC PLATES (U.S. CLS. 2, 13, 23, 29, 30, 33, 40 AND 50).

KAREN BRACEY, EXAMINING ATTORNEY

**CLASS 21—(Continued).**

SN 85-206,569. THE STEP2 COMPANY, LLC, STREETSBORO, OH. FILED 12-28-2010.

**STEP2 HOME**

THE MARK CONSISTS OF STANDARD CHARACTERS WITHOUT CLAIM TO ANY PARTICULAR FONT, STYLE, SIZE, OR COLOR.

OWNER OF U.S. REG. NOS. 1,705,038, 1,892,697 AND OTHERS.

NO CLAIM IS MADE TO THE EXCLUSIVE RIGHT TO USE "HOME", APART FROM THE MARK AS SHOWN.

FOR REFUSE BINS (U.S. CLS. 2, 13, 23, 29, 30, 33, 40 AND 50).

LAURIE MAYES, EXAMINING ATTORNEY

**CLASS 21—(Continued).**

SN 85-207,370. CONAIR CORPORATION, STAMFORD, CT. FILED 12-29-2010.

**SOHO**

THE MARK CONSISTS OF STANDARD CHARACTERS WITHOUT CLAIM TO ANY PARTICULAR FONT, STYLE, SIZE, OR COLOR.

OWNER OF U.S. REG. NOS. 2,857,567 AND 3,125,342.

FOR APPLICATOR STICKS FOR APPLYING MAKE-UP; COSMETIC BRUSHES (U.S. CLS. 2, 13, 23, 29, 30, 33, 40 AND 50).

GISELLE AGOSTO, EXAMINING ATTORNEY

SN 85-206,873. HEWY'S WINE CHILLERS, LLC, ORLANDO, FL. FILED 12-28-2010.

**Corksicle**

THE MARK CONSISTS OF STANDARD CHARACTERS WITHOUT CLAIM TO ANY PARTICULAR FONT, STYLE, SIZE, OR COLOR.

FOR BOTTLE STOPPERS SPECIALLY ADAPTED FOR USE WITH WINE BOTTLES; COOLERS FOR WINE (U.S. CLS. 2, 13, 23, 29, 30, 33, 40 AND 50).

MARC LEIPZIG, EXAMINING ATTORNEY

SN 85-208,600. GREEN MENU INC, GUELPH, CANADA, FILED 12-31-2010.

**Cupanion**

THE MARK CONSISTS OF STANDARD CHARACTERS WITHOUT CLAIM TO ANY PARTICULAR FONT, STYLE, SIZE, OR COLOR.

FOR CUPS AND MUGS (U.S. CLS. 2, 13, 23, 29, 30, 33, 40 AND 50).

FIRST USE 5-1-2009; IN COMMERCE 1-1-2010.

GEORGE LORENZO, EXAMINING ATTORNEY

SN 85-207,205. LACER, MARGIE, CYPRESS, CA. FILED 12-29-2010.

**Doodle Cones**

THE MARK CONSISTS OF STANDARD CHARACTERS WITHOUT CLAIM TO ANY PARTICULAR FONT, STYLE, SIZE, OR COLOR.

FOR SCOOPS FOR THE DISPOSAL OF PET WASTE (U.S. CLS. 2, 13, 23, 29, 30, 33, 40 AND 50).

JAMES GRIFFIN, EXAMINING ATTORNEY

SN 85-208,866. RUSH3, LLC, MOUNT PLEASANT, SC. FILED 1-2-2011.

**CHOMP STIX**

THE MARK CONSISTS OF STANDARD CHARACTERS WITHOUT CLAIM TO ANY PARTICULAR FONT, STYLE, SIZE, OR COLOR.

FOR CHOPSTICKS (U.S. CLS. 2, 13, 23, 29, 30, 33, 40 AND 50).

KYLE PEETE, EXAMINING ATTORNEY



**CLASS 21—(Continued).**

SN 85-209,047. KAHN, SANDRA L., WINTHROP, MA. FILED 1-3-2011.

# NurtureWare

THE MARK CONSISTS OF STANDARD CHARACTERS WITHOUT CLAIM TO ANY PARTICULAR FONT, STYLE, SIZE, OR COLOR.

FOR HOUSEHOLD CONTAINERS FOR FOODS (U.S. CLS. 2, 13, 23, 29, 30, 33, 40 AND 50).

JUSTINE D. PARKER, EXAMINING ATTORNEY

---

SN 85-209,186. FUELBELT, INC., WARREN, RI. FILED 1-3-2011.

# REVENGE

THE MARK CONSISTS OF STANDARD CHARACTERS WITHOUT CLAIM TO ANY PARTICULAR FONT, STYLE, SIZE, OR COLOR.

FOR SPORTS BOTTLES SOLD EMPTY; PORTABLE BEVERAGE DISPENSERS, NAMELY, SPORTS BOTTLES CARRIED ON A BELT; AND HOLDERS AND HOLDERS FOR HOLDING SPORTS BOTTLES (U.S. CLS. 2, 13, 23, 29, 30, 33, 40 AND 50).

JULIE GUTTADAURO, EXAMINING ATTORNEY

---

SN 85-209,190. FUELBELT, INC., WARREN, RI. FILED 1-3-2011.

# HYDROGEN

THE MARK CONSISTS OF STANDARD CHARACTERS WITHOUT CLAIM TO ANY PARTICULAR FONT, STYLE, SIZE, OR COLOR.

FOR SPORTS BOTTLES SOLD EMPTY; PORTABLE BEVERAGE DISPENSERS, NAMELY, SPORTS BOTTLES CARRIED ON A BELT; AND HOLDERS AND HOLDERS FOR HOLDING SPORTS BOTTLES (U.S. CLS. 2, 13, 23, 29, 30, 33, 40 AND 50).

JULIE GUTTADAURO, EXAMINING ATTORNEY

**CLASS 21—(Continued).**

SN 85-209,192. FUELBELT, INC., WARREN, RI. FILED 1-3-2011.

# HELIUM

THE MARK CONSISTS OF STANDARD CHARACTERS WITHOUT CLAIM TO ANY PARTICULAR FONT, STYLE, SIZE, OR COLOR.

FOR SPORTS BOTTLES SOLD EMPTY; PORTABLE BEVERAGE DISPENSERS, NAMELY, SPORTS BOTTLES CARRIED ON A BELT; AND HOLDERS AND HOLDERS FOR HOLDING SPORTS BOTTLES (U.S. CLS. 2, 13, 23, 29, 30, 33, 40 AND 50).

FIRST USE 1-1-2007; IN COMMERCE 3-1-2007.

JULIE GUTTADAURO, EXAMINING ATTORNEY

---

SN 85-209,200. FUELBELT, INC., WARREN, RI. FILED 1-3-2011.

# SPRINT

THE MARK CONSISTS OF STANDARD CHARACTERS WITHOUT CLAIM TO ANY PARTICULAR FONT, STYLE, SIZE, OR COLOR.

FOR SPORTS BOTTLES SOLD EMPTY; PORTABLE BEVERAGE DISPENSERS, NAMELY, SPORTS BOTTLES CARRIED ON A BELT; AND HOLDERS AND HOLDERS FOR HOLDING SPORTS BOTTLES (U.S. CLS. 2, 13, 23, 29, 30, 33, 40 AND 50).

FIRST USE 1-1-2002; IN COMMERCE 3-1-2002.

JULIE GUTTADAURO, EXAMINING ATTORNEY

---

SN 85-209,204. FUELBELT, INC., WARREN, RI. FILED 1-3-2011.

# STAY HYDRATED

THE MARK CONSISTS OF STANDARD CHARACTERS WITHOUT CLAIM TO ANY PARTICULAR FONT, STYLE, SIZE, OR COLOR.

FOR SPORTS BOTTLES SOLD EMPTY; PORTABLE BEVERAGE DISPENSERS, NAMELY, SPORTS BOTTLES CARRIED ON A BELT; AND HOLDERS AND HOLDERS FOR HOLDING SPORTS BOTTLES (U.S. CLS. 2, 13, 23, 29, 30, 33, 40 AND 50).

FIRST USE 10-1-1998; IN COMMERCE 10-31-1998.

JULIE GUTTADAURO, EXAMINING ATTORNEY

**CLASS 21—(Continued).**

SN 85-209,353. ACTIVEION CLEANING SOLUTIONS LLC,  
MINNEAPOLIS, MN. FILED 1-3-2011.

**ACTIVEION EXP**

THE MARK CONSISTS OF STANDARD CHARACTERS  
WITHOUT CLAIM TO ANY PARTICULAR FONT, STYLE,  
SIZE, OR COLOR.

OWNER OF U.S. REG. NOS. 3,842,362 AND 3,863,086.  
FOR CONTAINERS SOLD EMPTY, FOR HOUSEHOLD  
OR KITCHEN USE FOR DISPENSING LIQUIDS FOR  
USE IN CLEANING, SANITIZING, AND/OR DISIN-  
FECTING SURFACES; CONTAINERS SOLD EMPTY  
FOR DISPENSING LIQUIDS FOR USE IN PERSONAL  
CARE (U.S. CLS. 2, 13, 23, 29, 30, 33, 40 AND 50).  
DAVID TAYLOR, EXAMINING ATTORNEY

SN 85-209,420. SILVER BRACELETS, INC., ORLANDO, FL.  
FILED 1-3-2011.

**CALORIES**

THE MARK CONSISTS OF STANDARD CHARACTERS  
WITHOUT CLAIM TO ANY PARTICULAR FONT, STYLE,  
SIZE, OR COLOR.

FOR COCKTAIL SHAKERS; COCKTAIL STIRRERS;  
COCKTAIL STRAINERS; BEVERAGE GLASSWARE  
AND SHOT GLASSES; PITCHERS (U.S. CLS. 2, 13, 23,  
29, 30, 33, 40 AND 50).  
TINA BROWN, EXAMINING ATTORNEY

SN 85-209,774. CONAIR CORPORATION, STAMFORD, CT.  
FILED 1-4-2011.

**CUISINART CROWN**

THE MARK CONSISTS OF STANDARD CHARACTERS  
WITHOUT CLAIM TO ANY PARTICULAR FONT, STYLE,  
SIZE, OR COLOR.

OWNER OF U.S. REG. NOS. 1,048,883, 2,313,580 AND  
OTHERS.  
FOR NON-ELECTRIC KETTLES (U.S. CLS. 2, 13, 23, 29,  
30, 33, 40 AND 50).  
GISELLE AGOSTO, EXAMINING ATTORNEY

**CLASS 21—(Continued).**

SN 85-209,829. CONAIR CORPORATION, STAMFORD, CT.  
FILED 1-4-2011.

**CUISINART PRODIGY**

THE MARK CONSISTS OF STANDARD CHARACTERS  
WITHOUT CLAIM TO ANY PARTICULAR FONT, STYLE,  
SIZE, OR COLOR.

OWNER OF U.S. REG. NOS. 1,048,883, 2,313,580 AND  
OTHERS.  
FOR NON-ELECTRIC KETTLES (U.S. CLS. 2, 13, 23, 29,  
30, 33, 40 AND 50).  
GISELLE AGOSTO, EXAMINING ATTORNEY

SN 85-210,709. SALES CHANNELS, INC., DOWNINGTOWN,  
PA. FILED 1-5-2011.



THE MARK CONSISTS OF AN OVAL WITH THE STY-  
LIZED TEXT "GOLLY-GEE" AND THE FIRST LETTER "G"  
MAKING A BUMBLE BEE.

FOR COOKIE JARS; GRAVY BOATS; SALT AND  
PEPPER SHAKERS (U.S. CLS. 2, 13, 23, 29, 30, 33, 40  
AND 50).  
REBECCA POVARCHUK, EXAMINING ATTORNEY

SN 85-210,742. CONAIR CORPORATION, STAMFORD, CT.  
FILED 1-5-2011.

**CUISINART VALOR**

THE MARK CONSISTS OF STANDARD CHARACTERS  
WITHOUT CLAIM TO ANY PARTICULAR FONT, STYLE,  
SIZE, OR COLOR.

OWNER OF U.S. REG. NOS. 1,048,883, 2,313,580 AND  
OTHERS.  
FOR NON-ELECTRIC KETTLES (U.S. CLS. 2, 13, 23, 29,  
30, 33, 40 AND 50).  
GISELLE AGOSTO, EXAMINING ATTORNEY

**CLASS 21—(Continued).**

SN 85-211,576. STEWART J. LOVENVIRTH, INMAN, SC.  
FILED 1-6-2011.

# LITTERZAP

THE MARK CONSISTS OF STANDARD CHARACTERS  
WITHOUT CLAIM TO ANY PARTICULAR FONT, STYLE,  
SIZE, OR COLOR.

FOR ANIMAL LITTER BOXES (U.S. CLS. 2, 13, 23, 29,  
30, 33, 40 AND 50).

JOHN GARTNER, EXAMINING ATTORNEY

---

SN 85-212,106. ELIZABETH TRUONG, NORTH PALM  
BEACH, FL. FILED 1-6-2011.

# NO CRY

THE MARK CONSISTS OF STANDARD CHARACTERS  
WITHOUT CLAIM TO ANY PARTICULAR FONT, STYLE,  
SIZE, OR COLOR.

FOR HAIR BRUSHES (U.S. CLS. 2, 13, 23, 29, 30, 33, 40  
AND 50).

WILLIAM ROSSMAN, EXAMINING ATTORNEY

---

SN 85-212,532. LIFETIME BRANDS, INC., GARDEN CITY,  
NY. FILED 1-7-2011.

# OAKDALE

THE MARK CONSISTS OF STANDARD CHARACTERS  
WITHOUT CLAIM TO ANY PARTICULAR FONT, STYLE,  
SIZE, OR COLOR.

FOR DINNERWARE (U.S. CLS. 2, 13, 23, 29, 30, 33, 40  
AND 50).

ALICIA COLLINS, EXAMINING ATTORNEY

**CLASS 21—(Continued).**

SN 85-213,593. DAVIT, JEREMY WILLIAM, DBA TROPICAL  
REGARDS, CHICAGO, IL. FILED 1-9-2011.



THE MARK CONSISTS OF A BIRD WITH THE WORD  
"TROPICAL" IN A BANNER ABOVE AND THE WORD  
"REGARDS" IN A BANNER BELOW THE BIRD.

FOR CUTTING BOARDS (U.S. CLS. 2, 13, 23, 29, 30, 33,  
40 AND 50).

DAVID TAYLOR, EXAMINING ATTORNEY

---

SN 85-214,510. HEWY'S WINE CHILLERS, LLC, ORLANDO,  
FL. FILED 1-10-2011.

# Corkcicle

THE MARK CONSISTS OF STANDARD CHARACTERS  
WITHOUT CLAIM TO ANY PARTICULAR FONT, STYLE,  
SIZE, OR COLOR.

FOR BOTTLE STOPPERS SPECIALLY ADAPTED FOR  
USE WITH WINE BOTTLES; COOLERS FOR WINE (U.S.  
CLS. 2, 13, 23, 29, 30, 33, 40 AND 50).

MARC LEIPZIG, EXAMINING ATTORNEY

---

SN 85-216,258. BBBT, LLC, NEW EGYPT, NJ. FILED 1-12-  
2011.

# BLAST IN A GLASS

THE MARK CONSISTS OF STANDARD CHARACTERS  
WITHOUT CLAIM TO ANY PARTICULAR FONT, STYLE,  
SIZE, OR COLOR.

FOR BEVERAGeware (U.S. CLS. 2, 13, 23, 29, 30, 33,  
40 AND 50).

STEPHANIE ALI, EXAMINING ATTORNEY

**CLASS 21—(Continued).**

SN 85-223,225. TELEBRANDS CORP., FAIRFIELD, NJ. FILED 1-21-2011.

**CHEFDINI**

THE MARK CONSISTS OF STANDARD CHARACTERS WITHOUT CLAIM TO ANY PARTICULAR FONT, STYLE, SIZE, OR COLOR.

FOR HAND-OPERATED SALSA MAKER (U.S. CLS. 2, 13, 23, 29, 30, 33, 40 AND 50).

KRISTIN DAHLING, EXAMINING ATTORNEY

SN 85-223,910. EVRIHOLDER PRODUCTS LLC, ANAHEIM, CA. FILED 1-23-2011.

**FUZZY FINGERS**

THE MARK CONSISTS OF STANDARD CHARACTERS WITHOUT CLAIM TO ANY PARTICULAR FONT, STYLE, SIZE, OR COLOR.

FOR CLEANING MITTS OF FABRIC (U.S. CLS. 2, 13, 23, 29, 30, 33, 40 AND 50).

KAREN BRACEY, EXAMINING ATTORNEY

SN 85-228,194. FREMANTLE MEDIA NORTH AMERICA, INC., BURBANK, CA. AND SIMCO LIMITED, LONDON, UNITED KINGDOM, FILED 1-27-2011.

**THE X FACTOR**

THE MARK CONSISTS OF STANDARD CHARACTERS WITHOUT CLAIM TO ANY PARTICULAR FONT, STYLE, SIZE, OR COLOR.

FOR BATH SPONGES; BOXES FOR DISPENSING PAPER TOWELS; BREAD BINS; CANDLE HOLDERS; CHARMS FOR ATTACHMENT TO BEVERAGE GLASSWARE FOR IDENTIFICATION PURPOSES; MUGS; COMBS; CONTAINERS FOR HOUSEHOLD USE; CUPS; DINNERWARE; DISHWARE; HAIR, NAIL AND TOOTH BRUSHES; ELECTRIC TOOTHBRUSHES; IRONING BOARD COVERS; LUNCH BOXES; PLATES; WASTE BASKETS; CERAMIC TISSUE BOX COVER; TOILET TISSUE HOLDER; DISPENSERS FOR LIQUID SOAPS; DISPENSERS FOR PAPER TOWELS; SOAP DISPENSERS; TOILET PAPER DISPENSERS; TOOTHBRUSH HOLDERS; SOAP DISHES; SOAP HOLDERS; SHOWER CADDIES (U.S. CLS. 2, 13, 23, 29, 30, 33, 40 AND 50).

TAMARA FRAZIER, EXAMINING ATTORNEY

**CLASS 21—(Continued).**

SN 85-228,209. THE GLAD PRODUCTS COMPANY, OAKLAND, CA. FILED 1-27-2011.

**LOCKWARE**

THE MARK CONSISTS OF STANDARD CHARACTERS WITHOUT CLAIM TO ANY PARTICULAR FONT, STYLE, SIZE, OR COLOR.

OWNER OF U.S. REG. NOS. 2,055,001, 2,464,426 AND 3,620,543.

FOR RIGID PLASTIC CONTAINERS FOR FOOD (U.S. CLS. 2, 13, 23, 29, 30, 33, 40 AND 50).

PAUL E. FAHRENKOPF, EXAMINING ATTORNEY

SN 85-231,428. PACIFIC WORLD CORPORATION, LAKE FOREST, CA. FILED 2-1-2011.



THE MARK CONSISTS OF A STYLIZED LOWER CASE "G" FOLLOWED BY A STYLIZED UPPER CASE "G".

FOR MAKE-UP BRUSHES; COMBS; HAIR BRUSHES; BATH TOOLS, NAMELY, BRUSHES, SPONGES, LOOFAHS AND BODY SCRUBBING PUFFS (U.S. CLS. 2, 13, 23, 29, 30, 33, 40 AND 50).

HOWARD SMIGA, EXAMINING ATTORNEY

SN 85-232,725. HANNON GROUP LTD., BURLINGTON, WI. FILED 2-2-2011.

**KORA**

THE MARK CONSISTS OF STANDARD CHARACTERS WITHOUT CLAIM TO ANY PARTICULAR FONT, STYLE, SIZE, OR COLOR.

FOR INSULATED BAGS FOR FOOD OR BEVERAGE FOR DOMESTIC USE; INSULATED CONTAINERS FOR BEVERAGE CANS FOR DOMESTIC USE; INSULATED CONTAINERS FOR FOOD OR BEVERAGE FOR DOMESTIC USE; THERMAL INSULATED BAGS FOR FOOD OR BEVERAGES; THERMAL INSULATED CONTAINERS FOR FOOD OR BEVERAGES (U.S. CLS. 2, 13, 23, 29, 30, 33, 40 AND 50).

VERNA BETH RIRIE, EXAMINING ATTORNEY

**CLASS 21—(Continued).**

SN 85-235,793. ARDEN CORPORATION, BINGHAM FARMS, MI. FILED 2-7-2011.

# HEATZA

THE MARK CONSISTS OF STANDARD CHARACTERS WITHOUT CLAIM TO ANY PARTICULAR FONT, STYLE, SIZE, OR COLOR.

FOR THERMAL INSULATED BAGS FOR KEEPING PIZZA HOT (U.S. CLS. 2, 13, 23, 29, 30, 33, 40 AND 50).  
ROSELLE HERRERA, EXAMINING ATTORNEY

**CLASS 22—CORDAGE AND FIBERS**

SN 85-043,181. MEKLER, JOAN, OCEANSIDE, CA. FILED 5-19-2010.



THE STIPPLING IS FOR SHADING PURPOSES ONLY.

THE MARK CONSISTS OF THE STYLIZED WORDING "NO LOST SOCKS". THE TERM "NO" APPEARS VERTICALLY, WITH THE TERM "LOST" APPEARS HORIZONTALLY AND UTILIZES THE LETTER "O" IN THE WORD "NO". THE TERM "SOCKS" APPEARS VERTICALLY AND UTILIZES THE LETTER "S" IN "LOST", THE LETTER "C" IN "SOCKS" IS WITHIN A DESIGN OF A SOCK WITH A FACE WITH EYES AND THE LETTER "C" IN THE TERM "SOCKS" FORMS THE MOUTH.

FOR LAUNDRY BAGS (U.S. CLS. 1, 2, 7, 19, 22, 42 AND 50).

CHRISTINA SOBRAL, EXAMINING ATTORNEY

SN 85-235,802. ARDEN CORPORATION, BINGHAM FARMS, MI. FILED 2-7-2011.



THE MARK CONSISTS OF THE WORD HEATZA! ENCLOSED IN A FLAME.

FOR THERMAL INSULATED BAGS FOR KEEPING PIZZA HOT (U.S. CLS. 2, 13, 23, 29, 30, 33, 40 AND 50).  
ROSELLE HERRERA, EXAMINING ATTORNEY

SN 85-181,177. FIRST SLING TECHNOLOGY LLC, MUSTANG, OK. FILED 11-19-2010.



OWNER OF U.S. REG. NO. 3,357,427.

NO CLAIM IS MADE TO THE EXCLUSIVE RIGHT TO USE "FULL INSPECTION ROUNDSLING TECHNOLOGY", APART FROM THE MARK AS SHOWN.

THE MARK CONSISTS OF THE WORD "FIRST" IN UPPER CASE WITH THE WORDS "FULL INSPECTION ROUNDSLING TECHNOLOGY" IN SMALLER LETTERS UNDERNEATH, ALL IN A STYLIZED FORMAT.

FOR CARGO SLINGS OF ROPE OR FABRIC; NON-METAL SLINGS FOR LOADING (U.S. CLS. 1, 2, 7, 19, 22, 42 AND 50).

PAM WILLIS, EXAMINING ATTORNEY

**CLASS 22—(Continued).**

SN 85-198,821. LANUZA, CRAIG S., VENTURA, CA. FILED 12-15-2010.

# RECORE

THE MARK CONSISTS OF STANDARD CHARACTERS WITHOUT CLAIM TO ANY PARTICULAR FONT, STYLE, SIZE, OR COLOR.

FOR POLYESTER BATTING (U.S. CLS. 1, 2, 7, 19, 22, 42 AND 50).

FIRST USE 1-1-2002; IN COMMERCE 1-1-2002.  
MARY ROSSMAN, EXAMINING ATTORNEY

---

SN 85-205,049. TRITENDA, LLC, SPOKANE, WA. FILED 12-23-2010.

# TRITENDA

THE MARK CONSISTS OF STANDARD CHARACTERS WITHOUT CLAIM TO ANY PARTICULAR FONT, STYLE, SIZE, OR COLOR.

FOR TENTS; AWNINGS OF FABRIC; AWNINGS OF PLASTIC; PORTABLE CHANGING TENTS (U.S. CLS. 1, 2, 7, 19, 22, 42 AND 50).

MORGAN WYNNE, EXAMINING ATTORNEY

---

SN 85-209,020. LEIGH FIBERS, WELLFORD, SC. FILED 1-3-2011.

# QuietLeigh

THE MARK CONSISTS OF STANDARD CHARACTERS WITHOUT CLAIM TO ANY PARTICULAR FONT, STYLE, SIZE, OR COLOR.

FOR RAW TEXTILE FIBERS (U.S. CLS. 1, 2, 7, 19, 22, 42 AND 50).

HEATHER BIDDULPH, EXAMINING ATTORNEY

**CLASS 22—(Continued).**

SN 85-210,377. DEMCO INCORPORATED, LAGUNA BEACH, CA. FILED 1-4-2011.



THE MARK CONSISTS OF IMAGE OF A PALM TREE FOLLOWED BY THE WORDS SHADE SHACK.

FOR TENTS (U.S. CLS. 1, 2, 7, 19, 22, 42 AND 50).

FIRST USE 3-4-2009; IN COMMERCE 1-26-2010.

GINA FINK, EXAMINING ATTORNEY

**CLASS 23—YARNS AND THREADS**

SN 77-946,964. SAPONA MANUFACTURING COMPANY, INC., CEDAR FALLS, NC. FILED 3-1-2010.

# Cool-Wick

THE MARK CONSISTS OF STANDARD CHARACTERS WITHOUT CLAIM TO ANY PARTICULAR FONT, STYLE, SIZE, OR COLOR.

FOR COVERED RUBBER THREAD AND YARN; ELASTIC YARN; KNITTING YARN; REGENERATED FIBER THREAD AND YARN; SEWING THREAD AND YARN; SEWING YARN; SYNTHETIC FIBER THREAD AND YARN; SYNTHETIC YARN; THREADS AND YARNS; TWISTED YARN; WOOL BASE MIXED THREAD AND YARN; YARN; YARN AND THREAD FOR TEXTILE PURPOSES; YARNS AND THREADS FOR TEXTILE USE (U.S. CL. 43).

FIRST USE 2-1-2010; IN COMMERCE 2-1-2010.

LINDA ESTRADA, EXAMINING ATTORNEY

**CLASS 24—FABRICS**

SN 77-915,262. HARVEST CONSUMER INSULATION, INC., CLINTON, TN. FILED 1-19-2010.

**THE CONTINUOUS FILAMENT  
ADVANTAGE**

THE MARK CONSISTS OF STANDARD CHARACTERS WITHOUT CLAIM TO ANY PARTICULAR FONT, STYLE, SIZE, OR COLOR.

NO CLAIM IS MADE TO THE EXCLUSIVE RIGHT TO USE "CONTINUOUS FILAMENT", APART FROM THE MARK AS SHOWN.

FOR SYNTHETIC FIBER FABRICS FOR THERMAL INSULATION, MADE OF CONTINUOUS FILAMENTS, USED IN CONNECTION WITH THE MANUFACTURE OF OUTERWEAR, SLEEPING BAGS, FOOTWEAR, HATS, GLOVES, COMFORTERS, AND CLOTHING (U.S. CLS. 42 AND 50).

CHARISMA HAMPTON, EXAMINING ATTORNEY

**CLASS 24—(Continued).**

SN 85-071,755. VELCRO INDUSTRIES B.V., CURACAO, NETHERLANDS ANTILLES, FILED 6-25-2010.



OWNER OF U.S. REG. NOS. 1,846,829, 2,225,651 AND OTHERS.

THE MARK CONSISTS OF THE STYLIZED WORDING "VELCRO", TO THE LEFT OF WHICH IS A CIRCULAR DESIGN WITH A STYLIZED "V" STRETCHING FROM ONE SIDE OF THE CIRCULAR DESIGN TO THE OTHER. THE STIPPLING IN THE CIRCULAR DESIGN AND THE STYLIZED "V" IS INTENDED TO INDICATE CONTRAST.

FOR FABRICS AND TEXTILES AND SUBSTITUTES THEREFOR, NAMELY, WOVEN, MOLDED, NON-WOVEN OR EXTRUDED SYNTHETIC MATERIAL HAVING A SURFACE OF HOOKS AND WOVEN SYNTHETIC MATERIAL HAVING A SURFACE OF LOOPS (U.S. CLS. 42 AND 50).

JAMES STEIN, EXAMINING ATTORNEY

SN 85-123,118. WYATT, REBECCA ANN, DBA AUNT BUCKY, SANTA CRUZ, CA. FILED 9-3-2010.



THE MARK CONSISTS OF THE WORDS "MADE WITH" AND A HEART FIGURE OVER A SHADED RECTANGLE.

FOR BED BLANKETS; BED SHEETS; BED SKIRTS; BED THROWS; CRIB BUMPER PADS; QUILT COVERS; QUILTS; QUILTS OF TEXTILE (U.S. CLS. 42 AND 50).

FIRST USE 9-7-2008; IN COMMERCE 9-7-2008.

MICHAEL SOUDERS, EXAMINING ATTORNEY

SN 85-069,146. DISNEY ONLINE STUDIOS CANADA INC., VANCOUVER, CANADA, FILED 6-22-2010.

**CLUB PENGUIN**

THE MARK CONSISTS OF STANDARD CHARACTERS WITHOUT CLAIM TO ANY PARTICULAR FONT, STYLE, SIZE, OR COLOR.

FOR AFGHANS; BARBECUE MITTS; BATH LINEN; BED BLANKETS; BED CANOPIES; BED LINEN; CHILDREN'S BLANKETS; CLOTH PENNANTS; CRIB BUMPERS; CURTAINS; FABRICS FOR TEXTILE USE; FABRIC FLAGS; FELT PENNANTS; HANDKERCHIEFS; HOUSEHOLD LINEN; KITCHEN LINEN; RECEIVING BLANKETS; SILK BLANKETS; THROWS; TABLE LINEN; TOWELS; TEXTILE FABRICS FOR HOME INTERIORS; WOOLLEN BLANKETS (U.S. CLS. 42 AND 50).

ELIZABETH KAJUBI, EXAMINING ATTORNEY

SN 85-129,849. SPRINGS GLOBAL US, INC., FORT MILL, SC. FILED 9-15-2010.

**EZ TAB**

THE MARK CONSISTS OF STANDARD CHARACTERS WITHOUT CLAIM TO ANY PARTICULAR FONT, STYLE, SIZE, OR COLOR.

NO CLAIM IS MADE TO THE EXCLUSIVE RIGHT TO USE "TAB", APART FROM THE MARK AS SHOWN.

FOR DRAPERY; INDOOR AND OUTDOOR CURTAINS (U.S. CLS. 42 AND 50).

MARK SHINER, EXAMINING ATTORNEY

**CLASS 24—(Continued).**

SN 85-141,838. KAS AUSTRALIA PTY LIMITED, ALEXANDRIA, AUSTRALIA, FILED 9-30-2010.

## SMITH & BLAKE

THE MARK CONSISTS OF STANDARD CHARACTERS WITHOUT CLAIM TO ANY PARTICULAR FONT, STYLE, SIZE, OR COLOR.

FOR CUSHION COVERS; UNFITTED FABRIC FURNITURE COVERS FOR CHAIRS; CURTAINS; BED SHEETS; BED LINEN; BED COVERS, NAMELY, COMFORTERS, THROWS, AND BED BLANKETS; BED SKIRTS; QUILT SETS COMPRISED OF PILLOW CASES, BED SHEETS, QUILT COVERS AND QUILTS; COVERLETS IN THE NATURE OF BED RUGS; TEXTILE PLACEMATS; TEXTILE NAPKINS; TEXTILE TABLECLOTHS; TOWELS; TEA TOWELS (U.S. CLS. 42 AND 50).  
WILLIAM VERHOSEK, EXAMINING ATTORNEY

---

SN 85-147,340. DENA DESIGNS, INC., LAFAYETTE, CA. FILED 10-7-2010.

## HAUTE GIRL

THE MARK CONSISTS OF STANDARD CHARACTERS WITHOUT CLAIM TO ANY PARTICULAR FONT, STYLE, SIZE, OR COLOR.

THE ENGLISH TRANSLATION OF THE WORD "HAUTE" IN THE MARK IS "HIGH".

FOR TEXTILE NAPKINS, TABLECLOTHS NOT OF PAPER, TABLE LINENS, DINING LINENS, PLACE MATS NOT OF PAPER, FABRIC TABLE RUNNERS, FABRICS FOR TEXTILE USE, OVEN MITTS, KITCHEN TOWELS, BED BLANKETS, BED CANOPIES, DUST RUFFLES, BED LINENS, BED PADS, BED SHEETS, BABY BED SHEETS, DUVETS, DUVET COVERS, AFGHANS, CUSHION COVERS, DRAPERIES, CURTAINS, SWAGS, BATH TOWELS, FACE CLOTHS, WASH CLOTHS, BED SPREADS, PILLOW CASES, PILLOW COVERS, PILLOW SHAMS, UPHOLSTERY FABRICS, UNFITTED FABRIC FURNITURE COVERS (U.S. CLS. 42 AND 50).  
NAAKWAMA ANKRAH, EXAMINING ATTORNEY

**CLASS 24—(Continued).**

SN 85-162,216. KAS AUSTRALIA PTY LIMITED, ALEXANDRIA NSW, AUSTRALIA, FILED 10-27-2010.

## KAS

THE MARK CONSISTS OF STANDARD CHARACTERS WITHOUT CLAIM TO ANY PARTICULAR FONT, STYLE, SIZE, OR COLOR.

OWNER OF U.S. REG. NOS. 2,905,467 AND 2,905,471.  
FOR CUSHION COVERS; CURTAINS; BED SHEETS; BED LINEN; BED COVERS, NAMELY, COMFORTER, THROWS AND BED BLANKETS; BED SKIRTS; QUILT SETS COMPRISED OF PILLOW CASES, BED SHEETS, QUILT COVERS AND QUILTS; PILLOW CASES; COVERLETS IN THE NATURE OF BED RUGS; TEXTILE PLACEMATS; TEXTILE POT HOLDERS; TEXTILE OVEN GLOVES; TEXTILE NAPKINS; TOWELS; TEA TOWELS; UNFITTED FABRIC FURNITURE COVERS; TABLECLOTHS NOT OF PAPER (U.S. CLS. 42 AND 50).  
WILLIAM VERHOSEK, EXAMINING ATTORNEY

---

SN 85-166,261. ALDRIDGE, JANE, MILWAUKEE, WI. FILED 11-1-2010.

## HAPPY HEAD

THE MARK CONSISTS OF STANDARD CHARACTERS WITHOUT CLAIM TO ANY PARTICULAR FONT, STYLE, SIZE, OR COLOR.

NO CLAIM IS MADE TO THE EXCLUSIVE RIGHT TO USE "HEAD", APART FROM THE MARK AS SHOWN.

FOR MOISTURE-WICKING HEAD TOWELS (U.S. CLS. 42 AND 50).  
GIANCARLO CASTRO, EXAMINING ATTORNEY



**CLASS 24—(Continued).**

SN 85-182,445. SALT LIFE HOLDINGS, LLC, JACKSONVILLE, FL. FILED 11-22-2010.

# SALT LIFE

THE MARK CONSISTS OF STANDARD CHARACTERS WITHOUT CLAIM TO ANY PARTICULAR FONT, STYLE, SIZE, OR COLOR.

OWNER OF U.S. REG. NOS. 3,001,343, 3,843,123 AND OTHERS.

FOR BANNERS AND FLAGS OF TEXTILE; BATHROOM, BEDROOM AND KITCHEN LINENS AND TOWELS; BEACH TOWELS; BLANKETS, NAMELY, BED BLANKETS, BLANKET THROWS, BLANKETS FOR OUTDOOR USE, AND LAP BLANKETS; CLOTH BANNERS; FABRICS FOR TEXTILE USE; FURNISHING AND UPHOLSTERY FABRICS; BED SHEETS AND PILLOWCASES; TABLE LINEN, NAMELY, TABLE CLOTHS, COASTERS, PLACEMATS AND NAPKINS; TABLECLOTHS, NOT OF PAPER; TOWELS (U.S. CLS. 42 AND 50).

APRIL HESIK, EXAMINING ATTORNEY

**CLASS 24—(Continued).**

SN 85-188,941. MARC DE COURCY, COLLEGE PARK, GA. FILED 12-2-2010.

# Invigo Fresh

THE MARK CONSISTS OF STANDARD CHARACTERS WITHOUT CLAIM TO ANY PARTICULAR FONT, STYLE, SIZE, OR COLOR.

FOR BED BLANKETS; BED COVERS; BED LINEN; BED SHEETS; BED SPREADS; BLANKET THROWS; COMFORTERS; CONTOUR SHEETS; DUVET COVERS; DUVETS; FITTED BED SHEETS; FLAT BED SHEETS; MATTRESS COVERS; MATTRESS PADS; PILLOW SHAMS; PILLOWCASES; SHEET SETS (U.S. CLS. 42 AND 50).

PAUL MORENO, EXAMINING ATTORNEY

SN 85-203,683. ARDEN CORPORATION, BINGHAM FARMS, MI. FILED 12-22-2010.

# EVERTRU

THE MARK CONSISTS OF STANDARD CHARACTERS WITHOUT CLAIM TO ANY PARTICULAR FONT, STYLE, SIZE, OR COLOR.

FOR FABRIC FOR USE IN THE MANUFACTURE OF OUTDOOR PRODUCTS, NAMELY, CUSHIONS AND UMBRELLAS (U.S. CLS. 42 AND 50).

ROSELLE HERRERA, EXAMINING ATTORNEY

SN 85-205,871. AIKATERINA LLC, NEW ORLEANS, LA. FILED 12-27-2010.

# Body Flosser

THE MARK CONSISTS OF STANDARD CHARACTERS WITHOUT CLAIM TO ANY PARTICULAR FONT, STYLE, SIZE, OR COLOR.

FOR TOWELS; WASHCLOTHS (U.S. CLS. 42 AND 50). FIRST USE 11-10-2009; IN COMMERCE 11-10-2009.

EUGENIA MARTIN, EXAMINING ATTORNEY

SN 85-182,745. THOMAS ROTH, LLC, WESTPORT, CT. FILED 11-22-2010.



THE COLOR(S) BLUE IS/ARE CLAIMED AS A FEATURE OF THE MARK.

THE MARK CONSISTS OF AN OVAL WITH A DOUBLE OUTLINE, WITHIN WHICH IS A HORSE WEATHERVANE AND THE WORDS "WEATHERVANE HILL", ALL IN COLOR BLUE.

FOR CURTAIN FABRIC; CURTAINS; DRAPERIES; DRAPERY; FURNISHING AND UPHOLSTERY FABRICS; INTERIOR DECORATION FABRICS; TABLE AND BED LINEN; UPHOLSTERY FABRICS (U.S. CLS. 42 AND 50).

FIRST USE 7-8-1997; IN COMMERCE 7-8-1997.

SOPHIA S. KIM, EXAMINING ATTORNEY

**CLASS 24—(Continued).**

SN 85-206,489. LOFTEX USA LLC, NEW YORK, NY. FILED 12-28-2010.

**ROLL AND GO**

THE MARK CONSISTS OF STANDARD CHARACTERS WITHOUT CLAIM TO ANY PARTICULAR FONT, STYLE, SIZE, OR COLOR.  
FOR TOWELS (U.S. CLS. 42 AND 50).  
JESSICA FATHY, EXAMINING ATTORNEY

---

SN 85-206,507. LOFTEX USA LLC, NEW YORK, NY. FILED 12-28-2010.

**TEXTER DUDE**

THE MARK CONSISTS OF STANDARD CHARACTERS WITHOUT CLAIM TO ANY PARTICULAR FONT, STYLE, SIZE, OR COLOR.  
FOR TOWELS (U.S. CLS. 42 AND 50).  
JESSICA FATHY, EXAMINING ATTORNEY

---

SN 85-206,536. VICTORIA CLASSICS LTD, NEW YORK, NY. FILED 12-28-2010.

**MODERN ELEMENTS**

THE MARK CONSISTS OF STANDARD CHARACTERS WITHOUT CLAIM TO ANY PARTICULAR FONT, STYLE, SIZE, OR COLOR.  
FOR TEXTILE FABRICS FOR HOME AND COMMERCIAL INTERIORS (U.S. CLS. 42 AND 50).  
JAY FLOWERS, EXAMINING ATTORNEY

**CLASS 24—(Continued).**

SN 85-206,848. JC 23 ENTERTAINMENT, INC., BEVERLY HILLS, CA. FILED 12-28-2010.



THE MARK CONSISTS OF STYLIZED CHARACTER SITTING IN YOGA STYLE.  
FOR BEDDING, NAMELY, QUILTS, SHAMS, DUVET COVERS, PILLOW COVERS, LINENS, TOWELS; TABLE TOP GOODS, NAMELY, FABRIC TABLE CLOTHS, FABRIC TABLE RUNNERS, TEXTILE NAPKINS, FABRIC PLACE MATS, POT HOLDERS, DISH TOWELS; TAPESTRIES OF TEXTILE; PET BLANKETS (U.S. CLS. 42 AND 50).  
CYNTHIA SLOAN, EXAMINING ATTORNEY

---

SN 85-207,908. WADHWANI, CHANDRU, GARDEN GROVE, CA. FILED 12-30-2010.

THE MARK CONSISTS OF THE STYLIZED TEXT "HOMESENSE" INSIDE A RECTANGLE SHAPE.  
FOR BED BLANKETS; BED SHEETS; COMFORTERS; CUSHION COVERS; DUVETS; LAP BLANKETS; PILLOW CASES; THROWS; TOWELS (U.S. CLS. 42 AND 50).  
GEORGE LORENZO, EXAMINING ATTORNEY

---

SN 85-210,730. VICTORIA CLASSICS LTD, NEW YORK, NY. FILED 1-5-2011.

**REALITY**

THE MARK CONSISTS OF STANDARD CHARACTERS WITHOUT CLAIM TO ANY PARTICULAR FONT, STYLE, SIZE, OR COLOR.  
FOR TEXTILE FABRICS FOR HOME AND COMMERCIAL INTERIORS (U.S. CLS. 42 AND 50).  
JAY FLOWERS, EXAMINING ATTORNEY

**CLASS 24—(Continued).**

SN 85-212,131. VALSPAR SOURCING, INC., MINNEAPOLIS, MN. FILED 1-6-2011.

**COMFORTMARK**

THE MARK CONSISTS OF STANDARD CHARACTERS WITHOUT CLAIM TO ANY PARTICULAR FONT, STYLE, SIZE, OR COLOR.

FOR MATTRESS PROTECTORS; PILLOW PROTECTORS; BOX SPRING ENCASEMENTS (U.S. CLS. 42 AND 50).

HEATHER SAPP, EXAMINING ATTORNEY

SN 85-213,635. AMY SECKINGER, DELAFIELD, WI. FILED 1-9-2011.



THE MARK CONSISTS OF THE CONFIGURATION OF A BATH COVER.

FOR BATH COVERS, NAMELY, LARGE CLOTHS USED FOR INFANT AND CHILD BATHING (U.S. CLS. 42 AND 50).

FIRST USE 10-1-2007; IN COMMERCE 10-1-2007.  
ERNEST SHOSHO, EXAMINING ATTORNEY

**CLASS 24—(Continued).**

SN 85-214,258. SAINT LOUIS UNIVERSITY, ST. LOUIS, MO. FILED 1-10-2011.



THE MARK CONSISTS OF A STYLIZED DEPICTION OF THE HEAD OF A CHARM DOLL (A "BILLIKEN") WITH TWO POINTED EARS AND A TUFT OF HAIR ON THE TOP OF ITS HEAD. THE MOUTH IS CURVED AND THE RIGHT EYE IS CLOSED.

FOR CLOTH BANNERS; THROW BLANKETS; CLOTH PENNANTS; TABLECLOTHS OF TEXTILES (U.S. CLS. 42 AND 50).

FIRST USE 0-0-2000; IN COMMERCE 0-0-2000.

KARANENDRA S. CHHINA, EXAMINING ATTORNEY

SN 85-228,201. FREMANTLE MEDIA NORTH AMERICA, INC., BURBANK, CA. AND SIMCO LIMITED, LONDON, UNITED KINGDOM, FILED 1-27-2011.

**THE X FACTOR**

THE MARK CONSISTS OF STANDARD CHARACTERS WITHOUT CLAIM TO ANY PARTICULAR FONT, STYLE, SIZE, OR COLOR.

FOR BATH GLOVES; BATH LINEN; BATH SHEETS AND TOWELS; BEACH TOWELS; BED AND TABLE LINEN; COVERS FOR CUSHIONS; CURTAINS; DUVET COVERS; HANDKERCHIEFS; PILLOW COVERS; WALL HANGINGS OF TEXTILE; HOODED TOWELS; KITCHEN TOWELS; TOWEL SETS; TOWELS; QUILTS; BED SHEETS; DUST RUFFLES; FABRIC WINDOW COVERINGS AND TREATMENTS, NAMELY, CURTAINS, DRAPERIES, SHEERS, SWAGS AND VALANCES (U.S. CLS. 42 AND 50).

TAMARA FRAZIER, EXAMINING ATTORNEY

**CLASS 24—(Continued).**

SN 85-239,775. WADHWANI, CHANDRU, GARDEN GROVE, CA. FILED 2-11-2011.



THE MARK CONSISTS OF THE STYLIZED TEXT "HOMESENSE" WITH TWO BRUSH STROKES IN THE MIDDLE.

FOR BED BLANKETS; BED SHEETS; COMFORTERS; CUSHION COVERS; DUVETS; LAP BLANKETS; PILLOW CASES; TOWELS; TOWELS (U.S. CLS. 42 AND 50).

FIRST USE 1-18-2011; IN COMMERCE 1-18-2011.  
GEORGE LORENZO, EXAMINING ATTORNEY

**CLASS 25—(Continued).**

SN 76-705,807. TRAHIN, ELIZABETH L., LARWILL, IN. FILED 12-27-2010.

## EPIPHANY

THE MARK CONSISTS OF STANDARD CHARACTERS WITHOUT CLAIM TO ANY PARTICULAR FONT, STYLE, SIZE, OR COLOR.

FOR ABSORBENT LINING FOR UNDERWEAR USED BY THE ELDERLY (U.S. CLS. 22 AND 39).  
NAKIA HENRY, EXAMINING ATTORNEY

SN 76-705,808. HOCKER, TERRI, LA GRANDE, OR. FILED 12-27-2010.

## LUCKY 4 ME

**CLASS 25—CLOTHING**

SN 76-294,340. TREVIRA GMBH, FRANKFURT AM MAIN, FED REP GERMANY, FILED 8-2-2001.



FOR ARTICLE OF CLOTHING, NAMELY, JACKETS, COATS, RAINCOATS, WIND-RESISTANT JACKETS, PANTS, SKI WEAR, SHORTS, SKIRTS, BLOUSES, DRESSES, HEADWEAR, HATS, GLOVES, SHOES, FOUL-WEATHER GEAR, JOGGING SUITS, MUFFLERS, COVERALLS, SNOW SUITS, TENNIS WEAR AND UNDERWEAR, EXCLUDING HOSIERY (U.S. CLS. 22 AND 39).

JULIE WATSON, EXAMINING ATTORNEY

THE MARK CONSISTS OF STANDARD CHARACTERS WITHOUT CLAIM TO ANY PARTICULAR FONT, STYLE, SIZE, OR COLOR.

FOR PLASTIC DISPOSABLE BIB THAT IS USED BY ADULTS, ESPECIALLY SENIORS, TO COVER THEIR SHIRTS WHILE EATING (U.S. CLS. 22 AND 39).  
NAKIA HENRY, EXAMINING ATTORNEY

SN 76-705,916. IN MOCEAN GROUP, L.L.C., NEW YORK, NY. FILED 1-6-2011.

## SUDDENLY ADD TWO CUP SIZES

THE MARK CONSISTS OF STANDARD CHARACTERS WITHOUT CLAIM TO ANY PARTICULAR FONT, STYLE, SIZE, OR COLOR.

FOR CLOTHING, NAMELY, SWIMWEAR, BEACHWEAR, BATHING SUITS, SHIRTS, COVER-UPS, SWIM DRESSES, COVER DRESSES, TOPS, BODYSUITS, BRA TOPS, T-SHIRTS, TANK TOPS, AND JOGGING SUITS (U.S. CLS. 22 AND 39).

LINDA ORNDORFF, EXAMINING ATTORNEY

**CLASS 25—(Continued).**

SN 77-001,736. JACO PASTORIUS, INC., NEW YORK, NY. FILED 9-18-2006.

**JACO PASTORIUS**

THE MARK CONSISTS OF STANDARD CHARACTERS WITHOUT CLAIM TO ANY PARTICULAR FONT, STYLE, SIZE, OR COLOR.

"JACO PASTORIUS" IS THE NAME OF AN INDIVIDUAL WHO IS NOW DECEASED.

FOR SHIRTS (U.S. CLS. 22 AND 39).

KAREN K. BUSH, EXAMINING ATTORNEY

**CLASS 25—(Continued).**

SN 77-486,724. MADELYN LANDO, MILLSTONE, NJ. FILED 5-29-2008.



THE COLOR(S) RED AND ORANGE IS/ARE CLAIMED AS A FEATURE OF THE MARK.

THE MARK CONSISTS OF THE WORD "TANTRUMS" WRITTEN IN RED, AND THE BACKGROUND IS ORANGE. FOR INFANT WEAR; INFANTS' TROUSERS (U.S. CLS. 22 AND 39).

PAULA MAHONEY, EXAMINING ATTORNEY

SN 77-302,410. CURVE INC., DBA CURVE CYCLING COMPONENTS, BOULDER, CO. FILED 10-12-2007.



THE MARK CONSISTS OF THE WORD "CURVE" INSIDE AN ELLIPSE.

FOR TECHNICAL SPORTS CLOTHING SPECIFICALLY DESIGNED FOR BICYCLING, NAMELY, JERSEYS, SHORTS WITH SPECIAL PADDING, JACKETS, VESTS, HATS TO BE WORN UNDER CYCLING HELMETS, PADDED GLOVES, SOCKS, POLYPROPYLENE AND POLYESTER UNDERSHIRTS, AND LONG PANTS WITH SPECIAL PADDING, THE FOREGOING SOLD DIRECTLY TO CYCLING TEAMS AND THROUGH SPECIALTY CYCLING RETAILERS; TECHNICAL SPORTS CLOTHING SPECIFICALLY DESIGNED FOR BICYCLING AND CUSTOM MADE FOR THE CUSTOMER WITH LOGOS AND GRAPHICS SPECIFIED BY THE CUSTOMER, NAMELY, SHIRTS, PANTS, SHORTS, JACKETS, AND HATS (U.S. CLS. 22 AND 39).

FIRST USE 11-15-2003; IN COMMERCE 11-15-2003.

ELI HELLMAN, EXAMINING ATTORNEY

SN 77-597,222. TIE RACK TRADING LIMITED, BRENTFORD, MIDDLESEX, UNITED KINGDOM, FILED 10-21-2008.



PRIORITY CLAIMED UNDER SEC. 44(D) ON UNITED KINGDOM APPLICATION NO. 2497492, FILED 9-11-2008, REG. NO. 2497492, DATED 3-13-2009, EXPIRES 9-11-2018.

OWNER OF U.S. REG. NOS. 1,484,209, 2,855,493 AND OTHERS.

NO CLAIM IS MADE TO THE EXCLUSIVE RIGHT TO USE "TIE" AND "LONDON", APART FROM THE MARK AS SHOWN.

THE COLOR(S) BROWN, ORANGE, AND WHITE IS/ARE CLAIMED AS A FEATURE OF THE MARK.

THE MARK CONSISTS OF BROWN RECTANGULAR BOX WITH AN ORANGE BORDER. INSIDE THE BOX, ON THE FIRST LINE, THE WORDS "TIE RACK" APPEAR CENTERED, IN ALL CAPITAL WHITE LETTERS. DIRECTLY BELOW THE WORDS "TIE RACK" THE WORD "LONDON" APPEARS CENTERED, IN ALL CAPITAL WHITE LETTERS.

FOR CLOTHING, NAMELY, TIES, BOWTIES, SCARVES, WRAPS, SHIRTS, GLOVES, BELTS, BOXER SHORTS, HOSIERY, UNDERWEAR, BEACHWEAR, JUMPERS, AND HEADGEAR, NAMELY, HATS, CAPS, AND HEADWEAR (U.S. CLS. 22 AND 39).

MICHAEL GAFFAR, EXAMINING ATTORNEY

SN 77-459,882. PARADISE PROPERTY INVESTMENTS, LLC, ST. GEORGE, UT. FILED 4-28-2008.

**CELEBRITY GIRL**

THE MARK CONSISTS OF STANDARD CHARACTERS WITHOUT CLAIM TO ANY PARTICULAR FONT, STYLE, SIZE, OR COLOR.

NO CLAIM IS MADE TO THE EXCLUSIVE RIGHT TO USE "GIRL", APART FROM THE MARK AS SHOWN.

FOR WOMEN'S CLOTHING, NAMELY, DRESSES, JACKETS, SKIRTS, SLACKS, JEANS, TROUSERS, PANTS, SHORTS, JUMPERS, BLOUSES, TOPS, KNIT TOPS, SHIRTS, LEGGINGS, SCARVES, BELTS, HEADBANDS, AND SHOES (U.S. CLS. 22 AND 39).

ALICE BENMAMAN, EXAMINING ATTORNEY

**CLASS 25—(Continued).**

SN 77-644,727. BACO, ARBELLA, ELMA, NY. AND YAKO, SHAMIRAN, ELMA, NY. FILED 1-7-2009.

# MrsMuzik

THE MARK CONSISTS OF STANDARD CHARACTERS WITHOUT CLAIM TO ANY PARTICULAR FONT, STYLE, SIZE, OR COLOR.

FOR CLOTHING, NAMELY, T-SHIRTS, POLO SHIRTS, FLEECE T-SHIRTS, FLEECE SHIRTS, APRONS, HATS AND SWEATSHIRTS (U.S. CLS. 22 AND 39).

SAIMA MAKHDOOM, EXAMINING ATTORNEY

SN 77-652,015. JUMP APPAREL CO., INC., NEW YORK, NY. FILED 1-19-2009.

# T I A N A B.

THE NAME(S), PORTRAIT(S), AND/OR SIGNATURE(S) SHOWN IN THE MARK DOES NOT IDENTIFY A PARTICULAR LIVING INDIVIDUAL.

THE MARK CONSISTS OF "TIANA B." IN CAPITAL LETTERS.

FOR CLOTHING AND APPAREL, NAMELY, DRESSES, EVENING AND DAY-INTO-EVENING DRESSES, SOCIAL OCCASION DRESSES, SHIRTS, BLOUSES, JUMPSUITS, SWEATERS, SHORTS, JEANS, T-SHIRTS, SWEATSHIRTS, SWEATPANTS, HEAD BANDS, BELTS, SWEAT BANDS, SHAWLS, UNDERGARMENTS, TIGHTS, BICYCLE SHORTS, SCARVES, TIES, SWIM SUITS AND FOOTWEAR (U.S. CLS. 22 AND 39).

FIRST USE 5-0-2005; IN COMMERCE 7-0-2005.  
KIMBERLY FRYE, EXAMINING ATTORNEY

SN 77-683,553. DJ SALES LLC, WILMINGTON, DE. FILED 3-4-2009.

# DANIEL BUCHLER

THE MARK CONSISTS OF STANDARD CHARACTERS WITHOUT CLAIM TO ANY PARTICULAR FONT, STYLE, SIZE, OR COLOR.

THE NAME(S), PORTRAIT(S), AND/OR SIGNATURE(S) SHOWN IN THE MARK IDENTIFIES "DANIEL BUCHLER", WHOSE CONSENT(S) TO REGISTER IS MADE OF RECORD.

FOR MEN'S, WOMEN AND CHILDREN'S CLOTHING, NAMELY, PANTS, SHORTS, LONG SLEEVE TOPS, SHORT SLEEVE TOPS, SHIRTS, BLOUSES, JACKETS, SCARVES, SWEATERS, ROBES, UNDERWEAR, SLIPPERS, TANK TOPS, PAJAMAS, LONG UNDERWEAR, SOCKS (U.S. CLS. 22 AND 39).

FIRST USE 4-1-2010; IN COMMERCE 4-1-2010.  
WARREN L. OLANDRIA, EXAMINING ATTORNEY

**CLASS 25—(Continued).**

SN 77-745,001. CHRISTY, TINA MARIE, RICHMOND, RI. FILED 5-26-2009.



NO CLAIM IS MADE TO THE EXCLUSIVE RIGHT TO USE "COUTURE", APART FROM THE MARK AS SHOWN. THE MARK CONSISTS OF GLOBE WEARING A CROWN, "ROCK ROYAL-T COUTURE" UNDER THE GLOBE.

FOR ATHLETIC APPAREL, NAMELY, SHIRTS, PANTS, JACKETS, FOOTWEAR, HATS AND CAPS, ATHLETIC UNIFORMS; CHILDREN'S AND INFANT'S APPAREL, NAMELY, JUMPERS, OVERALL SLEEPWEAR, PAJAMAS, ROMPERS AND ONE-PIECE GARMENTS; CLOTH BIBS; CLOTHING, NAMELY, WRAP-AROUNDS; COATS FOR MEN AND WOMEN; CORSETS; DUSTERS; FOOTWEAR FOR MEN AND WOMEN; JEANS; MEN'S AND WOMEN'S JACKETS, COATS, TROUSERS, VESTS; SHIRTS; SHOULDER WRAPS; SWEAT SHIRTS; T-SHIRTS; WEARABLE GARMENTS AND CLOTHING, NAMELY, SHIRTS; WOMEN'S SHOES; WRAPS (U.S. CLS. 22 AND 39).

NAKIA HENRY, EXAMINING ATTORNEY

SN 77-746,493. SUMRALL, DAVID, LONE OAK, TX. FILED 5-28-2009.



THE STIPPLING IS FOR SHADING PURPOSES ONLY. THE MARK CONSISTS OF THE STYLIZED WORD "STOP HATE" INSIDE AN IMAGE OF A STOP SIGN. THE STYLIZED WORD ".COM" IS BELOW INSIDE A RECTANGULAR SHAPED BOX WITH ROUNDED CORNERS.

FOR HATS; JACKETS; SHIRTS; SWEAT SHIRTS (U.S. CLS. 22 AND 39).

FIRST USE 9-1-1992; IN COMMERCE 9-1-1992.  
BARBARA RUTLAND, EXAMINING ATTORNEY

**CLASS 25—(Continued).**

SN 77-807,020. IRON FIST INTERNATIONAL, INC., SAN DIEGO, CA. FILED 8-18-2009.



OWNER OF U.S. REG. NO. 2,753,163.  
THE MARK CONSISTS OF A SKULL WITH CONTOURS AND SHADING IN EMBEDDED IN THE CENTER OF A SPADE. THE SPADE IS DECORATED WITH TWO SCYTHE-LIKE WINGS EXTENDING FROM THE JAW TO THE EYE SOCKETS FORMING A U-SHAPE AROUND THE SKULL, WITH DIAMOND-SHAPED DESIGNS SURROUNDING THE SCYTHE-LIKE WINGS. SITUATED AT BOTH SIDE OF THE UPPER PORTION OF THE SKULL, AND RESTING AT THE TOP OF SKULL ARE STAR-SHAPED DESIGNS. "IRON FIST" IS WRITTEN IN LARGE SHADOW FONT. THE PHRASE "IRON FIST: ROYAL HOUSE OF THE IMMORTALS" IS WRITTEN DIRECTLY UNDER THE BASE OF THE SPADE.

FOR CLOTHING, NAMELY, SHIRTS, TEE-SHIRTS, PANTS, SHORTS, SWEATS, JACKETS, COATS, HATS, UNDERGARMENTS, BATHING SUITS, DRESSES, BLOUSES, VESTS, SOCKS, BELTS, GLOVES, SCARVES; FOOTWEAR (U.S. CLS. 22 AND 39).

FIRST USE 1-1-2001; IN COMMERCE 1-1-2001.  
DARRYL SPRUILL, EXAMINING ATTORNEY

SN 77-818,991. TOMMY G PRODUCTIONS, LLC, PUEBLO, CO. FILED 9-2-2009.

**WOOL GONE WILD**

THE MARK CONSISTS OF STANDARD CHARACTERS WITHOUT CLAIM TO ANY PARTICULAR FONT, STYLE, SIZE, OR COLOR.

FOR LONG-SLEEVED T-SHIRTS; SWEAT SHIRTS; T-SHIRTS; ALL SOLD EXCLUSIVELY IN RELATION TO AND FOR THE PROMOTION OF SHEEP-RIDING EVENTS (U.S. CLS. 22 AND 39).

RON FAIRBANKS, EXAMINING ATTORNEY

**CLASS 25—(Continued).**

SN 77-820,990. GREG OTHOLT, CARLSBAD, CA. FILED 9-5-2009.

**SHYST3R**

THE MARK CONSISTS OF STANDARD CHARACTERS WITHOUT CLAIM TO ANY PARTICULAR FONT, STYLE, SIZE, OR COLOR.

FOR BELTS FOR CLOTHING; COATS; FOOTWEAR; GLOVES; HATS; JACKETS; PANTS; SHIRTS; SOCKS; SWEAT SHIRTS; TEE SHIRTS (U.S. CLS. 22 AND 39).

FIRST USE 5-1-2009; IN COMMERCE 5-1-2009.  
RUSS HERMAN, EXAMINING ATTORNEY

SN 77-832,292. SINGH SHIVRATTIE SUNITA, DBA SHIVANI, JAMAICA, NY. FILED 9-22-2009.

**Shivani**

THE MARK CONSISTS OF STANDARD CHARACTERS WITHOUT CLAIM TO ANY PARTICULAR FONT, STYLE, SIZE, OR COLOR.

THE WORDING "SHIVANI" HAS NO MEANING IN A FOREIGN LANGUAGE.

FOR (BASED ON USE IN COMMERCE) MEN'S JACKETS, COATS, TROUSERS, VESTS (BASED ON INTENT TO USE) COATS FOR MEN; MEN'S SUITS (U.S. CLS. 22 AND 39).

FIRST USE 6-1-2009; IN COMMERCE 6-1-2009.  
MICHELLE DUBOIS, EXAMINING ATTORNEY

SN 77-834,961. OX PRODUCTION V/PETTERSEN, STOKMARKNES, NORWAY, FILED 9-25-2009.



PRIORITY CLAIMED UNDER SEC. 44(D) ON NORWAY APPLICATION NO. 200908587, FILED 8-24-2009, REG. NO. 253015, DATED 10-14-2009, EXPIRES 10-14-2019.

THE MARK CONSISTS OF THE WORDS "FUZZ CLUB" IN STYLIZED FONT SHOWN AGAINST A SHADED SQUARE.

FOR T-SHIRTS (U.S. CLS. 22 AND 39).  
FIRST USE 1-2-2006; IN COMMERCE 2-6-2008.  
ESTHER BELENKER, EXAMINING ATTORNEY

**CLASS 25—(Continued).**

SN 77-837,943. PROFESSIONAL BULL RIDERS, INC., PUEBLO, CO. FILED 9-30-2009.

**WOOL WARRIORS**

THE MARK CONSISTS OF STANDARD CHARACTERS WITHOUT CLAIM TO ANY PARTICULAR FONT, STYLE, SIZE, OR COLOR.

FOR CLOTHING, NAMELY, SHIRTS, SWEATSHIRTS, BASEBALL STYLE CAPS, KNIT CAPS AND JACKETS, SOLD TO PROMOTE COMPETITIONS FEATURING CHILDREN RIDING SHEEP (U.S. CLS. 22 AND 39).

FIRST USE 6-23-2010; IN COMMERCE 6-23-2010.  
NELSON SNYDER, EXAMINING ATTORNEY

---

SN 77-863,698. ECOSANDALS, INC., WILMINGTON, DE. FILED 11-3-2009.

**SOLE PROVIDER**

THE MARK CONSISTS OF STANDARD CHARACTERS WITHOUT CLAIM TO ANY PARTICULAR FONT, STYLE, SIZE, OR COLOR.

FOR CLOTHING, NAMELY, T-SHIRTS; FOOTWEAR (U.S. CLS. 22 AND 39).

BARBARA A. GOLD, EXAMINING ATTORNEY

**CLASS 25—(Continued).**

SN 77-866,626. JANG, JAE YEUN, SEOUL, REPUBLIC OF KOREA, FILED 11-6-2009.



PRIORITY CLAIMED UNDER SEC. 44(D) ON REPUBLIC OF KOREA APPLICATION NO. 40-2009-0051, FILED 10-22-2009, REG. NO. 0849032, DATED 1-6-2001, EXPIRES 1-6-2021. THE MARK CONSISTS OF TWO FACE-TO-FACE FIGURES ABOVE THE WORDING "VICTOVIVI".

FOR ANGLERS' SHOES; ANKLE BOOTS; ATHLETIC FOOTWEAR; ATHLETIC UNIFORMS; BALLET SHOES; BANDANAS; BASEBALL CAPS; BASEBALL SHOES; BASKETBALL SNEAKERS; BATHING CAPS; BATHING SUITS; BEACH SHOES; BELTS MADE OF LEATHER; BERETS; BLAZERS; BLOUSES; BOOTS; JEANS; BOW TIES; BOWLING SHOES; BOXING SHOES; CARDIGANS; CLIMBING BOOTS; COATS; COMBINATIONS; COVERALLS; CUFFS; DECK-SHOES; DRESS SHIRTS; DRESS SUITS; DRESSES; EVENING DRESSES; GOLF CAPS; GOLF SHIRTS; GOLF SHOES; GOLF TROUSERS; GOWNS; GYMNASTIC SHOES; HANDBALL SHOES; HEEL PIECES FOR SHOES; HEELS; HOCKEY SHOES; HORSE-RIDING BOOTS; INFANT WEAR; INSOLES; JACKETS; JUDO SUITS; JUMPERS; KENDO OUTFITS; KNITTED CAPS; LACE BOOTS; LEATHER BELTS; LEATHER HEADWEAR; LEATHER PANTS; LEATHER SHOES; LEGGINGS; LONG JACKETS; MANTLES; MASQUERADE COSTUMES; MEN'S SOCKS; MEN'S SUITS; MOTORCYCLIST BOOTS; MOUNTAINEERING BOOTS; MUFFLERS; NECKTIES; OVERCOATS; PAJAMAS; PANTS; PANTYHOSE; PAREOS; PARKAS; POLO SHIRTS; PULLOVERS; RAIN COATS; RAINPROOF JACKETS; RUGBY SHOES; SABOTS; SANDALS; SCARFS; SCHOOL UNIFORMS; SHAWLS; SHIRTS; SHIRTS AND SHORT-SLEEVED SHIRTS; SHOES; SHORTS; SHOWER CAPS; SINGLET; SKI WEAR; SKIRTS; SLIPPERS; SLIPS; SOCKS; SOLES FOR FOOTWEAR; SPORT SHIRTS; SPORTS JACKETS; STOCKINGS; SUEDE JACKETS; SUITS; SUITS OF LEATHER; SUSPENDERS; SWEAT PANTS; SWEAT SHIRTS; SWEAT SUITS; SWEATERS; TEE SHIRTS; TENNIS SHOES; TIGHTS; TRACK AND FIELD SHOES; TRENCH COATS; TROUSERS; TROUSERS OF LEATHER; TWIN SETS; UNDERSHIRTS; UNDERSKIRTS; VESTS; VOLLEYBALL SHOES; WATERPROOF JACKETS AND PANTS; WEDDING DRESSES; WEDDING GOWNS; WET SUITS FOR WATER-SKIING AND SUB-AQUA; WIND COATS; WINTER BOOTS; WOMEN'S SHOES; WORK SHOES AND BOOTS; GLOVES (U.S. CLS. 22 AND 39).

KIMBERLY FRYE, EXAMINING ATTORNEY

---

SN 77-883,256. WASTE MANAGEMENT, INC., HOUSTON, TX. FILED 12-1-2009.

**RECYCLING ROCKS**

THE MARK CONSISTS OF STANDARD CHARACTERS WITHOUT CLAIM TO ANY PARTICULAR FONT, STYLE, SIZE, OR COLOR.

FOR CLOTHING, NAMELY, HATS, SHIRTS, T-SHIRTS, JACKETS, AND WIND-JACKETS (U.S. CLS. 22 AND 39).

ANNE FARRELL, EXAMINING ATTORNEY



**CLASS 25—(Continued).**

SN 77-910,003. MARK ROBINS, CARLSBAD, CA. FILED 1-12-2010.

**O.G.DANKSTER BUDS**

THE MARK CONSISTS OF STANDARD CHARACTERS WITHOUT CLAIM TO ANY PARTICULAR FONT, STYLE, SIZE, OR COLOR.

FOR APPAREL, NAMELY, T-SHIRTS, SHIRTS, SHORTS, PANTS, SWEATSHIRTS, SWEATPANTS, JACKETS, HATS, VISORS, SHOES, SANDALS, JACKETS, UNDERWEAR, SOCKS, AND BELTS (U.S. CLS. 22 AND 39).

SIMON TENG, EXAMINING ATTORNEY

---

 SN 77-937,427. THRU DOGS EYES INC., NEW YORK, NY. FILED 2-17-2010.
**ThruDogsEyes**

THE MARK CONSISTS OF STANDARD CHARACTERS WITHOUT CLAIM TO ANY PARTICULAR FONT, STYLE, SIZE, OR COLOR.

FOR SHIRTS AND SHORT-SLEEVED SHIRTS; SHORT-SLEEVED OR LONG-SLEEVED T-SHIRTS; SHORT-SLEEVED SHIRTS; T-SHIRTS; TEE SHIRTS; WEARABLE GARMENTS AND CLOTHING, NAMELY, SHIRTS (U.S. CLS. 22 AND 39).

STEVEN JACKSON, EXAMINING ATTORNEY

---

 SN 77-943,005. SKECHERS U.S.A., INC. II, MANHATTAN BEACH, CA. FILED 2-23-2010.
**JOIN THE RESISTANCE**

THE MARK CONSISTS OF STANDARD CHARACTERS WITHOUT CLAIM TO ANY PARTICULAR FONT, STYLE, SIZE, OR COLOR.

FOR FOOTWEAR AND APPAREL, NAMELY, TOPS, SHIRTS, BLOUSES, T-SHIRTS, SWEAT SHIRTS, SPORTS JERSEYS, SWEATERS, BOTTOMS, TROUSERS, PANTS, SWEAT PANTS, SHORTS, JACKETS, COATS, OVERCOATS, PULLOVERS, JUMPERS, DRESSES, SKIRTS, BEACHWEAR, SWIMSUITS, UNDERWEAR, LINGERIE, HEADWEAR, HATS, CAPS, BEANIES, VISORS, TIES, SOCKS, BELTS, GLOVES, SCARVES AND WRISTBANDS (U.S. CLS. 22 AND 39).

INGA ERVIN, EXAMINING ATTORNEY

**CLASS 25—(Continued).**

SN 77-944,126. VANS, INC., CYPRESS, CA. FILED 2-24-2010.



OWNER OF U.S. REG. NO. 1,583,727.

THE MARK CONSISTS OF A THREE-DIMENSIONAL CONFIGURATION OF A CHECKERBOARD PATTERN ON THE TOE AND HEEL OF A SHOE. THE BROKEN LINES DEPICTING THE OUTLINE OF THE SHOE INDICATES PLACEMENT OF THE MARK ON THE GOODS AND ARE NOT PART OF THE MARK.

SEC. 2(F).

FOR FOOTWEAR (U.S. CLS. 22 AND 39).

FIRST USE 8-0-1981; IN COMMERCE 6-0-1982.

DEZMONA MIZELLE, EXAMINING ATTORNEY

---

 SN 77-944,127. VANS, INC., CYPRESS, CA. FILED 2-24-2010.

OWNER OF U.S. REG. NO. 1,583,727.

THE MARK CONSISTS OF A THREE-DIMENSIONAL CONFIGURATION OF A CHECKERBOARD PATTERN ON THE ENTIRE UPPER PORTION OF A SHOE. THE BROKEN LINES DEPICTING THE OUTLINE OF THE SHOE INDICATES PLACEMENT OF THE MARK ON THE GOODS AND ARE NOT PART OF THE MARK.

SEC. 2(F).

FOR FOOTWEAR (U.S. CLS. 22 AND 39).

FIRST USE 8-0-1981; IN COMMERCE 6-0-1982.

DEZMONA MIZELLE, EXAMINING ATTORNEY

**CLASS 25—(Continued).**

SN 77-949,039. APPAREL GROUP PTY LTD, WATERLOO  
NSW 2017, AUSTRALIA, FILED 3-3-2010.



PRIORITY CLAIMED UNDER SEC. 44(D) ON AUSTRALIA APPLICATION NO. 1344855, FILED 2-11-2010, REG. NO. 1344855, DATED 2-11-2010, EXPIRES 2-11-2020.

OWNER OF U.S. REG. NOS. 1,552,011 AND 3,089,390.

NO CLAIM IS MADE TO THE EXCLUSIVE RIGHT TO USE "ESTABLISHED 1952", APART FROM THE MARK AS SHOWN.

THE MARK CONSISTS OF A WAVY STRIPE WHICH FORMS THE LETTER "S" IN A WREATH. MARK ALSO FEATURES THE WORDS "SPORTSCRAFT ESTABLISHED 1952".

FOR WOMEN'S WEAR AND KNITWEAR, NAMELY, PANTS, SKIRTS, PLEATED SKIRTS, SUITS, JACKETS, POLO SHIRTS, SHIRTS, BLOUSES, T-SHIRTS, SHORTS, DRESSES, COATS, SCARVES, TIGHTS; HEADGEAR, NAMELY, HATS AND CAPS; MENSWEAR AND KNITWEAR, NAMELY, SLACKS, SHORTS, JACKETS, SUITS, COATS, SHIRTS, T-SHIRTS, TOPS, SOCKS; FOOTWEAR FOR MEN AND WOMEN; BELTS FOR CLOTHING (U.S. CLS. 22 AND 39).

ALEXANDER L. POWERS, EXAMINING ATTORNEY

SN 78-926,532. M47I INC., TORONTO, ONTARIO, CANADA,  
FILED 7-11-2006.

**FIREBREATHERS**

THE MARK CONSISTS OF STANDARD CHARACTERS WITHOUT CLAIM TO ANY PARTICULAR FONT, STYLE, SIZE, OR COLOR.

PRIORITY CLAIMED UNDER SEC. 44(D) ON CANADA APPLICATION NO. 1285840, FILED 1-12-2006, REG. NO. 789158, DATED 1-31-2011, EXPIRES 1-31-2026.

FOR WORKWEAR AND SPORTSWEAR, NAMELY, APRONS, COATS, COVERALLS, JACKETS, OVERALLS, PANTS, PARKAS, SHIRTS, SMOCKS, VESTS AND CAPS (U.S. CLS. 22 AND 39).

TINA BROWN, EXAMINING ATTORNEY

**CLASS 25—(Continued).**

SN 79-077,467. OBCHTCHESTVO S OGRANITCHENNOY OTVETSTVENNOSTYOU "GRICHKO", RU-113095 MOS-COU, RUSSIAN FED., FILED 10-21-2009.

*Miracle*

PRIORITY DATE OF 9-24-2009 IS CLAIMED.  
OWNER OF INTERNATIONAL REGISTRATION 1025332  
DATED 10-21-2009, EXPIRES 10-21-2019.

THE TRADEMARK CONSISTS OF THE WORD "MIRACLE", WRITTEN IN A SPECIAL FONT AND UNDERLINED WITH A HORIZONTAL LINE.

THE ENGLISH TRANSLATION OF THE FOREIGN WORD(S) IN THE MARK IS: "MIRACLE".

FOR BALLET SHOES, NAMELY, POINTE SHOES (U.S. CLS. 22 AND 39).

MARK PILARO, EXAMINING ATTORNEY

SN 79-081,883. JEFFREY HAMMOND, UNITED KINGDOM,  
FILED 3-26-2010.

**STEFANO CONTI**

THE MARK CONSISTS OF STANDARD CHARACTERS WITHOUT CLAIM TO ANY PARTICULAR FONT, STYLE, SIZE, OR COLOR.

PRIORITY DATE OF 9-28-2009 IS CLAIMED.  
OWNER OF INTERNATIONAL REGISTRATION 1036838  
DATED 3-26-2010, EXPIRES 3-26-2020.

THE NAME(S), PORTRAIT(S), AND/OR SIGNATURE(S) SHOWN IN THE MARK DOES NOT IDENTIFY A PARTICULAR LIVING INDIVIDUAL.

FOR CLOTHING, NAMELY, PANTS, TROUSERS, SHIRTS, CARDIGANS, WAISTCOATS, JACKETS, COATS, BLAZERS, SUITS, SHORTS; HEADGEAR, NAMELY, HATS AND CAPS; BELTS, SCARVES, HEAD-SCARVES, NECKTIES, POCKET SQUARES, GLOVES; FOOTWEAR; SOCKS, STOCKINGS AND PANTYHOSE (U.S. CLS. 22 AND 39).

ROBIN MITTLER, EXAMINING ATTORNEY

SN 79-084,385. DESMAZIERES DRINO BONNETERIE FAB-  
RICATION, FRANCE, FILED 5-20-2010.

**DUB & DRINO**

PRIORITY DATE OF 3-8-2010 IS CLAIMED.  
OWNER OF INTERNATIONAL REGISTRATION 1043491  
DATED 5-20-2010, EXPIRES 5-20-2020.

THE MARK CONSISTS OF "DUB" & "DRINO".  
FOR CLOTHING, NAMELY, TOPS, BOTTOMS, PANTS,

SHIRTS, SHORTS, SKIRTS, BATHING SUITS, BATH ROBES, UNDERWEAR, PAJAMAS, SINGLET, TEE-SHIRTS; FOOTWEAR, HEADGEAR, NAMELY, HATS AND CAPS; SHIRTS; LEATHER AND IMITATION OF LEATHER CLOTHING, NAMELY, TOPS, BOTTOMS, PANTS, SHIRTS, SHORTS, SKIRTS; BELTS; FURS, NAMELY, JACKETS, COATS; GLOVES; SCARVES; NECKTIES; HOSIERY; SOCKS; SLIPPERS; BEACH, SKI AND SPORTS FOOTWEAR; TEXTILE BABY DIAPERS; UNDERCLOTHING, NAMELY, BRAS, SOCKS, UNDERWEAR, TIGHTS, STOCKINGS, TEDDIES, PANTS (U.S. CLS. 22 AND 39).

DAVID HOFFMAN, EXAMINING ATTORNEY

**CLASS 25—(Continued).**

SN 79-084,998. COMPAGNIA MERCANTILE S.R.L., I-30035 MIRANO (VENEZIA), ITALY, FILED 6-24-2010.

# CINI

THE MARK CONSISTS OF STANDARD CHARACTERS WITHOUT CLAIM TO ANY PARTICULAR FONT, STYLE, SIZE, OR COLOR.

OWNER OF INTERNATIONAL REGISTRATION 1044977 DATED 6-24-2010, EXPIRES 6-24-2020.

FOR CLOTHING AND FOOTWEAR, NAMELY, PULL-OVERS, CARDIGANS, SWEATERS, TROUSERS, SKIRTS, JACKETS, BLOUSES, SHIRTS, JEANS, SWEATPANTS, SHORTS, SWEATSHIRTS, SUITS, DRESSES, OVERCOATS, COATS, RAINCOATS, BELTS, JERSEYS, NECKWEAR, SCARVES, SOCKS AND STOCKINGS, TIGHTS, VESTS, WAISTCOATS, JUMPERS, TRACKSUITS, BLOUSONS, GYMSUITS, KNICKERS, T-SHIRTS, ANORAKS, SUSPENDERS, LOUNGEWEAR, UNDERWEAR, BRASIERES, CORSETS, PETTICOATS, NIGHTGOWNS, DRESSING GOWNS, BATH ROBES, BEACHWEAR, SLEEPWEAR, HEADWEAR, OVERALLS, HATS AND CAPS, GLOVES, SHOES, SANDALS, BOOTS AND SLIPPERS; HEADWEAR, NAMELY, HATS AND CAPS, BERTS, BANDANAS (U.S. CLS. 22 AND 39).

AISHA CLARKE, EXAMINING ATTORNEY

**CLASS 25—(Continued).**

SN 79-087,715. FAST RETAILING CO., LTD., JAPAN, FILED 9-7-2010.

# NATURAL SKIN

THE MARK CONSISTS OF STANDARD CHARACTERS WITHOUT CLAIM TO ANY PARTICULAR FONT, STYLE, SIZE, OR COLOR.

PRIORITY DATE OF 8-19-2010 IS CLAIMED.

OWNER OF INTERNATIONAL REGISTRATION 1052139 DATED 9-7-2010, EXPIRES 9-7-2020.

FOR CLOTHING, NAMELY, PANTS, SHIRTS, SKIRTS, SHORTS, DRESSES, JACKETS, SWIMWEAR, UNDERWEAR, SLEEPWEAR, ROBES, T-SHIRTS, JEANS, COATS, SOCKS, TIGHTS, GLOVES, VESTS, ANORAKS, RAINWEAR, WIND RESISTANT JACKETS, SWEATSHIRTS, TANK TOPS, PULLOVERS, SWEATERS, KNIT SHIRTS, CARDIGANS, PARKAS, HATS, CAPS, AND MUFFLERS; BABY LAYETTES FOR CLOTHING; WATERPROOF CLOTHING, NAMELY, WATERPROOF SHIRTS, PANTS, JACKETS AND FOOTWEAR; WEDDING DRESSES; BATHING SUITS; HOSIERY; GLOVES AS CLOTHING; SCARVES; GARTERS; SOCK SUSPENDERS; SUSPENDERS; WAISTBANDS; BELTS FOR CLOTHING; SHOES; MASQUERADE COSTUMES; FOOTBALL SHOES (U.S. CLS. 22 AND 39).

ADA HAN, EXAMINING ATTORNEY

SN 79-088,477. RIPBOARD LIMITED, UNITED KINGDOM, FILED 5-7-2010.

SN 79-085,961. 2STEPZAHEAD B.V., NETHERLANDS, FILED 7-15-2010.

# SUPERTRASH

THE MARK CONSISTS OF STANDARD CHARACTERS WITHOUT CLAIM TO ANY PARTICULAR FONT, STYLE, SIZE, OR COLOR.

OWNER OF INTERNATIONAL REGISTRATION 1047399 DATED 7-15-2010, EXPIRES 7-15-2020.

OWNER OF U.S. REG. NO. 3,666,940.

FOR CLOTHING, NAMELY, SHIRTS, LEGGINGS, TROUSERS, PANTS, DRESSES, TOPS, TUNICS, SKIRTS, T-SHIRTS, SWEATERS, BLOUSES, SCARVES, TIES, GLOVES, COATS, JACKETS, LINGERIE, BIKINIS, BATHING SUITS, SWIMMING SUITS AND SWIMMING SHORTS; FOOTWEAR, NAMELY, BOOTS, SHOES, SLIPPERS, SANDALS, HIGH HEELS; HEADGEAR, NAMELY, HATS AND CAPS (U.S. CLS. 22 AND 39).

ERNEST SHOSHO, EXAMINING ATTORNEY

# Ripboard

PRIORITY DATE OF 3-2-2010 IS CLAIMED.

OWNER OF INTERNATIONAL REGISTRATION 1054323 DATED 5-7-2010, EXPIRES 5-7-2020.

THE MARK CONSISTS OF THE WORD "RIPBOARD" WITH A DESIGN OF A SILHOUETTE OF A BOY RIDING A SKATEBOARD ON THE RIGHT.

FOR CLOTHING, FOOTWEAR AND HEADGEAR, NAMELY, CASUAL WEAR, BEACHWEAR, SPORTSWEAR AND CLOTHING FOR SWIMMING, DIVING, SKIING, SNOWBOARDING AND SPORTS ACTIVITIES, NAMELY, T-SHIRTS, SWEAT SHIRTS, HOODED SWEAT SHIRTS AND HOODED JACKETS, SWEAT PANTS, SWIMMING COSTUMES AND SHORTS; AND MONEY BELTS (U.S. CLS. 22 AND 39).

DAWN FELDMAN, EXAMINING ATTORNEY

**CLASS 25—(Continued).**

SN 79-090,828. TRAN THI LAN, VIETNAM, FILED 10-27-2010.



**t\*l\*s**  
Vintage Fashion Shoes

OWNER OF INTERNATIONAL REGISTRATION 1060635 DATED 10-27-2010, EXPIRES 10-27-2020.

NO CLAIM IS MADE TO THE EXCLUSIVE RIGHT TO USE "VINTAGE FASHION SHOES", APART FROM THE MARK AS SHOWN.

THE MARK CONSISTS OF THE COINED STYLIZED TERM "T\*L\*S", AND THE WORDS "VINTAGE FASHION SHOES" SET UNDER THE TERM "T\*L\*S".

FOR FOOTWEAR, NAMELY, SHOES, SLIPPERS, SANDALS, BOOTS, SNEAKERS, SPORT SHOES (U.S. CLS. 22 AND 39).

JASON BLAIR, EXAMINING ATTORNEY

**CLASS 25—(Continued).**

SN 79-094,280. SYSTEM SERVICE S.R.L., ITALY, FILED 12-30-2010.



**FRESHYPE**

THE MARK CONSISTS OF STANDARD CHARACTERS WITHOUT CLAIM TO ANY PARTICULAR FONT, STYLE, SIZE, OR COLOR.

OWNER OF INTERNATIONAL REGISTRATION 1068928 DATED 12-30-2010, EXPIRES 12-30-2020.

FOR CLOTHING FOR MEN, WOMEN AND CHILDREN, NAMELY, SOCKS, ASCOTS, ATHLETIC UNIFORMS, WRISTBANDS, BATHING CAPS, BATHING SUITS, BATHROBES, GARTER BELTS, BELTS, BERETS, CLOTH BIBS, SKI BIBS, BIKINIS, BLAZERS, BLOOMERS, BLOUSES, BODY SUITS, BOOTIES, BOOTS, BOW TIES, BOXER SHORTS, SHOWER CAPS, HEADWEAR, NAMELY, CAPS, HATS, HEADBANDS, COATS, BEACH COVER-UPS, DRESSES, DUNGAREES, JEANS, EAR MUFFS; FOOTWEAR, NAMELY, SHOES, ATHLETIC FOOTWEAR, GLOVES, SKI GLOVES, GOLF SHIRTS, GOWNS, GYM SUITS, HOSIERY, INFANT WEAR, JACKETS, JERSEYS, JOGGING SUITS, JUMPSUITS, KERCHIEFS, LEG WARMERS, LEGGINGS, LEOTARDS, MITTENS, MOCCASINS, NECKTIES, OVERALLS, PAJAMAS, PANTIES, PANTS, RAINWEAR, ROBES, GALOSHES, SANDALS, SCARVES, SHIRTS, POLO-SHIRTS, SPORT SHIRTS, SWEAT SHIRTS, NIGHT SHIRTS, UNDERSHIRTS, BERMUDA SHORTS, SKIWEAR, SKIRTS, SLACKS, SLEEPWEAR, SNOW PANTS, SNOW SUITS, SUITS, SKI SUITS, WARM UP SUITS, WET SUITS, SUN VISORS, SUSPENDERS, SWEATERS, T-SHIRTS, TIGHTS, TANK TOPS AND HALTER TOPS (U.S. CLS. 22 AND 39).

JEFF DEFORD, EXAMINING ATTORNEY

SN 79-092,535. FITFLOP LIMITED, UNITED KINGDOM, FILED 12-23-2010.



**gogh**

THE MARK CONSISTS OF STANDARD CHARACTERS WITHOUT CLAIM TO ANY PARTICULAR FONT, STYLE, SIZE, OR COLOR.

PRIORITY DATE OF 8-12-2010 IS CLAIMED.

OWNER OF INTERNATIONAL REGISTRATION 1065029 DATED 12-23-2010, EXPIRES 12-23-2020.

FOR FOOTWEAR, NAMELY CLOGS (U.S. CLS. 22 AND 39).

EUGENIA MARTIN, EXAMINING ATTORNEY

SN 85-000,310. HILLIARD, SAMUEL, ARCATA, CA. FILED 3-28-2010.



**Somnoir**

THE MARK CONSISTS OF THE LETTERS: "SOMNOIR". THE WORDING "SOMNOIR" HAS NO MEANING IN A FOREIGN LANGUAGE.

FOR ATHLETIC APPAREL, NAMELY, SHIRTS, PANTS, JACKETS, FOOTWEAR, HATS AND CAPS, ATHLETIC UNIFORMS (U.S. CLS. 22 AND 39).

FIRST USE 4-2-2009; IN COMMERCE 4-2-2009.

ASMAT KHAN, EXAMINING ATTORNEY

**CLASS 25—(Continued).**

SN 85-031,195. ACTIVE APPAREL, LLC, LAGUNA BEACH, CA. FILED 5-5-2010.

# Code

THE MARK CONSISTS OF STANDARD CHARACTERS WITHOUT CLAIM TO ANY PARTICULAR FONT, STYLE, SIZE, OR COLOR.

FOR CLOTHING, NAMELY, SHIRTS, PANTS, JACKETS, FOOTWEAR, HATS AND CAPS, COATS, NECKWEAR, SWIM WEAR, SWEATERS (U.S. CLS. 22 AND 39).  
HOWARD B. LEVINE, EXAMINING ATTORNEY

SN 85-032,074. HOLDSWORTH LLC, OAKLAND, CA. FILED 5-6-2010.

# Rooted

THE MARK CONSISTS OF STANDARD CHARACTERS WITHOUT CLAIM TO ANY PARTICULAR FONT, STYLE, SIZE, OR COLOR.

FOR ATHLETIC APPAREL, NAMELY, SHIRTS, PANTS, JACKETS, FOOTWEAR, HATS AND CAPS, ATHLETIC UNIFORMS; CAPS; CHILDREN'S AND INFANT'S APPAREL, NAMELY, JUMPERS, OVERALL SLEEPWEAR, PAJAMAS, ROMPERS AND ONE-PIECE GARMENTS; HOODED SWEAT SHIRTS; KNIT SHIRTS; KNITTED CAPS; SHIRTS; SHORT-SLEEVED OR LONG-SLEEVED T-SHIRTS; SWEAT SHIRTS; T-SHIRTS; TEE SHIRTS (U.S. CLS. 22 AND 39).

JIM RINGLE, EXAMINING ATTORNEY

SN 85-032,172. JIMLAR CORPORATION, GREAT NECK, NY. FILED 5-6-2010.

# FRYE DAYS

THE MARK CONSISTS OF STANDARD CHARACTERS WITHOUT CLAIM TO ANY PARTICULAR FONT, STYLE, SIZE, OR COLOR.

OWNER OF U.S. REG. NOS. 1,084,873, 1,990,286 AND 2,998,603.

FOR CLOTHING, NAMELY, TOPS, T-SHIRTS, PANTS, JEANS, OUTERWEAR, NAMELY, JACKETS AND COATS, AND FOOTWEAR, NAMELY, BOOTS AND SHOES (U.S. CLS. 22 AND 39).

KATHRYN COWARD, EXAMINING ATTORNEY

**CLASS 25—(Continued).**

SN 85-033,828. VANSTEEN, DONALD, EAU CLAIRE, MI. FILED 5-10-2010.



THE COLOR(S) BLACK, WHITE AND YELLOW IS/ARE CLAIMED AS A FEATURE OF THE MARK.

THE MARK CONSISTS OF THE WORDS "VANSTEEN" WRITTEN IN BLACK COLOR WHEREIN THE LETTER "S" IS WRITTEN IN SUCH A STYLIZED WAY THAT IT BECOMES A PART OF LETTER "T". THE WORDS "VANSTEEN" IS WRITTEN INSIDE THE TWO OVALS WHEREIN THE INNER OVAL IS OUTLINED IN BLACK AND THE OUTER OVAL IS OUTLINED IN YELLOW COLOR AND THE CENTER IS WHITE.

FOR CLOTHING, NAMELY, T-SHIRTS, LONG SLEEVE SHIRTS, TANK TOPS, SWEAT SHIRTS, RUNNING PANTS, SOCKS, GLOVES, APRONS, WRISTBANDS, PANTS, SLACKS, JEANS, COATS, JACKETS, BOXER SHORTS, PAJAMAS, HEADWEAR (U.S. CLS. 22 AND 39).

LINDA MICKLEBURGH, EXAMINING ATTORNEY

SN 85-036,782. G-III LEATHER FASHIONS, INC., NEW YORK, NY. FILED 5-12-2010.



OWNER OF U.S. REG. NO. 2,382,504.

NO CLAIM IS MADE TO THE EXCLUSIVE RIGHT TO USE "SPORTS", APART FROM THE MARK AS SHOWN.

THE MARK CONSISTS OF A STYLIZED NUMBER "58" SUPERIMPOSED ON A DOUBLE-BORDER DIAMOND, BENEATH WHICH IS A STYLIZED BANNER CONTAINING THE WORD "SPORTS".

FOR (BASED ON USE IN COMMERCE) JACKETS, PULLOVERS, TOPS, SHIRTS (BASED ON INTENT TO USE) COATS, VESTS, PONCHOS, CLOAKS, DRESSES, BOTTOMS, PANTS, JEANS, SHORTS, SKIRTS, SWEATERS, GOLF SHIRTS, JOGGING SUITS, SWEAT SHIRTS, BLOUSES, SWIMWEAR, HEADWEAR, FOOTWEAR, SHOES AND BOOTS (U.S. CLS. 22 AND 39).

FIRST USE 8-0-1997; IN COMMERCE 8-0-1997.

HELENE LIWINSKI, EXAMINING ATTORNEY

**CLASS 25—(Continued).**

SN 85-037,247. BALTIMORE ORIOLES LIMITED PARTNER-  
SHIP, BALTIMORE, MD. FILED 5-13-2010.



OWNER OF U.S. REG. NOS. 3,291,902, 3,326,758 AND  
OTHERS.

THE MARK CONSISTS OF THE WORD "BALTIMORE" IN  
STYLIZED TEXT.

SEC. 2(F).  
FOR CLOTHING AND HEADWEAR, NAMELY,  
SHIRTS, JERSEYS AND HATS (U.S. CLS. 22 AND 39).  
FIRST USE 6-30-2008; IN COMMERCE 6-30-2008.  
KRISTIN DAHLING, EXAMINING ATTORNEY

**CLASS 25—(Continued).**

SN 85-038,453. WRANGLER APPAREL CORP., WILMING-  
TON, DE. FILED 5-14-2010.

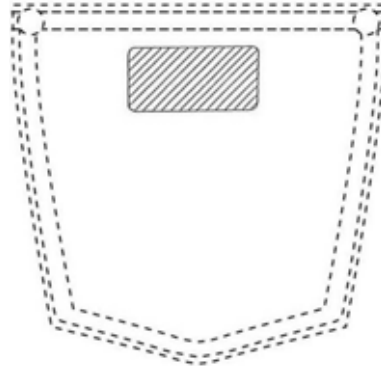

OWNER OF U.S. REG. NO. 2,361,033.  
THE LINING IN THE DRAWING IS FOR SHADING  
PURPOSES ONLY.

THE MARK CONSISTS OF THE IMPRESSION OF A  
RECTANGULAR LEATHER OR IMITATION LEATHER  
PATCH CENTERED NEAR THE TOP OF THE RIGHT BACK  
POCKET OF THE GARMENT. THE DOTTED LINES IN THE  
DRAWING SERVE TO INDICATE THE POSITIONING OF  
THE MARK IN RELATION TO THE POCKET AND DO NOT  
FORM PART OF THE MARK.

SEC. 2(F).  
FOR BOTTOMS (U.S. CLS. 22 AND 39).  
FIRST USE 6-5-2006; IN COMMERCE 6-6-2006.  
JULIE GUTTADAURO, EXAMINING ATTORNEY

SN 85-038,349. THE ARMED FORCES MILITARY MUSEUM,  
INC., LARGO, FL. FILED 5-13-2010.

THE ARMED FORCES MILITARY  
MUSEUM

THE MARK CONSISTS OF STANDARD CHARACTERS  
WITHOUT CLAIM TO ANY PARTICULAR FONT, STYLE,  
SIZE, OR COLOR.

NO CLAIM IS MADE TO THE EXCLUSIVE RIGHT TO  
USE "MILITARY MUSEUM", APART FROM THE MARK  
AS SHOWN.

FOR CLOTHING, NAMELY, SHIRTS, HATS AND TIES  
(U.S. CLS. 22 AND 39).  
FIRST USE 12-31-1996; IN COMMERCE 12-31-1996.  
PRISCILLA MILTON, EXAMINING ATTORNEY

SN 85-038,454. WRANGLER APPAREL CORP., WILMING-  
TON, DE. FILED 5-14-2010.

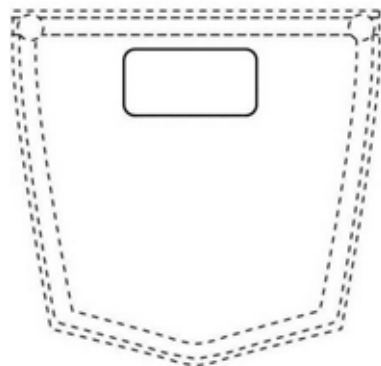

OWNER OF U.S. REG. NO. 2,361,033.  
THE MARK CONSISTS OF STITCHING IN THE SHAPE  
OF A RECTANGULAR LEATHER OR IMITATION  
LEATHER PATCH CENTERED NEAR THE TOP OF THE  
RIGHT BACK POCKET OF THE GARMENT. THE DOTTED  
LINES IN THE DRAWING SERVE TO INDICATE THE  
POSITIONING OF THE MARK IN RELATION TO THE  
POCKET AND DO NOT FORM PART OF THE MARK.

SEC. 2(F).  
FOR BOTTOMS (U.S. CLS. 22 AND 39).  
FIRST USE 3-6-2008; IN COMMERCE 3-7-2008.  
JULIE GUTTADAURO, EXAMINING ATTORNEY

**CLASS 25—(Continued).**

SN 85-039,417. LATERRA, STEPHEN, AVON, CO. FILED 5-14-2010.



THE MARK CONSISTS OF A CLUSTER OF FOUR STYLIZED PINE TREES WITH THREE TREE TRUNKS; THE TREES ARE OVERLAYING EACH OTHER IN A TRIANGLE SHAPE.

FOR SWEAT SHIRTS; TEE SHIRTS (U.S. CLS. 22 AND 39).

FIRST USE 2-16-2010; IN COMMERCE 2-16-2010.

LINDA MICKLEBURGH, EXAMINING ATTORNEY

SN 85-041,060. ALLEN, KATHY O., SIOUX FALLS, SD. FILED 5-18-2010.

THE MARK CONSISTS OF THE MARK IS THE WORD "GEBUT" IN SCRIPTED LETTERS WITH "OFFICIALLY OUT." UNDERNEATH IN BLOCK LETTERS.

FOR ANKLE SOCKS; ANKLETS; APRONS; ATHLETIC APPAREL, NAMELY, SHIRTS, PANTS, JACKETS, FOOTWEAR, HATS AND CAPS, ATHLETIC UNIFORMS; ATHLETIC FOOTWEAR; ATHLETIC SHOES; ATHLETIC UNIFORMS; BALL GOWNS; BALLET SHOES; BALLET SLIPPERS; BASEBALL CAPS; BASEBALL CAPS AND HATS; BASEBALL SHOES; BASEBALL UNIFORMS; BASKETBALL SNEAKERS; BATHING CAPS; BATHING SUITS; BATHROBES; BEACHWEAR; BELTS; BELTS FOR CLOTHING; BELTS MADE OF LEATHER; BLOUSES; BOOTIES; BOOTS; BOW TIES; BOXER BRIEFS; BOXER SHORTS; BRACES; BRAS; BRASSIERES; BRIDESMAID DRESSES; BRIEFS; BRIEFS; BUSTIERS; CAPS; CAPS WITH VISORS; CHAPS; CHEF'S HATS; CLOGS; COATS; COATS FOR MEN AND WOMEN; DANCE COSTUMES; DANCE SHOES; DANCE SLIPPERS; DENIM JACKETS; DENIMS; DICKIES; DO RAGS; DOWN JACKETS; DRESS SHIRTS; DRESS SUITS; DRESSES; DRESSING GOWNS; DRIVERS; EAR BANDS; EAR MUFFS; EAR WARMERS; EARBANDS; EVENING DRESSES; EVENING GOWNS; FLIP FLOPS; FOAM PEDICURE SLIPPERS; FOOTWEAR; FOOTWEAR FOR WOMEN; FULL-LENGTH KIMONOS (NAGAGI); G-STRINGS; GARTER BELTS; GARTERS; GIFT PACKAGES SOLD AS A UNIT CONSISTING PRIMARILY OF A SWEATSHIRT AND ALSO INCLUDING A PHOTO FRAME, A COFFEE MUG, AND A TOTE BAG; GLOVES; GLOVES FOR APPAREL; GOLF CAPS; GOLF PANTS, SHIRTS AND SKIRTS; GOWNS; GYM

**CLASS 25—(Continued).**

BOOTS; GYM PANTS; GYM SHORTS; GYM SUITS; GYMNASTIC SHOES; HALLOWEEN COSTUMES; HATS; HEAD SCARVES; HEAD SWEATBANDS; HEAD WEAR; HEADBANDS; HEADWEAR; HEELS; HIKING BOOTS; HOODED PULLOVERS; HOODED SWEAT SHIRTS; HORSE-RIDING BOOTS; HOSIERY; HOUSECOATS; JACKETS; JACKETS AND SOCKS; JEANS; JOGGING OUTFITS; JOGGING PANTS; JOGGING SUITS; KNEE HIGHS; KNEE-HIGH STOCKINGS; KNIT JACKETS; KNITTED CAPS; KNITTED GLOVES; KNITTED UNDERWEAR; LADIES' UNDERWEAR; LEATHER BELTS; LEATHER COATS; LEATHER SLIPPERS; LEGGINGS; LEOTARDS; LINGERIE; LONG JOHNS; LOUNGEWEAR; MASQUERADE COSTUMES AND MASKS SOLD IN CONNECTION THEREWITH; MEN'S DRESS SOCKS; MEN'S SOCKS; MEN'S SUITS; MEN'S SUITS, WOMEN'S SUITS; MEN'S UNDERWEAR; MONEY BELTS; NECKTIES; NECKWEAR; NIGHTWEAR; PAPER APRONS; PAPER HATS FOR USE AS CLOTHING ITEMS; PAPER SHOES USED WHEN GOING THROUGH METAL DETECTORS TO KEEP FEET AND SOCKS CLEAN; PARTY HATS; POLO KNIT TOPS; POLO SHIRTS; RAIN HATS; RAIN JACKETS; RAINCOATS; RAINWEAR; ROBES; RUNNING PADS THAT STRAP ONTO SHOES; RUNNING SHOES; SANDALS; SANDALS AND BEACH SHOES; SCARFS; SCARVES; SCHOOL UNIFORMS; SHIRTS; SHOES; SHOWER CAPS; SKI WEAR; SKULL CAPS; SKULLIES; SLEEP MASKS; SLEEPWEAR; SOCKS; SOCKS AND STOCKINGS; SPORT COATS; SPORT SHIRTS; SPORTS BRA; SPORTS BRAS; STOCKINGS; SUITS; SUN VISORS; SUNDRESSES; SUSPENDER BELTS; SUSPENDERS; SWEATERS; SWIM WEAR; SWIMSUITS; SWIMWEAR; T-SHIRTS; TEDDIES; TENNIS SHOES; TIES; TUXEDO BELTS; TUXEDOS; UNDERCLOTHES; UNIFORMS; WRIST BANDS; WRISTBANDS; YOGA PANTS; YOGA SHIRTS (U.S. CLS. 22 AND 39).

PRISCILLA MILTON, EXAMINING ATTORNEY

SN 85-042,127. J.DOUGLAS INC., PITTSBURGH, PA. FILED 5-19-2010.

THE MARK CONSISTS OF STANDARD CHARACTERS WITHOUT CLAIM TO ANY PARTICULAR FONT, STYLE, SIZE, OR COLOR.

FOR CLOTHING, NAMELY, T-SHIRTS, JACKETS, TOPS, BOTTOMS, HEADWEAR, FOOTWEAR (U.S. CLS. 22 AND 39).

COLLEEN DOMBROW, EXAMINING ATTORNEY

SN 85-042,224. ASICS CORPORATION, CHUO-KU, KOBE, JAPAN, FILED 5-19-2010.

THE MARK CONSISTS OF STANDARD CHARACTERS WITHOUT CLAIM TO ANY PARTICULAR FONT, STYLE, SIZE, OR COLOR.

FOR ATHLETIC APPAREL, NAMELY, SHIRTS AND SINGLET (U.S. CLS. 22 AND 39).

FIRST USE 5-31-2005; IN COMMERCE 5-31-2005.

JASON BLAIR, EXAMINING ATTORNEY

**CLASS 25—(Continued).**

SN 85-042,241. ASICS CORPORATION, CHUO-KU, KOBE, JAPAN, FILED 5-19-2010.

# MYLES II

THE MARK CONSISTS OF STANDARD CHARACTERS WITHOUT CLAIM TO ANY PARTICULAR FONT, STYLE, SIZE, OR COLOR.

THE NAME(S), PORTRAIT(S), AND/OR SIGNATURE(S) SHOWN IN THE MARK DOES NOT IDENTIFY A PARTICULAR LIVING INDIVIDUAL.

FOR ATHLETIC APPAREL, NAMELY, TIGHTS AND PANTS (U.S. CLS. 22 AND 39).

FIRST USE 5-31-2002; IN COMMERCE 5-31-2002.  
JASON BLAIR, EXAMINING ATTORNEY



SN 85-042,860. LOGAN, BRENT E., MOUNT VERNON, WA. FILED 5-19-2010.

# EcoFeet

THE MARK CONSISTS OF STANDARD CHARACTERS WITHOUT CLAIM TO ANY PARTICULAR FONT, STYLE, SIZE, OR COLOR.

FOR FOOTWEAR (U.S. CLS. 22 AND 39).  
BRIAN CALLAGHAN, EXAMINING ATTORNEY



SN 85-043,038. ZAPPALA, GREGORY R., PITTSBURGH, PA. FILED 5-19-2010.



THE NAME(S), PORTRAIT(S), AND/OR SIGNATURE(S) SHOWN IN THE MARK DOES NOT IDENTIFY A PARTICULAR LIVING INDIVIDUAL.

THE MARK CONSISTS OF THE EXPRESSION "EVEL" IN A SCRIPT HANDWRITING.

FOR JEANS (U.S. CLS. 22 AND 39).  
KEVIN CORWIN, EXAMINING ATTORNEY

**CLASS 25—(Continued).**

SN 85-043,297. RETAIL SOLUTIONS GROUP, INC., SYOSSET, NY. FILED 5-20-2010.

# ALPINE EDGE

THE MARK CONSISTS OF STANDARD CHARACTERS WITHOUT CLAIM TO ANY PARTICULAR FONT, STYLE, SIZE, OR COLOR.

FOR CLOTHING PRODUCTS, NAMELY, SKI PANTS, SKI BIBS, INSULATED AND NON-INSULATED SNOW PANTS, SKI JACKETS, SKI SUITS, SNOW SUITS, WATERPROOF PANTS, WIND RESISTANT PANTS, SWEATERS, GLOVES, SCARVES, RUBBER BOOTS, LEATHER BOOTS, LEATHER SHOES, LEATHER SNEAKERS, CANVAS SNEAKERS, KNIT HATS, CAPS (U.S. CLS. 22 AND 39).

HEATHER BIDDULPH, EXAMINING ATTORNEY



SN 85-044,535. HOLOBI, LLC, BOTHELL, WA. FILED 5-21-2010.



THE COLOR(S) SILVER, RED, GREEN, BLUE, BLACK AND WHITE IS/ARE CLAIMED AS A FEATURE OF THE MARK.

THE MARK CONSISTS OF THE BLACK WORDING "D.R.E.S.", BENEATH WHICH APPEARS THE BLACK WORDING "DIAMOND RUBY EMERALD SAPPHIRE", BENEATH WHICH APPEARS, FROM LEFT TO RIGHT, A SILVER DIAMOND IN THE SHAPE OF AN HOURGLASS, A RED RUBY IN THE SHAPE OF AN INVERTED PYRAMID, A GREEN EMERALD IN THE SHAPE OF A RECTANGLE AND A BLUE SAPPHIRE IN THE SHAPE OF A PYRAMID, EACH OF WHICH HAVING BEVELED CORNERS AND EACH OF WHICH HAVING SUPERIMPOSED OVER IT A BLACK AND WHITE REPRESENTATION OF A WOMAN WITH A BODY SHAPE CORRESPONDING TO THE SHAPE OF THE PARTICULAR GEM STONE.

FOR CLOTHING AND CLOTHING ACCESSORIES, NAMELY, JEANS, PANTS, SHORTS, DRESSES, SKIRTS, SHIRTS, T-SHIRTS, BLOUSES, SWEATERS, VESTS, JACKETS, COATS, PONCHOS, TIES, HATS, SCARVES, BELTS AND CORSETS (U.S. CLS. 22 AND 39).

AMY C. KEAN, EXAMINING ATTORNEY



**CLASS 25—(Continued).**

SN 85-044,544. MATHIAS, JASON, SARASOTA, FL. FILED 5-21-2010.

**SEA SPEARIT**

THE MARK CONSISTS OF STANDARD CHARACTERS WITHOUT CLAIM TO ANY PARTICULAR FONT, STYLE, SIZE, OR COLOR.

FOR CLOTHING, NAMELY, T-SHIRTS, JACKETS, PANTS, TOPS, BOTTOMS, FOOTWEAR, HEADWEAR (U.S. CLS. 22 AND 39).

MARTHA FROMM, EXAMINING ATTORNEY

---

SN 85-044,682. VIA PRIVE LLC, BOSTON, MA. FILED 5-21-2010.



THE MARK CONSISTS OF AN OPEN "HEART" DESIGN ROTATED 90 DEGREES CLOCKWISE AND CONTAINED WITHIN A ROUNDED SQUARE AND THE STYLIZED WORD "VIA" ON THE LEFT SIDE OF THE DESIGN AND THE STYLIZED WORD "PRIVE" ON THE RIGHT SIDE OF THE DESIGN.

THE ENGLISH TRANSLATION OF THE WORDS "VIA" AND "PRIVE" IN THE MARK IS WAY AND PRIVATE RESPECTIVELY.

FOR CLOTHING, NAMELY, SHIRTS, PANTS, SHORTS, TANK TOPS, CAPRIS, BRAS, SPORTS BRAS, VESTS, SWEATSHIRTS, HOODED SWEATSHIRTS, YOGA PANTS, YOGA SHIRTS, JACKETS, SOCKS, UNDERWEAR, SKIRTS, DRESSES, HEAD BANDS, GLOVES, SCARVES, WRISTBANDS, CAPS, VISORS AND HATS; FOOTWEAR (U.S. CLS. 22 AND 39).

ESTHER BELENKER, EXAMINING ATTORNEY

---

SN 85-045,198. KENNY JOHNSON, SAN DIEGO, CA. FILED 5-21-2010.

**SIGNATURE SLEEVE**

THE MARK CONSISTS OF STANDARD CHARACTERS WITHOUT CLAIM TO ANY PARTICULAR FONT, STYLE, SIZE, OR COLOR.

NO CLAIM IS MADE TO THE EXCLUSIVE RIGHT TO USE "SLEEVE", APART FROM THE MARK AS SHOWN.

FOR APPAREL TO BE WORN ON THE WEARER'S FOREARM, NAMELY, FOREARM SLEEVES TO BE WORN ON THE WEARER'S FOREARM WHERE THE FOREARM SLEEVES ARE CAPABLE OF RECEIVING AUTOGRAPHS (U.S. CLS. 22 AND 39).

RUSS HERMAN, EXAMINING ATTORNEY

**CLASS 25—(Continued).**

SN 85-045,634. OLSON, DAVID, UPTON, MA. FILED 5-22-2010.

**NANOGRIP**

THE MARK CONSISTS OF STANDARD CHARACTERS WITHOUT CLAIM TO ANY PARTICULAR FONT, STYLE, SIZE, OR COLOR.

FOR CLOTHING, NAMELY, GLOVES, HEADWEAR, FOOTWEAR, T-SHIRTS, PANTS, TOPS, BOTTOMS (U.S. CLS. 22 AND 39).

H. M. FISHER, EXAMINING ATTORNEY

---

SN 85-045,707. JAMIESON, MARK H., ORLANDO, FL. FILED 5-22-2010.

**YES DOGS DREAM**

THE MARK CONSISTS OF STANDARD CHARACTERS WITHOUT CLAIM TO ANY PARTICULAR FONT, STYLE, SIZE, OR COLOR.

FOR SHIRTS (U.S. CLS. 22 AND 39).

ARETHA SOMERVILLE, EXAMINING ATTORNEY

---

SN 85-045,940. MAXIMUM STRENGTH ENTERTAINMENT, HAYWARD, CA. FILED 5-24-2010.

**FREE THINKER**

THE MARK CONSISTS OF STANDARD CHARACTERS WITHOUT CLAIM TO ANY PARTICULAR FONT, STYLE, SIZE, OR COLOR.

FOR CLOTHING, NAMELY, T-SHIRTS, JACKETS, PANTS, SHORTS, TOPS, BOTTOMS, FOOTWEAR, HEADWEAR (U.S. CLS. 22 AND 39).

DANNEAN HETZEL, EXAMINING ATTORNEY

**CLASS 25—(Continued).**

SN 85-046,276. ARMYNAVYDEALS.COM CORP., NEW YORK, NY. FILED 5-24-2010.

**SEARCH & RESCUE**

THE MARK CONSISTS OF STANDARD CHARACTERS WITHOUT CLAIM TO ANY PARTICULAR FONT, STYLE, SIZE, OR COLOR.

FOR UNISEX FASHION URBAN CLOTHING, NAMELY, NEW AND USED VINTAGE CLOTHING, NAMELY, PANTS, HEADWEAR, TOPS, BOTTOMS, JACKETS, AND FOOTWEAR (U.S. CLS. 22 AND 39).

FIRST USE 4-1-2000; IN COMMERCE 4-1-2000.  
TRACY FLETCHER, EXAMINING ATTORNEY

SN 85-046,662. W2007 STRATOSPHERE PROPCO., L.P., LAS VEGAS, NV. FILED 5-24-2010.

**SKYJUMP**

THE MARK CONSISTS OF STANDARD CHARACTERS WITHOUT CLAIM TO ANY PARTICULAR FONT, STYLE, SIZE, OR COLOR.

FOR BOTTOMS; FOOTWEAR; HEADWEAR; LOUNGEWEAR; SCARVES; SLEEPWEAR; SWIMWEAR; TOPS; UNDERGARMENTS (U.S. CLS. 22 AND 39).

LOURDES AYALA, EXAMINING ATTORNEY

SN 85-046,673. W2007 STRATOSPHERE PROPCO., L.P., LAS VEGAS, NV. FILED 5-24-2010.



NO CLAIM IS MADE TO THE EXCLUSIVE RIGHT TO USE "LAS VEGAS", APART FROM THE MARK AS SHOWN.

THE MARK CONSISTS OF THE STYLIZED WORDS "SKY JUMP" STAGGERED HORIZONTALLY POSITIONED OVER A TARGET AND FIVE VERTICALLY POSITIONED INVERTED LONG TRIANGLES AND THE WORDS "LAS VEGAS" UNDER THE WORD "SKY" AND A DOTTED BACKGROUND ON THE BOTTOM.

FOR BOTTOMS; FOOTWEAR; HEADWEAR; LOUNGEWEAR; SCARVES; SLEEPWEAR; SWIMWEAR; TOPS; UNDERGARMENTS (U.S. CLS. 22 AND 39).

LOURDES AYALA, EXAMINING ATTORNEY

**CLASS 25—(Continued).**

SN 85-046,691. W2007 STRATOSPHERE PROPCO., L.P., LAS VEGAS, NV. FILED 5-24-2010.

**SKYJUMP LAS VEGAS**

THE MARK CONSISTS OF STANDARD CHARACTERS WITHOUT CLAIM TO ANY PARTICULAR FONT, STYLE, SIZE, OR COLOR.

NO CLAIM IS MADE TO THE EXCLUSIVE RIGHT TO USE "LAS VEGAS", APART FROM THE MARK AS SHOWN.

FOR BOTTOMS; FOOTWEAR; HEADWEAR; LOUNGEWEAR; SCARVES; SLEEPWEAR; SWIMWEAR; TOPS; UNDERGARMENTS (U.S. CLS. 22 AND 39).

LOURDES AYALA, EXAMINING ATTORNEY

SN 85-047,002. GARONI, KRISTIAN, FORT LAUDERDALE, FL. FILED 5-25-2010.

**KILOGRAM SNEAKERS**

THE MARK CONSISTS OF STANDARD CHARACTERS WITHOUT CLAIM TO ANY PARTICULAR FONT, STYLE, SIZE, OR COLOR.

NO CLAIM IS MADE TO THE EXCLUSIVE RIGHT TO USE "SNEAKERS", APART FROM THE MARK AS SHOWN.

FOR CLOTHING PRODUCTS, NAMELY, FOOTWEAR (U.S. CLS. 22 AND 39).

MARK PILARO, EXAMINING ATTORNEY

SN 85-048,613. TKEES, INC., HOLLYWOOD, FL. FILED 5-26-2010.

**TKEES**

THE MARK CONSISTS OF STANDARD CHARACTERS WITHOUT CLAIM TO ANY PARTICULAR FONT, STYLE, SIZE, OR COLOR.

FOR FOOTWEAR (U.S. CLS. 22 AND 39).

FIRST USE 12-31-2009; IN COMMERCE 12-31-2009.

HOWARD B. LEVINE, EXAMINING ATTORNEY

**CLASS 25—(Continued).**

SN 85-049,965. ZHENJIANG XINPENGXIANG LEATHER CO., LTD., JIANGSU PROVINCE, CHINA, FILED 5-28-2010.



THE MARK CONSISTS OF THE STYLIZED WORD "MUGGY" AND A DESIGNED SUN SPARKLING FLAME AS THE BACKGROUND.  
FOR GYMNASTIC SHOES; HOSIERY; SHOES; SKI BOOTS (U.S. CLS. 22 AND 39).  
FIRST USE 3-14-2008; IN COMMERCE 3-14-2008.  
SCOTT BIBB, EXAMINING ATTORNEY

**CLASS 25—(Continued).**

SN 85-050,911. SCOFIELD, JOHN P, DBA SOCIETY BRAND CLOTHING COMPANY, CITRUS HEIGHTS, CA. AND SCOFIELD, LAVINA J, DBA SOCIETY BRAND CLOTHING COMPANY, CITRUS HEIGHTS, CA. FILED 5-29-2010.



NO CLAIM IS MADE TO THE EXCLUSIVE RIGHT TO USE "BRAND CLOTHING CO.", APART FROM THE MARK AS SHOWN.

THE MARK CONSISTS OF THE STYLIZED WORDING "SOCIETY BRAND CLOTHING CO." ABOVE AN OVAL SHAPED GLOBE OF THE WORLD WITH THE STYLIZED WORDING "HUMANITY CULTURE CIVILIZATION" UNDERNEATH; ALL ON A RECTANGULAR BACKGROUND.  
FOR A-SHIRTS; APPAREL FOR DANCERS, NAMELY, TEE SHIRTS, SWEATSHIRTS, PANTS, LEGGINGS, SHORTS AND JACKETS; ATHLETIC APPAREL, NAMELY, SHIRTS, PANTS, JACKETS, FOOTWEAR, HATS AND CAPS, ATHLETIC UNIFORMS; BODY SHIRTS; BUTTON-FRONT ALOHA SHIRTS; CAMOUFLAGE SHIRTS; CAMP SHIRTS; CLOTHING FOR ATHLETIC USE, NAMELY, PADDED SHIRTS; CLOTHING SHIELDS, NAMELY, PADS APPLIED TO THE UNDERARMS OF SHIRTS, BLOUSES AND SWEATERS; DRESS SHIRTS; FISHING SHIRTS; GOLF PANTS, SHIRTS AND SKIRTS; GOLF SHIRTS; HOODED SWEAT SHIRTS; HUNTING SHIRTS; KNIT SHIRTS; LEATHER SHIRTS; LONG-SLEEVED SHIRTS; MOISTURE-WICKING SPORTS SHIRTS; NIGHT SHIRTS; OPEN-NECKED SHIRTS; OVER SHIRTS; PIQUE SHIRTS; POLO SHIRTS; RUGBY SHIRTS; SCIENTIFIC AND TECHNOLOGICAL APPAREL, NAMELY, SHIRTS, PANTS, JACKETS, FOOTWEAR, HATS AND CAPS, UNIFORMS; SHIRT FRONTS; SHIRT YOKES; SHIRTS; SHIRTS AND SHORT-SLEEVED SHIRTS; SHIRTS FOR INFANTS, BABIES, TODDLERS AND CHILDREN; SHIRTS FOR SUITS; SHORT-SLEEVED OR LONG-SLEEVED T-SHIRTS; SHORT-SLEEVED SHIRTS; SLEEP SHIRTS; SPORT SHIRTS; SPORTS SHIRTS; SPORTS SHIRTS WITH SHORT SLEEVES; SWEAT SHIRTS; T-SHIRTS; TEE SHIRTS; TRIATHLON CLOTHING, NAMELY, TRIATHLON TIGHTS, TRIATHLON SHORTS, TRIATHLON SINGLETTS, TRIATHLON SHIRTS, TRIATHLON SUITS; TURTLE NECK SHIRTS; WEARABLE GARMENTS AND CLOTHING, NAMELY, SHIRTS; WIND SHIRTS; YOGA SHIRTS (U.S. CLS. 22 AND 39).

FIRST USE 4-1-2010; IN COMMERCE 5-22-2010.

JULIE GUTTADAURO, EXAMINING ATTORNEY

SN 85-052,608. CALLAWAY GOLF COMPANY, CARLSBAD, CA. FILED 6-2-2010.

## Tour Approved

THE MARK CONSISTS OF STANDARD CHARACTERS WITHOUT CLAIM TO ANY PARTICULAR FONT, STYLE, SIZE, OR COLOR.

FOR FOOTWEAR; GLOVES; GOLF SHIRTS; HEADWEAR; JACKETS; PANTS; SHORTS; SOCKS; T-SHIRTS; WIND RESISTANT JACKETS (U.S. CLS. 22 AND 39).

DAVID C. REIHNER, EXAMINING ATTORNEY

**CLASS 25—(Continued).**

SN 85-054,287. HEISENPORT, INC., CIUDAD DE PANAMA, PANAMA, FILED 6-3-2010.

SANTIAGO GONZALEZ

THE MARK CONSISTS OF STANDARD CHARACTERS WITHOUT CLAIM TO ANY PARTICULAR FONT, STYLE, SIZE, OR COLOR.

THE NAME(S), PORTRAIT(S), AND/OR SIGNATURE(S) SHOWN IN THE MARK IDENTIFIES SANTIAGO BARBERI GONZALEZ, WHOSE CONSENT(S) TO REGISTER IS MADE OF RECORD.

FOR CLOTHING, NAMELY, COATS, JACKETS, GLOVES, PULLOVERS, SHIRTS, SUITS, SWEATERS, SWIM WEAR, SHORTS, SCARVES, PANTS, TIES, T-SHIRTS, JOGGING SUITS, SWEATSUITS, BATHROBES, UNDERWEAR; FOOTWEAR; HEAD WEAR; BELTS; SHOES; SLIPPERS (U.S. CLS. 22 AND 39).

JENNIFER MARTIN, EXAMINING ATTORNEY

**CLASS 25—(Continued).**

SN 85-057,738. LEADING LADY, INC., BEACHWOOD, OH. FILED 6-8-2010.

TOP SECRET

THE MARK CONSISTS OF STANDARD CHARACTERS WITHOUT CLAIM TO ANY PARTICULAR FONT, STYLE, SIZE, OR COLOR.

OWNER OF U.S. REG. NOS. 1,055,635 AND 1,913,392.

FOR BATHROBES; BEACH COVER-UPS; BEACHWEAR; BELTS; BIKINIS; BLOUSES; BODY SHAPERS; BODY SUITS; CAMISOLES; CLOTHING, NAMELY, WRAP-AROUNDS; CULOTTES; DENIM JACKETS; DRESSES; FOOTWEAR; FOUNDATION GARMENTS; GLOVES; GYM PANTS; GYM SHORTS; GYM SUITS; HALTER TOPS; HATS; HEADBANDS AGAINST SWEATING; HEADWEAR; JEANS; JOGGING PANTS; JOGGING SUITS; KNIT SHIRTS; LINGERIE; MINISKIRTS; NEGLIGENCE; NIGHT GOWNS; NIGHT SHIRTS; PAJAMAS; PANTS; SCARVES; SHIRTS; SHORTS; SKIRTS; SLEEPWEAR; SWEAT PANTS; SWEAT SHIRTS; SWEAT SHORTS; SWEAT SUITS; SWEATERS; SWIM WEAR; TANK TOPS; TENNIS WEAR; TIGHTS; UNDERGARMENTS; VESTS; WARM UP SUITS (U.S. CLS. 22 AND 39).

WARREN L. OLANDRIA, EXAMINING ATTORNEY

SN 85-058,834. ECO TEXTILES GROUP, INC., LOS ANGELES, CA. FILED 6-9-2010.

SN 85-057,091. MATTEL, INC., EL SEGUNDO, CA. FILED 6-8-2010.

WHAC ATTACK



THE COLOR(S) GREEN IS/ARE CLAIMED AS A FEATURE OF THE MARK.

THE MARK CONSISTS OF THE WORD "ECOTEX" IN STYLIZED FONT SURROUNDED BY AN ELLIPSE, WHICH IS BROKEN IN HALF AND INTERCEPTS THE LETTER "X", ALL IN THE COLOR GREEN.

FOR CLOTHING, NAMELY, WOMEN'S, MEN'S, AND CHILDREN'S KNITTED TEE SHIRTS, JACKETS, SWEATERS, HOODED SWEATERS, JACKETS, SHIRTS, TOPS, SKIRTS, SHORTS AND PANTS (U.S. CLS. 22 AND 39).

FIRST USE 6-1-1992; IN COMMERCE 6-1-1992.

STEPHANIE ALI, EXAMINING ATTORNEY

THE MARK CONSISTS OF STANDARD CHARACTERS WITHOUT CLAIM TO ANY PARTICULAR FONT, STYLE, SIZE, OR COLOR.

FOR CLOTHING, NAMELY, T-SHIRTS (U.S. CLS. 22 AND 39).

CHRIS DONINGER, EXAMINING ATTORNEY

**CLASS 25—(Continued).**

SN 85-059,080. PAISLEY, DAVID, MEDINA, WA. FILED 6-10-2010.

PUT EM IN THE WALL

THE MARK CONSISTS OF STANDARD CHARACTERS WITHOUT CLAIM TO ANY PARTICULAR FONT, STYLE, SIZE, OR COLOR.

FOR CLOTHING, NAMELY, T-SHIRTS AND HEADWEAR (U.S. CLS. 22 AND 39).

STEPHANIE ALI, EXAMINING ATTORNEY

SN 85-059,586. HEISENPORT, INC., CIUDAD DE PANAMA, PANAMA, FILED 6-10-2010.

SANTIAGO GONZALEZ  
✦

THE NAME(S), PORTRAIT(S), AND/OR SIGNATURE(S) SHOWN IN THE MARK IDENTIFIES SANTIAGO BARBERI GONZALEZ, WHOSE CONSENT(S) TO REGISTER IS MADE OF RECORD.

THE MARK CONSISTS OF THE WORDS "SANTIAGO GONZALEZ" CENTERED OVER A STAR BURST DESIGN.

FOR CLOTHING, NAMELY, COATS, JACKETS, GLOVES, PULLOVERS, SHIRTS, SUITS, SWEATERS, SWIM WEAR, SHORTS, SCARVES, PANTS, TIES, T-SHIRTS, JOGGING SUITS, SWEATSUITS, BATHROBES, UNDERWEAR; FOOTWEAR; HEAD WEAR; BELTS; SHOES; SLIPPERS (U.S. CLS. 22 AND 39).

JENNIFER MARTIN, EXAMINING ATTORNEY

**CLASS 25—(Continued).**

SN 85-060,627. ISACO INTERNATIONAL CORPORATION, MIAMI LAKES, FL. FILED 6-11-2010.



THE MARK CONSISTS OF THE STYLIZED WORDING "ROUTE NORTH" WITH AN ARROW REPRESENTING THE LETTER "T" FOR BOTH THE WORDS "ROUTE" AND "NORTH". THE ARROW HAVING A SOLID VERTICAL LINE AND TWO BROKEN VERTICAL LINES ON EITHER SIDE EXTENDING IN THE CENTER OF THE ARROW.

FOR CLOTHING, NAMELY, HOSIERY, SOCKS, TIES, UNDERWEAR, BOXERS, BRIEFS, NECKTIES, LOUNGEWEAR, PAJAMAS, NIGHTWEAR, ROBES, SLEEP PANTS, SLEEP SHORTS, BASEBALL CAPS, SWIMSUITS, UNDERSHIRTS, SHIRTS, ZIPPERED SWEATSHIRTS, SHORTS (U.S. CLS. 22 AND 39).

NICHOLAS COLEMAN, EXAMINING ATTORNEY

SN 85-060,656. ISACO INTERNATIONAL CORPORATION, MIAMI LAKES, FL. FILED 6-11-2010.

9two

THE MARK CONSISTS OF STANDARD CHARACTERS WITHOUT CLAIM TO ANY PARTICULAR FONT, STYLE, SIZE, OR COLOR.

FOR CLOTHING, NAMELY, HOSIERY, SOCKS, TIES, UNDERWEAR, BOXERS, BRIEFS, NECKTIES, LOUNGEWEAR, PAJAMAS, NIGHTWEAR, ROBES, SLEEP PANTS, SLEEP SHORTS, BASEBALL CAPS, SWIMSUITS, UNDERSHIRTS, SHIRTS, ZIPPERED SWEATSHIRTS, SHORTS (U.S. CLS. 22 AND 39).

NICHOLAS COLEMAN, EXAMINING ATTORNEY

**CLASS 25—(Continued).**

SN 85-060,664. MOUSSIAUX, KATHY G., COTO DE CAZA, CA. FILED 6-11-2010.

## Amanda Faith

THE MARK CONSISTS OF STANDARD CHARACTERS WITHOUT CLAIM TO ANY PARTICULAR FONT, STYLE, SIZE, OR COLOR.

THE NAME "AMANDA FAITH" IDENTIFIES "AMANDA FAITH" MOUSSIAUX, A LIVING INDIVIDUAL WHOSE CONSENT IS OF RECORD.

FOR A-SHIRTS; BERMUDA SHORTS; BIB SHORTS; BOXER SHORTS; CAPRI PANTS; CARGO PANTS; CHILDREN'S AND INFANT'S APPAREL, NAMELY, JUMPERS, OVERALL SLEEPWEAR, PAJAMAS, ROMPERS AND ONE-PIECE GARMENTS; CROP TOPS; DENIM JACKETS; DENIMS; DRESS SHIRTS; DRESS SUITS; DRESSES; GYM SHORTS; HALTER TOPS; HEAVY JACKETS; HOODED SWEAT SHIRTS; JACKETS; JACKETS AND SOCKS; JOGGING PANTS; KNIT JACKETS; KNIT SHIRTS; LEOTARDS AND TIGHTS FOR WOMEN, MEN AND CHILDREN OF NYLON, COTTON OR OTHER TEXTILE FIBERS; LONG JACKETS; LONG-SLEEVED SHIRTS; LOUNGE PANTS; MEN'S AND WOMEN'S JACKETS, COATS, TROUSERS, VESTS; NIGHT SHIRTS; OPEN-NECKED SHIRTS; OUTER JACKETS; PANTIES, SHORTS AND BRIEFS; PANTS; POLO KNIT TOPS; POLO SHIRTS; RUGBY SHIRTS; RUGBY SHORTS; RUGBY TOPS; SHELL JACKETS; SHIRTS; SHIRTS AND SHORT-SLEEVED SHIRTS; SHIRTS FOR INFANTS, BABIES, TODDLERS AND CHILDREN; SHIRTS FOR SUITS; SHORT SETS; SHORT TROUSERS; SHORT-SLEEVED OR LONG-SLEEVED T-SHIRTS; SHORT-SLEEVED SHIRTS; SHORTS; SKIRT SUITS; SKIRTS; SKIRTS AND DRESSES; SLEEP PANTS; SLEEP SHIRTS; SPORT SHIRTS; SPORTS JACKETS; SPORTS PANTS; SPORTS SHIRTS; SPORTS SHIRTS WITH SHORT SLEEVES; STRETCH PANTS; SWEAT JACKETS; SWEAT PANTS; SWEAT SHIRTS; SWEAT SHORTS; T-SHIRTS; TANK TOPS; TANK-TOPS; TEE SHIRTS; TOPS; TRACK JACKETS; TRACK PANTS; TUBE TOPS; TURTLE NECK SHIRTS; WALKING SHORTS; WIND-JACKETS; WOMEN'S TOPS, NAMELY, CAMIS (U.S. CLS. 22 AND 39).  
NICHOLAS COLEMAN, EXAMINING ATTORNEY

SN 85-061,650. BLOOD MONEY INDUSTRIES INC., YUCAIPA, CA. FILED 6-14-2010.

## IN BLOOD WE TRUST

THE MARK CONSISTS OF STANDARD CHARACTERS WITHOUT CLAIM TO ANY PARTICULAR FONT, STYLE, SIZE, OR COLOR.

FOR CLOTHING PRODUCTS, NAMELY, MEN'S LONG SLEEVE SHIRTS, MEN'S SHORT SLEEVE SHIRTS, WOMEN'S LONG SLEEVE SHIRTS, WOMEN'S SHORT SLEEVE SHIRTS, HOODED SWEATSHIRTS, JERSEYS, BELTS, HATS, BOARD SHORTS FOR MEN, WOMEN, ATHLETES, CHILDREN (U.S. CLS. 22 AND 39).  
NAKIA HENRY, EXAMINING ATTORNEY

**CLASS 25—(Continued).**

SN 85-062,161. STEPTRONIC FOOTWEAR LIMITED, NORWICH, UNITED KINGDOM, FILED 6-14-2010.

## STEPTRONIC

THE MARK CONSISTS OF STANDARD CHARACTERS WITHOUT CLAIM TO ANY PARTICULAR FONT, STYLE, SIZE, OR COLOR.

PRIORITY CLAIMED UNDER SEC. 44(D) ON CANADA APPLICATION NO. 1472540, FILED 3-10-2010, REG. NO. TMA785138, DATED 12-16-2010, EXPIRES 12-16-2025.

FOR MEN'S, WOMEN'S AND CHILDREN'S FOOTWEAR, NAMELY, INDOOR AND OUTDOOR BOOTS, SHOES, SLIPPERS AND SANDALS (U.S. CLS. 22 AND 39).

ANGELA M. MICHELI, EXAMINING ATTORNEY

SN 85-062,335. LONGFAST COMPANY LIMITED, HO MAN TIN, KOWLOON, HONG KONG, FILED 6-14-2010.

today  
is  
**COOL**

THE MARK CONSISTS OF THE STYLIZED WORDING "TODAY IS COOL", WITH THE LETTERS "OO" FORMED BY TWO EYES.

FOR CLOTHING, NAMELY, T-SHIRTS, SHIRTS, SWEAT SHIRTS, PANTS, SHORTS, TROUSERS, SKIRTS, DRESSES, JACKETS, JUMPERS, PULLOVERS, COATS, SUITS, SWEATERS, JEANS, TIES; HEADGEAR, NAMELY, HATS, CAPS (U.S. CLS. 22 AND 39).  
JEAN IM, EXAMINING ATTORNEY

SN 85-063,854. CHICAGO CUBS BASEBALL CLUB, LLC, CHICAGO, IL. FILED 6-15-2010.

**CHICAGO**

OWNER OF U.S. REG. NO. 1,612,016.  
THE MARK CONSISTS OF THE WORD "CHICAGO" IN STYLIZED TEXT.

SEC. 2(F).  
FOR CLOTHING, NAMELY, JERSEYS, JACKETS, SHIRTS, BOTTOMS, INFANTWEAR, TIES; HEADWEAR; FOOTWEAR (U.S. CLS. 22 AND 39).  
FIRST USE 0-0-1996; IN COMMERCE 0-0-1996.  
KHANH LE, EXAMINING ATTORNEY

**CLASS 25—(Continued).**

SN 85-069,072. C.I. SPATARO NAPOLI SA, CALI-COLOMBIA, COLOMBIA, FILED 6-22-2010.

# CAMERUCCI

THE MARK CONSISTS OF STANDARD CHARACTERS WITHOUT CLAIM TO ANY PARTICULAR FONT, STYLE, SIZE, OR COLOR.

OWNER OF COLOMBIA REG. NO. 397802, DATED 3-23-2010, EXPIRES 3-23-2020.

THE WORDING "CAMERUCCI" HAS NO MEANING IN A FOREIGN LANGUAGE.

FOR WARDROBE, NAMELY, SUITS, PANTS, SHIRTS, COATS, JACKETS, FORMAL WEAR IN THE NATURE OF SUITS, SPORT COATS, JACKETS, BLAZERS, TROUSERS, SHIRTS, AND BELTS FOR CLOTHING, INFORMAL WEAR IN THE NATURE OF UNDERWEAR, UNDERGARMENTS, SWEAT SUITS, SHORTS, BLOUSES, TOPS FOR WOMEN, JEANS, SWEAT PANTS, SWIM SUITS, SOCKS, SWEAT BANDS, GLOVES, AND BELTS FOR CLOTHING; FOOTWEAR, NAMELY, SHOES, BOOTS, AND SLIPPERS; HEADGEAR, NAMELY, HATS, CAPS, AND VISORS (U.S. CLS. 22 AND 39).

RAMONA ORTIGA, EXAMINING ATTORNEY

SN 85-070,086. YELL STEEL ENTERPRISE CO., INC., SANTA ANA, CA. FILED 6-23-2010.

# TEAM MAX

THE MARK CONSISTS OF STANDARD CHARACTERS WITHOUT CLAIM TO ANY PARTICULAR FONT, STYLE, SIZE, OR COLOR.

NO CLAIM IS MADE TO THE EXCLUSIVE RIGHT TO USE "TEAM", APART FROM THE MARK AS SHOWN.

FOR APRÈS-SKI SHOES; AQUA SHOES; ATHLETIC APPAREL, NAMELY, SHIRTS, PANTS, JACKETS, FOOTWEAR, HATS AND CAPS, ATHLETIC UNIFORMS; ATHLETIC SHOES; BALLET SHOES; BASEBALL CAPS; BASEBALL CAPS AND HATS; BASEBALL SHOES; BASEBALL UNIFORMS; BEACH FOOTWEAR; BEACH SHOES; BERMUDA SHORTS; BOARD SHORTS; BOWLING SHOES; BOXER BRIEFS; BOXER SHORTS; BOXING SHOES; BRIEFS; CANVAS SHOES; CAPRI PANTS; CLIMBING SHOES; CLOTHING FOR ATHLETIC USE, NAMELY, PADDED ELBOW COMPRESSION SLEEVES BEING PART OF AN ATHLETIC GARMENT; CYCLING SHOES; CYCLISTS' JERSEYS; FLEECE PULLOVERS; FLEECE SHORTS; FOOTBALL SHOES; GOLF CAPS; GOLF PANTS, SHIRTS AND SKIRTS; GOLF SHIRTS; GOLF SHOES; GOLF SHORTS; GOLF TROUSERS; GYM PANTS; GYM SHORTS; GYMNAS TIC SHOES; HANDBALL SHOES; HEADBANDS AGAINST SWEATING; HOCKEY SHOES; HOODED SWEAT SHIRTS; HUNTING PANTS; JERSEYS; JOGGING OUTFITS; JOGGING PANTS; JOGGING SUITS; KNIT JACKETS; KNIT SHIRTS; KNITTED UNDERWEAR; LONG SLEEVE

**CLASS 25—(Continued).**

PULLOVERS; LONG UNDERWEAR; LONG-SLEEVED SHIRTS; MEN'S UNDERWEAR; MOISTURE-WICKING SPORTS PANTS; MOISTURE-WICKING SPORTS SHIRTS; NIGHT SHIRTS; OPEN-NECKED SHIRTS; PANTS; PERSPIRATION ABSORBENT UNDERWEAR CLOTHING; PIQUE SHIRTS; POLO SHIRTS; RUBBER SHOES; RUGBY SHIRTS; RUGBY SHOES; RUGBY SHORTS; RUGBY TOPS; RUNNING SHOES; SHORT-SLEEVED OR LONG-SLEEVED T-SHIRTS; SHORT-SLEEVED SHIRTS; SKI PANTS; SLEEP PANTS; SLEEVELESS JERSEYS; SPORT SHIRTS; SPORTS JERSEYS; SPORTS JERSEYS AND BREECHES FOR SPORTS; SPORTS PANTS; SPORTS SHIRTS; STRETCH PANTS; SWEAT BANDS; SWEAT JACKETS; SWEAT PANTS; SWEAT SHIRTS; SWEAT SHORTS; SWEAT SUITS; T-SHIRTS; TEE SHIRTS; THERMAL UNDERWEAR; TRACK PANTS; UNDERWEAR; UNDERWEAR, NAMELY, BOY SHORTS; VOLLEYBALL JERSEYS; WATERPROOF JACKETS AND PANTS; WIND PANTS; WOVEN OR KNITTED UNDERWEAR (U.S. CLS. 22 AND 39).

EUGENIA MARTIN, EXAMINING ATTORNEY

SN 85-073,242. WAYNE H. BROUN, WARRIEWOOD BEACH NSW, AUSTRALIA, FILED 6-28-2010.

# BROUN OF COLSTOUN

THE MARK CONSISTS OF STANDARD CHARACTERS WITHOUT CLAIM TO ANY PARTICULAR FONT, STYLE, SIZE, OR COLOR.

THE NAME(S), PORTRAIT(S), AND/OR SIGNATURE(S) SHOWN IN THE MARK DOES NOT IDENTIFY A PARTICULAR LIVING INDIVIDUAL.

FOR MENS, WOMENS, CHILDRENS, BABIES, AND INFANTS CLOTHING, NAMELY, T-SHIRTS, SWEATSHIRTS, HOODED SWEATSHIRTS, TOPS, BOTTOMS, PANTS, SHORTS, SHIRTS, DRESSES, SKIRTS, KILTS, APRONS, SWEATERS, JACKETS, COATS, JEANS, HEADBANDS, WRISTBANDS, HATS, SHOES, BELTS, JACKETS AND COATS, MITTENS AND GLOVES, MONEY BELTS, NECKERCHIEFS, SCARVES, WRAPS, GOLF WEAR, TENNIS WEAR, WIND-RESISTANT JACKETS, HOSIERY AND SOCKS, BIBS, BOOTIES, INFANTWEAR; WATERPROOF, WATER RESISTANT, AND WINDPROOF CLOTHING, NAMELY, JACKETS, COATS, AND VESTS; LEATHER CLOTHING, NAMELY, JACKETS AND COATS (U.S. CLS. 22 AND 39).

MARTHA SANTOMARTINO, EXAMINING ATTORNEY

**CLASS 25—(Continued).**

SN 85-074,385. JENSEN, GREG N., DBA 404, CAPISTRANO BEACH, CA. FILED 6-29-2010.

# 404

THE MARK CONSISTS OF STANDARD CHARACTERS WITHOUT CLAIM TO ANY PARTICULAR FONT, STYLE, SIZE, OR COLOR.

FOR ATHLETIC APPAREL, NAMELY, SHIRTS, PANTS, JACKETS, FOOTWEAR, HATS AND CAPS, ATHLETIC UNIFORMS; SHORT-SLEEVED OR LONG-SLEEVED T-SHIRTS; SWEAT SHIRTS (U.S. CLS. 22 AND 39).

FIRST USE 12-20-2009; IN COMMERCE 12-20-2009.  
KAPIL BHANOT, EXAMINING ATTORNEY

SN 85-082,921. GUERCIO, JAMES W., BOULDER, CO. FILED 7-12-2010.



THE MARK CONSISTS OF THE WORDS "CARIBOU RANCH" IN STYLIZED SCRIPT LETTERING UNDERNEATH A FANCIFUL DESIGN OF A CARIBOU DEER WALKING IN A FIELD WITH TREES AND A MOUNTAIN IN THE BACKGROUND.

FOR CLOTHING, NAMELY, SHIRTS, T-SHIRTS; AND HEADWEAR (U.S. CLS. 22 AND 39).

FIRST USE 0-0-1974; IN COMMERCE 0-0-1974.  
TASNEEM HUSSAIN, EXAMINING ATTORNEY

SN 85-083,238. NATIONAL ASSOCIATION FOR STOCK CAR AUTO RACING, INC., DAYTONA BEACH, FL. FILED 7-13-2010.

# STRICTLY STOCK

THE MARK CONSISTS OF STANDARD CHARACTERS WITHOUT CLAIM TO ANY PARTICULAR FONT, STYLE, SIZE, OR COLOR.

FOR CLOTHING, NAMELY, CAPS, HATS, COLLARED SHIRTS, T-SHIRTS, TANK TOPS, SWEATERS, SWEAT SHIRTS, JACKETS, COATS, SWEAT PANTS, PANTS, SHORTS, NIGHTGOWNS, PAJAMAS, ROBES, VESTS, SOCKS, SHOES AND VISORS (U.S. CLS. 22 AND 39).

GRETTA YAO, EXAMINING ATTORNEY

**CLASS 25—(Continued).**

SN 85-083,908. PUREPLAY LLC, GARDEN CITY, NY. FILED 7-13-2010.

# CLOTHES FOR THE REGENERATION

THE MARK CONSISTS OF STANDARD CHARACTERS WITHOUT CLAIM TO ANY PARTICULAR FONT, STYLE, SIZE, OR COLOR.

NO CLAIM IS MADE TO THE EXCLUSIVE RIGHT TO USE "CLOTHES", APART FROM THE MARK AS SHOWN.

FOR SHIRTS; SWEAT SHIRTS (BASED ON USE); KNIT SHIRTS; SWEATERS; PANTS; TROUSERS; SHORTS; UNDERGARMENTS; JACKETS; COATS (BASED ON INTENT-TO-USE) (U.S. CLS. 22 AND 39).

FIRST USE 9-1-2007; IN COMMERCE 9-1-2007.  
TINA L. SNAPP, EXAMINING ATTORNEY

SN 85-085,653. HI-TEC SPORTS PLC, ESSEX SS2 6GH, UNITED KINGDOM, FILED 7-15-2010.

# V-LITE INFINITY

THE MARK CONSISTS OF STANDARD CHARACTERS WITHOUT CLAIM TO ANY PARTICULAR FONT, STYLE, SIZE, OR COLOR.

OWNER OF ERPN CMNTY TM OFC REG. NO. 009251398, DATED 12-27-2010, EXPIRES 7-15-2020.

OWNER OF U.S. REG. NO. 2,971,769.

FOR FOOTWEAR, NAMELY, SHOES AND BOOTS (U.S. CLS. 22 AND 39).

BARBARA GAYNOR, EXAMINING ATTORNEY

SN 85-092,263. FLYING PASTIES INTERNATIONAL LLC, LAS VEGAS, NV. FILED 7-24-2010.

# FLYING PASTIES

THE MARK CONSISTS OF STANDARD CHARACTERS WITHOUT CLAIM TO ANY PARTICULAR FONT, STYLE, SIZE, OR COLOR.

NO CLAIM IS MADE TO THE EXCLUSIVE RIGHT TO USE "PASTIES", APART FROM THE MARK AS SHOWN.

FOR UNDERGARMENTS, NAMELY, RUBBER PASTIES FOR INDIVIDUALS' PRIVATE PARTS FOR USE WHILE UNDERGOING FULL BODY SECURITY SCANNING (U.S. CLS. 22 AND 39).

FIRST USE 11-28-2010; IN COMMERCE 11-28-2010.  
MICHELE SWAIN, EXAMINING ATTORNEY



**CLASS 25—(Continued).**

SN 85-094,466. SHEEX, INC., PHILADELPHIA, PA. FILED 7-28-2010.

# SHEEX

THE MARK CONSISTS OF STANDARD CHARACTERS WITHOUT CLAIM TO ANY PARTICULAR FONT, STYLE, SIZE, OR COLOR.

OWNER OF U.S. REG. NOS. 3,632,848 AND 3,632,849.  
FOR NIGHTGOWNS; NIGHTSHIRTS; PAJAMAS;  
SLEEPWEAR (U.S. CLS. 22 AND 39).  
RONALD AIKENS, EXAMINING ATTORNEY

**CLASS 25—(Continued).**

SN 85-101,432. JOHNNIE-O, LOS ANGELES, CA. FILED 8-5-2010.



SN 85-097,469. LANG, LISA, PAIA, HI. FILED 7-31-2010.

THE MARK CONSISTS OF THE TERM "MISSCHIEF" IN STYLIZED FORM, WHERE THE DOT IN THE "I" OF "CHIEF" IS IN THE SHAPE OF A HEART, AND DIRECTLY ABOVE THE LETTERS "MISSC" IS AN ARROW WITH ITS POINT FACING TO THE RIGHT.

FOR CLOTHING, NAMELY, TOPS, BLOUSES, DRESSES, SKIRTS, PANTS, SHORTS, SARONGS AND BATHING SUITS FOR WOMEN (U.S. CLS. 22 AND 39).  
FIRST USE 6-6-2010; IN COMMERCE 7-4-2010.  
JOHN DWYER, EXAMINING ATTORNEY

OWNER OF U.S. REG. NO. 3,532,461.  
THE MARK CONSISTS OF A GRAPHIC DEPICTION OF A MAN WITH A SURFBOARD.  
FOR BELTS; BOTTOMS; HEADWEAR; TOPS (U.S. CLS. 22 AND 39).  
FIRST USE 5-0-2004; IN COMMERCE 5-0-2004.  
KATHY DE JONGE, EXAMINING ATTORNEY

SN 85-102,266. BALTIMORE ORIOLES LIMITED PARTNERSHIP, BALTIMORE, MD. FILED 8-6-2010.

SN 85-100,970. J BRAND, INC., LOS ANGELES, CA. FILED 8-5-2010.

## THE LITTLE BLACK JEAN

THE MARK CONSISTS OF STANDARD CHARACTERS WITHOUT CLAIM TO ANY PARTICULAR FONT, STYLE, SIZE, OR COLOR.

NO CLAIM IS MADE TO THE EXCLUSIVE RIGHT TO USE "BLACK JEAN", APART FROM THE MARK AS SHOWN.

FOR CLOTHING, NAMELY, JEANS (U.S. CLS. 22 AND 39).  
BARBARA BROWN, EXAMINING ATTORNEY

OWNER OF U.S. REG. NOS. 3,291,902, 3,326,758 AND OTHERS.

THE MARK CONSISTS OF THE WORD "BALTIMORE" IN STYLIZED FORM.

SEC. 2(F).  
FOR CLOTHING, NAMELY, JERSEYS AND SHIRTS (U.S. CLS. 22 AND 39).

FIRST USE 0-0-1990; IN COMMERCE 0-0-1990.  
KRISTIN DAHLING, EXAMINING ATTORNEY

**CLASS 25—(Continued).**

SN 85-107,331. WILD THINGS, LLC, NEWPORT, RI. FILED 8-13-2010.



THE MARK CONSISTS OF CLIMBING EQUIPMENT FORMING THE LETTERS "W" AND "T".

FOR MOUNTAIN CLIMBING CLOTHING, NAMELY, HIGH ALTITUDE SUITS, JACKETS, PULLOVERS AND SHIRTS; SPORTSWEAR, NAMELY, SHIRTS, PANTS, SHORTS, HATS, SWEATSHIRTS, JACKETS, PULLOVERS, GLOVES, FLEECE TOPS; MILITARY CLOTHING, NAMELY, COLD-WEATHER GEAR FOR USE WITH MILITARY UNIFORMS, NAMELY, COATS, JACKETS, SHIRTS, PANTS (U.S. CLS. 22 AND 39).

FIRST USE 11-22-2009; IN COMMERCE 11-22-2009.  
LAKEISHA LEWIS, EXAMINING ATTORNEY

SN 85-111,178. VISTAN DESIGN LLC, DBA TEST CLOTHING, MORRISTOWN, NJ. FILED 8-19-2010.

## Test Clothing

THE MARK CONSISTS OF STANDARD CHARACTERS WITHOUT CLAIM TO ANY PARTICULAR FONT, STYLE, SIZE, OR COLOR.

NO CLAIM IS MADE TO THE EXCLUSIVE RIGHT TO USE "CLOTHING", APART FROM THE MARK AS SHOWN.

FOR A-SHIRTS; BOAT SHOES; CANVAS SHOES; COLLARED SHIRTS; DENIMS; DRESS SHIRTS; SHIRTS; SHOES; T-SHIRTS; UNDERWEAR (U.S. CLS. 22 AND 39).

FIRST USE 7-31-2010; IN COMMERCE 7-31-2010.  
DEZMONA MIZELLE, EXAMINING ATTORNEY

SN 85-116,911. SKECHERS U.S.A., INC. II, MANHATTAN BEACH, CA. FILED 8-26-2010.



NO CLAIM IS MADE TO THE EXCLUSIVE RIGHT TO USE "RUNNER", APART FROM THE MARK AS SHOWN.

THE MARK CONSISTS OF STYLIZED LETTERS "SRR" WITH THE WORDS "POWER RUNNER" UNDERNEATH. FOR FOOTWEAR (U.S. CLS. 22 AND 39).

MARY ROSSMAN, EXAMINING ATTORNEY

**CLASS 25—(Continued).**

SN 85-116,999. SKECHERS U.S.A., INC. II, MANHATTAN BEACH, CA. FILED 8-26-2010.

## XT EXTENDED TRAINING

THE MARK CONSISTS OF STANDARD CHARACTERS WITHOUT CLAIM TO ANY PARTICULAR FONT, STYLE, SIZE, OR COLOR.

NO CLAIM IS MADE TO THE EXCLUSIVE RIGHT TO USE "XT" AND "TRAINING", APART FROM THE MARK AS SHOWN.

FOR FOOTWEAR (U.S. CLS. 22 AND 39).  
MARY ROSSMAN, EXAMINING ATTORNEY

SN 85-117,463. I THINK KID ENTERTAINMENT, LLC, FLOWER MOUND, TX. FILED 8-27-2010.

## T-X, THE LONE STAR HERO

THE MARK CONSISTS OF STANDARD CHARACTERS WITHOUT CLAIM TO ANY PARTICULAR FONT, STYLE, SIZE, OR COLOR.

NO CLAIM IS MADE TO THE EXCLUSIVE RIGHT TO USE "LONE STAR", APART FROM THE MARK AS SHOWN.

FOR CLOTHING, NAMELY, SHIRTS, PANTS, COATS, DRESSES, JERSEYS, JACKETS, HEADBANDS FOR CLOTHING, TIES, TOPS, FOOTWEAR, HATS AND CAPS, ATHLETIC UNIFORMS, ATHLETIC FOOTWEAR, ATHLETIC SHOES, BASEBALL CAPS AND HATS, GLOVES, PULLOVERS, SLEEPWEAR, SWIM WEAR, TANK TOPS, T-SHIRTS, AND ATHLETIC APPAREL, NAMELY, SHIRTS, PANTS, AND JACKETS (U.S. CLS. 22 AND 39).

NATALIE POLZER, EXAMINING ATTORNEY

SN 85-117,471. I THINK KID ENTERTAINMENT, LLC, FLOWER MOUND, TX. FILED 8-27-2010.

## 'Tude Up

THE MARK CONSISTS OF STANDARD CHARACTERS WITHOUT CLAIM TO ANY PARTICULAR FONT, STYLE, SIZE, OR COLOR.

FOR CLOTHING, NAMELY, SHIRTS, PANTS, COATS, DRESSES, JERSEYS, JACKETS, HEADBANDS FOR CLOTHING, TIES, TOPS, FOOTWEAR, HATS AND CAPS, ATHLETIC UNIFORMS, ATHLETIC FOOTWEAR, ATHLETIC SHOES, BASEBALL CAPS AND HATS, GLOVES, PULLOVERS, SLEEPWEAR, SWIM WEAR, TANK TOPS, T-SHIRTS, AND ATHLETIC APPAREL, NAMELY, SHIRTS, PANTS, AND JACKETS (U.S. CLS. 22 AND 39).

NATALIE POLZER, EXAMINING ATTORNEY

**CLASS 25—(Continued).**

SN 85-120,155. THE SINCLAIR MANUFACTURING GROUP LP, LOS ANGELES, CA. FILED 8-31-2010.



THE COLOR(S) RED IS/ARE CLAIMED AS A FEATURE OF THE MARK.

THE MARK CONSISTS OF A HAND DRAWN LETTER "X" WITH A CIRCLE AROUND IT ALL IN THE COLOR RED.

FOR BATHING SUITS; BATHROBES; BEACH COVER-UPS; BELTS; BOTTOMS; COATS; JACKETS; DRESSES; FOOTWEAR FOR MEN AND WOMEN; GLOVES; HEADWEAR; JACKETS; JEANS; PAJAMAS; PANTS; SCARVES; SOCKS; TIES; TOPS; T-SHIRTS; UNDERGARMENTS; VESTS (U.S. CLS. 22 AND 39).  
JAMES LOVELACE, EXAMINING ATTORNEY

SN 85-121,218. MILLERCOORS LLC, CHICAGO, IL. FILED 9-1-2010.

**FOOTBALLIDAY**

THE MARK CONSISTS OF STANDARD CHARACTERS WITHOUT CLAIM TO ANY PARTICULAR FONT, STYLE, SIZE, OR COLOR.

FOR T-SHIRTS (U.S. CLS. 22 AND 39).  
FIRST USE 4-1-2010; IN COMMERCE 4-1-2010.  
HEATHER BIDDULPH, EXAMINING ATTORNEY

**CLASS 25—(Continued).**

SN 85-126,212. SOURCE ADVANTAGE, LLC, DBA RED CARPET STUDIOS, LTD, CINCINNATI, OH. FILED 9-9-2010.



THE MARK CONSISTS OF THE TERM "ALL JAZZED UP" ENCLOSED WITHIN AN OVAL FOLLOWED BY THE TERM "BY RCS" OUTSIDE THE OVAL ON THE LOWER RIGHT SIDE.

FOR FOOTWEAR FOR WOMEN; LEOTARDS AND TIGHTS FOR WOMEN, MEN AND CHILDREN OF NYLON, COTTON OR OTHER TEXTILE FIBERS; WOMEN'S HATS AND HOODS; WOMEN'S SHOES (U.S. CLS. 22 AND 39).

FIRST USE 3-15-2009; IN COMMERCE 7-1-2009.  
MAUREEN DALL, EXAMINING ATTORNEY

SN 85-129,200. CONFECÇÕES DAL COSTA LTDA, SANTA CATARINA, BRAZIL, FILED 9-14-2010.

**dal.costa**

THE MARK CONSISTS OF THE WORDS "DAL COSTA" STYLIZED LETTERS WITH A SMALL LEAF LIKE DESIGN BETWEEN THE WORDS "DAL" AND "COSTA".

THE ENGLISH TRANSLATION OF "DAL COSTA" IN THE MARK IS "FROM THE COAST".

FOR BABY DOLL PYJAMAS; BATHING COSTUMES; BATHING SUITS; BATHING TRUNKS; BATHROBES; BEACH COVERUPS; BEACHWEAR; BELTS; BERMUDA SHORTS; BIKINIS; BLAZERS; BODICES; BRACES; PANTS; COATS; EAR BANDS; GLOVES; GYM PANTS; GYM SHORTS; GYM SUITS; HAT BANDS; HATS; HEAD SCARVES; HEAD SWEATBANDS; HEAD WEAR; JACKETS; JERSEYS; LAYETTES; LINGERIE; NECK BANDS; OVERALLS; OVERCOATS; PAJAMAS; PANTIES; PANTS; PARKAS; PULLOVERS; ROBES; SCARVES; SHAWLS; SHIRT YOKES; SHIRTS; SHORTS; SKIRTS; SLEEPWEAR; SLIPS; SMOCKS; SOCKS; STOLE; SUSPENDERS; SWEAT BANDS; SWIM TRUNKS; SWIM WEAR; SWIMSUITS; SWIMWEAR; T-SHIRTS; TIES; TUNICS; UNDERWEAR; UNIFORMS; VESTS; WAIST BANDS; WRIST BANDS (U.S. CLS. 22 AND 39).

FIRST USE 12-17-1998; IN COMMERCE 9-10-2007.  
APRIL ROACH, EXAMINING ATTORNEY

**CLASS 25—(Continued).**

SN 85-129,576. SKECHERS U.S.A., INC. II, MANHATTAN BEACH, CA. FILED 9-14-2010.

**RESISTANCE RUNNERS**

THE MARK CONSISTS OF STANDARD CHARACTERS WITHOUT CLAIM TO ANY PARTICULAR FONT, STYLE, SIZE, OR COLOR.

OWNER OF U.S. REG. NO. 3,823,164.

NO CLAIM IS MADE TO THE EXCLUSIVE RIGHT TO USE "RUNNERS", APART FROM THE MARK AS SHOWN. FOR APPAREL, NAMELY, TOPS, SHIRTS, BLOUSES, T-SHIRTS, SWEAT SHIRTS, SPORTS JERSEYS, SWEATERS, BOTTOMS, TROUSERS, PANTS, SWEAT PANTS, SHORTS, JACKETS, COATS, OVERCOATS, PULLOVERS, JUMPERS, DRESSES, SKIRTS, BEACHWEAR, SWIMSUITS, UNDERWEAR, LINGERIE, HEADWEAR, HATS, CAPS, BEANIES, VISORS, TIES, SOCKS, BELTS, GLOVES, SCARVES AND WRISTBANDS (U.S. CLS. 22 AND 39).

GEOFFREY FOSDICK, EXAMINING ATTORNEY

---

SN 85-131,773. KING, ROBERT, MANTI, UT. FILED 9-17-2010.

**MONSTER CAMO**

THE MARK CONSISTS OF STANDARD CHARACTERS WITHOUT CLAIM TO ANY PARTICULAR FONT, STYLE, SIZE, OR COLOR.

NO CLAIM IS MADE TO THE EXCLUSIVE RIGHT TO USE "CAMO", APART FROM THE MARK AS SHOWN.

FOR CLOTHING PRODUCTS, NAMELY, SHIRTS, SHORTS, COATS, PANTS, FOOTWEAR, HATS, CAPS, GLOVES, COATS, JACKETS; SPORTSWEAR, NAMELY, SHIRTS, SHORTS, COATS, PANTS, FOOTWEAR, HATS, CAPS, GLOVES, COATS, JACKETS; MOTORSPORTS RELATED CLOTHING, NAMELY, SHIRTS, SHORTS, COATS, PANTS, FOOTWEAR, HATS, CAPS, GLOVES, COATS, JACKETS (U.S. CLS. 22 AND 39).

GEOFFREY FOSDICK, EXAMINING ATTORNEY

**CLASS 25—(Continued).**

SN 85-131,788. GUANGZHOU NANDADI TEXTILE GARMENT CO., LTD, ZENGCHENG, GUANGZHOU, CHINA, FILED 9-17-2010.



THE MARK CONSISTS OF A STYLIZED FLOWER DESIGN.

FOR BANDANAS; BATH ROBES; BATHING SUITS; BEACHWEAR; BEANIES; BELTS; BIKINIS; BLAZERS; BLOOMERS; BLOUSES; BRAS; BRIEFS; CAPES; CAPS; COATS; COSTUMES, NAMELY, DANCE COSTUME AND MASQUERADE COSTUMES; DENIM JACKETS; DENIM PANTS; DRESS SHIRTS; DRESS SUITS; DRESSES; EAR MUFFS; FOOTWEAR; GIRDLES; GLOVES; GOLF CAPS; GOLF CLEATS; GOLF SHIRTS; GOLF SHOES; GOLF SPIKES; GOLF TROUSERS; GOWNS; G-STRINGS; HALLOWEEN COSTUMES; HATS; HEADGEAR FOR WEAR, NAMELY, HATS AND, CAPS; HOODS; HOSIERY; JACKETS; JEANS; JERSEYS; JUMPERS; KNITWEAR, NAMELY, KNIT SHIRTS, KNITTED CAPS, AND KNITTED UNDERWEAR; LINGERIE; MINISKIRTS; MITTENS; MUFFS; NECKTIES; OUTER CLOTHING, NAMELY, RAIN COATS; OVER COATS; OVERALLS; PAJAMAS; PANTIES; PANTS; PANTYHOSE; POLO SHIRTS; PONCHOS; PULLOVERS; PAJAMAS; RAINWEAR; BATH ROBES; SANDALS; SASHES; SASHES FOR WEAR; SCARVES; SHAWLS; SHIRTS; SHIRTS FOR SUITS; SHOES; SHORTS; SKI WEAR; SKIRTS; SKORTS; SLACKS; SLEEP MASKS; SLEEP SHIRTS; SLEEPING GARMENTS; SLEEPWEAR; SLIPS; SNOW SUITS; SOCKS; SPORT COATS; SPORT SHIRTS; SPORTS BRAS; SPORTS JACKETS; SPORTS JERSEYS; SPORTS OVER UNIFORMS; SPORTS SHIRTS; SPORTS SHOES; STOCKINGS; SUIT COATS; SUITS; BATHING SUITS; SUN SLEEVES; SUN VISORS; SUN SUITS; SURF WEAR; SUSPENDERS; SWEAT BANDS; SWEAT PANTS; SWEAT SHIRTS; SWEAT SHORTS; SWEAT SUITS; SWEATBANDS; SWEATERS; SWEAT SOCKS; SWIM TRUNKS; SWIM WEAR; SWIM WEAR FOR GENTLEMEN AND LADIES; SWIMMING CAPS; SWIMMING CAPS; SWIMMING COSTUME; SWIMMING TRUNKS; SWIMSUITS; TANK-TOPS; TEDDIES; TEE-SHIRTS; TIGHTS; TOPCOATS; TRENCH COATS; TROUSERS; TRUNKS; T-SHIRTS; TURBANS; TURTLENECKS; TUXEDOS; UNDERCLOTHING, NAMELY, UNDERWEAR, THERMAL UNDERWEAR, UNDERPANTS UNDER-SHIRTS; UNDERGARMENTS; UNDERPANTS; UNDER-SHIRTS; UNDERWEAR; UNIFORMS; VEILS; VESTS; VISORS; WAISTCOATS; AND WRIST BANDS (U.S. CLS. 22 AND 39).

FIRST USE 7-6-2007; IN COMMERCE 7-6-2007.

INGA ERVIN, EXAMINING ATTORNEY

**CLASS 25—(Continued).**

SN 85-136,714. GROOVE PHI GROOVE SOCIAL FELLOW-SHIP, INC., SILVER SPRING, MD. FILED 9-23-2010.



OWNER OF U.S. REG. NOS. 2,075,830, 3,413,897 AND 3,733,617.

NO CLAIM IS MADE TO THE EXCLUSIVE RIGHT TO USE "1962", APART FROM THE MARK AS SHOWN.

THE MARK CONSISTS OF A SHIELD WITH A RIBBON DISPOSED BELOW THE SHIELD WITH A SWORD AND SPEAR BISECTING THE SHIELD. ON THE FACE OF THE SHIELD IS DEPICTED A TORCH, A MUG AND A STACK OF BOOKS. EACH ITEM IS SEPARATED BY A CHAIN. THE RIBBON INCLUDES THE WORDING "GROOVE PHI GROOVE 1962".

FOR BATHING CAPS; HATS; JACKETS; SHIRTS; SPORTS JERSEYS; SWEAT SHIRTS; T-SHIRTS (U.S. CLS. 22 AND 39).

FIRST USE 6-1-2007; IN COMMERCE 6-1-2007.

RUDY R. SINGLETON, EXAMINING ATTORNEY

**CLASS 25—(Continued).**

SN 85-144,746. CHA INTERNATIONAL, LLC, NEW YORK, NY. FILED 10-4-2010.

CHETTA B EVENING

THE MARK CONSISTS OF STANDARD CHARACTERS WITHOUT CLAIM TO ANY PARTICULAR FONT, STYLE, SIZE, OR COLOR.

OWNER OF U.S. REG. NO. 3,717,712.

NO CLAIM IS MADE TO THE EXCLUSIVE RIGHT TO USE "EVENING", APART FROM THE MARK AS SHOWN.

THE NAME(S), PORTRAIT(S), AND/OR SIGNATURE(S) SHOWN IN THE MARK DOES NOT IDENTIFY A PARTICULAR LIVING INDIVIDUAL.

FOR BLOUSES; BOTTOMS; DRESSES; EVENING DRESSES; EVENING GOWNS; GOWNS; JACKETS; PANTS; SKIRTS; TOPS (U.S. CLS. 22 AND 39).

FIRST USE 5-0-2009; IN COMMERCE 5-0-2009.

RUSS HERMAN, EXAMINING ATTORNEY

SN 85-141,733. 71 % OCEAN LLC, NEW CANAAN, CT. FILED 9-30-2010.

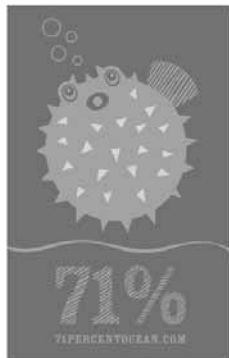

THE MARK CONSISTS OF A DRAWING OF A PUFFER FISH WITH A WAVE DESIGN UNDERNEATH. BELOW THAT ARE THE LETTERS "71%" IN LARGE PRINT AND BELOW THAT THE WORDS "71 PERCENTOCEAN.COM".

FOR BASEBALL CAPS AND HATS; PANTS; SHIRTS; SWIMSUITS; T-SHIRTS (U.S. CLS. 22 AND 39).

VIVIAN MICZNIK FIRST, EXAMINING ATTORNEY

SN 85-146,809. PITCHFORK MEDIA, INC., CHICAGO, ID. FILED 10-6-2010.

NOTHING MAJOR

THE MARK CONSISTS OF STANDARD CHARACTERS WITHOUT CLAIM TO ANY PARTICULAR FONT, STYLE, SIZE, OR COLOR.

FOR MEN'S AND WOMEN'S APPAREL, NAMELY, T-SHIRTS, JACKETS, SWEATSHIRTS, CAPS AND HATS, SHOES, PANTS AND JEANS, SHORTS, AND GLOVES (U.S. CLS. 22 AND 39).

MARC LEIPZIG, EXAMINING ATTORNEY

**CLASS 25—(Continued).**

SN 85-147,315. DENA DESIGNS, INC., LAFAYETTE, CA.  
FILED 10-7-2010.

**HAUTE GIRL**

THE MARK CONSISTS OF STANDARD CHARACTERS WITHOUT CLAIM TO ANY PARTICULAR FONT, STYLE, SIZE, OR COLOR.

NO CLAIM IS MADE TO THE EXCLUSIVE RIGHT TO USE "GIRL", APART FROM THE MARK AS SHOWN.

THE ENGLISH TRANSLATION OF THE WORD "HAUTE" IN THE MARK IS "HIGH".

FOR APPAREL, NAMELY, SHIRTS, T-SHIRTS, SWEATSHIRTS, SWEATPANTS, OUTERWEAR, NAMELY, COATS AND JACKETS, SWEATERS, UNDERCLOTHES, UNDERWEAR, SHORTS, SOCKS AND HOSIERY, LONG-SLEEVED SHIRTS AND LONG SLEEVED T-SHIRTS, PANTS, JEANS, FLEECE TOPS, FLEECE BOTTOMS, TANK TOPS, TROUSERS, SKIRTS, DRESSES, EXERCISE WEAR, NAMELY, WOMEN'S ATHLETIC TOPS WITH BUILT-IN BRAS, SWEATSUITS, JOGGING PANTS, YOGA SHIRTS AND YOGA PANTS, FOOTWEAR, SHOES, SNEAKERS, HEADWEAR, RAINWEAR, SWIMWEAR, BEACHWEAR, SLEEPWEAR, BATHROBES (U.S. CLS. 22 AND 39).

NAAKWAMA ANKRAH, EXAMINING ATTORNEY

SN 85-148,959. FRANCIS, NATALIE C, DBA NATURAL AND TING, CHARLOTTE, NC. FILED 10-9-2010.



NO CLAIM IS MADE TO THE EXCLUSIVE RIGHT TO USE "NATURAL AND EST. 2009", APART FROM THE MARK AS SHOWN.

THE COLOR(S) BLACK, RED, GREEN, YELLOW, WHITE AND GREY IS/ARE CLAIMED AS A FEATURE OF THE MARK.

THE MARK CONSISTS OF THE "N" IN "NATURAL" IS WRITTEN IN GREEN AND "ATURAL" IS WRITTEN IN BLACK. THE "A" IN "AND" IS WRITTEN IN YELLOW AND "ND" IS WRITTEN IN BLACK. THE "T" IN "TING" IS WRITTEN IN RED AND "ING" IS WRITTEN IN BLACK. THE "E" IN "EST" IS WRITTEN IN GREEN AND THE "ST" IS WRITTEN IN BLACK. THE "2" IN "2009" IS WRITTEN IN YELLOW, THE "0" IS WRITTEN IN BLACK AND THE "9" IS WRITTEN IN RED. "NATURAL AND TING" IS LOCATED WITHIN THE OUTER WHITE CIRCLE OF THE LOGO IN THE TOP SECTION. "EST 2009" IS LOCATED WITHIN THE GREY-EDGED OUTER WHITE CIRCLE OF

**CLASS 25—(Continued).**

THE LOGO IN THE BOTTOM SECTION. THE TREE IS LOCATED WITHIN THE INNER CIRCLE. THE INNER CIRCLE HAS A BLACK BACKGROUND. THE TREETOP IS GREEN HIGHLIGHTED IN LIGHT GREEN AND THE BARK IS DARK GREY HIGHLIGHTED IN LIGHT GREY. THE LETTERS "NAT" IS WRITTEN IN STYLIZED LETTERS ON THE BARK OF THE TREE. THE "N" IS WRITTEN IN GREEN AND OUTLINED IN BLACK. THE "A" IS WRITTEN IN YELLOW AND OUTLINED IN BLACK. THE "T" IS WRITTEN IN RED AND OUTLINED IN BLACK.

FOR BELTS MADE OF NATURAL FIBERS FOR CLOTHING; TANK-TOPS MADE OF NATURAL FIBERS; WEARABLE GARMENTS AND CLOTHING MADE OF NATURAL FIBERS, NAMELY, SHIRTS (U.S. CLS. 22 AND 39).

RONALD AIKENS, EXAMINING ATTORNEY

SN 85-150,480. ACI INTERNATIONAL, LOS ANGELES, CA.  
FILED 10-12-2010.

**CUSHION LITE**

THE MARK CONSISTS OF STANDARD CHARACTERS WITHOUT CLAIM TO ANY PARTICULAR FONT, STYLE, SIZE, OR COLOR.

FOR FOOTWEAR (U.S. CLS. 22 AND 39).

GIANCARLO CASTRO, EXAMINING ATTORNEY

SN 85-152,921. DENA DESIGNS, INC., LAFAYETTE, CA.  
FILED 10-14-2010.

**HAPPI BY DENA**

THE MARK CONSISTS OF STANDARD CHARACTERS WITHOUT CLAIM TO ANY PARTICULAR FONT, STYLE, SIZE, OR COLOR.

OWNER OF U.S. REG. NOS. 1,403,983 AND 3,131,547.

FOR APPAREL FOR BABIES AND CHILDREN, NAMELY, SHIRTS, T-SHIRTS, SWEATSHIRTS, SWEATPANTS, UNDERCLOTHES, UNDERWEAR, SHORTS, BELTS, SOCKS, PANTS, JEANS, DRESSES, SKIRTS, SWEATERS, FOOTWEAR, HEADWEAR, RAINWEAR, OUTERWEAR, NAMELY, JACKETS AND COATS, SWIMWEAR, BEACHWEAR, SLEEPWEAR, AND BATHROBES; CHILDREN'S AND INFANTS' CLOTH BIBS; CHILDREN'S AND INFANT'S APPAREL, NAMELY, JUMPERS, OVERALL SLEEPWEAR, PAJAMAS, ROMPERS AND ONE-PIECE GARMENTS; HATS FOR INFANTS, BABIES, TODDLERS AND CHILDREN; INFANT DIAPER COVERS; INFANT SLEEPERS; BABY BODYSUITS; INFANT WEAR; INFANT WEARABLE BLANKETS; INFANTS' SHOES AND BOOTS; BABY BOTTOMS; BABY TOPS; BABY LAYETTES FOR CLOTHING (U.S. CLS. 22 AND 39).

NAAKWAMA ANKRAH, EXAMINING ATTORNEY

**CLASS 25—(Continued).**

SN 85-161,412. SAFARI GIRL, LLC, RICHFIELD, WI. FILED 10-26-2010.

## SAFARI GIRL

THE MARK CONSISTS OF STANDARD CHARACTERS WITHOUT CLAIM TO ANY PARTICULAR FONT, STYLE, SIZE, OR COLOR.

NO CLAIM IS MADE TO THE EXCLUSIVE RIGHT TO USE "GIRL", APART FROM THE MARK AS SHOWN.

FOR SANDALS AND BEACH SHOES; FLIP FLOPS; BELTS FOR CLOTHING (U.S. CLS. 22 AND 39).

PAULA MAHONEY, EXAMINING ATTORNEY

---

SN 85-162,012. ROBINSON, STUART, SYLVAN LAKE, CANADA, FILED 10-27-2010.

## COLOR MATCH'UP

THE MARK CONSISTS OF STANDARD CHARACTERS WITHOUT CLAIM TO ANY PARTICULAR FONT, STYLE, SIZE, OR COLOR.

NO CLAIM IS MADE TO THE EXCLUSIVE RIGHT TO USE "COLOR", APART FROM THE MARK AS SHOWN.

FOR CLOTHING, NAMELY, T-SHIRTS, UNDERWEAR, SWEATSHIRTS, HOODED SWEATSHIRTS, COATS, AND HATS FOR SOCIAL NETWORKING PURPOSES (U.S. CLS. 22 AND 39).

ERIN FALK, EXAMINING ATTORNEY

---

SN 85-162,914. CROWLEY DESIGN GROUP INC., BUTTE, MT. FILED 10-27-2010.

## Regent & Company

THE MARK CONSISTS OF STANDARD CHARACTERS WITHOUT CLAIM TO ANY PARTICULAR FONT, STYLE, SIZE, OR COLOR.

NO CLAIM IS MADE TO THE EXCLUSIVE RIGHT TO USE "COMPANY", APART FROM THE MARK AS SHOWN.

FOR ATHLETIC APPAREL, NAMELY, SHIRTS, PANTS, JACKETS, FOOTWEAR, HATS AND CAPS, ATHLETIC UNIFORMS; CAPRI PANTS; CARGO PANTS; COATS; COATS FOR MEN AND WOMEN; DENIMS; FLEECE VESTS; FUR COATS AND JACKETS; GLOVES; GLOVES FOR APPAREL; JACKETS; KNIT JACKETS; KNITTED GLOVES; LEATHER COATS; LEATHER JACKETS; OUTDOOR GLOVES; OUTER JACKETS; PANTS; RAIN COATS; RAIN JACKETS; SHIRTS; SWEATERS; VESTS; WRAPS (U.S. CLS. 22 AND 39).

FIRST USE 10-1-2010; IN COMMERCE 10-1-2010.

CAROL SPILS, EXAMINING ATTORNEY

**CLASS 25—(Continued).**

SN 85-164,899. SPOON, SHAWNA K., LORTON, VA. FILED 10-29-2010.

## *In Liberty Apparel*

NO CLAIM IS MADE TO THE EXCLUSIVE RIGHT TO USE "APPAREL", APART FROM THE MARK AS SHOWN.

THE MARK CONSISTS OF STYLIZED LETTERS IN BOLD CHOPIN SCRIPT FONT, WITH THE BEGINNING LETTERS "I", "L" AND "A" IN CAPITAL FORM.

FOR HOODED SWEATSHIRTS; SHORT-SLEEVED OR LONG-SLEEVED T-SHIRTS; SPORTS CAPS AND HATS; SWEAT PANTS; TURTLE NECK SHIRTS (U.S. CLS. 22 AND 39).

BILL DAWE, EXAMINING ATTORNEY

---

SN 85-166,515. DELARENTIS IMPORTS INC, BOCA RATON, FL. FILED 11-1-2010.

## *Massimo Matteo Firenze*

NO CLAIM IS MADE TO THE EXCLUSIVE RIGHT TO USE "FIRENZE", APART FROM THE MARK AS SHOWN.

THE NAME "MASSIMO MATTEO" DOES NOT IDENTIFY A LIVING INDIVIDUAL.

THE MARK CONSISTS OF THE STYLIZED TEXT "MASSIMO MATTEO FIRENZE".

THE ENGLISH TRANSLATION OF THE WORD "MASSIMO" IN THE MARK IS MAXIMUS.

FOR FOOTWEAR; HEADWEAR; JACKETS; JEANS; SHIRTS; SUITS; UNDERWEAR (U.S. CLS. 22 AND 39).

MARK SPARACINO, EXAMINING ATTORNEY

---

SN 85-166,735. VOGL, BRIAN, KANSAS CITY, KS. FILED 11-2-2010.

## YX3Z

THE MARK CONSISTS OF STANDARD CHARACTERS WITHOUT CLAIM TO ANY PARTICULAR FONT, STYLE, SIZE, OR COLOR.

FOR CLOTHING, NAMELY, CHEMISETTES, JUMPERS, SHIRT FRONTS, SHIRT YOKES, SHIRTS, T-SHIRTS, LAPELS OF SHIRTS, SHIRT POCKETS (U.S. CLS. 22 AND 39).

BRIAN CALLAGHAN, EXAMINING ATTORNEY

**CLASS 25—(Continued).**

SN 85-170,687. SCULLY SPORTSWEAR, INC., OXNARD, CA. FILED 11-5-2010.

**THE CANTINA COLLECTION**

THE MARK CONSISTS OF STANDARD CHARACTERS WITHOUT CLAIM TO ANY PARTICULAR FONT, STYLE, SIZE, OR COLOR.

NO CLAIM IS MADE TO THE EXCLUSIVE RIGHT TO USE "COLLECTION", APART FROM THE MARK AS SHOWN.

FOR CLOTHING, NAMELY, TOPS, BOTTOMS, SHIRTS, PANTS, BLOUSES, SKIRTS, SHORTS, DRESSES, VESTS, SWEATERS, HEADWEAR, FOOTWEAR, BELTS, UNDERWEAR, JACKETS, COATS, AND SWIMWEAR (U.S. CLS. 22 AND 39).

HAI-LY LAM, EXAMINING ATTORNEY

---

SN 85-174,524. ALDRIDGE, JANE, MILWAUKEE, WI. FILED 11-11-2010.

**COZY CAPE**

THE MARK CONSISTS OF STANDARD CHARACTERS WITHOUT CLAIM TO ANY PARTICULAR FONT, STYLE, SIZE, OR COLOR.

NO CLAIM IS MADE TO THE EXCLUSIVE RIGHT TO USE "CAPE", APART FROM THE MARK AS SHOWN.

FOR CAPES FOR USE IN HAIR SALONS FOR PROTECTING CLOTHING AND SKIN WHILE RECEIVING SALON SERVICES (U.S. CLS. 22 AND 39).

GIANCARLO CASTRO, EXAMINING ATTORNEY

**CLASS 25—(Continued).**

SN 85-174,972. KAREN KLEIN FASHION, INC, SUNNYVALE, CA. FILED 11-11-2010.

**KARENKLEIN**

THE MARK CONSISTS OF STANDARD CHARACTERS WITHOUT CLAIM TO ANY PARTICULAR FONT, STYLE, SIZE, OR COLOR.

THE NAME(S), PORTRAIT(S), AND/OR SIGNATURE(S) SHOWN IN THE MARK IDENTIFIES "KAREN KLEIN", WHOSE CONSENT(S) TO REGISTER IS MADE OF RECORD.

FOR TOPS; SHIRTS; BLOUSES; BOTTOMS; DRESS PANTS; SKIRTS; SHORTS; DRESSES; SWEATERS; JACKETS; HATS; SCARVES; SASHES; SOCKS; STOCKINGS; FOOTWEAR; COATS; UNDERWEAR; BELTS; TIGHTS; LEGGINGS; PANTYHOSE; UNDERSHIRTS; TUNICS; TANK TOPS; BODY SUITS; GLOVES; VESTS; SHRUGS; MUFFLERS; BLOUSONS; CARDIGANS; UNIFORMS; WOMEN'S DRESS SUITS; JERSEYS; WOVEN BOTTOMS; KNIT BOTTOMS; OUTER JACKETS; OVER SHIRTS; AND WRAPS (U.S. CLS. 22 AND 39).

FIRST USE 12-8-2008; IN COMMERCE 12-8-2008.

MICHAEL ENGEL, EXAMINING ATTORNEY

---

SN 85-174,994. SHOOMAN, SCOTT, LOS ANGELES, CA. FILED 11-11-2010.

**HALBERD AND MACE**

THE MARK CONSISTS OF STANDARD CHARACTERS WITHOUT CLAIM TO ANY PARTICULAR FONT, STYLE, SIZE, OR COLOR.

FOR NECKTIES (U.S. CLS. 22 AND 39).

MICHELE SWAIN, EXAMINING ATTORNEY



**CLASS 25—(Continued).**

SN 85-175,976. SENDLER JOSEPH, DBA THE EARBEATAZ, COLUMBUS, OH. AND YARLEY GEFFRARD, DBA THE EARBEATAZ, COLUMBUS, OH. FILED 11-12-2010.



THE MARK CONSISTS OF A CIRCULAR SHAPED SMILEY FACE WITH "X"'S AS ITS EYES AND ITS TONGUE STICKING OUT, WEARING HEADPHONES, WITH THUNDER BOLTS ON EACH SIDE OF THE HEADPHONES. THE WORDING "EARBEATAZ" APPEARS IN STYLIZED FONT ABOVE THE FACE AND BELOW THE TOP OF THE HEADPHONES.

FOR T-SHIRTS, SHIRTS, CAPS, HATS, HEADWEAR, BANDANAS, SOCKS, SHOES, SNEAKERS, FOOTWEAR, UNDERWEAR, BOXERS, SHORTS, BRIEFS, BRAS, BATHING SUITS, PANTIES, STOCKINGS, JACKETS, COATS, WHITE BEATER, NAMELY, SLEEVELESS SHIRTS AND T-SHIRTS; TANK TOPS, JEANS, PANTS, CARGO PANTS, UNDERSHIRTS, FLIP FLOPS, SANDALS, GLOVES, MITTENS, WRIST BANDS, KNEE BANDS, NAMELY, SWEAT BANDS USED BELOW THE KNEE; DRESSES, SKIRTS (U.S. CLS. 22 AND 39).

FIRST USE 9-12-2010; IN COMMERCE 9-12-2010.

SAMUEL E. SHARPER JR., EXAMINING ATTORNEY

SN 85-176,092. EGOIIE, SEATTLE, WA. FILED 11-13-2010.



THE MARK CONSISTS OF THE WORDING "EGOIIE" WITH THE FIRST LETTER "I" AND THE SECOND LETTER "E" APPEARING IN AN INVERTED/BACKWARDS FORM; THE WORDING IS CONTAINED WITHIN AN INCOMPLETE CIRCULAR DESIGN THAT HAS A LOOP ON ONE END OF THE INCOMPLETE CIRCLE.

THE WORDING "EGOIIE" HAS NO MEANING IN A FOREIGN LANGUAGE.

FOR JEANS; JEGGINGS, NAMELY, PANTS THAT ARE PARTIALLY JEANS AND PARTIALLY LEGGINGS (U.S. CLS. 22 AND 39).

FIRST USE 9-26-2010; IN COMMERCE 9-26-2010.

MEGHAN REINHART, EXAMINING ATTORNEY

**CLASS 25—(Continued).**

SN 85-176,989. SALT LIFE HOLDINGS, LLC, JACKSONVILLE, FL. FILED 11-15-2010.

WHERE THE SALT MEETS YOUR  
LIFE

THE MARK CONSISTS OF STANDARD CHARACTERS WITHOUT CLAIM TO ANY PARTICULAR FONT, STYLE, SIZE, OR COLOR.

FOR MEN'S, WOMEN'S, CHILDREN'S, TODDLER'S AND INFANT'S CLOTHING, NAMELY, CAPS, SHIRTS, T-SHIRTS, UNDERWEAR, SOCKS, PANTS, SWEATERS, JACKETS, SHOES, SANDALS, FLIP FLOPS, BEACH SHOES, BOOTS, BATHING SUITS, BERMUDA SHORTS, WALKING SHORTS, WET SUITS, SWIM TRUNKS, CAPS WITH VISORS, VISORS, FLEECE PULLOVERS, SWEAT SHIRTS, SURF WEAR, BRIEFS, BOXER BRIEFS, PANTIES, WIND RESISTANT JACKETS, INFANT AND TODDLER ONE PIECE CLOTHING (U.S. CLS. 22 AND 39).

APRIL HESIK, EXAMINING ATTORNEY

SN 85-177,025. DOW JONES & COMPANY, INC., NEW YORK, NY. FILED 11-15-2010.

WSJ

THE MARK CONSISTS OF STANDARD CHARACTERS WITHOUT CLAIM TO ANY PARTICULAR FONT, STYLE, SIZE, OR COLOR.

OWNER OF U.S. REG. NOS. 2,119,170, 2,575,504 AND OTHERS.

FOR CLOTHING, NAMELY, SHIRTS, T-SHIRTS, SWEATSHIRTS, HATS, CAPS, SWEAT PANTS, SOCKS, TIES, WIND-RESISTANT JACKETS, BICYCLE JERSEYS, FLEECE JACKETS, FLEECE SWEATSHIRTS, BOXER SHORTS, SWEATERS, SWEATER VESTS, PULLOVERS, POLO SHIRTS, RAIN JACKETS, AND SHORTS (U.S. CLS. 22 AND 39).

MARK SHINER, EXAMINING ATTORNEY

**CLASS 25—(Continued).**

SN 85-177,485. GREGORY SYLVIA LLC, CHARLOTTE, NC. FILED 11-16-2010.

**GREGORY SYLVIA**

THE MARK CONSISTS OF STANDARD CHARACTERS WITHOUT CLAIM TO ANY PARTICULAR FONT, STYLE, SIZE, OR COLOR.

THE NAME(S), PORTRAIT(S), AND/OR SIGNATURE(S) SHOWN IN THE MARK DOES NOT IDENTIFY A PARTICULAR LIVING INDIVIDUAL.

FOR T-SHIRTS, DRESS SHIRTS, POLO SHIRTS, SPORT SHIRTS, SWEATSHIRTS, SWEATPANTS, WARM-UP SUITS, DRESSES, SKIRTS, BLOUSES, SWEATERS, SHORTS, COATS, JACKETS, SUITS, RAINCOATS, HATS, VISORS, PANTS, BELTS, SHOES, TIES, SCARVES, GLOVES, STOCKINGS, UNDERWEAR, BRAS, BOXER SHORTS, BRIEFS, PANTIES, SLEEPWEAR, AND SWIMWEAR (U.S. CLS. 22 AND 39).

FIRST USE 10-22-2010; IN COMMERCE 10-22-2010.  
JULIE VEPPUMTHARA, EXAMINING ATTORNEY

**CLASS 25—(Continued).**

SN 85-178,051. ZUMBA FITNESS, HOLLYWOOD, FL. FILED 11-16-2010.

**zPERFORMANCE**

THE MARK CONSISTS OF STANDARD CHARACTERS WITHOUT CLAIM TO ANY PARTICULAR FONT, STYLE, SIZE, OR COLOR.

FOR CLOTHING, NAMELY, BRAS, BATHING SUITS, LEGGINGS, TOPS, SHIRTS, PANTS, UNDER PANTS, UNDERWEAR, SLEEPWEAR, SUITS, DRESSES, SKIRTS, SHORTS, SOCKS, STOCKINGS, PULLOVERS, JACKETS, SWEATSHIRTS, CARGO PANTS, CAPRIS, CARDIGANS, WRISTBANDS, SCARVES, SHAWLS, GLOVES, BELTS, INFANT BODYSUITS; HEADGEAR, NAMELY, HATS, VISORS, CAPS, HEADBANDS AND HEADWEAR; FOOTWEAR, NAMELY, ATHLETIC FOOTWEAR, SNEAKERS, FLIP FLOPS, SANDALS (U.S. CLS. 22 AND 39).

Laurie Kaufman, Examining Attorney

SN 85-178,399. SKECHERS U.S.A., INC. II, MANHATTAN BEACH, CA. FILED 11-16-2010.

**PRIMA BALLERINA**

THE MARK CONSISTS OF STANDARD CHARACTERS WITHOUT CLAIM TO ANY PARTICULAR FONT, STYLE, SIZE, OR COLOR.

THE ENGLISH TRANSLATION OF "PRIMA" IN THE MARK IS "FIRST".

FOR FOOTWEAR (U.S. CLS. 22 AND 39).  
Paula Mahoney, Examining Attorney

SN 85-179,143. INKWRIGHT LLC, HUNTINGTON BEACH, CA. FILED 11-17-2010.

**RKS**

THE MARK CONSISTS OF STANDARD CHARACTERS WITHOUT CLAIM TO ANY PARTICULAR FONT, STYLE, SIZE, OR COLOR.

FOR CAMOUFLAGE SHIRTS; CLOTHING FOR BABIES, TODDLERS AND CHILDREN, TREATED WITH FIRE AND HEAT RETARDANTS, NAMELY, PAJAMAS, JACKETS, SHIRTS, PANTS, JUMPERS; COLLARED SHIRTS; FLEECE BOTTOMS; FOOTWEAR; POLO SHIRTS; A-SHIRTS; APPAREL FOR DANCERS, NAMELY, TEE SHIRTS, SWEATSHIRTS, PANTS, LEGGINGS, SHORTS AND JACKETS; ATHLETIC APPAREL, NAMELY, SHIRTS, PANTS, JACKETS, FOOTWEAR, HATS AND CAPS, ATHLETIC UNIFORMS; BOTTOMS; BUTTON DOWN SHIRTS; DENIMS; DRESS PANTS; DRESS SHIRTS; FLEECE TOPS; HATS; POLO KNIT TOPS; SOCKS (U.S. CLS. 22 AND 39).

Paul E. Fahrenkopf, Examining Attorney

SN 85-177,933. MAN AT LEISURE, LLC, PRESCOTT, AZ. FILED 11-16-2010.



THE COLOR(S) BLACK AND YELLOW IS/ARE CLAIMED AS A FEATURE OF THE MARK.

THE MARK CONSISTS OF A DESIGN OF A YELLOW DIAMOND-SHAPED STREET SIGN WITH THE WORDS "MAN AT LEISURE" IN BLACK IN THE CENTER AND A BORDER THAT ALTERNATES BLACK, YELLOW AND THEN BLACK.

FOR CLOTHING, NAMELY, SHIRTS, SHORTS, PANTS, SWEATSHIRTS, SWEATERS, JACKETS, TIES, BELTS (U.S. CLS. 22 AND 39).

Fred Carl, Examining Attorney

**CLASS 25—(Continued).**

SN 85-179,517. SEVEN CEDARS LLC, BEVERLY HILLS, CA. FILED 11-17-2010.

## Malibu Native

THE MARK CONSISTS OF STANDARD CHARACTERS WITHOUT CLAIM TO ANY PARTICULAR FONT, STYLE, SIZE, OR COLOR.

NO CLAIM IS MADE TO THE EXCLUSIVE RIGHT TO USE "MALIBU", APART FROM THE MARK AS SHOWN.

FOR BATHING SUITS; PANTS; SHIRTS; SHORTS; SWEAT SHIRTS; TANK TOPS (U.S. CLS. 22 AND 39).

FIRST USE 8-5-2010; IN COMMERCE 8-5-2010.

KRISTINA MORRIS, EXAMINING ATTORNEY

SN 85-179,792. EVANS, REBECCA, EL CERRITO, CA. FILED 11-18-2010.

## RYEP Recycled Cashmere

THE MARK CONSISTS OF STANDARD CHARACTERS WITHOUT CLAIM TO ANY PARTICULAR FONT, STYLE, SIZE, OR COLOR.

NO CLAIM IS MADE TO THE EXCLUSIVE RIGHT TO USE "RECYCLED CASHMERE", APART FROM THE MARK AS SHOWN.

FOR GLOVES, HATS, SCARVES AND SWEATERS ALL MADE FROM RECYCLED CASHMERE (U.S. CLS. 22 AND 39).

FIRST USE 1-1-2010; IN COMMERCE 1-1-2010.

PAUL MORENO, EXAMINING ATTORNEY

SN 85-179,914. DOOLIN SHOE COMPANY, INC., CARSON, CA. FILED 11-18-2010.



NO CLAIM IS MADE TO THE EXCLUSIVE RIGHT TO USE "HAND MADE IN CALIFORNIA", APART FROM THE MARK AS SHOWN.

THE MARK CONSISTS OF STYLIZED LETTERING FOR THE WORD "SBICCA" WITH A 6 PETAL DAISY USED AS THE DOT OVER THE LETTER "I" WITH "HAND MADE IN CALIFORNIA" IN SMALLER LETTERS CENTERED BELOW "SBICCA".

THE WORDING "SBICCA" HAS NO MEANING IN A FOREIGN LANGUAGE.

FOR FOOTWEAR, NAMELY, SHOES, SANDALS AND BOOTS (U.S. CLS. 22 AND 39).

AISHA SALEM, EXAMINING ATTORNEY

**CLASS 25—(Continued).**

SN 85-179,921. DOOLIN SHOE COMPANY, INC., CARSON, CA. FILED 11-18-2010.



NO CLAIM IS MADE TO THE EXCLUSIVE RIGHT TO USE "CALIFORNIA", APART FROM THE MARK AS SHOWN.

THE MARK CONSISTS OF STYLIZED LETTERING FOR THE WORD "SBICCA" WITH A 6 PETAL DAISY USED AS THE DOT OVER THE LETTER "I" WITH THE WORDS "OF CALIFORNIA" IN SMALLER STYLIZED LETTERS BELOW AND TO THE RIGHT MARGIN OF THE WORD "SBICCA".

THE WORDING "SBICCA" HAS NO MEANING IN A FOREIGN LANGUAGE.

FOR FOOTWEAR, NAMELY, SHOES, SANDALS AND BOOTS (U.S. CLS. 22 AND 39).

AISHA SALEM, EXAMINING ATTORNEY

SN 85-179,925. DOOLIN SHOE COMPANY, INC., CARSON, CA. FILED 11-18-2010.

## SBICCA

THE MARK CONSISTS OF STANDARD CHARACTERS WITHOUT CLAIM TO ANY PARTICULAR FONT, STYLE, SIZE, OR COLOR.

THE WORDING "SBICCA" HAS NO MEANING IN A FOREIGN LANGUAGE.

FOR FOOTWEAR, NAMELY, SHOES, SANDALS AND BOOTS (U.S. CLS. 22 AND 39).

AISHA SALEM, EXAMINING ATTORNEY

SN 85-179,934. DOOLIN SHOE COMPANY, INC., CARSON, CA. FILED 11-18-2010.

## SBICCA ORIGINALS

THE MARK CONSISTS OF STANDARD CHARACTERS WITHOUT CLAIM TO ANY PARTICULAR FONT, STYLE, SIZE, OR COLOR.

NO CLAIM IS MADE TO THE EXCLUSIVE RIGHT TO USE "ORIGINALS", APART FROM THE MARK AS SHOWN.

THE WORDING "SBICCA" HAS NO MEANING IN A FOREIGN LANGUAGE.

FOR FOOTWEAR, NAMELY, SHOES, SANDALS AND BOOTS (U.S. CLS. 22 AND 39).

AISHA SALEM, EXAMINING ATTORNEY

**CLASS 25—(Continued).**

SN 85-180,299. Z RAINWEAR CORPORATION, COMMACK, NY. FILED 11-18-2010.



THE MARK CONSISTS OF THE LETTER "Z" IN STYLIZED FONT.  
 FOR RAIN BOOTS; RAIN COATS; RAIN HATS; RAIN JACKETS; RAIN SUITS; RAIN TROUSERS; RAIN WEAR (U.S. CLS. 22 AND 39).  
 DAVID H. STINE, EXAMINING ATTORNEY

**CLASS 25—(Continued).**

SN 85-180,544. PHAM, CHRISTOPHER J., NAPLES, FL. FILED 11-18-2010.

Wuuff Wuuff

THE MARK CONSISTS OF STANDARD CHARACTERS WITHOUT CLAIM TO ANY PARTICULAR FONT, STYLE, SIZE, OR COLOR.  
 FOR T-SHIRTS (U.S. CLS. 22 AND 39).  
 ALLISON SCHRODY, EXAMINING ATTORNEY

SN 85-180,466. GERTZ, BRANDON, BROOKLYN, NY. FILED 11-18-2010.



NO CLAIM IS MADE TO THE EXCLUSIVE RIGHT TO USE "NYC.", APART FROM THE MARK AS SHOWN.  
 THE MARK CONSISTS OF THE STYLIZED TEXT "GRITS & GRAVY NYC."  
 FOR JACKETS; PANTS; SHIRTS (U.S. CLS. 22 AND 39).  
 ALLISON SCHRODY, EXAMINING ATTORNEY

SN 85-181,530. PRANA LIVING, LLC, VISTA, CA. FILED 11-19-2010.



OWNER OF U.S. REG. NOS. 1,803,298, 2,677,150 AND OTHERS.  
 THE MARK CONSISTS OF THE WORD "PRANA" AND A STYLIZED DRAWING OF A PERSON SITTING IN A YOGA POSE.

THE ENGLISH TRANSLATION OF "PRANA" IN THE MARK IS "BREATH OF LIFE".

FOR ADULT AND CHILDREN'S CLOTHING FOR BIKING, HIKING, CLIMBING, AND YOGA, NAMELY, SHORTS, T-SHIRTS, SWEATSHIRTS, HOODED SWEATSHIRTS, SCARVES, TANK TOPS, SWEATERS, JACKETS, VESTS, TROUSERS, SHORTS, PANTS, CAPRIS, CROP TOPS, SKIRTS, DRESSES, BELTS, MITTENS; CLOTHING ITEMS, NAMELY, BLINDFOLDS WORN OVER THE EYES DURING YOGA PRACTICE, AND SPORTS BRAS; HEADWEAR, NAMELY, HATS, CAPS AND HEADBANDS (U.S. CLS. 22 AND 39).

LINDA MICKLEBURGH, EXAMINING ATTORNEY

SN 85-180,473. DIAZ, JOSE LUIS, TEMPLE CITY, CA. AND RAY VALDEZ, RUBEN, TEMPLE CITY, CA. FILED 11-18-2010.

Morevil Clothing Company

THE MARK CONSISTS OF STANDARD CHARACTERS WITHOUT CLAIM TO ANY PARTICULAR FONT, STYLE, SIZE, OR COLOR.

NO CLAIM IS MADE TO THE EXCLUSIVE RIGHT TO USE "CLOTHING COMPANY", APART FROM THE MARK AS SHOWN.

FOR SHIRTS (U.S. CLS. 22 AND 39).  
 ALLISON SCHRODY, EXAMINING ATTORNEY

**CLASS 25—(Continued).**

SN 85-181,664. THE TAINOS GROUP INC, FORNEY, TX. FILED 11-19-2010.



THE STIPLING IS FOR SHADING PURPOSES ONLY.  
THE MARK CONSISTS OF "ANAKAONA" APPEARING IN BOLD LETTERS ABOVE A DESIGN THAT RESEMBLES A TRIBAL MASK. THE NUMERAL "1474" APPEARS BENEATH THE DESIGN.

FOR BANDANAS; BEACH COVER-UPS; BELTS OF TEXTILE; BERMUDA SHORTS; BLOUSES; BODY SUITS; CAPRI PANTS; CAPS; CARGO PANTS; COATS MADE OF COTTON; COATS OF DENIM; CREW NECK SWEATERS; DENIM JACKETS; DENIMS; DRESSES; EVENING DRESSES; FOOTWEAR FOR WOMEN; HAT BANDS; HEAD SCARVES; HEADBANDS FOR CLOTHING; HEADWEAR; JEANS; JUMPSUITS; KNIT DRESSES; KNIT JACKETS; KNIT SHIRTS; KNIT SKIRTS; KNIT TOPS; KNITTED CAPS; LONG SLEEVED VESTS; MANTLES; MUFFLERS; PANTS; POLO KNIT TOPS; POLO SHIRTS; PONCHOS; SANDAL-CLOGS; SANDALS; SCARFS; SHIRTS AND SHORT-SLEEVED SHIRTS; SHORT-SLEEVED OR LONG-SLEEVED T-SHIRTS; SHORTS; SUEDE JACKETS; SWIM TRUNKS; VESTS (U.S. CLS. 22 AND 39).

RONALD MCMORROW, EXAMINING ATTORNEY

SN 85-181,932. I WAS JUST A SEED, NASHVILLE, TN. FILED 11-21-2010.

## I Was Just A Seed

THE MARK CONSISTS OF STANDARD CHARACTERS WITHOUT CLAIM TO ANY PARTICULAR FONT, STYLE, SIZE, OR COLOR.

FOR BASEBALL CAPS AND HATS; SHORT-SLEEVED OR LONG-SLEEVED T-SHIRTS (U.S. CLS. 22 AND 39).

NAKWAMA ANKRAH, EXAMINING ATTORNEY

**CLASS 25—(Continued).**

SN 85-182,586. TURBIE TWIST, LLC, BUTLER, PA. FILED 11-22-2010.

## TURBIE BAND

THE MARK CONSISTS OF STANDARD CHARACTERS WITHOUT CLAIM TO ANY PARTICULAR FONT, STYLE, SIZE, OR COLOR.

NO CLAIM IS MADE TO THE EXCLUSIVE RIGHT TO USE "BAND", APART FROM THE MARK AS SHOWN.

FOR MICROFIBER CLOTH HEADBAND WITH ELASTIC, WORN ABOUT THE HAIRLINE FOR THE PURPOSE OF HOLDING THE HAIR AWAY FROM THE FACE (U.S. CLS. 22 AND 39).

FIRST USE 11-1-2010; IN COMMERCE 11-1-2010.

SALLY SHIH, EXAMINING ATTORNEY

SN 85-182,921. TUCKER, ASHLEY, CHARLOTTE, NC. FILED 11-22-2010.



THE MARK CONSISTS OF A GRAPHIC OF A MAN AND A WOMAN DRESSED FORMALLY STANDING TOGETHER HOLDING HANDS WITH A GRAPHIC OF AN "X" WHERE THEIR MOUTHS ARE LOCATED. UNDERNEATH THE COUPLE THERE IS THE STYLIZED TEXT "THECOMMON". ABOVE THE COUPLE IS A GRAPHIC OF A PROHIBITION SYMBOL.

FOR CLOTHING, NAMELY, SHIRTS, DRESSES, JEANS, SHORTS, LEGGINGS, JACKETS, BLAZERS, COATS, SWEATERS; PANTS, BLOUSES, BUTTON-DOWN SHIRTS, SKIRTS, TANK TOPS, AND SWIMWEAR (U.S. CLS. 22 AND 39).

ALYSSA STEEL, EXAMINING ATTORNEY

**CLASS 25—(Continued).**

SN 85-183,406. NATIVE INTIMATES LTD., NEW YORK, NY. FILED 11-23-2010.

# Lil' Vicky's

THE MARK CONSISTS OF STANDARD CHARACTERS WITHOUT CLAIM TO ANY PARTICULAR FONT, STYLE, SIZE, OR COLOR.

THE NAME(S), PORTRAIT(S), AND/OR SIGNATURE(S) SHOWN IN THE MARK DOES NOT IDENTIFY A PARTICULAR LIVING INDIVIDUAL.

FOR UNDERWEAR, CAMISOLES, PAJAMAS, THERMAL UNDERWEAR, BOXER SHORTS, INFANT AND TODDLER ONE-PIECE CLOTHING, SLIPPERS, SOCKS, LEGGINGS, ROBES, SWIMWEAR, BEACH COVER-UPS (U.S. CLS. 22 AND 39).

KATHERINE M. DUBRAY, EXAMINING ATTORNEY

---

SN 85-183,658. HOTEL CALIFORNIA BAJA LLC, BEVERLY HILLS, CA. FILED 11-23-2010.



HOTEL CALIFORNIA  
Todos Santos, México

OWNER OF U.S. REG. NO. 3,771,896.

NO CLAIM IS MADE TO THE EXCLUSIVE RIGHT TO USE "CALIFORNIA" AND "TODOS SANTOS, MEXICO", APART FROM THE MARK AS SHOWN.

THE MARK CONSISTS OF THE STYLIZED WORDING "HOTEL CALIFORNIA" APPEARING WITHIN A FANCIFUL ORNAMENTAL BORDER WITH THE WORDING "TODOS SANTOS, MEXICO" APPEARING BELOW THE ORNAMENTAL BORDER.

THE ENGLISH TRANSLATION OF "TODOS SANTOS" IN THE MARK IS "ALL SAINTS".

FOR CLOTHING, NAMELY, T-SHIRTS, SHORTS, SWEATSHIRTS, SWEAT PANTS, JACKETS, HOODED SWEATSHIRTS, SHIRTS, TOPS, PANTS, SKIRTS, JEANS, SLACKS, WOVEN SHIRTS, KNIT SHIRTS, TANK TOPS, SWEATERS; OUTERWEAR, NAMELY, JACKETS AND COATS; HATS, BEANIES, HEADBANDS, BELTS, SUSPENDERS, UNDERWEAR, LINGERIE; ACTIVEWEAR, NAMELY, JOGGING SUITS, SWEAT SUITS, TOPS, BOTTOMS, JACKETS, PANTS AND SHORTS; SOCKS, HOSIERY, FOOTWEAR, SHOES, BOOTS, SUSPENDERS, GLOVES, MITTENS, WOMEN'S SWIMWEAR AND BEACH COVER-UPS; TODDLERS' AND INFANTS' WEARING APPAREL, NAMELY, ONE PIECE GARMENTS AND SHIRTS; AND CAPS (U.S. CLS. 22 AND 39).

AMY KERTGATE, EXAMINING ATTORNEY

**CLASS 25—(Continued).**

SN 85-184,532. COLHOC LIMITED PARTNERSHIP, COLUMBUS, OH. FILED 11-24-2010.



OWNER OF U.S. REG. NOS. 2,442,976, 2,442,977 AND 3,806,141.

NO CLAIM IS MADE TO THE EXCLUSIVE RIGHT TO USE "COLUMBUS", APART FROM THE MARK AS SHOWN.

THE MARK CONSISTS OF THE WORDS "COLUMBUS BLUE JACKETS" IN A RIBBON EN CIRCLING A CANNON DESIGN WITH A STAR UNDERNEATH, ALL WITHIN TWO CONCENTRIC CIRCLES.

FOR CLOTHING, NAMELY, BANDANNAS, BEACH COVER-UPS, BELTS, BODY SUITS, BOXER SHORTS, CAPS, CLOTH BIBS, COATS, DRESSES, EAR MUFFS, GLOVES, HATS, HEADBANDS, HOSIERY, HOUSECOATS, JERSEYS, LEGGINGS, LEOTARDS, MITTENS, NIGHTSHIRTS, PAJAMAS, PANTS, RAIN COATS, RAIN WEAR, ROBES, SCARVES, SHIRTS, SHORTS, SKIRTS, SOCKS, SUITS, SUN VISORS, SUSPENDERS, SWEATERS, SWEATPANTS, SWEATSHIRTS, SWIMSUITS, SWIM TRUNKS, T-SHIRTS, TIES, TOQUES, UNDERWEAR, VESTS, WARM-UP SUITS AND WRISTBANDS (U.S. CLS. 22 AND 39).

STEVEN R. FINE, EXAMINING ATTORNEY

---

SN 85-185,165. BROWN, NATHAN OWEN, ISSAQUAH, WA. FILED 11-24-2010.

# Rulon Brown

THE MARK CONSISTS OF STANDARD CHARACTERS WITHOUT CLAIM TO ANY PARTICULAR FONT, STYLE, SIZE, OR COLOR.

"RULON BROWN" IDENTIFIES THE STAGE NAME OF NATHAN OWEN BROWN, A LIVING INDIVIDUAL WHOSE CONSENT IS OF RECORD.

FOR CLOTHING, NAMELY, T-SHIRTS, HATS, SHIRTS AND SWEATSHIRTS (U.S. CLS. 22 AND 39).

FIRST USE 10-18-2010; IN COMMERCE 10-23-2010.

REBECCA POVARCHUK, EXAMINING ATTORNEY

**CLASS 25—(Continued).**

SN 85-185,735. QUINN, SEAN T, WILLIAMS BAY, WI. FILED 11-28-2010.



THE MARK CONSISTS OF A STYLIZED LOWER CASE "G" WITH THE WORD "GLYPTIC" LOCATED UNDERNEATH IT. THE LETTER "T" IN THE WORD "GLYPTIC" IS ATTACHED TO THE BOTTOM OF THE STYLIZED "G".

FOR (BASED ON USE IN COMMERCE) HOODED SWEAT SHIRTS; SHORT-SLEEVED OR LONG-SLEEVED T-SHIRTS; SWEATSHIRTS; T-SHIRTS(BASED ON INTENT TO USE) BUTTON DOWN SHIRTS; LONG-SLEEVED SHIRTS; SHIRTS AND SHORT-SLEEVED SHIRTS; SHORT-SLEEVED SHIRTS; SKI WEAR; SNOWBOARD JACKETS; SNOWBOARD PANTS; SURF WEAR; SWIM WEAR (U.S. CLS. 22 AND 39).

FIRST USE 12-14-2009; IN COMMERCE 1-25-2010.  
SHAUNIA CARLYLE, EXAMINING ATTORNEY

**CLASS 25—(Continued).**

SN 85-185,993. BITE DOWN, AURORA, CO. FILED 11-29-2010.



THE MARK CONSISTS OF AN IMAGE OF A MAN'S FACE APPEARING INSIDE A CIRCLE WITH AN ARM EXTENDING FROM THE OUTSIDE OF THE CIRCLE WITH THE FIST OF THE HAND WRAPPED IN BANDAGE AND PUNCHING THE FACE, AN EXPLOSION DESIGN APPEARING ABOVE THE FIST, THE WORDING "BITE DOWN" WRITTEN ON THE MOUTH, A DESIGN OF LIQUID SPILLING FROM THE MOUTH, THE WORDING "BITE" APPEARS ON TOP OF THE CIRCLE, AND THE WORDING "DOWN" APPEARS AT THE BOTTOM OF THE CIRCLE.

FOR SHORTS; T-SHIRTS; TANK TOPS (U.S. CLS. 22 AND 39).

FIRST USE 8-20-2010; IN COMMERCE 9-1-2010.  
JENNY PARK, EXAMINING ATTORNEY

SN 85-185,778. IBL HOLDINGS LLC, WILMINGTON, DE. FILED 11-28-2010.



THE STIPPLING IS A FEATURE OF THE MARK AND DOES NOT INDICATE COLOR.

THE NAME(S), PORTRAIT(S), AND/OR SIGNATURE(S) SHOWN IN THE MARK DOES NOT IDENTIFY A PARTICULAR LIVING INDIVIDUAL.

THE MARK CONSISTS OF THE STYLIZED WORDS "LE' GAMB'I" IN UPPER AND LOWER CASE WITH AN ACCENT MARK OVER THE LETTER "E" AND IS WITHIN A BORDERED QUADRILATERAL BACKGROUND. COLOR IS NOT CLAIMED AS A FEATURE OF THE MARK. THE LINING AND STIPPLING IS A FEATURE OF THE MARK AND DOES NOT INDICATE COLOR.

THE WORDING LE' GAMB'I HAS NO MEANING IN A FOREIGN LANGUAGE.

FOR MEN'S AND WOMEN'S CLOTHING, NAMELY, SPANDEX STYLE SHAPEWEAR PANTS, SKIRTS, DRESSES, JACKETS, JUMPSUITS AND SHORTS THAT FREQUENTLY CONTAIN CERTAIN SIDE SEAM, STITCHING AND DESIGN ATTRIBUTES INDICATIVE OF JEANS; T-SHIRTS, TOPS, BELTS, CAPS AND SCARFS (U.S. CLS. 22 AND 39).

DAVID TAYLOR, EXAMINING ATTORNEY

SN 85-186,306. ANAHEIM DUCKS HOCKEY CLUB, LLC, ANAHEIM, CA. FILED 11-29-2010.



OWNER OF U.S. REG. NOS. 1,990,290, 3,321,727 AND OTHERS.

NO CLAIM IS MADE TO THE EXCLUSIVE RIGHT TO USE "ANAHEIM", APART FROM THE MARK AS SHOWN.

THE MARK CONSISTS OF THE WORDS "ANAHEIM DUCKS" SURROUNDING A DUCK MASK WITH CROSSED HOCKEY STICKS.

FOR CLOTHING, NAMELY, BANDANAS, BEACH COVER-UPS, BELTS, BODY SUITS, BOXER SHORTS, CAPS, CLOTH BIBS, COATS, DRESSES, FOOTWEAR, EAR MUFFS, GLOVES, HATS, HEADBANDS, HOSIERY, HOUSECOATS, JACKETS, JERSEYS, LEGGINGS, LEOTARDS, MITTENS, NIGHTSHIRTS, PAJAMAS, PANTS, RAIN COATS, RAIN WEAR, ROBES, SCARVES, SHIRTS, SHORTS, SKIRTS, SOCKS, SUITS, SUN VISORS, SUSPENDERS, SWEATERS, SWEATPANTS, SWEATSHIRTS, SWIMSUITS, SWIM TRUNKS, T-SHIRTS, TIES, TOQUES, UNDERWEAR, VESTS, WARM-UP SUITS AND WRISTBANDS (U.S. CLS. 22 AND 39).

TAMARA FRAZIER, EXAMINING ATTORNEY

**CLASS 25—(Continued).**

SN 85-186,358. JADEN LAM, LLC, NEW YORK, NY. FILED 11-29-2010.

JADEN LAM

THE MARK CONSISTS OF STANDARD CHARACTERS WITHOUT CLAIM TO ANY PARTICULAR FONT, STYLE, SIZE, OR COLOR.

"JADEN LAM" DOES NOT IDENTIFY A LIVING INDIVIDUAL.

FOR MEN'S CLOTHING, NAMELY, SHIRTS, BLAZERS, SUITS, VESTS, PANTS, SHORTS, SWEATERS, BELTS, HATS, TIES, SOCKS, SHOES, OUTERWEAR IN THE NATURE OF OVERCOATS, JACKETS AND RAINCOATS AND SPORTSWEAR IN THE NATURE OF SWEAT SHIRTS, SWEAT PANTS AND SWEAT SHORTS (U.S. CLS. 22 AND 39).

DAVID YONTEF, EXAMINING ATTORNEY

**CLASS 25—(Continued).**

SN 85-186,645. TALMADGE, JOHN ROBERT, SEBASTIAN, FL. FILED 11-29-2010.



NO CLAIM IS MADE TO THE EXCLUSIVE RIGHT TO USE "SEBASTIAN INLET, FLORIDA", APART FROM THE MARK AS SHOWN.

THE MARK CONSISTS OF GAPING SHARK JAWS WITH THE WORDS "MONSTER HOLE" IN THE MIDLINE IN A CHILLER FONT, THE WORDS "FISH SURF DIVE" OVER THE TOP OF THE JAWS AND SEPARATED BY TWO MIDDLE DOTS, AND THE WORDS "SEBASTIAN INLET, FLORIDA" UNDERNEATH.

FOR HATS; SHIRTS; SHORTS (U.S. CLS. 22 AND 39).

FIRST USE 9-15-2010; IN COMMERCE 10-21-2010.

ELLEN PERKINS, EXAMINING ATTORNEY

SN 85-186,643. JUSTBEME, LLC, PUEBLO, CO. FILED 11-29-2010.



THE MARK CONSISTS OF THE WORD "JUSTBEME-TEES" WITH THE TOP HALF OF A STICK FIGURE EXTENDING FROM THE LETTER "S" AND THE FACE OF THE STICK FIGURE HAS ITS TONGUE STUCK OUT.

FOR HATS; SWEAT SHIRTS; T-SHIRTS (U.S. CLS. 22 AND 39).

ELLEN PERKINS, EXAMINING ATTORNEY

SN 85-186,925. NELLA ZONA, LLC, BRANDON, MS. FILED 11-30-2010.

nella  zona

THE MARK CONSISTS OF THE WORDS "NELLA" AND "ZONA" SEPARATED BY A STYLIZED SYMBOL.

THE ENGLISH TRANSLATION OF "NELLA ZONA" IS "IN THE ZONE".

FOR ATHLETIC APPAREL, NAMELY, SHIRTS, PANTS, JACKETS, FOOTWEAR, HATS AND CAPS, ATHLETIC UNIFORMS (U.S. CLS. 22 AND 39).

KIMBERLY FRYE, EXAMINING ATTORNEY



**CLASS 25—(Continued).**

SN 85-187,053. LEVI STRAUSS & CO., SAN FRANCISCO, CA.  
FILED 11-30-2010.



OWNER OF U.S. REG. NOS. 1,139,254, 2,794,649 AND OTHERS.

THE MARK CONSISTS OF A DESIGN COMPRISED OF TWO ARCUATE-SHAPED ELEMENTS.

SEC. 2(F).

FOR JEANS (U.S. CLS. 22 AND 39).

FIRST USE 5-25-2010; IN COMMERCE 5-25-2010.

ELLEN BURNS, EXAMINING ATTORNEY

SN 85-187,105. BLACK DIAMOND GROUP, INC., WOBURN, MA. FILED 11-30-2010.

**KINGFIELD BOOT COMPANY**

THE MARK CONSISTS OF STANDARD CHARACTERS WITHOUT CLAIM TO ANY PARTICULAR FONT, STYLE, SIZE, OR COLOR.

NO CLAIM IS MADE TO THE EXCLUSIVE RIGHT TO USE "BOOT COMPANY", APART FROM THE MARK AS SHOWN.

FOR FOOTWEAR; BOOTS (U.S. CLS. 22 AND 39).

JEFFERY COWARD, EXAMINING ATTORNEY

SN 85-187,121. SKECHERS U.S.A., INC. II, MANHATTAN BEACH, CA. FILED 11-30-2010.

**SHAPE-UPS EVO**

THE MARK CONSISTS OF STANDARD CHARACTERS WITHOUT CLAIM TO ANY PARTICULAR FONT, STYLE, SIZE, OR COLOR.

OWNER OF U.S. REG. NOS. 3,732,331, 3,789,288 AND OTHERS.

FOR FOOTWEAR (U.S. CLS. 22 AND 39).

SKYE YOUNG, EXAMINING ATTORNEY

**CLASS 25—(Continued).**

SN 85-187,194. MANCIA, EBER J., DBA UNKNOWN HEROES COUTURE, GLENDORA, CA. FILED 11-30-2010.

**UNKNOWN HEROES COUTURE**

THE MARK CONSISTS OF STANDARD CHARACTERS WITHOUT CLAIM TO ANY PARTICULAR FONT, STYLE, SIZE, OR COLOR.

NO CLAIM IS MADE TO THE EXCLUSIVE RIGHT TO USE "COUTURE", APART FROM THE MARK AS SHOWN. FOR A-SHIRTS (U.S. CLS. 22 AND 39).

FONG HSU, EXAMINING ATTORNEY

SN 85-187,283. COLUMBIA SPORTSWEAR NORTH AMERICA, INC., PORTLAND, OR. FILED 11-30-2010.



OWNER OF U.S. REG. NO. 3,912,551 AND OTHERS.

NO CLAIM IS MADE TO THE EXCLUSIVE RIGHT TO USE "INSECT BLOCKER", APART FROM THE MARK AS SHOWN.

THE MARK CONSISTS OF A STYLIZED MOSQUITO OVER THE WORDS "INSECT BLOCKER" OVER BLACK AND WHITE ANGULAR STRIPES WITHIN A HEXAGON.

FOR HEADWEAR; PANTS; SHIRTS; SOCKS (U.S. CLS. 22 AND 39).

FIRST USE 10-1-2010; IN COMMERCE 10-1-2010.

THOMAS MANOR, EXAMINING ATTORNEY

SN 85-187,679. COMMA DESIGN CORPORATION, LOS ANGELES, CA. FILED 11-30-2010.



NO CLAIM IS MADE TO THE EXCLUSIVE RIGHT TO USE "U.S.A.", APART FROM THE MARK AS SHOWN.

THE COLOR(S) BLACK, GRAY AND WHITE IS/ARE CLAIMED AS A FEATURE OF THE MARK.

THE MARK CONSISTS OF THE WORDING "LOVE J U.S.A." IN WHITE AND GRAY, ALL IN A BLACK BACKGROUND.

FOR LEGGINGS; SKIRTS AND DRESSES; TOPS (U.S. CLS. 22 AND 39).

FIRST USE 11-30-2010; IN COMMERCE 11-30-2010.

MELISSA VALLILLO, EXAMINING ATTORNEY

**CLASS 25—(Continued).**

SN 85-187,855. PINTO, GERARDO A, ANTIOCH, CA. FILED 12-1-2010.

**LOOK FOWARD**

THE MARK CONSISTS OF STANDARD CHARACTERS WITHOUT CLAIM TO ANY PARTICULAR FONT, STYLE, SIZE, OR COLOR.

FOR CLOTHING, NAMELY, PANTS, SHORTS, JACKETS, SHIRTS, FOOTWEAR, HEADWEAR, CAPS AND HATS (U.S. CLS. 22 AND 39).

ROBERT STRUCK, EXAMINING ATTORNEY

---

SN 85-188,088. GARRY AUSTIN INVESTMENTS PTY LTD, HAWTHORN EAST VICTORIA, AUSTRALIA, FILED 12-1-2010.

**GAZ MAN**

THE MARK CONSISTS OF STANDARD CHARACTERS WITHOUT CLAIM TO ANY PARTICULAR FONT, STYLE, SIZE, OR COLOR.

OWNER OF AUSTRALIA REG. NO. 505575, DATED 12-11-1990, EXPIRES 2-24-2016.

NO CLAIM IS MADE TO THE EXCLUSIVE RIGHT TO USE "MAN", APART FROM THE MARK AS SHOWN.

FOR CLOTHING, NAMELY, T-SHIRTS, POLO SHIRTS, LONG-SLEEVED SHIRTS, PANTS, JEANS, SHORTS, SHIRTS, BELTS AND SOCKS (U.S. CLS. 22 AND 39).

MARK T. MULLEN, EXAMINING ATTORNEY

---

SN 85-188,943. BALGLOW FINANCE S/A, MONTEVIDEU, URUGUAY, FILED 12-2-2010.

**CHILLI BEANS**

THE MARK CONSISTS OF STANDARD CHARACTERS WITHOUT CLAIM TO ANY PARTICULAR FONT, STYLE, SIZE, OR COLOR.

FOR CLOTHING, NAMELY, T-SHIRTS, BEACHWEAR, BLOUSES, SPORTS SHIRTS, JERSEYS, SWIMWEAR, SWIMTRUNKS, SHORTS, UNDERWEAR, SHIRTS, PANTS, JEANS, VESTS, JACKETS, SWEATERS, PULLOVERS, COATS, SWEATPANTS, BANDANAS, SCARVES, AND FOOTWEAR, NAMELY, SHOES, SANDALS, ATHLETIC FOOTWEAR, ALL PURPOSE SPORTS FOOTWEAR, THONGS AND BOOTS (U.S. CLS. 22 AND 39).

JOHN WILKE, EXAMINING ATTORNEY

**CLASS 25—(Continued).**

SN 85-189,191. LANDAU UNIFORMS, INCORPORATED, OLIVE BRANCH, MS. FILED 12-2-2010.

**URBANE SPORT**

THE MARK CONSISTS OF STANDARD CHARACTERS WITHOUT CLAIM TO ANY PARTICULAR FONT, STYLE, SIZE, OR COLOR.

OWNER OF U.S. REG. NOS. 3,048,146 AND 3,267,061. NO CLAIM IS MADE TO THE EXCLUSIVE RIGHT TO USE "SPORT", APART FROM THE MARK AS SHOWN.

FOR LAB COATS; PANTS; SCRUBS NOT FOR MEDICAL PURPOSES; TOPS (U.S. CLS. 22 AND 39).

FIRST USE 1-1-2010; IN COMMERCE 1-1-2010.

JORDAN BAKER, EXAMINING ATTORNEY

---

SN 85-189,425. GUNAMUNA, INC., WALTHAM, MA. FILED 12-2-2010.

**GUNAPOD**

THE MARK CONSISTS OF STANDARD CHARACTERS WITHOUT CLAIM TO ANY PARTICULAR FONT, STYLE, SIZE, OR COLOR.

FOR WEARABLE BLANKET FOR INFANTS (U.S. CLS. 22 AND 39).

GEOFFREY FOSDICK, EXAMINING ATTORNEY

---

SN 85-189,488. JADEN LAM, LLC, NEW YORK, NY. FILED 12-2-2010.

**BECAUSE LIFE IS SHORT**

THE MARK CONSISTS OF STANDARD CHARACTERS WITHOUT CLAIM TO ANY PARTICULAR FONT, STYLE, SIZE, OR COLOR.

FOR MEN'S CLOTHING, NAMELY, SHIRTS, BLAZERS, SUITS, VESTS, PANTS, SHORTS, SWEATERS, BELTS, HATS, TIES, SOCKS, SHOES, OUTERWEAR IN THE NATURE OF OVERCOATS, JACKETS AND RAINCOATS AND SPORTSWEAR IN THE NATURE OF SWEAT SHIRTS, SWEAT PANTS AND SWEAT SHORTS (U.S. CLS. 22 AND 39).

DAVID YONTEF, EXAMINING ATTORNEY

**CLASS 25—(Continued).**

SN 85-189,900. MARCI KERBEN, MAITLAND, FL. FILED 12-3-2010.



THE MARK CONSISTS OF THE WORD "JUST SAY" ABOVE THE SYMBOL FOR "OM" AND THE WORD "OM" BELOW THE SYMBOL.

THE NON-LATIN CHARACTERS TRANSLITERATE TO "OM" AND THIS HAS NO MEANING IN A FOREIGN LANGUAGE. "OM" IS A MYSTIC SYLLABLE THAT IS SYMBOLIC OF THE THREE MAJOR HINDU DEITIES.

FOR SHIRTS AND SHORT-SLEEVED SHIRTS (U.S. CLS. 22 AND 39).

LEIGH CAROLINE CASE, EXAMINING ATTORNEY

SN 85-189,907. WOMEN RULE THE PLANET LLC, DECATUR, GA. FILED 12-3-2010.

## Women Rule The Planet

THE MARK CONSISTS OF STANDARD CHARACTERS WITHOUT CLAIM TO ANY PARTICULAR FONT, STYLE, SIZE, OR COLOR.

FOR CLOTHING, NAMELY, SHIRTS, JACKETS (U.S. CLS. 22 AND 39).

JIM RINGLE, EXAMINING ATTORNEY

SN 85-190,042. DILLARD'S, INC., LITTLE ROCK, AR. FILED 12-3-2010.

## Luster Soft

THE MARK CONSISTS OF STANDARD CHARACTERS WITHOUT CLAIM TO ANY PARTICULAR FONT, STYLE, SIZE, OR COLOR.

NO CLAIM IS MADE TO THE EXCLUSIVE RIGHT TO USE "SOFT", APART FROM THE MARK AS SHOWN.

FOR SHORT SLEEVE KNIT SHIRTS, LONG SLEEVE KNIT SHIRTS, SHORT SLEEVE WOVEN SHIRTS, LONG SLEEVE WOVEN SHIRTS, PANTS, SHORTS (U.S. CLS. 22 AND 39).

DEIRDRE ROBERTSON, EXAMINING ATTORNEY

**CLASS 25—(Continued).**

SN 85-190,357. MABU NATURALS INTERNATIONAL INC., TORONTO, CANADA, FILED 12-3-2010.

## MABU BABY

THE MARK CONSISTS OF STANDARD CHARACTERS WITHOUT CLAIM TO ANY PARTICULAR FONT, STYLE, SIZE, OR COLOR.

NO CLAIM IS MADE TO THE EXCLUSIVE RIGHT TO USE "BABY", APART FROM THE MARK AS SHOWN.

FOR BABY DIAPER SYSTEM, NAMELY, CLOTH DIAPERS HAVING REUSABLE CLOTH LINERS AND DISPOSABLE PAPER LINERS (U.S. CLS. 22 AND 39).

SANDRA BUJA, EXAMINING ATTORNEY

SN 85-190,466. SUREFIND PIPELINE MARKERS, LLC, ZAPATA, TX. FILED 12-3-2010.



THE MARK CONSISTS OF A CIRCLE WITH SHADED SECTIONS CREATING A PENTAGON SHAPE THEREIN; THE WORD "SUREFIND" IS LOCATED BELOW THE CIRCLE AND ABOVE THE WORDING "PIPELINE MARKERS".

FOR CAPS; SHIRTS (U.S. CLS. 22 AND 39).

FIRST USE 11-16-2010; IN COMMERCE 11-16-2010.

CHRISTOPHER BUONGIORNO, EXAMINING ATTORNEY

SN 85-190,659. CRYSTAL HARRIS, LOS ANGELES, CA. FILED 12-3-2010.

## BUNNY BODY

THE MARK CONSISTS OF STANDARD CHARACTERS WITHOUT CLAIM TO ANY PARTICULAR FONT, STYLE, SIZE, OR COLOR.

NO CLAIM IS MADE TO THE EXCLUSIVE RIGHT TO USE "BODY", APART FROM THE MARK AS SHOWN.

FOR CLOTHING, NAMELY, TOPS, SHIRTS, BOTTOMS, PANTS, SHORTS, SKIRTS, HEAD WEAR, NECKWEAR, FOOTWEAR, OUTERWEAR, NAMELY, COATS AND JACKETS, UNDERWEAR, HOSIERY, BELTS (U.S. CLS. 22 AND 39).

WILLIAM ROSSMAN, EXAMINING ATTORNEY

**CLASS 25—(Continued).**

SN 85-191,129. DRISCOLL, SHAWN, EL CAJON, CA. FILED 12-6-2010.

# SHONNER

FOR HATS; SHOES; T-SHIRTS (U.S. CLS. 22 AND 39).  
FIRST USE 2-10-2000; IN COMMERCE 5-8-2000.  
JOHN DWYER, EXAMINING ATTORNEY

SN 85-191,272. YAYA'S BIKINIS, BATON ROUGE, LA.  
FILED 12-6-2010.

# Invizaline Bikini

THE MARK CONSISTS OF STANDARD CHARACTERS WITHOUT CLAIM TO ANY PARTICULAR FONT, STYLE, SIZE, OR COLOR.

NO CLAIM IS MADE TO THE EXCLUSIVE RIGHT TO USE "BIKINI", APART FROM THE MARK AS SHOWN.  
FOR BIKINIS (U.S. CLS. 22 AND 39).  
FIRST USE 8-1-2010; IN COMMERCE 8-1-2010.  
KIM SAITO, EXAMINING ATTORNEY

SN 85-191,370. ANNEMARIE WATERS, KIRKLAND, WA.  
FILED 12-6-2010.



THE MARK CONSISTS OF THE WORD "POOPSIES" IN STYLIZED FONT, WITH A CARTOON OUTLINE OF THE BACKSIDE OF A BABY IN PLACE OF THE TWO O'S.

FOR INFANT AND CHILDREN'S CLOTHING, NAMELY, POLO SHIRTS FOR TODDLERS AND BABIES, T-SHIRTS, BABY BODY SUITS, SHORTALLS, PAJAMAS, PANTS, SHORTS, BATHING SUITS, PAJAMAS, AND BABY BIBS NOT OF PAPER (U.S. CLS. 22 AND 39).

FIRST USE 9-12-2010; IN COMMERCE 9-12-2010.  
SALLY SHIH, EXAMINING ATTORNEY

**CLASS 25—(Continued).**

SN 85-191,730. KITTRELL, DAN, FORT PIERCE, FL. AND WILLIAMS, ROBERT, FORT PIERCE, FL. FILED 12-6-2010.



THE MARK CONSISTS THE WORDS "BOOTY QUEST" ON EITHER SIDE OF A PIRATE SKULL WITH AN EYE PATCH, AN EYE, A DIVE FLAG BANDANA ON THE HEAD, AND SPEAR POLES RATHER THAN CROSS BONES.  
FOR HATS; SHIRTS (U.S. CLS. 22 AND 39).  
LEIGH CAROLINE CASE, EXAMINING ATTORNEY

SN 85-191,826. CAMPBELL, STANLEY, MORENO VALLEY, CA. FILED 12-7-2010.



THE COLOR(S) PINK, GREEN AND BLACK IS/ARE CLAIMED AS A FEATURE OF THE MARK.

THE MARK CONSISTS OF A PINK AND BLACK PIG HEAD WITH A STYLIZED HUNDRED DOLLAR BILL IN GREEN AND BLACK ACROSS ITS MOUTH, BLACK CENT SIGNS INSIDE OF THE EARS AND TWO DOLLAR SIGNS IN GREEN OUTLINED IN BLACK AS THE EYES; THE BLACK SQUARE CARRIER IS NOT PART OF THE MARK AND REPRESENTS TRANSPARENT BACKGROUND.

FOR CLOTHING, NAMELY, TSHIRTS, JACKETS, SWEATERS, TANK TOPS, VEST AND HATS (U.S. CLS. 22 AND 39).

KELLY CHOE, EXAMINING ATTORNEY

**CLASS 25—(Continued).**

SN 85-192,054. SASSY SHOES, LLC, PENSACOLA, FL. FILED 12-7-2010.



NO CLAIM IS MADE TO THE EXCLUSIVE RIGHT TO USE "SHOES LLC.", APART FROM THE MARK AS SHOWN. THE COLOR(S) GREEN IS/ARE CLAIMED AS A FEATURE OF THE MARK.

THE MARK CONSISTS OF THE WORDING "SASSY SHOES LLC" IN A GREEN SCRIPT FONT, WITH A SIDEWAYS DESIGN OF A BUTTERFLY BETWEEN "SASSY" AND "SHOES".

FOR SHOES; WOMEN'S SHOES (U.S. CLS. 22 AND 39).  
FIRST USE 12-4-2010; IN COMMERCE 12-4-2010.  
HEATHER SAPP, EXAMINING ATTORNEY

**CLASS 25—(Continued).**

SN 85-192,334. MUNRO & COMPANY, INC., HOT SPRINGS, AR. FILED 12-7-2010.

JJ TRAX

THE MARK CONSISTS OF STANDARD CHARACTERS WITHOUT CLAIM TO ANY PARTICULAR FONT, STYLE, SIZE, OR COLOR.

OWNER OF U.S. REG. NOS. 2,933,543 AND 3,264,257.  
THE NAME(S), PORTRAIT(S), AND/OR SIGNATURE(S) SHOWN IN THE MARK DOES NOT IDENTIFY A PARTICULAR LIVING INDIVIDUAL.  
FOR FOOTWEAR (U.S. CLS. 22 AND 39).  
WENDY JUN, EXAMINING ATTORNEY

SN 85-192,081. ANNEMARIE WATERS, KIRKLAND, WA. FILED 12-7-2010.



THE MARK CONSISTS OF A CARTOON OUTLINE OF THE BACKSIDE OF A BABY.

FOR INFANT AND CHILDREN'S CLOTHING, NAMELY, POLO SHIRTS FOR TODDLERS AND BABIES, T-SHIRTS, BABY BODY SUITS, SHORTALLS, PAJAMAS, PANTS, SHORTS, BATHING SUITS, PAJAMAS, AND BABY BIBS NOT OF PAPER (U.S. CLS. 22 AND 39).

FIRST USE 12-5-2010; IN COMMERCE 12-5-2010.  
SALLY SHIH, EXAMINING ATTORNEY

SN 85-192,437. THE MERAMEC GROUP, INC., SULLIVAN, MO. FILED 12-7-2010.



OWNER OF U.S. REG. NOS. 2,124,005, 3,079,080 AND OTHERS.

THE MARK CONSISTS OF A PARTIAL OVAL SURROUNDING THE WORD "MERAMEC".

FOR POLYURETHANE FOOTWEAR COMPONENTS, NAMELY MIDSOLES, INSOLES AND OUTSOLES (U.S. CLS. 22 AND 39).

FIRST USE 11-24-2010; IN COMMERCE 11-24-2010.  
MICHAEL SOUDERS, EXAMINING ATTORNEY

**CLASS 25—(Continued).**

SN 85-192,666. COONS, JAIME, TOPANGA, CA. FILED 12-7-2010.

YOU WERE BORN TO BE SPOILED

THE MARK CONSISTS OF STANDARD CHARACTERS WITHOUT CLAIM TO ANY PARTICULAR FONT, STYLE, SIZE, OR COLOR.

FOR CLOTHING FOR WOMEN, MEN AND CHILDREN, NAMELY, SHIRTS, T-SHIRTS, SWEATSHIRTS, BLOUSES, PULLOVERS, TANK TOPS, CROP SHIRTS, JACKETS, COATS, SWEATERS, VESTS, PANTS, SWEATPANTS, HOODED JACKETS, HOODED SWEATSHIRTS, SHORTS, WRAP AROUND HOODS, BOTTOMS, SKIRTS, AND DRESSES; FASHION ACCESSORIES, NAMELY, HEADWEAR, HATS, RAGLANS, CAPS, VISORS, HEADBANDS, WRISTBANDS, HOODS, SCARVES, BANDANAS, NECKTIES, MUFFLERS, GLOVES, MITTENS AND BELTS; UNDERWEAR AND UNDERGARMENTS, NAMELY, BOXER SHORTS, UNDERSHORTS, UNDERPANTS, BRAS, BOARD SHORTS, HOT PANTS, SOCKS, AND HOSIERY; FOOTWEAR, NAMELY, SHOES, SNEAKERS AND BOOTS; SWIM WEAR, BEACHWEAR, AND LOUNGEWEAR, NAMELY, PAJAMAS AND ROBES; HOLIDAY COSTUMES AND MASKS SOLD IN CONNECTION THEREWITH (U.S. CLS. 22 AND 39).

FIRST USE 12-6-2010; IN COMMERCE 12-6-2010.  
JAMES LOVELACE, EXAMINING ATTORNEY

SN 85-192,709. AUDIBLE LLC, HUNTERSVILLE, NC. FILED 12-7-2010.



SINGLE-USE BUSINESS SOCKS

NO CLAIM IS MADE TO THE EXCLUSIVE RIGHT TO USE "BLUE HEEL" OR "SINGLE-USE BUSINESS SOCKS", APART FROM THE MARK AS SHOWN.

THE MARK CONSISTS OF THE STYLIZED TEXT "BLUE HEEL SINGLE-USE BUSINESS SOCKS" WITH TWO FEET. FOR SOCKS (U.S. CLS. 22 AND 39).

KELLY BOULTON, EXAMINING ATTORNEY

**CLASS 25—(Continued).**

SN 85-192,725. MCINTOSH, LENWORTH, FORT WORTH, TX. FILED 12-7-2010.



THE MARK CONSISTS A COFFEE CUP WITH A HOVERING CROWN, A CUP HANDLE ON THE RIGHT, AND ON THE LEFT IS A HAND SHOWING THE PEACE SIGN. IT HAS THE WORDS "FRESH KAUFEE" IN THE MIDDLE OF THE CUP.

FOR HATS; HOODED SWEATSHIRTS; JACKETS; PANTS; SCARVES; SHIRTS; SHOES; SLIPPERS; SOCKS; SWIMSUITS; TIES; UNDERWEAR (U.S. CLS. 22 AND 39).  
KELLY BOULTON, EXAMINING ATTORNEY

SN 85-193,173. CAVANAUGH, CRYSTAL L., DBA COCO CAVANNA, MARION, IA. FILED 12-8-2010.



THE COLOR(S) PURPLE, PINK, YELLOW, AND BLACK IS/ARE CLAIMED AS A FEATURE OF THE MARK.

THE MARK CONSISTS OF PURPLE AND PINK HEARTS WRAPPED IN A YELLOW BANNER OUTLINED IN BLACK WITH THE WORDING "COCO CAVANNA" IN BLACK AND THE WORDING "WWW.COCOCAVANNA.COM" IN PINK; THE COLOR BLACK IN THE BACKGROUND OF THE MARK REPRESENTS TRANSPARENT AREAS AND IS NOT CLAIMED AS A FEATURE OF THE MARK FOR SHIRTS (U.S. CLS. 22 AND 39).

FIRST USE 9-1-2009; IN COMMERCE 8-10-2010.  
HEATHER BIDDULPH, EXAMINING ATTORNEY

SN 85-193,582. ME TOO LLC, NEW YORK, NY. FILED 12-8-2010.

SOHO by Me Too

THE MARK CONSISTS OF STANDARD CHARACTERS WITHOUT CLAIM TO ANY PARTICULAR FONT, STYLE, SIZE, OR COLOR.

OWNER OF U.S. REG. NO. 3,757,658.

NO CLAIM IS MADE TO THE EXCLUSIVE RIGHT TO USE "SOHO", APART FROM THE MARK AS SHOWN.

FOR WOMEN'S AND CHILDREN'S FOOTWEAR, NAMELY, BOOTS AND SANDALS (U.S. CLS. 22 AND 39).

JULIE GUTTADAURO, EXAMINING ATTORNEY

**CLASS 25—(Continued).**

SN 85-193,593. ME TOO LLC, NEW YORK, NY. FILED 12-8-2010.

**Me Too SOHO**

THE MARK CONSISTS OF STANDARD CHARACTERS WITHOUT CLAIM TO ANY PARTICULAR FONT, STYLE, SIZE, OR COLOR.

OWNER OF U.S. REG. NO. 3,757,658.

NO CLAIM IS MADE TO THE EXCLUSIVE RIGHT TO USE "SOHO", APART FROM THE MARK AS SHOWN.

FOR WOMEN'S AND CHILDREN'S FOOTWEAR, NAMELY, BOOTS AND SANDALS (U.S. CLS. 22 AND 39).

JULIE GUTTADAURO, EXAMINING ATTORNEY

SN 85-194,088. MISSION APPAREL, LLC, CHARLESTON, SC. FILED 12-9-2010.



THE MARK CONSISTS OF THE STYLIZED WORDING "LOVE MY BALLS" IN A CIRCLE WITH THE TWO L'S IN "BALLS" ILLUSTRATED TO LOOK LIKE A PAIR OF MENS' PANTS.

FOR BOXER SHORTS; HATS; SPORTS SHIRTS; SWEATSHIRTS; T-SHIRTS; TANK TOPS; VISORS; WRISTBANDS (U.S. CLS. 22 AND 39).

FIRST USE 6-1-2010; IN COMMERCE 6-1-2010.  
JAMES GRIFFIN, EXAMINING ATTORNEY

SN 85-194,669. WORK TO LIVE LLC, TUCSON, AZ. FILED 12-9-2010.

**WTL**

THE MARK CONSISTS OF STANDARD CHARACTERS WITHOUT CLAIM TO ANY PARTICULAR FONT, STYLE, SIZE, OR COLOR.

FOR DRESSES; HATS; HOODED SWEAT SHIRTS; JACKETS; LONG JACKETS; POLO SHIRTS; SHORT-SLEEVED OR LONG-SLEEVED T-SHIRTS; SKIRTS; TANK-TOPS (U.S. CLS. 22 AND 39).

FIRST USE 9-25-2010; IN COMMERCE 9-25-2010.  
CORY BOONE, EXAMINING ATTORNEY

**CLASS 25—(Continued).**

SN 85-194,931. BURTON, RONAILE, DALY CITY, CA. FILED 12-10-2010.



THE MARK CONSISTS OF A STYLIZED CARTOON FACE WITH HAIR, CLOSED EYELID, AND OPEN MOUTH, WITHIN TWO CIRCLES, A HEADPHONE WITH AN ANTENNA AND RADIO WAVES ON THE SIDE OF THE FACE, AND THE STYLIZED TEXT "FUTURISTIC COLA =" AT THE BOTTOM

FOR SHIRTS (U.S. CLS. 22 AND 39).  
JEAN IM, EXAMINING ATTORNEY

SN 85-195,748. BOSU FITNESS, LLC, SAN DIEGO, CA. FILED 12-10-2010.

**BOSU**

THE MARK CONSISTS OF STANDARD CHARACTERS WITHOUT CLAIM TO ANY PARTICULAR FONT, STYLE, SIZE, OR COLOR.

OWNER OF U.S. REG. NO. 2,518,696.

FOR ATHLETIC SHOES; GLOVES; HATS; PANTS; SHIRTS; SHOES; SHORTS; SWEAT JACKETS; SWEAT PANTS; SWEAT SHIRTS; SWEAT SHORTS; SWEAT SUITS; SWIM SUITS; T-SHIRTS; TRACK JACKETS; TRACK PANTS; TRACK SUITS; TRAINING SUITS; TRIATHLON CLOTHING, NAMELY, TRIATHLON TIGHTS, TRIATHLON SHORTS, TRIATHLON SINGLET, TRIATHLON SHIRTS, TRIATHLON SUITS; YOGA SHIRTS; BEANIES; SWEATBANDS (U.S. CLS. 22 AND 39).

MARK PILARO, EXAMINING ATTORNEY

**CLASS 25—(Continued).**

SN 85-195,940. MIDDENDORF IV, JOHN WILLIAM, PAGO-SA SPRINGS, CO. FILED 12-11-2010.



THE MARK CONSISTS OF THE LETTER "A" AND THE NUMERAL "5" IN A CIRCLE.

FOR ATHLETIC APPAREL, NAMELY, SHIRTS, PANTS, JACKETS, FOOTWEAR, HATS AND CAPS, ATHLETIC UNIFORMS (U.S. CLS. 22 AND 39).

FIRST USE 7-1-2010; IN COMMERCE 7-1-2010.  
TOBY BULLOFF, EXAMINING ATTORNEY

SN 85-196,894. OBBI, LLC, NEW YORK, NY. FILED 12-13-2010.

**LIVE IN LAYERS**

THE MARK CONSISTS OF STANDARD CHARACTERS WITHOUT CLAIM TO ANY PARTICULAR FONT, STYLE, SIZE, OR COLOR.

NO CLAIM IS MADE TO THE EXCLUSIVE RIGHT TO USE "LAYERS", APART FROM THE MARK AS SHOWN.

FOR BOTTOMS; BOXER SHORTS; BRAS; CAMISOLES; FOOTWEAR; FOUNDATION GARMENTS; HALTER TOPS; HATS; HEADWEAR; HOSIERY; JACKETS; KNITTED UNDERWEAR; LEGGINGS; LINGERIE; LONG UNDERWEAR; LOUNGEWEAR; PAJAMAS; PANTIES; ROBES; SARONGS; SHORTS; SLEEPWEAR; SLIPPERS; SOCKS; THERMAL SOCKS; THERMAL UNDERWEAR; TOPS; UNDERGARMENTS; UNDERWEAR; WEARABLE BLANKETS IN THE NATURE OF BLANKETS WITH SLEEVES (U.S. CLS. 22 AND 39).

TRACY FLETCHER, EXAMINING ATTORNEY

**CLASS 25—(Continued).**

SN 85-197,444. DESCENTE NORTH AMERICA, INC., LAYTON, UT. FILED 12-14-2010.



THE MARK CONSISTS OF DOUBLE HELIX, FOR CLOTHING, NAMELY, HOODED SWEATSHIRTS AND HOODED TOPS (U.S. CLS. 22 AND 39).  
FIRST USE 10-1-2000; IN COMMERCE 10-1-2000.  
HOWARD B. LEVINE, EXAMINING ATTORNEY

SN 85-197,491. DESCENTE NORTH AMERICA, INC., LAYTON, UT. FILED 12-14-2010.



THE MARK CONSISTS OF A DOUBLE HELIX ABOVE THE LETTERS "DNA".

FOR SKI AND SNOWBOARD CLOTHING, NAMELY, SHIRTS, T-SHIRTS, JACKETS, PANTS, VESTS, GLOVES AND HATS; CLOTHING, NAMELY, SHIRTS, T-SHIRTS, JACKETS, PANTS, VESTS, SHORTS AND HOODED SWEATSHIRTS AND HOODED TOPS (U.S. CLS. 22 AND 39).

HOWARD B. LEVINE, EXAMINING ATTORNEY

SN 85-197,522. DESCENTE NORTH AMERICA, INC., LAYTON, UT. FILED 12-14-2010.



THE MARK CONSISTS OF THE LETTERS "DNA" IN A STYLIZED FORM.

FOR SKI AND SNOWBOARDING CLOTHING, NAMELY, SHIRTS, T-SHIRTS, JACKETS, PANTS, VESTS, GLOVES AND HATS; CLOTHING, NAMELY, SHIRTS, T-SHIRTS, JACKETS, PANTS, VESTS, SHORTS AND HOODED SWEATSHIRTS AND HOODED TOPS (U.S. CLS. 22 AND 39).

FIRST USE 10-1-2000; IN COMMERCE 10-1-2000.  
HOWARD B. LEVINE, EXAMINING ATTORNEY



**CLASS 25—(Continued).**

SN 85-197,581. MANFRE, GUSTAVO GABRIEL, BUENOS AIRES, ARGENTINA, FILED 12-14-2010.

# HUIJA

THE MARK CONSISTS OF STANDARD CHARACTERS WITHOUT CLAIM TO ANY PARTICULAR FONT, STYLE, SIZE, OR COLOR.

THE WORDING "HUIJA" HAS NO MEANING IN A FOREIGN LANGUAGE.

FOR BLAZERS; BLOUSES; COATS; DRESSES; FOOTWEAR; JACKETS; JERSEYS; NIGHT SHIRTS; PAJAMAS; PANTS; SHIRTS; SHOES; SKIRTS; SLEEP SHIRTS; SLEEVED OR SLEEVELESS JACKETS; SPORT COATS; SUIT COATS; SWEATERS; T-SHIRTS; TUNICS; VESTS (U.S. CLS. 22 AND 39).

NANCY CLARKE, EXAMINING ATTORNEY

SN 85-197,704. MARCI KERBEN, MAITLAND, FL. FILED 12-14-2010.

# JUST SAY OM

THE MARK CONSISTS OF STANDARD CHARACTERS WITHOUT CLAIM TO ANY PARTICULAR FONT, STYLE, SIZE, OR COLOR.

"OM" HAS NO MEANING IN A FOREIGN LANGUAGE. IT IS A MYSTIC SYLLABLE THAT IS SYMBOLIC OF THE THREE MAJOR HINDU DEITIES.

FOR SHIRTS AND SHORT-SLEEVED SHIRTS (U.S. CLS. 22 AND 39).

LEIGH CAROLINE CASE, EXAMINING ATTORNEY

SN 85-198,055. RETAIL ROYALTY COMPANY, LAS VEGAS, NV. FILED 12-15-2010.



OWNER OF U.S. REG. NO. 2,996,149.

THE MARK CONSISTS OF INTERSECTING STRIPES ON THE SIDE OF ATHLETIC AND LEISURE FOOTWEAR, THE STRIPES BEING OF CONTRASTING COLOR TO THAT OF THE SIDE OF THE FOOTWEAR. THE DOTTED OUTLINE OF THE FOOTWEAR IS NOT CLAIMED AS PART OF THE MARK AND IS INTENDED ONLY TO SHOW THE POSITION OF THE MARK.

SEC. 2(F).

FOR ATHLETIC AND LEISURE FOOTWEAR (U.S. CLS. 22 AND 39).

FIRST USE 9-15-2002; IN COMMERCE 9-15-2002.

LINDA MICKLEBURGH, EXAMINING ATTORNEY

**CLASS 25—(Continued).**

SN 85-198,520. JEANNE SIMMONS ACCESSORIES INC, VISTA, CA. FILED 12-15-2010.

# Archibald

THE MARK CONSISTS OF STANDARD CHARACTERS WITHOUT CLAIM TO ANY PARTICULAR FONT, STYLE, SIZE, OR COLOR.

FOR GLOVES; HATS; SCARVES (U.S. CLS. 22 AND 39). FIRST USE 10-15-2010; IN COMMERCE 10-15-2010.

BRIAN PINO, EXAMINING ATTORNEY

SN 85-198,580. ESHEL LLC, NEW YORK, NY. FILED 12-15-2010.



THE MARK CONSISTS OF TREE BRANCHES WITH THE STYLIZED TEXT "ESHEL".

FOR BLOUSES; COATS; DRESSES; JACKETS; TROUSERS (U.S. CLS. 22 AND 39).

FIRST USE 7-1-2010; IN COMMERCE 7-15-2010.

ANNE MADDEN, EXAMINING ATTORNEY

SN 85-198,895. BRANDED, LLC, DALLAS, TX. FILED 12-15-2010.

# Bridgetown Collection

THE MARK CONSISTS OF STANDARD CHARACTERS WITHOUT CLAIM TO ANY PARTICULAR FONT, STYLE, SIZE, OR COLOR.

NO CLAIM IS MADE TO THE EXCLUSIVE RIGHT TO USE "COLLECTION", APART FROM THE MARK AS SHOWN.

FOR CLOTHING, NAMELY, T-SHIRTS, SHIRTS, BLOUSES, SWEATERS, TOPS, PANTS, SHORTS, JEANS, DRESSES, SKIRTS, JACKETS, BLAZERS, SUITS, COATS, LOUNGEWEAR, SWEATSHIRTS, SOCKS, BELTS, SCARVES; FOOTWEAR; HEADWEAR (U.S. CLS. 22 AND 39).

SAIMA MAKHDOOM, EXAMINING ATTORNEY

**CLASS 25—(Continued).**

SN 85-198,930. BRANDED, LLC, DALLAS, TX. FILED 12-15-2010.

## Ride Science

THE MARK CONSISTS OF STANDARD CHARACTERS WITHOUT CLAIM TO ANY PARTICULAR FONT, STYLE, SIZE, OR COLOR.

FOR CLOTHING FOR ADULTS AND CHILDREN, NAMELY, SKI WEAR, JACKETS, PANTS, VESTS, OVERALLS, PARKAS, HATS, GLOVES, HEADBANDS AND SKI SUITS (U.S. CLS. 22 AND 39).

SAIMA MAKHDOOM, EXAMINING ATTORNEY

**CLASS 25—(Continued).**

SN 85-200,054. SKECHERS U.S.A., INC. II, MANHATTAN BEACH, CA. FILED 12-16-2010.

## SHAPE-UPS EVOLUTION

THE MARK CONSISTS OF STANDARD CHARACTERS WITHOUT CLAIM TO ANY PARTICULAR FONT, STYLE, SIZE, OR COLOR.

OWNER OF U.S. REG. NOS. 3,732,331, 3,789,288 AND OTHERS.

FOR FOOTWEAR (U.S. CLS. 22 AND 39).

SKYE YOUNG, EXAMINING ATTORNEY

SN 85-198,974. WALIA, ROHIT, SHERMAN OAKS, CA. FILED 12-15-2010.

## Three-Heat

THE MARK CONSISTS OF STANDARD CHARACTERS WITHOUT CLAIM TO ANY PARTICULAR FONT, STYLE, SIZE, OR COLOR.

FOR CLOTHING NAMELY, SHIRTS, HATS, HOODED SWEATERS, AND APRONS (U.S. CLS. 22 AND 39).

FIRST USE 10-25-2010; IN COMMERCE 10-26-2010.

JOHN KELLY, EXAMINING ATTORNEY

SN 85-200,059. CHRISTOPHER T. JACOBS, PIERMONT, NH. FILED 12-16-2010.

SN 85-199,149. LOVELOSTENT. LLC, PHOENIX, AZ. FILED 12-16-2010.



THE COLOR(S) YELLOW, BLACK, GRAY AND RED IS/ ARE CLAIMED AS A FEATURE OF THE MARK.

THE MARK CONSISTS OF RED HEART AND SURROUNDED BY SEVERAL CLOUDS IN GRAY, BLACK AND YELLOW COLOR ALL SHARPLY OUTLINED IN BLACK COLOR. THE WORDS 'LOVE' AND 'ENT.' ARE WRITTEN IN YELLOW COLOR AND THE WORD 'LOST' IS WRITTEN IN BLACK COLOR ON THE CLOUD AS SHOWN IN THE MARK. THE YELLOW BACKGROUND IS CLAIMED AS A FEATURE OF THE MARK.

FOR CLOTHING, NAMELY, TOPS, BOTTOMS, SHIRTS, AND PANTS (U.S. CLS. 22 AND 39).

JAMES GRIFFIN, EXAMINING ATTORNEY

## Everyone Wants To Ride

THE MARK CONSISTS OF STANDARD CHARACTERS WITHOUT CLAIM TO ANY PARTICULAR FONT, STYLE, SIZE, OR COLOR.

FOR ATHLETIC APPAREL, NAMELY, SHIRTS, PANTS, JACKETS, FOOTWEAR, HATS AND CAPS, ATHLETIC UNIFORMS (U.S. CLS. 22 AND 39).

LINDA POWELL, EXAMINING ATTORNEY

**CLASS 25—(Continued).**

SN 85-200,846. BROWN, WAYNE H., WARRIEWOOD BEACH NSW, AUSTRALIA, FILED 12-17-2010.



THE MARK CONSISTS OF A COAT OF ARMS FEATURING A LION HOLDING A FLEUR-DE-LIS AND STANDING ATOP AN ARMOUR HELMET THAT IS ABOVE A SHIELD FEATURING A CHEVRON AND THREE FLEUR-DE-LIS, ALL SURROUNDED BY LEAVES. ABOVE THE LION IS A BANNER FEATURING THE WORDING "FLOREAT MAJESTAS".

THE ENGLISH TRANSLATION OF "FLOREAT MAJESTAS" IN THE MARK IS "LET MAJESTY FLOURISH".

FOR MEN'S, WOMEN'S, CHILDREN'S, BABIES, AND INFANTS CLOTHING, NAMELY, T-SHIRTS, SWEATSHIRTS, HOODED SWEATSHIRTS, TOPS, BOTTOMS, PANTS, SHORTS, SHIRTS, DRESSES, SKIRTS, KILTS, APRONS, SWEATERS, JACKETS, COATS, JEANS, HEADBANDS, WRISTBANDS, HATS, SHOES, BELTS, MITTENS AND GLOVES, MONEY BELTS, NECKERCHIEFS, SCARVES, WRAPS; GOLF WEAR, NAMELY, GOLF CAPS, CLEATS, PANTS, SHIRTS, SKIRTS, SHORTS, JACKETS AND TROUSERS; TENNIS WEAR, WIND-RESISTANT JACKETS, HOSIERY AND SOCKS; BIBS, NAMELY, CLOTH BIBS AND BIBS NOT OF PAPER; BOOTIES, INFANTWEAR; WATERPROOF, WATER RESISTANT, AND WINDPROOF CLOTHING, NAMELY, JACKETS, COATS, AND VESTS; LEATHER CLOTHING, NAMELY, JACKETS AND COATS (U.S. CLS. 22 AND 39).

LINDA LAVACHE, EXAMINING ATTORNEY

SN 85-200,901. SGBECK, MALIBU, CA. FILED 12-17-2010.

# SJOBECK

THE MARK CONSISTS OF STANDARD CHARACTERS WITHOUT CLAIM TO ANY PARTICULAR FONT, STYLE, SIZE, OR COLOR.

THE NAME(S), PORTRAIT(S), AND/OR SIGNATURE(S) SHOWN IN THE MARK IDENTIFIES A LIVING INDIVIDUAL, WHOSE CONSENT(S) TO REGISTER IS MADE OF RECORD.

SEC. 2(F).

FOR MEN'S AND WOMEN'S CLOTHING, NAMELY, BOTTOMS, SHORTS, PANTS, TOPS, DRESSES, JACKETS, ZIP UP SHIRTS, ZIP JACKETS, SWEAT SHIRTS, TUBE TOPS, TANK TOPS, CASUAL TOPS, TEE SHIRTS, CREW TOPS, FOOTWEAR AND BELTS (U.S. CLS. 22 AND 39).

FIRST USE 1-1-2005; IN COMMERCE 1-1-2005.  
PAUL MORENO, EXAMINING ATTORNEY

**CLASS 25—(Continued).**

SN 85-200,921. GLOBAL TRADEMARKS, INC., STOCKERTOWN, PA. FILED 12-17-2010.

As Amazing As It Sounds  
--You Will Appear to Lose  
Pounds

THE MARK CONSISTS OF STANDARD CHARACTERS WITHOUT CLAIM TO ANY PARTICULAR FONT, STYLE, SIZE, OR COLOR.

FOR JEANS; SWIMWEAR (U.S. CLS. 22 AND 39).  
INGA ERVIN, EXAMINING ATTORNEY

SN 85-200,992. SKECHERS U.S.A., INC. II, MANHATTAN BEACH, CA. FILED 12-17-2010.

# SHAPE-UPS PULSE

THE MARK CONSISTS OF STANDARD CHARACTERS WITHOUT CLAIM TO ANY PARTICULAR FONT, STYLE, SIZE, OR COLOR.

OWNER OF U.S. REG. NOS. 3,732,331, 3,789,288 AND OTHERS.  
FOR FOOTWEAR (U.S. CLS. 22 AND 39).  
SKYE YOUNG, EXAMINING ATTORNEY

SN 85-201,012. SKECHERS U.S.A., INC. II, MANHATTAN BEACH, CA. FILED 12-17-2010.

# PUNKIE ROSE

THE MARK CONSISTS OF STANDARD CHARACTERS WITHOUT CLAIM TO ANY PARTICULAR FONT, STYLE, SIZE, OR COLOR.

OWNER OF U.S. REG. NO. 2,914,695.  
FOR FOOTWEAR (U.S. CLS. 22 AND 39).  
SKYE YOUNG, EXAMINING ATTORNEY

**CLASS 25—(Continued).**

SN 85-201,021. SKECHERS U.S.A., INC. II, MANHATTAN BEACH, CA. FILED 12-17-2010.

# PUNKY ROSE

THE MARK CONSISTS OF STANDARD CHARACTERS WITHOUT CLAIM TO ANY PARTICULAR FONT, STYLE, SIZE, OR COLOR.

OWNER OF U.S. REG. NO. 2,914,695.  
FOR FOOTWEAR (U.S. CLS. 22 AND 39).  
SKYE YOUNG, EXAMINING ATTORNEY

---

SN 85-201,446. R.D. SIMPSON, INC., CARTERSVILLE, GA. FILED 12-19-2010.

# DRIVER

THE MARK CONSISTS OF STANDARD CHARACTERS WITHOUT CLAIM TO ANY PARTICULAR FONT, STYLE, SIZE, OR COLOR.

FOR JEANS, PANTS, SWEATERS, JACKETS, COATS, SHIRTS, T-SHIRTS, SKIRTS, VESTS, TOPS, HEADWEAR, FOOTWEAR (U.S. CLS. 22 AND 39).  
WENDY GOODMAN, EXAMINING ATTORNEY

---

SN 85-201,680. PHIL THE THRILL LLC, GAINESVILLE, FL. FILED 12-20-2010.



THE MARK CONSISTS OF A DESIGN MADE UP OF THREE DIFFERENT SIZE RECTANGLES MADE TO LOOK LIKE AN OLYMPIC PODIUM.

FOR CLOTHING, NAMELY, JERSEYS, T-SHIRTS, SHORTS, SOCKS, SHOES, HEADWEAR, ARM WARMERS, KNEE WARMERS, LEG WARMERS, SWEAT SHIRTS, HOODED SWEAT SHIRTS, PANTS, JACKETS, VESTS, AND GLOVES (U.S. CLS. 22 AND 39).  
FIRST USE 12-14-2010; IN COMMERCE 12-14-2010.  
MORGAN WYNNE, EXAMINING ATTORNEY

**CLASS 25—(Continued).**

SN 85-201,787. BRODY, ADRIEN, LAS VEGAS, NV. FILED 12-20-2010.



THE MARK CONSISTS OF THE LETTERS "AB" WITH THE WORD "REGALIA" DRAWN VERTICALLY BETWEEN THE LETTERS "A" AND "B."

FOR ATHLETIC APPAREL, NAMELY, SHIRTS, PANTS, JACKETS, FOOTWEAR, HATS AND CAPS, ATHLETIC UNIFORMS; BELTS FOR CLOTHING; DRESS SHIRTS; FOOTWEAR FOR MEN AND WOMEN; HATS; MEN'S AND WOMEN'S JACKETS, COATS, TROUSERS, VESTS; MEN'S SUITS, WOMEN'S SUITS; SCARVES; TOPS (U.S. CLS. 22 AND 39).

LINDSEY RUBIN, EXAMINING ATTORNEY

---

SN 85-201,882. LOYD IVEY, WINSLOW, IL. FILED 12-20-2010.

# Mad About the Plaid

THE MARK CONSISTS OF STANDARD CHARACTERS WITHOUT CLAIM TO ANY PARTICULAR FONT, STYLE, SIZE, OR COLOR.

FOR CLOTHING FOR MEN AND WOMEN, NAMELY, TEE SHIRTS, SPORT JERSEYS, SWEATSHIRTS, SKIRTS, KILTS, JACKETS, SOCKS, UNDERWEAR AND CAPS (U.S. CLS. 22 AND 39).

JOHN E. MICHOS, EXAMINING ATTORNEY

---

SN 85-201,906. J & F DESIGN, BELL, CA. FILED 12-20-2010.

# BLACK COPIUM

THE MARK CONSISTS OF STANDARD CHARACTERS WITHOUT CLAIM TO ANY PARTICULAR FONT, STYLE, SIZE, OR COLOR.

FOR BELTS; HATS; HOODED SWEATSHIRTS; JACKETS; KNIT BOTTOMS; KNIT JACKETS; KNIT SKIRTS; KNIT TOPS; LEATHER JACKETS; PANTS; SCARVES; SHIRTS; SHORT TROUSERS; SHORTS; SWEATSHIRTS; T-SHIRTS; WOVEN BOTTOMS; WOVEN TOPS (U.S. CLS. 22 AND 39).

MICHELE SWAIN, EXAMINING ATTORNEY

**CLASS 25—(Continued).**

SN 85-201,923. DIGITAL SCRIBE PRESS, LLC, GALLATIN, TN. FILED 12-20-2010.

**DIGITAL SCRIBE**

THE MARK CONSISTS OF STANDARD CHARACTERS WITHOUT CLAIM TO ANY PARTICULAR FONT, STYLE, SIZE, OR COLOR.  
FOR CLOTHING, NAMELY, SHIRTS, T-SHIRTS, SWEAT SHIRTS (U.S. CLS. 22 AND 39).  
ALICIA COLLINS, EXAMINING ATTORNEY

SN 85-201,982. CREATIVE VENTURES, LLC, TUCSON, AZ. FILED 12-20-2010.

**GOT MEDS**

THE MARK CONSISTS OF STANDARD CHARACTERS WITHOUT CLAIM TO ANY PARTICULAR FONT, STYLE, SIZE, OR COLOR.  
FOR HATS; POLO SHIRTS; T-SHIRTS (U.S. CLS. 22 AND 39).  
FIRST USE 12-10-2010; IN COMMERCE 12-10-2010.  
CIMMERIAN COLEMAN, EXAMINING ATTORNEY

SN 85-202,179. BAREFOOT, JASON, VIRGINIA BEACH, VA. FILED 12-20-2010.



THE MARK CONSISTS OF A STYLIZED DESIGN OF A CIRCLE DIVIDED INTO THREE QUADRANTS, THE LEFT QUADRANT CONTAINING THE LETTER "Y", THE RIGHT QUADRANT CONTAINING THE LETTERS "GRO" AND THE BOTTOM QUADRANT CONTAINING THE LETTERS "UP".  
FOR ATHLETIC TIGHTS; FOOTWEAR; HEADWEAR; JACKETS; LOUNGEWEAR; PANTS; SHIRTS; SLEEPWEAR; SOCKS; SWEATSHIRTS (U.S. CLS. 22 AND 39).  
PRISCILLA MILTON, EXAMINING ATTORNEY

**CLASS 25—(Continued).**

SN 85-202,199. KIM, MATTHEW, LOS ANGELES, CA. FILED 12-20-2010.



THE MARK CONSISTS OF 5 STARS TO THE LEFT OF THE STYLIZED TEXT "AK ASPIRED KNOWLEDGE".  
FOR HATS; JACKETS; PANTS; SHIRTS; SHORTS; SWEAT SHIRTS (U.S. CLS. 22 AND 39).  
ANDREA BUTLER, EXAMINING ATTORNEY

SN 85-202,380. KASHIE D'JANAE VERNON, FONTANA, CA. FILED 12-21-2010.

**I AM THE SALT**

THE MARK CONSISTS OF STANDARD CHARACTERS WITHOUT CLAIM TO ANY PARTICULAR FONT, STYLE, SIZE, OR COLOR.  
FOR T-SHIRTS (U.S. CLS. 22 AND 39).  
APRIL ROACH, EXAMINING ATTORNEY

SN 85-202,487. BRANDED, LLC, DALLAS, TX. FILED 12-21-2010.

**Canor Plarex**

THE MARK CONSISTS OF STANDARD CHARACTERS WITHOUT CLAIM TO ANY PARTICULAR FONT, STYLE, SIZE, OR COLOR.  
FOR CLOTHING, NAMELY, T-SHIRTS, SHIRTS, SWEATERS, PANTS, SHORTS, JACKETS, COATS, SWEATSHIRTS, SOCKS, BELTS, SCARVES; FOOTWEAR; HEADWEAR (U.S. CLS. 22 AND 39).  
TRACY CROSS, EXAMINING ATTORNEY

**CLASS 25—(Continued).**

SN 85-202,662. RAJSKI, DENNIS, NOBLESVILLE, IN. FILED 12-21-2010.

## One Purpose...One Goal

THE MARK CONSISTS OF STANDARD CHARACTERS WITHOUT CLAIM TO ANY PARTICULAR FONT, STYLE, SIZE, OR COLOR.

FOR CAPS; HATS; JACKETS; PANTS; POLO SHIRTS; SHIRTS; SHORTS; SOCKS; SWEATSHIRTS; T-SHIRTS; TANK TOPS; VISORS; WARM UP SUITS (U.S. CLS. 22 AND 39).

SUNG IN, EXAMINING ATTORNEY

SN 85-202,686. THORNLEY, TRISTAN GERARD, MARICOPA, AZ. FILED 12-21-2010.



THE MARK CONSISTS OF A STANDARD "P", A "CLUB SYMBOL" USED AS "O", A STYLIZED "K", "E" AND "R"; A STYLIZED "R" CONTAINING A LONG CURVING TAILING WITH AN ANIMATED "SPADE SYMBOL" WITH GLOVES, HANGING ON WITH ONE GLOVE TO THE TAIL END OF THE "R", A ROTATED "DIAMOND SYMBOL" AS "O", A STANDARD "L" AND "L", A STYLIZED "E" AND "R"; A STANDARD "C", A ROTATED "HEART SYMBOL" AS "O", A STANDARD "A", A STYLIZED "S", "T", "E", AND "R".

FOR HOODED SWEATSHIRTS; LONG-SLEEVED SHIRTS; SHIRTS AND SHORT-SLEEVED SHIRTS; SHORT-SLEEVED OR LONG-SLEEVED T-SHIRTS; SWEATSHIRTS; T-SHIRTS (U.S. CLS. 22 AND 39).

WILLIAM BRECKENFELD, EXAMINING ATTORNEY

SN 85-202,741. DJ JEANS INC., NEW YORK, NY. FILED 12-21-2010.

## U.R Attitude

THE MARK CONSISTS OF STANDARD CHARACTERS WITHOUT CLAIM TO ANY PARTICULAR FONT, STYLE, SIZE, OR COLOR.

FOR JEANS, PANTS, SHORTS, SKIRTS, BLOUSES, TOPS, SHIRTS AND T-SHIRTS (U.S. CLS. 22 AND 39).

KEVIN CORWIN, EXAMINING ATTORNEY

**CLASS 25—(Continued).**

SN 85-203,064. TOASTY KIDZ LLC, APPLE VALLEY, MN. FILED 12-21-2010.

## Go.Be outdoors

THE MARK CONSISTS OF STANDARD CHARACTERS WITHOUT CLAIM TO ANY PARTICULAR FONT, STYLE, SIZE, OR COLOR.

FOR CHILDREN'S HEADWEAR; HATS; HATS FOR INFANTS, BABIES, TODDLERS AND CHILDREN; MITTENS (U.S. CLS. 22 AND 39).

ANNE FARRELL, EXAMINING ATTORNEY

SN 85-203,409. THE UNTOUCHABLES BRAND, SHERMAN OAKS, CA. FILED 12-21-2010.



THE MARK CONSISTS OF THE STYLIZED TEXT "THE UNTOUCHABLES".

FOR BEANIES; BELTS; BRAS; GLOVES; HATS; JACKETS; PANTS; SHOES; SOCKS; SWEATSHIRTS; T-SHIRTS; UNDERWEAR (U.S. CLS. 22 AND 39).

FIRST USE 4-9-2008; IN COMMERCE 4-9-2008.

DAVID ELTON, EXAMINING ATTORNEY

SN 85-203,585. HENLEY, STEPHANIE, MAITLAND, FL. AND HENLEY-BEASLEY, CHARLES SPENCER, MAITLAND, FL. FILED 12-22-2010.

## IN AMERICA WHERE...

THE MARK CONSISTS OF STANDARD CHARACTERS WITHOUT CLAIM TO ANY PARTICULAR FONT, STYLE, SIZE, OR COLOR.

FOR CLOTHING, NAMELY T-SHIRTS, SWEATERS, SWEATSHIRTS, HATS, CAPS, SHIRTS (U.S. CLS. 22 AND 39).

PAUL E. FAHRENKOPF, EXAMINING ATTORNEY

**CLASS 25—(Continued).**

SN 85-203,725. PATTERSON III, JOE, MISSION, TX. FILED 12-22-2010.

**Will Power Is Real Power**

THE MARK CONSISTS OF STANDARD CHARACTERS WITHOUT CLAIM TO ANY PARTICULAR FONT, STYLE, SIZE, OR COLOR.

FOR JACKETS; PANTS; SHOES; T-SHIRTS (U.S. CLS. 22 AND 39).

ROBERT STRUCK, EXAMINING ATTORNEY

SN 85-203,898. JOHNSON, SHERRY, OLIVE BRANCH, MS. FILED 12-22-2010.

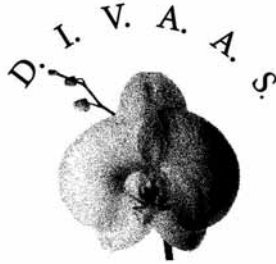

THE STIPPLING IS FOR SHADING PURPOSES ONLY. THE MARK CONSISTS OF THE ACRONYM "D.I.V.A.A.S." WHICH APPEARS AT THE TOP IN AN ARCH STYLE DISPLAY WITH THE PICTURE OF AN ORCHID BENEATH IT. THE ORCHID HAS THREE BUDS ON A STEM (PETIOLE) COMING FROM BEHIND IT. THE ACRONYM IS IN BOLD PRINT.

FOR BELTS; COATS; HATS; HOUSECOATS; JACKETS; SHIRTS; SHOES; SLEEPWEAR; SOCKS; UNDERWEAR (U.S. CLS. 22 AND 39).

KAPIL BHANOT, EXAMINING ATTORNEY

SN 85-203,973. SHASHI, LLC, DELRAY BEACH, FL. FILED 12-22-2010.



THE MARK CONSISTS OF THE WORD SHASHI WITH THE DESIGN OF A RUNNING DOG ON THE TOP RIGHT OF THE WORD.

FOR SOCKS (U.S. CLS. 22 AND 39).

FIRST USE 11-29-2010; IN COMMERCE 11-29-2010.

ANNE MADDEN, EXAMINING ATTORNEY

**CLASS 25—(Continued).**

SN 85-204,124. BARBARA BRIONES MARASOVIC, NEW YORK, NY. FILED 12-22-2010.



THE NAME "BARBARA BRIONES" IDENTIFIES A LIVING INDIVIDUAL WHOSE CONSENT IS OF RECORD.

THE MARK CONSISTS OF A DESIGN OF A DIAMOND TO THE SIDE OF THE NAME "BARBARA BRIONES".

FOR SHOES (U.S. CLS. 22 AND 39).

JENNIFER DIXON, EXAMINING ATTORNEY

SN 85-204,426. SUH, DANIEL, LOS ANGELES, CA. FILED 12-22-2010.

**WESTWOOD GROVE**

THE MARK CONSISTS OF STANDARD CHARACTERS WITHOUT CLAIM TO ANY PARTICULAR FONT, STYLE, SIZE, OR COLOR.

FOR JEANS (U.S. CLS. 22 AND 39).

FIRST USE 4-12-2004; IN COMMERCE 4-12-2004.

THEODORE MCBRIDE, EXAMINING ATTORNEY

SN 85-204,736. PROPHET CORPORATION, DBA GOPHER SPORT CORPORATION, OWATONNA, MN. FILED 12-23-2010.

**FitPro**

THE MARK CONSISTS OF STANDARD CHARACTERS WITHOUT CLAIM TO ANY PARTICULAR FONT, STYLE, SIZE, OR COLOR.

FOR PINNIES IN THE NATURE OF SCRIMMAGE VESTS FOR USE IN SPORTS; SPORTS VESTS (U.S. CLS. 22 AND 39).

FIRST USE 8-1-2010; IN COMMERCE 8-1-2010.

JOHN E. MICHOS, EXAMINING ATTORNEY

**CLASS 25—(Continued).**

SN 85-204,811. LEE, CALVIN, DBA FISH OF FURY, SAN MATEO, CA. FILED 12-23-2010.



THE MARK CONSISTS OF TWO STYLIZED FISH, ONE WHITE AND ONE BLACK, CONJOINED TO CREATE A CIRCLE.

FOR CLOTHING, NAMELY, SHIRTS, ROMPERS, SLEEPWEAR, BATHROBES, LOUNGEWEAR, HEADWEAR, SCARFS, FOOTWEAR, BELTS, APRONS, HALLOWEEN COSTUMES, COSTUMES FOR USE IN ROLE-PLAYING GAMES, PLASTIC BABY BIBS, CLOTH BABY BIBS, INFANT ONE-PIECE CLOTHING, INFANT SLEEPWEAR (U.S. CLS. 22 AND 39).

LAURIE MAYES, EXAMINING ATTORNEY

SN 85-204,818. MAMIYE BROTHERS, INC., NEW YORK, NY. FILED 12-23-2010.

# L'IL ME

THE MARK CONSISTS OF STANDARD CHARACTERS WITHOUT CLAIM TO ANY PARTICULAR FONT, STYLE, SIZE, OR COLOR.

OWNER OF U.S. REG. NOS. 1,450,882, 3,540,112 AND OTHERS.

FOR INFANT'S AND CHILDREN'S CLOTHING, NAMELY, COVERALLS, DRESSES, FOOTWEAR, HEADWEAR, JUMPERS, LAYETTES, OVERALLS, JACKETS, BLAZERS, SWEATERS, SWEATER VESTS, SHIRTS, COVER-UPS, CARDIGANS, PANTS, ROBES, SHORTS, SKIRTS, SLEEPWEAR, SWIMWEAR, MITTENS, BODY-SUITS, SOCKS AND TOPS; CLOTH BIBS, BIBS NOT OF PAPER; SHOES, UNDERWEAR (U.S. CLS. 22 AND 39).

NATALIE POLZER, EXAMINING ATTORNEY

**CLASS 25—(Continued).**

SN 85-204,940. ALL AMERICAN HEAVYWEIGHTS, LLC, PACIFIC PALISADES, CA. FILED 12-23-2010.



THE MARK CONSISTS OF STYLIZED LETTERS AAH USING STARS IN THE MIDDLE OF THE LETTERS.

FOR COLLARED SHIRTS; GYM PANTS; GYM SHORTS; HATS; HEADBANDS; JACKETS; SWEAT-PANTS; SWEATSHIRTS; T-SHIRTS; TANK TOPS (U.S. CLS. 22 AND 39).

PATRICIA EVANKO, EXAMINING ATTORNEY

SN 85-204,962. CHULICK, JOSEPH S., DBA POJO ENTERPRISES, HARMONY, NC. FILED 12-23-2010.

# What Do I Know?

THE MARK CONSISTS OF STANDARD CHARACTERS WITHOUT CLAIM TO ANY PARTICULAR FONT, STYLE, SIZE, OR COLOR.

FOR SPORTS CAPS AND HATS; T-SHIRTS (U.S. CLS. 22 AND 39).

FIRST USE 9-23-2009; IN COMMERCE 4-1-2010.

JAMES GRIFFIN, EXAMINING ATTORNEY

SN 85-204,966. MICHAEL DEHNI, BOSTON, MA. FILED 12-23-2010.

# keep yoga weird

THE MARK CONSISTS OF STANDARD CHARACTERS WITHOUT CLAIM TO ANY PARTICULAR FONT, STYLE, SIZE, OR COLOR.

FOR CLOTHING, NAMELY, T-SHIRTS AND HATS (U.S. CLS. 22 AND 39).

JAMES GRIFFIN, EXAMINING ATTORNEY



**CLASS 25—(Continued).**

SN 85-205,263. GORSEN, MICHAEL, REDONDO BEACH, CA. FILED 12-23-2010.

days off

THE MARK CONSISTS OF STANDARD CHARACTERS WITHOUT CLAIM TO ANY PARTICULAR FONT, STYLE, SIZE, OR COLOR.

FOR BASEBALL CAPS; HATS; JACKETS; LEGGINGS; PANTS; SHORTS; SKIRTS; SWEAT SHIRTS; T-SHIRTS; TANK TOPS; TOPS; VESTS (U.S. CLS. 22 AND 39).  
RONALD MCMORROW, EXAMINING ATTORNEY

**CLASS 25—(Continued).**

SN 85-205,302. MCCRAW, JARRETT, MOBILE, AL. FILED 12-23-2010.

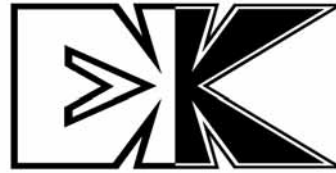

THE MARK CONSISTS OF A COMBINATION OF THE THREE LETTERS "E", "K" AND "K". THE FIRST "K" IS REVERSED TO MAKE UP THE "E".

FOR BANDANAS; BEANIES; BELTS; GLOVES; HATS; HEADBANDS; JERSEYS; PANTS; SHOES; SHORT-SLEEVED OR LONG-SLEEVED T-SHIRTS; SOCKS; SWEAT BANDS; SWEAT SHIRTS; WRISTBANDS (U.S. CLS. 22 AND 39).

FIRST USE 10-1-2003; IN COMMERCE 10-1-2003.  
DAVID TAYLOR, EXAMINING ATTORNEY

SN 85-205,347. JONES BACON, MALISHA, PIKESVILLE, MD. FILED 12-23-2010.

TeeMoco 28

THE MARK CONSISTS OF STANDARD CHARACTERS WITHOUT CLAIM TO ANY PARTICULAR FONT, STYLE, SIZE, OR COLOR.

FOR HATS; JACKETS; PANTS; SHIRTS; SLEEPWEAR; SWEATPANTS; SWEATSHIRTS; T-SHIRTS (U.S. CLS. 22 AND 39).

KELLY CHOE, EXAMINING ATTORNEY

SN 85-205,275. STEELE MUSIC, INC., BROOKLYN, NY. FILED 12-23-2010.

CHOCOLATE CHOCOBAR STEELE

THE MARK CONSISTS OF STANDARD CHARACTERS WITHOUT CLAIM TO ANY PARTICULAR FONT, STYLE, SIZE, OR COLOR.

THE NAME(S), PORTRAIT(S), AND/OR SIGNATURE(S) SHOWN IN THE MARK IDENTIFIES EERICA STEELE, WHOSE CONSENT(S) TO REGISTER IS MADE OF RECORD.

FOR APPAREL, SPORTSWEAR, DAYWEAR, INNERWEAR, AND OUTERWEAR, NAMELY, JEANS, SKIRTS, PANTS, SHIRTS, T-SHIRTS, DRESSES, MINISKIRTS, DRESS SHIRTS, TROUSERS, SHORT-SLEEVED AND LONG-SLEEVED SHIRTS, TOPS, SWEAT PANTS, HALTER TOPS, TANK TOPS, BLOUSES, VESTS, SKORTS, HOODS, WRAPS, HEADWEAR, CARDIGANS, JACKETS, COATS, BLAZERS, SHAWLS, SCARVES, GYM SUITS, SUITS, SWEAT SUITS, SWEATERS, TUNICS, CAMISOLES, UNDERSHIRTS, SLIPS, PAJAMAS, PANTIES, SHORTS AND BRIEFS, BODY SUITS, BATHING SUITS, BEACHWEAR, SOCKS, HOSIERY, BELTS, FOOTWEAR (U.S. CLS. 22 AND 39).

GIANCARLO CASTRO, EXAMINING ATTORNEY

SN 85-205,361. DIDOMENICO, BRETT, LAKE PLACID, FL. FILED 12-23-2010.

NUKE-LIFE

THE MARK CONSISTS OF STANDARD CHARACTERS WITHOUT CLAIM TO ANY PARTICULAR FONT, STYLE, SIZE, OR COLOR.

FOR CAPS; JACKETS; LINGERIE; SHIRTS; SWEAT SHIRTS; SWEATSHIRTS; SWIM SUITS; UNDERWEAR (U.S. CLS. 22 AND 39).

DARRYL SPRUILL, EXAMINING ATTORNEY

**CLASS 25—(Continued).**

SN 85-205,407. PG INVESTMENTS OF VIRGINIA, LLC, WILMINGTON, DE. FILED 12-23-2010.

# BLACKWATER

THE MARK CONSISTS OF STANDARD CHARACTERS WITHOUT CLAIM TO ANY PARTICULAR FONT, STYLE, SIZE, OR COLOR.

FOR SHIRTS, LONG SLEEVE SHIRTS, SWEATSHIRTS, POLO SHIRTS, FLANNEL SHIRTS, T-SHIRTS, PANTS, SHORTS, JACKETS, VESTS, SOCKS; HATS, CAPS (U.S. CLS. 22 AND 39).

ANGELA M. MICHELI, EXAMINING ATTORNEY

---

SN 85-205,482. NEW FRONTIER ENTERTAINMENT, INC., LOS ANGELES, CA. FILED 12-24-2010.

# PROLETARIAT

THE MARK CONSISTS OF STANDARD CHARACTERS WITHOUT CLAIM TO ANY PARTICULAR FONT, STYLE, SIZE, OR COLOR.

FOR CLOTHING, NAMELY TOPS, BOTTOMS, TEE SHIRTS, SHIRTS, JACKETS, PANTS, JEANS, BLOUSES, SKIRTS, DRESSES, SHORTS, COATS, TANK TOPS, SWEATERS, SWEATSHIRTS, SWEATPANTS AND SUITS; SCARVES; HEADWEAR; BELTS; LINGERIE; GLOVES; WRAPS; SHAWLS; FOOTWEAR; AND SOCKS (U.S. CLS. 22 AND 39).

AISHA SALEM, EXAMINING ATTORNEY

**CLASS 25—(Continued).**

SN 85-205,579. G2TEXTILE LLC, SANTA MONICA, CA. FILED 12-24-2010.



THE MARK CONSISTS OF A STYLIZED DEPICTION OF A RECYCLE SYMBOL IN WHICH EACH OF THE THREE ARROWS IS REPLACED BY A SILHOUETTE OF A SHORT-SLEEVED T-SHIRT FOLDED ON A DIAGONAL IN THE MIDDLE SUCH THAT THE NECK AND SLEEVES OF THE T-SHIRT REPRESENT THE POINTS OF THE ARROW AND THE BOTTOM OF THE T-SHIRT REPRESENT THE TAIL OF THE ARROW.

FOR CLOTHING, NAMELY, T-SHIRTS, SHIRTS, WOVEN SPORT SHIRTS, WOVEN YARN-DYE SPORT SHIRTS, TANK TOPS, SWEAT SHIRTS, SWEAT PANTS, SWEAT SUITS, JEANS, PANTS, SHORTS, OVERALLS, JUMPSUITS, SKIRTS, DRESSES, BLOUSES, JACKETS, SWEATERS, VESTS, SWIMWEAR, BATHING SUITS, COVER-UPS, SLEEPWEAR, PAJAMAS, ROBES, NIGHT-GOWNS, LEOTARDS, LINGERIE, PANTIES, BRAS, BOXER SHORTS, UNDERWEAR, SCARVES, BELTS, SOCKS, STOCKINGS, TIGHTS, LEGGINGS, GLOVES; OUTERWEAR, NAMELY, COATS AND RAINCOATS; HEADGEAR, NAMELY, HATS, CAPS, HEADBANDS, VISORS AND BANDANAS; FOOTWEAR, NAMELY, SHOES, SLIPPERS, BOOTS, SANDALS, FLIP-FLOPS, AND ATHLETIC SHOES (U.S. CLS. 22 AND 39).

JANICE L. MCMORROW, EXAMINING ATTORNEY

---

SN 85-205,655. SCHMITT, JOSEPH H., PHILADELPHIA, PA. FILED 12-25-2010.

# G. U. N Give Up Never

THE MARK CONSISTS OF STANDARD CHARACTERS WITHOUT CLAIM TO ANY PARTICULAR FONT, STYLE, SIZE, OR COLOR.

FOR SHIRTS AND SHORT-SLEEVED SHIRTS; SPORTS CAPS AND HATS; SWEAT BANDS; WRIST BANDS (U.S. CLS. 22 AND 39).

TARA PATE, EXAMINING ATTORNEY

**CLASS 25—(Continued).**

SN 85-205,657. GOD'S TEAM, INC., INDIANAPOLIS, IN. FILED 12-25-2010.

# Jesus Saves

THE MARK CONSISTS OF STANDARD CHARACTERS WITHOUT CLAIM TO ANY PARTICULAR FONT, STYLE, SIZE, OR COLOR.

FOR CLOTHING, NAMELY, PANTS, JEANS, SHORTS, SKIRTS, SHIRTS, DRESS SHIRTS, POLO SHIRTS, T-SHIRTS, TANK-TOPS, BOXER SHORTS, SWEATERS, VESTS, COATS, JACKETS, APRONS, HOODED SWEAT-SHIRTS, SWEAT PANTS, SWEAT SHIRTS, ATHLETIC SHORTS; FOOTWEAR, NAMELY, SHOES, SOCKS, STOCKINGS; HEADGEAR, NAMELY, CAPS, HATS, KNITTED CAPS, HEADBANDS; NECKWEAR, NAMELY, SCARVES, NECKTIES, BOW TIES; HAND AND WRIST WEAR, NAMELY, GLOVES, MITTENS, WRIST BANDS; NIGHTWEAR, NAMELY, PAJAMAS, NIGHTGOWNS; INFANTWEAR, NAMELY, BABY BOTTOMS, BABY TOPS, ONE-PIECE GARMENTS, CLOTH BIBS, BABY CAPS (U.S. CLS. 22 AND 39).  
RICHARD WHITE, EXAMINING ATTORNEY

SN 85-205,677. GOD'S TEAM, INC., INDIANAPOLIS, IN. FILED 12-26-2010.

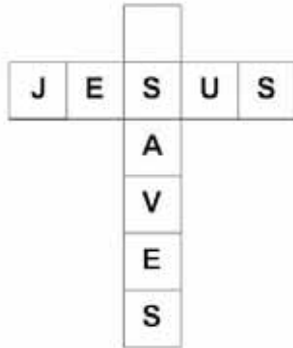

THE MARK CONSISTS OF LATIN CROSS (SHORTER HORIZONTAL LINES) WITH THE WORD "JESUS" HORIZONTALLY DISPLAYED INTERSECTING WITH THE WORD "SAVES" VERTICALLY DISPLAYED.

FOR CLOTHING, NAMELY, PANTS, JEANS, SHORTS, SKIRTS, SHIRTS, DRESS SHIRTS, POLO SHIRTS, T-SHIRTS, TANK-TOPS, BOXER SHORTS, SWEATERS, VESTS, COATS, JACKETS, APRONS, HOODED SWEAT-SHIRTS, SWEAT PANTS, SWEAT SHIRTS, ATHLETIC SHORTS; FOOTWEAR, NAMELY, SHOES, SOCKS, STOCKINGS; HEADGEAR, NAMELY, CAPS, HATS, KNITTED CAPS, HEADBANDS; NECKWEAR, NAMELY, SCARVES, NECKTIES, BOW TIES; HAND AND WRIST WEAR, NAMELY, GLOVES, MITTENS, WRIST BANDS; NIGHTWEAR, NAMELY, PAJAMAS, NIGHTGOWNS; INFANTWEAR, NAMELY, BABY BOTTOMS, BABY TOPS, ONE-PIECE GARMENTS, CLOTH BIBS, BABY CAPS (U.S. CLS. 22 AND 39).  
RICHARD WHITE, EXAMINING ATTORNEY

**CLASS 25—(Continued).**

SN 85-205,766. CAITAC KABUSHIKI KAISHA, OKAYAMA-KEN, JAPAN, FILED 12-27-2010.

# IMAGINE GREEN WOODS

THE MARK CONSISTS OF STANDARD CHARACTERS WITHOUT CLAIM TO ANY PARTICULAR FONT, STYLE, SIZE, OR COLOR.

FOR COATS; JACKETS; JEANS; PANTS; SHIRTS; SKIRTS (U.S. CLS. 22 AND 39).  
ANDREA HACK, EXAMINING ATTORNEY

SN 85-205,830. HOPSON, MICHAEL, CORONA, CA. FILED 12-27-2010.



THE MARK CONSISTS OF THE STYLIZED TEXT "ELEVATED".  
FOR HATS; T-SHIRTS (U.S. CLS. 22 AND 39).  
AMEEN IMAM, EXAMINING ATTORNEY

SN 85-206,021. YANG, JIN SEOK, PALMDALE, CA. FILED 12-27-2010.

# CLOFIT

THE MARK CONSISTS OF STANDARD CHARACTERS WITHOUT CLAIM TO ANY PARTICULAR FONT, STYLE, SIZE, OR COLOR.

FOR JACKETS; PANTS; SHIRTS; SHORTS; SOCKS; T-SHIRTS (U.S. CLS. 22 AND 39).  
FIRST USE 12-1-2010; IN COMMERCE 12-1-2010.  
ROBIN MITTLER, EXAMINING ATTORNEY

**CLASS 25—(Continued).**

SN 85-206,164. FUGGARWEE INC., RICHFIELD, UT. FILED 12-27-2010.

FUGGARWEE

THE MARK CONSISTS OF STANDARD CHARACTERS WITHOUT CLAIM TO ANY PARTICULAR FONT, STYLE, SIZE, OR COLOR.

FOR BASEBALL CAPS; CAPS; HATS; HOODED SWEAT SHIRTS; PANTS; SHIRTS; SHIRTS AND SHORT-SLEEVED SHIRTS; SHORT-SLEEVED OR LONG-SLEEVED T-SHIRTS; SWEAT JACKETS; SWEAT PANTS; SWEAT SHIRTS; SWEAT SUITS (U.S. CLS. 22 AND 39).

DEZMONA MIZELLE, EXAMINING ATTORNEY

SN 85-206,196. SAVITT, ROBIN, LAGUNA BEACH, CA. FILED 12-27-2010.

say-it wear

THE MARK CONSISTS OF STANDARD CHARACTERS WITHOUT CLAIM TO ANY PARTICULAR FONT, STYLE, SIZE, OR COLOR.

NO CLAIM IS MADE TO THE EXCLUSIVE RIGHT TO USE "WEAR", APART FROM THE MARK AS SHOWN. FOR BELTS; HATS; JACKETS; PANTS; SHIRTS; SHORTS (U.S. CLS. 22 AND 39).

FIRST USE 1-29-2010; IN COMMERCE 11-5-2010. NAKIA HENRY, EXAMINING ATTORNEY

**CLASS 25—(Continued).**

SN 85-206,211. JONATHAN WHITE, DBA CASHLAND APPAREL, BALTIMORE, MD. FILED 12-27-2010.



FOR APPAREL, NAMELY SHIRTS, T-SHIRTS, SWEATSHIRTS, SWEATERS, BLOUSES, SKIRTS, DRESSES, JERSEYS, SWEAT SUITS, TRACK SUITS, SWIMWEAR, SLEEPWEAR, OUTERWEAR, NAMELY, JACKETS, COATS, PARKAS, VARSITY JACKETS, VESTS, AND RAIN-WEAR, SHORTS, PANTS, DENIM JEANS, OVERALLS, HEAD-WEAR, HATS, HEADBANDS, AND CAPS (U.S. CLS. 22 AND 39).

DAVID TOOLEY, EXAMINING ATTORNEY

SN 85-206,212. GREGORY G. PLUMMER, PORTLAND, OR. FILED 12-27-2010.

VIVOMAN

THE MARK CONSISTS OF STANDARD CHARACTERS WITHOUT CLAIM TO ANY PARTICULAR FONT, STYLE, SIZE, OR COLOR.

FOR HATS (U.S. CLS. 22 AND 39). ANTHONY RINKER, EXAMINING ATTORNEY

**CLASS 25—(Continued).**

SN 85-206,270. RICHARD JAMES WILLIAMS, SOUTHFIELD, MI. FILED 12-27-2010.

# **DISTINCT LIFE**



THE MARK CONSISTS OF WORDS SITTING ON A LINE OVER A LOWER CASE R IN A CIRCLE.

FOR APPAREL FOR DANCERS, NAMELY, TEE SHIRTS, SWEATSHIRTS, PANTS, LEGGINGS, SHORTS AND JACKETS; ATHLETIC APPAREL, NAMELY, SHIRTS, PANTS, JACKETS, FOOTWEAR, HATS AND CAPS; ATHLETIC UNIFORMS; BUTTON DOWN SHIRTS; CAMOUFLAGE SHIRTS; CAMP SHIRTS; CHILDREN'S AND INFANT'S APPAREL, NAMELY, JUMPERS, OVERALL SLEEPWEAR, PAJAMAS, ROMPERS AND ONE-PIECE GARMENTS; COLLARED SHIRTS; CREW NECK SWEATERS; CREW NECKS; DRESS SHIRTS; HOODED SWEAT SHIRTS; HOODED SWEATSHIRTS; KNIT SHIRTS; PIQUE SHIRTS; POLO SHIRTS; RUGBY SHIRTS; SHIRTS; SWEATSHIRTS (U.S. CLS. 22 AND 39).

FIRST USE 11-25-2010; IN COMMERCE 11-25-2010.  
JENNIFER MARTIN, EXAMINING ATTORNEY

SN 85-206,307. PRATT, PAUL P., LOS ANGELES, CA. FILED 12-28-2010.

# **I Am Jamaica**

THE MARK CONSISTS OF STANDARD CHARACTERS WITHOUT CLAIM TO ANY PARTICULAR FONT, STYLE, SIZE, OR COLOR.

FOR CLOTHING FOR BABIES, TODDLERS AND CHILDREN, TREATED WITH FIRE AND HEAT RETARDANTS, NAMELY, PAJAMAS, JACKETS, SHIRTS, PANTS, JUMPERS; NIGHT SHIRTS; PANTS; SHIRTS; SHOES; SKULL CAPS; SOCCER SHOES; SPORTS CAPS AND HATS; SWEAT PANTS; SWEAT SHIRTS; T-SHIRTS; TEE SHIRTS (U.S. CLS. 22 AND 39).

JEFFERY COWARD, EXAMINING ATTORNEY

SN 85-206,341. JACKSON PAYNE ASSOCIATES, DALLAS, TX. FILED 12-28-2010.

# **Baker Benji**

THE MARK CONSISTS OF STANDARD CHARACTERS WITHOUT CLAIM TO ANY PARTICULAR FONT, STYLE, SIZE, OR COLOR.

FOR FOOTWEAR (U.S. CLS. 22 AND 39).

ANDREA K. NADELMAN, EXAMINING ATTORNEY

**CLASS 25—(Continued).**

SN 85-206,421. GREENOVO RESEARCH, INC., TAIPEI CITY, TAIWAN, FILED 12-28-2010.

# **SOLEFUTURE**

THE MARK CONSISTS OF STANDARD CHARACTERS WITHOUT CLAIM TO ANY PARTICULAR FONT, STYLE, SIZE, OR COLOR.

FOR NON-ORTHOPEDIC SHOE SOLES AND INSOLES, NAMELY, SHOE SOLES, INSOLES FOR SHOES AND BOOTS, POLYMER CUSTOM CUSHIONED SHOE INSERTS FOR PRIMARILY NON-ORTHOPEDIC PURPOSES, SHOE INSERTS FOR PRIMARILY NON-ORTHOPEDIC PURPOSES, SHOE SOLES FOR REPAIR, AND SHOE MIDDLE INSOLES (U.S. CLS. 22 AND 39).

FIRST USE 12-3-2010; IN COMMERCE 12-3-2010.  
DEBRA LEE, EXAMINING ATTORNEY

SN 85-206,497. ROBERTS, RAYMOND, ORLANDO, FL. AND FRANCISCO, ANTHONY, MAITLAND, FL. FILED 12-28-2010.

# **ATOMIC HARD WEAR**

THE MARK CONSISTS OF STANDARD CHARACTERS WITHOUT CLAIM TO ANY PARTICULAR FONT, STYLE, SIZE, OR COLOR.

FOR CLOTHING, NAMELY, PANTS, JACKETS, SWEATERS, T-SHIRTS, UNDERSHIRTS, CAPS, HEADBANDS, DRESS SLACKS, DRESS SHIRTS, DRESSES, SKIRTS, BLOUSES (U.S. CLS. 22 AND 39).

ALLISON SCHRODY, EXAMINING ATTORNEY

**CLASS 25—(Continued).**

SN 85-206,525. FIRE LICENSING, LLC, CULVER CITY, CA. FILED 12-28-2010.

OWNER OF U.S. REG. NO. 3,200,042.

THE MARK CONSISTS OF THE WORD LOVE IN LOWER CASE SCRIPT, FOLLOWED BY A COMMA, BOTH ABOVE THE WORD FIRE, CONSISTING OF THE UPPER CASE LETTERS F, R AND E, STYLIZED, AND THE LOWER CASE LETTER I, STYLIZED, DOTTED WITH A HEART.

FOR CLOTHING FOR MEN, WOMAN AND CHILDREN, NAMELY SHIRTS, PANTS, BLOUSES, SKIRTS, JEANS, OVERALLS, SWEATSHIRTS, HOODED SWEATSHIRTS, SWEAT PANTS, T-SHIRTS, HATS, HEADBANDS, JACKETS, SHORTS, SWEATERS, LEGGINGS AND VESTS (U.S. CLS. 22 AND 39).

SCOTT BIBB, EXAMINING ATTORNEY

SN 85-206,534. YU, KA WAI, ZHONGSHAN GUANGDONG, CHINA, FILED 12-28-2010.

## KAWAI & KIDS

THE MARK CONSISTS OF STANDARD CHARACTERS WITHOUT CLAIM TO ANY PARTICULAR FONT, STYLE, SIZE, OR COLOR.

NO CLAIM IS MADE TO THE EXCLUSIVE RIGHT TO USE "KIDS", APART FROM THE MARK AS SHOWN.

THE NAME(S), PORTRAIT(S), AND/OR SIGNATURE(S) SHOWN IN THE MARK IDENTIFIES KA WAI YU, WHOSE CONSENT(S) TO REGISTER IS MADE OF RECORD.

FOR ATHLETIC FOOTWEAR; BATHING SUITS; DENIM JACKETS; DRESS SUITS; FLIP FLOPS; FOOTWEAR; GOLF SHIRTS; HEADGEAR, NAMELY, HATS AND CAPS; JACKETS; JEANS; KNIT DRESSES; KNIT JACKETS; KNIT SHIRTS; KNIT SKIRTS; KNIT TOPS; KNITTED CAPS; SHIRTS; SPORT SHIRTS; T-SHIRTS (U.S. CLS. 22 AND 39).

SCOTT BIBB, EXAMINING ATTORNEY

**CLASS 25—(Continued).**

SN 85-206,558. SUMO SWIRL LLC, FORT LEE, NJ. FILED 12-28-2010.

## Sumo Swirl

THE MARK CONSISTS OF STANDARD CHARACTERS WITHOUT CLAIM TO ANY PARTICULAR FONT, STYLE, SIZE, OR COLOR.

FOR CLOTHING NAMELY, T-SHIRTS, BEANIES, VISORS, HATS, CAPS, SWEAT SHIRTS, HOODED SWEATSHIRTS, SHIRTS, PANTS, SWEATS, SHORTS, APRONS (U.S. CLS. 22 AND 39).

MICHAEL KEATING, EXAMINING ATTORNEY

SN 85-206,578. NORUS, MARY KAY, ENGLEWOOD, FL. FILED 12-28-2010.

THE MARK CONSISTS OF STYLIZED CAPITAL LETTERS SPELLING THE TWO-WORD PHRASE "DOCK OFF!". THE FIRST WORD ("DOCK") IS LOCATED ABOVE THE SECOND WORD ("OFF"), WHICH IS INDENTED AND FOLLOWED BY AN EXCLAMATION POINT ("!").

FOR ATHLETIC APPAREL, NAMELY, SHIRTS, PANTS, JACKETS, FOOTWEAR, HATS AND CAPS, ATHLETIC UNIFORMS; BASEBALL CAPS AND HATS; BELTS; BOTTOMS; BUTTON DOWN SHIRTS; CAMOUFLAGE PANTS; CAMOUFLAGE SHIRTS; CHILDREN'S AND INFANTS' CLOTH BIBS; DRESS SHIRTS; HEADBANDS FOR CLOTHING; HOODED SWEAT SHIRTS; INFANT AND TODDLER ONE PIECE CLOTHING; JERSEYS; JOGGING PANTS; LONG-SLEEVED SHIRTS; PANTS; POLO SHIRTS; RUGBY SHIRTS; SHIRTS; SHIRTS AND SHORT-SLEEVED SHIRTS; T-SHIRTS; TIES; TOPS (U.S. CLS. 22 AND 39).

ANNE MADDEN, EXAMINING ATTORNEY

**CLASS 25—(Continued).**

SN 85-206,583. SUMO SWIRL LLC, FORT LEE, NJ. FILED 12-28-2010.



THE MARK CONSISTS OF A STYLIZED WOMAN IN PROFILE, OUTLINED, INSIDE A DOUBLE CIRCLE.

FOR CLOTHING, NAMELY, T-SHIRTS, BEANIES, VISORS, HATS, CAPS, SWEAT SHIRTS, HOODED SWEATSHIRTS, SHIRTS, PANTS, SWEATS, SHORTS, APRONS (U.S. CLS. 22 AND 39).

MICHAEL KEATING, EXAMINING ATTORNEY

SN 85-206,587. URBAN WEAR INC, HOBOKEN, NJ. FILED 12-28-2010.

**GLAM DOLLZ**

THE MARK CONSISTS OF STANDARD CHARACTERS WITHOUT CLAIM TO ANY PARTICULAR FONT, STYLE, SIZE, OR COLOR.

FOR BLAZERS; BLOUSES; CAPRIS; CAPS; COATS; DRESSES; GLOVES; JACKETS; JUMPSUITS; LEGGINGS; PAJAMAS; PANTS; ROBES; ROMPERS; SCARVES; SHIRTS; SHORTS; SKIRTS; SKORTS; SWEATERS; TOPS (U.S. CLS. 22 AND 39).

JOHN WILKE, EXAMINING ATTORNEY

**CLASS 25—(Continued).**

SN 85-206,657. ELECTRA BICYCLE COMPANY, LLC, VISTA, CA. FILED 12-28-2010.

**STREAM RIDE**

THE MARK CONSISTS OF STANDARD CHARACTERS WITHOUT CLAIM TO ANY PARTICULAR FONT, STYLE, SIZE, OR COLOR.

OWNER OF U.S. REG. NOS. 2,744,133 AND 2,789,402.

FOR BICYCLE WEAR, NAMELY, BICYCLE SHIRTS, BICYCLE SHORTS AND BICYCLE PANTS; BICYCLE SHOES; BICYCLE GLOVES; BICYCLE BIBS; CLOTHING, NAMELY, PULLOVERS, VESTS, UNDERWEAR, SHORTS, PANTS, LEGGINGS, LONG SLEEVE SHIRTS, JERSEYS, BLOUSES, DRESSES, SKIRTS, SWEATERS, BANDANAS, SOCKS, TRACKSUITS, JACKETS, RAINCOATS, RAIN PONCHOS, WIND RESISTANT JACKETS; HEADWEAR, CAPS; SHOES, SNEAKERS, WRIST BANDS (U.S. CLS. 22 AND 39).

ALLISON SCHRODY, EXAMINING ATTORNEY

SN 85-206,717. CHICKED, LLC, MINNEAPOLIS, MN. FILED 12-28-2010.



THE MARK CONSISTS OF A SILHOUETTE OF A GROTESQUE WOMAN, WITH A ROUND HEAD THAT IS SEPARATE FROM THE BODY FORM, AND WITH RAISED ARMS, WITH BICEPS FLEXED, AND WITH ROUNDED HANDS AND NO FINGERS, AND WITH STRAIGHT LEGS, WITH ROUNDED FEET AND NO TOES OR SHOES, AND WITH CLOTHING THAT FLARES OUT FROM THE BODY FORM AT THE MIDDLE.

FOR CLOTHING, NAMELY SHIRTS AND PANTS (U.S. CLS. 22 AND 39).

FIRST USE 8-6-2010; IN COMMERCE 9-27-2010.

JUDITH HELFMAN, EXAMINING ATTORNEY

**CLASS 25—(Continued).**

SN 85-206,783. ROSENBERG, STEVE, ATLANTA, GA. AND STERN, RITA, ATLANTA, GA. FILED 12-28-2010.



THE MARK CONSISTS OF THE STYLIZED TEXT "TALKING TO KIDS" WITH A DESIGN OF A KID'S FACE ON EITHER SIDE OF THE TEXT.

FOR HATS; PAJAMAS; PANTS; T-SHIRTS (U.S. CLS. 22 AND 39).

TINA MAI, EXAMINING ATTORNEY

SN 85-206,797. MARTINEZ, KYLE, MORRISON, CO. FILED 12-28-2010.

# ATARAXIS

THE MARK CONSISTS OF STANDARD CHARACTERS WITHOUT CLAIM TO ANY PARTICULAR FONT, STYLE, SIZE, OR COLOR.

FOR HATS; HOODED SWEATSHIRTS; LONG-SLEEVED SHIRTS; SHIRTS; SHORT-SLEEVED OR LONG-SLEEVED T-SHIRTS; SHORT-SLEEVED SHIRTS; T-SHIRTS; WRISTBANDS (U.S. CLS. 22 AND 39).

ANDREA HACK, EXAMINING ATTORNEY

SN 85-206,872. BROOKS, ROBERT, PHOENIX, AZ. FILED 12-28-2010.

# DHC

THE MARK CONSISTS OF STANDARD CHARACTERS WITHOUT CLAIM TO ANY PARTICULAR FONT, STYLE, SIZE, OR COLOR.

FOR CLOTHING, NAMELY, T-SHIRTS, HATS, SWEATSHIRTS, SWEATPANTS, SHIRTS, PANTS, SKIRTS, DRESSES, BLOUSES, JACKETS, SWEATERS, COATS, SHOES, SHORTS, BATHING SUITS, AND BIKINIS, PAJAMAS, AND BOXER SHORTS (U.S. CLS. 22 AND 39).

JOHN GARTNER, EXAMINING ATTORNEY

**CLASS 25—(Continued).**

SN 85-206,882. MURPHY, TERRY, SPICEWOOD, TX. FILED 12-28-2010.

## Keep My Marriage Weird

THE MARK CONSISTS OF STANDARD CHARACTERS WITHOUT CLAIM TO ANY PARTICULAR FONT, STYLE, SIZE, OR COLOR.

FOR BANDANAS; BELTS; HATS; JACKETS; SCARVES; SHIRTS; SHOES; SHORTS; SOCKS; T-SHIRTS; UNDERWEAR (U.S. CLS. 22 AND 39).

ROBIN CHOSID, EXAMINING ATTORNEY

SN 85-206,916. SNEAKER HEADZ, LLC, DBA BURN RUBBER, ROYAL OAK, MI. FILED 12-28-2010.



THE MARK CONSISTS OF CARTOON CHARACTER WEARING A CHEF HAT, SMILING WITH AN X FOR AN EYE.

FOR APPAREL FOR DANCERS, NAMELY, TEE SHIRTS, SWEATSHIRTS, PANTS, LEGGINGS, SHORTS AND JACKETS; ATHLETIC APPAREL, NAMELY, SHIRTS, PANTS, JACKETS, FOOTWEAR, HATS AND CAPS, ATHLETIC UNIFORMS; BASEBALL CAPS AND HATS; BOMBER JACKETS; BUTTON DOWN SHIRTS; CAMOUFLAGE JACKETS; CAMOUFLAGE PANTS; CAMOUFLAGE SHIRTS; CAMP SHIRTS; CARGO PANTS; CHEF'S HATS; CLOTHING FOR ATHLETIC USE, NAMELY, PADDED SHIRTS; CLOTHING FOR BABIES, TODDLERS AND CHILDREN, TREATED WITH FIRE AND HEAT RETARDANTS, NAMELY, PAJAMAS, JACKETS, SHIRTS, PANTS, JUMPERS; COLLARED SHIRTS; DENIM JACKETS; DENIMS; DOWN JACKETS; DRESS PANTS; DRESS SHIRTS; FUR HATS; GOLF SHIRTS; GYM PANTS; HATS; HATS FOR INFANTS, BABIES, TODDLERS AND CHILDREN; HEAVY JACKETS; HOODED SWEAT SHIRTS; HUNTING PANTS; JACKETS AND SOCKS; JOGGING PANTS; KNIT SHIRTS; LONG-SLEEVED SHIRTS; MEN'S AND WOMEN'S JACKETS, COATS, TROUSERS, VESTS; POLO SHIRTS; RAIN JACKETS; RAINPROOF JACKETS; REVERSIBLE JACKETS; RUGBY SHIRTS; SHIRTS; SPORT SHIRTS; SWEAT PANTS; SWEAT SHIRTS; T-SHIRTS; TEE SHIRTS; TRACK PANTS; TURTLE NECK SHIRTS; WEARABLE GARMENTS AND CLOTHING, NAMELY, SHIRTS; WIND SHIRTS (U.S. CLS. 22 AND 39).

FIRST USE 12-8-2008; IN COMMERCE 1-10-2009.

JOSETTE BEVERLY, EXAMINING ATTORNEY



**CLASS 25—(Continued).**

SN 85-206,931. CAMPISI RICHARD, DBA R. M. CAMPISI, SANTA ROSA BEACH, FL. FILED 12-29-2010.

**Taste Life N Make it Real**

THE MARK CONSISTS OF STANDARD CHARACTERS WITHOUT CLAIM TO ANY PARTICULAR FONT, STYLE, SIZE, OR COLOR.  
FOR SHORT-SLEEVED OR LONG-SLEEVED T-SHIRTS (U.S. CLS. 22 AND 39).  
FIRST USE 12-10-2010; IN COMMERCE 12-10-2010.  
RUDY R. SINGLETON, EXAMINING ATTORNEY

SN 85-206,937. HENRY, KENT, KEY WEST, FL. FILED 12-29-2010.

**HOOSIER DADDY?**

THE MARK CONSISTS OF STANDARD CHARACTERS WITHOUT CLAIM TO ANY PARTICULAR FONT, STYLE, SIZE, OR COLOR.  
FOR CLOTHING, NAMELY, SHIRTS, SHORTS, PANTS, HEADWEAR, SHOES (U.S. CLS. 22 AND 39).  
FIRST USE 3-15-1990; IN COMMERCE 3-15-1990.  
JOHN SCHUYLER YARD, EXAMINING ATTORNEY

SN 85-206,950. DELUCA, DOMINICK, LOS ANGELES, CA. FILED 12-29-2010.

**BROOKLYN PROJECTS**

THE MARK CONSISTS OF STANDARD CHARACTERS WITHOUT CLAIM TO ANY PARTICULAR FONT, STYLE, SIZE, OR COLOR.  
FOR CLOTHING, NAMELY, TOPS, BOTTOMS, TEE SHIRTS, JACKETS, HOODED SWEATSHIRTS, FOOTWEAR, SNEAKERS, HEADWEAR, PANTS, JEANS, BUT-TON DOWN SHIRTS AND FLEECE JACKETS (U.S. CLS. 22 AND 39).  
LAURIE MAYES, EXAMINING ATTORNEY

**CLASS 25—(Continued).**

SN 85-207,051. MELMOTH, CHRISTOPHER, LAS VEGAS, NV. FILED 12-29-2010.

**ESOTERIC BODYWORK THE  
OTHER SIDE OF MASSAGE  
THERAPY**

THE MARK CONSISTS OF STANDARD CHARACTERS WITHOUT CLAIM TO ANY PARTICULAR FONT, STYLE, SIZE, OR COLOR.  
FOR T-SHIRTS (U.S. CLS. 22 AND 39).  
FIRST USE 2-24-2009; IN COMMERCE 2-24-2009.  
SUE LAWRENCE, EXAMINING ATTORNEY

SN 85-207,095. META MODA S.R.L., PRATO, ITALY, FILED 12-29-2010.

THE COLOR(S) RED AND BLACK IS/ARE CLAIMED AS A FEATURE OF THE MARK.

THE MARK CONSISTS OF THE WORDING "METAMODA"; THE FIRST OCCURRENCES OF THE LETTERS "M" AND "A" ARE IN STYLIZED RED UPPERCASE, THE REMAINING LETTERS APPEAR IN STYLIZED BLACK LOWERCASE.

THE ENGLISH TRANSLATION OF MODA IN THE MARK IS FASHION. THE WORDING METAMODA HAS NO MEANING IN A FOREIGN LANGUAGE.

FOR (BASED ON USE IN COMMERCE) SHIRTS; SUITS(BASED ON INTENT TO USE) BELTS FOR CLOTHING; CAMISOLES; COATS; FOOTWEAR; GLOVES; HATS; HOSIERY; JACKETS AND SOCKS; JEANS; PANTS; PULLOVERS; SCARVES; SHORTS; SWEATERS; T-SHIRTS; TIES (U.S. CLS. 22 AND 39).  
FIRST USE 6-0-2010; IN COMMERCE 6-0-2010.  
WENDY JUN, EXAMINING ATTORNEY

SN 85-207,253. ABERCROMBIE & FITCH TRADING CO., NEW ALBANY, OH. FILED 12-29-2010.

**HCO CALIF**

THE MARK CONSISTS OF STANDARD CHARACTERS WITHOUT CLAIM TO ANY PARTICULAR FONT, STYLE, SIZE, OR COLOR.  
OWNER OF U.S. REG. NOS. 3,393,268, 3,649,826 AND OTHERS.

NO CLAIM IS MADE TO THE EXCLUSIVE RIGHT TO USE "CALIF", APART FROM THE MARK AS SHOWN.  
FOR BELTS; BOTTOMS; COATS; DRESSES; FOOTWEAR; GLOVES; HEADWEAR; JACKETS; LEGGINGS; SCARVES; SLEEPWEAR; SWIM WEAR; TOPS; UNDER-GARMENTS (U.S. CLS. 22 AND 39).  
DOMINICK J. SALEMI, EXAMINING ATTORNEY

**CLASS 25—(Continued).**

SN 85-207,255. ABERCROMBIE & FITCH TRADING CO.,  
NEW ALBANY, OH. FILED 12-29-2010.

**HOLLISTER CALIF**

THE MARK CONSISTS OF STANDARD CHARACTERS  
WITHOUT CLAIM TO ANY PARTICULAR FONT, STYLE,  
SIZE, OR COLOR.

OWNER OF U.S. REG. NOS. 3,310,650, 3,605,286 AND  
OTHERS.

NO CLAIM IS MADE TO THE EXCLUSIVE RIGHT TO  
USE "CALIF", APART FROM THE MARK AS SHOWN.

FOR BELTS; BOTTOMS; COATS; DRESSES; FOOT-  
WEAR; GLOVES; HEADWEAR; JACKETS; LEGGINGS;  
SCARVES; SLEEPWEAR; SWIM WEAR; TOPS; UNDER-  
GARMENTS (U.S. CLS. 22 AND 39).

DOMINICK J. SALEMI, EXAMINING ATTORNEY

**CLASS 25—(Continued).**

SN 85-207,277. ABERCROMBIE & FITCH TRADING CO.,  
NEW ALBANY, OH. FILED 12-29-2010.

**HOLLISTER WAVE CHASERS**

THE MARK CONSISTS OF STANDARD CHARACTERS  
WITHOUT CLAIM TO ANY PARTICULAR FONT, STYLE,  
SIZE, OR COLOR.

OWNER OF U.S. REG. NOS. 3,310,650, 3,605,286 AND  
OTHERS.

FOR BELTS; BOTTOMS; COATS; DRESSES; FOOT-  
WEAR; GLOVES; HEADWEAR; JACKETS; LEGGINGS;  
SCARVES; SLEEPWEAR; SWIM WEAR; TOPS; UNDER-  
GARMENTS (U.S. CLS. 22 AND 39).

MICHELE SWAIN, EXAMINING ATTORNEY

SN 85-207,256. ABERCROMBIE & FITCH TRADING CO.,  
NEW ALBANY, OH. FILED 12-29-2010.

**HCO CALI**

THE MARK CONSISTS OF STANDARD CHARACTERS  
WITHOUT CLAIM TO ANY PARTICULAR FONT, STYLE,  
SIZE, OR COLOR.

OWNER OF U.S. REG. NOS. 3,393,268, 3,649,826 AND  
OTHERS.

NO CLAIM IS MADE TO THE EXCLUSIVE RIGHT TO  
USE "CALI", APART FROM THE MARK AS SHOWN.

FOR BELTS; BOTTOMS; COATS; DRESSES; FOOT-  
WEAR; GLOVES; HEADWEAR; JACKETS; LEGGINGS;  
SCARVES; SLEEPWEAR; SWIM WEAR; TOPS; UNDER-  
GARMENTS (U.S. CLS. 22 AND 39).

DOMINICK J. SALEMI, EXAMINING ATTORNEY

SN 85-207,295. JOE INTERNATIONAL CORPORATION,  
TOKYO 150-0044, JAPAN, FILED 12-29-2010.

**GALAXXXY ROCKS!**

THE MARK CONSISTS OF STANDARD CHARACTERS  
WITHOUT CLAIM TO ANY PARTICULAR FONT, STYLE,  
SIZE, OR COLOR.

FOR CLOTHING, NAMELY, T-SHIRTS, JACKETS,  
SWEATERS, TANK TOPS, PANTS, SHORTS, BOARD  
SHORTS, BIKINIS, HATS, DRESSES (U.S. CLS. 22 AND  
39).

FIRST USE 10-22-2010; IN COMMERCE 10-22-2010.

MAYUR VAGHANI, EXAMINING ATTORNEY

SN 85-207,276. ABERCROMBIE & FITCH TRADING CO.,  
NEW ALBANY, OH. FILED 12-29-2010.

**HCO WAVE CHASERS**

THE MARK CONSISTS OF STANDARD CHARACTERS  
WITHOUT CLAIM TO ANY PARTICULAR FONT, STYLE,  
SIZE, OR COLOR.

OWNER OF U.S. REG. NOS. 3,393,268, 3,649,826 AND  
OTHERS.

FOR BELTS; BOTTOMS; COATS; DRESSES; FOOT-  
WEAR; GLOVES; HEADWEAR; JACKETS; LEGGINGS;  
SCARVES; SLEEPWEAR; SWIM WEAR; TOPS; UNDER-  
GARMENTS (U.S. CLS. 22 AND 39).

MICHELE SWAIN, EXAMINING ATTORNEY

SN 85-207,301. ABERCROMBIE & FITCH TRADING CO.,  
NEW ALBANY, OH. FILED 12-29-2010.

**HCO GUARD DIV**

THE MARK CONSISTS OF STANDARD CHARACTERS  
WITHOUT CLAIM TO ANY PARTICULAR FONT, STYLE,  
SIZE, OR COLOR.

OWNER OF U.S. REG. NOS. 3,393,268, 3,649,826 AND  
OTHERS.

FOR BELTS; BOTTOMS; COATS; DRESSES; FOOT-  
WEAR; GLOVES; HEADWEAR; JACKETS; LEGGINGS;  
SCARVES; SLEEPWEAR; SWIM WEAR; TOPS; UNDER-  
GARMENTS (U.S. CLS. 22 AND 39).

JOHN DALIER, EXAMINING ATTORNEY

**CLASS 25—(Continued).**

SN 85-207,302. ABERCROMBIE & FITCH TRADING CO.,  
NEW ALBANY, OH. FILED 12-29-2010.

**HOLLISTER GUARD DIV**

THE MARK CONSISTS OF STANDARD CHARACTERS  
WITHOUT CLAIM TO ANY PARTICULAR FONT, STYLE,  
SIZE, OR COLOR.

OWNER OF U.S. REG. NOS. 3,310,650, 3,605,286 AND  
OTHERS.

FOR BELTS; BOTTOMS; COATS; DRESSES; FOOT-  
WEAR; GLOVES; HEADWEAR; JACKETS; LEGGINGS;  
SCARVES; SLEEPWEAR; SWIM WEAR; TOPS; UNDER-  
GARMENTS (U.S. CLS. 22 AND 39).

JOHN DALIER, EXAMINING ATTORNEY

SN 85-207,304. ABERCROMBIE & FITCH TRADING CO.,  
NEW ALBANY, OH. FILED 12-29-2010.

**HCO RESCUE**

THE MARK CONSISTS OF STANDARD CHARACTERS  
WITHOUT CLAIM TO ANY PARTICULAR FONT, STYLE,  
SIZE, OR COLOR.

OWNER OF U.S. REG. NOS. 3,393,268, 3,649,826 AND  
OTHERS.

FOR BELTS; BOTTOMS; COATS; DRESSES; FOOT-  
WEAR; GLOVES; HEADWEAR; JACKETS; LEGGINGS;  
SCARVES; SLEEPWEAR; SWIM WEAR; TOPS; UNDER-  
GARMENTS (U.S. CLS. 22 AND 39).

JOHN DALIER, EXAMINING ATTORNEY

SN 85-207,373. AUSTIN JOSEPH HILL, ASHEVILLE, NC.  
AND HEATHER ANNE BRANNON, ASHEVILLE, NC.  
FILED 12-29-2010.

**Gnarlorado**

THE MARK CONSISTS OF STANDARD CHARACTERS  
WITHOUT CLAIM TO ANY PARTICULAR FONT, STYLE,  
SIZE, OR COLOR.

FOR ATHLETIC APPAREL, NAMELY, SHIRTS,  
PANTS, JACKETS, FOOTWEAR, HATS AND CAPS,  
ATHLETIC UNIFORMS; HATS; HOODED SWEAT-  
SHIRTS; JACKETS; LONG-SLEEVED SHIRTS; MEN'S  
AND WOMEN'S JACKETS, COATS, TROUSERS, VESTS;  
MOISTURE-WICKING SPORTS SHIRTS; SHIRTS; SKI  
JACKETS; SNOWBOARD JACKETS; SPORTS CAPS  
AND HATS; SPORTS JACKETS; SPORTS SHIRTS;  
SPORTS SHIRTS WITH SHORT SLEEVES; T-SHIRTS  
(U.S. CLS. 22 AND 39).

JANET LEE, EXAMINING ATTORNEY

**CLASS 25—(Continued).**

SN 85-207,507. L4A, NORTH BRUNSWICK, NJ. FILED 12-29-  
2010.

**Luv4Anouka**

THE MARK CONSISTS OF STANDARD CHARACTERS  
WITHOUT CLAIM TO ANY PARTICULAR FONT, STYLE,  
SIZE, OR COLOR.

FOR HOODED SWEATSHIRTS; SWEATERS (U.S. CLS.  
22 AND 39).

ALICE BENMAMAN, EXAMINING ATTORNEY

SN 85-207,509. CHILUKURI, RAGHU, NORTH BRUNS-  
WICK, NJ. FILED 12-29-2010.

**Basic Romance**

THE MARK CONSISTS OF STANDARD CHARACTERS  
WITHOUT CLAIM TO ANY PARTICULAR FONT, STYLE,  
SIZE, OR COLOR.

FOR HOODED SWEATSHIRTS (U.S. CLS. 22 AND 39).  
ALICE BENMAMAN, EXAMINING ATTORNEY

SN 85-207,514. EID, LLC., BEND, OR. FILED 12-29-2010.

**every 1 deserves**

THE MARK CONSISTS OF STANDARD CHARACTERS  
WITHOUT CLAIM TO ANY PARTICULAR FONT, STYLE,  
SIZE, OR COLOR.

FOR BEACHWEAR; BEANIES; GOLF SHIRTS; HATS;  
JACKETS; LOUNGEWEAR; SHIRTS; SWEATPANTS;  
SWEATSHIRTS; T-SHIRTS; TANK TOPS (U.S. CLS. 22  
AND 39).

BILL DAWE, EXAMINING ATTORNEY

**CLASS 25—(Continued).**

SN 85-207,525. POPE, RANDY, SURPRISE, AZ. FILED 12-29-2010.

**Warning: I Do Dumb Things**

THE MARK CONSISTS OF STANDARD CHARACTERS WITHOUT CLAIM TO ANY PARTICULAR FONT, STYLE, SIZE, OR COLOR.

FOR BASEBALL CAPS; HEADWEAR; HOODED SWEAT SHIRTS; JACKETS; SWEAT SHIRTS; T-SHIRTS (U.S. CLS. 22 AND 39).

FIRST USE 10-25-2010; IN COMMERCE 10-25-2010.  
MICHAEL TANNER, EXAMINING ATTORNEY

SN 85-207,554. LABEL, SUSAN, STROUDSBURG, PA. FILED 12-29-2010.

**by accident**

THE MARK CONSISTS OF STANDARD CHARACTERS WITHOUT CLAIM TO ANY PARTICULAR FONT, STYLE, SIZE, OR COLOR.

FOR HATS; T-SHIRTS (U.S. CLS. 22 AND 39).  
ANDREA K. NADELMAN, EXAMINING ATTORNEY

SN 85-207,681. PICKIN' COTTON COMMUNICATIONS, LLC, LAFAYETTE, LA. FILED 12-30-2010.

**FRATTY**

THE MARK CONSISTS OF STANDARD CHARACTERS WITHOUT CLAIM TO ANY PARTICULAR FONT, STYLE, SIZE, OR COLOR.

FOR ADULT NOVELTY GAG CLOTHING ITEM, NAMELY, SOCKS; BABY LAYETTES FOR CLOTHING; BELTS; BELTS FOR CLOTHING; BELTS MADE OUT OF CLOTH; BIBS NOT OF CLOTH OR PAPER; BOTTOMS; CHILDREN'S AND INFANTS' CLOTH BIBS; CHILDREN'S CLOTH EATING BIBS; CLOTH BIBS; CLOTH BIBS FOR ADULT DINERS; CLOTH BIBS FOR USE BY SENIOR CITIZENS OR PHYSICALLY- OR MENTALLY-CHALLENGED PERSONS; CLOTH DIAPERS; CLOTHING EXTENSION USED TO EXTEND THE NORMAL SIZE RANGE OF CLOTHING ITEMS TO ACCOMMODATE PREGNANCY SIZE CHANGES; CLOTHING FOR ATHLETIC USE, NAMELY, PADDED ELBOW COMPRESSION SLEEVES BEING PART OF AN ATHLETIC GARMENT; CLOTHING FOR ATHLETIC USE, NAMELY, PADDED PANTS; CLOTHING FOR ATHLETIC USE, NAMELY, PADDED SHIRTS; CLOTHING FOR ATHLETIC USE, NAMELY, PADDED SHORTS; CLOTHING FOR BABIES, TODDLERS AND CHILDREN, TREATED WITH FIRE AND HEAT RETARDANTS, NAMELY, PAJAMAS, JACKETS, SHIRTS, PANTS, JUMPERS; CLOTHING FOR WEAR IN JUDO PRACTICES; CLOTHING FOR WEAR IN WRESTLING GAMES;

**CLASS 25—(Continued).**

CLOTHING ITEMS, NAMELY, ADHESIVE POCKETS THAT MAY BE AFFIXED DIRECTLY TO THE BODY AS A DECORATIVE PIECE OF CLOTHING WITH UTILITY; CLOTHING ITEMS, NAMELY, ADHESIVE POCKETS THAT MAY BE AFFIXED DIRECTLY TO THE INSIDE OF CLOTHING FOR STORAGE AND SAFEKEEPING OF PERSONAL ITEMS; CLOTHING SHIELDS, NAMELY, PADS APPLIED TO THE UNDERARMS OF SHIRTS, BLOUSES AND SWEATERS; CLOTHING, NAMELY, ARM WARMERS; CLOTHING, NAMELY, ATHLETIC SLEEVES; CLOTHING, NAMELY, BASE LAYERS; CLOTHING, NAMELY, FOLK COSTUMES; CLOTHING, NAMELY, HAND-WARMERS; CLOTHING, NAMELY, KHAKIS; CLOTHING, NAMELY, KNEE WARMERS; CLOTHING, NAMELY, MATERNITY BANDS; CLOTHING, NAMELY, NECK TUBES; CLOTHING, NAMELY, THOBES; CLOTHING, NAMELY, WRAP-AROUNDS; CORSETS; DUSTERS; EYESHADES; FOULARDS; GLOVES AS CLOTHING; HEADBANDS FOR CLOTHING; HOODS; INFANT AND TODDLER ONE PIECE CLOTHING; INFANT CLOTH DIAPERS; INSERTS SPECIALLY ADAPTED FOR CLOTH DIAPERS MADE OF BAMBOO; INSERTS SPECIALLY ADAPTED FOR CLOTH DIAPERS MADE OF HEMP; INSERTS SPECIALLY ADAPTED FOR CLOTH DIAPERS MADE OF MICROFIBER; JACKETS; JERSEYS; LEATHER BELTS; MANTLES; MUFFLERS; NON-DISPOSABLE CLOTH TRAINING PANTS; PAPER HATS FOR USE AS CLOTHING ITEMS; PARTS OF CLOTHING, NAMELY, GUSSETS FOR TIGHTS, GUSSETS FOR STOCKINGS, GUSSETS FOR BATHING SUITS, GUSSETS FOR UNDERWEAR, GUSSETS FOR LEOTARDS AND GUSSETS FOR FOOTLETS; PARTS OF CLOTHING, NAMELY, UNDERARM GUSSETS; PARTY HATS; PERSPIRATION ABSORBENT UNDERWEAR CLOTHING; POCKET SQUARES; SHIRTS; SHORT SETS; SHOULDER WRAPS; SHOULDER WRAPS FOR CLOTHING; SWADDLING CLOTHES; TIES; TOPS; TRAVEL CLOTHING CONTAINED IN A PACKAGE COMPRISING REVERSIBLE JACKETS, PANTS, SKIRTS, TOPS AND A BELT OR SCARF; TRIATHLON CLOTHING, NAMELY, TRIATHLON TIGHTS, TRIATHLON SHORTS, TRIATHLON SINGLET, TRIATHLON SHIRTS, TRIATHLON SUITS; UNDERARM CLOTHING SHIELDS; WEARABLE GARMENTS AND CLOTHING, NAMELY, SHIRTS; WRAPS (U.S. CLS. 22 AND 39).

DEZMONA MIZELLE, EXAMINING ATTORNEY

SN 85-207,699. SAUTER, BRADFORD, GILFORD, NH. FILED 12-30-2010.

**EGO PACIFIER**

THE MARK CONSISTS OF STANDARD CHARACTERS WITHOUT CLAIM TO ANY PARTICULAR FONT, STYLE, SIZE, OR COLOR.

FOR CLOTHING, NAMELY, T-SHIRTS, SWEAT-PANTS, BANDANAS, TIES, BELTS (U.S. CLS. 22 AND 39).

EUGENIA MARTIN, EXAMINING ATTORNEY

**CLASS 25—(Continued).**

SN 85-207,766. SEEK SIMPLE, INC., SARASOTA, FL. FILED 12-30-2010.

**TIME TO LIVE**

THE MARK CONSISTS OF STANDARD CHARACTERS WITHOUT CLAIM TO ANY PARTICULAR FONT, STYLE, SIZE, OR COLOR.

FOR BEANIES; HATS; HOODED SWEATSHIRTS; SWEATSHIRTS; T-SHIRTS (U.S. CLS. 22 AND 39).  
FIRST USE 11-23-2010; IN COMMERCE 11-23-2010.  
JULIE GUTTADAURO, EXAMINING ATTORNEY

SN 85-207,832. YOUNG, ALFRED, SPRING, TX. AND JOSEPH, MARCUS, SPRING, TX. FILED 12-30-2010.

**Golf Gives Me Balance**

THE MARK CONSISTS OF STANDARD CHARACTERS WITHOUT CLAIM TO ANY PARTICULAR FONT, STYLE, SIZE, OR COLOR.

FOR CAPS; COLLARED SHIRTS; T-SHIRTS; WRISTBANDS (U.S. CLS. 22 AND 39).  
MELISSA VALLILLO, EXAMINING ATTORNEY

SN 85-207,859. HECK, JODI L., ARNOLD, MO. AND HECK, TYLER J., ARNOLD, MO. FILED 12-30-2010.



THE MARK CONSISTS OF PAIRED CURVED STREAMS FROM LEFT MERGE WITH PAIRED CURVED STREAMS FROM RIGHT AT LOWER ELEVATION TO COMMON ELEVATION AND WORDS EAST WEST CHEST STACKED VERTICALLY INTERIORLY OF RIGHT STREAMS, LEFT STREAMS HAVE APPEARANCE SIMILAR TO LETTER J AND RIGHT STREAMS HAVE APPEARANCE SIMILAR TO LETTER L.

FOR CLOTHING, NAMELY, T-SHIRTS, SHIRTS, JACKETS, AND HATS (U.S. CLS. 22 AND 39).  
MARK SPARACINO, EXAMINING ATTORNEY

**CLASS 25—(Continued).**

SN 85-208,040. ZAIDI, HAMMAD, REDONDO BEACH, CA. FILED 12-30-2010.

**LONELY SEAL APPAREL**

THE MARK CONSISTS OF STANDARD CHARACTERS WITHOUT CLAIM TO ANY PARTICULAR FONT, STYLE, SIZE, OR COLOR.

NO CLAIM IS MADE TO THE EXCLUSIVE RIGHT TO USE "APPAREL", APART FROM THE MARK AS SHOWN.

FOR MEN'S, WOMEN'S AND CHILDREN'S CLOTHING, NAMELY, SHIRTS, PANTS, JACKETS, SWEATERS, SWIMWEAR, SLEEPWEAR, UNDERWEAR, BELTS; HEADWEAR; FOOTWEAR (U.S. CLS. 22 AND 39).  
FIRST USE 10-1-2010; IN COMMERCE 10-1-2010.

CHARLES L. JENKINS, EXAMINING ATTORNEY

SN 85-208,156. RUFF WEAR, INC., BEND, OR. FILED 12-30-2010.

**RUFFWEAR**

THE MARK CONSISTS OF STANDARD CHARACTERS WITHOUT CLAIM TO ANY PARTICULAR FONT, STYLE, SIZE, OR COLOR.

OWNER OF U.S. REG. NOS. 3,622,548, 3,630,484 AND OTHERS.

FOR HATS; T-SHIRTS (U.S. CLS. 22 AND 39).

FIRST USE 0-0-1994; IN COMMERCE 0-0-1994.

HENRY S. ZAK, EXAMINING ATTORNEY

SN 85-208,170. MANTEL, DAVID, NEW YORK, NY. FILED 12-30-2010.

**HOW MANY FEET DOES IT TAKE? JUST TWO. YOURS.**

THE MARK CONSISTS OF STANDARD CHARACTERS WITHOUT CLAIM TO ANY PARTICULAR FONT, STYLE, SIZE, OR COLOR.

FOR CLOTHING, NAMELY, SHIRTS, T-SHIRTS, UNDER SHIRTS, NIGHT SHIRTS, RUGBY SHIRTS, POLO SHIRTS, CARDIGANS, JERSEYS, UNIFORMS, SCRUBS NOT FOR MEDICAL PURPOSES, SMOCKS, DRESS SHIRTS, PANTS, TROUSERS, SLACKS, JEANS, CULOTTES, CARGO PANTS, STRETCH PANTS, DENIM JEANS, OVERALLS, COVERALLS, JUMPERS, JUMP SUITS, SHORTS, BOXER SHORTS, TOPS, STRETCH TOPS, CROP TOPS, TANK TOPS, HALTER TOPS, SWEAT SHIRTS, SWEAT SHORTS, SWEAT PANTS, WRAPS, WARM-UP SUITS, JOGGING SUITS, TRACK SUITS, PLAY SUITS, BLOUSES, SKIRTS, DRESSES, GOWNS, SWEATERS, VESTS, FLEECE VESTS, PULLOVERS, SNOW SUITS, PARKAS, CAPES, ANORAKS, PONCHOS, JACKETS, REVERSIBLE JACKETS, SHELL JACKETS, COATS, HEAVY COATS, BLAZERS, SUITS, TURTLE-NECKS, CLOTH SKI BIBS, SWIMWEAR, BEACHWEAR,

**CLASS 25—(Continued).**

TENNIS WEAR, SURF WEAR, SKI WEAR, LAYETTES, INFANTWEAR, INFANTS SLEEPERS, BOOTIES, BABY BIBS NOT OF PAPER, CLOTH DIAPERS, CAPS, SWIM CAPS, BERETS, BEANIES, HATS, VISORS, HEADBANDS, WRIST BANDS, SWEAT BANDS, HEADWEAR, EAR MUFFS, APRONS, SCARVES, BANDANAS, BELTS, SUSPENDERS, NECKWEAR, TIES, NECKERCHIEFS, ASCOTS, UNDERWEAR, THERMAL UNDERWEAR, LONG UNDERWEAR, BRIEFS, SWIM AND BATHING TRUNKS, BRAS, SPORTS BRAS, BRASSIERES, BUSTIERS, CORSETS, PANTIES, THONGS, G-STRINGS, GARTERS AND GARTER BELTS, TEDDIES, GIRDLES, FOUNDATION GARMENTS, SINGLETTS, SOCKS, LOUNGEWEAR, ROBES, SMOCKS, UNDERCLOTHES, PAJAMAS, SLEEPWEAR, NIGHT GOWNS, LINGERIE, CAMISOLES, NEGLIGEEES, CHEMISES, CHEMISETTES, SLIPS, SARONGS, LEG WARMERS, HOSE, HOSE, BODY STOCKINGS, KNEE HIGHS, LEGGINGS, TIGHTS, LEOTARDS, BODY SUITS, UNITARDS, BODY SHAPERS, GLOVES, MITTENS, RAINWEAR, FOOTWEAR, SHOES, SNEAKERS, BOOTS, GALOSHES, SANDALS, FLIP-FLOPS, AND SLIPPERS (U.S. CLS. 22 AND 39).

HENRY S. ZAK, EXAMINING ATTORNEY

SN 85-208,238. PIG EVIL, INC., OLYMPIA, WA. FILED 12-30-2010.

## PIG EVIL

THE MARK CONSISTS OF STANDARD CHARACTERS WITHOUT CLAIM TO ANY PARTICULAR FONT, STYLE, SIZE, OR COLOR.

FOR HOODED PULLOVERS; HOODED SWEAT SHIRTS; SHIRTS; SPORT SHIRTS; SPORTS CAPS AND HATS; SPORTS SHIRTS WITH SHORT SLEEVES; SWEAT SHIRTS; WEARABLE GARMENTS AND CLOTHING, NAMELY, SHIRTS (U.S. CLS. 22 AND 39).

FIRST USE 12-1-2010; IN COMMERCE 12-1-2010.

PAUL E. FAHRENKOPF, EXAMINING ATTORNEY

SN 85-208,280. MARTIN, JAMES, LAKE OSWEGO, OR. FILED 12-30-2010.

## CON BRO CHILL

THE MARK CONSISTS OF STANDARD CHARACTERS WITHOUT CLAIM TO ANY PARTICULAR FONT, STYLE, SIZE, OR COLOR.

FOR BELTS; HATS; HOODED SWEAT SHIRTS; SHORTS; SOCKS; SWEAT SHIRTS; SWEATBANDS; SWEATERS; T-SHIRTS; UNDERWEAR (U.S. CLS. 22 AND 39).

FIRST USE 12-16-2009; IN COMMERCE 10-1-2010.

CORY BOONE, EXAMINING ATTORNEY

**CLASS 25—(Continued).**

SN 85-208,394. MANAGES, SAMUELA EUDORA, VAN BUREN, ME. FILED 12-30-2010.

## Bykaholic

THE MARK CONSISTS OF STANDARD CHARACTERS WITHOUT CLAIM TO ANY PARTICULAR FONT, STYLE, SIZE, OR COLOR.

FOR ADULT NOVELTY GAG CLOTHING ITEM, NAMELY, SOCKS; BABY LAYETTES FOR CLOTHING; BELTS; BELTS FOR CLOTHING; BELTS MADE OUT OF CLOTH; BIBS NOT OF CLOTH OR PAPER; BOTTOMS; CHILDREN'S AND INFANTS' CLOTH BIBS; CHILDREN'S CLOTH EATING BIBS; CLOTH BIBS; CLOTH BIBS FOR ADULT DINERS; CLOTH BIBS FOR USE BY SENIOR CITIZENS OR PHYSICALLY- OR MENTALLY- CHALLENGED PERSONS; CLOTH DIAPERS; CLOTHING EXTENSION USED TO EXTEND THE NORMAL SIZE RANGE OF CLOTHING ITEMS TO ACCOMMODATE PREGNANCY SIZE CHANGES; CLOTHING FOR ATHLETIC USE, NAMELY, PADDED ELBOW COMPRESSION SLEEVES BEING PART OF AN ATHLETIC GARMENT; CLOTHING FOR ATHLETIC USE, NAMELY, PADDED PANTS; CLOTHING FOR ATHLETIC USE, NAMELY, PADDED SHIRTS; CLOTHING FOR ATHLETIC USE, NAMELY, PADDED SHORTS; CLOTHING FOR BABIES, TODDLERS AND CHILDREN, TREATED WITH FIRE AND HEAT RETARDANTS, NAMELY, PAJAMAS, JACKETS, SHIRTS, PANTS, JUMPERS; CLOTHING FOR WEAR IN JUDO PRACTICES; CLOTHING FOR WEAR IN WRESTLING GAMES; CLOTHING ITEMS, NAMELY, ADHESIVE POCKETS THAT MAY BE AFFIXED DIRECTLY TO THE BODY AS A DECORATIVE PIECE OF CLOTHING WITH UTILITY; CLOTHING ITEMS, NAMELY, ADHESIVE POCKETS THAT MAY BE AFFIXED DIRECTLY TO THE INSIDE OF CLOTHING FOR STORAGE AND SAFEKEEPING OF PERSONAL ITEMS; CLOTHING SHIELDS, NAMELY, PADS APPLIED TO THE UNDERARMS OF SHIRTS, BLOUSES AND SWEATERS; CLOTHING, NAMELY, ARM WARMERS; CLOTHING, NAMELY, ATHLETIC SLEEVES; CLOTHING, NAMELY, BASE LAYERS; CLOTHING, NAMELY, FOLK COSTUMES; CLOTHING, NAMELY, HAND-WARMERS; CLOTHING, NAMELY, KHAKIS; CLOTHING, NAMELY, KNEE WARMERS; CLOTHING, NAMELY, MATERNITY BANDS; CLOTHING, NAMELY, NECK TUBES; CLOTHING, NAMELY, THOBES; CLOTHING, NAMELY, WRAP-AROUNDS; CORSETS; DUSTERS; EYESHADES; FABRIC SOLD AS AN INTEGRAL COMPONENT OF FINISHED CLOTHING ITEMS, NAMELY, SHORTS, SOCKS, UNDERGARMENT, SUITS, PANTS, SHIRTS, TIGHTS, JACKET, TANK TOPS, LEGGINGS AND SKIRTS; FIGURE SKATING CLOTHING, NAMELY, DRESS, LEGGINGS, SHIRTS AND PANTS; FOULARDS; GLOVES AS CLOTHING; HEADBANDS FOR CLOTHING; HOODS; INFANT AND TODDLER ONE PIECE CLOTHING; INFANT CLOTH DIAPERS; INSERTS SPECIALLY ADAPTED FOR CLOTH DIAPERS MADE OF BAMBOO; INSERTS SPECIALLY ADAPTED FOR CLOTH DIAPERS MADE OF HEMP; INSERTS SPECIALLY ADAPTED FOR CLOTH DIAPERS MADE OF MICROFIBER; JACKETS; JERSEYS; LEATHER BELTS; MANTLES; MUFFLERS; NON-DISPOSABLE CLOTH TRAINING PANTS; PAPER HATS FOR USE AS CLOTHING ITEMS; PARTS OF CLOTHING, NAMELY, GUSSETS FOR TIGHTS, GUSSETS FOR STOCKINGS, GUSSETS FOR BATHING SUITS, GUSSETS FOR UNDERWEAR, GUSSETS FOR LEOTARDS AND GUSSETS FOR FOOTLETS; PARTS OF CLOTHING, NAMELY, UNDERARM GUSSETS; PARTY

**CLASS 25—(Continued).**

HATS; PERSPIRATION ABSORBENT UNDERWEAR CLOTHING; POCKET SQUARES; SHIFTS; SHORT SETS; SHOULDER WRAPS; SHOULDER WRAPS FOR CLOTHING; SWADDLING CLOTHES; TIES; TOPS; TRAVEL CLOTHING CONTAINED IN A PACKAGE COMPRISING REVERSIBLE JACKETS, PANTS, SKIRTS, TOPS AND A BELT OR SCARF; TRIATHLON CLOTHING, NAMELY, TRIATHLON TIGHTS, TRIATHLON SHORTS, TRIATHLON SINGLET, TRIATHLON SHIRTS, TRIATHLON SUITS; UNDERARM CLOTHING SHIELDS; WEARABLE GARMENTS AND CLOTHING, NAMELY, SHIRTS; WRAPS (U.S. CLS. 22 AND 39).

KARANENDRA S. CHHINA, EXAMINING ATTORNEY

SN 85-208,399. MANAGES, SAMUELA EUDORA, VAN BUREN, ME. FILED 12-30-2010.

# Cyklaholic

THE MARK CONSISTS OF STANDARD CHARACTERS WITHOUT CLAIM TO ANY PARTICULAR FONT, STYLE, SIZE, OR COLOR.

FOR ADULT NOVELTY GAG CLOTHING ITEM, NAMELY, SOCKS; BABY LAYETTES FOR CLOTHING; BELTS; BELTS FOR CLOTHING; BELTS MADE OUT OF CLOTH; BIBS NOT OF CLOTH OR PAPER; BOTTOMS; CHILDREN'S AND INFANTS' CLOTH BIBS; CHILDREN'S CLOTH EATING BIBS; CLOTH BIBS; CLOTH BIBS FOR ADULT DINERS; CLOTH BIBS FOR USE BY SENIOR CITIZENS OR PHYSICALLY- OR MENTALLY-CHALLENGED PERSONS; CLOTH DIAPERS; CLOTHING EXTENSION USED TO EXTEND THE NORMAL SIZE RANGE OF CLOTHING ITEMS TO ACCOMMODATE PREGNANCY SIZE CHANGES; CLOTHING FOR ATHLETIC USE, NAMELY, PADDED ELBOW COMPRESSION SLEEVES BEING PART OF AN ATHLETIC GARMENT; CLOTHING FOR ATHLETIC USE, NAMELY, PADDED PANTS; CLOTHING FOR ATHLETIC USE, NAMELY, PADDED SHIRTS; CLOTHING FOR ATHLETIC USE, NAMELY, PADDED SHORTS; CLOTHING FOR BABIES, TODDLERS AND CHILDREN, TREATED WITH FIRE AND HEAT RETARDANTS, NAMELY, PAJAMAS, JACKETS, SHIRTS, PANTS, JUMPERS; CLOTHING FOR WEAR IN JUDO PRACTICES; CLOTHING FOR WEAR IN WRESTLING GAMES; CLOTHING ITEMS, NAMELY, ADHESIVE POCKETS THAT MAY BE AFFIXED DIRECTLY TO THE BODY AS A DECORATIVE PIECE OF CLOTHING WITH UTILITY; CLOTHING ITEMS, NAMELY, ADHESIVE POCKETS THAT MAY BE AFFIXED DIRECTLY TO THE INSIDE OF CLOTHING FOR STORAGE AND SAFEKEEPING OF PERSONAL ITEMS; CLOTHING SHIELDS, NAMELY, PADS APPLIED TO THE UNDERARMS OF SHIRTS, BLOUSES AND SWEATERS; CLOTHING, NAMELY, ARM WARMERS; CLOTHING, NAMELY, ATHLETIC SLEEVES; CLOTHING, NAMELY, BASE LAYERS; CLOTHING, NAMELY, FOLK COSTUMES; CLOTHING, NAMELY, HAND-WARMERS; CLOTHING, NAMELY, KHAKIS; CLOTHING, NAMELY, KNEE WARMERS; CLOTHING, NAMELY, MATERNITY BANDS; CLOTHING, NAMELY, NECK TUBES; CLOTHING, NAMELY, THOBES; CLOTHING, NAMELY, WRAP-AROUNDS; CORSETS; DUSTERS; EYESHADES; FABRIC SOLD AS AN INTEGRAL COMPONENT OF FINISHED CLOTHING ITEMS, NAMELY, SHORTS, SOCKS, UNDERGARMENT, SUITS, PANTS, SHIRTS, TIGHTS, JACKET, TANK TOPS, LEGGINGS AND SKIRTS.; FIGURE SKATING CLOTHING, NAMELY, DRESS, LEGGINGS, SHIRTS AND PANTS.; FOULARDS; GLOVES AS CLOTHING; HEADBANDS FOR CLOTHING; HOODS; INFANT AND TODDLER ONE PIECE CLOTHING; INFANT CLOTH DIAPERS; INSERTS SPECIALLY ADAPTED FOR CLOTH DIAPERS MADE OF BAMBOO; INSERTS SPECIALLY ADAPTED FOR CLOTH DIAPERS MADE OF HEMP; INSERTS SPECIALLY ADAPTED FOR

**CLASS 25—(Continued).**

CLOTH DIAPERS MADE OF MICROFIBER; JACKETS; JERSEYS; LEATHER BELTS; MANTLES; MUFFLERS; NON-DISPOSABLE CLOTH TRAINING PANTS; PAPER HATS FOR USE AS CLOTHING ITEMS; PARTS OF CLOTHING, NAMELY, GUSSETS FOR TIGHTS, GUSSETS FOR STOCKINGS, GUSSETS FOR BATHING SUITS, GUSSETS FOR UNDERWEAR, GUSSETS FOR LEOTARDS AND GUSSETS FOR FOOTLETS; PARTS OF CLOTHING, NAMELY, UNDERARM GUSSETS; PARTY HATS; PERSPIRATION ABSORBENT UNDERWEAR CLOTHING; POCKET SQUARES; SHIFTS; SHORT SETS; SHOULDER WRAPS; SHOULDER WRAPS FOR CLOTHING; SWADDLING CLOTHES; TIES; TOPS; TRAVEL CLOTHING CONTAINED IN A PACKAGE COMPRISING REVERSIBLE JACKETS, PANTS, SKIRTS, TOPS AND A BELT OR SCARF; TRIATHLON CLOTHING, NAMELY, TRIATHLON TIGHTS, TRIATHLON SHORTS, TRIATHLON SINGLET, TRIATHLON SHIRTS, TRIATHLON SUITS; UNDERARM CLOTHING SHIELDS; WEARABLE GARMENTS AND CLOTHING, NAMELY, SHIRTS; WRAPS (U.S. CLS. 22 AND 39).

KARANENDRA S. CHHINA, EXAMINING ATTORNEY

SN 85-208,542. URIBE,SIMON, CORAL SPRINGS, FL. FILED 12-31-2010.

# OMN

THE MARK CONSISTS OF STANDARD CHARACTERS WITHOUT CLAIM TO ANY PARTICULAR FONT, STYLE, SIZE, OR COLOR.

FOR A-SHIRTS; ATHLETIC APPAREL, NAMELY, SHIRTS, PANTS, JACKETS, FOOTWEAR, HATS AND CAPS, ATHLETIC UNIFORMS; BRIEFS; BUTTON DOWN SHIRTS; CARGO PANTS; DENIM JACKETS; DENIMS; DOWN JACKETS; DRESS PANTS; DRESS SHIRTS; HEAVY JACKETS; HOODED SWEAT SHIRTS (U.S. CLS. 22 AND 39).

RAMONA ORTIGA, EXAMINING ATTORNEY

SN 85-208,560. DOMINGEZ MUÑOZ, ELIANA MARGOT, MEDELLIN, ANTIOQUIA, COLOMBIA, AND DOMINGEZ MUÑOZ, EDWIN CAMILO, MEDELLIN, ANTIOQUIA, COLOMBIA, FILED 12-31-2010.

# Di TWO

THE MARK CONSISTS OF STANDARD CHARACTERS WITHOUT CLAIM TO ANY PARTICULAR FONT, STYLE, SIZE, OR COLOR.

FOR BLOUSES; BRAS; DRESSES; JEANS; SHIRTS; SHORT TROUSERS; SHORTS; SKIRTS; SOCKS; SWIMWEAR; T-SHIRTS; THONGS (U.S. CLS. 22 AND 39).

BRIDGETT SMITH, EXAMINING ATTORNEY

**CLASS 25—(Continued).**

SN 85-208,564. URIBE, SIMON, CORAL SPRINGS, FL. FILED 12-31-2010.

# OMN ETHER

THE MARK CONSISTS OF STANDARD CHARACTERS WITHOUT CLAIM TO ANY PARTICULAR FONT, STYLE, SIZE, OR COLOR.

FOR A-SHIRTS; ATHLETIC APPAREL, NAMELY, SHIRTS, PANTS, JACKETS, FOOTWEAR, HATS AND CAPS, ATHLETIC UNIFORMS (U.S. CLS. 22 AND 39).

RAMONA ORTIGA, EXAMINING ATTORNEY

SN 85-208,634. ALLRED, DENNISE J, MOBILE, AL. FILED 12-31-2010.

# Grace Haven

THE MARK CONSISTS OF STANDARD CHARACTERS WITHOUT CLAIM TO ANY PARTICULAR FONT, STYLE, SIZE, OR COLOR.

FOR CANVAS SHOES; CHILDREN'S AND INFANT'S APPAREL, NAMELY, JUMPERS, OVERALL SLEEPWEAR, PAJAMAS, ROMPERS AND ONE-PIECE GARMENTS; CHILDREN'S HEADWEAR; DRESSES; INFANTS' SHOES AND BOOTS; LEATHER SHOES; SANDALS AND BEACH SHOES; SHIRTS FOR INFANTS, BABIES, TODDLERS AND CHILDREN; SKIRTS (U.S. CLS. 22 AND 39).

JUSTINE D. PARKER, EXAMINING ATTORNEY

SN 85-208,731. DOSTALEK, ROBERT DOUGLAS, DBA LEISURIST, HUNTINGTON BEACH, CA. FILED 12-31-2010.

# LEISURIST

THE MARK CONSISTS OF STANDARD CHARACTERS WITHOUT CLAIM TO ANY PARTICULAR FONT, STYLE, SIZE, OR COLOR.

FOR (BASED ON USE IN COMMERCE) SHIRTS; T-SHIRTS(BASED ON INTENT TO USE) HATS; JACKETS; PANTS; SHORTS (U.S. CLS. 22 AND 39).

FIRST USE 4-28-2004; IN COMMERCE 12-8-2010.  
HEATHER SAPP, EXAMINING ATTORNEY

**CLASS 25—(Continued).**

SN 85-208,867. MCRAE, MICHAEL W., PARK CITY, UT. FILED 1-2-2011.

# Q.E.D.

THE MARK CONSISTS OF STANDARD CHARACTERS WITHOUT CLAIM TO ANY PARTICULAR FONT, STYLE, SIZE, OR COLOR.

FOR BELTS FOR CLOTHING; CREW NECK SWEATERS; GOLF CAPS; GOLF PANTS, SHIRTS AND SKIRTS; GOLF TROUSERS (U.S. CLS. 22 AND 39).

JOHN DALIER, EXAMINING ATTORNEY

SN 85-208,879. 4 LACES, LLC, ATLANTA, GA. FILED 1-2-2011.

# FOR GAMES FOR LIFE

THE MARK CONSISTS OF STANDARD CHARACTERS WITHOUT CLAIM TO ANY PARTICULAR FONT, STYLE, SIZE, OR COLOR.

FOR CLOTHING, NAMELY, DRESSES, SKIRTS, SHIRTS, JACKETS, COATS, TANK TOPS, AND SCARVES, NONE OF FOREGOING CONTAINING FOUR LACES (U.S. CLS. 22 AND 39).

FIRST USE 12-0-2009; IN COMMERCE 3-15-2010.  
JANICE KIM, EXAMINING ATTORNEY

SN 85-209,014. CHARLES DAVID CAIN, COLUMBIA, SC. FILED 1-3-2011.

# VOCO

THE MARK CONSISTS OF STANDARD CHARACTERS WITHOUT CLAIM TO ANY PARTICULAR FONT, STYLE, SIZE, OR COLOR.

FOR COATS; HATS; JACKETS; JEANS; KNIT SHIRTS; LEATHER BELTS; PANTS; POLO SHIRTS; SHIRTS; SHOES; SOCKS; SWEAT PANTS; SWEATERS; T-SHIRTS; TOPS; UNDERWEAR (U.S. CLS. 22 AND 39).

SHAUNIA CARLYLE, EXAMINING ATTORNEY



**CLASS 25—(Continued).**

SN 85-209,073. LIVEIAM LLC, NEW YORK, NY. FILED 1-3-2011.



THE MARK CONSISTS OF A DESIGN OF AN HIBISCUS FLOWER WITH TWO ADDITIONAL SMALLER FLOWERS.

FOR INFANTS' AND CHILDREN'S CLOTHING, NAMELY, T-SHIRTS, SHIRTS, TOPS, PANTS, BOTTOMS, SHORT SETS, SHORTS, SKIRTS, SKORTS, DRESSES, BODY SUITS, COORDINATING SETS COMPRISING TOPS AND BOTTOMS, JEANS, JUMPSUITS, LAYETTE SETS COMPRISING TOPS AND PANTS, OVERALLS, SWEATSHIRTS, SWEATPANTS, PAJAMAS, SLEEPERS, ROBES, SWIMSUITS, COVERUPS, COATS, JACKETS, RAIN JACKETS, SNOWSUITS, SWEATERS, WIND RESISTANT JACKETS, CLOTH BABY BIBS, COSTUMES, HEADBANDS, TIGHTS, SOCKS, BOOTIES, SHOES, CAPS, HATS, MITTENS, GLOVES (U.S. CLS. 22 AND 39).  
TINA L. SNAPP, EXAMINING ATTORNEY

SN 85-209,097. DILLARD'S, INC., LITTLE ROCK, AR. FILED 1-3-2011.

# Bechamel

THE MARK CONSISTS OF STANDARD CHARACTERS WITHOUT CLAIM TO ANY PARTICULAR FONT, STYLE, SIZE, OR COLOR.

OWNER OF U.S. REG. NOS. 1,211,665 AND 2,914,378.  
FOR CLOTHING, NAMELY, DRESSES, JUMPERS, PANTS, SKIRTS, SHORTS, KNIT TOPS, WOVEN TOPS, JACKETS AND SWEATERS (U.S. CLS. 22 AND 39).  
DEIRDRE ROBERTSON, EXAMINING ATTORNEY

**CLASS 25—(Continued).**

SN 85-209,139. BROWN MOLASSES CO., INCORPORATED, CUTLER, IN. FILED 1-3-2011.

## No Uglies Allowed

THE MARK CONSISTS OF STANDARD CHARACTERS WITHOUT CLAIM TO ANY PARTICULAR FONT, STYLE, SIZE, OR COLOR.

FOR SWEAT SHIRTS; TEE SHIRTS (U.S. CLS. 22 AND 39).

FIRST USE 12-6-1999; IN COMMERCE 12-6-1999.  
NAKIA HENRY, EXAMINING ATTORNEY

SN 85-209,248. STATON, LISA, WHITESTOWN, IN. FILED 1-3-2011.

## CLEAR MINDS ROCK!

THE MARK CONSISTS OF STANDARD CHARACTERS WITHOUT CLAIM TO ANY PARTICULAR FONT, STYLE, SIZE, OR COLOR.

FOR HATS; PANTS; SHIRTS; SHORTS; SWEATSHIRTS; TANK-TOPS (U.S. CLS. 22 AND 39).

MICHAEL WEBSTER, EXAMINING ATTORNEY

SN 85-209,338. BARNETT, LAUREN E., DBA THE DOMESTIC DAME, NORTH HOLLYWOOD, CA. FILED 1-3-2011.



THE COLOR(S) LIGHT PINK, BLACK, WHITE IS/ARE CLAIMED AS A FEATURE OF THE MARK.

THE MARK CONSISTS OF BLACK TEXT THAT SAYS "THE DOMESTIC DAME" AND "WWW.THEDOMESTICDAME.COM", A WHITE BOW APPEARS BEHIND THE LEFT SIDE OF THE WORD "DOMESTIC". ALL OF THESE THINGS APPEAR TOGETHER INSIDE A LIGHT PINK HEART WITH A WHITE CROSS HATCH DETAIL. THE PINK HEART SITS DIAGONALLY WITHIN A BLACK SQUARE.

FOR APRONS; SLEEPWEAR (U.S. CLS. 22 AND 39).  
FIRST USE 2-23-2009; IN COMMERCE 5-1-2009.

JOHN SCHUYLER YARD, EXAMINING ATTORNEY

**CLASS 25—(Continued).**

SN 85-209,367. SILVER BRACELETS, INC., ORLANDO, FL. FILED 1-3-2011.

# CALORIES

THE MARK CONSISTS OF STANDARD CHARACTERS WITHOUT CLAIM TO ANY PARTICULAR FONT, STYLE, SIZE, OR COLOR.  
FOR APRONS, HATS AND T-SHIRTS (U.S. CLS. 22 AND 39).  
TINA BROWN, EXAMINING ATTORNEY

**CLASS 25—(Continued).**

SN 85-209,448. KETCHUM, MICHAEL, KENOSHA, WI. AND MAURER, SCOTT, KENOSHA, WI. FILED 1-3-2011.

# Busted Lip

THE MARK CONSISTS OF STANDARD CHARACTERS WITHOUT CLAIM TO ANY PARTICULAR FONT, STYLE, SIZE, OR COLOR.  
FOR HATS; JACKETS; SHIRTS (U.S. CLS. 22 AND 39).  
FIRST USE 10-5-2010; IN COMMERCE 10-5-2010.  
CHRISTINE COOPER, EXAMINING ATTORNEY

SN 85-209,390. MATHIE, JAMES, M, DEERFIELD BEACH, FL. FILED 1-3-2011.

# CHIEFY

THE MARK CONSISTS OF STANDARD CHARACTERS WITHOUT CLAIM TO ANY PARTICULAR FONT, STYLE, SIZE, OR COLOR.  
FOR ATHLETIC APPAREL, NAMELY, SHIRTS, PANTS, JACKETS, FOOTWEAR, HATS AND CAPS, ATHLETIC UNIFORMS (U.S. CLS. 22 AND 39).  
FIRST USE 1-5-2007; IN COMMERCE 12-24-2010.  
DAVID TAYLOR, EXAMINING ATTORNEY

SN 85-209,518. TOTAL FORCE IMPACT LLC, LAS VEGAS, NV. FILED 1-3-2011.

# TOTAL FORCE IMPACT

THE MARK CONSISTS OF STANDARD CHARACTERS WITHOUT CLAIM TO ANY PARTICULAR FONT, STYLE, SIZE, OR COLOR.  
FOR BELTS; BOTTOMS; DRESSES; FOOTWEAR; HEADWEAR; JACKETS; LOUNGEWEAR; SCARVES; SLEEPWEAR; SWEATBANDS; SWIMWEAR; TOPS; UNDERGARMENTS; WARM UP SUITS (U.S. CLS. 22 AND 39).  
SCOTT BIBB, EXAMINING ATTORNEY

SN 85-209,406. CHART 13, LLC, JACKSONVILLE, FL. FILED 1-3-2011.



THE MARK CONSISTS OF AN ABSTRACT DESIGN AND THE TEXT "CHART 13".  
FOR BATHING SUITS; HATS; JACKETS; PANTS; SHIRTS; SHORTS; SWEATSHIRTS (U.S. CLS. 22 AND 39).  
ANGELA DUONG, EXAMINING ATTORNEY

SN 85-209,524. TOTAL FORCE IMPACT LLC, LAS VEGAS, NV. FILED 1-3-2011.

# TFI

THE MARK CONSISTS OF STANDARD CHARACTERS WITHOUT CLAIM TO ANY PARTICULAR FONT, STYLE, SIZE, OR COLOR.  
FOR BELTS; BOTTOMS; DRESSES; FOOTWEAR; HEADWEAR; JACKETS; LOUNGEWEAR; SCARVES; SLEEPWEAR; SWEATBANDS; SWIMWEAR; TOPS; UNDERGARMENTS; WARM UP SUITS (U.S. CLS. 22 AND 39).  
SCOTT BIBB, EXAMINING ATTORNEY

**CLASS 25—(Continued).**

SN 85-209,525. TOTAL FORCE IMPACT LLC, LAS VEGAS, NV. FILED 1-3-2011.



THE MARK CONSISTS OF THE STYLIZED LETTERS "TFI" OVER A SHIELD WITH FOUR STARS ACROSS THE TOP OF THE SHIELD AND THREE STARS UNDER THE TEXT AT THE BOTTOM OF THE SHIELD.

FOR BELTS; BOTTOMS; DRESSES; FOOTWEAR; HEADWEAR; JACKETS; LOUNGEWEAR; SCARVES; SLEEPWEAR; SWEATBANDS; SWIMWEAR; TOPS; UNDERGARMENTS; WARM UP SUITS (U.S. CLS. 22 AND 39).

SCOTT BIBB, EXAMINING ATTORNEY

SN 85-209,722. KATE SPADE, LLC, NEW YORK, NY. FILED 1-4-2011.

**JACK SPADE**

THE MARK CONSISTS OF STANDARD CHARACTERS WITHOUT CLAIM TO ANY PARTICULAR FONT, STYLE, SIZE, OR COLOR.

OWNER OF U.S. REG. NOS. 2,341,633, 2,871,175 AND OTHERS.

THE NAME(S), PORTRAIT(S), AND/OR SIGNATURE(S) SHOWN IN THE MARK DOES NOT IDENTIFY A PARTICULAR LIVING INDIVIDUAL.

FOR BEANIES; BLAZERS; COATS; DRESS SHIRTS; GLOVES; JACKETS; JEANS; PANTS; SHIRTS; SOCKS; SUITS; SWEATERS; TIES (U.S. CLS. 22 AND 39).

FIRST USE 10-0-2009; IN COMMERCE 10-0-2009.  
GEORGE LORENZO, EXAMINING ATTORNEY

SN 85-209,919. SLOMKA, THOMAS, CLEVELAND, OH. FILED 1-4-2011.

**ROYAL STATUS**

THE MARK CONSISTS OF STANDARD CHARACTERS WITHOUT CLAIM TO ANY PARTICULAR FONT, STYLE, SIZE, OR COLOR.

FOR CLOTHING, NAMELY, T-SHIRTS, SWEATSHIRTS, SHIRTS, PANTS, SWEATPANTS, HATS, SHORTS, TANK TOPS, JERSEYS AND JACKETS (U.S. CLS. 22 AND 39).

ANNE MADDEN, EXAMINING ATTORNEY

**CLASS 25—(Continued).**

SN 85-209,920. UNGER, TODD, TOWSON, MD. FILED 1-4-2011.

**BOHTIMORE**

THE MARK CONSISTS OF STANDARD CHARACTERS WITHOUT CLAIM TO ANY PARTICULAR FONT, STYLE, SIZE, OR COLOR.

FOR FLIP FLOPS; HATS; JACKETS; SANDALS; SHIRTS; SHOES; SHORTS; SWEAT PANTS; SWEATERS; SWEATSHIRTS; T-SHIRTS (U.S. CLS. 22 AND 39).

ARETHA SOMERVILLE, EXAMINING ATTORNEY

SN 85-209,925. RHEAULT, PEGGY, RANCHO CORDOVA, CA. FILED 1-4-2011.

**EMBRACE LIFE TODAY**

THE MARK CONSISTS OF STANDARD CHARACTERS WITHOUT CLAIM TO ANY PARTICULAR FONT, STYLE, SIZE, OR COLOR.

FOR CAPS; SWEATSHIRTS; TEE SHIRTS; VISORS (U.S. CLS. 22 AND 39).

FIRST USE 6-0-2007; IN COMMERCE 6-0-2007.

ARETHA SOMERVILLE, EXAMINING ATTORNEY

SN 85-209,986. LOUISE PARIS LTD., NEW YORK, NY. FILED 1-4-2011.

**MISS JANE**

THE MARK CONSISTS OF STANDARD CHARACTERS WITHOUT CLAIM TO ANY PARTICULAR FONT, STYLE, SIZE, OR COLOR.

FOR WEARING APPAREL FOR WOMEN, CHILDREN AND BABIES, NAMELY JACKETS, COATS, SUITS, SHIRTS, TOPS, SWEATERS, SKIRTS, DRESSES, ROMPERS PANTS, SHORTS, LEGGINGS, HOSIERY AND HATS (U.S. CLS. 22 AND 39).

MARIA-VICTORIA SUAREZ, EXAMINING ATTORNEY

**CLASS 25—(Continued).**

SN 85-210,309. AGIT GLOBAL (USA), INC., GLENDORA, CA.  
FILED 1-4-2011.

# oZoboard

THE MARK CONSISTS OF STANDARD CHARACTERS WITHOUT CLAIM TO ANY PARTICULAR FONT, STYLE, SIZE, OR COLOR.

FOR CLOTHING, NAMELY, T-SHIRTS, SWEAT SHIRTS, TANK TOPS, HATS, CAPS, SWIM TRUNKS, SHORTS, AND BOARD SHORTS (U.S. CLS. 22 AND 39).  
TRACY CROSS, EXAMINING ATTORNEY

SN 85-210,328. TWO IN THE SHIRT, DBA T.I.T.S., RENTON, WA. FILED 1-4-2011.

# KNOW NAME

THE MARK CONSISTS OF STANDARD CHARACTERS WITHOUT CLAIM TO ANY PARTICULAR FONT, STYLE, SIZE, OR COLOR.

FOR CLOTHING, NAMELY, SHIRTS, PANTS, SHORTS, BLOUSES, SWIMWEAR, T-SHIRTS AND SUN VISORS (U.S. CLS. 22 AND 39).  
SANDRA BUJA, EXAMINING ATTORNEY

SN 85-210,344. GET YOUR BITCH ON, COPIAGUE, NY. FILED 1-4-2011.

# Getchabitchon

THE MARK CONSISTS OF STANDARD CHARACTERS WITHOUT CLAIM TO ANY PARTICULAR FONT, STYLE, SIZE, OR COLOR.

FOR GLOVES; HATS; PANTS; SCARVES; SHIRTS; SHOES; SHORTS; SOCKS (U.S. CLS. 22 AND 39).  
TRACY CROSS, EXAMINING ATTORNEY

**CLASS 25—(Continued).**

SN 85-210,347. AGIT GLOBAL (USA), INC., GLENDORA, CA.  
FILED 1-4-2011.

# Snubz

THE MARK CONSISTS OF STANDARD CHARACTERS WITHOUT CLAIM TO ANY PARTICULAR FONT, STYLE, SIZE, OR COLOR.

FOR CLOTHING, NAMELY, T-SHIRTS, SWEAT SHIRTS, TANK TOPS, HATS, CAPS, SWIM TRUNKS, SHORTS, AND BOARD SHORTS (U.S. CLS. 22 AND 39).  
TRACY CROSS, EXAMINING ATTORNEY

SN 85-210,550. WALKER, KAHLID, VALLEJO, CA. FILED 1-5-2011.

# ANCESTRIE

THE MARK CONSISTS OF STANDARD CHARACTERS WITHOUT CLAIM TO ANY PARTICULAR FONT, STYLE, SIZE, OR COLOR.

FOR CLOTHING, NAMELY, TOPS, BOTTOMS AND JEANS (U.S. CLS. 22 AND 39).  
TINA MAI, EXAMINING ATTORNEY

SN 85-210,604. STUDIO RAY, LLC, NEW YORK, NY. FILED 1-5-2011.



NO CLAIM IS MADE TO THE EXCLUSIVE RIGHT TO USE "SURF", APART FROM THE MARK AS SHOWN.

THE MARK CONSISTS OF "Z" WITH AN EXTENDED BOTTOM LINE AND HORIZONTAL LINED RUNNING THROUGHOUT THE LETTER, AN "X" WITH AN EXTENDED LINE RUNNING FROM LEFT TO RIGHT, "SURF" WITH THE "R" HAVING AN EXTENDED VERTICAL LINE AND THE "F" HAVING AN EXTENDED HORIZONTAL LINE.

FOR SWIMWEAR, NAMELY, BATHING SUITS, WET SUITS, AND LEGGINGS (U.S. CLS. 22 AND 39).  
FIRST USE 11-5-2010; IN COMMERCE 11-5-2010.  
FLORENTINA BLANDU, EXAMINING ATTORNEY

**CLASS 25—(Continued).**

SN 85-210,868. HELGESON, CHRISTOPHER, SALEM, OR.  
FILED 1-5-2011.

**Beer Capital of the World**

THE MARK CONSISTS OF STANDARD CHARACTERS  
WITHOUT CLAIM TO ANY PARTICULAR FONT, STYLE,  
SIZE, OR COLOR.

FOR JACKETS; POLO SHIRTS; T-SHIRTS (U.S. CLS. 22  
AND 39).

BRIDGETT SMITH, EXAMINING ATTORNEY

**CLASS 25—(Continued).**

SN 85-211,016. SOCK AND ACCESSORY BRANDS GLOBAL,  
LLC, MOCKSVILLE, NC. FILED 1-5-2011.

**MIX 'EM**

THE MARK CONSISTS OF STANDARD CHARACTERS  
WITHOUT CLAIM TO ANY PARTICULAR FONT, STYLE,  
SIZE, OR COLOR.

FOR SOCKS AND HOSIERY (U.S. CLS. 22 AND 39).

ANNE FARRELL, EXAMINING ATTORNEY

SN 85-210,907. LISA T. WILES, KNOXVILLE, TN. FILED 1-5-  
2011.

**FAN-E SHAKER**

THE MARK CONSISTS OF STANDARD CHARACTERS  
WITHOUT CLAIM TO ANY PARTICULAR FONT, STYLE,  
SIZE, OR COLOR.

FOR CLOTHING, NAMELY, BELTS, SKIRTS, AND  
SKIRTS FORMED FROM A BELT WITH INTER-  
CHANGEABLE ACCESSORIES ATTACHED THERETO  
(U.S. CLS. 22 AND 39).

MICHAEL ENGEL, EXAMINING ATTORNEY

SN 85-211,033. HERNANDEZ, MICHELLE, D., DBA RACE  
MOM, PHOENIX, AZ. FILED 1-5-2011.

**Racebrat**

THE MARK CONSISTS OF STANDARD CHARACTERS  
WITHOUT CLAIM TO ANY PARTICULAR FONT, STYLE,  
SIZE, OR COLOR.

FOR ATHLETIC APPAREL, NAMELY, SHIRTS,  
PANTS, JACKETS, FOOTWEAR, HATS AND CAPS,  
ATHLETIC UNIFORM; BELTS; CAPS; DRESS SHIRTS;  
HOODED SWEAT SHIRTS; HOODS; JERSEYS; LEATHER  
BELTS; LONG-SLEEVED SHIRTS; POLO SHIRTS;  
SHORT SETS (U.S. CLS. 22 AND 39).

KEVIN DINALLO, EXAMINING ATTORNEY

SN 85-211,006. CLIFF CHISM, VALLEJO, CA. FILED 1-5-2011.

**ZILLANOMICS**

THE MARK CONSISTS OF STANDARD CHARACTERS  
WITHOUT CLAIM TO ANY PARTICULAR FONT, STYLE,  
SIZE, OR COLOR.

FOR ATHLETIC APPAREL, NAMELY, SHIRTS,  
PANTS, JACKETS, FOOTWEAR, HATS AND CAPS,  
ATHLETIC UNIFORMS; COLLARED SHIRTS; FOOT-  
WEAR NOT FOR SPORTS; HATS; HEADWEAR;  
HOODED SWEATSHIRTS; HOODS; JACKETS; SHIRTS;  
SWEAT PANTS; TOPS; WEARABLE GARMENTS AND  
CLOTHING, NAMELY, SHIRTS (U.S. CLS. 22 AND 39).

KATHERINE M. DUBRAY, EXAMINING ATTORNEY

SN 85-211,038. CLEVERHOOD, LLC, PROVIDENCE, RI.  
FILED 1-5-2011.

**CLEVERHOOD**

THE MARK CONSISTS OF STANDARD CHARACTERS  
WITHOUT CLAIM TO ANY PARTICULAR FONT, STYLE,  
SIZE, OR COLOR.

FOR CAPES FOR OUTDOOR ACTIVITIES; JACKETS  
FOR OUTDOOR ACTIVITIES; HATS AND GLOVES FOR  
OUTDOOR ACTIVITIES (U.S. CLS. 22 AND 39).

MARTHA SANTOMARTINO, EXAMINING ATTORNEY

**CLASS 25—(Continued).**

SN 85-211,302. KARZ ENTERTAINMENT, INC., LOS ANGELES, CA. FILED 1-5-2011.

# G FAMILY

THE MARK CONSISTS OF STANDARD CHARACTERS WITHOUT CLAIM TO ANY PARTICULAR FONT, STYLE, SIZE, OR COLOR.

FOR CLOTHING, NAMELY, T-SHIRTS, SHIRTS, BLOUSES, DRESSES, SKIRTS, PANTS, SHORTS, SWEATERS, SWEATSHIRTS, SWEAT PANTS, COATS, JACKETS, GLOVES, HATS, CAPS, BELTS, TIES, RAINWEAR, SHOES, SLIPPERS, SOCKS (U.S. CLS. 22 AND 39).

MAUREEN DALL, EXAMINING ATTORNEY

**CLASS 25—(Continued).**

SN 85-211,391. SHEN LING GROUP INC., VERNON, CA. FILED 1-5-2011.



THE MARK CONSISTS OF THE WORD "ROSEGIRL" AND A LINE DESIGN UNDER IT.

FOR SHOES; WOMEN'S SHOES (U.S. CLS. 22 AND 39).  
FIRST USE 11-30-2010; IN COMMERCE 11-30-2010.

RONALD DELGIZZI, EXAMINING ATTORNEY

SN 85-211,365. CLEARY, KEVIN P, MANHATTAN BEACH, CA. FILED 1-5-2011.

# COMMIT TO THE LIFESTYLE

THE MARK CONSISTS OF STANDARD CHARACTERS WITHOUT CLAIM TO ANY PARTICULAR FONT, STYLE, SIZE, OR COLOR.

FOR BATHING SUITS; BOTTOMS; HATS; HEADWEAR; PANTS; SHIRTS; SHORTS; SWEAT SHIRTS; SWIMWEAR; TOPS (U.S. CLS. 22 AND 39).

SANI KHOURI, EXAMINING ATTORNEY

SN 85-211,402. SHEN LING GROUP INC., VERNON, CA. FILED 1-5-2011.

SN 85-211,369. KNOX, RACHEL, CAMBRIDGE, MA. FILED 1-5-2011.

# BTICH



THE MARK CONSISTS OF STANDARD CHARACTERS WITHOUT CLAIM TO ANY PARTICULAR FONT, STYLE, SIZE, OR COLOR.

FOR BELTS; BLOUSES; BRALETTES; BUSTIERS; CAPS; COATS; DENIM JACKETS; DENIMS; DRESSES; FUR HATS; FUR JACKETS; GLOVES; GLOVES FOR PERSONAL HAND CONDITIONING USE; HATS; JACKETS; MEN'S AND WOMEN'S JACKETS, COATS, TROUSERS, VESTS; MEN'S DRESS SOCKS; MORNING COATS; PANTIES; PANTS; ROBES; SCARVES; SHIRTS; SHORTS; SKIRTS; SLEEPWEAR; SOCKS; STOCKINGS; STOCKINGS; SWEATERS; SWEATPANTS; SWEATSHIRTS; SWIMWEAR; T-SHIRTS; TANK-TOPS; TIGHTS; TOP COATS; TUNICS (U.S. CLS. 22 AND 39).

FIRST USE 12-9-2010; IN COMMERCE 12-25-2010.

ELLEN PERKINS, EXAMINING ATTORNEY

THE MARK CONSISTS OF AN INCOMPLETE CIRCLE OUTLINE WITH TWO SOLID TRIANGLES AND TWO CYLINDER DESIGNS INSIDE. THE CYLINDER DESIGN ON THE LEFT HAS ONE TIP, AND THE CYLINDER DESIGN ON THE RIGHT HAS TWO TIPS. THERE ARE ANOTHER TWO CYLINDER DESIGNS IN THE LEFT TRIANGLE.

FOR SHOES (U.S. CLS. 22 AND 39).

FIRST USE 11-30-2010; IN COMMERCE 11-30-2010.

RONALD DELGIZZI, EXAMINING ATTORNEY

**CLASS 25—(Continued).**

SN 85-211,430. HALF OUNCE OF LIFE LLC, AKA HALF OUNCE OF LIFE CLOTHING, HARRISBURG, PA. FILED 1-5-2011.



THE MARK CONSISTS OF A STYLIZED LETTER H. FOR A-SHIRTS; APPAREL FOR DANCERS, NAMELY, TEE SHIRTS, SWEATSHIRTS, PANTS, LEGGINGS, SHORTS AND JACKETS; ATHLETIC APPAREL, NAMELY, SHIRTS, PANTS, JACKETS, FOOTWEAR, HATS AND CAPS, ATHLETIC UNIFORMS; BANDANAS; BASEBALL CAPS; BASEBALL CAPS AND HATS; BEANIES; BELTS; BELTS FOR CLOTHING; BELTS MADE FROM IMITATION LEATHER; BELTS MADE OF LEATHER; BELTS MADE OUT OF CLOTH; BELTS OF TEXTILE; BLAZERS; BLOUSES; BOARD SHORTS; BODY LINEN; BODY SHIRTS; BODY SUITS; BOMBER JACKETS; BOTTOMS; BOW TIES; BOXER BRIEFS; BOXER SHORTS; BRIEFS; BRIEFS; BUTTON DOWN SHIRTS; CANVAS SHOES; CAPRI PANTS; CAPRIS; CAPS; CAPS WITH VISORS; CARDIGANS; CARGO PANTS; CLOTHING ITEMS, NAMELY, ADHESIVE POCKETS THAT MAY BE AFFIXED DIRECTLY TO THE BODY AS A DECORATIVE PIECE OF CLOTHING WITH UTILITY; CLOTHING ITEMS, NAMELY, ADHESIVE POCKETS THAT MAY BE AFFIXED DIRECTLY TO THE INSIDE OF CLOTHING FOR STORAGE AND SAFEKEEPING OF PERSONAL ITEMS; CLOTHING SHIELDS, NAMELY, PADS APPLIED TO THE UNDERARMS OF SHIRTS, BLOUSES AND SWEATERS; CLOTHING, NAMELY, KHAKIS; CLOTHING, NAMELY, WRAP-AROUNDS; COATS; COATS FOR MEN AND WOMEN; COATS MADE OF COTTON; COATS OF DENIM; COLLAR PROTECTORS; COLLARED SHIRTS; CORSETS; CREW NECK SWEATERS; CREW NECKS; CROP TOPS; DENIM JACKETS; DENIMS; DRESS PANTS; DRESS SHIRTS; DRESSES; FABRIC BELTS; FABRIC SOLD AS AN INTEGRAL COMPONENT OF FINISHED CLOTHING ITEMS, NAMELY, SHIRTS; FLEECE PULLOVERS; FLEECE TOPS; FLEECE VESTS; FOOTWEAR FOR MEN; G-STRINGS; GOLF PANTS, SHIRTS AND SKIRTS; HOODED PULLOVERS; HOODED SWEAT SHIRTS; HOODED SWEATSHIRTS; JACKETS; JEANS; JEGGINGS, NAMELY, PANTS THAT ARE PARTIALLY JEANS AND PARTIALLY LEGGINGS; KNIT TOPS; LADIES' UNDERWEAR; LEATHER BELTS; LEATHER COATS; LEATHER JACKETS; LEGGINGS; LONG

**CLASS 25—(Continued).**

JOHNS; LONG SLEEVE PULLOVERS; LONG-SLEEVED SHIRTS; MEN'S AND WOMEN'S JACKETS, COATS, TROUSERS, VESTS; MEN'S SUITS, WOMEN'S SUITS; MEN'S UNDERWEAR; MINISKIRTS; PANTIES, SHORTS AND BRIEFS; PANTS; POLO KNIT TOPS; POLO SHIRTS; SHIRTS; SHIRTS AND SHORT-SLEEVED SHIRTS; SHORT-SLEEVED OR LONG-SLEEVED T-SHIRTS; SHORT-SLEEVED SHIRTS; SHORTS; SKIRTS AND DRESSES; SKULL CAPS; SKULLIES; SNOW BOARDING SUITS; SNOWBOARD JACKETS; SOCKS; SPORT COATS; SPORTS CAPS AND HATS; SWEAT JACKETS; SWEAT PANTS; SWEAT SHIRTS; SWEATERS; SWEATPANTS; SWEATSHIRTS; SWEATSUITS; SWIM WEAR FOR GENTLEMEN AND LADIES; T-SHIRTS; TANK TOPS; TEE SHIRTS; THERMAL UNDERWEAR; THONGS; TIES; TOPS; TRACK JACKETS; TRACK PANTS; TRACK SUITS; TRACKSUITS; TUBE TOPS; UNDERSHIRTS; UNDERWEAR; UNDERWEAR, NAMELY, BOY SHORTS; V-NECK SWEATERS; VESTS; WOMEN'S HATS AND HOODS; WOMEN'S UNDERWEAR; WOVEN TOPS (U.S. CLS. 22 AND 39).

FIRST USE 11-20-2008; IN COMMERCE 11-20-2008.  
PATRICIA EVANKO, EXAMINING ATTORNEY

SN 85-211,434. VALERIUS, DAPHNE, LOS ANGELES, CA. FILED 1-5-2011.

i.am.her

THE MARK CONSISTS OF STANDARD CHARACTERS WITHOUT CLAIM TO ANY PARTICULAR FONT, STYLE, SIZE, OR COLOR.

FOR T-SHIRTS (U.S. CLS. 22 AND 39).  
PAUL E. FAHRENKOPF, EXAMINING ATTORNEY

SN 85-211,459. ALEXANDRE KRASDEV, HUNTINGTON BEACH, CA. FILED 1-5-2011.

Future Seas

THE MARK CONSISTS OF STANDARD CHARACTERS WITHOUT CLAIM TO ANY PARTICULAR FONT, STYLE, SIZE, OR COLOR.

FOR SHORT-SLEEVED OR LONG-SLEEVED T-SHIRTS (U.S. CLS. 22 AND 39).  
STEVEN JACKSON, EXAMINING ATTORNEY

**CLASS 25—(Continued).**

SN 85-211,492. SEBOLD, MEGHAN CASHMAN, BROOKLYN, NY. FILED 1-5-2011.

# AFIA

THE MARK CONSISTS OF STANDARD CHARACTERS WITHOUT CLAIM TO ANY PARTICULAR FONT, STYLE, SIZE, OR COLOR.

FOR BOTTOMS; DRESSES; FABRIC BELTS; ROMPERS; SHORTS; SKIRTS; TIES; TOPS (U.S. CLS. 22 AND 39).

CHERYL CLAYTON, EXAMINING ATTORNEY

**CLASS 25—(Continued).**

SN 85-211,551. SHILSON, CHAD, MAPLE GROVE, MN. FILED 1-6-2011.

# BROKENEAR

THE MARK CONSISTS OF STANDARD CHARACTERS WITHOUT CLAIM TO ANY PARTICULAR FONT, STYLE, SIZE, OR COLOR.

FOR CLOTHING, NAMELY SHIRTS, HATS, JACKETS, SWEATSHIRTS (U.S. CLS. 22 AND 39).

NICHOLAS COLEMAN, EXAMINING ATTORNEY

SN 85-211,548. WICKETT, AMANDA, COLORADO SPRINGS, CO. FILED 1-6-2011.

# WE'RE TAKING IT BACK!

THE MARK CONSISTS OF STANDARD CHARACTERS WITHOUT CLAIM TO ANY PARTICULAR FONT, STYLE, SIZE, OR COLOR.

FOR CLOTHING, NAMELY, CAPS, APRONS, WRIST BANDS (U.S. CLS. 22 AND 39).

DORITT L. CARROLL, EXAMINING ATTORNEY

SN 85-211,657. WHITE, ANDREW, EAST PROVIDENCE, RI. FILED 1-6-2011.

# Beyond All Reach

THE MARK CONSISTS OF STANDARD CHARACTERS WITHOUT CLAIM TO ANY PARTICULAR FONT, STYLE, SIZE, OR COLOR.

FOR JACKETS; SHIRTS; SWEATSHIRTS (U.S. CLS. 22 AND 39).

KARANENDRA S. CHHINA, EXAMINING ATTORNEY

SN 85-211,549. SHILSON, CHAD, MAPLE GROVE, MN. FILED 1-6-2011.

# BROKEN EAR

THE MARK CONSISTS OF STANDARD CHARACTERS WITHOUT CLAIM TO ANY PARTICULAR FONT, STYLE, SIZE, OR COLOR.

FOR CLOTHING, NAMELY, SHIRTS, HATS, JACKETS, SWEATSHIRTS (U.S. CLS. 22 AND 39).

NICHOLAS COLEMAN, EXAMINING ATTORNEY

SN 85-211,716. HOLMES, ASHLEY, FRANKLIN LAKES, NJ. FILED 1-6-2011.

# P.ASH.N

THE MARK CONSISTS OF STANDARD CHARACTERS WITHOUT CLAIM TO ANY PARTICULAR FONT, STYLE, SIZE, OR COLOR.

FOR DENIMS; FOOTWEAR; SWEATSHIRTS; T-SHIRTS (U.S. CLS. 22 AND 39).

WENDY JUN, EXAMINING ATTORNEY



**CLASS 25—(Continued).**

SN 85-211,726. BBBT, LLC, NEW EGYPT, NJ. FILED 1-6-2011.

**BLAST IN A GLASS**

THE MARK CONSISTS OF STANDARD CHARACTERS WITHOUT CLAIM TO ANY PARTICULAR FONT, STYLE, SIZE, OR COLOR.  
FOR WEARABLE GARMENTS AND CLOTHING, NAMELY, SHIRTS (U.S. CLS. 22 AND 39).  
STEPHANIE ALI, EXAMINING ATTORNEY

**CLASS 25—(Continued).**

SN 85-211,873. DESSY MARKETING & DISTRIBUTION, INC., NEW YORK, NY. FILED 1-6-2011.

**SOCIAL BRIDESMAIDS**

THE MARK CONSISTS OF STANDARD CHARACTERS WITHOUT CLAIM TO ANY PARTICULAR FONT, STYLE, SIZE, OR COLOR.  
NO CLAIM IS MADE TO THE EXCLUSIVE RIGHT TO USE "BRIDESMAIDS", APART FROM THE MARK AS SHOWN.  
FOR BRIDESMAID DRESSES, FORMAL DRESSES, AND OTHER SPECIAL OCCASION DRESSES, AND RELATED BRIDAL PARTY ACCESSORIES, NAMELY, BRIDESMAIDS SHOES AND TIES FOR GROOMSMEN (U.S. CLS. 22 AND 39).  
KEVON CHISOLM, EXAMINING ATTORNEY

SN 85-211,813. SCHERING-PLOUGH HEALTHCARE PRODUCTS, INC., MEMPHIS, TN. FILED 1-6-2011.

**ENERGY RENEWAL**

THE MARK CONSISTS OF STANDARD CHARACTERS WITHOUT CLAIM TO ANY PARTICULAR FONT, STYLE, SIZE, OR COLOR.  
FOR FOOTWEAR (U.S. CLS. 22 AND 39).  
AISHA CLARKE, EXAMINING ATTORNEY

SN 85-211,878. DEBRA J. READING, CARY, IL. FILED 1-6-2011.

SN 85-211,815. FRONZIE, LLC, LENEXA, KS. FILED 1-6-2011.



**THERMA-HEAT**

THE MARK CONSISTS OF A BOX WITH ROUNDED CORNERS ENCLOSING TWO CHEVRONS POINTING TO THE RIGHT WITH A DOT LOCATED WITHIN THE LEFT CHEVRON.  
FOR SWIM WEAR (U.S. CLS. 22 AND 39).  
AISHA CLARKE, EXAMINING ATTORNEY

THE MARK CONSISTS OF STANDARD CHARACTERS WITHOUT CLAIM TO ANY PARTICULAR FONT, STYLE, SIZE, OR COLOR.  
FOR PATIENT SLIPPERS; SLIPPER SOCKS; SLIPPER SOLES; SLIPPERS; WOMEN'S FOLDABLE SLIPPERS (U.S. CLS. 22 AND 39).  
FIRST USE 10-11-2010; IN COMMERCE 10-15-2010.  
APRIL HESIK, EXAMINING ATTORNEY

**CLASS 25—(Continued).**

SN 85-212,211. GREYWELL LLC, AKA GREYWELL, WEST CALDWELL, NJ. FILED 1-6-2011.



COLOR IS NOT CLAIMED AS A FEATURE OF THE MARK. THE MARK CONSISTS OF A STYLIZED FORM OF THE LETTER "G".

FOR COATS; COATS FOR MEN AND WOMEN; COATS MADE OF COTTON; COATS OF DENIM; CUSTOM MADE TO MEASURE SUITS FOR MEN AND WOMEN; DENIM JACKETS; DENIMS; DRESS SUITS; LEISURE SUITS; MEN'S AND WOMEN'S JACKETS, COATS, TROUSERS, VESTS; MEN'S SUITS, WOMEN'S SUITS; OVER COATS; SHIRTS FOR SUITS; SPORT COATS; SUIT COATS; SUITS OF LEATHER; SWEAT SUITS; TOP COATS; TRENCH COATS; VESTED SUITS (U.S. CLS. 22 AND 39).

FIRST USE 8-24-2010; IN COMMERCE 10-3-2010.  
CIMMERIAN COLEMAN, EXAMINING ATTORNEY

**CLASS 25—(Continued).**

SN 85-212,339. THE TOPLINE CORPORATION, BELLEVUE, WA. FILED 1-6-2011.



THE MARK CONSISTS OF THE WORDS "CEDAR" AND "SPRUCE" AND TWO CURVED LINES FORMING PART OF AN INCOMPLETE CIRCLE THAT SURROUNDS A STYLIZED LETTER "C" AND A STYLIZED LETTER "S" FORMING A STYLIZED AMPERSAND.

FOR FOOTWEAR (U.S. CLS. 22 AND 39).  
EDWARD NELSON, EXAMINING ATTORNEY

SN 85-212,345. THE TOPLINE CORPORATION, BELLEVUE, WA. FILED 1-6-2011.

SN 85-212,330. THE TOPLINE CORPORATION, BELLEVUE, WA. FILED 1-6-2011.



THE MARK CONSISTS OF THE WORDS CEDAR SPRUCE WITH A STYLIZED LETTER "C" AND A STYLIZED LETTER "S" FORMING A STYLIZED AMPERSAND.  
FOR FOOTWEAR (U.S. CLS. 22 AND 39).  
EDWARD NELSON, EXAMINING ATTORNEY

THE MARK CONSISTS OF A STYLIZED LETTER "C" AND A STYLIZED LETTER "S" FORMING A STYLIZED AMPERSAND.  
FOR FOOTWEAR (U.S. CLS. 22 AND 39).  
EDWARD NELSON, EXAMINING ATTORNEY

**CLASS 25—(Continued).**

SN 85-212,433. EDDIE JOHNSON LLC, WASHINGTON, DC. FILED 1-6-2011.

## EDDIE JOHNSON

THE MARK CONSISTS OF STANDARD CHARACTERS WITHOUT CLAIM TO ANY PARTICULAR FONT, STYLE, SIZE, OR COLOR.

THE NAME(S), PORTRAIT(S), AND/OR SIGNATURE(S) SHOWN IN THE MARK IDENTIFIES EDDIE JOHNSON, WHOSE CONSENT(S) TO REGISTER IS MADE OF RECORD.

FOR ASCOTS; KERCHIEFS; SCARVES; TIES (U.S. CLS. 22 AND 39).

FIRST USE 1-1-1997; IN COMMERCE 5-1-1997.  
KRISTINA MORRIS, EXAMINING ATTORNEY

SN 85-212,489. CECIL MARVIN NEAL, DULUTH, GA. FILED 1-7-2011.

## MRVLUS

THE MARK CONSISTS OF STANDARD CHARACTERS WITHOUT CLAIM TO ANY PARTICULAR FONT, STYLE, SIZE, OR COLOR.

FOR HATS; T-SHIRTS (U.S. CLS. 22 AND 39).  
REBECCA POVARCHUK, EXAMINING ATTORNEY

SN 85-212,503. SHEEP IN THE ROAD, LLC, PEMBROKE, MA. FILED 1-7-2011.

## SHEEP IN THE ROAD

THE MARK CONSISTS OF STANDARD CHARACTERS WITHOUT CLAIM TO ANY PARTICULAR FONT, STYLE, SIZE, OR COLOR.

FOR APRONS; BEACH COVER-UPS; BELTS; BLOUSES; CAPS; CLOTH BIBS; DRESSES; FLEECE PULLOVERS; FOOTWEAR; GLOVES; HATS; JACKETS; MITTENS; ONE-PIECE GARMENTS FOR CHILDREN; PAJAMAS; PANTS; RAINWEAR; SCARVES; SHAWLS; SHIRTS; SHORTS; SKIRTS; SLIPPERS; SOCKS; SWEATERS; SWEATSHIRTS; SWIMWEAR; TIES; TOPS; UNDERWEAR; VESTS; WARM-UP SUITS (U.S. CLS. 22 AND 39).

EUGENIA MARTIN, EXAMINING ATTORNEY

**CLASS 25—(Continued).**

SN 85-212,550. TRAILERLOGIC, DBA MORTUARY RESPONSE SOLUTIONS, BELTON, SC. FILED 1-7-2011.

 The logo for MRS consists of three slanted vertical lines to the left of the letters "MRS" in a bold, italicized, sans-serif font.

THE MARK CONSISTS OF SLANTED VERTICAL LINES AND THE LETTERS MRS.

FOR CLOTHING, NAMELY, CAPS (U.S. CLS. 22 AND 39).

FIRST USE 1-31-2010; IN COMMERCE 1-31-2010.  
KHANH LE, EXAMINING ATTORNEY

SN 85-212,580. BALLINGER, RONALD, ROCK HILL, SC. FILED 1-7-2011.

## Docu-Gloves

THE MARK CONSISTS OF STANDARD CHARACTERS WITHOUT CLAIM TO ANY PARTICULAR FONT, STYLE, SIZE, OR COLOR.

FOR GLOVES (U.S. CLS. 22 AND 39).  
INGRID C. EULIN, EXAMINING ATTORNEY

SN 85-212,612. ROBINSON, PEARLENE, SAN ANTONIO, TX. FILED 1-7-2011.

 The logo for God Inspired Writing features the words "GOD INSPIRED" in a bold, serif font, with a cross symbol above the letter "I" in "INSPIRED". Below "GOD INSPIRED" is the word "WRITING" in a smaller, bold, serif font. To the right of the text is a stylized quill pen.

THE STIPPLING IS FOR SHADING PURPOSES ONLY. THE MARK CONSISTS OF THE STYLIZED TEXT "GOD INSPIRED WRITING" WITH A CROSS IN PLACE OF THE LETTER "I" AND AT THE END OF WRITING IS A OLD STYLE FEATHERED TIPPED PIN.

FOR T-SHIRTS (U.S. CLS. 22 AND 39).  
DAVID TAYLOR, EXAMINING ATTORNEY

**CLASS 25—(Continued).**

SN 85-212,783. RITTNER, KARL, CITY OF INDUSTRY, CA.  
FILED 1-7-2011.

121Boulevard.com

THE MARK CONSISTS OF STANDARD CHARACTERS WITHOUT CLAIM TO ANY PARTICULAR FONT, STYLE, SIZE, OR COLOR.

FOR SHIRTS; PANTS; JACKETS; FOOTWEAR; HATS AND CAPS; ATHLETIC UNIFORMS; BELTS; BLAZERS; BLOUSES; BOOTS; BRAS; BUSTIERS; CAMISOLES; CORSETS; DRESSES; GARTER BELTS; GLOVES; HEELS; HOODED SWEAT SHIRTS; HOSIERY; JACKETS; JEANS; LINGERIE; MITTENS; PANTIES; PANTS; ROBES; SANDALS; SHIRTS; SHOES; SHORTS; SLEEPWEAR; SLIPS; SOCKS; SPORT COATS; SUITS; SWEAT SHIRTS; SWEATERS; SWIM WEAR; TANK TOPS; TEDDIES; TOPS; UNDERWEAR; WEDDING DRESSES; SKIRTS; MASQUERADE COSTUMES (U.S. CLS. 22 AND 39).

APRIL ROACH, EXAMINING ATTORNEY

**CLASS 25—(Continued).**

SN 85-212,843. GREENE JR., OSWALD, DEER PARK, NY.  
FILED 1-7-2011.



THE MARK CONSISTS OF AN ALIEN HEAD WITH HEADPHONE ON ITS EARS. THE TEXT "NOKU" APPEARS ON TOP OF THE ALIEN HEAD, AND THE TEXT "APPARELLAX" APPEARS BELOW THE ALIEN HEAD.

THE WORDING NOKU APPARELLAX HAS NO MEANING IN A FOREIGN LANGUAGE.

FOR BOOTS; CAPS; COATS; GLOVES; HATS; JACKETS; PANTS; ROBES; SCARVES; SHOES; SLEEPWEAR; SNEAKERS; SOCKS; SWEATERS; SWEATPANTS; SWEATSHIRTS; T-SHIRTS (U.S. CLS. 22 AND 39).

HEATHER BIDDULPH, EXAMINING ATTORNEY

SN 85-212,866. HIGH POINT DESIGN LLC, NEW YORK, NY.  
FILED 1-7-2011.

FUZZY BABBA

THE MARK CONSISTS OF STANDARD CHARACTERS WITHOUT CLAIM TO ANY PARTICULAR FONT, STYLE, SIZE, OR COLOR.

FOR SLIPPERS, SLIPPER SOCKS, SOCKS, BOOTIES (U.S. CLS. 22 AND 39).

FIRST USE 8-6-2010; IN COMMERCE 8-6-2010.

EUGENIA MARTIN, EXAMINING ATTORNEY

ROADHOUSE

SN 85-212,975. F&M HAT COMPANY, INC., DENVER, PA.  
FILED 1-7-2011.

BLACK CREEK

THE MARK CONSISTS OF STANDARD CHARACTERS WITHOUT CLAIM TO ANY PARTICULAR FONT, STYLE, SIZE, OR COLOR.

FOR CAPRI PANTS; CARGO PANTS; DENIM JACKETS; DENIMS; DRESSES; JACKETS; KNIT TOPS; POLO SHIRTS; SHIRTS; SWEAT SHIRTS; T-SHIRTS; TOPS (U.S. CLS. 22 AND 39).

FIRST USE 11-4-2010; IN COMMERCE 1-1-2011.

KYLE PEETE, EXAMINING ATTORNEY

THE MARK CONSISTS OF STANDARD CHARACTERS WITHOUT CLAIM TO ANY PARTICULAR FONT, STYLE, SIZE, OR COLOR.

FOR HATS (U.S. CLS. 22 AND 39).

FIRST USE 5-0-2008; IN COMMERCE 5-0-2008.

MARIA-VICTORIA SUAREZ, EXAMINING ATTORNEY

**CLASS 25—(Continued).**

SN 85-212,979. F&M HAT COMPANY, INC., DENVER, PA. FILED 1-7-2011.



THE MARK CONSISTS OF A LEAF DESIGN WITHIN AN INCOMPLETE CIRCLE OVER THE PHRASE "BLACK CREEK".

FOR HATS (U.S. CLS. 22 AND 39).  
FIRST USE 5-0-2008; IN COMMERCE 5-0-2008.  
MARIA-VICTORIA SUAREZ, EXAMINING ATTORNEY

SN 85-213,029. PINKETTE CLOTHING, INC., LOS ANGELES, CA. FILED 1-7-2011.

**LOVEWELL**

THE MARK CONSISTS OF STANDARD CHARACTERS WITHOUT CLAIM TO ANY PARTICULAR FONT, STYLE, SIZE, OR COLOR.

FOR CLOTHING, NAMELY TOPS, BOTTOMS AND DRESSES (U.S. CLS. 22 AND 39).  
JANICE KIM, EXAMINING ATTORNEY

SN 85-213,406. SEATOWN HULL LLC, HULL, MA. FILED 1-8-2011.

**START WITH LOVE**

THE MARK CONSISTS OF STANDARD CHARACTERS WITHOUT CLAIM TO ANY PARTICULAR FONT, STYLE, SIZE, OR COLOR.

FOR HOODED SWEATSHIRTS; SHORT-SLEEVED OR LONG-SLEEVED T-SHIRTS; SWEATSHIRTS; T-SHIRTS (U.S. CLS. 22 AND 39).  
LAURA HAMMEL, EXAMINING ATTORNEY

**CLASS 25—(Continued).**

SN 85-213,408. SEATOWN HULL LLC, HULL, MA. FILED 1-8-2011.

**MY HEART'S IN**

THE MARK CONSISTS OF STANDARD CHARACTERS WITHOUT CLAIM TO ANY PARTICULAR FONT, STYLE, SIZE, OR COLOR.

FOR HOODED SWEATSHIRTS; SHORT-SLEEVED OR LONG-SLEEVED T-SHIRTS; SWEATSHIRTS; T-SHIRTS (U.S. CLS. 22 AND 39).  
LAURA HAMMEL, EXAMINING ATTORNEY

SN 85-213,414. 100% OFFICIAL, WEST HAVEN, CT. FILED 1-8-2011.

**100% OFFICIAL**

THE MARK CONSISTS OF STANDARD CHARACTERS WITHOUT CLAIM TO ANY PARTICULAR FONT, STYLE, SIZE, OR COLOR.

FOR CLOTHING, NAMELY, SHIRTS (U.S. CLS. 22 AND 39).  
DANNEAN HETZEL, EXAMINING ATTORNEY

SN 85-213,415. J S YACHTS INC., PORT ST. LUCIE, FL. FILED 1-8-2011.

**THE BITCH SWITCH**

THE MARK CONSISTS OF STANDARD CHARACTERS WITHOUT CLAIM TO ANY PARTICULAR FONT, STYLE, SIZE, OR COLOR.

FOR CLOTHING, NAMELY, SHIRTS, HATS (U.S. CLS. 22 AND 39).  
DANNEAN HETZEL, EXAMINING ATTORNEY

**CLASS 25—(Continued).**

SN 85-213,511. WILLIAMS, EMORY L., MIAMI, FL. FILED 1-8-2011.

**PRO DAY**

THE MARK CONSISTS OF STANDARD CHARACTERS WITHOUT CLAIM TO ANY PARTICULAR FONT, STYLE, SIZE, OR COLOR.

OWNER OF U.S. REG. NO. 3,343,140.  
FOR ATHLETIC FOOTWEAR (U.S. CLS. 22 AND 39).  
FIRST USE 8-30-2008; IN COMMERCE 8-30-2008.  
ARETHA SOMERVILLE, EXAMINING ATTORNEY

**CLASS 25—(Continued).**

SN 85-213,939. TIMES THREE CLOTHIER, LLC, NEW YORK, NY. FILED 1-10-2011.

**LIVE.SHAPE.HAPPY.**

THE MARK CONSISTS OF STANDARD CHARACTERS WITHOUT CLAIM TO ANY PARTICULAR FONT, STYLE, SIZE, OR COLOR.

FOR CLOTHING, NAMELY, SWIMWEAR, COATS, JACKETS, VESTS, DRESSES, SHIRTS, SWEATERS, PANTS, UNDERGARMENTS, LINGERIE, SLEEPWEAR, SHORTS, SKIRTS, HOSIERY, LEGGINGS, FOOTWEAR, AND BODYSUITS (U.S. CLS. 22 AND 39).  
HEATHER SAPP, EXAMINING ATTORNEY

SN 85-213,524. KENT J RODRIGUEZ, TYLER, TX. FILED 1-8-2011.

**BLOOD BROTHERS**

THE MARK CONSISTS OF STANDARD CHARACTERS WITHOUT CLAIM TO ANY PARTICULAR FONT, STYLE, SIZE, OR COLOR.

FOR ATHLETIC APPAREL, NAMELY, SHIRTS, PANTS, JACKETS, FOOTWEAR, HATS AND CAPS, ATHLETIC UNIFORMS (U.S. CLS. 22 AND 39).  
EUGENIA MARTIN, EXAMINING ATTORNEY

SN 85-214,217. ANJELIER NIJMEGEN B.V., 6544 AG NIJMEGEN, NETHERLANDS, FILED 1-10-2011.



THE MARK CONSISTS OF THE TERM STADELMAIER WITH STYLIZED LETTERS SN OVER THE LETTERS ELMAIER WITH A SEWING NEEDLE BETWEEN THE LETTERS S AND N.

FOR CANONICAL CLOTHING, NAMELY CHASUBLES, ALBS, STOLES, COPE, PRAYER ROBES AND CLERGY SHIRTS (U.S. CLS. 22 AND 39).  
FIRST USE 5-0-2004; IN COMMERCE 5-0-2004.  
HELENE LIWINSKI, EXAMINING ATTORNEY

SN 85-213,787. LOUISE PARIS LTD., NEW YORK, NY. FILED 1-10-2011.

**FLIRTYJANE**

THE MARK CONSISTS OF STANDARD CHARACTERS WITHOUT CLAIM TO ANY PARTICULAR FONT, STYLE, SIZE, OR COLOR.

FOR WEARING APPAREL FOR WOMEN, GIRLS' AND BABIES, NAMELY JACKETS, COATS, PANTS, SHORTS, ROMPERS, SHIRTS, TOPS, SWEATERS, VESTS, SUITS, DRESSES, SKIRTS, HATS, LEGGINGS AND HOSIERY (U.S. CLS. 22 AND 39).  
MARIA-VICTORIA SUAREZ, EXAMINING ATTORNEY

SN 85-214,268. BRANCH, BRADLEY, NEWPORT BEACH, CA. FILED 1-10-2011.

**definitely not low**

THE MARK CONSISTS OF STANDARD CHARACTERS WITHOUT CLAIM TO ANY PARTICULAR FONT, STYLE, SIZE, OR COLOR.

FOR BEANIES; BOXER SHORTS; BUTTON DOWN SHIRTS; CLOTHING FOR ATHLETIC USE, NAMELY, PADDED PANTS; DENIMS; DRESS PANTS; HATS; HOODED SWEAT SHIRTS; LONG-SLEEVED SHIRTS; PANTS; SHORT-SLEEVED SHIRTS; SHORTS; SNOWBOARD JACKETS; SNOWBOARD PANTS; SOCKS; SWEAT PANTS; SWEAT SHIRTS; THERMAL SOCKS; WIND RESISTANT JACKETS (U.S. CLS. 22 AND 39).  
CHERYL CLAYTON, EXAMINING ATTORNEY

**CLASS 25—(Continued).**

SN 85-214,481. CURIODYSSEY, SAN MATEO, CA. FILED 1-10-2011.

**CURIODYSSEY**

THE MARK CONSISTS OF STANDARD CHARACTERS WITHOUT CLAIM TO ANY PARTICULAR FONT, STYLE, SIZE, OR COLOR.

FOR CLOTHING, NAMELY, SHIRTS, JACKETS AND HEADWEAR (U.S. CLS. 22 AND 39).

WILLIAM BRECKENFELD, EXAMINING ATTORNEY

SN 85-214,794. GLOBAL TRADEMARKS, INC., STOCKERTOWN, PA. FILED 1-11-2011.

**HYDROSHAPER**

THE MARK CONSISTS OF STANDARD CHARACTERS WITHOUT CLAIM TO ANY PARTICULAR FONT, STYLE, SIZE, OR COLOR.

FOR SWIMWEAR (U.S. CLS. 22 AND 39).

JILL PRATER, EXAMINING ATTORNEY

SN 85-215,569. SOCK AND ACCESSORY BRANDS GLOBAL, LLC, MOCKSVILLE, NC. FILED 1-12-2011.

**MIXAROOS**

THE MARK CONSISTS OF STANDARD CHARACTERS WITHOUT CLAIM TO ANY PARTICULAR FONT, STYLE, SIZE, OR COLOR.

FOR SOCKS AND HOSIERY (U.S. CLS. 22 AND 39).

ANNE FARRELL, EXAMINING ATTORNEY

SN 85-216,241. BBBT, LLC, NEW EGYPT, NJ. FILED 1-12-2011.

**WALKING HOLIDAY**

THE MARK CONSISTS OF STANDARD CHARACTERS WITHOUT CLAIM TO ANY PARTICULAR FONT, STYLE, SIZE, OR COLOR.

FOR WEARABLE GARMENTS AND CLOTHING, NAMELY, SHIRTS (U.S. CLS. 22 AND 39).

STEPHANIE ALI, EXAMINING ATTORNEY

**CLASS 25—(Continued).**

SN 85-216,242. WARNER BROS. ENTERTAINMENT INC., BURBANK, CA. FILED 1-12-2011.

**HARRY POTTER AND THE PRISONER OF AZKABAN**

THE MARK CONSISTS OF STANDARD CHARACTERS WITHOUT CLAIM TO ANY PARTICULAR FONT, STYLE, SIZE, OR COLOR.

OWNER OF U.S. REG. NOS. 2,530,755, 2,685,932 AND OTHERS.

FOR CLOTHING FOR MEN, WOMEN AND CHILDREN - NAMELY, SHIRTS, T-SHIRTS, SWEATSHIRTS, JOGGING SUITS, TROUSERS, PANTS, SHORTS, TANK TOPS, RAINWEAR, CLOTH BABY BIBS, SKIRTS, BLOUSES, DRESSES, SUSPENDERS, SWEATERS, JACKETS, COATS, RAINCOATS, SNOW SUITS, TIES, ROBES, HATS, CAPS, SUNVISORS, BELTS, SCARVES, SLEEPWEAR, PAJAMAS, LINGERIE, UNDERWEAR, BOOTS, SHOES, SNEAKERS, SANDALS, SOCKS, BOOTIES, SLIPPER SOCKS, SWIMWEAR AND MASQUERADE AND HALLOWEEN COSTUMES AND MASKS SOLD IN CONNECTION THEREWITH (U.S. CLS. 22 AND 39).

PRISCILLA MILTON, EXAMINING ATTORNEY

SN 85-216,278. BBBT, LLC, NEW EGYPT, NJ. FILED 1-12-2011.

**PARTY IN A BODY**

THE MARK CONSISTS OF STANDARD CHARACTERS WITHOUT CLAIM TO ANY PARTICULAR FONT, STYLE, SIZE, OR COLOR.

FOR WEARABLE GARMENTS AND CLOTHING, NAMELY, SHIRTS (U.S. CLS. 22 AND 39).

STEPHANIE ALI, EXAMINING ATTORNEY

SN 85-216,671. PICALATA PRODUCTIONS, LLC, PONTEVEDRA, FL. FILED 1-13-2011.

**PICALATA KIDS**

THE MARK CONSISTS OF STANDARD CHARACTERS WITHOUT CLAIM TO ANY PARTICULAR FONT, STYLE, SIZE, OR COLOR.

NO CLAIM IS MADE TO THE EXCLUSIVE RIGHT TO USE "KIDS", APART FROM THE MARK AS SHOWN.

FOR SHIRTS AND PAJAMAS (U.S. CLS. 22 AND 39).

RAMONA ORTIGA, EXAMINING ATTORNEY

**CLASS 25—(Continued).**

SN 85-219,301. GLOBAL TRADEMARKS, INC., STOCKERTOWN, PA. FILED 1-17-2011.

## ECO BABE

THE MARK CONSISTS OF STANDARD CHARACTERS WITHOUT CLAIM TO ANY PARTICULAR FONT, STYLE, SIZE, OR COLOR.

FOR COVERUPS; SWIMWEAR (U.S. CLS. 22 AND 39).  
JILL PRATER, EXAMINING ATTORNEY

SN 85-220,961. CLIFF CHISM, VALLEJO, CA. FILED 1-19-2011.

## ZILLA'S HOUSE

THE MARK CONSISTS OF STANDARD CHARACTERS WITHOUT CLAIM TO ANY PARTICULAR FONT, STYLE, SIZE, OR COLOR.

FOR ATHLETIC APPAREL, NAMELY, SHIRTS, PANTS, JACKETS, FOOTWEAR, HATS AND CAPS, ATHLETIC UNIFORMS; BELTS FOR CLOTHING; COLARED SHIRTS; DRESS SHIRTS; FOOTWEAR; HEADBANDS; JERSEYS; SHIRTS; SHIRTS AND SHORT-SLEEVED SHIRTS; SLEEVED OR SLEEVELESS JACKETS; SWEATSHIRTS; T-SHIRTS (U.S. CLS. 22 AND 39).  
KATHERINE M. DUBRAY, EXAMINING ATTORNEY

SN 85-222,271. SEATOWN HULL LLC, HULL, MA. FILED 1-20-2011.



THE MARK CONSISTS OF A HEART IMAGE WITH THE WORD "MY" ABOVE THE HEART IMAGE, THE WORD "IN" UNDER THE HEART IMAGE, AND AN APOSTROPHE FOLLOWED BY THE LETTER "S" TO THE RIGHT OF THE HEART IMAGE.

FOR HOODED SWEATSHIRTS; SHORT-SLEEVED OR LONG-SLEEVED T-SHIRTS; SWEATSHIRTS; T-SHIRTS (U.S. CLS. 22 AND 39).

LAURA HAMMEL, EXAMINING ATTORNEY

**CLASS 25—(Continued).**

SN 85-222,932. ABERCROMBIE & FITCH TRADING CO., NEW ALBANY, OH. FILED 1-21-2011.

OWNER OF U.S. REG. NOS. 3,836,281, 3,849,017 AND OTHERS.

THE NAME(S), PORTRAIT(S), AND/OR SIGNATURE(S) SHOWN IN THE MARK DOES NOT IDENTIFY A PARTICULAR LIVING INDIVIDUAL.

THE MARK CONSISTS OF A STYLIZATION OF THE PHRASE "GILLY HICKS."

FOR BELTS; BOTTOMS; COATS; DRESSES; FOOTWEAR; GLOVES; HEADWEAR; JACKETS; LEGGINGS; LINGERIE; SCARVES; SLEEPWEAR; SWIM WEAR; TOPS; UNDERGARMENTS (U.S. CLS. 22 AND 39).

JOHN DALIER, EXAMINING ATTORNEY

SN 85-223,719. LITTLE, JASON D, LA MIRADA, CA. FILED 1-21-2011.

## Killer Breed

THE MARK CONSISTS OF STANDARD CHARACTERS WITHOUT CLAIM TO ANY PARTICULAR FONT, STYLE, SIZE, OR COLOR.

FOR BASEBALL CAPS AND HATS; BEANIES; BELTS; JACKETS; LONG-SLEEVED SHIRTS; SHORT-SLEEVED SHIRTS; SPORT SHIRTS; T-SHIRTS; TANK TOPS; WRISTBANDS (U.S. CLS. 22 AND 39).

EVELYN BRADLEY, EXAMINING ATTORNEY



**CLASS 25—(Continued).**

SN 85-223,925. IBL HOLDINGS LLC, WILMINGTON, DE. FILED 1-23-2011.



NO CLAIM IS MADE TO THE EXCLUSIVE RIGHT TO USE "ORIGINAL", APART FROM THE MARK AS SHOWN. THE STIPPLING IS A FEATURE OF THE MARK AND DOES NOT INDICATE COLOR.

THE MARK CONSISTS OF THE WORDS "A BOJEANGLES ORIGINAL SKIN-EASE" WITHIN A BORDERED QUADRILATERAL BACKGROUND. THE WORD "BOJEANGLES" IS LOWER CASE LETTERS, THE WORD "ORIGINAL" AND "SKIN-EASE" ARE STYLIZED.

FOR MEN'S AND WOMEN'S CLOTHING, NAMELY, SPANDEX STYLE SHAPEWEAR PANTS, SKIRTS, DRESSES, JACKETS, JUMPSUITS AND SHORTS THAT FREQUENTLY CONTAIN CERTAIN SIDE SEAM, STITCHING AND DESIGN ATTRIBUTES INDICATIVE OF JEANS; T-SHIRTS, TOPS, BELTS, CAPS AND SCARFS (U.S. CLS. 22 AND 39).

DAVID TAYLOR, EXAMINING ATTORNEY

SN 85-224,332. DILLARD'S, INC., LITTLE ROCK, AR. FILED 1-24-2011.

Q.U.E.

THE MARK CONSISTS OF STANDARD CHARACTERS WITHOUT CLAIM TO ANY PARTICULAR FONT, STYLE, SIZE, OR COLOR.

OWNER OF U.S. REG. NOS. 2,917,761 AND 2,929,409.

FOR CLOTHING, NAMELY, JACKETS, VESTS, PANTS, SKIRTS, SKORTS, JUMPERS, DRESSES, SHIRTS, BLOUSES, KNIT TOPS, SWEATERS AND COATS (U.S. CLS. 22 AND 39).

DEIRDRE ROBERTSON, EXAMINING ATTORNEY

**CLASS 25—(Continued).**

SN 85-226,057. RECALDE, FELIPE, BURBANK, CA. AND HUNT, AARON, BURBANK, CA. FILED 1-25-2011.



THE MARK CONSISTS OF A SHIELD WITH THE STYLIZED TEXT "CURE COUTURE" APPEARING BELOW, WITH THE TEXT "FASHION FOR HEROES" APPEARING BELOW "CURE COUTURE".

FOR PANTS; SHIRTS; SHORTS; SWEATERS (U.S. CLS. 22 AND 39).

THOMAS MANOR, EXAMINING ATTORNEY

SN 85-228,848. CARTER, SHAWN, NEW YORK, NY. FILED 1-28-2011.

AKA SHAWN CARTER

THE MARK CONSISTS OF STANDARD CHARACTERS WITHOUT CLAIM TO ANY PARTICULAR FONT, STYLE, SIZE, OR COLOR.

THE NAME(S), PORTRAIT(S), AND/OR SIGNATURE(S) SHOWN IN THE MARK IDENTIFIES SHAWN CARTER, WHOSE CONSENT(S) TO REGISTER IS MADE OF RECORD.

FOR CLOTHING, NAMELY, SHIRTS, PANTS, JACKETS, COATS, SUITS, TEE SHIRTS, JEANS, SHORTS, SWEATERS, TIES, SWEAT SHIRTS, SWEAT PANTS, SKIRTS, DRESSES, BATHING SUITS, HATS, UNDERWEAR AND FOOTWEAR (U.S. CLS. 22 AND 39).

MATTHEW EINSTEIN, EXAMINING ATTORNEY

**CLASS 25—(Continued).**

SN 85-230,387. RAJSKI, DENNIS, NOBLESVILLE, IN. FILED 1-31-2011.



THE MARK CONSISTS OF THE LETTER P FORMED WITH THE NUMBER 1, AND THE LETTER G CONNECTS WITH THE NUMBER 1 AT THE BOTTOM.

FOR CAPS; HATS; JACKETS; PANTS; POLO SHIRTS; SHIRTS; SHORTS; SOCKS; SWEAT SHIRTS; T-SHIRTS; TANK TOPS; VISORS; WARM UP SUITS (U.S. CLS. 22 AND 39).

SUNG IN, EXAMINING ATTORNEY

**CLASS 25—(Continued).**

SN 85-236,190. SKECHERS U.S.A., INC. II, MANHATTAN BEACH, CA. FILED 2-7-2011.

**SHAPE-UPS SURGE**

THE MARK CONSISTS OF STANDARD CHARACTERS WITHOUT CLAIM TO ANY PARTICULAR FONT, STYLE, SIZE, OR COLOR.

OWNER OF U.S. REG. NOS. 3,732,331, 3,789,288 AND OTHERS.

FOR FOOTWEAR (U.S. CLS. 22 AND 39).  
SKYE YOUNG, EXAMINING ATTORNEY

SN 85-236,795. SCHERING-PLOUGH HEALTHCARE PRODUCTS, INC., MEMPHIS, TN. FILED 2-8-2011.

**FABUFLEX**

THE MARK CONSISTS OF STANDARD CHARACTERS WITHOUT CLAIM TO ANY PARTICULAR FONT, STYLE, SIZE, OR COLOR.

FOR INSOLES (U.S. CLS. 22 AND 39).

AISHA CLARKE, EXAMINING ATTORNEY

SN 85-234,826. LEVI STRAUSS & CO., SAN FRANCISCO, CA. FILED 2-4-2011.



OWNER OF U.S. REG. NO. 2,698,128.  
THE MARK CONSISTS OF A WING AND ANCHOR DESIGN.

FOR BELTS; HATS; JACKETS; PANTS; SHIRTS; SHOES; SHORTS; SOCKS; SWEATERS; TIES; VESTS (U.S. CLS. 22 AND 39).

ELLEN BURNS, EXAMINING ATTORNEY

SN 85-236,802. SCHERING-PLOUGH HEALTHCARE PRODUCTS, INC., MEMPHIS, TN. FILED 2-8-2011.

**FABUGEL**

THE MARK CONSISTS OF STANDARD CHARACTERS WITHOUT CLAIM TO ANY PARTICULAR FONT, STYLE, SIZE, OR COLOR.

FOR INSOLES (U.S. CLS. 22 AND 39).

AISHA CLARKE, EXAMINING ATTORNEY

**CLASS 25—(Continued).**

SN 85-238,590. TRACTOR SUPPLY CO. OF TEXAS, LP, BRENTWOOD, TN. FILED 2-10-2011.

# C.E. SCHMIDT

THE MARK CONSISTS OF STANDARD CHARACTERS WITHOUT CLAIM TO ANY PARTICULAR FONT, STYLE, SIZE, OR COLOR.

OWNER OF U.S. REG. NOS. 2,828,045 AND 2,909,216. THE NAME "C.E. SCHMIDT" DOES NOT IDENTIFY A LIVING INDIVIDUAL.

FOR BELTS; SOCKS (U.S. CLS. 22 AND 39).  
FIRST USE 10-0-2007; IN COMMERCE 10-0-2007.  
ALLISON SCHRODY, EXAMINING ATTORNEY

SN 85-238,894. GLOBAL TRADEMARKS, INC., STOCKERTOWN, PA. FILED 2-10-2011.

# ECO STUDIO

THE MARK CONSISTS OF STANDARD CHARACTERS WITHOUT CLAIM TO ANY PARTICULAR FONT, STYLE, SIZE, OR COLOR.

FOR COVERUPS; SWIMWEAR (U.S. CLS. 22 AND 39).  
JILL PRATER, EXAMINING ATTORNEY

SN 85-243,743. SAINT LOUIS UNIVERSITY, ST. LOUIS, MO. FILED 2-16-2011.



**SAINT LOUIS  
UNIVERSITY**

OWNER OF U.S. REG. NOS. 1,729,449 AND 2,087,374. NO CLAIM IS MADE TO THE EXCLUSIVE RIGHT TO USE "SAINT LOUIS" AND "1818", APART FROM THE MARK AS SHOWN.

THE MARK CONSISTS OF THE WORDS "SAINT LOUIS

**CLASS 25—(Continued).**

UNIVERSITY" IN STYLIZED FONT, A STYLIZED RENDERING OF A FLEUR-DE-LIS AND CROWN AND A SHIELD DESIGN FEATURING A CROSS, A BANNER CONTAINING THE YEAR "1818" SHOWN THEREIN, A CIRCLE CONTAINING THE LETTERS "IHS", A CROSS AND THREE NAILS AND TWO WOLVES SEPARATED BY A KETTLE ALL SURROUNDED BY A GEOMETRIC SHAPE RESEMBLING THE LETTER "U" FEATURING THE WORDS "AD . MAJOREM . DEI . GLORIAM" SHOWN IN STYLIZED FONT.

THE ENGLISH TRANSLATION OF "AD MAJOREM DEI GLORIAM" IN THE MARK IS "FOR THE GREATER GLORY OF GOD".

FOR CLOTHING, NAMELY, T-SHIRTS, LONG SLEEVED SHIRTS AND SWEATSHIRTS (U.S. CLS. 22 AND 39).

FIRST USE 0-0-2000; IN COMMERCE 0-0-2000.  
KARANENDRA S. CHHINA, EXAMINING ATTORNEY

SN 85-244,210. CUMMINS INC., COLUMBUS, IN. FILED 2-16-2011.



THE MARK CONSISTS OF CUMMINS AND C DESIGN. FOR MEN'S AND WOMEN'S CLOTHING, NAMELY, SWEATSHIRTS, HOODED SWEATSHIRTS, APRONS, SHIRTS, SPORT SHIRTS, JACKETS, T-SHIRTS, POLO SHIRTS, BASEBALL CAPS AND HATS, SKI CAPS, FLEECE CAPS, HEADBANDS, SCARVES, QUILTED VESTS, COVERALLS, LEATHER JACKETS, T-SHIRTS FOR TODDLERS AND CHILDREN (U.S. CLS. 22 AND 39).

HEATHER THOMPSON, EXAMINING ATTORNEY

SN 85-245,239. SCHERING-PLOUGH HEALTHCARE PRODUCTS, INC., MEMPHIS, TN. FILED 2-17-2011.

# FABULITIS

THE MARK CONSISTS OF STANDARD CHARACTERS WITHOUT CLAIM TO ANY PARTICULAR FONT, STYLE, SIZE, OR COLOR.

FOR FOOTWEAR; INSOLES; AND NON-ORTHOPEDIC FOOTWEAR INSERTS (U.S. CLS. 22 AND 39).

AISHA CLARKE, EXAMINING ATTORNEY

**CLASS 25—(Continued).**

SN 85-246,949. D-GENERATION, INC, DAYTONA BEACH, FL. FILED 2-19-2011.

L3

THE MARK CONSISTS OF STANDARD CHARACTERS WITHOUT CLAIM TO ANY PARTICULAR FONT, STYLE, SIZE, OR COLOR.

FOR FOOTWEAR; HATS; PANTS; SHIRTS; VISORS (U.S. CLS. 22 AND 39).

FIRST USE 11-13-2008; IN COMMERCE 11-13-2008.  
JUSTINE D. PARKER, EXAMINING ATTORNEY

SN 85-248,813. PINNACLE ENTERTAINMENT, INC., LAS VEGAS, NV. FILED 2-22-2011.

RIVER DOWNS

THE MARK CONSISTS OF STANDARD CHARACTERS WITHOUT CLAIM TO ANY PARTICULAR FONT, STYLE, SIZE, OR COLOR.

FOR HEADGEAR, NAMELY, HATS AND CAPS; JACKETS; SHIRTS; SWEAT SHIRTS; T-SHIRTS; TANK TOPS (U.S. CLS. 22 AND 39).

JULIE GUTTADAURO, EXAMINING ATTORNEY

SN 85-251,079. WILLIAMS, EMORY L., MIAMI, FL. FILED 2-24-2011.

40 SPEED SHOE

THE MARK CONSISTS OF STANDARD CHARACTERS WITHOUT CLAIM TO ANY PARTICULAR FONT, STYLE, SIZE, OR COLOR.

NO CLAIM IS MADE TO THE EXCLUSIVE RIGHT TO USE "SHOE", APART FROM THE MARK AS SHOWN.

FOR ATHLETIC SHOES (U.S. CLS. 22 AND 39).  
FIRST USE 8-15-2009; IN COMMERCE 8-15-2009.  
ARETHA SOMERVILLE, EXAMINING ATTORNEY

**CLASS 25—(Continued).**

SN 85-251,512. SKECHERS U.S.A., INC. II, MANHATTAN BEACH, CA. FILED 2-25-2011.

*Shape-ups*  
LIV  
By *Skechers*

OWNER OF U.S. REG. NOS. 3,732,331, 3,789,288 AND OTHERS.

THE MARK CONSISTS OF THE WORDS "SHAPE-UPS LIV BY SKECHERS" IN STYLIZED SCRIPT.

FOR FOOTWEAR (U.S. CLS. 22 AND 39).  
SKYE YOUNG, EXAMINING ATTORNEY

SN 85-251,568. GINLACK, SAA TAMBA, KAPAA, HI. FILED 2-25-2011.



THE MARK CONSISTS OF A DESIGN OF A WARRIOR, FOR CLOTHING, NAMELY, SHORTS, HATS, JEANS, PANTS, DRESS SHIRTS, SHIRTS, FOOTWEAR (U.S. CLS. 22 AND 39).

ANGELA M. MICHELI, EXAMINING ATTORNEY

SN 85-255,714. GLOBAL TRADEMARKS, INC., STOCKERTOWN, PA. FILED 3-2-2011.

ECO HOLIDAY

THE MARK CONSISTS OF STANDARD CHARACTERS WITHOUT CLAIM TO ANY PARTICULAR FONT, STYLE, SIZE, OR COLOR.

FOR BOTTOMS; COVERUPS; DRESSES; SWIMWEAR; TOPS (U.S. CLS. 22 AND 39).

JILL PRATER, EXAMINING ATTORNEY

**CLASS 25—(Continued).**

SN 85-255,730. GLOBAL TRADEMARKS, INC., STOCKERTOWN, PA. FILED 3-2-2011.

# ECO SPA

THE MARK CONSISTS OF STANDARD CHARACTERS WITHOUT CLAIM TO ANY PARTICULAR FONT, STYLE, SIZE, OR COLOR.  
FOR BOTTOMS; COVERUPS; DRESSES; SWIMWEAR; TOPS (U.S. CLS. 22 AND 39).  
JILL PRATER, EXAMINING ATTORNEY

**CLASS 25—(Continued).**

SN 85-269,514. SCHERING-PLOUGH HEALTHCARE PRODUCTS, INC., MEMPHIS, TN. FILED 3-17-2011.

# FABUGLIDE

THE MARK CONSISTS OF STANDARD CHARACTERS WITHOUT CLAIM TO ANY PARTICULAR FONT, STYLE, SIZE, OR COLOR.  
FOR INSOLES (U.S. CLS. 22 AND 39).  
AISHA CLARKE, EXAMINING ATTORNEY

SN 85-260,055. COLLECTIVE BRANDS COOPERATIEF U.A., AMSTERDAM, NETHERLANDS, FILED 3-7-2011.

# COURT MAX

THE MARK CONSISTS OF STANDARD CHARACTERS WITHOUT CLAIM TO ANY PARTICULAR FONT, STYLE, SIZE, OR COLOR.  
FOR CLOTHING, NAMELY, SHIRTS, SHORTS, JACKETS, JERSEYS, COATS, PANTS, SWEATERS, SWEATSHIRTS, SWEATPANTS, SWEATSUITS, WARM-UP SUITS, SWIMWEAR, SOCKS, BELTS, SUSPENDERS, WRIST BANDS; HEADGEAR, NAMELY HATS, HEADBANDS AND VISORS (U.S. CLS. 22 AND 39).  
DAVID ELTON, EXAMINING ATTORNEY

**CLASS 26—FANCY GOODS**

SN 79-091,549. ZHEJIANG AOHUA GARMENT & ORNAMENT INDUSTRIAL CO., LTD., CHINA, FILED 8-17-2010.



SN 85-260,507. SCHERING-PLOUGH HEALTHCARE PRODUCTS, INC., MEMPHIS, TN. FILED 3-8-2011.

# FABUSTEP

THE MARK CONSISTS OF STANDARD CHARACTERS WITHOUT CLAIM TO ANY PARTICULAR FONT, STYLE, SIZE, OR COLOR.  
FOR INSOLES (U.S. CLS. 22 AND 39).  
AISHA CLARKE, EXAMINING ATTORNEY

OWNER OF INTERNATIONAL REGISTRATION 1062313 DATED 8-17-2010, EXPIRES 8-17-2020.

THE MARK CONSISTS OF A LARGE STYLIZED LETTER "A" CENTERED ABOVE THE WORDING "AOHUA", WHICH IS CENTERED ABOVE TWO CHINESE CHARACTERS.

THE ENGLISH TRANSLATION OF THE FOREIGN WORD(S) IN THE MARK IS: THE FIRST CHARACTER MEANS "ABSTRUSE" AND THE SECOND CHARACTER MEANS "PROSPEROUS"; THE COMBINATION OF THE CHARACTERS HAS NO MEANING IN ENGLISH OR OTHER FOREIGN LANGUAGE.

THE TRANSLITERATION OF THE NON-LATIN CHARACTERS IN THE MARK IS: "AO" AND "HUA".

FOR BUTTONS; ZIP FASTENERS; HAIR GRIPS, NAMELY, SLIDES; TRIMMINGS FOR CLOTHING; HAIR ORNAMENTS; TOP-KNOTS, NAMELY, POMPONS; LACE FOR EDGINGS; EDGINGS FOR CLOTHING; HAIR BANDS; ELASTIC RIBBONS; EMBROIDERY; LACES (U.S. CLS. 37, 39, 40, 42 AND 50).

SUZANNE BLANE, EXAMINING ATTORNEY

**CLASS 26—(Continued).**

SN 85-155,422. CLARK, LAWRENCE, MANTECA, CA. AND CLARK, WINTHROP, MANTECA, CA. FILED 10-18-2010.

**KINGS OF CALI MC**

THE MARK CONSISTS OF STANDARD CHARACTERS WITHOUT CLAIM TO ANY PARTICULAR FONT, STYLE, SIZE, OR COLOR.

NO CLAIM IS MADE TO THE EXCLUSIVE RIGHT TO USE "MC", APART FROM THE MARK AS SHOWN.

FOR CLOTH PATCHES FOR CLOTHING; EMBROIDERED PATCHES FOR CLOTHING (U.S. CLS. 37, 39, 40, 42 AND 50).

DAVID TOOLEY, EXAMINING ATTORNEY

SN 85-181,464. HARRISON, SUSAN L., LUBBOCK, TX. FILED 11-19-2010.

**FUN FASHIONABLE HAIR**

THE MARK CONSISTS OF STANDARD CHARACTERS WITHOUT CLAIM TO ANY PARTICULAR FONT, STYLE, SIZE, OR COLOR.

NO CLAIM IS MADE TO THE EXCLUSIVE RIGHT TO USE "HAIR", APART FROM THE MARK AS SHOWN.

FOR WIGS (U.S. CLS. 37, 39, 40, 42 AND 50).

ALLISON SCHRODY, EXAMINING ATTORNEY

SN 85-191,012. U-LACE, LLC, BUFFALO, NY. FILED 12-6-2010.



THE MARK CONSISTS OF A STYLIZED, GRAPHIC AND PERSONIFIED REPRESENTATION OF A SINGLE U-LACE SHOELACE SEGMENT WEARING GLOVES AND SHOES.

FOR LACES FOR FOOTWEAR; SHOE LACES (U.S. CLS. 37, 39, 40, 42 AND 50).

COLLEEN DOMBROW, EXAMINING ATTORNEY

**CLASS 26—(Continued).**

SN 85-200,872. BROUN, WAYNE H., WARRIEWOOD BEACH NSW, AUSTRALIA, FILED 12-17-2010.



THE MARK CONSISTS OF A COAT OF ARMS FEATURING A LION HOLDING A FLEUR-DE-LIS AND STANDING ATOP AN ARMOUR HELMET THAT IS ABOVE A SHIELD FEATURING A CHEVRON AND THREE FLEUR-DE-LIS, ALL SURROUNDED BY LEAVES. ABOVE THE LION IS A BANNER FEATURING THE WORDING "FLOREAT MAJESTAS".

THE ENGLISH TRANSLATION OF "FLOREAT MAJESTAS" IN THE MARK IS "LET MAJESTY FLOURISH".

FOR BELT BUCKLES NOT OF PRECIOUS METAL; BELT CLASPS; BROOCHES; BRAIDS; CLOTHING BUCKLES; HAIR BUCKLES; SHOE BUCKLES; BUTTONS FOR CLOTHING; CLASPS FOR CLOTHING; CLOTH PATCHES FOR CLOTHING; EMBROIDERED EMBLEMS; FABRIC APPLIQUES; HAIR ORNAMENTS; NEEDLEPOINT KITS CONSISTING OF NEEDLES, THREADS, PATTERNS AND CANVAS; ORNAMENTAL NOVELTY BUTTONS; ORNAMENTAL NOVELTY PINS; ORNAMENTAL RIBBONS MADE OF TEXTILES; ORNAMENTAL CLOTH PATCHES; HAT ORNAMENTS NOT OF PRECIOUS METAL; SHOE ORNAMENTS NOT OF PRECIOUS METAL; PASSEMENTERIE (U.S. CLS. 37, 39, 40, 42 AND 50).

LINDA LAVACHE, EXAMINING ATTORNEY

SN 85-204,541. BEAUTY PLUS TRADING CO., INC., MOON-ACHIE, NJ. FILED 12-22-2010.

**HOT POP**

THE MARK CONSISTS OF STANDARD CHARACTERS WITHOUT CLAIM TO ANY PARTICULAR FONT, STYLE, SIZE, OR COLOR.

FOR HAIR EXTENSIONS; WIGS (U.S. CLS. 37, 39, 40, 42 AND 50).

YAT SYE, LEE, EXAMINING ATTORNEY

**CLASS 26—(Continued).**

SN 85-210,117. MILAN INDUSTRIES, INC., NORWOOD, NJ. FILED 1-4-2011.

**ZENOBIAS**

THE MARK CONSISTS OF STANDARD CHARACTERS WITHOUT CLAIM TO ANY PARTICULAR FONT, STYLE, SIZE, OR COLOR.

FOR BACK-HAIRPIECES FIXING PINS FOR JAPANESE HAIR STYLING (TABODOME); BACK-HAIRPIECES FOR JAPANESE HAIR STYLING (TABOMINO); CLOWN WIGS; HAIR PIECES AND WIGS; RIBBONS AND BRAID; RIBBONS AND BRAIDS; WIGS; WIGS, HAIRPIECES, AND ADD-IN AND ADD-ON HAIR ACCESSORIES CONSTRUCTED PRIMARILY OF SYNTHETIC AND/OR HUMAN HAIR (U.S. CLS. 37, 39, 40, 42 AND 50).

FIRST USE 12-6-2010; IN COMMERCE 12-6-2010.  
PAUL F. GAST, EXAMINING ATTORNEY

SN 85-228,216. FREMANTLE MEDIA NORTH AMERICA, INC., BURBANK, CA. AND SIMCO LIMITED, LONDON, UNITED KINGDOM. FILED 1-27-2011.

**THE X FACTOR**

THE MARK CONSISTS OF STANDARD CHARACTERS WITHOUT CLAIM TO ANY PARTICULAR FONT, STYLE, SIZE, OR COLOR.

FOR BARRETTES; BELT BUCKLES; CLOTHING HOOKS; HAIR ACCESSORIES, NAMELY, TWISTERS, CLAW CLIPS, HAIR STICKS, HAIR CLIPS, HAIR EXTENSIONS, HAIR ELASTICS; NON-ELECTRIC HAIR CURLERS; NON-ELECTRIC HAIR ROLLERS; ORNAMENTAL NOVELTY BADGES, PINS AND BUTTONS (U.S. CLS. 37, 39, 40, 42 AND 50).

TAMARA FRAZIER, EXAMINING ATTORNEY

**CLASS 27—FLOOR COVERINGS**

SN 76-705,889. FLOORTEX EUROPE LIMITED, GLOUCESTERSHIRE, UNITED KINGDOM, FILED 1-4-2011.

**ADVANTAGEMAT**

THE MARK CONSISTS OF STANDARD CHARACTERS WITHOUT CLAIM TO ANY PARTICULAR FONT, STYLE, SIZE, OR COLOR.

FOR FLOOR PROTECTION, NAMELY, FLOOR MATS (U.S. CLS. 19, 20, 37, 42 AND 50).

FIRST USE 11-10-2010; IN COMMERCE 11-10-2010.  
JENNIFER VASQUEZ, EXAMINING ATTORNEY

**CLASS 27—(Continued).**

SN 76-705,891. FLOORTEX EUROPE LIMITED, GLOUCESTERSHIRE, UNITED KINGDOM, FILED 1-4-2011.

**VALUEMAT**

THE MARK CONSISTS OF STANDARD CHARACTERS WITHOUT CLAIM TO ANY PARTICULAR FONT, STYLE, SIZE, OR COLOR.

FOR FLOOR PROTECTION, NAMELY, FLOOR MATS (U.S. CLS. 19, 20, 37, 42 AND 50).

FIRST USE 11-10-2010; IN COMMERCE 11-10-2010.  
JENNIFER VASQUEZ, EXAMINING ATTORNEY

SN 76-705,892. FLOORTEX EUROPE LIMITED, GLOUCESTERSHIRE, UNITED KINGDOM, FILED 1-4-2011.

**ULTIMAT**

THE MARK CONSISTS OF STANDARD CHARACTERS WITHOUT CLAIM TO ANY PARTICULAR FONT, STYLE, SIZE, OR COLOR.

FOR FLOOR PROTECTION, NAMELY, FLOOR MATS (U.S. CLS. 19, 20, 37, 42 AND 50).

FIRST USE 11-10-2010; IN COMMERCE 11-10-2010.  
JENNIFER VASQUEZ, EXAMINING ATTORNEY

SN 76-705,896. FLOORTEX EUROPE LIMITED, GLOUCESTERSHIRE, UNITED KINGDOM, FILED 1-4-2011.

**CLEARTEX**

THE MARK CONSISTS OF STANDARD CHARACTERS WITHOUT CLAIM TO ANY PARTICULAR FONT, STYLE, SIZE, OR COLOR.

FOR FLOOR PROTECTION, NAMELY, FLOOR MATS (U.S. CLS. 19, 20, 37, 42 AND 50).

FIRST USE 11-10-2010; IN COMMERCE 11-10-2010.  
JENNIFER VASQUEZ, EXAMINING ATTORNEY

**CLASS 27—(Continued).**

SN 76-705,897. FLOORTEX EUROPE LIMITED, GLOUCESTERSHIRE, UNITED KINGDOM, FILED 1-4-2011.

# COMPUTEX

THE MARK CONSISTS OF STANDARD CHARACTERS WITHOUT CLAIM TO ANY PARTICULAR FONT, STYLE, SIZE, OR COLOR.

FOR FLOOR PROTECTION, NAMELY, FLOOR MATS (U.S. CLS. 19, 20, 37, 42 AND 50).

FIRST USE 11-10-2010; IN COMMERCE 11-10-2010.  
JENNIFER VASQUEZ, EXAMINING ATTORNEY

SN 76-705,898. FLOORTEX EUROPE LIMITED, GLOUCESTERSHIRE, UNITED KINGDOM, FILED 1-4-2011.

# DOORTEX

THE MARK CONSISTS OF STANDARD CHARACTERS WITHOUT CLAIM TO ANY PARTICULAR FONT, STYLE, SIZE, OR COLOR.

FOR FLOOR PROTECTION, NAMELY, FLOOR MATS (U.S. CLS. 19, 20, 37, 42 AND 50).

FIRST USE 11-10-2010; IN COMMERCE 11-10-2010.  
JENNIFER VASQUEZ, EXAMINING ATTORNEY

SN 79-091,071. DESSO B.V., NL-5142 PA WAALWIJK, NETHERLANDS, FILED 10-27-2010.



OWNER OF INTERNATIONAL REGISTRATION 0750171 DATED 12-22-2000, EXPIRES 12-22-2020.

OWNER OF U.S. REG. NOS. 1,309,173 AND 3,835,150. THE COLOR(S) RED AND WHITE IS/ARE CLAIMED AS A FEATURE OF THE MARK.

THE MARK CONSISTS OF THE STYLIZED WORDING "DESSO" IN WHITE WITH A RED BACKGROUND.

FOR CARPETS, RUGS, AND FLOOR MATS (U.S. CLS. 19, 20, 37, 42 AND 50).

GINA FINK, EXAMINING ATTORNEY

**CLASS 27—(Continued).**

SN 85-137,306. ORIENTAL WEAVERS USA, INC., DALTON, GA. FILED 9-24-2010.



NO CLAIM IS MADE TO THE EXCLUSIVE RIGHT TO USE "HOSPITALITY", APART FROM THE MARK AS SHOWN.

THE MARK CONSISTS OF THE WORDS "OW HOSPITALITY" ON ONE LINE, BENEATH A SQUARE STANDING ON ONE CORNER CONTAINING TWO INTERSECTING PARTIAL LOOPS.

FOR FLOOR COVERINGS, NAMELY, CARPETS AND RUGS (U.S. CLS. 19, 20, 37, 42 AND 50).

KATHRYN COWARD, EXAMINING ATTORNEY

SN 85-186,352. KRACO ENTERPRISES, LLC, COMPTON, CA. FILED 11-29-2010.

# FLOOR ARMOR

THE MARK CONSISTS OF STANDARD CHARACTERS WITHOUT CLAIM TO ANY PARTICULAR FONT, STYLE, SIZE, OR COLOR.

NO CLAIM IS MADE TO THE EXCLUSIVE RIGHT TO USE "FLOOR", APART FROM THE MARK AS SHOWN.

FOR FLOOR MATS FOR VEHICLES (U.S. CLS. 19, 20, 37, 42 AND 50).

TAMARA FRAZIER, EXAMINING ATTORNEY

SN 85-188,701. INHABIT, INC., INDIANAPOLIS, IN. FILED 12-1-2010.

# WALL FLATS

THE MARK CONSISTS OF STANDARD CHARACTERS WITHOUT CLAIM TO ANY PARTICULAR FONT, STYLE, SIZE, OR COLOR.

NO CLAIM IS MADE TO THE EXCLUSIVE RIGHT TO USE "WALL", APART FROM THE MARK AS SHOWN.

FOR NON-TEXTILE WALL COVERINGS (U.S. CLS. 19, 20, 37, 42 AND 50).

JOHN SCHUYLER YARD, EXAMINING ATTORNEY



**CLASS 27—(Continued).**

SN 85-194,818. NOVALIS HOLDINGS LIMITED, WAN CHAI, HONG KONG, FILED 12-10-2010.

# NeoClic

THE MARK CONSISTS OF STANDARD CHARACTERS WITHOUT CLAIM TO ANY PARTICULAR FONT, STYLE, SIZE, OR COLOR.

FOR FLOORING PRODUCTS, NAMELY, HARD SOLID VINYL COVERINGS FOR FLOORS (U.S. CLS. 19, 20, 37, 42 AND 50).

SEAN CROWLEY, EXAMINING ATTORNEY

---

SN 85-206,020. JOANNE DUGAN PHOTOGRAPHY LLC, DBA THE ALPHABET CITY, NEW YORK, NY. FILED 12-27-2010.

# THE ALPHABET CITY

THE MARK CONSISTS OF STANDARD CHARACTERS WITHOUT CLAIM TO ANY PARTICULAR FONT, STYLE, SIZE, OR COLOR.

FOR WALL HANGINGS, NAMELY WORD ART CONSTITUTING ART WORK DEPICTING INDIVIDUAL LETTERS (U.S. CLS. 19, 20, 37, 42 AND 50).

FIRST USE 11-23-2010; IN COMMERCE 11-23-2010.

ROBIN MITTLER, EXAMINING ATTORNEY

---

SN 85-208,643. D-GENERATION, INC, DAYTONA BEACH, FL. FILED 12-31-2010.

# LIVE LOVE LAUGH

THE MARK CONSISTS OF STANDARD CHARACTERS WITHOUT CLAIM TO ANY PARTICULAR FONT, STYLE, SIZE, OR COLOR.

OWNER OF U.S. REG. NOS. 3,440,470 AND 3,877,139.

FOR BATH MATS; BEACH MATS; DOOR MATS; RUGS; WALLCOVERINGS (U.S. CLS. 19, 20, 37, 42 AND 50).

FIRST USE 11-12-1999; IN COMMERCE 11-12-1999.

JUSTINE D. PARKER, EXAMINING ATTORNEY

**CLASS 27—(Continued).**

SN 85-213,003. JOAN LUNDEN PRODUCTIONS, INC., ARMONK, NY. FILED 1-7-2011.

# JOAN LUNDEN HOME

THE MARK CONSISTS OF STANDARD CHARACTERS WITHOUT CLAIM TO ANY PARTICULAR FONT, STYLE, SIZE, OR COLOR.

NO CLAIM IS MADE TO THE EXCLUSIVE RIGHT TO USE "HOME", APART FROM THE MARK AS SHOWN.

THE NAME(S), PORTRAIT(S), AND/OR SIGNATURE(S) SHOWN IN THE MARK IDENTIFIES JOAN LUNDEN, WHOSE CONSENT(S) TO REGISTER IS MADE OF RECORD.

FOR BATH MATS (U.S. CLS. 19, 20, 37, 42 AND 50).

THEODORE MCBRIDE, EXAMINING ATTORNEY

**CLASS 28—TOYS AND SPORTING GOODS**

SN 76-701,571. ZOOM TV PRODUCTS, LLC, BOCA RATON, FL. FILED 2-12-2010.

# FUSHIGI

THE MARK CONSISTS OF STANDARD CHARACTERS WITHOUT CLAIM TO ANY PARTICULAR FONT, STYLE, SIZE, OR COLOR.

THE ENGLISH TRANSLATION OF "FUSHIGI" IN THE MARK IS "WONDER, MYSTERY, OR MIRACLE".

FOR EXERCISE BALLS, EXERCISE MACHINES, MANUALLY-OPERATED EXERCISE EQUIPMENT, STRESS RELIEF BALLS FOR HAND EXERCISE, ACTION SKILL GAMES, BALLS FOR GAMES, MANIPULATIVE GAMES, MAGIC TRICKS, BALLS FOR JUGGLING, JUGGLING EQUIPMENT, PRISM GLASSES (U.S. CLS. 22, 23, 38 AND 50).

FIRST USE 1-10-2010; IN COMMERCE 2-5-2010.

JULIE VEPPUMTHARA, EXAMINING ATTORNEY

**CLASS 28—(Continued).**

SN 76-702,481. EB EXCALIBUR, INC, MIAMI, FL. FILED 4-14-2010.

**JAM FEST**

THE MARK CONSISTS OF STANDARD CHARACTERS WITHOUT CLAIM TO ANY PARTICULAR FONT, STYLE, SIZE, OR COLOR.

FOR TOYS, NAMELY, A BATTERY OPERATED TOY WITH SOUND, NAMELY, A TOY GUITAR WITH BUILT IN KEY BOARD AND DRUM SOUNDS (U.S. CLS. 22, 23, 38 AND 50).

TRACY WHITTAKER-BROWN, EXAMINING ATTORNEY

**CLASS 28—(Continued).**

SN 77-043,071. KINGKA LLC, TEANECK, NJ. FILED 11-13-2006.

**LITTLE CONFUCIUS**

THE MARK CONSISTS OF STANDARD CHARACTERS WITHOUT CLAIM TO ANY PARTICULAR FONT, STYLE, SIZE, OR COLOR.

FOR BOARD GAMES; CARD GAMES (U.S. CLS. 22, 23, 38 AND 50).

FIRST USE 11-9-2006; IN COMMERCE 11-13-2006.  
BENJAMIN OKEKE, EXAMINING ATTORNEY

SN 76-705,453. HOUGHTON, BRYAN, GARY, SIDCUP, KENT DA14 4JH, UNITED KINGDOM, FILED 11-22-2010.

**SPOMB**

THE MARK CONSISTS OF STANDARD CHARACTERS WITHOUT CLAIM TO ANY PARTICULAR FONT, STYLE, SIZE, OR COLOR.

OWNER OF UNITED KINGDOM REG. NO. 2502920, DATED 3-20-2009, EXPIRES 11-20-2018.

FOR (BASED ON USE IN COMMERCE AND 44(E)) FISHING TACKLE, NAMELY, A BAIT DISPENSER USED FOR DISPENSING BAIT CONTAINED THEREIN; (BASED ON INTENT TO USE) FISHING TACKLE, NAMELY, A BAIT LOADER SUCH AS A CONTAINER FOR STORING BAIT TO BE LOADED INTO ANOTHER CONTAINER (U.S. CLS. 22, 23, 38 AND 50).

FIRST USE 3-4-2010; IN COMMERCE 7-30-2010.

WILLIAM VERHOSEK, EXAMINING ATTORNEY

SN 77-583,785. NINTENDO OF AMERICA INC., REDMOND, WA. FILED 10-2-2008.

**NINTENDO ZONE**

THE MARK CONSISTS OF STANDARD CHARACTERS WITHOUT CLAIM TO ANY PARTICULAR FONT, STYLE, SIZE, OR COLOR.

OWNER OF JAPAN REG. NO. 5324018, DATED 5-21-2010, EXPIRES 5-21-2020.

OWNER OF U.S. REG. NOS. 1,213,822, 1,628,966 AND OTHERS.

FOR CARD GAME TOYS AND THEIR ACCESSORIES, NAMELY, TRADING CARD GAMES; HAND-HELD GAMES WITH LIQUID CRYSTAL DISPLAYS; HAND-HELD GAMES WITH LIQUID CRYSTAL DISPLAYS, NAMELY, POWER CORDS, ADAPTORS, CABLES; TOYS, NAMELY, DOLLS, TALKING DOLLS AND NON-TALKING DOLLS; CARD GAMES AND THEIR FITTINGS; DICE; DICE CUPS; DOMINOES; PLAYING CARDS; AMUSEMENT GAME MACHINES AND COIN OPERATED AMUSEMENT MACHINES FOR USE IN AMUSEMENT PARK; SPORTS EQUIPMENT, NAMELY, GOLF BALLS; ACTION SKILL GAMES; ACTION TYPE TARGET GAMES; BATH TOYS; BOARD GAMES; CARD GAMES; CASES FOR PLAY ACCESSORIES; COIN-OPERATED VIDEO GAMES; COLLECTABLE TOY FIGURES; COSTUME MASKS; ELECTRIC ACTION TOYS; ELECTRONIC GAME EQUIPMENT WITH A WATCH FUNCTION; ELECTRONIC INTERACTIVE BOARD GAMES FOR USE WITH EXTERNAL MONITORS; EQUIPMENT SOLD AS A UNIT FOR PLAYING BOARD GAMES, FLYING DISCS; HAND-HELD GAME UNITS FOR PLAYING PINBALL GAMES; HAND-HELD GAME UNITS FOR PLAYING ELECTRONIC GAMES; HAND-HELD UNITS FOR PLAYING ELECTRONIC GAMES IN THE NATURE OF A VIRTUAL PET; HAND-HELD UNITS FOR PLAYING VIDEO GAMES; HAND-HELD VIDEO GAME SYSTEMS, PRIMARILY COMPRISING HAND-HELD UNITS FOR PLAYING VIDEO GAMES AND GAME CARTRIDGES AND GAME MEMORY CARDS, ALL PACKAGED AS A UNIT; INFLATABLE TOYS; JACK-IN-THE-BOXES; JIGSAW PUZZLES; KITES; MANIPULATIVE GAMES; MANIPULATIVE PUZZLES; MUSIC BOX TOYS; MUSICAL TOYS; PAPER DOLLS; PARLOR GAMES; PARTY FAVORS IN THE NATURE OF SMALL TOYS; PLAY FIGURES; PLAYING CARD CASES; PLAYING CARDS; PLUSH DOLLS; PLUSH

SN 76-705,479. BOREN, JOHN, HOUSTON, TX. FILED 11-26-2010.

**SOMATRAC**

THE MARK CONSISTS OF STANDARD CHARACTERS WITHOUT CLAIM TO ANY PARTICULAR FONT, STYLE, SIZE, OR COLOR.

FOR MANUALLY-OPERATED EXERCISE EQUIPMENT, NAMELY, AN APPARATUS FOR STRETCHING AND EXERCISING THE HUMAN BODY (U.S. CLS. 22, 23, 38 AND 50).

FIRST USE 1-31-2010; IN COMMERCE 1-31-2010.

MARLENE BELL, EXAMINING ATTORNEY

**CLASS 28—(Continued).**

TOYS; POSITIONABLE TOY FIGURES; PROMOTIONAL GAME CARDS; PULL TOYS; PUNCHING TOYS; PUPPETS; PUSH TOYS; REMOTE CONTROL TOY CARS; RIDE-ON TOYS; ROLE PLAYING GAMES; ROLLER SKATES; RUBBER ACTION BALLS; RUBBER CHARACTER TOYS; SPINNING TOPS; STAND ALONE VIDEO GAME MACHINES; STUFFED TOYS; TOY ACTION BALLS; TOY ACTION FIGURES; TOY BAKEWARE AND COOKWARE; TOY BALLOONS; TOY BANKS; TOY BINOCULARS; TOY BUILDING BLOCKS; TOY CAP PISTOLS; TOY CLOCKS AND WATCHES; TOY CONSTRUCTION PLAYSETS; TOY DECORATIVE WIND SOCKS; TOY FIGURINES; TOY KEY CHAINS WITH AND WITHOUT SOUND DEVICE; TOY MOBILES; TOY MUSICAL INSTRUMENTS; TOY PUNCHING BAGS; TOY TEA SETS; TOY VEHICLES; TOY WHISTLES; TOYS FOR PETS; WATER SQUIRTING TOYS; WIND-UP TOYS; YO-YOS; TOYS FOR DOMESTIC PETS; IN-LINE SKATES, JUMP ROPES, SKATEBOARDS, SNOWBOARDS, SNOW SKIS, SPORTS BALLS (U.S. CLS. 22, 23, 38 AND 50).

MATTHEW MCDOWELL, EXAMINING ATTORNEY

**CLASS 28—(Continued).**

TOYS; POSITIONABLE TOY FIGURES; PROMOTIONAL GAME CARDS; PULL TOYS; PUNCHING TOYS; PUPPETS; PUSH TOYS; REMOTE CONTROL TOY CARS; RIDE-ON TOYS; ROLE PLAYING GAMES; ROLLER SKATES; RUBBER ACTION BALLS; RUBBER CHARACTER TOYS; SPINNING TOPS; STAND ALONE VIDEO GAME MACHINES; STUFFED TOYS; TOY ACTION BALLS; TOY ACTION FIGURES; TOY BAKEWARE AND COOKWARE; TOY BALLOONS; TOY BANKS; TOY BINOCULARS; TOY BUILDING BLOCKS; TOY CAP PISTOLS; TOY CLOCKS AND WATCHES; TOY CONSTRUCTION PLAYSETS; TOY DECORATIVE WIND SOCKS; TOY FIGURINES; TOY KEY CHAINS WITH AND WITHOUT SOUND DEVICE; TOY MOBILES; TOY MUSICAL INSTRUMENTS; TOY PUNCHING BAGS; TOY TEA SETS; TOY VEHICLES; TOY WHISTLES; TOYS FOR PETS; WATER SQUIRTING TOYS; WIND-UP TOYS; YO-YOS; TOYS FOR DOMESTIC PETS; IN-LINE SKATES, JUMP ROPES, SKATEBOARDS, SNOWBOARDS, SNOW SKIS, SPORTS BALLS (U.S. CLS. 22, 23, 38 AND 50).

MATTHEW MCDOWELL, EXAMINING ATTORNEY

SN 77-583,809. NINTENDO OF AMERICA INC., REDMOND, WA. FILED 10-2-2008.

  
nintendo zone

OWNER OF JAPAN REG. NO. 5324017, DATED 5-21-2010, EXPIRES 5-21-2020.

OWNER OF U.S. REG. NOS. 1,213,822, 1,628,966 AND OTHERS.

THE MARK CONSISTS OF THE WORDS "NINTENDO ZONE"; WITH TRANSMISSION WAVES EMANATING FROM THE DOT ABOVE THE LETTER "I".

FOR CARD GAME TOYS AND THEIR ACCESSORIES, NAMELY, TRADING CARD GAMES; HAND-HELD GAMES WITH LIQUID CRYSTAL DISPLAYS; HAND-HELD GAMES WITH LIQUID CRYSTAL DISPLAYS, NAMELY, POWER CORDS, ADAPTORS, CABLES; TOYS, NAMELY, DOLLS, TALKING DOLLS AND NON-TALKING DOLLS; CARD GAMES AND THEIR FITTINGS; DICE; DICE CUPS; DOMINOES; PLAYING CARDS; AMUSEMENT GAME MACHINES AND COIN OPERATED AMUSEMENT MACHINES FOR USE IN AMUSEMENT PARK; SPORTS EQUIPMENT, NAMELY, GOLF BALLS; ACTION SKILL GAMES; ACTION TYPE TARGET GAMES; BATH TOYS; BOARD GAMES; CARD GAMES; CASES FOR PLAY ACCESSORIES; COIN-OPERATED VIDEO GAMES; COLLECTABLE TOY FIGURES; COSTUME MASKS; ELECTRIC ACTION TOYS; ELECTRONIC GAME EQUIPMENT WITH A WATCH FUNCTION; ELECTRONIC INTERACTIVE BOARD GAMES FOR USE WITH EXTERNAL MONITORS; EQUIPMENT SOLD AS A UNIT FOR PLAYING BOARD GAMES, FLYING DISCS; HAND-HELD GAME UNITS FOR PLAYING PINBALL GAMES; HAND-HELD GAME UNITS FOR PLAYING ELECTRONIC GAMES; HAND-HELD UNITS FOR PLAYING ELECTRONIC GAMES IN THE NATURE OF A VIRTUAL PET; HAND-HELD UNITS FOR PLAYING VIDEO GAMES; HAND-HELD VIDEO GAME SYSTEMS, PRIMARILY COMPRISING HAND-HELD UNITS FOR PLAYING VIDEO GAMES AND GAME CARTRIDGES AND GAME MEMORY CARDS, ALL PACKAGED AS A UNIT; INFLATABLE TOYS; JACK-IN-THE-BOXES; JIGSAW PUZZLES; KITES; MANIPULATIVE GAMES; MANIPULATIVE PUZZLES; MUSIC BOX TOYS; MUSICAL TOYS; PAPER DOLLS; PARLOR GAMES; PARTY FAVORS IN THE NATURE OF SMALL TOYS; PLAY FIGURES; PLAYING CARD CASES; PLAYING CARDS; PLUSH DOLLS; PLUSH

SN 77-840,984. WILLIAM T. WILKINSON, DBA INNOVATION INDUSTRIES, MEDIA, PA. FILED 10-4-2009.

Box'n Bounce

THE MARK CONSISTS OF STANDARD CHARACTERS WITHOUT CLAIM TO ANY PARTICULAR FONT, STYLE, SIZE, OR COLOR.

FOR MANUALLY-OPERATED EXERCISE EQUIPMENT FOR PHYSICAL FITNESS PURPOSES (U.S. CLS. 22, 23, 38 AND 50).

KELLY TRUSILO, EXAMINING ATTORNEY

SN 77-909,518. CHEEZBURGER, INC., SEATTLE, WA. FILED 1-11-2010.

LOLMART

THE MARK CONSISTS OF STANDARD CHARACTERS WITHOUT CLAIM TO ANY PARTICULAR FONT, STYLE, SIZE, OR COLOR.

FOR PLUSH TOYS; NOVELTY TOYS, NAMELY, MOLDED TOYS FEATURING A LIQUID FILLED CONTAINER INSIDE WITH A FLOATING ICOSAHEDRON THAT DISPLAYS ANSWERS THAT ARE VIEWABLE THROUGH A WINDOW FROM OUTSIDE THE TOYS (U.S. CLS. 22, 23, 38 AND 50).

KATHLEEN LORENZO, EXAMINING ATTORNEY

**CLASS 28—(Continued).**

SN 77-918,874. NATHANIEL GEORGE, SAN JOSE, CA. FILED 1-24-2010.



THE MARK CONSISTS OF A CROWN WITH 4 PROJECTIONS, A BASKETBALL APPEARS ABOVE THE FIRST PROJECTION, A GOLF BALL APPEARS ABOVE THE SECOND PROJECTION, A FOOTBALL APPEARS ABOVE THE THIRD PROJECTION, A BASEBALL APPEARS ABOVE THE FOURTH PROJECTION, FOUR CIRCLES APPEAR ON THE BAND OF THE CROWN AND THE NUMBER "4" APPEARS WITHIN AN OVAL ON THE BAND OF THE CROWN.

FOR SPORTS TRAINING BELTS, NAMELY, BELTS FOR USE IN IMPROVING BALANCE, ALIGNMENT AND SUPPORT (U.S. CLS. 22, 23, 38 AND 50). FIRST USE 11-30-2008; IN COMMERCE 12-31-2008. KATHLEEN LORENZO, EXAMINING ATTORNEY

**CLASS 28—(Continued).**

SN 77-981,501. CARROLL HALL SHELBY TRUST, LOS ANGELES, CA. FILED 12-19-2007.



THE MARK CONSISTS OF THE OUTWARD APPEARANCE OF A VEHICLE.

SEC. 2(F). FOR DIE-CAST METAL MODEL CARS AND PLASTIC MODEL CARS (U.S. CLS. 22, 23, 38 AND 50). FIRST USE 9-1-1967; IN COMMERCE 1-1-1998. WILLIAM BRECKENFELD, EXAMINING ATTORNEY

SN 77-981,498. CARROLL HALL SHELBY TRUST, LOS ANGELES, CA. FILED 12-19-2007.

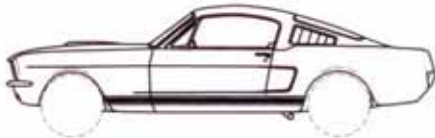

THE MARK CONSISTS OF THE OUTWARD APPEARANCE OF A VEHICLE.

SEC. 2(F). FOR DIE-CAST METAL MODEL CARS AND PLASTIC MODEL CARS (U.S. CLS. 22, 23, 38 AND 50). FIRST USE 1-1-1965; IN COMMERCE 1-1-1998. WILLIAM BRECKENFELD, EXAMINING ATTORNEY

SN 79-091,874. DIRECT SURF LIFESTYLES INDUSTRIES LTD, CHINA, FILED 10-28-2010.



PRIORITY DATE OF 7-30-2010 IS CLAIMED. OWNER OF INTERNATIONAL REGISTRATION 1063234 DATED 10-28-2010, EXPIRES 10-28-2020.

THE MARK CONSISTS OF THE STYLIZED WORDING "BENWILSONSURF" WITH SIX HORIZONTAL LINES TO THE RIGHT OF THE WORDING AND A CURVED INCOMPLETE SQUARE DESIGN ON THE LEFT.

FOR KITEBOARDS; APPARATUS FOR SPORTS FOR USE WITH WATER, NAMELY, BOARDS, HANDLE GRIPS, ROPES AND LEASHES USED IN THE PRACTICE OF WATER SPORTS; SURF SKIS; SURFBOARDS (U.S. CLS. 22, 23, 38 AND 50).

TOBY BULLOFF, EXAMINING ATTORNEY

SN 77-981,499. CARROLL HALL SHELBY TRUST, LOS ANGELES, CA. FILED 12-19-2007.

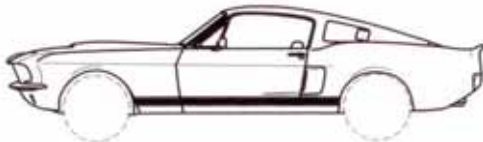

THE MARK CONSISTS OF THE OUTWARD APPEARANCE OF A VEHICLE.

SEC. 2(F). FOR DIE-CAST METAL MODEL CARS AND PLASTIC MODEL CARS (U.S. CLS. 22, 23, 38 AND 50). FIRST USE 9-1-1966; IN COMMERCE 1-1-1998. WILLIAM BRECKENFELD, EXAMINING ATTORNEY

SN 85-030,735. JACKSON & JACKSON ELECTRONIC ALL STAR LURES, INC., FLOWER MOUND, TX. FILED 5-5-2010.

**SHOCK BAIT**

THE MARK CONSISTS OF STANDARD CHARACTERS WITHOUT CLAIM TO ANY PARTICULAR FONT, STYLE, SIZE, OR COLOR.

NO CLAIM IS MADE TO THE EXCLUSIVE RIGHT TO USE "BAIT", APART FROM THE MARK AS SHOWN.

FOR FISHING LURES (U.S. CLS. 22, 23, 38 AND 50). FIRST USE 5-4-2010; IN COMMERCE 5-4-2010.

DAVID HOFFMAN, EXAMINING ATTORNEY

**CLASS 28—(Continued).**

SN 85-032,270. IMPERIAL TOY, LLC, NORTH HILLS, CA.  
FILED 5-6-2010.



THE MARK CONSISTS OF STANDARD CHARACTERS WITHOUT CLAIM TO ANY PARTICULAR FONT, STYLE, SIZE, OR COLOR.

FOR TOYS, GAMES AND PLAYTHINGS, NAMELY, ACTION FIGURES AND ACCESSORIES THEREFOR; STUFFED TOY ANIMALS; BABY'S MULTIPLE ACTIVITY TOYS; TOY BAKEWARE AND COOKWARE; BALLOONS; TOY BANKS; BATH TOYS; BATHTUB TOYS; INFLATABLE BATH TOYS; RIDE-ON TOYS; INFLATABLE RIDE-ON TOYS, EQUIPMENT SOLD AS A UNIT FOR PLAYING CARD GAMES; TOY CARS; DOLLS, BEANBAG DOLLS; PAPER DOLLS, RAG DOLLS, SOFT SCULPTURE DOLLS, DOLL ACCESSORIES AND PLAYSETS THEREFOR, NAMELY, DOLL CASES, DOLL CLOTHING; DOLL HOUSE FURNISHINGS, DOLL COSTUMES; STUFFED TOYS; CHECKER SETS; CHESS SETS; CHILDREN'S PLAY COSMETICS; CHILD'S MULTIPLE ACTIVITY TOYS; TOY CONSTRUCTION BLOCKS; INFANT'S ACTION CRIB TOYS; FLYING DISCS; ELECTRONIC HAND HELD GAME UNITS OTHER THAN THOSE ADAPTED FOR USE WITH AN EXTERNAL DISPLAY SCREEN OR MONITOR; ELECTRONIC GAME EQUIPMENT WITH A WATCH FUNCTION; ELECTRONICALLY OPERATED TOY MOTOR VEHICLES; BOARD GAMES AND GAME EQUIPMENT SOLD AS A UNIT FOR PLAYING BOARD GAMES; CARD GAMES; MANIPULATIVE GAMES; PARLOR GAMES; ROLE-PLAYING GAMES; STAND-ALONE VIDEO PARLOR COMPUTER GAME MACHINES; ACTION TYPE TARGET GAMES; ROCKING HORSES; JIGSAW PUZZLES; KITES; MANIPULATIVE PUZZLES; PAPER FACE MASKS; TOY MODEL TRAIN SETS; TOY MODEL VEHICLES AND RELATED ACCESSORIES SOLD AS A UNIT; ELECTRONICALLY OPERATED TOY MOTOR VEHICLES; ELECTRONIC BATTERY OPERATED ACTION TOYS; TOY MAGIC TRICKS, TOY NOISE-MAKERS; TOY WHISTLES; PARTY FAVORS IN THE NATURE OF SMALL TOYS; TOY CAP PISTOLS; PLUSH TOYS; SOFT SCULPTURE PLUSH TOYS; MANIPULATIVE PUZZLES, NAMELY, THREE DIMENSIONAL CUBE TYPE PUZZLES; TOY RECORD PLAYER FOR PLAYING TUNES AND CASSETTES AND DISCS THEREFOR; SKATEBOARDS; ICE SKATES; TOY ROLLER SKATES; TOY IN-LINE SKATES AND ACCESSORIES, NAMELY, KNEE, WRIST, AND ELBOW PADS; WATER SQUIRTING TOYS; TEDDY BEARS; WIND UP WALKING TOYS; WIND UP TOYS; NON-MOTORIZED NON-ELECTRIC MOBILE SELF-PROPELLED NON-RIDING TRANSPORTATION TOYS; RIDE-ON TOYS; TOY TRUCKS; TWIRLING BATONS; TOY ZIP GUNS; GYMNASIAC APPARATUS; BALLS, NAMELY, PLAYGROUND BALLS, SOCCER BALLS, SPORT BALLS, BASEBALLS, BASKETBALLS; BASEBALL GLOVES; SWIMMING AIDS, NAMELY, SWIMMING FLOATS FOR RECREATIONAL USE; INFLATABLE SWIMMING POOLS FOR RECREATIONAL USE; KICKBOARD FLOATATION DEVICES FOR RECREATIONAL USE; GYMNASIAC PARALLEL BARS; SKIS; SNOW SKIS; SNOWBOARDS; SKIPPING ROPES; JUMP ROPES; SNOW SLEDS FOR RECREATIONAL USE; SURF FINS; SURFBOARDS; SWIM BOARDS FOR RECREATIONAL USE;

**CLASS 28—(Continued).**

BODYBOARDS; SWIM FINS; INFLATABLE AND BUOYANT BATH TOYS; SWIMMING AND RIDE ON TOYS; MUSICAL TOYS; LATEX SQUEEZE TOYS; PLAYING CARDS; COIN OPERATED AND NON COIN OPERATED STAND-ALONE VIDEO OUTPUT GAME MACHINES; WATER TOYS; TOYS FOR PLAY IN OR WITH LIQUIDS; TOYS, NAMELY, BUBBLE TOYS, TOYS INVOLVING BUBBLES AND BLOWING BUBBLES; BUBBLE WANDS; BUBBLE BLOWING TOYS; WATER TOYS; WATER BALLOON LAUNCHERS AND BALLOONS; GAMES INVOLVING WATER BALLOON LAUNCHERS AND BALLOONS (U.S. CLS. 22, 23, 38 AND 50).  
DEBRA LEE, EXAMINING ATTORNEY

SN 85-032,272. IMPERIAL TOY, LLC, NORTH HILLS, CA.  
FILED 5-6-2010.

## SMB PREMIUM PLUS

THE MARK CONSISTS OF STANDARD CHARACTERS WITHOUT CLAIM TO ANY PARTICULAR FONT, STYLE, SIZE, OR COLOR.

NO CLAIM IS MADE TO THE EXCLUSIVE RIGHT TO USE "PREMIUM", APART FROM THE MARK AS SHOWN.

FOR TOYS, GAMES AND PLAYTHINGS, NAMELY ACTION FIGURES AND ACCESSORIES THEREFOR; STUFFED TOY ANIMALS; BABY'S MULTIPLE ACTIVITY TOYS; TOY BAKEWARE AND COOKWARE; BALLOONS; TOY BANKS; BATH TOYS; BATHTUB TOYS; INFLATABLE BATH TOYS; RIDE-ON TOYS; INFLATABLE RIDE-ON TOYS, EQUIPMENT SOLD AS A UNIT FOR PLAYING CARD GAMES; TOY CARS; DOLLS, BEANBAG DOLLS; PAPER DOLLS, RAG DOLLS, SOFT SCULPTURE DOLLS, DOLL ACCESSORIES AND PLAYSETS THEREFOR, NAMELY DOLL CASES, DOLL CLOTHING; DOLL HOUSE FURNISHINGS, DOLL COSTUMES; STUFFED TOYS; CHECKER SETS; CHESS SETS; CHILDREN'S PLAY COSMETICS; CHILD'S MULTIPLE ACTIVITY TOYS; TOY CONSTRUCTION BLOCKS; INFANT'S ACTION CRIB TOYS; FLYING DISCS; ELECTRONIC HAND HELD GAME UNITS OTHER THAN THOSE ADAPTED FOR USE WITH AN EXTERNAL DISPLAY SCREEN OR MONITOR; ELECTRONIC GAME EQUIPMENT WITH A WATCH FUNCTION; ELECTRONICALLY OPERATED TOY MOTOR VEHICLES; BOARD GAMES AND GAME EQUIPMENT SOLD AS A UNIT FOR PLAYING BOARD GAMES; CARD GAMES; MANIPULATIVE GAMES; PARLOR GAMES; ROLE-PLAYING GAMES; STAND-ALONE VIDEO PARLOR COMPUTER GAME MACHINES; ACTION TYPE TARGET GAMES; ROCKING HORSES; JIGSAW PUZZLES; KITES; MANIPULATIVE PUZZLES; PAPER FACE MASKS; TOY MODEL TRAIN SETS; TOY MODEL VEHICLES AND RELATED ACCESSORIES SOLD AS A UNIT; ELECTRONICALLY OPERATED TOY MOTOR VEHICLES; ELECTRONIC BATTERY OPERATED ACTION TOYS; TOY MAGIC TRICKS, TOY NOISE-MAKERS; TOY WHISTLES; PARTY FAVORS IN THE NATURE OF SMALL TOYS; TOY CAP PISTOLS; PLUSH TOYS; SOFT SCULPTURE PLUSH TOYS; MANIPULATIVE PUZZLES, NAMELY, THREE DIMENSIONAL CUBE TYPE PUZZLES; TOY RECORD PLAYER FOR PLAYING TUNES AND CASSETTES AND DISCS THEREFOR; SKATEBOARDS; ICE SKATES; TOY ROLLER SKATES; TOY IN-LINE SKATES AND ACCESSORIES, NAMELY KNEE, WRIST, AND ELBOW PADS; WATER SQUIRTING TOYS; TEDDY BEARS; WIND UP WALKING TOYS; WIND UP TOYS; NON-MOTORIZED NON-ELECTRIC MOBILE SELF-PROPELLED NON-RIDING TRANSPORTATION TOYS; RIDE-ON TOYS; TOY TRUCKS; TWIRLING BATONS; TOY ZIP GUNS; GYMNASIAC APPARATUS; BALLS, NAMELY PLAYGROUND BALLS, SOCCER BALLS, SPORT BALLS, BASEBALLS, BASKETBALLS; BASEBALL GLOVES; SWIMMING AIDS, NAMELY, SWIMMING FLOATS

**CLASS 28—(Continued).**

FOR RECREATIONAL USE; INFLATABLE SWIMMING POOLS FOR RECREATIONAL USE; KICKBOARD FLOATATION DEVICES FOR RECREATIONAL USE; GYMNASIAC PARALLEL BARS; SKIS; SNOW SKIS; SNOWBOARDS; SKIPPING ROPES; JUMP ROPES; SNOW SLEDS FOR RECREATIONAL USE; SURF FINS; SURFBOARDS; SWIM BOARDS FOR RECREATIONAL USE; BODYBOARDS; SWIM FINS; INFLATABLE AND BUOYANT BATH TOYS; SWIMMING AND RIDE ON TOYS; MUSICAL TOYS; LATEX SQUEEZE TOYS; PLAYING CARDS; COIN OPERATED AND NON COIN OPERATED STAND-ALONE VIDEO OUTPUT GAME MACHINES; WATER TOYS; TOYS FOR PLAY IN OR WITH LIQUIDS; TOYS, NAMELY, BUBBLE TOYS, TOYS INVOLVING BUBBLES AND BLOWING BUBBLES; BUBBLE WANDS; BUBBLE BLOWING TOYS; WATER TOYS; WATER BALLOON LAUNCHERS AND BALLOONS; GAMES INVOLVING WATER BALLOON LAUNCHERS AND BALLOONS (U.S. CLS. 22, 23, 38 AND 50).

DEBRA LEE, EXAMINING ATTORNEY

**CLASS 28—(Continued).**

SN 85-044,204. TECH 4 KIDS INC., MISSISSAUGA, ONTARIO, CANADA, FILED 5-20-2010.

**PROJECT-A-SKETCH**

SN 85-034,346. MARKY SPARKY, INC., ESCONDIDO, CA. FILED 5-10-2010.



THE MARK CONSISTS OF A STYLIZED "WAHOO", FOR INFLATABLE RIDE-ON TOYS (U.S. CLS. 22, 23, 38 AND 50).  
FIRST USE 1-16-2009; IN COMMERCE 1-16-2009.  
LINDA POWELL, EXAMINING ATTORNEY

THE MARK CONSISTS OF STANDARD CHARACTERS WITHOUT CLAIM TO ANY PARTICULAR FONT, STYLE, SIZE, OR COLOR.

FOR SKETCHING TOYS (U.S. CLS. 22, 23, 38 AND 50).  
JEFFREY LOOK, EXAMINING ATTORNEY

SN 85-040,724. TOMY COMPANY, LTD., TOKYO, JAPAN, FILED 5-17-2010.



OWNER OF U.S. REG. NO. 3,002,216.  
NO CLAIM IS MADE TO THE EXCLUSIVE RIGHT TO USE "METAL", APART FROM THE MARK AS SHOWN.

THE MARK CONSISTS OF THE WORDS "BEYBLADE METAL FUSION" IN THE MIDDLE OF A SWIRLING SET OF IRREGULAR OVALS AND CURVES, JAPANESE CHARACTERS TO THE UPPER LEFT AND A HORSE'S HEAD IN A CONCENTRIC CIRCLE TO THE UPPER RIGHT.

THE ENGLISH TRANSLATION OF THE JAPANESE CHARACTERS IN THE MARK IS "BEYBLADE". THE NON-LATIN CHARACTERS IN THE MARK TRANSLITERATE TO BEIBUREIDO, WHICH HAS NO KNOWN MEANING IN A FOREIGN LANGUAGE.

FOR TOY SPINNING TOPS, PLAYSETS THEREFORE, NAMELY, SPINNERS FOR SPINNING TOY TOPS AND PLAYING SURFACE BOARDS FOR PLAYING TOY TOPS THEREON; AND ACCESSORIES FOR TOY SPINNING TOPS (U.S. CLS. 22, 23, 38 AND 50).

SAMUEL E. SHARPER JR., EXAMINING ATTORNEY

SN 85-044,951. EBSCO INDUSTRIES, INC., BIRMINGHAM, AL. FILED 5-21-2010.

**PRO BOO BUG**

THE MARK CONSISTS OF STANDARD CHARACTERS WITHOUT CLAIM TO ANY PARTICULAR FONT, STYLE, SIZE, OR COLOR.

OWNER OF U.S. REG. NOS. 2,302,310, 3,494,513 AND OTHERS.

NO CLAIM IS MADE TO THE EXCLUSIVE RIGHT TO USE "BUG", APART FROM THE MARK AS SHOWN.

FOR FISHING LURES; FISHING TACKLE (U.S. CLS. 22, 23, 38 AND 50).

FIRST USE 7-1-2004; IN COMMERCE 7-1-2004.

MICHAEL GAFFAR, EXAMINING ATTORNEY

**CLASS 28—(Continued).**

SN 85-045,318. GLOBAL GOLF TRAINING PRODUCTS, INC., CANTON, MA. FILED 5-21-2010.



OWNER OF U.S. REG. NO. 2,641,104.  
NO CLAIM IS MADE TO THE EXCLUSIVE RIGHT TO USE "THUMB", APART FROM THE MARK AS SHOWN.  
THE MARK CONSISTS OF THE OUTLINED WORDS "THUMB" ATOP "CADDY" WITH THE LETTER "C" IN A CRESCENT SHAPE THAT IS LACED THROUGH THE LETTERS "M" AND "B".  
FOR TRAINING AND PLAYING AIDS FOR GOLFERS, NAMELY, GRIP POSITIONING GUIDES (U.S. CLS. 22, 23, 38 AND 50).  
FIRST USE 4-0-2008; IN COMMERCE 5-2-2008.  
ALEXANDER L. POWERS, EXAMINING ATTORNEY

SN 85-045,875. BOCCENATION.COM LLC, PALM BEACH GARDENS, FL. FILED 5-23-2010.

**BocceNation.com**

THE MARK CONSISTS OF STANDARD CHARACTERS WITHOUT CLAIM TO ANY PARTICULAR FONT, STYLE, SIZE, OR COLOR.  
FOR GAME APPARATUS AND EQUIPMENT, NAMELY, BOCCE BALLS, BOUNDARY MARKERS; BOCCE GAME KIT IN THE FORM OF A BAG CONSISTING PRIMARILY OF BOCCE BALLS AND BOUNDARY MARKERS ALONG WITH A SCORE BOARD, A MEASURING DEVICE, AND RULES OF PLAY (U.S. CLS. 22, 38 AND 50).  
KAREN SEVERSON, EXAMINING ATTORNEY

**CLASS 28—(Continued).**

SN 85-046,290. GATOR LURES, LLC, MILLINGTON, NJ. FILED 5-24-2010.

**KINGSPOON**

THE MARK CONSISTS OF STANDARD CHARACTERS WITHOUT CLAIM TO ANY PARTICULAR FONT, STYLE, SIZE, OR COLOR.  
FOR FISHING LURES (U.S. CLS. 22, 23, 38 AND 50).  
FIRST USE 10-3-1982; IN COMMERCE 10-3-1982.  
JESSICA FATHY, EXAMINING ATTORNEY

SN 85-047,580. GENERAL GROWTH MANAGEMENT, INC., CHICAGO, IL. FILED 5-25-2010.

**SANTASTIC**

THE MARK CONSISTS OF STANDARD CHARACTERS WITHOUT CLAIM TO ANY PARTICULAR FONT, STYLE, SIZE, OR COLOR.  
OWNER OF U.S. REG. NOS. 3,406,326, 3,638,116 AND 3,684,888.  
FOR STUFFED TOY ANIMALS (U.S. CLS. 22, 23, 38 AND 50).  
FIRST USE 11-10-2007; IN COMMERCE 11-10-2007.  
GINA HAYES, EXAMINING ATTORNEY

SN 85-052,083. MATTEL, INC., EL SEGUNDO, CA. FILED 6-1-2010.

**STEALTH ATTACK CLAW**

THE MARK CONSISTS OF STANDARD CHARACTERS WITHOUT CLAIM TO ANY PARTICULAR FONT, STYLE, SIZE, OR COLOR.  
NO CLAIM IS MADE TO THE EXCLUSIVE RIGHT TO USE "CLAW", APART FROM THE MARK AS SHOWN.  
FOR TOY ACTION FIGURES AND ACCESSORIES THEREFOR (U.S. CLS. 22, 23, 38 AND 50).  
KATHERINE CHANG, EXAMINING ATTORNEY

**CLASS 28—(Continued).**

SN 85-052,110. MATTEL, INC., EL SEGUNDO, CA. FILED 6-1-2010.

**SEA STINGERS**

THE MARK CONSISTS OF STANDARD CHARACTERS WITHOUT CLAIM TO ANY PARTICULAR FONT, STYLE, SIZE, OR COLOR.

OWNER OF U.S. REG. NO. 3,773,314.  
FOR TOY ACTION FIGURES AND ACCESSORIES THEREFOR (U.S. CLS. 22, 23, 38 AND 50).  
JOHN DALIER, EXAMINING ATTORNEY

---

SN 85-052,719. THROWDOWN INDUSTRIES, INC., TAMPA, FL. FILED 6-2-2010.

**THE HEX**

THE MARK CONSISTS OF STANDARD CHARACTERS WITHOUT CLAIM TO ANY PARTICULAR FONT, STYLE, SIZE, OR COLOR.

FOR CONTACT SPORT CAGES IN THE NATURE OF BOXING RINGS AND MIXED MARTIAL ARTS CAGES (U.S. CLS. 22, 23, 38 AND 50).  
JILL PRATER, EXAMINING ATTORNEY

---

SN 85-053,014. OURPET'S COMPANY, FAIRPORT HARBOR, OH. FILED 6-2-2010.

**RealMouse**

THE MARK CONSISTS OF STANDARD CHARACTERS WITHOUT CLAIM TO ANY PARTICULAR FONT, STYLE, SIZE, OR COLOR.

FOR SIMULATED MOUSE SOUND REPRODUCTION DEVICES SOLD AS AN INTEGRAL COMPONENT OF PET TOYS (U.S. CLS. 22, 23, 38 AND 50).  
FIRST USE 2-1-2008; IN COMMERCE 2-1-2008.  
CHARLOTTE CORWIN, EXAMINING ATTORNEY

**CLASS 28—(Continued).**

SN 85-054,310. KONAMI DIGITAL ENTERTAINMENT CO., LTD., TOKYO, JAPAN, FILED 6-3-2010.

**POP'N MUSIC**

THE MARK CONSISTS OF STANDARD CHARACTERS WITHOUT CLAIM TO ANY PARTICULAR FONT, STYLE, SIZE, OR COLOR.

NO CLAIM IS MADE TO THE EXCLUSIVE RIGHT TO USE "MUSIC", APART FROM THE MARK AS SHOWN.

FOR ARCADE GAME MACHINES; ARCADE AND COIN-OPERATED GAME MACHINES, NAMELY, ARCADE-TYPE ELECTRONIC VIDEO GAMES, COIN-OPERATED VIDEO GAMES, STAND ALONE VIDEO GAME MACHINES; ELECTRONIC ARCADE GAMES; COIN-OPERATED VIDEO GAMES (U.S. CLS. 22, 23, 38 AND 50).

FRED CARL, EXAMINING ATTORNEY

---

SN 85-055,890. NORSEMEN OUTDOORS, INC., LAKE MILLS, IA. FILED 6-7-2010.

**VAT Vibration  
Amplification Technology**

THE MARK CONSISTS OF STANDARD CHARACTERS WITHOUT CLAIM TO ANY PARTICULAR FONT, STYLE, SIZE, OR COLOR.

NO CLAIM IS MADE TO THE EXCLUSIVE RIGHT TO USE "VIBRATION AMPLIFICATION TECHNOLOGY", APART FROM THE MARK AS SHOWN.

FOR FISHING ROD COMPONENT, NAMELY, METALLIC DISCS AROUND A BLANK INSIDE THE HANDLE WHICH TRANSMIT VIBRATIONS FROM THE ROD TIP SOLD AS AN INTEGRAL COMPONENT OF THE FISHING RODS (U.S. CLS. 22, 23, 38 AND 50).

FIRST USE 1-1-2010; IN COMMERCE 1-1-2010.  
TRICIA SONNEBORN, EXAMINING ATTORNEY



**CLASS 28—(Continued).**

SN 85-057,796. WARNER BROS. ENTERTAINMENT INC., BURBANK, CA. FILED 6-8-2010.

**LEAKY CAULDRON**

THE MARK CONSISTS OF STANDARD CHARACTERS WITHOUT CLAIM TO ANY PARTICULAR FONT, STYLE, SIZE, OR COLOR.

FOR TOYS AND SPORTING GOODS, INCLUDING GAMES AND PLAYTHINGS, NAMELY, ACTION FIGURES AND ACCESSORIES THEREFOR; PLUSH TOYS; BALLOONS; BATHTUB TOYS; RIDE-ON TOYS; EQUIPMENT SOLD AS A UNIT FOR PLAYING CARD GAMES; TOY VEHICLES; DOLLS; FLYING DISCS; ELECTRONIC HAND-HELD GAME UNIT OTHER THAN THOSE ADAPTED FOR USE WITH AN EXTERNAL DISPLAY SCREEN OR MONITOR; GAME EQUIPMENT SOLD AS A UNIT FOR PLAYING A BOARD GAME, A CARD GAME, A MANIPULATIVE GAME, A PARLOR GAME AND AN ACTION TYPE TARGET GAME; STAND ALONE VIDEO OUTPUT GAME MACHINES; JIGSAW AND MANIPULATIVE PUZZLES; PAPER FACE MASKS; SKATEBOARDS; ICE SKATES; WATER SQUIRTING TOYS; BALLS, NAMELY, PLAYGROUND BALLS, SOCCER BALLS, BASEBALLS, BASKETBALLS; BASEBALL GLOVES; SWIMMING FLOATS FOR RECREATIONAL USE; KICKBOARD FLOTATION DEVICES FOR RECREATIONAL USE; SURFBOARDS; SWIM BOARDS FOR RECREATIONAL USE; SWIM FINS; TOY BAKEWARE AND TOY COOKWARE; TOY BANKS; TOY SNOW GLOBES; PAPER PARTY HATS; AND CHRISTMAS TREE ORNAMENTS (U.S. CLS. 22, 23, 38 AND 50).  
KATHLEEN M. VANSTON, EXAMINING ATTORNEY

SN 85-066,118. UBISOFT ENTERTAINMENT, RENNES, FRANCE, FILED 6-18-2010.



THE MARK CONSISTS OF A TRIANGLE IN A CIRCLE SURROUNDED BY DOUBLE PARENTHESES.

FOR TOYS AND PLAYTHINGS, NAMELY, DOLLS, TOY ACTION FIGURES, PLUSH TOYS AND ACCESSORIES THEREOF, PLAYSETS FOR DOLLS AND TOY ACTION FIGURES, TOY VEHICLES AND HAND HELD UNITS FOR PLAYING ELECTRONIC GAMES OTHER THAN ADAPTED FOR USE WITH AN EXTERNAL DISPLAY SCREEN OR MONITOR (U.S. CLS. 22, 23, 38 AND 50).

JENNY PARK, EXAMINING ATTORNEY

**CLASS 28—(Continued).**

SN 85-068,358. HASBRO, INC., PAWTUCKET, RI. FILED 6-22-2010.

**DAISY JO**

THE MARK CONSISTS OF STANDARD CHARACTERS WITHOUT CLAIM TO ANY PARTICULAR FONT, STYLE, SIZE, OR COLOR.

FOR TOY PONIES AND ACCESSORIES FOR USE THEREWITH (U.S. CLS. 22, 23, 38 AND 50).  
WILLIAM P. SHANAHAN, EXAMINING ATTORNEY

SN 85-068,360. HASBRO, INC., PAWTUCKET, RI. FILED 6-22-2010.

**SUNNY DAZE**

THE MARK CONSISTS OF STANDARD CHARACTERS WITHOUT CLAIM TO ANY PARTICULAR FONT, STYLE, SIZE, OR COLOR.

FOR TOY PONIES AND ACCESSORIES FOR USE THEREWITH (U.S. CLS. 22, 23, 38 AND 50).  
WILLIAM P. SHANAHAN, EXAMINING ATTORNEY

SN 85-072,460. GECCO VISION, LOS ANGELES, CA. FILED 6-27-2010.

**TOP TONER**

THE MARK CONSISTS OF STANDARD CHARACTERS WITHOUT CLAIM TO ANY PARTICULAR FONT, STYLE, SIZE, OR COLOR.

NO CLAIM IS MADE TO THE EXCLUSIVE RIGHT TO USE "TONER", APART FROM THE MARK AS SHOWN. FOR MANUALLY-OPERATED EXERCISE EQUIPMENT (U.S. CLS. 22, 23, 38 AND 50).  
FIRST USE 6-1-2010; IN COMMERCE 6-1-2010.  
AMY HELLA, EXAMINING ATTORNEY

**CLASS 28—(Continued).**

SN 85-075,571. JAVED, MIAN M N, LOS ANGELES, CA.  
FILED 7-1-2010.



THE MARK CONSISTS OF SEVERAL BLACK CURVED BAND DESIGNS.

FOR AMUSEMENT PRODUCTS, NAMELY, INFLATABLE BALLS; BALLS FOR GAMES; BALLS FOR SPORTS; BASEBALL BAT BAGS; BASEBALL BAT CASES; BASEBALL BAT RACKS; BASEBALL BATS; BASEBALL BATTING GLOVES; BASEBALL BATTING TEES; BASEBALL GLOVES; BASEBALL MITTS; BASEBALLS; BASEBALLS; BASKET BALLS; BEACH BALLS; EXERCISE BALLS; EXERCISE EQUIPMENT, NAMELY, INFLATABLE BALLS; FOOTBALL OR SOCCER GOALS; FOOTBALLS; GOALKEEPERS' GLOVES; PUMPS ESPECIALLY ADAPTED FOR USE WITH BALLS FOR GAMES; SHIN PADS FOR USE IN SOCCER; SOCCER BALL GOAL NETS; SOCCER BALL KNEE PADS; SOCCER BALLS; SOCCER GOALS; SPORT BALLS; SPORTING GOODS, NAMELY, CARRIERS SPECIALLY ADAPTED FOR SPORT BALLS; TETHER BALLS; VOLLEY BALLS; WEIGHT LIFTING BELTS (U.S. CLS. 22, 23, 38 AND 50).

FIRST USE 10-17-1997; IN COMMERCE 10-17-1997.  
KAPIL BHANOT, EXAMINING ATTORNEY

SN 85-093,385. NORDCO, LLC, DBA DEAD-ON ARCHERY,  
MISSOULA, MT. FILED 7-27-2010.

**DEAD-ON RANGE FINDER**

THE MARK CONSISTS OF STANDARD CHARACTERS WITHOUT CLAIM TO ANY PARTICULAR FONT, STYLE, SIZE, OR COLOR.

NO CLAIM IS MADE TO THE EXCLUSIVE RIGHT TO USE "RANGE FINDER", APART FROM THE MARK AS SHOWN.

FOR ARCHERY EQUIPMENT, NAMELY, BOW MOUNTED, NON-ELECTRONIC, NON-TELESCOPIC RANGE FINDER (U.S. CLS. 22, 23, 38 AND 50).

FIRST USE 1-25-2002; IN COMMERCE 1-25-2002.  
DAVID TOOLEY, EXAMINING ATTORNEY

**CLASS 28—(Continued).**

SN 85-094,891. NEWMAN, MICHAEL J, SHERMAN OAKS, CA. FILED 7-28-2010.

**Grip Solid**

THE MARK CONSISTS OF STANDARD CHARACTERS WITHOUT CLAIM TO ANY PARTICULAR FONT, STYLE, SIZE, OR COLOR.

NO CLAIM IS MADE TO THE EXCLUSIVE RIGHT TO USE "GRIP", APART FROM THE MARK AS SHOWN.

FOR GOLF CLUB SWING AIDS, NAMELY, A THIN RUBBER STRAP WITH A RAISED FLEXIBLE BAR WORN ON THE HAND TO AID IN GRIP POSITION AND GRIP PRESSURE (U.S. CLS. 22, 23, 38 AND 50).

FIRST USE 6-1-2010; IN COMMERCE 6-19-2010.  
ASMAT KHAN, EXAMINING ATTORNEY

SN 85-108,081. DODSON, LISA E., DBA THE TOTAL SERVE,  
OAKLAND, CA. FILED 8-16-2010.

**The Total Serve**

THE MARK CONSISTS OF STANDARD CHARACTERS WITHOUT CLAIM TO ANY PARTICULAR FONT, STYLE, SIZE, OR COLOR.

NO CLAIM IS MADE TO THE EXCLUSIVE RIGHT TO USE "SERVE", APART FROM THE MARK AS SHOWN.

FOR SPORTING GOODS, NAMELY, A SPORTS TRAINING DEVICE TO IMPROVE STRENGTH, TONING, CONDITIONING, BALANCE, AND PROPRIOCEPTION (U.S. CLS. 22, 23, 38 AND 50).

FIRST USE 5-27-2009; IN COMMERCE 5-27-2009.  
RICHARD WHITE, EXAMINING ATTORNEY

**CLASS 28—(Continued).**

SN 85-108,178. FISH N STIK, INC, WEST PALM BEACH, FL. FILED 8-16-2010.



NO CLAIM IS MADE TO THE EXCLUSIVE RIGHT TO USE "TACKY WAX RIGGING FLOSS AND TOURNAMENT PRODUCTS USA", APART FROM THE MARK AS SHOWN.

THE MARK CONSISTS OF THE DESIGN OF A SAILFISH WITH A FIN WITH ELEVEN STARS INSIDE A DOUBLE RIMMED CIRCLE WITH THE WORDING "TACKY WAX RIGGING FLOSS" AT THE TOP OF THE DESIGN AND THE WORDING "BY TOURNAMENT PRODUCTS USA" AND THE BOTTOM OF THE DESIGN.

FOR WAXED NYLON FISHING FLOSS USED FOR BAIT RIGGING (U.S. CLS. 22, 23, 38 AND 50).

LESLEY LAMOTHE, EXAMINING ATTORNEY

SN 85-110,047. KABUSHIKI KAISHA SEGA, DBA SEGA CORPORATION, OHTA-KU, TOKYO, JAPAN, FILED 8-18-2010.



OWNER OF U.S. REG. NOS. 2,864,927, 3,374,118 AND OTHERS.

NO CLAIM IS MADE TO THE EXCLUSIVE RIGHT TO USE "TICKET", APART FROM THE MARK AS SHOWN.

THE MARK CONSISTS OF "SUPER" IN LIGHT LETTERS WITH EACH LETTER IN SEPARATE DARKER CIRCLES, ABOVE "MONKEY BALL" IN LIGHT LETTERS WITH A DARKER OUTLINE, ABOVE "TICKET BLITZ", WITH THE TOP HALF OF THE LETTERS LIGHTER THAN THE BOTTOM HALF OF THE LETTERS, ALL WITH A DARK OUTLINE. THE WHOLE MARK HAS A LIGHT BACKGROUND WITH A CONTOURED DARKER OUTLINE.

FOR STAND ALONE VIDEO GAME MACHINES; ARCADE AMUSEMENT GAME MACHINES WITH BUILT-IN SCREENS; ARCADE REDEMPTION GAME MACHINES WHICH DISPENSE TICKETS OR THE LIKE TO SUCCESSFUL PLAYERS (U.S. CLS. 22, 23, 38 AND 50).

MAUREEN DALL, EXAMINING ATTORNEY

**CLASS 28—(Continued).**

SN 85-112,982. WILD PLANET ENTERTAINMENT, INC., SAN FRANCISCO, CA. FILED 8-22-2010.

**FREEZE BALL**

THE MARK CONSISTS OF STANDARD CHARACTERS WITHOUT CLAIM TO ANY PARTICULAR FONT, STYLE, SIZE, OR COLOR.

NO CLAIM IS MADE TO THE EXCLUSIVE RIGHT TO USE "BALL", APART FROM THE MARK AS SHOWN.

FOR TOYS, GAMES, AND PLAYTHINGS, NAMELY, AN ACTIVITY GAME IN THE NATURE OF A TAG SET PRIMARILY COMPRISED OF A FOAM SPORTS BALL AND ALSO CONTAINING RUBBER WRISTBANDS (U.S. CLS. 22, 23, 38 AND 50).

SETH A. RAPPAPORT, EXAMINING ATTORNEY

SN 85-124,873. MATTEL, INC., EL SEGUNDO, CA. FILED 9-8-2010.

**GALACTIC GATOR**

THE MARK CONSISTS OF STANDARD CHARACTERS WITHOUT CLAIM TO ANY PARTICULAR FONT, STYLE, SIZE, OR COLOR.

NO CLAIM IS MADE TO THE EXCLUSIVE RIGHT TO USE "GATOR", APART FROM THE MARK AS SHOWN.

FOR TOY ACTION FIGURES AND ACCESSORIES THEREFOR (U.S. CLS. 22, 23, 38 AND 50).

JANICE KIM, EXAMINING ATTORNEY

SN 85-154,453. DONNA A. RAMERE, YORK, SC. FILED 10-17-2010.

**PUMPONINI**

THE MARK CONSISTS OF STANDARD CHARACTERS WITHOUT CLAIM TO ANY PARTICULAR FONT, STYLE, SIZE, OR COLOR.

OWNER OF U.S. REG. NO. 3,813,159.

FOR PUMPING DEVICE USED FOR INFLATING TOY BALLOONS WITH AIR; PUMPING DEVICE USED FOR INFLATING TOY BALLOONS WITH WATER (U.S. CLS. 22, 23, 38 AND 50).

FIRST USE 8-31-2010; IN COMMERCE 8-31-2010.

CYNTHIA TRIPI, EXAMINING ATTORNEY

**CLASS 28—(Continued).**

SN 85-169,090. DUODESK, RIVER FOREST, IL. AND K & A MANUFACTURING, DBA RIGHT ANGLE PRODUCTS, SCHOFIELD, WI. FILED 11-4-2010.



THE COLOR(S) BLACK, RED AND WHITE IS/ARE CLAIMED AS A FEATURE OF THE MARK.

THE MARK CONSISTS OF AN OVAL WITH BLACK AS THE BACKGROUND COLOR. THE WORDS "LIFEBALANCE STATION" APPEAR IN RED AND CENTERED IN THE OVAL. THE WORDS "BY RA RIGHTANGLE" ARE CENTERED UNDERNEATH "LIFEBALANCE STATION". THE WORD "BY" APPEARS IN WHITE IN A SMALLER FONT IN SUPERSCRIPIT. THE LETTER "R" IN "RA" APPEARS IN RED AND "A" IS IN BLACK. BOTH LETTERS "R" AND "A" APPEAR IN A SMALL WHITE SQUARE. THE REST OF THE LETTERS "RIGHTANGLE" ARE WHITE.

FOR ELLIPTICAL EXERCISE MACHINES (U.S. CLS. 22, 23, 38 AND 50).

FIRST USE 6-14-2010; IN COMMERCE 6-14-2010.  
MICHELLE DUBOIS, EXAMINING ATTORNEY

---

SN 85-173,360. GLOBAL PRODUCTS INTERNATIONAL, LTD., HUNGHOM, KOWLOON, HONG KONG, FILED 11-10-2010.

**LOTS A FUN TOYS**

THE MARK CONSISTS OF STANDARD CHARACTERS WITHOUT CLAIM TO ANY PARTICULAR FONT, STYLE, SIZE, OR COLOR.

NO CLAIM IS MADE TO THE EXCLUSIVE RIGHT TO USE "TOYS", APART FROM THE MARK AS SHOWN.

FOR INFLATABLE TOYS (U.S. CLS. 22, 23, 38 AND 50).  
RONALD AIKENS, EXAMINING ATTORNEY

**CLASS 28—(Continued).**

SN 85-174,069. ULLOA, ROBERT H., VALENCIA, CA. AND ULLOA, KATHLEEN D., VALENCIA, CA. AND ULLOA, ROBERT P., VALENCIA, CA. AND ULLOA, MICHAEL J., VALENCIA, CA. FILED 11-10-2010.

**CITATION  
SKATEBOARDS**

NO CLAIM IS MADE TO THE EXCLUSIVE RIGHT TO USE "SKATEBOARDS", APART FROM THE MARK AS SHOWN.

THE MARK CONSISTS OF A CRESCENT DESIGN SIMILAR TO THE LETTER "C" TURNED ON ITS SIDE. THE DESIGN IS ABOVE THE STYLIZED WORDING "CITATION SKATEBOARDS".

FOR BALL BEARINGS FOR SKATEBOARDS; SKATEBOARD DECKS; SKATEBOARD GRIP TAPES; SKATEBOARD WHEELS (U.S. CLS. 22, 23, 38 AND 50).

MAUREEN DALL, EXAMINING ATTORNEY

---

SN 85-175,930. THE CHENILLE KRAFT COMPANY, GURNEE, IL. FILED 11-12-2010.

**SQUISHY FOAM**

THE MARK CONSISTS OF STANDARD CHARACTERS WITHOUT CLAIM TO ANY PARTICULAR FONT, STYLE, SIZE, OR COLOR.

NO CLAIM IS MADE TO THE EXCLUSIVE RIGHT TO USE "FOAM", APART FROM THE MARK AS SHOWN.

FOR SOFT SCULPTURE EDUCATIONAL TOYS; EDUCATIONAL HOBBY CRAFT KIT COMPRISING FOAM SHAPES AND DESIGNS (U.S. CLS. 22, 23, 38 AND 50).

KAPIL BHANOT, EXAMINING ATTORNEY

**CLASS 28—(Continued).**

SN 85-177,745. J PECHAUER CUSTOM CUES INC, GREEN BAY, WI. FILED 11-16-2010.

# J Pechauer

THE MARK CONSISTS OF STANDARD CHARACTERS WITHOUT CLAIM TO ANY PARTICULAR FONT, STYLE, SIZE, OR COLOR.

THE NAME(S), PORTRAIT(S), AND/OR SIGNATURE(S) SHOWN IN THE MARK IDENTIFIES JERROLD J PECHAUER, WHOSE CONSENT(S) TO REGISTER IS MADE OF RECORD.

FOR BILLIARD CUES; BILLIARD EQUIPMENT; BILLIARD GAME PLAYING EQUIPMENT; BILLIARD MARKERS; BILLIARD TABLES; BILLIARD TIPS; CHALK FOR BILLIARD CUES; CUE STICKS; POOL CUE CASES; POOL CUE CHALK; POOL CUE RACKS; POOL CUE TIPS; POOL CUES (U.S. CLS. 22, 23, 38 AND 50).

FIRST USE 11-0-1980; IN COMMERCE 11-0-1980.  
JOHN DALIER, EXAMINING ATTORNEY

SN 85-178,552. FATSEAS, TONY, COOGEE NSW, AUSTRALIA, FILED 11-17-2010.

# LOYD

THE MARK CONSISTS OF STANDARD CHARACTERS WITHOUT CLAIM TO ANY PARTICULAR FONT, STYLE, SIZE, OR COLOR.

SEC. 2(F).

FOR PUZZLES (U.S. CLS. 22, 23, 38 AND 50).  
FIRST USE 3-11-2006; IN COMMERCE 7-14-2006.  
KIMBERLY PERRY, EXAMINING ATTORNEY

SN 85-178,891. SPORTSPOWER, LTD., HUNGHOM KOWLOON, HONG KONG, FILED 11-17-2010.



OWNER OF U.S. REG. NO. 3,448,852.

NO CLAIM IS MADE TO THE EXCLUSIVE RIGHT TO USE "TRAMPOLINE", APART FROM THE MARK AS SHOWN.

THE MARK CONSISTS OF THE STYLIZED WORDING "MY 1ST TRAMPOLINE" WITH "MY 1ST" STACKED ON TOP OF "TRAMPOLINE". THE WORDING APPEARS WITHIN A RECTANGLE, WHICH IN TURN APPEARS WITHIN A ROUNDED CORNER RECTANGLE BORDER.

FOR EXERCISE TRAMPOLINES; TRAMPOLINES (U.S. CLS. 22, 23, 38 AND 50).

FIRST USE 11-17-2010; IN COMMERCE 11-17-2010.  
JERI J. FICKES, EXAMINING ATTORNEY

**CLASS 28—(Continued).**

SN 85-180,032. DIBECCA, INC., LAKE MARY, FL. FILED 11-18-2010.

# THE DOG GONE IT GAME

THE MARK CONSISTS OF STANDARD CHARACTERS WITHOUT CLAIM TO ANY PARTICULAR FONT, STYLE, SIZE, OR COLOR.

NO CLAIM IS MADE TO THE EXCLUSIVE RIGHT TO USE "GAME", APART FROM THE MARK AS SHOWN.

FOR BOARD GAMES (U.S. CLS. 22, 23, 38 AND 50).  
ANNE FARRELL, EXAMINING ATTORNEY

SN 85-180,611. LEVEL BODYBOARDING CLOTHING COMPANY SA, VALENCIA, VENEZUELA, FILED 11-18-2010.

# LEVEL BODYBOARDING

THE MARK CONSISTS OF STANDARD CHARACTERS WITHOUT CLAIM TO ANY PARTICULAR FONT, STYLE, SIZE, OR COLOR.

NO CLAIM IS MADE TO THE EXCLUSIVE RIGHT TO USE "BODYBOARDING", APART FROM THE MARK AS SHOWN.

FOR BODY BOARDS; LEASHES FOR SURFBOARDS; LEASHES USED IN CONJUNCTION WITH SURFING; SURF BOARDS; SWIM FINS (U.S. CLS. 22, 23, 38 AND 50).

HOWARD SMIGA, EXAMINING ATTORNEY

SN 85-181,631. SCENTSY, INC., MERIDIAN, ID. FILED 11-19-2010.

# LENNY THE LAMB

THE MARK CONSISTS OF STANDARD CHARACTERS WITHOUT CLAIM TO ANY PARTICULAR FONT, STYLE, SIZE, OR COLOR.

NO CLAIM IS MADE TO THE EXCLUSIVE RIGHT TO USE "LAMB", APART FROM THE MARK AS SHOWN.

FOR STUFFED TOY ANIMALS (U.S. CLS. 22, 23, 38 AND 50).

FIRST USE 9-1-2010; IN COMMERCE 9-1-2010.  
JANICE KIM, EXAMINING ATTORNEY

**CLASS 28—(Continued).**

SN 85-181,635. SCENTSY, INC., MERIDIAN, ID. FILED 11-19-2010.

**MOLLIE THE MONKEY**

THE MARK CONSISTS OF STANDARD CHARACTERS WITHOUT CLAIM TO ANY PARTICULAR FONT, STYLE, SIZE, OR COLOR.

NO CLAIM IS MADE TO THE EXCLUSIVE RIGHT TO USE "MONKEY", APART FROM THE MARK AS SHOWN.

FOR STUFFED TOY ANIMALS (U.S. CLS. 22, 23, 38 AND 50).

FIRST USE 9-1-2010; IN COMMERCE 9-1-2010.  
JANICE KIM, EXAMINING ATTORNEY

**CLASS 28—(Continued).**

SN 85-181,653. SCENTSY, INC., MERIDIAN, ID. FILED 11-19-2010.

**RIBBERT THE FROG**

THE MARK CONSISTS OF STANDARD CHARACTERS WITHOUT CLAIM TO ANY PARTICULAR FONT, STYLE, SIZE, OR COLOR.

NO CLAIM IS MADE TO THE EXCLUSIVE RIGHT TO USE "FROG", APART FROM THE MARK AS SHOWN.

FOR STUFFED TOY ANIMALS (U.S. CLS. 22, 23, 38 AND 50).

FIRST USE 9-1-2010; IN COMMERCE 9-1-2010.  
JANICE KIM, EXAMINING ATTORNEY

SN 85-181,641. SCENTSY, INC., MERIDIAN, ID. FILED 11-19-2010.

**OLLIE THE ELEPHANT**

THE MARK CONSISTS OF STANDARD CHARACTERS WITHOUT CLAIM TO ANY PARTICULAR FONT, STYLE, SIZE, OR COLOR.

NO CLAIM IS MADE TO THE EXCLUSIVE RIGHT TO USE "ELEPHANT", APART FROM THE MARK AS SHOWN.

FOR STUFFED TOY ANIMALS (U.S. CLS. 22, 23, 38 AND 50).

FIRST USE 9-1-2010; IN COMMERCE 9-1-2010.  
JANICE KIM, EXAMINING ATTORNEY

SN 85-181,660. SCENTSY, INC., MERIDIAN, ID. FILED 11-19-2010.

**ROARBERT THE LION**

THE MARK CONSISTS OF STANDARD CHARACTERS WITHOUT CLAIM TO ANY PARTICULAR FONT, STYLE, SIZE, OR COLOR.

NO CLAIM IS MADE TO THE EXCLUSIVE RIGHT TO USE "LION", APART FROM THE MARK AS SHOWN.

FOR STUFFED TOY ANIMALS (U.S. CLS. 22, 23, 38 AND 50).

FIRST USE 9-1-2010; IN COMMERCE 9-1-2010.  
JANICE KIM, EXAMINING ATTORNEY

SN 85-181,647. SCENTSY, INC., MERIDIAN, ID. FILED 11-19-2010.

**PENNY THE PIG**

THE MARK CONSISTS OF STANDARD CHARACTERS WITHOUT CLAIM TO ANY PARTICULAR FONT, STYLE, SIZE, OR COLOR.

NO CLAIM IS MADE TO THE EXCLUSIVE RIGHT TO USE "PIG", APART FROM THE MARK AS SHOWN.

FOR STUFFED TOY ANIMALS (U.S. CLS. 22, 23, 38 AND 50).

FIRST USE 9-1-2010; IN COMMERCE 9-1-2010.  
JANICE KIM, EXAMINING ATTORNEY

SN 85-181,764. FATSEAS, TONY, COOGEE NSW, AUSTRALIA, FILED 11-20-2010.

**S. LOYD.**

THE MARK CONSISTS OF STANDARD CHARACTERS WITHOUT CLAIM TO ANY PARTICULAR FONT, STYLE, SIZE, OR COLOR.

OWNER OF U.S. REG. NO. 3,338,037.

SEC. 2(F).

FOR PUZZLES (U.S. CLS. 22, 23, 38 AND 50).

FIRST USE 3-11-2006; IN COMMERCE 7-14-2006.

KIMBERLY PERRY, EXAMINING ATTORNEY

**CLASS 28—(Continued).**

SN 85-183,286. GAMING PARTNERS INTERNATIONAL USA, INC., LAS VEGAS, NV. FILED 11-23-2010.



The logo for Paulson PRO SERIES features the word "Paulson" in a large, bold, black serif font. The letter "o" in "Paulson" is replaced by a red spade symbol. Below "Paulson" is the text "PRO SERIES" in a smaller, bold, red sans-serif font.

OWNER OF U.S. REG. NOS. 3,089,726, 3,191,146 AND OTHERS.

NO CLAIM IS MADE TO THE EXCLUSIVE RIGHT TO USE "PRO SERIES", APART FROM THE MARK AS SHOWN. THE COLOR(S) BLACK AND RED IS/ARE CLAIMED AS A FEATURE OF THE MARK.

THE MARK CONSISTS OF THE STYLIZED WORD "PAULSON" WHICH IS BLACK OVER THE STYLIZED WORDS "PRO SERIES" WHICH ARE RED. THE CENTER OF THE LETTER "O" IN "PAULSON" IS COMPRISED OF A RED SPADE.

FOR DICE; GAMING EQUIPMENT, NAMELY, GAME WHEELS; GAMING EQUIPMENT, NAMELY, PLAYING CARDS, CHIPS, GAMING TABLES AND GAMING CLOTHS (U.S. CLS. 22, 23, 38 AND 50).

LANA PHAM, EXAMINING ATTORNEY

SN 85-186,770. DONALD L. WRIGHT, DBA INVISIBLE MINNOW RIG, ALLENWOOD, PA. FILED 11-29-2010.

## Invisible Minnow Rig

THE MARK CONSISTS OF STANDARD CHARACTERS WITHOUT CLAIM TO ANY PARTICULAR FONT, STYLE, SIZE, OR COLOR.

NO CLAIM IS MADE TO THE EXCLUSIVE RIGHT TO USE "MINNOW RIG", APART FROM THE MARK AS SHOWN.

FOR FISH HOOKS; FISHING BAIT HOLDER; FISHING HOOKS; FISHING LURES; FISHING SPINNERS; FISHING TACKLE; FISHING TACKLE CONTAINERS (U.S. CLS. 22, 23, 38 AND 50).

FIRST USE 6-1-1946; IN COMMERCE 6-1-1946.

SKYE YOUNG, EXAMINING ATTORNEY

SN 85-186,928. J & O PLASTICS, INC., RITTMAN, OH. FILED 11-30-2010.

## MONSTER BLOCKS

THE MARK CONSISTS OF STANDARD CHARACTERS WITHOUT CLAIM TO ANY PARTICULAR FONT, STYLE, SIZE, OR COLOR.

NO CLAIM IS MADE TO THE EXCLUSIVE RIGHT TO USE "BLOCKS", APART FROM THE MARK AS SHOWN.

FOR TOYS, NAMELY, CONSTRUCTION BLOCKS (U.S. CLS. 22, 23, 38 AND 50).

KIMBERLY FRYE, EXAMINING ATTORNEY

**CLASS 28—(Continued).**

SN 85-187,093. HATRIDGE, PACER, SALEM, MO. AND HATRIDGE, BRENDA, SALEM, MO. FILED 11-30-2010.

## Big Buck Advantage

THE MARK CONSISTS OF STANDARD CHARACTERS WITHOUT CLAIM TO ANY PARTICULAR FONT, STYLE, SIZE, OR COLOR.

NO CLAIM IS MADE TO THE EXCLUSIVE RIGHT TO USE "BUCK", APART FROM THE MARK AS SHOWN.

FOR ANIMAL ATTRACTANT SCENTS (U.S. CLS. 22, 23, 38 AND 50).

JEFFERY COWARD, EXAMINING ATTORNEY

SN 85-187,587. TJ TACKLE ENTERPRISES, LLC, HELENA, MT. FILED 11-30-2010.

## Kit's Tackle "Jiggin' the Dream"

THE MARK CONSISTS OF STANDARD CHARACTERS WITHOUT CLAIM TO ANY PARTICULAR FONT, STYLE, SIZE, OR COLOR.

NO CLAIM IS MADE TO THE EXCLUSIVE RIGHT TO USE "TACKLE", APART FROM THE MARK AS SHOWN.

FOR FISHING LURES (U.S. CLS. 22, 23, 38 AND 50).

FIRST USE 6-0-2008; IN COMMERCE 12-0-2008.

GEOFFREY FOSDICK, EXAMINING ATTORNEY

SN 85-187,597. RIPCORD TECHNOLOGIES, INC., DILLON, MT. FILED 11-30-2010.

## CODE RED

THE MARK CONSISTS OF STANDARD CHARACTERS WITHOUT CLAIM TO ANY PARTICULAR FONT, STYLE, SIZE, OR COLOR.

FOR ARCHERY EQUIPMENT, NAMELY, FALL-AWAY ARROW RESTS (U.S. CLS. 22, 23, 38 AND 50).

FIRST USE 1-1-2010; IN COMMERCE 1-15-2010.

BARNEY CHARLON, EXAMINING ATTORNEY

**CLASS 28—(Continued).**

SN 85-188,450. THE ORIGINAL KNOCKOFF, L.L.C., DESPERES, MO. FILED 12-1-2010.

**The Original Knockoff**

THE MARK CONSISTS OF STANDARD CHARACTERS WITHOUT CLAIM TO ANY PARTICULAR FONT, STYLE, SIZE, OR COLOR.

NO CLAIM IS MADE TO THE EXCLUSIVE RIGHT TO USE "ORIGINAL", APART FROM THE MARK AS SHOWN. FOR OUTDOOR ACTIVITY GAMES IN THE NATURE OF THROWING AN OBJECT IN ORDER TO HIT SET UP TARGETS (U.S. CLS. 22, 23, 38 AND 50).

HOWARD SMIGA, EXAMINING ATTORNEY

SN 85-189,569. WILLIAMS, JOHN, T., SAINT STEPHEN, SC. FILED 12-2-2010.

**Monster Bear**

THE MARK CONSISTS OF STANDARD CHARACTERS WITHOUT CLAIM TO ANY PARTICULAR FONT, STYLE, SIZE, OR COLOR.

NO CLAIM IS MADE TO THE EXCLUSIVE RIGHT TO USE "BEAR", APART FROM THE MARK AS SHOWN. FOR STUFFED TOY BEARS (U.S. CLS. 22, 23, 38 AND 50).

TINA BROWN, EXAMINING ATTORNEY

SN 85-189,637. YOUNG, BRADLEY E, DBA MADFISH RODS, CLEVELAND, TN. FILED 12-2-2010.



NO CLAIM IS MADE TO THE EXCLUSIVE RIGHT TO USE "RODS", APART FROM THE MARK AS SHOWN.

THE MARK CONSISTS OF THE WORDING "MAD FISH" WITH A GRAPHIC OF AN ANGRY FISH SEPARATING THE TERMS. BELOW THE GRAPHIC OF THE FISH IS THE TERM "RODS".

FOR FISHING POLES; FISHING ROD BLANKS; FISHING RODS; RODS FOR FISHING (U.S. CLS. 22, 23, 38 AND 50).

FIRST USE 9-14-2004; IN COMMERCE 9-14-2004. ALYSSA STEEL, EXAMINING ATTORNEY

**CLASS 28—(Continued).**

SN 85-190,547. BATTAT INCORPORATED, PLATTSBURGH, NY. FILED 12-3-2010.

**BAZILLION BUCKETS**

THE MARK CONSISTS OF STANDARD CHARACTERS WITHOUT CLAIM TO ANY PARTICULAR FONT, STYLE, SIZE, OR COLOR.

NO CLAIM IS MADE TO THE EXCLUSIVE RIGHT TO USE "BUCKETS", APART FROM THE MARK AS SHOWN. FOR STACKING TOYS (U.S. CLS. 22, 23, 38 AND 50).

GILBERT SWIFT, EXAMINING ATTORNEY

SN 85-190,790. KILLION, DARRYL, IRVINE, CA. FILED 12-4-2010.

**Mojo Baseball**

THE MARK CONSISTS OF STANDARD CHARACTERS WITHOUT CLAIM TO ANY PARTICULAR FONT, STYLE, SIZE, OR COLOR.

OWNER OF U.S. REG. NO. 3,110,636. NO CLAIM IS MADE TO THE EXCLUSIVE RIGHT TO USE "BASEBALL", APART FROM THE MARK AS SHOWN. FOR ACTION SKILL GAMES; BASEBALLS (U.S. CLS. 22, 23, 38 AND 50).

FIRST USE 8-15-2010; IN COMMERCE 8-15-2010. REBECCA EISINGER, EXAMINING ATTORNEY

SN 85-191,428. CEC ENTERTAINMENT CONCEPTS, L.P., IRVING, TX. FILED 12-6-2010.

**TICKET BLASTER**

NO CLAIM IS MADE TO THE EXCLUSIVE RIGHT TO USE "TICKET BLASTER", APART FROM THE MARK AS SHOWN.

THE MARK CONSISTS OF THE WORDS "TICKET BLASTER" WITH CASCADING STARS AROUND THE WORDS.

FOR AMUSEMENT GAME MACHINES CONSISTING OF AN ENCLOSED BOOTH WHERE COUPONS, TICKETS OR OTHER PAPER ITEMS ARE SUSPENDED IN AN AIR DRAFT. AND A PLAYER POSITIONED IN THE BOOTH GRABS ALL THE TICKETS POSSIBLE DURING A PREDETERMINED PERIOD (U.S. CLS. 22, 23, 38 AND 50).

FIRST USE 11-30-2009; IN COMMERCE 11-30-2009. ALEXANDER L. POWERS, EXAMINING ATTORNEY



**CLASS 28—(Continued).**

SN 85-191,491. BATTAT INCORPORATED, PLATTSBURGH, NY. FILED 12-6-2010.

**HUGS : ) LINKS**

THE MARK CONSISTS OF STANDARD CHARACTERS WITHOUT CLAIM TO ANY PARTICULAR FONT, STYLE, SIZE, OR COLOR.

NO CLAIM IS MADE TO THE EXCLUSIVE RIGHT TO USE "LINKS", APART FROM THE MARK AS SHOWN.

FOR CONSTRUCTION TOYS; TOY BUILDING BLOCKS CAPABLE OF INTERCONNECTION; TOYS DESIGNED TO BE ATTACHED TO CRIBS (U.S. CLS. 22, 23, 38 AND 50).

GILBERT SWIFT, EXAMINING ATTORNEY

**CLASS 28—(Continued).**

SN 85-192,864. ELAUT USA, INC., LAKEWOOD, NJ. FILED 12-8-2010.

**HOOP JAM STADIUM**

THE MARK CONSISTS OF STANDARD CHARACTERS WITHOUT CLAIM TO ANY PARTICULAR FONT, STYLE, SIZE, OR COLOR.

NO CLAIM IS MADE TO THE EXCLUSIVE RIGHT TO USE "HOOP", APART FROM THE MARK AS SHOWN.

FOR ARCADE GAMES (U.S. CLS. 22, 23, 38 AND 50).

SANDRA BUJA, EXAMINING ATTORNEY

SN 85-192,147. FOXPRO, INC., LEWISTOWN, PA. FILED 12-7-2010.

**BLACK JACK**

THE MARK CONSISTS OF STANDARD CHARACTERS WITHOUT CLAIM TO ANY PARTICULAR FONT, STYLE, SIZE, OR COLOR.

FOR ANIMAL HUNTING DECOYS FOR ATTRACTING WILDLIFE (U.S. CLS. 22, 23, 38 AND 50).

JANET LEE, EXAMINING ATTORNEY

SN 85-192,384. BETWISER GAMES, LLC, LAS VEGAS, NV. FILED 12-7-2010.

**U-Pik Poker**

THE MARK CONSISTS OF STANDARD CHARACTERS WITHOUT CLAIM TO ANY PARTICULAR FONT, STYLE, SIZE, OR COLOR.

NO CLAIM IS MADE TO THE EXCLUSIVE RIGHT TO USE "POKER", APART FROM THE MARK AS SHOWN.

FOR EQUIPMENT SOLD AS A UNIT FOR PLAYING CASINO GAMES, NAMELY, LAYOUT CLOTHS, PROCEDURE MANUALS AND PLAYER ADVICE CARDS; EQUIPMENT FOR PLAYING CASINO GAMES, NAMELY, LAYOUT CLOTHS AND PLAYING CARDS; CARD GAMES AND CASINO CARD GAMES (U.S. CLS. 22, 23, 38 AND 50).

CARYN GLASSER, EXAMINING ATTORNEY

SN 85-194,252. FOXPRO, INC., LEWISTOWN, PA. FILED 12-9-2010.

**JACK ATTACK**

THE MARK CONSISTS OF STANDARD CHARACTERS WITHOUT CLAIM TO ANY PARTICULAR FONT, STYLE, SIZE, OR COLOR.

FOR ANIMAL HUNTING DECOYS FOR ATTRACTING WILDLIFE (U.S. CLS. 22, 23, 38 AND 50).

FIRST USE 10-29-2010; IN COMMERCE 10-29-2010.

JANET LEE, EXAMINING ATTORNEY

SN 85-194,640. CHINKES, SAM, DBA SOUND ADVERTISING, LAS VEGAS, NV. FILED 12-9-2010.

**HALF NAKED TEXAS HOLD'EM**

THE MARK CONSISTS OF STANDARD CHARACTERS WITHOUT CLAIM TO ANY PARTICULAR FONT, STYLE, SIZE, OR COLOR.

NO CLAIM IS MADE TO THE EXCLUSIVE RIGHT TO USE "TEXAS HOLD'EM", APART FROM THE MARK AS SHOWN.

FOR CARD GAMES (U.S. CLS. 22, 23, 38 AND 50).

BARBARA BROWN, EXAMINING ATTORNEY

**CLASS 28—(Continued).**

SN 85-197,213. LANNY JOHNSON, OKEMOS, MI. FILED 12-14-2010.

**PRESCRIPTION PUTTING**

THE MARK CONSISTS OF STANDARD CHARACTERS WITHOUT CLAIM TO ANY PARTICULAR FONT, STYLE, SIZE, OR COLOR.

NO CLAIM IS MADE TO THE EXCLUSIVE RIGHT TO USE "PUTTING", APART FROM THE MARK AS SHOWN.

FOR GOLF CLUB GRIPS; GOLF PUTTERS (U.S. CLS. 22, 23, 38 AND 50).

APRIL HESIK, EXAMINING ATTORNEY

SN 85-197,223. LANNY JOHNSON, OKEMOS, MI. FILED 12-14-2010.

**PRESCRIPTION GOLF**

THE MARK CONSISTS OF STANDARD CHARACTERS WITHOUT CLAIM TO ANY PARTICULAR FONT, STYLE, SIZE, OR COLOR.

NO CLAIM IS MADE TO THE EXCLUSIVE RIGHT TO USE "GOLF", APART FROM THE MARK AS SHOWN.

FOR GOLF CLUB GRIPS; GOLF PUTTERS (U.S. CLS. 22, 23, 38 AND 50).

APRIL HESIK, EXAMINING ATTORNEY

SN 85-197,956. QUICKPOLES, LLC, SANDIA PARK, NM. FILED 12-14-2010.



THE MARK CONSISTS OF THE WORD QUICKPOLES IN A STYLIZED LOWER-CASE FONT.

FOR SKI POLES (U.S. CLS. 22, 23, 38 AND 50).

BRIAN NEVILLE, EXAMINING ATTORNEY

**CLASS 28—(Continued).**

SN 85-199,207. HASBRO, INC., PAWTUCKET, RI. FILED 12-16-2010.



THE MARK CONSISTS OF THE WORD "KRE-O" IN STYLIZED LETTERS, WHEREIN THE CENTER OF THE LETTER "O" CONTAINS A SQUARE WITH ROUNDED CORNERS, WHICH CONTAINS A CIRCLE AT ITS CENTER.

FOR CONSTRUCTION TOYS, NAMELY, TOY BUILDING BLOCKS AND ACCESSORIES FOR USE THEREWITH; TOY FIGURES; TOY VEHICLES (U.S. CLS. 22, 23, 38 AND 50).

KIM SAITO, EXAMINING ATTORNEY

SN 85-199,812. MUDDY WATER CAMO, LLC, RIDGELAND, MS. FILED 12-16-2010.

**MUDDY WATER**

THE MARK CONSISTS OF STANDARD CHARACTERS WITHOUT CLAIM TO ANY PARTICULAR FONT, STYLE, SIZE, OR COLOR.

FOR CAMOUFLAGE NETTING USED IN HUNTING; CAMOUFLAGE SCREENS; CAMOUFLAGE SCREENS FOR HUNTING PURPOSES; CAMOUFLAGE TAPE USED IN HUNTING; HUNTERS' SCENT CAMOUFLAGE; HUNTING CAMOUFLAGE USED AS HUNTING BLINDS (U.S. CLS. 22, 23, 38 AND 50).

REGINA DRUMMOND, EXAMINING ATTORNEY

SN 85-200,658. MATTEL, INC., EL SEGUNDO, CA. FILED 12-17-2010.



THE MARK CONSISTS OF STANDARD CHARACTERS WITHOUT CLAIM TO ANY PARTICULAR FONT, STYLE, SIZE, OR COLOR.

FOR DOLLS, DOLL CLOTHING AND DOLL ACCESSORIES (U.S. CLS. 22, 23, 38 AND 50).

RAMONA ORTIGA, EXAMINING ATTORNEY

**CLASS 28—(Continued).**

SN 85-201,121. ORBOTIX, INC., BOULDER, CO. FILED 12-17-2010.

**SPHERO**

THE MARK CONSISTS OF STANDARD CHARACTERS WITHOUT CLAIM TO ANY PARTICULAR FONT, STYLE, SIZE, OR COLOR.

FOR TOY ROBOTS; REMOTE CONTROL TOYS, NAMELY MOVING BALLS; ELECTRONIC ACTION TOYS; EDUCATIONAL TOYS, NAMELY PROGRAMMABLE ROBOTS FOR THE PURPOSE OF DEMONSTRATING ROBOTICS AND PROGRAMMING (U.S. CLS. 22, 23, 38 AND 50).

DOMINIC FATHY, EXAMINING ATTORNEY

SN 85-201,267. AIR TO GROUND CALLS INC, GAINESVILLE, GA. FILED 12-18-2010.



THE MARK CONSISTS OF THE STYLIZED INITIALS "ATG" AND THE DESIGN OF A WATERFOWL WITH OUTSTRETCHED WINGS. THE WATERFOWL APPEARS JUST TO THE LEFT OF THE INITIALS, FACING RIGHT, WITH THE LEFT WING STRETCHING OVER THE FIRST TWO LETTERS IN "ATG".

FOR HUNTING GAME CALLS (U.S. CLS. 22, 23, 38 AND 50).

FIRST USE 9-1-2010; IN COMMERCE 10-1-2010.  
JERI J. FICKES, EXAMINING ATTORNEY

SN 85-201,806. SHADOW HUNTER, LLC, MARCELLUS, MI. FILED 12-20-2010.

**TOTAL VIEW**

THE MARK CONSISTS OF STANDARD CHARACTERS WITHOUT CLAIM TO ANY PARTICULAR FONT, STYLE, SIZE, OR COLOR.

FOR SPORTING EQUIPMENT, NAMELY, HUNTING BLINDS (U.S. CLS. 22, 23, 38 AND 50).

KAELIE KUNG, EXAMINING ATTORNEY

**CLASS 28—(Continued).**

SN 85-202,325. LEVEL 10 FITNESS PRODUCTS LLC, PORTLAND, OR. FILED 12-20-2010.

**OCTOFIT**

THE MARK CONSISTS OF STANDARD CHARACTERS WITHOUT CLAIM TO ANY PARTICULAR FONT, STYLE, SIZE, OR COLOR.

FOR MANUALLY-OPERATED EXERCISE EQUIPMENT (U.S. CLS. 22, 23, 38 AND 50).

LAURA KOVALSKY, EXAMINING ATTORNEY

SN 85-202,798. MATTEL, INC., EL SEGUNDO, CA. FILED 12-21-2010.

**SMACK ATTACK**

THE MARK CONSISTS OF STANDARD CHARACTERS WITHOUT CLAIM TO ANY PARTICULAR FONT, STYLE, SIZE, OR COLOR.

FOR TOY ACTION FIGURE PLAYSETS AND ACCESSORIES THEREFOR; TOY ACTION FIGURES AND ACCESSORIES THEREFOR (U.S. CLS. 22, 23, 38 AND 50).

RAMONA ORTIGA, EXAMINING ATTORNEY

SN 85-202,801. MATTEL, INC., EL SEGUNDO, CA. FILED 12-21-2010.

**SUPER STYLE SHOPS**

THE MARK CONSISTS OF STANDARD CHARACTERS WITHOUT CLAIM TO ANY PARTICULAR FONT, STYLE, SIZE, OR COLOR.

FOR DOLL PLAYSETS AND ACCESSORIES THEREFOR; DOLLS, DOLL CLOTHING AND DOLL ACCESSORIES (U.S. CLS. 22, 23, 38 AND 50).

RAMONA ORTIGA, EXAMINING ATTORNEY

**CLASS 28—(Continued).**

SN 85-202,807. MATTEL, INC., EL SEGUNDO, CA. FILED 12-21-2010.

**SOUR APPLES TO APPLES**

THE MARK CONSISTS OF STANDARD CHARACTERS WITHOUT CLAIM TO ANY PARTICULAR FONT, STYLE, SIZE, OR COLOR.

OWNER OF U.S. REG. NOS. 2,326,461 AND 3,880,255.  
FOR CARD GAMES; PARLOR GAMES (U.S. CLS. 22, 23, 38 AND 50).  
RAMONA ORTIGA, EXAMINING ATTORNEY

**CLASS 28—(Continued).**

SN 85-204,293. LUCKY CRAFT CO., LTD., OYABE-SHI, TOYAMA, JAPAN, FILED 12-22-2010.

**SMASHER**

THE MARK CONSISTS OF STANDARD CHARACTERS WITHOUT CLAIM TO ANY PARTICULAR FONT, STYLE, SIZE, OR COLOR.

FOR FISHING EQUIPMENT NAMELY FISHING TACKLES, FISHING LURES, FISHING RODS AND FISHING LINES (U.S. CLS. 22, 23, 38 AND 50).  
JANET LEE, EXAMINING ATTORNEY

SN 85-203,624. BUZZ BEE TOYS, INC., MT. LAUREL, NJ. FILED 12-22-2010.

**TORRENT**

THE MARK CONSISTS OF STANDARD CHARACTERS WITHOUT CLAIM TO ANY PARTICULAR FONT, STYLE, SIZE, OR COLOR.

FOR TOY PROJECTILE SHOOTERS AND ACCESSORIES THEREFOR (U.S. CLS. 22, 23, 38 AND 50).  
TAMARA FRAZIER, EXAMINING ATTORNEY

SN 85-204,794. PROPHET CORPORATION, DBA GOPHER SPORT CORPORATION, OWATONNA, MN. FILED 12-23-2010.

**TumblePro**

THE MARK CONSISTS OF STANDARD CHARACTERS WITHOUT CLAIM TO ANY PARTICULAR FONT, STYLE, SIZE, OR COLOR.

FOR EXERCISE MATS (U.S. CLS. 22, 23, 38 AND 50).  
FIRST USE 1-1-2008; IN COMMERCE 1-1-2008.  
JOHN E. MICHOS, EXAMINING ATTORNEY

SN 85-204,080. ANAGRAM INTERNATIONAL, INC., EDEN PRAIRIE, MN. FILED 12-22-2010.

**Prematex**

THE MARK CONSISTS OF STANDARD CHARACTERS WITHOUT CLAIM TO ANY PARTICULAR FONT, STYLE, SIZE, OR COLOR.

FOR BALLOONS (U.S. CLS. 22, 23, 38 AND 50).  
BRIAN PINO, EXAMINING ATTORNEY

SN 85-204,847. PROPHET CORPORATION, DBA GOPHER SPORT CORPORATION, OWATONNA, MN. FILED 12-23-2010.

**RinkPro**

THE MARK CONSISTS OF STANDARD CHARACTERS WITHOUT CLAIM TO ANY PARTICULAR FONT, STYLE, SIZE, OR COLOR.

FOR HOCKEY GOALS (U.S. CLS. 22, 23, 38 AND 50).  
FIRST USE 12-15-2010; IN COMMERCE 12-15-2010.  
JOHN E. MICHOS, EXAMINING ATTORNEY

**CLASS 28—(Continued).**

SN 85-205,299. FAGERSTROM, TODD R., WAUKESHA, WI. FILED 12-23-2010.



THE MARK CONSISTS OF STYLIZED LETTERING OF THE WORD BULLETAILS INCLUDING TWO "T'S IN THE FORM OF FISH HOOKS WITH A BULLET AS THE UPPER PORTION OF THE "T'S.

FOR ARTIFICIAL FISHING LURES (U.S. CLS. 22, 23, 38 AND 50).

TRACY CROSS, EXAMINING ATTORNEY

**CLASS 28—(Continued).**

SN 85-205,872. ANDERSON REISBERG, JOANNE, ROBBINSDALE, MN. FILED 12-27-2010.

**ROME OF NUMERALS**

THE MARK CONSISTS OF STANDARD CHARACTERS WITHOUT CLAIM TO ANY PARTICULAR FONT, STYLE, SIZE, OR COLOR.

FOR EQUIPMENT SOLD AS A UNIT FOR PLAYING A BOARD GAME CONSISTING OF A GAME BOARD, DICE, CARDS, AND PLAYER TOKENS (U.S. CLS. 22, 23, 38 AND 50).

EUGENIA MARTIN, EXAMINING ATTORNEY

SN 85-205,328. ALLRED, ALAN, ELON, NC. FILED 12-23-2010.



THE MARK CONSISTS OF THE STYLIZED TEXT "VOLLEZE" WITH TWO ARMS TOGETHER MAKING THE LETTER V AND A VOLLEYBALL FOR THE LETTER O TO MAKE THE WORD VOLLEZE WITH THE STYLIZED TEXT "PASS WITHOUT PAIN" UNDERNEATH THE WORD "VOLLEZE".

FOR SPORTS ACCESSORY, NAMELY, A PROTECTIVE VOLLEYBALL PASSING SLEEVE (U.S. CLS. 22, 23, 38 AND 50).

FIRST USE 10-25-2010; IN COMMERCE 10-25-2010.  
STEPHANIE ALI, EXAMINING ATTORNEY

SN 85-206,102. DOUBLETAKE ARCHERY, LA VERNIA, TX. FILED 12-27-2010.

**BOWPLANE**

THE MARK CONSISTS OF STANDARD CHARACTERS WITHOUT CLAIM TO ANY PARTICULAR FONT, STYLE, SIZE, OR COLOR.

FOR ARCHERY EQUIPMENT, NAMELY, BOW ALIGNMENT SYSTEMS (U.S. CLS. 22, 23, 38 AND 50).

FIRST USE 1-18-2007; IN COMMERCE 1-18-2007.  
KATINA MISTER, EXAMINING ATTORNEY

SN 85-205,389. G-FORCE CORP., LAS VEGAS, NV. FILED 12-23-2010.

**NANO SECOND**

THE MARK CONSISTS OF STANDARD CHARACTERS WITHOUT CLAIM TO ANY PARTICULAR FONT, STYLE, SIZE, OR COLOR.

FOR EXERCISE MACHINES; MANUALLY-OPERATED EXERCISE EQUIPMENT (U.S. CLS. 22, 23, 38 AND 50).

JANET LEE, EXAMINING ATTORNEY

SN 85-206,157. PLANO MOLDING COMPANY, PLANO, IL. FILED 12-27-2010.

**MANTA**

THE MARK CONSISTS OF STANDARD CHARACTERS WITHOUT CLAIM TO ANY PARTICULAR FONT, STYLE, SIZE, OR COLOR.

FOR CROSSBOW CASES (U.S. CLS. 22, 23, 38 AND 50).  
GRETTA YAO, EXAMINING ATTORNEY

**CLASS 28—(Continued).**

SN 85-206,161. PLANO MOLDING COMPANY, PLANO, IL.  
FILED 12-27-2010.

**HYDRO-FLO**

THE MARK CONSISTS OF STANDARD CHARACTERS WITHOUT CLAIM TO ANY PARTICULAR FONT, STYLE, SIZE, OR COLOR.

FOR FISHING TACKLE BAGS (U.S. CLS. 22, 23, 38 AND 50).

FIRST USE 5-31-2010; IN COMMERCE 8-31-2010.  
GRETTA YAO, EXAMINING ATTORNEY

SN 85-206,215. HARLAN J. MOOSE PRODUCTIONS LLC,  
SAG HARBOR, NY. FILED 12-27-2010.

**Harlan J. Moose is Loose**

THE MARK CONSISTS OF STANDARD CHARACTERS WITHOUT CLAIM TO ANY PARTICULAR FONT, STYLE, SIZE, OR COLOR.

FOR BOARD GAMES (U.S. CLS. 22, 23, 38 AND 50).  
ANTHONY RINKER, EXAMINING ATTORNEY

SN 85-206,432. KOSKI ENTERPRISES, LLC, SOMERSET  
CENTER, MI. FILED 12-28-2010.

**WHAT'S IN THE BOX? I  
CAN'T TELL YA!**

THE MARK CONSISTS OF STANDARD CHARACTERS WITHOUT CLAIM TO ANY PARTICULAR FONT, STYLE, SIZE, OR COLOR.

FOR POP-OUT TOYS (U.S. CLS. 22, 23, 38 AND 50).  
AISHA CLARKE, EXAMINING ATTORNEY

SN 85-206,778. STORM PRODUCTS, INC., BRIGHAM CITY,  
UT. FILED 12-28-2010.

**ROLLING THUNDER**

THE MARK CONSISTS OF STANDARD CHARACTERS WITHOUT CLAIM TO ANY PARTICULAR FONT, STYLE, SIZE, OR COLOR.

FOR BOWLING BAGS (U.S. CLS. 22, 23, 38 AND 50).  
SCOTT BIBB, EXAMINING ATTORNEY

**CLASS 28—(Continued).**

SN 85-206,785. STORM PRODUCTS, INC., BRIGHAM CITY,  
UT. FILED 12-28-2010.



THE MARK CONSISTS OF A GRAPHIC BACKWARDS R AND A T IN A BOX WITH A LIGHTNING BOLT AS PART OF THE LETTER R. TO THE RIGHT OF THE BOX ARE THE WORDS ROLLING THUNDER. THE WORD ROLLING IS ABOVE THUNDER AND THE TWO ARE SEPARATED BY A LINE, AND A LIGHTNING BOLT IS PART OF THE LETTER R IN THUNDER.

FOR BOWLING BAGS (U.S. CLS. 22, 23, 38 AND 50).  
SCOTT BIBB, EXAMINING ATTORNEY

SN 85-206,958. STUFFLESS, INC., PORTLAND, OR. FILED  
12-29-2010.

**STUFFLESS**

THE MARK CONSISTS OF STANDARD CHARACTERS WITHOUT CLAIM TO ANY PARTICULAR FONT, STYLE, SIZE, OR COLOR.

FOR TOY PLUSH DOLLS (U.S. CLS. 22, 23, 38 AND 50).  
CHERYL CLAYTON, EXAMINING ATTORNEY

SN 85-207,116. ORBOTIX, INC., BOULDER, CO. FILED 12-29-  
2010.



THE MARK CONSISTS OF THE STYLIZED WORD "SPHERO" WITH THE DESIGN OF A CIRCLE LOCATED ABOVE THE STYLIZED WORD THAT CONTAINS A TAIL-LIKE FEATURE AT THE TOP OF THE CIRCLE WITH THE DESIGN OF TWO DIFFERENT SIZE OVALS WITHIN THE CIRCLE.

FOR TOY ROBOTS; REMOTE CONTROL TOYS, NAMELY, MOVING BALLS; ELECTRONIC ACTION TOYS; EDUCATIONAL TOYS, NAMELY, PROGRAMMABLE ROBOTS FOR THE PURPOSE OF DEMONSTRATING ROBOTICS AND PROGRAMMING (U.S. CLS. 22, 23, 38 AND 50).

DOMINIC FATHY, EXAMINING ATTORNEY

**CLASS 28—(Continued).**

SN 85-207,120. ORBOTIX, INC., BOULDER, CO. FILED 12-29-2010.



THE MARK CONSISTS OF THE STYLIZED WORD "SPHERO" WITH THE DESIGN OF A CIRCLE LOCATED TO THE LEFT OF THE STYLIZED WORD THAT CONTAINS A TAIL-LIKE FEATURE AT THE TOP OF THE CIRCLE WITH THE DESIGN OF TWO DIFFERENT SIZE OVALS WITHIN THE CIRCLE.

FOR TOY ROBOTS; REMOTE CONTROL TOYS, NAMELY, MOVING BALLS; ELECTRONIC ACTION TOYS; EDUCATIONAL TOYS, NAMELY, PROGRAMMABLE ROBOTS FOR THE PURPOSE OF DEMONSTRATING ROBOTICS AND PROGRAMMING (U.S. CLS. 22, 23, 38 AND 50).

DOMINIC FATHY, EXAMINING ATTORNEY

SN 85-207,198. DOUBLETAKE ARCHERY, LA VERNIA, TX. FILED 12-29-2010.

## Transition

THE MARK CONSISTS OF STANDARD CHARACTERS WITHOUT CLAIM TO ANY PARTICULAR FONT, STYLE, SIZE, OR COLOR.

FOR ARCHERY EQUIPMENT, NAMELY, PEEP SIGHTS (U.S. CLS. 22, 23, 38 AND 50).

FIRST USE 1-13-2010; IN COMMERCE 1-13-2010.

KATINA MISTER, EXAMINING ATTORNEY

SN 85-207,216. LIEFKE, NORMAN WILLIAM, SURREY, B.C., CANADA, FILED 12-29-2010.

## StoneWood

THE MARK CONSISTS OF STANDARD CHARACTERS WITHOUT CLAIM TO ANY PARTICULAR FONT, STYLE, SIZE, OR COLOR.

FOR MODULAR PLAY CENTERS CONSISTING OF PANELS, DECKS, PLATFORMS, HANDRAILS, SLIDES, AND STEPS ALL SOLD SEPARATELY OR IN SELECTED COMBINATIONS (U.S. CLS. 22, 23, 38 AND 50).

HEATHER SAPP, EXAMINING ATTORNEY

**CLASS 28—(Continued).**

SN 85-207,226. KEE ACTION SPORTS I LLC, SEWELL, NJ. FILED 12-29-2010.

## PREMISE

THE MARK CONSISTS OF STANDARD CHARACTERS WITHOUT CLAIM TO ANY PARTICULAR FONT, STYLE, SIZE, OR COLOR.

FOR PAINTBALL GUNS (U.S. CLS. 22, 23, 38 AND 50).  
LAURA HAMMEL, EXAMINING ATTORNEY

SN 85-207,248. DOUBLETAKE ARCHERY, LA VERNIA, TX. FILED 12-29-2010.

## Nockturnal

THE MARK CONSISTS OF STANDARD CHARACTERS WITHOUT CLAIM TO ANY PARTICULAR FONT, STYLE, SIZE, OR COLOR.

FOR ARCHERY EQUIPMENT, NAMELY, NOCKS (U.S. CLS. 22, 23, 38 AND 50).

FIRST USE 1-13-2010; IN COMMERCE 1-13-2010.

KATINA MISTER, EXAMINING ATTORNEY

SN 85-207,254. LIEFKE, NORMAN WILLIAM, SURREY, B.C., CANADA, FILED 12-29-2010.

## DeckTile

THE MARK CONSISTS OF STANDARD CHARACTERS WITHOUT CLAIM TO ANY PARTICULAR FONT, STYLE, SIZE, OR COLOR.

FOR MODULAR PLAY CENTERS CONSISTING OF PANELS, DECKS, PLATFORMS, HANDRAILS, SLIDES, AND STEPS ALL SOLD SEPARATELY OR IN SELECTED COMBINATIONS (U.S. CLS. 22, 23, 38 AND 50).

HEATHER SAPP, EXAMINING ATTORNEY

**CLASS 28—(Continued).**

SN 85-207,718. QUEEN GAMES GMBH, TROISDORF, FED REP GERMANY, FILED 12-30-2010.

**Connecting Generations**

THE MARK CONSISTS OF STANDARD CHARACTERS WITHOUT CLAIM TO ANY PARTICULAR FONT, STYLE, SIZE, OR COLOR.

FOR BOARD GAMES (U.S. CLS. 22, 23, 38 AND 50).  
FIRST USE 11-16-2009; IN COMMERCE 6-23-2010.  
JILL PRATER, EXAMINING ATTORNEY

---

SN 85-208,594. KRISTA SMITH, BIG LAKE, MN. FILED 12-31-2010.

**THE SLIPPERY SLOPE**

THE MARK CONSISTS OF STANDARD CHARACTERS WITHOUT CLAIM TO ANY PARTICULAR FONT, STYLE, SIZE, OR COLOR.

FOR BOARD GAMES (U.S. CLS. 22, 23, 38 AND 50).  
FIRST USE 0-0-2009; IN COMMERCE 0-0-2009.  
ADA HAN, EXAMINING ATTORNEY

---

SN 85-208,662. IPG HOLDING SA, APPENZELL, SWITZERLAND, FILED 12-31-2010.

**IDENTITY PURSUIT**

THE MARK CONSISTS OF STANDARD CHARACTERS WITHOUT CLAIM TO ANY PARTICULAR FONT, STYLE, SIZE, OR COLOR.

FOR BOARD GAMES (U.S. CLS. 22, 23, 38 AND 50).  
FIRST USE 11-20-2010; IN COMMERCE 11-20-2010.  
AMY C. KEAN, EXAMINING ATTORNEY

**CLASS 28—(Continued).**

SN 85-208,819. AUGUSTUS INTERNATIONAL, LIMITED, DENVER, CO. FILED 1-2-2011.

**BOOMTOWN**

THE MARK CONSISTS OF STANDARD CHARACTERS WITHOUT CLAIM TO ANY PARTICULAR FONT, STYLE, SIZE, OR COLOR.

FOR BOARD GAMES AND COMPONENT GAME PIECES, NAMELY, ILLUSTRATED GAME BOARDS, TOY HOUSES, TOY BUILDING STRUCTURES, TOY VEHICLES, TOY MONEY, DICE AND CARDS, USED IN THE PLAYING OF THE GAME (U.S. CLS. 22, 23, 38 AND 50).

FIRST USE 1-1-2011; IN COMMERCE 1-1-2011.  
JANET LEE, EXAMINING ATTORNEY

---

SN 85-208,979. THE HIPCHECK, LLC, CHARLOTTE, VT. FILED 1-3-2011.



THE COLOR(S) DARK GREEN, LIGHT GREEN IS/ARE CLAIMED AS A FEATURE OF THE MARK.

THE MARK CONSISTS OF THE WORD "HIPCHECK" AS ONE WORD WITH THE "H" IN "HIP" CAPITALIZED AND THE FIRST "C" IN "CHECK" CAPITALIZED, WITH "HIP" IN A BOLD, LIGHT GREEN FONT AND "CHECK" IN A THINNER LINE AND DARK GREEN FONT. THE WORD "THE" IS SMALL, ABOVE THE "H" IN "HIPCHECK" AND MATCHES THE COLOR AND WEIGHT OF "CHECK". THE MARK INCLUDES A GOLF BALL ABOVE THE SECOND "C" IN "CHECK" WITH ARCHED LINES CONNECTING THE BALL TO THE HOLE IN THE "P" IN "HIP" SHOWING THE PATH OF THE BALL'S FLIGHT. THERE IS A LIGHT GREEN TRIANGULAR FLAG FLYING FROM THE VERTICAL LINE IN THE "K" IN "HIPCHECK". IT IS AN ISOSCELES TRIANGLE WITH THE APEX POINTING TO THE RIGHT AND THE BASE, CONCAVE RIGHT, ATTACHED TO THE "K".

FOR GOLF CLUB SWING AIDS, NAMELY, HIP-MOUNTED DIRECTIONAL POINTER (U.S. CLS. 22, 23, 38 AND 50).

FIRST USE 6-14-2010; IN COMMERCE 6-14-2010.  
CHERYL CLAYTON, EXAMINING ATTORNEY



**CLASS 28—(Continued).**

SN 85-209,061. CLUB-CONEX, INC., ROCKFORD, IL. FILED 1-3-2011.

# FAZ-FIT

THE MARK CONSISTS OF STANDARD CHARACTERS WITHOUT CLAIM TO ANY PARTICULAR FONT, STYLE, SIZE, OR COLOR.

FOR GOLF CLUB PARTS, NAMELY, CONNECTORS FOR ATTACHING OR ASSEMBLING GOLF CLUBS (U.S. CLS. 22, 23, 38 AND 50).

FIRST USE 0-0-2010; IN COMMERCE 0-0-2010.  
TINA L. SNAPP, EXAMINING ATTORNEY

**CLASS 28—(Continued).**

SN 85-210,062. SHOOT THE MOON PRODUCTS II, LLC, PLEASANTON, CA. FILED 1-4-2011.

# YAK BAK

THE MARK CONSISTS OF STANDARD CHARACTERS WITHOUT CLAIM TO ANY PARTICULAR FONT, STYLE, SIZE, OR COLOR.

FOR TOYS, NAMELY, MUSIC AND VOICE RECORDING TOYS (U.S. CLS. 22, 23, 38 AND 50).

HELENE LIWINSKI, EXAMINING ATTORNEY

SN 85-209,084. CLUB-CONEX, INC., ROCKFORD, IL. FILED 1-3-2011.

# FUSE-FIT

THE MARK CONSISTS OF STANDARD CHARACTERS WITHOUT CLAIM TO ANY PARTICULAR FONT, STYLE, SIZE, OR COLOR.

FOR GOLF CLUB PARTS, NAMELY, CONNECTORS FOR ATTACHING OR ASSEMBLING GOLF CLUBS (U.S. CLS. 22, 23, 38 AND 50).

TINA L. SNAPP, EXAMINING ATTORNEY

SN 85-210,378. HYBEAMZ, WAYNE, NJ. FILED 1-4-2011.

# Cavehands

THE MARK CONSISTS OF STANDARD CHARACTERS WITHOUT CLAIM TO ANY PARTICULAR FONT, STYLE, SIZE, OR COLOR.

FOR FANTASY CHARACTER TOYS (U.S. CLS. 22, 23, 38 AND 50).

GINA FINK, EXAMINING ATTORNEY

SN 85-209,922. BRICKFORGE, SPRINGFIELD, OH. FILED 1-4-2011.

# BrickForge

THE MARK CONSISTS OF STANDARD CHARACTERS WITHOUT CLAIM TO ANY PARTICULAR FONT, STYLE, SIZE, OR COLOR.

FOR TOY ACTION FIGURES AND ACCESSORIES THEREFOR (U.S. CLS. 22, 23, 38 AND 50).

FIRST USE 5-7-2007; IN COMMERCE 7-7-2008.

ARETHA SOMERVILLE, EXAMINING ATTORNEY

SN 85-210,465. SUN WAVE TECHNOLOGIES LTD., FRUITLAND, NM. FILED 1-4-2011.

# Humm Bug

THE MARK CONSISTS OF STANDARD CHARACTERS WITHOUT CLAIM TO ANY PARTICULAR FONT, STYLE, SIZE, OR COLOR.

FOR SOLAR POWERED FISHING LURES (U.S. CLS. 22, 23, 38 AND 50).

ALICIA COLLINS, EXAMINING ATTORNEY

**CLASS 28—(Continued).**

SN 85-210,606. CLOUDCO, INC., CLEVELAND, OH. FILED 1-5-2011.

**BGDCMC**

THE MARK CONSISTS OF STANDARD CHARACTERS WITHOUT CLAIM TO ANY PARTICULAR FONT, STYLE, SIZE, OR COLOR.

FOR PLUSH TOYS; TOY FIGURES (U.S. CLS. 22, 23, 38 AND 50).

HEATHER SAPP, EXAMINING ATTORNEY

**CLASS 28—(Continued).**

SN 85-210,763. LIBERTY SKIS CORPORATION, NEW YORK, NY. FILED 1-5-2011.

**HELIX**

THE MARK CONSISTS OF STANDARD CHARACTERS WITHOUT CLAIM TO ANY PARTICULAR FONT, STYLE, SIZE, OR COLOR.

FOR SNOW SKIS AND SNOW SKI BINDINGS; SNOWBOARDS AND SNOWBOARD BINDINGS (U.S. CLS. 22, 23, 38 AND 50).

FIRST USE 10-31-2008; IN COMMERCE 10-31-2008.  
NATALIE POLZER, EXAMINING ATTORNEY

SN 85-210,609. CLOUDCO, INC., CLEVELAND, OH. FILED 1-5-2011.

**BOY GIRL DOG CAT MOUSE  
CHEESE**

THE MARK CONSISTS OF STANDARD CHARACTERS WITHOUT CLAIM TO ANY PARTICULAR FONT, STYLE, SIZE, OR COLOR.

FOR PLUSH TOYS; TOY FIGURES (U.S. CLS. 22, 23, 38 AND 50).

HEATHER SAPP, EXAMINING ATTORNEY

SN 85-211,232. SCHECHTMAN, ADAM G., SEVEN VALLEYS, PA. FILED 1-5-2011.



SN 85-210,612. CLOUDCO, INC., CLEVELAND, OH. FILED 1-5-2011.

**BOY, GIRL, DOG, CAT,  
MOUSE, CHEESE**

THE MARK CONSISTS OF STANDARD CHARACTERS WITHOUT CLAIM TO ANY PARTICULAR FONT, STYLE, SIZE, OR COLOR.

FOR PLUSH TOYS; TOY FIGURES (U.S. CLS. 22, 23, 38 AND 50).

HEATHER SAPP, EXAMINING ATTORNEY

THE COLOR(S) ORANGE, BLACK, RED, ROYAL BLUE, GREEN, SKY BLUE, WHITE, GRAY IS/ARE CLAIMED AS A FEATURE OF THE MARK.

THE MARK CONSISTS OF A LARGE, CAPITAL, STYLIZED, ORANGE LETTER Q THAT GRADATES TO WHITE IN MIDDLE WITH BLACK OUTLINE. THE LARGE Q CONSISTS OF FEATURES OF AN OLD FASHIONED, TWO BELL ALARM CLOCK ON TOP WITH TWO GRADATED RED BELLS WITH BLACK OUTLINE AND AN OVAL ALARM PIN/RINGER IN THE MIDDLE, WHICH IS GRAY, WHITE AND BLACK. THE STYLIZED TERM QTIME WRAPS AROUND THE UPPER RIGHT SIDE OF THE LARGE STYLIZED Q. THE TERM QTIME CONSISTS OF THE FOLLOWING: A STYLIZED, GRADATED ROYAL BLUE, CAPITAL Q WITH BLACK OUTLINE, A STYLIZED CAPITAL T WHICH IS GRADATED GREEN WITH BLACK OUTLINE, A STYLIZED LOWER CASE I WHICH IS GRADATED ORANGE WITH BLACK OUTLINE, A STYLIZED LOWER CASE M WHICH IS GRADATED RED WITH BLACK OUTLINE AND A STYLIZED LOWER CASE E AND STYLIZED ! WHICH ARE GRADATED SKY BLUE WITH BLACK OUTLINE.

FOR BOARD GAMES (U.S. CLS. 22, 23, 38 AND 50).  
JILL PRATER, EXAMINING ATTORNEY

**CLASS 28—(Continued).**

SN 85-211,381. MAYNARD'S, LLC, MINNEAPOLIS, MN.  
FILED 1-5-2011.



THE COLOR(S) BLACK, WHITE, GRAY, GREEN, RED, YELLOW, AND BLUE IS/ARE CLAIMED AS A FEATURE OF THE MARK.

THE MARK CONSISTS OF A SPHERE MADE FROM FOUR JIGSAW PUZZLE PIECES, A GREEN UPPER LEFT JIGSAW PUZZLE PIECE, A RED UPPER RIGHT JIGSAW PUZZLE PIECE, A YELLOW LOWER RIGHT JIGSAW PUZZLE PIECE, AND A BLUE LOWER LEFT JIGSAW PUZZLE PIECE. THE OUTLINES OF THE JIGSAW PUZZLE PIECES ARE IN WHITE. THERE IS A GRAY SHADOW BENEATH THE SPHERE. TO THE RIGHT OF THE SPHERE IS THE WORD PUZZLETWIST WITH A CAPITALIZED P AND A CAPITALIZED T IN THE CENTER OF THE WORD. THE LETTERS IN THE WORD PUZZLETWIST ARE BLACK.

FOR JIGSAW PUZZLES (U.S. CLS. 22, 23, 38 AND 50).  
FIRST USE 12-4-2010; IN COMMERCE 12-16-2010.  
BARBARA BROWN, EXAMINING ATTORNEY

**CLASS 28—(Continued).**

SN 85-213,263. CABELA'S INC., SIDNEY, NE. FILED 1-7-2011.

# X50

THE MARK CONSISTS OF STANDARD CHARACTERS WITHOUT CLAIM TO ANY PARTICULAR FONT, STYLE, SIZE, OR COLOR.

FOR FISHING LINES (U.S. CLS. 22, 23, 38 AND 50).  
FIRST USE 1-3-2011; IN COMMERCE 1-3-2011.  
SHAUNIA CARLYLE, EXAMINING ATTORNEY

SN 85-214,126. STOUT STUFF, LLC, BENTONVILLE, AR.  
FILED 1-10-2011.

# STRATEGY

SN 85-211,732. MITSUSHBIA INTERNATIONAL, INC., DBA  
PARAGON SPORTS, FULLERTON, CA. FILED 1-6-2011.

# PARAGON

THE MARK CONSISTS OF STANDARD CHARACTERS WITHOUT CLAIM TO ANY PARTICULAR FONT, STYLE, SIZE, OR COLOR.

FOR HUNTING BLINDS (U.S. CLS. 22, 23, 38 AND 50).  
TRACY CROSS, EXAMINING ATTORNEY

SN 85-214,183. TRUE TEMPER SPORTS, INC., MEMPHIS,  
TN. FILED 1-10-2011.

# SPEED COAT

THE MARK CONSISTS OF STANDARD CHARACTERS WITHOUT CLAIM TO ANY PARTICULAR FONT, STYLE, SIZE, OR COLOR.

FOR COVERS FOR GOLF CLUBS; FITTED HEAD COVERS FOR GOLF CLUBS; GLOVES FOR GOLF; GOLF ACCESSORIES, NAMELY, CARRIERS AND DISPENSERS FOR GOLF BALLS; GOLF BAG TAGS; GOLF BAGS; GOLF BAGS WITH OR WITHOUT WHEELS; GOLF BALLS; GOLF CLUB BAGS; GOLF CLUB COVERS; GOLF CLUB GRIPS; GOLF CLUB HEADS; GOLF CLUB SHAFTS; GOLF CLUBS; GOLF GLOVES; GOLF IRONS; GOLF PUTTER COVERS; GOLF PUTTERS; GOLF TEES; HAND GRIPS FOR GOLF CLUBS; HEAD COVERS FOR GOLF CLUBS; NON-MOTORIZED GOLF CARTS; TROLLEY BAGS FOR GOLF EQUIPMENT (U.S. CLS. 22, 23, 38 AND 50).

FIRST USE 7-30-1987; IN COMMERCE 8-1-1987.  
STEPHANIE ALI, EXAMINING ATTORNEY

THE MARK CONSISTS OF STANDARD CHARACTERS WITHOUT CLAIM TO ANY PARTICULAR FONT, STYLE, SIZE, OR COLOR.

FOR GOLF CLUB SHAFTS (U.S. CLS. 22, 23, 38 AND 50).  
JACQUELINE A. LAVINE, EXAMINING ATTORNEY

**CLASS 28—(Continued).**

SN 85-214,222. MEGA BRANDS INTERNATIONAL, LUXEMBOURG, ZUG BRANCH, ZUG, SWITZERLAND, FILED 1-10-2011.

**CLIP-A-BLANK**

THE MARK CONSISTS OF STANDARD CHARACTERS WITHOUT CLAIM TO ANY PARTICULAR FONT, STYLE, SIZE, OR COLOR.  
FOR HOBBY CRAFT KIT FOR DECORATING TOY FIGURES (U.S. CLS. 22, 23, 38 AND 50).  
JOHN SCHUYLER YARD, EXAMINING ATTORNEY

SN 85-214,288. PURPLE COWS, INC., PROVO, UT. FILED 1-10-2011.

**CraftGeek**

THE MARK CONSISTS OF STANDARD CHARACTERS WITHOUT CLAIM TO ANY PARTICULAR FONT, STYLE, SIZE, OR COLOR.  
FOR HOBBY CRAFT KIT COMPRISING WAYS TO DECORATE FABRIC, PLASTIC OR PAPER CRAFT PROJECTS (U.S. CLS. 22, 23, 38 AND 50).  
FIRST USE 1-6-2011; IN COMMERCE 1-6-2011.  
JACQUELINE A. LAVINE, EXAMINING ATTORNEY

SN 85-214,669. KEE ACTION SPORTS I LLC, SEWELL, NJ. FILED 1-11-2011.

**PRODIGY**

THE MARK CONSISTS OF STANDARD CHARACTERS WITHOUT CLAIM TO ANY PARTICULAR FONT, STYLE, SIZE, OR COLOR.  
FOR PAINTBALL GUNS (U.S. CLS. 22, 23, 38 AND 50).  
LAURA HAMMEL, EXAMINING ATTORNEY

**CLASS 28—(Continued).**

SN 85-215,362. PONDERING ARMORED VEHICLE LLC, DBA MOONRACER, TAYLORS, SC. FILED 1-11-2011.

**WORDY WORD**

THE MARK CONSISTS OF STANDARD CHARACTERS WITHOUT CLAIM TO ANY PARTICULAR FONT, STYLE, SIZE, OR COLOR.  
FOR BOARD GAMES (U.S. CLS. 22, 23, 38 AND 50).  
GISELLE AGOSTO, EXAMINING ATTORNEY

SN 85-215,697. MATTEL, INC., EL SEGUNDO, CA. FILED 1-12-2011.

**FALL FIESTA**

THE MARK CONSISTS OF STANDARD CHARACTERS WITHOUT CLAIM TO ANY PARTICULAR FONT, STYLE, SIZE, OR COLOR.  
FOR TOY FIGURES AND ACCESSORIES THEREFOR; DOLLS, DOLL CLOTHING AND DOLL ACCESSORIES (U.S. CLS. 22, 23, 38 AND 50).  
HENRY S. ZAK, EXAMINING ATTORNEY

SN 85-218,760. GRAND GOLF COMPANY, LLC, LAGUNA NIGUEL, CA. FILED 1-16-2011.

**GRAND**

THE MARK CONSISTS OF STANDARD CHARACTERS WITHOUT CLAIM TO ANY PARTICULAR FONT, STYLE, SIZE, OR COLOR.  
FOR GOLF BAGS; GOLF CLUB HEADS; GOLF CLUB SHAFTS; GOLF CLUBS; HAND GRIPS FOR GOLF CLUBS; HEAD COVERS FOR GOLF CLUBS (U.S. CLS. 22, 23, 38 AND 50).  
FIRST USE 1-26-1996; IN COMMERCE 1-26-1996.  
LANA PHAM, EXAMINING ATTORNEY

**CLASS 28—(Continued).**

SN 85-218,909. THE OHIO ART COMPANY, BRYAN, OH.  
FILED 1-17-2011.

# AIR PICKS

THE MARK CONSISTS OF STANDARD CHARACTERS WITHOUT CLAIM TO ANY PARTICULAR FONT, STYLE, SIZE, OR COLOR.

NO CLAIM IS MADE TO THE EXCLUSIVE RIGHT TO USE "PICKS", APART FROM THE MARK AS SHOWN.  
FOR MUSICAL TOYS (U.S. CLS. 22, 23, 38 AND 50).  
DAVID TAYLOR, EXAMINING ATTORNEY

SN 85-220,550. GRAND GOLF COMPANY, LLC, LAGUNA NIGUEL, CA. FILED 1-19-2011.



NO CLAIM IS MADE TO THE EXCLUSIVE RIGHT TO USE "GOLF", APART FROM THE MARK AS SHOWN.

THE MARK CONSISTS OF A STYLIZED LETTER "G" AND THE STYLIZED LETTER WORDING, "GRAND" AND "GOLF".

FOR GOLF BAGS; GOLF CLUB HEADS; GOLF CLUB SHAFTS; GOLF CLUBS; HEAD COVERS FOR GOLF CLUBS (U.S. CLS. 22, 23, 38 AND 50).

FIRST USE 1-26-1996; IN COMMERCE 1-26-1996.  
LANA PHAM, EXAMINING ATTORNEY

SN 85-221,875. BUZZ BEE TOYS, INC., MT. LAUREL, NJ.  
FILED 1-20-2011.



OWNER OF U.S. REG. NOS. 2,949,896 AND 3,696,694.

THE MARK CONSISTS OF THE WORDS SNAP-IT BLASTERS WITH THREE SMALL TRIANGLES IN THE SPACE BETWEEN THE T AND B, ALL WITHIN A HORIZONTAL RECTANGULAR BOX.

FOR TOY GUNS, NAMELY, TOY FOAM PROJECTILE SHOOTERS AND ACCESSORIES THEREFOR (U.S. CLS. 22, 23, 38 AND 50).

TAMARA FRAZIER, EXAMINING ATTORNEY

**CLASS 28—(Continued).**

SN 85-222,036. BUZZ BEE TOYS, INC., MT. LAUREL, NJ.  
FILED 1-20-2011.



OWNER OF U.S. REG. NOS. 2,949,896 AND 3,696,694.

THE MARK CONSISTS OF THE WORD NEW INSIDE A CIRCLE, THE WORDS CONNECT THEM ALL IN THE OUTSIDE CIRCLE, THE WORDS SNAP IT FOLLOWED BY THREE SMALL TRIANGLES ON TOP OF BLASTERS WITHIN A HORIZONTAL RECTANGULAR BOX UNDERNEATH THE CIRCULAR DESIGN.

FOR TOY GUNS, NAMELY, TOY FOAM PROJECTILE SHOOTERS AND ACCESSORIES THEREFOR (U.S. CLS. 22, 23, 38 AND 50).

TAMARA FRAZIER, EXAMINING ATTORNEY

SN 85-231,290. BANANA REPUBLIC (APPAREL), LLC, SAN FRANCISCO, CA. FILED 2-1-2011.

# BANANA REPUBLIC

THE MARK CONSISTS OF STANDARD CHARACTERS WITHOUT CLAIM TO ANY PARTICULAR FONT, STYLE, SIZE, OR COLOR.

OWNER OF U.S. REG. NO. 2,922,926.

FOR BOARD GAMES, NAMELY, BACKGAMMON GAME SETS AND CHECKER SETS; DICE; DOMINOES; PLAYING CARDS; JACKS; STUFFED TOY ANIMALS (U.S. CLS. 22, 23, 38 AND 50).

LOURDES AYALA, EXAMINING ATTORNEY

**CLASS 28—(Continued).**

SN 85-231,415. PACIFIC WORLD CORPORATION, LAKE FOREST, CA. FILED 2-1-2011.



THE MARK CONSISTS OF A STYLIZED LOWER CASE "G" FOLLOWED BY A STYLIZED UPPER CASE "G".  
FOR ACTION SKILL GAMES (U.S. CLS. 22, 23, 38 AND 50).  
HOWARD SMIGA, EXAMINING ATTORNEY

SN 85-238,286. IPG HOLDING SA, APPENZELL, SWITZERLAND, FILED 2-9-2011.

**COME FIND YOURSELF**

THE MARK CONSISTS OF STANDARD CHARACTERS WITHOUT CLAIM TO ANY PARTICULAR FONT, STYLE, SIZE, OR COLOR.  
FOR BOARD GAMES (U.S. CLS. 22, 23, 38 AND 50).  
FIRST USE 11-20-2010; IN COMMERCE 11-20-2010.  
AMY C. KEAN, EXAMINING ATTORNEY

SN 85-239,100. HARTLINE INDUSTRIES, INC., SANDY, UT. FILED 2-10-2011.



THE MARK CONSISTS OF A SHAPE IN THE GENERAL FORM OF A GOLF TEE; AND TWO HALO-STYLE ELEMENTS STACKED ABOVE THE GENERAL FORM OF A GOLF TEE. THE HIGHER HALO-STYLE ELEMENT BEING LARGER IN DIAMETER THAN THEN LOWER HALO-STYLE ELEMENT.

FOR GOLF TEES (U.S. CLS. 22, 23, 38 AND 50).  
FIRST USE 12-16-2010; IN COMMERCE 12-16-2010.  
MARGARET POWER, EXAMINING ATTORNEY

**CLASS 28—(Continued).**

SN 85-245,033. BATTAT INCORPORATED, PLATTSBURGH, NY. FILED 2-17-2011.

**THIS IS OUR STORY**

THE MARK CONSISTS OF STANDARD CHARACTERS WITHOUT CLAIM TO ANY PARTICULAR FONT, STYLE, SIZE, OR COLOR.

FOR DOLL ACCESSORIES; DOLL CLOTHING; DOLL FURNITURE; DOLL HOUSE FURNISHINGS; DOLLS (U.S. CLS. 22, 23, 38 AND 50).  
GILBERT SWIFT, EXAMINING ATTORNEY

**CLASS 29—MEATS AND PROCESSED FOODS**

SN 76-705,742. GONZALEZ AND TAPANES FOODS, INC., MOONACHIE, NJ. FILED 12-20-2010.

THE MARK CONSISTS OF STANDARD CHARACTERS WITHOUT CLAIM TO ANY PARTICULAR FONT, STYLE, SIZE, OR COLOR.

OWNER OF U.S. REG. NO. 1,625,108.  
FOR FROZEN VEGETABLES (U.S. CL. 46).  
FIRST USE 1-17-1980; IN COMMERCE 1-17-1980.  
RAUL CORDOVA, EXAMINING ATTORNEY

SN 76-705,840. MALGOR & CO., INC., CATANO, PUERTO RICO, FILED 12-29-2010.



FOR CORN OIL (U.S. CL. 46).  
FIRST USE 0-0-1963; IN COMMERCE 0-0-1997.  
JOHN SCHUYLER YARD, EXAMINING ATTORNEY

**CLASS 29—(Continued).**

SN 77-189,762. 6567452 CANADA INC., DBA OCEAN CONCEPT, MONT-SAINT-HILAIRE, CANADA, FILED 5-24-2007.

**SALMO SOSCIUTTO**

THE MARK CONSISTS OF STANDARD CHARACTERS WITHOUT CLAIM TO ANY PARTICULAR FONT, STYLE, SIZE, OR COLOR.

THE WORDING "SALMO SOSCIUTTO" HAS NO MEANING IN A FOREIGN LANGUAGE.

FOR FISH CURED IN A SECRET FORMULA, SLICED AND PRESENTED FRESH OR FROZEN (U.S. CL. 46).

JANICE L. MCMORROW, EXAMINING ATTORNEY

SN 77-438,473. POLITI, PAMELA, REDDING, CA. FILED 4-2-2008.

**Revolutionary Food Co.**

THE MARK CONSISTS OF STANDARD CHARACTERS WITHOUT CLAIM TO ANY PARTICULAR FONT, STYLE, SIZE, OR COLOR.

NO CLAIM IS MADE TO THE EXCLUSIVE RIGHT TO USE "FOOD CO.", APART FROM THE MARK AS SHOWN.

FOR OLIVE OIL ; TUNA PATTIES (U.S. CL. 46).

FIRST USE 7-7-2007; IN COMMERCE 7-7-2007.

VERNA BETH RIRIE, EXAMINING ATTORNEY

SN 77-867,571. CLIF BAR FAMILY WINERY AND FARM, LLC, SAINT HELENA, CA. FILED 11-6-2009.

**GARY & KIT'S**

THE MARK CONSISTS OF STANDARD CHARACTERS WITHOUT CLAIM TO ANY PARTICULAR FONT, STYLE, SIZE, OR COLOR.

FOR TRAIL MIX CONSISTING PRIMARILY OF PROCESSED NUTS, SEEDS, DRIED FRUIT AND ALSO INCLUDING CHOCOLATE; FRUIT AND NUT-BASED FOOD BARS (U.S. CL. 46).

JOHN DALIER, EXAMINING ATTORNEY

**CLASS 29—(Continued).**

SN 77-942,677. STARKIST CO., PITTSBURGH, PA. FILED 2-23-2010.

**Royal Pacific**

THE MARK CONSISTS OF STANDARD CHARACTERS WITHOUT CLAIM TO ANY PARTICULAR FONT, STYLE, SIZE, OR COLOR.

OWNER OF U.S. REG. NO. 378,256.

FOR SEAFOOD (U.S. CL. 46).

DAVID I, EXAMINING ATTORNEY

SN 79-082,180. BONGRAIN S.A., FRANCE, FILED 4-13-2010.

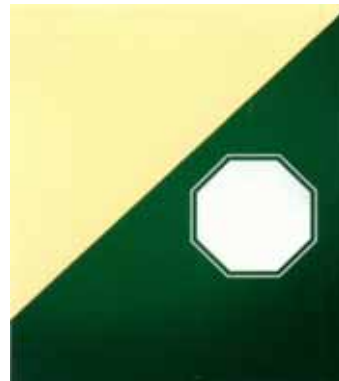

PRIORITY DATE OF 10-13-2009 IS CLAIMED.  
OWNER OF INTERNATIONAL REGISTRATION 1037616 DATED 4-13-2010, EXPIRES 4-13-2020.

THE COLOR(S) GREEN AND IVORY IS/ARE CLAIMED AS A FEATURE OF THE MARK.

THE MARK CONSISTS OF A RECTANGLE DIVIDED DIAGONALLY INTO TWO SECTIONS. ONE SECTION IS IVORY. THE OTHER SECTION IS GREEN AND FEATURES A TRANSPARENT OCTAGON, WHICH ALSO CONTAINS A TRANSPARENT OUTLINE. THE WHITE IN THE DRAWING REPRESENTS BACKGROUND, OUTLINING, SHADING AND/OR TRANSPARENT AREAS AND IS NOT A PART OF THE MARK.

FOR CHEESE; DAIRY PRODUCTS, EXCLUDING ICE CREAM, ICE MILK AND FROZEN YOGURT (U.S. CL. 46).

MARIAM MAHMOUDI, EXAMINING ATTORNEY

**CLASS 29—(Continued).**

SN 79-083,550. MINISTERO DELLE POLITICHE AGRICOLE.; ALIMENTARI E FORESTALI -; DIPARTIMENTO DELLE POLITICHE; COMPETITIVE DEL MONDO RURALE; E DELLA QUALITA' -; DIREZIONE GENERALE PER LO SVILUPPO AGROALIMENTARE.; LA QUALITA' E LA TUTELA; DEL CONSUMATORE, ROMA, ITALY, FILED 4-21-2010.

# RAGUSANO

THE MARK CONSISTS OF STANDARD CHARACTERS WITHOUT CLAIM TO ANY PARTICULAR FONT, STYLE, SIZE, OR COLOR.

PRIORITY DATE OF 2-12-2010 IS CLAIMED.

OWNER OF INTERNATIONAL REGISTRATION 1041428 DATED 4-21-2010, EXPIRES 4-21-2020.

THE CERTIFICATION MARK, AS INTENDED TO BE USED BY PERSONS AUTHORIZED BY THE CERTIFIER, IS INTENDED TO CERTIFY THAT THE GOODS PROVIDED ORIGINATE IN THE ENTIRE AREA OF THE COMMUNES OF: ACATE, CHIARAMONTE GULFI, COMISO, CIARRATANA, ISPICA, MODICA, MONTEROSSO ALMO, POZZALLO, RAGUSA, SANTA CROCE CAMERINA, SCICLI AND VITTORIA IN THE PROVINCE OF RAGUSA, AND THE COMMUNES OF NOTO, PALAZZOLO ACREIDE AND ROSOLINI IN THE PROVINCE OF SIRACUSA IN ITALY, AND THAT THE PREPARATION, PRODUCTION, AND/OR PROCESSING OF THE GOODS TAKE PLACE ACCORDING TO THE STANDARD OF RECORD.

FOR CHEESE (U.S. CL. 46).

JUDITH HELFMAN, EXAMINING ATTORNEY

SN 79-086,584. ITALGELATINE SPA, ITALY, FILED 6-9-2010.

# ITALGEL

THE MARK CONSISTS OF STANDARD CHARACTERS WITHOUT CLAIM TO ANY PARTICULAR FONT, STYLE, SIZE, OR COLOR.

OWNER OF INTERNATIONAL REGISTRATION 1049019 DATED 6-9-2010, EXPIRES 6-9-2020.

FOR ALIMENTARY UNFLAVORED AND UNSWEETENED GELATINS (U.S. CL. 46).

SCOTT BIBB, EXAMINING ATTORNEY

SN 79-090,643. URBANI TARTUFI S.R.L., ITALY, FILED 9-30-2010.



PRIORITY DATE OF 8-18-2010 IS CLAIMED.

OWNER OF INTERNATIONAL REGISTRATION 1060203 DATED 9-30-2010, EXPIRES 9-30-2020.

OWNER OF U.S. REG. NOS. 2,829,477, 2,977,165 AND 3,060,624.

NO CLAIM IS MADE TO THE EXCLUSIVE RIGHT TO USE "MARCA DI FABBRICA", "FUNGHI" AND "MUSHROOMS", APART FROM THE MARK AS SHOWN.

THE MARK CONSISTS OF THE WORDING "URBANI", UNDERNEATH IS A SERIES OF THREE COINS ON LEFT

**CLASS 29—(Continued).**

HAND CONSISTING OF THE 1ST COIN ON THE LEFT SIDE WITH THE WORDING VITTORIO EMANUELE ILL RE DITALIA AND STYLIZED HEAD OF A MALE FIGURE. THE 2ND COIN ON THE LEFT SIDE WITH THE WORDING ESPOSIZIONE INTERNAZIONALE IN ROMA 1912 TORINO 1911 WITH STYLIZED WREATH, SUPERIMPOSED ON TOP OF THIRD COIN WITH GODDESS FIGURE; AND THREE COINS ON THE RIGHT HAND SIDE CONSISTING OF THE 1ST UPPER COIN ON THE RIGHT SIDE WITH THE WORDING ESPOSIZIONE INTERNAZIONALE TORINO 1911 - A PAOLO "URBANI". THE 2ND COIN ON THE RIGHT SIDE BELOW WITH THE WORDING PARIGI 1910 WITH STYLIZED WREATH. THE THIRD COIN CONSISTS OF STYLIZED SIDE HEAD PROFILE OF A MALE FIGURE; IN THE CENTER OF THE COINS IS A FARMER WITH A DOG WITH LANDSCAPE IN THE BACKGROUND. UNDERNEATH THE FARMER APPEARS THE WORDING "MARCA DI FABBRICA" WITHIN A BANNER. THE WORDING "FUNGHI-MUSHROOMS" APPEARS UNDERNEATH.

THE ENGLISH TRANSLATION OF "FUNGHI", "MARCA DI FABBRICA", "A URBANI PAOLO", "ESPOSIZIONE INTERNAZIONALE TORINO 1911 - A PAOLO URBANI", "PARIGI 1910", "VITTORIO EMANUELE ILL RE DITALIA", "ESPOSIZIONE INTERNAZIONALE IN ROMA 1912 TORINO 1911", IN THE MARK IS "MUSHROOMS", "BRAND OR TRADEMARK", "TO PAOLO URBANI", "INTERNATIONAL EXHIBITION TURIN 1911 - TO PAOLO URBANI", "PARIS 1910", "VITTORIO EMANUELE THE THIRD KING OF ITALY", "INTERNATIONAL EXHIBITION IN ROME 1912 TURIN 1911".

FOR PRESERVED MUSHROOMS (U.S. CL. 46).

JOSETTE BEVERLY, EXAMINING ATTORNEY

SN 85-025,376. GRUPO BIMBO, S.A.B. DE C.V., MEXICO CITY 01210, MEXICO, FILED 4-28-2010.

# TOREADOS

THE MARK CONSISTS OF STANDARD CHARACTERS WITHOUT CLAIM TO ANY PARTICULAR FONT, STYLE, SIZE, OR COLOR.

OWNER OF U.S. REG. NO. 3,166,161.

THE ENGLISH TRANSLATION OF "TOREADOS" IS "THE ART OF THE MOVEMENTS BY A BULLFIGHTER WITH A CAPE".

FOR PROCESSED PEANUTS (U.S. CL. 46).

FIRST USE 5-31-2007; IN COMMERCE 5-31-2007.

HELENE LIWINSKI, EXAMINING ATTORNEY



**CLASS 29—(Continued).**

SN 85-031,793. EQUAL EXCHANGE, INC., WEST BRIDGE-WATER, MA. FILED 5-6-2010.



**Principle Six**  
co-operative trade movement

NO CLAIM IS MADE TO THE EXCLUSIVE RIGHT TO USE "CO-OPERATIVE TRADE MOVEMENT", APART FROM THE MARK AS SHOWN.

THE MARK CONSISTS OF ON TOP THE "P6" MARK WITH IMAGES OF LEAVES IN THE LOOP AREA OF EACH CHARACTER, BENEATH WHICH APPEARS THE "PRINCIPLE SIX", MARK, BENEATH WHICH APPEARS THE "CO-OPERATIVE TRADE MOVEMENT" SLOGAN.

FOR CREAM CHEESE; MILLED FLAX SEEDS; DRIED SOYBEANS; PROCESSED EDIBLE SEEDS; PROCESSED ALMONDS; PROCESSED NUTS; OLIVE OILS; NUT BUTTERS; SNACK MIX CONSISTING PRIMARILY OF PROCESSED FRUITS, PROCESSED NUTS AND/OR RAISINS; SOUP MIXES; DRIED VEGETABLES; POWDERED MILK; BROTH; CHEESE; TAHINI; YOGURT; SALAMI; SOUPS; TURKEY; HAM; ROAST BEEF; BACON; BOLOGNA; BISON; BRATWURST; SAUSAGES; KIELBASA; CHORIZO; HOT DOGS; PROCESSED LAMB; CORNED BEEF; LARD; BEEF; FROZEN VEGETABLES; MEAT PIES; SHEPHERDS PIE; WALNUT BURGER PATTIES; TOFU BURGER PATTIES; VEGGIE BURGER PATTIES; GRAIN BURGER PATTIES; FROZEN PRE-PACKAGED ENTREES CONSISTING PRIMARILY OF SEAFOOD; FISH CAKES; CRAB CAKES; EGGS; MILK; BUTTER; CHOCOLATE MILK; EGG NOG; CREAM; FROZEN MUSHROOM PATTIES; FROZEN FRUITS; FROZEN, PREPARED OR PACKAGED ENTREES CONSISTING PRIMARILY OF MEAT, FISH, POULTRY OR VEGETABLES; DRIED PERSIMMONS; DRIED CORN; DRIED PEAS; DRIED APRICOTS; DRIED FRUIT SNACKS; DRIED PEACHES; DRIED TOMATO BITS; DRIED FRUIT SALAD; DRIED BLUEBERRIES; DRIED CHERRIES; DRIED POMEGRANATE; DRIED MANGO; DRIED BLACKBERRIES; DRIED RASPBERRIES; DRIED STRAWBERRIES; EVAPORATED MILK; FRUIT-BASED SPREADS; VEGETABLE BASED SPREADS; SALAD OIL; DIP MIXES; JAMS; FRUIT PRESERVES; MARMALADES; JELLIES; PICKLED MUSHROOMS; PICKLED GARLIC FOR USE AS VEGETABLE; NUT AND SEED-BASED SNACK BARS; PROTEIN BASED, NUTRIENT-DENSE SNACK BARS; PEANUT BUTTER; PROCESSED CRANBERRIES; CANNED CRANBERRIES; DRIED CRANBERRIES, PRESERVED CRANBERRIES; PROCESSED ALFALFA SPROUT; PROCESSED, EDIBLE ALARIA, DULSE, AND KELP; BAKED BEANS; CHOWDER; BISQUES; CRANBERRY APPLESAUCE; POTATO CHIPS; PICKLES; DAIRY-BASED POWDERS FOR MAKING DAIRY-BASED FOOD BEVERAGES AND SHAKES; PREPARED PISTACHIO; JERKY; ROAST BEEF; UN-

**CLASS 29—(Continued).**

COOKED HAMBURGER PATTIES; PROCESSED BLUEBERRIES, CANNED BLUEBERRIES, DRIED BLUEBERRIES, PRESERVED BLUEBERRIES; PROCESSED BLACKBERRIES; CANNED BLACKBERRIES; CANNED BLACKBERRIES; PRESERVED BLACKBERRIES; PROCESSED RASPBERRIES; CANNED RASPBERRIES; DRIED RASPBERRIES; PRESERVED RASPBERRIES; PROCESSED PEPPERS; PROCESSED EGGPLANT; CANNED EGGPLANT; DRIED EGGPLANT; PRESERVED EGGPLANT; PROCESSED RADICCHIO; CANNED RADICCHIO; DRIED RADICCHIO; PRESERVED RADICCHIO; PROCESSED VEGETABLES AND FRUITS; SAUERKRAUT; HALF AND HALF; BUTTERMILK; COTTAGE CHEESE; EGG WHITES; SOUR CREAM; TOFU; WHIPPING CREAM; KEFIR; FALAFEL; PROCESSED BEANS; PROCESSED CHARD; CHEESE; DRIED EGG POWDER; HUMMUS; PEANUT BUTTER; PROCESSED BEE POLLEN FOR FOOD PURPOSES; RICE PROTEIN FOR USE AS A FOOD ADDITIVE; PROCESSED SALAD SPROUTING SEEDS; PROCESSED SANDWICH SPROUTING SEEDS; TEMPEH (U.S. CL. 46).  
ANN E. SAPPENFIELD, EXAMINING ATTORNEY

SN 85-041,396. PERU FOOD IMPORTS, INC., WEST NEW YORK, NJ. FILED 5-18-2010.



OWNER OF U.S. REG. NOS. 3,150,334, 3,152,500 AND 3,254,498.

NO CLAIM IS MADE TO THE EXCLUSIVE RIGHT TO USE "PERU FOOD FLORIDA", APART FROM THE MARK AS SHOWN.

THE COLOR(S) RED, WHITE, ORANGE, BLACK, GREEN, WHITE IS/ARE CLAIMED AS A FEATURE OF THE MARK.

THE MARK CONSISTS OF WORDING "PERU FOOD" IN WHITE WITH BLACK SHADING INSIDE A RED BANNER WITH BLACK AND WHITE OUTLINING. ABOVE THE WORDING IS A PARALLELOGRAM WITH A BLACK OUTLINE INSIDE OF WHICH APPEARS A GREEN BODY OF WATER IN FRONT OF A GREEN MOUNTAIN WITH AN ORANGE SUNSET. BELOW THE BANNER IS THE WORDING "FLORIDA" IN GREEN WITH BLACK SHADING. ALL OF THE FOREGOING APPEARS ON TOP OF A BACKGROUND CONSISTING OF VERTICAL RED STRIPES TO THE RIGHT AND LEFT OF THE MARK WITH A VERTICAL WHITE STRIPE IN THE CENTER.

FOR TINNED FISH; TUNA FISH (U.S. CL. 46).  
MARK SPARACINO, EXAMINING ATTORNEY

**CLASS 29—(Continued).**

SN 85-046,715. MUSCO OLIVE PRODUCTS, INC., DBA MUSCO FAMILY OLIVE COMPANY, TRACY, CA. FILED 5-24-2010.

## EARLY CALIFORNIA SPECIALTIES

THE MARK CONSISTS OF STANDARD CHARACTERS WITHOUT CLAIM TO ANY PARTICULAR FONT, STYLE, SIZE, OR COLOR.

OWNER OF U.S. REG. NO. 3,448,909.

NO CLAIM IS MADE TO THE EXCLUSIVE RIGHT TO USE "CALIFORNIA SPECIALTIES", APART FROM THE MARK AS SHOWN.

FOR PROCESSED OLIVES (U.S. CL. 46).  
CHRIS WELLS, EXAMINING ATTORNEY

**CLASS 29—(Continued).**

SN 85-046,766. MUSCO OLIVE PRODUCTS, INC., DBA MUSCO FAMILY OLIVE COMPANY, TRACY, CA. FILED 5-24-2010.

## EARLY CALIFORNIA INFUSIONS

THE MARK CONSISTS OF STANDARD CHARACTERS WITHOUT CLAIM TO ANY PARTICULAR FONT, STYLE, SIZE, OR COLOR.

OWNER OF U.S. REG. NO. 3,448,909.

NO CLAIM IS MADE TO THE EXCLUSIVE RIGHT TO USE "CALIFORNIA INFUSIONS", APART FROM THE MARK AS SHOWN.

FOR PROCESSED OLIVES (U.S. CL. 46).  
CHRIS WELLS, EXAMINING ATTORNEY

SN 85-046,760. MUSCO OLIVE PRODUCTS, INC., DBA MUSCO FAMILY OLIVE COMPANY, TRACY, CA. FILED 5-24-2010.

## EARLY CALIFORNIA GOURMET

THE MARK CONSISTS OF STANDARD CHARACTERS WITHOUT CLAIM TO ANY PARTICULAR FONT, STYLE, SIZE, OR COLOR.

OWNER OF U.S. REG. NO. 3,448,909.

NO CLAIM IS MADE TO THE EXCLUSIVE RIGHT TO USE "CALIFORNIA GOURMET", APART FROM THE MARK AS SHOWN.

FOR PROCESSED OLIVES (U.S. CL. 46).  
CHRIS WELLS, EXAMINING ATTORNEY

SN 85-048,624. WILD PLANET FOODS, INC., MCKINLEYVILLE, CA. FILED 5-26-2010.

## Wild Planet Fitness

THE MARK CONSISTS OF STANDARD CHARACTERS WITHOUT CLAIM TO ANY PARTICULAR FONT, STYLE, SIZE, OR COLOR.

OWNER OF U.S. REG. NOS. 3,110,320, 3,634,332 AND 3,679,090.

NO CLAIM IS MADE TO THE EXCLUSIVE RIGHT TO USE "FITNESS", APART FROM THE MARK AS SHOWN.

FOR SEAFOOD, NAMELY, TUNA, SHRIMP, SALMON AND SARDINES (U.S. CL. 46).  
APRIL HESIK, EXAMINING ATTORNEY

SN 85-046,762. MUSCO OLIVE PRODUCTS, INC., DBA MUSCO FAMILY OLIVE COMPANY, TRACY, CA. FILED 5-24-2010.

## EARLY CALIFORNIA FRESH CURED

THE MARK CONSISTS OF STANDARD CHARACTERS WITHOUT CLAIM TO ANY PARTICULAR FONT, STYLE, SIZE, OR COLOR.

OWNER OF U.S. REG. NO. 3,448,909.

NO CLAIM IS MADE TO THE EXCLUSIVE RIGHT TO USE "CALIFORNIA FRESH CURED", APART FROM THE MARK AS SHOWN.

FOR PROCESSED OLIVES (U.S. CL. 46).  
CHRIS WELLS, EXAMINING ATTORNEY

SN 85-049,671. ICELANDIC (USA), INC., NEWPORT NEWS, VA. FILED 5-27-2010.

## CHEF SAUTE

THE MARK CONSISTS OF STANDARD CHARACTERS WITHOUT CLAIM TO ANY PARTICULAR FONT, STYLE, SIZE, OR COLOR.

NO CLAIM IS MADE TO THE EXCLUSIVE RIGHT TO USE "SAUTE", APART FROM THE MARK AS SHOWN.

FOR FISH AND SEAFOOD (U.S. CL. 46).  
DAVID I, EXAMINING ATTORNEY

**CLASS 29—(Continued).**

SN 85-052,732. KAWASHO FOODS CORPORATION, TOKYO, JAPAN, FILED 6-2-2010.



OWNER OF U.S. REG. NO. 1,162,935.  
THE MARK CONSISTS OF A STYLIZED ASIAN WOMAN, WITH PINS IN HER HAIR, WEARING A KIMONO, HOLDING A FAN.

FOR PROCESSED MEATS, FISH, SHELLFISH, POULTRY, GAME, FRUITS AND VEGETABLES; MEAT EXTRACT; VEGETABLE JUICE FOR COOKING; VEGETABLE BROTH FOR COOKING; EGGS; MILK; EDIBLE OILS AND FATS; PREPARATIONS FOR MAKING SOUP; PROTEIN FOR HUMAN CONSUMPTION; BEAN CURD (TOFU); BEAN MILK (TONYU) (U.S. CL. 46).

FIRST USE 5-11-1912; IN COMMERCE 2-26-1918.  
LAURA KOVALSKY, EXAMINING ATTORNEY

SN 85-053,414. OURANT, MARK, WAXHAW, NC. FILED 6-3-2010.

# PEPOLI'S

THE MARK CONSISTS OF STANDARD CHARACTERS WITHOUT CLAIM TO ANY PARTICULAR FONT, STYLE, SIZE, OR COLOR.

FOR STAPLE FOOD PRODUCTS, NAMELY, MEAT AND CHEESE FOR CONSUMERS (U.S. CL. 46).

ALEXANDER L. POWERS, EXAMINING ATTORNEY

**CLASS 29—(Continued).**

SN 85-056,518. TARGET BRANDS, INC., MINNEAPOLIS, MN. FILED 6-7-2010.



OWNER OF U.S. REG. NOS. 2,290,302, 2,954,200 AND OTHERS.

NO CLAIM IS MADE TO THE EXCLUSIVE RIGHT TO USE "FARMS", APART FROM THE MARK AS SHOWN.

THE MARK CONSISTS OF THE STYLIZED WORDS "ARCHER FARMS" WRITTEN HORIZONTALLY ABOVE A ROOSTER IMAGE.

FOR FOOD AND BEVERAGE PRODUCTS IN THE CLASS, NAMELY, PROCESSED, FROZEN, CANNED, DRIED AND PRESERVED FRUITS AND VEGETABLES; FROZEN, PREPARED AND PACKAGED ENTREES AND MEALS CONSISTING PRIMARILY OF MEAT, FISH, POULTRY OR VEGETABLES; FROZEN, PREPARED AND PACKAGED VEGETABLE-BASED ENTREES; FROZEN APPETIZERS CONSISTING PRIMARILY OF CHICKEN OR SEAFOOD; PROCESSED AND CANNED BEANS; PICKLES; PROCESSED OLIVES; CHILI; PROCESSED FRUIT AND NUT-BASED FOOD BARS; FRUIT-BASED SNACK FOODS; SOY-BASED SNACK FOOD; SNACK MIX CONSISTING PRIMARILY OF PROCESSED FRUITS, PROCESSED NUTS AND/OR RAISINS; PROCESSED, ROASTED, PRESERVED, CANDIED AND SEASONED NUTS AND EDIBLE SEEDS; PROCESSED LUNCHEON MEATS; DRIED MEAT; BACON; SAUSAGES; MEAT, POULTRY, SEAFOOD NOT LIVE, PORK, FISH NOT LIVE; BUTTER; BUTTER SUBSTITUTES; MARGARINE; COOKING OIL; OLIVE OIL; MILK; NON-DAIRY CREAMER; DAIRY OR NON-DAIRY WHIPPED TOPPING; EGGS; YOGURT; SOUR CREAM; CHEESE; COTTAGE CHEESE; CREAM CHEESE; PEANUT BUTTER; FRUIT PRESERVES; JELLIES AND JAMS; DIPS, EXCLUDING SALSA AND OTHER SAUCES USED AS DIPS; POTATO CHIPS AND POTATO-BASED SNACK FOODS; APPLESAUCE; SOUP AND SOUP MIX; BROTH; BOUILLON; FRUIT AND VEGETABLE SALADS; POTATO SALAD; BAGGED GARDEN SALAD; MARASCHINO CHERRIES (U.S. CL. 46).

ALEXANDER L. POWERS, EXAMINING ATTORNEY

SN 85-058,671. VALIO LTD, HELSINKI, FINLAND, FILED 6-9-2010.

# SNACK LIGHTS

THE MARK CONSISTS OF STANDARD CHARACTERS WITHOUT CLAIM TO ANY PARTICULAR FONT, STYLE, SIZE, OR COLOR.

NO CLAIM IS MADE TO THE EXCLUSIVE RIGHT TO USE "SNACK", APART FROM THE MARK AS SHOWN.

FOR CHEESE (U.S. CL. 46).

FIRST USE 12-30-2009; IN COMMERCE 12-30-2009.

JULIE GUTTADAURO, EXAMINING ATTORNEY

**CLASS 29—(Continued).**

SN 85-058,699. VALIO LTD, HELSINKI, FINLAND, FILED 6-9-2010.

**SNACK RIGHTS**

THE MARK CONSISTS OF STANDARD CHARACTERS WITHOUT CLAIM TO ANY PARTICULAR FONT, STYLE, SIZE, OR COLOR.

NO CLAIM IS MADE TO THE EXCLUSIVE RIGHT TO USE "SNACK", APART FROM THE MARK AS SHOWN FOR CHEESE (U.S. CL. 46).  
FIRST USE 8-17-2010; IN COMMERCE 8-17-2010.  
JULIE GUTTADAURO, EXAMINING ATTORNEY

**CLASS 29—(Continued).**

SN 85-070,846. RALUN EXPORT S.A., CORONEL, CHILE, FILED 6-24-2010.



SN 85-060,244. QUALITY PLUS TRADING LLC., CALABASAS, CA. FILED 6-11-2010.

**FUSION BURGER**

THE MARK CONSISTS OF STANDARD CHARACTERS WITHOUT CLAIM TO ANY PARTICULAR FONT, STYLE, SIZE, OR COLOR.

NO CLAIM IS MADE TO THE EXCLUSIVE RIGHT TO USE "BURGER", APART FROM THE MARK AS SHOWN.  
FOR MEATS AND PROCESSED FOOD PRODUCTS CONSISTING OF GROUND PROTEIN COMBINED WITH VEGETABLES, NUTS, LEGUMES, GRAINS AND NUTRACEUTICALS, SOLD FOR CONSUMPTION IN THE FORM OF A BURGER PATTY (U.S. CL. 46).  
RUSS HERMAN, EXAMINING ATTORNEY

THE MARK CONSISTS OF THE WORD "RALUN" IN STYLIZED LETTERS WITH A REPRESENTATION OF A HAND.

"RALUN" MEANS VALLEY IN MAPUDUNGUNG, THE LANGUAGE OF THE MAPUCHES PEOPLE OF CHILE. THERE IS A RALUN VALLEY LOCATED IN PUERTO VARAS IN THE SOUTH OF CHILE.

FOR MEAT, FISH, POULTRY AND GAME; MEAT EXTRACTS; PRESERVED, FROZEN, DRIED AND COOKED FRUITS AND VEGETABLES; JELLIES, JAMS, COMPOTES; EGGS, MILK AND MILK PRODUCTS EXCLUDING ICE CREAM, ICE MILK AND FROZEN YOGURT; EDIBLE OILS AND FATS (U.S. CL. 46).  
TRACY CROSS, EXAMINING ATTORNEY

SN 85-067,625. GPB VENTURES LLC, CALABASAS, CA. FILED 6-21-2010.

**SORRELLS PICKARD GOURMET  
PEANUT BUTTER**

THE MARK CONSISTS OF STANDARD CHARACTERS WITHOUT CLAIM TO ANY PARTICULAR FONT, STYLE, SIZE, OR COLOR.

NO CLAIM IS MADE TO THE EXCLUSIVE RIGHT TO USE "GOURMET PEANUT BUTTER", APART FROM THE MARK AS SHOWN.  
THE NAME "SORRELLS PICKARD" DOES NOT IDENTIFY A LIVING INDIVIDUAL.  
FOR PEANUT BUTTER (U.S. CL. 46).  
MICHAEL KEATING, EXAMINING ATTORNEY

SN 85-081,659. UNILEVER SUPPLY CHAIN, INC., CLINTON, CT. FILED 7-9-2010.

**100% BUTTERTASTIC**

THE MARK CONSISTS OF STANDARD CHARACTERS WITHOUT CLAIM TO ANY PARTICULAR FONT, STYLE, SIZE, OR COLOR.

FOR VEGETABLE OIL SPREAD, BUTTER SUBSTITUTES (U.S. CL. 46).  
JANICE L. MCMORROW, EXAMINING ATTORNEY

**CLASS 29—(Continued).**

SN 85-100,950. H.C. FOODS CO., LTD., COMMERCE, CA.  
FILED 8-5-2010.



THE MARK CONSISTS OF A DEPICTION OF A TYPICAL MALAYSIAN KITE HAVING AN ASIAN DESIGN AND PROTRUDING, UPRIGHT TAIL WITH THE WORD "WAU" BENEATH AND HAVING ADJACENT NON-LATIN CHARACTERS TO THE RIGHT.

THE NON-LATIN CHARACTERS IN THE MARK TRANSLITERATE TO "WAU" AND THIS MEANS KITE IN ENGLISH.

FOR DRIED SEAFOOD (U.S. CL. 46).  
DAVID ELTON, EXAMINING ATTORNEY

SN 85-117,862. TED & ANDY, LLC, SAINT LOUIS, MO.  
FILED 8-27-2010.



NO CLAIM IS MADE TO THE EXCLUSIVE RIGHT TO USE "DIP", APART FROM THE MARK AS SHOWN.

THE MARK CONSISTS OF THE WORD "MAN", AN IMAGE OF A THUMBS-UP, AND THE WORD "DIP", WITH A LINE ABOVE THE WORDS, AND A LINE BELOW THE WORDS.

FOR SNACK DIPS (U.S. CL. 46).  
FIRST USE 5-2-2008; IN COMMERCE 5-2-2008.  
JEFFERY COWARD, EXAMINING ATTORNEY

**CLASS 29—(Continued).**

SN 85-139,121. KINDLY EGGS CO., LTD., PING TUNG  
HSIEN, TAIWAN, FILED 9-27-2010.



NO CLAIM IS MADE TO THE EXCLUSIVE RIGHT TO USE "EGGS", APART FROM THE MARK AS SHOWN.

THE MARK CONSISTS OF TWO CHINESE CHARACTERS UNDER WHICH APPEARS A DEPICTION OF THE SHAPE OF AN EGG WITHIN WHICH APPEARS A CIRCLE REPRESENTING THE YOLK OF AN EGG AND THE WORDS "YANGLE EGGS", ALL ON A SQUARE BACKGROUND.

THE NON-LATIN CHARACTERS IN THE MARK TRANSLITERATE TO "JANG" AND "LE" AND THIS MEANS "TO RAISE (ANIMALS); TO BRING UP (CHILDREN); TO GIVE BIRTH AND HAPPY; PLEASURE; CHEERFUL" IN ENGLISH.

FOR PRESERVED EGGS, EGGS, EGG POWDERS, DUCK EGGS, SALTED DUCK EGGS, QUAIL EGGS, BIRD EGGS NOT FOR HATCHING (U.S. CL. 46).

FIRST USE 2-20-2007; IN COMMERCE 1-10-2010.  
TEJBIR SINGH, EXAMINING ATTORNEY

SN 85-142,313. G3 ENTERPRISES, INC., MODESTO, CA.  
FILED 9-30-2010.

LOUIS M. MARTINI

OWNER OF U.S. REG. NOS. 2,741,309 AND 3,109,165.  
THE NAME(S), PORTRAIT(S), AND/OR SIGNATURE(S) SHOWN IN THE MARK DOES NOT IDENTIFY A PARTICULAR LIVING INDIVIDUAL.

THE MARK CONSISTS OF THE LETTERS "LOUIS M MARTINI" IN STYLIZED CAPITAL LETTERS WITH THE LETTER "M" IN SMALLER FONT WITH ONE SMALL CIRCLE ON EACH SIDE OF THE LETTER "M" WITH A DIAMOND UNDER THE LETTER "M".

FOR OLIVE OIL (U.S. CL. 46).  
TEJBIR SINGH, EXAMINING ATTORNEY

**CLASS 29—(Continued).**

SN 85-149,654. KING & PRINCE SEAFOOD CORPORATION,  
BRUNSWICK, GA. FILED 10-11-2010.

**SEAFOOD SENSATIONS**

THE MARK CONSISTS OF STANDARD CHARACTERS  
WITHOUT CLAIM TO ANY PARTICULAR FONT, STYLE,  
SIZE, OR COLOR.

OWNER OF U.S. REG. NO. 2,290,987.  
NO CLAIM IS MADE TO THE EXCLUSIVE RIGHT TO  
USE "SEAFOOD", APART FROM THE MARK AS SHOWN.  
FOR SEAFOOD (U.S. CL. 46).  
FIRST USE 6-0-1998; IN COMMERCE 6-0-1998.  
MARK T. MULLEN, EXAMINING ATTORNEY

---

SN 85-150,443. PUEBLO INC., GUAYNABO, PUERTO RICO,  
FILED 10-12-2010.

**PUEBLO**

THE MARK CONSISTS OF STANDARD CHARACTERS  
WITHOUT CLAIM TO ANY PARTICULAR FONT, STYLE,  
SIZE, OR COLOR.

OWNER OF U.S. REG. NOS. 1,997,786, 3,006,003 AND  
OTHERS.

THE ENGLISH TRANSLATION OF "PUEBLO" IN THE  
MARK IS "VILLAGE" OR "TOWN".

FOR CHILE VERDE; CORN OIL; CORNED BEEF;  
CREAM; DAIRY PRODUCTS EXCLUDING ICE CREAM,  
ICE MILK AND FROZEN YOGURT; FISH FILLETS;  
FRIED PLANTAIN; FRIED PLATANO; GUAVA PASTE;  
LUNCHEON MEATS; MEAT, FROZEN; MILK; PRO-  
CESSED BEANS; PROCESSED CHICKPEAS; SAUSAGES;  
VEGETABLE OILS (U.S. CL. 46).

FIRST USE 8-22-2009; IN COMMERCE 8-22-2009.  
GILBERT SWIFT, EXAMINING ATTORNEY

**CLASS 29—(Continued).**

SN 85-151,635. MAID-RITE STEAK CO., INC., DUNMORE,  
PA. FILED 10-13-2010.



NO CLAIM IS MADE TO THE EXCLUSIVE RIGHT TO  
USE "RANCH", APART FROM THE MARK AS SHOWN.

THE COLOR(S) GREEN, BLUE, BROWN, YELLOW  
BLACK AND WHITE IS/ARE CLAIMED AS A FEATURE  
OF THE MARK.

THE MARK CONSISTS OF THE WORDING "RUFF  
CREEK RANCH" IN BLACK, AND A SCENE OF BROWN  
MOUNTAINS, GREEN HILLS OUTLINED IN BLACK,  
BLACK COWS, GREEN AND BROWN TREES, A BROWN  
FENCE AND SIGN WITH THE WORDING "RUFF CREEK  
RANCH" IN WHITE, A BLUE STREAM WITH A WHITE  
ROCK EDGE, A BLUE SKY WITH WHITE CLOUDS AND A  
YELLOW SUN, ALL ENCLOSED WITHIN A BLACK OVAL  
WITH A WHITE INTERIOR BORDER.

FOR MEAT, NAMELY, RAW AND FULLY COOKED  
AND SEASONED BEEF (U.S. CL. 46).  
APRIL ROACH, EXAMINING ATTORNEY

---

SN 85-159,204. KING & PRINCE SEAFOOD CORPORATION,  
BRUNSWICK, GA. FILED 10-22-2010.

**OCEANWAY ENGLISH PUB STYLE**

THE MARK CONSISTS OF STANDARD CHARACTERS  
WITHOUT CLAIM TO ANY PARTICULAR FONT, STYLE,  
SIZE, OR COLOR.

OWNER OF U.S. REG. NO. 1,184,409.

NO CLAIM IS MADE TO THE EXCLUSIVE RIGHT TO  
USE "ENGLISH PUB STYLE", APART FROM THE MARK  
AS SHOWN.

FOR SEAFOOD (U.S. CL. 46).  
MARK T. MULLEN, EXAMINING ATTORNEY

**CLASS 29—(Continued).**

SN 85-166,612. SANCHEZ ROMERO CARVAJAL JABUGO S.A., CADIZ, SPAIN, FILED 11-1-2010.



OWNER OF U.S. REG. NOS. 3,310,591 AND 3,322,402. NO CLAIM IS MADE TO THE EXCLUSIVE RIGHT TO USE "JABUGO SINCE 1879", APART FROM THE MARK AS SHOWN.

THE MARK CONSISTS OF THE NUMBER LETTER COMBINATION "5J" ADJACENT TO AN ACORN DESIGN ENCLOSED WITHIN A DOUBLE CIRCLE DESIGN ABOVE "JABUGO SINCE 1879" ALL ENCLOSED BY A RECTANGULAR BORDER LINE.

FOR CHARCUTERIE, HAM, TURKEY (U.S. CL. 46).  
JULIE VEPPUMTHARA, EXAMINING ATTORNEY

SN 85-170,313. L. & J. GENERAL INTERNATIONAL, CORP., MIAMI, FL. FILED 11-5-2010.

**EL SEGADOR**

THE MARK CONSISTS OF STANDARD CHARACTERS WITHOUT CLAIM TO ANY PARTICULAR FONT, STYLE, SIZE, OR COLOR.

OWNER OF U.S. REG. NOS. 1,641,398, 3,771,379 AND OTHERS.

THE ENGLISH TRANSLATION OF "EL SEGADOR" IN THE MARK IS "THE HARVESTER".

FOR PROCESSED YUCCA; FROZEN AND PROCESSED FRUITS; FROZEN CHICKEN, HAM AND CHEESE CROQUETTES; PRESERVED, DRIED, CANNED AND COOKED FRUITS AND VEGETABLES; CANNED BEANS, DRIED BEANS, PIGEON PEAS, TOMATO PASTE, GUAVA PASTE; PROCESSED HEARTS OF PALM; VEGETABLE OIL, CORN OIL, FRIED PLANTAINS, FRUIT PULPS; CANNED SARDINES, FISH NOT LIVE, COD NOT LIVE AND FISH FILLETS (U.S. CL. 46).  
MORGAN WYNNE, EXAMINING ATTORNEY

SN 85-178,031. MILLICAN, JAMES M., JR., RALEIGH, NC. FILED 11-16-2010.

**TATERMAN**

THE MARK CONSISTS OF STANDARD CHARACTERS WITHOUT CLAIM TO ANY PARTICULAR FONT, STYLE, SIZE, OR COLOR.

FOR SNACK MIX CONSISTING PRIMARILY OF PROCESSED VEGETABLES AND FRUITS (U.S. CL. 46).  
ERIN FALK, EXAMINING ATTORNEY

**CLASS 29—(Continued).**

SN 85-178,245. KINETIX LIVING CORP., SEATTLE, WA. FILED 11-16-2010.



THE MARK CONSISTS OF A STYLIZED DESIGN OF THE CAPITAL LETTER "K" FOLLOWED BY A LOWER CASE "X" WITHIN A SQUARE SHAPED DESIGN FOLLOWED BY THE WORD "KINETIX" IN CAPITAL LETTERING WITH THE ENTIRE MARK APPEARING IN A RECTANGLE SHAPED DESIGN.

FOR PACKAGED MEALS CONSISTING PRIMARILY OF MEAT, POULTRY, FISH, OR VEGETABLES; DAIRY BASED BEVERAGES; DAIRY BASED FOOD BEVERAGES; SOUPS, SOUP MIXES; SOY BASED SNACK FOODS; PROTEIN BASED SNACK BARS (U.S. CL. 46).  
SANI KHOURI, EXAMINING ATTORNEY

SN 85-179,032. IP WING KONG, SUFFERN, NY. FILED 11-17-2010.



NO CLAIM IS MADE TO THE EXCLUSIVE RIGHT TO USE "SOY KITCHEN", APART FROM THE MARK AS SHOWN.

THE MARK CONSISTS OF A SQUARE IN WHICH THERE IS A RECTANGLE. BENEATH THE RECTANGLE, THERE IS A HORIZONTAL BAR. IN BETWEEN THE BAR AND THE RECTANGLE THERE ARE TWO WORDS READING "SOY KITCHEN". IN THE MIDDLE OF THE RECTANGLE, THERE IS A CARTOON FIGURE OF A CHEF.

FOR SOY BASED FOODS, NAMELY, SOY MILK, TOFU, SHREDDED BEAN CURD; VEGETABLE-BASED FOOD BEVERAGE (U.S. CL. 46).

FIRST USE 11-1-2010; IN COMMERCE 11-1-2010.

KATHERINE M. DUBRAY, EXAMINING ATTORNEY

**CLASS 29—(Continued).**

SN 85-181,100. TWELVETWONINE, FRISCO, TX. FILED 11-19-2010.

## The Elves' Favorite Treat

THE MARK CONSISTS OF STANDARD CHARACTERS WITHOUT CLAIM TO ANY PARTICULAR FONT, STYLE, SIZE, OR COLOR.

OWNER OF U.S. REG. NO. 3,924,247.  
NO CLAIM IS MADE TO THE EXCLUSIVE RIGHT TO USE "TREAT", APART FROM THE MARK AS SHOWN.  
FOR CANDIED PECANS (U.S. CL. 46).  
DAVID COLLIER, EXAMINING ATTORNEY

SN 85-182,304. ELEMENTAL SUPERFOOD, INC., MANHATTAN BEACH, CA. FILED 11-22-2010.



THE COLOR(S) BLUE, ORANGE, BROWN, TURQUOISE, BLACK AND WHITE IS/ARE CLAIMED AS A FEATURE OF THE MARK.

THE MARK CONSISTS OF A SQUARE DIVIDED INTO FOUR SMALLER SQUARES IN BLUE, ORANGE, BROWN AND TURQUOISE. A STYLIZED LETTER "E" APPEARS ON THE SQUARE IN WHITE. BELOW THE AFOREMENTIONED IS THE STYLIZED WORD "ELEMENTAL" IN BLACK.

FOR NUT BASED SNACK BARS; SEED BASED SNACK BARS; PROCESSED FRUIT BASED ORGANIC SNACK BARS; ORGANIC NUT, SEED AND PROCESSED FRUIT BASED SNACK BARS; FRUIT BASED ORGANIC FOOD BARS, ALSO CONTAINING GRAIN (U.S. CL. 46).  
VIVIAN MICZNIK FIRST, EXAMINING ATTORNEY

**CLASS 29—(Continued).**

SN 85-183,581. THE NEST COLLECTIVE, INC., EMERYVILLE, CA. FILED 11-23-2010.



THE MARK CONSISTS OF A SPECIAL FORM DRAWING OF A LIQUID SPILLING, WITH THE WORD "MASHUPS" IN THE CENTER.

FOR FRUIT AND VEGETABLE PUREES (U.S. CL. 46).  
PAM WILLIS, EXAMINING ATTORNEY

SN 85-184,672. QUIRCH FOODS CO., MIAMI, FL. FILED 11-24-2010.



OWNER OF U.S. REG. NOS. 2,279,201, 2,283,028 AND 3,860,271.

THE COLOR(S) YELLOW, ORANGE AND BLACK IS/ARE CLAIMED AS A FEATURE OF THE MARK.

THE MARK CONSISTS OF THE WORDING "KIKIRI QUIRCH". EACH LETTER IN "KIKIRI QUIRCH" IS SHADED IN YELLOW AND OUTLINED IN ORANGE. EACH LETTER IS THEN OUTLINED IN THICKER BLACK OUTLINE. THE LETTER "Q" IN "QUIRCH" FORM THE DEPICTION OF A CHICKEN CHARACTER.

FOR POULTRY, NAMELY, CHICKEN, WHOLE CHICKEN, CHICKEN QUARTERS, CHICKEN DRUMSTICKS, AND CHICKEN BREASTS (U.S. CL. 46).

FIRST USE 3-0-2010; IN COMMERCE 3-0-2010.  
RUDY R. SINGLETON, EXAMINING ATTORNEY

SN 85-188,064. SUZUSHO LTD, TOKYO, JAPAN, FILED 12-1-2010.

## TENGU

THE MARK CONSISTS OF STANDARD CHARACTERS WITHOUT CLAIM TO ANY PARTICULAR FONT, STYLE, SIZE, OR COLOR.

OWNER OF U.S. REG. NOS. 1,736,806 AND 1,736,808.  
THE ENGLISH TRANSLATION OF "TENGU" IS "LONG NOSED GOBLIN".

FOR PORK STEAK JERKY, CHICKEN STEAK JERKY, TURKEY STEAK JERKY, BUFFALO STEAK JERKY, DEER STEAK JERKY AND FISH STEAK JERKY (U.S. CL. 46).

CORY BOONE, EXAMINING ATTORNEY



**CLASS 29—(Continued).**

SN 85-188,070. SUZUSHO LTD, TOKYO, JAPAN, FILED 12-1-2010.



OWNER OF U.S. REG. NOS. 1,736,806 AND 1,736,808.  
THE MARK CONSISTS OF A STYLIZED DESIGN OF A FACE INSIDE A CIRCULAR BORDER. THE FACE IS THAT OF A "TENGU", A TYPE OF GOBLIN IN JAPANESE CULTURE, AND LOOKS LIKE A MAN WITH A LONG NOSE AND BUSHY FACIAL HAIR.

FOR PORK STEAK JERKY, CHICKEN STEAK JERKY, TURKEY STEAK JERKY, BUFFALO STEAK JERKY, DEER STEAK JERKY AND FISH STEAK JERKY (U.S. CL. 46).

CORY BOONE, EXAMINING ATTORNEY

SN 85-188,262. CHOP CHOP PRODUCTS, INC., TARZANA, CA. FILED 12-1-2010.

# CHOP CHOP

THE MARK CONSISTS OF STANDARD CHARACTERS WITHOUT CLAIM TO ANY PARTICULAR FONT, STYLE, SIZE, OR COLOR.

FOR DRIED FRUIT AND VEGETABLES (U.S. CL. 46).

FIRST USE 7-6-2010; IN COMMERCE 7-6-2010.

CHRISTINE MARTIN, EXAMINING ATTORNEY

SN 85-188,425. PET INCORPORATED, MINNEAPOLIS, MN. FILED 12-1-2010.



OWNER OF U.S. REG. NOS. 3,614,621, 3,849,765 AND OTHERS.

NO CLAIM IS MADE TO THE EXCLUSIVE RIGHT TO USE "WORLD RECIPES", APART FROM THE MARK AS SHOWN.

THE MARK CONSISTS OF A WAVING BANNER WITH THE WORD "PROGRESSO" INSIDE THE BANNER. ABOVE THE BANNER IS A CLUSTER OF VEGETABLES: PEPPERS, ONION AND TOMATO. ABOVE THE VEGETABLE CLUSTER ARE THE WORDS "WORLD RECIPES" WITH A DOT AT EACH END OF THE WORDS.

FOR SOUPS (U.S. CL. 46).

ROBIN MITTLER, EXAMINING ATTORNEY

**CLASS 29—(Continued).**

SN 85-190,118. PERU FOOD IMPORTS, INC., WEST NEW YORK, NY. FILED 12-3-2010.



OWNER OF U.S. REG. NOS. 3,150,334, 3,152,500 AND 3,254,498.

NO CLAIM IS MADE TO THE EXCLUSIVE RIGHT TO USE "PERU FOOD", APART FROM THE MARK AS SHOWN.

THE COLOR(S) RED, WHITE, ORANGE, BLACK, GREEN IS/ARE CLAIMED AS A FEATURE OF THE MARK.

THE MARK CONSISTS OF THE WORDING "PERU FOOD" IN WHITE WITH BLACK SHADING INSIDE A RED BANNER WITH BLACK AND WHITE OUTLINING. ABOVE THE WORDING IS A PARALLELOGRAM WITH A BLACK OUTLINE INSIDE OF WHICH APPEARS A GREEN BODY OF WATER IN FRONT OF A GREEN MOUNTAIN WITH AN ORANGE SUNSET. BELOW THE BANNER IS THE WORDING "UNIVERSAL" IN RED WITH BLACK SHADING. ALL OF THE FOREGOING APPEARS ON TOP OF A BACKGROUND CONSISTING OF VERTICAL RED STRIPES TO THE RIGHT AND LEFT OF THE MARK WITH A VERTICAL WHITE STRIPE IN THE CENTER.

FOR DAIRY-BASED SNACK FOODS EXCLUDING ICE CREAM, ICE MILK AND FROZEN YOGURT; NON-DAIRY BASED MIX FOR MAKING WHIPPED TOPPINGS; PROCESSED SWEET POTATOES (U.S. CL. 46).

RONALD MCMORROW, EXAMINING ATTORNEY

SN 85-191,105. GANIX BIO-TECHNOLOGIES, INC., LAS VEGAS, NV. FILED 12-6-2010.

# BLUE OASIS SHRIMP

THE MARK CONSISTS OF STANDARD CHARACTERS WITHOUT CLAIM TO ANY PARTICULAR FONT, STYLE, SIZE, OR COLOR.

NO CLAIM IS MADE TO THE EXCLUSIVE RIGHT TO USE "SHRIMP", APART FROM THE MARK AS SHOWN.

FOR SEAFOOD; SHRIMP (U.S. CL. 46).

FLORENTINA BLANDU, EXAMINING ATTORNEY

SN 85-192,814. MITEVSKA, GABRIELA, NEWTON, MA. FILED 12-8-2010.

# OLYMPIC

THE MARK CONSISTS OF STANDARD CHARACTERS WITHOUT CLAIM TO ANY PARTICULAR FONT, STYLE, SIZE, OR COLOR.

FOR OLIVE OIL FOR FOOD, PROCESSED OLIVES (U.S. CL. 46).

FIRST USE 3-1-1946; IN COMMERCE 3-1-1946.

JEFFERY COWARD, EXAMINING ATTORNEY

**CLASS 29—(Continued).**

SN 85-194,355. DULCICH, INC., CLACKAMAS, OR. FILED 12-9-2010.

## SALMOLUX

THE MARK CONSISTS OF STANDARD CHARACTERS WITHOUT CLAIM TO ANY PARTICULAR FONT, STYLE, SIZE, OR COLOR.

OWNER OF U.S. REG. NO. 3,916,774.  
FOR FISH FILLETS; LOX; MARINATED FISH; PICKLED FISH; SALMON; SANDWICH SPREAD, NAMELY, SMOKED SEAFOOD SPREAD; SMOKED FISH; APPETIZERS CONSISTING OF SEAFOOD AND CHEESE; FISH CAKES (U.S. CL. 46).  
FIRST USE 12-31-1988; IN COMMERCE 12-31-1988.  
JEFF DEFORD, EXAMINING ATTORNEY

---

SN 85-200,056. COSMOS GRACE, INC., SOUTH PASADENA, CA. FILED 12-16-2010.

## NEXT GENERATION BLUEFIN TUNA

THE MARK CONSISTS OF STANDARD CHARACTERS WITHOUT CLAIM TO ANY PARTICULAR FONT, STYLE, SIZE, OR COLOR.

NO CLAIM IS MADE TO THE EXCLUSIVE RIGHT TO USE "BLUEFIN TUNA", APART FROM THE MARK AS SHOWN.

FOR FISH (U.S. CL. 46).  
LINDA POWELL, EXAMINING ATTORNEY

---

SN 85-201,259. WALKER, ROB, ENGLEWOOD, NJ. FILED 12-18-2010.



THE NAME(S), PORTRAIT(S), AND/OR SIGNATURE(S) SHOWN IN THE MARK DOES NOT IDENTIFY A PARTICULAR LIVING INDIVIDUAL.

THE MARK CONSISTS OF THE WORDS MAMA MAE'S IN A COOKING POT DESIGN.

FOR FROZEN MEALS CONSISTING PRIMARILY OF MEAT, FISH, POULTRY, OR VEGETABLES (U.S. CL. 46).  
LEIGH CAROLINE CASE, EXAMINING ATTORNEY

**CLASS 29—(Continued).**

SN 85-204,029. HIGH LINER FOODS INCORPORATED, LUNENBURG, NOVA SCOTIA, CANADA, FILED 12-22-2010.



OWNER OF U.S. REG. NOS. 722,334, 3,691,973 AND OTHERS.

THE LIKENESS (OR, "PORTRAIT") IN THE MARK DOES NOT IDENTIFY A LIVING INDIVIDUAL.

THE MARK CONSISTS OF THE WORDS FISHER BOY IN LARGE STYLIZED TYPE, ENCLOSED IN A MAINLY RECTANGULAR GEOMETRIC BORDER; ALONG THE BOTTOM BORDER ARE THE WORDS WE BRING THE FUN TO FISH IN SMALLER STYLIZED TYPE IN A SMALLER SHADED RECTANGLE; AT THE TOP OF THE GEOMETRIC BORDER IS AN OUTLINE IN THE SHAPE OF A FISH, WHICH CONTAINS A DEPICTION OF A BEARDED SEA CAPTAIN APPEARING BETWEEN THE WORDS HIGH AND LINER, WHICH ARE IN STYLIZED TYPE.

FOR FROZEN CHEESE STICKS; FROZEN POTATO STICKS; FROZEN CRAB CAKES; FROZEN FISH STICKS; FROZEN SHRIMP; FROZEN FISH PORTIONS; FROZEN FISH FILLETS; FROZEN FISH NUGGETS; FROZEN FISH TENDERS; FROZEN ENTREES CONSISTING PRIMARILY OF MEAT, FISH, POULTRY OR VEGETABLES (U.S. CL. 46).

JESSICA FATHY, EXAMINING ATTORNEY

---

SN 85-204,332. MARIANI PACKING CO., INC., VACAVILLE, CA. FILED 12-22-2010.

## TOUCHLock

THE MARK CONSISTS OF THE WORDS TOUCH AND LOCK AS ONE WORD WITH THE LETTERS H AND L COMBINED TO CREATE EACH LETTER.

FOR CUT FRUITS; DRIED FRUIT AND VEGETABLES; DRIED FRUIT-BASED SNACKS; FRUIT LEATHERS; FRUIT-BASED SNACK FOOD; FRUITS, NAMELY, DRIED FRUIT; PROCESSED VEGETABLES AND FRUITS; SNACK MIX CONSISTING PRIMARILY OF PROCESSED FRUITS, PROCESSED NUTS AND/OR RAISINS (U.S. CL. 46).

DAVID I, EXAMINING ATTORNEY

**CLASS 29—(Continued).**

SN 85-204,620. APPLGATE FARMS, LLC, BRIDGEWATER, NJ. FILED 12-23-2010.

**REAL FOOD HAS A STORY**

THE MARK CONSISTS OF STANDARD CHARACTERS WITHOUT CLAIM TO ANY PARTICULAR FONT, STYLE, SIZE, OR COLOR.

FOR DELI MEATS; ITALIAN SPECIALTY MEATS; HOT DOGS; BACON; SAUSAGE; BEEF; CHICKEN; TURKEY; PORK; FROZEN ENTREES CONSISTING PRIMARILY OF MEAT OR POULTRY; AND CHEESE (U.S. CL. 46).

REBECCA EISINGER, EXAMINING ATTORNEY

SN 85-204,667. C.P. YEATMAN & SONS, INC., WEST GROVE, PA. FILED 12-23-2010.

**MOTHER EARTH**

THE MARK CONSISTS OF STANDARD CHARACTERS WITHOUT CLAIM TO ANY PARTICULAR FONT, STYLE, SIZE, OR COLOR.

OWNER OF U.S. REG. NO. 708,474.  
FOR PROCESSED PRODUCE, NAMELY, PROCESSED MUSHROOMS (U.S. CL. 46).

FIRST USE 0-0-1935; IN COMMERCE 0-0-1935.

JESSICA A. POWERS, EXAMINING ATTORNEY

SN 85-204,689. ALLEN CREEK LLC, WESTPORT, MA. FILED 12-23-2010.

**WASONTUXET**

THE MARK CONSISTS OF STANDARD CHARACTERS WITHOUT CLAIM TO ANY PARTICULAR FONT, STYLE, SIZE, OR COLOR.

FOR BEEF IN THE NATURE OF PORTER HOUSE STEAK, DELMONICO STEAK, SIRLOIN STEAK, TENDERLOIN, T-BONE STEAK, LONDON BROIL, FLANK STEAK, GROUND BEEF, STEW MEAT, SIRLOIN TIPS, EYE ROUND ROAST, TOP ROUND ROAST, CHUCK SHOULDER ROAST, BRISKET, AND OX TAIL; BEEF SOUP BONES (U.S. CL. 46).

FIRST USE 10-0-2008; IN COMMERCE 10-0-2008.

CIMMERIAN COLEMAN, EXAMINING ATTORNEY

**CLASS 29—(Continued).**

SN 85-205,450. FREMANTLE MEDIA NORTH AMERICA, INC., BURBANK, CA. FILED 12-23-2010.



THE MARK CONSISTS OF NUMEROUS LAYERS OF THE LETTER "X" WITHIN AN OUTLINE WITH ONE HORIZONTAL BLACK STRIPE ALONG THE TOP WITH THE WORD "THE" AND ONE HORIZONTAL BLACK STRIPE ALONG THE BOTTOM WITH THE WORD "FACTOR".

FOR FROZEN FOODS AND ENTREES, CONSISTING PRIMARILY OF MEAT, SEAFOOD, POULTRY OR VEGETABLES; FRUIT JAMS, JELLIES AND COMPOTES; NUT BUTTERS (U.S. CL. 46).

TAMARA FRAZIER, EXAMINING ATTORNEY

SN 85-205,456. FREMANTLE MEDIA NORTH AMERICA, INC., BURBANK, CA. FILED 12-23-2010.

**THE X FACTOR**

THE MARK CONSISTS OF STANDARD CHARACTERS WITHOUT CLAIM TO ANY PARTICULAR FONT, STYLE, SIZE, OR COLOR.

FOR FROZEN FOODS AND ENTREES, CONSISTING PRIMARILY OF MEAT, SEAFOOD, POULTRY OR VEGETABLES; FRUIT JAMS, JELLIES AND COMPOTES; AND, NUT BUTTERS (U.S. CL. 46).

TAMARA FRAZIER, EXAMINING ATTORNEY

**CLASS 29—(Continued).**

SN 85-205,752. GEORGE C. BACON, SANTA CLARITA, CA. FILED 12-27-2010.

**SIX HEROES**

THE MARK CONSISTS OF STANDARD CHARACTERS WITHOUT CLAIM TO ANY PARTICULAR FONT, STYLE, SIZE, OR COLOR.

OWNER OF U.S. REG. NO. 3,554,226.  
FOR (BASED ON USE IN COMMERCE) OLIVE OIL; OLIVE OIL; OLIVE OILS(BASED ON INTENT TO USE) BEEF JERKY; BOLOGNA; CHEESE; CHEESE AND CRACKER COMBINATIONS; MOZZARELLA STICKS; PREPARED NUTS; PROCESSED NUTS; PROCESSED OLIVES; PROCESSED STUFFED OLIVES; RAISINS; ROASTED NUTS; SALAD OIL; SALAMI; SAUSAGES; SEASONED NUTS; SHELLED NUTS; SNACK MIX CONSISTING PRIMARILY OF PROCESSED FRUITS, PROCESSED NUTS AND/OR RAISINS; TRAIL MIX CONSISTING PRIMARILY OF PROCESSED NUTS, SEEDS, DRIED FRUIT AND ALSO INCLUDING CHOCOLATE (U.S. CL. 46).

FIRST USE 4-1-2010; IN COMMERCE 4-1-2010.  
SANJEEV VOHRA, EXAMINING ATTORNEY

SN 85-207,490. RESTAURANT TECHNOLOGIES, INC., MENDOTA HEIGHTS, MN. FILED 12-29-2010.

**SMART. SAFE. GREEN.**

THE MARK CONSISTS OF STANDARD CHARACTERS WITHOUT CLAIM TO ANY PARTICULAR FONT, STYLE, SIZE, OR COLOR.

FOR COOKING OIL (U.S. CL. 46).  
ANNE MADDEN, EXAMINING ATTORNEY

SN 85-207,503. RESTAURANT TECHNOLOGIES, INC., MENDOTA HEIGHTS, MN. FILED 12-29-2010.



THE MARK CONSISTS OF THE LETTERS RTI, ENCLOSED BY TWO CURVES FORMING AN ELLIPSE THAT OPENS TO THE RIGHT OF THE LETTER I.

FOR COOKING OIL (U.S. CL. 46).  
ANNE MADDEN, EXAMINING ATTORNEY

**CLASS 29—(Continued).**

SN 85-207,528. RESTAURANT TECHNOLOGIES, INC., MENDOTA HEIGHTS, MN. FILED 12-29-2010.

**RTI**

THE MARK CONSISTS OF STANDARD CHARACTERS WITHOUT CLAIM TO ANY PARTICULAR FONT, STYLE, SIZE, OR COLOR.

FOR COOKING OIL (U.S. CL. 46).  
ANNE MADDEN, EXAMINING ATTORNEY

SN 85-207,865. PROTOS FOODS, INC., GREENSBURG, PA. FILED 12-30-2010.

**OSTRIM**

THE MARK CONSISTS OF STANDARD CHARACTERS WITHOUT CLAIM TO ANY PARTICULAR FONT, STYLE, SIZE, OR COLOR.

FOR SNACK FOODS, CONSISTING OF ELK MEAT AND BEEF AND SEASONINGS; SNACK FOODS, CONSISTING OF ELK MEAT AND ALSO CONTAINING OTHER MEATS AND SEASONINGS; SNACK FOODS, CONSISTING OF ELK MEAT AND BEEF AND ALSO CONTAINING OTHER MEATS AND SEASONINGS (U.S. CL. 46).

MELISSA VALLILLO, EXAMINING ATTORNEY

SN 85-207,933. JOAN T. MCGRAW, DBA SASSY LADY FOODS, CORDOVA, TN. FILED 12-30-2010.

**The Link You've Been Missing**

THE MARK CONSISTS OF STANDARD CHARACTERS WITHOUT CLAIM TO ANY PARTICULAR FONT, STYLE, SIZE, OR COLOR.

FOR SAUSAGES (U.S. CL. 46).  
GEORGE LORENZO, EXAMINING ATTORNEY

**CLASS 29—(Continued).**

SN 85-208,082. MILLER, JOHN C., BEACH PARK, IL. FILED 12-30-2010.

**CLASS 29—(Continued).**

SN 85-208,235. DOLE FOOD COMPANY, INC., WESTLAKE VILLAGE, CA. FILED 12-30-2010.

## WHAT A JERK

## HEARTS DELIGHT

THE MARK CONSISTS OF STANDARD CHARACTERS WITHOUT CLAIM TO ANY PARTICULAR FONT, STYLE, SIZE, OR COLOR.  
FOR BEEF JERKY; LOX (U.S. CL. 46).  
SOPHIA S. KIM, EXAMINING ATTORNEY

THE MARK CONSISTS OF STANDARD CHARACTERS WITHOUT CLAIM TO ANY PARTICULAR FONT, STYLE, SIZE, OR COLOR.  
FOR PRE-CUT VEGETABLE SALAD (U.S. CL. 46).  
FIRST USE 10-31-2004; IN COMMERCE 10-31-2004.  
GRETTA YAO, EXAMINING ATTORNEY

---

SN 85-208,222. DOLE FOOD COMPANY, INC., WESTLAKE VILLAGE, CA. FILED 12-30-2010.

---

SN 85-208,254. DOLE FOOD COMPANY, INC., WESTLAKE VILLAGE, CA. FILED 12-30-2010.

## Asian Island Crunch

## PERFECT HARVEST

THE MARK CONSISTS OF STANDARD CHARACTERS WITHOUT CLAIM TO ANY PARTICULAR FONT, STYLE, SIZE, OR COLOR.  
FOR PRE-CUT VEGETABLE SALAD (U.S. CL. 46).  
FIRST USE 10-31-2010; IN COMMERCE 10-31-2010.  
GRETTA YAO, EXAMINING ATTORNEY

THE MARK CONSISTS OF STANDARD CHARACTERS WITHOUT CLAIM TO ANY PARTICULAR FONT, STYLE, SIZE, OR COLOR.  
FOR PRE-CUT VEGETABLE SALAD (U.S. CL. 46).  
FIRST USE 10-31-2007; IN COMMERCE 10-31-2007.  
GRETTA YAO, EXAMINING ATTORNEY

---

SN 85-208,228. DOLE FOOD COMPANY, INC., WESTLAKE VILLAGE, CA. FILED 12-30-2010.

---

SN 85-208,262. DOLE FOOD COMPANY, INC., WESTLAKE VILLAGE, CA. FILED 12-30-2010.

## AUTUMN SPLENDOR

## SPRING FLING

THE MARK CONSISTS OF STANDARD CHARACTERS WITHOUT CLAIM TO ANY PARTICULAR FONT, STYLE, SIZE, OR COLOR.  
FOR PRE-CUT VEGETABLE SALAD (U.S. CL. 46).  
FIRST USE 10-31-2009; IN COMMERCE 10-31-2009.  
GRETTA YAO, EXAMINING ATTORNEY

THE MARK CONSISTS OF STANDARD CHARACTERS WITHOUT CLAIM TO ANY PARTICULAR FONT, STYLE, SIZE, OR COLOR.  
FOR PRE-CUT VEGETABLE SALAD (U.S. CL. 46).  
FIRST USE 3-31-2010; IN COMMERCE 3-31-2010.  
GRETTA YAO, EXAMINING ATTORNEY

**CLASS 29—(Continued).**

SN 85-208,279. DOLE FOOD COMPANY, INC., WESTLAKE VILLAGE, CA. FILED 12-30-2010.

**CLASS 29—(Continued).**

SN 85-209,603. INTERNATIONAL MEAT SNACK SOURCING, LLC, SALT LAKE CITY, UT. FILED 1-3-2011.

**SELECTIONS OF THE SEASON**

THE MARK CONSISTS OF STANDARD CHARACTERS WITHOUT CLAIM TO ANY PARTICULAR FONT, STYLE, SIZE, OR COLOR.

FOR PRE-CUT VEGETABLE SALAD (U.S. CL. 46).  
FIRST USE 10-31-2006; IN COMMERCE 10-31-2006.  
GRETTA YAO, EXAMINING ATTORNEY

---

SN 85-208,611. ASHTARAK-KAT CJSC, ARAGATSOTN PROVINCE, ARMENIA, FILED 12-31-2010.

**GALIE**

THE MARK CONSISTS OF STANDARD CHARACTERS WITHOUT CLAIM TO ANY PARTICULAR FONT, STYLE, SIZE, OR COLOR.

FOR CHEESE (U.S. CL. 46).  
ANGELA DUONG, EXAMINING ATTORNEY

---

SN 85-209,462. NAMDAR MOGHADDAM, NIMA, CHICAGO, IL. FILED 1-3-2011.



The logo for OliveGranet features the word "Olive" in a green, rounded, sans-serif font and "Granet" in a red, serif font. The "G" in "Granet" is significantly larger and more stylized than the other letters.

THE COLOR(S) GREEN, RED IS/ARE CLAIMED AS A FEATURE OF THE MARK.

THE MARK CONSISTS OF WORD "OLIVEGRANET" WHERE "OLIVE" IS IN COLOR GREEN AND "GRANET" IS IN COLOR RED. THE FONT OF FIRST LETTER OF OLIVE "O" IS "FRENCH SCRIPT MT" AND UPPER CASE. THE FONT OF FIRST LETTER OF GRANET "G" IS "FRENCH SCRIPT MT" AND UPPER CASE. THE OTHER LETTERS ARE LOWER CASE AND "BASKERVILLE OLD FACE" FONT HAS BEEN USED.

FOR DIP MIXES; DIPS; DRIED FRUIT AND VEGETABLES; FRUIT PASTE; OLIVE PASTES; PATE'; PROCESSED OLIVES; SNACK DIPS; SNACK FOOD DIPS; STUFFED OLIVES WITH PESTO IN SUNFLOWER OIL; TAPENADES; VEGETABLE PASTE; VEGETABLES IN VINEGAR (U.S. CL. 46).

SANDRA BUJA, EXAMINING ATTORNEY

**CANYON COUNTRY**

THE MARK CONSISTS OF STANDARD CHARACTERS WITHOUT CLAIM TO ANY PARTICULAR FONT, STYLE, SIZE, OR COLOR.

FOR BEEF JERKY; DRIED MEAT; MEAT AND MEAT EXTRACTS (U.S. CL. 46).  
JEFF DEFORD, EXAMINING ATTORNEY

---

SN 85-209,691. WHITEWAVE SERVICES, INC., DALLAS, TX. FILED 1-4-2011.

**SILK FOR MILK**

THE MARK CONSISTS OF STANDARD CHARACTERS WITHOUT CLAIM TO ANY PARTICULAR FONT, STYLE, SIZE, OR COLOR.

OWNER OF U.S. REG. NOS. 2,302,273, 3,254,327 AND OTHERS.

FOR SOY-BASED FOOD BEVERAGE USED AS A MILK SUBSTITUTE (U.S. CL. 46).  
JEFFREY LOOK, EXAMINING ATTORNEY

---

SN 85-209,923. DEW - DRINK EAT WELL, INC., LAWRENCE, KS. FILED 1-4-2011.

**DRINK EAT WELL**

THE MARK CONSISTS OF STANDARD CHARACTERS WITHOUT CLAIM TO ANY PARTICULAR FONT, STYLE, SIZE, OR COLOR.

FOR ORGANIC, ALLERGEN FREE OR GLUTEN FREE FOODS, NAMELY, VEGGIE BURGERS AND VEGGIE BITES (U.S. CL. 46).

MORGAN WYNNE, EXAMINING ATTORNEY

**CLASS 29—(Continued).**

SN 85-212,145. WILD PITCH IMPORTS, LLC, WOODMERE, NY. FILED 1-6-2011.

**POTATO DELIGHTS**

THE MARK CONSISTS OF STANDARD CHARACTERS WITHOUT CLAIM TO ANY PARTICULAR FONT, STYLE, SIZE, OR COLOR.  
NO CLAIM IS MADE TO THE EXCLUSIVE RIGHT TO USE "POTATO", APART FROM THE MARK AS SHOWN.  
FOR PROCESSED POTATOES (U.S. CL. 46).  
ADA HAN, EXAMINING ATTORNEY

SN 85-212,282. SUN-MAID GROWERS OF CALIFORNIA, KINGSBURG, CA. FILED 1-6-2011.

**SUN-MAID FRUIT STICKS**

THE MARK CONSISTS OF STANDARD CHARACTERS WITHOUT CLAIM TO ANY PARTICULAR FONT, STYLE, SIZE, OR COLOR.  
OWNER OF U.S. REG. NOS. 115,368, 1,827,595 AND 3,008,771.  
NO CLAIM IS MADE TO THE EXCLUSIVE RIGHT TO USE "FRUIT STICKS", APART FROM THE MARK AS SHOWN.  
FOR DRIED FRUITS (U.S. CL. 46).  
MARIA-VICTORIA SUAREZ, EXAMINING ATTORNEY

SN 85-212,658. NATIONAL FISH & SEAFOOD, INC., GLOUCESTER, MA. FILED 1-7-2011.

**CAPTAIN'S TABLE**

THE MARK CONSISTS OF STANDARD CHARACTERS WITHOUT CLAIM TO ANY PARTICULAR FONT, STYLE, SIZE, OR COLOR.  
FOR FROZEN SEAFOOD (U.S. CL. 46).  
JACQUELINE A. LAVINE, EXAMINING ATTORNEY

**CLASS 29—(Continued).**

SN 85-213,838. ALDI INC., BATAVIA, IL. FILED 1-10-2011.

**LUNCH BUDDIES**

THE MARK CONSISTS OF STANDARD CHARACTERS WITHOUT CLAIM TO ANY PARTICULAR FONT, STYLE, SIZE, OR COLOR.  
OWNER OF U.S. REG. NOS. 3,782,300 AND 3,842,889.  
NO CLAIM IS MADE TO THE EXCLUSIVE RIGHT TO USE "LUNCH", APART FROM THE MARK AS SHOWN.  
FOR CANDIED FRUIT SNACKS; FRUIT-BASED SNACK FOOD (U.S. CL. 46).  
NAKIA HENRY, EXAMINING ATTORNEY

SN 85-214,340. SAN-J INTERNATIONAL, INC., RICHMOND, VA. FILED 1-10-2011.

**SAN-J**

THE MARK CONSISTS OF STANDARD CHARACTERS WITHOUT CLAIM TO ANY PARTICULAR FONT, STYLE, SIZE, OR COLOR.  
OWNER OF U.S. REG. NOS. 1,615,947 AND 2,151,500.  
FOR INSTANT OR PRE-COOKED MISO SOUP; INSTANT OR PRE-COOKED SOUP; SOUPS (U.S. CL. 46).  
FIRST USE 12-31-1992; IN COMMERCE 12-31-1992.  
SUNG IN, EXAMINING ATTORNEY

SN 85-214,348. SAN-J INTERNATIONAL, INC., RICHMOND, VA. FILED 1-10-2011.



OWNER OF U.S. REG. NO. 1,620,230.  
THE MARK CONSISTS OF A SHADED CIRCLE WITH TWO HORIZONTAL LINES.  
FOR INSTANT OR PRE-COOKED MISO SOUP; INSTANT OR PRE-COOKED SOUP; SOUPS (U.S. CL. 46).  
FIRST USE 12-31-1992; IN COMMERCE 12-31-1992.  
SUNG IN, EXAMINING ATTORNEY

**CLASS 29—(Continued).**

SN 85-214,447. BLACK MICHAEL L, BELLEVUE, WA. FILED 1-10-2011.

# NUE

THE MARK CONSISTS OF STANDARD CHARACTERS WITHOUT CLAIM TO ANY PARTICULAR FONT, STYLE, SIZE, OR COLOR.

FOR SOY BURGER PATTIES; TOFU BURGER PATTIES; VEGGIE BURGER PATTIES (U.S. CL. 46).  
FIRST USE 4-15-2010; IN COMMERCE 10-15-2010.  
VIVIAN MICZNIK FIRST, EXAMINING ATTORNEY

SN 85-221,302. SAPUTO CHEESE USA INC., LINCOLNSHIRE, IL. FILED 1-19-2011.

# MOZZERIA

THE MARK CONSISTS OF STANDARD CHARACTERS WITHOUT CLAIM TO ANY PARTICULAR FONT, STYLE, SIZE, OR COLOR.

FOR CHEESE (U.S. CL. 46).  
DAVID ELTON, EXAMINING ATTORNEY

SN 85-223,143. BELLISIO FOODS, INC., DULUTH, MN. FILED 1-21-2011.

# GRILL'EMS

THE MARK CONSISTS OF STANDARD CHARACTERS WITHOUT CLAIM TO ANY PARTICULAR FONT, STYLE, SIZE, OR COLOR.

FOR FROZEN APPETIZERS CONSISTING PRIMARILY OF VEGETABLES, MEAT, POULTRY, SEAFOOD, AND/OR CHEESE; FROZEN APPETIZERS, NAMELY, BREADED AND COATED VEGETABLES, MEAT, POULTRY, SEAFOOD, AND/OR CHEESE COMBINATIONS (U.S. CL. 46).

CHRISTINE COOPER, EXAMINING ATTORNEY

**CLASS 29—(Continued).**

SN 85-227,388. ALDI INC., BATAVIA, IL. FILED 1-27-2011.

# LUNCH BUDDIES

THE MARK CONSISTS OF STANDARD CHARACTERS WITHOUT CLAIM TO ANY PARTICULAR FONT, STYLE, SIZE, OR COLOR.

OWNER OF U.S. REG. NOS. 3,782,300 AND 3,842,889.  
NO CLAIM IS MADE TO THE EXCLUSIVE RIGHT TO USE "LUNCH", APART FROM THE MARK AS SHOWN.  
FOR APPLESAUCE; PROCESSED FRUITS (U.S. CL. 46).

NAKIA HENRY, EXAMINING ATTORNEY

**CLASS 30—STAPLE FOODS**

SN 77-705,440. METRO-GOLDWYN-MAYER STUDIOS INC., LOS ANGELES, CA. FILED 4-2-2009.

# PINK PANTHER

THE MARK CONSISTS OF STANDARD CHARACTERS WITHOUT CLAIM TO ANY PARTICULAR FONT, STYLE, SIZE, OR COLOR.

FOR CHOCOLATES, CANDY, FROZEN CONFECTIONS AND ICE CREAM (U.S. CL. 46).

SANJEEV VOHRA, EXAMINING ATTORNEY

SN 77-726,702. THE ALLAN CANDY COMPANY LIMITED, MISSISSAUGA, ONTARIO, CANADA, FILED 5-1-2009.

# LILLIPUT EGGZTRA

THE MARK CONSISTS OF STANDARD CHARACTERS WITHOUT CLAIM TO ANY PARTICULAR FONT, STYLE, SIZE, OR COLOR.

PRIORITY CLAIMED UNDER SEC. 44(D) ON CANADA APPLICATION NO. 1435696, FILED 4-23-2009, REG. NO. TMA791147, DATED 2-18-2011, EXPIRES 2-18-2026.

FOR CONFECTION, NAMELY, CHOCOLATE AND CANDY (U.S. CL. 46).

C. DIONNE CLYBURN, EXAMINING ATTORNEY



**CLASS 30—(Continued).**

SN 77-726,745. THE ALLAN CANDY COMPANY LIMITED, MISSISSAUGA, ONTARIO, CANADA, FILED 5-1-2009.

**LILLIPUT EGGHEADZ**

THE MARK CONSISTS OF STANDARD CHARACTERS WITHOUT CLAIM TO ANY PARTICULAR FONT, STYLE, SIZE, OR COLOR.

PRIORITY CLAIMED UNDER SEC. 44(D) ON CANADA APPLICATION NO. 1435699, FILED 4-23-2009, REG. NO. TMA791146, DATED 2-18-2011, EXPIRES 2-18-2026.

FOR CONFECTION, NAMELY, CHOCOLATE AND CANDY (U.S. CL. 46).

C. DIONNE CLYBURN, EXAMINING ATTORNEY

SN 77-876,540. LUU, JOHN, MALDEN, MA. FILED 11-19-2009.

**Hoan Ngoc Tea 7 Nga Tay Ninh**

THE MARK CONSISTS OF STANDARD CHARACTERS WITHOUT CLAIM TO ANY PARTICULAR FONT, STYLE, SIZE, OR COLOR.

NO CLAIM IS MADE TO THE EXCLUSIVE RIGHT TO USE "HOAN NGOC TEA" AND "NGA TAY NINH", APART FROM THE MARK AS SHOWN.

THE ENGLISH TRANSLATION OF "HOAN NGOC" AND "NGA" IN THE MARK IS PSEUDERANTHEMUM PALATIFERUM AND RUSSIAN.

FOR TEA; TEA BAGS (U.S. CL. 46).

KIM MONINGHOFF, EXAMINING ATTORNEY

SN 77-881,220. GREENIES, LLC, DBA TERRA SPICE COMPANY, WALKERTON, IN. FILED 11-25-2009.

**TERRA SPICE**

THE MARK CONSISTS OF STANDARD CHARACTERS WITHOUT CLAIM TO ANY PARTICULAR FONT, STYLE, SIZE, OR COLOR.

NO CLAIM IS MADE TO THE EXCLUSIVE RIGHT TO USE "SPICE", APART FROM THE MARK AS SHOWN.

THE ENGLISH TRANSLATION OF "TERRA" IN THE MARK IS EARTH.

FOR BAKING SPICES; CINNAMON POWDER; CLOVE POWDER; CURRY; CURRY POWDER; DRY SPICE RUB FOR MEATS AND FISH; EDIBLE SPICES; GINGER; HOT PEPPER POWDER; JAPANESE HORSERADISH POWDER SPICE (WASABI POWDER); JAPANESE PEPPER POWDER SPICE (SANSHO POWDER); MASALA POWDER AND SPICES; MUSTARD POWDER; PEPPER; PEPPER POWDER; PEPPER SPICE; SPICE BLENDS; SPICE RUBS; SPICES (U.S. CL. 46).

FIRST USE 11-2-2001; IN COMMERCE 1-12-2002.

JANICE KIM, EXAMINING ATTORNEY

**CLASS 30—(Continued).**

SN 77-935,287. LUM, SELENE, PASADENA, CA. FILED 2-13-2010.

**Joie**

THE MARK CONSISTS OF STANDARD CHARACTERS WITHOUT CLAIM TO ANY PARTICULAR FONT, STYLE, SIZE, OR COLOR.

THE ENGLISH TRANSLATION OF "JOIE" IN THE MARK IS JOY.

FOR BAKERY GOODS (U.S. CL. 46).

FIRST USE 2-1-2010; IN COMMERCE 2-1-2010.

LINDA ESTRADA, EXAMINING ATTORNEY

SN 79-082,739. CHONGQING HONGJIUJIU FOOD CO., LTD., CHINA, FILED 4-20-2010.

OWNER OF INTERNATIONAL REGISTRATION 1039222 DATED 4-20-2010, EXPIRES 4-20-2020.

THE MARK CONSISTS OF CHINESE CHARACTERS THAT TRANSLITERATE TO "HONG", WHICH MEANS "RED" IN ENGLISH, FOLLOWED BY THE NUMBER "99".

THE ENGLISH TRANSLATION OF THE FOREIGN WORD(S) IN THE MARK IS: "HONG" WHICH MEANS RED. THE TRANSLITERATION OF THE NON-LATIN CHARACTERS IN THE MARK IS: "HONG".

FOR ROYAL JELLY FOR HUMAN CONSUMPTION, NOT FOR MEDICAL PURPOSES; FOOD LEAVENING AGENTS; AROMATIC PREPARATIONS FOR FOOD, NAMELY, SEASONINGS; MEAT TENDERIZERS, FOR HOUSEHOLD PURPOSES; SOYA FLOUR; CHOCOLATE-BASED BEVERAGES; TEA; SWEETMEATS, NAMELY, CANDY; PASTRIES; PASTIES; CONDIMENTS, NAMELY, SPICES, PEPPER, RELISH, MEAT GRAVIES; FLOUR; POPCORN; EDIBLE ICES; STARCH FOR USE IN MANUFACTURING FOOD (U.S. CL. 46).

BRIAN CALLAGHAN, EXAMINING ATTORNEY

**CLASS 30—(Continued).**

SN 79-082,938. INOSTRANNOE OBCHTCHESTVO S OGRANITCHENNOI OTVETSTVENNOSTIOU "MOROZPRODUKT", BELARUS, FILED 3-29-2010.



PRIORITY DATE OF 2-10-2010 IS CLAIMED.  
OWNER OF INTERNATIONAL REGISTRATION 1039794  
DATED 3-29-2010, EXPIRES 3-29-2020.

OWNER OF U.S. REG. NO. 3,822,025.

NO CLAIM IS MADE TO THE EXCLUSIVE RIGHT TO USE "THE NON-LATIN CHARACTERS THAT TRANSLITERATE TO MOROZENOE PLOMBIR", APART FROM THE MARK AS SHOWN.

THE MARK CONSISTS OF A DESIGN IN THE TOP-LEFT PORTION FEATURING A PAIR OF PENGUINS WITH THREE TRIANGLES ABOVE AND BY 7 TRIANGLES BELOW; THE BOTTOM-LEFT PORTION FEATURES THE DESIGN OF A SUN RISING OR SETTING ABOVE SEVEN TRIANGLE DESIGNS, WITH CYRILLIC WORDING INCORPORATING THE NUMBER 28 APPEARING BENEATH THE TRIANGLE DESIGNS; THE DESIGNS IN THE TOP-LEFT PORTION OF THE MARK ARE REPEATED IN THE BOTTOM-RIGHT QUADRANT, AND THE DESIGNS AND WORDING IN THE BOTTOM-LEFT PORTION OF THE MARK ARE REPEATED IN THE UPPER RIGHT QUADRANT; THE TOP AND BOTTOM EDGES FEATURE A THIN DOTTED HORIZONTAL LINE.

THE NON-LATIN CHARACTERS IN THE MARK TRANSLITERATE TO "MOROZENOE PLOMBIR", AND THIS MEANS "ICE CREAM" IN ENGLISH, AND TRANSLITERATE TO "28 KOPEEK", AND THIS MEANS "28 KOPECKS" IN ENGLISH.

FOR ICE CREAM (U.S. CL. 46).

KEVIN CORWIN, EXAMINING ATTORNEY

SN 79-084,311. NEWBY TEAS (U.K.) LIMITED, UNITED KINGDOM, FILED 6-2-2010.

OWNER OF INTERNATIONAL REGISTRATION 0835479  
DATED 6-25-2004, EXPIRES 6-25-2014.

FOR TEA (U.S. CL. 46).

INGRID C. EULIN, EXAMINING ATTORNEY

**CLASS 30—(Continued).**

SN 79-084,657. LIDL STIFTUNG & CO. KG, FED REP GERMANY, FILED 6-14-2010.



OWNER OF INTERNATIONAL REGISTRATION 0975487  
DATED 8-18-2008, EXPIRES 8-18-2018.

OWNER OF U.S. REG. NO. 2,855,481.

THE COLOR(S) RED, DARK RED, LIGHT BROWN, BLACK AND WHITE IS/ARE CLAIMED AS A FEATURE OF THE MARK.

THE MARK CONSISTS OF A RED AND DARK RED OVAL OUTLINED IN BLACK, INSIDE OF WHICH APPEARS A WHITE OVAL RING OUTLINED IN LIGHT BROWN AND BLACK, IN THE CENTER OF WHICH APPEARS THE STYLIZED WORD "DANIELI" IN WHITE WITH LIGHT BROWN AND BLACK OUTLINING.

FOR PASTA (U.S. CL. 46).

HEATHER THOMPSON, EXAMINING ATTORNEY

SN 79-085,468. AACHENER PRINTEN- UND SCHOKOLADENFABRIK HENRY LAMBERTZ GMBH & CO. KG, FED REP GERMANY, FILED 6-2-2010.



PRIORITY DATE OF 3-19-2010 IS CLAIMED.  
OWNER OF INTERNATIONAL REGISTRATION 1046066  
DATED 6-2-2010, EXPIRES 6-2-2020.

OWNER OF U.S. REG. NO. 2,397,652.

THE NAME(S), PORTRAIT(S), AND/OR SIGNATURE(S) SHOWN IN THE MARK DOES NOT IDENTIFY A PARTICULAR LIVING INDIVIDUAL.

THE MARK CONSISTS OF THE WORDING "HENRY LAMBERTZ" IN STYLIZED FONT WITH A DESIGN OF A SUN WITH A HUMAN FACE IN A CIRCLE.

FOR BAKERY PRODUCTS, NAMELY, LONG-LIFE BAKERY PRODUCTS, PASTRIES, BISCUITS, BISCUIT ASSORTMENTS, AND BISCUIT BARS; FROZEN CONFECTIONERY; CONFECTIONERY MADE OF SUGAR AND CONFECTIONERY FOR DECORATING CHRISTMAS TREES; PREPARATIONS MADE FROM CEREALS, NAMELY, COOKIES, BISCUITS, AND CEREAL BREAKFAST BARS; CHOCOLATE AND CHOCOLATE PRODUCTS, NAMELY, CANDY, COOKIES, AND BISCUITS, AS WELL AS SUGAR CONFECTIONERY ARTICLES IN THE NATURE OF COOKIES, BISCUITS, AND CANDY; SWEETS (U.S. CL. 46).

WILLIAM ROSSMAN, EXAMINING ATTORNEY

**CLASS 30—(Continued).**

SN 79-086,072. TOVARYSTVO Z OBMEZHENOIU VIDPOVIDALNISTIU "KOMPANIA "RIDNA YIZHA", KIEV 03039, UKRAINE, FILED 6-17-2010.



OWNER OF INTERNATIONAL REGISTRATION 1047664 DATED 6-17-2010, EXPIRES 6-17-2020.

THE ENGLISH TRANSLATION OF "OVSYANUSHKA" IN THE MARK IS "SMALL, LOVED PORRIDGE".

THE TRANSLITERATION OF THE NON-LATIN CHARACTERS IN THE MARK IS: "OVSYANUSHKA".

FOR COCOA; SUGAR; RICE; TAPIOCA; SAGO; FLOUR; FARINACEOUS FOOD, NAMELY, BISCUITS, COOKIES, CRACKERS; PREPARATIONS MADE FROM CEREALS, NAMELY, OAT-BASED SNACK BARS, OAT FLAKES, OATMEAL, SNACK FOOD, GROATS, GRUEL, CORN CHIPS, GRAIN-BASED CHIPS, CORN FLAKES, HUSKED OATS, CRUSHED OATS, PORRIDGE MADE FROM OATS OR BUCKWHEATS OR OTHER GRAINS; BREAD; PASTRY; FROZEN CONFECTIONERY, CONFECTIONERY MADE FROM SUGAR; FLAVORED ICES, EDIBLE ICES; HONEY; TREACLE; YEAST; BAKING-POWDER; PASTY; SAUCES (U.S. CL. 46).

JOHN SCHUYLER YARD, EXAMINING ATTORNEY

SN 79-087,071. PERFETTI VAN MELLE S.P.A., ITALY, FILED 6-11-2010.

## LIFE LESS SERIOUS

THE MARK CONSISTS OF STANDARD CHARACTERS WITHOUT CLAIM TO ANY PARTICULAR FONT, STYLE, SIZE, OR COLOR.

PRIORITY DATE OF 5-5-2010 IS CLAIMED.

OWNER OF INTERNATIONAL REGISTRATION 1050382 DATED 6-11-2010, EXPIRES 6-11-2020.

FOR CANDIES, CONFECTIONERY, NAMELY, CONFECTIONERY MADE OF SUGAR, FONDANTS, FROZEN CONFECTIONERY, CONFECTIONERIES, NAMELY, SNACK FOODS, NAMELY, CHOCOLATE, PASTRY, SWEETS, CHEWING GUMS, CARAMELS, CHOCOLATE, JELLIES (CONFECTIONERY), SOFT CANDIES, LOLLIPOPS, TOFFEES, MINTS, PASTILLES, LICORICE, SUGAR, COFFEE, COCOA (U.S. CL. 46).

RICHARD WHITE, EXAMINING ATTORNEY

SN 79-087,339. MOLINO PASINI S.P.A., ITALY, FILED 8-4-2010.

## FARINA DEL MIO SACCO

THE MARK CONSISTS OF STANDARD CHARACTERS WITHOUT CLAIM TO ANY PARTICULAR FONT, STYLE, SIZE, OR COLOR.

OWNER OF INTERNATIONAL REGISTRATION 1051011 DATED 8-4-2010, EXPIRES 8-4-2020.

NO CLAIM IS MADE TO THE EXCLUSIVE RIGHT TO USE "FARINA" AND "SACCO", APART FROM THE MARK AS SHOWN.

THE ENGLISH TRANSLATION OF THE FOREIGN WORD(S) IN THE MARK IS: FLOUR OF MY BAG.

FOR FLOUR FOR FOOD (U.S. CL. 46).

JOSETTE BEVERLY, EXAMINING ATTORNEY

**CLASS 30—(Continued).**

SN 79-092,784. ILLYCAFFÈ S.P.A., ITALY, FILED 9-16-2010.

## MONOARABICA

THE MARK CONSISTS OF STANDARD CHARACTERS WITHOUT CLAIM TO ANY PARTICULAR FONT, STYLE, SIZE, OR COLOR.

PRIORITY DATE OF 3-18-2010 IS CLAIMED.

OWNER OF INTERNATIONAL REGISTRATION 1065724 DATED 9-16-2010, EXPIRES 9-16-2020.

FOR COFFEE, TEA, TEA AND COFFEE SUBSTITUTES; ARTIFICIAL COFFEE AND TEA; COCOA, SUGAR, CHOCOLATE; BREAD, PASTRY AND CONFECTIONERY, NAMELY, PASTILLES, CONFECTIONERY CHIPS FOR BAKING, FROZEN CONFECTIONERY, FONDANTS AND CRYSTAL SUGAR PIECES; EDIBLE ICES; FLAVOURED ICES AND EDIBLE FRUIT ICES; COFFEE-BASED BEVERAGES; BEVERAGES MADE OF TEA; TEA-BASED BEVERAGES WITH FRUIT FLAVORING; BEVERAGES MADE OF COFFEE; COFFEE BEVERAGES WITH MILK; COFFEE FLAVORED SYRUP USED IN MAKING FOOD BEVERAGES; PASTA; BISCUITS, CAKES, EDIBLE FLAVORED ICES; HONEY; SPICES, ICE CREAM (U.S. CL. 46).

DAVID I, EXAMINING ATTORNEY

SN 85-006,234. MOLINOS VALLE DEL CIBAO C POR A, SANTIAGO, DOMINICAN REP, FILED 4-5-2010.



OWNER OF DOMINICAN REP REG. NO. 177042, DATED 11-2-2009, EXPIRES 11-2-2019.

NO CLAIM IS MADE TO THE EXCLUSIVE RIGHT TO USE "GALLETAS", APART FROM THE MARK AS SHOWN. THE COLOR(S) RED, GREY IS/ARE CLAIMED AS A FEATURE OF THE MARK.

THE MARK CONSISTS OF THE WORD PRINCESA APPEARING IN RED AND THE WORD "GALLETAS" APPEARING IN GREY.

THE ENGLISH TRANSLATION OF "GALLETAS PRINCESA" IN THE MARK IS CAKES PRINCESS.

FOR FLOURS AND CEREAL-BASED MIXES FOR MAKING SWEET AND SALTED COOKIES (U.S. CL. 46).

KATHLEEN M. VANSTON, EXAMINING ATTORNEY

SN 85-011,919. JANSEN, ALICIA, BELLINGHAM, WA, FILED 4-12-2010.

## ONLY THE GOOD STUFF

THE MARK CONSISTS OF STANDARD CHARACTERS WITHOUT CLAIM TO ANY PARTICULAR FONT, STYLE, SIZE, OR COLOR.

FOR GRANOLA; GRANOLA SNACKS; GRANOLA-BASED SNACK BARS (U.S. CL. 46).

JACLYN KIDWELL WALKER, EXAMINING ATTORNEY

**CLASS 30—(Continued).**

SN 85-018,937. CRYSTAL RIVER ORGANICS LLC, CARBON-DALE, CO. FILED 4-21-2010.

## DOC DAWA'S NUDE NUTRITIONALS

THE MARK CONSISTS OF STANDARD CHARACTERS WITHOUT CLAIM TO ANY PARTICULAR FONT, STYLE, SIZE, OR COLOR.

NO CLAIM IS MADE TO THE EXCLUSIVE RIGHT TO USE "NUTRITIONALS", APART FROM THE MARK AS SHOWN.

THE NAME(S), PORTRAIT(S), AND/OR SIGNATURE(S) SHOWN IN THE MARK DOES NOT IDENTIFY A PARTICULAR LIVING INDIVIDUAL.

FOR CEREAL BASED SNACK BARS; CEREAL BASED HIGH PROTEIN SNACK BARS; CEREAL BASED HIGH ENERGY BARS NOT FOR USE AS A MEAL REPLACEMENT; CEREALS AND PREPARATIONS MADE FROM CEREALS, NAMELY, BREAKFAST CEREALS, PROCESSED CEREALS AND CEREAL BASED SNACK FOODS; SALAD DRESSINGS, CONDIMENTS, NAMELY, SALSAS, MARINADES; PREPARED AND PACKAGED READY TO EAT MEALS CONSISTING PRIMARILY OF PASTA OR RICE (U.S. CL. 46).

ERNEST SHOSHO, EXAMINING ATTORNEY

---

SN 85-018,987. 3J FOODS CORPORATION, RANCHO CUCA-MONGA, CA. FILED 4-21-2010.

## PARK'S ARABICA

THE MARK CONSISTS OF STANDARD CHARACTERS WITHOUT CLAIM TO ANY PARTICULAR FONT, STYLE, SIZE, OR COLOR.

NO CLAIM IS MADE TO THE EXCLUSIVE RIGHT TO USE "ARABICA", APART FROM THE MARK AS SHOWN.

FOR STAPLE FOODS, NAMELY, COFFEE, TEA, COCOA, SUGAR, RICE, TAPIOCA, SAGO, ARTIFICIAL COFFEE; FLOUR AND PREPARATIONS MADE FROM CEREALS, NAMELY, CEREAL BASED SNACK FOODS; BREAD, PASTRY AND CONFECTIONERY MADE OF SUGAR, ICES; HONEY, TREACLE; YEAST, BAKING POWDER; SALT, MUSTARD; VINEGAR, SAUCES; SPICES AND ICE FOR CONSUMERS (U.S. CL. 46).

FIRST USE 4-20-2010; IN COMMERCE 4-20-2010.  
TARAH HARDY, EXAMINING ATTORNEY

**CLASS 30—(Continued).**

SN 85-020,562. THE ALLAN CANDY COMPANY LIMITED, MISSISSAUGA, ONTARIO, CANADA, FILED 4-22-2010.

## MRS. FRUIT & NUT

THE MARK CONSISTS OF STANDARD CHARACTERS WITHOUT CLAIM TO ANY PARTICULAR FONT, STYLE, SIZE, OR COLOR.

PRIORITY CLAIMED UNDER SEC. 44(D) ON CANADA APPLICATION NO. 1477287, FILED 4-16-2010, REG. NO. TMA790985, DATED 2-17-2011, EXPIRES 2-17-2026.

NO CLAIM IS MADE TO THE EXCLUSIVE RIGHT TO USE "FRUIT & NUT", APART FROM THE MARK AS SHOWN.

FOR CHOCOLATE, CHOCOLATES AND CHOCOLATE BARS (U.S. CL. 46).

RICHARD WHITE, EXAMINING ATTORNEY

---

SN 85-026,388. INNOVATIVE BEVERAGE PRODUCTS, LLC, LAS VEGAS, NV. FILED 4-29-2010.

## ENERGY SLAM

THE MARK CONSISTS OF STANDARD CHARACTERS WITHOUT CLAIM TO ANY PARTICULAR FONT, STYLE, SIZE, OR COLOR.

FOR COFFEE, TEA AND COCOA; FLAVORINGS FOR BEVERAGES; CANDY; CHEWING GUM; BUBBLE GUM; CANDY BARS (U.S. CL. 46).

JULIE WATSON, EXAMINING ATTORNEY

---

SN 85-026,415. INNOVATIVE BEVERAGE PRODUCTS, LLC, LAS VEGAS, NV. FILED 4-29-2010.

## ENERGY SLAMMER

THE MARK CONSISTS OF STANDARD CHARACTERS WITHOUT CLAIM TO ANY PARTICULAR FONT, STYLE, SIZE, OR COLOR.

FOR COFFEE, TEA AND COCOA; FLAVORINGS FOR BEVERAGES; CANDY; CHEWING GUM; BUBBLE GUM; CANDY BARS (U.S. CL. 46).

JULIE WATSON, EXAMINING ATTORNEY

**CLASS 30—(Continued).**

SN 85-040,610. ROWLEY, CYNTHIA, NEW YORK, NY.  
FILED 5-17-2010.

**CURIOUS CANDY**

THE MARK CONSISTS OF STANDARD CHARACTERS WITHOUT CLAIM TO ANY PARTICULAR FONT, STYLE, SIZE, OR COLOR.

NO CLAIM IS MADE TO THE EXCLUSIVE RIGHT TO USE "CANDY", APART FROM THE MARK AS SHOWN.

FOR CANDY (U.S. CL. 46).

TRICIA SONNEBORN, EXAMINING ATTORNEY

SN 85-041,665. LUCKY ELEPHANT FOODS, INC., BELLEVUE, WA. FILED 5-18-2010.

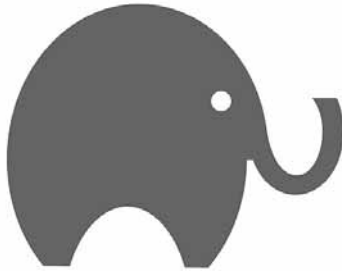

THE MARK CONSISTS OF AN ARTISTIC ILLUSTRATION OF AN ELEPHANT.

FOR COFFEE; TEA; DESSERT PUDDINGS; FROZEN CONFECTIONS; SORBET (U.S. CL. 46).

LAURIE KAUFMAN, EXAMINING ATTORNEY

SN 85-044,594. KRAMEDJIAN, ARMAND, ATLANTA, GA. AND KRAMEDJIAN, RUTH, ATLANTA, GA. FILED 5-21-2010.

**CHEATERS**

THE MARK CONSISTS OF STANDARD CHARACTERS WITHOUT CLAIM TO ANY PARTICULAR FONT, STYLE, SIZE, OR COLOR.

FOR CANDY (U.S. CL. 46).

JOHN SCHUYLER YARD, EXAMINING ATTORNEY

**CLASS 30—(Continued).**

SN 85-045,203. GASTRONOMÍA AVANZADA PASTELERÍAS S.A. DE C.V., DISTRITO FEDERAL, MEXICO, FILED 5-21-2010.

**EL GLOBO**

THE MARK CONSISTS OF STANDARD CHARACTERS WITHOUT CLAIM TO ANY PARTICULAR FONT, STYLE, SIZE, OR COLOR.

OWNER OF MEXICO REG. NO. 395721, DATED 5-29-1991, EXPIRES 10-26-2015.

THE ENGLISH TRANSLATION OF "EL GLOBO" IN THE MARK IS HOT AIR BALLOON.

FOR FLOURS AND PREPARATIONS MADE FROM CEREALS, NAMELY, SNACK FOODS, BREAD (U.S. CL. 46).

AISHA CLARKE, EXAMINING ATTORNEY

SN 85-047,858. SCHOENBECK, DEBRA, WALWORTH, WI. FILED 5-26-2010.

**HOMETOWN FUDGE**

THE MARK CONSISTS OF STANDARD CHARACTERS WITHOUT CLAIM TO ANY PARTICULAR FONT, STYLE, SIZE, OR COLOR.

NO CLAIM IS MADE TO THE EXCLUSIVE RIGHT TO USE "FUDGE", APART FROM THE MARK AS SHOWN.

FOR MILK PRODUCTS, NAMELY, FUDGE (U.S. CL. 46).

FIRST USE 9-30-2009; IN COMMERCE 9-30-2009.

JOHN GARTNER, EXAMINING ATTORNEY

**CLASS 30—(Continued).**

SN 85-048,889. DEFOSSEY, TRICIA L, MARINA DEL REY, CA. FILED 5-27-2010.



NO CLAIM IS MADE TO THE EXCLUSIVE RIGHT TO USE "MATCHA" AND THE NON-LATIN CHARACTER THAT TRANSLITERATES TO "MATCHA", APART FROM THE MARK AS SHOWN.

THE MARK CONSISTS OF THE WORD "MATCHA" APPEARING ABOVE THE WORD "MATCHA" WITH A BAR APPEARING BETWEEN THE WORDS, ALL SUPERIMPOSED OVER A STYLIZED NON-LATIN CHARACTER AND A STYLIZED INCOMPLETE CIRCLE.

THE ENGLISH TRANSLATION OF THE WORD "MATCHA" IN THE MARK IS "POWDERED GREEN TEA".

THE NON-LATIN CHARACTERS IN THE MARK TRANSLITERATE TO "MATCHA".

FOR JAPANESE GREEN TEA (U.S. CL. 46).

FIRST USE 3-1-2009; IN COMMERCE 6-1-2009.

CHRISTINE MARTIN, EXAMINING ATTORNEY

**CLASS 30—(Continued).**

SN 85-054,500. FTF SWEETS LTD, BOLTON, LANCASHIRE, UNITED KINGDOM, FILED 6-4-2010.



NO CLAIM IS MADE TO THE EXCLUSIVE RIGHT TO USE "GOODY", APART FROM THE MARK AS SHOWN.

THE MARK CONSISTS OF THE STYLIZED WORDING "GOODY GOOD STUFF", WITH THE TWO "O'S" IN "GOOD" FORMING THE IMAGE OF A PAIR OF EYES.

FOR CANDIES; GUMMY CANDIES (U.S. CL. 46).

FIRST USE 6-1-2010; IN COMMERCE 6-1-2010.

SAMUEL E. SHARPER JR., EXAMINING ATTORNEY

SN 85-055,827. OURANT, MARK, WAXHAW, NC. FILED 6-7-2010.



NO CLAIM IS MADE TO THE EXCLUSIVE RIGHT TO USE "PEPPERONI ROLLS", APART FROM THE MARK AS SHOWN.

THE NAME(S), PORTRAIT(S), AND/OR SIGNATURE(S) SHOWN IN THE MARK DOES NOT IDENTIFY A PARTICULAR LIVING INDIVIDUAL.

THE COLOR(S) YELLOW, BLACK, RED, GREEN AND WHITE IS/ARE CLAIMED AS A FEATURE OF THE MARK.

THE MARK CONSISTS OF THE WORDS "PEPOLI'S PEPPERONI ROLLS" WHEREIN THE WORD "PEPOLI'S" IS WRITTEN IN YELLOW COLOR AND THE WORDS "PEPPERONI ROLLS" ARE WRITTEN BELOW THE WORD "PEPOLI'S" IN BLACK COLOR. THERE IS A PICTURE OF BEAUTIFUL ITALIAN PEASANT GIRL WEARING WHITE TOP, RED JACKET, GREEN SKIRT, HAVING BLACK HAIRS WITH YELLOW BAND HOLDING A PEPOLI'S PEPPERONI ROLL BEHIND THE WORDS "PEPOLI'S PEPPERONI ROLLS" WITH A BACKGROUND OF GREEN, WHITE AND RED COLOR VERTICAL LINES WITH BLACK AND WHITE COLOR OUTLINE. THERE IS AN ARCH IN BLACK COLOR BELOW THE IMAGE AS SHOWN IN THE MARK.

FOR PEPPERONI ROLLS (U.S. CL. 46).

ALEXANDER L. POWERS, EXAMINING ATTORNEY

SN 85-051,073. KOESSL, DEENA, WINDSOR, CO. FILED 5-31-2010.

**ALPINE TOFFEE**

THE MARK CONSISTS OF STANDARD CHARACTERS WITHOUT CLAIM TO ANY PARTICULAR FONT, STYLE, SIZE, OR COLOR.

NO CLAIM IS MADE TO THE EXCLUSIVE RIGHT TO USE "TOFFEE", APART FROM THE MARK AS SHOWN.

FOR STAPLE FOOD, NAMELY, CANDY FOR FOOD (U.S. CL. 46).

FIRST USE 12-1-2006; IN COMMERCE 12-1-2006.

TINA L. SNAPP, EXAMINING ATTORNEY

**CLASS 30—(Continued).**

SN 85-056,511. TARGET BRANDS, INC., MINNEAPOLIS, MN. FILED 6-7-2010.



OWNER OF U.S. REG. NOS. 2,290,302, 2,954,200 AND OTHERS.

NO CLAIM IS MADE TO THE EXCLUSIVE RIGHT TO USE "FARMS", APART FROM THE MARK AS SHOWN.

THE MARK CONSISTS OF THE STYLIZED WORDS "ARCHER FARMS" WRITTEN HORIZONTALLY ABOVE A ROOSTER IMAGE.

FOR FOOD AND BEVERAGE PRODUCTS IN THE CLASS, NAMELY, FROZEN, PREPARED AND PACKAGED ENTREES CONSISTING PRIMARILY OF PASTA OR RICE; PASTA; RICE; PASTA AND RICE SALADS; BAKERY PRODUCTS; TORTILLAS; BISCUITS; BREADS AND BREAD ROLLS; PIZZA; CROUTONS; SANDWICHES; MIXES FOR BAKERY GOODS; OATMEAL; BREAKFAST CEREALS; GRANOLA; BAGELS; BUNS; CROISSANTS; SCONES; CINNAMON ROLLS; PASTRIES; MUFFINS; CRACKERS; PRETZELS; SESAME STICKS; SNACK MIX CONSISTING PRIMARILY OF CRACKERS, PRETZELS, AND/OR POPPED POPCORN; POPCORN; CORN CHIPS AND CORN-BASED SNACK FOODS; TORTILLA CHIPS; COOKIES AND COOKIE MIXES; CANDY AND CANDY MINTS; CHOCOLATE COVERED NUTS; CHEWING GUM; CEREAL-BASED SNACK FOODS; COCOA; COFFEE; TEA; BAKERY DESSERTS; CAKES, CAKE MIXES AND FROSTINGS; PIES; TARTS; FROZEN CONFECTIONS; FROZEN SOY-BASED DESSERTS; FROZEN DESSERT CONSISTING OF FRUIT AND CREAM OR CREAM SUBSTITUTES; ICE CREAM AND ICE CREAM CONES; FROZEN YOGURT; DESSERT MOUSSE, PUDDINGS AND FLAVORED GELATIN; CHEESECAKE; BROWNIES; MARSHMALLOWS; SALAD DRESSINGS; HONEY; MUSTARD; KETCHUP; MAYONNAISE; MARINADES; SAUCES; GRAVY; SALSA; RELISHES; VINEGAR; PROCESSED HERBS; SEASONING MIXES AND SEASONINGS; EXTRACTS USED AS FLAVORINGS; FLOUR; SUGAR; BAKING POWDER; BAKING SODA; SALT; SPICES AND SPICE RUBS; CHOCOLATE; TOPPING SYRUP; PANCAKE SYRUP; FLAVORING SYRUPS (U.S. CL. 46).

ALEXANDER L. POWERS, EXAMINING ATTORNEY

SN 85-060,270. CONFETTI LLC, VIRGINIA BEACH, VA. FILED 6-11-2010.

**CONFETTI GELATO**

THE MARK CONSISTS OF STANDARD CHARACTERS WITHOUT CLAIM TO ANY PARTICULAR FONT, STYLE, SIZE, OR COLOR.

NO CLAIM IS MADE TO THE EXCLUSIVE RIGHT TO USE "GELATO", APART FROM THE MARK AS SHOWN.

FOR GELATO (U.S. CL. 46).

JOHN SCHUYLER YARD, EXAMINING ATTORNEY

**CLASS 30—(Continued).**

SN 85-064,456. ARTINIAN, INC., WARREN, MI. FILED 6-16-2010.



THE MARK CONSISTS OF A STYLIZED MALE FIGURE WEARING A BASEBALL HAT BACKWARDS, SNEAKERS, SHORTS, AND A SHIRT WITH THE LETTERS "JB" ON THE FRONT. THE FIGURE IS HOLDING A BREADSTICK.

FOR BREAD STICKS; PIZZA (U.S. CL. 46).

FIRST USE 0-0-1998; IN COMMERCE 0-0-1998.

CAROLYN CATALDO, EXAMINING ATTORNEY

SN 85-071,095. KD DID, INC., DBA ENERGY ESSENTIALS, CALABASAS, CA. FILED 6-24-2010.

**Catie's Whole Food Weigh  
Less Sprouted Grains**

THE MARK CONSISTS OF STANDARD CHARACTERS WITHOUT CLAIM TO ANY PARTICULAR FONT, STYLE, SIZE, OR COLOR.

OWNER OF U.S. REG. NOS. 3,777,229 AND 3,789,677.

NO CLAIM IS MADE TO THE EXCLUSIVE RIGHT TO USE "WHOLE FOOD" AND "SPROUTED GRAINS", APART FROM THE MARK AS SHOWN.

FOR HUSKED RICE; PACKAGED MEAL KITS CONSISTING PRIMARILY OF PASTA OR RICE; PACKAGED MEAL MIXES CONSISTING PRIMARILY OF PASTA OR RICE; RICE (U.S. CL. 46).

FIRST USE 12-1-2009; IN COMMERCE 3-31-2010.

WILLIAM BRECKENFELD, EXAMINING ATTORNEY

**CLASS 30—(Continued).**

SN 85-082,127. POTRERO TRADING COMPANY, SAN FRANCISCO, CA. FILED 7-12-2010.

Potrero Tea  
TEA. Give the Gift of Good  
Health

THE MARK CONSISTS OF STANDARD CHARACTERS WITHOUT CLAIM TO ANY PARTICULAR FONT, STYLE, SIZE, OR COLOR.

NO CLAIM IS MADE TO THE EXCLUSIVE RIGHT TO USE "TEA", APART FROM THE MARK AS SHOWN.

THE ENGLISH TRANSLATION OF "POTRERO" IN THE MARK IS "PASTURE".

FOR COFFEE AND TEA; GREEN TEA; ICED TEA; INSTANT TEA; JAPANESE GREEN TEA; OOLONG TEA; TEA; TEA BAGS (U.S. CL. 46).

FIRST USE 12-29-2009; IN COMMERCE 4-1-2010.  
DOMINIC FATHY, EXAMINING ATTORNEY

---

SN 85-091,965. RICH PRODUCTS CORPORATION, BUFFALO, NY. FILED 7-23-2010.

## BIRTHDAY PARTY

THE MARK CONSISTS OF STANDARD CHARACTERS WITHOUT CLAIM TO ANY PARTICULAR FONT, STYLE, SIZE, OR COLOR.

FOR NON-DAIRY ICINGS; NON-DAIRY CREAM FILLINGS FOR CAKES AND DESSERT PRODUCTS (U.S. CL. 46).

JENNY PARK, EXAMINING ATTORNEY

---

SN 85-094,078. ORION CORPORATION, SEOUL, REPUBLIC OF KOREA, FILED 7-27-2010.



OWNER OF REPUBLIC OF KOREA REG. NO. 400771423000, DATED 12-5-2008, EXPIRES 12-5-2018.

THE MARK CONSISTS OF THE WORDS "DR. YOU" UNDERLINED WITH A PERSON AT THE END OF THE WORDING.

FOR COOKIES, CRACKERS, EDIBLE WAFERS, CORN CHIPS, BREAD, PASTRIES, CAKES, PIES, DESSERT PUDDINGS, SHERBETS, ICE CREAMS, CANDY, CARAMELS, CHEWING GUM (U.S. CL. 46).

LEIGH CAROLINE CASE, EXAMINING ATTORNEY

**CLASS 30—(Continued).**

SN 85-094,195. RED MARIACHI FOOD COMPANY, S.A. DE C.V., MEXICO, D.F. 11590, MEXICO, FILED 7-27-2010.

## EL RED MARIACHI

THE MARK CONSISTS OF STANDARD CHARACTERS WITHOUT CLAIM TO ANY PARTICULAR FONT, STYLE, SIZE, OR COLOR.

OWNER OF MEXICO REG. NO. 984424, DATED 5-21-2007, EXPIRES 12-21-2015.

THE ENGLISH TRANSLATION OF THE WORD "EL" IN THE MARK IS "THE".

FOR SAUCES, NAMELY, HOT SAUCE, TACO SAUCE, RANCH SAUCE, HOMEMADE SAUCES, SNACK DIPPING SAUCE, SPICY SALAD DRESSINGS MADE FROM A MIXTURE OF CONDIMENTS AND CHILIES (U.S. CL. 46).

KAREN BRACEY, EXAMINING ATTORNEY

---

SN 85-094,198. RED MARIACHI FOOD COMPANY, S.A. DE C.V., MEXICO, D.F. 11590, MEXICO, FILED 7-27-2010.

## LA COCOREÑA

THE MARK CONSISTS OF STANDARD CHARACTERS WITHOUT CLAIM TO ANY PARTICULAR FONT, STYLE, SIZE, OR COLOR.

OWNER OF MEXICO REG. NO. 1013558, DATED 11-27-2007, EXPIRES 1-23-2017.

THE WORDING "LA COCOREÑA" HAS NO MEANING IN A FOREIGN LANGUAGE.

FOR CONDIMENTS IN THE NATURE OF SAUCES (U.S. CL. 46).

KAREN BRACEY, EXAMINING ATTORNEY



**CLASS 30—(Continued).**

SN 85-097,802. OLÉ MEXICAN FOODS, INC., NORCROSS, GA. FILED 8-2-2010.



THE MARK CONSISTS OF TWO CONCENTRIC RINGS. BETWEEN THE RINGS AT THE TOP AND BOTTOM IS A WHITE BACKGROUND AND BETWEEN THE RINGS ON THE LEFT AND RIGHT SIDES IS A BLACK BACKGROUND. BETWEEN THE TOP OF THE RINGS ARE THE WORDS "LA SABROSITA". INSIDE THE RINGS IS A FLAG WITH A STACK OF STEAMING TORTILLAS. UNDERNEATH THE FLAG IS A TRAY WITH THREE STEAMING TORTILLAS ON IT.

THE ENGLISH TRANSLATION OF "LA SABROSITA" IN THE MARK IS "THE TASTY LITTLE ONE".

FOR TORTILLAS (U.S. CL. 46).

GEOFFREY FOSDICK, EXAMINING ATTORNEY

**CLASS 30—(Continued).**

SN 85-111,299. APJ GROUP BR CO., DALLAS, TX. FILED 8-19-2010.



NO CLAIM IS MADE TO THE EXCLUSIVE RIGHT TO USE "COFFEE & SUGAR", APART FROM THE MARK AS SHOWN.

THE MARK CONSISTS OF AN OUTLINE OF THE PROFILE OF A BIRD ABOVE THE WORD "SOCÓ'S" WRITTEN ABOVE THE WORDS "COFFEE & SUGAR".

THE WORDING "SOCÓ'S" HAS NO MEANING IN A FOREIGN LANGUAGE.

FOR SUGAR; GRANULATED SUGAR FOR FOOD; CANDY FOR FOOD; COFFEE; UNROASTED COFFEE; GROUND COFFEE; INSTANT COFFEE; COFFEE BEANS (U.S. CL. 46).

MARTHA FROMM, EXAMINING ATTORNEY

SN 85-106,420. LIGA MASIVA, LTD., NEW YORK, NY. FILED 8-12-2010.

# Liga Masiva

THE MARK CONSISTS OF STANDARD CHARACTERS WITHOUT CLAIM TO ANY PARTICULAR FONT, STYLE, SIZE, OR COLOR.

THE ENGLISH TRANSLATION OF THE WORDS "LIGA MASIVA" IN THE MARK IS MASSIVE LEAGUE.

FOR (BASED ON USE IN COMMERCE) COFFEE (BASED ON INTENT TO USE) BEVERAGES WITH A CHOCOLATE BASE; CHOCOLATE AND CHOCOLATES; COFFEE AND TEA; COFFEE BASED BEVERAGES (U.S. CL. 46).

FIRST USE 12-1-2008; IN COMMERCE 3-13-2009.

C. DIONNE CLYBURN, EXAMINING ATTORNEY

SN 85-114,981. HAN, LEJING, DBA DUMPLING GIRL, SANTA MONICA, CA. FILED 8-24-2010.

# Dumpling Girl

THE MARK CONSISTS OF STANDARD CHARACTERS WITHOUT CLAIM TO ANY PARTICULAR FONT, STYLE, SIZE, OR COLOR.

NO CLAIM IS MADE TO THE EXCLUSIVE RIGHT TO USE "DUMPLING", APART FROM THE MARK AS SHOWN.

FOR CHINESE STEAMED DUMPLINGS (SHUMAI, COOKED); CHINESE STUFFED DUMPLINGS (GYOZA, COOKED); DUMPLINGS (U.S. CL. 46).

ANNE MADDEN, EXAMINING ATTORNEY

**CLASS 30—(Continued).**

SN 85-126,741. DULCES DE LECHE LA VAQUITA, S.A. DE C.V., SAN LUIS POTOSI, MEXICO, FILED 9-10-2010.

## TUENI CHUP

THE MARK CONSISTS OF STANDARD CHARACTERS WITHOUT CLAIM TO ANY PARTICULAR FONT, STYLE, SIZE, OR COLOR.

PRIORITY CLAIMED UNDER SEC. 44(D) ON MEXICO APPLICATION NO. 1118479, FILED 9-9-2010, REG. NO. 1187748, DATED 9-9-2010, EXPIRES 9-9-2020.

OWNER OF U.S. REG. NO. 3,274,705.

THE WORDING "TUENI CHUP" HAS NO MEANING IN A FOREIGN LANGUAGE.

FOR CONFECTIONERY, NAMELY, CANDIES, CARAMELS, CHOCOLATES, LOLLIPOPS AND CHEWING GUM (U.S. CL. 46).

DAVID I, EXAMINING ATTORNEY

SN 85-130,061. INCREDIBLE BREADS, LLC, NEW PORT RICHEY, FL. FILED 9-15-2010.



NO CLAIM IS MADE TO THE EXCLUSIVE RIGHT TO USE "BREAD", APART FROM THE MARK AS SHOWN.

THE MARK CONSISTS OF INTERLOCKING RINGS WHICH ARE A PLAY ON THE CELTIC CROSS CONTAINING A HEART. WITHIN THE HEART IS A SHAFT OF WHEAT. UNDERNEATH THAT IMAGERY ARE THE WORDS "INCREDIBLE" AND "BREAD" IN A CELTIC-INSPIRED FONT.

FOR BREAD; BREAD BASES; BREAD MIXES; FROZEN BREADS; FRUIT BREADS (U.S. CL. 46).

DOMINICK J. SALEMI, EXAMINING ATTORNEY

SN 85-131,540. GORRIS, MARK D., ST. LOUIS, MO. FILED 9-16-2010.

## SATISFACTIONS

THE MARK CONSISTS OF STANDARD CHARACTERS WITHOUT CLAIM TO ANY PARTICULAR FONT, STYLE, SIZE, OR COLOR.

FOR MULTIGRAIN-BASED SNACK FOOD CONTAINING CINNAMON (U.S. CL. 46).

DARRYL SPRUILL, EXAMINING ATTORNEY

**CLASS 30—(Continued).**

SN 85-137,039. OLÉ MEXICAN FOODS, INC., NORCROSS, GA. FILED 9-23-2010.



NO CLAIM IS MADE TO THE EXCLUSIVE RIGHT TO USE "HEALTHY HEART", APART FROM THE MARK AS SHOWN.

THE COLOR(S) RED, GOLD, WHITE, AND TAN IS/ARE CLAIMED AS A FEATURE OF THE MARK.

THE MARK CONSISTS OF AT THE TOP, A DRAWING OF A HEART IN RED WITH A TAN OUTLINE SURROUNDED BY A GOLD OUTLINE; IN THE MIDDLE ARE THE WORDS "HEALTHY HEART" IN WHITE WITH A GOLD OUTLINE; AND, AT THE BOTTOM IS THE WORD "LIFESTYLE" IN TAN WITH A GOLD OUTLINE.

FOR TORTILLAS (U.S. CL. 46).

FIRST USE 12-0-2007; IN COMMERCE 12-0-2007.

GEOFFREY FOSDICK, EXAMINING ATTORNEY

SN 85-137,880. PRODUCTOS ALIMENTICIOS Y DIETETICOS RELAMPAGO, S.A. DE C.V., COLONIA LA JOYA, MEXICO, FILED 9-24-2010.



OWNER OF U.S. REG. NOS. 1,940,178 AND 3,296,738.

THE COLOR(S) WHITE, BEIGE, RED, BROWN, SILVER, BLACK AND YELLOW IS/ARE CLAIMED AS A FEATURE OF THE MARK.

THE MARK CONSISTS OF THE WORDS "D'GARI" IN SPECIAL SCRIPT IN WHITE ON A RED BACKGROUND ENCLOSED A DRAWING OF THE HEAD OF A SMILING BOY WITH BROWN HAIR BLACK EYES, RED TONGUE, BEIGE SKIN. ANOTHER BOY, IN BEIGE, BROWN, BLACK, RED, AND YELLOW, HOLDING A SILVER SPOON AND A YELLOW, WHITE, AND BEIGE CUP. ALL SURROUNDED BY A WHITE SPLASH AND BEIGE COLORED CONE LIKE ENCLOSURE.

FOR FLAVORED AND SWEETENED GELATIN WITH MILK (U.S. CL. 46).

GRETTA YAO, EXAMINING ATTORNEY

**CLASS 30—(Continued).**

SN 85-138.001. PRODUCTOS ALIMENTICIOS Y DIETETICOS RELAMPAGO, S.A. DE C.V., COLONIA LA JOYA, MEXICO, FILED 9-24-2010.



OWNER OF U.S. REG. NOS. 1,940,178 AND 3,296,738.  
THE COLOR(S) WHITE, BEIGE, RED, BROWN, BLACK, YELLOW, AND BLUE IS/ARE CLAIMED AS A FEATURE OF THE MARK.

THE MARK CONSISTS OF THE WORDS "D'GARI" IN SPECIAL SCRIPT IN WHITE ON A RED BACKGROUND ENCLOSING A DRAWING OF THE HEAD OF A SMILING BOY WITH BROWN HAIR BLACK EYES, RED TONGUE, BEIGE SKIN, ON A BLUE AND WHITE CONE LIKE BACKGROUND. ANOTHER BOY, IN BEIGE, BROWN, BLACK, RED, YELLOW, AND BLUE, HOLDING A YELLOW AND WHITE CUP, WITH HIS THUMB UP, WITH BLUE CURVED LINES BEHIND HIM, ABOVE THE BLUE PORTION OF THE CONE DESIGN.

FOR RICE PUDDING (U.S. CL. 46).

GRETTA YAO, EXAMINING ATTORNEY

---

SN 85-138.050. PRODUCTOS ALIMENTICIOS Y DIETETICOS RELAMPAGO, S.A. DE C.V., COLONIA LA JOYA, MEXICO, FILED 9-24-2010.



OWNER OF U.S. REG. NOS. 1,940,178 AND 3,296,738.  
THE COLOR(S) SILVER, WHITE, BEIGE, RED, BROWN, BLACK, BLUE AND YELLOW IS/ARE CLAIMED AS A FEATURE OF THE MARK.

THE MARK CONSISTS OF THE WORDS "D'GARI" IN SPECIAL SCRIPT IN WHITE ON A RED BACKGROUND ENCLOSING A DRAWING OF THE HEAD OF A SMILING BOY WITH BROWN HAIR BLACK EYES, RED TONGUE, AND BEIGE SKIN, ON A BEIGE AND YELLOW CONE LIKE BACKGROUND. ANOTHER BOY, IN BEIGE, BROWN, BLACK, RED, YELLOW, AND BLUE, HOLDING A SILVER SPOON AND A YELLOW, RED, AND WHITE CUP, ABOVE THE YELLOW PORTION OF THE CONE DESIGN.

FOR CUSTARD (U.S. CL. 46).

GRETTA YAO, EXAMINING ATTORNEY

**CLASS 30—(Continued).**

SN 85-138.103. PRODUCTOS ALIMENTICIOS Y DIETETICOS RELAMPAGO, S.A. DE C.V., COLONIA LA JOYA, MEXICO, FILED 9-24-2010.



OWNER OF U.S. REG. NOS. 1,940,178 AND 3,296,738.

THE COLOR(S) SILVER, WHITE, BEIGE, RED, BROWN, BLACK, AND YELLOW IS/ARE CLAIMED AS A FEATURE OF THE MARK.

THE MARK CONSISTS OF THE WORDS "D'GARI" IN SPECIAL SCRIPT IN WHITE ON A RED BACKGROUND ENCLOSING A DRAWING OF THE HEAD OF A SMILING BOY WITH BROWN HAIR BLACK EYES, RED TONGUE, BEIGE SKIN, ON A BEIGE AND BROWN CONE LIKE BACKGROUND ANOTHER BOY, IN BEIGE, BROWN, BLACK, RED, YELLOW, AND BLUE, HOLDING A SILVER SPOON AND A YELLOW, RED, AND WHITE CUP, ABOVE THE BROWN PORTION OF THE CONE DESIGN.

FOR CUSTARD (U.S. CL. 46).

GRETTA YAO, EXAMINING ATTORNEY

---

SN 85-145.357. BESTTHORN LIMITED, MANCHESTER, UNITED KINGDOM, FILED 10-5-2010.

## A MAYO ZING

THE MARK CONSISTS OF STANDARD CHARACTERS WITHOUT CLAIM TO ANY PARTICULAR FONT, STYLE, SIZE, OR COLOR.

PRIORITY CLAIMED UNDER SEC. 44(D) ON ERPNTY TM OFC APPLICATION NO. 009316184, FILED 8-18-2010, REG. NO. 009315284, DATED 1-27-2011, EXPIRES 8-16-2020.

FOR MAYONNAISE, FLAVORED MAYONNAISE (U.S. CL. 46).

HENRY S. ZAK, EXAMINING ATTORNEY

**CLASS 30—(Continued).**

SN 85-149,875. IMAGE BRANDS INC., SAN DIEGO, CA. FILED 10-11-2010.

## Quiche Toppers

THE MARK CONSISTS OF STANDARD CHARACTERS WITHOUT CLAIM TO ANY PARTICULAR FONT, STYLE, SIZE, OR COLOR.

NO CLAIM IS MADE TO THE EXCLUSIVE RIGHT TO USE "QUICHE", APART FROM THE MARK AS SHOWN.

FOR QUICHE (U.S. CL. 46).

JANICE KIM, EXAMINING ATTORNEY

**CLASS 30—(Continued).**

SN 85-152,053. MCKEE FOODS KINGMAN, INC., KINGMAN, AZ. FILED 10-13-2010.

## TOTALLY MULTIGRAIN

THE MARK CONSISTS OF STANDARD CHARACTERS WITHOUT CLAIM TO ANY PARTICULAR FONT, STYLE, SIZE, OR COLOR.

NO CLAIM IS MADE TO THE EXCLUSIVE RIGHT TO USE "MULTIGRAIN", APART FROM THE MARK AS SHOWN.

FOR GRAIN-BASED SNACK BARS (U.S. CL. 46).

ANNE MADDEN, EXAMINING ATTORNEY

SN 85-150,137. OLÉ MEXICAN FOODS, INC., NORCROSS, GA. FILED 10-11-2010.



OWNER OF U.S. REG. NOS. 2,493,644 AND 3,476,298. NO CLAIM IS MADE TO THE EXCLUSIVE RIGHT TO USE "FIBER", APART FROM THE MARK AS SHOWN.

THE COLOR(S) YELLOW, RED, WHITE AND DARK RED IS/ARE CLAIMED AS A FEATURE OF THE MARK.

THE MARK CONSISTS OF THE PHRASE "XTREME! FIBER" IN YELLOW LETTERS ON A RED BACKGROUND WITH A DARK RED OUTLINE AROUND THE LETTERS AND A WHITE OUTLINE AND DARK RED OUTLINE AROUND THE BACKGROUND.

FOR TORTILLAS (U.S. CL. 46).

FIRST USE 2-0-2008; IN COMMERCE 2-0-2008.

AISHA CLARKE, EXAMINING ATTORNEY

SN 85-154,861. ATLANTIC HILL CONSTRUCTION INC., MILTON, MA. FILED 10-18-2010.

## Bent's Cookie Factory

THE MARK CONSISTS OF STANDARD CHARACTERS WITHOUT CLAIM TO ANY PARTICULAR FONT, STYLE, SIZE, OR COLOR.

NO CLAIM IS MADE TO THE EXCLUSIVE RIGHT TO USE "COOKIE FACTORY", APART FROM THE MARK AS SHOWN.

SEC. 2(F).

FOR BAKED GOODS, NAMELY, COOKIES AND CRACKERS, MUFFINS SCONES COFFEE CAKES BROWNIES, CONGOS, TURNOVERS LOAF CAKES, BREADS, PIES, HALF MOONS CUPCAKES, LEMON SQUARES, FIG SQUARES, COOKED BEANS, COOKIE DOUGH (U.S. CL. 46).

FIRST USE 0-0-1801; IN COMMERCE 0-0-1801.

DOMINICK J. SALEMI, EXAMINING ATTORNEY

SN 85-150,538. PUEBLO INC., GUAYNABO, PUERTO RICO, FILED 10-12-2010.

# PUEBLO

THE MARK CONSISTS OF STANDARD CHARACTERS WITHOUT CLAIM TO ANY PARTICULAR FONT, STYLE, SIZE, OR COLOR.

OWNER OF U.S. REG. NOS. 1,997,786, 2,455,009 AND 3,768,051.

THE ENGLISH TRANSLATION OF "PUEBLO" IN THE MARK IS "TOWN", "VILLAGE".

FOR CANDIES; CANDY BARS; COFFEE; CONDIMENT, NAMELY, PEPPER SAUCE; COOKIES; CORN FLOUR; CRACKERS; FLAVOURINGS OF ALMOND; HONEY; MEAT TURNOVERS; RICE; RICE FLOUR; SESAME STICKS; TOMATO SAUCE (U.S. CL. 46).

FIRST USE 11-14-2009; IN COMMERCE 11-14-2009.

GILBERT SWIFT, EXAMINING ATTORNEY

SN 85-156,703. ZARDAIN, EDUARDO ALVAREZ, VERACRUZ, MEXICO, FILED 10-20-2010.



THE COLOR(S) WHITE, BROWN, RED AND ORANGE IS/ARE CLAIMED AS A FEATURE OF THE MARK.

THE MARK CONSISTS OF AN ANTIQUE MAP OF THE WORLD WITH THE WORDS "IL MONDO" IN WHITE ON A BROWN, REDDISH AND ORANGE BACKGROUND.

THE ENGLISH TRANSLATION OF THE WORD "IL MONDO" IN THE MARK IS THE WORLD.

FOR COFFEE, NAMELY, ROASTED COFFEE BEANS, ROASTED AND GROUND COFFEE, SOLUBLE COFFEE (U.S. CL. 46).

NAKWAMA ANKRAH, EXAMINING ATTORNEY

**CLASS 30—(Continued).**

SN 85-161,888. FIORINA, STACEY, HAWTHORNE, NJ.  
FILED 10-26-2010.



NO CLAIM IS MADE TO THE EXCLUSIVE RIGHT TO USE "BLACK TEA", "TEA", AND "RASPBERRY JUICE", APART FROM THE MARK AS SHOWN.

THE MARK CONSISTS OF THE WORDS "TEA" AND "JU" SEPARATED BY DESIGN OF TWO DROPS. ABOVE ARE THE WORDS "BLACK TEA", AND BELOW ARE THE WORDS "RASPBERRY JUICE". ALL SURROUNDED BY A CIRCLE FRAMED BY A DECORATIVE BORDER.

THE WORD(S) "JU" HAS NO MEANING IN A FOREIGN LANGUAGE.

FOR TEA-BASED BEVERAGES (U.S. CL. 46).  
GRETTA YAO, EXAMINING ATTORNEY

**CLASS 30—(Continued).**

SN 85-166,810. PBM PRODUCTS, LLC, GORDONSVILLE, VA.  
FILED 11-2-2010.

**BANANA BITERS**

THE MARK CONSISTS OF STANDARD CHARACTERS WITHOUT CLAIM TO ANY PARTICULAR FONT, STYLE, SIZE, OR COLOR.

NO CLAIM IS MADE TO THE EXCLUSIVE RIGHT TO USE "BANANA", APART FROM THE MARK AS SHOWN.

FOR BISCUITS (U.S. CL. 46).  
SKYE YOUNG, EXAMINING ATTORNEY

SN 85-166,815. PBM PRODUCTS, LLC, GORDONSVILLE, VA.  
FILED 11-2-2010.

**PANDA GRAHAMS**

THE MARK CONSISTS OF STANDARD CHARACTERS WITHOUT CLAIM TO ANY PARTICULAR FONT, STYLE, SIZE, OR COLOR.

NO CLAIM IS MADE TO THE EXCLUSIVE RIGHT TO USE "GRAHAMS", APART FROM THE MARK AS SHOWN.

FOR COOKIES AND CRACKERS (U.S. CL. 46).  
SKYE YOUNG, EXAMINING ATTORNEY

SN 85-166,579. OILNOIL,LLC, CHICAGO, IL. FILED 11-1-2010.



OWNER OF U.S. REG. NO. 3,824,231.

NO CLAIM IS MADE TO THE EXCLUSIVE RIGHT TO USE "PREMIO AUTENTICO", APART FROM THE MARK AS SHOWN.

THE COLOR(S) RED, WHITE, GOLD, BLACK, AND GREEN IS/ARE CLAIMED AS A FEATURE OF THE MARK.

THE MARK CONSISTS OF A RED OVAL WITH GOLD, WHITE, AND BLACK TRIM; A GOLD CREST IS IN THE CENTER BOTTOM OF THE OVAL WITH GREEN LEAVES UNDER THE OVAL; THE STYLIZED WORDING "VIOLI" IS WHITE WITH BLACK OUTLINE; THE WORDING "PREMIO AUTENTICO" IS IN BLACK.

THE ENGLISH TRANSLATION OF THE WORDS "PREMIO AUTENTICO" IN THE MARK IS PREMIUM AUTHENTIC.

FOR CHUTNEYS; DIPPING SAUCES; DRIED PASTA; PASTA AND NOODLES; PASTA SAUCE; SALAD DRESSINGS; SEA SALT FOR COOKING; SPAGHETTI; TOMATO SAUCE; VINEGAR; WINE VINEGAR (U.S. CL. 46).  
KEVIN CORWIN, EXAMINING ATTORNEY

SN 85-171,413. SOKOL AND COMPANY, COUNTRYSIDE, IL. FILED 11-8-2010.



THE MARK CONSISTS OF A HUMANLIKE CHARACTER IN AN OVERALL CIRCULAR SHAPE WITH LARGE EYES, EYEBROWS, NOSE, SMILING MOUTH AND OUT-STRETCHED HANDS.

FOR MIXES FOR BAKERY GOODS (U.S. CL. 46).  
FIRST USE 9-1-2010; IN COMMERCE 9-1-2010.  
GENE MACIOL, EXAMINING ATTORNEY

**CLASS 30—(Continued).**

SN 85-175,661. MAIN ST. HOLDINGS, LLC, PLATTE CITY, MO. FILED 11-12-2010.

**GRANDMA'S HOUSE**

THE MARK CONSISTS OF STANDARD CHARACTERS WITHOUT CLAIM TO ANY PARTICULAR FONT, STYLE, SIZE, OR COLOR.

FOR BAKERY GOODS, BASES FOR BAKERY GOODS, MIXES FOR BAKERY GOODS, UNCOOKED, PREPARED BAKERY GOODS (U.S. CL. 46).

FIRST USE 9-24-2010; IN COMMERCE 9-24-2010.  
HOWARD B. LEVINE, EXAMINING ATTORNEY

**CLASS 30—(Continued).**

SN 85-178,713. RANKINE, DENNIS, HASTINGS, MN. FILED 11-17-2010.

**DR. MIKE'S ORIGINAL JERK CATSUP**

THE MARK CONSISTS OF STANDARD CHARACTERS WITHOUT CLAIM TO ANY PARTICULAR FONT, STYLE, SIZE, OR COLOR.

NO CLAIM IS MADE TO THE EXCLUSIVE RIGHT TO USE "ORIGINAL JERK CATSUP", APART FROM THE MARK AS SHOWN.

FOR SAUCES AND FOOD CONDIMENTS, SPECIFICALLY JERK FLAVORED KETCHUP (U.S. CL. 46).

JEFFREY LOOK, EXAMINING ATTORNEY

SN 85-178,307. KINETIX LIVING CORP., SEATTLE, WA. FILED 11-16-2010.



THE MARK CONSISTS OF A STYLIZED DESIGN OF THE CAPITAL LETTER "K" FOLLOWED BY A LOWER CASE "X" WITHIN A SQUARE SHAPED DESIGN FOLLOWED BY THE WORD "KINETIX" IN CAPITAL LETTERING WITH THE ENTIRE MARK APPEARING IN A RECTANGLE SHAPED DESIGN.

FOR READY-TO-EAT CEREAL DERIVED FOOD BARS; GRANOLA SNACK BARS; CEREAL-BASED SNACK FOODS; PACKAGED MEALS CONSISTING PRIMARILY OF PASTA OR RICE (U.S. CL. 46).  
SANI KHOURI, EXAMINING ATTORNEY

SN 85-178,951. SPICE JUNGLE, LLC, GRAND RAPIDS, MI. FILED 11-17-2010.

SN 85-178,311. KINETIX LIVING CORP., SEATTLE, WA. FILED 11-16-2010.

**SPICE JUNGLE**

THE MARK CONSISTS OF STANDARD CHARACTERS WITHOUT CLAIM TO ANY PARTICULAR FONT, STYLE, SIZE, OR COLOR.

FOR BAKING POWDERS; BAKING SPICES; COFFEE AND TEA; COOKING SALT; EDIBLE SALT; EDIBLE SPICES; EXTRACTS USED AS FLAVORING; FLAVORINGS; FLAVOURINGS; FLAVOURINGS; FOOD FLAVOURINGS; SALT; SEA SALT FOR COOKING; SEASONING MIXES; SEASONING PASTES; SEASONINGS; SPICE BLENDS; SPICES; SUGAR AND SUGAR SUBSTITUTES; VANILLA; VANILLA BEANS; VANILLA FLAVORINGS (U.S. CL. 46).

FIRST USE 2-1-2006; IN COMMERCE 10-28-2009.  
JAMES STEIN, EXAMINING ATTORNEY

THE MARK CONSISTS OF A STYLIZED DESIGN OF THE CAPITAL LETTER "K" FOLLOWED BY A LOWER CASE "X" ALL WITHIN A SQUARE SHAPED DESIGN.

FOR READY-TO-EAT CEREAL DERIVED FOOD BARS; GRANOLA SNACK BARS; CEREAL-BASED SNACK FOODS; PACKAGED MEALS CONSISTING PRIMARILY OF PASTA OR RICE (U.S. CL. 46).

SANI KHOURI, EXAMINING ATTORNEY

**CLASS 30—(Continued).**

SN 85-180,675. ADMINISTRADORA DE MARCAS LICENCIAS Y DISEÑOS S.A. DE C.V., GUADALAJARA, JALISCO, MEXICO, FILED 11-19-2010.



OWNER OF U.S. REG. NOS. 1,902,902, 3,452,315 AND OTHERS.

THE COLOR(S) RED, YELLOW, BROWN, WHITE, ORANGE AND GREEN IS/ARE CLAIMED AS A FEATURE OF THE MARK.

THE MARK CONSISTS OF A DESIGN WITH RED BORDERS ON THE RIGHT AND LEFT SIDES, A YELLOW BACKGROUND IN THE MIDDLE AND THE DESIGN OF A YELLOW BLAZING SUN IN THE MIDDLE OF WHICH APPEARS THE WORD "PULPARINROKS" IN BROWN LETTERS WITH WHITE AND RED OUTLINES. THERE IS THE DESIGN OF AN ORANGE FIGURE WITH GREEN PUPILS WEARING A RED BASEBALL CAP WITH A GREEN BRIM AND GREEN SANDALS IN A RED CIRCLE ABOVE THE LETTERS "PULP" AND A SQUARE DESIGN WITH A RED OUTER BORDER THE DESIGN OF A RED ROSE WITH GREEN PETALS AND THE WORDS "DE LA ROSA" ABOVE THE LETTERS "OKS".

THE ENGLISH TRANSLATION OF "DE LA ROSA" IN THE MARK IS OF THE ROSE.

FOR CANDY, CHOCOLATE, CHEWING GUM AND CONFECTIONERY MADE OF SUGAR (U.S. CL. 46).

JILL PRATER, EXAMINING ATTORNEY

SN 85-184,981. IMPERIAL TEAS (PVT) LTD, KELANIYA, SRI LANKA, FILED 11-24-2010.

# MIAD

THE MARK CONSISTS OF STANDARD CHARACTERS WITHOUT CLAIM TO ANY PARTICULAR FONT, STYLE, SIZE, OR COLOR.

FOR TEA AND TEA BASED PRODUCTS, NAMELY, MIXES IN THE NATURE OF CONCENTRATES, SYRUPS, GRANULES AND POWDERS (U.S. CL. 46).

FIRST USE 5-12-1995; IN COMMERCE 7-9-2010.

AISHA CLARKE, EXAMINING ATTORNEY

**CLASS 30—(Continued).**

SN 85-185,107. BENCHMARK FOODS, LLC, STUDIO CITY, CA. FILED 11-24-2010.

# SWEET ABANDON

THE MARK CONSISTS OF STANDARD CHARACTERS WITHOUT CLAIM TO ANY PARTICULAR FONT, STYLE, SIZE, OR COLOR.

OWNER OF U.S. REG. NO. 2,909,137.

NO CLAIM IS MADE TO THE EXCLUSIVE RIGHT TO USE "SWEET", APART FROM THE MARK AS SHOWN.

FOR CAKES (U.S. CL. 46).

SIMON TENG, EXAMINING ATTORNEY

SN 85-186,570. KEENAN, LAURA, LA QUINTA, CA. FILED 11-29-2010.



NO CLAIM IS MADE TO THE EXCLUSIVE RIGHT TO USE "PALEO", APART FROM THE MARK AS SHOWN.

THE MARK CONSISTS OF A RECTANGLE WITH "PALEO" ACROSS THE TOP AND "PEOPLE" RUNNING VERTICALLY DOWN THE LEFT SIDE. THERE ARE 2 IMAGES – ONE OF A MAN IN FRONT AND ONE OF A LADY IN BACK OF THE MAN. THE BACKGROUND IS TEXTURED LIKE A CAVE WALL.

FOR COOKIES; GRANOLA; GRANOLA SNACKS (U.S. CL. 46).

TOBY BULLOFF, EXAMINING ATTORNEY

SN 85-187,189. CHOCOMAKER, INC., BUFFALO, NY. FILED 11-30-2010.

# SIMPLY MELT

THE MARK CONSISTS OF STANDARD CHARACTERS WITHOUT CLAIM TO ANY PARTICULAR FONT, STYLE, SIZE, OR COLOR.

NO CLAIM IS MADE TO THE EXCLUSIVE RIGHT TO USE "MELT", APART FROM THE MARK AS SHOWN.

FOR CHOCOLATE (U.S. CL. 46).

FIRST USE 10-15-2010; IN COMMERCE 10-15-2010.

SANDRA BUJA, EXAMINING ATTORNEY

**CLASS 30—(Continued).**

SN 85-187,294. ED'S RED, INCORPORATED, PORT ST. JOE, FL. FILED 11-30-2010.

## ED'S RED

THE MARK CONSISTS OF STANDARD CHARACTERS WITHOUT CLAIM TO ANY PARTICULAR FONT, STYLE, SIZE, OR COLOR.

NO CLAIM IS MADE TO THE EXCLUSIVE RIGHT TO USE "RED", APART FROM THE MARK AS SHOWN. FOR HOT SAUCE; SAUCES (U.S. CL. 46). FIRST USE 1-1-2000; IN COMMERCE 1-1-2000. SANDRA BUJA, EXAMINING ATTORNEY

SN 85-187,456. CJ GROUP LTD, TUCKER, GA. FILED 11-30-2010.

## SEQUOIA FREEZE POPS

THE MARK CONSISTS OF STANDARD CHARACTERS WITHOUT CLAIM TO ANY PARTICULAR FONT, STYLE, SIZE, OR COLOR.

NO CLAIM IS MADE TO THE EXCLUSIVE RIGHT TO USE "FREEZE POPS", APART FROM THE MARK AS SHOWN.

FOR FROZEN CONFECTIONS, NAMELY, FREEZER POPS (U.S. CL. 46). DORITT L. CARROLL, EXAMINING ATTORNEY

SN 85-188,185. AMERICAN SKIN FOOD GROUP, LLC, BURGAW, NC. FILED 12-1-2010.

## GRANDMA LUCY'S

THE MARK CONSISTS OF STANDARD CHARACTERS WITHOUT CLAIM TO ANY PARTICULAR FONT, STYLE, SIZE, OR COLOR.

THE NAME "GRANDMA LUCY" DOES NOT IDENTIFY A LIVING INDIVIDUAL. FOR CORN BREAD MIX WITH PORK CRACKLINS ADDED INTO THE MIX (U.S. CL. 46).

FIRST USE 11-12-2004; IN COMMERCE 11-12-2004. MICHAEL GAAFAR, EXAMINING ATTORNEY

**CLASS 30—(Continued).**

SN 85-188,508. STAR KAY WHITE, INC., CONGERS, NY. FILED 12-1-2010.

## CAPPUCCINO BAMBINO

THE MARK CONSISTS OF STANDARD CHARACTERS WITHOUT CLAIM TO ANY PARTICULAR FONT, STYLE, SIZE, OR COLOR.

NO CLAIM IS MADE TO THE EXCLUSIVE RIGHT TO USE "CAPPUCCINO", APART FROM THE MARK AS SHOWN.

FOR CANDIES; CHOCOLATE CANDIES (U.S. CL. 46). FIRST USE 10-2-2009; IN COMMERCE 10-2-2009. CIMMERIAN COLEMAN, EXAMINING ATTORNEY

SN 85-188,743. LUNASOL SALSA LLC, HOUSTON, TX. FILED 12-1-2010.

## LunaSol

THE MARK CONSISTS OF STANDARD CHARACTERS WITHOUT CLAIM TO ANY PARTICULAR FONT, STYLE, SIZE, OR COLOR.

THE ENGLISH TRANSLATION OF "LUNA" IN THE MARK IS "MOON" AND THE ENGLISH TRANSLATION OF "SOL" IN THE MARK IS "SUN."

FOR HOT SAUCE (U.S. CL. 46). LINDA LAVACHE, EXAMINING ATTORNEY

SN 85-188,866. INTERSTATE CATERERS, INC, SOUTH PLAINFIELD, NJ. FILED 12-2-2010.



THE MARK CONSISTS OF A CARTOON CHARACTER IN THE FORM OF A TURNOVER OR EMPANADA WEARING A HAT WITH THE STYLIZED WORD "TASTEE'S" ON IT.

FOR MEAT TURNOVERS; SEAFOOD TURNOVERS; EMPANADAS; ALL THE FOREGOING NOT RELATING TO SPORTS OR A SPORTS TEAM (U.S. CL. 46).

KATHLEEN LORENZO, EXAMINING ATTORNEY



**CLASS 30—(Continued).**

SN 85-189,170. CADARETTE, STEPHEN, BERNARDSTON, MA. FILED 12-2-2010.



NO CLAIM IS MADE TO THE EXCLUSIVE RIGHT TO USE "FRANKS", APART FROM THE MARK AS SHOWN.

THE MARK CONSISTS OF A DRAWING PORTION OF THE MARK, WHICH IS A PERSONIFIED CARTOON IMAGE OF A HOTDOG PLACED AS THE DRIVER IN A WHEELED VEHICLE COMPRISING A HOTDOG ROLL. THE HOTDOG DRIVER IS SQUEEZING A CONTAINER WHICH APPEARS TO BE DISPENSING A CONDIMENT ONTO THE HOTDOG. THE WORDS "FAST FRANKS" ARE ABOVE THE DESIGN IN UPPER CASE LETTERS ARRANGED IN AN ARC.

FOR HOT DOG SANDWICHES (U.S. CL. 46).  
KATHLEEN LORENZO, EXAMINING ATTORNEY

SN 85-189,213. BOGAN, COLLEEN, WATERVILLE, NY. AND BOGAN, BRIAN, WATERVILLE, NY. FILED 12-2-2010.



NO CLAIM IS MADE TO THE EXCLUSIVE RIGHT TO USE "COOKIES", APART FROM THE MARK AS SHOWN.

THE MARK CONSISTS OF A SHAMROCK FORMING THE UNDERSIDE OF THE "H" IN THE WORD "IRISH". THE "I" IS IN THE FORM OF AN IRISH SHILLELEIGH. THE WORD "COOKIES" IS TYPED IN WORD ART. THE WORDS "IRISH DREAMS COOKIES" ARE SET AT A 45 DEGREE ANGLE.

FOR COOKIE MIXES; COOKIES (U.S. CL. 46).  
FIRST USE 8-23-2010; IN COMMERCE 8-23-2010.  
JOHN WILKE, EXAMINING ATTORNEY

**CLASS 30—(Continued).**

SN 85-189,558. BRAAAP ENERGY, LLC, FORT COLLINS, CO. FILED 12-2-2010.

# BRAAAP

THE MARK CONSISTS OF STANDARD CHARACTERS WITHOUT CLAIM TO ANY PARTICULAR FONT, STYLE, SIZE, OR COLOR.

FOR CEREAL BASED ENERGY BARS (U.S. CL. 46).  
ALYSSA STEEL, EXAMINING ATTORNEY

SN 85-189,750. GIMBAL BROTHERS, INC., SOUTH SAN FRANCISCO, CA. FILED 12-2-2010.



OWNER OF U.S. REG. NOS. 3,684,347, 3,806,083 AND 3,872,534.

NO CLAIM IS MADE TO THE EXCLUSIVE RIGHT TO USE "SOUR", APART FROM THE MARK AS SHOWN.

THE STIPPLING IS A FEATURE OF THE MARK AND DOES NOT INDICATE COLOR; THE STIPPLING IS FOR SHADING PURPOSES ONLY.

THE MARK CONSISTS OF THE WORDS "SOUR" AND "LOVERS" IN A HOLLOW LETTER FONT, THE WORD "SOUR" ABOVE THE WORD "LOVERS", BOTH WORDS AT AN UPWARD ANGLE FROM LEFT TO RIGHT.

FOR CANDY (U.S. CL. 46).  
FIRST USE 11-23-2010; IN COMMERCE 11-23-2010.  
BARNEY CHARLON, EXAMINING ATTORNEY

SN 85-190,122. PERU FOOD IMPORTS, INC., WEST NEW YORK, NY. FILED 12-3-2010.



OWNER OF U.S. REG. NOS. 3,150,334, 3,152,500 AND 3,254,498.

NO CLAIM IS MADE TO THE EXCLUSIVE RIGHT TO USE "PERU FOOD", APART FROM THE MARK AS SHOWN.

THE COLOR(S) RED, WHITE, ORANGE, BLACK, GREEN IS/ARE CLAIMED AS A FEATURE OF THE MARK.

THE MARK CONSISTS OF THE WORDING "PERU FOOD" IN WHITE WITH BLACK SHADING INSIDE A

**CLASS 30—(Continued).**

RED BANNER WITH BLACK AND WHITE OUTLINING. ABOVE THE WORDING IS A PARALLELOGRAM WITH A BLACK OUTLINE INSIDE OF WHICH APPEARS A GREEN BODY OF WATER IN FRONT OF A GREEN MOUNTAIN WITH AN ORANGE SUNSET. BELOW THE BANNER IS THE WORDING "UNIVERSAL" IN RED WITH BLACK SHADING. ALL OF THE FOREGOING APPEARS ON TOP OF A BACKGROUND CONSISTING OF VERTICAL RED STRIPES TO THE RIGHT AND LEFT OF THE MARK WITH A VERTICAL WHITE STRIPE IN THE CENTER.

FOR FRUIT JELLIES; MAIZE-BASED PUDDING DESERT (MAZAMORRA MORADA) (U.S. CL. 46).  
RONALD MCMORROW, EXAMINING ATTORNEY

---

SN 85-190,291. LAURENCE AFRIAT, DOLLARD-DES-OR-MEAUX, CANADA, FILED 12-3-2010.

**THE MAGIC MUFFIN DIET**

THE MARK CONSISTS OF STANDARD CHARACTERS WITHOUT CLAIM TO ANY PARTICULAR FONT, STYLE, SIZE, OR COLOR.

NO CLAIM IS MADE TO THE EXCLUSIVE RIGHT TO USE "MUFFIN DIET", APART FROM THE MARK AS SHOWN.

FOR BAKERY GOODS, BAKERY PRODUCTS AND MUFFINS FOR USE IN WEIGHT LOSS BUT NOT FOR MEDICAL PURPOSES (U.S. CL. 46).

CHARLOTTE CORWIN, EXAMINING ATTORNEY

---

SN 85-190,504. VALENTE, PAUL, LOUDONVILLE, NY. FILED 12-3-2010.

**Three Little Pigs Macaroni  
& Cheese**

THE MARK CONSISTS OF STANDARD CHARACTERS WITHOUT CLAIM TO ANY PARTICULAR FONT, STYLE, SIZE, OR COLOR.

NO CLAIM IS MADE TO THE EXCLUSIVE RIGHT TO USE "MACARONI & CHEESE", APART FROM THE MARK AS SHOWN.

FOR MACARONI AND CHEESE MADE WITH THREE DIFFERENT TYPES OF PORK (U.S. CL. 46).

FIRST USE 4-20-2010; IN COMMERCE 4-20-2010.  
JUDITH HELFMAN, EXAMINING ATTORNEY

**CLASS 30—(Continued).**

SN 85-190,972. JAZZYBIRD CAFE, INC., GEISMAR, LA. FILED 12-6-2010.

**JAZZYBIRD COFFEE**

THE MARK CONSISTS OF STANDARD CHARACTERS WITHOUT CLAIM TO ANY PARTICULAR FONT, STYLE, SIZE, OR COLOR.

NO CLAIM IS MADE TO THE EXCLUSIVE RIGHT TO USE "COFFEE", APART FROM THE MARK AS SHOWN.

FOR COFFEE; TEA; FROZEN ESPRESSO SHOTS, NAMELY, FROZEN CONCENTRATES FOR MAKING ESPRESSO DRINKS; LIQUID CONCENTRATES FOR MAKING COFFEE; LIQUID CONCENTRATES FOR MAKING ESPRESSO DRINKS (U.S. CL. 46).

FIRST USE 12-0-2007; IN COMMERCE 5-14-2009.  
KATHERINE CHANG, EXAMINING ATTORNEY

---

SN 85-190,982. ORGANIC NECTARS, MALDEN, NY. FILED 12-6-2010.

**PalmSweet**

THE MARK CONSISTS OF STANDARD CHARACTERS WITHOUT CLAIM TO ANY PARTICULAR FONT, STYLE, SIZE, OR COLOR.

FOR NATURAL SWEETENER (U.S. CL. 46).

FIRST USE 12-5-2010; IN COMMERCE 12-5-2010.  
ALICE BENMAMAN, EXAMINING ATTORNEY

---

SN 85-191,710. QUARRY, ADRIENNE, SHERMAN OAKS, CA. FILED 12-6-2010.

**Tiny Tots Teething Pops**

THE MARK CONSISTS OF STANDARD CHARACTERS WITHOUT CLAIM TO ANY PARTICULAR FONT, STYLE, SIZE, OR COLOR.

NO CLAIM IS MADE TO THE EXCLUSIVE RIGHT TO USE "TEETHING POPS", APART FROM THE MARK AS SHOWN.

FOR FROZEN CONFECTIONS, NAMELY, FREEZER POPS (U.S. CL. 46).

MELISSA VALLILLO, EXAMINING ATTORNEY

**CLASS 30—(Continued).**

SN 85-191,896. TACUPETO CHIPS & SALSA INC., CARLSBAD, CA. FILED 12-7-2010.

**TACUPETO CHIPS & SALSA**

THE MARK CONSISTS OF STANDARD CHARACTERS WITHOUT CLAIM TO ANY PARTICULAR FONT, STYLE, SIZE, OR COLOR.

OWNER OF U.S. REG. NO. 3,685,633.

NO CLAIM IS MADE TO THE EXCLUSIVE RIGHT TO USE "CHIPS & SALSA", APART FROM THE MARK AS SHOWN.

FOR SALSA; TORTILLA CHIPS (U.S. CL. 46).

FIRST USE 6-0-2005; IN COMMERCE 6-0-2005.

HOWARD B. LEVINE, EXAMINING ATTORNEY

**CLASS 30—(Continued).**

SN 85-192,296. PIZZA HUT, INC., DALLAS, TX. FILED 12-7-2010.

**UNSTOPPABLE TOPPABLE  
STUFFED CRUST**

THE MARK CONSISTS OF STANDARD CHARACTERS WITHOUT CLAIM TO ANY PARTICULAR FONT, STYLE, SIZE, OR COLOR.

NO CLAIM IS MADE TO THE EXCLUSIVE RIGHT TO USE "STUFFED CRUST", APART FROM THE MARK AS SHOWN.

FOR PIZZA FOR CONSUMPTION ON OR OFF THE PREMISES (U.S. CL. 46).

COURTNEY ALVAREZ, EXAMINING ATTORNEY

SN 85-192,872. ENTERTAINMENT PUBLICATIONS LLC, TROY, MI. FILED 12-8-2010.

**CLASSIC RECIPES**

THE MARK CONSISTS OF STANDARD CHARACTERS WITHOUT CLAIM TO ANY PARTICULAR FONT, STYLE, SIZE, OR COLOR.

OWNER OF U.S. REG. NO. 3,259,577.

NO CLAIM IS MADE TO THE EXCLUSIVE RIGHT TO USE "RECIPES", APART FROM THE MARK AS SHOWN.

FOR COOKIE DOUGH (U.S. CL. 46).

FIRST USE 6-1-2006; IN COMMERCE 6-1-2006.

TEJBIR SINGH, EXAMINING ATTORNEY

SN 85-192,884. THE SAUCE MASTERS LLC, KANSAS CITY, MO. FILED 12-8-2010.



NO CLAIM IS MADE TO THE EXCLUSIVE RIGHT TO USE "WING SAUCE", APART FROM THE MARK AS SHOWN.

THE COLOR(S) RED, YELLOW, ORANGE AND BLACK IS/ARE CLAIMED AS A FEATURE OF THE MARK.

THE MARK CONSISTS OF STYLIZED WORDS "PARTY FOWL" COMPRISED OF COLORS FADING FROM TOP TO BOTTOM IN RED TO ORANGE THEN YELLOW AND OUTLINED IN BLACK. THE WORDS "WING SAUCE" APPEAR IN STYLIZED SOLID BLACK LETTERS.

FOR CHICKEN WING SAUCE (U.S. CL. 46).

SKYE YOUNG, EXAMINING ATTORNEY

SN 85-192,099. ALONSO RODRIGUEZ, JOSE DE JESUS, CHIHUAHUA, MEXICO, FILED 12-7-2010.



NO CLAIM IS MADE TO THE EXCLUSIVE RIGHT TO USE "SUPER", APART FROM THE MARK AS SHOWN.

THE COLOR(S) BLACK, WHITE, BLUE, YELLOW, PURPLE, PINK, RED, AND BROWN IS/ARE CLAIMED AS A FEATURE OF THE MARK.

THE MARK CONSISTS OF STYLISTIC PICTURE OF THE UPPER BODY AND HEAD OF A WHITE POLAR BEAR OUTLINED IN BLACK WITH BLACK NOSE, EYES, AND MOUTH WITH RED TONGUE; WEARING A LIGHT BLUE SCARF CONTAINING STYLISTIC PURPLE AND YELLOW ICE CREAM CONE DESIGNS; HOLDING AN ICE CREAM CONE WITH PURPLE AND PINK ICE CREAM AND A BROWN CONE; ABOVE AN OBLONG SHAPE OUTLINED IN DARK BLUE WITH A WHITE BACKGROUND, CONTAINING THE WORD, "SUPER", IN DARK BLUE OUTLINE LETTERS; NEXT TO A LARGE VERSION OF THE PURPLE AND YELLOW ICE CREAM CONE DESIGN AS FOUND ON THE SCARF; NEXT TO THE WORD, "COLDY", IN DARK BLUE OUTLINE LETTERS.

FOR EDIBLE ICES; ICE-CREAM; SHERBET; SORBETS (U.S. CL. 46).

ELLEN PERKINS, EXAMINING ATTORNEY

**CLASS 30—(Continued).**

SN 85-195,807. TABLE DE FRANCE, DBA MICHEL DE FRANCE, ONTARIO, CA. FILED 12-11-2010.

# NORIGAMI

THE MARK CONSISTS OF STANDARD CHARACTERS WITHOUT CLAIM TO ANY PARTICULAR FONT, STYLE, SIZE, OR COLOR.  
FOR FOOD PRODUCT IN THE NATURE OF SOY WRAPS (U.S. CL. 46).  
MIDGE BUTLER, EXAMINING ATTORNEY

---

SN 85-199,551. ENCORE SPECIALTY FOODS, LLC, HINGHAM, MA. FILED 12-16-2010.

# Domaine des Vignes

THE MARK CONSISTS OF STANDARD CHARACTERS WITHOUT CLAIM TO ANY PARTICULAR FONT, STYLE, SIZE, OR COLOR.  
OWNER OF U.S. REG. NOS. 3,018,754 AND 3,383,431.  
THE ENGLISH TRANSLATION OF "DOMAINE DES VIGNES" IN THE MARK IS "PROPERTY OF THE VINES".  
FOR MUSTARD (U.S. CL. 46).  
FIRST USE 1-8-2010; IN COMMERCE 1-8-2010.  
KHANH LE, EXAMINING ATTORNEY

---

SN 85-202,506. WELLS ENTERPRISES, INC., LE MARS, IA. FILED 12-21-2010.

# FRUIT SMOOTHERS

THE MARK CONSISTS OF STANDARD CHARACTERS WITHOUT CLAIM TO ANY PARTICULAR FONT, STYLE, SIZE, OR COLOR.  
NO CLAIM IS MADE TO THE EXCLUSIVE RIGHT TO USE "FRUIT", APART FROM THE MARK AS SHOWN.  
FOR FROZEN CONFECTIONS (U.S. CL. 46).  
BRIAN PINO, EXAMINING ATTORNEY

**CLASS 30—(Continued).**

SN 85-203,899. U.S. RESTAURANTS CORPORATION, ARDEN HILLS, MN. FILED 12-22-2010.

# GREEN MILL

THE MARK CONSISTS OF STANDARD CHARACTERS WITHOUT CLAIM TO ANY PARTICULAR FONT, STYLE, SIZE, OR COLOR.  
OWNER OF U.S. REG. NOS. 1,440,264, 2,919,979 AND OTHERS.  
FOR FROZEN PIZZA (U.S. CL. 46).  
FIRST USE 7-0-2008; IN COMMERCE 7-0-2008.  
LANA PHAM, EXAMINING ATTORNEY

---

SN 85-204,453. GO FAST SPORTS & BEVERAGE COMPANY, DENVER, CO. FILED 12-22-2010.

# GF7

THE MARK CONSISTS OF STANDARD CHARACTERS WITHOUT CLAIM TO ANY PARTICULAR FONT, STYLE, SIZE, OR COLOR.  
OWNER OF U.S. REG. NOS. 2,929,528, 3,640,651 AND OTHERS.  
FOR CHEWING GUM (U.S. CL. 46).  
LINDA ORNDORFF, EXAMINING ATTORNEY

---

SN 85-204,455. GO FAST SPORTS & BEVERAGE COMPANY, DENVER, CO. FILED 12-22-2010.

# GF8

THE MARK CONSISTS OF STANDARD CHARACTERS WITHOUT CLAIM TO ANY PARTICULAR FONT, STYLE, SIZE, OR COLOR.  
OWNER OF U.S. REG. NOS. 2,929,528, 3,640,651 AND OTHERS.  
FOR CHEWING GUM (U.S. CL. 46).  
LINDA ORNDORFF, EXAMINING ATTORNEY

**CLASS 30—(Continued).**

SN 85-204,664. KAREN JOSEPH, BAYTOWN, TX. FILED 12-23-2010.

# WAGALAX

THE MARK CONSISTS OF STANDARD CHARACTERS WITHOUT CLAIM TO ANY PARTICULAR FONT, STYLE, SIZE, OR COLOR.

FOR BEVERAGES MADE OF TEA (U.S. CL. 46).  
FIRST USE 11-2-2010; IN COMMERCE 11-2-2010.  
JESSICA A. POWERS, EXAMINING ATTORNEY

SN 85-204,768. VITALICIOUS INC., NEW YORK, NY. FILED 12-23-2010.

# MAKE THE BEST OF EAT

THE MARK CONSISTS OF STANDARD CHARACTERS WITHOUT CLAIM TO ANY PARTICULAR FONT, STYLE, SIZE, OR COLOR.

FOR CAKE BATTER AND MUFFIN BATTER; PREPARED FOOD MIXES, NAMELY BREAD MIXES AND MIXES WITH BREAD AS A SUBSTANTIAL INGREDIENT, NAMELY, HOT BREAD MIXES, STUFFING MIXES CONTAINING BREAD; MUFFIN MIXES, PANCAKE MIXES, DOUGHNUT MIXES, CAKE MIXES, FROSTING MIXES, PASTRY MIXES, FLOUR-BASED BAKING MIXES FOR MAKING BAKERY GOODS AND BREAD CRUMBS; BROWNIES, CAKES, MUFFINS, MUFFIN TOPS, PROCESSED CEREALS, COOKIES, BISCOTTI, GRAIN-BASED SNACK FOODS, CORN-BASED SNACK FOODS, RICE-BASED SNACK FOODS (U.S. CL. 46).  
MARY BOAGNI, EXAMINING ATTORNEY

SN 85-205,065. ALAKEF COFFEE ROASTERS, INC., DULUTH, MN. FILED 12-23-2010.

# SYMPHONY IN WHITE

THE MARK CONSISTS OF STANDARD CHARACTERS WITHOUT CLAIM TO ANY PARTICULAR FONT, STYLE, SIZE, OR COLOR.

FOR COFFEE BEANS; GROUND COFFEE BEANS (U.S. CL. 46).  
FIRST USE 11-19-2010; IN COMMERCE 11-24-2010.  
MORGAN WYNNE, EXAMINING ATTORNEY

**CLASS 30—(Continued).**

SN 85-205,531. CHARLES J. SILLARI, JR., SOMERVILLE, MA. FILED 12-24-2010.

# Hot Mess

THE MARK CONSISTS OF STANDARD CHARACTERS WITHOUT CLAIM TO ANY PARTICULAR FONT, STYLE, SIZE, OR COLOR.

FOR BURGERS CONTAINED IN BREAD ROLLS (U.S. CL. 46).  
FIRST USE 9-1-2009; IN COMMERCE 9-1-2009.  
REGINA DRUMMOND, EXAMINING ATTORNEY

SN 85-205,597. GO FAST GUM COMPANY, DENVER, CO. FILED 12-24-2010.

# xybrid-8

THE MARK CONSISTS OF STANDARD CHARACTERS WITHOUT CLAIM TO ANY PARTICULAR FONT, STYLE, SIZE, OR COLOR.

FOR CHEWING GUM (U.S. CL. 46).  
GEOFFREY FOSDICK, EXAMINING ATTORNEY

SN 85-205,640. GEORGES MARCELLUS JR., SUNNY ISLES, FL. FILED 12-25-2010.

# dorpare

THE MARK CONSISTS OF STANDARD CHARACTERS WITHOUT CLAIM TO ANY PARTICULAR FONT, STYLE, SIZE, OR COLOR.

FOR GINGER TEA (U.S. CL. 46).  
ALICIA COLLINS, EXAMINING ATTORNEY

**CLASS 30—(Continued).**

SN 85-206,008. SKLAR, STUART A., PLYMOUTH, MN. FILED 12-27-2010.

# Icky Sick

THE MARK CONSISTS OF STANDARD CHARACTERS WITHOUT CLAIM TO ANY PARTICULAR FONT, STYLE, SIZE, OR COLOR.

FOR CHEWING GUM; CHEWING GUM WITH VITAMINS; SUGAR-FREE CHEWING GUM (U.S. CL. 46).  
SANJEEV VOHRA, EXAMINING ATTORNEY

---

SN 85-206,103. MOTHERGOOD INC., SAN DIEGO, CA. FILED 12-27-2010.

# NUMA

THE MARK CONSISTS OF STANDARD CHARACTERS WITHOUT CLAIM TO ANY PARTICULAR FONT, STYLE, SIZE, OR COLOR.

THE WORDING NUMA HAS NO MEANING IN A FOREIGN LANGUAGE.  
FOR GRAIN BASED SNACK FOOD FORTIFIED WITH VITAMINS AND MINERALS (U.S. CL. 46).  
FIRST USE 8-1-2010; IN COMMERCE 10-6-2010.  
KEVON CHISOLM, EXAMINING ATTORNEY

---

SN 85-206,180. VOSGES IP, LLC, CHICAGO, IL. FILED 12-27-2010.

# WILD OPHELIA

THE MARK CONSISTS OF STANDARD CHARACTERS WITHOUT CLAIM TO ANY PARTICULAR FONT, STYLE, SIZE, OR COLOR.

FOR SPECIALTY CONFECTIONERY PRODUCTS, NAMELY, SPECIALTY CHOCOLATES, CHOCOLATE BARS, AND CHOCOLATE TRUFFLES (U.S. CL. 46).  
REBECCA POVARCHUK, EXAMINING ATTORNEY

**CLASS 30—(Continued).**

SN 85-206,277. JOSE GONZALES, VERNON, CA. FILED 12-28-2010.

# TADIN LIFESTYLE AWARENESS

THE MARK CONSISTS OF STANDARD CHARACTERS WITHOUT CLAIM TO ANY PARTICULAR FONT, STYLE, SIZE, OR COLOR.

OWNER OF U.S. REG. NOS. 1,623,867 AND 2,570,890.  
FOR DRIED PROCESSED HERBS AND TEA SOLD LOOSE OR BAGGED FOR INDIVIDUAL SERVING (U.S. CL. 46).  
KEVON CHISOLM, EXAMINING ATTORNEY

---

SN 85-206,313. DOUMAK INC., ELK GROVE VILLAGE, IL. FILED 12-28-2010.

# HALLOWMALLOWS

THE MARK CONSISTS OF STANDARD CHARACTERS WITHOUT CLAIM TO ANY PARTICULAR FONT, STYLE, SIZE, OR COLOR.

FOR MARSHMALLOWS (U.S. CL. 46).  
LANA PHAM, EXAMINING ATTORNEY

---

SN 85-206,791. MORRISON, MICHAEL C, WOODSTOCK, GA. FILED 12-28-2010.

# REDNECK CHEFS

THE MARK CONSISTS OF STANDARD CHARACTERS WITHOUT CLAIM TO ANY PARTICULAR FONT, STYLE, SIZE, OR COLOR.

FOR BARBECUE SAUCE; HOT SAUCE; READY-MADE SAUCES (U.S. CL. 46).  
JENNIFER DIXON, EXAMINING ATTORNEY

**CLASS 30—(Continued).**

SN 85-206,876. TERRY HARRIS, CORDOVA, TN. FILED 12-28-2010.

PUNCHING SLEEPY IN THE FACE

THE MARK CONSISTS OF STANDARD CHARACTERS WITHOUT CLAIM TO ANY PARTICULAR FONT, STYLE, SIZE, OR COLOR.  
FOR BROWNIES; CAKES (U.S. CL. 46).  
ROBIN CHOSID, EXAMINING ATTORNEY

SN 85-207,870. NEUROCHOCOLATE LLC, WASHINGTON, DC. FILED 12-30-2010.

neurochocolate

THE MARK CONSISTS OF STANDARD CHARACTERS WITHOUT CLAIM TO ANY PARTICULAR FONT, STYLE, SIZE, OR COLOR.  
FOR CONFECTIONERIES, NAMELY, SNACK FOODS, NAMELY, CHOCOLATE (U.S. CL. 46).  
FIRST USE 2-15-2007; IN COMMERCE 8-1-2008.  
ANNE E. GUSTASON, EXAMINING ATTORNEY

SN 85-207,877. DORSCH, JAMES M, MUNDELEIN, IL. FILED 12-30-2010.

chocolotto

THE MARK CONSISTS OF STANDARD CHARACTERS WITHOUT CLAIM TO ANY PARTICULAR FONT, STYLE, SIZE, OR COLOR.  
FOR CHOCOLATE FOOD BEVERAGES NOT BEING DAIRY-BASED OR VEGETABLE BASED; CHOCOLATE-BASED BEVERAGES WITH MILK (U.S. CL. 46).  
ANNE E. GUSTASON, EXAMINING ATTORNEY

**CLASS 30—(Continued).**

SN 85-208,199. KNUCKLE SANDWICH, LLC, SANTA ROSA, CA. FILED 12-30-2010.

WOK & SAUCE

THE MARK CONSISTS OF STANDARD CHARACTERS WITHOUT CLAIM TO ANY PARTICULAR FONT, STYLE, SIZE, OR COLOR.  
NO CLAIM IS MADE TO THE EXCLUSIVE RIGHT TO USE "SAUCE", APART FROM THE MARK AS SHOWN.  
FOR SAUCES (U.S. CL. 46).  
CHARLES L. JENKINS, EXAMINING ATTORNEY

SN 85-208,213. AGROS TRADING CONFECTIONERY SPOLKA Z O.O., WARSZAWA, POLAND. FILED 12-30-2010.

AMKI

THE MARK CONSISTS OF STANDARD CHARACTERS WITHOUT CLAIM TO ANY PARTICULAR FONT, STYLE, SIZE, OR COLOR.  
FOR CONFECTIONERY, NAMELY SESAME SNAPS (U.S. CL. 46).  
ANGELA M. MICHELI, EXAMINING ATTORNEY

SN 85-208,381. PRICE, JEFFREY, W., BROOKVILLE, NY. FILED 12-30-2010.

CORN IN THE U.S.A.

THE MARK CONSISTS OF STANDARD CHARACTERS WITHOUT CLAIM TO ANY PARTICULAR FONT, STYLE, SIZE, OR COLOR.  
FOR CORN-BASED SNACK FOODS; GRAIN-BASED SNACK FOODS (U.S. CL. 46).  
WANDA KAY PRICE, EXAMINING ATTORNEY

**CLASS 30—(Continued).**

SN 85-208,597. PAMELA'S PRODUCTS, INC., UKIAH, CA. FILED 12-31-2010.

**PAMELA'S**

THE MARK CONSISTS OF STANDARD CHARACTERS WITHOUT CLAIM TO ANY PARTICULAR FONT, STYLE, SIZE, OR COLOR.

OWNER OF U.S. REG. NO. 2,949,450.  
FOR BAKERY DESSERTS; BAKERY GOODS; BREAD; BREAD ROLLS; BROWNIES; CAKE MIXES; CAKES; COOKIES; FLOUR; MIXES FOR BAKERY GOODS; PANCAKE MIXES; RICE-BASED SNACK FOODS (U.S. CL. 46).

FIRST USE 4-1-1988; IN COMMERCE 4-1-1988.  
FLORENTINA BLANDU, EXAMINING ATTORNEY

SN 85-209,025. PAN AMERICAN GRAIN MFG. CO., INC., GUAYNABO, PUERTO RICO, FILED 1-3-2011.



OWNER OF U.S. REG. NO. 2,476,004.  
THE COLOR(S) RED, BLUE AND YELLOW IS/ARE CLAIMED AS A FEATURE OF THE MARK.

THE MARK CONSISTS OF THE WORD "MAMI" IN COLOR BLUE WITH THE BORDERS IN COLOR RED ENCLOSED IN A YELLOW RECTANGLE WITH ROUNDED CORNERS AND AN OUTSIDE LINE AROUND THE RECTANGLE IN COLOR RED. THE LETTER "I" HAS A RED HEART SHAPE AND AN OUTSIDE LINE IN COLOR YELLOW ABOVE IT INSTEAD OF A DOT. THE LETTERS ARE IN A ROUND AND BOLDED DESIGN.

THE ENGLISH TRANSLATION OF "MAMI" IN THE MARK IS MOMMY.

FOR BEAN, ROASTED, GROUND AND INSTANT COFFEE (U.S. CL. 46).

FIRST USE 3-15-2007; IN COMMERCE 3-15-2007.  
BENJAMIN OKEKE, EXAMINING ATTORNEY

SN 85-209,247. THE CUPCAKE STATION INCORPORATED, BIRMINGHAM, MI. FILED 1-3-2011.

**BUMP-A-LICIOUS**

THE MARK CONSISTS OF STANDARD CHARACTERS WITHOUT CLAIM TO ANY PARTICULAR FONT, STYLE, SIZE, OR COLOR.

FOR CUP CAKES (U.S. CL. 46).  
FIRST USE 7-1-2010; IN COMMERCE 7-1-2010.  
JERI J. FICKES, EXAMINING ATTORNEY

**CLASS 30—(Continued).**

SN 85-209,449. AMERICAN POP CORN COMPANY, SIOUX CITY, IA. FILED 1-3-2011.

**WHITE & BUTTERY**

THE MARK CONSISTS OF STANDARD CHARACTERS WITHOUT CLAIM TO ANY PARTICULAR FONT, STYLE, SIZE, OR COLOR.

OWNER OF U.S. REG. NO. 2,436,034.  
SEC. 2(F).  
FOR UNPOPPED MICROWAVE POP CORN (U.S. CL. 46).

FIRST USE 10-29-1999; IN COMMERCE 10-29-1999.  
CHRISTINE COOPER, EXAMINING ATTORNEY

SN 85-209,532. HAMADE, CHARLES, ENGLEWOOD, NJ. FILED 1-3-2011.

**BABA CHARLES**

THE MARK CONSISTS OF STANDARD CHARACTERS WITHOUT CLAIM TO ANY PARTICULAR FONT, STYLE, SIZE, OR COLOR.

FOR COOKING SAUCES; ICE CREAM; MARINADES; SALAD DRESSING; SALAD SAUCES; SAUCES (U.S. CL. 46).

FIRST USE 9-0-2010; IN COMMERCE 9-0-2010.  
FRED CARL, EXAMINING ATTORNEY

SN 85-209,821. PEPPERIDGE FARM, INCORPORATED, NORWALK, CT. FILED 1-4-2011.

**GOLDFISH**

THE MARK CONSISTS OF STANDARD CHARACTERS WITHOUT CLAIM TO ANY PARTICULAR FONT, STYLE, SIZE, OR COLOR.

OWNER OF U.S. REG. NOS. 739,118, 2,721,288 AND OTHERS.  
FOR BREAD (U.S. CL. 46).  
KYLE PEETE, EXAMINING ATTORNEY



**CLASS 30—(Continued).**

SN 85-209,983. LEWIS BROTHERS BAKERIES, INCORPORATED, DBA LEWIS BAKERIES, INC., EVANSVILLE, IN. FILED 1-4-2011.

# TRIMWISE

THE MARK CONSISTS OF STANDARD CHARACTERS WITHOUT CLAIM TO ANY PARTICULAR FONT, STYLE, SIZE, OR COLOR.  
FOR BUNS (U.S. CL. 46).  
MARGARET POWER, EXAMINING ATTORNEY

SN 85-210,265. COBIZCO FOOD INDUSTRIES SDN. BHD., PENANG, MALAYSIA, FILED 1-4-2011.

# 好行得

THE MARK CONSISTS OF THREE CHINESE CHARACTERS.  
THE NON-LATIN CHARACTERS IN THE MARK TRANSLITERATE TO "HAO SIN TE" AND THIS MEANS "GOOD ALL RIGHT GAIN" IN ENGLISH.  
FOR BASED ON USE: PREMIXED COFFEE; COFFEE-BASED BEVERAGES; WHITE COFFEE; BASED ON INTENT-TO-USE: PREMIXED TEA; TEA-BASED BEVERAGES (U.S. CL. 46).  
FIRST USE 12-7-2010; IN COMMERCE 12-16-2010.  
AISHA SALEM, EXAMINING ATTORNEY

SN 85-210,281. ARBUCKLE COFFEE SERVICE, INC., TUCSON, AZ. FILED 1-4-2011.

# SOUTH OF THE CLOUDS

THE MARK CONSISTS OF STANDARD CHARACTERS WITHOUT CLAIM TO ANY PARTICULAR FONT, STYLE, SIZE, OR COLOR.  
FOR COFFEE (U.S. CL. 46).  
BARBARA BROWN, EXAMINING ATTORNEY

**CLASS 30—(Continued).**

SN 85-210,304. NEW WORLD PASTA COMPANY, HARRISBURG, PA. FILED 1-4-2011.

# RONZONI BISTRO

THE MARK CONSISTS OF STANDARD CHARACTERS WITHOUT CLAIM TO ANY PARTICULAR FONT, STYLE, SIZE, OR COLOR.  
OWNER OF U.S. REG. NOS. 518,709, 3,592,899 AND OTHERS.  
FOR PASTA (U.S. CL. 46).  
HELENE LIWINSKI, EXAMINING ATTORNEY

SN 85-210,807. COBIZCO FOOD INDUSTRIES SDN. BHD., PENANG, MALAYSIA, FILED 1-5-2011.

# COBIZCO

THE MARK CONSISTS OF STANDARD CHARACTERS WITHOUT CLAIM TO ANY PARTICULAR FONT, STYLE, SIZE, OR COLOR.  
THE WORDING "COBIZCO" HAS NO MEANING IN A FOREIGN LANGUAGE.  
FOR BASED ON INTENT-TO-USE: PREMIXED TEA; PREMIXED OATMEAL; PREMIXED CHOCOLATE MALT DRINK; TEA-BASED BEVERAGES; OATMEAL-BASED BEVERAGES; CHOCOLATE-BASED BEVERAGES; BASED ON USE: PREMIXED COFFEE; PREMIXED CEREAL; COFFEE-BASED BEVERAGES; CEREAL-BASED BEVERAGES; CAPPUCCINO; WHITE COFFEE (U.S. CL. 46).  
FIRST USE 6-27-2000; IN COMMERCE 12-16-2010.  
AISHA SALEM, EXAMINING ATTORNEY

SN 85-210,986. BABY LOU BRILLIANT PRODUCTS, LLC, FARMINGTON, CT. FILED 1-5-2011.

# KEVMAN'S

THE MARK CONSISTS OF STANDARD CHARACTERS WITHOUT CLAIM TO ANY PARTICULAR FONT, STYLE, SIZE, OR COLOR.  
FOR CHIPOTLE SAUCE (U.S. CL. 46).  
FIRST USE 7-14-2010; IN COMMERCE 7-14-2010.  
ALLISON HOLTZ, EXAMINING ATTORNEY

**CLASS 30—(Continued).**

SN 85-211,189. MAD MEX TRADEMARK HOLDING COMPANY, LLC, PITTSBURGH, PA. FILED 1-5-2011.

## Gobblerito

THE MARK CONSISTS OF STANDARD CHARACTERS WITHOUT CLAIM TO ANY PARTICULAR FONT, STYLE, SIZE, OR COLOR.

FOR BURRITOS (U.S. CL. 46).  
FIRST USE 11-20-2006; IN COMMERCE 11-20-2006.  
TINA L. SNAPP, EXAMINING ATTORNEY

---

SN 85-211,460. SMITH, PRESTON, SEBASTOPOL, CA. FILED 1-5-2011.

## HARD TIMES BAIL OUT

THE MARK CONSISTS OF STANDARD CHARACTERS WITHOUT CLAIM TO ANY PARTICULAR FONT, STYLE, SIZE, OR COLOR.

FOR SAUCES (U.S. CL. 46).  
STEVEN JACKSON, EXAMINING ATTORNEY

---

SN 85-211,477. OOTY INT INC, ELMHURST, NY. FILED 1-5-2011.

## Social ResponsibiliTea

THE MARK CONSISTS OF STANDARD CHARACTERS WITHOUT CLAIM TO ANY PARTICULAR FONT, STYLE, SIZE, OR COLOR.

FOR TEA (U.S. CL. 46).  
CHERYL CLAYTON, EXAMINING ATTORNEY

---

SN 85-211,602. CITY MICRO FARMS, LLC, LINCOLNSHIRE, IL. FILED 1-6-2011.

## here

THE MARK CONSISTS OF STANDARD CHARACTERS WITHOUT CLAIM TO ANY PARTICULAR FONT, STYLE, SIZE, OR COLOR.

FOR SALAD DRESSINGS (U.S. CL. 46).  
DARRYL SPRUILL, EXAMINING ATTORNEY

**CLASS 30—(Continued).**

SN 85-211,837. COW & CRUMB BAKING COMPANY LLC, CAMBRIDGE, MA. FILED 1-6-2011.



THE MARK CONSISTS OF A DRAWN HEAD OF A COW EATING A COOKIE.

FOR COOKIES; FOOD PACKAGE COMBINATIONS CONSISTING PRIMARILY OF BREAD, CRACKERS AND/OR COOKIES; GRANOLA; SUGARED NUTS; WHEAT-BASED SNACK FOODS (U.S. CL. 46).  
FIRST USE 2-1-2008; IN COMMERCE 6-1-2008.  
JENNIFER VASQUEZ, EXAMINING ATTORNEY

---

SN 85-211,848. COW & CRUMB BAKING COMPANY LLC, CAMBRIDGE, MA. FILED 1-6-2011.

## Cow & Crumb

THE MARK CONSISTS OF STANDARD CHARACTERS WITHOUT CLAIM TO ANY PARTICULAR FONT, STYLE, SIZE, OR COLOR.

FOR COOKIES; FOOD PACKAGE COMBINATIONS CONSISTING PRIMARILY OF BREAD, CRACKERS AND/OR COOKIES; GRANOLA; SUGARED NUTS; WHEAT-BASED SNACK FOODS (U.S. CL. 46).  
FIRST USE 2-1-2008; IN COMMERCE 6-1-2008.  
JENNIFER VASQUEZ, EXAMINING ATTORNEY

---

SN 85-212,423. CARTER, STEPHEN THOMAS, CENTREVILLE, VA. FILED 1-6-2011.

## TUNANNAISE

THE MARK CONSISTS OF STANDARD CHARACTERS WITHOUT CLAIM TO ANY PARTICULAR FONT, STYLE, SIZE, OR COLOR.

FOR MAYONNAISE (U.S. CL. 46).  
DANIEL CAPSHAW, EXAMINING ATTORNEY

**CLASS 30—(Continued).**

SN 85-212,642. AMADASUN, PATRICK, I, JOHNS CREEK, GA. FILED 1-7-2011.

## St. Patrick's Rice

THE MARK CONSISTS OF STANDARD CHARACTERS WITHOUT CLAIM TO ANY PARTICULAR FONT, STYLE, SIZE, OR COLOR.  
NO CLAIM IS MADE TO THE EXCLUSIVE RIGHT TO USE "RICE", APART FROM THE MARK AS SHOWN.  
FOR RICE (U.S. CL. 46).  
FIRST USE 4-21-2003; IN COMMERCE 4-21-2003.  
NAKIA HENRY, EXAMINING ATTORNEY

SN 85-212,726. MARGARITA SELENA CONTRERAS OBREGON, VILLA RICA - OXAPAMPA, PERU, FILED 1-7-2011.

## FINCA SANTA ROSA

THE MARK CONSISTS OF STANDARD CHARACTERS WITHOUT CLAIM TO ANY PARTICULAR FONT, STYLE, SIZE, OR COLOR.  
FOR COFFEE (U.S. CL. 46).  
JILL C. ALT, EXAMINING ATTORNEY

SN 85-213,582. FRANCIS DRAB, RYDAL, PA. FILED 1-9-2011.

## When It Comes to Pretzels We Got You Covered

THE MARK CONSISTS OF STANDARD CHARACTERS WITHOUT CLAIM TO ANY PARTICULAR FONT, STYLE, SIZE, OR COLOR.  
FOR CHOCOLATE COVERED PRETZELS; CHOCOLATE TOPPED PRETZELS; PRETZELS; YOGURT-COVERED PRETZELS (U.S. CL. 46).  
BARBARA GAYNOR, EXAMINING ATTORNEY

**CLASS 30—(Continued).**

SN 85-213,659. IBAKEFOODS, LLC, BROOKLYN, NY. FILED 1-9-2011.

## Fun Naturally

THE MARK CONSISTS OF STANDARD CHARACTERS WITHOUT CLAIM TO ANY PARTICULAR FONT, STYLE, SIZE, OR COLOR.  
FOR COOKIE DOUGH; COOKIES (U.S. CL. 46).  
FIRST USE 0-0-2010; IN COMMERCE 0-0-2010.  
ELI HELLMAN, EXAMINING ATTORNEY

SN 85-217,376. PAMELA'S PRODUCTS, INC., UKIAH, CA. FILED 1-13-2011.

## PAMELA'S ALL NATURAL

THE MARK CONSISTS OF STANDARD CHARACTERS WITHOUT CLAIM TO ANY PARTICULAR FONT, STYLE, SIZE, OR COLOR.  
OWNER OF U.S. REG. NO. 2,949,450.  
NO CLAIM IS MADE TO THE EXCLUSIVE RIGHT TO USE "ALL NATURAL", APART FROM THE MARK AS SHOWN.  
FOR BAKERY DESSERTS; BAKERY GOODS; BREAD; BREAD ROLLS; BROWNIES; CAKE MIXES; CAKES; COOKIES; FLOUR; MIXES FOR BAKERY GOODS; PANCAKE MIXES; RICE-BASED SNACK FOODS (U.S. CL. 46).  
FLORENTINA BLANDU, EXAMINING ATTORNEY

SN 85-218,007. APURE FOODS COMPANY, WHEAT RIDGE, CO. FILED 1-14-2011.

## COCOASOURCE

THE MARK CONSISTS OF STANDARD CHARACTERS WITHOUT CLAIM TO ANY PARTICULAR FONT, STYLE, SIZE, OR COLOR.  
FOR COCOA (U.S. CL. 46).  
CHERYL CLAYTON, EXAMINING ATTORNEY

**CLASS 30—(Continued).**

SN 85-218,900. APURE FOODS COMPANY, WHEAT RIDGE, CO. FILED 1-17-2011.

**COCOABLOOM**

THE MARK CONSISTS OF STANDARD CHARACTERS WITHOUT CLAIM TO ANY PARTICULAR FONT, STYLE, SIZE, OR COLOR.

FOR COCOA (U.S. CL. 46).  
CHERYL CLAYTON, EXAMINING ATTORNEY

SN 85-218,901. APURE FOODS COMPANY, WHEAT RIDGE, CO. FILED 1-17-2011.

**COCOASTRONG**

THE MARK CONSISTS OF STANDARD CHARACTERS WITHOUT CLAIM TO ANY PARTICULAR FONT, STYLE, SIZE, OR COLOR.

FOR COCOA (U.S. CL. 46).  
CHERYL CLAYTON, EXAMINING ATTORNEY

SN 85-219,240. WEAVER POPCORN COMPANY INC, NO-BLESVILLE, IN. FILED 1-17-2011.

**MIGHTY POP**

THE MARK CONSISTS OF STANDARD CHARACTERS WITHOUT CLAIM TO ANY PARTICULAR FONT, STYLE, SIZE, OR COLOR.

OWNER OF U.S. REG. NO. 3,264,107.  
FOR POPPED POPCORN AND FLAVOR-COATED POPCORN (U.S. CL. 46).  
BRIAN CALLAGHAN, EXAMINING ATTORNEY

SN 85-228,860. UNILEVER SUPPLY CHAIN, INC., CLINTON, CT. FILED 1-28-2011.

**LINEA**

THE MARK CONSISTS OF STANDARD CHARACTERS WITHOUT CLAIM TO ANY PARTICULAR FONT, STYLE, SIZE, OR COLOR.

FOR TEA AND TEA BASED BEVERAGES (U.S. CL. 46).  
ANNE MADDEN, EXAMINING ATTORNEY

**CLASS 30—(Continued).**

SN 85-232,047. KRAFT FOODS GLOBAL BRANDS LLC, NORTHFIELD, IL. FILED 2-2-2011.

**BE RIDICULOUSLY LONG  
LASTING**

THE MARK CONSISTS OF STANDARD CHARACTERS WITHOUT CLAIM TO ANY PARTICULAR FONT, STYLE, SIZE, OR COLOR.

OWNER OF U.S. REG. NO. 3,246,916.  
FOR CHEWING GUM (U.S. CL. 46).  
EVELYN BRADLEY, EXAMINING ATTORNEY

SN 85-233,658. ALDI INC., BATAVIA, IL. FILED 2-3-2011.

**MAMA COZZI PARTY CLASSICS**

THE MARK CONSISTS OF STANDARD CHARACTERS WITHOUT CLAIM TO ANY PARTICULAR FONT, STYLE, SIZE, OR COLOR.

OWNER OF U.S. REG. NOS. 1,625,101, 3,032,725 AND OTHERS.  
FOR PIZZA (U.S. CL. 46).  
NAKIA HENRY, EXAMINING ATTORNEY

SN 85-237,073. TYSON FOODS, INC., SPRINGDALE, AR. FILED 2-8-2011.



OWNER OF U.S. REG. NOS. 1,205,623 AND 3,204,061.  
THE MARK CONSISTS OF THE WORD "TYSON" IN STYLIZED LETTERING IS ANGLED AT THE UPPER LEFT; THE WORD "POWER" IN LARGER STYLIZED LETTERING IS ANGLED BELOW THE WORD "TYSON"; THE WORD "UPZ" IN STYLIZED LETTERING IS UNDER THE WORD "POWER"; THE LETTERS "UP" ARE LARGER THAN THE LETTERS IN "POWER"; THE LETTER "Z" IS SMALLER THAN THE LETTERS "UP"; THE LETTER "U" IS FORMED BY AN ARROW POINTING UP WITH THE POINT BEING ON THE LEFT SIDE OF THE LETTER "U"; THERE IS AN INCOMPLETE CIRCLE AROUND THE WORD "UPZ", AND THERE ARE SHADOWS AROUND THE LETTERS COMPRISING THE WORD "UPZ".

FOR SANDWICH OR WRAP, NAMELY, CHICKEN, BEEF, PORK, EGG AND/OR CHEESE COMBINED WITH TORTILLAS, WAFFLES, PANCAKES, ENGLISH MUFFINS, BISCUITS, BAGELS, BREAD ROLLS OR BUNS (U.S. CL. 46).

HEATHER SAPP, EXAMINING ATTORNEY

**CLASS 30—(Continued).**

SN 85-250,487. CITY MICRO FARMS, LLC, LINCOLNSHIRE, IL. FILED 2-24-2011.

# HARVESTED HERE

THE MARK CONSISTS OF STANDARD CHARACTERS WITHOUT CLAIM TO ANY PARTICULAR FONT, STYLE, SIZE, OR COLOR.  
FOR SALAD DRESSING (U.S. CL. 46).  
DARRYL SPRULL, EXAMINING ATTORNEY

---

SN 85-257,171. TYSON FOODS, INC., SPRINGDALE, AR. FILED 3-3-2011.

# TYSON

THE MARK CONSISTS OF STANDARD CHARACTERS WITHOUT CLAIM TO ANY PARTICULAR FONT, STYLE, SIZE, OR COLOR.  
OWNER OF U.S. REG. NOS. 1,748,683, 2,833,874 AND OTHERS.  
FOR CHICKEN SANDWICH (U.S. CL. 46).  
FIRST USE 3-15-2010; IN COMMERCE 3-15-2010.  
HEATHER SAPP, EXAMINING ATTORNEY

---

SN 85-264,415. TYSON FOODS, INC., SPRINGDALE, AR. FILED 3-11-2011.

# EMPANITAS

THE MARK CONSISTS OF STANDARD CHARACTERS WITHOUT CLAIM TO ANY PARTICULAR FONT, STYLE, SIZE, OR COLOR.  
FOR MEXICAN STYLE BREAD FILLED WITH MEAT, POULTRY AND CHEESE (U.S. CL. 46).  
HEATHER SAPP, EXAMINING ATTORNEY

**CLASS 31—NATURAL AGRICULTURAL PRODUCTS**

SN 76-703,199. DLF INTERNATIONAL SEEDS, INC., HALSEY, OR. FILED 6-1-2010.



NO CLAIM IS MADE TO THE EXCLUSIVE RIGHT TO USE "WILD GAME ATTRACTANT", APART FROM THE MARK AS SHOWN.

FOR AGRICULTURAL SEEDS, NAMELY, GRASS SEEDS, DOVER SEEDS, OAT SEEDS AND BRASSICA SEEDS MARKETED TO HUNTERS AS A GAME ATTRACTANT (U.S. CLS. 1 AND 46).  
FIRST USE 4-0-2010; IN COMMERCE 4-0-2010.  
MARK T. MULLEN, EXAMINING ATTORNEY

---

SN 77-963,453. BUSCH, DOUGLAS, MALIBU, CA. FILED 3-19-2010.

# Farm In A Box

THE MARK CONSISTS OF STANDARD CHARACTERS WITHOUT CLAIM TO ANY PARTICULAR FONT, STYLE, SIZE, OR COLOR.  
FOR ORGANIC GARDENING KIT FOR INDOOR AND OUTDOOR PLANTING COMPOSED PRIMARILY OF ORGANIC AGRICULTURAL SEEDS AND ALSO INCLUDING GROWING MEDIUM AND WATERING SYSTEM (U.S. CLS. 1 AND 46).  
JOHN KELLY, EXAMINING ATTORNEY

---

SN 78-967,715. KENT FEEDS, INC., MUSCATINE, IA. FILED 9-6-2006.

# SIMPLICITY

THE MARK CONSISTS OF STANDARD CHARACTERS WITHOUT CLAIM TO ANY PARTICULAR FONT, STYLE, SIZE, OR COLOR.  
FOR HORSE FEED (U.S. CLS. 1 AND 46).  
EVELYN BRADLEY, EXAMINING ATTORNEY

**CLASS 31—(Continued).**

SN 79-084,227. MINISTERO DELLE POLITICHE AGRICOLE.; ALIMENTARI E FORESTALI -; DIPARTIMENTO DELLE POLITICHE; COMPETITIVE DEL MONDO RURALE; E DELLA QUALITA' -; DIREZIONE GENERALE PER LO SVILUPPO AGROALIMENTARE.; LA QUALITA' E LA TUTELA; DEL CONSUMATORE, I-00187 ROMA, ITALY, FILED 4-23-2010.

**SCALOGNO DI ROMAGNA**

THE MARK CONSISTS OF STANDARD CHARACTERS WITHOUT CLAIM TO ANY PARTICULAR FONT, STYLE, SIZE, OR COLOR.

PRIORITY DATE OF 2-12-2010 IS CLAIMED.

OWNER OF INTERNATIONAL REGISTRATION 1043246 DATED 4-23-2010, EXPIRES 4-23-2020.

NO CLAIM IS MADE TO THE EXCLUSIVE RIGHT TO USE "SCALOGNO", APART FROM THE MARK AS SHOWN.

THE ENGLISH TRANSLATION OF "SCALOGNO DI ROMAGNA" IN THE MARK IS "SHALLOT OF ROMAGNA".

THE CERTIFICATION MARK, AS INTENDED TO BE USED BY PERSONS AUTHORIZED BY THE CERTIFIER, IS INTENDED TO CERTIFY THAT THE GOODS PROVIDED ORIGINATE IN AN ENTIRE GEOGRAPHICAL REGION KNOWN AS ROMAGNA, COMPRISED OF THE PROVINCE OF RAVENNA: BRISIGHELLA, CASOLA VALSENIO, CASTELBOLOGNESE, FAENA, RIOLO TERME, AND SOLAROLO, THE PROVINCE OF FORLÌ: MODIGLIANA AND TREDIZIO, AND THE PROVINCE OF BOLOGNA: BORGO TOSSIGNANO, CASALFUMANESE, CASTEL DEL RIO, CASTEL GUELFO, DOZZA, FONTANELICE, IMOLA AND MORDANO IN ITALY, AND THAT THE PREPARATION, PRODUCTION, AND/OR PROCESSING OF THE GOODS TAKE PLACE ACCORDING TO THE STANDARD OF RECORD.

FOR UNPROCESSED SHALLOTS (U.S. CLS. 1 AND 46).  
JUDITH HELFMAN, EXAMINING ATTORNEY

**CLASS 31—(Continued).**

SN 79-084,240. MINISTERO DELLE POLITICHE AGRICOLE.; ALIMENTARI E FORESTALI -; DIPARTIMENTO DELLE POLITICHE; COMPETITIVE DEL MONDO RURALE; E DELLA QUALITA' -; DIREZIONE GENERALE PER LO SVILUPPO AGROALIMENTARE.; LA QUALITA' E LA TUTELA; DEL CONSUMATORE, ROMA, ITALY, FILED 4-19-2010.

**MARRONE DEL MUGELLO**

THE MARK CONSISTS OF STANDARD CHARACTERS WITHOUT CLAIM TO ANY PARTICULAR FONT, STYLE, SIZE, OR COLOR.

PRIORITY DATE OF 2-10-2010 IS CLAIMED.

OWNER OF INTERNATIONAL REGISTRATION 1043259 DATED 4-19-2010, EXPIRES 4-19-2020.

NO CLAIM IS MADE TO THE EXCLUSIVE RIGHT TO USE "MARRONE", APART FROM THE MARK AS SHOWN.

THE ENGLISH TRANSLATION OF "MARRONE DEL MUGELLO" IN THE MARK IS "MUGELLO CHESTNUT".

THE CERTIFICATION MARK, AS INTENDED TO BE USED BY PERSONS AUTHORIZED BY THE CERTIFIER, IS INTENDED TO CERTIFY THAT THE GOODS PROVIDED ORIGINATE IN PART OF THE TERRITORY OF THE PROVINCE OF FLORENCE, WHICH CORRESPONDS TO PART OF THE MUGELLO AREA, ENTIRELY INCLUDING THE TERRITORY OF THE COMMUNES OF DICOMANO, MARRADI AND PALAZZUOLO SUL SENIO, AND PART OF THE TERRITORY OF THE COMMUNES OF BORGO SAN LORENZO, FIRENZUOLA, LONDA, RUFINA, SAN GONENZO, SCARPERIA AND VICCHIO DI MUGELLO IN ITALY, AND THAT THE PREPARATION, PRODUCTION, AND/OR PROCESSING OF THE GOODS TAKE PLACE ACCORDING TO THE STANDARD OF RECORD.

FOR FRESH CHESTNUTS (U.S. CLS. 1 AND 46).  
JUDITH HELFMAN, EXAMINING ATTORNEY

SN 79-084,239. MINISTERO DELLE POLITICHE AGRICOLE.; ALIMENTARI E FORESTALI -; DIPARTIMENTO DELLE POLITICHE; COMPETITIVE DEL MONDO RURALE; E DELLA QUALITA' -; DIREZIONE GENERALE PER LO SVILUPPO AGROALIMENTARE.; LA QUALITA' E LA TUTELA; DEL CONSUMATORE, ROMA, ITALY, FILED 4-19-2010.

**MARRONE DI ROCCADASPIDE**

THE MARK CONSISTS OF STANDARD CHARACTERS WITHOUT CLAIM TO ANY PARTICULAR FONT, STYLE, SIZE, OR COLOR.

PRIORITY DATE OF 2-10-2010 IS CLAIMED.

OWNER OF INTERNATIONAL REGISTRATION 1043258 DATED 4-19-2010, EXPIRES 4-19-2020.

NO CLAIM IS MADE TO THE EXCLUSIVE RIGHT TO USE "MARRONE", APART FROM THE MARK AS SHOWN.

THE ENGLISH TRANSLATION OF "MARRONE DI ROCCADASPIDE" IN THE MARK IS "ROCCADASPIDE CHESTNUT".

THE CERTIFICATION MARK, AS INTENDED TO BE USED BY PERSONS AUTHORIZED BY THE CERTIFIER, IS INTENDED TO CERTIFY THAT THE GOODS PROVIDED ORIGINATE IN THE LAND SITUATED MORE THAN 250 METERS ABOVE SEA LEVEL IN THE MUNICIPALITIES OF THE PROVINCE OF SALERNO IN ITALY, KNOWN AS ROCCADASPIDE, AND THAT THE PREPARATION, PRODUCTION, AND/OR PROCESSING OF THE GOODS TAKE PLACE ACCORDING TO THE STANDARD OF RECORD.

FOR FRESH CHESTNUTS (U.S. CLS. 1 AND 46).  
JUDITH HELFMAN, EXAMINING ATTORNEY

SN 79-084,248. MINISTERO DELLE POLITICHE AGRICOLE.; ALIMENTARI E FORESTALI -; DIPARTIMENTO DELLE POLITICHE; COMPETITIVE DEL MONDO RURALE; E DELLA QUALITA' -; DIREZIONE GENERALE PER LO SVILUPPO AGROALIMENTARE.; LA QUALITA' E LA TUTELA; DEL CONSUMATORE, ROMA, ITALY, FILED 4-16-2010.

**CASTAGNA DI MONTELLA**

THE MARK CONSISTS OF STANDARD CHARACTERS WITHOUT CLAIM TO ANY PARTICULAR FONT, STYLE, SIZE, OR COLOR.

PRIORITY DATE OF 2-8-2010 IS CLAIMED.

OWNER OF INTERNATIONAL REGISTRATION 1043267 DATED 4-16-2010, EXPIRES 4-16-2020.

NO CLAIM IS MADE TO THE EXCLUSIVE RIGHT TO USE "CASTAGNA", APART FROM THE MARK AS SHOWN.

THE ENGLISH TRANSLATION OF "CASTAGNA DI MONTELLA" IN THE MARK IS "MONTELLA CHESTNUT".

THE CERTIFICATION MARK, AS INTENDED TO BE USED BY PERSONS AUTHORIZED BY THE CERTIFIER, IS INTENDED TO CERTIFY THAT THE GOODS PROVIDED ORIGINATE IN THE AREA IN THE COMMUNES OF MONTELLA, BOGNOLI IRPINO, CASSANO IRPINO, NUSCO, MONTEMARANO AND VOLTURARA IRPINA, LOCATED IN THE PROVINCE OF AVELLINO IN ITALY, AND THAT THE PREPARATION, PRODUCTION, AND/OR PROCESSING OF THE GOODS TAKE PLACE ACCORDING TO THE STANDARD OF RECORD.

FOR FRESH CHESTNUTS (U.S. CLS. 1 AND 46).  
JUDITH HELFMAN, EXAMINING ATTORNEY

**CLASS 31—(Continued).**

SN 79-084,249. MINISTERO DELLE POLITICHE AGRICOLE.; ALIMENTARI E FORESTALI -; DIPARTIMENTO DELLE POLITICHE; COMPETITIVE DEL MONDO RURALE; E DELLA QUALITA' -; DIREZIONE GENERALE PER LO SVILUPPO AGROALIMENTARE.; LA QUALITA' E LA TUTELA; DEL CONSUMATORE, ROMA, ITALY, FILED 4-23-2010.

CASTAGNA DI VALLERANO

THE MARK CONSISTS OF STANDARD CHARACTERS WITHOUT CLAIM TO ANY PARTICULAR FONT, STYLE, SIZE, OR COLOR.

PRIORITY DATE OF 2-8-2010 IS CLAIMED.

OWNER OF INTERNATIONAL REGISTRATION 1043268 DATED 4-23-2010, EXPIRES 4-23-2020.

NO CLAIM IS MADE TO THE EXCLUSIVE RIGHT TO USE "CASTAGNA", APART FROM THE MARK AS SHOWN.

THE ENGLISH TRANSLATION OF "CASTAGNA DI VALLERANO" IN THE MARK IS "VALLERANO CHESTNUT".

THE CERTIFICATION MARK, AS INTENDED TO BE USED BY PERSONS AUTHORIZED BY THE CERTIFIER, IS INTENDED TO CERTIFY THAT THE GOODS PROVIDED ORIGINATE IN THE TERRITORY OF THE MUNICIPALITY OF VALLERANO, IN THE PROVINCE OF VITERBO IN ITALY, AND THAT THE PREPARATION, PRODUCTION, AND/OR PROCESSING OF THE GOODS TAKE PLACE ACCORDING TO THE STANDARD OF RECORD.

FOR FRESH CHESTNUTS (U.S. CLS. 1 AND 46).

JUDITH HELFMAN, EXAMINING ATTORNEY

---

SN 85-015,232. BAR ALE, INC., WILLIAMS, CA. FILED 4-15-2010.

ESTEEM

THE MARK CONSISTS OF STANDARD CHARACTERS WITHOUT CLAIM TO ANY PARTICULAR FONT, STYLE, SIZE, OR COLOR.

FOR HORSE FEED (U.S. CLS. 1 AND 46).

FIRST USE 1-20-2010; IN COMMERCE 1-20-2010.

KATHERINE CHANG, EXAMINING ATTORNEY

**CLASS 31—(Continued).**

SN 85-031,802. EQUAL EXCHANGE, INC., WEST BRIDGE-WATER, MA. FILED 5-6-2010.



Principle Six  
co-operative trade movement

NO CLAIM IS MADE TO THE EXCLUSIVE RIGHT TO USE "CO-OPERATIVE TRADE MOVEMENT", APART FROM THE MARK AS SHOWN.

THE MARK CONSISTS OF ON TOP THE "P6" MARK WITH IMAGES OF LEAVES IN THE LOOP AREA OF EACH CHARACTER, BENEATH WHICH APPEARS THE "PRINCIPLE SIX", MARK, BENEATH WHICH APPEARS THE "CO-OPERATIVE TRADE MOVEMENT" SLOGAN.

FOR BEETS (UNPROCESSED); BASIL; CARROTS (UNPROCESSED); CAT FOOD; CELERY (UNPROCESSED); COLLARDS; UNPROCESSED); CUT FLOWERS; DIGESTIBLE CHEWING BONES FOR DOGS; DOG FOOD; FLOWERS; FRESH APPLES; UNPROCESSED BEETS; FRESH BASIL; UNPROCESSED CARROTS; CAT FOOD; UNPROCESSED CELERY; UNPROCESSED COLLARD GREENS; CUT FLOWERS; DIGESTIBLE CHEWING BONES FOR DOGS; DOG FOOD; FLOWERS; FRESH APPLES; FRESH BANANAS; FRESH BEETS; FRESH CABBAGE; FRESH GINGER; FRESH OATS; FRESH ONIONS; FRESH PEACHES; FRESH PEAS; FRESH POTATOES; FRESH TOMATOES; PEARS, FRESH; RAW ALMONDS; SEEDLINGS; FRESH SOYBEANS IN THE POD; SUCANET IN THE NATURE OF NATURAL SUGAR CANE; SUGAR CANE; UNPOPPED POPCORN; UNPROCESSED BERRIES; UNPROCESSED GARLIC; UNPROCESSED RHUBARB; UNPROCESSED SUGAR CANE; UNPROCESSED VEGETABLES; UNPROCESSED RYE; FRESH WATERMELON; UNPROCESSED CRANBERRIES, ALFALFA SPROUTS, BLUEBERRIES, BLACKBERRIES RASPBERRIES, EGGPLANT AND RADICCHIO; RAW BEANS; RAW CHARD; RAW CILANTRO; RAW SALAD SPROUTING SEEDS; RAW SANDWICH SPROUTING SEEDS; UNPROCESSED CORN; UNPROCESSED NUTS (U.S. CLS. 1 AND 46).

ANN E. SAPPENFIELD, EXAMINING ATTORNEY

---

SN 85-042,262. SOCIETE DES PRODUITS NESTLE S.A., VEVEY, SWITZERLAND, FILED 5-19-2010.

FRISKIES FUSIONS

THE MARK CONSISTS OF STANDARD CHARACTERS WITHOUT CLAIM TO ANY PARTICULAR FONT, STYLE, SIZE, OR COLOR.

OWNER OF U.S. REG. NOS. 668,470 AND 2,412,558.

FOR PET FOOD (U.S. CLS. 1 AND 46).

LINDA ESTRADA, EXAMINING ATTORNEY

**CLASS 31—(Continued).**

SN 85-049,457. MULLANE, BECKY, PENNA BLANCA, NM. FILED 5-27-2010.

CHAMPAGNE

THE MARK CONSISTS OF STANDARD CHARACTERS WITHOUT CLAIM TO ANY PARTICULAR FONT, STYLE, SIZE, OR COLOR.

FOR FRESH APPLES (U.S. CLS. 1 AND 46).  
FIRST USE 10-1-1953; IN COMMERCE 10-1-1953.  
KATHERINE STOIDES, EXAMINING ATTORNEY

SN 85-055,873. DEL CAMPO Y ASOCIADOS S.A. DE C.V., CULIACAN, SINATO, MEXICO, FILED 6-7-2010.



OWNER OF U.S. REG. NO. 2,693,208.  
NO CLAIM IS MADE TO THE EXCLUSIVE RIGHT TO USE "PINK PEARL", APART FROM THE MARK AS SHOWN.

THE MARK CONSISTS OF THE WORDS "PINK PEARL" IN STYLIZED LETTERS TO THE LEFT OF WHICH IS THE DESIGN OF THE SUN RISING OVER THE FIELDS.  
FOR FRESH TOMATOES (U.S. CLS. 1 AND 46).  
SEAN CROWLEY, EXAMINING ATTORNEY

SN 85-055,880. DEL CAMPO Y ASOCIADOS S.A. DE C.V., CULIACAN, SINATO, MEXICO, FILED 6-7-2010.



OWNER OF U.S. REG. NO. 2,693,208.  
NO CLAIM IS MADE TO THE EXCLUSIVE RIGHT TO USE "YELLOW PEARL", APART FROM THE MARK AS SHOWN.

THE MARK CONSISTS OF THE WORDS "YELLOW PEARL" TO THE LEFT OF WHICH IS THE DESIGN OF THE SUN RISING OVER THE FIELDS.  
FOR FRESH TOMATOES (U.S. CLS. 1 AND 46).  
SEAN CROWLEY, EXAMINING ATTORNEY

**CLASS 31—(Continued).**

SN 85-055,892. DEL CAMPO Y ASOCIADOS S.A. DE C.V., CULIACAN, SINATO, MEXICO, FILED 6-7-2010.



OWNER OF U.S. REG. NO. 2,693,208.  
NO CLAIM IS MADE TO THE EXCLUSIVE RIGHT TO USE "GOURMET TOMATOES", APART FROM THE MARK AS SHOWN.

THE MARK CONSISTS OF THE WORD "GOURMET" IN LARGE STYLIZED LETTERS BENEATH WHICH IS THE WORD "TOMATOES" IN SMALLER STYLIZED LETTERS. TO THE LEFT OF THE WORDS IS THE DESIGN OF THE SUN RISING OVER THE FIELDS.  
FOR FRESH TOMATOES (U.S. CLS. 1 AND 46).  
SEAN CROWLEY, EXAMINING ATTORNEY

SN 85-056,506. TARGET BRANDS, INC., MINNEAPOLIS, MN. FILED 6-7-2010.



OWNER OF U.S. REG. NOS. 2,290,302, 2,954,200 AND OTHERS.

NO CLAIM IS MADE TO THE EXCLUSIVE RIGHT TO USE "FARMS", APART FROM THE MARK AS SHOWN.  
THE MARK CONSISTS OF THE STYLIZED WORDS "ARCHER FARMS" WRITTEN HORIZONTALLY ABOVE A ROOSTER IMAGE.  
FOR RAW AND FRESH FRUITS AND VEGETABLES; FRESH, RAW AND UNPROCESSED NUTS; UN-PROCESSED LETTUCE (U.S. CLS. 1 AND 46).  
ALEXANDER L. POWERS, EXAMINING ATTORNEY

SN 85-096,607. KALMBACH FEEDS, INC., UPPER SANDUSKY, OH. FILED 7-30-2010.

TROPHY BUCK TRAIL MIX

THE MARK CONSISTS OF STANDARD CHARACTERS WITHOUT CLAIM TO ANY PARTICULAR FONT, STYLE, SIZE, OR COLOR.

OWNER OF U.S. REG. NO. 3,825,958.  
NO CLAIM IS MADE TO THE EXCLUSIVE RIGHT TO USE "BUCK TRAIL MIX", APART FROM THE MARK AS SHOWN.  
FOR ANIMAL FEED (U.S. CLS. 1 AND 46).  
JERI J. FICKES, EXAMINING ATTORNEY



**CLASS 31—(Continued).**

SN 85-100,548. JOHN CROSBIE GOOLD, CAMPERDOWN, AUSTRALIA, FILED 8-5-2010.

**BIOTIC PLUS**

THE MARK CONSISTS OF STANDARD CHARACTERS WITHOUT CLAIM TO ANY PARTICULAR FONT, STYLE, SIZE, OR COLOR.

FOR FOODSTUFFS FOR ANIMALS (U.S. CLS. 1 AND 46).

YAT SYE, LEE, EXAMINING ATTORNEY

---

SN 85-126,226. GREENHOUSE GROWN FOODS INC., DELTA BRITISH COLOMBIA, CANADA, FILED 9-9-2010.

**ALLEGRO**

THE MARK CONSISTS OF STANDARD CHARACTERS WITHOUT CLAIM TO ANY PARTICULAR FONT, STYLE, SIZE, OR COLOR.

THE ENGLISH TRANSLATION OF "ALLEGRO" IN THE MARK IS "CHEERFUL".

FOR FRESH TOMATOES (U.S. CLS. 1 AND 46).

FIRST USE 3-0-2009; IN COMMERCE 3-0-2009.

JOSETTE BEVERLY, EXAMINING ATTORNEY

---

SN 85-135,678. VENTURE MILLING, INC., SALISBURY, MD, FILED 9-22-2010.



OWNER OF U.S. REG. NOS. 2,756,922, 2,826,135 AND 2,826,136.

NO CLAIM IS MADE TO THE EXCLUSIVE RIGHT TO USE "SELECT", APART FROM THE MARK AS SHOWN.

THE MARK CONSISTS OF THE WORD "PROVAAL" WITH THE NUMBER "2" DISPLAYED IN SUPERScript BY THE "L" AND A CIRCLE DESIGN SURROUNDING THE "P". A SWIRL DESIGN INTERSECTS THE WORD "PROVAAL2" AND SURROUNDS THE TERM "SAALECT".

FOR ANIMAL FEED, NAMELY, BLENDED BY-PASS PROTEIN FEED DEVELOPED FOR THE DAIRY FEED INGREDIENT MARKET (U.S. CLS. 1 AND 46).

KAREN K. BUSH, EXAMINING ATTORNEY

**CLASS 31—(Continued).**

SN 85-143,141. CLIFFORD PRODUCE SALES INC., RUTHVEN, ONTARIO, CANADA, FILED 10-1-2010.

**CLIFFORD PRODUCE**

THE MARK CONSISTS OF STANDARD CHARACTERS WITHOUT CLAIM TO ANY PARTICULAR FONT, STYLE, SIZE, OR COLOR.

NO CLAIM IS MADE TO THE EXCLUSIVE RIGHT TO USE "PRODUCE", APART FROM THE MARK AS SHOWN. FOR FRESH FRUITS AND VEGETABLES (U.S. CLS. 1 AND 46).

FIRST USE 1-0-1971; IN COMMERCE 1-0-1971.

SETH A. RAPPAPORT, EXAMINING ATTORNEY

---

SN 85-159,516. SANTA MARIA SEEDS, INC., SANTA MARIA, CA. FILED 10-22-2010.



NO CLAIM IS MADE TO THE EXCLUSIVE RIGHT TO USE "FARMER", APART FROM THE MARK AS SHOWN.

THE COLOR(S) GREEN AND BLACK IS/ARE CLAIMED AS A FEATURE OF THE MARK.

THE MARK CONSISTS OF THE WORDS "HOME FARMER" IN BLACK STYLIZED LETTERING WITH A GREEN ROOF OVER THE "H" AND A SPROUT WITH A GREEN LEAF COMING OUT OF THE "O".

FOR VEGETABLE SEEDS, FRUIT SEEDS, AND HERB SEEDS FOR PLANTING (U.S. CLS. 1 AND 46).

JAMES A. RAUEN, EXAMINING ATTORNEY

**CLASS 31—(Continued).**

SN 85-178,071. RAY & MASCARI INC., INDIANAPOLIS, IN.  
FILED 11-16-2010.



THE COLOR(S) RED, GREEN, BLACK, AND WHITE IS/  
ARE CLAIMED AS A FEATURE OF THE MARK.  
THE MARK CONSISTS OF A RED TOMATO, WITH A  
GREEN STEM, WEARING BLACK SUNGLASSES, WITH  
WHITE GLARE MARKS ON BOTH LENSES.  
FOR FRESH TOMATOES (U.S. CLS. 1 AND 46).  
FIRST USE 1-20-1989; IN COMMERCE 1-20-1989.  
YAT SYE, LEE, EXAMINING ATTORNEY

**CLASS 31—(Continued).**

SN 85-183,260. CLIFFORD PRODUCE SALES INC., RUTH-  
VEN, ONTARIO, CANADA, FILED 11-23-2010.



NO CLAIM IS MADE TO THE EXCLUSIVE RIGHT TO  
USE "FRESH PRODUCE", APART FROM THE MARK AS  
SHOWN.  
THE MARK CONSISTS OF A "PAYSANNE" IN CURSIVE  
WITH "COUNTRY FRESH PRODUCE" IN SMALLER LET-  
TERS EXTENDING BELOW "SANNE". AN ARC EXTENDS  
FROM THE "P" ABOVE TO THE SECOND "A" WITH A  
DRAWING OF A YOUNG GIRL STARTING JUST BELOW  
THE SHOULDERS WITH A THIN STRAP BLOUSE, HAVING  
DARK SHOULDER LENGTH HAIR AND A POLKA DOT  
BOW.  
THE ENGLISH TRANSLATION OF THE WORD "PAY-  
SANNE" IN THE MARK IS "COUNTRY WOMAN".  
FOR FRESH FRUITS AND VEGETABLES (U.S. CLS. 1  
AND 46).  
FIRST USE 9-0-2009; IN COMMERCE 9-0-2009.  
SETH A. RAPPAPORT, EXAMINING ATTORNEY

SN 85-183,236. CLIFFORD PRODUCE SALES INC., RUTH-  
VEN, ONTARIO, CANADA, FILED 11-23-2010.



NO CLAIM IS MADE TO THE EXCLUSIVE RIGHT TO  
USE "PRODUCE", APART FROM THE MARK AS SHOWN.  
THE MARK CONSISTS OF "CLIFFORD" WITH A LEAF  
DESIGN ABOVE THE "R" AND A SMALLER "PRODUCE"  
ORIENTED BELOW THE LETTERS "FORD".  
FOR FRESH FRUITS AND VEGETABLES (U.S. CLS. 1  
AND 46).  
FIRST USE 9-0-2009; IN COMMERCE 9-0-2009.  
SETH A. RAPPAPORT, EXAMINING ATTORNEY

SN 85-187,927. PURINA MILLS, LLC, GREY SUMMIT, MO.  
FILED 12-1-2010.

**FLOCK BLOCK**

THE MARK CONSISTS OF STANDARD CHARACTERS  
WITHOUT CLAIM TO ANY PARTICULAR FONT, STYLE,  
SIZE, OR COLOR.  
NO CLAIM IS MADE TO THE EXCLUSIVE RIGHT TO  
USE "BLOCK", APART FROM THE MARK AS SHOWN.  
FOR ANIMAL FEED (U.S. CLS. 1 AND 46).  
FIRST USE 12-30-2005; IN COMMERCE 12-30-2005.  
DAVID TAYLOR, EXAMINING ATTORNEY

**CLASS 31—(Continued).**

SN 85-188,698. PORTERFIELD, MICHAEL, ASHEVILLE, NC.  
FILED S.R. 12-1-2010; AM. P.R. 3-15-2011.

**Gladheart**  
 **FARMS**

NO CLAIM IS MADE TO THE EXCLUSIVE RIGHT TO USE "FARMS", APART FROM THE MARK AS SHOWN.

THE MARK CONSISTS OF STACKED TEXT WITH A LEAF ELEMENT GROWING OUT OF THE LETTER "F" IN THE WORD "FARM".

FOR FRESH VEGETABLES (U.S. CLS. 1 AND 46).

FIRST USE 5-11-2008; IN COMMERCE 5-11-2008.

JOHN SCHUYLER YARD, EXAMINING ATTORNEY

**CLASS 31—(Continued).**

SN 85-190,947. CAN TECHNOLOGIES, INC., HOPKINS, MN.  
FILED 12-6-2010.

**PROVO**

THE MARK CONSISTS OF STANDARD CHARACTERS WITHOUT CLAIM TO ANY PARTICULAR FONT, STYLE, SIZE, OR COLOR.

THE ENGLISH TRANSLATION OF "PROVO" IN THE MARK IS "I PROVE".

FOR ANIMAL FEED (U.S. CLS. 1 AND 46).

CAROL SPILS, EXAMINING ATTORNEY

SN 85-189,922. ASSOCIATED FRUIT COMPANY, PHOENIX, OR. FILED 12-3-2010.

**PIGGY PEARS**

THE MARK CONSISTS OF STANDARD CHARACTERS WITHOUT CLAIM TO ANY PARTICULAR FONT, STYLE, SIZE, OR COLOR.

NO CLAIM IS MADE TO THE EXCLUSIVE RIGHT TO USE "PEARS", APART FROM THE MARK AS SHOWN.

FOR PEARS, FRESH (U.S. CLS. 1 AND 46).

FIRST USE 10-15-1942; IN COMMERCE 10-15-1942.

BARNEY CHARLON, EXAMINING ATTORNEY

SN 85-195,153. 2941538 CANADA INC, MONT-ROYAL, CANADA, FILED 12-10-2010.

**SUPERTEK PERFECT GRASS**

THE MARK CONSISTS OF STANDARD CHARACTERS WITHOUT CLAIM TO ANY PARTICULAR FONT, STYLE, SIZE, OR COLOR.

NO CLAIM IS MADE TO THE EXCLUSIVE RIGHT TO USE "GRASS", APART FROM THE MARK AS SHOWN.

FOR GRASS SEED; MIXTURE CONSISTING OF GRASS SEED, MULCH AND FERTILIZER SOLD AS A UNIT TO REPAIR LAWNS (U.S. CLS. 1 AND 46).

JOHN GARTNER, EXAMINING ATTORNEY

SN 85-190,946. CAN TECHNOLOGIES, INC., HOPKINS, MN.  
FILED 12-6-2010.

**METIER**

THE MARK CONSISTS OF STANDARD CHARACTERS WITHOUT CLAIM TO ANY PARTICULAR FONT, STYLE, SIZE, OR COLOR.

THE ENGLISH TRANSLATION OF "METIER" IN THE MARK IS TRADE.

FOR ANIMAL FEED (U.S. CLS. 1 AND 46).

CAROL SPILS, EXAMINING ATTORNEY

SN 85-200,644. CO-OPERATIVE FEED DEALERS, INC., CONKLIN, NY. FILED 12-17-2010.

**Loved by Birds and Bird  
Lovers**

THE MARK CONSISTS OF STANDARD CHARACTERS WITHOUT CLAIM TO ANY PARTICULAR FONT, STYLE, SIZE, OR COLOR.

FOR BIRD SEED (U.S. CLS. 1 AND 46).

FIRST USE 5-31-2008; IN COMMERCE 5-31-2008.

THOMAS MANOR, EXAMINING ATTORNEY

**CLASS 31—(Continued).**

SN 85-200,663. CO-OPERATIVE FEED DEALERS, INC.,  
CONKLIN, NY. FILED 12-17-2010.

Your yard is your  
sanctuary: feed the choir.

THE MARK CONSISTS OF STANDARD CHARACTERS  
WITHOUT CLAIM TO ANY PARTICULAR FONT, STYLE,  
SIZE, OR COLOR.

FOR BIRD SEED (U.S. CLS. 1 AND 46).  
FIRST USE 8-31-2010; IN COMMERCE 8-31-2010.  
THOMAS MANOR, EXAMINING ATTORNEY

**CLASS 31—(Continued).**

SN 85-205,177. AGUILA MANAGEMENT, L.L.C., SCOTTS-  
DALE, AZ. FILED 12-23-2010.

LEMON DROP

THE MARK CONSISTS OF STANDARD CHARACTERS  
WITHOUT CLAIM TO ANY PARTICULAR FONT, STYLE,  
SIZE, OR COLOR.

FOR FRESH FRUITS AND FRESH VEGETABLES (U.S.  
CLS. 1 AND 46).  
RENEE MCCRAY, EXAMINING ATTORNEY

SN 85-203,583. RICACHON INVESTMENT ENTERPRISES,  
INC., WEST COVINA, CA. FILED 12-22-2010.

AFFECTION

THE MARK CONSISTS OF STANDARD CHARACTERS  
WITHOUT CLAIM TO ANY PARTICULAR FONT, STYLE,  
SIZE, OR COLOR.

FOR FRESH FRUIT (U.S. CLS. 1 AND 46).  
BRIAN CALLAGHAN, EXAMINING ATTORNEY

SN 85-205,288. BONE SCIENCE, INC., STILLWATER, OK.  
FILED 12-23-2010.

Hero by Bone Science

THE MARK CONSISTS OF STANDARD CHARACTERS  
WITHOUT CLAIM TO ANY PARTICULAR FONT, STYLE,  
SIZE, OR COLOR.

FOR DOG FOOD (U.S. CLS. 1 AND 46).  
TRACY CROSS, EXAMINING ATTORNEY

SN 85-204,981. PHYDEAUX ENTERPRISES, INC., CLINTON  
TOWNSHIP, MI. FILED 12-23-2010.

SUPER BREATH

THE MARK CONSISTS OF STANDARD CHARACTERS  
WITHOUT CLAIM TO ANY PARTICULAR FONT, STYLE,  
SIZE, OR COLOR.

FOR DIGESTIBLE CHEWING BONES FOR DOGS (U.S.  
CLS. 1 AND 46).  
FIRST USE 11-0-2009; IN COMMERCE 11-0-2009.  
PAM WILLIS, EXAMINING ATTORNEY

SN 85-205,337. ACOCK, JAMES, PORTLAND, OR. FILED 12-  
23-2010.

Eco-Proteins

THE MARK CONSISTS OF STANDARD CHARACTERS  
WITHOUT CLAIM TO ANY PARTICULAR FONT, STYLE,  
SIZE, OR COLOR.

FOR PROTEIN FOR ANIMAL CONSUMPTION (U.S.  
CLS. 1 AND 46).  
FIRST USE 12-1-2009; IN COMMERCE 6-1-2010.  
KATINA MISTER, EXAMINING ATTORNEY

**CLASS 31—(Continued).**

SN 85-206,817. GS3 QUALITY SEED INC., MONMOUTH, OR.  
FILED 12-28-2010.

# TILTH PRO

THE MARK CONSISTS OF STANDARD CHARACTERS  
WITHOUT CLAIM TO ANY PARTICULAR FONT, STYLE,  
SIZE, OR COLOR.

FOR PLANT SEEDS (U.S. CLS. 1 AND 46).  
RONALD DELGIZZI, EXAMINING ATTORNEY

---

SN 85-207,146. RUSS DAVIS WHOLESALE, INC., WADENA,  
MN. FILED 12-29-2010.

# CRAZY FRESH

THE MARK CONSISTS OF STANDARD CHARACTERS  
WITHOUT CLAIM TO ANY PARTICULAR FONT, STYLE,  
SIZE, OR COLOR.

NO CLAIM IS MADE TO THE EXCLUSIVE RIGHT TO  
USE "FRESH", APART FROM THE MARK AS SHOWN.  
FOR FRESH FRUIT AND VEGETABLES (U.S. CLS. 1  
AND 46).

FIRST USE 11-1-2010; IN COMMERCE 11-1-2010.  
ELIZABETH KAJUBI, EXAMINING ATTORNEY

---

SN 85-207,240. EVANGER'S DOG & CAT FOOD CO., INC.,  
WHEELING, IL. FILED 12-29-2010.

# Against the Grain

THE MARK CONSISTS OF STANDARD CHARACTERS  
WITHOUT CLAIM TO ANY PARTICULAR FONT, STYLE,  
SIZE, OR COLOR.

FOR PET FOOD; PET TREATS (U.S. CLS. 1 AND 46).  
JILL C. ALT, EXAMINING ATTORNEY

**CLASS 31—(Continued).**

SN 85-209,715. PARKER, HACKNEY, WILMINGTON, NC.  
FILED 1-4-2011.



NO CLAIM IS MADE TO THE EXCLUSIVE RIGHT TO  
USE "MULCH", APART FROM THE MARK AS SHOWN.

THE MARK CONSISTS OF THE WORDS "SEASIDE  
MULCH" WRITTEN OVER AN OVAL WITH THE WORD  
"SEASIDE" OVERLAYING THE TOP PORTION OF THE  
OVAL, AND THE WORD "MULCH" OVERLAYING THE  
BOTTOM PORTION OF THE OVAL. THE TOP HALF OF  
THE LETTERS OF THE WORD "SEASIDE" HANG OFF OF  
THE OVAL. THE LETTER "M" OF THE WORD "MULCH" IS  
UNDER THE LETTER "A" OF THE WORD "SEASIDE." TWO  
LEAVES ASCEND THE LEFT EDGE OF THE OVAL. THE  
FIRST LEAF IS TURNED AWAY FROM THE OVAL AND IS  
JUST ADJACENT TO THE OVAL. THE SECOND LEAF IS IN  
THE SHAPE OF THE LETTER "S." THIS SECOND LEAF  
BACKGROUND THE FIRST LETTER "S" IN THE WORD  
"SEASIDE" AND IS OVERLAID BY THE LEFT EDGE OF  
THE OVAL AND BY THE FIRST LEAF. THE LETTER "I" OF  
"SEASIDE" IS DOTTED WITH A DIAMOND SHAPE.

FOR MULCH (U.S. CLS. 1 AND 46).  
FIRST USE 11-13-1998; IN COMMERCE 3-2-1999.  
SANDRA BUJA, EXAMINING ATTORNEY

---

SN 85-209,728. C.P. YEATMAN & SONS, INC., WEST GROVE,  
PA. FILED 1-4-2011.

# MOTHER EARTH

THE MARK CONSISTS OF STANDARD CHARACTERS  
WITHOUT CLAIM TO ANY PARTICULAR FONT, STYLE,  
SIZE, OR COLOR.

OWNER OF U.S. REG. NO. 708,474.  
FOR FRESH PRODUCE, NAMELY MUSHROOMS (U.S.  
CLS. 1 AND 46).

FIRST USE 0-0-1990; IN COMMERCE 0-0-1990.  
JESSICA A. POWERS, EXAMINING ATTORNEY

---

SN 85-210,314. MARS, INCORPORATED, MCLEAN, VA.  
FILED 1-4-2011.

# HOLY COW!

THE MARK CONSISTS OF STANDARD CHARACTERS  
WITHOUT CLAIM TO ANY PARTICULAR FONT, STYLE,  
SIZE, OR COLOR.

FOR PET FOOD (U.S. CLS. 1 AND 46).  
AISHA SALEM, EXAMINING ATTORNEY

**CLASS 31—(Continued).**

SN 85-210,318. MARS, INCORPORATED, MCLEAN, VA.  
FILED 1-4-2011.

**CAPTAIN'S CATCH**

THE MARK CONSISTS OF STANDARD CHARACTERS  
WITHOUT CLAIM TO ANY PARTICULAR FONT, STYLE,  
SIZE, OR COLOR.  
FOR PET FOOD (U.S. CLS. 1 AND 46).  
AISHA SALEM, EXAMINING ATTORNEY

SN 85-210,691. GOPETDIRECT INC., ANN ARBOR, MI.  
FILED 1-5-2011.



THE MARK CONSISTS OF THE STYLIZED WORDS  
"GOPETDIRECT.COM". AN IMAGE OF ONE DOG AND  
ONE CAT ABOVE THE TEXT.  
FOR PET FOOD (U.S. CLS. 1 AND 46).  
WILLIAM P. SHANAHAN, EXAMINING ATTORNEY

SN 85-212,929. BLUE BUFFALO COMPANY, LTD., WILTON,  
CT. FILED 1-7-2011.



OWNER OF U.S. REG. NOS. 3,620,259 AND 3,833,287.  
NO CLAIM IS MADE TO THE EXCLUSIVE RIGHT TO  
USE "CO.", APART FROM THE MARK AS SHOWN.  
THE MARK CONSISTS OF A DIAMOND-SHAPED LOGO  
ENCOMPASSING A BUFFALO DESIGN ABOVE THE  
WORDING "BLUE", THE TRADE NAME "THE BLUE  
BUFFALO CO." WRITTEN ON ALL FOUR SIDES, AND  
THE DESIGN APPEARS ABOVE THE WORDS "TURKEY  
DAY FEAST" APPEARING IN A LARGE AND SMALL CAPS  
IN A STYLIZED MANNER.  
FOR DOG BISCUITS; DOG FOOD; DOG TREATS; CAT  
FOOD; CAT TREATS; PET BEVERAGES; PET FOOD;  
PET TREATS (U.S. CLS. 1 AND 46).  
DARRYL SPRUILL, EXAMINING ATTORNEY

**CLASS 31—(Continued).**

SN 85-228,900. PENNINGTON SEED, INC. OF NEBRASKA,  
MADISON, GA. FILED 1-28-2011.

**WATER STAR**

THE MARK CONSISTS OF STANDARD CHARACTERS  
WITHOUT CLAIM TO ANY PARTICULAR FONT, STYLE,  
SIZE, OR COLOR.  
OWNER OF U.S. REG. NO. 3,474,131.  
FOR SOD (U.S. CLS. 1 AND 46).  
SCOTT BIBB, EXAMINING ATTORNEY

SN 85-242,814. PRISCELLA ANN HOLDSWORTH, HOUS-  
TON, TX. FILED 2-15-2011.

**WHOLECTABLE**

THE MARK CONSISTS OF STANDARD CHARACTERS  
WITHOUT CLAIM TO ANY PARTICULAR FONT, STYLE,  
SIZE, OR COLOR.  
FOR PET FOOD (U.S. CLS. 1 AND 46).  
STEPHANIE ALI, EXAMINING ATTORNEY

SN 85-244,697. KALMBACH FEEDS, INC., UPPER SANDUS-  
KY, OH. FILED 2-17-2011.

**AUTUMN HARVEST**

THE MARK CONSISTS OF STANDARD CHARACTERS  
WITHOUT CLAIM TO ANY PARTICULAR FONT, STYLE,  
SIZE, OR COLOR.  
FOR ANIMAL FEED (U.S. CLS. 1 AND 46).  
FIRST USE 12-31-2004; IN COMMERCE 12-31-2004.  
ANDREA BUTLER, EXAMINING ATTORNEY

SN 85-245,480. MARS, INCORPORATED, MCLEAN, VA.  
FILED 2-17-2011.

**EVERY DOG DESERVES A GREAT  
START TO LIFE**

THE MARK CONSISTS OF STANDARD CHARACTERS  
WITHOUT CLAIM TO ANY PARTICULAR FONT, STYLE,  
SIZE, OR COLOR.  
FOR PET FOOD (U.S. CLS. 1 AND 46).  
AISHA SALEM, EXAMINING ATTORNEY

**CLASS 31—(Continued).**

SN 85-245,493. MARS, INCORPORATED, MCLEAN, VA.  
FILED 2-17-2011.

**EVERY DOG DESERVES**

THE MARK CONSISTS OF STANDARD CHARACTERS  
WITHOUT CLAIM TO ANY PARTICULAR FONT, STYLE,  
SIZE, OR COLOR.

FOR PET FOOD (U.S. CLS. 1 AND 46).  
AISHA SALEM, EXAMINING ATTORNEY

SN 85-245,505. MARS, INCORPORATED, MCLEAN, VA.  
FILED 2-17-2011.

**EVERY DOG DESERVES LEADING  
NUTRITION**

THE MARK CONSISTS OF STANDARD CHARACTERS  
WITHOUT CLAIM TO ANY PARTICULAR FONT, STYLE,  
SIZE, OR COLOR.

FOR PET FOOD (U.S. CLS. 1 AND 46).  
AISHA SALEM, EXAMINING ATTORNEY

SN 85-246,456. MARS, INCORPORATED, MCLEAN, VA.  
FILED 2-18-2011.



THE COLOR(S) RED, PINK, YELLOW, ORANGE AND  
WHITE IS/ARE CLAIMED AS A FEATURE OF THE MARK.  
THE MARK CONSISTS OF THE WORD "CRAVE" IN  
WHITE ON TOP OF RED SOLID CIRCLES OF VARYING  
SIZES AND SURROUNDED BY RED, PINK, YELLOW AND  
ORANGE SOLID CIRCLES OF VARYING SIZES.

FOR PET FOOD (U.S. CLS. 1 AND 46).  
AISHA SALEM, EXAMINING ATTORNEY

**CLASS 32—LIGHT BEVERAGES**

SN 77-928,419. ENVASADORA AGUIDA, S.A. DE C.V.,  
DOLORES HIDALGO, GTO, MEXICO, FILED 2-4-2010.

**RANCHO NATURA**

THE MARK CONSISTS OF STANDARD CHARACTERS  
WITHOUT CLAIM TO ANY PARTICULAR FONT, STYLE,  
SIZE, OR COLOR.

OWNER OF MEXICO REG. NO. 680455, DATED 8-18-2000,  
EXPIRES 8-18-2020.

OWNER OF U.S. REG. NO. 2,864,111.  
THE ENGLISH TRANSLATION OF "RANCHO NATURA"  
IN THE MARK IS "NATURE RANCH".

FOR MINERAL AND AERATED WATER; SOFT  
DRINKS; FRUIT DRINKS; FRUIT JUICES; SYRUPS  
FOR MAKING SOFT DRINKS AND FRUIT DRINKS  
(U.S. CLS. 45, 46 AND 48).

CAROLYN CATALDO, EXAMINING ATTORNEY

SN 77-932,560. SALES USA INC, LONGVIEW, TX. FILED 2-  
10-2010.

**SQUEEZE ON THE FLAVOR!**

THE MARK CONSISTS OF STANDARD CHARACTERS  
WITHOUT CLAIM TO ANY PARTICULAR FONT, STYLE,  
SIZE, OR COLOR.

FOR FRUIT JUICE (U.S. CLS. 45, 46 AND 48).  
FIRST USE 1-1-1977; IN COMMERCE 1-1-1977.  
DAVID I, EXAMINING ATTORNEY

SN 79-089,589. HIRAFU PTY LTD, BEAUMARIS VIC 3193,  
AUSTRALIA, FILED 9-21-2010.

**AEROTONIC**

THE MARK CONSISTS OF STANDARD CHARACTERS  
WITHOUT CLAIM TO ANY PARTICULAR FONT, STYLE,  
SIZE, OR COLOR.

OWNER OF INTERNATIONAL REGISTRATION 1057215  
DATED 9-21-2010, EXPIRES 9-21-2020.

FOR MINERAL AND AERATED WATERS; DRINK-  
ING WATERS; FLAVOURED WATERS; HYPOTONIC,  
ISOTONIC AND HYPERTONIC BEVERAGES; ENERGY  
DRINKS AND SPORTS DRINKS; FRUIT DRINKS AND  
JUICES; SYRUPS, CONCENTRATES AND POWDERS  
USED IN THE PREPARATION OF FLAVOURED  
WATERS, HYPOTONIC, ISOTONIC AND HYPERTONIC  
BEVERAGES, ENERGY DRINKS, SPORTS DRINKS,  
FRUIT DRINKS AND JUICES (U.S. CLS. 45, 46 AND 48).

ANNE FARRELL, EXAMINING ATTORNEY

**CLASS 32—(Continued).**

SN 79-089,690. HIRAFU PTY LTD, BEAUMARIS VIC 3193, AUSTRALIA, FILED 9-21-2010.

# 1ABOVE

THE MARK CONSISTS OF STANDARD CHARACTERS WITHOUT CLAIM TO ANY PARTICULAR FONT, STYLE, SIZE, OR COLOR.

OWNER OF INTERNATIONAL REGISTRATION 1057460 DATED 9-21-2010, EXPIRES 9-21-2020.

FOR MINERAL AND AERATED WATERS; DRINKING WATERS; FLAVOURED WATERS; HYPOTONIC, ISOTONIC AND HYPERTONIC BEVERAGES; ENERGY DRINKS AND SPORTS DRINKS; FRUIT DRINKS AND JUICES; SYRUPS, CONCENTRATES AND POWDERS USED IN THE PREPARATION OF FLAVOURED WATERS, HYPOTONIC, ISOTONIC AND HYPERTONIC BEVERAGES, ENERGY DRINKS, SPORTS DRINKS, FRUIT DRINKS AND JUICES (U.S. CLS. 45, 46 AND 48).

ANNE FARRELL, EXAMINING ATTORNEY

SN 79-092,960. MARSTON'S PLC, UNITED KINGDOM, FILED 12-24-2010.

# HOBGOBLIN

THE MARK CONSISTS OF STANDARD CHARACTERS WITHOUT CLAIM TO ANY PARTICULAR FONT, STYLE, SIZE, OR COLOR.

OWNER OF INTERNATIONAL REGISTRATION 1066193 DATED 12-24-2010, EXPIRES 12-24-2020.

FOR BEERS AND ALES (U.S. CLS. 45, 46 AND 48).

LEIGH LOWRY, EXAMINING ATTORNEY

SN 85-021,124. SHAWN AND SUZAN'S FRESH NATURALS, LLC, NEW YORK, NY. FILED 4-22-2010.

## Nature's Soda

THE MARK CONSISTS OF STANDARD CHARACTERS WITHOUT CLAIM TO ANY PARTICULAR FONT, STYLE, SIZE, OR COLOR.

NO CLAIM IS MADE TO THE EXCLUSIVE RIGHT TO USE "SODA", APART FROM THE MARK AS SHOWN.

FOR FRUIT-BASED BEVERAGES (U.S. CLS. 45, 46 AND 48).

ELIZABETH KAJUBI, EXAMINING ATTORNEY

**CLASS 32—(Continued).**

SN 85-038,112. RIHA RICHARD HARTINGER GETRAENKE GMBH & CO. HANDELS-KG, 31737 RINTELN, FED REP GERMANY, FILED 5-13-2010.



NO CLAIM IS MADE TO THE EXCLUSIVE RIGHT TO USE "PURE FRUIT", APART FROM THE MARK AS SHOWN.

THE COLOR(S) GREEN, ORANGE, RED, YELLOW, BROWN, BLUE AND WHITE IS/ARE CLAIMED AS A FEATURE OF THE MARK.

THE MARK CONSISTS OF A BANNER IN SHADES OF GREEN WITH THE BORDER OF THE BANNER IN YELLOW WITH A BLUE SHADOW EFFECT ALONG THE BOTTOM AND RIGHT SIDE OF THE BANNER. THE WORDS "PURE FRUIT" APPEAR ON THE FRONT OF THE BANNER IN WHITE. ABOVE THE BANNER IS AN ORANGE, IN ORANGE AND GREEN, AN ORANGE SLICE IN ORANGE AND WHITE, A PINEAPPLE IN YELLOW AND BROWN WITH GREEN LEAVES AND WHITE SHADING, AND AN APPLE IN YELLOW, RED AND GREEN SHADING WITH A BROWN STEM AND A GREEN LEAF.

FOR AERATED WATER, TABLE WATER, MINERAL WATER, LEMONADES, FRUIT EXTRACTS FOR MAKING SOFT DRINKS, FRUIT JUICE, SYRUPS FOR MAKING SOFT DRINKS, SYRUPS FOR MAKING LEMONADES, TOMATO JUICE, VEGETABLE JUICE, NON-ALCOHOLIC PREPARATIONS FOR MAKING SOFT DRINKS (U.S. CLS. 45, 46 AND 48).

PAULA MAHONEY, EXAMINING ATTORNEY

SN 85-040,311. GOLD RUSH BRANDS, LLC, SCARSDALE, NY. FILED 5-17-2010.

## SURGE

THE MARK CONSISTS OF STANDARD CHARACTERS WITHOUT CLAIM TO ANY PARTICULAR FONT, STYLE, SIZE, OR COLOR.

FOR SOFT DRINKS (U.S. CLS. 45, 46 AND 48).

CORY BOONE, EXAMINING ATTORNEY



**CLASS 32—(Continued).**

SN 85-040,546. SUNFRESH NATURAL LLC, PASSAIC, NJ. FILED 5-17-2010.

**SUNFRESH GARDEN**

THE MARK CONSISTS OF STANDARD CHARACTERS WITHOUT CLAIM TO ANY PARTICULAR FONT, STYLE, SIZE, OR COLOR.  
FOR FRUIT JUICES SOLD EXCLUSIVELY TO RETAIL STORES (U.S. CLS. 45, 46 AND 48).  
JEFFREY LOOK, EXAMINING ATTORNEY

SN 85-046,353. ENGLISH, ROBERT, WRENTHAM, MA. FILED 5-24-2010.

**REAL AMERICAN BEER**

THE MARK CONSISTS OF STANDARD CHARACTERS WITHOUT CLAIM TO ANY PARTICULAR FONT, STYLE, SIZE, OR COLOR.  
NO CLAIM IS MADE TO THE EXCLUSIVE RIGHT TO USE "AMERICAN BEER", APART FROM THE MARK AS SHOWN.  
FOR LIGHT BEVERAGE PRODUCTS, NAMELY, BEER, AND MALT BEER (U.S. CLS. 45, 46 AND 48).  
CARYN GLASSER, EXAMINING ATTORNEY

**CLASS 32—(Continued).**

SN 85-047,808. WORLD TRIATHLON CORPORATION, TAMPA, FL. FILED 5-25-2010.

**IRONMAN POWER**

THE MARK CONSISTS OF STANDARD CHARACTERS WITHOUT CLAIM TO ANY PARTICULAR FONT, STYLE, SIZE, OR COLOR.  
OWNER OF U.S. REG. NOS. 1,258,881, 2,869,852 AND OTHERS.  
FOR SPORTS DRINKS, NAMELY, FLAVORED NON-CARBONATED ISOTONIC, HYPERTONIC AND HYPOTONIC BEVERAGES; DRINKING WATER WITH VITAMINS, STILL WATER, SPRING WATER, MINERAL WATER, FLAVORED WATERS, PROCESSED DRINKING WATER, SPARKLING WATER; NON-ALCOHOLIC FRUIT FLAVORED BEVERAGES, FRUIT AND VEGETABLE JUICES; SOFT DRINKS; SYRUPS, NON-ALCOHOLIC FRUIT EXTRACTS AND ESSENCES FOR MAKING NON-ALCOHOLIC, NON-CARBONATED AND CARBONATED SOFT DRINKS; PROTEIN AND CARBOHYDRATE DRINKS FOR USE AS FOOD FILLERS AND NOT FOR USE AS MEAL REPLACEMENTS; FRUIT JUICES AND ENERGY DRINKS CONTAINING NUTRITIONAL SUPPLEMENTS; POWDERS AND SYRUPS USED IN THE PREPARATION OF ISOTONIC, HYPERTONIC AND HYPOTONIC SPORTS DRINKS, SPORTS BEVERAGES AND FRUIT-BASED BEVERAGES, WHICH ARE MARKETED IN ASSOCIATION WITH CONTESTS CONSISTING OF SWIMMING, BIKING AND RUNNING (U.S. CLS. 45, 46 AND 48).  
MICHAEL WEBSTER, EXAMINING ATTORNEY

SN 85-054,196. SURRY LICENSING LLC, KEENE, NH. FILED 6-3-2010.

**MOUNTAIN BEST**

THE MARK CONSISTS OF STANDARD CHARACTERS WITHOUT CLAIM TO ANY PARTICULAR FONT, STYLE, SIZE, OR COLOR.  
NO CLAIM IS MADE TO THE EXCLUSIVE RIGHT TO USE "BEST", APART FROM THE MARK AS SHOWN.  
FOR BEVERAGES, NAMELY, SOFT DRINKS (U.S. CLS. 45, 46 AND 48).  
CARYN GLASSER, EXAMINING ATTORNEY

**CLASS 32—(Continued).**

SN 85-056,499. TARGET BRANDS, INC., MINNEAPOLIS, MN. FILED 6-7-2010.



OWNER OF U.S. REG. NOS. 2,290,302, 2,954,200 AND OTHERS.

NO CLAIM IS MADE TO THE EXCLUSIVE RIGHT TO USE "FARMS", APART FROM THE MARK AS SHOWN.

THE MARK CONSISTS OF THE STYLIZED WORDS "ARCHER FARMS" WRITTEN HORIZONTALLY ABOVE A ROOSTER IMAGE.

FOR BEVERAGES, NAMELY, FRUIT JUICES, FRUIT DRINKS, SMOOTHIES, SODA POP, BOTTLED WATER INCLUDING MINERAL, DRINKING, SPARKLING AND FLAVORED WATER, VEGETABLE JUICES, ENERGY DRINKS; NON-ALCOHOLIC FRUIT EXTRACTS USED IN THE PREPARATION OF BEVERAGES; FRUIT JUICE CONCENTRATES (U.S. CLS. 45, 46 AND 48).

ALEXANDER L. POWERS, EXAMINING ATTORNEY

SN 85-071,243. XL ENERGY DRINK CORP., NEW YORK, NY. FILED 6-24-2010.



OWNER OF U.S. REG. NOS. 3,339,184, 3,796,008 AND OTHERS.

NO CLAIM IS MADE TO THE EXCLUSIVE RIGHT TO USE "USA" AND "SUGAR FREE", APART FROM THE MARK AS SHOWN.

THE COLOR(S) RED AND GRAY IS/ARE CLAIMED AS A FEATURE OF THE MARK.

THE MARK CONSISTS OF THE LETTERS "USA" IN STYLIZED FONT IN GRAY AND TO THE LEFT OF THE LETTERS "XL" WHICH APPEAR IN STYLIZED FONT IN RED BORDERED IN GRAY AND THE WORDING "SUGAR FREE BLAST" IN GRAY AND BELOW THE LETTERS "XL". THE ENTIRE MARK HAS A GRAY BACKGROUND THAT HAS A DARK GRAY BUBBLE TYPE DESIGN AT THE TOP AND AT THE BOTTOM WITH A FADING TO A SOLID DARK GRAY BACKGROUND ON THE BOTTOM.

FOR NON-ALCOHOLIC BEVERAGES, NAMELY, ENERGY DRINKS (U.S. CLS. 45, 46 AND 48).

JULIE WATSON, EXAMINING ATTORNEY

**CLASS 32—(Continued).**

SN 85-071,248. XL ENERGY DRINK CORP., NEW YORK, NY. FILED 6-24-2010.

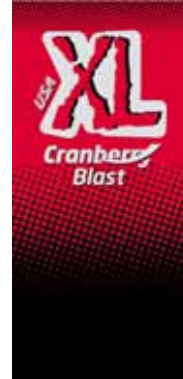

OWNER OF U.S. REG. NOS. 3,339,184, 3,796,008 AND OTHERS.

NO CLAIM IS MADE TO THE EXCLUSIVE RIGHT TO USE "USA" AND "CRANBERRY", APART FROM THE MARK AS SHOWN.

THE COLOR(S) RED, GRAY, BLACK IS/ARE CLAIMED AS A FEATURE OF THE MARK.

THE MARK CONSISTS OF THE LETTERS "USA" IN STYLIZED FONT IN GRAY AND TO THE LEFT OF THE LETTERS "XL" WHICH APPEAR IN STYLIZED FONT IN RED BORDERED IN BLACK AND GRAY WITH THE WORDING "CRANBERRY BLAST" IN STYLIZED FONT IN GRAY AND BELOW THE LETTERS "XL". THE ENTIRE MARK HAS A RED BACKGROUND THAT HAS A DARK GRAY BUBBLE TYPE DESIGN AT THE TOP AND AT THE BOTTOM WITH A FADING TO A SOLID BLACK BACKGROUND ON THE BOTTOM.

FOR NON-ALCOHOLIC BEVERAGES, NAMELY, ENERGY DRINKS (U.S. CLS. 45, 46 AND 48).

JULIE WATSON, EXAMINING ATTORNEY

SN 85-071,251. XL ENERGY DRINK CORP., NEW YORK, NY. FILED 6-24-2010.



OWNER OF U.S. REG. NOS. 3,339,184, 3,796,008 AND OTHERS.

NO CLAIM IS MADE TO THE EXCLUSIVE RIGHT TO USE "USA" AND "LIME&LEMON", APART FROM THE MARK AS SHOWN.

THE COLOR(S) RED, GRAY AND GREEN IS/ARE CLAIMED AS A FEATURE OF THE MARK.

THE MARK CONSISTS OF THE LETTERS "USA" IN

**CLASS 32—(Continued).**

STYLIZED FONT IN DARK GREEN WITH A BORDER AND TO THE LEFT OF THE LETTERS "XL" WHICH APPEAR IN STYLIZED FONT IN RED BORDERED IN GRAY WITH THE WORDING "LIME&LEMON BLAST" IN STYLIZED FONT IN DARK GREEN WITH A GRAY BORDER AND BELOW THE LETTERS "XL". THE ENTIRE MARK HAS A DARK GREEN AND LIGHT GREEN BACKGROUND THAT HAS A DARK GREEN BUBBLE TYPE DESIGN AT THE TOP AND AT THE BOTTOM WITH A FADING TO A SOLID DARK GREEN BACKGROUND ON THE BOTTOM.

FOR NON-ALCOHOLIC BEVERAGES, NAMELY, ENERGY DRINKS (U.S. CLS. 45, 46 AND 48).  
JULIE WATSON, EXAMINING ATTORNEY

**CLASS 32—(Continued).**

SN 85-071,257. XL ENERGY DRINK CORP., NEW YORK, NY. FILED 6-24-2010.



SN 85-071,255. XL ENERGY DRINK CORP., NEW YORK, NY. FILED 6-24-2010.



OWNER OF U.S. REG. NOS. 3,339,184, 3,796,008 AND OTHERS.

NO CLAIM IS MADE TO THE EXCLUSIVE RIGHT TO USE "USA" AND "ENERGY", APART FROM THE MARK AS SHOWN.

THE MARK CONSISTS OF THE LETTERS "USA" IN STYLIZED FONT TO THE LEFT OF THE LETTERS "XL" IN STYLIZED FONT AND THE WORDING "ENERGY BLAST" IN STYLIZED FONT DIRECTLY UNDER THE LETTERS "XL".

FOR NON-ALCOHOLIC BEVERAGES, NAMELY, ENERGY DRINKS (U.S. CLS. 45, 46 AND 48).

FIRST USE 2-0-2010; IN COMMERCE 2-0-2010.

JULIE WATSON, EXAMINING ATTORNEY

OWNER OF U.S. REG. NOS. 3,339,184, 3,796,008 AND OTHERS.

NO CLAIM IS MADE TO THE EXCLUSIVE RIGHT TO USE "USA" AND "ENERGY SHOT", APART FROM THE MARK AS SHOWN.

THE COLOR(S) RED, GREY AND BLUE IS/ARE CLAIMED AS A FEATURE OF THE MARK.

THE MARK CONSISTS OF THE LETTERS "USA" IN STYLIZED FONT IN GREY AND TO THE LEFT OF THE LETTERS "XL" WHICH APPEAR IN STYLIZED FONT IN RED BORDERED IN BLUE AND GREY AND THE WORDING "ENERGY SHOT BLAST" IN STYLIZED FONT IN GREY LETTERS DIRECTLY UNDER THE LETTERS "XL". THE ENTIRE MARK HAS A BLUE BACKGROUND THAT HAS A DARK BLUE BUBBLE TYPE DESIGN AT THE TOP AND AT THE BOTTOM WITH A FADING TO A SOLID DARK BLUE BACKGROUND ON THE BOTTOM.

FOR NON-ALCOHOLIC BEVERAGES, NAMELY, ENERGY DRINKS (U.S. CLS. 45, 46 AND 48).

JULIE WATSON, EXAMINING ATTORNEY

SN 85-090,179. THE KNIGHT ORGANISATION PTY LTD, MELBOURNE 3001 VICT., AUSTRALIA, FILED 7-22-2010.

**REHYDRATE YOUR INNER MATE**

THE MARK CONSISTS OF STANDARD CHARACTERS WITHOUT CLAIM TO ANY PARTICULAR FONT, STYLE, SIZE, OR COLOR.

FOR AERATED SPRING WATERS; AERATED MINERAL WATERS; MINERAL AND AERATED WATERS; TABLE WATERS; NON-MEDICATED MINERAL SPRING WATERS; SPRING WATER OTHER THAN FOR MEDICAL PURPOSES; FLAVOURED MINERAL WATER (U.S. CLS. 45, 46 AND 48).

SALLY SHIH, EXAMINING ATTORNEY

**CLASS 32—(Continued).**

SN 85-098,009. JENKINS, WILLIE, EAST POINT, GA. AND JENKINS, FREDERICK, MARIETTA, GA. FILED 8-2-2010.

## CALCIUM 365

THE MARK CONSISTS OF STANDARD CHARACTERS WITHOUT CLAIM TO ANY PARTICULAR FONT, STYLE, SIZE, OR COLOR.

NO CLAIM IS MADE TO THE EXCLUSIVE RIGHT TO USE "CALCIUM", APART FROM THE MARK AS SHOWN.

FOR AERATED MINERAL WATERS; AERATED WATER; AERATED WATER; BOTTLED ARTESIAN WATER; BOTTLED DRINKING WATER; BOTTLED WATER; CARBONATED WATERS; COCONUT WATER; DISTILLED DRINKING WATER; DRINKING WATER; DRINKING WATER WITH VITAMINS; DRINKING WATERS; ESSENCES FOR MAKING FLAVOURED MINERAL WATER; ESSENCES FOR THE PREPARATION OF MINERAL WATERS; FLAVORED BOTTLED WATER; FLAVORED WATERS; FLAVOURED MINERAL WATER; FLAVOURED WATERS; GLACIAL WATER; LITHIA WATER; MAGNETICALLY TREATED WATER FOR HUMAN CONSUMPTION AND NOT FOR MEDICAL PURPOSES; MINERAL AND AERATED WATER; MINERAL AND AERATED WATERS; MINERAL AND CARBONATED WATERS; MINERAL WATER; PURIFIED BOTTLED DRINKING WATER; QUININE WATER; SCENTED WATER FOR MAKING BEVERAGES; SELTZER WATER; SODA WATER; SPARKLING WATER; SPRING WATER; STILL WATER; STILL WATERS; SYRUPS FOR MAKING FLAVOURED MINERAL WATERS; TABLE WATER; TABLE WATERS; WATER BEVERAGES (U.S. CLS. 45, 46 AND 48).

KAREN BRACEY, EXAMINING ATTORNEY

SN 85-119,977. HOME BREW MART, INC., SAN DIEGO, CA. FILED 8-31-2010.

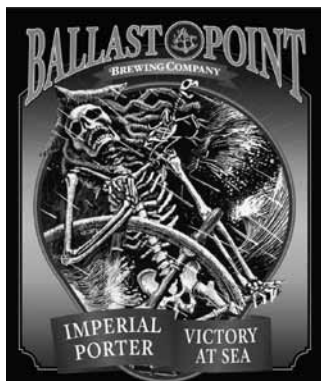

OWNER OF U.S. REG. NOS. 3,475,098, 3,693,175 AND 3,885,844.

NO CLAIM IS MADE TO THE EXCLUSIVE RIGHT TO USE "BREWING COMPANY" AND "IMPERIAL PORTER", APART FROM THE MARK AS SHOWN.

THE MARK CONSISTS OF A PIRATE SKELETON WITH A PARROT SKELETON ON ITS LEFT SHOULDER STANDING BEHIND AND HOLDING ON TO A STEERING

**CLASS 32—(Continued).**

WHEEL; SLANTED RAIN, LIGHTNING AND CRASHING WAVES IN THE BACKGROUND DEPICT A STORM; ABOVE THE SKELETON IMAGE ARE THE TERMS "BALLAST POINT BREWING COMPANY" IN STYLIZED FORM, WHERE A SEXTANT LOGO IN A CIRCLE WITH A ROPE BORDER APPEARS BETWEEN "BALLAST" AND "POINT", AND A RIBBON/BANNER WITH THE TERMS "BREWING COMPANY" APPEARS BELOW; THE STYLIZED TERMS "IMPERIAL PORTER VICTORY AT SEA" IN A RIBBON/BANNER APPEAR BELOW THE SKELETON IMAGE.

FOR BEER (U.S. CLS. 45, 46 AND 48).  
ERIN FALK, EXAMINING ATTORNEY

SN 85-128,137. TALLGRASS BREWING COMPANY, MANHATTAN, KS. FILED 9-13-2010.



OWNER OF U.S. REG. NO. 3,821,622.

NO CLAIM IS MADE TO THE EXCLUSIVE RIGHT TO USE "BREWING CO." AND "STOUT", APART FROM THE MARK AS SHOWN.

THE COLOR(S) LIGHT BROWN, DARK BROWN AND TAN IS/ARE CLAIMED AS A FEATURE OF THE MARK.

THE MARK CONSISTS OF THE WORDS "TALLGRASS BUFFALO SWEAT" APPEARING IN DARK BROWN AND THE WORD "STOUT" APPEARING IN TAN. THE WORDS APPEAR INSIDE A DARK BROWN, LIGHT BROWN AND TAN BISON HEAD WHICH APPEARS INSIDE A DARK BROWN AND TAN RECTANGULAR CARRIER.

FOR BEER, ALE, LAGER, STOUT AND PORTER (U.S. CLS. 45, 46 AND 48).

FIRST USE 5-1-2009; IN COMMERCE 5-1-2009.

SAIMA MAKHDOOM, EXAMINING ATTORNEY

SN 85-143,984. COTLEIGH BREWERY LIMITED, WIVELISCOMBE, TA4 2RE, ENGLAND, FILED 10-4-2010.

## BEERS OF PREY

THE MARK CONSISTS OF STANDARD CHARACTERS WITHOUT CLAIM TO ANY PARTICULAR FONT, STYLE, SIZE, OR COLOR.

NO CLAIM IS MADE TO THE EXCLUSIVE RIGHT TO USE "BEERS", APART FROM THE MARK AS SHOWN.

FOR BEER, ALE, LAGER, STOUT, PORTER, SHANDY (U.S. CLS. 45, 46 AND 48).

KIMBERLY FRYE, EXAMINING ATTORNEY

**CLASS 32—(Continued).**

SN 85-172,807. AIRWAYS BREWING COMPANY LLC, DBA AIRWAYS BREWING COMPANY, KENT, WA. FILED 11-9-2010.

# Sky Hag IPA

THE MARK CONSISTS OF STANDARD CHARACTERS WITHOUT CLAIM TO ANY PARTICULAR FONT, STYLE, SIZE, OR COLOR.

NO CLAIM IS MADE TO THE EXCLUSIVE RIGHT TO USE "IPA", APART FROM THE MARK AS SHOWN.

FOR BEER; BEER WORT; BEER, ALE AND LAGER; BEER, ALE AND PORTER; BEER, ALE, LAGER, STOUT AND PORTER; BEERS; BREWED MALT-BASED ALCOHOLIC BEVERAGE IN THE NATURE OF A BEER; PALE BEER (U.S. CLS. 45, 46 AND 48).

FIRST USE 6-1-2010; IN COMMERCE 7-1-2010.  
CHERYL CLAYTON, EXAMINING ATTORNEY

SN 85-178,715. MALHER, S.A., GUATEMALA CITY, GUATEMALA, FILED 11-17-2010.

## LA FRUTA HECHA AGUA FRESCA

THE MARK CONSISTS OF STANDARD CHARACTERS WITHOUT CLAIM TO ANY PARTICULAR FONT, STYLE, SIZE, OR COLOR.

THE ENGLISH TRANSLATION OF "LA FRUTA HECHA AGUA FRESCA" IN THE MARK IS FRUIT MADE FRESH WATER.

FOR BEVERAGES, NAMELY, NON ALCOHOLIC SOFT DRINKS, FRUIT DRINKS AND FRUIT JUICES; SYRUPS AND POWDERS FOR MAKING SOFT DRINK BEVERAGES, FRUIT DRINKS AND FRUIT JUICES (U.S. CLS. 45, 46 AND 48).

FIRST USE 5-30-2010; IN COMMERCE 5-30-2010.  
JEFFREY LOOK, EXAMINING ATTORNEY

SN 85-179,086. ROLLING MEADOWS BREWERY LLC, AKA ROLLING MEADOWS BREWERY, CANTRALL, IL. FILED 11-17-2010.

# Lincoln Logger

THE MARK CONSISTS OF STANDARD CHARACTERS WITHOUT CLAIM TO ANY PARTICULAR FONT, STYLE, SIZE, OR COLOR.

NO CLAIM IS MADE TO THE EXCLUSIVE RIGHT TO USE "LAGER", APART FROM THE MARK AS SHOWN.

FOR BEER; BEER, ALE AND LAGER; BEER, ALE AND PORTER; BEER, ALE, LAGER, STOUT AND PORTER; BEER, ALE, LAGER, STOUT, PORTER, SHANDY; BEERS (U.S. CLS. 45, 46 AND 48).

FRED CARL, EXAMINING ATTORNEY

**CLASS 32—(Continued).**

SN 85-179,611. CHERRY BAY ORCHARDS, INC., SUTTONS BAY, MI. FILED 11-18-2010.

## CHERRY BAY ORCHARDS

THE MARK CONSISTS OF STANDARD CHARACTERS WITHOUT CLAIM TO ANY PARTICULAR FONT, STYLE, SIZE, OR COLOR.

NO CLAIM IS MADE TO THE EXCLUSIVE RIGHT TO USE "ORCHARDS", APART FROM THE MARK AS SHOWN.

FOR FRUIT JUICE AND FRUIT JUICE CONCENTRATE (U.S. CLS. 45, 46 AND 48).

FIRST USE 5-15-2010; IN COMMERCE 5-15-2010.  
KRISTIN CARLSON, EXAMINING ATTORNEY

SN 85-180,476. EASTERLING, CHRISTOPHER J., DBA FLATLINE, VISTA, CA. AND EASTERLING, RHONDA L., DBA FLATLINE, VISTA, CA. FILED 11-18-2010.



NO CLAIM IS MADE TO THE EXCLUSIVE RIGHT TO USE "ENERGY DRINK", APART FROM THE MARK AS SHOWN.

THE COLOR(S) RED, GREEN, BLACK, GRAY AND WHITE IS/ARE CLAIMED AS A FEATURE OF THE MARK.

THE MARK CONSISTS OF A BLACK BANNER BACKGROUND HAVING A GRAY CROSS HATCH PATTERN AND THE TERMS "FLATLINE" IN RED WITH GRAY OUTLINE AND "ENERGY DRINK" IN WHITE WITH RED OUTLINE IN THE CENTRAL PORTION OF THE BLACK BANNER BACKGROUND, A GRAY SKULL FIGURE ON THE LEFT SIDE OF THE BLACK BANNER BACKGROUND WITH WHITE TEETH AND A WHITE EYEBALL HAVING A BLACK AND GRAY IRIS AND PUPIL WITH RED OUTLINING THE EYEBALL AND IRIS, A GREEN LINE EXTENDING HORIZONTALLY ACROSS THE BLACK BANNER BACKGROUND AND HAVING INTERMITTENT JAGGED PORTIONS AND FADING TO LIGHTER GREEN AT BOTH ENDS.

FOR ENERGY DRINKS (U.S. CLS. 45, 46 AND 48).  
GENE MACIOL, EXAMINING ATTORNEY

**CLASS 32—(Continued).**

SN 85-181,155. EASTERLING, CHRISTOPHER J., DBA FLATLINE, VISTA, CA. AND EASTERLING, RHONDA L., DBA FLATLINE, VISTA, CA. FILED 11-19-2010.



THE COLOR(S) RED, GREEN, BLACK AND GRAY IS/ARE CLAIMED AS A FEATURE OF THE MARK.  
 THE MARK CONSISTS OF THE TERM "FL" IN RED WITH GRAY OUTLINE AND BLACK SHADING, A GREEN LINE EXTENDING HORIZONTALLY TO THE LEFT AND RIGHT OF THE TERM "FL" AND HAVING INTERMITTENT JAGGED PORTIONS AND FADING TO LIGHTER GREEN AT BOTH ENDS, AND THE WHITE APPEARING IN THE DRAWING IS BACKGROUND AND NOT PART OF THE MARK.  
 FOR ENERGY DRINKS (U.S. CLS. 45, 46 AND 48).  
 GENE MACIOL, EXAMINING ATTORNEY

SN 85-181,518. VAN TINE, KURT A., HILLSDALE, NJ. FILED 11-19-2010.

**Jack Pot Energy Shot Your  
 Chance to WIN up to  
 1,000,000 dollars with  
 every Shot!**

THE MARK CONSISTS OF STANDARD CHARACTERS WITHOUT CLAIM TO ANY PARTICULAR FONT, STYLE, SIZE, OR COLOR.  
 NO CLAIM IS MADE TO THE EXCLUSIVE RIGHT TO USE "ENERGY SHOT" OR "SHOT", APART FROM THE MARK AS SHOWN.  
 FOR ENERGY DRINKS (U.S. CLS. 45, 46 AND 48).  
 ALYSSA STEEL, EXAMINING ATTORNEY

SN 85-184,764. MAD SCIENTISTS BREWING PARTNERS LLC, DBA SIXPOINT CRAFT ALES, BROOKLYN, NY. FILED 11-24-2010.

**SEHR CRISP PILSNER**

THE MARK CONSISTS OF STANDARD CHARACTERS WITHOUT CLAIM TO ANY PARTICULAR FONT, STYLE, SIZE, OR COLOR.  
 NO CLAIM IS MADE TO THE EXCLUSIVE RIGHT TO USE "CRISP PILSNER", APART FROM THE MARK AS SHOWN.  
 THE ENGLISH TRANSLATION OF THE WORD "SEHR" IN THE MARK IS "VERY."  
 FOR BEERS (U.S. CLS. 45, 46 AND 48).  
 MARY ROSSMAN, EXAMINING ATTORNEY

**CLASS 32—(Continued).**

SN 85-184,934. M.H. ZEIGLER & SONS, LLC, LANDSDALE, PA. FILED 11-24-2010.

**ZEIGLER'S**

THE MARK CONSISTS OF STANDARD CHARACTERS WITHOUT CLAIM TO ANY PARTICULAR FONT, STYLE, SIZE, OR COLOR.  
 OWNER OF U.S. REG. NOS. 1,331,172, 1,775,411 AND OTHERS.  
 SEC. 2(F).  
 FOR SPARKLING NON-ALCOHOLIC APPLE CIDER (U.S. CLS. 45, 46 AND 48).  
 FIRST USE 9-0-2009; IN COMMERCE 9-0-2009.  
 BERYL GARDNER, EXAMINING ATTORNEY

SN 85-186,603. FIRESTONE WALKER LLC, BUELLTON, CA. FILED 11-29-2010.

**PALE 31**

THE MARK CONSISTS OF STANDARD CHARACTERS WITHOUT CLAIM TO ANY PARTICULAR FONT, STYLE, SIZE, OR COLOR.  
 NO CLAIM IS MADE TO THE EXCLUSIVE RIGHT TO USE "PALE", APART FROM THE MARK AS SHOWN.  
 FOR BEER (U.S. CLS. 45, 46 AND 48).  
 FIRST USE 2-28-2007; IN COMMERCE 2-28-2007.  
 ROBIN CHOSID, EXAMINING ATTORNEY

SN 85-186,685. FIRESTONE WALKER LLC, BUELLTON, CA. FILED 11-29-2010.

**DOUBLE JACK**

THE MARK CONSISTS OF STANDARD CHARACTERS WITHOUT CLAIM TO ANY PARTICULAR FONT, STYLE, SIZE, OR COLOR.  
 NO CLAIM IS MADE TO THE EXCLUSIVE RIGHT TO USE "DOUBLE", APART FROM THE MARK AS SHOWN.  
 FOR BEER (U.S. CLS. 45, 46 AND 48).  
 ROBIN CHOSID, EXAMINING ATTORNEY

**CLASS 32—(Continued).**

SN 85-188,452. WARNER & WORTH, INC., DBA THE CANNON BREWPUB, COLUMBUS, GA. FILED 12-1-2010.

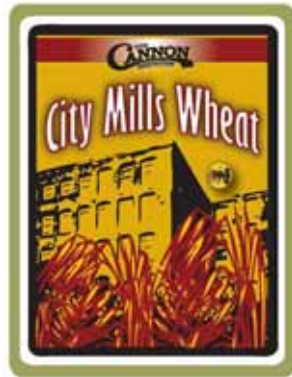

OWNER OF U.S. REG. NOS. 3,622,477, 3,642,602 AND OTHERS.

NO CLAIM IS MADE TO THE EXCLUSIVE RIGHT TO USE "WHEAT" AND "BREW PUB", APART FROM THE MARK AS SHOWN.

THE COLOR(S) GREEN, WHITE, BLACK, RED, YELLOW, AND GOLD IS/ARE CLAIMED AS A FEATURE OF THE MARK.

THE MARK CONSISTS OF GREEN, WHITE AND BLACK CONCENTRIC RECTANGLES WITH A RED AND WHITE BAND ACROSS THE TOP AND CONTAINING A STYLIZED IMAGE OF A GOLD AND BLACK MILL AND RED AND GOLD WHEAT GRASS, WITH THE WORDS "CITY MILLS WHEAT" IN AN ARC OVER THE MILL AND A STYLIZED VERSION OF THE WORDS "THE CANNON BREWPUB" IN BLACK, OUTLINED IN YELLOW WITH A DESIGN OF YELLOW WHEAT PARTIALLY COVERING THE RED AND WHITE BAND. THE WORDS "CITY MILLS WHEAT" ARE IN WHITE AND OUTLINED IN RED WITH BLACK SHADING. OFF TO THE RIGHT OF THE MIDDLE OF THE MARK IS A SMALL YELLOW BUBBLE CONTAINING A STYLIZED IMAGE OF A BLACK CANNON.

FOR BEER (U.S. CLS. 45, 46 AND 48).  
FIRST USE 10-31-1996; IN COMMERCE 10-31-1996.  
MATTHEW EINSTEIN, EXAMINING ATTORNEY

**CLASS 32—(Continued).**

SN 85-188,521. WARNER & WORTH, INC., DBA THE CANNON BREWPUB, COLUMBUS, GA. FILED 12-1-2010.



OWNER OF U.S. REG. NOS. 3,622,477, 3,642,602 AND OTHERS.

NO CLAIM IS MADE TO THE EXCLUSIVE RIGHT TO USE "ALE" AND "BREW PUB", APART FROM THE MARK AS SHOWN.

THE COLOR(S) BLACK, WHITE, RED, ORANGE, YELLOW, YELLOW-GOLD, TAN, CORN-MEAL AND GREEN IS/ARE CLAIMED AS A FEATURE OF THE MARK.

THE MARK CONSISTS OF BLACK, WHITE, GREEN AND RED CONCENTRIC RECTANGLES WITH BLACK, ORANGE, WHITE AND BLACK CONCENTRIC OVALS OVERLAYING SAID RECTANGLES CONTAINING A BLACK STRIPE ACROSS THE MIDDLE WITH A YELLOW-GOLD CIRCLE CONTAINING AN IMAGE OF A CANNON IN BLACK. ABOVE THE BLACK STRIPE ARE THE STYLIZED WORDS "THE CANNON BREWPUB" IN BLACK AND YELLOW OVERLAYING WHITE AND TAN SUNBURSTS OVER A CORN-MEAL BACKGROUND. BELOW THE BLACK STRIP AND OVERLAYING THE OVALS AND PORTIONS OF THE RED RECTANGLE ARE THE WORDS "RED JACKET ALE" OVER AN ARCHED GREEN RECTANGLE, SUCH WORDS BEING WHITE, OUTLINED IN BLACK WITH BLACK SHADING. EMANATING FROM BEHIND THE OVALS AND OVERLAYING THE TOP RIGHT AND LEFT CORNERS OF THE CONCENTRIC RECTANGLES ARE STYLIZED IMAGES OF WHEAT IN YELLOW AND YELLOW-GOLD.

FOR ALE; BEER (U.S. CLS. 45, 46 AND 48).  
FIRST USE 10-31-1996; IN COMMERCE 10-31-1996.  
MATTHEW EINSTEIN, EXAMINING ATTORNEY

SN 85-188,544. PURETECH WATERS OF AMERICA, LLC, GLASTONBURY, CT. FILED 12-1-2010.

## Whale Ade

THE MARK CONSISTS OF STANDARD CHARACTERS WITHOUT CLAIM TO ANY PARTICULAR FONT, STYLE, SIZE, OR COLOR.

NO CLAIM IS MADE TO THE EXCLUSIVE RIGHT TO USE "ADE", APART FROM THE MARK AS SHOWN.

FOR DRINKING WATER; SPORTS DRINKS (U.S. CLS. 45, 46 AND 48).

TARA PATE, EXAMINING ATTORNEY

**CLASS 32—(Continued).**

SN 85-188,572. PURETECH WATERS OF AMERICA, LLC,  
GLASTONBURY, CT. FILED 12-1-2010.

# Whale Aid

THE MARK CONSISTS OF STANDARD CHARACTERS WITHOUT CLAIM TO ANY PARTICULAR FONT, STYLE, SIZE, OR COLOR.

FOR DRINKING WATER; SPORTS DRINKS (U.S. CLS. 45, 46 AND 48).

TARA PATE, EXAMINING ATTORNEY

SN 85-189,029. WARNER & WORTH, INC., DBA THE  
CANNON BREWPUB, COLUMBUS, GA. FILED 12-2-2010.



NO CLAIM IS MADE TO THE EXCLUSIVE RIGHT TO USE "DARK STOUT", APART FROM THE MARK AS SHOWN.

THE COLOR(S) LIGHT GREEN, GREEN, TAN, WHITE, LIME-GREEN, RED, OLIVE, ORANGE, BLACK, AND YELLOW-GOLD IS/ARE CLAIMED AS A FEATURE OF THE MARK.

THE MARK CONSISTS OF LIGHT GREEN, WHITE, AND OLIVE CONCENTRIC RECTANGLES SURROUNDING A GREEN BACKGROUND AND HAVING CONCENTRIC TAN AND ORANGE DIAMONDS OVER A DIAMOND SHAPED OLIVE BACKGROUND. AT THE TOP OF AND OVERLAYING THE DIAMOND SHAPES AND PART OF THE GREEN RECTANGLE BACKGROUND IS THE WORK "IRONCLAD" IN WHITE WITH BLACK SHADING IN AN ARC OVER A RED RECTANGULAR ARC. EMANATING FROM THE TOP OF THE OUTSIDE DIAMOND SHAPE ARE SEVEN LIME-GREEN SPIRES. IN THE UPPER PORTION OF THE OLIVE DIAMOND SHAPED BACKGROUND IS A STYLIZED IMAGE OF A RIVER BOAT SET AGAINST LIGHT OLIVE SUNBURSTS. IN THE CENTER OF THE OLIVE DIAMOND SHAPED BACKGROUND IS A RED STRIPE WITH ORANGE ENDS THAT OVERLAY PORTIONS OF THE ORANGE SHAPED DIAMOND. ACROSS THE RED STRIPE IS THE WORK "DARK" IN WHITE WITH BLACK SHADING BEHIND IT. IN THE LOWER PORTION OF THE OLIVE DIAMOND SHAPED BACKGROUND IS AN OLIVE RECTANGLE BOX WITH A SLIGHT ARC AND HAVING AN ORANGE BORDER. INSIDE THE BOX IS THE WORD "STOUT" IN WHITE WITH A WHITE CONCENTRIC OUTLINE. BELOW THE CONCENTRIC DIAMONDS AND SLIGHTLY OVERLAPPING THEM ARE TWO STYLIZED IMAGES OF WHEAT IN YELLOW AND YELLOW-GOLD, THE ENDS OF WHICH MEET AT A YELLOW-GOLD CIRCLE WITH A BLACK BORDER AND CONTAINING AN IMAGE OF A CANNON IN BLACK.

FOR BEER; STOUT (U.S. CLS. 45, 46 AND 48).  
FIRST USE 10-31-1996; IN COMMERCE 10-31-1996.  
MATTHEW EINSTEIN, EXAMINING ATTORNEY

**CLASS 32—(Continued).**

SN 85-189,206. WARNER & WORTH, INC., DBA THE  
CANNON BREWPUB, COLUMBUS, GA. FILED 12-2-2010.



OWNER OF U.S. REG. NOS. 3,622,477, 3,642,602 AND OTHERS.

NO CLAIM IS MADE TO THE EXCLUSIVE RIGHT TO USE "BREW PUB" AND "ROOT BEER", APART FROM THE MARK AS SHOWN.

THE COLOR(S) RED, YELLOW-GOLD, GOLD, BLACK AND TAN IS/ARE CLAIMED AS A FEATURE OF THE MARK.

THE MARK CONSISTS OF RED PARALLELOGRAM WITH CONVEX CURVED TOP AND BOTTOM OUTLINED IN BLACK AND CONTAINING AN INTERNAL, CONCENTRIC GOLD COLORED BAND, INSIDE OF WHICH ARE THE STYLIZED WORDS "THE" IN BLACK WITH WHITE OUTLINE, "CANNON" IN BLACK WITH YELLOW-GOLD SHADING, AND "BREW PUB" IN BLACK WITH WHITE OUTLINE. OVERLAPPING SUCH FIGURE AT THE BOTTOM IS AN ARCHED RECTANGLE WITH YELLOW-GOLD OUTLINE AND TAN SHADING AND CONTAINING THE WORDS "ROOT BEER", SUCH WORDS BEING IN WHITE WITH BLACK SHADING.

FOR SOFT DRINKS, NAMELY, ROOT BEER (U.S. CLS. 45, 46 AND 48).

FIRST USE 10-31-1996; IN COMMERCE 10-31-1996.  
MATTHEW EINSTEIN, EXAMINING ATTORNEY

SN 85-189,464. CHICAGO BEER COMPANY, ELGIN, IL.  
FILED 12-2-2010.

# Sweet Home Stout

THE MARK CONSISTS OF STANDARD CHARACTERS WITHOUT CLAIM TO ANY PARTICULAR FONT, STYLE, SIZE, OR COLOR.

NO CLAIM IS MADE TO THE EXCLUSIVE RIGHT TO USE "STOUT", APART FROM THE MARK AS SHOWN.

FOR BEER (U.S. CLS. 45, 46 AND 48).  
HOWARD SMIGA, EXAMINING ATTORNEY



**CLASS 32—(Continued).**

SN 85-189,486. CHICAGO BEER COMPANY, CHICAGO, IL. FILED 12-2-2010.

## Pier Pale Ale

THE MARK CONSISTS OF STANDARD CHARACTERS WITHOUT CLAIM TO ANY PARTICULAR FONT, STYLE, SIZE, OR COLOR.

NO CLAIM IS MADE TO THE EXCLUSIVE RIGHT TO USE "PALE ALE", APART FROM THE MARK AS SHOWN. FOR BEER (U.S. CLS. 45, 46 AND 48). HOWARD SMIGA, EXAMINING ATTORNEY

SN 85-189,798. MCMANUS, THOMAS, RALEIGH, NC. FILED 12-2-2010.

## MeM Water

THE MARK CONSISTS OF STANDARD CHARACTERS WITHOUT CLAIM TO ANY PARTICULAR FONT, STYLE, SIZE, OR COLOR.

NO CLAIM IS MADE TO THE EXCLUSIVE RIGHT TO USE "WATER", APART FROM THE MARK AS SHOWN. FOR DRINKING WATER, NAMELY, BAGGED DRINKING WATER (U.S. CLS. 45, 46 AND 48). REBECCA POVARCHUK, EXAMINING ATTORNEY

SN 85-190,182. PERU FOOD IMPORTS, INC., WEST NEW YORK, NY. FILED 12-3-2010.



OWNER OF U.S. REG. NOS. 3,150,334, 3,152,500 AND 3,254,498.

NO CLAIM IS MADE TO THE EXCLUSIVE RIGHT TO USE "PERU FOOD", APART FROM THE MARK AS SHOWN.

THE COLOR(S) RED, WHITE, ORANGE, BLACK, GREEN IS/ARE CLAIMED AS A FEATURE OF THE MARK.

THE MARK CONSISTS OF THE WORDING "PERU FOOD" IN WHITE WITH BLACK SHADING INSIDE A RED BANNER WITH BLACK AND WHITE OUTLINING. ABOVE THE WORDING IS A PARALLELOGRAM WITH A BLACK OUTLINE INSIDE OF WHICH APPEARS A GREEN BODY OF WATER IN FRONT OF A GREEN MOUNTAIN WITH AN ORANGE SUNSET. BELOW THE BANNER IS THE WORDING "UNIVERSAL" IN RED WITH BLACK SHADING. ALL OF THE FOREGOING APPEARS ON TOP OF A BACKGROUND CONSISTING OF VERTICAL RED STRIPES TO THE RIGHT AND LEFT OF THE MARK WITH A VERTICAL WHITE STRIPE IN THE CENTER.

FOR FRUIT BEVERAGES (U.S. CLS. 45, 46 AND 48). RONALD MCMORROW, EXAMINING ATTORNEY

**CLASS 32—(Continued).**

SN 85-193,901. NICOLLE, KENNETH, VICTORIA, BC, CANADA, FILED 12-9-2010.



NO CLAIM IS MADE TO THE EXCLUSIVE RIGHT TO USE "CANADIAN BAGGED WATER" AND "THE DESIGN OF THE MAPLE LEAF", APART FROM THE MARK AS SHOWN.

THE COLOR(S) BLACK, BLUE AND RED IS/ARE CLAIMED AS A FEATURE OF THE MARK.

THE MARK CONSISTS OF THE WORDS "CANADIAN BAGGED WATER" IN BLACK WITH BLUE WAVES BELOW AND A RED CANADIAN MAPLE LEAF.

FOR WATER BEVERAGES (U.S. CLS. 45, 46 AND 48). SIMON TENG, EXAMINING ATTORNEY

SN 85-197,898. RUTA MAYA ROYALTY LTD, AUSTIN, TX. FILED 12-14-2010.

## Ruta Maya

THE MARK CONSISTS OF STANDARD CHARACTERS WITHOUT CLAIM TO ANY PARTICULAR FONT, STYLE, SIZE, OR COLOR.

THE ENGLISH TRANSLATION OF THE MARK IS "MAYAN" ROUTE.

FOR BEERS (U.S. CLS. 45, 46 AND 48). WENDY JUN, EXAMINING ATTORNEY

**CLASS 32—(Continued).**

SN 85-199,667. WAN TAI FENG FOOD CO., LTD., TAOYUAN COUNTY 33045, TAIWAN, FILED 12-16-2010.



THE MARK CONSISTS OF THREE CHINESE CHARACTERS ABOVE THE WORDING MIZUMI WITH A BACKGROUND OF THREE CONCENTRIC OVALS.

THE WORDING MIZUMI HAS NO MEANING IN A FOREIGN LANGUAGE.

THE NON-LATIN CHARACTERS IN THE MARK TRANSLITERATE TO MEI, ZI, MEI AND THIS MEANS BEAUTY, POSTURE, BEAUTY IN ENGLISH.

FOR ALOE VERA DRINKS; FRUIT JUICES; FRUIT JUICE CONCENTRATES; FRUIT DRINKS; VEGETABLE DRINKS; LEMON JUICE BEVERAGES; STRAWBERRY JUICE BEVERAGES; PINEAPPLE JUICE BEVERAGES; GRAPE JUICE BEVERAGES; ORANGE JUICE BEVERAGES; WHEATGRASS JUICE BEVERAGES; COCONUT WATER; SOFT DRINKS; NON-ALCOHOLIC HONEY-BASED BEVERAGES; BEER; MINERAL WATER; BOTTLED WATER; PURIFIED BOTTLED DRINKING WATER; GINSENG JUICE BEVERAGES NOT FOR MEDICAL PURPOSES; PLUM JUICE BEVERAGES; HERBAL JUICES (U.S. CLS. 45, 46 AND 48).

FIRST USE 10-9-2003; IN COMMERCE 10-9-2003.  
BRIAN CALLAGHAN, EXAMINING ATTORNEY

---

SN 85-201,198. MARCELLEEN INC., DEVILS TOWER, WY. FILED 12-18-2010.

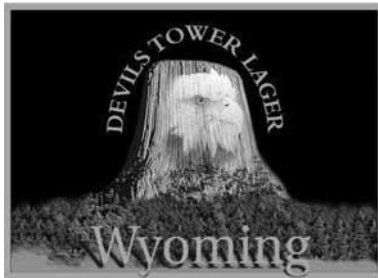

NO CLAIM IS MADE TO THE EXCLUSIVE RIGHT TO USE "LAGER WYOMING", APART FROM THE MARK AS SHOWN.

THE STIPPLING IS FOR SHADING PURPOSES.

THE MARK CONSISTS OF A TOWER WITH THE FACE OF AN EAGLE INSET IN THE TOWER AND WORDS "DEVILS TOWER LAGER" IN ARCH ABOVE THE TOWER. SHRUBS ARE SHOWN BELOW THE TOWER, IN FRONT OF WHICH IS THE WORD "WYOMING".

FOR BEER (U.S. CLS. 45, 46 AND 48).  
FIRST USE 5-1-2005; IN COMMERCE 5-1-2005.  
ALEXANDER L. POWERS, EXAMINING ATTORNEY

**CLASS 32—(Continued).**

SN 85-202,522. MEHRAN BOTTLERS (PVT.) LTD., KARACHI-75700, PAKISTAN, FILED 12-21-2010.

JUCINA

THE MARK CONSISTS OF STANDARD CHARACTERS WITHOUT CLAIM TO ANY PARTICULAR FONT, STYLE, SIZE, OR COLOR.

FOR FRUIT JUICES AND FRUIT DRINK (U.S. CLS. 45, 46 AND 48).

FLORENTINA BLANDU, EXAMINING ATTORNEY

---

SN 85-202,650. BAVARIA S.A., SANTAFE DE BOGOTA, D.C. COLOMBIA, FILED 12-21-2010.

COSTEÑA

THE MARK CONSISTS OF STANDARD CHARACTERS WITHOUT CLAIM TO ANY PARTICULAR FONT, STYLE, SIZE, OR COLOR.

THE ENGLISH TRANSLATION OF "COSTEÑA" IN THE MARK IS "COAST" OR "COASTAL"

FOR BEER (U.S. CLS. 45, 46 AND 48).  
ANGELA DUONG, EXAMINING ATTORNEY

---

SN 85-202,655. BAVARIA S.A., SANTAFE DE BOGOTA, D.C. COLOMBIA, FILED 12-21-2010.

PONY MALTA

THE MARK CONSISTS OF STANDARD CHARACTERS WITHOUT CLAIM TO ANY PARTICULAR FONT, STYLE, SIZE, OR COLOR.

OWNER OF U.S. REG. NO. 1,620,274.

NO CLAIM IS MADE TO THE EXCLUSIVE RIGHT TO USE "MALTA", APART FROM THE MARK AS SHOWN.

THE ENGLISH TRANSLATION OF MALTA IN THE MARK IS "MALT"

FOR NON-ALCOHOLIC MALT BEVERAGE (U.S. CLS. 45, 46 AND 48).

FIRST USE 0-0-1953; IN COMMERCE 0-0-1990.  
ANGELA DUONG, EXAMINING ATTORNEY

**CLASS 32—(Continued).**

SN 85-202,674. CORONADO BREWING COMPANY, INC.,  
CORONADO, CA. FILED 12-21-2010.

# Islander

THE MARK CONSISTS OF STANDARD CHARACTERS WITHOUT CLAIM TO ANY PARTICULAR FONT, STYLE, SIZE, OR COLOR.

FOR BEER; BEER, ALE AND LAGER; BEER, ALE AND PORTER; BEER, ALE, LAGER, STOUT AND PORTER; BEER-BASED COOLERS; BEERS; BREWED MALT-BASED ALCOHOLIC BEVERAGE IN THE NATURE OF A BEER; COFFEE-FLAVORED BEER; FLAVORED BEERS; MALT BEER; MALT LIQUOR; NON-ALCOHOLIC BEER; PALE BEER; PORTER (U.S. CLS. 45, 46 AND 48).

FIRST USE 1-1-2005; IN COMMERCE 6-1-2009.  
MATTHEW PAPPAS, EXAMINING ATTORNEY

SN 85-202,692. CORONADO BREWING COMPANY, INC.,  
CORONADO, CA. FILED 12-21-2010.

# Idiot

THE MARK CONSISTS OF STANDARD CHARACTERS WITHOUT CLAIM TO ANY PARTICULAR FONT, STYLE, SIZE, OR COLOR.

FOR BEER; BEER, ALE AND LAGER; BEER, ALE AND PORTER; BEER, ALE, LAGER, STOUT AND PORTER; BEER-BASED COOLERS; BEERS; BREWED MALT-BASED ALCOHOLIC BEVERAGE IN THE NATURE OF A BEER; COFFEE-FLAVORED BEER; FLAVORED BEERS; MALT BEER; MALT LIQUOR; NON-ALCOHOLIC BEER; PALE BEER; PORTER (U.S. CLS. 45, 46 AND 48).

FIRST USE 4-1-2007; IN COMMERCE 6-1-2009.  
MATTHEW PAPPAS, EXAMINING ATTORNEY

SN 85-202,706. CORONADO BREWING COMPANY, INC.,  
CORONADO, CA. FILED 12-21-2010.

# Hoppy Daze

THE MARK CONSISTS OF STANDARD CHARACTERS WITHOUT CLAIM TO ANY PARTICULAR FONT, STYLE, SIZE, OR COLOR.

FOR BEER; BEER, ALE AND LAGER; BEER, ALE AND PORTER; BEER, ALE, LAGER, STOUT AND PORTER; BEER-BASED COOLERS; BEERS; BREWED MALT-BASED ALCOHOLIC BEVERAGE IN THE NATURE OF A BEER; COFFEE-FLAVORED BEER; FLAVORED BEERS; MALT BEER; MALT LIQUOR; NON-ALCOHOLIC BEER; PALE BEER; PORTER (U.S. CLS. 45, 46 AND 48).

FIRST USE 4-1-2008; IN COMMERCE 8-1-2009.  
MATTHEW PAPPAS, EXAMINING ATTORNEY

**CLASS 32—(Continued).**

SN 85-202,759. CORONADO BREWING COMPANY, INC.,  
CORONADO, CA. FILED 12-21-2010.

# Nutter Brown

THE MARK CONSISTS OF STANDARD CHARACTERS WITHOUT CLAIM TO ANY PARTICULAR FONT, STYLE, SIZE, OR COLOR.

NO CLAIM IS MADE TO THE EXCLUSIVE RIGHT TO USE "BROWN", APART FROM THE MARK AS SHOWN.

FOR BEER; BEER, ALE AND LAGER; BEER, ALE AND PORTER; BEER, ALE, LAGER, STOUT AND PORTER; BEER-BASED COOLERS; BEERS; BREWED MALT-BASED ALCOHOLIC BEVERAGE IN THE NATURE OF A BEER; COFFEE-FLAVORED BEER; FLAVORED BEERS; MALT BEER; MALT LIQUOR; NON-ALCOHOLIC BEER; PALE BEER; PORTER (U.S. CLS. 45, 46 AND 48).

FIRST USE 3-1-2004; IN COMMERCE 7-1-2010.  
MATTHEW PAPPAS, EXAMINING ATTORNEY

SN 85-202,780. BAVARIA S.A., SANTAFE DE BOGOTA, D.C.,  
COLOMBIA, FILED 12-21-2010.



OWNER OF U.S. REG. NO. 1,620,274.

NO CLAIM IS MADE TO THE EXCLUSIVE RIGHT TO USE "MALTA ENERGIA NUTRITIVA Y REFRESCANTE", APART FROM THE MARK AS SHOWN.

THE COLOR(S) RED, WHITE, YELLOW, BLUE, AND BROWN IS/ARE CLAIMED AS A FEATURE OF THE MARK.

THE MARK CONSISTS OF A STYLIZED RECTANGULAR LABEL IN RED, WHITE, YELLOW, BLUE, AND BROWN; A WHITE PONY STANDING UP ON ITS REAR LEGS APPEARS IN THE CENTER OF THE LABEL IN FRONT OF A YELLOW HORSESHOE WITH RED NAIL HOLES; TWO YELLOW GRAIN STALKS APPEAR TO THE RIGHT AND TO THE LEFT OF THE HORSESHOE; THE WORDING "PONY" APPEARS IN WHITE UNDERNEATH THE HORSESHOE; THE WORDING "MALTA" APPEARS IN WHITE DIRECTLY UNDERNEATH THE WORDING "PONY"; AND THE WORDING "ENERGIA NUTRITIVA Y REFRESCANTE" APPEARS IN THE UPPER-RIGHT CORNER OF THE LABEL IN YELLOW.

THE ENGLISH TRANSLATION OF MALTA IS "MALT" AND THE ENGLISH TRANSLATION OF ENERGIA NUTRITIVA Y REFRESCANTE IS "ENERGY NUTRITIOUS AND REFRESHING"

FOR NON-ALCOHOLIC MALT BEVERAGE (U.S. CLS. 45, 46 AND 48).

FIRST USE 1-0-2008; IN COMMERCE 1-0-2008.  
ANGELA DUONG, EXAMINING ATTORNEY

**CLASS 32—(Continued).**

SN 85-203,830. STONY CREEK BREWERY, LLC, BRANFORD, CT. FILED 12-22-2010.

# 203

THE MARK CONSISTS OF STANDARD CHARACTERS WITHOUT CLAIM TO ANY PARTICULAR FONT, STYLE, SIZE, OR COLOR.

FOR BEER (U.S. CLS. 45, 46 AND 48).  
MARILYN IZZI, EXAMINING ATTORNEY

---

SN 85-203,832. STONY CREEK BREWERY, LLC, BRANFORD, CT. FILED 12-22-2010.

# 860

THE MARK CONSISTS OF STANDARD CHARACTERS WITHOUT CLAIM TO ANY PARTICULAR FONT, STYLE, SIZE, OR COLOR.

FOR BEER (U.S. CLS. 45, 46 AND 48).  
MARILYN IZZI, EXAMINING ATTORNEY

---

SN 85-204,776. WYETH HOLDINGS CORPORATION, MADISON, NJ. FILED 12-23-2010.

# VING

THE MARK CONSISTS OF STANDARD CHARACTERS WITHOUT CLAIM TO ANY PARTICULAR FONT, STYLE, SIZE, OR COLOR.

FOR ENERGY DRINKS (U.S. CLS. 45, 46 AND 48).  
AMY C. KEAN, EXAMINING ATTORNEY

---

SN 85-204,820. OSKAR BLUES BREWERY, LLC, DBA OSKAR BLUES BREWERY, LYONS, CO. FILED 12-23-2010.

# G'KNIGHT.

THE MARK CONSISTS OF STANDARD CHARACTERS WITHOUT CLAIM TO ANY PARTICULAR FONT, STYLE, SIZE, OR COLOR.

FOR BEER (U.S. CLS. 45, 46 AND 48).  
FIRST USE 12-23-2010; IN COMMERCE 12-23-2010.  
CHARLOTTE CORWIN, EXAMINING ATTORNEY

**CLASS 32—(Continued).**

SN 85-204,841. FLAT EARTH HOLDINGS, LLC, ST. PAUL, MN. FILED 12-23-2010.

# ANGRY PLANET

THE MARK CONSISTS OF STANDARD CHARACTERS WITHOUT CLAIM TO ANY PARTICULAR FONT, STYLE, SIZE, OR COLOR.

FOR BEER (U.S. CLS. 45, 46 AND 48).  
FIRST USE 5-3-2007; IN COMMERCE 5-3-2007.  
KATHERINE CHANG, EXAMINING ATTORNEY

---

SN 85-204,868. FLAT EARTH HOLDINGS, LLC, ST. PAUL, MN. FILED 12-23-2010.

# CYGNUS X-1

THE MARK CONSISTS OF STANDARD CHARACTERS WITHOUT CLAIM TO ANY PARTICULAR FONT, STYLE, SIZE, OR COLOR.

FOR BEER (U.S. CLS. 45, 46 AND 48).  
FIRST USE 5-16-2007; IN COMMERCE 5-16-2007.  
KATHERINE CHANG, EXAMINING ATTORNEY

---

SN 85-204,883. FLAT EARTH HOLDINGS, LLC, ST. PAUL, MN. FILED 12-23-2010.

# NORTHWEST PASSAGE

THE MARK CONSISTS OF STANDARD CHARACTERS WITHOUT CLAIM TO ANY PARTICULAR FONT, STYLE, SIZE, OR COLOR.

FOR BEER (U.S. CLS. 45, 46 AND 48).  
FIRST USE 5-16-2007; IN COMMERCE 5-16-2007.  
KATHERINE CHANG, EXAMINING ATTORNEY

**CLASS 32—(Continued).**

SN 85-205,120. JANET BARHORST SCHNUR, LOUISVILLE, KY. FILED 12-23-2010.

## OERTELS '92

THE MARK CONSISTS OF STANDARD CHARACTERS WITHOUT CLAIM TO ANY PARTICULAR FONT, STYLE, SIZE, OR COLOR.

NO CLAIM IS MADE TO THE EXCLUSIVE RIGHT TO USE "'92", APART FROM THE MARK AS SHOWN.

FOR BEER (U.S. CLS. 45, 46 AND 48).  
KIM SAITO, EXAMINING ATTORNEY

SN 85-205,195. BAVARIA S.A., BOGOTA, COLOMBIA, FILED 12-23-2010.



OWNER OF U.S. REG. NOS. 2,129,388, 2,714,763 AND 2,892,108.

NO CLAIM IS MADE TO THE EXCLUSIVE RIGHT TO USE "LA CERVEZA DE COLOMBIA AND FAMOSA DESDE 1913", APART FROM THE MARK AS SHOWN.

THE COLOR(S) BLUE, WHITE, RED, BLACK, YELLOW, BROWN, AND GOLD IS/ARE CLAIMED AS A FEATURE OF THE MARK.

THE MARK CONSISTS OF A YELLOW-COLORED OVAL WITH CONCENTRIC BLACK-, RED-, WHITE-, AND BLUE-COLORED LINES AROUND ITS BORDER; INSIDE THE YELLOW-COLORED OVAL, THE WORDING "LA CERVEZA DE COLOMBIA" APPEARS IN BLUE BLOCK LETTERS ALONG THE TOP OF THE OVAL; A BLUE RIBBON WITH A BLACK-COLORED BORDER APPEARS ACROSS THE MIDDLE OF THE YELLOW-COLORED OVAL; THE WORDING "AGUILA" APPEARS IN WHITE BLOCK LETTERS WITH BLACK SHADOWS ACROSS THE RIBBON; A RED LINE RUNS ACROSS THE RIBBON DIRECTLY ABOVE AND DIRECTLY BELOW THE WORDING "AGUILA"; A BLUE-COLORED HALF-SPHERE WITH WHITE-COLORED GRID LINES SITS ATOP THE CENTER OF THE BLUE RIBBON; A BROWN EAGLE WITH A WHITE HEAD, GOLD BEAK, AND GOLD TALONS IS PERCHED ATOP THE HALF-SPHERE WITH ITS WINGS OUTSPREAD; FIVE RED-COLORED RAYS EXTEND OUTWARDS FROM THE HALF-SPHERE TO THE EDGE OF THE YELLOW-COLORED OVAL; THE WORDING "FAMOSA DESDE" APPEARS IN RED BLOCK LETTERS DIRECTLY BELOW THE CENTER OF THE BLUE RIBBON; THE WORDING "1913" APPEARS IN RED BLOCK

**CLASS 32—(Continued).**

LETTERS DIRECTLY BELOW THE CENTER OF THE WORDING "FAMOSA DESDE"; A RED-COLORED, STYLIZED LETTER "B" APPEARS BELOW THE CENTER OF THE WORDING "1913" AND THE HEAD OF AN EAGLE APPEARS IN PROFILE DIRECTLY ABOVE THE LETTER "B"; A BLUE-COLORED CLUSTER OF HOPS APPEARS TO THE LEFT AND TO THE RIGHT OF THE LETTER "B"; AND THE WORDING "SIN IGUAL Y SIEMPRE IGUAL" APPEARS IN RED BLOCK LETTERS BELOW THE LETTER "B" ALONG THE BOTTOM OF THE OVAL.

THE ENGLISH TRANSLATION OF AGUILA, LA CERVEZA DE COLOMBIA, FAMOSA DESDE 1913, AND SIN IGUAL Y SIEMPRE IGUAL IN THE MARK IS EAGLE, THE BEER OF COLOMBIA, FAMOUS SINCE 1913, AND WITHOUT EQUAL AND ALWAYS THE SAME.

FOR BEER (U.S. CLS. 45, 46 AND 48).

FIRST USE 6-10-2010; IN COMMERCE 6-10-2010.

ANGELA DUONG, EXAMINING ATTORNEY

SN 85-205,659. ROGERS, BRUCE A., HAVERTOWN, PA. FILED 12-26-2010.

## Super Duper

THE MARK CONSISTS OF STANDARD CHARACTERS WITHOUT CLAIM TO ANY PARTICULAR FONT, STYLE, SIZE, OR COLOR.

FOR BEAUTY BEVERAGES, NAMELY, FRUIT JUICES AND ENERGY DRINKS CONTAINING NUTRITIONAL SUPPLEMENTS; DRINKING WATER; ENERGY DRINKS; FRUIT DRINKS AND JUICES; POP; PREPARED ENTREES CONSISTING OF FRUIT DRINKS AND FRUIT JUICES, FRUIT-BASED BEVERAGES, NON-ALCOHOLIC BEVERAGES CONTAINING FRUIT JUICES, NON-ALCOHOLIC FRUIT EXTRACTS USED IN THE PREPARATION OF BEVERAGES, NON-ALCOHOLIC FRUIT JUICE BEVERAGES, VEGETABLE JUICES, VEGETABLE-FRUIT JUICES AND SMOOTHIES; SMOOTHIES; SMOOTHIES CONTAINING GRAINS AND OATS; SOFT DRINKS; SPORTS DRINKS; VEGETABLE DRINKS (U.S. CLS. 45, 46 AND 48).

ALLISON HOLTZ, EXAMINING ATTORNEY

SN 85-205,694. SERVANTHOOD, INC., LAURELTON, NY. FILED 12-26-2010.

## THE WINNING DIFFERENCE

THE MARK CONSISTS OF STANDARD CHARACTERS WITHOUT CLAIM TO ANY PARTICULAR FONT, STYLE, SIZE, OR COLOR.

FOR NON ALCOHOLIC BEVERAGES, NAMELY, DRINKING WATER AND FLAVORED DRINKING WATER ENHANCED WITH VITAMINS (U.S. CLS. 45, 46 AND 48).

DANNEAN HETZEL, EXAMINING ATTORNEY

**CLASS 32—(Continued).**

SN 85-206,096. FOO DOG SPIRITS, LLC, HALIFAX, MA.  
FILED 12-27-2010.

# FOO DOG

THE MARK CONSISTS OF STANDARD CHARACTERS  
WITHOUT CLAIM TO ANY PARTICULAR FONT, STYLE,  
SIZE, OR COLOR.

FOR BOTTLED WATER; ENERGY DRINKS; SOFT  
DRINKS (U.S. CLS. 45, 46 AND 48).

KEVON CHISOLM, EXAMINING ATTORNEY

**CLASS 32—(Continued).**

SN 85-208,549. ROYAL ELITE, INC., GIG HARBOR, WA.  
FILED 12-31-2010.

# ROYAL ELITE

THE MARK CONSISTS OF STANDARD CHARACTERS  
WITHOUT CLAIM TO ANY PARTICULAR FONT, STYLE,  
SIZE, OR COLOR.

FOR BEAUTY BEVERAGES, NAMELY, FRUIT JUICES  
AND ENERGY DRINKS CONTAINING NUTRITIONAL  
SUPPLEMENTS; ENERGY DRINKS (U.S. CLS. 45, 46  
AND 48).

BRIDGETT SMITH, EXAMINING ATTORNEY

SN 85-206,239. VANBERG & DEWULF CO, INC., COOPERS-  
TOWN, NY. FILED 12-27-2010.

# BIRALINO

THE MARK CONSISTS OF STANDARD CHARACTERS  
WITHOUT CLAIM TO ANY PARTICULAR FONT, STYLE,  
SIZE, OR COLOR.

FOR NON-ALCOHOLIC ADULT MALT BEVERAGE  
(U.S. CLS. 45, 46 AND 48).

SIMON TENG, EXAMINING ATTORNEY

SN 85-208,733. CHICAGO BEER COMPANY, CHICAGO, IL.  
FILED 12-31-2010.

# Chi Time

THE MARK CONSISTS OF STANDARD CHARACTERS  
WITHOUT CLAIM TO ANY PARTICULAR FONT, STYLE,  
SIZE, OR COLOR.

FOR BEER (U.S. CLS. 45, 46 AND 48).

HOWARD SMIGA, EXAMINING ATTORNEY

SN 85-207,623. DOLE FOOD COMPANY, INC., WESTLAKE  
VILLAGE, CA. FILED 12-29-2010.

# PARADISE ISLAND

THE MARK CONSISTS OF STANDARD CHARACTERS  
WITHOUT CLAIM TO ANY PARTICULAR FONT, STYLE,  
SIZE, OR COLOR.

FOR FRUIT JUICES AND FRUIT DRINKS; NON-  
ALCOHOLIC BEVERAGES CONTAINING FRUIT  
JUICES (U.S. CLS. 45, 46 AND 48).

GRETTA YAO, EXAMINING ATTORNEY

SN 85-208,946. TCOY BRNAD, LLC, MEDIA, PA. FILED 1-3-  
2011.

# BIDO JUICE

THE MARK CONSISTS OF STANDARD CHARACTERS  
WITHOUT CLAIM TO ANY PARTICULAR FONT, STYLE,  
SIZE, OR COLOR.

NO CLAIM IS MADE TO THE EXCLUSIVE RIGHT TO  
USE "JUICE", APART FROM THE MARK AS SHOWN.

FOR SOFT DRINKS (U.S. CLS. 45, 46 AND 48).

HOWARD B. LEVINE, EXAMINING ATTORNEY

**CLASS 32—(Continued).**

SN 85-209,197. PALENZONA FOODS, LLC, MIAMI, FL. FILED 1-3-2011.

# SPACHO

THE MARK CONSISTS OF STANDARD CHARACTERS WITHOUT CLAIM TO ANY PARTICULAR FONT, STYLE, SIZE, OR COLOR.  
FOR SOFT DRINKS, FRUIT JUICES AND VEGETABLE JUICES (U.S. CLS. 45, 46 AND 48).  
LANA PHAM, EXAMINING ATTORNEY

SN 85-209,295. WARNER, RICHARD, HONOLULU, HI. FILED 1-3-2011.

# DIAMOND HEAD BREWERY

THE MARK CONSISTS OF STANDARD CHARACTERS WITHOUT CLAIM TO ANY PARTICULAR FONT, STYLE, SIZE, OR COLOR.  
NO CLAIM IS MADE TO THE EXCLUSIVE RIGHT TO USE "BREWERY", APART FROM THE MARK AS SHOWN.  
FOR BEER (U.S. CLS. 45, 46 AND 48).  
JOHN DWYER, EXAMINING ATTORNEY

SN 85-209,744. CHAMBERS, EDWARD, MELROSE, MA. AND CHAMBERS, KENDRA, MELROSE, MA. FILED 1-4-2011.

# SLUTTY WITCH

THE MARK CONSISTS OF STANDARD CHARACTERS WITHOUT CLAIM TO ANY PARTICULAR FONT, STYLE, SIZE, OR COLOR.  
FOR BEER, ALE AND LAGER (U.S. CLS. 45, 46 AND 48).  
NANCY CLARKE, EXAMINING ATTORNEY

**CLASS 32—(Continued).**

SN 85-209,946. STONY CREEK BREWERY, LLC, BRANFORD, CT. FILED 1-4-2011.

# TWO FISH

THE MARK CONSISTS OF STANDARD CHARACTERS WITHOUT CLAIM TO ANY PARTICULAR FONT, STYLE, SIZE, OR COLOR.  
FOR BEER (U.S. CLS. 45, 46 AND 48).  
MARILYN IZZI, EXAMINING ATTORNEY

SN 85-209,961. STONY CREEK BREWERY, LLC, BRANFORD, CT. FILED 1-4-2011.

# ONE FISH

THE MARK CONSISTS OF STANDARD CHARACTERS WITHOUT CLAIM TO ANY PARTICULAR FONT, STYLE, SIZE, OR COLOR.  
FOR BEER (U.S. CLS. 45, 46 AND 48).  
MARILYN IZZI, EXAMINING ATTORNEY

SN 85-209,966. STONY CREEK BREWERY, LLC, BRANFORD, CT. FILED 1-4-2011.

# SIMPLY GREAT BEER, FROM GREAT PEOPLE, FOR GREAT PEOPLE

THE MARK CONSISTS OF STANDARD CHARACTERS WITHOUT CLAIM TO ANY PARTICULAR FONT, STYLE, SIZE, OR COLOR.  
FOR BEER (U.S. CLS. 45, 46 AND 48).  
MARILYN IZZI, EXAMINING ATTORNEY

SN 85-210,449. SOMMER, CODY, MOORESVILLE, NC. FILED 1-4-2011.

# STOUT21

THE MARK CONSISTS OF THE STYLIZED TEXT "STOUT21" UNDERLINED.  
FOR BEER (U.S. CLS. 45, 46 AND 48).  
MAYUR VAGHANI, EXAMINING ATTORNEY

**CLASS 32—(Continued).**

SN 85-211,919. MVP GROUP INTERNATIONAL, INC., CHARLESTON, SC. FILED 1-6-2011.

**COLD NUTS**

THE MARK CONSISTS OF STANDARD CHARACTERS WITHOUT CLAIM TO ANY PARTICULAR FONT, STYLE, SIZE, OR COLOR.  
FOR COCONUT WATER; COCONUT-BASED BEVERAGES (U.S. CLS. 45, 46 AND 48).  
THEODORE MCBRIDE, EXAMINING ATTORNEY

SN 85-213,169. BODY ARMOR NUTRITION, LLC, BEVERLY HILLS, CA. FILED 1-7-2011.

**Strength From Within**

THE MARK CONSISTS OF STANDARD CHARACTERS WITHOUT CLAIM TO ANY PARTICULAR FONT, STYLE, SIZE, OR COLOR.  
FOR BEAUTY BEVERAGES, NAMELY, FRUIT JUICES AND ENERGY DRINKS CONTAINING NUTRITIONAL SUPPLEMENTS; ENERGY DRINKS; FRUIT FLAVORED DRINKS; SPORTS DRINKS, NAMELY, ENERGY DRINKS (U.S. CLS. 45, 46 AND 48).  
ANDREA K. NADELMAN, EXAMINING ATTORNEY

SN 85-220,606. NEW YORK SPRING WATER, INC., NEW YORK, NY. FILED 1-19-2011.

**KEEPIN' IT FRESH**

THE MARK CONSISTS OF STANDARD CHARACTERS WITHOUT CLAIM TO ANY PARTICULAR FONT, STYLE, SIZE, OR COLOR.  
FOR BOTTLED WATER; DRINKING WATER; FLAVORED WATERS; SODA WATER; SPARKLING WATER; SPRING WATER; TABLE WATER (U.S. CLS. 45, 46 AND 48).  
CORY BOONE, EXAMINING ATTORNEY

**CLASS 32—(Continued).**

SN 85-223,177. STONY CREEK BREWERY, LLC, BRANFORD, CT. FILED 1-21-2011.

**617**

THE MARK CONSISTS OF STANDARD CHARACTERS WITHOUT CLAIM TO ANY PARTICULAR FONT, STYLE, SIZE, OR COLOR.  
FOR BEER (U.S. CLS. 45, 46 AND 48).  
MARILYN IZZI, EXAMINING ATTORNEY

SN 85-223,183. STONY CREEK BREWERY, LLC, BRANFORD, CT. FILED 1-21-2011.

**401**

THE MARK CONSISTS OF STANDARD CHARACTERS WITHOUT CLAIM TO ANY PARTICULAR FONT, STYLE, SIZE, OR COLOR.  
FOR BEER (U.S. CLS. 45, 46 AND 48).  
MARILYN IZZI, EXAMINING ATTORNEY

SN 85-223,189. STONY CREEK BREWERY, LLC, BRANFORD, CT. FILED 1-21-2011.

**917**

THE MARK CONSISTS OF STANDARD CHARACTERS WITHOUT CLAIM TO ANY PARTICULAR FONT, STYLE, SIZE, OR COLOR.  
FOR BEER (U.S. CLS. 45, 46 AND 48).  
MARILYN IZZI, EXAMINING ATTORNEY

SN 85-223,192. STONY CREEK BREWERY, LLC, BRANFORD, CT. FILED 1-21-2011.

**516**

THE MARK CONSISTS OF STANDARD CHARACTERS WITHOUT CLAIM TO ANY PARTICULAR FONT, STYLE, SIZE, OR COLOR.  
FOR BEER (U.S. CLS. 45, 46 AND 48).  
MARILYN IZZI, EXAMINING ATTORNEY



**CLASS 32—(Continued).**

SN 85-229,372. WINERY EXCHANGE, INC., NOVATO, CA. FILED 1-29-2011.

**DOUBLE TAKE BREWING CO.**

THE MARK CONSISTS OF STANDARD CHARACTERS WITHOUT CLAIM TO ANY PARTICULAR FONT, STYLE, SIZE, OR COLOR.

NO CLAIM IS MADE TO THE EXCLUSIVE RIGHT TO USE "BREWING CO.", APART FROM THE MARK AS SHOWN.

FOR BEER (U.S. CLS. 45, 46 AND 48).  
GRETTA YAO, EXAMINING ATTORNEY

**CLASS 32—(Continued).**

SN 85-242,507. BBBT, LLC, NEW EGYPT, NJ. FILED 2-15-2011.

**BLAST IN A GLASS**

THE MARK CONSISTS OF STANDARD CHARACTERS WITHOUT CLAIM TO ANY PARTICULAR FONT, STYLE, SIZE, OR COLOR.

FOR ENERGY DRINKS (U.S. CLS. 45, 46 AND 48).  
STEPHANIE ALI, EXAMINING ATTORNEY

SN 85-230,195. ANHEUSER-BUSCH, INCORPORATED, ST. LOUIS, MO. FILED 1-31-2011.

**THE FAVORITE BEER OF FOOTBALL FANS**

THE MARK CONSISTS OF STANDARD CHARACTERS WITHOUT CLAIM TO ANY PARTICULAR FONT, STYLE, SIZE, OR COLOR.

FOR BEER (U.S. CLS. 45, 46 AND 48).  
JAY FLOWERS, EXAMINING ATTORNEY

SN 85-269,225. NEW HOLLAND BREWING COMPANY, LLC, HOLLAND, MI. FILED 3-17-2011.

**GOLDEN CAP**

THE MARK CONSISTS OF STANDARD CHARACTERS WITHOUT CLAIM TO ANY PARTICULAR FONT, STYLE, SIZE, OR COLOR.

FOR BEER (U.S. CLS. 45, 46 AND 48).  
FIRST USE 5-0-2008; IN COMMERCE 5-0-2008.  
GINA FINK, EXAMINING ATTORNEY

SN 85-236,841. ANHEUSER-BUSCH, INCORPORATED, ST. LOUIS, MO. FILED 2-8-2011.

**NATTY DADDY**

THE MARK CONSISTS OF STANDARD CHARACTERS WITHOUT CLAIM TO ANY PARTICULAR FONT, STYLE, SIZE, OR COLOR.

OWNER OF U.S. REG. NOS. 2,282,182, 3,030,109 AND OTHERS.  
FOR BEER (U.S. CLS. 45, 46 AND 48).  
JAY FLOWERS, EXAMINING ATTORNEY

SN 85-269,327. NEW HOLLAND BREWING COMPANY, LLC, HOLLAND, MI. FILED 3-17-2011.

**BLUE SUNDAY**

THE MARK CONSISTS OF STANDARD CHARACTERS WITHOUT CLAIM TO ANY PARTICULAR FONT, STYLE, SIZE, OR COLOR.

FOR BEER (U.S. CLS. 45, 46 AND 48).  
FIRST USE 7-0-2009; IN COMMERCE 7-0-2009.  
GINA FINK, EXAMINING ATTORNEY

**CLASS 32—(Continued).**

SN 85-269,769. NEW HOLLAND BREWING COMPANY, LLC, HOLLAND, MI. FILED 3-17-2011.

# ENVIOUS

THE MARK CONSISTS OF STANDARD CHARACTERS WITHOUT CLAIM TO ANY PARTICULAR FONT, STYLE, SIZE, OR COLOR.

FOR BEER (U.S. CLS. 45, 46 AND 48).  
FIRST USE 10-0-2009; IN COMMERCE 10-0-2009.  
GINA FINK, EXAMINING ATTORNEY

**CLASS 33—WINES AND SPIRITS**

SN 77-536,337. CADENA LEON JOSE MIGUEL, ZAPOPAN, MEXICO, FILED 7-31-2008.

# DUBAI

THE MARK CONSISTS OF STANDARD CHARACTERS WITHOUT CLAIM TO ANY PARTICULAR FONT, STYLE, SIZE, OR COLOR.

OWNER OF MEXICO REG. NO. 1024267, DATED 2-19-2008, EXPIRES 12-13-2017.  
FOR ALCOHOLIC BEVERAGES EXCEPT BEERS (U.S. CLS. 47 AND 49).  
RENEE MCCRAY, EXAMINING ATTORNEY

SN 77-637,758. TOPA SPIRITS, LLC, LOS ANGELES, CA. FILED 12-22-2008.

# TOPA

THE MARK CONSISTS OF STANDARD CHARACTERS WITHOUT CLAIM TO ANY PARTICULAR FONT, STYLE, SIZE, OR COLOR.

THE ENGLISH TRANSLATION OF "TOPA" IN THE MARK IS TO STRIKE AGAINST.  
FOR ALCOHOLIC BEVERAGES EXCEPT BEERS (U.S. CLS. 47 AND 49).  
MARY BOAGNI, EXAMINING ATTORNEY

**CLASS 33—(Continued).**

SN 77-745,261. ALTO DE CASABLANCA S.A., CASABLANCA, CHILE, FILED 5-27-2009.

# CRUZ ANDINA

THE MARK CONSISTS OF STANDARD CHARACTERS WITHOUT CLAIM TO ANY PARTICULAR FONT, STYLE, SIZE, OR COLOR.

PRIORITY CLAIMED UNDER SEC. 44(D) ON CHILE APPLICATION NO. 863.980, FILED 5-13-2009, REG. NO. 906.980, DATED 1-5-2011, EXPIRES 1-5-2021.

NO CLAIM IS MADE TO THE EXCLUSIVE RIGHT TO USE "ANDINA", APART FROM THE MARK AS SHOWN. THE ENGLISH TRANSLATION OF "CRUZ ANDINA" IN THE MARK IS "ANDEAN CROSS".

FOR WINES (U.S. CLS. 47 AND 49).  
CORY BOONE, EXAMINING ATTORNEY

SN 77-818,893. AIRPORT RANCH ESTATES, LLC, DBA AIRFIELD ESTATES, PROSSER, WA. FILED 9-2-2009.

# Lightning

THE MARK CONSISTS OF STANDARD CHARACTERS WITHOUT CLAIM TO ANY PARTICULAR FONT, STYLE, SIZE, OR COLOR.

FOR WINE (U.S. CLS. 47 AND 49).  
FIRST USE 8-1-2008; IN COMMERCE 8-25-2008.  
WARREN L. OLANDRIA, EXAMINING ATTORNEY

SN 77-884,263. DESTILADOS OLE SA DE CV, MAZATLAN, SINALOA, MEXICO, FILED 12-2-2009.



OWNER OF MEXICO REG. NO. 1056230, DATED 8-26-2009, EXPIRES 8-26-2019.

THE MARK CONSISTS OF A THREE DIMENSIONAL SHAPE FOR A BOTTLE INCLUDING TWO SECTIONS OF

**CLASS 33—(Continued).**

GLASS, A GOODS CONTAINER SECTION AND A BASE SECTION; THE GOODS CONTAINER SECTION HAS THE GENERAL SHAPE OF AN UPSIDE DOWN TEAR DROP AND THE BASE SECTION HAS A QUASI CONICAL SHAPE THAT NARROWS AS IT EXTENDS GENERALLY UPWARDS; AN UPPER PORTION OF THE BASE SECTION FORMS A STYLIZED IMAGE OF A CHILI PEPPER; THE MATTER SHOWN IN BROKEN LINES IS NOT PART OF THE MARK AND SERVES ONLY TO SHOW THE POSITION AND PLACEMENT OF THE MARK.

FOR ALCOHOLIC BEVERAGES, NAMELY, TEQUILA (U.S. CLS. 47 AND 49).

DAVID ELTON, EXAMINING ATTORNEY

**CLASS 33—(Continued).**

SN 77-963,445. LACHETEAU S.A.S., 44330 VALLET, FRANCE, FILED 3-19-2010.



NO CLAIM IS MADE TO THE EXCLUSIVE RIGHT TO USE "MERLOT CABERNET SAUVIGNON" AND THE SHAPE OF THE BOTTLE, APART FROM THE MARK AS SHOWN.

THE COLOR(S) BLACK, WHITE, PINK, SILVER, AND YELLOW IS/ARE CLAIMED AS A FEATURE OF THE MARK.

THE MARK CONSISTS OF A BLACK BOTTLE WITH THE COLOR WHITE IN THE WORDS "BOIRE & MANGER" AND "DRINK & EAT" ON THE FRONT OF THE BOTTLE; THE COLOR BLACK APPEARS IN THE WORDS "DRINK & EAT" ON THE BOTTLE NECK ON A PINK STRIPE; THE COLOR PINK APPEARS IN THE WORDS "MERLOT CABERNET SAUVIGNON"; A COW APPEARS IN WHITE, WITH BLACK SPOTS, SILVER HORNS, HOOVES, AND BELL, A PINK UDDER AND NOSE, AND A YELLOW COLLAR ON A SILVER BACKGROUND WITH SILVER ROCKS BELOW THE COW; THE COW AND ROCKS ARE OUTLINED IN BLACK; THE BOTTLE OF THE NECK APPEARS IN ALTERNATING BLACK AND PINK STRIPES.

THE ENGLISH TRANSLATION OF "BOIRE & MANGER" IN THE MARK IS "DRINK & EAT".

FOR WINE (U.S. CLS. 47 AND 49).

HEATHER BIDDULPH, EXAMINING ATTORNEY

SN 77-962,218. KING CAR FOOD INDUSTRIAL CO., LTD., TAIPEI, TAIWAN, FILED 3-18-2010.

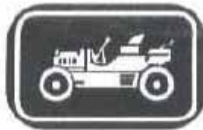

**KING CAR**

PRIORITY CLAIMED UNDER SEC. 44(D) ON TAIWAN APPLICATION NO. 099009318, FILED 3-3-2010, REG. NO. 01435369, DATED 10-16-2010, EXPIRES 10-15-2020.

OWNER OF U.S. REG. NO. 1,409,679.

THE MARK CONSISTS OF A DESIGN OF AN AUTOMOBILE IN WHITE INSIDE OF A BLACK BOX WHICH IS OUTLINED IN WHITE AND AGAIN IN BLACK ABOVE THE WORDS "KING CAR".

FOR WHISKY, VODKA, FRUIT WINE, PREPARED ALCOHOLIC COCKTAILS, RUM, GIN, ABSINTHE, GRAPE WINE, SPIRITS, SPARKLING WINE, DISTILLED LIQUORS, ALCOHOLIC BEVERAGES EXCEPT BEERS, NAMELY, WINE COOLERS, RUM, WHITE WINE, APERITIFS WITH A DISTILLED ALCOHOLIC LIQUOR BASE, WINE, RED WINE, BRANDY (U.S. CLS. 47 AND 49).

ROBIN CHOSID, EXAMINING ATTORNEY

SN 79-060,061. SOCIETE AGRICOLE DE LA DURANCOLE, LANCON DE PROVENCE, FRANCE, FILED 8-22-2008.

# CLOS VICTOIRE

OWNER OF INTERNATIONAL REGISTRATION 0980079 DATED 8-22-2008, EXPIRES 8-22-2018.

NO CLAIM IS MADE TO THE EXCLUSIVE RIGHT TO USE "CLOS", APART FROM THE MARK AS SHOWN.

THE NAME DOES NOT IDENTIFY A LIVING INDIVIDUAL

THE ENGLISH TRANSLATION OF "CLOS VICTOIRE" IN THE MARK IS ENCLOSURE OR ESTATE OF VICTOIRE.

FOR WINES OF GUARANTEED LABEL OF ORIGIN CÔTEAUX D'AIX-EN- PROVENCE, CÔTE DE PROVENCE (U.S. CLS. 47 AND 49).

CARYN GLASSER, EXAMINING ATTORNEY

**CLASS 33—(Continued).**

SN 79-080,109. PREMIUM S.R.L., ITALY, FILED 1-20-2010.



PRIORITY DATE OF 1-14-2010 IS CLAIMED.  
OWNER OF INTERNATIONAL REGISTRATION 1032004  
DATED 1-20-2010, EXPIRES 1-20-2020.  
OWNER OF U.S. REG. NOS. 1,548,559, 2,901,555 AND  
3,725,871.

NO CLAIM IS MADE TO THE EXCLUSIVE RIGHT TO  
USE "1 IN ITALIA", APART FROM THE MARK AS  
SHOWN.

THE MARK CONSISTS OF A GRAPHIC OF A HALF-  
FILLED WINE GLASS BEHIND THE NUMBER "1". WRIT-  
TEN VERTICALLY IN THE "1" IS THE STYLIZED TERM  
"TAVERNELLO" IN FRONT OF A GRAPHIC OF TWO  
LEAVES. WRITTEN IN THE BASE OF THE "1" IS THE  
UNDERLINED STYLIZED WORDING "1 IN ITALIA". AT  
THE UPPER RIGHT CORNER OF THE "1" IS A GRAPHIC  
OF A CIRCLE WITH A STEM AT THE TOP.

THE ENGLISH TRANSLATION OF "1 IN ITALIA" IN  
THE MARK IS "FIRST IN ITALY". THE WORDING  
"TAVERNELLO" HAS NO MEANING IN A FOREIGN  
LANGUAGE.

FOR WINES, SPARKLING WINES (U.S. CLS. 47 AND  
49).

ALYSSA STEEL, EXAMINING ATTORNEY

SN 79-083,271. JOSEPH PERRIER FILS & CIE, FRANCE,  
FILED 5-4-2010.



PRIORITY DATE OF 4-7-2010 IS CLAIMED.  
OWNER OF INTERNATIONAL REGISTRATION 1040702  
DATED 5-4-2010, EXPIRES 5-4-2020.

OWNER OF U.S. REG. NOS. 2,363,774 AND 3,606,196.  
NO CLAIM IS MADE TO THE EXCLUSIVE RIGHT TO  
USE "THE SHAPE OF THE BOTTLE, CORK, AND WIRE  
CORK HOLDER", APART FROM THE MARK AS SHOWN.  
THE NAME(S), PORTRAIT(S), AND/OR SIGNATURE(S)  
SHOWN IN THE MARK DOES NOT IDENTIFY A PARTI-  
CULAR LIVING INDIVIDUAL.

THE MARK CONSISTS OF A DEPICTION OF A FLAT

**CLASS 33—(Continued).**

BOTTOMED WINE BOTTLE WITH THE WORDING "JO-  
SEPH PERRIER" IN STYLIZED FONT VERTICALLY SITU-  
ATED ON THE UPPER NECK AND CORK LABEL. THE  
WORDING "JOSEPH PERRIER" IN STYLIZED FONT AP-  
PEARS AGAIN ON THE CENTER OF THE LABEL ON THE  
BOTTOM OF THE BOTTLE. BENEATH A CROWN, WITH  
DOTTED AND SOLID HORIZONTAL LINES, EACH AP-  
PEARING AT THE TOP AND BOTTOM OF THE LABEL. A  
CHEVRON SHAPE FORMED BY TWO PARALLEL  
ANGLED ROWS OF DOTS IS BLOWN INTO THE GLASS  
AT THE BOTTOM OF THE BOTTLE.

FOR ALCOHOLIC BEVERAGES EXCEPT BEERS (U.S.  
CLS. 47 AND 49).

LIEF MARTIN, EXAMINING ATTORNEY

SN 79-083,429. LIQUEUR AND VODKA DISTILLERY;  
"OSHA", LTD., OMSK REGION, RUSSIAN FED., FILED  
5-28-2010.



OWNER OF INTERNATIONAL REGISTRATION 1041093  
DATED 5-28-2010, EXPIRES 5-28-2020.

THE COLOR(S) WHITE, BLACK AND YELLOW IS/ARE  
CLAIMED AS A FEATURE OF THE MARK.

THE MARK CONSISTS OF THE LITERAL ELEMENT  
MONARHIJA, AND A STYLIZED CROWN DESIGN WITH  
THREE CURVED LINES UNDER MONARHIJA. THE O IN  
MONARHIJA CONTAINS A DESIGN ELEMENT. THE  
COLORS BLACK AND YELLOW APPEAR IN THE LITERAL  
ELEMENT AND DESIGNS. THE COLOR WHITE APPEARS  
AS BACKGROUND.

THE ENGLISH TRANSLATION OF THE FOREIGN  
WORD(S) IN THE MARK IS: MONARCHY.

THE TRANSLITERATION OF THE NON-LATIN CHAR-  
ACTERS IN THE MARK IS: MONARHIJA.

FOR VODKA (U.S. CLS. 47 AND 49).

PAUL MORENO, EXAMINING ATTORNEY

**CLASS 33—(Continued).**

SN 79-084,101. ENOSIS S.R.L., ITALY, FILED 5-20-2010.



PRIORITY DATE OF 12-23-2009 IS CLAIMED.  
OWNER OF INTERNATIONAL REGISTRATION 1042882  
DATED 5-20-2010, EXPIRES 5-20-2020.

NO CLAIM IS MADE TO THE EXCLUSIVE RIGHT TO  
USE "VINO" AND "MARCHIO", APART FROM THE MARK  
AS SHOWN.

THE COLOR(S) GARNET, BLACK, LIGHT GARNET AND  
WHITE IS/ARE CLAIMED AS A FEATURE OF THE MARK.

THE MARK CONSISTS OF A DESIGN OF A MAN,  
WHOSE LEGS AND THE OUTLINES OF HIS FACE AND  
STOMACH ARE IN THE COLOR GARNET. THE MAN'S  
FACE IS IN THE COLOR WHITE. THE MAN'S STOMACH IS  
IN THE COLOR LIGHT GARNET, EXCEPT THE CENTER  
OF THE STOMACH WHICH IS IN THE COLOR WHITE. THE  
MAN IS WEARING A HAT IN THE COLOR GARNET. ON  
THE TOP CENTER OF THE STOMACH THERE IS A BOW  
TIE IN THE COLOR GARNET. ON THE RIGHT SIDE OF  
THE STOMACH IS A HEART WHICH APPEARS IN THE  
COLOR GARNET. AROUND THE LEFT SIDE OF THE  
STOMACH IS THE WORDING "UOMO DEL VINO" IN THE  
COLOR BLACK. AROUND THE RIGHT SIDE OF THE  
STOMACH IS THE WORDING "E DELLA TERRA" IN THE  
COLOR BLACK. UNDER THE MAN IS THE WORDING  
"MARCHIO CERTEZZA" IN THE COLOR BLACK, AND  
"ENOSIS" IN THE COLOR GARNET.

THE ENGLISH TRANSLATION OF "UOMO DEL VINO E  
DELLA TERRA MARCHIO CERTEZZA" IN THE MARK IS  
"MAN OF THE WINE AND OF THE EARTH CERTAINTY  
TRADEMARK".

FOR ALCOHOLIC BEVERAGES EXCEPT BEERS (U.S.  
CLS. 47 AND 49).

MICHAEL WIENER, EXAMINING ATTORNEY

**CLASS 33—(Continued).**SN 79-086,195. MR TRADE DI RABELLINO MARCO, I-12058  
SANTO STEFANO BELBO (CN), ITALY, FILED 6-15-2010.

PRIORITY DATE OF 6-11-2010 IS CLAIMED.  
OWNER OF INTERNATIONAL REGISTRATION 1047981  
DATED 6-15-2010, EXPIRES 6-15-2020.

THE MARK CONSISTS OF THE STYLIZED WORDING  
"INALTO" APPEARING BENEATH A STYLIZED DEPICTION  
OF A LEAFLESS TREE.

THE ENGLISH TRANSLATION OF "INALTO" IS  
"ALOFT".

FOR ALCOHOLIC BEVERAGES EXCEPT BEERS (U.S.  
CLS. 47 AND 49).

FRED CARL, EXAMINING ATTORNEY

SN 79-087,905. POSITSIOON OÜ, ESTONIA, FILED 3-15-2010.

# Seoirse de Brún

THE MARK CONSISTS OF STANDARD CHARACTERS  
WITHOUT CLAIM TO ANY PARTICULAR FONT, STYLE,  
SIZE, OR COLOR.

PRIORITY DATE OF 9-15-2009 IS CLAIMED.  
OWNER OF INTERNATIONAL REGISTRATION 1052627  
DATED 3-15-2010, EXPIRES 3-15-2020.

THE NAME(S), PORTRAIT(S), AND/OR SIGNATURE(S)  
SHOWN IN THE MARK DOES NOT IDENTIFY A PARTI-  
CULAR LIVING INDIVIDUAL.

FOR STRONG ALCOHOLIC BEVERAGES EXCEPT  
BEER, INCLUDING DISTILLED DRINKING SPIRIT  
AND SPIRITS; VODKA (U.S. CLS. 47 AND 49).

LAURIE KAUFMAN, EXAMINING ATTORNEY

**CLASS 33—(Continued).**

SN 79-088,315. SHANXI XINGHUACUN FENJIU DISTILLERY CO., LTD., CHINA, FILED 9-24-2010.

汾酒

OWNER OF INTERNATIONAL REGISTRATION 1053809 DATED 9-24-2010, EXPIRES 9-24-2020.

NO CLAIM IS MADE TO THE EXCLUSIVE RIGHT TO USE THE NON-LATIN CHARACTER THAT MEANS "DISTILLED SPIRIT", APART FROM THE MARK AS SHOWN.

THE MARK CONSISTS OF TWO CHINESE CHARACTERS IN STYLIZED FONT.

THE ENGLISH TRANSLATION OF THE FOREIGN WORD(S) IN THE MARK IS: "FEN" MEANS IS THE NAME OF A RIVER AND "JIU" MEANS "DISTILLED SPIRIT".

THE TRANSLITERATION OF THE NON-LATIN CHARACTERS IN THE MARK IS: "FEN JIU".

FOR ALCOHOLIC FRUIT EXTRACTS; APERITIFS; ARRACK; DISTILLED BEVERAGES, NAMELY, DISTILLED SPIRITS; WINE; DISTILLED SPIRITS AS BEVERAGES; ALCOHOLIC EXTRACTS; ALCOHOLIC BEVERAGES, EXCEPT BEER; YELLOW RICE WINE (U.S. CLS. 47 AND 49).

WILLIAM ROSSMAN, EXAMINING ATTORNEY

SN 79-091,748. CASTELLI DEL GREVEPESA SOCIETÀ COOPERATIVA AGRICOLA, ITALY, FILED 10-1-2010.

CASTELLI DEL  
GREVEPESA

THE MARK CONSISTS OF STANDARD CHARACTERS WITHOUT CLAIM TO ANY PARTICULAR FONT, STYLE, SIZE, OR COLOR.

PRIORITY DATE OF 7-1-2010 IS CLAIMED.

OWNER OF INTERNATIONAL REGISTRATION 1062828 DATED 10-1-2010, EXPIRES 10-1-2020.

OWNER OF U.S. REG. NO. 1,610,725.

THE ENGLISH TRANSLATION OF THE WORDS "CASTELLI DEL GREVEPESA" IN THE MARK IS CASTLE OF GREVEPESA.

FOR ALCOHOLIC BEVERAGES EXCEPT BEERS, INCLUDING WINE, LIGHT WINE, HOLY WINE, GRAPPA (U.S. CLS. 47 AND 49).

KATHRYN COWARD, EXAMINING ATTORNEY

SN 79-091,893. R G & R T TROTT PTY LTD, AUSTRALIA, FILED 12-21-2010.

THE ABSCONDER

THE MARK CONSISTS OF STANDARD CHARACTERS WITHOUT CLAIM TO ANY PARTICULAR FONT, STYLE, SIZE, OR COLOR.

PRIORITY DATE OF 11-25-2010 IS CLAIMED.

OWNER OF INTERNATIONAL REGISTRATION 1063281 DATED 12-21-2010, EXPIRES 12-21-2020.

FOR WINE (U.S. CLS. 47 AND 49).

FRED CARL, EXAMINING ATTORNEY

**CLASS 33—(Continued).**

SN 79-092,402. COGNAC DE LUZE, FRANCE, FILED 12-23-2010.

The Choice of Delight

THE MARK CONSISTS OF STANDARD CHARACTERS WITHOUT CLAIM TO ANY PARTICULAR FONT, STYLE, SIZE, OR COLOR.

PRIORITY DATE OF 12-8-2010 IS CLAIMED.

OWNER OF INTERNATIONAL REGISTRATION 1064648 DATED 12-23-2010, EXPIRES 12-23-2020.

FOR ALCOHOLIC BEVERAGES EXCEPT BEER (U.S. CLS. 47 AND 49).

INGA ERVIN, EXAMINING ATTORNEY

SN 85-007,717. DISTILLERIE TUONI E CANEPA, S.R.L., LIVORNO, ITALY, FILED 4-6-2010.



OWNER OF U.S. REG. NOS. 830,728, 3,511,049 AND OTHERS.

NO CLAIM IS MADE TO THE EXCLUSIVE RIGHT TO USE "LIQUORE ORIGINALE" AND "LIQUEUR" AND "1938", APART FROM THE MARK AS SHOWN.

THE MARK CONSISTS OF THE WORDING "TUACA, TUONI & CANEPA, 1938, LIQUORE ORIGINALE, LIQUEUR" AND A CONFIGURATION OF LION CREST MOTIF ON THE SHOULDER OF THE BOTTLE AND THE RAISED WORDS "TUONI & CANEPA" AT THE BOTTOM OF THE BOTTLE. THE SHAPE OF THE BOTTLE AND BOTTLE CAP ARE NOT CLAIMED AS PART OF THE MARK AND APPEAR IN DOTTED LINES.

THE ENGLISH TRANSLATION OF "LIQUORE ORIGINALE" IN THE MARK IS ORIGINAL LIQUEUR.

FOR DISTILLED SPIRITS (U.S. CLS. 47 AND 49).

ALICIA COLLINS, EXAMINING ATTORNEY

**CLASS 33—(Continued).**

SN 85-018,902. MITCHELL, PIERRE, TWENTYNINE PALMS, CA. FILED 4-20-2010.

**CLIFF RAVEN**

THE MARK CONSISTS OF STANDARD CHARACTERS WITHOUT CLAIM TO ANY PARTICULAR FONT, STYLE, SIZE, OR COLOR.

OWNER OF U.S. REG. NO. 3,423,926.

THE NAME "CLIFF RAVEN" SHOWN IN THE MARK DOES NOT IDENTIFY A PARTICULAR LIVING INDIVIDUAL.

SEC. 2(F).

FOR DISTILLED SPIRITS; LIQUOR; NATURAL SPARKLING WINES; RED WINES; SPARKLING WINES; TABLE WINES; WHITE WINE; WINES; WINES AND LIQUEURS; WINES AND SPARKLING WINES (U.S. CLS. 47 AND 49).

CHARISMA HAMPTON, EXAMINING ATTORNEY

**CLASS 33—(Continued).**

SN 85-031,383. GANSU BINHE FOODSTUFF INDUSTRY GROUP CO. LTD., GANSU PROVINCE., CHINA, FILED 5-6-2010.



SN 85-021,470. DIAGEO BRANDS B.V., AMSTERDAM 1014 BG, NETHERLANDS, FILED 4-23-2010.

**DIGAN JOHNNIE**

THE MARK CONSISTS OF STANDARD CHARACTERS WITHOUT CLAIM TO ANY PARTICULAR FONT, STYLE, SIZE, OR COLOR.

OWNER OF U.S. REG. NOS. 78,556, 3,280,168 AND OTHERS.

THE NAME "DIGAN JOHNNIE" DOES NOT IDENTIFY A LIVING INDIVIDUAL.

FOR ALCOHOLIC BEVERAGES EXCEPT BEERS (U.S. CLS. 47 AND 49).

TARA PATE, EXAMINING ATTORNEY

THE MARK CONSISTS OF CHINESE CHARACTERS WHICH TRANSLITERATE TO "JIU LIANG YE".

THE NON-LATIN CHARACTERS IN THE MARK TRANSLITERATE TO "JIU LIANG YE" AND THIS MEANS "JUICE OF NINE CEREALS" IN ENGLISH.

FOR ABSINTHE; ALCOHOLIC APERITIF BITTERS; ALCOHOLIC BEVERAGE PRODUCED FROM A BREWED MALT BASE WITH NATURAL FLAVORS; ALCOHOLIC BEVERAGES OF FRUIT; ALCOHOLIC BEVERAGES EXCEPT BEERS; ALCOHOLIC BEVERAGES, NAMELY, FLAVOR-INFUSED WHISKEY; ALCOHOLIC BEVERAGES, NAMELY, DIGESTIFS; ALCOHOLIC BITTERS; ALCOHOLIC COCKTAIL MIXES; ALCOHOLIC COCKTAILS CONTAINING MILK; ALCOHOLIC COFFEE-BASED BEVERAGE; ALCOHOLIC EGG NOG; ALCOHOLIC ENERGY DRINKS; ALCOHOLIC ESSENCES; ALCOHOLIC EXTRACTS; ALCOHOLIC FRUIT COCKTAIL DRINKS; ALCOHOLIC FRUIT EXTRACTS; ALCOHOLIC MALT COOLERS; ALCOHOLIC PUNCH; ALCOHOLIC PUNCHES; ALCOHOLIC TEA-BASED BEVERAGE; AMONTILLADO; ANISE; ANISETTE; APERITIF WINES; APERITIFS; APERITIFS WITH A DISTILLED ALCOHOLIC LIQUOR BASE; APERITIFS WITH A WINE BASE; AQUAVIT; ARAK; ARMAGNAC; ARRACK; BLACKCURRANT LIQUEUR; BOURBON; BRANDY; BRANDY SPIRITS; CACHACA; CALVADOS; CHAMPAGNE; CHERRY BRANDY; CHINESE BREWED LIQUOR, NAMELY, LAO-JIOU; CHINESE MIXED LIQUOR, NAMELY, WUJIAPIE-JIOU; CHINESE SPIRIT OF SORGHUM, NAMELY, GAOLIAN-JIOU; CHINESE WHITE LIQUOR, NAMELY, BAIGANR; COFFEE-BASED LIQUEURS; COGNAC; COOKING BRANDY; COOKING WINE; CORDIALS; CREAM LIQUEURS; CURACAO; DISTILLED SPIRITS; DISTILLED SPIRITS OF RICE, NAMELY, AWAMORI; EXTRACTS OF SPIRITUOUS LIQUORS; FLAVORED BREWED MALT BEVERAGE; FORTIFIED WINES; FRENCH BRANDY; FRUIT WINE; GIN; GRAPE WINE; GRAPPA; HARD CIDER; HERB LIQUEURS; HONEY WINE; JAPANESE REGENERATED LIQUORS, NAMELY, NAOSHI; JAPANESE SHOCHU-BASED

SN 85-030,128. VIÑA SANTA CAROLINA S.A., SANTIAGO, CHILE, FILED 5-4-2010.

**SANTA CAROLINA HERENCIA  
VIVA**

THE MARK CONSISTS OF STANDARD CHARACTERS WITHOUT CLAIM TO ANY PARTICULAR FONT, STYLE, SIZE, OR COLOR.

OWNER OF U.S. REG. NO. 1,153,350.

THE ENGLISH TRANSLATION OF "HERENCIA VIVA" IN THE MARK IS HERITAGE ALIVE.

FOR WINE (U.S. CLS. 47 AND 49).

MARTHA FROMM, EXAMINING ATTORNEY

**CLASS 33—(Continued).**

MIXED LIQUOR, NAMELY, MIRIN; JAPANESE SWEET RICE-BASED MIXED LIQUOR, NAMELY, SHIRO-ZAKE; JAPANESE WHITE LIQUOR, NAMELY, SHOCHU; KIRSCH; KITS FOR MAKING WINE; LIQUEURS; DISTILLED LIQUOR; MEAD; MESCAL; NATURAL SPARKLING WINES; OUZO; PERRY; POMMEAU; PORT; PORT WINES; POTABLE SPIRITS; PREPARED ALCOHOLIC COCKTAIL; PREPARED WINE COCKTAILS; RED WINES; RUM; RUM INFUSED WITH VITAMINS; SAKE; SAMBUCA; SANGRIA; SCHNAPPS; SCOTCH; SHERRY; SPARKLING FRUIT WINE; SPARKLING GRAPE WINE; SPARKLING WINES; SPIRITS AND LIQUEURS; STILL WINES; STRAWBERRY WINE; SUGAR CANE JUICE RUM; SWEET WINES; TABLE WINES; TEQUILA; TEQUILA INFUSED WITH VITAMINS; TONIC LIQUOR CONTAINING HERB EXTRACTS, NAMELY, HOMEISHU; VERMOUTH; VODKA; WHISKY; WHITE WINE; WINE COOLERS; WINE PUNCHES; WINES; WINES AND FORTIFIED WINES; WINES AND LIQUEURS; WINES AND SPARKLING WINES; WINE-BASED DRINKS (U.S. CLS. 47 AND 49).

MICHAEL GAAFAR, EXAMINING ATTORNEY

SN 85-031,977. NUMBRANDS INC., WHITE PLAINS, NY.  
FILED 5-6-2010.



NO CLAIM IS MADE TO THE EXCLUSIVE RIGHT TO USE "SPIRIT", APART FROM THE MARK AS SHOWN.

THE MARK CONSISTS OF A LARGE REPRESENTATION OF THE LETTER "A" WITH A SUPERScript LETTER "V" TO THE UPPER RIGHT HAND CORNER; THE WORDING "ANESTASIA" APPEARS UNDERNEATH IN INITIAL CAP STYLIZED TYPEFACE; THE WORDING "SENSATIONAL SPIRIT" APPEARS UNDERNEATH IN ALL CAPITAL LETTERS IN A STANDARD TYPEFACE.

FOR DISTILLED SPIRITS (U.S. CLS. 47 AND 49).  
KHANH LE, EXAMINING ATTORNEY

**CLASS 33—(Continued).**

SN 85-040,366. VINELAND ESTATES WINERY LTD., VINELAND, ONTARIO, CANADA, FILED 5-17-2010.

# VICE

THE MARK CONSISTS OF STANDARD CHARACTERS WITHOUT CLAIM TO ANY PARTICULAR FONT, STYLE, SIZE, OR COLOR.

OWNER OF CANADA REG. NO. TMA762,089, DATED 3-19-2010, EXPIRES 3-19-2025.

FOR ALCOHOLIC BEVERAGES CONSISTING OF VODKA AND ICEWINE (U.S. CLS. 47 AND 49).  
FIRST USE 4-7-2010; IN COMMERCE 4-7-2010.  
KELLY BOULTON, EXAMINING ATTORNEY

SN 85-040,756. BLASTED CHURCH VINEYARDS INC., OKANAGAN FALLS, B.C., CANADA, FILED 5-17-2010.

# BLASTED CHURCH

THE MARK CONSISTS OF STANDARD CHARACTERS WITHOUT CLAIM TO ANY PARTICULAR FONT, STYLE, SIZE, OR COLOR.

OWNER OF CANADA REG. NO. TMA600,786, DATED 1-28-2004, EXPIRES 1-28-2019.

FOR WINE (U.S. CLS. 47 AND 49).  
EDWARD NELSON, EXAMINING ATTORNEY

SN 85-040,968. CONFIDENTIAL VINTNERS LLC, ST. HELENA, CA. FILED 5-18-2010.

# VIRAGE

THE MARK CONSISTS OF STANDARD CHARACTERS WITHOUT CLAIM TO ANY PARTICULAR FONT, STYLE, SIZE, OR COLOR.

THE ENGLISH TRANSLATION OF "VIRAGE" IN THE MARK IS A CURVE OR BEND IN THE ROAD.

FOR WINE (U.S. CLS. 47 AND 49).  
ANNE MADDEN, EXAMINING ATTORNEY



**CLASS 33—(Continued).**

SN 85-068,865. OGDEN'S OWN DISTILLERY, LLC, OGDEN, UT. FILED 6-22-2010.

**UNDERGROUND HERBAL SPIRIT**

THE MARK CONSISTS OF STANDARD CHARACTERS WITHOUT CLAIM TO ANY PARTICULAR FONT, STYLE, SIZE, OR COLOR.

NO CLAIM IS MADE TO THE EXCLUSIVE RIGHT TO USE "HERBAL SPIRIT", APART FROM THE MARK AS SHOWN.

FOR ALCOHOLIC BEVERAGES, NAMELY, HERBAL LIQUEURS; ALCOHOLIC BITTERS; DISTILLED SPIRITS (U.S. CLS. 47 AND 49).

FIRST USE 6-1-2010; IN COMMERCE 6-1-2010.  
MICHAEL KEATING, EXAMINING ATTORNEY

SN 85-069,897. RICHARD FINE, NEW YORK, NY. FILED 6-23-2010.

**& ASSOCIATES**

THE MARK CONSISTS OF STANDARD CHARACTERS WITHOUT CLAIM TO ANY PARTICULAR FONT, STYLE, SIZE, OR COLOR.

FOR READY-TO-DRINK WINE COCKTAIL (U.S. CLS. 47 AND 49).

ANTHONY RINKER, EXAMINING ATTORNEY

SN 85-070,861. CC1 BEER DISTRIBUTORS, INC., DBA MEDALLA DISTRIBUTORS PUERTO RICO, TOA BAJA, PUERTO RICO, FILED 6-24-2010.

**RON PASEO CARIBE**

THE MARK CONSISTS OF STANDARD CHARACTERS WITHOUT CLAIM TO ANY PARTICULAR FONT, STYLE, SIZE, OR COLOR.

NO CLAIM IS MADE TO THE EXCLUSIVE RIGHT TO USE "RON" AND "CARIBE", APART FROM THE MARK AS SHOWN.

THE ENGLISH TRANSLATION OF "RON", "PASEO" & "CARIBE" IN THE MARK IS RUM, WALKWAY & CARIBBEAN.

FOR RUM (U.S. CLS. 47 AND 49).  
STEPHANIE ALI, EXAMINING ATTORNEY

**CLASS 33—(Continued).**

SN 85-074,909. CHEVALIER COLLECTION, LTD, BEVERLY HILLS, CA. FILED 6-30-2010.

**DOUBLE AGENT**

THE MARK CONSISTS OF STANDARD CHARACTERS WITHOUT CLAIM TO ANY PARTICULAR FONT, STYLE, SIZE, OR COLOR.

FOR WINE; GIN; BOURBON; VODKA; SCOTCH; DISTILLED SPIRITS; SPIRITS AND LIQUEURS (U.S. CLS. 47 AND 49).

JOHN SCHUYLER YARD, EXAMINING ATTORNEY

SN 85-078,796. ZIVENKO, SERGEY VIKTOROVICH, MOSCOW, RUSSIAN FED., FILED 7-6-2010.



OWNER OF U.S. REG. NOS. 2,801,797 AND 3,577,938.  
NO CLAIM IS MADE TO THE EXCLUSIVE RIGHT TO USE "RUSSIAN", APART FROM THE MARK AS SHOWN.

THE COLOR(S) GREY, BLACK, WHITE IS/ARE CLAIMED AS A FEATURE OF THE MARK.

THE MARK CONSISTS OF THE WORDS "RUSSIAN WHITE GOLD" IN BLACK ON A GREY SHIELD WITH A WHITE BORDER SURROUNDED BY PARALLEL BARS IN GREY AND WHITE AND A BACKGROUND OF WHITE WITH MULTIPLE DIAMONDS IN GREY.

FOR VODKA (U.S. CLS. 47 AND 49).  
FONG HSU, EXAMINING ATTORNEY

**CLASS 33—(Continued).**

SN 85-079,249. DIAGEO NORTH AMERICA, INC., NORWALK, CT. FILED 7-7-2010.



NO CLAIM IS MADE TO THE EXCLUSIVE RIGHT TO USE "CREAM", APART FROM THE MARK AS SHOWN. THE MARK CONSISTS OF A STYLIZED LETTER "Q" TOPPED WITH A CROWN OVER THE WORD "QREAM". THE TAIL OF THE STYLIZED "Q" REACHES DOWNWARD TO CROSS THE "A" IN THE WORD "QREAM".

FOR ALCOHOLIC BEVERAGES EXCEPT BEERS (U.S. CLS. 47 AND 49).

KATHERINE M. DUBRAY, EXAMINING ATTORNEY

**CLASS 33—(Continued).**

SN 85-084,884. THE AWATERE RIVER WINE COMPANY LIMITED, MARLBOROUGH, NEW ZEALAND, FILED 7-14-2010.



OWNER OF NEW ZEALAND REG. NO. 811439, DATED 8-21-2009, EXPIRES 8-21-2019.

THE COLOR(S) BROWN, BLUE, GREY, BLACK AND WHITE IS/ARE CLAIMED AS A FEATURE OF THE MARK.

THE MARK CONSISTS OF THE WORDING "AWATERE RIVER" IN BROWN WITH A RIVER VALLEY SCENE CONSISTING OF WHITE SKY, BLACK AND GRAY MOUNTAINS, BROWN FOOTHILLS, BROWN, BLACK AND WHITE CLIFFS AND WHITE AND BLUE RAPIDS PARTIALLY OUTLINED IN BLACK.

FOR WINES (U.S. CLS. 47 AND 49).

BRIAN CALLAGHAN, EXAMINING ATTORNEY

SN 85-084,879. BODEGAS PAGO DE LARRAINZAR SL, AYEGUL, SPAIN, FILED 7-14-2010.



OWNER OF U.S. REG. NOS. 3,533,532 AND 3,536,357. NO CLAIM IS MADE TO THE EXCLUSIVE RIGHT TO USE "2007", APART FROM THE MARK AS SHOWN.

THE COLOR(S) RED, WHITE, GREY AND BLACK IS/ARE CLAIMED AS A FEATURE OF THE MARK.

THE MARK CONSISTS OF A RED AND WHITE HEAD WITH ITS HAIR ADORNED WITH RED AND WHITE GRAPES, VINES AND RIBBONS WITH "RASO" IN RED AND "DE LARRAINZAR 2007" IN GREY ON A WHITE BACKGROUND ALL CONTAINED IN A BLACK SINGLE LINE POLYGON.

THE ENGLISH TRANSLATION OF "RASO" IN THE MARK IS SATIN.

FOR ALCOHOLIC BEVERAGES, EXCEPT BEERS (U.S. CLS. 47 AND 49).

BRENDAN MCCAULEY, EXAMINING ATTORNEY

SN 85-094,279. TEQUILA CUERVO LA ROJENA, S.A. DE C.V., CODIGO, MEXICO, FILED 7-27-2010.

**TAMARIN**

THE MARK CONSISTS OF STANDARD CHARACTERS WITHOUT CLAIM TO ANY PARTICULAR FONT, STYLE, SIZE, OR COLOR.

FOR ALCOHOLIC BEVERAGES, NAMELY, TEQUILA (U.S. CLS. 47 AND 49).

AISHA SALEM, EXAMINING ATTORNEY

**CLASS 33—(Continued).**

SN 85-095,682. ZIVENKO, SERGEY VIKTOROVICH, MOSCOW, RUSSIAN FED., FILED 7-29-2010.



OWNER OF U.S. REG. NO. 2,801,797.

NO CLAIM IS MADE TO THE EXCLUSIVE RIGHT TO USE "RUSSIAN", APART FROM THE MARK AS SHOWN.

THE COLOR(S) GOLD, BLACK, RED AND WHITE IS/ARE CLAIMED AS A FEATURE OF THE MARK.

THE MARK CONSISTS OF A REPRESENTATION OF A BOTTLE WITH A GOLD CAP, A BLACK NECKBAND WITH A THICK AND THIN GOLD LINING TOP AND BOTTOM, THE WORDS "RUSSIAN GOLD" APPEAR IN GOLD OUTLINED IN BLACK AND A RED RIBBON BELOW IT, ALL ON A WHITE DECORATIVE BACKGROUND ETCHED OVERLAPPING OPAQUE GLASS, ALONG WITH CROSS-HATCHED ETCHING ON THE BOTTLE, A BAND OF OPAQUE GLASS WITH WHITE BANDS TOP AND BOTTOM A DECORATIVE BASE CONSISTING OF A SERIES OF PARALLEL VERTICAL LINES WITH A HORIZONTAL LINE TOP AND BOTTOM. THE BROKEN LINES IN THE DRAWING INDICATE THE PLACEMENT OF THE MARK ON THE CONTAINER FOR THE GOODS. THE SHAPE OF THE BOTTLE IS NOT CLAIMED AS A FEATURE OF THE MARK.

FOR VODKA, APERITIF WINES, DISTILLED LIQUOR, NAMELY, ARAK, BRANDY, WINE, WHISKY, KIRSCH, GIN, DISTILLED LIQUOR, NAMELY, HYDROMEL, ALCOHOLIC BITTERS, DISTILLED LIQUOR, NAMELY, PERRY, PREPARED ALCOHOLIC COCKTAILS, CURACAO, LIQUEURS, DISTILLED LIQUOR, DISTILLED SPIRITS, DISTILLED LIQUOR, NAMELY, WINE-BASED BEVERAGE, NAMELY, PIQUETTE, RUM, SAKE, HARD CIDER, EXTRACTS OF SPIRITUOUS LIQUORS AND ALCOHOLIC ESSENCES FOR THE MANUFACTURE OF LIQUEURS NOT IN THE NATURE OF ESSENTIAL OILS (U.S. CLS. 47 AND 49).

ESTHER A. BORSUK, EXAMINING ATTORNEY

SN 85-125,310. JOSE CANEPA Y CIA. LTDA., SANTIAGO, CHILE, FILED 9-8-2010.

**CANEPA MAGNIFICUM**

THE MARK CONSISTS OF STANDARD CHARACTERS WITHOUT CLAIM TO ANY PARTICULAR FONT, STYLE, SIZE, OR COLOR.

OWNER OF U.S. REG. NOS. 1,421,380 AND 2,882,130.

THE ENGLISH TRANSLATION OF THE LATIN WORD "MAGNIFICUM" IN THE MARK IS GREAT.

FOR WINES (U.S. CLS. 47 AND 49).

FIRST USE 8-0-1993; IN COMMERCE 7-0-1997.

ANTHONY RINKER, EXAMINING ATTORNEY

**CLASS 33—(Continued).**

SN 85-145,702. LONE STAR DISTILLERY, LLC, AUSTIN, TX, FILED 10-5-2010.

**GARRISON BROTHERS TEXAS'  
FIRST AND OLDEST LEGAL  
WHISKEY DISTILLERY**

THE MARK CONSISTS OF STANDARD CHARACTERS WITHOUT CLAIM TO ANY PARTICULAR FONT, STYLE, SIZE, OR COLOR.

OWNER OF U.S. REG. NO. 3,790,736.

NO CLAIM IS MADE TO THE EXCLUSIVE RIGHT TO USE "TEXAS' FIRST AND OLDEST LEGAL WHISKEY DISTILLERY", APART FROM THE MARK AS SHOWN.

FOR WHISKEY (U.S. CLS. 47 AND 49).

DAVID HOFFMAN, EXAMINING ATTORNEY

SN 85-147,919. TEQUILA CUERVO LA ROJENA, S.A. DE C.V., CODIGO, MEXICO, FILED 10-7-2010.



NO CLAIM IS MADE TO THE EXCLUSIVE RIGHT TO USE THE GOLD COLOR OF THE LIQUID IN THE BOTTLE, APART FROM THE MARK AS SHOWN.

THE COLOR(S) WHITE, PURPLE AND GOLD IS/ARE CLAIMED AS A FEATURE OF THE MARK.

THE MARK CONSISTS OF A REPRESENTATION OF A BOTTLE WITH THE WORDS "EL ZARCO" IN STYLIZED WHITE LETTERS ON A PURPLE BACKGROUND ON THE TOP HALF OF THE BOTTLE, THE BOTTOM HALF OF THE BOTTLE IS GOLD. THE MATTER SHOWN IN BROKEN LINES REPRESENTS THE BOTTLE SHAPE AND WHERE A LABEL WOULD BE PLACED ON THE BOTTLE AND IS NOT PART OF THE MARK AND SERVES ONLY TO SHOW THE POSITION OR PLACEMENT OF THE MARK. THE OVERALL BOTTLE AND NECK SHAPE ARE NOT CLAIMED AS FEATURES OF THE MARK.

THE ENGLISH TRANSLATION OF "EL ZARCO" IN THE MARK IS "THE LIGHT BLUE".

FOR TEQUILA (U.S. CLS. 47 AND 49).

FIRST USE 6-22-2010; IN COMMERCE 6-22-2010.

RONALD MCMORROW, EXAMINING ATTORNEY

**CLASS 33—(Continued).**

SN 85-147,942. TEQUILA CUERVO LA ROJENA, S.A. DE C.V., CODIGO, MEXICO, FILED 10-7-2010.



THE COLOR(S) BLUE, WHITE AND SILVER IS/ARE CLAIMED AS A FEATURE OF THE MARK.

THE MARK CONSISTS OF A REPRESENTATION OF A BOTTLE WITH THE WORDS "EL ZARCO" IN STYLIZED WHITE LETTERS ON A BLUE BACKGROUND ON THE TOP HALF OF THE BOTTLE. THE BOTTOM HALF OF THE BOTTLE IS SILVER. THE MATTER SHOWN IN BROKEN LINES REPRESENTS THE BOTTLE SHAPE AND WHERE A LABEL WOULD BE PLACED ON THE BOTTLE AND IS NOT PART OF THE MARK AND SERVES ONLY TO SHOW THE POSITION OR PLACEMENT OF THE MARK. THE OVERALL BOTTLE AND NECK SHAPE ARE NOT CLAIMED AS FEATURES OF THE MARK.

THE ENGLISH TRANSLATION OF "EL ZARCO" IN THE MARK IS "THE LIGHT BLUE".

FOR TEQUILA (U.S. CLS. 47 AND 49).  
FIRST USE 6-22-2010; IN COMMERCE 6-22-2010.  
RONALD MCMORROW, EXAMINING ATTORNEY

SN 85-148,408. AVV WINERY CO., LLC, HEALDSBURG, CA. FILED 10-8-2010.



OWNER OF U.S. REG. NOS. 1,432,158, 3,023,360 AND 3,201,485.

NO CLAIM IS MADE TO THE EXCLUSIVE RIGHT TO USE "ALEXANDER VALLEY", APART FROM THE MARK AS SHOWN.

THE COLOR(S) BROWN, BLACK AND RED IS/ARE CLAIMED AS A FEATURE OF THE MARK.

THE MARK CONSISTS OF A BLACK CHAIN LINK CABLE IS ATTACHED TO A BROWN BENCH SUSPENDED AGAINST A WHITE BACKGROUND WITH THE WORDS "SWING TIME" IN RED AND "ALEXANDER VALLEY" IN BLACK.

FOR WINE (U.S. CLS. 47 AND 49).  
FIRST USE 1-1-2010; IN COMMERCE 8-30-2010.  
KAREN K. BUSH, EXAMINING ATTORNEY

**CLASS 33—(Continued).**

SN 85-165,954. SHINAS, GEORGE, MILDURA, VICTORIA, AUSTRALIA, FILED 11-1-2010.

## THE EXECUTIONER SHINAS ESTATE

THE MARK CONSISTS OF STANDARD CHARACTERS WITHOUT CLAIM TO ANY PARTICULAR FONT, STYLE, SIZE, OR COLOR.

OWNER OF U.S. REG. NOS. 3,157,355, 3,166,777 AND 3,567,032.

NO CLAIM IS MADE TO THE EXCLUSIVE RIGHT TO USE "ESTATE", APART FROM THE MARK AS SHOWN, FOR ALCOHOLIC BEVERAGES, NAMELY, WINE (U.S. CLS. 47 AND 49).

DAWN HAN, EXAMINING ATTORNEY

SN 85-169,624. CARIBBEAN DISTILLERS, LLC, LAKE ALFRED, FL. FILED 11-4-2010.

## Draco Rum

THE MARK CONSISTS OF STANDARD CHARACTERS WITHOUT CLAIM TO ANY PARTICULAR FONT, STYLE, SIZE, OR COLOR.

NO CLAIM IS MADE TO THE EXCLUSIVE RIGHT TO USE "RUM", APART FROM THE MARK AS SHOWN.

THE ENGLISH TRANSLATION OF "DRACO" IN THE MARK IS DRAGON.

FOR RUM (U.S. CLS. 47 AND 49).  
BRIDGETT SMITH, EXAMINING ATTORNEY

SN 85-177,216. L&P SPIRITS IMPORTS, LLC, SAN FRANCISCO, CA. FILED 11-15-2010.

## SWANS NECK

THE MARK CONSISTS OF STANDARD CHARACTERS WITHOUT CLAIM TO ANY PARTICULAR FONT, STYLE, SIZE, OR COLOR.

OWNER OF U.S. REG. NO. 3,234,207.  
FOR DISTILLED SPIRITS; VODKA (U.S. CLS. 47 AND 49).

FRED CARL, EXAMINING ATTORNEY

**CLASS 33—(Continued).**

SN 85-178,006. LOPEZ BELTRAN, JUAN FRANCISCO, PELIGROS, GRANADA, SPAIN, AND LOPEZ BELTRAN, FRANCISCO JAVIER, PELIGROS, GRANADA, SPAIN, FILED 11-16-2010.



NO CLAIM IS MADE TO THE EXCLUSIVE RIGHT TO USE "RED WINE SODA", APART FROM THE MARK AS SHOWN.

THE MARK CONSISTS OF THE WORDS "TINTANO RED WINE SODA" IN STYLIZED LETTERS, THE WORD "TINTANO" APPEARING OVER A BANNER, AND THE WORD "RED WINE SODA" APPEARING OVER A BIGGER BANNER POSITIONED JUST BELOW THE WORD TINTANO'S BANNER. THE BACK CONSISTS OF MANY CIRCLES AND RINGS OF DIFFERENT SIZES.

THE WORDING TINTANO HAS NO MEANING IN A FOREIGN LANGUAGE.

FOR ALCOHOLIC BEVERAGES EXCEPT BEERS CONTAINING RED WINE (U.S. CLS. 47 AND 49).

JAY BESCH, EXAMINING ATTORNEY

**CLASS 33—(Continued).**

SN 85-183,110. GLENELLY CELLARS (PROPRIETARY) LIMITED, STELLENBOSCH, SOUTH AFRICA, FILED 11-23-2010.



THE MARK CONSISTS OF A STYLIZED "G" WITH THE OUTLINE OF A WOMAN RIDING A RHINOCEROS ON TOP OF THE "G".

FOR ALCOHOLIC BEVERAGES EXCEPT BEERS; WINES, SPIRITS AND LIQUEURS (U.S. CLS. 47 AND 49). FIRST USE 8-1-2010; IN COMMERCE 8-1-2010.

MICHAEL SOUDERS, EXAMINING ATTORNEY

SN 85-180,960. DESTILERÍA CANÉCA, LLC, MIAMI, FL. FILED 11-19-2010.

**AZÚKA SUGARCANE VODKA**

THE MARK CONSISTS OF STANDARD CHARACTERS WITHOUT CLAIM TO ANY PARTICULAR FONT, STYLE, SIZE, OR COLOR.

NO CLAIM IS MADE TO THE EXCLUSIVE RIGHT TO USE "SUGARCANE VODKA", APART FROM THE MARK AS SHOWN.

THE WORDING "AZUKA" HAS NO MEANING IN A FOREIGN LANGUAGE.

FOR DISTILLED SPIRITS (U.S. CLS. 47 AND 49).

JOHN DALIER, EXAMINING ATTORNEY

SN 85-185,906. SPIRIT IMPORTS, INC., SUNRISE, FL. FILED 11-29-2010.

**THE CLASSIC CASK**

THE MARK CONSISTS OF STANDARD CHARACTERS WITHOUT CLAIM TO ANY PARTICULAR FONT, STYLE, SIZE, OR COLOR.

NO CLAIM IS MADE TO THE EXCLUSIVE RIGHT TO USE "CASK", APART FROM THE MARK AS SHOWN.

FOR ALCOHOLIC BEVERAGES FROM A SINGLE CASK, SOLD AT CASK STRENGTH, NAMELY, SINGLE MALT SCOTCH WHISKY, BOURBON, WHISKEY, RUM, COGNAC, RYE WHISKY, ARMAGNAC AND BRANDY (U.S. CLS. 47 AND 49).

FIRST USE 5-26-1998; IN COMMERCE 5-26-1998.

DAVID TAYLOR, EXAMINING ATTORNEY

**CLASS 33—(Continued).**

SN 85-186,157. FLEMISH LION LLC, HERNDON, VA. FILED 11-29-2010.

NO CLAIM IS MADE TO THE EXCLUSIVE RIGHT TO USE "9", APART FROM THE MARK AS SHOWN.

THE MARK CONSISTS OF THE WORDING "DIEP 9" IN A STYLIZED GRAY FONT.

THE ENGLISH TRANSLATION OF "DIEP" IN THE MARK IS "DEEP".

FOR LIQUOR (U.S. CLS. 47 AND 49).

FIRST USE 10-24-2010; IN COMMERCE 10-24-2010.

MARK SHINER, EXAMINING ATTORNEY

**CLASS 33—(Continued).**

SN 85-189,784. CATTUZZATO, STEFANO, SANFLORIANO D'COLLIO, GO, ITALY, FILED 12-2-2010.

# TRICARDI

THE MARK CONSISTS OF STANDARD CHARACTERS WITHOUT CLAIM TO ANY PARTICULAR FONT, STYLE, SIZE, OR COLOR.

FOR FORTIFIED WINES; FRUIT WINE; GRAPE WINE; NATURAL SPARKLING WINES; PORT WINES; RED WINE; RED WINES; SPARKLING WINES; STILL WINES; STRAWBERRY WINE; SWEET WINES; TABLE WINES; WHITE WINE; WINE; WINE COOLERS; WINE-BASED DRINKS; WINES; WINES AND LIQUEURS; WINES AND SPARKLING WINES (U.S. CLS. 47 AND 49).

FIRST USE 4-22-2005; IN COMMERCE 4-22-2005.

RUSS HERMAN, EXAMINING ATTORNEY

SN 85-190,709. ZEV, LLC, PLANO, TX. FILED 12-4-2010.

# ZEV VODKA

THE MARK CONSISTS OF STANDARD CHARACTERS WITHOUT CLAIM TO ANY PARTICULAR FONT, STYLE, SIZE, OR COLOR.

NO CLAIM IS MADE TO THE EXCLUSIVE RIGHT TO USE "VODKA", APART FROM THE MARK AS SHOWN.

FOR ALCOHOLIC BEVERAGES, NAMELY, VODKA (U.S. CLS. 47 AND 49).

SANDRA BUJA, EXAMINING ATTORNEY

SN 85-186,341. BEVERAGE ACQUISITION GROUP, LLC., MIDDLEBURY, VT. FILED 11-29-2010.

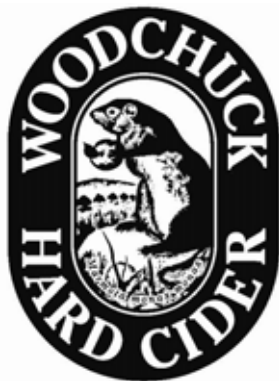

OWNER OF U.S. REG. NOS. 1,731,480, 2,463,147 AND 3,195,593.

NO CLAIM IS MADE TO THE EXCLUSIVE RIGHT TO USE "HARD CIDER", APART FROM THE MARK AS SHOWN.

THE MARK CONSISTS OF DARK CONCENTRIC OVALS CONTAINING THE WORDS "WOODCHUCK HARD CIDER", SURROUNDING A LIGHTER INNER OVAL, SURROUNDING A WOODCHUCK STANDING ON A ROCK AND HOLDING AN APPLE. IN THE BACKGROUND OF THE WOODCHUCK ARE ROWS OF TREES AND MOUNTAINS, AND IN THE FOREGROUND OF THE WOODCHUCK ARE PLANTS. THE WORDS "MARMOTA MONAX" APPEAR BELOW THE WOODCHUCK AT THE BOTTOM OF THE DESIGN IN THE LIGHT COLORED INNER CIRCLE.

THE ENGLISH TRANSLATION OF THE WORD "MARMOTA" AND "MONAX" IN THE MARK IS "WOODCHUCK"

FOR HARD CIDER (U.S. CLS. 47 AND 49).

FIRST USE 4-1-1991; IN COMMERCE 5-28-1991.

TAMARA FRAZIER, EXAMINING ATTORNEY

SN 85-191,552. PREMIUM BLEND, INC., HIALEAH, FL. FILED 12-6-2010.

# KAFE-LUNA

THE MARK CONSISTS OF STANDARD CHARACTERS WITHOUT CLAIM TO ANY PARTICULAR FONT, STYLE, SIZE, OR COLOR.

THE ENGLISH TRANSLATION OF "KAFE-LUNA" IN THE MARK IS "CAFE-MOON".

FOR ALCOHOLIC BEVERAGES EXCEPT BEERS (U.S. CLS. 47 AND 49).

ANDREW RHIM, EXAMINING ATTORNEY

**CLASS 33—(Continued).**

SN 85-193,573. TALL GUY WINES, LLC, ST. HELENA, CA.  
FILED 12-8-2010.

## Tall Guy Wines

THE MARK CONSISTS OF STANDARD CHARACTERS WITHOUT CLAIM TO ANY PARTICULAR FONT, STYLE, SIZE, OR COLOR.

NO CLAIM IS MADE TO THE EXCLUSIVE RIGHT TO USE "WINES", APART FROM THE MARK AS SHOWN.  
FOR WINE (U.S. CLS. 47 AND 49).  
JULIE GUTTADAURO, EXAMINING ATTORNEY

**CLASS 33—(Continued).**

SN 85-199,135. RESERVA DE LOS REYES, S. DE R. L. DE C. V., GUADALAJARA, JALISCO, MEXICO, FILED 12-16-2010.

## BRÍO

THE MARK CONSISTS OF STANDARD CHARACTERS WITHOUT CLAIM TO ANY PARTICULAR FONT, STYLE, SIZE, OR COLOR.

THE ENGLISH TRANSLATION OF BRÍO IN THE MARK IS ELAN OR ZEST OR PRIDE.  
FOR ALCOHOLIC BEVERAGES EXCEPT BEERS; TEQUILA (U.S. CLS. 47 AND 49).  
JAMES GRIFFIN, EXAMINING ATTORNEY

SN 85-193,725. BROWN, KEVIN G., DBA SIREN SONG WINES, SEATTLE, WA. FILED 12-8-2010.

## Siren Song Wines

THE MARK CONSISTS OF STANDARD CHARACTERS WITHOUT CLAIM TO ANY PARTICULAR FONT, STYLE, SIZE, OR COLOR.

NO CLAIM IS MADE TO THE EXCLUSIVE RIGHT TO USE "WINES", APART FROM THE MARK AS SHOWN.  
FOR WINES (U.S. CLS. 47 AND 49).  
TARAH HARDY, EXAMINING ATTORNEY

SN 85-199,557. FIRE TAIL BRANDS, LLC, LAKE ST. LOUIS, MO. FILED 12-16-2010.

## CHOCOLATIER WINE COMPANY

THE MARK CONSISTS OF STANDARD CHARACTERS WITHOUT CLAIM TO ANY PARTICULAR FONT, STYLE, SIZE, OR COLOR.

NO CLAIM IS MADE TO THE EXCLUSIVE RIGHT TO USE "WINE COMPANY", APART FROM THE MARK AS SHOWN.  
FOR WINE (U.S. CLS. 47 AND 49).  
BARNEY CHARLON, EXAMINING ATTORNEY

SN 85-195,890. MIGUEL ANGEL PALAFOX, DBA MIGUEL ANGEL PALAFOX, SYLMAR, CA. FILED 12-11-2010.

## ARTE NUEVO

THE MARK CONSISTS OF STANDARD CHARACTERS WITHOUT CLAIM TO ANY PARTICULAR FONT, STYLE, SIZE, OR COLOR.

THE ENGLISH TRANSLATION OF ARTE NUEVO IN THE MARK IS NEW ART.  
FOR TEQUILA (U.S. CLS. 47 AND 49).  
DAWN HAN, EXAMINING ATTORNEY

SN 85-201,154. DIAGEO CHATEAU & ESTATE WINES COMPANY, NAPA, CA. FILED 12-17-2010.

## ONE OF ITALY'S SHINING LITTLE SECRETS

THE MARK CONSISTS OF STANDARD CHARACTERS WITHOUT CLAIM TO ANY PARTICULAR FONT, STYLE, SIZE, OR COLOR.

FOR ALCOHOLIC BEVERAGES EXCEPT BEERS (U.S. CLS. 47 AND 49).  
MORGAN WYNNE, EXAMINING ATTORNEY

**CLASS 33—(Continued).**

SN 85-201,156. DIAGEO CHATEAU & ESTATE WINES COMPANY, NAPA, CA. FILED 12-17-2010.

VIBRANT WINES, EASY TIMES  
AUTHENTICALLY NEW ZEALAND

THE MARK CONSISTS OF STANDARD CHARACTERS WITHOUT CLAIM TO ANY PARTICULAR FONT, STYLE, SIZE, OR COLOR.

NO CLAIM IS MADE TO THE EXCLUSIVE RIGHT TO USE "NEW ZEALAND", APART FROM THE MARK AS SHOWN.

FOR WINES (U.S. CLS. 47 AND 49).  
MORGAN WYNNE, EXAMINING ATTORNEY

**CLASS 33—(Continued).**

SN 85-202,395. WALDBROEL, THORSTEN, BERLIN, FED REP GERMANY, FILED 12-21-2010.

SAINT CRYSTAL

THE MARK CONSISTS OF STANDARD CHARACTERS WITHOUT CLAIM TO ANY PARTICULAR FONT, STYLE, SIZE, OR COLOR.

FOR SPARKLING VODKA (U.S. CLS. 47 AND 49).  
KATHLEEN M. VANSTON, EXAMINING ATTORNEY

SN 85-201,157. DIAGEO ARGENTINA S.A., BUENOS AIRES C1106ABJ, ARGENTINA, FILED 12-17-2010.

A FAMILY LEGACY, AN  
ARGENTINE CLASSIC

THE MARK CONSISTS OF STANDARD CHARACTERS WITHOUT CLAIM TO ANY PARTICULAR FONT, STYLE, SIZE, OR COLOR.

NO CLAIM IS MADE TO THE EXCLUSIVE RIGHT TO USE "ARGENTINE", APART FROM THE MARK AS SHOWN.

FOR ALCOHOLIC BEVERAGES EXCEPT BEERS (U.S. CLS. 47 AND 49).  
MORGAN WYNNE, EXAMINING ATTORNEY

SN 85-202,777. COOPER VINEYARDS, LLC, PLYMOUTH, CA. FILED 12-21-2010.

Pink Lady

THE MARK CONSISTS OF STANDARD CHARACTERS WITHOUT CLAIM TO ANY PARTICULAR FONT, STYLE, SIZE, OR COLOR.

FOR WINE (U.S. CLS. 47 AND 49).  
ANGELA DUONG, EXAMINING ATTORNEY

SN 85-201,419. ANLEMMA WINES LLC, MOSIER, OR. FILED 12-19-2010.

ATAVUS

THE MARK CONSISTS OF STANDARD CHARACTERS WITHOUT CLAIM TO ANY PARTICULAR FONT, STYLE, SIZE, OR COLOR.

FOR SPARKLING WINES; WINE; WINES (U.S. CLS. 47 AND 49).  
KELLY BOULTON, EXAMINING ATTORNEY

SN 85-202,783. COOPER VINEYARDS, LLC, PLYMOUTH, CA. FILED 12-21-2010.

Thistledown

THE MARK CONSISTS OF STANDARD CHARACTERS WITHOUT CLAIM TO ANY PARTICULAR FONT, STYLE, SIZE, OR COLOR.

FOR WINE (U.S. CLS. 47 AND 49).  
ANGELA DUONG, EXAMINING ATTORNEY



**CLASS 33—(Continued).**

SN 85-203,873. PAPA JAC, CORP., SAN JUAN, PUERTO RICO, FILED 12-22-2010.



THE MARK CONSISTS OF AN ANIMAL DRINKING FROM A BEVERAGE CUP, WITH A MISSING FRONT TOOTH, AND WEARING AN EYE PATCH OVER HIS LEFT EYE, OVER THE WORDS "PAPA JAC".

FOR ALCOHOLIC BEVERAGES CONTAINING FRUIT JUICE (U.S. CLS. 47 AND 49).

FIRST USE 4-1-1992; IN COMMERCE 4-1-1992.  
MARK SPARACINO, EXAMINING ATTORNEY

SN 85-204,380. MUTUAL WHOLESALE LIQUOR, INC., DBA INTERNATIONAL IMPORT EXPORT, LOS ANGELES, CA. FILED 12-22-2010.

## ROMANELLI

THE MARK CONSISTS OF STANDARD CHARACTERS WITHOUT CLAIM TO ANY PARTICULAR FONT, STYLE, SIZE, OR COLOR.

THE NAME(S), PORTRAIT(S), AND/OR SIGNATURE(S) SHOWN IN THE MARK DOES NOT IDENTIFY A PARTICULAR LIVING INDIVIDUAL.

SEC. 2(F).  
FOR WINE; WINES (U.S. CLS. 47 AND 49).  
FIRST USE 5-17-1984; IN COMMERCE 5-17-1984.  
LAKEISHA LEWIS, EXAMINING ATTORNEY

**CLASS 33—(Continued).**

SN 85-204,386. MUTUAL WHOLESALE LIQUOR, INC., DBA INTERNATIONAL IMPORT EXPORT, LOS ANGELES, CA. FILED 12-22-2010.

## PIERRE DUCHENE

THE MARK CONSISTS OF STANDARD CHARACTERS WITHOUT CLAIM TO ANY PARTICULAR FONT, STYLE, SIZE, OR COLOR.

THE NAME(S), PORTRAIT(S), AND/OR SIGNATURE(S) SHOWN IN THE MARK DOES NOT IDENTIFY A PARTICULAR LIVING INDIVIDUAL.

FOR BRANDY; FRENCH BRANDY (U.S. CLS. 47 AND 49).

FIRST USE 12-6-1983; IN COMMERCE 12-6-1983.  
LAKEISHA LEWIS, EXAMINING ATTORNEY

SN 85-204,389. MUTUAL WHOLESALE LIQUOR, INC., DBA INTERNATIONAL IMPORT EXPORT, LOS ANGELES, CA. FILED 12-22-2010.

## JOSEPH HÄNDLER

THE MARK CONSISTS OF STANDARD CHARACTERS WITHOUT CLAIM TO ANY PARTICULAR FONT, STYLE, SIZE, OR COLOR.

THE NAME(S), PORTRAIT(S), AND/OR SIGNATURE(S) SHOWN IN THE MARK DOES NOT IDENTIFY A PARTICULAR LIVING INDIVIDUAL.

FOR WINE; WINES (U.S. CLS. 47 AND 49).

FIRST USE 4-9-2009; IN COMMERCE 4-9-2009.  
LAKEISHA LEWIS, EXAMINING ATTORNEY

SN 85-204,675. GENUWINE LLC, PASADENA, CA. FILED 12-23-2010.

## REVEAL

THE MARK CONSISTS OF STANDARD CHARACTERS WITHOUT CLAIM TO ANY PARTICULAR FONT, STYLE, SIZE, OR COLOR.

FOR WINE (U.S. CLS. 47 AND 49).

RONALD DELGIZZI, EXAMINING ATTORNEY

**CLASS 33—(Continued).**

SN 85-205,054. BRUCE MURRAY, BROOKLYN, NY. FILED 12-23-2010.

**BOUNDARY BREAKS**

THE MARK CONSISTS OF STANDARD CHARACTERS WITHOUT CLAIM TO ANY PARTICULAR FONT, STYLE, SIZE, OR COLOR.

FOR WINES (U.S. CLS. 47 AND 49).  
KELLEY WELLS, EXAMINING ATTORNEY

SN 85-205,282. SMASHING GRAPES, LLC, REDWOOD CITY, CA. FILED 12-23-2010.

**TIMARK**

THE MARK CONSISTS OF STANDARD CHARACTERS WITHOUT CLAIM TO ANY PARTICULAR FONT, STYLE, SIZE, OR COLOR.

FOR ALCOHOLIC BEVERAGES EXCEPT BEERS (U.S. CLS. 47 AND 49).  
GIANCARLO CASTRO, EXAMINING ATTORNEY

SN 85-205,573. RED ISLAND INDUSTRIES, MERIDIAN, ID. FILED 12-24-2010.

**RED ISLAND**

THE MARK CONSISTS OF STANDARD CHARACTERS WITHOUT CLAIM TO ANY PARTICULAR FONT, STYLE, SIZE, OR COLOR.

FOR RUM (U.S. CLS. 47 AND 49).  
FIRST USE 8-31-2010; IN COMMERCE 12-23-2010.  
JANICE L. MCMORROW, EXAMINING ATTORNEY

**CLASS 33—(Continued).**

SN 85-205,742. CLARE RANCH LLC, DBA FALCON AND HIPPO WINERY, TEMPLETON, CA. FILED 12-26-2010.

**FALCON AND HIPPO**

THE MARK CONSISTS OF STANDARD CHARACTERS WITHOUT CLAIM TO ANY PARTICULAR FONT, STYLE, SIZE, OR COLOR.

FOR ALCOHOLIC BEVERAGES, NAMELY, WINES (U.S. CLS. 47 AND 49).  
FIRST USE 2-11-2002; IN COMMERCE 2-11-2002.  
ANNE E. GUSTASON, EXAMINING ATTORNEY

SN 85-206,089. DAVIS & DYKE WINERY LLC, ALAMEDA, CA. FILED 12-27-2010.

**STRIX**

THE MARK CONSISTS OF STANDARD CHARACTERS WITHOUT CLAIM TO ANY PARTICULAR FONT, STYLE, SIZE, OR COLOR.

FOR WINE (U.S. CLS. 47 AND 49).  
KEVON CHISOLM, EXAMINING ATTORNEY

SN 85-206,094. FOO DOG SPIRITS, LLC, HALIFAX, MA. FILED 12-27-2010.

**FOO DOG**

THE MARK CONSISTS OF STANDARD CHARACTERS WITHOUT CLAIM TO ANY PARTICULAR FONT, STYLE, SIZE, OR COLOR.

FOR DISTILLED SPIRITS (U.S. CLS. 47 AND 49).  
KEVON CHISOLM, EXAMINING ATTORNEY

**CLASS 33—(Continued).**

SN 85-206,165. HACK, KEVIN R., APPLETON, WI. FILED 12-27-2010.

vo.la.say

THE MARK CONSISTS OF STANDARD CHARACTERS WITHOUT CLAIM TO ANY PARTICULAR FONT, STYLE, SIZE, OR COLOR.

THE WORDING VO.LA.SAY HAS NO MEANING IN A FOREIGN LANGUAGE.

FOR ALCOHOLIC BEVERAGES, NAMELY DISTILLED SPIRITS (U.S. CLS. 47 AND 49).

MARILYN IZZI, EXAMINING ATTORNEY

**CLASS 33—(Continued).**

SN 85-206,440. GUINAN FAMILY WINERY & VINEYARD, INC., DBA SANTA MARIA VINEYARD & WINERY, CARROLL, IA. FILED 12-28-2010.

Rhuby Dooby

THE MARK CONSISTS OF STANDARD CHARACTERS WITHOUT CLAIM TO ANY PARTICULAR FONT, STYLE, SIZE, OR COLOR.

FOR WINE (U.S. CLS. 47 AND 49).

FIRST USE 2-12-2010; IN COMMERCE 2-12-2010.

AISHA CLARKE, EXAMINING ATTORNEY

SN 85-206,279. VIGNERON LLC, DBA VIGNERON, HUNTINGTON BEACH, CA. FILED 12-28-2010.

GRANPETRIE

THE MARK CONSISTS OF STANDARD CHARACTERS WITHOUT CLAIM TO ANY PARTICULAR FONT, STYLE, SIZE, OR COLOR.

THE WORDING GRANPETRIE HAS NO MEANING IN A FOREIGN LANGUAGE.

FOR BRANDY SPIRITS (U.S. CLS. 47 AND 49).

SAIMA MAKHDOOM, EXAMINING ATTORNEY

SN 85-206,518. ZWANENBERG FOOD GROUP (USA) INC., CINCINNATI, OH. FILED 12-28-2010.

Longridge

THE MARK CONSISTS OF STANDARD CHARACTERS WITHOUT CLAIM TO ANY PARTICULAR FONT, STYLE, SIZE, OR COLOR.

FOR WINES AND SPIRITS (U.S. CLS. 47 AND 49).

ELISSA GARBER KON, EXAMINING ATTORNEY

SN 85-206,284. VIGNERON LLC, DBA VIGNERON, HUNTINGTON BEACH, CA. FILED 12-28-2010.

GOLD LEAF

THE MARK CONSISTS OF STANDARD CHARACTERS WITHOUT CLAIM TO ANY PARTICULAR FONT, STYLE, SIZE, OR COLOR.

NO CLAIM IS MADE TO THE EXCLUSIVE RIGHT TO USE "GOLD", APART FROM THE MARK AS SHOWN.

FOR BRANDY SPIRITS (U.S. CLS. 47 AND 49).

SAIMA MAKHDOOM, EXAMINING ATTORNEY

SN 85-206,523. TATSUUMA-HONKE BREWING CO., LTD, HYOGO, JAPAN, FILED 12-28-2010.

TANUKI SAKE

THE MARK CONSISTS OF STANDARD CHARACTERS WITHOUT CLAIM TO ANY PARTICULAR FONT, STYLE, SIZE, OR COLOR.

NO CLAIM IS MADE TO THE EXCLUSIVE RIGHT TO USE "SAKE", APART FROM THE MARK AS SHOWN.

THE ENGLISH TRANSLATION OF TANUKI IN THE MARK IS RACCOON DOG.

FOR SAKE (U.S. CLS. 47 AND 49).

ALLISON HOLTZ, EXAMINING ATTORNEY

**CLASS 33—(Continued).**

SN 85-206,692. MARILYNN THOMA, CHICAGO, IL. FILED 12-28-2010.

# PARASOL

THE MARK CONSISTS OF STANDARD CHARACTERS WITHOUT CLAIM TO ANY PARTICULAR FONT, STYLE, SIZE, OR COLOR.

FOR WINE (U.S. CLS. 47 AND 49).  
FIRST USE 12-17-2003; IN COMMERCE 12-17-2003.  
IRA J. GOODSaid, EXAMINING ATTORNEY

**CLASS 33—(Continued).**

SN 85-208,339. SMITH, MARIA, LEXINGTON, KY. AND SMITH, DANIEL, LEXINGTON, KY. FILED 12-30-2010.

# ELOPE

THE MARK CONSISTS OF STANDARD CHARACTERS WITHOUT CLAIM TO ANY PARTICULAR FONT, STYLE, SIZE, OR COLOR.

FOR SPIRITS AND LIQUEURS (U.S. CLS. 47 AND 49).  
JOHN GARTNER, EXAMINING ATTORNEY

SN 85-207,648. JL BEVERAGE COMPANY LLC, HENDERSON, NV. FILED 12-29-2010.



OWNER OF U.S. REG. NO. 2,986,519.  
THE MARK CONSISTS OF HUMAN LIPS OR MOUTHS.  
FOR DISTILLED SPIRITS (U.S. CLS. 47 AND 49).  
FIRST USE 7-27-2004; IN COMMERCE 7-27-2004.  
AMY HELLA, EXAMINING ATTORNEY

SN 85-208,347. THE SCION SPIRITS COMPANY LIMITED, DUBLIN 2, IRELAND, FILED 12-30-2010.

COOLE SWAN SUPERIOR IRISH  
CREAM LIQUEUR

SN 85-207,761. WYBOROWA S.A., 61-023 POZNAN, POLAND, FILED 12-30-2010.

# WYBOROWA

THE MARK CONSISTS OF STANDARD CHARACTERS WITHOUT CLAIM TO ANY PARTICULAR FONT, STYLE, SIZE, OR COLOR.

OWNER OF ERPN CMNTY TM OFC REG. NO. 003126208, DATED 6-5-2004, EXPIRES 9-4-2013.

OWNER OF U.S. REG. NOS. 3,385,290, 3,557,531 AND OTHERS.

THE ENGLISH TRANSLATION OF WYBOROWA IN THE MARK IS SELECT.

FOR ALCOHOLIC BEVERAGES, NAMELY VODKA (U.S. CLS. 47 AND 49).

JULIE GUTTADAURO, EXAMINING ATTORNEY

THE MARK CONSISTS OF STANDARD CHARACTERS WITHOUT CLAIM TO ANY PARTICULAR FONT, STYLE, SIZE, OR COLOR.

OWNER OF U.S. REG. NOS. 3,635,781 AND 3,635,782.  
NO CLAIM IS MADE TO THE EXCLUSIVE RIGHT TO USE "SUPERIOR IRISH CREAM LIQUEUR", APART FROM THE MARK AS SHOWN.

FOR ALCOHOLIC BEVERAGES, NAMELY, DAIRY CREAM LIQUEURS (U.S. CLS. 47 AND 49).

JOHN DWYER, EXAMINING ATTORNEY

**CLASS 33—(Continued).**

SN 85-208,355. THE SCION SPIRITS COMPANY LIMITED, DUBLIN 2, IRELAND, FILED 12-30-2010.

**COOLE SWAN**  
*Superior*  
IRISH CREAM LIQUEUR

OWNER OF U.S. REG. NOS. 3,635,781 AND 3,635,782.  
NO CLAIM IS MADE TO THE EXCLUSIVE RIGHT TO USE "SUPERIOR IRISH CREAM LIQUEUR", APART FROM THE MARK AS SHOWN.

THE MARK CONSISTS OF THE WORDS COOLE SWAN SUPERIOR IRISH CREAM LIQUEUR DISPLAYED IN A STYLIZED FONT IN THREE SEPARATE HORIZONTAL LINES, WITH "COOLE SWAN" APPEARING ON THE TOP LINE, "SUPERIOR" APPEARING ON THE MIDDLE LINE, AND "IRISH CREAM LIQUEUR" APPEARING ON THE BOTTOM LINE.

FOR ALCOHOLIC BEVERAGES, NAMELY, DAIRY CREAM LIQUEURS (U.S. CLS. 47 AND 49).  
JOHN DWYER, EXAMINING ATTORNEY

SN 85-208,668. MAJESTIC LIQUOR STORES, INC., FORT WORTH, TX. FILED 12-31-2010.

**CELTIC DREAM**

THE MARK CONSISTS OF STANDARD CHARACTERS WITHOUT CLAIM TO ANY PARTICULAR FONT, STYLE, SIZE, OR COLOR.

FOR ALCOHOLIC BEVERAGES EXCEPT BEERS (U.S. CLS. 47 AND 49).

FIRST USE 11-1-2009; IN COMMERCE 11-1-2009.  
JILL PRATER, EXAMINING ATTORNEY

SN 85-208,756. CONSEAL INTERNATIONAL INCORPORATED, NORWOOD, MA. FILED 1-1-2011.

**COCOVINO**

THE MARK CONSISTS OF STANDARD CHARACTERS WITHOUT CLAIM TO ANY PARTICULAR FONT, STYLE, SIZE, OR COLOR.

FOR WINE; CHOCOLATE-FLAVORED WINE (U.S. CLS. 47 AND 49).

KEVON CHISOLM, EXAMINING ATTORNEY

**CLASS 33—(Continued).**

SN 85-209,169. KRUPP BROTHERS WINERY LLC, NAPA, CA. FILED 1-3-2011.

**WATER WITCH**

THE MARK CONSISTS OF STANDARD CHARACTERS WITHOUT CLAIM TO ANY PARTICULAR FONT, STYLE, SIZE, OR COLOR.

FOR ALCOHOLIC BEVERAGES EXCEPT BEERS (U.S. CLS. 47 AND 49).

CAROL SPILS, EXAMINING ATTORNEY

SN 85-209,215. BLATANT BREWERY, LLC, BONDSVILLE, MA. FILED 1-3-2011.

**BLATANT**

THE MARK CONSISTS OF STANDARD CHARACTERS WITHOUT CLAIM TO ANY PARTICULAR FONT, STYLE, SIZE, OR COLOR.

FOR BEER (U.S. CLS. 47 AND 49).

ANNE E. GUSTASON, EXAMINING ATTORNEY

SN 85-209,822. AUTHENTICITY INC, DBA SAINTS & GENERALS, LAREDO, TX. FILED 1-4-2011.

**Citrine**

THE MARK CONSISTS OF STANDARD CHARACTERS WITHOUT CLAIM TO ANY PARTICULAR FONT, STYLE, SIZE, OR COLOR.

FOR LIQUOR AND LIQUEUR BEVERAGES, NAMELY, TEQUILA (U.S. CLS. 47 AND 49).

KYLE PEETE, EXAMINING ATTORNEY

**CLASS 33—(Continued).**

SN 85-209,884. SCHAFER WINERY, LLC, WALLA WALLA, WA. FILED 1-4-2011.

# SPARROW

THE MARK CONSISTS OF STANDARD CHARACTERS WITHOUT CLAIM TO ANY PARTICULAR FONT, STYLE, SIZE, OR COLOR.

FOR WINES (U.S. CLS. 47 AND 49).  
FIRST USE 7-0-2009; IN COMMERCE 7-0-2009.  
BARBARA BROWN, EXAMINING ATTORNEY

---

SN 85-209,941. XAMAY IMPORTERS, INC., POMONA, CA. FILED 1-4-2011.

# ALMA DE AGAVE

THE MARK CONSISTS OF STANDARD CHARACTERS WITHOUT CLAIM TO ANY PARTICULAR FONT, STYLE, SIZE, OR COLOR.

OWNER OF U.S. REG. NO. 3,737,817.  
NO CLAIM IS MADE TO THE EXCLUSIVE RIGHT TO USE "AGAVE", APART FROM THE MARK AS SHOWN.  
THE ENGLISH TRANSLATION OF "ALMA DE AGAVE" IN THE MARK IS "SOUL OF AGAVE".  
FOR TEQUILA (U.S. CLS. 47 AND 49).  
FIRST USE 10-1-2008; IN COMMERCE 5-2-2009.  
JULIE GUTTADAURO, EXAMINING ATTORNEY

---

SN 85-209,967. SAZERAC COMPANY, INC., NEW ORLEANS, LA. FILED 1-4-2011.

# SKINNY . . . YET OH SO SWEET

THE MARK CONSISTS OF STANDARD CHARACTERS WITHOUT CLAIM TO ANY PARTICULAR FONT, STYLE, SIZE, OR COLOR.

FOR DISTILLED SPIRITS (U.S. CLS. 47 AND 49).  
MARIA-VICTORIA SUAREZ, EXAMINING ATTORNEY

**CLASS 33—(Continued).**

SN 85-210,142. GREENAWALT, NATHAN, MADISON, WI. FILED 1-4-2011.

# Cane & Abe

THE MARK CONSISTS OF STANDARD CHARACTERS WITHOUT CLAIM TO ANY PARTICULAR FONT, STYLE, SIZE, OR COLOR.

FOR DISTILLED SPIRITS OF CANE SUGAR (U.S. CLS. 47 AND 49).  
FIRST USE 9-1-2010; IN COMMERCE 9-1-2010.  
ERNEST SHOSHO, EXAMINING ATTORNEY

---

SN 85-210,423. RBZ VINEYARDS, LLC, SANTA BARBARA, CA. FILED 1-4-2011.

# CROOKED PATH

THE MARK CONSISTS OF STANDARD CHARACTERS WITHOUT CLAIM TO ANY PARTICULAR FONT, STYLE, SIZE, OR COLOR.

FOR WINE; WINES (U.S. CLS. 47 AND 49).  
GILBERT SWIFT, EXAMINING ATTORNEY

---

SN 85-210,446. PLATA WINE PARTNERS, LLC, NAPA, CA. FILED 1-4-2011.

# GHOST BRIDGE

THE MARK CONSISTS OF STANDARD CHARACTERS WITHOUT CLAIM TO ANY PARTICULAR FONT, STYLE, SIZE, OR COLOR.

FOR WINE (U.S. CLS. 47 AND 49).  
ALICIA COLLINS, EXAMINING ATTORNEY

**CLASS 33—(Continued).**

SN 85-210,575. MARILYNN THOMA, CHICAGO, IL. FILED 1-5-2011.

**SORCERY**

THE MARK CONSISTS OF STANDARD CHARACTERS WITHOUT CLAIM TO ANY PARTICULAR FONT, STYLE, SIZE, OR COLOR.  
FOR WINES (U.S. CLS. 47 AND 49).  
FIRST USE 5-1-1997; IN COMMERCE 5-1-1997.  
IRA J. GOODSaid, EXAMINING ATTORNEY

**CLASS 33—(Continued).**

SN 85-211,289. THE WINE GROUP LLC, TRACY, CA. FILED 1-5-2011.

**OFFICIAL WINE OF  
REFRIGERATORS ACROSS  
AMERICA**

THE MARK CONSISTS OF STANDARD CHARACTERS WITHOUT CLAIM TO ANY PARTICULAR FONT, STYLE, SIZE, OR COLOR.  
FOR WINE (U.S. CLS. 47 AND 49).  
MARGARET POWER, EXAMINING ATTORNEY

SN 85-210,805. BRONCO WINE COMPANY, CERES, CA. FILED 1-5-2011.

**FOREST HILL**

THE MARK CONSISTS OF STANDARD CHARACTERS WITHOUT CLAIM TO ANY PARTICULAR FONT, STYLE, SIZE, OR COLOR.  
FOR WINE (U.S. CLS. 47 AND 49).  
KAREN K. BUSH, EXAMINING ATTORNEY

SN 85-211,561. AGAVE VENTURES LLC, BARDSTOWN, KY. FILED 1-6-2011.

**SACRIFICE NOTHING**

THE MARK CONSISTS OF STANDARD CHARACTERS WITHOUT CLAIM TO ANY PARTICULAR FONT, STYLE, SIZE, OR COLOR.  
FOR TEQUILA (U.S. CLS. 47 AND 49).  
STEVEN JACKSON, EXAMINING ATTORNEY

SN 85-211,045. SAZERAC COMPANY INC., NEW ORLEANS, LA. FILED 1-5-2011.

**RON CINCO PALMAS**

THE MARK CONSISTS OF STANDARD CHARACTERS WITHOUT CLAIM TO ANY PARTICULAR FONT, STYLE, SIZE, OR COLOR.  
NO CLAIM IS MADE TO THE EXCLUSIVE RIGHT TO USE "RON", APART FROM THE MARK AS SHOWN.  
THE ENGLISH TRANSLATION OF "RON CINCO PALMAS" IN THE MARK IS "FIVE PALMS RUM".  
FOR RUM (U.S. CLS. 47 AND 49).  
KIM SAITO, EXAMINING ATTORNEY

SN 85-211,781. SHERLOCK, MICHAEL T., SEATTLE, WA. FILED 1-6-2011.

**Sintillation**

THE MARK CONSISTS OF STANDARD CHARACTERS WITHOUT CLAIM TO ANY PARTICULAR FONT, STYLE, SIZE, OR COLOR.  
FOR APERITIFS WITH A DISTILLED ALCOHOLIC LIQUOR BASE; DISTILLED SPIRITS; SPIRITS AND LIQUEURS (U.S. CLS. 47 AND 49).  
MAYUR VAGHANI, EXAMINING ATTORNEY

**CLASS 33—(Continued).**

SN 85-211,928. STAPHYLE S.A., LUJAN DE CUYO, MENDOZA, ARGENTINA, FILED 1-6-2011.



VÁSTAGO DE  
**GEA**

THE MARK CONSISTS OF A DESIGN OF FOUR MEN RUNNING WITHIN A RECTANGLE. THE STYLIZED WORD GEA APPEARS BELOW THE RECTANGLE WITH THE STYLIZED WORDING VÁSTAGO DE APPEARING ABOVE THE LETTERS E AND A OF THE WORD GEA IN A SMALLER FONT.

THE ENGLISH TRANSLATION OF VÁSTAGO DE GEA IN THE MARK IS DECENDANT OF GEA.

FOR WINES AND SPARKLING WINES (U.S. CLS. 47 AND 49).

ROBIN CHOSID, EXAMINING ATTORNEY

SN 85-212,159. BLANCO, GABRIEL, LUJAN DE CUYO, MENDOZA, ARGENTINA, FILED 1-6-2011.



THE MARK CONSISTS OF THE STYLIZED WORD MAIRENA WITH A DESIGN OF A WOMAN'S BUST AND HAIR FLOWING TO THE RIGHT APPEARING IN THE BACKGROUND.

FOR WINES AND SPARKLING WINES (U.S. CLS. 47 AND 49).

FIRST USE 8-0-2006; IN COMMERCE 1-0-2007.  
BRIAN NEVILLE, EXAMINING ATTORNEY

**CLASS 33—(Continued).**

SN 85-212,434. ALASKA DISTILLERY LLC, WASILLA, AK, FILED 1-6-2011.

**TWISTED FISH**

THE MARK CONSISTS OF STANDARD CHARACTERS WITHOUT CLAIM TO ANY PARTICULAR FONT, STYLE, SIZE, OR COLOR.

FOR DISTILLED SPIRITS (U.S. CLS. 47 AND 49).  
KAREN BRACEY, EXAMINING ATTORNEY

SN 85-212,535. RKM WINES, LLC, SAN FRANCISCO, CA, FILED 1-7-2011.

**ARGONAUT**

THE MARK CONSISTS OF STANDARD CHARACTERS WITHOUT CLAIM TO ANY PARTICULAR FONT, STYLE, SIZE, OR COLOR.

FOR WINE (U.S. CLS. 47 AND 49).  
DAWN FELDMAN, EXAMINING ATTORNEY

SN 85-212,538. RKM WINES, LLC, SAN FRANCISCO, CA, FILED 1-7-2011.

**OVERLAND**

THE MARK CONSISTS OF STANDARD CHARACTERS WITHOUT CLAIM TO ANY PARTICULAR FONT, STYLE, SIZE, OR COLOR.

FOR WINE (U.S. CLS. 47 AND 49).  
DAWN FELDMAN, EXAMINING ATTORNEY

SN 85-212,585. JOEL ESTRADA DAMIAN, ZAPOPAN, JALISCO, MEXICO, FILED 1-7-2011.

**TQ21**

THE MARK CONSISTS OF THE LETTERS T AND Q, AS WELL AS THE NUMBER 21 IN STYLIZED FORM.

FOR ALCOHOLIC BEVERAGES, NAMELY, TEQUILA (U.S. CLS. 47 AND 49).

ALICIA COLLINS, EXAMINING ATTORNEY



**CLASS 33—(Continued).**

SN 85-212,710. SUTTER HOME WINERY, INC., ST. HELENA, CA. FILED 1-7-2011.

# AVISSI

THE MARK CONSISTS OF STANDARD CHARACTERS WITHOUT CLAIM TO ANY PARTICULAR FONT, STYLE, SIZE, OR COLOR.

FOR ALCOHOLIC BEVERAGES EXCEPT BEERS (U.S. CLS. 47 AND 49).

ERNEST SHOSHO, EXAMINING ATTORNEY

**CLASS 33—(Continued).**

SN 85-217,170. WENTE BROS., LIVERMORE, CA. FILED 1-13-2011.

# WENTE, FIRST FAMILY OF CHARDONNAY

THE MARK CONSISTS OF STANDARD CHARACTERS WITHOUT CLAIM TO ANY PARTICULAR FONT, STYLE, SIZE, OR COLOR.

OWNER OF U.S. REG. NOS. 1,366,981, 2,128,552 AND OTHERS.

NO CLAIM IS MADE TO THE EXCLUSIVE RIGHT TO USE "CHARDONNAY", APART FROM THE MARK AS SHOWN.

FOR WINE (U.S. CLS. 47 AND 49).

KATHERINE M. DUBRAY, EXAMINING ATTORNEY

SN 85-212,961. SAZERAC COMPANY INC., NEW ORLEANS, LA. FILED 1-7-2011.

# RON CUATRO PALMAS

THE MARK CONSISTS OF STANDARD CHARACTERS WITHOUT CLAIM TO ANY PARTICULAR FONT, STYLE, SIZE, OR COLOR.

NO CLAIM IS MADE TO THE EXCLUSIVE RIGHT TO USE "RON", APART FROM THE MARK AS SHOWN.

THE ENGLISH TRANSLATION OF "RON CUATRO PALMAS" IN THE MARK IS "FOUR PALMS RUM".

FOR RUM (U.S. CLS. 47 AND 49).

KIM SAITO, EXAMINING ATTORNEY

SN 85-220,033. NEW HOLLAND BREWING COMPANY, LLC, HOLLAND, MI. FILED 1-18-2011.

# HOPQUILA

THE MARK CONSISTS OF STANDARD CHARACTERS WITHOUT CLAIM TO ANY PARTICULAR FONT, STYLE, SIZE, OR COLOR.

FOR DISTILLED SPIRITS (U.S. CLS. 47 AND 49).

FIRST USE 1-0-2010; IN COMMERCE 1-0-2010.

GINA FINK, EXAMINING ATTORNEY

SN 85-213,382. FULLER, INC., EL MONTE, CA. FILED 1-7-2011.

# BARACA

THE MARK CONSISTS OF STANDARD CHARACTERS WITHOUT CLAIM TO ANY PARTICULAR FONT, STYLE, SIZE, OR COLOR.

FOR WINES (U.S. CLS. 47 AND 49).

ANNE E. GUSTASON, EXAMINING ATTORNEY

SN 85-220,329. THE WINE GROUP LLC, TRACY, CA. FILED 1-18-2011.

# RED CUP

THE MARK CONSISTS OF STANDARD CHARACTERS WITHOUT CLAIM TO ANY PARTICULAR FONT, STYLE, SIZE, OR COLOR.

NO CLAIM IS MADE TO THE EXCLUSIVE RIGHT TO USE "RED", APART FROM THE MARK AS SHOWN.

FOR LIQUEURS; PREPARED ALCOHOLIC COCKTAIL; PREPARED WINE COCKTAILS; SPIRITS; WINE; WINE-BASED DRINKS (U.S. CLS. 47 AND 49).

MARGARET POWER, EXAMINING ATTORNEY

**CLASS 33—(Continued).**

SN 85-223,513. THE WINE GROUP LLC, TRACY, CA. FILED 1-21-2011.

**FLIPPIN' GOOD WINES**

THE MARK CONSISTS OF STANDARD CHARACTERS WITHOUT CLAIM TO ANY PARTICULAR FONT, STYLE, SIZE, OR COLOR.

NO CLAIM IS MADE TO THE EXCLUSIVE RIGHT TO USE "GOOD WINES", APART FROM THE MARK AS SHOWN.

FOR LIQUEURS; PREPARED ALCOHOLIC COCKTAIL; PREPARED WINE COCKTAILS; SPIRITS; WINE; WINE-BASED DRINKS (U.S. CLS. 47 AND 49).

MARGARET POWER, EXAMINING ATTORNEY

SN 85-225,570. THE WINE GROUP LLC, TRACY, CA. FILED 1-25-2011.

**SMOKE SHOW**

THE MARK CONSISTS OF STANDARD CHARACTERS WITHOUT CLAIM TO ANY PARTICULAR FONT, STYLE, SIZE, OR COLOR.

FOR LIQUEURS; PREPARED ALCOHOLIC COCKTAIL; PREPARED WINE COCKTAILS; SPIRITS; WINE; WINE-BASED DRINKS (U.S. CLS. 47 AND 49).

MARGARET POWER, EXAMINING ATTORNEY

SN 85-225,923. THE WINE GROUP LLC, TRACY, CA. FILED 1-25-2011.

**DECADENCE D'VINE**

THE MARK CONSISTS OF STANDARD CHARACTERS WITHOUT CLAIM TO ANY PARTICULAR FONT, STYLE, SIZE, OR COLOR.

FOR WINE (U.S. CLS. 47 AND 49).

MARGARET POWER, EXAMINING ATTORNEY

**CLASS 33—(Continued).**

SN 85-227,249. THE WINE GROUP LLC, TRACY, CA. FILED 1-26-2011.

**BROWNIE POINTS**

THE MARK CONSISTS OF STANDARD CHARACTERS WITHOUT CLAIM TO ANY PARTICULAR FONT, STYLE, SIZE, OR COLOR.

FOR LIQUEURS; PREPARED ALCOHOLIC COCKTAIL; PREPARED WINE COCKTAILS; SPIRITS; WINE; WINE-BASED DRINKS (U.S. CLS. 47 AND 49).

MARGARET POWER, EXAMINING ATTORNEY

SN 85-228,110. PREMIUM BLEND, INC., HIALEAH, FL. FILED 1-27-2011.

**V'NILLA NOIR**

THE MARK CONSISTS OF STANDARD CHARACTERS WITHOUT CLAIM TO ANY PARTICULAR FONT, STYLE, SIZE, OR COLOR.

NO CLAIM IS MADE TO THE EXCLUSIVE RIGHT TO USE "VANILLA", APART FROM THE MARK AS SHOWN.

THE ENGLISH TRANSLATION OF "NOIR" IN THE MARK IS "BLACK". THE MARK AS A WHOLE HAS NO MEANING IN A FOREIGN LANGUAGE.

FOR ALCOHOLIC BEVERAGES EXCEPT BEERS; WINE (U.S. CLS. 47 AND 49).

ANDREW RHIM, EXAMINING ATTORNEY

SN 85-229,059. SUTTER HOME WINERY, INC., ST. HELENA, CA. FILED 1-28-2011.

**LONG ROCKS**

THE MARK CONSISTS OF STANDARD CHARACTERS WITHOUT CLAIM TO ANY PARTICULAR FONT, STYLE, SIZE, OR COLOR.

FOR ALCOHOLIC BEVERAGES EXCEPT BEERS (U.S. CLS. 47 AND 49).

ERNEST SHOSHO, EXAMINING ATTORNEY

**CLASS 33—(Continued).**

SN 85-230,092. THE WINE GROUP LLC, TRACY, CA. FILED 1-31-2011.

# OCCHIALI

THE MARK CONSISTS OF STANDARD CHARACTERS WITHOUT CLAIM TO ANY PARTICULAR FONT, STYLE, SIZE, OR COLOR.

THE ENGLISH TRANSLATION OF OCCHIALI IN THE MARK IS EYEGLASSES.

FOR LIQUEURS; PREPARED ALCOHOLIC COCKTAIL; PREPARED WINE COCKTAILS; SPIRITS; WINE; WINE-BASED DRINKS (U.S. CLS. 47 AND 49).

MARGARET POWER, EXAMINING ATTORNEY

**CLASS 33—(Continued).**

SN 85-232,183. HIGH WEST DISTILLERY, LLC, PARK CITY, UT. FILED 2-2-2011.

# Rocky Mountain Creme

THE MARK CONSISTS OF STANDARD CHARACTERS WITHOUT CLAIM TO ANY PARTICULAR FONT, STYLE, SIZE, OR COLOR.

OWNER OF U.S. REG. NOS. 3,588,978 AND 3,609,461.

NO CLAIM IS MADE TO THE EXCLUSIVE RIGHT TO USE "CREME", APART FROM THE MARK AS SHOWN.

FOR ALCOHOLIC BEVERAGES, NAMELY, FLAVOR-INFUSED WHISKEY; CREAM LIQUEURS; WHISKEY (U.S. CLS. 47 AND 49).

AMY HELLA, EXAMINING ATTORNEY

SN 85-230,612. RBZ VINEYARDS, LLC, DBA SEXTANT, SANTA BARBARA, CA. FILED 1-31-2011.

# SEASTONE

THE MARK CONSISTS OF STANDARD CHARACTERS WITHOUT CLAIM TO ANY PARTICULAR FONT, STYLE, SIZE, OR COLOR.

FOR WINE; WINES (U.S. CLS. 47 AND 49).

GILBERT SWIFT, EXAMINING ATTORNEY

SN 85-235,990. SUTTER HOME WINERY, INC., ST. HELENA, CA. FILED 2-7-2011.

# A3

THE MARK CONSISTS OF STANDARD CHARACTERS WITHOUT CLAIM TO ANY PARTICULAR FONT, STYLE, SIZE, OR COLOR.

FOR ALCOHOLIC BEVERAGES EXCEPT BEERS (U.S. CLS. 47 AND 49).

ERNEST SHOSHO, EXAMINING ATTORNEY

SN 85-230,621. RBZ VINEYARDS, LLC, SANTA BARBARA, CA. FILED 1-31-2011.

# WHEELSTONE

THE MARK CONSISTS OF STANDARD CHARACTERS WITHOUT CLAIM TO ANY PARTICULAR FONT, STYLE, SIZE, OR COLOR.

FOR WINE; WINES (U.S. CLS. 47 AND 49).

GILBERT SWIFT, EXAMINING ATTORNEY

SN 85-237,515. INTERCONTINENTAL PACKAGING CO., ST. PAUL, MN. FILED 2-9-2011.

# LE CLUZET

THE MARK CONSISTS OF STANDARD CHARACTERS WITHOUT CLAIM TO ANY PARTICULAR FONT, STYLE, SIZE, OR COLOR.

THE ENGLISH TRANSLATION OF LE IN THE MARK IS THE. THE WORDING CLUZET HAS NO MEANING IN A FOREIGN LANGUAGE.

FOR WINES (U.S. CLS. 47 AND 49).

MARY BOAGNI, EXAMINING ATTORNEY

**CLASS 33—(Continued).**

SN 85-239,226. MARGARITAVILLE ENTERPRISES, LLC, PALM BEACH, FL. FILED 2-10-2011.



OWNER OF U.S. REG. NOS. 1,877,860, 2,284,131 AND OTHERS.

THE MARK CONSISTS OF THE WORD MARGARITAVILLE CENTERED WITHIN A FURLED WEATHERED BANNER.

FOR ALCOHOLIC BEVERAGE PRODUCED FROM A BREWED MALT BASE WITH NATURAL FLAVORS; ALCOHOLIC MALT COOLERS; FLAVORED BREWED MALT BEVERAGE (U.S. CLS. 47 AND 49).

C. DIONNE CLYBURN, EXAMINING ATTORNEY

**CLASS 33—(Continued).**

SN 85-239,228. MARGARITAVILLE ENTERPRISES, LLC, PALM BEACH, FL. FILED 2-10-2011.



OWNER OF U.S. REG. NOS. 1,877,860, 3,728,391 AND OTHERS.

THE MARK CONSISTS OF A CARTOUCHE DESIGN CONSISTING OF THE WORDS NO SHIRT NO SHOES NO PROBLEM WITHIN THE PERIMETER OF A CIRCULAR BAND, WITH A STYLIZED PLANE AND ISLAND WITH TREES ALL WITHIN THE CENTER OF THE CIRCLE WITH LEAVES ON BOTH SIDES OF THE CIRCLE, ALL CENTERED OVER A WEATHERED BANNER CONTAINING THE WORD MARGARITAVILLE.

FOR ALCOHOLIC BEVERAGE PRODUCED FROM A BREWED MALT BASE WITH NATURAL FLAVORS; ALCOHOLIC MALT COOLERS; FLAVORED BREWED MALT BEVERAGE (U.S. CLS. 47 AND 49).

C. DIONNE CLYBURN, EXAMINING ATTORNEY

SN 85-239,227. MARGARITAVILLE ENTERPRISES, LLC, PALM BEACH, FL. FILED 2-10-2011.



OWNER OF U.S. REG. NOS. 1,877,860, 3,728,391 AND OTHERS.

THE MARK CONSISTS OF A CARTOUCHE DESIGN CONSISTING OF THE WORDS NO SHIRT NO SHOES NO PROBLEM WITHIN THE PERIMETER OF A CIRCULAR BAND, WITH A STYLIZED PLANE AND ISLAND WITH TREES ALL WITHIN THE CENTER OF THE CIRCLE WITH LEMONS ON BOTH SIDES OF THE CIRCLE, ALL CENTERED OVER A WEATHERED BANNER CONTAINING THE WORD MARGARITAVILLE.

FOR ALCOHOLIC BEVERAGE PRODUCED FROM A BREWED MALT BASE WITH NATURAL FLAVORS; ALCOHOLIC MALT COOLERS; FLAVORED BREWED MALT BEVERAGE (U.S. CLS. 47 AND 49).

C. DIONNE CLYBURN, EXAMINING ATTORNEY

SN 85-239,229. MARGARITAVILLE ENTERPRISES, LLC, PALM BEACH, FL. FILED 2-10-2011.



OWNER OF U.S. REG. NOS. 1,877,860, 3,728,391 AND OTHERS.

THE MARK CONSISTS OF A CARTOUCHE DESIGN CONSISTING OF THE WORDS NO SHIRT NO SHOES NO PROBLEM WITHIN THE PERIMETER OF A CIRCULAR BAND, WITH A STYLIZED PLANE AND ISLAND WITH TREES ALL WITHIN THE CENTER OF THE CIRCLE, ALL CENTERED OVER A WEATHERED BANNER CONTAINING THE WORD MARGARITAVILLE.

FOR ALCOHOLIC BEVERAGE PRODUCED FROM A BREWED MALT BASE WITH NATURAL FLAVORS; ALCOHOLIC MALT COOLERS; FLAVORED BREWED MALT BEVERAGE (U.S. CLS. 47 AND 49).

C. DIONNE CLYBURN, EXAMINING ATTORNEY

**CLASS 33—(Continued).**

SN 85-239,367. MARGARITAVILLE ENTERPRISES, LLC,  
PALM BEACH, FL. FILED 2-10-2011.



OWNER OF U.S. REG. NOS. 1,877,860, 2,284,131 AND  
OTHERS.

THE MARK CONSISTS OF THE WORD MARGARITA-  
VILLE CENTERED WITHIN A FURLED WEATHERED  
BANNER WITH A STYLIZED PALM TREE ON EACH SIDE.

FOR ALCOHOLIC BEVERAGE PRODUCED FROM A  
BREWED MALT BASE WITH NATURAL FLAVORS;  
ALCOHOLIC MALT COOLERS; FLAVORED BREWED  
MALT BEVERAGE (U.S. CLS. 47 AND 49).

C. DIONNE CLYBURN, EXAMINING ATTORNEY

SN 85-241,461. FOO DOG SPIRITS, LLC, HALIFAX, MA.  
FILED 2-14-2011.

WARD OFF EVIL SPIRITS,  
DRINK FOO DOG

THE MARK CONSISTS OF STANDARD CHARACTERS  
WITHOUT CLAIM TO ANY PARTICULAR FONT, STYLE,  
SIZE, OR COLOR.

FOR DISTILLED SPIRITS (U.S. CLS. 47 AND 49).  
KEVON CHISOLM, EXAMINING ATTORNEY

SN 85-241,469. FOO DOG SPIRITS, LLC, HALIFAX, MA.  
FILED 2-14-2011.

WARD OFF DEMON SPIRITS,  
DRINK FOO DOG

THE MARK CONSISTS OF STANDARD CHARACTERS  
WITHOUT CLAIM TO ANY PARTICULAR FONT, STYLE,  
SIZE, OR COLOR.

FOR DISTILLED SPIRITS (U.S. CLS. 47 AND 49).  
KEVON CHISOLM, EXAMINING ATTORNEY

**CLASS 33—(Continued).**

SN 85-244,825. SUTTER HOME WINERY, INC., ST. HELENA,  
CA. FILED 2-17-2011.

ADORED

THE MARK CONSISTS OF STANDARD CHARACTERS  
WITHOUT CLAIM TO ANY PARTICULAR FONT, STYLE,  
SIZE, OR COLOR.

FOR ALCOHOLIC BEVERAGES EXCEPT BEERS (U.S.  
CLS. 47 AND 49).

ERNEST SHOSHO, EXAMINING ATTORNEY

SN 85-244,968. INTERCONTINENTAL PACKAGING CO., ST.  
PAUL, MN. FILED 2-17-2011.

SHELLBACK

THE MARK CONSISTS OF STANDARD CHARACTERS  
WITHOUT CLAIM TO ANY PARTICULAR FONT, STYLE,  
SIZE, OR COLOR.

OWNER OF U.S. REG. NO. 3,386,150.

FOR DISTILLED SPIRITS (U.S. CLS. 47 AND 49).

MARY BOAGNI, EXAMINING ATTORNEY

SN 85-245,834. INTERCONTINENTAL PACKAGING CO., ST.  
PAUL, MN. FILED 2-18-2011.

BARLUME

THE MARK CONSISTS OF STANDARD CHARACTERS  
WITHOUT CLAIM TO ANY PARTICULAR FONT, STYLE,  
SIZE, OR COLOR.

THE ENGLISH TRANSLATION OF BARLUME IN THE  
MARK IS GLIMMER.

FOR WINES (U.S. CLS. 47 AND 49).

MARY BOAGNI, EXAMINING ATTORNEY

**CLASS 33—(Continued).**

SN 85-249,278. SAZERAC COMPANY, INC., NEW ORLEANS, LA. FILED 2-23-2011.

**WHITE BUFFALO**

THE MARK CONSISTS OF STANDARD CHARACTERS WITHOUT CLAIM TO ANY PARTICULAR FONT, STYLE, SIZE, OR COLOR.

FOR VODKA; WHISKEY (U.S. CLS. 47 AND 49).  
MARIA-VICTORIA SUAREZ, EXAMINING ATTORNEY

**CLASS 34—(Continued).**

SN 85-052,271. STARBUZZ TOBACCO, INC., ANAHEIM, CA. FILED 6-1-2010.

**Apple Madness**

THE MARK CONSISTS OF STANDARD CHARACTERS WITHOUT CLAIM TO ANY PARTICULAR FONT, STYLE, SIZE, OR COLOR.

NO CLAIM IS MADE TO THE EXCLUSIVE RIGHT TO USE "APPLE", APART FROM THE MARK AS SHOWN.  
FOR PIPE TOBACCO; MOLASSES TOBACCO; TOBACCO; SMOKING TOBACCO; FLAVORED TOBACCO; TOBACCO SUBSTITUTE, NAMELY, HERBAL MOLASSES (U.S. CLS. 2, 8, 9 AND 17).  
SAIMA MAKHDOOM, EXAMINING ATTORNEY

**CLASS 34—SMOKERS' ARTICLES**

SN 79-085,060. OETTINGER IMEX AG, SWITZERLAND, FILED 6-30-2010.

**BOGO**

THE MARK CONSISTS OF STANDARD CHARACTERS WITHOUT CLAIM TO ANY PARTICULAR FONT, STYLE, SIZE, OR COLOR.

PRIORITY DATE OF 4-16-2010 IS CLAIMED.  
OWNER OF INTERNATIONAL REGISTRATION 1045220 DATED 6-30-2010, EXPIRES 6-30-2020.

FOR TOBACCO ARTICLES, NAMELY, CIGARS, CIGARILLOS, SMOKING TOBACCO; SMOKERS' ARTICLES, NAMELY, CIGAR CUTTERS, NON-ELECTRICAL CIGAR AND CIGARETTE LIGHTERS INCLUDED IN THIS CLASS, CIGAR HUMIDIFIERS, CIGAR BOXES WITH HUMIDIFIERS; TOBACCO JARS, CIGAR CASES AND ASHTRAYS FOR SMOKERS, LIGHTERS FOR SMOKERS, MATCHES (U.S. CLS. 2, 8, 9 AND 17).  
WILLIAM ROSSMAN, EXAMINING ATTORNEY

SN 85-010,753. HAMMOUD, MOHAMAD, DEARBORN, MI. FILED 4-9-2010.

**Horoscopes**

THE MARK CONSISTS OF STANDARD CHARACTERS WITHOUT CLAIM TO ANY PARTICULAR FONT, STYLE, SIZE, OR COLOR.

FOR HOOKAH TOBACCO; MOLASSES TOBACCO; PIPE TOBACCO; SMOKING TOBACCO; TOBACCO (U.S. CLS. 2, 8, 9 AND 17).  
FIRST USE 12-28-2009; IN COMMERCE 12-28-2009.  
DAVID I, EXAMINING ATTORNEY

SN 85-071,450. VAN NELLE CANADA LIMITED, NEW BRUNSWICK, CANADA, FILED 6-25-2010.

**ROLL-RITE**

THE MARK CONSISTS OF STANDARD CHARACTERS WITHOUT CLAIM TO ANY PARTICULAR FONT, STYLE, SIZE, OR COLOR.

OWNER OF CANADA REG. NO. TMA373961, DATED 10-5-1990, EXPIRES 10-5-2020.

FOR CIGARETTE PAPERS; CIGARETTE PAPER TUBES; BOOKLETS OF PAPER USED TO MAKE CIGARETTES; CIGARETTE ROLLING MACHINES (U.S. CLS. 2, 8, 9 AND 17).  
PAUL F. GAST, EXAMINING ATTORNEY

SN 85-095,117. LABADI TRADING, INC., DBA HOOKAH WORKS, CORTLAND, IL. FILED 7-28-2010.

**Twilight Premium Molasses**

THE MARK CONSISTS OF STANDARD CHARACTERS WITHOUT CLAIM TO ANY PARTICULAR FONT, STYLE, SIZE, OR COLOR.

NO CLAIM IS MADE TO THE EXCLUSIVE RIGHT TO USE "PREMIUM MOLASSES", APART FROM THE MARK AS SHOWN.

FOR HOOKAH TOBACCO; MOLASSES TOBACCO; TOBACCO (U.S. CLS. 2, 8, 9 AND 17).  
WILLIAM VERHOSEK, EXAMINING ATTORNEY

**CLASS 34—(Continued).**

SN 85-163,252. TIDEWATER RETAIL GROUP, LLC, DBA EMERSON'S CIGARS, VIRGINIA BEACH, VA. FILED 10-28-2010.

# GRAN VIDA

THE MARK CONSISTS OF STANDARD CHARACTERS WITHOUT CLAIM TO ANY PARTICULAR FONT, STYLE, SIZE, OR COLOR.

THE ENGLISH TRANSLATION OF "GRAN VIDA" IN THE MARK IS GREAT LIFE.

FOR CIGARS (U.S. CLS. 2, 8, 9 AND 17).

FIRST USE 9-30-2009; IN COMMERCE 2-13-2010.

GISELLE AGOSTO, EXAMINING ATTORNEY

SN 85-182,777. BBK TOBACCO & FOODS, L.L.P., PHOENIX, AZ. FILED 11-22-2010.

# KINGPIN CAPO DEI CAPI

THE MARK CONSISTS OF STANDARD CHARACTERS WITHOUT CLAIM TO ANY PARTICULAR FONT, STYLE, SIZE, OR COLOR.

OWNER OF U.S. REG. NO. 2,874,945.

THE ENGLISH TRANSLATION OF "CAPO DEI CAPI" IN THE MARK IS BOSS OF ALL BOSSES.

FOR CIGAR WRAPS; CIGARS; TOBACCO, CIGARS AND CIGARETTES (U.S. CLS. 2, 8, 9 AND 17).

FIRST USE 11-13-2009; IN COMMERCE 11-13-2009.

PAUL F. GAST, EXAMINING ATTORNEY

SN 85-186,615. FORDHAM, BOONE G, DBA KASHTRAY, SEATTLE, WA. FILED 11-29-2010.

THE MARK CONSISTS OF THE STYLIZED TERMS "KASHTRAY KASHTRAY" ARRANGED IN A CIRCLE.

FOR ASHTRAYS (U.S. CLS. 2, 8, 9 AND 17).

FIRST USE 9-9-2010; IN COMMERCE 3-5-2011.

HOWARD B. LEVINE, EXAMINING ATTORNEY

**CLASS 34—(Continued).**

SN 85-193,839. BUENAVISTA TOBACCO COMPANY BTF SWITZERLAND SA, MORGES 1110, SWITZERLAND, FILED 12-9-2010.

# MARAVILLA TOBACCO

NO CLAIM IS MADE TO THE EXCLUSIVE RIGHT TO USE "TOBACCO", APART FROM THE MARK AS SHOWN.

THE MARK CONSISTS OF THE TERMS "MARAVILLA TOBACCO" IN STYLIZED LETTERING.

THE ENGLISH TRANSLATION OF "MARAVILLA" IN THE MARK IS MARVELOUS.

FOR HAND-ROLLING TOBACCO; SMOKING TOBACCO; TOBACCO; TOBACCO, CIGARS AND CIGARETTES (U.S. CLS. 2, 8, 9 AND 17).

MICHAEL WIENER, EXAMINING ATTORNEY

SN 85-193,847. BUENAVISTA TOBACCO COMPANY BTF SWITZERLAND SA, MORGES 1110, SWITZERLAND, FILED 12-9-2010.



NO CLAIM IS MADE TO THE EXCLUSIVE RIGHT TO USE "TOBACCO", APART FROM THE MARK AS SHOWN. THE COLOR(S) BLACK, SILVER AND RED IS/ARE CLAIMED AS A FEATURE OF THE MARK.

THE MARK CONSISTS OF A SHIELD IN THE SHAPE OF A DIAMOND, IN BLACK, OUTLINED IN SILVER, AND OUTLINED AROUND THE SIDES OF THE SHIELD IN RED. INSIDE THE SHIELD APPEARS THE WORDING "MARAVILLA TOBACCO" IN BLACK, CHEVRONS IN SILVER ABOVE AND BELOW THE WORDING, AND LEAF SHAPES IN SILVER ABOVE AND BELOW THE CHEVRONS. ABOVE THE TOP RIGHT AND LEFT AND BELOW THE BOTTOM RIGHT AND LEFT SIDES OF THE SHIELD APPEARS FLORETS IN THE COLORS BLACK, RED AND SILVER.

THE ENGLISH TRANSLATION OF "MARAVILLA" IN THE MARK IS MARVELOUS.

FOR HAND-ROLLING TOBACCO; SMOKING TOBACCO; TOBACCO; TOBACCO, CIGARS AND CIGARETTES (U.S. CLS. 2, 8, 9 AND 17).

MICHAEL WIENER, EXAMINING ATTORNEY

**CLASS 34—(Continued).**

SN 85-193,871. BUENAVISTA TOBACCO COMPANY BTF SWITZERLAND SA, MORGES, SWITZERLAND, FILED 12-9-2010.



NO CLAIM IS MADE TO THE EXCLUSIVE RIGHT TO USE "CIGARS", APART FROM THE MARK AS SHOWN. THE MARK CONSISTS OF THE TERMS "MARAVILLA CIGARS" IN STYLIZED LETTERING.

THE ENGLISH TRANSLATION OF "MARAVILLA" IN THE MARK IS MARVELOUS.

FOR HAND-ROLLING TOBACCO; SMOKING TOBACCO; TOBACCO; TOBACCO, CIGARS AND CIGARETTES (U.S. CLS. 2, 8, 9 AND 17).

MICHAEL WIENER, EXAMINING ATTORNEY

SN 85-193,883. BUENAVISTA TOBACCO COMPANY BTF SWITZERLAND SA, MORGES, SWITZERLAND, FILED 12-9-2010.



NO CLAIM IS MADE TO THE EXCLUSIVE RIGHT TO USE "CIGARS", APART FROM THE MARK AS SHOWN.

THE COLOR(S) BLACK, RED AND SILVER IS/ARE CLAIMED AS A FEATURE OF THE MARK.

THE MARK CONSISTS OF A SHIELD IN THE SHAPE OF A DIAMOND, IN BLACK, OUTLINED IN SILVER, AND OUTLINED AROUND THE SIDES OF THE SHIELD IN RED. INSIDE THE SHIELD APPEARS THE WORDING "MARAVILLA CIGARS" IN BLACK, CHEVRONS IN SILVER ABOVE AND BELOW THE WORDING, AND LEAF SHAPES IN SILVER ABOVE AND BELOW THE CHEVRONS. ABOVE THE TOP RIGHT AND LEFT AND BELOW THE BOTTOM RIGHT AND LEFT SIDES OF THE SHIELD APPEARS FLORETS IN THE COLORS BLACK, RED AND SILVER.

THE ENGLISH TRANSLATION OF "MARAVILLA" IN THE MARK IS MARVELOUS.

FOR HAND-ROLLING TOBACCO; SMOKING TOBACCO; TOBACCO; TOBACCO, CIGARS AND CIGARETTES (U.S. CLS. 2, 8, 9 AND 17).

MICHAEL WIENER, EXAMINING ATTORNEY

**CLASS 34—(Continued).**

SN 85-197,557. ITC LIMITED, KOLKATA, INDIA, FILED 12-14-2010.



NO CLAIM IS MADE TO THE EXCLUSIVE RIGHT TO USE "KINGS", APART FROM THE MARK AS SHOWN.

THE NAME(S), PORTRAIT(S), AND/OR SIGNATURE(S) SHOWN IN THE MARK DOES NOT IDENTIFY A PARTICULAR LIVING INDIVIDUAL.

THE MARK CONSISTS OF THE WORDS "HONEYDEW SMOOTH" SET FORTH IN UPPERCASE LETTERING ON A DARK RECTANGULAR BAR, WHICH APPEARS BENEATH A STYLIZED OVERLAPPED EIGHT-POINT STAR DESIGN; THE FOREGOING IS SET FORTH ABOVE A BACKGROUND DESIGN COMPRISED OF 13 THIN VERTICAL BARS; A STYLIZED BANNER/EMBLEM GRAPHIC IS SUPERIMPOSED ON THE FOREGOING BAR DESIGN; THE WORDING "W.D. & H.O. WILLS" APPEARS IN UPPERCASE LETTERING WITHIN THE UPPER CURVE OF THE EMBLEM GRAPHIC AND THE WORDING "HONEY DEW" APPEARS IN UPPERCASE LETTERING WITHIN THE LOWER CURVE OF THE EMBLEM GRAPHIC; THE WORDS "GOLD FLAKE" APPEARS IN UPPERCASE LETTERING ON A RECTANGULAR BACKGROUND ACROSS THE EMBLEM GRAPHIC; THE WORD "KINGS" APPEARS IN SCRIPT LETTERING BENEATH ALL OF THE FOREGOING.

FOR CIGARETTES (U.S. CLS. 2, 8, 9 AND 17).

JAMES GRIFFIN, EXAMINING ATTORNEY

SN 85-203,982. SENECA, J. CONRAD, IRVING, NY. FILED 12-22-2010.

**SIX NATIONS**

THE MARK CONSISTS OF STANDARD CHARACTERS WITHOUT CLAIM TO ANY PARTICULAR FONT, STYLE, SIZE, OR COLOR.

FOR CHEWING TOBACCO; CIGARETTES; CIGARS; HAND-ROLLING TOBACCO; ROLL YOUR OWN TOBACCO; SNUFF (U.S. CLS. 2, 8, 9 AND 17).

JACQUELINE A. LAVINE, EXAMINING ATTORNEY



**CLASS 34—(Continued).**

SN 85-204,238. SMOKETRONIC, LLC, ST. LOUIS, MO. FILED 12-22-2010.

# NOIR

THE MARK CONSISTS OF STANDARD CHARACTERS WITHOUT CLAIM TO ANY PARTICULAR FONT, STYLE, SIZE, OR COLOR.

THE ENGLISH TRANSLATION OF NOIR IN THE MARK IS BLACK.

FOR ELECTRONIC CIGARETTES AND COMPONENTS THEREFOR (U.S. CLS. 2, 8, 9 AND 17).

FIRST USE 10-0-2010; IN COMMERCE 10-0-2010.  
EUGENIA MARTIN, EXAMINING ATTORNEY

---

SN 85-206,113. FANTASIA DISTRIBUTION, INC., ANAHEIM, CA. FILED 12-27-2010.

# SURFER ON ACID

THE MARK CONSISTS OF STANDARD CHARACTERS WITHOUT CLAIM TO ANY PARTICULAR FONT, STYLE, SIZE, OR COLOR.

FOR HOOKAH TOBACCO; MOLASSES TOBACCO; SMOKING TOBACCO; TOBACCO (U.S. CLS. 2, 8, 9 AND 17).

FIRST USE 11-24-2009; IN COMMERCE 11-24-2009.  
MORGAN WYNNE, EXAMINING ATTORNEY

---

SN 85-207,838. FAIRMONT HOLDINGS, INC., DANIA, FL. FILED 12-30-2010.

# POST EMBARGO

THE MARK CONSISTS OF STANDARD CHARACTERS WITHOUT CLAIM TO ANY PARTICULAR FONT, STYLE, SIZE, OR COLOR.

FOR CIGARS; TOBACCO; CIGAR BOXES; CIGAR CUTTERS AND CIGAR TUBES (U.S. CLS. 2, 8, 9 AND 17).

KHANH LE, EXAMINING ATTORNEY

**CLASS 34—(Continued).**

SN 85-207,974. SHENZHEN BAUWAY TECHNOLOGY LIMITED, BAO'AN DIST., SHENZHEN, CHINA, FILED 12-30-2010.



THE MARK CONSISTS OF A FLOWER FOLLOWED BY THE WORD BAUWAY IN PROMINENT STYLIZED LETTERS BELOW OF WHICH APPEARS A THIN HORIZONTAL LINE AND BELOW THE HORIZONTAL LINE APPEARS THE WORDING SOLUTION PARTNER IN SMALLER STYLIZED CAPITAL LETTERS.

THE WORDING BAUWAY HAS NO MEANING IN A FOREIGN LANGUAGE.

FOR MOUTHPIECES OF YELLOW AMBER FOR CIGAR AND CIGARETTE HOLDERS; TOBACCO POUCHES; CIGARETTE TIPS; TOBACCO PIPES; CIGAR CUTTERS; CIGAR CASES; CIGARETTE CASES; CIGAR HOLDERS; CIGARETTES; CIGARETTE HOLDERS; PIPE CLEANERS FOR TOBACCO PIPES; PIPE RACKS FOR TOBACCO PIPES; TOBACCO JARS; SNUFF BOXES; ASHTRAYS FOR SMOKERS; SPITTOONS FOR TOBACCO USERS; HUMIDORS; CIGARETTE FILTERS AND ELECTRIC CIGARETTES (U.S. CLS. 2, 8, 9 AND 17).

FIRST USE 4-5-2009; IN COMMERCE 4-5-2009.  
DANIEL CAPSHAW, EXAMINING ATTORNEY

---

SN 85-209,775. FAMILY TOBACCO TRADERS LLC, CORAL GABLES, FL. FILED 1-4-2011.

# OLÉ

THE MARK CONSISTS OF STANDARD CHARACTERS WITHOUT CLAIM TO ANY PARTICULAR FONT, STYLE, SIZE, OR COLOR.

THE ENGLISH TRANSLATION OF OLÉ IN THE MARK IS BRAVO.

FOR CIGARS (U.S. CLS. 2, 8, 9 AND 17).  
SKYE YOUNG, EXAMINING ATTORNEY

---

SN 85-210,808. UETA, INC., PANAMA, PANAMA, FILED 1-5-2011.

# SHERIFF

THE MARK CONSISTS OF STANDARD CHARACTERS WITHOUT CLAIM TO ANY PARTICULAR FONT, STYLE, SIZE, OR COLOR.

OWNER OF U.S. REG. NO. 3,477,391.

FOR TOBACCO (U.S. CLS. 2, 8, 9 AND 17).  
KAREN K. BUSH, EXAMINING ATTORNEY

**CLASS 34—(Continued).**

SN 85-211,715. SANTA CLARA, INC., WHIPPANY, NJ. FILED 1-6-2011.

**Shane**

THE MARK CONSISTS OF STANDARD CHARACTERS WITHOUT CLAIM TO ANY PARTICULAR FONT, STYLE, SIZE, OR COLOR.

THE NAME(S), PORTRAIT(S), AND/OR SIGNATURE(S) SHOWN IN THE MARK DOES NOT IDENTIFY A PARTICULAR LIVING INDIVIDUAL.

FOR CIGARS (U.S. CLS. 2, 8, 9 AND 17).  
MAYUR VAGHANI, EXAMINING ATTORNEY

**CLASS 34—(Continued).**

SN 85-218,289. FANTASIA DISTRIBUTION, INC., ANAHEIM, CA. FILED 1-14-2011.

**CUPID'S ARROW**

THE MARK CONSISTS OF STANDARD CHARACTERS WITHOUT CLAIM TO ANY PARTICULAR FONT, STYLE, SIZE, OR COLOR.

FOR HOOKAH TOBACCO; MOLASSES TOBACCO; SMOKING TOBACCO; TOBACCO (U.S. CLS. 2, 8, 9 AND 17).

FIRST USE 1-16-2009; IN COMMERCE 1-16-2009.  
MORGAN WYNNE, EXAMINING ATTORNEY

SN 85-215,606. VAPOR CORP., HALLANDALE, FL. FILED 1-12-2011.

**VAPORMAX**

THE MARK CONSISTS OF STANDARD CHARACTERS WITHOUT CLAIM TO ANY PARTICULAR FONT, STYLE, SIZE, OR COLOR.

FOR ELECTRONIC CIGARETTES (U.S. CLS. 2, 8, 9 AND 17).

FIRST USE 10-5-2010; IN COMMERCE 12-14-2010.  
KRISTIN DAHLING, EXAMINING ATTORNEY

SN 85-218,293. FANTASIA DISTRIBUTION, INC., ANAHEIM, CA. FILED 1-14-2011.

**CACTUS BREEZE**

THE MARK CONSISTS OF STANDARD CHARACTERS WITHOUT CLAIM TO ANY PARTICULAR FONT, STYLE, SIZE, OR COLOR.

FOR HOOKAH TOBACCO; MOLASSES TOBACCO; SMOKING TOBACCO; TOBACCO (U.S. CLS. 2, 8, 9 AND 17).

FIRST USE 1-16-2009; IN COMMERCE 1-16-2009.  
MORGAN WYNNE, EXAMINING ATTORNEY

SN 85-218,287. FANTASIA DISTRIBUTION, INC., ANAHEIM, CA. FILED 1-14-2011.

**ICE**

THE MARK CONSISTS OF STANDARD CHARACTERS WITHOUT CLAIM TO ANY PARTICULAR FONT, STYLE, SIZE, OR COLOR.

FOR HOOKAH TOBACCO; MOLASSES TOBACCO; SMOKING TOBACCO; TOBACCO (U.S. CLS. 2, 8, 9 AND 17).

FIRST USE 11-24-2009; IN COMMERCE 11-24-2009.  
MORGAN WYNNE, EXAMINING ATTORNEY

SN 85-218,300. FANTASIA DISTRIBUTION, INC., ANAHEIM, CA. FILED 1-14-2011.

**DRAGON'S BREATH**

THE MARK CONSISTS OF STANDARD CHARACTERS WITHOUT CLAIM TO ANY PARTICULAR FONT, STYLE, SIZE, OR COLOR.

FOR HOOKAH TOBACCO; MOLASSES TOBACCO; SMOKING TOBACCO; TOBACCO (U.S. CLS. 2, 8, 9 AND 17).

FIRST USE 11-24-2009; IN COMMERCE 11-24-2009.  
MORGAN WYNNE, EXAMINING ATTORNEY

**CLASS 34—(Continued).**

SN 85-227,481. FAIRMONT HOLDINGS, INC., DANIA, FL. FILED 1-27-2011.

**Alchemy**

THE MARK CONSISTS OF STANDARD CHARACTERS WITHOUT CLAIM TO ANY PARTICULAR FONT, STYLE, SIZE, OR COLOR.

FOR CIGARS, TOBACCO, CIGAR BOXES, CIGAR CUTTERS AND CIGAR TUBES (U.S. CLS. 2, 8, 9 AND 17).

KHANH LE, EXAMINING ATTORNEY

---

**SERVICE MARKS**

**CLASS 35—ADVERTISING AND BUSINESS**

SN 76-702,774. HOLT, DIANE K., WILLIAMSBURG, MI. FILED 5-3-2010.

**MOTHERS OF INVENTION**

THE MARK CONSISTS OF STANDARD CHARACTERS WITHOUT CLAIM TO ANY PARTICULAR FONT, STYLE, SIZE, OR COLOR.

FOR BUSINESS DEVELOPMENT AND MANAGEMENT SERVICES, NAMELY, OFFERING BUSINESS RESEARCH, EVALUATIONS, MARKETING ASSISTANCE AND OTHER BUSINESS START-UP SUPPORT, TO HELP WOMEN ESTABLISH SUCCESSFUL COMMERCIAL UNDERTAKINGS (U.S. CLS. 100, 101 AND 102).

NELSON SNYDER, EXAMINING ATTORNEY

**CLASS 35—(Continued).**

SN 76-704,047. CHESTNUT HILL ADVISORS LLC, CHESTNUT HILL, MA. FILED 8-9-2010.



NO CLAIM IS MADE TO THE EXCLUSIVE RIGHT TO USE "CHESTNUT HILL ADVISORS", APART FROM THE MARK AS SHOWN.

THE COLOR(S) GREEN AND ORANGE IS/ARE CLAIMED AS A FEATURE OF THE MARK.

THE MARK CONSISTS OF THE WORDING "CHESTNUT HILL" IN THE COLOR GREEN AND THE WORDING "ADVISORS" IN THE COLOR ORANGE AND A DESIGN OF TWO TRIANGLE SHAPES IN THE COLOR GREEN, A SINGLE TRIANGLE SHAPE IN THE COLOR ORANGE AND A SMALL ORANGE CIRCLE.

FOR BUSINESS MANAGEMENT CONSULTING WITH RELATION TO STRATEGY, MARKETING, SALES, OPERATION, PRODUCT DESIGN PARTICULARLY SPECIALIZING IN THE USE OF ANALYTIC AND STATISTIC MODELS FOR THE UNDERSTANDING AND PREDICTING OF CONSUMERS, BUSINESSES, AND MARKET TRENDS AND ACTIONS (U.S. CLS. 100, 101 AND 102).

FIRST USE 1-1-2007; IN COMMERCE 1-1-2007.

WILLIAM ROSSMAN, EXAMINING ATTORNEY

---

**CHANGE IS GOOD**

THE MARK CONSISTS OF STANDARD CHARACTERS WITHOUT CLAIM TO ANY PARTICULAR FONT, STYLE, SIZE, OR COLOR.

FOR RECRUITMENT OF COLLEGE STUDENTS FOR OTHER EDUCATIONAL INSTITUTIONS (U.S. CLS. 100, 101 AND 102).

ALYSSA STEEL, EXAMINING ATTORNEY

**CLASS 35—(Continued).**

SN 76-705,686. INTERNATIONAL DIGITAL ENTERPRISE ALLIANCE, INC., ALEXANDRIA, VA. FILED 12-14-2010.

P3

THE MARK CONSISTS OF STANDARD CHARACTERS WITHOUT CLAIM TO ANY PARTICULAR FONT, STYLE, SIZE, OR COLOR.

FOR BUSINESS NETWORKING SERVICES, PROVIDING BUSINESS NETWORKING OPPORTUNITIES, BUSINESS MEETING PLANNING, AND PROVIDING CAREER INFORMATION, ALL IN THE FIELDS OF GRAPHIC COMMUNICATIONS, PRINT PRODUCTION, PUBLISHING AND NEW MEDIA (U.S. CLS. 100, 101 AND 102).

FIRST USE 11-1-2003; IN COMMERCE 11-1-2003.  
REBECCA POVARCHUK, EXAMINING ATTORNEY

SN 76-705,850. MUSIC CITY METALS CO., INC., NASHVILLE, TN. FILED 12-30-2010.

MUSIC CITY METALS

THE MARK CONSISTS OF STANDARD CHARACTERS WITHOUT CLAIM TO ANY PARTICULAR FONT, STYLE, SIZE, OR COLOR.

NO CLAIM IS MADE TO THE EXCLUSIVE RIGHT TO USE "MUSIC CITY" APART FROM THE MARK AS SHOWN., APART FROM THE MARK AS SHOWN.

FOR DISTRIBUTORSHIP SERVICES IN THE FIELD OF AS GRILL PARTS; NAMELY, VALVES, CONTROL KNOBS, HEAT INDICATORS, IGNITOR COMPONENTS, LID HANDLES, ACCESSORIES, ROTISSERIE HOUSINGS, REGULATORS, HOSES, GRILL PLUMBING, NATURAL GAS GRILL POSTS, WARMING RACKS, GASLIGHT PARTS AND SUPPLIES, HOT PLATES, BURNERS AND VENTURIS, COOKING GRIDS, AND ROCK GRATES/HEAT PLATES (U.S. CLS. 100, 101 AND 102).

FIRST USE 1-30-1989; IN COMMERCE 1-30-1989.  
SUE LAWRENCE, EXAMINING ATTORNEY

**CLASS 35—(Continued).**

SN 76-705,851. MUSIC CITY METALS CO., INC., NASHVILLE, TN. FILED 12-30-2010.



NO CLAIM IS MADE TO THE EXCLUSIVE RIGHT TO USE "MUSIC CITY" APART FROM THE MARK AS SHOWN., APART FROM THE MARK AS SHOWN.

FOR DISTRIBUTORSHIP SERVICES IN THE FIELD OF AS GRILL PARTS; NAMELY, VALVES, CONTROL KNOBS, HEAT INDICATORS, IGNITOR COMPONENTS, LID HANDLES, ACCESSORIES, ROTISSERIE HOUSINGS, REGULATORS, HOSES, GRILL PLUMBING, NATURAL GAS GRILL POSTS, WARMING RACKS, GASLIGHT PARTS AND SUPPLIES, HOT PLATES, BURNERS AND VENTURIS, COOKING GRIDS, AND ROCK GRATES/HEAT PLATES (U.S. CLS. 100, 101 AND 102).

FIRST USE 1-30-1989; IN COMMERCE 1-30-1989.  
SUE LAWRENCE, EXAMINING ATTORNEY

SN 76-705,852. MUSIC CITY METALS CO., INC., NASHVILLE, TN. FILED 12-30-2010.

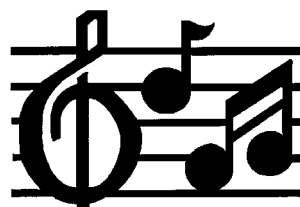

FOR DISTRIBUTORSHIP SERVICES IN THE FIELD OF AS GRILL PARTS; NAMELY, VALVES, CONTROL KNOBS, HEAT INDICATORS, IGNITOR COMPONENTS, LID HANDLES, ACCESSORIES, ROTISSERIE HOUSINGS, REGULATORS, HOSES, GRILL PLUMBING, NATURAL GAS GRILL POSTS, WARMING RACKS, GASLIGHT PARTS AND SUPPLIES, HOT PLATES, BURNERS AND VENTURIS, COOKING GRIDS, AND ROCK GRATES/HEAT PLATES (U.S. CLS. 100, 101 AND 102).

FIRST USE 1-30-1989; IN COMMERCE 1-30-1989.  
SUE LAWRENCE, EXAMINING ATTORNEY

**CLASS 35—(Continued).**

SN 77-069,115. PAXTON, GRAHAM, EVANSVILLE, IN.  
FILED 12-21-2006.

# Swift Athletics

THE MARK CONSISTS OF STANDARD CHARACTERS WITHOUT CLAIM TO ANY PARTICULAR FONT, STYLE, SIZE, OR COLOR.

NO CLAIM IS MADE TO THE EXCLUSIVE RIGHT TO USE "ATHLETICS", APART FROM THE MARK AS SHOWN. FOR RETAIL STORES FEATURING RUNNING SHOES, APPAREL, AND RELATED ACCESSORIES (U.S. CLS. 100, 101 AND 102).

MARY CRAWFORD, EXAMINING ATTORNEY

SN 77-069,502. PAXTON, GRAHAM, EVANSVILLE, IN.  
FILED 12-21-2006.

NO CLAIM IS MADE TO THE EXCLUSIVE RIGHT TO USE "ATHLETICS", APART FROM THE MARK AS SHOWN. FOR RETAIL STORES FEATURING RUNNING SHOES, APPAREL, AND RELATED ACCESSORIES (U.S. CLS. 100, 101 AND 102).

MARY CRAWFORD, EXAMINING ATTORNEY

SN 77-188,510. SOPARES INC., MONTREAL, PROVINCE OF  
QUÉBEC, CANADA, FILED 5-23-2007.

# THE EGG

THE MARK CONSISTS OF STANDARD CHARACTERS WITHOUT CLAIM TO ANY PARTICULAR FONT, STYLE, SIZE, OR COLOR.

PRIORITY CLAIMED UNDER SEC. 44(D) ON CANADA APPLICATION NO. 1348379, FILED 5-23-2007, REG. NO. TMA771806, DATED 7-13-2010, EXPIRES 7-13-2025.

FOR CONSULTANCY SERVICES REGARDING BUSINESS STRATEGIES FEATURING THE IDENTIFICATION AND ANALYSIS OF STRATEGIC POSITIONING OF A BUSINESS ACTIVITY (U.S. CLS. 100, 101 AND 102).

SARA BENJAMIN, EXAMINING ATTORNEY

**CLASS 35—(Continued).**

SN 77-583,807. NINTENDO OF AMERICA INC., REDMOND, WA. FILED 10-2-2008.

OWNER OF JAPAN REG. NO. 5324017, DATED 5-21-2010, EXPIRES 5-21-2020.

OWNER OF U.S. REG. NOS. 1,213,822, 1,628,966 AND OTHERS.

THE MARK CONSISTS OF THE WORDS "NINTENDO ZONE"; WITH TRANSMISSION WAVES EMANATING FROM THE DOT ABOVE THE LETTER "I".

FOR ADVERTISING AND PUBLICITY SERVICES; PROMOTING THE GOODS AND SERVICES OF OTHERS VIA THE ISSUANCE OF TRADING STAMPS; BUSINESS MANAGEMENT AND CONSULTATION; MARKETING RESEARCH; PROVIDING INFORMATION AND ADVICE TO CONSUMERS REGARDING THE SELECTION OF PRODUCTS AND ITEMS TO BE PURCHASED; RETAIL STORE SERVICES AND WHOLESALE STORE SERVICES ALL FEATURING SPORTING GOODS; RETAIL STORE SERVICES AND WHOLESALE STORE SERVICES ALL FEATURING VIDEO GAME PROGRAMS; RETAIL STORE SERVICES AND WHOLESALE STORE SERVICES ALL FEATURING ROM CARDS, ROM CARTRIDGES, CD-ROMS, DVD-ROMS AND OTHER DIGITAL STORAGE MEDIA RECORDED WITH PROGRAMS FOR VIDEO GAMES; RETAIL STORE SERVICES AND WHOLESALE STORE SERVICES ALL FEATURING CONTROLLERS, JOYSTICKS AND MEMORY CARDS FOR CONSUMER VIDEO GAMES; RETAIL STORE SERVICES AND WHOLESALE STORE SERVICES ALL FEATURING PARTS AND FITTINGS FOR CONSUMER VIDEO GAMES; RETAIL STORE SERVICES AND WHOLESALE STORE SERVICES ALL FEATURING HAND-HELD GAMES WITH LIQUID CRYSTAL DISPLAYS; RETAIL STORE SERVICES AND WHOLESALE STORE SERVICES ALL FEATURING PROGRAMS FOR HAND-HELD GAMES WITH LIQUID CRYSTAL DISPLAYS; RETAIL STORE SERVICES AND WHOLESALE STORE SERVICES ALL FEATURING ROM CARDS, ROM CARTRIDGES, CD-ROMS, DVD-ROMS AND OTHER STORAGE MEDIA RECORDED WITH PROGRAMS FOR HAND-HELD GAMES WITH LIQUID CRYSTAL DISPLAYS; RETAIL STORE SERVICES AND WHOLESALE STORE SERVICES ALL FEATURING CARD GAMES AND THEIR COMPONENTS; RETAIL STORE SERVICES AND WHOLESALE STORE SERVICES ALL FEATURING DOLLS; RETAIL STORE SERVICES AND WHOLESALE STORE SERVICES ALL FEATURING GO GAMES; RETAIL STORE SERVICES AND WHOLESALE STORE SERVICES ALL FEATURING JAPANESE PLAYING CARDS ALSO KNOWN AS UTAGARUTA; RETAIL STORE SERVICES AND WHOLESALE STORE SERVICES ALL FEATURING JAPANESE CHESS ALSO KNOWN AS SHOGI GAMES; RETAIL STORE SERVICES AND WHOLESALE STORE SERVICES ALL FEATURING CARD GAMES EQUIPMENT; RETAIL STORE SERVICES AND WHOLESALE STORE SERVICES ALL FEATURING DICE; RETAIL STORE SERVICES AND WHOLESALE STORE SERVICES ALL FEATURING JAPANESE DICE GAMES ALSO KNOWN AS SUGOROKU; RETAIL STORE SERVICES AND WHOLESALE STORE SERVICES ALL FEATURING DICE CUPS; RETAIL STORE SERVICES AND WHOLESALE STORE SERVICES ALL FEATURING DIAMOND GAMES; RETAIL STORE SERVICES AND WHOLESALE STORE SERVICES ALL FEATURING CHESS GAMES; RETAIL STORE SERVICES AND WHOLESALE STORE SERVICES ALL FEATURING CHECKER SETS; RETAIL STORE SERVICES AND WHOLESALE STORE SERVICES ALL FEATURING MAGIC PLAY KITS; RETAIL STORE SERVICES AND WHOLESALE STORE SERVICES ALL FEATURING DOMINOES; RETAIL STORE SERVICES AND WHOLESALE STORE SERVICES ALL FEATURING PLAYING CARDS; RETAIL STORE SERVICES AND WHOLESALE STORE SERVICES JAPANESE PLAYING CARDS ALSO KNOWN AS HANAFUDA; RETAIL STORE SERVICES AND WHOLESALE STORE SERVICES FOR

**CLASS 35—(Continued).**

MAH-JONG; RETAIL STORE SERVICES AND WHOLESALE STORE SERVICES ALL FEATURING GAME MACHINES; RETAIL STORE SERVICES AND WHOLESALE STORE SERVICES ALL FEATURING BILLIARD EQUIPMENT; RETAIL STORE SERVICES AND WHOLESALE STORE SERVICES ALL FEATURING TOYS, DOLLS AND GAME MACHINES; RETAIL STORE SERVICES AND WHOLESALE STORE SERVICES ALL FEATURING MUSICAL INSTRUMENTS AND RECORDS; RETAIL STORE SERVICES AND WHOLESALE STORE SERVICES ALL FEATURING DIGITAL CAMERAS AND DIGITAL EQUIPMENT FOR PRINTING PHOTOGRAPHS; RETAIL STORE SERVICES AND WHOLESALE STORE SERVICES ALL FEATURING CLOCKS, WATCHES, SPECTACLES, EYEGLASSES AND GOGGLES; ON-LINE RETAIL STORE SERVICES FEATURING DOWNLOADABLE COMPUTER AND VIDEO GAMES; OPERATING AN ON-LINE SHOPPING SITE IN THE FIELD OF COMPUTER AND VIDEO GAMES; PROVIDING CONSUMER INFORMATION ABOUT COMPUTER AND VIDEO GAMES VIA THE INTERNET; PROVIDING CONSUMER INFORMATION ABOUT THE GOODS OF OTHERS VIA A GLOBAL COMPUTER NETWORK; RETAIL STORE SERVICES FEATURING COMPUTER AND VIDEO GAMES; CUSTOMER LOYALTY SERVICES AND CUSTOMER CLUB SERVICES, FOR PROMOTION OF VIDEO AND COMPUTER GAMES; PROVIDING INCENTIVE AWARD PROGRAMS FOR CUSTOMERS THROUGH THE DISTRIBUTION OF PREPAID STORED VALUE CARDS FOR THE PURPOSE OF PROMOTING AND REWARDING LOYALTY (U.S. CLS. 100, 101 AND 102).

MATTHEW MCDOWELL, EXAMINING ATTORNEY

SN 77-597,294. TIE RACK TRADING LIMITED, BRENTFORD, MIDDLESEX, UNITED KINGDOM, FILED 10-21-2008.



PRIORITY CLAIMED UNDER SEC. 44(D) ON UNITED KINGDOM APPLICATION NO. 2497492, FILED 9-11-2008, REG. NO. 2497492, DATED 3-13-2009, EXPIRES 9-11-2018.

OWNER OF U.S. REG. NOS. 1,484,209, 2,855,493 AND OTHERS.

NO CLAIM IS MADE TO THE EXCLUSIVE RIGHT TO USE "TIE" AND "LONDON", APART FROM THE MARK AS SHOWN.

THE COLOR(S) BROWN, ORANGE, AND WHITE IS/ARE CLAIMED AS A FEATURE OF THE MARK.

THE MARK CONSISTS OF A BROWN RECTANGULAR BOX WITH AN ORANGE BORDER. INSIDE THE BOX, ON THE FIRST LINE, THE WORDS "TIE RACK" APPEAR CENTERED, IN ALL CAPITAL WHITE LETTERS. DIRECTLY BELOW THE WORDS "TIE RACK" THE WORD "LONDON" APPEARS CENTERED, IN ALL CAPITAL WHITE LETTERS.

FOR RETAIL CLOTHES AND FASHION ACCESSORY STORES FEATURING JEWELRY, CLOTHING, AND FASHION ACCESSORIES; ON-LINE RETAIL STORE SERVICES FEATURING JEWELRY, CLOTHING, AND FASHION ACCESSORY GOODS, WHICH ALLOW CONSUMERS TO CONVENIENTLY VIEW AND PURCHASE JEWELRY, CLOTHING, AND FASHION ACCESSORY GOODS BY MEANS OF AN INTERNET WEBSITE; THE BRINGING TOGETHER, FOR THE BENEFIT OF OTHERS, OF A VARIETY OF GOODS, ENABLING CUSTOMERS TO CONVENIENTLY VIEW AND PURCHASE THOSE GOODS IN THE FIELD OF CLOTHING, JEWELRY, AND FASHION ACCESSORIES BY MEANS OF TELECOMMUNICATIONS (U.S. CLS. 100, 101 AND 102).

MICHAEL GAAFAR, EXAMINING ATTORNEY

**CLASS 35—(Continued).**

SN 77-617,794. PHIZZLE, INC., SAN FRANCISCO, CA. FILED 11-19-2008.

# PHIZZLE

THE MARK CONSISTS OF STANDARD CHARACTERS WITHOUT CLAIM TO ANY PARTICULAR FONT, STYLE, SIZE, OR COLOR.

FOR BUSINESS MARKETING SERVICES, NAMELY, TEXT MESSAGE MARKETING OF PRODUCTS AND SERVICES (U.S. CLS. 100, 101 AND 102).

FIRST USE 5-31-2005; IN COMMERCE 5-31-2005.

MICHAEL LITZAU, EXAMINING ATTORNEY

SN 77-685,354. LARK L.L.C., DBA ONTRACK STAFFING, OKLAHOMA CITY, OK. FILED 3-6-2009.

# ONTRACK STAFFING

THE MARK CONSISTS OF STANDARD CHARACTERS WITHOUT CLAIM TO ANY PARTICULAR FONT, STYLE, SIZE, OR COLOR.

NO CLAIM IS MADE TO THE EXCLUSIVE RIGHT TO USE "STAFFING", APART FROM THE MARK AS SHOWN. FOR TEMPORARY EMPLOYMENT AGENCIES (U.S. CLS. 100, 101 AND 102).

FIRST USE 4-3-2006; IN COMMERCE 4-3-2006.

KEVIN DINALLO, EXAMINING ATTORNEY

SN 77-833,121. MCGARRY INTERNET LTD., DBA FRANCHISE DIRECT USA., ATLANTA, GA. FILED 9-23-2009.



OWNER OF U.S. REG. NO. 2,926,327.

NO CLAIM IS MADE TO THE EXCLUSIVE RIGHT TO USE "FRANCHISE DIRECT" AND "TOP 100 GLOBAL" AND "FRANCHISES AWARDS", APART FROM THE MARK AS SHOWN.

THE COLOR(S) YELLOW, GOLD, BEIGE, PEACH AND WHITE IS/ARE CLAIMED AS A FEATURE OF THE MARK.

THE MARK CONSISTS OF A THIN CIRCULAR BAND WHICH IS BEIGE IN COLOR, SURROUNDING A WIDER CIRCULAR BAND WHICH IS PEACH IN COLOR WITH A

**CLASS 35—(Continued).**

VERY THIN WHITE BAND BETWEEN THEM, THE PEACH BAND CONTAINING THE WORDS "FRANCHISE DIRECT" WRITTEN IN GOLD ACROSS THE TOP OF THE CIRCLE, AND THE WORDS "FRANCHISES AWARD" WRITTEN IN GOLD ACROSS THE BOTTOM OF THE CIRCLE, WITH ONE LARGE YELLOW STAR ON THE LEFT AND RIGHT SEPARATING THE TWO WORDS ON THE TOP FROM THE TWO WORDS ON THE BOTTOM; IN THE WHITE CIRCLE IN THE CENTER OF THE PEACH BAND THE THREE WORDS "TOP 100 GLOBAL" ARE WRITTEN IN GOLD, ONE ON TOP OF THE OTHER, SURROUNDED BY 14 YELLOW STARS IN A CIRCLE AS FOLLOWS: THREE SMALL YELLOW STARS ON EACH SIDE OF "100", TWO LARGE YELLOW STARS ON EACH SIDE OF "TOP", AND ON THE TOP AND BOTTOM OF THE CIRCLE (ABOVE THE WORD "TOP" AND BELOW THE WORD "GLOBAL"), TWO SMALL YELLOW STARS WITH A LARGE STAR IN BETWEEN THEM (ALL LARGE STARS AND ALL SMALL STARS BEING THE SAME SIZE, RESPECTIVELY).

FOR ADVERTISING AND MARKETING SERVICES, NAMELY, PROMOTING THE GOODS AND SERVICES OF OTHERS (U.S. CLS. 100, 101 AND 102).

FIRST USE 7-23-2009; IN COMMERCE 7-23-2009.

KELLY TRUSILO, EXAMINING ATTORNEY

**CLASS 35—(Continued).**

SN 77-849,347. GENERAL GROWTH MANAGEMENT, INC., CHICAGO, IL. FILED 10-15-2009.



NO CLAIM IS MADE TO THE EXCLUSIVE RIGHT TO USE "COLLECTION", APART FROM THE MARK AS SHOWN.

THE MARK CONSISTS OF A SQUARE BOX WITH THE WORDS "LOCAL COLLECTION". THREE CURVING LINES CREATE ARCHES ON THE LEFT PORTION OF THE SQUARE. EACH LINE VARIES IN DENSITY AND TWO OF THE LINES INTERSECT.

FOR RETAIL STORE SERVICES IN THE FIELD OF CLOTHING, FOOTWEAR, HEADWEAR, CLOTHING ACCESSORIES, BAGS, LEATHER GOODS, JEWELRY, ART, STATIONERY, AND GIFTWARE (U.S. CLS. 100, 101 AND 102).

FIRST USE 10-2-2009; IN COMMERCE 10-2-2009.  
DAVID C. REIHNER, EXAMINING ATTORNEY

SN 77-849,269. GENERAL GROWTH MANAGEMENT, INC., CHICAGO, IL. FILED 10-15-2009.

LOCAL COLLECTION

SN 77-855,283. THE RETAIL EQUATION, INC., IRVINE, CA. FILED 10-22-2009.

VERIFY RETURN AUTHORIZATION

THE MARK CONSISTS OF STANDARD CHARACTERS WITHOUT CLAIM TO ANY PARTICULAR FONT, STYLE, SIZE, OR COLOR.

NO CLAIM IS MADE TO THE EXCLUSIVE RIGHT TO USE "COLLECTION", APART FROM THE MARK AS SHOWN.

FOR RETAIL STORE SERVICES IN THE FIELD OF CLOTHING, FOOTWEAR, HEADWEAR, CLOTHING ACCESSORIES, BAGS, LEATHER GOODS, JEWELRY, ART, STATIONERY, AND GIFTWARE (U.S. CLS. 100, 101 AND 102).

FIRST USE 10-2-2009; IN COMMERCE 10-2-2009.  
DAVID C. REIHNER, EXAMINING ATTORNEY

THE MARK CONSISTS OF STANDARD CHARACTERS WITHOUT CLAIM TO ANY PARTICULAR FONT, STYLE, SIZE, OR COLOR.

OWNER OF U.S. REG. NO. 2,429,343.

SEC. 2(F).

FOR PROVIDING A COMPUTER DATABASE TO AUTHORIZE MERCHANDISE RETURN BY CONSUMERS THROUGH VERIFICATION OF A CUSTOMER'S PERSONAL DATA ALONG WITH BASIC INFORMATION REGARDING THE MERCHANDISE BEING RETURNED, SUCH AS AN ORDER NUMBER OR ORDER CODE (U.S. CLS. 100, 101 AND 102).

FIRST USE 11-8-1999; IN COMMERCE 11-17-1999.  
GINA HAYES, EXAMINING ATTORNEY

**CLASS 35—(Continued).**

SN 77-863,253. SUPER HEALTH INSTITUTE, INC., DIAMOND BAR, CA. FILED 11-2-2009.

**수퍼헬스**

OWNER OF U.S. REG. NO. 2,290,648.  
THE MARK CONSISTS OF KOREAN CHARACTERS IN THE MARK TRANSLITERATE INTO SOO PER HEL SU WHICH TRANSLATES TO MEAN SUPER HEALTH.

THE ENGLISH TRANSLATION OF THE WORD SOO PER HEL SU IN THE MARK IS SUPER HEALTH.

THE NON-LATIN CHARACTERS IN THE MARK TRANSLITERATE TO SOO PER HEL SU AND THIS MEANS SUPER HEALTH IN ENGLISH.

SEC. 2(F).

FOR RETAIL STORE SERVICES FEATURING NUTRITIONAL SUPPLEMENTS (U.S. CLS. 100, 101 AND 102).

FIRST USE 11-0-1996; IN COMMERCE 11-0-1996.

B. PARADEWELAI, EXAMINING ATTORNEY

SN 77-872,770. RAY, VERONICA R, DBA RAY, VERONICA R, WASHINGTON, DC. FILED 11-14-2009.



**DIFFERENT DIMENSIONS**

THE MARK CONSISTS OF STYLIZED LETTER "D" ATTACHED TO ANOTHER STYLIZED LETTER "D" THAT IS WRITTEN BACKWARDS. THERE ARE TWO STYLIZED LETTER "D'S" THE SECOND ONE IS WRITTEN BACKWARDS FACING THE FIRST. UNDER THE "D'S" IS "DIFFERENT DIMENSIONS".

FOR ENTERTAINMENT MARKETING SERVICES, NAMELY, MARKETING, PROMOTION AND ADVERTISING FOR INDEPENDENT RECORDING ARTISTS (U.S. CLS. 100, 101 AND 102).

FIRST USE 3-25-2008; IN COMMERCE 2-11-2009.

AMY HELLA, EXAMINING ATTORNEY

**CLASS 35—(Continued).**

SN 77-882,968. SEARS BRANDS, LLC, HOFFMAN ESTATES, IL. FILED 12-1-2009.

**AMERICA'S TOOL BOX**

THE MARK CONSISTS OF STANDARD CHARACTERS WITHOUT CLAIM TO ANY PARTICULAR FONT, STYLE, SIZE, OR COLOR.

NO CLAIM IS MADE TO THE EXCLUSIVE RIGHT TO USE "AMERICA'S TOOL", APART FROM THE MARK AS SHOWN.

FOR RETAIL STORE SERVICES AND ONLINE RETAIL STORE SERVICES IN THE NATURE OF DEPARTMENT STORES FEATURING GENERAL PURPOSE TOOLS (U.S. CLS. 100, 101 AND 102).

ELISSA GARBER KON, EXAMINING ATTORNEY

SN 77-886,063. MONEYPINCHERS, INC., WILMINGTON, DE. FILED 12-4-2009.

**SQUINCH**

THE MARK CONSISTS OF STANDARD CHARACTERS WITHOUT CLAIM TO ANY PARTICULAR FONT, STYLE, SIZE, OR COLOR.

FOR OPERATING ON-LINE MARKETPLACES FOR SELLERS OF GOODS AND/OR SERVICES; PROVIDING CONSUMER PRODUCT INFORMATION VIA THE INTERNET; ONLINE AUCTION SERVICES (U.S. CLS. 100, 101 AND 102).

AISHA CLARKE, EXAMINING ATTORNEY

SN 77-890,761. SMITH MOUNTAIN INDUSTRIES, INC., FOREST, VA. FILED 12-10-2009.

**ATMOSPHERE**

THE MARK CONSISTS OF STANDARD CHARACTERS WITHOUT CLAIM TO ANY PARTICULAR FONT, STYLE, SIZE, OR COLOR.

FOR ONLINE RETAIL STORE AND RETAIL STORE SERVICES, ALL IN THE FIELDS OF CANDLES, CANDLE ACCESSORIES, ELECTRIC ROOM FRAGRANCE DISPENSERS, SCENTED OILS, REED DIFFUSERS AND HOME FRAGRANCE PRODUCTS (U.S. CLS. 100, 101 AND 102).

IRA J. GOODSID, EXAMINING ATTORNEY



**CLASS 35—(Continued).**

SN 77-901,712. COARSE BROADS, INC., SAGLE, ID. FILED 12-28-2009.



NO CLAIM IS MADE TO THE EXCLUSIVE RIGHT TO USE "CERTIFIED SORTED", APART FROM THE MARK AS SHOWN.

THE COLOR(S) BLUE AND BEIGE IS/ARE CLAIMED AS A FEATURE OF THE MARK.

THE MARK CONSISTS OF A STYLIZED DRAWING OF A BLUE SWAN FORMING THE LETTER "C" AND "S" OF THE STYLIZED BLUE WORDING "CERTIFIED SORTED"; THE STYLIZED WORDING AND STYLIZED DRAWING APPEAR ON A BEIGE BACKGROUND.

FOR ALPACA FIBER EVALUATION (U.S. CLS. 100, 101 AND 102).

FIRST USE 3-3-2007; IN COMMERCE 5-3-2007.  
AMEEN IMAM, EXAMINING ATTORNEY

**CLASS 35—(Continued).**

SN 77-925,719. PARTNERSHIP FOR A DRUG-FREE NEW JERSEY, THE, MILLBURN, NJ. FILED 2-2-2010.



NO CLAIM IS MADE TO THE EXCLUSIVE RIGHT TO USE "THE AMERICAN MEDICINE" AND "CHALLENGE", APART FROM THE MARK AS SHOWN.

THE MARK CONSISTS OF A STAR WITH STARS AND STRIPES INSIDE THE STAR AND A PRESCRIPTION BOTTLE.

FOR ARRANGING AND CONDUCTING SPECIAL EVENTS FOR DISPOSAL OF EXPIRED AND UNUSED MEDICATIONS FOR BUSINESS PURPOSES, NAMELY, FOR PUBLIC SERVICE PURPOSES (U.S. CLS. 100, 101 AND 102).

MICHELE SWAIN, EXAMINING ATTORNEY

SN 77-945,307. HOWARD, DERRICK, SAN ANTONIO, TX. FILED 2-25-2010.

SN 77-905,606. THINKFIRST FOUNDATION, WARREN-VILLE, IL. FILED 1-5-2010.

THE COLOR(S) RED AND BLACK IS/ARE CLAIMED AS A FEATURE OF THE MARK.

THE MARK CONSISTS OF "THINKFIRST" WITH "THINK" IN THE COLOR BLACK AND "FIRST" IN THE COLOR RED.

FOR PROMOTING PUBLIC AWARENESS OF THE NEED FOR INJURY PREVENTION (U.S. CLS. 100, 101 AND 102).

FIRST USE 11-0-2001; IN COMMERCE 11-0-2001.  
TAMARA FRAZIER, EXAMINING ATTORNEY



NO CLAIM IS MADE TO THE EXCLUSIVE RIGHT TO USE "TEXAS HUNTING & OUTDOOR CLASSIC", APART FROM THE MARK AS SHOWN.

THE MARK CONSISTS OF A LOGO COMPRISED OF THE WORDING "TEXAS HUNTING & OUTDOOR CLASSIC" IN STYLIZED BLOCK LETTERING WITH THE OUTLINE OF A DEER HEAD WITHIN A SHIELD AND STAR UPON THE FACE OF THE DEER IN THE CENTER OF THE MARK.

FOR CONDUCTING TRADE SHOWS IN THE FIELD OF HUNTING AND FISHING (U.S. CLS. 100, 101 AND 102).

FIRST USE 1-7-2010; IN COMMERCE 1-8-2010.  
HEATHER THOMPSON, EXAMINING ATTORNEY

**CLASS 35—(Continued).**

SN 77-949,400. CAFE NEGRO GALLERIA, S. DE R.L. DE C.V., ZAPOCAN, JALISCO, MEXICO, FILED 3-3-2010.



PRIORITY CLAIMED UNDER SEC. 44(D) ON MEXICO APPLICATION NO. 1070668, FILED 2-26-2010, REG. NO. 1153888, DATED 4-21-2010, EXPIRES 2-26-2020.

NO CLAIM IS MADE TO THE EXCLUSIVE RIGHT TO USE "COFFEE GALLERY", APART FROM THE MARK AS SHOWN.

THE MARK CONSISTS OF AN ABSTRACT CUP OF COFFEE, ON EACH SIDE OF IT, THE WORDS "BLACK" AND "COFFEE", AND BELOW THE WORDS "GALLERY", "ART AND COFFEE MADE BY ARTISTS".

FOR ADVERTISING AND ADVERTISEMENT SERVICES; BUSINESS ADMINISTRATION AND MANAGEMENT; BUSINESS MANAGEMENT; OFFICE ADMINISTRATION SERVICES (U.S. CLS. 100, 101 AND 102).

C. DIONNE CLYBURN, EXAMINING ATTORNEY

**CLASS 35—(Continued).**

SN 77-963,749. VINUM WINE IMPORTERS & DISTRIBUTORS, LLC, SEATTLE, WA. FILED 3-19-2010.

VINUM WINE IMPORTING &  
DISTRIBUTING

THE MARK CONSISTS OF STANDARD CHARACTERS WITHOUT CLAIM TO ANY PARTICULAR FONT, STYLE, SIZE, OR COLOR.

NO CLAIM IS MADE TO THE EXCLUSIVE RIGHT TO USE "WINE IMPORTING & DISTRIBUTING", APART FROM THE MARK AS SHOWN.

FOR IMPORT AGENCIES IN THE FIELD OF WINE; WHOLESALE DISTRIBUTORSHIP IN THE FIELD OF WINE (U.S. CLS. 100, 101 AND 102).

FIRST USE 6-0-2004; IN COMMERCE 6-0-2004.

SALLY SHIH, EXAMINING ATTORNEY

SN 77-954,018. AKADEMOS, INC., NORWALK, CT. FILED 3-9-2010.

Beyond the Bookstore

THE MARK CONSISTS OF STANDARD CHARACTERS WITHOUT CLAIM TO ANY PARTICULAR FONT, STYLE, SIZE, OR COLOR.

NO CLAIM IS MADE TO THE EXCLUSIVE RIGHT TO USE "BOOKSTORE", APART FROM THE MARK AS SHOWN.

FOR ONLINE RETAIL BOOKSTORE SERVICES FEATURING NEW AND USED TEXTBOOKS, BOOKS, SOFTWARE, DVDS, PRE-RECORDED BOOKS ON CD AND CASSETTE, AND OPERATING ONLINE MARKETPLACES FEATURING NEW AND USED BOOKS (U.S. CLS. 100, 101 AND 102).

FIRST USE 11-1-2009; IN COMMERCE 11-1-2009.

CHRISIE B. KING, EXAMINING ATTORNEY

SN 77-981,032. GENBAND INC., PLANO, TX. FILED 12-5-2008.

GENVIEW

THE MARK CONSISTS OF STANDARD CHARACTERS WITHOUT CLAIM TO ANY PARTICULAR FONT, STYLE, SIZE, OR COLOR.

FOR ASSOCIATION SERVICES, NAMELY, PROMOTING THE INTERESTS OF THE TELECOMMUNICATIONS HARDWARE AND SOFTWARE INDUSTRIES (U.S. CLS. 100, 101 AND 102).

SARA BENJAMIN, EXAMINING ATTORNEY

**CLASS 35—(Continued).**

SN 79-088,016. SHENYANG BOYU NONFERROUS METAL & FERROALLOY CO., LTD., CHINA, FILED 8-11-2010.



**BO YU**

OWNER OF INTERNATIONAL REGISTRATION 1052916 DATED 8-11-2010, EXPIRES 8-11-2020.

THE MARK CONSISTS OF THE WORDING "BO YU" AND A DESIGN OF A SQUARE WITH CHINESE CHARACTERS IN THE UPPER LEFT CORNER AND LOWER RIGHT CORNER OF THE SQUARE.

THE NON-LATIN CHARACTERS IN THE MARK TRANSLITERATE TO "BO YU" AND THIS MEANS WIDE OR BROAD SPACE IN ENGLISH.

FOR FRANCHISE SERVICES, NAMELY, OFFERING BUSINESS MANAGEMENT ASSISTANCE IN THE ESTABLISHMENT AND OPERATION OF NONFERROUS METALS AND STEEL FURNACE CHARGE, ON-LINE ADVERTISING SERVICES, BUSINESS ADVISORY SERVICES, CONSULTANCY AND INFORMATION, DISSEMINATION OF ADVERTISING MATTER, BUSINESS MANAGEMENT AND ORGANIZATION CONSULTANCY, SALES PROMOTION FOR OTHERS, IMPORT-EXPORT AGENCIES, PERSONNEL MANAGEMENT CONSULTANCY, COMPILATION OF INFORMATION INTO COMPUTER DATABASES, BOOK-KEEPING AND ACCOUNTING (U.S. CLS. 100, 101 AND 102).  
CURTIS FRENCH, EXAMINING ATTORNEY

SN 79-088,693. JASON CROPPER, LOWER DARWEN BB3 0PR, UNITED KINGDOM, FILED 10-2-2010.



OWNER OF INTERNATIONAL REGISTRATION 1054861 DATED 10-2-2010, EXPIRES 10-2-2020.

THE COLOR(S) BLACK, WHITE, AND RED IS/ARE CLAIMED AS A FEATURE OF THE MARK.

THE MARK CONSISTS OF A VERTICAL RECTANGLE

**CLASS 35—(Continued).**

WITH A RED AND BLACK BACKGROUND CONTAINING A STYLED REPRESENTATION OF A RED DEVIL FACE WEARING BLACK AND WHITE EYEGLASSES WITH WHITE HORNS LINED IN BLACK, WITH WHITE TEETH, AND A WHITE AND RED CIGARETTE IN ITS MOUTH WITH RED, WHITE AND BLACK SMOKE FLOWING UPWARD, AND A REFLECTION OF THE CIGARETTE IN THE LOWER PORTION OF ONE SIDE OF THE EYEGLASS LENS, WITH A WHITE HORIZONTAL BAR ACROSS THE UPPER PORTION OF THE RECTANGLE.

FOR RETAIL AND WHOLESALE STORE SERVICES, AND ONLINE RETAIL STORE AND MAIL ORDER SERVICES, WITH ALL FEATURING SMOKERS ARTICLES (U.S. CLS. 100, 101 AND 102).

ODESSA BIBBINS, EXAMINING ATTORNEY

SN 85-001,716. PRICEWATERHOUSECOOPERS LLP, NEW YORK, NY. FILED 3-30-2010.

**EMBRACING CHANGE**

THE MARK CONSISTS OF STANDARD CHARACTERS WITHOUT CLAIM TO ANY PARTICULAR FONT, STYLE, SIZE, OR COLOR.

FOR CONSULTING SERVICES IN THE NATURE OF ASSISTING COMPANIES TO ASSESS THE BUSINESS AND BUSINESS OPERATIONAL IMPACTS OF CHANGING FINANCIAL ACCOUNTING STANDARDS (U.S. CLS. 100, 101 AND 102).

MICHAEL SOUDERS, EXAMINING ATTORNEY

SN 85-013,907. CONSTELLATION ENERGY GROUP, INC., BALTIMORE, MD. FILED 4-14-2010.

**CONSTELLATION ELECTRIC  
CLEANENERGY**

THE MARK CONSISTS OF STANDARD CHARACTERS WITHOUT CLAIM TO ANY PARTICULAR FONT, STYLE, SIZE, OR COLOR.

OWNER OF U.S. REG. NOS. 2,161,537, 3,133,438 AND OTHERS.

NO CLAIM IS MADE TO THE EXCLUSIVE RIGHT TO USE "ELECTRIC CLEAN ENERGY", APART FROM THE MARK AS SHOWN.

FOR ENERGY USAGE MANAGEMENT SERVICE IN THE NATURE OF PROVIDING RENEWABLE ENERGY CERTIFICATES WHICH MAY THEN BE REDEEMED FOR ENERGY; ENERGY RISK MANAGEMENT SERVICES, NAMELY, PROVIDING A SERVICE THAT ALLOWS CUSTOMERS TO PURCHASE RENEWABLE ENERGY IN FIXED AMOUNTS OR BASED ON A PERCENTAGE OF USE; PROMOTING THE USE OF RENEWABLE ENERGY BY ARRANGING THE PURCHASE, OFFER AND EXCHANGE OF RENEWABLE ENERGY CERTIFICATES (U.S. CLS. 100, 101 AND 102).

JOHN E. MICHOS, EXAMINING ATTORNEY

**CLASS 35—(Continued).**

SN 85-015,643. U.S. TRANSCRIPTION, INC., DUBUQUE, IA. FILED 4-16-2010.



NO CLAIM IS MADE TO THE EXCLUSIVE RIGHT TO USE "MOBILE ASSISTANT", APART FROM THE MARK AS SHOWN.

THE MARK CONSISTS OF THE WORDS "MOBILE ASSISTANT" WITH THE FANCIFUL SILHOUETTE OF A PERSON WITH A TELEPHONE TO THE LEFT OF THE WORD "MOBILE", AND THE FANCIFUL SILHOUETTE OF A PERSON WITH A COMPUTER MONITOR TO THE RIGHT OF THE WORD "MOBILE", AND THE WHOLE MARK BEING PARTIALLY SURROUNDED BY A PARTIAL RECTANGLE.

FOR MESSAGE TRANSCRIPTION; SERVICES COMPRISING THE RECORDING OF DICTATION SUBMITTED TELEPHONICALLY FROM A REMOTE SOURCE; TRANSCRIPTION SERVICES, NAMELY, TRANSCRIBING RECORDED TELEPHONICALLY RECEIVED DICTATION AND ELECTRONICALLY SUBMITTING THE TRANSCRIPTIONS OF THE DICTATIONS TO THE ORIGINATOR OF THE DICTATION (U.S. CLS. 100, 101 AND 102).

FIRST USE 9-0-2009; IN COMMERCE 9-0-2009.  
AMEEN IMAM, EXAMINING ATTORNEY

SN 85-017,262. PROCONGPS, INC., KNOXVILLE, TN. FILED 4-19-2010.

## LoanPlus

THE MARK CONSISTS OF STANDARD CHARACTERS WITHOUT CLAIM TO ANY PARTICULAR FONT, STYLE, SIZE, OR COLOR.

FOR TRACKING, LOCATING AND MONITORING OF VEHICLES FOR COMMERCIAL PURPOSES, NAMELY, ASSET TRACKING SERVICES FOR FINANCIAL LENDING INSTITUTIONS IN THE NATURE OF DETECTING THE GLOBAL POSITION OF AN ASSET WHICH SERVES AS COLLATERAL FOR A LOAN AND TRANSMITTING THE POSITION INFORMATION VIA WIRELESS COMMUNICATION NETWORKS (U.S. CLS. 100, 101 AND 102).

FIRST USE 10-30-2009; IN COMMERCE 10-30-2009.  
APRIL HESIK, EXAMINING ATTORNEY

**CLASS 35—(Continued).**

SN 85-020,388. FASHIONS AT LARGE, INC., DBA NATALIE M., OVERLAND PARK, KS. FILED 4-22-2010.

## ALI'S RUNWAY

THE MARK CONSISTS OF STANDARD CHARACTERS WITHOUT CLAIM TO ANY PARTICULAR FONT, STYLE, SIZE, OR COLOR.

NO CLAIM IS MADE TO THE EXCLUSIVE RIGHT TO USE "RUNWAY", APART FROM THE MARK AS SHOWN.

THE NAME(S), PORTRAIT(S), AND/OR SIGNATURE(S) SHOWN IN THE MARK DOES NOT IDENTIFY A PARTICULAR LIVING INDIVIDUAL.

FOR ORGANIZING AND CONDUCTING A FASHION SHOW FOR CHARITABLE FUNDRAISING PURPOSES (U.S. CLS. 100, 101 AND 102).

FIRST USE 3-10-2007; IN COMMERCE 3-10-2007.  
NAKIA HENRY, EXAMINING ATTORNEY

SN 85-022,207. EMERGING ENERGY RESEARCH, LLC, CAMBRIDGE, MA. FILED 4-23-2010.

## EMERGING ENERGY RESEARCH

THE MARK CONSISTS OF STANDARD CHARACTERS WITHOUT CLAIM TO ANY PARTICULAR FONT, STYLE, SIZE, OR COLOR.

NO CLAIM IS MADE TO THE EXCLUSIVE RIGHT TO USE "ENERGY RESEARCH", APART FROM THE MARK AS SHOWN.

SEC. 2(F).

FOR MARKET RESEARCH STUDIES; BUSINESS CONSULTING SERVICES IN THE FIELDS OF MARKET ENTRY STRATEGIES, COMPETITIVE ANALYSIS, ALLIANCES, FUNDING STRATEGIES, REGULATORY STRATEGIES, BEST PRACTICES, AND BENCHMARKING; BUSINESS ADVISORY SERVICES, CONSULTANCY AND INFORMATION (U.S. CLS. 100, 101 AND 102).

FIRST USE 6-1-2003; IN COMMERCE 6-1-2003.  
MICHELE SWAIN, EXAMINING ATTORNEY

SN 85-022,889. PERFORMANCE MEDIA INC., OZARK, MO. FILED 4-26-2010.

## The Branson Insider

THE MARK CONSISTS OF STANDARD CHARACTERS WITHOUT CLAIM TO ANY PARTICULAR FONT, STYLE, SIZE, OR COLOR.

NO CLAIM IS MADE TO THE EXCLUSIVE RIGHT TO USE "BRANSON", APART FROM THE MARK AS SHOWN.

FOR PROMOTING RECREATION AND TOURISM IN BRANSON, MISSOURI, USA (U.S. CLS. 100, 101 AND 102).

APRIL HESIK, EXAMINING ATTORNEY

**CLASS 35—(Continued).**

SN 85-024,294. HENNING SEIP, BRIDGEPORT, CT. FILED 4-27-2010.

**SKILLPROOF**

THE MARK CONSISTS OF STANDARD CHARACTERS WITHOUT CLAIM TO ANY PARTICULAR FONT, STYLE, SIZE, OR COLOR.

OWNER OF U.S. REG. NO. 3,928,059.

FOR PROVIDING AN ON-LINE SEARCHABLE DATABASE FEATURING EMPLOYMENT OPPORTUNITIES AND CONTENT ABOUT EMPLOYMENT IN THE NATURE OF CAREER INFORMATION OF USE BY JOB SEEKERS (U.S. CLS. 100, 101 AND 102).

FIRST USE 7-1-1997; IN COMMERCE 7-1-1997.  
DARRYL SPRUILL, EXAMINING ATTORNEY

SN 85-024,385. LIVECAREER, LTD., NEW YORK, NY. FILED 4-27-2010.

**TEXTTUNER**

THE MARK CONSISTS OF STANDARD CHARACTERS WITHOUT CLAIM TO ANY PARTICULAR FONT, STYLE, SIZE, OR COLOR.

FOR PROVIDING CAREER INFORMATION IN THE FIELD OF RESUME REVIEW, GUIDANCE AND ADVICE; RESUME PREPARATION; PROVIDING AN INTERACTIVE WEB SITE THAT FACILITATES THE PREPARATION OF RESUMES AND RESUME REVIEW BY OTHERS; PROVIDING ON-LINE INFORMATION IN THE FIELDS OF EMPLOYMENT, PERSONNEL RECRUITMENT, CAREERS, PERSONAL ISSUES RELATED TO CAREERS AND WORK LIFE, JOB RESOURCES, JOB LISTINGS AND RESUMES; PROVIDING ON-LINE INTERACTIVE EMPLOYMENT COUNSELING, RESUME PREPARATION AND PERSONNEL RECRUITMENT SERVICES; EMPLOYMENT COUNSELING, NAMELY, ADVICE IN THE DRAFTING AND PREPARATION OF RESUMES; EMPLOYMENT COUNSELING, NAMELY, ADVICE IN THE FIELD OF CHOOSING A CAREER; EMPLOYMENT COUNSELING IN THE FIELDS OF EMPLOYMENT, PERSONNEL RECRUITMENT, CAREERS, PERSONAL ISSUES RELATED TO CAREERS AND WORK LIFE, JOB RESOURCES, JOB LISTINGS AND RESUMES; PROVIDING CAREER INFORMATION VIA THE INTERNET (U.S. CLS. 100, 101 AND 102).

FIRST USE 5-3-2010; IN COMMERCE 5-3-2010.  
YAT SYE, LEE, EXAMINING ATTORNEY

**CLASS 35—(Continued).**

SN 85-025,710. SPINTRUST LLC, INMAN, SC. FILED 4-28-2010.

**JACKEDUP**

THE MARK CONSISTS OF STANDARD CHARACTERS WITHOUT CLAIM TO ANY PARTICULAR FONT, STYLE, SIZE, OR COLOR.

FOR PROVIDING ADVERTISING, MARKETING AND PROMOTIONAL SERVICES, NAMELY, DEVELOPMENT OF ADVERTISING CAMPAIGNS PROVIDED THROUGH CABLE TELEVISION BROADCAST, WEB CASTS, RADIO BROADCASTS, NEWSPAPERS, MAGAZINES, ONLINE BANNERS, OUTDOOR BILLBOARDS, WILD POSTINGS, BUS AND SUBWAY ADS (U.S. CLS. 100, 101 AND 102).

JAY FLOWERS, EXAMINING ATTORNEY

SN 85-026,256. LUCKY MOTORS, INC., ADDISON, IL. FILED 4-29-2010.

**LUCKY MOTORS**

THE MARK CONSISTS OF STANDARD CHARACTERS WITHOUT CLAIM TO ANY PARTICULAR FONT, STYLE, SIZE, OR COLOR.

OWNER OF U.S. REG. NO. 3,440,256.

NO CLAIM IS MADE TO THE EXCLUSIVE RIGHT TO USE "MOTORS", APART FROM THE MARK AS SHOWN.

FOR AUTOMOBILE DEALERSHIPS; ON-LINE RETAIL STORE SERVICES FEATURING AUTOMOBILE AND AUTOMOTIVE RELATED PRODUCTS; COMPUTERIZED ONLINE RETAIL STORE SERVICES FEATURING AUTOMOBILE AND AUTOMOTIVE PRODUCTS (U.S. CLS. 100, 101 AND 102).

FIRST USE 10-24-2007; IN COMMERCE 10-24-2007.  
ESTHER BELENKER, EXAMINING ATTORNEY

SN 85-027,269. NORTH AMERICA DIRECT, INC., ASHEVILLE, NC. FILED 4-30-2010.

**SECUREYOURSALE**

THE MARK CONSISTS OF STANDARD CHARACTERS WITHOUT CLAIM TO ANY PARTICULAR FONT, STYLE, SIZE, OR COLOR.

FOR BUSINESS MANAGEMENT SERVICES, NAMELY, MANAGING TRANSPORTATION AND LOGISTICS, INCLUDING PROVIDING FULL LANDED COST ESTIMATES (U.S. CLS. 100, 101 AND 102).

MARGARET POWER, EXAMINING ATTORNEY

**CLASS 35—(Continued).**

SN 85-027,331. 32ND STREET 99 CENTS CORP., NEW YORK, NY. FILED 4-30-2010.

**JACK'S 99¢ STORES**

THE MARK CONSISTS OF STANDARD CHARACTERS WITHOUT CLAIM TO ANY PARTICULAR FONT, STYLE, SIZE, OR COLOR.

NO CLAIM IS MADE TO THE EXCLUSIVE RIGHT TO USE "99¢ STORES", APART FROM THE MARK AS SHOWN.

FOR RETAIL STORE SERVICES FEATURING A WIDE VARIETY OF CONSUMER GOODS OF OTHERS (U.S. CLS. 100, 101 AND 102).

FIRST USE 10-0-1992; IN COMMERCE 10-0-1992.

VIVIAN MICZNIK FIRST, EXAMINING ATTORNEY

SN 85-029,360. ALEXANDRIA ECONOMIC DEVELOPMENT PARTNERSHIP, INC., ALEXANDRIA, VA. FILED 5-4-2010.

**ALEXANDRIA**  
*ideal*

NO CLAIM IS MADE TO THE EXCLUSIVE RIGHT TO USE "ALEXANDRIA", APART FROM THE MARK AS SHOWN.

THE COLOR(S) RED, GOLD AND BROWN IS/ARE CLAIMED AS A FEATURE OF THE MARK.

THE MARK CONSISTS OF THE WORD "ALEXANDRIA" IN RED, THEN UNDERNEATH A GOLD LINE FOLLOWED BY THE WORD "IDEAL" IN BROWN.

FOR PROMOTING ECONOMIC DEVELOPMENT IN THE CITY OF ALEXANDRIA, VIRGINIA (U.S. CLS. 100, 101 AND 102).

FIRST USE 2-16-2010; IN COMMERCE 2-16-2010.

BARNEY CHARLON, EXAMINING ATTORNEY

SN 85-030,907. NIEMIEC, TIM, CHICAGO, IL. FILED 5-5-2010.

**BE BASIC**

THE MARK CONSISTS OF STANDARD CHARACTERS WITHOUT CLAIM TO ANY PARTICULAR FONT, STYLE, SIZE, OR COLOR.

FOR RETAIL, WHOLESALE, AND ONLINE STORE SERVICES FEATURING ORGANIC, NATURAL, AND HEALTH FOODS (U.S. CLS. 100, 101 AND 102).

JASON BLAIR, EXAMINING ATTORNEY

**CLASS 35—(Continued).**

SN 85-031,315. DIAGEO SCOTLAND LIMITED, EDINBURGH, UNITED KINGDOM, FILED 5-5-2010.

**MALT MATCHER**

THE MARK CONSISTS OF STANDARD CHARACTERS WITHOUT CLAIM TO ANY PARTICULAR FONT, STYLE, SIZE, OR COLOR.

PRIORITY CLAIMED UNDER SEC. 44(D) ON ERPNCMNTY TM OFC APPLICATION NO. 008666075, FILED 11-5-2009, REG. NO. 008666075, DATED 5-27-2010, EXPIRES 11-5-2019.

NO CLAIM IS MADE TO THE EXCLUSIVE RIGHT TO USE "MALT", APART FROM THE MARK AS SHOWN.

FOR COMPARISON SHOPPING SERVICES FOR ALCOHOL, NAMELY, MALT WHISKY; COST PRICE ANALYSIS SERVICES; PROVIDING A PRICE AND PRODUCT COMPARISON SHOPPING SERVICE ON GLOBAL AND LOCAL COMPUTER NETWORKS, NAMELY, THE INTERNET; PROVIDING A PRICE AND PRODUCT COMPARISON SHOPPING SERVICE TO INCLUDE DESCRIBING, LOCALISING, GRADING AND EVALUATING CONSUMER GOODS, ALL THE AFORESAID PROVIDED VIA AN ONLINE DATABASE AND/OR WEBSITE; PROVIDING A PRICE AND PRODUCT COMPARISON SHOPPING SERVICE THAT INCLUDES REVIEWS, REFERENCES AND DETAILS OF RETAILERS, SUPPLIERS AND DISTRIBUTORS, ALL THE AFORESAID PROVIDED VIA AN ONLINE DATABASE AND/OR WEBSITE; PROVIDING PRODUCT INFORMATION AND PRICE COMPARISONS TO CONSUMERS OR BUSINESSES SO THAT THEY CAN MAKE A DECISION TO BUY; ADVERTISING OF GOODS, NAMELY, COMPARISON SHOPPING SERVICES WHICH ENABLE CUSTOMERS TO CONVENIENTLY VIEW AND COMPARE THE GOODS OF VENDORS; PROVIDING INFORMATION ABOUT PRODUCTS VIA TELECOMMUNICATION NETWORKS FOR ADVERTISING AND SALES PURPOSES (U.S. CLS. 100, 101 AND 102).

COURTNEY ALVAREZ, EXAMINING ATTORNEY

SN 85-031,708. CROWE, JESSE A., DBA VMBC, IRVINE, CA. FILED 5-6-2010.

**Social Agent Management System**

THE MARK CONSISTS OF STANDARD CHARACTERS WITHOUT CLAIM TO ANY PARTICULAR FONT, STYLE, SIZE, OR COLOR.

NO CLAIM IS MADE TO THE EXCLUSIVE RIGHT TO USE "MANAGEMENT SYSTEM", APART FROM THE MARK AS SHOWN.

FOR BUSINESS ASSISTANCE, MANAGEMENT AND INFORMATION SERVICES; PROVIDING CONSUMER INFORMATION AND RELATED NEWS IN THE FIELD OF PROVIDING INFORMATION TO CONSUMERS AND BUSINESSES THROUGH SOCIAL MEDIA CHANNELS AND OTHER CHANNELS WHICH ASSIST CONSUMERS AND BUSINESSES IN FORMULATING OPINIONS, IDENTIFYING SAVINGS OPPORTUNITIES, EVALUATING QUALITY, UNDERSTANDING FEATURES AND BENEFITS, AND MAKING DECISIONS CONCERNING BRANDS, PRODUCTS AND SERVICES (U.S. CLS. 100, 101 AND 102).

CAROLINE WOOD, EXAMINING ATTORNEY

**CLASS 35—(Continued).**

SN 85-032,016. DAVIS, LINDA R., MECHANICSBURG, PA.  
FILED 5-6-2010.

**QUALITY CRITERIA SOLUTIONS**

THE MARK CONSISTS OF STANDARD CHARACTERS WITHOUT CLAIM TO ANY PARTICULAR FONT, STYLE, SIZE, OR COLOR.

NO CLAIM IS MADE TO THE EXCLUSIVE RIGHT TO USE "QUALITY CRITERIA", APART FROM THE MARK AS SHOWN.

FOR BUSINESS DATA ANALYSIS IN THE FIELD OF HEALTH CARE AND DRUG UTILIZATION REVIEW SERVICES TO DETERMINE CRITERIA OF CARE (U.S. CLS. 100, 101 AND 102).

DAWN HAN, EXAMINING ATTORNEY

SN 85-033,063. TOTALFACILITY, INC., MALVERN, PA.  
FILED 5-7-2010.

**ONDEMAND FM**

THE MARK CONSISTS OF STANDARD CHARACTERS WITHOUT CLAIM TO ANY PARTICULAR FONT, STYLE, SIZE, OR COLOR.

NO CLAIM IS MADE TO THE EXCLUSIVE RIGHT TO USE "FM", APART FROM THE MARK AS SHOWN.

FOR BUSINESS INFORMATION MANAGEMENT SERVICES REGARDING VOICE AND DATA CABLING; BUSINESS MANAGEMENT SERVICES IN THE FIELD MAINTENANCE, REPAIR AND OPERATIONS, AND MATERIALS AND LABOR; MANAGEMENT OF REPAIRS AND MAINTENANCE, NAMELY, SCHEDULING MAINTENANCE AND REPAIRS FOR OTHERS; SUPPLY CHAIN MANAGEMENT SERVICES FOR REPAIR AND MAINTENANCE MATERIALS; AND PERSONNEL MANAGEMENT FOR MAINTENANCE AND REPAIR BUSINESSES (U.S. CLS. 100, 101 AND 102).

FIRST USE 9-0-2009; IN COMMERCE 9-0-2009.

APRIL ROACH, EXAMINING ATTORNEY

SN 85-033,924. THE SHOE HIVE, L.L.C., ALEXANDRIA, VA.  
FILED 5-10-2010.

**THE SHOE HIVE**

THE MARK CONSISTS OF STANDARD CHARACTERS WITHOUT CLAIM TO ANY PARTICULAR FONT, STYLE, SIZE, OR COLOR.

NO CLAIM IS MADE TO THE EXCLUSIVE RIGHT TO USE "SHOE", APART FROM THE MARK AS SHOWN.

FOR RETAIL SHOE, CLOTHING AND ACCESSORIES STORE SERVICES (U.S. CLS. 100, 101 AND 102).

FIRST USE 10-2-2003; IN COMMERCE 10-2-2003.

JOHN KELLY, EXAMINING ATTORNEY

**CLASS 35—(Continued).**

SN 85-033,928. THE SHOE HIVE, L.L.C., ALEXANDRIA, VA.  
FILED 5-10-2010.



NO CLAIM IS MADE TO THE EXCLUSIVE RIGHT TO USE "SHOE", APART FROM THE MARK AS SHOWN.

THE MARK CONSISTS OF DRAWING OF SHOE WITH BEEHIVE DESIGN AND THE WORDS "THE SHOE HIVE".

FOR RETAIL SHOE, CLOTHING AND ACCESSORIES STORE SERVICES (U.S. CLS. 100, 101 AND 102).

FIRST USE 10-2-2003; IN COMMERCE 10-2-2003.

JOHN KELLY, EXAMINING ATTORNEY

SN 85-034,300. TARGUS INFORMATION CORPORATION,  
VIENNA, VA. FILED 5-10-2010.

**INFOZONE**

THE MARK CONSISTS OF STANDARD CHARACTERS WITHOUT CLAIM TO ANY PARTICULAR FONT, STYLE, SIZE, OR COLOR.

FOR PROVIDING A WEB-BASED SYSTEM AND ONLINE PORTAL IN THE FIELD OF CUSTOMER SERVICE, BUSINESS, HUMAN RESOURCES AND MARKETING; PROVIDING A WEB-BASED SYSTEM AND ONLINE PORTAL FEATURING PRODUCT DEMONSTRATIONS OF BUSINESS SOFTWARE (U.S. CLS. 100, 101 AND 102).

FIRST USE 3-31-2008; IN COMMERCE 3-31-2008.

JANET LEE, EXAMINING ATTORNEY

SN 85-034,336. INIGRAL, INC., SAN FRANCISCO, CA.  
FILED 5-10-2010.

**INIGRAL**

THE MARK CONSISTS OF STANDARD CHARACTERS WITHOUT CLAIM TO ANY PARTICULAR FONT, STYLE, SIZE, OR COLOR.

THE WORDING "INIGRAL" HAS NO MEANING IN A FOREIGN LANGUAGE.

FOR PROVIDING AN ONLINE DIRECTORY INFORMATION SERVICE FEATURING INFORMATION REGARDING, AND IN THE NATURE OF, ACADEMICS, EDUCATION, CAMPUS LIFE, VIRTUAL COMMUNITY AND SOCIAL NETWORKING (U.S. CLS. 100, 101 AND 102).

LINDA POWELL, EXAMINING ATTORNEY

**CLASS 35—(Continued).**

SN 85-034,419. SIGNATURE STYLES, LLC, NEW YORK, NY. FILED 5-10-2010.

**JEANOLOGY BASIC**

THE MARK CONSISTS OF STANDARD CHARACTERS WITHOUT CLAIM TO ANY PARTICULAR FONT, STYLE, SIZE, OR COLOR.  
OWNER OF U.S. REG. NOS. 2,334,899, 2,343,072 AND OTHERS.

NO CLAIM IS MADE TO THE EXCLUSIVE RIGHT TO USE "BASIC", APART FROM THE MARK AS SHOWN.  
FOR MAIL ORDER CATALOG SERVICES FEATURING CLOTHING (U.S. CLS. 100, 101 AND 102).  
FIRST USE 6-0-2009; IN COMMERCE 6-0-2009.  
FRED CARL, EXAMINING ATTORNEY

SN 85-035,168. RELIABLE POWER ALTERNATIVES CORPORATION, GARDEN CITY, NY. FILED 5-11-2010.



THE MARK CONSISTS OF A CIRCULAR IMAGE WITH TWO STRIPES HALFWAY ALONG THE TOP WITH THE LETTERS "RPAC" BELOW.

FOR BUSINESS CONSULTING AND ADVISORY SERVICES IN THE ELECTRIC AND NATURAL GAS INDUSTRY; ENERGY USAGE MANAGEMENT; PROCUREMENT SERVICES, NAMELY, PURCHASING ENERGY FOR OTHERS (U.S. CLS. 100, 101 AND 102).  
FIRST USE 10-0-2009; IN COMMERCE 10-0-2009.  
CAROLINE WOOD, EXAMINING ATTORNEY

**CLASS 35—(Continued).**

SN 85-035,174. RELIABLE POWER ALTERNATIVES CORPORATION, GARDEN CITY, NY. FILED 5-11-2010.

**RPAC**

THE MARK CONSISTS OF STANDARD CHARACTERS WITHOUT CLAIM TO ANY PARTICULAR FONT, STYLE, SIZE, OR COLOR.

FOR BUSINESS CONSULTING AND ADVISORY SERVICES IN THE ELECTRIC AND NATURAL GAS INDUSTRY; ENERGY USAGE MANAGEMENT; PROCUREMENT SERVICES, NAMELY, PURCHASING ENERGY FOR OTHERS (U.S. CLS. 100, 101 AND 102).  
FIRST USE 8-0-2002; IN COMMERCE 8-0-2002.  
CAROLINE WOOD, EXAMINING ATTORNEY

SN 85-035,191. RELIABLE POWER ALTERNATIVES CORPORATION, GARDEN CITY, NY. FILED 5-11-2010.

**RELIABLE POWER  
ALTERNATIVES CORPORATION**

THE MARK CONSISTS OF STANDARD CHARACTERS WITHOUT CLAIM TO ANY PARTICULAR FONT, STYLE, SIZE, OR COLOR.

NO CLAIM IS MADE TO THE EXCLUSIVE RIGHT TO USE "POWER ALTERNATIVES CORPORATION", APART FROM THE MARK AS SHOWN.

FOR BUSINESS CONSULTING AND ADVISORY SERVICES IN THE ELECTRIC AND NATURAL GAS ENERGY INDUSTRY; ENERGY USAGE MANAGEMENT; PROCUREMENT SERVICES, NAMELY, PURCHASING ENERGY FOR OTHERS (U.S. CLS. 100, 101 AND 102).  
FIRST USE 8-0-2002; IN COMMERCE 8-0-2002.  
CAROLINE WOOD, EXAMINING ATTORNEY

SN 85-035,530. TRION, LLC, DALLAS, TX. FILED 5-11-2010.

**TRION ACCELERATOR**

THE MARK CONSISTS OF STANDARD CHARACTERS WITHOUT CLAIM TO ANY PARTICULAR FONT, STYLE, SIZE, OR COLOR.

NO CLAIM IS MADE TO THE EXCLUSIVE RIGHT TO USE "ACCELERATOR", APART FROM THE MARK AS SHOWN.

FOR PROVIDING BUSINESS MANAGEMENT AND CONSULTATION (U.S. CLS. 100, 101 AND 102).  
EUGENIA MARTIN, EXAMINING ATTORNEY



**CLASS 35—(Continued).**

SN 85-037,703. TRADES LABOR CORPORATION, NORTH VANCOUVER, BC, CANADA, FILED 5-13-2010.



PRIORITY CLAIMED UNDER SEC. 44(D) ON CANADA APPLICATION NO. 1480983, FILED 5-13-2010, REG. NO. TMA792,518, DATED 3-9-2011, EXPIRES 3-9-2026.

NO CLAIM IS MADE TO THE EXCLUSIVE RIGHT TO USE "TRADES LABOR CORPORATION", APART FROM THE MARK AS SHOWN.

THE MARK CONSISTS OF THE WORDING "TLC TRADES LABOR CORPORATION" WITH THE LETTERS "TLC" DISPLAYED IN A QUADRILATERAL.

FOR JOB PLACEMENT AND PERSONNEL RECRUITMENT SERVICES IN THE INDUSTRIAL TRADES FIELD (U.S. CLS. 100, 101 AND 102).

FIRST USE 0-0-2007; IN COMMERCE 0-0-2007.  
EVELYN BRADLEY, EXAMINING ATTORNEY

---

SN 85-038,391. OAKTREE CAPITAL MANAGEMENT, L.P., LOS ANGELES, CA. FILED 5-14-2010.

**OPTERRA ENERGY GROUP**

THE MARK CONSISTS OF STANDARD CHARACTERS WITHOUT CLAIM TO ANY PARTICULAR FONT, STYLE, SIZE, OR COLOR.

NO CLAIM IS MADE TO THE EXCLUSIVE RIGHT TO USE "ENERGY GROUP", APART FROM THE MARK AS SHOWN.

FOR BUSINESS CONSULTING AND ADVISORY SERVICES IN THE FIELD OF ENERGY EFFICIENCY; CONDUCTING ENERGY AUDITS OF COMMERCIAL AND INSTITUTIONAL FACILITIES FOR THE PURPOSE OF IMPROVING ENERGY EFFICIENCY; CONSULTATION IN THE FIELD OF ENERGY EFFICIENCY; CONSULTING SERVICES IN THE FIELD OF ENERGY EFFICIENCY FOR COMMERCIAL AND INSTITUTIONAL FACILITIES; CONSULTING SERVICES IN THE FIELD OF ENERGY USAGE MANAGEMENT AND ENERGY EFFICIENCY; CONSULTING SERVICES IN THE FIELDS OF ENERGY CONSUMPTION AND USAGE CONSERVATION TO IMPROVE ENERGY EFFICIENCY; ENERGY AUDITING; INFORMATION IN THE FIELD OF ENERGY EFFICIENCY (U.S. CLS. 100, 101 AND 102).

ALLISON HOLTZ, EXAMINING ATTORNEY

**CLASS 35—(Continued).**

SN 85-038,822. LIFE AND HEALTH INSURANCE FOUNDATION FOR EDUCATION, ARLINGTON, DC. FILED 5-14-2010.



THE COLOR(S) BLUE, GREEN, RED AND GRAY IS/ARE CLAIMED AS A FEATURE OF THE MARK.

THE MARK CONSISTS OF THE LITERAL ELEMENT "WONDERS" IN BLUE AND OUTLINED IN GRAY IN WHICH THE "O" IS REPLACED BY A GIANT BLUE BALL WITH SWIRL PATTERNS ALL OF WHICH IS STACKED ABOVE THE LITERAL ELEMENT "OF" IN GREEN AND OUTLINED IN GRAY, STACKED ABOVE THE LITERAL ELEMENT "LIFE" IN RED AND OUTLINED IN GRAY. TO THE LEFT OF THE "OF" AND "LIFE" ELEMENTS AND UNDER THE GIANT BLUE SWIRLED BALL APPEARS THE BLUE SILHOUETTE OF A LITTLE GIRL WITH HER HANDS OUTSTRETCHED OVER HER HEAD. THE COLOR WHITE IN THE BLUE SWIRLED BALL REPRESENTS BACKGROUND AND IS NOT PART OF THE MARK.

FOR PROMOTING PUBLIC AWARENESS OF THE NEED FOR LIFE AND HEALTH INSURANCE AND THE UNDERSTANDING OF THE SERVICES PROVIDED BY PROFESSIONAL LIFE AND HEALTH INSURANCE AGENTS (U.S. CLS. 100, 101 AND 102).

FIRST USE 7-0-2009; IN COMMERCE 7-0-2009.  
ANGELA M. MICHELI, EXAMINING ATTORNEY

---

SN 85-039,307. L1 TECHNOLOGIES, INC., SAN DIEGO, CA. FILED 5-14-2010.

**MAPZOO**

THE MARK CONSISTS OF STANDARD CHARACTERS WITHOUT CLAIM TO ANY PARTICULAR FONT, STYLE, SIZE, OR COLOR.

FOR PROVIDING INFORMATION ABOUT AND MAKING REFERRALS IN THE FIELD OF CONSUMER PRODUCTS AND SERVICES FOR RETAIL SERVICES CONCERNING PRODUCTS, SERVICES, EVENTS, ACTIVITIES, ATTRACTIONS AND FACILITIES IN PARTICULAR GEOGRAPHIC LOCATIONS; PROVIDING RATINGS VIA A GLOBAL COMPUTER NETWORK FOR HOME PRODUCTS AND SERVICES RECOMMENDED BY CONSUMERS; PROVIDING A WEBSITE FOR USERS WITH SPECIFIC INFORMED RECOMMENDATIONS OF SPECIFIC CONSUMER PRODUCTS AND SERVICES VALIDATED BY THE USERS' INPUTTED PREFERENCES AND SOCIAL NETWORK; PROVIDING A WEB SITE WHERE USERS CAN POST RATINGS, REVIEWS AND RECOMMENDATIONS ON PRODUCTS AND SERVICES FOR COMMERCIAL PURPOSES (U.S. CLS. 100, 101 AND 102).

WENDY GOODMAN, EXAMINING ATTORNEY

**CLASS 35—(Continued).**

SN 85-039,835. TILLMAN, BENNY A, DBA AREA 1 ENTERTAINMENT, COLLEGE PARK, GA. FILED 5-17-2010.



NO CLAIM IS MADE TO THE EXCLUSIVE RIGHT TO USE "ENTERTAINMENT", APART FROM THE MARK AS SHOWN.

THE COLOR(S) SILVER, ORANGE, BLUE, GRAY, AND BLACK IS/ARE CLAIMED AS A FEATURE OF THE MARK. THE MARK CONSISTS OF A SPACESHIP AND THE WORDS "AREA1 ENTERTAINMENT" FLOATING IN THE SKY OVER A MOUNTAIN; THE SPACESHIP AND THE WORDS "AREA1 ENTERTAINMENT" ARE SILVER; THE SPACESHIP AND THE WORDS "AREA1 ENTERTAINMENT" BOTH HAVE REFLECTION OF ORANGE; THE SKY IS ORANGE, BLUE, GRAY AND BLACK; THE MOUNTAIN IS BLACK.

FOR ENTERTAINMENT MARKETING SERVICES, NAMELY, MARKETING, PROMOTION AND ADVERTISING FOR INDEPENDENT RECORDING ARTISTS (U.S. CLS. 100, 101 AND 102).

MICHELE SWAIN, EXAMINING ATTORNEY

---

SN 85-039,887. STARBRANDS NETWORKS, LLC, HENDERSON, NV. FILED 5-17-2010.

## LP TUNES

THE MARK CONSISTS OF STANDARD CHARACTERS WITHOUT CLAIM TO ANY PARTICULAR FONT, STYLE, SIZE, OR COLOR.

SEC. 2(F). FOR ONLINE RETAIL STORE SERVICES FEATURING AUDIO PRODUCTS (U.S. CLS. 100, 101 AND 102).

FIRST USE 6-10-2004; IN COMMERCE 6-10-2004.

KEVIN CORWIN, EXAMINING ATTORNEY

---

SN 85-041,080. PRECISION BENEFIT SERVICES, INC., AMHERST, NY. FILED 5-18-2010.



NO CLAIM IS MADE TO THE EXCLUSIVE RIGHT TO USE "BENEFIT SERVICES, INC.", APART FROM THE MARK AS SHOWN.

THE MARK CONSISTS OF A TWO-DIMENSIONAL REPRESENTATION OF A SPHERE HAVING HORIZONTAL STRIPES, THE SPHERE BEING POSITIONED TO THE LEFT OF THE LITERAL PORTION OF THE MARK, THE WORDING "PRECISION BENEFIT SERVICES, INC."

FOR COST MANAGEMENT FOR THE HEALTH CARE BENEFIT PLANS OF OTHERS (U.S. CLS. 100, 101 AND 102).

ALICIA COLLINS, EXAMINING ATTORNEY

**CLASS 35—(Continued).**

SN 85-041,141. ARCHIMEDES GLOBAL, INC., TAMPA, FL. FILED 5-18-2010.



THE MARK CONSISTS OF A LANTERN WITH THE WORDS "ARCHIMEDES LANTERN" IN A STYLIZED FONT BELOW.

FOR BUSINESS CONSULTING SERVICES, NAMELY, PROVIDING QUANTITATIVE CUSTOMER POPULATION RESEARCH AND ANALYSIS FOR OTHERS AND CONSULTING RELATED THERETO (U.S. CLS. 100, 101 AND 102).

FIRST USE 10-1-2009; IN COMMERCE 10-1-2009.  
NATALIE POLZER, EXAMINING ATTORNEY

---

SN 85-041,724. MOM, INC., PACIFIC PALISADES, CA. FILED 5-18-2010.

## MODERN MOM

THE MARK CONSISTS OF STANDARD CHARACTERS WITHOUT CLAIM TO ANY PARTICULAR FONT, STYLE, SIZE, OR COLOR.

OWNER OF U.S. REG. NOS. 3,483,872 AND 3,714,545. NO CLAIM IS MADE TO THE EXCLUSIVE RIGHT TO USE "MOM", APART FROM THE MARK AS SHOWN.

FOR MARKETING SERVICES, NAMELY, MARKET RESEARCH, CONSULTATION AND FOCUS GROUPS (U.S. CLS. 100, 101 AND 102).

FIRST USE 2-21-2008; IN COMMERCE 2-21-2008.  
LIEF MARTIN, EXAMINING ATTORNEY

**CLASS 35—(Continued).**

SN 85-042,101. SONOVA HOLDING AG, 8712 STÄFA, SWITZERLAND, FILED 5-18-2010.

# UNITE

THE MARK CONSISTS OF STANDARD CHARACTERS WITHOUT CLAIM TO ANY PARTICULAR FONT, STYLE, SIZE, OR COLOR.

PRIORITY CLAIMED UNDER SEC. 44(D) ON CANADA APPLICATION NO. 1480036, FILED 5-6-2010.

FOR PROMOTING THE SALE OF GOODS AND SERVICES THROUGH A CONSUMER LOYALTY PROGRAM FOR COMMERCIAL, PROMOTIONAL, AND ADVERTISING PURPOSES RELATING TO HEARING AIDS PRODUCTS AND ACCESSORIES; CUSTOMER LOYALTY SERVICES FOR PROMOTIONAL AND ADVERTISING PURPOSES ENABLING PARTICIPANTS TO OBTAIN DISCOUNTS, CONSUMER PRODUCT AND BENEFIT INFORMATION, AND ADVICE TO CONSUMERS, ALL RELATING TO HEARING AIDS PRODUCTS AND ACCESSORIES THEREFOR (U.S. CLS. 100, 101 AND 102).

TRICIA SONNEBORN, EXAMINING ATTORNEY

---

SN 85-042,212. DATA FOUNDRY, INC., AUSTIN, TX. FILED 5-19-2010.

# DATA RANCH

THE MARK CONSISTS OF STANDARD CHARACTERS WITHOUT CLAIM TO ANY PARTICULAR FONT, STYLE, SIZE, OR COLOR.

NO CLAIM IS MADE TO THE EXCLUSIVE RIGHT TO USE "DATA", APART FROM THE MARK AS SHOWN.

FOR BUSINESS SERVICES, NAMELY, FACILITIES MANAGEMENT AND TECHNICAL OPERATION SERVICES, NAMELY, PROVIDING MANAGEMENT AND OPERATION OF DATA CENTERS WITH NETWORK AND INTERNET INFRASTRUCTURE AND INTERCONNECTION, SAID CENTERS PROVIDING DATA SECURITY, PROVIDING ENVIRONMENTAL CONTROLS AND PROVIDING POWER MANAGEMENT; BUSINESS CONSULTING SERVICES RELATING TO THE OPERATION, ADMINISTRATION AND MANAGEMENT OF DATA CENTERS; BUSINESS MANAGEMENT AND OPERATION OF DATA CENTERS (U.S. CLS. 100, 101 AND 102).

ASMAT KHAN, EXAMINING ATTORNEY

**CLASS 35—(Continued).**

SN 85-043,891. OFF-PRICE SPECIALIST CENTER, BROOKFIELD, WI. FILED 5-20-2010.

# OFFPRICE

OWNER OF U.S. REG. NOS. 2,359,597, 2,359,601 AND 2,370,258.

THE MARK CONSISTS OF STYLIZED LETTERING FOR THE WORDS "OFFPRICE".

SEC. 2(F).

FOR ARRANGING AND CONDUCTING TRADE SHOW EXHIBITIONS IN THE FIELD OF DISCOUNT MERCHANDISE AND APPAREL (U.S. CLS. 100, 101 AND 102).

FIRST USE 4-6-2010; IN COMMERCE 4-6-2010.

DOUGLAS LEE, EXAMINING ATTORNEY

---

SN 85-044,121. BW BOULDER, LLC, AKA BENJAMIN WEST, LAFAYETTE, CO. FILED 5-20-2010.



THE MARK CONSISTS OF THE GRAPHIC REPRESENTATION OF A DIAL WITH EQUAL DIVISIONS FROM THE "6" O'CLOCK POSITION TO APPROXIMATELY THE "3" O'CLOCK POSITION, EACH HAVING A SUCCESSIVELY HIGHER INTEGER STARTING WITH "0" AT THE "6" O'CLOCK POSITION TO "11" AT THE "3" O'CLOCK POSITION, AND HAVING A NEEDLE APPROXIMATELY POINTING TO THE "12" O'CLOCK POSITION. "RPM" IN BLOCK LETTERS IS SUPERIMPOSED OVER THE LOWER RIGHT QUADRANT OF THE DIAL AND EXTENDING TO THE RIGHT.

FOR ADMINISTRATIVE PROCESSING OF PURCHASE ORDERS, PARTICULARLY FOR OWNERS AND DESIGN CONSULTANTS OF RESORTS, HOTELS AND MOTELS AND THEIR SELECTION AND PURCHASING OF FURNISHINGS AND DECORATIVE ITEMS FROM OTHERS FOR THEIR INTERIOR DESIGN (U.S. CLS. 100, 101 AND 102).

MICHAEL KEATING, EXAMINING ATTORNEY

---

SN 85-044,511. WATSON, ALVIN, VIRGINIA BEACH, VA. FILED 5-21-2010.

# DA-BRA-YATT!!!

THE MARK CONSISTS OF STANDARD CHARACTERS WITHOUT CLAIM TO ANY PARTICULAR FONT, STYLE, SIZE, OR COLOR.

FOR ADVERTISING; BUSINESS MANAGEMENT; BUSINESS ADMINISTRATION; PROVIDING OFFICE FUNCTIONS (U.S. CLS. 100, 101 AND 102).

AMY C. KEAN, EXAMINING ATTORNEY

**CLASS 35—(Continued).**

SN 85-044,841. PLATINUM GUILD INTERNATIONAL JEWELRY USA, INC., NEW YORK, NY. FILED 5-21-2010.

**ENTRY PLATINUM**

THE MARK CONSISTS OF STANDARD CHARACTERS WITHOUT CLAIM TO ANY PARTICULAR FONT, STYLE, SIZE, OR COLOR.

NO CLAIM IS MADE TO THE EXCLUSIVE RIGHT TO USE "PLATINUM", APART FROM THE MARK AS SHOWN. FOR ADVERTISING AND PROMOTION SERVICES, NAMELY, PROMOTING PLATINUM AND PLATINUM JEWELRY AND PROMOTING PUBLIC AWARENESS ABOUT PLATINUM AND PLATINUM JEWELRY (U.S. CLS. 100, 101 AND 102).

Laurie Mayes, Examining Attorney

---

SN 85-045,406. JACKSON, YAMILE C., LA JOLLA, CA. FILED 5-21-2010.



THE COLOR(S) PURPLE, LIGHT BLUE, DARK BLUE, ORANGE, BLACK IS/ARE CLAIMED AS A FEATURE OF THE MARK.

THE MARK CONSISTS OF THE STYLIZED WORDING "NURTURED BY DESIGN" IN BLACK; BETWEEN THE WORDS "NURTURED" AND "BY DESIGN" ARE MULTI-COLORED BUTTERFLY-STYLE WINGS, WHEREIN SAID WINGS ARE PURPLE, LIGHT BLUE, ORANGE AND DARK BLUE.

FOR ON-LINE RETAIL STORE SERVICES FEATURING MATERNITY AND BABY-RELATED GOODS (U.S. CLS. 100, 101 AND 102).

FIRST USE 9-30-2008; IN COMMERCE 9-30-2008.  
Julie Guttadauro, Examining Attorney

---

SN 85-046,162. DONOVAN MARINE, INC., HARAHAH, LA. FILED 5-24-2010.

**DONOVAN MARINE**

THE MARK CONSISTS OF STANDARD CHARACTERS WITHOUT CLAIM TO ANY PARTICULAR FONT, STYLE, SIZE, OR COLOR.

NO CLAIM IS MADE TO THE EXCLUSIVE RIGHT TO USE "MARINE", APART FROM THE MARK AS SHOWN.

FOR WHOLESALE ORDERING SERVICES IN THE FIELD OF MARINE PRODUCTS (U.S. CLS. 100, 101 AND 102).

FIRST USE 12-31-1913; IN COMMERCE 12-31-1913.  
Frank Lattuca, Examining Attorney

**CLASS 35—(Continued).**

SN 85-046,229. DONOVAN MARINE, INC., HARAHAH, LA. FILED 5-24-2010.

**PARTS XPRESS BY DONOVAN**

THE MARK CONSISTS OF STANDARD CHARACTERS WITHOUT CLAIM TO ANY PARTICULAR FONT, STYLE, SIZE, OR COLOR.

NO CLAIM IS MADE TO THE EXCLUSIVE RIGHT TO USE "PARTS", APART FROM THE MARK AS SHOWN.

FOR WHOLESALE ORDERING SERVICES IN THE FIELD OF ENGINES AND MARINE AND BOATING PRODUCTS; CONSULTATION SERVICES, NAMELY, SELECTING AND ORGANIZING OF COMPATIBLE PARTS FOR ENGINES AND MARINE AND BOATING APPLICATIONS INTO KITS FOR OTHERS TO PURCHASE (U.S. CLS. 100, 101 AND 102).

Frank Lattuca, Examining Attorney

---

SN 85-046,310. HEFFRON, LAURA, SAN FRANCISCO, CA. FILED 5-24-2010.

**Candid Philanthropy**

THE MARK CONSISTS OF STANDARD CHARACTERS WITHOUT CLAIM TO ANY PARTICULAR FONT, STYLE, SIZE, OR COLOR.

NO CLAIM IS MADE TO THE EXCLUSIVE RIGHT TO USE "PHILANTHROPY", APART FROM THE MARK AS SHOWN.

FOR CHARITABLE SERVICES, NAMELY, ORGANIZING AND CONDUCTING VOLUNTEER PROGRAMS AND COMMUNITY SERVICE PROJECTS; PROMOTION AND MARKETING SERVICES AND RELATED CONSULTING; PUBLIC RELATIONS (U.S. CLS. 100, 101 AND 102).

Alex Keam, Examining Attorney

**CLASS 35—(Continued).**

SN 85-046,566. W2007 STRATOSPHERE PROPCO., L.P., LAS VEGAS, NV. FILED 5-24-2010.



NO CLAIM IS MADE TO THE EXCLUSIVE RIGHT TO USE "LAS VEGAS", APART FROM THE MARK AS SHOWN.

THE MARK CONSISTS OF THE STYLIZED WORDS "SKY JUMP" STAGGERED HORIZONTALLY POSITIONED OVER A TARGET AND FIVE VERTICALLY POSITIONED INVERTED LONG TRIANGLES AND THE WORDS "LAS VEGAS" UNDER THE WORD "SKY" AND A DOTTED BACKGROUND ON THE BOTTOM.

FOR CUSTOMER LOYALTY SERVICES AND CUSTOMER CLUB SERVICES, FOR COMMERCIAL, PROMOTIONAL AND/OR ADVERTISING PURPOSES; RETAIL GIFT SHOPS (U.S. CLS. 100, 101 AND 102).

LOURDES AYALA, EXAMINING ATTORNEY

SN 85-046,573. W2007 STRATOSPHERE PROPCO., L.P., LAS VEGAS, NV. FILED 5-24-2010.

# SKYJUMP

THE MARK CONSISTS OF STANDARD CHARACTERS WITHOUT CLAIM TO ANY PARTICULAR FONT, STYLE, SIZE, OR COLOR.

FOR CUSTOMER LOYALTY SERVICES AND CUSTOMER CLUB SERVICES, FOR COMMERCIAL, PROMOTIONAL AND/OR ADVERTISING PURPOSES; RETAIL GIFT SHOPS (U.S. CLS. 100, 101 AND 102).

LOURDES AYALA, EXAMINING ATTORNEY

SN 85-046,584. W2007 STRATOSPHERE PROPCO., L.P., LAS VEGAS, NV. FILED 5-24-2010.

# SKYJUMP LAS VEGAS

THE MARK CONSISTS OF STANDARD CHARACTERS WITHOUT CLAIM TO ANY PARTICULAR FONT, STYLE, SIZE, OR COLOR.

NO CLAIM IS MADE TO THE EXCLUSIVE RIGHT TO USE "LAS VEGAS", APART FROM THE MARK AS SHOWN.

FOR CUSTOMER LOYALTY SERVICES AND CUSTOMER CLUB SERVICES, FOR COMMERCIAL, PROMOTIONAL AND/OR ADVERTISING PURPOSES; RETAIL GIFT SHOPS (U.S. CLS. 100, 101 AND 102).

LOURDES AYALA, EXAMINING ATTORNEY

**CLASS 35—(Continued).**

SN 85-046,850. KIDOLO, LLC, NEW YORK, NY. FILED 5-24-2010.

# KIDOLO

THE MARK CONSISTS OF STANDARD CHARACTERS WITHOUT CLAIM TO ANY PARTICULAR FONT, STYLE, SIZE, OR COLOR.

FOR ADVERTISING AND MARKETING OTHERS' GOODS AND SERVICES; AND PROMOTING THE GOODS AND SERVICES OF OTHERS BY DISTRIBUTING ADVERTISING MATERIALS THROUGH A VARIETY OF METHODS; BUSINESS MARKETING AND CONSULTING SERVICES; PROMOTING THE GOODS AND SERVICES OF OTHERS VIA PRINT, SMART PHONE AND INTERNET FEATURING COUPONS, REBATES, PRICE COMPARISON INFORMATION, DISCOUNT INFORMATION, REVIEWS OF PRODUCTS AND SERVICES, AND LINKS TO RETAIL WEB SITES; BUYING CLUBS; PURCHASING AND PROCUREMENT SERVICES, NAMELY, ARRANGING OF BUYING GOODS, SERVICES AND CONTRACTS FOR THIRD PARTIES; PROVIDING AN ON-LINE ADVERTISING WEBSITE AND GUIDE FEATURING THE GOODS AND SERVICES OF OTHERS VIA THE INTERNET (U.S. CLS. 100, 101 AND 102).

SAMUEL E. SHARPER JR., EXAMINING ATTORNEY

SN 85-046,857. WORLDWIDEMANIAC, INC, AUSTIN, TX. FILED 5-24-2010.

# WORLDWIDE MANIAC

THE MARK CONSISTS OF STANDARD CHARACTERS WITHOUT CLAIM TO ANY PARTICULAR FONT, STYLE, SIZE, OR COLOR.

NO CLAIM IS MADE TO THE EXCLUSIVE RIGHT TO USE "WORLDWIDE", APART FROM THE MARK AS SHOWN.

FOR BRAND IMAGERY CONSULTING SERVICES; BRANDING SERVICES, NAMELY, CONSULTING, DEVELOPMENT, MANAGEMENT AND MARKETING OF BRANDS FOR BUSINESSES; BUSINESS ADVISORY SERVICES, CONSULTANCY AND INFORMATION; BUSINESS CONSULTATION; BUSINESS CONSULTATION SERVICES; BUSINESS CONSULTING AND INFORMATION SERVICES; BUSINESS CONSULTING AND MANAGEMENT IN THE FIELD OF CLINICAL TRIALS, NAMELY, PROVIDING INFORMATION MANAGEMENT SERVICES; BUSINESS CONSULTING SERVICES RELATING TO PRODUCT DISTRIBUTION, OPERATIONS MANAGEMENT SERVICES, LOGISTICS, REVERSE LOGISTICS, SUPPLY CHAIN, AND PRODUCTION SYSTEMS AND DISTRIBUTION SOLUTIONS; BUSINESS CONSULTING SERVICES, NAMELY, PROVIDING ASSISTANCE IN DEVELOPMENT OF BUSINESS STRATEGIES AND CREATIVE IDEATION; BUSINESS CONSULTING, BUSINESS MANAGEMENT AND PROVIDING INFORMATION IN THE MUSIC BUSINESS FIELD; BUSINESS CONSULTING, MANAGE-

**CLASS 35—(Continued).**

MENT, PLANNING AND SUPERVISION; BUSINESS DEVELOPMENT CONSULTING SERVICES; BUSINESS MANAGEMENT CONSULTANCY AND ADVISORY SERVICES; BUSINESS MANAGEMENT CONSULTANCY AS WELL AS DEVELOPMENT OF PROCESSES FOR THE ANALYSIS AND THE IMPLEMENTATION OF STRATEGY PLANS AND MANAGEMENT PROJECTS; BUSINESS MANAGEMENT CONSULTING; BUSINESS MANAGEMENT CONSULTING AND ADVISORY SERVICES; BUSINESS ORGANIZATION AND MANAGEMENT CONSULTING; BUSINESS ORGANIZATION CONSULTING; CONSULTING SERVICES IN BUSINESS LEADERSHIP DEVELOPMENT AND BUSINESS MANAGEMENT; CONSULTING SERVICES RELATED TO THE ADMINISTRATIVE COORDINATION OF ORGANIZATIONS PROVIDING HUMANITARIAN ACTIVITIES; CONSULTING SERVICES RELATING TO PUBLICITY; MARKETING CONSULTING; NEW BUSINESS VENTURE DEVELOPMENT AND FORMATION CONSULTING SERVICES; PROMOTION AND MARKETING SERVICES AND RELATED CONSULTING (U.S. CLS. 100, 101 AND 102).

FIRST USE 12-1-2009; IN COMMERCE 5-2-2010.  
SAMUEL E. SHARPER JR., EXAMINING ATTORNEY

SN 85-046,912. STEPHEN D. TOWNES, GREENVILLE, SC.  
FILED 5-25-2010.



*Quality Leadership in Client Services*

NO CLAIM IS MADE TO THE EXCLUSIVE RIGHT TO USE "PARTNERS", APART FROM THE MARK AS SHOWN.

THE MARK CONSISTS OF A SHIELD WITH A LIGHTNING BOLT IN THE MIDDLE; TO THE RIGHT OF THE SHIELD ARE THE WORDS "RANGER PARTNERS" IN ALL CAPITALS IN A BROKEN STENCIL STYLIZED FONT ENCLOSED WITHIN AN OUTLINED RECTANGLE; BELOW THE SHIELD AND THE BOXED WORDS "RANGER PARTNERS" ARE THE WORDS "QUALITY LEADERSHIP IN CLIENT SERVICES" IN A STYLIZED SCRIPT FONT.

FOR MERGER AND ACQUISITION CONSULTING SERVICES (U.S. CLS. 100, 101 AND 102).

FIRST USE 9-30-1988; IN COMMERCE 12-31-1988.  
LINDA POWELL, EXAMINING ATTORNEY

**CLASS 35—(Continued).**

SN 85-047,407. HEALTHPRIZE TECHNOLOGIES, LLC, NORWALK, CT. FILED 5-25-2010.

**FORTUNE COOKIE**

THE MARK CONSISTS OF STANDARD CHARACTERS WITHOUT CLAIM TO ANY PARTICULAR FONT, STYLE, SIZE, OR COLOR.

FOR PROVIDING AN INTERACTIVE WEB SITE THAT OFFERS PARTICIPANTS REWARDS FOR PROVIDING INFORMATION ABOUT HEALTH AND FITNESS IN THE NATURE OF THEIR HEALTH PROGRAMS, PERSONAL HEALTH DATA AND PRESCRIPTION AND HEALTH CONDITIONS, FOR DATA COLLECTION USED IN IMPROVING HEALTH CARE ADMINISTRATION AND COST MANAGEMENT; PROVIDING AN INTERACTIVE WEB SITE THAT OFFERS PARTICIPANTS REWARDS FOR RECEIVING INFORMATION ABOUT HEALTH AND FITNESS, IN THE NATURE OF DIRECT MARKETING AND PROMOTING HEALTH AWARENESS (U.S. CLS. 100, 101 AND 102).

HANNO RITTNER, EXAMINING ATTORNEY

SN 85-047,453. COUNCIL OF SUPPLY CHAIN MANAGEMENT PROFESSIONALS, LOMBARD, IL. FILED 5-25-2010.

**SUPPLY CHAIN CONCIERGE**

THE MARK CONSISTS OF STANDARD CHARACTERS WITHOUT CLAIM TO ANY PARTICULAR FONT, STYLE, SIZE, OR COLOR.

NO CLAIM IS MADE TO THE EXCLUSIVE RIGHT TO USE "SUPPLY CHAIN", APART FROM THE MARK AS SHOWN.

FOR PROVIDING AND FACILITATING BUSINESS SERVICES, NAMELY, MAKING REQUESTED ARRANGEMENTS, RESERVATIONS, AND PROVIDING INFORMATION TO MEET THE NEEDS OF BUSINESS INDIVIDUALS AND ASSISTING IN OBTAINING AND PROVIDING BUSINESS PRODUCTS AND SERVICES TO MEET AN INDIVIDUAL BUSINESS PERSON'S NEEDS (U.S. CLS. 100, 101 AND 102).

JORDAN BAKER, EXAMINING ATTORNEY

**CLASS 35—(Continued).**

SN 85-048,139. MICRONOTES, INC., CAMBRIDGE, MA.  
FILED 5-26-2010.

**MICROINTERVIEW**

THE MARK CONSISTS OF STANDARD CHARACTERS WITHOUT CLAIM TO ANY PARTICULAR FONT, STYLE, SIZE, OR COLOR.

FOR INTERACTIVE MARKETING SERVICES, NAMELY, THE RETRIEVAL AND ANALYSIS OF CONSUMER DATA, CONSUMER INTERVIEWS, MARKET RESEARCH SERVICES AND ADVERTISING SERVICES FOR OTHERS (U.S. CLS. 100, 101 AND 102).

FIRST USE 11-30-2009; IN COMMERCE 11-30-2009.

MARIA-VICTORIA SUAREZ, EXAMINING ATTORNEY

SN 85-048,227. MICRONOTES, INC., CAMBRIDGE, MA.  
FILED 5-26-2010.

**MICRONOTES**

THE MARK CONSISTS OF STANDARD CHARACTERS WITHOUT CLAIM TO ANY PARTICULAR FONT, STYLE, SIZE, OR COLOR.

FOR INTERACTIVE MARKETING SERVICES USING A COMMUNICATIONS SYSTEM SUCH AS THE INTERNET, A NETWORKED COMPUTER SYSTEM OR A TELEPHONE SYSTEM, NAMELY, ADVERTISING OF GOODS AND SERVICES USING THE COMMUNICATION SYSTEM, MARKETING CONSULTING SERVICES, MARKET RESEARCH SERVICES AND ADVERTISING SERVICES FOR OTHERS (U.S. CLS. 100, 101 AND 102).

FIRST USE 11-30-2009; IN COMMERCE 11-30-2009.

MARIA-VICTORIA SUAREZ, EXAMINING ATTORNEY

SN 85-048,327. CUNET, LLC, PARAMUS, NJ. FILED 5-26-2010.

**CollegeQuest**

THE MARK CONSISTS OF STANDARD CHARACTERS WITHOUT CLAIM TO ANY PARTICULAR FONT, STYLE, SIZE, OR COLOR.

OWNER OF U.S. REG. NO. 1,219,375.

FOR ADVERTISING SERVICES, NAMELY, PROMOTING AND MARKETING THE GOODS AND SERVICES OF OTHERS THROUGH ALL PUBLIC COMMUNICATION MEANS; PROVIDING DEMAND CREATION AND LEAD GENERATION ACTIVITIES AND SERVICES; PROVIDING RECOMMENDATIONS OF SERVICE PROVIDERS TO CONSUMERS FOR COMMERCIAL PURPOSES (U.S. CLS. 100, 101 AND 102).

FIRST USE 4-1-2010; IN COMMERCE 4-1-2010.

ALICE BENMAMAN, EXAMINING ATTORNEY

**CLASS 35—(Continued).**

SN 85-049,954. PINWOOD FARMERS' MARKET, MUNDS PARK, AZ. FILED 5-27-2010.

**Pinewood Farmers' Market**

THE MARK CONSISTS OF STANDARD CHARACTERS WITHOUT CLAIM TO ANY PARTICULAR FONT, STYLE, SIZE, OR COLOR.

NO CLAIM IS MADE TO THE EXCLUSIVE RIGHT TO USE "FARMERS' MARKET", APART FROM THE MARK AS SHOWN.

FOR FARMERS' MARKETS (U.S. CLS. 100, 101 AND 102).

MARK T. MULLEN, EXAMINING ATTORNEY

SN 85-050,007. LOMBARD, DAVID, WINTHROP, MA. FILED 5-28-2010.

**TEAPUBLICAN**

THE MARK CONSISTS OF STANDARD CHARACTERS WITHOUT CLAIM TO ANY PARTICULAR FONT, STYLE, SIZE, OR COLOR.

FOR INFORMATION ABOUT POLITICAL ELECTIONS; POLITICAL CONSULTANCY; POLITICAL PARTY SERVICES, NAMELY, PROMOTING THE INTERESTS OF A POLITICAL ORGANIZATION; PROVIDING A WEBSITE FEATURING INFORMATION ABOUT POLITICAL ISSUES; PROVIDING AN ON-LINE SEARCHABLE DATABASE FOR POLITICAL CAMPAIGNS WHICH ALLOW USERS TO COLLECT AND ANALYZE POLITICAL INFORMATION ELECTRONICALLY; PROVIDING INFORMATION REGARDING POLITICAL ISSUES, KNOWING HOW TO VOTE AND KNOWING HOW TO REGISTER TO VOTE (U.S. CLS. 100, 101 AND 102).

JULIE GUTTADAURO, EXAMINING ATTORNEY

SN 85-052,124. PAULTWO LLC, BATON ROUGE, LA. FILED 6-1-2010.

**PAULTWO**

THE MARK CONSISTS OF STANDARD CHARACTERS WITHOUT CLAIM TO ANY PARTICULAR FONT, STYLE, SIZE, OR COLOR.

FOR CREATIVE SERVICES, NAMELY, BRAND DEVELOPMENT SERVICES FOR CORPORATE AND INDIVIDUAL CLIENTS, BUSINESS MARKETING STRATEGY SERVICES, BUSINESS CONSULTATION IN THE NATURE OF BUSINESS PLAN DEVELOPMENT, AND PRODUCTION OF ADVERTISING MATERIALS (U.S. CLS. 100, 101 AND 102).

REBECCA EISINGER, EXAMINING ATTORNEY

**CLASS 35—(Continued).**

SN 85-053,697. ENVU LLC, DAYTON, OH. FILED 6-3-2010.

EnForm

THE MARK CONSISTS OF STANDARD CHARACTERS WITHOUT CLAIM TO ANY PARTICULAR FONT, STYLE, SIZE, OR COLOR.

FOR ADVERTISING SERVICES, NAMELY, DISSEMINATION OF ADVERTISING FOR OTHERS VIA PUBLIC WIRELESS NETWORKS FOR DISPLAY OF INTERACTIVE MEDIA ADVERTISING, NAMELY, PROMOTING THE GOODS AND SERVICES OF THIRD PARTIES THROUGH MEDIUMS INCLUDING AUDIO, VIDEO, DIGITAL INTERACTIVE, DOWNLOAD TO MOBILE, AND MOBILE INTERACTIVE VIA ELECTRONIC FLOOR, WALL, FREESTANDING PROJECTION, OR OTHER VIDEO SURFACE DISPLAY (U.S. CLS. 100, 101 AND 102).

JANICE KIM, EXAMINING ATTORNEY

SN 85-054,322. HOK, INC., TORONTO, ONTARIO, CANADA, FILED 6-3-2010.

OEP - OCCUPANT ENGAGEMENT PROGRAM FOR SUSTAINABLE PRACTICE

THE MARK CONSISTS OF STANDARD CHARACTERS WITHOUT CLAIM TO ANY PARTICULAR FONT, STYLE, SIZE, OR COLOR.

OWNER OF CANADA REG. NO. TMA772,767, DATED 7-23-2010, EXPIRES 7-23-2025.

NO CLAIM IS MADE TO THE EXCLUSIVE RIGHT TO USE "OCCUPANT ENGAGEMENT PROGRAM FOR SUSTAINABLE PRACTICE", APART FROM THE MARK AS SHOWN.

FOR BUSINESS CONSULTING IN THE FIELD OF ENVIRONMENTAL MANAGEMENT, NAMELY, ADVISING BUSINESSES IN THE NATURE OF BUILDING OWNERS, OCCUPANTS AND TENANTS ON ISSUES OF ENVIRONMENTALLY SUSTAINABLE PERFORMANCE, PROGRAMS AND PRACTICES FOR BUSINESS PURPOSES (U.S. CLS. 100, 101 AND 102).

MARK T. MULLEN, EXAMINING ATTORNEY

**CLASS 35—(Continued).**

SN 85-055,114. PARKVIEW HEALTH SYSTEM, INC., FORT WAYNE, IN. FILED 6-4-2010.



NO CLAIM IS MADE TO THE EXCLUSIVE RIGHT TO USE "DON'T TEXT & DRIVE" AND "TRAUMA CENTER", APART FROM THE MARK AS SHOWN.

THE COLOR(S) WHITE, BLACK AND GREEN IS/ARE CLAIMED AS A FEATURE OF THE MARK.

THE MARK CONSISTS OF THE TERMS "DON'T TEXT & DRIVE", WITH THE R AND V IN "DRIVE" IN GREEN AND ALL OTHER LETTERS IN WHITE, SET AGAINST A BACKGROUND OF BLACK HIGHWAY PAVEMENT, WITH A DIAMOND AND THE TERMS "PARKVIEW TRAUMA CENTER", ALL IN WHITE, ORIENTED IN THE LOWER RIGHT HAND ONE-THIRD OF THE DESIGN AND SET AGAINST A LIGHT GREEN SLOPING BACKGROUND THAT IS OUTLINED BY A DARKER GREEN LINE.

FOR PROMOTING PUBLIC AWARENESS ABOUT THE DANGERS OF DRIVING WHILE DISTRACTED; AND, PROMOTING PUBLIC AWARENESS ABOUT THE DANGERS OF DRIVING WHILE USING MOBILE COMMUNICATION DEVICES (U.S. CLS. 100, 101 AND 102).

FIRST USE 2-0-2010; IN COMMERCE 2-0-2010.  
KATINA MISTER, EXAMINING ATTORNEY

SN 85-055,524. HOBSON, LARRY, PALMDALE, CA. FILED 6-5-2010.

THE ERA CARD

THE MARK CONSISTS OF STANDARD CHARACTERS WITHOUT CLAIM TO ANY PARTICULAR FONT, STYLE, SIZE, OR COLOR.

NO CLAIM IS MADE TO THE EXCLUSIVE RIGHT TO USE "CARD", APART FROM THE MARK AS SHOWN.

FOR ADVERTISING AND BUSINESS SERVICES, NAMELY, ADMINISTRATION OF A DISCOUNT PROGRAM FOR ENABLING PARTICIPANTS TO OBTAIN DISCOUNTS ON GOODS AND SERVICES THROUGH USE OF A DISCOUNT MEMBERSHIP CARD, FOR NONPROFIT GROUPS AND CONSUMERS WHO WILL PAY FOR A MEMBERSHIP (U.S. CLS. 100, 101 AND 102).

JEAN IM, EXAMINING ATTORNEY



**CLASS 35—(Continued).**

SN 85-057,272. INTELGRID LLC, LOCUST GROVE, VA.  
FILED 6-8-2010.

**CLASS 35—(Continued).**

SN 85-059,531. KGPR INC, DBA AIRHEAD PARTS, VEN-  
TURA, CA. FILED 6-10-2010.

# intelaHome

THE MARK CONSISTS OF STANDARD CHARACTERS WITHOUT CLAIM TO ANY PARTICULAR FONT, STYLE, SIZE, OR COLOR.

FOR PROVIDING ENERGY USAGE MANAGEMENT AND USAGE INFORMATION IN CONNECTION WITH SMART HOME ENERGY COMMAND AND CONTROL SYSTEMS; PROVIDING A WEBSITE WITH GENERAL INFORMATION OF INTEREST TO THE FIELDS OF ENERGY USAGE MANAGEMENT AND MONITORING IN CONNECTION WITH SMART HOME ENERGY COMMAND AND CONTROL SYSTEMS; ENERGY AUDITING SERVICES RELATING TO REAL TIME, AND HISTORICAL USAGE, OF ELECTRIC, WATER AND GAS (U.S. CLS. 100, 101 AND 102).

FIRST USE 3-1-2009; IN COMMERCE 3-1-2009.  
CHRISTINE COOPER, EXAMINING ATTORNEY



SN 85-058,980. KIM, JONG MYOUNG, YORBA LINDA, CA.  
FILED 6-9-2010.

THE COLOR(S) RED AND BLACK IS/ARE CLAIMED AS A FEATURE OF THE MARK.

THE MARK CONSISTS OF THE NAME OF "WIZADDRESS", WITH "WIZ" IN RED AND "ADDRESS" IN BLACK, WITH A RED CURVING LINE THROUGH THE NAME ITSELF PUNCTUATED BY A RED STAR IN THE END.

FOR ON-LINE RETAIL STORE SERVICES FEATURING A WIDE VARIETY OF CONSUMER GOODS OF OTHERS (U.S. CLS. 100, 101 AND 102).

FIRST USE 6-1-2010; IN COMMERCE 6-1-2010.  
LAURIE MAYES, EXAMINING ATTORNEY

THE COLOR(S) BLACK, WHITE AND GRAY IS/ARE CLAIMED AS A FEATURE OF THE MARK.

THE MARK CONSISTS OF A STICK FIGURE WITH LARGE CIRCULAR HEAD AND A SIDEWAYS BALL-CAP. THE BODY IS AN INVERTED ARROW WITHOUT STEM WITH THICK ARMS THAT BEGIN AT THE SHOULDERS IN A SHARP POINT AND END IN A SHARP POINT AT THE WRISTS WITHOUT HANDS. THE STICK FIGURE IS HOLDING A LARGE GRAY WRENCH. THE COLOR BLACK APPEARS ON THE STICK FIGURE AND BALL-CAP DESIGN. THE COLOR GRAY APPEARS ON THE WRENCH. THE COLOR BLACK APPEARS ON THE STICK FIGURE AND THE BALL-CAP DESIGN. THE COLOR GRAY APPEARS ON THE WRENCH. THE COLOR WHITE APPEARS WITHIN THE CIRCULAR HEAD DESIGN.

FOR IMPORT AGENCY SERVICES IN THE FIELD OF AUTO PARTS AND ACCESSORIES; MAIL ORDER CATALOG SERVICES FEATURING AUTO PARTS AND ACCESSORIES; MAIL ORDER SERVICES FEATURING AUTO PARTS AND ACCESSORIES; ON-LINE ORDERING SERVICES FEATURING AUTO PARTS AND ACCESSORIES (U.S. CLS. 100, 101 AND 102).

FIRST USE 2-1-2005; IN COMMERCE 2-1-2005.  
CIMMERIAN COLEMAN, EXAMINING ATTORNEY

**CLASS 35—(Continued).**

SN 85-061,354. MYBPORT, LLC, RIVERBANK, CA. FILED 6-12-2010.



NO CLAIM IS MADE TO THE EXCLUSIVE RIGHT TO USE "BRAND", APART FROM THE MARK AS SHOWN.

THE COLOR(S) BLUE, GREY, WHITE, BLACK IS/ARE CLAIMED AS A FEATURE OF THE MARK.

THE MARK CONSISTS OF BLUE EARTH GLOBE WITH GREY CONTINENTS. LEFT SIDE OF THE GLOBE HAS THREE PEOPLE ON IT, WHITE IN COLOR, WITH THEIR ARMS RAISED. NEXT TO THE GLOBE ARE THE WORDS "MYBPORT.COM" AND "BRAND YOURSELF" IN BLACK. "BPORT.COM" IS PARTIALLY UNDERLINED AND OVERLINED IN BLACK.

FOR ADVERTISING AND BUSINESS SERVICES, NAMELY, PROVIDING AN ONLINE WEBSITE WHERE ADVERTISERS, MARKETERS, AND CONTENT PROVIDERS CAN INTERACT WITH USERS FOR ADVERTISING, BRANDING, AND PROMOTING KNOWLEDGE, PRODUCTS, AND SERVICES, AND TRADESHOWS, ON BEHALF OF THEMSELVES AND OTHERS, AND FOR EVALUATING AND RATING THE SAME, ALL THE FOREGOING RELEVANT TO HUMAN ACTIVITIES AFFECTING CLIMATE CHANGE AND RELATED FIELDS; ADVERTISING AND DIRECTORY SERVICES, NAMELY, PROMOTING THE SERVICES OF OTHERS BY PROVIDING A WEB PAGE FEATURING LINKS TO THE WEBSITES OF OTHERS; COMMERCIAL INFORMATION AND DIRECTORY AGENCY; COMPILATION OF BUSINESS DIRECTORIES; ON-LINE BUSINESS DIRECTORIES FEATURING COMMERCIAL INFORMATION OF BUSINESSES, GROUPS, AND ORGANIZATIONS (U.S. CLS. 100, 101 AND 102).

FIRST USE 11-10-2007; IN COMMERCE 4-18-2009.  
KATHLEEN LORENZO, EXAMINING ATTORNEY

SN 85-061,486. INFOTRAC, INC., DBA INFOTRAC, INC., ATLANTA, GA. FILED 6-13-2010.

## Total Alignment

THE MARK CONSISTS OF STANDARD CHARACTERS WITHOUT CLAIM TO ANY PARTICULAR FONT, STYLE, SIZE, OR COLOR.

NO CLAIM IS MADE TO THE EXCLUSIVE RIGHT TO USE "ALIGNMENT", APART FROM THE MARK AS SHOWN.

FOR MANAGEMENT CONSULTING AND ADVISORY SERVICES IN THE AREAS OF CORPORATE GROWTH STRATEGY, INNOVATION AND GROWTH PROCESSES, ORGANIZATIONAL TRANSFORMATION, AND TALENT MANAGEMENT AND DEVELOPMENT STRATEGIES (U.S. CLS. 100, 101 AND 102).

FIRST USE 5-27-1999; IN COMMERCE 5-27-1999.  
KEVIN CORWIN, EXAMINING ATTORNEY

**CLASS 35—(Continued).**

SN 85-061,490. INFOTRAC, INC., DBA INFOTRAC, INC., ATLANTA, GA. FILED 6-13-2010.

## Alineación Total

THE MARK CONSISTS OF STANDARD CHARACTERS WITHOUT CLAIM TO ANY PARTICULAR FONT, STYLE, SIZE, OR COLOR.

NO CLAIM IS MADE TO THE EXCLUSIVE RIGHT TO USE "ALINEACION", APART FROM THE MARK AS SHOWN.

THE ENGLISH TRANSLATION OF "ALINEACION TOTAL" IN THE MARK IS "TOTAL ALIGNMENT".

FOR MANAGEMENT CONSULTING AND ADVISORY SERVICES IN THE AREAS OF CORPORATE GROWTH STRATEGY, INNOVATION AND GROWTH PROCESSES, ORGANIZATIONAL TRANSFORMATION, AND TALENT MANAGEMENT AND DEVELOPMENT STRATEGIES (U.S. CLS. 100, 101 AND 102).

FIRST USE 10-11-2002; IN COMMERCE 10-11-2002.  
KEVIN CORWIN, EXAMINING ATTORNEY

SN 85-063,836. RELEVANT ADS, INC., FOUNTAIN VALLEY, CA. FILED 6-15-2010.

## LOCAL SPLASH

THE MARK CONSISTS OF STANDARD CHARACTERS WITHOUT CLAIM TO ANY PARTICULAR FONT, STYLE, SIZE, OR COLOR.

NO CLAIM IS MADE TO THE EXCLUSIVE RIGHT TO USE "LOCAL", APART FROM THE MARK AS SHOWN.

FOR ADVERTISING AND PUBLICITY SERVICES; PUBLICITY CONSULTATION; PROMOTION OF BUSINESS OPPORTUNITIES; PROMOTING THE GOODS AND SERVICES OF OTHERS BY PROVIDING A COMMUNITY-DRIVEN WEB SITE FEATURING USER-SUBMITTED CONTENT IN THE NATURE OF PRODUCT AND SERVICE REVIEWS, REFERRALS, COUPONS, REBATES, PRICE-COMPARISON INFORMATION, AND LINKS TO THE RETAIL WEBSITES OF OTHERS; PROVIDING TELEPHONE DIRECTORY INFORMATION VIA GLOBAL COMMUNICATIONS NETWORKS; PROVIDING AN ONLINE INTERACTIVE WEBSITE OBTAINING CONSUMER'S COMMENTS CONCERNING BUSINESS ORGANIZATIONS AND SERVICE PROVIDERS FOR COMMERCIAL PURPOSES; PROVIDING CONSUMER INFORMATION, NAMELY, COMPILATIONS OF BUSINESS INFORMATION AND BUSINESS LOCATIONS, RANKINGS, RATINGS, REVIEWS, REFERRALS AND RECOMMENDATIONS RELATING TO BUSINESS ORGANIZATIONS AND SERVICE PROVIDERS FOR COMMERCIAL PURPOSES USING A GLOBAL COMPUTER NETWORK (U.S. CLS. 100, 101 AND 102).

FIRST USE 6-30-2008; IN COMMERCE 6-30-2008.  
CHRISTINE COOPER, EXAMINING ATTORNEY

**CLASS 35—(Continued).**

SN 85-066,273. RAINBOW REWARDS USA, INC., DENVER, CO. FILED 6-18-2010.

### MAIN STREET MERCHANT PARTNERSHIP

THE MARK CONSISTS OF STANDARD CHARACTERS WITHOUT CLAIM TO ANY PARTICULAR FONT, STYLE, SIZE, OR COLOR.

NO CLAIM IS MADE TO THE EXCLUSIVE RIGHT TO USE "MERCHANT PARTNERSHIP", APART FROM THE MARK AS SHOWN.

FOR PROVIDING LOYALTY REWARD PROGRAMS FOR CUSTOMERS THAT PROMOTE THE SALE OF PRODUCTS AND SERVICES OF PARTICIPATING LOCAL BUSINESSES (U.S. CLS. 100, 101 AND 102).

KATHERINE M. DUBRAY, EXAMINING ATTORNEY

SN 85-066,572. BENNU, LLC, NEW YORK, NY. FILED 6-18-2010.

### BENNU

THE MARK CONSISTS OF STANDARD CHARACTERS WITHOUT CLAIM TO ANY PARTICULAR FONT, STYLE, SIZE, OR COLOR.

FOR BUSINESS CONSULTING SERVICE THAT PROVIDES TRANSFORMATIONAL STRATEGIES TO COMPANIES WISHING TO MOVE TOWARDS SUSTAINABILITY AND SOCIALLY RESPONSIBLE BUSINESS PRACTICES, PROVIDED MAINLY TO THE CONSUMER PRODUCTS INDUSTRY (U.S. CLS. 100, 101 AND 102).

FIRST USE 7-13-2009; IN COMMERCE 7-13-2009.  
ANTHONY RINKER, EXAMINING ATTORNEY

SN 85-068,802. WRITE QUICK, INC., PETALUMA, CA. FILED 6-22-2010.

### TECHPUBS IN A BOX

THE MARK CONSISTS OF STANDARD CHARACTERS WITHOUT CLAIM TO ANY PARTICULAR FONT, STYLE, SIZE, OR COLOR.

NO CLAIM IS MADE TO THE EXCLUSIVE RIGHT TO USE "TECHPUBS", APART FROM THE MARK AS SHOWN.

FOR BUSINESS CONSULTING SERVICES, NAMELY, PROVIDING A TURNKEY SOLUTION FOR REVIEWING PRODUCT AND SERVICE DOCUMENTATION AND WORKFLOW, MANAGING PROJECTS FOR BUSINESS PURPOSES, TRACKING USER SATISFACTION, AND RUNNING USABILITY STUDIES FOR BUSINESS PURPOSES (U.S. CLS. 100, 101 AND 102).

FIRST USE 8-13-2009; IN COMMERCE 8-13-2009.  
MORGAN WYNNE, EXAMINING ATTORNEY

**CLASS 35—(Continued).**

SN 85-068,938. PAGANS MOTORCYCLE CLUB L.L.C., HERMINIE, PA. FILED 6-22-2010.



NO CLAIM IS MADE TO THE EXCLUSIVE RIGHT TO USE "M.C.", APART FROM THE MARK AS SHOWN.

THE COLOR(S) RED, WHITE, BLUE, YELLOW, BLACK IS/ARE CLAIMED AS A FEATURE OF THE MARK.

THE MARK CONSISTS OF THE WORDING "PAGAN'S MC" SHOWN IN BLUE, WITH THE WORD "PAGAN'S" CONTAINED WITHIN A RED OBLONG OVAL, AND THE LETTERS "MC" EACH CONTAINED WITHIN RED SQUARES. BETWEEN THE WORDING "PAGAN'S" AND "MC" IS A DESIGN SUTAR, GOD OF FIRE, SHOWN IN YELLOW AND BLACK, HOLDING A SWORD SHOWN IN RED AND YELLOW, AND SITTING ALONG AN ARC OF RED FIRE BORDERED IN YELLOW. THE BACKGROUND AND SPACES ARE SHOWN IN WHITE.

FOR CLUB SERVICES, NAMELY, PROMOTING THE INTERESTS OF MOTORCYCLE ENTHUSIASM AND FELLOWSHIP (U.S. CLS. 100, 101 AND 102).

FIRST USE 1-1-1959; IN COMMERCE 1-1-1959.  
FRED CARL, EXAMINING ATTORNEY

SN 85-069,370. SHABOOM MEDIA LLC, BOSTON, MA. FILED 6-23-2010.

### MONATION

THE MARK CONSISTS OF STANDARD CHARACTERS WITHOUT CLAIM TO ANY PARTICULAR FONT, STYLE, SIZE, OR COLOR.

FOR PROMOTING THE CHARITABLE SERVICES OF OTHERS, NAMELY, PROVIDING INDIVIDUALS WITH INFORMATION FOR THE PURPOSE OF MAKING DONATIONS TO CHARITIES VIA DONOR WIRELESS COMMUNICATIONS DEVICES (U.S. CLS. 100, 101 AND 102).

NATALIE POLZER, EXAMINING ATTORNEY

**CLASS 35—(Continued).**

SN 85-070,646. INGENIX, INC., EDEN PRAIRIE, MN. FILED 6-24-2010.

**CLASS 35—(Continued).**

SN 85-071,727. THE TRUSTEES OF THE FAO SCHWARZ FAMILY FOUNDATION, NEW YORK, NY. FILED 6-25-2010.

**ONLY AT FAO**

THE MARK CONSISTS OF STANDARD CHARACTERS WITHOUT CLAIM TO ANY PARTICULAR FONT, STYLE, SIZE, OR COLOR.

FOR RETAIL STORES, ONLINE RETAIL STORES, AND MAIL ORDER CATALOG SERVICES FEATURING CHILDREN'S TOYS AND GAMES, NAMELY, PLUSH TOYS AND ANIMALS, PUPPETS, ROCKING HORSES, BABY MULTIPLE ACTIVITY TOYS, TOY TRAINS, MARBLE GAMES, TOY BEADS FOR ACTIVITY KITS, MODEL CARS, AND TOY MUSICAL INSTRUMENTS, RAG DOLLS, DOLLS AND DOLLS ACCESSORIES, CHILDREN'S PLAY COSMETICS, CHILDREN'S HOBBY SCIENCE KITS, TOY LAB KITS, TOY CHEMISTRY KITS AND TOY EDUCATIONAL ACTIVITY KITS COMPRISING CHILDREN'S TELESCOPES, BINOCULARS AND MICROSCOPES (U.S. CLS. 100, 101 AND 102).

FIRST USE 9-0-2008; IN COMMERCE 9-0-2008.  
BARBARA A. GOLD, EXAMINING ATTORNEY

SN 85-073,948. STATE BAR OF WISCONSIN, MADISON, WI.  
FILED 6-29-2010.

OWNER OF U.S. REG. NOS. 2,979,431, 3,388,821 AND OTHERS.

THE COLOR(S) RED AND WHITE IS/ARE CLAIMED AS A FEATURE OF THE MARK.

THE MARK CONSISTS OF A LOWER CASE LETTER "i" AND NUMERAL "3" IN WHITE TEXT WITHIN A RED SQUARE.

FOR PROVIDING DATA MANAGEMENT AND BIostatistics SERVICES OF A BUSINESS NATURE FOR THE PHARMACEUTICAL AND BIOTECHNOLOGY INDUSTRIES; MANAGEMENT SERVICES OF A BUSINESS NATURE FOR CLINICAL TRIALS IN THE FIELD OF INVESTIGATIONAL DRUGS, NAMELY, ARRANGING FOR SITES TO PERFORM CLINICAL TRIALS, ARRANGING FOR THE IMPORT, PACKAGING, SHIPPING, LABELING AND DISTRIBUTION OF DRUGS AND OTHER INVESTIGATIONAL SUPPLIES TO AND FROM THE CLINICAL TRIAL SITES, ARRANGING FOR THE CENTRAL COLLECTION OF LABORATORY SPECIMENS FROM CLINICAL TRIAL SITES, MAKING ANY AND ALL FILINGS REQUIRED BY THE FOOD AND DRUG ADMINISTRATION FOR INVESTIGATIONAL NEW DRUGS, AND PREPARING STATISTICAL REPORTS RESULTING FROM CLINICAL TRIALS (U.S. CLS. 100, 101 AND 102).

FIRST USE 11-3-2003; IN COMMERCE 11-3-2003.  
CARRIE GENOVESE, EXAMINING ATTORNEY

**Leaders in the law.  
Advocates for justice.**

THE MARK CONSISTS OF STANDARD CHARACTERS WITHOUT CLAIM TO ANY PARTICULAR FONT, STYLE, SIZE, OR COLOR.

NO CLAIM IS MADE TO THE EXCLUSIVE RIGHT TO USE "ADVOCATES FOR JUSTICE", APART FROM THE MARK AS SHOWN.

FOR ASSOCIATION SERVICES, NAMELY, PROMOTING THE INTEREST OF LAWYERS AND IMPROVING THE DELIVERY OF LEGAL SERVICES (U.S. CLS. 100, 101 AND 102).

JEFF DEFORD, EXAMINING ATTORNEY

**CLASS 35—(Continued).**

SN 85-074,839. BREVARD SOFTBALL MAGAZINE, INC., MERRITT ISLAND, FL. FILED 6-30-2010.

# Bat Wars

THE MARK CONSISTS OF STANDARD CHARACTERS WITHOUT CLAIM TO ANY PARTICULAR FONT, STYLE, SIZE, OR COLOR.

NO CLAIM IS MADE TO THE EXCLUSIVE RIGHT TO USE "BAT", APART FROM THE MARK AS SHOWN.

FOR ORGANIZING, PROMOTING AND CONDUCTING EXHIBITIONS, TRADESHOWS, AND EVENTS FOR BUSINESS PURPOSES, NAMELY, FOR BASEBALL AND SOFTBALL EQUIPMENT VENDORS (U.S. CLS. 100, 101 AND 102).

FIRST USE 8-1-1997; IN COMMERCE 8-1-1997.  
DAVID I, EXAMINING ATTORNEY

**CLASS 35—(Continued).**

SN 85-081,634. RAINCLOUD MEDIA LLC, SOUTHLAKE, TX. FILED 7-9-2010.



THE MARK CONSISTS OF THE WORD "SOCIALRAIN" TO THE LEFT OF A SQUARE CONTAINING THE LETTERS "SR".

FOR BUSINESS STRATEGY DEVELOPMENT SERVICES, BUSINESS DATA ANALYSIS, AND BUSINESS MARKETING CONSULTING SERVICES IN THE FIELD OF ADVERTISING, PROMOTING, TRACKING AND MANAGING THE DELIVERY OF GOODS AND SERVICES OF OTHERS THROUGH SOCIAL MEDIA NETWORKS (U.S. CLS. 100, 101 AND 102).

LINDSEY RUBIN, EXAMINING ATTORNEY

SN 85-081,991. STAUFFENBERG, DANIEL E, EGG HARBOR TOWNSHIP, NJ. FILED S.R. 7-10-2010; AM. P.R. 3-7-2011.

SN 85-076,687. AQUASCORP, INC., LAS VEGAS, NV. FILED 7-2-2010.

# SPEARHEAD INTERNATIONAL



NO CLAIM IS MADE TO THE EXCLUSIVE RIGHT TO USE "ICE" AND "BEST TREATS", APART FROM THE MARK AS SHOWN.

THE COLOR(S) GREEN, BLUE, ORANGE, YELLOW, WHITE AND BLACK IS/ARE CLAIMED AS A FEATURE OF THE MARK.

THE MARK CONSISTS OF A BLUE ROUND CIRCLE REPRESENTING A PLANET WITH SEVERAL WHITE ASTERISKS DEPICTING STARS AND AN ORANGE BANANA SHAPED OBJECT DEPICTING LAND MASS. ON THE BOTTOM LEFT OF THE PLANET IS A YELLOW AND WHITE CIRCLE DEPICTING A MOON REVOLVING AROUND THE PLANET. THE WORDS "PLANET ICE" ARE WRITTEN ACROSS THE PLANET IN WHITE AND OUTLINED IN GREEN AND BLACK WITH THE WORDS EXCEEDING THE SIZE OF THE PLANET. ON THE BOTTOM LEFT OF THE PLANET ARE THE WORDS "THE GALAXY'S BEST TREATS" IN GREEN. THE BLACK BACKGROUND REPRESENTS A TRANSPARENT AREA AND IS NOT A PART OF THE MARK.

FOR RETAIL ICE CREAM STORE SERVICES (U.S. CLS. 100, 101 AND 102).

FIRST USE 4-3-2010; IN COMMERCE 4-3-2010.

KATHERINE M. DUBRAY, EXAMINING ATTORNEY

THE MARK CONSISTS OF STANDARD CHARACTERS WITHOUT CLAIM TO ANY PARTICULAR FONT, STYLE, SIZE, OR COLOR.

NO CLAIM IS MADE TO THE EXCLUSIVE RIGHT TO USE "INTERNATIONAL", APART FROM THE MARK AS SHOWN.

FOR ADVERTISING SERVICES FOR OTHERS; BUSINESS MANAGEMENT CONSULTING WITH RELATION TO STRATEGY, MARKETING, PRODUCTION, PERSONNEL AND RETAIL SALE MATTER; BUSINESS MANAGEMENT CONSULTING; BUSINESS ORGANIZATIONAL CONSULTATION; BUSINESS ACQUISITIONS CONSULTATION; BUSINESS DEVELOPMENT SERVICES, NAMELY, PROVIDING START-UP SUPPORT FOR BUSINESSES OF OTHERS (U.S. CLS. 100, 101 AND 102).

FIRST USE 11-1-2005; IN COMMERCE 12-30-2005.  
JOHN DALIER, EXAMINING ATTORNEY

**CLASS 35—(Continued).**

SN 85-083,715. WISDOM FOODS, LLC, WILMINGTON, DE.  
FILED 7-13-2010.

**ELLARY'S GREENS**

THE MARK CONSISTS OF STANDARD CHARACTERS WITHOUT CLAIM TO ANY PARTICULAR FONT, STYLE, SIZE, OR COLOR.

NO CLAIM IS MADE TO THE EXCLUSIVE RIGHT TO USE "GREENS", APART FROM THE MARK AS SHOWN.

FOR RETAIL STORE SERVICES FEATURING SALADS, SANDWICHES, FRUITS, VEGETABLES, SOUPS, BEVERAGES, DAIRY PRODUCTS, BABY FOOD, PREPARED MEALS, VEGAN FOODS, HERBAL PRODUCTS, AROMATHERAPY PRODUCTS, BATH AND SHOWER PRODUCTS, PERSONAL TOILETRIES, AND RELATED ITEMS (U.S. CLS. 100, 101 AND 102).

KEVIN CORWIN, EXAMINING ATTORNEY

---

SN 85-085,650. MARKETING EVOLUTION, INC., EL DORADO HILLS, CA. FILED 7-15-2010.

**VOOM**

THE MARK CONSISTS OF STANDARD CHARACTERS WITHOUT CLAIM TO ANY PARTICULAR FONT, STYLE, SIZE, OR COLOR.

FOR BUSINESS MARKETING CONSULTING SERVICES; MARKETING SERVICES, NAMELY, CONSUMER MARKETING RESEARCH FOR OTHERS; MARKETING ANALYSIS RESEARCH FOR OTHERS (U.S. CLS. 100, 101 AND 102).

BERYL GARDNER, EXAMINING ATTORNEY

---

SN 85-088,243. CELESTIA TRACY, STEVEN TRACY, PHOENIX, AZ. FILED 7-20-2010.

**GLOBAL HOPE RESOURCES**

THE MARK CONSISTS OF STANDARD CHARACTERS WITHOUT CLAIM TO ANY PARTICULAR FONT, STYLE, SIZE, OR COLOR.

NO CLAIM IS MADE TO THE EXCLUSIVE RIGHT TO USE "RESOURCES", APART FROM THE MARK AS SHOWN.

FOR ONLINE RETAIL STORE SERVICES FEATURING BOOKS, CDS, DVDS, PHOTOGRAPHS, ARTWORK, GREETING CARDS AND JEWELRY (U.S. CLS. 100, 101 AND 102).

FIRST USE 8-31-2009; IN COMMERCE 8-31-2009.  
JOHN DALIER, EXAMINING ATTORNEY

**CLASS 35—(Continued).**

SN 85-088,594. HESS CORPORATION, NEW YORK, NY.  
FILED 7-20-2010.

**Hess Energy 360**

THE MARK CONSISTS OF STANDARD CHARACTERS WITHOUT CLAIM TO ANY PARTICULAR FONT, STYLE, SIZE, OR COLOR.

OWNER OF U.S. REG. NOS. 832,393, 3,394,038 AND OTHERS.

NO CLAIM IS MADE TO THE EXCLUSIVE RIGHT TO USE "ENERGY", APART FROM THE MARK AS SHOWN.

FOR CONSUMER LOYALTY SERVICES AND CUSTOMER CLUB SERVICES, FOR COMMERCIAL, PROMOTIONAL AND/OR ADVERTISING PURPOSES IN CONNECTION WITH THE SUPPLY OF ENERGY COMMODITIES, NAMELY, GAS, ELECTRIC, AND PETROLEUM AND SERVICES RELATED TO ENERGY MANAGEMENT AND SUPPLY (U.S. CLS. 100, 101 AND 102).

ALICIA COLLINS, EXAMINING ATTORNEY

---

SN 85-089,966. IGRS ENGINEERING LAB LTD., BEIJING, CHINA, FILED 7-21-2010.



NO CLAIM IS MADE TO THE EXCLUSIVE RIGHT TO USE "IGRS ALLIANCE", APART FROM THE MARK AS SHOWN.

THE MARK CONSISTS OF A CIRCULAR MULTIPLE-DOT SHAPE DESIGN OF VARIOUS SIZES TO THE LEFT OF THE STYLIZED WORDING "IGRS ALLIANCE", WHICH INCLUDES A DESIGN DEPICTING A RADIO WAVE ABOVE THE LETTER I IN "ALLIANCE".

FOR ASSOCIATION SERVICES, NAMELY, PROMOTING THE INTERESTS OF THE CONSUMER ELECTRONICS INDUSTRY AND STANDARDS FOR NETWORKED DIGITAL CONSUMER ELECTRONICS PRODUCTS AND SERVICES (U.S. CLS. 100, 101 AND 102).

FIRST USE 6-1-2010; IN COMMERCE 6-1-2010.  
HOWARD FRIEDMAN, EXAMINING ATTORNEY

**CLASS 35—(Continued).**

SN 85-094,460. PACIFIC INTERNATIONAL REALTY, HONOLULU, HI. FILED 7-28-2010.



NO CLAIM IS MADE TO THE EXCLUSIVE RIGHT TO USE "HAWAII" AND "LOCALLY OWNED", APART FROM THE MARK AS SHOWN.

THE MARK CONSISTS OF THE STYLIZED WORDS "HAWAII GROWN" DISPLAYED IN A HALF CIRCLE AROUND A CIRCLE CONTAINING THE IMAGE OF A FLAG, ABOVE 2 LEAVES EMERGING FROM ROOTS. BELOW THE 2 LEAVES, ON EITHER SIDE OF THE ROOTS ARE THE STYLIZED WORDS "LOCALLY OWNED".

FOR COMPILATION OF BUSINESS DIRECTORIES; ON-LINE BUSINESS DIRECTORIES FEATURING LOCALLY OWNED BUSINESSES (U.S. CLS. 100, 101 AND 102).

RONALD AIKENS, EXAMINING ATTORNEY

SN 85-094,685. ECOLAB USA INC., SAINT PAUL, MN. FILED 7-28-2010.

# ECOLAB

THE MARK CONSISTS OF STANDARD CHARACTERS WITHOUT CLAIM TO ANY PARTICULAR FONT, STYLE, SIZE, OR COLOR.

OWNER OF U.S. REG. NOS. 1,497,423, 1,538,458 AND OTHERS.

FOR BUSINESS CONSULTING AND INFORMATION SERVICES; BUSINESS DATA ANALYSIS; BUSINESS INFORMATION MANAGEMENT; PROVIDING A SECURED ACCESS DATABASE VIA THE INTERNET THROUGH WHICH DOCUMENTS AND IMAGES CAN BE VIEWED, COPIED, AND PRINTED FOR PURPOSES OF CONDUCTING CORPORATE TRANSACTIONS; PROVIDING BUSINESS INFORMATION; BUSINESS AUDITING; CONSULTING SERVICES IN THE FIELD OF ENERGY USAGE MANAGEMENT AND ENERGY EFFICIENCY; BUSINESS CONSULTING SERVICES IN THE FIELD OF WATER USAGE EFFICIENCY AND WATER USAGE MANAGEMENT; BUSINESS CONSULTING SERVICES IN THE FIELD OF SELECTION OF PREPARATIONS FOR CLEANING AND SANITIZING FOR COMMERCIAL, INDUSTRIAL, AND INSTITUTIONAL USE; CONSULTING SERVICES IN THE FIELD OF SUSTAINABLE BUSINESS SOLUTIONS; BUSINESS CONSULTING SERVICES IN THE FIELD OF THE OPERATION OF WATER TREATMENT SYSTEMS FOR INDUSTRIAL, COMMERCIAL, AND INSTITUTIONAL USES; BUSINESS CONSULTING SERVICES IN THE FIELD OF CAR WASHING SYSTEMS; DESIGN OF ADVERTISING MATERIALS FOR OTHERS; BUSINESS CONSULTING SERVICES IN THE FIELD OF THE OPERATION OF WATER FILTRATION AND CONDI-

**CLASS 35—(Continued).**

TIONING SYSTEMS FOR INDUSTRIAL, COMMERCIAL, AND INSTITUTIONAL USES; CUSTOMER SERVICE IN THE FIELD OF COMMERCIAL KITCHEN EQUIPMENT; ONLINE RETAIL STORE SERVICES AND MAIL ORDER CATALOG SERVICES FOR THE RESTAURANT AND FOOD SERVICES INDUSTRIES FEATURING GOODS IN THE FOOD PREPARATION, FOOD HANDLING, FOOD LABELING, CLEANING, PERSONAL SAFETY, PERSONAL HYGIENE, EMERGENCY RESPONSE, PROTECTIVE APPAREL, MATERIAL HANDLING, SHELVING, AND OFFICE SUPPLIES FIELDS; POLITICAL ACTION COMMITTEE SERVICES, NAMELY, PROMOTING THE INTERESTS OF MANAGEMENT AND EMPLOYEES IN THE FOOD SERVICES, FOOD AND BEVERAGE, FOOD PROCESSING, HEALTHCARE, HOSPITALITY, GOVERNMENT, EDUCATION, RETAIL, COMMERCIAL, FACILITIES, TEXTILE CARE, AND VEHICLE CARE INDUSTRIES IN THE FIELD OF POLITICS; PREPARING BUSINESS REPORTS; PROVIDING INFORMATION REGARDING POLITICAL ISSUES; BUSINESS CONSULTING AND BUSINESS STRATEGY DEVELOPMENT SERVICES THAT PROVIDE STRATEGIES TO COMPANIES WISHING TO MOVE TOWARD SUSTAINABILITY AND SOCIALLY RESPONSIBLE BUSINESS PRACTICES THROUGH THE USE OF EFFECTIVE PRODUCTS AND CONTROLLED DISPENSING AND MONITORING TECHNOLOGY, PROVIDED MAINLY TO THE BEVERAGE INDUSTRY, DAIRY INDUSTRY, FOOD INDUSTRY, FOOD PROCESSING INDUSTRY, FOOD RETAIL INDUSTRY, FOOD SERVICES INDUSTRY, RESTAURANT INDUSTRY, HEALTHCARE INDUSTRY, MEDICAL INDUSTRY, PHARMACEUTICAL INDUSTRY, INDUSTRIAL LAUNDRY INDUSTRY, INSTITUTIONAL LAUNDRY INDUSTRY, VEHICLE CARE INDUSTRY, AND WATER CARE INDUSTRY (U.S. CLS. 100, 101 AND 102).

FIRST USE 1-1-1992; IN COMMERCE 1-1-1992.  
JIM RINGLE, EXAMINING ATTORNEY

SN 85-094,789. WPP PROPERTIES, NEW YORK, NY. FILED 7-28-2010.

# PivotRed

THE MARK CONSISTS OF STANDARD CHARACTERS WITHOUT CLAIM TO ANY PARTICULAR FONT, STYLE, SIZE, OR COLOR.

FOR ADVERTISING AGENCY SERVICES; PUBLIC RELATIONS SERVICES; MEDIA RELATIONS SERVICES NAMELY, SECURING AIRTIME ON ALL FORMS OF MEDIA COMMUNICATIONS STATIONS, SYSTEMS, NETWORKS, AND SERVICES FOR THE PURPOSE OF PROMOTING THE GOODS AND SERVICES OF OTHERS; MARKETING RESEARCH SERVICES; CONDUCTING AND ANALYZING PUBLIC OPINION SURVEYS; DEVELOPING ADVERTISING AND PROMOTIONAL CAMPAIGNS FOR BUSINESSES TO GENERATE AWARENESS, DISSEMINATE INFORMATION, MANAGE PERCEPTIONS AND ENHANCE THE REPUTATION OF OTHERS IN ORDER TO MOTIVATE BEHAVIORS THAT CREATE POSITIVE BUSINESS RESULTS (U.S. CLS. 100, 101 AND 102).

RICHARD WHITE, EXAMINING ATTORNEY

**CLASS 35—(Continued).**

SN 85-098,754. DAP BRANDS COMPANY, MEDINA, OH. FILED 8-3-2010.

**BUILD IT STRONG. BUILD IT  
TOUGH. BUILD IT DAP.**

THE MARK CONSISTS OF STANDARD CHARACTERS WITHOUT CLAIM TO ANY PARTICULAR FONT, STYLE, SIZE, OR COLOR.

FOR PROVIDING CONSUMER PRODUCT NEWS, INFORMATION, AND TECHNICAL DATA IN THE FIELD OF CAULK, SEALANTS, ADHESIVES AND REPAIR PRODUCTS; CUSTOMER SERVICE, NAMELY, PROVIDING AN ADVISORY SERVICE AND ASSISTANCE TO CONSUMERS OF CAULK, SEALANTS, ADHESIVES AND REPAIR PRODUCTS (U.S. CLS. 100, 101 AND 102).

EMILY CARLSEN, EXAMINING ATTORNEY

**CLASS 35—(Continued).**

SN 85-102,058. BANK OF AMERICA CORPORATION, CHARLOTTE, NC. FILED 8-6-2010.

**AWARDCHOICE FINANCIALS**

THE MARK CONSISTS OF STANDARD CHARACTERS WITHOUT CLAIM TO ANY PARTICULAR FONT, STYLE, SIZE, OR COLOR.

OWNER OF U.S. REG. NO. 3,109,726.

NO CLAIM IS MADE TO THE EXCLUSIVE RIGHT TO USE "FINANCIALS", APART FROM THE MARK AS SHOWN.

FOR FINANCIAL REPORTING SERVICES TO EMPLOYEE BENEFITS PROGRAM ADMINISTRATORS REGARDING ACCOUNTING STANDARDS COMPLIANCE FOR EQUITY COMPENSATION (U.S. CLS. 100, 101 AND 102).

MARC LEIPZIG, EXAMINING ATTORNEY

SN 85-104,926. EAT FIT, LLC, CHICAGO, IL. FILED 8-11-2010.

**Eat Fit**

THE MARK CONSISTS OF STANDARD CHARACTERS WITHOUT CLAIM TO ANY PARTICULAR FONT, STYLE, SIZE, OR COLOR.

FOR RETAIL SERVICES THROUGH DIRECT SOLICITATION BY DISTRIBUTORS DIRECTED TO END-USERS FEATURING PREPACKAGED HEALTH FOOD (U.S. CLS. 100, 101 AND 102).

FIRST USE 10-27-2008; IN COMMERCE 10-27-2008.

JEFFREY LOOK, EXAMINING ATTORNEY

SN 85-100,042. AMERICAN PUBLIC TRANSPORTATION ASSOCIATION, WASHINGTON, DC. FILED 8-4-2010.



OWNER OF U.S. REG. NO. 2,674,599.

NO CLAIM IS MADE TO THE EXCLUSIVE RIGHT TO USE "EXPO PUBLIC TRANSPORTATION'S PREMIER SHOWCASE", APART FROM THE MARK AS SHOWN.

THE MARK CONSISTS OF THE WORDING "APTA EXPO PUBLIC TRANSPORTATION'S PREMIER SHOWCASE", WHEREIN A DESIGN ELEMENT PASSES THROUGH THE LETTER "X" IN "EXPO", SAID DESIGN ELEMENT COMPRISING AN UPPER PORTION THAT EXTENDS UPWARDLY FROM THE "X" AND THEN EXTENDS TO THE RIGHT AND FORKS INTO TWO PARALLEL LINES AND COMPRISING A LOWER PORTION THAT EXTENDS DOWNWARDLY FROM THE "X" AND THEN EXTENDS TO THE LEFT IN A SEGMENTED FASHION.

FOR ARRANGING EXHIBITIONS AND TRADE FAIRS FOR THE PUBLIC TRANSPORTATION INDUSTRY (U.S. CLS. 100, 101 AND 102).

KATHLEEN LORENZO, EXAMINING ATTORNEY

SN 85-105,536. LAZKANI, NANCY J, VAN NUYS, CA. FILED S.R. 8-11-2010; AM. P.R. 3-7-2011.

**demosuasion**

THE MARK CONSISTS OF STANDARD CHARACTERS WITHOUT CLAIM TO ANY PARTICULAR FONT, STYLE, SIZE, OR COLOR.

THE ENGLISH TRANSLATION OF "DEMOSUASION" IN THE MARK IS "DEMONSTRATING THE BENEFITS OF A GOOD OR SERVICE, WHILE PERSUADING THE CONSUMER TO BUY".

FOR ADVERTISING SERVICES, NAMELY, PROMOTING AND MARKETING THE GOODS AND SERVICES OF OTHERS THROUGH PRODUCT DEMONSTRATION AND CONSUMER PERSUASION (U.S. CLS. 100, 101 AND 102).

KIMBERLY PERRY, EXAMINING ATTORNEY



**CLASS 35—(Continued).**

SN 85-111,295. ONE IOWA, DES MOINES, IA. FILED 8-19-2010.

# ONE IOWA

THE MARK CONSISTS OF STANDARD CHARACTERS WITHOUT CLAIM TO ANY PARTICULAR FONT, STYLE, SIZE, OR COLOR.

NO CLAIM IS MADE TO THE EXCLUSIVE RIGHT TO USE "IOWA", APART FROM THE MARK AS SHOWN.

FOR ASSOCIATION SERVICES, NAMELY, PROMOTING EQUAL RIGHTS FOR LESBIAN, GAY, BISEXUAL, AND TRANSGENDER (LGBT) IOWANS, PARTICULARLY IN THE AREAS OF LEGAL MARRIAGE, PUBLIC SAFETY, EMPLOYMENT, HEALTH, WELFARE, EDUCATION AND GENERAL CIVIL RIGHTS INCLUDING MARRIAGE (U.S. CLS. 100, 101 AND 102).

FIRST USE 11-0-2005; IN COMMERCE 11-0-2005.  
JAMES STEIN, EXAMINING ATTORNEY

**CLASS 35—(Continued).**

SN 85-117,060. A&A MARKETING, INC., BUFFALO GROVE, IL. FILED 8-26-2010.

# INCENTIVE RABBIT

THE MARK CONSISTS OF STANDARD CHARACTERS WITHOUT CLAIM TO ANY PARTICULAR FONT, STYLE, SIZE, OR COLOR.

NO CLAIM IS MADE TO THE EXCLUSIVE RIGHT TO USE "INCENTIVE", APART FROM THE MARK AS SHOWN.

FOR ADVERTISING AND ADVERTISEMENT SERVICES; ADVERTISING AND COMMERCIAL INFORMATION SERVICES, VIA THE INTERNET; ADVERTISING AND MARKETING; ADVERTISING AND PUBLICITY SERVICES; ADVERTISING AND PUBLICITY SERVICES, NAMELY, PROMOTING THE GOODS, SERVICES, BRAND IDENTITY AND COMMERCIAL INFORMATION AND NEWS OF THIRD PARTIES THROUGH PRINT, AUDIO, VIDEO, DIGITAL AND ON-LINE MEDIUM; ADVERTISING VIA ELECTRONIC MEDIA AND SPECIFICALLY THE INTERNET; ANALYSIS OF MARKET RESEARCH DATA AND STATISTICS; BUSINESS RESEARCH AND SURVEYS; COLLECTION OF MARKET RESEARCH INFORMATION; CONDUCTING BUSINESS AND MARKET RESEARCH SURVEYS; CONDUCTING BUSINESS RESEARCH AND SURVEYS; CONDUCTING MARKET SURVEYS; CONDUCTING MARKETING STUDIES; CONDUCTING ON-LINE BUSINESS MANAGEMENT RESEARCH SURVEYS; CONSUMER MARKETING RESEARCH AND CONSULTING RELATED THERETO; CONSUMER SURVEY SERVICES; DISSEMINATION OF ADVERTISING FOR OTHERS VIA AN ON-LINE COMMUNICATIONS NETWORK ON THE INTERNET; DISSEMINATION OF ADVERTISING FOR OTHERS VIA THE INTERNET; MARKET ANALYSIS; MARKET ANALYSIS AND RESEARCH SERVICES; MARKET MANIPULATION, RESEARCH AND ANALYSIS, WHETHER OR NOT VIA THE INTERNET; MARKET OPINION POLLING STUDIES; MARKET REPORTS AND STUDIES; MARKET RESEARCH; MARKET RESEARCH AND BUSINESS ANALYSES; MARKET RESEARCH AND MARKET INTELLIGENCE SERVICES; MARKET RESEARCH BY MEANS OF A COMPUTER DATABASE; MARKET RESEARCH CONSULTATION; MARKET RESEARCH SERVICES; MARKET RESEARCH STUDIES; MARKET SEGMENTATION CONSULTATION; MARKET STUDY AND ANALYSIS OF MARKET STUDIES; MARKETING ANALYSIS SERVICES; MARKETING RESEARCH SERVICES; MARKETING SERVICES, NAMELY, CONDUCTING CONSUMER TRACKING BEHAVIOR RESEARCH AND CONSUMER TREND ANALYSIS; MARKETING SERVICES, NAMELY, CONSUMER MARKETING RESEARCH; ON-LINE ADVERTISING AND MARKETING SERVICES; ONLINE BUSINESS RESEARCH SERVICES THAT ALLOW USERS TO SHARE OPINIONS WITH A MARKETING RESEARCH COMPANY RELATED TO EVERYDAY CONSUMER PRODUCTS AND SERVICES; PROFIT SURVEY AND ANALYSIS; PROVISION OF MARKET RESEARCH INFORMATION; PUBLIC OPINION SURVEYS; STATISTICAL EVALUATIONS OF MARKETING DATA (U.S. CLS. 100, 101 AND 102).

FIRST USE 7-15-2010; IN COMMERCE 7-15-2010.  
LAKEISHA LEWIS, EXAMINING ATTORNEY

SN 85-111,361. MR CHURROS INTERNATIONAL, CORP., MIAMI, FL. FILED 8-19-2010.



NO CLAIM IS MADE TO THE EXCLUSIVE RIGHT TO USE "USA OR CREAM FILLED CHURROS" OR THE REPRESENTATION OF THE AMERICAN FLAG, APART FROM THE MARK AS SHOWN.

THE MARK CONSISTS OF THE WORDING, "MR. CHURROS USA", WITH THE DESIGN OF A CREAM FILLED "CHURRO" UNDER "USA" AND THE "S" OF "CHURROS"; THE LETTERS OF "CHURROS" ARE COMPRISED OF A SHADED BRICK DESIGN, AND APPEAR ABOVE THE WORDS "CREAM FILLED CHURROS", APPEARING AT THE BOTTOM EDGE OF A REPRESENTATION OF THE AMERICAN FLAG.

FOR VENDING MACHINE SERVICES; DISTRIBUTORSHIP SERVICES IN THE FIELD OF FOOD PRODUCTS FOR VENDING MACHINES (U.S. CLS. 100, 101 AND 102).

FIRST USE 2-28-1998; IN COMMERCE 2-28-1998.  
BARBARA A. GOLD, EXAMINING ATTORNEY

**CLASS 35—(Continued).**

SN 85-117,864. KAISER FOUNDATION HEALTH PLAN, INC., OAKLAND, CA. FILED 8-27-2010.



NO CLAIM IS MADE TO THE EXCLUSIVE RIGHT TO USE "INNOVATION LEARNING NETWORK", APART FROM THE MARK AS SHOWN.

THE COLOR(S) ORANGE, BLUE, GREEN AND BLACK IS/ARE CLAIMED AS A FEATURE OF THE MARK.

THE MARK CONSISTS OF TEN CIRCLES WITH THE TOP ROW OF FIVE CIRCLES COLORED ORANGE, GREEN, BLUE, ORANGE AND GREEN FROM LEFT TO RIGHT; AND THE BOTTOM ROW OF FIVE CIRCLES COLORED GREEN, BLUE, ORANGE, GREEN AND BLUE FROM LEFT TO RIGHT; TO THE RIGHT OF THE CIRCLES ARE THE LOWERCASE LETTERS, "ILN" IN THE COLOR BLACK; THE BLACK WORDING "INNOVATION LEARNING NETWORK" APPEARS BELOW ALL OF THE ELEMENTS REFERENCED ABOVE.

FOR BUSINESS COLLABORATION SERVICES, NAMELY, PROVIDING A NATIONAL COMPUTER-BASED NETWORKING WEB SITE FOR HEALTH CARE EDUCATORS AND MEDICAL EDUCATORS TO COLLABORATE ACROSS DISCIPLINES TO HELP IMPROVE HEALTH CARE EDUCATION AND MEDICAL EDUCATION; PROMOTING COLLABORATION WITHIN THE SCIENTIFIC, RESEARCH AND MEDICAL COMMUNITIES TO ACHIEVE ADVANCES IN THE FIELD OF HEALTHCARE; PROVIDING INFORMATION IN THE FIELDS OF BUSINESS INNOVATION PROCESS, BUSINESS MANAGEMENT AND BUSINESS OPPORTUNITIES (U.S. CLS. 100, 101 AND 102).

FIRST USE 2-1-2006; IN COMMERCE 2-1-2006. CHRISTOPHER BUONGIORNO, EXAMINING ATTORNEY

**CLASS 35—(Continued).**

SN 85-121,528. THE INSURANCE HOUSE, INC., MARIETTA, GA. FILED 9-2-2010.

**KEYHOLDER'S CIRCLE**

THE MARK CONSISTS OF STANDARD CHARACTERS WITHOUT CLAIM TO ANY PARTICULAR FONT, STYLE, SIZE, OR COLOR.

FOR INCENTIVE AWARD PROGRAMS TO PROMOTE THE SALE OF INSURANCE POLICIES OF OTHERS (U.S. CLS. 100, 101 AND 102).

CHRISTOPHER BUONGIORNO, EXAMINING ATTORNEY

SN 85-121,765. BUY FROM A CHRISTIAN, LLC, AKA BUYFROMACHRISTIAN.COM, MADISON, MS. FILED 9-2-2010.

SN 85-121,493. THE INSURANCE HOUSE, INC., MARIETTA, GA. FILED 9-2-2010.

**IH INDEX**

THE MARK CONSISTS OF STANDARD CHARACTERS WITHOUT CLAIM TO ANY PARTICULAR FONT, STYLE, SIZE, OR COLOR.

OWNER OF U.S. REG. NOS. 3,452,319 AND 3,470,393. NO CLAIM IS MADE TO THE EXCLUSIVE RIGHT TO USE "INDEX", APART FROM THE MARK AS SHOWN.

FOR PROVIDING A PERFORMANCE INDEX FOR OTHERS IN THE FIELD OF INSURANCE BASED ON QUANTITATIVE MEASUREMENTS, NAMELY, SALES OR RENEWAL OF INSURANCE POLICIES, THE NUMBER OF SPECIFIC TYPES OF POLICIES, PREMIUM VOLUME, ANNUAL GROWTH, POLICY WRITE-OFFS, AND AVERAGE PAID LOSS (U.S. CLS. 100, 101 AND 102).

CHRISTOPHER BUONGIORNO, EXAMINING ATTORNEY

**bfac**

THE MARK CONSISTS OF STANDARD CHARACTERS WITHOUT CLAIM TO ANY PARTICULAR FONT, STYLE, SIZE, OR COLOR.

FOR (BASED ON USE IN COMMERCE) ADVERTISING AND DIRECTORY SERVICES, NAMELY, PROMOTING THE SERVICES OF OTHERS BY PROVIDING A WEB PAGE FEATURING LINKS TO THE WEBSITES OF OTHERS (BASED ON INTENT TO USE) PROMOTION, ADVERTISING AND MARKETING OF ON-LINE WEBSITES; PROVIDING A SEARCHABLE WEBSITE FEATURING THE GOODS AND SERVICES OF OTHER VENDORS (U.S. CLS. 100, 101 AND 102).

FIRST USE 12-10-2006; IN COMMERCE 2-15-2007. REBECCA POVARCHUK, EXAMINING ATTORNEY

**CLASS 35—(Continued).**

SN 85-123,672. FREUND, LILY, EMERYVILLE, CA. FILED 9-7-2010.



NO CLAIM IS MADE TO THE EXCLUSIVE RIGHT TO USE THE NON-LATIN CHARACTERS THAT TRANSLITERATE TO MEI BAI HE, APART FROM THE MARK AS SHOWN.

THE COLOR(S) RED, BLUE AND WHITE IS/ARE CLAIMED AS A FEATURE OF THE MARK.

THE MARK CONSISTS OF A SIX PETAL LILY FLOWER IN RED WITH A BLUE PARTIAL BORDER. TO THE RIGHT OF THE FLOWER, AND EVEN WITH THE TOP PETAL IS THE WORDING "USLILY" IN BLUE, AND DIRECTLY BENEATH THIS WORDING, IN RED, ARE THE CHINESE CHARACTERS WHICH TRANSLATE TO "US LILY", ALL ON A WHITE BACKGROUND.

THE NON-LATIN CHARACTERS IN THE MARK TRANSLITERATE TO MEI BAI HE AND THIS MEANS "US LILY" IN ENGLISH.

FOR ON-LINE WHOLESALE AND RETAIL STORE SERVICES FEATURING WOMEN'S APPAREL (U.S. CLS. 100, 101 AND 102).

FIRST USE 6-19-2010; IN COMMERCE 7-4-2010.

ANDREA K. NADELMAN, EXAMINING ATTORNEY

SN 85-125,992. TEXAS EDUCATION AGENCY, AUSTIN, TX. FILED 9-9-2010.



THE MARK CONSISTS OF THE LETTERS "TEA" WITH A GRADUATION CAP OVER THE "A" AND THE WORDS "TEXAS EDUCATION AGENCY" UNDERNEATH.

FOR CONSULTING SERVICES IN THE FIELD OF HIGHER EDUCATION ADMINISTRATION; EDUCATION LEADERSHIP DEVELOPMENT; PROMOTING PUBLIC INTEREST IN EDUCATION; PUBLIC ADVOCACY TO PROMOTE AWARENESS OF THE IMPORTANCE OF EDUCATION (U.S. CLS. 100, 101 AND 102).

FIRST USE 7-0-2008; IN COMMERCE 7-0-2009.

RONALD AIKENS, EXAMINING ATTORNEY

**CLASS 35—(Continued).**

SN 85-126,593. MEDICAL REIMBURSEMENT SYSTEMS, INC., BEDFORD, MA. FILED 9-10-2010.

## LOGIXHealth

THE MARK CONSISTS OF STANDARD CHARACTERS WITHOUT CLAIM TO ANY PARTICULAR FONT, STYLE, SIZE, OR COLOR.

FOR MEDICAL CODING FOR HOSPITALS, HOSPITAL EMERGENCY DEPARTMENTS AND PHYSICIANS; RECEIVABLES MANAGEMENT, ADMINISTRATION, AND RECONCILIATION OF ACCOUNTS ON BEHALF OF HOSPITALS, HOSPITAL EMERGENCY DEPARTMENTS AND PHYSICIANS; RECORDS MANAGEMENT SERVICES, NAMELY, DOCUMENT INDEXING FOR HOSPITALS, HOSPITAL EMERGENCY DEPARTMENTS AND PHYSICIANS (U.S. CLS. 100, 101 AND 102).

ALICE BENMAMAN, EXAMINING ATTORNEY

SN 85-126,745. ABEBOOKS INC., VICTORIA, BC, CANADA, FILED 9-10-2010.

## ABE

THE MARK CONSISTS OF STANDARD CHARACTERS WITHOUT CLAIM TO ANY PARTICULAR FONT, STYLE, SIZE, OR COLOR.

OWNER OF U.S. REG. NOS. 2,682,429 AND 3,016,106.

FOR PROVIDING AN ONLINE ELECTRONIC DATABASE ON GLOBAL COMPUTER NETWORKS IN THE FIELD OF RETAIL SERVICES FEATURING BOOKS AND BOOKSELLERS; PROVIDING A WEBSITE ON GLOBAL COMPUTER NETWORKS FEATURING CONSUMER INFORMATION IN THE FIELD OF BOOKS AND LOCATING BOOKS; COMPUTERIZED ONLINE RETAIL STORE SERVICES IN THE FIELD OF BOOKS; COMPILATION OF COMPUTERIZED DATABASES FOR OTHERS IN THE FIELD OF BOOKS AND BOOKSELLERS. ADVERTISING; BUSINESS MANAGEMENT; BUSINESS ADMINISTRATION; ADVERTISING AND PROMOTIONAL SERVICES PROVIDED VIA AN ONLINE ELECTRONIC DATABASE ON A GLOBAL COMPUTER NETWORK; PROVIDING ADVERTISING AND PROMOTIONAL INFORMATION OF OTHERS VIA AN ONLINE ELECTRONIC DATABASE ON A GLOBAL COMPUTER NETWORK; BUSINESS INFORMATION SERVICES, ALL PROVIDED VIA AN ONLINE ELECTRONIC DATABASE ON A GLOBAL COMPUTER NETWORK; DISSEMINATION OF ADVERTISING FOR OTHERS VIA AN ONLINE ELECTRONIC COMMUNICATIONS NETWORK; THE BRINGING TOGETHER FOR THE BENEFIT OF OTHERS A WIDE VARIETY OF BOOKS AND BOOKSELLERS SO OTHERS MAY CONVENIENTLY VIEW AND PURCHASE BOOKS; COMPUTERIZED ON-LINE RETAIL STORE SERVICES BY ELECTRONIC OR COMPUTER MEANS RELATING TO THE SALE OF A WIDE VARIETY OF BOOKS; COST PRICE ANALYSIS; SALES PROMOTION FOR OTHERS; COMPUTERIZED ONLINE ORDERING FEATURING BOOKS AND BOOKSELLERS; PROVIDING AN ONLINE COMMERCIAL INFORMATION DIRECTORY ON THE INTERNET; PROVIDING A SEARCHABLE DATABASE

**CLASS 35—(Continued).**

IN THE FIELD OF BOOKS AND BOOKSELLERS AVAILABLE VIA A GLOBAL COMPUTER NETWORK FOR THE PURPOSE OF SELLING BOOKS AND ADVERTISING THE SERVICES OF OTHERS; PROVIDING A SEARCHABLE, ONLINE ADVERTISING GUIDE FEATURING THE GOODS AND SERVICES OF BOOKSELLERS; DATABASE MANAGEMENT SERVICES; AND COMPUTER SERVICES IN THE NATURE OF BUSINESS INFORMATION SERVICES, NAMELY, PROVIDING DIRECTORIES FOR BUSINESS ADDRESSES, ELECTRONIC MAIL ADDRESSES, NETWORK HOME PAGE ADDRESSES, ADDRESSES AND TELEPHONE NUMBERS OF PEOPLE, PLACES AND ORGANIZATIONS, THAT ARE MADE AVAILABLE TO OTHER COMPANIES FOR COMMERCIAL PURPOSES; COMPUTERIZED ONLINE SEARCH AND ORDERING SERVICE IN THE NATURE OF ONLINE RETAIL AND WHOLESALE STORE SERVICES FEATURING BOOKS, IN THE FORM OF PRINTED BOOKS, AUDIOCASSETTES, COMPACT DISKS, CD ROM'S, AND DIRECT DIGITAL TRANSMISSION (U.S. CLS. 100, 101 AND 102).

BRIAN PINO, EXAMINING ATTORNEY

**CLASS 35—(Continued).**

SN 85-127,267. THE INSURANCE HOUSE, INC., MARIETTA, GA. FILED 9-10-2010.



THE MARK CONSISTS OF THREE CONCENTRIC CIRCLES WITH A DESIGN OF A KEY IN THE INNER CIRCLE; INSIDE THE SQUARE PORTION OF THE KEY IS THE OUTLINE OF THE CAPITAL LETTER "I"; IN THE OUTER, SHADED CIRCLE APPEARS THE WORDING "KEYHOLDER'S CIRCLE" AT THE BOTTOM OF THE CIRCLE.

FOR INCENTIVE AWARD PROGRAMS TO PROMOTE THE SALE OF INSURANCE POLICIES OF OTHERS (U.S. CLS. 100, 101 AND 102).

CHRISTOPHER BUONGIORNO, EXAMINING ATTORNEY

SN 85-127,224. MICHIGAN ECONOMIC DEVELOPMENT CORPORATION, LANSING, MI. FILED 9-10-2010.



OWNER OF U.S. REG. NOS. 2,422,375 AND 3,239,362. NO CLAIM IS MADE TO THE EXCLUSIVE RIGHT TO USE "MICHIGAN" AND "ECONOMIC DEVELOPMENT CORPORATION", APART FROM THE MARK AS SHOWN. THE MARK CONSISTS OF THE WORDS "MICHIGAN ECONOMIC DEVELOPMENT CORPORATION" AND A STYLIZED LETTER "G" THAT IS INTENDED TO LOOSELY REPRESENT THE SHAPE OF THE STATE OF MICHIGAN INCLUDING THE UPPER PENINSULA.

FOR PROMOTING ECONOMIC DEVELOPMENT IN THE STATE OF MICHIGAN (U.S. CLS. 100, 101 AND 102).

FIRST USE 7-1-2010; IN COMMERCE 7-1-2010. SARA BENJAMIN, EXAMINING ATTORNEY

SN 85-131,621. FLAXINGTON, BEVERLY, WALPOLE, MA. FILED 9-16-2010.

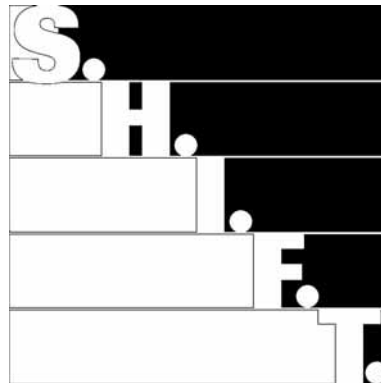

THE MARK CONSISTS OF A SQUARE DIVIDED DIAGONALLY BY A STAIR DESIGN DESCENDING FROM THE UPPER LEFT TO THE LOWER RIGHT WITH HORIZONTAL LINES CROSSING THE ENTIRE SQUARE ON EACH STAIR LEVEL. DESCENDING ON THE FIVE STAIRS FROM THE UPPER LEFT TO THE LOWER RIGHT ARE THE LETTERS "S.H.I.F.T."

FOR BUSINESS ORGANIZATION AND MANAGEMENT CONSULTING (U.S. CLS. 100, 101 AND 102).

FIRST USE 3-1-2010; IN COMMERCE 4-1-2010. JOHN DWYER, EXAMINING ATTORNEY

**CLASS 35—(Continued).**

SN 85-132,388. CENTERPOINT ENERGY, INC., HOUSTON, TX. FILED 9-17-2010.



OWNER OF U.S. REG. NOS. 2,753,890, 2,867,046 AND OTHERS.

NO CLAIM IS MADE TO THE EXCLUSIVE RIGHT TO USE "ENERGY", APART FROM THE MARK AS SHOWN.

THE MARK CONSISTS OF THE WORD "EXTRAS" WITH THE "X" FORMED BY FOUR OFF-CENTER TRIANGLES WITH A GIFT BOW ON THE TOP TRIANGLE AND A SOLID CIRCLE BESIDE THE UNDERLINED WORD "CENTERPOINT" AND OVERLINED WORD "ENERGY".

FOR PROVIDING INCENTIVE AWARD PROGRAMS TO PROMOTE THE SALE OF PRODUCTS AND SERVICES OF OTHERS BY PROVIDING DISCOUNTS AND PROMOTIONAL OFFERS TO ENERGY CUSTOMERS AND EMPLOYEES (U.S. CLS. 100, 101 AND 102).

FIRST USE 6-18-2010; IN COMMERCE 6-18-2010.  
MARY ROSSMAN, EXAMINING ATTORNEY

**CLASS 35—(Continued).**

SN 85-134,265. RESEARCH CORPORATION TECHNOLOGIES, INC., AKA RCT, TUCSON, AZ. FILED 9-21-2010.

# FreE coli

THE MARK CONSISTS OF STANDARD CHARACTERS WITHOUT CLAIM TO ANY PARTICULAR FONT, STYLE, SIZE, OR COLOR.

NO CLAIM IS MADE TO THE EXCLUSIVE RIGHT TO USE "COLI", APART FROM THE MARK AS SHOWN.

FOR BUSINESS SERVICES, NAMELY, COMMERCIAL ADMINISTRATION OF THE LICENSING OF GENETICALLY-ENGINEERED BACTERIAL STRAINS AND PRODUCTION METHODS FOR REPRODUCING THESE STRAINS FOR BIOTECHNICAL APPLICATIONS (U.S. CLS. 100, 101 AND 102).

MAUREEN DALL, EXAMINING ATTORNEY

SN 85-133,510. FOCUSED MARKETING SOLUTIONS, INC., TOMS RIVER, NJ. FILED 9-20-2010.

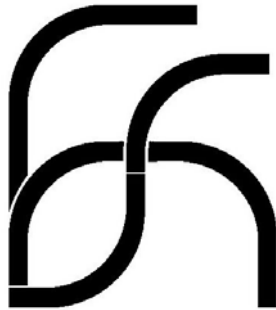

THE MARK CONSISTS OF THE HIGHLY STYLIZED ACRONYM "FMS".

FOR BUSINESS CONSULTATION; INDEPENDENT SALES REPRESENTATIVES IN THE FIELD OF CONSUMER ELECTRONICS; INVENTORY MANAGEMENT IN THE FIELD OF CONSUMER ELECTRONICS (U.S. CLS. 100, 101 AND 102).

FIRST USE 10-1-1986; IN COMMERCE 8-1-2006.  
BILL DAWE, EXAMINING ATTORNEY

SN 85-134,676. CYBERTRAILS LLC, PHOENIX, AZ. FILED 9-21-2010.



NO CLAIM IS MADE TO THE EXCLUSIVE RIGHT TO USE "BUSINESS", APART FROM THE MARK AS SHOWN.

THE COLOR(S) RED, BLACK, GRAY IS/ARE CLAIMED AS A FEATURE OF THE MARK.

THE MARK CONSISTS OF THE STYLIZED WORDING "QHOST ENABLING BUSINESS". "QHOST" IS PRESENTED IN LARGER TYPE, WITH THE "Q" IN RED AND "HOST" IN BLACK. BELOW THE "OST" PORTION OF THE MARK APPEARS THE WORDING "ENABLING BUSINESS" IN GRAY.

FOR PROVIDING A WEBSITE AT WHICH CUSTOMERS CAN MANAGE ACCOUNT INFORMATION RELATED TO TELECOMMUNICATIONS PRODUCTS AND SERVICES (U.S. CLS. 100, 101 AND 102).

FIRST USE 8-5-2010; IN COMMERCE 9-15-2010.  
JERI J. FICKES, EXAMINING ATTORNEY

**CLASS 35—(Continued).**

SN 85-135,155. DOWNEAST LAKES LAND TRUST, GRAND LAKE STREAM, ME. FILED 9-22-2010.



NO CLAIM IS MADE TO THE EXCLUSIVE RIGHT TO USE "LAND TRUST", APART FROM THE MARK AS SHOWN.

THE MARK CONSISTS OF A FANCIFUL DEPICTION OF A PINE TREE WITH A MOON CRESCENT AND WAVES ABOVE THE PHRASE "DOWNEAST LAKES", WHICH IS ABOVE THE PHRASE "LAND TRUST".

SEC. 2(F) AS TO "DOWNEAST LAKES".

FOR CHARITABLE SERVICES, NAMELY, ORGANIZING AND DEVELOPING PROJECTS TO PROMOTE AWARENESS OF TREE AND ENVIRONMENTAL CONSERVATION (U.S. CLS. 100, 101 AND 102).

FIRST USE 12-31-2007; IN COMMERCE 12-31-2007.

SARA BENJAMIN, EXAMINING ATTORNEY

SN 85-135,231. DON BUMGARDNER, FORTH WORTH, TX. FILED 9-22-2010.

**BUNK BED KING**

THE MARK CONSISTS OF STANDARD CHARACTERS WITHOUT CLAIM TO ANY PARTICULAR FONT, STYLE, SIZE, OR COLOR.

NO CLAIM IS MADE TO THE EXCLUSIVE RIGHT TO USE "BUNK BED", APART FROM THE MARK AS SHOWN.

FOR RETAIL STORE SERVICES FEATURING CHILDREN'S FURNITURE (U.S. CLS. 100, 101 AND 102).

FIRST USE 1-1-1998; IN COMMERCE 1-1-1998.

DEZMONA MIZELLE, EXAMINING ATTORNEY

SN 85-136,111. BRAND ADOPTION, LLC, DBA BRAND ADOPTION, MESA, AZ. FILED 9-22-2010.



NO CLAIM IS MADE TO THE EXCLUSIVE RIGHT TO USE "BRAND ADOPTION", APART FROM THE MARK AS SHOWN.

THE COLOR(S) RED, BLACK, WHITE AND GRAY IS/ARE CLAIMED AS A FEATURE OF THE MARK.

THE MARK CONSISTS OF A RED SQUARE WITH A WHITE STYLIZED LETTER "A" AND A RED LOWERCASE LETTER "B" WITHIN THE WHITE "A" TO THE LEFT OF THE WORDING "BRAND ADOPTION" IN BLACK.

FOR ADVERTISING AND MARKETING (U.S. CLS. 100, 101 AND 102).

FIRST USE 3-23-2010; IN COMMERCE 3-23-2010.

BARBARA BROWN, EXAMINING ATTORNEY

**CLASS 35—(Continued).**

SN 85-140,105. TECH COMMERCIALIZATION, LLC, ARLINGTON, TX. FILED 9-28-2010.



NO CLAIM IS MADE TO THE EXCLUSIVE RIGHT TO USE "TECHCOMM TECHNOLOGY COMMERCIALIZATION & MANUFACTURING", APART FROM THE MARK AS SHOWN.

THE MARK CONSISTS OF A SHOOTING STAR ABOVE "TECHCOMM" WHEREIN THE SECOND "M" IS EN-CIRCLED AND THE WORDS "TECHNOLOGY COMMERCIALIZATION & MANUFACTURING" ARE UNDERNEATH.

FOR BUSINESS SERVICES, NAMELY, PROVIDING TECHNOLOGY TRANSFER ASSISTANCE IN THE NATURE OF BUSINESS ASSISTANCE TO BUSINESS AND INDUSTRY APPLICANTS IN LICENSING FEDERAL PATENT TECHNOLOGIES FOR DEVELOPMENT AND COMMERCIALIZATION; PROVIDING OUTSOURCING SERVICES TO FEDERAL, PRIVATE SECTOR AND UNIVERSITY LABORATORIES TO FACILITATE AND ENCOURAGE COOPERATIVE RESEARCH AND DEVELOPMENT AGREEMENTS BETWEEN THE PRIVATE AND PUBLIC FEATURING ADVANCE RESEARCH FROM BOTH INDUSTRY AND UNIVERSITIES THAT ARE ALIGNED WITH FEDERAL RESEARCH PRIORITIES (U.S. CLS. 100, 101 AND 102).

EMILY CHUO, EXAMINING ATTORNEY

SN 85-142,306. BERNARDO SHTEREMBERG, DORAL, FL. FILED 9-30-2010.



NO CLAIM IS MADE TO THE EXCLUSIVE RIGHT TO USE "ELECTRONIC RESOURCES LTD.", APART FROM THE MARK AS SHOWN.

THE COLOR(S) BLACK, NAVY BLUE, AND WHITE IS/ARE CLAIMED AS A FEATURE OF THE MARK.

THE MARK CONSISTS OF THE LETTERS "E" AND "R" ARE STYLIZED, ITALICIZED AND JOINED BY THE LOWER STRIKE OF THE LETTER "E" AND THE LEFT STRIKE OF THE LETTER "R" AND THIS JOINING PORTION IS THE ONLY PORTION IN A NAVY BLUE COLOR; THE LEFT STRIKE OF THE LETTER "E" IS INTENTIONALLY MISSING AND THE REMAINDER OF THE MARK IS IN BLACK COLOR. EXTENDING FROM THE RIGHT LOWER TIP OF THE LETTER "R" IS A CONTINUED BLACK LINE WHICH UNDERLINES BOTH LETTERS AND CONTAINED WITHIN THIS LINE ARE THE FOLLOWING WORDS AND LETTERS "ELECTRONIC RESOURCES LTD." WRITTEN IN WHITE.

FOR WHOLESALE AND RETAIL STORE SERVICES AND ON-LINE RETAIL AND WHOLESALE STORE SERVICES FEATURING ELECTRONIC COMPONENTS AND TOOLS (U.S. CLS. 100, 101 AND 102).

FIRST USE 5-1-1985; IN COMMERCE 6-1-1985.

KAELIE KUNG, EXAMINING ATTORNEY

**CLASS 35—(Continued).**

SN 85-144,075. PROJECT HEALTH, INC., BOSTON, MA. FILED 10-4-2010.

NO CLAIM IS MADE TO THE EXCLUSIVE RIGHT TO USE "HEALTH", APART FROM THE MARK AS SHOWN. THE MARK CONSISTS OF STYLIZED FORM WHERE THE FIRST LETTER OF EACH WORD ARE JOINED AND THE "S" FORMS AN ARROW.

FOR SOCIAL WELFARE SERVICES, NAMELY, ORGANIZING VOLUNTEER COLLEGE STUDENTS TO ASSIST PATIENTS ENCOUNTERED AT VARIOUS HEALTHCARE PROVIDERS WITH SECURING RESOURCES, SUCH AS FOOD AND HOUSING ASSISTANCE (U.S. CLS. 100, 101 AND 102).

DORITT L. CARROLL, EXAMINING ATTORNEY

---

SN 85-144,097. BERCH MEDIA LLC, SHERMAN OAKS, CA. FILED 10-4-2010.

NO CLAIM IS MADE TO THE EXCLUSIVE RIGHT TO USE "MEDIA", APART FROM THE MARK AS SHOWN.

THE MARK CONSISTS OF THE STYLIZED LETTER "B" IN WHITE AND OUTLINED IN BLACK WITH THE STYLIZED WORDS "BERCH MEDIA" IN BLACK.

FOR DEVELOPMENT OF MARKETING STRATEGIES AND CONCEPTS (U.S. CLS. 100, 101 AND 102).

MARTHA FROMM, EXAMINING ATTORNEY

---

SN 85-145,389. MT GROUP LTD., DALLAS, TX. FILED 10-5-2010.

**BIG SAVINGS. MORE FLOORING**

THE MARK CONSISTS OF STANDARD CHARACTERS WITHOUT CLAIM TO ANY PARTICULAR FONT, STYLE, SIZE, OR COLOR.

FOR WHOLESALE AND RETAIL STORE SERVICES FEATURING TILE AND FLOORING (U.S. CLS. 100, 101 AND 102).

KATHERINE E. HALMEN, EXAMINING ATTORNEY

**CLASS 35—(Continued).**

SN 85-146,297. APPLIED INDUSTRIAL TECHNOLOGIES, INC., CLEVELAND, OH. FILED 10-6-2010.

**NEVEROUT**

THE MARK CONSISTS OF STANDARD CHARACTERS WITHOUT CLAIM TO ANY PARTICULAR FONT, STYLE, SIZE, OR COLOR.

OWNER OF U.S. REG. NO. 2,426,746.

FOR DISTRIBUTORSHIP IN THE FIELD OF INDUSTRIAL COMPONENTS FEATURING BEARINGS, POWER TRANSMISSION DEVICES, RUBBER PRODUCTS, ELECTRICAL PRODUCTS, LINEAR PRODUCTS, SPECIALTY PRODUCTS, NAMELY, ADHESIVES, EPOXIES, CLEANERS, DEGREASERS, LUBRICANTS, LUBRICATION DEVICES, PAINTS, STENCILING, AND SEALANTS, GENERAL INDUSTRIAL/MILL SUPPLIES, PRECISION MECHANICAL COMPONENTS, SPINDLES-LIVE/DEAD CENTER UNIVERSAL JOINTS, MAINTENANCE RELATED PRODUCTS, ANALYTICAL TOOLS AND ACCESSORIES, AND FLUID POWER PRODUCTS (U.S. CLS. 100, 101 AND 102).

FIRST USE 11-15-1999; IN COMMERCE 11-15-1999.

RAMONA ORTIGA, EXAMINING ATTORNEY

---

SN 85-146,366. HOLT TEXAS, LTD., SAN ANTONIO, TX. FILED 10-6-2010.

**HOLT**

THE MARK CONSISTS OF STANDARD CHARACTERS WITHOUT CLAIM TO ANY PARTICULAR FONT, STYLE, SIZE, OR COLOR.

OWNER OF U.S. REG. NOS. 1,188,395, 3,661,890 AND 3,709,970.

SEC. 2(F).

FOR RETAIL STORE SERVICES IN THE FIELD OF LIGHT, HEAVY AND/OR CONSTRUCTION EQUIPMENT, NAMELY, TRUCKS, TRAILERS, CRANES, BACKHOES, GENERATORS, INDUSTRIAL ENGINES, MARINE ENGINES, GAS COMPRESSORS, WATER TANKERS, GRADERS, PLOWS AND HYDRAULIC EXCAVATORS; RETAIL STORE SERVICES IN THE FIELD OF WORK TOOL ATTACHMENTS, NAMELY, RIPPERS, RAKES, AUGERS, BLADES, SCRAPERS, COUPLERS, FORKS, HAMMERS, TILLERS, AND SHREDDERS (U.S. CLS. 100, 101 AND 102).

FIRST USE 12-31-1965; IN COMMERCE 12-31-1965.

RUSS HERMAN, EXAMINING ATTORNEY

**CLASS 35—(Continued).**

SN 85-146,444. PHOENIX LEGAL INC., TORONTO, CANADA, FILED 10-6-2010.

**PHOENIX LEGAL**

THE MARK CONSISTS OF STANDARD CHARACTERS WITHOUT CLAIM TO ANY PARTICULAR FONT, STYLE, SIZE, OR COLOR.

NO CLAIM IS MADE TO THE EXCLUSIVE RIGHT TO USE "LEGAL", APART FROM THE MARK AS SHOWN.

THE WORDING "PHOENIX" HAS NO MEANING OTHER THAN TRADEMARK SIGNIFICANCE. APPLICANT STATES THAT THE SERVICES DO NOT ORIGINATE AND ARE NOT RENDERED IN "PHOENIX, ARIZONA".

FOR CONSULTING FOR LAW FIRMS AND LEGAL DEPARTMENTS, NAMELY, PROVIDING BUSINESS CONSULTING AND STRATEGIC PLANNING SERVICES FOR LAW FIRMS AND LEGAL DEPARTMENTS IN THE AREAS OF PROFESSIONAL DEVELOPMENT, GOVERNANCE AND MANAGEMENT, RETREATS AND PRESENTATIONS, SUCCESSION PLANNING, CULTURE AND CHANGE, COMPENSATION, ADMINISTRATIVE MANAGEMENT, REORGANIZATIONS, AND STUDENT AND LAWYER PROGRAMS AND OUTPLACEMENT (U.S. CLS. 100, 101 AND 102).

FIRST USE 5-31-2002; IN COMMERCE 5-31-2002.  
ANDREW RHIM, EXAMINING ATTORNEY

SN 85-147,094. CHOCOLADEFABRIKEN LINDT & SPRÜNGLI AG, KILCHBERG, SWITZERLAND, FILED 10-7-2010.

**LINDT CHOCOLATE UNWRAPPED**

THE MARK CONSISTS OF STANDARD CHARACTERS WITHOUT CLAIM TO ANY PARTICULAR FONT, STYLE, SIZE, OR COLOR.

OWNER OF U.S. REG. NOS. 87,306, 3,439,413 AND OTHERS.

NO CLAIM IS MADE TO THE EXCLUSIVE RIGHT TO USE "CHOCOLATE", APART FROM THE MARK AS SHOWN.

FOR PROVIDING AN INTERNET WEBSITE FEATURING CORPORATE AND COMPANY BUSINESS INFORMATION FOR OTHERS RELATING TO CHOCOLATE (U.S. CLS. 100, 101 AND 102).

ANDREW RHIM, EXAMINING ATTORNEY

**CLASS 35—(Continued).**

SN 85-148,048. KING, ROBERT, MANTI, UT. FILED 10-8-2010.

**XBANDITS**

THE MARK CONSISTS OF STANDARD CHARACTERS WITHOUT CLAIM TO ANY PARTICULAR FONT, STYLE, SIZE, OR COLOR.

THE WORDING "XBANDITS" HAS NO MEANING IN A FOREIGN LANGUAGE.

FOR ADVERTISING AND MARKETING; PROMOTING THE GOODS AND SERVICES OF OTHERS THROUGH SEARCH ENGINE REFERRAL TRAFFIC ANALYSIS AND REPORTING (U.S. CLS. 100, 101 AND 102).

FIRST USE 4-1-2006; IN COMMERCE 4-1-2008.

GEOFFREY FOSDICK, EXAMINING ATTORNEY

SN 85-148,222. GANXY, INC., BROOKLYN, NY. FILED 10-8-2010.

**GANXY**

THE MARK CONSISTS OF STANDARD CHARACTERS WITHOUT CLAIM TO ANY PARTICULAR FONT, STYLE, SIZE, OR COLOR.

FOR COMPUTERIZED ON-LINE RETAIL STORE SERVICES IN THE FIELD OF DIGITAL INFORMATION AND CONTENT FEATURING DOWNLOADABLE SOUND, MUSIC, IMAGE, VIDEO AND GAME FILES; MARKETING, ADVERTISING, AND PROMOTING THE RETAIL GOODS AND SERVICES OF OTHERS TO WIRELESS ELECTRONIC DEVICES; MOBILE RETAIL STORE SERVICES FEATURING DIGITAL INFORMATION AND CONTENT, NAMELY, DOWNLOADABLE SOUND, MUSIC, IMAGE, VIDEO AND GAME FILES; ON-LINE RETAIL CONSIGNMENT STORES FEATURING DIGITAL INFORMATION AND CONTENT, NAMELY, DOWNLOADABLE SOUND, MUSIC, IMAGE, VIDEO AND GAME FILES; ON-LINE RETAIL STORE SERVICES FEATURING DOWNLOADABLE PRE-RECORDED MUSIC AND VIDEO FILES; ON-LINE RETAIL STORE SERVICES FEATURING PHYSICAL AND VIRTUAL MERCHANDISE FOR USE BY MEMBERS OF AN ONLINE COMMUNITY IN CONNECTION WITH A DESIGNATED WEBSITE FEATURING FICTIONAL CHARACTERS; ON-LINE RETAIL STORE SERVICES FEATURING DIGITAL INFORMATION AND CONTENT, NAMELY, DOWNLOADABLE SOUND, MUSIC, IMAGE, VIDEO AND GAME FILES; ON-LINE WHOLESALE AND RETAIL STORE SERVICES FEATURING DOWNLOADABLE SOUND, MUSIC, IMAGE, VIDEO AND GAME FILES; ON-LINE WHOLESALE AND RETAIL STORE SERVICES FEATURING DIGITAL INFORMATION AND CONTENT, NAMELY, DOWNLOADABLE SOUND, MUSIC, IMAGE, VIDEO AND GAME FILES; WHOLESALE AND RETAIL STORE SERVICES AND ON-LINE RETAIL AND WHOLESALE STORE SERVICES FEATURING DIGITAL INFORMATION AND CONTENT, NAMELY, DOWNLOADABLE SOUND, MUSIC, IMAGE, VIDEO AND GAME FILES (U.S. CLS. 100, 101 AND 102).

RICHARD WHITE, EXAMINING ATTORNEY



**CLASS 35—(Continued).**

SN 85-148,710. PURPLE RAM, LLC, DBA REVEL ADVERTISING, SPRINGFIELD, MO. FILED 10-8-2010.



NO CLAIM IS MADE TO THE EXCLUSIVE RIGHT TO USE "ADVERTISING", APART FROM THE MARK AS SHOWN.

THE COLOR(S) DARK BLUE, LIGHT BLUE IS/ARE CLAIMED AS A FEATURE OF THE MARK.

THE MARK CONSISTS OF A LOWERCASE R IN DARK BLUE, FOLLOWED BY A LOWERCASE R REFLECTED AND INVERTED IN LIGHT BLUE. THE WORDS REVEL AND ADVERTISING FOLLOW THE SHAPE WITH REVEL BEING IN ALL LOWERCASE DARK BLUE LETTERING AND ADVERTISING BEING IN ALL UPPERCASE LIGHT BLUE LETTERING.

FOR ADVERTISING AGENCIES (U.S. CLS. 100, 101 AND 102).

FIRST USE 9-25-2010; IN COMMERCE 9-25-2010.  
SUSAN LESLIE DUBOIS, EXAMINING ATTORNEY

SN 85-149,324. MEARS ACQUISITION COMPANY, ORLANDO, FL. FILED 10-11-2010.



OWNER OF U.S. REG. NOS. 2,669,981 AND 3,511,943.

NO CLAIM IS MADE TO THE EXCLUSIVE RIGHT TO USE "WASHINGTON D.C.", APART FROM THE MARK AS SHOWN.

THE COLOR(S) RED, BLUE, AND PURPLE IS/ARE CLAIMED AS A FEATURE OF THE MARK.

THE MARK CONSISTS OF THE FOLLOWING: THE STYLIZED TEXT "HELLO WASHINGTON D.C.!", ABOVE A BAR COMPRISING STARS AND CONTAINING THE "D.C." PORTION OF THE MARK, AND THE DESIGN OF A CAPITOL DOME. "HELLO" AND "!" ARE PURPLE; "WASHINGTON" IS RED, THE CAPITAL DOME IS BLUE; THE BAR COMPRISING THE STARS AND "D.C." IS BLUE. THE WHITE REPRESENTS BACKGROUND AND IS NOT PART OF THE MARK.

FOR TRAVEL MANAGEMENT (U.S. CLS. 100, 101 AND 102).

KIM SAITO, EXAMINING ATTORNEY

**CLASS 35—(Continued).**

SN 85-149,978. PROMOTIONAL ALLIANCE INTERNATIONAL, INC., RANCHO CUCAMONGA, CA. FILED 10-11-2010.

**PROMOTIONAL ALLIANCE  
INTERNATIONAL**

THE MARK CONSISTS OF STANDARD CHARACTERS WITHOUT CLAIM TO ANY PARTICULAR FONT, STYLE, SIZE, OR COLOR.

NO CLAIM IS MADE TO THE EXCLUSIVE RIGHT TO USE "PROMOTIONAL", APART FROM THE MARK AS SHOWN.

SEC. 2(F).

FOR ADVERTISING AND PROMOTION SERVICES AND RELATED CONSULTING, AND PREPARING PROMOTIONAL AND MERCHANDISING MATERIAL FOR OTHERS; PROVIDING ADVERTISING, MARKETING AND PROMOTIONAL SERVICES FOR THE GOODS AND SERVICES OF OTHERS; BUSINESS CONSULTATION SERVICES, NAMELY, CONCEPT AND BRAND DEVELOPMENT SERVICES (U.S. CLS. 100, 101 AND 102).

FIRST USE 6-0-2003; IN COMMERCE 6-0-2003.

APRIL ROACH, EXAMINING ATTORNEY

SN 85-150,292. VARSITY SPIRIT CORPORATION, MEMPHIS, TN. FILED 10-12-2010.



OWNER OF U.S. REG. NOS. 1,576,926 AND 3,799,507.

NO CLAIM IS MADE TO THE EXCLUSIVE RIGHT TO USE "NATIONAL HIGH SCHOOL STUNT ASSOCIATION", APART FROM THE MARK AS SHOWN.

THE STIPPLING IS A FEATURE OF THE MARK AND DOES NOT INDICATE COLOR.

THE MARK CONSISTS OF A CIRCLE SHAPE WITH THE LEFT SIDE STIPPLING AND THE RIGHT SIDE BLACK; ABOVE TWO ANGLES FACING EACH OTHER WITH THE LEFT SIDE STIPPLING AND THE RIGHT SIDE BLACK; ABOVE A CIRCLE SHAPE WITH THE LEFT SIDE STIPPLING AND THE RIGHT SIDE BLACK; ABOVE FOUR ANGLES FACING EACH OTHER AND INWARD WITH THE LEFT SIDE STIPPLING AND THE RIGHT SIDE BLACK; ALL ABOVE THE PHRASE "NATIONAL HIGH SCHOOL", WHICH IS ABOVE THE PHRASE "STUNT", WHICH IS ABOVE THE PHRASE "ASSOCIATION".

FOR ASSOCIATION SERVICES, NAMELY, PROMOTING THE INTERESTS OF PARTICIPANTS, COACHES AND ADMINISTRATORS IN THE SPORT OF STUNT AT THE HIGH SCHOOL LEVEL (U.S. CLS. 100, 101 AND 102).

ALICE BENMAMAN, EXAMINING ATTORNEY

**CLASS 35—(Continued).**

SN 85-151,472. DORIS CLAYTON ENTERPRISE, FAYETTEVILLE, NC. FILED 10-13-2010.



NO CLAIM IS MADE TO THE EXCLUSIVE RIGHT TO USE "ENTERPRISE", APART FROM THE MARK AS SHOWN.

THE NAME "DORIS CLAYTON" IDENTIFIES A LIVING INDIVIDUAL WHOSE CONSENT IS OF RECORD.

THE MARK CONSISTS OF A GLOBE WITH THE STYLIZED TEXT "DORIS CLAYTON ENTERPRISE".

FOR ON-LINE RETAIL STORE SERVICES FEATURING A WIDE VARIETY OF CONSUMER GOODS OF OTHERS, EXCLUDING FOOD ITEMS (U.S. CLS. 100, 101 AND 102).

ELIZABETH HUGHITT, EXAMINING ATTORNEY

**CLASS 35—(Continued).**

SN 85-154,911. TALENT ON HOLD, LLC, SAINT CHARLES, MO. FILED 10-18-2010.



NO CLAIM IS MADE TO THE EXCLUSIVE RIGHT TO USE "THE ON-HOLD AND VOICEMAIL TALENT COMPANY", APART FROM THE MARK AS SHOWN.

THE MARK CONSISTS OF THE NAME "TALENT ON HOLD" WITH BORDERING LOCATED IN AN OUTLINED OVAL ABOVE A TELEPHONE HAND PIECE TO THE BOTTOM LEFT. ADDITIONALLY THERE IS AN EXTENDED TEXT BUBBLE JUTTING FROM THE UPPER RIGHT OF THE BORDERING OVAL WITH THE WORDS "THE ON-HOLD AND VOICEMAIL TALENT COMPANY".

FOR ADVERTISING SERVICES (U.S. CLS. 100, 101 AND 102).

FIRST USE 7-12-2010; IN COMMERCE 8-16-2010.

GRETTA YAO, EXAMINING ATTORNEY

SN 85-154,481. AMERICAN VILLAGE, WOODBRIDGE, VA. FILED 10-17-2010.

*American Village*

NO CLAIM IS MADE TO THE EXCLUSIVE RIGHT TO USE "AMERICAN", APART FROM THE MARK AS SHOWN.

THE MARK CONSISTS OF THE WORDING "AMERICAN VILLAGE" IN STYLIZED SCRIPT.

FOR THE BRINGING TOGETHER, FOR THE BENEFIT OF OTHERS, OF A VARIETY OF GOODS AND SERVICES, ENABLING CUSTOMERS TO CONVENIENTLY VIEW AND PURCHASE THOSE GOODS AND SERVICES FROM AN INTERNET WEB SITE PARTICULARLY SPECIALIZING IN THE MARKETING OF THE SALE OF GOODS AND SERVICES OF OTHERS (U.S. CLS. 100, 101 AND 102).

FIRST USE 1-15-2010; IN COMMERCE 6-15-2010.

CORY BOONE, EXAMINING ATTORNEY

SN 85-154,973. PILLAR HOTELS AND RESORTS, L.P., IRVING, TX. FILED 10-18-2010.

PILLAR HOTELS AND RESORTS

THE MARK CONSISTS OF STANDARD CHARACTERS WITHOUT CLAIM TO ANY PARTICULAR FONT, STYLE, SIZE, OR COLOR.

NO CLAIM IS MADE TO THE EXCLUSIVE RIGHT TO USE "HOTELS AND RESORTS", APART FROM THE MARK AS SHOWN.

FOR BUSINESS AND ADMINISTRATIVE MANAGEMENT OF HOTEL AND RESORT PROPERTIES FOR OTHERS (U.S. CLS. 100, 101 AND 102).

FRED CARL, EXAMINING ATTORNEY

**CLASS 35—(Continued).**

SN 85-154,974. PILLAR HOTELS AND RESORTS, L.P., IRVING, TX. FILED 10-18-2010.



NO CLAIM IS MADE TO THE EXCLUSIVE RIGHT TO USE "HOTELS & RESORTS", APART FROM THE MARK AS SHOWN.

THE MARK CONSISTS OF THE WORD "PILLAR", WITH THE LOWER PORTION OF THE LETTER "P" COMPRISING A GRAPHICAL DEPICTION OF A PILLAR, THE LETTER "P" ENCOMPASSED WITHIN A RECTANGULAR BOX, A HORIZONTAL LINE BELOW THE WORD "PILLAR", AND THE PHRASE "HOTELS & RESORTS" APPEARING BELOW THE HORIZONTAL LINE.

FOR BUSINESS AND ADMINISTRATIVE MANAGEMENT OF HOTEL AND RESORT PROPERTIES FOR OTHERS (U.S. CLS. 100, 101 AND 102).

FRED CARL, EXAMINING ATTORNEY

**CLASS 35—(Continued).**

SN 85-158,875. FOR SALE BY BUILDER AND OWNER, INC., RALEIGH, NC. FILED 10-22-2010.



OWNER OF U.S. REG. NO. 2,819,721.

NO CLAIM IS MADE TO THE EXCLUSIVE RIGHT TO USE "FOR SALE BY BUILDER & OWNER", APART FROM THE MARK AS SHOWN.

THE MARK CONSISTS OF THE WORDS "FOR SALE BY BUILDER & OWNER" WITH "FOR SALE" ABOVE "BY BUILDER", AND "& OWNER" INSIDE A CIRCLE. THERE IS A DEPICTION OF A HOUSE IN THE BACKGROUND AND A SHADOW EFFECT ON THE WORDS "FOR SALE" AND THE CIRCLE.

FOR REAL ESTATE ADVERTISING SERVICES, NAMELY, PROMOTING PROPERTIES FOR SALE VIA THE INTERNET AND PRINTED PUBLICATIONS (U.S. CLS. 100, 101 AND 102).

FIRST USE 10-11-2010; IN COMMERCE 10-11-2010.

ANNE FARRELL, EXAMINING ATTORNEY

SN 85-159,858. WILLIAM, JEAN, DBA GREENVESTING, LLC, WASHINGTON, DC. FILED 10-24-2010.

SN 85-158,416. DOCTORS IMPROVING HEALTHCARE, INC., SAN FRANCISCO, CA. FILED 10-21-2010.

## Doctors Improving Healthcare

THE MARK CONSISTS OF STANDARD CHARACTERS WITHOUT CLAIM TO ANY PARTICULAR FONT, STYLE, SIZE, OR COLOR.

FOR PROVIDING AN ON-LINE SERVICE THAT ALLOWS PROSPECTIVE PATIENTS TO MEET DOCTORS AND DENTISTS THROUGH ONLINE VIDEO AND THEN BOOK MEDICAL AND DENTAL APPOINTMENTS ONLINE (U.S. CLS. 100, 101 AND 102).

FIRST USE 3-16-2009; IN COMMERCE 3-16-2009.

JEFF DEFORD, EXAMINING ATTORNEY



NO CLAIM IS MADE TO THE EXCLUSIVE RIGHT TO USE "USGREENJOBS" AND "NETWORK", APART FROM THE MARK AS SHOWN.

THE COLOR(S) BLUE, GREEN, WHITE, GREY IS/ARE CLAIMED AS A FEATURE OF THE MARK.

THE MARK CONSISTS OF A GREEN US MAP WITH IMAGE OF WHITE BODIES CONNECTED TO EACH OTHER THROUGHOUT THE MAP. THE WORD MARK CONSIST OF "US" IN BLUE, THE WORD "GREEN" IN THE COLOR GREEN, THE WORD "JOBS" IN BLUE, THE WORD "NETWORK" IN GREY.

FOR ADVERTISING SERVICES, NAMELY, DIRECTORY, MARKETING, PROMOTIONS, PUBLIC AND INVESTOR RELATIONS (U.S. CLS. 100, 101 AND 102).

FIRST USE 10-20-2010; IN COMMERCE 10-20-2010.

JOHN DALIER, EXAMINING ATTORNEY

**CLASS 35—(Continued).**

SN 85-160,342. EFA PROCESSING, L.P., FRISCO, TX. FILED 10-25-2010.

**EFAMATCHPAY**

THE MARK CONSISTS OF STANDARD CHARACTERS WITHOUT CLAIM TO ANY PARTICULAR FONT, STYLE, SIZE, OR COLOR.

OWNER OF U.S. REG. NOS. 3,800,739 AND 3,800,740.  
FOR PROVIDING AN ONLINE DATABASE FEATURING BUSINESS INFORMATION IN THE FIELD OF DEBT SETTLEMENT AND DEBT NEGOTIATION SERVICES FOR CREDIT AND DEBT AGENCIES (U.S. CLS. 100, 101 AND 102).

FONG HSU, EXAMINING ATTORNEY

---

SN 85-160,899. PENINSULA BEAUTY, INC, BURLINGAME, CA. FILED 10-26-2010.

**BEAUTY SOLVED**

THE MARK CONSISTS OF STANDARD CHARACTERS WITHOUT CLAIM TO ANY PARTICULAR FONT, STYLE, SIZE, OR COLOR.

NO CLAIM IS MADE TO THE EXCLUSIVE RIGHT TO USE "BEAUTY", APART FROM THE MARK AS SHOWN.

FOR RETAIL BEAUTY PRODUCTS AND BEAUTY EQUIPMENT STORES; ONLINE RETAIL STORE SERVICES FEATURING BEAUTY PRODUCTS AND BEAUTY EQUIPMENT (U.S. CLS. 100, 101 AND 102).

AMY C. KEAN, EXAMINING ATTORNEY

---

SN 85-162,203. ACCURATE MARKETING ADVANTAGES INC., BELLEVUE, NE. FILED 10-27-2010.

**FTW MAGS**

THE MARK CONSISTS OF STANDARD CHARACTERS WITHOUT CLAIM TO ANY PARTICULAR FONT, STYLE, SIZE, OR COLOR.

NO CLAIM IS MADE TO THE EXCLUSIVE RIGHT TO USE "MAGS", APART FROM THE MARK AS SHOWN.

FOR MAGAZINE AND BOOK SUBSCRIPTION AND FULFILLMENT SERVICES (U.S. CLS. 100, 101 AND 102).  
FIRST USE 10-18-2010; IN COMMERCE 10-18-2010.

WENDY GOODMAN, EXAMINING ATTORNEY

**CLASS 35—(Continued).**

SN 85-162,906. GALLOWAY, SHAMARO N., DBA UNIK PARTIES & MORE, SOLE PROPRIETORSHIP OF MISSISSIPPI, JACKSON, MS. FILED 10-27-2010.



NO CLAIM IS MADE TO THE EXCLUSIVE RIGHT TO USE "PARTIES", APART FROM THE MARK AS SHOWN.  
THE COLOR(S) YELLOW, PINK, BLACK, AND WHITE IS/ARE CLAIMED AS A FEATURE OF THE MARK.

THE MARK CONSISTS OF A CROWN IN THE COLOR YELLOW OUTLINED IN THE COLOR BLACK, A SMILEY FACE IN THE COLOR PINK OUTLINED IN THE COLOR BLACK WITH A SMALL WHITE DOT ON THE SMILEY FACE, AND THE WORDING "UNIK PARTIES & MORE" IN THE COLOR BLACK OF WHICH THE LETTER "U" ALSO REPRESENTS THE MOUTH OF THE SMILEY FACE.

FOR PROVIDING CONSUMER INFORMATION SERVICES AND MAKING REFERRALS IN THE FIELD OF ENTERTAINMENT SERVICES FOR PRODUCTS, SERVICES, EVENTS, ACTIVITIES, FACILITIES AND LOCATIONS (U.S. CLS. 100, 101 AND 102).

FIRST USE 10-21-2010; IN COMMERCE 10-21-2010.

CAROL SPILS, EXAMINING ATTORNEY

**CLASS 35—(Continued).**

SN 85-164,049. SEED AND GARDEN LLC, SOUTH LYON, MI. FILED 10-28-2010.



NO CLAIM IS MADE TO THE EXCLUSIVE RIGHT TO USE "SEED AND GARDEN", APART FROM THE MARK AS SHOWN.

THE MARK CONSISTS OF THE WORDS "SEED AND GARDEN". THE WORD "SEED" IS ABOVE THE WORD "GARDEN". THE "G" IS SHAPED LIKE A GARDEN POT AND THE LETTER "S" IS SHAPED LIKE A SPROUTING PLANT. TOGETHER THE "S" AND "G" LOOK LIKE A PLANT SPROUTING OUT OF A POT.

FOR ON-LINE RETAIL STORE SERVICES FEATURING LAWN AND GARDEN TOOLS, CULTIVATORS, GARDENING SHEARS AND SCISSORS, GARDEN TOOLS, TROWELS, WEEDING FORKS, METAL GARDEN STAKES, PLASTIC GARDEN STAKES, WOOD GARDEN STAKES, GARDENING GLOVES, GARDEN HOSES, SPRAYER NOZZLES FOR GARDEN HOSES, BIODEGRADABLE POTS, FRUIT SEEDS, GRASS SEEDS, HERB SEEDS FOR PLANTING, PLANT SEEDS, VEGETABLE SEEDS, FLOWER SEEDS, SHRUB AND TREE SEEDS, WILDLIFE SEED MIXTURES, SEEDS AND BULBS, TREE GROWING KITS, PEAT POTS, PEAT PELLETS, COWPOTS, GARDEN TWINE, GARDEN TIES, SOIL TESTING METERS, LIGHT AND MOISTURE METERS, GARDEN SOIL MIX, PEST CONTROL, PLANT TRAYS, GROW DOMES, SOIL THERMOMETER, GARDEN FERTILIZER, PLANT FUNGICIDE, AND POTTING SOIL (U.S. CLS. 100, 101 AND 102).

FIRST USE 8-17-2010; IN COMMERCE 8-23-2010.

KATHLEEN LORENZO, EXAMINING ATTORNEY

SN 85-165,989. LANDMAN, DAVID A., DBA PRIMEONERE-ALTY LLC, ENGLEWOOD, CO. FILED 11-1-2010.



NO CLAIM IS MADE TO THE EXCLUSIVE RIGHT TO USE "REALTY", APART FROM THE MARK AS SHOWN.

THE COLOR(S) BLACK, YELLOW AND WHITE IS/ARE CLAIMED AS A FEATURE OF THE MARK.

THE MARK CONSISTS OF THE WORDING "PRIMEONE REALTY" IN BLACK AND A TRIANGLE IN YELLOW AND OUTLINED IN BLACK SUPERIMPOSED AGAINST A WHITE RECTANGLE WITH ROUNDED EDGES OUTLINED IN BLACK.

FOR MATCHING POTENTIAL BUYERS TO FACILITATE CO-OWNERSHIP OF RESIDENTIAL REAL PROPERTY (U.S. CLS. 100, 101 AND 102).

FIRST USE 11-1-2010; IN COMMERCE 11-1-2010.

DEIRDRE ROBERTSON, EXAMINING ATTORNEY

**CLASS 35—(Continued).**

SN 85-166,486. MAE MAE HOLDINGS INC., SAN FRANCISCO, CA. FILED 11-1-2010.



THE COLOR(S) RED, WHITE, AND BLACK IS/ARE CLAIMED AS A FEATURE OF THE MARK.

THE MARK CONSISTS OF A DESIGN OF A RED FISH WITH BLACK AND WHITE EYES, AND BLACK OUTLINES, BLOWING WHITE BUBBLES. THERE ARE WHITE LINES ON THE FISH TO SHOW THAT THE FISH IS SHINY. THE WORDING "MAE MAE" IS UNDERNEATH THE DESIGN OF THE FISH IN THE COLOR BLACK.

FOR ADVERTISING AND ADVERTISEMENT SERVICES; BUSINESS ADMINISTRATION ASSISTANCE; RETAIL STORE SERVICES AND ONLINE RETAIL STORE SERVICES FEATURING GENERAL CONSUMER MERCHANDISE; WHOLESALE DISTRIBUTORSHIP SERVICES FEATURING CONSUMER GOODS; DISTRIBUTORSHIPS IN THE FIELD OF CONSUMER GOODS THROUGH VARIOUS CHANNELS OF TRADE; GOODS IMPORT-EXPORT AGENCIES IN THE FIELD OF CONSUMER GOODS (U.S. CLS. 100, 101 AND 102).

FIRST USE 11-1-2010; IN COMMERCE 11-1-2010.

JANET LEE, EXAMINING ATTORNEY

SN 85-166,495. NOAR FOUNDATION FOR GLOBAL COMMUNITY DEVELOPMENT, TOWSON, MD. FILED 11-1-2010.

Think Globally - Act  
Locally

THE MARK CONSISTS OF STANDARD CHARACTERS WITHOUT CLAIM TO ANY PARTICULAR FONT, STYLE, SIZE, OR COLOR.

FOR CHARITABLE SERVICES, NAMELY, ORGANIZING AND DEVELOPING PROJECTS THAT AIM TO IMPROVE THE LIVES OF UNDERPRIVILEGED AND IMPOVERISHED PEOPLE (U.S. CLS. 100, 101 AND 102).

RICHARD WHITE, EXAMINING ATTORNEY

**CLASS 35—(Continued).**

SN 85-169,128. SMITH, SCOTT D, DBA GHOUTLIDE GATHERING, KALAMAZOO, MI. FILED 11-4-2010.

**Ghoultime Gathering**

THE MARK CONSISTS OF STANDARD CHARACTERS WITHOUT CLAIM TO ANY PARTICULAR FONT, STYLE, SIZE, OR COLOR.

NO CLAIM IS MADE TO THE EXCLUSIVE RIGHT TO USE "GATHERING", APART FROM THE MARK AS SHOWN.

FOR ORGANIZATION OF A HALLOWEEN FOLK ART SHOW FOR COMMERCIAL PURPOSES (U.S. CLS. 100, 101 AND 102).

FIRST USE 2-1-2007; IN COMMERCE 10-6-2007.  
ROBIN MITTLER, EXAMINING ATTORNEY

SN 85-169,730. ERGO CUSTOMIZED COMFORT, INC, IRVINE, CA. FILED 11-4-2010.

**ERGO BEDROOM**

THE MARK CONSISTS OF STANDARD CHARACTERS WITHOUT CLAIM TO ANY PARTICULAR FONT, STYLE, SIZE, OR COLOR.

OWNER OF U.S. REG. NOS. 2,800,775 AND 3,532,475.

NO CLAIM IS MADE TO THE EXCLUSIVE RIGHT TO USE "BEDROOM", APART FROM THE MARK AS SHOWN.

FOR ON-LINE WHOLESALE AND RETAIL STORE SERVICES FEATURING BEDS, MATTRESSES, LINENS AND BEDCOVERS; RETAIL FURNITURE STORES; RETAIL STORE AND ON-LINE RETAIL STORE SERVICES FEATURING BEDS, MATTRESSES, LINENS AND BEDCOVERS; WHOLESALE STORES FEATURING BEDS, MATTRESSES, LINENS AND BEDCOVERS (U.S. CLS. 100, 101 AND 102).

DAWN HAN, EXAMINING ATTORNEY

SN 85-171,445. CROSSHAIRS USA, LLC, TORRANCE, CA. FILED 11-8-2010.



NO CLAIM IS MADE TO THE EXCLUSIVE RIGHT TO USE "TACTICAL GEAR USA", APART FROM THE MARK AS SHOWN.

THE MARK CONSISTS OF A RIFLE SCOPE RETICLE WITH MIL DOTS, A RIFELMAN OUTFITTED IN TACTICAL GEAR WALKING WITH HIS RIFLE SHOULDERED AND AIMING HIS RIFLE AT THE RETICLE, WITH THE STYLIZED TEXT "CROSSHAIRS TACTICAL GEAR USA" APPEARING CENTERED AND EXTENDING TO THE RIGHT OF THE RETICLE.

FOR RETAIL STORE AND ON-LINE RETAIL STORE SERVICES FEATURING FIREARMS, AMMUNITION, TACTICAL EQUIPMENT, TACTICAL CLOTHING, AND TACTICAL RELATED PRODUCTS (U.S. CLS. 100, 101 AND 102).

ASMAT KHAN, EXAMINING ATTORNEY

**CLASS 35—(Continued).**

SN 85-171,687. NUÑEZ, KELVYN L., DBA EGO VANITY STORE, EGO, ARECIBO, PUERTO RICO, FILED 11-8-2010.

**EGO Shoes**

THE MARK CONSISTS OF STANDARD CHARACTERS WITHOUT CLAIM TO ANY PARTICULAR FONT, STYLE, SIZE, OR COLOR.

NO CLAIM IS MADE TO THE EXCLUSIVE RIGHT TO USE "SHOES", APART FROM THE MARK AS SHOWN.  
FOR RETAIL STORE SERVICES FEATURING SHOES (U.S. CLS. 100, 101 AND 102).

FIRST USE 11-2-2010; IN COMMERCE 11-2-2010.  
EDWARD FENNESSY, EXAMINING ATTORNEY

SN 85-172,543. Z MOBILE VENTURES, LLC, IRVING, TX. FILED 11-9-2010.



THE MARK CONSISTS OF THE LITERAL ELEMENT "WOWPONS" IN STYLIZED FORM WHERE THE TERM "WOW" IS BACKED BY A DESIGN SUGGESTING AN EXPLOSION AND WHERE THE "S" IS IN THE FORM OF A DOLLAR SIGN.

FOR PROMOTING THE GOODS AND SERVICES OF OTHERS BY PROVIDING A MOBILE PHONE APPLICATION AND WEBSITE FEATURING COUPONS (U.S. CLS. 100, 101 AND 102).

CHRIS WELLS, EXAMINING ATTORNEY

SN 85-172,622. INSTAMART LLC, DENVER, CO. FILED 11-9-2010.

**instamart**

THE MARK CONSISTS OF STANDARD CHARACTERS WITHOUT CLAIM TO ANY PARTICULAR FONT, STYLE, SIZE, OR COLOR.

FOR RETAIL AND ON-LINE GROCERY STORE SERVICES FEATURING HOME DELIVERY SERVICE; RETAIL GROCERY STORES; RETAIL GROCERY STORES FEATURING PHONE-IN ORDERS (U.S. CLS. 100, 101 AND 102).

HAI-LY LAM, EXAMINING ATTORNEY

**CLASS 35—(Continued).**

SN 85-173,026. LOPEZ, BLANCA, MILWAUKEE, WI. FILED 11-9-2010.



NO CLAIM IS MADE TO THE EXCLUSIVE RIGHT TO USE "M C", APART FROM THE MARK AS SHOWN.

THE MARK CONSISTS OF THE STYLIZED WORDING "ALL ABOUT SPEED" "M C" AND THE NUMBERS "1 2 3 4 5 6 7" AS WELL AS THE DEPICTION OF A HELMETED PERSON RIDING A MOTORCYCLE, AN INDICATOR GAUGE, AND TWO ADVERTISING BANNERS. THE TWO ADVERTISING BANNERS APPEAR AS THE TOP AND BOTTOM PORTION OF A BROKEN OVAL WHICH SURROUNDS A MOTORCYCLE, HELMETED MOTORCYCLE RIDER AND INDICATOR GAUGE. THE INDICATOR GAUGE CONTAINS THE NUMBERS "1 2 3 4 5 6 7" IS LOCATED ABOVE THE MOTORCYCLE AND HELMETED MOTORCYCLE RIDER AND HAS A BENT INDICATOR ARROW THAT EXTENDS BEYOND THE GAUGE AND POINTS UP AFTER THE NUMBER "7". THE WORDING "ALL ABOUT SPEED" APPEARS LOCATED IN THE CENTER SECTION OF THE ADVERTISING BANNER AT THE TOP OF THE OVAL, THE CAPITAL LETTER "M" APPEARS LOCATED TO THE LEFT OF THE MOTORCYCLE AND HELMETED MOTORCYCLE RIDER, WHILE THE CAPITAL LETTER "C" APPEARS TO THE RIGHT OF THE MOTORCYCLE AND HELMETED MOTORCYCLE RIDER.

FOR CLUB SERVICES, NAMELY, PROMOTING THE INTERESTS OF MOTORCYCLE ENTHUSIASTS (U.S. CLS. 100, 101 AND 102).

FIRST USE 2-1-2008; IN COMMERCE 2-1-2008.  
MICHAEL TANNER, EXAMINING ATTORNEY

SN 85-173,832. CASSIDY & ASSOCIATES, INC., WASHINGTON, DC. FILED 11-10-2010.

## Your Trusted Advisor in Washington

THE MARK CONSISTS OF STANDARD CHARACTERS WITHOUT CLAIM TO ANY PARTICULAR FONT, STYLE, SIZE, OR COLOR.

NO CLAIM IS MADE TO THE EXCLUSIVE RIGHT TO USE "WASHINGTON", APART FROM THE MARK AS SHOWN.

FOR COMMERCIAL LOBBYING SERVICES; LOBBYING SERVICES, NAMELY, PROMOTING THE INTERESTS OF PROFIT AND NOT FOR PROFIT BUSINESSES, ORGANIZATIONS AND INSTITUTIONS IN THE FIELDS OF LEGISLATION AND REGULATION (U.S. CLS. 100, 101 AND 102).

FIRST USE 10-25-2010; IN COMMERCE 10-25-2010.  
CAROLYN CATALDO, EXAMINING ATTORNEY

**CLASS 35—(Continued).**

SN 85-174,436. NATIONAL SHOOTING SPORTS FOUNDATION, INC., NEWTOWN, CT. FILED 11-11-2010.

WHERE TOSHOOT.ORG

THE MARK CONSISTS OF STANDARD CHARACTERS WITHOUT CLAIM TO ANY PARTICULAR FONT, STYLE, SIZE, OR COLOR.

SEC. 2(F).

FOR PROVIDING AN ON-LINE DIRECTORY INFORMATION SERVICE FEATURING INFORMATION REGARDING TARGET SHOOTING FACILITIES (U.S. CLS. 100, 101 AND 102).

FIRST USE 1-22-1997; IN COMMERCE 12-5-1998.  
CURTIS FRENCH, EXAMINING ATTORNEY

SN 85-174,600. PERSONALIZATIONMALL.COM, INC., BURR RIDGE, IL. FILED 11-11-2010.

YOUR LOGO. THEIR NAME. OUR  
SPECIALTY.

THE MARK CONSISTS OF STANDARD CHARACTERS WITHOUT CLAIM TO ANY PARTICULAR FONT, STYLE, SIZE, OR COLOR.

FOR ON-LINE RETAIL STORE SERVICES FEATURING PERSONALIZED MERCHANDISE AND GIFTS, NAMELY, GREETING CARDS, BLANK CARDS, BOOKS, CALENDARS, STATIONERY, CANDLES, WORKS OF ART, VASES, BASKETS, HOLIDAY AND SPECIAL OCCASION DECORATIVE GOODS, WRITING UTENSILS, HOUSEWARES, TEXTILES, CLOTHING, FLOOR COVERINGS, PICTURE FRAMES, HOLIDAY AND SPECIAL OCCASION ORNAMENTS, TOYS, SPORTS EQUIPMENT, GAMES, JEWELRY, HAND TOOLS, COOKWARE, DISHES, GLASSWARE, CUTLERY, FURNITURE, LUGGAGE, LEATHER GOODS, WATCHES, CLOCKS, BIBS, DOLLS, AND PLUSH ANIMALS (U.S. CLS. 100, 101 AND 102).

EDWARD NELSON, EXAMINING ATTORNEY

**CLASS 35—(Continued).**

SN 85-174,646. PERSONALIZATIONMALL.COM, INC., BURR RIDGE, IL. FILED 11-11-2010.

PERSONALIZATIONMALL.COM

THE MARK CONSISTS OF STANDARD CHARACTERS WITHOUT CLAIM TO ANY PARTICULAR FONT, STYLE, SIZE, OR COLOR.

OWNER OF U.S. REG. NOS. 2,561,853 AND 3,491,562. FOR ON-LINE RETAIL STORE SERVICES FEATURING PERSONALIZED MERCHANDISE AND GIFTS, NAMELY, GREETING CARDS, BLANK CARDS, BOOKS, CALENDARS, STATIONERY, CANDLES, WORKS OF ART, VASES, BASKETS, HOLIDAY AND SPECIAL OCCASION DECORATIVE GOODS, WRITING UTENSILS, HOUSEWARES, TEXTILES, CLOTHING, FLOOR COVERINGS, PICTURE FRAMES, HOLIDAY AND SPECIAL OCCASION ORNAMENTS, TOYS, SPORTS EQUIPMENT, GAMES, JEWELRY, AND HAND TOOLS, COOKWARE, DISHES, GLASSWARE, CUTLERY, FURNITURE, LUGGAGE, LEATHER GOODS, WATCHES, CLOCKS, BIBS, DOLLS, AND PLUSH ANIMALS (U.S. CLS. 100, 101 AND 102).

FIRST USE 6-22-1999; IN COMMERCE 6-22-1999. EDWARD NELSON, EXAMINING ATTORNEY

SN 85-175,540. COLEMAN, CASSANDRA, BURLINGTON, NJ, AND BROWN, FAWN, BURLINGTON, NJ. FILED 11-12-2010.



THE COLOR(S) BLACK, GRAY, PINK, GREEN, BLUE, RED, WHITE AND CREAM IS/ARE CLAIMED AS A FEATURE OF THE MARK.

THE MARK CONSISTS OF DIAMOND IN GREEN, WHITE, BLACK, RED AND BLUE IN THE BACKGROUND WITH A GIRL ON A MOTORCYCLE IN THE FOREFRONT; THE GIRL HAS CREAM SKIN, BLACK AND WHITE EYES, RED LIPS, A BLUE SHIRT, GRAY PANTS AND BLUE SHOES ON; SHE IS RIDING A BLACK, GRAY, BLUE AND GREEN MOTORCYCLE; SURROUNDING THE RIDER IS A PINK, GRAY AND BLACK STRING OF PEARLS.

FOR CLUB SERVICES, NAMELY, PROMOTING THE INTERESTS OF MOTORCYCLE ENTHUSIASTS (U.S. CLS. 100, 101 AND 102).

FIRST USE 8-0-2000; IN COMMERCE 8-0-2000. SOPHIA S. KIM, EXAMINING ATTORNEY

**CLASS 35—(Continued).**

SN 85-176,053. GETAWAY MEDIA CORP, SAN MARCOS, CA. FILED 11-12-2010.

Getaway Media Corp

THE MARK CONSISTS OF STANDARD CHARACTERS WITHOUT CLAIM TO ANY PARTICULAR FONT, STYLE, SIZE, OR COLOR.

NO CLAIM IS MADE TO THE EXCLUSIVE RIGHT TO USE "MEDIA CORP", APART FROM THE MARK AS SHOWN.

FOR ADVERTISING AND BUSINESS SERVICES, NAMELY, PROVIDING ONLINE WEBSITES WHERE ADVERTISERS, MARKETERS, AND CONTENT PROVIDERS CAN INTERACT WITH USERS FOR ADVERTISING AND BRANDING, ALL THE FOREGOING RELEVANT TO THE TRAVEL INDUSTRY (U.S. CLS. 100, 101 AND 102).

FIRST USE 1-13-2006; IN COMMERCE 1-13-2006. DOMINIC J. FERRAIUOLO, EXAMINING ATTORNEY

SN 85-176,366. RUN WITH THE KENYANS, LLC, WORCESTER, MA. FILED 11-15-2010.

Run With Kenyans

THE MARK CONSISTS OF STANDARD CHARACTERS WITHOUT CLAIM TO ANY PARTICULAR FONT, STYLE, SIZE, OR COLOR.

FOR ADVERTISING AND BUSINESS SERVICES, NAMELY, PROVIDING AN ONLINE WEBSITE WHERE ADVERTISERS, MARKETERS, AND CONTENT PROVIDERS CAN INTERACT WITH USERS FOR ADVERTISING, BRANDING, AND PROMOTING KNOWLEDGE, PRODUCTS, AND SERVICES, AND TRADE SHOWS, ON BEHALF OF THEMSELVES AND OTHERS, AND FOR EVALUATING AND RATING THE SAME, ALL THE FOREGOING RELEVANT TO HUMAN ACTIVITIES AFFECTING CLIMATE CHANGE AND RELATED FIELDS; ADVERTISING AND MARKETING CONSULTANCY; ADVERTISING AND MARKETING SERVICES, NAMELY, PROMOTING THE GOODS AND SERVICES OF OTHERS; ADVERTISING, INCLUDING PROMOTION OF PRODUCTS AND SERVICES OF THIRD PARTIES THROUGH SPONSORING ARRANGEMENTS AND LICENSE AGREEMENTS RELATING TO INTERNATIONAL SPORTS EVENTS; PROMOTING SPORTS COMPETITIONS AND/OR EVENTS OF OTHERS; PROMOTING THE GOODS AND SERVICES OF OTHERS BY ARRANGING FOR SPONSORS TO AFFILIATE THEIR GOODS AND SERVICES WITH KENYAN RUNNERS (U.S. CLS. 100, 101 AND 102).

FIRST USE 7-8-2010; IN COMMERCE 11-13-2010. LESLIE RICHARDS, EXAMINING ATTORNEY



**CLASS 35—(Continued).**

SN 85-177,466. RSVP DEVELOPMENT CORP., TAMPA, FL.  
FILED 11-16-2010.

**TALKING CARDS**

THE MARK CONSISTS OF STANDARD CHARACTERS WITHOUT CLAIM TO ANY PARTICULAR FONT, STYLE, SIZE, OR COLOR.

NO CLAIM IS MADE TO THE EXCLUSIVE RIGHT TO USE "CARDS", APART FROM THE MARK AS SHOWN.

FOR ADVERTISING SERVICES, NAMELY, PREPARING AND CIRCULATING DIRECT MAIL POSTCARDS CONTAINING A TWO-DIMENSIONAL BARCODE FOR OTHERS (U.S. CLS. 100, 101 AND 102).

JULIE VEPPUMTHARA, EXAMINING ATTORNEY

---

SN 85-177,944. MAN AT LEISURE, LLC, PRESCOTT, AZ.  
FILED 11-16-2010.



THE COLOR(S) BLACK AND YELLOW IS/ARE CLAIMED AS A FEATURE OF THE MARK.

THE MARK CONSISTS OF A DESIGN OF A YELLOW DIAMOND-SHAPED STREET SIGN WITH THE WORDS "MAN AT LEISURE" IN BLACK IN THE CENTER AND A BORDER THAT ALTERNATES BLACK, YELLOW AND THEN BLACK.

FOR RETAIL STORE AND ONLINE RETAIL STORE SERVICES FEATURING CLOTHING (U.S. CLS. 100, 101 AND 102).

FRED CARL, EXAMINING ATTORNEY

**CLASS 35—(Continued).**

SN 85-177,959. COLLECTIVE EDITORIAL, LLC, SEATTLE, WA. FILED 11-16-2010.

**Collective Editorial**

THE MARK CONSISTS OF STANDARD CHARACTERS WITHOUT CLAIM TO ANY PARTICULAR FONT, STYLE, SIZE, OR COLOR.

NO CLAIM IS MADE TO THE EXCLUSIVE RIGHT TO USE "EDITORIAL", APART FROM THE MARK AS SHOWN.

FOR POST-PRODUCTION EDITING SERVICES IN THE FIELD OF TELEVISION COMMERCIALS (U.S. CLS. 100, 101 AND 102).

FIRST USE 7-6-2007; IN COMMERCE 7-6-2007.

MELISSA VALLILLO, EXAMINING ATTORNEY

---

SN 85-178,314. WIKE, TERRY L., LAS VEGAS, NV. FILED 11-16-2010.

**THE IDROP STORE**

THE MARK CONSISTS OF STANDARD CHARACTERS WITHOUT CLAIM TO ANY PARTICULAR FONT, STYLE, SIZE, OR COLOR.

NO CLAIM IS MADE TO THE EXCLUSIVE RIGHT TO USE "STORE", APART FROM THE MARK AS SHOWN.

FOR ONLINE RETAIL STORE SERVICES FEATURING ACCESSORIES FOR USE WITH PORTABLE ELECTRONIC DEVICES (U.S. CLS. 100, 101 AND 102).

LINDA ESTRADA, EXAMINING ATTORNEY

**CLASS 35—(Continued).**

SN 85-178,587. SOCIETY FOR PEDIATRIC ANESTHESIA, RICHMOND, VA. FILED 11-17-2010.



OWNER OF U.S. REG. NO. 2,216,414.  
NO CLAIM IS MADE TO THE EXCLUSIVE RIGHT TO USE "SOCIETY FOR PEDIATRIC ANESTHESIA", "EDUCATION", "RESEARCH" AND "PATIENT SAFETY", APART FROM THE MARK AS SHOWN.

THE MARK CONSISTS OF THE IMAGE OF EIGHT CHILDREN STANDING BESIDE ONE ANOTHER HOLDING HANDS. ABOVE THE IMAGE OF THE CHILDREN ARE FOUR SPARSELY DRAWN ARCHES WITH THE WORDS "SOCIETY FOR PEDIATRIC ANESTHESIA". UNDERNEATH THE IMAGE OF THE CHILDREN ARE THE WORDS "EDUCATION RESEARCH PATIENT SAFETY" WITH DOTS BETWEEN THE WORDS "EDUCATION, RESEARCH, AND PATIENT".

FOR ASSOCIATION SERVICES, NAMELY, PROMOTING AND FURTHERING THE INTERESTS OF THE PEDIATRIC MEDICINE PROFESSION AS IT RELATES TO ANESTHESIA (U.S. CLS. 100, 101 AND 102).

FIRST USE 10-27-2010; IN COMMERCE 10-27-2010.  
ARETHA SOMERVILLE, EXAMINING ATTORNEY

**CLASS 35—(Continued).**

SN 85-179,194. CLEAREDCANDIDATES.COM LLC., BURTONSVILLE, MD. FILED 11-17-2010.

ClearedCandidates.com

THE MARK CONSISTS OF STANDARD CHARACTERS WITHOUT CLAIM TO ANY PARTICULAR FONT, STYLE, SIZE, OR COLOR.

FOR PROVIDING HUMAN RESOURCES CONSULTING SERVICES; PERSONNEL RECRUITMENT; PROVIDING A WEBSITE AT WHICH EMPLOYERS CAN POST JOB VACANCIES; PROVIDING A WEBSITE AT WHICH EMPLOYEES CAN POST RESUMES AND EMPLOYERS CAN SEARCH RESUMES; PROVIDING A WEBSITE WITH PERSONNEL MANAGEMENT INFORMATION IN THE NATURE OF PAY SCALE INFORMATION AND CANDIDATE PROFILES; PROVIDING INTERACTIVE COMPUTER DATABASE OFFERING RECRUITMENT AND EMPLOYMENT INFORMATION, EMPLOYMENT ADVERTISING; ON-LINE JOB SEARCH INFORMATION SERVICES, RESUME CREATION AND CAREER RESOURCE INFORMATION; PROVIDING A WEBSITE WITH INFORMATION REGARDING BUSINESS LISTINGS IN THE DEFENSE INDUSTRIES, EMPLOYMENT LISTINGS, COMPANY PROFILE LISTINGS AND JOB FAIR LISTINGS; ADVERTISING SERVICES, NAMELY, PROVIDING SPACE FOR BANNER ADS ON A WEBSITE; ON-LINE RETAIL STORE FEATURING BOOKS (U.S. CLS. 100, 101 AND 102).

FIRST USE 11-17-2010; IN COMMERCE 11-17-2010.  
FRED CARL, EXAMINING ATTORNEY

SN 85-178,989. NATIONAL AUTOMATED CLEARING HOUSE ASSOCIATION, HERNDON, VA. FILED 11-17-2010.



NO CLAIM IS MADE TO THE EXCLUSIVE RIGHT TO USE "AFFILIATE PROGRAM", APART FROM THE MARK AS SHOWN.

THE MARK CONSISTS OF THE WORDING "AFFILIATE PROGRAM", NEXT TO A CIRCLE DESIGN AND SIX THREE-DIMENSIONAL SWIRLS.

FOR ASSOCIATION SERVICES, NAMELY, PROMOTING THE INTERESTS OF THE ELECTRONIC BILLING AND PAYMENT INDUSTRIES (U.S. CLS. 100, 101 AND 102).

FIRST USE 0-0-2005; IN COMMERCE 0-0-2005.  
ADA HAN, EXAMINING ATTORNEY

SN 85-179,460. SALVA, MARTIN J., VERONA, WI. FILED 11-17-2010.

Timber Lane Advisors, LLC

THE MARK CONSISTS OF STANDARD CHARACTERS WITHOUT CLAIM TO ANY PARTICULAR FONT, STYLE, SIZE, OR COLOR.

NO CLAIM IS MADE TO THE EXCLUSIVE RIGHT TO USE "ADVISORS, LLC", APART FROM THE MARK AS SHOWN.

FOR BUSINESS MANAGEMENT AND CONSULTATION (U.S. CLS. 100, 101 AND 102).

COLLEEN KEARNEY, EXAMINING ATTORNEY

**CLASS 35—(Continued).**

SN 85-179,655. GENTING INTERNATIONAL MANAGEMENT LIMITED, DOUGLAS, BRITISH ISLES, ISLE OF MAN, FILED 11-18-2010.

GENTING REWARDS

THE MARK CONSISTS OF STANDARD CHARACTERS WITHOUT CLAIM TO ANY PARTICULAR FONT, STYLE, SIZE, OR COLOR.

NO CLAIM IS MADE TO THE EXCLUSIVE RIGHT TO USE "REWARDS", APART FROM THE MARK AS SHOWN. THE ENGLISH TRANSLATION OF THE WORD "GENTING" IN THE MARK IS "ON TOP OF THE CLOUDS".

FOR CONSUMER LOYALTY SERVICES FOR COMMERCIAL, PROMOTIONAL, AND/OR ADVERTISING PURPOSES, FOR THE PURPOSE OF PROMOTING AND REWARDING LOYALTY FOR THE USE OF ENTERTAINMENT SERVICES, NAMELY, BAR SERVICES, COCKTAIL LOUNGES, RESTAURANTS, HOTELS, RESORT HOTELS, CONDOMINIUM HOTELS (U.S. CLS. 100, 101 AND 102).

DAVID HOFFMAN, EXAMINING ATTORNEY

SN 85-179,677. GENTING INTERNATIONAL MANAGEMENT LIMITED, DOUGLAS, BRITISH ISLES, ISLE OF MAN, FILED 11-18-2010.



NO CLAIM IS MADE TO THE EXCLUSIVE RIGHT TO USE "REWARDS", APART FROM THE MARK AS SHOWN. THE MARK CONSISTS OF THE WORDS "GENTING REWARDS" INSIDE AN OVAL DESIGN.

THE ENGLISH TRANSLATION OF THE WORD "GENTING" IN THE MARK IS "ON TOP OF THE CLOUDS".

FOR CONSUMER LOYALTY SERVICES FOR COMMERCIAL, PROMOTIONAL, AND/OR ADVERTISING PURPOSES, FOR THE PURPOSE OF PROMOTING AND REWARDING LOYALTY FOR THE USE OF ENTERTAINMENT SERVICES, NAMELY, GAMING, BAR SERVICES, THEME PARK SERVICES, COCKTAIL LOUNGES, RESTAURANTS, HOTELS, RESORT HOTELS, CONDOMINIUM HOTELS (U.S. CLS. 100, 101 AND 102).

DAVID HOFFMAN, EXAMINING ATTORNEY

**CLASS 35—(Continued).**

SN 85-179,688. GENTING INTERNATIONAL MANAGEMENT LIMITED, DOUGLAS, BRITISH ISLES, ISLE OF MAN, FILED 11-18-2010.



NO CLAIM IS MADE TO THE EXCLUSIVE RIGHT TO USE "REWARDS", APART FROM THE MARK AS SHOWN.

THE MARK CONSISTS OF TRADITIONAL CHINESE CHARACTERS ABOVE THE WORDS "GENTING REWARDS" WHICH WORDS ARE IN AN OVAL DESIGN.

THE ENGLISH TRANSLATION OF THE WORD "GENTING" IN THE MARK IS "ON TOP OF THE CLOUDS".

THE NON-LATIN CHARACTERS IN THE MARK TRANSLITERATE TO "ZUN" AND THIS MEANS "TO HONOUR" AND "TO RESPECT" IN ENGLISH.

FOR CONSUMER LOYALTY SERVICES FOR COMMERCIAL, PROMOTIONAL, AND/OR ADVERTISING PURPOSES, FOR THE PURPOSE OF PROMOTING AND REWARDING LOYALTY FOR THE USE OF ENTERTAINMENT SERVICES, NAMELY, GAMING, BAR SERVICES, THEME PARK SERVICES, COCKTAIL LOUNGES, RESTAURANTS, HOTELS, RESORT HOTELS, CONDOMINIUM HOTELS (U.S. CLS. 100, 101 AND 102).

DAVID HOFFMAN, EXAMINING ATTORNEY

SN 85-179,706. GENTING INTERNATIONAL MANAGEMENT LIMITED, DOUGLAS, BRITISH ISLES, ISLE OF MAN, FILED 11-18-2010.



NO CLAIM IS MADE TO THE EXCLUSIVE RIGHT TO USE "REWARDS", APART FROM THE MARK AS SHOWN.

THE MARK CONSISTS OF SIMPLIFIED CHINESE CHARACTERS ABOVE THE WORDS "GENTING REWARDS" WHICH WORDS ARE IN AN OVAL DESIGN.

THE ENGLISH TRANSLATION OF THE WORD "GENTING" IN THE MARK IS "ON TOP OF THE CLOUDS".

THE NON-LATIN CHARACTERS IN THE MARK TRANSLITERATE TO "YUN" AND THIS MEANS "CLOUD" IN ENGLISH.

FOR CONSUMER LOYALTY SERVICES FOR COMMERCIAL, PROMOTIONAL, AND/OR ADVERTISING PURPOSES, FOR THE PURPOSE OF PROMOTING AND REWARDING LOYALTY FOR THE USE OF ENTERTAINMENT SERVICES, NAMELY, GAMING, BAR SERVICES, THEME PARK SERVICES, COCKTAIL LOUNGES, RESTAURANTS, HOTELS, RESORT HOTELS, CONDOMINIUM HOTELS (U.S. CLS. 100, 101 AND 102).

DAVID HOFFMAN, EXAMINING ATTORNEY

**CLASS 35—(Continued).**

SN 85-179,730. PS HOLDINGS, L.L.C., OVERLAND PARK, KS. FILED 11-18-2010.

## SUBRONETWORK

THE MARK CONSISTS OF STANDARD CHARACTERS WITHOUT CLAIM TO ANY PARTICULAR FONT, STYLE, SIZE, OR COLOR.

FOR ONLINE SEARCHABLE DATABASE FEATURING HISTORICAL INFORMATION REGARDING THE AVAILABILITY, PROPERTY DESCRIPTIONS, VALUE AND PRICE OF VEHICLES, VEHICLE PARTS AND VEHICLE EQUIPMENT (U.S. CLS. 100, 101 AND 102).

FIRST USE 11-11-2010; IN COMMERCE 11-11-2010.  
PAUL F. GAST, EXAMINING ATTORNEY

SN 85-179,874. BIKING BILLBOARDS, LLC, SEATTLE, WA. FILED 11-18-2010.

## BIKINGBILLBOARDS

THE MARK CONSISTS OF STANDARD CHARACTERS WITHOUT CLAIM TO ANY PARTICULAR FONT, STYLE, SIZE, OR COLOR.

FOR ADVERTISING AND PROMOTIONAL SERVICES (U.S. CLS. 100, 101 AND 102).

FIRST USE 10-30-2010; IN COMMERCE 10-30-2010.  
KIM MONINGHOFF, EXAMINING ATTORNEY

SN 85-180,624. NUPRENU INC., AKA NUPRENU, HOUSTON, TX. FILED 11-19-2010.



THE COLOR(S) ORANGE AND NAVY BLUE IS/ARE CLAIMED AS A FEATURE OF THE MARK.

THE MARK CONSISTS OF THE WORDING "NUPRENU", WITH THE FIRST "NU" IN ORANGE, FOLLOWED BY "PRENU" IN NAVY BLUE. A NAVY BLUE BROKEN LINE SEPARATES THE TOP LINE FROM THE WORDING "ESTABLISHING NEW ENTREPRENEURS" IN NAVY BLUE.

FOR AD SERVING, NAMELY, PLACING ADVERTISEMENTS ON WEBSITES FOR OTHERS USING SPECIALIZED COMPUTER SOFTWARE; ADVERTISING AND BUSINESS SERVICES, NAMELY, PROVIDING AN ONLINE WEBSITE WHERE ADVERTISERS, MARKETERS, AND CONTENT PROVIDERS CAN INTERACT WITH USERS FOR ADVERTISING, BRANDING, AND PROMOTING KNOWLEDGE, PRODUCTS, AND SERVICES, AND TRADE SHOWS, ON BEHALF OF THEMSELVES AND OTHERS, AND FOR EVALUATING AND RATING THE SAME, ALL THE FOREGOING RELEVANT TO HUMAN ACTIVITIES AFFECTING CLIMATE CHANGE AND RELATED FIELDS; ADVERTISING AND DIRECTORY SERVICES, NAMELY, PROMOTING THE SERVICES OF OTHERS BY PROVIDING A WEB PAGE FEATURING LINKS TO THE WEBSITES OF OTHERS; ADVERTISING SERVICES, NAMELY, PROVIDING A WEBSITE FOR THE PROMOTION OF THE BOOKS OF OTHERS IN THE FIELD OF LAW, INCLUDING NEWS

**CLASS 35—(Continued).**

AND REVIEWS REGARDING SAME; ADVERTISING THE SERVICES OF OTHERS VIA WEB PAGES OPTIMIZED FOR ONLINE SEARCH ENGINES; ARRANGING SUBSCRIPTIONS OF THE ONLINE PUBLICATIONS OF OTHERS; CHARITABLE SERVICES, NAMELY, PROVIDING A FREE ONLINE RESOURCE IN THE NATURE OF A WEBSITE FOR CONNECTING PEOPLE WHO HAVE SERVICE NEEDS WITH PEOPLE WHO ARE WILLING TO PROVIDE VOLUNTEER SERVICES; DEVELOPMENT OF MARKETING STRATEGIES, CONCEPTS AND TACTICS, NAMELY, AUDIENCE DEVELOPMENT, BRAND AWARENESS, CUSTOMER RELATIONS, ONLINE COMMUNITY BUILDING AND DIGITAL WORD OF MOUTH COMMUNICATIONS; INFORMATION, ADVISORY, CONSULTING, BUSINESS RESEARCH AND PLANNING SERVICES RELATING TO PUBLICITY, MARKETING COMMUNICATIONS, REPUTATION MANAGEMENT OR BUSINESS ADMINISTRATION, INCLUDING SUCH SERVICES PROVIDED ONLINE OR VIA THE INTERNET; ON-LINE RETAIL STORE SERVICES FEATURING PHYSICAL AND VIRTUAL MERCHANDISE FOR USE BY MEMBERS OF AN ONLINE COMMUNITY IN CONNECTION WITH A DESIGNATED WEBSITE FEATURING FICTIONAL CHARACTERS; ONLINE ADVERTISEMENTS; ONLINE ADVERTISING AND PROMOTIONAL SERVICES; PLANNING, DESIGN, DEVELOPMENT, MAINTENANCE, TRACKING AND REPORTING OF ONLINE MARKETING ACTIVITIES FOR THIRD PARTIES; PROMOTING VISUAL AND PERFORMING ARTS EVENTS BY MEANS OF PROVIDING AN ONLINE EVENTS CALENDAR, ORIGINAL ARTICLES, INTERVIEWS, AND INFORMATION ABOUT ART, ARTISTS AND ARTS EVENTS VIA AN INTERNET WEB SITE, ALL FOR PROMOTIONAL PURPOSES; PROMOTING, ADVERTISING AND MARKETING OF THE BRANDS, PRODUCTS, SERVICES OR ONLINE WEBSITES OF INDIVIDUALS, BUSINESSES AND NONPROFIT ORGANIZATIONS; PROVIDING A SEARCHABLE ONLINE ADVERTISING GUIDE FEATURING THE GOODS AND SERVICES OF ONLINE VENDORS; PROVIDING A SEARCHABLE ONLINE ADVERTISING GUIDE FEATURING THE GOODS AND SERVICES OF OTHER ON-LINE VENDORS ON THE INTERNET; PROVIDING AN ONLINE DIRECTORY INFORMATION SERVICE FEATURING INFORMATION REGARDING VEHICLES IN THE NATURE OF CLASSIFIED ADVERTISEMENTS (U.S. CLS. 100, 101 AND 102).

FIRST USE 5-1-2009; IN COMMERCE 6-20-2010.  
HEATHER SAPP, EXAMINING ATTORNEY

SN 85-180,873. EFFIE WORLDWIDE, INC., NEW YORK, NY. FILED 11-19-2010.

## Effie Effectiveness Index

THE MARK CONSISTS OF STANDARD CHARACTERS WITHOUT CLAIM TO ANY PARTICULAR FONT, STYLE, SIZE, OR COLOR.

OWNER OF U.S. REG. NOS. 1,308,373 AND 3,524,551.

NO CLAIM IS MADE TO THE EXCLUSIVE RIGHT TO USE "EFFECTIVENESS INDEX", APART FROM THE MARK AS SHOWN.

FOR BUSINESS RESEARCH SERVICES, NAMELY, DEVELOPMENT AND PUBLISHING OF PERFORMANCE RANKINGS MEASURING THE EFFECTIVENESS OF MARKETING AND ADVERTISING CAMPAIGNS AND GENERAL MARKETING COMMUNICATION PROGRAMS, BASED ON PERFORMANCES IN AWARD COMPETITIONS AND STATISTICAL ANALYSIS THEREOF (U.S. CLS. 100, 101 AND 102).

BARBARA RUTLAND, EXAMINING ATTORNEY

**CLASS 35—(Continued).**

SN 85-180,892. EFFIE WORLDWIDE, INC., NEW YORK, NY.  
FILED 11-19-2010.

# Effie Index

THE MARK CONSISTS OF STANDARD CHARACTERS WITHOUT CLAIM TO ANY PARTICULAR FONT, STYLE, SIZE, OR COLOR.

OWNER OF U.S. REG. NOS. 1,308,373 AND 3,524,551.

NO CLAIM IS MADE TO THE EXCLUSIVE RIGHT TO USE "INDEX", APART FROM THE MARK AS SHOWN.

FOR BUSINESS RESEARCH SERVICES, NAMELY, DEVELOPMENT AND PUBLISHING OF PERFORMANCE RANKINGS MEASURING THE EFFECTIVENESS OF MARKETING AND ADVERTISING CAMPAIGNS AND GENERAL MARKETING COMMUNICATION PROGRAMS, BASED ON PERFORMANCES IN AWARD COMPETITIONS AND STATISTICAL ANALYSIS THEREOF (U.S. CLS. 100, 101 AND 102).  
BARBARA RUTLAND, EXAMINING ATTORNEY

**CLASS 35—(Continued).**

SN 85-181,437. ADOBE SYSTEMS INCORPORATED, SAN JOSE, CA. FILED 11-19-2010.

# ADOBE GENESIS

THE MARK CONSISTS OF STANDARD CHARACTERS WITHOUT CLAIM TO ANY PARTICULAR FONT, STYLE, SIZE, OR COLOR.

OWNER OF U.S. REG. NOS. 1,475,793, 1,988,712 AND OTHERS.

FOR MARKET RESEARCH; CONDUCTING ONLINE MARKET RESEARCH SURVEYS RELATING TO CUSTOMER AND EMPLOYEE SATISFACTION AND ATTITUDE, AND ORGANIZATIONAL CLIMATE OR EFFECTIVENESS; PREPARING BUSINESS REPORTS ELECTRONICALLY RELATING TO CUSTOMER AND EMPLOYEE SATISFACTION AND ATTITUDE, ORGANIZATIONAL CLIMATE OR EFFECTIVENESS, AND THE USE OF WEB SITES AND OTHER DATA FROM VARIOUS SOURCES; COLLECTION, REPORTING, ANALYSIS AND INTEGRATION OF BUSINESS DATA RELATED TO THE USE OF WEBSITES, THE USE OF OTHER DATA FROM VARIOUS SOURCES, AND THE EFFECTIVENESS OF MARKETING CAMPAIGNS; COMPUTERIZED DATABASE MANAGEMENT (U.S. CLS. 100, 101 AND 102).

FIRST USE 7-22-2010; IN COMMERCE 7-22-2010.

RENEE MCCRAY, EXAMINING ATTORNEY

SN 85-181,124. GAMING PARTNERS INTERNATIONAL USA, INC., LAS VEGAS, NV. FILED 11-19-2010.

# PAULSON PRO SERIES

THE MARK CONSISTS OF STANDARD CHARACTERS WITHOUT CLAIM TO ANY PARTICULAR FONT, STYLE, SIZE, OR COLOR.

OWNER OF U.S. REG. NOS. 1,972,584, 3,089,726 AND OTHERS.

NO CLAIM IS MADE TO THE EXCLUSIVE RIGHT TO USE "PRO SERIES", APART FROM THE MARK AS SHOWN.

FOR ON-LINE RETAIL STORE SERVICES FEATURING GAMING EQUIPMENT (U.S. CLS. 100, 101 AND 102).

LANA PHAM, EXAMINING ATTORNEY

SN 85-182,144. STATE OF MARYLAND DEPARTMENT OF BUSINESS AND ECONOMIC DEVELOPMENT, BALTIMORE, MD. FILED 11-22-2010.

# MARYLAND OF OPPORTUNITY.

THE COLOR(S) RED, BLACK AND YELLOW IS/ARE CLAIMED AS A FEATURE OF THE MARK.

THE MARK CONSISTS OF THE STYLIZED WORDING "MARYLAND OF OPPORTUNITY." WITH "MARYLAND" IN RED AND "OF OPPORTUNITY." IN BLACK AND THE WORDS "LAND OF OPPORTUNITY." PORTION OF THE MARK HIGHLIGHTED IN SHADES OF YELLOW AND LIGHT YELLOW WITHIN A TILTED RECTANGULAR CARRIER.

FOR PROMOTING THE ECONOMIC DEVELOPMENT IN THE STATE OF MARYLAND (U.S. CLS. 100, 101 AND 102).

FIRST USE 12-15-2009; IN COMMERCE 12-15-2009.

BARBARA RUTLAND, EXAMINING ATTORNEY

**CLASS 35—(Continued).**

SN 85-182,199. MLEX LTD, LONDON, ENGLAND, FILED 11-22-2010.

**MLEX**

THE MARK CONSISTS OF STANDARD CHARACTERS WITHOUT CLAIM TO ANY PARTICULAR FONT, STYLE, SIZE, OR COLOR.

FOR MARKET RESEARCH AND ANALYSIS AND MARKET INTELLIGENCE SERVICES PROVIDED TO FINANCE, INVESTMENT AND LEGAL PROFESSIONALS (U.S. CLS. 100, 101 AND 102).

MATTHEW KLINE, EXAMINING ATTORNEY

**CLASS 35—(Continued).**

SN 85-182,874. TYLER BAILEY, DBA FATTY HITS MARKETING, ROCHESTER, MN. FILED 11-22-2010.

**Fatty Hits  
mktg.**

NO CLAIM IS MADE TO THE EXCLUSIVE RIGHT TO USE "MKTG.", APART FROM THE MARK AS SHOWN.

THE MARK CONSISTS OF THE STYLIZED WORDING "FATTY HITS MKTG." WITH A DESIGN APPEARING ABOVE AND TO THE RIGHT OF THE TERM "HITS" CONSISTING OF TWO LETTER "F'S" JOINED IN THE CENTER TO CREATE AN "H" THEN MODIFIED INTO A CIRCULAR SHAPE.

FOR ENTERTAINMENT MARKETING SERVICES, NAMELY, MARKETING, PROMOTION AND ADVERTISING FOR INDEPENDENT RECORDING ARTISTS (U.S. CLS. 100, 101 AND 102).

FIRST USE 11-15-2008; IN COMMERCE 10-18-2009.

KATHERINE CONNOLLY, EXAMINING ATTORNEY

SN 85-182,944. WORLD INTERNSHIPS INC., FORT COLLINS, CO. FILED 11-22-2010.



SN 85-182,655. AFFINITON, WILLIAMSPORT, PA. FILED 11-22-2010.



THE COLOR(S) MAROON, BLUE AND WHITE IS/ARE CLAIMED AS A FEATURE OF THE MARK.

THE MARK CONSISTS OF BLUE LINEAR BANDS ON THE RIGHT SIDE AND MAROON LINEAR BANDS ON THE LEFT SIDE COMING TOGETHER TO MEET IN ORDER TO FORM A GLOBE, WITH WHITE SEPARATIONS IN BETWEEN. THE WORD "AFFINITON" IS MAROON IN COLOR.

FOR BRANDING SERVICES, NAMELY, CONSULTING, DEVELOPMENT, MANAGEMENT AND MARKETING OF BRANDS FOR BUSINESSES (U.S. CLS. 100, 101 AND 102).

FIRST USE 10-1-2010; IN COMMERCE 10-1-2010.

HOWARD SMIGA, EXAMINING ATTORNEY

NO CLAIM IS MADE TO THE EXCLUSIVE RIGHT TO USE "WORLD INTERNSHIPS", APART FROM THE MARK AS SHOWN.

THE COLOR(S) PURPLE, YELLOW, GREEN, WHITE IS/ARE CLAIMED AS A FEATURE OF THE MARK.

THE MARK CONSISTS OF A RING WITH A STYLIZED WEAVE OF THE COLORS GREEN, YELLOW AND PURPLE. THE WEAVE OF COLORS CONSISTS OF TWO YELLOW BANDS AT THE TOP AND BOTTOM OF THE CIRCLE, TWO GREEN BANDS AT THE TOP LEFT AND BOTTOM RIGHT, AND TWO PURPLE BANDS, AT THE BOTTOM LEFT AND TOP RIGHT OF THE CIRCLE. A THIN WHITE SPACE SEPARATES EACH OF THE BANDS. THE TOP OF THE RING IS YELLOW AND AS YOU MOVE CLOCKWISE ALONG THE RING. THE THICKNESS OF THE RING IS ROUGHLY FIFTEEN PERCENT OF THE DIAMETER OF THE ENTIRE RING. INSIDE THE RING IS A BLUE CIRCLE. THERE IS A SPACE BETWEEN THE BLUE CIRCLE AND THE RING THAT ARE ROUGHLY EQUAL TO THE THICKNESS OF THE RING, IN WHITE. INSIDE THE BLUE CIRCLE IS A LETTER "W" AND A LETTER "I". BOTH LETTERS ARE IN WHITE TEXT. AT A DISTANCE ROUGHLY TWICE THE WIDTH OF THE RING, TO THE RIGHT OF THE RING ARE THE WORDS "WORLD INTERNSHIPS". THE TWO WORDS ARE ON TOP OF EACH OTHER AND TOGETHER SPAN THE ROUGHLY NINETY PERCENT OF THE HEIGHT OF THE RING. THE WORD "WORLD" IS IN BLACK FONT AND IS ON TOP OF "WORD INTERNSHIPS", WHICH IS ALSO IN BLACK FONT. UN-

**CLASS 35—(Continued).**

DERNEATH THE WORD "INTERNSHIPS" IS THE PHRASE "A WORLD OF EXPERIENCE". THESE WORDS ARE WRITTEN IN GREY FONT HORIZONTALLY UNDERNEATH THE WORD "INTERNSHIPS". THE FONT SIZE OF THE GREY WORDS IS ROUGHLY FORTY PERCENT OF THE SIZE OF THE WORDS "WORLD" AND "INTERNSHIPS". UNDERNEATH THE RING IS A SLIGHT GREY SHADOW THAT IS THE SAME COLOR AND IS AT THE SAME HEIGHT AS THE BOTTOM OF THE GREY WORDS "A WORLD OF EXPERIENCE".

FOR INTERNSHIP PLACEMENT SERVICES (U.S. CLS. 100, 101 AND 102).

DAVID HOFFMAN, EXAMINING ATTORNEY

SN 85-182,998. COMPOCLAY USA LLC, ALAMEDA, CA. FILED 11-22-2010.



THE COLOR(S) LIGHT GREEN AND GREEN IS/ARE CLAIMED AS A FEATURE OF THE MARK.

THE MARK CONSISTS OF THE COMPANY NAME "COMPOCLAY" IN GREEN/LIGHT GREEN PRINT WITH THE LIGHT GREEN LEAF DESIGN ABOVE THE SECOND LETTER "O". THE COLOR WHITE APPEARS IN THE BACKGROUND AND IS NOT CLAIMED AS A FEATURE OF THE MARK.

FOR RETAIL STORE SERVICES FEATURING GREEN AND ECO-FRIENDLY PRODUCTS IN THE NATURE OF FURNITURE, HOME DECOR, BUILDING MATERIALS (U.S. CLS. 100, 101 AND 102).

FIRST USE 11-1-2010; IN COMMERCE 11-15-2010.  
ANGELA DUONG, EXAMINING ATTORNEY

SN 85-183,327. CAMELEER INC., THE, CULPEPER, VA. FILED 11-23-2010.



THE MARK CONSISTS OF THE STYLIZED WORDING "THE CAMELEER" AND STYLIZED PROFILE OF THREE CAMELS WALKING IN A LINE.

FOR RETAIL GIFT SHOPS (U.S. CLS. 100, 101 AND 102).

FIRST USE 9-10-1993; IN COMMERCE 9-10-1993.  
BRIAN PINO, EXAMINING ATTORNEY

**CLASS 35—(Continued).**

SN 85-183,370. GAMING PARTNERS INTERNATIONAL USA, INC., LAS VEGAS, NV. FILED 11-23-2010.



OWNER OF U.S. REG. NOS. 1,972,584, 3,089,726 AND OTHERS.

NO CLAIM IS MADE TO THE EXCLUSIVE RIGHT TO USE "PRO SERIES", APART FROM THE MARK AS SHOWN. THE COLOR(S) BLACK AND RED IS/ARE CLAIMED AS A FEATURE OF THE MARK.

THE MARK CONSISTS OF THE STYLIZED WORD "PAULSON" WHICH IS BLACK OVER THE STYLIZED WORDS "PRO SERIES" WHICH ARE RED. THE CENTER OF THE LETTER "O" IN "PAULSON" IS COMPRISED OF A RED SPADE.

FOR ON-LINE RETAIL STORE SERVICES FEATURING GAMING EQUIPMENT (U.S. CLS. 100, 101 AND 102).

LANA PHAM, EXAMINING ATTORNEY

SN 85-183,810. ELLA INTERNET TECHNOLOGIES, INC., SANTA BARBARA, CA. FILED 11-23-2010.

# BONQO

THE MARK CONSISTS OF STANDARD CHARACTERS WITHOUT CLAIM TO ANY PARTICULAR FONT, STYLE, SIZE, OR COLOR.

FOR ADVERTISING AND INFORMATION DISTRIBUTION SERVICES, NAMELY, PROVIDING CLASSIFIED ADVERTISING SERVICES AND CONSUMER PRODUCT AND SERVICE INFORMATION VIA THE INTERNET; PROMOTING THE GOODS AND SERVICES OF OTHERS BY MEANS OF DISTRIBUTING ADVERTISING OVER THE INTERNET; PROVIDING ON-LINE COMPUTER DATABASES AND ON-LINE SEARCHABLE DATABASES FEATURING CLASSIFIED AD LISTINGS AND EMPLOYMENT OPPORTUNITIES; PROVIDING ON-LINE COMPUTER DATABASES AND ON-LINE SEARCHABLE DATABASES FEATURING INFORMATION, CLASSIFIED LISTINGS AND ANNOUNCEMENTS REGARDING EMPLOYMENT INFORMATION, JOB OPENINGS, VOLUNTEER INFORMATION AND VOLUNTEER OPPORTUNITIES THROUGH COMMUNITY AND CHARITABLE ORGANIZATIONS AND BUSINESSES, INFORMATION REGARDING COMMUNITY SERVICE PROGRAMS, COMMERCIAL NOTICES, AND BUSINESS MEETINGS AND INFORMATION IN THE NATURE OF AN ONLINE EVENT CALENDAR FEATURING LOCAL EVENTS; CLASSIFIED AD LISTINGS FOR RENTALS OF A WIDE VARIETY OF CONSUMER AND BUSINESS GOODS AND PROPERTY; PROVIDING A WEBSITE WHERE USERS CAN POST ITEMS FOR SALE THROUGH ONLINE CLASSIFIED ADVERTISEMENTS (U.S. CLS. 100, 101 AND 102).

FIRST USE 10-22-2010; IN COMMERCE 10-22-2010.  
ELISSA GARBER KON, EXAMINING ATTORNEY

**CLASS 35—(Continued).**

SN 85-183,819. UNITED STATES GENERAL SERVICES ADMINISTRATION, WASHINGTON, DC. FILED 11-23-2010.



OWNER OF U.S. REG. NOS. 2,604,877, 3,220,039 AND 3,802,064.

NO CLAIM IS MADE TO THE EXCLUSIVE RIGHT TO USE "CONTRACT HOLDER", APART FROM THE MARK AS SHOWN.

THE MARK CONSISTS OF THE LETTERS "GSA" IN STYLIZED FONT FEATURING A FIVE-POINTED STAR WITHIN THE LETTER "A" ALL WITHIN A SQUARE AND ALONGSIDE THE STYLIZED WORDS "CONTRACT HOLDER".

FOR PURCHASING AND PROCUREMENT SERVICES, NAMELY, PROCURING OF CONTRACTS FOR OTHERS FOR THE PURCHASE OF GOODS AND LABOR CONTRACTING SERVICES (U.S. CLS. 100, 101 AND 102).

DAVID YONTEF, EXAMINING ATTORNEY

---

SN 85-184,671. UDRESSIT COMPANY, MAQUOKETA, IA. FILED 11-24-2010.

## ONE LAST SALUTE

THE MARK CONSISTS OF STANDARD CHARACTERS WITHOUT CLAIM TO ANY PARTICULAR FONT, STYLE, SIZE, OR COLOR.

OWNER OF U.S. REG. NO. 3,842,949.

FOR ADVERTISING AND MARKETING; ADVERTISING AND MARKETING SERVICES, NAMELY, PROMOTING THE GOODS AND SERVICES OF OTHERS (U.S. CLS. 100, 101 AND 102).

KAREN SEVERSON, EXAMINING ATTORNEY

---

SN 85-184,673. UDRESSIT COMPANY, MAQUOKETA, IA. FILED 11-24-2010.

## ONE LAST TOAST

THE MARK CONSISTS OF STANDARD CHARACTERS WITHOUT CLAIM TO ANY PARTICULAR FONT, STYLE, SIZE, OR COLOR.

OWNER OF U.S. REG. NO. 3,842,949.

FOR ADVERTISING AND MARKETING; ADVERTISING AND MARKETING SERVICES, NAMELY, PROMOTING THE GOODS AND SERVICES OF OTHERS (U.S. CLS. 100, 101 AND 102).

KAREN SEVERSON, EXAMINING ATTORNEY

**CLASS 35—(Continued).**

SN 85-184,754. SLIGHTLY HEROIC MARKETING, LLC, HICKORY, NC. FILED 11-24-2010.



NO CLAIM IS MADE TO THE EXCLUSIVE RIGHT TO USE "APPROVED" AND "OFFICIAL SEAL", APART FROM THE MARK AS SHOWN.

THE COLOR(S) GOLD AND WHITE IS/ARE CLAIMED AS A FEATURE OF THE MARK.

THE MARK CONSISTS OF A DESIGN ELEMENT OF A SEAL IN THE COLORS GOLD AND WHITE. THE SEAL CONSISTS OF TWO OUTER RINGS SEPARATED BY WHITE SPACE. WITHIN THE WHITE SPACE, THE WORDING "ARMORMAN APPROVED" APPEARS IN GOLD IN THE UPPER PORTION AND THE WORDING "OFFICIAL SEAL" APPEARS IN GOLD IN THE LOWER PORTION. INSIDE THE TWO OUTER GOLDEN RINGS IS A CIRCULAR DESIGN ELEMENT IN GOLD THAT IS SEPARATED FROM THE INNER RING OF THE TWO OUTER RINGS BY WHITE SPACE. UPON THE INNER CIRCULAR DESIGN ELEMENT IN GOLD IS LOCATED THE WORDING "PEACE OF MIND" IN THE COLOR WHITE.

FOR ADVERTISING AND MARKETING (U.S. CLS. 100, 101 AND 102).

FIRST USE 2-1-2010; IN COMMERCE 2-1-2010.

NAPOLEON SHARMA, EXAMINING ATTORNEY

---

SN 85-184,859. NUNNA, SRINI R., CHICAGO, IL. FILED 11-24-2010.

## Racquet Sports FlexLeagues - Play a Match at Your Convenience

THE MARK CONSISTS OF STANDARD CHARACTERS WITHOUT CLAIM TO ANY PARTICULAR FONT, STYLE, SIZE, OR COLOR.

NO CLAIM IS MADE TO THE EXCLUSIVE RIGHT TO USE "RACQUET SPORTS FLEXLEAGUES", APART FROM THE MARK AS SHOWN.

FOR ADMINISTRATION OF COMMUNITY RECREATIONAL SPORTS LEAGUES; COORDINATION OF RECREATIONAL SPORTING OPPORTUNITIES FOR INDIVIDUALS WHO WISH TO PARTICIPATE IN TEAM LEAGUE SPORTS (U.S. CLS. 100, 101 AND 102).

ELLEN BURNS, EXAMINING ATTORNEY



**CLASS 35—(Continued).**

SN 85-184,863. ACADEMY AT YOUR SERVICE, LLC, ST. LOUIS PARK, MN. FILED 11-24-2010.

ACADEMY AT YOUR SERVICE

THE MARK CONSISTS OF STANDARD CHARACTERS WITHOUT CLAIM TO ANY PARTICULAR FONT, STYLE, SIZE, OR COLOR.

FOR ONLINE RETAIL STORE SERVICES AND MAIL ORDER CATALOG SERVICES FEATURING PRERECORDED DVDS ON THE SUBJECTS OF SOCIAL SCIENCES, PSYCHOLOGY, HISTORY, LITERATURE, FINE ARTS, PHILOSOPHY, THEOLOGY, LINGUISTICS, RELIGION, MUSIC, PERFORMING ARTS AND CREATIVE WRITING AND RELATED COURSE TRANSCRIPTS, OUTLINES AND GUIDEBOOKS (U.S. CLS. 100, 101 AND 102).

ELLEN BURNS, EXAMINING ATTORNEY

SN 85-184,869. DIAMOND OIL, LLC, OCALA, FL. FILED 11-24-2010.



NO CLAIM IS MADE TO THE EXCLUSIVE RIGHT TO USE "MART", APART FROM THE MARK AS SHOWN.

THE COLOR(S) WHITE, BLUE AND RED IS/ARE CLAIMED AS A FEATURE OF THE MARK.

THE MARK CONSISTS OF A RECTANGULAR DESIGN INCORPORATING THE WORDING "MART" IN STYLIZED LETTERING BELOW THE DESIGN OF A DIAMOND WITHIN TWO DIAMOND-SHAPED BORDER ELEMENTS. THE WORDING "MART", THE EXTERIOR DIAMOND SHAPED BORDER ELEMENT AND THE DIAMOND ARE WHITE. THE OUTLINE OF THE WORDING "MART" AND THE INTERIOR DIAMOND BORDER ELEMENT ARE RED. THE BACKGROUND OF THE RECTANGULAR DESIGN IS BLUE. THE LATTICE LINE OF THE DIAMOND DESIGN IS BLUE.

FOR RETAIL STORE SERVICES FEATURING CONVENIENCE STORE ITEMS; PROVIDING ASSISTANCE TO PROSPECTIVE OWNERS AND CUSTOMERS IN CONNECTION WITH THE LOCATION, DEVELOPMENT, ACQUISITION MANAGEMENT AND OPERATION OF RETAIL CONVENIENCE STORES (U.S. CLS. 100, 101 AND 102).

JOHN HWANG, EXAMINING ATTORNEY

**CLASS 35—(Continued).**

SN 85-185,460. STEPHENS, WAYNE L., DBA ARMADILLO CONSIGNMENT, SEATTLE, WA. FILED 11-26-2010.



NO CLAIM IS MADE TO THE EXCLUSIVE RIGHT TO USE "CONSIGNMENT", APART FROM THE MARK AS SHOWN.

THE MARK CONSISTS OF THE STYLIZED WORDING "ARMADILLO" ABOVE THE STYLIZED WORDING "CONSIGNMENT", AND THE STYLIZED DEPICTION OF AN ARMADILLO TO THE LEFT OF THE WORDING FORMED BY THREE CIRCULAR OUTLINES FORMING THE BODY, A TRIANGLE REPRESENTING THE HEAD, AND A HORIZONTAL LINE REPRESENTING THE TAIL.

FOR RETAIL CONSIGNMENT STORES FEATURING CLOTHING, HOUSEWARES, FURNITURE (U.S. CLS. 100, 101 AND 102).

FIRST USE 2-3-2010; IN COMMERCE 2-3-2010.

JAY BESCH, EXAMINING ATTORNEY

SN 85-185,527. CHIVITCHIAN, GRIGOR, HOLLYWOOD, CA. FILED 11-26-2010.

PINE FALLS

THE MARK CONSISTS OF STANDARD CHARACTERS WITHOUT CLAIM TO ANY PARTICULAR FONT, STYLE, SIZE, OR COLOR.

FOR RETAIL STORE SERVICES FEATURING A WIDE VARIETY OF CONSUMER GOODS, CAR ELECTRONICS, CELL PHONES, COMPUTER AND OFFICE PRODUCTS, ELECTRONICS, HEALTH AND BEAUTY SUPPLIES, HOME ENTERTAINMENT PRODUCTS, SPORTS AND OUTDOOR PRODUCTS, VIDEO GAMES AND CONSOLES, WATCHES AND JEWELRY, DIGITAL DOWNLOADS AND COSMETICS (U.S. CLS. 100, 101 AND 102).

MATTHEW EINSTEIN, EXAMINING ATTORNEY

**CLASS 35—(Continued).**

SN 85-185,638. GAPWORK CONSULTING LLC, ST. PAUL, MN. FILED 11-27-2010.



THE MARKS CONSISTS OF ADJACENT STYLIZED HUMAN FIGURES FORMING AN ARCHING STRUCTURE.

FOR PROVIDING EMPLOYMENT COUNSELING IN THE FIELD OF PROFESSIONAL DEVELOPMENT AND CAREER GROWTH; CONSULTING SERVICES IN THE FIELD OF HUMAN RESOURCES DEVELOPMENT, NAMELY, FOR THE PROMOTION OF PROFESSIONAL DEVELOPMENT AND CAREER GROWTH AND FOR ATTAINING GOALS IN THE NATURE OF INCREASED PRODUCTIVITY AND IMPROVED BUSINESS NETWORKING FOR THE EMPLOYED AND THE UNEMPLOYED (U.S. CLS. 100, 101 AND 102).

FIRST USE 10-3-2010; IN COMMERCE 10-3-2010.  
KRISTINA MORRIS, EXAMINING ATTORNEY

**CLASS 35—(Continued).**

SN 85-185,714. KHAN, LAWRENCE, FARMINGVILLE, NY. FILED 11-28-2010.

trademybook

THE MARK CONSISTS OF STANDARD CHARACTERS WITHOUT CLAIM TO ANY PARTICULAR FONT, STYLE, SIZE, OR COLOR.

FOR PROVIDING A WEB SITE WHERE USERS CAN POST ITEMS FOR SALE THROUGH ON-LINE CLASSIFIED ADVERTISEMENTS FEATURING ACADEMIC RELATED GOODS, NAMELY, CLASS NOTES AND BOOKS FOR UNIVERSITIES; PROVIDING AN ON-LINE SEARCHABLE DATABASE FEATURING CLASSIFIED AD LISTING FOR UNIVERSITIES (U.S. CLS. 100, 101 AND 102).

FIRST USE 4-24-2009; IN COMMERCE 4-24-2009.  
AMEEN IMAM, EXAMINING ATTORNEY

SN 85-185,642. GAPWORK CONSULTING LLC, ST. PAUL, MN. FILED 11-27-2010.

GAPWORK

THE MARK CONSISTS OF STANDARD CHARACTERS WITHOUT CLAIM TO ANY PARTICULAR FONT, STYLE, SIZE, OR COLOR.

FOR PROVIDING EMPLOYMENT COUNSELING IN THE FIELD OF PROFESSIONAL DEVELOPMENT AND CAREER GROWTH; CONSULTING SERVICES IN THE FIELD OF HUMAN RESOURCES DEVELOPMENT, NAMELY, FOR THE PROMOTION OF PROFESSIONAL DEVELOPMENT AND CAREER GROWTH AND FOR ATTAINING GOALS IN THE NATURE OF INCREASED PRODUCTIVITY AND IMPROVED BUSINESS NETWORKING FOR THE EMPLOYED AND THE UNEMPLOYED (U.S. CLS. 100, 101 AND 102).

FIRST USE 9-23-2010; IN COMMERCE 9-23-2010.  
KRISTINA MORRIS, EXAMINING ATTORNEY

SN 85-186,007. ENVIROPACK, LLC, LONGWOOD, FL. FILED 11-29-2010.

EnviroPack

THE COLOR(S) ORANGE, YELLOW, GREEN AND BLUE IS/ARE CLAIMED AS A FEATURE OF THE MARK.

THE MARK CONSISTS OF A STYLIZED, CAPITAL LETTER "E" IN THE COLOR ORANGE, A LOWER-CASE LETTER "N" IN PART ORANGE/PART YELLOW, A LOWER-CASE LETTER "V" IN THE COLOR YELLOW, A LOWER-CASE LETTER "I" IN PART YELLOW/PART GREEN, A LOWER-CASE LETTER "R" IN PART YELLOW/PART GREEN, A LOWER-CASE LETTER "O" IN THE COLOR GREEN, AN UPPER-CASE LETTER "P" IN THE COLOR "GREEN", A LOWER-CASE LETTER "A" IN PART GREEN/PART BLUE, A LOWER-CASE LETTER "C" IN PART GREEN/PART BLUE AND A LOWER-CASE LETTER "K" IN THE COLOR BLUE. ALL OF THE LETTERS ARE ALSO OUTLINED IN THE COLOR GREEN.

FOR ASSISTANCE IN BUSINESS MANAGEMENT AND PRODUCT COMMERCIALIZATION, WITHIN THE FRAMEWORK OF A FRANCHISE CONTRACT (U.S. CLS. 100, 101 AND 102).

FIRST USE 9-17-2010; IN COMMERCE 9-17-2010.  
LINDA ESTRADA, EXAMINING ATTORNEY

**CLASS 35—(Continued).**

SN 85-186,058. K2 ELECTRONICS, FLUSHING, NY. FILED 11-29-2010.



THE COLOR(S) BLUE, RED, WHITE IS/ARE CLAIMED AS A FEATURE OF THE MARK.

THE MARK CONSISTS OF A "V" WITH IN THE COLOR BLUE WITH WHITE TRIM. THE "V" APPEARS AS A POINTED ARROW WITH WINGS ON THE SIDE. THE LETTER "T" IN THE COLOR RED WITH WHITE TRIM APPEARS INSIDE THE "V". THE TERM, "TECVOZ", IN BLUE WITH WHITE TRIM APPEARS TO THE RIGHT OF THE "TV". THE "T" AND "V" IN "TECVOZ" APPEAR IN A SLIGHTLY BIGGER FONT THAN THE REST OF THE TERMS. THE ENTIRE MARK APPEARS ON A WHITE BACKGROUND.

FOR RETAIL ELECTRONIC SECURITY SYSTEMS STORES (U.S. CLS. 100, 101 AND 102).

CAROLINE WOOD, EXAMINING ATTORNEY

---

SN 85-186,068. MINNESOTA DEPARTMENT OF EMPLOYMENT AND ECONOMIC DEVELOPMENT, FORMERLY MINNESOTA DEPARTMENT OF TRADE AND ECONOMIC DEVELOPMENT, ST. PAUL, MN. FILED 11-29-2010.

**POSITIVELY MINNESOTA**

THE MARK CONSISTS OF STANDARD CHARACTERS WITHOUT CLAIM TO ANY PARTICULAR FONT, STYLE, SIZE, OR COLOR.

NO CLAIM IS MADE TO THE EXCLUSIVE RIGHT TO USE "MINNESOTA", APART FROM THE MARK AS SHOWN.

SEC. 2(F).

FOR PROMOTING PUBLIC AWARENESS OF THE OPPORTUNITIES AND ADVANTAGES OF WORKING AND LOCATING OR EXPANDING BUSINESSES IN MINNESOTA (U.S. CLS. 100, 101 AND 102).

FIRST USE 7-23-1996; IN COMMERCE 7-23-1996.

CAROLINE WOOD, EXAMINING ATTORNEY

---

SN 85-186,105. HARVEST LOCAL FOODS LLC, LANSDOWNE, PA. FILED 11-29-2010.

**Harvest Local Foods**

THE MARK CONSISTS OF STANDARD CHARACTERS WITHOUT CLAIM TO ANY PARTICULAR FONT, STYLE, SIZE, OR COLOR.

NO CLAIM IS MADE TO THE EXCLUSIVE RIGHT TO USE "LOCAL FOODS", APART FROM THE MARK AS SHOWN.

FOR RETAIL AND ON-LINE GROCERY STORE SERVICES FEATURING HOME DELIVERY SERVICE (U.S. CLS. 100, 101 AND 102).

FIRST USE 3-1-2010; IN COMMERCE 3-1-2010.

MARK SHINER, EXAMINING ATTORNEY

**CLASS 35—(Continued).**

SN 85-186,143. PAULA GRAFSTEIN-SUAREZ, COMMACK, NY. FILED 11-29-2010.

**COURTSIDE MARKET**

THE MARK CONSISTS OF STANDARD CHARACTERS WITHOUT CLAIM TO ANY PARTICULAR FONT, STYLE, SIZE, OR COLOR.

NO CLAIM IS MADE TO THE EXCLUSIVE RIGHT TO USE "MARKET", APART FROM THE MARK AS SHOWN.

FOR MAIL ORDER CATALOG SERVICES FEATURING A WIDE VARIETY OF CONSUMER GOODS OF OTHERS; ON-LINE RETAIL STORE SERVICES FEATURING A WIDE VARIETY OF CONSUMER GOODS OF OTHERS; RETAIL STORE AND ON-LINE RETAIL STORE SERVICES FEATURING A WIDE VARIETY OF CONSUMER GOODS OF OTHERS; RETAIL STORE SERVICES FEATURING A WIDE VARIETY OF CONSUMER GOODS OF OTHERS (U.S. CLS. 100, 101 AND 102).

BENJAMIN OKEKE, EXAMINING ATTORNEY

---

SN 85-186,151. OMX, INC., NAPERVILLE, IL. FILED 11-29-2010.

**AMERICA SAVES**

THE MARK CONSISTS OF STANDARD CHARACTERS WITHOUT CLAIM TO ANY PARTICULAR FONT, STYLE, SIZE, OR COLOR.

FOR RETAIL STORE SERVICES AND ON-LINE RETAIL STORE SERVICES FEATURING OFFICE AND SCHOOL SUPPLIES, OFFICE FURNITURE, PRINTING PRODUCTS AND SERVICES, AND CLEANING AND BREAKROOM SUPPLIES; BUSINESS SERVICES, NAMELY, COMBINED STRATEGIC GOODS SOURCING AND COOPERATIVE PURCHASING FOR OTHERS; AND PROVIDING REBATES FOR PARTICIPATING IN COOPERATIVE PURCHASING PROGRAM AS PART OF A CUSTOMER LOYALTY PROGRAM (U.S. CLS. 100, 101 AND 102).

FIRST USE 6-0-2004; IN COMMERCE 6-0-2004.

ANDREW RHIM, EXAMINING ATTORNEY

**CLASS 35—(Continued).**

SN 85-186,257. GENERATION SEVEN STRATEGIC PARTNERS, LLC, SCOTTSDALE, AZ. FILED 11-29-2010.



NO CLAIM IS MADE TO THE EXCLUSIVE RIGHT TO USE "STRATEGIC PARTNERS", APART FROM THE MARK AS SHOWN.

THE MARK CONSISTS OF THE TERM "G7" IN STYLIZED FONT ABOVE THE WORDS "GENERATIONSEVEN" AND "STRATEGIC PARTNERS".

FOR BUSINESS ADVISORY SERVICES, CONSULTANCY AND INFORMATION IN THE FIELD OF TRIBAL GOVERNMENT RELATIONS (U.S. CLS. 100, 101 AND 102).

FIRST USE 2-16-2005; IN COMMERCE 4-16-2005.  
DAVID YONTEF, EXAMINING ATTORNEY

SN 85-186,296. GENESIS REHABILITATION SERVICES, INC., KENNETT SQUARE, PA. FILED 11-29-2010.

CREATING REMARKABLE  
EXPERIENCES

THE MARK CONSISTS OF STANDARD CHARACTERS WITHOUT CLAIM TO ANY PARTICULAR FONT, STYLE, SIZE, OR COLOR.

FOR EMPLOYEE RECRUITMENT IN THE FIELDS OF REHABILITATION THERAPY, NURSING FACILITIES AND ASSISTED LIVING CENTERS (U.S. CLS. 100, 101 AND 102).

REBECCA GILBERT, EXAMINING ATTORNEY

SN 85-186,342. GENERATION SEVEN STRATEGIC PARTNERS, LLC, SCOTTSDALE, AZ. FILED 11-29-2010.



THE COLOR(S) COPPER IS/ARE CLAIMED AS A FEATURE OF THE MARK.

THE MARK CONSISTS OF THE TERM "G7" IN COPPER STYLIZED FONT.

FOR BUSINESS CONSULTATION IN THE FIELD OF TRIBAL GOVERNMENT RELATIONS (U.S. CLS. 100, 101 AND 102).

FIRST USE 2-16-2005; IN COMMERCE 4-16-2005.  
DAVID YONTEF, EXAMINING ATTORNEY

**CLASS 35—(Continued).**

SN 85-186,490. WALSH, DAVID, FALLS CHURCH, VA. FILED 11-29-2010.



FOR BUSINESS CONSULTING AND INFORMATION SERVICES; CONSULTING IN THE FIELD OF PROCURING GOVERNMENT CONTRACTS FOR THE PURCHASE OF GOODS AND LABOR CONTRACTING SERVICES; CONSULTING REGARDING INTELLECTUAL PROPERTY BUSINESS RISK MITIGATION PROCESSES; DISASTER RECOVERY SERVICES, NAMELY, BUSINESS PLANNING AND BUSINESS CONTINUITY CONSULTING; PROVIDING BUSINESS INTELLIGENCE SERVICES (U.S. CLS. 100, 101 AND 102).

FIRST USE 3-13-2008; IN COMMERCE 3-13-2008.  
DAVID ELTON, EXAMINING ATTORNEY

SN 85-186,627. CAUTHEN COMPANIES LLC, GILBERT, AZ. FILED 11-29-2010.



THE MARK CONSISTS OF THE STYLIZED TEXT "THE PINK TRAILER" IN A STACKED FORMATION.

FOR MOBILE RETAIL CLOTHING BOUTIQUE SERVICES FEATURING JEWELRY, BAGS, CLOTHING, AND ACCESSORIES (U.S. CLS. 100, 101 AND 102).

ARETHA SOMERVILLE, EXAMINING ATTORNEY

SN 85-186,721. BUMANGLAG, ANTONIO, RIVER FOREST, IL. FILED 11-29-2010.



NO CLAIM IS MADE TO THE EXCLUSIVE RIGHT TO USE "MMA GEAR GUIDE", APART FROM THE MARK AS SHOWN.

THE MARK CONSISTS OF A FIST WITH THE STYLIZED TEXT "MMA GEAR GUIDE".

FOR PROVIDING A WEBSITE FEATURING CONSUMER INFORMATION ABOUT MIXED MARTIAL ARTS EQUIPMENT AND CLOTHING (U.S. CLS. 100, 101 AND 102).

PAUL E. FAHRENKOPF, EXAMINING ATTORNEY

**CLASS 35—(Continued).**

SN 85-186,971. KEY, DAVID, CLOVIS, CA. AND ASAY, MARCUS, CLOVIS, CA. FILED 11-30-2010.



THE MARK CONSISTS OF THE STYLIZED WORD "SNEAKLET". AN IMAGE OF A "GO" BUTTON WITHIN A VIDEO FILM CLIP TO THE LEFT OF THE TEXT.

FOR PROVIDING AN INTERNET WEBSITE PORTAL FEATURING SHORT VIDEO PREVIEWS OF EMPLOYMENT OPPORTUNITIES, JOB POSTINGS, TEXT AND VIDEO RESUMES, AND ADVERTISEMENTS (U.S. CLS. 100, 101 AND 102).

RONALD MCMORROW, EXAMINING ATTORNEY

---

SN 85-187,032. MEDLINE INDUSTRIES, INC., MUNDELEIN, IL. FILED 11-30-2010.

**PINK GLOVE DANCE DAY**

THE MARK CONSISTS OF STANDARD CHARACTERS WITHOUT CLAIM TO ANY PARTICULAR FONT, STYLE, SIZE, OR COLOR.

NO CLAIM IS MADE TO THE EXCLUSIVE RIGHT TO USE "DANCE DAY", APART FROM THE MARK AS SHOWN.

FOR PROMOTING THE PUBLIC INTEREST AND AWARENESS IN CANCER RESEARCH AND EDUCATION (U.S. CLS. 100, 101 AND 102).

ALYSSA STEEL, EXAMINING ATTORNEY

---

SN 85-187,123. FARRAN MEDIA, L.L.C., PHOENIX, AZ. FILED 11-30-2010.

**With Dentaltown... no  
dentist will ever have to  
practice solo again.**

THE MARK CONSISTS OF STANDARD CHARACTERS WITHOUT CLAIM TO ANY PARTICULAR FONT, STYLE, SIZE, OR COLOR.

OWNER OF U.S. REG. NOS. 2,686,132, 2,890,978 AND OTHERS.

FOR ADVERTISING AND DIRECTORY SERVICES, NAMELY, PROMOTING THE PRODUCTS AND SERVICES OF OTHERS DIRECTED TO DENTISTS AND DENTAL OFFICES BY PROVIDING A WEB PAGE FEATURING LINKS TO THE WEBSITES OF OTHERS (U.S. CLS. 100, 101 AND 102).

FIRST USE 10-15-2010; IN COMMERCE 10-15-2010.

JEFFERY COWARD, EXAMINING ATTORNEY

**CLASS 35—(Continued).**

SN 85-187,149. TECHCFO HOLDING, INC., ATLANTA, GA. FILED 11-30-2010.



OWNER OF U.S. REG. NOS. 3,539,901 AND 3,886,251.

THE COLOR(S) YELLOW AND BLUE IS/ARE CLAIMED AS A FEATURE OF THE MARK.

THE MARK CONSISTS OF A ONE WORD MARK WITH "TECH" IN YELLOW AND "CMO" IN BLUE.

FOR BUSINESS CONSULTING SERVICES FOR MARKETING STRATEGY, MESSAGING, POSITIONING, DEMAND GENERATION, PRODUCT MARKETING, CHANNEL MARKETING, PUBLIC RELATIONS, AND MARKETING BEST PRACTICES AND TRAINING (U.S. CLS. 100, 101 AND 102).

PAULA MAHONEY, EXAMINING ATTORNEY

---

SN 85-187,226. RADIATOREXPRESS.COM, INC. MANA-HAWKIN, NJ. FILED 11-30-2010.



OWNER OF U.S. REG. NO. 3,759,554.

NO CLAIM IS MADE TO THE EXCLUSIVE RIGHT TO USE "RADIATOR EXPRESS", APART FROM THE MARK AS SHOWN.

THE MARK CONSISTS OF THE WORD "RADIATOR" ON TOP OF THE WORD "EXPRESS" IN STYLIZED LETTERING WITH A CHECKERED FLAG TO ATTACHED TO THE RIGHT SIDE OF THE WORDS.

FOR MAIL ORDER SERVICES FEATURING VEHICLE PARTS AND ACCESSORIES FOR AUTOMOBILES AND TRUCKS; ON-LINE RETAIL STORE SERVICES FEATURING VEHICLE PARTS AND ACCESSORIES FOR AUTOMOBILES AND TRUCKS; WHOLESALE AND RETAIL STORE SERVICES FEATURING AUTOMOBILE PARTS AND ACCESSORY (U.S. CLS. 100, 101 AND 102).

FIRST USE 9-0-2010; IN COMMERCE 9-0-2010.

MICHAEL WEBSTER, EXAMINING ATTORNEY

**CLASS 35—(Continued).**

SN 85-187,265. BADEAU, FRANCOIS, LAS VEGAS, NV.  
FILED 11-30-2010.

## JUST FORGET ABOUT IT, LET'S GO TO VEGAS

THE MARK CONSISTS OF STANDARD CHARACTERS WITHOUT CLAIM TO ANY PARTICULAR FONT, STYLE, SIZE, OR COLOR.

NO CLAIM IS MADE TO THE EXCLUSIVE RIGHT TO USE "VEGAS", APART FROM THE MARK AS SHOWN.

FOR PROMOTING THE LAS VEGAS, NEVADA AREA AS A DESTINATION FOR LEISURE AND BUSINESS (U.S. CLS. 100, 101 AND 102).

PAULA MAHONEY, EXAMINING ATTORNEY

---

SN 85-187,289. BADEAU, FRANCOIS, LAS VEGAS, NV.  
FILED 11-30-2010.

## I NEED MY VEGAS FIX

THE MARK CONSISTS OF STANDARD CHARACTERS WITHOUT CLAIM TO ANY PARTICULAR FONT, STYLE, SIZE, OR COLOR.

NO CLAIM IS MADE TO THE EXCLUSIVE RIGHT TO USE "VEGAS", APART FROM THE MARK AS SHOWN.

FOR PROMOTING THE LAS VEGAS, NEVADA AREA AS A DESTINATION FOR LEISURE AND BUSINESS (U.S. CLS. 100, 101 AND 102).

PAULA MAHONEY, EXAMINING ATTORNEY

---

SN 85-187,303. WILSON, MARTIN, DBA ALKEMY BUSINESS SYSTEMS, MESA, AZ. FILED 11-30-2010.

## Alkemy Business Systems

THE MARK CONSISTS OF STANDARD CHARACTERS WITHOUT CLAIM TO ANY PARTICULAR FONT, STYLE, SIZE, OR COLOR.

NO CLAIM IS MADE TO THE EXCLUSIVE RIGHT TO USE "BUSINESS SYSTEMS", APART FROM THE MARK AS SHOWN.

FOR BUSINESS CONSULTING SERVICES IN THE FIELD OF INTERNET MARKETING (U.S. CLS. 100, 101 AND 102).

JOHN WILKE, EXAMINING ATTORNEY

**CLASS 35—(Continued).**

SN 85-187,369. THE GET IN TOUCH FOUNDATION, INC.,  
MILFORD, CT. FILED 11-30-2010.

## GIT PINKIFIED

THE MARK CONSISTS OF STANDARD CHARACTERS WITHOUT CLAIM TO ANY PARTICULAR FONT, STYLE, SIZE, OR COLOR.

OWNER OF U.S. REG. NO. 3,736,678.

FOR PROMOTING PUBLIC AWARENESS OF THE PROPER PROCEDURE FOR SELF-BREAST EXAMINATION, OF THE DISEASE OF CANCER, OF CANCER PREVENTION, OF CANCER TREATMENTS, AND OF CANCER CURES; PROMOTING PUBLIC AWARENESS OF THE NEED FOR EDUCATING PEOPLE ON THE SUBJECTS OF THE PROPER PROCEDURE FOR SELF-BREAST EXAMINATION, CANCER, CANCER PREVENTION, CANCER TREATMENT, AND CANCER CURE; PROMOTING PUBLIC AWARENESS OF THE PROPER PROCEDURE FOR SELF-BREAST EXAMINATION, OF THE DISEASE OF CANCER, OF CANCER PREVENTION, OF CANCER TREATMENTS, AND OF CANCER CURES THROUGH THE DISTRIBUTION OF PRINTED MATERIALS, INTERNET WEBSITES, AUDIO AND VIDEO RECORDINGS, AND OTHER MEDIUMS AIMED AT REACHING THE PUBLIC (U.S. CLS. 100, 101 AND 102).

ANTHONY RINKER, EXAMINING ATTORNEY

---

SN 85-187,380. MEDICAL BIDLINE, INC., LAKE MARY, FL.  
FILED 11-30-2010.

## MEDICAL BIDLINE

THE MARK CONSISTS OF STANDARD CHARACTERS WITHOUT CLAIM TO ANY PARTICULAR FONT, STYLE, SIZE, OR COLOR.

NO CLAIM IS MADE TO THE EXCLUSIVE RIGHT TO USE "MEDICAL", APART FROM THE MARK AS SHOWN.

FOR ON-LINE AUCTION BIDDING FOR OTHERS IN THE FIELD OF MEDICAL GOODS AND SERVICES (U.S. CLS. 100, 101 AND 102).

FIRST USE 4-2-2010; IN COMMERCE 4-2-2010.

EDWARD FENNESSY, EXAMINING ATTORNEY

**CLASS 35—(Continued).**

SN 85-187,507. UNITED DATA TECHNOLOGIES, INC., DORAL, FL. FILED 11-30-2010.

# MD IN A BOX

THE MARK CONSISTS OF STANDARD CHARACTERS WITHOUT CLAIM TO ANY PARTICULAR FONT, STYLE, SIZE, OR COLOR.

NO CLAIM IS MADE TO THE EXCLUSIVE RIGHT TO USE "MD", APART FROM THE MARK AS SHOWN.

FOR PROVIDING A WEB-BASED SYSTEM AND ON-LINE PORTAL IN THE FIELD OF CONSUMER-TO-BUSINESS COMMERCE FOR CONSUMERS TO ENTER, MANAGE AND PURCHASE PRODUCTS AND SERVICES FROM A SINGLE SOURCE FOR USE BY HOSPITALS, PHYSICIANS' OFFICES, MEDICAL PRACTITIONERS, INSURANCE COMPANIES AND HOME HEALTH AGENCIES (U.S. CLS. 100, 101 AND 102).

MARGERY A. TIERNEY, EXAMINING ATTORNEY

SN 85-187,750. THE MK ELEMENT LLC, ATLANTA, GA. FILED 11-30-2010.



NO CLAIM IS MADE TO THE EXCLUSIVE RIGHT TO USE "MARKETING", APART FROM THE MARK AS SHOWN.

THE MARK CONSISTS OF THE NUMBER "360" ABOVE AND TO THE RIGHT THE LETTERS "MK", THE TERM "MARKETING" BELOW THE LETTERS "MK" AND THE WORDING "6E+10" BELOW THE TERM "MARKETING", ALL WITHIN A RECTANGULAR CARRIER.

FOR MARKETING CONSULTING (U.S. CLS. 100, 101 AND 102).

FIRST USE 7-1-2010; IN COMMERCE 7-1-2010.  
SALLY SHIH, EXAMINING ATTORNEY

**CLASS 35—(Continued).**

SN 85-187,897. ALDRIDGE, MICHAEL D., NEWARK, DE. FILED 12-1-2010.



NO CLAIM IS MADE TO THE EXCLUSIVE RIGHT TO USE "AUTOS.COM", "OUTSTANDING SERVICE", "QUALITY CARS", AND "NO PAYMENTS", APART FROM THE MARK AS SHOWN.

THE COLOR(S) RED, BLACK, BLUE, AND GOLD IS/ARE CLAIMED AS A FEATURE OF THE MARK.

THE MARK CONSISTS OF A RED OUTLINE REPRESENTING A CAR, THE WORD "5KORLESS" WITH THE "5K" IN RED AND THE "ORLESS" IN BLACK; A GOLD STAR WITH BLACK OUTLINE TO THE RIGHT; THE WORDS "AUTOS.COM" IN BLUE BELOW; A BLACK HORIZONTAL LINE BELOW "AUTOS.COM" WITH THE FOLLOWING WORDING BELOW: "OUTSTANDING SERVICE" "QUALITY CARS" "NO PAYMENTS" IN BLACK.

FOR AUTOMOBILE DEALERSHIPS (U.S. CLS. 100, 101 AND 102).

FIRST USE 7-1-2010; IN COMMERCE 7-1-2010.

MAYUR VAGHANI, EXAMINING ATTORNEY

SN 85-188,014. MEDLINE INDUSTRIES, INC., MUNDELEIN, IL. FILED 12-1-2010.

# PINK GLOVE DANCE

THE MARK CONSISTS OF STANDARD CHARACTERS WITHOUT CLAIM TO ANY PARTICULAR FONT, STYLE, SIZE, OR COLOR.

NO CLAIM IS MADE TO THE EXCLUSIVE RIGHT TO USE "DANCE", APART FROM THE MARK AS SHOWN.

FOR PROMOTING THE PUBLIC INTEREST AND AWARENESS IN CANCER RESEARCH AND EDUCATION (U.S. CLS. 100, 101 AND 102).

FIRST USE 10-0-2009; IN COMMERCE 10-0-2009.

ALYSSA STEEL, EXAMINING ATTORNEY

**CLASS 35—(Continued).**

SN 85-188,058. SIMROD OUTDOORS, LLC, LA VERNIA, TX. FILED 12-1-2010.



NO CLAIM IS MADE TO THE EXCLUSIVE RIGHT TO USE "REDFISH ANGLERS ASSOCIATION", APART FROM THE MARK AS SHOWN.

THE MARK CONSISTS OF THE WORDING "RAA REDFISH ANGLERS ASSOCIATION" WITH THE DESIGN OF TWO FISHERMEN ON A FISHING BOAT, ALL WITHIN A RECTANGLE WITH ROUNDED CORNERS.

FOR ASSOCIATION SERVICES, NAMELY, PROMOTING THE INTERESTS OF ANGLERS (U.S. CLS. 100, 101 AND 102).

IRA J. GOODSAY, EXAMINING ATTORNEY

SN 85-188,077. MEDIACOM COMMUNICATIONS CORPORATION, MIDDLETOWN, NY. FILED 12-1-2010.



OWNER OF U.S. REG. NO. 3,796,336.

THE MARK CONSISTS OF THE WORD "RAVVID" IN STYLIZED LETTERING WITH A STAR DESIGN ABOVE THE LETTER "I".

FOR ONLINE BUSINESS DIRECTORY SERVICES REGARDING THE PURCHASE AND SALE OF A WIDE VARIETY OF PRODUCTS AND SERVICES OF OTHERS; ADVERTISING AND MARKETING SERVICES (U.S. CLS. 100, 101 AND 102).

CORY BOONE, EXAMINING ATTORNEY

SN 85-188,264. TYNER, VINCENT, BROWNSVILLE, TX. FILED 12-1-2010.



THE MARK CONSISTS OF THE STYLIZED TEXT "ZOMBIE THINGS.COM", WITH "ZOMBIE" ON TOP AND "THINGS.COM" ON THE BOTTOM. IN THE MIDDLE IS THE DESIGN OF A ZOMBIE HOLDING THE HEAD OF ANOTHER ZOMBIE WHICH IS FORMING THE LETTER "O" IN "ZOMBIE".

FOR ON-LINE RETAIL STORE SERVICES FEATURING CLOTHING AND ACCESSORIES (U.S. CLS. 100, 101 AND 102).

SCOTT BIBB, EXAMINING ATTORNEY

**CLASS 35—(Continued).**

SN 85-188,460. TRAMPS AND REJECTS, INC., SAN DIEGO, CA. FILED 12-1-2010.

**L.E.D. PRESENTS**

THE MARK CONSISTS OF STANDARD CHARACTERS WITHOUT CLAIM TO ANY PARTICULAR FONT, STYLE, SIZE, OR COLOR.

NO CLAIM IS MADE TO THE EXCLUSIVE RIGHT TO USE "PRESENTS", APART FROM THE MARK AS SHOWN.

FOR PROMOTING LIVE ENTERTAINMENT EVENTS FOR OTHERS AND MERCHANDISE RELATED THERETO; BUSINESS AND EVENT MANAGEMENT OF LIVE ENTERTAINMENT EVENTS; OPERATION AND MANAGEMENT OF ENTERTAINMENT VENUES; RETAIL STORE SERVICES FEATURING ARTIST AND TOUR-RELATED MERCHANDISE; PROMOTING TICKET SALES FOR LIVE ENTERTAINMENT EVENTS (U.S. CLS. 100, 101 AND 102).

FIRST USE 1-1-2009; IN COMMERCE 1-1-2009.

JOHN WILKE, EXAMINING ATTORNEY

SN 85-188,752. K AND G CYCLES LLC, DBA K AND G CYCLES, LAWRENCE, KS. FILED 12-1-2010.



NO CLAIM IS MADE TO THE EXCLUSIVE RIGHT TO USE "CYCLES", APART FROM THE MARK AS SHOWN.

THE COLOR(S) BLUE-SILVER CHROME, BLACK, AND GRAY ARE CLAIMED AS A FEATURE OF THE MARK. IS/ ARE CLAIMED AS A FEATURE OF THE MARK.

THE MARK CONSISTS OF THE BLUE-SILVER CHROME AND BLACK STYLIZED LETTER "K" WITH BLACK SHADOW NEXT TO THE SYMBOL "&" IN BLACK WITH GRAY SHADOW NEXT TO THE BLUE-SILVER CHROME AND BLACK STYLIZED WORD "CYCLES" CONTAINING INCOMPLETE BOTTOMS AND A BLACK SHADOW, AND THE BLUE-SILVER CHROME AND BLACK STYLIZED LETTER G WITH BLACK SHADOW TOUCHING THE BOTTOM RIGHT CORNER OF THE LETTER "K" AND THE BOTTOM LEFT CORNER OF THE FIRST "C" IN "CYCLES".

FOR RETAIL STORE SERVICES FEATURING MOTORCYCLE PARTS AND ACCESSORIES, EXHAUSTS, SEATS, MIRRORS, TIRES, WHEELS, CLUTCHES, RISERS, HELMETS, HANDLEBARS, LIGHTS, WINDSHIELDS, SHOCKS, FRAMES AND SADDLEBAGS, FOR ALL TYPES OF MOTORCYCLES (U.S. CLS. 100, 101 AND 102).

FIRST USE 2-4-2009; IN COMMERCE 2-4-2009.

KATHERINE CONNOLLY, EXAMINING ATTORNEY



**CLASS 35—(Continued).**

SN 85-188,823. VISTAEDGE INC, MORRISVILLE, NC. FILED 12-1-2010.

HALFDEALS.COM

THE MARK CONSISTS OF STANDARD CHARACTERS WITHOUT CLAIM TO ANY PARTICULAR FONT, STYLE, SIZE, OR COLOR.

FOR PROMOTING THE GOODS AND SERVICES OF OTHERS BY PROVIDING A WEBSITE FEATURING COUPONS, REBATES, PRICE-COMPARISON INFORMATION, PRODUCT REVIEWS, LINKS TO THE RETAIL WEBSITES OF OTHERS, AND DISCOUNT INFORMATION (U.S. CLS. 100, 101 AND 102).

FIRST USE 5-1-2006; IN COMMERCE 5-1-2006.  
FLORENTINA BLANDU, EXAMINING ATTORNEY

**CLASS 35—(Continued).**

SN 85-188,932. ASSOCIAÇÃO BRASILEIRA DA INDÚSTRIA DE HIGIENE PESSOAL, PERFUMARIA E COSMÉTICOS ABIHPEC, SÃO PAULO, BRAZIL, FILED 12-2-2010.

beautycare   
BRAZIL

NO CLAIM IS MADE TO THE EXCLUSIVE RIGHT TO USE "BEAUTYCARE BRAZIL", APART FROM THE MARK AS SHOWN.

THE MARK CONSISTS OF THE WORD "BEAUTYCARE" ABOVE THE WORD "BRAZIL", ALL IN STYLIZED LETTERING, TO THE LEFT OF A STYLIZED DESIGN OF LEAVES.

FOR PROMOTIONAL SERVICES, NAMELY, DISTRIBUTION OF CATALOGS AND PROMOTIONAL ITEMS OF OTHERS; PROVIDING COMMERCIAL MANAGEMENT ASSISTANCE ADVICE; PROVIDING BUSINESS CONSULTING AND BUSINESS TECHNICAL INFORMATION FOR COMPANIES IN THE INDUSTRY SECTORS OF HYGIENE, PERFUMERY AND COSMETICS; BUSINESS ADVISORY AND CONSULTANCY SERVICES RELATING TO EXPORT, EXPORT SERVICES, EXPORT PROMOTION INFORMATION AND SERVICES, CONSULTATION RELATING TO TRADE FAIRS, CONSULTATION RELATING TO EVENTS FOR COMMERCIAL OR ADVERTISING PURPOSES; SALES PROMOTION FOR OTHERS; ORGANIZATION OF TRADE FAIRS FOR COMMERCIAL OR ADVERTISING PURPOSES; BUSINESS ADVICE AND INFORMATION; DISTRIBUTION OF ADVERTISING MATERIALS; DISTRIBUTION OF PROMOTIONAL SAMPLES PROVIDING BUSINESS CONSULTING AND BUSINESS TECHNICAL INFORMATION FOR COMPANIES IN THE INDUSTRY SECTORS OF HYGIENE, PERFUMERY AND COSMETICS (U.S. CLS. 100, 101 AND 102).

REBECCA POVARCHUK, EXAMINING ATTORNEY

SN 85-188,840. GUMANGAN, MAILENE, VAN NUYS, CA. FILED 12-2-2010.

FUNNEL BITES

THE MARK CONSISTS OF STANDARD CHARACTERS WITHOUT CLAIM TO ANY PARTICULAR FONT, STYLE, SIZE, OR COLOR.

NO CLAIM IS MADE TO THE EXCLUSIVE RIGHT TO USE "FUNNEL", APART FROM THE MARK AS SHOWN.

FOR DESSERT SHOPS (U.S. CLS. 100, 101 AND 102).  
ADA HAN, EXAMINING ATTORNEY

SN 85-188,970. GAJIC, MOMIR, CHICAGO, IL. FILED 12-2-2010.



THE COLOR(S) BLUE, WHITE AND GREY IS/ARE CLAIMED AS A FEATURE OF THE MARK.

THE MARK CONSISTS OF THE WORDS "IT'S" AND "PLAY" IN LIGHT GREY TYPE ON A DARKER GREY BACKGROUND. BETWEEN THOSE WORDS IS A BLUE RECTANGLE WITH A TRIANGLE CUT OUT OF THE LEFT SIDE AND THE WORD "MY" IN WHITE APPEARS ON THE BLUE RECTANGLE.

FOR ADVERTISEMENT FOR OTHERS ON THE INTERNET; ADVERTISING AND DIRECTORY SERVICES, NAMELY, PROMOTING THE SERVICES OF OTHERS BY PROVIDING A WEB PAGE FEATURING LINKS TO THE WEBSITES OF OTHERS; SPORTS RECRUITING SERVICES FOR HIGH SCHOOL ATHLETES; THE BRINGING TOGETHER OF CONSUMERS AND PROVIDERS OF A VARIETY OF GOODS AND SERVICES IN THE FIELD OF ATHLETICS FOR COMMERCIAL PURPOSES VIA THE INTERNET (U.S. CLS. 100, 101 AND 102).

FIRST USE 6-18-2010; IN COMMERCE 6-18-2010.  
DOMINICK J. SALEMI, EXAMINING ATTORNEY

**CLASS 35—(Continued).**

SN 85-189,015. GINDER GREENHOUSE & GARDEN CENTER, INC., BANGOR, PA. FILED 12-2-2010.



NO CLAIM IS MADE TO THE EXCLUSIVE RIGHT TO USE "GREENHOUSE & GARDEN CENTER, INC." AND "SPECIAL FERTILIZER GUARANTEED", APART FROM THE MARK AS SHOWN.

THE MARK CONSISTS OF A DISPLAY OF FLOWERS AND BAG OF FERTILIZER WITH THE WORDING "BOB'S SPECIAL FERTILIZER GUARANTEED" THEREON, IN FRONT OF A GREENHOUSE WINDOW WITH THE WORD "GINDER" IN AN ARC OVER THE TOP OF THE GREENHOUSE WINDOW AND THE WORDING "GREENHOUSE & GARDEN CENTER, INC." BELOW THE WINDOW.

FOR RETAIL GARDEN STORE SERVICES (U.S. CLS. 100, 101 AND 102).

FIRST USE 11-1-2010; IN COMMERCE 11-1-2010.  
LAURA KOVALSKY, EXAMINING ATTORNEY

SN 85-189,050. FOCUS HEALTHCARE GROUP, LLC, FORT COLLINS, CO. FILED 12-2-2010.



NO CLAIM IS MADE TO THE EXCLUSIVE RIGHT TO USE "INNOVATIVE SEARCH SOLUTIONS", APART FROM THE MARK AS SHOWN.

THE MARK CONSISTS OF A 5 SECTIONED, STYLIZED PINWHEEL WITH THE STYLIZED TEXT "FOCUSHEALTHCAREGROUP INNOVATIVE SEARCH SOLUTIONS" BELOW THE PINWHEEL DESIGN.

FOR MEDICAL PERSONNEL RECRUITMENT SERVICES AND CONSULTATION RELATED THERETO (U.S. CLS. 100, 101 AND 102).

FIRST USE 9-16-2010; IN COMMERCE 9-16-2010.  
NANCY CLARKE, EXAMINING ATTORNEY

**CLASS 35—(Continued).**

SN 85-189,162. ACCOUNTAGILITY, LLC, WAXHAW, NC. FILED 12-2-2010.

## Accountagility, LLC

THE MARK CONSISTS OF STANDARD CHARACTERS WITHOUT CLAIM TO ANY PARTICULAR FONT, STYLE, SIZE, OR COLOR.

NO CLAIM IS MADE TO THE EXCLUSIVE RIGHT TO USE "LLC", APART FROM THE MARK AS SHOWN.

FOR BUSINESS DEVELOPMENT CONSULTING SERVICES (U.S. CLS. 100, 101 AND 102).

FIRST USE 11-3-2010; IN COMMERCE 11-3-2010.  
SIMON TENG, EXAMINING ATTORNEY

SN 85-189,264. DIABETICARE LLC, DBA ALL VITAMINS PLUS.COM, LAKE WORTH, FL. FILED 12-2-2010.



NO CLAIM IS MADE TO THE EXCLUSIVE RIGHT TO USE "VITAMINS", APART FROM THE MARK AS SHOWN.

THE COLOR(S) BLUE AND GREEN IS/ARE CLAIMED AS A FEATURE OF THE MARK.

THE MARK CONSISTS OF OVAL OUTLINE IN BLUE, "ALL VITAMINS PLUS.COM" IN BLUE, A LEAF IMAGE IN BLUE, TWO LINES IN GREEN.

FOR PROVIDING A SEARCHABLE ONLINE ADVERTISING WEBSITE AND INFORMATIONAL GUIDE FEATURING THE GOODS AND SERVICES OF OTHER VENDORS VIA THE INTERNET IN THE FIELD OF VITAMINS AND MINERALS, BEAUTY PRODUCTS, SUPPLEMENTS, HOME PRODUCTS AND PET CARE (U.S. CLS. 100, 101 AND 102).

FIRST USE 10-15-2007; IN COMMERCE 10-15-2007.  
MIDGE BUTLER, EXAMINING ATTORNEY

**CLASS 35—(Continued).**

SN 85-189,400. IRWIN, JASON, OAK PARK, IL. AND APPLASAMY, PRAMEN, CHICAGO, IL. AND KONERU, NAGENDRA, CHICAGO, IL. FILED 12-2-2010.



THE COLOR(S) GREEN, BROWN, BEIGE, RED, BLACK AND GRAY IS/ARE CLAIMED AS A FEATURE OF THE MARK.

THE MARK CONSISTS OF THE WORDS "SCRUBMONKEY" WITH A BROWN AND BEIGE MONKEY WITH BLACK EYES AND A RED MOUTH, WEARING GREEN MEDICAL SCRUBS AND A BLACK AND GRAY STETHOSCOPE AROUND ITS NECK DANGLING FROM THE "E" IN "SCRUBMONKEY". THE WORDS "SCRUBMONKEY" ARE IN GRAY LETTERS.

FOR PROVIDING ONLINE EMPLOYMENT INFORMATION IN THE FIELD OF JOB RESOURCES, JOB LISTINGS AND JOB POSTINGS FOR HEALTHCARE PROFESSIONALS; PROVIDING ONLINE JOB SEARCH INFORMATION, CAREER INFORMATION AND EMPLOYMENT PLACEMENT INFORMATION IN THE MEDICAL CAREER FIELD; PROVIDING ONLINE BUSINESS NETWORKING SERVICES FOR HEALTHCARE PROFESSIONALS (U.S. CLS. 100, 101 AND 102).

MARGERY A. TIERNEY, EXAMINING ATTORNEY

---

SN 85-189,581. TEAM ESTROGEN, INC., HILLSBORO, OR. FILED 12-2-2010.

**team estrogen**

THE MARK CONSISTS OF STANDARD CHARACTERS WITHOUT CLAIM TO ANY PARTICULAR FONT, STYLE, SIZE, OR COLOR.

FOR ON-LINE RETAIL APPAREL STORES (U.S. CLS. 100, 101 AND 102).

FIRST USE 8-1-1998; IN COMMERCE 9-1-1998.

ANDREA K. NADELMAN, EXAMINING ATTORNEY

**CLASS 35—(Continued).**

SN 85-189,616. SKY 26 ENTERPRISE INC., NEW YORK, NY. FILED 12-2-2010.

**ALLUREZ**

THE MARK CONSISTS OF STANDARD CHARACTERS WITHOUT CLAIM TO ANY PARTICULAR FONT, STYLE, SIZE, OR COLOR.

THE WORDING "ALLUREZ" HAS NO MEANING IN A FOREIGN LANGUAGE.

FOR COMPUTERIZED ON-LINE ORDERING SERVICES IN THE FIELD OF DIAMONDS, JEWELRY AND WATCHES (U.S. CLS. 100, 101 AND 102).

FIRST USE 5-31-2010; IN COMMERCE 5-31-2010.

GILBERT SWIFT, EXAMINING ATTORNEY

---

SN 85-189,675. AMERICAN SOCIETY ON AGING, SAN FRANCISCO, CA. FILED 12-2-2010.

**American Society on Aging**

THE MARK CONSISTS OF STANDARD CHARACTERS WITHOUT CLAIM TO ANY PARTICULAR FONT, STYLE, SIZE, OR COLOR.

SEC. 2(F).

FOR CHARITABLE SERVICES, NAMELY, ORGANIZING AND DEVELOPING PROJECTS THAT AIM TO IMPROVE THE LIVES AND WELFARE OF OLDER PERSONS (U.S. CLS. 100, 101 AND 102).

FIRST USE 4-15-1985; IN COMMERCE 4-15-1985.

STEVEN JACKSON, EXAMINING ATTORNEY

---

SN 85-189,751. COASTAL CLASSIC CREATIONS, MONTARA, CA. FILED 12-2-2010.



THE MARK CONSISTS OF FOUR STYLIZED SHELLS ARRANGED IN A CIRCULAR DESIGN WITH THE STYLIZED TEXT "COASTAL CLASSIC CREATIONS".

FOR ON-LINE RETAIL STORE SERVICES FEATURING COSMETICS AND PERSONAL CARE PRODUCTS (U.S. CLS. 100, 101 AND 102).

FIRST USE 6-9-2009; IN COMMERCE 6-9-2009.

ROBIN CHOSID, EXAMINING ATTORNEY

**CLASS 35—(Continued).**

SN 85-189,937. MEDIACOM COMMUNICATIONS CORPORATION, MIDDLETOWN, NY. FILED 12-3-2010.

RAVVID DEALS IN YOUR WORLD

THE MARK CONSISTS OF STANDARD CHARACTERS WITHOUT CLAIM TO ANY PARTICULAR FONT, STYLE, SIZE, OR COLOR.

OWNER OF U.S. REG. NO. 3,796,336.

FOR ONLINE BUSINESS DIRECTORY SERVICES REGARDING THE PURCHASE AND SALE OF A WIDE VARIETY OF PRODUCTS AND SERVICES OF OTHERS; ADVERTISING AND MARKETING SERVICES (U.S. CLS. 100, 101 AND 102).

CORY BOONE, EXAMINING ATTORNEY

**CLASS 35—(Continued).**

SN 85-190,079. PALA, INC, PALM CITY, FL. FILED 12-3-2010.



NO CLAIM IS MADE TO THE EXCLUSIVE RIGHT TO USE "HARDWARE CENTER", APART FROM THE MARK AS SHOWN.

THE MARK CONSISTS OF THE STYLIZED WORDING "PETER'S HARDWARE CENTER" WITH A DESIGN OF A HAMMER, A PORTION OF WHICH IS DISPLAYED WITHIN A CIRCLE.

FOR RETAIL STORE SERVICES FEATURING HARDWARE EQUIPMENT AND SUPPLIES (U.S. CLS. 100, 101 AND 102).

FIRST USE 9-1-2010; IN COMMERCE 9-1-2010.

EVELYN BRADLEY, EXAMINING ATTORNEY

SN 85-190,248. TWO PRINCE TOFFEE, PEARLAND, TX. FILED 12-3-2010.

SN 85-189,964. PREMIER, INC., CHARLOTTE, NC. FILED 12-3-2010.

PROVIDERSELECT: MD



THE MARK CONSISTS OF STANDARD CHARACTERS WITHOUT CLAIM TO ANY PARTICULAR FONT, STYLE, SIZE, OR COLOR.

OWNER OF U.S. REG. NO. 2,394,825.

NO CLAIM IS MADE TO THE EXCLUSIVE RIGHT TO USE "MD", APART FROM THE MARK AS SHOWN.

FOR MEDICAL COST MANAGEMENT AND PROCUREMENT, NAMELY, PURCHASING MEDICAL AND OFFICE SUPPLIES, MEDICAL AND OFFICE EQUIPMENT, AND PHARMACEUTICALS FOR OTHERS; AND DISTRIBUTORSHIP SERVICES IN THE FIELD OF MEDICAL AND OFFICE SUPPLIES, MEDICAL AND OFFICE EQUIPMENT, AND PHARMACEUTICALS (U.S. CLS. 100, 101 AND 102).

FIRST USE 12-0-2006; IN COMMERCE 12-0-2006.

KATHERINE STOIDES, EXAMINING ATTORNEY

NO CLAIM IS MADE TO THE EXCLUSIVE RIGHT TO USE "TOFFEE", APART FROM THE MARK AS SHOWN.

THE MARK CONSISTS OF AN OVAL DESIGN WITH A BORDER. IN THE INTERIOR IS A PICTORIAL LOGO WHICH CONTAINS TWO BACK TO BACK CAPITAL "P'S" ON EITHER SIDE, WITH A CROWN ON TOP. THE WORDS "TWO PRINCE TOFFEE" ARE IN THE OVAL, AND "WWW.TWOPRINCETOFFEE.COM" WRITTEN ALONG THE BOTTOM BORDER OF THE LOGO.

FOR ON-LINE RETAIL STORE SERVICES FEATURING TOFFEE WHICH CONTAIN EITHER ALMONDS, PECANS, AND OR HAZELNUTS COVERED IN CHOCOLATE AND COVERED IN NUTS (U.S. CLS. 100, 101 AND 102).

JOHN GARTNER, EXAMINING ATTORNEY

**CLASS 35—(Continued).**

SN 85-190,544. SITTER PALS LLC, TULSA, OK. FILED 12-3-2010.



The logo for "Sitter Pals" features the word "Sitter" in a serif font, with a stylized black and white icon of a person sitting on a chair, and the word "Pals" in a sans-serif font.

NO CLAIM IS MADE TO THE EXCLUSIVE RIGHT TO USE "SITTER", APART FROM THE MARK AS SHOWN.

THE MARK CONSISTS OF THE STYLIZED TEXT "SITTER PALS" WITH THE TWO "T'S IN SITTER SUBSTITUTED BY AN INTERLOCKING "T" AND UPSIDEDOWN "T" IMAGE WITH 4 DOTS.

FOR REFERRALS FROM A NETWORK OF FRIENDS IN THE FIELD OF SITTERS FOR CHILDREN, PETS, AND HOMES (U.S. CLS. 100, 101 AND 102).

ELISSA GARBER KON, EXAMINING ATTORNEY

---

SN 85-190,585. ZONE 3 ENVIRONMENTAL, CORP, HUNTINGTON BEACH, CA. FILED 12-3-2010.



The logo for "ZONE 3 ENVIRONMENTAL CORP." features the word "ZONE" in a large, blue, 3D-style font. The letter "O" is replaced by three blue spheres arranged in a triangle. Below "ZONE" is a green number "3". Underneath the "3" is the text "ENVIRONMENTAL CORP." in a green, sans-serif font.

NO CLAIM IS MADE TO THE EXCLUSIVE RIGHT TO USE "ENVIRONMENTAL CORP.", APART FROM THE MARK AS SHOWN.

THE COLOR(S) BLUE, GREEN, AND WHITE IS/ARE CLAIMED AS A FEATURE OF THE MARK.

THE MARK CONSISTS OF THE BLUE TERM "ZONE" WITH THREE CIRCULAR BLUE BALLS WITH WHITE HIGHLIGHTING AROUND THE "O" IN "ZONE", AND WITH THE GREEN NUMBER "3" TO THE LOWER RIGHT OF THE LETTER "O" TO FORM THE CHEMICAL SYMBOL FOR OZONE. BELOW THIS IS THE GREEN WORDING "ENVIRONMENTAL CORP.". THE REMAINDER OF WHITE IN THE MARK REPRESENTS A TRANSPARENT BACKGROUND THAT IS NOT PART OF THE MARK.

FOR MASTER DISTRIBUTOR SERVICES, NAMELY, DISTRIBUTORSHIP SERVICES IN THE FIELD OF ENVIRONMENTALLY FRIENDLY HOUSEHOLD GOODS, COMMERCIAL LIGHTING PRODUCTS, AND JANITORIAL SUPPLIES AND EQUIPMENT, PROVIDED TO OTHER DISTRIBUTORS AND COMMERCIAL END USERS (U.S. CLS. 100, 101 AND 102).

FIRST USE 7-2-2010; IN COMMERCE 7-2-2010.

KIM MONINGHOFF, EXAMINING ATTORNEY

**CLASS 35—(Continued).**

SN 85-190,610. ROMERO, FERNANDO, LAS VEGAS, NV. FILED 12-3-2010.

## TEQUILA PARTY

THE MARK CONSISTS OF STANDARD CHARACTERS WITHOUT CLAIM TO ANY PARTICULAR FONT, STYLE, SIZE, OR COLOR.

NO CLAIM IS MADE TO THE EXCLUSIVE RIGHT TO USE "PARTY", APART FROM THE MARK AS SHOWN.

FOR ECONOMIC FORECASTING AND ANALYSIS; INFORMATION ABOUT POLITICAL ELECTIONS; POLITICAL ACTION COMMITTEE SERVICES, NAMELY, PROMOTING THE INTERESTS OF MEMBERS OF THE HISPANIC COMMUNITY, AND THEIR SUPPORTERS, IN THE FIELD OF POLITICS; POLITICAL CONSULTANCY; POLITICAL PARTY SERVICES, NAMELY, PROMOTING THE INTERESTS OF A POLITICAL ORGANIZATION; PROVIDING A WEBSITE FEATURING INFORMATION ABOUT POLITICAL ISSUES; PROVIDING AN ON-LINE SEARCHABLE DATABASE FOR POLITICAL CAMPAIGNS WHICH ALLOW USERS TO COLLECT AND ANALYZE POLITICAL INFORMATION ELECTRONICALLY; PROVIDING INFORMATION AND NEWS IN THE FIELD OF BUSINESS, NAMELY, INFORMATION AND NEWS ON CURRENT EVENTS AND ON ECONOMIC, LEGISLATIVE, AND REGULATORY DEVELOPMENTS AS IT RELATES TO AND CAN IMPACT BUSINESSES; PROVIDING INFORMATION IN THE FIELD OF ECONOMICS; PROVIDING INFORMATION REGARDING POLITICAL ISSUES, KNOWING HOW TO VOTE AND KNOWING HOW TO REGISTER TO VOTE (U.S. CLS. 100, 101 AND 102).

DOUGLAS LEE, EXAMINING ATTORNEY

---

SN 85-190,854. FEDERAL MARKETING CORP., UPPLER SADDLE RIVER, NJ. FILED 12-5-2010.

## EZ QUOTE

THE MARK CONSISTS OF STANDARD CHARACTERS WITHOUT CLAIM TO ANY PARTICULAR FONT, STYLE, SIZE, OR COLOR.

OWNER OF U.S. REG. NO. 3,030,850.

NO CLAIM IS MADE TO THE EXCLUSIVE RIGHT TO USE "QUOTE", APART FROM THE MARK AS SHOWN.

SEC. 2(F).

FOR ESTIMATING CONTRACTING WORK (U.S. CLS. 100, 101 AND 102).

FIRST USE 6-21-2004; IN COMMERCE 6-21-2004.

DORITT L. CARROLL, EXAMINING ATTORNEY

**CLASS 35—(Continued).**

SN 85-190,860. POND ENVIRO, LLC, CLEVELAND, TN. FILED 12-5-2010.

**PONDENVIRO**

THE MARK CONSISTS OF STANDARD CHARACTERS WITHOUT CLAIM TO ANY PARTICULAR FONT, STYLE, SIZE, OR COLOR.

FOR ON-LINE, WHOLESALE AND RETAIL STORE SERVICES FEATURING POND AND STREAM MAINTENANCE GOODS (U.S. CLS. 100, 101 AND 102).  
CARYN GLASSER, EXAMINING ATTORNEY

**CLASS 35—(Continued).**

SN 85-191,159. MEREDITH CORPORATION, DES MOINES, IA. FILED 12-6-2010.



OWNER OF U.S. REG. NOS. 858,969, 2,438,649 AND OTHERS.

THE COLOR(S) GREEN, ORANGE, PINK, PURPLE, WHITE AND BLUE IS/ARE CLAIMED AS A FEATURE OF THE MARK.

THE MARK CONSISTS OF FOUR OVERLAPPING CIRCLES OF VARYING SIZES WITH A LARGE GREEN CIRCLE AT THE TOP LEFT, A LARGE PINK CIRCLE AT THE TOP RIGHT, A SMALLER ORANGE CIRCLE AT THE BOTTOM LEFT AND THE SMALLEST PURPLE CIRCLE AT THE BOTTOM RIGHT, AND BELOW THE CIRCLE DESIGN, THE WORDING "FAMILYCIRCLE" SHOWN IN WHITE WITH A WHITE UNDERSCORE, ALL ENCLOSED IN A RECTANGLE WITH A BLUE BACKGROUND.

FOR FRANCHISING SERVICES, NAMELY, PROVIDING INFORMATION AND ADVICE REGARDING THE ESTABLISHMENT AND/OR OPERATION OF HOTELS AND MOTELS (U.S. CLS. 100, 101 AND 102).

JENNIFER DIXON, EXAMINING ATTORNEY

SN 85-191,116. MEREDITH CORPORATION, DES MOINES, IA. FILED 12-6-2010.

**FAMILY CIRCLE**

THE MARK CONSISTS OF STANDARD CHARACTERS WITHOUT CLAIM TO ANY PARTICULAR FONT, STYLE, SIZE, OR COLOR.

OWNER OF U.S. REG. NOS. 858,969, 2,438,649 AND OTHERS.

FOR FRANCHISING SERVICES, NAMELY, PROVIDING INFORMATION AND ADVICE REGARDING THE ESTABLISHMENT AND/OR OPERATION OF HOTELS AND MOTELS (U.S. CLS. 100, 101 AND 102).  
JENNIFER DIXON, EXAMINING ATTORNEY

SN 85-191,170. MEREDITH CORPORATION, DES MOINES, IA. FILED 12-6-2010.



THE COLOR(S) GREEN, ORANGE, PINK AND PURPLE IS/ARE CLAIMED AS A FEATURE OF THE MARK.

THE MARK CONSISTS OF FOUR OVERLAPPING CIRCLES OF VARYING SIZES WITH A LARGE GREEN CIRCLE AT THE TOP LEFT, A LARGE PINK CIRCLE AT THE TOP RIGHT, A SMALLER ORANGE CIRCLE AT THE BOTTOM LEFT AND THE SMALLEST PURPLE CIRCLE AT THE BOTTOM RIGHT.

FOR FRANCHISING SERVICES, NAMELY, PROVIDING INFORMATION AND ADVICE REGARDING THE ESTABLISHMENT AND/OR OPERATION OF HOTELS AND MOTELS (U.S. CLS. 100, 101 AND 102).  
JENNIFER DIXON, EXAMINING ATTORNEY

**CLASS 35—(Continued).**

SN 85-191,201. MEREDITH CORPORATION, DES MOINES, IA. FILED 12-6-2010.



OWNER OF U.S. REG. NOS. 858,969, 2,438,649 AND OTHERS.

THE COLOR(S) GREEN, ORANGE, PINK, PURPLE AND BLUE IS/ARE CLAIMED AS A FEATURE OF THE MARK.

THE MARK CONSISTS OF FOUR OVERLAPPING CIRCLES OF VARYING SIZES WITH A LARGE GREEN CIRCLE AT THE TOP LEFT, A LARGE PINK CIRCLE AT THE TOP RIGHT, A SMALLER ORANGE CIRCLE AT THE BOTTOM LEFT AND THE SMALLEST PURPLE CIRCLE AT THE BOTTOM RIGHT, AND BELOW THE CIRCLE DESIGN, THE WORDING "FAMILYCIRCLE" SHOWN IN BLUE WITH A BLUE UNDERScore. THE COLOR WHITE REPRESENTS TRANSPARENT BACKGROUND AND IS NOT CLAIMED AS A FEATURE OF THE MARK.

FOR FRANCHISING SERVICES, NAMELY, PROVIDING INFORMATION AND ADVICE REGARDING THE ESTABLISHMENT AND/OR OPERATION OF HOTELS AND MOTELS (U.S. CLS. 100, 101 AND 102).

JENNIFER DIXON, EXAMINING ATTORNEY

**CLASS 35—(Continued).**

SN 85-191,322. FU WONG, OAKLAND, CA. FILED 12-6-2010.

## SAVVY BRIDE

THE MARK CONSISTS OF STANDARD CHARACTERS WITHOUT CLAIM TO ANY PARTICULAR FONT, STYLE, SIZE, OR COLOR.

NO CLAIM IS MADE TO THE EXCLUSIVE RIGHT TO USE "BRIDE", APART FROM THE MARK AS SHOWN.

FOR PROVIDING AN ONLINE MARKETPLACE BRINGING TOGETHER BUYERS AND PROVIDERS OF PHOTOGRAPHY SERVICES (U.S. CLS. 100, 101 AND 102).

FIRST USE 11-29-2010; IN COMMERCE 11-29-2010.  
JESSICA A. POWERS, EXAMINING ATTORNEY

SN 85-191,501. TOWN OF ADDISON, TEXAS, ADDISON, TX. FILED 12-6-2010.



SN 85-191,267. SHOWPLACE WOOD PRODUCTS, INC., HARRISBURG, SD. FILED 12-6-2010.

## Refacing And More

THE MARK CONSISTS OF STANDARD CHARACTERS WITHOUT CLAIM TO ANY PARTICULAR FONT, STYLE, SIZE, OR COLOR.

NO CLAIM IS MADE TO THE EXCLUSIVE RIGHT TO USE "REFACING", APART FROM THE MARK AS SHOWN. FOR RETAIL STORE SERVICES FEATURING CABINETS (U.S. CLS. 100, 101 AND 102).

FIRST USE 7-15-2010; IN COMMERCE 7-15-2010.  
COLLEEN KEARNEY, EXAMINING ATTORNEY

OWNER OF U.S. REG. NOS. 1,859,942, 3,753,951 AND OTHERS.

NO CLAIM IS MADE TO THE EXCLUSIVE RIGHT TO USE "VISIT ADDISON VISITOR SERVICES ARTISAN CENTER", APART FROM THE MARK AS SHOWN.

THE COLOR(S) GREY, RED, LIGHT GREEN, TEAL, PURPLE, ORANGE, BLUE IS/ARE CLAIMED AS A FEATURE OF THE MARK.

THE MARK CONSISTS OF THE WORD "VISIT" WRITTEN IN GREY STYLIZED FONT ABOVE THE WORD "ADDISON" WRITTEN IN STYLIZED FONT CONSISTING OF THE FOLLOWING: A RED "A", A LIGHT GREEN "D", A TEAL "D", A PURPLE "I" WITH A LIGHT GREEN LEAF AS THE DOT ON THE "I", AN ORANGE "S", A BLUE "O", AND A RED "N" ALL WRITTEN ABOVE THE WORDS "VISITOR SERVICES" AND "ARTISAN CENTER" BOTH WRITTEN IN GREY STYLIZED FONT, WITH A GREY DOT BETWEEN THE PHRASES.

FOR CONVENTION AND VISITOR ASSISTANCE SERVICES, NAMELY, PROMOTION OF TOURISM AND THE HOTEL AND CONVENTION INDUSTRIES IN THE ADDISON, TEXAS AREA (U.S. CLS. 100, 101 AND 102).

ALEXANDER L. POWERS, EXAMINING ATTORNEY

**CLASS 35—(Continued).**

SN 85-192,073. FAUNUS GROUP INTERNATIONAL, INC., NEW YORK, NY. FILED 12-7-2010.

**WORLDWATCH**

THE MARK CONSISTS OF STANDARD CHARACTERS WITHOUT CLAIM TO ANY PARTICULAR FONT, STYLE, SIZE, OR COLOR.

FOR ASSOCIATION SERVICES, NAMELY, PROMOTING THE INTERESTS OF THE COMMERCIAL FINANCE INDUSTRY; ASSOCIATION SERVICES IN THE NATURE OF COMMERCIAL LOBBYING TO SUPPORT AND ENHANCE THE INTERESTS OF THE COMMERCIAL FINANCE INDUSTRY (U.S. CLS. 100, 101 AND 102).

KATHY DE JONGE, EXAMINING ATTORNEY

---

SN 85-192,570. FNC, INC., OXFORD, MS. FILED 12-7-2010.

**FNC Residential Price Index**

THE MARK CONSISTS OF STANDARD CHARACTERS WITHOUT CLAIM TO ANY PARTICULAR FONT, STYLE, SIZE, OR COLOR.

OWNER OF U.S. REG. NO. 2,685,217.

NO CLAIM IS MADE TO THE EXCLUSIVE RIGHT TO USE "RESIDENTIAL PRICE INDEX", APART FROM THE MARK AS SHOWN.

FOR PROVIDING, MAINTAINING, AND UPDATING AN HEDONIC INDEX OF RESIDENTIAL REAL ESTATE PRICES (U.S. CLS. 100, 101 AND 102).

FIRST USE 6-1-2010; IN COMMERCE 9-1-2010.

MARK PILARO, EXAMINING ATTORNEY

---

SN 85-192,669. GLENWOOD SPRINGS CHAMBER RESORT ASSOCIATION, INC., GLENWOOD SPRINGS, CO. FILED 12-7-2010.

**VISITGLENWOOD.COM**

THE MARK CONSISTS OF STANDARD CHARACTERS WITHOUT CLAIM TO ANY PARTICULAR FONT, STYLE, SIZE, OR COLOR.

FOR CHAMBER OF COMMERCE SERVICES, NAMELY, PROMOTING BUSINESS AND TOURISM IN THE GLENWOOD SPRINGS, COLORADO AREA; PROMOTING PUBLIC AWARENESS OF THE GREATER GLENWOOD SPRINGS, COLORADO AREA; PROVIDING BUSINESS AND PERSONNEL RELOCATION INFORMATION IN THE GREATER GLENWOOD SPRINGS, COLORADO AREA (U.S. CLS. 100, 101 AND 102).

FIRST USE 6-0-2005; IN COMMERCE 6-0-2005.

MARY CRAWFORD, EXAMINING ATTORNEY

**CLASS 35—(Continued).**

SN 85-192,706. SNEAKERCHANGE, CORONA, NY. FILED 12-7-2010.



THE STIPPLING IS A FEATURE OF THE MARK. THE MARK CONSISTS OF AN ARROW WITH THE STYLIZED TEXT "SNEAKERCHANGE" SURROUNDED BY A RECTANGULAR CARRIER WITH STIPPLING.

FOR ONLINE RETAIL STORE SERVICES FEATURING FOOTWEAR; OPERATING ONLINE MARKETPLACES FEATURING FOOTWEAR; PROVIDING A WEBSITE FEATURING AN ONLINE MARKETPLACE FOR EXCHANGING FOOTWEAR WITH OTHER USERS (U.S. CLS. 100, 101 AND 102).

FIRST USE 5-1-2010; IN COMMERCE 11-16-2010.

SUSAN STIGLITZ, EXAMINING ATTORNEY

---

SN 85-192,784. AKURANVYKA USA INC., DBA CURRY UP NOW, SOUTH SAN FRANCISCO, CA. FILED 12-8-2010.



NO CLAIM IS MADE TO THE EXCLUSIVE RIGHT TO USE "INDIAN STREET FOOD", APART FROM THE MARK AS SHOWN.

THE COLOR(S) MAROON AND ORANGE IS/ARE CLAIMED AS A FEATURE OF THE MARK.

THE MARK CONSISTS OF MAROON BACKGROUND WITH TEXT AND A STREET CART IN ORANGE. AT THE TOP IS A TWO-WHEELED ORANGE STREETCART WITH ORANGE STEAM RISING FROM IT. BELOW THAT IS THE NAME "CURRY UP NOW" IN ORANGE AND APPEARING AS THOUGH IT WAS PRINTED USING A TYPEWRITER. AT THE BOTTOM, THE COLOR SCHEME IS REVERSED. THE TEXT "INDIAN STREET FOOD" IS IN MAROON INSIDE AN ORANGE RECTANGULAR BOX. THE MARK CONTAINS AN ORANGE BORDER.

FOR MOBILE FOOD KIOSK SERVICES; MOBILE STREET VENDOR SERVICES FEATURING FOOD AND DRINK (U.S. CLS. 100, 101 AND 102).

FIRST USE 9-0-2009; IN COMMERCE 9-0-2009.

ROBIN MITTLER, EXAMINING ATTORNEY



**CLASS 35—(Continued).**

SN 85-193,073. FRANCZEK, WILLIAM E., NORFOLK, VA.  
FILED 12-8-2010.

**CLASS 35—(Continued).**

SN 85-193,664. W. W. GRAINGER, INC., LAKE FOREST, IL.  
FILED 12-8-2010.

# MEGAVENTION

THE MARK CONSISTS OF STANDARD CHARACTERS WITHOUT CLAIM TO ANY PARTICULAR FONT, STYLE, SIZE, OR COLOR.

FOR PROMOTING, ORGANIZING AND CONDUCTING TRADE SHOWS AND BUSINESS CONVENTIONS IN THE FIELDS OF CONSTRUCTION, REAL ESTATE AND ECONOMIC DEVELOPMENT (U.S. CLS. 100, 101 AND 102).

FIRST USE 4-19-2010; IN COMMERCE 4-19-2010.  
CYNTHIA TRIPI, EXAMINING ATTORNEY

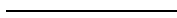

SN 85-193,527. ELMHURST MEMORIAL HOSPITAL, ELMHURST, IL. FILED 12-8-2010.

# KEEPSTOCK MOBILE

THE MARK CONSISTS OF STANDARD CHARACTERS WITHOUT CLAIM TO ANY PARTICULAR FONT, STYLE, SIZE, OR COLOR.

OWNER OF U.S. REG. NO. 3,332,077.  
NO CLAIM IS MADE TO THE EXCLUSIVE RIGHT TO USE "MOBILE", APART FROM THE MARK AS SHOWN.

FOR INVENTORY CONTROL AND BUSINESS CONSULTATION SERVICES IN THE FIELD OF TOOL CRIB REPLENISHMENT AND MAINTENANCE (U.S. CLS. 100, 101 AND 102).

MARC LEIPZIG, EXAMINING ATTORNEY

# THE WILD ROSE

THE MARK CONSISTS OF STANDARD CHARACTERS WITHOUT CLAIM TO ANY PARTICULAR FONT, STYLE, SIZE, OR COLOR.

NO CLAIM IS MADE TO THE EXCLUSIVE RIGHT TO USE "ROSE", APART FROM THE MARK AS SHOWN.

FOR RETAIL GIFT SHOPS; RETAIL FLORIST SHOPS (U.S. CLS. 100, 101 AND 102).

SCOTT BIBB, EXAMINING ATTORNEY



SN 85-193,662. W. W. GRAINGER, INC., LAKE FOREST, IL.  
FILED 12-8-2010.

SN 85-193,665. W. W. GRAINGER, INC., LAKE FOREST, IL.  
FILED 12-8-2010.

# KEEPSTOCK ONSITE

# KEEPSTOCK LABEL

THE MARK CONSISTS OF STANDARD CHARACTERS WITHOUT CLAIM TO ANY PARTICULAR FONT, STYLE, SIZE, OR COLOR.

OWNER OF U.S. REG. NO. 3,332,077.  
NO CLAIM IS MADE TO THE EXCLUSIVE RIGHT TO USE "LABEL", APART FROM THE MARK AS SHOWN.

FOR INVENTORY CONTROL AND BUSINESS CONSULTATION SERVICES IN THE FIELD OF TOOL CRIB REPLENISHMENT AND MAINTENANCE (U.S. CLS. 100, 101 AND 102).

MARC LEIPZIG, EXAMINING ATTORNEY

THE MARK CONSISTS OF STANDARD CHARACTERS WITHOUT CLAIM TO ANY PARTICULAR FONT, STYLE, SIZE, OR COLOR.

OWNER OF U.S. REG. NO. 3,332,077.  
NO CLAIM IS MADE TO THE EXCLUSIVE RIGHT TO USE "ONSITE", APART FROM THE MARK AS SHOWN.

FOR INVENTORY CONTROL AND BUSINESS CONSULTATION SERVICES IN THE FIELD OF TOOL CRIB REPLENISHMENT AND MAINTENANCE (U.S. CLS. 100, 101 AND 102).

MARC LEIPZIG, EXAMINING ATTORNEY

**CLASS 35—(Continued).**

SN 85-193,688. DARKSIDE RECORDS 7 GALLERY, LLC, POUGHKEEPSIE, NY. FILED 12-8-2010.



NO CLAIM IS MADE TO THE EXCLUSIVE RIGHT TO USE "RECORDS & GALLERY", APART FROM THE MARK AS SHOWN.

THE MARK CONSISTS OF A STYLIZED RECORD WITH AN EGYPTIAN LOOKING EYE IN THE CENTER. AROUND THE RECORD IS THE WORDING "DARKSIDE" ON TOP AND "RECORDS & GALLERY" ON THE BOTTOM. ON BOTH SIDES SEPARATING THE WORDING ARE THREE STARS.

FOR RETAIL MUSIC AND RECORD STORES (U.S. CLS. 100, 101 AND 102).

TARAH HARDY, EXAMINING ATTORNEY

SN 85-193,838. ILLINOIS AGRICULTURAL ASSOCIATION, BLOOMINGTON, IL. FILED 12-9-2010.

**ILLINOIS FARM FAMILIES**

THE MARK CONSISTS OF STANDARD CHARACTERS WITHOUT CLAIM TO ANY PARTICULAR FONT, STYLE, SIZE, OR COLOR.

NO CLAIM IS MADE TO THE EXCLUSIVE RIGHT TO USE "ILLINOIS FARM", APART FROM THE MARK AS SHOWN.

FOR PROMOTING PUBLIC AWARENESS OF AGRICULTURAL PRACTICES BY PROVIDING INFORMATION TO NON-FARMERS ABOUT FARMING AND FOOD PRODUCTION (U.S. CLS. 100, 101 AND 102).

FIRST USE 11-23-2010; IN COMMERCE 11-23-2010.

Laurie Kaufman, Examining Attorney

**CLASS 35—(Continued).**

SN 85-193,925. SD FIRM LLC, COMPTON, CA. FILED 12-9-2010.



NO CLAIM IS MADE TO THE EXCLUSIVE RIGHT TO USE "HIGH PERFORMANCE FILTERS", APART FROM THE MARK AS SHOWN.

THE COLOR(S) GREEN AND WHITE IS/ARE CLAIMED AS A FEATURE OF THE MARK.

THE MARK CONSISTS OF THE STYLIZED WORD "FÜHREN" WITH A LEAF IN BETWEEN "H" AND THE "R" AND THE PHRASE "HIGH PERFORMANCE FILTERS" BELOW. ALL OF THE ABOVE IN GREEN EXCEPT FOR THE VEIN OF THE LEAF WHICH IS IN WHITE.

THE ENGLISH TRANSLATION OF "FÜHREN" IN THE MARK IS "TO LEAD".

FOR ONLINE RETAIL STORE AND RETAIL STORE SERVICES IN THE FIELD OF AIR FILTERS FOR HEAVY DUTY VEHICLES; DISTRIBUTORSHIP SERVICES IN THE FIELD OF AIR FILTERS FOR HEAVY DUTY VEHICLES (U.S. CLS. 100, 101 AND 102).

SIMON TENG, EXAMINING ATTORNEY

SN 85-193,974. ILLINOIS AGRICULTURAL ASSOCIATION, BLOOMINGTON, IL. FILED 12-9-2010.



NO CLAIM IS MADE TO THE EXCLUSIVE RIGHT TO USE "ILLINOIS FARM", APART FROM THE MARK AS SHOWN.

THE MARK CONSISTS OF THE WORDING "ILLINOIS FARM FAMILIES" AND A DESIGN ELEMENT COMPRISING A SPOON, FORK, AND KNIFE LOCATED BELOW THE WORDING. THE LETTERS "ILI" IN "FAMILIES" APPEAR AS ABSTRACT BUILDINGS.

FOR PROMOTING PUBLIC AWARENESS OF AGRICULTURAL PRACTICES BY PROVIDING INFORMATION TO NON-FARMERS ABOUT FARMING AND FOOD PRODUCTIONS (U.S. CLS. 100, 101 AND 102).

FIRST USE 11-23-2010; IN COMMERCE 11-23-2010.

Laurie Kaufman, Examining Attorney

**CLASS 35—(Continued).**

SN 85-194,084. ETAILSALES ASSOCIATES, LLC, MURRYSVILLE, PA. FILED 12-9-2010.



THE MARK CONSISTS OF THE WORDING "ETAILSALES" WITH THE LOWER CASE "E" AT THE BEGINNING OF "ETAIL" DESIGNED LIKE AN @ SIGN BUT INSTEAD OF A LOWER CASE A IT IS AN "E". ABOVE THE WORDING IS A DESIGN OF THREE INTERLOCKING RINGS INSIDE A CIRCLE.

FOR MANUFACTURER REPRESENTATIVES IN THE FIELD OF HOME FURNISHINGS AND HOME DECOR (U.S. CLS. 100, 101 AND 102).

FIRST USE 10-1-2009; IN COMMERCE 10-1-2009.  
JAMES GRIFFIN, EXAMINING ATTORNEY

SN 85-194,574. HUMOR WITH PORPOISE, LLC, DURHAM, NC. FILED 12-9-2010.

# PLEDGED

THE MARK CONSISTS OF STANDARD CHARACTERS WITHOUT CLAIM TO ANY PARTICULAR FONT, STYLE, SIZE, OR COLOR.

FOR ON-LINE RETAIL STORE SERVICES FEATURING CONSUMER GOODS IN THE NATURE OF SHIRTS, CAPS, CUPS, BOWLS, PET TOYS, AND PET SUPPLIES (U.S. CLS. 100, 101 AND 102).

LAURIE KAUFMAN, EXAMINING ATTORNEY

SN 85-194,670. INNORDIC USA INC, MISSION VIEJO, CO. FILED 12-9-2010.

# INNORDIC

THE MARK CONSISTS OF STANDARD CHARACTERS WITHOUT CLAIM TO ANY PARTICULAR FONT, STYLE, SIZE, OR COLOR.

FOR DISTRIBUTORSHIP SERVICES IN THE FIELD OF EQUESTRIAN PRODUCTS, NAMELY, FEEDS, FEED SUPPLEMENTS, AND CARETAKING PRODUCTS (U.S. CLS. 100, 101 AND 102).

CORY BOONE, EXAMINING ATTORNEY

**CLASS 35—(Continued).**

SN 85-194,704. THE FERNEBORG GROUP, INC., SAN MATEO, CA. FILED 12-9-2010.



THE COLOR(S) BLACK AND LIGHT BLUE IS/ARE CLAIMED AS A FEATURE OF THE MARK.

THE MARK CONSISTS OF THE PHRASE "SEARCH AROUND THE WORLD" IN BLACK LETTERING, APPEARING BELOW THE WORD "PANORAMA" IN BLACK LETTERING, WITH ALL OF THE WORDING APPEARING BELOW AN ARC DESIGN IN THE COLOR LIGHT BLUE.

FOR EXECUTIVE SEARCH AND PLACEMENT SERVICES (U.S. CLS. 100, 101 AND 102).

FIRST USE 6-1-2010; IN COMMERCE 6-1-2010.  
JOHN GARTNER, EXAMINING ATTORNEY

SN 85-195,573. BROUN, WAYNE H, WARRIEWOOD BEACH NSW, AUSTRALIA, FILED 12-10-2010.

## BROUN OF COLSTOUN

THE MARK CONSISTS OF STANDARD CHARACTERS WITHOUT CLAIM TO ANY PARTICULAR FONT, STYLE, SIZE, OR COLOR.

THE NAME(S), PORTRAIT(S), AND/OR SIGNATURE(S) SHOWN IN THE MARK DOES NOT IDENTIFY A PARTICULAR LIVING INDIVIDUAL.

FOR RETAIL STORE, ONLINE RETAIL STORE AND WHOLESALE STORE SERVICES ALL FEATURING CLOTHING AND FASHION ACCESSORIES, BELT BUCKLES, JEWELRY, BOOKS, PRINTED PAPER PRODUCTS, STATIONERY, POSTERS, BANNERS AND FLAGS (U.S. CLS. 100, 101 AND 102).

LINDA LAVACHE, EXAMINING ATTORNEY

SN 85-196,107. LCO DESTINY, LLC, WATERTOWN, NY. FILED 12-13-2010.

## Timeless Frames, Décor & Expressions

THE MARK CONSISTS OF STANDARD CHARACTERS WITHOUT CLAIM TO ANY PARTICULAR FONT, STYLE, SIZE, OR COLOR.

FOR ORDER FULFILLMENT SERVICES (U.S. CLS. 100, 101 AND 102).

ROBIN CHOSID, EXAMINING ATTORNEY

**CLASS 35—(Continued).**

SN 85-196,125. JONES, DARROW, DBA JONES & SON FINE JEWELRY, LITTLE ROCK, AR. FILED 12-13-2010.

# BlingFinder

THE MARK CONSISTS OF STANDARD CHARACTERS WITHOUT CLAIM TO ANY PARTICULAR FONT, STYLE, SIZE, OR COLOR.

FOR ON-LINE WHOLESALE AND RETAIL STORE SERVICES FEATURING JEWELRY (U.S. CLS. 100, 101 AND 102).

ROBIN CHOSID, EXAMINING ATTORNEY

SN 85-196,597. BULBSTORM, INC., PHOENIX, AZ. FILED 12-13-2010.

# idea CHALLENGES

THE MARK CONSISTS OF STANDARD CHARACTERS WITHOUT CLAIM TO ANY PARTICULAR FONT, STYLE, SIZE, OR COLOR.

FOR PROVIDING INCENTIVE AWARD PROGRAMS FOR CUSTOMERS THROUGH THE DISTRIBUTION OF ONLINE AND/OR VIRTUAL UNITS OF CREDITS FOR THE PURPOSE OF PROMOTING AND REWARDING CONSUMER LOYALTY AND TO PURCHASE ADVERTISING, SERVICES, AND/OR PRODUCTS (U.S. CLS. 100, 101 AND 102).

FIRST USE 3-4-2010; IN COMMERCE 10-4-2010.  
AMEEN IMAM, EXAMINING ATTORNEY

SN 85-196,695. CHAVARRIA, CESAR, EL CENTRO, CA. FILED 12-13-2010.

# OJO OFERTAS.COM

THE MARK CONSISTS OF STANDARD CHARACTERS WITHOUT CLAIM TO ANY PARTICULAR FONT, STYLE, SIZE, OR COLOR.

THE ENGLISH TRANSLATION OF "OJO OFERTAS.COM" IN THE MARK IS "EYE OFFERS.COM".

FOR PROVIDING A SEARCHABLE ONLINE ADVERTISING GUIDE FEATURING THE GOODS AND SERVICES OF ONLINE VENDORS; PROVIDING A SEARCHABLE ONLINE EVALUATION DATABASE FOR BUYERS AND SELLERS; ADVERTISING AND ADVERTISEMENT SERVICES; CUSTOMER LOYALTY SERVICES AND CUSTOMER CLUB SERVICES FOR COMMERCIAL, PROMOTIONAL AND ADVERTISING PURPOSES; PROMOTING THE GOODS AND SERVICES OF OTHERS (U.S. CLS. 100, 101 AND 102).

FIRST USE 12-13-2010; IN COMMERCE 12-13-2010.  
ALLISON HOLTZ, EXAMINING ATTORNEY

**CLASS 35—(Continued).**

SN 85-196,770. PLANTIER ENTERPRISES, INC, ARLINGTON HEIGHTS, IL. FILED 12-13-2010.

# "Just Great Products" that work

THE MARK CONSISTS OF STANDARD CHARACTERS WITHOUT CLAIM TO ANY PARTICULAR FONT, STYLE, SIZE, OR COLOR.

FOR RETAIL SERVICES BY DIRECT SOLICITATION OF AUTOMOBILE DEALERSHIPS BY SALES AGENTS IN THE FIELD OF AUTOMOTIVE PRODUCTS (U.S. CLS. 100, 101 AND 102).

BARBARA GAYNOR, EXAMINING ATTORNEY

SN 85-197,086. CORE ANALYTICS, LLC, FOREST PARK, IL. FILED 12-14-2010.

# Core Analytics

THE MARK CONSISTS OF STANDARD CHARACTERS WITHOUT CLAIM TO ANY PARTICULAR FONT, STYLE, SIZE, OR COLOR.

NO CLAIM IS MADE TO THE EXCLUSIVE RIGHT TO USE "ANALYTICS", APART FROM THE MARK AS SHOWN.

FOR ANALYSIS OF MARKET RESEARCH DATA AND STATISTICS; BRANDING SERVICES, NAMELY, CONSULTING, DEVELOPMENT, MANAGEMENT AND MARKETING OF BRANDS FOR BUSINESSES; BUSINESS ADVICE AND ANALYSIS OF MARKETS; BUSINESS CONSULTATION AND MANAGEMENT REGARDING MARKETING ACTIVITIES AND LAUNCHING OF NEW PRODUCTS; BUSINESS INFORMATION MANAGEMENT, NAMELY, ELECTRONIC REPORTING OF BUSINESS INFORMATION, BUSINESS ANALYTICS, NAMELY, BUSINESS INVESTIGATIONS, EVALUATIONS, EXPERT APPRAISALS, INFORMATION AND RESEARCH, TRADE SPEND BUSINESS MANAGEMENT; BUSINESS MANAGEMENT AND CONSULTING SERVICES FOR THE HEALTH CARE INDUSTRY, NAMELY, CUSTOMER SERVICE, ACCOUNTING SERVICES, AND MARKETING SERVICES; BUSINESS MONITORING AND CONSULTING SERVICES, NAMELY, TRACKING WEB SITES AND APPLICATIONS OF OTHERS TO PROVIDE STRATEGY, INSIGHT, MARKETING, SALES, OPERATION, PRODUCT DESIGN, PARTICULARLY SPECIALIZING IN THE USE OF ANALYTIC AND STATISTIC MODELS FOR THE UNDERSTANDING AND PREDICTING OF CONSUMERS, BUSINESSES, AND MARKET TRENDS AND ACTIONS; CONSULTING SERVICES IN THE FIELD OF INTERNET MARKETING (U.S. CLS. 100, 101 AND 102).

FIRST USE 1-30-2000; IN COMMERCE 1-30-2001.  
JOHN WILKE, EXAMINING ATTORNEY

**CLASS 35—(Continued).**

SN 85-197,134. WIZLY TECHNOLOGIES SARL, COLOMBES, FRANCE, FILED 12-14-2010.



THE COLOR(S) WHITE AND BLUE IS/ARE CLAIMED AS A FEATURE OF THE MARK.

THE MARK CONSISTS OF THE WORDS "SHOPWIZ" WRITTEN AS ONE WORD WITH THE WORD "SHOP" IN WHITE OUTLINED IN BLUE AND THE WORD "WIZ" IN BLUE OUTLINED IN WHITE. THE WORD "WIZ" IS SURROUNDED BY BLUE LINES AND DOTS IN THE FORM OF A NETWORK.

FOR PROVIDING A WEB SITE WHERE USERS CAN POST RATINGS, REVIEWS AND RECOMMENDATIONS ON PRODUCTS AND SERVICES FOR COMMERCIAL PURPOSES (U.S. CLS. 100, 101 AND 102).

FIRST USE 12-13-2010; IN COMMERCE 12-13-2010.

GISELLE AGOSTO, EXAMINING ATTORNEY

**CLASS 35—(Continued).**

SN 85-197,833. PINNACLE PROCESS SOLUTIONS, INTERNATIONAL, CEDAR PARK, TX. FILED 12-14-2010.

ILEAN

THE MARK CONSISTS OF STANDARD CHARACTERS WITHOUT CLAIM TO ANY PARTICULAR FONT, STYLE, SIZE, OR COLOR.

OWNER OF U.S. REG. NOS. 3,662,629, 3,699,884 AND OTHERS.

FOR BUSINESS CONSULTING, MANAGEMENT, PLANNING AND SUPERVISION (U.S. CLS. 100, 101 AND 102).

FIRST USE 3-23-2009; IN COMMERCE 3-23-2009.

LESLIE RICHARDS, EXAMINING ATTORNEY

SN 85-197,604. FIORE LLC, BASS HARBOR, ME. FILED 12-14-2010.



NO CLAIM IS MADE TO THE EXCLUSIVE RIGHT TO USE "ARTISAN OLIVE OILS AND VINEGARS", APART FROM THE MARK AS SHOWN.

THE MARK CONSISTS OF OLIVE LEAVES ARCHED AT THE TOP AND THE BOTTOM OF THE LOGO WITH THE WORDS "FIORE ARTISAN OLIVE OILS AND VINEGARS" NESTED INSIDE THE TWO SETS OF OLIVE LEAVES.

THE ENGLISH TRANSLATION OF "FIORE" IS "FLOWER".

FOR RETAIL STORE SERVICES FEATURING OLIVE OILS AND BALSAMIC VINEGARS (U.S. CLS. 100, 101 AND 102).

FIRST USE 7-10-2009; IN COMMERCE 7-10-2009.

JOHN WILKE, EXAMINING ATTORNEY

SN 85-197,927. BRANDILLA HOLDINGS LLC, SUNNYSIDE, NY. FILED 12-14-2010.

Winevilla

THE MARK CONSISTS OF STANDARD CHARACTERS WITHOUT CLAIM TO ANY PARTICULAR FONT, STYLE, SIZE, OR COLOR.

FOR MARKETING, ADVERTISING, AND PROMOTING THE RETAIL GOODS AND SERVICES OF OTHERS TO WIRELESS ELECTRONIC DEVICES; PROVIDING ADVERTISING, MARKETING AND PROMOTIONAL SERVICES, NAMELY, DEVELOPMENT OF ADVERTISING CAMPAIGNS FOR WINE, SPIRITS, ENTERTAINMENT, TRAVEL (U.S. CLS. 100, 101 AND 102).

FIRST USE 12-12-2010; IN COMMERCE 12-12-2010.

ERNEST SHOSHO, EXAMINING ATTORNEY

**CLASS 35—(Continued).**

SN 85-197,948. PIGNATARO, ANTHONY, DEER PARK, NY.  
FILED 12-14-2010.

**CLASS 35—(Continued).**

SN 85-198,871. SANDERS, DAVID G., FRANKLIN, TN.  
FILED 12-15-2010.

**COUCH CONTENT**

THE MARK CONSISTS OF STANDARD CHARACTERS WITHOUT CLAIM TO ANY PARTICULAR FONT, STYLE, SIZE, OR COLOR.

NO CLAIM IS MADE TO THE EXCLUSIVE RIGHT TO USE "CONTENT", APART FROM THE MARK AS SHOWN.

FOR PROMOTING THE GOODS AND SERVICES OF OTHERS BY PROVIDING A WEBSITE FEATURING COUPONS, REBATES, PRICE-COMPARISON INFORMATION, PRODUCT REVIEWS, LINKS TO THE RETAIL WEBSITES OF OTHERS, AND DISCOUNT INFORMATION; PROVIDING A SEARCHABLE WEBSITE FEATURING THE GOODS AND SERVICES OF OTHER VENDORS; PROVIDING A SEARCHABLE ON-LINE ADVERTISING WEBSITE AND GUIDE FEATURING THE GOODS AND SERVICES OF OTHER VENDORS VIA THE INTERNET (U.S. CLS. 100, 101 AND 102).

FIRST USE 12-8-2010; IN COMMERCE 12-11-2010.

CAROL SPILS, EXAMINING ATTORNEY

**Delta Auction**

THE MARK CONSISTS OF STANDARD CHARACTERS WITHOUT CLAIM TO ANY PARTICULAR FONT, STYLE, SIZE, OR COLOR.

NO CLAIM IS MADE TO THE EXCLUSIVE RIGHT TO USE "AUCTION", APART FROM THE MARK AS SHOWN.

FOR ARRANGING AND CONDUCTING AUCTIONS; ARRANGING AND CONDUCTING AUCTIONS IN THE FIELD OF PROPERTY; ARRANGING AND CONDUCTION OF AUCTION SALES; ARRANGING OF AUCTION SALES; AUCTION MANAGEMENT SERVICES PROVIDED TO OTHERS OVER AN ON-LINE WEB SITE ACCESSED THROUGH A GLOBAL COMPUTER NETWORK; AUCTIONEERING; AUCTIONEERING OF PROPERTY; AUCTIONEERING PROVIDED ON THE INTERNET; AUCTIONING VIA TELECOMMUNICATION NETWORKS; BUSINESS MANAGEMENT ASSISTANCE AND PARTICULARLY CARRYING OUT TASKS NECESSARY FOR THE SMOOTH CONDUCT OF SALES BY AUCTION; CARRYING OUT AUCTION SALES; CONDUCTING OF AUCTION SALES; INDUSTRIAL ASSET MANAGEMENT SERVICES, NAMELY, AUCTIONING, LIQUIDATING AND REMARKETING INDUSTRIAL ASSETS OF OTHERS; ON-LINE AUCTION BIDDING FOR OTHERS; ON-LINE AUCTION SERVICES; ON-LINE AUCTION SERVICES IN WHICH BUYERS WHO DONATE TO CHARITY RECEIVE ADDITIONAL BIDDING RIGHTS; ON-LINE AUCTIONEERING SERVICES VIA THE INTERNET; ON-LINE CONSIGNMENT SERVICES WHEREBY GOODS ARE RECEIVED ON CONSIGNMENT FOR AUCTION ON AN ONLINE AUCTION SITE; ON-LINE TRADING SERVICES IN WHICH SELLER POSTS PRODUCTS TO BE AUCTIONED AND BIDDING IS DONE VIA THE INTERNET; ORGANIZATION OF INTERNET AUCTIONS; ORGANIZING AND CONDUCTING CHARITY AUCTIONS FOR CHARITABLE FUNDRAISING PURPOSES; PROVIDING A WEB SITE THAT FEATURES AN ON-LINE MARKET FOR USERS TO LIST OFFERED OR WANTED PERSONAL AND BUSINESS ASSETS AND SKILLS FOR HIRE, RENT, SALE OR AUCTION TRANSACTIONS ON THE BASIS OF PREDEFINED PERFORMANCE AND CLOSING TERMS AND CONDITIONS; PROVIDING A WEBSITE FOR MANAGING, CONDUCTING AND ORGANIZING ONLINE AUCTIONS THAT ARE DESIGNED TO RAISE MONEY FOR SELECTED CHARITIES; PROVIDING ON-LINE AUCTION SERVICES; REAL ESTATE AUCTIONS; TELEPHONE AND TELEVISION AUCTIONS (U.S. CLS. 100, 101 AND 102).

ARETHA SOMERVILLE, EXAMINING ATTORNEY

---

SN 85-198,217. UNIVERSITY OF SOUTH CAROLINA, COLUMBIA, SC. FILED 12-15-2010.

**SUSME**

THE MARK CONSISTS OF STANDARD CHARACTERS WITHOUT CLAIM TO ANY PARTICULAR FONT, STYLE, SIZE, OR COLOR.

OWNER OF U.S. REG. NO. 3,659,549.

FOR ASSOCIATION SERVICES, NAMELY, PROMOTING THE INTERESTS OF EDUCATORS INVOLVED IN THE FIELD OF MEDICAL EDUCATION ON CLINICAL ULTRASOUND PRINCIPLES AND TECHNIQUES (U.S. CLS. 100, 101 AND 102).

MARK PILARO, EXAMINING ATTORNEY

**CLASS 35—(Continued).**

SN 85-199,036. RATESPECIAL LLC, PASADENA, CA. FILED 12-15-2010.

# RATESPECIAL

THE MARK CONSISTS OF STANDARD CHARACTERS WITHOUT CLAIM TO ANY PARTICULAR FONT, STYLE, SIZE, OR COLOR.

FOR ADVERTISING AND DIRECTORY SERVICES, NAMELY, PROMOTING THE SERVICES OF OTHERS BY PROVIDING A WEB PAGE FEATURING LINKS TO THE WEBSITES OF OTHERS; MARKETING SERVICES, NAMELY, PROVIDING INFORMATIONAL WEB PAGES DESIGNED TO GENERATE SALES TRAFFIC VIA HYPERLINKS TO OTHER WEB SITES; ONLINE ADVERTISING AND PROMOTIONAL SERVICES (U.S. CLS. 100, 101 AND 102).

ANN E. SAPPENFIELD, EXAMINING ATTORNEY

**CLASS 35—(Continued).**

SN 85-199,542. 310 LABS, INC., SANTA MONICA, CA. FILED 12-16-2010.

# GOTCHOO

THE MARK CONSISTS OF STANDARD CHARACTERS WITHOUT CLAIM TO ANY PARTICULAR FONT, STYLE, SIZE, OR COLOR.

FOR PROMOTING THE GOODS AND SERVICES OF OTHERS, NAMELY, BY PROVIDING AN INTERACTIVE WEBSITE WHERE USERS CAN REQUEST DISCOUNTS AND SPECIAL OFFERS FROM POTENTIAL LOCAL AND NATIONAL MERCHANTS AND WHERE THE INTERACTIVE WEBSITE NEGOTIATES WITH GOODS AND SERVICE PROVIDERS FOR PROVIDING CUSTOMERS WITH TARGETED DISCOUNTS AND SPECIAL OFFERS (U.S. CLS. 100, 101 AND 102).

FIRST USE 9-29-2010; IN COMMERCE 9-29-2010.

MICHAEL WIENER, EXAMINING ATTORNEY

SN 85-199,460. WORLD MEDIA GROUP, LLC, BASKING RIDGE, NJ. FILED 12-16-2010.



NO CLAIM IS MADE TO THE EXCLUSIVE RIGHT TO USE "CERTIFIED AUTO CARE", APART FROM THE MARK AS SHOWN.

THE COLOR(S) BLUE AND GREEN IS/ARE CLAIMED AS A FEATURE OF THE MARK.

THE MARK CONSISTS OF THE WORDING "CERTIFIED AUTO CARE" IN STYLIZED FONT AND IN BLUE, CAPITAL LETTERS. THE DESIGN PRECEDING THE WORDING CONSISTS OF A GREEN CHECK MARK AND A BLUE CURVED LINE DEPICTED TO LOOK LIKE A ROAD THAT RUNS PARALLEL TO THE BODY OF THE MARK. THE WORDS "AUTO" AND "CARE" ARE SEPARATED BY A GREEN CIRCLE.

FOR AN ONLINE BUSINESS DIRECTORY FEATURING ONLINE LISTINGS FOR AUTO REPAIR SHOPS AND PROVIDING REFERRALS IN THE AUTO REPAIR FIELD (U.S. CLS. 100, 101 AND 102).

FIRST USE 8-11-2010; IN COMMERCE 8-11-2010.

MICHAEL WIENER, EXAMINING ATTORNEY

SN 85-200,218. PROST, WILLIAM, FREDONIA, NY. FILED 12-17-2010.



THE MARK CONSISTS OF TWO ARMS CLASPING AT THE HANDS WITH THE WORD "BROTHERS" ABOVE, THE LETTER "T" COMPOSED OF A CROSS OF FOUR EQUAL SIDES. THE TERM "OF THE ROAD" APPEARS WRITTEN BELOW.

FOR CLUB SERVICES, NAMELY, PROMOTING THE INTERESTS OF MOTORCYCLE ENTHUSIASTS (U.S. CLS. 100, 101 AND 102).

FIRST USE 5-14-2004; IN COMMERCE 5-14-2004.

CHARLES L. JENKINS, EXAMINING ATTORNEY

**CLASS 35—(Continued).**

SN 85-200,326. BANAH INTERNATIONAL GROUP, INC., MIAMI, FL. FILED 12-17-2010.

**BANAH**

THE MARK CONSISTS OF STANDARD CHARACTERS WITHOUT CLAIM TO ANY PARTICULAR FONT, STYLE, SIZE, OR COLOR.

FOR WHOLESALE AND RETAIL STORE SERVICES AND ON-LINE RETAIL AND WHOLESALE STORE SERVICES FEATURING SUGAR (U.S. CLS. 100, 101 AND 102).

FIRST USE 5-0-2009; IN COMMERCE 5-0-2009.  
JUSTINE D. PARKER, EXAMINING ATTORNEY

SN 85-200,336. BANAH INTERNATIONAL GROUP, INC., MIAMI, FL. FILED 12-17-2010.



THE COLOR(S) GREEN AND GOLD IS/ARE CLAIMED AS A FEATURE OF THE MARK.

THE MARK CONSISTS OF A STYLIZED GOLD LETTER "B" WITH A GOLD HORIZONTAL LINE EXTENDING FROM THE RIGHT AND LEFT, ABOVE THE GREEN WORD "BANAH".

FOR WHOLESALE AND RETAIL STORE SERVICES AND ON-LINE RETAIL AND WHOLESALE STORE SERVICES FEATURING SUGAR (U.S. CLS. 100, 101 AND 102).

FIRST USE 5-0-2009; IN COMMERCE 5-0-2009.  
JUSTINE D. PARKER, EXAMINING ATTORNEY

**CLASS 35—(Continued).**

SN 85-200,415. U.S. Highbush Blueberry Council, FOLSOM, CA. FILED 12-17-2010.



NO CLAIM IS MADE TO THE EXCLUSIVE RIGHT TO USE "BLUEBERRIES" APART FROM THE MARK AS SHOWN., APART FROM THE MARK AS SHOWN.

THE MARK CONSISTS OF THE WORDS "BLUEBERRIES" AND "LITTLE BLUE DYNAMOS" WRITTEN IN A CIRCLE AROUND A STYLIZED DESIGN OF A BLUEBERRY AND CROWN.

FOR ASSOCIATION SERVICES, NAMELY PROMOTING THE INTERESTS OF THE HIGHBUSH BLUEBERRY INDUSTRY BY DISSEMINATING ADVERTISING AND PROMOTIONAL MATERIALS AND CONSUMER AND INDUSTRY INFORMATION ABOUT BLUEBERRIES AND BLUEBERRY PRODUCTS (U.S. CLS. 100, 101 AND 102).

KHANH LE, EXAMINING ATTORNEY

SN 85-200,427. U. S. Highbush Blueberry Council, FOLSOM, CA. FILED 12-17-2010.



NO CLAIM IS MADE TO THE EXCLUSIVE RIGHT TO USE "BLUEBERRIES", APART FROM THE MARK AS SHOWN.

THE MARK CONSISTS OF THE WORD "BLUEBERRIES" WITH A STYLIZED BLUEBERRY AND CROWN IN THE PLACE OF THE DOT ON THE LETTER "I".

FOR PROMOTING THE INTERESTS OF THE HIGHBUSH BLUEBERRY INDUSTRY BY DISSEMINATING ADVERTISING AND PROMOTIONAL MATERIALS AND CONSUMER AND INDUSTRY INFORMATION ABOUT BLUEBERRIES AND BLUEBERRY PRODUCTS (U.S. CLS. 100, 101 AND 102).

KHANH LE, EXAMINING ATTORNEY



**CLASS 35—(Continued).**

SN 85-200,535. PROGRESSIVE CASUALTY INSURANCE COMPANY, MAYFIELD VILLAGE, OH. FILED 12-17-2010.

**CLASS 35—(Continued).**

SN 85-200,818. U.S. FOODSERVICE, INC., ROSEMONT, IL. FILED 12-17-2010.

# PerkShare

THE MARK CONSISTS OF STANDARD CHARACTERS WITHOUT CLAIM TO ANY PARTICULAR FONT, STYLE, SIZE, OR COLOR.

FOR ADMINISTRATION OF A PROGRAM FOR ENABLING PARTICIPANTS TO OBTAIN DISCOUNTS ON PRODUCTS AND SERVICES (U.S. CLS. 100, 101 AND 102).

ALLISON SCHRODY, EXAMINING ATTORNEY



SN 85-200,704. SAKS & COMPANY, NEW YORK, NY. FILED 12-17-2010.

# OFF 5TH

THE MARK CONSISTS OF STANDARD CHARACTERS WITHOUT CLAIM TO ANY PARTICULAR FONT, STYLE, SIZE, OR COLOR.

FOR RETAIL DEPARTMENT STORE SERVICES (U.S. CLS. 100, 101 AND 102).

FIRST USE 4-3-1995; IN COMMERCE 4-3-1995.  
JANICE KIM, EXAMINING ATTORNEY

OWNER OF U.S. REG. NOS. 2,088,117, 3,004,484 AND 3,293,530.

NO CLAIM IS MADE TO THE EXCLUSIVE RIGHT TO USE "COFFEE COMPANY" OR "SINCE 1996", APART FROM THE MARK AS SHOWN.

THE MARK CONSISTS OF THE WORD "RITUALS" APPEARING INSIDE A SERIES OF CONCENTRIC CIRCLES, ALONG WITH A STEAMING CUP DESIGN. THE PHRASE "COFFEE COMPANY SINCE 1996" ENCIRCLES "RITUALS" AND CUP DESIGN.

FOR SPECIALTY MERCHANDISING SERVICES, NAMELY, PROMOTING THE GOODS AND SERVICES OF OTHERS IN RESTAURANTS AND FOOD KIOSKS THROUGH THE DISTRIBUTION OF CUSTOMIZED ADVERTISING MATERIALS, NAMELY, BANNERS, POSTERS, TABLE TENTS, MENUS, AIRPOT MERCHANDISERS, AIRPOT WRAPS, CANOES, EURORAILS, DOOR DECALS (U.S. CLS. 100, 101 AND 102).

FIRST USE 1-0-2009; IN COMMERCE 1-0-2009.  
KAELIE KUNG, EXAMINING ATTORNEY

**CLASS 35—(Continued).**

SN 85-200,894. BROUN, WAYNE H., WARRIEWOOD BEACH NSW, AUSTRALIA, FILED 12-17-2010.

**CLASS 35—(Continued).**

SN 85-200,902. ROBERT B. FOGNER, DBA DO YOU BUDDY, VISTA, CA. FILED 12-17-2010.

## Do You Buddy?

THE MARK CONSISTS OF STANDARD CHARACTERS WITHOUT CLAIM TO ANY PARTICULAR FONT, STYLE, SIZE, OR COLOR.

FOR ADMINISTRATION OF A PROGRAM FOR ENABLING PARTICIPANTS TO OBTAIN DISCOUNTS ON PRODUCTS AND SERVICES; AN INTERACTIVE WEB SITE FOR USERS TO REVIEW AND RATE INTERNET CONTENT, PEOPLE, COMPANIES, PRODUCTS AND/OR SERVICES UTILIZING A SOFTWARE APPLICATION TO AWARD POINTS WHEREBY WEB SITE USERS ARE ELIGIBLE TO EXCHANGE POINTS EARNED FOR PROMOTIONAL ITEMS CONSISTING OF COUPONS, REBATES, DISCOUNTS OR SPECIAL OFFERINGS ON GOODS AND/OR SERVICE PROVIDED BY WEB SITE SPONSORS; ONLINE SERVICE FOR CONNECTING SOCIAL NETWORK USERS WITH RETAILERS FOR THE PURPOSE OF FACILITATING DISCOUNTED PURCHASES; PROMOTING THE GOODS AND SERVICES OF OTHERS BY PROVIDING A WEB SITE FEATURING COUPONS, REBATES, PRICE-COMPARISON INFORMATION, PRODUCT REVIEWS, LINKS TO THE RETAIL WEB SITES OF OTHERS, AND DISCOUNT INFORMATION; PROMOTING THE GOODS AND SERVICES OF OTHERS BY PROVIDING AN INTERACTIVE WEBSITE WHERE USERS CAN INCREASE THE CURRENT VALUE OF AN ONLINE DISCOUNT BEING OFFERED BY PURCHASING THE GOODS AND SERVICES ASSOCIATED WITH THAT DISCOUNT IN THE FORM OF AN ONLINE COUPON, VOUCHER OR GIFT CARD; PROMOTING THE SALE OF GOODS AND SERVICES OF OTHERS THROUGH ELECTRONIC COUPONING, PROMOTIONS AND DISCOUNTS (U.S. CLS. 100, 101 AND 102).

PAUL MORENO, EXAMINING ATTORNEY



THE MARK CONSISTS OF A COAT OF ARMS FEATURING A LION HOLDING A FLEUR-DE-LIS AND STANDING ATOP AN ARMOUR HELMET THAT IS ABOVE A SHIELD FEATURING A CHEVRON AND THREE FLEUR-DE-LIS, ALL SURROUNDED BY LEAVES. ABOVE THE LION IS A BANNER FEATURING THE WORDING "FLOREAT MAJESTAS".

THE ENGLISH TRANSLATION OF "FLOREAT MAJESTAS" IN THE MARK IS "LET MAJESTY FLOURISH".

FOR RETAIL STORE, ONLINE RETAIL STORE AND WHOLESALE STORE SERVICES ALL FEATURING CLOTHING AND FASHION ACCESSORIES, BELT BUCKLES, JEWELRY, BOOKS, PRINTED PAPER PRODUCTS, STATIONERY, POSTERS, BANNERS AND FLAGS (U.S. CLS. 100, 101 AND 102).

LINDA LAVACHE, EXAMINING ATTORNEY

SN 85-200,931. BANAH INTERNATIONAL GROUP, INC., MIAMI, FL. FILED 12-17-2010.

## SWEETEN YOUR LIFE

THE MARK CONSISTS OF STANDARD CHARACTERS WITHOUT CLAIM TO ANY PARTICULAR FONT, STYLE, SIZE, OR COLOR.

FOR WHOLESALE AND RETAIL STORE SERVICES AND ON-LINE RETAIL AND WHOLESALE STORE SERVICES FEATURING SUGAR (U.S. CLS. 100, 101 AND 102).

FIRST USE 12-6-2010; IN COMMERCE 12-6-2010.  
JUSTINE D. PARKER, EXAMINING ATTORNEY

**CLASS 35—(Continued).**

SN 85-201,074. EB2, INC, ROCKVILLE, MD. FILED 12-17-2010.

## Pine Point Outfitters

THE MARK CONSISTS OF STANDARD CHARACTERS WITHOUT CLAIM TO ANY PARTICULAR FONT, STYLE, SIZE, OR COLOR.

NO CLAIM IS MADE TO THE EXCLUSIVE RIGHT TO USE "OUTFITTERS", APART FROM THE MARK AS SHOWN.

FOR RETAIL STORE AND ON-LINE RETAIL STORE SERVICES FEATURING CLOTHING (U.S. CLS. 100, 101 AND 102).

COLLEEN KEARNEY, EXAMINING ATTORNEY

---

SN 85-201,137. ROCKET FUEL INC., REDWOOD SHORES, CA. FILED 12-17-2010.

## We're bringing rocket science to digital advertising.

THE MARK CONSISTS OF STANDARD CHARACTERS WITHOUT CLAIM TO ANY PARTICULAR FONT, STYLE, SIZE, OR COLOR.

NO CLAIM IS MADE TO THE EXCLUSIVE RIGHT TO USE "DIGITAL ADVERTISING", APART FROM THE MARK AS SHOWN.

FOR ADVERTISEMENT FOR OTHERS ON THE INTERNET; ADVERTISEMENT VIA MOBILE PHONE NETWORKS; ADVERTISING VIA ELECTRONIC MEDIA AND SPECIFICALLY THE INTERNET; ANALYSIS OF ADVERTISING RESPONSE; DISSEMINATION OF ADVERTISING FOR OTHERS VIA THE INTERNET; MEDIA BUYING ADVICE, NAMELY, ADVISING THE CLIENT HOW MUCH MEDIA TIME, AND AT WHAT TIMES THE CLIENT SHOULD BE PURCHASING ADVERTISING; ONLINE ADVERTISEMENTS; ONLINE ADVERTISING AND PROMOTIONAL SERVICES (U.S. CLS. 100, 101 AND 102).

FIRST USE 6-1-2010; IN COMMERCE 6-1-2010.  
NAKIA HENRY, EXAMINING ATTORNEY

---

SN 85-201,148. PEACE OF MIND, INC, LAKE OSWEGO, OR. FILED 12-17-2010.

## Chicks Connect

THE MARK CONSISTS OF STANDARD CHARACTERS WITHOUT CLAIM TO ANY PARTICULAR FONT, STYLE, SIZE, OR COLOR.

FOR PROVIDING A WEB SITE FEATURING BUSINESS INFORMATION IN THE FORM OF AUDIO AND VIDEO INTERVIEWS, TRANSCRIPTS AND OTHER EDUCATIONAL MATERIALS (U.S. CLS. 100, 101 AND 102).

ANDREA K. NADELMAN, EXAMINING ATTORNEY

**CLASS 35—(Continued).**

SN 85-201,775. HABITAT FOR HUMANITY INTERNATIONAL, INC., AMERICUS, GA. FILED 12-20-2010.

## HABITAT FOR HUMANITY

THE MARK CONSISTS OF STANDARD CHARACTERS WITHOUT CLAIM TO ANY PARTICULAR FONT, STYLE, SIZE, OR COLOR.

FOR RETAIL STORE SERVICES, NAMELY, SELLING USED AND DONATED HOUSEHOLD GOODS, APPLIANCES, AND BUILDING AND HOME IMPROVEMENT MATERIALS TO SUPPORT CHARITABLE ACTIVITIES (U.S. CLS. 100, 101 AND 102).

FIRST USE 12-31-1992; IN COMMERCE 12-31-1992.  
JANET LEE, EXAMINING ATTORNEY

---

SN 85-201,793. STAPLES THE OFFICE SUPERSTORE, LLC., FRAMINGHAM, MA. FILED 12-20-2010.

## IDECIDE

THE MARK CONSISTS OF STANDARD CHARACTERS WITHOUT CLAIM TO ANY PARTICULAR FONT, STYLE, SIZE, OR COLOR.

FOR ONLINE OFFICE SUPPLY MANAGEMENT SERVICES, NAMELY, A WEB BASED SERVICE FOR TRACKING INVENTORY OF PRINTER CONSUMABLES SUCH AS PRINTER INK, PRINTER TONER, PRINTER PAPER AND ONLINE ORDERING SERVICES FOR PURCHASING PRINTER SUPPLIES OVER THE INTERNET; RETAIL STORE SERVICES, ONLINE RETAIL STORE SERVICES AND RETAIL CATALOG SERVICES FEATURING LASER PRINTER, FAX MACHINE AND MULTI-FUNCTION PRINTER FUSER TRANSFERS, CHARGE ROLLERS AND PICK UP ROLLERS (U.S. CLS. 100, 101 AND 102).

KAELIE KUNG, EXAMINING ATTORNEY

**CLASS 35—(Continued).**

SN 85-202,054. H2 WHOLESALE, LLC, SCOTTSDALE, AZ. FILED 12-20-2010.

## H2W

THE MARK CONSISTS OF STANDARD CHARACTERS WITHOUT CLAIM TO ANY PARTICULAR FONT, STYLE, SIZE, OR COLOR.

FOR MATCHING DOMESTICALLY BASED MANUFACTURERS WITH INTERNATIONAL DISTRIBUTERS; PROMOTING COMMERCIAL, TRADE, AND OTHER BUSINESS RELATIONSHIPS BETWEEN UNITED STATES BASED MANUFACTURERS AND INTERNATIONAL DISTRIBUTORS IN THE INDUSTRIAL, SAFETY AND ENVIRONMENTAL MARKETS; INTERNATIONAL BUSINESS CONSULTING SERVICES RELATING TO MERCHANDISE TRADING; PRODUCT MERCHANDISING; WHOLESALE AND RETAIL STORE SERVICES AND ON-LINE RETAIL AND WHOLESALE STORE SERVICES FEATURING SAFETY AND ENVIRONMENTAL PRODUCTS, NAMELY, PROTECTIVE EYEWEAR AND EYEWASH, SHOP TOWELS AND DISPOSABLE WIPERS, CHEMICAL SORBENTS, INDUSTRIAL SORBENTS AND OIL SORBENTS, SECONDARY CONTAINMENT BERMS, SAFETY CABINETS AND OIL CONTAINMENT BOOMS (U.S. CLS. 100, 101 AND 102).

FIRST USE 12-0-2010; IN COMMERCE 12-0-2010.  
NANCY CLARKE, EXAMINING ATTORNEY

SN 85-202,333. BREAKING NEWS, LLC, BEVERLY HILLS, CA. FILED 12-20-2010.

## Breaking News

THE MARK CONSISTS OF STANDARD CHARACTERS WITHOUT CLAIM TO ANY PARTICULAR FONT, STYLE, SIZE, OR COLOR.

FOR PUBLIC RELATIONS; PUBLIC RELATIONS IN THE ENTERTAINMENT INDUSTRY; PUBLIC RELATIONS FOR CELEBRITY CLIENTS (U.S. CLS. 100, 101 AND 102).

LAURA KOVALSKY, EXAMINING ATTORNEY

SN 85-202,466. WASHINGTON, NATALIE C, DBA SUCCESS ANGELS ISRAEL, WASHINGTON, DC. FILED 12-21-2010.

## Success Angels

THE MARK CONSISTS OF STANDARD CHARACTERS WITHOUT CLAIM TO ANY PARTICULAR FONT, STYLE, SIZE, OR COLOR.

FOR OFFICE ADMINISTRATION SERVICES (U.S. CLS. 100, 101 AND 102).

FIRST USE 12-16-2010; IN COMMERCE 12-16-2010.  
WILLIAM VERHOSEK, EXAMINING ATTORNEY

**CLASS 35—(Continued).**

SN 85-202,481. POLY AUCTION, INC., ALBANY, NY. FILED 12-21-2010.

## POLY

THE MARK CONSISTS OF STANDARD CHARACTERS WITHOUT CLAIM TO ANY PARTICULAR FONT, STYLE, SIZE, OR COLOR.

FOR ARRANGING AND CONDUCTING AUCTIONS (U.S. CLS. 100, 101 AND 102).

FIRST USE 3-0-2000; IN COMMERCE 3-0-2000.  
PATRICIA EVANKO, EXAMINING ATTORNEY

SN 85-202,643. SACRAMENTO TELEVISION STATIONS INC., NEW YORK, NY. FILED 12-21-2010.

## GOOD DAY SACRAMENTO

THE MARK CONSISTS OF STANDARD CHARACTERS WITHOUT CLAIM TO ANY PARTICULAR FONT, STYLE, SIZE, OR COLOR.

NO CLAIM IS MADE TO THE EXCLUSIVE RIGHT TO USE "SACRAMENTO", APART FROM THE MARK AS SHOWN.

FOR RETAIL STORE SERVICES FEATURING A WIDE VARIETY OF CONSUMER GOODS (U.S. CLS. 100, 101 AND 102).

KELLY CHOE, EXAMINING ATTORNEY

SN 85-202,682. SARASOTA CONVENTION AND VISITORS BUREAU, INC., SARASOTA, FL. FILED 12-21-2010.



NO CLAIM IS MADE TO THE EXCLUSIVE RIGHT TO USE "SARASOTA", APART FROM THE MARK AS SHOWN.

THE MARK CONSISTS OF THE WORDING "I HEART SARASOTA" COMBINED WITH A STYLIZED HEART DESIGN AND THE WORD HEART IS CONTAINED WITHIN THIS HEART DESIGN.

FOR CONVENTION AND VISITORS BUREAU SERVICES, NAMELY, PROMOTING TOURISM, BUSINESS AND CONVENTIONS IN AND AROUND THE SARASOTA COUNTY, FLORIDA AREA (U.S. CLS. 100, 101 AND 102).

FIRST USE 8-3-2010; IN COMMERCE 8-3-2010.  
SUNG IN, EXAMINING ATTORNEY

**CLASS 35—(Continued).**

SN 85-202,790. ALTRUSA INTERNATIONAL, INC., CHICAGO, IL. FILED 12-21-2010.

## Leading to a Better Community

THE MARK CONSISTS OF STANDARD CHARACTERS WITHOUT CLAIM TO ANY PARTICULAR FONT, STYLE, SIZE, OR COLOR.

FOR CHARITABLE SERVICES, NAMELY, ORGANIZING AND CONDUCTING VOLUNTEER PROGRAMS AND COMMUNITY SERVICE PROJECTS (U.S. CLS. 100, 101 AND 102).

ASMAT KHAN, EXAMINING ATTORNEY

SN 85-202,830. ARTIXAN CONSULTING GROUP LLC, NEW YORK, NY. FILED 12-21-2010.

## Artixan

THE MARK CONSISTS OF STANDARD CHARACTERS WITHOUT CLAIM TO ANY PARTICULAR FONT, STYLE, SIZE, OR COLOR.

FOR HUMAN RESOURCES CONSULTANCY (U.S. CLS. 100, 101 AND 102).

FIRST USE 8-22-2010; IN COMMERCE 8-22-2010.

DOMINICK J. SALEMI, EXAMINING ATTORNEY

SN 85-202,987. HIDDEN CRUSH, INC., CONCORD, CA. FILED 12-21-2010.



THE MARK CONSISTS OF A BADGE, THAT INCLUDES A SILHOUETTE OF CUPID, IN MID FLIGHT, HOLDING A BOW AND ARROW. BELOW HIM IS A BANNER, THAT INCLUDES THE STYLIZED TEXT "HIDDEN CRUSH".

FOR ON-LINE RETAIL STORE SERVICES FEATURING ARTIFICIAL, FRESH CUT, AND DRIED FLOWER, FLORAL BOUQUETS AND ARRANGEMENTS, GIFTS, GIFT BASKETS, CLOTHING AND ACCESSORIES, ELECTRONICS AND ACCESSORIES, TOY AND ACCESSORIES, BODY CARE PRODUCTS AND ACCESSORIES, MUSIC, MOVIES, BOOKS, GIFT CARDS, AND PERFUMES AND FRAGRANCES, JEWELRY, FOOD (U.S. CLS. 100, 101 AND 102).

FIRST USE 3-1-2010; IN COMMERCE 3-1-2010.

CYNTHIA SLOAN, EXAMINING ATTORNEY

**CLASS 35—(Continued).**

SN 85-203,513. LIGHT IN THE BOX LIMITED, DES VOEUX RD C CENTRAL, HONG KONG, FILED 12-22-2010.



THE MARK CONSISTS OF THE WORD "OUKU" WITH STYLIZED DESIGN AND THREE WATER-DROPLET-SHAPED DEVICES ABOVE THE LETTER "O"

THE WORDING "OUKU" HAS NO MEANING IN A FOREIGN LANGUAGE.

FOR ADVERTISING AND PROMOTIONAL SERVICES; ADVERTISING SERVICES; BUSINESS ORGANIZATION AND MANAGEMENT CONSULTANCY INCLUDING PERSONNEL MANAGEMENT; ON-LINE RETAIL STORE SERVICES FEATURING A WIDE VARIETY OF CONSUMER GOODS OF OTHERS; ON-LINE RETAIL STORE SERVICES FEATURING DOWNLOADABLE PRE-RECORDED MUSIC AND VIDEO; ON-LINE RETAIL STORE SERVICES FEATURING DOWNLOADABLE RING TONES; PROCUREMENT, NAMELY, PURCHASING T-SHIRTS, SHIRTS, DRESSES, TROUSERS, JACKETS FOR OTHERS; PROVIDING BUSINESS MARKETING INFORMATION; RELOCATION SERVICES FOR BUSINESS (U.S. CLS. 100, 101 AND 102).

HEATHER BIDDULPH, EXAMINING ATTORNEY

SN 85-203,578. GANNETT CO., INC., MCLEAN, VA. FILED 12-22-2010.

## IT'S ALL WITHIN REACH

THE MARK CONSISTS OF STANDARD CHARACTERS WITHOUT CLAIM TO ANY PARTICULAR FONT, STYLE, SIZE, OR COLOR.

FOR DISSEMINATION OF ADVERTISING FOR OTHERS VIA TELEVISION, NEWSPAPERS AND THE INTERNET; PROVIDING INFORMATION ABOUT MERCHANDISE FOR SALE AND JOB LISTINGS VIA TELEVISION, NEWSPAPERS AND THE INTERNET (U.S. CLS. 100, 101 AND 102).

SOPHIA S. KIM, EXAMINING ATTORNEY

**CLASS 35—(Continued).**

SN 85-203,660. AARON, LAWRENCE D, DBA EVERBRAND, LLC, HACKETTSTOWN, NJ. FILED 12-22-2010.



THE COLOR(S) GREEN, TEAL, GREY IS/ARE CLAIMED AS A FEATURE OF THE MARK.

THE MARK CONSISTS OF AN INFINITY LOOP THAT CONSISTS OF TEAL AND GREEN WITH A GREY SHADOW AND THE WORDS "EVERBRAND" IN TEAL AND GREEN.

FOR ADVERTISEMENT FOR OTHERS ON THE INTERNET; ADVERTISING AGENCIES; ADVERTISING AGENCIES, NAMELY, PROMOTING THE GOODS AND SERVICES OF OTHERS; ADVERTISING AGENCY SPECIALIZING IN THE DESIGN AND EXECUTION OF WORD OF MOUTH, VIRAL, BUZZ AND EXPERIENTIAL MARKETING PROGRAMS; ADVERTISING AND ADVERTISEMENT SERVICES; ADVERTISING AND MARKETING; ADVERTISING AND MARKETING CONSULTANCY; ADVERTISING AND MARKETING SERVICES PROVIDED BY MEANS OF INDIRECT METHODS OF MARKETING COMMUNICATIONS, NAMELY, SOCIAL MEDIA, SEARCH ENGINE MARKETING, INQUIRY MARKETING, INTERNET MARKETING, MOBILE MARKETING, BLOGGING AND OTHER FORMS OF PASSIVE, SHARABLE OR VIRAL COMMUNICATIONS CHANNELS; ADVERTISING AND MARKETING SERVICES, NAMELY, PROMOTING THE GOODS AND SERVICES OF OTHERS; ADVERTISING AND PUBLICITY SERVICES, NAMELY, PROMOTING THE GOODS, SERVICES, BRAND IDENTITY AND COMMERCIAL INFORMATION AND NEWS OF THIRD PARTIES THROUGH PRINT, AUDIO, VIDEO, DIGITAL AND ON-LINE MEDIUM (U.S. CLS. 100, 101 AND 102).  
FIRST USE 12-17-2002; IN COMMERCE 12-17-2002.

CHRISTOPHER BUONGIORNO, EXAMINING ATTORNEY

SN 85-203,843. BOSTWICK, PETER J, MENLO PARK, CA. FILED 12-22-2010.

## Lobby Shop

THE MARK CONSISTS OF STANDARD CHARACTERS WITHOUT CLAIM TO ANY PARTICULAR FONT, STYLE, SIZE, OR COLOR.

FOR RETAIL CONVENIENCE STORES (U.S. CLS. 100, 101 AND 102).

FIRST USE 12-21-2010; IN COMMERCE 12-21-2010.  
SUZANNE BLANE, EXAMINING ATTORNEY

**CLASS 35—(Continued).**

SN 85-204,084. KUZMAK, JUDITH MARIE, BALTIMORE, MD. FILED 12-22-2010.



THE MARK CONSISTS OF A DESIGN IS OF THREE PEOPLE HOLDING HANDS.

FOR CHARITABLE SERVICES, NAMELY, COORDINATION OF NON-MONETARY CONTRIBUTIONS TO CHARITIES AND NON-PROFITS (U.S. CLS. 100, 101 AND 102).

ANNE E. GUSTASON, EXAMINING ATTORNEY

SN 85-204,181. HR 360, INC., STAMFORD, CT. FILED 12-22-2010.

## HR 360

THE MARK CONSISTS OF STANDARD CHARACTERS WITHOUT CLAIM TO ANY PARTICULAR FONT, STYLE, SIZE, OR COLOR.

NO CLAIM IS MADE TO THE EXCLUSIVE RIGHT TO USE "HR", APART FROM THE MARK AS SHOWN.

FOR PROVIDING EMPLOYMENT INFORMATION (U.S. CLS. 100, 101 AND 102).

FIRST USE 12-20-2010; IN COMMERCE 12-20-2010.  
KIM SAITO, EXAMINING ATTORNEY

**CLASS 35—(Continued).**

SN 85-204,584. CHHABRA AND SONS. INC., ARTESIA, CA. FILED 12-23-2010.

**Loveleen**

THE MARK CONSISTS OF STANDARD CHARACTERS WITHOUT CLAIM TO ANY PARTICULAR FONT, STYLE, SIZE, OR COLOR.

FOR ON-LINE WHOLESALE AND RETAIL STORE SERVICES FEATURING CLOTHES, JEWELRY, SCARVES, SHAWLS, SHOES AND FABRIC; RETAIL APPAREL STORES; RETAIL CLOTHING BOUTIQUES; RETAIL CLOTHING STORES; RETAIL JEWELRY STORES; WHOLESALE AND RETAIL STORE SERVICES AND ON-LINE RETAIL AND WHOLESALE STORE SERVICES FEATURING CLOTHES, JEWELRY, SCARVES, SHAWLS, SHOES AND FABRIC; WHOLESALE AND RETAIL STORE SERVICES FEATURING CLOTHES, JEWELRY, SCARVES, SHAWLS, SHOES AND FABRIC (U.S. CLS. 100, 101 AND 102).

FIRST USE 8-1-1991; IN COMMERCE 9-13-1991.  
HANNO RITTNER, EXAMINING ATTORNEY

**CLASS 35—(Continued).**

SN 85-204,639. NATIONAL TOUR ASSOCIATION, INC., LEXINGTON, KY. FILED 12-23-2010.

**BRINGING THE WORLD TO  
NORTH AMERICA AND NORTH  
AMERICA TO THE WORLD**

THE MARK CONSISTS OF STANDARD CHARACTERS WITHOUT CLAIM TO ANY PARTICULAR FONT, STYLE, SIZE, OR COLOR.

FOR ASSOCIATION SERVICES, NAMELY, PROMOTING THE INTERESTS OF THE PACKAGED TOUR AND TRAVEL INDUSTRY (U.S. CLS. 100, 101 AND 102).

FIRST USE 8-0-2010; IN COMMERCE 8-0-2010.  
ANDREA BUTLER, EXAMINING ATTORNEY

SN 85-204,749. TECHFELLOW 2010 FUND MANAGEMENT, LLC, SAN FRANCISCO, CA. FILED 12-23-2010.

**TECHFELLOW**

THE MARK CONSISTS OF STANDARD CHARACTERS WITHOUT CLAIM TO ANY PARTICULAR FONT, STYLE, SIZE, OR COLOR.

FOR NEW BUSINESS VENTURE DEVELOPMENT AND FORMATION CONSULTING SERVICES (U.S. CLS. 100, 101 AND 102).

AMY C. KEAN, EXAMINING ATTORNEY

SN 85-204,590. IGVault CO., LIMITED, WANCHAI, HONG KONG, FILED 12-23-2010.

**IGVault**

THE MARK CONSISTS OF STANDARD CHARACTERS WITHOUT CLAIM TO ANY PARTICULAR FONT, STYLE, SIZE, OR COLOR.

THE WORDING "IGVAULT" HAS NO MEANING IN A FOREIGN LANGUAGE.

FOR ON-LINE AUCTION SERVICES; ON-LINE WHOLESALE AND RETAIL STORE SERVICES FEATURING DOWNLOADABLE SOUND, MUSIC, IMAGE, VIDEO AND GAME FILES; OPERATING ON-LINE MARKETPLACES FOR SELLERS OF GOODS AND/OR SERVICES; PROVIDING A WEBSITE FEATURING AN ONLINE MARKETPLACE FOR EXCHANGING GOODS AND SERVICES WITH OTHER USERS (U.S. CLS. 100, 101 AND 102).

FIRST USE 2-8-2007; IN COMMERCE 2-8-2007.  
CARYN GLASSER, EXAMINING ATTORNEY

SN 85-204,767. TECHFELLOW 2010 FUND MANAGEMENT, LLC, SAN FRANCISCO, CA. FILED 12-23-2010.

**TECHFELLOW AWARDS**

THE MARK CONSISTS OF STANDARD CHARACTERS WITHOUT CLAIM TO ANY PARTICULAR FONT, STYLE, SIZE, OR COLOR.

FOR NEW BUSINESS VENTURE DEVELOPMENT AND FORMATION CONSULTING SERVICES (U.S. CLS. 100, 101 AND 102).

AMY C. KEAN, EXAMINING ATTORNEY

**CLASS 35—(Continued).**

SN 85-204,796. EXCEL SKATEBOARD SUPPLY, INC., COSTA MESA, CA. FILED 12-23-2010.



NO CLAIM IS MADE TO THE EXCLUSIVE RIGHT TO USE "DISTRIBUTION CO.", APART FROM THE MARK AS SHOWN.

THE MARK CONSISTS OF THE WORDS "THE NEST" IN LARGE STYLIZED FONT ABOVE THE WORDS "DISTRIBUTION CO." IN SMALLER STYLIZED FONT. TO THE LEFT OF THE WORDS IS A DRAWING OF A BIRD, ON ITS BACK WITH AN "X" FOR AN EYE.

FOR DISTRIBUTORSHIP SERVICES IN THE FIELD OF SKATEBOARDS, SKATEBOARD DECKS, SKATEBOARD WHEELS, SKATEBOARD TRUCKS, SKATEBOARD RAILS, SKATEBOARD GRIP TAPES, NUTS AND BOLTS FOR SKATEBOARDS, PROTECTIVE PADDING FOR SKATEBOARDING, POSTERS, MAGAZINES, PAMPHLETS, STICKERS, NOTE CARDS, POST CARDS, CALENDARS, CORRUGATED BOXES, CATALOGS IN THE FIELD OF SKATEBOARDING AND RELATED EQUIPMENT, ACCESSORIES AND APPAREL, SHIRTS, TOPS, SHORTS, PANTS, SWEATSHIRTS, HEADWEAR, HATS, BOARD SHORTS, SHOES, GLOVES, PROTECTIVE HELMETS, PROTECTIVE EYEWEAR, DIGITAL MEDIA, NAMELY, DVDS AND DOWNLOADABLE VIDEO FILES FEATURING SKATEBOARDING, SKATEBOARDING DEMONSTRATIONS AND SKATEBOARDING INSTRUCTION (U.S. CLS. 100, 101 AND 102).

PAULA MAHONEY, EXAMINING ATTORNEY

**CLASS 35—(Continued).**

SN 85-204,927. MEDASSURANT, INC., BOWIE, MD. FILED 12-23-2010.

HEALTHIER MEMBERS,  
HEALTHIER BUSINESS.

THE MARK CONSISTS OF STANDARD CHARACTERS WITHOUT CLAIM TO ANY PARTICULAR FONT, STYLE, SIZE, OR COLOR.

FOR HEALTHCARE BUSINESS INFORMATION SERVICES, NAMELY, DATA COMPILING AND ANALYZING IN THE FIELD OF HEALTHCARE FOR HEALTHCARE PROFESSIONALS TO IMPROVE TREATMENT, PAYMENT AND HEALTHCARE OPERATIONS (U.S. CLS. 100, 101 AND 102).

FIRST USE 10-25-2010; IN COMMERCE 10-25-2010.

JEAN IM, EXAMINING ATTORNEY

SN 85-204,937. IDEAS EXITOSAS EN INTERNET S.A. DE C.V., GUADALAJARA, MEXICO, FILED 12-23-2010.

ESLOMENOS

REAL FOOD HAS A STORY

THE MARK CONSISTS OF STANDARD CHARACTERS WITHOUT CLAIM TO ANY PARTICULAR FONT, STYLE, SIZE, OR COLOR.

FOR PROVIDING A WEBSITE FEATURING INFORMATION FOR CONSUMERS ABOUT THE SOURCES OF APPLICANT'S FOOD PRODUCTS (U.S. CLS. 100, 101 AND 102).

FIRST USE 9-1-2010; IN COMMERCE 9-1-2010.

REBECCA EISINGER, EXAMINING ATTORNEY

THE MARK CONSISTS OF STANDARD CHARACTERS WITHOUT CLAIM TO ANY PARTICULAR FONT, STYLE, SIZE, OR COLOR.

THE ENGLISH TRANSLATION OF "ESLOMENOS" IN THE MARK IS "IS THE LESS".

FOR ONLINE ADVERTISEMENTS; PROVIDING A SEARCHABLE WEBSITE FEATURING THE GOODS AND SERVICES OF OTHER VENDORS; PROVIDING A WEBSITE FOR CONNECTING SELLERS WITH BUYERS (U.S. CLS. 100, 101 AND 102).

INGA ERVIN, EXAMINING ATTORNEY

SN 85-204,877. APPLGATE FARMS, LLC, BRIDGEWATER, NJ. FILED 12-23-2010.



**CLASS 35—(Continued).**

SN 85-204,961. URBAN PARTNERSHIP BANK, CHICAGO, IL. FILED 12-23-2010.

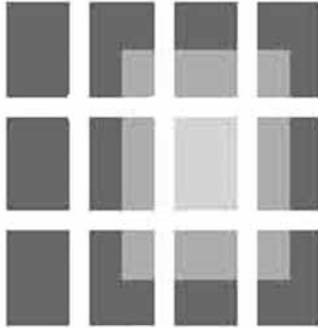

THE MARK CONSISTS OF TWELVE RECTANGLES FORMING RECTANGLE BOX WITH FOUR BOXES ACROSS AND THREE BOXES VERTICALLY PLACED WITH INTERSECTING LINES. SHADED RECTANGLE INSIDE RIGHT THREE ROWS.

FOR ASSISTANCE, ADVISORY SERVICES AND CONSULTANCY WITH REGARD TO BUSINESS PLANNING, BUSINESS ANALYSIS, BUSINESS MANAGEMENT, BUSINESS ORGANIZATION, MARKETING AND CUSTOMER ANALYSIS; CREDIT CARD REGISTRATION SERVICES; PROMOTING THE SALE OF GOODS AND SERVICES OF OTHERS BY AWARDED PURCHASE POINTS FOR CREDIT CARD USE; PROVIDING AN ON-LINE COMPUTER WEB SITE THAT PROVIDES COMMERCIAL FINANCIAL TRANSACTION DATA, ACCOUNT MANAGEMENT, FINANCIAL REPORTING, ACCOUNTING FEATURES AND RELATED REFERENCE INFORMATION (U.S. CLS. 100, 101 AND 102).

FIRST USE 12-10-2010; IN COMMERCE 12-10-2010.  
DAVID I, EXAMINING ATTORNEY

SN 85-205,041. HUMANCONCEPTS LIMITED LIABILITY COMPANY, SAUSALITO, CA. FILED 12-23-2010.

## HUMANCONCEPTS

THE MARK CONSISTS OF STANDARD CHARACTERS WITHOUT CLAIM TO ANY PARTICULAR FONT, STYLE, SIZE, OR COLOR.

FOR BUSINESS MANAGEMENT AND BUSINESS ORGANIZATIONAL CONSULTATION; LICENSING OF COMPUTER SOFTWARE TO OTHERS IN THE FIELD OF BUSINESS; AND BUSINESS DATA GATHERING SERVICES FOR OTHERS (U.S. CLS. 100, 101 AND 102).

FIRST USE 1-1-1999; IN COMMERCE 4-1-2000.  
SUE LAWRENCE, EXAMINING ATTORNEY

**CLASS 35—(Continued).**

SN 85-205,118. URBAN PARTNERSHIP BANK, CHICAGO, IL. FILED 12-23-2010.

## UPB

THE MARK CONSISTS OF STANDARD CHARACTERS WITHOUT CLAIM TO ANY PARTICULAR FONT, STYLE, SIZE, OR COLOR.

FOR ASSISTANCE, ADVISORY SERVICES AND CONSULTANCY WITH REGARD TO BUSINESS PLANNING, BUSINESS ANALYSIS, BUSINESS MANAGEMENT, BUSINESS ORGANIZATION, MARKETING AND CUSTOMER ANALYSIS; CREDIT CARD REGISTRATION SERVICES; PROMOTING THE SALE OF GOODS AND SERVICES OF OTHERS BY AWARDED PURCHASE POINTS FOR CREDIT CARD USE; PROVIDING AN ON-LINE COMPUTER WEB SITE THAT PROVIDES COMMERCIAL FINANCIAL TRANSACTION DATA, ACCOUNT MANAGEMENT, FINANCIAL REPORTING, ACCOUNTING FEATURES AND RELATED REFERENCE INFORMATION (U.S. CLS. 100, 101 AND 102).

SANI KHOURI, EXAMINING ATTORNEY

SN 85-205,130. AGDATA, LP, CHARLOTTE, NC. FILED 12-23-2010.



THE MARK CONSISTS OF A STYLIZED DEPICTION OF A MAGNIFYING GLASS WITH A LEAF IN THE UPPER RIGHT SIDE OF THE MAGNIFYING GLASS.

FOR PROVIDING A SUBSCRIPTION-BASED ONLINE REPORT FOR MANUFACTURERS AND DISTRIBUTORS OF PRODUCTS FOR THE AGRICULTURAL INDUSTRY COMPILING SUBSCRIBER MARKET DATA (U.S. CLS. 100, 101 AND 102).

JENNY PARK, EXAMINING ATTORNEY

**CLASS 35—(Continued).**

SN 85-205,156. SURGERE, INC., NORTH CANTON, OH.  
FILED 12-23-2010.

# PAAS

THE MARK CONSISTS OF STANDARD CHARACTERS WITHOUT CLAIM TO ANY PARTICULAR FONT, STYLE, SIZE, OR COLOR.

FOR BUSINESS CONSULTING SERVICES RELATING TO PRODUCT DISTRIBUTION, OPERATIONS MANAGEMENT SERVICES, LOGISTICS, REVERSE LOGISTICS, SUPPLY CHAIN, AND PRODUCTION SYSTEMS AND DISTRIBUTION SOLUTIONS (U.S. CLS. 100, 101 AND 102).

FIRST USE 1-24-2010; IN COMMERCE 1-24-2010.  
ALLISON SCHRODY, EXAMINING ATTORNEY

SN 85-205,222. ORLEA-GIAN SNOBALLS, LLC, DECATUR, GA. FILED 12-23-2010.

# ORLEAGIAN SNOWBALLS

THE MARK CONSISTS OF STANDARD CHARACTERS WITHOUT CLAIM TO ANY PARTICULAR FONT, STYLE, SIZE, OR COLOR.

NO CLAIM IS MADE TO THE EXCLUSIVE RIGHT TO USE "SNOWBALLS", APART FROM THE MARK AS SHOWN.

THE WORDING "ORLEAGIAN" HAS NO MEANING IN A FOREIGN LANGUAGE.

FOR RETAIL STORE SERVICES FEATURING FROZEN CONFECTIONS (U.S. CLS. 100, 101 AND 102).

FIRST USE 5-15-2006; IN COMMERCE 5-15-2006.  
SAMUEL E. SHARPER JR., EXAMINING ATTORNEY

SN 85-205,239. SURGERE, INC., NORTH CANTON, OH.  
FILED 12-23-2010.

# Surgere

THE MARK CONSISTS OF STANDARD CHARACTERS WITHOUT CLAIM TO ANY PARTICULAR FONT, STYLE, SIZE, OR COLOR.

FOR BUSINESS CONSULTING SERVICES RELATING TO PRODUCT DISTRIBUTION, OPERATIONS MANAGEMENT SERVICES, LOGISTICS, REVERSE LOGISTICS, SUPPLY CHAIN, AND PRODUCTION SYSTEMS AND DISTRIBUTION SOLUTIONS (U.S. CLS. 100, 101 AND 102).

FIRST USE 10-15-2003; IN COMMERCE 10-15-2003.  
ALLISON SCHRODY, EXAMINING ATTORNEY

**CLASS 35—(Continued).**

SN 85-205,441. BLOGME, LLC, WESTLAKE VILLAGE, CA.  
FILED 12-23-2010.

# BLOG ME

THE MARK CONSISTS OF STANDARD CHARACTERS WITHOUT CLAIM TO ANY PARTICULAR FONT, STYLE, SIZE, OR COLOR.

FOR BUSINESS MONITORING SERVICES, NAMELY, TRACKING WEB SITES AND APPLICATIONS OF OTHERS TO PROVIDE A RATING SERVICE WHICH RATES INDIVIDUAL USER'S ONLINE ACTIVITY FOR ANALYTIC AND STATISTICAL PREDICTIONS THAT GAUGE THEIR INFLUENCE FOR ADVERTISING AND MARKETING PURPOSES AND IMPACT ON BUSINESS AND MARKET TRENDS AND ACTIONS (U.S. CLS. 100, 101 AND 102).

TAMARA FRAZIER, EXAMINING ATTORNEY

SN 85-205,784. PUBLIX ASSET MANAGEMENT COMPANY, LAKELAND, FL. FILED 12-27-2010.

# GreenWise

OWNER OF U.S. REG. NOS. 2,520,595, 3,274,071 AND OTHERS.

THE MARK CONSISTS OF THE WORD "GREENWISE" IN A STYLIZED FONT.

FOR RETAIL GROCERY STORE SERVICES (U.S. CLS. 100, 101 AND 102).

FIRST USE 3-14-2001; IN COMMERCE 3-14-2001.  
JASON TURNER, EXAMINING ATTORNEY

SN 85-205,814. FLOWERS TODAY, INC., HAYMARKET, VA.  
FILED 12-27-2010.

# bloomstoday

OWNER OF U.S. REG. NOS. 3,005,701 AND 3,253,316.  
THE MARK CONSISTS OF THE WORD BLOOMSTODAY WITH THE DESIGN OF A FLOWER APPEARING OVER THE LETTER "M".

FOR ORDER FULFILLMENT SERVICES BY FLORISTS AND COMPUTERIZED ONLINE RETAIL STORE SERVICES PROVIDING FLOWERS, PLANTS, FLOWERING PLANTS, BALLOONS, CAKES, CANDY, GIFT BASKETS, AND OTHER RELATED GIFTS (U.S. CLS. 100, 101 AND 102).

FIRST USE 3-13-2006; IN COMMERCE 3-13-2006.  
DOMINICK J. SALEMI, EXAMINING ATTORNEY

**CLASS 35—(Continued).**

SN 85-205,865. JACKET PROPERTIES INC, FAYETTEVILLE, GA. FILED 12-27-2010.

# YO TOPS

THE MARK CONSISTS OF STANDARD CHARACTERS WITHOUT CLAIM TO ANY PARTICULAR FONT, STYLE, SIZE, OR COLOR.

FOR RETAIL FROZEN YOGURT SHOP (U.S. CLS. 100, 101 AND 102).

FIRST USE 9-1-2010; IN COMMERCE 9-25-2010.  
JENNY PARK, EXAMINING ATTORNEY

**CLASS 35—(Continued).**

SN 85-205,976. ROBERTS, DENNIS, MAMARONECK, NY. FILED 12-27-2010.

# transfoHRm

THE MARK CONSISTS OF STANDARD CHARACTERS WITHOUT CLAIM TO ANY PARTICULAR FONT, STYLE, SIZE, OR COLOR.

FOR BUSINESS CONSULTING SERVICES IN THE FIELD OF ORGANIZATIONAL CHANGE MANAGEMENT (U.S. CLS. 100, 101 AND 102).

FIRST USE 12-25-2010; IN COMMERCE 12-25-2010.  
JACQUELINE A. LAVINE, EXAMINING ATTORNEY

SN 85-205,906. SAVELA & ASSOCIATES, INC., BIRMINGHAM, AL. FILED 12-27-2010.



FOR EMPLOYMENT COUNSELING AND RECRUITING; EMPLOYMENT HIRING, RECRUITING, PLACEMENT, STAFFING AND CAREER NETWORKING SERVICES (U.S. CLS. 100, 101 AND 102).

DEBRA LEE, EXAMINING ATTORNEY

SN 85-205,978. VARGAS, JOSEPH, SAN ANGELO, TX. FILED 12-27-2010.

SN 85-205,962. DETROIT REGION AEROTROPOLIS DEVELOPMENT CORPORATION, DETROIT, MI. FILED 12-27-2010.

# AMERITROPLIS



THE MARK CONSISTS OF STANDARD CHARACTERS WITHOUT CLAIM TO ANY PARTICULAR FONT, STYLE, SIZE, OR COLOR.

FOR PROMOTING ECONOMIC DEVELOPMENT, BUSINESS AND TOURISM IN THE DETROIT REGION OF THE STATE OF MICHIGAN; PROVIDING ONLINE INFORMATION PERTAINING TO THE PROMOTION OF ECONOMIC DEVELOPMENT, BUSINESS AND TOURISM IN THE DETROIT REGION OF THE STATE OF MICHIGAN (U.S. CLS. 100, 101 AND 102).

MARY BOAGNI, EXAMINING ATTORNEY

THE MARK CONSISTS OF THE TEXT "PUROPARTY.-NET" WITH AUDIO IMAGE ABOVE.

FOR MUSIC MARKETING FOR OTHERS (U.S. CLS. 100, 101 AND 102).

FIRST USE 1-6-2000; IN COMMERCE 1-6-2000.

JACQUELINE A. LAVINE, EXAMINING ATTORNEY

**CLASS 35—(Continued).**

SN 85-206,007. EPIC STEP, LLC, LOS ANGELES, CA. FILED 12-27-2010.



THE MARK CONSISTS OF THE WORDING "EPIC STEP" WITH A MAN IN THE MIDDLE STANDING ON A MOUNTAIN TOP SHOUTING FROM A BULL HORN, AND A MIRROR IMAGE OF THE WORDING "EPIC STEP" REFLECTED BELOW THE WORDING.

FOR ADVERTISEMENT FOR OTHERS ON THE INTERNET; ADVERTISING AGENCIES; ADVERTISING AGENCIES, NAMELY, PROMOTING THE GOODS AND SERVICES OF OTHERS; ADVERTISING ON THE INTERNET FOR OTHERS; ADVERTISING, INCLUDING ON-LINE ADVERTISING ON A COMPUTER NETWORK; INTERNET ADVERTISING SERVICES; ON-LINE ADVERTISING ON COMPUTER NETWORKS; ONLINE ADVERTISEMENTS; PROVIDING ADVERTISING SERVICES; PROVIDING AND RENTAL OF ADVERTISING SPACE ON THE INTERNET; PROVISION OF ADVERTISING SPACE BY ELECTRONIC MEANS AND GLOBAL INFORMATION NETWORKS (U.S. CLS. 100, 101 AND 102).

HELENE LIWINSKI, EXAMINING ATTORNEY

SN 85-206,057. DETROIT REGION AEROTROPOLIS DEVELOPMENT CORPORATION, DETROIT, MI. FILED 12-27-2010.

**AMERITROPOLIS**

THE MARK CONSISTS OF STANDARD CHARACTERS WITHOUT CLAIM TO ANY PARTICULAR FONT, STYLE, SIZE, OR COLOR.

FOR PROMOTING ECONOMIC DEVELOPMENT, BUSINESS AND TOURISM IN THE DETROIT REGION OF THE STATE OF MICHIGAN; PROVIDING ONLINE INFORMATION PERTAINING TO THE PROMOTION OF ECONOMIC DEVELOPMENT, BUSINESS AND TOURISM IN THE DETROIT REGION OF THE STATE OF MICHIGAN (U.S. CLS. 100, 101 AND 102).

MARY BOAGNI, EXAMINING ATTORNEY

**CLASS 35—(Continued).**

SN 85-206,071. KOPPMAN, KIM, VICKSBURG, MS. FILED 12-27-2010.

**KIM KOPPMAN**

THE MARK CONSISTS OF STANDARD CHARACTERS WITHOUT CLAIM TO ANY PARTICULAR FONT, STYLE, SIZE, OR COLOR.

THE NAME(S), PORTRAIT(S), AND/OR SIGNATURE(S) SHOWN IN THE MARK IDENTIFIES "KIM KOPPMAN", WHOSE CONSENT(S) TO REGISTER IS MADE OF RECORD.

FOR ON-LINE ART GALLERIES; ON-LINE RETAIL STORE SERVICES FEATURING ARTWORK, NAMELY, PAINTINGS, PHOTOGRAPHS, DRAWINGS, SKETCHES, SCULPTURE AND WORKS OF CREATIVE WRITING (U.S. CLS. 100, 101 AND 102).

SANJEEV VOHRA, EXAMINING ATTORNEY

SN 85-206,090. R3D ENTERTAINMENT INCORPORATED, VALLEJO, CA. FILED 12-27-2010.



THE COLOR(S) WHITE, BLACK, YELLOW, BLUE PURPLE AND GRAY IS/ARE CLAIMED AS A FEATURE OF THE MARK.

THE MARK CONSISTS OF THE WORDING "DEFINITIVE" IN WHITE AND A BLACK BACKGROUND, "3" IN YELLOW WITH "D" IN GRAY WITH A PURPLE, BLUE AND YELLOW CENTER.

FOR CONCEPT AND BRAND DEVELOPMENT IN THE DIGITAL NAMING OF WEBSITES ASSOCIATED UNDER ONE BRAND NAME (U.S. CLS. 100, 101 AND 102).

KEVON CHISOLM, EXAMINING ATTORNEY

SN 85-206,097. INK4EVER.COM, INC., CITY OF INDUSTRY, CA. FILED 12-27-2010.

**INK4EVER.COM**

THE MARK CONSISTS OF STANDARD CHARACTERS WITHOUT CLAIM TO ANY PARTICULAR FONT, STYLE, SIZE, OR COLOR.

FOR RETAIL STORE AND ON-LINE RETAIL STORE SERVICES FEATURING PRINTER INK AND TONER CARTRIDGES (U.S. CLS. 100, 101 AND 102).

FIRST USE 5-0-2003; IN COMMERCE 5-0-2003.

KEVON CHISOLM, EXAMINING ATTORNEY

**CLASS 35—(Continued).**

SN 85-206,199. VIDEONU.NU INC, IRVINE, CA. FILED 12-27-2010.



THE MARK CONSISTS OF A LETTER "V" WITH A DOT IN THE CENTER OF THE "V" AND AN ARROW ON THE TOP.

FOR PROVIDING A WEB SITE THAT GIVES COMPUTER USERS THE ABILITY TO UPLOAD, EXCHANGE AND SHARE VIDEOS; FILE SHARING SERVICES, NAMELY, PROVIDING A WEBSITE FEATURING TECHNOLOGY ENABLING USERS TO UPLOAD AND DOWNLOAD ELECTRONIC FILES (U.S. CLS. 100, 101 AND 102).

NAKIA HENRY, EXAMINING ATTORNEY

SN 85-206,207. HEALTHY OUTCOMES, INC., DENVER, CO. FILED 12-27-2010.

**Engaged Public**

THE MARK CONSISTS OF STANDARD CHARACTERS WITHOUT CLAIM TO ANY PARTICULAR FONT, STYLE, SIZE, OR COLOR.

FOR ADMINISTRATION OF A PROGRAM TO PROMOTE COMMUNITY SERVICE; CONSULTING SERVICES, NAMELY, TO EMPLOYERS, COMMUNITY ORGANIZATIONS, BROKERS AND BENEFICIARIES, RELATED TO CONSUMER INFORMATION REGARDING HEALTH CARE PLAN OPTIONS, PRODUCTS AND PROGRAMS IN THE FIELD OF MANAGED CARE AND STATE AND FEDERAL MEDICAL CARE PROGRAMS; EDUCATION LEADERSHIP DEVELOPMENT; PUBLIC POLICY RESEARCH SERVICES (U.S. CLS. 100, 101 AND 102).

FIRST USE 9-4-2007; IN COMMERCE 5-9-2008.  
KAREN BRACEY, EXAMINING ATTORNEY**CLASS 35—(Continued).**

SN 85-206,433. XUBA, LLC, OMAHA, NE. FILED 12-28-2010.

**BuyingCircle**

THE MARK CONSISTS OF STANDARD CHARACTERS WITHOUT CLAIM TO ANY PARTICULAR FONT, STYLE, SIZE, OR COLOR.

FOR PROMOTING THE SALE OF PRODUCTS OF OTHERS THROUGH THE ADMINISTRATION OF INCENTIVE AWARD PROGRAMS (U.S. CLS. 100, 101 AND 102).

FIRST USE 12-6-2010; IN COMMERCE 12-6-2010.  
AISHA CLARKE, EXAMINING ATTORNEY

SN 85-206,437. XUBA, LLC, OMAHA, NE. FILED 12-28-2010.

**BloomDollars**

THE MARK CONSISTS OF STANDARD CHARACTERS WITHOUT CLAIM TO ANY PARTICULAR FONT, STYLE, SIZE, OR COLOR.

FOR ARRANGING AND CONDUCTING INCENTIVE REWARD PROGRAMS TO PROMOTE THE SALE OF HEALTH AND BEAUTY PRODUCTS (U.S. CLS. 100, 101 AND 102).

FIRST USE 12-6-2010; IN COMMERCE 12-6-2010.  
AISHA CLARKE, EXAMINING ATTORNEY

SN 85-206,450. PAUL M. HLETKO, EVANSTON, IL. FILED 12-28-2010.

**REPEAL DAY**

THE MARK CONSISTS OF STANDARD CHARACTERS WITHOUT CLAIM TO ANY PARTICULAR FONT, STYLE, SIZE, OR COLOR.

FOR ARRANGING AND CONDUCTING SPECIAL EVENTS FOR BUSINESS PURPOSES; ARRANGING AND CONDUCTING SPECIAL EVENTS FOR COMMERCIAL, PROMOTIONAL OR ADVERTISING PURPOSES; ORGANISATION OF EXHIBITIONS AND EVENTS FOR COMMERCIAL OR ADVERTISING PURPOSES; ORGANIZATION OF EVENTS, EXHIBITIONS, FAIRS AND SHOWS FOR COMMERCIAL, PROMOTIONAL AND ADVERTISING PURPOSES; ORGANIZING, PROMOTING AND CONDUCTING EXHIBITIONS, TRADESHOWS AND EVENTS FOR BUSINESS PURPOSES; PROMOTING PUBLIC AWARENESS OF THE UNIQUENESS AND DIVERSITY OF HUMANITY THROUGH A NATIONAL ANNUAL DAY EVENT (U.S. CLS. 100, 101 AND 102).

AISHA CLARKE, EXAMINING ATTORNEY

**CLASS 35—(Continued).**

SN 85-206,530. GLOBAL INVENTURES, INC., DBA INVENTURES, SAN RAMON, CA. FILED 12-28-2010.

# OPSaaS

THE MARK CONSISTS OF STANDARD CHARACTERS WITHOUT CLAIM TO ANY PARTICULAR FONT, STYLE, SIZE, OR COLOR.

FOR BUSINESS CONSULTATION SERVICES, NAMELY, GUIDING, LAUNCHING AND GROWING ALLIANCES, SPECIAL INTEREST GROUPS AND BUSINESS CONSORTIA, AND CREATING AND ACCELERATING MARKET AWARENESS AND ACCEPTANCE OF TECHNOLOGY INNOVATIONS, NEW STANDARDS AND BUSINESS INITIATIVES (U.S. CLS. 100, 101 AND 102).

NICHOLAS COLEMAN, EXAMINING ATTORNEY

SN 85-206,733. BRYDELS MARKETING, LLC, BATON ROUGE, LA. FILED 12-28-2010.

# LANYAP

THE MARK CONSISTS OF STANDARD CHARACTERS WITHOUT CLAIM TO ANY PARTICULAR FONT, STYLE, SIZE, OR COLOR.

FOR PROMOTING THE GOODS AND SERVICES OF OTHERS VIA THE ONLINE DISTRIBUTION OF DISCOUNT OFFERS, COUPONS, AND REBATES (U.S. CLS. 100, 101 AND 102).

DAVID TOOLEY, EXAMINING ATTORNEY

SN 85-206,741. BARKER, JENNIFER, BAKERSFIELD, CA. FILED 12-28-2010.

# I do and baby too

THE MARK CONSISTS OF STANDARD CHARACTERS WITHOUT CLAIM TO ANY PARTICULAR FONT, STYLE, SIZE, OR COLOR.

FOR RETAIL STORE SERVICES FEATURING BRIDAL GOWNS, BRIDESMAID DRESSES, JEWELRY, HANDBAGS, SHOES, BABY GEAR, DIAPER BAGS, STROLLERS, CLOTHES AND ACCESSORIES, BLANKETS, HATS, RIBBONS (U.S. CLS. 100, 101 AND 102).

SCOTT BIBB, EXAMINING ATTORNEY

**CLASS 35—(Continued).**

SN 85-206,822. BOYLE OGATA BREGMAN, IRVINE, CA. FILED 12-28-2010.

# Bringing Leaders to Smart Companies

THE MARK CONSISTS OF STANDARD CHARACTERS WITHOUT CLAIM TO ANY PARTICULAR FONT, STYLE, SIZE, OR COLOR.

FOR EXECUTIVE RECRUITING SERVICES; EXECUTIVE SEARCH AND PLACEMENT SERVICES (U.S. CLS. 100, 101 AND 102).

FIRST USE 11-1-2002; IN COMMERCE 11-1-2002.

JAMES GRIFFIN, EXAMINING ATTORNEY

SN 85-206,825. VISUAL IQ, INC., NEEDHAM, MA. FILED 12-28-2010.

# IQ SAGE

THE MARK CONSISTS OF STANDARD CHARACTERS WITHOUT CLAIM TO ANY PARTICULAR FONT, STYLE, SIZE, OR COLOR.

FOR MARKETING SERVICES, NAMELY, CONSUMER MARKETING RESEARCH; PROVIDING INFORMATION IN THE FIELD OF MARKETING AND ON-LINE MARKETING MEDIA VIA THE INTERNET (U.S. CLS. 100, 101 AND 102).

LINDA ORNDORFF, EXAMINING ATTORNEY

SN 85-206,847. VISUAL IQ, INC., NEEDHAM, MA. FILED 12-28-2010.



THE MARK CONSISTS OF THE LETTERS "IQ" INSIDE A CIRCLE WITH THE WORD "SAGE" TO THE RIGHT OF THE LETTERS "IQ".

FOR MARKETING SERVICES, NAMELY, CONSUMER MARKETING RESEARCH; PROVIDING INFORMATION IN THE FIELD OF MARKETING AND ON-LINE MARKETING MEDIA VIA THE INTERNET (U.S. CLS. 100, 101 AND 102).

LINDA ORNDORFF, EXAMINING ATTORNEY

**CLASS 35—(Continued).**

SN 85-206,883. GLOBAL INVENTURES, INC., DBA INVENTURES, SAN RAMON, CA. FILED 12-28-2010.

## Accelerating Results Through Collaboration

THE MARK CONSISTS OF STANDARD CHARACTERS WITHOUT CLAIM TO ANY PARTICULAR FONT, STYLE, SIZE, OR COLOR.

FOR BUSINESS CONSULTATION SERVICES, NAMELY, GUIDING, LAUNCHING AND GROWING ALLIANCES, SPECIAL INTEREST GROUPS AND BUSINESS CONSORTIA, AND CREATING AND ACCELERATING MARKET AWARENESS AND ACCEPTANCE OF TECHNOLOGY INNOVATIONS, NEW STANDARDS AND BUSINESS INITIATIVES (U.S. CLS. 100, 101 AND 102).

FIRST USE 1-1-2003; IN COMMERCE 1-1-2003.  
NICHOLAS COLEMAN, EXAMINING ATTORNEY

SN 85-206,919. JENNINGS, JOSEPH P, TUCSON, AZ. FILED 12-28-2010.

## MSCEO

THE MARK CONSISTS OF STANDARD CHARACTERS WITHOUT CLAIM TO ANY PARTICULAR FONT, STYLE, SIZE, OR COLOR.

FOR BUSINESS ADMINISTRATION CONSULTANCY (U.S. CLS. 100, 101 AND 102).  
ALLISON SCHRODY, EXAMINING ATTORNEY

SN 85-206,934. WOEB, INC, ATLANTA, GA. FILED 12-29-2010.

## ADIT

THE MARK CONSISTS OF STANDARD CHARACTERS WITHOUT CLAIM TO ANY PARTICULAR FONT, STYLE, SIZE, OR COLOR.

FOR ON-LINE ADVERTISING ON COMPUTER COMMUNICATION NETWORKS (U.S. CLS. 100, 101 AND 102).

FIRST USE 6-6-2007; IN COMMERCE 6-6-2007.  
JOHN SCHUYLER YARD, EXAMINING ATTORNEY

**CLASS 35—(Continued).**

SN 85-206,943. TALLARIDA, VICTOR, SAN DIEGO, CA. AND TALLARIDA, PAMELA, SAN DIEGO, CA. FILED 12-29-2010.

## CHIHUAHUANATOR

THE MARK CONSISTS OF STANDARD CHARACTERS WITHOUT CLAIM TO ANY PARTICULAR FONT, STYLE, SIZE, OR COLOR.

FOR RETAIL STORE SERVICES FEATURING DOGS AND DOG CLOTHING (U.S. CLS. 100, 101 AND 102).  
JOHN SCHUYLER YARD, EXAMINING ATTORNEY

SN 85-206,997. WORLD'S CHILDREN'S PRIZE FOUNDATION, MARIEFRED, SWEDEN, FILED 12-29-2010.

## WORLD'S CHILDREN'S PRESS CONFERENCE

THE MARK CONSISTS OF STANDARD CHARACTERS WITHOUT CLAIM TO ANY PARTICULAR FONT, STYLE, SIZE, OR COLOR.

OWNER OF U.S. REG. NO. 3,891,915.  
NO CLAIM IS MADE TO THE EXCLUSIVE RIGHT TO USE "PRESS CONFERENCE", APART FROM THE MARK AS SHOWN.

FOR PROMOTING PUBLIC AWARENESS OF CHILDREN'S RIGHTS (U.S. CLS. 100, 101 AND 102).  
ELIZABETH KAJUBI, EXAMINING ATTORNEY

SN 85-207,040. DELAWARE NORTH COMPANIES, INC., BUFFALO, NY. FILED 12-29-2010.

## GREENPATH

THE MARK CONSISTS OF STANDARD CHARACTERS WITHOUT CLAIM TO ANY PARTICULAR FONT, STYLE, SIZE, OR COLOR.

OWNER OF U.S. REG. NOS. 2,688,981 AND 2,788,576.  
FOR PROMOTING PUBLIC AWARENESS OF ENVIRONMENTAL ISSUES AND FOSTERING ENVIRONMENTALLY RESPONSIBLE INITIATIVES IN THE FIELDS OF TRADITIONAL CONCESSION OPERATIONS, RESTAURANT MANAGEMENT AND DINING, HOTEL MANAGEMENT AND HOSPITALITY, RECREATIONAL ACTIVITY AND RECREATIONAL EVENT MANAGEMENT, ENTERTAINMENT ACTIVITY AND ENTERTAINMENT EVENT MANAGEMENT, TRAVEL AND AIRPORT HOSPITALITY, PARKS AND ATTRACTIONS MANAGEMENT, SPORTS VENUE MANAGEMENT, AND RETAIL STORE MANAGEMENT (U.S. CLS. 100, 101 AND 102).

FIRST USE 4-23-2010; IN COMMERCE 4-23-2010.  
ROBIN MITTLER, EXAMINING ATTORNEY

**CLASS 35—(Continued).**

SN 85-207,111. FEDERAL RESERVE BANK OF ST. LOUIS, ST. LOUIS, MO. FILED 12-29-2010.

**VOICE YOUR VIEW**

THE MARK CONSISTS OF STANDARD CHARACTERS WITHOUT CLAIM TO ANY PARTICULAR FONT, STYLE, SIZE, OR COLOR.

FOR CONDUCTING ONLINE CONSUMER AND PUBLIC OPINION SURVEYS AND POLLS; PROVIDING A WEBSITE FEATURING CONSUMER AND PUBLIC OPINION SURVEYS AND POLLS (U.S. CLS. 100, 101 AND 102).

APRIL ROACH, EXAMINING ATTORNEY

---

SN 85-207,115. FEDERAL RESERVE BANK OF ST. LOUIS, ST. LOUIS, MO. FILED 12-29-2010.

**VYV**

THE MARK CONSISTS OF STANDARD CHARACTERS WITHOUT CLAIM TO ANY PARTICULAR FONT, STYLE, SIZE, OR COLOR.

FOR CONDUCTING ONLINE CONSUMER AND PUBLIC OPINION SURVEYS AND POLLS; PROVIDING A WEBSITE FEATURING CONSUMER AND PUBLIC OPINION SURVEYS AND POLLS (U.S. CLS. 100, 101 AND 102).

APRIL ROACH, EXAMINING ATTORNEY

---

SN 85-207,167. VINTAGE MARKETING, INC., SANTA MONICA, CA. FILED 12-29-2010.

**ih**

THE MARK CONSISTS OF THE LETTERS "IH", THE DOT OVER THE "I" HAVING A CIRCLE AROUND IT.

FOR PROVIDING BUSINESS MARKETING INFORMATION (U.S. CLS. 100, 101 AND 102).

JAMES GRIFFIN, EXAMINING ATTORNEY

**CLASS 35—(Continued).**

SN 85-207,181. DENNIS B. JARVIS, INC., HERMOSA BEACH, CA. FILED 12-29-2010.

**WE LIVE IT**

THE MARK CONSISTS OF STANDARD CHARACTERS WITHOUT CLAIM TO ANY PARTICULAR FONT, STYLE, SIZE, OR COLOR.

FOR RETAIL STORE AND ON-LINE RETAIL STORE SERVICES FEATURING CLOTHING AND ACCESSORIES, AND SPORTING GOODS AND EQUIPMENT (U.S. CLS. 100, 101 AND 102).

FIRST USE 0-0-2008; IN COMMERCE 0-0-2008.  
JAMES GRIFFIN, EXAMINING ATTORNEY

---

SN 85-207,196. NBC FOURTH REALTY CORP., NORTH LAS VEGAS, NV. FILED 12-29-2010.

**MIXX & MAXX**

THE MARK CONSISTS OF STANDARD CHARACTERS WITHOUT CLAIM TO ANY PARTICULAR FONT, STYLE, SIZE, OR COLOR.

OWNER OF U.S. REG. NOS. 1,403,563, 3,175,377 AND OTHERS.

FOR RETAIL DEPARTMENT STORE SERVICES (U.S. CLS. 100, 101 AND 102).

JAMES GRIFFIN, EXAMINING ATTORNEY

---

SN 85-207,201. NBC FOURTH REALTY CORP., NORTH LAS VEGAS, NV. FILED 12-29-2010.

**MAXX YOUR SPRING MIXX**

THE MARK CONSISTS OF STANDARD CHARACTERS WITHOUT CLAIM TO ANY PARTICULAR FONT, STYLE, SIZE, OR COLOR.

OWNER OF U.S. REG. NOS. 1,403,563, 3,175,377 AND OTHERS.

FOR RETAIL DEPARTMENT STORE SERVICES (U.S. CLS. 100, 101 AND 102).

JAMES GRIFFIN, EXAMINING ATTORNEY



**CLASS 35—(Continued).**

SN 85-207,230. NETRACORP, LLC, OLATHE, KS. FILED 12-29-2010.

**REAL SECURE**

THE MARK CONSISTS OF STANDARD CHARACTERS WITHOUT CLAIM TO ANY PARTICULAR FONT, STYLE, SIZE, OR COLOR.

FOR ON-LINE ADVERTISING SERVICES FOR OTHERS (U.S. CLS. 100, 101 AND 102).

MICHAEL WEBSTER, EXAMINING ATTORNEY

SN 85-207,326. HANA, LLC, DENVER, CO. FILED 12-29-2010.

**buymytronics**

THE MARK CONSISTS OF STANDARD CHARACTERS WITHOUT CLAIM TO ANY PARTICULAR FONT, STYLE, SIZE, OR COLOR.

FOR ELECTRONIC COMMERCE SERVICES, NAMELY, OPERATING ON-LINE MARKETPLACES FOR TRADING IN AND SELLING GOODS VIA A GLOBAL COMPUTER NETWORK (U.S. CLS. 100, 101 AND 102).

FIRST USE 11-15-2007; IN COMMERCE 11-15-2007.  
JAMES A. RAUEN, EXAMINING ATTORNEY

SN 85-207,330. MITUSA, LLC, NEW YORK, NY. FILED 12-29-2010.

**BRAND GNU**

THE MARK CONSISTS OF STANDARD CHARACTERS WITHOUT CLAIM TO ANY PARTICULAR FONT, STYLE, SIZE, OR COLOR.

FOR ADVERTISING AND MARKETING (U.S. CLS. 100, 101 AND 102).

H. M. FISHER, EXAMINING ATTORNEY

**CLASS 35—(Continued).**

SN 85-207,352. MY PHARMACY OF HOMESTEAD, INC., HOMESTEAD, FL. FILED 12-29-2010.

**My Pharmacy**

THE MARK CONSISTS OF STANDARD CHARACTERS WITHOUT CLAIM TO ANY PARTICULAR FONT, STYLE, SIZE, OR COLOR.

NO CLAIM IS MADE TO THE EXCLUSIVE RIGHT TO USE "PHARMACY", APART FROM THE MARK AS SHOWN.

FOR RETAIL PHARMACY SERVICES FEATURING PHARMACEUTICALS, HEALTH CARE PRODUCTS, AND HOME MEDICAL EQUIPMENT (U.S. CLS. 100, 101 AND 102).

FIRST USE 1-0-1974; IN COMMERCE 1-0-1974.  
GRETTA YAO, EXAMINING ATTORNEY

SN 85-207,417. ANDREW BETTIS AVIATION, LLC, MEMPHIS, TN. FILED 12-29-2010.

**A TO B CARD**

THE MARK CONSISTS OF STANDARD CHARACTERS WITHOUT CLAIM TO ANY PARTICULAR FONT, STYLE, SIZE, OR COLOR.

NO CLAIM IS MADE TO THE EXCLUSIVE RIGHT TO USE "CARD", APART FROM THE MARK AS SHOWN.

FOR ADMINISTRATION OF A MEMBERSHIP PROGRAM THAT ENABLES MEMBERS TO PURCHASE BLOCKS OF TIME FOR AIR CHARTER SERVICES (U.S. CLS. 100, 101 AND 102).

FIRST USE 10-1-2010; IN COMMERCE 10-1-2010.  
MICHAEL WIENER, EXAMINING ATTORNEY

SN 85-207,599. HR-HAVEN, INC., OVERLAND PARK, KS. FILED 12-29-2010.



NO CLAIM IS MADE TO THE EXCLUSIVE RIGHT TO USE "INC." "HR" "STARTUP" OR "TOOLKIT", APART FROM THE MARK AS SHOWN.

THE COLOR(S) BEIGE, DARK GREEN AND GREY-GREEN IS/ARE CLAIMED AS A FEATURE OF THE MARK.

THE MARK CONSISTS OF A DESIGN ELEMENT WITH A LITERAL ELEMENT. THE DESIGN ELEMENT IS A BEIGE SQUARE, DIVIDED INTO TWO HALVES (A LEFT HALF AND A RIGHT HALF) BY A WHITE VERTICAL DIVIDING BAR. SUPERIMPOSED ONTO THE LEFT HALF OF THE SQUARE IS A DARK GREEN SILHOUETTE IN THE SHAPE OF THE LEFT HALF OF A HEART. SUPERIMPOSED ONTO

**CLASS 35—(Continued).**

THE RIGHT HALF OF THE SQUARE IS A LIGHT GREY-GREEN SILHOUETTE IN THE SHAPE OF THE RIGHT HALF OF A HEART. THE LITERAL ELEMENT CONSISTS OF THE WORDS "HR-HAVEN, INC. HR STARTUP TOOLKIT" APPEARING IN TWO LINES OF TEXT, WITH THE WORDS THE FIRST LINE, "HR-HAVEN, INC." APPEARING IN DARK GREEN LETTERING ON THE FIRST LINE IN LARGER BOLD TEXT, AND WITH THE WORDS "HR STARTUP TOOLKIT" APPEARING IN DARK GREEN LETTERING ON THE SECOND LINE IN SMALLER TEXT.

FOR HUMAN RESOURCES CONSULTATION (U.S. CLS. 100, 101 AND 102).

FIRST USE 12-2-2010; IN COMMERCE 12-2-2010.  
JILL PRATER, EXAMINING ATTORNEY

**CLASS 35—(Continued).**

CONSULTING WITH RELATION TO STRATEGY, MARKETING, PRODUCTION, PERSONNEL AND RETAIL SALE MATTERS; BUSINESS MARKETING CONSULTING SERVICES; BUSINESS MARKETING SERVICES; PROMOTION AND MARKETING SERVICES AND RELATED CONSULTING; PROVIDING BUSINESS MARKETING INFORMATION; PRODUCT ARRANGING ON SHELF SPACE FOR OTHERS; PRODUCT CATEGORY MANAGEMENT SERVICES, NAMELY, ADVICE CONCERNING PRODUCT CATEGORY SALES AND PROFITS; PROVIDING EVALUATION, ANALYSIS AND REPORTS CONCERNING SALES AND PROFITS OF CONSUMER PACKAGE GOODS PRODUCTS SOLD AT RETAIL; BRANDED FOOD SERVICES, NAMELY, PROVIDING EQUIPMENT, MERCHANDISING, IN STORE MARKETING, IN STORE TRAINING AND BRANDED FOOD AND BEVERAGE PRODUCTS TO FOOD SERVICE OPERATORS; PROVIDING MARKETING SERVICES TO FOOD SERVICE OPERATORS; PROVIDING TURNKEY POINT OF SALE MERCHANDISING DISPLAYS AND KIOSKS (U.S. CLS. 100, 101 AND 102).

FIRST USE 3-13-2009; IN COMMERCE 3-13-2009.  
HEATHER SAPP, EXAMINING ATTORNEY

SN 85-207,612. CORE-MARK INTERNATIONAL, INC., SOUTH SAN FRANCISCO, CA. FILED 12-29-2010.



THE MARK CONSISTS OF TWO HALF CIRCLES, SURROUNDING A STYLIZED DEPICTION OF THE SUN, THE LEFT HALF CIRCLE IN THE FORM OF THE LETTER "C" AND THE RIGHT HALF CIRCLE OVERLAYED BY RAYS OF THE SUN.

FOR DISTRIBUTORSHIP SERVICES IN THE FIELDS OF GENERAL MERCHANDISE, CONSUMER PACKAGED GOODS PRODUCTS, TOBACCO, CANDY, CONFECTIONARY AND SUNDRY ITEMS; BUSINESS CONSULTING SERVICES RELATING TO PRODUCT DISTRIBUTION, OPERATIONS MANAGEMENT SERVICES, LOGISTICS, REVERSE LOGISTICS, SUPPLY CHAIN, AND PRODUCTION SYSTEMS AND DISTRIBUTION SOLUTIONS; BUSINESS MANAGEMENT SERVICES, NAMELY, MANAGING LOGISTICS, REVERSE LOGISTICS, SUPPLY CHAIN SERVICES, SUPPLY CHAIN VISIBILITY AND SYNCHRONIZATION, SUPPLY AND DEMAND FORECASTING AND PRODUCT DISTRIBUTION PROCESSES FOR OTHERS; LOGISTICS MANAGEMENT IN THE FIELD OF CONSUMER PACKAGED GOODS PRODUCTS; BUSINESS MERCHANDISING DISPLAY SERVICES; GENERAL BUSINESS MERCHANDISING SERVICES, NAMELY, MARKETING; PREPARATION OF CUSTOMIZED PROMOTIONAL AND MERCHANDISING MATERIALS FOR OTHERS; PREPARING PROMOTIONAL AND MERCHANDISING MATERIAL FOR OTHERS; PRODUCT MERCHANDISING; ADVICE IN THE FIELD OF BUSINESS MANAGEMENT AND MARKETING; BUSINESS MANAGEMENT

SN 85-207,613. CORE-MARK INTERNATIONAL, INC., SOUTH SAN FRANCISCO, CA. FILED 12-29-2010.

# CORE-MARK

THE MARK CONSISTS OF STANDARD CHARACTERS WITHOUT CLAIM TO ANY PARTICULAR FONT, STYLE, SIZE, OR COLOR.

FOR DISTRIBUTORSHIP SERVICES IN THE FIELDS OF GENERAL MERCHANDISE, CONSUMER PACKAGED GOODS PRODUCTS, TOBACCO, CANDY, CONFECTIONARY AND SUNDRY ITEMS; BUSINESS CONSULTING SERVICES RELATING TO PRODUCT DISTRIBUTION, OPERATIONS MANAGEMENT SERVICES, LOGISTICS, REVERSE LOGISTICS, SUPPLY CHAIN, AND PRODUCTION SYSTEMS AND DISTRIBUTION SOLUTIONS; BUSINESS MANAGEMENT SERVICES, NAMELY, MANAGING LOGISTICS, REVERSE LOGISTICS, SUPPLY CHAIN SERVICES, SUPPLY CHAIN VISIBILITY AND SYNCHRONIZATION, SUPPLY AND DEMAND FORECASTING AND PRODUCT DISTRIBUTION PROCESSES FOR OTHERS; LOGISTICS MANAGEMENT IN THE FIELD OF CONSUMER PACKAGED GOODS PRODUCTS; BUSINESS MERCHANDISING DISPLAY SERVICES; GENERAL BUSINESS MERCHANDISING SERVICES, NAMELY, MARKETING; PREPARATION OF CUSTOMIZED PROMOTIONAL AND MERCHANDISING MATERIALS FOR OTHERS; PREPARING PROMOTIONAL AND MERCHANDISING MATERIAL FOR OTHERS; PRODUCT MERCHANDISING; ADVICE IN THE FIELD OF BUSINESS MANAGEMENT AND MARKETING; BUSINESS MANAGEMENT

**CLASS 35—(Continued).**

CONSULTING WITH RELATION TO STRATEGY, MARKETING, PRODUCTION, PERSONNEL AND RETAIL SALE MATTERS; BUSINESS MARKETING CONSULTING SERVICES; BUSINESS MARKETING SERVICES; PROMOTION AND MARKETING SERVICES AND RELATED CONSULTING; PROVIDING BUSINESS MARKETING INFORMATION; PRODUCT ARRANGING ON SHELF SPACE FOR OTHERS; PRODUCT CATEGORY MANAGEMENT SERVICES, NAMELY, ADVICE CONCERNING PRODUCT CATEGORY SALES AND PROFITS; PROVIDING EVALUATION, ANALYSIS AND REPORTS CONCERNING SALES AND PROFITS OF CONSUMER PACKAGE GOODS PRODUCTS SOLD AT RETAIL; BRANDED FOOD SERVICES, NAMELY, PROVIDING EQUIPMENT, MERCHANDISING, IN STORE MARKETING, IN STORE TRAINING AND BRANDED FOOD AND BEVERAGE PRODUCTS TO FOOD SERVICE OPERATORS; PROVIDING MARKETING SERVICES TO FOOD SERVICE OPERATORS; PROVIDING TURNKEY POINT OF SALE MERCHANDISING DISPLAYS AND KIOSKS (U.S. CLS. 100, 101 AND 102).

FIRST USE 1-1-1982; IN COMMERCE 1-1-1982.  
HEATHER SAPP, EXAMINING ATTORNEY

---

SN 85-207,617. SARBER GARDNER INCORPORATED, LUTZ, FL. FILED 12-29-2010.

**Leadership Excellence.  
Organization Effectiveness**

THE MARK CONSISTS OF STANDARD CHARACTERS WITHOUT CLAIM TO ANY PARTICULAR FONT, STYLE, SIZE, OR COLOR.

FOR BUSINESS CONSULTING SERVICES IN THE FIELD OF ORGANIZATIONAL CHANGE MANAGEMENT; CONSULTING SERVICES IN THE FIELD OF HUMAN RESOURCES DEVELOPMENT, NAMELY, FOR THE PROMOTION OF EMPLOYEE RETENTION, CAREER GROWTH, AND INCREASED PRODUCTIVITY FOR EMPLOYEES AND EMPLOYERS; CONSULTING SERVICES IN THE FIELDS OF BUSINESS MANAGEMENT, HUMAN RESOURCES, AND BUSINESS ORGANIZATIONAL DESIGN (U.S. CLS. 100, 101 AND 102).

FIRST USE 11-1-2010; IN COMMERCE 11-1-2010.  
CARYN GLASSER, EXAMINING ATTORNEY

---

SN 85-207,795. BLUE CALYPSO, LLC, CARROLLTON, TX. FILED 12-30-2010.

**SOCIALLY YOURS**

THE MARK CONSISTS OF STANDARD CHARACTERS WITHOUT CLAIM TO ANY PARTICULAR FONT, STYLE, SIZE, OR COLOR.

FOR DIGITAL ADVERTISING DISTRIBUTED TO MOBILE DEVICES AND INTERNET USERS (U.S. CLS. 100, 101 AND 102).

ALLISON HOLTZ, EXAMINING ATTORNEY

**CLASS 35—(Continued).**

SN 85-207,901. ROWPAR PHARMACEUTICALS, INC., SCOTTSDALE, AZ. FILED 12-30-2010.

**A Cleaner Mouth. A  
Healthier You.**

THE MARK CONSISTS OF STANDARD CHARACTERS WITHOUT CLAIM TO ANY PARTICULAR FONT, STYLE, SIZE, OR COLOR.

FOR ON-LINE RETAIL STORE SERVICES FEATURING DENTAL CARE PRODUCTS (U.S. CLS. 100, 101 AND 102).

NELSON SNYDER, EXAMINING ATTORNEY

---

SN 85-207,955. WALDRON OF MARYLAND, INC., BALTIMORE, MD. FILED 12-30-2010.

**We're Engineering Air**

THE MARK CONSISTS OF STANDARD CHARACTERS WITHOUT CLAIM TO ANY PARTICULAR FONT, STYLE, SIZE, OR COLOR.

FOR WHOLESALE DISTRIBUTORSHIP FEATURING HEATING, VENTILATION AND AIR CONDITIONING MATERIALS (U.S. CLS. 100, 101 AND 102).

FIRST USE 11-16-2010; IN COMMERCE 11-16-2010.  
ANDREA HACK, EXAMINING ATTORNEY

---

SN 85-207,970. NUÑEZ, KELVYN L., DBA EGO VANITY STORE, EGO, EGOISTA AND NUNEZ RETAIL INVESTMENT COMPANY, ARECIBO, PUERTO RICO, FILED 12-30-2010.



THE MARK CONSISTS OF THE WORD "EGOISTA" IN UPPERCASE STYLIZED BLOCK-LIKE TYPEFACE, WITH THE HORIZONTAL BAR OF THE LETTER "G" MEETING WITH THE MIDDLE BAR OF THE UPPERCASE "E".

THE ENGLISH TRANSLATION OF "EGOISTA" IN THE MARK IS "SELFISH".

FOR RETAIL STORE SERVICES FEATURING SHOES (U.S. CLS. 100, 101 AND 102).

FIRST USE 12-27-2010; IN COMMERCE 12-27-2010.  
EDWARD FENNESSY, EXAMINING ATTORNEY

**CLASS 35—(Continued).**

SN 85-207,976. ROWPAR PHARMACEUTICALS, INC., SCOTTSDALE, AZ. FILED 12-30-2010.

# Cloralstan

THE MARK CONSISTS OF STANDARD CHARACTERS WITHOUT CLAIM TO ANY PARTICULAR FONT, STYLE, SIZE, OR COLOR.

FOR ON-LINE RETAIL STORE SERVICES FEATURING DENTAL CARE PRODUCTS (U.S. CLS. 100, 101 AND 102).

NELSON SNYDER, EXAMINING ATTORNEY

---

SN 85-207,984. DIGITAL VENTURES MEDIA, LLC, DBA AUTOBREEZE, DALLAS, TX. FILED 12-30-2010.

# AutoBreeze

THE MARK CONSISTS OF STANDARD CHARACTERS WITHOUT CLAIM TO ANY PARTICULAR FONT, STYLE, SIZE, OR COLOR.

FOR ONLINE MARKETING SERVICE THAT ALLOWS NEW VEHICLE BUYERS TO REQUEST AND REVIEW COMPETITIVE PRICING BIDS FROM NEW VEHICLE DEALERS WHICH DISCLOSE THE SALES COST OF PURCHASING A NEW VEHICLE AS SPECIFIED BY THE BUYER AND THE TRADE-IN VALUE OF THE BUYER'S CURRENT VEHICLE (U.S. CLS. 100, 101 AND 102).

FIRST USE 9-27-2010; IN COMMERCE 9-27-2010.  
ALICE BENMAMAN, EXAMINING ATTORNEY

---

SN 85-208,018. SCHUSSLER CREATIVE, INC., GOLDEN VALLEY, MN. FILED 12-30-2010.

# SETTING THE STANDARD FOR INDUSTRY FIRSTS

THE MARK CONSISTS OF STANDARD CHARACTERS WITHOUT CLAIM TO ANY PARTICULAR FONT, STYLE, SIZE, OR COLOR.

FOR ADVERTISING, MARKETING AND PROMOTION SERVICES (U.S. CLS. 100, 101 AND 102).

FIRST USE 5-4-2007; IN COMMERCE 5-4-2007.  
KATHRYN COWARD, EXAMINING ATTORNEY

**CLASS 35—(Continued).**

SN 85-208,077. MARIAH DAYE MCCARTHY SCHOLARSHIP FOUNDATION, LLC, DBA MARIAH'S CHALLENGE, BUTTE, MT. FILED 12-30-2010.



THE MARK CONSISTS OF THE TEXT MARIAH'S CHALLENGE IN STYLIZED FONT OVER A SILHOUETTE OF AN ANGEL.

FOR PROMOTING PUBLIC AWARENESS OF THE PREVENTION OF UNDERAGE DRINKING AND DRIVING WHILE DRINKING (U.S. CLS. 100, 101 AND 102).

FIRST USE 2-8-2008; IN COMMERCE 2-8-2008.  
SOPHIA S. KIM, EXAMINING ATTORNEY

---

SN 85-208,145. ENGRAVA, LLC, PHOENIX, AZ. FILED 12-30-2010.

# Engrava

THE MARK CONSISTS OF STANDARD CHARACTERS WITHOUT CLAIM TO ANY PARTICULAR FONT, STYLE, SIZE, OR COLOR.

FOR ON-LINE RETAIL STORE SERVICES FEATURING IMAGES (U.S. CLS. 100, 101 AND 102).

MATTHEW EINSTEIN, EXAMINING ATTORNEY

---

SN 85-208,154. PALAS SOFTWARE SYSTEMS, INC., CHARLESTON, SC. FILED 12-30-2010.

# INTELLIDEAL

THE MARK CONSISTS OF STANDARD CHARACTERS WITHOUT CLAIM TO ANY PARTICULAR FONT, STYLE, SIZE, OR COLOR.

FOR PROMOTING THE GOODS AND SERVICES OF OTHERS BY PROVIDING A WEBSITE FEATURING COUPONS, DISCOUNTED OFFERS, VOUCHERS, GIFT CERTIFICATES AND LINKS TO THE RETAIL WEBSITES OF OTHERS (U.S. CLS. 100, 101 AND 102).

HENRY S. ZAK, EXAMINING ATTORNEY

**CLASS 35—(Continued).**

SN 85-208,172. DEAL & U, INC., DBA DEALNU, NAPERVILLE, IL. FILED 12-30-2010.



THE COLOR(S) BLACK, WHITE, ORANGE, GREY IS/ARE CLAIMED AS A FEATURE OF THE MARK.

THE MARK CONSISTS OF LETTERS "D", "E", "A" AND "L" WITH WHITE COLOR, BOLDED LETTER "N" WITH ORANGE COLOR, BOLDED LETTER "U" WITH WHITE COLOR AND GREY SHADOW, A HAND WITH ORANGE EDGE, WHITE INSIDE COLOR, AND BLACK BACKGROUND.

FOR ADVERTISEMENT FOR OTHERS ON THE INTERNET; ADVERTISING AND COMMERCIAL INFORMATION SERVICES, VIA THE INTERNET; ADVERTISING AND MARKETING SERVICES PROVIDED BY MEANS OF INDIRECT METHODS OF MARKETING COMMUNICATIONS, NAMELY, SOCIAL MEDIA, SEARCH ENGINE MARKETING, INQUIRY MARKETING, INTERNET MARKETING, MOBILE MARKETING, BLOGGING AND OTHER FORMS OF PASSIVE, SHARABLE OR VIRAL COMMUNICATIONS CHANNELS; ADVERTISING ON THE INTERNET FOR OTHERS; ADVERTISING VIA ELECTRONIC MEDIA AND SPECIFICALLY THE INTERNET; ADVICE AND INFORMATION ABOUT CUSTOMER SERVICES AND PRODUCT MANAGEMENT AND PRICES ON INTERNET SITES IN CONNECTION WITH PURCHASES MADE OVER THE INTERNET; AN INTERACTIVE WEB SITE FOR USERS TO REVIEW AND RATE INTERNET CONTENT, PEOPLE, COMPANIES, PRODUCTS AND/OR SERVICES UTILIZING A SOFTWARE APPLICATION TO AWARD POINTS WHEREBY WEB SITE USERS ARE ELIGIBLE TO EXCHANGE POINTS EARNED FOR PROMOTIONAL ITEMS CONSISTING OF COUPONS, REBATES, DISCOUNTS OR SPECIAL OFFERINGS ON GOODS AND/OR SERVICE PROVIDED BY WEB SITE SPONSORS; BUSINESS ADMINISTRATION SERVICES FOR PROCESSING SALES MADE ON THE INTERNET; COMPILATION OF ADVERTISEMENTS FOR USE AS WEB PAGES ON THE INTERNET; CONSULTING SERVICES IN THE FIELD OF INTERNET MARKETING; DESIGN OF INTERNET ADVERTISING; INFORMATION, ADVISORY AND CONSULTANCY SERVICES RELATING TO BUSINESS AND MANAGEMENT OR BUSINESS ADMINISTRATION, INCLUDING SUCH SERVICES PROVIDED ON LINE OR VIA THE INTERNET; INTERNET ADVERTISING SERVICES; PROMOTING THE GOODS AND SERVICES OF OTHERS BY MEANS OF DISTRIBUTING ADVERTISING ON THE INTERNET; PROVIDING A SEARCHABLE ON-LINE ADVERTISING WEBSITE AND GUIDE FEATURING THE GOODS AND SERVICES OF OTHER VENDORS VIA THE INTERNET; PROVIDING A SEARCHABLE ONLINE ADVERTISING GUIDE FEATURING THE GOODS AND SERVICES OF OTHER ON-LINE VENDORS ON THE INTERNET; THE BRINGING TOGETHER, FOR THE BENEFIT OF OTHERS, OF A VARIETY OF GOODS AND SERVICES, ENABLING CUSTOMERS TO CONVENIENTLY VIEW AND PURCHASE THOSE GOODS AND SERVICES FROM AN INTERNET WEB SITE PARTICULARLY SPECIALIZING IN THE MARKETING OF THE SALE OF GOODS AND SERVICES OF OTHERS (U.S. CLS. 100, 101 AND 102).

FIRST USE 9-5-2010; IN COMMERCE 12-16-2010.

HENRY S. ZAK, EXAMINING ATTORNEY

**CLASS 35—(Continued).**

SN 85-208,209. TOHERSTYLE, CORONA, CA. FILED 12-30-2010.

THE MARK CONSISTS OF THE STYLIZED TEXT "TOHERSTYLE".

FOR ON-LINE RETAIL STORE SERVICES FEATURING GOWNS, COCKTAIL DRESSES, AND FORMAL WEAR (U.S. CLS. 100, 101 AND 102).

ANGELA M. MICHELI, EXAMINING ATTORNEY

SN 85-208,226. SCHNUCK MARKETS, INC., ST. LOUIS, MO. FILED 12-30-2010.

ENJOY PEACE OF MIND AT  
SCHNUCKS

THE MARK CONSISTS OF STANDARD CHARACTERS WITHOUT CLAIM TO ANY PARTICULAR FONT, STYLE, SIZE, OR COLOR.

FOR RETAIL GROCERY STORES (U.S. CLS. 100, 101 AND 102).

ANGELA M. MICHELI, EXAMINING ATTORNEY

SN 85-208,267. WISHWAVE INC., SAN FRANCISCO, CA. FILED 12-30-2010.

Wishwave

THE MARK CONSISTS OF STANDARD CHARACTERS WITHOUT CLAIM TO ANY PARTICULAR FONT, STYLE, SIZE, OR COLOR.

FOR PROVIDING A WEBSITE FOR USERS WITH SPECIFIC INFORMED RECOMMENDATIONS OF SPECIFIC CONSUMER PRODUCTS AND SERVICES VALIDATED BY THE USERS' INPUTTED PREFERENCES AND SOCIAL NETWORK (U.S. CLS. 100, 101 AND 102).

TRACY CROSS, EXAMINING ATTORNEY

**CLASS 35—(Continued).**

SN 85-208,270. PARADISE SPORTS, INC., VENTURA, CA. FILED 12-30-2010.

**Paradise Sports Warehouse**

THE MARK CONSISTS OF STANDARD CHARACTERS WITHOUT CLAIM TO ANY PARTICULAR FONT, STYLE, SIZE, OR COLOR.

NO CLAIM IS MADE TO THE EXCLUSIVE RIGHT TO USE "SPORTS WAREHOUSE", APART FROM THE MARK AS SHOWN.

FOR ONLINE RETAIL STORE SERVICES AND RETAIL STORE SERVICES FEATURING SPORTS EQUIPMENT, GOLF EQUIPMENT, APPAREL, ACCESSORIES AND LICENSED TEAM SPORTS FAN GEAR (U.S. CLS. 100, 101 AND 102).

FIRST USE 0-0-2006; IN COMMERCE 0-0-2006.  
STEVEN PEREZ, EXAMINING ATTORNEY

---

SN 85-208,278. ELLIS SR., ZARKO L., CHESTER SPRINGS, PA. FILED 12-30-2010.

**AmBlaCon**

THE MARK CONSISTS OF STANDARD CHARACTERS WITHOUT CLAIM TO ANY PARTICULAR FONT, STYLE, SIZE, OR COLOR.

FOR POLITICAL RESEARCH AND CONSULTING SPECIFICALLY TARGETED TO AFRO-AMERICAN CONSERVATIVES (U.S. CLS. 100, 101 AND 102).

CORY BOONE, EXAMINING ATTORNEY

---

SN 85-208,299. CYPHERS, DOUG, AURORA, CO. FILED 12-30-2010.

**DOYOUKNOWME.ORG**

THE MARK CONSISTS OF STANDARD CHARACTERS WITHOUT CLAIM TO ANY PARTICULAR FONT, STYLE, SIZE, OR COLOR.

FOR PROMOTING PUBLIC AWARENESS OF THE NEED FOR RACIAL RECONCILIATION AND ENCOURAGING PEOPLE TO KNOW THEIR NEIGHBOR AND THEN AFFECT CHANGE IN THEIR OWN SPHERE OF INFLUENCE (U.S. CLS. 100, 101 AND 102).

FIRST USE 11-1-2010; IN COMMERCE 1-1-2011.  
ELISSA GARBER KON, EXAMINING ATTORNEY

**CLASS 35—(Continued).**

SN 85-208,371. REALLIGHTING, INC., MENTOR, OH. FILED 12-30-2010.

**REALLIGHTING**

THE MARK CONSISTS OF STANDARD CHARACTERS WITHOUT CLAIM TO ANY PARTICULAR FONT, STYLE, SIZE, OR COLOR.

FOR ON-LINE RETAIL AND WHOLESALE DISTRIBUTORSHIP SERVICES FEATURING LIGHTING PRODUCTS; AND RETAIL AND WHOLESALE DISTRIBUTORSHIP SERVICES FEATURING LIGHTING PRODUCTS (U.S. CLS. 100, 101 AND 102).

FIRST USE 7-1-2003; IN COMMERCE 7-1-2003.  
ROBIN CHOSID, EXAMINING ATTORNEY

---

SN 85-208,453. NATIONAL VETERINARY BUSINESS MANAGEMENT ASSOCIATION, INC., DBA VBMA, ANNA-DALE, VA. FILED 12-31-2010.



NO CLAIM IS MADE TO THE EXCLUSIVE RIGHT TO USE "VETERINARY BUSINESS MANAGEMENT ASSOCIATION", APART FROM THE MARK AS SHOWN.

THE MARK CONSISTS OF A STAFF WHERE A SINGLE SERPENT EXPRESSED AS CONCENTRIC OFFSET CIRCLE FRAGMENTS OF VARYING SIZE ARE EXPRESSED IN A THREE DIMENSIONAL PERSPECTIVE AROUND THE STAFF, WITH TEXT OVERLAY OF VBMA VETERINARY BUSINESS MANAGEMENT ASSOCIATION.

FOR BUSINESS NETWORKING (U.S. CLS. 100, 101 AND 102).

FIRST USE 9-1-2006; IN COMMERCE 9-1-2006.  
FLORENTINA BLANDU, EXAMINING ATTORNEY

**CLASS 35—(Continued).**

SN 85-208,518. IMMIGRATION AND CUSTOMS SOLUTIONS, LLC, AKA ICS, LLC, EVANSTON, IL. FILED 12-31-2010.

smartI-9

THE MARK CONSISTS OF STANDARD CHARACTERS WITHOUT CLAIM TO ANY PARTICULAR FONT, STYLE, SIZE, OR COLOR.

FOR EMPLOYMENT VERIFICATION (U.S. CLS. 100, 101 AND 102).

FIRST USE 6-1-2010; IN COMMERCE 6-1-2010.  
THOMAS MANOR, EXAMINING ATTORNEY

SN 85-208,633. SKILLSOURCE, CINCINNATI, OH. FILED 12-31-2010.



OWNER OF U.S. REG. NO. 2,943,889.  
FOR BUSINESS CONSULTING SERVICES RELATING TO THE INTEGRATION OF THE AREAS OF BUSINESS PROCESS TECHNOLOGY, ORGANIZATIONAL LEARNING, CHANGE MANAGEMENT, AND OPERATIONAL SUSTAINABILITY (U.S. CLS. 100, 101 AND 102).

FIRST USE 5-20-2003; IN COMMERCE 5-20-2003.  
LAURIE KAUFMAN, EXAMINING ATTORNEY

SN 85-208,652. NUCRAFT COMPANY, LLC, ARLINGTON, VA. FILED 12-31-2010.

NUCRAFT + CO.

NO CLAIM IS MADE TO THE EXCLUSIVE RIGHT TO USE "CO.", APART FROM THE MARK AS SHOWN.

FOR BUSINESS CONSULTING SERVICES IN THE FIELDS OF ENTREPRENEURSHIP, LEADERSHIP, NEW BUSINESS MODEL DESIGN, NEW PRODUCT DEVELOPMENT, BUSINESS GROWTH STRATEGY, BUSINESS PERFORMANCE ENHANCEMENT, BUSINESS MANAGEMENT AND REVENUE ENHANCEMENT STRATEGIES; BUSINESS APPRAISALS; ADVISING ON BUSINESS ACQUISITIONS AND MERGERS; AND CONDUCTING BUSINESS AND MARKET RESEARCH SURVEYS (U.S. CLS. 100, 101 AND 102).

FIRST USE 8-29-2010; IN COMMERCE 8-29-2010.  
APRIL ROACH, EXAMINING ATTORNEY

**CLASS 35—(Continued).**

SN 85-208,657. NUCRAFT COMPANY, LLC, ARLINGTON, VA. FILED 12-31-2010.



THE MARK CONSISTS OF INTERSECTING "N" AND "U" WITHIN A CIRCLE.

FOR BUSINESS CONSULTING SERVICES IN THE FIELDS OF ENTREPRENEURSHIP, LEADERSHIP, NEW BUSINESS MODEL DESIGN, NEW PRODUCT DEVELOPMENT, BUSINESS GROWTH STRATEGY, BUSINESS PERFORMANCE ENHANCEMENT, BUSINESS MANAGEMENT AND REVENUE ENHANCEMENT STRATEGIES; BUSINESS APPRAISALS; ADVISING ON BUSINESS ACQUISITIONS AND MERGERS; AND CONDUCTING BUSINESS AND MARKET RESEARCH SURVEYS (U.S. CLS. 100, 101 AND 102).

FIRST USE 12-3-2010; IN COMMERCE 12-3-2010.  
APRIL ROACH, EXAMINING ATTORNEY

SN 85-208,661. THE FINE ART OF ROMANCE, INC., EUREKA SPRINGS, AR. FILED 12-31-2010.

THE FINE ART OF ROMANCE

THE MARK CONSISTS OF STANDARD CHARACTERS WITHOUT CLAIM TO ANY PARTICULAR FONT, STYLE, SIZE, OR COLOR.

FOR ART GALLERIES; RETAIL CLOTHING BOUTIQUES; RETAIL STORES FEATURING INTIMATE APPAREL (U.S. CLS. 100, 101 AND 102).

FIRST USE 12-15-2010; IN COMMERCE 12-15-2010.  
AMY C. KEAN, EXAMINING ATTORNEY

**CLASS 35—(Continued).**

SN 85-208,672. BECKER, LANE, SAN FRANCISCO, CA. FILED 12-31-2010.

**INCHVESTOR**

THE MARK CONSISTS OF STANDARD CHARACTERS WITHOUT CLAIM TO ANY PARTICULAR FONT, STYLE, SIZE, OR COLOR.

FOR BUSINESS SERVICES, NAMELY, MATCHING POTENTIAL PRIVATE INVESTORS WITH ENTREPRENEURS NEEDING FUNDING (U.S. CLS. 100, 101 AND 102).

JILL PRATER, EXAMINING ATTORNEY

**CLASS 35—(Continued).**

SN 85-208,759. SPECTOR, DONALD, NEW YORK, NY. FILED 1-1-2011.

**ADREVERB**

THE MARK CONSISTS OF STANDARD CHARACTERS WITHOUT CLAIM TO ANY PARTICULAR FONT, STYLE, SIZE, OR COLOR.

FOR ADVERTISING, PROMOTION, AND MARKETING SERVICES IN THE NATURE OF ARRANGING WITH RETAILERS OR SERVICE PROVIDERS TO PARTICIPATE IN PROMOTIONAL OFFERS OR COUPONS FOR COMPUTER USERS CONDUCTING SEARCHES FOR PARTICULAR GOODS AND SERVICES IN THE SAME FIELD AT THAT TIME (U.S. CLS. 100, 101 AND 102).

KEVON CHISOLM, EXAMINING ATTORNEY

SN 85-208,688. CHIRRPY, WARSAW, IN. FILED 12-31-2010.

**CHIRRPY**

THE MARK CONSISTS OF STANDARD CHARACTERS WITHOUT CLAIM TO ANY PARTICULAR FONT, STYLE, SIZE, OR COLOR.

FOR MANAGEMENT OF EVENT TICKETING FOR OTHERS (U.S. CLS. 100, 101 AND 102).

AMY C. KEAN, EXAMINING ATTORNEY

SN 85-208,785. GNL ENTERTAINMENT, INC., WASHINGTON, DC. FILED 1-1-2011.

**Painted On Water**

THE MARK CONSISTS OF STANDARD CHARACTERS WITHOUT CLAIM TO ANY PARTICULAR FONT, STYLE, SIZE, OR COLOR.

FOR PROVIDING AN INTERNET WEBSITE PORTAL FEATURING LINKS TO MUSIC-RELATED MERCHANDISE FOR RETAIL PURPOSES (U.S. CLS. 100, 101 AND 102).

ANDREA HACK, EXAMINING ATTORNEY

SN 85-208,726. PROMO INK, NEW YORK, NY. FILED 12-31-2010.

**BUSINESSWOMANHOOD**

THE MARK CONSISTS OF STANDARD CHARACTERS WITHOUT CLAIM TO ANY PARTICULAR FONT, STYLE, SIZE, OR COLOR.

FOR ASSOCIATION SERVICES, NAMELY, PROMOTING THE INTERESTS OF CAREER WOMEN (U.S. CLS. 100, 101 AND 102).

KIMBERLY FRYE, EXAMINING ATTORNEY

SN 85-208,812. CITY OF ANGELS, ANGELS CAMP, CA. FILED 1-1-2011.

**REDEFINING THE RUSH**

THE MARK CONSISTS OF STANDARD CHARACTERS WITHOUT CLAIM TO ANY PARTICULAR FONT, STYLE, SIZE, OR COLOR.

FOR PROMOTING THE ECONOMIC DEVELOPMENT OF THE CITY OF ANGELS (ALSO KNOWN AS THE CITY OF ANGELS CAMP), CALIFORNIA (U.S. CLS. 100, 101 AND 102).

FIRST USE 9-2-2008; IN COMMERCE 6-29-2010.

HEATHER BIDDULPH, EXAMINING ATTORNEY



**CLASS 35—(Continued).**

SN 85-208,971. TIGER MEDIA, INC., REGINA, SASKATCHEWAN, CANADA, FILED 1-3-2011.

# JuicyAds

THE MARK CONSISTS OF STANDARD CHARACTERS WITHOUT CLAIM TO ANY PARTICULAR FONT, STYLE, SIZE, OR COLOR.

FOR AD SERVING, NAMELY, PLACING ADVERTISEMENTS ON WEBSITES FOR OTHERS USING SPECIALIZED COMPUTER SOFTWARE; ADVERTISEMENT FOR OTHERS ON THE INTERNET; ADVERTISING AND ADVERTISEMENT SERVICES; ONLINE ADVERTISING VIA A COMPUTER COMMUNICATIONS NETWORK; PLACING ADVERTISEMENTS FOR OTHERS (U.S. CLS. 100, 101 AND 102).

FIRST USE 4-2-2006; IN COMMERCE 4-2-2006.  
CHERYL CLAYTON, EXAMINING ATTORNEY

---

SN 85-209,009. CURTIS C. GUNN, LTD., FORMERLY CURTIS C. GUNN, INC., SAN ANTONIO, TX. FILED 1-3-2011.

# ONE SIMPLE PRICE

THE MARK CONSISTS OF STANDARD CHARACTERS WITHOUT CLAIM TO ANY PARTICULAR FONT, STYLE, SIZE, OR COLOR.

OWNER OF U.S. REG. NO. 3,020,117.  
SEC. 2(F).  
FOR AUTOMOBILE DEALERSHIPS (U.S. CLS. 100, 101 AND 102).

FIRST USE 2-0-1995; IN COMMERCE 2-0-1995.  
CHARLES L. JENKINS, EXAMINING ATTORNEY

---

SN 85-209,076. FORTUNE, JORGE, IRVINE, CA. FILED 1-3-2011.

# FOXYGIGS.COM

THE MARK CONSISTS OF STANDARD CHARACTERS WITHOUT CLAIM TO ANY PARTICULAR FONT, STYLE, SIZE, OR COLOR.

FOR CLASSIFIED ADVERTISING SERVICES (U.S. CLS. 100, 101 AND 102).

TINA L. SNAPP, EXAMINING ATTORNEY

**CLASS 35—(Continued).**

SN 85-209,095. ONLINE NEWS ASSOCIATION, WILMINGTON, DE. FILED 1-3-2011.

# ONA

THE MARK CONSISTS OF STANDARD CHARACTERS WITHOUT CLAIM TO ANY PARTICULAR FONT, STYLE, SIZE, OR COLOR.

FOR ASSOCIATION SERVICES, NAMELY, PROMOTING THE INTERESTS OF JOURNALISTS IN MAINTAINING PROFESSIONALISM IN ONLINE JOURNALISM AND FOSTERING PRINCIPLES OF JOURNALISTIC FREEDOM TO GATHER AND DISSEMINATE INFORMATION VIA THE GLOBAL COMPUTER NETWORK (U.S. CLS. 100, 101 AND 102).

FIRST USE 5-0-1999; IN COMMERCE 5-0-1999.  
ALICIA COLLINS, EXAMINING ATTORNEY

---

SN 85-209,104. WIGS, WOMEN IN GOD'S SERVICE, JACKSONVILLE, AL. FILED 1-3-2011.

# WIGS

THE MARK CONSISTS OF STANDARD CHARACTERS WITHOUT CLAIM TO ANY PARTICULAR FONT, STYLE, SIZE, OR COLOR.

FOR ASSOCIATION SERVICES, NAMELY PROMOTING THE INTERESTS OF WOMEN IN FOSTERING FAITH-BASED COMMUNITY SERVICE AND MISSION PROJECTS; CHARITABLE SERVICES, NAMELY ORGANIZING AND CONDUCTING FAITH-BASED VOLUNTEER PROGRAMS AND COMMUNITY SERVICE PROJECTS (U.S. CLS. 100, 101 AND 102).

ANNE E. GUSTASON, EXAMINING ATTORNEY

---

SN 85-209,209. KORTERRA, INC., CHANHASSEN, MN. FILED 1-3-2011.

# KORPARTNERS

THE MARK CONSISTS OF STANDARD CHARACTERS WITHOUT CLAIM TO ANY PARTICULAR FONT, STYLE, SIZE, OR COLOR.

OWNER OF U.S. REG. NO. 2,897,438.  
FOR OPERATION OF TELEPHONE CALL CENTERS FOR OTHERS IN THE FIELD OF UTILITY LINE LOCATING SERVICES (U.S. CLS. 100, 101 AND 102).

FIRST USE 1-1-2011; IN COMMERCE 1-1-2011.  
JUSTINE D. PARKER, EXAMINING ATTORNEY

**CLASS 35—(Continued).**

SN 85-209,217. EMEIS COSMETICS PTY. LTD., FITZROY, AUSTRALIA, FILED 1-3-2011.

# Aēsop

OWNER OF U.S. REG. NO. 2,246,359.

THE MARK CONSISTS OF THE WORD "AESOP" WITH A MACRON ABOVE THE LETTER "E".

FOR RETAIL SHOPS FEATURING SKIN CARE PRODUCTS, HAIR CARE PRODUCTS, BODY CARE PRODUCTS, FRAGRANCES, GIFTS, AND MUSIC; RETAIL STORE AND ON-LINE RETAIL STORE SERVICES FEATURING SKIN CARE PRODUCTS, HAIR CARE PRODUCTS, BODY CARE PRODUCTS, FRAGRANCES, GIFTS, AND MUSIC; RETAIL STORE SERVICES FEATURING SKIN CARE PRODUCTS, HAIR CARE PRODUCTS, BODY CARE PRODUCTS, FRAGRANCES, GIFTS, AND MUSIC; WEB-BASED CATALOG SERVICES FEATURING SKIN CARE PRODUCTS, HAIR CARE PRODUCTS, BODY CARE PRODUCTS, FRAGRANCES, GIFTS, AND MUSIC (U.S. CLS. 100, 101 AND 102).

FIRST USE 8-1-2008; IN COMMERCE 8-1-2008.

ANNE E. GUSTASON, EXAMINING ATTORNEY

---

SN 85-209,220. WIGS, WOMEN IN GOD'S SERVICE, JACKSONVILLE, AL. FILED 1-3-2011.



THE MARK CONSISTS OF THE WORD "WIGS" IN A STYLIZED FONT LOCATED IN A FIRST OVAL WITH THE WORDS "WOMEN IN GOD'S SERVICE" IN A STYLIZED FONT LOCATED IN THE LOWER RIGHT PERIPHERY OF A LARGER OVAL ENCOMPASSING THE FIRST OVAL.

FOR ASSOCIATION SERVICES, NAMELY PROMOTING THE INTERESTS OF WOMEN IN FOSTERING FAITH-BASED COMMUNITY SERVICE AND MISSION PROJECTS; CHARITABLE SERVICES, NAMELY ORGANIZING AND CONDUCTING FAITH-BASED VOLUNTEER PROGRAMS AND COMMUNITY SERVICE PROJECTS (U.S. CLS. 100, 101 AND 102).

ANNE E. GUSTASON, EXAMINING ATTORNEY

**CLASS 35—(Continued).**

SN 85-209,383. MCCARTY, KRIS, LOCHBUIE, CO. FILED 1-3-2011.

# Sky Pigs

THE MARK CONSISTS OF STANDARD CHARACTERS WITHOUT CLAIM TO ANY PARTICULAR FONT, STYLE, SIZE, OR COLOR.

FOR ON-LINE RETAIL STORE SERVICES FEATURING STICKERS, GOOSE CALLS, CLOTHING AND ACCESSORIES (U.S. CLS. 100, 101 AND 102).

JASON TURNER, EXAMINING ATTORNEY

---

SN 85-209,564. DIRECT MARKETING STORE, RIDGEWOOD, NJ. FILED 1-3-2011.

# Coolercast

THE MARK CONSISTS OF STANDARD CHARACTERS WITHOUT CLAIM TO ANY PARTICULAR FONT, STYLE, SIZE, OR COLOR.

FOR DEVELOPMENT, OPERATION AND ADMINISTRATION OF DIGITAL SIGNAGE SYSTEMS AND DIGITAL ADVERTISING SYSTEMS FOR OTHERS, NAMELY, PROVIDING ADVERTISING SPACE BY ELECTRONIC MEANS AND GLOBAL COMPUTER INFORMATION NETWORKS (U.S. CLS. 100, 101 AND 102).

FIRST USE 10-11-2010; IN COMMERCE 10-11-2010.

JAMES GRIFFIN, EXAMINING ATTORNEY

---

SN 85-209,609. THE LETICIA E. SCHMIDT TRUST NO. 101, GENEVA, IL. FILED 1-3-2011.

# buildarosary.com

THE MARK CONSISTS OF STANDARD CHARACTERS WITHOUT CLAIM TO ANY PARTICULAR FONT, STYLE, SIZE, OR COLOR.

FOR RETAIL STORE AND ON-LINE RETAIL STORE SERVICES FEATURING THE SALE OF THE CUSTOMER EXPERIENCE WHEREBY THE CUSTOMER BUILDS THEIR OWN ROSARY (U.S. CLS. 100, 101 AND 102).

FIRST USE 2-1-2010; IN COMMERCE 3-15-2010.

JEFF DEFORD, EXAMINING ATTORNEY

**CLASS 35—(Continued).**

SN 85-209,613. ROGER HOLMES, HENDERSONVILLE, TN. FILED 1-4-2011.

# t.Autumn

THE MARK CONSISTS OF STANDARD CHARACTERS WITHOUT CLAIM TO ANY PARTICULAR FONT, STYLE, SIZE, OR COLOR.

FOR RETAIL STORE AND ON-LINE RETAIL STORE SERVICES FEATURING PERFUMERY, COSMETIC PRODUCTS, BEAUTY PRODUCTS, MAKE-UP PRODUCTS, HAIR LOTIONS, PREPARATIONS AND SHAMPOOS (U.S. CLS. 100, 101 AND 102).

BARBARA RUTLAND, EXAMINING ATTORNEY

SN 85-209,699. YATH, SCOTT, ANAHEIM, CA. FILED 1-4-2011.



NO CLAIM IS MADE TO THE EXCLUSIVE RIGHT TO USE "HOCKEY", APART FROM THE MARK AS SHOWN.

THE COLOR(S) BLACK, WHITE, RED AND SILVER IS/ARE CLAIMED AS A FEATURE OF THE MARK.

THE MARK CONSISTS OF "NINJA" IN RED STYLIZED LETTERS WITH A BLACK NINJA FIGURE HOLDING A HOCKEY STICK WITH WHITE EYES; BELOW "NINJA" IS THE WORD "HOCKEY" IN SILVER STYLIZED LETTERS OUTLINE IN BLACK.

FOR ON-LINE RETAIL STORE SERVICES FEATURING HOCKEY APPAREL, TRAINING AIDS AND EQUIPMENT (U.S. CLS. 100, 101 AND 102).

FIRST USE 10-0-2010; IN COMMERCE 10-0-2010.

JEFFREY LOOK, EXAMINING ATTORNEY

**CLASS 35—(Continued).**

SN 85-209,727. MYBODY, L.L.C., PHOENIX, AZ. FILED 1-4-2011.



THE COLOR(S) WHITE, BLUE AND GRAY IS/ARE CLAIMED AS A FEATURE OF THE MARK.

THE MARK CONSISTS OF A WHITE DESIGN HEART WITHIN A BLUE DESIGN HEART WITH THE WORD "MYBODY" IN GRAY.

FOR ON-LINE RETAIL STORE SERVICES FEATURING SKIN CARE PRODUCTS, PERFUME, VITAMINS AND NUTRACEUTICALS; RETAIL STORE SERVICES FEATURING SKIN CARE PRODUCTS, PERFUME, VITAMINS AND NUTRACEUTICALS (U.S. CLS. 100, 101 AND 102).

MAYUR VAGHANI, EXAMINING ATTORNEY

SN 85-209,729. MYBODY, L.L.C., PHOENIX, AZ. FILED 1-4-2011.



THE COLOR(S) WHITE, PINK AND GRAY IS/ARE CLAIMED AS A FEATURE OF THE MARK.

THE MARK CONSISTS OF A WHITE DESIGN HEART WITHIN A PINK DESIGN HEART WITH THE WORD "MYBODY" IN GRAY.

FOR ON-LINE RETAIL STORE SERVICES FEATURING SKIN CARE PRODUCTS, PERFUME, VITAMINS AND NUTRACEUTICALS; RETAIL STORE SERVICES FEATURING SKIN CARE PRODUCTS, PERFUME, VITAMINS AND NUTRACEUTICALS (U.S. CLS. 100, 101 AND 102).

MAYUR VAGHANI, EXAMINING ATTORNEY

SN 85-209,730. EAST GEORGIA HEALTH COOPERATIVE, INC., SANDERSVILLE, GA. FILED 1-4-2011.

**RURAL LIVING ROCKS**

THE MARK CONSISTS OF STANDARD CHARACTERS WITHOUT CLAIM TO ANY PARTICULAR FONT, STYLE, SIZE, OR COLOR.

FOR COOPERATIVE ADVERTISING AND MARKETING; TALENT RECRUITING SERVICES IN THE FIELD OF RECRUITMENT OF PHYSICIANS AND HEALTH-CARE PROFESSIONALS (U.S. CLS. 100, 101 AND 102).

FIRST USE 6-22-2010; IN COMMERCE 10-5-2010.

JENNIFER VASQUEZ, EXAMINING ATTORNEY

**CLASS 35—(Continued).**

SN 85-209,735. MYBODY, L.L.C., PHOENIX, AZ. FILED 1-4-2011.



THE COLOR(S) WHITE, GREEN AND GRAY IS/ARE CLAIMED AS A FEATURE OF THE MARK.

THE MARK CONSISTS OF A WHITE DESIGN HEART WITHIN A GREEN DESIGN HEART WITH THE WORD "MYBODY" IN GRAY.

FOR ON-LINE RETAIL STORE SERVICES FEATURING SKIN CARE PRODUCTS, PERFUME, VITAMINS AND NUTRACEUTICALS; RETAIL STORE SERVICES FEATURING SKIN CARE PRODUCTS, PERFUME, VITAMINS AND NUTRACEUTICALS (U.S. CLS. 100, 101 AND 102).

MAYUR VAGHANI, EXAMINING ATTORNEY

SN 85-209,944. SELECT INTELLECTUAL, LLC, PITTSBURGH, PA. FILED 1-4-2011.

## NURSEFIT

THE MARK CONSISTS OF STANDARD CHARACTERS WITHOUT CLAIM TO ANY PARTICULAR FONT, STYLE, SIZE, OR COLOR.

FOR BUSINESS SERVICES, NAMELY, PROVIDING PERSONNEL SELECTION AND ASSESSMENT SERVICES BY IDENTIFYING, AND SCREENING OF EMPLOYMENT SKILLS OF EMPLOYEE CANDIDATES (U.S. CLS. 100, 101 AND 102).

DORITT L. CARROLL, EXAMINING ATTORNEY

SN 85-209,948. MEDICAL COST CONTAINMENTSERVICES, INC., DBA MEDCOM, JACKSONVILLE, FL. FILED 1-4-2011.

## Exec-U-Perk

THE MARK CONSISTS OF STANDARD CHARACTERS WITHOUT CLAIM TO ANY PARTICULAR FONT, STYLE, SIZE, OR COLOR.

FOR ADMINISTRATION OF BENEFIT REIMBURSEMENT PLANS OFFERED ON AN AFTER TAX BASIS BY EMPLOYERS (U.S. CLS. 100, 101 AND 102).

COLLEEN KEARNEY, EXAMINING ATTORNEY

**CLASS 35—(Continued).**

SN 85-210,104. SAVING PROMISE INC., WASHINGTON, DC. FILED 1-4-2011.

## Gotta talk about it

THE MARK CONSISTS OF STANDARD CHARACTERS WITHOUT CLAIM TO ANY PARTICULAR FONT, STYLE, SIZE, OR COLOR.

FOR PROMOTING PUBLIC AWARENESS OF THE CAUSES OF AND RESPONSES TO DOMESTIC VIOLENCE (U.S. CLS. 100, 101 AND 102).

FIRST USE 9-15-2010; IN COMMERCE 9-15-2010.

JOHN SCHUYLER YARD, EXAMINING ATTORNEY

SN 85-210,129. MOVIE TICKETS.COM, INC., BOCA RATON, FL. FILED 1-4-2011.

## BECAUSE EVERYONE LOVES THE MOVIES

THE MARK CONSISTS OF STANDARD CHARACTERS WITHOUT CLAIM TO ANY PARTICULAR FONT, STYLE, SIZE, OR COLOR.

FOR ONLINE ORDERING SERVICES FEATURING THE PURCHASE OF MOVIE GIFT CARDS OVER THE INTERNET AND PROMOTIONAL CODES (U.S. CLS. 100, 101 AND 102).

PAUL F. GAST, EXAMINING ATTORNEY

SN 85-210,130. ERC WIPING PRODUCTS, INC., LYNN, MA. FILED 1-4-2011.

## WE MAKE WIPING EASY

THE MARK CONSISTS OF STANDARD CHARACTERS WITHOUT CLAIM TO ANY PARTICULAR FONT, STYLE, SIZE, OR COLOR.

FOR ON-LINE WHOLESALE AND RETAIL STORE SERVICES FEATURING TOWELS, CLOTHS, RAGS, WIPES, HAND SANITIZER AND MOPS (U.S. CLS. 100, 101 AND 102).

FIRST USE 12-31-1995; IN COMMERCE 12-31-1995.

ERNEST SHOSHO, EXAMINING ATTORNEY

**CLASS 35—(Continued).**

SN 85-210,175. SAVING PROMISE INC., WASHINGTON, DC.  
FILED 1-4-2011.

**CLASS 35—(Continued).**

SN 85-210,235. NETWORKING RESEARCH GROUP, INC.,  
DENVER, CO. FILED 1-4-2011.

# Between Us

THE MARK CONSISTS OF STANDARD CHARACTERS WITHOUT CLAIM TO ANY PARTICULAR FONT, STYLE, SIZE, OR COLOR.

FOR PROMOTING PUBLIC AWARENESS OF THE CAUSES OF AND RESPONSES TO DOMESTIC VIOLENCE (U.S. CLS. 100, 101 AND 102).

JOHN SCHUYLER YARD, EXAMINING ATTORNEY



SN 85-210,214. ENTERPRISE HOLDINGS, INC., ST. LOUIS,  
MO. FILED 1-4-2011.



OWNER OF U.S. REG. NOS. 1,234,835, 2,136,409 AND OTHERS.

THE COLOR(S) GREEN, WHITE, BLACK, BLUE AND BROWN IS/ARE CLAIMED AS A FEATURE OF THE MARK.

THE MARK CONSISTS OF A WHITE BANNER BEARING A WHITE LETTER "E" INSIDE A GREEN SQUARE AND THE LITERAL ELEMENT "NTERPRISE" IN BLACK TO THE RIGHT OF THE GREEN SQUARE, AND A TEARDROP-SHAPED DEPICTION OF THE EARTH IN THE COLORS BLUE, WHITE, GREEN AND BROWN.

FOR PROMOTING PUBLIC AWARENESS OF ENVIRONMENTAL ISSUES BY PROVIDING A WEBSITE, PRINTED AND BROADCAST MARKETING MATERIALS FEATURING INFORMATION IN THE FIELDS OF ENVIRONMENTAL SUSTAINABILITY, CONSERVATION AND STEWARDSHIP (U.S. CLS. 100, 101 AND 102).

JOHN WILKE, EXAMINING ATTORNEY

THE COLOR(S) BLUE AND BLACK IS/ARE CLAIMED AS A FEATURE OF THE MARK.

THE MARK CONSISTS OF FOUR TRAPEZOIDS WITH A CIRCLE ATTACHED TO THE TOP LEFT OF EACH TRAPEZOID ARRANGED AT NINETY DEGREE ANGLES TO EACH OTHER. THE UPPER RIGHT TRAPEZOID IS LIGHT BLUE AND THE OTHER THREE TRAPEZOIDS ARE DARK BLUE WITH THE TWO TRAPEZOIDS IMMEDIATELY TO THE LEFT OF THE LIGHT BLUE TRAPEZOID GRADUALLY DARKENING IN COLOR AS THEY MOVE AWAY FROM THE LIGHT BLUE TRAPEZOID. ALL TRAPEZOIDS ARE REPRESENTED IN THREE DIMENSIONS WITH SHADOWING IN BLACK TO THE BOTTOM OF EACH TRAPEZOID. THE TRAPEZOIDS ARE ORIENTED APPROXIMATELY 30 DEGREES FROM CENTER.

FOR ADVERTISING, MARKETING AND PROMOTIONAL SERVICES RELATED TO ALL INDUSTRIES FOR THE PURPOSE OF FACILITATING NETWORKING AND SOCIALIZING OPPORTUNITIES FOR BUSINESS PURPOSES (U.S. CLS. 100, 101 AND 102).

FIRST USE 4-2-2010; IN COMMERCE 4-2-2010.

JASON TURNER, EXAMINING ATTORNEY

**CLASS 35—(Continued).**

SN 85-210,244. NETWORKING RESEARCH GROUP, INC., DENVER, CO. FILED 1-4-2011.



THE COLOR(S) BLUE IS/ARE CLAIMED AS A FEATURE OF THE MARK.

THE MARK CONSISTS OF FOUR TRAPEZOIDS WITH A CIRCLE ATTACHED TO THE UPPER LEFT SIDE OF EACH TRAPEZOID. THE TRAPEZOIDS ARE ARRANGED AT RIGHT ANGLES TO EACH OTHER AND ALL FOUR ARE ORIENTED APPROXIMATELY 30 DEGREES FROM CENTER. THE UPPER RIGHT TRAPEZOID IS LIGHT BLUE AND THE OTHER THREE ARE DARK BLUE.

FOR ADVERTISING, MARKETING AND PROMOTIONAL SERVICES RELATED TO ALL INDUSTRIES FOR THE PURPOSE OF FACILITATING NETWORKING AND SOCIALIZING OPPORTUNITIES FOR BUSINESS PURPOSES (U.S. CLS. 100, 101 AND 102).

FIRST USE 4-2-2010; IN COMMERCE 4-2-2010.  
JASON TURNER, EXAMINING ATTORNEY

SN 85-210,277. CMT MILESTONES UNLIMITED INTERNATIONAL LLC, RIVERDALE, NJ. FILED 1-4-2011.



THE MARK CONSISTS OF THE WORD "GOULD" WITH THE "G" ENCASED IN A SQUARE, AND THE NUMBER "2" LINKED TO THE "O", AND THE WORD "GOLD" TO THE RIGHT OF THE NUMBER "2".

FOR BUSINESS CONSULTING AND ADVISORY SERVICES IN THE FIELD OF EXPENSE REDUCTION, CASH FLOW MANAGEMENT AND BUSINESS STRATEGY AND DEVELOPMENT (U.S. CLS. 100, 101 AND 102).

FIRST USE 4-20-2010; IN COMMERCE 4-20-2010.  
BARBARA BROWN, EXAMINING ATTORNEY

**CLASS 35—(Continued).**

SN 85-210,372. TRUCKITNOW, INC., TUCSON, AZ. FILED 1-4-2011.

**POST.BID.SHIP.**

THE MARK CONSISTS OF STANDARD CHARACTERS WITHOUT CLAIM TO ANY PARTICULAR FONT, STYLE, SIZE, OR COLOR.

FOR AN ONLINE AUCTION BIDDING SERVICE FOR OTHERS, NAMELY A SEARCHABLE INTERNET DATABASE OF TRUCKING LOGISTICS POSTINGS IN WHICH BIDDING IS DONE VIA THE INTERNET, IN THE FIELD OF TRANSPORTATION AND DELIVERY OF FREIGHT AND OTHER ITEMS FOR OTHERS BY TRUCK (U.S. CLS. 100, 101 AND 102).

GILBERT SWIFT, EXAMINING ATTORNEY

SN 85-210,381. YOUNG MASTER MINDS, LLC, CINCINNATI, OH. FILED 1-4-2011.

**PRIVEO**

THE MARK CONSISTS OF STANDARD CHARACTERS WITHOUT CLAIM TO ANY PARTICULAR FONT, STYLE, SIZE, OR COLOR.

FOR PROVIDING SPACE AT A WEB SITE FOR THE ADVERTISEMENT OF THE GOODS AND SERVICES OF OTHERS (U.S. CLS. 100, 101 AND 102).

GINA FINK, EXAMINING ATTORNEY

SN 85-210,457. WEATHERFLOW, INC., SCOTTS VALLEY, CA. FILED 1-4-2011.

**COZYBOOTS**

THE MARK CONSISTS OF STANDARD CHARACTERS WITHOUT CLAIM TO ANY PARTICULAR FONT, STYLE, SIZE, OR COLOR.

FOR ON-LINE RETAIL STORE SERVICES FEATURING SHOES AND BOOTS (U.S. CLS. 100, 101 AND 102).

FIRST USE 10-13-2004; IN COMMERCE 10-13-2004.  
REGINA DRUMMOND, EXAMINING ATTORNEY

**CLASS 35—(Continued).**

SN 85-210,468. WMLEE, LLC, WASHINGTON, DC. FILED 1-4-2011.



THE MARK CONSISTS OF THE TEXT "FORKING-DEALS" AND A SYMBOL OF A FORK GOING THROUGH A PRICE TAG.

FOR PROMOTING THE GOODS OR SERVICES OF OTHERS BY PROVIDING A WEBSITE THAT FEATURES DAILY DEALS BY SENDING OUT A DAILY EMAIL TO END USERS OFFERING THE SALE OF A COUPON OR DISCOUNT REDEEMABLE AT THIRD PARTY SERVICES (U.S. CLS. 100, 101 AND 102).

FIRST USE 12-1-2010; IN COMMERCE 12-1-2010.  
TIMOTHY FINNEGAN, EXAMINING ATTORNEY

SN 85-210,482. LF SPORTSWEAR, INC., LOS ANGELES, CA. FILED 1-4-2011.



THE MARK CONSISTS OF THE LETTERS "L" AND "F" WITH THE "L" CONNECTING TO THE "F" AT THE BOTTOM OF THE IMAGE; THE LETTERS "L" AND "F" ARE CONTAINED WITHIN A BOX THAT ALSO INCLUDES 4 SPACES ONE ON EACH SIDE OF THE LETTER "L" AND TWO WITHIN THE NEGATIVE SPACES OF THE LETTER "F".

FOR RETAIL APPAREL STORES (U.S. CLS. 100, 101 AND 102).  
FIRST USE 4-8-2004; IN COMMERCE 4-8-2004.  
LANA PHAM, EXAMINING ATTORNEY

SN 85-210,488. KIM, PHILIP Y., SANTA ROSA, CA. FILED 1-4-2011.



THE MARK CONSISTS OF THE WORDS "IMAGI-MOVIES", STYLIZED AS SHOWN.

FOR ADVERTISING, MARKETING AND PROMOTION SERVICES; ADVERTISING, PROMOTION, AND MARKETING SERVICES IN THE NATURE OF ONLINE, PRINT AND MULTI-MEDIA DISPLAYS AND INFORMATION FOR FILMS, FILM FESTIVALS AND ENTERTAINMENT SPECIAL EVENTS; PROMOTING A SERIES OF FILMS OF OTHERS; PROVIDING MARKETING AND PROMOTION OF SPECIAL EVENTS (U.S. CLS. 100, 101 AND 102).

FIRST USE 12-1-2010; IN COMMERCE 12-14-2010.  
CHERYL CLAYTON, EXAMINING ATTORNEY

**CLASS 35—(Continued).**

SN 85-210,492. RENE A. HILL, DBA X CLUTTER, ST ALBANS, NY. FILED 1-4-2011.

# X CLUTTER

THE MARK CONSISTS OF STANDARD CHARACTERS WITHOUT CLAIM TO ANY PARTICULAR FONT, STYLE, SIZE, OR COLOR.

FOR ADVICE RELATING TO THE ORGANISATION AND MANAGEMENT OF BUSINESS; ASSISTANCE AND ADVICE REGARDING BUSINESS ORGANIZATION AND MANAGEMENT; ASSISTANCE IN MANAGEMENT OF BUSINESS ACTIVITIES; BUSINESS ASSISTANCE, ADVISORY SERVICES AND CONSULTANCY IN THE FIELDS OF BUDGETING, BOOKKEEPING, PREPARATION AND FILING OF CLAIMS, PREPARATION AND FILING OF FORMS, BILL PAYING, ORGANIZING AND PROCESSING PAPERWORK, DEVELOPMENT OF PLAN TO ACHIEVE GOALS AND REFERRAL SERVICES TO BEREAVEMENT COUNSELORS; BUSINESS ASSISTANCE, MANAGEMENT AND INFORMATION SERVICES; BUSINESS CONSULTATION; BUSINESS CONSULTING SERVICES RELATING TO THE INTEGRATION OF THE AREAS OF BUSINESS PROCESS TECHNOLOGY, ORGANIZATIONAL LEARNING, CHANGE MANAGEMENT, AND OPERATIONAL SUSTAINABILITY; BUSINESS CONSULTING, MANAGEMENT, PLANNING AND SUPERVISION; BUSINESS EFFICIENCY ADVICE; BUSINESS MANAGEMENT ADVICE; BUSINESS MANAGEMENT AND CONSULTATION; CONSULTING SERVICES IN BUSINESS ORGANIZATION AND MANAGEMENT; PROVIDING ORGANIZING SERVICES FOR INDIVIDUALS AT HOME, IN HOME OFFICES AND IN BUSINESS OFFICES, THAT PROVIDES HELP WITH TIME AND PAPER MANAGEMENT (U.S. CLS. 100, 101 AND 102).

CHERYL CLAYTON, EXAMINING ATTORNEY

SN 85-210,519. COONAN, JAMES WILLIAM, DBA COONAN, JAMES WILLIAM, FEDERAL WAY, WA. FILED 1-4-2011.

## COONAN, JAMES WILLIAM

THE MARK CONSISTS OF STANDARD CHARACTERS WITHOUT CLAIM TO ANY PARTICULAR FONT, STYLE, SIZE, OR COLOR.

THE NAME "JAMES WILLIAM COONAN" IDENTIFIES A LIVING INDIVIDUAL WHOSE CONSENT IS OF RECORD.

FOR ACCOUNTING CONSULTATION; ACCOUNTING SERVICES; ADMINISTRATIVE ACCOUNTING; ASSISTANCE, ADVISORY SERVICES AND CONSULTANCY WITH REGARD TO BUSINESS PLANNING, BUSINESS ANALYSIS, BUSINESS MANAGEMENT, BUSINESS ORGANIZATION, MARKETING AND CUSTOMER ANALYSIS; BUSINESS CONSULTING IN THE FIELD OF ENVIRONMENTAL MANAGEMENT, NAMELY, ADVISING BUSINESSES AND INDIVIDUALS ON ISSUES OF ENVIRONMENTAL IMPACT, CONSERVATION, PRESERVATION AND PROTECTION, AND ECONOMIC ANALYSIS FOR BUSINESS PURPOSES; FORENSIC ACCOUNTING SERVICES (U.S. CLS. 100, 101 AND 102).

MARLENE BELL, EXAMINING ATTORNEY

**CLASS 35—(Continued).**

SN 85-210,543. HAUBEN, MICHAEL R., BRONX, NY. FILED 1-5-2011.

# CEZZON

THE MARK CONSISTS OF STANDARD CHARACTERS WITHOUT CLAIM TO ANY PARTICULAR FONT, STYLE, SIZE, OR COLOR.

FOR ADVERTISEMENT FOR OTHERS ON THE INTERNET; ADVERTISING AND BUSINESS SERVICES, NAMELY, SECURING AIRTIME ON ALL FORMS OF MEDIA COMMUNICATIONS STATIONS, SYSTEMS, NETWORKS, AND SERVICES FOR THE PURPOSE OF PROMOTING THE GOODS AND SERVICES OF OTHERS; ADVERTISING AND COMMERCIAL INFORMATION SERVICES, VIA THE INTERNET; ADVERTISING AND MARKETING SERVICES PROVIDED BY MEANS OF INDIRECT METHODS OF MARKETING COMMUNICATIONS, NAMELY, SOCIAL MEDIA, SEARCH ENGINE MARKETING, INQUIRY MARKETING, INTERNET MARKETING, MOBILE MARKETING, BLOGGING AND OTHER FORMS OF PASSIVE, SHARABLE OR VIRAL COMMUNICATIONS CHANNELS; ADVERTISING AND PUBLICITY SERVICES, NAMELY, PROMOTING THE GOODS, SERVICES, BRAND IDENTITY AND COMMERCIAL INFORMATION AND NEWS OF THIRD PARTIES THROUGH PRINT, AUDIO, VIDEO, DIGITAL AND ON-LINE MEDIUM; ADVERTISING ON THE INTERNET FOR OTHERS; ADVERTISING SERVICES, NAMELY, PROMOTING AND MARKETING THE GOODS AND SERVICES OF OTHERS IN THE FIELD OF UPSCALE CHOICES SUCH AS CULTURAL EVENTS, RESTAURANTS, SHOPPING, AND TRAVEL VIA PRINT AND ELECTRONIC MEDIA; ADVERTISING SERVICES, NAMELY, PROMOTING PROPERTIES FOR SALE BY OWNER VIA THE INTERNET; ADVERTISING VIA ELECTRONIC MEDIA AND SPECIFICALLY THE INTERNET; ADVICE AND INFORMATION ABOUT CUSTOMER SERVICES AND PRODUCT MANAGEMENT AND PRICES ON INTERNET SITES IN CONNECTION WITH PURCHASES MADE OVER THE INTERNET; AN INTERACTIVE WEB SITE FOR USERS TO REVIEW AND RATE INTERNET CONTENT, PEOPLE, COMPANIES, PRODUCTS AND/OR SERVICES UTILIZING A SOFTWARE APPLICATION TO AWARD POINTS WHEREBY WEB SITE USERS ARE ELIGIBLE TO EXCHANGE POINTS EARNED FOR PROMOTIONAL ITEMS CONSISTING OF COUPONS, REBATES, DISCOUNTS OR SPECIAL OFFERINGS ON GOODS AND/OR SERVICE PROVIDED BY WEB SITE SPONSORS; BARTER EXCHANGE SERVICES, NAMELY, PROVIDING COMMERCIAL BARTER AND TRADE EXCHANGE OF PRODUCTS AND SERVICES VIA A GLOBAL COMPUTER INFORMATION NETWORK; BUSINESS ADMINISTRATION SERVICES FOR PROCESSING SALES MADE ON THE INTERNET; BUSINESS ADVICE AND COMMERCIAL INFORMATION; BUSINESS ADVICE AND INFORMATION; BUSINESS ADVISORY SERVICES, CONSULTANCY AND INFORMATION; BUSINESS CONSULTING AND INFORMATION SERVICES; BUSINESS CONSULTING, INQUIRIES OR INFORMATION; BUSINESS INFORMATION SERVICES, NAMELY, GATHERING AND REPORTING INFORMATION REGARDING E-MAIL ADDRESSES OF OTHERS THAT ARE MADE AVAILABLE TO OTHER COMPANIES FOR COMMERCIAL PURPOSES; COLLECTION AND SYSTEMATISATION OF INFORMATION INTO COMPUTER DATABASES; COLLECTION OF MARKET RESEARCH INFORMATION; COMMERCIAL INFORMATION AGENCIES; COMMERCIAL INFORMATION AND ADVICE FOR CONSUMERS; COMMERCIAL INFORMATION AND DIRECTORY AGENCY; COMPILATION AND SYSTEMIZATION OF INFORMATION INTO COMPUTER DATABASES; COMPILATION OF ADVERTISEMENTS FOR USE AS WEB PAGES ON THE INTERNET; COMPUTER-ASSISTED BUSINESS INFORMATION AND RESEARCH SERVICES; CONSULTING SERVICES IN THE FIELD OF INTERNET MARKETING; CONSULTING SERVICES, NAMELY, PROVIDING EXPECTANT

**CLASS 35—(Continued).**

PARENTS WITH CONSUMER INFORMATION ON ALL TYPES OF BABY PRODUCTS AND SERVICES; COOPERATIVE ADVERTISING AND MARKETING SERVICES BY WAY OF SOLICITATION, CUSTOMER SERVICE AND PROVIDING MARKETING INFORMATION VIA WEB SITES ON A GLOBAL COMPUTER NETWORK; DESIGN OF INTERNET ADVERTISING; DEVELOPMENT, OPERATION AND ADMINISTRATION OF DIGITAL SIGNAGE SYSTEMS AND DIGITAL ADVERTISING SYSTEMS FOR OTHERS, NAMELY, PROVIDING ADVERTISING SPACE BY ELECTRONIC MEANS AND GLOBAL COMPUTER INFORMATION NETWORKS; DISSEMINATION OF ADVERTISING FOR OTHERS VIA AN ON-LINE COMMUNICATIONS NETWORK ON THE INTERNET; DISSEMINATION OF ADVERTISING FOR OTHERS VIA THE INTERNET; ELECTRONIC COMMERCE SERVICES, NAMELY, PROVIDING INFORMATION ABOUT PRODUCTS VIA TELECOMMUNICATION NETWORKS FOR ADVERTISING AND SALES PURPOSES; INFOMEDIARY SERVICES, NAMELY, FACILITATING TRANSACTIONS BETWEEN BUYERS AND SELLERS THROUGH PROVIDING BUYERS WITH INFORMATION ABOUT SELLERS, GOODS, AND/OR SERVICES; INFORMATION AND EXPERT OPINIONS RELATING TO COMPANIES AND BUSINESS; INFORMATION MANAGEMENT SERVICES, NAMELY, SHIPMENT PROCESSING, PREPARING SHIPPING DOCUMENTS AND INVOICES, TRACKING DOCUMENTS, PACKAGES AND FREIGHT OVER COMPUTER NETWORKS, INTRANETS AND INTERNETS; INFORMATION OR ENQUIRIES ON BUSINESS AND MARKETING; INFORMATION SERVICES RELATING TO BUSINESS MATTERS; INFORMATION, ADVISORY AND CONSULTANCY SERVICES RELATING TO BUSINESS AND MANAGEMENT OR BUSINESS ADMINISTRATION, INCLUDING SUCH SERVICES PROVIDED ON LINE OR VIA THE INTERNET; INFORMATION, ADVISORY, CONSULTING, BUSINESS RESEARCH AND PLANNING SERVICES RELATING TO PUBLICITY, MARKETING COMMUNICATIONS, REPUTATION MANAGEMENT OR BUSINESS ADMINISTRATION, INCLUDING SUCH SERVICES PROVIDED ONLINE OR VIA THE INTERNET; INTERNET ADVERTISING SERVICES; MARKETING AND CONSULTING SERVICES IN THE FIELD OF PROMOTING AND TRACKING THE GOODS, SERVICES, AND BRANDS OF OTHERS THROUGH ALL PUBLIC COMMUNICATION MEANS, PARTICULARLY SPECIALIZING IN THE USE OF MOBILE, SOCIAL, AND PRINT MEDIA TO DRIVE CONSUMER INTEREST, ENGAGEMENT AND ACTION; MARKETING SERVICES, NAMELY, PROVIDING INFORMATIONAL WEB PAGES DESIGNED TO GENERATE SALES TRAFFIC VIA HYPERLINKS TO OTHER WEB SITES; MARKETING, ADVERTISING AND PROMOTING THE GOODS AND SERVICES OF OTHERS IN THE FIELD OF TRAVEL AND TOURISM, NAMELY, PROVIDING INFORMATION VIA MAIL AND ELECTRONIC MAIL; MEDIA BUYING ADVICE, NAMELY, ADVISING THE CLIENT HOW MUCH MEDIA TIME, AND AT WHAT TIMES THE CLIENT SHOULD BE PURCHASING ADVERTISING; MEDIA MONITORING SERVICES, NAMELY, MONITORING PRINT MEDIA, TELEVISION, RADIO, AND OTHER MEDIA FOR CUSTOMER-SPECIFIED TOPICS, GATHERING RELEVANT CONTENT ON THOSE TOPICS, AND PROVIDING DOCUMENTATION AND ANALYSIS OF THAT MEDIA CONTENT TO OTHERS FOR BUSINESS PURPOSES; MEDIA PLANNING, NAMELY, ADVISING THE CLIENT ON THE CORRECT TIMES AND STATIONS TO ADVERTISE BASED ON MEDIA ANALYSIS OF THE MARKET FOR THAT MEDIA; MEDIA PRODUCTION LOCATION SCOUTING SERVICES FOR ADVERTISING PURPOSES; MEMBERSHIP CLUB SERVICES, NAMELY, PROVIDING ON-LINE INFORMATION TO MEMBERS IN THE FIELDS OF BRANDING, BUSINESS DEVELOPMENT, BUSINESS MARKETING, AND MARKETING; ON-LINE BUSINESS RESEARCH SERVICE THAT ALLOWS THE USER TO ANALYZE OPINION TRENDS CONTAINED IN DOCUMENTS ON THE INTERNET; ON-LINE POSTING OF REWARDS FOR INFORMATION; ON-LINE TRADING SERVICES IN WHICH SELLER POSTS PRODUCTS TO BE AUCTIONED AND BIDDING IS DONE VIA THE INTERNET; ONLINE MEDIA MONITORING SERVICES USING COMPUTER SOFTWARE TO AUTOMATICALLY MONITOR INTERNET WEBSITES AND ONLINE PUBLICATIONS FOR CUSTOMER-SPECIFIED TOPICS AND TO CAPTURE RELEVANT CONTENT ON



**CLASS 35—(Continued).**

THOSE TOPICS, AND PROVIDING DOCUMENTATION AND ANALYSIS OF THAT ONLINE CONTENT TO OTHERS FOR BUSINESS PURPOSES; ORGANISATION OF INTERNET AUCTIONS; ORGANISATION OF PROMOTIONS USING AUDIOVISUAL MEDIA; PREPARATION AND REALIZATION OF MEDIA AND ADVERTISING PLANS AND CONCEPTS; PREPARING ADVERTISEMENTS FOR OTHERS, NAMELY, PREPARING VIDEO ADVERTISING AND PROMOTIONAL VIDEOS FOR COMMERCIAL USE VIA THE INTERNET AND TELEVISION, DIGITAL CABLE AND VIDEO-ON-DEMAND OR DOWNLOAD; PRESENTATION OF GOODS ON COMMUNICATION MEDIA FOR RETAIL PURPOSES; PROMOTING THE CHARITABLE SERVICES OF OTHERS, NAMELY, PROVIDING INDIVIDUALS WITH INFORMATION FOR THE PURPOSE OF MAKING DONATIONS TO CHARITIES; PROMOTING THE GOODS AND SERVICES OF OTHERS BY MEANS OF DISTRIBUTING ADVERTISING ON THE INTERNET; PROMOTING THE GOODS AND SERVICES OF OTHERS BY PROVIDING A COMMUNITY-DRIVEN WEB SITE FEATURING USER-SUBMITTED CONTENT IN THE NATURE OF COUPONS, REBATES, PRICE-COMPARISON INFORMATION, PRODUCT REVIEWS, LINKS TO THE RETAIL WEB SITES OF OTHERS, AND DISCOUNT INFORMATION; PROMOTING THE GOODS AND SERVICES OF OTHERS BY PROVIDING A WEB SITE FEATURING COUPONS, REBATES, PRICE-COMPARISON INFORMATION, PRODUCT REVIEWS, LINKS TO THE RETAIL WEB SITES OF OTHERS, AND DISCOUNT INFORMATION; PROMOTING THE GOODS AND SERVICES OF OTHERS BY PROVIDING A WEBSITE FEATURING COUPONS, REBATES, PRICE-COMPARISON INFORMATION, PRODUCT REVIEWS, LINKS TO THE RETAIL WEBSITES OF OTHERS, AND DISCOUNT INFORMATION; PROMOTING THE GOODS OF OTHERS, NAMELY, PROVIDING INFORMATION REGARDING DISCOUNTS, COUPONS, REBATES, VOUCHERS AND SPECIAL OFFERS FOR THE GOODS OF OTHERS; PROMOTING VISUAL AND PERFORMING ARTS EVENTS BY MEANS OF PROVIDING AN ONLINE EVENTS CALENDAR, ORIGINAL ARTICLES, INTERVIEWS, AND INFORMATION ABOUT ART, ARTISTS AND ARTS EVENTS VIA AN INTERNET WEB SITE, ALL FOR PROMOTIONAL PURPOSES; PROMOTIONAL MARKETING SERVICES USING AUDIOVISUAL MEDIA; PROVIDING A SEARCHABLE ON-LINE ADVERTISING WEBSITE AND GUIDE FEATURING THE GOODS AND SERVICES OF OTHER VENDORS VIA THE INTERNET; PROVIDING A SEARCHABLE ONLINE ADVERTISING GUIDE FEATURING THE GOODS AND SERVICES OF OTHER ON-LINE VENDORS ON THE INTERNET; PROVIDING A SECURED ACCESS DATABASE VIA THE INTERNET THROUGH WHICH DOCUMENTS AND IMAGES CAN BE VIEWED, COPIED, AND PRINTED FOR PURPOSES OF CONDUCTING CORPORATE TRANSACTIONS; PROVIDING A WEB SITE FEATURING BUSINESS INFORMATION IN THE FORM OF AUDIO AND VIDEO INTERVIEWS, TRANSCRIPTS AND OTHER EDUCATIONAL MATERIALS; PROVIDING A WEB SITE FEATURING CONSUMER INFORMATION ON VARIOUS PUBLICATIONS AND PROVIDING HYPERLINKS TO ON-LINE RETAILERS THAT SELL THE PUBLICATIONS; PROVIDING A WEB-BASED SYSTEM AND ONLINE PORTALS IN THE FIELD OF CONSUMER-TO-BUSINESS COMMERCE FOR CONSUMERS TO ENTER, MANAGE AND MODIFY THEIR CONSUMER PREFERENCE INFORMATION FOR USE BY MERCHANTS TO CREATE AND MANAGE OFFERS FOR DELIVERY TO CONSUMERS; PROVIDING A WEBSITE FEATURING INFORMATION FOR CONSUMERS IN THE FIELD OF PET FOOD, PET TREATS AND PET TOYS FOR PARTICULAR PET BREEDS; PROVIDING A WEBSITE FOR USERS WITH SPECIFIC INFORMED RECOMMENDATIONS OF SPECIFIC CONSUMER PRODUCTS AND SERVICES VALIDATED BY THE USERS' INPUTTED PREFERENCES AND SOCIAL NETWORK; PROVIDING ADVERTISING SERVICE TO DISTRIBUTE ADVERTISEMENTS FOR DISPLAY ON INTERNET, NAMELY, IN WEBSITES, SOCIAL CONVERSATIONS OVER THE INTERNET, E-MAILS, MICROBLOGS, BLOGS, ELECTRONIC MESSAGES, INSTANT MESSAGES, TEXT MESSAGES, MULTIMEDIA MESSAGES, SOCIAL NETWORKS, STATUS UPDATES, FORUMS, ELECTRONIC BULLETIN BOARDS; PROVIDING AN INTERACTIVE REAL ESTATE WEBSITE WHICH PROMOTES HOUSING AND APARTMENT

**CLASS 35—(Continued).**

PROPERTIES THROUGH OFFERING PROSPECTIVE TENANTS VIDEO WALK THROUGHS, PROPERTY DESCRIPTIONS, TEXT, PRICE, LOCATION, MAPS AND OTHER INFORMATION THAT WOULD BE INFLUENTIAL TO A PROSPECTIVE TENANT IN MAKING A RENTAL DECISION; PROVIDING AN INTERNET WEBSITE PORTAL FEATURING LINKS TO MUSIC-RELATED MERCHANDISE FOR RETAIL PURPOSES; PROVIDING AN INTERNET WEBSITE PORTAL FEATURING PROMOTION AND ADVERTISING FOR HOME SERVICE PROVIDERS AND PRODUCT MANUFACTURERS; PROVIDING AN ON-LINE COMMERCIAL INFORMATION DIRECTORY ON THE INTERNET; PROVIDING AN ON-LINE COMPUTER DATABASE IN THE FIELD OF BUSINESS INFORMATION AND BUSINESS CONTACTS; PROVIDING AN ON-LINE SEARCHABLE DATABASE FEATURING BUSINESS INFORMATION AND BUSINESS CONTACTS; PROVIDING AN ON-LINE SEARCHABLE DATABASE FEATURING USED BOOK BEING OFFERED FOR SALE AND BUYER/SELLER CONTACT INFORMATION; PROVIDING AND RENTAL OF ADVERTISING SPACE ON THE INTERNET; PROVIDING BUSINESS AND COMMERCIAL INFORMATION IN THE FIELD OF BUSINESS TRAVEL MANAGEMENT AND THE BUSINESS TRAVEL INDUSTRY; PROVIDING BUSINESS INFORMATION, ALSO VIA INTERNET, THE CABLE NETWORK OR OTHER FORMS OF DATA TRANSFER; PROVIDING BUSINESS MANAGEMENT INFORMATION IN CONNECTION WITH CONSULTING AND ADVISORY SERVICES IN THE FIELD OF STRATEGIC PLANNING; PROVIDING BUSINESS MARKETING INFORMATION; PROVIDING COMMERCIAL INFORMATION UPDATES ONLINE AND OVER A GLOBAL COMPUTER NETWORK IN THE FIELDS OF BUSINESS, COMMERCE, AND INDUSTRY; PROVIDING CONSULTING SERVICES IN THE FIELD OF FACILITATING THE PLANNING, BUYING, AND SELLING OF MEDIA; PROVIDING CONSUMER INFORMATION SERVICES AND MAKING REFERRALS IN THE FIELD OF ENTERTAINMENT SERVICES FOR PRODUCTS, SERVICES, EVENTS, ACTIVITIES, FACILITIES AND LOCATIONS; PROVIDING CONSUMER PRODUCT INFORMATION VIA THE INTERNET; PROVIDING INFORMATION ABOUT AND MAKING REFERRALS IN THE FIELD OF CONSUMER PRODUCTS AND SERVICES FOR RETAIL SERVICES CONCERNING PRODUCTS, SERVICES, EVENTS, ACTIVITIES, ATTRACTIONS AND FACILITIES IN PARTICULAR GEOGRAPHIC LOCATIONS; PROVIDING INFORMATION ABOUT AUTOMOBILES FOR SALE BY MEANS OF THE INTERNET; PROVIDING INFORMATION ABOUT THE GOODS AND SERVICES OF OTHERS VIA THE GLOBAL COMPUTER NETWORK; PROVIDING INFORMATION AND NEWS IN THE FIELD OF BUSINESS; PROVIDING INFORMATION IN THE FIELD OF MARKETING AND ON-LINE MARKETING MEDIA VIA THE INTERNET; PROVIDING INFORMATION PERTAINING TO PROCUREMENT, BUYING, SELLING AND TENDERING INFORMATION AND OPPORTUNITIES RELATING TO GOODS, SERVICES, AND CONSTRUCTION VIA COMPUTER, COMPUTER NETWORKS, TELEPHONE, THE INTERNET OR ELECTRONIC MAIL; PROVIDING ON-LINE BUSINESS INFORMATION OF OTHERS, NAMELY, ADVERTISEMENTS OR SOLICITATIONS; PROVIDING ON-LINE CONSUMER INFORMATION CONCERNING THE LOCATION OF MOBILE RESTAURANTS; PROVIDING ON-LINE DIRECTORY INFORMATION SERVICES ALSO FEATURING HYPERLINKS TO OTHER WEB SITES; PROVIDING PROMOTIONAL MARKETING SERVICES TO BUSINESSES IN THE BROADBAND AND MEDIA INDUSTRIES; PROVIDING STATISTICAL INFORMATION; PROVISION OF A WEB SITE FEATURING COMMERCIAL INFORMATION ON SHOPPING; PROVISION OF ADVERTISING SPACE BY ELECTRONIC MEANS AND GLOBAL INFORMATION NETWORKS; PROVISION OF BUSINESS INFORMATION VIA GLOBAL COMPUTER NETWORKS; PROVISION OF INFORMATION AND ADVICE TO CONSUMERS REGARDING THE SELECTION OF PRODUCTS AND ITEMS TO BE PURCHASED; PROVISION OF INFORMATION CONCERNING COMMERCIAL SALES; PROVISION OF INFORMATION, ADVICE AND CONSULTANCY IN RELATION TO ENERGY EFFICIENCY; PROVISION OF MARKET RESEARCH INFORMATION; PUBLIC RELATIONS, ADVERTISING AND

**CLASS 35—(Continued).**

MARKETING SERVICES FOR THE TOURISM AND CONVENTION INDUSTRY, NAMELY, ORGANIZING AND HOSTING SITE INSPECTIONS AND FAMILIARIZATION TOURS FOR WHOLESALERS, TOUR OPERATORS, TRAVEL AGENTS, MEETING AND INCENTIVE TRAVEL PLANNERS AND TRAVEL MEDIA; SHOPPERS' GUIDE INFORMATION; SHOPPING FACILITATION SERVICES, NAMELY, PROVIDING AN ONLINE COMPARISON-SHOPPING SEARCH ENGINE FOR OBTAINING PURCHASING INFORMATION; SOCIAL MEDIA STRATEGY AND MARKETING CONSULTANCY FOCUSING ON HELPING CLIENTS CREATE AND EXTEND THEIR PRODUCT AND BRAND STRATEGIES BY BUILDING VIRALLY ENGAGING MARKETING SOLUTIONS; SUBSCRIPTION TO AN INFORMATION MEDIA PACKAGE; THE BRINGING TOGETHER OF CONSUMERS AND PROVIDERS OF A VARIETY OF GOODS AND SERVICES IN THE FIELD OF ATHLETICS FOR COMMERCIAL PURPOSES VIA THE INTERNET; THE BRINGING TOGETHER, FOR THE BENEFIT OF OTHERS, OF A VARIETY OF GOODS AND SERVICES, ENABLING CUSTOMERS TO CONVENIENTLY VIEW AND PURCHASE THOSE GOODS AND SERVICES FROM AN INTERNET WEB SITE PARTICULARLY SPECIALIZING IN THE MARKETING OF THE SALE OF GOODS AND SERVICES OF OTHERS (U.S. CLS. 100, 101 AND 102).

PAM WILLIS, EXAMINING ATTORNEY

SN 85-210,560. NATIONAL RESTAURANT ASSOCIATION, WASHINGTON, DC. FILED 1-5-2011.

**AMERICA WORKS HERE**

THE MARK CONSISTS OF STANDARD CHARACTERS WITHOUT CLAIM TO ANY PARTICULAR FONT, STYLE, SIZE, OR COLOR.

FOR LOBBYING SERVICES, NAMELY, PROMOTING THE INTERESTS OF THE RESTAURANT AND HOSPITALITY INDUSTRIES IN THE FIELDS OF LEGISLATION AND REGULATION (U.S. CLS. 100, 101 AND 102).

TINA L. SNAPP, EXAMINING ATTORNEY

SN 85-210,657. ONLINE HOLDINGS LLC, ST. CHARLES, IL. FILED 1-5-2011.

**im▶in.com**

THE MARK CONSISTS OF THE STYLIZED TEXT "IM IN.COM" WITH A TRIANGLE SHAPE BETWEEN THE TEXT "IM" AND "IN.COM".

FOR PROMOTING THE GOODS AND SERVICES OF OTHERS BY PROVIDING A COMMUNITY DRIVEN WEBSITE WHERE USERS CAN PURCHASE GOODS AND SERVICES AT A PREDETERMINED DISCOUNT IN THE FORM OF A VOUCHER (U.S. CLS. 100, 101 AND 102).

FIRST USE 11-23-2010; IN COMMERCE 11-23-2010.

AISHA SALEM, EXAMINING ATTORNEY

**CLASS 35—(Continued).**

SN 85-210,694. PRESTIGE WORLDWIDE, SCOTTSDALE, AZ. FILED 1-5-2011.

**Nerdwestern**

THE MARK CONSISTS OF STANDARD CHARACTERS WITHOUT CLAIM TO ANY PARTICULAR FONT, STYLE, SIZE, OR COLOR.

FOR WHOLESALE DISTRIBUTORSHIPS FEATURING CLOTHING (U.S. CLS. 100, 101 AND 102).

FIRST USE 2-15-2006; IN COMMERCE 2-15-2006.

WILLIAM P. SHANAHAN, EXAMINING ATTORNEY

SN 85-210,724. GOLOCO MEDIA GROUP, INC., FORMERLY MIDTEN MEDIA, INC., HENDERSONVILLE, TN. FILED 1-5-2011.

**Tycoonier**

THE MARK CONSISTS OF STANDARD CHARACTERS WITHOUT CLAIM TO ANY PARTICULAR FONT, STYLE, SIZE, OR COLOR.

FOR PROVIDING ADVERTISING SERVICE TO DISTRIBUTE ADVERTISEMENTS FOR DISPLAY ON INTERNET, NAMELY, IN WEBSITES, SOCIAL CONVERSATIONS OVER THE INTERNET, E-MAILS, MICROBLOGS, BLOGS, ELECTRONIC MESSAGES, INSTANT MESSAGES, TEXT MESSAGES, MULTIMEDIA MESSAGES, SOCIAL NETWORKS, STATUS UPDATES, FORUMS, ELECTRONIC BULLETIN BOARDS (U.S. CLS. 100, 101 AND 102).

SIMON TENG, EXAMINING ATTORNEY

SN 85-210,746. OFFERPOP CORPORATION, NEW YORK, NY. FILED 1-5-2011.

**Tug Of War**

THE MARK CONSISTS OF STANDARD CHARACTERS WITHOUT CLAIM TO ANY PARTICULAR FONT, STYLE, SIZE, OR COLOR.

FOR ADVERTISING, MARKETING AND PROMOTION SERVICES PROVIDED BY MEANS OF DIRECT AND INDIRECT METHODS OF MARKETING COMMUNICATIONS, NAMELY, SOCIAL MEDIA, E-MAIL BLAST CAMPAIGNS, MOBILE MARKETING, SEARCH ENGINE MARKETING, INQUIRY MARKETING, INTERNET MARKETING, BLOGGING AND OTHER FORMS OF PASSIVE, SHARABLE OR VIRAL COMMUNICATIONS CHANNELS (U.S. CLS. 100, 101 AND 102).

HOWARD SMIGA, EXAMINING ATTORNEY

**CLASS 35—(Continued).**

SN 85-210,838. GUITAR CENTER, INC., WESTLAKE VIL-  
LAGE, CA. FILED 1-5-2011.

**SHARE THE PASSION**

THE MARK CONSISTS OF STANDARD CHARACTERS WITHOUT CLAIM TO ANY PARTICULAR FONT, STYLE, SIZE, OR COLOR.

FOR ON-LINE RETAIL STORE SERVICES FEATURING GUITARS, AMPLIFIERS, KEYBOARDS, PERCUSSION PRO-AUDIO, DRUMS, SHEET MUSIC, MUSIC BOOKS AND ACCESSORIES AND PRODUCTS RELATED THERETO; RETAIL STORE SERVICES FEATURING GUITARS, AMPLIFIERS, KEYBOARDS, PERCUSSION PRO-AUDIO, DRUMS, SHEET MUSIC, MUSIC BOOKS AND ACCESSORIES AND PRODUCTS RELATED THERETO (U.S. CLS. 100, 101 AND 102).

FIRST USE 9-1-2008; IN COMMERCE 9-1-2008.

ANNE E. GUSTASON, EXAMINING ATTORNEY

---

SN 85-210,857. WOOD, PAMELA, NEW YORK, NY. FILED 1-  
5-2011.



THE MARK CONSISTS OF THE WORD "SKINNY" IN A TALL SLENDER FONT. "BILLIONAIRESS" IN A FAT THICK FONT NEXT TO THE WORD "SKINNY". THREE CARTOON FEMALE MODELS, ALL IN DRESSES, A HALTER ON BLACK MODEL, ONE SHOULDERED DRESS ON WHITE MODEL, TANK TOP DRESS ON LATINA MODEL. BLACK MODEL IS CENTER, WHITE MODEL ON HER LEFT, LATINA ON BLACK MODEL'S RIGHT. THEY ALL WEAR HEELS, HOOP EARRINGS, AND WRIST CUFFS.

FOR RETAIL STORE SERVICES FEATURING JEWELRY (U.S. CLS. 100, 101 AND 102).

FIRST USE 1-1-2007; IN COMMERCE 6-1-2010.

LAKEISHA LEWIS, EXAMINING ATTORNEY

**CLASS 35—(Continued).**

SN 85-210,875. HARMONY INVESTMENTS LIMITED PART-  
NERSHIP, BEAVERTON, OR. FILED 1-5-2011.

**SPEED & SIMPLICITY**

THE MARK CONSISTS OF STANDARD CHARACTERS WITHOUT CLAIM TO ANY PARTICULAR FONT, STYLE, SIZE, OR COLOR.

FOR WHOLESALE DISTRIBUTORSHIP AND ONLINE ORDERING SERVICES FEATURING ALL OF THE FOLLOWING PRODUCTS, NAMELY, ELECTRICAL EQUIPMENT IN THE NATURE OF ELECTRICAL CONSTRUCTION EQUIPMENT, ELECTRICAL CONTROL EQUIPMENT, ELECTRICAL MAINTENANCE EQUIPMENT AND ACCESSORIES THEREFORE, ELECTRIC POWER DISTRIBUTION EQUIPMENT, CONTROL AND AUTOMATION DEVICES FOR MANUFACTURING PROCESSES AND BUILDING OPERATIONS, DATA COMMUNICATION CABLING AND EQUIPMENT, DIGITAL SURVEILLANCE SYSTEMS, PREMISE SECURITY SYSTEMS, POWER AND HAND TOOLS, ELECTRICAL AND COMMUNICATIONS TESTING EQUIPMENT, ELECTRICAL AND LOW VOLTAGE WIRING DEVICES, HARDWARE AND FASTENERS FOR ELECTRICAL AND LOW VOLTAGE WIRING, HEATERS, FANS, SMOKE AND CARBON DIOXIDE DETECTORS, LIGHTING FIXTURES AND ACCESSORIES THEREFORE, NAMELY, LIGHT BULBS AND BALLASTS, LIGHTING CONTROLS, ELECTRICAL CONDUITS, ELECTRICAL WIRE AND ELECTRICAL AND LOW VOLTAGE CABLES, ELECTRICAL AND LOW VOLTAGE CONDUIT AND RACEWAY FITTINGS, ELECTRICAL UTILITY PRODUCTS AND SOLAR EQUIPMENT (U.S. CLS. 100, 101 AND 102).

FIRST USE 9-1-2010; IN COMMERCE 9-1-2010.

KIM SAITO, EXAMINING ATTORNEY

---

SN 85-210,973. FINCH MANAGEMENT & INVESTMENT,  
INC., HOUSTON, TX. FILED 1-5-2011.

**THE GOOD PEOPLE PEOPLE**

THE MARK CONSISTS OF STANDARD CHARACTERS WITHOUT CLAIM TO ANY PARTICULAR FONT, STYLE, SIZE, OR COLOR.

FOR EMPLOYMENT COUNSELING AND RECRUITING, EMPLOYMENT AND TEMPORARY EMPLOYMENT AGENCIES (U.S. CLS. 100, 101 AND 102).

FIRST USE 9-11-2010; IN COMMERCE 9-11-2010.

LAURIE KAUFMAN, EXAMINING ATTORNEY

**CLASS 35—(Continued).**

SN 85-211,066. SYNERGOS TECHNOLOGIES, INC., AUSTIN, TX. FILED 1-5-2011.

# COLOSSUS

THE MARK CONSISTS OF STANDARD CHARACTERS WITHOUT CLAIM TO ANY PARTICULAR FONT, STYLE, SIZE, OR COLOR.

FOR MARKET ANALYSIS AND RESEARCH SERVICES; MARKET RESEARCH STUDIES; PROVISION OF MARKET RESEARCH INFORMATION (U.S. CLS. 100, 101 AND 102).

FIRST USE 10-30-2010; IN COMMERCE 10-30-2010.  
CORY BOONE, EXAMINING ATTORNEY

SN 85-211,147. EXECUTIVES IN ACTION, DALLAS, TX. FILED 1-5-2011.



THE COLOR(S) RED AND WHITE IS/ARE CLAIMED AS A FEATURE OF THE MARK.

THE MARK CONSISTS OF A WHITE "E" INSIDE A RED STAR WITH THE RED COLOR GRADUALLY GETTING DARKER FROM THE LEFT TOP CORNER TO THE BOTTOM RIGHT CORNER.

FOR CHARITABLE SERVICES, NAMELY, COORDINATION OF EXPERIENCED LEADERS FROM BUSINESS SECTOR AS PRO BONO CONSULTANTS TO CHARITABLE AGENCIES (U.S. CLS. 100, 101 AND 102).

FIRST USE 2-17-2009; IN COMMERCE 2-17-2009.  
KATHRYN COWARD, EXAMINING ATTORNEY

**CLASS 35—(Continued).**

SN 85-211,210. AVANI HOLDINGS LLC, DBA AVANI, SANTA FE SPRINGS, CA. FILED 1-5-2011.

# avani

THE MARK CONSISTS OF STANDARD CHARACTERS WITHOUT CLAIM TO ANY PARTICULAR FONT, STYLE, SIZE, OR COLOR.

OWNER OF U.S. REG. NO. 3,508,473.

THE ENGLISH TRANSLATION OF THE SANSKRIT WORD "AVANI" IN THE MARK IS "EARTH".

FOR ON-LINE RETAIL STORE SERVICES FEATURING CLOTHING (U.S. CLS. 100, 101 AND 102).

FIRST USE 12-1-2010; IN COMMERCE 12-1-2010.

AMEEN IMAM, EXAMINING ATTORNEY

SN 85-211,417. DREAMBIDS INC., WEST LIBERTY, KY. FILED 1-5-2011.

# DreamBid\$

THE MARK CONSISTS OF A HALO OVER THE "D" IN "DREAMBIDS". THE "S" IN "DREAMBIDS" IS A DOLLAR SIGN. THE WORDS "DREAM" AND "BIDS" ARE COMBINED INTO 1 WORD.

FOR ON-LINE AUCTION SERVICES (U.S. CLS. 100, 101 AND 102).

FIRST USE 8-8-2010; IN COMMERCE 11-15-2010.

LINDA ORNDORFF, EXAMINING ATTORNEY

SN 85-211,490. HENDERSON, JOEL PARKER, DBA SIXARM, SAN FRANCISCO, CA. FILED 1-5-2011.

# SixArm

THE MARK CONSISTS OF STANDARD CHARACTERS WITHOUT CLAIM TO ANY PARTICULAR FONT, STYLE, SIZE, OR COLOR.

FOR BUSINESS CONSULTATION (U.S. CLS. 100, 101 AND 102).

FIRST USE 8-1-2007; IN COMMERCE 8-1-2007.

CHERYL CLAYTON, EXAMINING ATTORNEY

**CLASS 35—(Continued).**

SN 85-211,550. WICKETT, AMANDA, COLORADO SPRINGS, CO. FILED 1-6-2011.



THE COLOR(S) BLUE, RED, WHITE AND BLACK IS/ARE CLAIMED AS A FEATURE OF THE MARK.

THE MARK CONSISTS OF A HOUSE COLORED LIKE AMERICAN FLAG IN RED, BLUE, AND WHITE COLOR AND THE WORDS "TAKING BACK OF AMERICA" IS WRITTEN ON THE RIGHT HAND SIDE OF THE HOUSE IN BLACK COLOR. THERE IS A BLUE LINE WITH TWO WHITE STARS AT THE BOTTOM AS SHOWN IN THE MARK.

FOR RETAIL STORE SERVICES FEATURING HOUSEHOLD PRODUCTS (U.S. CLS. 100, 101 AND 102).  
DORITT L. CARROLL, EXAMINING ATTORNEY

---

SN 85-211,565. BRUCE MELNICK, DAYTON, OH. FILED 1-6-2011.

## A Roguish Highlander

THE MARK CONSISTS OF STANDARD CHARACTERS WITHOUT CLAIM TO ANY PARTICULAR FONT, STYLE, SIZE, OR COLOR.

FOR ON-LINE RETAIL STORE SERVICES FEATURING SCOTTISH GENTLEMAN'S CLOTHING, ACCOUTERMENTS AND KILTS.; RETAIL STORES FEATURING SCOTTISH GENTLEMAN'S CLOTHING, ACCOUTERMENTS AND KILTS (U.S. CLS. 100, 101 AND 102).

FIRST USE 4-1-2006; IN COMMERCE 4-1-2006.  
JENNIFER MARTIN, EXAMINING ATTORNEY

---

SN 85-211,623. CONSULTNET, LLC, SOUTH JORDAN, UT. FILED 1-6-2011.

## First. Fast. Flawless.

THE MARK CONSISTS OF STANDARD CHARACTERS WITHOUT CLAIM TO ANY PARTICULAR FONT, STYLE, SIZE, OR COLOR.

FOR EMPLOYMENT HIRING, RECRUITING, PLACEMENT, STAFFING AND CAREER NETWORKING SERVICES; EMPLOYMENT STAFFING CONSULTATION SERVICES; PROFESSIONAL STAFFING AND RECRUITING SERVICES; STRATEGIC SOURCING, NAMELY, STAFFING IN THE FIELD OF ENGINEERING (U.S. CLS. 100, 101 AND 102).

MARY ROSSMAN, EXAMINING ATTORNEY

**CLASS 35—(Continued).**

SN 85-211,624. CARRILES, ALONSO, MEXICO CITY, MEXICO, FILED 1-6-2011.

## What's Kool?

THE MARK CONSISTS OF STANDARD CHARACTERS WITHOUT CLAIM TO ANY PARTICULAR FONT, STYLE, SIZE, OR COLOR.

FOR PROVIDING A WEBSITE FOR USERS WITH SPECIFIC INFORMED RECOMMENDATIONS OF SPECIFIC CONSUMER PRODUCTS AND SERVICES VALIDATED BY THE USERS' INPUTTED PREFERENCES AND SOCIAL NETWORK; PROVIDING ADVERTISING SERVICE TO DISTRIBUTE ADVERTISEMENTS FOR DISPLAY ON INTERNET, NAMELY, IN WEBSITES, SOCIAL CONVERSATIONS OVER THE INTERNET, E-MAILS, MICROBLOGS, BLOGS, ELECTRONIC MESSAGES, INSTANT MESSAGES, TEXT MESSAGES, MULTIMEDIA MESSAGES, SOCIAL NETWORKS, STATUS UPDATES, FORUMS, ELECTRONIC BULLETIN BOARDS (U.S. CLS. 100, 101 AND 102).

WANDA KAY PRICE, EXAMINING ATTORNEY

---

SN 85-211,662. 3DREX & ANIREX STUDIOS, INC., GRAYSLAKE, IL. FILED 1-6-2011.

## 3DREX

THE MARK CONSISTS OF STANDARD CHARACTERS WITHOUT CLAIM TO ANY PARTICULAR FONT, STYLE, SIZE, OR COLOR.

OWNER OF U.S. REG. NOS. 2,917,066, 2,927,472 AND 2,927,475.

FOR ADVERTISING AND PUBLICITY SERVICES, NAMELY, PROMOTING THE GOODS, SERVICES, BRAND IDENTITY AND COMMERCIAL INFORMATION AND NEWS OF THIRD PARTIES THROUGH PRINT, AUDIO, VIDEO, DIGITAL AND ON-LINE MEDIUM; PREPARATION OF CUSTOM ADVERTISEMENTS FOR OTHERS; PREPARATION OF CUSTOM OR NON-CUSTOM ADVERTISING FOR BUSINESSES FOR DISSEMINATION VIA THE WEB, CD OR DVD FOR OPTIONAL UPLOAD OR DOWNLOAD TO A COMPUTER; PREPARING ADVERTISEMENTS FOR OTHERS; PREPARING ADVERTISEMENTS FOR OTHERS, NAMELY, PREPARING VIDEO ADVERTISING AND PROMOTIONAL VIDEOS FOR COMMERCIAL USE VIA THE INTERNET AND TELEVISION, DIGITAL CABLE AND VIDEO-ON-DEMAND OR DOWNLOAD; PREPARING PROMOTIONAL AND MERCHANDISING MATERIAL FOR OTHERS; PROVIDING ADVERTISING, MARKETING AND PROMOTIONAL SERVICES, NAMELY, DEVELOPMENT OF ADVERTISING CAMPAIGNS FOR PRINT, CD-ROM, DVD, AND WEB DESIGN (U.S. CLS. 100, 101 AND 102).

FIRST USE 5-30-2003; IN COMMERCE 5-30-2003.  
HEATHER THOMPSON, EXAMINING ATTORNEY

**CLASS 35—(Continued).**

SN 85-211,683. EMBLEM, LLC, NEW YORK, NY. FILED 1-6-2011.

# MBLM

THE MARK CONSISTS OF STANDARD CHARACTERS WITHOUT CLAIM TO ANY PARTICULAR FONT, STYLE, SIZE, OR COLOR.

FOR BUSINESS CONSULTING SERVICES IN THE FIELD OF BRAND AND MARKETING STRATEGY (U.S. CLS. 100, 101 AND 102).

JOHN SCHUYLER YARD, EXAMINING ATTORNEY

---

SN 85-211,847. THE GOODY BOX!, LOS ANGELES, CA. FILED 1-6-2011.

# The Goody Box!

THE MARK CONSISTS OF STANDARD CHARACTERS WITHOUT CLAIM TO ANY PARTICULAR FONT, STYLE, SIZE, OR COLOR.

FOR ON-LINE RETAIL STORE SERVICES FEATURING GLUTEN-FREE FOOD PRODUCTS (U.S. CLS. 100, 101 AND 102).

TINA BROWN, EXAMINING ATTORNEY

---

SN 85-211,984. POSH, LLC, BIRMINGHAM, AL. FILED 1-6-2011.

# POSH

THE MARK CONSISTS OF STANDARD CHARACTERS WITHOUT CLAIM TO ANY PARTICULAR FONT, STYLE, SIZE, OR COLOR.

FOR PROMOTING THE GOODS AND SERVICES OF OTHERS BY PROVIDING A WEBSITE FEATURING GIFT CERTIFICATES AND LINKS TO THE RETAIL WEBSITES OF OTHERS (U.S. CLS. 100, 101 AND 102).

FIRST USE 7-23-2010; IN COMMERCE 7-23-2010.  
EDWARD FENNESSY, EXAMINING ATTORNEY

**CLASS 35—(Continued).**

SN 85-212,055. UNITED NATURAL FOODS, INC., PROVIDENCE, RI. FILED 1-6-2011.

# AMERICA'S PREMIER CERTIFIED ORGANIC DISTRIBUTOR

THE MARK CONSISTS OF STANDARD CHARACTERS WITHOUT CLAIM TO ANY PARTICULAR FONT, STYLE, SIZE, OR COLOR.

OWNER OF U.S. REG. NO. 2,986,653.

NO CLAIM IS MADE TO THE EXCLUSIVE RIGHT TO USE "DISTRIBUTOR", APART FROM THE MARK AS SHOWN.

SEC. 2(F).

FOR DISTRIBUTORSHIP SERVICES IN THE FIELD OF ORGANIC GROCERY AND GENERAL MERCHANDISE, PERSONAL CARE ITEMS AND NUTRITIONAL SUPPLEMENTS (U.S. CLS. 100, 101 AND 102).

FIRST USE 10-3-2002; IN COMMERCE 10-3-2002.

TINA MAI, EXAMINING ATTORNEY

---

SN 85-212,238. GUITAR CENTER, INC., WESTLAKE VILLAGE, CA. FILED 1-6-2011.

# MIDNIGHT MADNESS

THE MARK CONSISTS OF STANDARD CHARACTERS WITHOUT CLAIM TO ANY PARTICULAR FONT, STYLE, SIZE, OR COLOR.

FOR ON-LINE RETAIL STORE SERVICES FEATURING GUITARS, AMPLIFIERS, KEYBOARDS, PERCUSSION PRO-AUDIO, DRUMS, SHEET MUSIC, MUSIC BOOKS AND ACCESSORIES AND PRODUCTS RELATED THERETO; RETAIL STORE SERVICES FEATURING GUITARS, AMPLIFIERS, KEYBOARDS, PERCUSSION PRO-AUDIO, DRUMS, SHEET MUSIC, MUSIC BOOKS AND ACCESSORIES AND PRODUCTS RELATED THERETO (U.S. CLS. 100, 101 AND 102).

ANNE E. GUSTASON, EXAMINING ATTORNEY

**CLASS 35—(Continued).**

SN 85-212,274. HOTFLOCK LLC, ATLANTA, GA. FILED 1-6-2011.

# HOTFLOCK

THE MARK CONSISTS OF STANDARD CHARACTERS WITHOUT CLAIM TO ANY PARTICULAR FONT, STYLE, SIZE, OR COLOR.

FOR MARKETING AND CONSULTING SERVICES IN THE FIELD OF PROMOTING AND TRACKING THE GOODS, SERVICES, AND BRANDS OF OTHERS THROUGH ALL PUBLIC COMMUNICATION MEANS, PARTICULARLY SPECIALIZING IN THE USE OF MOBILE, SOCIAL, AND PRINT MEDIA TO DRIVE CONSUMER INTEREST, ENGAGEMENT AND ACTION; PROMOTING THE GOODS AND SERVICES OF OTHERS BY PROVIDING A WEBSITE FEATURING COUPONS, REBATES, PRICE-COMPARISON INFORMATION, PRODUCT REVIEWS, LINKS TO THE RETAIL WEBSITES OF OTHERS, AND DISCOUNT INFORMATION (U.S. CLS. 100, 101 AND 102).

MARIA-VICTORIA SUAREZ, EXAMINING ATTORNEY



SN 85-212,311. MOPIX, LLC, SUWANEE, GA. FILED 1-6-2011.

# MOPIX

THE MARK CONSISTS OF STANDARD CHARACTERS WITHOUT CLAIM TO ANY PARTICULAR FONT, STYLE, SIZE, OR COLOR.

FOR ADVERTISING AND MARKETING SERVICES, NAMELY, PROMOTING THE GOODS AND SERVICES OF OTHERS (U.S. CLS. 100, 101 AND 102).

FIRST USE 6-14-2005; IN COMMERCE 6-14-2005.  
APRIL HESIK, EXAMINING ATTORNEY



SN 85-212,439. BENDAHAN, DAVID ROBERT, DBA DISTRICTBYDESIGN, WASHINGTON, DC. FILED 1-7-2011.

# DISTRICTBYDESIGN

THE MARK CONSISTS OF STANDARD CHARACTERS WITHOUT CLAIM TO ANY PARTICULAR FONT, STYLE, SIZE, OR COLOR.

FOR PROMOTIONAL SERVICES, NAMELY, PROVIDING A WEBSITE AT WHICH ARTISTS CAN SHOWCASE THEIR TALENTS VIA AN ONLINE PORTFOLIO (U.S. CLS. 100, 101 AND 102).

KARANENDRA S. CHHINA, EXAMINING ATTORNEY

**CLASS 35—(Continued).**

SN 85-212,456. CALL STAGE, LLC, DRAPER, UT. FILED 1-7-2011.

# CALLSTAGE

THE MARK CONSISTS OF STANDARD CHARACTERS WITHOUT CLAIM TO ANY PARTICULAR FONT, STYLE, SIZE, OR COLOR.

FOR BUSINESS MONITORING SERVICES, NAMELY, TRACKING TELEPHONE CALLS TO DETERMINE EFFICACY OF ADVERTISING AND MARKETING; MARKETING CONSULTATION IN THE FIELD OF CALL TRACKING, CALL MONITORING, CALL MANAGEMENT, AND MARKETING STRATEGIES (U.S. CLS. 100, 101 AND 102).

FIRST USE 12-28-2010; IN COMMERCE 1-3-2011.  
GEOFFREY FOSDICK, EXAMINING ATTORNEY



SN 85-212,515. WASNICK, STEVE, ST. ANTHONY, MN. FILED 1-7-2011.

# WINNING CAUSE

THE MARK CONSISTS OF STANDARD CHARACTERS WITHOUT CLAIM TO ANY PARTICULAR FONT, STYLE, SIZE, OR COLOR.

FOR ONLINE AUCTION SERVICES (U.S. CLS. 100, 101 AND 102).

WILLIAM P. SHANAHAN, EXAMINING ATTORNEY



SN 85-212,517. WASNICK, STEVE, ST. ANTHONY, MN. FILED 1-7-2011.



THE MARK CONSISTS OF A RIBBON FOLDED IN THE SHAPE OF A PERSON WITH ARMS RAISED IN THE FORM OF A "W".

FOR ONLINE AUCTION SERVICES (U.S. CLS. 100, 101 AND 102).

WILLIAM P. SHANAHAN, EXAMINING ATTORNEY

**CLASS 35—(Continued).**

SN 85-212,549. JJNS CAPITAL LLC, AUSTIN, TX. FILED 1-7-2011.

## Hello Handy

THE MARK CONSISTS OF STANDARD CHARACTERS WITHOUT CLAIM TO ANY PARTICULAR FONT, STYLE, SIZE, OR COLOR.

FOR ADVERTISING AND COMMERCIAL INFORMATION SERVICES, VIA THE INTERNET; ADVERTISING AND MARKETING SERVICES PROVIDED BY MEANS OF INDIRECT METHODS OF MARKETING COMMUNICATIONS, NAMELY, SOCIAL MEDIA, SEARCH ENGINE MARKETING, INQUIRY MARKETING, INTERNET MARKETING, MOBILE MARKETING, BLOGGING AND OTHER FORMS OF PASSIVE, SHARABLE OR VIRAL COMMUNICATIONS CHANNELS; ADVERTISING THE SERVICES OF OTHERS VIA WEB PAGES OPTIMIZED FOR ONLINE SEARCH ENGINES; ADVICE AND INFORMATION ABOUT CUSTOMER SERVICES AND PRODUCT MANAGEMENT AND PRICES ON INTERNET SITES IN CONNECTION WITH PURCHASES MADE OVER THE INTERNET; ON-LINE AUCTIONEERING SERVICES VIA THE INTERNET; PROVIDING AN ON-LINE COMMERCIAL INFORMATION DIRECTORY ON THE INTERNET; PROVIDING INFORMATION PERTAINING TO PROCUREMENT, BUYING, SELLING AND TENDERING INFORMATION AND OPPORTUNITIES RELATING TO GOODS, SERVICES, AND CONSTRUCTION VIA COMPUTER, COMPUTER NETWORKS, TELEPHONE, THE INTERNET OR ELECTRONIC MAIL; THE BRINGING TOGETHER, FOR THE BENEFIT OF OTHERS, OF A VARIETY OF GOODS AND SERVICES, ENABLING CUSTOMERS TO CONVENIENTLY VIEW AND PURCHASE THOSE GOODS AND SERVICES FROM AN INTERNET WEB SITE PARTICULARLY SPECIALIZING IN THE MARKETING OF THE SALE OF GOODS AND SERVICES OF OTHERS (U.S. CLS. 100, 101 AND 102).

FIRST USE 4-1-2010; IN COMMERCE 8-1-2010.  
KAREN BRACEY, EXAMINING ATTORNEY

SN 85-212,647. CARPENTER, GREG, DBA YUMMY TREASURES, PITTSFIELD, MA. FILED 1-7-2011.

## Yummy Treasures

THE MARK CONSISTS OF STANDARD CHARACTERS WITHOUT CLAIM TO ANY PARTICULAR FONT, STYLE, SIZE, OR COLOR.

FOR ONLINE RETAIL STORE SERVICES FEATURING COSTUME JEWELRY, BEADS AND CABOCHON (U.S. CLS. 100, 101 AND 102).

FIRST USE 3-22-2008; IN COMMERCE 4-7-2008.  
HELENE LIWINSKI, EXAMINING ATTORNEY

**CLASS 35—(Continued).**

SN 85-213,031. PARADISE SPORTS, INC., VENTURA, CA. FILED 1-7-2011.

## Paradise GolfWarehouse

THE MARK CONSISTS OF STANDARD CHARACTERS WITHOUT CLAIM TO ANY PARTICULAR FONT, STYLE, SIZE, OR COLOR.

NO CLAIM IS MADE TO THE EXCLUSIVE RIGHT TO USE "GOLF WAREHOUSE", APART FROM THE MARK AS SHOWN.

FOR ONLINE RETAIL STORE SERVICES AND RETAIL STORE SERVICES FEATURING SPORTS EQUIPMENT, GOLF EQUIPMENT, APPAREL, ACCESSORIES AND LICENSED TEAM SPORTS FAN GEAR (U.S. CLS. 100, 101 AND 102).

FIRST USE 0-0-2006; IN COMMERCE 0-0-2006.  
STEVEN PEREZ, EXAMINING ATTORNEY

SN 85-213,032. INTERNATIONAL SANITARY SUPPLY ASSOCIATION, LINCOLNWOOD, IL. FILED 1-7-2011.

## TRANSPARE

THE MARK CONSISTS OF STANDARD CHARACTERS WITHOUT CLAIM TO ANY PARTICULAR FONT, STYLE, SIZE, OR COLOR.

FOR ASSOCIATION SERVICES, NAMELY, PROMOTING ENVIRONMENTAL SAFETY, RESPONSIBILITY AND INFORMATION IN THE CLEANING AND MAINTENANCE INDUSTRY (U.S. CLS. 100, 101 AND 102).

PAM WILLIS, EXAMINING ATTORNEY

SN 85-213,229. SOUTHERN PRIDE DISTRIBUTING, LLC, MARION, IL. FILED 1-7-2011.

## ROTATION NATION

THE MARK CONSISTS OF STANDARD CHARACTERS WITHOUT CLAIM TO ANY PARTICULAR FONT, STYLE, SIZE, OR COLOR.

FOR PROVIDING A WEBSITE FEATURING CONSUMER INFORMATION REGARDING BARBECUE AND BARBECUING (U.S. CLS. 100, 101 AND 102).

LINDA LAVACHE, EXAMINING ATTORNEY



**CLASS 35—(Continued).**

SN 85-213,329. JORGLLE LLC, ARLINGTON, VA. FILED 1-7-2011.

# Jorgle

THE MARK CONSISTS OF STANDARD CHARACTERS WITHOUT CLAIM TO ANY PARTICULAR FONT, STYLE, SIZE, OR COLOR.

FOR ADVERTISING AND PROMOTIONAL SERVICES, NAMELY, PROVIDING A WEBSITE FOR PROMOTING THE GOODS AND SERVICES OF OTHERS BY FEATURING AND ORGANIZING DISCOUNT INFORMATION, COUPONS, REBATES, VOUCHERS, AND SPECIAL OFFERS (U.S. CLS. 100, 101 AND 102).

ALYSSA STEEL, EXAMINING ATTORNEY

SN 85-213,506. FIREWEED LLC, ANCHORAGE, AK. FILED 1-8-2011.

# storio

THE MARK CONSISTS OF STANDARD CHARACTERS WITHOUT CLAIM TO ANY PARTICULAR FONT, STYLE, SIZE, OR COLOR.

FOR BUSINESS ADMINISTRATION AND MANAGEMENT; BUSINESS ADMINISTRATION SERVICES FOR PROCESSING SALES MADE ON THE INTERNET; BUSINESS INFORMATION MANAGEMENT; BUSINESS MANAGEMENT AND CONSULTATION IN THE FIELD OF HOSTING DATA AND INFORMATION; BUSINESS MANAGEMENT SERVICES, NAMELY, ADMINISTRATION OF BUSINESS ENGAGED IN HOSTING DATA AND INFORMATION; BUSINESS SERVICES, NAMELY, FACILITIES MANAGEMENT OF TECHNICAL OPERATIONS; COMPUTER FILE MANAGEMENT; COMPUTERIZED AND CENTRAL FILE MANAGEMENT AND BUSINESS FILE MANAGEMENT; DATABASE MANAGEMENT; MANAGEMENT OF COMPUTERIZED FILES (U.S. CLS. 100, 101 AND 102).

H. M. FISHER, EXAMINING ATTORNEY

**CLASS 35—(Continued).**

SN 85-214,264. PENNWELL CORPORATION, TULSA, OK. FILED 1-10-2011.



OWNER OF U.S. REG. NO. 2,857,234.

NO CLAIM IS MADE TO THE EXCLUSIVE RIGHT TO USE "MIDDLE EAST", "POWER GENERATION, T&D AND WATER" AND THE NON-LATIN CHARACTERS THAT TRANSLITERATE TO MO TAMAR WA MA'RED AL KAHRABA WA AL MA, APART FROM THE MARK AS SHOWN.

THE MARK CONSISTS OF "POWER-GEN MIDDLE EAST FOCUSING ON POWER GENERATION, T&D AND WATER", WITH A CURVING BAND DESIGN OVER THE WORDS "POWER-GEN" WITH A LARGE SOLID CIRCLE DESIGN TO THE LEFT OF THE CURVING BAND DESIGN, WITH THE WORDS "FOCUSING ON POWER GENERATION, T&D AND WATER" BENEATH THE WORDS "MIDDLE EAST", AND WITH WORDS IN ARABIC UNDERNEATH THE WORDS "FOCUSING ON POWER GENERATION, T&D AND WATER".

THE ENGLISH TRANSLATION OF THE ARABIC WORDS IN THE MARK IS "ELECTRICITY AND WATER CONFERENCE AND EXHIBITION".

THE NON-LATIN CHARACTERS IN THE MARK TRANSLITERATE TO "MO'TAMAR WA MA'RED AL KAHRABA WA AL MA" AND THIS MEANS "ELECTRICITY AND WATER CONFERENCE AND EXHIBITION" IN ENGLISH.

FOR ARRANGING AND CONDUCTING BUSINESS CONFERENCES IN THE FIELD OF POWER GENERATION (U.S. CLS. 100, 101 AND 102).

FIRST USE 1-22-2007; IN COMMERCE 1-22-2007.

ELISSA GARBER KON, EXAMINING ATTORNEY

SN 85-214,283. LIBERTY LEADERSHIP DEVELOPMENT, POWELL, OH. FILED 1-10-2011.

# Share what you want

THE MARK CONSISTS OF STANDARD CHARACTERS WITHOUT CLAIM TO ANY PARTICULAR FONT, STYLE, SIZE, OR COLOR.

FOR ON-LINE RETAIL STORE SERVICES FEATURING CLOTHING, AUTOMOTIVE PARTS, ELECTRONICS, SHOES, SPORTING GOODS, FOOD, GIFT CARDS, FURNITURE, APPLIANCES AND HOME/OFFICE GOODS, AND OTHER ACCESSORIES (U.S. CLS. 100, 101 AND 102).

CHERYL CLAYTON, EXAMINING ATTORNEY

**CLASS 35—(Continued).**

SN 85-216,004. SUTTER HOME WINERY, INC., ST. HELENA, CA. FILED 1-12-2011.

**ONE STOP WINE SHOP**

THE MARK CONSISTS OF STANDARD CHARACTERS WITHOUT CLAIM TO ANY PARTICULAR FONT, STYLE, SIZE, OR COLOR.

NO CLAIM IS MADE TO THE EXCLUSIVE RIGHT TO USE "WINE SHOP", APART FROM THE MARK AS SHOWN. FOR ON-LINE RETAIL STORE SERVICES FEATURING WINE (U.S. CLS. 100, 101 AND 102).

FIRST USE 12-16-2010; IN COMMERCE 12-16-2010.  
ERNEST SHOSHO, EXAMINING ATTORNEY

SN 85-218,237. TARGET BRANDS, INC., MINNEAPOLIS, MN. FILED 1-14-2011.

**GOOD PRODUCTS GOOD PRICES  
FOR GOOD PEOPLE**

THE MARK CONSISTS OF STANDARD CHARACTERS WITHOUT CLAIM TO ANY PARTICULAR FONT, STYLE, SIZE, OR COLOR.

FOR RETAIL STORE SERVICES FEATURING A WIDE VARIETY OF CONSUMER GOODS (U.S. CLS. 100, 101 AND 102).

TRACY CROSS, EXAMINING ATTORNEY

SN 85-218,435. ROBBINS BROS. JEWELRY, INC., AZUSA, CA. FILED 1-14-2011.

**ENGAGEMENT DREAMS**

THE MARK CONSISTS OF STANDARD CHARACTERS WITHOUT CLAIM TO ANY PARTICULAR FONT, STYLE, SIZE, OR COLOR.

FOR RETAIL JEWELRY STORES (U.S. CLS. 100, 101 AND 102).

JAY BESCH, EXAMINING ATTORNEY

**CLASS 35—(Continued).**

SN 85-219,630. HUBBINGTONS, INC., BARRINGTON, NH. FILED 1-18-2011.



THE MARK CONSISTS OF A TREE ON THE LEFT HAND SIDE OF THE IMAGE AND GROUND STRETCHING TO THE RIGHT WITH THE WORD "HUBBINGTONS" BETWEEN THE TREE AND THE GROUND.

FOR RETAIL STORE SERVICES FEATURING FURNITURE, HOME DECOR AND HOME DECORATING ITEMS (U.S. CLS. 100, 101 AND 102).

FIRST USE 9-0-1994; IN COMMERCE 9-0-1994.  
KELLY BOULTON, EXAMINING ATTORNEY

SN 85-219,944. ANHEUSER-BUSCH INCORPORATED, ST. LOUIS, MO. FILED 1-18-2011.

**BUD LIGHT CLUTCH PLAYERS**

THE MARK CONSISTS OF STANDARD CHARACTERS WITHOUT CLAIM TO ANY PARTICULAR FONT, STYLE, SIZE, OR COLOR.

OWNER OF U.S. REG. NOS. 1,261,873, 1,485,363 AND 2,802,093.

FOR PROMOTING PUBLIC AWARENESS OF THE RESPONSIBLE USE OF ALCOHOL (U.S. CLS. 100, 101 AND 102).

SCOTT BIBB, EXAMINING ATTORNEY

SN 85-220,140. MARGARITAVILLE ENTERPRISES, LLC, PALM BEACH, FL. FILED 1-18-2011.

**LANDSHARK SURFSHACK**

THE MARK CONSISTS OF STANDARD CHARACTERS WITHOUT CLAIM TO ANY PARTICULAR FONT, STYLE, SIZE, OR COLOR.

OWNER OF U.S. REG. NOS. 3,424,713, 3,773,466 AND 3,773,467.

FOR RETAIL STORE SERVICES FEATURING A WIDE ARRAY OF MERCHANDISE IN THE NATURE OF NOVELTY ITEMS, SOUVENIRS, CLOTHING, HEADWEAR, BOOKS, RECORDINGS, BEVERAGEWARE, AND PRINTED MATERIAL (U.S. CLS. 100, 101 AND 102).

C. DIONNE CLYBURN, EXAMINING ATTORNEY

**CLASS 35—(Continued).**

SN 85-220,369. CASTFAM, INC., EL CAJON, CA. FILED 1-18-2011.

## Suddenly Darling

THE MARK CONSISTS OF STANDARD CHARACTERS WITHOUT CLAIM TO ANY PARTICULAR FONT, STYLE, SIZE, OR COLOR.

OWNER OF U.S. REG. NO. 3,691,865.

FOR ON-LINE BUYERS GUIDE SERVICE PROVIDING INFORMATION IN THE FIELD OF YOUNG WOMEN AND GIRLS FASHION AND APPAREL AND CELEBRITY FASHION AND INFORMATION ABOUT HOW AND WHERE ITEMS SIMILAR WORN BY CELEBRITIES CAN BE PURCHASED (U.S. CLS. 100, 101 AND 102).

FIRST USE 10-1-2008; IN COMMERCE 10-1-2008.  
THEODORE MCBRIDE, EXAMINING ATTORNEY

SN 85-220,621. SEBAGO USA, LLC, ROCKFORD, MI. FILED 1-19-2011.

## SEBAGO

THE MARK CONSISTS OF STANDARD CHARACTERS WITHOUT CLAIM TO ANY PARTICULAR FONT, STYLE, SIZE, OR COLOR.

OWNER OF U.S. REG. NOS. 1,301,822, 2,401,830 AND OTHERS.

FOR RETAIL STORE AND ON-LINE RETAIL STORE SERVICES FEATURING FOOTWEAR, CLOTHING, HEADGEAR, BAGS AND ACCESSORIES (U.S. CLS. 100, 101 AND 102).

CORY BOONE, EXAMINING ATTORNEY

SN 85-221,356. TRUE VALUE COMPANY, CHICAGO, IL. FILED 1-19-2011.

## ACHIEVER LEVEL

THE MARK CONSISTS OF STANDARD CHARACTERS WITHOUT CLAIM TO ANY PARTICULAR FONT, STYLE, SIZE, OR COLOR.

NO CLAIM IS MADE TO THE EXCLUSIVE RIGHT TO USE "LEVEL", APART FROM THE MARK AS SHOWN.

FOR RETAIL HARDWARE STORE SERVICES FEATURING A BONUS INCENTIVE PROGRAM FOR CUSTOMERS (U.S. CLS. 100, 101 AND 102).

PATRICIA EVANKO, EXAMINING ATTORNEY

**CLASS 35—(Continued).**

SN 85-221,667. BREAKING NEWS, LLC, BEVERLY HILLS, CA. FILED 1-19-2011.



NO CLAIM IS MADE TO THE EXCLUSIVE RIGHT TO USE "PR", APART FROM THE MARK AS SHOWN.

THE MARK CONSISTS OF A CIRCULAR PATTERN WITH UNEVEN EDGES, INCLUDING A SMALL OPENING IN THE CIRCLE'S LOWER'S RIGHT PORTION. INSIDE THE CIRCLE, THE WORD "BREAKING" APPEARS IN THE UPPER PART. THE WORD "NEWS" WITH A VERTICAL SEPARATION LINE FOLLOWED BY THE TERM "PR" SITS AT THE CENTER OF THE CIRCLE. TOWARDS THE BOTTOM OF THE CIRCLE ARE THE WORDS "YOU'RE COVERED".

FOR PUBLIC RELATIONS; PUBLIC RELATIONS IN THE ENTERTAINMENT INDUSTRY; PUBLIC RELATIONS FOR CELEBRITY CLIENTS (U.S. CLS. 100, 101 AND 102).

LAURA KOVALSKY, EXAMINING ATTORNEY

SN 85-221,786. AUTO WASH MAINTENANCE CORP., MALDEN, MA. FILED 1-20-2011.

NO CLAIM IS MADE TO THE EXCLUSIVE RIGHT TO USE "AUTO WASH ONLINE", APART FROM THE MARK AS SHOWN.

THE MARK CONSISTS OF THE WORDS AUTOWASHONLINE WITH A WAVE EXTENDING THROUGH THE WORD ONLINE AND AN ABSTRACT DESIGN WITHIN THE O IN AUTOWASH.

FOR DISTRIBUTORSHIP SERVICES IN THE FIELD OF VEHICLE WASHING EQUIPMENT, PARTS, AND SUPPLIES; ONLINE DISTRIBUTORSHIP SERVICES IN THE FIELD OF VEHICLE WASHING EQUIPMENT, PARTS, AND SUPPLIES (U.S. CLS. 100, 101 AND 102).

LAURIE MAYES, EXAMINING ATTORNEY

**CLASS 35—(Continued).**

SN 85-222,008. MARGARITAVILLE ENTERPRISES, LLC, PALM BEACH, FL. FILED 1-20-2011.



OWNER OF U.S. REG. NOS. 3,301,624, 3,773,467 AND OTHERS.

THE MARK CONSISTS OF A BROKEN BANDED CIRCLE WITH THE WORDS "LANDSHARK SURF Shack" ALONG THE INSIDE PERIMETER OF THE CIRCLE WITH A STYLIZED DESIGN OF A FLOATING FIN ISLAND WITH TREES AND MOUNDS WITH THE APPEARANCE OF HILLS ON THE FIN ISLAND TOGETHER WITH LINES OF WAVES IN FRONT OF THE FIN ISLAND IN THE CENTER OF THE CIRCLE.

FOR RETAIL STORE SERVICES FEATURING A WIDE ARRAY OF MERCHANDISE IN THE NATURE OF NOVELTY ITEMS, SOUVENIRS, CLOTHING, HEADWEAR, BOOKS, RECORDINGS, BEVERAGWARE, AND PRINTED MATERIAL (U.S. CLS. 100, 101 AND 102).

C. DIONNE CLYBURN, EXAMINING ATTORNEY

SN 85-226,076. WEISS, BOB, NEW YORK, NY. FILED 1-25-2011.

## Gouverneur Gardens

THE MARK CONSISTS OF STANDARD CHARACTERS WITHOUT CLAIM TO ANY PARTICULAR FONT, STYLE, SIZE, OR COLOR.

FOR MATCHING CONSUMERS WITH REAL ESTATE PROFESSIONALS IN THE FIELD OF REAL ESTATE SERVICES VIA COMPUTER NETWORK; MATCHING POTENTIAL BUYERS TO FACILITATE CO-OWNERSHIP OF RESIDENTIAL REAL PROPERTY; NEGOTIATION AND RENEGOTIATION FOR OTHERS OF LEASES AND SUBLEASES AND REAL ESTATE PURCHASE AGREEMENTS; PROVIDING AN INTERACTIVE REAL ESTATE WEBSITE WHICH PROMOTES HOUSING AND APARTMENT PROPERTIES THROUGH OFFERING PROSPECTIVE TENANTS VIDEO WALK THROUGH, PROPERTY DESCRIPTIONS, TEXT, PRICE, LOCATION, MAPS AND OTHER INFORMATION THAT WOULD BE INFLUENTIAL TO A PROSPECTIVE TENANT IN MAKING A RENTAL DECISION; PROVIDING REAL ESTATE LEADS FOR PROSPECTIVE PURCHASERS; REAL ESTATE ADVERTISING SERVICES; REAL ESTATE MARKETING ANALYSIS; REAL ESTATE MARKETING SERVICES, NAMELY, ON-LINE SERVICES FEATURING TOURS OF RESIDENTIAL AND COMMERCIAL REAL ESTATE (U.S. CLS. 100, 101 AND 102).

BARNEY CHARLON, EXAMINING ATTORNEY

**CLASS 35—(Continued).**

SN 85-226,262. HOPE & JOY, CORP., VEGA BAJA, PUERTO RICO, FILED 1-26-2011.

## IDOJOY

THE MARK CONSISTS OF STANDARD CHARACTERS WITHOUT CLAIM TO ANY PARTICULAR FONT, STYLE, SIZE, OR COLOR.

FOR ADVERTISING AND COMMERCIAL INFORMATION SERVICES, VIA THE INTERNET; PROVIDING A SEARCHABLE WEBSITE FEATURING THE GOODS AND SERVICES OF OTHER VENDORS; PROVIDING A WEB SITE AT WHICH USERS CAN OFFER GOODS FOR SALE AND BUY GOODS OFFERED BY OTHERS; PROVISION OF SPACE ON WEBSITES FOR ADVERTISING GOODS AND SERVICES (U.S. CLS. 100, 101 AND 102).

FIRST USE 12-3-2010; IN COMMERCE 12-3-2010.  
KELLY BOULTON, EXAMINING ATTORNEY

SN 85-228,268. HAUBEN, MICHAEL R., BRONX, NY. FILED 1-27-2011.

## VOUQUET

THE MARK CONSISTS OF STANDARD CHARACTERS WITHOUT CLAIM TO ANY PARTICULAR FONT, STYLE, SIZE, OR COLOR.

FOR AD SERVING, NAMELY, PLACING ADVERTISEMENTS ON WEBSITES FOR OTHERS USING SPECIALIZED COMPUTER SOFTWARE; ADVERTISEMENT FOR OTHERS ON THE INTERNET; ADVERTISEMENT VIA MOBILE PHONE NETWORKS; ADVERTISING AGENCIES PROVIDING THE STRATEGY, DESIGN AND EXECUTION OF PROGRAMS TO PROMOTE BUSINESSES IN THE FOOD AND FOODSERVICE INDUSTRIES; ADVERTISING AGENCIES, NAMELY, PROMOTING THE GOODS AND SERVICES OF OTHERS; ADVERTISING AGENCY SPECIALIZING IN THE DESIGN AND EXECUTION OF WORD OF MOUTH, VIRAL, BUZZ AND EXPERIENTIAL MARKETING PROGRAMS; ADVERTISING AND ADVERTISEMENT SERVICES; ADVERTISING AND BUSINESS SERVICES, NAMELY, PROVIDING AN ONLINE WEBSITE WHERE ADVERTISERS, MARKETERS, AND CONTENT PROVIDERS CAN INTERACT WITH USERS FOR ADVERTISING, BRANDING, AND PROMOTING KNOWLEDGE, PRODUCTS, AND SERVICES, AND TRADESHOWS, ON BEHALF OF THEMSELVES AND OTHERS, AND FOR EVALUATING AND RATING THE SAME, ALL THE FOREGOING RELEVANT TO HUMAN ACTIVITIES AFFECTING CLIMATE CHANGE AND RELATED FIELDS; ADVERTISING AND DIRECTORY SERVICES, NAMELY, PROMOTING THE SERVICES OF OTHERS BY PROVIDING A WEB PAGE FEATURING LINKS TO THE WEBSITES OF OTHERS; ADVERTISING AND MARKETING SERVICES PROVIDED BY MEANS OF INDIRECT METHODS OF MARKETING COMMUNICATIONS, NAMELY, SOCIAL MEDIA, SEARCH ENGINE MARKETING, INQUIRY MARKETING, INTERNET MARKETING, MOBILE MARKETING, BLOGGING AND OTHER FORMS OF PASSIVE, SHARABLE OR VIRAL COMMUNICATIONS CHANNELS; ADVERTISING AND MARKETING SERVICES, NAMELY, PROMOTING THE GOODS AND SERVICES OF OTHERS; ADVERTISING AND PROMOTING THE GOODS AND SERVICES OF A VISUAL ARTIST; ADVERTISING AND

**CLASS 35—(Continued).**

PROMOTION SERVICES AND RELATED CONSULTING; ADVERTISING AND PUBLICITY SERVICES, NAMELY, PROMOTING THE GOODS, SERVICES, BRAND IDENTITY AND COMMERCIAL INFORMATION AND NEWS OF THIRD PARTIES THROUGH PRINT, AUDIO, VIDEO, DIGITAL AND ON-LINE MEDIUM; ADVERTISING CONSULTATION; ADVERTISING OF THE PUBLISHED TEXTS OF OTHERS; ADVERTISING ON THE INTERNET FOR OTHERS; ADVERTISING RELATING TO TRANSPORT AND DELIVERY; ADVERTISING SERVICES; ADVERTISING SERVICES, NAMELY, COST-PER-ACTION ON-LINE ADVERTISING; ADVERTISING SERVICES, NAMELY, PROMOTING AND MARKETING THE GOODS AND SERVICES OF OTHERS IN THE FIELD OF UPSCALE CHOICES SUCH AS CULTURAL EVENTS, RESTAURANTS, SHOPPING, AND TRAVEL VIA PRINT AND ELECTRONIC MEDIA; ADVERTISING SERVICES, NAMELY, PROMOTING PROPERTIES FOR SALE BY OWNER VIA THE INTERNET; ADVERTISING SERVICES, NAMELY, PROMOTING THE BRANDS, GOODS AND SERVICES OF OTHERS; ADVERTISING SERVICES, NAMELY, PROMOTING THE FOOD AND WINE OF OTHERS; ADVERTISING SERVICES, NAMELY, PROVIDING ADVERTISING SPACE IN A PERIODICAL; ADVERTISING VIA ELECTRONIC MEDIA AND SPECIFICALLY THE INTERNET; ADVERTISING, MARKETING AND PROMOTIONAL SERVICES RELATED TO ALL INDUSTRIES FOR THE PURPOSE OF FACILITATING NETWORKING AND SOCIALIZING OPPORTUNITIES FOR BUSINESS PURPOSES; ADVERTISING, PROMOTION AND MARKETING SERVICES IN THE NATURE OF E-MAIL BLAST CAMPAIGNS FOR OTHERS; ANALYSIS OF ADVERTISING RESPONSE; ARRANGING AND CONDUCTING OF FAIRS AND EXHIBITIONS FOR BUSINESS AND ADVERTISING PURPOSES; BANNER ADVERTISING; CLASSIFIED ADVERTISING SERVICES; COMPILATION OF ADVERTISEMENTS FOR USE AS WEB PAGES ON THE INTERNET; CONDUCTING, ARRANGING AND ORGANIZING TRADE SHOWS AND TRADE FAIRS FOR COMMERCIAL AND ADVERTISING PURPOSES; DESIGN OF ADVERTISING MATERIALS FOR OTHERS; DESIGN OF INTERNET ADVERTISING; DIRECT MARKETING ADVERTISING FOR OTHERS; DISSEMINATION OF ADVERTISING FOR OTHERS VIA AN ON-LINE COMMUNICATIONS NETWORK ON THE INTERNET; DISSEMINATION OF ADVERTISING FOR OTHERS VIA THE INTERNET; DISTRIBUTION OF ADVERTISEMENTS AND COMMERCIAL ANNOUNCEMENTS; ELECTRONIC COMMERCE SERVICES, NAMELY, PROVIDING INFORMATION ABOUT PRODUCTS VIA TELECOMMUNICATION NETWORKS FOR ADVERTISING AND SALES PURPOSES; EVENT PLANNING AND MANAGEMENT FOR MARKETING, BRANDING, PROMOTING OR ADVERTISING THE GOODS AND SERVICES OF OTHERS; INTERNET ADVERTISING SERVICES; MARKETING AND CONSULTING SERVICES IN THE FIELD OF PROMOTING AND TRACKING THE GOODS, SERVICES, AND BRANDS OF OTHERS THROUGH ALL PUBLIC COMMUNICATION MEANS, PARTICULARLY SPECIALIZING IN THE USE OF MOBILE, SOCIAL, AND PRINT MEDIA TO DRIVE CONSUMER INTEREST, ENGAGEMENT AND ACTION; MARKETING, ADVERTISING AND PROMOTING THE GOODS AND SERVICES OF OTHERS IN THE FIELD OF TRAVEL AND TOURISM, NAMELY, PROVIDING INFORMATION VIA MAIL AND ELECTRONIC MAIL; MEDIA BUYING ADVICE, NAMELY, ADVISING THE CLIENT HOW MUCH MEDIA TIME, AND AT WHAT TIMES THE CLIENT SHOULD BE PURCHASING ADVERTISING; MEDIA MONITORING SERVICES, NAMELY, MONITORING PRINT MEDIA, TELEVISION, RADIO, AND OTHER MEDIA FOR CUSTOMER-SPECIFIED TOPICS, GATHERING RELEVANT CONTENT ON THOSE TOPICS, AND PROVIDING DOCUMENTATION AND ANALYSIS OF THAT MEDIA CONTENT TO OTHERS FOR BUSINESS PURPOSES; MEDIA PLANNING, NAMELY, ADVISING THE CLIENT ON THE CORRECT TIMES AND STATIONS TO ADVERTISE BASED ON MEDIA ANALYSIS OF THE MARKET FOR THAT MEDIA; ON-LINE ADVERTISING AND MARKETING SERVICES; ON-LINE ADVERTISING SERVICES FOR OTHERS; ONLINE ADVERTISING AND PROMOTIONAL SERVICES; ONLINE MEDIA MONITORING SERVICES USING COMPUTER SOFTWARE TO AUTOMATICALLY MONITOR INTERNET WEBSITES AND ONLINE PUBLICATIONS FOR CUSTO-

**CLASS 35—(Continued).**

MER-SPECIFIED TOPICS AND TO CAPTURE RELEVANT CONTENT ON THOSE TOPICS, AND PROVIDING DOCUMENTATION AND ANALYSIS OF THAT ONLINE CONTENT TO OTHERS FOR BUSINESS PURPOSES; ORGANISATION AND HOLDING OF FAIRS FOR COMMERCIAL OR ADVERTISING PURPOSES; ORGANISATION OF EXHIBITIONS AND EVENTS FOR COMMERCIAL OR ADVERTISING PURPOSES; ORGANISATION OF EXHIBITIONS FOR COMMERCIAL OR ADVERTISING PURPOSES; ORGANISING EXHIBITIONS FOR COMMERCIAL OR ADVERTISING PURPOSES; ORGANIZATION OF EVENTS, EXHIBITIONS, FAIRS AND SHOWS FOR COMMERCIAL, PROMOTIONAL AND ADVERTISING PURPOSES; ORGANIZATION OF EXHIBITIONS FOR COMMERCIAL OR ADVERTISING PURPOSES; ORGANIZATION OF FAIRS AND EXHIBITIONS FOR COMMERCIAL AND ADVERTISING PURPOSES; ORGANIZATION OF FAIRS FOR COMMERCIAL AND ADVERTISING PURPOSES; ORGANIZING EXHIBITIONS FOR COMMERCIAL OR ADVERTISING PURPOSES; PREPARATION AND REALIZATION OF MEDIA AND ADVERTISING PLANS AND CONCEPTS; PREPARATION OF CUSTOM ADVERTISEMENTS FOR OTHERS; PREPARING ADVERTISEMENTS FOR OTHERS; PREPARING ADVERTISEMENTS FOR OTHERS, NAMELY, PREPARING VIDEO ADVERTISING AND PROMOTIONAL VIDEOS FOR COMMERCIAL USE VIA THE INTERNET AND TELEVISION, DIGITAL CABLE AND VIDEO-ON-DEMAND OR DOWNLOAD; PREPARING AND PLACING ADVERTISEMENTS FOR OTHERS; PREPARING AND PLACING OF ADVERTISEMENTS; PRESENTATION OF GOODS ON COMMUNICATION MEDIA FOR RETAIL PURPOSES; PRODUCTION OF ADVERTISING MATTER AND COMMERCIALS; PROMOTING THE GOODS AND SERVICES OF OTHERS BY DISTRIBUTING ADVERTISING MATERIALS THROUGH A VARIETY OF METHODS; PROMOTING THE GOODS AND SERVICES OF OTHERS BY MEANS OF DISTRIBUTING ADVERTISING ON THE INTERNET; PROMOTING THE GOODS AND SERVICES OF OTHERS BY PREPARING AND PLACING ADVERTISEMENTS IN AN ELECTRONIC MAGAZINE ACCESSED THROUGH A GLOBAL COMPUTER NETWORK; PROMOTING, ADVERTISING AND MARKETING OF THE ON-LINE WEB SITES OF OTHERS; PROMOTING, ADVERTISING AND MARKETING THE ON-LINE DATABASES AND ELECTRONIC PUBLICATIONS OF OTHERS; PROMOTION, ADVERTISING AND MARKETING OF ON-LINE WEBSITES; PROMOTIONAL MARKETING SERVICES USING AUDIOVISUAL MEDIA; PROVIDING A SEARCHABLE ON-LINE ADVERTISING WEBSITE AND GUIDE FEATURING THE GOODS AND SERVICES OF OTHER VENDORS VIA THE INTERNET; PROVIDING A SEARCHABLE ONLINE ADVERTISING GUIDE FEATURING THE GOODS AND SERVICES OF ONLINE VENDORS; PROVIDING A SEARCHABLE ONLINE ADVERTISING GUIDE FEATURING THE GOODS AND SERVICES OF OTHER ONLINE VENDORS ON THE INTERNET; PROVIDING A WEB SITE WHERE USERS CAN POST ITEMS FOR SALE THROUGH ON-LINE CLASSIFIED ADVERTISEMENTS; PROVIDING A WEB SITE WHICH FEATURES ADVERTISEMENTS FOR THE GOODS AND SERVICES OF OTHERS ON A GLOBAL COMPUTER NETWORK; PROVIDING ADVERTISING AND ADVERTISEMENT SERVICES; PROVIDING ADVERTISING SERVICE TO DISTRIBUTE ADVERTISEMENTS FOR DISPLAY ON INTERNET, NAMELY, IN WEBSITES, SOCIAL CONVERSATIONS OVER THE INTERNET, E-MAILS, MICROBLOGS, BLOGS, ELECTRONIC MESSAGES, INSTANT MESSAGES, TEXT MESSAGES, MULTIMEDIA MESSAGES, SOCIAL NETWORKS, STATUS UPDATES, FORUMS, ELECTRONIC BULLETIN BOARDS; PROVIDING ADVERTISING SERVICES; PROVIDING ADVERTISING SPACE IN PERIODICALS, NEWSPAPERS AND MAGAZINES; PROVIDING ADVERTISING, MARKETING AND PROMOTIONAL SERVICES, NAMELY, DEVELOPMENT OF ADVERTISING CAMPAIGNS PROVIDED THROUGH CABLE TELEVISION BROADCAST, WEB CASTS, RADIO BROADCASTS, NEWSPAPERS, MAGAZINES, ONLINE BANNERS, OUTDOOR BILLBOARDS, WILD POSTINGS, BUS AND SUBWAY ADS; PROVIDING AND RENTAL OF ADVERTISING SPACE ON THE INTERNET; PROVIDING CONSULTING SERVICES IN THE FIELD OF FACILITATING THE PLANNING, BUYING, AND SELLING OF MEDIA; PROVIDING INFORMATION IN THE FIELD OF MAR-

**CLASS 35—(Continued).**

KETING AND ON-LINE MARKETING MEDIA VIA THE INTERNET; PROVIDING ON-LINE BUSINESS INFORMATION OF OTHERS, NAMELY, ADVERTISEMENTS OR SOLICITATIONS; PROVIDING PROMOTIONAL MARKETING SERVICES TO BUSINESSES IN THE BROADBAND AND MEDIA INDUSTRIES; PROVIDING SPACE AT A WEB SITE FOR THE ADVERTISEMENT OF THE GOODS AND SERVICES OF OTHERS; PROVISION OF ADVERTISING SPACE BY ELECTRONIC MEANS AND GLOBAL INFORMATION NETWORKS; PROVISION OF SPACE ON WEBSITES FOR ADVERTISING GOODS AND SERVICES; PUBLIC RELATIONS, ADVERTISING AND MARKETING SERVICES FOR THE TOURISM AND CONVENTION INDUSTRY, NAMELY, ORGANIZING AND HOSTING SITE INSPECTIONS AND FAMILIARIZATION TOURS FOR WHOLESALER-S, TOUR OPERATORS, TRAVEL AGENTS, MEETING AND INCENTIVE TRAVEL PLANNERS AND TRAVEL MEDIA; SERVICES OF ADVERTISING AGENCIES; SERVICES TO DETERMINE THE AUDIENCE AFFECTED BY ADVERTISEMENTS; SOCIAL MEDIA STRATEGY AND MARKETING CONSULTANCY FOCUSING ON HELPING CLIENTS CREATE AND EXTEND THEIR PRODUCT AND BRAND STRATEGIES BY BUILDING VIRALLY ENGAGING MARKETING SOLUTIONS (U.S. CLS. 100, 101 AND 102).

PAM WILLIS, EXAMINING ATTORNEY

**CLASS 35—(Continued).**

SN 85-230,060. MEREDITH CORPORATION, DES MOINES, IA. FILED 1-31-2011.

**REAL WOMEN TALKING**

THE MARK CONSISTS OF STANDARD CHARACTERS WITHOUT CLAIM TO ANY PARTICULAR FONT, STYLE, SIZE, OR COLOR.

FOR CONDUCTING MARKET RESEARCH BY MEANS OF COLLECTING DATA FROM A PRIVATE ONLINE COMMUNITY FOR REGISTERED USERS TO PARTICIPATE IN DISCUSSIONS, SURVEYS AND PROVIDE FEEDBACK IN THE FIELDS OF HOME, FAMILY, HEALTH AND WELLNESS, PERSONAL DEVELOPMENT AND BEHAVIOR, AND CONSUMER PRODUCTS AND SERVICES; PROVISION OF MARKET RESEARCH INFORMATION (U.S. CLS. 100, 101 AND 102).

FIRST USE 4-1-2007; IN COMMERCE 4-1-2007.

JENNIFER DIXON, EXAMINING ATTORNEY

SN 85-231,342. D.L. RYAN & COMPANIES, LTD., WILTON, CT. FILED 2-1-2011.

**SUBTEXT**

THE MARK CONSISTS OF STANDARD CHARACTERS WITHOUT CLAIM TO ANY PARTICULAR FONT, STYLE, SIZE, OR COLOR.

FOR ADVERTISING, MARKETING AND PROMOTION SERVICES (U.S. CLS. 100, 101 AND 102).

DAVID HOFFMAN, EXAMINING ATTORNEY

SN 85-229,077. CARTER, SHAWN, NEW YORK, NY. FILED 1-28-2011.

**AKA SHAWN CARTER**

SN 85-234,350. PUBLIX ASSET MANAGEMENT COMPANY, LAKELAND, FL. FILED 2-4-2011.

**GreenWise**

OWNER OF U.S. REG. NOS. 2,520,595, 3,274,071 AND OTHERS.

THE COLOR(S) GREEN IS/ARE CLAIMED AS A FEATURE OF THE MARK.

THE MARK CONSISTS OF THE WORD GREENWISE IN A STYLIZED FONT, WITH ALL THE LETTERS IN GREEN (PMS 583).

FOR RETAIL GROCERY STORE SERVICES (U.S. CLS. 100, 101 AND 102).

FIRST USE 9-0-2007, THE MARK WAS FIRST USED ANYWHERE IN A DIFFERENT FORM OTHER THAN THAT SOUGHT TO BE REGISTERED AT LEAST AS EARLY AS 03/14/2001; IN COMMERCE 9-0-2007, THE MARK WAS FIRST USED IN COMMERCE IN A DIFFERENT FORM OTHER THAN THAT SOUGHT TO BE REGISTERED AT LEAST AS EARLY AS 03/14/2001.

JASON TURNER, EXAMINING ATTORNEY

THE MARK CONSISTS OF STANDARD CHARACTERS WITHOUT CLAIM TO ANY PARTICULAR FONT, STYLE, SIZE, OR COLOR.

THE NAME(S), PORTRAIT(S), AND/OR SIGNATURE(S) SHOWN IN THE MARK IDENTIFIES SHAWN CARTER, WHOSE CONSENT(S) TO REGISTER IS MADE OF RECORD.

FOR RETAIL AND ON LINE RETAIL STORE SERVICES IN THE FIELD OF GENERAL MERCHANDISE, NAMELY, CLOTHING, BAGS, JEWELRY, FRAGRANCES AND EYEWEAR (U.S. CLS. 100, 101 AND 102).

MATTHEW EINSTEIN, EXAMINING ATTORNEY

**CLASS 35—(Continued).**

SN 85-236,244. AVB, INC., MILWAUKIE, OR. FILED 2-8-2011.

**KILLER BREADQUARTERS**

THE MARK CONSISTS OF STANDARD CHARACTERS WITHOUT CLAIM TO ANY PARTICULAR FONT, STYLE, SIZE, OR COLOR.

OWNER OF U.S. REG. NOS. 3,186,344 AND 3,802,374.  
FOR RETAIL SHOPS FEATURING BREAD, COOKIES AND OTHER BAKED GOODS (U.S. CLS. 100, 101 AND 102).

FIRST USE 4-0-2008; IN COMMERCE 4-0-2008.  
MARK PILARO, EXAMINING ATTORNEY

**CLASS 35—(Continued).**

SN 85-242,897. ANHEUSER-BUSCH, INCORPORATED, ST. LOUIS, MO. FILED 2-15-2011.

**OUR EMPLOYEES. OUR RESPONSIBILITY.**

THE MARK CONSISTS OF STANDARD CHARACTERS WITHOUT CLAIM TO ANY PARTICULAR FONT, STYLE, SIZE, OR COLOR.

FOR PROMOTING PUBLIC AWARENESS OF THE NEED FOR RESPONSIBLE CONSUMPTION OF ALCOHOLIC BEVERAGES AND THE PREVENTION OF DRUNK DRIVING AND UNDERAGE DRINKING (U.S. CLS. 100, 101 AND 102).

JAY FLOWERS, EXAMINING ATTORNEY

SN 85-238,864. STATE FARM MUTUAL AUTOMOBILE INSURANCE COMPANY, BLOOMINGTON, IL. FILED 2-10-2011.

**NNID**

THE MARK CONSISTS OF STANDARD CHARACTERS WITHOUT CLAIM TO ANY PARTICULAR FONT, STYLE, SIZE, OR COLOR.

FOR PROMOTING PUBLIC AWARENESS OF THE DANGER OF TEXTING AND DRIVING AMONGST TEEN DRIVERS (U.S. CLS. 100, 101 AND 102).

FIRST USE 9-30-2010; IN COMMERCE 9-30-2010.  
DAVID ELTON, EXAMINING ATTORNEY

SN 85-244,924. SKECHERS U.S.A., INC. II, MANHATTAN BEACH, CA. FILED 2-17-2011.

**SKECHERS**

THE MARK CONSISTS OF STANDARD CHARACTERS WITHOUT CLAIM TO ANY PARTICULAR FONT, STYLE, SIZE, OR COLOR.

OWNER OF U.S. REG. NO. 2,313,660.  
FOR RETAIL FOOTWEAR STORE SERVICES, AND ON-LINE RETAIL STORE SERVICES FEATURING FOOTWEAR (U.S. CLS. 100, 101 AND 102).

FIRST USE 6-30-1995; IN COMMERCE 6-30-1995.  
SKYE YOUNG, EXAMINING ATTORNEY

SN 85-239,134. HWA FUNDRAISING, LLC, PORTSMOUTH, NH. FILED 2-10-2011.

**Join the Club!**

THE MARK CONSISTS OF STANDARD CHARACTERS WITHOUT CLAIM TO ANY PARTICULAR FONT, STYLE, SIZE, OR COLOR.

FOR BUSINESS CONSULTATION SERVICES TO ASSIST NON-PROFIT ORGANIZATIONS IN PLANNING, MANAGING, AND CONDUCTING FUNDRAISING ACTIVITIES VIA A GLOBAL COMPUTER NETWORK (U.S. CLS. 100, 101 AND 102).

DANNEAN HETZEL, EXAMINING ATTORNEY

SN 85-245,355. APPEL, JENNIFER C., NEW YORK, NY. FILED 2-17-2011.

**BUTTERCUP BAKE SHOP**

THE MARK CONSISTS OF STANDARD CHARACTERS WITHOUT CLAIM TO ANY PARTICULAR FONT, STYLE, SIZE, OR COLOR.

NO CLAIM IS MADE TO THE EXCLUSIVE RIGHT TO USE "BAKE SHOP", APART FROM THE MARK AS SHOWN.  
FOR RETAIL BAKERY SHOP FEATURING PREMIUM, FRESH BAKED GOODS (U.S. CLS. 100, 101 AND 102).

FIRST USE 1-14-1999; IN COMMERCE 1-14-1999.  
ANTHONY RINKER, EXAMINING ATTORNEY

**CLASS 35—(Continued).**

SN 85-245,487. MARS, INCORPORATED, MCLEAN, VA. FILED 2-17-2011.

**EVERY DOG DESERVES A  
LOVING HOME**

THE MARK CONSISTS OF STANDARD CHARACTERS WITHOUT CLAIM TO ANY PARTICULAR FONT, STYLE, SIZE, OR COLOR.

FOR PROMOTION OF PUBLIC AWARENESS ABOUT THE NEED FOR ADOPTING ANIMALS, RESPONSIBLE PET OWNERSHIP, AND THE PROPER CARE AND TREATMENT OF PETS (U.S. CLS. 100, 101 AND 102).

AISHA SALEM, EXAMINING ATTORNEY

SN 85-248,884. PINNACLE ENTERTAINMENT, INC., LAS VEGAS, NV. FILED 2-22-2011.

**THE RIVER GIFT SHOP**

THE MARK CONSISTS OF STANDARD CHARACTERS WITHOUT CLAIM TO ANY PARTICULAR FONT, STYLE, SIZE, OR COLOR.

NO CLAIM IS MADE TO THE EXCLUSIVE RIGHT TO USE "GIFT SHOP", APART FROM THE MARK AS SHOWN. FOR RETAIL GIFT SHOP PROVIDED IN CONNECTION WITH HORSE TRACK FACILITIES (U.S. CLS. 100, 101 AND 102).

FIRST USE 1-28-2011; IN COMMERCE 1-28-2011.  
JULIE GUTTADAURO, EXAMINING ATTORNEY

SN 85-248,984. PINNACLE ENTERTAINMENT, INC., LAS VEGAS, NV. FILED 2-22-2011.



NO CLAIM IS MADE TO THE EXCLUSIVE RIGHT TO USE "GIFT SHOP", APART FROM THE MARK AS SHOWN. THE COLOR(S) BLACK, YELLOW AND WHITE IS/ARE CLAIMED AS A FEATURE OF THE MARK.

THE MARK CONSISTS OF THE STYLIZED WORD "THE" IN BLACK OVER THE STYLIZED WORD "RIVER" IN BLACK OVER THE THREE-DIMENSIONAL STYLIZED WORDS "GIFT SHOP" WHICH ARE YELLOW, OUTLINED IN BLACK AND FEATURE WHITE HIGHLIGHTS.

FOR RETAIL GIFT SHOP PROVIDED IN CONNECTION WITH HORSE TRACK FACILITIES (U.S. CLS. 100, 101 AND 102).

FIRST USE 1-28-2011; IN COMMERCE 1-28-2011.  
JULIE GUTTADAURO, EXAMINING ATTORNEY

**CLASS 35—(Continued).**

SN 85-254,729. FEDERAL EXPRESS CORPORATION, MEMPHIS, TN. FILED 3-1-2011.

**FEDEX CUSTOM CRITICAL  
ShipmentWatch**

THE MARK CONSISTS OF STANDARD CHARACTERS WITHOUT CLAIM TO ANY PARTICULAR FONT, STYLE, SIZE, OR COLOR.

NO CLAIM IS MADE TO THE EXCLUSIVE RIGHT TO USE "SHIPMENTWATCH", APART FROM THE MARK AS SHOWN.

FOR COMPUTERIZED TRACKING OF THE PICKUP, TRANSPORTATION AND DELIVERY OF CARGO (U.S. CLS. 100, 101 AND 102).

JOHN E. MICHOS, EXAMINING ATTORNEY

**CLASS 36—INSURANCE AND FINANCIAL**

SN 76-705,684. INTERNATIONAL DIGITAL ENTERPRISE ALLIANCE, INC., ALEXANDRIA, VA. FILED 12-14-2010.

**LUMINAIRE AWARDS**

THE MARK CONSISTS OF STANDARD CHARACTERS WITHOUT CLAIM TO ANY PARTICULAR FONT, STYLE, SIZE, OR COLOR.

NO CLAIM IS MADE TO THE EXCLUSIVE RIGHT TO USE "AWARDS", APART FROM THE MARK AS SHOWN.

FOR CHARITABLE FUNDRAISING SERVICES, NAMELY, ORGANIZING AND CONDUCTING AN ANNUAL DINNER TO RAISE FUNDS TO PROVIDE SCHOLARSHIPS AND OTHER FINANCIAL ASSISTANCE TO STUDENTS WITH A DEMONSTRATED INTEREST IN ADVERTISING, MEDIA, PRINTING AND PUBLISHING (U.S. CLS. 100, 101 AND 102).

FIRST USE 5-1-1988; IN COMMERCE 5-1-1988.  
REBECCA POVARCHUK, EXAMINING ATTORNEY

SN 76-705,770. ASHLEY FURNITURE INDUSTRIES, INC., ARCADIA, WI. FILED 12-23-2010.



THE MARK CONSISTS OF A RECTANGLE CONTAINING AN UPSIDE DOWN HEART BETWEEN TWO HANDS, TO THE LEFT OF THE STYLIZED WORDING "A HOPE TO DREAM".

FOR CHARITABLE FUNDRAISING SERVICES BY MEANS OF SELLING MATTRESSES TO RAISE FUNDS FOR DONATING MATTRESSES OR MATTRESS SETS TO NEEDY CHILDREN (U.S. CLS. 100, 101 AND 102).

FIRST USE 9-17-2010; IN COMMERCE 9-17-2010.  
ELLEN B. AWRICH, EXAMINING ATTORNEY



**CLASS 36—(Continued).**

SN 77-094,792. PENNANT CAPITAL MANAGEMENT, LLC, CHATHAM, NJ. FILED 1-30-2007.

# PENNANT

THE MARK CONSISTS OF STANDARD CHARACTERS WITHOUT CLAIM TO ANY PARTICULAR FONT, STYLE, SIZE, OR COLOR.

FOR FINANCIAL SERVICES, NAMELY, INVESTMENT MANAGEMENT AND ADVISORY SERVICES (U.S. CLS. 100, 101 AND 102).

FIRST USE 1-16-2001; IN COMMERCE 1-16-2001.  
LINDA ESTRADA, EXAMINING ATTORNEY

SN 77-638,107. MPK, INC., COLUMBIA, MD. FILED 12-22-2008.

# EPI.CENTER

THE MARK CONSISTS OF STANDARD CHARACTERS WITHOUT CLAIM TO ANY PARTICULAR FONT, STYLE, SIZE, OR COLOR.

FOR PROVIDING A WEBSITE THAT PROCESSES MULTIPLE TYPES OF ELECTRONIC PAYMENTS, NAMELY, CREDIT CARD, DEBIT CARD AND ACH TRANSACTIONS (U.S. CLS. 100, 101 AND 102).

REBECCA EISINGER, EXAMINING ATTORNEY

**CLASS 36—(Continued).**

SN 77-838,409. CAPITAL ONE FINANCIAL CORPORATION, RICHMOND, VA. FILED 9-30-2009.



NO CLAIM IS MADE TO THE EXCLUSIVE RIGHT TO USE "FREE CHECKING WITH REWARDS" OR THE LITERAL ELEMENTS ON THE DESIGN OF THE CHECK AND THE DESIGN OF THE CREDIT CARD INCLUDING "PAY TO THE ORDER OF", "DATE", "\$", "DEBIT", "CUSTOMER SINCE", "GOOD THRU" AND NO CLAIM IS MADE TO THE DESIGN OF A CHECK OR THE DESIGN OF A CREDIT CARD, APART FROM THE MARK AS SHOWN.

THE NAME(S), PORTRAIT(S), AND/OR SIGNATURE(S) SHOWN IN THE MARK DOES NOT IDENTIFY A PARTICULAR LIVING INDIVIDUAL.

THE MARK CONSISTS OF THE WORDS "FREE CHECKING WITH REWARDS" SUPERIMPOSED OVER THE DRAWN IMAGE OF A BANKING CHECK, COMPUTER MOUSE AND CREDIT CARD THAT ARE ARRANGED IN A FAN SHAPE AND INCLUDE THE FOLLOWING WORDS, NUMBERS AND SYMBOLS ON THE DRAWN IMAGE - "CAPITAL O DEBIT BA 0123 4567 89 CUSTOMER SINCE 96 GOOD THRU 08/10 CAPITAL ONE CUSTOMER L WALKER PLANO, TX PAY TO THE ORDER OF DATE \$ 1024 C 30".

FOR BANKING AND RELATED FINANCIAL SERVICES (U.S. CLS. 100, 101 AND 102).

FIRST USE 8-31-2009; IN COMMERCE 8-31-2009.  
C. DIONNE CLYBURN, EXAMINING ATTORNEY

SN 77-899,910. HUMANA INC., LOUISVILLE, KY. FILED 12-23-2009.

## HUMANA COMMUNITIES BENEFIT

THE MARK CONSISTS OF STANDARD CHARACTERS WITHOUT CLAIM TO ANY PARTICULAR FONT, STYLE, SIZE, OR COLOR.

NO CLAIM IS MADE TO THE EXCLUSIVE RIGHT TO USE "COMMUNITIES BENEFIT", APART FROM THE MARK AS SHOWN.

FOR CHARITABLE FUND RAISING; FINANCIAL SPONSORSHIP OF CHARITABLE FUND RAISING SERVICES OF OTHERS (U.S. CLS. 100, 101 AND 102).

BRIAN PINO, EXAMINING ATTORNEY

**CLASS 36—(Continued).**

SN 77-939,984. UTICA MUTUAL INSURANCE COMPANY, DBA UTICA NATIONAL INSURANCE GROUP, NEW HARTFORD, NY. FILED 2-19-2010.



THE MARK CONSISTS OF A MAN WITH A MUSTACHE WAVING AND A LITTLE DOG.

FOR INSURANCE SERVICES, NAMELY, INSURANCE UNDERWRITING, INSURANCE CLAIMS PROCESSING AND INSURANCE CLAIMS ADMINISTRATION FOR PROPERTY AND CASUALTY INSURANCE, FIDELITY INSURANCE, SURETY INSURANCE, INLAND MARINE INSURANCE AND OCEAN MARINE INSURANCE (U.S. CLS. 100, 101 AND 102).

FIRST USE 7-0-2009; IN COMMERCE 7-0-2009.  
JOHN DWYER, EXAMINING ATTORNEY

SN 79-091,414. ALLIANZ SE, FED REP GERMANY, FILED 10-26-2010.

**With you from A - Z. Allianz**

THE MARK CONSISTS OF STANDARD CHARACTERS WITHOUT CLAIM TO ANY PARTICULAR FONT, STYLE, SIZE, OR COLOR.

PRIORITY DATE OF 8-16-2010 IS CLAIMED.

OWNER OF INTERNATIONAL REGISTRATION 1062121 DATED 10-26-2010, EXPIRES 10-26-2020.

OWNER OF U.S. REG. NOS. 2,256,628, 3,418,553 AND OTHERS.

FOR INSURANCE SERVICES, NAMELY, INSURANCE AGENCIES AND A FULL LINE OF INSURANCE AND REINSURANCE SERVICES IN THE FIELDS OF LIFE INSURANCE, MARINE INSURANCE, HEALTH INSURANCE, ACCIDENT INSURANCE, HOME INSURANCE, FINANCIAL LOSS INSURANCE, MEDICAL INSURANCE, VEHICLE INSURANCE, TRAVEL INSURANCE, FIRE INSURANCE, GUARANTEE INSURANCE, PENSION INSURANCE, LIABILITY INSURANCE, THEFT INSURANCE, SPORTS INJURY INSURANCE, CREDIT CARD INSURANCE, SURETYSHIP INSURANCE, ERECTION ALL RISK INSURANCE, CONSTRUCTION ALL RISK INSURANCE, AVIATION INSURANCE, TRANSPORTATION INSURANCE, MACHINERY BREAKDOWN INSURANCE, LEGAL PROTECTION INSURANCE, AND ASSISTANCE INSURANCE, NAMELY, ALTERNATIVE RISK TRANSFER, CAPTIVE INSURANCE CONSULTING, CAPTIVE INSURANCE MANAGEMENT, ANNUITY UNDERWRITING AND INVESTMENT MANAGEMENT OF AND DISTRIBUTION OF ANNUITIES, INSURANCE BROKERAGE, INSURANCE ADMINISTRATION, INSURANCE ACTUARIAL SERVICES, APPRAISAL FOR INSURANCE CLAIMS OF PERSONAL PROPERTY, REAL ESTATE, AND ASSETS, INSURANCE AND REINSURANCE CLAIMS PROCESSING AND ADJUSTMENT, INSURANCE AND REINSURANCE CONSULTATION, INSURANCE SUBROGATION AND SALVAGE, INSURANCE UNDERWRITING SERVICES FOR ALL TYPES OF INSURANCE, REINSURANCE UNDERWRITING, INSURANCE ESTIMATION, INSURANCE AMOUNT ASSESSMENT; FINANCIAL SERVICES, NAMELY, ACTUARIAL SERVICES, FINANCIAL MANAGEMENT, NAMELY, ASSET MANAGEMENT, FINAN-

**CLASS 36—(Continued).**

CIAL ANALYSIS, CAPITAL AND FUND INVESTMENT, ADVISORY AND CONSULTATION, PROVIDING FINANCIAL INFORMATION, FINANCIAL FORECASTING, FINANCIAL MANAGEMENT, FINANCIAL PLANNING, FINANCIAL RESEARCH, CASH MANAGEMENT, COMMERCIAL FINANCING, CONSULTATION RELATING TO COMMODITY INVESTMENTS, CONSULTATION RELATING TO CREDIT, CURRENCY EXCHANGE, FINANCIAL CLEARINGHOUSES, ELECTRONIC FUNDS TRANSFER, PROVIDING FINANCIAL INFORMATION IN THE NATURE OF RATES OF EXCHANGE, PROVIDING FINANCIAL INFORMATION VIA A GLOBAL COMPUTER INFORMATION NETWORK, PORTFOLIO MANAGEMENT AND RESEARCH, SECURITIES INVESTMENT, FINANCING SERVICES, NAMELY, ARRANGING LOANS AND CREDIT FOR NEW TECHNOLOGY BUSINESSES, TRUSTEE, SURETY, AND GUARANTOR SERVICES RELATING TO INVESTMENTS, GUARANTEEING LOANS, INTERNATIONAL FINANCING, INVESTMENT OF FUNDS FOR OTHERS, LEASE-PURCHASE FINANCING, LEASING AND RENTAL OF REAL ESTATE, LOAN FINANCING, MONETARY EXCHANGE, INVESTMENT ADMINISTRATION, CONSULTATION AND MANAGEMENT, OFFERING, DISTRIBUTION, AND MANAGEMENT OF LIMITED PARTNERSHIPS, PRIVATE EQUITY, NAMELY, RAISING OF INVESTMENT CAPITAL FOR SMALL AND MEDIUM-SIZED BUSINESSES, RISK MANAGEMENT SERVICES, BANKING, BANKING CONSULTATION, INVESTMENT BANKING SERVICES, MORTGAGE BANKING, MORTGAGE BANKING SERVICES, NAMELY, ORIGINATION, ACQUISITION, SERVICING, SECURITIZATION AND BROKERAGE OF MORTGAGE LOANS, AND ON-LINE BANKING SERVICES (U.S. CLS. 100, 101 AND 102).

KEVON CHISOLM, EXAMINING ATTORNEY

SN 85-004,651. FIRST AMERICAN FINANCIAL CORPORATION, SANTA ANA, CA. FILED 4-1-2010.

**PARCEL IQ**

THE MARK CONSISTS OF STANDARD CHARACTERS WITHOUT CLAIM TO ANY PARTICULAR FONT, STYLE, SIZE, OR COLOR.

NO CLAIM IS MADE TO THE EXCLUSIVE RIGHT TO USE "PARCEL", APART FROM THE MARK AS SHOWN.

FOR PROVIDING AN ON-LINE SEARCHABLE DATABASE FEATURING INFORMATION ON REAL PROPERTY, INCLUDING THE DELIVERY OF PROPERTY OWNERSHIP REPORTS, LEGAL AND VESTING REPORTS, REAL ESTATE DOCUMENT IMAGES, AUTOMATED VALUATION MODELS AND FLOOD REPORTS (U.S. CLS. 100, 101 AND 102).

HENRY S. ZAK, EXAMINING ATTORNEY

**CLASS 36—(Continued).**

SN 85-004,800. MINDFILE, INC., NEW YORK, NY. FILED 4-1-2010.

**MINDCASH**

THE MARK CONSISTS OF STANDARD CHARACTERS WITHOUT CLAIM TO ANY PARTICULAR FONT, STYLE, SIZE, OR COLOR.

FOR ELECTRONIC COMMERCE PAYMENT SERVICES, NAMELY, ESTABLISHING FUNDED ACCOUNTS USED TO PURCHASE GOODS AND SERVICES ON THE INTERNET; FINANCIAL SERVICES, NAMELY, PROVIDING A VIRTUAL CURRENCY FOR USE BY MEMBERS OF AN ON-LINE COMMUNITY VIA A GLOBAL COMPUTER NETWORK; PAYMENT PROCESSING SERVICES, NAMELY, CREDIT CARD AND DEBIT CARD TRANSACTION PROCESSING SERVICES (U.S. CLS. 100, 101 AND 102).

FIRST USE 2-1-2003; IN COMMERCE 2-1-2003.  
MATTHEW MCDOWELL, EXAMINING ATTORNEY

SN 85-016,071. FIFTH THIRD BANCORP, CINCINNATI, OH. FILED 4-16-2010.

**PURCHASE DIRECT BY FIFTH  
THIRD MORTGAGE**

THE MARK CONSISTS OF STANDARD CHARACTERS WITHOUT CLAIM TO ANY PARTICULAR FONT, STYLE, SIZE, OR COLOR.

OWNER OF U.S. REG. NOS. 1,645,502, 1,876,892 AND 3,248,998.

NO CLAIM IS MADE TO THE EXCLUSIVE RIGHT TO USE "PURCHASE DIRECT" AND "MORTGAGE", APART FROM THE MARK AS SHOWN.

FOR BANKING SERVICES, NAMELY MORTGAGE LENDING SERVICES (U.S. CLS. 100, 101 AND 102).  
JERI J. FICKES, EXAMINING ATTORNEY

SN 85-017,212. LANSING AUTOMAKERS FEDERAL CREDIT UNION, LANSING, MI. FILED 4-19-2010.

**Write to Educate**

THE MARK CONSISTS OF STANDARD CHARACTERS WITHOUT CLAIM TO ANY PARTICULAR FONT, STYLE, SIZE, OR COLOR.

FOR CREDIT UNION SERVICES (U.S. CLS. 100, 101 AND 102).

FIRST USE 3-1-2009; IN COMMERCE 3-1-2009.  
ALICE BENMAMAN, EXAMINING ATTORNEY

**CLASS 36—(Continued).**

SN 85-024,478. LAZARD CAPITAL MARKETS LLC, NEW YORK, NY. FILED 4-27-2010.

**LCM Portfolio**

THE MARK CONSISTS OF STANDARD CHARACTERS WITHOUT CLAIM TO ANY PARTICULAR FONT, STYLE, SIZE, OR COLOR.

OWNER OF U.S. REG. NO. 3,267,246.

NO CLAIM IS MADE TO THE EXCLUSIVE RIGHT TO USE "PORTFOLIO", APART FROM THE MARK AS SHOWN.

FOR FINANCIAL ANALYSIS AND CONSULTING FINANCIAL SERVICES, NAMELY, ASSISTING OTHERS WITH THE COMPLETION OF FINANCIAL TRANSACTIONS FOR STOCKS, BONDS, SECURITIES AND EQUITIES (U.S. CLS. 100, 101 AND 102).

CHARISMA HAMPTON, EXAMINING ATTORNEY

SN 85-025,726. TRUSTED ESCAPES, INC., SOUTH BOSTON, MA. FILED 4-28-2010.

**VRIFY**

THE MARK CONSISTS OF STANDARD CHARACTERS WITHOUT CLAIM TO ANY PARTICULAR FONT, STYLE, SIZE, OR COLOR.

FOR EVALUATION OF REAL PROPERTY, NAMELY, VACATION RENTAL PROPERTIES; PROPERTY INFORMATION PROVIDED IN CONNECTION WITH VACATION PROPERTY RENTALS, NAMELY, PROVIDING INFORMATION REGARDING CONDITION, ATTRIBUTES, AND AMENITIES (U.S. CLS. 100, 101 AND 102).

CHRISTOPHER BUONGIORNO, EXAMINING ATTORNEY

SN 85-026,305. PROPHET EQUITY LLC, SOUTHLAKE, TX. FILED 4-29-2010.

**PROPHET ALPHA EQUITY**

THE MARK CONSISTS OF STANDARD CHARACTERS WITHOUT CLAIM TO ANY PARTICULAR FONT, STYLE, SIZE, OR COLOR.

NO CLAIM IS MADE TO THE EXCLUSIVE RIGHT TO USE "EQUITY", APART FROM THE MARK AS SHOWN.

FOR FINANCIAL AND INVESTMENT SERVICES, NAMELY, MANAGEMENT AND BROKERAGE IN THE FIELDS OF STOCKS, BONDS, OPTIONS, COMMODITIES, FUTURES AND OTHER SECURITIES, AND THE INVESTMENT OF FUNDS OF OTHERS (U.S. CLS. 100, 101 AND 102).

TEJBIR SINGH, EXAMINING ATTORNEY

**CLASS 36—(Continued).**

SN 85-026,315. PROPHET EQUITY LLC, SOUTHLAKE, TX.  
FILED 4-29-2010.

**ALPHA EQUITY PROPHET**

THE MARK CONSISTS OF STANDARD CHARACTERS WITHOUT CLAIM TO ANY PARTICULAR FONT, STYLE, SIZE, OR COLOR.

NO CLAIM IS MADE TO THE EXCLUSIVE RIGHT TO USE "EQUITY", APART FROM THE MARK AS SHOWN.

FOR FINANCIAL AND INVESTMENT SERVICES, NAMELY, MANAGEMENT AND BROKERAGE IN THE FIELDS OF STOCKS, BONDS, OPTIONS, COMMODITIES, FUTURES AND OTHER SECURITIES, AND THE INVESTMENT OF FUNDS OF OTHERS (U.S. CLS. 100, 101 AND 102).

TEJBIR SINGH, EXAMINING ATTORNEY

SN 85-026,333. PROPHET EQUITY LLC, SOUTHLAKE, TX.  
FILED 4-29-2010.

**PROPHET PRIVATE EQUITY**

THE MARK CONSISTS OF STANDARD CHARACTERS WITHOUT CLAIM TO ANY PARTICULAR FONT, STYLE, SIZE, OR COLOR.

NO CLAIM IS MADE TO THE EXCLUSIVE RIGHT TO USE "PRIVATE EQUITY", APART FROM THE MARK AS SHOWN.

FOR FINANCIAL AND INVESTMENT SERVICES, NAMELY, MANAGEMENT AND BROKERAGE IN THE FIELDS OF STOCKS, BONDS, OPTIONS, COMMODITIES, FUTURES AND OTHER SECURITIES, AND THE INVESTMENT OF FUNDS OF OTHERS (U.S. CLS. 100, 101 AND 102).

TEJBIR SINGH, EXAMINING ATTORNEY

SN 85-026,342. PROPHET EQUITY LLC, SOUTHLAKE, TX.  
FILED 4-29-2010.

**PRIVATE EQUITY PROPHET**

THE MARK CONSISTS OF STANDARD CHARACTERS WITHOUT CLAIM TO ANY PARTICULAR FONT, STYLE, SIZE, OR COLOR.

NO CLAIM IS MADE TO THE EXCLUSIVE RIGHT TO USE "PRIVATE EQUITY", APART FROM THE MARK AS SHOWN.

FOR FINANCIAL AND INVESTMENT SERVICES, NAMELY, MANAGEMENT AND BROKERAGE IN THE FIELDS OF STOCKS, BONDS, OPTIONS, COMMODITIES, FUTURES AND OTHER SECURITIES, AND THE INVESTMENT OF FUNDS OF OTHERS (U.S. CLS. 100, 101 AND 102).

TEJBIR SINGH, EXAMINING ATTORNEY

**CLASS 36—(Continued).**

SN 85-026,353. PROPHET EQUITY LLC, SOUTHLAKE, TX.  
FILED 4-29-2010.

**ALPHA PROPHET**

THE MARK CONSISTS OF STANDARD CHARACTERS WITHOUT CLAIM TO ANY PARTICULAR FONT, STYLE, SIZE, OR COLOR.

FOR FINANCIAL AND INVESTMENT SERVICES, NAMELY, MANAGEMENT AND BROKERAGE IN THE FIELDS OF STOCKS, BONDS, OPTIONS, COMMODITIES, FUTURES AND OTHER SECURITIES, AND THE INVESTMENT OF FUNDS OF OTHERS (U.S. CLS. 100, 101 AND 102).

TEJBIR SINGH, EXAMINING ATTORNEY

SN 85-026,366. PROPHET EQUITY LLC, SOUTHLAKE, TX.  
FILED 4-29-2010.

**PRIVATE PROPHET EQUITY**

THE MARK CONSISTS OF STANDARD CHARACTERS WITHOUT CLAIM TO ANY PARTICULAR FONT, STYLE, SIZE, OR COLOR.

NO CLAIM IS MADE TO THE EXCLUSIVE RIGHT TO USE "EQUITY", APART FROM THE MARK AS SHOWN.

FOR FINANCIAL AND INVESTMENT SERVICES, NAMELY, MANAGEMENT AND BROKERAGE IN THE FIELDS OF STOCKS, BONDS, OPTIONS, COMMODITIES, FUTURES AND OTHER SECURITIES, AND THE INVESTMENT OF FUNDS OF OTHERS (U.S. CLS. 100, 101 AND 102).

TEJBIR SINGH, EXAMINING ATTORNEY

SN 85-029,552. DATA INTELLIGENCE CORPORATION,  
ATLANTA, GA. FILED 5-4-2010.

**HOMESTAT**

THE MARK CONSISTS OF STANDARD CHARACTERS WITHOUT CLAIM TO ANY PARTICULAR FONT, STYLE, SIZE, OR COLOR.

FOR PROVIDING REAL ESTATE LISTINGS AND REAL ESTATE INFORMATION VIA THE INTERNET (U.S. CLS. 100, 101 AND 102).

FIRST USE 1-0-2010; IN COMMERCE 1-0-2010.

KRISTIN DAHLING, EXAMINING ATTORNEY

**CLASS 36—(Continued).**

SN 85-032,657. CATHOLIC FINANCIAL LIFE, MILWAUKEE, WI. FILED 5-7-2010.

CATHOLIC FINANCIAL SERVICES

THE MARK CONSISTS OF STANDARD CHARACTERS WITHOUT CLAIM TO ANY PARTICULAR FONT, STYLE, SIZE, OR COLOR.

OWNER OF U.S. REG. NOS. 2,799,551, 2,826,749 AND OTHERS.

NO CLAIM IS MADE TO THE EXCLUSIVE RIGHT TO USE "FINANCIAL SERVICES", APART FROM THE MARK AS SHOWN.

SEC. 2(F).

FOR INSURANCE CONSULTATION; INSURANCE BROKERAGE; FINANCIAL CONSULTATION; INVESTMENT CONSULTATION; INVESTMENT OF FUNDS FOR OTHERS; INVESTMENT MANAGEMENT; MUTUAL FUND INVESTMENT (U.S. CLS. 100, 101 AND 102).

FIRST USE 7-1-1996; IN COMMERCE 7-1-1996.

DORITT L. CARROLL, EXAMINING ATTORNEY

SN 85-041,574. UNITED SERVICES AUTOMOBILE ASSOCIATION, SAN ANTONIO, TX. FILED 5-18-2010.

THE HOME CIRCLE

THE MARK CONSISTS OF STANDARD CHARACTERS WITHOUT CLAIM TO ANY PARTICULAR FONT, STYLE, SIZE, OR COLOR.

NO CLAIM IS MADE TO THE EXCLUSIVE RIGHT TO USE "HOME", APART FROM THE MARK AS SHOWN.

FOR REAL ESTATE SERVICES, NAMELY, AGENCY SERVICES (U.S. CLS. 100, 101 AND 102).

FIRST USE 3-0-2005; IN COMMERCE 3-0-2005.

DAVID HOFFMAN, EXAMINING ATTORNEY

**CLASS 36—(Continued).**

SN 85-041,980. FREEWAY INSURANCE SERVICES, INC., CYPRESS, CA. FILED 5-18-2010.



OWNER OF U.S. REG. NOS. 3,448,643 AND 3,591,103.

NO CLAIM IS MADE TO THE EXCLUSIVE RIGHT TO USE "INSURANCE", APART FROM THE MARK AS SHOWN.

THE COLOR(S) BLUE, GREEN AND WHITE IS/ARE CLAIMED AS A FEATURE OF THE MARK.

THE MARK CONSISTS OF THE STYLIZED WORD "FREEWAY" IN BLUE. THE WORD "INSURANCE" APPEARS IN GREEN BELOW. TO THE LEFT IS A GREEN GLOBE WITH A VIEW OF A BLUE HIGHWAY, INCLUDING A WHITE LANE DIVIDER.

FOR INSURANCE AGENCY AND BROKERAGE; INSURANCE CONSULTATION; INSURANCE PREMIUM RATE COMPUTING; INSURANCE SERVICES, NAMELY, WRITING PROPERTY AND CASUALTY INSURANCE; INSURANCE UNDERWRITING IN THE FIELD OF AUTOMOBILE, PROPERTY, LIFE AND HEALTH INSURANCE (U.S. CLS. 100, 101 AND 102).

FIRST USE 6-0-2009; IN COMMERCE 10-0-2009.

KATHERINE CHANG, EXAMINING ATTORNEY

SN 85-043,051. NHB HOLDINGS, INC., JACKSONVILLE, FL. FILED 5-19-2010.



FOR PROVIDING BANKING SERVICES, ELECTRONIC BANKING SERVICES, MORTGAGE LOAN SERVICES, MORTGAGE BANKING SERVICES, MORTGAGE ADMINISTRATIVE SERVICES, NAMELY, MORTGAGE PROCUREMENT FOR OTHERS, HOME LOAN SERVICES, NAMELY, MORTGAGE LENDING SERVICES, HOME EQUITY LOAN SERVICES, SECOND HOME MORTGAGE SERVICES, NAMELY, PROVIDING SECOND HOME MORTGAGES, CONSUMER LOAN SERVICES, COMMERCIAL LOAN SERVICES, LOAN APPROVAL SERVICES IN THE FIELDS OF CONSUMER LOANS, COMMERCIAL LOANS AND MORTGAGE LOANS, DEPOSIT ACCOUNT SERVICES, NAMELY, CERTIFICATE OF DEPOSIT ACCOUNT SERVICES, BANKING ACCOUNT SERVICES, NAMELY, PROVIDING BANK ACCOUNT INFORMATION BY TELEPHONE, SAVINGS ACCOUNT SERVICES, CHECKING ACCOUNT SERVICES, AND AUTOMATED CASH MANAGEMENT ACCOUNT SERVICES THAT PERMIT CUSTOMER ACCESS TO BANK ACCOUNT INFORMATION AND ACCOUNT BALANCES THROUGH PERSONAL COMPUTERS OR ELECTRONIC TERMINALS; AND PROVIDING ONLINE INFORMATION, DATA, INSTRUCTIONS, NAMELY, FINANCIAL ADVICE, COM-

**CLASS 36—(Continued).**

MENTARY IN THE NATURE OF FINANCIAL INFORMATION, FINANCIAL INFORMATION IN THE NATURE OF CHECKING AND SAVINGS ACCOUNT BALANCES AND TRANSACTIONS AND FINANCIAL REPORTS, IN THE FIELDS OF BANKING, ELECTRONIC BANKING, MONEY LENDING, MORTGAGES, MORTGAGE LOANS, MORTGAGE BANKING, MORTGAGE ADMINISTRATION IN THE NATURE OF MORTGAGE PROCUREMENT, HOME LOANS IN THE NATURE OF MORTGAGE LENDING, HOME EQUITY LOANS, SECOND HOME MORTGAGES, CONSUMER LOANS, COMMERCIAL LOANS, LOAN APPROVALS IN THE FIELDS OF CONSUMER LOANS, COMMERCIAL LOANS AND MORTGAGE LOANS, CERTIFICATE OF DEPOSIT ACCOUNTS, SAVINGS ACCOUNTS, CHECKING ACCOUNTS, CERTIFICATES OF DEPOSIT, AND AUTOMATED CASH MANAGEMENT ACCOUNTS THAT PERMIT CUSTOMER ACCESS TO BANK ACCOUNT INFORMATION AND ACCOUNT BALANCES THROUGH PERSONAL COMPUTERS OR ELECTRONIC TERMINALS (U.S. CLS. 100, 101 AND 102).

FIRST USE 3-31-2007; IN COMMERCE 3-31-2007.  
SIMON TENG, EXAMINING ATTORNEY

---

SN 85-047,051. CENTRE GROUP HOLDINGS LIMITED, PEMBROKE, BERMUDA, FILED 5-25-2010.

**CENTRE INSURANCE COMPANY**

THE MARK CONSISTS OF STANDARD CHARACTERS WITHOUT CLAIM TO ANY PARTICULAR FONT, STYLE, SIZE, OR COLOR.

OWNER OF U.S. REG. NO. 2,344,490.

NO CLAIM IS MADE TO THE EXCLUSIVE RIGHT TO USE "INSURANCE COMPANY", APART FROM THE MARK AS SHOWN.

FOR INSURANCE UNDERWRITING SERVICES IN FIELDS OF PROPERTY AND CASUALTY AND REINSURANCE (U.S. CLS. 100, 101 AND 102).

FIRST USE 0-0-1988; IN COMMERCE 0-0-1988.  
KATHY DE JONGE, EXAMINING ATTORNEY

---

SN 85-047,054. CENTRE GROUP HOLDINGS LIMITED, PEMBROKE, BERMUDA, FILED 5-25-2010.

**CENTRE**

THE MARK CONSISTS OF STANDARD CHARACTERS WITHOUT CLAIM TO ANY PARTICULAR FONT, STYLE, SIZE, OR COLOR.

OWNER OF U.S. REG. NO. 2,344,490.

FOR INSURANCE UNDERWRITING SERVICES IN THE FIELDS OF PROPERTY AND CASUALTY, LIFE, SURETY AND REINSURANCE (U.S. CLS. 100, 101 AND 102).

FIRST USE 0-0-1988; IN COMMERCE 0-0-1988.  
KATHY DE JONGE, EXAMINING ATTORNEY

**CLASS 36—(Continued).**

SN 85-048,183. KC LOUIS WOODROW INC., WILDOMAR, CA. FILED 5-26-2010.

**UNIVERSE'S UGLIEST DOG**

THE MARK CONSISTS OF STANDARD CHARACTERS WITHOUT CLAIM TO ANY PARTICULAR FONT, STYLE, SIZE, OR COLOR.

NO CLAIM IS MADE TO THE EXCLUSIVE RIGHT TO USE "UGLIEST DOG", APART FROM THE MARK AS SHOWN.

FOR CHARITABLE SERVICES, NAMELY, ORGANIZING FUNDRAISING SERVICES AND EVENTS TO RAISE FUNDS IN THE FIELD OF ANIMAL RESCUE AND ADOPTION BY PROVIDING ENTERTAINMENT IN THE NATURE OF A REVIEW AND COMPETITION RELATED TO THE APPEARANCE AND PERSONALITIES OF DOGS AND THEIR OWNERS (U.S. CLS. 100, 101 AND 102).

APRIL HESIK, EXAMINING ATTORNEY

---

SN 85-060,603. IPM INFORMED PORTFOLIO MANAGEMENT AB, STOCKHOLM, SWEDEN, FILED 6-11-2010.

**GDRA**

THE MARK CONSISTS OF STANDARD CHARACTERS WITHOUT CLAIM TO ANY PARTICULAR FONT, STYLE, SIZE, OR COLOR.

FOR MUTUAL FUND MANAGEMENT; CAPITAL INVESTMENT; FUNDS INVESTMENT AND FINANCIAL MANAGEMENT (U.S. CLS. 100, 101 AND 102).

DAVID C. REIHNER, EXAMINING ATTORNEY

**CLASS 36—(Continued).**

SN 85-063,165. BEACH BUSINESS BANK, MANHATTAN BEACH, CA. FILED 6-15-2010.

**BEACH BUSINESS BANK**

THE MARK CONSISTS OF STANDARD CHARACTERS WITHOUT CLAIM TO ANY PARTICULAR FONT, STYLE, SIZE, OR COLOR.

NO CLAIM IS MADE TO THE EXCLUSIVE RIGHT TO USE "BUSINESS BANK", APART FROM THE MARK AS SHOWN.

SEC. 2(F).

FOR BANKING SERVICES; AND FINANCIAL SERVICES, NAMELY, PROVIDING FINANCIAL ANALYSIS, CONSULTATION, PLANNING AND MANAGEMENT, COMMERCIAL AND CONSUMER LENDING AND LEASE-PURCHASE FINANCING SERVICES; MORTGAGE LENDING, AND LOAN FINANCING; CREDIT CARD SERVICES; DEBIT CARD SERVICES; ELECTRONIC PAYMENT, NAMELY, ELECTRONIC PROCESSING AND TRANSMISSION OF BILL PAYMENT DATA; FINANCIAL INFORMATION IN THE NATURE OF RATES OF EXCHANGE; CASH MANAGEMENT; MORTGAGE BANKING; SAVINGS ACCOUNT SERVICES; PROVIDING EDUCATIONAL AND COLLEGE LOANS; AUTOMATED TELLER MACHINE SERVICES; INVESTMENT SERVICES, NAMELY, PROVIDING INVESTMENT ANALYSIS, CONSULTATION, PLANNING, BANKING, AND RESEARCH SERVICES WITH RESPECT TO BONDS; AND PROVIDING BANKING, AND FINANCIAL, CONSULTATION AND INFORMATION VIA GLOBAL COMPUTER NETWORKS, INTERNAL COMPUTER INFORMATION NETWORKS AND TELECOMMUNICATION NETWORKS; AND PROVIDING INTERACTIVE BANKING, FINANCIAL CONSULTATION AND INFORMATION VIA GLOBAL COMPUTER NETWORKS, INTERNAL COMPUTER INFORMATION NETWORKS AND TELECOMMUNICATION NETWORKS; PROVIDING INFORMATION ON INTERNATIONAL FINANCE AND FOREIGN EXCHANGE RATES VIA GLOBAL COMPUTER NETWORKS, INTERNAL COMPUTER INFORMATION NETWORKS AND TELECOMMUNICATION NETWORKS FOR ELECTRONIC, TELEPHONIC AND TELEFACSIMILE TRANSMISSION (U.S. CLS. 100, 101 AND 102).

FIRST USE 6-1-2004; IN COMMERCE 6-1-2004.

JESSICA A. POWERS, EXAMINING ATTORNEY

SN 85-068,615. TORRENT TECHNOLOGIES, INC., KALISPELL, MT. FILED 6-22-2010.

**TorrentClaims**

THE MARK CONSISTS OF STANDARD CHARACTERS WITHOUT CLAIM TO ANY PARTICULAR FONT, STYLE, SIZE, OR COLOR.

FOR ELECTRONIC PROCESSING OF INSURANCE CLAIMS AND PAYMENT DATA (U.S. CLS. 100, 101 AND 102).

FIRST USE 12-25-2007; IN COMMERCE 12-25-2007.

EDWARD NELSON, EXAMINING ATTORNEY

**CLASS 36—(Continued).**

SN 85-071,949. ITAÚ UNIBANCO HOLDING S.A., SÃO PAULO, BRAZIL, FILED 6-25-2010.



OWNER OF U.S. REG. NOS. 1,198,257, 2,677,383 AND OTHERS.

THE COLOR(S) BLUE AND YELLOW IS/ARE CLAIMED AS A FEATURE OF THE MARK.

THE MARK CONSISTS OF A BLUE RECTANGLE WITH ROUNDED EDGES WITH THE YELLOW STYLIZED WORD "ITAÚ" PLACED IN THE LOWER HALF OF THE RECTANGLE AND THE BLUE STYLIZED LETTERS "BBA" TO THE RIGHT OF THE RECTANGLE.

THE ENGLISH TRANSLATION OF "ITAÚ" IN THE MARK IS "BLACK STONES".

FOR BROKERAGE IN THE FIELDS OF FINANCIAL INVESTMENTS, CAPITAL INVESTMENTS, SECURITIES, STOCKS, BONDS, DERIVATIVES, OPTIONS AND FUTURES; CAPITAL INVESTMENT SERVICES; SECURITIES BROKERAGE; STOCK EXCHANGE QUOTATIONS; STOCKS AND BONDS BROKERAGE; FINANCIAL INVESTMENT RESEARCH; FINANCIAL INFORMATION; FINANCIAL SERVICES, NAMELY, THE TRADING OF DERIVATIVES, OPTIONS, FUTURES AND COMMODITIES CONTRACTS (U.S. CLS. 100, 101 AND 102).

MARC LEIPZIG, EXAMINING ATTORNEY

SN 85-071,971. ITAÚ UNIBANCO HOLDING S.A., SÃO PAULO, BRAZIL, FILED 6-25-2010.

**ITAÚ BBA**

THE MARK CONSISTS OF STANDARD CHARACTERS WITHOUT CLAIM TO ANY PARTICULAR FONT, STYLE, SIZE, OR COLOR.

OWNER OF U.S. REG. NOS. 1,198,257, 2,677,383 AND OTHERS.

THE ENGLISH TRANSLATION OF "ITAÚ" IN THE MARK IS "BLACK STONES".

FOR BROKERAGE IN THE FIELDS OF FINANCIAL INVESTMENTS, CAPITAL INVESTMENTS, SECURITIES, STOCKS, BONDS, DERIVATIVES, OPTIONS AND FUTURES; CAPITAL INVESTMENT SERVICES; SECURITIES BROKERAGE; STOCK EXCHANGE QUOTATIONS; STOCKS AND BONDS BROKERAGE; FINANCIAL INVESTMENT RESEARCH; FINANCIAL INFORMATION; FINANCIAL SERVICES, NAMELY, THE TRADING OF DERIVATIVES, OPTIONS, FUTURES AND COMMODITIES CONTRACTS (U.S. CLS. 100, 101 AND 102).

MARC LEIPZIG, EXAMINING ATTORNEY

**CLASS 36—(Continued).**

SN 85-072,081. ITAÚ UNIBANCO HOLDING S.A., SÃO PAULO, BRAZIL, FILED 6-25-2010.



OWNER OF U.S. REG. NOS. 1,198,257, 2,677,383 AND OTHERS.

THE MARK CONSISTS OF A SHADED RECTANGLE WITH ROUNDED EDGES WITH THE STYLIZED WORD "ITAÚ" PLACED IN THE LOWER HALF OF THE RECTANGLE AND THE STYLIZED LETTERS "BBA" TO THE RIGHT OF THE RECTANGLE.

THE ENGLISH TRANSLATION OF "ITAÚ" IN THE MARK IS "BLACK STONES".

FOR BROKERAGE IN THE FIELDS OF FINANCIAL INVESTMENTS, CAPITAL INVESTMENTS, SECURITIES, STOCKS, BONDS, DERIVATIVES, OPTIONS AND FUTURES; CAPITAL INVESTMENT SERVICES; SECURITIES BROKERAGE; STOCK EXCHANGE QUOTATIONS; STOCKS AND BONDS BROKERAGE; FINANCIAL INVESTMENT RESEARCH; FINANCIAL INFORMATION; FINANCIAL SERVICES, NAMELY, THE TRADING OF DERIVATIVES, OPTIONS, FUTURES AND COMMODITIES CONTRACTS (U.S. CLS. 100, 101 AND 102).

MARC LEIPZIG, EXAMINING ATTORNEY

SN 85-078,563. MARSHALL & ILSLEY CORPORATION, MILWAUKEE, WI. FILED 7-6-2010.

# MIFORCE

THE MARK CONSISTS OF STANDARD CHARACTERS WITHOUT CLAIM TO ANY PARTICULAR FONT, STYLE, SIZE, OR COLOR.

FOR BANKING AND FINANCIAL SERVICES, NAMELY, CREDIT CARD SERVICES; MORTGAGE LENDING AND HOME EQUITY LOANS; BUSINESS LOANS; LOAN FINANCING, SECURED AND UNSECURED INSTALLMENT LOANS; BANKING SERVICES, NAMELY, CERTIFICATE OF DEPOSIT, INDIVIDUAL RETIREMENT ACCOUNT, MONEY MARKET, AND CHECKING ACCOUNT SERVICES; INVESTMENT SERVICES, NAMELY, INVESTMENT BROKERAGE INCLUDING STOCKS, BONDS AND MUTUAL FUNDS; RETIREMENT PLANNING, NAMELY, FINANCIAL PLANNING FOR RETIREMENT; TRUST SERVICES, NAMELY, TRUST MANAGEMENT SERVICES, INVESTMENT AND TRUST COMPANY SERVICES, ESTATE TRUST MANAGEMENT, FINANCIAL TRUST OPERATIONS; AND MANAGEMENT OF MUTUAL FUNDS; ONLINE BANKING AND FINANCIAL SERVICES, NAMELY, ON-LINE TRADING OF FINANCIAL INSTRUMENTS, SHARES, OPTIONS AND OTHER DERIVATIVE PRODUCTS, ON-LINE FINANCIAL PLANNING SERVICES; FINANCIAL PLANNING, FINANCIAL PORTFOLIO MANAGEMENT, FINANCIAL FORECASTING, FINANCIAL ANALYSIS AND CONSULTATION (U.S. CLS. 100, 101 AND 102).

ALICE BENMAMAN, EXAMINING ATTORNEY

**CLASS 36—(Continued).**

SN 85-082,234. IRONSHORE INC., GEORGE TOWN, CAYMAN ISLANDS, FILED 7-12-2010.

## IRONSHORE VACANCYASSURE

THE MARK CONSISTS OF STANDARD CHARACTERS WITHOUT CLAIM TO ANY PARTICULAR FONT, STYLE, SIZE, OR COLOR.

OWNER OF U.S. REG. NOS. 3,340,749, 3,791,377 AND OTHERS.

FOR INSURANCE UNDERWRITING SERVICES IN THE FIELDS OF PROPERTY AND ENVIRONMENTAL PROPERTY (U.S. CLS. 100, 101 AND 102).

STEVEN R. FINE, EXAMINING ATTORNEY

SN 85-113,644. ROYAL BANK OF CANADA, MONTREAL, CANADA, FILED 8-23-2010.

# THOR

THE MARK CONSISTS OF STANDARD CHARACTERS WITHOUT CLAIM TO ANY PARTICULAR FONT, STYLE, SIZE, OR COLOR.

FOR FINANCIAL SERVICES, NAMELY, SECURITIES TRADE EXECUTION SERVICES; AND FINANCIAL SERVICES, NAMELY, ASSISTING OTHERS WITH ELECTRONIC TRADING OF SECURITIES (U.S. CLS. 100, 101 AND 102).

FIRST USE 12-0-2009; IN COMMERCE 12-0-2009.

VERNA BETH RIRIE, EXAMINING ATTORNEY

SN 85-115,653. SOLID GROUP, LLC, RALEIGH, NC. FILED 8-25-2010.

## CYBER-CASHIER

THE MARK CONSISTS OF STANDARD CHARACTERS WITHOUT CLAIM TO ANY PARTICULAR FONT, STYLE, SIZE, OR COLOR.

FOR ON-LINE CASH ACCOUNT SERVICES (U.S. CLS. 100, 101 AND 102).

FIRST USE 12-10-2005; IN COMMERCE 8-11-2010.

PAUL MORENO, EXAMINING ATTORNEY



**CLASS 36—(Continued).**

SN 85-117,583. MPC PROPERTIES, LLC, JACKSON HEIGHTS, NY. FILED 8-27-2010.



NO CLAIM IS MADE TO THE EXCLUSIVE RIGHT TO USE "FRACTIONS", APART FROM THE MARK AS SHOWN.

THE MARK CONSISTS OF A RECTANGLE CONTAINING THE WORDS "FRACTIONS TO GO" WITH THE "I" IN "FRACTIONS" BEING A NUMBER "1". TO THE RIGHT IS AN ARROW WITH BROKEN SQUARES AS THE SHAFT.

FOR ASSESSMENT AND MANAGEMENT OF REAL ESTATE; FINANCIAL INVESTMENT IN THE FIELD OF REAL ESTATE; FINANCIAL VALUATION OF REAL ESTATE; LEASING OF REAL ESTATE; OPERATING ONLINE MARKETPLACES FOR SELLERS OF GOODS AND/OR SERVICES IN CONNECTION WITH REAL ESTATE; PROVIDING INFORMATION IN THE FIELD OF REAL ESTATE BY MEANS OF LINKING THE WEB SITE TO OTHER WEB SITES FEATURING REAL ESTATE INFORMATION; REAL ESTATE ACQUISITION SERVICES; REAL ESTATE AGENCIES; REAL ESTATE BROKERAGE; REAL ESTATE CONSULTATION; REAL ESTATE EQUITY SHARING, NAMELY, MANAGING AND ARRANGING FOR CO-OWNERSHIP OF REAL ESTATE; REAL ESTATE INVESTMENT; REAL ESTATE LISTING; REAL ESTATE MANAGEMENT; REAL ESTATE MANAGEMENT CONSULTATION; REAL ESTATE PROCUREMENT FOR OTHERS; REAL ESTATE SYNDICATION; REAL ESTATE VALUATION SERVICES; OFFERING FRACTIONAL OWNERSHIP PROGRAMS TO OTHERS IN THE FIELD OF AIRCRAFT, AUTOMOBILES, AND GOLF CLUB MEMBERSHIPS (U.S. CLS. 100, 101 AND 102).

LINDA MICKLEBURGH, EXAMINING ATTORNEY

SN 85-125,509. STONEHOUSE, SUSAN, FORMERLY BUNKO FOR BREAST CANCER, SANTA ROSA VALLEY, CA. AND MACCALLUM, PAMELA R., FORMERLY BUNKO FOR BREAST CANCER, CAMARILLO, CA. FILED 9-9-2010.

## Rolling for Pink

THE MARK CONSISTS OF STANDARD CHARACTERS WITHOUT CLAIM TO ANY PARTICULAR FONT, STYLE, SIZE, OR COLOR.

FOR CHARITABLE FUNDRAISING SERVICES BY MEANS OF ORGANIZING AND CONDUCTING SPECIAL EVENTS; CHARITABLE SERVICES, NAMELY, ORGANIZING FUNDRAISING SERVICES AND EVENTS TO RAISE FUNDS IN THE FIELD OF BREAST CANCER RESEARCH (U.S. CLS. 100, 101 AND 102).

MARTHA SANTOMARTINO, EXAMINING ATTORNEY

**CLASS 36—(Continued).**

SN 85-125,623. CITYWIDE MEDIA INC., LONG ISLAND CITY, NY. FILED 9-9-2010.



NO CLAIM IS MADE TO THE EXCLUSIVE RIGHT TO USE "SEARCH" AND "MULTIPLE LISTING SERVICE EXPRESS", APART FROM THE MARK AS SHOWN.

THE MARK CONSISTS OF THE WORDING "MLSEXP" WITH THE WORD "SEARCH" INSIDE OF A MAGNIFYING GLASS ".COM" AND UNDERNEATH THE WORDING AND DESIGN IS THE WORDING "MULTIPLE LISTING SERVICE EXPRESS".

FOR PROVIDING REAL ESTATE LISTINGS AND REAL ESTATE INFORMATION VIA THE INTERNET; PROVIDING REAL ESTATE LISTINGS VIA THE INTERNET; REAL ESTATE LISTING; REAL ESTATE MULTIPLE LISTING SERVICES (U.S. CLS. 100, 101 AND 102).

FIRST USE 8-5-2010; IN COMMERCE 8-5-2010.

REGINA DRUMMOND, EXAMINING ATTORNEY

SN 85-126,151. MARRIOTT INTERNATIONAL, INC., BETHESDA, MD. FILED 9-9-2010.

## FIND YOUR WORLD

THE MARK CONSISTS OF STANDARD CHARACTERS WITHOUT CLAIM TO ANY PARTICULAR FONT, STYLE, SIZE, OR COLOR.

FOR REAL ESTATE SERVICES, NAMELY, LISTING, LEASING, MANAGEMENT, RENTAL, AND BROKERAGE OF RESIDENTIAL PROPERTIES AND TIMESHARE PROPERTIES; REAL ESTATE TIMESHARING; REAL ESTATE FINANCING; VACATION REAL ESTATE TIMESHARE EXCHANGE SERVICES (U.S. CLS. 100, 101 AND 102).

REBECCA POVARCHUK, EXAMINING ATTORNEY

SN 85-126,190. IMAGINATION HOLDINGS, LLC, LAS VEGAS, NV. FILED 9-9-2010.

## LIVE HERE EAT FREE

THE MARK CONSISTS OF STANDARD CHARACTERS WITHOUT CLAIM TO ANY PARTICULAR FONT, STYLE, SIZE, OR COLOR.

FOR LEASING OF APARTMENTS AND APARTMENT HOUSE MANAGEMENT (U.S. CLS. 100, 101 AND 102).

FIRST USE 8-0-2008; IN COMMERCE 8-0-2008.

JOSETTE BEVERLY, EXAMINING ATTORNEY

**CLASS 36—(Continued).**

SN 85-127,317. BLOOM HEALTH CORPORATION, MINNEAPOLIS, MN. FILED 9-10-2010.

**OUR HELP. YOUR BENEFIT.**

THE MARK CONSISTS OF STANDARD CHARACTERS WITHOUT CLAIM TO ANY PARTICULAR FONT, STYLE, SIZE, OR COLOR.

FOR CONSULTING SERVICES, NAMELY, PROVIDING CUSTOMIZED GUIDANCE AND INFORMATION ABOUT INSURANCE TO HELP INDIVIDUALS SELECT AND OBTAIN HEALTH INSURANCE COVERAGE; CONSULTING SERVICES, NAMELY, PROVIDING FINANCIAL GUIDANCE TO EMPLOYERS ON THE AMOUNT OF DOLLARS TO ALLOCATE TO EMPLOYEE PERSONAL HEALTH ACCOUNTS FOR SPENDING ON HEALTH INSURANCE COVERAGE; OFFERING AND ADMINISTERING PERSONAL HEALTH ACCOUNTS; PROVIDING INFORMATION VIA THE INTERNET, NAMELY, DESCRIPTION OF HEALTH CARE PLANS, HEALTH CARE BENEFITS, AND EMPLOYEE WELFARE BENEFIT PLANS (U.S. CLS. 100, 101 AND 102).

SIMON TENG, EXAMINING ATTORNEY

---

SN 85-131,329. EASTERN BANK, BOSTON, MA. FILED 9-16-2010.

**EASTERN OFFICECONNECT**

THE MARK CONSISTS OF STANDARD CHARACTERS WITHOUT CLAIM TO ANY PARTICULAR FONT, STYLE, SIZE, OR COLOR.

OWNER OF U.S. REG. NOS. 2,272,297, 3,578,129 AND OTHERS.

FOR PROVIDING FINANCIAL INFORMATION BY ELECTRONIC MEANS; PROVIDING BANKING SERVICES VIA GLOBAL COMPUTER NETWORK (U.S. CLS. 100, 101 AND 102).

DARRYL SPRUILL, EXAMINING ATTORNEY

**CLASS 36—(Continued).**

SN 85-142,752. ANONYMOUS HOME, LLC, DRIPPING SPRINGS, TX. FILED 10-1-2010.

**VANDERPAL METHOD**

THE MARK CONSISTS OF STANDARD CHARACTERS WITHOUT CLAIM TO ANY PARTICULAR FONT, STYLE, SIZE, OR COLOR.

OWNER OF U.S. REG. NO. 3,856,738.

NO CLAIM IS MADE TO THE EXCLUSIVE RIGHT TO USE "METHOD", APART FROM THE MARK AS SHOWN.

FOR FUNDS INVESTMENT; HEDGE FUND INVESTMENT SERVICES; INVESTMENT ADVICE; INVESTMENT ADVISORY SERVICES; INVESTMENT BROKERAGE; INVESTMENT BY ELECTRONIC MEANS; INVESTMENT CONSULTANCY; INVESTMENT MANAGEMENT; INVESTMENT OF FUNDS FOR OTHERS; PROVIDING FINANCIAL SERVICES WITH RESPECT TO SECURITIES AND OTHER FINANCIAL INSTRUMENTS AND PRODUCTS, NAMELY, TRADING OF AND INVESTMENTS IN SECURITIES AND FINANCIAL INSTRUMENTS AND PRODUCTS FOR OTHERS (U.S. CLS. 100, 101 AND 102).

FIRST USE 5-1-2010; IN COMMERCE 5-1-2010.

LAURA HAMMEL, EXAMINING ATTORNEY

---

SN 85-146,503. BELLESTAR PARTNERS, LLC, BOCA RATON, FL. FILED 10-6-2010.

**AMERICAN REBOUND**

THE MARK CONSISTS OF STANDARD CHARACTERS WITHOUT CLAIM TO ANY PARTICULAR FONT, STYLE, SIZE, OR COLOR.

NO CLAIM IS MADE TO THE EXCLUSIVE RIGHT TO USE "AMERICAN", APART FROM THE MARK AS SHOWN.

FOR INVESTMENT SERVICES, NAMELY, PURCHASES OF MORTGAGES ON REAL ESTATE; INVESTMENT FUND SERVICES, NAMELY, OPERATING A FUND OWNING AND OPERATING REAL ESTATE ON WHICH IT HAS FORECLOSED; REAL ESTATE MANAGEMENT (U.S. CLS. 100, 101 AND 102).

FIRST USE 4-30-2009; IN COMMERCE 4-30-2009.

CAROLYN CATALDO, EXAMINING ATTORNEY

**CLASS 36—(Continued).**

SN 85-146,675. HERBERT J. SIMS & CO. INC., SOUTHPORT, CT. FILED 10-6-2010.

**THE OUTCOME IS INCOME**

THE MARK CONSISTS OF STANDARD CHARACTERS WITHOUT CLAIM TO ANY PARTICULAR FONT, STYLE, SIZE, OR COLOR.

NO CLAIM IS MADE TO THE EXCLUSIVE RIGHT TO USE "INCOME", APART FROM THE MARK AS SHOWN.

FOR BROKERAGE OF BONDS; BROKERAGE SERVICES FOR STOCKS AND BONDS; BROKERAGE SERVICES FOR CAPITAL INVESTMENTS; BROKERAGE SERVICES IN THE FIELD OF SECURITIES AND COMMODITIES INVESTING; COMMODITY BROKERAGE; FINANCIAL AND INVESTMENT SERVICES, NAMELY, MANAGEMENT AND BROKERAGE IN THE FIELDS OF STOCKS, BONDS, OPTIONS, COMMODITIES, FUTURES AND OTHER SECURITIES, AND THE INVESTMENT OF FUNDS OF OTHERS; FINANCIAL INVESTMENT BROKERAGE SERVICES; INVESTMENT BROKERAGE; SECURITIES BROKERAGE SERVICES; DERIVATIVES BROKERAGE (U.S. CLS. 100, 101 AND 102).

TINA MAI, EXAMINING ATTORNEY

SN 85-148,455. KEYCORP, CLEVELAND, OH. FILED 10-8-2010.



NO CLAIM IS MADE TO THE EXCLUSIVE RIGHT TO USE "FINANCE", APART FROM THE MARK AS SHOWN.

THE COLOR(S) RED IS/ARE CLAIMED AS A FEATURE OF THE MARK.

THE MARK CONSISTS OF 4 INTERLOCKING SOLID DISKS DESIGNED TO FORM A CLOVER SHAPE, WITH A GEOMETRIC SHAPE IN THE CENTER. THE WORDS "YOUR KEY" ARE IN THE CENTER. THE PHRASES "SAFEGUARD SAFEGUARD YOUR BUSINESS.", "FINANCE FINANCE YOUR FUTURE.", "PLAN PLAN PERSONAL AND EMPLOYEE FINANCES." AND "MANAGE MANAGE YOUR CASH." ARE PLACED SO THAT ONE OF THE PHRASES APPEARS IN EACH OF THE INTERLOCKING DISKS.

FOR BANKING AND FINANCING SERVICES (U.S. CLS. 100, 101 AND 102).

KIMBERLY PERRY, EXAMINING ATTORNEY

**CLASS 36—(Continued).**

SN 85-149,649. HUMANA INC., LOUISVILLE, KY. FILED 10-11-2010.

**HUMANA VOLUNTARY INSURANCE PARTNERS**

THE MARK CONSISTS OF STANDARD CHARACTERS WITHOUT CLAIM TO ANY PARTICULAR FONT, STYLE, SIZE, OR COLOR.

OWNER OF U.S. REG. NOS. 3,565,877, 3,565,878 AND OTHERS.

NO CLAIM IS MADE TO THE EXCLUSIVE RIGHT TO USE "VOLUNTARY INSURANCE PARTNERS", APART FROM THE MARK AS SHOWN.

FOR BROKERAGE IN THE FIELD OF INSURANCE; INSURANCE ADMINISTRATION; INSURANCE AGENCIES; INSURANCE ADVICE AND CONSULTANCY SERVICES; INSURANCE AGENCY AND BROKERAGE SERVICES FOR ALL TYPES OF INSURANCE; INSURANCE BROKERAGE AND INSURANCE ADMINISTRATION SERVICES IN THE FIELDS OF SUPPLEMENTAL HEALTH, LIFE, DENTAL, LEGAL AND DISABILITY INSURANCE FOR EMPLOYER GROUPS AND INDIVIDUALS; INSURANCE UNDERWRITING IN THE FIELD OF SUPPLEMENTAL HEALTH, LIFE, DENTAL, LEGAL AND DISABILITY INSURANCE; BROKERAGE IN THE FIELD OF SUPPLEMENTAL HEALTH INSURANCE, LIFE, DENTAL, LEGAL AND DISABILITY INSURANCE; INSURANCE CLAIMS PROCESSING AND INSURANCE CLAIMS ADMINISTRATION (U.S. CLS. 100, 101 AND 102).

SARA BENJAMIN, EXAMINING ATTORNEY

SN 85-156,711. APARTMENT RENTAL EXPERTS LLC, CAMBRIDGE, MA. FILED 10-20-2010.

**APARTMENT RENTAL EXPERTS  
THE EASY WAY HOME**

THE MARK CONSISTS OF STANDARD CHARACTERS WITHOUT CLAIM TO ANY PARTICULAR FONT, STYLE, SIZE, OR COLOR.

OWNER OF U.S. REG. NO. 3,131,466.

NO CLAIM IS MADE TO THE EXCLUSIVE RIGHT TO USE "APARTMENT RENTAL EXPERTS", APART FROM THE MARK AS SHOWN.

FOR REAL ESTATE LISTING SERVICES FOR HOUSING RENTALS AND APARTMENT RENTALS (U.S. CLS. 100, 101 AND 102).

FIRST USE 1-1-2010; IN COMMERCE 1-1-2010.

NAKWAMA ANKRAH, EXAMINING ATTORNEY

**CLASS 36—(Continued).**

SN 85-157,909. CHRISTOPHER A. WUHRER, ALEXANDRIA, VA. FILED 10-21-2010.

# SwipePay

THE MARK CONSISTS OF STANDARD CHARACTERS WITHOUT CLAIM TO ANY PARTICULAR FONT, STYLE, SIZE, OR COLOR.

FOR PREPAID CARD SERVICES IN THE NATURE OF MAKING PAYMENT FOR ADDING AIRTIME TO PREPAID OR PAY-AS-YOU-GO WIRELESS SERVICES (U.S. CLS. 100, 101 AND 102).

FIRST USE 5-1-2008; IN COMMERCE 3-1-2009.  
JOHN E. MICHOS, EXAMINING ATTORNEY

**CLASS 36—(Continued).**

SN 85-163,521. DOUTHITT, JEANIE KAY, PLANO, TX. FILED 10-28-2010.

## SMART WOMEN BUY HOMES

THE MARK CONSISTS OF STANDARD CHARACTERS WITHOUT CLAIM TO ANY PARTICULAR FONT, STYLE, SIZE, OR COLOR.

NO CLAIM IS MADE TO THE EXCLUSIVE RIGHT TO USE "WOMEN BUY HOMES", APART FROM THE MARK AS SHOWN.

FOR REAL ESTATE SERVICES, NAMELY, REAL ESTATE LISTING AND AGENCY SERVICES (U.S. CLS. 100, 101 AND 102).

FIRST USE 1-1-2010; IN COMMERCE 1-1-2010.  
APRIL ROACH, EXAMINING ATTORNEY

SN 85-164,472. PIERCE AGENCY OF PORTSMOUTH, INC., MIDDLETOWN, RI. FILED 10-29-2010.

SN 85-163,288. VERTICAL CLAIMS MANAGEMENT, LLC, PITTSBURGH, PA. FILED 10-28-2010.



OWNER OF U.S. REG. NO. 2,970,746.  
THE MARK CONSISTS OF A DARKENED SQUARE WITH TWO CURVING LINES EACH RUNNING FROM THE TOP CENTER OF THE SQUARE TO THE RESPECTIVE LOWER CORNERS OF THE SQUARE AND EACH TAPERED TO BE BROAD AT THE TOP AND NARROW AT THE BOTTOM.

FOR PROVIDING CLAIMS MANAGEMENT SERVICES TO ENTITIES IN THE ALTERNATIVE INSURANCE MARKET, NAMELY, INSURANCE CLAIMS ADMINISTRATION AND PROCESSING SERVICES (U.S. CLS. 100, 101 AND 102).

FIRST USE 10-13-2010; IN COMMERCE 10-13-2010.  
MARGARET POWER, EXAMINING ATTORNEY

## BLUEBLANKET

THE MARK CONSISTS OF STANDARD CHARACTERS WITHOUT CLAIM TO ANY PARTICULAR FONT, STYLE, SIZE, OR COLOR.

FOR INSURANCE SERVICES, NAMELY, UNDERWRITING, ISSUANCE AND ADMINISTRATION OF HOME, AUTO, RENTER, COMMERCIAL AND BOATER (U.S. CLS. 100, 101 AND 102).

FIRST USE 4-21-2010; IN COMMERCE 4-21-2010.  
DOMINIC FATHY, EXAMINING ATTORNEY

SN 85-167,036. ASPEN GROVE, INC., FREDERICK, MD. FILED 11-2-2010.

## Aspen iClient

THE MARK CONSISTS OF STANDARD CHARACTERS WITHOUT CLAIM TO ANY PARTICULAR FONT, STYLE, SIZE, OR COLOR.

OWNER OF U.S. REG. NOS. 3,422,242 AND 3,899,110.  
NO CLAIM IS MADE TO THE EXCLUSIVE RIGHT TO USE "ICLIENT", APART FROM THE MARK AS SHOWN.

FOR PROVIDING A WEB-BASED SYSTEM AND ONLINE PORTAL FOR CUSTOMERS TO VIEW AND MANAGE INFORMATION, IN THE FIELD OF REAL ESTATE (U.S. CLS. 100, 101 AND 102).

FIRST USE 3-1-2008; IN COMMERCE 3-1-2008.  
ANNE FARRELL, EXAMINING ATTORNEY

**CLASS 36—(Continued).**

SN 85-167,128. IPFS CORPORATION, KANSAS CITY, MO. FILED 11-2-2010.



NO CLAIM IS MADE TO THE EXCLUSIVE RIGHT TO USE "CREDIT CORPORATION", APART FROM THE MARK AS SHOWN.

THE COLOR(S) BLUE, LIGHT BLUE AND WHITE IS/ARE CLAIMED AS A FEATURE OF THE MARK.

THE MARK CONSISTS OF A CUBE TO THE LEFT HAND SIDE OF THE WORDS "IMPERIAL CREDIT CORPORATION", THE CUBE DISPLAYING THE LETTERS "I" "C" AND "C" ONE ON EACH EXPOSED SURFACE OF THE CUBE WITH THE LETTER "I" IN WHITE ON A BLUE FIELD ON THE LEFT SURFACE OF THE CUBE, THE LETTER "C" IN WHITE ON A LIGHT BLUE FIELD ON THE TOP SURFACE OF THE CUBE AND THE OTHER LETTER "C" AND THE WORDS "IMPERIAL CREDIT CORPORATION" IN BLUE.

FOR FINANCING OF INSURANCE PREMIUM FOR OTHERS (U.S. CLS. 100, 101 AND 102).

FIRST USE 2-19-2010; IN COMMERCE 2-19-2010.

MARK RADEMACHER, EXAMINING ATTORNEY

**CLASS 36—(Continued).**

SN 85-168,548. IQ PAYMENT SYSTEMS, DBA ALPINE PAYMENT SYSTEMS, VANCOUVER, WA. FILED 11-3-2010.



OWNER OF U.S. REG. NO. 3,802,148.

NO CLAIM IS MADE TO THE EXCLUSIVE RIGHT TO USE "PAYMENT SYSTEMS", APART FROM THE MARK AS SHOWN.

THE MARK CONSISTS OF A GLOBE WITH MERIDIAN LINES, SURROUNDED BY A SOLID THICK CIRCLE, WHICH IN TURN IS SURROUNDED BY A THIN SOLID CIRCLE. TO THE RIGHT OF THIS GLOBE ARE THE WORDS "ALPINE PAYMENT SYSTEMS". THE WORD "ALPINE" IS IN LINE WITH THE TOP OF THE GLOBE. THE WORD "PAYMENT" IS IN LINE WITH THE MIDDLE OF THE GLOBE. THE WORD "SYSTEMS" IS IN LINE WITH THE BOTTOM OF THE GLOBE.

FOR CREDIT CARD AND DEBIT CARD SERVICES; CREDIT CARD AND PAYMENT CARD SERVICES; ELECTRONIC CREDIT CARD TRANSACTIONS (U.S. CLS. 100, 101 AND 102).

FIRST USE 1-15-2008; IN COMMERCE 1-15-2008.

KEVIN CORWIN, EXAMINING ATTORNEY

SN 85-167,241. THE SUNSHINE HOUSE, INC., MADISON, CT. FILED 11-2-2010.



NO CLAIM IS MADE TO THE EXCLUSIVE RIGHT TO USE "COMFORT CARE FOR CHILDREN", APART FROM THE MARK AS SHOWN.

THE MARK CONSISTS OF THE WORDS "SUNSHINE HOUSE, COMFORT CARE FOR CHILDREN", TOGETHER WITH A STYLIZED FLOWER HAVING A FACE, A BUTTERFLY, AND HEARTS.

FOR CHARITABLE SERVICES, NAMELY, ORGANIZING FUNDRAISING SERVICES AND EVENTS TO RAISE FUNDS IN THE FIELD OF OUTREACH, PLANNING, AND CARE FOR CHILDREN WITH LIMITED LIFE EXPECTANCY AND THEIR FAMILIES (U.S. CLS. 100, 101 AND 102).

FIRST USE 7-6-2007; IN COMMERCE 7-12-2007.

DARRYL SPRUILL, EXAMINING ATTORNEY

SN 85-173,247. FIFTH STREET CAPITAL LLC, WHITE PLAINS, NY. FILED 11-10-2010.



**FIFTH STREET**

OWNER OF U.S. REG. NOS. 3,068,244, 3,667,343 AND OTHERS.

THE MARK CONSISTS OF A STYLIZED "F" DESIGN INSIDE A SQUARE APPEARING ABOVE THE WORDING "FIFTHSTREET".

FOR FINANCIAL SERVICES, NAMELY, FIRST LIEN, SECOND LIEN AND MEZZANINE FINANCING SERVICES; INVESTMENT SERVICES, NAMELY, INVESTMENT OF DEBT AND EQUITY TO SUPPORT BUSINESS EXPANSIONS, ACQUISITIONS, MANAGEMENT BUY-OUTS AND RECAPITALIZATIONS; AND INVESTMENT SERVICES, NAMELY, INVESTMENT OF DEBT AND EQUITY IN INVESTMENT VEHICLES, INCLUDING BUYOUT FUNDS (U.S. CLS. 100, 101 AND 102).

FIRST USE 11-16-2010; IN COMMERCE 11-16-2010.

KAELIE KUNG, EXAMINING ATTORNEY

**CLASS 36—(Continued).**

SN 85-173,536. MIDDLE OFFICE SOLUTIONS, L.L.C., NEW YORK, NY. FILED 11-10-2010.

**DIVIDENDSTATION**

THE MARK CONSISTS OF STANDARD CHARACTERS WITHOUT CLAIM TO ANY PARTICULAR FONT, STYLE, SIZE, OR COLOR.

FOR PROVIDING A WEBSITE FEATURING FINANCIAL INFORMATION IN THE NATURE OF POST-TRADE-DATE DATA FOR EQUITIES AND OTHER SECURITIES, AND FOR PROVIDING STATISTICAL ANALYSIS INFORMATION ON MARKET EXPOSURE AND RISK ON DIVIDENDS (U.S. CLS. 100, 101 AND 102).

MEGHAN REINHART, EXAMINING ATTORNEY



SN 85-173,772. EMERALD GATE LLC, SAN FRANCISCO, CA. FILED 11-10-2010.

**EMERALD GATE CAPITAL**

THE MARK CONSISTS OF STANDARD CHARACTERS WITHOUT CLAIM TO ANY PARTICULAR FONT, STYLE, SIZE, OR COLOR.

NO CLAIM IS MADE TO THE EXCLUSIVE RIGHT TO USE "CAPITAL", APART FROM THE MARK AS SHOWN.

FOR FINANCIAL SERVICES IN THE FIELD OF PRIVATE EQUITY INVESTMENT MANAGEMENT AND CONSULTING SERVICES RELATED THERETO (U.S. CLS. 100, 101 AND 102).

MARTHA FROMM, EXAMINING ATTORNEY



SN 85-173,781. EMERALD GATE LLC, SAN FRANCISCO, CA. FILED 11-10-2010.

**SILVER GATE CAPITAL**

THE MARK CONSISTS OF STANDARD CHARACTERS WITHOUT CLAIM TO ANY PARTICULAR FONT, STYLE, SIZE, OR COLOR.

NO CLAIM IS MADE TO THE EXCLUSIVE RIGHT TO USE "CAPITAL", APART FROM THE MARK AS SHOWN.

FOR FINANCIAL SERVICES IN THE FIELD OF PRIVATE EQUITY INVESTMENT MANAGEMENT AND CONSULTING SERVICES RELATED THERETO (U.S. CLS. 100, 101 AND 102).

MARTHA FROMM, EXAMINING ATTORNEY

**CLASS 36—(Continued).**

SN 85-173,788. EMERALD GATE LLC, SAN FRANCISCO, CA. FILED 11-10-2010.

**SAPPHIRE GATE CAPITAL**

THE MARK CONSISTS OF STANDARD CHARACTERS WITHOUT CLAIM TO ANY PARTICULAR FONT, STYLE, SIZE, OR COLOR.

NO CLAIM IS MADE TO THE EXCLUSIVE RIGHT TO USE "CAPITAL", APART FROM THE MARK AS SHOWN.

FOR FINANCIAL SERVICES IN THE FIELD OF PRIVATE EQUITY INVESTMENT MANAGEMENT AND CONSULTING SERVICES RELATED THERETO (U.S. CLS. 100, 101 AND 102).

MARTHA FROMM, EXAMINING ATTORNEY



SN 85-174,486. IPFS CORPORATION, KANSAS CITY, MO. FILED 11-11-2010.



THE COLOR(S) BLUE, LIGHT BLUE AND WHITE IS/ARE CLAIMED AS A FEATURE OF THE MARK.

THE MARK CONSISTS OF A CUBE DISPLAYING THE LETTERS "I" "C" AND "C" ONE ON EACH EXPOSED SURFACE OF THE CUBE WITH THE LETTER "I" IN WHITE ON A BLUE FIELD ON THE LEFT SURFACE OF THE CUBE, THE LETTER "C" IN WHITE ON A LIGHT BLUE FIELD ON THE TOP SURFACE OF THE CUBE AND THE OTHER LETTER "C" IN BLUE.

FOR FINANCING OF INSURANCE PREMIUMS FOR OTHERS (U.S. CLS. 100, 101 AND 102).

FIRST USE 2-17-2010; IN COMMERCE 2-17-2010.

MARK RADEMACHER, EXAMINING ATTORNEY

**CLASS 36—(Continued).**

SN 85-175,852. THE TRAVELERS INDEMNITY COMPANY, HARTFORD, CT. FILED 11-12-2010.

# Ag XTRA

THE MARK CONSISTS OF STANDARD CHARACTERS WITHOUT CLAIM TO ANY PARTICULAR FONT, STYLE, SIZE, OR COLOR.

NO CLAIM IS MADE TO THE EXCLUSIVE RIGHT TO USE "AG", APART FROM THE MARK AS SHOWN.

FOR PROPERTY AND CASUALTY INSURANCE UNDERWRITING SERVICES IN THE FIELD OF AGRICULTURE (U.S. CLS. 100, 101 AND 102).

KATINA MISTER, EXAMINING ATTORNEY

SN 85-176,500. IPFS CORPORATION, KANSAS CITY, MO. FILED 11-15-2010.



NO CLAIM IS MADE TO THE EXCLUSIVE RIGHT TO USE "PREMIUM FINANCING SPECIALISTS", APART FROM THE MARK AS SHOWN.

THE COLOR(S) BLUE AND WHITE IS/ARE CLAIMED AS A FEATURE OF THE MARK.

THE MARK CONSISTS OF A BLUE SQUARE HAVING A WHITE CURVED LINE, THE SQUARE ON THE LEFT HAND SIDE OF THE MARK WITH THE WHITE LETTERS "PFS" LOCATED THEREON AND THE BLUE WORDS "PREMIUM FINANCING" ABOVE A BLUE LINE WITH THE BLUE WORD "SPECIALISTS" BELOW THE LINE.

FOR FINANCING OF INSURANCE PREMIUMS FOR OTHERS (U.S. CLS. 100, 101 AND 102).

FIRST USE 2-1-2007; IN COMMERCE 2-1-2007.  
MARK RADEMACHER, EXAMINING ATTORNEY

SN 85-176,827. SCF SECURITIES, INC., FRESNO, CA. FILED 11-15-2010.

## Experience the diamond standard

THE MARK CONSISTS OF STANDARD CHARACTERS WITHOUT CLAIM TO ANY PARTICULAR FONT, STYLE, SIZE, OR COLOR.

FOR FINANCIAL ADVISORY AND CONSULTANCY SERVICES; FINANCIAL AND INVESTMENT SERVICES, NAMELY, MANAGEMENT AND BROKERAGE IN THE FIELDS OF STOCKS, BONDS, OPTIONS, COMMODITIES, FUTURES AND OTHER SECURITIES, AND THE INVESTMENT OF FUNDS OF OTHERS; FINANCIAL SERVICES, NAMELY, BROKER/DEALER SERVICES ON SECURITIES EXCHANGES AND OVER-THE-COUNTER MARKETS; FINANCIAL SERVICES, NAMELY, INVESTMENT ADVICE, INVESTMENT MANAGEMENT, INVESTMENT CONSULTATION AND INVESTMENT OF FUNDS FOR OTHERS, INCLUDING PRIVATE AND PUBLIC EQUITY AND DEBT INVESTMENT SERVICES (U.S. CLS. 100, 101 AND 102).

FIRST USE 11-12-2010; IN COMMERCE 11-12-2010.  
BILL DAWE, EXAMINING ATTORNEY

**CLASS 36—(Continued).**

SN 85-177,679. AMERICA INSURANCE AGENCY, INC., PHILADELPHIA, PA. FILED 11-16-2010.



THE STIPLING IS A FEATURE OF THE MARK AND DOES NOT INDICATE COLOR.

THE MARK CONSISTS OF THE WORD "AMERICA" IN STYLIZED FONT INSIDE AN UNEVEN POLYGON CARRIER CENTERED IN AN OVAL WITH A FRAME AT THE TOP OF WHICH IS AN EAGLE'S HEAD. FROM EITHER SIDE OF THE FRAME AROUND THE OVAL ARE AMERICAN FLAGS.

SEC. 2(F) AS TO "AMERICA".

FOR INSURANCE SERVICES CONSISTING OF UNDERWRITING INSURANCE POLICIES, BROKERING INSURANCE POLICIES, AND ADMINISTERING INSURANCE POLICIES, NAMELY, HOMEOWNERS, APARTMENT RENTERS, CONDOMINIUM HOMEOWNERS, FIRE, PERSONAL LIABILITY, PROFESSIONAL LIABILITY, EXCESS LIABILITY, HOMEOWNER POLICIES FOR CUSTOM DWELLINGS, FLOOD, AUTOMOBILE, DISABILITY, MEDICARE SUPPLEMENT, LONG-TERM HEALTH CARE, GROUP HEALTH INSURANCE PLANS, GROUP LIFE INSURANCE PLANS, LIFE, MORTGAGE, LONG-TERM MEDICAL CARE, TERM LIFE, UNIVERSAL LIFE, HEALTH, HOSPITALIZATION, AND MAJOR MEDICAL INSURANCE POLICIES (U.S. CLS. 100, 101 AND 102).

FIRST USE 4-12-1999; IN COMMERCE 4-12-1999.  
ELLEN PERKINS, EXAMINING ATTORNEY

SN 85-178,198. 4WARRANTY CORPORATION, ORANGE PARK, FL. FILED 11-16-2010.



NO CLAIM IS MADE TO THE EXCLUSIVE RIGHT TO USE "EXTENDED SERVICE PLAN", APART FROM THE MARK AS SHOWN.

THE MARK CONSISTS OF STYLIZED WORDS "POWER ADVANTAGE EXTENDED SERVICE PLANS" WITH THE IMAGE OF A LIGHTNING BOLT IN THE BACKGROUND. FOR PROVIDING WARRANTIES ON MOTORIZED SPORTS EQUIPMENT MANUFACTURED BY OTHERS (U.S. CLS. 100, 101 AND 102).

FIRST USE 10-0-2010; IN COMMERCE 10-0-2010.  
DOMINICK J. SALEMI, EXAMINING ATTORNEY

**CLASS 36—(Continued).**

SN 85-178,391. CLAIRENT ADVISORS LLC, BELMONT, CA. FILED 11-16-2010.



OWNER OF U.S. REG. NOS. 3,873,425 AND 3,876,600.  
NO CLAIM IS MADE TO THE EXCLUSIVE RIGHT TO USE "ADVISORS" AND "VALUATION AND TRANSACTION SPECIALISTS", APART FROM THE MARK AS SHOWN.

THE COLOR(S) DARK BLUE, BLUE, LIGHT BLUE, GRAY, BLACK, AND WHITE IS/ARE CLAIMED AS A FEATURE OF THE MARK.

THE MARK CONSISTS OF A STYLIZED LETTER "A" IN GRADIENT GRAY AND BLACK ABOVE A STYLIZED LETTER "C" IN GRADIENT DARK BLUE AND BLUE ON LEFTMOST PART OF IMAGE. THE WORD "CLAIRENT" APPEARS IN GRADIENT DARK BLUE, BLUE, AND LIGHT BLUE IN CAPITALIZED LETTERS. THE WORD "CLAIRENT" IS FOLLOWED BY THE WORD "ADVISORS" IN GRADIENT BLACK AND GRAY IN CAPITALIZED LETTERS. A SINGLE GRAY LINE IS CENTERED BELOW THE TERMS "CLAIRENTADVISORS". THE WORDING "VALUATION AND TRANSACTION SPECIALISTS" IS IN BLACK AND APPEARS UNDERNEATH THE AFOREMENTIONED GRAY LINE. THE ENTIRE DESIGN IS AGAINST A WHITE BACKGROUND.

FOR BUSINESS, STOCK OPTION AND PENSION VALUATION SERVICES; FINANCIAL VALUATIONS; INTELLECTUAL PROPERTY VALUATION SERVICES (U.S. CLS. 100, 101 AND 102).

FIRST USE 4-25-2010; IN COMMERCE 4-25-2010.  
PAULA MAHONEY, EXAMINING ATTORNEY

SN 85-182,013. ETAGE REAL ESTATE, LLC, NEW YORK, NY. FILED 11-22-2010.

**ETAGE REAL ESTATE**

THE MARK CONSISTS OF STANDARD CHARACTERS WITHOUT CLAIM TO ANY PARTICULAR FONT, STYLE, SIZE, OR COLOR.

NO CLAIM IS MADE TO THE EXCLUSIVE RIGHT TO USE "REAL ESTATE", APART FROM THE MARK AS SHOWN.

THE ENGLISH TRANSLATION OF THE WORD "ETAGE" IN THE MARK IS "FLOOR".

FOR REAL ESTATE SERVICES, NAMELY, REAL ESTATE CONSULTATION, MANAGEMENT AND BROKERAGE (U.S. CLS. 100, 101 AND 102).

FIRST USE 11-1-2010; IN COMMERCE 11-1-2010.  
CHRISTINE MARTIN, EXAMINING ATTORNEY

**CLASS 36—(Continued).**

SN 85-183,308. TRINITY FIDUCIARY PARTNERS, LLC, ARLINGTON, TX. FILED 11-23-2010.

**FFV Scorecard**

THE MARK CONSISTS OF STANDARD CHARACTERS WITHOUT CLAIM TO ANY PARTICULAR FONT, STYLE, SIZE, OR COLOR.

NO CLAIM IS MADE TO THE EXCLUSIVE RIGHT TO USE "SCORECARD", APART FROM THE MARK AS SHOWN.

FOR MUTUAL FUND ADVISORY SERVICES (U.S. CLS. 100, 101 AND 102).

FIRST USE 1-1-2008; IN COMMERCE 1-1-2008.  
AMY ALFIERI, EXAMINING ATTORNEY

SN 85-183,701. FR CAPITAL HOLDINGS, L.P., WEST CONSHOHOCKEN, PA. FILED 11-23-2010.



NO CLAIM IS MADE TO THE EXCLUSIVE RIGHT TO USE "CAPITAL", APART FROM THE MARK AS SHOWN.

THE MARK CONSISTS OF THE LITERAL ELEMENT "FIRST ROUND CAPITAL" AND TWO CONCENTRIC, ELLIPTICAL-SHAPED FIGURES POSITIONED ABOVE THE LETTER "F".

FOR VENTURE CAPITAL FINANCING; VENTURE CAPITAL FUNDING SERVICES TO EMERGING AND START-UP COMPANIES (U.S. CLS. 100, 101 AND 102).

FIRST USE 10-29-2004; IN COMMERCE 10-29-2004.  
EVELYN BRADLEY, EXAMINING ATTORNEY

SN 85-184,006. 4WARRANTY CORPORATION, ORANGE PARK, FL. FILED 11-23-2010.

**REPAIR6**

THE MARK CONSISTS OF STANDARD CHARACTERS WITHOUT CLAIM TO ANY PARTICULAR FONT, STYLE, SIZE, OR COLOR.

FOR PROVIDING WARRANTIES ON APPLIANCES MANUFACTURED BY OTHERS (U.S. CLS. 100, 101 AND 102).

FIRST USE 11-15-2010; IN COMMERCE 11-15-2010.  
DOMINICK J. SALEMI, EXAMINING ATTORNEY



**CLASS 36—(Continued).**

SN 85-184,087. HOWARD, CURTIS, YUBA CITY, CA. FILED 11-23-2010.

**QuickLifePLUS**  
The 10 minute solution ■■

NO CLAIM IS MADE TO THE EXCLUSIVE RIGHT TO USE "THE 10 MINUTE SOLUTION", APART FROM THE MARK AS SHOWN.

THE MARK CONSISTS OF THE STYLIZED TEXT "QUICKLIFEPLUS THE 10 MINUTE SOLUTION" WITH 4 SQUARES AT THE END.

FOR ADVISORY SERVICES IN THE FIELD OF EMPLOYEE BENEFITS FOR GROUP HEALTHCARE AND BUSINESS INSURANCE OFFERED TO EMPLOYEES IN ADDITION TO STANDARD BENEFITS SUCH AS MEDICAL, DENTAL, LIFE INSURANCE INCLUDING SHORT TERM DISABILITY, LONG TERM DISABILITY, CANCER INSURANCE, ACCIDENTAL DEATH AND DISMEMBERMENT (U.S. CLS. 100, 101 AND 102).

FIRST USE 9-20-2010; IN COMMERCE 9-20-2010.  
JOHN DALIER, EXAMINING ATTORNEY

**CLASS 36—(Continued).**

SN 85-185,281. APPRAISER LOFT, LLC, SAN DIEGO, CA. FILED 11-25-2010.



THE COLOR(S) BLUE, ORANGE, WHITE AND GRAY IS/ ARE CLAIMED AS A FEATURE OF THE MARK.

THE MARK CONSISTS OF AN IMAGE OF A HOUSE IN ORANGE, INSIDE A BLUE SQUARE WITH ROUNDED CORNERS AND AN ORANGE, WHITE AND GRAY BORDER.

FOR BUSINESS SERVICES, NAMELY, PROVIDING REAL ESTATE VALUATION SERVICES TO CLIENTS (U.S. CLS. 100, 101 AND 102).

FIRST USE 1-4-2007; IN COMMERCE 1-4-2007.  
JAMES MACFARLANE, EXAMINING ATTORNEY

SN 85-184,423. NATIONAL STOCK EXCHANGE, INC., CHICAGO, IL. FILED 11-24-2010.

**NSXDIRECT**

THE MARK CONSISTS OF STANDARD CHARACTERS WITHOUT CLAIM TO ANY PARTICULAR FONT, STYLE, SIZE, OR COLOR.

OWNER OF U.S. REG. NOS. 3,246,912, 3,720,212 AND OTHERS.

FOR PROVIDING A NETWORK SOLUTION THAT CONNECTS SECURITIES EXCHANGES, FINANCIAL CENTERS AND MARKET PARTICIPANTS IN THE FINANCIAL INDUSTRY, NAMELY, FINANCIAL SECURITIES EXCHANGE SERVICES VIA AN INTRANET COMPUTER NETWORK (U.S. CLS. 100, 101 AND 102).

INGRID C. EULIN, EXAMINING ATTORNEY

SN 85-185,877. DUPAGE CREDIT UNION, NAPERVILLE, IL. FILED 11-29-2010.

**DuPage<sup>^</sup>mortgage**

NO CLAIM IS MADE TO THE EXCLUSIVE RIGHT TO USE "DUPAGE MORTGAGE", APART FROM THE MARK AS SHOWN.

THE MARK CONSISTS OF THE WORDS "DUPAGE MORTGAGE" BELOW A STYLIZED HOUSE ROOF WITH WINDOW AND CHIMNEY.

FOR FINANCIAL SERVICES, NAMELY, MORTGAGE REFINANCING; MORTGAGE LENDING (U.S. CLS. 100, 101 AND 102).

PATRICIA EVANKO, EXAMINING ATTORNEY

**CLASS 36—(Continued).**

SN 85-186,197. NATIONAL STOCK EXCHANGE, INC., JERSEY CITY, NJ. FILED 11-29-2010.

**NSX EXCHANGE IN A BOX**

THE MARK CONSISTS OF STANDARD CHARACTERS WITHOUT CLAIM TO ANY PARTICULAR FONT, STYLE, SIZE, OR COLOR.

OWNER OF U.S. REG. NOS. 3,056,835, 3,553,265 AND OTHERS.

FOR PROVIDING A NETWORK SOLUTION THAT CONNECTS SECURITIES EXCHANGES, FINANCIAL CENTERS AND MARKET PARTICIPANTS IN THE FINANCIAL INDUSTRY, NAMELY, FINANCIAL SECURITIES EXCHANGE SERVICES VIA AN INTRANET COMPUTER NETWORK (U.S. CLS. 100, 101 AND 102).  
INGRID C. EULIN, EXAMINING ATTORNEY

---

SN 85-186,709. IVILLA, LLC, MILL VALLEY, CA. FILED 11-29-2010.

**IVILLA**

THE MARK CONSISTS OF STANDARD CHARACTERS WITHOUT CLAIM TO ANY PARTICULAR FONT, STYLE, SIZE, OR COLOR.

OWNER OF U.S. REG. NO. 3,854,798.

FOR PROVIDING AN ONLINE PORTAL THAT CONNECTS TRAVELERS WITH VACATION RENTAL HOME OWNERS OR THEIR AGENTS FOR THE PURPOSE OF SHORT TERM OCCUPANCY OF SAID PROPERTIES (U.S. CLS. 100, 101 AND 102).

FIRST USE 9-1-2009; IN COMMERCE 9-9-2009.

PAUL E. FAHRENKOPF, EXAMINING ATTORNEY

---

SN 85-186,835. PALLOTTA, DAX, CEDAR PARK, TX. FILED 11-30-2010.

**OUT FOX THE BULL AND THE BEAR!**

THE MARK CONSISTS OF STANDARD CHARACTERS WITHOUT CLAIM TO ANY PARTICULAR FONT, STYLE, SIZE, OR COLOR.

FOR FINANCIAL SERVICES, NAMELY, PROVIDING FINANCIAL ADVICE IN THE FIELD OF STOCK PICK RECOMMENDATIONS FOR REGISTERED USERS (U.S. CLS. 100, 101 AND 102).

KATHERINE E. HALMEN, EXAMINING ATTORNEY

**CLASS 36—(Continued).**

SN 85-187,266. VISTA ENDOWMENT FUND, INC., WEST-BROOK, CT. FILED 11-30-2010.

**Vista Endowment Fund**

THE MARK CONSISTS OF STANDARD CHARACTERS WITHOUT CLAIM TO ANY PARTICULAR FONT, STYLE, SIZE, OR COLOR.

NO CLAIM IS MADE TO THE EXCLUSIVE RIGHT TO USE "ENDOWMENT FUND", APART FROM THE MARK AS SHOWN.

FOR PHILANTHROPIC SERVICES, NAMELY, FINANCIAL ENDOWMENT OF VISTA VOCATIONAL AND LIFE SKILLS CENTER AND ITS STUDENTS AND MEMBERS (U.S. CLS. 100, 101 AND 102).

FIRST USE 8-12-2005; IN COMMERCE 8-12-2005.

CHRISTOPHER BUONGIORNO, EXAMINING ATTORNEY

---

SN 85-187,453. LINCOLN NATIONAL LIFE INSURANCE COMPANY, THE, FORT WAYNE, IN. FILED 11-30-2010.

**LINCOLN DENTALCONNECT**

THE MARK CONSISTS OF STANDARD CHARACTERS WITHOUT CLAIM TO ANY PARTICULAR FONT, STYLE, SIZE, OR COLOR.

OWNER OF U.S. REG. NOS. 2,048,697, 3,875,323 AND OTHERS.

FOR DENTAL INSURANCE UNDERWRITING, ADMINISTRATION AND CLAIMS PROCESSING FOR DENTAL INSURANCE PLANS (U.S. CLS. 100, 101 AND 102).

FIRST USE 7-2-2008; IN COMMERCE 7-2-2008.

ANDREW RHIM, EXAMINING ATTORNEY

**CLASS 36—(Continued).**

SN 85-187,494. HECHT INTERNATIONAL TRADING INC., QUÉBEC, CANADA, FILED 11-30-2010.

**GLOBAL PEACE FUNDS**

THE MARK CONSISTS OF STANDARD CHARACTERS WITHOUT CLAIM TO ANY PARTICULAR FONT, STYLE, SIZE, OR COLOR.

NO CLAIM IS MADE TO THE EXCLUSIVE RIGHT TO USE "GLOBAL", APART FROM THE MARK AS SHOWN.

FOR FUNDS INVESTMENT; INVESTMENT MANAGEMENT; INVESTMENT OF FUNDS FOR OTHERS; INVESTMENT SERVICES, NAMELY, ASSET ACQUISITION, CONSULTATION, DEVELOPMENT AND MANAGEMENT SERVICES; PRIVATE EQUITY FUND INVESTMENT SERVICES; PROVIDING FINANCIAL SERVICES WITH RESPECT TO SECURITIES AND OTHER FINANCIAL INSTRUMENTS AND PRODUCTS, NAMELY, TRADING OF AND INVESTMENTS IN SECURITIES AND FINANCIAL INSTRUMENTS AND PRODUCTS FOR OTHERS (U.S. CLS. 100, 101 AND 102).

HEATHER SAPP, EXAMINING ATTORNEY

---

SN 85-187,920. ESSENT GUARANTY, INC., RADNOR, PA. FILED 12-1-2010.

**CLARITY OF COVERAGE**

THE MARK CONSISTS OF STANDARD CHARACTERS WITHOUT CLAIM TO ANY PARTICULAR FONT, STYLE, SIZE, OR COLOR.

NO CLAIM IS MADE TO THE EXCLUSIVE RIGHT TO USE "COVERAGE", APART FROM THE MARK AS SHOWN.

FOR INSURANCE SERVICES, NAMELY, UNDERWRITING AND ISSUING MORTGAGE GUARANTY INSURANCE TO FINANCIAL INSTITUTIONS (U.S. CLS. 100, 101 AND 102).

MARK RADEMACHER, EXAMINING ATTORNEY

---

SN 85-188,592. FIDELITY BANK CORPORATION, DBA FIDELITY BANK, WICHITA, KS. FILED 12-1-2010.

**OPT FREE CHECKING**

THE MARK CONSISTS OF STANDARD CHARACTERS WITHOUT CLAIM TO ANY PARTICULAR FONT, STYLE, SIZE, OR COLOR.

NO CLAIM IS MADE TO THE EXCLUSIVE RIGHT TO USE "FREE CHECKING", APART FROM THE MARK AS SHOWN.

FOR BANKING SERVICES (U.S. CLS. 100, 101 AND 102).

FIRST USE 10-12-2009; IN COMMERCE 10-12-2009.

CHRISTINA SOBRAL, EXAMINING ATTORNEY

**CLASS 36—(Continued).**

SN 85-188,775. DALL, RENEE ELIZABETH, ESSEX JUNCTION, VT. FILED 12-1-2010.



THE COLOR(S) PINK, GREEN AND BLACK IS/ARE CLAIMED AS A FEATURE OF THE MARK.

THE MARK CONSISTS OF THE PINK WORDS "COCKTAILS CURING CANCER", EXCEPT THE "O" IN COCKTAILS WHICH IS SHAPED LIKE AN OLIVE WHERE THE OLIVE IS GREEN WITH BLACK OUTLINING AND A PINK TOP. THE PINK E IN CANCER IS SHAPED LIKE A RIBBON. A MARTINI GLASS OUTLINED IN BLACK WITH PINK LIQUID OUTLINED IN BLACK AND A GREEN OLIVE OUTLINED IN BLACK IS TO THE RIGHT OF THE WORDS. THE WHITE IN THE MARK IS BACKGROUND AREA WHICH IS NOT A PART OF THE MARK.

FOR CHARITABLE FUNDRAISING (U.S. CLS. 100, 101 AND 102).

FIRST USE 8-1-2008; IN COMMERCE 8-1-2008.

REBECCA GILBERT, EXAMINING ATTORNEY

---

SN 85-188,952. HARTFORD LIFE INSURANCE COMPANY, HARTFORD, CT. FILED 12-2-2010.

**LifeAccess Care Rider**

THE MARK CONSISTS OF STANDARD CHARACTERS WITHOUT CLAIM TO ANY PARTICULAR FONT, STYLE, SIZE, OR COLOR.

OWNER OF U.S. REG. NO. 3,450,391.

NO CLAIM IS MADE TO THE EXCLUSIVE RIGHT TO USE "CARE RIDER", APART FROM THE MARK AS SHOWN.

FOR UNDERWRITING AND INSURANCE ADMINISTRATION OF A LONG-TERM CARE RIDER OF A LIFE INSURANCE POLICY (U.S. CLS. 100, 101 AND 102).

DAVID H. STINE, EXAMINING ATTORNEY

**CLASS 36—(Continued).**

SN 85-189,185. RESIDENTIAL PROPERTY MANAGEMENT, INC., SANTA FE, NM. FILED 12-2-2010.

KOKOPELLI REAL ESTATE AND  
PROPERTY MANAGEMENT

THE MARK CONSISTS OF STANDARD CHARACTERS WITHOUT CLAIM TO ANY PARTICULAR FONT, STYLE, SIZE, OR COLOR.

NO CLAIM IS MADE TO THE EXCLUSIVE RIGHT TO USE "REAL ESTATE AND PROPERTY MANAGEMENT", APART FROM THE MARK AS SHOWN.

FOR REAL ESTATE SERVICES, NAMELY, BROKERAGE, LEASING AND MANAGEMENT OF COMMERCIAL AND RESIDENTIAL PROPERTIES (U.S. CLS. 100, 101 AND 102).

FIRST USE 12-10-1996; IN COMMERCE 12-10-1996.  
CARYN GLASSER, EXAMINING ATTORNEY

---

SN 85-189,437. FACTOR ADVISORS, LLC, NEW YORK, NY. FILED 12-2-2010.

factor

THE MARK CONSISTS OF STANDARD CHARACTERS WITHOUT CLAIM TO ANY PARTICULAR FONT, STYLE, SIZE, OR COLOR.

FOR FINANCIAL INVESTMENT IN THE FIELD OF SECURITIES (U.S. CLS. 100, 101 AND 102).

CHRISTINE COOPER, EXAMINING ATTORNEY

---

SN 85-189,537. SOUTH FERRY CAPITAL MANAGEMENT, L.P., NEW YORK, NY. FILED 12-2-2010.

SOUTH FERRY

THE MARK CONSISTS OF STANDARD CHARACTERS WITHOUT CLAIM TO ANY PARTICULAR FONT, STYLE, SIZE, OR COLOR.

FOR INVESTMENT ADVISORY SERVICES (U.S. CLS. 100, 101 AND 102).

FIRST USE 8-1-2010; IN COMMERCE 8-1-2010.  
REBECCA GILBERT, EXAMINING ATTORNEY

**CLASS 36—(Continued).**

SN 85-189,550. FREDERICK, TANNA, LOS ANGELES, CA. FILED 12-2-2010.



NO CLAIM IS MADE TO THE EXCLUSIVE RIGHT TO USE SURF, APART FROM THE MARK AS SHOWN. THE COLOR(S) GREEN AND BLUE IS/ARE CLAIMED AS A FEATURE OF THE MARK.

THE MARK CONSISTS OF A CIRCULAR SHAPE REPRESENTING THE BARREL OF A WAVE WITH "SURF 24" IN GREEN OUTLINED IN BLUE ON LOWER RIGHT COMPLETING THE CIRCLE. THE CURVED BANDS OF THE WAVE ARE GREEN OUTLINED IN BLUE. THE WHITE IN THE MARK IS BACKGROUND AREA WHICH IS NOT A PART OF THE MARK.

FOR ACCEPTING AND ADMINISTERING MONETARY CHARITABLE CONTRIBUTIONS (U.S. CLS. 100, 101 AND 102).

FIRST USE 6-1-2009; IN COMMERCE 6-1-2009.  
REBECCA GILBERT, EXAMINING ATTORNEY

---

SN 85-189,617. SOUTH FERRY CAPITAL MANAGEMENT, L.P., NEW YORK, NY. FILED 12-2-2010.



THE MARK CONSISTS OF THE UPPERCASE LETTERS "SF" IN THE CENTER OF A CIRCLE THAT IS CONTAINED WITHIN TWO CIRCULAR BORDERS AROUND THE PERIMETER OF THE MAIN CIRCLE WITH A SMALLER CIRCLE WITHIN A CIRCULAR BORDER LOCATED AT THE BOTTOM OF THE DESIGN OF THE LARGER CIRCLES.

FOR INVESTMENT ADVISORY SERVICES (U.S. CLS. 100, 101 AND 102).

FIRST USE 8-1-2010; IN COMMERCE 8-1-2010.  
REBECCA GILBERT, EXAMINING ATTORNEY

**CLASS 36—(Continued).**

SN 85-190,538. ADVANCED WEALTH ADVISERS, LLC, NOVI, MI. FILED 12-3-2010.

**ADVANCED WEALTH ADVISERS**

THE MARK CONSISTS OF STANDARD CHARACTERS WITHOUT CLAIM TO ANY PARTICULAR FONT, STYLE, SIZE, OR COLOR.

NO CLAIM IS MADE TO THE EXCLUSIVE RIGHT TO USE "WEALTH ADVISERS", APART FROM THE MARK AS SHOWN.

FOR ESTATE PLANNING; ESTATE TRUST PLANNING; FINANCIAL CONSULTANCY AND INSURANCE CONSULTANCY; FINANCIAL PLANNING AND INVESTMENT ADVISORY SERVICES; FINANCIAL SERVICES, NAMELY, BROKER/DEALER SERVICES ON SECURITIES EXCHANGES AND OVER-THE-COUNTER MARKETS; INSURANCE BROKERAGE; INSURANCE BROKERAGE IN THE FIELD OF LIFE INSURANCE, HEALTH INSURANCE, AND PROPERTY AND CASUALTY INSURANCE; INSURANCE CONSULTANCY; PROVIDING STOCK/SECURITIES MARKET INFORMATION; SECURITY BROKERAGE (U.S. CLS. 100, 101 AND 102).

APRIL ROACH, EXAMINING ATTORNEY

SN 85-191,205. BMP STANDARD, LLC, BOSTON, MA. FILED 12-6-2010.



OWNER OF U.S. REG. NO. 3,698,206.

THE MARK CONSISTS OF A SPHERE STYLED WITH DIAGONAL LINES APPEARING TO THE LEFT OF THE WORDING "BMFN" AND "GLOBAL MARKETS DELIVERED LOCALLY".

FOR BROKERAGE HOUSES IN THE FIELD OF STOCKS, COMMODITIES, AND FUTURES; BROKERAGE SERVICES IN THE FIELD OF SECURITIES AND COMMODITIES INVESTING; FINANCIAL AND INVESTMENT SERVICES, NAMELY, MANAGEMENT AND BROKERAGE IN THE FIELDS OF STOCKS, BONDS, OPTIONS, COMMODITIES, FUTURES AND OTHER SECURITIES, AND THE INVESTMENT OF FUNDS OF OTHERS; FINANCIAL ASSET MANAGEMENT; FINANCIAL INVESTMENT BROKERAGE; FINANCIAL INVESTMENT BROKERAGE SERVICES; FINANCIAL SERVICES, NAMELY, ASSISTING OTHERS WITH THE COMPLETION OF FINANCIAL TRANSACTIONS FOR STOCKS, BONDS, SECURITIES AND EQUITIES; FINANCIAL SERVICES, NAMELY, BROKER/DEALER SERVICES ON SECURITIES EXCHANGES AND OVER-THE-COUNTER MARKETS; FINANCIAL SERVICES, NAMELY, COMMODITY TRADING AND MANAGED FUTURES ADVISORY AND MANAGEMENT SERVICES; FINANCIAL SERVICES, NAMELY, CONDUCTING A SECURITIES AND DERIVATIVES EXCHANGE; FINANCIAL SERVICES, NAMELY, THE TRADING OF FINANCIAL INSTRUMENTS, SECURITIES, SHARES, OPTIONS AND OTHER DERIVATIVE PRODUCTS; ON-LINE TRADING OF FINANCIAL INSTRUMENTS, SHARES, OPTIONS AND OTHER DERIVATIVE PRODUCTS; SECURITIES BROKERAGE; SECURITIES BROKERAGE SERVICES; SECURITY BROKERAGE; STOCK BROKERAGE (U.S. CLS. 100, 101 AND 102).

FIRST USE 0-0-2008; IN COMMERCE 0-0-2008.

JULIE VEPPUMTHARA, EXAMINING ATTORNEY

**CLASS 36—(Continued).**

SN 85-191,633. REDHAWK WEALTH ADVISORS, INC., MINNEAPOLIS, MN. FILED 12-6-2010.



THE MARK CONSISTS OF A CIRCULAR DRAWING OF THE HEAD OF A RED-TAILED HAWK, A PREDATORY BIRD, TO THE LEFT OF THE TEXT, "REDHAWK".

FOR INSURANCE AGENCIES IN THE FIELD OF LIFE; INVESTMENT ADVISORY SERVICES; ISSUANCE AND ADMINISTRATION OF ANNUITIES; PROVIDING FINANCIAL SERVICES WITH RESPECT TO SECURITIES AND OTHER FINANCIAL INSTRUMENTS AND PRODUCTS, NAMELY, MONEY MANAGEMENT SERVICES (U.S. CLS. 100, 101 AND 102).

FIRST USE 1-2-2008; IN COMMERCE 4-1-2008.  
ODESSA BIBBINS, EXAMINING ATTORNEY

SN 85-191,828. CUPAR, LLC, ELGIN, IL. FILED 12-7-2010.

**MEMBER ASSIST**

THE MARK CONSISTS OF STANDARD CHARACTERS WITHOUT CLAIM TO ANY PARTICULAR FONT, STYLE, SIZE, OR COLOR.

NO CLAIM IS MADE TO THE EXCLUSIVE RIGHT TO USE "MEMBER", APART FROM THE MARK AS SHOWN.

FOR AUTO LOAN SERVICES (U.S. CLS. 100, 101 AND 102).

FIRST USE 7-30-2010; IN COMMERCE 8-18-2010.  
KELLY CHOE, EXAMINING ATTORNEY

SN 85-192,587. HITON FINANCIAL SERVICES, LLC, NORTHBROOK, IL. FILED 12-7-2010.



NO CLAIM IS MADE TO THE EXCLUSIVE RIGHT TO USE "MORTGAGE LENDING", APART FROM THE MARK AS SHOWN.

THE MARK CONSISTS OF THE STYLIZED WORD "MORTGAGE LENDING MADE CRYSTAL CLEAR" TO THE RIGHT OF A STYLIZED TRIANGLE.

FOR FINANCIAL ADVICE; FINANCIAL CONSULTATION; FINANCIAL CONSULTING; MORTGAGE BANKING; MORTGAGE BROKERAGE; MORTGAGE FORECLOSURE SERVICES; MORTGAGE LENDING; MORTGAGE PROCUREMENT FOR OTHERS; PROVIDING POST-COMPLIANCE FINANCIAL REVIEWS FOR THE MORTGAGE INDUSTRY; REAL ESTATE BROKERAGE; REAL ESTATE CONSULTANCY; REAL ESTATE CONSULTATION; REAL ESTATE FINANCING SERVICES; REAL ESTATE PROCUREMENT FOR OTHERS; REAL ESTATE SERVICES TO STOP FORECLOSURE, NAMELY, MORTGAGE DEBT MANAGEMENT (U.S. CLS. 100, 101 AND 102).

DAVID TOOLEY, EXAMINING ATTORNEY

**CLASS 36—(Continued).**

SN 85-192,740. NEW ALLIANCE REALTY, INC., DBA NEW ALLIANCE REALTY, SANTA MARIA, CA. FILED 12-7-2010.



NO CLAIM IS MADE TO THE EXCLUSIVE RIGHT TO USE "REALTY", APART FROM THE MARK AS SHOWN.

THE COLOR(S) BLACK AND RED IS/ARE CLAIMED AS A FEATURE OF THE MARK.

THE MARK CONSISTS OF A BLACK HOME CONTAINING A RED CROWN DESIGN AND THE RED LETTERS "N", "A", "R". THE WORDING "NEW ALLIANCE REALTY" IS IN BLACK BELOW THE HOUSE AND TWO POINTED LINES OPPOSING EACH OTHER ARE BELOW THE WORDING. WHITE AS IT APPEARS WITHIN THE HOME REPRESENTS BACKGROUND ONLY AND IS NOT A CLAIMED FEATURE OF THE MARK.

FOR REAL ESTATE BROKERAGE (U.S. CLS. 100, 101 AND 102).

FIRST USE 1-1-2008; IN COMMERCE 1-1-2008.

REBECCA POVARCHUK, EXAMINING ATTORNEY

SN 85-192,822. APPRAISER LOFT, LLC, SAN DIEGO, CA. FILED 12-8-2010.

**VALUCONNECT**

THE MARK CONSISTS OF STANDARD CHARACTERS WITHOUT CLAIM TO ANY PARTICULAR FONT, STYLE, SIZE, OR COLOR.

FOR FINANCIAL SERVICES, NAMELY, PROVIDING REAL ESTATE APPRAISALS WITH AN ATTACHED ADDENDUM THAT RECONCILES AUTOMATED VALUATION MODEL (AVM) RESULTS TO THE APPRAISAL (U.S. CLS. 100, 101 AND 102).

FIRST USE 2-1-2010; IN COMMERCE 2-1-2010.

JAMES MACFARLANE, EXAMINING ATTORNEY

**CLASS 36—(Continued).**

SN 85-192,824. APPRAISER LOFT, LLC, SAN DIEGO, CA. FILED 12-8-2010.

**VALUCLEAR**

THE MARK CONSISTS OF STANDARD CHARACTERS WITHOUT CLAIM TO ANY PARTICULAR FONT, STYLE, SIZE, OR COLOR.

FOR FINANCIAL SERVICES, NAMELY, PROVIDING RESIDENTIAL PRE-VALUATION REPORTS IN THE NATURE OF REAL ESTATE APPRAISALS THROUGH LOCAL MARKET EXPERTS (U.S. CLS. 100, 101 AND 102).

FIRST USE 10-4-2010; IN COMMERCE 11-1-2010.

JAMES MACFARLANE, EXAMINING ATTORNEY

SN 85-192,899. ZENO CONSULTING GROUP, LLC, BETHESDA, MD. FILED 12-8-2010.

**ZENO**

THE MARK CONSISTS OF STANDARD CHARACTERS WITHOUT CLAIM TO ANY PARTICULAR FONT, STYLE, SIZE, OR COLOR.

FOR INSTITUTIONAL INVESTMENT CONSULTANT SERVICES TO PENSION FUNDS, MUTUAL FUND BOARDS AND INSTITUTIONS EXERCISING OVERSIGHT OVER THIRD PARTY ASSET MANAGERS IN THE FIELD OF MONITORING AND EXERCISING OVERSIGHT OVER EXTERNAL ASSET MANAGERS TO INSURE ADHERENCE TO BEST FINANCIAL PRACTICES AND APPROPRIATE FIDUCIARY STANDARDS AND THE FIELD OF DEVELOPING APPROPRIATE STRATEGIES FOR SUCH PENSION FUNDS, MUTUAL FUND BOARDS AND INSTITUTIONS EXERCISING OVERSIGHT OVER THIRD PARTY ASSET MANAGERS TO TRANSFER INVESTMENT PORTFOLIOS FROM AN EXISTING INVESTMENT MANAGER TO ANOTHER INVESTMENT MANAGER IN ADHERENCE TO BEST FINANCIAL PRACTICES AND APPROPRIATE FIDUCIARY STANDARDS (U.S. CLS. 100, 101 AND 102).

FIRST USE 3-12-2010; IN COMMERCE 3-12-2010.

RUDY R. SINGLETON, EXAMINING ATTORNEY

**CLASS 36—(Continued).**

SN 85-192,915. ZENO CONSULTING GROUP, LLC, BETHESDA, MD. FILED 12-8-2010.

## Zeno Consulting Group

THE MARK CONSISTS OF STANDARD CHARACTERS WITHOUT CLAIM TO ANY PARTICULAR FONT, STYLE, SIZE, OR COLOR.

NO CLAIM IS MADE TO THE EXCLUSIVE RIGHT TO USE "CONSULTING GROUP", APART FROM THE MARK AS SHOWN.

FOR INSTITUTIONAL INVESTMENT CONSULTANT SERVICES TO PENSION FUNDS, MUTUAL FUND BOARDS AND INSTITUTIONS EXERCISING OVERSIGHT OVER THIRD PARTY ASSET MANAGERS IN THE FIELD OF MONITORING AND EXERCISING OVERSIGHT OVER EXTERNAL ASSET MANAGERS TO INSURE ADHERENCE TO BEST FINANCIAL PRACTICES AND APPROPRIATE FIDUCIARY STANDARDS AND THE FIELD OF DEVELOPING APPROPRIATE STRATEGIES FOR SUCH PENSION FUNDS, MUTUAL FUND BOARDS AND INSTITUTIONS EXERCISING OVERSIGHT OVER THIRD PARTY ASSET MANAGERS TO TRANSFER INVESTMENT PORTFOLIOS FROM AN EXISTING INVESTMENT MANAGER TO ANOTHER INVESTMENT MANAGER IN ADHERENCE TO BEST FINANCIAL PRACTICES AND APPROPRIATE FIDUCIARY STANDARDS (U.S. CLS. 100, 101 AND 102).

FIRST USE 3-12-2010; IN COMMERCE 3-12-2010.  
RUDY R. SINGLETON, EXAMINING ATTORNEY

SN 85-192,958. PAYMENT LOOP LLC, BROOKLYN, NY. FILED 12-8-2010.

## RENT MADE EASY

THE MARK CONSISTS OF STANDARD CHARACTERS WITHOUT CLAIM TO ANY PARTICULAR FONT, STYLE, SIZE, OR COLOR.

FOR PROVIDING AN ONLINE PORTAL FOR RENTAL PROPERTY MANAGEMENT SERVICES (U.S. CLS. 100, 101 AND 102).

SANDRA BUJA, EXAMINING ATTORNEY

**CLASS 36—(Continued).**

SN 85-193,320. ESQUIRE BANK FSB, GARDEN CITY, NY. FILED 12-8-2010.

## Attorney Advantage Checking

THE MARK CONSISTS OF STANDARD CHARACTERS WITHOUT CLAIM TO ANY PARTICULAR FONT, STYLE, SIZE, OR COLOR.

NO CLAIM IS MADE TO THE EXCLUSIVE RIGHT TO USE "ATTORNEY" OR "CHECKING", APART FROM THE MARK AS SHOWN.

FOR BANKING SERVICES (U.S. CLS. 100, 101 AND 102).

FIRST USE 12-1-2010; IN COMMERCE 12-1-2010.  
RUDY R. SINGLETON, EXAMINING ATTORNEY

SN 85-193,828. AARC, INC., SPARTANBURG, SC. FILED 12-9-2010.

## STRAIGHT TALK STATEMENT

THE MARK CONSISTS OF STANDARD CHARACTERS WITHOUT CLAIM TO ANY PARTICULAR FONT, STYLE, SIZE, OR COLOR.

NO CLAIM IS MADE TO THE EXCLUSIVE RIGHT TO USE "STATEMENT", APART FROM THE MARK AS SHOWN.

FOR CONSUMER LENDING SERVICES; FINANCIAL SERVICES IN THE NATURE OF MONEY LENDING, CHECK CASHING, DEFERRED DEPOSITS, FINANCIAL OVERDRAFT PROTECTION, AND SHORT-TERM CONSUMER LOANS (U.S. CLS. 100, 101 AND 102).

KIM MONINGHOFF, EXAMINING ATTORNEY

SN 85-193,929. MONY LIFE INSURANCE COMPANY, NEW YORK, NY. FILED 12-9-2010.



OWNER OF U.S. REG. NOS. 1,286,421 AND 2,404,636.

THE MARK CONSISTS OF THE WORD "MONY" INSIDE A PARTIAL RECTANGLE AND A PARTIAL SCROLL APPEARS AT THE BOTTOM LEFT CORNER OF THE PARTIAL RECTANGLE.

FOR LIFE INSURANCE UNDERWRITING AND ADMINISTRATION, HEALTH INSURANCE ADMINISTRATION, SECURITIES AND MUTUAL FUND BROKERAGE (U.S. CLS. 100, 101 AND 102).

FIRST USE 11-16-1998; IN COMMERCE 11-16-1998.  
SIMON TENG, EXAMINING ATTORNEY

**CLASS 36—(Continued).**

SN 85-194,334. BELL PARTNERS, INC., GREENSBORO, NC. FILED 12-9-2010.

## APARTMENT LIVING AT ITS BEST

THE MARK CONSISTS OF STANDARD CHARACTERS WITHOUT CLAIM TO ANY PARTICULAR FONT, STYLE, SIZE, OR COLOR.

NO CLAIM IS MADE TO THE EXCLUSIVE RIGHT TO USE "APARTMENT LIVING", APART FROM THE MARK AS SHOWN.

FOR LEASING AND MANAGEMENT OF APARTMENTS (U.S. CLS. 100, 101 AND 102).

JEFF DEFORD, EXAMINING ATTORNEY

**CLASS 36—(Continued).**

SN 85-195,059. INDIANA SPORTS OUTREACH, INC., INDIANAPOLIS, IN. FILED 12-10-2010.

## BALL PROJECT

THE MARK CONSISTS OF STANDARD CHARACTERS WITHOUT CLAIM TO ANY PARTICULAR FONT, STYLE, SIZE, OR COLOR.

NO CLAIM IS MADE TO THE EXCLUSIVE RIGHT TO USE "PROJECT", APART FROM THE MARK AS SHOWN.

FOR CHARITABLE FUNDRAISING SERVICES (U.S. CLS. 100, 101 AND 102).

FIRST USE 12-31-2005; IN COMMERCE 12-31-2005.

PAUL F. GAST, EXAMINING ATTORNEY

SN 85-195,223. ZENO CONSULTING GROUP, LLC, BETHESDA, MD. FILED 12-10-2010.

SN 85-194,351. ZENO CONSULTING GROUP, LLC, BETHESDA, MD. FILED 12-9-2010.



NO CLAIM IS MADE TO THE EXCLUSIVE RIGHT TO USE "CONSULTING GROUP", APART FROM THE MARK AS SHOWN.

THE MARK CONSISTS OF THE WORDS "ZENO" ABOVE A HORIZONTAL LINE WITH WORDS "CONSULTING GROUP" BELOW THE HORIZONTAL LINE, THE BACKGROUND BEING AN "ICEBERG".

FOR INSTITUTIONAL INVESTMENT CONSULTANT SERVICES TO PENSION FUNDS, MUTUAL FUND BOARDS AND INSTITUTIONS EXERCISING OVERSIGHT OVER THIRD PARTY ASSET MANAGERS IN THE FIELD OF MONITORING AND EXERCISING OVERSIGHT OVER EXTERNAL ASSET MANAGERS TO INSURE ADHERENCE TO BEST FINANCIAL PRACTICES AND APPROPRIATE FIDUCIARY STANDARDS AND THE FIELD OF DEVELOPING APPROPRIATE STRATEGIES FOR SUCH PENSION FUNDS, MUTUAL FUND BOARDS AND INSTITUTIONS EXERCISING OVERSIGHT OVER THIRD PARTY ASSET MANAGERS TO TRANSFER INVESTMENT PORTFOLIOS FROM AN EXISTING INVESTMENT MANAGER TO ANOTHER INVESTMENT MANAGER IN ADHERENCE TO BEST FINANCIAL PRACTICES AND APPROPRIATE FIDUCIARY STANDARDS (U.S. CLS. 100, 101 AND 102).

FIRST USE 3-12-2010; IN COMMERCE 3-12-2010.

RUDY R. SINGLETON, EXAMINING ATTORNEY

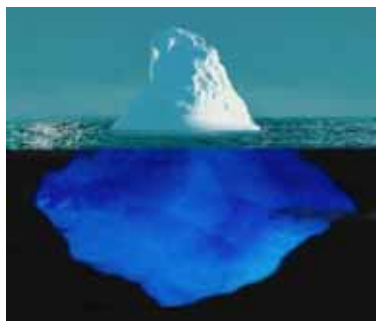

THE COLOR(S) BLUE, WHITE AND BLACK IS/ARE CLAIMED AS A FEATURE OF THE MARK.

THE MARK CONSISTS OF A WHITE AND BLUE ICEBERG AGAINST A BLUE SKY AND IN A SEA, WITH THE SEA SURFACE BEING BLUE AND HAVING WAVES, WITH THE BLUE BOTTOM PORTION OF THE ICEBERG EXTENDING BELOW THE SEA SURFACE INTO A BLACK UNDERWATER

FOR INSTITUTIONAL INVESTMENT CONSULTANT SERVICES TO PENSION FUNDS, MUTUAL FUND BOARDS AND INSTITUTIONS EXERCISING OVERSIGHT OVER THIRD PARTY ASSET MANAGERS IN THE FIELD OF MONITORING AND EXERCISING OVERSIGHT OVER EXTERNAL ASSET MANAGERS TO INSURE ADHERENCE TO BEST FINANCIAL PRACTICES AND APPROPRIATE FIDUCIARY STANDARDS AND THE FIELD OF DEVELOPING APPROPRIATE STRATEGIES FOR SUCH PENSION FUNDS, MUTUAL FUND BOARDS AND INSTITUTIONS EXERCISING OVERSIGHT OVER THIRD PARTY ASSET MANAGERS TO TRANSFER INVESTMENT PORTFOLIOS FROM AN EXISTING INVESTMENT MANAGER TO ANOTHER INVESTMENT MANAGER IN ADHERENCE TO BEST FINANCIAL PRACTICES AND APPROPRIATE FIDUCIARY STANDARDS (U.S. CLS. 100, 101 AND 102).

FIRST USE 5-4-2010; IN COMMERCE 5-4-2010.

RUDY R. SINGLETON, EXAMINING ATTORNEY



**CLASS 36—(Continued).**

SN 85-195,225. FIXED INCOME LIVE, LP, ORANGE, CA. FILED 12-10-2010.

## the Daily Hoot

THE MARK CONSISTS OF STANDARD CHARACTERS WITHOUT CLAIM TO ANY PARTICULAR FONT, STYLE, SIZE, OR COLOR.

NO CLAIM IS MADE TO THE EXCLUSIVE RIGHT TO USE "DAILY", APART FROM THE MARK AS SHOWN.

FOR PROVIDING A WEBSITE FEATURING FINANCIAL NEWS AND INFORMATION IN THE FORM OF NON-DOWNLOADABLE VIDEO SEGMENTS GIVING CURRENT MARKET UPDATES FROM VARIOUS MARKET PARTICIPANTS, NAMELY, ECONOMISTS, TRADERS, ANALYSTS, INVESTORS AND SALES PERSONS, IN ORDER TO KEEP ABREAST OF THE FIXED INCOME MARKETS AND ECONOMY (U.S. CLS. 100, 101 AND 102).

FIRST USE 7-15-2010; IN COMMERCE 7-15-2010.  
JOHN E. MICHOS, EXAMINING ATTORNEY

SN 85-195,922. MARYLAND AREA REGIONAL CENTER LLC, CHEVY CHASE, MD. FILED 12-11-2010.



**MARYLAND AREA REGIONAL CENTER LLC (MARC)**

NO CLAIM IS MADE TO THE EXCLUSIVE RIGHT TO USE "MARYLAND AREA REGIONAL CENTER LLC", APART FROM THE MARK AS SHOWN.

THE MARK CONSISTS OF THE IMAGE OF A HANDSHAKE WITH ONE HAND CONSISTING OF STARS AND STRIPES, WITH THE WORDING "MARYLAND AREA REGIONAL CENTER LLC (MARC)" LOCATED BELOW THE IMAGE.

FOR FINANCING OF REAL ESTATE DEVELOPMENT PROJECTS; REAL ESTATE FUNDS INVESTMENT SERVICES; REAL ESTATE INVESTMENT SERVICES (U.S. CLS. 100, 101 AND 102).

FIRST USE 7-0-2010; IN COMMERCE 7-0-2010.  
SEAN CROWLEY, EXAMINING ATTORNEY

SN 85-196,789. SWISS WATCH INTERNATIONAL, INC., HOLLYWOOD, FL. FILED 12-13-2010.

## Stress-Free Payment

THE MARK CONSISTS OF STANDARD CHARACTERS WITHOUT CLAIM TO ANY PARTICULAR FONT, STYLE, SIZE, OR COLOR.

NO CLAIM IS MADE TO THE EXCLUSIVE RIGHT TO USE "PAYMENT", APART FROM THE MARK AS SHOWN.

FOR FINANCING OF PURCHASES (U.S. CLS. 100, 101 AND 102).

MARK T. MULLEN, EXAMINING ATTORNEY

**CLASS 36—(Continued).**

SN 85-197,120. ZENO CONSULTING GROUP, LLC, BETHESDA, MD. FILED 12-14-2010.



THE COLOR(S) BLUE AND WHITE IS/ARE CLAIMED AS A FEATURE OF THE MARK.

THE MARK CONSISTS OF A WHITE AND BLUE ICEBERG, AGAINST A BLUE AND WHITE SKY, IN A SMOOTH BLUE SEA

FOR INSTITUTIONAL INVESTMENT CONSULTANT SERVICES TO PENSION FUNDS, MUTUAL FUND BOARDS AND INSTITUTIONS EXERCISING OVERSIGHT OVER THIRD PARTY ASSET MANAGERS IN THE FIELD OF MONITORING AND EXERCISING OVERSIGHT OVER EXTERNAL ASSET MANAGERS TO INSURE ADHERENCE TO BEST FINANCIAL PRACTICES AND APPROPRIATE FIDUCIARY STANDARDS AND THE FIELD OF DEVELOPING APPROPRIATE STRATEGIES FOR SUCH PENSION FUNDS, MUTUAL FUND BOARDS AND INSTITUTIONS EXERCISING OVERSIGHT OVER THIRD PARTY ASSET MANAGERS TO TRANSFER INVESTMENT PORTFOLIOS FROM AN EXISTING INVESTMENT MANAGER TO ANOTHER INVESTMENT MANAGER IN ADHERENCE TO BEST FINANCIAL PRACTICES AND APPROPRIATE FIDUCIARY STANDARDS (U.S. CLS. 100, 101 AND 102).

RUDY R. SINGLETON, EXAMINING ATTORNEY

SN 85-198,410. INDIANA SPORTS OUTREACH, INC., INDIANAPOLIS, IN. FILED 12-15-2010.



THE COLOR(S) BLACK, BROWN, RED, BLUE, AND WHITE IS/ARE CLAIMED AS A FEATURE OF THE MARK.

THE MARK CONSISTS OF A SOCCER BALL WITH A BLACK BORDER BETWEEN ALTERNATING RED AND WHITE, BROWN AND WHITE, AND BLUE AND WHITE SEGMENTS CONTAINING RANDOM DESIGNS.

FOR CHARITABLE FUNDRAISING SERVICES (U.S. CLS. 100, 101 AND 102).

FIRST USE 12-31-2005; IN COMMERCE 12-31-2005.  
PAUL F. GAST, EXAMINING ATTORNEY

**CLASS 36—(Continued).**

SN 85-199,842. LIFELINK LEGACY FUND, INC., TAMPA, FL. FILED 12-16-2010.

**TOUR DE TRANSPLANT**

THE MARK CONSISTS OF STANDARD CHARACTERS WITHOUT CLAIM TO ANY PARTICULAR FONT, STYLE, SIZE, OR COLOR.

FOR CHARITABLE FUNDRAISING SERVICES (U.S. CLS. 100, 101 AND 102).

KARANENDRA S. CHHINA, EXAMINING ATTORNEY

---

SN 85-199,986. C&S WHOLESALE GROCERS, INC., KEENE, NH. FILED 12-16-2010.

**C&S CHARITIES, INC.**

THE MARK CONSISTS OF STANDARD CHARACTERS WITHOUT CLAIM TO ANY PARTICULAR FONT, STYLE, SIZE, OR COLOR.

OWNER OF U.S. REG. NOS. 2,850,936, 3,722,278 AND OTHERS.

NO CLAIM IS MADE TO THE EXCLUSIVE RIGHT TO USE "CHARITIES, INC.", APART FROM THE MARK AS SHOWN.

FOR CHARITABLE FUNDRAISING; CHARITABLE FUNDRAISING SERVICES; CHARITABLE FUND RAISING SERVICES BY MEANS OF A GOLF EVENT; CHARITABLE SERVICES, NAMELY, PROVIDING FINANCIAL SUPPORT TO CHARITIES SUPPORTING CHILDREN (U.S. CLS. 100, 101 AND 102).

FIRST USE 8-3-2010; IN COMMERCE 8-3-2010.  
MAYUR VAGHANI, EXAMINING ATTORNEY

---

SN 85-200,063. GROSVENOR USA LIMITED, SAN FRANCISCO, CA. FILED 12-16-2010.



THE MARK CONSISTS OF THREE EARS OF WHEAT CURVED TO FORM CIRCLE.

FOR FINANCIAL SERVICES, NAMELY, CAPITAL INVESTMENT; REAL ESTATE MANAGEMENT SERVICES; LEASING OF REAL ESTATE (U.S. CLS. 100, 101 AND 102).

FIRST USE 2-0-2004; IN COMMERCE 2-0-2004.  
ZHALEH DELANEY, EXAMINING ATTORNEY

**CLASS 36—(Continued).**

SN 85-200,076. GROSVENOR USA LIMITED, SAN FRANCISCO, CA. FILED 12-16-2010.

**LIVING CITIES**

THE MARK CONSISTS OF STANDARD CHARACTERS WITHOUT CLAIM TO ANY PARTICULAR FONT, STYLE, SIZE, OR COLOR.

FOR FINANCIAL SERVICES, NAMELY, CAPITAL INVESTMENT; REAL ESTATE MANAGEMENT SERVICES; LEASING OF REAL ESTATE (U.S. CLS. 100, 101 AND 102).

FIRST USE 5-0-2005; IN COMMERCE 5-0-2005.  
ZHALEH DELANEY, EXAMINING ATTORNEY

---

SN 85-200,325. WIERENGA ASSET MANAGEMENT, INC., DBA SOLOMON'S PLAN, BYRON CENTER, MI. FILED 12-17-2010.



THE COLOR(S) BROWN AND GREEN IS/ARE CLAIMED AS A FEATURE OF THE MARK.

THE MARK CONSISTS OF THE FIRST PORTION OF THE LITERAL ELEMENT, "SOLOMON'S PLAN", IS WRITTEN IN CAPITAL LETTERS IN BROWN (PMS 4625) WITH A STYLIZED TREE OF SEVEN BRANCHES INTEGRATED INTO THE APOSTROPHE. THE STYLIZED TREE'S LEAVES ARE GREEN (PMS 5753). A BROWN (PMS 4625) DIVIDING LINE APPEARS BELOW THE FIRST LITERAL ELEMENT AND EXTENDS EDGE TO EDGE. BELOW THAT LINE, THE SECOND PORTION OF THE LITERAL ELEMENT, "INVEST WISELY. LIVE ABUNDANTLY.", APPEARS IN ALL CAPS IN BROWN (PMS 4625) AS A TAGLINE.

FOR ADVICE RELATING TO INVESTMENTS; PROVIDING FINANCIAL SERVICES WITH RESPECT TO SECURITIES AND OTHER FINANCIAL INSTRUMENTS AND PRODUCTS, NAMELY, TRADING OF AND INVESTMENTS IN SECURITIES AND FINANCIAL INSTRUMENTS AND PRODUCTS FOR OTHERS (U.S. CLS. 100, 101 AND 102).

FIRST USE 9-22-2010; IN COMMERCE 10-24-2010.  
ARETHA SOMERVILLE, EXAMINING ATTORNEY

**CLASS 36—(Continued).**

SN 85-200,569. THE SALVATION ARMY, ATLANTA, GA.  
FILED 12-17-2010.

## Cashless Kettle

THE MARK CONSISTS OF STANDARD CHARACTERS WITHOUT CLAIM TO ANY PARTICULAR FONT, STYLE, SIZE, OR COLOR.

FOR CHARITABLE SERVICES, NAMELY CHARITABLE FUND RAISING FOR A RELIGIOUS AND CHARITABLE ENTITY (U.S. CLS. 100, 101 AND 102).

FIRST USE 11-17-2008; IN COMMERCE 11-17-2008.  
PAUL E. FAHRENKOPF, EXAMINING ATTORNEY

SN 85-200,975. DOUBLEWIDE PARTNERS I, LLC, RICHARDSON, TX. FILED 12-17-2010.

## BLINKPAY

THE MARK CONSISTS OF STANDARD CHARACTERS WITHOUT CLAIM TO ANY PARTICULAR FONT, STYLE, SIZE, OR COLOR.

FOR BILL PAYMENT SERVICES; BILL PAYMENT SERVICES PROVIDED THROUGH A WEBSITE; CREDIT CARD AND PAYMENT CARD SERVICES; CREDIT CARD PAYMENT PROCESSING SERVICES; ELECTRONIC PAYMENT, NAMELY, ELECTRONIC PROCESSING AND TRANSMISSION OF BILL PAYMENT DATA; FINANCIAL TRANSACTION SERVICES, NAMELY, PROVIDING SECURE COMMERCIAL TRANSACTIONS AND PAYMENT OPTIONS; PAYMENT PROCESSING SERVICES, NAMELY, CREDIT CARD AND DEBIT CARD TRANSACTION PROCESSING SERVICES; PROVIDING ELECTRONIC PROCESSING OF CREDIT CARD TRANSACTIONS AND ELECTRONIC PAYMENTS VIA A GLOBAL COMPUTER NETWORK; PROVIDING ELECTRONIC PROCESSING OF ELECTRONIC FUNDS TRANSFER, ACH, CREDIT CARD, DEBIT CARD, ELECTRONIC CHECK AND ELECTRONIC PAYMENTS (U.S. CLS. 100, 101 AND 102).

CAROLYN CATALDO, EXAMINING ATTORNEY

SN 85-201,798. THE BANCORP BANK, WILMINGTON, DE.  
FILED 12-20-2010.

## COLI+PLUS

THE MARK CONSISTS OF STANDARD CHARACTERS WITHOUT CLAIM TO ANY PARTICULAR FONT, STYLE, SIZE, OR COLOR.

FOR LENDING SERVICES, NAMELY, COMMERCIAL LOANS AND COMMERCIAL LOAN FINANCING (U.S. CLS. 100, 101 AND 102).

KAELIE KUNG, EXAMINING ATTORNEY

**CLASS 36—(Continued).**

SN 85-202,423. TRICERION GROUP, LLC, ALPHARETTA, GA. FILED 12-21-2010.



THE MARK CONSISTS OF A SERIES OF FIVE CIRCLES OF VARYING SIZE LINEARLY ARRANGED IN A DIAGONAL ORIENTATION, WITH TWO CIRCLES LINEARLY ARRANGED IN A PERPENDICULAR FASHION TO THE SERIES OF FIVE CIRCLES.

FOR PROCESSING, ADMINISTERING AND MANAGING EMPLOYEE BENEFIT PLANS CONCERNING INSURANCE AND FINANCE (U.S. CLS. 100, 101 AND 102).

FIRST USE 9-30-2007; IN COMMERCE 9-30-2007.  
CHERYL CLAYTON, EXAMINING ATTORNEY

SN 85-202,603. LANSING AUTOMAKERS FEDERAL CREDIT UNION, LANSING, MI. FILED 12-21-2010.

**LAFCU**

THE MARK CONSISTS OF BLOCK LETTERS "LAFCU" WITH THREE LINES FOR THE LEADING EDGE OF THE LETTER "A".

FOR CREDIT UNION SERVICES (U.S. CLS. 100, 101 AND 102).

FIRST USE 1-26-2004; IN COMMERCE 1-26-2004.  
ARETHA SOMERVILLE, EXAMINING ATTORNEY

**CLASS 36—(Continued).**

SN 85-202,669. R. V. NUCCIO & ASSOCIATES INSURANCE BROKERS, INC., TOLUCA LAKE, CA. FILED 12-21-2010.

# WEDSURE

THE MARK CONSISTS OF STANDARD CHARACTERS WITHOUT CLAIM TO ANY PARTICULAR FONT, STYLE, SIZE, OR COLOR.

FOR PROPERTY AND CASUALTY UNDERWRITING SERVICES (U.S. CLS. 100, 101 AND 102).

FIRST USE 4-0-2008; IN COMMERCE 4-0-2008.  
SUNG IN, EXAMINING ATTORNEY

SN 85-202,849. ALS HOPE FOUNDATION, PHILADELPHIA, PA. FILED 12-21-2010.

# PhIND

THE MARK CONSISTS OF STANDARD CHARACTERS WITHOUT CLAIM TO ANY PARTICULAR FONT, STYLE, SIZE, OR COLOR.

FOR CHARITABLE FUNDRAISING TO FINANCE RESEARCH, PROMOTE COLLABORATION, ORGANIZE CONFERENCES, AND TRAIN SCIENTISTS FOR FINDING A CURE FOR NERVOUS SYSTEM INJURIES AND NEUROLOGICAL DISORDERS (U.S. CLS. 100, 101 AND 102).

CHERYL CLAYTON, EXAMINING ATTORNEY

**CLASS 36—(Continued).**

SN 85-203,248. FIRST TECHNOLOGY CREDIT UNION, DBA FIRST TECH CREDIT UNION, PORTLAND, OR. FILED 12-21-2010.



The logo for First Tech federal credit union features the words "First Tech" in a bold, sans-serif font. The word "First" is in black and "Tech" is in a dark blue color. To the right of "Tech" is a stylized blue icon consisting of two triangles pointing towards each other to form a square. Below "First Tech" is the text "federal credit union" in a smaller, lowercase, sans-serif font.

OWNER OF U.S. REG. NOS. 3,163,172, 3,888,198 AND OTHERS.

NO CLAIM IS MADE TO THE EXCLUSIVE RIGHT TO USE "FIRST AND FEDERAL CREDIT UNION", APART FROM THE MARK AS SHOWN.

THE MARK CONSISTS OF "FIRST 1 TECH FEDERAL CREDIT UNION" WITH STYLIZED NUMERAL "1" CREATED AS SILHOUETTE BETWEEN OPPOSING BASES OF TRIANGLES ALIGNED VERTICALLY.

FOR ATM BANKING SERVICES; BANKING SERVICES; CHECKING ACCOUNT SERVICES; CREDIT AND LOAN SERVICES; CREDIT CARD AND DEBIT CARD SERVICES; CREDIT UNION SERVICES; CREDIT UNION SERVICES PROVIDED BY MOBILE TELEPHONE CONNECTIONS; CREDIT UNIONS; DEBIT CARD SERVICES; ELECTRONIC BANKING VIA A GLOBAL COMPUTER NETWORK; ELECTRONIC DEBIT TRANSACTIONS; FINANCIAL CONSULTING SERVICES, NAMELY, EXPERT ANALYSIS IN FINANCE; FINANCIAL SERVICES, NAMELY, SAVINGS PROGRAMS FOR YOUTHS; FINANCING AND LOAN SERVICES; FINANCING OF PURCHASES; FINANCING RELATING TO AUTOMOBILES; FINANCING SERVICES; HOME BANKING; HOME EQUITY LOANS; INSTALLMENT LOANS; ISSUANCE OF CREDIT CARDS; LOAN FINANCING; MORTGAGE BANKING SERVICES, NAMELY, ORIGINATION, ACQUISITION, SERVICING, SECURITIZATION AND BROKERAGE OF MORTGAGE LOANS; ON-LINE BANKING SERVICES; PROVIDING BANK ACCOUNT INFORMATION BY TELEPHONE; PROVIDING ELECTRONIC PROCESSING OF ACH AND CREDIT CARD TRANSACTIONS AND ELECTRONIC PAYMENTS VIA A GLOBAL COMPUTER NETWORK; PROVIDING ELECTRONIC PROCESSING OF ELECTRONIC FUNDS TRANSFER, ACH, CREDIT CARD, DEBIT CARD, ELECTRONIC CHECK AND ELECTRONIC PAYMENTS; PROVIDING INFORMATION AND ADVICE IN THE FIELD OF FINANCE, FINANCIAL INVESTMENTS, FINANCIAL VALUATIONS, AND THE FINANCIAL ASPECTS OF RETIREMENT; PROVIDING STUDENT LOAN INFORMATION; PROVIDING STUDENT LOANS; PROVIDING TEMPORARY LOANS; REVOLVING LOANS; SAFE DEPOSIT BOX SERVICES; SAVINGS ACCOUNT SERVICES; STUDENT LOAN SERVICES; TEMPORARY LOANS (U.S. CLS. 100, 101 AND 102).

DAVID I, EXAMINING ATTORNEY

**CLASS 36—(Continued).**

SN 85-203,346. NEUBERGER BERMAN MANAGEMENT LLC, NEW YORK, NY. FILED 12-21-2010.

NEUBERGER BERMAN GUARDIAN  
FUND

THE MARK CONSISTS OF STANDARD CHARACTERS WITHOUT CLAIM TO ANY PARTICULAR FONT, STYLE, SIZE, OR COLOR.

OWNER OF U.S. REG. NO. 1,959,844.

NO CLAIM IS MADE TO THE EXCLUSIVE RIGHT TO USE "FUND", APART FROM THE MARK AS SHOWN.

FOR INVESTMENT ADVISORY AND MUTUAL FUND SERVICES, NAMELY SPONSORING MUTUAL FUNDS, PROVIDING ADMINISTRATION AND SHAREHOLDER SERVICES TO MUTUAL FUNDS, DISTRIBUTING MUTUAL FUND SHARES AND MANAGING FUNDS, STOCKS AND BONDS AND OTHER INVESTMENTS FOR INSTITUTIONS AND THE GENERAL PUBLIC (U.S. CLS. 100, 101 AND 102).

FIRST USE 6-1-1950; IN COMMERCE 6-1-1950.  
HEATHER SAPP, EXAMINING ATTORNEY

SN 85-203,347. FIRST TECHNOLOGY FEDERAL CREDIT UNION, DBA FIRST TECH CREDIT UNION, PORTLAND, OR. FILED 12-21-2010.

First  Tech  
insurance services

OWNER OF U.S. REG. NOS. 3,163,172, 3,888,198 AND OTHERS.

NO CLAIM IS MADE TO THE EXCLUSIVE RIGHT TO USE "FIRST" OR "INSURANCE SERVICES", APART FROM THE MARK AS SHOWN.

THE MARK CONSISTS OF "FIRST 1 TECH INSURANCE SERVICES" WITH A STYLIZED NUMERAL "1" CREATED AS A SILHOUETTE BETWEEN OPPOSING BASES OF TRIANGLES ALIGNED VERTICALLY.

FOR CONSULTING AND INFORMATION CONCERNING INSURANCE; FINANCIAL CONSULTANCY AND INSURANCE CONSULTANCY; FINANCIAL EVALUATION FOR INSURANCE PURPOSES; INSURANCE AGENCY AND BROKERAGE; INSURANCE AND FINANCIAL INFORMATION AND CONSULTANCY SERVICES; INSURANCE CONSULTANCY SERVICES, NAMELY, PROVIDING ADVICE IN THE FIELD OF PROPERTY AND CASUALTY INSURANCE; INSURANCE SERVICES, NAMELY, UNDERWRITING, ISSUING AND ADMINISTRATION OF LIFE INSURANCE; INSURANCE SERVICES, NAMELY, WRITING PROPERTY AND CASUALTY INSURANCE (U.S. CLS. 100, 101 AND 102).

LAURIE KAUFMAN, EXAMINING ATTORNEY

**CLASS 36—(Continued).**

SN 85-203,362. FIRST TECHNOLOGY CREDIT UNION, DBA FIRST TECH CREDIT UNION, PORTLAND, OR. FILED 12-21-2010.

Addison  Avenue  
investment services

OWNER OF U.S. REG. NOS. 2,608,032, 3,423,442 AND 3,425,023.

NO CLAIM IS MADE TO THE EXCLUSIVE RIGHT TO USE "INVESTMENT SERVICES", APART FROM THE MARK AS SHOWN.

THE MARK CONSISTS OF "ADDISON 1 AVENUE INVESTMENT SERVICES" WITH A STYLIZED NUMERAL "1" CREATED AS A SILHOUETTE BETWEEN OPPOSING BASES OF TRIANGLE ALIGNED VERTICALLY.

FOR FINANCIAL AND INVESTMENT SERVICES, NAMELY, MANAGEMENT AND BROKERAGE IN THE FIELDS OF STOCKS, BONDS, OPTIONS, COMMODITIES, FUTURES AND OTHER SECURITIES, AND THE INVESTMENT OF FUNDS OF OTHERS; FINANCIAL INVESTMENT ANALYSIS AND STOCK RESEARCH; FINANCIAL INVESTMENT BROKERAGE SERVICES; FINANCIAL PLANNING AND INVESTMENT ADVISORY SERVICES; FINANCIAL SERVICES, NAMELY, ADMINISTRATION OF TRANSACTIONS INVOLVING FUNDS DRAWN FROM SECURITIES, STOCKS, FUNDS, EQUITIES, BONDS, CASH, OR OTHER TYPES OF FINANCIAL INVESTMENTS IN RETIREMENT PLANS USING A CHECK OR NEGOTIABLE ORDER OF WITHDRAWAL OVER A GLOBAL DATA NETWORK; FINANCIAL SERVICES, NAMELY, ADMINISTRATION OF TRANSACTIONS INVOLVING FUNDS DRAWN FROM SECURITIES, STOCKS, FUNDS, EQUITIES, BONDS, CASH, OR OTHER TYPES OF FINANCIAL INVESTMENTS IN RETIREMENT PLANS USING A CREDIT OR DEBIT CARD OVER A GLOBAL DATA NETWORK; FINANCIAL SERVICES, NAMELY, COORDINATION, WITHIN A SINGLE ACCOUNT, OF AN INVESTMENT PORTFOLIO'S MAINTENANCE, TRADING, REBALANCING, AND TAX MANAGEMENT NEEDS; FINANCIAL SERVICES, NAMELY, INVESTMENT ADVICE, INVESTMENT MANAGEMENT, INVESTMENT CONSULTATION AND INVESTMENT OF FUNDS FOR OTHERS, INCLUDING PRIVATE AND PUBLIC EQUITY AND DEBT INVESTMENT SERVICES; INVESTMENT ADVISORY SERVICES; INVESTMENT BY ELECTRONIC MEANS; INVESTMENT MANAGEMENT OF AND DISTRIBUTION OF ANNUITIES; MUTUAL FUND INVESTMENT; MUTUAL FUNDS AND CAPITAL INVESTMENT; PROVIDING FINANCIAL SERVICES WITH RESPECT TO SECURITIES AND OTHER FINANCIAL INSTRUMENTS AND PRODUCTS, NAMELY, TRADING OF AND INVESTMENTS IN SECURITIES AND FINANCIAL INSTRUMENTS AND PRODUCTS FOR OTHERS; PROVIDING INFORMATION AND ADVICE IN THE FIELD OF FINANCE, FINANCIAL INVESTMENTS, FINANCIAL VALUATIONS, AND THE FINANCIAL ASPECTS OF RETIREMENT; PROVIDING INFORMATION AND RESEARCH IN THE FIELD OF FINANCE AND FINANCIAL INVESTMENTS (U.S. CLS. 100, 101 AND 102).

DAVID I, EXAMINING ATTORNEY

**CLASS 36—(Continued).**

SN 85-203,512. CALAMOS HOLDINGS LLC, NAPERVILLE, IL. FILED 12-22-2010.

**DRIVEN BY INDEPENDENT  
THINKING**

THE MARK CONSISTS OF STANDARD CHARACTERS WITHOUT CLAIM TO ANY PARTICULAR FONT, STYLE, SIZE, OR COLOR.

FOR FINANCIAL ADVICE; FINANCIAL ANALYSES; FINANCIAL ANALYSIS AND CONSULTATION; FINANCIAL ASSET MANAGEMENT; FINANCIAL CONSULTING; FINANCIAL INVESTMENT IN THE FIELD OF SECURITIES; FINANCIAL PORTFOLIO MANAGEMENT; INVESTMENT SERVICES, NAMELY, ASSET ACQUISITION, CONSULTATION, DEVELOPMENT AND MANAGEMENT SERVICES (U.S. CLS. 100, 101 AND 102).

EDWARD FENNESSY, EXAMINING ATTORNEY

SN 85-203,592. BIG BROTHERS BIG SISTERS LONE STAR, IRVING, TX. FILED 12-22-2010.

**Little Big Shot**

THE MARK CONSISTS OF STANDARD CHARACTERS WITHOUT CLAIM TO ANY PARTICULAR FONT, STYLE, SIZE, OR COLOR.

FOR CHARITABLE FUNDRAISING SERVICES (U.S. CLS. 100, 101 AND 102).

INGA ERVIN, EXAMINING ATTORNEY

SN 85-203,659. 38 KEYES AVE SUITE 200, SAN FRANCISCO, CA. FILED 12-22-2010.



THE MARK CONSISTS OF THE DEPICTION OF A MAN SUPPORTING AN ARMILLARY SPHERE ON HIS SHOULDERS.

FOR FINANCIAL ADVISORY AND CONSULTANCY SERVICES (U.S. CLS. 100, 101 AND 102).

FIRST USE 1-5-2003; IN COMMERCE 1-5-2003.  
CHRISTOPHER BUONGIORNO, EXAMINING ATTORNEY

**CLASS 36—(Continued).**

SN 85-203,870. THOMVEST SEED CAPITAL INC., TORONTO, ONTARIO, CANADA, FILED 12-22-2010.



THE MARK CONSISTS OF A STYLIZED "T" AND "V" CONTRASTING AND CENTERED ON AN OVAL BACKGROUND DESIGN.

FOR PROVIDING WORKING CAPITAL FINANCING TO BUSINESSES AND BUSINESS OWNERS; VENTURE CAPITAL SERVICES, NAMELY, PROVIDING FINANCING TO EMERGING AND START-UP COMPANIES; FINANCIAL SERVICES, NAMELY INVESTMENT ADVICE, INVESTMENT MANAGEMENT, AND INVESTMENT CONSULTATION; MANAGEMENT OF A CAPITAL INVESTMENT FUND (U.S. CLS. 100, 101 AND 102).

FIRST USE 11-5-2010; IN COMMERCE 11-5-2010.  
MARK SPARACINO, EXAMINING ATTORNEY

SN 85-203,927. NAV ADVISORS INC, PORT CHARLOTTE, FL. FILED 12-22-2010.

**Navigating All Your Needs**

THE MARK CONSISTS OF STANDARD CHARACTERS WITHOUT CLAIM TO ANY PARTICULAR FONT, STYLE, SIZE, OR COLOR.

FOR FINANCIAL PLANNING AND INVESTMENT ADVISORY SERVICES; FINANCIAL PLANNING FOR RETIREMENT; INSURANCE AGENCIES IN THE FIELD OF HEALTH AND LIFE POLICIES; TRUST SERVICES, NAMELY, INVESTMENT AND TRUST COMPANY SERVICES (U.S. CLS. 100, 101 AND 102).

FIRST USE 2-1-2010; IN COMMERCE 2-1-2010.  
KEVIN DINALLO, EXAMINING ATTORNEY

**CLASS 36—(Continued).**

SN 85-203,934. ASSOCIATED BANC-CORP, GREEN BAY, WI. FILED 12-22-2010.

## BUSINESS CHOICE

THE MARK CONSISTS OF STANDARD CHARACTERS WITHOUT CLAIM TO ANY PARTICULAR FONT, STYLE, SIZE, OR COLOR.

NO CLAIM IS MADE TO THE EXCLUSIVE RIGHT TO USE "BUSINESS", APART FROM THE MARK AS SHOWN, FOR CHECKING ACCOUNT SERVICES FOR SOLE PROPRIETORS AND BUSINESSES (U.S. CLS. 100, 101 AND 102).

FIRST USE 2-7-2006; IN COMMERCE 2-7-2006.  
DAVID TOOLEY, EXAMINING ATTORNEY

---

SN 85-203,966. NANCY TAYLOR BUBES, WASHINGTON, DC. FILED 12-22-2010.

## A Taylor House

THE MARK CONSISTS OF STANDARD CHARACTERS WITHOUT CLAIM TO ANY PARTICULAR FONT, STYLE, SIZE, OR COLOR.

NO CLAIM IS MADE TO THE EXCLUSIVE RIGHT TO USE "HOUSE", APART FROM THE MARK AS SHOWN.

FOR COMMERCIAL AND RESIDENTIAL REAL ESTATE AGENCY SERVICES (U.S. CLS. 100, 101 AND 102).

FIRST USE 9-1-1991; IN COMMERCE 9-1-1991.  
JACQUELINE A. LAVINE, EXAMINING ATTORNEY

---

SN 85-203,967. SAM SCHMIDT FOUNDATION, DBA SAM SCHMIDT PARALYSIS FOUNDATION, PRINCETON, NJ. FILED 12-22-2010.

## RACING TO RECOVERY

THE MARK CONSISTS OF STANDARD CHARACTERS WITHOUT CLAIM TO ANY PARTICULAR FONT, STYLE, SIZE, OR COLOR.

OWNER OF U.S. REG. NO. 2,658,991.

FOR CHARITABLE FUND RAISING, NAMELY, TO RAISE FUNDS TO SUPPORT RESEARCH TO DEVELOP EFFECTIVE TREATMENTS AND A CURE FOR PARALYSIS CAUSED BY SPINAL CORD AND OTHER CENTRAL NERVOUS SYSTEM DISORDERS TO PROVIDE EDUCATION, REHABILITATION AND ASSISTANCE WITH MEDICAL EXPENSES OF INDIVIDUALS WITH SPINAL CORD INJURIES AND OTHER CENTRAL NERVOUS SYSTEM DISORDERS (U.S. CLS. 100, 101 AND 102).

FIRST USE 2-17-2000; IN COMMERCE 2-17-2000.  
JACQUELINE A. LAVINE, EXAMINING ATTORNEY

**CLASS 36—(Continued).**

SN 85-204,237. ODESS, DANIEL B., CORAL GABLES, FL. FILED 12-22-2010.

## CLAIMS TO FAME

THE MARK CONSISTS OF STANDARD CHARACTERS WITHOUT CLAIM TO ANY PARTICULAR FONT, STYLE, SIZE, OR COLOR.

FOR INSURANCE ADJUSTING AND APPRAISAL SERVICES (U.S. CLS. 100, 101 AND 102).

BRIAN NEVILLE, EXAMINING ATTORNEY

---

SN 85-204,270. ODESS, DANIEL B., CORAL GABLES, FL. FILED 12-22-2010.

## DON'T SETTLE FOR LESS

THE MARK CONSISTS OF STANDARD CHARACTERS WITHOUT CLAIM TO ANY PARTICULAR FONT, STYLE, SIZE, OR COLOR.

FOR INSURANCE ADJUSTING AND APPRAISAL SERVICES (U.S. CLS. 100, 101 AND 102).

FIRST USE 8-0-2010; IN COMMERCE 8-0-2010.  
BRIAN NEVILLE, EXAMINING ATTORNEY

---

SN 85-204,406. BUYERMLS, LLC, OAKS, PA. FILED 12-22-2010.

## OPENING DOORS TO CLOSING DEALS

THE MARK CONSISTS OF STANDARD CHARACTERS WITHOUT CLAIM TO ANY PARTICULAR FONT, STYLE, SIZE, OR COLOR.

FOR PROVIDING INFORMATION IN THE FIELD OF REAL ESTATE VIA THE INTERNET (U.S. CLS. 100, 101 AND 102).

JAMES MACFARLANE, EXAMINING ATTORNEY

**CLASS 36—(Continued).**

SN 85-204,540. NIELSEN, JOHN M, SAN FRANCISCO, CA. FILED 12-22-2010.

# BizRisk

THE MARK CONSISTS OF STANDARD CHARACTERS WITHOUT CLAIM TO ANY PARTICULAR FONT, STYLE, SIZE, OR COLOR.

FOR INSURANCE AGENCIES IN THE FIELD OF HEALTH CARE, EMPLOYEE BENEFITS, PROPERTY, CASUALTY INSURANCE, ERRORS AND OMISSIONS, DIRECTORS AND OFFICERS COVERAGE, PROPERTY, CASUALTY, COMMERCIAL AUTOMOBILE COVERAGE, CRIME COVERAGE, AVIATION INSURANCE, ENVIRONMENTAL INSURANCE, ACCIDENT AND HEALTH, KIDNAP AND RANSOM INSURANCE, DISABILITY INSURANCE, BUSINESS INTERRUPTION INSURANCE, INLAND MARINE INSURANCE, OCEAN CARGO INSURANCE; INSURANCE BROKERAGE IN THE FIELD OF HEALTH CARE, DENTAL INSURANCE, EMPLOYEE BENEFITS, PROPERTY, CASUALTY INSURANCE, ERRORS AND OMISSIONS, DIRECTORS AND OFFICERS COVERAGE, PROPERTY, CASUALTY, COMMERCIAL AUTOMOBILE COVERAGE, CRIME COVERAGE, AVIATION INSURANCE, ENVIRONMENTAL INSURANCE, ACCIDENT AND HEALTH, KIDNAP AND RANSOM INSURANCE, DISABILITY INSURANCE, BUSINESS INTERRUPTION INSURANCE, INLAND MARINE INSURANCE, OCEAN CARGO INSURANCE (U.S. CLS. 100, 101 AND 102).

JENNIFER MARTIN, EXAMINING ATTORNEY

---

SN 85-204,637. A NEW FINANCIAL PLAN, LLC, TULSA, OK. FILED 12-23-2010.



THE MARK CONSISTS OF A SUN, RISING OR SETTING (PARTIALLY EXPOSED OR PARTIALLY OBSTRUCTED) ATOP A CURVED LINE, OVER THE WORDS "A NEW FINANCIAL PLAN DREAM BIG. LIVE SMALL".

FOR PROVIDING INFORMATION IN THE FIELD OF PERSONAL FINANCE (U.S. CLS. 100, 101 AND 102). FIRST USE 12-19-2010; IN COMMERCE 12-19-2010. ANDREA BUTLER, EXAMINING ATTORNEY

**CLASS 36—(Continued).**

SN 85-204,758. TECHFELLOW 2010 FUND MANAGEMENT, LLC, SAN FRANCISCO, CA. FILED 12-23-2010.

# TECHFELLOW

THE MARK CONSISTS OF STANDARD CHARACTERS WITHOUT CLAIM TO ANY PARTICULAR FONT, STYLE, SIZE, OR COLOR.

FOR VENTURE CAPITAL FUNDING SERVICES TO EMERGING AND START-UP COMPANIES (U.S. CLS. 100, 101 AND 102).

AMY C. KEAN, EXAMINING ATTORNEY

---

SN 85-204,774. TECHFELLOW 2010 FUND MANAGEMENT, LLC, SAN FRANCISCO, CA. FILED 12-23-2010.

# TECHFELLOW AWARDS

THE MARK CONSISTS OF STANDARD CHARACTERS WITHOUT CLAIM TO ANY PARTICULAR FONT, STYLE, SIZE, OR COLOR.

FOR VENTURE CAPITAL FUNDING SERVICES TO EMERGING AND START-UP COMPANIES (U.S. CLS. 100, 101 AND 102).

AMY C. KEAN, EXAMINING ATTORNEY

---

SN 85-204,805. THE ANNEXUS GROUP, LLC, SCOTTSDALE, AZ. FILED 12-23-2010.

# BalancedChoice

THE MARK CONSISTS OF THE WORDS "BALANCED" AND "CHOICE" RUN-TOGETHER AND DISPLAYED IN DIFFERENT FONTS.

FOR ISSUANCE AND ADMINISTRATION OF ANNUITIES (U.S. CLS. 100, 101 AND 102).

SCOTT BIBB, EXAMINING ATTORNEY



**CLASS 36—(Continued).**

SN 85-204,852. ARCANO ASESORES FINANCIEROS, S.L., MADRID, SPAIN, FILED 12-23-2010.

**ARCANO**

THE MARK CONSISTS OF THE WORD "ARCANO" IN STYLIZED CAPITAL LETTERS.  
 THE ENGLISH TRANSLATION OF ARCANO IN THE MARK IS SECRET/MYSTERY.  
 FOR FINANCIAL ADVICE AND CONSULTANCY SERVICES; FINANCIAL CONSULTING (U.S. CLS. 100, 101 AND 102).  
 FIRST USE 6-30-2003; IN COMMERCE 2-28-2006.  
 JOHN E. MICHOS, EXAMINING ATTORNEY

SN 85-204,980. URBAN PARTNERSHIP BANK, CHICAGO, IL. FILED 12-23-2010.

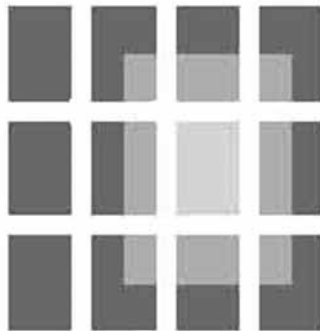

THE MARK CONSISTS OF TWELVE RECTANGLES FORMING RECTANGLE BOX WITH FOUR BOXES ACROSS AND THREE BOXES VERTICALLY PLACED WITH INTERSECTING LINES. SHADED RECTANGLE INSIDE RIGHT THREE ROWS.  
 FOR FINANCIAL INFORMATION IN THE NATURE OF RATES OF EXCHANGE; FINANCIAL SERVICES, NAMELY, PROVIDING FOR THE EXCHANGE OF FOREIGN CURRENCY, COMMODITIES, FINANCIAL DERIVATIVES, INTEREST RATE PRODUCTS, AND EQUITIES VIA THE INTERNET AND INTRANET SYSTEMS (U.S. CLS. 100, 101 AND 102).  
 DAVID I, EXAMINING ATTORNEY

**CLASS 36—(Continued).**

SN 85-205,002. EMPOWHR, INC., ATLANTA, GA. FILED 12-23-2010.

**PARCPlace**

THE MARK CONSISTS OF STANDARD CHARACTERS WITHOUT CLAIM TO ANY PARTICULAR FONT, STYLE, SIZE, OR COLOR.  
 FOR ADMINISTRATION OF EMPLOYEE BENEFIT PLANS CONCERNING INSURANCE AND FINANCE (U.S. CLS. 100, 101 AND 102).  
 FIRST USE 12-19-2010; IN COMMERCE 12-19-2010.  
 SUSAN STIGLITZ, EXAMINING ATTORNEY

SN 85-205,073. URBAN PARTNERSHIP BANK, CHICAGO, IL. FILED 12-23-2010.

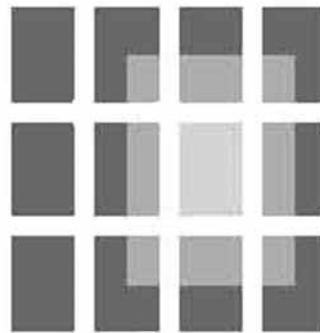

THE MARK CONSISTS OF TWELVE RECTANGLES FORMING RECTANGLE BOX WITH FOUR BOXES ACROSS AND THREE BOXES VERTICALLY PLACED WITH INTERSECTING LINES. SHADED RECTANGLE INSIDE RIGHT THREE ROWS.  
 FOR ARRANGING AND PROVISION OF CREDIT, LOANS, INSURANCE, CURRENCY EXCHANGE AND TRAVELLERS CHEQUES; ATM BANKING SERVICES; BANKING; BANKING AND FINANCING SERVICES; BANKING CONSULTATION; BANKING SERVICES; CHARGE CARD AND CREDIT CARD SERVICES; CLEARING AND RECONCILING FINANCIAL TRANSACTIONS VIA A GLOBAL COMPUTER NETWORK; CREDIT AND CASH CARD SERVICES; CREDIT AND DEBIT CARD SERVICES; CREDIT AND FINANCIAL CONSULTATION; CREDIT AND LOAN SERVICES; CREDIT CARD AND DEBIT CARD SERVICES; CREDIT CARD AND PAYMENT CARD SERVICES; CREDIT CARD SERVICES; CREDIT CARD TRANSACTION PROCESSING SERVICES; CREDIT CARD VERIFICATION; ELECTRONIC BANKING VIA A GLOBAL COMPUTER NETWORK; ELECTRONIC CREDIT CARD TRANSACTIONS; EVALUATION OF THE CREDIT WORTHINESS OF COMPANIES AND PRIVATE INDIVIDUALS; FINANCIAL ADMINISTRATION OF CREDIT CARD ACCOUNTS; FINANCIAL ADVICE AND CONSULTANCY SERVICES; FINANCIAL ADVISORY AND CONSULTANCY SERVICES, NAMELY, THE CREATION OF PERSONALIZED STRATEGIES TO ACHIEVE FINANCIAL INDEPENDENCE; FINANCIAL AFFAIRS AND MONETARY AFFAIRS, NAMELY, FINANCIAL INFORMATION, MANAGEMENT AND ANALYSIS SERVICES; FINANCIAL CONSULTANCY; FINANCIAL COUNSELING SERVICES, NAMELY, HELPING OTHERS BUILD A BETTER WORKING RELATIONSHIP WITH THEIR MONEY; FINANCIAL EVALUATION, TRACKING, ANALYSIS, FORECASTING, CONSULTANCY, ADVI-

**CLASS 36—(Continued).**

SORY AND RESEARCH SERVICES RELATING TO SECURITIES AND OTHER FINANCIAL INSTRUMENTS; FINANCIAL INFORMATION; FINANCIAL LOAN CONSULTATION; FINANCIAL PLANNING; FINANCIAL PLANNING CONSULTATION; FINANCIAL PLANNING FOR RETIREMENT; FINANCIAL PORTFOLIO MANAGEMENT; FINANCIAL SERVICES RENDERED IN CONNECTION WITH THE ISSUANCE, RECEIPT AND TRANSFER OF LINES OF CREDIT, NAMELY, CREDIT PROCESSING SERVICES; FINANCIAL SERVICES, NAMELY, ADMINISTRATION OF TRANSACTIONS INVOLVING FUNDS DRAWN FROM SECURITIES, STOCKS, FUNDS, EQUITIES, BONDS, CASH, OR OTHER TYPES OF FINANCIAL INVESTMENTS IN RETIREMENT PLANS USING A CHECK OR NEGOTIABLE ORDER OF WITHDRAWAL OVER A GLOBAL DATA NETWORK; FINANCIAL SERVICES, NAMELY, ARRANGING OF MODIFIED LOAN TERMS DESIGNED TO PREVENT HOME FORECLOSURE; FINANCIAL SERVICES, NAMELY, ELECTRONIC REMOTE CHECK DEPOSIT SERVICES; FINANCIAL SERVICES, NAMELY, FUNDING ONLINE CASH ACCOUNTS FROM PREPAID CASH CARDS, BANK ACCOUNTS AND CREDIT CARD ACCOUNTS; FINANCIAL SERVICES, NAMELY, INVESTMENT ADVICE, INVESTMENT MANAGEMENT, INVESTMENT CONSULTATION AND INVESTMENT OF FUNDS FOR OTHERS, INCLUDING PRIVATE AND PUBLIC EQUITY AND DEBT INVESTMENT SERVICES; FINANCIAL SERVICES, NAMELY, INVESTMENT FUND TRANSFER AND TRANSACTION SERVICES; FINANCIAL SERVICES, NAMELY, ISSUANCE AND MANAGEMENT OF CERTIFICATES BACKED BY LOAN PORTFOLIOS WHICH ARE SUBSEQUENTLY MANAGED TO INSURE THE INTEGRITY OF THE CERTIFICATES; FINANCIAL SERVICES, NAMELY, LOAN DEFAULT MITIGATION SERVICES; FINANCIAL SERVICES, NAMELY, MONEY LENDING; FINANCIAL SERVICES, NAMELY, MORTGAGE PLANNING; FINANCIAL SERVICES, NAMELY, PROVIDING ON-LINE STORED VALUE ACCOUNTS IN AN ELECTRONIC ENVIRONMENT; FINANCIAL SERVICES, NAMELY, RAISING DEBT AND EQUITY CAPITAL FOR OTHERS; FINANCIAL SERVICES, NAMELY, REAL ESTATE NOTE BROKERAGE; FINANCIAL SERVICES, NAMELY, SAVINGS PROGRAMS FOR YOUTHS; FRAUD REIMBURSEMENT SERVICES IN THE FIELD OF CREDIT CARD PURCHASES; ISSUANCE OF CREDIT CARDS; ISSUING CREDIT CARDS; ISSUING OF BANK CHEQUES; ISSUING OF CHECKS AND LETTERS OF CREDIT; ISSUING OF CREDIT CARDS; ISSUING OF LETTERS OF CREDIT; MERCHANT BANKING SERVICES; MORTGAGE BANKING; MORTGAGE BANKING SERVICES, NAMELY, ORIGINATION, ACQUISITION, SERVICING, SECURITIZATION AND BROKERAGE OF MORTGAGE LOANS; MORTGAGE BROKERAGE; ON-LINE BANKING SERVICES; ON-LINE FINANCIAL PLANNING SERVICES; PROVIDING FINANCIAL INFORMATION; PROVISION OF FINANCIAL INFORMATION; PROVISION OF FINANCIAL INFORMATION RELATING TO THE FINANCE INDUSTRY INVOLVED IN ENVIRONMENTALLY FOCUSED INVESTMENTS; STRATEGIC CORPORATE FINANCIAL ADVISORY SERVICES; STRATEGIC FINANCIAL ADVISORY SERVICES; TELEPHONE BANKING SERVICES (U.S. CLS. 100, 101 AND 102).

FIRST USE 12-10-2010; IN COMMERCE 12-10-2010.  
DAVID I, EXAMINING ATTORNEY

**CLASS 36—(Continued).**

SN 85-205,104. AMERICAN LEBANESE SYRIAN ASSOCIATED CHARITIES, INC., MEMPHIS, TN. FILED 12-23-2010.

**GAME DAY. GIVE BACK.**

THE MARK CONSISTS OF STANDARD CHARACTERS WITHOUT CLAIM TO ANY PARTICULAR FONT, STYLE, SIZE, OR COLOR.

FOR CHARITABLE FUNDRAISING (U.S. CLS. 100, 101 AND 102).

FIRST USE 8-15-2010; IN COMMERCE 8-15-2010.  
JENNY PARK, EXAMINING ATTORNEY

SN 85-205,154. URBAN PARTNERSHIP BANK, CHICAGO, IL. FILED 12-23-2010.

**UPB**

THE MARK CONSISTS OF STANDARD CHARACTERS WITHOUT CLAIM TO ANY PARTICULAR FONT, STYLE, SIZE, OR COLOR.

FOR ARRANGING AND PROVISION OF CREDIT, LOANS, INSURANCE, CURRENCY EXCHANGE AND TRAVELLERS CHEQUES; ATM BANKING SERVICES; BANKING; BANKING AND FINANCING SERVICES; BANKING CONSULTATION; BANKING SERVICES; BANKING SERVICES PROVIDED BY MOBILE TELEPHONE CONNECTIONS; CHARGE CARD AND CREDIT CARD SERVICES; CLEARING AND RECONCILING FINANCIAL TRANSACTIONS VIA A GLOBAL COMPUTER NETWORK; CREDIT AND CASH CARD SERVICES; CREDIT AND DEBIT CARD SERVICES; CREDIT AND FINANCIAL CONSULTATION; CREDIT CARD AND PAYMENT CARD SERVICES; CREDIT CARD PAYMENT PROCESSING SERVICES; CREDIT CARD SERVICES; CREDIT CARD TRANSACTION PROCESSING SERVICES; ELECTRONIC BANKING VIA A GLOBAL COMPUTER NETWORK; ELECTRONIC CREDIT CARD TRANSACTIONS; EVALUATION OF THE CREDIT WORTHINESS OF COMPANIES AND PRIVATE INDIVIDUALS; FINANCIAL ADMINISTRATION OF CREDIT CARD ACCOUNTS; FINANCIAL ADVICE AND CONSULTANCY SERVICES; FINANCIAL ADVISORY AND CONSULTANCY SERVICES; FINANCIAL ADVISORY AND CONSULTANCY SERVICES, NAMELY, THE CREATION OF PERSONALIZED STRATEGIES TO ACHIEVE FINANCIAL INDEPENDENCE; FINANCIAL AFFAIRS AND MONETARY AFFAIRS, NAMELY, FINANCIAL INFORMATION, MANAGEMENT AND ANALYSIS SERVICES; FINANCIAL CONSULTANCY; FINANCIAL COUNSELING SERVICES, NAMELY, HELPING OTHERS BUILD A BETTER WORKING RELATIONSHIP WITH THEIR MONEY; FINANCIAL EVALUATION, TRACKING, ANALYSIS, FORECASTING, CONSULTANCY, ADVISORY AND RESEARCH SERVICES RELATING TO SECURITIES AND OTHER FINANCIAL INSTRUMENTS; FINANCIAL INFORMATION; FINANCIAL INFORMATION IN THE NATURE OF RATES OF EXCHANGE; FINANCIAL LOAN CONSULTATION; FINANCIAL PLANNING CONSULTATION; FINANCIAL PLANNING FOR RETIREMENT; FINANCIAL PORTFOLIO MANAGEMENT; FINANCIAL SERVICES RENDERED IN CONNECTION WITH THE ISSUANCE, RECEIPT AND TRANSFER OF LINES OF CREDIT, NAMELY, CREDIT PROCESSING SERVICES; FINANCIAL SERVICES, NAMELY, ADMIN-

**CLASS 36—(Continued).**

ISTRATION OF TRANSACTIONS INVOLVING FUNDS DRAWN FROM SECURITIES, STOCKS, FUNDS, EQUITIES, BONDS, CASH, OR OTHER TYPES OF FINANCIAL INVESTMENTS IN RETIREMENT PLANS USING A CHECK OR NEGOTIABLE ORDER OF WITHDRAWAL OVER A GLOBAL DATA NETWORK; FINANCIAL SERVICES, NAMELY, ARRANGING OF MODIFIED LOAN TERMS DESIGNED TO PREVENT HOME FORECLOSURE; FINANCIAL SERVICES, NAMELY, ELECTRONIC REMOTE CHECK DEPOSIT SERVICES; FINANCIAL SERVICES, NAMELY, FUNDING ONLINE CASH ACCOUNTS FROM PREPAID CASH CARDS, BANK ACCOUNTS AND CREDIT CARD ACCOUNTS; FINANCIAL SERVICES, NAMELY, INVESTMENT ADVICE, INVESTMENT MANAGEMENT, INVESTMENT CONSULTATION AND INVESTMENT OF FUNDS FOR OTHERS, INCLUDING PRIVATE AND PUBLIC EQUITY AND DEBT INVESTMENT SERVICES; FINANCIAL SERVICES, NAMELY, ISSUANCE AND MANAGEMENT OF CERTIFICATES BACKED BY LOAN PORTFOLIOS WHICH ARE SUBSEQUENTLY MANAGED TO INSURE THE INTEGRITY OF THE CERTIFICATES; FINANCIAL SERVICES, NAMELY, LOAN DEFAULT MITIGATION SERVICES; FINANCIAL SERVICES, NAMELY, LOSS MITIGATION SERVICES FOR UNDER- OR NON-PERFORMING MORTGAGE LOANS; FINANCIAL SERVICES, NAMELY, MONEY LENDING; FINANCIAL SERVICES, NAMELY, PROVIDING FOR THE EXCHANGE OF FOREIGN CURRENCY, COMMODITIES, FINANCIAL DERIVATIVES, INTEREST RATE PRODUCTS, AND EQUITIES VIA THE INTERNET AND INTRANET SYSTEMS; FINANCIAL SERVICES, NAMELY, PROVIDING ON-LINE STORED VALUE ACCOUNTS IN AN ELECTRONIC ENVIRONMENT; FINANCIAL SERVICES, NAMELY, RAISING DEBT AND EQUITY CAPITAL FOR OTHERS; FINANCIAL SERVICES, NAMELY, REAL ESTATE NOTE BROKERAGE; FINANCIAL SERVICES, NAMELY, SAVINGS PROGRAMS FOR YOUTHS; FRAUD REIMBURSEMENT SERVICES IN THE FIELD OF CREDIT CARD PURCHASES; ISSUANCE OF CREDIT CARDS; ISSUING CREDIT CARDS; ISSUING OF BANK CHEQUES; ISSUING OF CHECKS AND LETTERS OF CREDIT; ISSUING OF CREDIT CARDS; ISSUING OF LETTERS OF CREDIT; MERCHANT BANKING SERVICES; MORTGAGE BANKING; MORTGAGE BANKING SERVICES, NAMELY, ORIGINATION, ACQUISITION, SERVICING, SECURITIZATION AND BROKERAGE OF MORTGAGE LOANS; MORTGAGE COMPLIANCE CONSULTING SERVICES CONCERNING FINANCIAL REQUIREMENTS FOR MORTGAGES FOR MORTGAGE LENDERS AND SERVICERS AND MORTGAGE BROKERS; ON-LINE BANKING SERVICES; ON-LINE FINANCIAL PLANNING SERVICES; PROVIDING ELECTRONIC PROCESSING OF CREDIT CARD TRANSACTIONS AND ELECTRONIC PAYMENTS VIA A GLOBAL COMPUTER NETWORK; PROVIDING ELECTRONIC PROCESSING OF ELECTRONIC FUNDS TRANSFER, ACH, CREDIT CARD, DEBIT CARD, ELECTRONIC CHECK AND ELECTRONIC PAYMENTS; PROVISION AND FINANCIAL ADMINISTRATION OF A DEBIT CARD SAVINGS PROGRAM; PROVISION OF FINANCIAL INFORMATION; PROVISION OF FINANCIAL INFORMATION RELATING TO THE FINANCE INDUSTRY INVOLVED IN ENVIRONMENTALLY FOCUSED INVESTMENTS; STRATEGIC CORPORATE FINANCIAL ADVISORY SERVICES; STRATEGIC FINANCIAL ADVISORY SERVICES; TELEPHONE BANKING SERVICES (U.S. CLS. 100, 101 AND 102).

SANI KHOURI, EXAMINING ATTORNEY

**CLASS 36—(Continued).**

SN 85-205,502. COMMUTER CHECK SERVICES CORPORATION, WATERTOWN, MA. FILED 12-24-2010.

**COMMUTER CHECK OFFICE**

THE MARK CONSISTS OF STANDARD CHARACTERS WITHOUT CLAIM TO ANY PARTICULAR FONT, STYLE, SIZE, OR COLOR.

OWNER OF U.S. REG. NOS. 2,465,014, 3,890,984 AND OTHERS.

SEC. 2(F) AS TO "COMMUTER CHECK".

FOR TRAVEL VOUCHER SERVICES, NAMELY, PROVIDING VOUCHERS FOR PAYMENT OF TRANSPORTATION AND PARKING EXPENSES; ISSUING STORED VALUE CARDS FOR USE BY COMMUTERS TO PAY TRANSPORTATION AND PARKING EXPENSES; ADMINISTRATION OF EMPLOYEE BENEFIT PLANS PROVIDING FOR PAYMENT OF TRANSPORTATION AND PARKING EXPENSES (U.S. CLS. 100, 101 AND 102).

FIRST USE 1-0-2007; IN COMMERCE 1-0-2007.

DANIEL CAPSHAW, EXAMINING ATTORNEY

SN 85-205,503. COMMUTER CHECK SERVICES CORPORATION, WATERTOWN, MA. FILED 12-24-2010.

**MY COMMUTER CHECK**

THE MARK CONSISTS OF STANDARD CHARACTERS WITHOUT CLAIM TO ANY PARTICULAR FONT, STYLE, SIZE, OR COLOR.

OWNER OF U.S. REG. NOS. 2,465,014, 3,890,984 AND OTHERS.

SEC. 2(F) AS TO "COMMUTER CHECK".

FOR TRAVEL VOUCHER SERVICES, NAMELY, PROVIDING VOUCHERS FOR PAYMENT OF TRANSPORTATION AND PARKING EXPENSES; ISSUING STORED VALUE CARDS FOR USE BY COMMUTERS TO PAY TRANSPORTATION AND PARKING EXPENSES; ADMINISTRATION OF EMPLOYEE BENEFIT PLANS PROVIDING FOR PAYMENT OF TRANSPORTATION AND PARKING EXPENSES (U.S. CLS. 100, 101 AND 102).

FIRST USE 10-20-2010; IN COMMERCE 10-20-2010.

DANIEL CAPSHAW, EXAMINING ATTORNEY

**CLASS 36—(Continued).**

SN 85-205,506. COMMUTER CHECK SERVICES CORPORATION, WATERTOWN, MA. FILED 12-24-2010.

### COMMUTER CHECK FOR BICYCLING

THE MARK CONSISTS OF STANDARD CHARACTERS WITHOUT CLAIM TO ANY PARTICULAR FONT, STYLE, SIZE, OR COLOR.

OWNER OF U.S. REG. NOS. 2,465,014, 3,890,984 AND OTHERS.

NO CLAIM IS MADE TO THE EXCLUSIVE RIGHT TO USE "FOR BICYCLING", APART FROM THE MARK AS SHOWN.

SEC. 2(F) AS TO "COMMUTER CHECK".

FOR TRAVEL VOUCHER SERVICES, NAMELY, PROVIDING VOUCHERS FOR PAYMENT OF EXPENSES ASSOCIATED WITH BICYCLING; ADMINISTRATION OF EMPLOYEE BENEFIT PLANS PROVIDING FOR PAYMENT OF EXPENSES ASSOCIATED WITH BICYCLING (U.S. CLS. 100, 101 AND 102).

FIRST USE 1-0-2009; IN COMMERCE 1-0-2009.

DANIEL CAPSHAW, EXAMINING ATTORNEY

**CLASS 36—(Continued).**

SN 85-205,930. PARTNER CREDIT UNION, ARVADA, CO. FILED 12-27-2010.



OWNER OF U.S. REG. NO. 3,040,791.

THE MARK CONSISTS OF A STYLIZED DEPICTION OF AN EAGLE.

FOR CREDIT UNION SERVICES (U.S. CLS. 100, 101 AND 102).

FIRST USE 1-10-2003; IN COMMERCE 1-10-2003.

ELLEN PERKINS, EXAMINING ATTORNEY

SN 85-205,637. AMERICAN BOMBSHELLS ENTERTAINMENT, INC., MELVILLE, NY. FILED 12-25-2010.

### AMERICAN BOMBSHELLS

THE MARK CONSISTS OF STANDARD CHARACTERS WITHOUT CLAIM TO ANY PARTICULAR FONT, STYLE, SIZE, OR COLOR.

FOR CHARITABLE FUNDRAISING SERVICES BY MEANS OF AN ENTERTAINMENT EVENT (U.S. CLS. 100, 101 AND 102).

FIRST USE 8-19-2010; IN COMMERCE 8-19-2010.

DAVID ELTON, EXAMINING ATTORNEY

SN 85-205,974. MERIDIAN HOME MORTGAGE CORPORATION, HAMPSTEAD, MD. FILED 12-27-2010.

### CASHNOWREFI.COM

THE MARK CONSISTS OF STANDARD CHARACTERS WITHOUT CLAIM TO ANY PARTICULAR FONT, STYLE, SIZE, OR COLOR.

FOR MORTGAGE BROKERAGE (U.S. CLS. 100, 101 AND 102).

FIRST USE 7-0-2008; IN COMMERCE 7-0-2008.

JACQUELINE A. LAVINE, EXAMINING ATTORNEY

SN 85-205,896. ROCK FOR THE HEART, INC., HARRISON CITY, PA. FILED 12-27-2010.

### ROCK FOR THE HEART

THE MARK CONSISTS OF STANDARD CHARACTERS WITHOUT CLAIM TO ANY PARTICULAR FONT, STYLE, SIZE, OR COLOR.

FOR CHARITABLE FUNDRAISING SERVICES BY MEANS OF MUSICAL CONCERTS (U.S. CLS. 100, 101 AND 102).

LINDA LAVACHE, EXAMINING ATTORNEY

SN 85-206,024. FLORIDA FAMILY INSURANCE SERVICES, LLC, BONITA SPRINGS, FL. FILED 12-27-2010.

### FLORIDA FAMILY

THE MARK CONSISTS OF STANDARD CHARACTERS WITHOUT CLAIM TO ANY PARTICULAR FONT, STYLE, SIZE, OR COLOR.

OWNER OF U.S. REG. NO. 2,521,396.

SEC. 2(F).

FOR INSURANCE SERVICES, NAMELY WRITING, UNDERWRITING AND SERVICING INSURANCE POLICIES TO INSURE RESIDENTIAL REAL ESTATE PROPERTIES AND RELATED PERSONAL PROPERTY (U.S. CLS. 100, 101 AND 102).

FIRST USE 1-30-1996; IN COMMERCE 1-30-1996.

ALEXANDER L. POWERS, EXAMINING ATTORNEY

**CLASS 36—(Continued).**

SN 85-206,042. FLORIDA FAMILY INSURANCE SERVICES, LLC, BONITA SPRINGS, FL. FILED 12-27-2010.

**WELCOME TO THE FAMILY**

THE MARK CONSISTS OF STANDARD CHARACTERS WITHOUT CLAIM TO ANY PARTICULAR FONT, STYLE, SIZE, OR COLOR.

FOR INSURANCE SERVICES, NAMELY WRITING, UNDERWRITING AND SERVICING INSURANCE POLICIES TO INSURE RESIDENTIAL REAL ESTATE PROPERTIES AND RELATED PERSONAL PROPERTY (U.S. CLS. 100, 101 AND 102).

FIRST USE 11-30-1996; IN COMMERCE 11-30-1996.  
ALEXANDER L. POWERS, EXAMINING ATTORNEY

SN 85-206,075. FLORIDA FAMILY INSURANCE SERVICES, LLC, BONITA SPRINGS, FL. FILED 12-27-2010.

**FLORIDA FAMILY INSURANCE**

THE MARK CONSISTS OF STANDARD CHARACTERS WITHOUT CLAIM TO ANY PARTICULAR FONT, STYLE, SIZE, OR COLOR.

OWNER OF U.S. REG. NO. 2,521,396.  
NO CLAIM IS MADE TO THE EXCLUSIVE RIGHT TO USE "INSURANCE", APART FROM THE MARK AS SHOWN.

SEC. 2(F) AS TO "FLORIDA FAMILY".  
FOR INSURANCE SERVICES, NAMELY, WRITING, UNDERWRITING AND SERVICING INSURANCE POLICIES TO INSURE RESIDENTIAL REAL ESTATE PROPERTIES AND RELATED PERSONAL PROPERTY (U.S. CLS. 100, 101 AND 102).

FIRST USE 1-30-1996; IN COMMERCE 1-30-1996.  
ALEXANDER L. POWERS, EXAMINING ATTORNEY

SN 85-206,086. HILTON & HYLAND REAL ESTATE, INC., BEVERLY HILLS, CA. FILED 12-27-2010.

**HILTON & HYLAND**

THE MARK CONSISTS OF STANDARD CHARACTERS WITHOUT CLAIM TO ANY PARTICULAR FONT, STYLE, SIZE, OR COLOR.

FOR REAL ESTATE BROKERAGE SERVICES (U.S. CLS. 100, 101 AND 102).  
FIRST USE 3-1-1993; IN COMMERCE 3-1-1993.  
VERNA BETH RIRIE, EXAMINING ATTORNEY

**CLASS 36—(Continued).**

SN 85-206,265. HILTON & HYLAND REAL ESTATE, INC., BEVERLY HILLS, CA. FILED 12-27-2010.

**HILTON & HYLAND**

THE MARK CONSISTS OF THE WORDS/SYMBOL "HILTON & HYLAND".

FOR REAL ESTATE BROKERAGE SERVICES (U.S. CLS. 100, 101 AND 102).

FIRST USE 3-1-1993; IN COMMERCE 3-1-1993.  
VERNA BETH RIRIE, EXAMINING ATTORNEY

SN 85-206,402. VANHORN, JONATHAN L. ADA, OK. AND VANHORN, JUSTIN P, ADA, OK. FILED 12-28-2010.

**PAWNS WITH CROWNS**

THE MARK CONSISTS OF STANDARD CHARACTERS WITHOUT CLAIM TO ANY PARTICULAR FONT, STYLE, SIZE, OR COLOR.

FOR FUNDS INVESTMENT (U.S. CLS. 100, 101 AND 102).  
ALLISON HOLTZ, EXAMINING ATTORNEY

SN 85-206,434. BLUE EDGE CAPITAL, LLC, RICHMOND, VA. FILED 12-28-2010.

**Rethinking Asset Management**

THE MARK CONSISTS OF STANDARD CHARACTERS WITHOUT CLAIM TO ANY PARTICULAR FONT, STYLE, SIZE, OR COLOR.

NO CLAIM IS MADE TO THE EXCLUSIVE RIGHT TO USE "ASSET MANAGEMENT", APART FROM THE MARK AS SHOWN.

FOR FINANCIAL ASSET MANAGEMENT; FINANCIAL MANAGEMENT; FINANCIAL MANAGEMENT VIA THE INTERNET; FINANCIAL PLANNING AND INVESTMENT ADVISORY SERVICES; FINANCIAL PORTFOLIO MANAGEMENT; FINANCIAL SERVICES, NAMELY, A TOTAL PORTFOLIO OFFERING FOR HIGH NET WORTH CLIENTS CONSISTING OF BOTH SEPARATE ACCOUNTS AND MUTUAL FUNDS FOR EQUITY AND FIXED INCOME INVESTMENTS; FINANCIAL SERVICES, NAMELY, INVESTMENT ADVICE, INVESTMENT MANAGEMENT, INVESTMENT CONSULTATION AND INVESTMENT OF FUNDS FOR OTHERS, INCLUDING PRIVATE AND PUBLIC EQUITY AND DEBT INVESTMENT SERVICES; FINANCIAL SERVICES, NAMELY, WEALTH MANAGEMENT SERVICES; PROVIDING A WEB SITE FEATURING PERSONAL FINANCIAL INFORMATION AND FINANCIAL ADVICE; PROVIDING FINANCIAL SERVICES WITH RESPECT TO SECURITIES AND OTHER FINANCIAL INSTRUMENTS AND PRODUCTS, NAMELY, MONEY MANAGEMENT SERVICES; STRATEGIC FINANCIAL ADVISORY SERVICES (U.S. CLS. 100, 101 AND 102).

FIRST USE 11-5-2010; IN COMMERCE 11-5-2010.  
COLLEEN DOMBROW, EXAMINING ATTORNEY

**CLASS 36—(Continued).**

SN 85-206,594. COMFORT CHORUS, KINGS MILLS, OH. FILED 12-28-2010.

**COMFORT CHORUS**

THE MARK CONSISTS OF STANDARD CHARACTERS WITHOUT CLAIM TO ANY PARTICULAR FONT, STYLE, SIZE, OR COLOR.

FOR CHARITABLE FUNDRAISING (U.S. CLS. 100, 101 AND 102).

SCOTT BIBB, EXAMINING ATTORNEY

**CLASS 36—(Continued).**

SN 85-207,067. DEALER SERVICES CORPORATION, CARMEL, IN. FILED 12-29-2010.

**INNOVATIVE SOLUTIONS.  
OUTSTANDING SERVICE.  
GREAT PEOPLE.**

THE MARK CONSISTS OF STANDARD CHARACTERS WITHOUT CLAIM TO ANY PARTICULAR FONT, STYLE, SIZE, OR COLOR.

FOR FINANCING SERVICES (U.S. CLS. 100, 101 AND 102).

FIRST USE 11-1-2010; IN COMMERCE 11-1-2010.

JEFFERY COWARD, EXAMINING ATTORNEY

SN 85-206,610. OPPORTUNITY VILLAGE FOUNDATION, LAS VEGAS, NV. FILED 12-28-2010.

**MAGICAL FOREST**

THE MARK CONSISTS OF STANDARD CHARACTERS WITHOUT CLAIM TO ANY PARTICULAR FONT, STYLE, SIZE, OR COLOR.

FOR CHARITABLE FUNDRAISING SERVICES (U.S. CLS. 100, 101 AND 102).

FIRST USE 11-30-1992; IN COMMERCE 11-30-1992.

ERNEST SHOSHO, EXAMINING ATTORNEY

SN 85-207,096. ROCKY MOUNTAIN HEALTH MAINTENANCE ORGANIZATION, INCORPORATED, GRAND JUNCTION, CO. FILED 12-29-2010.

**SOLO OUTLOOK**

THE MARK CONSISTS OF STANDARD CHARACTERS WITHOUT CLAIM TO ANY PARTICULAR FONT, STYLE, SIZE, OR COLOR.

FOR ADMINISTRATION AND ORGANIZATION OF PRE-PAID HEALTH CARE PLANS (U.S. CLS. 100, 101 AND 102).

FIRST USE 10-1-2010; IN COMMERCE 10-1-2010.

KRISTIN CARLSON, EXAMINING ATTORNEY

SN 85-207,023. RESIMODEL, LLC, BRONX, NY. FILED 12-29-2010.



SN 85-207,354. EXECUTIVE FINANCIAL PLANNING, BRIGHTON, MI. FILED 12-29-2010.

**Focusing on your future**

THE MARK CONSISTS OF TWO OVERLAPPING ARROWHEADS WITH A SHADOW UNDERNEATH TO THE LEFT OF THE TERM "RESIMODEL".

FOR VALUATION OF COMMERCIAL AND RESIDENTIAL REAL ESTATE (U.S. CLS. 100, 101 AND 102).

KRISTIN CARLSON, EXAMINING ATTORNEY

THE MARK CONSISTS OF STANDARD CHARACTERS WITHOUT CLAIM TO ANY PARTICULAR FONT, STYLE, SIZE, OR COLOR.

FOR FINANCIAL ADVISORY AND CONSULTANCY SERVICES (U.S. CLS. 100, 101 AND 102).

FIRST USE 2-1-2010; IN COMMERCE 2-1-2010.

GRETTA YAO, EXAMINING ATTORNEY

**CLASS 36—(Continued).**

SN 85-207,423. EVERY TRIBE ENTERTAINMENT LLC, OKLAHOMA CITY, OK. FILED 12-29-2010.

EVERY TRIBE EVERY NATION

THE MARK CONSISTS OF STANDARD CHARACTERS WITHOUT CLAIM TO ANY PARTICULAR FONT, STYLE, SIZE, OR COLOR.

OWNER OF U.S. REG. NO. 3,228,515.  
FOR CHARITABLE FUNDRAISING SERVICES FOR PROMOTING RESEARCH, EDUCATION AND OTHER ACTIVITIES RELATING TO THE TRANSLATION AND DISSEMINATION OF THE HOLY BIBLE IN VARIOUS MEDIA (U.S. CLS. 100, 101 AND 102).  
SHAUNIA CARLYLE, EXAMINING ATTORNEY

SN 85-207,427. THE MOSAIC COMPANY, PLYMOUTH, MN. FILED 12-29-2010.

RISKESSENTIALS

THE MARK CONSISTS OF STANDARD CHARACTERS WITHOUT CLAIM TO ANY PARTICULAR FONT, STYLE, SIZE, OR COLOR.

FOR FINANCIAL RISK MANAGEMENT SERVICES FOR AGRICULTURAL COMMODITIES (U.S. CLS. 100, 101 AND 102).  
PAUL F. GAST, EXAMINING ATTORNEY

SN 85-207,939. SANCTIFIED REAL ESTATE, SAN JOSE, CA. FILED 12-30-2010.



THE MARK CONSISTS OF AN IMAGE OF A CROWN WITH JEWELS, DIAMONDS, CROSS AND FISH SYMBOL. FOR REAL ESTATE AGENCIES (U.S. CLS. 100, 101 AND 102).

FIRST USE 12-1-2010; IN COMMERCE 12-1-2010.  
TRACY CROSS, EXAMINING ATTORNEY

**CLASS 36—(Continued).**

SN 85-208,124. THE MENKE GROUP, INC., SAN FRANCISCO, CA. FILED 12-30-2010.



THE COLOR(S) BLUE AND GOLD IS/ARE CLAIMED AS A FEATURE OF THE MARK.

THE MARK CONSISTS OF AN UPPER CASE LETTER "M" IN A LIGHT SHADE OF GOLD OUTLINED IN BLUE WITHIN A CIRCLE OF GOLD. THE GOLD CIRCLE IS WITHIN A BLUE BOX WITH HORIZONTAL GOLD BARS ON THE TOP AND BOTTOM OF THE BLUE BOX.

FOR INVESTMENT BANKING SERVICES IN THE FIELD OF EMPLOYEE STOCK OWNERSHIP PLANS (ESOP) (U.S. CLS. 100, 101 AND 102).

FIRST USE 5-12-2003; IN COMMERCE 5-12-2003.  
DAVID TAYLOR, EXAMINING ATTORNEY

SN 85-208,140. HANSON, HEIDI, BEVERLY, MA. FILED 12-30-2010.

JUST ONE

THE MARK CONSISTS OF STANDARD CHARACTERS WITHOUT CLAIM TO ANY PARTICULAR FONT, STYLE, SIZE, OR COLOR.

FOR FINANCIAL PLANNING AND INVESTMENT ADVISORY SERVICES; FINANCIAL PLANNING CONSULTATION (U.S. CLS. 100, 101 AND 102).

FIRST USE 12-1-2009; IN COMMERCE 12-1-2009.  
JUDITH HELFMAN, EXAMINING ATTORNEY

**CLASS 36—(Continued).**

SN 85-208,341. AMERICO LIFE, INC., KANSAS CITY, MO.  
FILED 12-30-2010.

**LIFETIME LEGACY**

THE MARK CONSISTS OF STANDARD CHARACTERS  
WITHOUT CLAIM TO ANY PARTICULAR FONT, STYLE,  
SIZE, OR COLOR.

OWNER OF U.S. REG. NO. 3,024,837.  
SEC. 2(F).  
FOR LIFE INSURANCE UNDERWRITING AND  
BROKERAGE SERVICES (U.S. CLS. 100, 101 AND 102).  
FIRST USE 2-1-2005; IN COMMERCE 2-1-2005.  
JOHN GARTNER, EXAMINING ATTORNEY

SN 85-208,477. CITIZENS FINANCIAL GROUP, INC., PRO-  
VIDENCE, RI. FILED 12-31-2010.

**BANKING ON YOUR TERMS, AT  
YOUR PLACE**

THE MARK CONSISTS OF STANDARD CHARACTERS  
WITHOUT CLAIM TO ANY PARTICULAR FONT, STYLE,  
SIZE, OR COLOR.

NO CLAIM IS MADE TO THE EXCLUSIVE RIGHT TO  
USE "BANKING", APART FROM THE MARK AS SHOWN.  
FOR BANKING SERVICES (U.S. CLS. 100, 101 AND  
102).  
VIVIAN MICZNIK FIRST, EXAMINING ATTORNEY

SN 85-208,920. BRENNAN AGENCY, INC., OVERLAND  
PARK, KS. FILED 1-3-2011.

**THE SAFE MONEY GUY**

THE MARK CONSISTS OF STANDARD CHARACTERS  
WITHOUT CLAIM TO ANY PARTICULAR FONT, STYLE,  
SIZE, OR COLOR.

FOR INSURANCE BROKERAGE; FINANCIAL PLAN-  
NING SERVICES; ESTATE PLANNING SERVICES (U.S.  
CLS. 100, 101 AND 102).  
DAVID ELTON, EXAMINING ATTORNEY

**CLASS 36—(Continued).**

SN 85-209,018. THOMPSON INSURANCE ENTERPRISES,  
LLC, KENNESAW, GA. FILED 1-3-2011.

**THOMCO**

THE MARK CONSISTS OF STANDARD CHARACTERS  
WITHOUT CLAIM TO ANY PARTICULAR FONT, STYLE,  
SIZE, OR COLOR.

FOR INSURANCE SERVICES, NAMELY, PROVIDING  
PROPERTY AND CASUALTY INSURANCE (U.S. CLS.  
100, 101 AND 102).  
FIRST USE 12-0-1977; IN COMMERCE 12-0-1977.  
HEATHER BIDDULPH, EXAMINING ATTORNEY

SN 85-209,028. FRESH5, TRAVERSE CITY, MI. FILED 1-3-  
2011.

**Fresh5**

THE MARK CONSISTS OF STANDARD CHARACTERS  
WITHOUT CLAIM TO ANY PARTICULAR FONT, STYLE,  
SIZE, OR COLOR.

FOR CHARITABLE FUNDRAISING SERVICES FOR  
PROMOTING RESEARCH, EDUCATION AND OTHER  
ACTIVITIES RELATING TO THE PRESERVATION OF  
THE GREAT LAKES BASIN (U.S. CLS. 100, 101 AND 102).  
JUSTINE D. PARKER, EXAMINING ATTORNEY

SN 85-209,094. CLARK-MORTENSON AGENCY, INC.,  
KEENE, NH. FILED 1-3-2011.

**BE READY FOR ANYTHING**

THE MARK CONSISTS OF STANDARD CHARACTERS  
WITHOUT CLAIM TO ANY PARTICULAR FONT, STYLE,  
SIZE, OR COLOR.

FOR FINANCIAL INFORMATION AND ADVISORY  
SERVICES; INSURANCE AGENCIES (U.S. CLS. 100, 101  
AND 102).  
FIRST USE 12-1-2007; IN COMMERCE 12-1-2007.  
JANET LEE, EXAMINING ATTORNEY



**CLASS 36—(Continued).**

SN 85-209,366. MIDWEST REALTY VENTURES LLC, DBA PRUDENTIAL RUBLOFF PROPERTIES, CHICAGO, IL. FILED 1-3-2011.

**ONE MAGNIFICENT LIFE**

THE MARK CONSISTS OF STANDARD CHARACTERS WITHOUT CLAIM TO ANY PARTICULAR FONT, STYLE, SIZE, OR COLOR.

FOR RESIDENTIAL REAL ESTATE AGENCY SERVICES; REAL ESTATE BROKERAGE; REAL ESTATE LISTING; LEASING OF REAL ESTATE; PROVIDING INFORMATION IN THE FIELD OF REAL ESTATE VIA THE INTERNET; REAL ESTATE CONSULTANCY; REAL ESTATE MANAGEMENT SERVICES; FINANCIAL VALUATION OF REAL ESTATE; REAL ESTATE FINANCING SERVICES; FINANCIAL SERVICES, NAMELY, MORTGAGE PLANNING (U.S. CLS. 100, 101 AND 102).

FIRST USE 6-27-2010; IN COMMERCE 6-27-2010.  
JERI J. FICKES, EXAMINING ATTORNEY

---

SN 85-209,475. SMITH, JASON L., AVON, OH. FILED 1-3-2011.

**CLARITY 2 PROSPERITY**

THE MARK CONSISTS OF STANDARD CHARACTERS WITHOUT CLAIM TO ANY PARTICULAR FONT, STYLE, SIZE, OR COLOR.

FOR ESTATE PLANNING; FINANCIAL PLANNING (U.S. CLS. 100, 101 AND 102).

FIRST USE 5-31-2010; IN COMMERCE 5-31-2010.  
CHRISTINE COOPER, EXAMINING ATTORNEY

---

SN 85-209,828. OPENAIR EQUITY PARTNERS, LLC, KANSAS CITY, MO. FILED 1-4-2011.

**OPENAIR**

THE MARK CONSISTS OF STANDARD CHARACTERS WITHOUT CLAIM TO ANY PARTICULAR FONT, STYLE, SIZE, OR COLOR.

OWNER OF U.S. REG. NO. 3,735,121.  
FOR PRIVATE EQUITY FUND INVESTING SERVICES (U.S. CLS. 100, 101 AND 102).

FIRST USE 10-0-2010; IN COMMERCE 10-0-2010.  
JEAN IM, EXAMINING ATTORNEY

**CLASS 36—(Continued).**

SN 85-209,860. MASSEY, QUICK & CO., LLC, MORRISTOWN, NJ. FILED 1-4-2011.

**Massey Quick**

THE MARK CONSISTS OF STANDARD CHARACTERS WITHOUT CLAIM TO ANY PARTICULAR FONT, STYLE, SIZE, OR COLOR.

FOR FINANCIAL PLANNING AND INVESTMENT ADVISORY SERVICES; FINANCIAL SERVICES, NAMELY, WEALTH MANAGEMENT SERVICES; INVESTMENT CONSULTATION (U.S. CLS. 100, 101 AND 102).

FIRST USE 6-4-2004; IN COMMERCE 6-4-2004.  
ALLISON SCHRODY, EXAMINING ATTORNEY

---

SN 85-210,473. LYNN, AMY N, MONROE, CT. AND LYNN, JOHN A, MONROE, CT. FILED 1-4-2011.

**Cocktails and Crooning  
For a Cure**

THE MARK CONSISTS OF STANDARD CHARACTERS WITHOUT CLAIM TO ANY PARTICULAR FONT, STYLE, SIZE, OR COLOR.

FOR CHARITABLE FUNDRAISING; CHARITABLE FUNDRAISING SERVICES BY MEANS OF AN ENTERTAINMENT EVENT; CHARITABLE FUNDRAISING SERVICES FOR PROMOTING RESEARCH, EDUCATION AND OTHER ACTIVITIES RELATING TO DIABETES AND MULTIPLE SCLEROSIS; CHARITABLE FUNDRAISING SERVICES FOR SENDING CHILDREN AND YOUNG ADULTS WITH DISABILITIES TO A SUMMER CAMP; CHARITABLE FUNDRAISING SERVICES, NAMELY, ORGANIZING AND CONDUCTING MUSICAL ENTERTAINMENT EVENTS FEATURING FOOD AND WINE; CHARITABLE SERVICES, NAMELY, ORGANIZING FUNDRAISING SERVICES AND EVENTS TO RAISE FUNDS IN THE FIELD OF DIABETES AND MULTIPLE SCLEROSIS (U.S. CLS. 100, 101 AND 102).

FIRST USE 4-1-2009; IN COMMERCE 4-1-2009.  
TIMOTHY FINNEGAN, EXAMINING ATTORNEY

---

SN 85-210,598. EVERETT, CRAIG R, WEST LAFAYETTE, IN. FILED 1-5-2011.

**Invest Your Conscience**

THE MARK CONSISTS OF STANDARD CHARACTERS WITHOUT CLAIM TO ANY PARTICULAR FONT, STYLE, SIZE, OR COLOR.

FOR ADVICE RELATING TO INVESTMENTS; FINANCIAL INVESTMENT ANALYSIS AND STOCK RESEARCH; INVESTMENT MANAGEMENT (U.S. CLS. 100, 101 AND 102).

REGINA DRUMMOND, EXAMINING ATTORNEY

**CLASS 36—(Continued).**

SN 85-210,601. LUNGEVITY FOUNDATION, CHICAGO, IL.  
FILED 1-5-2011.

# Breathe Deep

THE MARK CONSISTS OF STANDARD CHARACTERS WITHOUT CLAIM TO ANY PARTICULAR FONT, STYLE, SIZE, OR COLOR.

FOR CHARITABLE FUNDRAISING SERVICES, NAMELY, RAISING MONEY FOR LUNG CANCER RESEARCH AND RAISING MONEY FOR LUNG CANCER SUPPORT PROGRAMS (U.S. CLS. 100, 101 AND 102).

FIRST USE 6-1-2009; IN COMMERCE 6-1-2009.

JULIE VEPPUMTHARA, EXAMINING ATTORNEY

**CLASS 36—(Continued).**

SN 85-211,028. BENITECTS, LLC, ST. LOUIS, MO. FILED 1-5-2011.

# Benitects

THE MARK CONSISTS OF STANDARD CHARACTERS WITHOUT CLAIM TO ANY PARTICULAR FONT, STYLE, SIZE, OR COLOR.

FOR ADVISORY SERVICES IN THE FIELD OF EMPLOYEE BENEFITS FOR GROUP HEALTHCARE AND BUSINESS INSURANCE OFFERED TO EMPLOYEES IN ADDITION TO STANDARD BENEFITS SUCH AS MEDICAL, DENTAL, LIFE INSURANCE INCLUDING SHORT TERM DISABILITY, LONG TERM DISABILITY, CANCER INSURANCE, ACCIDENTAL DEATH AND DISMEMBERMENT INSURANCE AND RELATED VOLUNTARY SERVICES (U.S. CLS. 100, 101 AND 102).

FIRST USE 4-9-2008; IN COMMERCE 7-1-2008.

JOHN E. MICHOS, EXAMINING ATTORNEY

SN 85-210,656. IPFS CORPORATION, KANSAS CITY, NJ.  
FILED 1-5-2011.



THE COLOR(S) BLUE AND WHITE IS/ARE CLAIMED AS A FEATURE OF THE MARK.

THE MARK CONSISTS OF A CUBE WITH A BLUE BACKGROUND (PMS 2955) AND THE LETTERS "IPFS" ARE IN WHITE WITH A WHITE CURVED LINE ACROSS THE CUBE.

FOR FINANCING OF INSURANCE PREMIUMS FOR OTHERS (U.S. CLS. 100, 101 AND 102).

FIRST USE 9-1-2007; IN COMMERCE 9-1-2007.

WILLIAM P. SHANAHAN, EXAMINING ATTORNEY

SN 85-211,074. SUSAN DEITZ, NEW YORK, NY. FILED 1-5-2011.

# SINGLE FILE

THE MARK CONSISTS OF STANDARD CHARACTERS WITHOUT CLAIM TO ANY PARTICULAR FONT, STYLE, SIZE, OR COLOR.

FOR CREDIT CARD SERVICES; DEBIT CARD SERVICES; AFFINITY CARD SERVICES (U.S. CLS. 100, 101 AND 102).

ALICE BENMAMAN, EXAMINING ATTORNEY

**CLASS 36—(Continued).**

SN 85-211,104. INNOVATIVE RISK CONCEPTS, INC., RIDGEWOOD, NJ. FILED 1-5-2011.



THE COLOR(S) RED IS/ARE CLAIMED AS A FEATURE OF THE MARK.

THE MARK CONSISTS OF AMPERSAND IN COMPLETE RED COLOR.

FOR ADMINISTRATION OF EMPLOYEE BENEFIT PLANS CONCERNING INSURANCE AND FINANCE; ADVISORY SERVICES IN THE FIELD OF EMPLOYEE BENEFITS FOR GROUP HEALTHCARE AND BUSINESS INSURANCE OFFERED TO EMPLOYEES IN ADDITION TO STANDARD BENEFITS SUCH AS MEDICAL, DENTAL, LIFE INSURANCE INCLUDING SHORT TERM DISABILITY, LONG TERM DISABILITY, CANCER INSURANCE, ACCIDENTAL DEATH AND DISMEMBERMENT; INSURANCE ACTUARIAL SERVICES; INSURANCE BROKERAGE; INSURANCE CLAIMS ADMINISTRATION; INSURANCE CONSULTATION; INSURANCE INFORMATION; INSURANCE INFORMATION AND CONSULTANCY; INSURANCE SERVICES IN THE NATURE OF LOSS CONTROL MANAGEMENT FOR OTHERS (U.S. CLS. 100, 101 AND 102).

FIRST USE 9-1-1993; IN COMMERCE 9-1-1993.  
HELENE LIWINSKI, EXAMINING ATTORNEY

SN 85-211,420. THE WATERFORD FOUNDATION, FRESNO, CA. FILED 1-5-2011.

**HOME OF HOPE**

THE MARK CONSISTS OF STANDARD CHARACTERS WITHOUT CLAIM TO ANY PARTICULAR FONT, STYLE, SIZE, OR COLOR.

FOR CHARITABLE FUNDRAISING; CHARITABLE FUNDRAISING SERVICES BY MEANS OF ORGANIZING AND CONDUCTING SPECIAL EVENTS; CHARITABLE FUNDRAISING SERVICES BY MEANS OF SELLING RAFFLE TICKETS TO RAISE FUNDS FOR OTHER CHARITABLE ORGANIZATIONS (U.S. CLS. 100, 101 AND 102).

FIRST USE 5-22-2006; IN COMMERCE 5-22-2006.  
LINDA ORNDORFF, EXAMINING ATTORNEY

**CLASS 36—(Continued).**

SN 85-211,478. THE JEFF ARNOLD COMPANIES, INC., TUCSON, AZ. FILED 1-5-2011.

**RightSure**

THE MARK CONSISTS OF STANDARD CHARACTERS WITHOUT CLAIM TO ANY PARTICULAR FONT, STYLE, SIZE, OR COLOR.

FOR INSURANCE AGENCIES IN THE FIELD OF AUTO, HOME, COMMERCIAL INSURANCE (U.S. CLS. 100, 101 AND 102).

FIRST USE 2-10-2004; IN COMMERCE 7-31-2007.  
CHERYL CLAYTON, EXAMINING ATTORNEY

SN 85-211,677. RESTORE FINANCIAL SERVICES NETWORK, LLC, PORTLAND, OR. FILED 1-6-2011.

**Restoring Financial Trust**

THE MARK CONSISTS OF STANDARD CHARACTERS WITHOUT CLAIM TO ANY PARTICULAR FONT, STYLE, SIZE, OR COLOR.

FOR COLLECTION OF DEBTS; DEBT COLLECTION; DEBT COLLECTION AGENCIES; DEBT RECOVERY AND COLLECTION AGENCIES; REPOSSESSION SERVICES IN THE NATURE OF DEBT COLLECTION (U.S. CLS. 100, 101 AND 102).

JOHN SCHUYLER YARD, EXAMINING ATTORNEY

SN 85-212,706. IVY FUNDS DISTRIBUTOR, INC., SHAWNEE MISSION, KS. FILED 1-7-2011.

**THE WORLD COVERED**

THE MARK CONSISTS OF STANDARD CHARACTERS WITHOUT CLAIM TO ANY PARTICULAR FONT, STYLE, SIZE, OR COLOR.

FOR MUTUAL FUND INVESTMENT SERVICES (U.S. CLS. 100, 101 AND 102).

TINA BROWN, EXAMINING ATTORNEY

**CLASS 36—(Continued).**

SN 85-212,853. RESIDENTIAL FINANCE CORPORATION, COLUMBUS, OH. FILED 1-7-2011.

**PROBRANCH**

THE MARK CONSISTS OF STANDARD CHARACTERS WITHOUT CLAIM TO ANY PARTICULAR FONT, STYLE, SIZE, OR COLOR.

FOR FINANCIAL SERVICES, NAMELY, MORTGAGE REFINANCING; MORTGAGE BANKING; MORTGAGE BANKING SERVICES, NAMELY, ORIGINATION, ACQUISITION, SERVICING, SECURITIZATION AND BROKERAGE OF MORTGAGE LOANS (U.S. CLS. 100, 101 AND 102).

LAURIE KAUFMAN, EXAMINING ATTORNEY

**CLASS 36—(Continued).**

SN 85-216,894. RESIDENTIAL FINANCE CORPORATION, COLUMBUS, OH. FILED 1-13-2011.

**YOU'VE EARNED IT.**

THE MARK CONSISTS OF STANDARD CHARACTERS WITHOUT CLAIM TO ANY PARTICULAR FONT, STYLE, SIZE, OR COLOR.

FOR MORTGAGE BANKING; MORTGAGE BANKING SERVICES, NAMELY, ORIGINATION, ACQUISITION, SERVICING, SECURITIZATION AND BROKERAGE OF MORTGAGE LOANS; MORTGAGE LENDING (U.S. CLS. 100, 101 AND 102).

FIRST USE 1-12-2011; IN COMMERCE 1-12-2011.  
LAURIE KAUFMAN, EXAMINING ATTORNEY

SN 85-213,352. IDO IZKOVICH, LAS VEGAS, NV. FILED 1-7-2011.

**FIRSTDIAMONDBANK.COM**

THE MARK CONSISTS OF STANDARD CHARACTERS WITHOUT CLAIM TO ANY PARTICULAR FONT, STYLE, SIZE, OR COLOR.

FOR BANKING; ON-LINE BANKING SERVICES (U.S. CLS. 100, 101 AND 102).

DAVID TAYLOR, EXAMINING ATTORNEY

SN 85-221,434. MB FIELD SERVICES, INC., ATLANTA, GA. FILED 1-19-2011.

**INSPECT**

THE MARK CONSISTS OF STANDARD CHARACTERS WITHOUT CLAIM TO ANY PARTICULAR FONT, STYLE, SIZE, OR COLOR.

FOR REAL ESTATE SERVICES, NAMELY, PROPERTY MANAGEMENT SERVICES FOR LENDERS OF REPOSSESSED PROPERTIES (U.S. CLS. 100, 101 AND 102).

FLORENTINA BLANDU, EXAMINING ATTORNEY

SN 85-214,472. CACHET BANQ, PASADENA, CA. FILED 1-10-2011.

**PAYTAX**

THE MARK CONSISTS OF STANDARD CHARACTERS WITHOUT CLAIM TO ANY PARTICULAR FONT, STYLE, SIZE, OR COLOR.

FOR ONLINE PAYROLL TAX PROCESSING SERVICES (U.S. CLS. 100, 101 AND 102).

MAYUR VAGHANI, EXAMINING ATTORNEY

SN 85-222,564. MB FIELD SERVICES, INC., ATLANTA, GA. FILED 1-20-2011.

**RESTORE**

THE MARK CONSISTS OF STANDARD CHARACTERS WITHOUT CLAIM TO ANY PARTICULAR FONT, STYLE, SIZE, OR COLOR.

FOR REAL ESTATE SERVICES, NAMELY, PROPERTY MANAGEMENT SERVICES FOR LENDERS OF REPOSSESSED PROPERTIES (U.S. CLS. 100, 101 AND 102).

FLORENTINA BLANDU, EXAMINING ATTORNEY

**CLASS 36—(Continued).**

SN 85-227,861. AUSTRALIA AND NEW ZEALAND BANKING GROUP LIMITED, DOCKLANDS, VIC 3008, AUSTRALIA, FILED 1-27-2011.

**ANZ TRANSACTIVE**

THE MARK CONSISTS OF STANDARD CHARACTERS WITHOUT CLAIM TO ANY PARTICULAR FONT, STYLE, SIZE, OR COLOR.

OWNER OF U.S. REG. NOS. 2,929,930, 3,548,988 AND OTHERS.

FOR FINANCIAL SERVICES, NAMELY, BANKING SERVICES, ELECTRONIC FUNDS TRANSFER SERVICES, INTERNET BANKING SERVICES, CHECKING ACCOUNT SERVICES, SAVINGS ACCOUNT SERVICES, CREDIT CARD SERVICES, DEBIT CARD SERVICES, INSURANCE UNDERWRITING AND BROKERAGE SERVICES IN THE FIELD OF LIFE INSURANCE, ACCIDENT INSURANCE, FIRE INSURANCE, BUSINESS INSURANCE, HOME AND CONTENTS INSURANCE, TRAVEL INSURANCE, HEALTH INSURANCE, CREDIT CARD INSURANCE, MORTGAGE INSURANCE, EXCHANGING MONEY, FINANCIAL INFORMATION, FINANCIAL MANAGEMENT, FINANCING, FUND INVESTMENTS, HOME BANKING, HIRE-PURCHASE FINANCING, MORTGAGE LENDING, REAL ESTATE LENDING, BUSINESS LENDING, COMMERCIAL LENDING, CONSUMER LENDING, MORTGAGE BANKING, SAFE DEPOSIT BOX SERVICES, ISSUING TRAVELERS' CHECKS (U.S. CLS. 100, 101 AND 102).  
JAMES LOVELACE, EXAMINING ATTORNEY

**CLASS 36—(Continued).**

SN 85-230,163. ENTERPRISE HOLDINGS, INC., ST. LOUIS, MO. FILED 1-31-2011.



THE COLOR(S) GREEN AND BLUE IS/ARE CLAIMED AS A FEATURE OF THE MARK.

THE MARK CONSISTS OF A BLUE LETTER "T" AND A GREEN STEM CURVED INTO THE SHAPE OF A LETTER "C" WITH LEAVES EXTENDING FROM THE UPPER END OF THE STEM, AND THE BOTTOM OF THE STEM CROSSING OVER THE LOWER PORTION OF THE LETTER "T".

FOR CHARITABLE FOUNDATION SERVICES, NAMELY, PROVIDING FUNDING TO PROJECTS AND ORGANIZATIONS IN THE FIELDS OF HEALTH CARE, EDUCATION, HUMAN SERVICES, AND THE PERFORMING ARTS (U.S. CLS. 100, 101 AND 102).  
JOHN WILKE, EXAMINING ATTORNEY

SN 85-229,753. HARTFORD LIFE INSURANCE COMPANY, HARTFORD, CT. FILED 1-31-2011.

**Longevity Access  
Accelerated Benefit Rider**

THE MARK CONSISTS OF STANDARD CHARACTERS WITHOUT CLAIM TO ANY PARTICULAR FONT, STYLE, SIZE, OR COLOR.

NO CLAIM IS MADE TO THE EXCLUSIVE RIGHT TO USE "ACCELERATED BENEFIT RIDER", APART FROM THE MARK AS SHOWN.

FOR UNDERWRITING AND INSURANCE ADMINISTRATION OF AN ACCELERATED DEATH BENEFIT RIDER OF AN INSURANCE POLICY (U.S. CLS. 100, 101 AND 102).

DAVID H. STINE, EXAMINING ATTORNEY

SN 85-230,405. CITIZENS FINANCIAL GROUP, INC., PROVIDENCE, RI. AND THE ROYAL BANK OF SCOTLAND GROUP PLC, EDINBURGH, SCOTLAND, FILED 1-31-2011.

**RBS CITIZENS**

THE MARK CONSISTS OF STANDARD CHARACTERS WITHOUT CLAIM TO ANY PARTICULAR FONT, STYLE, SIZE, OR COLOR.

OWNER OF U.S. REG. NOS. 3,185,538, 3,269,702 AND OTHERS.

FOR RETAIL AND COMMERCIAL BANKING SERVICES (U.S. CLS. 100, 101 AND 102).

VIVIAN MICZNIK FIRST, EXAMINING ATTORNEY

**CLASS 36—(Continued).**

SN 85-230,413. CITIZENS FINANCIAL GROUP, INC., PROVIDENCE, RI. AND THE ROYAL BANK OF SCOTLAND GROUP PLC, EDINBURGH, SCOTLAND, FILED 1-31-2011.

 **RBS Citizens**

OWNER OF U.S. REG. NOS. 3,185,538, 3,269,702 AND OTHERS.

THE MARK CONSISTS OF THE WORDS "RBS CITIZENS" IN STYLIZED TYPE; TO THE LEFT APPEARS A DESIGN CONSISTING OF A STYLIZED DEPICTION OF A DAISY.

FOR RETAIL AND COMMERCIAL BANKING SERVICES (U.S. CLS. 100, 101 AND 102).

VIVIAN MICZNIK FIRST, EXAMINING ATTORNEY

SN 85-232,932. THE PRUDENTIAL INSURANCE COMPANY OF AMERICA, NEWARK, NJ. FILED 2-3-2011.

**BRIGHT IDEAS**

THE MARK CONSISTS OF STANDARD CHARACTERS WITHOUT CLAIM TO ANY PARTICULAR FONT, STYLE, SIZE, OR COLOR.

FOR MUTUAL FUND INVESTMENT, BROKERAGE AND DISTRIBUTION SERVICES; INVESTMENT MANAGEMENT SERVICES; FINANCIAL PORTFOLIO MANAGEMENT SERVICES (U.S. CLS. 100, 101 AND 102).

FIRST USE 7-12-2010; IN COMMERCE 7-12-2010.  
MARK SHINER, EXAMINING ATTORNEY

SN 85-233,051. THE PRUDENTIAL INSURANCE COMPANY OF AMERICA, NEWARK, NJ. FILED 2-3-2011.

 **Bright  
Ideas**

THE MARK CONSISTS OF THE WORD "IDEAS" APPEARING ON THE BOTTOM LEFT HAND CORNER OF THE WORD "BRIGHT". A STAR SHAPE APPEARS ABOVE THE WORD "BRIGHT".

FOR MUTUAL FUND INVESTMENT, BROKERAGE AND DISTRIBUTION SERVICES; INVESTMENT MANAGEMENT SERVICES; FINANCIAL PORTFOLIO MANAGEMENT SERVICES (U.S. CLS. 100, 101 AND 102).

FIRST USE 7-12-2010; IN COMMERCE 7-12-2010.  
MARK SHINER, EXAMINING ATTORNEY

**CLASS 36—(Continued).**

SN 85-233,094. THE PRUDENTIAL INSURANCE COMPANY OF AMERICA, NEWARK, NJ. FILED 2-3-2011.

 **Bright  
Ideas**

THE MARK CONSISTS OF THE WORD "IDEAS" APPEARING TO THE BOTTOM RIGHT HAND CORNER OF THE WORD "BRIGHT" AND A STAR SHAPE APPEARING ABOVE THE WORD "BRIGHT".

FOR MUTUAL FUND INVESTMENT, BROKERAGE AND DISTRIBUTION SERVICES; INVESTMENT MANAGEMENT SERVICES; FINANCIAL PORTFOLIO MANAGEMENT SERVICES (U.S. CLS. 100, 101 AND 102).

FIRST USE 7-12-2010; IN COMMERCE 7-12-2010.  
MARK SHINER, EXAMINING ATTORNEY

SN 85-235,645. BELL PARTNERS, INC., GREENSBORO, NC. FILED 2-7-2011.

**BELL**

THE MARK CONSISTS OF STANDARD CHARACTERS WITHOUT CLAIM TO ANY PARTICULAR FONT, STYLE, SIZE, OR COLOR.

OWNER OF U.S. REG. NO. 3,711,328.  
FOR LEASING AND MANAGEMENT OF APARTMENTS (U.S. CLS. 100, 101 AND 102).

FIRST USE 3-0-2009; IN COMMERCE 3-0-2009.  
JEFF DEFORD, EXAMINING ATTORNEY

SN 85-238,204. CITIZENS FINANCIAL GROUP, INC., PROVIDENCE, RI. FILED 2-9-2011.

**CITIZENS FOR SENSIBLE  
LENDING**

THE MARK CONSISTS OF STANDARD CHARACTERS WITHOUT CLAIM TO ANY PARTICULAR FONT, STYLE, SIZE, OR COLOR.

OWNER OF U.S. REG. NOS. 2,482,203, 2,668,486 AND OTHERS.

FOR BANKING SERVICES (U.S. CLS. 100, 101 AND 102).

VIVIAN MICZNIK FIRST, EXAMINING ATTORNEY

**CLASS 36—(Continued).**

SN 85-254,389. HARTFORD LIFE INSURANCE COMPANY, HARTFORD, CT. FILED 3-1-2011.

## LongevityAccess Rider

THE MARK CONSISTS OF STANDARD CHARACTERS WITHOUT CLAIM TO ANY PARTICULAR FONT, STYLE, SIZE, OR COLOR.

NO CLAIM IS MADE TO THE EXCLUSIVE RIGHT TO USE "RIDER", APART FROM THE MARK AS SHOWN.

FOR INSURANCE UNDERWRITING AND ADMINISTRATION OF A MINIMUM WITHDRAWAL BENEFIT RIDER OF AN INSURANCE POLICY (U.S. CLS. 100, 101 AND 102).

DAVID H. STINE, EXAMINING ATTORNEY

SN 85-262,899. JUST PEANUTS!, LEE'S SUMMIT, MO. FILED 3-10-2011.

## JUST God

THE MARK CONSISTS OF STANDARD CHARACTERS WITHOUT CLAIM TO ANY PARTICULAR FONT, STYLE, SIZE, OR COLOR.

FOR CHARITABLE FUNDRAISING (U.S. CLS. 100, 101 AND 102).

KARANENDRA S. CHHINA, EXAMINING ATTORNEY

**CLASS 37—CONSTRUCTION AND REPAIR**

SN 77-937,063. SAGE CREEK DEVELOPMENT, L.L.C., YAKIMA, WA. FILED 2-16-2010.

## MAN LODGES

THE MARK CONSISTS OF STANDARD CHARACTERS WITHOUT CLAIM TO ANY PARTICULAR FONT, STYLE, SIZE, OR COLOR.

NO CLAIM IS MADE TO THE EXCLUSIVE RIGHT TO USE "LODGES", APART FROM THE MARK AS SHOWN.

FOR CONSTRUCTION OF STORAGE AND SHOP STRUCTURES (U.S. CLS. 100, 103 AND 106).

FIRST USE 7-1-2007; IN COMMERCE 7-1-2007.

PAUL E. FAHRENKOPF, EXAMINING ATTORNEY

**CLASS 37—(Continued).**

SN 79-084,680. LOXIN 2002, S.L., SPAIN, FILED 2-19-2010.

# LOXIN

THE MARK CONSISTS OF STANDARD CHARACTERS WITHOUT CLAIM TO ANY PARTICULAR FONT, STYLE, SIZE, OR COLOR.

OWNER OF INTERNATIONAL REGISTRATION 1044203 DATED 2-19-2010, EXPIRES 2-19-2020.

FOR SERVICES OF INSTALLATION, REPAIRING, AND MAINTAINING OF ALL KINDS OF INDUSTRIAL PLANTS AND MACHINES, PARTICULARLY IN THE FIELD OF AERONAUTICS AND PARALLEL KINEMATICS; NOT INTENDED FOR USE IN THE FIELD OF CONSTRUCTION, BUILDING AND PUBLIC WORKS (U.S. CLS. 100, 103 AND 106).

LAURA HAMMEL, EXAMINING ATTORNEY

SN 85-018,702. WINNER CONSTRUCTION GROUP, INC., BALTIMORE, MD. FILED 4-20-2010.

## Winner Construction

THE MARK CONSISTS OF STANDARD CHARACTERS WITHOUT CLAIM TO ANY PARTICULAR FONT, STYLE, SIZE, OR COLOR.

NO CLAIM IS MADE TO THE EXCLUSIVE RIGHT TO USE "CONSTRUCTION", APART FROM THE MARK AS SHOWN.

FOR BUILDING CONSTRUCTION, REMODELING AND REPAIR; CONSTRUCTION AND RENOVATION OF BUILDINGS; CONSTRUCTION MANAGEMENT; CUSTOM CONSTRUCTION AND BUILDING RENOVATION; GENERAL CONSTRUCTION CONTRACTING; REAL ESTATE DEVELOPMENT AND CONSTRUCTION OF COMMERCIAL, RESIDENTIAL AND HOTEL PROPERTY; RESIDENTIAL AND COMMERCIAL BUILDING CONSTRUCTION (U.S. CLS. 100, 103 AND 106).

FIRST USE 12-1-1996; IN COMMERCE 12-1-1996.

WILLIAM P. SHANAHAN, EXAMINING ATTORNEY

SN 85-023,864. DASSAULT FALCON JET CORP., LITTLE FERRY, NJ. FILED 4-27-2010.

## WHATEVER IT TAKES

THE MARK CONSISTS OF STANDARD CHARACTERS WITHOUT CLAIM TO ANY PARTICULAR FONT, STYLE, SIZE, OR COLOR.

FOR AIRCRAFT MAINTENANCE AND REPAIR SERVICES (U.S. CLS. 100, 103 AND 106).

FIRST USE 2-1-2010; IN COMMERCE 2-1-2010.

ELIZABETH KAJUBI, EXAMINING ATTORNEY

**CLASS 37—(Continued).**

SN 85-032,851. WORLDWIDE DEEPWATER SOLUTIONS, LLC, RICHMOND, TX. FILED 5-7-2010.



NO CLAIM IS MADE TO THE EXCLUSIVE RIGHT TO USE "WORLDWIDE DEEPWATER SOLUTIONS LLC.", APART FROM THE MARK AS SHOWN.

THE COLOR(S) BLACK, WHITE AND BLUE IS/ARE CLAIMED AS A FEATURE OF THE MARK.

THE MARK CONSISTS OF A GLOBE SHAPED DESIGN WITH AN OUTER CIRCULAR RIM IN BLACK AND WHITE BEARING THE WORD "WORLDWIDE DEEPWATER SOLUTIONS LLC." IN WHITE COLOR AGAINST A BLACK BACKGROUND ALONG WITH AN INNER GLOBE DESIGN WITH TWO SHADES OF BLUE AS ITS BACKGROUND WITH THE LETTERS "WDS" APPEARING IN WHITE COLOR ACROSS THE CENTER AS WELL AS A DIAGRAM OF A SHIP IN BLACK ON THE TOP PORTION OF THE INNER GLOBE DESIGN AND LONGITUDE LINES IN WHITE WHICH FORM A GLOBE IN BOTH THE TOP AND BOTTOM PORTIONS OF THE INNER GLOBE DESIGN.

FOR OIL AND GAS DRILLING SERVICES; RENTAL OF OIL AND GAS WELL DRILLING TOOLS; CONSTRUCTION PROJECT MANAGEMENT SERVICES IN THE FIELD OF CONSTRUCTION OF OFFSHORE OIL AND GAS FACILITIES (U.S. CLS. 100, 103 AND 106).

FIRST USE 9-1-2009; IN COMMERCE 9-1-2009.  
DANIEL CAPSHAW, EXAMINING ATTORNEY

SN 85-044,135. ILLINOIS HARLEY-DAVIDSON SALES, INC., BERWYN, IL. FILED 5-20-2010.

**Horsepower Is Adjustable**

THE MARK CONSISTS OF STANDARD CHARACTERS WITHOUT CLAIM TO ANY PARTICULAR FONT, STYLE, SIZE, OR COLOR.

FOR MOTORCYCLE ENGINE MODIFICATION (U.S. CLS. 100, 103 AND 106).

FIRST USE 6-30-1992; IN COMMERCE 2-11-2008.  
ANNE MADDEN, EXAMINING ATTORNEY

**CLASS 37—(Continued).**

SN 85-047,904. JD REINFORCING COMPANY, SAN DIEGO, CA. FILED 5-26-2010.

**BUILDING FOUNDATIONS FOR FUTURE GENERATIONS**

THE MARK CONSISTS OF STANDARD CHARACTERS WITHOUT CLAIM TO ANY PARTICULAR FONT, STYLE, SIZE, OR COLOR.

FOR CONSTRUCTION AND REPAIR SERVICES, NAMELY, NEW CONSTRUCTION OF RESIDENTIAL AND COMMERCIAL BUILDINGS; RESIDENTIAL AND COMMERCIAL BUILDING CONSTRUCTION FOR GENERAL CONTRACTORS; HOME BUILDERS AND CONCRETE COMPANIES; NAMELY, HOUSE BUILDING AND REPAIR SERVICES AND CONCRETE CONSTRUCTION SERVICES (U.S. CLS. 100, 103 AND 106).

KATHY DE JONGE, EXAMINING ATTORNEY

SN 85-050,318. UNITEK GLOBAL SERVICES, INC., BLUE BELL, PA. FILED 5-28-2010.

**CONNECTING THE WIRED AND WIRELESS WORLDS**

THE MARK CONSISTS OF STANDARD CHARACTERS WITHOUT CLAIM TO ANY PARTICULAR FONT, STYLE, SIZE, OR COLOR.

FOR CONSTRUCTION OF TELECOMMUNICATION TOWERS FOR WIRELESS TELECOMMUNICATION SYSTEMS; INSTALLATION OF CABLE AND FIBER OPTIC TELECOMMUNICATION LINES (U.S. CLS. 100, 103 AND 106).

FIRST USE 1-27-2010; IN COMMERCE 1-27-2010.  
EVELYN BRADLEY, EXAMINING ATTORNEY

SN 85-057,937. TANCOR CORPORATION, MIDLAND, MI. FILED 6-8-2010.

**Tancor Corporation**

THE MARK CONSISTS OF STANDARD CHARACTERS WITHOUT CLAIM TO ANY PARTICULAR FONT, STYLE, SIZE, OR COLOR.

NO CLAIM IS MADE TO THE EXCLUSIVE RIGHT TO USE "CORPORATION", APART FROM THE MARK AS SHOWN.

FOR BUILDING CONSTRUCTION SERVICES; CONSTRUCTION CONSULTATION; CONSTRUCTION PROJECT MANAGEMENT SERVICES (U.S. CLS. 100, 103 AND 106).

FIRST USE 6-30-1992; IN COMMERCE 2-11-2008.  
EMILY CHUO, EXAMINING ATTORNEY



**CLASS 37—(Continued).**

SN 85-071,722. KELLY-MOORE PAINT COMPANY, INC.,  
SAN CARLOS, CA. FILED 6-25-2010.



NO CLAIM IS MADE TO THE EXCLUSIVE RIGHT TO USE "REFLECTIVE", APART FROM THE MARK AS SHOWN.

THE MARK CONSISTS OF A STYLIZED SEMI-CIRCULAR SUN; A STYLIZED SUN RAY OVERLAPPING A LEFT SIDE OF AND INTERSECTING THE PERIMETER OF THE SUN; A STYLIZED ARROW OVERLAPPING A RIGHT SIDE OF AND INTERSECTING THE PERIMETER OF THE SUN; AND THE WORD "REFLECTIVE" POSITIONED BENEATH THE DESIGN ELEMENTS.

FOR PROVIDING A WEBSITE AND ONLINE INFORMATION IN THE FIELDS OF PAINTING TECHNIQUES, NAMELY, PROVIDING INFORMATION IN THE FIELD OF PAINTING, VIA THE INTERNET; AND CONSULTING IN THE FIELD OF PAINTING AND SURFACE PREPARATION TECHNIQUES, NAMELY, CONSULTATION RELATING TO PAINTING OF BUILDINGS; ALL OF THE AFORESAID RELATING TO THE USE OF PAINT PRIMARILY HAVING REFLECTIVE QUALITIES (U.S. CLS. 100, 103 AND 106).

ESTHER BELENKER, EXAMINING ATTORNEY

SN 85-074,799. WESTLINE COMMERCIAL REALTY, LLC,  
TA WESTLINE COMMERCIAL REALTY, HERNDON, VA.  
FILED 6-30-2010.

THE MARK CONSISTS OF THE WORDING "WESTLINE" IN A STYLIZED FONT, WITH A LINE TRACING THE INTERIOR OF THE LETTER "W" TO CREATE A DESIGN OF ONE "W" OVERLAID ON TOP OF ANOTHER "W".

FOR REAL ESTATE DEVELOPMENT; REAL ESTATE CONSTRUCTION SERVICES, NAMELY, PLANNING, IMPLEMENTING AND MANAGING CONSTRUCTION OF COMMERCIAL REAL ESTATE BUILDINGS; BROKERAGE SERVICES FOR COMMERCIAL REAL ESTATE, NAMELY, ASSISTANCE IN SELECTION AND SALE OF COMMERCIAL PROPERTY (U.S. CLS. 100, 103 AND 106).

FIRST USE 4-8-2009; IN COMMERCE 4-8-2009.

JAMES MACFARLANE, EXAMINING ATTORNEY

**CLASS 37—(Continued).**

SN 85-080,408. BOLSTER LLC, DES PLAINES, IL. FILED 7-8-2010.

# SAFEMART

THE MARK CONSISTS OF STANDARD CHARACTERS WITHOUT CLAIM TO ANY PARTICULAR FONT, STYLE, SIZE, OR COLOR.

OWNER OF U.S. REG. NO. 2,947,974.

FOR TECHNICAL SUPPORT SERVICES, NAMELY, TECHNICAL ADVICE CONCERNING THE INSTALLATION, REPAIR AND MAINTENANCE OF SURVEILLANCE, MONITORING, SECURITY, INTRUSION, DETECTION, DETERRENT, SAFETY AND FIRE ALARMS AND SYSTEMS AND PARTS THEREOF (U.S. CLS. 100, 103 AND 106).

FIRST USE 12-20-2002; IN COMMERCE 1-15-2003.

HENRY S. ZAK, EXAMINING ATTORNEY

SN 85-090,401. CAPE CORAL DEVELOPMENT ASSOCIATES,  
LLC, BONITA SPRINGS, FL. FILED 7-22-2010.

# SANDOVAL

THE MARK CONSISTS OF STANDARD CHARACTERS WITHOUT CLAIM TO ANY PARTICULAR FONT, STYLE, SIZE, OR COLOR.

OWNER OF U.S. REG. NO. 3,251,875.

SEC. 2(F).

FOR REAL ESTATE DEVELOPMENT (U.S. CLS. 100, 103 AND 106).

FIRST USE 10-12-2004; IN COMMERCE 10-12-2004.

DOMINICK J. SALEMI, EXAMINING ATTORNEY

SN 85-091,814. U.S.M.M., INC., SKOKIE, IL. FILED 7-23-2010.

# U.S.M.M., Inc.

THE MARK CONSISTS OF STANDARD CHARACTERS WITHOUT CLAIM TO ANY PARTICULAR FONT, STYLE, SIZE, OR COLOR.

NO CLAIM IS MADE TO THE EXCLUSIVE RIGHT TO USE "INC.", APART FROM THE MARK AS SHOWN.

FOR MACHINERY INSTALLATION; MACHINERY MAINTENANCE AND REPAIR; EXCLUDING, HOWEVER, THE INSTALLATION, MAINTENANCE, OR REPAIR OF MACHINERY FOR MAKING SHOES (U.S. CLS. 100, 103 AND 106).

FIRST USE 5-13-1999; IN COMMERCE 5-13-1999.

MAUREEN DALL, EXAMINING ATTORNEY

**CLASS 37—(Continued).**

SN 85-094,599. MAIDS ON THE RUN INC, JACKSONVILLE, FL. FILED 7-28-2010.



NO CLAIM IS MADE TO THE EXCLUSIVE RIGHT TO USE "HOME CONCIERGE", APART FROM THE MARK AS SHOWN.

THE MARK CONSISTS OF A LADY HOLDING A SHOPPING BAG IN ONE HAND AND PUSHING A VACUUM IN THE OTHER HAND. TO THE RIGHT THERE IS THE STYLIZED TEXT "MAIDS ON THE RUN HOME CONCIERGE WE TAKE CARE OF YOUR HOME SO YOU CAN TAKE CARE OF YOUR FAMILY".

FOR CLEANING OF RESIDENTIAL HOUSES (U.S. CLS. 100, 103 AND 106).

FIRST USE 5-1-2008; IN COMMERCE 5-1-2008.  
REBECCA SMITH, EXAMINING ATTORNEY

**CLASS 37—(Continued).**

SN 85-133,680. RICKY ROOTER, BOYSTOWN, NE. FILED 9-20-2010.

When things get icky, just call Ricky!

THE MARK CONSISTS OF STANDARD CHARACTERS WITHOUT CLAIM TO ANY PARTICULAR FONT, STYLE, SIZE, OR COLOR.

THE NAME(S), PORTRAIT(S), AND/OR SIGNATURE(S) SHOWN IN THE MARK IDENTIFIES RICKY RUTHERFORD, WHOSE CONSENT(S) TO REGISTER IS MADE OF RECORD.

FOR DRAIN AND SEWER CLEANING AND ROOTER-ING SERVICES (U.S. CLS. 100, 103 AND 106).

FIRST USE 3-29-2009; IN COMMERCE 3-29-2009.  
CHARLES L. JENKINS, EXAMINING ATTORNEY

SN 85-122,348. CANEZ, IVONNE R., SAN ANTONIO, TX. FILED 9-2-2010.



NO CLAIM IS MADE TO THE EXCLUSIVE RIGHT TO USE "MAID" AND "MESS" AND "TEXAS", APART FROM THE MARK AS SHOWN.

THE COLOR(S) RED, BLACK, PINK, AND GRAY IS/ARE CLAIMED AS A FEATURE OF THE MARK.

THE MARK CONSISTS OF THE STYLIZED WORDING "MAID SQUAD NO MESS IN TEXAS" WITH A MAID WEARING AN APRON AND HOLDING A DUSTER WITH HER RIGHT HAND. THE COLOR RED IS IN THE WORDING "NO MESS IN TEXAS" AND IN THE MAID'S HAIR ORNAMENT, DRESS, APRON, AND SHOES. THE COLOR BLACK IS IN THE WORDING "MAID SQUAD", IN THE MAID'S DRESS AND HAIR, AND IN THE DUSTER. THE COLOR PINK IS IN THE MAID'S FACE, ARMS, AND LEGS. THE COLOR GRAY IS IN THE DUSTER.

FOR CLEANING OF OFFICES AND BUILDING; CLEANING OF RESIDENTIAL HOUSES; CLEANING OF INDUSTRIAL PREMISES; WINDOW CLEANING; CARPET AND RUG CLEANING; CLEANING OF CLOTHING; EVENT CLEAN-UP SERVICES (U.S. CLS. 100, 103 AND 106).

MARGARET POWER, EXAMINING ATTORNEY

SN 85-134,906. BRINK, WILLIAM R, SAN DIEGO, CA. FILED 9-21-2010.



NO CLAIM IS MADE TO THE EXCLUSIVE RIGHT TO USE "GAS" "POOL" "SPA" "SEWER" "DRAINS" "FIRE SPRINKLERS" "POTABLE" OR "DRINKING", APART FROM THE MARK AS SHOWN.

THE MARK CONSISTS OF THE STYLIZED PHRASE "ANY PIPE" ABOVE THE DESIGN OF FIVE PIPES THAT GO FROM SHORTER TO LONGER FROM TOP TO BOTTOM AND WHERE THE RIGHT SIDE OF EACH OF THE PIPES HAS A SMALLER PORTION TELESCOPING OUT TO THE RIGHT, AND WITH THE STYLIZED TERM "GAS" ON THE TOP PIPE, THE STYLIZED PHRASE "POOL - SPA" ON THE SECOND FROM THE TOP PIPE, THE STYLIZED PHRASE "SEWER - DRAINS" ON THE MIDDLE BOTTOM, THE STYLIZED PHRASE "FIRE SPRINKLERS" ON THE SECOND FROM THE BOTTOM PIPE AND THE STYLIZED PHRASE "POTABLE - DRINKING" ON THE BOTTOM PIPE, ALL ABOVE THE STYLIZED PHRASE "ANY PLACE!".

FOR REPAIRING CORROSIVE OR LEAKING PIPES THROUGH PIPELINING, NAMELY, COATING THE INSIDE OF THE PIPE WITH A DURABLE SAFE EPOXY (U.S. CLS. 100, 103 AND 106).

FIRST USE 0-0-2007; IN COMMERCE 0-0-2007.  
MYRIAH HABEEB, EXAMINING ATTORNEY

**CLASS 37—(Continued).**

SN 85-145,149. ACADIA HOMES & NEIGHBORHOODS, LLC, ATLANTA, GA. FILED 10-5-2010.



NO CLAIM IS MADE TO THE EXCLUSIVE RIGHT TO USE "HOMES & NEIGHBORHOODS", APART FROM THE MARK AS SHOWN.

THE COLOR(S) RED, BLUE AND WHITE IS/ARE CLAIMED AS A FEATURE OF THE MARK.

THE MARK CONSISTS OF THE WORD "ACADIA" IN LARGE BLUE CAPITALIZED LETTERS WITH RED AND WHITE SHADING WITH THE FIRST AND LAST LETTERS "A" APPEARING SLIGHTLY LARGER THAN THE LETTERS "CADI". DIRECTLY BELOW THE LETTERS "CADI" APPEAR THE WORDS "HOMES & NEIGHBORHOODS" IN SMALL BLUE CAPITALIZED LETTERS BOTH UNDERSCORED AND OVERSCORED WITH BLUE HORIZONTAL LINES.

FOR RESIDENTIAL BUILDING CONSTRUCTION AND REAL ESTATE DEVELOPMENT (U.S. CLS. 100, 103 AND 106).

FIRST USE 9-18-2010; IN COMMERCE 9-18-2010.  
BARNEY CHARLON, EXAMINING ATTORNEY

SN 85-148,088. CARPET CLEANING PLUS, INC., CUMMING, GA. FILED 10-8-2010.

## Carpet Cleaning Plus

THE MARK CONSISTS OF STANDARD CHARACTERS WITHOUT CLAIM TO ANY PARTICULAR FONT, STYLE, SIZE, OR COLOR.

NO CLAIM IS MADE TO THE EXCLUSIVE RIGHT TO USE "CARPET CLEANING", APART FROM THE MARK AS SHOWN.

FOR CARPET AND RUG CLEANING; CARPET CLEANING; CLEANING OF COMMERCIAL PREMISES; CLEANING OF GROUT AND GROUT SEALING; FURNITURE MAINTENANCE; RUG CLEANING (U.S. CLS. 100, 103 AND 106).

FIRST USE 2-3-2010; IN COMMERCE 2-3-2010.  
BRIAN NEVILLE, EXAMINING ATTORNEY

**CLASS 37—(Continued).**

SN 85-165,052. RADWELL INTERNATIONAL, INC., LUMBERTON, NJ. FILED 10-29-2010.

## PLCCENTER

THE MARK CONSISTS OF STANDARD CHARACTERS WITHOUT CLAIM TO ANY PARTICULAR FONT, STYLE, SIZE, OR COLOR.

OWNER OF U.S. REG. NOS. 2,906,483, 2,923,461 AND 3,129,072.

FOR MAINTENANCE, REPAIR AND INSTALLATION OF INDUSTRIAL AUTOMATION EQUIPMENT (U.S. CLS. 100, 103 AND 106).

FIRST USE 3-1-2004; IN COMMERCE 3-1-2004.  
JOSETTE BEVERLY, EXAMINING ATTORNEY

SN 85-169,020. HORIZON MECHANICAL SERVICES, CLINTON, MD. FILED 11-4-2010.



NO CLAIM IS MADE TO THE EXCLUSIVE RIGHT TO USE "MECHANICAL SERVICES LLC", APART FROM THE MARK AS SHOWN.

THE MARK CONSISTS OF THE STYLIZED TEXT "HORIZON MECHANICAL SERVICES LLC" WITH THREE WAVES AROUND THE LETTER "O".

FOR HVAC CONTRACTOR SERVICES (U.S. CLS. 100, 103 AND 106).

FIRST USE 4-1-2001; IN COMMERCE 4-1-2001.  
NAAKWAMA ANKRAH, EXAMINING ATTORNEY

SN 85-170,001. GENTRY HEATING, INC., DBA ECODUCTS ENVIRONMENTAL AIR QUALITY, SWANNANOVA, NC. FILED 11-5-2010.



THE COLOR(S) GRAY AND GREEN IS/ARE CLAIMED AS A FEATURE OF THE MARK.

THE MARK CONSISTS OF THE WORD "ECODUCTS" IN GRAY LOWER CASE FONT, STYLIZED SUCH THAT THE CONVERGENCE OF THE "O" AND "D" IN "ECODUCTS" FORMS A GREEN LEAF. ALL OF THIS ON A WHITE BACKGROUND.

FOR AIR DUCT CLEANING SERVICES (U.S. CLS. 100, 103 AND 106).

FIRST USE 5-1-2009; IN COMMERCE 5-1-2009.  
DOMINICK J. SALEMI, EXAMINING ATTORNEY

**CLASS 37—(Continued).**

SN 85-172,110. SCHIEFELBEIN, DAN, ORANGE, CA. FILED 11-9-2010.

**FLAW HIDE**

THE MARK CONSISTS OF STANDARD CHARACTERS WITHOUT CLAIM TO ANY PARTICULAR FONT, STYLE, SIZE, OR COLOR.

FOR DRYWALL CONTRACTOR SERVICES SPECIFICALLY DRYWALL SURFACE PREPARATION (U.S. CLS. 100, 103 AND 106).

KIMBERLY PERRY, EXAMINING ATTORNEY

SN 85-172,863. THE CARPET GUYS, LLC, HARRISON TOWNSHIP, MI. FILED 11-9-2010.

**THE CARPET GUYS**

THE MARK CONSISTS OF STANDARD CHARACTERS WITHOUT CLAIM TO ANY PARTICULAR FONT, STYLE, SIZE, OR COLOR.

NO CLAIM IS MADE TO THE EXCLUSIVE RIGHT TO USE "CARPET", APART FROM THE MARK AS SHOWN.

FOR INSTALLATION, MAINTENANCE AND REPAIR OF PROTECTIVE COATINGS FOR FLOORS; INSTALLING CARPET; INSTALLING FLOOR TILE; INSTALLING WOOD FLOORING; LAYING OF CARPET; TILE INSTALLATION SERVICES (U.S. CLS. 100, 103 AND 106).

FIRST USE 1-15-2010; IN COMMERCE 4-1-2010.

LINDA E. BLOHM, EXAMINING ATTORNEY

SN 85-176,921. EXCEL ROOFING, INCORPORATED, ENGLEWOOD, CO. FILED 11-15-2010.

**EXCEL ROOFING**

THE MARK CONSISTS OF STANDARD CHARACTERS WITHOUT CLAIM TO ANY PARTICULAR FONT, STYLE, SIZE, OR COLOR.

NO CLAIM IS MADE TO THE EXCLUSIVE RIGHT TO USE "ROOFING", APART FROM THE MARK AS SHOWN.

FOR ROOFING INSTALLATION AND REPAIR SERVICES (U.S. CLS. 100, 103 AND 106).

FIRST USE 6-1-1994; IN COMMERCE 8-1-2007.

EDWARD NELSON, EXAMINING ATTORNEY

**CLASS 37—(Continued).**

SN 85-177,078. E & P RECON PEST CONTROL, LLC, MURPHY, TX. FILED 11-15-2010.



NO CLAIM IS MADE TO THE EXCLUSIVE RIGHT TO USE "PEST CONTROL", APART FROM THE MARK AS SHOWN.

THE COLOR(S) BLUE, YELLOW, RED, WHITE, BLACK AND GREEN IS/ARE CLAIMED AS A FEATURE OF THE MARK.

THE MARK CONSISTS OF THE YELLOW, BLACK-OUTLINED WORDING "RECON PEST CONTROL" AND A SHIELD DESIGN. THE SHIELD ELEMENTS, WHICH ARE ALL OUTLINED IN BLACK, ARE YELLOW AND RED STYLIZED LETTERS "E" AND "P"; BLUE UPPER FIELD; GREEN LOWER FIELD; DIAGONAL STRIPES IN RED AND YELLOW; AND A CENTERED WHITE HEXAGON WITH FOUR BLACK LINES AND A CENTRAL BLACK CIRCLE WITH TWO RED TRIANGLES ON IT.

FOR PEST CONTROL AND EXTERMINATION OTHER THAN FOR AGRICULTURAL PURPOSES (U.S. CLS. 100, 103 AND 106).

FIRST USE 6-18-2010. THE MARK WAS FIRST USED ANYWHERE IN A DIFFERENT FORM OTHER THAN THAT SOUGHT TO BE REGISTERED AT LEAST AS EARLY AS 06/18/2010; IN COMMERCE 6-18-2010. THE MARK WAS FIRST USED IN COMMERCE IN A DIFFERENT FORM OTHER THAN THAT SOUGHT TO BE REGISTERED AT LEAST AS EARLY AS 06/18/2010.

REBECCA EISINGER, EXAMINING ATTORNEY

**CLASS 37—(Continued).**

SN 85-179,825. IRON CROSS AUDIO LLC, OAKLAND, NJ. FILED 11-18-2010.



NO CLAIM IS MADE TO THE EXCLUSIVE RIGHT TO USE "AUDIO", APART FROM THE MARK AS SHOWN.

THE STIPPLING IS FOR SHADING PURPOSES ONLY. THE MARK CONSISTS OF A CROSS WITH THE STYLIZED TEXT "IRON CROSS AUDIO" APPEARING BELOW IT.

FOR MAINTENANCE AND/OR REPAIR OF ELECTRONIC AND STEREO SYSTEMS IN MOTORCYCLES AND AUTOMOBILES (U.S. CLS. 100, 103 AND 106).

FIRST USE 4-9-2009; IN COMMERCE 4-9-2009.  
 NAAKWAMA ANKRAH, EXAMINING ATTORNEY

**CLASS 37—(Continued).**

SN 85-188,683. SAL MANZO'S PLUMBING & HEATING, INC., WANTAGH, NY. FILED 12-1-2010.



THE MARK CONSISTS OF THE PHRASE "YOUR SATISFACTION IS OUR #1 PRIORITY" IN SCRIPT BELOW A DRAWING OF AN ALLIGATOR IN A CAP AND SHIRT HOLDING A PLUNGER IN HIS RIGHT HAND AND USING HIS LEFT HAND TO PUSH UP THE SLEEVE ON HIS RIGHT ARM.

FOR PLUMBING SERVICES AND MAINTENANCE AND REPAIR OF HEATING INSTALLATIONS (U.S. CLS. 100, 103 AND 106).

FIRST USE 5-0-1986; IN COMMERCE 5-0-1986.  
 BENJAMIN OKEKE, EXAMINING ATTORNEY

SN 85-187,098. HUMMINGBIRD ENTERPRISES, INC., RIVER VALE, NJ. FILED 11-30-2010.



NO CLAIM IS MADE TO THE EXCLUSIVE RIGHT TO USE "THE BBQ CLEANER", APART FROM THE MARK AS SHOWN.

THE COLOR(S) BLACK, RED, AND WHITE. IS/ARE CLAIMED AS A FEATURE OF THE MARK.

THE MARK CONSISTS OF THE WORDING "THE BBQ" IS IN THE COLOR BLACK; BELOW THE WORDING "THE BBQ" IS THE TERM "CLEANER" WHICH IS IN THE COLOR RED, OUTLINED IN THE COLOR BLACK AND UNDERSCORED WITH A RED CURVED LINE; TO THE RIGHT OF THE WORDING IS A BLACK GRILL WHICH HAS SMALL PATCHES OF THE COLOR WHITE APPEARING IN ALL PARTS OF THE GRILL; A RED FOUR POINT STAR APPEARS SUPERIMPOSED ON THE UPPER LEFT CORNER OF THE GRILL AND A RED FOUR POINT STAR APPEARS JUST BELOW THE BODY OF THE GRILL ON ITS RIGHT SIDE.

FOR CLEANING OF BBQ GRILLS.; INSTALLATION, MAINTENANCE AND REPAIR OF BBQ GRILLS (U.S. CLS. 100, 103 AND 106).

FIRST USE 3-1-2009; IN COMMERCE 4-15-2009.  
 CHARLOTTE CORWIN, EXAMINING ATTORNEY

SN 85-189,658. TRAPPER JOHN ANIMAL CONTROL, INC., BOCA RATON, FL. FILED 12-2-2010.

## Trapper John Rodent & Animal Specialist

THE MARK CONSISTS OF STANDARD CHARACTERS WITHOUT CLAIM TO ANY PARTICULAR FONT, STYLE, SIZE, OR COLOR.

NO CLAIM IS MADE TO THE EXCLUSIVE RIGHT TO USE "TRAPPER" OR "RODENT & ANIMAL SPECIALIST", APART FROM THE MARK AS SHOWN.

THE NAME(S), PORTRAIT(S), AND/OR SIGNATURE(S) SHOWN IN THE MARK DOES NOT IDENTIFY A PARTICULAR LIVING INDIVIDUAL.

FOR NUISANCE WILDLIFE, PEST CONTROL AND VERMIN EXTERMINATION OTHER THAN FOR AGRICULTURE, NAMELY, THE CAPTURE AND REMOVAL OF ANIMALS SUCH AS RATS, MICE, SKUNKS, BEES, BIRDS, SQUIRRELS, SNAKES OPOSSUMS, ARMADILLOS, BATS AND PIGEONS (U.S. CLS. 100, 103 AND 106).

FIRST USE 7-15-1990; IN COMMERCE 7-15-1990.  
 KAELE KUNG, EXAMINING ATTORNEY

**CLASS 37—(Continued).**

SN 85-189,968. TAKENAKA CORPORATION, OSAKA, JAPAN, FILED 12-3-2010.



OWNER OF U.S. REG. NO. 1,376,286.  
 THE MARK CONSISTS OF THE WORD "TAKENAKA" AND A DIVIDED CIRCLE DESIGN.  
 FOR BUILDING DEMOLITION; BUILDING MAINTENANCE AND REPAIR; CONSTRUCTION CONSULTANCY; CONSTRUCTION OF BUILDINGS; CONSTRUCTION PLANNING; CONSTRUCTION PROJECT MANAGEMENT SERVICES; GENERAL BUILDING CONTRACTOR SERVICES; RENOVATION AND RESTORATION OF BUILDINGS (U.S. CLS. 100, 103 AND 106).  
 FIRST USE 0-0-1985; IN COMMERCE 0-0-1985.  
 SHAUNIA CARLYLE, EXAMINING ATTORNEY

SN 85-192,694. ECONOMY PEST CONTROL, INC., GRASS VALLEY, CA. FILED 12-7-2010.



THE MARK CONSISTS OF A SCOTTISH MAN'S HEAD WITH A FISH SYMBOL INCORPORATED INTO HIS CHIN, WEARING A SCOTTISH HAT, ABOVE WHICH APPEARS THE WORDING "MATTHEW 5:16" ANGLED UPWARDS FROM LEFT TO RIGHT.  
 FOR PEST CONTROL (U.S. CLS. 100, 103 AND 106).  
 FIRST USE 3-1-2008; IN COMMERCE 3-1-2008.  
 EDWARD FENNESSY, EXAMINING ATTORNEY

**CLASS 37—(Continued).**

SN 85-194,142. J.C. CHEEK CONTRACTORS, INC., KOSCIUSKO, MS. FILED 12-9-2010.

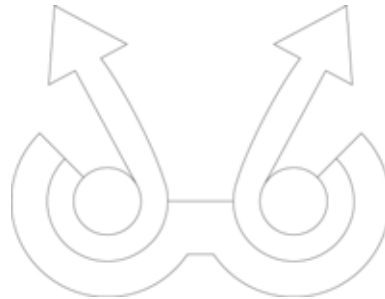

THE MARK CONSISTS OF A STYLIZED MISCELLANEOUS DESIGN CONSISTING OF TWO CURVED MIRROR IMAGE ARROWS AND CIRCLES WITHIN THE CURVES OF THE ARROW, AND A MISCELLANEOUS DOUBLE CURVED DESIGN CONNECTING THE TWO ARROWS AT THE BOTTOM.  
 FOR ROAD AND HIGHWAY CONSTRUCTION (U.S. CLS. 100, 103 AND 106).  
 FIRST USE 7-31-1995; IN COMMERCE 7-31-1995.  
 JEAN IM, EXAMINING ATTORNEY

SN 85-199,990. CAN-B-GREEN, LLC, BOISE, ID. FILED 12-16-2010.

**CAN-B-GREEN**

THE MARK CONSISTS OF STANDARD CHARACTERS WITHOUT CLAIM TO ANY PARTICULAR FONT, STYLE, SIZE, OR COLOR.  
 FOR CLEANING OF WASTE CONTAINERS (U.S. CLS. 100, 103 AND 106).  
 FIRST USE 9-30-2009; IN COMMERCE 9-30-2009.  
 DAVID TAYLOR, EXAMINING ATTORNEY

**CLASS 37—(Continued).**

SN 85-202,664. SEAL-TITE LLC, MADISONVILLE, LA.  
FILED 12-21-2010.



OWNER OF U.S. REG. NO. 3,138,367.  
THE MARK CONSISTS OF A GLOBE WITH WORD  
MARK "SEAL-TITE" SITUATED MEDIALY TO THE  
RIGHT THEREOF.

FOR INDUSTRIAL LEAK MITIGATION SERVICES,  
NAMELY, REPAIR OF LEAKS IN PRESSURIZED FLUID  
CONDUITS, CONTAINMENT VESSELS, AND APPARA-  
TUS IN THE OIL, GAS, AND/OR PETROCHEMICAL  
INDUSTRIES, NAMELY, WELLS, PRODUCTION FACIL-  
ITIES, HYDRAULIC SYSTEMS, TUBING, CASING,  
PACKERS, SLEEVES, JOINTS, RECEPTACLES, FIT-  
TINGS, CONNECTIONS, VALVES, WELLHEADS,  
TREES, HANGERS, PIPELINES, INJECTION SYSTEMS,  
UMBILICALS, CONTROL LINES, MICROANNULUS,  
STORAGE AND CONTAINMENT FACILITIES, AND  
ANALYSIS ASSOCIATED THEREWITH (U.S. CLS. 100,  
103 AND 106).

SUNG IN, EXAMINING ATTORNEY

SN 85-203,217. BROOKSTONE TELECOM, INC., TEMECU-  
LA, CA. FILED 12-21-2010.

# ZONETECH

THE MARK CONSISTS OF STANDARD CHARACTERS  
WITHOUT CLAIM TO ANY PARTICULAR FONT, STYLE,  
SIZE, OR COLOR.

FOR CONSTRUCTING AND REPAIRING CELL  
PHONE TOWERS, AND MAINTAINING AND REPLAC-  
ING WIRELESS FACILITIES (U.S. CLS. 100, 103 AND  
106).

JOHN WILKE, EXAMINING ATTORNEY

**CLASS 37—(Continued).**

SN 85-204,655. MEMA MATES LLC, DBA MEMA MATES  
LLC, NEWTOWN, PA. FILED 12-23-2010.

# MeMa Mates

THE MARK CONSISTS OF STANDARD CHARACTERS  
WITHOUT CLAIM TO ANY PARTICULAR FONT, STYLE,  
SIZE, OR COLOR.

FOR BUILDING CONSTRUCTION AND REPAIR;  
BUILDING CONSTRUCTION, REMODELING AND RE-  
PAIR; BUILDING MAINTENANCE AND REPAIR; CAB-  
INET REFACING; CABINET REPAIR; CHARITABLE  
SERVICES, NAMELY, PROVIDING MAINTENANCE  
AND REPAIRS ON THE HOMES OF THOSE IN NEED;  
COMPUTER HARDWARE INSTALLATION AND RE-  
PAIR, INCLUDING MOBILE PERFORMANCE OF SUCH  
SERVICES ON CUSTOMER PREMISES; COMPUTER  
INSTALLATION AND REPAIR; CONSTRUCTION AND  
REPAIR OF BUILDINGS; CONSULTATION IN THE  
FIELD OF REPAIRING AND MAINTAINING HOME  
APPLIANCES; DOOR REPAIR SERVICES; ELECTRIC  
APPLIANCE INSTALLATION AND REPAIR; ELECTRICAL  
REPAIRS, MAINTENANCE, AND INSTALLATION  
OF ELECTRICAL WIRING, OUTLETS, LIGHT FIX-  
TURES, AND ELECTRICAL PANELS; FIRE ALARM  
INSTALLATION AND REPAIR; FIRE AND/OR BUR-  
GLAR ALARM INSTALLATION AND/OR REPAIR;  
FREEZING EQUIPMENT INSTALLATION AND RE-  
PAIR; FURNACE INSTALLATION AND REPAIR; FUR-  
NITURE REPAIR; FURNITURE RESTORATION,  
REPAIR AND MAINTENANCE; HANDYMAN SERVICE,  
NAMELY, BUILDING REPAIR AND MAINTENANCE;  
HEATING EQUIPMENT INSTALLATION AND REPAIR;  
HOUSE BUILDING AND REPAIR; HOUSING SERVICES,  
NAMELY, DEVELOPMENT OF REAL PROPERTY,  
NAMELY, REPAIR, IMPROVEMENT, AND NEW CON-  
STRUCTION; HOUSING SERVICES, NAMELY, REPAIR,  
IMPROVEMENT, AND CONSTRUCTION OF RESIDEN-  
TIAL REAL PROPERTY; INSTALLATION AND REPAIR  
OF AIR CONDITIONING APPARATUS; INSTALLATION  
AND REPAIR OF BLINDS; INSTALLATION AND RE-  
PAIR OF BUSINESS AND OFFICE MACHINERY AND  
EQUIPMENT; INSTALLATION AND REPAIR OF COM-  
PUTER HARDWARE; INSTALLATION AND REPAIR OF  
FREEZING APPARATUS; INSTALLATION AND RE-  
PAIR OF HEATING, VENTILATING AND AIR CONDI-  
TIONING EQUIPMENT; INSTALLATION OF KITCHEN  
CABINETS; INSTALLATION, CHANGING, REPLAC-  
EMENT AND REPAIR OF LOCKS; INSTALLATION,  
MAINTENANCE AND REPAIR OF COMPUTER HARD-  
WARE; INSTALLATION, MAINTENANCE AND REPAIR  
OF DOORS; INSTALLATION, MAINTENANCE AND  
REPAIR OF ETHERNET AND WIRELESS NETWORK-  
ING HARDWARE; INSTALLATION, MAINTENANCE  
AND REPAIR OF PROTECTIVE COATINGS FOR  
FLOORS; INSTALLATION, MAINTENANCE, AND RE-  
PAIR OF OUTDOOR AUTOMATED MIST SYSTEMS FOR  
INSECT AND PEST CONTROL; INSTALLATION, RE-  
PAIR AND MAINTENANCE OF CLEANROOM FACIL-  
ITIES AND EQUIPMENT; INSTALLATION, REPAIR  
AND MAINTENANCE OF COMPUTERS AND COMPU-  
TER PERIPHERALS; INSTALLATION, REPAIR AND  
MAINTENANCE OF HEATING EQUIPMENT; LOCK  
REPAIR SERVICES; LUGGAGE REPAIR; MAINTEN-  
ANCE AND REPAIR OF BUILDINGS; MAINTENANCE  
AND REPAIR OF HEATING INSTALLATIONS; PLATE  
GLASS INSTALLATION AND REPAIR SERVICES; PRO-  
VIDING INFORMATION IN THE FIELD OF HOME  
RENOVATIONS AND REPAIRS; PUMP REPAIR; PUMP  
REPAIR AND MAINTENANCE; PUMP REPAIR OR  
MAINTENANCE; PUMP REPAIRING; REAL ESTATE  
PROPERTY CLEANING, REPAIR AND MAINTENANCE  
SERVICES; REPAIR AND INSTALLATION SERVICES,  
NAMELY, THE INSTALLATION OF HEATING, COOL-  
ING AND ENVIRONMENTAL CONTROL SYSTEMS  
PRIMARILY USING SOLAR ENERGY, RENEWABLE  
ENERGY RESOURCES AND RAINWATER; REPAIR  
AND MAINTENANCE OF BUILDINGS IN CASE OF  
DEMOLITION; REPAIR OF BUILDINGS; REPAIR OF

**CLASS 37—(Continued).**

DAMAGED COMPUTERS; REPAIR OF SECURITY LOCKS; REPAIR OF TOYS OR DOLLS; REPAIR OR MAINTENANCE OF COMPUTERS; REPAIR OR MAINTENANCE OF ELECTRIC LIGHTING APPARATUS; REPAIR OR MAINTENANCE OF FIRE ALARMS; REPAIR OR MAINTENANCE OF GAS WATER HEATERS; REPAIR WORK ON BUILDINGS; ROOFING REPAIR; SATELLITE DISH INSTALLATION AND REPAIR; SET-UP OR REPAIR OF LOCKS; UPHOLSTERY REPAIR; VENETIAN BLIND INSTALLATION AND REPAIR; WINDOW BLIND INSTALLATION AND REPAIR (U.S. CLS. 100, 103 AND 106).

FIRST USE 9-22-2010; IN COMMERCE 9-22-2010.  
DANIEL CAPSHAW, EXAMINING ATTORNEY

---

SN 85-204,686. F.L. ROBERTS & CO., INC., SPRINGFIELD, MA. FILED 12-23-2010.

**GOLDEN NOZZLE**

THE MARK CONSISTS OF STANDARD CHARACTERS WITHOUT CLAIM TO ANY PARTICULAR FONT, STYLE, SIZE, OR COLOR.

FOR VEHICLE PREVENTATIVE MAINTENANCE SERVICES, NAMELY, LUBRICATING CHASSIS, CHANGING MOTOR OIL, CHANGING OIL AND AIR FILTERS, REFILLING TRANSMISSION, DIFFERENTIAL, BRAKE, POWER STEERING, RADIATOR, WINDSHIELD WASHER AND BATTERY RESERVOIRS TO PROPER FLUID LEVELS, CHANGING WINDSHIELD WIPER BLADES, INFLATING TIRES TO PROPER PRESSURE, VACUUMING INTERIORS, AND WASHING WINDOWS (U.S. CLS. 100, 103 AND 106).

BRIAN PINO, EXAMINING ATTORNEY

---

SN 85-204,842. RED COATS, INC., BETHESDA, MD. FILED 12-23-2010.

**RED COATS**

THE MARK CONSISTS OF STANDARD CHARACTERS WITHOUT CLAIM TO ANY PARTICULAR FONT, STYLE, SIZE, OR COLOR.

FOR JANITORIAL SERVICES; CLEANING OF BUILDINGS; CLEANING OF COMMERCIAL PREMISES; WINDOW CLEANING; REFINISHING OF FLOORS; CARPET AND RUG CLEANING; NATURAL STONE AND TILE RESTORATION; UPHOLSTERY, DRAPERY, AND WINDOW TREATMENT CLEANING (U.S. CLS. 100, 103 AND 106).

FIRST USE 0-0-1960; IN COMMERCE 0-0-1960.  
HANNO RITTNER, EXAMINING ATTORNEY

**CLASS 37—(Continued).**

SN 85-205,559. MAXSUS, LLC, DULUTH, GA. FILED 12-24-2010.

**LEARN THE TRUTH ABOUT YOUR  
ROOF**

THE MARK CONSISTS OF STANDARD CHARACTERS WITHOUT CLAIM TO ANY PARTICULAR FONT, STYLE, SIZE, OR COLOR.

FOR ROOFING SERVICES (U.S. CLS. 100, 103 AND 106).

KYLE PEETE, EXAMINING ATTORNEY

---

SN 85-205,564. MAXSUS, LLC, DULUTH, GA. FILED 12-24-2010.

**MORE ADJUSTERS SAY YES**

THE MARK CONSISTS OF STANDARD CHARACTERS WITHOUT CLAIM TO ANY PARTICULAR FONT, STYLE, SIZE, OR COLOR.

FOR ROOFING SERVICES (U.S. CLS. 100, 103 AND 106).

KYLE PEETE, EXAMINING ATTORNEY

---

SN 85-206,358. FINE LINE COLLISION CENTER, LLC, MIAMI, FL. FILED 12-28-2010.

**Fine Line**

THE MARK CONSISTS OF STANDARD CHARACTERS WITHOUT CLAIM TO ANY PARTICULAR FONT, STYLE, SIZE, OR COLOR.

FOR AUTOMOBILE BODY REPAIR AND FINISHING FOR OTHERS (U.S. CLS. 100, 103 AND 106).

FIRST USE 8-2-2007; IN COMMERCE 8-2-2007.  
GISELLE AGOSTO, EXAMINING ATTORNEY



**CLASS 37—(Continued).**

SN 85-207,031. REED & REED, INC., WOOLWICH, ME.  
FILED 12-29-2010.



THE MARK CONSISTS OF AN OVAL BORDER AROUND THE WORDS "REED & REED" WITH 1 LARGE CAPITAL "R" AND 1 LARGE CAPITAL "D" WITH "EE" TWICE BETWEEN THEM WITH AN AMPERSAND IN THE MIDDLE.

FOR CONSTRUCTION PROJECT MANAGEMENT SERVICES; GENERAL CONSTRUCTION CONTRACTING (U.S. CLS. 100, 103 AND 106).

FIRST USE 1-1-1985; IN COMMERCE 1-1-1985.  
JENNY PARK, EXAMINING ATTORNEY

SN 85-207,106. RED COATS, INC., BETHESDA, MD. FILED  
12-29-2010.



THE MARK CONSISTS OF THE LETTERS "RC".  
FOR JANITORIAL SERVICES; CLEANING OF BUILDINGS; CLEANING OF COMMERCIAL PREMISES; WINDOW CLEANING; REFINISHING OF FLOORS; CARPET AND RUG CLEANING; NATURAL STONE AND TILE RESTORATION; UPHOLSTERY, DRAPERY, AND WINDOW TREATMENT CLEANING (U.S. CLS. 100, 103 AND 106).

FIRST USE 0-0-1985; IN COMMERCE 0-0-1985.  
HANNO RITTNER, EXAMINING ATTORNEY

**CLASS 37—(Continued).**

SN 85-207,328. CERTA PROPAINTERS, LTD., OAKS, PA.  
FILED 12-29-2010.

PAINTING SMILES ON FACES  
EVERYWHERE

THE MARK CONSISTS OF STANDARD CHARACTERS WITHOUT CLAIM TO ANY PARTICULAR FONT, STYLE, SIZE, OR COLOR.

NO CLAIM IS MADE TO THE EXCLUSIVE RIGHT TO USE "PAINTING", APART FROM THE MARK AS SHOWN. FOR PAINTING SERVICES, NAMELY, PAINTING RESIDENTIAL AND COMMERCIAL BUILDINGS (U.S. CLS. 100, 103 AND 106).

FIRST USE 3-1-2010; IN COMMERCE 3-1-2010.  
SANJEEV VOHRA, EXAMINING ATTORNEY

SN 85-207,438. RESTAURANT TECHNOLOGIES, INC., MENDOTA HEIGHTS, MN. FILED 12-29-2010.

SMART. SAFE. GREEN.

THE MARK CONSISTS OF STANDARD CHARACTERS WITHOUT CLAIM TO ANY PARTICULAR FONT, STYLE, SIZE, OR COLOR.

FOR INSTALLATION AND MAINTENANCE OF RESTAURANT COOKING OIL HANDLING SYSTEMS (U.S. CLS. 100, 103 AND 106).

FIRST USE 1-7-2010; IN COMMERCE 1-7-2010.  
ANNE MADDEN, EXAMINING ATTORNEY

SN 85-207,450. RESTAURANT TECHNOLOGIES, INC., MENDOTA HEIGHTS, MN. FILED 12-29-2010.



THE MARK CONSISTS OF THE LETTERS "RTI", EN-CIRCLED BY TWO CURVES FORMING AN ELLIPSE THAT OPENS TO THE RIGHT OF THE LETTER "I".

FOR INSTALLATION AND MAINTENANCE OF RESTAURANT COOKING OIL HANDLING SYSTEMS (U.S. CLS. 100, 103 AND 106).

FIRST USE 1-7-2010; IN COMMERCE 1-7-2010.  
ANNE MADDEN, EXAMINING ATTORNEY

**CLASS 37—(Continued).**

SN 85-207,471. RESTAURANT TECHNOLOGIES, INC., MENDOTA HEIGHTS, MN. FILED 12-29-2010.

# RTI

THE MARK CONSISTS OF STANDARD CHARACTERS WITHOUT CLAIM TO ANY PARTICULAR FONT, STYLE, SIZE, OR COLOR.

FOR INSTALLATION AND MAINTENANCE OF RESTAURANT COOKING OIL HANDLING SYSTEMS (U.S. CLS. 100, 103 AND 106).

FIRST USE 12-31-1999; IN COMMERCE 12-31-1999.  
ANNE MADDEN, EXAMINING ATTORNEY

---

SN 85-209,324. MACDONALD MACHINERY COMPANY, INC., FORT WAYNE, IN. FILED 1-3-2011.

# MACLUBE

THE MARK CONSISTS OF STANDARD CHARACTERS WITHOUT CLAIM TO ANY PARTICULAR FONT, STYLE, SIZE, OR COLOR.

FOR REFUELING AND LUBRICATION SERVICES FOR VEHICLES AND EQUIPMENT (U.S. CLS. 100, 103 AND 106).

ROBIN CHOSID, EXAMINING ATTORNEY

---

SN 85-210,087. THE PROSSER GROUP, BROOKLYN, NY. FILED 1-4-2011.



THE MARK CONSISTS OF A TREE.  
FOR CHARGING STATION SERVICES FOR ELECTRIC VEHICLES (U.S. CLS. 100, 103 AND 106).  
PATRICIA EVANKO, EXAMINING ATTORNEY

**CLASS 37—(Continued).**

SN 85-210,373. HAFREDAM GROUP, LAUREL, MD. FILED 1-4-2011.



# Hafredam

THE MARK CONSISTS OF A CIRCLE WITH AN EAGLE AND THE STYLIZED TEXT "HAFREDAM".

FOR REAL ESTATE DEVELOPMENT (U.S. CLS. 100, 103 AND 106).

MAYUR VAGHANI, EXAMINING ATTORNEY

---

SN 85-210,407. REFRESH ENVIRONMENTAL, L.L.C., NEW ORLEANS, LA. FILED 1-4-2011.

# REFRESH ENVIRONMENTAL

THE MARK CONSISTS OF STANDARD CHARACTERS WITHOUT CLAIM TO ANY PARTICULAR FONT, STYLE, SIZE, OR COLOR.

FOR RECYCLING SERVICES, NAMELY, COLLECTING USED FAT OR VEGETABLE OIL OR COOKING OIL FOR PURPOSES OF CONVERTING IT TO BIOFUEL OR BLENDING IT WITH PETROLEUM DIESEL TO CREATE BIODIESEL FUEL (U.S. CLS. 100, 103 AND 106).

JACQUELINE A. LAVINE, EXAMINING ATTORNEY

---

SN 85-210,559. HI-TECH CONCRETE COATINGS, INC., LITITZ, PA. FILED 1-5-2011.

# Surfaces and Substrates We've Got You Covered

THE MARK CONSISTS OF STANDARD CHARACTERS WITHOUT CLAIM TO ANY PARTICULAR FONT, STYLE, SIZE, OR COLOR.

FOR INSTALLATION, MAINTENANCE AND REPAIR OF PROTECTIVE COATINGS FOR FLOORS (U.S. CLS. 100, 103 AND 106).

FIRST USE 10-20-2010; IN COMMERCE 10-20-2010.  
DANNEAN HETZEL, EXAMINING ATTORNEY

**CLASS 37—(Continued).**

SN 85-211,939. SWIFTPRO AUTO GLASS, LLC, HOLLADAY, UT. FILED 1-6-2011.

**CLASS 38—COMMUNICATION**

SN 77-688,372. VOYAGES NORTH AMERICA, INC., NEW YORK, NY. FILED 3-11-2009.

# SwiftPro

# VOYAGE.TV

THE MARK CONSISTS OF STANDARD CHARACTERS WITHOUT CLAIM TO ANY PARTICULAR FONT, STYLE, SIZE, OR COLOR.

FOR INSTALLATION AND REPAIR OF GLASS IN AUTOMOTIVE TYPE VEHICLES, NAMELY, AUTOMOBILES AND TRUCKS (U.S. CLS. 100, 103 AND 106).

FIRST USE 1-5-2011; IN COMMERCE 1-5-2011.  
BARBARA BROWN, EXAMINING ATTORNEY

THE MARK CONSISTS OF STANDARD CHARACTERS WITHOUT CLAIM TO ANY PARTICULAR FONT, STYLE, SIZE, OR COLOR.

OWNER OF U.S. REG. NOS. 3,443,233, 3,915,497 AND 3,915,862.

FOR BROADCASTING OF VIDEO AND AUDIO PROGRAMMING IN THE FIELD OF TRAVEL AND TRAVEL DESTINATIONS OVER TELEVISION, CABLE TELEVISION, VIDEO ON DEMAND, CABLE VISION, THE INTERNET AND OTHER ELECTRONIC COMMUNICATIONS NETWORKS (U.S. CLS. 100, 101 AND 104).

LESLIE RICHARDS, EXAMINING ATTORNEY

SN 85-216,369. GORILLA PEST CONTROL, LOS ANGELES, CA. FILED 1-12-2011.

SN 85-010,242. SINGLESAROUNDME INC., OTTAWA, ON, CANADA, FILED 4-9-2010.

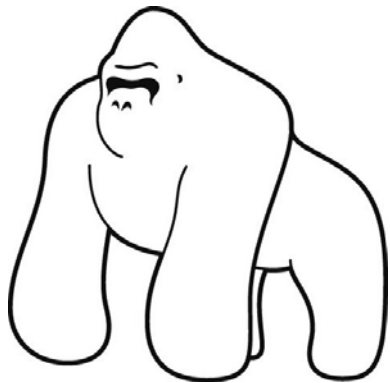

# SINGLES AROUND ME

THE MARK CONSISTS OF A CARICATURE OF A GORILLA.

FOR PEST CONTROL AND EXTERMINATION OTHER THAN FOR AGRICULTURAL PURPOSES (U.S. CLS. 100, 103 AND 106).

PAUL MORENO, EXAMINING ATTORNEY

THE MARK CONSISTS OF STANDARD CHARACTERS WITHOUT CLAIM TO ANY PARTICULAR FONT, STYLE, SIZE, OR COLOR.

PRIORITY CLAIMED UNDER SEC. 44(D) ON CANADA APPLICATION NO. 1455481, FILED 10-15-2009, REG. NO. TMA792,466, DATED 3-9-2011, EXPIRES 3-9-2026.

FOR PROVIDING USER ACCESS TO AN INTERACTIVE COMPUTER DATABASE FEATURING SOCIAL INTRODUCTION, DATING AND MATCHMAKING SERVICES FOR THE PURPOSE OF GENERATING INTRODUCTIONS, ACQUAINTANCES, FRIENDSHIPS, DATING AND LONG-TERM RELATIONSHIPS; PROVIDING ACCESS TO THIRD PARTY INTERACTIVE COMPUTER DATABASES FEATURING THE SAME OR SIMILAR SOCIAL INTRODUCTION, DATING AND MATCHMAKING TYPE OF SERVICES (U.S. CLS. 100, 101 AND 104).

CHRISTINA SOBRAL, EXAMINING ATTORNEY

**CLASS 38—(Continued).**

SN 85-034,339. INIGRAL, INC., SAN FRANCISCO, CA. FILED 5-10-2010.

**INIGRAL**

THE MARK CONSISTS OF STANDARD CHARACTERS WITHOUT CLAIM TO ANY PARTICULAR FONT, STYLE, SIZE, OR COLOR.

THE WORDING "INIGRAL" HAS NO MEANING IN A FOREIGN LANGUAGE.

FOR PROVIDING AN ONLINE MESSAGING SERVICE FOR REGISTERED USERS FOR TRANSMISSION OF MESSAGES CONCERNING ACADEMICS, EDUCATION, CLASSES, CAMPUS LIFE, VIRTUAL COMMUNITY AND SOCIAL NETWORKING (U.S. CLS. 100, 101 AND 104).

LINDA POWELL, EXAMINING ATTORNEY

---

SN 85-037,549. LISTON, VASILIKI, HINSDALE, IL. FILED 5-13-2010.

**KEFI**

THE MARK CONSISTS OF STANDARD CHARACTERS WITHOUT CLAIM TO ANY PARTICULAR FONT, STYLE, SIZE, OR COLOR.

FOR AUDIO AND VIDEO BROADCASTING SERVICES OVER THE INTERNET; AUDIO BROADCASTING; BROADCASTING OF RADIO PROGRAMMES; PODCASTING SERVICES; RADIO BROADCASTING; RADIO BROADCASTING OF INFORMATION AND OTHER PROGRAMS; RADIO PROGRAM BROADCASTING (U.S. CLS. 100, 101 AND 104).

FIRST USE 1-1-2009; IN COMMERCE 1-1-2009.

MATTHEW EINSTEIN, EXAMINING ATTORNEY

---

SN 85-037,571. LISTON, VASILIKI, HINSDALE, IL. FILED 5-13-2010.

**KEEP ENERGY FLOWING IN AND OUT**

THE MARK CONSISTS OF STANDARD CHARACTERS WITHOUT CLAIM TO ANY PARTICULAR FONT, STYLE, SIZE, OR COLOR.

FOR AUDIO AND VIDEO BROADCASTING SERVICES OVER THE INTERNET; AUDIO BROADCASTING; BROADCASTING OF RADIO PROGRAMMES; INTERNET RADIO SERVICES, NAMELY, TRANSMISSION OF AUDIO MATERIAL VIA THE INTERNET; PODCASTING SERVICES (U.S. CLS. 100, 101 AND 104).

FIRST USE 1-1-2009; IN COMMERCE 1-1-2009.

MATTHEW EINSTEIN, EXAMINING ATTORNEY

**CLASS 38—(Continued).**

SN 85-042,226. DATA FOUNDRY, INC., AUSTIN, TX. FILED 5-19-2010.

**DATA RANCH**

THE MARK CONSISTS OF STANDARD CHARACTERS WITHOUT CLAIM TO ANY PARTICULAR FONT, STYLE, SIZE, OR COLOR.

NO CLAIM IS MADE TO THE EXCLUSIVE RIGHT TO USE "DATA", APART FROM THE MARK AS SHOWN.

FOR PROVIDING TELECOMMUNICATIONS CONNECTIVITY SERVICES FOR DATA TRANSFER OR STORAGE; DATA TRANSFER OR RECEPTION SERVICES VIA TELECOMMUNICATIONS MEANS; PROVIDING CO-LOCATION SERVICES FOR VOICE, VIDEO OR DATA COMMUNICATIONS APPLICATIONS; TELECOMMUNICATIONS CONSULTATION; TELECOMMUNICATION SERVICES, NAMELY, PROVIDING MULTIPLE USER ACCESS TO A GLOBAL COMPUTER NETWORK; PROVIDING MULTIPLE USER ACCESS TO ELECTRONIC BUSINESS SERVICES OF OTHERS VIA A GLOBAL COMPUTER NETWORK; PROVIDING MULTIPLE USER ACCESS TO DATABASES AND COMPUTER SERVICES OF OTHERS VIA A GLOBAL COMPUTER NETWORK; PROVIDING TELECOMMUNICATIONS CONSULTATION SERVICES FOR USERS REGARDING TELECOMMUNICATIONS CONNECTIVITY AND NETWORKING RELATED TO GLOBAL COMPUTER NETWORKS; DATA CENTER SERVICES, NAMELY, PROVIDING TELECOMMUNICATIONS CONNECTIONS TO THE INTERNET OR DATABASES (U.S. CLS. 100, 101 AND 104).

ASMAT KHAN, EXAMINING ATTORNEY

---

SN 85-050,644. CBS INTERACTIVE INC., NEW YORK, NY. FILED 5-28-2010.

**CELEB CIRCUIT**

THE MARK CONSISTS OF STANDARD CHARACTERS WITHOUT CLAIM TO ANY PARTICULAR FONT, STYLE, SIZE, OR COLOR.

NO CLAIM IS MADE TO THE EXCLUSIVE RIGHT TO USE "CELEB", APART FROM THE MARK AS SHOWN.

FOR AUDIO AND VIDEO BROADCASTING SERVICES OVER THE INTERNET OR OTHER COMMUNICATIONS NETWORK, NAMELY, ELECTRONICALLY TRANSMITTING INFORMATION IN THE NATURE OF AUDIO AND VIDEO CLIPS; PROVIDING INTERNET ACCESS, NAMELY, PROVIDING INTERNET ACCESS TO ALLOW USERS TO SEND AND RECEIVE INFORMATION, AUDIO, AND VIDEO VIA WEBSITES, ONLINE FORUMS, CHAT ROOMS, LISTSERVS AND BLOGS; PROVIDING ON-LINE CHAT ROOMS AND ELECTRONIC BULLETIN BOARDS FOR TRANSMISSION OF MESSAGES AMONG USERS IN THE FIELD OF ENTERTAINMENT; PROVIDING ON-LINE LISTSERVS FOR TRANSMISSION OF MESSAGES AMONG COMPUTER USERS CONCERNING INFORMATION, AUDIO CLIPS, AND VIDEO CLIPS IN THE FIELD OF ENTERTAINMENT; PROVIDING AN ON-LINE FORUM FOR THE TRANSMISSION OF MESSAGES AMONG USERS IN THE FIELD OF ENTERTAINMENT (U.S. CLS. 100, 101 AND 104).

KEVIN CORWIN, EXAMINING ATTORNEY

**CLASS 38—(Continued).**

SN 85-055,413. T-MOBILE USA, INC., BELLEVUE, WA. FILED 6-4-2010.

**MYTOUCH 3G SLIDE**

THE MARK CONSISTS OF STANDARD CHARACTERS WITHOUT CLAIM TO ANY PARTICULAR FONT, STYLE, SIZE, OR COLOR.

OWNER OF U.S. REG. NOS. 3,729,926, 3,769,048 AND 3,794,822.

NO CLAIM IS MADE TO THE EXCLUSIVE RIGHT TO USE "3G", APART FROM THE MARK AS SHOWN.

FOR TELECOMMUNICATIONS SERVICES, NAMELY, TRANSMISSION OF VOICE, VIDEO CONTENT, AUDIO FILES, DATA AND TEXT BETWEEN WIRELESS PHONES, WIRELESS COMPUTERS, TELECOMMUNICATION TERMINALS AND COMPUTERS, PROVIDING ACCESS TO NETWORK-BASED PERSONALIZED INFORMATION, NAMELY, ADDRESS BOOK INFORMATION, AND PROVIDING MULTIPLE-USER ACCESS TO A GLOBAL COMPUTER NETWORK (U.S. CLS. 100, 101 AND 104).

WILLIAM VERHOSEK, EXAMINING ATTORNEY

SN 85-055,417. T-MOBILE USA, INC., BELLEVUE, WA. FILED 6-4-2010.



OWNER OF U.S. REG. NOS. 3,729,926, 3,769,048 AND 3,794,822.

NO CLAIM IS MADE TO THE EXCLUSIVE RIGHT TO USE "3G", APART FROM THE MARK AS SHOWN.

THE COLOR(S) FOREST GREEN AND LIME GREEN IS/ ARE CLAIMED AS A FEATURE OF THE MARK.

THE MARK CONSISTS OF THE COLOR FOREST GREEN USED FOR THE WORD "MY" WHICH APPEARS IN LOWER CASE LETTERS ABOVE THE WORD "TOUCH" WHERE THE LETTERS "T" AND "UCH" APPEAR IN LIME GREEN, AS DO THE LETTERS "3G" WHICH APPEAR IN SUPERSCRIPT TO THE RIGHT OF THE WORD "TOUCH". ADDITIONALLY, THE BOTTOM OF THE LETTER "Y" IN "MY" IS USED TO REPRESENT THE LETTER "O" IN THE WORD "TOUCH" WHICH APPEARS IN FOREST GREEN. THE WORD "SLIDE" APPEARS BELOW THE LETTER "H" IN "TOUCH" IN FOREST GREEN.

FOR TELECOMMUNICATIONS SERVICES, NAMELY, TRANSMISSION OF VOICE, VIDEO CONTENT, AUDIO FILES, DATA AND TEXT BETWEEN WIRELESS PHONES, WIRELESS COMPUTERS, TELECOMMUNICATION TERMINALS AND COMPUTERS, PROVIDING ACCESS TO NETWORK-BASED PERSONALIZED INFORMATION, NAMELY, ADDRESS BOOK INFORMATION, AND PROVIDING MULTIPLE-USER ACCESS TO A GLOBAL COMPUTER NETWORK (U.S. CLS. 100, 101 AND 104).

WILLIAM VERHOSEK, EXAMINING ATTORNEY

**CLASS 38—(Continued).**

SN 85-061,230. CONNECT PUBLIC RELATIONS, INC., PROVO, UT. FILED 6-11-2010.

**CONNECT MARKETING**

THE MARK CONSISTS OF STANDARD CHARACTERS WITHOUT CLAIM TO ANY PARTICULAR FONT, STYLE, SIZE, OR COLOR.

OWNER OF U.S. REG. NOS. 2,365,074, 3,330,353 AND OTHERS.

NO CLAIM IS MADE TO THE EXCLUSIVE RIGHT TO USE "MARKETING", APART FROM THE MARK AS SHOWN.

FOR COMMUNICATIONS SERVICES, NAMELY, DELIVERY OF MESSAGES BY ELECTRONIC TRANSMISSION (U.S. CLS. 100, 101 AND 104).

LINDA LAVACHE, EXAMINING ATTORNEY

SN 85-068,151. LEVEL 3 COMMUNICATIONS, LLC, BROOMFIELD, CO. FILED 6-21-2010.

**BUSINESS DEMANDS IT.  
LEVEL 3 DELIVERS IT.**

THE MARK CONSISTS OF STANDARD CHARACTERS WITHOUT CLAIM TO ANY PARTICULAR FONT, STYLE, SIZE, OR COLOR.

OWNER OF U.S. REG. NOS. 2,400,493, 2,586,143 AND 3,698,129.

FOR COMMUNICATIONS SERVICES, NAMELY, PROVIDING NETWORK ACCESS POINTS THROUGH WHICH INFORMATION ON THE GLOBAL COMPUTER INFORMATION NETWORK PASSES FROM ONE GLOBAL COMPUTER INFORMATION NETWORK SERVICE PROVIDER TO ANOTHER; COMMUNICATIONS SERVICES, NAMELY, TRANSMISSION OF INFORMATION FROM ONE GLOBAL COMPUTER INFORMATION NETWORK SERVICE PROVIDER TO ANOTHER; TELECOMMUNICATIONS SERVICES, NAMELY, VOICE TELEPHONY LOCAL AND LONG DISTANCE SERVICES, VOICE MAIL SERVICES, FACSIMILE SERVICES, AND DATA TRANSMISSION SERVICES VIA A FIBER OPTIC NETWORK; TELECOMMUNICATIONS SERVICES, NAMELY, TRANSMISSION OF VOICE, VIDEO AND DATA VIA ELECTRONIC MEANS; TELECOMMUNICATIONS GATEWAY SERVICES; PROVIDING MULTIPLE USER ACCESS TO A GLOBAL COMPUTER INFORMATION NETWORK; PROVIDING FACILITIES AND EQUIPMENT FOR TELECOMMUNICATIONS SERVICES; LEASING OF TELECOMMUNICATIONS LINES AND EQUIPMENT; ELECTRONIC STREAMING OF AUDIO AND VIDEO DATA AND IMAGES ON THE INTERNET OR AN INTRANET; TRANSMISSION AND DELIVERY OF AUDIO AND VIDEO MESSAGES AND IMAGES ON THE INTERNET OR AN INTRANET; TELEVISION TRANSMISSION SERVICES AND SATELLITE TRANSMISSION SERVICES (U.S. CLS. 100, 101 AND 104).

MARTHA FROMM, EXAMINING ATTORNEY

**CLASS 38—(Continued).**

SN 85-075,284. DIVX, LLC, SAN DIEGO, CA. FILED 6-30-2010.

# HiQ

THE MARK CONSISTS OF STANDARD CHARACTERS WITHOUT CLAIM TO ANY PARTICULAR FONT, STYLE, SIZE, OR COLOR.

FOR INTERNET, INFORMATION SERVICES NETWORKS AND DATA NETWORKS; COMMUNICATION SERVICES, NAMELY, TRANSMISSION OF VOICE, AUDIO, VISUAL IMAGES AND DATA BY TELECOMMUNICATIONS NETWORKS, WIRELESS COMMUNICATION NETWORKS, THE INTERNET, INFORMATION SERVICES NETWORKS AND DATA NETWORKS; COMPUTER SERVICES, NAMELY, PROVIDING ON-LINE FACILITIES FOR COMMUNICATION, CONTENT SHARING AND REAL-TIME INTERACTION WITH OTHER COMPUTER USERS CONCERNING TOPICS OF GENERAL INTEREST; INTERNET PROTOCOL TELEVISION (IPTV) TRANSMISSION SERVICES; STREAMING OF AUDIO, VISUAL AND AUDIOVISUAL MATERIAL VIA A GLOBAL COMPUTER NETWORK AND THE INTERNET; TRANSMISSION AND DISTRIBUTION OF DATA OR AUDIO VISUAL IMAGES VIA A GLOBAL COMPUTER NETWORK OR THE INTERNET; VIDEO AND VIDEO STREAMING VIA A GLOBAL COMPUTER NETWORK AND THE INTERNET; INTERACTIVE DELIVERY OF VIDEO OVER DIGITAL NETWORKS; MOBILE MEDIA SERVICES IN THE NATURE OF ELECTRONIC TRANSMISSION OF ENTERTAINMENT MEDIA CONTENT; PROVIDING MULTIPLE-USER ACCESS TO A GLOBAL COMPUTER INFORMATION NETWORK; AND PROVIDING ON-LINE COMMUNICATIONS LINKS WHICH TRANSFER THE WEB SITE USER TO OTHER LOCAL AND GLOBAL WEB PAGES (U.S. CLS. 100, 101 AND 104).

KATINA MISTER, EXAMINING ATTORNEY

**CLASS 38—(Continued).**

SN 85-087,642. PRIVATE SOCIAL NETWORKS, INC., DALLAS, TX. FILED 7-19-2010.



SN 85-081,375. FOX INTERNATIONAL CHANNELS (US), INC., LOS ANGELES, CA. FILED 7-9-2010.

# UTILISIMA

THE MARK CONSISTS OF STANDARD CHARACTERS WITHOUT CLAIM TO ANY PARTICULAR FONT, STYLE, SIZE, OR COLOR.

OWNER OF U.S. REG. NO. 2,534,372.

THE ENGLISH TRANSLATION OF "UTILISIMA" IN THE MARK IS "VERY USEFUL".

FOR TELEVISION TRANSMISSION AND BROADCASTING SERVICES; RADIO BROADCASTING SERVICES; PROVIDING ON-LINE CHAT ROOMS AND ELECTRONIC BULLETIN BOARDS FOR TRANSMISSION OF MESSAGES AMONG USERS IN THE FIELD OF GENERAL INTEREST; STREAMING AUDIO AND VIDEO MATERIAL ON THE INTERNET; VIDEO ON DEMAND TRANSMISSION SERVICES (U.S. CLS. 100, 101 AND 104).

ELLEN B. AWRICH, EXAMINING ATTORNEY

THE COLOR(S) RED AND/OR WHITE IS/ARE CLAIMED AS A FEATURE OF THE MARK.

THE MARK CONSISTS OF THE WORDING "CONNECT2HEALTH" ABOVE THE PHRASE "PATIENT-CENTERED ONLINE CARE COMMUNITIES FOR YOUR HOSPITAL". ALL WORDING IS IN WHITE AND APPEARS ON A RED BACKGROUND.

FOR PEER-TO-PEER NETWORK COMPUTER SERVICES, NAMELY, ELECTRONIC TRANSMISSION OF AUDIO, VIDEO AND OTHER DATA AND DOCUMENTS AMONG COMPUTERS; PROVIDING ON-LINE FORUMS FOR TRANSMISSION OF MESSAGES AMONG COMPUTER USERS CONCERNING PRIVATE HEALTHCARE INFORMATION; PROVIDING TELECOMMUNICATIONS CONNECTIONS TO THE INTERNET OR DATABASES; PROVIDING THIRD PARTY USERS WITH ACCESS TO TELECOMMUNICATION INFRASTRUCTURE (U.S. CLS. 100, 101 AND 104).

FIRST USE 6-1-2009; IN COMMERCE 5-1-2010.

BILL DAWE, EXAMINING ATTORNEY

**CLASS 38—(Continued).**

SN 85-094,068. LEVEL 3 COMMUNICATIONS, LLC, BROOMFIELD, CO. FILED 7-27-2010.

AGENCIES DEMAND IT. LEVEL  
3 DELIVERS IT.

THE MARK CONSISTS OF STANDARD CHARACTERS WITHOUT CLAIM TO ANY PARTICULAR FONT, STYLE, SIZE, OR COLOR.

OWNER OF U.S. REG. NOS. 2,400,493, 2,586,143 AND 3,698,129.

FOR COMMUNICATIONS SERVICES, NAMELY, PROVIDING NETWORK ACCESS POINTS THROUGH WHICH INFORMATION ON THE GLOBAL COMPUTER INFORMATION NETWORK PASSES FROM ONE GLOBAL COMPUTER INFORMATION NETWORK SERVICE PROVIDER TO ANOTHER; COMMUNICATIONS SERVICES, NAMELY, TRANSMISSION OF INFORMATION FROM ONE GLOBAL COMPUTER INFORMATION NETWORK SERVICE PROVIDER TO ANOTHER; TELECOMMUNICATIONS SERVICES, NAMELY, VOICE TELEPHONY LOCAL AND LONG DISTANCE SERVICES, VOICE MAIL SERVICES, FACSIMILE SERVICES, AND DATA TRANSMISSION SERVICES VIA A FIBER OPTIC NETWORK; TELECOMMUNICATIONS SERVICES, NAMELY, TRANSMISSION OF VOICE, VIDEO AND DATA VIA ELECTRONIC MEANS; TELECOMMUNICATIONS GATEWAY SERVICES; PROVIDING MULTIPLE USER ACCESS TO A GLOBAL COMPUTER INFORMATION NETWORK; PROVIDING FACILITIES AND EQUIPMENT FOR TELECOMMUNICATIONS SERVICES; LEASING OF TELECOMMUNICATIONS LINES AND EQUIPMENT; ELECTRONIC STREAMING OF AUDIO AND VIDEO DATA AND IMAGES ON THE INTERNET OR AN INTRANET; TRANSMISSION AND DELIVERY OF AUDIO AND VIDEO MESSAGES AND IMAGES ON THE INTERNET OR AN INTRANET; TELEVISION TRANSMISSION SERVICES AND SATELLITE TRANSMISSION SERVICES (U.S. CLS. 100, 101 AND 104).

MARTHA FROMM, EXAMINING ATTORNEY

SN 85-119,219. SARPONG, JUNE, ALTADENA, CA. FILED 8-30-2010.

ROW6.com

THE MARK CONSISTS OF STANDARD CHARACTERS WITHOUT CLAIM TO ANY PARTICULAR FONT, STYLE, SIZE, OR COLOR.

FOR PROVIDING ON-LINE CHAT ROOMS AND ELECTRONIC BULLETIN BOARDS FOR TRANSMISSION OF MESSAGES AMONG USERS IN THE FIELD OF CELEBRITIES, FASHION, FILM, TELEVISION, MUSIC, AND SOCIAL NETWORKING (U.S. CLS. 100, 101 AND 104).

ANGELA DUONG, EXAMINING ATTORNEY

**CLASS 38—(Continued).**

SN 85-129,106. CITRIX ONLINE LLC, GOLETA, CA. FILED 9-14-2010.

OPEN VOICE

THE MARK CONSISTS OF STANDARD CHARACTERS WITHOUT CLAIM TO ANY PARTICULAR FONT, STYLE, SIZE, OR COLOR.

NO CLAIM IS MADE TO THE EXCLUSIVE RIGHT TO USE "VOICE", APART FROM THE MARK AS SHOWN.

FOR TELECOMMUNICATIONS AND INFORMATION TECHNOLOGY SERVICES, NAMELY, TRANSMISSION OF VOICE, DATA, IMAGES, AUDIO, VIDEO, AND INFORMATION VIA TELEPHONE AND GLOBAL COMMUNICATION NETWORKS; TELEPHONE SWITCHING SERVICES, VOICE OVER INTERNET PROTOCOL (VOIP) AND SESSION INITIATED PROTOCOL (SIP) TELEPHONE AND DATA COMMUNICATION SERVICES; COMPUTERIZED TELEPHONY AND DATA COMMUNICATIONS SERVICES, NAMELY, TELEPHONY AND TELECOMMUNICATIONS SOLUTION FACILITATING TOTAL SESSION INITIATION PROTOCOL (SIP), VOICE OVER INTERNET PROTOCOL (VOIP) AND PUBLIC SWITCHED TELEPHONE NETWORK (PSTN) CONNECTIVITY; TELECOMMUNICATION ACCESS SERVICES; RENTAL OF TELECOMMUNICATIONS APPARATUS AND FACILITIES, NAMELY, VIRTUAL PORTALS TO MANAGE TELECOMMUNICATIONS SERVICES AND BANDWIDTH (U.S. CLS. 100, 101 AND 104).

REBECCA EISINGER, EXAMINING ATTORNEY

SN 85-159,012. SCANTRON CORPORATION, EAGAN, MN. FILED 10-22-2010.

SERVICE COMMAND

THE MARK CONSISTS OF STANDARD CHARACTERS WITHOUT CLAIM TO ANY PARTICULAR FONT, STYLE, SIZE, OR COLOR.

OWNER OF U.S. REG. NO. 2,780,634.

NO CLAIM IS MADE TO THE EXCLUSIVE RIGHT TO USE "SERVICE", APART FROM THE MARK AS SHOWN.

FOR COMMUNICATION SERVICES, NAMELY, PROVIDING TELECOMMUNICATION CONNECTIONS TO A GLOBAL COMPUTER NETWORK FEATURING A WIRELESS CALL PROCESSING UTILITY, CALL PLACEMENT, PROCESSING AND REPORTING AND MONITORING CAPABILITIES (U.S. CLS. 100, 101 AND 104).

FIRST USE 1-1-2002; IN COMMERCE 1-1-2002.

ROBERT STRUCK, EXAMINING ATTORNEY

**CLASS 38—(Continued).**

SN 85-169,722. FAIRCALL CORPORATION, SAN DIEGO, CA. FILED 11-4-2010.

# FAIRCALL

THE MARK CONSISTS OF STANDARD CHARACTERS WITHOUT CLAIM TO ANY PARTICULAR FONT, STYLE, SIZE, OR COLOR.

FOR TELECOMMUNICATION ACCESS SERVICES; TELECOMMUNICATIONS GATEWAY SERVICES FEATURING REVERSE CHARGE CALLS TO MOBILE AND FIXED LINE TELEPHONE NUMBERS (U.S. CLS. 100, 101 AND 104).

FIRST USE 0-0-1994; IN COMMERCE 0-0-1994.  
DAWN HAN, EXAMINING ATTORNEY

---

SN 85-169,725. FAIRCALL CORPORATION, SAN DIEGO, CA. FILED 11-4-2010.



THE COLOR(S) BLUE AND RED IS/ARE CLAIMED AS A FEATURE OF THE MARK.

THE MARK CONSISTS OF THE BLUE WORDING "FAIRCALL" APPEARING TO THE RIGHT OF A BLUE SOLID SQUARE INTERSECTED BY A CURVED RED LINE.

FOR TELECOMMUNICATION ACCESS SERVICES; TELECOMMUNICATIONS GATEWAY SERVICES FEATURING REVERSE CHARGE CALLS TO MOBILE AND FIXED LINE TELEPHONE NUMBERS (U.S. CLS. 100, 101 AND 104).

FIRST USE 0-0-1994; IN COMMERCE 0-0-1994.  
DAWN HAN, EXAMINING ATTORNEY

---

SN 85-177,168. CAREONSITE, INC., LONG BEACH, CA. FILED 11-15-2010.

## Any time Any location

THE MARK CONSISTS OF STANDARD CHARACTERS WITHOUT CLAIM TO ANY PARTICULAR FONT, STYLE, SIZE, OR COLOR.

FOR PROVIDING TELEPHONE AND VIDEO CONFERENCE SERVICES FOR USE BY MEDICAL PERSONNEL DURING MEDICAL CASE-MANAGEMENT, EVALUATION AND TREATMENT OF PATIENTS (U.S. CLS. 100, 101 AND 104).

FIRST USE 12-1-2009; IN COMMERCE 12-1-2009.  
ERIN FALK, EXAMINING ATTORNEY

**CLASS 38—(Continued).**

SN 85-177,222. INDEPENDENT WORLD TELEVISION INC., NEW YORK, NY. FILED 11-15-2010.

## THE REAL NEWS NETWORK

THE MARK CONSISTS OF STANDARD CHARACTERS WITHOUT CLAIM TO ANY PARTICULAR FONT, STYLE, SIZE, OR COLOR.

NO CLAIM IS MADE TO THE EXCLUSIVE RIGHT TO USE "NEWS NETWORK", APART FROM THE MARK AS SHOWN.

FOR VIDEO BROADCASTING SERVICES VIA THE INTERNET, FEATURING VIDEO NEWS AND DOCUMENTARIES SUPPORTED BY VIEWERS AND WITHOUT GOVERNMENT OR CORPORATE FUNDING (U.S. CLS. 100, 101 AND 104).

FIRST USE 2-9-2003; IN COMMERCE 2-9-2003.  
FRED CARL, EXAMINING ATTORNEY

---

SN 85-178,812. CAREONSITE, INC., LONG BEACH, CA. FILED 11-17-2010.

## Any location Any time

THE MARK CONSISTS OF STANDARD CHARACTERS WITHOUT CLAIM TO ANY PARTICULAR FONT, STYLE, SIZE, OR COLOR.

FOR PROVIDING TELEPHONE AND VIDEO CONFERENCE SERVICES FOR USE BY MEDICAL PERSONNEL DURING MEDICAL CASE-MANAGEMENT, EVALUATION AND TREATMENT OF PATIENTS (U.S. CLS. 100, 101 AND 104).

FIRST USE 12-1-2009; IN COMMERCE 12-1-2009.  
ERIN FALK, EXAMINING ATTORNEY



**CLASS 38—(Continued).**

SN 85-181,432. COMEDY PARTNERS, NEW YORK, NY.  
FILED 11-19-2010.

**CLASS 38—(Continued).**

SN 85-181,449. COMEDY PARTNERS, NEW YORK, NY.  
FILED 11-19-2010.

**COMEDY CENTRAL**

OWNER OF U.S. REG. NOS. 1,741,737, 1,745,015 AND 2,533,788.

NO CLAIM IS MADE TO THE EXCLUSIVE RIGHT TO USE "COMEDY", APART FROM THE MARK AS SHOWN.

THE MARK CONSISTS OF THE WORD "COMEDY" WITH WORD "CENTRAL" INVERTED.

FOR TELEVISION BROADCASTING SERVICES; BROADCASTING PRE-RECORDED VIDEOS FEATURING MOTION PICTURES, MUSIC, TELEVISION PROGRAMS, NEWS, SPORTS, GAMES, CULTURAL EVENTS, AND ENTERTAINMENT RELATED PROGRAMS VIA COMPUTER AND OTHER COMMUNICATIONS NETWORKS; VIDEO ON DEMAND TRANSMISSION SERVICES; BROADCASTING SERVICES, NAMELY, THE ELECTRONIC TRANSMISSION AND STREAMING OF DIGITAL AUDIO, VIDEO, GRAPHICS, TEXT AND DATA VIA THE INTERNET, BROADBAND SYSTEMS, TELEPHONES, AND PORTABLE AND WIRELESS COMMUNICATION DEVICES; PROVIDING ONLINE CHAT ROOMS AND BULLETIN BOARDS FOR ELECTRONIC TRANSMISSION OF MESSAGES AMONG USERS IN THE FIELD OF MOTION PICTURES, MUSIC, TELEVISION PROGRAMS, NEWS, SPORTS, GAMES, CULTURAL EVENTS, AND ENTERTAINMENT RELATED PROGRAMS VIA COMPUTER AND OTHER COMMUNICATIONS NETWORKS; AND TELEPHONE RING BACK SERVICES FEATURING CONTENT RELATED TO MOTION PICTURES AND TELEVISION PROGRAMMING (U.S. CLS. 100, 101 AND 104).

MARK PILARO, EXAMINING ATTORNEY

OWNER OF U.S. REG. NOS. 1,741,737, 1,745,015 AND 2,533,788.

NO CLAIM IS MADE TO THE EXCLUSIVE RIGHT TO USE "COMEDY", APART FROM THE MARK AS SHOWN.

THE MARK CONSISTS OF DESIGN LETTERS "C" WITHIN A REVERSED "C" AND THE WORD "COMEDY" WITH WORD "CENTRAL" INVERTED.

FOR TELEVISION BROADCASTING SERVICES; BROADCASTING PRE-RECORDED VIDEOS FEATURING MOTION PICTURES, MUSIC, TELEVISION PROGRAMS, NEWS, SPORTS, GAMES, CULTURAL EVENTS, AND ENTERTAINMENT RELATED PROGRAMS VIA COMPUTER AND OTHER COMMUNICATIONS NETWORKS; VIDEO ON DEMAND TRANSMISSION SERVICES; BROADCASTING SERVICES, NAMELY, THE ELECTRONIC TRANSMISSION AND STREAMING OF DIGITAL AUDIO, VIDEO, GRAPHICS, TEXT AND DATA VIA THE INTERNET, BROADBAND SYSTEMS, TELEPHONES, AND PORTABLE AND WIRELESS COMMUNICATION DEVICES; PROVIDING ONLINE CHAT ROOMS AND BULLETIN BOARDS FOR ELECTRONIC TRANSMISSION OF MESSAGES AMONG USERS IN THE FIELD OF MOTION PICTURES, MUSIC, TELEVISION PROGRAMS, NEWS, SPORTS, GAMES, CULTURAL EVENTS, AND ENTERTAINMENT RELATED PROGRAMS VIA COMPUTER AND OTHER COMMUNICATIONS NETWORKS; AND TELEPHONE RING BACK SERVICES FEATURING CONTENT RELATED TO MOTION PICTURES AND TELEVISION PROGRAMMING (U.S. CLS. 100, 101 AND 104).

MARK PILARO, EXAMINING ATTORNEY

SN 85-183,574. VISIONSYNC, INC, PALO ALTO, CA. FILED 11-23-2010.

**SMARTSEARCH**

THE MARK CONSISTS OF STANDARD CHARACTERS WITHOUT CLAIM TO ANY PARTICULAR FONT, STYLE, SIZE, OR COLOR.

OWNER OF U.S. REG. NOS. 3,692,541 AND 3,888,002.

FOR GLOBAL COMMUNICATION SERVICES, NAMELY, PROVIDING ELECTRONIC MESSAGING IN THE FIELDS OF DATING AND SOCIAL NETWORKING FOR DELIVERY OVER AND VIA THE GLOBAL COMPUTER AND WIRELESS NETWORKS, INCLUDING BUT NOT LIMITED TO THE INTERNET, MOBILE PHONES, VOIP, AND IP TELEPHONY (U.S. CLS. 100, 101 AND 104).

JULIE VEPPUMTHARA, EXAMINING ATTORNEY

**CLASS 38—(Continued).**

SN 85-184,282. SMITH, DOUGLAS, SAN ANTONIO, TX. FILED 11-24-2010.

HITECH RADCLOUD DOWNPOUR

THE MARK CONSISTS OF STANDARD CHARACTERS WITHOUT CLAIM TO ANY PARTICULAR FONT, STYLE, SIZE, OR COLOR.

FOR ELECTRONIC DATA TRANSMISSION SERVICES FROM A CLOUD COMPUTING BASED NETWORK USING HIGHLY ENCRYPTED AND DATA COMPRESSED METHODOLOGY (U.S. CLS. 100, 101 AND 104).

JAMES LOVELACE, EXAMINING ATTORNEY

---

SN 85-185,935. BORGER, ERIN, SUNNY ISLES, FL. FILED 11-29-2010.

CABCONCERT

THE MARK CONSISTS OF STANDARD CHARACTERS WITHOUT CLAIM TO ANY PARTICULAR FONT, STYLE, SIZE, OR COLOR.

FOR TELECOMMUNICATION SERVICES, NAMELY, ELECTRONIC TRANSMISSION OF DATA IN THE NATURE OF AUDIO OR VIDEO DIGITAL INFORMATION AND MAINTENANCE INFORMATION FOR REMOTE MAINTENANCE AND STATISTICAL INFORMATION (U.S. CLS. 100, 101 AND 104).

CHRISTINE MARTIN, EXAMINING ATTORNEY

---

SN 85-198,435. WREAL LLC, MIAMI, FL. FILED 12-15-2010.

Every stream, every screen.

THE MARK CONSISTS OF STANDARD CHARACTERS WITHOUT CLAIM TO ANY PARTICULAR FONT, STYLE, SIZE, OR COLOR.

FOR STREAMING OF VIDEO MATERIAL ON THE INTERNET; BROADCASTING SERVICES AND PROVISION OF TELECOMMUNICATION ACCESS TO VIDEO AND AUDIO CONTENT PROVIDED VIA A VIDEO-ON-DEMAND SERVICE VIA THE INTERNET; COMMUNICATIONS SERVICES, NAMELY, TRANSMITTING STREAMED SOUND AND AUDIO-VISUAL RECORDINGS VIA THE INTERNET (U.S. CLS. 100, 101 AND 104).

SOPHIA S. KIM, EXAMINING ATTORNEY

**CLASS 38—(Continued).**

SN 85-201,227. BLANCSQUARE, LLC, DALLAS, TX. FILED 12-18-2010.



THE MARK CONSISTS OF THE WORD 'BLANC' AND 'SQUARE' INSIDE THE OUTLINE OF A SQUARE SHAPE.

FOR COMMUNICATION SERVICES, NAMELY, TRANSMISSION OF VOICE, AUDIO, VISUAL IMAGES AND DATA BY TELECOMMUNICATIONS NETWORKS, WIRELESS COMMUNICATION NETWORKS, THE INTERNET, INFORMATION SERVICES NETWORKS AND DATA NETWORKS (U.S. CLS. 100, 101 AND 104).

FIRST USE 11-1-2007; IN COMMERCE 12-6-2010.

LEIGH CAROLINE CASE, EXAMINING ATTORNEY

---

SN 85-201,406. OAK RIDGE FM, INC, KNOXVILLE, TN. FILED 12-19-2010.

WNOX

THE MARK CONSISTS OF STANDARD CHARACTERS WITHOUT CLAIM TO ANY PARTICULAR FONT, STYLE, SIZE, OR COLOR.

FOR BROADCASTING OF RADIO AND TELEVISION PROGRAMMES (U.S. CLS. 100, 101 AND 104).

FIRST USE 5-17-2005; IN COMMERCE 5-17-2005.

KELLY BOULTON, EXAMINING ATTORNEY

---

SN 85-203,576. GANNETT CO., INC., MCLEAN, VA. FILED 12-22-2010.

IT'S ALL WITHIN REACH

THE MARK CONSISTS OF STANDARD CHARACTERS WITHOUT CLAIM TO ANY PARTICULAR FONT, STYLE, SIZE, OR COLOR.

FOR PROVIDING TELEVISION BROADCASTING AND TRANSMISSION SERVICES (U.S. CLS. 100, 101 AND 104).

SOPHIA S. KIM, EXAMINING ATTORNEY

**CLASS 38—(Continued).**

SN 85-203,929. EVOGH, INC., PASADENA, CA. FILED 12-22-2010.

# SeeVogh

THE MARK CONSISTS OF STANDARD CHARACTERS WITHOUT CLAIM TO ANY PARTICULAR FONT, STYLE, SIZE, OR COLOR.  
FOR COMMUNICATION BY ELECTRONIC COMPUTER TERMINALS (U.S. CLS. 100, 101 AND 104).  
HENRY S. ZAK, EXAMINING ATTORNEY

SN 85-203,944. EVOGH, INC., PASADENA, CA. FILED 12-22-2010.

# SeeVo

THE MARK CONSISTS OF STANDARD CHARACTERS WITHOUT CLAIM TO ANY PARTICULAR FONT, STYLE, SIZE, OR COLOR.  
FOR COMMUNICATION BY ELECTRONIC COMPUTER TERMINALS (U.S. CLS. 100, 101 AND 104).  
HENRY S. ZAK, EXAMINING ATTORNEY

SN 85-205,131. K-BROOKS, LEIF C, PORTLAND, OR. FILED 12-23-2010.

# Omegle

THE MARK CONSISTS OF STANDARD CHARACTERS WITHOUT CLAIM TO ANY PARTICULAR FONT, STYLE, SIZE, OR COLOR.  
FOR PROVIDING INTERNET CHATROOMS (U.S. CLS. 100, 101 AND 104).  
FIRST USE 3-25-2009; IN COMMERCE 3-25-2009.  
KIM MONINGHOFF, EXAMINING ATTORNEY

**CLASS 38—(Continued).**

SN 85-205,146. K-BROOKS, LEIF C, PORTLAND, OR. FILED 12-23-2010.

# Talk to strangers!

THE MARK CONSISTS OF STANDARD CHARACTERS WITHOUT CLAIM TO ANY PARTICULAR FONT, STYLE, SIZE, OR COLOR.  
FOR PROVIDING INTERNET CHATROOMS (U.S. CLS. 100, 101 AND 104).  
FIRST USE 3-25-2009; IN COMMERCE 3-25-2009.  
KIM MONINGHOFF, EXAMINING ATTORNEY

SN 85-205,739. CREATIONS INTERACTIVE, LLC, MANVILLE, NJ. FILED 12-26-2010.

# NuBeatz

THE MARK CONSISTS OF STANDARD CHARACTERS WITHOUT CLAIM TO ANY PARTICULAR FONT, STYLE, SIZE, OR COLOR.  
FOR AUDIO AND VIDEO BROADCASTING SERVICES OVER THE INTERNET; BROADCASTING PROGRAMS VIA A GLOBAL COMPUTER NETWORK; INTERNET BROADCASTING SERVICES; INTERNET RADIO BROADCASTING SERVICES; RADIO AND TELEVISION BROADCASTING SERVICES; RADIO BROADCASTING; RADIO BROADCASTING OF INFORMATION AND OTHER PROGRAMS; STREAMING OF AUDIO MATERIAL ON THE INTERNET; STREAMING OF VIDEO MATERIAL ON THE INTERNET; TELEVISION AND RADIO BROADCASTING SERVICES; WEBCASTING SERVICES (U.S. CLS. 100, 101 AND 104).  
CHERYL CLAYTON, EXAMINING ATTORNEY

SN 85-205,973. LARSON, CHRISTOPHER, LAS VEGAS, NV. FILED 12-27-2010.

# You Have The Floor

THE MARK CONSISTS OF STANDARD CHARACTERS WITHOUT CLAIM TO ANY PARTICULAR FONT, STYLE, SIZE, OR COLOR.  
FOR PROVIDING ON-LINE FORUMS FOR TRANSMISSION OF MESSAGES AMONG COMPUTER USERS (U.S. CLS. 100, 101 AND 104).  
ELI HELLMAN, EXAMINING ATTORNEY

**CLASS 38—(Continued).**

SN 85-206,552. CONNECTWE, INC., CHICAGO, IL. FILED 12-28-2010.

connectWE / cWE

THE MARK CONSISTS OF STANDARD CHARACTERS WITHOUT CLAIM TO ANY PARTICULAR FONT, STYLE, SIZE, OR COLOR.

FOR PROVIDING PRIVATE AND PUBLIC ON-LINE CHAT ROOMS FOR SOCIAL NETWORKING (U.S. CLS. 100, 101 AND 104).

SCOTT BIBB, EXAMINING ATTORNEY

SN 85-207,274. PST DIGITAL, L.L.C., SULLY, IA. FILED 12-29-2010.

ConnectPoint

THE MARK CONSISTS OF STANDARD CHARACTERS WITHOUT CLAIM TO ANY PARTICULAR FONT, STYLE, SIZE, OR COLOR.

FOR PROVIDING MULTIPLE USER WIRELESS ACCESS TO THE INTERNET; TELECOMMUNICATION SERVICES, NAMELY, LOCAL AND LONG DISTANCE TRANSMISSION OF VOICE, DATA, GRAPHICS AND VIDEO BY MEANS OF BROADBAND OPTICAL OR WIRELESS NETWORKS; TELECOMMUNICATION SERVICES, NAMELY, LOCAL AND LONG DISTANCE TRANSMISSION OF VOICE, DATA, GRAPHICS AND VIDEO BY MEANS OF BROADBAND, COPPER AND OPTICAL OR WIRELESS NETWORKS; TELECOMMUNICATION SERVICES, NAMELY, PROVIDING INTERNET ACCESS VIA BROADBAND OPTICAL OR WIRELESS NETWORKS; TELECOMMUNICATION SERVICES, NAMELY, TRANSMISSION OF VOICE, DATA, GRAPHICS, IMAGES, AUDIO AND VIDEO BY MEANS OF TELECOMMUNICATIONS NETWORKS, WIRELESS COMMUNICATION NETWORKS, AND THE INTERNET; TELECOMMUNICATION SERVICES, NAMELY, TRANSMISSION OF VOICE, DATA, GRAPHICS, SOUND AND VIDEO BY MEANS OF BROADBAND POWER LINE OR WIRELESS NETWORKS; TELECOMMUNICATION SERVICES, NAMELY, WIRELESS TELEPHONE SERVICES; TELECOMMUNICATIONS SERVICES, NAMELY, WIRELESS TELEPHONY AND WIRELESS BROADBAND COMMUNICATIONS SERVICES FOR THE TRANSMISSION OF VOICE AND DATA; TEXT AND NUMERIC WIRELESS DIGITAL MESSAGING SERVICES; WIRELESS BROADBAND COMMUNICATION SERVICES; WIRELESS DIGITAL MESSAGING SERVICES; WIRELESS ELECTRONIC TRANSMISSION OF VOICE SIGNALS, DATA, FACSIMILES, IMAGES AND INFORMATIONS; WIRELESS TELEPHONE TELECOMMUNICATIONS SERVICES, NAMELY, WIRELESS MOBILE TELEPHONE CALLING PLANS; WIRELESS VOICE MAIL SERVICES (U.S. CLS. 100, 101 AND 104).

MARK SHINER, EXAMINING ATTORNEY

**CLASS 38—(Continued).**

SN 85-208,043. KORTH, JOEL, NEW BALTIMORE, MI. FILED 12-30-2010.

SOCIALCYNICS

THE MARK CONSISTS OF STANDARD CHARACTERS WITHOUT CLAIM TO ANY PARTICULAR FONT, STYLE, SIZE, OR COLOR.

FOR TRANSMISSION OF MESSAGES, DATA AND CONTENT VIA THE INTERNET AND OTHER COMMUNICATIONS NETWORKS; PROVIDING ONLINE COMMUNITY FORUMS AND CHAT ROOMS FOR THE TRANSMISSION OF MESSAGES, COMMENTS AND MULTIMEDIA CONTENT AMONG MULTIMEDIA DEVICE USERS IN THE FIELD OF GENERAL INTEREST, VIRTUAL COMMUNITIES, SOCIAL NETWORKING, PHOTO SHARING, AND TRANSMISSION OF GRAPHIC IMAGES, DATA, AND VIDEO SHARING VIA THE INTERNET AND OTHER COMMUNICATIONS NETWORKS; TRANSMISSION OF ELECTRONIC MEDIA, MULTIMEDIA CONTENT, VIDEOS, MOVIES, PICTURES, IMAGES, TEXT, PHOTOS, USER-GENERATED CONTENT, AUDIO CONTENT, AND INFORMATION VIA THE INTERNET AND OTHER COMMUNICATIONS NETWORKS; PROVIDING COMMUNITY FORUMS FOR USERS TO POST, SEARCH, WATCH, SHARE, CRITIQUE, RATE, AND COMMENT ON, VIDEOS AND OTHER MULTIMEDIA CONTENT VIA THE INTERNET AND OTHER COMMUNICATIONS NETWORKS; PROVIDING ON-LINE CHAT ROOMS FOR SOCIAL NETWORKING; PROVIDING AN ONLINE COMMUNITY FORUM FOR REGISTERED AND UNREGISTERED USERS TO SHARE GENERAL INTEREST INFORMATION, PHOTOS, AUDIO AND VIDEO CONTENT ABOUT THEMSELVES AND OTHERS, TO RECEIVE FEEDBACK FROM THEIR PEERS, TO FORM VIRTUAL COMMUNITIES, TO ENGAGE IN SOCIAL NETWORKING, PHOTO SHARING, AND TRANSMISSION OF PHOTOGRAPHIC IMAGES; PROVIDING AUDIO AND VIDEO BROADCASTING SERVICES OVER THE INTERNET OR OTHER COMMUNICATIONS NETWORK, NAMELY, ELECTRONICALLY TRANSMITTING INFORMATION, AUDIO, AND VIDEO CLIPS (U.S. CLS. 100, 101 AND 104).

ERNEST SHOSHO, EXAMINING ATTORNEY

SN 85-208,488. PARADIGMRADIO.COM, INC., NEW CASTLE, DE. FILED 12-31-2010.

PARADIGM RADIO

THE MARK CONSISTS OF STANDARD CHARACTERS WITHOUT CLAIM TO ANY PARTICULAR FONT, STYLE, SIZE, OR COLOR.

NO CLAIM IS MADE TO THE EXCLUSIVE RIGHT TO USE "RADIO", APART FROM THE MARK AS SHOWN.

FOR INTERNET RADIO BROADCASTING SERVICES (U.S. CLS. 100, 101 AND 104).

MORGAN WYNNE, EXAMINING ATTORNEY

**CLASS 38—(Continued).**

SN 85-208,502. PARADIGMRADIO.COM, INC., NEW CASTLE, DE. FILED 12-31-2010.



THE MARK CONSISTS OF A GRAPHIC REPRESENTATION OF RADIO ANTENNA AND RADIO SIGNAL TRANSMISSIONS WITH STYLIZED "P" AND "R" DISPLAYED IN TELESCOPED LETTERING, ALL INSIDE A CIRCLE.  
FOR INTERNET RADIO BROADCASTING SERVICES (U.S. CLS. 100, 101 AND 104).  
MORGAN WYNNE, EXAMINING ATTORNEY

SN 85-209,005. STUART H. EHRENBERG, SHENANDOAH JUNCTION, WV. AND EDGAR B. WENDLANDT, SAINT JOHNS, FL. FILED 1-3-2011.

**SemperComm**

THE MARK CONSISTS OF STANDARD CHARACTERS WITHOUT CLAIM TO ANY PARTICULAR FONT, STYLE, SIZE, OR COLOR.  
FOR CONSULTING SERVICES IN THE FIELD OF COMMUNICATIONS (U.S. CLS. 100, 101 AND 104).  
SANDRA BUJA, EXAMINING ATTORNEY

**CLASS 38—(Continued).**

SN 85-209,848. THE MCGRAW-HILL COMPANIES, INC., NEW YORK, NY. FILED 1-4-2011.



OWNER OF U.S. REG. NO. 3,561,938.  
THE MARK CONSISTS OF THE COMPOUND WORD GRADEGURU WITH BOTH OF THE LETTERS "G" IN UPPERCASE LETTERS AND THE REMAINING LETTERS IN LOWERCASE LETTERS WITH THE OUTLINE OF A 5 POINTED STAR ABOVE THE LETTER "U" AND THE TERM "GURU" IS IN BOLD FONT.  
FOR PROVIDING A WEB SITE FEATURING SHARING OF STUDY NOTES BY UNIVERSITY STUDENTS, NAMELY, PROVIDING ON-LINE BULLETIN BOARDS FOR TRANSMISSION OF MESSAGES AMONG COMPUTER USERS CONCERNING CLASS NOTES IN A WIDE VARIETY OF UNIVERSITY-LEVEL ACADEMIC FIELDS (U.S. CLS. 100, 101 AND 104).  
FIRST USE 5-0-2009; IN COMMERCE 5-0-2009.  
SUNG IN, EXAMINING ATTORNEY

SN 85-211,043. LIBERTYNOW, LLC, FRISCO, TX. FILED 1-5-2011.

**PEOPLE LIKE YOU HELPING  
PEOPLE LIKE YOU**

THE MARK CONSISTS OF STANDARD CHARACTERS WITHOUT CLAIM TO ANY PARTICULAR FONT, STYLE, SIZE, OR COLOR.  
FOR PROVIDING ON-LINE CHAT ROOMS AND ELECTRONIC BULLETIN BOARDS FOR TRANSMISSION OF MESSAGES AND INFORMATION AMONG USERS ON THE SUBJECT OF DEBT SETTLEMENT AND CREDIT MANAGEMENT (U.S. CLS. 100, 101 AND 104).  
CHRISIE B. KING, EXAMINING ATTORNEY

SN 85-211,222. DREW TV, MOORPARK, CA. FILED 1-5-2011.

**DREW TV**

THE MARK CONSISTS OF STANDARD CHARACTERS WITHOUT CLAIM TO ANY PARTICULAR FONT, STYLE, SIZE, OR COLOR.  
NO CLAIM IS MADE TO THE EXCLUSIVE RIGHT TO USE "TV", APART FROM THE MARK AS SHOWN.  
FOR VIDEO BROADCASTING SERVICES OVER THE INTERNET OR OTHER COMMUNICATIONS NETWORK FEATURING THE UPLOADED, POSTED AND TAGGED VIDEOS OF OTHERS (U.S. CLS. 100, 101 AND 104).  
FIRST USE 12-15-2010; IN COMMERCE 12-15-2010.  
ALLISON HOLTZ, EXAMINING ATTORNEY

**CLASS 38—(Continued).**

SN 85-212,487. RUBICON HOLDINGS, LLC, DBA WHERE-ITSCHAT.COM, PETERSBURG, VA. FILED 1-7-2011.

**whereitschat.com**

THE MARK CONSISTS OF STANDARD CHARACTERS WITHOUT CLAIM TO ANY PARTICULAR FONT, STYLE, SIZE, OR COLOR.

FOR PROVIDING ON-LINE CHAT ROOMS AND ELECTRONIC BULLETIN BOARDS FOR TRANSMISSION OF MESSAGES AMONG USERS IN THE FIELD OF GENERAL INTEREST (U.S. CLS. 100, 101 AND 104).

FIRST USE 9-16-2010; IN COMMERCE 1-1-2011.  
REBECCA POVARCHUK, EXAMINING ATTORNEY

---

SN 85-223,397. SINCLAIR TELECABLE, INC., DBA SINCLAIR COMMUNICATIONS, NORFOLK, VA. FILED 1-21-2011.

**Real Music Real Variety**

THE MARK CONSISTS OF STANDARD CHARACTERS WITHOUT CLAIM TO ANY PARTICULAR FONT, STYLE, SIZE, OR COLOR.

NO CLAIM IS MADE TO THE EXCLUSIVE RIGHT TO USE "MUSIC", APART FROM THE MARK AS SHOWN.

FOR INTERNET RADIO BROADCASTING SERVICES; RADIO BROADCASTING (U.S. CLS. 100, 101 AND 104).  
SUNG IN, EXAMINING ATTORNEY

---

SN 85-223,423. GOOGLE INC., MOUNTAIN VIEW, CA. FILED 1-21-2011.

**SAYNOW BROADCAST**

THE MARK CONSISTS OF STANDARD CHARACTERS WITHOUT CLAIM TO ANY PARTICULAR FONT, STYLE, SIZE, OR COLOR.

NO CLAIM IS MADE TO THE EXCLUSIVE RIGHT TO USE BROADCAST, APART FROM THE MARK AS SHOWN.

FOR ELECTRONIC AND DIGITAL TRANSMISSION OF VOICE, MESSAGES, AND DATA (U.S. CLS. 100, 101 AND 104).

FIRST USE 3-31-2006; IN COMMERCE 3-31-2006.  
RONALD AIKENS, EXAMINING ATTORNEY

**CLASS 38—(Continued).**

SN 85-226,153. TIME WARNER CABLE INC., NEW YORK, NY. FILED 1-25-2011.

**SELECTRATE**

THE MARK CONSISTS OF STANDARD CHARACTERS WITHOUT CLAIM TO ANY PARTICULAR FONT, STYLE, SIZE, OR COLOR.

FOR TELEPHONE TELECOMMUNICATIONS SERVICES, NAMELY, LOCAL AND LONG DISTANCE TELEPHONE SERVICES, INTERNET TELEPHONE SERVICES; ELECTRONIC VOICE MESSAGING, NAMELY, THE RECORDING AND SUBSEQUENT TRANSMISSION OF VOICE MESSAGES BY TELEPHONE; WIRELESS TELEPHONE TELECOMMUNICATIONS SERVICES, NAMELY, WIRELESS MOBILE TELEPHONE SERVICES AND WIRELESS VOICE MAIL SERVICES (U.S. CLS. 100, 101 AND 104).

BARBARA GAYNOR, EXAMINING ATTORNEY

---

SN 85-232,097. SUMMER INFANT (USA), INC., WOONSOCKET, RI. FILED 2-2-2011.

**THE DOCTOR IS IN**

THE MARK CONSISTS OF STANDARD CHARACTERS WITHOUT CLAIM TO ANY PARTICULAR FONT, STYLE, SIZE, OR COLOR.

FOR PROVIDING A WEB-BASED ELECTRONIC BULLETIN BOARD AND MESSAGE SERVICE FOR TRANSMISSION AND POSTING OF MESSAGES AMONG USERS IN THE FIELD OF JUVENILE PRODUCTS, PARENTAL ADVICE AND INFORMATION, CHILD-CARE ADVICE AND INFORMATION, CARETAKER ADVICE AND INFORMATION, CHILD ACTIVITY ADVICE AND INFORMATION, CHILD-RAISING SUGGESTIONS AND INFORMATION, CHILD SAFETY ADVICE AND INFORMATION, CHILDREN'S HEALTH AND NUTRITION, AND PRE-NATAL ADVICE AND INFORMATION (U.S. CLS. 100, 101 AND 104).

FIRST USE 12-1-2010; IN COMMERCE 12-1-2010.  
JUDITH HELFMAN, EXAMINING ATTORNEY

**CLASS 38—(Continued).**

SN 85-975,106. DIGI INTERNATIONAL INC., MINNETONKA, MN. FILED 6-25-2010.

# DIGI X-GRID

THE MARK CONSISTS OF STANDARD CHARACTERS WITHOUT CLAIM TO ANY PARTICULAR FONT, STYLE, SIZE, OR COLOR.

OWNER OF U.S. REG. NOS. 2,317,478, 2,630,891 AND OTHERS.

FOR COMPUTER SERVICES, NAMELY, PROVIDING TELECOMMUNICATIONS ACCESS FOR DEVICE CONNECTIVITY, MANAGEMENT AND CONTROL VIA COMPUTER NETWORKS; PROVIDING TELECOMMUNICATIONS ACCESS FOR MOBILE DEVICE CONNECTIVITY BY MEANS OF A HOST PLATFORM ON THE INTERNET (U.S. CLS. 100, 101 AND 104).

LAURA HAMMEL, EXAMINING ATTORNEY

**CLASS 39—(Continued).**

SN 76-705,554. COACH AMERICA HOLDINGS, INC., DALLAS, TX. FILED 12-3-2010.

# DILLON'S

THE MARK CONSISTS OF STANDARD CHARACTERS WITHOUT CLAIM TO ANY PARTICULAR FONT, STYLE, SIZE, OR COLOR.

FOR TRANSPORTATION SERVICES BY BUS (U.S. CLS. 100 AND 105).

FIRST USE 12-0-1979; IN COMMERCE 12-0-1979.

BARNEY CHARLON, EXAMINING ATTORNEY

SN 76-705,946. COACH AMERICA HOLDINGS, INC., DALLAS, TX. FILED 1-10-2011.

**CLASS 39—TRANSPORTATION AND STORAGE**

SN 76-701,726. AER LINGUS LIMITED, DUBLIN, IRELAND, FILED 2-22-2010.

aerlingus.com 

OWNER OF U.S. REG. NO. 1,222,901.

THE MARK CONSISTS OF THE WORDS "AERLINGUS.COM" IN A DISTINCTIVE FONT AND A DEPICTION OF A THREE-LEAF CLOVER/SHAMROCK.

THE EXPRESSION "AER LINGUS" MAY BE TRANSLATED INTO ENGLISH AS "AIR FLEET".

SEC. 2(F) AS TO "AERLINGUS.COM".

FOR AIR TRANSPORTATION SERVICES (U.S. CLS. 100 AND 105).

FIRST USE 4-4-2007; IN COMMERCE 4-4-2007.

MARILYN IZZI, EXAMINING ATTORNEY

FOR TRANSPORTATION SERVICES BY BUS (U.S. CLS. 100 AND 105).

FIRST USE 12-0-1979; IN COMMERCE 12-0-1979.

BARNEY CHARLON, EXAMINING ATTORNEY

SN 77-569,325. GREEN SUV LLC, HOLLYWOOD, CA. FILED 9-13-2008.



NO CLAIM IS MADE TO THE EXCLUSIVE RIGHT TO USE "GREENSUV", APART FROM THE MARK AS SHOWN. THE COLOR(S) GREEN IS/ARE CLAIMED AS A FEATURE OF THE MARK.

THE MARK CONSISTS OF THE WORDING "GREENSUV" IN A GREEN-COLORED STYLIZED GARAMOND FONT WITH GREEN STYLIZED LEAVES RISING FROM THE LEFT AND RIGHT SIDES OF THE TOP OF THE LETTER "N".

FOR HIRED CAR TRANSPORT (U.S. CLS. 100 AND 105).

FIRST USE 8-1-2008; IN COMMERCE 9-11-2008.

GINA FINK, EXAMINING ATTORNEY

SN 76-703,951. STEMPINSKI, STANLEY, JOSEPH, SAYREVILLE, NJ. FILED 7-28-2010.

  
NEW JERSEY'S NO. 1 PROFESSIONAL SERVICE  
FOR FUNERAL DIRECTORS EXCLUSIVELY

NO CLAIM IS MADE TO THE EXCLUSIVE RIGHT TO USE "SERVICE INC.", APART FROM THE MARK AS SHOWN.

SEC. 2(F).

FOR TRANSPORTATION OF HUMAN REMAINS FROM HOSPITALS, INSTITUTIONS, NURSING HOMES, AND RESIDENCES FOR FUNERAL DIRECTORS ONLY (U.S. CLS. 100 AND 105).

FIRST USE 0-0-1972; IN COMMERCE 0-0-1972.

EVELYN BRADLEY, EXAMINING ATTORNEY

**CLASS 39—(Continued).**

SN 77-579,921. LAS VEGAS SANDS CORP., LAS VEGAS, NV. FILED 9-26-2008.



PRIORITY CLAIMED UNDER SEC. 44(D) ON MACAU APPLICATION NO. N/38606, FILED 9-19-2008, REG. NO. 38606, DATED 2-24-2009, EXPIRES 2-24-2016.

THE MARK CONSISTS OF THE STYLIZED SPRAY OF A WATER FOUNTAIN IN BETWEEN VARIOUS SIZED STARS.

FOR COORDINATING TRAVEL ARRANGEMENTS FOR INDIVIDUALS AND FOR GROUPS; TRAVEL AND TOUR TICKET RESERVATION SERVICE; ORGANIZATION OF EXCURSIONS, SIGHTSEEING TOURS, HOLIDAYS, TOURS AND TRAVEL; ORGANIZATION OF BOAT TRIPS; PROVIDING AN ON-LINE COMPUTER DATABASE IN THE FIELD OF TRAVEL INFORMATION SERVICES; TRAVEL PLANNING AND TOURS; TOUR GUIDE SERVICES; BUS AND LIMO TRANSPORT; PASSENGER TRANSPORT; SHIPPING AND DELIVERY SERVICES, NAMELY, PICKUP, TRANSPORTATION, AND DELIVERY OF PACKAGES AND LETTERS BY VARIOUS MODES OF TRANSPORTATION; AIRLINE BAGGAGE CHECK-IN SERVICES, AIRLINE PASSENGER CHECK-IN SERVICES (U.S. CLS. 100 AND 105).

LINDA ESTRADA, EXAMINING ATTORNEY

**CLASS 39—(Continued).**

SN 77-909,312. LANSDOWNE STATION SELF STORAGE, LLC, DBA STORE IT, OWINGS MILLS, MD. FILED 1-11-2010.



THE COLOR(S) RED, WHITE AND BLUE IS/ARE CLAIMED AS A FEATURE OF THE MARK.

THE MARK CONSISTS OF THE WORDS "STORE IT" IN CAPITAL WHITE LETTERS, WITH EACH LETTER APPEARING ON THE FACE OF A RED BLOCK AND WITH TWO BLUE BLOCKS APPEARING BETWEEN "STORE" AND "IT", WITH AN ARROW POINTING UP IN THE TOP BLUE BLOCK AND AN ARROW POINTING DOWN IN THE LOWER BLUE BLOCK.

FOR RENTAL OF SELF-STORAGE FACILITIES TO INDIVIDUALS AND BUSINESSES (U.S. CLS. 100 AND 105).

FIRST USE 1-7-2010; IN COMMERCE 1-7-2010.

ALYSSA STEEL, EXAMINING ATTORNEY

SN 77-965,237. VARIG LOGÍSTICA S.A, SÃO PAULO, BRAZIL, FILED 3-22-2010.



THE MARK CONSISTS OF THE LITERAL ELEMENT "VARIGLOG" BELOW AN ARROW, ITSELF INTERSECTING A PARTIAL CIRCLE MADE UP OF A SERIES OF LINES.

FOR AIR TRANSPORTATION; RENTAL OF STORAGE FACILITIES; STORAGE SERVICES, NAMELY, WAREHOUSE STORAGE, REFRIGERATION STORAGE, STORAGE OF GOODS; INFORMATION ON STORAGE SERVICES; RENTAL OF CONTAINERS FOR STORAGE; TRANSPORTATION BROKERAGE SERVICES; PACKAGING OF GOODS AND MERCHANDISE FOR TRANSPORTATION, FOR OTHERS; DELIVERY SERVICES, NAMELY, DELIVERY OF GOODS, MESSAGE DELIVERY; TRANSPORT OF GOODS; FREIGHT SERVICES, NAMELY, AIR FREIGHT SHIPPING SERVICES; INFORMATION ON TRANSPORTATION SERVICES; TRANSPORTATION SERVICES, NAMELY, AIR TRANSPORTATION, TRUCK TRANSPORTATION; WAREHOUSING SERVICES, NAMELY, STORAGE, DISTRIBUTION, PICK-UP, AND PACKING FOR SHIPMENT OF DOCUMENTS, PACKAGES, RAW MATERIALS, AND OTHER FREIGHT FOR OTHERS; BOOKING SERVICES FOR TRANSPORTATION OF MESSAGE AND GOODS (U.S. CLS. 100 AND 105).

LEIGH LOWRY, EXAMINING ATTORNEY

SN 77-866,177. BLUEKNIGHT ENERGY PARTNERS, L.P., TULSA, OK. FILED 11-5-2009.

**BLUEKNIGHT ENERGY PARTNERS**

THE MARK CONSISTS OF STANDARD CHARACTERS WITHOUT CLAIM TO ANY PARTICULAR FONT, STYLE, SIZE, OR COLOR.

NO CLAIM IS MADE TO THE EXCLUSIVE RIGHT TO USE "ENERGY PARTNERS", APART FROM THE MARK AS SHOWN.

FOR TRANSPORTATION, STORAGE AND TERMINALLING OF CRUDE OIL AND OTHER PETROLEUM BASED PRODUCTS, NAMELY, ASPHALT, NATURAL GAS LIQUIDS AND REFINED PETROLEUM PRODUCTS FOR OTHERS (U.S. CLS. 100 AND 105).

ANDREA BUTLER, EXAMINING ATTORNEY



**CLASS 39—(Continued).**

SN 77-965,242. VARIG LOGÍSTICA S.A, SÃO PAULO, BRAZIL, FILED 3-22-2010.



THE MARK CONSISTS OF THE LITERAL ELEMENT "VELOG" TO THE LEFT OF AN ARROW, ITSELF INTERSECTING A PARTIAL CIRCLE MADE UP OF A SERIES OF LINES.

FOR AIR TRANSPORTATION; RENTAL OF STORAGE FACILITIES; STORAGE SERVICES, NAMELY, WAREHOUSE STORAGE, REFRIGERATION STORAGE, STORAGE OF GOODS; INFORMATION ON STORAGE SERVICES; RENTAL OF CONTAINERS FOR STORAGE; TRANSPORTATION BROKERAGE SERVICES; PACKAGING OF GOODS AND MERCHANDISE FOR TRANSPORTATION, FOR OTHERS; DELIVERY SERVICES, NAMELY, DELIVERY OF GOODS, MESSAGE DELIVERY; TRANSPORT OF GOODS; FREIGHT SERVICES, NAMELY, AIR FREIGHT SHIPPING SERVICES; INFORMATION ON TRANSPORTATION SERVICES; TRANSPORTATION SERVICES, NAMELY, AIR TRANSPORTATION, TRUCK TRANSPORTATION; WAREHOUSING SERVICES, NAMELY, STORAGE, DISTRIBUTION, PICK-UP, AND PACKING FOR SHIPMENT OF DOCUMENTS, PACKAGES, RAW MATERIALS, AND OTHER FREIGHT FOR OTHERS; BOOKING SERVICES FOR TRANSPORTATION OF MESSAGE AND GOODS (U.S. CLS. 100 AND 105).

LEIGH LOWRY, EXAMINING ATTORNEY

**CLASS 39—(Continued).**

SN 85-028,434. MINISTRY TRAVEL, LLC, SAYREVILLE, NJ, FILED 5-3-2010.



NO CLAIM IS MADE TO THE EXCLUSIVE RIGHT TO USE "TRAVEL", APART FROM THE MARK AS SHOWN.

THE COLOR(S) PURPLE, WHITE, GOLD, TAN AND BLACK IS/ARE CLAIMED AS A FEATURE OF THE MARK.

THE MARK CONSISTS OF THE WORDING "MINISTRY TRAVEL" IN PURPLE LETTERS WITH WHITE OUTLINING, WITH A COMPASS DESIGN IN BETWEEN THE WORDS "MINISTRY" AND "TRAVEL"; THE COMPASS IS IN THE SHAPE OF A 16-POINT STAR DESIGN WHICH RESEMBLES A CROSS, ALL IN THE COLOR GOLD; THE FACE OF THE COMPASS IS IN THE COLOR TAN; THE NEEDLE OF THE COMPASS IS IN THE COLORS PURPLE AND BLACK, AND THE CENTER OF THE COMPASS IS A DIAMOND DESIGN IN THE COLOR WHITE.

FOR ARRANGING AND COORDINATING TRAVEL ARRANGEMENTS FOR INDIVIDUALS AND GROUPS, NAMELY, DESTINATION STAYS, HONEYMOONS, FAMILY VACATIONS, AND DESTINATION WEDDINGS (U.S. CLS. 100 AND 105).

JOHN GARTNER, EXAMINING ATTORNEY

SN 85-022,552. HUASI S.A., SALTA, ARGENTINA, FILED 4-25-2010.



LA ESTANCIA DE CAFAYATE  
WINE & GOLF

NO CLAIM IS MADE TO THE EXCLUSIVE RIGHT TO USE "LA ESTANCIA DE CAFAYATE WINE & GOLF", APART FROM THE MARK AS SHOWN.

THE COLOR(S) MAROON, BROWN AND ORANGE IS/ARE CLAIMED AS A FEATURE OF THE MARK.

THE MARK CONSISTS OF THE WORDING "LA ESTANCIA DE CAFAYATE WINE & GOLF" STYLIZED IN THE COLOR MAROON; ABOVE THE WORDING IS A BROWN RECTANGULAR DESIGN WITH BROWN WAVY LINES AND AN ORANGE DIAMOND IN THE CENTER.

THE ENGLISH TRANSLATION OF "LA ESTANCIA DE" IN THE MARK IS "THE RANCH OF". THE WORDING "CAFAYATE" HAS NO MEANING IN A FOREIGN LANGUAGE.

FOR ARRANGING TRAVEL TOURS; ORGANISATION OF TRAVEL (U.S. CLS. 100 AND 105).

FIRST USE 3-28-2008; IN COMMERCE 3-28-2008.

BERYL GARDNER, EXAMINING ATTORNEY

SN 85-042,242. DATA FOUNDRY, INC., AUSTIN, TX, FILED 5-19-2010.

DATA RANCH

THE MARK CONSISTS OF STANDARD CHARACTERS WITHOUT CLAIM TO ANY PARTICULAR FONT, STYLE, SIZE, OR COLOR.

NO CLAIM IS MADE TO THE EXCLUSIVE RIGHT TO USE "DATA", APART FROM THE MARK AS SHOWN.

FOR DATA CENTER SERVICES, NAMELY, PROVIDING STORAGE FACILITIES FOR OTHERS FOR STORAGE OF ELECTRONIC MEDIA AND EQUIPMENT (U.S. CLS. 100 AND 105).

ASMAT KHAN, EXAMINING ATTORNEY

**CLASS 39—(Continued).**

SN 85-055,430. ETRAVEL APPLICATIONS, LLC, PLEASANTON, CA. FILED 6-4-2010.

**HOTELGPS**

THE MARK CONSISTS OF STANDARD CHARACTERS WITHOUT CLAIM TO ANY PARTICULAR FONT, STYLE, SIZE, OR COLOR.

FOR PROVIDING AN ON-LINE COMPUTER DATABASE IN THE FIELD OF TRAVEL INFORMATION SERVICES; TRAVEL AGENCY SERVICES, NAMELY, MAKING RESERVATIONS AND BOOKINGS FOR TRANSPORTATION (U.S. CLS. 100 AND 105).

FIRST USE 2-7-2011; IN COMMERCE 2-7-2011.  
RENEE SERVANCE, EXAMINING ATTORNEY

SN 85-058,721. BARNHILL AVIATION, LLC, SANFORD, FL. FILED 6-9-2010.



NO CLAIM IS MADE TO THE EXCLUSIVE RIGHT TO USE "NATIONAL AIR CHARTERS INC.", APART FROM THE MARK AS SHOWN.

THE MARK CONSISTS OF THE LETTERS "N", "A", AND "C" WITH A STYLIZED SLASH IN THE "N" ABOVE A PARTIAL REFLECTION OF "N", "A", AND "C", FOLLOWED BY THE WORDS "NATIONAL AIR CHARTERS INC."

FOR AIR CHARTER SERVICES; AIR CHARTER TRANSPORTATION SERVICES (U.S. CLS. 100 AND 105).  
FIRST USE 12-7-1992; IN COMMERCE 7-1-2007.  
MICHELE SWAIN, EXAMINING ATTORNEY

SN 85-069,514. SAIL IN SAN DIEGO, SAN DIEGO, CA. FILED 6-23-2010.



THE MARK CONSISTS OF A STYLIZED SAIL BOAT WITH THE WORDING "SAIL SAN DIEGO" UNDERNEATH. SEC. 2(F) AS TO "SAIL SAN DIEGO".  
FOR CONDUCTING BOAT CHARTERS (U.S. CLS. 100 AND 105).

FIRST USE 6-12-1989; IN COMMERCE 6-30-1989.  
REGINA DRUMMOND, EXAMINING ATTORNEY

**CLASS 39—(Continued).**

SN 85-070,942. CB TRAVEL CORP., SALT LAKE CITY, UT. FILED 6-24-2010.

**CHRISTOPHERSON BUSINESS TRAVEL**

THE MARK CONSISTS OF STANDARD CHARACTERS WITHOUT CLAIM TO ANY PARTICULAR FONT, STYLE, SIZE, OR COLOR.

NO CLAIM IS MADE TO THE EXCLUSIVE RIGHT TO USE "BUSINESS TRAVEL", APART FROM THE MARK AS SHOWN.

SEC. 2(F).  
FOR TRAVEL INFORMATION SERVICES (U.S. CLS. 100 AND 105).  
FIRST USE 3-16-1998; IN COMMERCE 3-16-1998.  
DAVID TOOLEY, EXAMINING ATTORNEY

SN 85-079,562. TIME TRANSPORTATION HOLDINGS, LLC, OKLAHOMA CITY, OK. FILED 7-7-2010.



OWNER OF U.S. REG. NO. 3,766,737.

THE MARK CONSISTS OF A CLOCK IMAGE WITH THE HANDS AT 10 AND 2 AND THE WORD "TIMECAR" BELOW THE IMAGE.

FOR TEMPORARY AUTOMOBILE SHARING SERVICES PROVIDED ON A MEMBERSHIP BASIS (U.S. CLS. 100 AND 105).

FIRST USE 6-16-2010; IN COMMERCE 6-16-2010.  
JENNIFER VASQUEZ, EXAMINING ATTORNEY

**CLASS 39—(Continued).**

SN 85-088,472. VEOLIA ES ALARON, L.L.C., WAMPUM, PA. FILED 7-20-2010.



THE COLOR(S) LIGHT GREEN AND DARK GREEN IS/ ARE CLAIMED AS A FEATURE OF THE MARK.

THE MARK CONSISTS OF A DARK GREEN CIRCLE WITH SIX LIGHT GREEN CURVED INTERTWINED ARROWS OVER IT TO FORM AN ATOM IMAGE. FOUR SMALL LIGHT GREEN DOTS APPEAR WITHIN THE CIRCLE AT THE FOUR CORNERS OF THE INTERSECTION OF THE ARROWS.

FOR TRANSPORTATION SERVICES, NAMELY, TRANSPORTATION OF RADIOACTIVE SYSTEM COMPONENTS USED IN THE NUCLEAR INDUSTRY; SPACE LEASING SERVICES IN THE NATURE OF STORAGE SERVICES FOR RADIOACTIVE GOODS USED IN THE NUCLEAR INDUSTRY (U.S. CLS. 100 AND 105).

FIRST USE 6-27-1983; IN COMMERCE 6-27-1983.  
KAREN SEVERSON, EXAMINING ATTORNEY

SN 85-089,466. MOUNTAIN ENERGY SERVICES, INC., TUNKANNOCK, PA. FILED 7-21-2010.



THE COLOR(S) GREEN IS/ARE CLAIMED AS A FEATURE OF THE MARK.

THE MARK CONSISTS OF AN EVERGREEN TREE WITH THE LETTER "E" CUT-OUT OF THE RIGHT SIDE OF THE TREE. THE COLOR OF THE ENTIRE MARK IS GREEN.

FOR TRUCK HAULING; TRANSPORTATION OF WATER, BRINE AND OTHER DRILLING AND PRODUCTION FLUIDS FROM AND TO PITS, TANKS, STORAGE FACILITIES AND WELL LOCATIONS BY TRUCKS (U.S. CLS. 100 AND 105).

FIRST USE 6-4-2009; IN COMMERCE 6-4-2009.  
JULIE WATSON, EXAMINING ATTORNEY

**CLASS 39—(Continued).**

SN 85-104,322. US AIRWAYS, INC., TEMPE, AZ. FILED 8-10-2010.

**BUY MILES DIVIDEND MILES**

THE MARK CONSISTS OF STANDARD CHARACTERS WITHOUT CLAIM TO ANY PARTICULAR FONT, STYLE, SIZE, OR COLOR.

OWNER OF U.S. REG. NOS. 2,241,014, 2,269,473 AND 2,865,418.

NO CLAIM IS MADE TO THE EXCLUSIVE RIGHT TO USE "BUY MILES", APART FROM THE MARK AS SHOWN.

FOR TRANSPORTATION SERVICES, NAMELY, AIRLINE PASSENGER SERVICES IN THE NATURE OF A SPECIALIZED FREQUENT FLIER PROGRAM; AIR TRANSPORTATION SERVICES FEATURING AN AWARD PROGRAM FOR FREQUENT AIR TRAVELERS THAT FEATURES AUGMENTED FREQUENT FLIER MILEAGE AND BONUS MILEAGE (U.S. CLS. 100 AND 105).

FIRST USE 5-0-2002; IN COMMERCE 5-0-2002.  
ALLISON HOLTZ, EXAMINING ATTORNEY

SN 85-104,342. US AIRWAYS, INC., TEMPE, AZ. FILED 8-10-2010.

**GIFT MILES DIVIDEND MILES**

THE MARK CONSISTS OF STANDARD CHARACTERS WITHOUT CLAIM TO ANY PARTICULAR FONT, STYLE, SIZE, OR COLOR.

OWNER OF U.S. REG. NOS. 2,241,014, 2,269,473 AND 2,865,418.

NO CLAIM IS MADE TO THE EXCLUSIVE RIGHT TO USE "GIFT MILES", APART FROM THE MARK AS SHOWN.

FOR TRANSPORTATION SERVICES, NAMELY, AIRLINE PASSENGER SERVICES IN THE NATURE OF A SPECIALIZED FREQUENT FLIER PROGRAM; AIR TRANSPORTATION SERVICES FEATURING AN AWARD PROGRAM FOR FREQUENT AIR TRAVELERS THAT FEATURES DONATION OF FREQUENT FLIER MILES AMONG FAMILY MEMBERS, FRIENDS, AND OTHER FREQUENT FLIER PROGRAM MEMBERS AND FEATURING A FREQUENT FLYER BONUS PROGRAM OFFERING ADDITIONAL MILEAGE TO RECIPIENTS (U.S. CLS. 100 AND 105).

FIRST USE 5-0-2002; IN COMMERCE 5-0-2002.  
ALLISON HOLTZ, EXAMINING ATTORNEY

**CLASS 39—(Continued).**

SN 85-104,352. US AIRWAYS, INC., TEMPE, AZ. FILED 8-10-2010.

SHARE MILES DIVIDEND MILES

THE MARK CONSISTS OF STANDARD CHARACTERS WITHOUT CLAIM TO ANY PARTICULAR FONT, STYLE, SIZE, OR COLOR.

OWNER OF U.S. REG. NOS. 2,241,014, 2,269,473 AND 2,865,418.

NO CLAIM IS MADE TO THE EXCLUSIVE RIGHT TO USE "SHARE MILES", APART FROM THE MARK AS SHOWN.

FOR TRANSPORTATION SERVICES, NAMELY, AIRLINE PASSENGER SERVICES IN THE NATURE OF A SPECIALIZED FREQUENT FLIER PROGRAM; AIR TRANSPORTATION SERVICES FEATURING AN AWARD PROGRAM FOR FREQUENT AIR TRAVELERS THAT FEATURES DONATION OF FREQUENT FLIER MILES AMONG FAMILY MEMBERS, FRIENDS, AND OTHER FREQUENT FLIER PROGRAM MEMBERS AND FEATURING A FREQUENT FLYER BONUS PROGRAM OFFERING ADDITIONAL MILEAGE TO RECIPIENTS (U.S. CLS. 100 AND 105).

FIRST USE 1-0-2007; IN COMMERCE 1-0-2007.

ALLISON HOLTZ, EXAMINING ATTORNEY

SN 85-152,048. LOGISTICARE SOLUTIONS, LLC, ATLANTA, GA. FILED 10-13-2010.

**LogistiCare**  
Going The Extra Mile

OWNER OF U.S. REG. NOS. 2,419,882 AND 2,431,949. THE COLOR(S) BLACK, BLUE AND GREEN IS/ARE CLAIMED AS A FEATURE OF THE MARK.

THE MARK CONSISTS OF THE WORDS "LOGISTICARE GOING THE EXTRA MILE" IN STYLIZED LETTERS. "LOGIST" APPEARS IN BLUE AND "CARE" APPEARS IN GREEN. THE WORDS "GOING THE EXTRA MILE" APPEAR IN BLACK BENEATH THE WORDING "LOGISTICARE".

FOR MEDICAL TRANSPORTATION SERVICES, NAMELY, PROVIDING TRANSPORTATION FOR PEOPLE BY AMBULANCE, GROUND VEHICLES, MEDICAL HELICOPTER, AND MEDICAL AIRPLANE (U.S. CLS. 100 AND 105).

NAKWAMA ANKRAH, EXAMINING ATTORNEY

**CLASS 39—(Continued).**

SN 85-154,703. LONE STAR VALET PARKING SERVICES, INC., DALLAS, TX. FILED 10-18-2010.



**LONE STAR VALET**

NO CLAIM IS MADE TO THE EXCLUSIVE RIGHT TO USE "VALET", APART FROM THE MARK AS SHOWN.

THE MARK CONSISTS OF A FIVE-POINT STAR EN-CIRCLED BY A WREATH OF LAUREL LEAVES ABOVE THE WORDS, "LONE STAR VALET" IN STYLIZED FONT.

SEC. 2(F).

FOR VALET PARKING AND VEHICLE PARKING SERVICES (U.S. CLS. 100 AND 105).

FIRST USE 9-1-1999; IN COMMERCE 9-1-1999.

BARBARA GAYNOR, EXAMINING ATTORNEY

SN 85-156,148. LONE STAR VALET PARKING SERVICES, INC., DALLAS, TX. FILED 10-19-2010.

**LONE STAR VALET**

THE MARK CONSISTS OF STANDARD CHARACTERS WITHOUT CLAIM TO ANY PARTICULAR FONT, STYLE, SIZE, OR COLOR.

NO CLAIM IS MADE TO THE EXCLUSIVE RIGHT TO USE "VALET", APART FROM THE MARK AS SHOWN.

SEC. 2(F).

FOR VALET PARKING AND VEHICLE PARKING SERVICES (U.S. CLS. 100 AND 105).

FIRST USE 6-22-1995; IN COMMERCE 6-22-1995.

BARBARA GAYNOR, EXAMINING ATTORNEY

SN 85-159,935. JAPAN AIRLINES INTERNATIONAL CO., LTD., TOKYO, JAPAN, FILED 10-25-2010.

**SKY RECLINER**

THE MARK CONSISTS OF STANDARD CHARACTERS WITHOUT CLAIM TO ANY PARTICULAR FONT, STYLE, SIZE, OR COLOR.

NO CLAIM IS MADE TO THE EXCLUSIVE RIGHT TO USE "RECLINER", APART FROM THE MARK AS SHOWN.

FOR AIR TRANSPORT; TOUR CONDUCTING; TOUR CONDUCTING OR ESCORTING; TRAVEL BOOKING AGENCIES (U.S. CLS. 100 AND 105).

VERNA BETH RIRIE, EXAMINING ATTORNEY

**CLASS 39—(Continued).**

SN 85-172,637. KOBUSSEN BUSES LTD., KAUKAUNA, WI.  
FILED 11-9-2010.

**KOBUSSEN BUSES**

THE MARK CONSISTS OF STANDARD CHARACTERS WITHOUT CLAIM TO ANY PARTICULAR FONT, STYLE, SIZE, OR COLOR.

NO CLAIM IS MADE TO THE EXCLUSIVE RIGHT TO USE "BUSES", APART FROM THE MARK AS SHOWN.

SEC. 2(F).

FOR PROVIDING BUS CHARTER SERVICES TO SPECIAL EVENTS (U.S. CLS. 100 AND 105).

FIRST USE 5-10-1976; IN COMMERCE 5-10-1976.

DOMINIC FATHY, EXAMINING ATTORNEY

SN 85-182,125. ADVENTURATI, LLC, WASHINGTON, DC.  
FILED 11-22-2010.

**ADVENTURATI**

THE MARK CONSISTS OF STANDARD CHARACTERS WITHOUT CLAIM TO ANY PARTICULAR FONT, STYLE, SIZE, OR COLOR.

THE WORDING "ADVENTURATI" HAS NO MEANING IN A FOREIGN LANGUAGE.

FOR ARRANGING AND COORDINATING TRAVEL ARRANGEMENTS FOR INDIVIDUALS AND GROUPS, NAMELY, DESTINATIONS STAYS, HONEYMOONS, FAMILY VACATIONS, AND DESTINATION WEDDINGS; ARRANGING TRAVEL TOURS; COORDINATING TRAVEL ARRANGEMENTS FOR INDIVIDUALS AND FOR GROUPS; ONLINE TRIP AND TRAVEL RESERVATION SERVICES; ORGANIZATION OF TRAVEL; ORGANIZATION OF EXCURSIONS, SIGHTSEEING TOURS, HOLIDAYS, TOURS AND TRAVEL; ORGANIZATION OF TRAVEL AND BOAT TRIPS; RESERVATION AND BOOKING OF SEATS FOR TRAVEL; TRAVEL AGENCY SERVICES, NAMELY, MAKING RESERVATIONS AND BOOKINGS FOR TRANSPORTATION; TRAVEL AND TOUR INFORMATION SERVICE; TRAVEL, EXCURSION AND CRUISE ARRANGEMENT (U.S. CLS. 100 AND 105).

FIRST USE 3-29-2009; IN COMMERCE 3-29-2009.

BARBARA RUTLAND, EXAMINING ATTORNEY

**CLASS 39—(Continued).**

SN 85-183,027. ENDUROBOX LLC, TEMECULA, CA. FILED 11-23-2010.

**Pack It. Move It. Reuse It!**

THE MARK CONSISTS OF STANDARD CHARACTERS WITHOUT CLAIM TO ANY PARTICULAR FONT, STYLE, SIZE, OR COLOR.

FOR RENTAL OF MOVING EQUIPMENT, NAMELY, PADS, STRAPS, HITCHES, DOLLIES, BOXES, CARRIERS, AND HAND TRUCKS (U.S. CLS. 100 AND 105).

FIRST USE 11-1-2010; IN COMMERCE 11-2-2010.

DAVID H. STINE, EXAMINING ATTORNEY

SN 85-183,028. ENDUROBOX LLC, TEMECULA, CA. FILED 11-23-2010.

**EnduroBox**

THE MARK CONSISTS OF STANDARD CHARACTERS WITHOUT CLAIM TO ANY PARTICULAR FONT, STYLE, SIZE, OR COLOR.

FOR RENTAL OF MOVING EQUIPMENT, NAMELY, PADS, STRAPS, HITCHES, DOLLIES, BOXES, CARRIERS, AND HAND TRUCKS (U.S. CLS. 100 AND 105).

FIRST USE 11-1-2010; IN COMMERCE 11-2-2010.

DAVID H. STINE, EXAMINING ATTORNEY

SN 85-184,170. LRTGH, LLC, WHITE PLAINS, NY. FILED 11-23-2010.

**We Pay YOU Junk Removal**

THE MARK CONSISTS OF STANDARD CHARACTERS WITHOUT CLAIM TO ANY PARTICULAR FONT, STYLE, SIZE, OR COLOR.

NO CLAIM IS MADE TO THE EXCLUSIVE RIGHT TO USE "JUNK REMOVAL", APART FROM THE MARK AS SHOWN.

FOR JUNK, TRASH AND DEBRIS REMOVAL (U.S. CLS. 100 AND 105).

MAYUR VAGHANI, EXAMINING ATTORNEY

**CLASS 39—(Continued).**

SN 85-188,614. GOTHAM CORPORATION, FLUSHING, NY. FILED 12-1-2010.

**GOTHAM LIMOUSINE**

THE MARK CONSISTS OF STANDARD CHARACTERS WITHOUT CLAIM TO ANY PARTICULAR FONT, STYLE, SIZE, OR COLOR.

NO CLAIM IS MADE TO THE EXCLUSIVE RIGHT TO USE "LIMOUSINE", APART FROM THE MARK AS SHOWN.

FOR TRANSPORT OF PASSENGERS; TRANSPORT OF PERSONS; TRANSPORT OF PERSONS AND GOODS (U.S. CLS. 100 AND 105).

FIRST USE 6-9-1990; IN COMMERCE 6-9-1990.  
GISELLE AGOSTO, EXAMINING ATTORNEY

---

SN 85-188,963. WASHINGTON GROUP II, L.L.C., CHERRY HILL, NJ. FILED 12-2-2010.

**MatzaFun Tours**

THE MARK CONSISTS OF STANDARD CHARACTERS WITHOUT CLAIM TO ANY PARTICULAR FONT, STYLE, SIZE, OR COLOR.

NO CLAIM IS MADE TO THE EXCLUSIVE RIGHT TO USE "TOURS", APART FROM THE MARK AS SHOWN.

FOR ARRANGING OF TOURS; ARRANGING TRAVEL TOURS; COORDINATING TRAVEL ARRANGEMENTS FOR INDIVIDUALS AND FOR GROUPS; ORGANIZATION OF EXCURSIONS, SIGHTSEEING TOURS, HOLIDAYS, TOURS AND TRAVEL; TOUR OPERATING AND ORGANISING (U.S. CLS. 100 AND 105).

FIRST USE 11-0-1996; IN COMMERCE 11-0-1996.  
KATHERINE CONNOLLY, EXAMINING ATTORNEY

---

SN 85-188,969. HENNING, JULIE, SUN PRAIRIE, WI. FILED 12-2-2010.

**Going on VaCachen**

THE MARK CONSISTS OF STANDARD CHARACTERS WITHOUT CLAIM TO ANY PARTICULAR FONT, STYLE, SIZE, OR COLOR.

NO CLAIM IS MADE TO THE EXCLUSIVE RIGHT TO USE "VACATION", APART FROM THE MARK AS SHOWN.

FOR PROVIDING INFORMATION AND COMMENTARY IN THE FIELD OF TRAVEL; PROVIDING A WEBSITE FEATURING TRAVEL INFORMATION AND COMMENTARY; CONSULTING SERVICES IN THE FIELD OF TRAVEL IN RELATION TO ARRANGING TRAVEL TOURS (U.S. CLS. 100 AND 105).

LAURIE MAYES, EXAMINING ATTORNEY

**CLASS 39—(Continued).**

SN 85-193,671. PENNINGTON, SEAN D., DBA DESTINATION DRIVERS, ATASCADERO, CA. FILED 12-8-2010.

**DESTINATION DRIVERS**

THE MARK CONSISTS OF STANDARD CHARACTERS WITHOUT CLAIM TO ANY PARTICULAR FONT, STYLE, SIZE, OR COLOR.

NO CLAIM IS MADE TO THE EXCLUSIVE RIGHT TO USE "DRIVERS", APART FROM THE MARK AS SHOWN.

FOR CHAUFFEUR SERVICES (U.S. CLS. 100 AND 105).

FIRST USE 4-10-2010; IN COMMERCE 4-10-2010.  
LINDSEY RUBIN, EXAMINING ATTORNEY

---

SN 85-199,755. JARAMILLO, EDWARD TERRY, CORAL GABLES, FL. FILED 12-16-2010.

**vonJet**

THE MARK CONSISTS OF STANDARD CHARACTERS WITHOUT CLAIM TO ANY PARTICULAR FONT, STYLE, SIZE, OR COLOR.

FOR RENTAL OF AIRCRAFT; RENTAL OF AIRCRAFT ENGINES (U.S. CLS. 100 AND 105).

FIRST USE 4-3-2006; IN COMMERCE 4-3-2006.  
LINDA LAVACHE, EXAMINING ATTORNEY

---

SN 85-203,360. CONTINUUM PACKING SOLUTIONS LLC, MINDEN, NV. FILED 12-21-2010.



NO CLAIM IS MADE TO THE EXCLUSIVE RIGHT TO USE "PACKING SOLUTIONS LLC", APART FROM THE MARK AS SHOWN.

THE MARK CONSISTS OF A STYLIZED LETTER "C" WITH A DROPLET AND THE WORDS CONTINUUM AND PACKING SOLUTIONS LLC.

FOR BOTTLING AND PACKAGING SERVICES; FOOD AND BEVERAGE PACKAGING AND BOTTLING SERVICES; BOTTLING AND PACKAGING FOOD PRODUCTS, JUICES, PREPARED FRUIT PRODUCTS, DAIRY PRODUCTS, BROTHS, NON-ALCOHOLIC BEVERAGE PRODUCTS, ALCOHOL SPIRIT BEVERAGES, HIGH AND LOW ACID FOODS, AND SAUCES TO THE ORDER AND SPECIFICATION OF OTHERS (U.S. CLS. 100 AND 105).

DAVID I, EXAMINING ATTORNEY

**CLASS 39—(Continued).**

SN 85-203,630. LOUISVILLE WATER COMPANY, LOUISVILLE, KY. FILED 12-22-2010.



THE MARK CONSISTS OF THE LETTER "W" WITH A STYLIZED WAVE SUPER-IMPOSED ON THE BOTTOM.  
FOR WATER SUPPLY AND DISTRIBUTION SERVICES (U.S. CLS. 100 AND 105).  
BRENDAN MCCAULEY, EXAMINING ATTORNEY

SN 85-203,904. AARON DIRKS, NEW ORLEANS, LA. FILED 12-22-2010.

**MYAIRPORTTRIP.COM**

THE MARK CONSISTS OF STANDARD CHARACTERS WITHOUT CLAIM TO ANY PARTICULAR FONT, STYLE, SIZE, OR COLOR.  
FOR TRANSPORTATION SERVICES, NAMELY, AIRPORT GROUND, CHARTER, AND DOOR-TO-DOOR TRANSPORTATION SERVICES OF PASSENGERS BY MOTOR VEHICLES (U.S. CLS. 100 AND 105).  
FIRST USE 7-17-2010; IN COMMERCE 7-17-2010.  
JILL PRATER, EXAMINING ATTORNEY

SN 85-205,015. IDEAS EXITOSAS EN INTERNET S.A. DE C.V., GUADALAJARA, MEXICO, FILED 12-23-2010.

**YOINVITO**

THE MARK CONSISTS OF STANDARD CHARACTERS WITHOUT CLAIM TO ANY PARTICULAR FONT, STYLE, SIZE, OR COLOR.  
THE ENGLISH TRANSLATION OF YOINVITO IN THE MARK IS I INVITE.  
FOR ONLINE TRIP AND TRAVEL RESERVATION SERVICES; PROVIDING A WEBSITE FEATURING INFORMATION ON TRAVEL; PROVIDING INFORMATION ABOUT AUTOMOBILES FOR LEASE BY MEAN OF THE INTERNET; PROVIDING LINKS TO WEB SITES OF OTHERS FEATURING TRAVEL (U.S. CLS. 100 AND 105).  
INGA ERVIN, EXAMINING ATTORNEY

**CLASS 39—(Continued).**

SN 85-205,028. JOHN CLEVELAND, CHARLOTTESVILLE, VA. FILED 12-23-2010.

**zippymaps**

THE MARK CONSISTS OF STANDARD CHARACTERS WITHOUT CLAIM TO ANY PARTICULAR FONT, STYLE, SIZE, OR COLOR.  
FOR PROVIDING A WEB SITE AND WEB SITE LINKS TO GEOGRAPHIC INFORMATION, MAP IMAGES, AND TRIP ROUTING (U.S. CLS. 100 AND 105).  
LINDA LAVACHE, EXAMINING ATTORNEY

SN 85-205,610. DAN THE AFFORDABLE MOVING MAN, ANDOVER, NJ. FILED 12-24-2010.

**DAN THE AFFORDABLE MOVING  
MAN**

THE MARK CONSISTS OF STANDARD CHARACTERS WITHOUT CLAIM TO ANY PARTICULAR FONT, STYLE, SIZE, OR COLOR.  
FOR MOVING COMPANY SERVICES (U.S. CLS. 100 AND 105).  
REBECCA POVARCHUK, EXAMINING ATTORNEY

SN 85-206,286. RAYTHEON COMPANY, WALTHAM, MA. FILED 12-28-2010.



THE MARK CONSISTS OF A DESIGN COMPRISED OF A SHIELD FEATURING TWO LIGHTNING BOLTS.  
FOR RESCUE SERVICES; EMERGENCY RESCUE SERVICES, NAMELY, PROVIDING EMERGENCY RESCUE SERVICES TO INDIVIDUALS AT INCIDENT SITES REQUIRING PENETRATION OF STRUCTURES AND STRUCTURAL DEBRIS; CONSULTING SERVICES IN THE FIELD OF EMERGENCY RESCUE (U.S. CLS. 100 AND 105).  
SAIMA MAKHDOOM, EXAMINING ATTORNEY

**CLASS 39—(Continued).**

SN 85-206,524. ENTERPRISE HOLDINGS, INC., ST. LOUIS, MO. FILED 12-28-2010.

PROUD TO SERVE THOSE WHO  
SERVE

THE MARK CONSISTS OF STANDARD CHARACTERS WITHOUT CLAIM TO ANY PARTICULAR FONT, STYLE, SIZE, OR COLOR.

FOR VEHICLE RENTAL AND LEASING SERVICES; AND RESERVATION SERVICES FOR THE RENTAL AND LEASING OF VEHICLES (U.S. CLS. 100 AND 105).  
FIRST USE 3-31-2006; IN COMMERCE 3-31-2006.  
JOHN WILKE, EXAMINING ATTORNEY

SN 85-206,784. AMERICAN CRUISE LINES, INC., GUILFORD, CT. FILED 12-28-2010.

QUEEN OF THE MISSISSIPPI

THE MARK CONSISTS OF STANDARD CHARACTERS WITHOUT CLAIM TO ANY PARTICULAR FONT, STYLE, SIZE, OR COLOR.

NO CLAIM IS MADE TO THE EXCLUSIVE RIGHT TO USE "MISSISSIPPI", APART FROM THE MARK AS SHOWN.

FOR CRUISE SHIP SERVICES; TRANSPORTATION OF PASSENGERS BY SHIP; ARRANGING AND CONDUCTING CRUISES FOR OTHERS (U.S. CLS. 100 AND 105).  
TINA MAI, EXAMINING ATTORNEY

SN 85-207,620. CORE-MARK INTERNATIONAL, INC., SOUTH SAN FRANCISCO, CA. FILED 12-29-2010.

CORE-MARK

THE MARK CONSISTS OF STANDARD CHARACTERS WITHOUT CLAIM TO ANY PARTICULAR FONT, STYLE, SIZE, OR COLOR.

FOR GOODS WAREHOUSING; WAREHOUSING SERVICES, NAMELY, STORAGE, DISTRIBUTION, PICK-UP, PACKING, AND SHIPPING OF CONSUMER PACKAGED GOODS PRODUCTS; SPECIALTY MERCHANDISING SERVICES, NAMELY, PROMOTING THE GOODS AND SERVICES OF OTHERS THROUGH THE DISTRIBUTION OF CUSTOMIZED ADVERTISING MATERIALS, NAMELY, CONSUMER PACKAGED GOODS PRODUCTS; DISTRIBUTION SERVICES, NAMELY, DELIVERY OF CONSUMER PACKAGED GOODS PRODUCTS (U.S. CLS. 100 AND 105).

FIRST USE 1-1-1982; IN COMMERCE 1-1-1982.  
HEATHER SAPP, EXAMINING ATTORNEY

**CLASS 39—(Continued).**

SN 85-207,622. CORE-MARK INTERNATIONAL, INC., SOUTH SAN FRANCISCO, CA. FILED 12-29-2010.



THE MARK CONSISTS OF TWO HALF CIRCLES, SURROUNDING A STYLIZED DEPICTION OF THE SUN, THE LEFT HALF CIRCLE IN THE FORM OF THE LETTER "C" AND THE RIGHT HALF CIRCLE OVERLAYED BY RAYS OF THE SUN.

FOR GOODS WAREHOUSING; WAREHOUSING SERVICES, NAMELY, STORAGE, DISTRIBUTION, PICK-UP, PACKING, AND SHIPPING OF CONSUMER PACKAGED GOODS PRODUCTS; SPECIALTY MERCHANDISING SERVICES, NAMELY, PROMOTING THE GOODS AND SERVICES OF OTHERS THROUGH THE DISTRIBUTION OF CUSTOMIZED ADVERTISING MATERIALS, NAMELY, CONSUMER PACKAGED GOODS PRODUCTS; DISTRIBUTION SERVICES, NAMELY, DELIVERY OF CONSUMER PACKAGED GOODS PRODUCTS (U.S. CLS. 100 AND 105).

FIRST USE 3-13-2009; IN COMMERCE 3-13-2009.  
HEATHER SAPP, EXAMINING ATTORNEY

SN 85-209,434. OLUP, CHRISTOPHER M., PORT TOBACCO, MD. FILED 1-3-2011.

Somewhere in the Sun

THE MARK CONSISTS OF STANDARD CHARACTERS WITHOUT CLAIM TO ANY PARTICULAR FONT, STYLE, SIZE, OR COLOR.

FOR PROVIDING A WEB SITE FEATURING TRAVEL INFORMATION AND COMMENTARY; PROVIDING A WEBSITE FEATURING INFORMATION ON TRAVEL; PROVIDING INFORMATION, NEWS AND COMMENTARY IN THE FIELD OF TRAVEL; PROVIDING LINKS TO WEB SITES OF OTHERS FEATURING TRAVEL; TRAVEL BOOKING AGENCIES; TRAVEL GUIDE AND TRAVEL INFORMATION SERVICES (U.S. CLS. 100 AND 105).

TINA BROWN, EXAMINING ATTORNEY



**CLASS 39—(Continued).**

SN 85-210,156. MULTI-PACK SOLUTIONS LLC, BALLWIN, MO. FILED 1-4-2011.

**CLASS 39—(Continued).**

SN 85-214,320. EXTRANOMICAL ADVENTURES, INC. AKA EXTRANOMICAL TOURS, SAN LEANDRO, CA. FILED 1-10-2011.

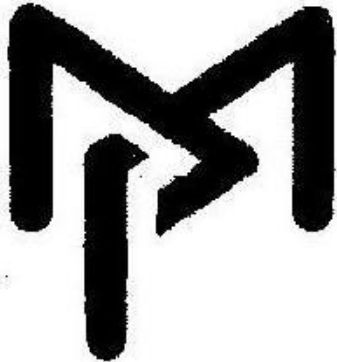

THE MARK CONSISTS OF LINES INTERCONNECTED AND FORMING AN "M" AND "P".  
FOR PACKAGING NON-FOOD PRODUCTS TO THE SPECIFICATION OF OTHERS (U.S. CLS. 100 AND 105).  
JOHN DWYER, EXAMINING ATTORNEY

# Extranomical

THE MARK CONSISTS OF STANDARD CHARACTERS WITHOUT CLAIM TO ANY PARTICULAR FONT, STYLE, SIZE, OR COLOR.  
FOR ARRANGING TRAVEL TOURS; CONDUCTING SIGHTSEEING TOURS BY BUS; CONDUCTING SIGHTSEEING TOURS FOR OTHERS; ORGANIZATION OF EXCURSIONS, SIGHTSEEING TOURS, HOLIDAYS, TOURS AND TRAVEL; ORGANIZATION, BOOKING AND ARRANGEMENT OF EXCURSIONS, DAY TRIPS AND SIGHTSEEING TOURS; PERSONAL TOUR GUIDE SERVICES; TOUR CONDUCTING OR ESCORTING; TOUR GUIDE SERVICES; TOUR OPERATING AND ORGANISING; TRAVEL AND TOUR INFORMATION SERVICE; TRAVEL AND TOUR TICKET RESERVATION SERVICE (U.S. CLS. 100 AND 105).  
FIRST USE 0-0-2002; IN COMMERCE 0-0-2002.  
SUNG IN, EXAMINING ATTORNEY

SN 85-244,015. ARIZONA PUBLIC SERVICE COMPANY, PHOENIX, AZ. FILED 2-16-2011.

SN 85-211,598. US AIRWAYS, INC., TEMPE, AZ. FILED 1-6-2011.

# EXPRESSFIRST



THE MARK CONSISTS OF STANDARD CHARACTERS WITHOUT CLAIM TO ANY PARTICULAR FONT, STYLE, SIZE, OR COLOR.  
FOR AIR TRANSPORTATION SERVICES FEATURING FREQUENT FLYER BONUS PROGRAM AND UPGRADE SEATING PROGRAM (U.S. CLS. 100 AND 105).  
MARY ROSSMAN, EXAMINING ATTORNEY

OWNER OF U.S. REG. NOS. 838,064, 2,318,647 AND OTHERS.  
THE MARK CONSISTS OF IDENTICAL GEOMETRICAL SHAPES FORMING A CIRCLE TO THE LEFT OF THE LETTERS "APS".  
FOR PUBLIC UTILITY SERVICES IN THE NATURE OF ELECTRICITY DISTRIBUTION; ENERGY SUPPLY SERVICES FOR OTHERS FEATURING THE TRANSMISSION OF ENERGY (U.S. CLS. 100 AND 105).  
REGINA DRUMMOND, EXAMINING ATTORNEY

**CLASS 40—MATERIAL TREATMENT**

SN 77-907,925. RAFTERY, WILLIAM, DBA BILL RAFTERY, FLORHAM PARK, NJ. FILED 1-8-2010.

## With a kiss

THE MARK CONSISTS OF STANDARD CHARACTERS WITHOUT CLAIM TO ANY PARTICULAR FONT, STYLE, SIZE, OR COLOR.

FOR IMPRINTING MESSAGES ON WEARING APPAREL, ACCESSORIES AND MUGS (U.S. CLS. 100, 103 AND 106).

BARBARA BROWN, EXAMINING ATTORNEY

---

SN 77-911,669. RAFTERY, WILLIAM, DBA WILLIAM RAFTERY ASSOCIATES, INC., FLORHAM PARK, NJ. FILED 1-14-2010.

## Onions Double Order

THE MARK CONSISTS OF STANDARD CHARACTERS WITHOUT CLAIM TO ANY PARTICULAR FONT, STYLE, SIZE, OR COLOR.

FOR IMPRINTING MESSAGES ON WEARING APPAREL, ACCESSORIES AND MUGS (U.S. CLS. 100, 103 AND 106).

BARBARA BROWN, EXAMINING ATTORNEY

---

SN 77-928,060. PROGRESSIVE MARKETING PRODUCTS, INC., ANAHEIM, CA. FILED 2-4-2010.

## PREMIER CUSTOM

THE MARK CONSISTS OF STANDARD CHARACTERS WITHOUT CLAIM TO ANY PARTICULAR FONT, STYLE, SIZE, OR COLOR.

OWNER OF U.S. REG. NOS. 3,239,817 AND 3,473,941. NO CLAIM IS MADE TO THE EXCLUSIVE RIGHT TO USE "CUSTOM", APART FROM THE MARK AS SHOWN.

FOR CUSTOM MANUFACTURING OF AUDIO VISUAL EQUIPMENT MOUNTS FOR OTHERS AND CONSULTING SERVICES RELATED THERETO (U.S. CLS. 100, 103 AND 106).

TINA MAI, EXAMINING ATTORNEY

**CLASS 40—(Continued).**

SN 85-051,852. V&M CORPORATION, DBA ROYAL OAK RECYCLING, ROYAL OAK, MI. FILED 6-1-2010.



## ROYAL OAK RECYCLING

THE MARK CONSISTS OF FOUR CURVED LINES WHICH DO NOT INTERSECT BUT ARE INTERLOCKING AND FORM AN ELLIPTICAL SHAPE WITH THE WORDS "ROYAL OAK RECYCLING" APPEARING IN CAPITAL LETTERS BELOW THE SHAPE.

FOR RECYCLING SERVICES, NAMELY, ON-SITE PROCESSING, OFF-SITE PROCESSING, SORTING, SECURE DESTRUCTION, BALING AND BROKERAGE OF PAPER, PLASTIC, METAL AND ELECTRONICS FOR REDISTRIBUTION (U.S. CLS. 100, 103 AND 106).

FIRST USE 1-1-2007; IN COMMERCE 1-1-2007.

ANNE E. GUSTASON, EXAMINING ATTORNEY

---

SN 85-054,986. IMAGEMARK BUSINESS SERVICES, INC., GASTONIA, NC. FILED 6-4-2010.

## FLIPMONKEY FOTO

THE MARK CONSISTS OF STANDARD CHARACTERS WITHOUT CLAIM TO ANY PARTICULAR FONT, STYLE, SIZE, OR COLOR.

NO CLAIM IS MADE TO THE EXCLUSIVE RIGHT TO USE "PHOTO", APART FROM THE MARK AS SHOWN.

FOR PHOTOGRAPHIC AND IMAGE PROCESSING SERVICES, NAMELY, PRINTING OF PHOTOGRAPHIC IMAGES FROM DIGITAL MEDIA; DIGITAL PRINTING, NAMELY, TRANSFERRING UPLOADED DIGITAL IMAGES TO IMPRINTABLE SURFACES (U.S. CLS. 100, 103 AND 106).

COURTNEY ALVAREZ, EXAMINING ATTORNEY

**CLASS 40—(Continued).**

SN 85-055,042. IMAGEMARK BUSINESS SERVICES, INC., GASTONIA, NC. FILED 6-4-2010.



NO CLAIM IS MADE TO THE EXCLUSIVE RIGHT TO USE "PHOTO", APART FROM THE MARK AS SHOWN.

THE COLOR(S) ORANGE, BROWN, BLACK, WHITE AND NAVY BLUE IS/ARE CLAIMED AS A FEATURE OF THE MARK.

THE MARK CONSISTS OF A DESIGN OF AN UPSIDE-DOWN MONKEY. THE BODY OF THE MONKEY IS ORANGE WITH BROWN SHADING AND OUTLINING, THE EYES OF THE MONKEY ARE WHITE WITH BLACK DOTS, AND THE MONKEY'S BELLY BUTTON IS A BLACK DOT. TO THE RIGHT OF THE MONKEY APPEARS THE STYLIZED WORDING "FLIP MONKEY FOTO" IN THE COLOR NAVY BLUE. THE TERM "FLIP" IS INVERTED AND APPEARS LARGER THAN THE WORDING "MONKEY FOTO".

FOR PHOTOGRAPHIC AND IMAGE PROCESSING SERVICES, NAMELY, PRINTING OF PHOTOGRAPHIC IMAGES FROM DIGITAL MEDIA; DIGITAL PRINTING, NAMELY, TRANSFERRING UPLOADED DIGITAL IMAGES TO IMPRINTABLE SURFACES (U.S. CLS. 100, 103 AND 106).

COURTNEY ALVAREZ, EXAMINING ATTORNEY

**CLASS 40—(Continued).**

SN 85-094,729. ECOLAB USA INC., SAINT PAUL, MN. FILED 7-28-2010.

# ECOLAB

THE MARK CONSISTS OF STANDARD CHARACTERS WITHOUT CLAIM TO ANY PARTICULAR FONT, STYLE, SIZE, OR COLOR.

OWNER OF U.S. REG. NOS. 1,497,423, 1,538,458 AND OTHERS.

FOR LEASING OF EQUIPMENT FOR USE IN TEXTILE CARE; ORIGINAL EQUIPMENT MANUFACTURING AND CONTRACT MANUFACTURING SERVICES IN THE FIELD OF MEDICAL PRODUCTS; PRINTING; PRINTING OF ADVERTISING MATTER; WASTE-TO-ENERGY GENERATION SERVICES; WATER TREATMENT SERVICES (U.S. CLS. 100, 103 AND 106).

FIRST USE 12-5-1986; IN COMMERCE 12-5-1986.

PAUL E. FAHRENKOPF, EXAMINING ATTORNEY

SN 85-130,077. PARKS, DONNA T, AUGUSTA, GA. FILED 9-15-2010.

SN 85-070,305. COLE, JASON, NEWINGTON, NH. FILED 6-24-2010.

DR HOOK TAXIDERMY, HAPPY  
FISH DAY!!



NO CLAIM IS MADE TO THE EXCLUSIVE RIGHT TO USE "CUSTOM WIGS", APART FROM THE MARK AS SHOWN.

THE COLOR(S) RED, BLUE, AND BLACK IS/ARE CLAIMED AS A FEATURE OF THE MARK.

THE MARK CONSISTS OF THE WORD "LUXURIOUS" IN RED WITH A BLACK OUTLINE, THE WORDING "CUSTOM WIGS" IN BLUE, A RED ARC WITH A BLACK OUTLINE, AND A SILHOUETTE OF A WOMAN'S FACE IN BLACK WITH WAVY HAIR, AN EYE, AND AN EYEBROW, ALL AGAINST A WHITE BACKGROUND THAT IS NOT CLAIMED AS A FEATURE OF THE MARK.

FOR CUSTOM CONSTRUCTION OF WIGS; CUSTOM CONSTRUCTION OF WIGS USING A LACE WIG CAP (U.S. CLS. 100, 103 AND 106).

ANGELA DUONG, EXAMINING ATTORNEY

THE MARK CONSISTS OF STANDARD CHARACTERS WITHOUT CLAIM TO ANY PARTICULAR FONT, STYLE, SIZE, OR COLOR.

NO CLAIM IS MADE TO THE EXCLUSIVE RIGHT TO USE "TAXIDERMY", APART FROM THE MARK AS SHOWN.

THE NAME "DR HOOK" DOES NOT IDENTIFY A LIVING INDIVIDUAL.

FOR TREATMENT AND PROCESSING OF MATERIALS SERVICES, NAMELY, TAXIDERMY FOR CONSUMERS (U.S. CLS. 100, 103 AND 106).

SKYE YOUNG, EXAMINING ATTORNEY

**CLASS 40—(Continued).**

SN 85-155,547. NO LABEL BREWING COMPANY, DBA NO LABEL, KATY, TX. FILED 10-18-2010.



NO CLAIM IS MADE TO THE EXCLUSIVE RIGHT TO USE "BREWING CO." AND "KATY, TEXAS", APART FROM THE MARK AS SHOWN.

THE MARK CONSISTS OF A SEMI CIRCLE WITH THE LETTERS "NL" INSIDE IT, THE SEMI CIRCLE IS RESTING ON RIBBONS WITH HOPS AND BARLEY GRAINS ON EACH SIDE, ATTACHED TO THE RIBBONS ARE THE WORDS "NO LABEL BREWING CO.", WITH THREE STARS UNDER IT, AND THE WORDS "KATY, TEXAS" UNDER THE STARS.

FOR MICROBREWERY SERVICES (U.S. CLS. 100, 103 AND 106).

FIRST USE 11-1-2009; IN COMMERCE 11-1-2009.  
JAY FLOWERS, EXAMINING ATTORNEY

SN 85-169,982. CARIBBEAN DISTILLERS, LLC, LAKE ALFRED, FL. FILED 11-5-2010.



NO CLAIM IS MADE TO THE EXCLUSIVE RIGHT TO USE "FLORIDA DISTILLERS", APART FROM THE MARK AS SHOWN.

THE COLOR(S) BROWN, ORANGE AND YELLOW IS/ ARE CLAIMED AS A FEATURE OF THE MARK.

THE MARK CONSISTS OF A BROWN LINE WITH A SEMI-CIRCLE IN THE MIDDLE. INSIDE THE SEMI-CIRCLE IS AN ORANGE SPIRAL WITH YELLOW RAYS, SIMULATING THE SUN. BENEATH THE BROWN LINE, THERE IS THE WORD "FLORIDA" IN BROWN LETTERS. BENEATH THAT, THE WORD "DISTILLERS" IS IN YELLOW LETTERS BENEATH THAT, THERE IS A BROWN LINE.

FOR SPIRITS DISTILLERY SERVICES (U.S. CLS. 100, 103 AND 106).

BRIDGETT SMITH, EXAMINING ATTORNEY

**CLASS 40—(Continued).**

SN 85-174,428. AWNEX, INC., BALL GROUND, GA. FILED 11-11-2010.

# AWNEX

THE MARK CONSISTS OF STANDARD CHARACTERS WITHOUT CLAIM TO ANY PARTICULAR FONT, STYLE, SIZE, OR COLOR.

FOR CUSTOM MANUFACTURE OF FABRIC AND METAL AWNINGS AND CANOPIES (U.S. CLS. 100, 103 AND 106).

MARGERY A. TIERNEY, EXAMINING ATTORNEY

SN 85-175,249. PARAMOUNT INDUSTRIAL COMPANIES, INC., NORFOLK, VA. FILED 11-12-2010.



NO CLAIM IS MADE TO THE EXCLUSIVE RIGHT TO USE "SLEEP", APART FROM THE MARK AS SHOWN.

THE MARK CONSISTS OF THE WORD "PARAMOUNT" WITH A LINEAR PYRAMID DESIGN ABOVE IT AND THE WORDS "ELEVATING SLEEP." BELOW IT.

FOR MANUFACTURING SERVICES FOR OTHERS IN THE FIELD OF MATTRESSES, MATTRESS FOUNDATIONS AND BOX SPRINGS (U.S. CLS. 100, 103 AND 106).

FIRST USE 4-30-2010; IN COMMERCE 4-30-2010.  
INGA ERVIN, EXAMINING ATTORNEY

SN 85-175,786. IMPERIAL WESTERN PRODUCTS, INC., COACHELLA, CA. FILED 11-12-2010.



NO CLAIM IS MADE TO THE EXCLUSIVE RIGHT TO USE THE DEPICTION OF THE RECYCLING SYMBOL AND "ORGANIC", APART FROM THE MARK AS SHOWN.

THE COLOR(S) GREEN AND WHITE IS/ARE CLAIMED AS A FEATURE OF THE MARK.

THE MARK CONSISTS OF THE WORDS "ORGANIC SOLUTIONS" IN GREEN. THE LETTER "O" IN HAS 3 LEAF, AND THE LETTER "A" HAS A RECYCLE SYMBOL AS PART OF THE LETTER. THE WORD "ORGANIC" AND THE RECYCLING SYMBOL HAVE A WHITE OUTLINE.

FOR RECYCLING (U.S. CLS. 100, 103 AND 106).  
FIRST USE 11-1-2009; IN COMMERCE 11-1-2009.

KELLY TRUSILO, EXAMINING ATTORNEY

**CLASS 40—(Continued).**

SN 85-181,243. GAMING PARTNERS INTERNATIONAL USA, INC., LAS VEGAS, NV. FILED 11-19-2010.

**PAULSON PRO SERIES**

THE MARK CONSISTS OF STANDARD CHARACTERS WITHOUT CLAIM TO ANY PARTICULAR FONT, STYLE, SIZE, OR COLOR.

OWNER OF U.S. REG. NOS. 1,972,584, 3,089,726 AND OTHERS.

NO CLAIM IS MADE TO THE EXCLUSIVE RIGHT TO USE "PRO SERIES", APART FROM THE MARK AS SHOWN. FOR CUSTOM MANUFACTURE OF GAMING EQUIPMENT FOR OTHERS (U.S. CLS. 100, 103 AND 106).

LANA PHAM, EXAMINING ATTORNEY

SN 85-181,244. R.J. RACE CARS, INC, GALESBURG, IL. FILED 11-19-2010.

**RJ Race Cars, Inc.**

THE MARK CONSISTS OF STANDARD CHARACTERS WITHOUT CLAIM TO ANY PARTICULAR FONT, STYLE, SIZE, OR COLOR.

NO CLAIM IS MADE TO THE EXCLUSIVE RIGHT TO USE "RACE CARS, INC.", APART FROM THE MARK AS SHOWN.

FOR CUSTOM MANUFACTURE OF RACING AUTOMOBILE CHASSIS AND RACING AUTOMOBILE PARTS (U.S. CLS. 100, 103 AND 106).

FIRST USE 1-14-1992; IN COMMERCE 1-14-1992.

LANA PHAM, EXAMINING ATTORNEY

SN 85-183,396. GAMING PARTNERS INTERNATIONAL USA, INC., LAS VEGAS, NV. FILED 11-23-2010.



The logo for Paulson Pro Series features the word "Paulson" in a large, bold, black serif font. The letter "o" in "Paulson" is replaced by a red spade symbol. Below "Paulson" is the phrase "PRO SERIES" in a smaller, bold, red sans-serif font.

OWNER OF U.S. REG. NOS. 2,579,724, 3,191,145 AND OTHERS.

NO CLAIM IS MADE TO THE EXCLUSIVE RIGHT TO USE "PRO SERIES", APART FROM THE MARK AS SHOWN. THE COLOR(S) BLACK AND RED IS/ARE CLAIMED AS A FEATURE OF THE MARK.

THE MARK CONSISTS OF THE STYLIZED WORD "PAULSON" WHICH IS BLACK OVER THE STYLIZED WORDS "PRO SERIES" WHICH ARE RED. THE CENTER OF THE LETTER "O" IN "PAULSON" IS COMPRISED OF A RED SPADE.

FOR CUSTOM MANUFACTURE OF GAMING EQUIPMENT OF OTHERS (U.S. CLS. 100, 103 AND 106).

LANA PHAM, EXAMINING ATTORNEY

**CLASS 40—(Continued).**

SN 85-184,474. AMERICAN REGISTRY, LLC, BOCA RATON, FL. FILED 11-24-2010.

**PLAQUE CONCIERGE**

THE MARK CONSISTS OF STANDARD CHARACTERS WITHOUT CLAIM TO ANY PARTICULAR FONT, STYLE, SIZE, OR COLOR.

NO CLAIM IS MADE TO THE EXCLUSIVE RIGHT TO USE "PLAQUE", APART FROM THE MARK AS SHOWN.

FOR CUSTOM MANUFACTURE OF PLAQUES, MARQUEES, CRYSTALS, COUNTER DISPLAYS, BANNERS; EMBOSSED SERVICES, NAMELY, EMBOSSED WORDS, DESIGNS OR IMAGES ON PLAQUES, MARQUEES, CRYSTALS, COUNTER DISPLAYS, BANNERS; MANUFACTURE OF PLAQUES, MARQUEES, CRYSTALS, COUNTER DISPLAYS, BANNERS TO ORDER AND/OR SPECIFICATION OF OTHERS (U.S. CLS. 100, 103 AND 106).

FIRST USE 7-0-2010; IN COMMERCE 7-0-2010.

FRED CARL, EXAMINING ATTORNEY

SN 85-187,858. METECH RECYCLING, INC., GILROY, CA. FILED 12-1-2010.

**RESPONSIBLE ELECTRONICS  
RECYCLING**

THE MARK CONSISTS OF STANDARD CHARACTERS WITHOUT CLAIM TO ANY PARTICULAR FONT, STYLE, SIZE, OR COLOR.

NO CLAIM IS MADE TO THE EXCLUSIVE RIGHT TO USE "ELECTRONIC RECYCLING", APART FROM THE MARK AS SHOWN.

FOR RECYCLING SERVICES OF USED ELECTRONIC GOODS (U.S. CLS. 100, 103 AND 106).

FIRST USE 7-15-2009; IN COMMERCE 7-15-2009.

DOMINICK J. SALEMI, EXAMINING ATTORNEY

**CLASS 40—(Continued).**

SN 85-188,190. ROCKAWAY RECYCLING, INC., ROCKAWAY, NJ. FILED 12-1-2010.



NO CLAIM IS MADE TO THE EXCLUSIVE RIGHT TO USE "SCRAP", APART FROM THE MARK AS SHOWN.

THE COLOR(S) BLACK, WHITE, LIGHT GRAY, DARK GRAY, GRAY, GREEN, LIGHT GREEN, LIME GREEN, AND DARK GREEN IS/ARE CLAIMED AS A FEATURE OF THE MARK.

THE MARK CONSISTS OF THE STYLIZED WORD "SCRAP" IN THE CENTER OF THE IMAGE IMMEDIATELY ADJACENT TO THE STYLIZED WORD "APP" ALSO CENTERED IN THE IMAGE. WHERE THE WORDS "SCRAP" AND "APP" ARE A BLACK COLOR. WHERE A CURVING ARROW BENDING UPWARDS AND TO THE LEFT APPEARS ABOVE THE WORDS "SCRAP" AND "APP"; AND THIS ARROW ORIGINATES WITH A LIGHT GREEN COLOR AND GRADUALLY DARKENS TO A DARK GREEN COLOR AT THE ZENITH OF ITS BEND AND THEN THE ARROW BEGINS TO GRADUALLY LIGHTEN AND IT CONCLUDES WITH A LIME GREEN COLOR. WHERE A CURVING ARROW BENDING DOWNWARDS AND TO THE RIGHT APPEARS BELOW THE WORDS "SCRAP" AND "APP"; AND THE ARROW ORIGINATES WITH A LIGHT GRAY COLOR AND GRADUALLY DARKENS TO A DARK GRAY AT THE ZENITH OF ITS BEND AND THEN THE ARROW BEGINS TO GRADUALLY LIGHTEN AS IT CONCLUDES WITH A LIGHT GRAY COLOR. THE BACKGROUND OF THE IMAGE IS A BLACK SQUARE WITH A SMALLER WHITE SQUARE WITH ROUNDED EDGES INSIDE THE BLACK SQUARE; WHERE THE WHITE SQUARE WITH ROUNDED EDGES ALSO HAS A DARK GRAY BORDER AND THE DESIGN FEATURES ARE CONTAINED WITHIN THE WHITE SQUARE WITH ROUNDED EDGES.

FOR MATERIAL TREATMENT SERVICES IN CONNECTION WITH RECYCLING; METAL RECLAMATION SERVICES; RECYCLING; SORTING OF WASTE AND RECYCLABLE MATERIAL (U.S. CLS. 100, 103 AND 106).

FIRST USE 11-15-2010; IN COMMERCE 11-15-2010.  
BRENDAN MCCAULEY, EXAMINING ATTORNEY

**CLASS 40—(Continued).**

SN 85-188,835. HERNANDEZ, CESAR, DBA CREATIVE CONCRETE, HELOTES, TX. FILED 12-2-2010.

## creative concrete

THE MARK CONSISTS OF STANDARD CHARACTERS WITHOUT CLAIM TO ANY PARTICULAR FONT, STYLE, SIZE, OR COLOR.

OWNER OF U.S. REG. NO. 2,831,873.

NO CLAIM IS MADE TO THE EXCLUSIVE RIGHT TO USE "CONCRETE", APART FROM THE MARK AS SHOWN. FOR CUSTOM IMPRINTING OF CONCRETE SLABS WITH DECORATIVE DESIGNS (U.S. CLS. 100, 103 AND 106).

FIRST USE 7-1-2000; IN COMMERCE 9-1-2000.  
DEIRDRE ROBERTSON, EXAMINING ATTORNEY

SN 85-190,207. SILLAMAN AND SONS, INC., SANFORD, NC. FILED 12-3-2010.



NO CLAIM IS MADE TO THE EXCLUSIVE RIGHT TO USE "DIGITAL PRINTING & DOCUMENT SERVICES", APART FROM THE MARK AS SHOWN.

THE MARK CONSISTS OF THE WORDS "ALL DIGITAL PRINTING & DOCUMENT SERVICE" WITH A LOGO DESIGN WITH THE "A" IN A REVERSE SQUARE BLOCK, INCLUDING A STYLIZED SWOOSH.

FOR DIGITAL ON-DEMAND PRINTING SERVICES OF BOOKS AND OTHER DOCUMENTS (U.S. CLS. 100, 103 AND 106).

FIRST USE 6-25-2006; IN COMMERCE 6-25-2006.  
MIDGE BUTLER, EXAMINING ATTORNEY

SN 85-191,393. SHOWPLACE WOOD PRODUCTS, INC., HARRISBURG, SD. FILED 12-6-2010.

## Refacing And More

THE MARK CONSISTS OF STANDARD CHARACTERS WITHOUT CLAIM TO ANY PARTICULAR FONT, STYLE, SIZE, OR COLOR.

NO CLAIM IS MADE TO THE EXCLUSIVE RIGHT TO USE "REFACING", APART FROM THE MARK AS SHOWN.

FOR CUSTOM MANUFACTURE OF CABINET REFACING SETS COMPRISED OF CABINETS, CABINET DOORS AND DRAWERS, AND HARDWARE (U.S. CLS. 100, 103 AND 106).

FIRST USE 7-15-2010; IN COMMERCE 7-15-2010.  
COLLEEN KEARNEY, EXAMINING ATTORNEY

**CLASS 40—(Continued).**

SN 85-193,911. RAILEAN, KELLY, LEAGUE CITY, TX. AND RAILEAN, MATTHEW, HOUSTON, TX. FILED 12-9-2010.

# RAILEAN

THE MARK CONSISTS OF STANDARD CHARACTERS WITHOUT CLAIM TO ANY PARTICULAR FONT, STYLE, SIZE, OR COLOR.

FOR ALCOHOL DISTILLERY SERVICES (U.S. CLS. 100, 103 AND 106).

FIRST USE 3-27-2000; IN COMMERCE 3-27-2000.  
SIMON TENG, EXAMINING ATTORNEY

---

SN 85-194,671. METECH RECYCLING, INC., GILROY, CA. FILED 12-9-2010.

# Metech Recycling

THE MARK CONSISTS OF STANDARD CHARACTERS WITHOUT CLAIM TO ANY PARTICULAR FONT, STYLE, SIZE, OR COLOR.

OWNER OF U.S. REG. NO. 3,698,041.

NO CLAIM IS MADE TO THE EXCLUSIVE RIGHT TO USE "RECYCLING", APART FROM THE MARK AS SHOWN.

FOR RECYCLING SERVICES OF USED ELECTRONIC GOODS (U.S. CLS. 100, 103 AND 106).

FIRST USE 7-1-2009; IN COMMERCE 7-1-2009.  
DOMINICK J. SALEMI, EXAMINING ATTORNEY

---

SN 85-204,925. RICARDO ALVAREZ, CHULA VISTA, CA. FILED 12-23-2010.

# RAA LEATHER

THE MARK CONSISTS OF STANDARD CHARACTERS WITHOUT CLAIM TO ANY PARTICULAR FONT, STYLE, SIZE, OR COLOR.

NO CLAIM IS MADE TO THE EXCLUSIVE RIGHT TO USE "LEATHER", APART FROM THE MARK AS SHOWN.

FOR CUSTOM MANUFACTURE OF LEATHER GOODS FOR MOTORCYCLES, NAMELY, SEATS, BACK RESTS, TANK GUARDS, BLANKET STRAPS, VEST CHAPS, KNIFE AND GUN HOLSTERS (U.S. CLS. 100, 103 AND 106).

FIRST USE 1-24-2010; IN COMMERCE 1-24-2010.  
CHRIS WELLS, EXAMINING ATTORNEY

**CLASS 40—(Continued).**

SN 85-205,340. MILLER, RANDY, MOUNTAIN HOME, ID. FILED 12-23-2010.

# Attachadoor

THE MARK CONSISTS OF STANDARD CHARACTERS WITHOUT CLAIM TO ANY PARTICULAR FONT, STYLE, SIZE, OR COLOR.

FOR CUSTOM MANUFACTURING OF DOOR CASINGS AND DOOR VENEERS (U.S. CLS. 100, 103 AND 106).

ROBIN CHOSID, EXAMINING ATTORNEY

---

SN 85-205,490. SOBECK, RYAN, HOBOKEN, NJ. FILED 12-24-2010.

# RECYCLETHAT

THE MARK CONSISTS OF STANDARD CHARACTERS WITHOUT CLAIM TO ANY PARTICULAR FONT, STYLE, SIZE, OR COLOR.

FOR RECYCLING OF WASTE AND TRASH; RECYCLING SERVICES FEATURING REWARD PROGRAMS (U.S. CLS. 100, 103 AND 106).

SCOTT BIBB, EXAMINING ATTORNEY

---

SN 85-205,917. FABTECH SYSTEMS LIMITED LIABILITY COMPANY, SANTA BARBARA, CA. FILED 12-27-2010.

# CLICKANDFIT

THE MARK CONSISTS OF STANDARD CHARACTERS WITHOUT CLAIM TO ANY PARTICULAR FONT, STYLE, SIZE, OR COLOR.

FOR CUSTOM MANUFACTURING OF PROSTHETICS; MAKING OF PROSTHETIC DEVICES TO ORDER (U.S. CLS. 100, 103 AND 106).

FIRST USE 10-18-2010; IN COMMERCE 10-18-2010.  
ELI HELLMAN, EXAMINING ATTORNEY

**CLASS 40—(Continued).**

SN 85-206,130. REKO INTERNATIONAL GROUP, INC., BLOOMFIELD HILLS, MI. FILED 12-27-2010.



THE MARK CONSISTS OF THE LETTERS "REKO" LOCATED ON THE TOP HALF OF A SLANTED TABLE. FOR MANUFACTURING SERVICES FOR OTHERS IN THE FIELD OF METAL FORMING AND PLASTIC MOLDING (U.S. CLS. 100, 103 AND 106). FIRST USE 10-25-1976; IN COMMERCE 10-25-1976. MICHAEL WEBSTER, EXAMINING ATTORNEY

SN 85-210,184. RICHARD E. BADWEY, ALEXANDRIA, VA. FILED 1-4-2011.



THE MARK CONSISTS OF DEPICTION OF A GRECO-ROMAN BUILDING FACADE. FOR FRAMING OF WORKS OF ART; MOUNTING OF WORKS OF ART AS PART OF THE FRAMING PROCESS (U.S. CLS. 100, 103 AND 106). FIRST USE 3-0-2009; IN COMMERCE 3-0-2009. DAVID TAYLOR, EXAMINING ATTORNEY

SN 85-210,394. ARIZONA PUBLIC SERVICE COMPANY, PHOENIX, AZ. FILED 1-4-2011.



OWNER OF U.S. REG. NOS. 838,064, 2,318,647 AND OTHERS.

THE COLOR(S) RED, GREEN AND BLUE IS/ARE CLAIMED AS A FEATURE OF THE MARK.

THE MARK CONSISTS OF RED, GREEN AND BLUE IDENTICAL GEOMETRICAL SHAPES FORMING A CIRCLE TO THE LEFT OF THE LETTERS "APS".

FOR PRODUCTION OF ENERGY IN THE FORM OF ELECTRIC POWER, WHETHER FOSSIL-FUELED, NUCLEAR, SOLAR, RENEWABLE ENERGIES OR OTHERWISE (U.S. CLS. 100, 103 AND 106).

REGINA DRUMMOND, EXAMINING ATTORNEY

**CLASS 40—(Continued).**

SN 85-210,842. ED QUINN AND COMPANY, ROSWELL, GA. FILED 1-5-2011.

## Pillow Tree

THE MARK CONSISTS OF STANDARD CHARACTERS WITHOUT CLAIM TO ANY PARTICULAR FONT, STYLE, SIZE, OR COLOR.

FOR MANUFACTURING SERVICES FOR OTHERS IN THE FIELD OF FURNITURE (U.S. CLS. 100, 103 AND 106).

ASMAT KHAN, EXAMINING ATTORNEY

SN 85-211,697. PROSSER HALLOCK, INC., JACKSONVILLE, FL. FILED 1-6-2011.

## Transforming Matters

THE MARK CONSISTS OF STANDARD CHARACTERS WITHOUT CLAIM TO ANY PARTICULAR FONT, STYLE, SIZE, OR COLOR.

FOR ENERGY GENERATION SERVICES; PRODUCTION OF WIND ENERGY; WASTE-TO-ENERGY GENERATION SERVICES (U.S. CLS. 100, 103 AND 106).

FIRST USE 4-1-2010; IN COMMERCE 4-1-2010.

ELLEN BURNS, EXAMINING ATTORNEY

SN 85-213,124. EWASKO, DAMON R., INCLINE VILLAGE, NV. AND CAMPBELL, MATTHEW, INCLINE VILLAGE, NV. FILED 1-7-2011.

## F.L.O.A.B. Word

THE MARK CONSISTS OF STANDARD CHARACTERS WITHOUT CLAIM TO ANY PARTICULAR FONT, STYLE, SIZE, OR COLOR.

FOR EMBOSSED SERVICES, NAMELY, EMBOSSED WORDS, DESIGNS OR IMAGES ON CLOTHING AND ACCESSORIES (U.S. CLS. 100, 103 AND 106).

ROSELLE HERRERA, EXAMINING ATTORNEY



**CLASS 40—(Continued).**

SN 85-213,599. MORASCH, STEVEN J., PORTLAND, OR. AND MORASCH, MICHAEL N., PORTLAND, OR. FILED 1-9-2011.

# PRESSURE SAFE

THE MARK CONSISTS OF STANDARD CHARACTERS WITHOUT CLAIM TO ANY PARTICULAR FONT, STYLE, SIZE, OR COLOR.  
FOR FOOD PRESERVATION SERVICES; FOOD PROCESSING; PROVIDING TECHNICAL INFORMATION IN THE FIELD OF FOOD PROCESSING (U.S. CLS. 100, 103 AND 106).  
DAVID TAYLOR, EXAMINING ATTORNEY

SN 85-214,305. DOTPOPS! BAKERY, INC., OMAHA, NE. FILED 1-10-2011.

# DotPops!

THE MARK CONSISTS OF STANDARD CHARACTERS WITHOUT CLAIM TO ANY PARTICULAR FONT, STYLE, SIZE, OR COLOR.  
FOR CUSTOM CAKE DECORATING SERVICES (U.S. CLS. 100, 103 AND 106).  
FIRST USE 9-6-2009; IN COMMERCE 9-6-2009.  
CHARLOTTE CORWIN, EXAMINING ATTORNEY

SN 85-216,002. B&D LITHO OF ARIZONA, INC., PHOENIX, AZ. FILED 1-12-2011.

# B&D LITHO

THE MARK CONSISTS OF STANDARD CHARACTERS WITHOUT CLAIM TO ANY PARTICULAR FONT, STYLE, SIZE, OR COLOR.  
NO CLAIM IS MADE TO THE EXCLUSIVE RIGHT TO USE "LITHO", APART FROM THE MARK AS SHOWN.  
FOR DESIGN PRINTING FOR OTHERS; PRINTING SERVICES (U.S. CLS. 100, 103 AND 106).  
FIRST USE 12-31-1960; IN COMMERCE 12-31-1960.  
KATHLEEN M. VANSTON, EXAMINING ATTORNEY

**CLASS 40—(Continued).**

SN 85-220,127. AMERICAN AXLE & MANUFACTURING, INC., DETROIT, MI. FILED 1-18-2011.

# WHERE INNOVATION MEETS SOPHISTICATION

THE MARK CONSISTS OF STANDARD CHARACTERS WITHOUT CLAIM TO ANY PARTICULAR FONT, STYLE, SIZE, OR COLOR.  
FOR CUSTOM MANUFACTURING SERVICES IN THE FIELD OF ELECTRIC DRIVELINE SYSTEMS (U.S. CLS. 100, 103 AND 106).  
MARILYN IZZI, EXAMINING ATTORNEY

**CLASS 41—EDUCATION AND ENTERTAINMENT**

SN 76-703,678. MODE OF FITNESS, INC, SEATTLE, WA. FILED 7-6-2010.

# MODE OF FITNESS

THE MARK CONSISTS OF STANDARD CHARACTERS WITHOUT CLAIM TO ANY PARTICULAR FONT, STYLE, SIZE, OR COLOR.  
NO CLAIM IS MADE TO THE EXCLUSIVE RIGHT TO USE "FITNESS", APART FROM THE MARK AS SHOWN.  
FOR PERSONAL FITNESS TRAINING SERVICES AND CONSULTANCY TO INDIVIDUALS AND THE EMPLOYEES OF ENTERPRISE CLIENTS; HEALTH CLUB SERVICES, NAMELY, PROVIDING INSTRUCTION AND EQUIPMENT IN THE FIELD OF PHYSICAL EXERCISE; AND PROVIDING A WEBSITE FEATURING ONLINE PERSONAL FITNESS TRAINING, PERSONAL FITNESS TRAINING INFORMATION AND OTHER INFORMATION ABOUT EXERCISE AND FITNESS (U.S. CLS. 100, 101 AND 107).  
FIRST USE 8-1-2006; IN COMMERCE 8-1-2006.  
KYLE PEETE, EXAMINING ATTORNEY

SN 76-705,767. NTENSE WORKOUT, INC., POLAND, OH. FILED 12-23-2010.

# NOT JUST ANOTHER GYM

THE MARK CONSISTS OF STANDARD CHARACTERS WITHOUT CLAIM TO ANY PARTICULAR FONT, STYLE, SIZE, OR COLOR.  
FOR PROVIDING FITNESS AND EXERCISE FACILITIES (U.S. CLS. 100, 101 AND 107).  
FIRST USE 4-25-2010; IN COMMERCE 4-25-2010.  
HOWARD B. LEVINE, EXAMINING ATTORNEY

**CLASS 41—(Continued).**

SN 77-192,457. AMIR, DANIEL, SAN JOSE, CA. FILED 5-29-2007.

# Dan-D

THE MARK CONSISTS OF STANDARD CHARACTERS WITHOUT CLAIM TO ANY PARTICULAR FONT, STYLE, SIZE, OR COLOR.

FOR ENTERTAINMENT IN THE NATURE OF LIVE PERFORMANCES BY AN INDIVIDUAL OR GROUP MUSICAL ACT (U.S. CLS. 100, 101 AND 107).

FIRST USE 8-4-2005; IN COMMERCE 12-30-2005.  
RONALD MCMORROW, EXAMINING ATTORNEY

---

SN 77-284,415. TATHAM JR., WILLIAM, SANTA BARBARA, CA. FILED 9-20-2007.

# BARBARIAN PRODUCTIONS

THE MARK CONSISTS OF STANDARD CHARACTERS WITHOUT CLAIM TO ANY PARTICULAR FONT, STYLE, SIZE, OR COLOR.

NO CLAIM IS MADE TO THE EXCLUSIVE RIGHT TO USE "PRODUCTIONS", APART FROM THE MARK AS SHOWN.

FOR ARRANGING AND CONDUCTING ATHLETIC COMPETITIONS; ENTERTAINMENT IN THE NATURE OF RUGBY GAMES; NEWS ANALYSIS AND FEATURES DISTRIBUTION IN THE NATURE OF SPORTING EVENTS AND ATHLETIC COMPETITIONS; PRODUCTION OF CABLE TELEVISION PROGRAMS; PRODUCTION OF RADIO AND TELEVISION PROGRAMS; PROVIDING VARIOUS FACILITIES FOR AN ARRAY OF SPORTING EVENTS, SPORTS AND ATHLETIC COMPETITIONS AND AWARDS PROGRAMMES (U.S. CLS. 100, 101 AND 107).

MICHAEL WIENER, EXAMINING ATTORNEY

**CLASS 41—(Continued).**

SN 77-421,825. NEWBOY FZCO, DUBAI, UNITED ARAB EMIR., FILED 3-14-2008.

# Scan2Go

THE MARK CONSISTS OF STANDARD CHARACTERS WITHOUT CLAIM TO ANY PARTICULAR FONT, STYLE, SIZE, OR COLOR.

PRIORITY CLAIMED UNDER SEC. 44(D) ON UNITED ARAB EMIR. APPLICATION NO. 105567, FILED 1-20-2008, REG. NO. 108107, DATED 10-10-2010, EXPIRES 1-20-2018.

FOR EDUCATIONAL SERVICES, NAMELY, DEVELOPING AND CONDUCTING TRAINING COURSES AND DISTRIBUTION OF TRAINING MATERIALS IN CONNECTION THEREWITH FOR SUBJECT MATTERS AS REQUESTED BY CUSTOMERS; ENCOURAGING AMATEUR SPORTS AND PHYSICAL EDUCATION BY ORGANIZING, SANCTIONING, CONDUCTING, REGULATING AND GOVERNING AMATEUR ATHLETIC PROGRAMS AND ACTIVITIES; ENTERTAINMENT AND EDUCATION SERVICES IN THE NATURE OF A SERIES OF SHORT SHOWS FEATURING SPORTS CAR RACING DISTRIBUTED TO MOBILE HANDSETS, WHICH MAY INCLUDE VIDEO, TEXT, PHOTOS, ILLUSTRATIONS OR HYPERTEXT; ENTERTAINMENT AND EDUCATIONAL SERVICES, NAMELY, PROVIDING ADVICE AND INFORMATION FOR MUSIC, VIDEO AND FILM CONCEPT AND SCRIPT DEVELOPMENT; ENTERTAINMENT SERVICES, NAMELY, PARTICIPATION IN THE SPORT OF RACING CARS; ENTERTAINMENT SERVICES IN THE NATURE OF AN AMUSEMENT PARK SHOW; ENTERTAINMENT SERVICES, NAMELY, LIVE, TELEVISED AND MOVIE APPEARANCES BY A PROFESSIONAL ENTERTAINER; ENTERTAINMENT SERVICES, NAMELY, BODY PAINTING SERVICES HELD AT SPECIAL EVENTS; ENTERTAINMENT SERVICES, NAMELY, MEAD TASTINGS; ENTERTAINMENT SERVICES, NAMELY, PROVIDING PODCASTS IN THE FIELD OF SPORTS CAR RACING; ENTERTAINMENT SERVICES, NAMELY, PRODUCTION OF SPECIAL EFFECTS INCLUDING MODEL-MAKING SERVICES, COMPUTER-GENERATED IMAGERY AND COMPUTER-GENERATED GRAPHICS FOR THE PRODUCTION OF MOTION PICTURES, VIDEOS, AND MOVIE TRAILERS; ENTERTAINMENT, NAMELY, LIGHTING PRODUCTION; FAN CLUBS; FIGURE SALONS; FILM AND VIDEO FILM PRODUCTION; FILM DISTRIBUTION; FILM EDITING; MARTIAL ARTS INSTRUCTION; MASTER OF CEREMONY SERVICES FOR PARTIES AND SPECIAL EVENTS; MODELING FOR ARTISTS; MOVIE THEATERS; MULTIMEDIA ENTERTAINMENT SOFTWARE PRODUCTION SERVICES; ORGANIZING AND CONDUCTING A RUNNING EVENT THE PROCEEDS OF WHICH ARE DONATED TO CHARITY; PRESENTATION OF MUSICAL PERFORMANCE; PRODUCING ONGOING TELEVISION PROGRAMS ON BLACKJACK CARD TOURNAMENTS; PRODUCTION AND DISTRIBUTION OF MOTION PICTURES; PRODUCTION OF CABLE TELEVISION PROGRAMS; PRODUCTION OF DVDS, VIDEOTAPES AND TELEVISION PROGRAMS FEATURING THE SPORT OF RACING CARS; PRODUCTION OF TELEVISION PROGRAMS; PRODUCTION OF VIDEO DISCS FOR OTHERS; PRODUCTION OF VIDEO CASSETTES; PRODUCTION OF VIDEO AND CREATION OF VISUAL EFFECTS FOR OTHERS FOR USE IN DVDS, TELEVISION PROGRAMS AND ON WEB SITES; PRODUCTION OF VIDEO DISCS AND TAPES; VIDEO RECORDING OF PERSONAL GENEALOGICAL DOCUMENTARIES (U.S. CLS. 100, 101 AND 107).

TRACY FLETCHER, EXAMINING ATTORNEY

**CLASS 41—(Continued).**

SN 77-583,810. NINTENDO OF AMERICA INC., REDMOND, WA. FILED 10-2-2008.

<sup>(•••)</sup>  
nintendo zone

OWNER OF JAPAN REG. NO. 5324017, DATED 5-21-2010, EXPIRES 5-21-2020.

OWNER OF U.S. REG. NOS. 1,213,822, 1,628,966 AND OTHERS.

THE MARK CONSISTS OF THE WORDS "NINTENDO ZONE"; WITH TRANSMISSION WAVES EMANATING FROM THE DOT ABOVE THE LETTER "I".

FOR ENTERTAINMENT SERVICES, NAMELY, PROVIDING ENTERTAINMENT INFORMATION FEATURING IMAGES AND SOUNDS FOR ELECTRONIC GAMES, GAME SUPPLIES, PHOTOGRAPHS AND MUSICAL VIDEOS ALL VIA HANDHELD GAMES WITH LIQUID CRYSTAL DISPLAYS; ENTERTAINMENT SERVICES, NAMELY, PROVIDING ENTERTAINMENT INFORMATION FEATURING IMAGES AND SOUNDS FOR ELECTRONIC GAMES, GAME SUPPLIES, PHOTOGRAPHS AND MUSICAL VIDEOS ALL VIA COMMUNICATION BY ELECTRONIC COMPUTER GAMES AND ELECTRONIC VIDEO GAMES; ENTERTAINMENT SERVICES, NAMELY, PROVIDING ENTERTAINMENT INFORMATION FEATURING IMAGES AND SOUNDS FOR ELECTRONIC GAMES, GAME SUPPLIES, PHOTOGRAPHS AND MUSICAL VIDEOS ALL VIA GLOBAL COMPUTER NETWORK, SATELLITE SYSTEM, DIGITAL AND ANALOG CABLE SYSTEMS OR TELECOMMUNICATIONS NETWORK; ENTERTAINMENT SERVICES, NAMELY, PROVIDING NETWORK-BASED VIDEO GAMES VIA VIDEO GAME MACHINES; ORGANIZING, CONDUCTING AND ARRANGING VIDEO GAME EVENTS; ENTERTAINMENT SERVICES, NAMELY, PROVIDING ONLINE COMPUTER GAMES; RENTAL OF VIDEO GAME SOFTWARE; RENTAL OF VIDEO GAME SOFTWARE PROGRAMS FOR HANDHELD GAMES WITH LIQUID CRYSTAL DISPLAYS; RENTAL OF COMPUTER GAME SOFTWARE; RENTAL OF HANDHELD GAMES WITH LIQUID CRYSTAL DISPLAYS; MOVIE THEATERS, MOVIE FILM PRODUCTION, MOVIE FILM DISTRIBUTION; PROVIDING AMUSEMENT FACILITIES; PRODUCTION OF VIDEO TAPE FILM IN THE FIELDS OF EDUCATION, CULTURE, ENTERTAINMENT OR SPORTS; ARRANGING AND CONDUCTING COMPETITIONS FOR VIDEO GAME PLAYERS AND COMPUTER GAME PLAYERS; ENTERTAINMENT IN THE NATURE OF AN ON-GOING TELEVISION PROGRAM IN THE FIELD OF CHILDREN'S ENTERTAINMENT; ENTERTAINMENT SERVICES, NAMELY, PROVIDING ONLINE ELECTRONIC GAMES; ENTERTAINMENT SERVICES, NAMELY, PROVIDING ONLINE COMPUTER GAMES FOR USE AMONG MULTIPLE PLAYERS; LEASING AND RENTING OF VIDEO GAME MACHINES FOR ONLINE NETWORK GAMES; PRODUCTION AND DISTRIBUTION OF MOTION PICTURES; PROVIDING ENTERTAINMENT INFORMATION, ALL RELATING TO VIDEO GAME AND COMPUTER GAMES; PROVIDING ONLINE NEWS, INFORMATION AND GAME STRATEGIES, ALL RELATING TO ELECTRONIC, COMPUTER AND VIDEO GAMES; PUBLICATION OF ELECTRONIC MAGAZINES; RENTAL OF MOTION PICTURES; RENTAL OF MOVIES; RENTAL OF VIDEO GAMES; SWEEPSTAKE SERVICES PROVIDED OVER A GLOBAL COMPUTER NETWORK (U.S. CLS. 100, 101 AND 107).

MATTHEW MCDOWELL, EXAMINING ATTORNEY

**CLASS 41—(Continued).**

SN 77-731,560. KAPLAN, INC., NEW YORK, NY. FILED 5-7-2009.

# SMARTPOINTS

THE MARK CONSISTS OF STANDARD CHARACTERS WITHOUT CLAIM TO ANY PARTICULAR FONT, STYLE, SIZE, OR COLOR.

FOR EDUCATIONAL SERVICES, NAMELY, PROVIDING CUSTOMIZED STUDY PROGRAMS AS A FEATURE OF TUTORING AND CLASSROOM LESSONS TO IMPROVE PERFORMANCE ON STANDARDIZED TESTS BY FOCUSING ON THE MOST FREQUENTLY TESTED SKILLS (U.S. CLS. 100, 101 AND 107).

LESLIE RICHARDS, EXAMINING ATTORNEY

SN 77-772,931. JANE SAUNDERS, YORBA LINDA, CA. FILED 7-1-2009.



THE COLOR(S) BLACK, BROWN, TAN, SILVER, PINK, BLUE, ORANGE, AND PURPLE IS/ARE CLAIMED AS A FEATURE OF THE MARK.

THE MARK CONSISTS OF A YOUNG GIRL WITH BROWN EYES, A BROWN PONY TAIL WITH PURPLE RIBBON, A PINK SHIRT, PINK SHOES AND BLUE PANTS WITH PINK AND ORANGE FLOWERS ON THE RIGHT LEG, RIDING ON A SILVER HANDLED ORANGE SCOOTER WITH BLACK WHEELS, A BROWN DOG WITH A TAN CHEST IS RUNNING ALONG SIDE THE GIRL.

FOR DISSEMINATION OF NEWS, INFORMATION AND COMMENTARY CONCERNING COMMUNITY ENTERTAINMENT AND SPORTING EVENTS AND ACTIVITIES VIA A GLOBAL COMPUTER NETWORK; ONLINE JOURNALS, NAMELY, BLOGS FEATURING NEWS, INFORMATION, AND COMMENTARY CONCERNING COMMUNITY ENTERTAINMENT AND SPORTING EVENTS AND ACTIVITIES (U.S. CLS. 100, 101 AND 107).

JOHN E. MICHOS, EXAMINING ATTORNEY

**CLASS 41—(Continued).**

SN 77-796,437. PAREJA, SHONNA, EDGEWATER, FL. FILED 8-4-2009.

## Master the NIC

THE MARK CONSISTS OF STANDARD CHARACTERS WITHOUT CLAIM TO ANY PARTICULAR FONT, STYLE, SIZE, OR COLOR.

NO CLAIM IS MADE TO THE EXCLUSIVE RIGHT TO USE "NIC", APART FROM THE MARK AS SHOWN.

FOR ANALYZING EDUCATIONAL TESTS SCORES AND DATA FOR OTHERS; ANALYZING OF EDUCATIONAL TEST SCORES AND DATA FOR OTHERS; ARRANGING AND CONDUCTING EDUCATIONAL CONFERENCES; CONDUCTING EDUCATIONAL EXHIBITIONS IN THE NATURE OF TEST PREPARATION; CONTINUING EDUCATION SERVICES, NAMELY, PROVIDING LIVE AND ON-LINE CONTINUING PROFESSIONAL EDUCATION SEMINARS IN THE FIELD OF TEST PREPARATION; DEVELOPING EDUCATIONAL MANUALS FOR OTHERS IN THE FIELD OF TEST PREPARATION; DEVELOPMENT AND DISSEMINATION OF EDUCATIONAL MATERIALS OF OTHERS IN THE FIELD OF TEST PREPARATION; EDUCATION IN THE FIELD OF TEST PREPARATION RENDERED THROUGH CORRESPONDENCE COURSES; EDUCATION IN THE FIELD OF TEST PREPARATION RENDERED THROUGH VIDEO CONFERENCE; EDUCATION INFORMATION; EDUCATION SERVICES, NAMELY, MENTORING IN THE FIELD OF TEST PREPARATION; EDUCATION SERVICES, NAMELY, ONE-ON-ONE MENTORING IN THE FIELD OF TEST PREPARATION; EDUCATION SERVICES, NAMELY, ONE-ON-ONE MENTORING IN THE FIELDS OF TEST PREPARATION; EDUCATION SERVICES, NAMELY, PROVIDING LIVE AND ON-LINE COURSES IN THE FIELD OF TEST PREPARATION; EDUCATION SERVICES, NAMELY, PROVIDING MENTORING, TUTORING, CLASSES, SEMINARS AND WORKSHOPS IN THE FIELD OF TEST PREPARATION; EDUCATION SERVICES, NAMELY, PROVIDING TUTORIAL SESSIONS IN THE FIELD(S) OF TEST PREPARATION; EDUCATION SERVICES, NAMELY, PROVIDING TUTORIAL SESSIONS IN THE FIELDS OF TEST PREPARATION; EDUCATION SERVICES, NAMELY, PROVIDING TUTORING IN THE FIELD OF TEST PREPARATION; EDUCATION SERVICES, NAMELY, PROVIDING TUTORING IN THE FIELDS OF TEST PREPARATION; EDUCATION SERVICES, NAMELY, PROVIDING COURSES IN THE FIELD OF TEST PREPARATION; EDUCATION SERVICES, NAMELY, PROVIDING COURSES IN THE FIELDS OF TEST PREPARATION; EDUCATIONAL AND ENTERTAINMENT SERVICES, NAMELY, PROVIDING MOTIVATIONAL AND EDUCATIONAL SPEAKERS; EDUCATIONAL AND ENTERTAINMENT SERVICES, NAMELY, PROVIDING MOTIVATIONAL SPEAKING SERVICES IN THE FIELD OF TEST PREPARATION; EDUCATIONAL ASSESSMENT; EDUCATIONAL COURSE MONITORING, NAMELY, TRACKING STUDENT PERFORMANCE; EDUCATIONAL DEMONSTRATIONS; EDUCATIONAL EXAMINATION SERVICES; EDUCATIONAL SERVICES IN THE NATURE OF TEST PREPARATION SCHOOLS; EDUCATIONAL SERVICES, NAMELY, CONDUCTING INFORMAL ON-LINE PROGRAMS IN THE FIELDS OF TEST PREPARATION, AND PRINTABLE MATERIALS DISTRIBUTED THEREWITH; EDUCATIONAL SERVICES, NAMELY, CONDUCTING INFORMAL PROGRAMS IN THE FIELDS OF TEST PREPARATION, USING ON-LINE ACTIVITIES AND INTERACTIVE EXHIBITS, AND PRINTABLE MATERIALS DISTRIBUTED THEREWITH; EDUCATIONAL SERVICES, NAMELY, CONDUCTING ON-LINE EXHIBITIONS AND DISPLAYS AND INTERACTIVE EXHIBITS IN THE FIELD OF TEST PREPARATION; EDUCATIONAL SERVICES, NAMELY, CONDUCTING PROGRAMS IN THE FIELD OF TEST PREPARATION; EDUCATIONAL SERVICES, NAMELY, CONDUCTING COURSES IN THE FIELD OF TEST PREPARATION AND DISTRIBUTION OF COURSE MA-

**CLASS 41—(Continued).**

TIERIAL IN CONNECTION THEREWITH; EDUCATIONAL SERVICES, NAMELY, DEVELOPING, ARRANGING, AND CONDUCTING EDUCATIONAL CONFERENCES AND PROGRAMS AND PROVIDING COURSES OF INSTRUCTION IN THE FIELD OF TEST PREPARATION; EDUCATIONAL SERVICES, NAMELY, PROVIDING CONTINUING PROFESSIONAL EDUCATION COURSES IN THE FIELD OF TEST PREPARATION; EDUCATIONAL TESTING; INFORMATION ABOUT EDUCATION; INFORMATION ON EDUCATION; INFORMATION RELATING TO ENTERTAINMENT AND EDUCATION, PROVIDED ON-LINE FROM A COMPUTER DATABASE OR THE INTERNET; PROVIDING INFORMATION AND NEWS IN THE FIELD OF TEACHING METHODOLOGY AND EDUCATION; PROVIDING INFORMATION ON-LINE RELATING TO EDUCATIONAL OPPORTUNITIES; PROVISION OF INFORMATION RELATING TO EDUCATIONAL SERVICES (U.S. CLS. 100, 101 AND 107).

FIRST USE 10-13-2007; IN COMMERCE 12-1-2007.

MARIAM MAHMOUDI, EXAMINING ATTORNEY

SN 77-805,068. MARTIE DUNCAN, BIRMINGHAM, AL. FILED 8-14-2009.

## MARTIE KNOWS PARTIES

THE MARK CONSISTS OF STANDARD CHARACTERS WITHOUT CLAIM TO ANY PARTICULAR FONT, STYLE, SIZE, OR COLOR.

NO CLAIM IS MADE TO THE EXCLUSIVE RIGHT TO USE "PARTIES", APART FROM THE MARK AS SHOWN, FOR SPECIAL EVENT, PARTY AND WEDDING PLANNING, COORDINATION AND CONSULTATION SERVICES (U.S. CLS. 100, 101 AND 107).

FIRST USE 12-1-2007; IN COMMERCE 12-1-2007.

DAVID HOFFMAN, EXAMINING ATTORNEY

SN 77-831,290. JOUBERT, LANCE, PARKER, CO. FILED 9-21-2009.

## NAILED

THE MARK CONSISTS OF STANDARD CHARACTERS WITHOUT CLAIM TO ANY PARTICULAR FONT, STYLE, SIZE, OR COLOR.

FOR ENTERTAINMENT SERVICES, NAMELY, ORGANIZING CULTURAL AND SPORTING ACTIVITIES; ORGANIZING AND CONDUCTING SOCIAL ENTERTAINMENT EVENTS; ORGANIZING MUSICAL, CULTURAL, LIVE AND SPORTING PERFORMANCES; RENTAL OF LIGHTING AND STAGE EQUIPMENT; RENTAL OF SOUND APPARATUS, NAMELY, SOUND RECORDINGS AND MUSICAL INSTRUMENTS; FILM AND VIDEO PRODUCTION; PRODUCTION OF RADIO AND TELEVISION PROGRAMS; PARTY PLANNING; THEATRE PRODUCTION; EDUCATIONAL SERVICES, NAMELY, CLASSES AND SEMINARS IN THE FIELD OF PARTY PLANNING AND EVENT MANAGEMENT (U.S. CLS. 100, 101 AND 107).

KELLY CHOE, EXAMINING ATTORNEY

**CLASS 41—(Continued).**

SN 77-849,635. FOOT PETALS, PICKERINGTON, OH. FILED 10-15-2009.

**TINA ALDATZ**

THE MARK CONSISTS OF STANDARD CHARACTERS WITHOUT CLAIM TO ANY PARTICULAR FONT, STYLE, SIZE, OR COLOR.

THE NAME(S), PORTRAIT(S), AND/OR SIGNATURE(S) SHOWN IN THE MARK IDENTIFIES "TINA ALDATZ", WHOSE CONSENT(S) TO REGISTER IS MADE OF RECORD.

FOR EDUCATIONAL SERVICES, NAMELY, PROVIDING SPEAKING SEMINARS IN THE FIELD OF FOOTWEAR, SHOE FITTING, AND ENTREPRENEURSHIP (U.S. CLS. 100, 101 AND 107).

FIRST USE 4-1-2010; IN COMMERCE 4-1-2010.  
MICHAEL WEBSTER, EXAMINING ATTORNEY

SN 77-865,748. HOSPICE BRAZOS VALLEY, INC., BRYAN, TX. FILED 11-5-2009.

**HOSPICE BRAZOS VALLEY**

THE MARK CONSISTS OF STANDARD CHARACTERS WITHOUT CLAIM TO ANY PARTICULAR FONT, STYLE, SIZE, OR COLOR.

NO CLAIM IS MADE TO THE EXCLUSIVE RIGHT TO USE "HOSPICE", APART FROM THE MARK AS SHOWN. SEC. 2(F).

FOR MEDICAL TRAINING AND TEACHING; DEVELOPMENT OF EDUCATIONAL MATERIALS FOR OTHERS IN THE FIELDS OF HOSPICE CARE AND HOSPICE SERVICES; DISSEMINATION OF EDUCATIONAL MATERIALS OF OTHERS IN THE FIELDS OF HOSPICE CARE AND HOSPICE SERVICES; EDUCATIONAL AND TRAINING SERVICES, NAMELY, ARRANGING AND PROVIDING SEMINARS, CONFERENCES, WORKSHOPS, PROGRAMS, CLASSES, TRAINING AND INSTRUCTION, ALL OF WHICH ARE PROVIDED TO HEALTH CARE PROFESSIONALS, HOME HEALTH CARE PROVIDERS, EMPLOYERS, EDUCATORS, MANAGED CARE ORGANIZATIONS, CARE GIVERS, VOLUNTEERS AND OTHERS, AND ALL OF WHICH ARE PROVIDED IN THE FIELDS OF HOSPICE CARE, HOSPICE SERVICES, GRIEF COUN-

**CLASS 41—(Continued).**

SELING AND BEREAVEMENT COUNSELING; AND EDUCATIONAL AND TRAINING SERVICES, NAMELY, ARRANGING AND PROVIDING SEMINARS, CONFERENCES, WORKSHOPS, PROGRAMS, CLASSES, TRAINING AND INSTRUCTION, ALL OF WHICH ARE PROVIDED IN THE FIELDS OF HOSPICE CARE, HOSPICE SERVICES, HOME HEALTH CARE, SELF CARE, ELDER CARE, NURSING, DEATH AND DYING, END OF LIFE ISSUES, END-OF-LIFE CARE, ETHICAL AND LEGAL ISSUES AT END-OF-LIFE, GRIEF AND LOSS, GRIEF COUNSELING, COPING WITH THE LOSS OF A CHILD, COPING WITH THE LOSS OF A LOVED ONE, BEREAVEMENT COUNSELING, SOCIAL WORK, SPIRITUAL CONCERNS OF THE DYING, PALLIATIVE CARE SERVICES, PAIN MANAGEMENT AND CONTROL, SYMPTOM MANAGEMENT AND CONTROL, CARE GIVER SUPPORT, VOLUNTEER OPPORTUNITIES, CASE MANAGEMENT AND RELATED HEALTH CARE SERVICES, AND DISTRIBUTION OF COURSE MATERIALS IN CONNECTION THEREWITH (U.S. CLS. 100, 101 AND 107).

FIRST USE 4-0-1994; IN COMMERCE 4-0-1994.  
CHARLOTTE CORWIN, EXAMINING ATTORNEY

SN 77-865,969. HOSPICE BRAZOS VALLEY, INC., BRYAN, TX. FILED 11-5-2009.



NO CLAIM IS MADE TO THE EXCLUSIVE RIGHT TO USE "HOSPICE", APART FROM THE MARK AS SHOWN.

THE MARK CONSISTS OF A TREE AND BUILDINGS DISPOSED INSIDE OF AN OVAL WITH THE WORDS "HOSPICE BRAZOS VALLEY" DISPOSED ABOVE THE OVAL.

SEC. 2(F) AS TO "HOSPICE BRAZOS VALLEY".

FOR MEDICAL TRAINING AND TEACHING; DEVELOPMENT OF EDUCATIONAL MATERIALS FOR OTHERS IN THE FIELDS OF HOSPICE CARE AND HOSPICE SERVICES; DISSEMINATION OF EDUCATIONAL MATERIALS OF OTHERS IN THE FIELDS OF HOSPICE CARE AND HOSPICE SERVICES; EDUCATIONAL AND TRAINING SERVICES, NAMELY, ARRANGING AND PROVIDING SEMINARS, CONFERENCES, WORKSHOPS, PROGRAMS, CLASSES, TRAINING AND INSTRUCTION, ALL OF WHICH ARE PROVIDED TO HEALTH CARE PROFESSIONALS, HOME HEALTH CARE PROVIDERS, EMPLOYERS, EDUCATORS, MANAGED CARE ORGANIZATIONS, CARE GIVERS, VOLUNTEERS AND OTHERS, AND ALL OF WHICH ARE PROVIDED IN THE FIELDS OF HOSPICE CARE, HOSPICE SERVICES, GRIEF COUN-

**CLASS 41—(Continued).**

SELING AND BEREAVEMENT COUNSELING; AND EDUCATIONAL AND TRAINING SERVICES, NAMELY, ARRANGING AND PROVIDING SEMINARS, CONFERENCES, WORKSHOPS, PROGRAMS, CLASSES, TRAINING AND INSTRUCTION, ALL OF WHICH ARE PROVIDED IN THE FIELDS OF HOSPICE CARE, HOSPICE SERVICES, HOME HEALTH CARE, SELF CARE, ELDER CARE, NURSING, DEATH AND DYING, END OF LIFE ISSUES, END-OF-LIFE CARE, ETHICAL AND LEGAL ISSUES AT END-OF-LIFE, GRIEF AND LOSS, GRIEF COUNSELING, COPING WITH THE LOSS OF A CHILD, COPING WITH THE LOSS OF A LOVED ONE, BEREAVEMENT COUNSELING, SOCIAL WORK, SPIRITUAL CONCERNS OF THE DYING, PALLIATIVE CARE SERVICES, PAIN MANAGEMENT AND CONTROL, SYMPTOM MANAGEMENT AND CONTROL, CARE GIVER SUPPORT, VOLUNTEER OPPORTUNITIES, CASE MANAGEMENT AND RELATED HEALTH CARE SERVICES, AND DISTRIBUTION OF COURSE MATERIALS IN CONNECTION THEREWITH (U.S. CLS. 100, 101 AND 107).

FIRST USE 0-0-1997; IN COMMERCE 0-0-1997.  
CHARLOTTE CORWIN, EXAMINING ATTORNEY

---

SN 77-868,983, VELOCITY INTERNATIONAL, INC., PITTSBURGH, PA. FILED 11-10-2009.



THE COLOR(S) BLACK, RED AND GRAY IS/ARE CLAIMED AS A FEATURE OF THE MARK.

THE MARK CONSISTS OF THE WORDS "MIND SHARE" IN STYLIZED FONT WITH "MIND" IN RED AND "SHARE" IN BLACK. ABOVE THE WORDING IS A BLACK SQUARE DESIGN WITH ROUNDED INDENTATIONS IN ITS UPPER LEFT AND LOWER RIGHT CORNERS WITH CONCENTRIC RED AND GRAY SEMI-CIRCLES EMANATING FROM THE INDENTED CORNERS TOWARD THE CENTER OF THE DESIGN. THE ABOVE ELEMENTS APPEAR ON A TRANSPARENT BACKGROUND.

FOR ENTERTAINMENT IN THE NATURE OF PROVIDING LIVE INTERACTIVE AUDIENCE PARTICIPATION GAMES AND ACTIVITIES EMPLOYING REAL TIME REMOTE RESPONSE TECHNOLOGY IN CONJUNCTION WITH LIVE MUSIC, COMEDY AND VARIETY ENTERTAINMENT PROGRAMS BROADCAST OVER TELEVISION, SATELLITE, AUDIO, AND VIDEO MEDIA; ORGANIZING EXHIBITIONS FOR ENTERTAINMENT PURPOSES FEATURING REAL TIME REMOTE RESPONSE TECHNOLOGY FOR REMOTE AUDIENCE PARTICIPATION (U.S. CLS. 100, 101 AND 107).

FIRST USE 9-30-2009; IN COMMERCE 9-30-2009.  
STEVEN PEREZ, EXAMINING ATTORNEY

**CLASS 41—(Continued).**

SN 77-871,625, AUNT BARBARA INC., FREEPORT, NY. FILED 11-12-2009.

## Aunt Barbara

THE MARK CONSISTS OF STANDARD CHARACTERS WITHOUT CLAIM TO ANY PARTICULAR FONT, STYLE, SIZE, OR COLOR.

THE NAME(S), PORTRAIT(S), AND/OR SIGNATURE(S) SHOWN IN THE MARK DOES NOT IDENTIFY A PARTICULAR LIVING INDIVIDUAL.

FOR ENTERTAINMENT SERVICES, NAMELY, CONDUCTING PARTIES; EDUCATIONAL SERVICES, NAMELY, PROVIDING WORKSHOP INFORMATION SESSIONS IN THE FIELD OF PLASTIC CONTAINERS FOR HOUSEHOLD USE, CUTLERY, COOKWARE AND KITCHEN ACCESSORIES; ENTERTAINMENT SERVICES IN THE NATURE OF LIVE DRAMATIC AND MUSICAL PERFORMANCES; EDUCATIONAL AND ENTERTAINMENT SERVICES, NAMELY, A CONTINUING PROGRAM ABOUT A SALES CONSULTANT FOR PLASTIC CONTAINERS FOR HOUSEHOLD USE, CUTLERY, COOKWARE AND KITCHEN ACCESSORIES, ACCESSIBLE BY RADIO, TELEVISION, SATELLITE, AUDIO, VIDEO AND COMPUTER NETWORKS (U.S. CLS. 100, 101 AND 107).

FIRST USE 12-25-1994; IN COMMERCE 12-25-1994.  
SIMON TENG, EXAMINING ATTORNEY

---

SN 77-877,044, MEYER, CINDY, BEVERLY HILLS, CA. FILED 11-20-2009.

## The Emotional Detective

THE MARK CONSISTS OF STANDARD CHARACTERS WITHOUT CLAIM TO ANY PARTICULAR FONT, STYLE, SIZE, OR COLOR.

FOR PROVIDING ON-LINE NON-DOWNLOADABLE EDUCATIONAL LECTURES AND ABSTRACTS OF EDUCATIONAL LECTURES IN THE FIELD OF PSYCHOLOGY (U.S. CLS. 100, 101 AND 107).

MARGERY A. TIERNEY, EXAMINING ATTORNEY

**CLASS 41—(Continued).**

SN 77-908,186. IGN ENTERTAINMENT, INC., SAN FRANCISCO, CA. FILED 1-8-2010.

**WHAT ARE YOU PLAYING?**

THE MARK CONSISTS OF STANDARD CHARACTERS WITHOUT CLAIM TO ANY PARTICULAR FONT, STYLE, SIZE, OR COLOR.

FOR PROVIDING ON-LINE INFORMATION IN THE FIELD OF COMPUTER GAMES AND VIDEO GAMES VIA THE INTERNET; PROVIDING AN ON-LINE COMPUTER DATABASE FEATURING INFORMATION IN THE FIELD OF COMPUTER GAMES AND VIDEO GAMES; ENTERTAINMENT SERVICES IN THE NATURE OF ON-LINE NON-DOWNLOADABLE VIDEOS AND PHOTOGRAPHS IN THE FIELD OF COMPUTER GAMES AND VIDEO GAMES TRANSMITTED VIA THE INTERNET AND WIRELESS COMMUNICATION NETWORKS; PRODUCTION OF NON-DOWNLOADABLE VIDEOS AND PHOTOGRAPHS IN THE FIELD OF COMPUTER GAMES AND VIDEO GAMES TRANSMITTED VIA THE INTERNET AND WIRELESS COMMUNICATION NETWORKS; ON-LINE PUBLISHING OF ELECTRONIC PUBLICATIONS; ENTERTAINMENT SERVICES, NAMELY, PROVIDING ON-LINE COMPUTER GAMES AND ON-LINE VIDEO GAMES; ON-LINE JOURNALS, NAMELY, BLOGS FEATURING PERSONAL OPINIONS IN THE FIELD OF GENERAL INTEREST, COMPUTER GAMES AND VIDEO GAMES; ENTERTAINMENT SERVICES IN THE NATURE OF ORGANIZING, ARRANGING AND CONDUCTING COMPUTER GAME AND VIDEO GAME EVENTS AND CONVENTIONS; ENTERTAINMENT IN THE NATURE OF CONTESTS, COMPETITIONS AND GAMES IN THE FIELDS OF COMPUTER GAMES AND VIDEO GAMES (U.S. CLS. 100, 101 AND 107).

LEIGH LOWRY, EXAMINING ATTORNEY

**CLASS 41—(Continued).**

SN 77-929,617. DISNEY ENTERPRISES, INC., BURBANK, CA. FILED 2-5-2010.

**THE MAGIC OF HEALTHY LIVING**

THE MARK CONSISTS OF STANDARD CHARACTERS WITHOUT CLAIM TO ANY PARTICULAR FONT, STYLE, SIZE, OR COLOR.

FOR PROVIDING EDUCATIONAL AND ENTERTAINMENT-RELATED INFORMATION VIA A GLOBAL COMPUTER NETWORK IN THE FIELDS OF LOCAL PARENT EDUCATIONAL AND ENTERTAINMENT RESOURCES AND EVENTS, LOCAL CHILDREN'S AND YOUNG ADULTS' ENTERTAINMENT ACTIVITIES, CHILDREN'S AND YOUNG ADULTS' EDUCATIONAL FACILITIES, CHILDREN'S AND YOUNG ADULTS' FITNESS, AND ONLINE JOURNALS, NAMELY, BLOGS FEATURING INFORMATION IN THE FIELDS OF CHILDREN'S AND YOUNG ADULTS' ISSUES, NAMELY, LOCAL PARENT RESOURCES AND EVENTS, CHILDREN'S AND YOUNG ADULTS' HEALTH, CHILDREN'S AND YOUNG ADULTS' ACTIVITIES, CHILDREN'S AND YOUNG ADULTS' DEVELOPMENT, CHILDREN'S AND YOUNG ADULTS' SOCIAL SKILLS, CHILDREN'S AND YOUNG ADULTS' EDUCATION, CHILDREN'S AND YOUNG ADULTS' FITNESS, CHILDREN'S AND YOUNG ADULTS' NUTRITION, RECIPES, AND WORK/FAMILY BALANCE (U.S. CLS. 100, 101 AND 107).

KATHERINE CONNOLLY, EXAMINING ATTORNEY

SN 77-947,812. ZIPZAPPLAY INC., SAN FRANCISCO, CA. FILED 3-1-2010.

**BAKING LIFE**

THE MARK CONSISTS OF STANDARD CHARACTERS WITHOUT CLAIM TO ANY PARTICULAR FONT, STYLE, SIZE, OR COLOR.

FOR ENTERTAINMENT SERVICES, NAMELY, PROVIDING ON-LINE COMPUTER GAMES; ENTERTAINMENT SERVICES, NAMELY, PROVIDING CUSTOMIZABLE ON-LINE COMPUTER GAMES; ENTERTAINMENT SERVICES, NAMELY, PROVIDING ON-LINE COMPUTER GAMES ON SOCIAL NETWORKING WEB SITES ON THE INTERNET; ENTERTAINMENT SERVICES, NAMELY, PROVIDING ON-LINE MULTIPLAYER COMPUTER GAMES; ENTERTAINMENT SERVICES, NAMELY, PROVIDING ON-LINE COMPUTER GAMES FEATURING VIRTUAL ENVIRONMENTS (U.S. CLS. 100, 101 AND 107).

FIRST USE 3-1-2010; IN COMMERCE 5-1-2010.

H. M. FISHER, EXAMINING ATTORNEY

**CLASS 41—(Continued).**

SN 79-085,892. ?WHAT IF! HOLDINGS LTD, LONDON, UNITED KINGDOM, FILED 5-24-2010.

**?WHAT IF! TRAINING**

THE MARK CONSISTS OF STANDARD CHARACTERS WITHOUT CLAIM TO ANY PARTICULAR FONT, STYLE, SIZE, OR COLOR.

OWNER OF INTERNATIONAL REGISTRATION 1047168 DATED 5-24-2010, EXPIRES 5-24-2020.

NO CLAIM IS MADE TO THE EXCLUSIVE RIGHT TO USE "TRAINING", APART FROM THE MARK AS SHOWN.

FOR EDUCATION IN THE NATURE OF PROVIDING SEMINARS, COURSES OF INSTRUCTION, CLASSES, WORKSHOPS AND DISTANCE LEARNING COURSES IN THE FIELD OF MARKETING, DESIGN, INNOVATION AND CREATIVITY; PROVISION OF TRAINING IN THE FIELDS OF MARKETING, DESIGN, INNOVATION AND CREATIVITY; PRACTICAL TRAINING RELATED TO DEMONSTRATION OF PRODUCTS AND TECHNIQUES FOR EDUCATIONAL PURPOSES IN THE FIELD OF MARKETING, DESIGN, INNOVATION AND CREATIVITY; EDUCATIONAL SERVICES, NAMELY, PROVIDING TRAINING FOR INTERVIEWERS IN THE FIELD OF INTERVIEW TECHNIQUE, AND INTERVIEWING INDIVIDUALS IN THE PRESENCE OF AN AUDIENCE; PROVIDING NON-DOWNLOADABLE ONLINE ELECTRONIC PUBLICATIONS IN THE NATURE OF MAGAZINES, BOOKS, MANUALS AND TEACHING MATERIALS FOR EDUCATIONAL PURPOSES IN THE FIELD OF MARKETING, DESIGN, INNOVATION AND CREATIVITY; PROVIDING INFORMATION RELATING TO EDUCATION TO BE BROWSED ON THE INTERNET; PUBLISHING OF ELECTRONIC PUBLICATIONS IN THE FIELD OF EDUCATION; ADVISORY, CONSULTANCY AND INFORMATION SERVICES RELATING TO THE PROVISION OF SEMINARS, COURSES OF INSTRUCTION, CLASSES, WORKSHOPS AND DISTANCE LEARNING COURSES IN THE FIELD OF MARKETING, DESIGN, INNOVATION AND CREATIVITY; ADVISORY, CONSULTANCY AND INFORMATION SERVICES RELATING TO THE PROVISION OF TRAINING IN THE FIELDS OF MARKETING, DESIGN, INNOVATION AND CREATIVITY; ADVISORY, CONSULTANCY AND INFORMATION SERVICES RELATING TO THE DEMONSTRATION OF PRODUCTS AND TECHNIQUES FOR EDUCATIONAL PURPOSES IN THE FIELD OF MARKETING, DESIGN, INNOVATION AND CREATIVITY; ADVISORY, CONSULTANCY AND INFORMATION SERVICES RELATING TO THE TRAINING OF INTERVIEWERS IN THE FIELD OF INTERVIEW TECHNIQUE AND INTERVIEWING INDIVIDUALS IN THE PRESENCE OF AN AUDIENCE; ADVISORY, CONSULTANCY AND INFORMATION SERVICES RELATING TO THE PROVISION OF NON-DOWNLOADABLE ONLINE ELECTRONIC PUBLICATIONS IN THE NATURE OF MAGAZINES, BOOKS, MANUALS AND TEACHING MATERIALS FOR EDUCATIONAL PURPOSES IN THE FIELD OF MARKETING, DESIGN, INNOVATION AND CREATIVITY; ADVISORY, CONSULTANCY AND INFORMATION SERVICES RELATING TO THE PROVISION OF INFORMATION ON EDUCATION ON THE INTERNET; ADVISORY, CONSULTANCY AND INFORMATION SERVICES RELATING TO THE PUBLICATION OF ELECTRONIC PUBLICATIONS IN THE FIELD OF EDUCATION (U.S. CLS. 100, 101 AND 107).

JULIE VEPPUMTHARA, EXAMINING ATTORNEY

**CLASS 41—(Continued).**

SN 79-085,977. FONDATION OUADJET, B-7000 MONS, BELGIUM, FILED 7-27-2010.



PRIORITY DATE OF 3-9-2010 IS CLAIMED.

OWNER OF INTERNATIONAL REGISTRATION 1047450 DATED 7-27-2010, EXPIRES 7-27-2020.

NO CLAIM IS MADE TO THE EXCLUSIVE RIGHT TO USE "FONDATION", APART FROM THE MARK AS SHOWN.

THE MARK CONSISTS OF THE STYLIZED WORDING "TRADITION MYSTIQUE EGYPTIENNE DU COBRA FONDATION OUADJET" AND THE DESIGN OF A STYLISED COBRA HEAD CONTAINING A STYLIZED FLOWER AND CROSS LOCATED ABOVE THREE TRIANGULAR STACKED SKULLS AND BETWEEN TWO FIGURES OF ANUBIS. THE FIGURES OF ANUBIS ARE BOTH WEARING ROBES AND HOLDING HAND DRUMS AND HAVE HUMAN BODIES BUT THE HEAD OF A JACKAL. THE STYLISED COBRA AND ANUBIS DESIGN IS LOCATED WITHIN A CIRCLE WHICH IS SURROUNDED BY THE CIRCULAR WORDING "TRADITION MYSTIQUE EGYPTIENNE DU COBRA FONDATION OUADJET".

THE ENGLISH TRANSLATION OF "TRADITION MYSTIQUE EGYPTIENNE DU COBRA FONDATION OUADJET" IN THE MARK IS "EGYPTIAN MYSTICAL TRADITION OF THE COBRA OUADJET FOUNDATION".

FOR PROVIDING TRAINING SERVICES IN THE FIELD OF PHILOSOPHY; ORGANIZATION OF SEMINARS AND CONFERENCES IN THE FIELDS OF PHILOSOPHY AND SPIRITUALITY; PUBLISHING OF BOOKS, E-BOOKS, AUDIO BOOKS, MUSIC AND ILLUSTRATIONS FOR OTHERS; EDUCATIONAL SERVICES, NAMELY, PROVIDING COURSES OF INSTRUCTION IN THE FIELD OF PHILOSOPHY; EDUCATIONAL SERVICES, NAMELY, PROVIDING INSTRUCTIONAL COURSES IN THE FIELD OF PHILOSOPHICAL THOUGHT AND SPIRITUAL PRACTICES; CULTURAL ACTIVITIES, NAMELY, ORGANIZATION OF EXHIBITIONS FOR CULTURAL OR EDUCATIONAL PURPOSES IN THE FIELD OF PHILOSOPHY AND SPIRITUALITY (U.S. CLS. 100, 101 AND 107).

MICHAEL TANNER, EXAMINING ATTORNEY



**CLASS 41—(Continued).**

SN 79-086,418. COMMON GROUND PUBLISHING PTY LTD, ALTONA VIC 3018, AUSTRALIA, FILED 4-7-2010.

**LEARNING BY DESIGN**

THE MARK CONSISTS OF STANDARD CHARACTERS WITHOUT CLAIM TO ANY PARTICULAR FONT, STYLE, SIZE, OR COLOR.

OWNER OF INTERNATIONAL REGISTRATION 1048572 DATED 4-7-2010, EXPIRES 4-7-2020.

NO CLAIM IS MADE TO THE EXCLUSIVE RIGHT TO USE "LEARNING", APART FROM THE MARK AS SHOWN.

FOR EDUCATIONAL RESEARCH FOR DESIGNING TESTING AND PROVIDING EDUCATION TOOLS USING DIGITAL TECHNOLOGIES TO AUGMENT LEARNING ENVIRONMENTS; EDUCATIONAL RESEARCH INCLUDING INVESTIGATING THE IMPLICATIONS OF NEW AND EMERGING LEARNING ENVIRONMENTS AND DEVELOPING TOOLS TO SUPPORT THESE ENVIRONMENTS; EDUCATIONAL RESEARCHING OF CULTURAL DIVERSITY, EDUCATION, LITERACY AND SOCIAL AND ORGANIZATIONAL CHANGE (U.S. CLS. 100, 101 AND 107).

MICHAEL WEBSTER, EXAMINING ATTORNEY

---

SN 85-007,755. APOLLO GROUP INC., PHOENIX, AZ. FILED 4-6-2010.

**PHOENIXCONNECT**

THE MARK CONSISTS OF STANDARD CHARACTERS WITHOUT CLAIM TO ANY PARTICULAR FONT, STYLE, SIZE, OR COLOR.

OWNER OF U.S. REG. NOS. 1,540,927, 3,431,022 AND OTHERS.

FOR ELECTRONIC NON-DOWNLOADABLE PUBLICATIONS IN THE NATURE OF SOCIAL DIRECTORIES (U.S. CLS. 100, 101 AND 107).

LEIGH CAROLINE CASE, EXAMINING ATTORNEY

---

SN 85-012,646. NICKLAUS COMPANIES, LLC, NORTH PALM BEACH, FL. FILED 4-13-2010.

**The Bear Trap**

THE MARK CONSISTS OF STANDARD CHARACTERS WITHOUT CLAIM TO ANY PARTICULAR FONT, STYLE, SIZE, OR COLOR.

NO CLAIM IS MADE TO THE EXCLUSIVE RIGHT TO USE "TRAP", APART FROM THE MARK AS SHOWN.

THE NAME(S), PORTRAIT(S), AND/OR SIGNATURE(S) SHOWN IN THE MARK IDENTIFIES JACK NICKLAUS, WHOSE CONSENT(S) TO REGISTER IS MADE OF RECORD.

FOR GOLF COURSES (U.S. CLS. 100, 101 AND 107).

FIRST USE 12-31-1992; IN COMMERCE 12-31-1992.

STEPHANIE ALI, EXAMINING ATTORNEY

**CLASS 41—(Continued).**

SN 85-013,057. TELEVISION FOOD NETWORK, G.P., NEW YORK, NY. FILED 4-13-2010.

**THE NEXT FOOD NETWORK STAR**

THE MARK CONSISTS OF STANDARD CHARACTERS WITHOUT CLAIM TO ANY PARTICULAR FONT, STYLE, SIZE, OR COLOR.

OWNER OF U.S. REG. NOS. 2,771,532, 2,791,044 AND 2,924,168.

NO CLAIM IS MADE TO THE EXCLUSIVE RIGHT TO USE "NETWORK", APART FROM THE MARK AS SHOWN. SEC. 2(F) AS TO "FOOD".

FOR EDUCATIONAL AND ENTERTAINMENT SERVICES, NAMELY, A CONTINUING PROGRAM ABOUT FOOD AND COOKING, ACCESSIBLE BY RADIO, TELEVISION, CABLE, FIBER OPTIC NETWORKS, WIRELESS NETWORKS, SATELLITE, AUDIO VIDEO, AND COMPUTER NETWORKS (U.S. CLS. 100, 101 AND 107).

FIRST USE 9-17-2005; IN COMMERCE 9-17-2005.

LAURA HAMMEL, EXAMINING ATTORNEY

---

SN 85-018,030. MAYBACH ENTERTAINMENT, LLC, BEAVERTON, OR. FILED 4-20-2010.

**Maybach Entertainment**

THE MARK CONSISTS OF STANDARD CHARACTERS WITHOUT CLAIM TO ANY PARTICULAR FONT, STYLE, SIZE, OR COLOR.

OWNER OF U.S. REG. NO. 3,823,080.

NO CLAIM IS MADE TO THE EXCLUSIVE RIGHT TO USE "ENTERTAINMENT", APART FROM THE MARK AS SHOWN.

FOR FILM PRODUCTION SERVICES; MUSIC PRODUCTION SERVICES; MUSIC VIDEO PRODUCTION SERVICES; PRODUCTION OF THEATRICAL PLAYS (U.S. CLS. 100, 101 AND 107).

KHANH LE, EXAMINING ATTORNEY

**CLASS 41—(Continued).**

SN 85-018,605. COLLABORATIVE FAMILY LAW INSTITUTE, INC., CORAL GABLES, FL. FILED 4-20-2010.



NO CLAIM IS MADE TO THE EXCLUSIVE RIGHT TO USE "COLLABORATIVE", "FAMILY", "LAW" AND "INSTITUTE", APART FROM THE MARK AS SHOWN.

THE MARK CONSISTS OF A CIRCULAR DESIGN COMPRISED OF CONCENTRIC CIRCLES WITH THE LETTERS "CFLI" WRITTEN DIAGONALLY WITHIN A SOLID CENTER CIRCLE WHICH IS IN TURN SURROUNDED BY A SINGLE LINE CIRCLE. THE NEXT CONCENTRIC CIRCLE IS A THICKER SINGLE LINE CIRCLE CONTAINING THE WORDING "COLLABORATIVE" "FAMILY" "LAW" "INSTITUTE" WRITTEN ALONG THE TOP AND THE WORDING "BREAKING THE CYCLE OF CONFLICT", PRECEDED AND FOLLOWED BY A TRIANGLE, WRITTEN ALONG THE BOTTOM OF THIS THICKER CIRCLE. THERE IS ONE REMAINING SINGLE LINE CIRCLE AROUND THE OUTSIDE OF THE ENTIRE DESIGN.

FOR EDUCATIONAL SERVICES, NAMELY, CONDUCTING CLASSES, SEMINARS AND WORKSHOPS IN THE FIELD OF FAMILY LAW AND DISTRIBUTION OF PRINTED MATERIALS IN CONNECTION THEREWITH IN HARD COPY OR ELECTRONIC FORMAT ON THE SAME TOPICS (U.S. CLS. 100, 101 AND 107).

FIRST USE 11-1-2010; IN COMMERCE 11-1-2010.  
MATTHEW MCDOWELL, EXAMINING ATTORNEY

SN 85-019,444. WOODBURN, CARRIE L., LAGUNA BEACH, CA. FILED 4-21-2010.

## Alchemy of the Heart Productions

THE MARK CONSISTS OF STANDARD CHARACTERS WITHOUT CLAIM TO ANY PARTICULAR FONT, STYLE, SIZE, OR COLOR.

NO CLAIM IS MADE TO THE EXCLUSIVE RIGHT TO USE "PRODUCTIONS", APART FROM THE MARK AS SHOWN.

FOR ENTERTAINMENT SERVICES, NAMELY, MULTIMEDIA PRODUCTION SERVICES; MULTIMEDIA PUBLISHING OF BOOKS, MAGAZINES, JOURNALS, SOFTWARE, GAMES, MUSIC, AND ELECTRONIC PUBLICATIONS (U.S. CLS. 100, 101 AND 107).

DAWN HAN, EXAMINING ATTORNEY

**CLASS 41—(Continued).**

SN 85-023,873. KELBY MEDIA GROUP, INC., OLDSMAR, FL. FILED 4-27-2010.

## LEARN ONLINE WITH THE PROS

THE MARK CONSISTS OF STANDARD CHARACTERS WITHOUT CLAIM TO ANY PARTICULAR FONT, STYLE, SIZE, OR COLOR.

FOR EDUCATIONAL SERVICES, NAMELY, ONLINE COURSES IN THE FIELDS OF PHOTOGRAPHY, WEB DESIGN, AND CREATIVE DESIGN (U.S. CLS. 100, 101 AND 107).

FIRST USE 11-0-2009; IN COMMERCE 11-0-2009.  
ADA HAN, EXAMINING ATTORNEY

SN 85-024,547. AMERICAN SOCIETY FOR MICROBIOLOGY, WASHINGTON, DC. FILED 4-27-2010.

## JOURNAL OF VIROLOGY

THE MARK CONSISTS OF STANDARD CHARACTERS WITHOUT CLAIM TO ANY PARTICULAR FONT, STYLE, SIZE, OR COLOR.

OWNER OF U.S. REG. NO. 2,822,375.

NO CLAIM IS MADE TO THE EXCLUSIVE RIGHT TO USE "JOURNAL", APART FROM THE MARK AS SHOWN. SEC. 2(F).

FOR PROVIDING ON-LINE NON-DOWNLOADABLE PUBLICATIONS IN THE NATURE OF ARTICLES AND JOURNALS IN THE FIELD OF SCIENCE AND MICROBIOLOGY; PUBLISHING SCIENTIFIC JOURNALS AND ARTICLES IN THE FIELD OF SCIENCE AND MICROBIOLOGY; PROVIDING A WEBSITE FEATURING INFORMATION IN THE FIELD OF SCIENCE AND MICROBIOLOGY (U.S. CLS. 100, 101 AND 107).

FIRST USE 1-0-1998; IN COMMERCE 1-0-1998.  
LESLEY LAMOTHE, EXAMINING ATTORNEY

SN 85-028,389. DELANEY, JASON, NEW ORLEANS, LA. FILED 5-3-2010.



THE NAME "JASON LYRIC" IDENTIFIES THE STAGE NAME/PSEUDONYM OF "JASON" DELANEY, A LIVING INDIVIDUAL WHOSE CONSENT IS OF RECORD

THE MARK CONSISTS OF AN ENCIRCLED FLEUR DE LIS WITH WINGS ON EITHER SIDE BELOW WHICH APPEARS THE STYLIZED WORDING "JASON LYRIC".

FOR ENTERTAINMENT SERVICES IN THE NATURE OF LIVE PERFORMANCES BY A MUSICAL ARTIST (U.S. CLS. 100, 101 AND 107).

HEATHER THOMPSON, EXAMINING ATTORNEY

**CLASS 41—(Continued).**

SN 85-029,649. TAMMIE B TAYLOR, DBA POTTS N PAINTS, CHESAPEAKE, VA. FILED 5-4-2010.

**Potts N Paints**

THE MARK CONSISTS OF STANDARD CHARACTERS WITHOUT CLAIM TO ANY PARTICULAR FONT, STYLE, SIZE, OR COLOR.

FOR INSTRUCTION IN THE FIELD OF CLAY HAND BUILDING; INSTRUCTION IN THE FIELD OF POTTERY WHEEL USE; INSTRUCTION IN THE FIELD OF GLASS FUSING AND SLUMPING; INSTRUCTION IN THE FIELD OF MOLD POURING; INSTRUCTION IN THE FIELD OF ART PROJECTS; INSTRUCTION IN THE FIELD OF MAKING MOSAICS (U.S. CLS. 100, 101 AND 107).

FIRST USE 7-1-2007; IN COMMERCE 7-1-2007.  
MARLENE BELL, EXAMINING ATTORNEY

SN 85-030,848. PPR NOTE ACADEMY, LLC, MEDIA, PA. FILED 5-5-2010.

**PPR NOTE ACADEMY**

THE MARK CONSISTS OF STANDARD CHARACTERS WITHOUT CLAIM TO ANY PARTICULAR FONT, STYLE, SIZE, OR COLOR.

NO CLAIM IS MADE TO THE EXCLUSIVE RIGHT TO USE "NOTE ACADEMY", APART FROM THE MARK AS SHOWN.

FOR EDUCATION SERVICES, NAMELY, PROVIDING EDUCATIONAL SEMINARS IN THE FIELD OF REAL ESTATE NOTE BROKERAGE (U.S. CLS. 100, 101 AND 107).

SUSAN STIGLITZ, EXAMINING ATTORNEY

SN 85-031,249. AF NETWORKS LLC, PALOS PARK, IL. FILED 5-5-2010.

**EDISON BEST NEW PRODUCT AWARDS**

THE MARK CONSISTS OF STANDARD CHARACTERS WITHOUT CLAIM TO ANY PARTICULAR FONT, STYLE, SIZE, OR COLOR.

OWNER OF U.S. REG. NOS. 1,624,124 AND 1,801,156.

NO CLAIM IS MADE TO THE EXCLUSIVE RIGHT TO USE "BEST NEW PRODUCT AWARDS", APART FROM THE MARK AS SHOWN.

FOR PROVIDING RECOGNITION AND INCENTIVES BY THE WAY OF AWARDS TO DEMONSTRATE EXCELLENCE IN THE FIELD OF CONSUMER PRODUCTS (U.S. CLS. 100, 101 AND 107).

FIRST USE 4-29-2010; IN COMMERCE 4-29-2010.  
SKYE YOUNG, EXAMINING ATTORNEY

**CLASS 41—(Continued).**

SN 85-033,532. COTTAGE CRAFT PRODUCTIONS, LLC, BORING, OR. FILED 5-7-2010.

**ART & SOUL**

THE MARK CONSISTS OF STANDARD CHARACTERS WITHOUT CLAIM TO ANY PARTICULAR FONT, STYLE, SIZE, OR COLOR.

NO CLAIM IS MADE TO THE EXCLUSIVE RIGHT TO USE "ART", APART FROM THE MARK AS SHOWN.

FOR PROVIDING WORKSHOPS IN THE FIELD OF ARTS AND CRAFTS (U.S. CLS. 100, 101 AND 107).

FIRST USE 2-0-2003; IN COMMERCE 2-0-2003.  
ALICIA COLLINS, EXAMINING ATTORNEY

SN 85-036,017. CROTEAU, TANYA, DANVERS, MA. FILED 5-12-2010.

**BARRE N9NE STUDIO**

THE MARK CONSISTS OF STANDARD CHARACTERS WITHOUT CLAIM TO ANY PARTICULAR FONT, STYLE, SIZE, OR COLOR.

NO CLAIM IS MADE TO THE EXCLUSIVE RIGHT TO USE "STUDIO", APART FROM THE MARK AS SHOWN.

FOR EDUCATION AND ENTERTAINMENT, NAMELY, PHYSICAL FITNESS CONDITIONING CLASSES, PHYSICAL FITNESS INSTRUCTION, PERSONAL TRAINING, DANCE CLASSES, AND WORKSHOPS AND SEMINARS IN THE FIELD OF NUTRITION FOR CONSUMERS (U.S. CLS. 100, 101 AND 107).

FIRST USE 2-17-2010; IN COMMERCE 2-17-2010.  
RENEE SERVANCE, EXAMINING ATTORNEY

SN 85-036,046. 1121507 ALBERTA LTD., OLDS, ALBERTA, CANADA, FILED 5-12-2010.

**INTERNET ELECTRICIAN**

THE MARK CONSISTS OF STANDARD CHARACTERS WITHOUT CLAIM TO ANY PARTICULAR FONT, STYLE, SIZE, OR COLOR.

NO CLAIM IS MADE TO THE EXCLUSIVE RIGHT TO USE "INTERNET", APART FROM THE MARK AS SHOWN. SEC. 2(F).

FOR EDUCATION AND ENTERTAINMENT SERVICES, NAMELY, PROVIDING OF TRAINING IN THE FIELD OF ELECTRICAL WIRING FOR THE HOME (U.S. CLS. 100, 101 AND 107).

FIRST USE 10-23-2004; IN COMMERCE 10-23-2004.  
RENEE SERVANCE, EXAMINING ATTORNEY

**CLASS 41—(Continued).**

SN 85-036,503. HANLEY III, ALBERT V., MIAMI, FL. FILED 5-12-2010.



NO CLAIM IS MADE TO THE EXCLUSIVE RIGHT TO USE "SCHOOL", APART FROM THE MARK AS SHOWN. THE MARK CONSISTS OF THE WORDS "THE CDL SCHOOL" TO THE LEFT AND BELOW AN IMAGE OF A TRUCK.

SEC. 2(F).

FOR EDUCATIONAL SERVICES IN THE NATURE OF COMMERCIAL VEHICLE DRIVING SCHOOLS (U.S. CLS. 100, 101 AND 107).

FIRST USE 5-0-1991; IN COMMERCE 5-0-1991. ALLISON HOLTZ, EXAMINING ATTORNEY

SN 85-037,915. MCGRAW, HOLLAND D, DBA SOME LIKE IT SHOT, SAN DIEGO, CA. AND MCGRAW, ALISHA R, DBA SOME LIKE IT SHOT, SAN DIEGO, CA. FILED 5-13-2010.

## Some Like It Shot

THE MARK CONSISTS OF STANDARD CHARACTERS WITHOUT CLAIM TO ANY PARTICULAR FONT, STYLE, SIZE, OR COLOR.

FOR AERIAL PHOTOGRAPHY; PORTRAIT PHOTOGRAPHY; PROVIDING FACILITIES FOR PRODUCING VIDEO, CINEMA AND PHOTOGRAPHY PRODUCTIONS; RENTAL OF PORTABLE PHOTOGRAPHY AND VIDEOGRAPHY BOOTHS FOR TAKING OF PICTURES AND VIDEOS; PHOTOGRAPHY (U.S. CLS. 100, 101 AND 107).

FIRST USE 6-1-2009; IN COMMERCE 6-1-2009. WILLIAM ROSSMAN, EXAMINING ATTORNEY

**CLASS 41—(Continued).**

SN 85-038,129. FLOWER, RACHEL, J, INCLINE VILLAGE, NV. FILED 5-13-2010.

## Be Curious

THE MARK CONSISTS OF STANDARD CHARACTERS WITHOUT CLAIM TO ANY PARTICULAR FONT, STYLE, SIZE, OR COLOR.

FOR ARRANGING AND CONDUCTING EDUCATIONAL CONFERENCES; BUSINESS EDUCATION AND TRAINING SERVICES, NAMELY, DEVELOPING, AND FACILITATING CUSTOMIZED IN-COMPANY LEADERSHIP AND EXECUTIVE DEVELOPMENT PROGRAMS, PROVIDING EXECUTIVE COACHING SERVICES, AND PROVIDING PUBLIC AND IN-COMPANY KEYNOTE PRESENTATIONS TO BUSINESS LEADERS; CONTINUING EDUCATION SERVICES, NAMELY, PROVIDING LIVE AND ON-LINE CONTINUING PROFESSIONAL EDUCATION SEMINARS IN THE FIELD OF PERSONAL DEVELOPMENT, SPIRITUAL GROWTH; DEVELOPING EDUCATIONAL MANUALS FOR OTHERS IN THE FIELD OF PERSONAL DEVELOPMENT, SPIRITUAL GROWTH; EDUCATION AND ENTERTAINMENT SERVICES, NAMELY, PRODUCTION AND DISTRIBUTION OF ONGOING TELEVISION PROGRAMS IN THE FIELD OF FAMILY MANAGEMENT AND RELATIONSHIPS; EDUCATION IN THE FIELD OF PERSONAL DEVELOPMENT, SPIRITUAL GROWTH RENDERED THROUGH VIDEO CONFERENCE; EDUCATION INFORMATION; EDUCATION SERVICES, NAMELY, MENTORING IN THE FIELD OF PERSONAL DEVELOPMENT, SPIRITUAL GROWTH; EDUCATION SERVICES, NAMELY, ONE-ON-ONE MENTORING IN THE FIELDS OF PERSONAL DEVELOPMENT, SPIRITUAL GROWTH; EDUCATION SERVICES, NAMELY, PROVIDING HANDS-ON OPPORTUNITIES FOR CHILDREN IN THE FIELD OF INTUITIVE ENGINEERING THROUGH LIVE, BROADCAST, AND ON-LINE CLASSES, SEMINARS, WORKSHOPS, TRAINING AND CURRICULUM DEVELOPMENT FOR CHILDREN, PARENTS AND EDUCATORS; EDUCATION SERVICES, NAMELY, PROVIDING MENTORING, TUTORING, CLASSES, SEMINARS AND WORKSHOPS IN THE FIELD OF PERSONAL DEVELOPMENT, SPIRITUAL GROWTH; EDUCATION SERVICES, NAMELY, PROVIDING ON-LINE RESOURCES, NAMELY, ONLINE TESTING IN THE FIELD OF PERSONAL DEVELOPMENT, SPIRITUAL GROWTH; EDUCATION SERVICES, NAMELY, PROVIDING ONLINE COGNITIVE ASSESSMENTS AND TRAINING PROGRAMS THAT HELP IDENTIFY COGNITIVE STRENGTHS AND WEAKNESSES OF AN INDIVIDUAL; EDUCATION SERVICES, NAMELY, PROVIDING PRE-KINDERGARTEN THROUGH 12TH GRADE CLASSROOM INSTRUCTION AT INTERNATIONAL SCHOOLS; EDUCATION SERVICES, NAMELY, PROVIDING TUTORIAL SESSIONS IN THE FIELDS OF PERSONAL DEVELOPMENT, SPIRITUAL GROWTH; EDUCATION SERVICES, NAMELY, TRAINING IN THE FIELDS OF PERSONAL DEVELOPMENT, SPIRITUAL GROWTH AND THE DISTRIBUTION OF TRAINING MATERIALS IN CONNECTION THEREWITH; EDUCATION SERVICES, NAMELY, TRAINING EDUCATORS TO TEACH THROUGH SERVICE LEARNING AND CIVIC ENGAGEMENT AND PROVIDING CURRICULA IN CONNECTION THEREWITH; EDUCATIONAL AND ENTERTAINMENT SERVICES FOR CHILDREN, NAMELY, PROVIDING INTERACTIVE PLAY AREAS, INSTRUCTIONAL CLASSES IN THE FIELD OF PERSONAL DEVELOPMENT, SPIRITUAL GROWTH AND SOCIAL GATHERINGS FOR CHILDREN; EDUCATIONAL AND ENTERTAINMENT SERVICES, NAMELY, A CONTINUING PROGRAM ABOUT PERSONAL DEVELOPMENT, SPIRITUAL GROWTH ACCESSIBLE BY RADIO, TELEVISION, SATELLITE, AUDIO, VIDEO AND COMPUTER NETWORKS; EDUCATIONAL AND ENTERTAINMENT SERVICES, NAMELY, PROVIDING MOTIVATIONAL AND EDUCATIONAL SPEAKERS; EDUCATIONAL AND ENTERTAINMENT SERVICES, NAMELY, PRO-

**CLASS 41—(Continued).**

VIDING MOTIVATIONAL AND EDUCATIONAL SPEAKERS IN THE FIELD OF SELF- AND PERSONAL IMPROVEMENT; EDUCATIONAL AND ENTERTAINMENT SERVICES, NAMELY, PROVIDING MOTIVATIONAL SPEAKING SERVICES IN THE FIELD OF PERSONAL DEVELOPMENT, SPIRITUAL GROWTH; EDUCATIONAL COUNSELING SERVICES TO ASSIST STUDENTS IN PLANNING AND PREPARING FOR FURTHER EDUCATION; EDUCATIONAL DEMONSTRATIONS; EDUCATIONAL RESEARCH IN THE FIELDS OF RIGHT-BRAIN ACTIVITY, PERSONAL DEVELOPMENT AND SPIRITUAL GROWTH; EDUCATIONAL SERVICES, NAMELY, PROVIDING THE FACILITIES FOR A LEARNING AND INNOVATION CENTER FEATURING FULLY CUSTOMIZED LEADERSHIP, MOTIVATIONAL, EDUCATIONAL, AND BRAINSTORMING TRAINING; EDUCATIONAL SERVICES, NAMELY, CONDUCTING DISTANCE LEARNING INSTRUCTION AT THE SECONDARY, COLLEGE AND GRADUATE LEVELS; EDUCATIONAL SERVICES, NAMELY, CONDUCTING INFORMAL ON-LINE PROGRAMS IN THE FIELDS OF PERSONAL DEVELOPMENT, SPIRITUAL GROWTH, AND PRINTABLE MATERIALS DISTRIBUTED THEREWITH; EDUCATIONAL SERVICES, NAMELY, CONDUCTING INFORMAL PROGRAMS IN THE FIELDS OF PERSONAL DEVELOPMENT, SPIRITUAL GROWTH, USING ON-LINE ACTIVITIES AND INTERACTIVE EXHIBITS, AND PRINTABLE MATERIALS DISTRIBUTED THEREWITH; EDUCATIONAL SERVICES, NAMELY, CONDUCTING ON LINE AND TELEPHONIC INSTRUCTION AND COURSES IN THE FIELD PERSONAL DEVELOPMENT, SPIRITUAL GROWTH; EDUCATIONAL SERVICES, NAMELY, CONDUCTING PROGRAMS IN THE FIELD OF PERSONAL DEVELOPMENT, SPIRITUAL GROWTH; EDUCATIONAL SERVICES, NAMELY, CONDUCTING SEMINARS, LECTURES, TELESEMINARS, TELECLASSES, AND WORKSHOPS IN PERSONAL AWARENESS; EDUCATIONAL SERVICES, NAMELY, CONDUCTING SEMINARS, WORKSHOPS, RETREATS IN THE FIELD OF PERSONAL DEVELOPMENT, SPIRITUAL GROWTH; EDUCATIONAL SERVICES, NAMELY, CONDUCTING SEMINARS, WORKSHOPS, RETREATS IN THE FIELD OF PERSONAL DEVELOPMENT, SPIRITUAL GROWTH AND DISTRIBUTION OF PRINTED MATERIALS IN CONNECTION THEREWITH IN HARD COPY OR ELECTRONIC FORMAT ON THE SAME TOPICS; EDUCATIONAL SERVICES, NAMELY, CONDUCTING SEMINARS, WORKSHOPS, RETREATS IN THE FIELD OF PERSONAL DEVELOPMENT, SPIRITUAL GROWTH AND DISTRIBUTION OF TRAINING MATERIAL IN CONNECTION THEREWITH; EDUCATIONAL SERVICES, NAMELY, DEVELOPING AND CONDUCTING TRAINING COURSES AND DISTRIBUTION OF TRAINING MATERIALS IN CONNECTION THEREWITH FOR SUBJECT MATTERS AS REQUESTED BY CUSTOMERS; EDUCATIONAL SERVICES, NAMELY, DEVELOPING AND CONDUCTING WORKOUTS, WORKSHOPS, PRESENTATIONS, RETREATS, AND PERSONAL TRAINING IN RIGHT-BRAIN FITNESS; EDUCATIONAL SERVICES, NAMELY, DEVELOPING CURRICULUM FOR EDUCATORS; EDUCATIONAL SERVICES, NAMELY, DEVELOPING CURRICULUM FOR TEACHERS; EDUCATIONAL SERVICES, NAMELY, DEVELOPING, ARRANGING, AND CONDUCTING EDUCATIONAL CONFERENCES AND PROGRAMS AND PROVIDING COURSES OF INSTRUCTION IN THE FIELD OF PERSONAL DEVELOPMENT, SPIRITUAL GROWTH; EDUCATIONAL SERVICES, NAMELY, PROVIDING A CONTINUING PRERECORDED AUDIO PROGRAM IN THE FIELD OF PERSONAL DEVELOPMENT, SPIRITUAL GROWTH ACCESSIBLE OVER THE INTERNET; EDUCATIONAL SERVICES, NAMELY, PROVIDING DISPLAYS AND EXHIBITS IN THE FIELD OF PERSONAL DEVELOPMENT, SPIRITUAL GROWTH; EDUCATIONAL SERVICES, NAMELY, PROVIDING INTERNSHIPS AND APPRENTICESHIPS IN THE FIELD OF PERSONAL DEVELOPMENT, SPIRITUAL GROWTH; EDUCATIONAL SERVICES, NAMELY, PROVIDING INTERNSHIPS AND EXCHANGE PROGRAMS IN THE FIELDS OF BUSINESS, SCIENCE, RESEARCH, AND HUMANITIES; EDUCATIONAL SERVICES, NAMELY, PROVIDING ON-LINE EDUCATIONAL COURSES AND TESTING IN THE FIELD OF PERSONAL DEVELOPMENT, SPIRITUAL GROWTH; ENTERTAINMENT AND EDUCATION SERVICES IN THE NATURE OF A SERIES

**CLASS 41—(Continued).**

OF SHORT RECORDED PROGRAMS FEATURING PERSONAL DEVELOPMENT, SPIRITUAL GROWTH DISTRIBUTED TO MOBILE HANDSETS, WHICH MAY INCLUDE VIDEO, TEXT, PHOTOS, ILLUSTRATIONS OR HYPERTEXT; ENTERTAINMENT AND EDUCATION SERVICES IN THE NATURE OF LIVE DANCE AND MUSICAL PERFORMANCES; ENTERTAINMENT AND EDUCATIONAL SERVICES, NAMELY, THE PRESENTATION OF SEMINARS, LECTURES, WORKSHOPS AND PANEL DISCUSSIONS, AND ONGOING TELEVISION AND RADIO TALK SHOWS ALL IN THE FIELD OF PUBLIC INTEREST CONCERNING PERSONAL DEVELOPMENT, SPIRITUAL GROWTH; PROVIDING CONTINUING BUSINESS EDUCATION COURSES (U.S. CLS. 100, 101 AND 107).

PAULA MAHONEY, EXAMINING ATTORNEY

---

SN 85-039,524. LECONTE, LUMONY R, AKA DJ LUMONEY, MIRAMAR, FL. FILED 5-15-2010.



NO CLAIM IS MADE TO THE EXCLUSIVE RIGHT TO USE "DJ", APART FROM THE MARK AS SHOWN.

THE NAME(S), PORTRAIT(S), AND/OR SIGNATURE(S) SHOWN IN THE MARK IDENTIFIES LUMONY LECONTE, WHOSE CONSENT(S) TO REGISTER IS MADE OF RECORD.

THE COLOR(S) BLACK, WHITE, AND GREEN IS/ARE CLAIMED AS A FEATURE OF THE MARK.

THE MARK CONSISTS OF A PICTURE OF THE HEAD AND FACE OF DJ LUMONEY IN BLACK AND WHITE AND BELOW THE PICTURE OF DJ LUMONEY'S HEAD AND FACE, THE WORD "DJ" IS WRITTEN IN WHITE LETTERS WITH A BLACK SHADOW AND TO THE RIGHT OF THE WORD "DJ", THE WORD "LUMONEY" IS WRITTEN IN GREEN LETTERS WITH A BLACK SHADOW.

FOR MULTIMEDIA ENTERTAINMENT SERVICES IN THE NATURE OF RECORDING, PRODUCTION AND POST-PRODUCTION SERVICES IN THE FIELDS OF MUSIC, VIDEO, AND FILMS (U.S. CLS. 100, 101 AND 107).

FIRST USE 3-26-2006; IN COMMERCE 3-26-2006.  
SHAUNIA CARLYLE, EXAMINING ATTORNEY

**CLASS 41—(Continued).**

SN 85-040,537. LEMAY-YATES ASSOCIATES INC., VERDUN, QUEBEC, CANADA, FILED 5-17-2010.

# C-AHEAD

THE MARK CONSISTS OF STANDARD CHARACTERS WITHOUT CLAIM TO ANY PARTICULAR FONT, STYLE, SIZE, OR COLOR.

FOR ON-LINE PUBLICATION OF MARKET RESEARCH AND REPORTS ON THE TELECOMMUNICATIONS AND INFORMATION TECHNOLOGY INDUSTRIES; PROVIDING ON-LINE NEWSLETTERS IN THE FIELD OF TELECOMMUNICATIONS AND INFORMATION TECHNOLOGY; PROVIDING ON-LINE PUBLICATIONS IN THE NATURE OF AN E-BOOK IN THE FIELD OF TELECOMMUNICATIONS AND INFORMATION TECHNOLOGY (U.S. CLS. 100, 101 AND 107).

FIRST USE 6-9-2010; IN COMMERCE 6-9-2010.  
VERNA BETH RIRIE, EXAMINING ATTORNEY

**CLASS 41—(Continued).**

SN 85-042,765. ISAAC W. BERNHEIM FOUNDATION, CLERMONT, KY. FILED 5-19-2010.

# Connect at Bernheim

THE MARK CONSISTS OF STANDARD CHARACTERS WITHOUT CLAIM TO ANY PARTICULAR FONT, STYLE, SIZE, OR COLOR.

OWNER OF U.S. REG. NOS. 1,496,231, 3,678,805 AND OTHERS.

FOR ENTERTAINMENT AND EDUCATIONAL SERVICES IN THE NATURE OF COMMUNITY FESTIVALS FEATURING ART EXHIBITIONS, LIVE MUSICAL PERFORMANCES, EDUCATIONAL SPEAKERS, PUBLIC DISCUSSIONS AND EDUCATIONAL DEMONSTRATIONS IN THE FIELDS OF ART, MUSIC, SCIENCE, NATURE AND SUSTAINABILITY AND THE INTERCONNECTION OF THE FOREGOING; EDUCATIONAL SERVICES, NAMELY, CONDUCTING PROGRAMS IN THE FIELDS OF ART, MUSIC, SCIENCE, NATURE AND SUSTAINABILITY AND THE INTERCONNECTION OF THE FOREGOING (U.S. CLS. 100, 101 AND 107).

FIRST USE 9-12-2009; IN COMMERCE 9-12-2009.  
DAVID TAYLOR, EXAMINING ATTORNEY

SN 85-042,561. SUTHUN INTERNATIONAL HOLDINGS CORPORATION, SARASOTA, FL. FILED 5-19-2010.



The logo for Suthun features the word "Suthun" in a blue, sans-serif font. A gold-colored diacritical mark, resembling a seed or a small leaf, is positioned above the letter "u".

THE COLOR(S) BLUE AND GOLD IS/ARE CLAIMED AS A FEATURE OF THE MARK.

THE MARK CONSISTS OF THE WORD "SUTHUN" IN BLUE WITH A GOLD DIACRITICAL MARK ABOVE THE LETTER "U". THE DIACRITICAL MARK USED IS IN THE FORM OF A SEED.

FOR ON-LINE FACILITATED EDUCATION IN THE NATURE OF CLASSES, SEMINARS, AND WORKSHOPS IN THE FIELD OF INTELLECTUAL PROPERTY; TRAINING IN THE FIELD OF INTELLECTUAL PROPERTY (U.S. CLS. 100, 101 AND 107).

SUNG IN, EXAMINING ATTORNEY

SN 85-045,001. ISCHOOL CAMPUS, LLC, PARK CITY, UT. FILED 5-21-2010.



The logo for iSchoolcampus features the word "iSchoolcampus" in a black, sans-serif font. The letter "i" is stylized as a lowercase "i" inside a white circle, which is surrounded by a grey apple graphic.

NO CLAIM IS MADE TO THE EXCLUSIVE RIGHT TO USE "ISCHOOLCAMPUS", APART FROM THE MARK AS SHOWN.

THE MARK CONSISTS OF THE WORDING "ISCHOOLCAMPUS" WITH AN APPLE GRAPHIC SURROUNDING THE LETTER "I" OF THE MARK.

FOR EDUCATIONAL SERVICES IN THE NATURE OF PROVIDING CLASSES IN THE FIELD OF GENERAL EDUCATION AND INSTRUCTION TO KINDERGARTEN THROUGH 12TH GRADE USING TECHNOLOGY IN A DIGITAL CLASSROOM FORMAT (U.S. CLS. 100, 101 AND 107).

TINA MAI, EXAMINING ATTORNEY

**CLASS 41—(Continued).**

SN 85-045,520. AYUH SPA & WELLNESS, UNION CITY, CA. FILED 5-21-2010.



**AYUH YOGA**

NO CLAIM IS MADE TO THE EXCLUSIVE RIGHT TO USE "YOGA", APART FROM THE MARK AS SHOWN.

THE MARK CONSISTS OF CONCENTRIC CIRCLES FEATURING AN INNER CIRCLE HAVING AN EXTERIOR BORDER OF LOTUS PETALS. THE INTERIOR OF THE INNER CIRCLE FEATURES WAVES IN ITS BOTTOM HALF AND A SETTING OR RISING SUN IN ITS UPPER HALF. BELOW THE DESIGN APPEARS THE WORDING "AYUH YOGA" IN STYLIZED FORM.

THE ENGLISH TRANSLATION OF "AYUH" IN THE MARK IS "AGE AS IN YEARS OF LIFE".

FOR PERSONAL FITNESS TRAINING SERVICES AND CONSULTANCY; PHYSICAL FITNESS CONDITIONING CLASSES; YOGA INSTRUCTION (U.S. CLS. 100, 101 AND 107).

FIRST USE 1-4-2010; IN COMMERCE 2-28-2010.  
ZHALEH DELANEY, EXAMINING ATTORNEY

**CLASS 41—(Continued).**

SN 85-045,915. TERNER, MONIQUE, WEST LINN, OR. FILED 5-24-2010.

SENSE OF WONDER COACHING

THE MARK CONSISTS OF STANDARD CHARACTERS WITHOUT CLAIM TO ANY PARTICULAR FONT, STYLE, SIZE, OR COLOR.

NO CLAIM IS MADE TO THE EXCLUSIVE RIGHT TO USE "COACHING", APART FROM THE MARK AS SHOWN.

FOR EDUCATION AND ENTERTAINMENT SERVICES, NAMELY, PROVIDING CLASSES AND WORKSHOPS IN THE FIELDS OF PHYSICAL EDUCATION, YOGA, ART, MUSIC AND NATURE FOR CHILDREN, PARENTS, EDUCATORS AND FAMILIES; INFORMATION ABOUT EDUCATION FOR CHILDREN, PARENTS, EDUCATORS AND FAMILIES; PHYSICAL EDUCATION FOR CHILDREN, PARENTS, EDUCATORS AND FAMILIES; YOGA INSTRUCTION FOR CHILDREN, PARENTS, EDUCATORS AND FAMILIES; INFORMATION IN THE FIELD OF PARENTING FOR PARENTS, EDUCATORS AND FAMILIES CONCERNING EDUCATION AND ENTERTAINMENT OF CHILDREN; ON-LINE EDUCATIONAL PARENTAL TRAINING CLASSES FOR PARENTS, EDUCATORS AND FAMILIES; EDUCATION SERVICES, NAMELY, PROVIDING TUTORIAL SESSIONS IN THE FIELDS OF PHYSICAL EDUCATION, YOGA, ART, MUSIC AND NATURE FOR CHILDREN, PARENTS, EDUCATORS AND FAMILIES; ART EXHIBITIONS FOR CHILDREN, PARENTS, EDUCATORS AND FAMILIES (U.S. CLS. 100, 101 AND 107).

ROBIN MITTLER, EXAMINING ATTORNEY

SN 85-045,908. NATIONAL COUNCIL ON CRIME AND DELINQUENCY, OAKLAND, CA. FILED 5-24-2010.

**GIRL MATTERS**

THE MARK CONSISTS OF STANDARD CHARACTERS WITHOUT CLAIM TO ANY PARTICULAR FONT, STYLE, SIZE, OR COLOR.

NO CLAIM IS MADE TO THE EXCLUSIVE RIGHT TO USE "GIRL", APART FROM THE MARK AS SHOWN.

FOR EDUCATION SERVICES, NAMELY, TRAINING SERVICES IN THE FIELD OF CRIME AND VIOLENCE DETERRENCE AND PREVENTION CURRICULUM, AND PROVIDING GENDER RESPONSIVE TRAINING IN THE FIELD OF SOCIAL REHABILITATION CURRICULUM FOR JUSTICE-INVOLVED GIRLS (U.S. CLS. 100, 101 AND 107).

FIRST USE 10-1-2008; IN COMMERCE 2-2-2009.  
CHRISTOPHER BUONGIORNO, EXAMINING ATTORNEY

SN 85-046,244. W2007 STRATOSPHERE PROPCO., L.P., LAS VEGAS, NV. FILED 5-24-2010.



NO CLAIM IS MADE TO THE EXCLUSIVE RIGHT TO USE "LAS VEGAS", APART FROM THE MARK AS SHOWN.

THE MARK CONSISTS OF THE STYLIZED WORDS "SKY JUMP" STAGGERED HORIZONTALLY POSITIONED OVER A TARGET AND FIVE VERTICALLY POSITIONED INVERTED LONG TRIANGLES AND THE WORDS LAS VEGAS UNDER THE WORD SKY AND A DOTTED BACKGROUND ON THE BOTTOM.

FOR ENTERTAINMENT IN THE NATURE OF AN AMUSEMENT PARK RIDE; AND ENTERTAINMENT SERVICES, NAMELY, CONDUCTING PARTIES (U.S. CLS. 100, 101 AND 107).

FIRST USE 4-21-2010; IN COMMERCE 4-21-2010.  
LOURDES AYALA, EXAMINING ATTORNEY

**CLASS 41—(Continued).**

SN 85-046,247. W2007 STRATOSPHERE PROPCO., L.P., LAS VEGAS, NV. FILED 5-24-2010.

**SKYJUMP LAS VEGAS**

THE MARK CONSISTS OF STANDARD CHARACTERS WITHOUT CLAIM TO ANY PARTICULAR FONT, STYLE, SIZE, OR COLOR.

NO CLAIM IS MADE TO THE EXCLUSIVE RIGHT TO USE "LAS VEGAS", APART FROM THE MARK AS SHOWN. FOR ENTERTAINMENT IN THE NATURE OF AN AMUSEMENT PARK RIDE; AND ENTERTAINMENT SERVICES, NAMELY, CONDUCTING PARTIES (U.S. CLS. 100, 101 AND 107).

FIRST USE 4-21-2010; IN COMMERCE 4-21-2010.  
LOURDES AYALA, EXAMINING ATTORNEY

---

SN 85-046,250. W2007 STRATOSPHERE PROPCO., L.P., LAS VEGAS, NV. FILED 5-24-2010.

**SKYJUMP**

THE MARK CONSISTS OF STANDARD CHARACTERS WITHOUT CLAIM TO ANY PARTICULAR FONT, STYLE, SIZE, OR COLOR.

FOR ENTERTAINMENT IN THE NATURE OF AN AMUSEMENT PARK RIDE; AND ENTERTAINMENT SERVICES, NAMELY, CONDUCTING PARTIES (U.S. CLS. 100, 101 AND 107).

FIRST USE 4-21-2010; IN COMMERCE 4-21-2010.  
LOURDES AYALA, EXAMINING ATTORNEY

---

SN 85-046,571. SNOWDEN, JULIA, DBA SNOWDEN CONSULTING, MURPHYS, CA. FILED 5-24-2010.

**shiftpoint**

THE MARK CONSISTS OF STANDARD CHARACTERS WITHOUT CLAIM TO ANY PARTICULAR FONT, STYLE, SIZE, OR COLOR.

FOR BUSINESS EDUCATION AND TRAINING SERVICES, NAMELY, DEVELOPING, AND FACILITATING CUSTOMIZED IN-COMPANY LEADERSHIP AND EXECUTIVE DEVELOPMENT PROGRAMS, PROVIDING EXECUTIVE COACHING SERVICES, AND PROVIDING PUBLIC AND IN-COMPANY KEYNOTE PRESENTATIONS TO BUSINESS LEADERS (U.S. CLS. 100, 101 AND 107).

FIRST USE 9-9-2010; IN COMMERCE 3-6-2010.  
CAROLYN CATALDO, EXAMINING ATTORNEY

**CLASS 41—(Continued).**

SN 85-046,643. WHELAN, JOAN MARIE, CORONA DEL MAR, CA. FILED 5-24-2010.

**JOAN MARIE**

THE MARK CONSISTS OF STANDARD CHARACTERS WITHOUT CLAIM TO ANY PARTICULAR FONT, STYLE, SIZE, OR COLOR.

OWNER OF U.S. REG. NOS. 3,503,592 AND 3,622,871. FOR ENTERTAINMENT SERVICES, IN THE NATURE OF AN ONGOING TALK, LIFESTYLE, SELF-IMPROVEMENT, PERSONAL AND PROFESSIONAL INSPIRATION AND REALITY PROGRAMS TO BE DISTRIBUTED VIA TELEVISION, CABLE TELEVISION, SATELLITE SYSTEMS, WIRELESS COMMUNICATION DEVICES AND GLOBAL COMMUNICATION NETWORK (U.S. CLS. 100, 101 AND 107).

SOPHIA S. KIM, EXAMINING ATTORNEY

---

SN 85-046,781. KENNEDY-KLINE, TARA, SHOEMAKERSVILLE, PA. FILED 5-24-2010.

**Multi Level Mom**

THE MARK CONSISTS OF STANDARD CHARACTERS WITHOUT CLAIM TO ANY PARTICULAR FONT, STYLE, SIZE, OR COLOR.

NO CLAIM IS MADE TO THE EXCLUSIVE RIGHT TO USE "MOM", APART FROM THE MARK AS SHOWN.

FOR EDUCATION SERVICES, NAMELY, PROVIDING CLASSES, SEMINARS IN THE FIELDS OF PERSONAL DEVELOPMENT AND LIFE BALANCING; EDUCATIONAL AND ENTERTAINMENT SERVICES, NAMELY, A CONTINUING PROGRAM ABOUT PERSONAL DEVELOPMENT AND LIFE BALANCING ACCESSIBLE BY RADIO, TELEVISION, SATELLITE, AUDIO, VIDEO AND COMPUTER NETWORKS; ON-LINE JOURNALS, NAMELY, BLOGS FEATURING LIFE EXPERIENCES, STORIES AND LESSONS ABOUT PERSONAL DEVELOPMENT AND LIFE BALANCING; PERSONAL COACHING SERVICES IN THE FIELD OF PERSONAL DEVELOPMENT AND LIFE BALANCING (U.S. CLS. 100, 101 AND 107).

CORY BOONE, EXAMINING ATTORNEY



**CLASS 41—(Continued).**

SN 85-047,196. KOTSCHENREUTHER, PHILIP, BEL AIR, MD. FILED 5-25-2010.



NO CLAIM IS MADE TO THE EXCLUSIVE RIGHT TO USE "FAITH-BASED FINANCIAL MANAGEMENT", APART FROM THE MARK AS SHOWN.

THE MARK CONSISTS OF A TREE SITTING AT THE TOP OF A HILL WITH A PATH LEADING UP TO IT. THE WORDS "FAITH-BASED FINANCIAL MANAGEMENT" ARE SITUATED BELOW THE TREE LOGO.

FOR CONDUCTING WORKSHOPS AND SEMINARS IN THE FIELD OF PERSONAL FINANCIAL MANAGEMENT AND FINANCIAL PLANNING (U.S. CLS. 100, 101 AND 107).

JULIE VEPPUMTHARA, EXAMINING ATTORNEY

SN 85-047,476. CBS INTERACTIVE INC., NEW YORK, NY. FILED 5-25-2010.

## Fantasy Baseball Commissioner

THE MARK CONSISTS OF STANDARD CHARACTERS WITHOUT CLAIM TO ANY PARTICULAR FONT, STYLE, SIZE, OR COLOR.

OWNER OF U.S. REG. NO. 2,277,453.

NO CLAIM IS MADE TO THE EXCLUSIVE RIGHT TO USE "FANTASY BASEBALL", APART FROM THE MARK AS SHOWN.

SEC. 2(F).

FOR COMPUTER SERVICES, NAMELY, ORGANIZING AND COORDINATING FANTASY SPORTS LEAGUES FOR OTHERS VIA A GLOBAL COMPUTER NETWORK (U.S. CLS. 100, 101 AND 107).

FIRST USE 2-5-1998; IN COMMERCE 2-5-1998.

KEVIN CORWIN, EXAMINING ATTORNEY

**CLASS 41—(Continued).**

SN 85-047,477. CBS INTERACTIVE INC., NEW YORK, NY. FILED 5-25-2010.

## Fantasy Football Commissioner

THE MARK CONSISTS OF STANDARD CHARACTERS WITHOUT CLAIM TO ANY PARTICULAR FONT, STYLE, SIZE, OR COLOR.

OWNER OF U.S. REG. NO. 2,277,453.

NO CLAIM IS MADE TO THE EXCLUSIVE RIGHT TO USE "FANTASY FOOTBALL", APART FROM THE MARK AS SHOWN.

SEC. 2(F).

FOR COMPUTER SERVICES, NAMELY, ORGANIZING AND COORDINATING FANTASY SPORTS LEAGUES FOR OTHERS VIA A GLOBAL COMPUTER NETWORK (U.S. CLS. 100, 101 AND 107).

FIRST USE 7-31-1997; IN COMMERCE 7-31-1997.

KEVIN CORWIN, EXAMINING ATTORNEY

SN 85-048,047. TREGOED INC., PRINCETON, NJ. FILED 5-26-2010.

## tregoED

THE MARK CONSISTS OF STANDARD CHARACTERS WITHOUT CLAIM TO ANY PARTICULAR FONT, STYLE, SIZE, OR COLOR.

FOR EDUCATIONAL SERVICES, NAMELY, PROVIDING WORKSHOPS TO EDUCATORS AND STUDENTS FOR PROBLEM SOLVING AND DECISION MAKING IN K-12 SCHOOLS AND DISTRICTS; PROVIDING ONLINE INTERACTIVE WEBSITES WHERE ELEMENTARY, MIDDLE AND HIGH SCHOOL TEACHERS CAN CONDUCT LESSONS IN THE FIELD OF PROBLEM SOLVING AND DECISION MAKING (U.S. CLS. 100, 101 AND 107).

WILLIAM P. SHANAHAN, EXAMINING ATTORNEY

SN 85-049,126. SWAY MUSIC, PRINCETON, NJ. FILED 5-27-2010.

NO CLAIM IS MADE TO THE EXCLUSIVE RIGHT TO USE "MUSIC", APART FROM THE MARK AS SHOWN.

THE MARK CONSISTS OF THE STYLIZED WORDS "SWAY MUSIC" IN LOWERCASE LETTERING WITH AN UNDERLINE UNDER THE WORD "SWAY".

FOR MUSIC DISTRIBUTION (U.S. CLS. 100, 101 AND 107).

ROSELLE HERRERA, EXAMINING ATTORNEY

**CLASS 41—(Continued).**

SN 85-049,358. JOHNSON & JOHNSON, NEW BRUNSWICK, NJ. FILED 5-27-2010.



THE MARK CONSISTS OF THE STYLIZED WORDS "BECAUSE YOU CARE BEYOND THE CHAIR" APPEARING AFTER A HEART DESIGN WITH A SMALL HEART EMBEDDED WITHIN IT.

FOR ORGANIZING AND CONDUCTING RECOGNITION AWARDS PROGRAM TO HONOR ORAL CARE AND MEDICAL HEALTH CARE PROFESSIONALS; EDUCATIONAL SERVICES, NAMELY, PROVIDING INTERACTIVE AND INFORMATIVE PROGRAMS REGARDING PROPER DENTAL ROUTINES USING CONSUMER PRODUCTS FOR NEW DENTISTS (U.S. CLS. 100, 101 AND 107).

KEVON CHISOLM, EXAMINING ATTORNEY

**CLASS 41—(Continued).**

SN 85-050,537. TGI FRIDAY'S OF MINNESOTA, INC., CARROLLTON, TX. FILED 5-28-2010.

**EARN YOUR STRIPES**

THE MARK CONSISTS OF STANDARD CHARACTERS WITHOUT CLAIM TO ANY PARTICULAR FONT, STYLE, SIZE, OR COLOR.

OWNER OF U.S. REG. NO. 3,636,407.

FOR EDUCATION AND TRAINING SERVICES, NAMELY, CONDUCTING EMPLOYEE TRAINING AND ASSESSMENT CLASSES, SEMINARS AND WORKSHOPS TO PROMOTE CUSTOMER SERVICE, EMPLOYEE ENGAGEMENT, OPERATIONAL EXCELLENCE, AND CUSTOMER LOYALTY IN THE RESTAURANT AND BAR SERVICES INDUSTRY AND DISTRIBUTION OF COURSE MATERIALS IN CONNECTION THEREWITH (U.S. CLS. 100, 101 AND 107).

FIRST USE 5-10-2010; IN COMMERCE 5-10-2010.

TRACY FLETCHER, EXAMINING ATTORNEY

SN 85-051,713. VOLLEYFROG, LLC, FORT MYERS, FL. FILED 6-1-2010.

**VOLLEYFROG**

THE MARK CONSISTS OF STANDARD CHARACTERS WITHOUT CLAIM TO ANY PARTICULAR FONT, STYLE, SIZE, OR COLOR.

FOR PROVIDING A WEBSITE FEATURING NEWS AND INFORMATION IN THE FIELD OF VOLLEYBALL; PROVIDING A WEBSITE FEATURING NON-DOWNLOADABLE INSTRUCTIONAL VIDEOS IN THE FIELD OF VOLLEYBALL (U.S. CLS. 100, 101 AND 107).

LINDA M. KING, EXAMINING ATTORNEY

SN 85-050,102. EUREKA PLAYLAND, LLC, ROGERSVILLE, MO. FILED 5-28-2010.



NO CLAIM IS MADE TO THE EXCLUSIVE RIGHT TO USE "PLAYLAND", APART FROM THE MARK AS SHOWN.

THE MARK CONSISTS OF THE WORD "EUREKA" IN STYLIZED FONT HAVING A BACKWARDS-FACING SECOND "E"; POSITIONED ABOVE AN ELONGATED OVAL CONTAINING THE WORD "PLAYLAND" IN STYLIZED FONT; WITH LEAVES POSITIONED BELOW THE WORD "PLAYLAND"; WITH A MONKEY HANGING BY ITS TAIL FROM THE FIRST "E" IN "EUREKA"; AND WITH A SECOND MONKEY SITTING ON TOP OF THE BACKWARDS-FACING "E" IN "EUREKA".

FOR AMUSEMENT ARCADES; PROVISION OF PLAY FACILITIES FOR CHILDREN; RECREATIONAL SERVICES IN THE NATURE OF A CHILDREN'S PLAY FACILITY FEATURING PLAY EQUIPMENT, VIDEO GAMES, AND ARCADE GAMES; VIDEO ARCADE SERVICES (U.S. CLS. 100, 101 AND 107).

FLORENTINA BLANDU, EXAMINING ATTORNEY

SN 85-051,845. TREGOED INC., PRINCETON, NJ. FILED 6-1-2010.

**TREGOED WE'RE CRITICAL TO THINKING!**

THE MARK CONSISTS OF STANDARD CHARACTERS WITHOUT CLAIM TO ANY PARTICULAR FONT, STYLE, SIZE, OR COLOR.

FOR EDUCATIONAL SERVICES, NAMELY, PROVIDING WORKSHOPS TO EDUCATORS AND STUDENTS FOR PROBLEM SOLVING AND DECISION MAKING IN K-12 SCHOOLS AND DISTRICTS; PROVIDING ONLINE INTERACTIVE WEBSITES WHERE ELEMENTARY, MIDDLE AND HIGH SCHOOL TEACHERS CAN CONDUCT LESSONS IN THE FIELD OF PROBLEM SOLVING AND DECISION MAKING (U.S. CLS. 100, 101 AND 107).

WILLIAM P. SHANAHAN, EXAMINING ATTORNEY

**CLASS 41—(Continued).**

SN 85-051,892. CASANOVAS NIGHTCLUB, MIAMI, FL.  
FILED 6-1-2010.

**CASANOVAS**

THE MARK CONSISTS OF STANDARD CHARACTERS WITHOUT CLAIM TO ANY PARTICULAR FONT, STYLE, SIZE, OR COLOR.

FOR ARRANGING AND CONDUCTING NIGHTCLUB ENTERTAINMENT EVENTS; ARRANGING AND CONDUCTING NIGHTCLUB PARTIES (U.S. CLS. 100, 101 AND 107).

FIRST USE 7-3-2006; IN COMMERCE 7-3-2006.  
BARBARA RUTLAND, EXAMINING ATTORNEY

SN 85-054,072. BRONCO BALL, LLC, FRISCO, TX. FILED 6-3-2010.

**Bronco Ball**

THE MARK CONSISTS OF STANDARD CHARACTERS WITHOUT CLAIM TO ANY PARTICULAR FONT, STYLE, SIZE, OR COLOR.

NO CLAIM IS MADE TO THE EXCLUSIVE RIGHT TO USE "BALL", APART FROM THE MARK AS SHOWN.

FOR ENTERTAINMENT IN THE NATURE OF HORSEBACK BALL GAMES FEATURING RIDERS THROWING AND CATCHING A BALL WITH TEAMMATES (U.S. CLS. 100, 101 AND 107).

ELI HELLMAN, EXAMINING ATTORNEY

SN 85-054,943. VOLLEYFROG, LLC, FORT MYERS, FL.  
FILED 6-4-2010.

**AS A TEAM WE ARE ONE**

THE MARK CONSISTS OF STANDARD CHARACTERS WITHOUT CLAIM TO ANY PARTICULAR FONT, STYLE, SIZE, OR COLOR.

FOR PROVIDING A WEBSITE FEATURING NEWS AND INFORMATION IN THE FIELD OF VOLLEYBALL; PROVIDING A WEBSITE FEATURING NON-DOWNLOADABLE INSTRUCTIONAL VIDEOS IN THE FIELD OF VOLLEYBALL (U.S. CLS. 100, 101 AND 107).

LINDA M. KING, EXAMINING ATTORNEY

**CLASS 41—(Continued).**

SN 85-055,336. GROSSMAN, RICHARD, LOS ANGELES, CA.  
FILED 6-4-2010.

**AMERICAN LETTERS PRESS**

THE MARK CONSISTS OF STANDARD CHARACTERS WITHOUT CLAIM TO ANY PARTICULAR FONT, STYLE, SIZE, OR COLOR.

NO CLAIM IS MADE TO THE EXCLUSIVE RIGHT TO USE "AMERICAN" AND "PRESS", APART FROM THE MARK AS SHOWN.

FOR MULTIMEDIA PUBLISHING OF BOOKS, ARTICLES, MAGAZINES, JOURNALS, GAMES, MUSIC AND ELECTRONIC PUBLICATIONS; DIGITAL VIDEO, AUDIO AND MULTIMEDIA PUBLISHING SERVICES (U.S. CLS. 100, 101 AND 107).

JEAN IM, EXAMINING ATTORNEY

SN 85-060,474. LB'S SPEEDSHOP, LLC, SAN JOSE, CA.  
FILED 6-11-2010.



THE COLOR(S) BLACK, RED, BLUE, WHITE, SILVER IS/ ARE CLAIMED AS A FEATURE OF THE MARK.

THE MARK CONSISTS OF RED OUTLINED TRIANGLE WITH LIGHT BLUE INTERIOR; TWO BLACK AND WHITE CHECKERED FLAGS CROSSED ON TOP OF THE TRIANGLE WITH A SILVER OUTLINED HIGHWAY SIGN OVER THE FLAGS; IN THE HIGHWAY SIGN IN BLACK OUTLINED LETTERS WITH RED INTERIOR "SHOW MY"; "RIDES" IS BELOW "SHOW MY" IN THE SAME STYLIZED FONT EXCEPT FOR A PORTION OF THE "R" IS A BLACK ROAD WITH WHITE LINES; ".COM" IS ON BLACK STYLIZED FONT.

FOR ENTERTAINMENT SERVICES, NAMELY, ARRANGING AND CONDUCTING OF COMPETITIONS FOR CAR SHOWS; ENTERTAINMENT SERVICES, NAMELY, PROVIDING A WEB SITE FEATURING PHOTOGRAPHIC, AUDIO, VIDEO AND PROSE PRESENTATIONS FEATURING CAR COMPETITIONS, VEHICLE DISPLAYS, COMMENTARY AND INFORMATION IN THE FIELD OF CLASSIC CARS, MUSCLE CARS, CUSTOM CARS, COLLECTOR CARS, EXOTIC CARS, STREET RODS, HOT RODS, RAT RODS, LOW RIDERS, TUNERS, RARE CARS, ANTIQUE CARS, CLASSIC TRUCKS, CUSTOM TRUCKS, RARE TRUCKS AND ANTIQUE TRUCKS (U.S. CLS. 100, 101 AND 107).

FIRST USE 1-1-2010; IN COMMERCE 1-1-2010.

KEVON CHISOLM, EXAMINING ATTORNEY

**CLASS 41—(Continued).**

SN 85-061,011. TATHAM, WILLIAM, FRESNO, CA. FILED 6-11-2010.

**GRAND PRIX NETWORK**

THE MARK CONSISTS OF STANDARD CHARACTERS WITHOUT CLAIM TO ANY PARTICULAR FONT, STYLE, SIZE, OR COLOR.

NO CLAIM IS MADE TO THE EXCLUSIVE RIGHT TO USE "NETWORK", APART FROM THE MARK AS SHOWN.

FOR ENTERTAINMENT SERVICES, NAMELY, CREATION AND PRODUCTION OF MULTIMEDIA ENTERTAINMENT, SPORTS AND GAMING CONTENT PROPERTIES IN THE NATURE OF FILMS, LIVE GAMES, SHOWS, AND GAMING IN THE NATURE OF RUGBY, RUGBY SEVENS, BASKETBALL, SOCCER AND FOOTBALL FOR INTERNATIONAL DISTRIBUTION VIA A MULTIMEDIA DELIVERY PLATFORM, NAMELY, WEBCAST VIA THE INTERNET, BROADCAST TELEVISION, CABLE, CLOSED CIRCUIT AND SATELLITE (U.S. CLS. 100, 101 AND 107).

CHRISTINA SOBRAL, EXAMINING ATTORNEY

---

SN 85-061,077. TATHAM, WILLIAM, FRESNO, CA. FILED 6-11-2010.

**GRAND PRIX MEDIA**

THE MARK CONSISTS OF STANDARD CHARACTERS WITHOUT CLAIM TO ANY PARTICULAR FONT, STYLE, SIZE, OR COLOR.

NO CLAIM IS MADE TO THE EXCLUSIVE RIGHT TO USE "MEDIA", APART FROM THE MARK AS SHOWN.

FOR ENTERTAINMENT SERVICES, NAMELY, CREATION AND PRODUCTION OF MULTIMEDIA ENTERTAINMENT, SPORTS AND GAMING CONTENT PROPERTIES IN THE NATURE OF FILMS, LIVE GAMES, SHOWS, AND GAMING IN THE NATURE OF RUGBY, RUGBY SEVENS, BASKETBALL, SOCCER AND FOOTBALL FOR INTERNATIONAL DISTRIBUTION VIA A MULTIMEDIA DELIVERY PLATFORM, NAMELY, WEBCAST VIA THE INTERNET, BROADCAST TELEVISION, CABLE, CLOSED CIRCUIT AND SATELLITE (U.S. CLS. 100, 101 AND 107).

CHRISTINA SOBRAL, EXAMINING ATTORNEY

**CLASS 41—(Continued).**

SN 85-061,126. TATHAM, WILLIAM, FRESNO, CA. FILED 6-11-2010.

**GRAND PRIX PRODUCTIONS**

THE MARK CONSISTS OF STANDARD CHARACTERS WITHOUT CLAIM TO ANY PARTICULAR FONT, STYLE, SIZE, OR COLOR.

NO CLAIM IS MADE TO THE EXCLUSIVE RIGHT TO USE "PRODUCTIONS", APART FROM THE MARK AS SHOWN.

FOR ENTERTAINMENT SERVICES, NAMELY, CREATION AND PRODUCTION OF MULTIMEDIA ENTERTAINMENT, SPORTS AND GAMING CONTENT PROPERTIES IN THE NATURE OF FILMS, LIVE GAMES, SHOWS, AND GAMING IN THE NATURE OF RUGBY, RUGBY SEVENS, BASKETBALL, SOCCER AND FOOTBALL FOR INTERNATIONAL DISTRIBUTION VIA A MULTIMEDIA DELIVERY PLATFORM, NAMELY, WEBCAST VIA THE INTERNET, BROADCAST TELEVISION, CABLE, CLOSED CIRCUIT AND SATELLITE (U.S. CLS. 100, 101 AND 107).

CHRISTINA SOBRAL, EXAMINING ATTORNEY

---

SN 85-062,816. VUESEUM LLC, MAPLEWOOD, NJ. FILED 6-15-2010.

**VUESEUM**

THE MARK CONSISTS OF STANDARD CHARACTERS WITHOUT CLAIM TO ANY PARTICULAR FONT, STYLE, SIZE, OR COLOR.

FOR COMPUTER SERVICES, NAMELY, PROVIDING AN ART-FOCUSED WEBSITE FOR THE INTERNET-BASED DISPLAY OF VIDEO, PHOTOGRAPHIC AND PROSE PRESENTATIONS FEATURING ARTWORK, PAINTINGS AND SCULPTURES (U.S. CLS. 100, 101 AND 107).

JAMES STEIN, EXAMINING ATTORNEY

**CLASS 41—(Continued).**

SN 85-063,338. BIG BROTHERS-BIG SISTERS OF AMERICA, PHILADELPHIA, PA. FILED 6-15-2010.



THE MARK CONSISTS OF A DEPICTION OF A LARGER FIGURE OF A PERSON REACHING OUT TO A SMALLER FIGURE OF A PERSON. EACH FIGURES OUTREACHED ARMS AND ITS RESPECTIVE SHADOW CREATE AN IMAGE OF A HEART.

FOR CHARITABLE SERVICES, NAMELY, PROVIDING ADULT-CHILD MENTORING PROGRAMS FOR SCHOOL AGE CHILDREN (U.S. CLS. 100, 101 AND 107). FIRST USE 0-0-1995; IN COMMERCE 0-0-1995. BENJAMIN OKEKE, EXAMINING ATTORNEY

**CLASS 41—(Continued).**

SN 85-064,888. DUMBDUMB ENTERPRISES LLC, BEVERLY HILLS, CA. FILED 6-16-2010.



THE MARK CONSISTS OF THE WORD "DUMBDUMB" ENCLOSED WITHIN A RECTANGULAR DESIGN.

FOR PRODUCTION AND DISTRIBUTION OF RADIO AND TELEVISION SHOWS; PROVIDING A WEBSITE FEATURING AUDIO-VISUAL CONTENT, SPECIFICALLY, TELEVISION PROGRAMMING AND PODCASTS FEATURING HUMOR; TELEVISION PROGRAM SYNDICATION SERVICES (U.S. CLS. 100, 101 AND 107). MICHAEL WEBSTER, EXAMINING ATTORNEY

SN 85-066,033. MEREDITH CORPORATION, DES MOINES, IA. FILED 6-18-2010.

SN 85-063,886. LIFE PURPOSE RESOURCES, FAIRFIELD, IA. FILED 6-16-2010.

BETTER HOMES AND GARDENS  
CHILL AND GRILL FESTIVAL

VOTE FOR PLANET EARTH

THE MARK CONSISTS OF STANDARD CHARACTERS WITHOUT CLAIM TO ANY PARTICULAR FONT, STYLE, SIZE, OR COLOR.

FOR EDUCATION AND ENTERTAINMENT SERVICES, NAMELY, PROVIDING RECOGNITION AND INCENTIVES BY MEANS OF AWARDS FOR INTEREST AND EXCELLENCE IN ENVIRONMENTAL STEWARDSHIP IN SCHOOLS, CITIES, AND COMMUNITIES BY VOTING, IN PERSON OR ONLINE FOR ENVIRONMENTALLY FRIENDLY OR SUSTAINABLE PROJECTS AND FOR THE INDIVIDUALS, OF ALL AGES, AND THE ORGANIZATIONS WHO HAVE CONTRIBUTED TO THE REALIZATION OF SUSTAINABLE AND ENVIRONMENTALLY FRIENDLY PROJECTS (U.S. CLS. 100, 101 AND 107).

FIRST USE 8-7-2008; IN COMMERCE 3-22-2010. JILL C. ALT, EXAMINING ATTORNEY

THE MARK CONSISTS OF STANDARD CHARACTERS WITHOUT CLAIM TO ANY PARTICULAR FONT, STYLE, SIZE, OR COLOR.

OWNER OF U.S. REG. NOS. 754,656, 1,573,340 AND OTHERS.

NO CLAIM IS MADE TO THE EXCLUSIVE RIGHT TO USE "FESTIVAL", APART FROM THE MARK AS SHOWN.

FOR EDUCATION AND ENTERTAINMENT IN THE NATURE OF ORGANIZING AND CONDUCTING EVENTS FEATURING CLASSES AND DEMONSTRATIONS ON FOOD AND BEVERAGE PREPARATION, SERVING AND STORAGE AND ON ENTERTAINING; ENTERTAINMENT IN THE NATURE OF AN ONGOING TELEVISION PROGRAM ON THE SUBJECTS OF FOOD AND BEVERAGE PREPARATION, SERVING AND STORAGE AND ON ENTERTAINING; PROVIDING INFORMATION VIA A WEBSITE ON THE SUBJECT OF ENTERTAINING AND HOSTING DINNER PARTIES (U.S. CLS. 100, 101 AND 107).

CARRIE GENOVESE, EXAMINING ATTORNEY

**CLASS 41—(Continued).**

SN 85-067,329. VOLLEYFROG, LLC, FORT MYERS, FL.  
FILED 6-21-2010.



THE MARK CONSISTS OF THE DESIGN OF A FROG ADJACENT TO A VOLLEYBALL.

FOR PROVIDING A WEBSITE FEATURING NEWS AND INFORMATION IN THE FIELD OF VOLLEYBALL; PROVIDING A WEBSITE FEATURING NON-DOWNLOADABLE INSTRUCTIONAL VIDEOS IN THE FIELD OF VOLLEYBALL (U.S. CLS. 100, 101 AND 107).

LINDA M. KING, EXAMINING ATTORNEY

**CLASS 41—(Continued).**

SN 85-069,770. CBS INTERACTIVE INC., NEW YORK, NY.  
FILED 6-23-2010.

## FANTASY BASKETBALL COMMISSIONER

THE MARK CONSISTS OF STANDARD CHARACTERS WITHOUT CLAIM TO ANY PARTICULAR FONT, STYLE, SIZE, OR COLOR.

OWNER OF U.S. REG. NO. 2,277,453.

NO CLAIM IS MADE TO THE EXCLUSIVE RIGHT TO USE "FANTASY BASKETBALL", APART FROM THE MARK AS SHOWN.

SEC. 2(F).

FOR ENTERTAINMENT SERVICES, NAMELY, ORGANIZING AND COORDINATING FANTASY SPORTS LEAGUES FOR OTHERS VIA A GLOBAL COMPUTER NETWORK, ELECTRONIC COMMUNICATION NETWORKS AND PORTABLE AND WIRELESS COMMUNICATION DEVICES; PROVIDING ONLINE NEWS, INFORMATION, ARTICLES AND GAMES IN THE FIELDS OF SPORT FANTASY GAMES, SPORTS FIGURES, ATHLETES, SPORTS EVENTS, PLAYER RANKINGS, ADVICE ON SELECTING PLAYERS FOR A FANTASY TEAM AND GENERAL FANTASY SPORTS AND FANTASY GAMES TIPS (U.S. CLS. 100, 101 AND 107).

FIRST USE 1-16-1999; IN COMMERCE 1-16-1999.

MORGAN WYNNE, EXAMINING ATTORNEY

SN 85-069,788. CBS INTERACTIVE INC., NEW YORK, NY.  
FILED 6-23-2010.

SN 85-067,386. VOLLEYFROG, LLC, FORT MYERS, FL.  
FILED 6-21-2010.



THE MARK CONSISTS OF THE WORD "VOLLEYFROG" AND THE ACCOMPANYING DESIGN OF A FROG AND A VOLLEYBALL WHEREIN THE VOLLEYBALL FORMS THE INITIAL LETTER "O".

FOR PROVIDING A WEBSITE FEATURING NEWS AND INFORMATION IN THE FIELD OF VOLLEYBALL; PROVIDING A WEBSITE FEATURING NON-DOWNLOADABLE INSTRUCTIONAL VIDEOS IN THE FIELD OF VOLLEYBALL (U.S. CLS. 100, 101 AND 107).

LINDA M. KING, EXAMINING ATTORNEY

## FANTASY HOCKEY COMMISSIONER

THE MARK CONSISTS OF STANDARD CHARACTERS WITHOUT CLAIM TO ANY PARTICULAR FONT, STYLE, SIZE, OR COLOR.

OWNER OF U.S. REG. NO. 2,277,453.

NO CLAIM IS MADE TO THE EXCLUSIVE RIGHT TO USE "FANTASY HOCKEY", APART FROM THE MARK AS SHOWN.

SEC. 2(F).

FOR ENTERTAINMENT SERVICES, NAMELY, ORGANIZING AND COORDINATING FANTASY SPORTS LEAGUES FOR OTHERS VIA A GLOBAL COMPUTER NETWORK, ELECTRONIC COMMUNICATION NETWORKS AND PORTABLE AND WIRELESS COMMUNICATION DEVICES; PROVIDING ONLINE NEWS, INFORMATION, ARTICLES AND GAMES IN THE FIELDS OF SPORT FANTASY GAMES, SPORTS FIGURES, ATHLETES, SPORTS EVENTS, PLAYER RANKINGS, ADVICE ON SELECTING PLAYERS FOR A FANTASY TEAM AND GENERAL FANTASY SPORTS AND FANTASY GAMES TIPS (U.S. CLS. 100, 101 AND 107).

FIRST USE 12-21-1997; IN COMMERCE 12-21-1997.

MORGAN WYNNE, EXAMINING ATTORNEY

**CLASS 41—(Continued).**

SN 85-071,937. SUNRAY GAMING OF NEW MEXICO, LLC,  
DBA SUNRAY PARK & CASINO, FARMINGTON, NM.  
FILED 6-25-2010.

**CLASS 41—(Continued).**

SN 85-072,987. MUSIC SUPERVISOR INC., PLAYA DEL REY,  
CA. FILED 6-28-2010.



# STINGRAYS

THE MARK CONSISTS OF STANDARD CHARACTERS  
WITHOUT CLAIM TO ANY PARTICULAR FONT, STYLE,  
SIZE, OR COLOR.

FOR ENTERTAINMENT IN THE NATURE OF SIMUL-  
CAST PRESENTATIONS OF LIVE SPORTING AND  
MUSICAL EVENTS (U.S. CLS. 100, 101 AND 107).

KAREN BRACEY, EXAMINING ATTORNEY

THE MARK CONSISTS OF THE WORDING "MUSIC  
SUPERVISOR" IN A STYLIZED FONT AND A DESIGN  
THAT CONSISTS OF AN IMAGE OF PHOTOGRAPHIC  
FILM WITH THREE MUSICAL NOTES APPEARING  
THEREON.

SEC. 2(F) AS TO "MUSIC SUPERVISOR".

FOR MUSIC SELECTION SERVICES FOR OTHERS  
USING ONLINE SEARCH ENGINES, NETWORK OF  
RECORD LABELS, MUSIC LIBRARIES, COMPOSERS,  
RECORDING ARTISTS AND MUSIC PUBLISHERS,  
NAMELY, FINDING AND DELIVERING TO OTHERS  
MUSIC, INCLUDING MUSICAL COMPOSITIONS,  
SOUND RECORDINGS AND MUSICAL PERFORM-  
ANCES, FOR USE IN FILMS, TELEVISION, VIDEO  
GAMES, RADIO, AND CONSULTATION AND ADVICE  
RELATED THERETO; PROVIDING AN EDUCATIONAL  
WEBSITE IN THE FIELD OF MUSIC; ONLINE LIBRARY  
SERVICES, NAMELY, PROVIDING ELECTRONIC LI-  
BRARY SERVICES WHICH FEATURE MUSIC, MUSI-  
CAL COMPOSITIONS, SOUND RECORDINGS AND  
MUSICAL PERFORMANCES FOR OTHERS TO LICENSE  
(U.S. CLS. 100, 101 AND 107).

FIRST USE 5-23-2005; IN COMMERCE 5-23-2005.

RENEE MCCRAY, EXAMINING ATTORNEY

SN 85-072,938. SYNERGETHICS, INC., PORTLAND, ME.  
FILED 6-28-2010.

SN 85-074,837. SPIRALEDGE, INC., SAN JOSE, CA. FILED 6-  
30-2010.

# LETT

THE MARK CONSISTS OF STANDARD CHARACTERS  
WITHOUT CLAIM TO ANY PARTICULAR FONT, STYLE,  
SIZE, OR COLOR.

FOR EDUCATIONAL SERVICES, NAMELY, CON-  
DUCTING TRAINING WORKSHOPS, SEMINARS, AND  
DEMONSTRATIONS IN THE FIELDS OF LEADERSHIP,  
DIVERSITY, SENSITIVITY, AND CROSS CULTURAL  
COMPETENCY AND DISTRIBUTION OF TRAINING  
MATERIALS IN CONNECTION THEREWITH (U.S. CLS.  
100, 101 AND 107).

FIRST USE 11-23-2009; IN COMMERCE 6-18-2010.

ROBERT C. CLARK JR., EXAMINING ATTORNEY

# SportDNA

THE MARK CONSISTS OF STANDARD CHARACTERS  
WITHOUT CLAIM TO ANY PARTICULAR FONT, STYLE,  
SIZE, OR COLOR.

FOR EDUCATIONAL SERVICES, NAMELY, PROVID-  
ING INFORMATION ON-LINE IN THE FIELD OF  
SPORTS, SPECIFICALLY, INFORMATION REGARDING  
THE SKILLS AND TRAITS ASSOCIATED WITH SPECI-  
FIC SPORTS AND PROVIDING ON-LINE CONSULTA-  
TION SERVICES IN THE FIELD OF SPORTS, NAMELY,  
TESTING USERS REGARDING THEIR PHYSICAL AND  
MENTAL TRAITS AND EVALUATING THEIR RESP-  
ONSES TO RANK THEIR SUITABILITY FOR SPECI-  
FIC SPORTS (U.S. CLS. 100, 101 AND 107).

FIRST USE 6-11-2010; IN COMMERCE 6-11-2010.

MICHAEL GAFFAR, EXAMINING ATTORNEY

**CLASS 41—(Continued).**

SN 85-075,471. WARNER BROS. ENTERTAINMENT INC., BURBANK, CA. FILED 6-30-2010.

**\$#! MY DAD SAYS**

THE MARK CONSISTS OF STANDARD CHARACTERS WITHOUT CLAIM TO ANY PARTICULAR FONT, STYLE, SIZE, OR COLOR.

FOR ENTERTAINMENT SERVICES IN THE NATURE OF ON-GOING LIVE-ACTION, COMEDY AND DRAMA TELEVISION PROGRAMS; PRODUCTION OF LIVE-ACTION, COMEDY AND DRAMA TELEVISION PROGRAMS (U.S. CLS. 100, 101 AND 107).

KATHLEEN M. VANSTON, EXAMINING ATTORNEY

SN 85-076,733. THE SECRET TO WRITING, LLC, ATLANTA, GA. FILED 7-2-2010.

**The Secret to Writing**

THE MARK CONSISTS OF STANDARD CHARACTERS WITHOUT CLAIM TO ANY PARTICULAR FONT, STYLE, SIZE, OR COLOR.

FOR EDUCATIONAL SERVICES, NAMELY, CLASSES AND TUTORING IN THE FIELD OF WRITING, INCLUDING WRITING ADMISSIONS ESSAYS TO COLLEGE, GRADUATE SCHOOL, OR PROFESSIONAL SCHOOL; WRITTEN TEXT EDITING FOR BUSINESS PROFESSIONALS (U.S. CLS. 100, 101 AND 107).

FIRST USE 9-1-2009; IN COMMERCE 9-5-2009.

AMY ALFIERI, EXAMINING ATTORNEY

SN 85-079,015. GUERCIO, JAMES W., BOULDER, CO. FILED 7-6-2010.

**CARIBOU RANCH**

THE MARK CONSISTS OF STANDARD CHARACTERS WITHOUT CLAIM TO ANY PARTICULAR FONT, STYLE, SIZE, OR COLOR.

NO CLAIM IS MADE TO THE EXCLUSIVE RIGHT TO USE "RANCH", APART FROM THE MARK AS SHOWN.

FOR ENTERTAINMENT AND RECORD COMPANY SERVICES, NAMELY, PRODUCTION OF AUDIO AND VIDEO RECORDINGS FEATURING MUSIC AND ENTERTAINMENT; SOUND RECORDING SERVICES; RECORDING STUDIO SERVICES; RECORD MASTER PRODUCTION; MUSIC PUBLISHING SERVICES; VIDEO EDITING; ENTERTAINMENT SERVICES, NAMELY, PROVIDING TELEVISION AND RADIO PROGRAMS FEATURING MUSICAL ARTISTS PERFORMING OR RECORDING MUSIC AND INFORMATION, COMMENTARY AND ARTICLES IN THE FIELD OF MUSIC AND ENTERTAINMENT (U.S. CLS. 100, 101 AND 107).

TASNEEM HUSSAIN, EXAMINING ATTORNEY

**CLASS 41—(Continued).**

SN 85-080,000. BETTER BASKETBALL, INC., ATLANTA, GA. FILED 7-8-2010.

**READ & REACT OFFENSE**

THE MARK CONSISTS OF STANDARD CHARACTERS WITHOUT CLAIM TO ANY PARTICULAR FONT, STYLE, SIZE, OR COLOR.

NO CLAIM IS MADE TO THE EXCLUSIVE RIGHT TO USE "OFFENSE", APART FROM THE MARK AS SHOWN.

FOR BASKETBALL INSTRUCTION SERVICES; PROVIDING A WEBSITE FEATURING BASKETBALL INSTRUCTION AND INFORMATION (U.S. CLS. 100, 101 AND 107).

FIRST USE 7-25-2008; IN COMMERCE 7-25-2008.

PRISCILLA MILTON, EXAMINING ATTORNEY

SN 85-082,628. HOUSE OF TORMENT LLC, AUSTIN, TX. FILED 7-12-2010.

**Mr Creep**

THE MARK CONSISTS OF STANDARD CHARACTERS WITHOUT CLAIM TO ANY PARTICULAR FONT, STYLE, SIZE, OR COLOR.

THE NAME(S), PORTRAIT(S), AND/OR SIGNATURE(S) SHOWN IN THE MARK DOES NOT IDENTIFY A PARTICULAR LIVING INDIVIDUAL.

FOR ENTERTAINMENT SERVICES IN THE NATURE OF A HAUNTED HOUSE ATTRACTION (U.S. CLS. 100, 101 AND 107).

FIRST USE 10-1-2005; IN COMMERCE 10-1-2005.

DAVID COLLIER, EXAMINING ATTORNEY

SN 85-082,851. SIMPLY LEARNING, INC., KING OF PRUSSIA, PA. FILED 7-12-2010.

**ASK THE AUTHOR . . . LIVE**

THE MARK CONSISTS OF STANDARD CHARACTERS WITHOUT CLAIM TO ANY PARTICULAR FONT, STYLE, SIZE, OR COLOR.

NO CLAIM IS MADE TO THE EXCLUSIVE RIGHT TO USE "LIVE", APART FROM THE MARK AS SHOWN.

FOR EDUCATION SERVICES, NAMELY, PROVIDING ON-LINE INTERACTIVE INSTRUCTIONAL SERVICES IN THE FIELD OF USE OF COMPUTER SOFTWARE (U.S. CLS. 100, 101 AND 107).

FIRST USE 7-1-2010; IN COMMERCE 7-1-2010.

SANJEEV VOHRA, EXAMINING ATTORNEY



**CLASS 41—(Continued).**

SN 85-084,207. F4 SHOWBINE, LLC, WILMINGTON, DE. FILED 7-14-2010.

# SHOWBINE

THE MARK CONSISTS OF STANDARD CHARACTERS WITHOUT CLAIM TO ANY PARTICULAR FONT, STYLE, SIZE, OR COLOR.

FOR CONDUCTING A COMBINATION LACROSSE TOURNAMENT FEATURING A TEAM ATHLETIC TOURNAMENT AND MEASUREMENT OF THE ATHLETES' INDIVIDUAL PHYSICAL ABILITIES; CONDUCTING AN ATHLETIC COMPETITION FEATURING A COMBINED TEAM ATHLETIC TOURNAMENT AND A MEASUREMENT OF THE ATHLETES' INDIVIDUAL PHYSICAL ABILITIES (U.S. CLS. 100, 101 AND 107).

FIRST USE 6-1-2010; IN COMMERCE 6-1-2010.  
B. PARADEWELAI, EXAMINING ATTORNEY

---

SN 85-085,511. FOR YOUR EASE ONLY, INC., CHICAGO, IL. FILED 7-15-2010.

## MAKE MY PRODUCT MAKE ME A MILLIONAIRE

THE MARK CONSISTS OF STANDARD CHARACTERS WITHOUT CLAIM TO ANY PARTICULAR FONT, STYLE, SIZE, OR COLOR.

FOR ENTERTAINMENT SERVICES, NAMELY, AN ONGOING REALITY-BASED TELEVISION SERIES FEATURING INVENTORS, ENTREPRENEURS AND PRODUCT DEVELOPMENT (U.S. CLS. 100, 101 AND 107).  
JIM RINGLE, EXAMINING ATTORNEY

---

SN 85-086,331. PAUL FANNY, HOOKSETT, NH. FILED 7-16-2010.

## Natural Health Is Our Birthright

THE MARK CONSISTS OF STANDARD CHARACTERS WITHOUT CLAIM TO ANY PARTICULAR FONT, STYLE, SIZE, OR COLOR.

FOR EDUCATIONAL SERVICES IN THE SPIRITUAL FIELD, NAMELY, PLANNING AND CONDUCTING CLASSES AND COURSES IN SPIRITUAL AND NATURAL HEALTH, HOLISTIC NUTRITION, HOLISTIC HEALING, AND DISTRIBUTION OF COURSE MATERIAL IN CONNECTION THEREWITH (U.S. CLS. 100, 101 AND 107).

FIRST USE 7-12-2010; IN COMMERCE 7-16-2010.  
RON FAIRBANKS, EXAMINING ATTORNEY

**CLASS 41—(Continued).**

SN 85-086,609. LOPEZ, BRANDON M., DBA BRANDUN'S TUNES PRODUCTIONS, SAN ANTONIO, TX. FILED 7-16-2010.



NO CLAIM IS MADE TO THE EXCLUSIVE RIGHT TO USE "TUNES PRODUCTION", APART FROM THE MARK AS SHOWN.

THE COLOR(S) BLUE, BLACK AND WHITE IS/ARE CLAIMED AS A FEATURE OF THE MARK.

THE MARK CONSISTS OF THE LETTERS "B", "R" AND "D" IN THE WORD "BRANDUN" IN THE COLOR BLUE; ALL OTHER REMAINING LETTERS IN THE WORDS "BRANDUN'S TUNES PRODUCTIONS" ARE IN WHITE COLOR; THE BACKGROUND, BUILDINGS AND PALM TREES ARE IN BLUE AND BLACK COLOR.

FOR COMPOSITION OF MUSIC FOR OTHERS; ENTERTAINMENT SERVICES IN THE NATURE OF RECORDING, PRODUCTION AND POST-PRODUCTION SERVICES IN THE FIELDS OF MUSIC; MUSIC COMPOSITION FOR OTHERS; MUSIC PRODUCTION SERVICES; POST-PRODUCTION EDITING SERVICES IN THE FIELD OF MUSIC, VIDEOS AND FILM; PRODUCTION OF MUSICAL SOUND RECORDING; PROVIDING AN INTERNET WEBSITE PORTAL IN THE FIELD OF MUSIC (U.S. CLS. 100, 101 AND 107).

RON FAIRBANKS, EXAMINING ATTORNEY

---

SN 85-089,035. AEROBICS AND FITNESS ASSOCIATION OF AMERICA, SHERMAN OAKS, CA. FILED 7-20-2010.

# TEAMPRO

THE MARK CONSISTS OF STANDARD CHARACTERS WITHOUT CLAIM TO ANY PARTICULAR FONT, STYLE, SIZE, OR COLOR.

FOR EDUCATIONAL AND ENTERTAINMENT SERVICES, NAMELY, PROVIDING ONLINE COURSES AND PROVIDING LIVE CLASSES AND WORKSHOPS, ALL ON THE SUBJECTS OF FITNESS, EXERCISE AND WEIGHT-LOSS; PROVIDING INFORMATION VIA WEBSITES ON THE INTERNET IN THE FIELD OF FITNESS, EXERCISE AND WEIGHT-LOSS; PRESENTING LIVE INTERACTIVE WEBINARS OVER THE INTERNET IN THE FIELD OF FITNESS, EXERCISE AND WEIGHT LOSS; PRESENTING LIVE INTERACTIVE WEBINARS OVER THE INTERNET IN THE FIELD OF FITNESS, EXERCISE AND WEIGHT LOSS (U.S. CLS. 100, 101 AND 107).

STEPHANIE ALI, EXAMINING ATTORNEY

**CLASS 41—(Continued).**

SN 85-089,688. BRONEAH, INC., TRAVERSE CITY, MI.  
FILED 7-21-2010.



OWNER OF U.S. REG. NOS. 3,348,635 AND 3,427,900.  
NO CLAIM IS MADE TO THE EXCLUSIVE RIGHT TO  
USE "CHALLENGE", APART FROM THE MARK AS  
SHOWN.

THE MARK CONSISTS OF SILHOUETTES OF THREE  
INDIVIDUALS ALONG WITH THE WORDS "THE M-22  
CHALLENGE". ONE INDIVIDUAL IS BIKING, ONE IS  
CANOEING, ONE IS RUNNING. THE RUNNING INDIV-  
DUAL'S LEGS MAKE UP THE TWO L'S IN THE WORD  
"CHALLENGE", AND THE SAME INDIVIDUAL BEARS A  
STYLIZED "M22" MARK ON THE CHEST: A DIAMOND  
CONTAINING "M22"

SEC. 2(F) AS TO "M-22".

FOR ENTERTAINMENT IN THE NATURE OF COM-  
PETITIONS IN THE FIELD OF ATHLETICS (U.S. CLS.  
100, 101 AND 107).

FIRST USE 2-1-2009; IN COMMERCE 2-1-2009.  
ANDREA HACK, EXAMINING ATTORNEY

SN 85-089,972. SAUCE INDUSTRIES, LLC, DBA GRAY V,  
LOUISVILLE, CO. FILED 7-21-2010.

# GRAY V

THE MARK CONSISTS OF STANDARD CHARACTERS  
WITHOUT CLAIM TO ANY PARTICULAR FONT, STYLE,  
SIZE, OR COLOR.

OWNER OF U.S. REG. NO. 3,170,634.  
FOR CUSTOM DIGITAL MUSIC PROGRAMMING  
SERVICES; AUDIO PRODUCTION SERVICES, NAMELY,  
CREATING DIGITAL MUSIC PROGRAMMING FOR  
OTHERS (U.S. CLS. 100, 101 AND 107).

FIRST USE 2-1-2002; IN COMMERCE 2-1-2002.  
MIDGE BUTLER, EXAMINING ATTORNEY

SN 85-089,982. SAUCE INDUSTRIES, LLC, DBA GRAY V,  
LOUISVILLE, CO. FILED 7-21-2010.

# SOUND. DESIGNED.

THE MARK CONSISTS OF STANDARD CHARACTERS  
WITHOUT CLAIM TO ANY PARTICULAR FONT, STYLE,  
SIZE, OR COLOR.

FOR CUSTOM DIGITAL MUSIC PROGRAMMING  
SERVICES; AUDIO PRODUCTION SERVICES, NAMELY,  
CREATING DIGITAL MUSIC PROGRAMMING FOR  
OTHERS (U.S. CLS. 100, 101 AND 107).

FIRST USE 7-20-2009; IN COMMERCE 7-20-2009.  
MIDGE BUTLER, EXAMINING ATTORNEY

**CLASS 41—(Continued).**

SN 85-090,742. UNIVISION COMMUNICATIONS INC., LOS  
ANGELES, CA. FILED 7-22-2010.



OWNER OF U.S. REG. NOS. 3,714,486, 3,830,142 AND  
OTHERS.

THE COLOR(S) PURPLE, GREEN, BLUE, RED, YELLOW,  
BLACK AND WHITE IS/ARE CLAIMED AS A FEATURE OF  
THE MARK.

THE MARK CONSISTS OF THE WORD "PREPÁRATE!"  
IN WHITE WITH BLACK OUTLINING, ABOVE A FANCI-  
FUL DEPICTION OF THE LETTER "U" COMPOSED OF  
FOUR QUADRANTS, WITH THE UPPER LEFT COM-  
PRISED OF A PURPLE QUARTER-CIRCLE, THE UPPER  
RIGHT COMPRISED OF A GREEN SQUARE, THE LOWER  
RIGHT COMPRISED OF A BLUE QUARTER-CIRCLE AND  
THE LOWER LEFT COMPRISED OF A RED QUARTER-  
CIRCLE. SUPERIMPOSED OVER THE FANCIFUL "U" IS A  
TARGET COMPRISED OF BLACK AND WHITE CON-  
CENTRIC CIRCLES, OVER WHICH ARE SUPERIMPOSED  
JAGGED BLACK VERTICAL LINES INTENDED TO RE-  
PRESENT THE LINES OF A SEISMIC MOTION MEASUR-  
ING DEVICE. BELOW ALL OF THE FOREGOING  
ELEMENTS IS THE WORDING "PROTEGE A TU FAMILIA"  
IN YELLOW WITH BLACK OUTLINING.

THE ENGLISH TRANSLATION OF "PREPÁRATE! PRO-  
TEGE A TU FAMILIA" IN THE MARK IS "PREPARE!  
PROTECT YOUR FAMILY".

FOR EDUCATION AND ENTERTAINMENT SER-  
VICES, NAMELY, ONGOING TELEVISED PUBLIC SER-  
VICE ANNOUNCEMENTS PROMOTING EMERGENCY  
PREPAREDNESS (U.S. CLS. 100, 101 AND 107).

FIRST USE 2-26-2007; IN COMMERCE 2-26-2007.  
LINDA LAVACHE, EXAMINING ATTORNEY

**CLASS 41—(Continued).**

SN 85-093,700. HOUSE OF TORMENT LLC, AUSTIN, TX. FILED 7-27-2010.



THE MARK CONSISTS OF A SKELETON WITH A TOP HAT UPON ITS HEAD.

FOR ENTERTAINMENT SERVICES IN THE NATURE OF A HAUNTED HOUSE ATTRACTION (U.S. CLS. 100, 101 AND 107).

FIRST USE 10-1-2005; IN COMMERCE 10-1-2005.  
DAVID COLLIER, EXAMINING ATTORNEY

**CLASS 41—(Continued).**

SN 85-096,109. CALIFORNIA INTERCONTINENTAL UNIVERSITY, INC., DIAMOND BAR, CA. FILED 7-29-2010.



NO CLAIM IS MADE TO THE EXCLUSIVE RIGHT TO USE "CALIFORNIA", "UNIVERSITY", AND "ESTABLISHED 1996", APART FROM THE MARK AS SHOWN.

THE MARK CONSISTS OF A WINGED SHIELD WITH EAGLE HOLDING A BOOK, THE WORD "CALUNIVERSITY" ENCIRCLING THE HEAD OF THE EAGLE AND THE WORDS "CALIFORNIA INTERCONTINENTAL UNIVERSITY" IN A BANNER BELOW THE EAGLE, AND THE WORDS "ESTABLISHED 1996" BELOW THE BANNER.

SEC. 2(F) AS TO "CALUNIVERSITY".

FOR EDUCATIONAL SERVICES, NAMELY, PROVIDING INNOVATIVE EDUCATIONAL OPPORTUNITIES THROUGH DISTANCE STUDY, CRITICAL RESEARCH AND QUALITY SERVICE TO STUDENTS (U.S. CLS. 100, 101 AND 107).

FIRST USE 3-10-2003; IN COMMERCE 6-1-2004.

HEATHER SAPP, EXAMINING ATTORNEY

SN 85-099,939. AUTOBEAT GROUP LLC, BLOOMFIELD HILLS, MI. FILED 8-4-2010.

**AUTOBEAT INSIDER**

THE MARK CONSISTS OF STANDARD CHARACTERS WITHOUT CLAIM TO ANY PARTICULAR FONT, STYLE, SIZE, OR COLOR.

OWNER OF U.S. REG. NO. 2,773,606.

FOR ENTERTAINMENT SERVICES, NAMELY, PROVIDING A WEB SITE CONTAINING AUTOMOTIVE RELATED INFORMATION IN THE FORM OF NEWS ARTICLES, VIDEOS AND REPORTS (U.S. CLS. 100, 101 AND 107).

LESLEY LAMOTHE, EXAMINING ATTORNEY

SN 85-095,184. WASHINGTON AREA GIRLS SOCCER LIMITED, FAIRFAX, VA. FILED 7-28-2010.



OWNER OF U.S. REG. NO. 3,100,211.  
NO CLAIM IS MADE TO THE EXCLUSIVE RIGHT TO USE "SOCCER", APART FROM THE MARK AS SHOWN.

THE MARK CONSISTS OF THE WORDING "LASTING FRIENDSHIPS THROUGH SOCCER" APPEARING OVER AN IMAGE OF A SOCCER BALL. BELOW THAT IS THE WORDING "WAGS" AND "WE ARE GIRL'S SOCCER".

FOR RECREATIONAL SERVICES, NAMELY, ORGANIZING AND CONDUCTING A SOCCER GAMES AND TOURNAMENTS; AND ORGANIZING AND CONDUCTING SOCCER CLINICS AND EVENTS (U.S. CLS. 100, 101 AND 107).

NAAKWAMA ANKRAH, EXAMINING ATTORNEY

SN 85-100,018. SANDY CHARLES MODELL, DBA CORNERSTONE PRESENTATIONS, WINTER PARK, FL. FILED 8-4-2010.

**Cornerstone Presentations**

THE MARK CONSISTS OF STANDARD CHARACTERS WITHOUT CLAIM TO ANY PARTICULAR FONT, STYLE, SIZE, OR COLOR.

NO CLAIM IS MADE TO THE EXCLUSIVE RIGHT TO USE "PRESENTATIONS", APART FROM THE MARK AS SHOWN.

FOR EDUCATIONAL AND ENTERTAINMENT SERVICES, NAMELY, PROVIDING SPEAKING SERVICES IN THE FIELD OF BUSINESS ETHICS AND BUSINESS COMMUNICATIONS (U.S. CLS. 100, 101 AND 107).

LESLEY LAMOTHE, EXAMINING ATTORNEY

**CLASS 41—(Continued).**

SN 85-101,841. TWEED-JEFFRIES, LLC, LOUISVILLE, KY.  
FILED 8-6-2010.



NO CLAIM IS MADE TO THE EXCLUSIVE RIGHT TO USE "ACADEMY FOR PRIVATE DUTY HOME CARE", APART FROM THE MARK AS SHOWN.

THE COLOR(S) PURPLE, LIGHT GREEN AND WHITE IS/ ARE CLAIMED AS A FEATURE OF THE MARK.

THE MARK CONSISTS OF THE WORDING "THE ACADEMY FOR PRIVATE DUTY HOME CARE" IN STANDARD INITIAL CAP TYPEFACE IN THE COLOR WHITE; TWO LEAVES APPEARING TO THE LEFT OF THE WORDING IN THE COLOR LIGHT GREEN; ALL ENCAPSULATED IN A PURPLE RECTANGULAR BACKGROUND.

FOR EDUCATIONAL SERVICES, NAMELY, PROVIDING ACADEMIC CONFERENCES, SEMINARS, WORKSHOPS AND RETREATS FOR HEALTHCARE PROFESSIONALS, AND DISTRIBUTING COURSE MATERIALS IN CONNECTION THEREWITH, IN THE FIELDS OF GROWING A HOME HEALTHCARE BUSINESS, DEVELOPING SALES AND MARKETING PLANS, INCREASING TEAM PERFORMANCE BY EMPLOYEES, AND ATTAINING AND MAINTAINING RECOGNITION IN THEIR COMPETENCIES (U.S. CLS. 100, 101 AND 107).  
FIRST USE 12-1-2009; IN COMMERCE 12-1-2009.  
REBECCA EISINGER, EXAMINING ATTORNEY

**CLASS 41—(Continued).**

SN 85-107,233. PEAK MOUNTAIN GUIDES LLC, RIDGWAY, CO. FILED 8-13-2010.

**PEAK MOUNTAIN GUIDES**

THE MARK CONSISTS OF STANDARD CHARACTERS WITHOUT CLAIM TO ANY PARTICULAR FONT, STYLE, SIZE, OR COLOR.

NO CLAIM IS MADE TO THE EXCLUSIVE RIGHT TO USE "MOUNTAIN GUIDES", APART FROM THE MARK AS SHOWN.

FOR EDUCATIONAL SERVICES, NAMELY, CONDUCTING INSTRUCTIONAL PROGRAMS IN MOUNTAINEERING, ICE CLIMBING, ROCK CLIMBING, BACKCOUNTRY SKIING, AND AVALANCHE AWARENESS (U.S. CLS. 100, 101 AND 107).

FIRST USE 6-1-2009; IN COMMERCE 6-1-2009.  
WENDY GOODMAN, EXAMINING ATTORNEY

SN 85-106,900. LOWENSTEIN, ALBERT L, DBA THE BALLOON FLIGHT SCHOOL, ALBUQUERQUE, NM. FILED 8-13-2010.



NO CLAIM IS MADE TO THE EXCLUSIVE RIGHT TO USE "BALLOON FLIGHT SCHOOL", APART FROM THE MARK AS SHOWN.

THE MARK CONSISTS OF THE WORDING "THE BALLOON FLIGHT SCHOOL" STYLIZED IN ITALICS AND "THE" CAPITALIZED, WITH THE GRAPHIC DESIGN OF A HOT AIR BALLOON WITH A STYLIZED GLOBE FORMING THE BALLOON, AND WITH DOUBLE UNDERLINES AND ARCH ABOVE THE IMAGE OF THE BALLOON.

FOR EDUCATIONAL SERVICES, NAMELY, CONDUCTING CLASSES, FLIGHT TRAINING, SEMINARS IN THE FIELD OF HOT AIR BALLOON FLIGHT AND GROUND INSTRUCTION AND DISTRIBUTION OF TRAINING MATERIAL IN CONNECTION THEREWITH (U.S. CLS. 100, 101 AND 107).

FIRST USE 8-1-2010; IN COMMERCE 8-1-2010.  
ASMAT KHAN, EXAMINING ATTORNEY

SN 85-110,805. INTERSECTIONS INC., CHANTILLY, VA. FILED 8-18-2010.

**THE DAILY SHIELD**

THE MARK CONSISTS OF STANDARD CHARACTERS WITHOUT CLAIM TO ANY PARTICULAR FONT, STYLE, SIZE, OR COLOR.

NO CLAIM IS MADE TO THE EXCLUSIVE RIGHT TO USE "DAILY", APART FROM THE MARK AS SHOWN.

FOR ON-LINE JOURNALS, NAMELY, BLOGS FEATURING INFORMATION IN THE FIELD OF IDENTITY THEFT AND FRAUD PROTECTION (U.S. CLS. 100, 101 AND 107).

FIRST USE 1-25-2010; IN COMMERCE 1-25-2010.  
EDWARD NELSON, EXAMINING ATTORNEY

**CLASS 41—(Continued).**

SN 85-119,597. VERY PERSONAL INCORPORATED, DBA COMPANYWORKS, SAINT PAUL, MN. FILED 8-31-2010.



OWNER OF U.S. REG. NO. 2,882,836.  
THE MARK CONSISTS OF A STYLIZED PERSON BESIDE THE WORDS "DOUBLE" ON TOP OF THE WORD "DUTCH".

FOR TRAINING SERVICES IN THE FIELD OF PERSONNEL DEVELOPMENT AND INDIVIDUAL AND ORGANIZATIONAL MANAGEMENT FOR A WORLD CLASS WORKFORCE (U.S. CLS. 100, 101 AND 107).  
NICHOLAS COLEMAN, EXAMINING ATTORNEY

---

SN 85-119,788. FAIRFIELD COUNTY LOOK, LLC, STAMFORD, CT. FILED 8-31-2010.

**FAIRFIELD COUNTY LOOK**

THE MARK CONSISTS OF STANDARD CHARACTERS WITHOUT CLAIM TO ANY PARTICULAR FONT, STYLE, SIZE, OR COLOR.

NO CLAIM IS MADE TO THE EXCLUSIVE RIGHT TO USE "FAIRFIELD COUNTY", APART FROM THE MARK AS SHOWN.

FOR ENTERTAINMENT SERVICES, NAMELY, PROVIDING A WEBSITE FEATURING INFORMATION CONCERNING CULTURAL EVENTS AND SOCIAL ENTERTAINMENT EVENTS (U.S. CLS. 100, 101 AND 107).

FIRST USE 7-31-2008; IN COMMERCE 7-31-2008.  
MICHELE SWAIN, EXAMINING ATTORNEY

---

SN 85-123,661. DREAM1122, LLC, ATLANTA, GA. FILED 9-6-2010.

**gotta trainer?**

THE MARK CONSISTS OF STANDARD CHARACTERS WITHOUT CLAIM TO ANY PARTICULAR FONT, STYLE, SIZE, OR COLOR.

FOR TRAINING COURSES IN STRATEGIC PLANNING RELATING TO ADVERTISING, PROMOTION, MARKETING AND BUSINESS (U.S. CLS. 100, 101 AND 107).

ERIN FALK, EXAMINING ATTORNEY

**CLASS 41—(Continued).**

SN 85-125,068. CITY OF WEBSTER GROVES, ST. LOUIS, MO. FILED 9-8-2010.

**THE OLD WEBSTER JAZZ & BLUES FESTIVAL**

THE MARK CONSISTS OF STANDARD CHARACTERS WITHOUT CLAIM TO ANY PARTICULAR FONT, STYLE, SIZE, OR COLOR.

NO CLAIM IS MADE TO THE EXCLUSIVE RIGHT TO USE "JAZZ & BLUES FESTIVAL", APART FROM THE MARK AS SHOWN.

SEC. 2(F).

FOR ENTERTAINMENT, NAMELY, LIVE MUSIC CONCERTS (U.S. CLS. 100, 101 AND 107).

FIRST USE 9-21-2002; IN COMMERCE 9-21-2002.  
BARNEY CHARLON, EXAMINING ATTORNEY

---

SN 85-125,385. BOOKISH LLC, NEW YORK, NY. FILED 9-8-2010.

**BOOKISH READING CLUB**

THE MARK CONSISTS OF STANDARD CHARACTERS WITHOUT CLAIM TO ANY PARTICULAR FONT, STYLE, SIZE, OR COLOR.

NO CLAIM IS MADE TO THE EXCLUSIVE RIGHT TO USE "READING CLUB", APART FROM THE MARK AS SHOWN.

FOR PROVIDING A WEBSITE FEATURING NON-DOWNLOADABLE FICTION AND NON-FICTION BOOKS (U.S. CLS. 100, 101 AND 107).

FIRST USE 10-20-2010; IN COMMERCE 10-20-2010.  
ANNE MADDEN, EXAMINING ATTORNEY

**CLASS 41—(Continued).**

SN 85-128,961. DOUDOUKJIAN, GEORGE, BELFORD, NJ. FILED 9-14-2010.



THE MARK CONSISTS OF THE LETTER "S" STYLIZED LIKE THE TREBLE CLEF SYMBOL IN MUSIC.

FOR ENTERTAINMENT SERVICES IN THE NATURE OF RECORDING, PRODUCTION AND POST-PRODUCTION SERVICES IN THE FIELD OF MUSIC; MUSIC COMPOSITION AND TRANSCRIPTION FOR OTHERS (U.S. CLS. 100, 101 AND 107).

AISHA CLARKE, EXAMINING ATTORNEY

SN 85-129,345. NORTHLAND COLLEGE, ASHLAND, WI. FILED 9-14-2010.

**NORTHLAND COLLEGE**

THE MARK CONSISTS OF STANDARD CHARACTERS WITHOUT CLAIM TO ANY PARTICULAR FONT, STYLE, SIZE, OR COLOR.

NO CLAIM IS MADE TO THE EXCLUSIVE RIGHT TO USE "COLLEGE", APART FROM THE MARK AS SHOWN. FOR EDUCATIONAL SERVICES, NAMELY, PROVIDING COURSES OF INSTRUCTION AT THE COLLEGE LEVEL (U.S. CLS. 100, 101 AND 107).

FIRST USE 10-1-1906; IN COMMERCE 5-1-1972.  
SHAUNIA CARLYLE, EXAMINING ATTORNEY

SN 85-129,880. JUPITER ENTERTAINMENT, INC., KNOXVILLE, TN. FILED 9-15-2010.

**VANISHED WITH BETH HOLLOWAY**

THE MARK CONSISTS OF STANDARD CHARACTERS WITHOUT CLAIM TO ANY PARTICULAR FONT, STYLE, SIZE, OR COLOR.

THE NAME "BETH HOLLOWAY" IDENTIFIES A LIVING INDIVIDUAL WHOSE CONSENT IS OF RECORD.

FOR ENTERTAINMENT IN THE NATURE OF AN ONGOING TRUE CRIME TELEVISION SERIES (U.S. CLS. 100, 101 AND 107).

SCOTT BIBB, EXAMINING ATTORNEY

**CLASS 41—(Continued).**

SN 85-129,909. JUPITER ENTERTAINMENT, INC., KNOXVILLE, TN. FILED 9-15-2010.

**VANISHED**

THE MARK CONSISTS OF STANDARD CHARACTERS WITHOUT CLAIM TO ANY PARTICULAR FONT, STYLE, SIZE, OR COLOR.

FOR ENTERTAINMENT IN THE NATURE OF AN ONGOING TRUE CRIME TELEVISION SERIES (U.S. CLS. 100, 101 AND 107).

SCOTT BIBB, EXAMINING ATTORNEY

SN 85-129,973. THIS LITTLE PIGGY, DAVIS, CA. FILED 9-15-2010.

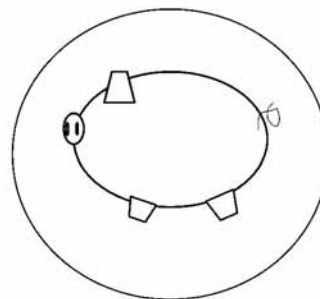

THE MARK CONSISTS OF A CIRCLE WITH A PIG INSIDE.

FOR EDUCATIONAL SERVICES, NAMELY, CONDUCTING CLASSES IN THE FIELD OF INFANT MASSAGE AND DISTRIBUTION OF PRINTED MATERIALS IN CONNECTION THEREWITH IN HARD COPY OR ELECTRONIC FORMAT ON THE SAME TOPICS (U.S. CLS. 100, 101 AND 107).

FIRST USE 4-15-2010; IN COMMERCE 4-15-2010.  
SAMUEL E. SHARPER JR., EXAMINING ATTORNEY

SN 85-131,283. MARKMARK PRODUCTIONS, LLC, NEW YORK, NY. FILED 9-16-2010.

**TRAILSIVIEW**

THE MARK CONSISTS OF STANDARD CHARACTERS WITHOUT CLAIM TO ANY PARTICULAR FONT, STYLE, SIZE, OR COLOR.

FOR PROVIDING AN ON-LINE VISUAL GUIDE TO SKIING, SNOWBOARDING, CYCLING, SNOWSHOEING, MOUNTAIN BIKING AND HIKING TRAILS (U.S. CLS. 100, 101 AND 107).

ASMAT KHAN, EXAMINING ATTORNEY

**CLASS 41—(Continued).**

SN 85-131,690. ARROYO SECO GOLF COURSE LLC., DOVE CANYON, CA. FILED 9-16-2010.

## Arroyo Seco Golf Course

THE MARK CONSISTS OF STANDARD CHARACTERS WITHOUT CLAIM TO ANY PARTICULAR FONT, STYLE, SIZE, OR COLOR.

NO CLAIM IS MADE TO THE EXCLUSIVE RIGHT TO USE "GOLF COURSE", APART FROM THE MARK AS SHOWN.

SEC. 2(F).

FOR GOLF COURSES (U.S. CLS. 100, 101 AND 107).

FIRST USE 6-1-1955; IN COMMERCE 6-1-1955.

MARK SHINER, EXAMINING ATTORNEY

**CLASS 41—(Continued).**

SN 85-132,547. QUARRY INTEGRATED COMMUNICATIONS INC., ST. JACOBS, ONTARIO, CANADA, FILED 9-17-2010.

## MARKETING MONDAYS

THE MARK CONSISTS OF STANDARD CHARACTERS WITHOUT CLAIM TO ANY PARTICULAR FONT, STYLE, SIZE, OR COLOR.

NO CLAIM IS MADE TO THE EXCLUSIVE RIGHT TO USE "MARKETING", APART FROM THE MARK AS SHOWN.

FOR CONDUCTING WORKSHOPS AND SEMINARS IN THE FIELD OF MARKETING (U.S. CLS. 100, 101 AND 107).

FIRST USE 8-9-2010; IN COMMERCE 8-9-2010.

TASNEEM HUSSAIN, EXAMINING ATTORNEY

SN 85-131,848. DRSMARTS, LLC, LOS ANGELES, CA. FILED 9-17-2010.

## eDividend

THE MARK CONSISTS OF STANDARD CHARACTERS WITHOUT CLAIM TO ANY PARTICULAR FONT, STYLE, SIZE, OR COLOR.

FOR EDUCATIONAL SERVICES, NAMELY, PROVIDING TRAINING IN THE FIELDS OF MEDICINE, DENTISTRY, LAW, AND BUSINESS (U.S. CLS. 100, 101 AND 107).

SANI KHOURI, EXAMINING ATTORNEY

SN 85-132,604. OREGON WATER EDUCATION FOUNDATION, OREGON CITY, OR. FILED 9-17-2010.

## ORWEF

SN 85-131,969. MILICH, LISA, BRISTOL, RI. FILED 9-17-2010.



NO CLAIM IS MADE TO THE EXCLUSIVE RIGHT TO USE "LEADERSHIP & WELLNESS CENTER", APART FROM THE MARK AS SHOWN.

THE MARK CONSISTS OF A WOMAN'S FACE TILED UPWARDS WITH HAIR THAT RESEMBLES A DOVE ON THE LEFT SIDE AND A LEAF DESIGN ON THE RIGHT SIDE.

FOR PROVIDING INDIVIDUAL AND GROUP COACHING AND LEARNING FORUMS IN THE FIELD OF LEADERSHIP DEVELOPMENT; EDUCATIONAL AND ENTERTAINMENT SERVICES, NAMELY, PROVIDING MOTIVATIONAL AND EDUCATIONAL SPEAKERS; LIFE COACHING SERVICES IN THE FIELD OF HEALTH, WELLNESS AND EQUINE CONNECTION; EDUCATION SERVICES, NAMELY, PROVIDING MENTORING, TUTORING, CLASSES, SEMINARS, HORSEBACK RIDING AND WORKSHOPS IN THE FIELD OF HEALTH AND WELLNESS (U.S. CLS. 100, 101 AND 107).

REBECCA EISINGER, EXAMINING ATTORNEY

THE MARK CONSISTS OF STANDARD CHARACTERS WITHOUT CLAIM TO ANY PARTICULAR FONT, STYLE, SIZE, OR COLOR.

FOR EDUCATION AND TRAINING SERVICES IN THE FIELD OF CLASSES ON WASTE WATER AND STORM WATER MANAGEMENT FOR WATER QUALITY AND ENVIRONMENTAL PROFESSIONALS (U.S. CLS. 100, 101 AND 107).

FIRST USE 11-19-2009; IN COMMERCE 1-21-2010.

YAT SYE, LEE, EXAMINING ATTORNEY

**CLASS 41—(Continued).**

SN 85-137,586. INTERNATIONAL CAREER DEVELOPMENT CENTER, INC., DBA ICDC COLLEGE, CULVER CITY, CA. FILED 9-24-2010.

**ICDC COLLEGE**

THE MARK CONSISTS OF STANDARD CHARACTERS WITHOUT CLAIM TO ANY PARTICULAR FONT, STYLE, SIZE, OR COLOR.

NO CLAIM IS MADE TO THE EXCLUSIVE RIGHT TO USE "COLLEGE", APART FROM THE MARK AS SHOWN.

FOR EDUCATING AT UNIVERSITY OR COLLEGES; EDUCATIONAL SERVICES, NAMELY, CONDUCTING DISTANCE LEARNING INSTRUCTION AT THE SECONDARY, COLLEGE AND GRADUATE LEVELS; EDUCATIONAL SERVICES, NAMELY, PROVIDING COURSES OF INSTRUCTION AT THE COLLEGE AND POSTSECONDARY LEVEL; EDUCATIONAL SERVICES, NAMELY, PROVIDING COURSES OF INSTRUCTION AT THE COLLEGE AND POSTSECONDARY LEVEL AND DISTRIBUTION OF COURSE MATERIAL IN CONNECTION THEREWITH; PROVIDING A WEB SITE THAT FEATURES INFORMATION ON ATTENDING COLLEGE AND UNIVERSITY WITH AN EMPHASIS ON NEWLY ENROLLED STUDENTS; PROVIDING COURSES OF INSTRUCTION AT THE COLLEGE AND POSTSECONDARY LEVEL; PROVIDING ON-LINE DOCUMENTS FOR APPLICATIONS CONCERNING COLLEGE AND POSTSECONDARY EDUCATION, CLASSES OFFERED AND ADMISSION (U.S. CLS. 100, 101 AND 107).

FIRST USE 11-13-1995; IN COMMERCE 11-13-1995.  
ADA HAN, EXAMINING ATTORNEY

SN 85-138,225. BEST EVER YOU, LLC, FALMOUTH, ME. FILED 9-25-2010.

**BEST EVER YOU**

THE MARK CONSISTS OF STANDARD CHARACTERS WITHOUT CLAIM TO ANY PARTICULAR FONT, STYLE, SIZE, OR COLOR.

FOR ONLINE JOURNALS, NAMELY, BLOGS IN THE FIELDS OF LIFESTYLE, FASHION, BEAUTY, HEALTH AND WELLNESS, BUSINESS AND FINANCIAL INFORMATION; PROVIDING ON-LINE NON-DOWNLOADABLE MAGAZINES AND PUBLICATIONS IN THE NATURE OF AN E-BOOK IN THE FIELD OF LIFESTYLE, FASHION, BEAUTY, HEALTH AND WELLNESS, BUSINESS AND FINANCIAL INFORMATION; ENTERTAINMENT SERVICES, NAMELY, PROVIDING AN ONGOING RADIO AND TELEVISION PROGRAM IN THE FIELD OF LIFESTYLE, FASHION, BEAUTY, HEALTH AND WELLNESS, BUSINESS AND FINANCIAL INFORMATION (U.S. CLS. 100, 101 AND 107).

FIRST USE 7-15-2008; IN COMMERCE 7-15-2008.  
TARAH HARDY, EXAMINING ATTORNEY

**CLASS 41—(Continued).**

SN 85-139,066. AMERICAN SOCIETY FOR REPRODUCTIVE MEDICINE, BIRMINGHAM, AL. FILED 9-27-2010.

**ASRM eLearn**

THE MARK CONSISTS OF STANDARD CHARACTERS WITHOUT CLAIM TO ANY PARTICULAR FONT, STYLE, SIZE, OR COLOR.

OWNER OF U.S. REG. NOS. 2,156,037, 2,344,145 AND OTHERS.

NO CLAIM IS MADE TO THE EXCLUSIVE RIGHT TO USE "ELEARN", APART FROM THE MARK AS SHOWN.

FOR EDUCATIONAL SERVICES IN THE NATURE OF ONLINE INSTRUCTION IN THE FIELD OF REPRODUCTIVE MEDICINE (U.S. CLS. 100, 101 AND 107).

ANNE MADDEN, EXAMINING ATTORNEY

SN 85-140,641. NETGAMIX LLC, CHICAGO, IL. FILED 9-29-2010.

**NETGAMIX**

THE MARK CONSISTS OF STANDARD CHARACTERS WITHOUT CLAIM TO ANY PARTICULAR FONT, STYLE, SIZE, OR COLOR.

FOR ENTERTAINMENT SERVICES, NAMELY PROVIDING ON-LINE VIDEO GAMES, GAMING COMPETITIONS, AND VIDEO GAME QUIZZES (U.S. CLS. 100, 101 AND 107).

ALEXANDER L. POWERS, EXAMINING ATTORNEY

SN 85-142,944. INTERNATIONAL CAREER DEVELOPMENT CENTER, INC., DBA ICDC COLLEGE, CULVER CITY, CA. FILED 10-1-2010.

**ICDC**

THE MARK CONSISTS OF STANDARD CHARACTERS WITHOUT CLAIM TO ANY PARTICULAR FONT, STYLE, SIZE, OR COLOR.

FOR EDUCATIONAL SERVICES, NAMELY, PROVIDING COURSES OF INSTRUCTION AT THE POSTSECONDARY/COLLEGE LEVEL AND DISTRIBUTION OF COURSE MATERIAL IN CONNECTION THEREWITH (U.S. CLS. 100, 101 AND 107).

FIRST USE 11-13-1995; IN COMMERCE 11-13-1995.  
ADA HAN, EXAMINING ATTORNEY



**CLASS 41—(Continued).**

SN 85-144,463. INTERNATIONAL SANITARY SUPPLY ASSOCIATION, LINCOLNWOOD, IL. FILED 10-4-2010.

**ISSA INTERCLEAN**

THE MARK CONSISTS OF STANDARD CHARACTERS WITHOUT CLAIM TO ANY PARTICULAR FONT, STYLE, SIZE, OR COLOR.

OWNER OF U.S. REG. NOS. 2,064,321, 3,827,693 AND OTHERS.

FOR EDUCATIONAL SERVICES, NAMELY, CONDUCTING CONFERENCES IN THE FIELD OF BUSINESS DEVELOPMENT; EXHIBITIONS FOR EDUCATIONAL PURPOSES; EDUCATION SERVICES, NAMELY, CONDUCTING WORKSHOPS, SEMINARS AND CLASSES IN THE FIELD OF COMMERCIAL CLEANING, MAINTENANCE AND BUILDING SERVICES (U.S. CLS. 100, 101 AND 107).

FIRST USE 7-24-1998; IN COMMERCE 7-24-1998.  
AISHA SALEM, EXAMINING ATTORNEY

SN 85-147,849. DAVIS, QUENTIN, TAMPA, FL. FILED 10-7-2010.

**Legendary**

THE MARK CONSISTS OF STANDARD CHARACTERS WITHOUT CLAIM TO ANY PARTICULAR FONT, STYLE, SIZE, OR COLOR.

FOR ENTERTAINMENT IN THE NATURE OF A LIVE MUSICAL PERFORMANCES; ENTERTAINMENT IN THE NATURE OF LIVE PERFORMANCES BY A MUSICAL ARTIST; ENTERTAINMENT, NAMELY, LIVE MUSIC CONCERTS; LIVE PERFORMANCES FEATURING PRERECORDED VOCAL AND INSTRUMENTAL PERFORMANCES VIEWED ON A BIG SCREEN; RECORD PRODUCTION; MUSIC PRODUCTION; AUDIO RECORDING AND PRODUCTION; VIDEOTAPE PRODUCTION; MOTION PICTURE SONG PRODUCTION; PRODUCTION OF VIDEO DISCS FOR OTHERS; RECORDING STUDIOS; ENTERTAINMENT SERVICES, NAMELY, PRODUCTION AND DISTRIBUTION OF MUSICAL AUDIO AND VIDEO PROGRAMS; PRODUCTION AND DISTRIBUTION OF MUSICAL AUDIO AND VIDEO RECORDINGS FOR BROADCAST; MUSIC COMPOSITION AND TRANSCRIPTION FOR OTHERS; SONG WRITING SERVICES; MUSIC PUBLISHING SERVICES; ENTERTAINMENT, NAMELY, PERSONAL APPEARANCES BY A MUSICIAN OR ENTERTAINER; ENTERTAINMENT SERVICES, NAMELY, LIVE, TELEVISED AND MOVIE APPEARANCES BY A PROFESSIONAL ENTERTAINER; ENTERTAINMENT SERVICES, NAMELY, PROVIDING A WEB SITE FEATURING NON-DOWNLOADABLE MUSICAL PERFORMANCES, MUSICAL VIDEOS, AND PHOTOGRAPHS; ENTERTAINMENT SERVICES, NAMELY, PROVIDING NON-DOWNLOADABLE PRERECORDED MUSIC, AND PROVIDING INFORMATION, COMMENTARY AND ARTICLES ABOUT MUSIC, ALL ONLINE VIA A GLOBAL COMPUTER NETWORK; ENTERTAINMENT IN THE NATURE OF LIVE TRAVELING TOUR PERFORMANCES BY A PROFESSIONAL ENTERTAINER FEATURING MUSIC (U.S. CLS. 100, 101 AND 107).

ANDREW LEASER, EXAMINING ATTORNEY

**CLASS 41—(Continued).**

SN 85-148,919. TRUITT, MONTY, MONTEREY, CA. FILED 10-8-2010.

**Zeative Spock**

THE MARK CONSISTS OF STANDARD CHARACTERS WITHOUT CLAIM TO ANY PARTICULAR FONT, STYLE, SIZE, OR COLOR.

FOR MULTIMEDIA CREATIVE ART PRODUCTION SERVICES, NAMELY, FILM AND VIDEO PRODUCTION, PHOTOGRAPHY SERVICES, VIDEOGRAPHY SERVICES, AND PROVIDING AN ONLINE INTERACTIVE DATABASE OF PHOTOS AND VIDEOS IN THE FIELD OF ART (U.S. CLS. 100, 101 AND 107).

YAT SYE, LEE, EXAMINING ATTORNEY

SN 85-149,122. TIMOTHY MONTGOMERY, NEWARK, CA. FILED 10-9-2010.

**Royal-T**

THE MARK CONSISTS OF STANDARD CHARACTERS WITHOUT CLAIM TO ANY PARTICULAR FONT, STYLE, SIZE, OR COLOR.

THE NAME(S), PORTRAIT(S), AND/OR SIGNATURE(S) SHOWN IN THE MARK IDENTIFIES TIMOTHY MONTGOMERY, WHOSE CONSENT(S) TO REGISTER IS MADE OF RECORD.

FOR AUDIO RECORDING AND PRODUCTION; ENTERTAINMENT IN THE NATURE OF LIVE PERFORMANCES BY A HIP-HOP ARTIST/RECORDING ARTIST; ENTERTAINMENT IN THE NATURE OF VISUAL AND AUDIO PERFORMANCES BY A HIP-HOP ARTIST/RECORDING ARTIST; ENTERTAINMENT SERVICES BY A MUSICAL ARTIST AND PRODUCER, NAMELY, MUSICAL COMPOSITION FOR OTHERS AND PRODUCTION OF MUSICAL SOUND RECORDINGS; ENTERTAINMENT SERVICES IN THE NATURE OF LIVE MUSICAL PERFORMANCES; ENTERTAINMENT SERVICES IN THE NATURE OF PRESENTING LIVE MUSICAL PERFORMANCES; ENTERTAINMENT SERVICES IN THE NATURE OF RECORDING, PRODUCTION AND POST-PRODUCTION SERVICES IN THE FIELD OF MUSIC; ENTERTAINMENT SERVICES, NAMELY, DANCE EVENTS BY A RECORDING ARTIST; ENTERTAINMENT SERVICES, NAMELY, LIVE, TELEVISED AND MOVIE APPEARANCES BY A PROFESSIONAL ENTERTAINER; ENTERTAINMENT SERVICES, NAMELY, PERSONAL APPEARANCES BY A HIP-HOP ARTIST/RECORDING ARTIST; ENTERTAINMENT, NAMELY, LIVE MUSIC CONCERTS; ENTERTAINMENT, NAMELY, LIVE PERFORMANCES BY A MUSICAL BAND; ENTERTAINMENT, NAMELY, LIVE PERFORMANCES BY ROCK GROUPS; LIVE PERFORMANCES BY A MUSICAL GROUP; PRODUCTION OF AUDIO RECORDING; RADIO ENTERTAINMENT PRODUCTION; RADIO ENTERTAINMENT SERVICES, NAMELY, RADIO PROGRAMS FEATURING PERFORMANCES BY A HIP-HOP ARTIST/RECORDING ARTIST (U.S. CLS. 100, 101 AND 107).

ELISSA GARBER KON, EXAMINING ATTORNEY

**CLASS 41—(Continued).**

SN 85-149,464. SMILE BRANDS INC., IRVINE, CA. FILED 10-11-2010.



OWNER OF U.S. REG. NOS. 2,453,217, 3,266,011 AND 3,331,039.

THE COLOR(S) LIGHT BLUE, DARK BLUE AND WHITE IS/ARE CLAIMED AS A FEATURE OF THE MARK.

THE MARK CONSISTS OF A WHITE STYLIZED DESIGN OF A TOOTH SUPERIMPOSED ON A SHIELD OR CREST DESIGN THAT IS LIGHT BLUE IN THE UPPER LEFT HAND SIDE AND DARK BLUE IN THE LOWER RIGHT HAND SIDE.

FOR EDUCATIONAL SERVICES, NAMELY, CONDUCTING CLASSES, SEMINARS, WORKSHOPS, CONFERENCES AND SYMPOSIA IN THE FIELD OF DENTISTRY AND DENTAL HEALTH CARE, BUSINESS MANAGEMENT, HUMAN RESOURCE MANAGEMENT, MARKETING AND LEADERSHIP, AND DISTRIBUTION OF COURSE MATERIALS IN CONNECTION THEREWITH; PROVIDING CONTINUING DENTAL EDUCATION COURSES, AND DISTRIBUTING COURSE MATERIALS IN CONNECTION THEREWITH; PROVIDING TRAINING ON ENSURING PATIENT SATISFACTION IN THE FIELD OF DENTISTRY (U.S. CLS. 100, 101 AND 107).

BRENDAN MCCAULEY, EXAMINING ATTORNEY

SN 85-151,589. KHRIPOUNOVA, ELIZAVETA, BEVERLY HILLS, CA. FILED 10-13-2010.

## ELIZAVETA

THE MARK CONSISTS OF STANDARD CHARACTERS WITHOUT CLAIM TO ANY PARTICULAR FONT, STYLE, SIZE, OR COLOR.

THE NAME "ELIZAVETA" IN THE MARK IDENTIFIES "ELIZAVETA" KHRIPOUNOVA, A LIVING INDIVIDUAL WHOSE CONSENT IS OF RECORD.

FOR ENTERTAINMENT SERVICES, NAMELY, LIVE PERFORMANCES BY A MUSICAL ENTERTAINER; PROVIDING A WEBSITE FEATURING INFORMATION ABOUT A MUSICAL ENTERTAINER AND THE ENTERTAINER'S MUSIC AND FEATURING NON-DOWNLOADABLE AUDIOVISUAL AND SOUND RECORDINGS FEATURING MUSIC AS WELL AS MUSICAL PERFORMANCE TOUR INFORMATION AND OTHER INFORMATION ABOUT THE MUSICAL PERFORMER (U.S. CLS. 100, 101 AND 107).

FIRST USE 3-7-2005; IN COMMERCE 3-7-2005.

LINDA ESTRADA, EXAMINING ATTORNEY

**CLASS 41—(Continued).**

SN 85-155,553. THE BRIGHT LIGHT SOCIAL HOUR, LLC, AUSTIN, TX. FILED 10-18-2010.

## The Bright Light Social Hour

THE MARK CONSISTS OF STANDARD CHARACTERS WITHOUT CLAIM TO ANY PARTICULAR FONT, STYLE, SIZE, OR COLOR.

FOR ENTERTAINMENT SERVICES, NAMELY, LIVE PERFORMANCES AND PERSONAL APPEARANCES BY A MUSICAL ARTIST; AUDIO AND VIDEO RECORDING SERVICES, PRODUCTION OF VIDEO AND AUDIO RECORDINGS ON CASSETTES, DVDS, COMPACT DISCS, RECORDS AND IN DIGITAL FORMATS FEATURING MUSIC; ENTERTAINMENT SERVICES, NAMELY, PROVIDING ONLINE NON-DOWNLOADABLE PRERECORDED MUSIC AND PROVIDING A WEBSITE FEATURING NON-DOWNLOADABLE ONLINE VIDEOS NAMELY, MUSIC VIDEOS, VIA A GLOBAL COMPUTER NETWORK (U.S. CLS. 100, 101 AND 107).

FIRST USE 9-1-2004; IN COMMERCE 12-1-2004.

SUE LAWRENCE, EXAMINING ATTORNEY

SN 85-157,627. AIROTIQUE MOVEMENT LLC, DBA AIROTIQUE MOVEMENT, VIRGINIA BEACH, VA. AND CYNTHIA SMITH, DBA AIROTIQUE MOVEMENT, VIRGINIA BEACH, VA. FILED 10-21-2010.

## AIrotique Movement

THE MARK CONSISTS OF STANDARD CHARACTERS WITHOUT CLAIM TO ANY PARTICULAR FONT, STYLE, SIZE, OR COLOR.

NO CLAIM IS MADE TO THE EXCLUSIVE RIGHT TO USE "MOVEMENT", APART FROM THE MARK AS SHOWN.

FOR EDUCATIONAL SERVICES, NAMELY, DEVELOPING, ARRANGING, AND CONDUCTING EDUCATIONAL CONFERENCES AND PROGRAMS AND PROVIDING COURSES OF INSTRUCTION IN THE FIELD OF SILK FITNESS; INSTRUCTION IN THE FIELD OF SILK FITNESS; PERSONAL FITNESS TRAINING SERVICES AND CONSULTANCY; PERSONAL FITNESS TRAINING SERVICES FEATURING AEROBIC AND ANAEROBIC ACTIVITIES COMBINED WITH RESISTANCE AND FLEXIBILITY TRAINING; PHYSICAL FITNESS CONDITIONING CLASSES; PHYSICAL FITNESS INSTRUCTION; PHYSICAL FITNESS STUDIO SERVICES, NAMELY, PROVIDING EXERCISE CLASSES, BODY SCULPTING CLASSES, AND GROUP FITNESS CLASSES; PHYSICAL FITNESS STUDIO SERVICES, NAMELY, PROVIDING GROUP EXERCISE INSTRUCTION, EQUIPMENT, AND FACILITIES;

**CLASS 41—(Continued).**

PHYSICAL FITNESS TRAINING OF INDIVIDUALS AND GROUPS; PHYSICAL FITNESS TRAINING SERVICES; PROVIDING ASSISTANCE, PERSONAL TRAINING AND PHYSICAL FITNESS CONSULTATION TO INDIVIDUALS TO HELP THEM MAKE PHYSICAL FITNESS, STRENGTH, CONDITIONING, AND EXERCISE IMPROVEMENT IN THEIR DAILY LIVING; PROVIDING CLASSES, WORKSHOPS, SEMINARS AND CAMPS IN THE FIELDS OF FITNESS, EXERCISE, BOXING, KICK BOXING AND MIXED MARTIAL ARTS; PROVIDING FITNESS AND EXERCISE FACILITIES; PROVIDING FITNESS AND EXERCISE STUDIO SERVICES, NAMELY, PILATES INSTRUCTION AND TRAINING; PROVIDING FITNESS AND EXERCISE STUDIO SERVICES, NAMELY, PROVIDING PILATES APPARATUSES AND TENNIS TRAINING EQUIPMENT; PROVIDING GENERAL FITNESS AND MIXED MARTIAL ARTS FACILITIES THAT REQUIRE MEMBERSHIPS AND ARE FOCUSED IN THE FIELDS OF GENERAL FITNESS, EXERCISE, AND MIXED MARTIAL ARTS (U.S. CLS. 100, 101 AND 107).

SEAN CROWLEY, EXAMINING ATTORNEY

---

SN 85-159,798. EUBANKS SAMMY D., POST FALLS, ID. FILED 10-24-2010.

**SAMMY EUBANKS**

THE MARK CONSISTS OF STANDARD CHARACTERS WITHOUT CLAIM TO ANY PARTICULAR FONT, STYLE, SIZE, OR COLOR.

THE NAME(S), PORTRAIT(S), AND/OR SIGNATURE(S) SHOWN IN THE MARK IDENTIFIES "SAMMY D. EUBANKS", WHOSE CONSENT(S) TO REGISTER IS MADE OF RECORD.

FOR ARRANGING AND CONDUCTING NIGHTCLUB ENTERTAINMENT EVENTS; ARRANGING FOR TICKET RESERVATIONS FOR SHOWS AND OTHER ENTERTAINMENT EVENTS; ARRANGING, ORGANIZING, CONDUCTING, AND HOSTING SOCIAL ENTERTAINMENT EVENTS; BOOKING OF ENTERTAINMENT HALLS; ENTERTAINMENT IN THE NATURE OF VISUAL AND AUDIO PERFORMANCES, NAMELY, MUSICAL BAND, ROCK GROUP, GYMNASTIC, DANCE, AND BALLET PERFORMANCES; ENTERTAINMENT SERVICES IN THE NATURE OF PRESENTING LIVE MUSICAL PERFORMANCES; ENTERTAINMENT, NAMELY, LIVE MUSIC CONCERTS; ENTERTAINMENT, NAMELY, LIVE PERFORMANCES BY A MUSICAL BAND; ENTERTAINMENT, NAMELY, LIVE PERFORMANCES BY MUSICAL BANDS; ENTERTAINMENT, NAMELY, LIVE PERFORMANCES BY ROCK GROUP; LIVE PERFORMANCES BY A MUSICAL GROUP; PLANNING ARRANGEMENT OF SHOWING MOVIES, SHOWS, PLAYS OR MUSICAL PERFORMANCES; PRESENTATION OF LIVE SHOW PERFORMANCES (U.S. CLS. 100, 101 AND 107).

FIRST USE 6-27-1997; IN COMMERCE 6-27-1997.

KAREN K. BUSH, EXAMINING ATTORNEY

**CLASS 41—(Continued).**

SN 85-160,104. SAME DAY TRANSLATIONS, PLEASANT GROVE, UT. FILED 10-25-2010.



NO CLAIM IS MADE TO THE EXCLUSIVE RIGHT TO USE "SAME DAY TRANSLATIONS", APART FROM THE MARK AS SHOWN.

THE MARK CONSISTS OF THE WORDING "SAMEDAY TRANSLATIONS" ABOVE A DESIGN OF TWO SPEECH BUBBLES WITH A CLOCK FACE IN BETWEEN.

FOR TRANSLATION AND LANGUAGE INTERPRETING SERVICES (U.S. CLS. 100, 101 AND 107).

FIRST USE 10-4-2007; IN COMMERCE 10-4-2007.

YAT SYE, LEE, EXAMINING ATTORNEY

---

SN 85-160,236. IDLE GAMES, INC., SAN FRANCISCO, CA. FILED 10-25-2010.

**GOD2GO**

THE MARK CONSISTS OF STANDARD CHARACTERS WITHOUT CLAIM TO ANY PARTICULAR FONT, STYLE, SIZE, OR COLOR.

FOR PROVIDING ENTERTAINMENT IN THE NATURE OF ELECTRONIC GAMES, AND MULTIPLAYER ELECTRONIC GAMING, AND MULTIPLAYER GAME COMPETITIONS, ALL BY MEANS OF ELECTRONIC OR OPTICAL COMMUNICATIONS NETWORKS; PROVIDING INFORMATION, NON-DOWNLOADABLE PUBLICATIONS IN THE NATURE OF NEWSLETTERS, MAGAZINES, REPORTS, JOURNALS, WIKIS AND MANUALS, AND ADVICE, ALL BY MEANS OF ELECTRONIC OR OPTICAL NETWORKS, IN THE FIELDS OF ELECTRONIC ENTERTAINMENT, GAMES, AMUSEMENT TYPE ACTIVITY GAMES AND MULTIPLAYER GAME COMPETITIONS; PROVIDING LINKS TO THE WEBSITES OF OTHERS IN THE FIELDS OF ELECTRONIC ENTERTAINMENT, GAMES, AMUSEMENT TYPE ACTIVITY GAMES AND MULTIPLAYER GAME COMPETITIONS; PROVIDING A WEBSITE FEATURING ONLINE COMPUTER GAMES, MUSICAL PERFORMANCES, MUSICAL VIDEOS, RELATED FILM CLIPS, PHOTOGRAPHS AND OTHER MULTIMEDIA MATERIALS, NAMELY, BLOGS AND NON-DOWNLOADABLE PUBLICATIONS IN THE NATURE OF NEWSLETTERS, MAGAZINES, REPORTS, JOURNALS, WIKIS AND MANUALS, AND ADVICE IN THE FIELDS OF ELECTRONIC ENTERTAINMENT, GAMES, AMUSEMENT TYPE ACTIVITY GAMES AND MULTIPLAYER GAME COMPETITIONS (U.S. CLS. 100, 101 AND 107).

DAVID I, EXAMINING ATTORNEY

**CLASS 41—(Continued).**

SN 85-161,541. BRAVO, ALECO, WASHINGTON, DC. AND D'ANDREA, CHRISTIAN, RESTON, VA. FILED 10-26-2010.

## Wiseguy Rehab

THE MARK CONSISTS OF STANDARD CHARACTERS WITHOUT CLAIM TO ANY PARTICULAR FONT, STYLE, SIZE, OR COLOR.

FOR PRODUCTION AND DISTRIBUTION OF TELEVISION PROGRAMS AND MOTION PICTURES (U.S. CLS. 100, 101 AND 107).

JAMES GRIFFIN, EXAMINING ATTORNEY

SN 85-161,942. WORLD RECORD SUMMIT, LLC, VENICE, CA. FILED 10-26-2010.



NO CLAIM IS MADE TO THE EXCLUSIVE RIGHT TO USE "WORLD RECORD SUMMIT", APART FROM THE MARK AS SHOWN.

THE COLOR(S) BLACK, ORANGE AND WHITE IS/ARE CLAIMED AS A FEATURE OF THE MARK.

THE MARK CONSISTS OF THE LETTERS "WRS" IN WHITE WITH A BLACK BACKGROUND AND WHITE BORDER AND BELOW IS THE LETTERS "WORLD RECORD SUMMIT" IN BLACK WITH A ORANGE BACKGROUND.

FOR ENTERTAINMENT IN THE NATURE OF AN ONGOING SPECIAL VARIETY, NEWS, MUSIC OR COMEDY SHOW FEATURING ELITE ACTION SPORTS ATHLETES, MUSICAL ACTS AND CELEBRITIES BROADCAST OVER TELEVISION, SATELLITE, AUDIO, AND VIDEO MEDIA; ENTERTAINMENT IN THE NATURE OF VISUAL AND AUDIO PERFORMANCES, AND MUSICAL, VARIETY, NEWS AND COMEDY SHOWS; ENTERTAINMENT IN THE NATURE OF A LIVE TELEVISION SHOW BROADCASTED VIA PAY-PER-VIEW AND INTERNET STREAMING FEATURING ELITE ACTION SPORTS ATHLETES, MUSICAL ACTS AND CELEBRITIES; ENTERTAINMENT SERVICES IN THE NATURE OF CREATION, DEVELOPMENT, AND PRODUCTION OF TELEVISION PROGRAMMING; ENTERTAINMENT SERVICES, NAMELY, LIVE, TELEVISED AND MOVIE APPEARANCES BY A PROFESSIONAL ENTERTAINER; OPERATION OF VIDEO EQUIPMENT OR AUDIO EQUIPMENT ETC. FOR PRODUCTION OF RADIO OR TELEVISION PROGRAMS; PRESENTATION OF LIVE SHOW PERFORMANCES; PRODUCTION OF CABLE TELEVISION PROGRAMS; PRODUCTION OF DVDS, VIDEOTAPES AND TELEVISION PROGRAMS FEATURING ELITE ACTION SPORTS ATHLETES, MUSICAL ACTS AND CELEBRITIES; PRODUCTION OF TELEVISION PROGRAMS; PROVIDING ON-LINE ENTERTAINMENT INFORMATION, NAMELY, INFORMATION ABOUT TELEVISION PROGRAMMING; TELEVISION SHOW PRODUCTION; TELEVISION, VIDEO AND MOVIE FILMING SERVICES (U.S. CLS. 100, 101 AND 107).

FIRST USE 10-1-2008; IN COMMERCE 10-1-2008.

LOURDES AYALA, EXAMINING ATTORNEY

**CLASS 41—(Continued).**

SN 85-162,143. ASSOCIATION SERVICES OF AMERICA, INC., CENTERVILLE, MA. FILED 10-27-2010.

## The WTA Wise Traveler

THE MARK CONSISTS OF STANDARD CHARACTERS WITHOUT CLAIM TO ANY PARTICULAR FONT, STYLE, SIZE, OR COLOR.

OWNER OF U.S. REG. NOS. 2,407,161, 2,519,494 AND 3,011,205.

NO CLAIM IS MADE TO THE EXCLUSIVE RIGHT TO USE "TRAVELER", APART FROM THE MARK AS SHOWN.

FOR ON-LINE ELECTRONIC NEWSLETTERS DELIVERED BY E-MAIL REGARDING TRAVEL NEWS, TRAVEL ADVICE AND TRAVEL SAFETY INFORMATION (U.S. CLS. 100, 101 AND 107).

FIRST USE 5-1-2000; IN COMMERCE 5-1-2000.

EUGENIA MARTIN, EXAMINING ATTORNEY

SN 85-163,896. MENDEZ & COMPANY, SAN JUAN, PUERTO RICO, FILED 10-28-2010.



NO CLAIM IS MADE TO THE EXCLUSIVE RIGHT TO USE "PUERTO RICO WINE CHALLENGE", APART FROM THE MARK AS SHOWN.

THE COLOR(S) LIGHT GREEN, MEDIUM GREEN, DARK GREEN AND BROWN IS/ARE CLAIMED AS A FEATURE OF THE MARK.

THE MARK CONSISTS OF AN ILLUSTRATION OF THREE WINE BOTTLES IN DARK GREEN VISUALLY INVERTED BY CIRCLES REPRESENTATIVE OF A CLUSTER OF GRAPES IN MEDIUM GREEN AND BROWN, WITH A GREEN GRAPE LEAF ON TOP OF THE BOTTLES. AT THE CENTER OF THE IMAGE IS THE LETTER "W" IN MEDIUM GREEN, THE ENTIRE IMAGE CONTAINED IN A DARK BROWN CIRCLE WITH THE LITERAL ELEMENT "PUERTO RICO WINE CHALLENGE" IN BROWN ALL INCLUDED WITHIN A MEDIUM GREEN SQUARE.

FOR ENTERTAINMENT SERVICES, NAMELY, WINE TASTINGS (U.S. CLS. 100, 101 AND 107).

FIRST USE 10-21-2010; IN COMMERCE 10-21-2010.

FONG HSU, EXAMINING ATTORNEY

**CLASS 41—(Continued).**

SN 85-164,663. 2030, INC., SANTA FE, NM. FILED 10-29-2010.

## 2030 Palette

THE MARK CONSISTS OF STANDARD CHARACTERS WITHOUT CLAIM TO ANY PARTICULAR FONT, STYLE, SIZE, OR COLOR.

NO CLAIM IS MADE TO THE EXCLUSIVE RIGHT TO USE "2030", APART FROM THE MARK AS SHOWN.

FOR EDUCATION SERVICES, NAMELY, PROVIDING ON-LINE INTERACTIVE EDUCATIONAL DESIGN PROGRAMS TO END USERS IN THE FIELD OF DESIGNING ENVIRONMENTALLY RESPONSIBLE AND RESILIENT BUILDINGS AND COMMUNITIES (U.S. CLS. 100, 101 AND 107).

TARA PATE, EXAMINING ATTORNEY

**CLASS 41—(Continued).**

SN 85-166,828. INSTITUTE OF HOLISTIC MIDWIFERY, LLC, MILTON, DE. FILED 11-2-2010.



NO CLAIM IS MADE TO THE EXCLUSIVE RIGHT TO USE "INSTITUTE OF HOLISTIC MIDWIFERY", APART FROM THE MARK AS SHOWN.

THE COLOR(S) PURPLE IS/ARE CLAIMED AS A FEATURE OF THE MARK.

THE MARK CONSISTS OF A MULTI-PETAL LOTUS FLOWER WITH CENTER AND PETALS IN VARYING SHADES OF PURPLE SURROUNDED BY THE WORDS "INSTITUTE OF HOLISTIC MIDWIFERY" IN DARK PURPLE LETTERING.

FOR CONTINUING EDUCATION SERVICES, NAMELY, PROVIDING LIVE AND ON-LINE CONTINUING PROFESSIONAL EDUCATION SEMINARS IN THE FIELD OF MIDWIFERY; EDUCATION SERVICES, NAMELY, PROVIDING LIVE AND ON-LINE CLASSES AND WORKSHOPS IN THE FIELD OF MIDWIFERY; PROVIDING COURSES OF INSTRUCTION AT THE POST-SECONDARY LEVEL (U.S. CLS. 100, 101 AND 107).

FIRST USE 9-15-2010; IN COMMERCE 9-15-2010.  
DAVID TAYLOR, EXAMINING ATTORNEY

SN 85-165,570. WALTERS, DAVID C., ALISO VIEJO, CA. FILED 10-30-2010.

## The 2nd most important book your kids will ever read

THE MARK CONSISTS OF STANDARD CHARACTERS WITHOUT CLAIM TO ANY PARTICULAR FONT, STYLE, SIZE, OR COLOR.

FOR BOOK PUBLISHING (U.S. CLS. 100, 101 AND 107).  
FIRST USE 8-10-2009; IN COMMERCE 9-2-2010.  
JOHN E. MICHOS, EXAMINING ATTORNEY

SN 85-166,547. THE RUNNING DOG RANCH, CORTE MADERA, CA. FILED 11-1-2010.



THE COLOR(S) WHITE, BLACK, GRAYISH BLUE, GREEN AND ORANGE IS/ARE CLAIMED AS A FEATURE OF THE MARK.

THE MARK CONSISTS OF A MOUNTAIN RANGE OF GRAYISH BLUE ON A WHITE BACKGROUND WITH WOMAN AND DOG RUNNING IN BLACK WITH THE WORDS "THE RUNNING DOG RANCH" IN THE COLORS GRAYISH BLUE, GREEN AND ORANGE. "THE" AND "RANCH" ARE IN GREEN, "RUNNING" IS IN GRAYISH BLUE, AND "DOG" IS IN ORANGE.

FOR DOG TRAINING (U.S. CLS. 100, 101 AND 107).  
FIRST USE 9-1-2010; IN COMMERCE 9-1-2010.  
THOMAS MANOR, EXAMINING ATTORNEY

SN 85-167,732. HEISEL, JACQUELINE, NORTH ADAMS, MA. FILED 11-3-2010.

## ENVISION YOGA

THE MARK CONSISTS OF STANDARD CHARACTERS WITHOUT CLAIM TO ANY PARTICULAR FONT, STYLE, SIZE, OR COLOR.

NO CLAIM IS MADE TO THE EXCLUSIVE RIGHT TO USE "YOGA", APART FROM THE MARK AS SHOWN.

FOR PROVIDING YOGA INSTRUCTIONS AND CLASSES; PROVIDING HEALTH AND FITNESS RELATED EDUCATION FOR SELF DEVELOPMENT (U.S. CLS. 100, 101 AND 107).

GINA HAYES, EXAMINING ATTORNEY

**CLASS 41—(Continued).**

SN 85-168,528. CHICAGO CITY MOMS, INC., CHICAGO, IL. FILED 11-3-2010.

**BUMP CLUB**

THE MARK CONSISTS OF STANDARD CHARACTERS WITHOUT CLAIM TO ANY PARTICULAR FONT, STYLE, SIZE, OR COLOR.

NO CLAIM IS MADE TO THE EXCLUSIVE RIGHT TO USE "CLUB", APART FROM THE MARK AS SHOWN.

FOR ARRANGING, ORGANIZING, CONDUCTING, AND HOSTING SOCIAL ENTERTAINMENT EVENTS; EDUCATIONAL SERVICES, NAMELY, ARRANGING, CONDUCTING, AND ORGANIZING LECTURES, SEMINARS AND AN EDUCATIONAL PANEL DISCUSSION SERIES RELATING TO PRE-NATAL AND POST-NATAL ISSUES (U.S. CLS. 100, 101 AND 107).

FIRST USE 3-2-2010; IN COMMERCE 3-2-2010.

SETH A. RAPPAPORT, EXAMINING ATTORNEY

SN 85-168,547. CHICAGO CITY MOMS, INC., CHICAGO, IL. FILED 11-3-2010.

**BUMP CLUB AND BEYOND**

THE MARK CONSISTS OF STANDARD CHARACTERS WITHOUT CLAIM TO ANY PARTICULAR FONT, STYLE, SIZE, OR COLOR.

NO CLAIM IS MADE TO THE EXCLUSIVE RIGHT TO USE "CLUB", APART FROM THE MARK AS SHOWN.

FOR ARRANGING, ORGANIZING, CONDUCTING, AND HOSTING SOCIAL ENTERTAINMENT EVENTS; EDUCATIONAL SERVICES, NAMELY, ARRANGING, CONDUCTING, AND ORGANIZING LECTURES, SEMINARS AND AN EDUCATIONAL PANEL DISCUSSION SERIES RELATING TO PRE-NATAL AND POST-NATAL ISSUES (U.S. CLS. 100, 101 AND 107).

SETH A. RAPPAPORT, EXAMINING ATTORNEY

**CLASS 41—(Continued).**

SN 85-170,381. K'HILLAH K'DOSHAH B'NAI YESHURUN, DBA ISAAC M. WISE TEMPLE, CINCINNATI, OH. FILED 11-5-2010.



NO CLAIM IS MADE TO THE EXCLUSIVE RIGHT TO USE "CINCINNATI CHOCOLATE FESTIVAL EST. 2010", APART FROM THE MARK AS SHOWN.

THE COLOR(S) BROWN, GREEN AND WHITE IS/ARE CLAIMED AS A FEATURE OF THE MARK.

THE MARK CONSISTS OF THE FOLLOWING: THE WORDING "CINCINNATI CHOCOLATE FESTIVAL EST. 2010" AND THE DESIGN OF A STYLIZED BROWN AND WHITE CHOCOLATE BAR SET ABOVE THREE CONCENTRIC CIRCLES IN GREEN AND BROWN, AND A CURVED DECORATIVE GREEN LINE. THE WORDING "CINCINNATI FESTIVAL" APPEARS IN BROWN, THE WORDING "CHOCOLATE" APPEARS IN WHITE, AND THE WORDING "EST. 2010" APPEARS IN GREEN.

FOR ENTERTAINMENT IN THE NATURE OF CHOCOLATE FESTIVALS (U.S. CLS. 100, 101 AND 107).

FIRST USE 4-30-2010; IN COMMERCE 4-30-2010.

SEAN CROWLEY, EXAMINING ATTORNEY

SN 85-170,541. NATIONAL ALLIANCE OF PRIVATE CLUBS, INC., ATLANTA, GA. FILED 11-5-2010.



OWNER OF U.S. REG. NO. 1,896,551.

NO CLAIM IS MADE TO THE EXCLUSIVE RIGHT TO USE "NATIONAL ALLIANCE OF PRIVATE CLUBS", APART FROM THE MARK AS SHOWN.

THE MARK CONSISTS OF A STYLIZED CAPITAL LETTER "A" SURROUNDED BY A STYLIZED RECTANGULAR BORDER FEATURING THE STYLIZED WORDING "NATIONAL ALLIANCE OF PRIVATE CLUBS" ALONG THE BORDER.

FOR GOLF AND COUNTRY CLUB SERVICES (U.S. CLS. 100, 101 AND 107).

BERYL GARDNER, EXAMINING ATTORNEY

**CLASS 41—(Continued).**

SN 85-171,126. NOVANTIUM SA DE CV, SALTILLO, MEXICO, FILED 11-8-2010.



THE COLOR(S) LIGHT BLUE, DARK BLUE, PURPLE, RED, GREEN, ORANGE, WHITE AND GRAY IS/ARE CLAIMED AS A FEATURE OF THE MARK.

THE MARK CONSISTS OF THE LETTERS "A", "N" AND "Q" APPEARING IN LIGHT BLUE, THE LETTERS "C" AND "T" APPEARING IN PURPLE, THE LETTERS "T" AND "S" APPEARING IN RED, THE LETTERS "I" AND "U" APPEARING IN GREEN, THE LETTERS "O" AND "E" APPEARING IN ORANGE WITH ALL LETTERS OUTLINED IN WHITE AND APPEARING ON A BACKGROUND OF BLUE OUTLINED IN WHITE, ALL WITH A GRAY CIRCULAR BORDER.

FOR CHILDREN'S ENTERTAINMENT AND AMUSEMENT CENTERS, NAMELY, INTERACTIVE PLAY AREAS (U.S. CLS. 100, 101 AND 107).

ANNE E. GUSTASON, EXAMINING ATTORNEY

SN 85-171,129. NOVANTIUM SA DE CV, SALTILLO, MEXICO, FILED 11-8-2010.

## Action Quest

THE MARK CONSISTS OF STANDARD CHARACTERS WITHOUT CLAIM TO ANY PARTICULAR FONT, STYLE, SIZE, OR COLOR.

FOR CHILDREN'S ENTERTAINMENT AND AMUSEMENT CENTERS, NAMELY, INTERACTIVE PLAY AREAS (U.S. CLS. 100, 101 AND 107).

ANNE E. GUSTASON, EXAMINING ATTORNEY

SN 85-171,784. SEATTLE TILTH ASSOCIATION, SEATTLE, WA. FILED 11-8-2010.

## SEATTLE TILTH

THE MARK CONSISTS OF STANDARD CHARACTERS WITHOUT CLAIM TO ANY PARTICULAR FONT, STYLE, SIZE, OR COLOR.

SEC. 2(F).

FOR EDUCATIONAL SERVICES, NAMELY, PROVIDING CLASSES AND WORKSHOPS IN THE FIELDS OF ORGANIC GARDENING (U.S. CLS. 100, 101 AND 107).

FIRST USE 12-31-1996; IN COMMERCE 12-31-1996.

JASON BLAIR, EXAMINING ATTORNEY

**CLASS 41—(Continued).**

SN 85-172,858. BASTIC, SHAWN, AURORA, IL. FILED 11-9-2010.

## Chicago Riot

THE MARK CONSISTS OF STANDARD CHARACTERS WITHOUT CLAIM TO ANY PARTICULAR FONT, STYLE, SIZE, OR COLOR.

NO CLAIM IS MADE TO THE EXCLUSIVE RIGHT TO USE "CHICAGO", APART FROM THE MARK AS SHOWN.

FOR ENTERTAINMENT IN THE NATURE OF FOOTBALL GAMES; ENTERTAINMENT IN THE NATURE OF COMPETITIONS IN THE FIELD OF RUNNING; ENTERTAINMENT IN THE NATURE OF RUGBY GAMES; ENTERTAINMENT IN THE NATURE OF SOCCER GAMES; PROVIDING A WEBSITE CONTAINING INFORMATION RELATING TO THE SPORT OF RUGBY, INCLUDING TEAM INFORMATION, PLAYER STATISTICS AND NEWS; PROVIDING A WEBSITE CONTAINING INFORMATION RELATING TO THE SPORT OF SOCCER, INCLUDING TEAM INFORMATION, PLAYER STATISTICS AND NEWS (U.S. CLS. 100, 101 AND 107).

FIRST USE 10-11-2006; IN COMMERCE 1-1-2007.

ALEXANDER L. POWERS, EXAMINING ATTORNEY

SN 85-173,177. THE CONTEMPORARY YOUTH ORCHESTRA, CLEVELAND HEIGHTS, OH. FILED 11-10-2010.

## CONTEMPORARY YOUTH ORCHESTRA

THE MARK CONSISTS OF STANDARD CHARACTERS WITHOUT CLAIM TO ANY PARTICULAR FONT, STYLE, SIZE, OR COLOR.

NO CLAIM IS MADE TO THE EXCLUSIVE RIGHT TO USE "ORCHESTRA", APART FROM THE MARK AS SHOWN.

SEC. 2(F).

FOR ENTERTAINMENT IN THE NATURE OF ORCHESTRA PERFORMANCES (U.S. CLS. 100, 101 AND 107).

FIRST USE 12-9-1995; IN COMMERCE 12-9-1995.

CHERYL CLAYTON, EXAMINING ATTORNEY

**CLASS 41—(Continued).**

SN 85-173,220. WAY COOL COOKING SCHOOL INCORPORATED, SAVAGE, MN. FILED 11-10-2010.

## WAY-COOL Cooking School

THE MARK CONSISTS OF STANDARD CHARACTERS WITHOUT CLAIM TO ANY PARTICULAR FONT, STYLE, SIZE, OR COLOR.

NO CLAIM IS MADE TO THE EXCLUSIVE RIGHT TO USE "COOKING SCHOOL", APART FROM THE MARK AS SHOWN.

FOR ARRANGING, ORGANIZING, CONDUCTING AND HOSTING BIRTHDAY PARTIES; DAY CAMP SERVICES; EDUCATION SERVICES, NAMELY, PROVIDING CLASSES AND WORKSHOPS IN THE FIELD OF COOKING, CORPORATE TEAM BUILDING, CULINARY SKILL TRAINING; EDUCATIONAL AND ENTERTAINMENT SERVICES FOR CHILDREN, NAMELY, PROVIDING INTERACTIVE PLAY AREAS, INSTRUCTIONAL CLASSES IN THE FIELD OF COOKING AND SOCIAL GATHERINGS FOR CHILDREN; EDUCATIONAL SERVICES IN THE NATURE OF COOKING SCHOOLS; ENTERTAINMENT SERVICES, NAMELY, CONDUCTING PARTIES (U.S. CLS. 100, 101 AND 107).

FIRST USE 10-22-2004; IN COMMERCE 10-22-2004.  
CHERYL CLAYTON, EXAMINING ATTORNEY

SN 85-174,721. STRATEGIC ENERGY COACHING, INC, SAN DIEGO, CA. FILED 11-11-2010.

## The Synergy Solution

THE MARK CONSISTS OF STANDARD CHARACTERS WITHOUT CLAIM TO ANY PARTICULAR FONT, STYLE, SIZE, OR COLOR.

NO CLAIM IS MADE TO THE EXCLUSIVE RIGHT TO USE "SYNERGY", APART FROM THE MARK AS SHOWN.

FOR EDUCATIONAL SERVICES, NAMELY, CONDUCTING CLASSES, SEMINARS, CONFERENCES, WORKSHOPS IN THE FIELD OF EMPLOYEE PERFORMANCE AND WELLNESS AND DISTRIBUTION OF COURSE MATERIAL IN CONNECTION THEREWITH (U.S. CLS. 100, 101 AND 107).

FIRST USE 8-1-2010; IN COMMERCE 9-9-2010.  
EUGENIA MARTIN, EXAMINING ATTORNEY

**CLASS 41—(Continued).**

SN 85-174,943. LUXURY MUSIC GROUP ENTERTAINMENT, JAMAICA, NY. FILED 11-11-2010.



NO CLAIM IS MADE TO THE EXCLUSIVE RIGHT TO USE "MUSIC GROUP ENTERTAINMENT", APART FROM THE MARK AS SHOWN.

THE MARK CONSISTS OF THE STYLIZED TEXT "LMG LUXURY MUSIC GROUP ENTERTAINMENT" WITHIN A RECTANGLE.

FOR MUSIC VIDEO PRODUCTION; VIDEO PRODUCTION SERVICES (U.S. CLS. 100, 101 AND 107).

TAMARA FRAZIER, EXAMINING ATTORNEY

SN 85-174,976. OKRONGLY, ANTHONY J, ARLINGTON, TX. AND OKRONGLY, DONNA D, ARLINGTON, TX. FILED 11-11-2010.

## Calm Dog

THE MARK CONSISTS OF STANDARD CHARACTERS WITHOUT CLAIM TO ANY PARTICULAR FONT, STYLE, SIZE, OR COLOR.

NO CLAIM IS MADE TO THE EXCLUSIVE RIGHT TO USE "DOG", APART FROM THE MARK AS SHOWN.

FOR ANIMAL TRAINING; DOG TRAINING; KENNEL SERVICES, NAMELY, DOG TRAINING SERVICES; OBEDIENCE SCHOOL TRAINING FOR ANIMALS; PET OBEDIENCE TRAINING SERVICES; PET TRAINING SERVICES; PROVIDING INFORMATION AND ADVICE IN THE FIELD OF PET TRAINING; TRAINING ANIMALS FOR OTHERS; TRAINING SERVICES IN THE FIELD OF DOGS (U.S. CLS. 100, 101 AND 107).

FIRST USE 11-1-2010; IN COMMERCE 11-1-2010.  
MATTHEW EINSTEIN, EXAMINING ATTORNEY



**CLASS 41—(Continued).**

SN 85-174,988. FEINBERG, BONNIE N., REDMOND, WA.  
FILED 11-11-2010.



NO CLAIM IS MADE TO THE EXCLUSIVE RIGHT TO USE "GROUP", APART FROM THE MARK AS SHOWN.

THE MARK CONSISTS OF THE WORDS "LAYER FIVE GROUP" ARRANGED IN A CIRCLE WHICH IS ENCLOSED WITHIN FIVE CONCENTRIC CIRCLES OF EVER INCREASING WIDTHS AND EVER REDUCING SPACING FROM THE INSIDE MOST CIRCLE TO THE OUTSIDE MOST CIRCLE.

FOR MULTIMEDIA PUBLISHING OF PRINTED MATERIALS, AUDIO AND VIDEO RECORDINGS, DIGITAL MEDIA, AND OF COMPUTER SOFTWARE IN THE NATURE OF CREATIVE WORKS IN MANY GENRES (U.S. CLS. 100, 101 AND 107).

Laurie Mayes, Examining Attorney

SN 85-175,300. SCOTT PETER KEARNEY, WESTWOOD, NJ.  
FILED 11-12-2010.

# HERO CAM

THE MARK CONSISTS OF STANDARD CHARACTERS WITHOUT CLAIM TO ANY PARTICULAR FONT, STYLE, SIZE, OR COLOR.

NO CLAIM IS MADE TO THE EXCLUSIVE RIGHT TO USE "CAM", APART FROM THE MARK AS SHOWN.

FOR ENTERTAINMENT IN THE NATURE OF ONGOING TELEVISION PROGRAMS IN THE FIELD OF HIDDEN CAMERA REALITY SHOWS (U.S. CLS. 100, 101 AND 107).

Caryn Glasser, Examining Attorney

**CLASS 41—(Continued).**

SN 85-176,090. TODO EL MUNDO INTERACTIVE LLC,  
LITTLE SILVER, NJ. FILED 11-13-2010.

## Todo el Mundo Interactive

THE MARK CONSISTS OF STANDARD CHARACTERS WITHOUT CLAIM TO ANY PARTICULAR FONT, STYLE, SIZE, OR COLOR.

NO CLAIM IS MADE TO THE EXCLUSIVE RIGHT TO USE "INTERACTIVE", APART FROM THE MARK AS SHOWN.

THE ENGLISH TRANSLATION OF "TODO EL MUNDO" IN THE MARK IS "EVERYBODY." THE LITERAL TRANSLATION IS "ALL THE WORLD."

FOR PROVIDING A WEBSITE FEATURING RESOURCES, NAMELY, NON-DOWNLOADABLE PUBLICATIONS IN THE NATURE OF MAGAZINES, BOOKS, TEACHING GUIDES, STUDENT GUIDES IN THE FIELD OF TEACHING AND LEARNING SPANISH AND ENGLISH (U.S. CLS. 100, 101 AND 107).

Edward Fennessy, Examining Attorney

SN 85-176,118. HILL-REED, OMEGA, FERGUSON, MO.  
FILED 11-13-2010.



NO CLAIM IS MADE TO THE EXCLUSIVE RIGHT TO USE "EDUCATORS RETIREE'S BREAKFAST CLUB", APART FROM THE MARK AS SHOWN.

THE MARK CONSISTS OF THE TEXT "GOLDEN EDUCATORS" WRITTEN ABOVE A STYLIZED LAMP. INSIDE THE IMAGE OF THE LAMP IS THE TEXT "RETIREE'S". BELOW THE STYLIZED LAMP IS THE TEXT "BREAKFAST CLUB".

FOR SOCIAL CLUB SERVICES, NAMELY, ARRANGING, ORGANIZING, AND HOSTING SOCIAL EVENTS, GET-TOGETHERS, AND PARTIES FOR CLUB MEMBERS (U.S. CLS. 100, 101 AND 107).

Leslie Richards, Examining Attorney

**CLASS 41—(Continued).**

SN 85-176,277. NU NORMAL PRODUCTIONS, LLC, CARMEL, IN. FILED 11-14-2010.



NO CLAIM IS MADE TO THE EXCLUSIVE RIGHT TO USE "PRODUCTIONS", APART FROM THE MARK AS SHOWN.

THE MARK CONSISTS OF ONE LARGE "N" FOR BOTH WORDS "NU" AND "NORMAL" WITH THE WORD "PRODUCTIONS" BELOW IN SMALLER FONT.

FOR FILM AND VIDEO PRODUCTION (U.S. CLS. 100, 101 AND 107).

FIRST USE 11-12-2010; IN COMMERCE 11-12-2010.  
MICHAEL WEBSTER, EXAMINING ATTORNEY

**CLASS 41—(Continued).**

SN 85-176,576. BELLEVUE UNIVERSITY, BELLEVUE, NE. FILED 11-15-2010.



NO CLAIM IS MADE TO THE EXCLUSIVE RIGHT TO USE "ONLINE STUDENT" AND "PROGRAM", APART FROM THE MARK AS SHOWN.

THE MARK CONSISTS OF THE LETTERS "OSSP" TO THE LEFT OF A VERTICAL LINE AND THE WORDS "ONLINE STUDENT" ABOVE THE WORDS "SUCCESS PROGRAM" AND TO THE RIGHT OF THE VERTICAL LINE.

FOR EDUCATIONAL SERVICES, NAMELY, STUDY SKILLS COURSES FOR STUDENTS OF ONLINE PROGRAMS (U.S. CLS. 100, 101 AND 107).

TRACY CROSS, EXAMINING ATTORNEY

---

SN 85-176,355. MARTIN, DONALD C., CHICAGO, IL. FILED 11-14-2010.



THE MARK CONSISTS OF A STYLIZED STREET SIGN BEARING A GRADUATION CAP.

FOR EDUCATIONAL SERVICES, NAMELY, PROVIDING CLASSES, SEMINARS AND WORKSHOPS TO PROSPECTIVE GRADUATE SCHOOL STUDENTS IN THE FIELD OF PRE-GRADUATE SCHOOL PLANNING; PROFESSIONAL COACHING TO PROSPECTIVE GRADUATE SCHOOL STUDENTS IN THE FIELD OF PRE-GRADUATE SCHOOL PLANNING; EDUCATIONAL COUNSELING TO ASSIST STUDENTS IN PLANNING AND PREPARING FOR FURTHER EDUCATION; INFORMATION ABOUT EDUCATION (U.S. CLS. 100, 101 AND 107).

FIRST USE 7-1-2009; IN COMMERCE 7-1-2009.  
CIMMERIAN COLEMAN, EXAMINING ATTORNEY

---

SN 85-177,361. COMEDIVA, LLC, BURBANK, CA. FILED 11-15-2010.



THE MARK CONSISTS OF STANDARD CHARACTERS WITHOUT CLAIM TO ANY PARTICULAR FONT, STYLE, SIZE, OR COLOR.

FOR ENTERTAINMENT SERVICES IN THE NATURE OF THE PRODUCTION OF MULTI-MEDIA ENTERTAINMENT WEB CONTENT, WEB SERIES, MOTION PICTURES, TELEVISION PROGRAMS, LASER DISCS, AND VIDEO AND AUDIO TAPES; ENTERTAINMENT SERVICES PROVIDING A WEB SITE FEATURING VIDEO, TEXT, IMAGE AND AUDIO PRESENTATIONS FEATURING HUMOR; PROVIDING A WEB SITE FEATURING AN ON-LINE NEWSLETTER CONTAINING VIDEO, TEXT, IMAGE AND AUDIO PRESENTATIONS IN THE FIELD OF HUMOR AND PROVIDING LINKS TO OTHER HUMOROUS CONTENT; PROVIDING A WEB SITE FEATURING AN ONGOING ENTERTAINMENT NEWS FEED SERVICE REGARDING THE ACTIVITIES OF OTHER USERS ON THE WEB SITE (U.S. CLS. 100, 101 AND 107).

FIRST USE 7-0-2010; IN COMMERCE 10-0-2010.  
RONALD MCMORROW, EXAMINING ATTORNEY

**CLASS 41—(Continued).**

SN 85-177,941. CARTOON NETWORK, INC., THE, ATLANTA, GA. FILED 11-16-2010.

## GUY SUAVÉ: HOMICIDAL SPY

THE MARK CONSISTS OF STANDARD CHARACTERS WITHOUT CLAIM TO ANY PARTICULAR FONT, STYLE, SIZE, OR COLOR.

THE NAME "GUY SUAVE" DOES NOT IDENTIFY A LIVING INDIVIDUAL.

FOR ENTERTAINMENT SERVICES, NAMELY, PROVISION OF ONGOING MULTIMEDIA PROGRAMS IN THE FIELD OF COMEDY, ACTION AND ADVENTURE DISTRIBUTED VIA VARIOUS PLATFORMS ACROSS MULTIPLE FORMS OF TRANSMISSION MEDIA (U.S. CLS. 100, 101 AND 107).

FRED CARL, EXAMINING ATTORNEY

SN 85-178,062. GREEN MOUNTAIN RANGERS, LLC, EAST NORWICH, NY. FILED 11-16-2010.



THE COLOR(S) OLIVE GREEN, GREEN, GRAY, BLACK, AND YELLOW IS/ARE CLAIMED AS A FEATURE OF THE MARK.

THE MARK CONSISTS OF A YELLOW AND BLACK SKULL, A GRAY AND BLACK DAGGER, A GREEN AND BLACK BANNER WITH "GREEN MOUNTAIN RANGERS" IN BLACK, ALL ON AN OLIVE GREEN BACKGROUND.

FOR ENTERTAINMENT SERVICES IN THE NATURE OF AIRSOFT COMPETITION BY AIRSOFT UNIT; ENTERTAINMENT SERVICES IN THE NATURE OF PARTICIPATION IN AIRSOFT COMPETITIONS, SHOWS AND EXHIBITIONS; ENTERTAINMENT SERVICES, NAMELY, AIRSOFT GAMES, COMPETITIONS, TOURNAMENTS AND EXHIBITIONS RENDERED LIVE; INFORMATION SERVICES, NAMELY, PROVIDING INFORMATION IN THE FIELD OF AIRSOFT GAMES; EDUCATIONAL SERVICES IN THE NATURE OF AIRSOFT SKILLS PROGRAMS AND AIRSOFT CAMPS; ENTERTAINMENT SERVICES, NAMELY, CONDUCTING SPORTING EVENTS IN THE NATURE OF AIRSOFT GAMES (U.S. CLS. 100, 101 AND 107).

FIRST USE 1-1-2003; IN COMMERCE 1-1-2003.

PAUL E. FAHRENKOPF, EXAMINING ATTORNEY

**CLASS 41—(Continued).**

SN 85-178,450. UPSIDE BROWN COMEDY, LLC, NEW HYDE PARK, NY. FILED 11-16-2010.



NO CLAIM IS MADE TO THE EXCLUSIVE RIGHT TO USE "COMEDY", APART FROM THE MARK AS SHOWN.

THE MARK CONSISTS OF THE STYLIZED TEXT "UPSIDE BROWN COMEDY". THERE IS A DOT OVER THE LETTER "I" IN "UPSIDE", A COCONUT IN PLACE OF A LETTER "O" IN "BROWN" AND A MAN WITH HIS LEGS STRETCHED IN THE SHAPE OF A "Y" IN "COMEDY".

FOR ENTERTAINMENT SERVICES, NAMELY, PROVIDING A WEBSITE WHERE USERS CAN VIEW COMEDIC PHOTOS AND VIDEOS FEATURING SKETCH COMEDY SKITS, IMPROV SKITS, AND MUSICAL PERFORMANCES (U.S. CLS. 100, 101 AND 107).

CAROLYN CATALDO, EXAMINING ATTORNEY

SN 85-178,980. AGNES ZAWADZKA, WHEELING, IL. FILED 11-17-2010.

## ENDLESS BOUDOIR

THE MARK CONSISTS OF STANDARD CHARACTERS WITHOUT CLAIM TO ANY PARTICULAR FONT, STYLE, SIZE, OR COLOR.

NO CLAIM IS MADE TO THE EXCLUSIVE RIGHT TO USE "BOUDOIR", APART FROM THE MARK AS SHOWN, FOR PHOTOGRAPHY AND DIGITAL PHOTO EDITING SERVICES (U.S. CLS. 100, 101 AND 107).

FIRST USE 11-0-2008; IN COMMERCE 1-0-2009.

MARK SPARACINO, EXAMINING ATTORNEY

**CLASS 41—(Continued).**

SN 85-179,102. RHINOCEROS VISUAL EFFECTS AND DESIGN, DBA GRAVITY NY, NEW YORK, NY. FILED 11-17-2010.

# GRAVITY

THE MARK CONSISTS OF STANDARD CHARACTERS WITHOUT CLAIM TO ANY PARTICULAR FONT, STYLE, SIZE, OR COLOR.

FOR MEDIA PRODUCTION SERVICES AND CONSULTING SERVICES IN THE FIELDS OF MOTION PICTURES, TELEVISION, ANIMATION, AND FILM PRODUCTION; SPECIAL EFFECTS ANIMATION SERVICES FOR FILM AND VIDEO; PRODUCTION OF VISUAL EFFECTS FOR FILM, TELEVISION, VIDEO, WEBSITES (U.S. CLS. 100, 101 AND 107).

PAUL E. FAHRENKOPF, EXAMINING ATTORNEY

---

SN 85-179,142. HAPPY HEART PHOTOGRAPHY, LLC, STONE RIDGE, VA. FILED 11-17-2010.

## Happy Heart Photography

THE MARK CONSISTS OF STANDARD CHARACTERS WITHOUT CLAIM TO ANY PARTICULAR FONT, STYLE, SIZE, OR COLOR.

NO CLAIM IS MADE TO THE EXCLUSIVE RIGHT TO USE "PHOTOGRAPHY", APART FROM THE MARK AS SHOWN.

FOR DIGITAL IMAGING SERVICES; PHOTOGRAPHY; PHOTOGRAPHY SERVICES; PORTRAIT PHOTOGRAPHY (U.S. CLS. 100, 101 AND 107).

FIRST USE 5-2-2008; IN COMMERCE 5-2-2008.

PAUL E. FAHRENKOPF, EXAMINING ATTORNEY

---

SN 85-179,321. SCHWANTZ RACING, INC., DBA SCHWANTZ SCHOOL, LEEDS, AL. FILED 11-17-2010.

# 34

THE MARK CONSISTS OF STANDARD CHARACTERS WITHOUT CLAIM TO ANY PARTICULAR FONT, STYLE, SIZE, OR COLOR.

FOR EDUCATIONAL SERVICES IN THE NATURE OF MOTORCYCLE RIDING SCHOOLS (U.S. CLS. 100, 101 AND 107).

FIRST USE 2-26-2002; IN COMMERCE 2-26-2002.

PRISCILLA MILTON, EXAMINING ATTORNEY

**CLASS 41—(Continued).**

SN 85-179,405. TOUMA ASSOCIATES GROUP, LLC, DBA MINDSCAPE, SALEM, NH. FILED 11-17-2010.

## Essence of the Warrior Queen

THE MARK CONSISTS OF STANDARD CHARACTERS WITHOUT CLAIM TO ANY PARTICULAR FONT, STYLE, SIZE, OR COLOR.

FOR PROFESSIONAL COACHING SERVICES IN THE FIELD OF BUSINESS AND PERSONAL DEVELOPMENT; PUBLISHING OF BOOKS AND TRAINING MANUALS ALL IN THE FIELDS OF BUSINESS AND PERSONAL DEVELOPMENT; ONLINE JOURNALS, NAMELY, PUBLISHED ARTICLES AND BLOGS FEATURING ADVICE ON BUSINESS AND PERSONAL DEVELOPMENT; ENTERTAINMENT SERVICES, NAMELY, A CONTINUING RADIO SHOW BROADCAST VIA THE INTERNET ALL RELATING TO ADVICE ON BUSINESS AND PERSONAL DEVELOPMENT; EDUCATIONAL SERVICES, NAMELY, CONDUCTING TRAINING SEMINARS AND WEBINARS ALL IN THE FIELDS OF BUSINESS AND PERSONAL DEVELOPMENT AND VIA THE INTERNET AND CABLE TELEVISION; PROVIDING A WEBSITE FEATURING NON-DOWNLOADABLE VIDEOS FEATURING TRAINING IN THE FIELDS OF BUSINESS AND PERSONAL DEVELOPMENT (U.S. CLS. 100, 101 AND 107).

FIRST USE 6-1-2010; IN COMMERCE 6-1-2010.

BERYL GARDNER, EXAMINING ATTORNEY

---

SN 85-179,513. WARNER BROS. ENTERTAINMENT INC., BURBANK, CA. FILED 11-17-2010.

## INCEPTION: MIND CRIME GAME

THE MARK CONSISTS OF STANDARD CHARACTERS WITHOUT CLAIM TO ANY PARTICULAR FONT, STYLE, SIZE, OR COLOR.

NO CLAIM IS MADE TO THE EXCLUSIVE RIGHT TO USE "GAME", APART FROM THE MARK AS SHOWN.

FOR ENTERTAINMENT SERVICES, NAMELY, PROVIDING ON-LINE COMPUTER GAMES (U.S. CLS. 100, 101 AND 107).

FIRST USE 12-21-2009; IN COMMERCE 12-21-2009.

MARK SPARACINO, EXAMINING ATTORNEY

**CLASS 41—(Continued).**

SN 85-179,954. HUMAN RESOURCES INSTITUTE, LLC, BURLINGTON, VT. FILED 11-18-2010.

## Wellness Culture Coaching

THE MARK CONSISTS OF STANDARD CHARACTERS WITHOUT CLAIM TO ANY PARTICULAR FONT, STYLE, SIZE, OR COLOR.

NO CLAIM IS MADE TO THE EXCLUSIVE RIGHT TO USE "WELLNESS" AND "COACHING", APART FROM THE MARK AS SHOWN.

FOR PROFESSIONAL COACHING SERVICES IN THE FIELD OF WELLNESS (U.S. CLS. 100, 101 AND 107).

FIRST USE 5-4-2010; IN COMMERCE 5-4-2010.  
PAM WILLIS, EXAMINING ATTORNEY

---

SN 85-180,877. SHAPIRO, LEE, FORT LEE, NJ. FILED 11-19-2010.

## The Critters

THE MARK CONSISTS OF STANDARD CHARACTERS WITHOUT CLAIM TO ANY PARTICULAR FONT, STYLE, SIZE, OR COLOR.

FOR ENTERTAINMENT SERVICES IN THE NATURE OF LIVE MUSICAL PERFORMANCES (U.S. CLS. 100, 101 AND 107).

FIRST USE 1-1-1965; IN COMMERCE 1-1-1965.  
SUSAN LESLIE DUBOIS, EXAMINING ATTORNEY

---

SN 85-180,926. MOM AT LAST, LLC, SEAFORD, DE. FILED 11-19-2010.

## Mom At Last

THE MARK CONSISTS OF STANDARD CHARACTERS WITHOUT CLAIM TO ANY PARTICULAR FONT, STYLE, SIZE, OR COLOR.

NO CLAIM IS MADE TO THE EXCLUSIVE RIGHT TO USE "MOM", APART FROM THE MARK AS SHOWN.

FOR ON-LINE JOURNALS, NAMELY, BLOGS FEATURING STORIES AND TIPS ABOUT MOTHERHOOD; ENTERTAINMENT SERVICES, NAMELY, PROVIDING ON-GOING TELEVISION PROGRAMS IN THE FIELD OF MOTHERHOOD VIA A GLOBAL COMPUTER NETWORK; ENTERTAINMENT SERVICES, NAMELY, PROVIDING VIDEO PODCASTS IN THE FIELD OF MOTHERHOOD (U.S. CLS. 100, 101 AND 107).

FIRST USE 9-10-2009; IN COMMERCE 9-10-2009.  
COURTNEY ALVAREZ, EXAMINING ATTORNEY

**CLASS 41—(Continued).**

SN 85-181,434. COMEDY PARTNERS, NEW YORK, NY. FILED 11-19-2010.



---

OWNER OF U.S. REG. NOS. 1,741,737, 1,745,015 AND 2,533,788.

NO CLAIM IS MADE TO THE EXCLUSIVE RIGHT TO USE "COMEDY", APART FROM THE MARK AS SHOWN.

THE MARK CONSISTS OF DESIGN LETTERS "C" WITHIN A REVERSED "C" AND THE WORD "COMEDY" WITH WORD "CENTRAL" INVERTED.

FOR ENTERTAINMENT SERVICES, NAMELY, PRODUCTION OF TELEVISION PROGRAMS FEATURING LIVE ACTION, DRAMA, COMEDY, ANIMATION, MUSIC, NEWS, AND GENERAL ENTERTAINMENT; PROVIDING ONLINE INFORMATION IN THE FIELD OF ENTERTAINMENT CONCERNING TELEVISION PROGRAMS (U.S. CLS. 100, 101 AND 107).

MARK PILARO, EXAMINING ATTORNEY

---

SN 85-181,445. COMEDY PARTNERS, NEW YORK, NY. FILED 11-19-2010.



---

OWNER OF U.S. REG. NOS. 1,741,737, 1,745,015 AND 2,533,788.

THE MARK CONSISTS OF DESIGN LETTERS "C" WITHIN A REVERSED "C".

FOR ENTERTAINMENT SERVICES, NAMELY, PRODUCTION OF TELEVISION PROGRAMS FEATURING LIVE ACTION, DRAMA, COMEDY, ANIMATION, MUSIC, NEWS, AND GENERAL ENTERTAINMENT; PROVIDING ONLINE INFORMATION IN THE FIELD OF ENTERTAINMENT CONCERNING TELEVISION PROGRAMS (U.S. CLS. 100, 101 AND 107).

MARK PILARO, EXAMINING ATTORNEY

**CLASS 41—(Continued).**

SN 85-181,456. COMEDY PARTNERS, NEW YORK, NY. FILED 11-19-2010.



OWNER OF U.S. REG. NOS. 1,741,737, 1,745,015 AND 2,533,788.

NO CLAIM IS MADE TO THE EXCLUSIVE RIGHT TO USE "COMEDY", APART FROM THE MARK AS SHOWN.

THE MARK CONSISTS OF THE WORD "COMEDY" WITH WORD "CENTRAL" INVERTED.

FOR ENTERTAINMENT SERVICES, NAMELY, PRODUCTION OF TELEVISION PROGRAMS FEATURING LIVE ACTION, DRAMA, COMEDY, ANIMATION, MUSIC, NEWS, AND GENERAL ENTERTAINMENT; PROVIDING ONLINE INFORMATION IN THE FIELD OF ENTERTAINMENT CONCERNING TELEVISION PROGRAMS (U.S. CLS. 100, 101 AND 107).

MARK PILARO, EXAMINING ATTORNEY

SN 85-182,157. RONCO, IGNACIO LACOSTA, ZARAGOZA, SPAIN, FILED 11-22-2010.



NO CLAIM IS MADE TO THE EXCLUSIVE RIGHT TO USE "STUDIO", APART FROM THE MARK AS SHOWN.

THE COLOR(S) GREY AND WHITE IS/ARE CLAIMED AS A FEATURE OF THE MARK.

THE MARK CONSISTS OF A RECTANGULAR BOX WITH THE BACKGROUND IN GREY AND INSIDE HAS THE WORDS "ENTROPY" ALL IN UPPER CASE LETTERS AND THE WORD "STUDIO" IN LOWER CASE LETTERS, ALL IN WHITE. OVER THE LETTER "E" IN "ENTROPY" IS A WHITE ANGLE DESIGN.

FOR PRODUCTION AND CREATION OF VISUAL EFFECTS FOR OTHERS FOR 3D FILM (U.S. CLS. 100, 101 AND 107).

EUGENIA MARTIN, EXAMINING ATTORNEY

**CLASS 41—(Continued).**

SN 85-182,491. WHAT IF? PRODUCTIONS, INC., NEW YORK, NY. FILED 11-22-2010.

## Earl & Grace Films

THE MARK CONSISTS OF STANDARD CHARACTERS WITHOUT CLAIM TO ANY PARTICULAR FONT, STYLE, SIZE, OR COLOR.

NO CLAIM IS MADE TO THE EXCLUSIVE RIGHT TO USE "FILMS", APART FROM THE MARK AS SHOWN.

FOR ENTERTAINMENT AND EDUCATIONAL SERVICES, NAMELY, PROVIDING ADVICE AND INFORMATION FOR MUSIC, VIDEO AND FILM CONCEPT AND SCRIPT DEVELOPMENT; MULTIMEDIA ENTERTAINMENT SERVICES IN THE NATURE OF DEVELOPMENT, PRODUCTION AND POST-PRODUCTION SERVICES IN THE FIELDS OF VIDEO AND FILMS; PRODUCTION OF TELEVISION PROGRAMS; PRODUCTION OF VIDEO AND CREATION OF VISUAL EFFECTS FOR OTHERS FOR USE IN DVDS, TELEVISION PROGRAMS AND ON WEB SITES; SCRIPT WRITING SERVICES (U.S. CLS. 100, 101 AND 107).

RUSS HERMAN, EXAMINING ATTORNEY

SN 85-182,906. WHITECAP INSTITUTE, LLC, HEBER, UT. FILED 11-22-2010.

## WHITECAP INSTITUTE

THE MARK CONSISTS OF STANDARD CHARACTERS WITHOUT CLAIM TO ANY PARTICULAR FONT, STYLE, SIZE, OR COLOR.

NO CLAIM IS MADE TO THE EXCLUSIVE RIGHT TO USE "INSTITUTE", APART FROM THE MARK AS SHOWN.

FOR CONTINUING EDUCATION SERVICES, NAMELY, PROVIDING CONTINUING PROFESSIONAL EDUCATION SEMINARS IN THE FIELD OF DENTISTRY (U.S. CLS. 100, 101 AND 107).

FIRST USE 6-30-2005; IN COMMERCE 6-30-2005.

JORDAN BAKER, EXAMINING ATTORNEY

SN 85-182,928. LISA D. FLYNN, SOUTH BERWICK, ME. FILED 11-22-2010.

## ChildLight Yoga

THE MARK CONSISTS OF STANDARD CHARACTERS WITHOUT CLAIM TO ANY PARTICULAR FONT, STYLE, SIZE, OR COLOR.

NO CLAIM IS MADE TO THE EXCLUSIVE RIGHT TO USE "YOGA", APART FROM THE MARK AS SHOWN.

FOR YOGA INSTRUCTION (U.S. CLS. 100, 101 AND 107).

FIRST USE 6-1-2005; IN COMMERCE 8-1-2005.

CHARLES L. JENKINS, EXAMINING ATTORNEY

**CLASS 41—(Continued).**

SN 85-183,449. 500 4TH LLC, SAN DIEGO, CA. FILED 11-23-2010.

# FLUXX

THE MARK CONSISTS OF STANDARD CHARACTERS WITHOUT CLAIM TO ANY PARTICULAR FONT, STYLE, SIZE, OR COLOR.

FOR ENTERTAINMENT SERVICES, NAMELY, NIGHT CLUBS; ARRANGING AND CONDUCTING PARTIES AND NIGHTCLUB ENTERTAINMENT EVENTS; ARRANGING AND CONDUCTING OF CONCERTS, SOCIAL ENTERTAINMENT EVENTS, AND COMEDY EVENTS; ENTERTAINMENT IN THE NATURE OF LIVE PERFORMANCES BY CELEBRITIES, SINGERS, ARTISTS, RAPPERS, DEEJAYS, AND OTHER MUSICAL AND THEATRICAL TALENT (U.S. CLS. 100, 101 AND 107).

KIMBERLY FRYE, EXAMINING ATTORNEY

---

SN 85-183,685. WILLIAMSON, DR. DECAROL, WILMINGTON, NC. FILED 11-23-2010.



NO CLAIM IS MADE TO THE EXCLUSIVE RIGHT TO USE "AG NETWORK", APART FROM THE MARK AS SHOWN.

THE COLOR(S) GOLD, BROWN, BLACK IS/ARE CLAIMED AS A FEATURE OF THE MARK.

THE MARK CONSISTS OF THE LETTERS "AG" IN THE COLOR GOLD, THE WORD "NETWORK" IN THE COLOR BROWN WITH THE "O" IN THE SHAPE OF A COG, THE WORDS "YOUR DAILY LIFE" IN THE COLOR BLACK, AND A WHEAT POD IN THE COLOR BROWN POSITIONED BESIDE THE "AG" AND ABOVE THE "E" IN "NETWORK".

FOR ENTERTAINMENT SERVICES, NAMELY, A CONTINUING NEWS SHOW IN THE FIELD OF AGRICULTURE BROADCAST OVER TELEVISION AND RADIO (U.S. CLS. 100, 101 AND 107).

NICHOLAS ALTREE, EXAMINING ATTORNEY

**CLASS 41—(Continued).**

SN 85-183,858. CALVERT SCHOOL, BALTIMORE, MD. FILED 11-23-2010.



OWNER OF U.S. REG. NOS. 1,593,508 AND 1,601,464. NO CLAIM IS MADE TO THE EXCLUSIVE RIGHT TO USE "SCHOOL", APART FROM THE MARK AS SHOWN.

THE COLOR(S) YELLOW, BLACK AND WHITE IS/ARE CLAIMED AS A FEATURE OF THE MARK.

THE MARK CONSISTS OF A SILHOUETTE OF A BOY'S HEAD IN BLACK APPEARING ON A YELLOW CIRCLE WHICH IS ENCLOSED WITHIN A LARGER CONCENTRIC WHITE CIRCLE SURROUNDED BY A BLACK CIRCLE AND HAVING STEM AND LEAF DESIGNS IN BLACK AND WHITE EXTENDING FROM ITS OPPOSITE SIDES WITH THE WORDS "CALVERT SCHOOL" BELOW IN STYLIZED BLACK LETTERS AND WITH THE WORDS "CURIOSITY, MASTERY, PURPOSE" ALSO IN STYLIZED BLACK LETTERS SEPARATED BY TWO BLACK DOTS AT THE VERY BOTTOM.

FOR EDUCATIONAL SERVICES, NAMELY, PROVIDING COURSES OF INSTRUCTION AT THE PRE-KINDERGARTEN THROUGH EIGHTH GRADE LEVELS (U.S. CLS. 100, 101 AND 107).

CHARLES L. JENKINS, EXAMINING ATTORNEY

---

SN 85-184,184. WISER TIME, BASKING RIDGE, NJ. FILED 11-23-2010.



THE MARK CONSISTS OF A SILHOUETTE OF A FEMALE TO THE LEFT WEARING HIGH HEELS, WITH ONE ARM ON HER WAIST AND THE OTHER RAISED, 4 HEART SILHOUETTES SURROUNDING THE TEXT "SHOW SOME LOVE", AND 2 LARGER HEART SILHOUETTES TO THE RIGHT.

FOR MULTIMEDIA ENTERTAINMENT SERVICES IN THE NATURE OF RECORDING, PRODUCTION AND POST-PRODUCTION SERVICES IN THE FIELDS OF MUSIC, VIDEO, AND FILMS (U.S. CLS. 100, 101 AND 107).

RICHARD WHITE, EXAMINING ATTORNEY

**CLASS 41—(Continued).**

SN 85-184,528. PLAY WITH WORDS, INC., FAIRFAX, VA. FILED 11-24-2010.

**PLAY WITH WORDS**

THE MARK CONSISTS OF STANDARD CHARACTERS WITHOUT CLAIM TO ANY PARTICULAR FONT, STYLE, SIZE, OR COLOR.

NO CLAIM IS MADE TO THE EXCLUSIVE RIGHT TO USE "WORDS", APART FROM THE MARK AS SHOWN.

FOR EDUCATIONAL AND ENTERTAINMENT SERVICES FOR CHILDREN, NAMELY, PROVIDING INTERACTIVE PLAY AREAS, INSTRUCTIONAL CLASSES IN THE FIELD OF LITERACY AND SOCIAL GATHERINGS FOR CHILDREN; MUSEUM SERVICES (U.S. CLS. 100, 101 AND 107).

FIRST USE 6-20-2008; IN COMMERCE 11-30-2008.  
INGA ERVIN, EXAMINING ATTORNEY

**CLASS 41—(Continued).**

SN 85-184,768. EVANS, THOMAS, GENEVA, IL. FILED 11-24-2010.

**Secret Colours**

THE MARK CONSISTS OF STANDARD CHARACTERS WITHOUT CLAIM TO ANY PARTICULAR FONT, STYLE, SIZE, OR COLOR.

FOR ENTERTAINMENT SERVICES, NAMELY, PROVIDING A WEB SITE FEATURING NON-DOWNLOADABLE MUSICAL PERFORMANCES, MUSICAL VIDEOS, RELATED FILM CLIPS, PHOTOGRAPHS, AND OTHER MULTIMEDIA MATERIALS FEATURING MUSICAL ENTERTAINMENT; ENTERTAINMENT SERVICES IN THE NATURE OF LIVE MUSICAL PERFORMANCES (U.S. CLS. 100, 101 AND 107).

FIRST USE 1-15-2008; IN COMMERCE 8-1-2009.  
MARY ROSSMAN, EXAMINING ATTORNEY

SN 85-185,132. BROWN, NATHAN OWEN, ISSAQUAH, WA. FILED 11-24-2010.

**Rulon Brown**

THE MARK CONSISTS OF STANDARD CHARACTERS WITHOUT CLAIM TO ANY PARTICULAR FONT, STYLE, SIZE, OR COLOR.

"RULON BROWN" IDENTIFIES THE STAGE NAME OF NATHAN OWEN BROWN, A LIVING INDIVIDUAL WHOSE CONSENT IS OF RECORD.

FOR ENTERTAINMENT SERVICES IN THE NATURE OF LIVE MUSICAL AND VOCAL PERFORMANCES BY A SOLO RECORDING ARTIST; PROVIDING INFORMATION RELATED TO A SOLO RECORDING ARTIST BY MEANS OF A GLOBAL COMPUTER INFORMATION NETWORK; FAN CLUB SERVICES RENDERED VIA A GLOBAL COMPUTER INFORMATION NETWORK (U.S. CLS. 100, 101 AND 107).

FIRST USE 10-18-2010; IN COMMERCE 10-18-2010.  
REBECCA POVARCHUK, EXAMINING ATTORNEY

SN 85-185,202. VAN CLEEF, BART PETER, TEMIXCO, MORELOS, MEXICO, FILED 11-24-2010.

**Anders Languages**

THE MARK CONSISTS OF STANDARD CHARACTERS WITHOUT CLAIM TO ANY PARTICULAR FONT, STYLE, SIZE, OR COLOR.

NO CLAIM IS MADE TO THE EXCLUSIVE RIGHT TO USE "LANGUAGES", APART FROM THE MARK AS SHOWN.

FOR EDUCATIONAL SERVICES, NAMELY, LANGUAGE TRAINING (U.S. CLS. 100, 101 AND 107).

FIRST USE 11-19-1998; IN COMMERCE 11-19-1998.  
WILLIAM ROSSMAN, EXAMINING ATTORNEY

SN 85-184,533. COLHOC LIMITED PARTNERSHIP, COLUMBUS, OH. FILED 11-24-2010.



OWNER OF U.S. REG. NOS. 2,462,014, 2,462,015 AND 3,792,741.

NO CLAIM IS MADE TO THE EXCLUSIVE RIGHT TO USE "COLUMBUS", APART FROM THE MARK AS SHOWN.

THE MARK CONSISTS OF THE WORDS "COLUMBUS BLUE JACKETS" IN A RIBBON ENCIRCLING A CANNON DESIGN WITH A STAR UNDERNEATH, ALL WITHIN TWO CONCENTRIC CIRCLES.

FOR ENTERTAINMENT SERVICES, NAMELY, PROFESSIONAL ICE HOCKEY EXHIBITIONS (U.S. CLS. 100, 101 AND 107).

STEVEN R. FINE, EXAMINING ATTORNEY



**CLASS 41—(Continued).**

SN 85-185,449. CITY OF MISSOULA, MISSOULA, MT. FILED 11-26-2010.



NO CLAIM IS MADE TO THE EXCLUSIVE RIGHT TO USE "MONTANA" AND "PARK" AND "MISSOULA", APART FROM THE MARK AS SHOWN.

THE COLOR(S) ORANGE, RED, BLUE, AND GREEN IS/ARE CLAIMED AS A FEATURE OF THE MARK.

THE MARK CONSISTS OF THE STYLIZED WORDING "SPLASH" SET ABOVE THE STYLIZED WORDING "MONTANA" WHICH IS STACKED ON "PLAYFAIR PARK" AND "MISSOULA" WITH A SHORT VERTICAL LINE PLACED BETWEEN THE WORDING PLAYFAIR PARK AND MISSOULA AND MONTANA. THE COLOR ORANGE APPEARS IN THE SHADING IN THE WORDING "SPLASH", WITH BLUE SHADOWING OUTLINE. THE COLOR RED APPEARS IN THE SHADING IN THE WORDING "MONTANA" WITH A BLUE OUTLINE ON THE LETTERS. THE WORDING "PLAYFAIR PARK - MISSOULA" APPEARS IN GREEN. BELOW THE WORDING "SPLASH" UNDER THE 'P' IS A STYLIZED DEPICTION OF BLUE WATER RINGS WITH BLUE WATER DROPLETS SPLASHING TO THE SIDES AND ABOVE THE WORD "SPLASH". IN THE BACKGROUND THERE IS A GREEN MOUNTAIN OUTLINED IN BROWN WITH DARK GREEN TREES ON THE FACE OF THE MOUNTAIN. THE COLOR WHITE APPEARS IN THE BACKGROUND AND IS NOT PART OF THE MARK, AND MERELY SHOWS THE SURFACE UPON WHICH THE MARK IS AFFIXED.

FOR RECREATIONAL SERVICES IN THE NATURE OF SWIMMING POOLS FOR AQUATIC ACTIVITIES (U.S. CLS. 100, 101 AND 107).

FIRST USE 6-1-2005; IN COMMERCE 6-1-2005.

TIMOTHY FINNEGAN, EXAMINING ATTORNEY

SN 85-185,484. FESTIVAL OF NORTH AMERICAN ORCHESTRAS INC., NEW YORK, NY. FILED 11-26-2010.

**UNCOMMON CONCERTS**

THE MARK CONSISTS OF STANDARD CHARACTERS WITHOUT CLAIM TO ANY PARTICULAR FONT, STYLE, SIZE, OR COLOR.

NO CLAIM IS MADE TO THE EXCLUSIVE RIGHT TO USE "CONCERTS", APART FROM THE MARK AS SHOWN.

FOR ENTERTAINMENT SERVICES IN THE NATURE OF LIVE MUSICAL PERFORMANCES (U.S. CLS. 100, 101 AND 107).

NAPOLEON SHARMA, EXAMINING ATTORNEY

**CLASS 41—(Continued).**

SN 85-185,488. WHITE, GEORGE H., LONG BEACH, CA. AND WHITE, MICHELE V., LONG BEACH, CA. FILED 11-26-2010.



OWNER OF U.S. REG. NO. 3,815,502.

NO CLAIM IS MADE TO THE EXCLUSIVE RIGHT TO USE "YOGA", APART FROM THE MARK AS SHOWN.

THE COLOR(S) BROWN, GREEN, AND WHITE IS/ARE CLAIMED AS A FEATURE OF THE MARK.

THE MARK CONSISTS OF THE COLOR BROWN IN THE BRUSHSTROKE BACKGROUND, THE COLOR WHITE IN THE LETTERS "H" AND "LLBILLY", AND THE COLOR GREEN IN THE FIRST LETTER "I" IN "HILLBILLY" AND IN THE TERM "YOGA".

FOR EDUCATION SERVICES, NAMELY, PROVIDING LIVE AND ON-LINE INSTRUCTION, AND CONDUCTING CLASSES, SEMINARS, CONFERENCES, AND INSTRUCTOR TRAINING IN THE FIELD OF YOGA INSTRUCTION, MARKETING OF YOGA INSTRUCTION, YOGA PHILOSOPHY, YOGA THEORY AND PRACTICE, STRETCHING AFTER RUNNING, PHYSICAL FITNESS, MEDITATION, MENTAL TRAINING AND DISCIPLINE AND HEALTH, DISTRIBUTING MARKETING AND COURSE MATERIALS IN CONNECTION THEREWITH (U.S. CLS. 100, 101 AND 107).

FIRST USE 9-1-2010; IN COMMERCE 9-1-2010.

SUNG IN, EXAMINING ATTORNEY

SN 85-185,517. HANNAH, ROBERT, KELLY, ASHEVILLE, NC. AND MCFEE SEAN MICHAEL, ASHEVEGAS, NC. FILED 11-26-2010.

**Kung Fu Dynamite**

THE MARK CONSISTS OF STANDARD CHARACTERS WITHOUT CLAIM TO ANY PARTICULAR FONT, STYLE, SIZE, OR COLOR.

FOR ENTERTAINMENT IN THE NATURE OF VISUAL AND AUDIO PERFORMANCES BY MUSICAL BANDS; ENTERTAINMENT IN THE NATURE OF VISUAL AND AUDIO PERFORMANCES, NAMELY, MUSICAL BAND, ROCK GROUP, GYMNASIUM, DANCE, AND BALLET PERFORMANCES; ENTERTAINMENT, NAMELY, LIVE PERFORMANCES BY A MUSICAL BAND; ENTERTAINMENT, NAMELY, LIVE PERFORMANCES BY MUSICAL BANDS; PROVIDING A WEBSITE FOR ENTERTAINMENT PURPOSES WHERE USERS CAN VIEW AND POST PHOTOS, VIDEOS FEATURING MUSICAL BANDS (U.S. CLS. 100, 101 AND 107).

FIRST USE 6-30-2006; IN COMMERCE 6-30-2006.

MATTHEW MCDOWELL, EXAMINING ATTORNEY

**CLASS 41—(Continued).**

SN 85-186,014. HERITAGE CHRISTIAN SERVICES, INC., EAST ROCHESTER, NY. FILED 11-29-2010.

# FUTURE YOU

THE MARK CONSISTS OF STANDARD CHARACTERS WITHOUT CLAIM TO ANY PARTICULAR FONT, STYLE, SIZE, OR COLOR.

FOR CAREER COUNSELING; CHARITABLE SERVICES, NAMELY, NON-RETAIL BUSINESS TRAINING FOR SOCIAL AND HUMANITARIAN SERVICES (U.S. CLS. 100, 101 AND 107).

FIRST USE 8-9-2010; IN COMMERCE 8-9-2010.  
BERYL GARDNER, EXAMINING ATTORNEY

SN 85-186,032. MARSHALL, GEORGE T., SANTA ROSA, CA. FILED 11-29-2010.

# SPEEDCROSS

THE MARK CONSISTS OF STANDARD CHARACTERS WITHOUT CLAIM TO ANY PARTICULAR FONT, STYLE, SIZE, OR COLOR.

FOR ENTERTAINMENT SERVICES IN THE NATURE OF MOTORCYCLE RACING AND EXHIBITIONS (U.S. CLS. 100, 101 AND 107).

PATRICIA EVANKO, EXAMINING ATTORNEY

SN 85-186,040. HERITAGE CHRISTIAN SERVICES, INC., EAST ROCHESTER, NY. FILED 11-29-2010.

# FUTUREYOU

THE MARK CONSISTS OF STANDARD CHARACTERS WITHOUT CLAIM TO ANY PARTICULAR FONT, STYLE, SIZE, OR COLOR.

FOR CAREER COUNSELING; CHARITABLE SERVICES, NAMELY, NON-RETAIL BUSINESS TRAINING FOR SOCIAL AND HUMANITARIAN SERVICES (U.S. CLS. 100, 101 AND 107).

FIRST USE 8-9-2010; IN COMMERCE 8-9-2010.  
BERYL GARDNER, EXAMINING ATTORNEY

**CLASS 41—(Continued).**

SN 85-186,042. SIX TOP PRODUCTIONS, LOS ANGELES, CA. FILED 11-29-2010.

# servitude

THE MARK CONSISTS OF THE STYLIZED TEXT "SERVITUDE".

FOR ENTERTAINMENT, NAMELY, A CONTINUING COMEDY SHOW BROADCAST OVER INTERNET (U.S. CLS. 100, 101 AND 107).

BERYL GARDNER, EXAMINING ATTORNEY

SN 85-186,070. OUTREACH MINISTRIES INTERNATIONAL, FLOWER MOUND, TX. FILED 11-29-2010.

# Gift of English



NO CLAIM IS MADE TO THE EXCLUSIVE RIGHT TO USE "ENGLISH", APART FROM THE MARK AS SHOWN.

THE MARK CONSISTS OF THE STYLIZED TEXT "GIFT OF ENGLISH" WITH A CHARACTER HOLDING A BOOK. FOR EDUCATION SERVICES, NAMELY, PROVIDING CLASSES IN THE FIELD OF ENGLISH (U.S. CLS. 100, 101 AND 107).

FIRST USE 6-1-2006; IN COMMERCE 6-1-2006.

CAROLINE WOOD, EXAMINING ATTORNEY

SN 85-186,318. ANAHEIM DUCKS HOCKEY CLUB, LLC, ANAHEIM, CA. FILED 11-29-2010.



OWNER OF U.S. REG. NOS. 1,853,330, 3,321,728 AND OTHERS.

NO CLAIM IS MADE TO THE EXCLUSIVE RIGHT TO USE "ANAHEIM", APART FROM THE MARK AS SHOWN. THE MARK CONSISTS OF THE WORDS "ANAHEIM DUCKS" SURROUNDING A DUCK MASK WITH CROSSED HOCKEY STICKS.

FOR ENTERTAINMENT SERVICES, NAMELY, ICE HOCKEY EXHIBITIONS (U.S. CLS. 100, 101 AND 107).

TAMARA FRAZIER, EXAMINING ATTORNEY

**CLASS 41—(Continued).**

SN 85-186,395. THE WEDDING ROW, LLC, CHARLESTON, SC. FILED 11-29-2010.

## THE WEDDING ROW

THE MARK CONSISTS OF STANDARD CHARACTERS WITHOUT CLAIM TO ANY PARTICULAR FONT, STYLE, SIZE, OR COLOR.

NO CLAIM IS MADE TO THE EXCLUSIVE RIGHT TO USE "WEDDING", APART FROM THE MARK AS SHOWN.

FOR PROVIDING INFORMATION IN THE FIELD OF WEDDING PARTY PLANNING; PROVIDING INFORMATION REGARDING WEDDING PLANNING FOR WEDDING PARTIES (U.S. CLS. 100, 101 AND 107).

FIRST USE 3-20-2010; IN COMMERCE 3-20-2010.  
JASON BLAIR, EXAMINING ATTORNEY

---

SN 85-186,497. NATIONAL HOSPITALITY INSTITUTE, LANSING, MI. FILED 11-29-2010.

## NATIONAL HOSPITALITY INSTITUTE

THE MARK CONSISTS OF STANDARD CHARACTERS WITHOUT CLAIM TO ANY PARTICULAR FONT, STYLE, SIZE, OR COLOR.

OWNER OF U.S. REG. NO. 3,278,831.

NO CLAIM IS MADE TO THE EXCLUSIVE RIGHT TO USE "INSTITUTE", APART FROM THE MARK AS SHOWN. SEC. 2(F).

FOR EDUCATIONAL SERVICES, NAMELY, CONDUCTING ONLINE AND IN-PERSON CLASSES, SEMINARS, CONFERENCES, WORKSHOPS AND CERTIFICATION COURSES IN THE FIELD OF LICENSED BEVERAGE RETAIL AND RESTAURANT INDUSTRIES ON THE TOPIC OF ALCOHOL MANAGEMENT AND DISTRIBUTION OF COURSE MATERIAL IN CONNECTION THEREWITH (U.S. CLS. 100, 101 AND 107).

FIRST USE 4-1-2003; IN COMMERCE 4-1-2003.  
ANTHONY RINKER, EXAMINING ATTORNEY

**CLASS 41—(Continued).**

SN 85-186,637. FAMILIES OF CHARACTER, GREENWOOD VILLAGE, CO. FILED 11-29-2010.



NO CLAIM IS MADE TO THE EXCLUSIVE RIGHT TO USE "CHARACTER", APART FROM THE MARK AS SHOWN.

THE COLOR(S) BLUE, HOT PINK, LIGHT GREEN, LIGHT ORANGE AND RED IS/ARE CLAIMED AS A FEATURE OF THE MARK.

THE MARK CONSISTS OF THE WORDING "FAMILIES OF CHARACTER" IN BLACK LOWER CASE LETTERING, APPEARING ATOP THE DESIGN OF 5 HANDPRINTS WHICH FORM A CIRCLE. THE HANDPRINTS APPEAR IN THE FOLLOWING COLORS FROM TOP LEFT TO RIGHT, CLOCKWISE: BLUE, HOT PINK, LIGHT GREEN, LIGHT ORANGE AND RED. THE COLOR WHITE REPRESENTS TRANSPARENT AREAS AND IS NOT PART OF THE MARK.

FOR EDUCATIONAL SERVICES, NAMELY, PROVIDING LIVE AND ON-LINE CLASSES, SEMINARS, DISCUSSIONS AND LEARNING FORUMS FOR PARENTS IN THE FIELD OF CHARACTER DEVELOPMENT AND PERSONAL VIRTUE; AND DISTRIBUTION OF COURSE MATERIAL IN CONNECTION THEREWITH (U.S. CLS. 100, 101 AND 107).

FIRST USE 9-21-2010; IN COMMERCE 11-19-2010.  
WENDY GOODMAN, EXAMINING ATTORNEY

---

SN 85-186,695. BE FLUENT NYC INC., NEW YORK, NY. FILED 11-29-2010.

## Be Fluent NYC

THE MARK CONSISTS OF STANDARD CHARACTERS WITHOUT CLAIM TO ANY PARTICULAR FONT, STYLE, SIZE, OR COLOR.

NO CLAIM IS MADE TO THE EXCLUSIVE RIGHT TO USE "NYC", APART FROM THE MARK AS SHOWN.

FOR EDUCATION SERVICES, NAMELY, PROVIDING MENTORING, TUTORING, CLASSES, SEMINARS AND WORKSHOPS IN THE FIELD OF AMERICAN ENGLISH LANGUAGE (U.S. CLS. 100, 101 AND 107).

FIRST USE 6-7-2008; IN COMMERCE 6-22-2008.

PAUL E. FAHRENKOPF, EXAMINING ATTORNEY

**CLASS 41—(Continued).**

SN 85-186,930. MAXWELL, M.D., ROBERT W., CRESTED BITE, CO. FILED 11-30-2010.

**CME Sam** 

NO CLAIM IS MADE TO THE EXCLUSIVE RIGHT TO USE "CME SAM", APART FROM THE MARK AS SHOWN. THE COLOR(S) PURPLE, YELLOW, AND BLACK IS/ARE CLAIMED AS A FEATURE OF THE MARK.

THE MARK CONSISTS OF THE BLACK WORDING "CME SAM" FOLLOWED BY THE DESIGN OF A DAISY WITH PURPLE PETALS AND A YELLOW CENTER.

FOR PROVIDING A WEBSITE FOR HEALTHCARE PROFESSIONALS FEATURING INFORMATION ABOUT AVAILABLE CONTINUING EDUCATION PROGRAMS (U.S. CLS. 100, 101 AND 107).

FIRST USE 3-1-2010; IN COMMERCE 3-1-2010.  
KIMBERLY FRYE, EXAMINING ATTORNEY

SN 85-186,962. THE BEST OF ORGANIC LLC, WEST BLOOMFIELD, MI. FILED 11-30-2010.

**GREAT HALLOWEEN TRADE**

THE MARK CONSISTS OF STANDARD CHARACTERS WITHOUT CLAIM TO ANY PARTICULAR FONT, STYLE, SIZE, OR COLOR.

NO CLAIM IS MADE TO THE EXCLUSIVE RIGHT TO USE "HALLOWEEN", APART FROM THE MARK AS SHOWN.

FOR EDUCATION SERVICES, NAMELY, PROVIDING CLASSES, SEMINARS, AND WORKSHOPS IN THE FIELD OF HEALTH, NUTRITION, AND LIFESTYLE (U.S. CLS. 100, 101 AND 107).

FIRST USE 10-0-2008; IN COMMERCE 10-0-2008.  
TOBY BULLOFF, EXAMINING ATTORNEY

SN 85-186,980. ECOFIC, LOUISVILLE, KY. FILED 11-30-2010.

**DIVOTDOG**

THE MARK CONSISTS OF STANDARD CHARACTERS WITHOUT CLAIM TO ANY PARTICULAR FONT, STYLE, SIZE, OR COLOR.

FOR PROVIDING A WEBSITE FEATURING INFORMATION ON GOLF AND GOLFERS' STATISTICS (U.S. CLS. 100, 101 AND 107).

FIRST USE 12-20-2008; IN COMMERCE 8-8-2009.  
RONALD MCMORROW, EXAMINING ATTORNEY

**CLASS 41—(Continued).**

SN 85-187,017. GOSPEL MESSENGERS INC., MT.VERNON, IL. FILED 11-30-2010.

**GOSPEL MESSENGERS**

THE MARK CONSISTS OF STANDARD CHARACTERS WITHOUT CLAIM TO ANY PARTICULAR FONT, STYLE, SIZE, OR COLOR.

NO CLAIM IS MADE TO THE EXCLUSIVE RIGHT TO USE "GOSPEL", APART FROM THE MARK AS SHOWN.

FOR ENTERTAINMENT SERVICES IN THE NATURE OF LIVE MUSICAL PERFORMANCES (U.S. CLS. 100, 101 AND 107).

FIRST USE 10-0-2007; IN COMMERCE 10-0-2007.  
NAPOLEON SHARMA, EXAMINING ATTORNEY

SN 85-187,046. LOVE LEE PHOTOGRAPHY, INC., SUGAR LAND, TX. FILED 11-30-2010.

**Love Lee Photography**

THE MARK CONSISTS OF STANDARD CHARACTERS WITHOUT CLAIM TO ANY PARTICULAR FONT, STYLE, SIZE, OR COLOR.

NO CLAIM IS MADE TO THE EXCLUSIVE RIGHT TO USE "PHOTOGRAPHY", APART FROM THE MARK AS SHOWN.

FOR PHOTOGRAPHY SERVICES (U.S. CLS. 100, 101 AND 107).

FIRST USE 8-1-2007; IN COMMERCE 4-1-2008.  
H. M. FISHER, EXAMINING ATTORNEY

SN 85-187,141. FENG, KEVIN, LOS ANGELES, CA. AND CHOI, STEPHEN, LOS ANGELES, CA. FILED 11-30-2010.

**Alpha Asian**

THE MARK CONSISTS OF STANDARD CHARACTERS WITHOUT CLAIM TO ANY PARTICULAR FONT, STYLE, SIZE, OR COLOR.

NO CLAIM IS MADE TO THE EXCLUSIVE RIGHT TO USE "ASIAN", APART FROM THE MARK AS SHOWN.

FOR LIFE COACHING SERVICES IN THE FIELD OF DATING; PERSONAL COACHING SERVICES IN THE FIELD OF DATING; PROFESSIONAL COACHING SERVICES IN THE FIELD OF DATING (U.S. CLS. 100, 101 AND 107).

FIRST USE 11-17-2010; IN COMMERCE 11-17-2010.  
SANDRA BUJA, EXAMINING ATTORNEY

**CLASS 41—(Continued).**

SN 85-187,191. AUTISM CARES FOUNDATION, RICHBORO, PA. FILED 11-30-2010.



NO CLAIM IS MADE TO THE EXCLUSIVE RIGHT TO USE "AUTISM" OR "FOUNDATION", APART FROM THE MARK AS SHOWN.

THE MARK CONSISTS OF A HEART AND A PUZZLE PIECE TO THE LEFT OF THE TEXT "AUTISM CARES FOUNDATION", AND A HEART IN PLACE OF THE DOT ABOVE THE LETTER "I" IN "AUTISM".

FOR ARRANGING, ORGANIZING, AND HOSTING SOCIAL ENTERTAINMENT EVENTS AND GET-TOGETHERS FOR FAMILIES OF PEOPLE WITH AUTISM, FOR THE PURPOSE OF FOSTERING A SENSE OF COMMUNITY AND CONNECTEDNESS (U.S. CLS. 100, 101 AND 107).

FIRST USE 10-9-2009; IN COMMERCE 10-9-2009.  
CHARLOTTE CORWIN, EXAMINING ATTORNEY

SN 85-187,463. MISS BEXAR COUNTY ORGANIZATION, INC, SAN ANTONIO, TX. FILED 11-30-2010.



NO CLAIM IS MADE TO THE EXCLUSIVE RIGHT TO USE "SAN ANTONIO", APART FROM THE MARK AS SHOWN.

THE MARK CONSISTS OF THE TEXT "MISS SAN ANTONIO", A CROWN ABOVE THE TEXT, AND TWO LINES UNDERNEATH WITH A STAR IN THE MIDDLE OF THE LINES.

FOR ENTERTAINMENT IN THE NATURE OF BEAUTY PAGEANTS (U.S. CLS. 100, 101 AND 107).

FIRST USE 1-0-1927; IN COMMERCE 1-0-1927.  
ANNE E. GUSTASON, EXAMINING ATTORNEY

**CLASS 41—(Continued).**

SN 85-187,620. BEAUTIFUL FEAT, FORTSON, GA. FILED 11-30-2010.



NO CLAIM IS MADE TO THE EXCLUSIVE RIGHT TO USE "LLC", APART FROM THE MARK AS SHOWN.

THE MARK CONSISTS OF THE STYLIZED TEXT "BEAUTIFUL FEAT LLC" INSIDE A DOUBLE-BORDERED TRIANGLE WITH A DRAWING INSIDE THE TRIANGLE OF A MAN WITH A BACKPACK PULLING ANOTHER MAN WITH A BACKPACK UP A HILL.

FOR PHYSICAL FITNESS INSTRUCTION (U.S. CLS. 100, 101 AND 107).

FIRST USE 7-0-2009; IN COMMERCE 7-0-2009.  
BARNEY CHARLON, EXAMINING ATTORNEY

SN 85-187,684. HENDERSON, JASMINE M., WASHINGTON, DC. FILED 11-30-2010.

## The Jasmine Brand

THE MARK CONSISTS OF STANDARD CHARACTERS WITHOUT CLAIM TO ANY PARTICULAR FONT, STYLE, SIZE, OR COLOR.

FOR PROVIDING INFORMATION, NEWS AND COMMENTARY IN THE FIELD OF ENTERTAINMENT (U.S. CLS. 100, 101 AND 107).

FIRST USE 2-28-2010; IN COMMERCE 2-28-2010.  
JAMES A. RAUEN, EXAMINING ATTORNEY

SN 85-187,722. THE BEST OF ORGANIC LLC, WEST BLOOMFIELD, MI. FILED 11-30-2010.

## RED LIGHT GREEN LIGHT FOODS

THE MARK CONSISTS OF STANDARD CHARACTERS WITHOUT CLAIM TO ANY PARTICULAR FONT, STYLE, SIZE, OR COLOR.

NO CLAIM IS MADE TO THE EXCLUSIVE RIGHT TO USE "FOODS", APART FROM THE MARK AS SHOWN.

FOR EDUCATION SERVICES, NAMELY, PROVIDING CLASSES, SEMINARS, AND WORKSHOPS IN THE FIELD OF HEALTH, NUTRITION, AND LIFESTYLE (U.S. CLS. 100, 101 AND 107).

FIRST USE 2-0-2008; IN COMMERCE 2-0-2008.  
TOBY BULLOFF, EXAMINING ATTORNEY

**CLASS 41—(Continued).**

SN 85-187,781. MEG RUNION STUDIOS, CHARLOTTESVILLE, VA. FILED 11-30-2010.

megrunion.com

THE MARK CONSISTS OF STANDARD CHARACTERS WITHOUT CLAIM TO ANY PARTICULAR FONT, STYLE, SIZE, OR COLOR.

FOR PHOTOGRAPHY SERVICES (U.S. CLS. 100, 101 AND 107).

REBECCA EISINGER, EXAMINING ATTORNEY

SN 85-187,784. MEG RUNION STUDIOS, CHARLOTTESVILLE, VA. FILED 11-30-2010.

Meg Runion

THE MARK CONSISTS OF STANDARD CHARACTERS WITHOUT CLAIM TO ANY PARTICULAR FONT, STYLE, SIZE, OR COLOR.

THE NAME "MEG RUNION" IDENTIFIES A LIVING INDIVIDUAL WHOSE CONSENT IS OF RECORD.

FOR PHOTOGRAPHY SERVICES (U.S. CLS. 100, 101 AND 107).

REBECCA EISINGER, EXAMINING ATTORNEY

SN 85-187,998. CIRQUE HOLDINGS, LLC, POMPANO BEACH, FL. FILED 12-1-2010.

BURLESQUE RHYTHM & MOVES

THE MARK CONSISTS OF STANDARD CHARACTERS WITHOUT CLAIM TO ANY PARTICULAR FONT, STYLE, SIZE, OR COLOR.

NO CLAIM IS MADE TO THE EXCLUSIVE RIGHT TO USE "BURLESQUE", APART FROM THE MARK AS SHOWN.

FOR ENTERTAINMENT SERVICES, NAMELY, PRODUCTION AND PRESENTATION OF THEATRICAL PERFORMANCES FEATURING ARTISTRY, COMEDY, ACROBATICS AND DANCE ACCOMPANIED BY MUSIC (U.S. CLS. 100, 101 AND 107).

JOHN WILKE, EXAMINING ATTORNEY

**CLASS 41—(Continued).**

SN 85-188,086. THE FINANCE INSTITUTE LLC, WILLIAMSVILLE, NY. FILED 12-1-2010.



NO CLAIM IS MADE TO THE EXCLUSIVE RIGHT TO USE "FINANCE INSTITUTE", APART FROM THE MARK AS SHOWN.

THE MARK CONSISTS OF A PIECE OF EARTH WITH THE STYLIZED TEXT "THE FINANCE INSTITUTE".

FOR EDUCATION SERVICES, NAMELY, PROVIDING WORKSHOPS IN THE FIELD OF ALTERNATIVE FINANCIAL SOLUTIONS; EDUCATIONAL SERVICES, NAMELY, PROVIDING ON-LINE SEMINARS IN THE FIELD OF ALTERNATIVE FINANCIAL SOLUTIONS (U.S. CLS. 100, 101 AND 107).

ADA HAN, EXAMINING ATTORNEY

SN 85-188,170. HARLEM GLOBETROTTERS INTERNATIONAL, INC., PHOENIX, AZ. FILED 12-1-2010.

HARLEM GLOBETROTTERS FOUR  
POINT SHOT

THE MARK CONSISTS OF STANDARD CHARACTERS WITHOUT CLAIM TO ANY PARTICULAR FONT, STYLE, SIZE, OR COLOR.

OWNER OF U.S. REG. NOS. 542,474, 2,374,778 AND OTHERS.

NO CLAIM IS MADE TO THE EXCLUSIVE RIGHT TO USE "FOUR POINT SHOT", APART FROM THE MARK AS SHOWN.

FOR ENTERTAINMENT SERVICES IN THE NATURE OF BASKETBALL EXHIBITIONS (U.S. CLS. 100, 101 AND 107).

ALEXANDER L. POWERS, EXAMINING ATTORNEY

**CLASS 41—(Continued).**

SN 85-188,197. AEROSTAR TRAINING SERVICES, LLC, TEQUESTA, FL. FILED 12-1-2010.



NO CLAIM IS MADE TO THE EXCLUSIVE RIGHT TO USE "TRAINING SERVICES, LLC", APART FROM THE MARK AS SHOWN.

THE COLOR(S) BLUE, WHITE, AND BLACK IS/ARE CLAIMED AS A FEATURE OF THE MARK.

THE MARK CONSISTS OF A BLUE GLOBE WITH WHITE VERTICAL LINES AND CIRCULAR BANDS, WITH A BLUE SWOOSH LEADING TO A BLUE STAR ATOP GLOBE, WITH THE STYLIZED WORDING "AEROSTAR" TO THE RIGHT OF THE GLOBE, WITH "AERO" IN BLACK AND "STAR" IN BLUE, WITH THE WORDING, "TRAINING SERVICES LLC", BELOW IN BLACK.

FOR EDUCATIONAL SERVICES, NAMELY, CONDUCTING TRAINING IN THE FIELD OF AVIATION AND DISTRIBUTION OF TRAINING MATERIAL IN CONNECTION THEREWITH (U.S. CLS. 100, 101 AND 107).

FIRST USE 9-22-2008; IN COMMERCE 9-22-2008.  
ODESSA BIBBINS, EXAMINING ATTORNEY

**CLASS 41—(Continued).**

SN 85-188,740. GONZALES, MISTY, DBA ROCK & ROLL FREEDOM SHOW, PASADENA, CA. AND WILSON, TOM, DBA ROCK & ROLL FREEDOM SHOW, PASADENA, CA. FILED 12-1-2010.

ROCK & ROLL FREEDOM SHOW

THE MARK CONSISTS OF STANDARD CHARACTERS WITHOUT CLAIM TO ANY PARTICULAR FONT, STYLE, SIZE, OR COLOR.

NO CLAIM IS MADE TO THE EXCLUSIVE RIGHT TO USE "ROCK & ROLL" AND "SHOW", APART FROM THE MARK AS SHOWN.

FOR ARRANGING AND CONDUCTING NIGHTCLUB ENTERTAINMENT EVENTS (U.S. CLS. 100, 101 AND 107).

FIRST USE 11-12-2010; IN COMMERCE 11-12-2010.  
FRANK LATTUCA, EXAMINING ATTORNEY

SN 85-189,054. FALMOUTH TRACK CLUB CORPORATION, FALMOUTH, MA. FILED 12-2-2010.

SN 85-188,292. SYNCRETICS GROUP, INC., THE, BRANFORD, CT. FILED 12-1-2010.

TeamEDGE

THE MARK CONSISTS OF STANDARD CHARACTERS WITHOUT CLAIM TO ANY PARTICULAR FONT, STYLE, SIZE, OR COLOR.

FOR EDUCATIONAL SERVICES, NAMELY, CONDUCTING PRESENTATIONS, SEMINARS, CONFERENCES, AND WORKSHOPS FOR CONVEYING PRINCIPLES, SKILLS AND STRATEGIES IN THE FIELD OF LEADERSHIP, TEAMWORK, AND CHANGE MANAGEMENT USING STORIES OF ADVENTURE AND SURVIVAL AND DISTRIBUTION OF COURSE MATERIAL IN CONNECTION THEREWITH (U.S. CLS. 100, 101 AND 107).

FIRST USE 10-13-2008; IN COMMERCE 10-13-2008.  
DANIEL CAPSHAW, EXAMINING ATTORNEY



NO CLAIM IS MADE TO THE EXCLUSIVE RIGHT TO USE "MARATHON", APART FROM THE MARK AS SHOWN.

THE MARK CONSISTS OF A SCALLOP SHELL INSIDE OF A CIRCLE WITH THE STYLIZED TEXT "CAPE COD" CENTERED ABOVE THE WORD "MARATHON" IN THE CENTER OF THE SHELL.

SEC. 2(F) AS TO "CAPE COD".  
FOR ATHLETIC AND SPORTS EVENT SERVICES, NAMELY, ARRANGING, ORGANIZING, OPERATING AND CONDUCTING MARATHON RACES (U.S. CLS. 100, 101 AND 107).

FIRST USE 12-10-1978; IN COMMERCE 6-1-1984.  
TINA BROWN, EXAMINING ATTORNEY

**CLASS 41—(Continued).**

SN 85-189,153. JONATHAN GORDON, NEW YORK, NY.  
FILED 12-2-2010.

# I LIVE FASHION.COM

THE MARK CONSISTS OF STANDARD CHARACTERS WITHOUT CLAIM TO ANY PARTICULAR FONT, STYLE, SIZE, OR COLOR.

NO CLAIM IS MADE TO THE EXCLUSIVE RIGHT TO USE "FASHION.COM", APART FROM THE MARK AS SHOWN.

FOR ON-LINE JOURNALS, NAMELY, BLOGS FEATURING FASHION (U.S. CLS. 100, 101 AND 107).

FIRST USE 10-15-2010; IN COMMERCE 10-15-2010.

SIMON TENG, EXAMINING ATTORNEY

**CLASS 41—(Continued).**

SN 85-189,538. GRAY DIGITAL MARKETING, INC.,  
QUEENSBURY, NY. FILED 12-2-2010.

# Digital Stream

THE MARK CONSISTS OF STANDARD CHARACTERS WITHOUT CLAIM TO ANY PARTICULAR FONT, STYLE, SIZE, OR COLOR.

NO CLAIM IS MADE TO THE EXCLUSIVE RIGHT TO USE "DIGITAL", APART FROM THE MARK AS SHOWN.

FOR ON-LINE JOURNALS, NAMELY, BLOGS FEATURING TECHNOLOGY NEWS AND INDUSTRY RELATED ARTICLES (U.S. CLS. 100, 101 AND 107).

FIRST USE 12-1-2010; IN COMMERCE 12-1-2010.

CHRISTINE MARTIN, EXAMINING ATTORNEY

SN 85-189,167. GOLFINGADE, LITTLETON, CO. FILED 12-2-2010.

# SportingAde

THE MARK CONSISTS OF STANDARD CHARACTERS WITHOUT CLAIM TO ANY PARTICULAR FONT, STYLE, SIZE, OR COLOR.

FOR RENTAL OF GOLF EQUIPMENT (U.S. CLS. 100, 101 AND 107).

SIMON TENG, EXAMINING ATTORNEY

SN 85-189,688. VICKIE D. NEWTON, SAINT LOUIS, MO.  
FILED 12-2-2010.

# TheVillageCelebration.com

SN 85-189,394. HEART HOUSE OF AUSTIN, AUSTIN, TX.  
FILED 12-2-2010.

# BE HIVE

THE MARK CONSISTS OF STANDARD CHARACTERS WITHOUT CLAIM TO ANY PARTICULAR FONT, STYLE, SIZE, OR COLOR.

FOR EDUCATIONAL SERVICES, NAMELY, PROVIDING COURSES OF INSTRUCTION AT THE PRIMARY, SECONDARY AND COLLEGE LEVELS; PROVIDING EDUCATIONAL PROGRAMS IN THE FIELDS OF MATH, READING, SCIENCE, SOCIAL STUDIES AND HEALTH; CONDUCTING BEFORE AND AFTER SCHOOL TUTORING PROGRAMS INCLUDING HOMEWORK ASSISTANCE; ART ENRICHMENT CLASSES; READING AND WRITING LITERACY CLASSES; HEALTH AND URBAN SAFETY CLASSES; COMPUTER LITERACY CLASSES; DANCE CLASSES; AND GOOD CITIZENSHIP EDUCATION TRAINING CLASSES TO CHILDREN (U.S. CLS. 100, 101 AND 107).

SUSAN STIGLITZ, EXAMINING ATTORNEY

THE MARK CONSISTS OF STANDARD CHARACTERS WITHOUT CLAIM TO ANY PARTICULAR FONT, STYLE, SIZE, OR COLOR.

FOR PROVIDING A WEBSITE FEATURING BLOGS AND NON-DOWNLOADABLE PUBLICATIONS IN THE NATURE OF ARTICLES THAT CONTAIN PICTURES AND TEXT IN THE FIELD OF ISSUES THAT INTEREST AFRICAN-AMERICANS, TO ENCOURAGE CONVERSATION ABOUT ISSUES THAT INTEREST AFRICAN-AMERICANS (U.S. CLS. 100, 101 AND 107).

FIRST USE 11-1-2010; IN COMMERCE 11-1-2010.

AMY HELLA, EXAMINING ATTORNEY



**CLASS 41—(Continued).**

SN 85-189,804. KEEN ENTERTAINMENT LLC, WESTMINSTER, CA. FILED 12-2-2010.

# INK-N-IRON

THE MARK CONSISTS OF STANDARD CHARACTERS WITHOUT CLAIM TO ANY PARTICULAR FONT, STYLE, SIZE, OR COLOR.

FOR CONDUCTING ENTERTAINMENT EXHIBITIONS IN THE NATURE OF ART, TATTOO, MOTOR VEHICLE, VEHICLE CUSTOMIZATION, BODY CUSTOMIZATION, NAMELY, BODY ALTERATION, LIVE MUSIC, AND CULTURE SHOWS AND FESTIVALS; ENTERTAINMENT, NAMELY, PRODUCTION OF AN ART, TATTOO, MOTOR VEHICLE, VEHICLE CUSTOMIZATION, BODY CUSTOMIZATION, NAMELY, BODY ALTERATION, AND LIVE MUSIC FESTIVAL; ORGANIZATION OF CULTURAL SHOWS; ORGANIZING COMMUNITY FESTIVALS FEATURING PRIMARILY ART, TATTOOS, MOTOR VEHICLES, VEHICLE CUSTOMIZATION, BODY CUSTOMIZATION, NAMELY, BODY ALTERATION, LIVE MUSIC AND RELATED CULTURE AND ALSO PROVIDING VENDORS, TATTOO ARTISTS AND CONTESTS; ORGANIZING CULTURAL AND ARTS EVENTS; ORGANIZATION OF EXHIBITIONS FOR CULTURAL PURPOSES; ORGANIZING AND ARRANGING EXHIBITIONS FOR ENTERTAINMENT PURPOSES (U.S. CLS. 100, 101 AND 107).

FIRST USE 4-0-2003; IN COMMERCE 4-28-2003.

BRENDAN MCCAULEY, EXAMINING ATTORNEY

SN 85-189,837. MEG RUNION STUDIOS, CHARLOTTESVILLE, VA. FILED 12-2-2010.



NO CLAIM IS MADE TO THE EXCLUSIVE RIGHT TO USE "STUDIOS", APART FROM THE MARK AS SHOWN. THE NAME "MEG RUNION" IDENTIFIES A LIVING INDIVIDUAL WHOSE CONSENT IS OF RECORD.

THE MARK CONSISTS OF A BRANCH WITH A SCROLL ON THE TOP AND AT THE BOTTOM. IN THE MIDDLE THERE IS THE STYLIZED TEXT "MEG RUNION STUDIOS".

FOR PHOTOGRAPHY SERVICES (U.S. CLS. 100, 101 AND 107).

FIRST USE 12-1-2009; IN COMMERCE 12-1-2009.

REBECCA EISINGER, EXAMINING ATTORNEY

**CLASS 41—(Continued).**

SN 85-189,920. CLOUD ON MUSIC INC., SOUTHPORT, CT. FILED 12-3-2010.

# Shankar Mahadevan Academy

THE MARK CONSISTS OF STANDARD CHARACTERS WITHOUT CLAIM TO ANY PARTICULAR FONT, STYLE, SIZE, OR COLOR.

NO CLAIM IS MADE TO THE EXCLUSIVE RIGHT TO USE "ACADEMY", APART FROM THE MARK AS SHOWN. THE NAME(S), PORTRAIT(S), AND/OR SIGNATURE(S) SHOWN IN THE MARK IDENTIFIES "SHANKAR MAHADEVAN", WHOSE CONSENT(S) TO REGISTER IS MADE OF RECORD.

FOR EDUCATION SERVICES, NAMELY, PROVIDING ON-LINE CLASSES IN THE FIELD OF MUSIC; PROVIDING AN EDUCATIONAL WEBSITE IN THE FIELDS OF MUSIC AND ENTERTAINMENT; PUBLISHING OF BOOKS, E-BOOKS, AUDIO BOOKS, MUSIC AND ILLUSTRATIONS; TEACHING IN THE FIELD OF MUSIC (U.S. CLS. 100, 101 AND 107).

FIRST USE 10-2-2010; IN COMMERCE 10-2-2010.

KATINA MISTER, EXAMINING ATTORNEY

SN 85-189,958. THE WELCH EXPERIENCE, INC., ATLANTA, GA. FILED 12-3-2010.



NO CLAIM IS MADE TO THE EXCLUSIVE RIGHT TO USE "MARTIAL ART EXPERIENCE", APART FROM THE MARK AS SHOWN.

THE MARK CONSISTS OF SERIES OF CONCENTRIC CIRCLES WITH SUPERIMPOSED TRIANGLES IN A SIX-POINTED STAR PATTERN ALTERNATING WITH HUMAN CHARACTERS IN MARTIAL ART POSITIONS THEREIN, SURROUNDED BY THE WORDS "THE WELCH MARTIAL ART EXPERIENCE FITNESS CONCEPTS EMPOWERING LIFE".

FOR FITNESS COACHING AND MOTIVATIONAL TRAINING (U.S. CLS. 100, 101 AND 107).

FIRST USE 2-28-2009; IN COMMERCE 2-28-2009.

DAVID H. STINE, EXAMINING ATTORNEY

**CLASS 41—(Continued).**

SN 85-189,993. EUREKA! INSTITUTE, INC., CINCINNATI, OH. FILED 12-3-2010.



OWNER OF U.S. REG. NOS. 3,529,059 AND 3,815,362.  
NO CLAIM IS MADE TO THE EXCLUSIVE RIGHT TO USE "INNOVATION", APART FROM THE MARK AS SHOWN.

THE MARK CONSISTS OF THREE CONSECUTIVE SQUARES WITH ROUNDED CORNERS CONTAINING AN EXCLAMATION MARK, QUOTATION MARKS AND A DOLLAR SIGN, RESPECTIVELY, WITH THE WORD "INNOVATION" IN BOLD LETTERS UNDER THE SQUARES AND THE NON-BOLD WORD "ENGINEERING" UNDER "INNOVATION".

FOR EDUCATION SERVICES, NAMELY, LICENSED ENTREPRENEURSHIP CLASSES TO BE PRESENTED BY ACCREDITED COLLEGES AND UNIVERSITIES (U.S. CLS. 100, 101 AND 107).

FIRST USE 9-30-2009; IN COMMERCE 9-30-2009.  
SUE LAWRENCE, EXAMINING ATTORNEY

**CLASS 41—(Continued).**

SN 85-190,635. FILEFRONT, LLC, LOS ANGELES, CA. FILED 12-3-2010.



NO CLAIM IS MADE TO THE EXCLUSIVE RIGHT TO USE "GAME", APART FROM THE MARK AS SHOWN.

THE COLOR(S) LIGHT BROWN IS/ARE CLAIMED AS A FEATURE OF THE MARK.

THE MARK CONSISTS OF THE WORD "GAMEFRONT" WITH A LIGHT BROWN VIDEO GAME JOYSTICK BETWEEN "GAME" AND "FRONT".

FOR ENTERTAINMENT SERVICES, NAMELY, PROVIDING INFORMATION, NEWS, COMMENTARY, CRITICAL REVIEWS WHICH ARE ALL ABOUT PLAYING TIPS AND SYNOPSES OF VIDEO GAMES VIA A GLOBAL COMPUTER NETWORK (U.S. CLS. 100, 101 AND 107).

FIRST USE 12-1-2010; IN COMMERCE 12-1-2010.  
JACQUELINE A. LAVINE, EXAMINING ATTORNEY

SN 85-190,406. INTERNATIONAL DRIVER TRAINING, INC., IRVING, TX. FILED 12-3-2010.

COMEDY DRIVING SCHOOL

THE MARK CONSISTS OF STANDARD CHARACTERS WITHOUT CLAIM TO ANY PARTICULAR FONT, STYLE, SIZE, OR COLOR.

OWNER OF U.S. REG. NOS. 1,798,916 AND 1,798,917.  
NO CLAIM IS MADE TO THE EXCLUSIVE RIGHT TO USE "DRIVING SCHOOL", APART FROM THE MARK AS SHOWN.

SEC. 2(F).  
FOR EDUCATIONAL SERVICES, NAMELY, CONDUCTING DRIVER SAFETY COURSES, DEFENSIVE DRIVING COURSES, TRAFFIC SCHOOL COURSES AND DRIVER EDUCATION COURSES TAUGHT BY COMEDIANS (U.S. CLS. 100, 101 AND 107).

FIRST USE 1-1-2009; IN COMMERCE 1-1-2009.  
TRACY CROSS, EXAMINING ATTORNEY

SN 85-190,698. EPICUREAN CATERING, LLC, CENTENNIAL, CO. FILED 12-4-2010.



NO CLAIM IS MADE TO THE EXCLUSIVE RIGHT TO USE "EPICUREAN CULINARY GROUP", APART FROM THE MARK AS SHOWN.

THE COLOR(S) YELLOW, BLACK, AND ORANGE IS/ARE CLAIMED AS A FEATURE OF THE MARK.

THE MARK CONSISTS OF YELLOW AND BLACK FIRE ON A BLACK PLATE, ABOVE THE WORD "EPICUREAN" IN ORANGE, AND THE WORDS "CULINARY GROUP" IN BLACK.

FOR ENTERTAINMENT SERVICES, NAMELY, WINE AND FOOD TASTINGS (U.S. CLS. 100, 101 AND 107).

FIRST USE 10-15-2007; IN COMMERCE 10-15-2007.  
TIMOTHY FINNEGAN, EXAMINING ATTORNEY

**CLASS 41—(Continued).**

SN 85-190,724. MERIYALA, SANTOSH KUMAR, HYDERABAD, INDIA, FILED 12-4-2010.

**ICD-10 Connect**

THE MARK CONSISTS OF STANDARD CHARACTERS WITHOUT CLAIM TO ANY PARTICULAR FONT, STYLE, SIZE, OR COLOR.

NO CLAIM IS MADE TO THE EXCLUSIVE RIGHT TO USE "ICD-10", APART FROM THE MARK AS SHOWN.

FOR EDUCATION SERVICES, NAMELY, PROVIDING ON-LINE TRAINING, SEMINARS IN THE FIELD OF ICD-10 CODING SYSTEM (U.S. CLS. 100, 101 AND 107).

FIRST USE 7-18-2010; IN COMMERCE 7-19-2010.  
KELLEY WELLS, EXAMINING ATTORNEY

---

SN 85-190,975. HOME BOX OFFICE, INC., NEW YORK, NY. FILED 12-6-2010.

**LEGENDS & LEGACIES**

THE MARK CONSISTS OF STANDARD CHARACTERS WITHOUT CLAIM TO ANY PARTICULAR FONT, STYLE, SIZE, OR COLOR.

FOR ENTERTAINMENT SERVICES IN THE NATURE OF ON-GOING DOCUMENTARY TELEVISION PROGRAMS IN THE FIELD OF SPORTS (U.S. CLS. 100, 101 AND 107).

STEVEN R. FINE, EXAMINING ATTORNEY

---

SN 85-191,018. DONOVAN, THOMAS, PHILADELPHIA, PA. FILED 12-6-2010.

**P.A.S.S. SYSTEM**

THE MARK CONSISTS OF STANDARD CHARACTERS WITHOUT CLAIM TO ANY PARTICULAR FONT, STYLE, SIZE, OR COLOR.

NO CLAIM IS MADE TO THE EXCLUSIVE RIGHT TO USE "SYSTEM", APART FROM THE MARK AS SHOWN.

FOR EDUCATIONAL SERVICES, NAMELY, CONDUCTING CLASSES AND SEMINARS IN THE FIELD OF DRIVING SAFETY AND DISTRIBUTION OF PRINTED MATERIALS IN CONNECTION THEREWITH IN HARD COPY OR ELECTRONIC FORMAT ON THE SAME TOPICS (U.S. CLS. 100, 101 AND 107).

FIRST USE 12-0-2008; IN COMMERCE 12-0-2008.  
JENNIFER VASQUEZ, EXAMINING ATTORNEY

**CLASS 41—(Continued).**

SN 85-191,033. BACKLINE MUSIC GROUP, LLC, TAMPA, FL. FILED 12-6-2010.



NO CLAIM IS MADE TO THE EXCLUSIVE RIGHT TO USE "ARTIST SHOWCASE", APART FROM THE MARK AS SHOWN.

THE COLOR(S) RED, ORANGE, BLACK AND WHITE IS/ ARE CLAIMED AS A FEATURE OF THE MARK.

THE MARK CONSISTS OF THE WORDING "ARTIST SHOWCASE" IN WHITE, TO THE LEFT OF A SILHOUETTE OF A WOMAN, A MAN PLAYING A GUITAR, AND A MAN WITH OUTSTRETCHED ARMS, IN BLACK, ALL AGAINST A RECTANGULAR BACKGROUND OF ALTERNATING ORANGE AND RED LINES RADIATING FROM A POINT NEAR THE CENTER OF THE MARK.

FOR PROVISION OF ENTERTAINMENT INFORMATION RELATING TO LIVE PERFORMANCES, ROAD SHOWS, LIVE STAGE EVENTS, THEATRICAL PERFORMANCES, LIVE MUSIC CONCERTS, AND TO AUDIENCE PARTICIPATION IN SUCH EVENTS (U.S. CLS. 100, 101 AND 107).

FIRST USE 9-1-2010; IN COMMERCE 9-1-2010.  
LIEF MARTIN, EXAMINING ATTORNEY

---

SN 85-191,180. OTOL INC, SHERMAN OAKS, CA. FILED 12-6-2010.

**NEUROATTENDANT**

THE MARK CONSISTS OF STANDARD CHARACTERS WITHOUT CLAIM TO ANY PARTICULAR FONT, STYLE, SIZE, OR COLOR.

FOR EDUCATIONAL SERVICES, NAMELY, CONDUCTING TRAINING/SUPERVISION IN THE FIELDS OF HOME HEALTH THERAPY AIDES WITH THE BRAIN INJURED AND DISTRIBUTION OF TRAINING MATERIALS IN CONNECTION THEREWITH (U.S. CLS. 100, 101 AND 107).

FIRST USE 6-10-1998; IN COMMERCE 6-10-1998.  
STEPHANIE ALI, EXAMINING ATTORNEY

**CLASS 41—(Continued).**

SN 85-191,466. CANLAN ICE SPORTS CORP., BURNABY, BC, CANADA, FILED 12-6-2010.

## BOUNCE MANIA

THE MARK CONSISTS OF STANDARD CHARACTERS WITHOUT CLAIM TO ANY PARTICULAR FONT, STYLE, SIZE, OR COLOR.

NO CLAIM IS MADE TO THE EXCLUSIVE RIGHT TO USE "BOUNCE", APART FROM THE MARK AS SHOWN.

FOR ENTERTAINMENT AND AMUSEMENT CENTERS FOR CHILDREN AND ADULTS, FEATURING INFLATABLE DEVICES FOR BOUNCING (U.S. CLS. 100, 101 AND 107).

FIRST USE 3-13-2009; IN COMMERCE 3-13-2009.  
ALICIA COLLINS, EXAMINING ATTORNEY

---

SN 85-191,630. EDGERTON, ANNIE, NEW YORK, NY. FILED 12-6-2010.

## WINE MINX

THE MARK CONSISTS OF STANDARD CHARACTERS WITHOUT CLAIM TO ANY PARTICULAR FONT, STYLE, SIZE, OR COLOR.

NO CLAIM IS MADE TO THE EXCLUSIVE RIGHT TO USE "WINE", APART FROM THE MARK AS SHOWN.

FOR ON-LINE JOURNALS, NAMELY, BLOGS FEATURING THE SUBJECT OF WINE ; EDUCATION SERVICES, NAMELY, PROVIDING CLASSES AND SEMINARS IN THE FIELD OF WINE (U.S. CLS. 100, 101 AND 107).

FIRST USE 5-13-2010; IN COMMERCE 5-13-2010.  
LINDSEY RUBIN, EXAMINING ATTORNEY

**CLASS 41—(Continued).**

SN 85-191,693. IVYSAGE EDUCATION, LLC, NEW YORK, NY. FILED 12-6-2010.

## IvySage

THE MARK CONSISTS OF STANDARD CHARACTERS WITHOUT CLAIM TO ANY PARTICULAR FONT, STYLE, SIZE, OR COLOR.

FOR EDUCATION SERVICES, NAMELY, PROVIDING MENTORING, TUTORING, CLASSES, SEMINARS AND WORKSHOPS AT THE MIDDLE SCHOOL, HIGH SCHOOL, COLLEGE, ADVANCED DEGREE, DOCTORAL AND MEDICAL, LEGAL AND OTHER PROFESSIONAL COURSE LEVELS IN THE FIELDS OF STANDARDIZED TEST TAKING, AND, ALL ACADEMIC SUBJECTS AT THE AFOREMENTIONED COURSE LEVELS, OFFERED VIA THE INTERNET; ADMISSIONS ADVISORY SERVICES, NAMELY, CONSULTING IN THE FIELD OF ADMISSIONS AT THE AFOREMENTIONED LEVELS IN THE NATURE OF ACADEMIC SELECTION, COMPLETING ADMISSIONS APPLICATIONS, AND PREPARATION FOR ADMISSION INTERVIEWS (U.S. CLS. 100, 101 AND 107).

FIRST USE 3-0-2009; IN COMMERCE 3-0-2009.  
HANNO RITTNER, EXAMINING ATTORNEY

---

SN 85-191,741. SLOBODY LLC, SEATTLE, WA. FILED 12-6-2010.

## SLOBODY

THE MARK CONSISTS OF THE "B" TRAVELING INTO THE FIRST "O" OF THE STYLIZED TEXT "SLOBODY".

FOR PHYSICAL FITNESS INSTRUCTION; PHYSICAL FITNESS TRAINING SERVICES; TRAINING SERVICES IN THE FIELD OF YOGA; YOGA INSTRUCTION (U.S. CLS. 100, 101 AND 107).

FIRST USE 5-1-2010; IN COMMERCE 5-1-2010.  
JEFF DEFORD, EXAMINING ATTORNEY

**CLASS 41—(Continued).**

SN 85-191,742. STOLL, SUSAN DIANE, DBA THE ART SPOT, RIDGEWOOD, NJ. FILED 12-6-2010.



NO CLAIM IS MADE TO THE EXCLUSIVE RIGHT TO USE "ART", APART FROM THE MARK AS SHOWN.

THE COLOR(S) WHITE, RED, BLUE, GREEN, YELLOW, BROWN, TAN, AND SILVER IS/ARE CLAIMED AS A FEATURE OF THE MARK.

THE MARK CONSISTS OF A RECTANGLE WITH A WHITE BACKGROUND WITH A RED, WHITE AND BLUE TRIPLE-LINED BORDER, THE WORD "THE" APPEARS IN GREEN AT AN ANGLE TO THE WORD "ART" WHICH APPEARS IN RED ABOVE THE LETTERS "SP" IN THE WORD "SPOT" WHICH APPEARS IN LARGE BLUE LETTERS WITH THE "O" IN "SPOT" BEING AN ARTIST'S WOODEN PAINT PALETTE IN BROWN AND TAN WITH 3 PAINT SPOTS IN RED, YELLOW, AND BLUE, A GREEN HANDLED PAINT BRUSH WITH A SILVER TIP AND BROWN BRUSH AND RED PAINT ON THE TIP APPEARS OVER THE PALETTE, THERE ARE GREEN, YELLOW, AND BLUE RANDOM PAINT DROPS ON THE WHITE BACKGROUND.

FOR EDUCATION SERVICES, NAMELY, PROVIDING MENTORING, TUTORING, CLASSES, SEMINARS AND WORKSHOPS IN THE FIELD OF DRAWING AND PAINTING (U.S. CLS. 100, 101 AND 107).

FIRST USE 5-15-2010; IN COMMERCE 9-2-2010.  
JEFF DEFORD, EXAMINING ATTORNEY

SN 85-191,795. KEY METRICS LLC, TALLAHASSEE, FL. FILED 12-7-2010.

## Metrics Mastermind

THE MARK CONSISTS OF STANDARD CHARACTERS WITHOUT CLAIM TO ANY PARTICULAR FONT, STYLE, SIZE, OR COLOR.

NO CLAIM IS MADE TO THE EXCLUSIVE RIGHT TO USE "METRICS", APART FROM THE MARK AS SHOWN.

FOR EDUCATIONAL SERVICES, NAMELY, CONDUCTING SEMINARS, WORKSHOPS, AND COURSES OF INSTRUCTION IN THE FIELD OF BUSINESS METRICS FORECASTING AND ANALYSIS (U.S. CLS. 100, 101 AND 107).

FIRST USE 7-8-2010; IN COMMERCE 9-17-2010.  
ZHALEH DELANEY, EXAMINING ATTORNEY

**CLASS 41—(Continued).**

SN 85-192,038. RAY LEONE, DBA THE LEONE RESOURCE GROUP, ST. AUGUSTINE, FL. FILED 12-7-2010.

## SALES FUNNEL

THE MARK CONSISTS OF STANDARD CHARACTERS WITHOUT CLAIM TO ANY PARTICULAR FONT, STYLE, SIZE, OR COLOR.

NO CLAIM IS MADE TO THE EXCLUSIVE RIGHT TO USE "SALES", APART FROM THE MARK AS SHOWN.

FOR EDUCATIONAL SERVICES, NAMELY, CONDUCTING SEMINARS IN THE FIELD OF SALES AND MARKETING (U.S. CLS. 100, 101 AND 107).

FIRST USE 1-31-1976; IN COMMERCE 1-31-1976.  
PAUL E. FAHRENKOPF, EXAMINING ATTORNEY

SN 85-192,574. ZUHAIRAH Y. SCOTT, AKA ZUHAIRAH Y. SCOTT WASHINGTON, WASHINGTON, DC. FILED 12-7-2010.

## THE GOODNESS

THE MARK CONSISTS OF STANDARD CHARACTERS WITHOUT CLAIM TO ANY PARTICULAR FONT, STYLE, SIZE, OR COLOR.

FOR PUBLICATION SERVICES, NAMELY, ONLINE PUBLICATIONS IN THE NATURE OF NEWSLETTERS FEATURING ENTERTAINMENT, INFORMATION, NEWS AND COMMENTARY ABOUT LIVING A THRIVING AND PURPOSEFUL LIFE AND CREATING A BETTER WORLD ACCESSIBLE VIA A WEBSITE AND WIRELESS MOBILE DEVICES; ONLINE ELECTRONIC NEWSLETTERS DELIVERED BY E-MAIL AND ELECTRONIC MESSAGES FEATURING ENTERTAINMENT, INFORMATION, NEWS AND COMMENTARY ABOUT LIVING A THRIVING AND PURPOSEFUL LIFE AND CREATING A BETTER WORLD; PROVIDING AN INTERACTIVE WEBSITE WITH NON-DOWNLOADABLE PUBLICATIONS IN THE NATURE OF NEWSLETTERS FEATURING ENTERTAINMENT, INFORMATION, NEWS AND COMMENTARY ABOUT LIVING A THRIVING AND PURPOSEFUL LIFE AND CREATING A BETTER WORLD; ARRANGING AND CONDUCTING SPECIAL EVENTS FOR SOCIAL ENTERTAINMENT PURPOSES (U.S. CLS. 100, 101 AND 107).

FIRST USE 8-3-2010; IN COMMERCE 8-3-2010.  
MARK SHINER, EXAMINING ATTORNEY

**CLASS 41—(Continued).**

SN 85-192,680. OVERTAKER, LLC, CREAM RIDGE, NJ. FILED 12-7-2010.

**CHRIS COLE**

THE MARK CONSISTS OF STANDARD CHARACTERS WITHOUT CLAIM TO ANY PARTICULAR FONT, STYLE, SIZE, OR COLOR.

THE NAME(S), PORTRAIT(S), AND/OR SIGNATURE(S) SHOWN IN THE MARK IDENTIFIES JAMES "CHRISTOPHER COLE", WHOSE CONSENT(S) TO REGISTER IS OF RECORD.

FOR ENTERTAINMENT SERVICES, NAMELY, PERSONAL APPEARANCES BY A SPORTS CELEBRITY; PROVIDING A WEBSITE FEATURING NON-DOWNLOADABLE PHOTOGRAPHS, VIDEO AND INFORMATION IN THE FIELD OF SKATEBOARDING; ENTERTAINMENT SERVICES, NAMELY, PARTICIPATION IN SKATEBOARDING COMPETITIONS, WORKSHOPS AND EXHIBITIONS (U.S. CLS. 100, 101 AND 107).  
FIRST USE 3-1-2004; IN COMMERCE 3-1-2004.  
JAMES LOVELACE, EXAMINING ATTORNEY

---

SN 85-192,826. THE MICHIGAN WOMEN'S FOUNDATION, GROSSE POINTE FARMS, MI. FILED 12-8-2010.

**LIFE UNPLUGGED**

THE MARK CONSISTS OF STANDARD CHARACTERS WITHOUT CLAIM TO ANY PARTICULAR FONT, STYLE, SIZE, OR COLOR.

FOR EDUCATIONAL SERVICES, NAMELY, CONDUCTING CLASSES, SEMINARS, CONFERENCES, AND WORKSHOPS TO TEACH TEENAGERS ABOUT THE COST OF LIVING AND THE LONG-TERM FINANCIAL IMPACT OF THEIR CHOICES REGARDING EDUCATION, CAREER, AND FAMILY SITUATIONS, AND DISTRIBUTION OF PRINTED MATERIALS IN CONNECTION THEREWITH IN HARD COPY OR ELECTRONIC FORMAT ON THE SAME TOPICS (U.S. CLS. 100, 101 AND 107).

FIRST USE 11-23-2010; IN COMMERCE 11-23-2010.  
ALEXANDER L. POWERS, EXAMINING ATTORNEY

**CLASS 41—(Continued).**

SN 85-192,955. NEW ORLEANS KATRINA MEMORIAL CORPORATION, NEW ORLEANS, LA. FILED 12-8-2010.



NO CLAIM IS MADE TO THE EXCLUSIVE RIGHT TO USE "NEW ORLEANS KATRINA MEMORIAL", APART FROM THE MARK AS SHOWN.

THE MARK CONSISTS OF A FLEUR DE LIS OVER CIRCULAR BANDS SURROUNDED BY THE WORDS "NEW ORLEANS KATRINA MEMORIAL".

FOR GUIDED TOURS OF A MUSEUM; MUSEUM SERVICES; MUSEUM SERVICES, NAMELY, EXHIBITING TO THE PUBLIC A HISTORICAL SITE; MUSEUMS (U.S. CLS. 100, 101 AND 107).

FIRST USE 12-1-2006; IN COMMERCE 12-1-2006.  
LINDSEY RUBIN, EXAMINING ATTORNEY

---

SN 85-193,086. UNITED STATES FOUNDATION FOR INSPIRATION AND RECOGNITION OF SCIENCE AND TECHNOLOGY, AKA US FIRST, MANCHESTER, NH. AND LEGO SYSTEMS, INC., AKA LEGO CORPORATION, ENFIELD, CT. FILED 12-8-2010.

**FOOD FACTOR**

THE MARK CONSISTS OF STANDARD CHARACTERS WITHOUT CLAIM TO ANY PARTICULAR FONT, STYLE, SIZE, OR COLOR.

NO CLAIM IS MADE TO THE EXCLUSIVE RIGHT TO USE "FOOD", APART FROM THE MARK AS SHOWN.

FOR EDUCATIONAL SERVICES, NAMELY, PROVIDING EDUCATIONAL PROGRAMS AND COMPETITIONS IN THE FIELDS OF SCIENCE, TECHNOLOGY, ENGINEERING, ROBOTICS, AND MATHEMATICS (U.S. CLS. 100, 101 AND 107).

FIRST USE 11-23-2010; IN COMMERCE 11-23-2010.  
COURTNEY ALVAREZ, EXAMINING ATTORNEY

**CLASS 41—(Continued).**

SN 85-193,168. DE LA LAMA, LUISA, ST. PETERSBURG, FL.  
FILED 12-8-2010.

## Smart Soul Mates

THE MARK CONSISTS OF STANDARD CHARACTERS WITHOUT CLAIM TO ANY PARTICULAR FONT, STYLE, SIZE, OR COLOR.

NO CLAIM IS MADE TO THE EXCLUSIVE RIGHT TO USE "SOUL MATES", APART FROM THE MARK AS SHOWN.

FOR CONDUCTING WORKSHOPS AND SEMINARS IN PERSONAL AWARENESS; CONDUCTING WORKSHOPS AND SEMINARS IN SELF AWARENESS; CONDUCTING WORKSHOPS AND SEMINARS IN RELATIONSHIPS; EDUCATION SERVICES, NAMELY, PROVIDING LIVE AND ON-LINE CLASSES, SEMINARS, CONFERENCES, WORKSHOPS, RETREATS, CAMPS, FIELD TRIPS IN THE FIELD OF RELATIONSHIPS AND DISTRIBUTION OF COURSE MATERIALS IN CONNECTION THEREWITH; EDUCATIONAL SERVICES, NAMELY, CONDUCTING CLASSES, SEMINARS, CONFERENCES, WORKSHOPS, RETREATS, CAMPS AND FIELD TRIPS IN THE FIELD OF RELATIONSHIPS AND DISTRIBUTION OF TRAINING MATERIAL IN CONNECTION THEREWITH; EDUCATIONAL SERVICES, NAMELY, CONDUCTING SEMINARS, LECTURES, TELESEMINARS, TELECLASSES, AND WORKSHOPS IN PERSONAL AWARENESS; ENTERTAINMENT AND EDUCATIONAL SERVICES, NAMELY, THE PRESENTATION OF SEMINARS, LECTURES, WORKSHOPS AND PANEL DISCUSSIONS, AND ONGOING TELEVISION AND RADIO TALK SHOWS ALL IN THE FIELD OF PUBLIC INTEREST CONCERNING RELATIONSHIPS; WORKSHOPS AND SEMINARS IN THE FIELD OF RELATIONSHIPS (U.S. CLS. 100, 101 AND 107).

SANDRA BUJA, EXAMINING ATTORNEY

SN 85-193,363. HOME BOX OFFICE, INC., NEW YORK, NY.  
FILED 12-8-2010.

## EPIC PROGRAMMING. MONUMENTAL VALUE

THE MARK CONSISTS OF STANDARD CHARACTERS WITHOUT CLAIM TO ANY PARTICULAR FONT, STYLE, SIZE, OR COLOR.

FOR ENTERTAINMENT SERVICES, NAMELY, PRODUCTION AND DISTRIBUTION OF TELEVISION FILMS, COMEDY AND DRAMATIC TELEVISION SERIES, DOCUMENTARIES, AND SPORTING EVENTS RENDERED THROUGH MEDIA OF TELEVISION, CABLE, SATELLITE AND TELEPHONE SYSTEMS, AND VIA THE INTERNET AND GLOBAL AND WIRELESS COMMUNICATION DEVICES; PROVIDING INFORMATION IN THE FIELD OF ENTERTAINMENT RENDERED VIA THE INTERNET, GLOBAL AND WIRELESS COMMUNICATION DEVICES, PRINT AND PREMIUM OR PAY TELEVISION; SUPPLYING AND DISTRIBUTING TELEVISION PROGRAMS TO CABLE TELEVISION AND/OR MASTER ANTENNA SYSTEMS (U.S. CLS. 100, 101 AND 107).

FIRST USE 9-30-2010; IN COMMERCE 9-30-2010.  
STEVEN R. FINE, EXAMINING ATTORNEY

**CLASS 41—(Continued).**

SN 85-193,715. EUGENE, LINDA, MIAMI, FL. AND CICERON, MARIO, MIAMI, FL. AND DULCIO, VLADIMIR, MIAMI, FL. AND BRYAN, TEN"NIQUWA, MIAMI, FL.  
FILED 12-8-2010.

## No Sleep Entertainment

THE MARK CONSISTS OF STANDARD CHARACTERS WITHOUT CLAIM TO ANY PARTICULAR FONT, STYLE, SIZE, OR COLOR.

NO CLAIM IS MADE TO THE EXCLUSIVE RIGHT TO USE "ENTERTAINMENT", APART FROM THE MARK AS SHOWN.

FOR MUSIC PRODUCTION SERVICES; POEM AND LYRIC WRITING; MUSIC VIDEO PRODUCTION; LIVE MUSIC CONCERTS (U.S. CLS. 100, 101 AND 107).

MATTHEW MCDOWELL, EXAMINING ATTORNEY

SN 85-193,724. SCENEWISE, INC., REDONDO BEACH, CA.  
FILED 12-8-2010.

## EEDAPTO

THE MARK CONSISTS OF STANDARD CHARACTERS WITHOUT CLAIM TO ANY PARTICULAR FONT, STYLE, SIZE, OR COLOR.

FOR PROVIDING A WEBSITE FEATURING NON-DOWNLOADABLE VIDEOS, NAMELY, VIDEO PRESENTATIONS OF A EDUCATIONAL NATURE IN THE FIELD OF CAREER COUNSELING, NAMELY, ADVICE CONCERNING EDUCATION OPTIONS; EDUCATIONAL SERVICES, NAMELY, PROVIDING TEMPORARY USE OF NON-DOWNLOADABLE COMPUTER LEARNING GAMES IN THE FIELD OF LIFE MANAGEMENT PERTAINING TO EDUCATION AND CAREER CHOICES (U.S. CLS. 100, 101 AND 107).

CAROL SPILS, EXAMINING ATTORNEY

**CLASS 41—(Continued).**

SN 85-193,729. SCENEWISE, INC., REDONDO BEACH, CA. FILED 12-8-2010.

## OUReeWORLD

THE MARK CONSISTS OF STANDARD CHARACTERS WITHOUT CLAIM TO ANY PARTICULAR FONT, STYLE, SIZE, OR COLOR.

FOR PROVIDING A WEBSITE FEATURING NON-DOWNLOADABLE VIDEOS, NAMELY, VIDEO PRESENTATIONS OF A EDUCATIONAL NATURE IN THE FIELD OF CAREER COUNSELING, NAMELY, ADVICE CONCERNING EDUCATION OPTIONS; EDUCATIONAL SERVICES, NAMELY, PROVIDING TEMPORARY USE OF NON-DOWNLOADABLE COMPUTER LEARNING GAMES IN THE FIELD OF LIFE MANAGEMENT PERTAINING TO EDUCATION AND CAREER CHOICES (U.S. CLS. 100, 101 AND 107).

CAROL SPILS, EXAMINING ATTORNEY

**CLASS 41—(Continued).**

SN 85-193,859. SEARS BRANDS, LLC, HOFFMAN ESTATES, IL. FILED 12-9-2010.

## PLAYDATE PLACE

THE MARK CONSISTS OF STANDARD CHARACTERS WITHOUT CLAIM TO ANY PARTICULAR FONT, STYLE, SIZE, OR COLOR.

NO CLAIM IS MADE TO THE EXCLUSIVE RIGHT TO USE "PLAYDATE", APART FROM THE MARK AS SHOWN.

FOR PROVISION OF INFORMATION RELATING TO EDUCATIONAL AND ENTERTAINMENT ACTIVITIES AND EVENTS FOR CHILDREN; PROVIDING ON-LINE RESOURCE GUIDES FOR PARENTS CONCERNING CHILDREN IN THE FIELDS OF EDUCATION, RECREATION AND ENTERTAINMENT; PROVIDING A WEBSITE FEATURING INFORMATION IN THE FIELDS OF EDUCATION AND ENTERTAINMENT FOR CHILDREN, NAMELY, INFORMATION AND RESOURCES FOR PARENTS TO ORGANIZE PLAYDATES FOR CHILDREN (U.S. CLS. 100, 101 AND 107).

LINDA M. KING, EXAMINING ATTORNEY

---

SN 85-193,731. BODY PROJECT FITNESS AND HEALTH, LLC, WINDSOR, NJ. FILED 12-8-2010.

## Body Project

THE MARK CONSISTS OF STANDARD CHARACTERS WITHOUT CLAIM TO ANY PARTICULAR FONT, STYLE, SIZE, OR COLOR.

NO CLAIM IS MADE TO THE EXCLUSIVE RIGHT TO USE "BODY", APART FROM THE MARK AS SHOWN.

FOR PERSONAL FITNESS TRAINING SERVICES AND CONSULTANCY; PHYSICAL FITNESS CONDITIONING CLASSES; PHYSICAL FITNESS INSTRUCTION; PHYSICAL FITNESS STUDIO SERVICES, NAMELY, PROVIDING EXERCISE CLASSES, BODY SCULPTING CLASSES, AND GROUP FITNESS CLASSES; PHYSICAL FITNESS TRAINING OF INDIVIDUALS AND GROUPS; PHYSICAL FITNESS TRAINING SERVICES; PROVIDING A WEB SITE FEATURING INFORMATION ON EXERCISE AND FITNESS (U.S. CLS. 100, 101 AND 107).

FIRST USE 1-31-2007; IN COMMERCE 1-31-2007.

CAROL SPILS, EXAMINING ATTORNEY

---

SN 85-194,004. STUDIO WED, LLC, DBA STUDIO WED, ASHEVILLE, NC. FILED 12-9-2010.

## StudioWed

THE MARK CONSISTS OF STANDARD CHARACTERS WITHOUT CLAIM TO ANY PARTICULAR FONT, STYLE, SIZE, OR COLOR.

NO CLAIM IS MADE TO THE EXCLUSIVE RIGHT TO USE "STUDIO", APART FROM THE MARK AS SHOWN.

FOR PARTY AND WEDDING PLANNING AND COORDINATION SERVICES; PARTY AND WEDDING PLANNING CONSULTATION SERVICES; PARTY AND WEDDING PLANNING, COORDINATION AND CONSULTATION SERVICES; PROVIDING INFORMATION IN THE FIELD OF WEDDING PARTY PLANNING; PROVIDING INFORMATION REGARDING WEDDING PLANNING FOR WEDDING PARTIES; WEDDING PLANNING AND COORDINATION SERVICES (U.S. CLS. 100, 101 AND 107).

FIRST USE 3-1-2007; IN COMMERCE 3-1-2007.

JACQUELINE A. LAVINE, EXAMINING ATTORNEY



**CLASS 41—(Continued).**

SN 85-194,190. HURWITZ, WENDY, NEW YORK, NY. FILED 12-9-2010.

## The Stress Code

THE MARK CONSISTS OF STANDARD CHARACTERS WITHOUT CLAIM TO ANY PARTICULAR FONT, STYLE, SIZE, OR COLOR.

NO CLAIM IS MADE TO THE EXCLUSIVE RIGHT TO USE "STRESS", APART FROM THE MARK AS SHOWN.

FOR CONDUCTING WORKSHOPS AND SEMINARS IN PERSONAL AWARENESS (U.S. CLS. 100, 101 AND 107).

KATHRYN COWARD, EXAMINING ATTORNEY

---

SN 85-194,499. NATIONAL ACADEMY FOUNDATION, NEW YORK, NY. FILED 12-9-2010.



OWNER OF U.S. REG. NOS. 2,905,565, 2,907,592 AND 2,916,908.

NO CLAIM IS MADE TO THE EXCLUSIVE RIGHT TO USE "NATIONAL ACADEMY FOUNDATION", APART FROM THE MARK AS SHOWN.

THE COLOR(S) DARK BLUE IS/ARE CLAIMED AS A FEATURE OF THE MARK.

THE MARK CONSISTS OF THE WORDS "NATIONAL ACADEMY FOUNDATION" IN THE COLOR DARK BLUE IN WHICH THE WORDS ARE STACKED ONE OVER THE OTHER AND IN WHICH THE INITIAL LETTER "A" OF "ACADEMY" IS A STYLIZED STAR.

FOR EDUCATIONAL SERVICES, NAMELY, CONDUCTING SEMINARS, INTERNSHIPS, AND COURSES IN THE FIELDS OF INDUSTRY SPECIFIC AREAS, NAMELY, ENGINEERING, FINANCE, TRAVEL AND TOURISM, AND INFORMATION TECHNOLOGY SERVICES AND DISTRIBUTION OF TRAINING MATERIALS IN CONNECTION THEREWITH (U.S. CLS. 100, 101 AND 107).

FIRST USE 9-1-2007, THE MARK WAS FIRST USED ANYWHERE IN A DIFFERENT FORM OTHER THAN THAT SOUGHT TO BE REGISTERED AT LEAST AS EARLY AS 06/30/2001 ; IN COMMERCE 9-1-2007, THE MARK WAS FIRST USED IN COMMERCE IN A DIFFERENT FORM OTHER THAN THAT SOUGHT TO BE REGISTERED AT LEAST AS EARLY AS 06/30/2001.

LINDA POWELL, EXAMINING ATTORNEY

**CLASS 41—(Continued).**

SN 85-194,515. NATIONAL ACADEMY FOUNDATION, NEW YORK, NY. FILED 12-9-2010.



OWNER OF U.S. REG. NOS. 2,905,565, 2,907,592 AND 2,916,908.

NO CLAIM IS MADE TO THE EXCLUSIVE RIGHT TO USE "ACADEMY OF ENGINEERING", APART FROM THE MARK AS SHOWN.

THE COLOR(S) LIGHT BLUE IS/ARE CLAIMED AS A FEATURE OF THE MARK.

THE MARK CONSISTS OF THE WORDS "ACADEMY OF ENGINEERING" IN THE COLOR LIGHT BLUE IN WHICH THE INITIAL LETTER "A" IN "ACADEMY" IS A STYLIZED STAR WITH THE WORD "ACADEMY" APPEARING OVER THE WORDS "OF ENGINEERING".

FOR EDUCATIONAL SERVICES, NAMELY, CONDUCTING SEMINARS, INTERNSHIPS, AND COURSES IN THE FIELD OF ENGINEERING (U.S. CLS. 100, 101 AND 107).

FIRST USE 9-1-2007; IN COMMERCE 9-1-2007.

LINDA POWELL, EXAMINING ATTORNEY

---

SN 85-194,524. NATIONAL ACADEMY FOUNDATION, NEW YORK, NY. FILED 12-9-2010.



OWNER OF U.S. REG. NOS. 2,905,565, 2,907,592 AND 2,916,908.

NO CLAIM IS MADE TO THE EXCLUSIVE RIGHT TO USE "ACADEMY OF INFORMATION TECHNOLOGY", APART FROM THE MARK AS SHOWN.

THE COLOR(S) LIGHT PURPLE IS/ARE CLAIMED AS A FEATURE OF THE MARK.

THE MARK CONSISTS OF THE WORDS "ACADEMY OF INFORMATION TECHNOLOGY" IN THE COLOR LIGHT PURPLE IN WHICH THE INITIAL LETTER "A" IN "ACADEMY" IS A STYLIZED STAR WITH THE WORD "ACADEMY" APPEARING OVER THE WORDS "OF INFORMATION TECHNOLOGY".

FOR EDUCATIONAL SERVICES, NAMELY, CONDUCTING SEMINARS, INTERNSHIPS, AND COURSES IN THE FIELD OF INFORMATION TECHNOLOGY (U.S. CLS. 100, 101 AND 107).

FIRST USE 9-1-2007; IN COMMERCE 9-1-2007.

LINDA POWELL, EXAMINING ATTORNEY

**CLASS 41—(Continued).**

SN 85-194,536. NATIONAL ACADEMY FOUNDATION, NEW YORK, NY. FILED 12-9-2010.



OWNER OF U.S. REG. NOS. 2,905,565, 2,907,592 AND 2,916,908.

NO CLAIM IS MADE TO THE EXCLUSIVE RIGHT TO USE "ACADEMY OF HOSPITALITY & TOURISM", APART FROM THE MARK AS SHOWN.

THE COLOR(S) LIGHT ORANGE IS/ARE CLAIMED AS A FEATURE OF THE MARK.

THE MARK CONSISTS OF THE WORDS "ACADEMY OF HOSPITALITY & TOURISM" IN THE COLOR LIGHT ORANGE IN WHICH THE INITIAL LETTER "A" IN "ACADEMY" IS A STYLIZED STAR WITH THE WORD "ACADEMY" APPEARING OVER THE WORDS "OF HOSPITALITY & TOURISM".

FOR EDUCATIONAL SERVICES, NAMELY, CONDUCTING SEMINARS, INTERNSHIPS, AND COURSES IN THE FIELD OF HOSPITALITY AND TOURISM (U.S. CLS. 100, 101 AND 107).

FIRST USE 9-1-2007; IN COMMERCE 9-1-2007.  
LINDA POWELL, EXAMINING ATTORNEY

**CLASS 41—(Continued).**

SN 85-195,339. BIALEK, CYNTHIA, FAIRFAX, VA. FILED 12-10-2010.

**YOGA AFLOAT**

THE MARK CONSISTS OF STANDARD CHARACTERS WITHOUT CLAIM TO ANY PARTICULAR FONT, STYLE, SIZE, OR COLOR.

NO CLAIM IS MADE TO THE EXCLUSIVE RIGHT TO USE "YOGA", APART FROM THE MARK AS SHOWN.

FOR EDUCATIONAL SERVICES, NAMELY, CONDUCTING CLASSES IN THE FIELD OF YOGA EXERCISES PERFORMED IN THE WATER AND CHOREOGRAPHED TO MUSIC; TRAINING OF AQUATIC INSTRUCTORS ON THE SPECIFIC FORMAT FOR WATER YOGA EXERCISES (U.S. CLS. 100, 101 AND 107).

FIRST USE 1-30-1998; IN COMMERCE 1-30-1998.  
SKYE YOUNG, EXAMINING ATTORNEY

---

SN 85-194,546. NATIONAL ACADEMY FOUNDATION, NEW YORK, NY. FILED 12-9-2010.



OWNER OF U.S. REG. NOS. 2,905,565, 2,907,592 AND 2,916,908.

NO CLAIM IS MADE TO THE EXCLUSIVE RIGHT TO USE "ACADEMY OF FINANCE", APART FROM THE MARK AS SHOWN.

THE COLOR(S) LIGHT GREEN IS/ARE CLAIMED AS A FEATURE OF THE MARK.

THE MARK CONSISTS OF THE WORDS "ACADEMY OF HOSPITALITY & TOURISM" IN THE COLOR LIGHT GREEN IN WHICH THE INITIAL LETTER "A" IN "ACADEMY" IS A STYLIZED STAR WITH THE WORD "ACADEMY" APPEARING OVER THE WORDS "OF FINANCE".

FOR ENTERTAINMENT SERVICES, NAMELY, ARRANGING AND CONDUCTING A LIVE DATING GAME SHOW FOR MEN AND WOMEN AT NIGHTCLUBS (U.S. CLS. 100, 101 AND 107).

FIRST USE 9-1-2007; IN COMMERCE 9-1-2007.  
LINDA POWELL, EXAMINING ATTORNEY

---

SN 85-195,474. HOWARD, VICTORIA, BOCA RATON, FL. FILED 12-10-2010.

**KICK EM TO THE CURB**

THE MARK CONSISTS OF STANDARD CHARACTERS WITHOUT CLAIM TO ANY PARTICULAR FONT, STYLE, SIZE, OR COLOR.

FOR ENTERTAINMENT SERVICES, NAMELY, ARRANGING AND CONDUCTING A LIVE DATING GAME SHOW FOR MEN AND WOMEN AT NIGHTCLUBS (U.S. CLS. 100, 101 AND 107).

FIRST USE 10-19-2010; IN COMMERCE 10-19-2010.  
MICHELE SWAIN, EXAMINING ATTORNEY

**CLASS 41—(Continued).**

SN 85-195,645. SMITH, COREY, DEL MAR, CA. FILED 12-10-2010.

**FITNESS FOR EXISTENCE**

THE MARK CONSISTS OF STANDARD CHARACTERS WITHOUT CLAIM TO ANY PARTICULAR FONT, STYLE, SIZE, OR COLOR.

NO CLAIM IS MADE TO THE EXCLUSIVE RIGHT TO USE "FITNESS", APART FROM THE MARK AS SHOWN.

FOR CONSULTING SERVICES IN THE FIELDS OF FITNESS AND EXERCISE; EDUCATIONAL AND ENTERTAINMENT SERVICES, NAMELY, A CONTINUING PROGRAM ABOUT HEALTH, FITNESS, EXERCISE, NUTRITION, MOTIVATION, AND/OR PERSONAL AWARENESS ACCESSIBLE BY RADIO, TELEVISION, SATELLITE, AUDIO, VIDEO AND COMPUTER NETWORKS; EDUCATIONAL AND ENTERTAINMENT SERVICES, NAMELY, PROVIDING MOTIVATIONAL AND EDUCATIONAL SPEAKERS; EDUCATIONAL SERVICES, NAMELY, CONDUCTING COACHING SESSIONS, SEMINARS, LECTURES, WORKSHOPS, CLASSES, CONFERENCES, TELESeminars, TELECLASSES, TUTORING, MENTORING, PANEL DISCUSSIONS AND KEY NOTE SPEECHES IN THE FIELD OF HEALTH, FITNESS, EXERCISE, NUTRITION, MOTIVATION, AND/OR PERSONAL AWARENESS AND DISTRIBUTION OF PRINTED MATERIALS IN CONNECTION THEREWITH IN HARD COPY OR ELECTRONIC FORMAT ON THE SAME TOPICS; ENTERTAINMENT SERVICES, NAMELY, PROVIDING A WEB SITE FEATURING PHOTOGRAPHIC AND PROSE PRESENTATIONS FEATURING INFORMATION ON HEALTH, FITNESS, EXERCISE, NUTRITION, MOTIVATION, AND/OR PERSONAL AWARENESS; HEALTH CLUB SERVICES, NAMELY, PROVIDING INSTRUCTION AND EQUIPMENT IN THE FIELD OF PHYSICAL EXERCISE; ORGANIZING EXHIBITIONS FOR ENTERTAINMENT AND EDUCATIONAL PURPOSES IN THE FIELDS OF FIELD OF HEALTH, FITNESS, EXERCISE, NUTRITION, MOTIVATION, AND/OR PERSONAL AWARENESS; PERSONAL AWARENESS; PERSONAL TRAINER SERVICES; PHYSICAL FITNESS CONSULTATION; PROVIDING A WEB SITE THAT FEATURES INFORMAL INSTRUCTION ON HEALTH, FITNESS, EXERCISE, NUTRITION, MOTIVATION, AND/OR PERSONAL AWARENESS; PROVIDING A WEBSITE FEATURING NON-DOWNLOADABLE PUBLICATIONS IN THE NATURE OF BOOKS, MAGAZINES, ARTICLES, NEWSLETTERS, PERSONAL JOURNAL ENTRIES, AND/OR BROCHURES IN THE FIELD OF HEALTH, FITNESS, EXERCISE, NUTRITION, MOTIVATION, AND/OR PERSONAL AWARENESS; PROVIDING A WEBSITE FEATURING ONLINE SPORTS TRAINING AND TRAINING ADVICE AND THE RECORDING OF TRAINING AND WORKOUTS; PROVIDING AN INTERACTIVE WEBSITE FEATURING INFORMATION AND LINKS RELATING TO FITNESS; PROVIDING INFORMATION, NEWS AND COMMENTARY IN THE FIELD OF RECREATION AND LEISURE ACTIVITIES; PROVIDING NEWSLETTERS IN THE FIELD OF HEALTH, FITNESS, EXERCISE, NUTRITION, MOTIVATION, AND/OR PERSONAL AWARENESS VIA E-MAIL; PROVIDING ON-LINE NEWSLETTERS IN THE FIELD OF HEALTH, FITNESS, EXERCISE, NUTRITION, MOTIVATION, AND/OR PERSONAL AWARENESS; PROVIDING ON-LINE TRAINING IN THE FORM OF COACHING SESSIONS, SEMINARS, LECTURES, WORKSHOPS, CLASSES, CONFERENCES, TUTORING, MENTORING, PANEL DISCUSSIONS IN THE FIELD OF HEALTH, FITNESS, EXERCISE, NUTRITION, MOTIVATION, AND/OR PERSONAL AWARENESS (U.S. CLS. 100, 101 AND 107).

WILLIAM VERHOSEK, EXAMINING ATTORNEY

**CLASS 41—(Continued).**

SN 85-196,135. AUDACIOUS IDEAS, INC., FLORHAM PARK, NJ. FILED 12-13-2010.

**I WANT TO BE**

THE MARK CONSISTS OF STANDARD CHARACTERS WITHOUT CLAIM TO ANY PARTICULAR FONT, STYLE, SIZE, OR COLOR.

FOR ENTERTAINMENT AND EDUCATIONAL SERVICES IN THE NATURE OF ON-LINE COMPETITIONS IN THE FIELD OF ENTERTAINMENT, EDUCATION, CULTURE, SPORTS, AND OTHER NON-BUSINESS AND NON-COMMERCIAL FIELDS (U.S. CLS. 100, 101 AND 107).

MARY ROSSMAN, EXAMINING ATTORNEY

SN 85-196,506. BS4L, INC., LISLE, IL. FILED 12-13-2010.



THE COLOR(S) LIGHT BLUE, DARK BLUE, LIGHT GREEN, DARK GREEN AND BLACK IS/ARE CLAIMED AS A FEATURE OF THE MARK.

THE MARK CONSISTS OF A STYLIZED LOGO COMBINING THE LETTERS "B", "S", "L" AND THE NUMBER "4", WITHIN A DIAGONAL RING, AND THE WORDS "B STRONG LIFE" BELOW, SEPARATED BY A DOT AND THE NUMBER "4" A BALL TO THE UPPER RIGHT, AND AN OVAL SLANTED CIRCLE REPRESENTING A SHADOW BELOW. THE GRADUATING COLORS DARK AND LIGHT BLUE APPEAR IN THE STYLIZED LOGO, THE BALL AND "B STRONG LIFE" THE GRADUATING COLORS DARK AND LIGHT GREEN APPEAR IN THE DIAGONAL RING, THE DOT AND THE NUMBER "4" AND THE COLOR BLACK APPEARS AS THE SHADOW.

FOR PHYSICAL TRAINING SERVICES, NAMELY, A PROPRIETARY PROTOCOL OF NEURO-MUSCULOSKELETAL STIMULATION TRAINING INVOLVING INDIVIDUALIZED ISOMETRIC EXERCISES PERFORMED IN A SPECIFIC COMBINATION, AND ON APPARATUS UNIQUELY DESIGNED FOR THE PURPOSE, TO IMPROVE BONE AND MUSCLE STRENGTH, JOINT HEALTH, AND WHEN APPLICABLE, BONE DENSITY (U.S. CLS. 100, 101 AND 107).

FIRST USE 1-12-2010; IN COMMERCE 1-12-2010.  
CARYN GLASSER, EXAMINING ATTORNEY

**CLASS 41—(Continued).**

SN 85-196,543. MWR HOLDINGS, LLC, BOCA RATON, FL. FILED 12-13-2010.

## THE LEARNING EXPERIENCE CHILDREN'S ACADEMY

THE MARK CONSISTS OF STANDARD CHARACTERS WITHOUT CLAIM TO ANY PARTICULAR FONT, STYLE, SIZE, OR COLOR.

OWNER OF U.S. REG. NOS. 2,762,752, 3,834,469 AND OTHERS.

NO CLAIM IS MADE TO THE EXCLUSIVE RIGHT TO USE "LEARNING" OR "CHILDREN'S ACADEMY", APART FROM THE MARK AS SHOWN.

FOR EDUCATION, NAMELY, DEVELOPING CURRICULUM FOR TEACHERS AND PROVIDING ACADEMIC COURSES OF INSTRUCTION AT THE PRESCHOOL AND ELEMENTARY LEVELS IN A CHILD CARE CENTER (U.S. CLS. 100, 101 AND 107).

MATTHEW MCDOWELL, EXAMINING ATTORNEY

---

SN 85-196,601. KITARA MEDIA, JERSEY CITY, NJ. FILED 12-13-2010.

## MYTOP FREEGAMES

THE MARK CONSISTS OF STANDARD CHARACTERS WITHOUT CLAIM TO ANY PARTICULAR FONT, STYLE, SIZE, OR COLOR.

NO CLAIM IS MADE TO THE EXCLUSIVE RIGHT TO USE "FREEGAMES", APART FROM THE MARK AS SHOWN.

FOR PROVIDING ONLINE COMPUTER GAMES IN THE FIELD OF BUSINESS, MARKETING, ADVERTISING AND CAREERS; PROVIDING OF INFORMATION RELATING TO COMPUTER GAMES; PROVIDING AN INTERNET WEBSITE PORTAL IN THE FIELD OF COMPUTER GAMES AND GAMING VIA MOBILE OR CELLULAR TELEPHONE, INTERNET OR OTHER COMPUTER NETWORK AND/OR OTHER WIRELESS DEVICES (U.S. CLS. 100, 101 AND 107).

FIRST USE 8-1-2010; IN COMMERCE 8-1-2010.

JEFFREY LOOK, EXAMINING ATTORNEY

---

SN 85-196,622. KITARA MEDIA, JERSEY CITY,, NJ. FILED 12-13-2010.

## PLAYPICKLE

THE MARK CONSISTS OF STANDARD CHARACTERS WITHOUT CLAIM TO ANY PARTICULAR FONT, STYLE, SIZE, OR COLOR.

FOR PROVIDING ONLINE COMPUTER GAMES IN THE FIELD OF BUSINESS, MARKETING, ADVERTISING AND CAREERS; PROVIDING OF INFORMATION RELATING TO COMPUTER GAMES; PROVIDING AN INTERNET WEBSITE PORTAL IN THE FIELD OF COMPUTER GAMES AND GAMING VIA MOBILE OR CELLULAR TELEPHONE, INTERNET OR OTHER COMPUTER NETWORK AND/OR OTHER WIRELESS DEVICES (U.S. CLS. 100, 101 AND 107).

FIRST USE 8-1-2010; IN COMMERCE 8-1-2010.

JEFFREY LOOK, EXAMINING ATTORNEY

**CLASS 41—(Continued).**

SN 85-196,742. SHPS HEALTH MANAGEMENT SOLUTIONS, INC., LOUISVILLE, KY. FILED 12-13-2010.

## WELLMOVEMENT

THE MARK CONSISTS OF STANDARD CHARACTERS WITHOUT CLAIM TO ANY PARTICULAR FONT, STYLE, SIZE, OR COLOR.

FOR INTERACTIVE ONLINE WEB JOURNAL, NAMELY, A BLOG IN THE FIELD OF HEALTH CARE, WELLNESS AND THE ECONOMY (U.S. CLS. 100, 101 AND 107).

MICHAEL GAAFAR, EXAMINING ATTORNEY

---

SN 85-197,372. HOME BOX OFFICE, INC., NEW YORK, NY. FILED 12-14-2010.



OWNER OF U.S. REG. NOS. 1,312,132, 2,422,041 AND 3,755,047.

NO CLAIM IS MADE TO THE EXCLUSIVE RIGHT TO USE "COMEDY", APART FROM THE MARK AS SHOWN.

THE MARK CONSISTS OF "HBO" LETTERS WITH A BULLET "O" STACKED ON TOP OF A CURVED LINE WITH THE WORD "COMEDY" UNDER.

FOR ENTERTAINMENT SERVICES, NAMELY, PRODUCTION AND DISTRIBUTION OF TELEVISION PROGRAMS RENDERED THROUGH MEDIA OF TELEVISION, CABLE, SATELLITE AND TELEPHONE SYSTEMS, AND VIA THE INTERNET AND GLOBAL AND WIRELESS COMMUNICATION DEVICES; SUPPLYING AND DISTRIBUTING TELEVISION PROGRAMS TO CABLE TELEVISION AND/OR MASTER ANTENNA SYSTEMS (U.S. CLS. 100, 101 AND 107).

FIRST USE 3-30-2000; IN COMMERCE 3-30-2000.

STEVEN R. FINE, EXAMINING ATTORNEY

**CLASS 41—(Continued).**

SN 85-197,670. BEY, DERRICK BALLARD, DBA BEYMOOR TECHNOLOGIES, LAUREL, MD. FILED 12-14-2010.

**REDEFINE YOUR MIND**

THE MARK CONSISTS OF STANDARD CHARACTERS WITHOUT CLAIM TO ANY PARTICULAR FONT, STYLE, SIZE, OR COLOR.

FOR ARRANGING, ORGANIZING, CONDUCTING, AND HOSTING SOCIAL ENTERTAINMENT EVENTS; EDUCATION SERVICES, NAMELY, MENTORING IN THE FIELD OF SELF-HELP; EDUCATION SERVICES, NAMELY, PROVIDING CLASSES, WORKSHOPS, SEMINARS, LECTURES, WEBINARS, TELESEMINARS, TRAINING AND PERSONAL AND PROFESSIONAL COACHING IN THE FIELD OF SELF HELP AND THE DISTRIBUTION OF COURSE AND TRAINING MATERIALS IN CONNECTION THEREWITH; EDUCATIONAL AND ENTERTAINMENT SERVICES, NAMELY, PROVIDING MOTIVATIONAL SPEAKING SERVICES IN THE FIELD OF SELF-HELP; ENTERTAINMENT SERVICES, NAMELY, PROVIDING AN ON-GOING RADIO PROGRAM IN THE FIELD OF SELF-HELP; ENTERTAINMENT SERVICES, NAMELY, PROVIDING PODCASTS IN THE FIELD OF SELF-HELP; ON-LINE JOURNALS, NAMELY, BLOGS IN THE FIELD OF SELF-HELP; PRODUCTION OF FILMS; PROVIDING ON-LINE PUBLICATIONS IN THE NATURE OF AN E-BOOK IN THE FIELD OF SELF-HELP (U.S. CLS. 100, 101 AND 107).

JULIE WATSON, EXAMINING ATTORNEY

SN 85-197,716. THE SCHOOL BOARD OF MIAMI-DADE COUNTY, MIAMI, FL. FILED 12-14-2010.

**MAST Academy**

THE MARK CONSISTS OF STANDARD CHARACTERS WITHOUT CLAIM TO ANY PARTICULAR FONT, STYLE, SIZE, OR COLOR.

NO CLAIM IS MADE TO THE EXCLUSIVE RIGHT TO USE "ACADEMY", APART FROM THE MARK AS SHOWN, FOR PROVIDING COURSES OF INSTRUCTION AT THE GRADE 9-12 LEVEL (U.S. CLS. 100, 101 AND 107). FIRST USE 12-31-1991; IN COMMERCE 12-31-1991.

TARA PATE, EXAMINING ATTORNEY

**CLASS 41—(Continued).**

SN 85-197,838. JAGADOWSKI, THOMAS J., CHICAGO, IL. AND PASQUESI, DAVID, CHICAGO, IL. FILED 12-14-2010.

**Trust Us This Is All Made Up**

THE MARK CONSISTS OF STANDARD CHARACTERS WITHOUT CLAIM TO ANY PARTICULAR FONT, STYLE, SIZE, OR COLOR.

FOR ENTERTAINMENT IN THE NATURE OF LIVE PERFORMANCES BY ACTORS PERFORMING IMPROVED SCENES (U.S. CLS. 100, 101 AND 107).

FIRST USE 3-1-2002; IN COMMERCE 3-1-2002.

ALYSSA STEEL, EXAMINING ATTORNEY

SN 85-197,907. PURNELL, JAMES E., FORT PIERCE, FL. FILED 12-14-2010.

**The Elemental Economist**

THE MARK CONSISTS OF STANDARD CHARACTERS WITHOUT CLAIM TO ANY PARTICULAR FONT, STYLE, SIZE, OR COLOR.

NO CLAIM IS MADE TO THE EXCLUSIVE RIGHT TO USE "ECONOMIST", APART FROM THE MARK AS SHOWN.

FOR ON-LINE JOURNALS, NAMELY, BLOGS FEATURING THE SUBJECT OF ECONOMICS (U.S. CLS. 100, 101 AND 107).

FIRST USE 8-1-2010; IN COMMERCE 8-1-2010.

ANDREW RHIM, EXAMINING ATTORNEY

SN 85-198,967. ENTERTAINMENT CONTENT, INC., LOS ANGELES, CA. FILED 12-15-2010.

**Who Wants to Date a Comedian**

THE MARK CONSISTS OF STANDARD CHARACTERS WITHOUT CLAIM TO ANY PARTICULAR FONT, STYLE, SIZE, OR COLOR.

FOR ENTERTAINMENT SERVICES, NAMELY ONGOING TELEVISION PROGRAMS IN THE FIELDS OF DATING AND COMEDY; ONGOING ENTERTAINMENT PROGRAMS IN THE FIELDS OF DATING AND COMEDY PRESENTED OVER THE INTERNET; ONGOING ENTERTAINMENT PROGRAMS IN THE FIELDS OF DATING AND COMEDY ACCESSIBLE BY CABLE, SATELLITE, TELEVISION, INTERNET, WIRELESS NETWORKS, AND THROUGH TRANSMISSION OF AUDIO AND/OR VIDEO SIGNALS TO ANY TYPE OF VISUAL DISPLAY DEVICE OR ANY DELIVERY MECHANISM; PRODUCTION AND DISTRIBUTION OF TELEVISION SHOWS (U.S. CLS. 100, 101 AND 107).

ARETHA SOMERVILLE, EXAMINING ATTORNEY

**CLASS 41—(Continued).**

SN 85-199,136. BOI PROMOTIONS INC., NEW YORK, NY. FILED 12-16-2010.

**BOIPARTY.COM**

THE MARK CONSISTS OF STANDARD CHARACTERS WITHOUT CLAIM TO ANY PARTICULAR FONT, STYLE, SIZE, OR COLOR.

FOR ENTERTAINMENT IN THE NATURE OF PROVIDING A WEBSITE FEATURING INFORMATION, MUSIC, LINKS, VIDEOS, AND PHOTOGRAPHS ON GAY AND BISEXUAL NIGHTLIFE, EVENTS, AND PARTIES (U.S. CLS. 100, 101 AND 107).

FIRST USE 0-0-2005; IN COMMERCE 0-0-2005.  
JAMES GRIFFIN, EXAMINING ATTORNEY

SN 85-199,143. DAVIES, EVAN, ALAMEDA, CA. FILED 12-16-2010.

**HYPERION**

THE MARK CONSISTS OF STANDARD CHARACTERS WITHOUT CLAIM TO ANY PARTICULAR FONT, STYLE, SIZE, OR COLOR.

FOR RENTAL OF EQUIPMENTS FOR THE PRODUCTION OF TELEVISION PROGRAMS, FILMS, MUSICAL AND THEATRICAL PRODUCTIONS, NAMELY, LIGHTING APPARATUS, FILM EQUIPMENTS, AND GRIP AND CAMERA SUPPORT EQUIPMENTS (U.S. CLS. 100, 101 AND 107).

JAMES GRIFFIN, EXAMINING ATTORNEY

SN 85-199,305. RED LEOPARD LOUNGE, LLC, BROOKLYN, NY. FILED 12-16-2010.

**Jaguars 3**

THE MARK CONSISTS OF STANDARD CHARACTERS WITHOUT CLAIM TO ANY PARTICULAR FONT, STYLE, SIZE, OR COLOR.

FOR ENTERTAINMENT SERVICES, NAMELY, CABARETS; NIGHT CLUBS (U.S. CLS. 100, 101 AND 107).  
MORGAN WYNNE, EXAMINING ATTORNEY

**CLASS 41—(Continued).**

SN 85-199,420. RINGLING COLLEGE OF ART AND DESIGN, INC., SARASOTA, FL. FILED 12-16-2010.

**SHATTERING THE MYTH OF THE STARVING ARTIST**

THE MARK CONSISTS OF STANDARD CHARACTERS WITHOUT CLAIM TO ANY PARTICULAR FONT, STYLE, SIZE, OR COLOR.

FOR EDUCATIONAL SERVICES, NAMELY, CONDUCTING CLASSES, SEMINARS, WORKSHOPS, AND CONFERENCES IN THE FIELD OF VISUAL ART AND DESIGN (U.S. CLS. 100, 101 AND 107).

GENE MACIOL, EXAMINING ATTORNEY

SN 85-199,433. RINGLING COLLEGE OF ART AND DESIGN, INC., SARASOTA, FL. FILED 12-16-2010.

**DESTROYING THE MYTH OF THE STARVING ARTIST**

THE MARK CONSISTS OF STANDARD CHARACTERS WITHOUT CLAIM TO ANY PARTICULAR FONT, STYLE, SIZE, OR COLOR.

FOR EDUCATIONAL SERVICES, NAMELY, CONDUCTING CLASSES, SEMINARS, WORKSHOPS, AND CONFERENCES IN THE FIELD OF VISUAL ART AND DESIGN (U.S. CLS. 100, 101 AND 107).

GENE MACIOL, EXAMINING ATTORNEY

SN 85-199,643. UNITED SOCCER LEAGUES, LLC, TAMPA, FL. FILED 12-16-2010.



OWNER OF U.S. REG. NOS. 2,340,635 AND 2,411,846.

NO CLAIM IS MADE TO THE EXCLUSIVE RIGHT TO USE "LEAGUE", "SOCCER LEAGUES" AND "INDOOR PROFESSIONAL SOCCER", APART FROM THE MARK AS SHOWN.

THE COLOR(S) RED, BLACK, YELLOW, GREEN, WHITE, ORANGE IS/ARE CLAIMED AS A FEATURE OF THE MARK.

THE MARK CONSISTS OF THE LETTER "I" IN RED WITH A SOCCER BALL IN THE VERTICAL PART OF THE "I" IN BLACK, YELLOW AND WHITE. THREE ARC DESIGNS POINTING DOWNWARD IN BLACK ARE ON EITHER SIDE OF IT. THE WORD "LEAGUE" IS UNDER THE DESIGN IN BLACK. TO THE LEFT OF THE WORD "LEAGUE", IS A SHIELD-SHAPED IMAGE WITH A SOCCER BALL IN BLACK AND WHITE INSIDE AND FLAMES IN ORANGE AND YELLOW EXTENDING FROM THE

**CLASS 41—(Continued).**

SOCCER BALL IMAGE, WITH THE WORDING "USL" IN WHITE ABOVE THE SOCCER BALL. THE SHIELD DESIGN HAS A GREEN BACKGROUND WITH A BLACK LINE TRACING INSIDE THE EDGE OF THE SHIELD DESIGN. THE WORDS "UNITED SOCCER LEAGUES" IS IN BLACK IN THE TOP PORTION OF THE SHIELD DESIGN WITH A YELLOW BACKGROUND. THE WORDS "INDOOR PROFESSIONAL SOCCER" ARE UNDERNEATH THAT IN YELLOW WITH A BLACK LINE ABOVE AND UNDERNEATH THE WORDS..

FOR ENTERTAINMENT SERVICES, NAMELY, ORGANIZING, CONDUCTING AND STAGING SPORTING EVENTS IN THE NATURE OF SOCCER EVENTS, SOCCER MATCHES AND SOCCER EXHIBITION GAMES (U.S. CLS. 100, 101 AND 107).

FIRST USE 7-0-2010; IN COMMERCE 7-0-2010.  
JEFFREY LOOK, EXAMINING ATTORNEY

---

SN 85-199,837. PIZZA HUT, INC., DALLAS, TX. FILED 12-16-2010.

**KNOWING IS GROWING**

THE MARK CONSISTS OF STANDARD CHARACTERS WITHOUT CLAIM TO ANY PARTICULAR FONT, STYLE, SIZE, OR COLOR.

FOR EDUCATIONAL SERVICES, NAMELY, CONDUCTING PROGRAMS OF INSTRUCTION IN THE FIELD OF READING AND DISTRIBUTION OF EDUCATIONAL MATERIALS PROVIDED IN CONNECTION THEREWITH (U.S. CLS. 100, 101 AND 107).

COURTNEY ALVAREZ, EXAMINING ATTORNEY

---

SN 85-200,165. SOCIETY FOR SCIENCE & THE PUBLIC, WASHINGTON, DC. FILED 12-17-2010.

**SCIENCE NEWS FOR KIDS**

THE MARK CONSISTS OF STANDARD CHARACTERS WITHOUT CLAIM TO ANY PARTICULAR FONT, STYLE, SIZE, OR COLOR.

OWNER OF U.S. REG. NOS. 1,155,569, 2,246,815 AND OTHERS.

SEC. 2(F).  
FOR PROVIDING AN ON-LINE EDUCATIONAL NEWS MAGAZINE FOR CHILDREN CONTAINING ARTICLES ABOUT SCIENCE (U.S. CLS. 100, 101 AND 107).

FIRST USE 7-23-2003; IN COMMERCE 7-23-2003.  
ARETHA SOMERVILLE, EXAMINING ATTORNEY

**CLASS 41—(Continued).**

SN 85-200,308. MICHAEL L TASH, GERMANTOWN, MD. FILED 12-17-2010.

**Bad Influence**

THE MARK CONSISTS OF STANDARD CHARACTERS WITHOUT CLAIM TO ANY PARTICULAR FONT, STYLE, SIZE, OR COLOR.

FOR ENTERTAINMENT SERVICES BY A MUSICAL ARTIST AND PRODUCER, NAMELY, MUSICAL COMPOSITION FOR OTHERS AND PRODUCTION OF MUSICAL SOUND RECORDINGS; ENTERTAINMENT SERVICES IN THE NATURE OF LIVE MUSICAL PERFORMANCES; ENTERTAINMENT SERVICES IN THE NATURE OF PRESENTING LIVE MUSICAL PERFORMANCES (U.S. CLS. 100, 101 AND 107).

FIRST USE 8-30-1989; IN COMMERCE 3-30-1993.  
DEZMONA MIZELLE, EXAMINING ATTORNEY

---

SN 85-200,327. NOTHIN' BUT NET HOLDING L.L.C., CINCINNATI, OH. FILED 12-17-2010.

**NOTHIN' BUT NET**

THE MARK CONSISTS OF STANDARD CHARACTERS WITHOUT CLAIM TO ANY PARTICULAR FONT, STYLE, SIZE, OR COLOR.

FOR PROVIDING SPORTS FACILITIES (U.S. CLS. 100, 101 AND 107).

FIRST USE 9-14-2009; IN COMMERCE 9-14-2009.  
ARETHA SOMERVILLE, EXAMINING ATTORNEY

---

SN 85-200,393. GARDNER, DIANA J., KAPAA, HI. FILED 12-17-2010.



NO CLAIM IS MADE TO THE EXCLUSIVE RIGHT TO USE "WEDDINGS", APART FROM THE MARK AS SHOWN. THE STIPPLING IS FOR SHADING PURPOSES ONLY.

THE MARK CONSISTS OF 2 ORCHIDS WITH THE STYLIZED TEXT "ALOHA WEDDINGS".

THE WORDING "ALOHA WEDDINGS" HAS NO MEANING IN A FOREIGN LANGUAGE.

FOR WEDDING PLANNING AND COORDINATION SERVICES (U.S. CLS. 100, 101 AND 107).

FIRST USE 7-1-2002; IN COMMERCE 7-1-2002.  
SUE LAWRENCE, EXAMINING ATTORNEY

**CLASS 41—(Continued).**

SN 85-200,567. GOOD, ELAINE, LOS ANGELES, CA. FILED 12-17-2010.

# good2eat4U

THE MARK CONSISTS OF STANDARD CHARACTERS WITHOUT CLAIM TO ANY PARTICULAR FONT, STYLE, SIZE, OR COLOR.

FOR EDUCATIONAL SERVICES, NAMELY, PROVIDING ONLINE INSTRUCTION IN THE FIELD OF CULINARY ARTS (U.S. CLS. 100, 101 AND 107).

PAUL E. FAHRENKOPF, EXAMINING ATTORNEY

**CLASS 41—(Continued).**

SN 85-200,817. THE GRECO CORPORATION, DULUTH, GA. FILED 12-17-2010.

# LEAD SERVE LOVE

THE MARK CONSISTS OF STANDARD CHARACTERS WITHOUT CLAIM TO ANY PARTICULAR FONT, STYLE, SIZE, OR COLOR.

FOR EDUCATIONAL AND ENTERTAINMENT SERVICES, NAMELY MOTIVATIONAL AND EDUCATIONAL SPEAKING ENGAGEMENTS ON THE TOPICS OF FAITH AND FAMILY (U.S. CLS. 100, 101 AND 107).

GINA FINK, EXAMINING ATTORNEY

SN 85-200,589. MONTEFORTE, CAMRYN, OCEANPORT, NJ. FILED 12-17-2010.

# Hollander

THE MARK CONSISTS OF STANDARD CHARACTERS WITHOUT CLAIM TO ANY PARTICULAR FONT, STYLE, SIZE, OR COLOR.

FOR ENTERTAINMENT, NAMELY, LIVE PERFORMANCES BY A MUSICAL BAND (U.S. CLS. 100, 101 AND 107).

FIRST USE 4-2-2005; IN COMMERCE 4-2-2005.

REGINA DRUMMOND, EXAMINING ATTORNEY

SN 85-200,871. THE MARIN GROUP, INC., SPRINGFIELD, VA. FILED 12-17-2010.

# THE R.I.P. FILES

THE MARK CONSISTS OF STANDARD CHARACTERS WITHOUT CLAIM TO ANY PARTICULAR FONT, STYLE, SIZE, OR COLOR.

FOR ENTERTAINMENT SERVICES IN THE NATURE OF AN ON-GOING REALITY BASED TELEVISION PROGRAM (U.S. CLS. 100, 101 AND 107).

FIRST USE 10-21-2008; IN COMMERCE 10-21-2008.

JASON TURNER, EXAMINING ATTORNEY

SN 85-200,786. DO YOU KNOW WHO I AM, INC., MINNETONKA, MN. FILED 12-17-2010.

# DO YOU KNOW WHO I AM?

THE MARK CONSISTS OF STANDARD CHARACTERS WITHOUT CLAIM TO ANY PARTICULAR FONT, STYLE, SIZE, OR COLOR.

FOR ENTERTAINMENT SERVICES, NAMELY TELEVISION, CABLE AND INTERNET PROGRAMMING (U.S. CLS. 100, 101 AND 107).

CAROL SPILS, EXAMINING ATTORNEY

SN 85-201,776. PFIP, LLC, NEWINGTON, NH. FILED 12-20-2010.

# LUNKINATOR

THE MARK CONSISTS OF STANDARD CHARACTERS WITHOUT CLAIM TO ANY PARTICULAR FONT, STYLE, SIZE, OR COLOR.

FOR PHYSICAL FITNESS INSTRUCTION AND TRAINING; HEALTH CLUB SERVICES, NAMELY, PROVIDING INSTRUCTION AND EQUIPMENT IN THE FIELD OF PHYSICAL EXERCISE (U.S. CLS. 100, 101 AND 107).

FIRST USE 10-31-2010; IN COMMERCE 10-31-2010.

JOHN DALIER, EXAMINING ATTORNEY



**CLASS 41—(Continued).**

SN 85-201,814. RANDOM HOUSE, INC., NEW YORK, NY.  
FILED 12-20-2010.

THE EBOOK INSIDER

THE MARK CONSISTS OF STANDARD CHARACTERS WITHOUT CLAIM TO ANY PARTICULAR FONT, STYLE, SIZE, OR COLOR.

NO CLAIM IS MADE TO THE EXCLUSIVE RIGHT TO USE "EBOOK", APART FROM THE MARK AS SHOWN.

FOR PROVIDING A WEBSITE FEATURING ENTERTAINMENT INFORMATION (U.S. CLS. 100, 101 AND 107).

FIRST USE 12-20-2010; IN COMMERCE 12-20-2010.  
KAELIE KUNG, EXAMINING ATTORNEY

**CLASS 41—(Continued).**

SN 85-202,277. SCENEWISE, INC, REDONDO BEACH, CA.  
FILED 12-20-2010.

EEDAPT

THE MARK CONSISTS OF STANDARD CHARACTERS WITHOUT CLAIM TO ANY PARTICULAR FONT, STYLE, SIZE, OR COLOR.

FOR PROVIDING A WEBSITE FEATURING NON-DOWNLOADABLE VIDEOS, NAMELY, VIDEO PRESENTATIONS OF A EDUCATIONAL NATURE IN THE FIELD OF CAREER COUNSELING, NAMELY, ADVICE CONCERNING EDUCATION OPTIONS; EDUCATIONAL SERVICES, NAMELY, PROVIDING TEMPORARY USE OF NON-DOWNLOADABLE COMPUTER LEARNING GAMES IN THE FIELD OF LIFE MANAGEMENT PERTAINING TO EDUCATION AND CAREER CHOICES (U.S. CLS. 100, 101 AND 107).

CAROL SPILS, EXAMINING ATTORNEY

SN 85-202,074. STUDIO ONE NETWORKS, INC., NEW YORK, NY. FILED 12-20-2010.



NO CLAIM IS MADE TO THE EXCLUSIVE RIGHT TO USE "DIGITAL INNOVATION GAZETTE", APART FROM THE MARK AS SHOWN.

THE MARK CONSISTS OF THE LETTERS "DIG" IN ALL CAPS IN THE BACKGROUND AND THE WORDING "DIGITAL INNOVATION GAZETTE" IN SMALL CAPS APPEARING IN THE FOREGROUND SUPERIMPOSED OVER THE LETTERS "DIG" THAT APPEAR IN THE BACKGROUND. ALL THE LETTERS AND WORDING APPEAR INSIDE A RECTANGLE THAT FORMS THE OVERALL BACKGROUND FOR THE LETTERS AND WORDING OF THE MARK.

FOR PROVIDING ON-LINE MAGAZINES IN THE FIELD OF DIGITAL ARTS FOR PROFESSIONALS IN THE FIELDS OF DIGITAL ARTISTRY, COMPUTER GAME DEVELOPMENT, SPECIAL EFFECTS, DIGITAL AUDIO, COMPUTER GRAPHICS AND RELATED TECHNOLOGY (U.S. CLS. 100, 101 AND 107).

FIRST USE 10-21-2010; IN COMMERCE 10-21-2010.  
PAUL F. GAST, EXAMINING ATTORNEY

SN 85-202,398. FISHER, FREDRICK, GREENSBORO, NC.  
FILED 12-21-2010.



THE MARK CONSISTS OF AN OPEN BOOK WITH POWER CORD UNDER THE LETTERS "EQP". THE POWER CORD RUNS THROUGH THE TILDE THING ON THE "Q". FOR ON-LINE PUBLICATION OF ELECTRONIC BOOKS AND JOURNALS (U.S. CLS. 100, 101 AND 107).

FIRST USE 3-3-2010; IN COMMERCE 11-24-2010.  
KATHLEEN M. VANSTON, EXAMINING ATTORNEY

**CLASS 41—(Continued).**

SN 85-202,719. NETWORK ENTERPRISES, NEW YORK, NY. FILED 12-21-2010.

**WORLD'S WORST TENANTS**

THE MARK CONSISTS OF STANDARD CHARACTERS WITHOUT CLAIM TO ANY PARTICULAR FONT, STYLE, SIZE, OR COLOR.

FOR ENTERTAINMENT SERVICES IN THE NATURE OF CONTINUING PROGRAM SERIES, FEATURING LIVE ACTION, COMEDY AND DRAMA PROVIDED THROUGH CABLE TELEVISION, BROADCAST TELEVISION, INTERNET, VIDEO-ON-DEMAND, AND THROUGH OTHER DISTRIBUTION PLATFORMS; PROVIDING ONLINE INFORMATION IN THE FIELD OF ENTERTAINMENT CONCERNING TELEVISION PROGRAMS (U.S. CLS. 100, 101 AND 107).  
SUNG IN, EXAMINING ATTORNEY

SN 85-203,121. DAVIS, THOMAS G, DBA DAVIS MEDIA, WILLIAMSBURG, VA. FILED 12-21-2010.

**You can do without the  
paper; you can't do  
without the news.**

THE MARK CONSISTS OF STANDARD CHARACTERS WITHOUT CLAIM TO ANY PARTICULAR FONT, STYLE, SIZE, OR COLOR.

FOR NEWS REPORTER SERVICES IN THE NATURE OF NEWS ANALYSIS AND NEWS COMMENTARY; PROVIDING AN INTERNET NEWS PORTAL FEATURING LINKS TO NEWS STORIES AND ARTICLES IN THE FIELD OF CURRENT EVENTS; PROVIDING CURRENT EVENT NEWS AND INFORMATION VIA A GLOBAL COMPUTER NETWORK; PROVIDING INFORMATION, NEWS AND COMMENTARY IN THE FIELD OF ENTERTAINMENT; PROVIDING INFORMATION, NEWS AND COMMENTARY IN THE FIELD OF RECREATION AND LEISURE ACTIVITIES; PROVIDING NEWS AND INFORMATION IN THE FIELD OF SPORTS; PROVIDING NEWS IN THE NATURE OF CURRENT EVENT REPORTING (U.S. CLS. 100, 101 AND 107).

FIRST USE 12-21-2010; IN COMMERCE 12-21-2010.

WILLIAM BRECKENFELD, EXAMINING ATTORNEY

**CLASS 41—(Continued).**

SN 85-203,228. CHON, MARO, BOSTON, MA. AND WOLDU, SAMSON, SOMERVILLE, MA. FILED 12-21-2010.

**Flav Entertainment**

THE MARK CONSISTS OF STANDARD CHARACTERS WITHOUT CLAIM TO ANY PARTICULAR FONT, STYLE, SIZE, OR COLOR.

NO CLAIM IS MADE TO THE EXCLUSIVE RIGHT TO USE "ENTERTAINMENT", APART FROM THE MARK AS SHOWN.

FOR ARRANGING AND CONDUCTING NIGHTCLUB ENTERTAINMENT EVENTS; ARRANGING AND CONDUCTING OF CONCERTS; ENTERTAINMENT SERVICES BY A MUSICAL ARTIST AND PRODUCER, NAMELY, MUSICAL COMPOSITION FOR OTHERS AND PRODUCTION OF MUSICAL SOUND RECORDINGS; ENTERTAINMENT SERVICES IN THE NATURE OF LIVE MUSICAL PERFORMANCES; ENTERTAINMENT SERVICES, NAMELY, PROVIDING A WEB SITE FEATURING NON-DOWNLOADABLE MUSICAL PERFORMANCES, MUSICAL VIDEOS, RELATED FILM CLIPS, PHOTOGRAPHS, AND OTHER MULTIMEDIA MATERIALS FEATURING MUSICAL ARTISTS; MUSICAL EVENT BOOKING AGENCIES (U.S. CLS. 100, 101 AND 107).

KYLE PEETE, EXAMINING ATTORNEY

SN 85-203,646. ANTIGONE COOK, DBA LIFE INTEGRATED FITNESS, CORVALLIS, OR. FILED 12-22-2010.

**Now We Dance!**

THE MARK CONSISTS OF STANDARD CHARACTERS WITHOUT CLAIM TO ANY PARTICULAR FONT, STYLE, SIZE, OR COLOR.

FOR DANCE EVENTS; DANCE INSTRUCTION; EDUCATION SERVICES, NAMELY, PROVIDING CLASSES AND INSTRUCTION IN THE FIELD OF DANCE (U.S. CLS. 100, 101 AND 107).

JOHN DALIER, EXAMINING ATTORNEY

SN 85-203,724. IOWA LOTTERY, DES MOINES, IA. FILED 12-22-2010.

**CODE GREEN**

THE MARK CONSISTS OF STANDARD CHARACTERS WITHOUT CLAIM TO ANY PARTICULAR FONT, STYLE, SIZE, OR COLOR.

FOR LOTTERY SERVICES (U.S. CLS. 100, 101 AND 107).

ROBERT STRUCK, EXAMINING ATTORNEY

**CLASS 41—(Continued).**

SN 85-204,134. FRED WEHREBERG CIRCUIT OF THEATRES, INC., ST. LOUIS, MO. FILED 12-22-2010.

**WEHREBERG THEATRES**

THE MARK CONSISTS OF STANDARD CHARACTERS WITHOUT CLAIM TO ANY PARTICULAR FONT, STYLE, SIZE, OR COLOR.

OWNER OF U.S. REG. NO. 3,855,793.

NO CLAIM IS MADE TO THE EXCLUSIVE RIGHT TO USE "THEATERS", APART FROM THE MARK AS SHOWN. SEC. 2(F).

FOR ENTERTAINMENT SERVICES, NAMELY, MOVIE THEATERS (U.S. CLS. 100, 101 AND 107).

FIRST USE 0-0-1906; IN COMMERCE 0-0-1906.

SHAUNIA CARLYLE, EXAMINING ATTORNEY

SN 85-204,140. JAVA GYM, LLC, ROCKFORD, MI. FILED 12-22-2010.

**JAVA GYM**

THE MARK CONSISTS OF STANDARD CHARACTERS WITHOUT CLAIM TO ANY PARTICULAR FONT, STYLE, SIZE, OR COLOR.

FOR CHILDREN'S ENTERTAINMENT AND AMUSEMENT CENTERS, NAMELY, INTERACTIVE PLAY AREAS LOCATED IN RESTAURANTS (U.S. CLS. 100, 101 AND 107).

KEVIN CORWIN, EXAMINING ATTORNEY

SN 85-204,233. GIBRALTAR LABORATORIES, INC., FAIRFIELD, NJ. FILED 12-22-2010.

**GIBRALTAR INSTITUTE FOR RESEARCH AND TRAINING**

THE MARK CONSISTS OF STANDARD CHARACTERS WITHOUT CLAIM TO ANY PARTICULAR FONT, STYLE, SIZE, OR COLOR.

NO CLAIM IS MADE TO THE EXCLUSIVE RIGHT TO USE "INSTITUTE, RESEARCH AND TRAINING", APART FROM THE MARK AS SHOWN.

FOR EDUCATIONAL SERVICES, NAMELY, THE PRESENTATION OF SEMINARS AND LECTURES IN THE FIELDS OF CONSUMER PRODUCT SAFETY, ENVIRONMENTAL MONITORING, MICROBIOLOGY, BACTERIOLOGY, MYCOLOGY, VIROLOGY, CHEMISTRY, BIOCOMPATIBILITY, IN VITRO TOXICOLOGY, BIOTECHNOLOGY, MEDICAL DEVICES, COSMETICS, FOOD INGREDIENTS, DRUG INGREDIENTS AND TISSUE BANKS, AND DISTRIBUTING COURSE MATERIALS IN CONNECTION THEREWITH (U.S. CLS. 100, 101 AND 107).

FIRST USE 1-1-1984; IN COMMERCE 1-1-1984.

EUGENIA MARTIN, EXAMINING ATTORNEY

**CLASS 41—(Continued).**

SN 85-204,261. HEALTH GURU MEDIA, INC., NEW YORK, NY. FILED 12-22-2010.

**HEALTHGURU**

THE MARK CONSISTS OF STANDARD CHARACTERS WITHOUT CLAIM TO ANY PARTICULAR FONT, STYLE, SIZE, OR COLOR.

OWNER OF U.S. REG. NOS. 3,694,007, 3,706,738 AND OTHERS.

FOR PRODUCTION AND DISTRIBUTION OF ONLINE VIDEOS ON ISSUES RELATING TO HEALTH AND WELLNESS (U.S. CLS. 100, 101 AND 107).

FIRST USE 12-21-2010; IN COMMERCE 12-21-2010.

BRIAN NEVILLE, EXAMINING ATTORNEY

SN 85-204,284. HEALTH GURU MEDIA, INC., NEW YORK, NY. FILED 12-22-2010.

**Healthguru**

OWNER OF U.S. REG. NOS. 3,694,007, 3,706,738 AND OTHERS.

THE MARK CONSISTS OF THE WORD MARK "HEALTHGURU" IN A STYLIZED FORMAT INCLUDING AN ARROW TO CREATE THE LETTER "H".

FOR PRODUCTION AND DISTRIBUTION OF ONLINE VIDEOS ON ISSUES RELATING TO HEALTH AND WELLNESS (U.S. CLS. 100, 101 AND 107).

FIRST USE 12-21-2010; IN COMMERCE 12-21-2010.

BRIAN NEVILLE, EXAMINING ATTORNEY

SN 85-204,459. REBECCA J. HARDER, PORTLAND, OR. FILED 12-22-2010.

**Gastra Girl**

THE MARK CONSISTS OF STANDARD CHARACTERS WITHOUT CLAIM TO ANY PARTICULAR FONT, STYLE, SIZE, OR COLOR.

FOR ON-LINE JOURNALS, NAMELY, BLOGS FEATURING DIGESTIVE HEALTH AND NATURAL RESOURCES FOR DIGESTIVE HEALTH (U.S. CLS. 100, 101 AND 107).

THEODORE MCBRIDE, EXAMINING ATTORNEY

**CLASS 41—(Continued).**

SN 85-204,591. IGVault CO., LIMITED, WANCHAI, HONG KONG, FILED 12-23-2010.

# IGVault

THE MARK CONSISTS OF STANDARD CHARACTERS WITHOUT CLAIM TO ANY PARTICULAR FONT, STYLE, SIZE, OR COLOR.

THE WORDING IGVault HAS NO MEANING IN A FOREIGN LANGUAGE.

FOR ELECTRONIC GAMES SERVICES PROVIDED BY MEANS OF THE INTERNET (U.S. CLS. 100, 101 AND 107).

FIRST USE 2-8-2007; IN COMMERCE 2-8-2007.  
CARYN GLASSER, EXAMINING ATTORNEY

SN 85-204,601. SEIBERT, DALE, SAN DIEGO, CA. FILED 12-23-2010.

# GOGO

THE MARK CONSISTS OF STANDARD CHARACTERS WITHOUT CLAIM TO ANY PARTICULAR FONT, STYLE, SIZE, OR COLOR.

FOR PRODUCTION AND DISTRIBUTION OF VIDEOS IN THE FIELD OF ADULT NATURE; PHOTOGRAPHY SERVICES (U.S. CLS. 100, 101 AND 107).

DEZMONA MIZELLE, EXAMINING ATTORNEY

SN 85-204,695. CHRISTIE MANSON & WOODS LTD., LONDON, UNITED KINGDOM, FILED 12-23-2010.

# CHRISTIE'S

THE MARK CONSISTS OF STANDARD CHARACTERS WITHOUT CLAIM TO ANY PARTICULAR FONT, STYLE, SIZE, OR COLOR.

OWNER OF U.S. REG. NOS. 3,223,187, 3,410,942 AND OTHERS.

FOR EDUCATION SERVICES, NAMELY, PROVIDING CLASSES, SEMINARS, WORKSHOPS AND COURSES OF INSTRUCTION IN THE FIELDS OF ART HISTORY, WINE AND JEWELRY AND THE PRACTICE IN AND THE HISTORY OF THE ART MARKET AND ART BUSINESS; CERTIFICATE AND GRADUATE LEVEL EDUCATION IN THE FIELDS OF ART HISTORY, WINE AND JEWELRY AND THE PRACTICE IN AND THE HISTORY OF THE ART MARKET AND ART BUSINESS (U.S. CLS. 100, 101 AND 107).

FIRST USE 0-0-1993; IN COMMERCE 0-0-1993.  
CIMMERIAN COLEMAN, EXAMINING ATTORNEY

**CLASS 41—(Continued).**

SN 85-204,708. LANNA, PAOLO, BRONX, NY. FILED 12-23-2010.

THE MARK CONSISTS OF THE WORDS "SHAKE, RHYTHM N' ROLL" IN A STYLIZED FONT. THE WORD "SHAKE" IS INTENTIONALLY DRAWN TO LOOK LIKE IT IS VIBRATING OR HAS BEEN SHAKEN TO EMPHASIZE ITS MEANING.

FOR DANCE EVENTS; DANCE INSTRUCTION; EDUCATION SERVICES, NAMELY, PROVIDING CLASSES AND INSTRUCTION IN THE FIELD OF DANCE; ENTERTAINMENT AND EDUCATION SERVICES IN THE NATURE OF LIVE DANCE AND MUSICAL PERFORMANCES; ORGANIZING COMMUNITY FESTIVALS FEATURING A VARIETY OF ACTIVITIES, NAMELY, ART EXHIBITIONS, HERITAGE MARKETS, ETHNIC DANCES, AND THE LIKE; ORGANIZING COMMUNITY FESTIVALS FEATURING A VARIETY OF ACTIVITIES, NAMELY, SPORTING EVENTS, ART EXHIBITIONS, FLEA MARKETS, ETHNIC DANCES AND THE LIKE; PROVIDING AN EDUCATIONAL WEBSITE IN THE FIELDS OF MUSIC AND ENTERTAINMENT (U.S. CLS. 100, 101 AND 107).

FIRST USE 10-12-2010; IN COMMERCE 11-14-2010.  
KHANH LE, EXAMINING ATTORNEY

SN 85-204,854. MORRIS, WILLIE, HYANNIS, MA. FILED 12-23-2010.

# ERRRTHANG

THE MARK CONSISTS OF STANDARD CHARACTERS WITHOUT CLAIM TO ANY PARTICULAR FONT, STYLE, SIZE, OR COLOR.

FOR ENTERTAINMENT SERVICES IN THE NATURE OF RECORDING, PRODUCTION AND POST-PRODUCTION SERVICES IN THE FIELD OF MUSIC (U.S. CLS. 100, 101 AND 107).

LINDSEY RUBIN, EXAMINING ATTORNEY

**CLASS 41—(Continued).**

SN 85-204,909. ALL AMERICAN HEAVYWEIGHTS, LLC,  
PACIFIC PALISADES, CA. FILED 12-23-2010.



THE MARK CONSISTS OF STYLIZED LETTERS "AAH"  
USING STARS IN THE MIDDLE OF THE LETTERS.  
FOR ATHLETIC TRAINING SERVICES (U.S. CLS. 100,  
101 AND 107).  
PATRICIA EVANKO, EXAMINING ATTORNEY

**CLASS 41—(Continued).**

SN 85-205,134. FOSU, LORI, STEVENSVILLE, MI. FILED 12-  
23-2010.



THE MARK CONSISTS OF TWO PEOPLE (A MAN WITH  
A CLERGY ROBE AND A WOMAN IN A BUSINESS SUIT)  
IN FRONT OF A GLOBE. BELOW THERE IS THE STY-  
LIZED TEXT "CHURCHCORP PURPOSE EXISTING IN  
BOTH WORLDS".

FOR ARRANGING, ORGANIZING, CONDUCTING,  
AND HOSTING SOCIAL ENTERTAINMENT EVENTS;  
EDUCATION SERVICES, NAMELY, PROVIDING SEMI-  
NARS IN THE FIELD OF BUSINESS MANAGEMENT  
AND LEADERSHIP DEVELOPMENT WITHIN A  
CHURCH; TRAINING SERVICES IN THE FIELD OF  
BUSINESS MANAGEMENT AND LEADERSHIP DEVEL-  
OPMENT WITHIN A CHURCH (U.S. CLS. 100, 101 AND  
107).

ROBERT C. CLARK JR., EXAMINING ATTORNEY

SN 85-204,996. DIJIPOP, PROVIDENCE, RI. FILED 12-23-  
2010.

shelf sense

THE MARK CONSISTS OF STANDARD CHARACTERS  
WITHOUT CLAIM TO ANY PARTICULAR FONT, STYLE,  
SIZE, OR COLOR.

FOR ON-LINE JOURNALS, NAMELY, BLOGS FEAT-  
URING INTERNET MARKETING AND DISCUSSION  
THEREOF (U.S. CLS. 100, 101 AND 107).

FIRST USE 11-1-2010; IN COMMERCE 11-1-2010.  
PATRICIA EVANKO, EXAMINING ATTORNEY

SN 85-205,249. LENIHAN, MARY GERARD, ST. LOUIS, MO.  
FILED 12-23-2010.

WNYHOO-NOW!

THE MARK CONSISTS OF STANDARD CHARACTERS  
WITHOUT CLAIM TO ANY PARTICULAR FONT, STYLE,  
SIZE, OR COLOR.

OWNER OF U.S. REG. NOS. 3,868,051 AND 3,868,055.  
FOR EDUCATIONAL SERVICES, NAMELY, PROVID-  
ING WORKSHOPS, SEMINARS, AND INDIVIDUAL IN-  
STRUCTION IN THE FIELDS OF INSPIRATION,  
SPIRITUALITY AND SPIRITUAL DEVELOPMENT (U.S.  
CLS. 100, 101 AND 107).

FIRST USE 11-13-2009; IN COMMERCE 11-13-2009.  
STEVEN JACKSON, EXAMINING ATTORNEY

**CLASS 41—(Continued).**

SN 85-205,278. STEELE MUSIC, INC., BROOKLYN, NY. FILED 12-23-2010.

## CHOCOLATE CHOCOBAR STEELE

THE MARK CONSISTS OF STANDARD CHARACTERS WITHOUT CLAIM TO ANY PARTICULAR FONT, STYLE, SIZE, OR COLOR.

THE NAME(S), PORTRAIT(S), AND/OR SIGNATURE(S) SHOWN IN THE MARK IDENTIFIES EERICA STEELE, WHOSE CONSENT(S) TO REGISTER IS MADE OF RECORD.

FOR ENTERTAINMENT SERVICES, NAMELY, PERFORMANCES AND PUBLIC APPEARANCES BY A LIVE MUSICAL ARTIST AND PROVIDING NON-DOWNLOADABLE PRERECORDED MUSIC ONLINE AND INFORMATION REGARDING A MUSICAL ARTIST ONLINE VIA A GLOBAL COMPUTER NETWORK (U.S. CLS. 100, 101 AND 107).

GIANCARLO CASTRO, EXAMINING ATTORNEY

SN 85-205,333. GAVEL BABBLE INC., DORAL, FL. FILED 12-23-2010.

GAVEL  
Babble

THE MARK CONSISTS OF THE STYLIZED TEXT "GAVEL BABBLE".

FOR ON-LINE JOURNALS, NAMELY, BLOGS FEATURING INFORMATION AND ADVICE ON RELATIONSHIPS, CAREER, AND FAMILY ISSUES (U.S. CLS. 100, 101 AND 107).

FIRST USE 12-1-2009; IN COMMERCE 5-11-2010.  
KATINA MISTER, EXAMINING ATTORNEY

SN 85-205,356. GAMBLE, ZENO, WOODBRIDGE, VA. FILED 12-23-2010.



Sotry House

THE MARK CONSISTS OF A HOUSE ON A HILL WITH THE STYLIZED TEXT "SOTRY HOUSE".

FOR PUBLISHING OF BOOKS, E-BOOKS, AUDIO BOOKS, MUSIC AND ILLUSTRATIONS (U.S. CLS. 100, 101 AND 107).

MAYUR VAGHANI, EXAMINING ATTORNEY

**CLASS 41—(Continued).**

SN 85-205,423. RIZOPOULOS, NATASHA, BOSTON, MA. FILED 12-23-2010.

## ALIGN YOUR FLOW

THE MARK CONSISTS OF STANDARD CHARACTERS WITHOUT CLAIM TO ANY PARTICULAR FONT, STYLE, SIZE, OR COLOR.

FOR PROVIDING INFORMATION IN THE FIELD OF YOGA VIA THE INTERNET (U.S. CLS. 100, 101 AND 107).

FIRST USE 12-22-2010; IN COMMERCE 12-22-2010.  
AISHA SALEM, EXAMINING ATTORNEY

SN 85-205,425. LIBERTY SCIENCE CENTER, JERSEY CITY, NJ. FILED 12-23-2010.

## THE TOUCH TUNNEL

THE MARK CONSISTS OF STANDARD CHARACTERS WITHOUT CLAIM TO ANY PARTICULAR FONT, STYLE, SIZE, OR COLOR.

FOR INTERACTIVE MUSEUM EXHIBITION FOR SENSORY ENHANCEMENT (U.S. CLS. 100, 101 AND 107).

GIANCARLO CASTRO, EXAMINING ATTORNEY

SN 85-205,463. HERTILUS, JONATHAN, NUTLEY, NJ. FILED 12-23-2010.

BFF

THE MARK CONSISTS OF STANDARD CHARACTERS WITHOUT CLAIM TO ANY PARTICULAR FONT, STYLE, SIZE, OR COLOR.

FOR PHYSICAL FITNESS CONDITIONING CLASSES; PHYSICAL FITNESS INSTRUCTION; PROVIDING ASSISTANCE, PERSONAL TRAINING AND PHYSICAL FITNESS CONSULTATION TO INDIVIDUALS TO HELP THEM MAKE PHYSICAL FITNESS, STRENGTH, CONDITIONING, AND EXERCISE IMPROVEMENT IN THEIR DAILY LIVING (U.S. CLS. 100, 101 AND 107).

FIRST USE 6-1-2010; IN COMMERCE 6-1-2010.  
BARBARA BROWN, EXAMINING ATTORNEY

**CLASS 41—(Continued).**

SN 85-205,517. LEGENZA, RICHARD, FORT ERIE, ONTARIO, CANADA, FILED 12-24-2010.

## Rapid Replay

THE MARK CONSISTS OF STANDARD CHARACTERS WITHOUT CLAIM TO ANY PARTICULAR FONT, STYLE, SIZE, OR COLOR.

FOR ENTERTAINMENT SERVICES, NAMELY, CASINO GAMING; GAMING SERVICES IN THE NATURE OF CASINO GAMING; LEASING OF CASINO GAMES (U.S. CLS. 100, 101 AND 107).

KYLE PEETE, EXAMINING ATTORNEY

SN 85-205,519. LEGENZA, RICHARD, FORT ERIE, ONTARIO, CANADA, FILED 12-24-2010.

## Nine Insurance

THE MARK CONSISTS OF STANDARD CHARACTERS WITHOUT CLAIM TO ANY PARTICULAR FONT, STYLE, SIZE, OR COLOR.

FOR ENTERTAINMENT SERVICES, NAMELY, AN ON-GOING TELEVISION GAME SHOW AND GAMES OF CHANCE TO BE PLAYED AT A CASINO; ENTERTAINMENT SERVICES, NAMELY, CASINO GAMING; GAMING SERVICES IN THE NATURE OF CASINO GAMING; LEASING OF CASINO GAMES (U.S. CLS. 100, 101 AND 107).

KYLE PEETE, EXAMINING ATTORNEY

SN 85-205,520. LEGENZA, RICHARD, FORT ERIE, ONTARIO, CANADA, FILED 12-24-2010.

## Table 21

THE MARK CONSISTS OF STANDARD CHARACTERS WITHOUT CLAIM TO ANY PARTICULAR FONT, STYLE, SIZE, OR COLOR.

FOR ENTERTAINMENT SERVICES, NAMELY, AN ON-GOING TELEVISION GAME SHOW AND GAMES OF CHANCE TO BE PLAYED AT A CASINO; ENTERTAINMENT SERVICES, NAMELY, CASINO GAMING; GAMING SERVICES IN THE NATURE OF CASINO GAMING; LEASING OF CASINO GAMES (U.S. CLS. 100, 101 AND 107).

KYLE PEETE, EXAMINING ATTORNEY

**CLASS 41—(Continued).**

SN 85-205,569. IMPROV WEST ASSOCIATES, LOS ANGELES, CA. FILED 12-24-2010.

## IMPROV TRAFFIC SCHOOL

THE MARK CONSISTS OF STANDARD CHARACTERS WITHOUT CLAIM TO ANY PARTICULAR FONT, STYLE, SIZE, OR COLOR.

NO CLAIM IS MADE TO THE EXCLUSIVE RIGHT TO USE "TRAFFIC SCHOOL", APART FROM THE MARK AS SHOWN.

FOR EDUCATION SERVICES, NAMELY, PROVIDING LIVE AND ON-LINE COURT APPROVED TRAFFIC SCHOOL CLASSES AND INSTRUCTION IN THE FIELD OF TRAFFIC VIOLATIONS AND MOTOR VEHICLE LAW AND SAFETY (U.S. CLS. 100, 101 AND 107).

FIRST USE 7-31-1999; IN COMMERCE 7-31-1999.

JANICE L. MCMORROW, EXAMINING ATTORNEY

SN 85-205,596. ROTHSTEIN, MARK S., EL SEGUNDO, CA. FILED 12-24-2010.

## MR. MONEY

THE MARK CONSISTS OF STANDARD CHARACTERS WITHOUT CLAIM TO ANY PARTICULAR FONT, STYLE, SIZE, OR COLOR.

OWNER OF U.S. REG. NOS. 2,757,394 AND 3,006,120.  
FOR EDUCATION SERVICES, NAMELY, CONDUCTING SEMINARS AND PRESENTATIONS IN THE FIELD OF FINANCIAL INVESTMENTS, REAL ESTATE, INSURANCE, ESTATE PLANNING AND FINANCIAL PLANNING (U.S. CLS. 100, 101 AND 107).

FIRST USE 1-31-2009; IN COMMERCE 1-31-2009.

GEOFFREY FOSDICK, EXAMINING ATTORNEY

SN 85-205,607. GOLDEN, HOPE, F., BRIGHTON, CO. FILED 12-24-2010.

## Temple Tune-Ups

THE MARK CONSISTS OF STANDARD CHARACTERS WITHOUT CLAIM TO ANY PARTICULAR FONT, STYLE, SIZE, OR COLOR.

FOR PROVIDING CLASSES, WORKSHOPS, SEMINARS AND CAMPS IN THE FIELDS OF FITNESS, EXERCISE, BOXING, KICK BOXING AND MIXED MARTIAL ARTS (U.S. CLS. 100, 101 AND 107).

KELLEY WELLS, EXAMINING ATTORNEY

**CLASS 41—(Continued).**

SN 85-205,749. DORIAN, ARMAND, PORTER RANCH, CA. FILED 12-27-2010.

**INSTAKILL**

THE MARK CONSISTS OF STANDARD CHARACTERS WITHOUT CLAIM TO ANY PARTICULAR FONT, STYLE, SIZE, OR COLOR.

FOR ENTERTAINMENT IN THE NATURE OF LIVE PERFORMANCES BY A PROFESSIONAL ENTERTAINER; ENTERTAINMENT SERVICES, NAMELY, LIVE, TELEVISED AND MOVIE APPEARANCES BY A PROFESSIONAL ENTERTAINER; ENTERTAINMENT SERVICES, NAMELY, PERSONAL APPEARANCES BY A PROFESSIONAL ENTERTAINER (U.S. CLS. 100, 101 AND 107).

FIRST USE 6-1-2007; IN COMMERCE 2-2-2009.  
SANJEEV VOHRA, EXAMINING ATTORNEY

SN 85-205,815. MOODSWING, LLC, DBA MOODSWING360, NEW YORK, NY. FILED 12-27-2010.

**Real Thugs Play Electro**

THE MARK CONSISTS OF STANDARD CHARACTERS WITHOUT CLAIM TO ANY PARTICULAR FONT, STYLE, SIZE, OR COLOR.

FOR ENTERTAINMENT IN THE NATURE OF A MUSIC FESTIVAL (U.S. CLS. 100, 101 AND 107).  
DOMINICK J. SALEMI, EXAMINING ATTORNEY

SN 85-205,841. WALSH, GREGORY, WALWORTH, NY. FILED 12-27-2010.

**wolf brigade**

THE MARK CONSISTS OF STANDARD CHARACTERS WITHOUT CLAIM TO ANY PARTICULAR FONT, STYLE, SIZE, OR COLOR.

FOR MARTIAL ARTS INSTRUCTION; PHYSICAL FITNESS TRAINING SERVICES; TRAINING SERVICES IN THE FIELD OF SELF DEFENSE (U.S. CLS. 100, 101 AND 107).

FIRST USE 3-1-2008; IN COMMERCE 3-1-2008.  
BARNEY CHARLON, EXAMINING ATTORNEY

**CLASS 41—(Continued).**

SN 85-205,845. CARDON, ROBYN, EDMOND, OK. FILED 12-27-2010.

**My Pink Stamper**

THE MARK CONSISTS OF STANDARD CHARACTERS WITHOUT CLAIM TO ANY PARTICULAR FONT, STYLE, SIZE, OR COLOR.

FOR PROVIDING A WEBSITE FEATURING NON-DOWNLOADABLE VIDEOS IN THE FIELD OF ARTS AND CRAFTS TUTORIALS (U.S. CLS. 100, 101 AND 107).

FIRST USE 4-27-2007; IN COMMERCE 8-1-2009.  
JESSICA FATHY, EXAMINING ATTORNEY

SN 85-205,983. THE GLORY BE THINE, ALPINE, UT. FILED 12-27-2010.

**The Glory Be Thine**

THE MARK CONSISTS OF STANDARD CHARACTERS WITHOUT CLAIM TO ANY PARTICULAR FONT, STYLE, SIZE, OR COLOR.

FOR PUBLISHING OF BOOKS, E-BOOKS, AUDIO BOOKS, MUSIC AND ILLUSTRATIONS (U.S. CLS. 100, 101 AND 107).

JACQUELINE A. LAVINE, EXAMINING ATTORNEY

SN 85-206,135. ROWBERRY, JILL, SALT LAKE CITY, UT. FILED 12-27-2010.

**THE ART OF BECOMING A REAL  
ADULT**

THE MARK CONSISTS OF STANDARD CHARACTERS WITHOUT CLAIM TO ANY PARTICULAR FONT, STYLE, SIZE, OR COLOR.

FOR LIFE COACHING AND PERSONAL COACHING SERVICES IN THE FIELDS OF THOUGHT CONTROL, POSITIVE PSYCHOLOGY, PERSONAL RELATIONSHIPS, SELF AND PERSONAL IMPROVEMENT, PERSONAL AWARENESS, AND THE ART AND SCIENCE OF HAPPINESS; PROVIDING PUBLIC PRESENTATIONS AND SPEECHES IN THE FIELDS OF THOUGHT CONTROL, POSITIVE PSYCHOLOGY, PERSONAL RELATIONSHIPS, SELF AND PERSONAL IMPROVEMENT, PERSONAL AWARENESS, AND THE ART AND SCIENCE OF HAPPINESS (U.S. CLS. 100, 101 AND 107).

MICHAEL WEBSTER, EXAMINING ATTORNEY



**CLASS 41—(Continued).**

SN 85-206,224. UPLYTE LLC, DANIA BEACH, FL. FILED 12-27-2010.

# Uplyte

THE MARK CONSISTS OF STANDARD CHARACTERS WITHOUT CLAIM TO ANY PARTICULAR FONT, STYLE, SIZE, OR COLOR.

FOR ENTERTAINMENT, NAMELY, LIGHTING PRODUCTION (U.S. CLS. 100, 101 AND 107).

FIRST USE 10-7-2008; IN COMMERCE 10-7-2008.

KAREN BRACEY, EXAMINING ATTORNEY

**CLASS 41—(Continued).**

SN 85-206,444. IN SHAPE KIDS, INC, SEAFORD, NY. FILED 12-28-2010.



THE COLOR(S) LIGHT BLUE, ORANGE AND PURPLE IS/ ARE CLAIMED AS A FEATURE OF THE MARK.

THE MARK CONSISTS OF TWO STYLIZED HALF MOONS THE LEFT IS LIGHT BLUE AND THE RIGHT IS PURPLE WHICH APPEAR TO BE THE UPPER BODY OF A PERSON EACH WITH AN ORANGE CIRCLE AS THE HEAD. THESE DESIGNS ARE ABOVE THE WORD "FORWARD" IN LIGHT BLUE WHICH IS TO THE LEFT OF THE WORD "STRIDES" WHICH IS ORANGE AND ITALICIZED.

FOR EDUCATION SERVICES, NAMELY, PROVIDING LIVE AND ON-LINE TRAINING, EDUCATION, CURRICULUM, PROGRAMMING AND INTERACTIVE COLLABORATION IN THE FIELD OF PHYSICAL EDUCATION (U.S. CLS. 100, 101 AND 107).

FIRST USE 11-1-2010; IN COMMERCE 11-1-2010.

AISHA CLARKE, EXAMINING ATTORNEY

SN 85-206,423. SETEBAID SERVICES, INC., WINFIELD, PA. FILED 12-28-2010.



THE MARK CONSISTS OF THE LETTERS "HDYC" AT THE BOTTOM OF A CIRCULAR BACKGROUND BEARING AN IMAGE OF A PINE TREE TO THE LEFT SIDE OF THE CIRCLE.

FOR MEDICALLY SUPERVISED RECREATIONAL AND EDUCATIONAL CAMP FOR CHILDREN WITH DIABETES (U.S. CLS. 100, 101 AND 107).

FIRST USE 3-16-1999; IN COMMERCE 3-16-1999.

INGA ERVIN, EXAMINING ATTORNEY

SN 85-206,451. FSP INC., LAS VEGAS, NV. FILED 12-28-2010.

# Quick Pick

THE MARK CONSISTS OF STANDARD CHARACTERS WITHOUT CLAIM TO ANY PARTICULAR FONT, STYLE, SIZE, OR COLOR.

FOR ENTERTAINMENT SERVICES IN THE NATURE OF FANTASY SPORTS LEAGUES (U.S. CLS. 100, 101 AND 107).

AISHA CLARKE, EXAMINING ATTORNEY

SN 85-206,478. THE COLLEGE NETWORK, INC., INDIANAPOLIS, IN. FILED 12-28-2010.

# IMPACT

THE MARK CONSISTS OF STANDARD CHARACTERS WITHOUT CLAIM TO ANY PARTICULAR FONT, STYLE, SIZE, OR COLOR.

FOR EDUCATIONAL SERVICES, NAMELY, DEVELOPING CURRICULUM FOR OTHERS IN THE FIELD OF HIGHER EDUCATION (U.S. CLS. 100, 101 AND 107).

FIRST USE 11-4-2010; IN COMMERCE 11-4-2010.

PAUL F. GAST, EXAMINING ATTORNEY

**CLASS 41—(Continued).**

SN 85-206,571. DAUTERIVE, JIM, BEVERLY HILLS, CA. FILED 12-28-2010.

**BUCK AND MILLIE PRODUCTIONS**

THE MARK CONSISTS OF STANDARD CHARACTERS WITHOUT CLAIM TO ANY PARTICULAR FONT, STYLE, SIZE, OR COLOR.

NO CLAIM IS MADE TO THE EXCLUSIVE RIGHT TO USE "PRODUCTIONS", APART FROM THE MARK AS SHOWN.

FOR ENTERTAINMENT MEDIA PRODUCTION SERVICES FOR MOTION PICTURES, TELEVISION AND INTERNET; ENTERTAINMENT SERVICES IN THE NATURE OF CREATION, DEVELOPMENT, AND PRODUCTION OF TELEVISION PROGRAMMING; MOTION PICTURE FILM PRODUCTION; PRODUCTION OF CABLE TELEVISION PROGRAMS; PRODUCTION OF TELEVISION PROGRAMS (U.S. CLS. 100, 101 AND 107).  
SANJEEV VOHRA, EXAMINING ATTORNEY

---

SN 85-206,634. OPPORTUNITY VILLAGE FOUNDATION, LAS VEGAS, NV. FILED 12-28-2010.

**MAGICAL FOREST**

THE MARK CONSISTS OF STANDARD CHARACTERS WITHOUT CLAIM TO ANY PARTICULAR FONT, STYLE, SIZE, OR COLOR.

FOR ORGANIZING COMMUNITY FESTIVALS FEATURING PRIMARILY AMUSEMENT RIDES, MINIATURE GOLF, AND ENTERTAINMENT SERVICES IN THE NATURE OF HOLIDAY LIGHT DISPLAYS, AND ALSO PROVIDING RECORDED MUSIC, AND HOLIDAY CRAFTS AND SOUVENIR GIFTS (U.S. CLS. 100, 101 AND 107).

FIRST USE 11-30-1992; IN COMMERCE 11-30-1992.  
ERNEST SHOSHO, EXAMINING ATTORNEY

---

SN 85-206,749. EQUINEXUS, DBA WEBX2020 AND WOMEN ENTREPRENEURS BUSINESS EXCHANGE 2020, BETHESDA, MD. FILED 12-28-2010.

**Learn to Earn to Live to  
Love to Give**

THE MARK CONSISTS OF STANDARD CHARACTERS WITHOUT CLAIM TO ANY PARTICULAR FONT, STYLE, SIZE, OR COLOR.

FOR EDUCATION SERVICES, NAMELY, PROVIDING LIVE AND ON-LINE SEMINARS, WORKSHOPS, TRAINING, AND COACHING SERVICES IN THE FIELD OF BUSINESS AND ENTREPRENEURSHIP (U.S. CLS. 100, 101 AND 107).

STEVEN R. FINE, EXAMINING ATTORNEY

**CLASS 41—(Continued).**

SN 85-206,763. SUSAN BERMAN, OLYMPIA, WA. FILED 12-28-2010.

**Whimsical**

THE MARK CONSISTS OF STANDARD CHARACTERS WITHOUT CLAIM TO ANY PARTICULAR FONT, STYLE, SIZE, OR COLOR.

FOR DIGITAL IMAGING SERVICES; PHOTOGRAPHY SERVICES; PORTRAIT PHOTOGRAPHY (U.S. CLS. 100, 101 AND 107).

FIRST USE 8-1-2007; IN COMMERCE 8-1-2007.  
MATTHEW KLINE, EXAMINING ATTORNEY

---

SN 85-206,904. WADE, TERENCE C., HONOLULU, HI. FILED 12-28-2010.

**Agents Of Progress**

THE MARK CONSISTS OF STANDARD CHARACTERS WITHOUT CLAIM TO ANY PARTICULAR FONT, STYLE, SIZE, OR COLOR.

FOR EDUCATION SERVICES, NAMELY, PROVIDING LIVE AND ON-LINE CLASSES, SEMINARS, CONFERENCES AND WORKSHOPS IN THE FIELD OF MARKETING AND SALES (U.S. CLS. 100, 101 AND 107).

JOSETTE BEVERLY, EXAMINING ATTORNEY

---

SN 85-206,963. THE CREATIVE LADY, LLC, CORDOVA, TN. FILED 12-29-2010.

**The Creative Lady**

THE MARK CONSISTS OF STANDARD CHARACTERS WITHOUT CLAIM TO ANY PARTICULAR FONT, STYLE, SIZE, OR COLOR.

FOR PHOTOGRAPHIC AND VIDEO SERVICES, NAMELY, PHOTOGRAPHIC AND VIDEO CAPTURE (U.S. CLS. 100, 101 AND 107).

FIRST USE 2-14-2002; IN COMMERCE 2-14-2002.  
CHERYL CLAYTON, EXAMINING ATTORNEY

**CLASS 41—(Continued).**

SN 85-206,986. WORLD'S CHILDREN'S PRIZE FOUNDATION, MARIEFRED, SWEDEN, FILED 12-29-2010.

**WORLD'S CHILDREN'S OMBUDSMAN**

THE MARK CONSISTS OF STANDARD CHARACTERS WITHOUT CLAIM TO ANY PARTICULAR FONT, STYLE, SIZE, OR COLOR.

OWNER OF U.S. REG. NO. 3,891,915. NO CLAIM IS MADE TO THE EXCLUSIVE RIGHT TO USE "OMBUDSMAN", APART FROM THE MARK AS SHOWN.

FOR PROVIDING RECOGNITION BY MEANS OF AWARDS TO HONOR OUTSTANDING ACHIEVEMENTS IN THE FIELD OF CHILDREN'S RIGHTS (U.S. CLS. 100, 101 AND 107).

ELIZABETH KAJUBI, EXAMINING ATTORNEY

**CLASS 41—(Continued).**

SN 85-207,325. E! ENTERTAINMENT TELEVISION, INC., LOS ANGELES, CA. FILED 12-29-2010.

**MY FAMILY IS A GAME SHOW**

THE MARK CONSISTS OF STANDARD CHARACTERS WITHOUT CLAIM TO ANY PARTICULAR FONT, STYLE, SIZE, OR COLOR.

FOR ENTERTAINMENT IN THE NATURE OF AN ONGOING TELEVISION GAME SHOW; ENTERTAINMENT SERVICES, NAMELY, PROVIDING AN ONGOING TELEVISION GAME SHOW AND INFORMATION RELATED TO SUCH PROGRAMS VIA A GLOBAL COMPUTER NETWORK AND VIA WIRELESS COMMUNICATION DEVICES (U.S. CLS. 100, 101 AND 107).

JAMES A. RAUEN, EXAMINING ATTORNEY

SN 85-207,195. JAMIE NOBLE, SANTA CRUZ, CA. FILED 12-29-2010.

**sportsmedix**

THE MARK CONSISTS OF STANDARD CHARACTERS WITHOUT CLAIM TO ANY PARTICULAR FONT, STYLE, SIZE, OR COLOR.

FOR PERSONAL FITNESS TRAINING SERVICES AND CONSULTANCY (U.S. CLS. 100, 101 AND 107).

PAUL E. FAHRENKOPF, EXAMINING ATTORNEY

SN 85-207,369. H.A.N. MADE LLC, LOS RANCHOS, NM. FILED 12-29-2010.

**AFTERMATH**

THE MARK CONSISTS OF STANDARD CHARACTERS WITHOUT CLAIM TO ANY PARTICULAR FONT, STYLE, SIZE, OR COLOR.

FOR EDUCATIONAL SERVICES, NAMELY, CONDUCTING CLASSES, SEMINARS, CONFERENCES, WORKSHOPS AND CAMPS IN THE FIELD OF MATH, SCIENCE AND LANGUAGE ARTS, AND DISTRIBUTION OF COURSE MATERIALS IN CONNECTION THEREWITH (U.S. CLS. 100, 101 AND 107).

FIRST USE 8-0-2010; IN COMMERCE 8-0-2010.

SUZANNE BLANE, EXAMINING ATTORNEY

SN 85-207,210. JAMIE NOBLE, SANTA CRUZ, CA. FILED 12-29-2010.

**sportsmedex**

THE MARK CONSISTS OF STANDARD CHARACTERS WITHOUT CLAIM TO ANY PARTICULAR FONT, STYLE, SIZE, OR COLOR.

FOR PERSONAL FITNESS TRAINING SERVICES AND CONSULTANCY (U.S. CLS. 100, 101 AND 107).

PAUL E. FAHRENKOPF, EXAMINING ATTORNEY

SN 85-207,467. QUANTUM PSYCH INK, CLEVELAND, OH. FILED 12-29-2010.

**YogaFunk**

THE MARK CONSISTS OF STANDARD CHARACTERS WITHOUT CLAIM TO ANY PARTICULAR FONT, STYLE, SIZE, OR COLOR.

FOR PHYSICAL FITNESS INSTRUCTION; YOGA INSTRUCTION (U.S. CLS. 100, 101 AND 107).

JULIE VEPPUMTHARA, EXAMINING ATTORNEY

**CLASS 41—(Continued).**

SN 85-207,543. SIETE DOS PUBLICATIONS, LLC, CARSON CITY, NV. FILED 12-29-2010.

# PCPC

THE MARK CONSISTS OF STANDARD CHARACTERS WITHOUT CLAIM TO ANY PARTICULAR FONT, STYLE, SIZE, OR COLOR.

FOR ENTERTAINMENT SERVICES, NAMELY, ORGANIZING AND CONDUCTING POKER TOURNAMENTS EVENTS; PROVISION OF SPECIAL EVENTS FEATURING CASINO AND GAMING CONTESTS AND CARD GAME TOURNAMENTS (U.S. CLS. 100, 101 AND 107).  
TINA BROWN, EXAMINING ATTORNEY

**CLASS 41—(Continued).**

SN 85-207,763. WRIGHT, LEROY I., JACKSON, NJ. FILED 12-30-2010.

# THE C4 EXPERIENCE

THE MARK CONSISTS OF STANDARD CHARACTERS WITHOUT CLAIM TO ANY PARTICULAR FONT, STYLE, SIZE, OR COLOR.

FOR ENTERTAINMENT, NAMELY, LIVE PERFORMANCES BY A MUSICAL BAND (U.S. CLS. 100, 101 AND 107).

FIRST USE 7-4-1993; IN COMMERCE 7-4-1993.  
JULIE GUTTADAURO, EXAMINING ATTORNEY

SN 85-207,589. LEVERING JR., CHARLES B., PHILADELPHIA, PA. FILED 12-29-2010.

# MyGuruDaddy

THE MARK CONSISTS OF STANDARD CHARACTERS WITHOUT CLAIM TO ANY PARTICULAR FONT, STYLE, SIZE, OR COLOR.

FOR ENTERTAINMENT SERVICES, NAMELY, PROVIDING A WEB SITE FEATURING PHOTOGRAPHIC, AUDIO, VIDEO AND PROSE PRESENTATIONS FEATURING COMEDY, JOKES AND ENTERTAINMENT CONTENT (U.S. CLS. 100, 101 AND 107).

BILL DAWE, EXAMINING ATTORNEY

SN 85-207,920. LOUDCLOUD SYSTEMS, INC, PLANO, TX. FILED 12-30-2010.

# LoudBooks

THE MARK CONSISTS OF STANDARD CHARACTERS WITHOUT CLAIM TO ANY PARTICULAR FONT, STYLE, SIZE, OR COLOR.

FOR ANALYZING EDUCATIONAL TESTS SCORES AND DATA FOR OTHERS; ANALYZING OF EDUCATIONAL TEST SCORES AND DATA FOR OTHERS; BUSINESS EDUCATION AND TRAINING SERVICES, NAMELY, DEVELOPING, AND FACILITATING CUSTOMIZED IN-COMPANY LEADERSHIP AND EXECUTIVE DEVELOPMENT PROGRAMS, PROVIDING EXECUTIVE COACHING SERVICES, AND PROVIDING PUBLIC AND IN-COMPANY KEYNOTE PRESENTATIONS TO BUSINESS LEADERS; COMPUTER EDUCATION TRAINING; COMPUTER EDUCATION TRAINING SERVICES; EDUCATING AT UNIVERSITY OR COLLEGES; EDUCATION SERVICES IN THE NATURE OF COURSES AT THE UNIVERSITY LEVEL; EDUCATIONAL COURSE MONITORING, NAMELY, TRACKING STUDENT PERFORMANCE; EDUCATIONAL DEMONSTRATIONS; EDUCATIONAL EXAMINATION; EDUCATIONAL EXAMINATION SERVICES; EDUCATIONAL SERVICES, NAMELY, CONDUCTING DISTANCE LEARNING INSTRUCTION AT THE SECONDARY, COLLEGE AND GRADUATE LEVELS; EDUCATIONAL SERVICES, NAMELY, CONDUCTING DISTANCE LEARNING INSTRUCTION AT THE UNIVERSITY LEVEL; EDUCATIONAL SERVICES, NAMELY, DEVELOPING AND CONDUCTING TRAINING COURSES AND DISTRIBUTION OF TRAINING MATERIALS IN CONNECTION THEREWITH FOR SUBJECT MATTERS AS REQUESTED BY CUSTOMERS; EDUCATIONAL SERVICES, NAMELY, DEVELOPING CURRICULUM FOR EDUCATORS; EDUCATIONAL SERVICES, NAMELY, DEVELOPING CURRICULUM FOR TEACHERS; PROVIDING COURSES OF INSTRUCTION AT THE UNDERGRADUATE AND GRADUATE LEVEL; PROVISION OF INFORMATION RELATING TO EDUCATIONAL SERVICES (U.S. CLS. 100, 101 AND 107).

CAROLYN CATALDO, EXAMINING ATTORNEY

SN 85-207,729. UBM IP LUXEMBOURG S.A.R.L., L-1724, LUXEMBOURG, FILED 12-30-2010.

# JOC TENS

THE MARK CONSISTS OF STANDARD CHARACTERS WITHOUT CLAIM TO ANY PARTICULAR FONT, STYLE, SIZE, OR COLOR.

FOR PROVIDING AN ONLINE COLUMN IN THE FIELD OF GLOBAL TRADE AND TRANSPORT (U.S. CLS. 100, 101 AND 107).

FIRST USE 10-24-2007; IN COMMERCE 10-24-2007.  
CHARLES L. JENKINS, EXAMINING ATTORNEY

**CLASS 41—(Continued).**

SN 85-207,930. LOUDCLOUD SYSTEMS, INC, PLANO, TX.  
FILED 12-30-2010.

# LoudAnalytics

THE MARK CONSISTS OF STANDARD CHARACTERS WITHOUT CLAIM TO ANY PARTICULAR FONT, STYLE, SIZE, OR COLOR.

FOR ANALYZING EDUCATIONAL TESTS SCORES AND DATA FOR OTHERS; ANALYZING OF EDUCATIONAL TEST SCORES AND DATA FOR OTHERS; BUSINESS EDUCATION AND TRAINING SERVICES, NAMELY, DEVELOPING, AND FACILITATING CUSTOMIZED IN-COMPANY LEADERSHIP AND EXECUTIVE DEVELOPMENT PROGRAMS, PROVIDING EXECUTIVE COACHING SERVICES, AND PROVIDING PUBLIC AND IN-COMPANY KEYNOTE PRESENTATIONS TO BUSINESS LEADERS; COMPUTER EDUCATION TRAINING; COMPUTER EDUCATION TRAINING SERVICES; EDUCATING AT UNIVERSITY OR COLLEGES; EDUCATION SERVICES IN THE NATURE OF COURSES AT THE UNIVERSITY LEVEL; EDUCATIONAL EXAMINATION; EDUCATIONAL EXAMINATION SERVICES; EDUCATIONAL SERVICES, NAMELY, DEVELOPING AND CONDUCTING TRAINING COURSES AND DISTRIBUTION OF TRAINING MATERIALS IN CONNECTION THEREWITH FOR SUBJECT MATTERS AS REQUESTED BY CUSTOMERS; EDUCATIONAL SERVICES, NAMELY, DEVELOPING CURRICULUM FOR EDUCATORS; EDUCATIONAL SERVICES, NAMELY, DEVELOPING CURRICULUM FOR TEACHERS; EDUCATIONAL SERVICES, NAMELY, THE OFFERING OF WEB BASED AND CLASSROOM TRAINING FOR CERTIFICATION OF TEACHERS AND CONTINUING EDUCATION FOR TEACHERS AND PRINCIPALS; EDUCATIONAL TESTING; ON-LINE EDUCATION CREDIT AND DEGREE EVALUATION AND COMPARISON SERVICES; PROVIDING INFORMATION ON-LINE RELATING TO EDUCATIONAL OPPORTUNITIES; PROVISION OF INFORMATION RELATING TO EDUCATIONAL SERVICES (U.S. CLS. 100, 101 AND 107).

CAROLYN CATALDO, EXAMINING ATTORNEY

SN 85-208,028. SCHUSSLER CREATIVE, INC., GOLDEN VALLEY, MN. FILED 12-30-2010.

## SETTING THE STANDARD FOR INDUSTRY FIRSTS

THE MARK CONSISTS OF STANDARD CHARACTERS WITHOUT CLAIM TO ANY PARTICULAR FONT, STYLE, SIZE, OR COLOR.

FOR EDUCATION SERVICES, NAMELY, PROVIDING MOTIVATIONAL SPEAKING SERVICES, SEMINARS, WORKSHOPS, AND TRAINING IN THE FIELDS OF ADVERTISING, MARKETING AND PROMOTION (U.S. CLS. 100, 101 AND 107).

FIRST USE 5-4-2007; IN COMMERCE 5-4-2007.

KATHRYN COWARD, EXAMINING ATTORNEY

**CLASS 41—(Continued).**

SN 85-208,098. TRENTACOSTA, THERESA, TINTON FALLS, NJ. FILED 12-30-2010.

## DATE-LIKE-A-MAN.COM

THE MARK CONSISTS OF STANDARD CHARACTERS WITHOUT CLAIM TO ANY PARTICULAR FONT, STYLE, SIZE, OR COLOR.

FOR ENTERTAINMENT SERVICES, NAMELY, PROVIDING A WEBSITE AT WHICH THE GENERAL PUBLIC CAN RECEIVE ADVICE FROM AN INDIVIDUAL CONCERNING RELATIONSHIPS, SUCH ADVICE BEING FOR ENTERTAINMENT PURPOSES ONLY (U.S. CLS. 100, 101 AND 107).

FIRST USE 10-10-2010; IN COMMERCE 10-10-2010.

SOPHIA S. KIM, EXAMINING ATTORNEY

SN 85-208,110. OKINAWA-TE ORGANIZATION, BEVERLY HILLS, CA. FILED 12-30-2010.



THE MARK CONSISTS OF TWO SNAKES INTERTWINED AROUND A HAND.

FOR MARTIAL ARTS INSTRUCTION; ORGANIZING LIVE MIXED MARTIAL ARTS EVENTS AND COMPETITIONS (U.S. CLS. 100, 101 AND 107).

FIRST USE 0-0-1965; IN COMMERCE 0-0-1966.

SOPHIA S. KIM, EXAMINING ATTORNEY

SN 85-208,285. ELEVITCH, NIKOLAS, PALISADES, NY. FILED 12-30-2010.

# AS5

THE MARK CONSISTS OF STANDARD CHARACTERS WITHOUT CLAIM TO ANY PARTICULAR FONT, STYLE, SIZE, OR COLOR.

FOR ENTERTAINMENT IN THE NATURE OF LIVE PERFORMANCES BY A MUSICAL PERFORMER OR GROUP (U.S. CLS. 100, 101 AND 107).

FIRST USE 12-17-2010; IN COMMERCE 12-17-2010.

CORY BOONE, EXAMINING ATTORNEY

**CLASS 41—(Continued).**

SN 85-208,331. SOCCER AND SMILES LLC, SAN CARLOS, CA. FILED 12-30-2010.

SOCCER & SMILES

THE MARK CONSISTS OF STANDARD CHARACTERS WITHOUT CLAIM TO ANY PARTICULAR FONT, STYLE, SIZE, OR COLOR.

NO CLAIM IS MADE TO THE EXCLUSIVE RIGHT TO USE "SOCCER", APART FROM THE MARK AS SHOWN.

FOR SOCCER CAMPS (U.S. CLS. 100, 101 AND 107).

FIRST USE 9-1-2008; IN COMMERCE 9-1-2008.

JOHN GARTNER, EXAMINING ATTORNEY

---

SN 85-208,334. PIXELTOWN ARTS, LLC, MARINA DEL REY, CA. FILED 12-30-2010.

PIXELTOWN

THE MARK CONSISTS OF STANDARD CHARACTERS WITHOUT CLAIM TO ANY PARTICULAR FONT, STYLE, SIZE, OR COLOR.

FOR ENTERTAINMENT SERVICES, NAMELY, PRODUCTION OF SPECIAL EFFECTS INCLUDING MODEL-MAKING SERVICES, COMPUTER-GENERATED IMAGERY AND COMPUTER-GENERATED GRAPHICS FOR THE PRODUCTION OF MOTION PICTURES, VIDEOS, AND MOVIE TRAILERS; MUSIC VIDEO PRODUCTION; POST-PRODUCTION EDITING SERVICES IN THE FIELD OF MUSIC, VIDEOS AND FILM; VIDEO PRODUCTION SERVICES (U.S. CLS. 100, 101 AND 107).

FIRST USE 3-19-2010; IN COMMERCE 9-1-2010.

JENNIFER MARTIN, EXAMINING ATTORNEY

**CLASS 41—(Continued).**

SN 85-208,340. SOCCER AND SMILES LLC, SAN CARLOS, CA. FILED 12-30-2010.



NO CLAIM IS MADE TO THE EXCLUSIVE RIGHT TO USE "SOCCER", APART FROM THE MARK AS SHOWN.

THE COLOR(S) GREEN, BLACK AND WHITE IS/ARE CLAIMED AS A FEATURE OF THE MARK.

THE MARK CONSISTS OF "SOCCER AND SMILES" SEPARATED BY AN AMPERSAND. THERE IS A CURVED DOTTED LINE ABOVE THE WORD "SOCCER" TO INDICATE THE PATH OF A SOCCER BALL. THE SOCCER BALL IS DIRECTLY ABOVE THE LETTER "R" IN "SOCCER". THE WORDS "SOCCER AND SMILES" ARE ACCENTED WITH BLADES OF GRASS. THE WORDING "SOCCER & SMILES" APPEARS IN BLACK. THE SOCCER BALL APPEARS BLACK AND WHITE. THE CURVED DOTTED LINE AND BLADES OF GRASS APPEAR GREEN.

FOR SOCCER CAMPS (U.S. CLS. 100, 101 AND 107).

FIRST USE 9-1-2008; IN COMMERCE 9-1-2008.

JOHN GARTNER, EXAMINING ATTORNEY

---

SN 85-208,432. GOEHNER, JESSIE, WAYNE, NJ. FILED 12-31-2010.

CUTLEAF

THE MARK CONSISTS OF STANDARD CHARACTERS WITHOUT CLAIM TO ANY PARTICULAR FONT, STYLE, SIZE, OR COLOR.

FOR BOOK PUBLISHING (U.S. CLS. 100, 101 AND 107).

IRA J. GOODSaid, EXAMINING ATTORNEY

**CLASS 41—(Continued).**

SN 85-208,438. BRYAN MCCLANAHAN, SAN DIEGO, CA. FILED 12-31-2010.



THE MARK CONSISTS OF A SEMI-CIRCLE THAT ENDS WITH AN ARROW SHAPE THAT POINTS COUNTER-CLOCKWISE, NEXT TO THE WORD "REVELUS".

FOR ENTERTAINMENT SERVICES, NAMELY, CONDUCTING PARTIES; ENTERTAINMENT SERVICES, NAMELY, DANCE EVENTS BY A RECORDING ARTIST; ENTERTAINMENT SERVICES, NAMELY, FIREWORKS DISPLAYS; ENTERTAINMENT, NAMELY, LIGHTING PRODUCTION; ENTERTAINMENT, NAMELY, LIVE MUSIC CONCERTS; ENTERTAINMENT, NAMELY, LIVE PERFORMANCES BY A MUSICAL BAND; ENTERTAINMENT, NAMELY, LIVE PERFORMANCES BY MUSICAL BANDS; ENTERTAINMENT, NAMELY, LIVE PERFORMANCES BY ROCK GROUPS; ENTERTAINMENT, NAMELY, PREPARATION OF SPECIAL EFFECTS; ENTERTAINMENT, NAMELY, PRODUCTION OF LIVE CONCERTS, DISC JOCKEY CONCERTS, MUSICAL AND ARTISTIC PERFORMANCES, NIGHT-CLUBS, DANCE PARTIES, LIGHT SHOWS AND PYROTECHNICS; ORGANIZING AND ARRANGING EXHIBITIONS FOR ENTERTAINMENT PURPOSES; PROVIDING ON-LINE RESOURCE GUIDES FOR RELATIVES CONCERNING CHILDREN IN THE FIELDS OF EDUCATION, RECREATION, AND ENTERTAINMENT; PROVISION OF INFORMATION RELATING TO LIVE ENTERTAINMENT (U.S. CLS. 100, 101 AND 107).

FIRST USE 12-23-2010; IN COMMERCE 12-29-2010.  
FLORENTINA BLANDU, EXAMINING ATTORNEY

SN 85-208,524. ORTIZ JR., JOSE A., GLENSIDE, PA. FILED 12-31-2010.

# MindChamber

THE MARK CONSISTS OF STANDARD CHARACTERS WITHOUT CLAIM TO ANY PARTICULAR FONT, STYLE, SIZE, OR COLOR.

FOR ANIMATION PRODUCTION SERVICES; VIDEO PRODUCTION SERVICES (U.S. CLS. 100, 101 AND 107).  
FIRST USE 0-0-2000; IN COMMERCE 0-0-2000.  
MARK PILARO, EXAMINING ATTORNEY

**CLASS 41—(Continued).**

SN 85-208,623. ARKEO, INC., FORT WORTH, TX. FILED 12-31-2010.

KNOWING GOD CHANGES YOUR  
LIFE

THE MARK CONSISTS OF STANDARD CHARACTERS WITHOUT CLAIM TO ANY PARTICULAR FONT, STYLE, SIZE, OR COLOR.

FOR EDUCATIONAL SERVICES, NAMELY, PROVIDING ONLINE TRAINING IN THE NATURE OF STUDENT SELECTABLE COURSES, LECTURES, TUTORIALS, INDIVIDUAL AND GROUP MENTORING PARTICIPATION, GROUP STUDY AND INTERACTION, TESTING, FEEDBACK AND ADVANCEMENT MONITORING IN THE FIELDS OF RELIGIOUS DISCIPLINE AND LITERATURE STUDY VIA INDIVIDUAL CHURCH WEBSITES OF CHURCHES THAT SUBSCRIBE TO APPLICANT'S SERVICES (U.S. CLS. 100, 101 AND 107).

FIRST USE 8-0-2007; IN COMMERCE 8-0-2007.  
LIEF MARTIN, EXAMINING ATTORNEY

SN 85-208,642. SKILLSOURCE, CINCINNATI, OH. FILED 12-31-2010.



OWNER OF U.S. REG. NO. 2,943,889.  
FOR EDUCATIONAL SERVICES, NAMELY, CONDUCTING CLASSES, SEMINARS, CONFERENCES, WORKSHOPS, RETREATS, CAMPS AND FIELD TRIPS IN THE FIELD OF SPIRITUAL DEVELOPMENT IN THE WORKPLACE AND DISTRIBUTION OF TRAINING MATERIAL IN CONNECTION THEREWITH (U.S. CLS. 100, 101 AND 107).

FIRST USE 5-20-2003; IN COMMERCE 5-20-2003.  
LAURIE KAUFMAN, EXAMINING ATTORNEY

SN 85-208,683. MERITT, GARY J., FLORISSANT, MO. FILED 12-31-2010.

# SCORIES

THE MARK CONSISTS OF STANDARD CHARACTERS WITHOUT CLAIM TO ANY PARTICULAR FONT, STYLE, SIZE, OR COLOR.

FOR ENTERTAINMENT SERVICES IN THE NATURE OF DEVELOPMENT, CREATION, PRODUCTION AND POST-PRODUCTION SERVICES OF MULTIMEDIA ENTERTAINMENT CONTENT (U.S. CLS. 100, 101 AND 107).

FIRST USE 10-21-1996; IN COMMERCE 10-21-1996.  
JILL PRATER, EXAMINING ATTORNEY

**CLASS 41—(Continued).**

SN 85-208,689. SOCIALNEXUS, INC., SPANISH FORK, UT. FILED 12-31-2010.

# FitSocial

THE MARK CONSISTS OF STANDARD CHARACTERS WITHOUT CLAIM TO ANY PARTICULAR FONT, STYLE, SIZE, OR COLOR.

FOR PROVIDING A WEBSITE FEATURING INFORMATION ON EXERCISE AND FITNESS (U.S. CLS. 100, 101 AND 107).

FIRST USE 12-30-2010; IN COMMERCE 12-30-2010.  
WENDY JUN, EXAMINING ATTORNEY

**CLASS 41—(Continued).**

SN 85-208,848. HOFFMAN, ALLISON M., WASHINGTON, DC. FILED 1-2-2011.

# BROWN BAG IT

*for books*

NO CLAIM IS MADE TO THE EXCLUSIVE RIGHT TO USE "BOOKS", APART FROM THE MARK AS SHOWN.

FOR EDUCATIONAL SERVICES, NAMELY, PROVIDING A READING PROGRAM DESIGNED TO MOTIVATE CHILDREN TO READ (U.S. CLS. 100, 101 AND 107).

FIRST USE 3-4-2010; IN COMMERCE 3-4-2010.  
ROBIN MITTLER, EXAMINING ATTORNEY

SN 85-208,714. GNL ENTERTAINMENT, INC., WASHINGTON, DC. FILED 12-31-2010.

# Painted On Water

THE MARK CONSISTS OF STANDARD CHARACTERS WITHOUT CLAIM TO ANY PARTICULAR FONT, STYLE, SIZE, OR COLOR.

FOR ENTERTAINMENT, NAMELY, LIVE PERFORMANCES BY A MUSICAL BAND (U.S. CLS. 100, 101 AND 107).

FIRST USE 10-29-2007; IN COMMERCE 4-16-2008.  
ANDREA HACK, EXAMINING ATTORNEY

SN 85-209,180. INDEPENDENCE TELEVISION CO., INC., LOUISVILLE, KY. FILED 1-3-2011.

# SNOW FOX

THE MARK CONSISTS OF STANDARD CHARACTERS WITHOUT CLAIM TO ANY PARTICULAR FONT, STYLE, SIZE, OR COLOR.

FOR FAN CLUBS (U.S. CLS. 100, 101 AND 107).  
FIRST USE 12-22-2009; IN COMMERCE 12-22-2009.  
JULIE GUTTADAURO, EXAMINING ATTORNEY

SN 85-208,717. BARTO, TERRY J, WEST HOLLYWOOD, CA. FILED 12-31-2010.

# Launch Me!

THE MARK CONSISTS OF STANDARD CHARACTERS WITHOUT CLAIM TO ANY PARTICULAR FONT, STYLE, SIZE, OR COLOR.

FOR PRODUCTION AND DISTRIBUTION OF TELEVISION SHOWS AND MOVIES (U.S. CLS. 100, 101 AND 107).

LINDSEY RUBIN, EXAMINING ATTORNEY

SN 85-209,294. LUCINDA JACOBS, SAN DIEGO, CA. FILED 1-3-2011.

# Powerthon

THE MARK CONSISTS OF STANDARD CHARACTERS WITHOUT CLAIM TO ANY PARTICULAR FONT, STYLE, SIZE, OR COLOR.

FOR ARRANGING AND CONDUCTING ATHLETIC COMPETITIONS (U.S. CLS. 100, 101 AND 107).

JOHN DWYER, EXAMINING ATTORNEY



**CLASS 41—(Continued).**

SN 85-209,316. SOUTHWESTERN/GREAT AMERICAN, INC., DBA THE SOUTHWESTERN COMPANY, NASHVILLE, TN. FILED 1-3-2011.

**SW ADVANTAGE**

THE MARK CONSISTS OF STANDARD CHARACTERS WITHOUT CLAIM TO ANY PARTICULAR FONT, STYLE, SIZE, OR COLOR.

OWNER OF U.S. REG. NOS. 3,343,052, 3,783,148 AND OTHERS.

FOR EDUCATIONAL SERVICES, NAMELY, PROVIDING ON-LINE INTERACTIVE LESSONS, TUTORING, COACHING, HOMEWORK AND STUDY TIME SCHEDULING, QUIZZES, AND QUESTION-AND-ANSWER FORUMS IN THE FIELD OF MATH, SCIENCE, HISTORY, COMPUTERS, TECHNOLOGY, BUSINESS, ECONOMICS, GOVERNMENT, LAW, SOCIOLOGY, POPULAR CULTURE, ENGLISH GRAMMAR, ENGLISH WRITING, FOREIGN LANGUAGES, ART, LITERATURE, CONTINENTS, COUNTRIES, STATES, GEOLOGY, GEOGRAPHY, ASTRONOMY, HEALTH, MEDICINE, ENVIRONMENT, ANIMALS, PLANTS, AND PEOPLE (U.S. CLS. 100, 101 AND 107).  
TRACY CROSS, EXAMINING ATTORNEY

SN 85-209,341. SOUTHWESTERN/GREAT AMERICAN, INC., DBA THE SOUTHWESTERN COMPANY, NASHVILLE, TN. FILED 1-3-2011.

**SOUTHWESTERN ADVANTAGE**

THE MARK CONSISTS OF STANDARD CHARACTERS WITHOUT CLAIM TO ANY PARTICULAR FONT, STYLE, SIZE, OR COLOR.

OWNER OF U.S. REG. NOS. 3,343,052, 3,783,148 AND OTHERS.

FOR EDUCATIONAL SERVICES, NAMELY, PROVIDING ON-LINE INTERACTIVE LESSONS, TUTORING, COACHING, HOMEWORK AND STUDY TIME SCHEDULING, QUIZZES, AND QUESTION-AND-ANSWER FORUMS IN THE FIELD OF MATH, SCIENCE, HISTORY, COMPUTERS, TECHNOLOGY, BUSINESS, ECONOMICS, GOVERNMENT, LAW, SOCIOLOGY, POPULAR CULTURE, ENGLISH GRAMMAR, ENGLISH WRITING, FOREIGN LANGUAGES, ART, LITERATURE, CONTINENTS, COUNTRIES, STATES, GEOLOGY, GEOGRAPHY, ASTRONOMY, HEALTH, MEDICINE, ENVIRONMENT, ANIMALS, PLANTS, AND PEOPLE (U.S. CLS. 100, 101 AND 107).  
TRACY CROSS, EXAMINING ATTORNEY

**CLASS 41—(Continued).**

SN 85-209,474. 1338299 ONTARIO LTD., DBA INTEGRITY MARKETING, ST. CATHERINES ONTARIO, CANADA, FILED 1-3-2011.

**LET'S GET REAL**

THE MARK CONSISTS OF STANDARD CHARACTERS WITHOUT CLAIM TO ANY PARTICULAR FONT, STYLE, SIZE, OR COLOR.

FOR PROVIDING EDUCATIONAL PROGRAMS IN THE FIELD OF DIET, EXERCISE AND WEIGHT MANAGEMENT (U.S. CLS. 100, 101 AND 107).

CHRISTINE COOPER, EXAMINING ATTORNEY

SN 85-209,499. JOHN E. PAGE, MISSION VIEJO, CA. FILED 1-3-2011.

**JOURNEY TO ATTORNEY**

THE MARK CONSISTS OF STANDARD CHARACTERS WITHOUT CLAIM TO ANY PARTICULAR FONT, STYLE, SIZE, OR COLOR.

FOR EDUCATIONAL AND ENTERTAINMENT SERVICES, NAMELY, PROVIDING MOTIVATIONAL SPEAKING SERVICES IN THE FIELD OF CAREER DEVELOPMENT (U.S. CLS. 100, 101 AND 107).

CHRISIE B. KING, EXAMINING ATTORNEY

SN 85-209,571. DWYER, MATTHEW, PALM BAY, FL. FILED 1-3-2011.

**Die Alone**

THE MARK CONSISTS OF STANDARD CHARACTERS WITHOUT CLAIM TO ANY PARTICULAR FONT, STYLE, SIZE, OR COLOR.

FOR ENTERTAINMENT SERVICES IN THE NATURE OF LIVE MUSICAL PERFORMANCES; MULTIMEDIA ENTERTAINMENT SERVICES IN THE NATURE OF RECORDING, PRODUCTION AND POST-PRODUCTION SERVICES IN THE FIELDS OF MUSIC, VIDEO, AND FILMS (U.S. CLS. 100, 101 AND 107).

JAMES GRIFFIN, EXAMINING ATTORNEY

**CLASS 41—(Continued).**

SN 85-209,589. DIP, GUILLERMO, MIDDLE VILLAGE, NY. FILED 1-3-2011.

**themadmixer**

THE MARK CONSISTS OF STANDARD CHARACTERS WITHOUT CLAIM TO ANY PARTICULAR FONT, STYLE, SIZE, OR COLOR.

FOR ENTERTAINMENT, NAMELY, A CONTINUING MUSIC SHOW BROADCAST OVER TELEVISION, SATELLITE, AUDIO, AND VIDEO MEDIA; ENTERTAINMENT, NAMELY, A CONTINUING MUSIC SHOW BROADCAST OVER RADIO, INTERNET (U.S. CLS. 100, 101 AND 107).

FIRST USE 3-3-2007; IN COMMERCE 3-3-2007.  
SHAUNIA CARLYLE, EXAMINING ATTORNEY

SN 85-209,908. THE MCGRAW-HILL COMPANIES, INC., NEW YORK, NY. FILED 1-4-2011.

**PAEASY**

THE MARK CONSISTS OF STANDARD CHARACTERS WITHOUT CLAIM TO ANY PARTICULAR FONT, STYLE, SIZE, OR COLOR.

FOR EDUCATIONAL SERVICES, NAMELY ON-LINE TEST PREPARATION IN THE FIELD OF PHYSICIAN'S ASSISTANT CERTIFICATION AND RE-CERTIFICATION (U.S. CLS. 100, 101 AND 107).

FIRST USE 0-0-2007; IN COMMERCE 0-0-2007.  
SUNG IN, EXAMINING ATTORNEY

SN 85-210,000. THE MCGRAW-HILL COMPANIES, INC., NEW YORK, NY. FILED 1-4-2011.

**RADREVIEWEASY**

THE MARK CONSISTS OF STANDARD CHARACTERS WITHOUT CLAIM TO ANY PARTICULAR FONT, STYLE, SIZE, OR COLOR.

FOR EDUCATIONAL SERVICES, NAMELY ON-LINE TEST PREPARATION IN THE FIELD OF RADIOLOGY (U.S. CLS. 100, 101 AND 107).

FIRST USE 0-0-2007; IN COMMERCE 0-0-2007.  
SUNG IN, EXAMINING ATTORNEY

**CLASS 41—(Continued).**

SN 85-210,002. BUTLER, CODY, SUPERIOR, NE. FILED 1-4-2011.

**DREAM CHASERS**

THE MARK CONSISTS OF STANDARD CHARACTERS WITHOUT CLAIM TO ANY PARTICULAR FONT, STYLE, SIZE, OR COLOR.

FOR ENTERTAINMENT SERVICES, NAMELY, THE PROVISION OF CONTINUING PROGRAMS, SEGMENTS AND SHOWS FEATURING HUNTING DELIVERED BY TELEVISION, RADIO, SATELLITE AND THE INTERNET (U.S. CLS. 100, 101 AND 107).

MAUREEN DALL, EXAMINING ATTORNEY

SN 85-210,015. BEGLER, DAVID, SAN FRANCISCO, CA. FILED 1-4-2011.

**BEYOND WORDS**

THE MARK CONSISTS OF STANDARD CHARACTERS WITHOUT CLAIM TO ANY PARTICULAR FONT, STYLE, SIZE, OR COLOR.

FOR PERSONAL AND PROFESSIONAL COACHING AND CONSULTING SESSIONS WITHIN THE CONTEXT OF GUIDED SILENT HIKES, NAMELY, CONDUCTING GROUP SESSIONS BY A PROFESSIONAL COACH TRAINED IN THE FIELDS OF PERSONAL DEVELOPMENT AND/OR BUSINESS STRATEGY (U.S. CLS. 100, 101 AND 107).

FIRST USE 11-30-2010; IN COMMERCE 11-30-2010.  
HELENE LIWINSKI, EXAMINING ATTORNEY

SN 85-210,113. NYT MANAGEMENT SERVICES, INC., TAMPA, FL. FILED 1-4-2011.

**The Big Picture**

THE MARK CONSISTS OF STANDARD CHARACTERS WITHOUT CLAIM TO ANY PARTICULAR FONT, STYLE, SIZE, OR COLOR.

FOR ON-LINE JOURNALS, NAMELY, BLOGS FEATURING NEWS AND INFORMATION IN THE FIELD OF CURRENT EVENTS SHOWN THROUGH PHOTOGRAPHS AND PHOTOGRAPHIC ESSAYS (U.S. CLS. 100, 101 AND 107).

FIRST USE 5-21-2008; IN COMMERCE 5-21-2008.  
AISHA SALEM, EXAMINING ATTORNEY

**CLASS 41—(Continued).**

SN 85-210,194. RAINFOREST PARTNERSHIP, AUSTIN, TX. FILED 1-4-2011.

**FILMS FOR THE FOREST**

THE MARK CONSISTS OF STANDARD CHARACTERS WITHOUT CLAIM TO ANY PARTICULAR FONT, STYLE, SIZE, OR COLOR.

FOR ENTERTAINMENT SERVICES, NAMELY ORGANIZING AND CONDUCTING A FILM FESTIVAL; PROVIDING A WEBSITE FEATURING NON-DOWNLOADABLE VIDEOS IN THE FIELD OF ENVIRONMENTAL MATTERS, ISSUES AND INITIATIVES; EDUCATIONAL SERVICES, NAMELY PROVIDING PROGRAMS AND CLASSES IN THE FIELD OF ENVIRONMENTAL MATTERS, ISSUES AND INITIATIVES, USING PRERECORDED VIDEOS AND PRINTABLE MATERIALS DISTRIBUTED THEREWITH; ENTERTAINMENT AND EDUCATIONAL SERVICES IN THE NATURE OF A CONTINUING AUDIO-VISUAL PROGRAM IN THE FIELD OF ENVIRONMENTAL MATTERS, ISSUES AND INITIATIVES BROADCAST OVER TELEVISION, SATELLITE, AUDIO, AND VIDEO MEDIA (U.S. CLS. 100, 101 AND 107).

ASMAT KHAN, EXAMINING ATTORNEY

**CLASS 41—(Continued).**

SN 85-210,371. PAN AMERICAN PRODUCTIONS INTERNATIONAL S.A., PANAMA CITY, PANAMA, FILED 1-4-2011.

**View Of The World**

THE MARK CONSISTS OF STANDARD CHARACTERS WITHOUT CLAIM TO ANY PARTICULAR FONT, STYLE, SIZE, OR COLOR.

FOR ENTERTAINMENT IN THE NATURE OF ONGOING TELEVISION PROGRAMS IN THE FIELD OF VACATIONING AND TRAVEL; PRODUCTION OF TELEVISION PROGRAMS; VIDEO PRODUCTION SERVICES (U.S. CLS. 100, 101 AND 107).

FIRST USE 2-2-2010; IN COMMERCE 2-2-2010.

GILBERT SWIFT, EXAMINING ATTORNEY

SN 85-210,469. LIFESPORT FITNESS, SAN JOSE, CA. FILED 1-4-2011.

SN 85-210,346. SAN MATEO COUNTY COMMUNITY COLLEGE DISTRICT, SAN MATEO, CA. FILED 1-4-2011.

**Jazz On The Hill**

THE MARK CONSISTS OF STANDARD CHARACTERS WITHOUT CLAIM TO ANY PARTICULAR FONT, STYLE, SIZE, OR COLOR.

NO CLAIM IS MADE TO THE EXCLUSIVE RIGHT TO USE "JAZZ", APART FROM THE MARK AS SHOWN.

FOR CONDUCTING ENTERTAINMENT EXHIBITIONS IN THE NATURE OF MUSIC FESTIVALS (U.S. CLS. 100, 101 AND 107).

FIRST USE 7-1-1992; IN COMMERCE 7-1-1992.

TRACY CROSS, EXAMINING ATTORNEY



THE MARK CONSISTS OF FOUR CRESCENT SHAPED FORMS, ARRANGED SOMEWHAT CONCENTRICALLY. THERE IS A SMALL CRESCENT IN THE MIDDLE. THERE IS A LARGER CRESCENT BELOW IT TO ITS RIGHT. IN THE UPPER LEFT THERE IS A LARGE CRESCENT, AND BELOW THAT THERE IS A SMALLER CRESCENT.

FOR EDUCATION SERVICES, NAMELY, PROVIDING LECTURES IN THE FIELDS OF HEALTHY LIVING AND PHYSICAL FITNESS; PERSONAL FITNESS TRAINING SERVICES AND CONSULTANCY; PHYSICAL FITNESS INSTRUCTION (U.S. CLS. 100, 101 AND 107).

FIRST USE 6-15-2006; IN COMMERCE 6-15-2006.

TIMOTHY FINNEGAN, EXAMINING ATTORNEY

**CLASS 41—(Continued).**

SN 85-210,525. VALLECILLO, KYLE, ESSEX, MD. FILED 1-4-2011.

# HON

THE MARK CONSISTS OF STANDARD CHARACTERS WITHOUT CLAIM TO ANY PARTICULAR FONT, STYLE, SIZE, OR COLOR.

FOR PROVIDING ADVICE AND INFORMATION TO ADULT FAMILY MEMBERS ON APPROPRIATE ENTERTAINMENT AND LEISURE ACTIVITIES FOR YOUNGER FAMILY MEMBERS; PROVIDING AN INTERNET WEBSITE PORTAL IN THE FIELD OF ENTERTAINMENT, CULTURAL AND SPORTING EVENTS (U.S. CLS. 100, 101 AND 107).

MARLENE BELL, EXAMINING ATTORNEY

**CLASS 41—(Continued).**

SN 85-210,615. CLOUDCO, INC., CLEVELAND, OH. FILED 1-5-2011.

# BGDCMC

THE MARK CONSISTS OF STANDARD CHARACTERS WITHOUT CLAIM TO ANY PARTICULAR FONT, STYLE, SIZE, OR COLOR.

FOR ENTERTAINMENT AND EDUCATIONAL SERVICES IN THE NATURE OF ON-GOING TELEVISION PROGRAMS IN THE FIELD OF CHILDREN'S ENTERTAINMENT; ENTERTAINMENT SERVICES IN THE NATURE OF ANIMATED MOTION PICTURE THEATRICAL FILM PRODUCTION; ENTERTAINMENT SERVICES, NAMELY, PRODUCTION OF ANIMATED CARTOONS ON DVDS AND VIDEO CASSETTES; ENTERTAINMENT SERVICES, NAMELY, PROVIDING INTERACTIVE DATABASE OF COMICS AND ANIMATED CARTOONS VIA GLOBAL COMPUTER NETWORK; ENTERTAINMENT SERVICES PROVIDED VIA GLOBAL COMPUTER NETWORKS AND WIRELESS COMMUNICATION NETWORKS FEATURING ONLINE COMPUTER GAMES, VIDEOS, MUSIC, AND ACTIVITIES IN THE NATURE OF COMEDY, DRAMA, ACTION, ADVENTURE, AND ANIMATION IN THE FIELD OF CHILDREN'S ENTERTAINMENT AND EDUCATION; ENTERTAINMENT, NAMELY, CONDUCTING ONLINE CONTESTS AND FAN CLUB SERVICES; PROVIDING INFORMATION RELATING TO ENTERTAINMENT ONLINE VIA A GLOBAL COMPUTER NETWORK CONTAINING INFORMATION REGARDING COMPUTER GAMES, INTERACTIVE CHILDREN'S ACTIVITIES, AND STORIES FOR CHILDREN AND THEIR PARENTS; PROVIDING ON-LINE NON-DOWNLOADABLE PUBLICATIONS IN THE NATURE OF MAGAZINES AND BOOKS FEATURING ENTERTAINMENT IN THE NATURE OF COMEDY, DRAMA, ACTION, ADVENTURE, AND ANIMATION, STORIES AND GAMES FOR CHILDREN; PROVIDING NON-DOWNLOADABLE ONLINE INTERACTIVE COMPUTER GAMES (U.S. CLS. 100, 101 AND 107).

HEATHER SAPP, EXAMINING ATTORNEY

SN 85-210,605. PARAMOUNT PRODUCTIONS LLC, MIAMI, FL. FILED 1-5-2011.

# 2575

THE MARK CONSISTS OF STANDARD CHARACTERS WITHOUT CLAIM TO ANY PARTICULAR FONT, STYLE, SIZE, OR COLOR.

FOR ENTERTAINMENT SERVICES NAMELY ARRANGING AND CONDUCTING ATHLETIC COMPETITIONS (U.S. CLS. 100, 101 AND 107).

AISHA SALEM, EXAMINING ATTORNEY

**CLASS 41—(Continued).**

SN 85-210,616. CLOUDCO, INC., CLEVELAND, OH. FILED 1-5-2011.

**BOY, GIRL, DOG, CAT,  
MOUSE, CHEESE**

THE MARK CONSISTS OF STANDARD CHARACTERS WITHOUT CLAIM TO ANY PARTICULAR FONT, STYLE, SIZE, OR COLOR.

FOR ENTERTAINMENT AND EDUCATIONAL SERVICES IN THE NATURE OF ON-GOING TELEVISION PROGRAMS IN THE FIELD OF CHILDREN'S ENTERTAINMENT; ENTERTAINMENT SERVICES IN THE NATURE OF ANIMATED MOTION PICTURE THEATRICAL FILM PRODUCTION; ENTERTAINMENT SERVICES, NAMELY, PRODUCTION OF ANIMATED CARTOONS ON DVDS AND VIDEO CASSETTES; ENTERTAINMENT SERVICES, NAMELY, PROVIDING INTERACTIVE DATABASE OF COMICS AND ANIMATED CARTOONS VIA GLOBAL COMPUTER NETWORK; ENTERTAINMENT SERVICES PROVIDED VIA GLOBAL COMPUTER NETWORKS AND WIRELESS COMMUNICATION NETWORKS FEATURING ONLINE COMPUTER GAMES, VIDEOS, MUSIC, AND ACTIVITIES IN THE NATURE OF COMEDY, DRAMA, ACTION, ADVENTURE, AND ANIMATION IN THE FIELD OF CHILDREN'S ENTERTAINMENT AND EDUCATION; ENTERTAINMENT, NAMELY, CONDUCTING ONLINE CONTESTS AND FAN CLUB SERVICES; PROVIDING INFORMATION RELATING TO ENTERTAINMENT ONLINE VIA A GLOBAL COMPUTER NETWORK CONTAINING INFORMATION REGARDING COMPUTER GAMES, INTERACTIVE CHILDREN'S ACTIVITIES, AND STORIES FOR CHILDREN AND THEIR PARENTS; PROVIDING ON-LINE NON-DOWNLOADABLE PUBLICATIONS IN THE NATURE OF MAGAZINES AND BOOKS FEATURING ENTERTAINMENT IN THE NATURE OF COMEDY, DRAMA, ACTION, ADVENTURE, AND ANIMATION, STORIES AND GAMES FOR CHILDREN; PROVIDING NON-DOWNLOADABLE ONLINE INTERACTIVE COMPUTER GAMES (U.S. CLS. 100, 101 AND 107).

HEATHER SAPP, EXAMINING ATTORNEY

SN 85-210,658. QIVANA, LLC, PROVO, UT. FILED 1-5-2011.

**SHAKE YOURSELF SLIM**

THE MARK CONSISTS OF STANDARD CHARACTERS WITHOUT CLAIM TO ANY PARTICULAR FONT, STYLE, SIZE, OR COLOR.

FOR ENTERTAINMENT SERVICES, NAMELY, CONDUCTING CONTESTS (U.S. CLS. 100, 101 AND 107).  
DORITT L. CARROLL, EXAMINING ATTORNEY

**CLASS 41—(Continued).**

SN 85-210,712. DOREY POHRTE, KATHYSUE, WILLIAMSVILLE, NY. FILED 1-5-2011.

**the chain of defense**

THE MARK CONSISTS OF STANDARD CHARACTERS WITHOUT CLAIM TO ANY PARTICULAR FONT, STYLE, SIZE, OR COLOR.

FOR EDUCATIONAL SERVICES, NAMELY, CONDUCTING CLASSES, CONFERENCES, SEMINARS AND WORKSHOPS IN THE FIELD OF KRAV MAGA AND PERSONAL SELF-DEFENSE AND DISTRIBUTION OF COURSE MATERIAL IN CONNECTION THEREWITH; TRAINING SERVICES IN THE FIELD OF KRAV MAGA AND PERSONAL SELF-DEFENSE (U.S. CLS. 100, 101 AND 107).

FIRST USE 12-3-2010; IN COMMERCE 12-3-2010.

JULIE VEPPUMTHARA, EXAMINING ATTORNEY

SN 85-210,818. CLOUDCO, INC., CLEVELAND, OH. FILED 1-5-2011.

**BOY GIRL DOG CAT MOUSE  
CHEESE**

THE MARK CONSISTS OF STANDARD CHARACTERS WITHOUT CLAIM TO ANY PARTICULAR FONT, STYLE, SIZE, OR COLOR.

FOR ENTERTAINMENT AND EDUCATIONAL SERVICES IN THE NATURE OF ON-GOING TELEVISION PROGRAMS IN THE FIELD OF CHILDREN'S ENTERTAINMENT; ENTERTAINMENT SERVICES IN THE NATURE OF ANIMATED MOTION PICTURE THEATRICAL FILM PRODUCTION; ENTERTAINMENT SERVICES, NAMELY, PRODUCTION OF ANIMATED CARTOONS ON DVDS AND VIDEO CASSETTES; ENTERTAINMENT SERVICES, NAMELY, PROVIDING INTERACTIVE DATABASE OF COMICS AND ANIMATED CARTOONS VIA GLOBAL COMPUTER NETWORK; ENTERTAINMENT SERVICES PROVIDED VIA GLOBAL COMPUTER NETWORKS AND WIRELESS COMMUNICATION NETWORKS FEATURING ONLINE COMPUTER GAMES, VIDEOS, MUSIC, AND ACTIVITIES IN THE NATURE OF COMEDY, DRAMA, ACTION, ADVENTURE, AND ANIMATION IN THE FIELD OF CHILDREN'S ENTERTAINMENT AND EDUCATION; ENTERTAINMENT, NAMELY, CONDUCTING ONLINE CONTESTS AND FAN CLUB SERVICES; PROVIDING INFORMATION RELATING TO ENTERTAINMENT ONLINE VIA A GLOBAL COMPUTER NETWORK CONTAINING INFORMATION REGARDING COMPUTER GAMES, INTERACTIVE CHILDREN'S ACTIVITIES, AND STORIES FOR CHILDREN AND THEIR PARENTS; PROVIDING ON-LINE NON-DOWNLOADABLE PUBLICATIONS IN THE NATURE OF MAGAZINES AND BOOKS FEATURING ENTERTAINMENT IN THE NATURE OF COMEDY, DRAMA, ACTION, ADVENTURE, AND ANIMATION, STORIES AND GAMES FOR CHILDREN; PROVIDING NON-DOWNLOADABLE ONLINE INTERACTIVE COMPUTER GAMES (U.S. CLS. 100, 101 AND 107).

HEATHER SAPP, EXAMINING ATTORNEY

**CLASS 41—(Continued).**

SN 85-210,978. THE MCGRAW-HILL COMPANIES, INC., NEW YORK, NY. FILED 1-5-2011.



THE MARK CONSISTS OF THE UPPERCASE LETTERS "P", "A", AND "E" FOLLOWED BY THE LOWERCASE LETTERS "A", "S", AND "Y" IN CURSIVE STYLE. FOR EDUCATIONAL SERVICES, NAMELY ON-LINE TEST PREPARATION IN THE FIELD OF PHYSICIAN'S ASSISTANT CERTIFICATION AND RE-CERTIFICATION (U.S. CLS. 100, 101 AND 107). FIRST USE 0-0-2007; IN COMMERCE 0-0-2007. SUNG IN, EXAMINING ATTORNEY

**CLASS 41—(Continued).**

SN 85-211,122. CARTER, SHAWN, NEW YORK, NY. FILED 1-5-2011.



THE MARK CONSISTS OF TWO BLACK HANDS FACING OUTWARD WITH THE THUMBS AND INDEX FINGERS TOUCHING. FOR ENTERTAINMENT SERVICES IN THE NATURE OF RECORDING, PRODUCTION AND POST PRODUCTION SERVICES IN THE FIELDS OF MUSIC, VIDEO, TELEVISION AND MOTION PICTURES (U.S. CLS. 100, 101 AND 107). MATTHEW EINSTEIN, EXAMINING ATTORNEY

SN 85-211,166. CARTER, SHAWN, NEW YORK, NY. FILED 1-5-2011.

SN 85-210,991. RESEARCH PUBLISHERS LLC, MADISON, WI. FILED 1-5-2011.

THE VIRTUAL TOUT



THE MARK CONSISTS OF STANDARD CHARACTERS WITHOUT CLAIM TO ANY PARTICULAR FONT, STYLE, SIZE, OR COLOR. FOR PROVIDING ON-LINE INFORMATION IN THE FIELD OF SPORTS VIA THE INTERNET (U.S. CLS. 100, 101 AND 107). FIRST USE 1-5-2011; IN COMMERCE 1-5-2011. JACQUELINE A. LAVINE, EXAMINING ATTORNEY

THE MARK CONSISTS OF TWO HANDS FACING OUTWARD WITH THE THUMBS AND INDEX FINGERS TOUCHING. FOR ENTERTAINMENT SERVICES IN THE NATURE OF RECORDING, PRODUCTION AND POST PRODUCTION SERVICES IN THE FIELDS OF MUSIC, VIDEO, TELEVISION AND MOTION PICTURES (U.S. CLS. 100, 101 AND 107). MATTHEW EINSTEIN, EXAMINING ATTORNEY

**CLASS 41—(Continued).**

SN 85-211,175. UNIVERSITY CITY PHYSICAL THERAPY, INC., DBA FUNCTIONSMART, SAN DIEGO, CA. FILED 1-5-2011.

# StrapFit

THE MARK CONSISTS OF STANDARD CHARACTERS WITHOUT CLAIM TO ANY PARTICULAR FONT, STYLE, SIZE, OR COLOR.

FOR PHYSICAL FITNESS CONDITIONING CLASSES (U.S. CLS. 100, 101 AND 107).

FIRST USE 1-5-2011; IN COMMERCE 1-5-2011.  
NELSON SNYDER, EXAMINING ATTORNEY

**CLASS 41—(Continued).**

SN 85-211,327. INSIGHTSNOW, INC., CORVALLIS, OR. FILED 1-5-2011.

# WEBINARSNOW

THE MARK CONSISTS OF STANDARD CHARACTERS WITHOUT CLAIM TO ANY PARTICULAR FONT, STYLE, SIZE, OR COLOR.

FOR PROVIDING CLASSES, SEMINARS, WORKSHOPS, AND TRAINING ON MARKET RESEARCH; EDUCATION SERVICES, NAMELY, PROVIDING LIVE AND ON-LINE CLASSES AND SEMINARS IN THE FIELD OF SALES AND DISTRIBUTION OF COURSE AND EDUCATIONAL MATERIALS IN CONNECTION THEREWITH (U.S. CLS. 100, 101 AND 107).

FIRST USE 8-0-2010; IN COMMERCE 8-0-2010.  
LINDA M. KING, EXAMINING ATTORNEY

SN 85-211,293. PLAYBOY ENTERPRISES INTERNATIONAL, INC., CHICAGO, IL. FILED 1-5-2011.

# MISS SOCIAL

OWNER OF U.S. REG. NOS. 2,709,639, 3,112,931 AND OTHERS.

THE MARK CONSISTS OF "MISS SOCIAL" WITH A RABBIT HEAD INSIDE A SPEECH BALLOON IN PLACE OF THE LETTER "O".

FOR ENTERTAINMENT SERVICES, NAMELY, A MODEL SEARCH CONTEST; ONLINE JOURNALS, NAMELY, BLOGS FEATURING MODEL SEARCH CONTEST WINNERS (U.S. CLS. 100, 101 AND 107).

FIRST USE 10-1-2010; IN COMMERCE 10-1-2010.  
AISHA SALEM, EXAMINING ATTORNEY

SN 85-211,640. ARKIDTECTS, INC., COMMACK, NY. FILED 1-6-2011.

# ARKIDTECTS

THE MARK CONSISTS OF STANDARD CHARACTERS WITHOUT CLAIM TO ANY PARTICULAR FONT, STYLE, SIZE, OR COLOR.

FOR PROVIDING AFTER SCHOOL EDUCATIONAL PROGRAMS IN THE FIELD OF ENGINEERING AND PLAY FACILITIES FOR CHILDREN; PROVIDING CHILDREN'S PARTY CENTERS FOR THE PURPOSE OF ENTERTAINING CHILDREN AND CELEBRATING BIRTHDAYS; RECREATIONAL CAMPS (U.S. CLS. 100, 101 AND 107).

ARETHA SOMERVILLE, EXAMINING ATTORNEY

SN 85-211,306. SWEENEY, KATHLEEN, INDIANAPOLIS, IN. FILED 1-5-2011.

# BeatTheBully

THE MARK CONSISTS OF STANDARD CHARACTERS WITHOUT CLAIM TO ANY PARTICULAR FONT, STYLE, SIZE, OR COLOR.

FOR PERSONAL COACHING SERVICES IN THE FIELD OF EMPLOYMENT AND EDUCATION (U.S. CLS. 100, 101 AND 107).

KATHERINE STOIDES, EXAMINING ATTORNEY

SN 85-211,688. MORRIS, ROBERT, NEWTOWN, PA. FILED 1-6-2011.

# Intervention Point

THE MARK CONSISTS OF STANDARD CHARACTERS WITHOUT CLAIM TO ANY PARTICULAR FONT, STYLE, SIZE, OR COLOR.

FOR PROVIDING ON-LINE PUBLICATIONS IN THE NATURE OF BOOKS, JOURNALS, MAGAZINES IN THE FIELD OF HEALTHCARE, EDUCATION AND FINANCE (U.S. CLS. 100, 101 AND 107).

REGINA DRUMMOND, EXAMINING ATTORNEY

**CLASS 41—(Continued).**

SN 85-211,698. ARKIDTECTS, INC., COMMACK, NY. FILED 1-6-2011.



THE COLOR(S) YELLOW, RED, BLACK, BLUE AND WHITE IS/ARE CLAIMED AS A FEATURE OF THE MARK.

THE MARK CONSISTS OF A YELLOW MALE FIGURE WEARING A RED SHIRT, BLACK PANTS, AND A BLUE AND WHITE HARD HAT STANDING NEXT TO THE WORD "ARKIDTECTS" WHEREIN THE LETTERS "AR" ARE BLACK, THE LETTERS "KID" ARE RED AND THE LETTERS "TECTS" ARE BLACK.

FOR PROVIDING AFTER SCHOOL EDUCATIONAL PROGRAMS IN THE FIELD OF ENGINEERING AND PLAY FACILITIES FOR CHILDREN; PROVIDING CHILDREN'S PARTY CENTERS FOR THE PURPOSE OF ENTERTAINING CHILDREN AND CELEBRATING BIRTHDAYS; RECREATIONAL CAMPS (U.S. CLS. 100, 101 AND 107).

ARETHA SOMERVILLE, EXAMINING ATTORNEY

SN 85-211,857. CITY OF MIRAMAR, MIRAMAR, FL. FILED 1-6-2011.

## Where community and culture converge.

THE MARK CONSISTS OF THE SENTENCE FRAGMENT "WHERE COMMUNITY AND CULTURE CONVERGE." THE "W" IN THE FIRST WORD IS CAPITALIZED.

FOR ORGANIZING COMMUNITY FESTIVALS AND EVENTS FEATURING A VARIETY OF ACTIVITIES, NAMELY, SPORTING EVENTS, ART EXHIBITIONS, FLEA MARKETS, ETHNIC DANCES, AND THE LIKE, AS WELL AS EDUCATIONAL SERVICES, NAMELY, PROVIDING LIFELONG LEARNING WORKSHOPS AND CLASSES IN THE FIELD OF FINE ARTS (U.S. CLS. 100, 101 AND 107).

FIRST USE 7-2-2007; IN COMMERCE 7-2-2007.

MARTHA SANTOMARTINO, EXAMINING ATTORNEY

SN 85-211,871. LIBERTY COUNSEL, INC., ORLANDO, FL. FILED 1-6-2011.

## Awakening

THE MARK CONSISTS OF STANDARD CHARACTERS WITHOUT CLAIM TO ANY PARTICULAR FONT, STYLE, SIZE, OR COLOR.

FOR EDUCATIONAL SERVICES, NAMELY, CONDUCTING CONFERENCES IN THE FIELD OF PUBLIC POLICY AND DISTRIBUTING COURSE MATERIALS IN CONNECTION THEREWITH (U.S. CLS. 100, 101 AND 107).

FIRST USE 8-26-2009; IN COMMERCE 1-15-2010.

DAVID TAYLOR, EXAMINING ATTORNEY

**CLASS 41—(Continued).**

SN 85-212,071. SISKIN, DAVID, KENTFIELD, CA. FILED 1-6-2011.

## Save My A

THE MARK CONSISTS OF STANDARD CHARACTERS WITHOUT CLAIM TO ANY PARTICULAR FONT, STYLE, SIZE, OR COLOR.

FOR EDUCATIONAL SERVICES, NAMELY, CONDUCTING DISTANCE LEARNING INSTRUCTION AT THE PRIMARY AND SECONDARY LEVELS; EDUCATIONAL SERVICES, NAMELY, CONDUCTING DISTANCE LEARNING INSTRUCTION AT THE SECONDARY, COLLEGE AND GRADUATE LEVELS; EDUCATIONAL SERVICES, NAMELY, CONDUCTING DISTANCE LEARNING INSTRUCTION AT THE UNIVERSITY LEVEL; PROVISION OF INFORMATION RELATING TO EDUCATIONAL SERVICES (U.S. CLS. 100, 101 AND 107).

JENNIFER MARTIN, EXAMINING ATTORNEY

SN 85-212,376. MARCUS A. PIERRE, BROOKLYN, NY. FILED 1-6-2011.

## FameUS

THE MARK CONSISTS OF STANDARD CHARACTERS WITHOUT CLAIM TO ANY PARTICULAR FONT, STYLE, SIZE, OR COLOR.

FOR ENTERTAINMENT SERVICES, NAMELY, NON-DOWNLOADABLE RINGTONES, PRE-RECORDED MUSIC, AND GRAPHICS PRESENTED TO MOBILE COMMUNICATIONS DEVICES VIA A GLOBAL COMPUTER NETWORK AND WIRELESS NETWORKS (U.S. CLS. 100, 101 AND 107).

DAVID HOFFMAN, EXAMINING ATTORNEY

SN 85-212,408. FIVE NINJAS MARTIAL ARTS, DBA KNOCKOUT BODIES, MINNEAPOLIS, MN. FILED 1-6-2011.

## Knockout Bodies

THE MARK CONSISTS OF STANDARD CHARACTERS WITHOUT CLAIM TO ANY PARTICULAR FONT, STYLE, SIZE, OR COLOR.

FOR PERSONAL FITNESS TRAINING SERVICES AND CONSULTANCY; PHYSICAL FITNESS CONDITIONING CLASSES (U.S. CLS. 100, 101 AND 107).

FIRST USE 8-15-2010; IN COMMERCE 11-15-2010.

DAWN FELDMAN, EXAMINING ATTORNEY



**CLASS 41—(Continued).**

SN 85-212,454. SUNDAY DRIVE MINISTRY, MEANS, KY. FILED 1-7-2011.

# ISAIAH'S CRY

THE MARK CONSISTS OF STANDARD CHARACTERS WITHOUT CLAIM TO ANY PARTICULAR FONT, STYLE, SIZE, OR COLOR.

FOR ENTERTAINMENT SERVICES, NAMELY, LIVE PERFORMANCES BY A MUSICAL BAND (U.S. CLS. 100, 101 AND 107).

HEATHER SAPP, EXAMINING ATTORNEY



SN 85-212,480. TV ONE, LLC, SILVER SPRING, MD. FILED 1-7-2011.

# UN Sung

THE MARK CONSISTS OF STANDARD CHARACTERS WITHOUT CLAIM TO ANY PARTICULAR FONT, STYLE, SIZE, OR COLOR.

FOR ENTERTAINMENT SERVICE IN THE NATURE OF ONGOING TELEVISION PROGRAMS IN THE FIELD OF BLACK MUSIC ARTIST BIOGRAPHIES (U.S. CLS. 100, 101 AND 107).

FIRST USE 10-15-2008; IN COMMERCE 11-27-2008.  
REBECCA POVARCHUK, EXAMINING ATTORNEY



SN 85-212,514. OFF PROPERTY PRODUCTIONS, LLC, SALT LAKE CITY, UT. FILED 1-7-2011.

# THE LEFT FIELD

THE MARK CONSISTS OF STANDARD CHARACTERS WITHOUT CLAIM TO ANY PARTICULAR FONT, STYLE, SIZE, OR COLOR.

FOR ENTERTAINMENT SERVICES, NAMELY, LIVE COMEDY SHOWS (U.S. CLS. 100, 101 AND 107).

FIRST USE 12-4-2010; IN COMMERCE 12-4-2010.  
WILLIAM P. SHANAHAN, EXAMINING ATTORNEY

**CLASS 41—(Continued).**

SN 85-212,529. RAWLINS, NANETTE T, HAMILTON, OH. FILED 1-7-2011.

# EQUIMAGE

THE MARK CONSISTS OF STANDARD CHARACTERS WITHOUT CLAIM TO ANY PARTICULAR FONT, STYLE, SIZE, OR COLOR.

FOR PHOTOGRAPHY SERVICES (U.S. CLS. 100, 101 AND 107).

FIRST USE 8-1-1994; IN COMMERCE 8-25-1994.  
HEATHER SAPP, EXAMINING ATTORNEY



SN 85-212,836. KIDGINEER, LLC, LAUREL, MD. FILED 1-7-2011.

I am a KidGINEER. When I grow up, I'll be an Engineer!

THE MARK CONSISTS OF STANDARD CHARACTERS WITHOUT CLAIM TO ANY PARTICULAR FONT, STYLE, SIZE, OR COLOR.

OWNER OF U.S. REG. NO. 3,826,399.

FOR EDUCATION SERVICES, NAMELY, MENTORING IN THE FIELD OF MATH, SCIENCE, ENGINEERING AND TECHNOLOGY; EDUCATION SERVICES, NAMELY, ONE-ON-ONE MENTORING IN THE FIELDS OF MATH, SCIENCE, ENGINEERING AND TECHNOLOGY; EDUCATION SERVICES, NAMELY, PROVIDING MENTORING, TUTORING, CLASSES, SEMINARS AND WORKSHOPS IN THE FIELD OF MATH, SCIENCE, ENGINEERING AND TECHNOLOGY; EDUCATION SERVICES, NAMELY, PROVIDING TUTORIAL SESSIONS IN THE FIELDS OF MATH, SCIENCE, ENGINEERING AND TECHNOLOGY; EDUCATIONAL AND ENTERTAINMENT SERVICES, NAMELY, PROVIDING MOTIVATIONAL AND EDUCATIONAL SPEAKERS; PROVIDING SCIENCE EDUCATIONAL MENTORING SERVICES AND PROGRAMS (U.S. CLS. 100, 101 AND 107).

LAURIE KAUFMAN, EXAMINING ATTORNEY

**CLASS 41—(Continued).**

SN 85-212,851. KIDGINEER, LLC, LAUREL, MD. FILED 1-7-2011.

## Inspiring Future Scientists & Engineers One Kid at a Time!

THE MARK CONSISTS OF STANDARD CHARACTERS WITHOUT CLAIM TO ANY PARTICULAR FONT, STYLE, SIZE, OR COLOR.

FOR ACADEMIC ENRICHMENT PROGRAMS IN THE FIELD(S) OF MATH, SCIENCE, ENGINEERING AND TECHNOLOGY; EDUCATION SERVICES, NAMELY, MENTORING IN THE FIELD OF MATH, SCIENCE, ENGINEERING AND TECHNOLOGY; EDUCATION SERVICES, NAMELY, ONE-ON-ONE MENTORING IN THE FIELDS OF MATH, SCIENCE, ENGINEERING AND TECHNOLOGY; EDUCATION SERVICES, NAMELY, PROVIDING MENTORING, TUTORING, CLASSES, SEMINARS AND WORKSHOPS IN THE FIELD OF MATH, SCIENCE, ENGINEERING AND TECHNOLOGY; EDUCATION SERVICES, NAMELY, PROVIDING TUTORIAL SESSIONS IN THE FIELDS OF MATH, SCIENCE, ENGINEERING AND TECHNOLOGY; EDUCATIONAL AND ENTERTAINMENT SERVICES, NAMELY, PROVIDING MOTIVATIONAL AND EDUCATIONAL SPEAKERS; PROVIDING SCIENCE EDUCATIONAL MENTORING SERVICES AND PROGRAMS (U.S. CLS. 100, 101 AND 107).

LAURIE KAUFMAN, EXAMINING ATTORNEY

SN 85-212,859. REEL ILLUSIONS, CHICAGO, IL. FILED 1-7-2011.

## Reel-ILLusions 42

THE MARK CONSISTS OF STANDARD CHARACTERS WITHOUT CLAIM TO ANY PARTICULAR FONT, STYLE, SIZE, OR COLOR.

FOR PHOTOGRAPHY; VIDEO PRODUCTION SERVICES (U.S. CLS. 100, 101 AND 107).

WILLIAM P. SHANAHAN, EXAMINING ATTORNEY

SN 85-212,877. ROTTGER, GARY, HALLANDALE, FL. FILED 1-7-2011.

## ZAVU

THE MARK CONSISTS OF STANDARD CHARACTERS WITHOUT CLAIM TO ANY PARTICULAR FONT, STYLE, SIZE, OR COLOR.

FOR ENTERTAINMENT IN THE NATURE OF VISUAL AND AUDIO PERFORMANCES, NAMELY, MUSICAL BAND, ROCK GROUP, GYMNASTIC, DANCE, AND BALLET PERFORMANCES (U.S. CLS. 100, 101 AND 107).

KEVIN DINALLO, EXAMINING ATTORNEY

**CLASS 41—(Continued).**

SN 85-212,878. SCHOLASTIC INC., NEW YORK, NY. FILED 1-7-2011.

## TRUEFLIX

THE MARK CONSISTS OF STANDARD CHARACTERS WITHOUT CLAIM TO ANY PARTICULAR FONT, STYLE, SIZE, OR COLOR.

OWNER OF U.S. REG. NOS. 3,399,135 AND 3,479,195.  
FOR EDUCATIONAL SERVICES, NAMELY, PROVIDING AN ONLINE READING PROGRAM FOR CHILDREN WHICH INCORPORATES THE USE OF INTERACTIVE NON-FICTION VIDEO STORYBOOKS WITH RELATED NON-FICTION PRINT CONTENT AND DISTRIBUTION OF THE NON-FICTION PRINT CONTENT IN CONNECTION THEREWITH (U.S. CLS. 100, 101 AND 107).

FIRST USE 1-7-2011; IN COMMERCE 1-7-2011.

TRACY CROSS, EXAMINING ATTORNEY

SN 85-212,894. PROSPX, INC., AUSTIN, TX. FILED 1-7-2011.

## InsiderConnect

THE MARK CONSISTS OF STANDARD CHARACTERS WITHOUT CLAIM TO ANY PARTICULAR FONT, STYLE, SIZE, OR COLOR.

FOR PROVIDING CUSTOMIZED NEWSLETTERS IN THE FIELD OF THE COMMERCIAL INSURANCE INDUSTRY VIA E-MAIL (U.S. CLS. 100, 101 AND 107).

FIRST USE 11-30-2010; IN COMMERCE 11-30-2010.

HEATHER BIDDULPH, EXAMINING ATTORNEY

SN 85-213,048. GRHK IP, LLC, MIAMI, FL. FILED 1-7-2011.

## Sausage Party

THE MARK CONSISTS OF STANDARD CHARACTERS WITHOUT CLAIM TO ANY PARTICULAR FONT, STYLE, SIZE, OR COLOR.

FOR ENTERTAINMENT SERVICES, NAMELY, PROVIDING A WEB SITE FEATURING PHOTOGRAPHIC, AUDIO, VIDEO AND PROSE PRESENTATIONS FEATURING ADULT-ORIENTED SUBJECT MATTER (U.S. CLS. 100, 101 AND 107).

FIRST USE 11-30-2010; IN COMMERCE 1-4-2011.

BRENDAN MCCAULEY, EXAMINING ATTORNEY

**CLASS 41—(Continued).**

SN 85-213,086. ECHELON RESORTS CORPORATION, LAS VEGAS, NV. FILED 1-7-2011.

EXPLORE. EMBRACE. ELEVATE.

THE MARK CONSISTS OF STANDARD CHARACTERS WITHOUT CLAIM TO ANY PARTICULAR FONT, STYLE, SIZE, OR COLOR.

FOR CASINOS; ENTERTAINMENT IN THE NATURE OF LIVE MUSIC, SINGING, DANCING, ACTORS, ACROBATS, LIVE BANDS, BOXING MATCHES, MAGICIANS, COMEDIANS, CONCERTS, PANTOMIMES, BOXING MATCHES AND MIXED MARTIAL ARTS; ENTERTAINMENT SERVICES, NAMELY, CASINO GAMING; PROVIDING CASINO FACILITIES; PROVIDING FACILITIES FOR EDUCATIONAL CONVENTIONS (U.S. CLS. 100, 101 AND 107).  
AMY HELLA, EXAMINING ATTORNEY

SN 85-213,114. GRHK IP, LLC, MIAMI, FL. FILED 1-7-2011.



THE COLOR(S) RED, YELLOW, BLACK, AND GRAY IS/ ARE CLAIMED AS A FEATURE OF THE MARK.

THE MARK CONSISTS OF THE WORD "SAUSAGE" WRITTEN IN A STYLIZED FONT AND WITH ITS LETTERS SURROUNDED BY A BLACK BORDER AND A GRAY SHADOW. THE INTERIOR OF EACH LETTER OF THE WORD "SAUSAGE" IS SHADED IN RED WITH A YELLOW EDGE. TO THE RIGHT OF THE WORD "SAUSAGE," THE WORD "PARTY" APPEARS, ALSO WRITTEN IN A STYLIZED FONT AND SURROUNDED BY A BLACK BORDER AND A GRAY SHADOW. THE INTERIOR OF EACH LETTER OF THE WORD "PARTY" IS SHADED IN YELLOW WITH A RED EDGE.

FOR ENTERTAINMENT SERVICES, NAMELY, PROVIDING A WEB SITE FEATURING PHOTOGRAPHIC, AUDIO, VIDEO AND PROSE PRESENTATIONS FEATURING ADULT-ORIENTED SUBJECT MATTER (U.S. CLS. 100, 101 AND 107).

FIRST USE 1-4-2011; IN COMMERCE 1-4-2011.

BRENDAN MCCAULEY, EXAMINING ATTORNEY

**CLASS 41—(Continued).**

SN 85-213,240. ECHELON RESORTS CORPORATION, LAS VEGAS, NV. FILED 1-7-2011.

## TAKE ME HIGHER

THE MARK CONSISTS OF STANDARD CHARACTERS WITHOUT CLAIM TO ANY PARTICULAR FONT, STYLE, SIZE, OR COLOR.

FOR CASINOS; CONDUCTING AND PROVIDING FACILITIES FOR SPECIAL EVENTS FEATURING CASINO AND GAMING CONTESTS AND TOURNAMENTS; EDUCATIONAL AND ENTERTAINMENT SERVICES, NAMELY, PROVIDING MOTIVATIONAL AND EDUCATIONAL SPEAKERS; ENTERTAINMENT IN THE NATURE OF LIVE MUSIC, SINGING, DANCING, ACTORS, ACROBATS, LIVE BANDS, BOXING MATCHES, MAGICIANS, COMEDIANS, CONCERTS, PANTOMIMES, AND MIXED MARTIAL ARTS (U.S. CLS. 100, 101 AND 107).  
AMY HELLA, EXAMINING ATTORNEY

SN 85-213,307. PARTY DEGREE, GAINESVILLE, FL. FILED 1-7-2011.

## Lazer Day

THE MARK CONSISTS OF STANDARD CHARACTERS WITHOUT CLAIM TO ANY PARTICULAR FONT, STYLE, SIZE, OR COLOR.

FOR ARRANGING AND CONDUCTING SOCIAL EVENTS INCORPORATING MUSIC, DANCE, AND ENTERTAINMENT (U.S. CLS. 100, 101 AND 107).  
JENNIFER MARTIN, EXAMINING ATTORNEY

SN 85-213,570. INNER BONDING HEALING TECHNOLOGIES, INC., LOS ANGELES, CA. FILED 1-9-2011.

## SELFQUEST

THE MARK CONSISTS OF STANDARD CHARACTERS WITHOUT CLAIM TO ANY PARTICULAR FONT, STYLE, SIZE, OR COLOR.

OWNER OF U.S. REG. NO. 3,018,410.  
FOR CONDUCTING WORKSHOPS AND SEMINARS IN SELF AWARENESS (U.S. CLS. 100, 101 AND 107).  
BRENDAN MCCAULEY, EXAMINING ATTORNEY

**CLASS 41—(Continued).**

SN 85-213,578. MIND THE GAP LLC, MCKINNEY, TX.  
FILED 1-9-2011.

# T-Coaching

THE MARK CONSISTS OF STANDARD CHARACTERS WITHOUT CLAIM TO ANY PARTICULAR FONT, STYLE, SIZE, OR COLOR.

FOR PROFESSIONAL COACHING SERVICES IN THE FIELD OF MANAGEMENT AND LEADERSHIP DEVELOPMENT; PROVIDING GROUP COACHING AND LEARNING FORUMS IN THE FIELD OF LEADERSHIP DEVELOPMENT (U.S. CLS. 100, 101 AND 107).

FIRST USE 5-15-2008; IN COMMERCE 8-8-2008.

RUDY R. SINGLETON, EXAMINING ATTORNEY

SN 85-213,718. UNITED STATES FOUNDATION FOR INSPIRATION AND RECOGNITION OF SCIENCE AND TECHNOLOGY, AKA US FIRST, MANCHESTER, NH.  
FILED 1-10-2011.

# LOGO MOTION

THE MARK CONSISTS OF STANDARD CHARACTERS WITHOUT CLAIM TO ANY PARTICULAR FONT, STYLE, SIZE, OR COLOR.

NO CLAIM IS MADE TO THE EXCLUSIVE RIGHT TO USE "LOGO", APART FROM THE MARK AS SHOWN.

FOR EDUCATION SERVICES, NAMELY, PROVIDING EDUCATIONAL PROGRAMS AND COMPETITIONS IN THE FIELDS OF SCIENCE, TECHNOLOGY, ENGINEERING, AND MATHEMATICS (U.S. CLS. 100, 101 AND 107).

FIRST USE 1-8-2011; IN COMMERCE 1-8-2011.

COURTNEY ALVAREZ, EXAMINING ATTORNEY

SN 85-214,175. ZUMASYS, INC., IRVINE, CA. FILED 1-10-2011.



THE MARK CONSISTS OF THE WORD "ZUMAPALOOZA" IN A STYLIZED FORM, WITH THE TWO "O'S" IN THE WORD PLACED ONE ON TOP OF THE OTHER.

FOR EDUCATION SERVICES, NAMELY, PROVIDING SEMINARS IN THE FIELD OF COMPUTERS, COMPUTER SOFTWARE, AND INFORMATION TECHNOLOGY (U.S. CLS. 100, 101 AND 107).

FIRST USE 1-1-2006; IN COMMERCE 1-1-2006.

JACQUELINE A. LAVINE, EXAMINING ATTORNEY

**CLASS 41—(Continued).**

SN 85-214,291. CURRIER, NOAH, POPLAR GROVE, IL.  
FILED 1-10-2011.



THE MARK CONSISTS OF THE STYLIZED TEXT "HOT" WITH A FLAME IN PLACE OF THE LETTER "O". INSIDE THE LETTER "O" THERE IS THE STYLIZED TEXT "HOUSE OF TUNES".

FOR NIGHTCLUB SERVICES WITH LIVE MUSIC AND ENTERTAINMENT (U.S. CLS. 100, 101 AND 107).

JACQUELINE A. LAVINE, EXAMINING ATTORNEY

SN 85-214,450. RACHEL ARAM, DBA CARDIO-TONE, SAN FRANCISCO, CA. FILED 1-10-2011.

# cardio-tone

THE MARK CONSISTS OF STANDARD CHARACTERS WITHOUT CLAIM TO ANY PARTICULAR FONT, STYLE, SIZE, OR COLOR.

FOR EDUCATION SERVICES, NAMELY, PROVIDING CLASSES, SEMINARS, WORKSHOPS AND ONE-ON-ONE TRAINING IN THE FIELD OF FITNESS, DANCE, ART AND MUSIC (U.S. CLS. 100, 101 AND 107).

FIRST USE 1-0-2010; IN COMMERCE 1-0-2010.

MAYUR VAGHANI, EXAMINING ATTORNEY

SN 85-214,480. CURIODYSSEY, SAN MATEO, CA. FILED 1-10-2011.

# CURIODYSSEY

THE MARK CONSISTS OF STANDARD CHARACTERS WITHOUT CLAIM TO ANY PARTICULAR FONT, STYLE, SIZE, OR COLOR.

FOR EDUCATIONAL AND ENTERTAINMENT SERVICES IN THE NATURE OF MUSEUM SERVICES AND SCIENCE EXHIBITS ON THE SUBJECTS OF PLANTS, ANIMALS, AND THE ENVIRONMENT; FACILITY RENTAL SERVICES FOR ENTERTAINMENT PURPOSES, NAMELY, COMPANY PICNICS, FAMILY AND GROUP GATHERINGS, PRIVATE PARTIES, WEDDING RECEPTIONS, DANCES, AND CORPORATE EVENTS AND MEETINGS (U.S. CLS. 100, 101 AND 107).

WILLIAM BRECKENFELD, EXAMINING ATTORNEY

**CLASS 41—(Continued).**

SN 85-216,193. A&E TELEVISION NETWORKS, LLC, NEW YORK, NY. FILED 1-12-2011.

**AMERICAN HARDHAT**

THE MARK CONSISTS OF STANDARD CHARACTERS WITHOUT CLAIM TO ANY PARTICULAR FONT, STYLE, SIZE, OR COLOR.

NO CLAIM IS MADE TO THE EXCLUSIVE RIGHT TO USE "AMERICAN", APART FROM THE MARK AS SHOWN.

FOR ENTERTAINMENT SERVICES IN THE NATURE OF AN ONGOING, REALITY-BASED TELEVISION SERIES IN WHICH PARTICIPANTS COMPETE AGAINST ONE ANOTHER USING INDUSTRIAL MACHINERY AND EQUIPMENT, ENGINEERING, TECHNOLOGY, AND INGENUITY; ENTERTAINMENT SERVICES IN THE NATURE OF AN ONGOING, REALITY-BASED COMPETITION MULTIMEDIA PROGRAM SERIES IN WHICH PARTICIPANTS COMPETE AGAINST ONE ANOTHER USING INDUSTRIAL MACHINERY AND EQUIPMENT, ENGINEERING, TECHNOLOGY, AND HUMAN INGENUITY DISTRIBUTED VIA VARIOUS PLATFORMS ACROSS MULTIPLE FORMS OF TRANSMISSION MEDIA; ENTERTAINMENT SERVICES, NAMELY, PROVIDING INFORMATION VIA THE INTERNET ON HOW TO USE INDUSTRIAL MACHINERY AND EQUIPMENT, SUCH INFORMATION FOR ENTERTAINMENT PURPOSES ONLY (U.S. CLS. 100, 101 AND 107).

KAPIL BHANOT, EXAMINING ATTORNEY

**CLASS 41—(Continued).**

SN 85-220,482. FREMANTLE MEDIA NORTH AMERICA, INC., BURBANK, CA. AND SOCIAL GAME UNIVERSE, INC., TORONTO, CANADA, FILED 1-18-2011.

**GROW OPS**

THE MARK CONSISTS OF STANDARD CHARACTERS WITHOUT CLAIM TO ANY PARTICULAR FONT, STYLE, SIZE, OR COLOR.

FOR ENTERTAINMENT SERVICES, NAMELY, PROVIDING ONLINE COMPUTER AND ELECTRONIC GAMES; ENTERTAINMENT SERVICES, NAMELY, PROVIDING ON-LINE COMPUTER GAMES, PROVIDING ENHANCEMENTS WITHIN ONLINE COMPUTER GAMES, AND GAME APPLICATIONS WITHIN ONLINE COMPUTER GAMES; PROVIDING ONLINE REVIEWS OF COMPUTER GAMES, AND PROVIDING OF INFORMATION RELATING TO COMPUTER GAMES; PROVIDING AN INTERNET WEBSITE PORTAL IN THE FIELD OF COMPUTER GAMES AND GAMING; ENTERTAINMENT SERVICES, NAMELY, PROVIDING VIRTUAL ENVIRONMENTS IN WHICH USERS CAN INTERACT THROUGH SOCIAL GAMES FOR RECREATIONAL, LEISURE OR ENTERTAINMENT PURPOSES (U.S. CLS. 100, 101 AND 107).

TAMARA FRAZIER, EXAMINING ATTORNEY

SN 85-217,534. MOGULDOM MEDIA GROUP, LLC, NEW YORK, NY. FILED 1-13-2011.

**24WiredTV**

THE MARK CONSISTS OF STANDARD CHARACTERS WITHOUT CLAIM TO ANY PARTICULAR FONT, STYLE, SIZE, OR COLOR.

FOR ENTERTAINMENT SERVICES, NAMELY, PROVIDING A WEB SITE FEATURING PHOTOGRAPHIC, AUDIO, VIDEO AND PROSE PRESENTATIONS FEATURING ENTERTAINMENT, NEWS, MUSIC VIDEOS, ORIGINAL SHOWS, INTERVIEWS, AND INFORMATION PERTAINING TO AFRICAN AMERICAN INTERESTS, PERSONS AND CULTURE (U.S. CLS. 100, 101 AND 107).

KAREN K. BUSH, EXAMINING ATTORNEY

SN 85-220,728. MARCHTALER, KENNETH ERVIN, DBA WARRIOR MARTIAL ARTS, VICTORIA, BC, CANADA, FILED 1-19-2011.

**30 Minute Warrior**

THE MARK CONSISTS OF STANDARD CHARACTERS WITHOUT CLAIM TO ANY PARTICULAR FONT, STYLE, SIZE, OR COLOR.

NO CLAIM IS MADE TO THE EXCLUSIVE RIGHT TO USE "30 MINUTE", APART FROM THE MARK AS SHOWN. FOR MARTIAL ARTS INSTRUCTION (U.S. CLS. 100, 101 AND 107).

FIRST USE 1-18-2010; IN COMMERCE 1-18-2010.  
LESLIE RICHARDS, EXAMINING ATTORNEY

**CLASS 41—(Continued).**

SN 85-221,085. ADRENALINE SPORTS MANAGEMENT INC., CARY, IL. FILED 1-19-2011.

**ASM**

THE MARK CONSISTS OF STANDARD CHARACTERS WITHOUT CLAIM TO ANY PARTICULAR FONT, STYLE, SIZE, OR COLOR.

FOR EDUCATION AND ENTERTAINMENT SERVICES, NAMELY, ORGANIZING, ARRANGING AND CONDUCTING RUNNING RACE EVENTS, MARATHONS, HALF-MARATHONS, 10KS, 8KS, 5KS, TRIATHLONS, AND ENDURANCE RACES; SPORTING EVENTS, NAMELY, ARRANGING AND CONDUCTING ATHLETIC COMPETITIONS, ATHLETIC TRAINING SERVICES; ENTERTAINMENT SERVICES, NAMELY, ORGANIZING COMMUNITY FAIRS FEATURING VENDOR BOOTHS OF FOOD AND RACE RELATED SPORTING GOODS (U.S. CLS. 100, 101 AND 107).

FIRST USE 1-30-2009; IN COMMERCE 1-30-2009.  
MICHELE SWAIN, EXAMINING ATTORNEY

SN 85-222,653. WARNER BROS. ENTERTAINMENT INC., BURBANK, CA. FILED 1-20-2011.

**ADDICTED TO LOVE**

THE MARK CONSISTS OF STANDARD CHARACTERS WITHOUT CLAIM TO ANY PARTICULAR FONT, STYLE, SIZE, OR COLOR.

FOR ENTERTAINMENT SERVICES IN THE NATURE OF LIVE-ACTION, COMEDY, DRAMA, ANIMATED, AND REALITY TELEVISION SERIES; PRODUCTION OF LIVE-ACTION, COMEDY, DRAMA, ANIMATED AND REALITY TELEVISION SERIES; DISTRIBUTION AND DISPLAY OF LIVE-ACTION, COMEDY, DRAMA AND ANIMATED MOTION PICTURE THEATRICAL FILMS; PRODUCTION OF LIVE-ACTION, COMEDY, DRAMA AND ANIMATED MOTION PICTURE THEATRICAL FILMS; THEATRICAL PERFORMANCES BOTH ANIMATED AND LIVE ACTION; INTERNET SERVICES PROVIDING INFORMATION VIA AN ELECTRONIC GLOBAL COMPUTER NETWORK IN THE FIELD OF ENTERTAINMENT RELATING SPECIFICALLY TO MOVIES, AND TELEVISION; PROVIDING NEWS ABOUT CURRENT EVENTS AND ENTERTAINMENT, AND INFORMATION RELATED TO EDUCATION AND CULTURAL EVENTS, VIA A GLOBAL COMPUTER NETWORK; AND PROVIDING INFORMATION FOR AND ACTUAL ENTERTAINMENT VIA AN ELECTRONIC GLOBAL COMMUNICATIONS NETWORK IN THE NATURE OF LIVE-ACTION, COMEDY, DRAMA AND ANIMATED PROGRAMS AND PRODUCTION OF LIVE-ACTION, COMEDY, DRAMA AND ANIMATED MOTION PICTURE FILMS FOR DISTRIBUTION VIA A GLOBAL COMPUTER NETWORK (U.S. CLS. 100, 101 AND 107).

PRISCILLA MILTON, EXAMINING ATTORNEY

**CLASS 41—(Continued).**

SN 85-224,470. PLAYBOY ENTERPRISES INTERNATIONAL, INC., CHICAGO, IL. FILED 1-24-2011.

**THE STASH**

THE MARK CONSISTS OF STANDARD CHARACTERS WITHOUT CLAIM TO ANY PARTICULAR FONT, STYLE, SIZE, OR COLOR.

FOR ENTERTAINMENT IN THE NATURE OF ONGOING TELEVISION PROGRAMS IN THE FIELD OF COMEDY (U.S. CLS. 100, 101 AND 107).

ASHA SALEM, EXAMINING ATTORNEY

SN 85-225,678. STOKELY-VAN CAMP, INC., CHICAGO, IL. FILED 1-25-2011.

The logo features the word "EVERYTHING" in a bold, black, sans-serif font. Below it, the word "TO" is written in a smaller, white, sans-serif font, centered within a horizontal grey bar. Below the bar, the word "PROVE" is written in a large, bold, black, sans-serif font.

THE MARK CONSISTS OF THE STYLIZED WORD "EVERYTHING", WITH A FOOTBALL PLAYER SILHOUETTE IMPOSED OVER THE LETTER "I", THE WORD "TO" IN A STYLIZED FORMAT IMPOSED OVER A BAR DESIGN ABOVE THE STYLIZED WORD "PROVE".

FOR ENTERTAINMENT SERVICES, NAMELY, CONTINUING SHOWS BROADCAST OVER TELEVISION AND THE INTERNET THAT CHRONICLE THE JOURNEY OF PROFESSIONAL FOOTBALL PLAYERS THROUGH THEIR FIRST YEAR OF PLAY (U.S. CLS. 100, 101 AND 107).

KIM SAITO, EXAMINING ATTORNEY

SN 85-225,717. STOKELY-VAN CAMP, INC., CHICAGO, IL. FILED 1-25-2011.

**EVERYTHING TO PROVE**

THE MARK CONSISTS OF STANDARD CHARACTERS WITHOUT CLAIM TO ANY PARTICULAR FONT, STYLE, SIZE, OR COLOR.

FOR ENTERTAINMENT SERVICES, NAMELY, CONTINUING SHOWS BROADCAST OVER TELEVISION AND THE INTERNET THAT CHRONICLE THE JOURNEY OF PROFESSIONAL FOOTBALL PLAYERS THROUGH THEIR FIRST YEAR OF PLAY (U.S. CLS. 100, 101 AND 107).

KIM SAITO, EXAMINING ATTORNEY

**CLASS 41—(Continued).**

SN 85-226,220. WP COMPANY LLC, WASHINGTON, DC.  
FILED 1-26-2011.

**2CHAMBERS**

THE MARK CONSISTS OF STANDARD CHARACTERS WITHOUT CLAIM TO ANY PARTICULAR FONT, STYLE, SIZE, OR COLOR.

FOR ONLINE JOURNALS, NAMELY, A BLOG ON THE SUBJECTS OF THE UNITED STATES CONGRESS AND ITS MEMBERS, COMMITTEES, SUBCOMMITTEES, STAFFERS AND LOBBYISTS, AND THEIR CONSIDERATION OF, INTERACTION WITH AND EFFECT ON DOMESTIC AND INTERNATIONAL LEGISLATION, PUBLIC POLICY ISSUES AND ELECTIONS (U.S. CLS. 100, 101 AND 107).

ANDREA BUTLER, EXAMINING ATTORNEY

---

SN 85-226,556. TIME WARNER CABLE INC., NEW YORK, NY. FILED 1-26-2011.

**STEP THRU THE SCREEN**

THE MARK CONSISTS OF STANDARD CHARACTERS WITHOUT CLAIM TO ANY PARTICULAR FONT, STYLE, SIZE, OR COLOR.

FOR TELEVISION AND VIDEO FILMING SERVICES; PRODUCTION OF SPORTS-RELATED VIDEOS FOR THE INTERNET; ENTERTAINMENT SERVICES, NAMELY PROVIDING CONSUMERS AN INTERACTIVE EXPERIENCE IN THE NATURE OF RECORDING A SPORTS NEWS SEGMENT WITH THEM AS SPORTSCASTERS AND NEWSCASTERS (U.S. CLS. 100, 101 AND 107).

FIRST USE 1-0-2010; IN COMMERCE 1-0-2010.  
BARBARA GAYNOR, EXAMINING ATTORNEY

---

SN 85-231,348. PINNACLE ENTERTAINMENT, INC., LAS VEGAS, NV. FILED 2-1-2011.

**LET'S GO**

THE MARK CONSISTS OF STANDARD CHARACTERS WITHOUT CLAIM TO ANY PARTICULAR FONT, STYLE, SIZE, OR COLOR.

FOR ENTERTAINMENT IN THE NATURE OF CASINO SERVICES, AND LIVE PERFORMANCES BY SINGERS, MUSICIANS, MUSICAL GROUPS AND COMEDIANS (U.S. CLS. 100, 101 AND 107).

JULIE GUTTADAURO, EXAMINING ATTORNEY

**CLASS 41—(Continued).**

SN 85-231,816. WARNER BROS. ENTERTAINMENT INC., BURBANK, CA. FILED 2-1-2011.

**HEADLINES ON TRIAL**

THE MARK CONSISTS OF STANDARD CHARACTERS WITHOUT CLAIM TO ANY PARTICULAR FONT, STYLE, SIZE, OR COLOR.

FOR ENTERTAINMENT SERVICES IN THE NATURE OF LIVE-ACTION, COMEDY, DRAMA, ANIMATED, AND REALITY TELEVISION SERIES; PRODUCTION OF LIVE-ACTION, COMEDY, DRAMA, ANIMATED AND REALITY TELEVISION SERIES; DISTRIBUTION AND DISPLAY OF LIVE-ACTION, COMEDY, DRAMA AND ANIMATED MOTION PICTURE THEATRICAL FILMS; PRODUCTION OF LIVE-ACTION, COMEDY, DRAMA AND ANIMATED MOTION PICTURE THEATRICAL FILMS; THEATRICAL PERFORMANCES BOTH ANIMATED AND LIVE ACTION; INTERNET SERVICES PROVIDING INFORMATION VIA AN ELECTRONIC GLOBAL COMPUTER NETWORK IN THE FIELD OF ENTERTAINMENT RELATING SPECIFICALLY TO MOVIES, AND TELEVISION; PROVIDING NEWS ABOUT CURRENT EVENTS AND ENTERTAINMENT, AND INFORMATION RELATED TO EDUCATION AND CULTURAL EVENTS, VIA A GLOBAL COMPUTER NETWORK; AND PROVIDING INFORMATION FOR AND ACTUAL ENTERTAINMENT VIA AN ELECTRONIC GLOBAL COMMUNICATIONS NETWORK IN THE NATURE OF LIVE-ACTION, COMEDY, DRAMA AND ANIMATED PROGRAMS AND PRODUCTION OF LIVE-ACTION, COMEDY, DRAMA AND ANIMATED MOTION PICTURE FILMS FOR DISTRIBUTION VIA A GLOBAL COMPUTER NETWORK (U.S. CLS. 100, 101 AND 107).

PRISCILLA MILTON, EXAMINING ATTORNEY

---

SN 85-234,254. FESTIVAL FUN PARKS, LLC, NEWPORT BEACH, CA. FILED 2-4-2011.

**LAKE COMPOUNCE**

THE MARK CONSISTS OF STANDARD CHARACTERS WITHOUT CLAIM TO ANY PARTICULAR FONT, STYLE, SIZE, OR COLOR.

FOR ENTERTAINMENT SERVICES IN THE NATURE OF AMUSEMENT PARKS AND CENTERS; ENTERTAINMENT SERVICES IN THE NATURE OF AMUSEMENT PARK RIDES AND AMUSEMENT PARK WATER ATTRACTIONS AND SLIDES (U.S. CLS. 100, 101 AND 107).

FIRST USE 0-0-1845; IN COMMERCE 0-0-1845.  
ASHA SALEM, EXAMINING ATTORNEY

**CLASS 41—(Continued).**

SN 85-234,276. FESTIVAL FUN PARKS, LLC, NEWPORT BEACH, CA. FILED 2-4-2011.

**STORY LAND**

THE MARK CONSISTS OF STANDARD CHARACTERS WITHOUT CLAIM TO ANY PARTICULAR FONT, STYLE, SIZE, OR COLOR.

FOR ENTERTAINMENT SERVICES IN THE NATURE OF AMUSEMENT PARKS AND CENTERS; ENTERTAINMENT SERVICES IN THE NATURE OF AMUSEMENT PARK RIDES; ENTERTAINMENT SERVICES IN THE NATURE OF THEATRICAL PERFORMANCES BY ENTERTAINERS (U.S. CLS. 100, 101 AND 107).

FIRST USE 0-0-1953; IN COMMERCE 0-0-1953.  
AISHA SALEM, EXAMINING ATTORNEY

---

SN 85-236,081. CHEGG, INC., SANTA CLARA, CA. FILED 2-7-2011.

**SITE TO SHELF**

THE MARK CONSISTS OF STANDARD CHARACTERS WITHOUT CLAIM TO ANY PARTICULAR FONT, STYLE, SIZE, OR COLOR.

FOR TEXTBOOK RENTAL SERVICES; PROVIDING NEWSLETTERS IN THE FIELD OF INFORMATION OF INTEREST TO STUDENTS VIA E-MAIL; ON-LINE JOURNALS, NAMELY, BLOGS FEATURING INFORMATION OF INTEREST TO STUDENTS; ENTERTAINMENT SERVICES, NAMELY CONDUCTING SWEEPSTAKES DIRECTED TO STUDENTS; ENTERTAINMENT SERVICES, NAMELY, PROVIDING ON-LINE COMPUTER GAMES; RENTAL OF TEXTBOOKS VIA AN ELECTRONIC KIOSK (U.S. CLS. 100, 101 AND 107).

MARGARET POWER, EXAMINING ATTORNEY

---

SN 85-237,121. VITAL PHARMACEUTICALS, INC., WESTON, FL. FILED 2-8-2011.

**AMP**

THE MARK CONSISTS OF STANDARD CHARACTERS WITHOUT CLAIM TO ANY PARTICULAR FONT, STYLE, SIZE, OR COLOR.

FOR ENTERTAINMENT MEDIA PRODUCTION SERVICES FOR MOTION PICTURES, TELEVISION AND INTERNET; MOTION PICTURE FILM PRODUCTION (U.S. CLS. 100, 101 AND 107).

ANNE MADDEN, EXAMINING ATTORNEY

**CLASS 41—(Continued).**

SN 85-241,183. UNITED STATES PILATES ASSOCIATION LLC, FORT LAUDERDALE, FL. FILED 2-14-2011.

**U.S.P.A.**

THE MARK CONSISTS OF STANDARD CHARACTERS WITHOUT CLAIM TO ANY PARTICULAR FONT, STYLE, SIZE, OR COLOR.

FOR EDUCATIONAL SERVICES, NAMELY, PROVIDING WORKSHOPS IN THE FIELD OF TEACHING THE PILATES PHYSICAL TRAINING SYSTEM AND EXERCISES; EDUCATIONAL SERVICES, NAMELY, CONDUCTING CLASSES, SEMINARS, CONFERENCES, WORKSHOPS AND INDIVIDUAL TUTORIAL SESSIONS IN THE FIELD OF TEACHING PHYSICAL FITNESS EXERCISES; CERTIFICATION SERVICES, NAMELY PROVIDING CERTIFICATION PROGRAMS IN THE FIELD OF TEACHING PHYSICAL FITNESS EXERCISES AND EXERCISING; TEACHER CERTIFICATION PROGRAMS IN THE FIELD OF TEACHING THE PILATES PHYSICAL FITNESS SYSTEM AND EXERCISES; EDUCATIONAL TESTING TO DETERMINE COMPETENCY IN TEACHING THE PILATES PHYSICAL FITNESS TRAINING SYSTEM AND EXERCISES FOR PURPOSES OF TEACHER CERTIFICATION; PROVIDING CERTIFICATION PROGRAMS IN THE FIELD OF TEACHING THE PILATES PHYSICAL FITNESS TRAINING SYSTEM AND EXERCISES; EDUCATIONAL TESTING TO DETERMINE COMPETENCY IN THE FIELD OF TEACHING THE PILATES PHYSICAL FITNESS TRAINING SYSTEM AND EXERCISES; AND EDUCATIONAL SERVICES, NAMELY, CONDUCTING CLASSES, SEMINARS, CONFERENCES, WORKSHOPS AND INDIVIDUAL TUTORIAL SESSIONS IN THE FIELD OF TEACHING THE PILATES PHYSICAL FITNESS SYSTEM AND EXERCISES (U.S. CLS. 100, 101 AND 107).

FIRST USE 6-0-2006; IN COMMERCE 11-0-2006.  
SCOTT BIBB, EXAMINING ATTORNEY

---

SN 85-242,261. GRHK IP, LLC, MIAMI, FL. FILED 2-15-2011.

**ThugHunter**

THE MARK CONSISTS OF STANDARD CHARACTERS WITHOUT CLAIM TO ANY PARTICULAR FONT, STYLE, SIZE, OR COLOR.

FOR ENTERTAINMENT SERVICES, NAMELY, PROVIDING A WEB SITE FEATURING PHOTOGRAPHIC, AUDIO, VIDEO AND PROSE PRESENTATIONS FEATURING ADULT-ORIENTED SUBJECT MATTER (U.S. CLS. 100, 101 AND 107).

BRENDAN MCCAULEY, EXAMINING ATTORNEY



**CLASS 41—(Continued).**

SN 85-243,604. NETWORK ENTERPRISES, NEW YORK, NY. FILED 2-16-2011.

**HUNGRY MEN AT WORK**

THE MARK CONSISTS OF STANDARD CHARACTERS WITHOUT CLAIM TO ANY PARTICULAR FONT, STYLE, SIZE, OR COLOR.

FOR ENTERTAINMENT SERVICES IN THE NATURE OF CONTINUING PROGRAM SERIES, FEATURING LIVE ACTION, COMEDY AND DRAMA PROVIDED THROUGH CABLE TELEVISION, BROADCAST TELEVISION, INTERNET, VIDEO-ON-DEMAND, AND THROUGH OTHER DISTRIBUTION PLATFORMS; PROVIDING ONLINE INFORMATION IN THE FIELD OF ENTERTAINMENT CONCERNING TELEVISION PROGRAMS (U.S. CLS. 100, 101 AND 107).

SUNG IN, EXAMINING ATTORNEY

SN 85-248,915. PINNACLE ENTERTAINMENT, INC., LAS VEGAS, NV. FILED 2-22-2011.

**GIDDY UP GAME ROOM**

THE MARK CONSISTS OF STANDARD CHARACTERS WITHOUT CLAIM TO ANY PARTICULAR FONT, STYLE, SIZE, OR COLOR.

NO CLAIM IS MADE TO THE EXCLUSIVE RIGHT TO USE "GAME ROOM", APART FROM THE MARK AS SHOWN.

FOR AMUSEMENT ARCADES (U.S. CLS. 100, 101 AND 107).

FIRST USE 1-28-2011; IN COMMERCE 1-28-2011.

JULIE GUTTADAURO, EXAMINING ATTORNEY

SN 85-248,974. PINNACLE ENTERTAINMENT, INC., LAS VEGAS, NV. FILED 2-22-2011.



NO CLAIM IS MADE TO THE EXCLUSIVE RIGHT TO USE "GAME ROOM", APART FROM THE MARK AS SHOWN.

THE COLOR(S) BLUE, WHITE, BLACK, TAN, BROWN, GREEN AND RED IS/ARE CLAIMED AS A FEATURE OF THE MARK.

THE MARK CONSISTS OF THE STYLIZED WORD

**CLASS 41—(Continued).**

"GIDDY" IN BLUE OUTLINED IN WHITE WHICH IS OUTLINED IN BLACK TO THE RIGHT OF WHICH IS A DRAWING OF A SMILING, RUNNING HORSE FEATURING A TAN BODY WITH BROWN HOOVES, TAIL AND MANE. TO THE RIGHT OF THE HORSE IS THE STYLIZED WORD "UP" WHICH IS GREEN OUTLINED IN WHITE WHICH IS OUTLINED IN BLACK. ALL OF THE AFOREMENTIONED IS CENTERED OVER THE STYLIZED WORDS "GAME ROOM" WHICH ARE RED OUTLINED IN WHITE WHICH IS OUTLINED IN BLACK.

FOR AMUSEMENT ARCADES (U.S. CLS. 100, 101 AND 107).

FIRST USE 1-28-2011; IN COMMERCE 1-28-2011.

JULIE GUTTADAURO, EXAMINING ATTORNEY

**CLASS 42—SCIENTIFIC AND COMPUTER SERVICES**

SN 76-705,582. EMPYREAL SCIENCES, LLC, TEMPE, AZ. FILED 12-6-2010.



THE MARK CONSISTS OF A CIRCLE WITH THREE PARALLEL LINES GOING DOWN THE FRONT ABOVE THE WORDING "EMPYREAL".

FOR SCIENTIFIC SERVICES, NAMELY, DESIGNING INTELLIGENCE, OPTO-ELECTRICAL AND BALLISTICS SOFTWARE FOR LAW ENFORCEMENT AND MILITARY APPLICATIONS (U.S. CLS. 100 AND 101).

FIRST USE 10-1-2008; IN COMMERCE 10-1-2008.

MORGAN WYNNE, EXAMINING ATTORNEY

SN 76-705,685. INTERNATIONAL DIGITAL ENTERPRISE ALLIANCE, INC., ALEXANDRIA, VA. FILED 12-14-2010.

**nextPub**

THE MARK CONSISTS OF STANDARD CHARACTERS WITHOUT CLAIM TO ANY PARTICULAR FONT, STYLE, SIZE, OR COLOR.

FOR DEVELOPMENT OF VOLUNTARY STANDARDS FOR DELIVERING AND DISPLAYING MAGAZINE, JOURNAL, SERIAL, NEWSPAPER AND OTHER RICH CONTENT FOR EREADER, TABLET AND OTHER ELECTRONIC DISPLAY DEVICES TO ENABLE THE INCLUSION OF SERIALIZED, BRANDED, AND INTERACTIVE CONTENT AND ADVERTISING MATERIALS IN ELECTRONIC PUBLISHING CHANNELS (U.S. CLS. 100 AND 101).

FIRST USE 8-1-2010; IN COMMERCE 8-1-2010.

REBECCA POVARCHUK, EXAMINING ATTORNEY

**CLASS 42—(Continued).**

SN 77-578,190. MAINCLOUD LLC, CHICAGO, IL. FILED 9-24-2008.



NO CLAIM IS MADE TO THE EXCLUSIVE RIGHT TO USE "REPORT.COM", APART FROM THE MARK AS SHOWN.

THE MARK CONSISTS OF THE WORDS "YOUREPORT.COM CUSTOMIZE YOUR NEWS" WITH THE WORD "YOU" SUPERIMPOSED UPON A PARTIALLY UNFOLDED PIECE OF PAPER WITH LINES IN THREE COLUMNS.

FOR COMPUTER SERVICES, NAMELY, PROVIDING A NEWS AGGREGATION SITE WHICH ALLOWS THE USER TO VIEW EXISTING FEEDS FROM NEWSPAPERS AND ONLINE PUBLICATIONS AND THEN ASSEMBLE THE INFORMATION TO CREATE USER SPECIFIC NEWSPAPERS OR REPORTS (U.S. CLS. 100 AND 101).

FIRST USE 11-6-2008; IN COMMERCE 11-6-2008.  
ANNE FARRELL, EXAMINING ATTORNEY

SN 77-587,798. NINTENDO OF AMERICA INC., REDMOND, WA. FILED 10-7-2008.

**nintendo zone**

PRIORITY CLAIMED UNDER SEC. 44(D) ON JAPAN APPLICATION NO. 2008-079565, FILED 9-30-2008, REG. NO. 5324017, DATED 5-21-2010, EXPIRES 5-21-2020.

OWNER OF U.S. REG. NOS. 1,213,822, 1,628,966 AND OTHERS.

THE MARK CONSISTS OF THE WORDS "NINTENDO ZONE"; WITH TRANSMISSION WAVES EMANATING FROM THE DOT ABOVE THE LETTER "I".

FOR COMPUTER SOFTWARE DESIGN; DESIGN OF COMPUTER HARDWARE FOR COMPUTER GAMES; DESIGN, PROGRAMMING, AND MAINTENANCE OF SOFTWARE FOR CONSUMER VIDEO GAMES; INFORMATION AND CONSULTANCY SERVICES RELATING TO DESIGN, PROGRAMMING, OR MAINTENANCE OF SOFTWARE FOR COMPUTER VIDEO GAMES; DESIGN, PROGRAMMING, AND MAINTENANCE OF SOFTWARE FOR ARCADE VIDEO GAME MACHINES; INFORMATION AND CONSULTANCY SERVICES RELATING TO DESIGN, PROGRAMMING, OR MAINTENANCE OF SOFTWARE FOR ARCADE VIDEO GAME MACHINES; CREATING OR MAINTAINING WEB SITES FOR OTHERS; DESIGN, PROGRAMMING, OR MAINTENANCE OF COMPUTER SOFTWARE FOR OTHERS; TECHNICAL ADVICE RELATING TO PERFORMANCE OR OPERATION OF COMPUTERS; RENTAL OF COMPUTERS; PROVIDING ONLINE NON-DOWNLOADABLE SOFTWARE FOR USE IN GRAPHIC DESIGN; DESIGNING, NAMELY, DESIGNING OF PACKAGING AND WRAPPING MATERIALS; DESIGNING WEBSITES FOR ADVERTISING PURPOSES; PROVIDING TEMPORARY USE OF ON-LINE, NON-DOWNLOADABLE SOFTWARE FOR USE IN DATABASE MANAGEMENT, FOR INVENTORY CONTROL, OR FOR PRODUCT WARRANTY PROCESSING (U.S. CLS. 100 AND 101).

MATTHEW MCDOWELL, EXAMINING ATTORNEY

**CLASS 42—(Continued).**

SN 77-651,914. PRIMESTONE, BOGOTA, COLOMBIA, FILED 1-19-2009.

**PRIME**

THE MARK CONSISTS OF STANDARD CHARACTERS WITHOUT CLAIM TO ANY PARTICULAR FONT, STYLE, SIZE, OR COLOR.

OWNER OF U.S. REG. NO. 2,772,399.

FOR INSTALLATION AND MAINTENANCE OF REVENUE MANAGEMENT COMPUTER SOFTWARE FOR BUSINESS; DESIGN AND DEVELOPMENT OF REVENUE MANAGEMENT COMPUTER SOFTWARE FOR BUSINESS (U.S. CLS. 100 AND 101).

ROSELLE HERRERA, EXAMINING ATTORNEY

SN 77-810,994. THE CYBRIX GROUP INC., TAMPA, FL. FILED 8-24-2009.

**Making IT Easy**

THE COLOR(S) BLUE AND PURPLE IS/ARE CLAIMED AS A FEATURE OF THE MARK.

THE MARK CONSISTS OF THE WORD "MAKING" IS SHOWN IN THE COLOR BLUE, THE WORD "IT" (WHICH STANDS FOR INFORMATION TECHNOLOGY) IS SHOWN ITALICIZED AND IN THE COLOR PURPLE AND THE WORD "EASY" IS SHOWN IN THE COLOR BLUE.

FOR COMPUTER SERVICES, NAMELY, REMOTE AND ON-SITE MANAGEMENT OF THE INFORMATION TECHNOLOGY (IT) SYSTEMS OF OTHERS (U.S. CLS. 100 AND 101).

FIRST USE 9-15-2008; IN COMMERCE 9-15-2008.

TIMOTHY FINNEGAN, EXAMINING ATTORNEY

SN 77-813,085. ALEXANDER, JAMES M., CHAPPAQUA, NY. FILED 8-26-2009.

**VIZIBILITY**

THE MARK CONSISTS OF STANDARD CHARACTERS WITHOUT CLAIM TO ANY PARTICULAR FONT, STYLE, SIZE, OR COLOR.

FOR PROVIDING TEMPORARY USE OF ONLINE, NONDOWNLOADABLE SOFTWARE FOR USE IN FORMULATING CUSTOM SEARCH QUERIES TO BE USED WITH SEARCH ENGINES (U.S. CLS. 100 AND 101).

AMY KERTGATE, EXAMINING ATTORNEY

**CLASS 42—(Continued).**

SN 77-880,916. AXISPOINT, INC., NEW YORK, NY. FILED 11-25-2009.

# AXISPOINT

THE MARK CONSISTS OF STANDARD CHARACTERS WITHOUT CLAIM TO ANY PARTICULAR FONT, STYLE, SIZE, OR COLOR.

OWNER OF U.S. REG. NO. 2,508,640.

FOR INFORMATION TECHNOLOGY CONSULTING SERVICES; COMPUTER HARDWARE AND SOFTWARE CONSULTING SERVICES; CONSULTING SERVICES IN THE FIELD OF SOFTWARE APPLICATION DEVELOPMENT AND CLOUD COMPUTING; INFORMATION TECHNOLOGY INTEGRATION SERVICES; INTEGRATION OF COMPUTER SYSTEMS AND NETWORKS; COMPUTER SERVICES, NAMELY, INTEGRATION OF COMPUTER SOFTWARE INTO MULTIPLE SYSTEMS AND NETWORKS; INTEGRATION OF COMPUTER SYSTEMS WITH COMPUTER SOFTWARE THAT ENABLES THE TRANSMISSION AND RECEPTION OF AUDIO, DATA AND VISUAL CONTENT OVER GLOBAL COMPUTER NETWORKS AND MOBILE ELECTRONIC DEVICES; PROVIDING TECHNOLOGY AND SECURITY ASSESSMENTS, NAMELY, COMPUTER SECURITY CONSULTANCY; UPDATING OF COMPUTER SOFTWARE RELATING TO COMPUTER SECURITY AND PREVENTION OF COMPUTER RISKS; DESIGN, DEVELOPMENT, INSTALLATION, IMPLEMENTATION, UPDATING, MAINTENANCE AND REPAIR OF COMPUTER SOFTWARE; HELP DESK SERVICES; 24/7 SERVICE DESK/HELP DESK SERVICES FOR IT INFRASTRUCTURE AND NETWORKS, OPERATING SYSTEMS, DATABASE SYSTEMS, AND WEB APPLICATIONS; REMOTE AND ON-SITE MANAGEMENT OF THE INFORMATION TECHNOLOGY (IT) SYSTEMS OF OTHERS; COMPUTER SOFTWARE DEVELOPMENT, WEB-BASED APPLICATION DEVELOPMENT, USER INTERFACE DESIGN AND WEB-SITE DESIGN; CUSTOMIZED SOFTWARE DEVELOPMENT SERVICES; COMPUTER PROJECT MANAGEMENT SERVICES; COMPUTER SYSTEM ADMINISTRATION FOR OTHERS; PLANNING, DESIGN AND MANAGEMENT OF INFORMATION TECHNOLOGY SYSTEMS; COMPUTER MONITORING SERVICE WHICH TRACKS HARDWARE PERFORMANCE AND PROCESSES AND SENDS OUT HISTORICAL REPORTS AND ALERTS; COMPUTER MONITORING SERVICE WHICH TRACKS APPLICATION SOFTWARE PERFORMANCE, PERFORMS PERIODIC MAINTENANCE AND PROVIDES REPORTS AND ALERTS CONCERNING SUCH PERFORMANCE; COMPUTER SERVICES, NAMELY, MONITORING AND REPORTING ON THE PERFORMANCE, AVAILABILITY, AND ERRORS OF WEB SITES AND NETWORKS OF OTHERS; WEBSITE HOSTING SERVICES; MAINTENANCE OF WEBSITES FOR OTHERS; DESIGN, DEPLOYMENT AND MANAGEMENT OF WIRELESS NETWORKS FOR OTHERS; COMPUTER NETWORK DESIGN FOR OTHERS; COMPUTER VIRUS PROTECTION SERVICES; ON-LINE SCANNING, DETECTING, QUARANTINING AND ELIMINATING VIRUSES, WORMS, TROJANS, SPYWARE, ADWARE, MALWARE AND UNAUTHORIZED DATA AND PROGRAMS ON COMPUTERS AND ELECTRONIC DEVICES; COMPUTER DIAGNOSTIC SERVICES; COMPUTER DATA RECOVERY SERVICES; DESIGN OF AUDIO AND VIDEO CONFERENCING ROOMS AND COMPUTER NETWORKS TO ENABLE AUDIO AND VIDEO CONFERENCING FOR OTHERS; DESIGN AND DEVELOPMENT OF COMMUNICATION SYSTEMS FOR TRANSMISSION AND RECEPTION OF VOICE AND DATA; DESIGN OF

**CLASS 42—(Continued).**

WIRELESS COMMUNICATION SYSTEMS; TECHNICAL CONSULTING SERVICES IN THE FIELD OF DATACENTER ARCHITECTURE; DATA MIGRATION SERVICES; DATA CONVERSION OF ELECTRONIC INFORMATION; DATA CONVERSION OF COMPUTER PROGRAMS AND DATA, NOT PHYSICAL CONVERSION; DATABASE DESIGN AND DEVELOPMENT; PROFESSIONAL COMPUTER SERVICES, NAMELY, NETWORK ANALYSIS, LAN/WAN DESIGN, WIRELESS ENGINEERING AND VIRTUALIZATION, AND COMPUTER AND SOFTWARE DEVELOPMENT PROJECT MANAGEMENT (U.S. CLS. 100 AND 101).

FIRST USE 6-1-1996; IN COMMERCE 6-1-1996.  
DAVID I, EXAMINING ATTORNEY

SN 77-900,477. EXPERTS EXCHANGE, LLC, SAN LUIS OBISPO, CA. FILED 12-23-2009.

# EXPERTS EXCHANGE

THE MARK CONSISTS OF STANDARD CHARACTERS WITHOUT CLAIM TO ANY PARTICULAR FONT, STYLE, SIZE, OR COLOR.

OWNER OF U.S. REG. NO. 2,143,685.  
SEC. 2(F).

FOR PROVIDING A WEB SITE THAT GIVES USERS THE ABILITY TO ASK QUESTIONS RELATED TO COMPUTER TECHNOLOGY AND RECEIVE ANSWERS THERETO FROM OTHER USERS OF THE WEB SITE, SAID QUESTIONS AND ANSWERS BEING AVAILABLE TO ALL USERS OF THE WEB SITE (U.S. CLS. 100 AND 101).

FIRST USE 6-20-1996; IN COMMERCE 8-21-1996.  
TINA L. SNAPP, EXAMINING ATTORNEY

SN 77-908,178. IGN ENTERTAINMENT, INC., SAN FRANCISCO, CA. FILED 1-8-2010.

# WHAT ARE YOU PLAYING?

THE MARK CONSISTS OF STANDARD CHARACTERS WITHOUT CLAIM TO ANY PARTICULAR FONT, STYLE, SIZE, OR COLOR.

FOR COMPUTER SERVICES IN THE NATURE OF CUSTOMIZED WEB PAGES FEATURING USER-DEFINED INFORMATION, PERSONAL PROFILES AND INFORMATION; COMPUTER SERVICES, NAMELY, HOSTING ON-LINE WEB FACILITIES FOR OTHERS FOR ORGANIZING AND CONDUCTING ONLINE MEETINGS, GATHERINGS, AND INTERACTIVE DISCUSSIONS; HOSTING OF DIGITAL CONTENT ON THE INTERNET IN THE NATURE OF ON-LINE JOURNALS AND BLOGS; PROVIDING TEMPORARY USE OF NON-DOWNLOADABLE COMPUTER SOFTWARE FOR USE IN THE CREATION AND PUBLICATION OF ON-LINE JOURNALS AND BLOGS (U.S. CLS. 100 AND 101).

LEIGH LOWRY, EXAMINING ATTORNEY

**CLASS 42—(Continued).**

SN 77-930,777. LOORZ, VICTORIA, VENTURA, CA. AND LOORZ, ALEC, VENTURA, CA. FILED 2-8-2010.

# IMATTER

THE MARK CONSISTS OF STANDARD CHARACTERS WITHOUT CLAIM TO ANY PARTICULAR FONT, STYLE, SIZE, OR COLOR.

FOR PROVIDING A WEBSITE FEATURING INFORMATION ABOUT GLOBAL WARMING AND ITS EFFECT ON NATURE AND THE ENVIRONMENT (U.S. CLS. 100 AND 101).

STEVEN JACKSON, EXAMINING ATTORNEY

---

SN 77-934,621. GLOBECOMM SYSTEMS, INC., HAUPAUGE, NY. FILED 2-12-2010.



NO CLAIM IS MADE TO THE EXCLUSIVE RIGHT TO USE "ENTERPRISE MEDIA PLATFORM", APART FROM THE MARK AS SHOWN.

THE MARK CONSISTS OF THE WORD "TEMPO" WITH AN ARROW POINTING OUT FROM THE LETTER "T" AND AN ARROW WITHIN THE LETTER "O" POSITIONED ABOVE THE WORDS "ENTERPRISE MEDIA PLATFORM".

FOR COMPUTER SERVICES, NAMELY, PROVIDING TEMPORARY USE OF NON-DOWNLOADABLE SOFTWARE FOR USE BY OTHERS FEATURING SOFTWARE FOR USE IN THE CREATION OF A WEB-BASED SYSTEM THAT ENABLES USERS TO CREATE PRIVATE NETWORKS FOR DISTRIBUTION OF INTERACTIVE RICH-MEDIA; PROVIDING TEMPORARY USE OF NON-DOWNLOADABLE SOFTWARE FOR ENCODING VIDEO, FOR STREAMING CONTENT OVER THE INTERNET, AND FOR VIDEO ON-DEMAND PROGRAMMING SERVICES (U.S. CLS. 100 AND 101).

ROBIN MITTLER, EXAMINING ATTORNEY

**CLASS 42—(Continued).**

SN 77-937,450. BAE SYSTEMS INFORMATION AND ELECTRONIC SYSTEMS INTEGRATION INC., NASHUA, NH. FILED 2-17-2010.

# DCIPHR

THE MARK CONSISTS OF STANDARD CHARACTERS WITHOUT CLAIM TO ANY PARTICULAR FONT, STYLE, SIZE, OR COLOR.

FOR CONSULTING SERVICES IN THE FIELD OF COMMERCIAL AND MILITARY VEHICLE ENGINEERING AND DESIGN, NAMELY, ANALYTICAL AND DESIGN CONSULTING SERVICES USING CUSTOM COMPUTER SOFTWARE FOR COLLECTING, PARSING, AND ORGANIZING APPLICATION, DESIGN, MAINTENANCE, AND LOGISTICS DATA FOR COMMERCIAL AND MILITARY VEHICLES, NAMELY, DEVELOPING AND ENHANCING DIAGNOSTIC AND PROGNOSTIC APPLICATIONS FOR SUCH VEHICLES (U.S. CLS. 100 AND 101).

KEVIN CORWIN, EXAMINING ATTORNEY

---

SN 77-938,804. CALIFORNIA HEALTHCARE FOUNDATION, OAKLAND, CA. FILED 2-18-2010.

# ONE E APP

THE MARK CONSISTS OF STANDARD CHARACTERS WITHOUT CLAIM TO ANY PARTICULAR FONT, STYLE, SIZE, OR COLOR.

SEC. 2(F).

FOR COMPUTER SERVICES, NAMELY, PROVIDING A WEB-BASED SYSTEM AND ONLINE PORTAL FEATURING ON-LINE NON-DOWNLOADABLE SOFTWARE USED FOR DETERMINING ELIGIBILITY AND ENROLLING INDIVIDUALS IN PUBLICLY-FUNDED HEALTH AND SOCIAL SERVICES PROGRAMS (U.S. CLS. 100 AND 101).

FIRST USE 12-31-2003; IN COMMERCE 12-31-2003.

ZHALEH DELANEY, EXAMINING ATTORNEY

**CLASS 42—(Continued).**

SN 79-088,052. KINETURA BVBA, BELGIUM, FILED 8-19-2010.

# KINETURA

THE MARK CONSISTS OF STANDARD CHARACTERS WITHOUT CLAIM TO ANY PARTICULAR FONT, STYLE, SIZE, OR COLOR.

OWNER OF INTERNATIONAL REGISTRATION 1053047 DATED 8-19-2010, EXPIRES 8-19-2020.

THE WORDING "KINETURA" HAS NO MEANING OTHER THAN TRADEMARK SIGNIFICANCE.

FOR SCIENTIFIC AND TECHNOLOGICAL SERVICES AND RESEARCH AND DESIGN RELATING THERETO, NAMELY, SCIENTIFIC RESEARCH AND RESEARCH AND DEVELOPMENT OF TECHNOLOGY IN THE FIELD OF ARCHITECTURAL DESIGN, DESIGN OF INTERIOR DECOR, GRAPHIC ARTS DESIGNING AND CONSTRUCTION DRAFTING; ARCHITECTURAL CONSULTATION; CONSULTATION SERVICES IN THE FIELD OF ENERGY MEASUREMENT TO IMPROVE ENERGY EFFICIENCY; ARCHITECTURAL DESIGN; DESIGN OF INTERIOR DECOR; CONSTRUCTION DRAFTING; ENGINEERING; GEOLOGICAL SURVEYS; SURVEYING; GRAPHIC ARTS DESIGNING; QUALITY CONTROL FOR OTHERS; RESEARCH AND DEVELOPMENT OF NEW PRODUCTS FOR OTHERS; LAND SURVEYING; TECHNICAL PROJECT STUDIES, NAMELY, CONDUCTING OF FEASIBILITY STUDIES, PLAN STUDIES, URBAN DEVELOPMENT STUDIES, STABILITY STUDIES, SECURITY STUDIES, GEOTECHNICS STUDIES AND ENERGY SUFFICIENCY STUDIES; URBAN PLANNING (U.S. CLS. 100 AND 101).

CIMMERIAN COLEMAN, EXAMINING ATTORNEY

SN 79-089,689. FORM FACTOR PTY LTD, ST KILDA VIC 3182, AUSTRALIA, FILED 10-7-2010.

# Form Factory

THE MARK CONSISTS OF STANDARD CHARACTERS WITHOUT CLAIM TO ANY PARTICULAR FONT, STYLE, SIZE, OR COLOR.

OWNER OF INTERNATIONAL REGISTRATION 1057459 DATED 10-7-2010, EXPIRES 10-7-2020.

FOR COMPUTER SOFTWARE PROGRAMMING SERVICES; CONSULTANCY IN THE FIELD OF COMPUTER SOFTWARE; ADVISORY SERVICES RELATING TO COMPUTER SOFTWARE; COMPUTER PROGRAM ADVISORY SERVICES; COMPUTER SOFTWARE CONSULTANCY; COMPUTER SOFTWARE DESIGN; COMPUTER SOFTWARE DEVELOPMENT; CONSULTANCY IN THE FIELD OF COMPUTER SOFTWARE; DESIGN AND DEVELOPMENT OF COMPUTER SOFTWARE FOR OTHERS; DESIGN OF COMPUTER SOFTWARE; DEVELOPMENT OF COMPUTER PROGRAMMES; DEVELOPMENT OF COMPUTER SOFTWARE; DEVELOPMENT OF COMPUTER SOFTWARE APPLICATION SOLUTIONS; MAINTENANCE OF COMPUTER PROGRAMS; MAINTENANCE OF COMPUTER SOFTWARE; PROVISION OF INFORMATION RELATING TO COMPUTER PROGRAMS; UPDATING OF COMPUTER PROGRAMS; WRITING OF COMPUTER PROGRAMS; WRITING OF COMPUTER SOFTWARE (U.S. CLS. 100 AND 101).

KATHLEEN M. VANSTON, EXAMINING ATTORNEY

**CLASS 42—(Continued).**

SN 85-009,127. EIFLER, PETER, BAD VILBEL, FED REP GERMANY, FILED 4-8-2010.

# FEELRACE

THE MARK CONSISTS OF STANDARD CHARACTERS WITHOUT CLAIM TO ANY PARTICULAR FONT, STYLE, SIZE, OR COLOR.

FOR PROVIDING A WEB SITE FEATURING TEMPORARY USE OF NON-DOWNLOADABLE SOFTWARE ALLOWING WEB SITE USERS AND PARTICIPANTS IN SPORTING EVENTS TO POST EXPECTED RACE TIMES AND ACTUAL RACE FINISH TIMES WHICH ALLOWS FOR COMPARISON AND ANALYSIS; PROVIDING AN ONLINE ELECTRONIC PORTAL FEATURING ON-LINE NON-DOWNLOADABLE SOFTWARE FOR BENCHMARKING RACE TIMES FOR RACE PARTICIPANTS (U.S. CLS. 100 AND 101).

KHANH LE, EXAMINING ATTORNEY

SN 85-013,218. J-U-B ENGINEERS, INC., KENNEWICK, WA, FILED 4-13-2010.

# J-U-B

THE MARK CONSISTS OF STANDARD CHARACTERS WITHOUT CLAIM TO ANY PARTICULAR FONT, STYLE, SIZE, OR COLOR.

FOR CIVIL ENGINEERING; SURVEYING SERVICES; PLANNING AND ENGINEERING SERVICES, NAMELY, MODELING AND MASTER PLANNING IN THE FIELDS OF CIVIL ENGINEERING, WATER, WASTEWATER, INFRASTRUCTURE, AND BUILDINGS; ENGINEERING SERVICES UTILIZING GEOGRAPHIC INFORMATION SYSTEMS, NAMELY, LOCATING AND MAPPING OF INFRASTRUCTURE ASSETS (U.S. CLS. 100 AND 101).

FIRST USE 5-1-1954; IN COMMERCE 5-1-1954.

ESTHER BELENKER, EXAMINING ATTORNEY

SN 85-017,115. PRIMEPAY, INC., WEST CHESTER, PA, FILED 4-19-2010.

# 3E

THE MARK CONSISTS OF STANDARD CHARACTERS WITHOUT CLAIM TO ANY PARTICULAR FONT, STYLE, SIZE, OR COLOR.

FOR PROVIDING ON-LINE NON-DOWNLOADABLE SOFTWARE TO ENABLE REMOTE AND SECURE ACCESS TO AND PROCESSING OF EMPLOYEE DATA AND PAYROLL INFORMATION, AND THE ELECTRONIC ADMINISTRATION AND MANAGEMENT THEREOF (U.S. CLS. 100 AND 101).

CHARISMA HAMPTON, EXAMINING ATTORNEY

**CLASS 42—(Continued).**

SN 85-019,647. PRIMEPAY, INC., WEST CHESTER, PA. FILED 4-21-2010.

**3E BY PRIMEPAY**

THE MARK CONSISTS OF STANDARD CHARACTERS WITHOUT CLAIM TO ANY PARTICULAR FONT, STYLE, SIZE, OR COLOR.

OWNER OF U.S. REG. NOS. 2,056,092, 2,294,575 AND 2,932,453.

FOR PROVIDING ON-LINE NON-DOWNLOADABLE SOFTWARE TO ENABLE REMOTE AND SECURE ACCESS TO AND PROCESSING OF EMPLOYEE DATA AND PAYROLL INFORMATION, AND THE ELECTRONIC ADMINISTRATION AND MANAGEMENT THEREOF (U.S. CLS. 100 AND 101).

FIRST USE 2-18-2009; IN COMMERCE 2-18-2009.  
CHARISMA HAMPTON, EXAMINING ATTORNEY

---

SN 85-027,991. LINKABLE, LLC, WILMINGTON, DE. FILED 4-30-2010.

**Linkable**

THE MARK CONSISTS OF STANDARD CHARACTERS WITHOUT CLAIM TO ANY PARTICULAR FONT, STYLE, SIZE, OR COLOR.

FOR APPLICATION SERVICE PROVIDER FEATURING APPLICATION PROGRAMMING INTERFACE (API) SOFTWARE FOR ALLOWING INTERNET USERS TO CREATE, BOOKMARK, ANNOTATE, AND PUBLICLY SHARE DATA (U.S. CLS. 100 AND 101).

ALYSSA STEEL, EXAMINING ATTORNEY

---

SN 85-029,654. APPTIS HOLDINGS, INC., CHANTILLY, VA. FILED 5-4-2010.

**APPTIS INSIGHT**

THE MARK CONSISTS OF STANDARD CHARACTERS WITHOUT CLAIM TO ANY PARTICULAR FONT, STYLE, SIZE, OR COLOR.

OWNER OF U.S. REG. NOS. 2,997,846, 3,011,003 AND 3,062,390.

FOR COMPUTER PROJECT MANAGEMENT SERVICES; CONSULTING IN THE FIELD OF IT PROJECT MANAGEMENT; AND PROVIDING QUALITY ASSURANCE SERVICES IN THE FIELD OF GOVERNMENT CONTRACTS AND PROJECTS (U.S. CLS. 100 AND 101).

WILLIAM P. SHANAHAN, EXAMINING ATTORNEY

**CLASS 42—(Continued).**

SN 85-032,730. THE TRAVELERS INDEMNITY COMPANY, HARTFORD, CT. FILED 5-7-2010.

**SMART CLASSIFICATION**

THE MARK CONSISTS OF STANDARD CHARACTERS WITHOUT CLAIM TO ANY PARTICULAR FONT, STYLE, SIZE, OR COLOR.

NO CLAIM IS MADE TO THE EXCLUSIVE RIGHT TO USE "CLASSIFICATION", APART FROM THE MARK AS SHOWN.

FOR PROVIDING AN ONLINE NON-DOWNLOADABLE SOFTWARE FOR INSURANCE AGENTS TO CLASSIFY BUSINESSES FOR QUOTING AND UNDERWRITING INSURANCE POLICIES (U.S. CLS. 100 AND 101).

LINDSEY RUBIN, EXAMINING ATTORNEY

---

SN 85-033,188. MEDTHINK COMMUNICATIONS, INC., RALEIGH, NC. FILED 5-7-2010.

**MEDTHINK MONITOR**

THE MARK CONSISTS OF STANDARD CHARACTERS WITHOUT CLAIM TO ANY PARTICULAR FONT, STYLE, SIZE, OR COLOR.

OWNER OF U.S. REG. NOS. 3,084,859 AND 3,780,346.

FOR PROVIDING TEMPORARY USE OF ON-LINE NON-DOWNLOADABLE SOFTWARE FOR TRACKING AND COMPILING INFORMATION RELATED TO THE DEVELOPMENT OF PHARMACEUTICAL PRODUCTS AND THE TREATMENT OF DISEASES IN THE FIELD OF DRUG DEVELOPMENT (U.S. CLS. 100 AND 101).

YAT SYE, LEE, EXAMINING ATTORNEY

**CLASS 42—(Continued).**

SN 85-034,335. BUILDING HEALTHY LIVES FOUNDATION, CINCINNATI, OH. FILED 5-10-2010.



OWNER OF U.S. REG. NO. 3,551,819.  
 NO CLAIM IS MADE TO THE EXCLUSIVE RIGHT TO USE "FITNESS", "NUTRITION", "SELF-ESTEEM", AND "ENVIRONMENT", APART FROM THE MARK AS SHOWN.  
 THE MARK CONSISTS OF A QUADRANT OF FOUR CIRCLES WITH THE CIRCLE IN UPPER LEFT CONTAINING AN APPLE, THE UPPER RIGHT IS A GLOBE, THE LOWER LEFT IS A SOCCER BALL AND THE LOWER RIGHT CONSISTS OF CLASPING HANDS WITH THE WORDING "SPEAKING TO KIDS ABOUT HEALTH" AND "FITNESS" - "NUTRITION" - "SELF-ESTEEM" - "ENVIRONMENT" TO RIGHT OF THE QUADRANT.  
 FOR HOSTING AN ON-LINE COMMUNITY WEB SITE FEATURING INFORMATION IN THE FIELD OF KIDS' HEALTH; HOSTING AN ON-LINE WEBSITE REGARDING THE EDUCATION OF ADULTS AND KIDS IN THE FIELD OF KIDS' HEALTH, IN PARTICULAR AS IT RELATES TO THEIR INTERACTIVE ROLES WITH EACH OTHER (U.S. CLS. 100 AND 101).  
 LAURA HAMMEL, EXAMINING ATTORNEY

SN 85-034,967. CHAINDRUGSTORE.NET INCORPORATED, ALEXANDRIA, VA. FILED 5-11-2010.

**SIMPLE. TRANSPARENT.**

THE MARK CONSISTS OF STANDARD CHARACTERS WITHOUT CLAIM TO ANY PARTICULAR FONT, STYLE, SIZE, OR COLOR.  
 FOR BUSINESS-TO-BUSINESS TECHNOLOGY PLATFORM IN THE NATURE OF PROVIDING TEMPORARY USE OF ON-LINE NON-DOWNLOADABLE SOFTWARE THAT FACILITATES THE PROCUREMENT AND DELIVERY OF PRODUCTS BETWEEN MANUFACTURERS AND PURCHASERS (U.S. CLS. 100 AND 101).  
 BRIAN PINO, EXAMINING ATTORNEY

**CLASS 42—(Continued).**

SN 85-038,327. IMEDIA DIGITAL MARKETING INC., SOUTH PASADENA, CA. FILED 5-13-2010.

**Dynamic Color Resonance**

THE MARK CONSISTS OF STANDARD CHARACTERS WITHOUT CLAIM TO ANY PARTICULAR FONT, STYLE, SIZE, OR COLOR.  
 NO CLAIM IS MADE TO THE EXCLUSIVE RIGHT TO USE "DYNAMIC COLOR", APART FROM THE MARK AS SHOWN.  
 FOR APPLICATION SERVICE PROVIDER (ASP) FEATURING SOFTWARE FOR USE IN COMPUTERIZED DYNAMIC ALLOCATION OF COLOR GRAPHICS INFORMATION INCLUDING ELECTRONIC COLOR HUES, TINTS AND SATURATION VALUES TO ELECTRONIC HARDWARE AND SOFTWARE DEVICES AND APPLICATIONS VIA CASCADING STYLE SHEETS AND OTHER FORMS OF ELECTRONIC CODING (U.S. CLS. 100 AND 101).  
 ANNE MADDEN, EXAMINING ATTORNEY

SN 85-039,180. ALLVIANT CORPORATION, SCOTTSDALE, AZ. FILED 5-14-2010.

**ALLVIANT**

THE MARK CONSISTS OF STANDARD CHARACTERS WITHOUT CLAIM TO ANY PARTICULAR FONT, STYLE, SIZE, OR COLOR.  
 FOR APPLICATION SERVICE PROVIDER (ASP) FEATURING SOFTWARE FOR GENERATING AND COORDINATING MESSAGES THAT ARE TRANSMITTED TO USERS VIA A GLOBAL COMPUTER NETWORK OR VIA TELEPHONY; APPLICATION SERVICE PROVIDER (ASP) FEATURING SOFTWARE FOR PROVIDING CONSUMER INFORMATION IN THE FIELDS OF HEALTH SERVICES, HEALTH BENEFITS, FINANCE, INSURANCE, TRAVEL, FOOD, ENTERTAINMENT, SHOPPING, NEWS AND EDUCATION VIA A GLOBAL COMPUTER NETWORK OR VIA TELEPHONY; PROVIDING TEMPORARY USE OF NON-DOWNLOADABLE SOFTWARE FOR USE IN COORDINATING THIRD PARTY INFORMATION TO GENERATE AND TRANSMIT MESSAGES TO USERS VIA A GLOBAL COMPUTER NETWORK OR VIA TELEPHONY (U.S. CLS. 100 AND 101).  
 FIRST USE 6-5-2009; IN COMMERCE 6-5-2009.  
 PRISCILLA MILTON, EXAMINING ATTORNEY

**CLASS 42—(Continued).**

SN 85-040,694. ALLVIANT CORPORATION, ACOTTSDALE, AZ. FILED 5-17-2010.



THE MARK CONSISTS OF THE WORDING "ALLVIANT" WITH A STAR ABOVE THE "I" AND A WEDGE BELOW THE WORD.

FOR APPLICATION SERVICE PROVIDER (ASP) FEATURING SOFTWARE FOR GENERATING AND COORDINATING MESSAGES THAT ARE TRANSMITTED TO USERS VIA A GLOBAL COMPUTER NETWORK OR VIA TELEPHONY; APPLICATION SERVICE PROVIDER (ASP) FEATURING SOFTWARE FOR PROVIDING CONSUMER INFORMATION IN THE FIELDS OF HEALTH SERVICES, HEALTH BENEFITS, FINANCE, INSURANCE, TRAVEL, FOOD, ENTERTAINMENT, SHOPPING, NEWS AND EDUCATION VIA A GLOBAL COMPUTER NETWORK OR VIA TELEPHONY; PROVIDING TEMPORARY USE OF NON-DOWNLOADABLE SOFTWARE FOR USE IN COORDINATING THIRD PARTY INFORMATION TO GENERATE AND TRANSMIT MESSAGES TO USERS VIA A GLOBAL COMPUTER NETWORK OR VIA TELEPHONY (U.S. CLS. 100 AND 101).

FIRST USE 6-5-2009; IN COMMERCE 6-5-2009.  
PRISCILLA MILTON, EXAMINING ATTORNEY

**CLASS 42—(Continued).**

SN 85-042,469. THERAGENCE, INC., SAN DIEGO, CA. FILED 5-19-2010.

## THERAGENCE

THE MARK CONSISTS OF STANDARD CHARACTERS WITHOUT CLAIM TO ANY PARTICULAR FONT, STYLE, SIZE, OR COLOR.

THE WORDING "THERAGENCE" HAS NO MEANING IN A FOREIGN LANGUAGE.

FOR COMPUTER SERVICES, NAMELY, PROVIDING ANALYSIS OF DATA IN THE FIELDS OF PHARMACEUTICAL DRUG RESEARCH AND DEVELOPMENT, AND COMPUTER SCIENCE; COMPUTER SERVICES, NAMELY, PROVIDING ASSESSMENT OF DATA IN THE FIELDS OF PHARMACEUTICAL DRUG RESEARCH AND DEVELOPMENT, AND COMPUTER SCIENCE; CONSULTATION SERVICES IN THE FIELDS OF PHARMACEUTICAL DRUG RESEARCH AND DEVELOPMENT, AND COMPUTER SCIENCE; COMPUTER SERVICES, NAMELY, PROVIDING ANALYSIS AND ASSESSMENT OF DATA IN THE FIELD OF DRUG DEVELOPMENT, NAMELY, THERAPEUTIC DEVELOPMENT AND BIOLOGY IN THE FIELD OF GENOMICS; CONSULTATION SERVICES IN THE FIELD OF DRUG DEVELOPMENT, NAMELY, THERAPEUTIC DEVELOPMENT AND BIOLOGY IN THE FIELD OF GENOMICS (U.S. CLS. 100 AND 101).

FIRST USE 12-16-2009; IN COMMERCE 12-16-2009.  
NAKIA HENRY, EXAMINING ATTORNEY

SN 85-042,076. UNIFIED DESIGN CORPORATION, ROCKAWAY, NJ. FILED 5-18-2010.

## UNIFIED DESIGN

THE MARK CONSISTS OF STANDARD CHARACTERS WITHOUT CLAIM TO ANY PARTICULAR FONT, STYLE, SIZE, OR COLOR.

NO CLAIM IS MADE TO THE EXCLUSIVE RIGHT TO USE "DESIGN", APART FROM THE MARK AS SHOWN.

FOR PRODUCT DESIGN AND DEVELOPMENT, ENGINEERING SERVICES, GRAPHIC DESIGN (U.S. CLS. 100 AND 101).

FIRST USE 2-23-2001; IN COMMERCE 2-23-2001.  
ROBERT STRUCK, EXAMINING ATTORNEY

SN 85-042,562. BRUZOS, ANGEL, NEWPORT BEACH, CA. FILED 5-19-2010.

## LEANGO ANALYTICS

THE MARK CONSISTS OF STANDARD CHARACTERS WITHOUT CLAIM TO ANY PARTICULAR FONT, STYLE, SIZE, OR COLOR.

NO CLAIM IS MADE TO THE EXCLUSIVE RIGHT TO USE "ANALYTICS", APART FROM THE MARK AS SHOWN.

FOR COMPUTER SERVICE, NAMELY, ACTING AS AN APPLICATION SERVICE PROVIDER IN THE FIELD OF KNOWLEDGE MANAGEMENT TO HOST COMPUTER APPLICATION SOFTWARE FOR THE COLLECTION, EDITING, ORGANIZING, MODIFYING, BOOK MARKING, TRANSMISSION, STORAGE AND SHARING OF DATA AND INFORMATION (U.S. CLS. 100 AND 101).

SUNG IN, EXAMINING ATTORNEY



**CLASS 42—(Continued).**

SN 85-048,857. APEX IMPACT MARKETING, LLC, DBA FOCUSMX, LEWES, DE. FILED 5-26-2010.

# FocusMX

THE MARK CONSISTS OF STANDARD CHARACTERS WITHOUT CLAIM TO ANY PARTICULAR FONT, STYLE, SIZE, OR COLOR.

FOR BUILDING AND MAINTAINING WEBSITES (U.S. CLS. 100 AND 101).

FIRST USE 2-1-2004; IN COMMERCE 2-1-2004.  
MIDGE BUTLER, EXAMINING ATTORNEY

**CLASS 42—(Continued).**

SN 85-050,393. ROBERT L. O'BLOCK REVOCABLE TRUST, SPRINGFIELD, MO. FILED 5-28-2010.



OWNER OF U.S. REG. NOS. 2,342,960, 3,835,060 AND OTHERS.

NO CLAIM IS MADE TO THE EXCLUSIVE RIGHT TO USE "AMERICAN BOARD FOR CERTIFICATION IN INFRASTRUCTURE PROTECTION", APART FROM THE MARK AS SHOWN.

FOR TESTING, ANALYSIS, AND EVALUATION OF THE SERVICES OF OTHERS FOR THE PURPOSE OF CERTIFICATION IN THE FIELD OF INFRASTRUCTURE PROTECTION (U.S. CLS. 100 AND 101).

FIRST USE 4-23-2010; IN COMMERCE 4-23-2010.  
MARIA-VICTORIA SUAREZ, EXAMINING ATTORNEY

SN 85-052,258. REZOLT CORPORATION, SARATOGA, CA. FILED 6-1-2010.

THE COLOR(S) BLUE AND RED IS/ARE CLAIMED AS A FEATURE OF THE MARK.

THE MARK CONSISTS OF THE WORD "REZOLT" WITH ALL LETTERS IN BLUE BESIDE THE LETTER "Z" WHICH IS IN RED AND LARGER THAN THE OTHER LETTERS.

FOR DESIGN AND DEVELOPMENT OF HARDWARE FOR EMBEDDED COMPUTER SYSTEMS; HARDWARE DESIGN SERVICES FOR EMBEDDED COMPUTER SYSTEMS; DESIGN AND DEVELOPMENT OF SOFTWARE FOR EMBEDDED SYSTEMS FOR NETWORK CONNECTIVITY, NAMELY, SOFTWARE FOR WIRED AND WIRELESS COMMUNICATIONS, SECURITY, PROVIDING APPLICATION DEVELOPMENT PLATFORMS FOR CUSTOMERS APPLICATIONS, AS WELL AS APPLICATIONS SOFTWARE; CONSULTING IN THE USE OF EMBEDDED SYSTEMS, NAMELY, CONSULTING SERVICES IN THE FIELD OF DESIGN, SELECTION, IMPLEMENTATION AND USE OF EMBEDDED COMPUTER HARDWARE AND SOFTWARE SYSTEMS FOR OTHERS, COMPUTER HARDWARE CONSULTING FOR EMBEDDED SYSTEMS; HARDWARE AND SOFTWARE SERVICES FOR EMBEDDED SYSTEMS, NAMELY, COMPUTER HARDWARE AND SOFTWARE CONSULTING, COMPUTER PROGRAMMING AND SOFTWARE DESIGN (U.S. CLS. 100 AND 101).

SAIMA MAKHDUM, EXAMINING ATTORNEY

SN 85-049,981. KHOUEIRY, ALAIN, BEIRUT, LEBANON, FILED 5-28-2010.

# FLIPPER7

THE MARK CONSISTS OF STANDARD CHARACTERS WITHOUT CLAIM TO ANY PARTICULAR FONT, STYLE, SIZE, OR COLOR.

FOR COMPUTER SERVICES, NAMELY, CREATING AN ON-LINE COMMUNITY FOR REGISTERED USERS TO PARTICIPATE IN DISCUSSIONS, GET FEEDBACK FROM THEIR PEERS, FORM VIRTUAL COMMUNITIES, AND ENGAGE IN SOCIAL NETWORKING (U.S. CLS. 100 AND 101).

PAM WILLIS, EXAMINING ATTORNEY

**CLASS 42—(Continued).**

SN 85-055,204. AURIONPRO SOLUTIONS, INC., SAN RAMON, CA. FILED 6-4-2010.

# SENA

THE MARK CONSISTS OF STANDARD CHARACTERS WITHOUT CLAIM TO ANY PARTICULAR FONT, STYLE, SIZE, OR COLOR.

THE WORDING "SENA" HAS NO MEANING IN A FOREIGN LANGUAGE.

FOR COMPUTER CONSULTATION IN THE FIELD OF COMPUTER SECURITY; COMPUTER SECURITY CONSULTANCY; COMPUTER SECURITY CONSULTANCY IN THE FIELD OF SCANNING AND PENETRATION TESTING OF COMPUTERS AND NETWORKS TO ASSESS INFORMATION SECURITY VULNERABILITY; COMPUTER SECURITY SERVICE, NAMELY, RESTRICTING ACCESS TO AND BY COMPUTER NETWORKS TO AND OF UNDESIRED WEB SITES, MEDIA AND INDIVIDUALS AND FACILITIES; COMPUTER SERVICES, NAMELY, REMOTE AND ON-SITE MANAGEMENT OF THE INFORMATION TECHNOLOGY (IT) SYSTEMS OF OTHERS; COMPUTER SYSTEMS INTEGRATION SERVICES; CONSULTING IN THE FIELD OF INFORMATION TECHNOLOGY; DESIGN AND DEVELOPMENT OF ELECTRONIC DATA SECURITY SYSTEMS; DESIGN OF COMPUTER DATABASE; DEVELOPMENT OF CUSTOMIZED SOFTWARE FOR OTHERS FOR USE IN RISK ASSESSMENT, INFORMATION SECURITY, BUSINESS ANALYSIS, AUDIT AND AUDIT PLANNING, AND SALES MANAGEMENT; INFORMATION TECHNOLOGY CONSULTATION; INTEGRATION OF COMPUTER SYSTEMS AND NETWORKS; IT INTEGRATION SERVICES (U.S. CLS. 100 AND 101).

FIRST USE 2-28-1999; IN COMMERCE 2-28-1999.  
SARA BENJAMIN, EXAMINING ATTORNEY

SN 85-056,950. CMPMR, LLC, NORTH DARTMOUTH, MA. FILED 6-8-2010.

# EMERALD EMR

THE MARK CONSISTS OF STANDARD CHARACTERS WITHOUT CLAIM TO ANY PARTICULAR FONT, STYLE, SIZE, OR COLOR.

NO CLAIM IS MADE TO THE EXCLUSIVE RIGHT TO USE "EMR", APART FROM THE MARK AS SHOWN.

FOR SOFTWARE AS A SERVICE (SAAS) SERVICES FEATURING SOFTWARE FOR MAINTAINING PATIENT RECORDS, GENERATING ELECTRONIC PRESCRIPTIONS, AND MAINTAINING PROCEDURE AND DIAGNOSTIC CODES IN THE FIELD OF MEDICAL PRACTICE MANAGEMENT, AND NOT FOR USE IN CONNECTION WITH AN ACCOUNTS RECEIVABLE DATABASE (U.S. CLS. 100 AND 101).

JENNIFER VASQUEZ, EXAMINING ATTORNEY

**CLASS 42—(Continued).**

SN 85-064,349. SCIENTIFIC CONSERVATION INC., ATLANTA, GA. FILED 6-16-2010.

# SCIENERGY

THE MARK CONSISTS OF STANDARD CHARACTERS WITHOUT CLAIM TO ANY PARTICULAR FONT, STYLE, SIZE, OR COLOR.

FOR SOFTWARE AS A SERVICE (SAAS) SERVICES FEATURING SOFTWARE FOR THE COLLECTION, ANALYSIS AND MANAGEMENT OF DATA IN THE FIELD OF MEASURABLE AND VERIFIABLE BASELINING, OPTIMIZATION, AND PREDICTIONS OF UTILITY USE FOR COMMERCIAL BUILDINGS (U.S. CLS. 100 AND 101).

FIRST USE 5-9-2010; IN COMMERCE 5-9-2010.  
JEFF DEFORD, EXAMINING ATTORNEY

SN 85-065,271. DONAGHY, BRIAN P., WEST DES MOINES, IA. FILED 6-17-2010.

# appcore

THE MARK CONSISTS OF THE WORD "APPCORE" IN STYLIZED LETTERS.

FOR COMPUTER AND SOFTWARE SERVICES, NAMELY, DESIGN, CREATION, HOSTING AND MAINTENANCE OF INTERNET SITES FOR THIRD PARTIES, AND REMOTE AND ON-SITE MANAGEMENT OF THE INFORMATION TECHNOLOGY (IT) SYSTEMS OF OTHERS; COMPUTER SERVICES, NAMELY, REMOTE AND ON-SITE MANAGEMENT OF CLOUD AND VIRTUALIZED COMPUTING SYSTEMS AND APPLICATIONS FOR OTHERS; APPLICATION SERVICE PROVIDER, NAMELY, HOSTING, MANAGING, DEVELOPING AND MAINTAINING APPLICATIONS, SOFTWARE, WEBSITES, AND DATABASES OF OTHERS IN THE FIELDS OF BUSINESS, MARKETING, DESIGN, DATA ANALYSIS, EDITING, CONTENT DEVELOPMENT, LEGAL SERVICES, HEALTHCARE, COMMUNICATIONS, ENERGY, ENGINEERING, FINANCE, EDUCATION, AND GOVERNMENT; CLOUD AND VIRTUALIZED COMPUTING FEATURING SOFTWARE FOR USE AS INTERNET-BASED APPLICATIONS FOR USE IN DATABASE MANAGEMENT, FOR USE AS SPREADSHEETS, DOCUMENTS, AND IMAGES, FOR WORD PROCESSING, FOR FILE CREATION, FOR CONTENT EDITING, AND FOR INTERACTIVE WEBSITES; CONSULTING SERVICES IN THE FIELD OF CLOUD AND VIRTUALIZED COMPUTING; TECHNICAL CONSULTING SERVICES IN THE FIELD OF PUBLIC AND PRIVATE CLOUD AND VIRTUALIZED COMPUTING SOLUTIONS; TECHNICAL SUPPORT SERVICES, NAMELY, REMOTE AND ON-SITE INFRASTRUCTURE MANAGEMENT SERVICES FOR MONITORING, ADMINISTRATION AND MANAGEMENT OF PUBLIC AND PRIVATE CLOUD AND VIRTUALIZED COMPUTING IT, SOFTWARE, AND APPLICATION SYSTEMS; SOFTWARE DEVELOPMENT SERVICES, NAMELY, DEVELOPMENT OF SOFTWARE OPERABLE WITH CLOUD AND VIRTUALIZED COMPUTING SYSTEMS (U.S. CLS. 100 AND 101).

FIRST USE 5-20-2010; IN COMMERCE 5-20-2010.  
DAVID ELTON, EXAMINING ATTORNEY

**CLASS 42—(Continued).**

SN 85-068,298. TELAPPRISE LLC, SAN JOSE, CA. FILED 6-22-2010.



THE COLOR(S) DARK GREEN AND LIGHT GREEN IS/ ARE CLAIMED AS A FEATURE OF THE MARK.

THE MARK CONSISTS OF THE WORDING "TELAPPRISE" IN STYLIZED FONT, ALL CAPITAL LETTERS, AND THE COLOR DARK GREEN, APPEARING TO THE LEFT OF THE "TELAPPRISE" WORDING TWELVE LIGHT GREEN GEOMETRIC OBJECTS APPEARING IN A THREE BY FOUR CONFIGURATION.

THE WORDING "TELAPPRISE" HAS NO MEANING IN A FOREIGN LANGUAGE.

FOR CONSULTING IN THE FIELD OF TELECOMMUNICATIONS TECHNOLOGY; COMPUTER PROJECT MANAGEMENT SERVICES IN THE FIELD OF TELECOMMUNICATIONS (U.S. CLS. 100 AND 101).

FIRST USE 8-18-2008; IN COMMERCE 8-18-2008.  
NICHOLAS ALTREE, EXAMINING ATTORNEY

---

SN 85-071,288. NUDYN TECHNOLOGIES, INC., SAN DIEGO, CA. FILED 6-24-2010.

**NUDYN**

THE MARK CONSISTS OF STANDARD CHARACTERS WITHOUT CLAIM TO ANY PARTICULAR FONT, STYLE, SIZE, OR COLOR.

FOR PROVIDING A WEBSITE FEATURING TEMPORARY USE OF ON-LINE NON-DOWNLOADABLE SOFTWARE FOR USERS TO MONITOR, MANAGE, AND ANALYZE RESIDENTIAL ENERGY PRODUCTION AND USAGE, TO OBTAIN INFORMATION FROM UTILITY COMPANIES, AND TO OBTAIN INFORMATION ON OPTIMAL PLACEMENT OF SOLAR COMPONENTS AND PRODUCTS ACCESSIBLE VIA MOBILE DEVICES AND THE WORLD WIDE WEB (U.S. CLS. 100 AND 101).

DAWN FELDMAN, EXAMINING ATTORNEY

**CLASS 42—(Continued).**

SN 85-074,835. BOARD OF TRUSTEES, MINNESOTA STATE COLLEGES AND UNIVERSITIES, AKA MNSCU, ST. PAUL, MN. FILED 6-30-2010.

**eFolioWorld**

THE MARK CONSISTS OF STANDARD CHARACTERS WITHOUT CLAIM TO ANY PARTICULAR FONT, STYLE, SIZE, OR COLOR.

FOR APPLICATION SERVICE PROVIDER (ASP) FEATURING SOFTWARE FOR USE IN BUILDING ELECTRONIC PORTFOLIOS USED TO DOCUMENT, MANAGE, AND DISPLAY STUDENT BODY ENROLLMENT, GRADUATION DEMOGRAPHICS AND ACADEMIC PROGRAM INFORMATION FOR ACCREDITATION PURPOSES FOR INSTITUTIONS OF HIGHER EDUCATION, SOFTWARE FOR USE BY STUDENTS TO BUILD THEIR OWN ELECTRONIC PORTFOLIOS USED TO DOCUMENT, MANAGE, AND DISPLAY STUDENT LEARNING ACHIEVEMENT, NAMELY, STUDENT EDUCATIONAL HISTORIES, AND EDUCATIONAL SOFTWARE FOR USE BY TEACHERS AND FACULTY IN COMPETENCY-BASED INSTRUCTION IN K-12 AND POST SECONDARY EDUCATIONAL ENVIRONMENTS TO DOCUMENT, MANAGE, AND DISPLAY STUDENT ACADEMIC PROGRESS AND INFORMATION (U.S. CLS. 100 AND 101).

FIRST USE 7-1-2008; IN COMMERCE 7-1-2008.

ANTHONY RINKER, EXAMINING ATTORNEY

---

SN 85-076,957. LIVEYEARBOOK, INC., NEENAH, WI. FILED 7-2-2010.

**LIVEYEARBOOK**

THE MARK CONSISTS OF STANDARD CHARACTERS WITHOUT CLAIM TO ANY PARTICULAR FONT, STYLE, SIZE, OR COLOR.

OWNER OF U.S. REG. NO. 2,985,066.

FOR COMPUTER SERVICES, NAMELY, PROVIDING AN INTERACTIVE WEB SITE THAT ALLOWS USERS TO CREATE AND GENERATE THEIR OWN CUSTOMIZED MULTIMEDIA BOOKS, NAMELY, REFERENCE BOOKS, YEARBOOKS, SCHOOL YEARBOOKS, AFFINITY-BASED BOOKS, DIRECTORIES, ACTIVITY BOOKS AND MEMORY BOOKS (U.S. CLS. 100 AND 101).

RUSS HERMAN, EXAMINING ATTORNEY

**CLASS 42—(Continued).**

SN 85-088,622. FITSEVEN INC., BURLINGAME, CA. FILED 7-20-2010.

**GYMGA**

THE MARK CONSISTS OF STANDARD CHARACTERS WITHOUT CLAIM TO ANY PARTICULAR FONT, STYLE, SIZE, OR COLOR.

FOR PROVIDING A WEB SITE FEATURING TECHNOLOGY THAT ENABLES USERS TO REQUEST AND RECORD IDEAS, SUGGESTIONS, AND COMMENTS FROM OTHER USERS IN THE FIELDS OF PHYSICAL FITNESS AND HEALTHY EATING HABITS (U.S. CLS. 100 AND 101).

TRACY WHITTAKER-BROWN, EXAMINING ATTORNEY

---

SN 85-088,802. AURORA BANK FSB, WILMINGTON, DE. FILED 7-20-2010.

**AURORA BANK WEALTH MANAGER**

THE MARK CONSISTS OF STANDARD CHARACTERS WITHOUT CLAIM TO ANY PARTICULAR FONT, STYLE, SIZE, OR COLOR.

OWNER OF U.S. REG. NOS. 3,188,673, 3,268,157 AND 3,354,898.

NO CLAIM IS MADE TO THE EXCLUSIVE RIGHT TO USE "BANK WEALTH MANAGER", APART FROM THE MARK AS SHOWN.

FOR PROVIDING TEMPORARY USE OF ON-LINE NON-DOWNLOADABLE SOFTWARE FOR ENABLING BANKING CUSTOMERS TO SET UP AUTOMATED TRANSACTIONS, ELECTRONIC FUND TRANSFERS AND ONLINE BILL PAYMENT, MANAGE BANKING ACCOUNTS, CREDIT CARD ACCOUNTS, CERTIFICATES OF DEPOSIT, RETIREMENT SAVINGS ACCOUNTS, LOAN AND MORTGAGE ACCOUNTS, AND TO MANAGE FINANCIAL PORTFOLIOS (U.S. CLS. 100 AND 101).

TARA PATE, EXAMINING ATTORNEY

---

SN 85-097,909. EXPAN, INC., NEW YORK, NY. FILED 8-20-2010.

**EXPAN**

THE MARK CONSISTS OF STANDARD CHARACTERS WITHOUT CLAIM TO ANY PARTICULAR FONT, STYLE, SIZE, OR COLOR.

FOR CLOUD COMPUTING FEATURING TECHNOLOGY, DATA AND SOFTWARE FOR USE IN CONNECTION WITH THE FINANCIAL SERVICES SECTOR (U.S. CLS. 100 AND 101).

SUSAN LESLIE DUBOIS, EXAMINING ATTORNEY

**CLASS 42—(Continued).**

SN 85-103,291. SILKROAD TECHNOLOGY, INC., WINSTON-SALEM, NC. FILED 8-9-2010.

**WINGSPAN**

THE MARK CONSISTS OF STANDARD CHARACTERS WITHOUT CLAIM TO ANY PARTICULAR FONT, STYLE, SIZE, OR COLOR.

FOR PROVIDING TEMPORARY USE OF ONLINE NON-DOWNLOADABLE SOFTWARE FOR USE IN THE FIELDS OF HUMAN RESOURCES, EMPLOYEE PERFORMANCE MANAGEMENT, AND USER MANUALS, SOLD TOGETHER AS A UNIT; PROVIDING TEMPORARY USE OF NON-DOWNLOADABLE SOFTWARE FOR USE IN THE FIELDS OF EMPLOYEE COMPENSATION, EMPLOYEE TRAINING MANAGEMENT, INTRANET CONTENT MANAGEMENT, AND EMPLOYEE RECORDS MANAGEMENT; CONSULTING SERVICES IN THE FIELD OF HUMAN RESOURCES SOFTWARE IMPLEMENTATION (U.S. CLS. 100 AND 101).

FIRST USE 10-0-2005; IN COMMERCE 10-0-2005.  
ALLISON SCHRODY, EXAMINING ATTORNEY

---

SN 85-110,176. LIVEWIRE MOBILE, INC., LITTLETON, MA. FILED 8-18-2010.

**MEDIADROME**

THE MARK CONSISTS OF STANDARD CHARACTERS WITHOUT CLAIM TO ANY PARTICULAR FONT, STYLE, SIZE, OR COLOR.

FOR PROVIDING ONLINE NON-DOWNLOADABLE SOFTWARE FOR WEBSITE DEVELOPMENT AND WEBSITE MANAGEMENT FOR USE BY RECORDING ARTISTS AND RECORD LABELS TO SELL AND MANAGE CONTENT; PROVIDING ON-LINE NON-DOWNLOADABLE SOFTWARE FOR MOBILE COMMUNICATION DEVICES FOR USE IN DESIGNING ON-LINE RETAIL WEBSITES, AND FOR USE IN REPORTING OF ONLINE WEBSITE PERFORMANCE (U.S. CLS. 100 AND 101).

BARBARA GAYNOR, EXAMINING ATTORNEY

**CLASS 42—(Continued).**

SN 85-115,387. NEXTERA ENERGY, INC., JUNO BEACH, FL. FILED 8-25-2010.

**WindLogics**

OWNER OF U.S. REG. NOS. 2,877,134 AND 3,042,903.  
THE MARK CONSISTS OF THE WORD "WINDLOGICS" WITH AN UPPER CASE "W" AND AN UPPER CASE "L" WITH THE WORD "WIND" APPEARING IN BOLD FONT. FOR CONSULTING RELATING TO STUDYING, MODELING AND FORECASTING METEOROLOGICAL AIR FLOW (U.S. CLS. 100 AND 101).  
FIRST USE 1-30-2003; IN COMMERCE 1-30-2003.  
MICHELE SWAIN, EXAMINING ATTORNEY

**CLASS 42—(Continued).**

SN 85-121,288. SPARKPLACE, INC., BOULDER, CO. FILED 9-1-2010.

**SPARKPLACE**

THE MARK CONSISTS OF STANDARD CHARACTERS WITHOUT CLAIM TO ANY PARTICULAR FONT, STYLE, SIZE, OR COLOR.  
FOR COMPUTER SERVICES, NAMELY, CREATING AN ONLINE COMMUNITY FOR REGISTERED USERS TO PARTICIPATE IN DISCUSSIONS, GET FEEDBACK FROM THEIR PEERS, FORM VIRTUAL COMMUNITIES, ENGAGE IN SOCIAL NETWORKING, UPLOAD IMAGES, TEXT, MULTIMEDIA CONTENT AND OTHER USER-GENERATED CONTENT AND SHARE INFORMATION, RECOMMENDATIONS, COMMENTARY AND EXPERIENCES IN THE FIELD OF TRAVEL, HOTELS, TEMPORARY ACCOMMODATIONS, RESTAURANTS, TOURS, ATTRACTIONS, POINTS OF INTEREST AND ACTIVITIES (U.S. CLS. 100 AND 101).  
JULIE WATSON, EXAMINING ATTORNEY

SN 85-119,086. REDPOINT GLOBAL INC., WELLESLEY HILLS, MA. FILED 8-30-2010.

**RedPoint**

THE COLOR(S) GRAY, RED, AND BLACK IS/ARE CLAIMED AS A FEATURE OF THE MARK.  
THE MARK CONSISTS OF THE WORD "REDPOINT" (ONE WORD WITH CAPITAL "R" AND CAPITAL "P") WRITTEN IN CENTURY GOTHIC (REGULAR) FONT WITH BODY OF LETTERS IN GRAY AND A THIN BLACK OUTLINE ON EACH LETTER AND THE OBJECT ABOVE THE "I" IS IN RED WITH A THIN BLACK OUTLINE.  
FOR DEVELOPING AND MAINTAINING COMPUTER SOFTWARE IN THE FIELDS OF ADVERTISING AND MARKETING (U.S. CLS. 100 AND 101).  
FIRST USE 5-1-2006; IN COMMERCE 5-1-2006.  
ELLEN BURNS, EXAMINING ATTORNEY

SN 85-126,737. RICARDO L. RODRIGUEZ, M.D., LLC, LUTHERVILLE, MD. FILED 9-10-2010.

**STEMSURG**

THE MARK CONSISTS OF STANDARD CHARACTERS WITHOUT CLAIM TO ANY PARTICULAR FONT, STYLE, SIZE, OR COLOR.  
FOR MEDICAL RESEARCH IN THE FIELD OF STEM CELLS (U.S. CLS. 100 AND 101).  
ROBERT C. CLARK JR., EXAMINING ATTORNEY

**CLASS 42—(Continued).**

SN 85-130,242. EXCELIMMUNE, INC, SOMERVILLE, MA.  
FILED 9-15-2010.

EXCELIMMUNE

THE MARK CONSISTS OF STANDARD CHARACTERS WITHOUT CLAIM TO ANY PARTICULAR FONT, STYLE, SIZE, OR COLOR.

FOR RESEARCH AND DEVELOPMENT IN THE PHARMACEUTICAL AND BIOTECHNOLOGY FIELDS; CONSULTING SERVICES IN THE FIELDS OF BIOTECHNOLOGY, PHARMACEUTICAL RESEARCH AND DEVELOPMENT, LABORATORY TESTING, DIAGNOSTICS, AND PHARMACOGENETICS; RESEARCH AND DEVELOPMENT AND CONSULTATION RELATED THERETO IN THE FIELD OF HUMAN RECOMBINANT POLYCLONAL ANTIBODIES; SOFTWARE AS A SERVICE (SAAS) SERVICES FEATURING SOFTWARE FOR MEDICAL DIAGNOSIS OR SCIENTIFIC ANALYSIS IN THE FIELD OF HUMAN RECOMBINANT POLYCLONAL ANTIBODIES; SOFTWARE DEVELOPMENT AND SOFTWARE CONSULTATION SERVICES RELATED TO THE FIELD OF HUMAN RECOMBINANT POLYCLONAL ANTIBODIES (U.S. CLS. 100 AND 101).

NICHOLAS COLEMAN, EXAMINING ATTORNEY

**CLASS 42—(Continued).**

SN 85-137,391. STRAND ASSOCIATES, INC., MADISON, WI.  
FILED 9-24-2010.



OWNER OF U.S. REG. NOS. 2,249,676 AND 2,260,915.  
NO CLAIM IS MADE TO THE EXCLUSIVE RIGHT TO USE "ASSOCIATES", APART FROM THE MARK AS SHOWN.

THE MARK CONSISTS OF THE STYLIZED LETTERS "S" AND "A" STACKED OVER THE TERM "STRAND" WHICH IS STACKED OVER THE TERM "ASSOCIATES".

FOR ENGINEERING AND ENGINEERING CONSULTING SERVICES TO UTILITY AND COMMERCIAL COMPANIES, GOVERNMENTS, AND OTHERS (U.S. CLS. 100 AND 101).

GEOFFREY FOSDICK, EXAMINING ATTORNEY

SN 85-131,003. PRN SOFTWARE LLC, WALTHAM, MA.  
FILED 9-16-2010.

DoseSpot

THE MARK CONSISTS OF STANDARD CHARACTERS WITHOUT CLAIM TO ANY PARTICULAR FONT, STYLE, SIZE, OR COLOR.

FOR PROVIDING TEMPORARY USE OF WEB-BASED SOFTWARE ALLOWING MEDICAL PROFESSIONALS TO ISSUE E-PRESCRIPTIONS FOR THE MEDICAL AND DENTAL INDUSTRY (U.S. CLS. 100 AND 101).

FIRST USE 9-23-2009; IN COMMERCE 12-4-2009.  
ASMAT KHAN, EXAMINING ATTORNEY

SN 85-139,141. HIKO ENERGY CORPORATION, CORPUS CHRISTI, TX. FILED 9-27-2010.

HIKO BELL MINING & OIL  
COMPANY

THE MARK CONSISTS OF STANDARD CHARACTERS WITHOUT CLAIM TO ANY PARTICULAR FONT, STYLE, SIZE, OR COLOR.

NO CLAIM IS MADE TO THE EXCLUSIVE RIGHT TO USE "MINING & OIL COMPANY", APART FROM THE MARK AS SHOWN.

FOR RESEARCH AND PROVIDING INFORMATION IN THE FIELD OF MINING, MINERALS, HYDROCARBON, OIL AND GAS EXPLORATION (U.S. CLS. 100 AND 101).

FIRST USE 12-31-1958; IN COMMERCE 12-31-1958.  
MORGAN WYNNE, EXAMINING ATTORNEY

**CLASS 42—(Continued).**

SN 85-140,999. EXTERRO, INC., PORTLAND, OR. FILED 9-29-2010.

**GENOME**

THE MARK CONSISTS OF STANDARD CHARACTERS WITHOUT CLAIM TO ANY PARTICULAR FONT, STYLE, SIZE, OR COLOR.

FOR ELECTRONIC LEGAL DISCOVERY CONSULTING SERVICES (U.S. CLS. 100 AND 101).

FIRST USE 12-21-2008; IN COMMERCE 1-28-2009.  
MARILYN IZZI, EXAMINING ATTORNEY

SN 85-141,121. EXTERRO, INC., PORTLAND, OR. FILED 9-29-2010.

**FUSION CLOUD**

THE MARK CONSISTS OF STANDARD CHARACTERS WITHOUT CLAIM TO ANY PARTICULAR FONT, STYLE, SIZE, OR COLOR.

NO CLAIM IS MADE TO THE EXCLUSIVE RIGHT TO USE "CLOUD", APART FROM THE MARK AS SHOWN.

FOR ELECTRONIC LEGAL DISCOVERY CONSULTING SERVICES (U.S. CLS. 100 AND 101).

FIRST USE 12-14-2009; IN COMMERCE 1-7-2010.  
MARILYN IZZI, EXAMINING ATTORNEY

SN 85-144,192. STRATEGIC RESOURCES GROUP, LLC, DBA HUMAN RESOURCES OUTSOURCING SERVICES, BIRMINGHAM, MI. FILED 10-4-2010.



NO CLAIM IS MADE TO THE EXCLUSIVE RIGHT TO USE "MANAGER", APART FROM THE MARK AS SHOWN.

THE COLOR(S) GREEN, TURQUOISE, RED, YELLOW, BLACK, AND WHITE IS/ARE CLAIMED AS A FEATURE OF THE MARK.

THE MARK CONSISTS OF STYLIZED STICK FIGURE WITH A RED HEAD AND A BLACK BODY WITH WHITE OUTLINES AND BLACK BORDER ON A CIRCULAR YELLOW BACKGROUND. TWO ARROWS POINT IN A CIRCULAR PATH AROUND THE STICK FIGURE. ONE ARROW IS TURQUOISE AND BLACK AND THE OTHER ARROW IS GREEN AND BLACK. NEXT IS "WORKLIFE MANGER" IN BLACK TEXT.

FOR COMPUTER SOFTWARE DEVELOPMENT; COMPUTER SOFTWARE DEVELOPMENT IN THE FIELD OF HUMAN RESOURCES (U.S. CLS. 100 AND 101).

FIRST USE 3-1-2007; IN COMMERCE 3-1-2007.  
RAUL CORDOVA, EXAMINING ATTORNEY

**CLASS 42—(Continued).**

SN 85-145,787. CREATE180, WINDERMERE, FL. FILED 10-5-2010.

**CREATE180 DESIGN**

THE MARK CONSISTS OF STANDARD CHARACTERS WITHOUT CLAIM TO ANY PARTICULAR FONT, STYLE, SIZE, OR COLOR.

NO CLAIM IS MADE TO THE EXCLUSIVE RIGHT TO USE "DESIGN", APART FROM THE MARK AS SHOWN.

FOR GRAPHIC DESIGN SERVICES; WEBSITE DESIGN AND DEVELOPMENT FOR OTHERS (U.S. CLS. 100 AND 101).

FIRST USE 6-15-2009; IN COMMERCE 7-0-2009.  
TINA L. SNAPP, EXAMINING ATTORNEY

SN 85-147,571. MYEWORKBOOK INC, CHARLOTTE, NC. FILED 10-7-2010.



THE COLOR(S) GREEN, BLUE, LIGHT BLUE AND WHITE IS/ARE CLAIMED AS A FEATURE OF THE MARK.

THE MARK CONSISTS OF THE TERM "BOOK" AND A STYLIZED DESIGN OF OPEN BOOK PAGES. THE TWO LETTER "O" S IN "BOOK" ARE REPRESENTED BY A DESIGN OF A GLOBE. THE COLOR GREEN APPEARS IN THE LETTER "B" AND IN THE FIRST PAGE DESIGN. THE COLOR BLUE APPEARS IN THE DESIGN OF THE GLOBE AND AS THE BACKGROUND FOR THE MARK. THE COLOR LIGHT BLUE APPEARS IN THE LAST OPEN PAGE DESIGN, AND THE COLOR WHITE APPEARS IN THE LETTER "K", THE MIDDLE OPEN PAGE DESIGN AND IN THE DESIGN OF THE GLOBE.

FOR COMPUTER SERVICES, NAMELY, CREATING AN ON-LINE COMMUNITY FOR REGISTERED USERS TO PARTICIPATE IN DISCUSSIONS, GET FEEDBACK FROM THEIR PEERS, FORM VIRTUAL COMMUNITIES, AND ENGAGE IN SOCIAL NETWORKING FOR STUDENTS WHO ARE PREPARING TO TAKE COMMERCIAL STANDARDIZED TESTS FOR ADMISSION TO SCHOOLS (U.S. CLS. 100 AND 101).

KAREN BRACEY, EXAMINING ATTORNEY

**CLASS 42—(Continued).**

SN 85-151,993. FUGRO SEISMIC IMAGING, INC., HOUSTON, TX. FILED 10-13-2010.

## Imaging the Possibilities

THE MARK CONSISTS OF STANDARD CHARACTERS WITHOUT CLAIM TO ANY PARTICULAR FONT, STYLE, SIZE, OR COLOR.

NO CLAIM IS MADE TO THE EXCLUSIVE RIGHT TO USE "IMAGING", APART FROM THE MARK AS SHOWN.

FOR SEISMIC ACQUISITION AND PROCESSING FOR SCIENTIFIC PURPOSES; SCIENTIFIC ANALYSIS OF GEOPHYSICAL DATA (U.S. CLS. 100 AND 101).

MICHELE SWAIN, EXAMINING ATTORNEY

---

SN 85-152,289. MOBIWORK, LLC, DELRAY BEACH, FL. FILED 10-14-2010.

## MobiWork

THE MARK CONSISTS OF STANDARD CHARACTERS WITHOUT CLAIM TO ANY PARTICULAR FONT, STYLE, SIZE, OR COLOR.

FOR CLOUD COMPUTING FEATURING SOFTWARE FOR USE IN PROJECT MANAGEMENT IN THE NATURE OF BUSINESS COMPUTER SOFTWARE FOR THE SCHEDULING, RESOURCING, BUDGETING AND TRACKING OF ENTERPRISE PROJECTS, INCLUDING THE BREAKDOWN OF TASKS THAT MAKE UP THE PROJECTS, AND THE ALLOCATION OF RESOURCES NEEDED TO COMPLETE SUCH PROJECTS (U.S. CLS. 100 AND 101).

KIM SAITO, EXAMINING ATTORNEY

---

SN 85-153,667. HNTB HOLDINGS LTD, KANSAS CITY, MO. FILED 10-15-2010.

## RAILADVISE

THE MARK CONSISTS OF STANDARD CHARACTERS WITHOUT CLAIM TO ANY PARTICULAR FONT, STYLE, SIZE, OR COLOR.

FOR PROVIDING ONLINE NONDOWNLOADABLE SOFTWARE AND SOFTWARE TOOLS FOR PROVIDING RAILROAD RAIL SYSTEM CONDITION DATA AND MONITORING AND CONTROLLING RAILROAD TRANSPORTATION ASSETS (U.S. CLS. 100 AND 101).

ANTHONY RINKER, EXAMINING ATTORNEY

**CLASS 42—(Continued).**

SN 85-163,584. REFRESH YOUR NEST, WASHINGTON, DC. FILED 10-28-2010.

## Refresh Your Nest

THE MARK CONSISTS OF STANDARD CHARACTERS WITHOUT CLAIM TO ANY PARTICULAR FONT, STYLE, SIZE, OR COLOR.

FOR DESIGN OF INTERIOR DECOR; HOME STAGING CONSULTATION, NAMELY, TEMPORARY INTERIOR AND EXTERIOR HOME DECORATION CONSULTATION FOR THE PURPOSE OF MAKING HOMES MORE APPEALING TO PROSPECTIVE BUYERS (U.S. CLS. 100 AND 101).

FIRST USE 10-1-2010; IN COMMERCE 10-1-2010.  
LIEF MARTIN, EXAMINING ATTORNEY

---

SN 85-166,428. 25EIGHT, INC., PITTSBURGH, PA. FILED 11-1-2010.



THE MARK CONSISTS OF A STYLIZED ELECTRICAL PLUG WITH DARKENED RECTANGLES RESEMBLING A PAIR OF EYES AND A SEMICIRCLE-RECTANGLE COMBINATION RESEMBLING A MOUTH.

FOR TECHNOLOGY CONSULTATION IN THE FIELD OF CONSUMER ELECTRONICS AND COMPUTERS, NAMELY, PROVIDING INTERACTIVE WEB-BASED AND IN-PERSON SERVICES AND INFORMATION IN THE FIELD OF HELPING CONSUMERS DISCOVER NEW ELECTRONIC DEVICES BASED ON WEB-BASED WIZARDS THAT UTILIZE AN INVENTORY OF DEVICES THE USER OWNS, AND PROVIDING CONTENT ABOUT HOW GROUPS OF SPECIFIC DEVICES OR DEVICES MEETING CERTAIN CRITERIA CAN BE USED TOGETHER TO ACCOMPLISH A GOAL; PROVIDING ON-LINE NON-DOWNLOADABLE SOFTWARE FOR ENABLING CONSUMERS TO CONNECT THEIR ELECTRONICS TO ONE ANOTHER (U.S. CLS. 100 AND 101).

FIRST USE 3-5-2010; IN COMMERCE 3-5-2010.  
ROBIN MITTLER, EXAMINING ATTORNEY



**CLASS 42—(Continued).**

SN 85-166,844. CRF, INC., DBA CRF HEATH, PLYMOUTH MEETING, PA. FILED 11-2-2010.

**TRIALMAX MOBILE**

THE MARK CONSISTS OF STANDARD CHARACTERS WITHOUT CLAIM TO ANY PARTICULAR FONT, STYLE, SIZE, OR COLOR.

OWNER OF U.S. REG. NOS. 3,114,603 AND 3,421,470. NO CLAIM IS MADE TO THE EXCLUSIVE RIGHT TO USE "MOBILE", APART FROM THE MARK AS SHOWN.

FOR SOFTWARE AS A SERVICE (SAAS) SERVICES FEATURING SOFTWARE FOR THE COLLECTION, EDITING, ORGANIZING, MODIFYING, BOOK MARKING, TRANSMISSION, STORAGE AND SHARING OF PATIENT REPORTED OUTCOMES ON WEB BASED, SHORT MESSAGE SERVICE, AND MOBILE DEVICES (U.S. CLS. 100 AND 101).

JOSETTE BEVERLY, EXAMINING ATTORNEY

SN 85-166,846. CRF, INC., DBA CRF HEALTH, PLYMOUTH MEETING, PA. FILED 11-2-2010.

**TRIALMAX WEB**

THE MARK CONSISTS OF STANDARD CHARACTERS WITHOUT CLAIM TO ANY PARTICULAR FONT, STYLE, SIZE, OR COLOR.

OWNER OF U.S. REG. NOS. 3,114,603 AND 3,421,470. NO CLAIM IS MADE TO THE EXCLUSIVE RIGHT TO USE "WEB", APART FROM THE MARK AS SHOWN.

FOR SOFTWARE AS A SERVICE (SAAS) SERVICES FEATURING SOFTWARE FOR THE COLLECTION, EDITING, ORGANIZING, MODIFYING, BOOK MARKING, TRANSMISSION, STORAGE AND SHARING OF PATIENT REPORTED OUTCOMES ON WEB BASED, SHORT MESSAGE SERVICE, AND MOBILE DEVICES (U.S. CLS. 100 AND 101).

JOSETTE BEVERLY, EXAMINING ATTORNEY

**CLASS 42—(Continued).**

SN 85-166,858. CRF, INC., DBA CRF HEALTH, PLYMOUTH MEETING, PA. FILED 11-2-2010.

**TRIALMAX SITE**

THE MARK CONSISTS OF STANDARD CHARACTERS WITHOUT CLAIM TO ANY PARTICULAR FONT, STYLE, SIZE, OR COLOR.

OWNER OF U.S. REG. NOS. 3,114,603 AND 3,421,470. NO CLAIM IS MADE TO THE EXCLUSIVE RIGHT TO USE "SITE", APART FROM THE MARK AS SHOWN.

FOR SOFTWARE AS A SERVICE (SAAS) SERVICES FEATURING SOFTWARE FOR THE COLLECTION, EDITING, ORGANIZING, MODIFYING, BOOK MARKING, TRANSMISSION, STORAGE AND SHARING OF PATIENT REPORTED OUTCOMES (U.S. CLS. 100 AND 101).

JOSETTE BEVERLY, EXAMINING ATTORNEY

SN 85-166,861. CRF, INC., DBA CRF HEALTH, PLYMOUTH MEETING, PA. FILED 11-2-2010.

**TRIALMAX SLATE**

THE MARK CONSISTS OF STANDARD CHARACTERS WITHOUT CLAIM TO ANY PARTICULAR FONT, STYLE, SIZE, OR COLOR.

OWNER OF U.S. REG. NOS. 3,114,603 AND 3,421,470. NO CLAIM IS MADE TO THE EXCLUSIVE RIGHT TO USE "SLATE", APART FROM THE MARK AS SHOWN.

FOR SOFTWARE AS A SERVICE (SAAS) SERVICES FEATURING SOFTWARE FOR THE COLLECTION, EDITING, ORGANIZING, MODIFYING, BOOK MARKING, TRANSMISSION, STORAGE AND SHARING OF PATIENT REPORTED OUTCOMES (U.S. CLS. 100 AND 101).

JOSETTE BEVERLY, EXAMINING ATTORNEY

SN 85-166,863. CRF, INC., DBA CRF HEALTH, PLYMOUTH MEETING, PA. FILED 11-2-2010.

**TRIALMAX TOUCH**

THE MARK CONSISTS OF STANDARD CHARACTERS WITHOUT CLAIM TO ANY PARTICULAR FONT, STYLE, SIZE, OR COLOR.

OWNER OF U.S. REG. NOS. 3,114,603 AND 3,421,470. NO CLAIM IS MADE TO THE EXCLUSIVE RIGHT TO USE "TOUCH", APART FROM THE MARK AS SHOWN.

FOR SOFTWARE AS A SERVICE (SAAS) SERVICES FEATURING SOFTWARE FOR THE COLLECTION, EDITING, ORGANIZING, MODIFYING, BOOK MARKING, TRANSMISSION, STORAGE AND SHARING OF PATIENT REPORTED OUTCOMES ON HANDHELDS AND PDAS (U.S. CLS. 100 AND 101).

JOSETTE BEVERLY, EXAMINING ATTORNEY

**CLASS 42—(Continued).**

SN 85-166,870. CRF, INC., DBA CRF HEALTH, PLYMOUTH MEETING, PA. FILED 11-2-2010.

TRIALMAX VOICE

THE MARK CONSISTS OF STANDARD CHARACTERS WITHOUT CLAIM TO ANY PARTICULAR FONT, STYLE, SIZE, OR COLOR.

OWNER OF U.S. REG. NOS. 3,114,603 AND 3,421,470.

NO CLAIM IS MADE TO THE EXCLUSIVE RIGHT TO USE "VOICE", APART FROM THE MARK AS SHOWN.

FOR SOFTWARE AS A SERVICE (SAAS) SERVICES FEATURING SOFTWARE FOR THE COLLECTION, EDITING, ORGANIZING, MODIFYING, BOOK MARKING, TRANSMISSION, STORAGE AND SHARING OF PATIENT REPORTED OUTCOMES (U.S. CLS. 100 AND 101).

JOSETTE BEVERLY, EXAMINING ATTORNEY

**CLASS 42—(Continued).**

SN 85-171,583. ROTAM AGROCHEM INTERNATIONAL CO. LTD., CHAI WAN, HONG KONG, FILED 11-8-2010.

**R R L**

THE MARK CONSISTS OF THE LETTERS "R R L" SEPARATED BY TRIANGLE DESIGNS WITH A GRADUALLY INCREASING SLOPE APPEARING BENEATH THE LETTERS.

FOR SCIENTIFIC AND INDUSTRIAL RESEARCH IN THE FIELD OF AGRICULTURE, HORTICULTURE AND FORESTRY; SCIENTIFIC AND TECHNOLOGICAL SERVICES, NAMELY SCIENTIFIC RESEARCH, ANALYSIS AND TESTING IN THE FIELD OF AGRICULTURE, HORTICULTURE AND FORESTRY; LABORATORY RESEARCH IN THE FIELD OF AGRICULTURE, HORTICULTURE AND FORESTRY (U.S. CLS. 100 AND 101).

RUSS HERMAN, EXAMINING ATTORNEY

SN 85-169,940. OCUTEC LIMITED, BELLSHILL, UNITED KINGDOM, FILED 11-5-2010.

OCUTEC

THE MARK CONSISTS OF STANDARD CHARACTERS WITHOUT CLAIM TO ANY PARTICULAR FONT, STYLE, SIZE, OR COLOR.

FOR RESEARCH AND DEVELOPMENT IN THE AREA OF CONTACT LENSES (U.S. CLS. 100 AND 101).

FIRST USE 4-27-2005; IN COMMERCE 11-12-2009.

KEVON CHISOLM, EXAMINING ATTORNEY

SN 85-172,979. PING IDENTITY CORPORATION, DENVER, CO. FILED 11-9-2010.

PINGID

THE MARK CONSISTS OF STANDARD CHARACTERS WITHOUT CLAIM TO ANY PARTICULAR FONT, STYLE, SIZE, OR COLOR.

OWNER OF U.S. REG. NOS. 2,987,203, 3,457,300 AND OTHERS.

FOR SOFTWARE AS A SERVICE (SAAS) SERVICES, NAMELY, HOSTING NON-DOWNLOADABLE COMPUTER SOFTWARE FOR USE BY OTHERS THAT FACILITATES IDENTITY FEDERATION IN THE FIELD OF DIGITAL SECURITY AND IDENTIFICATION (U.S. CLS. 100 AND 101).

WON TEAK OH, EXAMINING ATTORNEY

SN 85-170,779. COLLINS, JOSEPH, LAGRANGE, GA. FILED 11-5-2010.

DIGITALLY FLY

THE MARK CONSISTS OF STANDARD CHARACTERS WITHOUT CLAIM TO ANY PARTICULAR FONT, STYLE, SIZE, OR COLOR.

NO CLAIM IS MADE TO THE EXCLUSIVE RIGHT TO USE "DIGITALLY", APART FROM THE MARK AS SHOWN.

FOR COMPUTER SOFTWARE DEVELOPMENT SERVICES (U.S. CLS. 100 AND 101).

FIRST USE 11-5-2010; IN COMMERCE 11-5-2010.

TINA MAI, EXAMINING ATTORNEY

SN 85-174,072. FRYMIRE, JULIE L., DBA INTELLEWEB SOURCES, PETALUMA, CA. FILED 11-10-2010.



THE COLOR(S) WHITE, BLUE AND GREEN IS/ARE CLAIMED AS A FEATURE OF THE MARK.

THE MARK CONSISTS OF THE WORDING "INTELLEWEB SOURCES" NEXT TO A CIRCULAR YIN-YANG DESIGN WITH A CURVED LINE AND QUADRILATERAL ON ITS LEFT SIDE. THE COLOR GREEN APPEARS IN THE MAJORITY OF THE CURVED LINE, IN THE MAJORITY

**CLASS 42—(Continued).**

OF THE TOP PORTION OF THE YIN-YANG SYMBOL, AND IN THE WORD "INTELLEWEB". THE COLOR BLUE APPEARS IN THE MAJORITY OF THE QUADRILATERAL, IN THE MAJORITY OF THE LOWER PORTION OF THE YIN-YANG SYMBOL, AND IN THE WORD "SOURCES" IN THE MARK. THE COLOR WHITE APPEARS IN THE HIGHLIGHTS OF THE CURVED LINE, QUADRILATERAL, AND YIN-YANG DESIGN. THE REMAINDER OF THE WHITE IN THE DRAWING REPRESENTS BACKGROUND AREAS ONLY AND IS NOT PART OF THE MARK.

FOR BUILDING AND MAINTAINING WEBSITES (U.S. CLS. 100 AND 101).

FIRST USE 11-8-2010; IN COMMERCE 11-8-2010.  
MAUREEN DALL, EXAMINING ATTORNEY

---

SN 85-174,351. SCHMIDT & STACY CONSULTING ENGINEERS, INC., DALLAS, TX. FILED 11-11-2010.

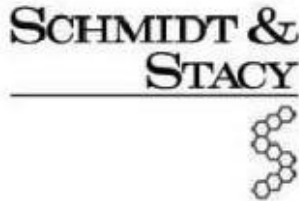

OWNER OF U.S. REG. NO. 2,510,670.

THE MARK CONSISTS OF THE WORDS "SCHMIDT &" OVER THE WORD "STACY" WITH A STRAIGHT LINE UNDERNEATH ALL WORDING, AND A STYLIZED CHAIN LINK DESIGN BELOW THE LINE.

FOR DESIGNING AND ENGINEERING HIGH PERFORMANCE, LOW MAINTENANCE BUILDING SUPPORT SYSTEMS, NAMELY, HVAC SYSTEMS, FIRE PROTECTION SYSTEMS, ENERGY MANAGEMENT SYSTEMS, INDUSTRIAL VENTILATION SYSTEMS, ELECTRICAL LIGHTING AND POWER SYSTEMS, UNINTERRUPTABLE POWER, DUAL FEED AND STANDBY POWER SYSTEMS, LIFE SAFETY SYSTEMS, AND PLUMBING SYSTEMS (U.S. CLS. 100 AND 101).

FIRST USE 6-0-1996; IN COMMERCE 6-0-1996.  
NAAKWAMA ANKRAH, EXAMINING ATTORNEY

---

SN 85-174,902. SMART UTILITY NETWORK ALLIANCE, ALLEN, TX. FILED 11-11-2010.

## Smart Utility Network Alliance

THE MARK CONSISTS OF STANDARD CHARACTERS WITHOUT CLAIM TO ANY PARTICULAR FONT, STYLE, SIZE, OR COLOR.

NO CLAIM IS MADE TO THE EXCLUSIVE RIGHT TO USE "UTILITY NETWORK ALLIANCE", APART FROM THE MARK AS SHOWN.

FOR DEVELOPMENT OF NEW TECHNOLOGY FOR OTHERS IN THE FIELD OF SMART UTILITY NETWORKS (U.S. CLS. 100 AND 101).

LINDA E. BLOHM, EXAMINING ATTORNEY

**CLASS 42—(Continued).**

SN 85-174,913. SH HOLDINGS, LLC, SARASOTA, FL. FILED 11-11-2010.

## STAY AT HOME SCORE

THE MARK CONSISTS OF STANDARD CHARACTERS WITHOUT CLAIM TO ANY PARTICULAR FONT, STYLE, SIZE, OR COLOR.

NO CLAIM IS MADE TO THE EXCLUSIVE RIGHT TO USE "SCORE", APART FROM THE MARK AS SHOWN.

FOR PROVIDING A STATISTICAL EVALUATION FOR QUALITY MANAGEMENT PURPOSES, NAMELY, QUALITY EVALUATION AND ANALYSIS WHICH CONSIDERS AN INDIVIDUALS' HEALTH, SAFETY, AND QUALITY OF LIFE GIVEN THEIR LIVING ENVIRONMENT (U.S. CLS. 100 AND 101).

FIRST USE 2-23-2011; IN COMMERCE 2-23-2011.  
JEFFREY LOOK, EXAMINING ATTORNEY

---

SN 85-175,049. SMART UTILITY NETWORK ALLIANCE, ALLEN, TN. FILED 11-11-2010.

## Suna Certified

THE MARK CONSISTS OF STANDARD CHARACTERS WITHOUT CLAIM TO ANY PARTICULAR FONT, STYLE, SIZE, OR COLOR.

NO CLAIM IS MADE TO THE EXCLUSIVE RIGHT TO USE "CERTIFIED", APART FROM THE MARK AS SHOWN.

FOR DEVELOPMENT OF NEW TECHNOLOGY FOR OTHERS IN THE FIELD OF SMART UTILITY NETWORKS (U.S. CLS. 100 AND 101).

LINDA E. BLOHM, EXAMINING ATTORNEY

---

SN 85-175,282. RATEINTEGRATION, INC., DURHAM, NC. FILED 11-12-2010.

## SIXTH SENSE MEDIA

THE MARK CONSISTS OF STANDARD CHARACTERS WITHOUT CLAIM TO ANY PARTICULAR FONT, STYLE, SIZE, OR COLOR.

NO CLAIM IS MADE TO THE EXCLUSIVE RIGHT TO USE "MEDIA", APART FROM THE MARK AS SHOWN.

FOR PROVIDING ON-LINE NON-DOWNLOADABLE SOFTWARE FOR USERS TO DELIVER ELECTRONIC ADVERTISING TO CONSUMERS (U.S. CLS. 100 AND 101).

ALLISON HOLTZ, EXAMINING ATTORNEY

**CLASS 42—(Continued).**

SN 85-175,556. MOJA, INC., MANASSAS, VA. FILED 11-12-2010.



OWNER OF U.S. REG. NO. 3,147,373.  
THE MARK CONSISTS OF THE WORD "MOJA" IN STYLIZED FONT.

THE WORDING "MOJA" HAS NO MEANING IN A FOREIGN LANGUAGE.

FOR INFORMATION TECHNOLOGY CONSULTATION, NAMELY, INTEGRATING HARDWARE, SOFTWARE, AND COMMUNICATIONS TECHNOLOGIES; REMOTE AND ON-SITE MANAGEMENT OF THE INFORMATION TECHNOLOGY (IT) SYSTEMS OF OTHERS; TECHNICAL CONSULTING AND ASSISTANCE WITH COMPUTER-BASED INFORMATION SYSTEMS AND COMPONENTS; CONSULTATION IN THE FIELDS OF INTELLIGENCE TECHNOLOGY AND SECURITY TECHNOLOGY; DESIGN, IMPLEMENTATION AND MANAGEMENT OF INTELLIGENCE AND SECURITY COMPUTER NETWORK SYSTEMS OF OTHERS; CONSULTATION IN THE FIELDS OF INTELLIGENCE TECHNOLOGY AND SECURITY TECHNOLOGY, SPECIFICALLY IN INTELLIGENCE SUPPORT AND INFORMATION GATHERING; DESIGN, IMPLEMENTATION AND MANAGEMENT OF INTELLIGENCE AND SECURITY COMPUTER NETWORK SYSTEMS OF OTHERS, SPECIFICALLY, INTELLIGENCE SUPPORT AND INFORMATION GATHERING COMPUTER NETWORK SYSTEMS; DEVELOPING APPLICATION SOFTWARE FOR OTHERS FOR USE IN THE INTELLIGENCE AND SECURITY COMMUNITY; APPLICATION SERVICE PROVIDER FEATURING SOFTWARE FOR THE PURPOSE OF PROVIDING INTELLIGENCE SUPPORT, INFORMATION GATHERING, INFORMATION AGGREGATION AND INFORMATION ANALYSIS TOOLS FOR USE IN THE INTELLIGENCE AND SECURITY COMMUNITY; DATA MINING (U.S. CLS. 100 AND 101).

FIRST USE 2-8-1995; IN COMMERCE 2-8-1995.  
SOPHIA S. KIM, EXAMINING ATTORNEY

SN 85-179,238. HEALTH CARE CONCEPTS, INC., AUSTIN, TX. FILED 11-17-2010.

## CIA ImpactIndex

THE MARK CONSISTS OF STANDARD CHARACTERS WITHOUT CLAIM TO ANY PARTICULAR FONT, STYLE, SIZE, OR COLOR.

OWNER OF U.S. REG. NO. 3,356,349.  
NO CLAIM IS MADE TO THE EXCLUSIVE RIGHT TO USE "IMPACTINDEX", APART FROM THE MARK AS SHOWN.

FOR APPLICATION SERVICE PROVIDER (ASP) FEATURING SOFTWARE FOR USE IN MEASURING THE IMPACT OF CERTAIN MEDICAL PRACTICES AND SOLUTIONS ON COST AND PATIENT SATISFACTION FOR USE IN SCIENTIFIC RESEARCH AND COMPARATIVE EVALUATION IN THE FIELD OF HEALTH CARE (U.S. CLS. 100 AND 101).

FIRST USE 7-12-2006; IN COMMERCE 7-12-2006.  
BRENDAN REGAN, EXAMINING ATTORNEY

**CLASS 42—(Continued).**

SN 85-179,314. GORDY, MARK, OAK RIDGE, NC. FILED 11-17-2010.



THE MARK CONSISTS OF STANDARD CHARACTERS WITHOUT CLAIM TO ANY PARTICULAR FONT, STYLE, SIZE, OR COLOR.

FOR FINANCIAL COMPUTER SOFTWARE TECHNOLOGY CONSULTING (U.S. CLS. 100 AND 101).  
FIRST USE 10-12-2010; IN COMMERCE 10-15-2010.  
FRED CARL, EXAMINING ATTORNEY

SN 85-180,178. ADVANCED NEUROMODULATION SYSTEMS, INC., PLANO, TX. FILED 11-18-2010.

## CHOICES

THE MARK CONSISTS OF STANDARD CHARACTERS WITHOUT CLAIM TO ANY PARTICULAR FONT, STYLE, SIZE, OR COLOR.

FOR MEDICAL AND SCIENTIFIC RESEARCH, NAMELY, CONDUCTING CLINICAL TRIALS (U.S. CLS. 100 AND 101).

ANGELA M. MICHELI, EXAMINING ATTORNEY

SN 85-180,195. ADVANCED NEUROMODULATION SYSTEMS, INC., PLANO, TX. FILED 11-18-2010.



THE MARK CONSISTS OF EMP3OWER WITH THE "3" BEING A SUPERSCRIPIT.

FOR MEDICAL AND SCIENTIFIC RESEARCH, NAMELY, CONDUCTING CLINICAL TRIALS (U.S. CLS. 100 AND 101).

ANGELA M. MICHELI, EXAMINING ATTORNEY

**CLASS 42—(Continued).**

SN 85-180,283. HEALTHCARESOURCE HR, INC., WOBURN, MA. FILED 11-18-2010.

**PERFORMANCE MANAGER**

THE MARK CONSISTS OF STANDARD CHARACTERS WITHOUT CLAIM TO ANY PARTICULAR FONT, STYLE, SIZE, OR COLOR.

NO CLAIM IS MADE TO THE EXCLUSIVE RIGHT TO USE "MANAGER", APART FROM THE MARK AS SHOWN. SEC. 2(F).

FOR PROVIDING TEMPORARY USE OF ONLINE, NON-DOWNLOADABLE COMPUTER SOFTWARE FOR USE IN STORING AND RETRIEVING EMPLOYEE INFORMATION, TRACKING EMPLOYEE APPRAISALS, CREATING JOB DESCRIPTIONS, TRACKING PERSONNEL CAREER DEVELOPMENT AND SUCCESSION PLANNING, TRACKING POSITION-SPECIFIC EMPLOYEE SKILL COMPETENCY AND EDUCATION INFORMATION FOR HOSPITALS AND THE HEALTH CARE INDUSTRY (U.S. CLS. 100 AND 101).

FIRST USE 11-1-2004; IN COMMERCE 11-1-2004.  
DEZMONA MIZELLE, EXAMINING ATTORNEY

---

SN 85-181,550. LEEDY, INGRAM, WINTER HAVEN, FL. FILED 11-19-2010.

**Protected  Trust**

NO CLAIM IS MADE TO THE EXCLUSIVE RIGHT TO USE "PROTECTED", APART FROM THE MARK AS SHOWN.

THE MARK CONSISTS OF THE STYLIZED TEXT "PROTECTED TRUST" WITH A TOWER AND A SHIELD. FOR DATA ENCRYPTION AND DECODING SERVICES (U.S. CLS. 100 AND 101).

FIRST USE 9-15-2010; IN COMMERCE 9-28-2010.  
ALLISON SCHRODY, EXAMINING ATTORNEY

---

SN 85-181,599. CANVAS INTERIOR DESIGN, INC., FOUNTAIN VALLEY, FL. FILED 11-19-2010.

**Canvas Interior Design**

THE MARK CONSISTS OF STANDARD CHARACTERS WITHOUT CLAIM TO ANY PARTICULAR FONT, STYLE, SIZE, OR COLOR.

NO CLAIM IS MADE TO THE EXCLUSIVE RIGHT TO USE "INTERIOR DESIGN", APART FROM THE MARK AS SHOWN.

FOR INTERIOR DESIGN SERVICES (U.S. CLS. 100 AND 101).

FIRST USE 5-4-2004; IN COMMERCE 5-4-2004.  
KIMBERLY PERRY, EXAMINING ATTORNEY

**CLASS 42—(Continued).**

SN 85-182,621. IDM USA LLC, DBA DATAFORMAT.COM, BRADENTON, FL. FILED 11-22-2010.

**DARMA**

THE MARK CONSISTS OF STANDARD CHARACTERS WITHOUT CLAIM TO ANY PARTICULAR FONT, STYLE, SIZE, OR COLOR.

FOR PROVIDING TEMPORARY USE OF ON-LINE NON-DOWNLOADABLE COMPUTER APPLICATION SOFTWARE FOR WEB BROWSERS, NAMELY, SOFTWARE FOR DIGITAL ASSET MANAGEMENT; PROVIDING TEMPORARY USE OF ON-LINE NON-DOWNLOADABLE COMPUTER PROGRAMS FOR DOCUMENT MANAGEMENT; PROVIDING TEMPORARY USE OF ON-LINE NON-DOWNLOADABLE COMPUTER SOFTWARE FOR CREATING SEARCHABLE DATABASES OF INFORMATION AND DATA; PROVIDING TEMPORARY USE OF ON-LINE NON-DOWNLOADABLE COMPUTER SOFTWARE FOR THE COLLECTION, EDITING, ORGANIZING, MODIFYING, BOOK MARKING, TRANSMISSION, STORAGE AND SHARING OF DATA AND INFORMATION; PROVIDING TEMPORARY USE OF ON-LINE NON-DOWNLOADABLE COMPUTER SOFTWARE FOR DIGITAL ASSET MANAGEMENT (U.S. CLS. 100 AND 101).

FIRST USE 2-1-2010; IN COMMERCE 3-1-2010.  
ROBERT STRUCK, EXAMINING ATTORNEY

---

SN 85-183,137. ONLINE-AUCTIONS SOFTWARE.COM, INC., BYRON CENTER, MI. FILED 11-23-2010.

**OAS**

THE MARK CONSISTS OF STANDARD CHARACTERS WITHOUT CLAIM TO ANY PARTICULAR FONT, STYLE, SIZE, OR COLOR.

FOR PROVIDING A WEBSITE FEATURING ON-LINE NON-DOWNLOADABLE SOFTWARE THAT SERVES AS AN ONLINE BIDDING PLATFORM FOR INDEPENDENT AUCTION OPERATORS (U.S. CLS. 100 AND 101).

FIRST USE 12-29-2009; IN COMMERCE 12-29-2009.  
JOHN WILKE, EXAMINING ATTORNEY

**CLASS 42—(Continued).**

SN 85-183,157. ONLINE-AUCTIONS SOFTWARE.COM, INC.,  
BYRON CENTER, MI. FILED 11-23-2010.



NO CLAIM IS MADE TO THE EXCLUSIVE RIGHT TO USE "ONLINE-AUCTION SOFTWARE.COM INC", APART FROM THE MARK AS SHOWN.

THE MARK CONSISTS OF THE WORDS "OAS ONLINE-AUCTIONS SOFTWARE.COM INC", WITH AN ARROW WITHIN THE "A".

FOR PROVIDING A WEBSITE FEATURING ON-LINE NON-DOWNLOADABLE SOFTWARE THAT SERVES AS AN ONLINE BIDDING PLATFORM FOR INDEPENDENT AUCTION OPERATORS (U.S. CLS. 100 AND 101).

FIRST USE 12-29-2009; IN COMMERCE 12-29-2009.

JOHN WILKE, EXAMINING ATTORNEY

SN 85-183,207. APPRISS, INC., LOUISVILLE, KY. FILED 11-23-2010.



NO CLAIM IS MADE TO THE EXCLUSIVE RIGHT TO USE "AUTOMATED MONEY SERVICE COMPLIANCE", APART FROM THE MARK AS SHOWN.

THE MARK CONSISTS OF THE LETTER "M" APPEARING ON A STYLIZED RENDITION OF A SPHERE WITH A SPIRAL LINE WRAPPING AROUND THE SPHERE FROM THE BOTTOM LEFT TO THE TOP RIGHT, ALL DISPLAYED TO THE LEFT OF THE WORD "MONEYTRACK" APPEARING ABOVE THE PHRASE "AUTOMATED MONEY SERVICE COMPLIANCE".

FOR SOFTWARE AS A SERVICE (SAAS) SERVICES FEATURING SOFTWARE FOR MONITORING THE SALE AND COMPLIANCE OF INSTRUMENTS FOR MONEY TRANSMISSION, TRAVELERS CHECKS, MONEY ORDERS, PREPAID CARDS, AND STORED VALUE CARDS (U.S. CLS. 100 AND 101).

KELLY BOULTON, EXAMINING ATTORNEY

**CLASS 42—(Continued).**

SN 85-183,215. NATALIA S PREISS, PLANO, TX. FILED 11-23-2010.

## Symbolic Spaces

THE MARK CONSISTS OF STANDARD CHARACTERS WITHOUT CLAIM TO ANY PARTICULAR FONT, STYLE, SIZE, OR COLOR.

NO CLAIM IS MADE TO THE EXCLUSIVE RIGHT TO USE "SPACES", APART FROM THE MARK AS SHOWN.

FOR COLOR ANALYSIS FOR PURPOSES OF INTERIOR DESIGN; CONSULTING SERVICES IN THE FIELD OF FENG SHUI; INTERIOR DESIGN SERVICES; INTERIOR DESIGN SERVICES IN THE NATURE OF AROMA CONSULTING SERVICES IN THE SELECTION AND USE OF AROMAS FOR HOTELS, CASINOS, RESORTS, CONFERENCE FACILITIES, RETAIL STORES, SPORTS AND FITNESS CENTERS, SPAS, HEALTH CARE FACILITIES, RESIDENTIAL BUILDINGS AND PRIVATE RESIDENCES; INTERIOR DESIGN SERVICES INCLUDING SPACE PLANNING, FURNITURE SELECTION, MATERIAL AND SURFACE SELECTION; PROVIDING A WEBSITE FEATURING INFORMATION ABOUT GREEN ARCHITECTURE, INTERIOR DESIGN, SUSTAINABLE COMMUNITY PLANNING AND INFRASTRUCTURE DEVELOPMENT; PROVIDING A WEBSITE FEATURING INFORMATION IN THE FIELD OF INTERIOR DESIGN AND ARCHITECTURE FOR USE BY INTERIOR DESIGNERS AND ARCHITECTS; PROVIDING TEMPORARY USE OF A WEB-BASED SOFTWARE APPLICATION FOR ANALYSIS OF FENG SHUI NEEDS, INCLUDING PERSONALITY TESTS AND SPACIAL ASSESSMENT (U.S. CLS. 100 AND 101).

FIRST USE 10-10-2010; IN COMMERCE 10-10-2010.

LEIGH CAROLINE CASE, EXAMINING ATTORNEY

SN 85-184,316. SMITH, DOUGLAS, SAN ANTONIO, TX. FILED 11-24-2010.

## RADCLOUD INFORMATION

THE MARK CONSISTS OF STANDARD CHARACTERS WITHOUT CLAIM TO ANY PARTICULAR FONT, STYLE, SIZE, OR COLOR.

NO CLAIM IS MADE TO THE EXCLUSIVE RIGHT TO USE "INFORMATION", APART FROM THE MARK AS SHOWN.

FOR PROVIDING TEMPORARY USE OF PROPRIETARY CLOUD-COMPUTING BASED ON-LINE NON-DOWNLOADABLE SOFTWARE THAT GATHERS DIAGNOSTIC IMAGING STUDIES FROM MULTIPLE MEDICAL IMAGING CENTERS AND COLLECTS ELECTRONIC MEDICAL RECORDS FROM MULTIPLE DOCTORS' OFFICES AND MEDICAL PROVIDERS AND COLLATES THIS INFORMATION INTO A SINGLE INTERACTIVE LISTING THAT CAN BE VIEWED IN COMPLIANCE WITH REGULATORY REQUIREMENTS (U.S. CLS. 100 AND 101).

JAMES LOVELACE, EXAMINING ATTORNEY

**CLASS 42—(Continued).**

SN 85-184,946. INTERNATIONAL GEMOLOGICAL INSTITUTE, INC., NEW YORK, NY. FILED 11-24-2010.

### I.G.I. HEARTS & ARROWS REPORT

THE MARK CONSISTS OF STANDARD CHARACTERS WITHOUT CLAIM TO ANY PARTICULAR FONT, STYLE, SIZE, OR COLOR.

OWNER OF U.S. REG. NOS. 2,687,886, 2,886,191 AND OTHERS.

NO CLAIM IS MADE TO THE EXCLUSIVE RIGHT TO USE "HEARTS & ARROWS REPORT", APART FROM THE MARK AS SHOWN.

FOR GEMOLOGICAL SERVICES, NAMELY, INSPECTING DIAMONDS FOR THE PURPOSE OF CERTIFYING THAT THE GEMS ARE CUT TO HEARTS AND ARROWS SPECIFICATIONS (U.S. CLS. 100 AND 101).

JEFF DEFORD, EXAMINING ATTORNEY

---

SN 85-186,725. SAMSON INVESTMENTS, LLC, LAKE CITY, FL. FILED 11-29-2010.



THE COLOR(S) ORANGE IS/ARE CLAIMED AS A FEATURE OF THE MARK.

THE MARK CONSISTS OF AN ORANGE SHADED CIRCLE WITH CLOCK HANDS CUT OUT OF THE CENTER AND THAT IS RENDERED INCOMPLETE BY A CURVED CUTOFF TO THE LOWER RIGHT, WITH HIGHLY STYLIZED ORANGE DEPICTIONS OF SEVEN PEOPLE APPEARING TO THE LOWER RIGHT; THE COLORS WHITE AND GRAY IN THE DRAWING REPRESENT BACKGROUND, OUTLINING, SHADING AND/OR TRANSPARENT AREAS AND ARE NOT PART OF THE MARK.

FOR PROVIDING A WEBSITE FEATURING NON-DOWNLOADABLE SOFTWARE FOR SCHEDULING (U.S. CLS. 100 AND 101).

FIRST USE 10-0-2007; IN COMMERCE 10-0-2007.

CYNTHIA TRIPI, EXAMINING ATTORNEY

**CLASS 42—(Continued).**

SN 85-186,951. MORFOLOGICA INC., MANASSAS, VA. FILED 11-30-2010.

### ALL NATURAL LANGUAGE PROCESSING

THE MARK CONSISTS OF STANDARD CHARACTERS WITHOUT CLAIM TO ANY PARTICULAR FONT, STYLE, SIZE, OR COLOR.

OWNER OF U.S. REG. NO. 3,901,175.

NO CLAIM IS MADE TO THE EXCLUSIVE RIGHT TO USE "NATURAL LANGUAGE PROCESSING", APART FROM THE MARK AS SHOWN.

FOR COMPUTER PROGRAMMING FOR OTHERS (U.S. CLS. 100 AND 101).

FIRST USE 8-31-2009; IN COMMERCE 8-31-2009.

TRICIA SONNEBORN, EXAMINING ATTORNEY

---

SN 85-186,954. MORFOLOGICA INC., MANASSAS, VA. FILED 11-30-2010.

### MORFOLOGICA

THE MARK CONSISTS OF STANDARD CHARACTERS WITHOUT CLAIM TO ANY PARTICULAR FONT, STYLE, SIZE, OR COLOR.

OWNER OF U.S. REG. NO. 3,924,470.

THE ENGLISH TRANSLATION OF "MORFOLOGICA" IN THE MARK IS "MORPHOLOGICAL".

FOR COMPUTER PROGRAMMING FOR OTHERS (U.S. CLS. 100 AND 101).

FIRST USE 11-30-2008; IN COMMERCE 11-30-2008.

TRICIA SONNEBORN, EXAMINING ATTORNEY

**CLASS 42—(Continued).**

SN 85-187,230. GOTOOTIE, INC., ORLANDO, FL. FILED 11-30-2010.



THE MARK CONSISTS OF THE LETTER "G" ON A SOLID SQUARE SHAPED BACKGROUND WITH A SINGLE LINE BORDER AROUND THE OUTER EDGE OF THE SQUARE.

FOR COMPUTER SERVICES, NAMELY, CREATING AN ON-LINE COMMUNITY FOR REGISTERED USERS TO PARTICIPATE IN DISCUSSIONS, GET FEEDBACK FROM THEIR PEERS, FORM VIRTUAL COMMUNITIES, AND ENGAGE IN SOCIAL NETWORKING FEATURING LOCATION RELEVANT INFORMATION (U.S. CLS. 100 AND 101).

TINA BROWN, EXAMINING ATTORNEY

**CLASS 42—(Continued).**

SN 85-189,055. OLSSON ASSOCIATES, LINCOLN, NE. FILED 12-2-2010.



NO CLAIM IS MADE TO THE EXCLUSIVE RIGHT TO USE "ASSOCIATES", APART FROM THE MARK AS SHOWN.

THE MARK CONSISTS OF A STYLIZED "O" CONNECTED TO A STYLIZED "A" NEXT TO THE WORD "OLSSON", WHICH IS ABOVE THE WORD "ASSOCIATES".

FOR ENGINEERING AND DESIGN FIRM PROVIDING CONSULTING FOR OTHERS IN THE FIELDS OF ENVIRONMENTAL SCIENCES, GEOTECHNICAL ENGINEERING, MECHANICAL ENGINEERING, ELECTRICAL ENGINEERING, WATER QUALITY CONTROL SERVICES, TRAFFIC AND TRANSPORTATION ENGINEERING, AND TRANSPORTATION AND TRAFFIC PLANNING SERVICES (U.S. CLS. 100 AND 101).

FIRST USE 2-28-2006; IN COMMERCE 6-6-2006.

AMEEN IMAM, EXAMINING ATTORNEY

SN 85-187,246. SLACKER ANIMATION, LLC, SKILLMAN, NJ. FILED 11-30-2010.

**SLACKER ANIMATION**

THE MARK CONSISTS OF STANDARD CHARACTERS WITHOUT CLAIM TO ANY PARTICULAR FONT, STYLE, SIZE, OR COLOR.

NO CLAIM IS MADE TO THE EXCLUSIVE RIGHT TO USE "ANIMATION", APART FROM THE MARK AS SHOWN.

FOR ANIMATION AND SPECIAL-EFFECTS DESIGN FOR OTHERS; GRAPHIC DESIGN SERVICES; GRAPHIC ILLUSTRATION SERVICES FOR OTHERS; GRAPHIC DESIGN OF CARTOONS FOR OTHERS (U.S. CLS. 100 AND 101).

FIRST USE 2-0-2009; IN COMMERCE 2-0-2009.

CHRISTOPHER BUONGIORNO, EXAMINING ATTORNEY

SN 85-189,551. BIZMOSIS, INC., DBA BIZMOSIS, CUMMING, GA. FILED 12-2-2010.

**Bizmosis**

THE MARK CONSISTS OF STANDARD CHARACTERS WITHOUT CLAIM TO ANY PARTICULAR FONT, STYLE, SIZE, OR COLOR.

FOR COMPUTER SOFTWARE DEVELOPMENT (U.S. CLS. 100 AND 101).

FIRST USE 10-1-2008; IN COMMERCE 10-1-2008.

GEOFFREY FOSDICK, EXAMINING ATTORNEY



**CLASS 42—(Continued).**

SN 85-190,481. TRUSTON TECHNOLOGIES, INC., ANNAPOLIS, MD. FILED 12-3-2010.



THE COLOR(S) BLUE, GREY, GOLD, AND BLACK IS/ ARE CLAIMED AS A FEATURE OF THE MARK.

THE MARK CONSISTS OF THE WORDING "TRUSTON" IN BLACK LETTERING WITH THE "T" FORMED BY TWO TRIDENT DESIGNS. THE "TRU" IS ON A SHIELD DESIGN WITH GOLD EDGES OUTLINED IN BLACK. THERE ARE TWO WAVE DESIGNS ON THE LEFT SIDE OF THE SHIELD. THE LEFT WAVE IS BLUE AND RIGHT WAVE IS GREY. A THIN GREY LINE ALSO EXTENDS FROM THE GREY WAVE DESIGN FORMING THE SHAPE OF THE SHIELD. WHITE IS NOT CLAIMED AS A FEATURE OF THE MARK AND IS ONLY USED AS A BACKGROUND.

FOR ENGINEERING SERVICES, NAMELY, CIVIL AND HEAVY ENGINEERING PARTICULARLY FOR HARSH ENVIRONMENTS (U.S. CLS. 100 AND 101).

FIRST USE 3-7-2005; IN COMMERCE 1-30-2009.

MATTHEW MCDOWELL, EXAMINING ATTORNEY

SN 85-191,268. THE RESEARCH FOUNDATION OF STATE UNIVERSITY OF NEW YORK, ALBANY, NY. FILED 12-6-2010.



OWNER OF U.S. REG. NO. 3,927,147.

NO CLAIM IS MADE TO THE EXCLUSIVE RIGHT TO USE "NEW YORK STATE REGIONAL CENTERS FOR AUTISM SPECTRUM DISORDERS" AND THE PICTORIAL REPRESENTATION OF THE MAP OF NEW YORK STATE, APART FROM THE MARK AS SHOWN.

THE MARK CONSISTS OF THE WORDS "NEW YORK STATE REGIONAL CENTERS FOR AUTISM SPECTRUM DISORDERS" AND THE LETTERS "NYSRCASD" WITH A DESIGN OF AN OUTLINE OF THE STATE OF NEW YORK AND A PUZZLE PIECE.

FOR SCIENTIFIC RESEARCH CONSISTENT WITH EVIDENCE-BASED PRACTICE TO IMPROVE OUTCOMES FOR INDIVIDUALS WITH AUTISM SPECTRUM DISORDER (U.S. CLS. 100 AND 101).

FIRST USE 10-1-2010; IN COMMERCE 10-1-2010.

KELLY CHOE, EXAMINING ATTORNEY

**CLASS 42—(Continued).**

SN 85-191,377. LAU, TED C, DBA PRETTY RED ROSE, LOS ALAMITOS, CA. FILED 12-6-2010.

PRETTY RED ROSE

THE MARK CONSISTS OF STANDARD CHARACTERS WITHOUT CLAIM TO ANY PARTICULAR FONT, STYLE, SIZE, OR COLOR.

FOR COMMERCIAL ART DESIGN (U.S. CLS. 100 AND 101).

FIRST USE 10-25-2008; IN COMMERCE 10-25-2008.

EUGENIA MARTIN, EXAMINING ATTORNEY

SN 85-191,827. PROVA, DEL MAR, CA. FILED 12-7-2010.

PROVA

THE MARK CONSISTS OF STANDARD CHARACTERS WITHOUT CLAIM TO ANY PARTICULAR FONT, STYLE, SIZE, OR COLOR.

THE WORDING "PROVA" HAS NO MEANING IN A FOREIGN LANGUAGE.

FOR GRAPHIC DESIGN SERVICES (U.S. CLS. 100 AND 101).

FIRST USE 10-31-2008; IN COMMERCE 1-2-2009.

KELLY CHOE, EXAMINING ATTORNEY

SN 85-192,217. SOCIAL123, LLC, CHARLESTON, SC. FILED 12-7-2010.

SOCIAL123

THE MARK CONSISTS OF STANDARD CHARACTERS WITHOUT CLAIM TO ANY PARTICULAR FONT, STYLE, SIZE, OR COLOR.

FOR PROVIDING A WEBSITE FEATURING TECHNOLOGY THAT ENABLES THE AGGREGATING, ORGANIZING, MANAGING, DISPLAYING, AND UPDATING OF CONTENT FROM VARIOUS INTERNET AND SOCIAL NETWORKING WEBSITES (U.S. CLS. 100 AND 101).

CHARLOTTE CORWIN, EXAMINING ATTORNEY

**CLASS 42—(Continued).**

SN 85-192,272. STRIKE ZONE PRECISION AG, LLC, JONESBORO, AR. FILED 12-7-2010.

**FIELD CONCEPTS**

THE MARK CONSISTS OF STANDARD CHARACTERS WITHOUT CLAIM TO ANY PARTICULAR FONT, STYLE, SIZE, OR COLOR.

NO CLAIM IS MADE TO THE EXCLUSIVE RIGHT TO USE "FIELD", APART FROM THE MARK AS SHOWN.

FOR AGRICULTURAL SERVICES, NAMELY, SOIL SAMPLING AND CROP OBSERVING FOR ANALYSIS PURPOSES; PROFESSIONAL CONSULTING SERVICES AND ADVICE ABOUT AGRICULTURAL CHEMISTRY (U.S. CLS. 100 AND 101).

FIRST USE 12-5-2010; IN COMMERCE 12-5-2010.  
HEATHER BIDDULPH, EXAMINING ATTORNEY

---

SN 85-192,564. HARDEEN, DAMIAN, QUEENS VILLAGE, NY. FILED 12-7-2010.



NO CLAIM IS MADE TO THE EXCLUSIVE RIGHT TO USE "THE BAND", APART FROM THE MARK AS SHOWN.

THE MARK CONSISTS OF A CIRCLE OVER AN UPSIDE DOWN TRIANGLE PLACE ON TOP OF A RECTANGULAR BLOCK WITH "STAMP THE BAND" WRITTEN UNDERNEATH IT.

FOR COMPUTER SERVICES, NAMELY, CREATING AN ON-LINE COMMUNITY FOR REGISTERED USERS TO PARTICIPATE IN DISCUSSIONS, GET FEEDBACK FROM THEIR PEERS, FORM VIRTUAL COMMUNITIES, AND ENGAGE IN SOCIAL NETWORKING; PROVIDING CUSTOMIZED ON-LINE WEB PAGES AND DATA FEEDS FEATURING USER-DEFINED INFORMATION, WHICH INCLUDES BLOG POSTS, NEW MEDIA CONTENT, OTHER ON-LINE CONTENT, AND ON-LINE WEB LINKS TO OTHER WEBSITES; PROVIDING TEMPORARY USE OF ON-LINE NON-DOWNLOADABLE SOFTWARE DEVELOPMENT TOOLS FOR ENABLING USERS TO SUBMIT MUSICAL DATA, PHOTOS, VIDEO CLIPS, GLOSSARY OF TERMS, BLOGGING, IMPLEMENTATION OF A RATING SYSTEM BASED OFF OF THE ANSWER OF SPECIFIC QUESTIONS, FEATURED NEWSLETTERS, WEBSITE BROADCASTS, TAPED OR LIVE EVENTS, AUDIO DATA, PHOTO EDITING OR MANIPULATION, ACTIVE PLAYLISTS, AND QUESTIONS AND ANSWERS SECTIONS (U.S. CLS. 100 AND 101).

FIRST USE 7-26-2010; IN COMMERCE 7-26-2010.  
MATTHEW EINSTEIN, EXAMINING ATTORNEY

**CLASS 42—(Continued).**

SN 85-192,701. DYNAMIC SOLUTIONS GROUP, INC., PALM HARBOR, FL. FILED 12-7-2010.

**Dynamic Solutions Group**

THE MARK CONSISTS OF STANDARD CHARACTERS WITHOUT CLAIM TO ANY PARTICULAR FONT, STYLE, SIZE, OR COLOR.

OWNER OF U.S. REG. NO. 3,590,602.

NO CLAIM IS MADE TO THE EXCLUSIVE RIGHT TO USE "GROUP", APART FROM THE MARK AS SHOWN.

SEC. 2(F).

FOR CONSULTING SERVICES IN THE FIELD OF IDENTIFICATION, SUPPORT, AND IMPLEMENTATION OF COMPUTER-BASED INFORMATION SYSTEMS FOR BUSINESSES (U.S. CLS. 100 AND 101).

FIRST USE 4-1-2000; IN COMMERCE 4-1-2000.

NANCY CLARKE, EXAMINING ATTORNEY

---

SN 85-193,544. COREMEDICA LABORATORIES, LLC, AKA COREMEDICA LABS, LEE'S SUMMIT, MO. FILED 12-8-2010.



NO CLAIM IS MADE TO THE EXCLUSIVE RIGHT TO USE "HEALTHY" OR "CONVENIENT, ACCURATE, AFFORDABLE", APART FROM THE MARK AS SHOWN.

THE COLOR(S) RED, BLACK, AND GRAY IS/ARE CLAIMED AS A FEATURE OF THE MARK.

THE MARK CONSISTS OF THE WORDING "HEALTHY" IN RED, A RECTANGLE LINED IN GRAY CONTAINING A RED CHECKMARK LINED IN BLACK, AND THE WORDING "CONVENIENT, ACCURATE, AFFORDABLE" IN RED. WHITE AS IT APPEARS IN THE RECTANGLE IS FOR BACKGROUND ONLY AND IS NOT CLAIMED AS A FEATURE OF THE MARK.

FOR MEDICAL LABORATORY SERVICES (U.S. CLS. 100 AND 101).

REBECCA POVARCHUK, EXAMINING ATTORNEY

**CLASS 42—(Continued).**

SN 85-193,602. PARIO, LLC, CARLSBAD, CA. FILED 12-8-2010.

# Pario

THE MARK CONSISTS OF STANDARD CHARACTERS WITHOUT CLAIM TO ANY PARTICULAR FONT, STYLE, SIZE, OR COLOR.

THE ENGLISH TRANSLATION OF "PARIO" IS "TO BRING FORTH, TO BEAR, TO PRODUCE, OCCASION, CREATE".

FOR NATIONAL AND INTERNATIONAL ENGINEERING, PRODUCT TESTING, PRODUCT RESEARCH AND DEVELOPMENT ALL IN THE FIELDS OF LIGHTING AND ENVIRONMENTAL SYSTEMS, PRODUCTS, AND EQUIPMENT, AND CONSULTATION RELATED THERETO (U.S. CLS. 100 AND 101).

TARAH HARDY, EXAMINING ATTORNEY

---

SN 85-195,242. UCOMPASS.COM, INC., TALLAHASSEE, FL. FILED 12-10-2010.

# OCTANE

THE MARK CONSISTS OF STANDARD CHARACTERS WITHOUT CLAIM TO ANY PARTICULAR FONT, STYLE, SIZE, OR COLOR.

FOR COMPUTER SERVICE, NAMELY, ACTING AS AN APPLICATION SERVICE PROVIDER IN THE FIELD OF INFORMATION MANAGEMENT TO HOST COMPUTER APPLICATION SOFTWARE FOR THE PURPOSE OF ENHANCING THE CONTENT OF INFORMATION DELIVERED VIA THE INTERNET (U.S. CLS. 100 AND 101).

WANDA KAY PRICE, EXAMINING ATTORNEY

---

SN 85-197,334. CENTENE CORPORATION, ST. LOUIS, MO. FILED 12-14-2010.

# CENTELLIGENCE

THE MARK CONSISTS OF STANDARD CHARACTERS WITHOUT CLAIM TO ANY PARTICULAR FONT, STYLE, SIZE, OR COLOR.

FOR PROVIDING TEMPORARY USE OF ON-LINE NON-DOWNLOADABLE SOFTWARE FOR USE IN THE MANAGEMENT OF MEDICAL INFORMATION IN THE HEALTH CARE FIELD (U.S. CLS. 100 AND 101).

JESSICA FATHY, EXAMINING ATTORNEY

**CLASS 42—(Continued).**

SN 85-197,982. MYARTSYLUM, INC., MIAMI, FL. FILED 12-15-2010.



THE MARK CONSISTS OF THE IMAGE OF A ROUND STYLIZED FACE WITH THE WORDING "MYARTSYLUM.COM".

FOR COMPUTER SERVICES, NAMELY, CREATING AN ON-LINE COMMUNITY FOR REGISTERED USERS TO PARTICIPATE IN DISCUSSIONS, GET FEEDBACK FROM THEIR PEERS, FORM VIRTUAL COMMUNITIES, AND ENGAGE IN SOCIAL NETWORKING; COMPUTER SERVICES, NAMELY, CREATING AN ON-LINE COMMUNITY FOR REGISTERED USERS TO PARTICIPATE IN DISCUSSIONS, GET FEEDBACK FROM THEIR PEERS, FORM VIRTUAL COMMUNITIES, AND ENGAGE IN SOCIAL NETWORKING FEATURING ARTISTS AND THEIR WORKS; HOSTING AN ON-LINE COMMUNITY WEB SITE FEATURING ARTISTS AND THEIR WORKS; PROVIDING A WEBSITE THAT GIVES COMPUTER USERS THE ABILITY TO ENGAGE IN SOCIAL NETWORKING WITH OTHER ARTISTS, PUBLISH THEIR WORKS ONLINE, COMMENT ON OTHER USERS' WORK, AND LINK TO THE WORKS OF OTHERS (U.S. CLS. 100 AND 101).

FIRST USE 10-0-2010; IN COMMERCE 10-0-2010.

DAVID HOFFMAN, EXAMINING ATTORNEY

---

SN 85-198,529. WOODLAND, TRACY, ATLANTA, GA. FILED 12-15-2010.

## Priastyle "Fashion with a twist of your Own"

THE MARK CONSISTS OF STANDARD CHARACTERS WITHOUT CLAIM TO ANY PARTICULAR FONT, STYLE, SIZE, OR COLOR.

FOR COMPUTER SERVICES, NAMELY, CREATING AN ON-LINE COMMUNITY FOR REGISTERED USERS TO PARTICIPATE IN DISCUSSIONS, GET FEEDBACK FROM THEIR PEERS, FORM VIRTUAL COMMUNITIES, AND ENGAGE IN SOCIAL NETWORKING; PROVIDING A WEB SITE FEATURING TECHNOLOGY THAT ENABLES INTERNET USERS TO SHARE DOCUMENTS, IMAGES AND VIDEOS (U.S. CLS. 100 AND 101).

RAUL CORDOVA, EXAMINING ATTORNEY

**CLASS 42—(Continued).**

SN 85-198,886. AFFINITON, WILLIAMSPORT, PA. FILED 12-15-2010.

**DRU!DS**  
Driving Under the Influence of Disabling Substances

THE COLOR(S) BLACK, MAROON AND WHITE IS/ARE CLAIMED AS A FEATURE OF THE MARK.

THE MARK CONSISTS OF THE LETTERS "DRU!DS" IN BLACK TEXT, WITH A MAROON EXCLAMATION POINT BETWEEN THE LETTERS "U" AND "D" TO SPELL THE WORD "DRUIDS". THE MAROON EXCLAMATION POINT HAS WHITE VERTICAL DASH MARKS DOWN THE CENTER. THE WORDS "DRIVING UNDER THE !NFLUENCE OF DISABLING SUBSTANCES" IS WRITTEN IN BLACK BELOW THE MARK AS A TAGLINE.

FOR DRUG, ALCOHOL AND DNA SCREENING FOR FORENSIC RESEARCH PURPOSES (U.S. CLS. 100 AND 101).

FIRST USE 12-14-2010; IN COMMERCE 12-15-2010.  
HOWARD SMIGA, EXAMINING ATTORNEY

SN 85-199,349. CROWDSCRIBED LLC, EDMOND, OK. FILED 12-16-2010.

**CROWDSCRIBED**

THE MARK CONSISTS OF STANDARD CHARACTERS WITHOUT CLAIM TO ANY PARTICULAR FONT, STYLE, SIZE, OR COLOR.

FOR PROVIDING AN INTERACTIVE WEBSITE FEATURING TECHNOLOGY THAT ALLOWS USERS TO PUBLISH BOOKS, E-BOOKS, MAGAZINES, WEB BOOKS AND ILLUSTRATIONS; PROVIDING AN INTERACTIVE WEBSITE FEATURING TECHNOLOGY THAT ALLOWS USERS TO HAVE BOOKS, E-BOOKS, MAGAZINES, WEB BOOKS AND ILLUSTRATIONS VETTED, WRITTEN, PROOFREAD, ILLUSTRATED AND DESIGNED; PROVIDING AN INTERACTIVE WEBSITE FEATURING TECHNOLOGY THAT ALLOWS USERS TO CONTRIBUTE CONTENT TO BOOKS, E-BOOKS, MAGAZINES, WEB BOOKS AND ILLUSTRATIONS AND TO COMPETE FOR A BOUNTY; PROVIDING AN INTERACTIVE WEBSITE FEATURING TECHNOLOGY THAT ALLOWS FOR THE AGGREGATION OF CONTENT INTO BOOKS, E-BOOKS, MAGAZINES, WEB BOOKS AND ILLUSTRATIONS (U.S. CLS. 100 AND 101).

DOMINIC J. FERRAIUOLO, EXAMINING ATTORNEY

**CLASS 42—(Continued).**

SN 85-199,863. SPRING WIRELESS USA, INC., SEATTLE, WA. FILED 12-16-2010.

BECAUSE BUSINESS MOVES.

THE MARK CONSISTS OF STANDARD CHARACTERS WITHOUT CLAIM TO ANY PARTICULAR FONT, STYLE, SIZE, OR COLOR.

FOR APPLICATION SERVICE PROVIDER, NAMELY, PROVIDING, HOSTING, MANAGING, DEVELOPING, AND MAINTAINING APPLICATIONS IN THE FIELDS OF WIRELESS COMMUNICATION, CUSTOMER RELATIONSHIP MANAGEMENT, MOBILE INFORMATION ACCESS, AND REMOTE DATA MANAGEMENT FOR WIRELESS DELIVERY OF CONTENT TO MOBILE ELECTRONIC DEVICES (U.S. CLS. 100 AND 101).

ANTHONY RINKER, EXAMINING ATTORNEY

SN 85-199,871. MAGNICODE, INC., SUNNYVALE, CA. FILED 12-16-2010.

**MAGNICODE**

THE MARK CONSISTS OF STANDARD CHARACTERS WITHOUT CLAIM TO ANY PARTICULAR FONT, STYLE, SIZE, OR COLOR.

FOR SOFTWARE DESIGN AND DEVELOPMENT (U.S. CLS. 100 AND 101).

FIRST USE 12-1-2008; IN COMMERCE 12-1-2008.

BARBARA RUTLAND, EXAMINING ATTORNEY

SN 85-199,935. CELL THERAPEUTICS, INC., SEATTLE, WA. FILED 12-16-2010.

**PIX-R**

THE MARK CONSISTS OF STANDARD CHARACTERS WITHOUT CLAIM TO ANY PARTICULAR FONT, STYLE, SIZE, OR COLOR.

FOR MEDICAL AND SCIENTIFIC RESEARCH, NAMELY, CONDUCTING CLINICAL TRIALS FOR PHARMACEUTICAL PREPARATIONS USED FOR THE TREATMENT OF CANCER (U.S. CLS. 100 AND 101).

ALICIA COLLINS, EXAMINING ATTORNEY

**CLASS 42—(Continued).**

SN 85-200,073. GROSVENOR USA LIMITED, SAN FRANCISCO, CA. FILED 12-16-2010.



THE MARK CONSISTS OF THREE EARS OF WHEAT CURVED TO FORM CIRCLE.  
FOR ARCHITECTURAL AND ENGINEERING SERVICES; SURVEYING (U.S. CLS. 100 AND 101).  
FIRST USE 2-0-2004; IN COMMERCE 2-0-2004.  
ZHALEH DELANEY, EXAMINING ATTORNEY

SN 85-200,079. GROSVENOR USA LIMITED, SAN FRANCISCO, CA. FILED 12-16-2010.

**LIVING CITIES**

THE MARK CONSISTS OF STANDARD CHARACTERS WITHOUT CLAIM TO ANY PARTICULAR FONT, STYLE, SIZE, OR COLOR.  
FOR ARCHITECTURAL AND ENGINEERING SERVICES; SURVEYING (U.S. CLS. 100 AND 101).  
FIRST USE 3-0-2007; IN COMMERCE 3-0-2007.  
ZHALEH DELANEY, EXAMINING ATTORNEY

SN 85-200,225. KOGER, INC., PARAMUS, NJ. FILED 12-17-2010.

**E\*TAS**

THE MARK CONSISTS OF STANDARD CHARACTERS WITHOUT CLAIM TO ANY PARTICULAR FONT, STYLE, SIZE, OR COLOR.

FOR NON-DOWNLOADABLE COMPUTER SOFTWARE FOR USE IN THE FINANCIAL AND INVESTMENT FIELDS TO RECORD INVESTMENT TRANSACTIONS, TO MONITOR INVESTMENT FUND RULES, TO CALCULATE PERFORMANCE AND MANAGEMENT FEES, TO POST TRADES, TO CREATE REPORTS TO INVESTORS, AND TO ALLOW INVESTORS TO RETRIEVE TRADE CONFIRMATIONS, STATEMENTS AND INVESTMENT REPORTS ONLINE (U.S. CLS. 100 AND 101).

FIRST USE 1-0-2000; IN COMMERCE 1-0-2000.  
ANNE MADDEN, EXAMINING ATTORNEY

**CLASS 42—(Continued).**

SN 85-200,248. ELECTRA INFORMATION SYSTEMS, INC., NEW YORK, NY. FILED 12-17-2010.

**FAILSAFE**

THE MARK CONSISTS OF STANDARD CHARACTERS WITHOUT CLAIM TO ANY PARTICULAR FONT, STYLE, SIZE, OR COLOR.

FOR PROVIDING ON-LINE NON-DOWNLOADABLE SOFTWARE FOR COLLECTING, AGGREGATING, MAINTAINING, ANALYZING, REPORTING AND TRACKING DATA IN CONNECTION WITH FINANCIAL AND INVESTMENT TRANSACTIONS (U.S. CLS. 100 AND 101).

FIRST USE 4-21-2009; IN COMMERCE 4-21-2009.  
SUSAN RICHARDS, EXAMINING ATTORNEY

SN 85-200,251. MYSCORECARD LLC, BELMONT, MA. FILED 12-17-2010.

**MYSCORECARD**

THE MARK CONSISTS OF STANDARD CHARACTERS WITHOUT CLAIM TO ANY PARTICULAR FONT, STYLE, SIZE, OR COLOR.

FOR SOFTWARE AS A SERVICE, NAMELY, ONLINE NON-DOWNLOADABLE SOFTWARE FOR TRACKING, CALCULATING, AND SHARING GOLF SCORES, HANDICAPS, AND STATISTICS; SOFTWARE AS A SERVICE, NAMELY, ONLINE NON-DOWNLOADABLE SOFTWARE FOR CREATING AND ORGANIZING VIRTUAL GOLF CLUBS AND ONLINE COMMUNITIES IN THE FIELD OF SPORTS; COMPUTER SERVICES, NAMELY, CREATING AN ONLINE COMMUNITY FOR USERS TO PARTICIPATE IN DISCUSSIONS, GET FEEDBACK FROM THEIR PEERS, FORM VIRTUAL CLUBS AND COMMUNITIES, AND ENGAGE IN SOCIAL NETWORKING FEATURING SPORTS (U.S. CLS. 100 AND 101).

FIRST USE 4-30-1999; IN COMMERCE 4-30-1999.  
SUSAN RICHARDS, EXAMINING ATTORNEY

**CLASS 42—(Continued).**

SN 85-200,599. DP SQUARED, INC., PALO ALTO, CA. FILED 12-17-2010.

# BANJO

THE MARK CONSISTS OF STANDARD CHARACTERS WITHOUT CLAIM TO ANY PARTICULAR FONT, STYLE, SIZE, OR COLOR.

FOR COMPUTER SERVICES, NAMELY, CREATING A GEOGRAPHY-BASED ON-LINE COMMUNITY FOR REGISTERED USERS TO PARTICIPATE IN DISCUSSIONS, GET FEEDBACK FROM THEIR PEERS, FORM VIRTUAL COMMUNITIES, AND ENGAGE IN SOCIAL NETWORKING WITH USERS IN THE SAME GEOGRAPHIC AREA (U.S. CLS. 100 AND 101).

FIRST USE 12-13-2010; IN COMMERCE 12-13-2010.  
CAROL SPILS, EXAMINING ATTORNEY

SN 85-200,616. DP SQUARED, INC., PALO ALTO, CA. FILED 12-17-2010.

# BAN

THE MARK CONSISTS OF STANDARD CHARACTERS WITHOUT CLAIM TO ANY PARTICULAR FONT, STYLE, SIZE, OR COLOR.

FOR COMPUTER SERVICES, NAMELY, CREATING A GEOGRAPHY-BASED ON-LINE COMMUNITY FOR REGISTERED USERS TO PARTICIPATE IN DISCUSSIONS, GET FEEDBACK FROM THEIR PEERS, FORM VIRTUAL COMMUNITIES, AND ENGAGE IN SOCIAL NETWORKING WITH USERS IN THE SAME GEOGRAPHIC AREA (U.S. CLS. 100 AND 101).

CAROL SPILS, EXAMINING ATTORNEY

SN 85-200,681. CONVNATION, LLC, JERSEY CITY, NJ. FILED 12-17-2010.



THE MARK CONSISTS OF THE WORD "CONVNATION" WITH THE SECOND "O" STYLIZED BOTH AS A GLOBE AND AS A QUOTATION MARK.

FOR COMPUTER SERVICES, NAMELY, CREATING AN ON-LINE COMMUNITY FOR REGISTERED USERS TO PARTICIPATE IN DISCUSSIONS, GET FEEDBACK FROM THEIR PEERS, FORM VIRTUAL COMMUNITIES, AND ENGAGE IN SOCIAL NETWORKING (U.S. CLS. 100 AND 101).

FIRST USE 10-30-2010; IN COMMERCE 10-30-2010.  
PRISCILLA MILTON, EXAMINING ATTORNEY

**CLASS 42—(Continued).**

SN 85-201,713. I85MEDIA, INC., ATLANTA, GA. FILED 12-20-2010.

# i85media

THE MARK CONSISTS OF STANDARD CHARACTERS WITHOUT CLAIM TO ANY PARTICULAR FONT, STYLE, SIZE, OR COLOR.

FOR COMPUTER SERVICES, NAMELY, SEARCH ENGINE OPTIMIZATION; WEBSITE DESIGN AND DEVELOPMENT FOR OTHERS (U.S. CLS. 100 AND 101).

FIRST USE 5-29-2006; IN COMMERCE 9-29-2006.  
PAUL E. FAHRENKOPF, EXAMINING ATTORNEY

SN 85-202,009. PEOPLE PRODUCTIONS VIDEO SERVICES, INC., BOULDER, CO. FILED 12-20-2010.

# UPSYNC

THE MARK CONSISTS OF STANDARD CHARACTERS WITHOUT CLAIM TO ANY PARTICULAR FONT, STYLE, SIZE, OR COLOR.

FOR PROVIDING TEMPORARY USE OF A WEB-BASED SOFTWARE APPLICATION FOR CREATION, COLLECTION, CUSTOMIZATION, EDITING, ORGANIZATION, MANAGEMENT, TRANSMISSION AND SHARING OF DATA, INFORMATION AND BUSINESS, SALES AND MARKETING MATERIALS (U.S. CLS. 100 AND 101).

CIMMERIAN COLEMAN, EXAMINING ATTORNEY

SN 85-202,367. SACON, ERIC, WALPOLE, MA. FILED 12-21-2010.

# POINTLINEPOLY

THE MARK CONSISTS OF STANDARD CHARACTERS WITHOUT CLAIM TO ANY PARTICULAR FONT, STYLE, SIZE, OR COLOR.

FOR COMPUTER SERVICES IN THE FIELD OF GEOSPATIAL INFORMATION SYSTEMS, NAMELY GEOSPATIAL ANALYTICAL SERVICES, DESIGN AND DEVELOPMENT OF SPATIALLY-BASED DECISION SUPPORT SYSTEMS AND DATABASES, AND CONSULTATION RELATED THERETO (U.S. CLS. 100 AND 101).

MATTHEW EINSTEIN, EXAMINING ATTORNEY

**CLASS 42—(Continued).**

SN 85-203,515. LIGHT IN THE BOX LIMITED, DES VOEUX RD C CENTRAL, HONG KONG, FILED 12-22-2010.



THE MARK CONSISTS OF THE WORD "OUKU" WITH STYLIZED DESIGN AND THREE WATER-DROPLET-SHAPED DEVICES ABOVE THE LETTER "O"  
THE WORDING OUKU HAS NO MEANING IN A FOREIGN LANGUAGE.  
FOR COMPUTER PROGRAMMING; COMPUTER SOFTWARE CONSULTANCY; COMPUTER SOFTWARE DESIGN; COMPUTER SYSTEMS ANALYSIS; CREATING OR MAINTAINING WEB SITES FOR OTHERS; DATA CONVERSION OF COMPUTER PROGRAMS AND DATA, NOT PHYSICAL CONVERSION; HOSTING THE WEB SITES OF OTHERS ON A COMPUTER SERVER FOR A GLOBAL COMPUTER NETWORK; MAINTENANCE OF COMPUTER SOFTWARE; RECOVERY OF COMPUTER DATA; UPDATING AND DESIGN OF COMPUTER SOFTWARE (U.S. CLS. 100 AND 101).  
HEATHER BIDDULPH, EXAMINING ATTORNEY

SN 85-203,802. RXPLAINER, MORRISON, CO. FILED 12-22-2010.

# RXPLAINER

THE MARK CONSISTS OF STANDARD CHARACTERS WITHOUT CLAIM TO ANY PARTICULAR FONT, STYLE, SIZE, OR COLOR.  
FOR APPLICATION SERVICE PROVIDER FEATURING A SOFTWARE PLATFORM FOR DELIVERING CUSTOMIZABLE CONTENT IN THE FIELD OF HEALTH AND WELLNESS VIA A GLOBAL COMPUTER NETWORK AND MOBILE DEVICES (U.S. CLS. 100 AND 101).  
ROBIN MITTLER, EXAMINING ATTORNEY

**CLASS 42—(Continued).**

SN 85-203,862. MIS QUALITY MANAGEMENT CORP., WILMINGTON, DE. FILED 12-22-2010.

# METRO WORKSTATION

THE MARK CONSISTS OF STANDARD CHARACTERS WITHOUT CLAIM TO ANY PARTICULAR FONT, STYLE, SIZE, OR COLOR.  
OWNER OF U.S. REG. NOS. 2,823,980, 2,832,896 AND 2,848,886.  
FOR PROVIDING TEMPORARY USE OF A WEB-BASED SOFTWARE APPLICATION FOR OBTAINING ECONOMIC DATA AND ANALYSIS TO MONITOR AND EVALUATE ECONOMIC CONDITIONS (U.S. CLS. 100 AND 101).  
FIRST USE 9-2-2010; IN COMMERCE 9-2-2010.  
RAUL CORDOVA, EXAMINING ATTORNEY

SN 85-203,897. DATAMATICS GLOBAL SERVICES, INC., LIVONIA, MI. FILED 12-22-2010.

# InvoiceTiger

THE MARK CONSISTS OF STANDARD CHARACTERS WITHOUT CLAIM TO ANY PARTICULAR FONT, STYLE, SIZE, OR COLOR.  
FOR COMPUTER SERVICES, NAMELY, PROVIDING A WEB-BASED SYSTEM AND ONLINE PORTAL FEATURING SECURE NON-DOWNLOADABLE ACCOUNTS PAYABLE SOFTWARE (U.S. CLS. 100 AND 101).  
FIRST USE 9-20-2010; IN COMMERCE 9-20-2010.  
MATTHEW KLINE, EXAMINING ATTORNEY

SN 85-204,524. C2LOGIX, INC., FORMERLY WASTBID-COM, FAIRFAX, VA. FILED 12-22-2010.

# C2RouteAPP

THE MARK CONSISTS OF STANDARD CHARACTERS WITHOUT CLAIM TO ANY PARTICULAR FONT, STYLE, SIZE, OR COLOR.  
FOR SOFTWARE AS A SERVICE (SAAS) SERVICES FEATURING SOFTWARE IN THE FIELD OF ROUTE OPTIMIZATION, CONSISTING OF SOFTWARE THAT ALLOWS COMPANIES WITH FIELD WORKERS THAT MUST BE DIRECTED FROM STOP TO STOP DURING THE WORK PERIOD IN THE MOST EFFICIENT AND ECONOMIC WAY POSSIBLE (U.S. CLS. 100 AND 101).  
FIRST USE 12-1-2009; IN COMMERCE 3-1-2010.  
EMILY CHUO, EXAMINING ATTORNEY

**CLASS 42—(Continued).**

SN 85-204,603. DELUCIA, DAVID, LEBANON, NH. FILED 12-23-2010.

# IMMUNEXT

THE MARK CONSISTS OF STANDARD CHARACTERS WITHOUT CLAIM TO ANY PARTICULAR FONT, STYLE, SIZE, OR COLOR.

FOR PHARMACEUTICAL RESEARCH AND DEVELOPMENT (U.S. CLS. 100 AND 101).  
DEZMONA MIZELLE, EXAMINING ATTORNEY

---

SN 85-204,650. WP COMPANY LLC, WASHINGTON, DC. FILED 12-23-2010.

# PostWeather.com

THE MARK CONSISTS OF STANDARD CHARACTERS WITHOUT CLAIM TO ANY PARTICULAR FONT, STYLE, SIZE, OR COLOR.

FOR PROVIDING INFORMATION AND NEWS ON THE SUBJECT OF WEATHER VIA THE INTERNET, MOBILE NETWORKS AND OTHER ELECTRONIC COMMUNICATIONS NETWORKS (U.S. CLS. 100 AND 101).  
ANDREA BUTLER, EXAMINING ATTORNEY

---

SN 85-204,712. ALL STAR PREMIUM PRODUCTS INC., FISKDALE, MA. FILED 12-23-2010.

# Towering Pride

THE MARK CONSISTS OF STANDARD CHARACTERS WITHOUT CLAIM TO ANY PARTICULAR FONT, STYLE, SIZE, OR COLOR.

FOR PROVIDING A WEB SITE FEATURING TECHNOLOGY THAT ENABLES COMPANIES AND ORGANIZATIONS TO ADMINISTER AND MANAGE INCENTIVE AWARD PROGRAMS FOR EMPLOYEES WORKING AT THE SITE OF THE FORMER WORLD TRADE CENTER IN NEW YORK CITY TO PROMOTE EMPLOYEE SAFETY, TO INCREASE AND REWARD SAFETY ACHIEVEMENTS, AND ENCOURAGE IMPROVED SAFETY PRACTICES (U.S. CLS. 100 AND 101).

FIRST USE 6-30-2010; IN COMMERCE 6-30-2010.  
ANNE MADDEN, EXAMINING ATTORNEY

**CLASS 42—(Continued).**

SN 85-204,858. QUIRKY, INC., NEW YORK, NY. FILED 12-23-2010.

## MAKING INVENTION ACCESSIBLE

THE MARK CONSISTS OF STANDARD CHARACTERS WITHOUT CLAIM TO ANY PARTICULAR FONT, STYLE, SIZE, OR COLOR.

FOR PRODUCT DEVELOPMENT, RESEARCH, DESIGN AND ENGINEERING SERVICES FOR OTHERS; CONSULTATION IN THE FIELD OF NEW PRODUCT DEVELOPMENT, RESEARCH, DESIGN AND ENGINEERING; INNOVATION CONSULTING SERVICES, NAMELY, ADVISING OTHERS IN THE AREAS OF PRODUCT DEVELOPMENT; COMPUTER SERVICES, NAMELY, CREATING AN ONLINE COMMUNITY FOR REGISTERED USERS TO PARTICIPATE IN DISCUSSIONS, GET FEEDBACK FROM THEIR PEERS, FORM VIRTUAL COMMUNITIES, AND ENGAGE IN SOCIAL NETWORKING FEATURING THE CONTRIBUTION OF IDEAS, SUGGESTIONS, AND COMMENTS INTENDED TO ENHANCE PRODUCT DESIGN AND DEVELOPMENT AND BRINGING PRODUCTS TO MARKET (U.S. CLS. 100 AND 101).

HANNO RITTNER, EXAMINING ATTORNEY

---

SN 85-204,861. QUIRKY, INC., NEW YORK, NY. FILED 12-23-2010.

## WE MAKE INVENTION ACCESSIBLE

THE MARK CONSISTS OF STANDARD CHARACTERS WITHOUT CLAIM TO ANY PARTICULAR FONT, STYLE, SIZE, OR COLOR.

FOR PRODUCT DEVELOPMENT, RESEARCH, DESIGN AND ENGINEERING SERVICES FOR OTHERS; CONSULTATION IN THE FIELD OF NEW PRODUCT DEVELOPMENT, RESEARCH, DESIGN AND ENGINEERING; INNOVATION CONSULTING SERVICES, NAMELY, ADVISING OTHERS IN THE AREAS OF PRODUCT DEVELOPMENT; COMPUTER SERVICES, NAMELY, CREATING AN ONLINE COMMUNITY FOR REGISTERED USERS TO PARTICIPATE IN DISCUSSIONS, GET FEEDBACK FROM THEIR PEERS, FORM VIRTUAL COMMUNITIES, AND ENGAGE IN SOCIAL NETWORKING FEATURING THE CONTRIBUTION OF IDEAS, SUGGESTIONS, AND COMMENTS INTENDED TO ENHANCE PRODUCT DESIGN AND DEVELOPMENT AND BRINGING PRODUCTS TO MARKET (U.S. CLS. 100 AND 101).

HANNO RITTNER, EXAMINING ATTORNEY



**CLASS 42—(Continued).**

SN 85-204,948. ARCH WEB LABS, LLC, TUSTIN, CA. FILED 12-23-2010.

**THREADSTR**

THE MARK CONSISTS OF STANDARD CHARACTERS WITHOUT CLAIM TO ANY PARTICULAR FONT, STYLE, SIZE, OR COLOR.

THE WORDING THREADSTR HAS NO MEANING IN A FOREIGN LANGUAGE.

FOR PROVIDING A WEBSITE FEATURING NON-DOWNLOADABLE SOFTWARE FOR THE FASHION INDUSTRY THAT INCLUDES THE FUNCTIONALITY TO INCLUDE WEBSITE CONTENT MANAGEMENT, CUSTOMER RELATIONSHIP MANAGEMENT, LINE SHEET AUTOMATION, AND OTHER BUSINESS UTILITY TOOLS FOR THE FASHION INDUSTRY (U.S. CLS. 100 AND 101).

FIRST USE 8-1-2010; IN COMMERCE 8-1-2010.  
DEBRA LEE, EXAMINING ATTORNEY

**CLASS 42—(Continued).**

SN 85-205,235. ESSENCE GROUP HOLDINGS CORPORATION, MARYLAND HEIGHTS, MO. FILED 12-23-2010.

**EGHC**

THE MARK CONSISTS OF STANDARD CHARACTERS WITHOUT CLAIM TO ANY PARTICULAR FONT, STYLE, SIZE, OR COLOR.

FOR APPLICATION SERVICE PROVIDER FEATURING SOFTWARE FOR AGGREGATING INSURANCE CLAIM, PHARMACY, LABORATORY AND OTHER PERTINENT DATA FROM ACROSS THE CONTINUUM OF CARE WITHIN A DATABASE, AND FOR ANALYZING SUCH DATA TO PROVIDE ACTIONABLE OUTPUT INFORMATION AND DECISION SUPPORT TO INSURANCE COMPANIES, PHYSICIANS AND OTHER ORGANIZATION STAKEHOLDERS WITHIN A PROVIDER NETWORK (U.S. CLS. 100 AND 101).

JENNIFER MARTIN, EXAMINING ATTORNEY

SN 85-205,231. ESSENCE GROUP HOLDINGS CORPORATION, MARYLAND HEIGHTS, MO. FILED 12-23-2010.



THE MARK CONSISTS OF A STYLIZED DESIGN RESEMBLING A CADUCEUS SYMBOL.

FOR APPLICATION SERVICE PROVIDER FEATURING SOFTWARE FOR AGGREGATING INSURANCE CLAIM, PHARMACY, LABORATORY AND OTHER PERTINENT DATA FROM ACROSS THE CONTINUUM OF CARE WITHIN A DATABASE, AND FOR ANALYZING SUCH DATA TO PROVIDE ACTIONABLE OUTPUT INFORMATION AND DECISION SUPPORT TO INSURANCE COMPANIES, PHYSICIANS AND OTHER ORGANIZATION STAKEHOLDERS WITHIN A PROVIDER NETWORK (U.S. CLS. 100 AND 101).

JENNIFER MARTIN, EXAMINING ATTORNEY

SN 85-205,238. ESSENCE GROUP HOLDINGS CORPORATION, MARYLAND HEIGHTS, MO. FILED 12-23-2010.



THE MARK CONSISTS OF THE LETTERS "EGHC" IN STYLIZED FORM.

FOR APPLICATION SERVICE PROVIDER FEATURING SOFTWARE FOR AGGREGATING INSURANCE CLAIM, PHARMACY, LABORATORY AND OTHER PERTINENT DATA FROM ACROSS THE CONTINUUM OF CARE WITHIN A DATABASE, AND FOR ANALYZING SUCH DATA TO PROVIDE ACTIONABLE OUTPUT INFORMATION AND DECISION SUPPORT TO INSURANCE COMPANIES, PHYSICIANS AND OTHER ORGANIZATION STAKEHOLDERS WITHIN A PROVIDER NETWORK (U.S. CLS. 100 AND 101).

JENNIFER MARTIN, EXAMINING ATTORNEY

**CLASS 42—(Continued).**

SN 85-205,266. THE RED BRICK ROAD, LONDON, UNITED KINGDOM, FILED 12-23-2010.

**THE RED BRICK ROAD**

THE MARK CONSISTS OF STANDARD CHARACTERS WITHOUT CLAIM TO ANY PARTICULAR FONT, STYLE, SIZE, OR COLOR.

OWNER OF ERPN CMNTY TM OFC REG. NO. 004861449, DATED 7-5-2007, EXPIRES 1-26-2016.

FOR GRAPHIC DESIGN SERVICES; WEB SITE DESIGN SERVICES; DESIGNING WEBSITES FOR ADVERTISING PURPOSES; DESIGN AND TESTING OF NEW INDUSTRIAL PRODUCTS FOR OTHERS; PACKAGING DESIGN FOR OTHERS; COMPUTER CONSULTATION SERVICES; WEBSITE DESIGN SERVICES, NAMELY, DESIGN, DRAWING AND COMMISSIONING OF WRITING FOR THE CREATION OF WEB SITES FOR OTHERS; CREATING, MAINTAINING AND HOSTING THE WEBSITES OF OTHERS; CONSULTANCY SERVICES IN RELATION TO INFORMATION TECHNOLOGY; INFORMATION, ADVISORY AND CONSULTANCY SERVICES RELATING TO THE AFORESAID SERVICES (U.S. CLS. 100 AND 101).

REGINA DRUMMOND, EXAMINING ATTORNEY

SN 85-205,523. LAVAHOUND, INC., WAYNE, PA. FILED 12-24-2010.

**LAVAHOUND**

THE MARK CONSISTS OF STANDARD CHARACTERS WITHOUT CLAIM TO ANY PARTICULAR FONT, STYLE, SIZE, OR COLOR.

FOR COMPUTER SOFTWARE DESIGN; COMPUTER SOFTWARE DEVELOPMENT; COMPUTER SOFTWARE CONSULTING; COMPUTER SOFTWARE DEVELOPMENT IN THE FIELD OF MOBILE APPLICATIONS (U.S. CLS. 100 AND 101).

LAURIE MAYES, EXAMINING ATTORNEY

SN 85-205,706. ARIES DESIGN AUTOMATION, LLC, CHICAGO, IL. FILED 12-26-2010.

**HighCheck**

THE MARK CONSISTS OF STANDARD CHARACTERS WITHOUT CLAIM TO ANY PARTICULAR FONT, STYLE, SIZE, OR COLOR.

FOR COMPUTER SOFTWARE FOR MATHEMATICALLY PROVING THE CORRECTNESS, I.E., FORMALLY VERIFYING, OF DIGITAL CIRCUITS (U.S. CLS. 100 AND 101).

FIRST USE 12-24-2010; IN COMMERCE 12-24-2010.

DAVID ELTON, EXAMINING ATTORNEY

**CLASS 42—(Continued).**

SN 85-205,939. WEB CHICK, LLC, LANCASTER, OH. FILED 12-27-2010.

**WebChick**

THE MARK CONSISTS OF STANDARD CHARACTERS WITHOUT CLAIM TO ANY PARTICULAR FONT, STYLE, SIZE, OR COLOR.

FOR BUILDING AND MAINTAINING WEBSITES; DESIGN OF HOMEPAGES AND WEBSITES; DESIGN, CREATION, HOSTING, MAINTENANCE OF WEBSITES FOR OTHERS; DESIGNING WEBSITES FOR ADVERTISING PURPOSES; DESIGNING, CREATING, MAINTAINING AND HOSTING ONLINE RETAIL AND ELECTRONIC COMMERCE WEBSITES FOR OTHERS; HOSTING WEBSITES ON THE INTERNET; MAINTENANCE OF WEBSITES AND HOSTING ON-LINE WEB FACILITIES FOR OTHERS; PLANNING, DESIGN, DEVELOPMENT, MAINTENANCE AND OPTIMIZATION OF ONLINE WEBSITES FOR THIRD PARTIES; PROVIDING A MEMBERS-ONLY WEBSITE FEATURING TECHNOLOGY WHICH PROVIDES MEMBERS WITH THE ABILITY TO ACCESS MULTIPLE DATABASES AND AUTOMOBILE INDUSTRY SERVICES FOR THE PURPOSE OF CONDUCTING AUTOMOBILE PURCHASE AND SALE TRANSACTIONS; PROVIDING A SECURED-ACCESS WEBSITE THAT GIVES REGISTERED INTERNET NETWORKED INSTITUTIONS THE ABILITY TO UPLOAD, VIEW, COPY, PRINT, DOWNLOAD AND SHARE DOCUMENTS AND IMAGES FOR THE PURPOSES OF CONDUCTING CONSUMER-DRIVEN TRANSACTIONS; PROVIDING A WEBSITE FEATURING TECHNOLOGY THAT ENABLES SUBSCRIBERS TO TRANSFER FILES TO AND FROM A FILE TRANSFER PROTOCOL SERVER; UPDATING WEBSITES FOR OTHERS; WEB PUBLISHING, NAMELY, CREATING A WEBSITE AND UPLOADING IT ONTO AN INTERNET SERVER; WEBSITE DESIGN AND DEVELOPMENT FOR OTHERS; WEBSITE DEVELOPMENT FOR OTHERS (U.S. CLS. 100 AND 101).

FIRST USE 10-21-2002; IN COMMERCE 10-21-2003.

ELLEN PERKINS, EXAMINING ATTORNEY

SN 85-206,291. LEONESIO, MICHAEL, OAKLAND, CA. FILED 12-28-2010.

**THE PURSUIT OF TRUTH**

THE MARK CONSISTS OF STANDARD CHARACTERS WITHOUT CLAIM TO ANY PARTICULAR FONT, STYLE, SIZE, OR COLOR.

FOR ELECTROSHOCK WEAPONS TESTING, INSPECTION AND ANALYSIS SERVICES (U.S. CLS. 100 AND 101).

BILL DAWE, EXAMINING ATTORNEY

**CLASS 42—(Continued).**

SN 85-206,567. CONSTANT BIOTECHNOLOGY, CINCINNATI, OH. FILED 12-28-2010.

Great medicines, naturally

THE MARK CONSISTS OF STANDARD CHARACTERS WITHOUT CLAIM TO ANY PARTICULAR FONT, STYLE, SIZE, OR COLOR.  
FOR SCIENTIFIC RESEARCH AND DEVELOPMENT (U.S. CLS. 100 AND 101).  
FIRST USE 12-15-2010; IN COMMERCE 12-15-2010.  
JOHN WILKE, EXAMINING ATTORNEY

SN 85-206,596. WALKER, JENNIFER, DOUGLASVILLE, GA. FILED 12-28-2010.

The Dead and The Documented

THE MARK CONSISTS OF STANDARD CHARACTERS WITHOUT CLAIM TO ANY PARTICULAR FONT, STYLE, SIZE, OR COLOR.  
FOR RESEARCH IN THE FIELD OF THE PARANORMAL (U.S. CLS. 100 AND 101).  
EUGENIA MARTIN, EXAMINING ATTORNEY

SN 85-206,746. LIVERAIL INC., SAN FRANCISCO, CA. FILED 12-28-2010.

LiveRail

THE MARK CONSISTS OF STANDARD CHARACTERS WITHOUT CLAIM TO ANY PARTICULAR FONT, STYLE, SIZE, OR COLOR.  
FOR APPLICATION SERVICE PROVIDER (ASP) FEATURING SOFTWARE FOR USE IN INTERNET ADVERTISING (U.S. CLS. 100 AND 101).  
FIRST USE 7-9-2007; IN COMMERCE 7-9-2007.  
STEVEN R. FINE, EXAMINING ATTORNEY

**CLASS 42—(Continued).**

SN 85-207,009. AMERICAN ASSOCIATION OF PHYSICIAN SPECIALISTS, INC., TAMPA, FL. FILED 12-29-2010.

BCFMO

THE MARK CONSISTS OF STANDARD CHARACTERS WITHOUT CLAIM TO ANY PARTICULAR FONT, STYLE, SIZE, OR COLOR.  
FOR ACCREDITATION SERVICES, NAMELY, DEVELOPING AND ADMINISTERING STANDARDS AND PROCEDURES FOR CERTIFYING PROFESSIONALS IN THE FIELD OF FAMILY MEDICINE OBSTETRICS (U.S. CLS. 100 AND 101).  
FIRST USE 12-22-2010; IN COMMERCE 12-22-2010.  
ALYSSA STEEL, EXAMINING ATTORNEY

SN 85-207,179. TALENTFOCUS, INC., CAMBRIDGE, MA. FILED 12-29-2010.

TalentFocus

THE MARK CONSISTS OF STANDARD CHARACTERS WITHOUT CLAIM TO ANY PARTICULAR FONT, STYLE, SIZE, OR COLOR.  
FOR PROVIDING AN ON-LINE, NON-DOWNLOADABLE, INTERNET-BASED SOFTWARE APPLICATION FOR PROFESSIONAL TRAINING AND DEVELOPMENT, EMPLOYEE MANAGEMENT AND REVIEW, AND MANAGEMENT OF VIDEOS RELATED TO THE SAME (U.S. CLS. 100 AND 101).  
FIRST USE 12-29-2010; IN COMMERCE 12-29-2010.  
MAUREEN DALL, EXAMINING ATTORNEY

SN 85-207,309. OFLOWS INCORPORATED, SAN FRANCISCO, CA. FILED 12-29-2010.

We take the paper out of  
paperwork

THE MARK CONSISTS OF STANDARD CHARACTERS WITHOUT CLAIM TO ANY PARTICULAR FONT, STYLE, SIZE, OR COLOR.  
FOR SOFTWARE AS A SERVICE (SAAS) SERVICES FEATURING SOFTWARE FOR ELECTRONIC LOAN AND DEPOSIT ORIGINATION PROCESSING AND ELECTRONIC APPLICATION PROCESSING FOR NEW ACCOUNTS AND MEMBERSHIPS FOR FINANCIAL INSTITUTIONS (U.S. CLS. 100 AND 101).  
FIRST USE 12-20-2010; IN COMMERCE 12-20-2010.  
JOHN DALIER, EXAMINING ATTORNEY

**CLASS 42—(Continued).**

SN 85-207,421. RESTAURANT TECHNOLOGIES, INC., MEN-DOTA HEIGHTS, MN. FILED 12-29-2010.

SMART. SAFE. GREEN.

THE MARK CONSISTS OF STANDARD CHARACTERS WITHOUT CLAIM TO ANY PARTICULAR FONT, STYLE, SIZE, OR COLOR.

FOR PLATFORM AS A SERVICE (PAAS) FEATURING COMPUTER SOFTWARE PLATFORMS FOR RESTAURANTS FOR EQUIPMENT MONITORING, ANALYZING, AND REPORTING, DATA MANAGEMENT, RESTAURANT DRIVE-THROUGH PERFORMANCE MONITORING, AND REMOTE ONLINE ACCESS TO EQUIPMENT (U.S. CLS. 100 AND 101).

FIRST USE 1-7-2010; IN COMMERCE 1-7-2010.  
ANNE MADDEN, EXAMINING ATTORNEY

SN 85-207,444. RESTAURANT TECHNOLOGIES, INC., MEN-DOTA HEIGHTS, MN. FILED 12-29-2010.



THE MARK CONSISTS OF THE LETTERS "RTI", EN-CIRCLED BY TWO CURVES FORMING AN ELLIPSE THAT OPENS TO THE RIGHT OF THE LETTER "I".

FOR PLATFORM AS A SERVICE (PAAS) FEATURING COMPUTER SOFTWARE PLATFORMS FOR RESTAURANTS FOR EQUIPMENT MONITORING, ANALYZING, AND REPORTING, DATA MANAGEMENT, RESTAURANT DRIVE-THROUGH PERFORMANCE MONITORING, AND REMOTE ONLINE ACCESS TO EQUIPMENT (U.S. CLS. 100 AND 101).

FIRST USE 1-7-2010; IN COMMERCE 1-7-2010.  
ANNE MADDEN, EXAMINING ATTORNEY

**CLASS 42—(Continued).**

SN 85-207,462. RESTAURANT TECHNOLOGIES, INC., MEN-DOTA HEIGHTS, MN. FILED 12-29-2010.

RTI

THE MARK CONSISTS OF STANDARD CHARACTERS WITHOUT CLAIM TO ANY PARTICULAR FONT, STYLE, SIZE, OR COLOR.

FOR PLATFORM AS A SERVICE (PAAS) FEATURING COMPUTER SOFTWARE PLATFORMS FOR RESTAURANTS FOR EQUIPMENT MONITORING, ANALYZING, AND REPORTING, DATA MANAGEMENT, RESTAURANT DRIVE-THROUGH PERFORMANCE MONITORING, AND REMOTE ONLINE ACCESS TO EQUIPMENT (U.S. CLS. 100 AND 101).

FIRST USE 12-31-1999; IN COMMERCE 12-31-1999.  
ANNE MADDEN, EXAMINING ATTORNEY

SN 85-207,470. BROWN, SILVIA, BROOKLYN, NY. FILED 12-29-2010.

SillySil

THE MARK CONSISTS OF STANDARD CHARACTERS WITHOUT CLAIM TO ANY PARTICULAR FONT, STYLE, SIZE, OR COLOR.

FOR VISUAL DESIGN SERVICES IN THE NATURE OF DESIGNING VISUAL ELEMENTS FOR ON-LINE, BROADCAST, PRINT, OUTDOOR AND OTHER COMMUNICATION MEDIA (U.S. CLS. 100 AND 101).

FIRST USE 9-17-2001; IN COMMERCE 5-15-2006.  
ANNE E. GUSTASON, EXAMINING ATTORNEY

SN 85-207,485. RESTAURANT TECHNOLOGIES, INC., MEN-DOTA HEIGHTS, MN. FILED 12-29-2010.

TOM

THE MARK CONSISTS OF STANDARD CHARACTERS WITHOUT CLAIM TO ANY PARTICULAR FONT, STYLE, SIZE, OR COLOR.

FOR PLATFORM AS A SERVICE (PAAS) FEATURING COMPUTER SOFTWARE PLATFORMS FOR RESTAURANTS FOR EQUIPMENT MONITORING, ANALYZING, AND REPORTING, DATA MANAGEMENT, RESTAURANT DRIVE-THROUGH PERFORMANCE MONITORING, AND REMOTE ONLINE ACCESS TO EQUIPMENT (U.S. CLS. 100 AND 101).

ANNE MADDEN, EXAMINING ATTORNEY

**CLASS 42—(Continued).**

SN 85-207,633. NATIVE RIDERS, SEBASTOPOL, CA. FILED 12-29-2010.



THE MARK CONSISTS OF AN ABSTRACT DESIGN AND THE STYLIZED TEXT "NATIVE RIDERS".

FOR DESIGN FOR OTHERS IN THE FIELDS OF CLOTHING, WORKS OF ART, PURSES, BELTS, MOC-CASINS, LEATHER, AND DECORATIONS FOR MOTOR-CYCLES (U.S. CLS. 100 AND 101).

FIRST USE 8-5-2005; IN COMMERCE 8-5-2005.

WILLIAM ROSSMAN, EXAMINING ATTORNEY

**CLASS 42—(Continued).**

SN 85-208,033. SCHUSSLER CREATIVE, INC., GOLDEN VALLEY, MN. FILED 12-30-2010.

SETTING THE STANDARD FOR  
INDUSTRY FIRSTS

THE MARK CONSISTS OF STANDARD CHARACTERS WITHOUT CLAIM TO ANY PARTICULAR FONT, STYLE, SIZE, OR COLOR.

FOR PRODUCT DESIGN SERVICES, NAMELY, PRODUCT RESEARCH AND DEVELOPMENT CONSULTATION AND DESIGN FOR OTHERS (U.S. CLS. 100 AND 101).

FIRST USE 5-4-2007; IN COMMERCE 5-4-2007.

KATHRYN COWARD, EXAMINING ATTORNEY

SN 85-207,719. A. J. TUCKER SUPPLY, INC., MIDLAND, NC. FILED 12-30-2010.

ROADMAP€\$

THE MARK CONSISTS OF STANDARD CHARACTERS WITHOUT CLAIM TO ANY PARTICULAR FONT, STYLE, SIZE, OR COLOR.

FOR APPLICATION SERVICE PROVIDER (ASP) FEATURING SOFTWARE FOR USE IN INVENTORY MANAGEMENT (U.S. CLS. 100 AND 101).

APRIL ROACH, EXAMINING ATTORNEY

SN 85-208,096. CORRECT COLLECT, INC., CORAL SPRINGS, FL. FILED 12-30-2010.

CorrectCollect

THE MARK CONSISTS OF STANDARD CHARACTERS WITHOUT CLAIM TO ANY PARTICULAR FONT, STYLE, SIZE, OR COLOR.

FOR PROVIDING AN ONLINE TOOL IN THE NATURE OF PROVIDING TEMPORARY USE OF NON-DOWNLOADABLE COMPUTER SOFTWARE USED TO ESTIMATE AUTO-BODY REPAIRS (U.S. CLS. 100 AND 101).

FIRST USE 9-1-2005; IN COMMERCE 8-22-2006.

SOPHIA S. KIM, EXAMINING ATTORNEY

SN 85-207,981. ROBBINS, WENDY, EL PRADO, NM. AND PAULL, KAREN, EL PRADO, NM. FILED 12-30-2010.

TINGLE TRIBE

THE MARK CONSISTS OF STANDARD CHARACTERS WITHOUT CLAIM TO ANY PARTICULAR FONT, STYLE, SIZE, OR COLOR.

FOR COMPUTER SERVICES, NAMELY, CREATING AN ON-LINE COMMUNITY FOR REGISTERED USERS TO PARTICIPATE IN DISCUSSIONS, GET FEEDBACK FROM THEIR PEERS, FORM VIRTUAL COMMUNITIES, AND ENGAGE IN SOCIAL NETWORKING; PROVIDING A WEBSITE FEATURING A MEDIA AGGREGATOR AND SEARCH ENGINE FOR INTERNET CONTENT (U.S. CLS. 100 AND 101).

FIRST USE 1-0-2010; IN COMMERCE 1-0-2010.

ALICE BENMAMAN, EXAMINING ATTORNEY

SN 85-208,239. KOHORT.COM INC., BURLINGTON, VT. FILED 12-30-2010.

Kohort

THE MARK CONSISTS OF STANDARD CHARACTERS WITHOUT CLAIM TO ANY PARTICULAR FONT, STYLE, SIZE, OR COLOR.

FOR COMPUTER SERVICES, NAMELY, CREATING AN ON-LINE COMMUNITY FOR REGISTERED USERS TO PARTICIPATE IN DISCUSSIONS, GET FEEDBACK FROM THEIR PEERS, FORM VIRTUAL COMMUNITIES, AND ENGAGE IN SOCIAL NETWORKING (U.S. CLS. 100 AND 101).

ANGELA M. MICHELI, EXAMINING ATTORNEY

**CLASS 42—(Continued).**

SN 85-208,495. SUNDAYBELL, INC., BURLINGTON, CANADA, FILED 12-31-2010.

## SUNDAYBELL

THE MARK CONSISTS OF STANDARD CHARACTERS WITHOUT CLAIM TO ANY PARTICULAR FONT, STYLE, SIZE, OR COLOR.

FOR PROVIDING A WEBSITE FEATURING NON-DOWNLOADABLE SOFTWARE FOR INFORMATION SHARING, MEMBERSHIP AND ANONYMOUS DISCUSSION BETWEEN REAL ESTATE PROFESSIONALS AND POTENTIAL CUSTOMERS (U.S. CLS. 100 AND 101).

FIRST USE 12-1-2010; IN COMMERCE 12-1-2010.  
MORGAN WYNNE, EXAMINING ATTORNEY

---

SN 85-208,679. CENTRILLION TECHNOLOGY HOLDINGS CORPORATION, MOUNTAIN VIEW, CA. FILED 12-31-2010.

## Centrillion

THE MARK CONSISTS OF STANDARD CHARACTERS WITHOUT CLAIM TO ANY PARTICULAR FONT, STYLE, SIZE, OR COLOR.

FOR BIOMEDICAL RESEARCH SERVICES (U.S. CLS. 100 AND 101).

FIRST USE 6-1-2010; IN COMMERCE 6-1-2010.  
ELISSA GARBER KON, EXAMINING ATTORNEY

---

SN 85-208,691. ADTASTIC HOSTING AND INTERNET SERVICES, LLC, SHIRLEY, AR. FILED 12-31-2010.

## Adtastic

THE MARK CONSISTS OF STANDARD CHARACTERS WITHOUT CLAIM TO ANY PARTICULAR FONT, STYLE, SIZE, OR COLOR.

FOR DESIGN, CREATION, HOSTING AND MAINTENANCE OF INTERNET SITES FOR THIRD PARTIES; DESIGNING AND DEVELOPING WEBPAGES ON THE INTERNET; HOSTING WEBSITES ON THE INTERNET (U.S. CLS. 100 AND 101).

FIRST USE 5-1-2004; IN COMMERCE 5-1-2004.  
JUSTINE D. PARKER, EXAMINING ATTORNEY

**CLASS 42—(Continued).**

SN 85-209,041. BLUE LINK VENTURES, LLC, NEW YORK, NY. FILED 1-3-2011.

## Thankster

THE MARK CONSISTS OF STANDARD CHARACTERS WITHOUT CLAIM TO ANY PARTICULAR FONT, STYLE, SIZE, OR COLOR.

FOR PROVIDING A WEB SITE FEATURING TEMPORARY USE OF NON-DOWNLOADABLE SOFTWARE FOR USE IN DESIGNING, ORDERING AND SENDING GREETING CARDS, ANNOUNCEMENT CARDS, PERSONALIZED NOTES, PLACE CARDS, AND ENVELOPES FOR ALL OCCASIONS, FEATURING STANDARD AND CUSTOMIZED GREETINGS, DESIGNS, TYPE FONTS, AND PHOTOGRAPHS (U.S. CLS. 100 AND 101).

FIRST USE 7-0-2008; IN COMMERCE 7-0-2008.  
TINA L. SNAPP, EXAMINING ATTORNEY

---

SN 85-209,090. KONTRAST WORKSHOP, LLC, PHILADELPHIA, PA. FILED 1-3-2011.



THE MARK CONSISTS OF A ROBOT HEAD WHICH IS TORN FROM THE BODY AND IS SMILING AND HAS WIRES COMING FROM UNDER HIS HEAD.

FOR COMPUTER AIDED GRAPHIC DESIGN; COMPUTER GRAPHICS DESIGN SERVICES, NAMELY, CREATION OF WEB ANIMATIONS; GRAPHIC DESIGN; GRAPHIC DESIGN SERVICES (U.S. CLS. 100 AND 101).

FIRST USE 9-1-2010; IN COMMERCE 9-1-2010.  
MAYUR VAGHANI, EXAMINING ATTORNEY

**CLASS 42—(Continued).**

SN 85-209,221. MERCHANT LINK, LLC, SILVER SPRING, MD. FILED 1-3-2011.

TRANSACTIONSHIELD

THE MARK CONSISTS OF STANDARD CHARACTERS WITHOUT CLAIM TO ANY PARTICULAR FONT, STYLE, SIZE, OR COLOR.

FOR DATA ENCRYPTION SERVICES (U.S. CLS. 100 AND 101).

ANNE E. GUSTASON, EXAMINING ATTORNEY

**CLASS 42—(Continued).**

SN 85-209,458. CHRISTOPHER DYMENTALI MOLOKWU, DBA I3NC, BROOKLYN, NY. FILED 1-3-2011.

I3NC

THE MARK CONSISTS OF STANDARD CHARACTERS WITHOUT CLAIM TO ANY PARTICULAR FONT, STYLE, SIZE, OR COLOR.

FOR NEW PRODUCT DESIGN SERVICES; INDUSTRIAL DESIGN; RESEARCH AND DEVELOPMENT OF NEW PRODUCTS (U.S. CLS. 100 AND 101).

CHARLOTTE CORWIN, EXAMINING ATTORNEY

SN 85-209,246. SEMANTIC SPACE TECHNOLOGIES LIMITED, HYDERABAD, INDIA, FILED 1-3-2011.

SemanticSpace

THE MARK CONSISTS OF STANDARD CHARACTERS WITHOUT CLAIM TO ANY PARTICULAR FONT, STYLE, SIZE, OR COLOR.

FOR DESIGN, DEVELOPMENT, INSTALLATION AND MAINTENANCE OF COMPUTER SOFTWARE (U.S. CLS. 100 AND 101).

FIRST USE 9-8-2010; IN COMMERCE 9-8-2010.

PRISCILLA MILTON, EXAMINING ATTORNEY

SN 85-209,718. SKYLINE CHILI, INC., FAIRFIELD, OH. FILED 1-4-2011.

WHENEVER YOU'RE FEELING  
GOOD AND HUNGRY, IT'S  
SKYLINE TIME.

THE MARK CONSISTS OF STANDARD CHARACTERS WITHOUT CLAIM TO ANY PARTICULAR FONT, STYLE, SIZE, OR COLOR.

OWNER OF U.S. REG. NOS. 1,293,403, 2,461,787 AND OTHERS.

FOR RESTAURANT AND CARRYOUT RESTAURANT SERVICES (U.S. CLS. 100 AND 101).

FIRST USE 8-29-2010; IN COMMERCE 8-29-2010.

CARYN GLASSER, EXAMINING ATTORNEY

SN 85-209,278. SEMANTIC SPACE TECHNOLOGIES LIMITED, HYDERABAD, INDIA, FILED 1-3-2011.

SST

THE MARK CONSISTS OF STANDARD CHARACTERS WITHOUT CLAIM TO ANY PARTICULAR FONT, STYLE, SIZE, OR COLOR.

FOR DESIGN, DEVELOPMENT, INSTALLATION AND MAINTENANCE OF COMPUTER SOFTWARE (U.S. CLS. 100 AND 101).

FIRST USE 9-8-2010; IN COMMERCE 9-8-2010.

PRISCILLA MILTON, EXAMINING ATTORNEY

SN 85-209,902. JOURNELLA, LLC, BELFAIR, WA. FILED 1-4-2011.

Journella

THE MARK CONSISTS OF STANDARD CHARACTERS WITHOUT CLAIM TO ANY PARTICULAR FONT, STYLE, SIZE, OR COLOR.

FOR COMPUTER SERVICES, NAMELY, HOSTING ONLINE WEB FACILITIES FOR OTHERS FOR ORGANIZING PERSONAL INFORMATION, AUDIO RECORDINGS, IMAGES, VIDEOS, AND MULTIMEDIA; COMPUTER SERVICES, NAMELY, HOSTING AN ONLINE COMMUNITY WHERE USERS MAY INTERACT, SHARE INFORMATION, FORM VIRTUAL COMMUNITIES, AND ENGAGE IN SOCIAL AND BUSINESS NETWORKING (U.S. CLS. 100 AND 101).

CAROLYN CATALDO, EXAMINING ATTORNEY

**CLASS 42—(Continued).**

SN 85-209,915. NATIONAL ASSOCIATION OF PROFESSIONAL PET SITTERS, INC., MT. LAUREL, NJ. FILED 1-4-2011.

# myNAPPS

THE MARK CONSISTS OF STANDARD CHARACTERS WITHOUT CLAIM TO ANY PARTICULAR FONT, STYLE, SIZE, OR COLOR.

FOR WEBSITE DESIGN AND DEVELOPMENT FOR OTHERS (U.S. CLS. 100 AND 101).

FIRST USE 6-0-2008; IN COMMERCE 6-0-2008.  
ANNE MADDEN, EXAMINING ATTORNEY

**CLASS 42—(Continued).**

SN 85-210,419. FILTER PLATFORMS, INC., LOS ANGELES, CA. FILED 1-4-2011.

# FILTER FOUNDRY

THE MARK CONSISTS OF STANDARD CHARACTERS WITHOUT CLAIM TO ANY PARTICULAR FONT, STYLE, SIZE, OR COLOR.

FOR COMPUTER SERVICES, NAMELY, PROVIDING A WEBSITE FOR STORING AND SHARING ARTISTIC WORKS CREATED BY USERS (U.S. CLS. 100 AND 101).

FIRST USE 9-14-2010; IN COMMERCE 9-14-2010.  
REGINA DRUMMOND, EXAMINING ATTORNEY

SN 85-209,947. INTERNATIONAL PAPER COMPAY, MEMPHIS, TN. FILED 1-4-2011.

# TREE HOUSE

THE MARK CONSISTS OF STANDARD CHARACTERS WITHOUT CLAIM TO ANY PARTICULAR FONT, STYLE, SIZE, OR COLOR.

FOR DESIGN OF CONSUMER PRODUCT PACKAGING (U.S. CLS. 100 AND 101).

COLLEEN KEARNEY, EXAMINING ATTORNEY

SN 85-210,509. AMERIFOLIO, INC., LEWISBURG, PA. FILED 1-4-2011.

# FOLIOFUND

THE MARK CONSISTS OF STANDARD CHARACTERS WITHOUT CLAIM TO ANY PARTICULAR FONT, STYLE, SIZE, OR COLOR.

FOR PROVIDING A WEBSITE FEATURING NON-DOWNLOADABLE SOFTWARE FOR SELLING AND BUYING BOOKS (U.S. CLS. 100 AND 101).

FIRST USE 10-0-2009; IN COMMERCE 10-0-2009.  
SANDRA BUJA, EXAMINING ATTORNEY

SN 85-210,166. STATE FARM MUTUAL AUTOMOBILE INSURANCE COMPANY, BLOOMINGTON, IL. FILED 1-4-2011.

# State Farm Nation

THE MARK CONSISTS OF STANDARD CHARACTERS WITHOUT CLAIM TO ANY PARTICULAR FONT, STYLE, SIZE, OR COLOR.

OWNER OF U.S. REG. NOS. 1,979,585, 2,591,039 AND OTHERS.

FOR COMPUTER SERVICES, NAMELY, CREATING AN ON-LINE COMMUNITY FOR REGISTERED USERS TO PARTICIPATE IN DISCUSSIONS, GET FEEDBACK FROM THEIR PEERS, FORM VIRTUAL COMMUNITIES, AND ENGAGE IN SOCIAL NETWORKING FEATURING SOCIAL MEDIA AND TOPICS ON A VARIETY OF ISSUES (U.S. CLS. 100 AND 101).

FIRST USE 9-23-2010; IN COMMERCE 9-24-2010.  
ELISSA GARBER KON, EXAMINING ATTORNEY

SN 85-210,637. SIMPLY CHARGED, YUBA CITY, CA. FILED 1-5-2011.



The logo for SIMPLYCHARGED features a stylized 'S' and 'C' intertwined within a square frame, followed by the text 'SIMPLYCHARGED' in a bold, sans-serif font.

THE MARK CONSISTS OF THE STYLIZED TEXT "SC SIMPLYCHARGED" WITH THE "S" AND A "C" INTERLINKED SURROUNDED BY ELECTRONS IN ORBIT.

FOR REVERSE ENGINEERING SERVICES TO PROVIDE AFTERMARKET REPLACEMENT PARTS AND ACCESSORIES FOR ELECTRONICS (U.S. CLS. 100 AND 101).

FIRST USE 11-1-2010; IN COMMERCE 11-22-2010.  
WENDY JUN, EXAMINING ATTORNEY



**CLASS 42—(Continued).**

SN 85-211,661. EVENTFAST.COM LLC, CLEVELAND, OH. FILED 1-6-2011.

# EventFast

THE MARK CONSISTS OF STANDARD CHARACTERS WITHOUT CLAIM TO ANY PARTICULAR FONT, STYLE, SIZE, OR COLOR.

FOR PROVIDING TEMPORARY USE OF ON-LINE NON-DOWNLOADABLE SOFTWARE DEVELOPMENT TOOLS FOR ALLOWING USERS TO CREATE, PLAN, HOST AND PROMOTE THEIR OWN EVENTS AND FOR FACILITATING ONLINE TICKETING (U.S. CLS. 100 AND 101).

FIRST USE 1-1-2008; IN COMMERCE 1-30-2008.  
HEATHER THOMPSON, EXAMINING ATTORNEY

**CLASS 42—(Continued).**

SN 85-212,152. THE CENTER FOR PLANNING EXCELLENCE, INC., BATON ROUGE, LA. FILED 1-6-2011.

# CPEX

THE MARK CONSISTS OF STANDARD CHARACTERS WITHOUT CLAIM TO ANY PARTICULAR FONT, STYLE, SIZE, OR COLOR.

FOR URBAN PLANNING (U.S. CLS. 100 AND 101).  
FIRST USE 10-5-2005; IN COMMERCE 10-5-2005.  
BRIAN NEVILLE, EXAMINING ATTORNEY

SN 85-211,985. ACCAM, ALFRED T, SUGAR LAND, TX. FILED 1-6-2011.

# thegoodguide

THE MARK CONSISTS OF THE STYLIZED TEXT "THE-GOODGUIDE".

FOR PROVIDING A WEB SITE THAT GIVES COMPUTER USERS THE ABILITY TO UPLOAD AND SHARE USER-GENERATED VIDEOS, PHOTOS, QUESTIONS AND ANSWERS, ESSAYS AND ARTICLES ON A WIDE VARIETY OF TOPICS AND SUBJECTS (U.S. CLS. 100 AND 101).

FIRST USE 11-1-2010; IN COMMERCE 11-1-2010.  
EDWARD FENNESSY, EXAMINING ATTORNEY

SN 85-212,458. DESIGNO INC., LAS VEGAS, NV. FILED 1-7-2011.

# DESIGNO

SN 85-212,007. PATIENT-CENTERED OUTCOMES RESEARCH INSTITUTE, WASHINGTON, DC. FILED 1-6-2011.

# PCORI

THE MARK CONSISTS OF STANDARD CHARACTERS WITHOUT CLAIM TO ANY PARTICULAR FONT, STYLE, SIZE, OR COLOR.

FOR ARRANGING AND CONDUCTING MEDICAL AND SCIENTIFIC RESEARCH PROJECTS TO ASSIST PATIENTS, CLINICIANS, PURCHASERS AND POLICY-MAKERS IN MAKING INFORMED HEALTH DECISIONS; PROVIDING AND DISSEMINATING MEDICAL AND SCIENTIFIC RESEARCH INFORMATION RELATED TO HOW DISEASES, DISORDERS AND OTHER HEALTH CONDITIONS CAN BE EFFECTIVELY AND APPROPRIATELY PREVENTED, DIAGNOSED, TREATED AND MONITORED TO ENABLE PATIENTS, CLINICIANS, PURCHASERS AND POLICY-MAKERS TO MAKE INFORMED HEALTH DECISIONS (U.S. CLS. 100 AND 101).

JEFF DEFORD, EXAMINING ATTORNEY

THE MARK CONSISTS OF STANDARD CHARACTERS WITHOUT CLAIM TO ANY PARTICULAR FONT, STYLE, SIZE, OR COLOR.

FOR IT CONSULTING SERVICES; INSTALLATION, REPAIR AND MAINTENANCE OF COMPUTER SOFTWARE; GRAPHIC DESIGN SERVICES; DESIGN, CREATION, HOSTING, MAINTENANCE OF WEBSITES FOR OTHERS; DATABASE DESIGN AND DEVELOPMENT SERVICES; COMPUTER PROGRAMMING AND MAINTENANCE OF COMPUTER PROGRAMS (U.S. CLS. 100 AND 101).

FIRST USE 6-8-2004; IN COMMERCE 8-12-2008.  
GEOFFREY FOSDICK, EXAMINING ATTORNEY

**CLASS 42—(Continued).**

SN 85-213,507. FIREWEED LLC, ANCHORAGE, AK. FILED 1-8-2011.

# storio

THE MARK CONSISTS OF STANDARD CHARACTERS WITHOUT CLAIM TO ANY PARTICULAR FONT, STYLE, SIZE, OR COLOR.

FOR APPLICATION SERVICE PROVIDER (ASP), NAMELY, HOSTING COMPUTER SOFTWARE APPLICATIONS OF OTHERS; COMPUTER CO-LOCATION SERVICES, NAMELY, PROVIDING FACILITIES FOR THE LOCATION OF COMPUTER SERVERS WITH THE EQUIPMENT OF OTHERS; COMPUTER SERVICE, NAMELY, ACTING AS AN APPLICATION SERVICE PROVIDER IN THE FIELD OF KNOWLEDGE MANAGEMENT TO HOST COMPUTER APPLICATION SOFTWARE FOR THE COLLECTION, EDITING, ORGANIZING, MODIFYING, BOOK MARKING, TRANSMISSION, STORAGE AND SHARING OF DATA AND INFORMATION; COMPUTER SERVICES, NAMELY, CREATING, MAINTAINING, DESIGNING AND IMPLEMENTING WEB SITES FOR OTHERS AND HOSTING THE WEB SITE OF OTHERS ON A COMPUTER SERVER FOR A GLOBAL COMPUTER NETWORK; DEVELOPING AND HOSTING A SERVER ON A GLOBAL COMPUTER NETWORK FOR THE PURPOSE OF FACILITATING E-COMMERCE VIA SUCH A SERVER; HOSTING OF DIGITAL CONTENT ON THE INTERNET; HOSTING OF WEB SITES; HOSTING THE WEB SITES OF OTHERS ON A COMPUTER SERVER FOR A GLOBAL COMPUTER NETWORK; PROVIDING AN ON-LINE NETWORK ENVIRONMENT THAT FEATURES TECHNOLOGY THAT ENABLES USERS TO SHARE DATA; RENTAL OF WEB SERVERS; TECHNICAL SUPPORT SERVICES, NAMELY, MIGRATION OF DATACENTER, SERVER AND DATABASE APPLICATIONS (U.S. CLS. 100 AND 101).

H. M. FISHER, EXAMINING ATTORNEY

SN 85-214,224. ANA-DATA CONSULTING, INC, JERSEY CITY, NJ. FILED 1-10-2011.

# CLEAR-123

THE MARK CONSISTS OF STANDARD CHARACTERS WITHOUT CLAIM TO ANY PARTICULAR FONT, STYLE, SIZE, OR COLOR.

FOR TECHNICAL CONSULTING AND ASSISTANCE WITH COMPUTER-BASED INFORMATION SYSTEMS AND COMPONENTS (U.S. CLS. 100 AND 101).

JOHN SCHUYLER YARD, EXAMINING ATTORNEY

**CLASS 42—(Continued).**

SN 85-214,349. SUTTON, CYRUS, VISTA, CA. FILED 1-10-2011.

# korduroy

THE MARK CONSISTS OF STANDARD CHARACTERS WITHOUT CLAIM TO ANY PARTICULAR FONT, STYLE, SIZE, OR COLOR.

FOR COMPUTER SERVICES, NAMELY, CREATING AN ON-LINE COMMUNITY FOR REGISTERED USERS TO PARTICIPATE IN DISCUSSIONS, GET FEEDBACK FROM THEIR PEERS, FORM VIRTUAL COMMUNITIES, AND ENGAGE IN SOCIAL NETWORKING (U.S. CLS. 100 AND 101).

FIRST USE 1-1-2007; IN COMMERCE 2-1-2009.

SUNG IN, EXAMINING ATTORNEY

SN 85-225,592. QUESTAR CORPORATION, SALT LAKE CITY, UT. FILED 1-25-2011.

APPLIED TECHNOLOGY SERVICES

THE MARK CONSISTS OF STANDARD CHARACTERS WITHOUT CLAIM TO ANY PARTICULAR FONT, STYLE, SIZE, OR COLOR.

NO CLAIM IS MADE TO THE EXCLUSIVE RIGHT TO USE "SERVICES", APART FROM THE MARK AS SHOWN. SEC. 2(F).

FOR PRODUCTION AUTOMATION AND ELECTRICAL SYSTEMS DESIGN AND DEVELOPMENT SERVICES IN THE NATURAL GAS INDUSTRY; ONSITE GAS MEASUREMENT EVALUATIONS AND ANALYSIS IN THE NATURAL GAS INDUSTRY; GREENHOUSE GAS EMISSIONS TESTING IN THE NATURAL GAS INDUSTRY (U.S. CLS. 100 AND 101).

FIRST USE 1-30-1998; IN COMMERCE 1-30-1998.

JUDITH HELFMAN, EXAMINING ATTORNEY

**CLASS 42—(Continued).**

SN 85-225,724. QUESTAR CORPORATION, SALT LAKE CITY, UT. FILED 1-25-2011.



THE MARK CONSISTS OF THE STYLIZED LETTERS "ATS" IN A VERTICAL AND OVERLAPPING ARRANGEMENT AND AN INTEGRATED ORBITAL DESIGN PATTERN COMPRISED OF TWO SHADED CIRCLES AND TWO CURVES FORMING AN INCOMPLETE RING.

FOR PRODUCTION AUTOMATION AND ELECTRICAL SYSTEMS DESIGN AND DEVELOPMENT SERVICES IN THE NATURAL GAS INDUSTRY; ONSITE GAS MEASUREMENT EVALUATIONS AND ANALYSIS IN THE NATURAL GAS INDUSTRY; GREENHOUSE GAS EMISSIONS TESTING IN THE NATURAL GAS INDUSTRY (U.S. CLS. 100 AND 101).

FIRST USE 4-1-2002; IN COMMERCE 4-1-2002.  
JUDITH HELFMAN, EXAMINING ATTORNEY

**CLASS 42—(Continued).**

SN 85-256,478. SMITH, DOUGLAS, SAN ANTONIO, TX. FILED 3-3-2011.

**RADCLOUD**

THE MARK CONSISTS OF STANDARD CHARACTERS WITHOUT CLAIM TO ANY PARTICULAR FONT, STYLE, SIZE, OR COLOR.

FOR COMPUTER SERVICES, NAMELY, PROVIDING A WEB-BASED SYSTEM AND ONLINE PORTAL FEATURING ONLINE NON-DOWNLOADABLE SOFTWARE FOR USERS TO VIEW RADIOLOGY IMAGES AND REPORTS, REQUEST CONSULTATION, EXCHANGE ELECTRONIC HEALTH INFORMATION, ORDER RADIOLOGY IMAGING STUDIES, AND INITIATE INTERACTIVE CONSULTATION WITH RADIOLOGIST OR PHYSICIANS; COMPUTER SERVICES, NAMELY, PROVIDING A WEB-BASED SYSTEM AND ONLINE PORTAL FEATURING ONLINE NON-DOWNLOADABLE SOFTWARE FOR USERS TO EXCHANGE AND VIEW MEDICAL INFORMATION (U.S. CLS. 100 AND 101).

FIRST USE 7-5-2010; IN COMMERCE 7-5-2010.  
JAMES LOVELACE, EXAMINING ATTORNEY

**CLASS 43—HOTEL AND RESTAURANT SERVICES**

SN 76-698,134. AL-BASHA, PATERSON, NJ. FILED 6-29-2009.



THE NAME(S), PORTRAIT(S), AND/OR SIGNATURE(S) SHOWN IN THE MARK DOES NOT IDENTIFY A PARTICULAR LIVING INDIVIDUAL.

THE COLOR(S) BLACK, WHITE AND RED IS/ARE CLAIMED AS A FEATURE OF THE MARK.

THE MARK CONSISTS OF THE LETTERING "AL-BASHA" IN WHITE ABOVE A DESIGN SHOWING A MALE FIGURE IN BLACK-AND-WHITE ATTIRE AND A RED HAT AND TIE IN A SOLID WHITE OVAL SURROUNDED BY A WHITE OVAL LINE. THE COLOR GRAY REPRESENTS BACKGROUND AND IS NOT PART OF THE MARK.

THE ENGLISH TRANSLATION OF "AL-BASHA" IN THE MARK IS "THE PASHA".

FOR RESTAURANT SERVICES, NAMELY, PREPARING ARABIC FOOD, SERVING IT TO CUSTOMERS, DINING-IN SERVICES, CATERING SERVICES AND TAKE-OUT RESTAURANT SERVICES (U.S. CLS. 100 AND 101).

FIRST USE 8-0-1998; IN COMMERCE 8-0-1998.

ANN E. SAPPENFIELD, EXAMINING ATTORNEY

SN 85-231,374. THE FONT BUREAU, INC., BOSTON, MA. FILED 2-1-2011.

**FONT SINUSE**

THE MARK CONSISTS OF STANDARD CHARACTERS WITHOUT CLAIM TO ANY PARTICULAR FONT, STYLE, SIZE, OR COLOR.

FOR CONSULTING SERVICES FOR OTHERS IN THE FIELD OF DESIGN, PLANNING, AND IMPLEMENTATION PROJECT MANAGEMENT OF DESIGN FOR PUBLICATIONS (U.S. CLS. 100 AND 101).

FIRST USE 12-10-2010; IN COMMERCE 12-10-2010.

KARANENDRA S. CHHINA, EXAMINING ATTORNEY

**CLASS 43—(Continued).**

SN 76-705,603. AURELIO'S PIZZA, INC., HOMEWOOD, IL.  
FILED 12-7-2010.

**LIFE BEGINS AT AURELIO'S**

THE MARK CONSISTS OF STANDARD CHARACTERS WITHOUT CLAIM TO ANY PARTICULAR FONT, STYLE, SIZE, OR COLOR.

OWNER OF U.S. REG. NOS. 1,230,598, 1,230,599 AND 3,393,848.

FOR RESTAURANT SERVICES (U.S. CLS. 100 AND 101).

FIRST USE 1-2-1970; IN COMMERCE 1-2-1970.  
JAMES GRIFFIN, EXAMINING ATTORNEY

**CLASS 43—(Continued).**

SN 77-579,940. LAS VEGAS SANDS CORP., LAS VEGAS, NV.  
FILED 9-26-2008.



PRIORITY CLAIMED UNDER SEC. 44(D) ON MACAO APPLICATION NO. N/38608, FILED 9-19-2008, REG. NO. N/38608, DATED 2-24-2009, EXPIRES 2-24-2016.

THE MARK CONSISTS OF THE STYLIZED SPRAY OF A WATER FOUNTAIN IN BETWEEN VARIOUS SIZED STARS.

FOR SERVICES FOR PROVIDING FOOD AND DRINK; TEMPORARY ACCOMMODATION; HOTEL, BAR AND RESTAURANT SERVICES; TRAVEL AGENCY SERVICES, NAMELY, MAKING RESERVATIONS AND BOOKINGS FOR RESTAURANTS AND MEALS (U.S. CLS. 100 AND 101).

LINDA ESTRADA, EXAMINING ATTORNEY

SN 77-310,181. CAFE RIO, INCORPORATED, SALT LAKE CITY, UT. FILED 10-22-2007.



THE COLOR(S) GREEN, YELLOW, ORANGE, RED AND PURPLE IS/ARE CLAIMED AS A FEATURE OF THE MARK.

THE MARK CONSISTS OF COLORED DESIGNS ON THE SURFACE OF TABLES AND CHAIRS. THE MARK CONSISTS OF THE SURFACES OF THREE CHAIRS AND A TABLE IN THE FOLLOWING ORDER FROM LEFT TO RIGHT: ONE SUBSTANTIALLY GREEN, YELLOW AND PURPLE CHAIR, ONE SUBSTANTIALLY GREEN AND RED CHAIR AND ONE SUBSTANTIALLY ORANGE, PURPLE AND RED CHAIR WITH A TABLE IN THE MIDDLE, WHICH IS SUBSTANTIALLY YELLOW AND ORANGE. THE SHAPE OF THE TABLE AND CHAIRS IS REPRESENTED IN BROKEN OR DOTTED LINES IN THE DRAWING TO SHOW PLACEMENT OF THE MARK AND TO DEPICT THE COMMERCIAL IMPRESSION OF THE MARK. THE SHAPE OF THE TABLE AND CHAIRS IS NOT CLAIMED AS A FEATURE OF THE MARK.

SEC. 2(F).

FOR RESTAURANT SERVICES FEATURING MEXICAN FOOD (U.S. CLS. 100 AND 101).

FIRST USE 6-0-1997; IN COMMERCE 6-0-1997.  
DAWN FELDMAN, EXAMINING ATTORNEY

SN 77-907,278. BARU GROUP, LLC, MIAMI, FL. FILED 1-7-2010.

**BARÚ URBANO**

THE MARK CONSISTS OF STANDARD CHARACTERS WITHOUT CLAIM TO ANY PARTICULAR FONT, STYLE, SIZE, OR COLOR.

THE ENGLISH TRANSLATION OF "URBANO" IN THE MARK IS "URBAN". THE WORDING "BARU" HAS NO MEANING IN A FOREIGN LANGUAGE.

FOR RESTAURANT AND BAR SERVICES FEATURING AN INTERNATIONAL MENU WITH LATIN FLARE AND SPECIFICALLY EXCLUDING PASTRY, CHOCOLATE, CHOCOLATES, PRALINES, ICE CREAM, SORBETS, SHERBETS, EDIBLE ICES, BISCUITS, CAKES, MUFFINS, PASTILLES, FONDANTS, AND COCOA (U.S. CLS. 100 AND 101).

FIRST USE 12-23-2009; IN COMMERCE 12-23-2009.  
MEGHAN REINHART, EXAMINING ATTORNEY

**CLASS 43—(Continued).**

SN 77-907,295. BARU GROUP, LLC, MIAMI, FL. FILED 1-7-2010.

# BARÚ

THE MARK CONSISTS OF STANDARD CHARACTERS WITHOUT CLAIM TO ANY PARTICULAR FONT, STYLE, SIZE, OR COLOR.

THE WORDING "BARU" HAS NO MEANING IN A FOREIGN LANGUAGE.

FOR RESTAURANT AND BAR SERVICES FEATURING AN INTERNATIONAL MENU WITH LATIN FLARE AND SPECIFICALLY EXCLUDING PASTRY, CHOCOLATE, CHOCOLATES, PRALINES, ICE CREAM, SORBETS, SHERBETS, EDIBLE ICES, BISCUITS, CAKES, MUFFINS, PASTILLES, FONDANTS, AND COCOA (U.S. CLS. 100 AND 101).

FIRST USE 12-23-2009; IN COMMERCE 12-23-2009.  
MEGHAN REINHART, EXAMINING ATTORNEY

---

SN 77-912,903. PERELMAN, DEBORAH L., NEW YORK, NY. FILED 1-15-2010.

# smitten kitchen

THE MARK CONSISTS OF STANDARD CHARACTERS WITHOUT CLAIM TO ANY PARTICULAR FONT, STYLE, SIZE, OR COLOR.

NO CLAIM IS MADE TO THE EXCLUSIVE RIGHT TO USE "KITCHEN", APART FROM THE MARK AS SHOWN.

FOR PROVIDING ON-LINE COMPUTER DATABASES FEATURING INFORMATION IN THE FIELD OF COOKING, FOOD, WINE, BEVERAGES, BAKING, RECIPES, AND KITCHENWARE, COOKING EQUIPMENT AND ACCESSORIES USED IN COOKING (U.S. CLS. 100 AND 101).

FIRST USE 6-30-2006; IN COMMERCE 6-30-2006.  
DAVID TAYLOR, EXAMINING ATTORNEY

**CLASS 43—(Continued).**

SN 77-948,824. ALISSA BARTHEL, MINNEAPOLIS, MN. FILED 3-2-2010.



THE COLOR(S) BLACK, WHITE, PURPLE AND GREEN IS/ARE CLAIMED AS A FEATURE OF THE MARK.

THE MARK CONSISTS OF A BLACK RECORD WITH A PURPLE LABEL WHICH HAS A GREEN BANNER DRAPED ACROSS IT THAT SAYS "RAWK" IN BLACK AND WHITE; THE WORDS "PUNK" AND "LABS" APPEAR IN WHITE.

FOR PREPARATION OF FOOD AND BEVERAGES (U.S. CLS. 100 AND 101).

FIRST USE 1-1-2010; IN COMMERCE 1-1-2010.  
SAIMA MAKHDOOM, EXAMINING ATTORNEY

---

SN 77-962,385. MAC'S SUSHI INC., TORONTO, ONTARIO, CANADA, FILED 3-18-2010.

# MAC'S SUSHI

THE MARK CONSISTS OF STANDARD CHARACTERS WITHOUT CLAIM TO ANY PARTICULAR FONT, STYLE, SIZE, OR COLOR.

PRIORITY CLAIMED UNDER SEC. 44(D) ON CANADA APPLICATION NO. 1472831, FILED 3-11-2010, REG. NO. TMA789144, DATED 1-31-2011, EXPIRES 1-31-2026.

NO CLAIM IS MADE TO THE EXCLUSIVE RIGHT TO USE "SUSHI", APART FROM THE MARK AS SHOWN.

FOR RESTAURANT, SIT-DOWN AND TAKE-OUT RESTAURANT SERVICES, ALL RELATED TO SUSHI AND JAPANESE CUISINE (U.S. CLS. 100 AND 101).

HEATHER THOMPSON, EXAMINING ATTORNEY

**CLASS 43—(Continued).**

SN 79-086,033. SARA LOPEZ AGUADO, E-28043 MADRID, SPAIN, FILED 6-4-2010.

**BELIVE HOTELS**

THE MARK CONSISTS OF STANDARD CHARACTERS WITHOUT CLAIM TO ANY PARTICULAR FONT, STYLE, SIZE, OR COLOR.

PRIORITY DATE OF 6-2-2010 IS CLAIMED. OWNER OF INTERNATIONAL REGISTRATION 1047539 DATED 6-4-2010, EXPIRES 6-4-2020.

NO CLAIM IS MADE TO THE EXCLUSIVE RIGHT TO USE "HOTELS", APART FROM THE MARK AS SHOWN.

FOR TRAVEL AGENCY SERVICES, NAMELY, MAKING RESERVATIONS AND BOOKING FOR TEMPORARY LODGING; MAKING HOTEL RESERVATIONS FOR OTHERS; HOTEL SERVICES (U.S. CLS. 100 AND 101).

JAMES STEIN, EXAMINING ATTORNEY

---

SN 85-002,774. ANGUS GRAHAM ALEXANDER CRAWFORD, TORONTO, ONTARIO, CANADA, FILED 3-31-2010.

**RAWLICIOUS**

THE MARK CONSISTS OF STANDARD CHARACTERS WITHOUT CLAIM TO ANY PARTICULAR FONT, STYLE, SIZE, OR COLOR.

OWNER OF CANADA REG. NO. TMA734089, DATED 2-9-2009, EXPIRES 2-9-2024.

FOR RESTAURANT SERVICES, CAFE SERVICES AND CATERING SERVICES (U.S. CLS. 100 AND 101).

MARTHA SANTOMARTINO, EXAMINING ATTORNEY

---

SN 85-022,114. LE, HUNG, DBA THE YABBY HUT, LAKEWOOD, CO. AND THE YABBY HUT, LLC, DBA THE YABBY HUT, LAKEWOOD, CO. FILED 4-23-2010.

**The Yabby Hut**

THE MARK CONSISTS OF STANDARD CHARACTERS WITHOUT CLAIM TO ANY PARTICULAR FONT, STYLE, SIZE, OR COLOR.

NO CLAIM IS MADE TO THE EXCLUSIVE RIGHT TO USE "YABBY", APART FROM THE MARK AS SHOWN.

FOR CAJUN SEAFOOD RESTAURANT SERVICES FEATURING CRAWFISH, OYSTER, SNOW CRAB LEG, KING CRAB LEG, BLUE CRAB, SHRIMP, CLAM AND LOBSTER, FRIES, CALAMARI, CORN, AND SAUSAGE AND IMPORT AND DOMESTIC BEERS (U.S. CLS. 100 AND 101).

FIRST USE 4-21-2010; IN COMMERCE 6-24-2010.

MATTHEW KLINE, EXAMINING ATTORNEY

**CLASS 43—(Continued).**

SN 85-030,442. RESTAURANT INVESTMENTS, INC., LAMETA, TX. FILED 5-5-2010.



NO CLAIM IS MADE TO THE EXCLUSIVE RIGHT TO USE "PIZZA REAL PIZZA. REAL CHEESE. REAL FAST", APART FROM THE MARK AS SHOWN.

THE MARK CONSISTS OF "PINOCCHIOS" IN BLOCK LETTERING ORGANIZED IN A CURVED FASHION ABOVE AN OVAL DESIGN WITH THE WORD "PIZZA" WITHIN THE OVAL DESIGN WITH CURVED LINES AROUND THE WORD AND THE WORDS "REAL PIZZA. REAL CHEESE. REAL FAST!" WITH THREE STYLIZED ARROWS ALL BELOW THE OVAL.

FOR RESTAURANT SERVICES, FEATURING PIZZA (U.S. CLS. 100 AND 101).

FIRST USE 12-1-1997; IN COMMERCE 2-1-1998.

APRIL HESIK, EXAMINING ATTORNEY

---

SN 85-031,164. DAVID LISSNER, CHICAGO, IL. FILED 5-5-2010.

**THE FOOD DUDE**

THE MARK CONSISTS OF STANDARD CHARACTERS WITHOUT CLAIM TO ANY PARTICULAR FONT, STYLE, SIZE, OR COLOR.

"THE FOOD DUDE" IDENTIFIES THE PSEUDONYM OF DAVID LISSNER, A LIVING INDIVIDUAL WHOSE CONSENT IS OF RECORD.

FOR PROVIDING REVIEWS OF RESTAURANTS (U.S. CLS. 100 AND 101).

FIRST USE 12-31-1991; IN COMMERCE 12-31-1991.

BRENDAN MCCAULEY, EXAMINING ATTORNEY

**CLASS 43—(Continued).**

SN 85-032,801. JSS RESTAURANT GROUP, INC., SAN FRANCISCO, CA. FILED 5-7-2010.



OWNER OF U.S. REG. NO. 3,858,295.  
NO CLAIM IS MADE TO THE EXCLUSIVE RIGHT TO USE "ARTISAN BURGERS", APART FROM THE MARK AS SHOWN.

THE COLOR(S) RED AND DARK RED IS/ARE CLAIMED AS A FEATURE OF THE MARK.

THE MARK CONSISTS OF STYLIZED LETTERING, "ROAM ARTISAN BURGERS", "ROAM" IN THE CENTER OF THE STYLIZED SEMI CIRCLE WITH HORIZONTAL CURVED LINES ABOVE AND BELOW "ROAM". THE WORD "ARTISAN" ABOVE "ROAM", THE WORD IS CURVED UP INSIDE THE HALF CIRCLE LIKE SHAPE, "BURGERS", IS BELOW "ROAM", THE WORD IS CURVED DOWN INSIDE THE HALF CIRCLE LIKE SHAPE. THE HORIZONTAL LINES AND THE CIRCLES HAVE SMALL LINES COMING OUT FROM THEM. THE LETTERING IS IN RED AND DARK RED AND THE LINES AND CIRCLES ARE IN RED.

FOR GOURMET BURGER RESTAURANTS (U.S. CLS. 100 AND 101).

FIRST USE 4-14-2010; IN COMMERCE 4-14-2010.  
ANNE FARRELL, EXAMINING ATTORNEY

SN 85-034,548. MICHAEL D. SIMENS, CLEVELAND, OH. FILED 5-10-2010.

# WINGTON

THE MARK CONSISTS OF STANDARD CHARACTERS WITHOUT CLAIM TO ANY PARTICULAR FONT, STYLE, SIZE, OR COLOR.

FOR RESTAURANT SERVICES (U.S. CLS. 100 AND 101).

FIRST USE 3-9-2010; IN COMMERCE 3-9-2010.  
HOWARD B. LEVINE, EXAMINING ATTORNEY

**CLASS 43—(Continued).**

SN 85-034,918. GARONI, KRISTIAN, FORT LAUDERDALE, FL. FILED 5-11-2010.

# SUSHI TRAIN

THE MARK CONSISTS OF STANDARD CHARACTERS WITHOUT CLAIM TO ANY PARTICULAR FONT, STYLE, SIZE, OR COLOR.

NO CLAIM IS MADE TO THE EXCLUSIVE RIGHT TO USE "SUSHI", APART FROM THE MARK AS SHOWN.

FOR RESTAURANT SERVICES, NAMELY, SERVICES FOR PROVIDING JAPANESE FOOD AND DRINKS FOR CONSUMERS (U.S. CLS. 100 AND 101).

MARK PILARO, EXAMINING ATTORNEY

SN 85-038,630. SCRIPPS NETWORKS, LLC, KNOXVILLE, TN. FILED 5-14-2010.



OWNER OF U.S. REG. NOS. 3,658,542, 3,658,544 AND OTHERS.

SEC. 2(F).

FOR PROVIDING INFORMATION VIA A GLOBAL COMPUTER INFORMATION NETWORK IN THE FIELDS OF COOKING AND CULINARY ARTS (U.S. CLS. 100 AND 101).

SIMON TENG, EXAMINING ATTORNEY

SN 85-041,924. VAQUERO STRATEGY AND ENTERTAINMENT, LLC, SAN ANTONIO, TX 78240, TX. FILED 5-18-2010.

# RED RIVER DANCE HALL AND SALOON

THE MARK CONSISTS OF STANDARD CHARACTERS WITHOUT CLAIM TO ANY PARTICULAR FONT, STYLE, SIZE, OR COLOR.

NO CLAIM IS MADE TO THE EXCLUSIVE RIGHT TO USE "DANCE HALL AND SALOON", APART FROM THE MARK AS SHOWN.

FOR BAR AND COCKTAIL LOUNGE SERVICES; BAR AND RESTAURANT SERVICES; BAR SERVICES; CAFE AND RESTAURANT SERVICES; PROVISION OF FOOD AND DRINK IN RESTAURANTS; RESTAURANT; RESTAURANT SERVICES (U.S. CLS. 100 AND 101).

MARC LEIPZIG, EXAMINING ATTORNEY

**CLASS 43—(Continued).**

SN 85-046,953. HOUSE OF GREENS, INC., FORT WAYNE, IN. FILED 5-25-2010.



NO CLAIM IS MADE TO THE EXCLUSIVE RIGHT TO USE "HOUSE OF GREENS", APART FROM THE MARK AS SHOWN.

THE MARK CONSISTS OF THE WORDS "HOUSE OF GREENS" SURROUNDED BY THE LIKENESS OF A TOMATO. THE "O" IN "HOUSE" IS THE LIKENESS OF A HEAD OF LETTUCE.

FOR RESTAURANT SERVICES, NAMELY, PROVIDING OF FOOD AND BEVERAGES FOR CONSUMPTION ON AND OFF THE PREMISES (U.S. CLS. 100 AND 101).

FIRST USE 3-2-2009; IN COMMERCE 3-2-2009.

KEVIN CORWIN, EXAMINING ATTORNEY

SN 85-057,804. WARNER BROS. ENTERTAINMENT INC., BURBANK, CA. FILED 6-8-2010.

**LEAKY CAULDRON**

THE MARK CONSISTS OF STANDARD CHARACTERS WITHOUT CLAIM TO ANY PARTICULAR FONT, STYLE, SIZE, OR COLOR.

FOR RESTAURANT SERVICES; BUFFET RESTAURANT SERVICES; SELF-SERVICE RESTAURANT, SNACK BAR, COFFEE SHOP AND CAFE SERVICES (U.S. CLS. 100 AND 101).

KATHLEEN M. VANSTON, EXAMINING ATTORNEY

**CLASS 43—(Continued).**

SN 85-062,362. MEDICAL DIAGNOSTIC LABORATORIES, LLC, HAMILTON, NJ. FILED 6-14-2010.



NO CLAIM IS MADE TO THE EXCLUSIVE RIGHT TO USE "CHOCOLATE CAFE", APART FROM THE MARK AS SHOWN.

THE COLOR(S) DARK BLUE, LIGHT BLUE, DARK BROWN, LIGHT BROWN, LIGHT GOLDEN BROWN AND WHITE IS/ARE CLAIMED AS A FEATURE OF THE MARK.

THE MARK CONSISTS OF THE LITERAL ELEMENTS "ARTISSERIE" IN DARK BLUE AND "CHOCOLATE CAFE" IN WHITE. THE "A" IN THE WORD "ARTISSERIE" IS DEPICTED AS THE EIFFEL TOWER IN DARK BLUE. A SHADOW IS DEPICTED IN LIGHT BLUE BENEATH THE EIFFEL TOWER AND THE COLOR LIGHT GOLDEN BROWN APPEARS IN THE SHADING BEHIND THE EIFFEL TOWER. THE LETTERS "R," "T," "I," "S," "S," "E" AND "R" IN THE WORD "ARTISSERIE" ARE OUTLINED IN WHITE. CHOCOLATE IN ALTERNATING DARK BROWN AND LIGHT BROWN IS DEPICTED FLOWING FROM THE TOP OF THE EIFFEL TOWER WHICH FORMS A DARK BROWN BANNER WITH LIGHT BROWN SHADING ACROSS THE BOTTOM OF THE MARK. THE PHRASE "CHOCOLATE CAFE" IN WHITE IS CONTAINED WITHIN THE DARK BROWN BANNER WITH LIGHT BROWN SHADING. AN ACCENT MARK IN WHITE IS DEPICTED ABOVE THE LETTER "E" IN THE WORD "CAFE." AN ARTIST'S PALETTE IN LIGHT GOLDEN BROWN AND PARTIALLY OUTLINED IN DARK BLUE IS DEPICTED IN THE BACKGROUND. THE THUMB-HOLE OF THE PALETTE IS DEPICTED BY A WHITE OVAL ABOVE THE LETTERS "SS" IN THE WORD "ARTISSERIE".

THE WORDING "ARTISSERIE" HAS NO MEANING IN A FOREIGN LANGUAGE.

FOR RESTAURANT AND CAFE SERVICES (U.S. CLS. 100 AND 101).

MYRIAH HABEEB, EXAMINING ATTORNEY



**CLASS 43—(Continued).**

SN 85-063,182. CHICAGO DELIGHTS, LLC, DBA IKIWI, OVIEDO, FL. FILED 6-15-2010.



NO CLAIM IS MADE TO THE EXCLUSIVE RIGHT TO USE "KIWI", APART FROM THE MARK AS SHOWN.

THE COLOR(S) DARK GREEN, GREEN, PINK, TAN, BROWN AND WHITE IS/ARE CLAIMED AS A FEATURE OF THE MARK.

THE MARK CONSISTS OF TWO LEAVES AND A SPIRAL LINE ABOVE THE CONE WHICH ARE DARK GREEN, OUTER CURVE IS GREEN, THE OVAL ON TOP OF THE CONE IS PINK, THE SPACE BETWEEN THE CURVED LINE AND THE CONE AND THE OVAL AND THE CONE IS WHITE, THE DIAMOND SHAPES ON THE CONE ARE BROWN, THE HATCH MARKS ON THE CONE ARE TAN, THE WORDING "I" AND "KIWI" IS GREEN AND THE DOT BETWEEN THE "I" AND "K" PINK.

FOR FROZEN YOGURT SHOP SERVICES IN THE NATURE OF A RESTAURANT (U.S. CLS. 100 AND 101).

FIRST USE 6-20-2008; IN COMMERCE 3-17-2009.  
LAURA HAMMEL, EXAMINING ATTORNEY

SN 85-066,063. JMWILLIAMS LLC, NEW YORK, NY. FILED 6-18-2010.

**BUVETTE GASTROTEQUE**

THE MARK CONSISTS OF STANDARD CHARACTERS WITHOUT CLAIM TO ANY PARTICULAR FONT, STYLE, SIZE, OR COLOR.

NO CLAIM IS MADE TO THE EXCLUSIVE RIGHT TO USE "BUVETTE", APART FROM THE MARK AS SHOWN.

THE ENGLISH TRANSLATION OF "BUVETTE" IN THE MARK IS "REFRESHMENT AREA" OR "REFRESHMENT BAR".

FOR RESTAURANT SERVICES (U.S. CLS. 100 AND 101).

FIRST USE 1-0-2009; IN COMMERCE 1-0-2009.  
JOHN SCHUYLER YARD, EXAMINING ATTORNEY

**CLASS 43—(Continued).**

SN 85-067,153. BUBBA'S SANI-SERV, INC., DANVILLE, VA. FILED 6-20-2010.

**BUBBA'S ICE CREAM**

THE MARK CONSISTS OF STANDARD CHARACTERS WITHOUT CLAIM TO ANY PARTICULAR FONT, STYLE, SIZE, OR COLOR.

NO CLAIM IS MADE TO THE EXCLUSIVE RIGHT TO USE "ICE CREAM", APART FROM THE MARK AS SHOWN. FOR ICE CREAM PARLORS; ICE CREAM SHOP SERVICES IN THE NATURE OF A RESTAURANT (U.S. CLS. 100 AND 101).

FIRST USE 1-1-1959; IN COMMERCE 1-1-1959.

BARBARA RUTLAND, EXAMINING ATTORNEY

SN 85-070,568. BLUE BANANA FROZEN YOGURT INC, TUCSON, AZ. FILED 6-24-2010.

**Blue Banana Frozen Yogurt,  
Inc.**

THE MARK CONSISTS OF STANDARD CHARACTERS WITHOUT CLAIM TO ANY PARTICULAR FONT, STYLE, SIZE, OR COLOR.

NO CLAIM IS MADE TO THE EXCLUSIVE RIGHT TO USE "FROZEN YOGURT, INC.", APART FROM THE MARK AS SHOWN.

FOR FROZEN YOGURT SHOP SERVICES IN THE NATURE OF A RESTAURANT (U.S. CLS. 100 AND 101).

MARTHA FROMM, EXAMINING ATTORNEY

SN 85-088,334. GENERAL MILLS, INC., MINNEAPOLIS, MN. FILED 7-20-2010.



OWNER OF U.S. REG. NO. 3,746,785.

THE MARK CONSISTS OF AN ARROW CIRCLE BEGINNING WITH A DOTTED LINE WHICH TRANSITIONS TO A SOLID LINE SURROUNDING A STYLIZED APPLE WHICH APPEARS IN FRONT OF THE WORD "HEALTHIFIED".

FOR PROVIDING RECIPES VIA AN INTERNET WEB SITE (U.S. CLS. 100 AND 101).

FIRST USE 7-1-2008; IN COMMERCE 7-1-2008.

KAELIE KUNG, EXAMINING ATTORNEY

**CLASS 43—(Continued).**

SN 85-113,895. GOOD TO GO CAFE, STAMFORD, CT. FILED 8-23-2010.

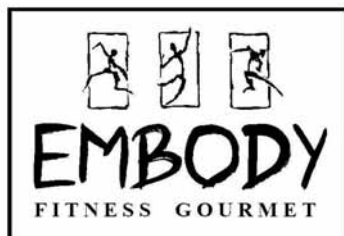

NO CLAIM IS MADE TO THE EXCLUSIVE RIGHT TO USE "GOURMET", APART FROM THE MARK AS SHOWN. THE MARK CONSISTS OF A SQUARE CONTAINING THE WORDING "EMBODY FITNESS GOURMET" THE WORDING IS IN TWO DIFFERENT FONTS. ABOVE THE WORDING ARE THREE STYLIZED STICK FIGURES IN THREE DIFFERENT POSES, EACH WITHIN A RECTANGLE.

FOR CAFE; SNACK BARS (U.S. CLS. 100 AND 101).  
FIRST USE 2-15-2010; IN COMMERCE 3-1-2010.  
LINDA E. BLOHM, EXAMINING ATTORNEY

**CLASS 43—(Continued).**

SN 85-124,383. GÜLLÜOĞLU, MEHMET NEJAT, ISTANBUL, TURKEY, FILED 9-7-2010.



OWNER OF U.S. REG. NO. 2,362,909.

NO CLAIM IS MADE TO THE EXCLUSIVE RIGHT TO USE "SINCE 1871", APART FROM THE MARK AS SHOWN.

THE MARK CONSISTS OF THE WORD "GÜLLÜOĞLU" UNDERNEATH THE PHRASE "SINCE 1871" ON THE LEFT AND, IN THE CENTER, A DESIGN CONSISTING OF A CIRCLE DIVIDED BY HORIZONTAL, VERTICAL AND DIAGONAL LINES, AND CONTAINING THREE SMALLER CIRCLES, RESTING ON A BROAD U-SHAPE, AND HAVING NINE SPIKE-LIKE PROTRUSIONS AT THE TOP.

FOR CAFE AND RESTAURANT SERVICES (U.S. CLS. 100 AND 101).

FIRST USE 1-1-2005; IN COMMERCE 1-1-2005.

JASON TURNER, EXAMINING ATTORNEY

SN 85-124,840. CIPRIANI GROUP, INC., NEW YORK, NY. FILED 9-8-2010.

**CIPRIANI DOWNTOWN**

THE MARK CONSISTS OF STANDARD CHARACTERS WITHOUT CLAIM TO ANY PARTICULAR FONT, STYLE, SIZE, OR COLOR.

OWNER OF U.S. REG. NOS. 2,330,449, 2,598,197 AND 2,844,146.

FOR RESTAURANT SERVICES (U.S. CLS. 100 AND 101).

FIRST USE 3-1-1996; IN COMMERCE 3-1-1996.

REBECCA EISINGER, EXAMINING ATTORNEY

SN 85-120,691. BENNETT, KENNETH, FORT WAYNE, IN. FILED 9-1-2010.

**PIZZA BY VITO'S**

THE MARK CONSISTS OF STANDARD CHARACTERS WITHOUT CLAIM TO ANY PARTICULAR FONT, STYLE, SIZE, OR COLOR.

NO CLAIM IS MADE TO THE EXCLUSIVE RIGHT TO USE "PIZZA", APART FROM THE MARK AS SHOWN.

FOR CARRY-OUT RESTAURANTS FEATURING PIZZA, SUBS, PASTA, RIBS, CHICKEN AND FISH (U.S. CLS. 100 AND 101).

SCOTT BIBB, EXAMINING ATTORNEY

SN 85-127,216. RESORT RENTAL, LLC, PARSIPPANY, NJ. FILED 9-10-2010.

**MYWEBREZ.COM**

THE MARK CONSISTS OF STANDARD CHARACTERS WITHOUT CLAIM TO ANY PARTICULAR FONT, STYLE, SIZE, OR COLOR.

FOR TRAVEL AGENCY SERVICES, NAMELY, MAKING RESERVATIONS AND BOOKINGS FOR TEMPORARY LODGING (U.S. CLS. 100 AND 101).

FIRST USE 3-0-2010; IN COMMERCE 3-0-2010.

APRIL ROACH, EXAMINING ATTORNEY

**CLASS 43—(Continued).**

SN 85-130,136. AVILA'S EL RANCHITO, INC., NEWPORT BEACH, CA. FILED 9-15-2010.



THE MARK CONSISTS OF THE WORDING "AVILA'S" IN STYLIZED FONT.

SEC. 2(F).  
FOR RESTAURANT AND BAR SERVICES (U.S. CLS. 100 AND 101).  
FIRST USE 11-11-1987; IN COMMERCE 12-31-1987.  
PAM WILLIS, EXAMINING ATTORNEY

---

SN 85-135,144. MAXIMUS MAX LLC, SPRINGFIELD GARDENS, NY. FILED 9-22-2010.

**CREATIVE WRAPS**

THE MARK CONSISTS OF STANDARD CHARACTERS WITHOUT CLAIM TO ANY PARTICULAR FONT, STYLE, SIZE, OR COLOR.

NO CLAIM IS MADE TO THE EXCLUSIVE RIGHT TO USE "WRAPS", APART FROM THE MARK AS SHOWN.  
FOR PROVIDING FOOD AND DRINK (U.S. CLS. 100 AND 101).

FIRST USE 1-10-2010; IN COMMERCE 1-10-2010.  
CHRISTINA SOBRAL, EXAMINING ATTORNEY

**CLASS 43—(Continued).**

SN 85-136,643. YUMYUM WARRIOR, INC., RALEIGH, NC. FILED 9-23-2010.



THE COLOR(S) RED, BLACK AND WHITE IS/ARE CLAIMED AS A FEATURE OF THE MARK.

THE MARK CONSISTS OF THE MARK CONSISTS OF RED FRAME ON SHIELD, BLACK AND WHITE COLORS WITHIN SHIELD DIVIDED INTO QUARTERS, BLACK FLEUR-DE-LIS ON WHITE BACKGROUND IN UPPER LEFT QUARTER, WHITE FORK, KNIFE, SPOON ON BLACK BACKGROUND IN UPPER RIGHT QUARTER, "YUMYUM WARRIOR" IN RED TEXT OVER THE BOTTOM HALF OF SHIELD ON ALTERNATE BLACK AND WHITE BACKGROUND, WHITE RIBBON DESIGN WITH "POWERFUL FOOD FOR EVERYDAY WARRIORS" TEXT IN BLACK ON IT OVERLAPPING THE SHIELD BENEATH YUMYUM WARRIOR TEXT.

FOR CONSULTING SERVICES IN THE FIELD OF CULINARY ARTS (U.S. CLS. 100 AND 101).  
FIRST USE 3-0-2009; IN COMMERCE 3-0-2009.  
TRACY CROSS, EXAMINING ATTORNEY

---

SN 85-136,944. CHAMELEON CHAIRS LLC, TORRANCE, CA. FILED 9-23-2010.

**CHAMELEON CHAIR COLLECTION**

THE MARK CONSISTS OF STANDARD CHARACTERS WITHOUT CLAIM TO ANY PARTICULAR FONT, STYLE, SIZE, OR COLOR.

OWNER OF U.S. REG. NO. 3,173,431.  
NO CLAIM IS MADE TO THE EXCLUSIVE RIGHT TO USE "CHAIR COLLECTION", APART FROM THE MARK AS SHOWN.

FOR RENTAL OF FURNITURE (U.S. CLS. 100 AND 101).

FIRST USE 2-27-2005; IN COMMERCE 2-27-2005.  
EUGENIA MARTIN, EXAMINING ATTORNEY

**CLASS 43—(Continued).**

SN 85-144,322. TURBO SUDS LAUNDROMAT, HILLSIDE, NJ. FILED 10-4-2010.

# Skinny Italian

THE MARK CONSISTS OF STANDARD CHARACTERS WITHOUT CLAIM TO ANY PARTICULAR FONT, STYLE, SIZE, OR COLOR.

NO CLAIM IS MADE TO THE EXCLUSIVE RIGHT TO USE "ITALIAN", APART FROM THE MARK AS SHOWN. FOR CAFE AND RESTAURANT SERVICES (U.S. CLS. 100 AND 101).

BRIAN NEVILLE, EXAMINING ATTORNEY

SN 85-147,409. CIPRIANI GROUP, INC., NEW YORK, NY. FILED 10-7-2010.



OWNER OF U.S. REG. NOS. 2,330,449, 2,598,197 AND 2,844,146.

THE MARK CONSISTS OF THE DESIGN OF A BARTENDER HOLDING A COCKTAIL MIXER, WITH THREE BEVERAGE GLASSES IN FRONT OF HIM. BELOW THE DESIGN IS THE STYLIZED TEXT "CIPRIANI DOWNTOWN."

FOR RESTAURANT SERVICES (U.S. CLS. 100 AND 101).

FIRST USE 3-1-1996; IN COMMERCE 3-1-1996.

REBECCA EISINGER, EXAMINING ATTORNEY

**CLASS 43—(Continued).**

SN 85-150,541. BELL, JULA, LOS ANGELES, CA. FILED 10-12-2010.



NO CLAIM IS MADE TO THE EXCLUSIVE RIGHT TO USE "DOG CAMP LA", APART FROM THE MARK AS SHOWN.

THE MARK CONSISTS OF THE WORDS "DOG CAMP LA" INSIDE THE DESIGN OF A CANOE SITTING IN WATER. THERE ARE ALSO EVERGREEN TREES DRAWN ON THE CANOE. INSIDE THE CANOE IS DOG WITH ITS PAWS ON THE SIDE OF THE CANOE. ABOVE THE CANOE THERE IS A SUN WITH A SMILING FACE SHINING DOWN ON THE CANOE.

FOR KENNEL SERVICES, NAMELY, BOARDING FOR PETS; PET DAY CARE SERVICES (U.S. CLS. 100 AND 101).

FIRST USE 8-25-2000; IN COMMERCE 4-8-2002.

DAWN FELDMAN, EXAMINING ATTORNEY

SN 85-160,156. FISCHER, ROBERT, EAST MORICHES, NY. FILED 10-25-2010.

# GHOST CHILI MEXICAN GRILL

THE MARK CONSISTS OF STANDARD CHARACTERS WITHOUT CLAIM TO ANY PARTICULAR FONT, STYLE, SIZE, OR COLOR.

NO CLAIM IS MADE TO THE EXCLUSIVE RIGHT TO USE "CHILI MEXICAN GRILL", APART FROM THE MARK AS SHOWN.

FOR FAST-FOOD RESTAURANTS (U.S. CLS. 100 AND 101).

BRENDAN REGAN, EXAMINING ATTORNEY

**CLASS 43—(Continued).**

SN 85-169,634. ASJ DEVELOPMENT, LC, WEST VALLEY CITY, UT. FILED 11-4-2010.



OWNER OF U.S. REG. NOS. 2,792,584, 2,807,276 AND 3,405,011.

NO CLAIM IS MADE TO THE EXCLUSIVE RIGHT TO USE "CAFE" AND "BAKERY" AND "WE DELIVER" AND "QUALITY FOOD", APART FROM THE MARK AS SHOWN. THE MARK CONSISTS OF A SQUARED OFF HALF OVAL WITH DOUBLE LINED BORDER WITH THE WORDS "APPLE SPICE" UNDER THE TOP PART OF THE ARC; THE TOP HALF OF AN APPLE LOCATED AT THE CENTER BOTTOM OF THE HALF OVAL WITH THE WORD "CAFE" TO ITS LEFT AND THE WORD "BAKERY" TO ITS RIGHT; A BANNER UNDER THE APPLE WITH THE WORDS "WE DELIVER QUALITY FOOD" INSIDE.

FOR RESTAURANT AND CATERING SERVICES (U.S. CLS. 100 AND 101).

FIRST USE 2-1-2010; IN COMMERCE 9-13-2010.  
JOHN WILKE, EXAMINING ATTORNEY

---

SN 85-176,074. KETTLEHOUSE BREWING COMPANY, LLC, MISSOULA, MT. FILED 11-12-2010.



THE MARK CONSISTS OF A SILHOUETTE OF A HOUSE OVERLAID BY A CAPITAL LETTER "K".

FOR BREW PUB SERVICES; BREW PUB SERVICES, NAMELY, TAPROOM SERVICES (U.S. CLS. 100 AND 101).

FIRST USE 9-30-2010; IN COMMERCE 9-30-2010.  
LINDA ESTRADA, EXAMINING ATTORNEY

**CLASS 43—(Continued).**

SN 85-176,697. MARGARITAVILLE ENTERPRISES, LLC, PALM BEACH, FL. FILED 11-15-2010.

**MARGARITAVILLE GRILLE**

THE MARK CONSISTS OF STANDARD CHARACTERS WITHOUT CLAIM TO ANY PARTICULAR FONT, STYLE, SIZE, OR COLOR.

OWNER OF U.S. REG. NOS. 3,117,273, 3,855,017 AND OTHERS.

NO CLAIM IS MADE TO THE EXCLUSIVE RIGHT TO USE "GRILLE", APART FROM THE MARK AS SHOWN.

FOR RESTAURANT SERVICES (U.S. CLS. 100 AND 101).

FIRST USE 2-0-2005; IN COMMERCE 2-0-2005.  
LINDSEY RUBIN, EXAMINING ATTORNEY

---

SN 85-178,585. DIABLOS ROJOS, LLC, MILWAUKEE, WI. FILED 11-17-2010.

**CAFÉ BENELUX**

THE MARK CONSISTS OF STANDARD CHARACTERS WITHOUT CLAIM TO ANY PARTICULAR FONT, STYLE, SIZE, OR COLOR.

NO CLAIM IS MADE TO THE EXCLUSIVE RIGHT TO USE "CAFÉ", APART FROM THE MARK AS SHOWN.

FOR BAR AND RESTAURANT SERVICES (U.S. CLS. 100 AND 101).

GIANCARLO CASTRO, EXAMINING ATTORNEY

---

SN 85-178,803. 223 EAGLE, LLC, FAIRFAX, VA. FILED 11-17-2010.

**MuShu Mojo**

THE MARK CONSISTS OF STANDARD CHARACTERS WITHOUT CLAIM TO ANY PARTICULAR FONT, STYLE, SIZE, OR COLOR.

NO CLAIM IS MADE TO THE EXCLUSIVE RIGHT TO USE "MU SHU", APART FROM THE MARK AS SHOWN.

FOR RESTAURANT SERVICES; RESTAURANT SERVICES, INCLUDING SIT-DOWN SERVICE OF FOOD AND TAKE-OUT RESTAURANT SERVICES; RESTAURANT SERVICES, NAMELY, PROVIDING OF FOOD AND BEVERAGES FOR CONSUMPTION ON AND OFF THE PREMISES (U.S. CLS. 100 AND 101).

CAROLYN CATALDO, EXAMINING ATTORNEY

**CLASS 43—(Continued).**

SN 85-182,218. CAPITAL STEAK HOUSE COMÉRCIO DE ALIMENTOS LTDA, CRUZEIRO/DF 706170-401, BRAZIL, FILED 11-22-2010.

**CAPITAL STEAK HOUSE**

THE MARK CONSISTS OF STANDARD CHARACTERS WITHOUT CLAIM TO ANY PARTICULAR FONT, STYLE, SIZE, OR COLOR.

NO CLAIM IS MADE TO THE EXCLUSIVE RIGHT TO USE "STEAK HOUSE", APART FROM THE MARK AS SHOWN.

FOR BAR AND RESTAURANT SERVICES (U.S. CLS. 100 AND 101).

PAULA MAHONEY, EXAMINING ATTORNEY

**CLASS 43—(Continued).**

SN 85-182,914. MIRAGE RESORTS, INCORPORATED, LAS VEGAS, NV. FILED 11-22-2010.



OWNER OF U.S. REG. NO. 2,407,909.

NO CLAIM IS MADE TO THE EXCLUSIVE RIGHT TO USE "MEMPHIS" AND "SMOKEHOUSE & BARBECUE", APART FROM THE MARK AS SHOWN.

THE MARK CONSISTS OF THE WORD "MEMPHIS" IN STYLIZED LETTERS OVERLAPPING A STYLIZED "Q" WITH THE WORDS "SMOKEHOUSE & BARBECUE" POSITIONED HORIZONTALLY UNDERNEATH.

FOR RESTAURANT AND BAR SERVICES (U.S. CLS. 100 AND 101).

FIRST USE 8-29-2006; IN COMMERCE 8-29-2006.

PAUL E. FAHRENKOPF, EXAMINING ATTORNEY

SN 85-183,711. MICHAEL STAW, STAMFORD, CT. FILED 11-23-2010.

**RIPKA'S MARKET**

THE MARK CONSISTS OF STANDARD CHARACTERS WITHOUT CLAIM TO ANY PARTICULAR FONT, STYLE, SIZE, OR COLOR.

NO CLAIM IS MADE TO THE EXCLUSIVE RIGHT TO USE "MARKET", APART FROM THE MARK AS SHOWN.

FOR CATERING SERVICES; RESTAURANT SERVICES, NAMELY, PROVIDING OF FOOD AND BEVERAGES FOR CONSUMPTION ON AND OFF THE PREMISES (U.S. CLS. 100 AND 101).

JENNY PARK, EXAMINING ATTORNEY

SN 85-184,028. KAOHELO ENTERPRISE LLC, DBA ISLAND FROYO, LAHAINA, HI. FILED 11-23-2010.

**Island Froyo**

THE MARK CONSISTS OF STANDARD CHARACTERS WITHOUT CLAIM TO ANY PARTICULAR FONT, STYLE, SIZE, OR COLOR.

NO CLAIM IS MADE TO THE EXCLUSIVE RIGHT TO USE "FROYO", APART FROM THE MARK AS SHOWN.

FOR RESTAURANTS FEATURING FROZEN YOGURT (U.S. CLS. 100 AND 101).

FIRST USE 7-18-2010; IN COMMERCE 7-18-2010.

GIANCARLO CASTRO, EXAMINING ATTORNEY

SN 85-182,235. BUSE, INC., DBA KUMA'S CORNER, CHICAGO, IL. FILED 11-22-2010.



THE COLOR(S) ORANGE, BLACK AND WHITE IS/ARE CLAIMED AS A FEATURE OF THE MARK.

THE MARK CONSISTS OF THE FOLLOWING: LARGE BLACK BEAR WITH ITS EYES, NOSE, EARS AND LINES ALONG THE BOTTOM OF THE BEAR DEPICTED IN WHITE WITH ITS MOUTH OPEN AS IF GROWLING WITH A LARGE BRIGHT ORANGE SUN IN THE BACKGROUND.

FOR BAR AND RESTAURANT SERVICES; PROVISION OF FOOD AND DRINK IN RESTAURANTS; RESTAURANT; RESTAURANT AND BAR SERVICES; RESTAURANT AND BAR SERVICES, INCLUDING RESTAURANT CARRYOUT SERVICES; RESTAURANT SERVICES; RESTAURANTS (U.S. CLS. 100 AND 101).

FIRST USE 4-10-2005; IN COMMERCE 4-10-2005.

BRIDGETT SMITH, EXAMINING ATTORNEY

**CLASS 43—(Continued).**

SN 85-184,773. ANNIES FROZEN YOGURT, INC., EDINA, MN. FILED 11-24-2010.

# RITTERGUT

THE MARK CONSISTS OF STANDARD CHARACTERS WITHOUT CLAIM TO ANY PARTICULAR FONT, STYLE, SIZE, OR COLOR.

THE ENGLISH TRANSLATION OF "RITTERGUT" IS "MANOR".  
FOR RESTAURANT AND BAR SERVICES (U.S. CLS. 100 AND 101).  
MARY ROSSMAN, EXAMINING ATTORNEY

**CLASS 43—(Continued).**

SN 85-185,401. MALTA, ROBERT, NEW YORK, NY. FILED 11-26-2010.

# FILM CENTER CAFE

THE MARK CONSISTS OF STANDARD CHARACTERS WITHOUT CLAIM TO ANY PARTICULAR FONT, STYLE, SIZE, OR COLOR.

NO CLAIM IS MADE TO THE EXCLUSIVE RIGHT TO USE "CAFE", APART FROM THE MARK AS SHOWN.  
FOR BAR AND RESTAURANT SERVICES (U.S. CLS. 100 AND 101).  
FIRST USE 1-1-1996; IN COMMERCE 1-1-1996.  
JAMES GRIFFIN, EXAMINING ATTORNEY

SN 85-184,775. EAT GOOD FEEL GOOD INC., NEW YORK, NY. FILED 11-24-2010.

# Eat Good City Sandwich Feel Good

NO CLAIM IS MADE TO THE EXCLUSIVE RIGHT TO USE "SANDWICH", APART FROM THE MARK AS SHOWN.  
FOR RESTAURANT, BAR AND CATERING SERVICES (U.S. CLS. 100 AND 101).  
FIRST USE 10-4-2010; IN COMMERCE 10-4-2010.  
MARY ROSSMAN, EXAMINING ATTORNEY

SN 85-186,110. FITDOG SPORTS CLUB, SANTA MONICA, CA. FILED 11-29-2010.

# fitdog

THE MARK CONSISTS OF STANDARD CHARACTERS WITHOUT CLAIM TO ANY PARTICULAR FONT, STYLE, SIZE, OR COLOR.

OWNER OF U.S. REG. NO. 3,850,025.  
FOR DOG DAY CARE SERVICES; PET BOARDING SERVICES (U.S. CLS. 100 AND 101).  
FIRST USE 6-1-2009; IN COMMERCE 6-1-2009.  
TARAH HARDY, EXAMINING ATTORNEY

SN 85-185,272. LIMESTONE, LLC, WICHITA, KS. FILED 11-25-2010.

# WICKED BURRITO

THE MARK CONSISTS OF STANDARD CHARACTERS WITHOUT CLAIM TO ANY PARTICULAR FONT, STYLE, SIZE, OR COLOR.

NO CLAIM IS MADE TO THE EXCLUSIVE RIGHT TO USE "BURRITO", APART FROM THE MARK AS SHOWN.  
FOR RESTAURANT SERVICES, NAMELY, PROVIDING FAST CASUAL MEXICAN FOOD AND ALCOHOL (U.S. CLS. 100 AND 101).  
CARYN GLASSER, EXAMINING ATTORNEY

SN 85-186,380. MALTA, ROBERT, NEW YORK, NY. FILED 11-29-2010.



THE MARK CONSISTS OF THE WORD "PUTTANESCA" STYLIZED. THE BLACK IN THE MARK IS INTENDED TO INDICATE BACKGROUND AND IS NOT PART OF THE MARK.

THE ENGLISH TRANSLATION OF "PUTTANESCA" IN THE MARK IS "LADY OF THE NIGHT".  
FOR RESTAURANT AND BAR SERVICES (U.S. CLS. 100 AND 101).  
FIRST USE 10-1-1993; IN COMMERCE 10-1-1993.  
JAMES GRIFFIN, EXAMINING ATTORNEY

**CLASS 43—(Continued).**

SN 85-186,708. BONNERT, ROBERT, ROGERS, AR. AND HAWKINS, JOHN, ROGERS, AR. AND SHELDEN, LORI, ROGERS, AR. FILED 11-29-2010.

## The Healthier Cup

THE MARK CONSISTS OF STANDARD CHARACTERS WITHOUT CLAIM TO ANY PARTICULAR FONT, STYLE, SIZE, OR COLOR.

NO CLAIM IS MADE TO THE EXCLUSIVE RIGHT TO USE "CUP", APART FROM THE MARK AS SHOWN.

FOR MOBILE COFFEE SHOP SERVICES (U.S. CLS. 100 AND 101).

PAUL E. FAHRENKOPF, EXAMINING ATTORNEY

SN 85-187,419. REGENCY HOTEL MANAGEMENT, LLC, SIOUX FALLS, SD. FILED 11-30-2010.

## Eco-ficient

THE MARK CONSISTS OF STANDARD CHARACTERS WITHOUT CLAIM TO ANY PARTICULAR FONT, STYLE, SIZE, OR COLOR.

FOR HOTEL AND MOTEL SERVICES (U.S. CLS. 100 AND 101).

MARK PILARO, EXAMINING ATTORNEY

SN 85-187,746. AKBAR, INC., WICHITA FALLS, TX. FILED 11-30-2010.



NO CLAIM IS MADE TO THE EXCLUSIVE RIGHT TO USE "BURRITO", APART FROM THE MARK AS SHOWN.

THE STIPPLING IS FOR SHADING PURPOSES ONLY.

THE MARK CONSISTS OF THE WORDING "EL DIABLO BURRITO", WITH THE WORD "BURRITO" APPEARING ON A BANNER. BELOW THE WORDING IS AN IMAGE OF A SMILING DEVIL HOLDING A TRIDENT.

THE ENGLISH TRANSLATION OF "EL DIABLO" IN THE MARK IS "THE DEVIL".

FOR RESTAURANT SERVICES (U.S. CLS. 100 AND 101).

FIRST USE 7-12-2010; IN COMMERCE 7-12-2010.  
REBECCA EISINGER, EXAMINING ATTORNEY

**CLASS 43—(Continued).**

SN 85-188,798. TAQUERIA FLETCHER, LLC, TAMPA, FL. FILED 12-1-2010.



NO CLAIM IS MADE TO THE EXCLUSIVE RIGHT TO USE "TAQUERIA" AND "MEXICAN GRILL", APART FROM THE MARK AS SHOWN.

THE MARK CONSISTS OF A TOROID, WITH THE WORD "TAQUERIA" ON THE TOP HALF OF THE TOROID AND THE WORDS "MEXICAN GRILL" ON THE BOTTOM HALF OF THE TOROID, AND A RECTANGLE IN THE MIDDLE OF THE TOROID WITH THE WORD "MONTERREY" CENTERED AND IN THE MIDDLE OF THE TOROID; BETWEEN "TAQUERIA" AND THE RECTANGLE IS A FIRE AND BETWEEN "MEXICAN GRILL" AND THE RECTANGLE IS THE SHADOW OF A MOUNTAIN.

FOR CAFE AND RESTAURANT SERVICES; CARRY-OUT RESTAURANTS; FAST-FOOD RESTAURANTS; RESTAURANT; RESTAURANT SERVICES FEATURING TRADITIONAL MEXICAN FARE (U.S. CLS. 100 AND 101).

FIRST USE 4-1-1997; IN COMMERCE 4-1-1997.  
JENNIFER MARTIN, EXAMINING ATTORNEY

SN 85-190,032. THE CRASH PAD, LLC, CHATTANOOGA, TN. FILED 12-3-2010.



NO CLAIM IS MADE TO THE EXCLUSIVE RIGHT TO USE "HOSTEL", APART FROM THE MARK AS SHOWN.

THE MARK CONSISTS OF A ROUGH EDGED DOUBLE CIRCLE CONTAINING SNOW CAPPED MOUNTAINS WITH THE WORDS "THE CRASH PAD" AND "AN UNCOMMON HOSTEL".

FOR HOTEL, BAR AND RESTAURANT SERVICES (U.S. CLS. 100 AND 101).

SALLY SHIH, EXAMINING ATTORNEY



**CLASS 43—(Continued).**

SN 85-190,332. SPEEDWAY LLC, ENON, OH. FILED 12-3-2010.

**COFFEE STREET CAFE**

THE MARK CONSISTS OF STANDARD CHARACTERS WITHOUT CLAIM TO ANY PARTICULAR FONT, STYLE, SIZE, OR COLOR.

OWNER OF U.S. REG. NOS. 3,020,337 AND 3,049,521.

NO CLAIM IS MADE TO THE EXCLUSIVE RIGHT TO USE "COFFEE" AND "CAFE", APART FROM THE MARK AS SHOWN.

FOR COFFEE BAR SERVICES LOCATED IN A CONVENIENCE STORE (U.S. CLS. 100 AND 101).

KELLY CHOE, EXAMINING ATTORNEY

---

SN 85-190,694. BEST MARKETING SERVICES, INC., LAS VEGAS, NV. FILED 12-3-2010.

**EGGLAND'S BEST**

THE MARK CONSISTS OF STANDARD CHARACTERS WITHOUT CLAIM TO ANY PARTICULAR FONT, STYLE, SIZE, OR COLOR.

OWNER OF U.S. REG. NOS. 1,780,450, 1,850,387 AND 2,975,371.

NO CLAIM IS MADE TO THE EXCLUSIVE RIGHT TO USE "BEST", APART FROM THE MARK AS SHOWN.

FOR RESTAURANTS (U.S. CLS. 100 AND 101).

MARK T. MULLEN, EXAMINING ATTORNEY

---

SN 85-190,910. WHOLLY MOSES, LLC, DBA POST NO BILLS, SEASIDE, CA. FILED 12-5-2010.

**POST NO BILLS CRAFT BEER HOUSE**

THE MARK CONSISTS OF STANDARD CHARACTERS WITHOUT CLAIM TO ANY PARTICULAR FONT, STYLE, SIZE, OR COLOR.

NO CLAIM IS MADE TO THE EXCLUSIVE RIGHT TO USE "CRAFT BEER HOUSE", APART FROM THE MARK AS SHOWN.

FOR BAR AND RESTAURANT SERVICES, INCLUDING CARRYOUT SERVICES (U.S. CLS. 100 AND 101).

CYNTHIA SLOAN, EXAMINING ATTORNEY

**CLASS 43—(Continued).**

SN 85-191,125. MEREDITH CORPORATION, DES MOINES, IA. FILED 12-6-2010.



OWNER OF U.S. REG. NOS. 858,969, 2,438,649 AND OTHERS.

THE COLOR(S) GREEN, ORANGE, PINK, PURPLE, WHITE AND BLUE IS/ARE CLAIMED AS A FEATURE OF THE MARK.

THE MARK CONSISTS OF FOUR OVERLAPPING CIRCLES OF VARYING SIZES WITH A LARGE GREEN CIRCLE AT THE TOP LEFT, A LARGE PINK CIRCLE AT THE TOP RIGHT, A SMALLER ORANGE CIRCLE AT THE BOTTOM LEFT AND THE SMALLEST PURPLE CIRCLE AT THE BOTTOM RIGHT, AND BELOW THE CIRCLE DESIGN, THE WORDING "FAMILYCIRCLE" SHOWN IN WHITE WITH A WHITE UNDERSCORE, ALL ENCLOSED IN A RECTANGLE WITH A BLUE BACKGROUND.

FOR HOTEL AND MOTEL SERVICES; HOTEL AND MOTEL RESERVATION SERVICES FOR OTHERS; ON-LINE HOTEL AND MOTEL RESERVATION SERVICES; RESTAURANT SERVICES (U.S. CLS. 100 AND 101).

JENNIFER DIXON, EXAMINING ATTORNEY

---

SN 85-191,151. MEREDITH CORPORATION, DES MOINES, IA. FILED 12-6-2010.



THE COLOR(S) GREEN, ORANGE, PINK AND PURPLE IS/ARE CLAIMED AS A FEATURE OF THE MARK.

THE MARK CONSISTS OF FOUR OVERLAPPING CIRCLES OF VARYING SIZES WITH A LARGE GREEN CIRCLE AT THE TOP LEFT, A LARGE PINK CIRCLE AT THE TOP RIGHT, A SMALLER ORANGE CIRCLE AT THE BOTTOM LEFT AND THE SMALLEST PURPLE CIRCLE AT THE BOTTOM RIGHT.

FOR HOTEL AND MOTEL SERVICES; HOTEL AND MOTEL RESERVATION SERVICES FOR OTHERS; ON-LINE HOTEL AND MOTEL RESERVATION SERVICES; RESTAURANT SERVICES (U.S. CLS. 100 AND 101).

JENNIFER DIXON, EXAMINING ATTORNEY

**CLASS 43—(Continued).**

SN 85-191,186. MEREDITH CORPORATION, DES MOINES, IA. FILED 12-6-2010.



OWNER OF U.S. REG. NOS. 858,969, 2,438,649 AND OTHERS.

THE COLOR(S) GREEN, ORANGE, PINK, PURPLE AND BLUE IS/ARE CLAIMED AS A FEATURE OF THE MARK.

THE MARK CONSISTS OF FOUR OVERLAPPING CIRCLES OF VARYING SIZES WITH A LARGE GREEN CIRCLE AT THE TOP LEFT, A LARGE PINK CIRCLE AT THE TOP RIGHT, A SMALLER ORANGE CIRCLE AT THE BOTTOM LEFT AND THE SMALLEST PURPLE CIRCLE AT THE BOTTOM RIGHT, AND BELOW THE CIRCLE DESIGN, THE WORDING "FAMILYCIRCLE" SHOWN IN BLUE WITH A BLUE UNDERSCORE. THE COLOR WHITE REPRESENTS TRANSPARENT BACKGROUND AND IS NOT CLAIMED AS A FEATURE OF THE MARK.

FOR HOTEL AND MOTEL SERVICES; HOTEL AND MOTEL RESERVATION SERVICES FOR OTHERS; ONLINE HOTEL AND MOTEL RESERVATION SERVICES; RESTAURANT SERVICES (U.S. CLS. 100 AND 101).  
JENNIFER DIXON, EXAMINING ATTORNEY

---

SN 85-191,636. TH PARAISO AZUL, S.A. DE C.V., PUERTO VALLARTA JALISC, MEXICO, FILED 12-6-2010.

**PAP**

THE MARK CONSISTS OF STANDARD CHARACTERS WITHOUT CLAIM TO ANY PARTICULAR FONT, STYLE, SIZE, OR COLOR.

FOR FOOD PREPARATION SERVICES; AND PROVIDING TEMPORARY ACCOMMODATIONS, NAMELY, HOTEL SERVICES AND PROVIDING TEMPORARY HOUSING IN BOARDING HOUSES (U.S. CLS. 100 AND 101).

DORITT L. CARROLL, EXAMINING ATTORNEY

---

SN 85-191,724. WALKER, DEREK, DENAIR, CA. FILED 12-6-2010.

**Forbidden Pizza**

THE MARK CONSISTS OF STANDARD CHARACTERS WITHOUT CLAIM TO ANY PARTICULAR FONT, STYLE, SIZE, OR COLOR.

NO CLAIM IS MADE TO THE EXCLUSIVE RIGHT TO USE "PIZZA", APART FROM THE MARK AS SHOWN.

FOR RESTAURANT SERVICES (U.S. CLS. 100 AND 101).

ODESSA BIBBINS, EXAMINING ATTORNEY

**CLASS 43—(Continued).**

SN 85-192,461. LUMAT INC., SAN FRANCISCO, CA. FILED 12-7-2010.



THE COLOR(S) ORANGE AND RED IS/ARE CLAIMED AS A FEATURE OF THE MARK.

THE MARK CONSISTS OF STYLIZED DRAWING OF A FLAME IN ORANGE AND RED.

FOR RESTAURANT, BAR AND CATERING SERVICES (U.S. CLS. 100 AND 101).

FIRST USE 8-31-2008; IN COMMERCE 8-31-2008.  
KEVIN DINALLO, EXAMINING ATTORNEY

---

SN 85-193,441. SHARMA, SATINDER, REGO PARK, NY. FILED 12-8-2010.



NO CLAIM IS MADE TO THE EXCLUSIVE RIGHT TO USE "PASTA & RISOTTO CO.", APART FROM THE MARK AS SHOWN.

THE MARK CONSISTS OF THE STYLIZED TEXT "RADICCHIO PASTA & RISOTTO CO." WITH A LINE UNDER "RADICCHIO".

FOR RESTAURANT SERVICES (U.S. CLS. 100 AND 101).

FIRST USE 10-1-2010; IN COMMERCE 11-1-2010.  
APRIL HESIK, EXAMINING ATTORNEY

**CLASS 43—(Continued).**

SN 85-193,570. HOROWITZ, WILLIAM, NEW YORK, NY.  
FILED 12-8-2010.



NO CLAIM IS MADE TO THE EXCLUSIVE RIGHT TO USE "EATERY", APART FROM THE MARK AS SHOWN.

THE MARK CONSISTS OF A PICTURE OF A DUCK DIVIDED IN PARTS; EACH PART NUMBERED "1" THROUGH "6" OVER THE WORDS "DUCKS EATERY".

FOR SERVICES FOR PROVIDING FOOD AND DRINK, NAMELY, RESTAURANT SERVICES (U.S. CLS. 100 AND 101).

FIRST USE 4-1-2010; IN COMMERCE 4-1-2010.

HOWARD B. LEVINE, EXAMINING ATTORNEY

SN 85-193,776. EDDIE AND SAM'S NY PIZZA, LLC, TAMPA, FL. FILED 12-9-2010.

**EDDIE & SAM'S NEW YORK  
PIZZA**

THE MARK CONSISTS OF STANDARD CHARACTERS WITHOUT CLAIM TO ANY PARTICULAR FONT, STYLE, SIZE, OR COLOR.

NO CLAIM IS MADE TO THE EXCLUSIVE RIGHT TO USE "NEW YORK PIZZA", APART FROM THE MARK AS SHOWN.

FOR PIZZA PARLORS (U.S. CLS. 100 AND 101).

FIRST USE 0-0-1998; IN COMMERCE 0-0-1998.

KATHERINE CHANG, EXAMINING ATTORNEY

**CLASS 43—(Continued).**

SN 85-196,270. GYPSY QUEENS, LLC, BALTIMORE, MD.  
FILED 12-13-2010.

**Gypsy Queen Café**

THE MARK CONSISTS OF STANDARD CHARACTERS WITHOUT CLAIM TO ANY PARTICULAR FONT, STYLE, SIZE, OR COLOR.

NO CLAIM IS MADE TO THE EXCLUSIVE RIGHT TO USE "CAFÉ", APART FROM THE MARK AS SHOWN.

FOR PROVIDING OF FOOD AND DRINK VIA A MOBILE TRUCK (U.S. CLS. 100 AND 101).

FIRST USE 6-17-2010; IN COMMERCE 10-20-2010.

TIMOTHY FINNEGAN, EXAMINING ATTORNEY

SN 85-198,143. TSH ENTERTAINMENT, INC., MIAMI, FL.  
FILED 12-15-2010.



OWNER OF U.S. REG. NO. 3,417,569.

NO CLAIM IS MADE TO THE EXCLUSIVE RIGHT TO USE "SUSHI", APART FROM THE MARK AS SHOWN.

THE MARK CONSISTS OF THE LITERAL ELEMENT "SUSHI RUNNER" WITH A DRAWING OF A FISH THAT IS PARTIALLY ENCIRCLED BY AN OVAL AND LINES SUGGESTING MOVEMENT STEMMING FROM THE REAR OF THE FISH.

FOR CARRY-OUT RESTAURANTS; FAST-FOOD RESTAURANT SERVICES; RESTAURANT; RESTAURANT SERVICES (U.S. CLS. 100 AND 101).

FIRST USE 9-1-2005; IN COMMERCE 9-1-2005.

ROBERT STRUCK, EXAMINING ATTORNEY

SN 85-198,149. BRAVO BRIO RESTAURANT GROUP, COLUMBUS, OH. FILED 12-15-2010.

**BRAVO BRIO Restaurant Group**

THE MARK CONSISTS OF STANDARD CHARACTERS WITHOUT CLAIM TO ANY PARTICULAR FONT, STYLE, SIZE, OR COLOR.

OWNER OF U.S. REG. NOS. 2,018,983, 3,602,082 AND 3,602,083.

NO CLAIM IS MADE TO THE EXCLUSIVE RIGHT TO USE "RESTAURANT GROUP", APART FROM THE MARK AS SHOWN.

FOR RESTAURANT SERVICES (U.S. CLS. 100 AND 101).

FIRST USE 5-0-2009; IN COMMERCE 5-0-2009.

KEVON CHISOLM, EXAMINING ATTORNEY

**CLASS 43—(Continued).**

SN 85-199,622. SILVERCUP STUDIOS ASSOCIATES LIMITED PARTNERSHIP, LONG ISLAND CITY, NY. FILED 12-16-2010.



OWNER OF U.S. REG. NOS. 2,043,232, 3,368,826 AND 3,372,049.

THE MARK CONSISTS OF THE WORD SILVERCUP IN BOLD, STYLIZED CAPITAL LETTERS IN THE SHAPE OF AN ARC.

FOR RESTAURANT, CAFÉ, BAR AND CATERING SERVICES (U.S. CLS. 100 AND 101).

REGINA DRUMMOND, EXAMINING ATTORNEY



SN 85-199,931. GLAZE TERIYAKI LLC, NEW YORK, NY. FILED 12-16-2010.

**GLAZE**

THE MARK CONSISTS OF STANDARD CHARACTERS WITHOUT CLAIM TO ANY PARTICULAR FONT, STYLE, SIZE, OR COLOR.

FOR RESTAURANT SERVICES (U.S. CLS. 100 AND 101).

FIRST USE 11-29-2010; IN COMMERCE 12-8-2010.  
TRICIA SONNEBORN, EXAMINING ATTORNEY



SN 85-200,096. HARWELL, MARK, SANJOSE, CA. FILED 12-16-2010.

**Frie with us**

THE MARK CONSISTS OF STANDARD CHARACTERS WITHOUT CLAIM TO ANY PARTICULAR FONT, STYLE, SIZE, OR COLOR.

FOR RESTAURANT SERVICES (U.S. CLS. 100 AND 101).

DAWN HAN, EXAMINING ATTORNEY

**CLASS 43—(Continued).**

SN 85-200,585. KING'S SEAFOOD COMPANY, LLC, DBA WATER GRILL, COSTA MESA, CA. FILED 12-17-2010.

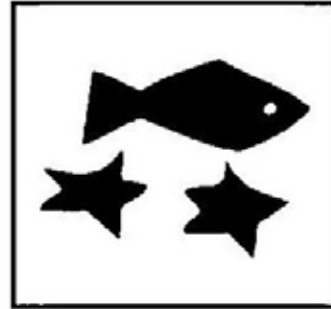

THE MARK CONSISTS OF A FISH DESIGN ABOVE TWO STAR DESIGNS, ALL ENCOMPASSED IN A SQUARE BORDER.

FOR RESTAURANT SERVICES (U.S. CLS. 100 AND 101).

FIRST USE 6-0-1991; IN COMMERCE 6-0-1991.  
REGINA DRUMMOND, EXAMINING ATTORNEY



SN 85-201,836. MARTIN YAN MANAGEMENT, LLC, SAN MATEO, CA. FILED 12-20-2010.

**MADE IN CHINA**

THE MARK CONSISTS OF STANDARD CHARACTERS WITHOUT CLAIM TO ANY PARTICULAR FONT, STYLE, SIZE, OR COLOR.

FOR RESTAURANT, BAR AND CATERING SERVICES (U.S. CLS. 100 AND 101).

LINDA LAVACHE, EXAMINING ATTORNEY



SN 85-202,052. BARLEY CREEK BREWING COMPANY INC., TANNERSVILLE, PA. FILED 12-20-2010.



OWNER OF U.S. REG. NO. 2,934,431.  
NO CLAIM IS MADE TO THE EXCLUSIVE RIGHT TO USE "BREWING COMPANY EST. 1995", APART FROM THE MARK AS SHOWN.

THE MARK CONSISTS OF A BARLEY LEAF OVER THE WORDS "BARLEY CREEK BREWING COMPANY EST. 1995".

FOR PROVIDING OF FOOD AND DRINK (U.S. CLS. 100 AND 101).

FIRST USE 9-0-2007; IN COMMERCE 9-0-2007.  
RUSS HERMAN, EXAMINING ATTORNEY

**CLASS 43—(Continued).**

SN 85-202,479. VOLCUE, LLC, KNOXVILLE, TN. FILED 12-21-2010.

**PULEO'S GRILLE**

THE MARK CONSISTS OF STANDARD CHARACTERS WITHOUT CLAIM TO ANY PARTICULAR FONT, STYLE, SIZE, OR COLOR.

OWNER OF U.S. REG. NO. 2,918,281.

NO CLAIM IS MADE TO THE EXCLUSIVE RIGHT TO USE "GRILLE", APART FROM THE MARK AS SHOWN.

SEC. 2(F).  
FOR RESTAURANT SERVICES (U.S. CLS. 100 AND 101).

FIRST USE 8-20-2002; IN COMMERCE 8-20-2002.  
PATRICIA EVANKO, EXAMINING ATTORNEY

**CLASS 43—(Continued).**

SN 85-204,162. JAVA GYM, LLC, ROCKFORD, MI. FILED 12-22-2010.

**JAVA GYM**

THE MARK CONSISTS OF STANDARD CHARACTERS WITHOUT CLAIM TO ANY PARTICULAR FONT, STYLE, SIZE, OR COLOR.

FOR RESTAURANT SERVICES, FEATURING COFFEE, COFFEE BASED DRINKS AND OTHER FOOD PRODUCTS (U.S. CLS. 100 AND 101).

KEVIN CORWIN, EXAMINING ATTORNEY

SN 85-202,496. STEPHEN RUFF, CHULUOTA, FL. FILED 12-21-2010.

**Tacoberfest**

THE MARK CONSISTS OF STANDARD CHARACTERS WITHOUT CLAIM TO ANY PARTICULAR FONT, STYLE, SIZE, OR COLOR.

FOR RESTAURANT (U.S. CLS. 100 AND 101).

FIRST USE 10-1-2010; IN COMMERCE 10-1-2010.  
WILLIAM VERHOSEK, EXAMINING ATTORNEY

SN 85-204,436. GREENE, ADAM, NEW YORK, NY. FILED 12-22-2010.

**BAR CAR**

THE MARK CONSISTS OF STANDARD CHARACTERS WITHOUT CLAIM TO ANY PARTICULAR FONT, STYLE, SIZE, OR COLOR.

FOR BAR AND RESTAURANT SERVICES (U.S. CLS. 100 AND 101).

THEODORE MCBRIDE, EXAMINING ATTORNEY

SN 85-203,303. STEVE BERGER, FRANKLIN, TN. AND SARAH BERGER, FRANKLIN, TN. FILED 12-21-2010.

**Have Heart**

THE MARK CONSISTS OF STANDARD CHARACTERS WITHOUT CLAIM TO ANY PARTICULAR FONT, STYLE, SIZE, OR COLOR.

FOR CHILD WELFARE SERVICES, NAMELY, PROVIDING CHILDREN'S RESIDENTIAL HOMES AND FOOD TO CHILDREN IN NEED (U.S. CLS. 100 AND 101).

FIRST USE 11-15-2009; IN COMMERCE 11-15-2009.  
SHAUNIA CARLYLE, EXAMINING ATTORNEY

SN 85-204,626. IMPACT RESTAURANT MANAGEMENT INC., VALPARAISO, IN. FILED 12-23-2010.

**INDUSTRIAL REVOLUTION**

THE MARK CONSISTS OF STANDARD CHARACTERS WITHOUT CLAIM TO ANY PARTICULAR FONT, STYLE, SIZE, OR COLOR.

FOR RESTAURANT AND BAR SERVICES (U.S. CLS. 100 AND 101).

FIRST USE 5-6-2010; IN COMMERCE 5-6-2010.  
ODESSA BIBBINS, EXAMINING ATTORNEY

**CLASS 43—(Continued).**

SN 85-204,627. IMPACT RESTAURANT MANAGEMENT INC., VALPARAISO, IN. FILED 12-23-2010.



THE MARK CONSISTS OF A FIGURE OF THE TORSO OF A MAN IN PROFILE.  
FOR RESTAURANT AND BAR SERVICES (U.S. CLS. 100 AND 101).  
FIRST USE 5-6-2010; IN COMMERCE 5-6-2010.  
ODESSA BIBBINS, EXAMINING ATTORNEY

SN 85-204,628. IMPACT RESTAURANT MANAGEMENT INC., VALPARAISO, IN. FILED 12-23-2010.

**SALUTING AMERICA'S  
GREATNESS**

THE MARK CONSISTS OF STANDARD CHARACTERS WITHOUT CLAIM TO ANY PARTICULAR FONT, STYLE, SIZE, OR COLOR.  
FOR RESTAURANT AND BAR SERVICES (U.S. CLS. 100 AND 101).  
FIRST USE 5-6-2010; IN COMMERCE 5-6-2010.  
ODESSA BIBBINS, EXAMINING ATTORNEY

SN 85-204,680. GENUWINE LLC, PASADENA, CA. FILED 12-23-2010.

**REVEAL**

THE MARK CONSISTS OF STANDARD CHARACTERS WITHOUT CLAIM TO ANY PARTICULAR FONT, STYLE, SIZE, OR COLOR.  
FOR RESTAURANT SERVICES; WINE BARS (U.S. CLS. 100 AND 101).  
RONALD DELGIZZI, EXAMINING ATTORNEY

**CLASS 43—(Continued).**

SN 85-204,757. PASSION FOOD SIX, LLC, DBA DISTRICT COMMONS, WASHINGTON, DC. FILED 12-23-2010.

**DISTRICT COMMONS**

THE MARK CONSISTS OF STANDARD CHARACTERS WITHOUT CLAIM TO ANY PARTICULAR FONT, STYLE, SIZE, OR COLOR.  
FOR RESTAURANT AND BAR SERVICES, INCLUDING RESTAURANT CARRYOUT SERVICES (U.S. CLS. 100 AND 101).  
FIRST USE 11-1-2010; IN COMMERCE 11-1-2010.  
FLORENTINA BLANDU, EXAMINING ATTORNEY

SN 85-205,373. WINTER, DONIEL, ASHEVILLE, NC. FILED 12-23-2010.

**RELAXATION IS WELLNESS.  
WELLNESS IS HAPPINESS.**

THE MARK CONSISTS OF STANDARD CHARACTERS WITHOUT CLAIM TO ANY PARTICULAR FONT, STYLE, SIZE, OR COLOR.  
FOR BED AND BREAKFAST INN SERVICES (U.S. CLS. 100 AND 101).  
FIRST USE 10-8-2010; IN COMMERCE 10-8-2010.  
GINA FINK, EXAMINING ATTORNEY

SN 85-205,480. GOTHE, AXEL, NEW YORK, NY. FILED 12-24-2010.



THE MARK CONSISTS OF THE WORD "PLANET" IN UPPER CASE LETTERS AND THE STYLIZED WORD "LOVE" IN LOWER CASE LETTERS BENEATH, WITH THE IMAGE OF THE EARTH IN THE LETTER "O" OF THE WORD "LOVE".  
FOR SERVICES, NAMELY, CAFE-RESTAURANT, COCKTAIL LOUNGE; HOTEL SERVICES (U.S. CLS. 100 AND 101).  
HANNO RITTNER, EXAMINING ATTORNEY

**CLASS 43—(Continued).**

SN 85-205,487. NAANSTOP, LLC, LOS ANGELES, CA. FILED 12-24-2010.

# NaanStop

THE MARK CONSISTS OF STANDARD CHARACTERS WITHOUT CLAIM TO ANY PARTICULAR FONT, STYLE, SIZE, OR COLOR.

FOR FAST-FOOD RESTAURANTS; FAST-FOOD RESTAURANTS AND SNACKBARS; RESTAURANT AND BAR SERVICES, INCLUDING RESTAURANT CARRY-OUT SERVICES; RESTAURANTS; RESTAURANTS FEATURING HOME DELIVERY; SELF-SERVICE RESTAURANTS (U.S. CLS. 100 AND 101).

FIRST USE 10-14-2010; IN COMMERCE 10-23-2010.  
LEIGH LOWRY, EXAMINING ATTORNEY

**CLASS 43—(Continued).**

SN 85-206,720. LI, ZONGYAN, ROWLAND HEIGHTS, CA. FILED 12-28-2010.

# 福地

SN 85-206,245. KRISTIE WILDER, TEMPLE, GA. FILED 12-27-2010.

# iWag

THE MARK CONSISTS OF STANDARD CHARACTERS WITHOUT CLAIM TO ANY PARTICULAR FONT, STYLE, SIZE, OR COLOR.

FOR KENNEL SERVICES, NAMELY, BOARDING FOR PETS (U.S. CLS. 100 AND 101).

ANTHONY RINKER, EXAMINING ATTORNEY

SN 85-206,415. KEYNOTE HOLDINGS, LLC, FORNEY, TX. FILED 12-28-2010.

# QUATTRO TASTI

THE MARK CONSISTS OF STANDARD CHARACTERS WITHOUT CLAIM TO ANY PARTICULAR FONT, STYLE, SIZE, OR COLOR.

THE ENGLISH TRANSLATION OF "QUATTRO TASTI" IN THE MARK IS "FOUR KEYS."

FOR RESTAURANT AND CATERING SERVICES (U.S. CLS. 100 AND 101).

TINA BROWN, EXAMINING ATTORNEY

THE MARK CONSISTS OF TWO CHINESE CHARACTERS THAT TRANSLITERATE INTO "FU DI" AND TRANSLATE INTO ENGLISH AS "BLESSED LAND".

THE NON-LATIN CHARACTERS IN THE MARK TRANSLITERATE TO FU DI AND THIS MEANS "BLESSED LAND" IN ENGLISH.

FOR BAR AND RESTAURANT SERVICES; CAFE AND RESTAURANT SERVICES; CAFE-RESTAURANTS; CAFETERIA AND RESTAURANT SERVICES; CARRY-OUT RESTAURANTS; RESTAURANT; RESTAURANT AND BAR SERVICES; RESTAURANT AND BAR SERVICES, INCLUDING RESTAURANT CARRYOUT SERVICES; RESTAURANT AND CAFE SERVICES; RESTAURANT AND CATERING SERVICES; RESTAURANT SERVICES; RESTAURANT SERVICES, INCLUDING SIT-DOWN SERVICE OF FOOD AND TAKE-OUT RESTAURANT SERVICES; RESTAURANT SERVICES, NAMELY, PROVIDING OF FOOD AND BEVERAGES FOR CONSUMPTION ON AND OFF THE PREMISES; RESTAURANT, BAR AND CATERING SERVICES; RESTAURANTS; RESTAURANTS FEATURING HOME DELIVERY; SELF-SERVICE RESTAURANTS; SELF-SERVICE RESTAURANTS; TAKE-OUT RESTAURANT SERVICES (U.S. CLS. 100 AND 101).

NATALIE POLZER, EXAMINING ATTORNEY

**CLASS 43—(Continued).**

SN 85-206,740. LI, ZONGYAN, ROWLAND HEIGHTS, CA. FILED 12-28-2010.

龙福地

THE MARK CONSISTS OF THREE CHINESE CHARACTERS THAT TRANSLITERATE INTO "LONG FU DI" AND TRANSLATE INTO ENGLISH AS "DRAGON BLESSED LAND".

THE NON-LATIN CHARACTERS IN THE MARK TRANSLITERATE TO LONG FU DI AND THIS MEANS "DRAGON BLESSED LAND" IN ENGLISH.

FOR BAR AND RESTAURANT SERVICES; CAFE AND RESTAURANT SERVICES; CAFE-RESTAURANTS; CAFETERIA AND RESTAURANT SERVICES; CARRY-OUT RESTAURANTS; RESTAURANT; RESTAURANT AND BAR SERVICES; RESTAURANT AND BAR SERVICES, INCLUDING RESTAURANT CARRYOUT SERVICES; RESTAURANT AND CAFE SERVICES; RESTAURANT AND CATERING SERVICES; RESTAURANT SERVICES; RESTAURANT SERVICES, INCLUDING SIT-DOWN SERVICE OF FOOD AND TAKE-OUT RESTAURANT SERVICES; RESTAURANT SERVICES, NAMELY, PROVIDING OF FOOD AND BEVERAGES FOR CONSUMPTION ON AND OFF THE PREMISES; RESTAURANT, BAR AND CATERING SERVICES; RESTAURANTS; RESTAURANTS FEATURING HOME DELIVERY; SELF SERVICE RESTAURANTS; SELF-SERVICE RESTAURANTS; TAKE-OUT RESTAURANT SERVICES (U.S. CLS. 100 AND 101).

NATALIE POLZER, EXAMINING ATTORNEY

**CLASS 43—(Continued).**

SN 85-206,765. LI, ZONGYAN, ROWLAND HEIGHTS, CA. FILED 12-28-2010.

龙地

THE MARK CONSISTS OF TWO CHINESE CHARACTERS THAT TRANSLITERATE INTO "LONG DI" AND TRANSLATE INTO ENGLISH AS "DRAGON LAND".

THE NON-LATIN CHARACTERS IN THE MARK TRANSLITERATE TO LONG DI AND THIS MEANS "DRAGON LAND" IN ENGLISH.

FOR BAR AND RESTAURANT SERVICES; CAFE AND RESTAURANT SERVICES; CAFE-RESTAURANTS; CAFETERIA AND RESTAURANT SERVICES; CARRY-OUT RESTAURANTS; RESTAURANT; RESTAURANT AND BAR SERVICES; RESTAURANT AND BAR SERVICES, INCLUDING RESTAURANT CARRYOUT SERVICES; RESTAURANT AND CAFE SERVICES; RESTAURANT AND CATERING SERVICES; RESTAURANT SERVICES; RESTAURANT SERVICES, INCLUDING SIT-DOWN SERVICE OF FOOD AND TAKE-OUT RESTAURANT SERVICES; RESTAURANT SERVICES, NAMELY, PROVIDING OF FOOD AND BEVERAGES FOR CONSUMPTION ON AND OFF THE PREMISES; RESTAURANT, BAR AND CATERING SERVICES; RESTAURANTS; RESTAURANTS FEATURING HOME DELIVERY; SELF SERVICE RESTAURANTS; SELF-SERVICE RESTAURANTS; TAKE-OUT RESTAURANT SERVICES (U.S. CLS. 100 AND 101).

NATALIE POLZER, EXAMINING ATTORNEY

SN 85-207,407. TACO ANA FRANCHISING LLC, DES MOINES, IA. FILED 12-29-2010.

ALWAYS TOP TASTE

THE MARK CONSISTS OF STANDARD CHARACTERS WITHOUT CLAIM TO ANY PARTICULAR FONT, STYLE, SIZE, OR COLOR.

FOR RESTAURANT SERVICES (U.S. CLS. 100 AND 101).

LAKEISHA LEWIS, EXAMINING ATTORNEY



**CLASS 43—(Continued).**

SN 85-207,576. LI, ZONGYAN, ROWLAND HEIGHTS, CA.  
FILED 12-29-2010.

3000 浦

THE MARK CONSISTS OF "3000" AND A CHINESE CHARACTER.

THE ENGLISH TRANSLATION OF THE CHINESE CHARACTER IN THE MARK IS "SHORE".

THE NON-LATIN CHARACTERS IN THE MARK TRANSLITERATE TO "PU" AND THIS MEANS "SHORE" IN ENGLISH.

FOR BAR AND RESTAURANT SERVICES; CAFE AND RESTAURANT SERVICES; CAFE-RESTAURANTS; CAFETERIA AND RESTAURANT SERVICES; CARRY-OUT RESTAURANTS; RESTAURANT; RESTAURANT AND BAR SERVICES; RESTAURANT AND BAR SERVICES, INCLUDING RESTAURANT CARRYOUT SERVICES; RESTAURANT AND CAFE SERVICES; RESTAURANT AND CATERING SERVICES; RESTAURANT SERVICES; RESTAURANT SERVICES, INCLUDING SIT-DOWN SERVICE OF FOOD AND TAKE-OUT RESTAURANT SERVICES; RESTAURANT SERVICES, NAMELY, PROVIDING OF FOOD AND BEVERAGES FOR CONSUMPTION ON AND OFF THE PREMISES; RESTAURANT, BAR AND CATERING SERVICES; RESTAURANTS; RESTAURANTS FEATURING HOME DELIVERY; SELF SERVICE RESTAURANTS; SELF-SERVICE RESTAURANTS; TAKE-OUT RESTAURANT SERVICES (U.S. CLS. 100 AND 101).

NATALIE POLZER, EXAMINING ATTORNEY

SN 85-207,666. RFT INVESTORS, L.P., SAN DIEGO, CA.  
FILED 12-29-2010.

Monster Burrito

THE MARK CONSISTS OF STANDARD CHARACTERS WITHOUT CLAIM TO ANY PARTICULAR FONT, STYLE, SIZE, OR COLOR.

NO CLAIM IS MADE TO THE EXCLUSIVE RIGHT TO USE "BURRITO", APART FROM THE MARK AS SHOWN.

FOR FAST-FOOD RESTAURANT SERVICES; RESTAURANT SERVICES FEATURING HISPANIC FOODS, NAMELY, BURRITOS; RESTAURANT SERVICES, INCLUDING SIT-DOWN SERVICE OF FOOD AND TAKE-OUT RESTAURANT SERVICES (U.S. CLS. 100 AND 101).

FIRST USE 4-15-2001; IN COMMERCE 4-15-2001.

TINA L. SNAPP, EXAMINING ATTORNEY

**CLASS 43—(Continued).**

SN 85-208,014. PROVIDENT ISLAND RESORTS, LLC, DBA SUNSET VISTAS BEACHFRONT SUITES, CLEARWATER, FL. FILED 12-30-2010.

SUNSET VISTAS

THE MARK CONSISTS OF STANDARD CHARACTERS WITHOUT CLAIM TO ANY PARTICULAR FONT, STYLE, SIZE, OR COLOR.

FOR PROVIDING TEMPORARY LODGING SERVICES IN THE NATURE OF A CONDOMINIUM HOTEL (U.S. CLS. 100 AND 101).

FIRST USE 2-1-2007; IN COMMERCE 2-1-2007.

HEATHER SAPP, EXAMINING ATTORNEY

SN 85-209,135. JED REICHL INVESTMENTS, LLC, CHICAGO, IL. FILED 1-3-2011.

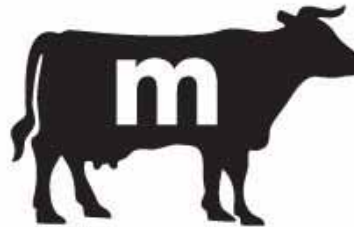

THE MARK CONSISTS OF A BLACK SILHOUETTE OF A COW WITH THE LETTER M IN THE SILHOUETTE.

FOR RESTAURANT SERVICES (U.S. CLS. 100 AND 101).

FIRST USE 11-30-2007; IN COMMERCE 11-30-2007.

ERNEST SHOSHO, EXAMINING ATTORNEY

SN 85-209,163. JED REICHL INVESTMENTS, LLC, CHICAGO, IL. FILED 1-3-2011.

get your angus in here

THE MARK CONSISTS OF STANDARD CHARACTERS WITHOUT CLAIM TO ANY PARTICULAR FONT, STYLE, SIZE, OR COLOR.

FOR RESTAURANT SERVICES (U.S. CLS. 100 AND 101).

FIRST USE 8-31-2009; IN COMMERCE 8-31-2009.

ERNEST SHOSHO, EXAMINING ATTORNEY

**CLASS 43—(Continued).**

SN 85-209,303. TRAN, DAO, SACRAMENTO, CA. FILED 1-3-2011.

**WAYSIDE NOODLES**

THE MARK CONSISTS OF STANDARD CHARACTERS WITHOUT CLAIM TO ANY PARTICULAR FONT, STYLE, SIZE, OR COLOR.

NO CLAIM IS MADE TO THE EXCLUSIVE RIGHT TO USE "NOODLES", APART FROM THE MARK AS SHOWN. FOR RESTAURANT SERVICES (U.S. CLS. 100 AND 101).

FIRST USE 9-0-2010; IN COMMERCE 9-0-2010.  
PRISCILLA MILTON, EXAMINING ATTORNEY

**CLASS 43—(Continued).**

SN 85-209,779. SQUID, INC., CARBORRO, NC. FILED 1-4-2011.



THE MARK CONSISTS OF SILHOUETTE OF A PIG. FOR RESTAURANT SERVICES (U.S. CLS. 100 AND 101).

FIRST USE 10-13-1997; IN COMMERCE 10-13-1997.  
GEORGE LORENZO, EXAMINING ATTORNEY

SN 85-209,347. JERRY D. ANNONI, SACRAMENTO, CA. FILED 1-3-2011.

**IF YOU DON'T KNOW OUR,  
THEN YOU DON'T KNOW JACK**

THE MARK CONSISTS OF STANDARD CHARACTERS WITHOUT CLAIM TO ANY PARTICULAR FONT, STYLE, SIZE, OR COLOR.

FOR RESTAURANT SERVICES (U.S. CLS. 100 AND 101).

TRACY CROSS, EXAMINING ATTORNEY

SN 85-209,874. WO-WOO, L.L.C., COVINGTON, LA. FILED 1-4-2011.

**WO-WOO**

THE MARK CONSISTS OF STANDARD CHARACTERS WITHOUT CLAIM TO ANY PARTICULAR FONT, STYLE, SIZE, OR COLOR.

FOR RESTAURANT SERVICES (U.S. CLS. 100 AND 101).

ARETHA SOMERVILLE, EXAMINING ATTORNEY

SN 85-209,758. THE GOOD EARTH CORPORATION, MONTVALE, NJ. FILED 1-4-2011.

**GOOD EARTH NATURALLY**

THE MARK CONSISTS OF STANDARD CHARACTERS WITHOUT CLAIM TO ANY PARTICULAR FONT, STYLE, SIZE, OR COLOR.

OWNER OF U.S. REG. NOS. 943,714, 1,627,516 AND OTHERS.

FOR RESTAURANT SERVICES (U.S. CLS. 100 AND 101).

FIRST USE 9-0-2008; IN COMMERCE 9-0-2008.  
DAVID I, EXAMINING ATTORNEY

SN 85-210,010. OCM DEVELOPMENT, LLC, DBA TWISTED ROOSTER, GRAND RAPIDS, MI. FILED 1-4-2011.

**Twisted Rooster**

THE MARK CONSISTS OF STANDARD CHARACTERS WITHOUT CLAIM TO ANY PARTICULAR FONT, STYLE, SIZE, OR COLOR.

FOR RESTAURANT AND BAR SERVICES, INCLUDING RESTAURANT CARRYOUT SERVICES (U.S. CLS. 100 AND 101).

FIRST USE 7-21-2010; IN COMMERCE 7-21-2010.  
DARRYL SPRUILL, EXAMINING ATTORNEY

**CLASS 43—(Continued).**

SN 85-210,028. INTER-CONTINENTAL HOTELS CORPORATION, ATLANTA, GA. FILED 1-4-2011.



OWNER OF U.S. REG. NOS. 877,550, 1,635,689 AND OTHERS.

NO CLAIM IS MADE TO THE EXCLUSIVE RIGHT TO USE "RESORTS", APART FROM THE MARK AS SHOWN.

THE MARK CONSISTS OF THE LETTER "I" IN AN OVAL CIRCLE CENTERED ABOVE THE WORDS "INTERCONTINENTAL ALLIANCE RESORTS".

FOR HOTEL SERVICES; RESORT HOTELS (U.S. CLS. 100 AND 101).

PAM WILLIS, EXAMINING ATTORNEY

SN 85-210,493. GRILL CONCEPTS, INC., WOODLAND HILLS, CA. FILED 1-4-2011.

**PUBLIC SCHOOL**

THE MARK CONSISTS OF STANDARD CHARACTERS WITHOUT CLAIM TO ANY PARTICULAR FONT, STYLE, SIZE, OR COLOR.

FOR RESTAURANT AND BAR SERVICES (U.S. CLS. 100 AND 101).

CHERYL CLAYTON, EXAMINING ATTORNEY

SN 85-210,608. BRUNSWICK CORPORATION, LAKE FOREST, IL. FILED 1-5-2011.

**MOONLIGHT MADNESS**

THE MARK CONSISTS OF STANDARD CHARACTERS WITHOUT CLAIM TO ANY PARTICULAR FONT, STYLE, SIZE, OR COLOR.

FOR RESTAURANT AND BAR SERVICES (U.S. CLS. 100 AND 101).

HELENE LIWINSKI, EXAMINING ATTORNEY

**CLASS 43—(Continued).**

SN 85-210,938. DALLAS, JAN, FATE, TX. AND DALLAS, MIKE, FATE, TX. FILED 1-5-2011.

**HU-LINE**

THE MARK CONSISTS OF STANDARD CHARACTERS WITHOUT CLAIM TO ANY PARTICULAR FONT, STYLE, SIZE, OR COLOR.

FOR BOARDING FOR ANIMALS; KENNEL SERVICES, NAMELY, BOARDING FOR PETS; PET BOARDING SERVICES; PET DAY CARE SERVICES (U.S. CLS. 100 AND 101).

GISELLE AGOSTO, EXAMINING ATTORNEY

SN 85-211,130. U.S.A. HARVEST, INC., LOUISVILLE, KY. FILED 1-5-2011.

**THE POWER OF 80**

THE MARK CONSISTS OF STANDARD CHARACTERS WITHOUT CLAIM TO ANY PARTICULAR FONT, STYLE, SIZE, OR COLOR.

FOR CHARITABLE SERVICES, NAMELY, PROVIDING FOOD TO NEEDY PERSONS (U.S. CLS. 100 AND 101).

AISHA SALEM, EXAMINING ATTORNEY

SN 85-211,464. FRIENDSCOOK INC., BELMONT, CA. FILED 1-5-2011.

**FriendsCook**

THE MARK CONSISTS OF STANDARD CHARACTERS WITHOUT CLAIM TO ANY PARTICULAR FONT, STYLE, SIZE, OR COLOR.

FOR PROVIDING AN ONLINE COMPUTER DATABASE TO CONSUMERS CONCERNING RECIPES, INGREDIENTS AND COOKING INFORMATION (U.S. CLS. 100 AND 101).

FIRST USE 1-15-2005; IN COMMERCE 1-15-2010.

AMY HELLA, EXAMINING ATTORNEY

**CLASS 43—(Continued).**

SN 85-212,169. BASH BROTHERS LLC, SILVER SPRING, MD. FILED 1-6-2011.

sealeaf

THE MARK CONSISTS OF STANDARD CHARACTERS WITHOUT CLAIM TO ANY PARTICULAR FONT, STYLE, SIZE, OR COLOR.  
FOR RESTAURANT, BAR, AND CATERING SERVICES (U.S. CLS. 100 AND 101).  
BRIAN NEVILLE, EXAMINING ATTORNEY

SN 85-212,286. WE ARE CHICKEN TOO, INC., DBA CHICKEN BONZ, SPRINGFIELD, OR. FILED 1-6-2011.

Chicken With Attitude

THE MARK CONSISTS OF STANDARD CHARACTERS WITHOUT CLAIM TO ANY PARTICULAR FONT, STYLE, SIZE, OR COLOR.  
NO CLAIM IS MADE TO THE EXCLUSIVE RIGHT TO USE "CHICKEN", APART FROM THE MARK AS SHOWN.  
FOR FAST-FOOD RESTAURANTS (U.S. CLS. 100 AND 101).  
FIRST USE 12-1-2001; IN COMMERCE 4-18-2006.  
WILLIAM BRECKENFELD, EXAMINING ATTORNEY

SN 85-212,361. 953 ASSOCIATES, LLC, DBA EATERY NYC, NEW YORK, NY. FILED 1-6-2011.



THE MARK CONSISTS OF A LOWERCASE LETTER "E" IN STYLIZED FONT CENTERED INSIDE A SOLID CIRCLE CARRIER.  
FOR RESTAURANT SERVICES (U.S. CLS. 100 AND 101).  
FIRST USE 9-6-2000; IN COMMERCE 9-6-2000.  
KEVON CHISOLM, EXAMINING ATTORNEY

**CLASS 43—(Continued).**

SN 85-212,781. JAR.INC, DBA RICKY'S, SAN LEANDRO, CA. FILED 1-7-2011.

Ricky's

THE MARK CONSISTS OF STANDARD CHARACTERS WITHOUT CLAIM TO ANY PARTICULAR FONT, STYLE, SIZE, OR COLOR.  
FOR RESTAURANT AND BAR SERVICES (U.S. CLS. 100 AND 101).  
FIRST USE 2-22-1948; IN COMMERCE 2-22-1948.  
HEATHER SAPP, EXAMINING ATTORNEY

SN 85-213,221. ECHELON RESORTS CORPORATION, LAS VEGAS, NV. FILED 1-7-2011.

EXPLORE. EMBRACE. ELEVATE.

THE MARK CONSISTS OF STANDARD CHARACTERS WITHOUT CLAIM TO ANY PARTICULAR FONT, STYLE, SIZE, OR COLOR.  
FOR ARENA SERVICES, NAMELY, PROVIDING FACILITIES FOR SPORTS, CONCERTS, CONVENTIONS AND EXHIBITIONS; HOTEL, BAR AND RESTAURANT SERVICES; PROVIDING CONVENTION FACILITIES; RESORT HOTELS (U.S. CLS. 100 AND 101).  
AMY HELLA, EXAMINING ATTORNEY

SN 85-213,267. ECHELON RESORTS CORPORATION, LAS VEGAS, NV. FILED 1-7-2011.

TAKE ME HIGHER

THE MARK CONSISTS OF STANDARD CHARACTERS WITHOUT CLAIM TO ANY PARTICULAR FONT, STYLE, SIZE, OR COLOR.  
FOR ARENA SERVICES, NAMELY, PROVIDING FACILITIES FOR SPORTS, CONCERTS, CONVENTIONS AND EXHIBITIONS; HOTEL, BAR AND RESTAURANT SERVICES; PROVISION OF FACILITIES FOR CONVENTIONS; RESORT HOTELS (U.S. CLS. 100 AND 101).  
AMY HELLA, EXAMINING ATTORNEY

**CLASS 43—(Continued).**

SN 85-213,481. BERTUCCI'S RESTAURANT CORP., NORTH-BOROUGH, MA. FILED 1-8-2011.

EVERYTHING IS BETTER BY  
THE BRICK OVEN

THE MARK CONSISTS OF STANDARD CHARACTERS WITHOUT CLAIM TO ANY PARTICULAR FONT, STYLE, SIZE, OR COLOR.

FOR RESTAURANT SERVICES, TAKE-OUT RESTAURANT SERVICES, BAR SERVICES AND CATERING SERVICES (U.S. CLS. 100 AND 101).

FIRST USE 10-14-2010; IN COMMERCE 10-14-2010.  
DAVID HOFFMAN, EXAMINING ATTORNEY

**CLASS 43—(Continued).**

SN 85-217,540. GRILL CONCEPTS, INC., WOODLAND HILLS, CA. FILED 1-13-2011.

PUBLIC <sup>NO</sup> 612 SCHOOL

THE MARK CONSISTS OF THE WORDS "PUBLIC SCHOOL", THE WORD "NO" WITHIN A CIRCLE, AND THE NUMBERS "612".

FOR RESTAURANT AND BAR SERVICES (U.S. CLS. 100 AND 101).

CHERYL CLAYTON, EXAMINING ATTORNEY

SN 85-214,479. INDIA HOUSE OF MASSACHUSETTS, INC., LEXINGTON, MA. FILED 1-10-2011.



THE MARK CONSISTS OF DESIGN OF AN INDIAN WOMAN WITH FOLDED HANDS. FOR RESTAURANT, BAR AND CATERING SERVICES (U.S. CLS. 100 AND 101).

FIRST USE 12-0-1991; IN COMMERCE 12-0-1991.  
WILLIAM BRECKENFELD, EXAMINING ATTORNEY

SN 85-223,109. SILVER BRACELETS, INC., ORLANDO, FL. FILED 1-21-2011.

CALO

THE MARK CONSISTS OF STANDARD CHARACTERS WITHOUT CLAIM TO ANY PARTICULAR FONT, STYLE, SIZE, OR COLOR.

FOR BAR AND RESTAURANT SERVICES (U.S. CLS. 100 AND 101).

TINA BROWN, EXAMINING ATTORNEY

SN 85-214,565. MCMENAMINS, INC., PORTLAND, OR. FILED 1-11-2011.

PAT'S CORNER

THE MARK CONSISTS OF STANDARD CHARACTERS WITHOUT CLAIM TO ANY PARTICULAR FONT, STYLE, SIZE, OR COLOR.

FOR RESTAURANT AND BAR SERVICES (U.S. CLS. 100 AND 101).

MATTHEW EINSTEIN, EXAMINING ATTORNEY

SN 85-228,965. PINNACLE ENTERTAINMENT, INC., LAS VEGAS, NV. FILED 1-28-2011.

SIP - SAVOR - CELEBRATE

THE MARK CONSISTS OF STANDARD CHARACTERS WITHOUT CLAIM TO ANY PARTICULAR FONT, STYLE, SIZE, OR COLOR.

FOR BAR AND RESTAURANT SERVICES; SOMMELIER SERVICES, NAMELY, PROVIDING ADVICE ON WINE AND WINE AND FOOD PAIRING (U.S. CLS. 100 AND 101).

JULIE GUTTADAURO, EXAMINING ATTORNEY

**CLASS 43—(Continued).**

SN 85-231,304. PINNACLE ENTERTAINMENT, INC., LAS VEGAS, NV. FILED 2-1-2011.

# LET'S GO

THE MARK CONSISTS OF STANDARD CHARACTERS WITHOUT CLAIM TO ANY PARTICULAR FONT, STYLE, SIZE, OR COLOR.

FOR HOTEL, BAR AND RESTAURANT SERVICES (U.S. CLS. 100 AND 101).

JULIE GUTTADAURO, EXAMINING ATTORNEY

---

SN 85-248,844. PINNACLE ENTERTAINMENT, INC., LAS VEGAS, NV. FILED 2-22-2011.

## THIRST N' HOWL TIKI BAR

THE MARK CONSISTS OF STANDARD CHARACTERS WITHOUT CLAIM TO ANY PARTICULAR FONT, STYLE, SIZE, OR COLOR.

NO CLAIM IS MADE TO THE EXCLUSIVE RIGHT TO USE "TIKI BAR", APART FROM THE MARK AS SHOWN.

FOR BAR SERVICES (U.S. CLS. 100 AND 101).

FIRST USE 1-28-2011; IN COMMERCE 1-28-2011.

JULIE GUTTADAURO, EXAMINING ATTORNEY

---

SN 85-248,873. PINNACLE ENTERTAINMENT, INC., LAS VEGAS, NV. FILED 2-22-2011.

## TURF TERRACE RESTAURANT

THE MARK CONSISTS OF STANDARD CHARACTERS WITHOUT CLAIM TO ANY PARTICULAR FONT, STYLE, SIZE, OR COLOR.

NO CLAIM IS MADE TO THE EXCLUSIVE RIGHT TO USE "RESTAURANT", APART FROM THE MARK AS SHOWN.

FOR BAR AND RESTAURANT SERVICES; PROVIDING BANQUET AND SOCIAL FUNCTION FACILITIES FOR SPECIAL OCCASIONS (U.S. CLS. 100 AND 101).

FIRST USE 1-28-2011; IN COMMERCE 1-28-2011.

JULIE GUTTADAURO, EXAMINING ATTORNEY

**CLASS 43—(Continued).**

SN 85-248,967. PINNACLE ENTERTAINMENT, INC., LAS VEGAS, NV. FILED 2-22-2011.



NO CLAIM IS MADE TO THE EXCLUSIVE RIGHT TO USE "TIKI BAR", APART FROM THE MARK AS SHOWN.

THE COLOR(S) BLACK, ORANGE, YELLOW, WHITE AND BLUE IS/ARE CLAIMED AS A FEATURE OF THE MARK.

THE MARK CONSISTS OF THE STYLIZED WORDS "THIRST N HOWL" WHERE THE LETTERS ARE ORANGE FADING TO YELLOW AND THE WORD "HOWL" IS OVER THE STYLIZED WORDS "TIKI BAR" WHICH ARE BLACK. EACH OF THE LETTERS IN THE WORD "THIRST N HOWL" IS OUTLINED IN WHITE WHICH IS OUTLINED IN BLACK ALL OF WHICH IS SUPERIMPOSED OVER A DRAWING OF TWO BLACK PALMS TREES SILHOUETTED AGAINST A SETTING SUN WHICH IS IN THE COLORS OF ORANGE FADING TO YELLOW AND IS OUTLINED IN BLACK BELOW WHICH ARE THREE STYLIZED OCEAN WAVES IN BLUE.

FOR BAR SERVICES (U.S. CLS. 100 AND 101).

FIRST USE 1-28-2011; IN COMMERCE 1-28-2011.

JULIE GUTTADAURO, EXAMINING ATTORNEY

---

SN 85-248,971. PINNACLE ENTERTAINMENT, INC., LAS VEGAS, NV. FILED 2-22-2011.



NO CLAIM IS MADE TO THE EXCLUSIVE RIGHT TO USE "RESTAURANT", APART FROM THE MARK AS SHOWN.

THE MARK CONSISTS OF THE STYLIZED WORDS "TURF TERRACE" WHERE THE WORDS "TURF" AND "TERRACE" ARE SEPARATED BY THE DRAWING OF A FOUR LEAF CLOVER ALL OF WHICH IS OVER A SOLID LINE WHICH IS OVER THE WORD "RESTAURANT" IN STYLIZED FORM.

FOR BAR AND RESTAURANT SERVICES; PROVIDING BANQUET AND SOCIAL FUNCTION FACILITIES FOR SPECIAL OCCASIONS (U.S. CLS. 100 AND 101).

FIRST USE 1-28-2011; IN COMMERCE 1-28-2011.

JULIE GUTTADAURO, EXAMINING ATTORNEY

**CLASS 43—(Continued).**

SN 85-249,747. UNITED AUBURN INDIAN COMMUNITY,  
LINCOLN, CA. FILED 2-23-2011.



OWNER OF U.S. REG. NOS. 2,872,370 AND 2,872,371.  
NO CLAIM IS MADE TO THE EXCLUSIVE RIGHT TO  
USE "CASINO RESORT", APART FROM THE MARK AS  
SHOWN.

THE MARK CONSISTS OF FIVE UPWARD POINTING  
ARROWS THE BASES OF WHICH FORM AN INVERTED  
"V" ALL OF WHICH IS A REPRESENTATION OF TREES  
UPON A MOUNTAIN PEAK WHICH IS OVER THE STY-  
LIZED LETTER "T" WHICH IS OVER A STYLIZED REPRE-  
SENTATION OF A VALLEY ALL OF WHICH IS TO THE  
LEFT OF THE STYLIZED WORD "THUNDER" WHICH IS  
OVER THE STYLIZED WORD "VALLEY" WHICH IS OVER  
THE STYLIZED WORDS "CASINO RESORT" WHERE THE  
WORD "CASINO" AND THE WORD "RESORT" ARE  
SEPARATED BY A BULLET POINT.

FOR HOTEL SERVICES; RESORT HOTELS (U.S. CLS.  
100 AND 101).

FIRST USE 6-1-2010; IN COMMERCE 6-1-2010.  
KATHY DE JONGE, EXAMINING ATTORNEY

**CLASS 44—MEDICAL, BEAUTY AND AGRI-  
CULTURAL SERVICES**

SN 76-705,933. PLASTIC SURGERY & DERMATOLOGY OF  
NYC PLLC, NEW YORK, NY. FILED 1-6-2011.



THE MARK CONSISTS OF A DESIGN OF TWO RAISED  
HANDS HOLDING A FLOWER ALL INSIDE A SQUARE  
BOX.

FOR MEDICAL AND SURGICAL SERVICES (U.S. CLS.  
100 AND 101).

FIRST USE 8-7-2007; IN COMMERCE 8-7-2007.  
COLLEEN DOMBROW, EXAMINING ATTORNEY

SN 85-261,304. FOOD BANK OF SOUTH JERSEY, INC.,  
PENNSAUKEN, NJ. FILED 3-8-2011.

SN 77-776,751. CRI-HELP, INC., NORTH HOLLYWOOD, CA.  
FILED 7-8-2009.

THE CURE FOR HUNGER IS FOOD

Socorro

THE MARK CONSISTS OF STANDARD CHARACTERS  
WITHOUT CLAIM TO ANY PARTICULAR FONT, STYLE,  
SIZE, OR COLOR.

FOR CHARITABLE SERVICES, NAMELY, PROVID-  
ING FOOD TO NEEDY PERSONS (U.S. CLS. 100 AND  
101).

FIRST USE 12-14-2009; IN COMMERCE 12-14-2009.  
BRIDGETT SMITH, EXAMINING ATTORNEY

THE MARK CONSISTS OF STANDARD CHARACTERS  
WITHOUT CLAIM TO ANY PARTICULAR FONT, STYLE,  
SIZE, OR COLOR.

THE ENGLISH TRANSLATION OF "SOCORRO" IN THE  
MARK IS "AID".

FOR ADDICTION TREATMENT SERVICES (U.S. CLS.  
100 AND 101).

FIRST USE 1-21-1987; IN COMMERCE 1-21-1987.  
SHAUNIA CARLYLE, EXAMINING ATTORNEY

**CLASS 44—(Continued).**

SN 77-865,843. HOSPICE BRAZOS VALLEY, INC., BRYAN, TX. FILED 11-5-2009.

HOSPICE BRAZOS VALLEY

THE MARK CONSISTS OF STANDARD CHARACTERS WITHOUT CLAIM TO ANY PARTICULAR FONT, STYLE, SIZE, OR COLOR.

NO CLAIM IS MADE TO THE EXCLUSIVE RIGHT TO USE "HOSPICE", APART FROM THE MARK AS SHOWN.

SEC. 2(F).

FOR HOSPICE CARE; HOSPICE SERVICES; HEALTH CARE; HOME HEALTH CARE SERVICES; NURSING CARE; NURSING SERVICES; VISITING NURSE SERVICES; HOME NURSING AID SERVICES; SKILLED NURSING CARE; MEDICAL COUNSELING; PROVIDING HEALTH INFORMATION; CONSULTING SERVICES IN THE FIELD OF HEALTH; GERIATRIC HEALTH CARE MANAGEMENT SERVICES; TRANSITIONAL HEALTH CARE SERVICES; PALLIATIVE CARE SERVICES; DISEASE MANAGEMENT PROGRAMS; HEALTH CARE AND MEDICAL SERVICES, NAMELY, PAIN MANAGEMENT AND CONTROL SERVICES; HEALTH CARE AND MEDICAL SERVICES, NAMELY, SYMPTOM MANAGEMENT AND CONTROL SERVICES; PROVIDING INFORMATION IN THE FIELDS OF HOSPICE AND PALLIATIVE CARE; CONSULTATION SERVICES IN THE FIELDS OF HOSPICE AND PALLIATIVE CARE; CONSULTING SERVICES TO HEALTH CARE PROFESSIONALS, HEALTH CARE PROVIDERS AND CARE GIVERS IN THE FIELDS OF TREATING LIFE-LIMITING OR LIFE-THREATENING ILLNESSES; AND CHARITABLE SERVICES, NAMELY, PROVIDING HOSPICE CARE, HOSPICE SERVICES, HEALTH CARE, HOME HEALTH CARE SERVICES, NURSING SERVICES AND SKILLED NURSING CARE (U.S. CLS. 100 AND 101).

FIRST USE 4-0-1994; IN COMMERCE 4-0-1994.

CHARLOTTE CORWIN, EXAMINING ATTORNEY

**CLASS 44—(Continued).**

SN 77-865,997. HOSPICE BRAZOS VALLEY, INC., BRYAN, TX. FILED 11-5-2009.



NO CLAIM IS MADE TO THE EXCLUSIVE RIGHT TO USE "HOSPICE", APART FROM THE MARK AS SHOWN.

THE MARK CONSISTS OF A TREE AND BUILDINGS DISPOSED INSIDE OF AN OVAL WITH THE WORDS "HOSPICE BRAZOS VALLEY" DISPOSED ABOVE THE OVAL.

SEC. 2(F) AS TO "HOSPICE BRAZOS VALLEY".

FOR HOSPICE CARE; HOSPICE SERVICES; HEALTH CARE; HOME HEALTH CARE SERVICES; NURSING CARE; NURSING SERVICES; VISITING NURSE SERVICES; HOME NURSING AID SERVICES; SKILLED NURSING CARE; MEDICAL COUNSELING; PROVIDING HEALTH INFORMATION; CONSULTING SERVICES IN THE FIELD OF HEALTH; GERIATRIC HEALTH CARE MANAGEMENT SERVICES; TRANSITIONAL HEALTH CARE SERVICES; PALLIATIVE CARE SERVICES; DISEASE MANAGEMENT PROGRAMS; HEALTH CARE AND MEDICAL SERVICES, NAMELY, PAIN MANAGEMENT AND CONTROL SERVICES; HEALTH CARE AND MEDICAL SERVICES, NAMELY, SYMPTOM MANAGEMENT AND CONTROL SERVICES; PROVIDING INFORMATION IN THE FIELDS OF HOSPICE AND PALLIATIVE CARE; CONSULTATION SERVICES IN THE FIELDS OF HOSPICE AND PALLIATIVE CARE; CONSULTING SERVICES TO HEALTH CARE PROFESSIONALS, HEALTH CARE PROVIDERS AND CARE GIVERS IN THE FIELDS OF TREATING LIFE-LIMITING OR LIFE-THREATENING ILLNESSES; AND CHARITABLE SERVICES, NAMELY, PROVIDING HOSPICE CARE, HOSPICE SERVICES, HEALTH CARE, HOME HEALTH CARE SERVICES, NURSING SERVICES AND SKILLED NURSING CARE (U.S. CLS. 100 AND 101).

FIRST USE 0-0-1997; IN COMMERCE 0-0-1997.

CHARLOTTE CORWIN, EXAMINING ATTORNEY



**CLASS 44—(Continued).**

SN 78-934,532. AURORA HEALTH CARE, INC., MILWAUKEE, WI. FILED 7-21-2006.

**AURORA QUICKCARE**

THE MARK CONSISTS OF STANDARD CHARACTERS WITHOUT CLAIM TO ANY PARTICULAR FONT, STYLE, SIZE, OR COLOR.

SUBJECT TO A CONCURRENT USE PROCEEDING WITH OWNER OF U.S. REG. NO. 3,353,607, JEFFREY M. ROSENFELD, 13030 LIVINGSTON ROAD, NAPLES, FLORIDA 34105. THE APPLICANT CLAIMS THE EXCLUSIVE RIGHT TO USE THE MARK IN THE AREA COMPRISING ILLINOIS, INDIANA, IOWA, KANSAS, KENTUCKY, MICHIGAN, MINNESOTA, MISSOURI, NEBRASKA, NORTH DAKOTA, SOUTH DAKOTA AND WISCONSIN.

OWNER OF U.S. REG. NOS. 1,979,169, 3,158,546 AND OTHERS.

SEC. 2(F) AS TO "QUICKCARE".

FOR HEALTH CARE; MEDICAL CLINICS; MEDICAL CONSULTATIONS; MEDICAL SERVICES; MEDICAL TESTING; PROVIDING HEALTH INFORMATION (U.S. CLS. 100 AND 101).

FIRST USE 4-15-2004; IN COMMERCE 4-15-2004.  
MARY ROSSMAN, EXAMINING ATTORNEY

**CLASS 44—(Continued).**

SN 85-039,456. CAPNA MANAGEMENT, INC., LAS VEGAS, NV. FILED 5-14-2010.



NO CLAIM IS MADE TO THE EXCLUSIVE RIGHT TO USE "COMPANION ANIMAL PRACTICES, NORTH AMERICA", APART FROM THE MARK AS SHOWN.

THE MARK CONSISTS OF A DOUBLE CONCENTRIC CIRCLE, THE OUTER CIRCLE BEING THICKER AND OF SLIGHTLY LARGER DIAMETER THAN THE INNER. THE INNER CIRCLE HAS A BAND THROUGH ITS MIDDLE, DELINEATED BY DOUBLE LINES TOP AND BOTTOM, THE OUTER LINES BEING THICKER THAN THE INNER. THROUGH THE CENTER OF THE BAND THROUGH THE MIDDLE OF THE INNER CIRCLE ARE THREE LINES OF TEXT, CENTERED, THE FIRST BEING "CAPNA" IN ALL CAPS, THE MIDDLE BEING "COMPANION ANIMAL PRACTICES," INCLUDING THE COMMA, AND THE LAST BEING "NORTH AMERICA" WITH THE FIRST LETTER OF EACH WORD OF THE LATTER TWO LINES BEING CAPITALIZED.

FOR VETERINARY SERVICES (U.S. CLS. 100 AND 101).

RUDY R. SINGLETON, EXAMINING ATTORNEY

SN 85-027,325. CLEARCHOICE HOLDINGS, LLC, GREENWOOD VILLAGE, CO. FILED 4-30-2010.

**Perfect Choice**

THE MARK CONSISTS OF STANDARD CHARACTERS WITHOUT CLAIM TO ANY PARTICULAR FONT, STYLE, SIZE, OR COLOR.

FOR DENTIST SERVICES, NAMELY, DENTAL IMPLANT SERVICES (U.S. CLS. 100 AND 101).

KATHRYN COWARD, EXAMINING ATTORNEY

SN 85-045,229. ASICO LLC, WESTMONT, IL. FILED 5-21-2010.

**MICRO PHACO HQ**

THE MARK CONSISTS OF STANDARD CHARACTERS WITHOUT CLAIM TO ANY PARTICULAR FONT, STYLE, SIZE, OR COLOR.

NO CLAIM IS MADE TO THE EXCLUSIVE RIGHT TO USE "MICRO PHACO", APART FROM THE MARK AS SHOWN.

FOR PROVIDING GENERAL INFORMATION ABOUT SURGICAL METHODS AND INSTRUMENTS USED IN OPHTHALMOLOGIC SURGERY (U.S. CLS. 100 AND 101).

KELLEY WELLS, EXAMINING ATTORNEY

**CLASS 44—(Continued).**

SN 85-045,921. BLANCHARD, ALAN, PARLIN, NJ. FILED 5-24-2010.

## BEAUTY SOLUTIONS INTERNATIONAL

THE MARK CONSISTS OF STANDARD CHARACTERS WITHOUT CLAIM TO ANY PARTICULAR FONT, STYLE, SIZE, OR COLOR.

NO CLAIM IS MADE TO THE EXCLUSIVE RIGHT TO USE "INTERNATIONAL", APART FROM THE MARK AS SHOWN.

FOR HEALTHCARE AND MEDICAL TOURISM SERVICES, NAMELY, ESTABLISHING AND MAINTAINING A HEALTHCARE PROVIDER NETWORK IN OTHER COUNTRIES FOR THE PROVISION OF HEALTHCARE SERVICES (U.S. CLS. 100 AND 101).

FIRST USE 1-12-2010; IN COMMERCE 5-10-2010.  
BARBARA GAYNOR, EXAMINING ATTORNEY

SN 85-048,685. HOFFMAN, YAEL, LINCOLNWOOD, IL. FILED 5-26-2010.

## AN INJURED BREAST CAN BLOOM AGAIN

THE MARK CONSISTS OF STANDARD CHARACTERS WITHOUT CLAIM TO ANY PARTICULAR FONT, STYLE, SIZE, OR COLOR.

FOR PROVIDING INFORMATION IN THE FIELD OF BREAST CANCER PREVENTION, SCREENING, DIAGNOSIS AND TREATMENT (U.S. CLS. 100 AND 101).

PAUL MORENO, EXAMINING ATTORNEY

SN 85-049,538. GENESIS REHABILITATION SERVICES, INC., KENNETT SQUARE, PA. FILED 5-27-2010.



FOR PHYSICAL REHABILITATION SERVICES AND HEALTH CARE SERVICES, NAMELY, WELLNESS PROGRAMS (U.S. CLS. 100 AND 101).

FIRST USE 10-1-2009; IN COMMERCE 10-1-2009.  
DAVID TOOLEY, EXAMINING ATTORNEY

**CLASS 44—(Continued).**

SN 85-052,027. YA LOOK GREAT, LLC, SCOTTSDALE, AZ. FILED 6-1-2010.

## Ya look great!

THE MARK CONSISTS OF STANDARD CHARACTERS WITHOUT CLAIM TO ANY PARTICULAR FONT, STYLE, SIZE, OR COLOR.

FOR PROVIDING A WEBSITE FEATURING INFORMATION AND ADVICE IN THE FIELDS OF DIET, WEIGHT LOSS, DIET PLANNING AND LIFESTYLE WELLNESS (U.S. CLS. 100 AND 101).

FIRST USE 5-1-2010; IN COMMERCE 5-1-2010.  
CHRIS WELLS, EXAMINING ATTORNEY

SN 85-052,516. THE VEGAN COMPANY, SANTA FE, NM. FILED 6-2-2010.

## Hot Hair Ballooning

THE MARK CONSISTS OF STANDARD CHARACTERS WITHOUT CLAIM TO ANY PARTICULAR FONT, STYLE, SIZE, OR COLOR.

FOR HAIR COLOR SALON SERVICES; HAIR COLOURING SERVICES; HAIR SALON SERVICES; HAIR SALON SERVICES, NAMELY, HAIR CUTTING, STYLING, COLORING, AND HAIR EXTENSION SERVICES; HAIR STYLING; PROVIDING INFORMATION IN THE FIELD OF HAIR STYLING (U.S. CLS. 100 AND 101).

MARK PILARO, EXAMINING ATTORNEY

SN 85-055,217. MEDICAL CENTER ANESTHESIOLOGISTS, PC, DES MOINES, IA. FILED 6-4-2010.



NO CLAIM IS MADE TO THE EXCLUSIVE RIGHT TO USE "PAIN SPECIALISTS OF IOWA", APART FROM THE MARK AS SHOWN.

THE MARK CONSISTS OF THE STYLIZED LETTERS "PSI" JOINED IN A DOWNWARD DIAGONAL TO THE RIGHT, WHERE TO THE RIGHT OF "PSI" IS THE STYLIZED WORDING "PAIN SPECIALISTS OF IOWA".

FOR HEALTHCARE SERVICES IN THE NATURE OF PAIN MANAGEMENT SERVICES; MEDICAL SERVICES IN THE NATURE OF PAIN MANAGEMENT SERVICES (U.S. CLS. 100 AND 101).

FIRST USE 12-15-2009; IN COMMERCE 12-15-2009.  
ADA HAN, EXAMINING ATTORNEY

**CLASS 44—(Continued).**

SN 85-055,410. INVIVOSCRIBE TECHNOLOGIES, INC., SAN DIEGO, CA. FILED 6-4-2010.



NO CLAIM IS MADE TO THE EXCLUSIVE RIGHT TO USE "AML ALLIANCE", APART FROM THE MARK AS SHOWN.

THE MARK CONSISTS OF A RIBBON FORMED INTO A TEAR-DROP SHAPE WITH A SOLID CIRCLE PLACED ABOVE SO AS TO SUGGEST A STYLIZED PERSON WITH WORDS AND OR LETTERS "AML ALLIANCE" TO THE RIGHT OF THE RIBBON.

FOR PROVIDING INFORMATION SERVICES REGARDING THE DIAGNOSIS, MONITORING AND OPTIONS IN THE TREATMENT OF LEUKEMIA (U.S. CLS. 100 AND 101).

RAMONA ORTIGA, EXAMINING ATTORNEY

SN 85-062,899. ABOVE ALL INTELLECTUAL PROPERTIES, CORDOVA, TN. FILED 6-15-2010.



THE COLOR(S) BLUE, GRAY AND BLACK IS/ARE CLAIMED AS A FEATURE OF THE MARK.

THE MARK CONSISTS OF TWO STYLIZED CHEVRONS, ONE LOCATED ABOVE THE OTHER, WHOSE LEFT ARMS ARE THE COLOR BLUE AND WHOSE RIGHT ARMS ARE THE COLOR GRAY, LOCATED TO THE LEFT OF THE WORDS "ABOVE ALL" IN THE COLOR BLACK.

FOR LANDSCAPE DESIGN; LAWN CARE; WEED CONTROL (U.S. CLS. 100 AND 101).

FIRST USE 1-1-2009; IN COMMERCE 1-1-2009.

ALICIA COLLINS, EXAMINING ATTORNEY

SN 85-064,256. THE TRUSTEES OF INDIANA UNIVERSITY, BLOOMINGTON, IN. FILED 6-16-2010.

# RILEY

THE MARK CONSISTS OF STANDARD CHARACTERS WITHOUT CLAIM TO ANY PARTICULAR FONT, STYLE, SIZE, OR COLOR.

OWNER OF U.S. REG. NO. 2,912,661.

FOR MEDICAL AND HEALTH CARE SERVICES; HOSPITALS; MEDICAL CLINICS; MEDICAL TESTING FOR DIAGNOSTIC OR TREATMENT PURPOSES; COUNSELING IN THE FIELD OF HEALTH CARE; MEDICINE AND HOSPITAL CARE (U.S. CLS. 100 AND 101).

FIRST USE 12-31-1950; IN COMMERCE 12-31-1950.

AISHA CLARKE, EXAMINING ATTORNEY

**CLASS 44—(Continued).**

SN 85-064,261. THE TRUSTEES OF INDIANA UNIVERSITY, BLOOMINGTON, IN. FILED 6-16-2010.

RILEY HOSPITAL FOR CHILDREN

THE MARK CONSISTS OF STANDARD CHARACTERS WITHOUT CLAIM TO ANY PARTICULAR FONT, STYLE, SIZE, OR COLOR.

OWNER OF U.S. REG. NO. 2,912,661.

NO CLAIM IS MADE TO THE EXCLUSIVE RIGHT TO USE "HOSPITAL FOR CHILDREN", APART FROM THE MARK AS SHOWN.

FOR MEDICAL AND HEALTH CARE SERVICES; HOSPITALS; MEDICAL CLINICS; MEDICAL TESTING FOR DIAGNOSTIC OR TREATMENT PURPOSES; COUNSELING IN THE FIELD OF HEALTH CARE; MEDICINE AND HOSPITAL CARE (U.S. CLS. 100 AND 101).

FIRST USE 12-31-1950; IN COMMERCE 12-31-1950.

AISHA CLARKE, EXAMINING ATTORNEY

SN 85-064,510. THE TRUSTEES OF INDIANA UNIVERSITY, BLOOMINGTON, IN. FILED 6-16-2010.

# RILEY HOSPITAL

THE MARK CONSISTS OF STANDARD CHARACTERS WITHOUT CLAIM TO ANY PARTICULAR FONT, STYLE, SIZE, OR COLOR.

OWNER OF U.S. REG. NO. 2,912,661.

NO CLAIM IS MADE TO THE EXCLUSIVE RIGHT TO USE "HOSPITAL", APART FROM THE MARK AS SHOWN.

FOR MEDICAL AND HEALTH CARE SERVICES; HOSPITALS; MEDICAL CLINICS; MEDICAL TESTING FOR DIAGNOSTIC OR TREATMENT PURPOSES; COUNSELING IN THE FIELD OF HEALTH CARE; MEDICINE AND HOSPITAL CARE (U.S. CLS. 100 AND 101).

FIRST USE 12-31-1950; IN COMMERCE 12-31-1950.

AISHA CLARKE, EXAMINING ATTORNEY

SN 85-065,575. SCHINDLER, CASSIE W., DBA THE ALTERNATE PATH, SAN MATEO, CA. FILED 6-17-2010.

# Stop, Balance, Go!

THE MARK CONSISTS OF STANDARD CHARACTERS WITHOUT CLAIM TO ANY PARTICULAR FONT, STYLE, SIZE, OR COLOR.

FOR STRESS REDUCTION THERAPY (U.S. CLS. 100 AND 101).

FIRST USE 5-1-2010; IN COMMERCE 5-1-2010.

TRACY CROSS, EXAMINING ATTORNEY

**CLASS 44—(Continued).**

SN 85-109,905. JEFFREY J. ZAHORSKY, ELYRIA, OH.  
FILED 8-17-2010.



NO CLAIM IS MADE TO THE EXCLUSIVE RIGHT TO USE "EXPRESS FOOT MASSAGE", APART FROM THE MARK AS SHOWN.

THE COLOR(S) RED, BLACK, AND WHITE IS/ARE CLAIMED AS A FEATURE OF THE MARK.

THE MARK CONSISTS OF THE WORDING "AGONY OF DAFEET EXPRESS FOOT MASSAGE" IN STYLIZED FONT. THE WORDS "AGONY" AND "DAFEEET" APPEAR IN RED, "OF" APPEARS IN WHITE INSIDE OF A BLACK CIRCLE, AND "EXPRESS FOOT MASSAGE" APPEARS IN WHITE WITH BLACK HORIZONTAL LINES GOING THROUGH THE LETTERS, INSIDE OF A BLACK RECTANGLE. THE WORDING ALL APPEARS TO THE RIGHT OF TWO WHITE FEET WITH RED ZIG-ZAG LINES GOING THROUGH THE HEELS, SUPERIMPOSED ON A RED CIRCLE INSIDE OF A BLACK CRESCENT.

FOR MASSAGE THERAPY SERVICES; MASSAGES (U.S. CLS. 100 AND 101).

LIEF MARTIN, EXAMINING ATTORNEY

**CLASS 44—(Continued).**

SN 85-114,866. BUSBY, EVELYN JONES, UPPER HOLLAND, PA. FILED 8-24-2010.



CONNECTIVE  
TRANSFORMATIVE  
THERAPY

NO CLAIM IS MADE TO THE EXCLUSIVE RIGHT TO USE "TRANSFORMATIVE THERAPY", APART FROM THE MARK AS SHOWN.

THE COLOR(S) BLUE, PURPLE, GREEN AND GRAY IS/ARE CLAIMED AS A FEATURE OF THE MARK.

THE MARK CONSISTS OF A SQUARE DESIGN CONSISTING OF PURPLE, BLUE AND GREEN TRIANGLES, ABOVE THE GRAY WORD "CONNECTIVE", ABOVE THE GRAY WORD "TRANSFORMATIVE", ABOVE THE GRAY WORD "THERAPY". THE COLOR WHITE REPRESENTS BACKGROUND, OUTLINING, SHADING AND/OR TRANSPARENT AREAS AND IS NOT PART OF THE MARK.

FOR CONSULTING SERVICES IN THE FIELD OF MENTAL HEALTH AND WELLNESS; MENTAL HEALTH COUNSELING AND PSYCHOTHERAPY AS IT RELATES TO RELATIONSHIPS; MENTAL HEALTH SERVICES; PROVIDING A WEB SITE FEATURING INFORMATION IN THE FIELD OF MENTAL HEALTH AND PHYSICAL HEALTH, INCLUDING LIVING A HEALTHY AND DISEASE FREE LIFE; PROVIDING A WEB SITE FEATURING INFORMATION IN THE FIELD OF MENTAL HEALTH AND WELLNESS; PSYCHOLOGICAL ASSESSMENT SERVICES; PSYCHOLOGICAL COUNSELING SERVICES IN THE FIELD OF SPORTS; PSYCHOLOGICAL SERVICES, NAMELY, PROVIDING DIAGNOSTIC SERVICES TO CHILDREN WITH SPECIAL NEEDS AND THEIR FAMILIES; PSYCHOLOGICAL SERVICES, NAMELY, PROVIDING THERAPEUTIC SERVICES TO CHILDREN WITH SPECIAL NEEDS AND THEIR FAMILIES; PSYCHOLOGICAL TESTING SERVICES (U.S. CLS. 100 AND 101).

ROBIN MITTLER, EXAMINING ATTORNEY

SN 85-122,413. DOCTORS ON WHEELS S.C., WESTMONT, IL. FILED 9-3-2010.



NO CLAIM IS MADE TO THE EXCLUSIVE RIGHT TO USE "DOCTORS", APART FROM THE MARK AS SHOWN. THE COLOR(S) RED, BLACK AND WHITE IS/ARE CLAIMED AS A FEATURE OF THE MARK.

THE MARK CONSISTS OF A RED WHEELED SUITCASE WITH A WHITE POSITIVE SYMBOL CENTERED ON THE FRONT OF THE SUITCASE TO THE LEFT OF THE WORDING "DOCTORS ON WHEELS" IN BLACK STYLIZED FONT WHERE THE WORD "DOCTORS" APPEARS ABOVE THE WORD "ON" AND THE LETTERS "WHEE" OF THE WORD "WHEELS".

FOR HOME HEALTH CARE SERVICES, NAMELY, GERIATRIC HEALTH CARE (U.S. CLS. 100 AND 101).

FIRST USE 9-18-2008; IN COMMERCE 9-18-2008.

TINA BROWN, EXAMINING ATTORNEY

**CLASS 44—(Continued).**

SN 85-129,027. SIGNATURE HEALTHCARE, LLC, LOUISVILLE, KY. FILED 9-14-2010.



THE MARK CONSISTS OF THE WORD "SIGNATURE" AND THE SHADOWED "S".  
FOR HEALTH CARE (U.S. CLS. 100 AND 101).  
FIRST USE 11-1-2007; IN COMMERCE 11-1-2007.  
RAMONA ORTIGA, EXAMINING ATTORNEY

**CLASS 44—(Continued).**

SN 85-146,158. CAROLINAEAST HEALTH SYSTEM, NEW BERN, NC. FILED 10-6-2010.



SN 85-133,826. LOS ANGELES BRAIN AND SPINE INSTITUTE, GLENDALE, CA. FILED 9-20-2010.



THE COLOR(S) DARK GREEN, DARK BLUE, AND LIGHT GREEN IS/ARE CLAIMED AS A FEATURE OF THE MARK.

THE MARK CONSISTS OF THREE STYLIZED AND STACKED HUMAN VERTEBRAE, THE BOTTOM VERTEBRAE APPEARS IN DARK GREEN, THE MIDDLE VERTEBRAE APPEARS IN DARK BLUE, AND THE TOP VERTEBRAE APPEARS IN LIGHT GREEN. A LIGHT GREEN CIRCLE ALSO APPEARS ABOVE THE TOP VERTEBRAE TO SIGNIFY THE SPINAL CORD.

FOR MEDICAL ASSISTANCE CONSULTANCY PROVIDED BY DOCTORS AND OTHER SPECIALIZED MEDICAL PERSONNEL (U.S. CLS. 100 AND 101).  
FIRST USE 2-20-2008; IN COMMERCE 2-20-2008.  
STEVEN PEREZ, EXAMINING ATTORNEY

OWNER OF U.S. REG. NO. 3,907,340.  
NO CLAIM IS MADE TO THE EXCLUSIVE RIGHT TO USE "HEALTH SYSTEM", APART FROM THE MARK AS SHOWN.

THE COLOR(S) BLUE AND GRAY IS/ARE CLAIMED AS A FEATURE OF THE MARK.

THE MARK CONSISTS OF THE WORDS "CAROLINA EAST" IN BLUE AND UNDER THAT THE WORDS "HEALTH SYSTEM" IN GRAY WITH A DESIGN OF BLUES LINE TO THE LEFT OF THESE WORDS.

FOR HOSPITALS (U.S. CLS. 100 AND 101).  
FIRST USE 1-15-2010; IN COMMERCE 1-15-2010.  
MARK SPARACINO, EXAMINING ATTORNEY

SN 85-153,818. AMERICAN MANAGEMETN GROUP, LLC, FORT WASHINGTON, PA. FILED 10-15-2010.

SN 85-141,795. NORTH BREVARD COUNTY HOSPITAL DISTRICT, DBA PARRISH MEDICAL CENTER, TITUSVILLE, FL. FILED 9-30-2010.

**HEALING GENERATIONS FOR  
GENERATIONS OF HEALING**

THE MARK CONSISTS OF STANDARD CHARACTERS WITHOUT CLAIM TO ANY PARTICULAR FONT, STYLE, SIZE, OR COLOR.

FOR PROVIDING HEALTHCARE INFORMATION (U.S. CLS. 100 AND 101).

TRACY FLETCHER, EXAMINING ATTORNEY

**MY FAMILY DENTAL CARE.COM**

THE MARK CONSISTS OF STANDARD CHARACTERS WITHOUT CLAIM TO ANY PARTICULAR FONT, STYLE, SIZE, OR COLOR.

NO CLAIM IS MADE TO THE EXCLUSIVE RIGHT TO USE "FAMILY DENTAL CARE.COM", APART FROM THE MARK AS SHOWN.

FOR DENTIST SERVICES (U.S. CLS. 100 AND 101).  
FIRST USE 1-1-2004; IN COMMERCE 1-1-2004.

DANIEL CAPSHAW, EXAMINING ATTORNEY

**CLASS 44—(Continued).**

SN 85-155,540. GARY W. MALLOW, M.D., P.A., PLANTATION, FL. FILED 10-18-2010.

# TRIN-PHEN

THE MARK CONSISTS OF STANDARD CHARACTERS WITHOUT CLAIM TO ANY PARTICULAR FONT, STYLE, SIZE, OR COLOR.

FOR MEDICAL AND PHARMACEUTICAL CONSULTATION; MEDICAL ASSISTANCE SERVICES; MEDICAL CLINICS; MEDICAL CONSULTATIONS; MEDICAL COUNSELING; MEDICAL SERVICES; MEDICAL SERVICES, IN THE FIELDS OF SMOKING CESSATION AND WEIGHT LOSS; PREPARATION AND DISPENSING OF MEDICATIONS; PROVIDING MEDICAL INFORMATION; PROVIDING MEDICAL INFORMATION, CONSULTANCY AND ADVISORY SERVICES (U.S. CLS. 100 AND 101).

DAWN HAN, EXAMINING ATTORNEY

**CLASS 44—(Continued).**

SN 85-168,251. WESTAR ENERGY, INC., TOPEKA, KS. FILED 11-3-2010.



The logo for Reliabilitytree features the word "Reliabilitytree" in a green, sans-serif font. The letter "i" in "Reliability" has a small green tree icon above it. The word "tree" is in a brown, sans-serif font. The "t" in "tree" is stylized to resemble a tree trunk with two horizontal cross-bars at the top, and the word is surrounded by green foliage.

THE COLOR(S) GREEN AND BROWN IS/ARE CLAIMED AS A FEATURE OF THE MARK.

THE MARK CONSISTS OF THE WORD "RELIABILITY-TREE" WHERE "RELIABILITY" IS GREEN AND "TREE" IS BROWN, WITH THE "T" MADE TO RESEMBLE A TREE WITH THE CENTRAL TRUNK BEING A TELEPHONE POLE WITH TWO CROSS-BARS AT THE TOP SURROUNDED BY THE GREEN "LEAVES" OF THE TREE.

FOR HORTICULTURAL SERVICES, NAMELY, VEGETATION MANAGEMENT (U.S. CLS. 100 AND 101).

FIRST USE 10-26-2010; IN COMMERCE 10-26-2010.

TINA L. SNAPP, EXAMINING ATTORNEY

SN 85-158,113. CHILDREN'S DENTAL GROUP, INC., LAS VEGAS, NV. FILED 10-21-2010.



The logo for Children's dental group features a stylized black and white icon of a person's head and shoulders inside a circle, with a white swoosh above it. Below the icon, the words "Children's" and "dental group" are written in a black, sans-serif font.

NO CLAIM IS MADE TO THE EXCLUSIVE RIGHT TO USE "CHILDREN'S DENTAL GROUP", APART FROM THE MARK AS SHOWN.

THE MARK CONSISTS OF A STYLIZED FIGURE SUPERIMPOSED OVER A CIRCLE, ALL OF WHICH IS OVER THE STYLIZED WORDS "CHILDREN'S DENTAL GROUP".

FOR DENTIST SERVICES (U.S. CLS. 100 AND 101).

FIRST USE 11-4-2009; IN COMMERCE 11-4-2009.

MICHELE SWAIN, EXAMINING ATTORNEY

SN 85-170,638. CONSCIOUS SUCCESS LLC, NATICK, MA. FILED 11-5-2010.



The logo for Conscious Success features the word "CONSCIOUS" in a bold, black, sans-serif font. The letters "CO" are partially enclosed by a circular design of overlapping black lines. Below "CONSCIOUS", the word "SUCCESS" is written in a black, sans-serif font.

THE MARK CONSISTS OF A CIRCULAR DESIGN AROUND THE LETTERS "CO" IN THE WORDING "CONSCIOUS" WITH THE WORDING "SUCCESS" BELOW THE DESIGN AND WORDING "CONSCIOUS".

FOR CONSULTING SERVICES IN THE FIELD OF STRESS MANAGEMENT (U.S. CLS. 100 AND 101).

FIRST USE 11-1-2008; IN COMMERCE 11-1-2008.

DANIEL CAPSHAW, EXAMINING ATTORNEY

**CLASS 44—(Continued).**

SN 85-170,905. FORGIE, ELAYNE, LAKE WORTH, FL.  
FILED 11-6-2010.



NO CLAIM IS MADE TO THE EXCLUSIVE RIGHT TO USE "ELDERCARE AT HOME", APART FROM THE MARK AS SHOWN.

THE COLOR(S) WHITE AND MAROON IS/ARE CLAIMED AS A FEATURE OF THE MARK.

THE MARK CONSISTS OF A MAROON AND WHITE HOUSE SURROUNDED BY BUSHES AND TREES, ALSO IN THE COLOR MAROON. BELOW THE HOUSE ARE A MAROON LINE WITH A MAROON HEART-SHAPED LEAF DESIGN AND THE STYLIZED WORDING IN MAROON, "ELDERCARE AT HOME". UNDERNEATH THIS WORDING ARE ANOTHER MAROON LINE AND THE WORDING "KEEPING FAMILIES TOGETHER" IN MAROON.

FOR HOME HEALTH CARE SERVICES (U.S. CLS. 100 AND 101).

FIRST USE 5-11-2001; IN COMMERCE 5-11-2001.  
YAT SYE, LEE, EXAMINING ATTORNEY

**CLASS 44—(Continued).**

SN 85-173,584. NATION'S HOME INFUSION, LLC, OWINGS MILLS, MD. FILED 11-10-2010.

## Nation's Home Infusion

THE MARK CONSISTS OF STANDARD CHARACTERS WITHOUT CLAIM TO ANY PARTICULAR FONT, STYLE, SIZE, OR COLOR.

NO CLAIM IS MADE TO THE EXCLUSIVE RIGHT TO USE "HOME INFUSION", APART FROM THE MARK AS SHOWN.

FOR HOME HEALTH CARE SERVICES; LEASING HOME INFUSION MEDICAL EQUIPMENT AND SUPPLIES; PREPARATION AND DISPENSING HOME INFUSION MEDICATIONS (U.S. CLS. 100 AND 101).

FIRST USE 2-14-2006; IN COMMERCE 2-14-2006.  
GINA FINK, EXAMINING ATTORNEY

SN 85-174,189. FOOD FITNESS FIRST, INC., VIDALIA, GA.  
FILED 11-11-2010.

SN 85-172,804. THE CULTURAL LANDSCAPE FOUNDATION, WASHINGTON, DC. FILED 11-9-2010.

## WHAT'S OUT THERE

THE MARK CONSISTS OF STANDARD CHARACTERS WITHOUT CLAIM TO ANY PARTICULAR FONT, STYLE, SIZE, OR COLOR.

FOR LANDSCAPE INFORMATION SERVICES, NAMELY, PROVIDING AN INTERNET DATABASE FEATURING LANDSCAPE DESIGNS, ALONG WITH BIOGRAPHICAL INFORMATION OF LANDSCAPE ARCHITECTS AND LANDSCAPE DESIGNERS ASSOCIATED WITH SAID LANDSCAPE DESIGNS (U.S. CLS. 100 AND 101).

FIRST USE 3-1-2008; IN COMMERCE 3-1-2008.  
BRIAN CALLAGHAN, EXAMINING ATTORNEY

## FOOD SPIRAL

THE MARK CONSISTS OF STANDARD CHARACTERS WITHOUT CLAIM TO ANY PARTICULAR FONT, STYLE, SIZE, OR COLOR.

NO CLAIM IS MADE TO THE EXCLUSIVE RIGHT TO USE "FOOD", APART FROM THE MARK AS SHOWN.

FOR CONSULTING SERVICES IN THE FIELDS OF HEALTH AND NUTRITION; PROVIDING A WEB SITE FEATURING INFORMATION ON HEALTH AND NUTRITION (U.S. CLS. 100 AND 101).

FIRST USE 6-1-2004; IN COMMERCE 6-1-2004.  
JAMES MACFARLANE, EXAMINING ATTORNEY

**CLASS 44—(Continued).**

SN 85-174,469. 9 DOLLAR NAILS INC., DENVER, CO. FILED 11-11-2010.



NO CLAIM IS MADE TO THE EXCLUSIVE RIGHT TO USE "9 DOLLAR NAILS", APART FROM THE MARK AS SHOWN.

THE MARK CONSISTS OF AN OVAL CONTAINING THE WORDS "9 DOLLAR NAILS" CENTERED AND A SILHOUETTE OF A FEMALE IN A DRESS INSIDE THE OVAL POSITIONED TO THE RIGHT.

FOR BEAUTY SPA SERVICES, NAMELY, COSMETIC BODY CARE; DAY SPA SERVICES, NAMELY, NAIL CARE, MANICURES, PEDICURES AND NAIL ENHANCEMENTS; HEALTH SPA SERVICES FOR HEALTH AND WELLNESS OF THE BODY AND SPIRIT, NAMELY, PROVIDING MASSAGE, FACIAL AND BODY TREATMENT SERVICES, COSMETIC BODY CARE SERVICES; HEALTH SPA SERVICES, NAMELY, COSMETIC BODY CARE SERVICES (U.S. CLS. 100 AND 101).

REBECCA SMITH, EXAMINING ATTORNEY

SN 85-175,822. VITALAE CORPORATE SERVICES, INC., IRVINE, CA. FILED 11-12-2010.

## MyVitaLink.com

THE MARK CONSISTS OF STANDARD CHARACTERS WITHOUT CLAIM TO ANY PARTICULAR FONT, STYLE, SIZE, OR COLOR.

FOR PROVIDING A WEBSITE FEATURING CONTENT REGARDING HEALTHY LIVING AND LIFESTYLE WELLNESS (U.S. CLS. 100 AND 101).

FIRST USE 6-1-2010; IN COMMERCE 6-15-2010.

KAREN BRACEY, EXAMINING ATTORNEY

SN 85-177,843. PREMIER VISION OPTOMETRY, INC., ARCADIA, CA. FILED 11-16-2010.



## PREMIER VISION

NO CLAIM IS MADE TO THE EXCLUSIVE RIGHT TO USE "VISION", APART FROM THE MARK AS SHOWN.

THE MARK CONSISTS OF STYLIZED LETTERS "P" AND "V" FORMING A SHAPE OF AN EYE WITH THE WORDS "PREMIER VISION".

FOR OPTOMETRY SERVICES (U.S. CLS. 100 AND 101). FIRST USE 5-1-2010; IN COMMERCE 5-1-2010.

WILLIAM P. SHANAHAN, EXAMINING ATTORNEY

**CLASS 44—(Continued).**

SN 85-178,440. ERIC A. COLEMAN, AURORA, CO. FILED 11-16-2010.

## Care Transitions Program

THE MARK CONSISTS OF STANDARD CHARACTERS WITHOUT CLAIM TO ANY PARTICULAR FONT, STYLE, SIZE, OR COLOR.

NO CLAIM IS MADE TO THE EXCLUSIVE RIGHT TO USE "CARE" AND "PROGRAM", APART FROM THE MARK AS SHOWN.

SEC. 2(F).

FOR HEALTH CARE SERVICES FOR IMPROVING QUALITY CARE AND SAFETY OF PATIENTS DURING TRANSITIONS ACROSS CARE SETTINGS (U.S. CLS. 100 AND 101).

FIRST USE 3-0-2005; IN COMMERCE 3-0-2005.

BRIAN NEVILLE, EXAMINING ATTORNEY

SN 85-178,449. COLEMAN, ERIC A., AURORA, CO. FILED 11-16-2010.

## Care Transitions Intervention

THE MARK CONSISTS OF STANDARD CHARACTERS WITHOUT CLAIM TO ANY PARTICULAR FONT, STYLE, SIZE, OR COLOR.

NO CLAIM IS MADE TO THE EXCLUSIVE RIGHT TO USE "CARE", APART FROM THE MARK AS SHOWN.

SEC. 2(F).

FOR HEALTH CARE SERVICES FOR IMPROVING QUALITY CARE AND SAFETY OF PATIENTS DURING TRANSITIONS ACROSS CARE SETTINGS (U.S. CLS. 100 AND 101).

FIRST USE 3-0-2005; IN COMMERCE 3-0-2005.

BRIAN NEVILLE, EXAMINING ATTORNEY

SN 85-179,799. DUFF, JASON, EDGEWATER PARK, NJ. FILED 11-18-2010.

## Mr Tattoo

THE MARK CONSISTS OF STANDARD CHARACTERS WITHOUT CLAIM TO ANY PARTICULAR FONT, STYLE, SIZE, OR COLOR.

NO CLAIM IS MADE TO THE EXCLUSIVE RIGHT TO USE "TATTOO", APART FROM THE MARK AS SHOWN.

FOR TATTOOING SERVICES; BODY PIERCING SERVICES; PROVIDING A WEBSITE FEATURING INFORMATION IN THE FIELD OF TATTOOING AND BODY PIERCING (U.S. CLS. 100 AND 101).

FIRST USE 3-1-2008; IN COMMERCE 3-1-2008.

MORGAN WYNNE, EXAMINING ATTORNEY



**CLASS 44—(Continued).**

SN 85-180,233. THRIVERS, LLC, BOULDER, CO. FILED 11-18-2010.

**CANCER THRIVERS**

THE MARK CONSISTS OF STANDARD CHARACTERS WITHOUT CLAIM TO ANY PARTICULAR FONT, STYLE, SIZE, OR COLOR.

NO CLAIM IS MADE TO THE EXCLUSIVE RIGHT TO USE "CANCER", APART FROM THE MARK AS SHOWN.

FOR PROVIDING INFORMATION IN THE FIELD OF HEALTHCARE AND WELLNESS VIA THE INTERNET (U.S. CLS. 100 AND 101).

FIRST USE 9-30-2010; IN COMMERCE 9-30-2010.  
MICHELE SWAIN, EXAMINING ATTORNEY

---

SN 85-181,013. MICHAEL B. BAYLESS AND ASSOCIATES INC., DBA BAYLESS BEHAVIORAL HEALTH SOLUTIONS, PHOENIX, AZ. FILED 11-19-2010.



THE COLOR(S) LIME GREEN (PANTONE 398C AND PANTONE 397U) IS/ARE CLAIMED AS A FEATURE OF THE MARK.

THE MARK CONSISTS OF TWO LETTERS "B", THE RIGHT ONE IN LIME GREEN, THE LEFT ONE BACKWARDS, TILTED, AND IN A LIGHTER SHADE OF LIME GREEN.

FOR PSYCHOLOGICAL SERVICES, NAMELY, PROVIDING DIAGNOSTIC SERVICES TO CHILDREN WITH SPECIAL NEEDS AND THEIR FAMILIES (U.S. CLS. 100 AND 101).

FIRST USE 11-1-2010; IN COMMERCE 11-18-2010.  
REBECCA EISINGER, EXAMINING ATTORNEY

**CLASS 44—(Continued).**

SN 85-183,168. SSM SELECT REHAB ST. LOUIS, LLC, ST. LOUIS, MO. FILED 11-23-2010.

**HOPE. HEALING.  
REHABILITATION.**

THE MARK CONSISTS OF STANDARD CHARACTERS WITHOUT CLAIM TO ANY PARTICULAR FONT, STYLE, SIZE, OR COLOR.

FOR MEDICAL REHABILITATION SERVICES, NAMELY, PHYSICAL THERAPY SERVICES, OCCUPATIONAL THERAPY SERVICES, SPEECH THERAPY, PHYSICAL THERAPY SERVICES FOR THE HAND, PHYSICAL REHABILITATION SERVICES FOR SPORTS INJURIES AND WORK-RELATED INJURIES, NEUROLOGICAL REHABILITATION, VESTIBULAR REHABILITATION, AND ORTHOPEDIC REHABILITATION; MEDICAL TREATMENT AND THERAPY IN THE FIELD OF PAIN MANAGEMENT; MEDICAL CONSULTATION IN THE FIELD OF WORK-RELATED INJURY PREVENTION AND INJURY MANAGEMENT; MEDICAL EVALUATION SERVICES, NAMELY, FUNCTIONAL ASSESSMENT PROGRAM FOR PATIENTS RECEIVING MEDICAL REHABILITATION SERVICES FOR PURPOSES OF GUIDING TREATMENT AND ASSESSING PROGRAM EFFECTIVENESS; MEDICAL SERVICES, NAMELY, PAIN AND WOUND MANAGEMENT; OCCUPATIONAL MEDICAL SERVICES FOR THE TREATMENT OF WORK-RELATED INJURIES; MEDICAL TREATMENT OF, AND PHYSICAL REHABILITATION SERVICES FOR, BACK PAIN AND BACK INJURIES; OUTPATIENT MEDICAL AND REHABILITATION CLINICS; WORK SERVICES PROGRAMS, NAMELY, PROVIDING PHYSICAL AND OCCUPATIONAL THERAPY, CONDUCTING MEDICAL EXAMS AND FUNCTIONAL CAPACITY EVALUATIONS TO ENSURE ONE IS PHYSICALLY FIT TO CONTINUE THEIR EMPLOYMENT RESPONSIBILITIES, CONDUCTING MEDICAL SCREENING AND MEDICAL TESTING TO ENSURE ONE IS PHYSICALLY FIT TO CONTINUE THEIR EMPLOYMENT RESPONSIBILITIES; PROVISION OF ACUTE HEALTH CARE SERVICES, NAMELY, PROVIDING MEDICAL CARE SERVICES IN AN INPATIENT HOSPITAL SETTING (U.S. CLS. 100 AND 101).

FIRST USE 1-1-2010; IN COMMERCE 1-1-2010.  
MICHAEL TANNER, EXAMINING ATTORNEY

---

SN 85-183,382. VICAR OPERATING, INC., LOS ANGELES, CA. FILED 11-23-2010.

**VCA ADVANCED VETERINARY  
CARE CENTER**

THE MARK CONSISTS OF STANDARD CHARACTERS WITHOUT CLAIM TO ANY PARTICULAR FONT, STYLE, SIZE, OR COLOR.

OWNER OF U.S. REG. NOS. 2,847,530, 3,708,234 AND OTHERS.

NO CLAIM IS MADE TO THE EXCLUSIVE RIGHT TO USE "ADVANCED VETERINARY CARE CENTER", APART FROM THE MARK AS SHOWN.

FOR ANIMAL HOSPITAL SERVICES (U.S. CLS. 100 AND 101).

EVELYN BRADLEY, EXAMINING ATTORNEY

**CLASS 44—(Continued).**

SN 85-184,326. HORTICOPIA, INC., HARWOOD, MD. FILED 11-24-2010.

# HORTICOPIA

THE MARK CONSISTS OF STANDARD CHARACTERS WITHOUT CLAIM TO ANY PARTICULAR FONT, STYLE, SIZE, OR COLOR.

OWNER OF U.S. REG. NOS. 1,905,480 AND 2,405,921. FOR PROVIDING A WEBSITE FEATURING INFORMATION ABOUT HORTICULTURE (U.S. CLS. 100 AND 101).

FIRST USE 1-0-2006; IN COMMERCE 1-0-2006.  
WENDY GOODMAN, EXAMINING ATTORNEY

**CLASS 44—(Continued).**

SN 85-186,550. NICHOLSON, WESLEY, CHINO HILLS, CA. FILED 11-29-2010.

# Speech Guy

THE MARK CONSISTS OF STANDARD CHARACTERS WITHOUT CLAIM TO ANY PARTICULAR FONT, STYLE, SIZE, OR COLOR.

NO CLAIM IS MADE TO THE EXCLUSIVE RIGHT TO USE "SPEECH", APART FROM THE MARK AS SHOWN.

FOR SPEECH PATHOLOGY THERAPY SERVICES; PROVIDING ASSESSMENT, THERAPY, AND CONSULTATION SERVICES FOR CHILDREN AND ADULTS WITH VARIOUS SPEECH, LANGUAGE, VOICE, AND SWALLOWING DIFFICULTIES, IMPAIRMENTS, AND DISORDERS OF ALL KINDS (U.S. CLS. 100 AND 101).

FIRST USE 12-8-2009; IN COMMERCE 7-22-2010.  
HOWARD B. LEVINE, EXAMINING ATTORNEY

SN 85-186,108. KAHN, REBECCA, SURPRISE, AZ. FILED 11-29-2010.



THE MARK CONSISTS OF A HEART CONTAINING SCISSORS AND WAVY LINES TO THE LEFT. THE HEART IS HANGING FROM A RIBBON THAT IS "T" SHAPED. THE RIGHT HALF OF THE "T" IS COVERED IN STARS.

FOR BEAUTY SALONS (U.S. CLS. 100 AND 101).  
TARAH HARDY, EXAMINING ATTORNEY

SN 85-187,095. BROWN, CHRIS, JOHNSON CITY, TN. FILED 11-30-2010.



NO CLAIM IS MADE TO THE EXCLUSIVE RIGHT TO USE "TAN", APART FROM THE MARK AS SHOWN.

THE COLOR(S) YELLOW, RED, AND ORANGE IS/ARE CLAIMED AS A FEATURE OF THE MARK.

THE MARK CONSISTS OF THE ARTISTIC RENDERING OF A SUN WITH THE RAYS APPEARING IN ORANGE AND YELLOW AND THE CENTER CIRCLE OF THE SUN APPEARING IN ORANGE AND YELLOW WITH A RED OUTLINE. THE WORDING "TAN 2000" APPEARS TO THE RIGHT OF THE SUN DESIGN IN THE COLORS ORANGE AND YELLOW WITH A RED OUTLINE. THE WORDING "NOTHING BEATS A DAY IN THE SUN" APPEARS IN THE COLOR RED BELOW THE WORDING "TAN 2000". THE WHITE APPEARING IN THE DRAWING REPRESENTS A TRANSPARENT BACKGROUND AND IS NOT BEING CLAIMED AS A FEATURE OF THE MARK.

FOR TANNING SALONS (U.S. CLS. 100 AND 101).  
FIRST USE 6-0-1999; IN COMMERCE 6-0-1999.  
JEFFERY COWARD, EXAMINING ATTORNEY

**CLASS 44—(Continued).**

SN 85-187,146. DIMMICK, STEPHEN, NEW YORK, NY. FILED 11-30-2010.

## Stephen Dimmick

THE MARK CONSISTS OF STANDARD CHARACTERS WITHOUT CLAIM TO ANY PARTICULAR FONT, STYLE, SIZE, OR COLOR.

THE NAME "STEPHEN DIMMICK" IDENTIFIES A LIVING INDIVIDUAL WHOSE CONSENT IS OF RECORD.

FOR CONSULTATION SERVICES IN THE FIELD OF MAKEUP, NAMELY, ON-LINE MAKEUP CONSULTATION SERVICES AND IN-PERSON MAKEUP CONSULTATION AND APPLICATION SERVICES (U.S. CLS. 100 AND 101).

FIRST USE 1-30-1998; IN COMMERCE 1-30-1998.  
VIVIAN MICZNIK FIRST, EXAMINING ATTORNEY

---

SN 85-187,187. MEHMETI, BEKIM, NILES, IL. FILED 11-30-2010.

## Betty's & Nick's

THE MARK CONSISTS OF STANDARD CHARACTERS WITHOUT CLAIM TO ANY PARTICULAR FONT, STYLE, SIZE, OR COLOR.

THE NAMES "BETTY & NICK" DO NOT IDENTIFY LIVING INDIVIDUALS.

FOR HAIR CARE AND SALON SERVICES, NAMELY, HAIR CUTTING, COLORING, STYLING, BODY WAXING AND EYEBROW THREADING SERVICES (U.S. CLS. 100 AND 101).

FIRST USE 2-1-1986; IN COMMERCE 2-1-1986.  
MARGERY A. TIERNEY, EXAMINING ATTORNEY

---

SN 85-187,357. HOROWITZ MOILANEN, NANCY, WILLITS, CA. FILED 11-30-2010.

## Well Together Neuro Rehab

THE MARK CONSISTS OF STANDARD CHARACTERS WITHOUT CLAIM TO ANY PARTICULAR FONT, STYLE, SIZE, OR COLOR.

NO CLAIM IS MADE TO THE EXCLUSIVE RIGHT TO USE "NEURO REHAB", APART FROM THE MARK AS SHOWN.

FOR SPEECH PATHOLOGY THERAPY SERVICES (U.S. CLS. 100 AND 101).

FIRST USE 11-15-2010; IN COMMERCE 11-16-2010.  
KELLEY WELLS, EXAMINING ATTORNEY

**CLASS 44—(Continued).**

SN 85-187,504. DAY SPA DEVELOPMENT CONSULTANT CORP., THORNWOOD, NY. FILED 11-30-2010.

## MIRIANA DAY SPA

THE MARK CONSISTS OF STANDARD CHARACTERS WITHOUT CLAIM TO ANY PARTICULAR FONT, STYLE, SIZE, OR COLOR.

NO CLAIM IS MADE TO THE EXCLUSIVE RIGHT TO USE "DAY SPA", APART FROM THE MARK AS SHOWN.

THE NAME "MIRIANA" DOES NOT IDENTIFY A LIVING INDIVIDUAL.

FOR HEALTH SPA SERVICES FOR HEALTH AND WELLNESS OF THE BODY AND SPIRIT, NAMELY, PROVIDING MASSAGE, REFLEXOLOGY, FACIAL AND BODY TREATMENT SERVICES, COSMETIC BODY CARE SERVICES (U.S. CLS. 100 AND 101).

FIRST USE 7-1-2006; IN COMMERCE 7-1-2006.  
MARGERY A. TIERNEY, EXAMINING ATTORNEY

---

SN 85-187,952. DOUCETTE, MICHELE M, GOLDEN, CO. FILED 12-1-2010.

## Focus 4 Health

THE MARK CONSISTS OF STANDARD CHARACTERS WITHOUT CLAIM TO ANY PARTICULAR FONT, STYLE, SIZE, OR COLOR.

NO CLAIM IS MADE TO THE EXCLUSIVE RIGHT TO USE "HEALTH", APART FROM THE MARK AS SHOWN.

FOR CONSULTING SERVICES IN THE FIELD OF MENTAL HEALTH AND WELLNESS; CONSULTING SERVICES IN THE FIELDS OF HEALTH AND NUTRITION; CONSULTING SERVICES TO HEALTH CARE PROVIDERS IN THE FIELD OF TREATING LIFE-CHANGING OR LIFE-THREATENING DISEASES; HEALTH CARE SERVICES, NAMELY, WELLNESS PROGRAMS; PROVIDING A WEB SITE FEATURING INFORMATION ON HEALTH AND NUTRITION; PROVIDING A WEBSITE FEATURING INFORMATION ABOUT HEALTH, WELLNESS AND NUTRITION; PROVIDING AN ON-LINE COMPUTER DATABASE FEATURING INFORMATION REGARDING HEALTH AND NUTRITION; PROVIDING ASSISTANCE, FITNESS EVALUATION AND CONSULTATION TO CORPORATE CLIENTS TO HELP THEIR EMPLOYEES MAKE HEALTH, WELLNESS AND NUTRITIONAL CHANGES IN THEIR DAILY LIVING TO IMPROVE HEALTH; PROVIDING ASSISTANCE, FITNESS EVALUATION AND CONSULTATION TO INDIVIDUALS TO HELP THEM MAKE HEALTH, WELLNESS AND NUTRITIONAL CHANGES IN THEIR DAILY LIVING TO IMPROVE HEALTH; PROVIDING HEALTH INFORMATION; PROVIDING INFORMATION, NEWS AND COMMENTARY IN THE FIELD OF NUTRITION, HEALTH AND WELLNESS; WELLNESS AND HEALTH-RELATED CONSULTING SERVICES (U.S. CLS. 100 AND 101).

MARK SPARACINO, EXAMINING ATTORNEY

**CLASS 44—(Continued).**

SN 85-188,268. WELLESLEY NEUROLOGY GROUP, P.C., DBA CNS MULTISPECIALTY CLINIC, WELLESLEY, MA. FILED 12-1-2010.



NO CLAIM IS MADE TO THE EXCLUSIVE RIGHT TO USE "CNS MULTISPECIALTY CLINIC", APART FROM THE MARK AS SHOWN.

THE MARK CONSISTS OF A DESIGN CONSISTING OF THE WORD "CNS" IN THE CENTER OF A SHIELD-LIKE SYMMETRICAL DESIGN. TO THE RIGHT OF THIS DESIGN ARE THE WORDS "MULTISPECIALTY CLINIC".

FOR MEDICAL CLINICS; MEDICAL SERVICES; PROVIDING MEDICAL INFORMATION, CONSULTANCY AND ADVISORY SERVICES (U.S. CLS. 100 AND 101).

FIRST USE 9-27-2010; IN COMMERCE 9-27-2010.  
MARK RADEMACHER, EXAMINING ATTORNEY

**CLASS 44—(Continued).**

SN 85-189,192. UP DIAGNOSTICS LLC, AKA UNIVERSITY PATHOLOGISTS DIAGNOSTICS, WARWICK, RI. FILED 12-2-2010.



NO CLAIM IS MADE TO THE EXCLUSIVE RIGHT TO USE "UNIVERSITY PATHOLOGISTS DIAGNOSTICS", APART FROM THE MARK AS SHOWN.

THE COLOR(S) DARK BLUE, TEAL AND WHITE IS/ARE CLAIMED AS A FEATURE OF THE MARK.

THE MARK CONSISTS OF A CIRCLE IN THE COLORS TEAL AND DARK BLUE WITH THE WHITE LETTERS "UPDX" IN THE CENTER, WITH THE RIGHT SIDE OF THE "U" FORMING THE LEFT STEM OF THE "P", WITH THE DARK BLUE WORDING, "UNIVERSITY PATHOLOGISTS" AND THE WORD "DIAGNOSTICS" IN TEAL, PRINTED IN A SEMI-CIRCLE OUTSIDE THE LOWER PORTION OF THE CIRCLE.

FOR MEDICAL DIAGNOSTIC SERVICES IN THE FIELD OF CLINICAL PATHOLOGY (U.S. CLS. 100 AND 101).

FIRST USE 1-1-2010; IN COMMERCE 4-1-2010.  
MIDGE BUTLER, EXAMINING ATTORNEY

SN 85-188,282. PEDIATRIC AND INTERNAL MEDICINE SPECIALISTS, PA, LECANTO, FL. FILED 12-1-2010.



NO CLAIM IS MADE TO THE EXCLUSIVE RIGHT TO USE "SLEEP CLINIC OF AMERICA", APART FROM THE MARK AS SHOWN.

THE MARK CONSISTS OF THE STYLIZED TEXT "SLEEP CLINIC OF AMERICA" WITH A DESIGN OF A MOON BETWEEN THE WORDS "SLEEP" AND "CLINIC".

FOR MEDICAL SERVICES (U.S. CLS. 100 AND 101).  
FIRST USE 2-25-2010; IN COMMERCE 11-1-2010.  
LOURDES AYALA, EXAMINING ATTORNEY

SN 85-189,201. TIMOTHY DAWSON, INC., SAN RAFAEL, CA. FILED 12-2-2010.



NO CLAIM IS MADE TO THE EXCLUSIVE RIGHT TO USE "RESTORE", APART FROM THE MARK AS SHOWN.

THE MARK CONSISTS OF THE TEXT "RESTORE" AND A STYLIZED IMAGE OF A PERSON WITH ARMS AND LEGS OUTSTRETCHED.

FOR PROVIDING MEDICAL SERVICES, PSYCHOLOGICAL COUNSELING SERVICES, HEALTH CARE WELLNESS SERVICES, AND PHYSICAL REHABILITATION GEARED TOWARD THE TREATMENT AND REHABILITATION OF INJURED WORKERS AND PATIENTS WITH CHRONIC PAIN, AS PART OF A MULTIDISCIPLINARY FUNCTIONAL RESTORATION PROGRAM (U.S. CLS. 100 AND 101).

KIM MONINGHOFF, EXAMINING ATTORNEY

**CLASS 44—(Continued).**

SN 85-189,934. HOME AGAIN HEALTH CARE, LLC, WILMINGTON, MA. FILED 12-3-2010.

**HOME AGAIN HEALTH CARE**

THE MARK CONSISTS OF STANDARD CHARACTERS WITHOUT CLAIM TO ANY PARTICULAR FONT, STYLE, SIZE, OR COLOR.

NO CLAIM IS MADE TO THE EXCLUSIVE RIGHT TO USE "HOME" AND "HEALTH CARE", APART FROM THE MARK AS SHOWN.

FOR MEDICAL SERVICES, NAMELY, PROVIDING LIMITED IN-HOME PATIENT CARE SERVICES IN THE NATURE OF PERSONAL MEDICAL SERVICES FOR INDIVIDUALS INCLUDING CHECKING VITAL SIGNS, MED COMPLIANCE AND INDIVIDUAL HYGIENE, SCHEDULING DOCTOR APPOINTMENTS, PICKING UP PRESCRIPTIONS, CHECKING MEDICAL EQUIPMENT AND SUPPLIES, AND PROVIDING ON-LINE INFORMATION RELATED TO THE PERSONAL MEDICAL SERVICES, FOR INDIVIDUALS WHO HAVE BEEN DISCHARGED FROM HOSPITALIZATION OR ARE OTHERWISE IN NEED OF IN-HOME MEDICAL CARE (U.S. CLS. 100 AND 101).

BARNEY CHARLON, EXAMINING ATTORNEY

SN 85-190,898. AFFORDABLE VETERINARY SERVICES LLC, COLUMBUS, GA. FILED 12-5-2010.



NO CLAIM IS MADE TO THE EXCLUSIVE RIGHT TO USE "AFFORDABLE VETERINARY SERVICES", APART FROM THE MARK AS SHOWN.

THE COLOR(S) ORANGE, TURQUOISE, AND BLACK IS/ARE CLAIMED AS A FEATURE OF THE MARK.

THE MARK CONSISTS OF THE WORD "AFFORDABLE" IN ORANGE WITH A STYLIZED DOG'S HEAD SUBSTITUTED FOR THE LETTER "O" IN BLACK AND THE WORDING "VETERINARY SERVICES" BELOW IN TURQUOISE WITH A BLACK LINE BETWEEN THE WORDING. FOR VETERINARY SERVICES (U.S. CLS. 100 AND 101).

FIRST USE 1-1-2010; IN COMMERCE 2-1-2010.

DOUGLAS LEE, EXAMINING ATTORNEY

SN 85-191,049. PREVITY SURGICAL, PLLC, BEAUMONT, TX. FILED 12-6-2010.



NO CLAIM IS MADE TO THE EXCLUSIVE RIGHT TO USE "CLINIC FOR SURGICAL CARE", APART FROM THE MARK AS SHOWN.

THE MARK CONSISTS OF THE WORD "PREVITY", THE

**CLASS 44—(Continued).**

WORDS "CLINIC FOR SURGICAL CARE", THE WORDS "WHERE PREVENTION AND LONGEVITY MEET", AND A LOGO DESIGN WHICH IS DESCRIBED AS FOLLOWS. THE WORD "PREVITY" APPEARS IN LARGE CAPITAL LETTERS. THE WORDS "CLINIC FOR SURGICAL CARE" APPEAR IN STANDARD UPPER AND LOWER CASE LETTERS AND APPEAR TO THE RIGHT OF THE WORD "PREVITY" AND ARE SEPARATED FROM THE WORD "PREVITY" BY A VERTICAL LINE. THE WORDS "WHERE PREVENTION AND LONGEVITY MEET" APPEAR BELOW THE WORD "PREVITY" IN ITALICIZED UPPER AND LOWER CASE LETTERS. IN THE UPPER LEFT CORNER OF THE MARK, A DESIGN IS SHOWN AND CONTAINS THREE DARKENED CIRCLES POSITIONED ABOVE A DARKENED CRESCENT-SHAPED FIGURE.

FOR MINIMALLY INVASIVE SURGICAL SERVICES (U.S. CLS. 100 AND 101).

FIRST USE 8-21-2009; IN COMMERCE 8-21-2009.

KIM SAITO, EXAMINING ATTORNEY

SN 85-191,111. XQUISITE TANS LLC, DBA XQUISITE TAN, RAHWAY, NJ. FILED 12-6-2010.



NO CLAIM IS MADE TO THE EXCLUSIVE RIGHT TO USE "TAN", APART FROM THE MARK AS SHOWN.

THE COLOR(S) BLACK, WHITE, ORANGE, AND YELLOW IS/ARE CLAIMED AS A FEATURE OF THE MARK.

THE MARK CONSISTS OF A STYLIZED "X" WITH THE COLORS ORANGE, YELLOW AND WHITE, THE COLORS FADE FROM THE BOTTOM OF THE LETTER "X", FROM DARK ORANGE TO LIGHT ORANGE TO YELLOW TO WHITE, REST OF NAME IN WHITE LETTERS WITH BLACK BACKGROUND.

FOR TANNING SALON THAT PROVIDES INDOOR UV TANNING, SUNLESS SPRAY TANNING AND TEETH WHITENING SERVICES (U.S. CLS. 100 AND 101).

FIRST USE 2-1-2009; IN COMMERCE 2-1-2009.

FLORENTINA BLANDU, EXAMINING ATTORNEY

SN 85-191,581. LCPS FRANCHISING LLC, NORTHFIELD, IL. FILED 12-6-2010.



NO CLAIM IS MADE TO THE EXCLUSIVE RIGHT TO USE "GROOMING AND PET SERVICES", APART FROM THE MARK AS SHOWN.

THE MARK CONSISTS OF A HEART PLACED BETWEEN THE WORDS "LOVING" AND "CARE" AND THE PHRASE "GROOMING AND PET SERVICES" APPEARING BELOW. FOR DOG WALKING SERVICES; PET GROOMING SERVICES (U.S. CLS. 100 AND 101).

FIRST USE 2-1-2005; IN COMMERCE 2-15-2005.

GISELLE AGOSTO, EXAMINING ATTORNEY

**CLASS 44—(Continued).**

SN 85-192,448. PASSPORT HEALTH COMMUNICATIONS, INC., FRANKLIN, TN. FILED 12-7-2010.

**PAYMENT CERTAINTY FOR  
EVERY PATIENT**

THE MARK CONSISTS OF STANDARD CHARACTERS WITHOUT CLAIM TO ANY PARTICULAR FONT, STYLE, SIZE, OR COLOR.

FOR PROVISION OF HEALTHCARE INFORMATION BY ELECTRONIC MEANS (U.S. CLS. 100 AND 101).  
KYLE PEETE, EXAMINING ATTORNEY

SN 85-192,941. AMERICAN SOCIETY FOR CLINICAL PATHOLOGY, CHICAGO, IL. FILED 12-8-2010.

**PATHTERMS**

THE MARK CONSISTS OF STANDARD CHARACTERS WITHOUT CLAIM TO ANY PARTICULAR FONT, STYLE, SIZE, OR COLOR.

FOR PROVIDING AN ON-LINE COMPUTER DATABASE FEATURING TERMS AND METADATA TO BE UTILIZED IN ON-LINE SEARCHABLE DATABASES RELATED TO PATHOLOGY (U.S. CLS. 100 AND 101).  
SUNG IN, EXAMINING ATTORNEY

SN 85-194,784. NUTRITION CLICK CORPORATION, ORO VALLEY, AZ. FILED 12-10-2010.

**Type 1 Writer**

THE MARK CONSISTS OF STANDARD CHARACTERS WITHOUT CLAIM TO ANY PARTICULAR FONT, STYLE, SIZE, OR COLOR.

FOR PROVIDING INFORMATION IN THE FIELD OF DIABETES (U.S. CLS. 100 AND 101).  
AISHA CLARKE, EXAMINING ATTORNEY

**CLASS 44—(Continued).**

SN 85-197,201. LIFE Banc, CLEVELAND, OH. FILED 12-14-2010.

**LIFE Banc**

THE MARK CONSISTS OF STANDARD CHARACTERS WITHOUT CLAIM TO ANY PARTICULAR FONT, STYLE, SIZE, OR COLOR.

OWNER OF U.S. REG. NO. 1,560,240.  
FOR ARRANGING FOR THE DONATION AND PROCUREMENT OF HUMAN ORGANS, EYES, AND TISSUES FOR SUBSEQUENT TRANSPLANT, AND ARRANGING FOR BEREAVEMENT SERVICES (U.S. CLS. 100 AND 101).

FIRST USE 8-15-1986; IN COMMERCE 8-15-1986.  
DAWN HAN, EXAMINING ATTORNEY

SN 85-198,416. HEALTH GRADES, INC., DENVER, CO. FILED 12-15-2010.

**GUIDING AMERICANS TO THEIR  
BEST HEALTH**

THE MARK CONSISTS OF STANDARD CHARACTERS WITHOUT CLAIM TO ANY PARTICULAR FONT, STYLE, SIZE, OR COLOR.

OWNER OF U.S. REG. NO. 3,210,435.  
FOR PROVIDING INFORMATION IN THE FIELD OF HEALTH CARE, NAMELY PROFILES, QUALITY OF CARE RATINGS AND SAFETY RATINGS ON HOSPITALS, PHYSICIANS AND NURSING HOMES VIA THE INTERNET; CONSULTING SERVICES IN THE FIELD OF HEALTH CARE, NAMELY HOSPITAL, PHYSICIAN AND NURSING HOME CARE (U.S. CLS. 100 AND 101).

FIRST USE 6-8-2010; IN COMMERCE 6-8-2010.  
KIM SAITO, EXAMINING ATTORNEY

SN 85-202,799. IMIS, PLLC, FT. LAUDERDALE, FL. FILED 12-21-2010.

**IMISSURGERY**

THE MARK CONSISTS OF STANDARD CHARACTERS WITHOUT CLAIM TO ANY PARTICULAR FONT, STYLE, SIZE, OR COLOR.

FOR MEDICAL SERVICES, NAMELY, SPINAL SURGICAL SERVICES (U.S. CLS. 100 AND 101).  
FIRST USE 12-20-2010; IN COMMERCE 12-20-2010.  
ASMAT KHAN, EXAMINING ATTORNEY

**CLASS 44—(Continued).**

SN 85-203,160. THE MAKEUP LAB, NEW ORLEANS, LA.  
FILED 12-21-2010.

themakeupLAB Artistry

THE MARK CONSISTS OF STANDARD CHARACTERS WITHOUT CLAIM TO ANY PARTICULAR FONT, STYLE, SIZE, OR COLOR.

NO CLAIM IS MADE TO THE EXCLUSIVE RIGHT TO USE "ARTISTRY", APART FROM THE MARK AS SHOWN, FOR APPLICATION SERVICES IN THE FIELD OF MAKEUP, NAMELY, IN PERSON MAKEUP CONSULTATION AND MAKEUP APPLICATION; ONLINE MAKEUP CONSULTATION SERVICES; ON-LOCATION MAKEUP APPLICATION SERVICES FOR WEDDINGS, PHOTO SHOTS, FASHION, HORROR EFFECTS, BODY PAINTING, TELEVISION, FILM, AND THEATER (U.S. CLS. 100 AND 101).

FIRST USE 1-18-2009; IN COMMERCE 1-18-2009.  
ADA HAN, EXAMINING ATTORNEY

**CLASS 44—(Continued).**

SN 85-203,697. SAINT LUKE'S HEALTH SYSTEM, INC.,  
KANSAS CITY, MO. FILED 12-22-2010.

NEVER SETTLE

THE MARK CONSISTS OF STANDARD CHARACTERS WITHOUT CLAIM TO ANY PARTICULAR FONT, STYLE, SIZE, OR COLOR.

FOR HOSPITALS; MEDICAL SERVICES; HEALTH-CARE SERVICES (U.S. CLS. 100 AND 101).

DAVID ELTON, EXAMINING ATTORNEY

SN 85-205,265. SAFE SEDATION MANAGEMENT LLC,  
BETHESDA, MD. FILED 12-23-2010.

Aesthesis

THE MARK CONSISTS OF STANDARD CHARACTERS WITHOUT CLAIM TO ANY PARTICULAR FONT, STYLE, SIZE, OR COLOR.

FOR ANESTHESIOLOGY SERVICES; ANESTHESIOLOGY SERVICES, NAMELY CARDIOTHORACIC ANESTHESIOLOGY, CRITICAL CARE, NEUROANESTHESIA, OBSTETRICAL ANESTHESIOLOGY, PAIN MANAGEMENT, PEDIATRIC ANESTHESIOLOGY, AND AMBULATORY ANESTHESIA (U.S. CLS. 100 AND 101).

REGINA DRUMMOND, EXAMINING ATTORNEY

SN 85-205,276. RAFAEL, JOURAK, LOS ANGELES, CA.  
FILED 12-23-2010.

Health & Fitness Through  
Movement & Balance

THE MARK CONSISTS OF STANDARD CHARACTERS WITHOUT CLAIM TO ANY PARTICULAR FONT, STYLE, SIZE, OR COLOR.

FOR PHYSICAL REHABILITATION; PHYSICAL THERAPY (U.S. CLS. 100 AND 101).

FIRST USE 9-8-2010; IN COMMERCE 9-8-2010.  
DAVID TAYLOR, EXAMINING ATTORNEY

SN 85-203,290. MISI, PA, IRVING, TX. FILED 12-21-2010.

MISI

THE MARK CONSISTS OF STANDARD CHARACTERS WITHOUT CLAIM TO ANY PARTICULAR FONT, STYLE, SIZE, OR COLOR.

FOR SURGERY FOR BACK AND NECK CONDITIONS (U.S. CLS. 100 AND 101).

COLLEEN KEARNEY, EXAMINING ATTORNEY

SN 85-203,693. JAY-CREW LANDSCAPE, INC., MUNCIE, IN.  
FILED 12-22-2010.

Building Lasting  
Impressions

THE MARK CONSISTS OF STANDARD CHARACTERS WITHOUT CLAIM TO ANY PARTICULAR FONT, STYLE, SIZE, OR COLOR.

FOR LANDSCAPE DESIGN (U.S. CLS. 100 AND 101).  
EDWARD FENNESSY, EXAMINING ATTORNEY

**CLASS 44—(Continued).**

SN 85-206,148. MERIDIAN HEALTH SYSTEM, INC., NEPTUNE, NJ. FILED 12-27-2010.

**MERIDIAN CANCER CARE**

THE MARK CONSISTS OF STANDARD CHARACTERS WITHOUT CLAIM TO ANY PARTICULAR FONT, STYLE, SIZE, OR COLOR.

OWNER OF U.S. REG. NOS. 2,188,836 AND 2,911,541. NO CLAIM IS MADE TO THE EXCLUSIVE RIGHT TO USE "CANCER CARE", APART FROM THE MARK AS SHOWN.

FOR HOSPITAL SERVICES (U.S. CLS. 100 AND 101).  
FIRST USE 7-0-2010; IN COMMERCE 7-0-2010.  
WENDY GOODMAN, EXAMINING ATTORNEY

---

SN 85-206,420. A WEIGH OF LIFE LLC, WEST BLOOMFIELD, MI. FILED 12-28-2010.

**WHAT'S IN YOUR CART?**

THE MARK CONSISTS OF STANDARD CHARACTERS WITHOUT CLAIM TO ANY PARTICULAR FONT, STYLE, SIZE, OR COLOR.

FOR NUTRITION COUNSELING (U.S. CLS. 100 AND 101).  
FIRST USE 1-1-2010; IN COMMERCE 1-1-2010.  
APRIL ROACH, EXAMINING ATTORNEY

---

SN 85-206,886. HEALTH RESOURCE SOLUTIONS, INC., LOMBARD, IL. FILED 12-28-2010.

**HRS**

THE MARK CONSISTS OF STANDARD CHARACTERS WITHOUT CLAIM TO ANY PARTICULAR FONT, STYLE, SIZE, OR COLOR.

FOR HOME HEALTH CARE SERVICES (U.S. CLS. 100 AND 101).  
FIRST USE 1-1-2008; IN COMMERCE 1-1-2008.  
JOHN GARTNER, EXAMINING ATTORNEY

**CLASS 44—(Continued).**

SN 85-206,939. ULTRATAN, INC., GREENVILLE, SC. FILED 12-29-2010.

**ULTRASKIN**

THE MARK CONSISTS OF STANDARD CHARACTERS WITHOUT CLAIM TO ANY PARTICULAR FONT, STYLE, SIZE, OR COLOR.

FOR BODY WAXING SERVICES; COSMETIC SKIN CARE SERVICES; MASSAGES (U.S. CLS. 100 AND 101).  
FIRST USE 12-10-2010; IN COMMERCE 12-10-2010.  
JOHN SCHUYLER YARD, EXAMINING ATTORNEY

---

SN 85-207,473. RUFFIN' WRANGLERS LLC, PROVIDENCE, RI. FILED 12-29-2010.

**Ruffin' Wranglers**

THE MARK CONSISTS OF STANDARD CHARACTERS WITHOUT CLAIM TO ANY PARTICULAR FONT, STYLE, SIZE, OR COLOR.

FOR PET CARE SERVICES, NAMELY, DOG WALKING, DOG BATHING, NON-MEDICATED PET GROOMING AND IN-HOME MEDICAL CARE (U.S. CLS. 100 AND 101).

FIRST USE 12-19-2010; IN COMMERCE 12-19-2010.  
ANNE E. GUSTASON, EXAMINING ATTORNEY

---

SN 85-207,607. DEPARTMENT OF VETERANS AFFAIRS, WASHINGTON, DC. FILED 12-29-2010.

**BLUE BUTTON**

THE MARK CONSISTS OF STANDARD CHARACTERS WITHOUT CLAIM TO ANY PARTICULAR FONT, STYLE, SIZE, OR COLOR.

FOR PROVIDING INFORMATION IN THE FIELD OF HEALTH; PROVIDING INFORMATION IN THE FIELD OF MEDICINE (U.S. CLS. 100 AND 101).

FIRST USE 8-31-2010; IN COMMERCE 8-31-2010.  
HOWARD B. LEVINE, EXAMINING ATTORNEY



**CLASS 44—(Continued).**

SN 85-207,644. DEPARTMENT OF VETERANS AFFAIRS, WASHINGTON, DC. FILED 12-29-2010.

**CLASS 44—(Continued).**

SN 85-208,220. INTELLECT2, SAN FRANCISCO, CA. FILED 12-30-2010.

**DOWNLOAD MY DATA**

**Tattoo Hotel**

THE MARK CONSISTS OF STANDARD CHARACTERS WITHOUT CLAIM TO ANY PARTICULAR FONT, STYLE, SIZE, OR COLOR.

FOR PROVIDING INFORMATION IN THE FIELD OF HEALTH; PROVIDING INFORMATION IN THE FIELD OF MEDICINE (U.S. CLS. 100 AND 101).

FIRST USE 8-31-2010; IN COMMERCE 8-31-2010.  
HOWARD B. LEVINE, EXAMINING ATTORNEY

THE MARK CONSISTS OF STANDARD CHARACTERS WITHOUT CLAIM TO ANY PARTICULAR FONT, STYLE, SIZE, OR COLOR.

NO CLAIM IS MADE TO THE EXCLUSIVE RIGHT TO USE "TATTOO", APART FROM THE MARK AS SHOWN.

FOR TATTOOING SERVICES (U.S. CLS. 100 AND 101).  
ANGELA M. MICHELI, EXAMINING ATTORNEY

SN 85-208,081. D. MARINA JOHNSON MD, PA, IRVING, TX. FILED 12-30-2010.

SN 85-208,534. ROSENBERG, JUDY, SHERMAN OAKS, CA. FILED 12-31-2010.

**DR. MARINA JOHNSON**

**Be The Cause**

THE MARK CONSISTS OF STANDARD CHARACTERS WITHOUT CLAIM TO ANY PARTICULAR FONT, STYLE, SIZE, OR COLOR.

THE NAME "DR. MARINA JOHNSON" IDENTIFIES A LIVING INDIVIDUAL WHOSE CONSENT IS OF RECORD.

FOR MEDICAL SERVICES (U.S. CLS. 100 AND 101).  
FIRST USE 0-0-1982; IN COMMERCE 0-0-1982.  
KHANH LE, EXAMINING ATTORNEY

THE MARK CONSISTS OF STANDARD CHARACTERS WITHOUT CLAIM TO ANY PARTICULAR FONT, STYLE, SIZE, OR COLOR.

FOR PSYCHOLOGICAL ASSESSMENT SERVICES; PSYCHOLOGICAL CONSULTATION; PSYCHOLOGICAL COUNSELING (U.S. CLS. 100 AND 101).

FIRST USE 1-1-2010; IN COMMERCE 1-1-2010.  
RONALD DELGIZZI, EXAMINING ATTORNEY

SN 85-208,153. ACTIVECARE, INC., SALT LAKE CITY, UT. FILED 12-30-2010.

SN 85-208,684. SOCIALNEXUS, INC., SPANISH FORK, UT. FILED 12-31-2010.

**ActiveHome**

**CancerSocial**

THE MARK CONSISTS OF STANDARD CHARACTERS WITHOUT CLAIM TO ANY PARTICULAR FONT, STYLE, SIZE, OR COLOR.

FOR REMOTE EMERGENCY, CONVENIENCE AND MONITORING SUPPORT SERVICES, NAMELY, REMOTE MONITORING OF THE HEALTH OR CONDITION OF AN INDIVIDUAL OR GROUP OF INDIVIDUALS (U.S. CLS. 100 AND 101).

HENRY S. ZAK, EXAMINING ATTORNEY

THE MARK CONSISTS OF STANDARD CHARACTERS WITHOUT CLAIM TO ANY PARTICULAR FONT, STYLE, SIZE, OR COLOR.

FOR PROVIDING INFORMATION IN THE FIELD OF CANCER PREVENTION, SCREENING, DIAGNOSIS AND TREATMENT (U.S. CLS. 100 AND 101).

FIRST USE 12-30-2010; IN COMMERCE 12-30-2010.  
WENDY JUN, EXAMINING ATTORNEY

**CLASS 44—(Continued).**

SN 85-208,696. SOCIALNEXUS, INC., SPANISH FORK, UT.  
FILED 12-31-2010.

# HealthSocial

THE MARK CONSISTS OF STANDARD CHARACTERS WITHOUT CLAIM TO ANY PARTICULAR FONT, STYLE, SIZE, OR COLOR.

FOR PROVIDING HEALTH INFORMATION (U.S. CLS. 100 AND 101).

FIRST USE 12-30-2010; IN COMMERCE 12-30-2010.  
WENDY JUN, EXAMINING ATTORNEY

SN 85-208,749. SOCIALNEXUS, INC., SPANISH FORK, UT.  
FILED 1-1-2011.

# RecoverySocial

THE MARK CONSISTS OF STANDARD CHARACTERS WITHOUT CLAIM TO ANY PARTICULAR FONT, STYLE, SIZE, OR COLOR.

FOR INTERNET-BASED HEALTH CARE INFORMATION SERVICES (U.S. CLS. 100 AND 101).

FIRST USE 12-30-2010; IN COMMERCE 12-30-2010.  
WENDY JUN, EXAMINING ATTORNEY

SN 85-208,750. SOCIALNEXUS, INC., SPANISH FORK, UT.  
FILED 1-1-2011.

# WeightSocial

THE MARK CONSISTS OF STANDARD CHARACTERS WITHOUT CLAIM TO ANY PARTICULAR FONT, STYLE, SIZE, OR COLOR.

FOR PROVIDING A WEBSITE FEATURING INFORMATION AND ADVICE IN THE FIELDS OF DIET, WEIGHT LOSS, DIET PLANNING AND LIFESTYLE WELLNESS (U.S. CLS. 100 AND 101).

FIRST USE 12-30-2010; IN COMMERCE 12-30-2010.  
WENDY JUN, EXAMINING ATTORNEY

**CLASS 44—(Continued).**

SN 85-208,754. TAKING BEAUTY, LLC, PHILADELPHIA, PA. FILED 1-1-2011.

# AMERICAN MORTALS

THE MARK CONSISTS OF STANDARD CHARACTERS WITHOUT CLAIM TO ANY PARTICULAR FONT, STYLE, SIZE, OR COLOR.

FOR BEAUTY SALONS: HAIRDRESSING SALONS; HAIR CARE SERVICES, NAMELY, HAIR CUTTING, STYLING, COLORING, AND HAIR EXTENSION SERVICES; AND HAIR SALON SERVICES (U.S. CLS. 100 AND 101).

FIRST USE 2-0-2001; IN COMMERCE 2-0-2001.  
MAYUR VAGHANI, EXAMINING ATTORNEY

SN 85-208,970. BE-THIN, INC., DBA THE CENTER FOR MEDICAL WEIGHT LOSS, TARRYTOWN, NY. FILED 1-3-2011.

# Treating what diets can't.

THE MARK CONSISTS OF STANDARD CHARACTERS WITHOUT CLAIM TO ANY PARTICULAR FONT, STYLE, SIZE, OR COLOR.

FOR PROVIDING INFORMATION ON MAINTAINING A HEALTHY LIFESTYLE AND LOSING WEIGHT; PROVIDING WEIGHT LOSS PROGRAM SERVICES; WEIGHT MANAGEMENT SERVICES, NAMELY, PROVIDING WEIGHT LOSS AND/OR WEIGHT MAINTENANCE PROGRAMS; WEIGHT REDUCTION DIET PLANNING AND SUPERVISION (U.S. CLS. 100 AND 101).

FIRST USE 1-1-2011; IN COMMERCE 1-1-2011.  
CHERYL CLAYTON, EXAMINING ATTORNEY

SN 85-208,972. BE-THIN, INC., DBA THE CENTER FOR MEDICAL WEIGHT LOSS, TARRYTOWN, NY. FILED 1-3-2011.

# We treat what diets can't.

THE MARK CONSISTS OF STANDARD CHARACTERS WITHOUT CLAIM TO ANY PARTICULAR FONT, STYLE, SIZE, OR COLOR.

FOR PROVIDING INFORMATION ON MAINTAINING A HEALTHY LIFESTYLE AND LOSING WEIGHT; PROVIDING WEIGHT LOSS PROGRAM SERVICES; WEIGHT MANAGEMENT SERVICES, NAMELY, PROVIDING WEIGHT LOSS AND/OR WEIGHT MAINTENANCE PROGRAMS; WEIGHT REDUCTION DIET PLANNING AND SUPERVISION (U.S. CLS. 100 AND 101).

FIRST USE 1-1-2011; IN COMMERCE 1-1-2011.  
CHERYL CLAYTON, EXAMINING ATTORNEY

**CLASS 44—(Continued).**

SN 85-208,976. BE-THIN, INC., DBA THE CENTER FOR MEDICAL WEIGHT LOSS, TARRYTOWN, NY. FILED 1-3-2011.

## Doctors treat what diets can't.

THE MARK CONSISTS OF STANDARD CHARACTERS WITHOUT CLAIM TO ANY PARTICULAR FONT, STYLE, SIZE, OR COLOR.

FOR PROVIDING INFORMATION ON MAINTAINING A HEALTHY LIFESTYLE AND LOSING WEIGHT; PROVIDING WEIGHT LOSS PROGRAM SERVICES; WEIGHT MANAGEMENT SERVICES, NAMELY, PROVIDING WEIGHT LOSS AND/OR WEIGHT MAINTENANCE PROGRAMS; WEIGHT REDUCTION DIET PLANNING AND SUPERVISION (U.S. CLS. 100 AND 101).

FIRST USE 1-1-2011; IN COMMERCE 1-1-2011.  
CHERYL CLAYTON, EXAMINING ATTORNEY

SN 85-208,977. BE-THIN, INC., DBA THE CENTER FOR MEDICAL WEIGHT LOSS, TARRYTOWN, NY. FILED 1-3-2011.

## Doctors treating what diets can't.

THE MARK CONSISTS OF STANDARD CHARACTERS WITHOUT CLAIM TO ANY PARTICULAR FONT, STYLE, SIZE, OR COLOR.

FOR PROVIDING INFORMATION ON MAINTAINING A HEALTHY LIFESTYLE AND LOSING WEIGHT; PROVIDING WEIGHT LOSS PROGRAM SERVICES; WEIGHT MANAGEMENT SERVICES, NAMELY, PROVIDING WEIGHT LOSS AND/OR WEIGHT MAINTENANCE PROGRAMS; WEIGHT REDUCTION DIET PLANNING AND SUPERVISION (U.S. CLS. 100 AND 101).

FIRST USE 1-1-2011; IN COMMERCE 1-1-2011.  
CHERYL CLAYTON, EXAMINING ATTORNEY

SN 85-209,988. FRANKLIN, EDMOND M., ATLANTA, GA. FILED 1-4-2011.

## Vivid Smile Dental Center

THE MARK CONSISTS OF STANDARD CHARACTERS WITHOUT CLAIM TO ANY PARTICULAR FONT, STYLE, SIZE, OR COLOR.

NO CLAIM IS MADE TO THE EXCLUSIVE RIGHT TO USE "DENTAL CENTER", APART FROM THE MARK AS SHOWN.

FOR DENTIST SERVICES; DENTISTRY (U.S. CLS. 100 AND 101).  
MARIA-VICTORIA SUAREZ, EXAMINING ATTORNEY

**CLASS 44—(Continued).**

SN 85-210,462. LEE CHU, KIT YING, CASTRO VALLEY, CA. FILED 1-4-2011.

## Bling Your Nails

THE MARK CONSISTS OF STANDARD CHARACTERS WITHOUT CLAIM TO ANY PARTICULAR FONT, STYLE, SIZE, OR COLOR.

FOR MANICURING (U.S. CLS. 100 AND 101).  
FIRST USE 9-10-2009; IN COMMERCE 9-10-2009.  
ALICIA COLLINS, EXAMINING ATTORNEY

SN 85-210,819. FERNANDEZ, JERIEL, BRONX, NY. FILED 1-5-2011.



THE MARK CONSISTS OF A TATTOOING MACHINE WITH A PAINT BRUSH IN THE MACHINE'S VICE. THE PAINT BRUSH HAS A TATTOO GRIP NEAR THE BRISTLES.

FOR BODY PIERCING SERVICES; TATTOOING SERVICES (U.S. CLS. 100 AND 101).  
KYLE PEETE, EXAMINING ATTORNEY

SN 85-210,977. MID ATLANTIC CAT SPECIALISTS, LLC, CORDOVA, MD. FILED 1-5-2011.



THE MARK CONSISTS OF A STYLIZED DRAWING OF A FELINE HEAD AND FACE.

FOR VETERINARY SERVICES, NAMELY, MEDICAL, DIAGNOSTIC, AND SURGICAL SERVICES FOR CATS (U.S. CLS. 100 AND 101).

FIRST USE 2-1-1999; IN COMMERCE 2-1-2001.  
GISELLE AGOSTO, EXAMINING ATTORNEY

**CLASS 44—(Continued).**

SN 85-214,317. YOUNGER, COLE, ZEBULON, NC. FILED 1-10-2011.



THE MARK CONSISTS OF A SINGLE TOOTH.  
FOR DENTISTRY (U.S. CLS. 100 AND 101).  
SUNG IN, EXAMINING ATTORNEY

SN 85-222,570. FERNANDEZ, JERIEL, BRONX, NY. FILED 1-20-2011.

## Inflikt Ink

THE MARK CONSISTS OF STANDARD CHARACTERS  
WITHOUT CLAIM TO ANY PARTICULAR FONT, STYLE,  
SIZE, OR COLOR.  
FOR BODY PIERCING SERVICES; TATTOOING (U.S.  
CLS. 100 AND 101).  
KYLE PEETE, EXAMINING ATTORNEY

SN 85-225,795. TRUGREEN LIMITED PARTNERSHIP, MEM-  
PHIS, TN. FILED 1-25-2011.

## AGROLAWN

THE MARK CONSISTS OF STANDARD CHARACTERS  
WITHOUT CLAIM TO ANY PARTICULAR FONT, STYLE,  
SIZE, OR COLOR.  
FOR LAWN, TREE, AND SHRUB CARE (U.S. CLS. 100  
AND 101).  
FIRST USE 1-15-1980; IN COMMERCE 1-15-1980.  
ODESSA BIBBINS, EXAMINING ATTORNEY

**CLASS 44—(Continued).**

SN 85-243,701. PALA BAND OF MISSION INDIANS, DBA  
PALA CASINO, PALA, CA. FILED 2-16-2011.



OWNER OF U.S. REG. NOS. 2,722,138, 2,903,211 AND  
OTHERS.

NO CLAIM IS MADE TO THE EXCLUSIVE RIGHT TO  
USE "SPA", APART FROM THE MARK AS SHOWN.

THE MARK CONSISTS OF TWO SOLID RECTANGLES  
ARRANGED VERTICALLY, WHEREIN THE TOP RECTAN-  
GLE CONTAINS THREE SWIRLS OF VARYING SIZES AND  
THE BOTTOM RECTANGLE CONTAINS THE STYLIZED  
TERM "PALA SPA"; A ROW OF NINE SMALL SOLID  
SQUARES ARE LOCATED ON TOP AND BOTTOM OF  
THE RECTANGLE DESIGN.

THE ENGLISH TRANSLATION OF "PALA" IN THE  
MARK IS "WATER".

FOR HEALTH SPA SERVICES FOR HEALTH AND  
WELLNESS OF THE BODY AND SPIRIT (U.S. CLS. 100  
AND 101).

FIRST USE 8-0-2003; IN COMMERCE 8-0-2003.

KATHY DE JONGE, EXAMINING ATTORNEY

SN 85-248,699. BLUE CROSS AND BLUE SHIELD ASSOCIA-  
TION, AKA BLUECROSS BLUESHIELD ASSOCIATION,  
CHICAGO, IL. FILED 2-22-2011.

## MyBlue

THE MARK CONSISTS OF STANDARD CHARACTERS  
WITHOUT CLAIM TO ANY PARTICULAR FONT, STYLE,  
SIZE, OR COLOR.

FOR HEALTH CARE SERVICES, NAMELY, WELL-  
NESS PROGRAMS (U.S. CLS. 100 AND 101).

ANGELA M. MICHELI, EXAMINING ATTORNEY

**CLASS 44—(Continued).**

SN 85-262,264. URGENT CARES OF AMERICA HOLDINGS, LLC, CLAYTON, NC. FILED 3-9-2011.



THE COLOR(S) PURPLE, WHITE, YELLOW-GOLD AND ORANGE IS/ARE CLAIMED AS A FEATURE OF THE MARK.

THE MARK CONSISTS OF A STYLIZED VERSION OF THE VITRUVIAN MAN IN PURPLE AND WHITE SET INSIDE A CIRCLE OF YELLOW GOLD WHICH IS SET INSIDE AN ORANGE DIAMOND.

FOR HEALTH CARE SERVICES, MEDICAL DIAGNOSTIC SERVICES, MEDICAL SERVICES, RADIOLOGY SERVICES, EMERGENCY MEDICINE SERVICES AND URGENT/IMMEDIATE CARE SERVICES, AMBULATORY CARE CENTERS AND MEDICAL CLINICS (U.S. CLS. 100 AND 101).

KRISTIN CARLSON, EXAMINING ATTORNEY

**CLASS 45—(Continued).**

SN 77-855,378. STEWART TITLE GUARANTY COMPANY, HOUSTON, TX. FILED 10-22-2009.



OWNER OF U.S. REG. NOS. 1,871,543, 3,733,688 AND OTHERS.

NO CLAIM IS MADE TO THE EXCLUSIVE RIGHT TO USE "AGENCY", "SECURE", AND "FRAUD AND TITLE CLAIM PREVENTION", APART FROM THE MARK AS SHOWN.

THE MARK CONSISTS OF A PICTURE OF A LOCK IN THE CENTER OF A CIRCLE AND "AGENCY" WRITTEN ABOVE THE LOCK WITHIN THE CIRCLE AND "SECURE" WRITTEN BELOW THE LOCK WITHIN THE CIRCLE. TO THE RIGHT SIDE OF THIS CIRCLE ARE THE WORDS "STEWART FRAUD AND TITLE CLAIM PREVENTION" INSIDE A CURVED BOX.

FOR REAL ESTATE SETTLEMENT SERVICES, NAMELY, FACILITATING REAL ESTATE TRANSACTIONS FOR SECURITY PURPOSES BY MONITORING ESCROW ACCOUNTS, FILE INFORMATION, PROPERTY INFORMATION AND FRAUD ALERT DATABASES TO ASSIST AGENCIES INVOLVED IN THE TRANSACTION BY SAFEGUARDING AGAINST LOSSES AND CLAIMS RESULTING FROM FRAUD OR SUSPICIOUS ACTIVITY BY INTERNAL OR EXTERNAL PARTIES (U.S. CLS. 100 AND 101).

MARC LEIPZIG, EXAMINING ATTORNEY

SN 77-865,888. HOSPICE BRAZOS VALLEY, INC., BRYAN, TX. FILED 11-5-2009.

**HOSPICE BRAZOS VALLEY**

THE MARK CONSISTS OF STANDARD CHARACTERS WITHOUT CLAIM TO ANY PARTICULAR FONT, STYLE, SIZE, OR COLOR.

NO CLAIM IS MADE TO THE EXCLUSIVE RIGHT TO USE "HOSPICE", APART FROM THE MARK AS SHOWN. SEC. 2(F).

FOR BEREAVEMENT CONSULTING; BEREAVEMENT COUNSELING; GRIEF COUNSELING; PASTORAL COUNSELING; SPIRITUAL COUNSELING; MINISTERIAL SERVICES; ORGANIZING, COORDINATING AND CONDUCTING CEREMONIES AND MEMORIAL SERVICES FOR BEREAVED FAMILIES, VOLUNTEERS AND CARE GIVERS TO COMMEMORATE THE DEATH OF A LOVED ONE; ORGANIZING BEREAVEMENT CAMPS FOR INDIVIDUALS WHO HAVE EXPERIENCED THE DEATH OF A LOVED ONE; ORGANIZING, COORDINATING AND CONDUCTING SUPPORT GROUPS FOR INDIVIDUALS AND FAMILIES WHO HAVE EXPERIENCED THE DEATH OF A LOVED ONE; ORGANIZING, COORDINATING AND CONDUCTING SUPPORT GROUPS FOR INDIVIDUALS AND FAMILIES IN THE FIELDS OF DEATH, DYING AND BEREAVEMENT; MATCHING INDIVIDUALS WITH A LIFE-LIMITING OR LIFE-THREATENING HEALTH CONDITION AND THEIR FAMILIES WITH OTHER INDIVIDUALS AND FAMILIES WHO HAVE EXPERIENCED THE SAME OR A SIMILAR HEALTH CONDITION FOR THE PURPOSE OF EMOTIONAL SUPPORT; SOCIAL SERVICES, NAMELY, COMPANIONSHIP SERVICES FOR INDIVI-

**CLASS 45—PERSONAL AND LEGAL SERVICES**

SN 77-479,222. MOTION PICTURE LICENSING CORPORATION, LOS ANGELES, CA. FILED 5-20-2008.

**UMBRELLA LICENSE**

THE MARK CONSISTS OF STANDARD CHARACTERS WITHOUT CLAIM TO ANY PARTICULAR FONT, STYLE, SIZE, OR COLOR.

OWNER OF U.S. REG. NO. 2,610,843.

NO CLAIM IS MADE TO THE EXCLUSIVE RIGHT TO USE "LICENSE", APART FROM THE MARK AS SHOWN. SEC. 2(F).

FOR BLANKET LICENSING OF PERFORMANCE RIGHTS TO MOTION PICTURES AND OTHER AUDIO-VISUAL PROGRAMS (U.S. CLS. 100 AND 101).

FIRST USE 12-1-1986; IN COMMERCE 12-1-1986.

LAURIE MAYES, EXAMINING ATTORNEY

**CLASS 45—(Continued).**

DUALS UNDER HOSPICE CARE AND THEIR FAMILIES; PROVIDING PATIENT ADVOCATE SERVICES TO PATIENTS WITH LIFE-LIMITING OR LIFE-THREATENING ILLNESSES; PROVIDING PERSONAL CARE ASSISTANCE TO INDIVIDUALS WITH LIFE-LIMITING OR LIFE-THREATENING ILLNESSES, NAMELY, PROVIDING ASSISTANCE WITH BATHING, GROOMING, PERSONAL MOBILITY, AND ACTIVITIES OF DAILY LIVING; PROVIDING GRIEF AND BEREAVEMENT SUPPORT TO INDIVIDUALS WITH LIFE-LIMITING OR LIFE-THREATENING ILLNESSES AND THEIR FAMILIES; AND PROVIDING PERSONAL SUPPORT SERVICES AND IN-HOME SUPPORT SERVICES TO INDIVIDUALS WITH LIFE-LIMITING AND LIFE-THREATENING DISORDERS AND THEIR FAMILIES, NAMELY, ASSISTING WITH PERFORMANCE OF DAILY PERSONAL TASKS IN THE HOUSEHOLD, ASSISTING INDIVIDUALS TO PERFORM DAILY TASKS, RUNNING ERRANDS, HELP WITH MEDICAL FORMS, COMPANIONSHIP, EMOTIONAL COUNSELING AND EMOTIONAL SUPPORT (U.S. CLS. 100 AND 101).

FIRST USE 4-0-1994; IN COMMERCE 4-0-1994.  
CHARLOTTE CORWIN, EXAMINING ATTORNEY

**CLASS 45—(Continued).**

DUALS UNDER HOSPICE CARE AND THEIR FAMILIES; PROVIDING PATIENT ADVOCATE SERVICES TO PATIENTS WITH LIFE-LIMITING OR LIFE-THREATENING ILLNESSES; PROVIDING PERSONAL CARE ASSISTANCE TO INDIVIDUALS WITH LIFE-LIMITING OR LIFE-THREATENING ILLNESSES, NAMELY, PROVIDING ASSISTANCE WITH BATHING, GROOMING, PERSONAL MOBILITY, AND ACTIVITIES OF DAILY LIVING; PROVIDING GRIEF AND BEREAVEMENT SUPPORT TO INDIVIDUALS WITH LIFE-LIMITING OR LIFE-THREATENING ILLNESSES AND THEIR FAMILIES; AND PROVIDING PERSONAL SUPPORT SERVICES AND IN-HOME SUPPORT SERVICES TO INDIVIDUALS WITH LIFE-LIMITING AND LIFE-THREATENING DISORDERS AND THEIR FAMILIES, NAMELY, ASSISTING WITH PERFORMANCE OF DAILY PERSONAL TASKS IN THE HOUSEHOLD, ASSISTING INDIVIDUALS TO PERFORM DAILY TASKS, RUNNING ERRANDS, HELP WITH MEDICAL FORMS, COMPANIONSHIP, EMOTIONAL COUNSELING AND EMOTIONAL SUPPORT (U.S. CLS. 100 AND 101).

FIRST USE 0-0-1997; IN COMMERCE 0-0-1997.  
CHARLOTTE CORWIN, EXAMINING ATTORNEY

SN 77-866,065. HOSPICE BRAZOS VALLEY, INC., BRYAN, TX. FILED 11-5-2009.

SN 77-866,216. HOSPICE BRAZOS VALLEY, INC., BRYAN, TX. FILED 11-5-2009.



NO CLAIM IS MADE TO THE EXCLUSIVE RIGHT TO USE "HOSPICE", APART FROM THE MARK AS SHOWN.

THE MARK CONSISTS OF A TREE AND BUILDINGS DISPOSED INSIDE OF AN OVAL WITH THE WORDS "HOSPICE BRAZOS VALLEY" DISPOSED ABOVE THE OVAL.

SEC. 2(F) AS TO "HOSPICE BRAZOS VALLEY".

FOR BEREAVEMENT CONSULTING; BEREAVEMENT COUNSELING; GRIEF COUNSELING; PASTORAL COUNSELING; SPIRITUAL COUNSELING; MINISTERIAL SERVICES; ORGANIZING, COORDINATING AND CONDUCTING CEREMONIES AND MEMORIAL SERVICES FOR BEREAVED FAMILIES, VOLUNTEERS AND CARE GIVERS TO COMMEMORATE THE DEATH OF A LOVED ONE; ORGANIZING BEREAVEMENT CAMPS FOR INDIVIDUALS WHO HAVE EXPERIENCED THE DEATH OF A LOVED ONE; ORGANIZING, COORDINATING AND CONDUCTING SUPPORT GROUPS FOR INDIVIDUALS AND FAMILIES WHO HAVE EXPERIENCED THE DEATH OF A LOVED ONE; ORGANIZING, COORDINATING AND CONDUCTING SUPPORT GROUPS FOR INDIVIDUALS AND FAMILIES IN THE FIELDS OF DEATH, DYING AND BEREAVEMENT; MATCHING INDIVIDUALS WITH A LIFE-LIMITING OR LIFE-THREATENING HEALTH CONDITION AND THEIR FAMILIES WITH OTHER INDIVIDUALS AND FAMILIES WHO HAVE EXPERIENCED THE SAME OR A SIMILAR HEALTH CONDITION FOR THE PURPOSE OF EMOTIONAL SUPPORT; SOCIAL SERVICES, NAMELY, COMPANIONSHIP SERVICES FOR INDIVI-

THE MARK CONSISTS OF A TREE AND BUILDINGS DISPOSED INSIDE OF AN OVAL.

FOR BEREAVEMENT CONSULTING; BEREAVEMENT COUNSELING; GRIEF COUNSELING; PASTORAL COUNSELING; SPIRITUAL COUNSELING; MINISTERIAL SERVICES; ORGANIZING, COORDINATING AND CONDUCTING CEREMONIES AND MEMORIAL SERVICES FOR BEREAVED FAMILIES, VOLUNTEERS AND CARE GIVERS TO COMMEMORATE THE DEATH OF A LOVED ONE; ORGANIZING BEREAVEMENT CAMPS FOR INDIVIDUALS WHO HAVE EXPERIENCED THE DEATH OF A LOVED ONE; ORGANIZING, COORDINATING AND CONDUCTING SUPPORT GROUPS FOR INDIVIDUALS AND FAMILIES WHO HAVE EXPERIENCED THE DEATH OF A LOVED ONE; ORGANIZING, COORDINATING AND CONDUCTING SUPPORT GROUPS FOR INDIVIDUALS AND FAMILIES IN THE FIELDS OF DEATH, DYING AND BEREAVEMENT; MATCHING INDIVIDUALS WITH A LIFE-LIMITING OR LIFE-THREATENING HEALTH CONDITION AND THEIR FAMILIES WITH OTHER INDIVIDUALS AND FAMILIES WHO HAVE EXPERIENCED THE SAME OR A SIMILAR HEALTH CONDITION FOR THE PURPOSE OF EMOTIONAL SUPPORT; SOCIAL SERVICES, NAMELY, COMPANIONSHIP SERVICES FOR INDIVI-

**CLASS 45—(Continued).**

DUALS UNDER HOSPICE CARE AND THEIR FAMILIES; PROVIDING PATIENT ADVOCATE SERVICES TO PATIENTS WITH LIFE-LIMITING OR LIFE-THREATENING ILLNESSES; PROVIDING PERSONAL CARE ASSISTANCE TO INDIVIDUALS WITH LIFE-LIMITING OR LIFE-THREATENING ILLNESSES, NAMELY, PROVIDING ASSISTANCE WITH BATHING, GROOMING, PERSONAL MOBILITY, AND ACTIVITIES OF DAILY LIVING; PROVIDING GRIEF AND BEREAVEMENT SUPPORT TO INDIVIDUALS WITH LIFE-LIMITING OR LIFE-THREATENING ILLNESSES AND THEIR FAMILIES; AND PROVIDING PERSONAL SUPPORT SERVICES AND IN-HOME SUPPORT SERVICES TO INDIVIDUALS WITH LIFE-LIMITING AND LIFE-THREATENING DISORDERS AND THEIR FAMILIES, NAMELY, ASSISTING WITH PERFORMANCE OF DAILY PERSONAL TASKS IN THE HOUSEHOLD, ASSISTING INDIVIDUALS TO PERFORM DAILY TASKS, RUNNING ERRANDS, HELP WITH MEDICAL FORMS, COMPANIONSHIP, EMOTIONAL COUNSELING AND EMOTIONAL SUPPORT (U.S. CLS. 100 AND 101).

FIRST USE 0-0-1997; IN COMMERCE 0-0-1997.  
CHARLOTTE CORWIN, EXAMINING ATTORNEY

SN 77-937,343. THE CRADLE SOCIETY, EVANSTON, IL. FILED 2-17-2010.



THE COLOR(S) BLACK AND BLUE IS/ARE CLAIMED AS A FEATURE OF THE MARK.  
THE MARK CONSISTS OF THE "CRADLE" IN BLACK TEXT WITH A BLUE "C".

FOR ADOPTION PLACEMENT SERVICES AND ADOPTION AGENCY SERVICES (U.S. CLS. 100 AND 101).

FIRST USE 0-0-1993; IN COMMERCE 0-0-1993.  
DORITT L. CARROLL, EXAMINING ATTORNEY

SN 77-947,073. PELZMAN, BRIAN M., OCALA, FL. FILED 3-1-2010.



NO CLAIM IS MADE TO THE EXCLUSIVE RIGHT TO USE "INTERNATIONAL", APART FROM THE MARK AS SHOWN.

THE COLOR(S) BLACK, GRAY, GOLD, TAN, BLUE, AND WHITE IS/ARE CLAIMED AS A FEATURE OF THE MARK.  
THE MARK CONSISTS OF BLACK BACKGROUND; GOLD CIRCULAR BORDER WITH TAN COG-LIKE OUTLINE; BLUE SHIELD OUTLINED IN GOLD WITH GRAY

**CLASS 45—(Continued).**

CROSSED SABERS IN FRONT OF SHIELD AND ONE GOLD STAR AT THE BOTTOM OF THE SHIELD; LARGE BLACK "Z" IN FRONT OF THE CROSSED SABERS; THREE BRANCHES WITH GOLD LEAVES, ONE ABOVE THE SHIELD AND ONE ON EITHER SIDE OF THE BOTTOM OF THE SHIELD; GOLD MILITARY EMBLEM BELOW SHIELD WITH SIX GOLD STARS ON EITHER SIDE OF EMBLEM; "ZEROHAWK INTERNATIONAL" IN WHITE INSIDE OUTER GOLD RING, BETWEEN OUTER GOLD RING AND UPPER GOLD BRANCH WITH LEAVES.

FOR ADVISORY SERVICES IN THE FIELD OF HOME SECURITY SYSTEMS; COMPUTER SECURITY SERVICES IN THE NATURE OF PROVIDING AN INTERNET TRUST CENTER, NAMELY, COMPUTER SECURITY ASSURANCE AND ADMINISTRATION OF DIGITAL KEYS AND DIGITAL CERTIFICATES; COMPUTERIZED SECURITY SERVICES, NAMELY, ELECTRONICALLY MONITORING, DETECTING AND REPORTING ON SUSPICIOUS AND ABNORMAL PATTERNS OF POINT OF SALE ACTIVITY WHICH TYPICALLY INDICATE PROBLEMS SUCH AS THEFT, WRONGDOING, TRAINING ISSUES, OR CUSTOMER SERVICE ISSUES; CONSULTANCY SERVICES IN THE FIELD OF HOME SECURITY; CONSULTATION SERVICES CONCERNING HOMELAND SAFETY AND SECURITY ISSUES; CONSULTING SERVICES IN THE FIELD OF MAINTAINING THE SECURITY AND INTEGRITY OF DATABASES; CONSULTING SERVICES IN THE FIELD OF NATIONAL SECURITY; EMERGENCY RESPONSE ALARM MONITORING SERVICES, NAMELY, MONITORING OF ALERT DEVICES BY A REMOTE MONITORING CENTER FOR THE DISPATCH OF EMERGENCY PUBLIC HEALTH AND SECURITY SERVICES AND NOTIFICATION TO THIRD PARTIES; IDENTIFICATION VERIFICATION SERVICES, NAMELY, PROVIDING AUTHENTICATION OF PERSONAL IDENTIFICATION INFORMATION VIA SECURE STORAGE AND TRANSMITTING SUCH INFORMATION VIA THE INTERNET; INVESTIGATION OF ASSETS, CREDIT REPORTS, FISCAL ASSESSMENTS, AND COLLECTION REPORTS FOR SECURITY OR AUTHENTICATION PURPOSES; LEASING OF ELECTRONIC TRACKING DEVICES FOR USE IN CONNECTION WITH HOMELAND SECURITY; MONITORING OF COMPUTER SYSTEMS FOR SECURITY PURPOSES; MONITORING SECURITY SYSTEMS; PERSONAL SECURITY CONSULTATION; PROVIDING A WEB SITE FEATURING INFORMATION IN THE FIELD OF SECURITY; PROVIDING INFORMATION CONCERNING HOMELAND SAFETY AND SECURITY ISSUES; PROVIDING INFORMATION IN THE FIELD OF PERSONAL PHYSICAL SECURITY; PROVIDING NEWS CONCERNING HOMELAND SAFETY AND SECURITY ISSUES; SECURITY CONSULTANCY; SECURITY CONTROL OF PERSONS AND LUGGAGE IN AIRPORTS; SECURITY DUE DILIGENCE SERVICES FOR INDIVIDUALS OR BUSINESSES TRAVELING OR OPENING AN OFFICE OVERSEAS, IN THE NATURE OF DETAILED FOREIGN COUNTRY BRIEFINGS, VETTING OF LOCAL PERSONNEL, ESTABLISHING HOST COUNTRY GOVERNMENT CONTACTS, AND PROVIDING INFORMATION ON SUSTAINABLE SECURITY MEASURES OVERSEAS; SECURITY GUARDING FOR FACILITIES; SECURITY INSPECTION SERVICES FOR OTHERS; SECURITY SERVICES FOR BUILDINGS, NAMELY, PROVIDING PHYSICAL ACCESS TO PROPERTIES VIA A REMOTE CALL-IN LOCKING DEVICE; SECURITY SERVICES, NAMELY, CONDUCTING RECOVERY OPERATIONS FOR THE RECOVERY OF PROPERTY AND PERSONNEL; SECURITY SERVICES, NAMELY, PROVIDING EXECUTIVE PROTECTION; SECURITY SERVICES, NAMELY, PROVIDING SECURITY ASSESSMENTS FOR BUSINESSES AND GOVERNMENTAL AGENCIES; SECURITY SERVICES, NAMELY, PROVIDING SECURITY ASSESSMENTS OF PHYSICAL LOCATIONS, INFORMATION SYSTEMS, AND WORKING ENVIRONMENTS; SECURITY SERVICES, NAMELY, THREAT SIMULATION VULNERABILITY ANALYSIS AND MITIGATION AND EMERGENCY AND CRISIS RESPONSE (U.S. CLS. 100 AND 101).

FIRST USE 2-15-2010; IN COMMERCE 2-15-2010.  
EUGENIA MARTIN, EXAMINING ATTORNEY

**CLASS 45—(Continued).**

SN 79-092,081. DOT COM VENTURES PTY LTD, AUSTRALIA, FILED 12-21-2010.

**LoveID**

THE MARK CONSISTS OF STANDARD CHARACTERS WITHOUT CLAIM TO ANY PARTICULAR FONT, STYLE, SIZE, OR COLOR.

OWNER OF INTERNATIONAL REGISTRATION 1063783 DATED 12-21-2010, EXPIRES 12-21-2020.

FOR DATING AND SOCIAL INTRODUCTION SERVICES PROVIDED VIA ONLINE PERSONAL ADVERTISEMENTS (U.S. CLS. 100 AND 101).

KRISTINA MORRIS, EXAMINING ATTORNEY

---

SN 85-036,283. MED QUEST, LTD, NEW YORK, NY. FILED 5-12-2010.

**CURBSIDE COUNSEL**

THE MARK CONSISTS OF STANDARD CHARACTERS WITHOUT CLAIM TO ANY PARTICULAR FONT, STYLE, SIZE, OR COLOR.

NO CLAIM IS MADE TO THE EXCLUSIVE RIGHT TO USE "COUNSEL", APART FROM THE MARK AS SHOWN.

FOR EXPERT WITNESS SERVICES IN LEGAL MATTERS IN THE FIELD OF MEDICINE; LITIGATION SUPPORT SERVICES (U.S. CLS. 100 AND 101).

FIRST USE 4-6-2010; IN COMMERCE 4-6-2010.  
JASON TURNER, EXAMINING ATTORNEY

---

SN 85-039,513. GARLAND, MYRENE, CHICAGO, IL. FILED 5-15-2010.

**CRAVING PASSION**

THE MARK CONSISTS OF STANDARD CHARACTERS WITHOUT CLAIM TO ANY PARTICULAR FONT, STYLE, SIZE, OR COLOR.

FOR LEGAL SERVICES; SECURITY SERVICES, NAMELY, SECURITY GUARD SERVICES FOR THE PROTECTION OF PROPERTY AND INDIVIDUALS; PERSONAL AND SOCIAL SERVICES FOR CONSUMERS, NAMELY, ON-LINE SOCIAL NETWORKING SERVICES (U.S. CLS. 100 AND 101).

SHAUNIA CARLYLE, EXAMINING ATTORNEY

**CLASS 45—(Continued).**

SN 85-044,538. HOLOBI, LLC, BOTHELL, WA. FILED 5-21-2010.



THE COLOR(S) SILVER, RED, GREEN, BLUE, BLACK AND WHITE IS/ARE CLAIMED AS A FEATURE OF THE MARK.

THE MARK CONSISTS OF THE BLACK WORDING "D.R.E.S.", BENEATH WHICH APPEARS THE BLACK WORDING "DIAMOND RUBY EMERALD SAPPHIRE", BENEATH WHICH APPEARS, FROM LEFT TO RIGHT, A SILVER DIAMOND IN THE SHAPE OF AN HOURGLASS, A RED RUBY IN THE SHAPE OF AN INVERTED PYRAMID, A GREEN EMERALD IN THE SHAPE OF A RECTANGLE AND A BLUE SAPPHIRE IN THE SHAPE OF A PYRAMID, EACH OF WHICH HAVING BEVELED CORNERS AND EACH OF WHICH HAVING SUPERIMPOSED OVER IT A BLACK AND WHITE REPRESENTATION OF A WOMAN WITH A BODY SHAPE CORRESPONDING TO THE SHAPE OF THE PARTICULAR GEM STONE.

FOR PERSONAL WARDROBE STYLING SERVICES, NAMELY, COORDINATION CONSULTATION SERVICES FOR CLOTHING, FASHION ACCESSORIES, TRAVEL WARDROBE PLANNING, WARDROBE MAKEOVER, WARDROBE CLOTHING MANAGEMENT AND CONSULTATION SERVICES; BODY SHAPE ASSESSMENT CONSULTING SERVICES FOR WARDROBE AND FASHION SELECTION (U.S. CLS. 100 AND 101).

FIRST USE 5-20-2010; IN COMMERCE 5-20-2010.  
AMY C. KEAN, EXAMINING ATTORNEY

---

SN 85-051,454. MAPLES INTERNATIONAL HOLDINGS LIMITED, GRAND CAYMAN, CAYMAN ISLANDS, FILED 6-1-2010.

**MAPLES**

THE MARK CONSISTS OF STANDARD CHARACTERS WITHOUT CLAIM TO ANY PARTICULAR FONT, STYLE, SIZE, OR COLOR.

FOR LEGAL SERVICES, NAMELY, PROVIDING ADVICE ON APPLICABLE LAWS IN THE CAYMAN ISLANDS, BRITISH VIRGIN ISLANDS AND IRELAND (U.S. CLS. 100 AND 101).

AMY KERTGATE, EXAMINING ATTORNEY



**CLASS 45—(Continued).**

SN 85-052,992. JAVAHERI, PJ, CENTURY CITY, CA. FILED 6-2-2010.

**Bigger is not Better.  
Better is Better.**

THE MARK CONSISTS OF STANDARD CHARACTERS WITHOUT CLAIM TO ANY PARTICULAR FONT, STYLE, SIZE, OR COLOR.

FOR LEGAL SERVICES (U.S. CLS. 100 AND 101).  
FIRST USE 5-25-2010; IN COMMERCE 5-25-2010.  
JOHN SCHUYLER YARD, EXAMINING ATTORNEY

SN 85-088,443. PERRY, MARKAARON, ATTLEBORO, MA. FILED 7-20-2010.

**NORTH POLE POSTMAN**

THE MARK CONSISTS OF STANDARD CHARACTERS WITHOUT CLAIM TO ANY PARTICULAR FONT, STYLE, SIZE, OR COLOR.

FOR PREPARATION IN THE NATURE OF PERSONAL LETTER WRITING OF CHRISTMAS-SEASON LETTERS, NOTES AND CARDS (U.S. CLS. 100 AND 101).  
ANDREA HACK, EXAMINING ATTORNEY

SN 85-091,150. PATRICK J.S. INOUYE, P.S., SEATTLE, WA. FILED 7-22-2010.

**CASCADIA IP**

THE MARK CONSISTS OF STANDARD CHARACTERS WITHOUT CLAIM TO ANY PARTICULAR FONT, STYLE, SIZE, OR COLOR.

OWNER OF U.S. REG. NO. 3,315,498.  
NO CLAIM IS MADE TO THE EXCLUSIVE RIGHT TO USE "IP", APART FROM THE MARK AS SHOWN.  
FOR LEGAL SERVICES; LEGAL COUNSELING IN THE FIELD OF INTELLECTUAL PROPERTY AND RELATED FIELDS (U.S. CLS. 100 AND 101).  
FIRST USE 7-22-2010; IN COMMERCE 7-22-2010.  
CHRISTINA SOBRAL, EXAMINING ATTORNEY

**CLASS 45—(Continued).**

SN 85-092,258. SNABBO, INC., DALLAS, TX. FILED 7-24-2010.

**SNABBO SELECT**

THE MARK CONSISTS OF STANDARD CHARACTERS WITHOUT CLAIM TO ANY PARTICULAR FONT, STYLE, SIZE, OR COLOR.

OWNER OF U.S. REG. NO. 3,702,933.  
FOR SOCIAL NETWORKING SERVICES, NAMELY, PROVIDING AN ONLINE COMMUNITY FOR REGISTERED USERS TO CREATE A PERSONAL PROFILE OUTLINING THEIR PAST HISTORY OF NAMES THEY WERE KNOWN AS, HOMETOWNS THEY LIVED IN, SCHOOLS THEY ATTENDED, ORGANIZATIONS/CLUBS OF WHICH THEY WERE MEMBERS, COMPANIES THEY WORKED FOR, USE A PHOTOGRAPH TAKEN DURING THE 1950'S, 1960'S, 1970'S, 1980'S OR 1990'S AS THEIR PROFILE PHOTOGRAPH, SEARCH FOR PEOPLE, PARTICIPATE IN DISCUSSIONS, JOIN AN ONLINE CLUB, GET FEEDBACK FROM THEIR PEERS, FORM VIRTUAL COMMUNITIES, BLOG, DISCOVER RELATIONSHIP POSSIBILITIES, BE ENTERTAINED BY VIEWING NOSTALGIA IN THE FORM OF OLD PHOTOGRAPHS AND VINTAGE ADVERTISING AND ENGAGE IN SOCIAL NETWORKING (U.S. CLS. 100 AND 101).

MATTHEW KLINE, EXAMINING ATTORNEY

SN 85-116,189. LISA NICOLE POOLE, NEW YORK, NY. FILED 8-26-2010.

**THRIFT STORE CONFIDENTIAL**

THE MARK CONSISTS OF STANDARD CHARACTERS WITHOUT CLAIM TO ANY PARTICULAR FONT, STYLE, SIZE, OR COLOR.

NO CLAIM IS MADE TO THE EXCLUSIVE RIGHT TO USE "THRIFT STORE", APART FROM THE MARK AS SHOWN.

FOR INFORMATION SERVICES, NAMELY, PROVIDING A WEB SITE FEATURING AUDIO, VIDEO, PHOTOGRAPHIC AND PROSE PRESENTATIONS FEATURING INFORMATION GEARED TOWARDS PERSONAL WARDROBE AND STYLING WHILE STAYING ON A BUDGET AND UTILIZING THRIFT STORES (U.S. CLS. 100 AND 101).

FIRST USE 2-11-2009; IN COMMERCE 2-11-2009.  
BRENDAN MCCAULEY, EXAMINING ATTORNEY

**CLASS 45—(Continued).**

SN 85-121,780. ZARZAND, INC., BEAVERTON, OR. FILED 9-2-2010.

# ZARZAND

THE MARK CONSISTS OF STANDARD CHARACTERS WITHOUT CLAIM TO ANY PARTICULAR FONT, STYLE, SIZE, OR COLOR.

THE WORDING "ZARZAND" HAS NO MEANING OTHER THAN TRADEMARK SIGNIFICANCE.

FOR PROVIDING A WEBSITE IN THE FIELD OF SOCIAL AND NON-MEDICAL ADVICE REGARDING PERSONAL RELATIONSHIPS AND SEXUALITY (U.S. CLS. 100 AND 101).

TRACY CROSS, EXAMINING ATTORNEY

---

SN 85-121,790. ZARZAND, INC., BEAVERTON, OR. FILED 9-2-2010.

WHERE SENSE & SENSUALITY  
MEET

THE MARK CONSISTS OF STANDARD CHARACTERS WITHOUT CLAIM TO ANY PARTICULAR FONT, STYLE, SIZE, OR COLOR.

FOR PROVIDING A WEBSITE IN THE FIELD OF SOCIAL AND NON-MEDICAL ADVICE REGARDING PERSONAL RELATIONSHIPS AND SEXUALITY (U.S. CLS. 100 AND 101).

TRACY CROSS, EXAMINING ATTORNEY

---

SN 85-138,251. WILLIAMS, SUSAN L., GREENFIELD, MA. AND THOMAS, JONATHAN, NORTHAMPTON, MA. FILED 9-25-2010.

# Family Redesign

THE MARK CONSISTS OF STANDARD CHARACTERS WITHOUT CLAIM TO ANY PARTICULAR FONT, STYLE, SIZE, OR COLOR.

NO CLAIM IS MADE TO THE EXCLUSIVE RIGHT TO USE "FAMILY", APART FROM THE MARK AS SHOWN.

FOR COUNSELING IN THE FIELD OF DEVELOPING, STRENGTHENING AND SUSTAINING WELL-BALANCED FAMILIES AND FAMILY RELATIONSHIPS (U.S. CLS. 100 AND 101).

FIRST USE 7-17-2009; IN COMMERCE 7-17-2009.  
BRIAN NEVILLE, EXAMINING ATTORNEY

**CLASS 45—(Continued).**

SN 85-151,149. M.A.V. MEDIA WORKS, L.L.C., PORT SAINT LUCIE, FL. FILED 10-12-2010.

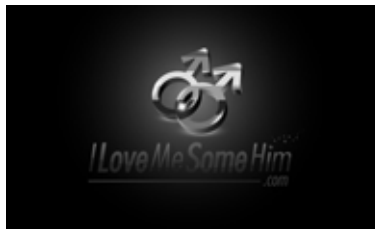

NO CLAIM IS MADE TO THE EXCLUSIVE RIGHT TO USE ".COM", APART FROM THE MARK AS SHOWN.

THE MARK CONSISTS OF THE WORDS "ILOVEME-SOMEHIM" WITH A SERIES OF HEARTS FORMING THE DOT OVER THE LETTER "I". A LINE APPEARS BENEATH THE WORDING FOLLOWED BY ".COM" AND ABOVE THE WORDING ARE INTERLOCKING MALE BIOLOGICAL SYMBOLS AND ALL OF WHICH APPEAR UPON A RECTANGLE.

FOR INTERNET BASED SOCIAL NETWORKING, INTRODUCTION, AND DATING SERVICES (U.S. CLS. 100 AND 101).

FIRST USE 2-27-2009; IN COMMERCE 2-27-2009.  
EDWARD NELSON, EXAMINING ATTORNEY

---

SN 85-164,838. HOWE-PETERSON, INC., DEARBORN, MI. FILED 10-29-2010.

# EXPERIENCE OF FAMILY

THE MARK CONSISTS OF STANDARD CHARACTERS WITHOUT CLAIM TO ANY PARTICULAR FONT, STYLE, SIZE, OR COLOR.

FOR FUNERAL HOMES (U.S. CLS. 100 AND 101).

FIRST USE 7-15-2001; IN COMMERCE 7-15-2001.

SKYE YOUNG, EXAMINING ATTORNEY

---

SN 85-171,299. SHARE M2, LLC, BERRYVILLE, VA. FILED 11-8-2010.

*Treatment diaries!*  
Your Diary. Shared Healing.

NO CLAIM IS MADE TO THE EXCLUSIVE RIGHT TO USE "TREATMENT DIARIES", APART FROM THE MARK AS SHOWN.

THE MARK CONSISTS OF THE STYLIZED TEXT "TREATMENT DIARIES! YOUR DIARY. SHARED HEALING."

FOR ON-LINE SOCIAL NETWORKING SERVICES (U.S. CLS. 100 AND 101).

FIRST USE 3-1-2010; IN COMMERCE 8-23-2010.  
HOWARD SMIGA, EXAMINING ATTORNEY

**CLASS 45—(Continued).**

SN 85-172,965. BIALYS, MICHAEL K, CANYON COUNTRY, CA. FILED 11-9-2010.

**The DUI DUDE**

THE MARK CONSISTS OF STANDARD CHARACTERS WITHOUT CLAIM TO ANY PARTICULAR FONT, STYLE, SIZE, OR COLOR.

NO CLAIM IS MADE TO THE EXCLUSIVE RIGHT TO USE "DUI", APART FROM THE MARK AS SHOWN.  
FOR LITIGATION SERVICES (U.S. CLS. 100 AND 101).  
WON TEAK OH, EXAMINING ATTORNEY

SN 85-174,049. CONGLOMERATE MARKETING LLC, WOODLAND HILLS, CA. FILED 11-10-2010.

**ADULTSPACE**

THE MARK CONSISTS OF STANDARD CHARACTERS WITHOUT CLAIM TO ANY PARTICULAR FONT, STYLE, SIZE, OR COLOR.

FOR WEB SITE SERVICES FEATURING ON-LINE DATING CLUB; ONLINE SOCIAL NETWORKING IN THE FIELD DATING AND PROMISCUITY; INTERNET-BASED SOCIAL INTRODUCTION SERVICES (U.S. CLS. 100 AND 101).

FIRST USE 1-10-2005; IN COMMERCE 2-10-2005.  
FRED CARL, EXAMINING ATTORNEY

SN 85-174,198. FOSTERQUAN, LLP, HOUSTON, TX. FILED 11-11-2010.

**I-9 SOLVER**

THE MARK CONSISTS OF STANDARD CHARACTERS WITHOUT CLAIM TO ANY PARTICULAR FONT, STYLE, SIZE, OR COLOR.

NO CLAIM IS MADE TO THE EXCLUSIVE RIGHT TO USE "I-9", APART FROM THE MARK AS SHOWN.

FOR LEGAL SERVICES, NAMELY, REVIEWING STANDARDS AND PRACTICES TO ASSURE EMPLOYERS' COMPLIANCE WITH IMMIGRATION LAWS AND REGULATIONS IN CONNECTION TO FORM I-9 REQUIREMENTS UNDER THE IMMIGRATION REFORM AND CONTROL ACT OF 1986; CONSULTATION IN THE FIELD OF EMPLOYERS' COMPLIANCE WITH IMMIGRATION LAWS AND REGULATIONS, NAMELY, FORM I-9 REQUIREMENTS UNDER THE IMMIGRATION REFORM AND CONTROL ACT OF 1986 (U.S. CLS. 100 AND 101).

FIRST USE 9-30-2010; IN COMMERCE 9-30-2010.  
WENDY JUN, EXAMINING ATTORNEY

**CLASS 45—(Continued).**

SN 85-179,880. BEACON LAW ADVISORS, PLLC, SEATTLE, WA. FILED 11-18-2010.

**Beacon Law Advisors, PLLC**

OWNER OF U.S. REG. NOS. 3,205,118, 3,235,961 AND 3,913,959.

NO CLAIM IS MADE TO THE EXCLUSIVE RIGHT TO USE "LAW ADVISORS, PLLC", APART FROM THE MARK AS SHOWN.

THE MARK CONSISTS OF THE WORDS "BEACON LAW ADVISORS, PLLC", A SILHOUETTED IMAGE OF A LIGHTHOUSE, PROJECTING A TRIANGULAR-SHAPED SEARCHLIGHT BEAM TOWARDS THE RIGHT, AND UNDER THE BEAM THE WORDS "BEACON LAW ADVISORS, PLLC".

FOR LEGAL SERVICES (U.S. CLS. 100 AND 101).  
FIRST USE 8-1-2010; IN COMMERCE 8-1-2010.  
BRIAN CALLAGHAN, EXAMINING ATTORNEY

SN 85-181,494. INFO CUBIC, LLC, GREENWOOD VILLAGE, CO. FILED 11-19-2010.

**INFO CUBIC**

THE MARK CONSISTS OF STANDARD CHARACTERS WITHOUT CLAIM TO ANY PARTICULAR FONT, STYLE, SIZE, OR COLOR.

NO CLAIM IS MADE TO THE EXCLUSIVE RIGHT TO USE "INFO", APART FROM THE MARK AS SHOWN.

FOR EMPLOYMENT BACKGROUND SCREENING, NAMELY, BACKGROUND SCREENING OF CURRENT EMPLOYEES OF OTHERS; PRE-EMPLOYMENT BACKGROUND SCREENING (U.S. CLS. 100 AND 101).

FIRST USE 3-22-2002; IN COMMERCE 3-22-2002.  
CHARLES L. JENKINS, EXAMINING ATTORNEY

**CLASS 45—(Continued).**

SN 85-182,221. VISTA ADVOCACY SERVICES, INC., WESTBROOK, CT. FILED 11-22-2010.

Vista Advocacy Services

THE MARK CONSISTS OF STANDARD CHARACTERS WITHOUT CLAIM TO ANY PARTICULAR FONT, STYLE, SIZE, OR COLOR.

NO CLAIM IS MADE TO THE EXCLUSIVE RIGHT TO USE "ADVOCACY SERVICES", APART FROM THE MARK AS SHOWN.

FOR PROVIDING PERSONAL SUPPORT SERVICES TO INDEPENDENTLY LIVING DEVELOPMENTALLY AND/OR PHYSICALLY DISABLED STUDENT MEMBERS AND GRADUATES AND THEIR FAMILIES IN THE NATURE OF EMOTIONAL COUNSELING, EMOTIONAL SUPPORT AND COORDINATION OF NECESSARY SERVICES FOR PERSONAL CARE, NAMELY, ASSISTANCE WITH MAKING DOCTOR APPOINTMENTS, PURCHASING DECISIONS, RENTAL AGREEMENTS, JOB SEARCHES, DECISIONS REGARDING ROOMMATES (U.S. CLS. 100 AND 101).

FIRST USE 4-5-2010; IN COMMERCE 4-5-2010.  
JENNIFER DIXON, EXAMINING ATTORNEY

**CLASS 45—(Continued).**

SN 85-183,706. VISITING ORPHANS INC., NASHVILLE, TN. FILED 11-23-2010.



THE MARK CONSISTS OF A PERSON HOLDING THEIR HANDS UP IN THE SHAPE OF A "V" AND THE HEAD BEING AN "O".

FOR CHRISTIAN MINISTRY SERVICES (U.S. CLS. 100 AND 101).

FIRST USE 9-3-2010; IN COMMERCE 9-3-2010.  
JOHN KELLY, EXAMINING ATTORNEY

SN 85-182,917. BENJAMIN MAHAN, DBA WWW.EBONYNUPTIALS.COM, DETROIT, MI. FILED S.R. 11-22-2010; AM. P.R. 3-10-2011.

Www.EbonyNuptials.com

THE MARK CONSISTS OF STANDARD CHARACTERS WITHOUT CLAIM TO ANY PARTICULAR FONT, STYLE, SIZE, OR COLOR.

FOR DATING SERVICES, NAMELY, PROVIDING AN ON-LINE COMPUTER DATABASE FEATURING SINGLE PEOPLE INTERESTED IN MEETING OTHER SINGLE PEOPLE (U.S. CLS. 100 AND 101).

FIRST USE 11-21-2010; IN COMMERCE 11-21-2010.  
RENEE MCCRAY, EXAMINING ATTORNEY

SN 85-184,523. DOMESTIPOL, LLC, GOSHEN, NY. FILED 11-24-2010.

DOMESTIPOL

THE MARK CONSISTS OF STANDARD CHARACTERS WITHOUT CLAIM TO ANY PARTICULAR FONT, STYLE, SIZE, OR COLOR.

FOR PROVIDING INTELLIGENCE AND INFORMATION TO LOCAL, STATE, AND FEDERAL LAW ENFORCEMENT AGENCIES RELATING TO ORGANIZED CRIME AND TERRORIST NETWORKS THAT OPERATE ACROSS JURISDICTIONAL LINES (U.S. CLS. 100 AND 101).

JAY FLOWERS, EXAMINING ATTORNEY

**CLASS 45—(Continued).**

SN 85-184,731. TROVA HOME CARE, INC., THOUSAND OAKS, CA. FILED 11-24-2010.



NO CLAIM IS MADE TO THE EXCLUSIVE RIGHT TO USE "HOME CARE", APART FROM THE MARK AS SHOWN.

THE COLOR(S) BLUE AND GOLD IS/ARE CLAIMED AS A FEATURE OF THE MARK.

THE MARK CONSISTS OF THE WORD "TROVA" IN BLUE, WITH AN OUTLINE OF A ROOF IN GOLD EXTENDING FROM THE "T" IN "TROVA". A GOLD HEART INSIDE THE "O" IN "TROVA", AND THE WORDS "HOME CARE" IN GOLD.

THE ENGLISH TRANSLATION OF "TROVA" IN THE MARK IS "TO FIND".

FOR PROVIDING NON-MEDICAL ASSISTED LIVING HOME CARE IN THE NATURE OF ACTIVITIES OF DAILY LIVING, SUCH AS BATHING, GROOMING AND PERSONAL MOBILITY FOR MENTALLY OR PHYSICALLY CHALLENGED PEOPLE (U.S. CLS. 100 AND 101).

NICHOLAS ALTREE, EXAMINING ATTORNEY

SN 85-185,101. JT PERSONAL SERVICES, LLC, DBA MORE THAN A BUTLER, NORTH PALM BEACH, FL. FILED 11-24-2010.



NO CLAIM IS MADE TO THE EXCLUSIVE RIGHT TO USE "BUTLER", APART FROM THE MARK AS SHOWN.

THE COLOR(S) RED, WHITE, AND BLACK IS/ARE CLAIMED AS A FEATURE OF THE MARK.

THE MARK CONSISTS OF BLACK SHIELD IN THE BACK, RED OVAL SHAPE ON TOP OF SHIELD, UPPER CHEST WITH RED BOW TIE OF A BUTLER'S WHITE SHIRT AND BLACK APRON ON TOP OF THE GRAPHIC. THE WORDS "MORE THAN A" IN RED ABOVE A BLACK LINE WITH THE WORD "BUTLER" IN BLACK UNDERNEATH THE LINE.

FOR RUNNING ERRANDS FOR OTHERS (U.S. CLS. 100 AND 101).

SIMON TENG, EXAMINING ATTORNEY

**CLASS 45—(Continued).**

SN 85-185,680. RACHELLE CHANNELL, CLARKSBURG, WV. FILED 11-27-2010.

## PostaDump

THE MARK CONSISTS OF STANDARD CHARACTERS WITHOUT CLAIM TO ANY PARTICULAR FONT, STYLE, SIZE, OR COLOR.

FOR ONLINE SOCIAL NETWORKING SERVICE AND WEBSITE THAT FACILITATES THE TERMINATION OF A RELATIONSHIP BY PUBLISHING THE BREAKUP VIA ONLINE MEDIA (U.S. CLS. 100 AND 101).

ARETHA SOMERVILLE, EXAMINING ATTORNEY

SN 85-186,492. NATIONAL COALITION FOR COMMUNITY EMPOWERMENT STRATEGIES (NCCES), WANTAGH, NY. FILED 11-29-2010.



THE MARK CONSISTS OF A CROSS-LIKE, STAR-LIKE COMPASS WITH A CIRCLE AS A BORDER ABOVE THE STYLIZED WORDING "JOURNEY TO EXPERIENCE".

FOR ARRANGING AND CONDUCTING EVENTS THAT WILL ASSIST THOSE IN ATTENDANCE WITH SPIRITUAL COUNSELING AND EMOTIONAL SUPPORT (U.S. CLS. 100 AND 101).

FIRST USE 9-1-2009; IN COMMERCE 9-1-2009.

MICHAEL ENGEL, EXAMINING ATTORNEY

SN 85-186,927. LAWRENCE G. WALTERS, P.A., DBA WALTERS LAW GROUP, ALTAMONTE SPRINGS, FL. FILED 11-30-2010.



NO CLAIM IS MADE TO THE EXCLUSIVE RIGHT TO USE "LEGAL REPRESENTATION BY" OR "FIRSTAMENDMENT.COM", APART FROM THE MARK AS SHOWN.

THE NAME "LAWRENCE G. WALTERS" IDENTIFIES A LIVING INDIVIDUAL WHOSE CONSENT IS OF RECORD.

FOR LEGAL SERVICES (U.S. CLS. 100 AND 101).

FIRST USE 11-30-2002; IN COMMERCE 11-30-2002.

KIMBERLY FRYE, EXAMINING ATTORNEY

**CLASS 45—(Continued).**

SN 85-187,541. BROWN AND HELLER, P.A., MIAMI, FL.  
FILED 11-30-2010.

**BH** BROWN AND HELLER, P.A.

NO CLAIM IS MADE TO THE EXCLUSIVE RIGHT TO USE "P.A.", APART FROM THE MARK AS SHOWN.

THE MARK CONSISTS OF THE STYLIZED LETTERS "BH" WITH A SMALL DIAMOND SHAPE BETWEEN THEM, FOLLOWED BY THE WORDS "BROWN AND HELLER, P.A." ALSO IN STYLIZED LETTERING.

FOR LEGAL SERVICES (U.S. CLS. 100 AND 101).  
FIRST USE 5-0-2010; IN COMMERCE 5-0-2010.  
CURTIS FRENCH, EXAMINING ATTORNEY

**CLASS 45—(Continued).**

SN 85-188,424. TALENTED TENTH NETWORK, LOS ANGELES, CA. FILED 12-1-2010.

Talented Tenth Network

SN 85-187,641. MARK WALMESLEY, INC, CYPRESS, TX.  
FILED 11-30-2010.



NO CLAIM IS MADE TO THE EXCLUSIVE RIGHT TO USE THE SIX POINTED STAR DESIGN, APART FROM THE MARK AS SHOWN.

THE MARK CONSISTS OF A SIX POINTED STAR WITH OUTER TRIM AND CONTAINING A TELEPHONE RECEIVER WITH THREE LIGHTNING BOLT EMANATING FROM THE EAR PIECE.

FOR NOTIFYING EMERGENCY CONTACTS OF MEDICAL EMERGENCIES (U.S. CLS. 100 AND 101).  
FIRST USE 11-1-2009; IN COMMERCE 4-5-2010.  
LEIGH CAROLINE CASE, EXAMINING ATTORNEY

THE MARK CONSISTS OF STANDARD CHARACTERS WITHOUT CLAIM TO ANY PARTICULAR FONT, STYLE, SIZE, OR COLOR.

NO CLAIM IS MADE TO THE EXCLUSIVE RIGHT TO USE "NETWORK", APART FROM THE MARK AS SHOWN.

FOR PROVIDING FAITH-BASED DEVOTIONALS VIA SOCIAL NETWORKS (U.S. CLS. 100 AND 101).  
ELLEN B. AWRICH, EXAMINING ATTORNEY

SN 85-189,004. NEATLY NESTED, LLC, AKA NEATLY NESTED ORGANIZING SERVICES, HILLIARD, OH.  
FILED 12-2-2010.

Neatly  Nested  
Organizing Services

SN 85-187,951. MUNICIO, FRANCISCO JOSE CARBALLO, BARCELONA, SPAIN, FILED 12-1-2010.

**tobefan** 

THE COLOR(S) BLACK, GOLD, YELLOW AND WHITE IS/ARE CLAIMED AS A FEATURE OF THE MARK.

THE MARK CONSISTS OF THE STYLIZED LETTERING "TOBE" IN GOLD AND "FAN" IN WHITE. A YELLOW AND WHITE STAR APPEARS ABOVE THE "A" IN "FAN". THE AFOREMENTIONED IS ON A BLACK BACKGROUND.

FOR INTERNET-BASED SOCIAL NETWORKING SERVICES (U.S. CLS. 100 AND 101).  
FIRST USE 11-15-2010; IN COMMERCE 11-15-2010.  
NANCY CLARKE, EXAMINING ATTORNEY

NO CLAIM IS MADE TO THE EXCLUSIVE RIGHT TO USE "ORGANIZING SERVICES", APART FROM THE MARK AS SHOWN.

THE COLOR(S) BLUE AND BROWN IS/ARE CLAIMED AS A FEATURE OF THE MARK.

THE MARK CONSISTS OF THE WORDS "NEATLY NESTED" IN BLUE AND A BROWN BIRD NEST WITH THREE BLUE EGGS BETWEEN THE WORDS. THE WORDING "ORGANIZING SERVICES" APPEARS IN BROWN BELOW THE WORD, "NESTED."

FOR ORGANIZATIONAL SERVICES FOR HOME OR PERSONAL PURPOSES, NAMELY, ORGANIZING CLUTTERED OR DISORGANIZED ROOMS AND SPACES IN THE HOME (U.S. CLS. 100 AND 101).

FIRST USE 3-5-2009; IN COMMERCE 3-5-2009.  
ROBIN CHOSID, EXAMINING ATTORNEY

**CLASS 45—(Continued).**

SN 85-189,334. NEW LEAF LEGAL, LLC, BOSTON, MA. FILED 12-2-2010.



THE COLOR(S) BLUE, GREEN, AND WHITE IS/ARE CLAIMED AS A FEATURE OF THE MARK.

THE MARK CONSISTS OF VARIOUSLY SIZED BLUE GRADIENT SPHERES EACH CONNECTED TO A STRAIGHT GREEN LINES WHICH CONNECT TO A GREEN LEAF IN THE CENTER OF THE MARK. THE GREEN LEAF FEATURES A WHITE STYLIZED LETTER "N" IN ITS CENTER.

FOR LEGAL RESEARCH; LEGAL SERVICES; LICENSING OF INTELLECTUAL PROPERTY (U.S. CLS. 100 AND 101).

FIRST USE 5-1-2010; IN COMMERCE 6-1-2010.  
ODESSA BIBBINS, EXAMINING ATTORNEY

**CLASS 45—(Continued).**

SN 85-192,433. LIBERATED SPACES, SAN FRANCISCO, CA. FILED 12-7-2010.

## Liberated Spaces

THE MARK CONSISTS OF STANDARD CHARACTERS WITHOUT CLAIM TO ANY PARTICULAR FONT, STYLE, SIZE, OR COLOR.

NO CLAIM IS MADE TO THE EXCLUSIVE RIGHT TO USE "SPACES", APART FROM THE MARK AS SHOWN.

FOR ORGANIZATIONAL SERVICES FOR HOME OR PERSONAL PURPOSES, NAMELY, ORGANIZING RESIDENCES, RESIDENTIAL LIVING SPACES, KITCHENS, PERSONAL OFFICES, HOME OFFICES, WARDROBES, KITCHENS, BATHROOMS, GARAGES, CLOSETS, BOOKSHELVES, BEDROOMS, HOUSEHOLD SHELVING, PERSONAL SCHEDULES, PERSONAL LIVING SPACES, AND PERSONAL WORK SPACES; PROVIDING INFORMATION AND CONSULTATION IN THE FIELD OF TIME MANAGEMENT TO INDIVIDUALS FOR PERSONAL PURPOSES; PROVIDING INFORMATION AND CONSULTATION IN THE FIELD OF PERSONAL EMERGENCY RESPONSE PREPARATION, AND COMPILING INVENTORIES OF PERSONAL ITEMS, POSSESSIONS AND HOUSEHOLD SUPPLIES IN CONNECTION THEREWITH (U.S. CLS. 100 AND 101).

FIRST USE 10-14-2009; IN COMMERCE 10-25-2009.  
BARBARA A. GOLD, EXAMINING ATTORNEY

SN 85-190,540. ALL, ANDREW, LOS ANGELES, CA. FILED 12-3-2010.

## Pet Circle

THE MARK CONSISTS OF STANDARD CHARACTERS WITHOUT CLAIM TO ANY PARTICULAR FONT, STYLE, SIZE, OR COLOR.

NO CLAIM IS MADE TO THE EXCLUSIVE RIGHT TO USE "PET", APART FROM THE MARK AS SHOWN.

FOR ON-LINE SOCIAL NETWORKING SERVICES FOR PET OWNERS (U.S. CLS. 100 AND 101).

LINDA LAVACHE, EXAMINING ATTORNEY

SN 85-192,465. STYLEAUTEUR CORPORATION, ALEXANDRIA, VA. FILED 12-7-2010.

## STYLEAUTEUR

THE MARK CONSISTS OF STANDARD CHARACTERS WITHOUT CLAIM TO ANY PARTICULAR FONT, STYLE, SIZE, OR COLOR.

FOR FASHION CONSULTING SERVICES, FASHION TREND CONSULTING SERVICES, PERSONAL FASHION CONSULTING SERVICES (U.S. CLS. 100 AND 101).

FIRST USE 4-0-2006; IN COMMERCE 4-0-2006.  
TINA MAI, EXAMINING ATTORNEY

**CLASS 45—(Continued).**

SN 85-192,985. ROY S. GORDET, DALY CITY, CA. FILED 12-8-2010.

**CopyrightDirection**

THE MARK CONSISTS OF STANDARD CHARACTERS WITHOUT CLAIM TO ANY PARTICULAR FONT, STYLE, SIZE, OR COLOR.

FOR LEGAL SERVICES; LEGAL RESEARCH; CONSULTING AND LEGAL SERVICES IN THE FIELDS OF COPYRIGHT LAW AND LITIGATION, TRADEMARK LAW AND LITIGATION, INTELLECTUAL PROPERTY LAW AND LITIGATION, PUBLISHING AND MEDIA LAW, AND COPYRIGHT MANAGEMENT (U.S. CLS. 100 AND 101).

FIRST USE 5-27-2010; IN COMMERCE 5-27-2010.  
HOWARD SMIGA, EXAMINING ATTORNEY

SN 85-193,077. NEW LEAF LEGAL, LLC, BOSTON, MA. FILED 12-8-2010.



THE COLOR(S) GREEN AND WHITE IS/ARE CLAIMED AS A FEATURE OF THE MARK.

THE MARK CONSISTS OF A GREEN LEAF WITH A WHITE LOWERCASE LETTER "N" IN THE MIDDLE.

FOR INTELLECTUAL PROPERTY CONSULTATION; LEGAL RESEARCH; LEGAL SERVICES; LICENSING OF INTELLECTUAL PROPERTY (U.S. CLS. 100 AND 101).

FIRST USE 5-1-2010; IN COMMERCE 6-1-2010.  
ODESSA BIBBINS, EXAMINING ATTORNEY

SN 85-193,497. OFFIT KURMAN, P.A., MAPLE LAWN, MD. FILED 12-8-2010.

**NEW PARADIGM COUNSEL**

THE MARK CONSISTS OF STANDARD CHARACTERS WITHOUT CLAIM TO ANY PARTICULAR FONT, STYLE, SIZE, OR COLOR.

NO CLAIM IS MADE TO THE EXCLUSIVE RIGHT TO USE "COUNSEL", APART FROM THE MARK AS SHOWN.

FOR LEGAL SERVICES, NAMELY, PROVIDING OUT-SOURCED LEGAL DEPARTMENTS FOR BUSINESSES (U.S. CLS. 100 AND 101).

FIRST USE 12-6-2010; IN COMMERCE 12-6-2010.  
RONALD AIKENS, EXAMINING ATTORNEY

**CLASS 45—(Continued).**

SN 85-196,620. TOM COSTELLO JR, RADNOR, PA. FILED 12-13-2010.

**THE JOY OF SOX**

THE MARK CONSISTS OF STANDARD CHARACTERS WITHOUT CLAIM TO ANY PARTICULAR FONT, STYLE, SIZE, OR COLOR.

FOR CHARITABLE SERVICES, NAMELY, PROVIDING SOCKS TO NEEDY PERSONS (U.S. CLS. 100 AND 101).

FIRST USE 1-18-2010; IN COMMERCE 1-18-2010.  
JUDITH HELFMAN, EXAMINING ATTORNEY

SN 85-196,642. ZENKAS, LTD., BRAINTREE, MA. FILED 12-13-2010.



NO CLAIM IS MADE TO THE EXCLUSIVE RIGHT TO USE "GIFTS", APART FROM THE MARK AS SHOWN.

THE MARK CONSISTS OF THE LETTER "Z" INSIDE A CIRCLE, WITH A GIFT BOW ON THE TOP OF THE CIRCLE AND THE WORDS "ZENKAS GIFTS OF DISTINCTION" TO THE RIGHT OF THE LETTER "Z".

FOR PREPARATION OF CUSTOMIZED GIFT BASKETS (U.S. CLS. 100 AND 101).

CARYN GLASSER, EXAMINING ATTORNEY

SN 85-196,692. SAVVIS COMMUNICATIONS CORPORATION, TOWN & COUNTRY, MO. FILED 12-13-2010.

**AUDIT READY BY DESIGN**

THE MARK CONSISTS OF STANDARD CHARACTERS WITHOUT CLAIM TO ANY PARTICULAR FONT, STYLE, SIZE, OR COLOR.

NO CLAIM IS MADE TO THE EXCLUSIVE RIGHT TO USE "AUDIT", APART FROM THE MARK AS SHOWN.

FOR MONITORING OF COMPUTER SYSTEMS FOR SECURITY PURPOSES; NETWORK SECURITY SERVICES IN THE NATURE OF PROVIDING AN INTERNET TRUST CENTER, NAMELY, COMPUTER SECURITY ASSURANCE AND ADMINISTRATION OF DIGITAL KEYS AND DIGITAL CERTIFICATES; COMPUTER SECURITY SERVICES, NAMELY, COMPUTER NETWORK SECURITY MONITORING SERVICES (U.S. CLS. 100 AND 101).

Laurie Kaufman, Examining Attorney



**CLASS 45—(Continued).**

SN 85-197,262. NOVAK DRUCE & QUIGG LLP, WASHINGTON, DC. FILED 12-14-2010.

# NOVAK DRUCE +

THE MARK CONSISTS OF STANDARD CHARACTERS WITHOUT CLAIM TO ANY PARTICULAR FONT, STYLE, SIZE, OR COLOR.

OWNER OF U.S. REG. NOS. 3,098,102 AND 3,098,103.  
FOR LEGAL SERVICES; LEGAL SERVICES IN THE FIELD OF INTELLECTUAL PROPERTY; MEDIATION (U.S. CLS. 100 AND 101).  
BRENDAN MCCAULEY, EXAMINING ATTORNEY

**CLASS 45—(Continued).**

SN 85-200,357. SMITH & WESSON CORP, SPRINGFIELD, MA. FILED 12-17-2010.

# PROTECTING YOU SINCE 1852

THE MARK CONSISTS OF STANDARD CHARACTERS WITHOUT CLAIM TO ANY PARTICULAR FONT, STYLE, SIZE, OR COLOR.

FOR SECURITY SERVICES, NAMELY, ALARM MONITORING (U.S. CLS. 100 AND 101).  
FIRST USE 2-1-2010; IN COMMERCE 2-1-2010.  
KHANH LE, EXAMINING ATTORNEY

SN 85-199,452. TELLURIDE ALARM INC., TELLURIDE, CO. FILED 12-16-2010.

# Water Boss

THE MARK CONSISTS OF STANDARD CHARACTERS WITHOUT CLAIM TO ANY PARTICULAR FONT, STYLE, SIZE, OR COLOR.

NO CLAIM IS MADE TO THE EXCLUSIVE RIGHT TO USE "WATER", APART FROM THE MARK AS SHOWN.  
FOR HOME SECURITY MONITORING USING WIRELESS AND WIRED SENSORS FOR GLASS BREAKAGE, MOTION DETECTORS, CAMERAS, POOL ALARMS, WATER ALARMS AND SHUTOFF VALVES, GATE, DOOR AND WINDOW CONTACT SENSORS, SEVERE WEATHER ALARMS (U.S. CLS. 100 AND 101).  
GENE MACIOL, EXAMINING ATTORNEY

SN 85-200,583. JAMES F. MCKEOWN, WASHINGTON, DC. FILED 12-17-2010.

# IPEACE

HELPING SURVIVORS SURVIVE

THE MARK CONSISTS OF STANDARD CHARACTERS WITHOUT CLAIM TO ANY PARTICULAR FONT, STYLE, SIZE, OR COLOR.

FOR PROVIDING PERSONAL SUPPORT SERVICES FOR VICTIMS OF DRUNK DRIVING AND THEIR FAMILIES AND FRIENDS, NAMELY, COMPANIONSHIP, HELP WITH LEGAL, FINANCIAL AND MEDICAL FORMS, COUNSELING AND EMOTIONAL SUPPORT (U.S. CLS. 100 AND 101).  
FIRST USE 12-10-2009; IN COMMERCE 12-10-2009.  
TRACY FLETCHER, EXAMINING ATTORNEY

THE MARK CONSISTS OF STANDARD CHARACTERS WITHOUT CLAIM TO ANY PARTICULAR FONT, STYLE, SIZE, OR COLOR.

FOR MEDIATION (U.S. CLS. 100 AND 101).  
STEVEN PEREZ, EXAMINING ATTORNEY

**CLASS 45—(Continued).**

SN 85-201,204. SPRIEGEL & ASSOCIATES, LLC, HUDSON, OH. FILED 12-18-2010.

Your intellect. Your  
property.

THE MARK CONSISTS OF STANDARD CHARACTERS WITHOUT CLAIM TO ANY PARTICULAR FONT, STYLE, SIZE, OR COLOR.

FOR CARTOON CHARACTER LICENSING; DOMAIN NAME REGISTRATION SERVICES, NAMELY, CONDUCTING DOMAIN NAME SEARCHES FOR THE PURPOSE OF PROVIDING LEGAL ADVICE ON DOMAIN NAME REGISTRATION; LEGAL RESEARCH; LEGAL SERVICES; LEGAL SERVICES, NAMELY, INTELLECTUAL PROPERTY CONSULTING SERVICES IN THE FIELD OF INVENTION, IDENTIFICATION, STRATEGY, ANALYTICS, AND INVENTION; LEGAL SERVICES, NAMELY, PREPARATION OF APPLICATIONS FOR TRADEMARK REGISTRATION; LEGAL SERVICES, NAMELY, TRADEMARK MAINTENANCE SERVICES; LEGAL SERVICES, NAMELY, TRADEMARK SEARCHING AND CLEARANCE SERVICES; LICENSING OF ADVERTISING SLOGANS AND CARTOON CHARACTERS; LICENSING OF INTELLECTUAL PROPERTY; PATENT LICENSING; PROVIDING INFORMATION IN THE FIELD OF INTELLECTUAL PROPERTY LEGAL SERVICES ; PROVIDING ON-LINE INFORMATION IN THE FIELD OF INTELLECTUAL PROPERTY LEGAL SERVICES; REGISTRATION OF DOMAIN NAMES FOR IDENTIFICATION OF USERS ON A GLOBAL COMPUTER NETWORK (U.S. CLS. 100 AND 101).

FIRST USE 12-17-2010; IN COMMERCE 12-17-2010.  
JOHN DWYER, EXAMINING ATTORNEY

SN 85-201,407. HOPE & JOY, CORP., VEGA BAJA, PUERTO RICO, FILED 12-19-2010.

IDOJOY

THE MARK CONSISTS OF STANDARD CHARACTERS WITHOUT CLAIM TO ANY PARTICULAR FONT, STYLE, SIZE, OR COLOR.

FOR ONLINE SOCIAL NETWORKING SERVICES PROVIDED THROUGH A COMMUNITY WEBSITE (U.S. CLS. 100 AND 101).

FIRST USE 12-3-2010; IN COMMERCE 12-3-2010.  
KELLY BOULTON, EXAMINING ATTORNEY

**CLASS 45—(Continued).**

SN 85-201,758. AENON INC., INDIAN TRAIL, NC. FILED 12-20-2010.



NO CLAIM IS MADE TO THE EXCLUSIVE RIGHT TO USE "LEGAL", APART FROM THE MARK AS SHOWN.

THE COLOR(S) BLACK, GREY, AND ORANGE IS/ARE CLAIMED AS A FEATURE OF THE MARK.

THE MARK CONSISTS OF THE WORD "LEGAL" IN BLACK AND THE WORD "LOOP" IN GREY, ENCIRCLED BY AN INTERSECTING ELLIPTICAL BAND OF ORANGE.

FOR LEGAL SERVICES (U.S. CLS. 100 AND 101).  
TIMOTHY FINNEGAN, EXAMINING ATTORNEY

SN 85-203,203. ATOMICME, LOS ANGELES, CA. FILED 12-21-2010.

atomicme



THE MARK CONSISTS OF THE CENTER OF THE "A" IN "ATOMICME" RESEMBLING THE STRUCTURE OF AN ATOM, AND TWO BOXES, WITH EACH ONE HAVING A SINGLE "A" AND CENTER THAT RESEMBLES A STRUCTURE OF AN ATOM.

FOR ON-LINE SOCIAL NETWORKING SERVICES (U.S. CLS. 100 AND 101).

C. DIONNE CLYBURN, EXAMINING ATTORNEY

SN 85-203,535. MALMAN, STEVEN, CHICAGO, IL. FILED 12-22-2010.

THE SITE FOR YOUR RIGHTS

THE MARK CONSISTS OF STANDARD CHARACTERS WITHOUT CLAIM TO ANY PARTICULAR FONT, STYLE, SIZE, OR COLOR.

FOR LEGAL SERVICES, NAMELY, PROVIDING CUSTOMIZED INFORMATION, COUNSELING, ADVICE AND LITIGATION SERVICES IN ALL AREAS OF PERSONAL INJURY (U.S. CLS. 100 AND 101).

DARRYL SPRULL, EXAMINING ATTORNEY

**CLASS 45—(Continued).**

SN 85-203,763. STEPHEN M. POTTS & ASSOCIATES, INC., DBA POTTS LAW GROUP, DALLAS, TX. FILED 12-22-2010.

THE GPS OF BUSINESS LAW

THE MARK CONSISTS OF STANDARD CHARACTERS WITHOUT CLAIM TO ANY PARTICULAR FONT, STYLE, SIZE, OR COLOR.

NO CLAIM IS MADE TO THE EXCLUSIVE RIGHT TO USE "BUSINESS LAW", APART FROM THE MARK AS SHOWN.

FOR LEGAL SERVICES (U.S. CLS. 100 AND 101).  
FIRST USE 11-19-2010; IN COMMERCE 11-19-2010.  
DANNEAN HETZEL, EXAMINING ATTORNEY

**CLASS 45—(Continued).**

SN 85-206,742. CALIBAN SYCORAX (CALAX), PROSPER, TX. FILED 12-28-2010.

VONABY

THE MARK CONSISTS OF 3 LITTLE LEAF ON THE BOTTOM OF THE LETTER "V" IN THE STYLIZED TEXT "VONABY".

FOR ON-LINE SOCIAL NETWORKING SERVICES (U.S. CLS. 100 AND 101).

FIRST USE 5-1-2010; IN COMMERCE 5-1-2010.  
GEORGE LORENZO, EXAMINING ATTORNEY

SN 85-204,009. DOOSTANG, INC, PALO ALTO, CA. FILED 12-22-2010.

SHORTTRAX

THE MARK CONSISTS OF STANDARD CHARACTERS WITHOUT CLAIM TO ANY PARTICULAR FONT, STYLE, SIZE, OR COLOR.

FOR ONLINE SOCIAL NETWORKING SERVICES (U.S. CLS. 100 AND 101).  
KAREN BRACEY, EXAMINING ATTORNEY

SN 85-206,899. FARRELL, KAREN M., FOLCROFT, PA. FILED 12-28-2010.

JUST PUSH THRU IT

THE MARK CONSISTS OF STANDARD CHARACTERS WITHOUT CLAIM TO ANY PARTICULAR FONT, STYLE, SIZE, OR COLOR.

FOR LICENSING OF ADVERTISING SLOGANS AND CARTOON CHARACTERS (U.S. CLS. 100 AND 101).  
JOSETTE BEVERLY, EXAMINING ATTORNEY

SN 85-204,227. BILLY GRAHAM EVANGELISTIC ASSOCIATION, CHARLOTTE, NC. FILED 12-22-2010.

ROCK THE RANGE

THE MARK CONSISTS OF STANDARD CHARACTERS WITHOUT CLAIM TO ANY PARTICULAR FONT, STYLE, SIZE, OR COLOR.

FOR EVANGELISTIC MINISTERIAL SERVICES (U.S. CLS. 100 AND 101).  
EUGENIA MARTIN, EXAMINING ATTORNEY

SN 85-207,019. REBOOT PARTNERS LLC, SAG HARBOR, NY. FILED 12-29-2010.

Reboot Your Life

THE MARK CONSISTS OF STANDARD CHARACTERS WITHOUT CLAIM TO ANY PARTICULAR FONT, STYLE, SIZE, OR COLOR.

FOR COUNSELING IN THE FIELD OF PERSONAL DEVELOPMENT, NAMELY, SELF-IMPROVEMENT, SELF-FULFILLMENT, AND INTERPERSONAL COMMUNICATION (U.S. CLS. 100 AND 101).

FIRST USE 10-1-2008; IN COMMERCE 10-1-2008.  
SUE LAWRENCE, EXAMINING ATTORNEY

**CLASS 45—(Continued).**

SN 85-207,048. REBOOT PARTNERS LLC, SAG HARBOR, NY. FILED 12-29-2010.

## Sabbatical Sisters

THE MARK CONSISTS OF STANDARD CHARACTERS WITHOUT CLAIM TO ANY PARTICULAR FONT, STYLE, SIZE, OR COLOR.

FOR COUNSELING IN THE FIELD OF PERSONAL DEVELOPMENT, NAMELY, SELF-IMPROVEMENT, SELF-FULFILLMENT, AND INTERPERSONAL COMMUNICATION (U.S. CLS. 100 AND 101).

FIRST USE 10-1-2008; IN COMMERCE 10-1-2008.  
SUE LAWRENCE, EXAMINING ATTORNEY

SN 85-208,216. TRUNNELL & SELLERS, P.C., DENVER, CO. FILED 12-30-2010.

## No Debt Club

THE MARK CONSISTS OF STANDARD CHARACTERS WITHOUT CLAIM TO ANY PARTICULAR FONT, STYLE, SIZE, OR COLOR.

FOR LEGAL SERVICES (U.S. CLS. 100 AND 101).  
ANGELA M. MICHELI, EXAMINING ATTORNEY

SN 85-208,377. ANDRESEN & ASSOCIATES, P.C., CHICAGO, IL. FILED 12-30-2010.

## LAWBRARY

THE MARK CONSISTS OF STANDARD CHARACTERS WITHOUT CLAIM TO ANY PARTICULAR FONT, STYLE, SIZE, OR COLOR.

FOR PROVIDING INFORMATION RELATING TO LEGAL AFFAIRS; PROVIDING ON-LINE INFORMATION AND NEWS IN THE FIELD OF LAW (U.S. CLS. 100 AND 101).

ROBIN CHOSID, EXAMINING ATTORNEY

**CLASS 45—(Continued).**

SN 85-208,599. YESNER & BOSS, P.L., ST. PETERSBURG, FL. FILED 12-31-2010.

## PROTECT YOUR FUTURE

THE MARK CONSISTS OF STANDARD CHARACTERS WITHOUT CLAIM TO ANY PARTICULAR FONT, STYLE, SIZE, OR COLOR.

FOR LEGAL SERVICES (U.S. CLS. 100 AND 101).  
KATHERINE CHANG, EXAMINING ATTORNEY

SN 85-208,939. KAVOUKLIS, NIKKI, TARPON SPRINGS, FL. FILED 1-3-2011.

## KEEP GIGGING

THE MARK CONSISTS OF STANDARD CHARACTERS WITHOUT CLAIM TO ANY PARTICULAR FONT, STYLE, SIZE, OR COLOR.

FOR PROVIDING A WEBSITE FEATURING INSPIRATIONAL AND MOTIVATIONAL TOPICS AND INFORMATION AND THAT ENABLES USERS TO INTERACT AND SHARE INSPIRATIONAL AND MOTIVATIONAL INFORMATION (U.S. CLS. 100 AND 101).

ERNEST SHOSHO, EXAMINING ATTORNEY

SN 85-209,157. NEW COVENANT BELIEVERS' CHURCH, COLUMBUS, OH. FILED 1-3-2011.



THE MARK CONSISTS OF "HEALING A GENERATION" IN STYLIZED FONT WITH AN OVAL OUTLINED IN THE BACKGROUND WITH SMALL DOTS PLACED AROUND, FOR MINISTERIAL SERVICES (U.S. CLS. 100 AND 101).

FIRST USE 6-30-1999; IN COMMERCE 6-30-1999.  
ALEXANDER L. POWERS, EXAMINING ATTORNEY

**CLASS 45—(Continued).**

SN 85-210,035. JOEL J. KOFKY, PHILADELPHIA, PA.  
FILED 1-4-2011.

## WINNING CASES IS NO ACCIDENT

THE MARK CONSISTS OF STANDARD CHARACTERS  
WITHOUT CLAIM TO ANY PARTICULAR FONT, STYLE,  
SIZE, OR COLOR.

FOR LEGAL SERVICES (U.S. CLS. 100 AND 101).  
FIRST USE 1-3-2011; IN COMMERCE 1-3-2011.  
PAUL F. GAST, EXAMINING ATTORNEY

SN 85-210,332. CHRISTIAN BIBLE, MISSOURI CITY, TX.  
FILED 1-4-2011.

## Victorious Women of the King

THE MARK CONSISTS OF STANDARD CHARACTERS  
WITHOUT CLAIM TO ANY PARTICULAR FONT, STYLE,  
SIZE, OR COLOR.

FOR CHRISTIAN MINISTRY SERVICES (U.S. CLS. 100  
AND 101).  
FIRST USE 1-0-2007; IN COMMERCE 1-0-2007.  
KARANENDRA S. CHHINA, EXAMINING ATTORNEY

SN 85-210,421. FILTER PLATFORMS, INC., LOS ANGELES,  
CA. FILED 1-4-2011.

## FILTER FOUNDRY

THE MARK CONSISTS OF STANDARD CHARACTERS  
WITHOUT CLAIM TO ANY PARTICULAR FONT, STYLE,  
SIZE, OR COLOR.

FOR ONLINE SOCIAL NETWORKING SERVICES FOR  
ARTISTIC AND CREATIVE PROFESSIONALS (U.S. CLS.  
100 AND 101).  
REGINA DRUMMOND, EXAMINING ATTORNEY

**CLASS 45—(Continued).**

SN 85-210,514. MCKENNA, DEVON JOHN, DBA MCKENNA,  
DEVON JOHN, FEDERAL WAY, WA. FILED 1-4-2011.

## MCKENNA, DEVON JOHN

THE MARK CONSISTS OF STANDARD CHARACTERS  
WITHOUT CLAIM TO ANY PARTICULAR FONT, STYLE,  
SIZE, OR COLOR.

THE NAME "DEVON JOHN MCKENNA" IDENTIFIES A  
LIVING INDIVIDUAL WHOSE CONSENT IS OF RECORD.

FOR PROVIDING SPIRITUAL REHABILITATION  
SERVICES; PROVIDING SPIRITUAL RETREATS IN  
THE FIELD OF HEALING; PROVIDING SPIRITUAL  
RETREATS IN THE FIELDS OF TOGETHERNESS AND  
HOW TO BE BETTER MEN; RELIGIOUS AND SPIRI-  
TUAL SERVICES, NAMELY, PROVIDING GATHER-  
INGS AND RETREATS TO DEVELOP AND ENHANCE  
THE SPIRITUAL LIVES OF INDIVIDUALS; SPIRITUAL  
COUNSELING (U.S. CLS. 100 AND 101).  
MARLENE BELL, EXAMINING ATTORNEY

SN 85-210,552. HEALY, TIMOTHY, UNIVERSITY PLACE,  
WA. FILED 1-5-2011.

## PROSECUTORS FEAR ME, COPS DESPISE ME

THE MARK CONSISTS OF STANDARD CHARACTERS  
WITHOUT CLAIM TO ANY PARTICULAR FONT, STYLE,  
SIZE, OR COLOR.

FOR LEGAL AND CONSULTING SERVICES IN THE  
FIELDS OF CRIMINAL DEFENSE (U.S. CLS. 100 AND  
101).  
DANNEAN HETZEL, EXAMINING ATTORNEY

SN 85-210,794. STROMBERG, JACK, WEST FARGO, ND.  
FILED 1-5-2011.

## Vooba

THE MARK CONSISTS OF STANDARD CHARACTERS  
WITHOUT CLAIM TO ANY PARTICULAR FONT, STYLE,  
SIZE, OR COLOR.

FOR INTERNET-BASED SOCIAL NETWORKING SER-  
VICES (U.S. CLS. 100 AND 101).  
FIRST USE 2-1-2010; IN COMMERCE 12-1-2010.  
JUSTINE D. PARKER, EXAMINING ATTORNEY

**CLASS 45—(Continued).**

SN 85-211,255. BLONDVIC ENTERPRISES, LLC, ST PAUL, MN. FILED 1-5-2011.

Have fun. Date Differently!

THE MARK CONSISTS OF STANDARD CHARACTERS WITHOUT CLAIM TO ANY PARTICULAR FONT, STYLE, SIZE, OR COLOR.

FOR INTERNET-BASED DATING, SOCIAL INTRODUCTION AND SOCIAL NETWORKING SERVICES (U.S. CLS. 100 AND 101).

FIRST USE 9-24-2010; IN COMMERCE 9-24-2010.

JILL PRATER, EXAMINING ATTORNEY

SN 85-211,440. ADOPTIMISM, BROOKLYN, NY. FILED 1-5-2011.

ADOPTIMISM

THE MARK CONSISTS OF STANDARD CHARACTERS WITHOUT CLAIM TO ANY PARTICULAR FONT, STYLE, SIZE, OR COLOR.

FOR ON-LINE SOCIAL NETWORKING SERVICES (U.S. CLS. 100 AND 101).

FIRST USE 11-1-2010; IN COMMERCE 11-1-2010.

JENNIFER MARTIN, EXAMINING ATTORNEY

SN 85-211,607. SELECTION MANAGEMENT SYSTEMS, INC., CINCINNATI, OH. FILED 1-6-2011.

XPEDITE

THE MARK CONSISTS OF STANDARD CHARACTERS WITHOUT CLAIM TO ANY PARTICULAR FONT, STYLE, SIZE, OR COLOR.

FOR DATA SEARCH AND SCREENING SERVICES AND INVESTIGATION SERVICES, NAMELY CONDUCTING BACKGROUND INVESTIGATIONS, CRIMINAL INVESTIGATIONS, PERSONAL HISTORY INVESTIGATIONS, AND FACT VERIFICATION INVESTIGATIONS (U.S. CLS. 100 AND 101).

FIRST USE 12-1-1999; IN COMMERCE 12-1-1999.

ASMAT KHAN, EXAMINING ATTORNEY

**CLASS 45—(Continued).**

SN 85-211,611. SELECTION MANAGEMENT SYSTEMS, INC., CINCINNATI, OH. FILED 1-6-2011.

MEDVERIFY

THE MARK CONSISTS OF STANDARD CHARACTERS WITHOUT CLAIM TO ANY PARTICULAR FONT, STYLE, SIZE, OR COLOR.

FOR DATA SEARCH AND SCREENING SERVICES, NAMELY PRE-EMPLOYMENT BACKGROUND SCREENING, PERSONAL HISTORY BACKGROUND SCREENING, AND FACT VERIFICATION SERVICES (U.S. CLS. 100 AND 101).

FIRST USE 10-0-2004; IN COMMERCE 10-0-2004.

ASMAT KHAN, EXAMINING ATTORNEY

SN 85-211,974. MANNING, FULTON & SKINNER, P.A., RALEIGH, NC. FILED 1-6-2011.

WE FOCUS ON WHAT MATTERS

THE MARK CONSISTS OF STANDARD CHARACTERS WITHOUT CLAIM TO ANY PARTICULAR FONT, STYLE, SIZE, OR COLOR.

FOR LEGAL SERVICES (U.S. CLS. 100 AND 101).

HAI-LY LAM, EXAMINING ATTORNEY

SN 85-212,215. EARTHBONGO, INC., SEATTLE, WA. FILED 1-6-2011.

Amplify the good.

THE MARK CONSISTS OF STANDARD CHARACTERS WITHOUT CLAIM TO ANY PARTICULAR FONT, STYLE, SIZE, OR COLOR.

FOR INTERNET-BASED SOCIAL NETWORKING SERVICES, NAMELY PROVIDING ACTIVITY AND PROJECT INFORMATION ON THE WEB FOR PEOPLE AND ORGANIZATIONS TO SHARE ACTIVITIES THEY ARE INVOLVED WITH, TO FIND PARTICIPANTS AND VOLUNTEERS FOR THESE ACTIVITIES, TO TRACK WHAT PARTICIPANTS HAVE DONE, TO ALLOW PEOPLE TO UPLOAD STORIES AND PICTURES ABOUT WHAT THEY HAVE DONE FOR THESE ACTIVITIES, TO CREATE REPORTS AND GRAPH METRICS FOR THESE ACTIVITIES AND TO USE SOCIAL MEDIA TO ALLOW PARTICIPANTS TO SHARE THEIR RESULTS RELATING TO THESE ACTIVITIES (U.S. CLS. 100 AND 101).

FIRST USE 10-1-2010; IN COMMERCE 10-1-2010.

CIMMERIAN COLEMAN, EXAMINING ATTORNEY

**CLASS 45—(Continued).**

SN 85-213,574. INNER BONDING HEALING TECHNOLOGIES, INC., LOS ANGELES, CA. FILED 1-9-2011.

# SELFQUEST

THE MARK CONSISTS OF STANDARD CHARACTERS WITHOUT CLAIM TO ANY PARTICULAR FONT, STYLE, SIZE, OR COLOR.

OWNER OF U.S. REG. NO. 3,018,410.  
FOR COUNSELING IN THE FIELD OF PERSONAL DEVELOPMENT, NAMELY, SELF-IMPROVEMENT, SELF-FULFILLMENT, AND INTERPERSONAL COMMUNICATION (U.S. CLS. 100 AND 101).  
BRENDAN MCCAULEY, EXAMINING ATTORNEY

SN 85-213,586. CEWE, JOHN DONALD, FAIRFAX STATION, VA. AND KIERNAN, CHAD ANDREW, CLIFTON, VA. AND PROFANS LLC, FAIRFAX STATION, VA. FILED 1-9-2011.

# ProFans

THE MARK CONSISTS OF STANDARD CHARACTERS WITHOUT CLAIM TO ANY PARTICULAR FONT, STYLE, SIZE, OR COLOR.

FOR ON-LINE SOCIAL NETWORKING SERVICES (U.S. CLS. 100 AND 101).  
DAVID TAYLOR, EXAMINING ATTORNEY

**CLASS 45—(Continued).**

SN 85-222,863. PEOPLE MEDIA, INC., WEST HOLLYWOOD, CA. FILED 1-21-2011.

# LOVEANDSEEK.COM

THE MARK CONSISTS OF STANDARD CHARACTERS WITHOUT CLAIM TO ANY PARTICULAR FONT, STYLE, SIZE, OR COLOR.

OWNER OF U.S. REG. NO. 2,786,102.  
FOR DATING SERVICES; INTERNET BASED SOCIAL NETWORKING, INTRODUCTION, AND DATING SERVICES (U.S. CLS. 100 AND 101).  
WANDA KAY PRICE, EXAMINING ATTORNEY

SN 85-230,606. BARBER, CORY, RIVERSIDE, CA. FILED 1-31-2011.

# VITAL SIGNING

THE MARK CONSISTS OF STANDARD CHARACTERS WITHOUT CLAIM TO ANY PARTICULAR FONT, STYLE, SIZE, OR COLOR.

NO CLAIM IS MADE TO THE EXCLUSIVE RIGHT TO USE "SIGNING", APART FROM THE MARK AS SHOWN.

FOR NOTARY PUBLIC SERVICES (U.S. CLS. 100 AND 101).

FIRST USE 2-4-1997; IN COMMERCE 0-0-1998.  
GINA HAYES, EXAMINING ATTORNEY

SN 85-259,491. 1-800-CANT-WORK, LLC, CHERRY HILL, NJ. FILED 3-7-2011.

# 1-800-CANT-WORK

THE MARK CONSISTS OF STANDARD CHARACTERS WITHOUT CLAIM TO ANY PARTICULAR FONT, STYLE, SIZE, OR COLOR.

FOR LEGAL SERVICES (U.S. CLS. 100 AND 101).  
FIRST USE 1-0-2006; IN COMMERCE 1-0-2006.  
MATTHEW MCDOWELL, EXAMINING ATTORNEY

## SECTION 3.—PRIOR UNITED STATES CLASSIFICATION

### APPLICATION IN MORE THAN ONE CLASS

SN 85-124,757. AMERICAN SOCIETY FOR TESTING AND MATERIALS, WEST CONSHOHOCKEN, PA. FILED 9-8-2010.



OWNER OF U.S. REG. NOS. 2,685,857, 3,592,567 AND OTHERS.

NO CLAIM IS MADE TO THE EXCLUSIVE RIGHT TO USE "CERTIFIED" AND "INTERNATIONAL", APART FROM THE MARK AS SHOWN.

THE MARK CONSISTS OF THE WORDS "CERTIFIED ASTM INTERNATIONAL" IN A CIRCLE AROUND THE LETTERS "ASTM" WITH A CHECK MARK THROUGH THE LETTERS "ASTM".

THE CERTIFICATION MARK, AS INTENDED TO BE

USED BY AUTHORIZED PERSONS, IS INTENDED TO CERTIFY THAT SAMPLES OF THE PRODUCTS THAT WERE TESTED IN CLASS A CONFORM TO MANUFACTURING, QUALITY CONTROL, RISK, HEALTH, SAFETY, INFORMATION SECURITY, ENVIRONMENTAL SUSTAINABILITY, AND CORPORATE SOCIAL RESPONSIBILITY STANDARDS SET BY THE CERTIFIER, AND THAT THE SERVICES IN CLASS B ARE BEING PERFORMED BY A PERSON OR BUSINESS WHOSE PERSONNEL HAVE MET PREREQUISITE LEVELS OF RELEVANT EDUCATION AND EXPERIENCE, HAVE PASSED AN OBJECTIVE EXAMINATION, AND HAVE PARTICIPATED IN APPROVED CONTINUING EDUCATION ACTIVITIES TO MAINTAIN THEIR PROFESSIONAL COMPETENCIES.

#### CLASS A—GOODS

FOR BUILDINGS AND BUILDING CONSTRUCTION, CONSUMER PRODUCTS; IRON AND STEEL; NONFERROUS METALS; PETROLEUM; PAINTS AND COATINGS; TEXTILES; PLASTICS; RUBBER; ELECTRICAL AND ELECTRONICS PRODUCTS; MEDICAL DEVICES; CHEMICALS; CERAMICS; PHARMACEUTICALS; PACKAGING; SECURITY; SUSTAINABILITY; GENERAL SCIENTIFIC METHODS, INSTRUMENTATION, AND EQUIPMENT.

#### CLASS B—SERVICES

FOR PERSONNEL, SYSTEMS AND SERVICES OF OTHERS IN VARIOUS INDUSTRIES, NAMELY, BUILDINGS AND CONSTRUCTION, CONSUMER PRODUCTS; IRON AND STEEL; NONFERROUS METALS; PETROLEUM; PAINTS AND COATINGS; TEXTILES; PLASTICS; RUBBER; ELECTRICAL AND ELECTRONICS PRODUCTS; MEDICAL DEVICES; CHEMICALS; CERAMICS; PHARMACEUTICALS; PACKAGING; SECURITY; SUSTAINABILITY; GENERAL SCIENTIFIC METHODS, INSTRUMENTATION, AND EQUIPMENT.

WILLIAM P. SHANAHAN, EXAMINING ATTORNEY

\* \* \* \* \*



SECTION 4.—PRIOR UNITED STATES CLASSIFICATION

APPLICATION IN ONE CLASS

COLLECTIVE MEMBERSHIP MARKS

SN 77-883,616. AMERICA'S HEALTH INSURANCE PLANS, INC., WASHINGTON, DC. FILED 12-1-2009.

CLASS 200—COLLECTIVE MEMBERSHIP  
SN 85-150,645. FORBIDDEN WHEELS M.C. INC., DETROIT, MI. FILED 10-12-2010.

FHIAS



THE MARK CONSISTS OF STANDARD CHARACTERS WITHOUT CLAIM TO ANY PARTICULAR FONT, STYLE, SIZE, OR COLOR.

THE CERTIFICATION MARK, AS INTENDED TO BE USED BY AUTHORIZED PERSONS, IS INTENDED TO CERTIFY THAT THE SERVICES PROVIDED BY INDIVIDUALS HAVE MET THE CRITERIA OF KNOWLEDGE AND COMPETENCE IN THE FIELD OF HEALTH INSURANCE AS ESTABLISHED BY THE CERTIFIER THROUGH A CERTIFICATION PROGRAM.

FOR SERVICES RENDERED BY PERSONS WHO WORK IN THE FIELD OF HEALTH INSURANCE.  
CYNTHIA SLOAN, EXAMINING ATTORNEY

OWNER OF U.S. REG. NO. 2,907,675.  
NO CLAIM IS MADE TO THE EXCLUSIVE RIGHT TO USE "MC" AND "DETROIT", APART FROM THE MARK AS SHOWN.

THE MARK CONSISTS OF A SPOKED MOTORCYCLE WHEEL HAVING A SNAKE PASSING THROUGH THE SPOKES, A PAIR OF WINGS EXTENDING OUTWARDLY FROM THE SIDES, THE WORDS "FORBIDDEN WHEELS" ABOVE THE WHEEL, THE WORD "DETROIT" BELOW THE WHEEL, AND "MC" IN THE HUB OF THE WHEEL.

FOR INDICATING MEMBERSHIP IN A CLUB OF MOTORCYCLISTS.

FIRST USE 3-18-1968; IN COMMERCE 3-18-1968.  
NELSON SNYDER, EXAMINING ATTORNEY

SN 77-883,620. AMERICA'S HEALTH INSURANCE PLANS, INC., WASHINGTON, DC. FILED 12-1-2009.

PHIAS

THE MARK CONSISTS OF STANDARD CHARACTERS WITHOUT CLAIM TO ANY PARTICULAR FONT, STYLE, SIZE, OR COLOR.

THE CERTIFICATION MARK, AS INTENDED TO BE USED BY AUTHORIZED PERSONS, IS INTENDED TO CERTIFY THAT THE SERVICES PROVIDED BY INDIVIDUALS HAVE MET THE CRITERIA OF KNOWLEDGE AND COMPETENCE IN THE FIELD OF HEALTH INSURANCE AS ESTABLISHED BY THE CERTIFIER THROUGH A CERTIFICATION PROGRAM.

FOR SERVICES RENDERED BY PERSONS WHO WORK IN THE FIELD OF HEALTH INSURANCE.  
CYNTHIA SLOAN, EXAMINING ATTORNEY

CERTIFICATION MARKS

CLASS B—SERVICES

\* \* \* \* \*

# TRADEMARK REGISTRATIONS ISSUED

## PRINCIPAL REGISTER

### SECTION 1.— INTERNATIONAL CLASSIFICATION

The short titles associated below with the international class numbers are terms designed merely for quick identification and are not an official part of the international classification. The full names of international classes are given in section 6.1 of the trademark rules of practice.

The designation "U.S. Cl." appearing in this section refers to the U.S. class in effect prior to Sep. 1, 1973 rather than the international class which applies to applications filed on or after that date. For adoption of international classification see notice in the OFFICIAL GAZETTE of Jun. 26, 1973 (911 O.G. TM 210).

#### CLASS 1—CHEMICALS

- 3,953,002. **HERC (STANDARD CHARACTER)**. NISSAN CHEMICAL INDUSTRIES, LTD., (U.S. CLS. 1, 5, 6, 10, 26 AND 46). SN 77-057,114. PUB. 1-1-2008. FILED 12-5-2006.
- 3,953,083. **STATOIL AND DESIGN**. STATOILHYDRO ASA, MULTIPLE CLASS, (INT. CLS. 1, 3, 4, 7, 9, 11, 17, 29, 30, 31, 35, 36, 37, 39, 40, 41, 42 AND 43), (U.S. CLS. 1, 4, 5, 6, 10, 12, 13, 15, 19, 21, 23, 26, 31, 34, 35, 36, 38, 46, 50, 51, 52, 100, 101, 102, 103, 105, 106 AND 107). SN 77-762,071. PUB. 2-15-2011. FILED 6-17-2009.
- 3,953,147. **GARDEN PUZZLE FOOD PAVERS (STANDARD CHARACTER)**. HARGER, PAUL, (U.S. CLS. 1, 5, 6, 10, 26 AND 46). SN 77-823,949. PUB. 2-15-2011. FILED 9-10-2009.
- 3,953,230. **IRIOTEC (STANDARD CHARACTER)**. MERCK KGAA, (U.S. CLS. 1, 5, 6, 10, 26 AND 46). SN 77-910,256. PUB. 11-2-2010. FILED 1-12-2010.
- 3,953,382. **FIX IT FIRST (STANDARD CHARACTER)**. ADHESIVES TECHNOLOGY CORPORATION, (U.S. CLS. 1, 5, 6, 10, 26 AND 46). SN 77-955,161. PUB. 2-15-2011. FILED 3-10-2010.
- 3,953,394. **SMARTPOND (STANDARD CHARACTER)**. GEO-GLOBAL PARTNERS, LLC, MULTIPLE CLASS, (INT. CLS. 1, 2, 5, 9, 11, 17, 19, 21, 22 AND 31), (U.S. CLS. 1, 2, 5, 6, 7, 10, 11, 12, 13, 16, 18, 19, 21, 22, 23, 26, 29, 30, 31, 33, 34, 35, 36, 38, 40, 42, 44, 46, 50, 51 AND 52). SN 77-956,774. PUB. 2-15-2011. FILED 3-11-2010.
- 3,953,410. **LIGNIN LS-50 (STANDARD CHARACTER)**. PRINCE MINERALS, INC., (U.S. CLS. 1, 5, 6, 10, 26 AND 46). SN 77-959,252. PUB. 2-15-2011. FILED 3-15-2010.
- 3,953,513. **OCI (STYLIZED)**. OCI COMPANY LTD., MULTIPLE CLASS, (INT. CLS. 1, 2, 3, 4, 5, 6, 7, 9, 17, 19, 22, 35 AND 36), (U.S. CLS. 1, 2, 4, 5, 6, 7, 10, 11, 12, 13, 14, 15, 16, 18, 19, 21, 22, 23, 25, 26, 31, 33, 34, 35, 36, 38, 42, 44, 46, 50, 51, 52, 100, 101 AND 102). SN 79-073,861. PUB. 10-12-2010. FILED 6-24-2009.
- 3,953,541. **CT ATLANTIC (STANDARD CHARACTER)**. CT ATLANTIC LTD., MULTIPLE CLASS, (INT. CLS. 1, 5 AND 42), (U.S. CLS. 1, 5, 6, 10, 18, 26, 44, 46, 51, 52, 100 AND 101). SN 79-079,465. PUB. 2-15-2011. FILED 12-15-2009.
- 3,953,546. **ZINCLEAR IM AND DESIGN**. ANTARIA LIMITED, (U.S. CLS. 1, 5, 6, 10, 26 AND 46). SN 79-080,306. PUB. 2-15-2011. FILED 2-16-2010.
- 3,953,617. **G-PET (STANDARD CHARACTER)**. GURIT (UK) LTD, MULTIPLE CLASS, (INT. CLS. 1, 17 AND 19), (U.S. CLS. 1, 5, 6, 10, 12, 13, 26, 33, 35, 46 AND 50). SN 79-084,177. PUB. 2-15-2011. FILED 3-4-2010.
- 3,953,633. **HYDROSENN+ (STYLIZED)**. SEPHORA, (U.S. CLS. 1, 5, 6, 10, 26 AND 46). SN 79-085,997. PUB. 2-15-2011. FILED 7-13-2010.
- 3,953,637. **LUHUA AND DESIGN**. TIANJIN CHANGLU HANGU SALTERS CO., LTD., (U.S. CLS. 1, 5, 6, 10, 26 AND 46). SN 79-086,269. PUB. 2-15-2011. FILED 5-27-2010.
- 3,953,653. **POLYTHERM (STANDARD CHARACTER)**. MSC POLYMER AG, (U.S. CLS. 1, 5, 6, 10, 26 AND 46). SN 79-087,656. PUB. 2-15-2011. FILED 6-17-2010.
- 3,953,661. **TRIBOFORCE (STANDARD CHARACTER)**. LEIS POLYTECHNIK - POLYMERE WERKSTOFFE GMBH, (U.S. CLS. 1, 5, 6, 10, 26 AND 46). SN 79-087,916. PUB. 2-15-2011. FILED 8-31-2010.
- 3,953,676. **BARRECOTE (STANDARD CHARACTER)**. SA-CRON INNOVATIONS PTY LIMITED, (U.S. CLS. 1, 5, 6, 10, 26 AND 46). SN 79-089,776. PUB. 2-15-2011. FILED 7-27-2010.
- 3,953,826. **CORRMAX (STANDARD CHARACTER)**. CEL CHEMICAL & SUPPLIES, INC., (U.S. CLS. 1, 5, 6, 10, 26 AND 46). SN 85-044,374. PUB. 10-19-2010. FILED 5-20-2010.
- 3,953,840. **RHEONIX (STANDARD CHARACTER)**. RHEONIX, INC., (U.S. CLS. 1, 5, 6, 10, 26 AND 46). SN 85-051,230. PUB. 2-15-2011. FILED 5-31-2010.
- 3,953,841. **RHEONIX AND DESIGN**. RHEONIX, INC., (U.S. CLS. 1, 5, 6, 10, 26 AND 46). SN 85-051,231. PUB. 2-15-2011. FILED 5-31-2010.
- 3,953,847. **ENVIROTHAW ASALT (STANDARD CHARACTER)**. SOUTHWEST ENVIROTECH PARTNERS LLC, FORMERLY SOUTHWEST ENVIROTECH PARTNERS LP, (U.S. CLS. 1, 5, 6, 10, 26 AND 46). SN 85-053,622. PUB. 2-15-2011. FILED 6-3-2010.
- 3,953,858. **CRAFTBOND (STANDARD CHARACTER)**. ELMER'S PRODUCTS, INC., MULTIPLE CLASS, (INT. CLS. 1 AND 16), (U.S. CLS. 1, 2, 5, 6, 10, 22, 23, 26, 29, 37, 38, 46 AND 50). SN 85-057,690. PUB. 2-15-2011. FILED 6-8-2010.
- 3,953,921. **MICROXYME TECHNOLOGIES (STANDARD CHARACTER)**. CLINE, RODNEY, (U.S. CLS. 1, 5, 6, 10, 26 AND 46). SN 85-076,020. PUB. 2-15-2011. FILED 7-1-2010.
- 3,953,937. **THYMOX (STANDARD CHARACTER)**. LABORATOIRE M2 INC., MULTIPLE CLASS, (INT. CLS. 1, 3 AND 5), (U.S. CLS. 1, 4, 5, 6, 10, 18, 26, 44, 46, 50, 51 AND 52). SN 85-080,058. PUB. 2-15-2011. FILED 7-8-2010.
- 3,953,945. **PERMANNA (STANDARD CHARACTER)**. REFINED TECHNOLOGIES, INC., (U.S. CLS. 1, 5, 6, 10, 26 AND 46). SN 85-083,077. PUB. 2-15-2011. FILED 7-13-2010.
- 3,953,948. **DRI-IT (STANDARD CHARACTER)**. DRI-IT CORPORATION, (U.S. CLS. 1, 5, 6, 10, 26 AND 46). SN 85-083,622. PUB. 2-15-2011. FILED 7-13-2010.
- 3,954,013. **DRY-PACKS AND DESIGN**. FAIRLY ODD TREASURES, LLC., DBA ABSORBENT INDUSTRIES, (U.S. CLS. 1, 5, 6, 10, 26 AND 46). SN 85-099,028. PUB. 2-15-2011. FILED 8-3-2010.
- 3,954,103. **VINYLD0C (STANDARD CHARACTER)**. FENSKE, DAVID J., AKA VINYLD0C, MULTIPLE CLASS, (INT. CLS. 1, 37 AND 40), (U.S. CLS. 1, 5, 6, 10, 26, 46, 100, 103 AND 106). SN 85-109,515. PUB. 2-15-2011. FILED 8-17-2010.
- 3,954,127. **POWER GREEN (STANDARD CHARACTER)**. OSIAN, INC., (U.S. CLS. 1, 5, 6, 10, 26 AND 46). SN 85-110,982. PUB. 2-15-2011. FILED 8-19-2010.
- 3,954,278. **TAMASHII ORGANICS (STANDARD CHARACTER)**. MICHAEL PIRETTI, (U.S. CLS. 1, 5, 6, 10, 26 AND 46). SN 85-115,843. PUB. 2-15-2011. FILED 8-25-2010.
- 3,954,345. **SUNSWEEP (STANDARD CHARACTER)**. SUN DRILLING PRODUCTS CORPORATION, (U.S. CLS. 1, 5, 6, 10, 26 AND 46). SN 85-117,098. PUB. 2-15-2011. FILED 8-26-2010.
- 3,954,450. **G-LISA (STANDARD CHARACTER)**. CYTOSKELETON, INC., (U.S. CLS. 1, 5, 6, 10, 26 AND 46). SN 85-118,478. PUB. 2-15-2011. FILED 8-30-2010.
- 3,954,535. **SOLARFLUOR (STANDARD CHARACTER)**. ROGER CUBICCIOTTI, TA NANOMEDIA, INC., (U.S. CLS. 1, 5, 6, 10, 26 AND 46). SN 85-119,234. PUB. 2-15-2011. FILED 8-30-2010.

- 3,954,598. **FUELON (STANDARD CHARACTER)**. FUEL PLUS TECHNOLOGY, INC., (U.S. CLS. 1, 5, 6, 10, 26 AND 46). SN 85-119,985. PUB. 2-15-2011. FILED 8-31-2010.
- 3,954,705. **LINDE PLATINUM PARTNER (STANDARD CHARACTER)**. LINDE AKTIENGESELLSCHAFT, MULTIPLE CLASS, (INT. CLS. 1 AND 6), (U.S. CLS. 1, 2, 5, 6, 10, 12, 13, 14, 23, 25, 26, 46 AND 50). SN 85-120,995. PUB. 2-15-2011. FILED 9-1-2010.
- 3,954,720. **IQ GLUE (STANDARD CHARACTER)**. SMARTADHESIVES LLC, MULTIPLE CLASS, (INT. CLS. 1, 16, 17 AND 35), (U.S. CLS. 1, 2, 5, 6, 10, 12, 13, 22, 23, 26, 29, 35, 37, 38, 46, 50, 100, 101 AND 102). SN 85-121,252. PUB. 2-15-2011. FILED 9-1-2010.
- 3,954,906. **AQUATROLS PIVOT SOIL PENETRANT AND DESIGN**. AQUATROLS CORPORATION OF AMERICA, (U.S. CLS. 1, 5, 6, 10, 26 AND 46). SN 85-123,740. PUB. 2-15-2011. FILED 9-7-2010.
- 3,954,976. **ARBORCIDE (STANDARD CHARACTER)**. ACTIVE CONCEPTS LLC, (U.S. CLS. 1, 5, 6, 10, 26 AND 46). SN 85-128,284. PUB. 2-15-2011. FILED 9-13-2010.
- 3,955,016. **MICROPURE (STANDARD CHARACTER)**. ISP INVESTMENTS INC., (U.S. CLS. 1, 5, 6, 10, 26 AND 46). SN 85-135,557. PUB. 2-15-2011. FILED 9-22-2010.
- 3,955,080. **CLAYSURF-EZ (STANDARD CHARACTER)**. HAL-LIBURTON ENERGY SERVICES, INC., (U.S. CLS. 1, 5, 6, 10, 26 AND 46). SN 85-148,590. PUB. 2-15-2011. FILED 10-8-2010.
- 3,955,105. **HIQ (STANDARD CHARACTER)**. LINDE AKTIENGESELLSCHAFT, AKA LINDE AG, (U.S. CLS. 1, 5, 6, 10, 26 AND 46). SN 85-161,193. PUB. 2-15-2011. FILED 10-26-2010.

## CLASS 2—PAINTS

- 3,953,065. **IRIOTEC (STANDARD CHARACTER)**. MERCK KGAA, MULTIPLE CLASS, (INT. CLS. 2 AND 17), (U.S. CLS. 1, 5, 6, 11, 12, 13, 16, 35 AND 50). SN 77-730,857. PUB. 8-3-2010. FILED 5-6-2009.
- 3,953,205. **PRESS SMART AND DESIGN**. PRESS SMART PRINTING PRODUCTS LLC, (U.S. CLS. 6, 11 AND 16). SN 77-879,247. PUB. 2-15-2011. FILED 11-23-2009.
- 3,953,369. **MISCELLANEOUS DESIGN**. NEXTLIFE LICENSING, LLC, MULTIPLE CLASS, (INT. CLS. 2, 35, 41 AND 42), (U.S. CLS. 6, 11, 16, 100, 101, 102 AND 107). SN 77-953,680. PUB. 2-15-2011. FILED 3-8-2010.
- 3,953,394 ( *See Class 1 for this trademark* ).
- 3,953,474. **ULTRA (STANDARD CHARACTER)**. RPM WOOD FINISHES GROUP, INC., (U.S. CLS. 6, 11 AND 16). SN 78-705,124. PUB. 2-15-2011. FILED 9-1-2005.
- 3,953,513 ( *See Class 1 for this trademark* ).
- 3,953,931. **COMON CONSABLE (STYLIZED)**. COMONCONSABLE INC., (U.S. CLS. 6, 11 AND 16). SN 85-077,912. PUB. 2-15-2011. FILED 7-5-2010.
- 3,954,588. **WOODSONG (STANDARD CHARACTER)**. SWIMC, INC., (U.S. CLS. 6, 11 AND 16). SN 85-119,870. PUB. 2-15-2011. FILED 8-31-2010.
- 3,954,775. **E-212-F (STANDARD CHARACTER)**. WISE CHEM LLC, (U.S. CLS. 6, 11 AND 16). SN 85-121,924. PUB. 2-15-2011. FILED 9-2-2010.
- 3,954,806. **O AND DESIGN**. COMPANY OF ARTISTS, LLC, MULTIPLE CLASS, (INT. CLS. 2 AND 25), (U.S. CLS. 6, 11, 16, 22 AND 39). SN 85-122,327. PUB. 2-15-2011. FILED 9-2-2010.
- 3,954,824. **KEYPLAST (STANDARD CHARACTER)**. KEYSTONE ANILINE CORPORATION, (U.S. CLS. 6, 11 AND 16). SN 85-122,508. PUB. 2-15-2011. FILED 9-3-2010.
- 3,954,872. **MR. PAINT KELLY MOORE PAINTS AND DESIGN**. KELLY-MOORE PAINT COMPANY, INC., (U.S. CLS. 6, 11 AND 16). SN 85-123,094. PUB. 2-15-2011. FILED 9-3-2010.
- 3,954,873. **GOT TONER? (STANDARD CHARACTER)**. WAZANA BROTHERS INTERNATIONAL, INC., DBA MICRO SOLUTIONS ENTERPRISES, (U.S. CLS. 6, 11 AND 16). SN 85-123,101. PUB. 2-15-2011. FILED 9-3-2010.
- 3,954,884. **MSE (STANDARD CHARACTER)**. WAZANA BROTHERS INTERNATIONAL, INC., DBA MICRO SOLUTIONS ENTERPRISES, MULTIPLE CLASS, (INT. CLS. 2 AND 40), (U.S. CLS. 6, 11, 16, 100, 103 AND 106). SN 85-123,294. PUB. 2-15-2011. FILED 9-3-2010.
- 3,954,964. **VAN SON SELECT (STANDARD CHARACTER)**. VAN SON HOLLAND INK CORPORATION OF AMERICA, (U.S. CLS. 6, 11 AND 16). SN 85-126,827. PUB. 2-15-2011. FILED 9-10-2010.
- 3,954,981. **SIMPLE INNOVATIONS (STANDARD CHARACTER)**. THE SHERWIN-WILLIAMS COMPANY, (U.S. CLS. 6, 11 AND 16). SN 85-129,076. PUB. 2-15-2011. FILED 9-14-2010.
- 3,955,040. **MAXBOND (STANDARD CHARACTER)**. THE SHERWIN-WILLIAMS COMPANY, (U.S. CLS. 6, 11 AND 16). SN 85-138,516. PUB. 2-15-2011. FILED 9-27-2010.
- 3,955,092. **SKYSCAPES AND DESIGN**. THE SHERWIN-WILLIAMS COMPANY, (U.S. CLS. 6, 11 AND 16). SN 85-151,379. PUB. 2-15-2011. FILED 10-13-2010.
- 3,955,107. **ECO-SET (STANDARD CHARACTER)**. HEXION SPECIALTY CHEMICALS, INC., (U.S. CLS. 6, 11 AND 16). SN 85-161,619. PUB. 2-15-2011. FILED 10-26-2010.
- 3,955,108. **ECO-WEB (STANDARD CHARACTER)**. HEXION SPECIALTY CHEMICALS, INC., (U.S. CLS. 6, 11 AND 16). SN 85-161,678. PUB. 2-15-2011. FILED 10-26-2010.

## CLASS 3—COSMETICS AND CLEANING PREPARATIONS

- 3,952,955. **ELEGANCE (STANDARD CHARACTER)**. SPPC PARIS BLEU, SAS, (U.S. CLS. 1, 4, 6, 50, 51 AND 52). SN 76-668,617. PUB. 4-24-2007. FILED 11-6-2006.
- 3,953,000. **SIMPLY KIDS (STANDARD CHARACTER)**. STAR CHILD DESIGN INC., MULTIPLE CLASS, (INT. CLS. 3, 5, 9, 10, 14, 16, 18, 20, 21, 24, 25, 28, 30 AND 32), (U.S. CLS. 1, 2, 3, 4, 5, 6, 13, 18, 21, 22, 23, 25, 26, 27, 28, 29, 30, 32, 33, 36, 37, 38, 39, 40, 41, 42, 44, 45, 46, 48, 50, 51 AND 52). SN 77-022,162. PUB. 1-15-2008. FILED 10-16-2006.
- 3,953,043. **SULWHASOO SPA (STYLIZED)**. AMOREPACIFIC CORPORATION, (U.S. CLS. 1, 4, 6, 50, 51 AND 52). SN 77-646,162. PUB. 8-3-2010. FILED 1-8-2009.
- 3,953,063. **NAILEZEE (STANDARD CHARACTER)**. ADVANCED NAIL GROWTH SYSTEMS, INC., (U.S. CLS. 1, 4, 6, 50, 51 AND 52). SN 77-723,006. PUB. 12-1-2009. FILED 4-27-2009.
- 3,953,073. **COMFORTÉ (STANDARD CHARACTER)**. 938023 ONTARIO INC., MULTIPLE CLASS, (INT. CLS. 3 AND 5), (U.S. CLS. 1, 4, 6, 18, 44, 46, 50, 51 AND 52). SN 77-744,647. PUB. 2-15-2011. FILED 5-26-2009.
- 3,953,075. **ELUTION (STANDARD CHARACTER)**. PIERRE FABRE DERMO-COSMETIQUE, MULTIPLE CLASS, (INT. CLS. 3 AND 5), (U.S. CLS. 1, 4, 6, 18, 44, 46, 50, 51 AND 52). SN 77-747,782. PUB. 2-15-2011. FILED 5-29-2009.
- 3,953,076. **EYE SLICES AND DESIGN**. I-SLICES INNOVATIONS (PTY) LTD, (U.S. CLS. 1, 4, 6, 50, 51 AND 52). SN 77-750,690. PUB. 7-27-2010. FILED 6-3-2009.
- 3,953,083 ( *See Class 1 for this trademark* ).
- 3,953,089. **SILK INFUSION (STANDARD CHARACTER)**. FAROUK SYSTEMS, INC., (U.S. CLS. 1, 4, 6, 50, 51 AND 52). SN 77-769,368. PUB. 2-15-2011. FILED 6-26-2009.
- 3,953,099. **BIOCYTE ULTIMATE BEAUTY (STANDARD CHARACTER)**. BIOCYTE SARL, MULTIPLE CLASS, (INT. CLS. 3 AND 5), (U.S. CLS. 1, 4, 6, 18, 44, 46, 50, 51 AND 52). SN 77-793,042. PUB. 1-4-2011. FILED 7-30-2009.
- 3,953,105. **SWISSPERS (STANDARD CHARACTER)**. FLAWA AG, MULTIPLE CLASS, (INT. CLS. 3 AND 21), (U.S. CLS. 1, 2, 4, 6, 13, 23, 29, 30, 33, 40, 50, 51 AND 52). SN 77-796,577. PUB. 2-15-2011. FILED 8-4-2009.
- 3,953,122. **FUTURE RESPONSE AGE DEFENSE CREME (STANDARD CHARACTER)**. AMOREPACIFIC CORPORATION, (U.S. CLS. 1, 4, 6, 50, 51 AND 52). SN 77-812,712. PUB. 8-3-2010. FILED 8-25-2009.
- 3,953,123. **LINE PROOF TECHNOLOGY (STANDARD CHARACTER)**. AMOREPACIFIC CORPORATION, (U.S. CLS. 1, 4, 6, 50, 51 AND 52). SN 77-812,715. PUB. 8-3-2010. FILED 8-25-2009.
- 3,953,124. **PREPERFECTION (STANDARD CHARACTER)**. AMOREPACIFIC CORPORATION, (U.S. CLS. 1, 4, 6, 50, 51 AND 52). SN 77-812,720. PUB. 8-17-2010. FILED 8-25-2009.

- 3,953,144. **FEEL LIFE F&L (STYLIZED)**. TOPSEE INTERNATIONAL CO., LIMITED, MULTIPLE CLASS, (INT. CLS. 3 AND 9), (U.S. CLS. 1, 4, 6, 21, 23, 26, 36, 38, 50, 51 AND 52). SN 77-822,286. PUB. 2-15-2011. FILED 9-8-2009.
- 3,953,196. **CRYSTALTEK AND DESIGN**. WEST END PRODUCTS, LLC, (U.S. CLS. 1, 4, 6, 50, 51 AND 52). SN 77-863,378. PUB. 2-15-2011. FILED 11-2-2009.
- 3,953,255. **EVER LASH AND DESIGN**. RYU IL INTERNATIONAL, INC., DBA JR BEAUTY, (U.S. CLS. 1, 4, 6, 50, 51 AND 52). SN 77-926,366. PUB. 11-9-2010. FILED 2-2-2010.
- 3,953,318. **NANOBLUR (STANDARD CHARACTER)**. INDEED LABORATORIES INC., (U.S. CLS. 1, 4, 6, 50, 51 AND 52). SN 77-947,051. PUB. 2-15-2011. FILED 3-1-2010.
- 3,953,319. **SNOXIN (STANDARD CHARACTER)**. INDEED LABORATORIES INC., (U.S. CLS. 1, 4, 6, 50, 51 AND 52). SN 77-947,063. PUB. 2-15-2011. FILED 3-1-2010.
- 3,953,354. **BOTAMINE (STANDARD CHARACTER)**. MESYL LIMITED, (U.S. CLS. 1, 4, 6, 50, 51 AND 52). SN 77-951,646. PUB. 2-15-2011. FILED 3-5-2010.
- 3,953,363. **LIQUID GEM (STANDARD CHARACTER)**. GLEYZER, MARINA, (U.S. CLS. 1, 4, 6, 50, 51 AND 52). SN 77-952,860. PUB. 2-15-2011. FILED 3-8-2010.
- 3,953,383. **ECO COOL AND DESIGN**. MAX ECO, LLC, (U.S. CLS. 1, 4, 6, 50, 51 AND 52). SN 77-955,478. PUB. 2-15-2011. FILED 3-10-2010.
- 3,953,389. **PYTHON (STANDARD CHARACTER)**. TRUSSARDI S.P.A., (U.S. CLS. 1, 4, 6, 50, 51 AND 52). SN 77-956,304. PUB. 8-3-2010. FILED 3-11-2010.
- 3,953,438. **CONTROL TACTICS (STANDARD CHARACTER)**. BIOPELLE, INC., (U.S. CLS. 1, 4, 6, 50, 51 AND 52). SN 77-962,197. PUB. 2-15-2011. FILED 3-18-2010.
- 3,953,453. **BETROTHAL (STANDARD CHARACTER)**. J. GROSSMITH & SON LIMITED, (U.S. CLS. 1, 4, 6, 50, 51 AND 52). SN 77-965,749. PUB. 2-15-2011. FILED 3-23-2010.
- 3,953,471. **BYFORD (STYLIZED)**. DONALD BYFORD & SONS SDN. BHD., MULTIPLE CLASS, (INT. CLS. 3, 9, 14, 18, 24, 25 AND 35), (U.S. CLS. 1, 2, 3, 4, 6, 21, 22, 23, 26, 27, 28, 36, 38, 39, 41, 42, 50, 51, 52, 100, 101 AND 102). SN 78-627,843. PUB. 2-15-2011. FILED 5-11-2005.
- 3,953,480. **REGENA CELL (STYLIZED)**. ENERGETIC NUTRITION, INC., (U.S. CLS. 1, 4, 6, 50, 51 AND 52). SN 78-916,062. PUB. 2-15-2011. FILED 6-23-2006.
- 3,953,485. **CANALI SPORTSWEAR AND DESIGN**. CANALI IRELAND LIMITED, MULTIPLE CLASS, (INT. CLS. 3, 9, 14, 18, 24, 25 AND 28), (U.S. CLS. 1, 2, 3, 4, 6, 21, 22, 23, 26, 27, 28, 36, 38, 39, 41, 42, 50, 51 AND 52). SN 79-007,163. PUB. 2-21-2006. FILED 4-26-2004.
- 3,953,496. **M.T.O. SHAHMAGHSUDI HOLISTIC CENTER (STANDARD CHARACTER)**. NADER ANGHA, MULTIPLE CLASS, (INT. CLS. 3, 5, 41 AND 44), (U.S. CLS. 1, 4, 6, 18, 44, 46, 50, 51, 52, 100, 101 AND 107). SN 79-067,874. PUB. 2-15-2011. FILED 3-3-2009.
- 3,953,499. **GAMMARICH (STANDARD CHARACTER)**. DAVOS LIFE SCIENCE PTE. LTD., MULTIPLE CLASS, (INT. CLS. 3 AND 5), (U.S. CLS. 1, 4, 6, 18, 44, 46, 50, 51 AND 52). SN 79-068,279. PUB. 2-15-2011. FILED 10-31-2008.
- 3,953,513 ( *See Class 1 for this trademark*).
- 3,953,535. **ORCHIDARIUM RESEARCH PLATFORM GUERLAIN AND DESIGN**. GUERLAIN S.A., SOCIÉTÉ ANONYME, MULTIPLE CLASS, (INT. CLS. 3 AND 42), (U.S. CLS. 1, 4, 6, 50, 51, 52, 100 AND 101). SN 79-078,367. PUB. 2-15-2011. FILED 10-28-2009.
- 3,953,536. **MISCELLANEOUS DESIGN**. GUERLAIN S.A. (SOCIÉTÉ ANONYME), (U.S. CLS. 1, 4, 6, 50, 51 AND 52). SN 79-078,416. PUB. 2-15-2011. FILED 12-15-2009.
- 3,953,588. **L'HEURE DIAPHANE (STANDARD CHARACTER)**. CARTIER INTERNATIONAL AG, (U.S. CLS. 1, 4, 6, 50, 51 AND 52). SN 79-082,280. PUB. 2-15-2011. FILED 3-30-2010.
- 3,953,591. **L'HEURE DEFENDUE (STANDARD CHARACTER)**. CARTIER INTERNATIONAL AG, (U.S. CLS. 1, 4, 6, 50, 51 AND 52). SN 79-082,315. PUB. 2-15-2011. FILED 3-30-2010.
- 3,953,621. **FF AND DESIGN**. FENDI ADELE S.R.L., MULTIPLE CLASS, (INT. CLS. 3 AND 21), (U.S. CLS. 1, 2, 4, 6, 13, 23, 29, 30, 33, 40, 50, 51 AND 52). SN 79-084,625. PUB. 2-15-2011. FILED 4-8-2010.
- 3,953,632. **TEZENIS (STYLIZED)**. M.F.H. FEJLESZTŐ KORLATOLT FELELŐSSÉGŰ TÁRSASÁG, MULTIPLE CLASS, (INT. CLS. 3, 25 AND 35), (U.S. CLS. 1, 4, 6, 22, 39, 50, 51, 52, 100, 101 AND 102). SN 79-085,843. PUB. 2-15-2011. FILED 7-19-2010.
- 3,953,634. **MUSTELA. THERE WHEN YOU NEED IT THE MOST (STANDARD CHARACTER)**. LABORATOIRES EXPANSCIENCE, (U.S. CLS. 1, 4, 6, 50, 51 AND 52). SN 79-086,136. PUB. 2-15-2011. FILED 6-24-2010.
- 3,953,643. **JO NO FUI (STANDARD CHARACTER)**. GIACOBINO ALESSIA, MULTIPLE CLASS, (INT. CLS. 3, 9, 20, 21 AND 24), (U.S. CLS. 1, 2, 4, 6, 13, 21, 22, 23, 25, 26, 29, 30, 32, 33, 36, 38, 40, 42, 50, 51 AND 52). SN 79-087,186. PUB. 2-15-2011. FILED 6-29-2010.
- 3,953,694. **STRUTZ (STANDARD CHARACTER)**. STRUTZ, INC., MULTIPLE CLASS, (INT. CLS. 3 AND 10), (U.S. CLS. 1, 4, 6, 26, 39, 44, 50, 51 AND 52). SN 85-002,442. PUB. 2-15-2011. FILED 3-30-2010.
- 3,953,726. **IKELIA (STANDARD CHARACTER)**. PIERRE FABRE MEDICAMENT, MULTIPLE CLASS, (INT. CLS. 3 AND 5), (U.S. CLS. 1, 4, 6, 18, 44, 46, 50, 51 AND 52). SN 85-012,103. PUB. 2-15-2011. FILED 4-12-2010.
- 3,953,757. **CHIQUÍ BEAUTÉ AND DESIGN**. NIC MANAGEMENT, INC., (U.S. CLS. 1, 4, 6, 50, 51 AND 52). SN 85-024,872. PUB. 2-15-2011. FILED 4-28-2010.
- 3,953,827. **MISCELLANEOUS DESIGN**. GUERLAIN SOCIÉTÉ ANONYME, (U.S. CLS. 1, 4, 6, 50, 51 AND 52). SN 85-045,126. PUB. 2-15-2011. FILED 5-21-2010.
- 3,953,833. **MINE (STANDARD CHARACTER)**. MARKET AMERICA, INC., (U.S. CLS. 1, 4, 6, 50, 51 AND 52). SN 85-047,947. PUB. 2-15-2011. FILED 5-26-2010.
- 3,953,834. **LASHIQUE (STANDARD CHARACTER)**. VIDE-SANTE PHARMACEUTICALS, LLC, (U.S. CLS. 1, 4, 6, 50, 51 AND 52). SN 85-048,200. PUB. 2-15-2011. FILED 5-26-2010.
- 3,953,874. **MINI NIGHTS OF PASSION (STANDARD CHARACTER)**. PURE ROMANCE, INC., MULTIPLE CLASS, (INT. CLS. 3 AND 5), (U.S. CLS. 1, 4, 6, 18, 44, 46, 50, 51 AND 52). SN 85-062,457. PUB. 2-15-2011. FILED 6-14-2010.
- 3,953,903. **TRUTH (STANDARD CHARACTER)**. LANIAK, MAUREEN L, DBA IMAGO DEI, (U.S. CLS. 1, 4, 6, 50, 51 AND 52). SN 85-071,534. PUB. 2-15-2011. FILED 6-25-2010.
- 3,953,906. **CHEMQUEST (STANDARD CHARACTER)**. HOB0 INC, (U.S. CLS. 1, 4, 6, 50, 51 AND 52). SN 85-071,917. PUB. 2-15-2011. FILED 6-25-2010.
- 3,953,914. **20 20 20 SERENITY 20 MINUTES TO SERENITY AND DESIGN**. 20 SERENITY, MULTIPLE CLASS, (INT. CLS. 3 AND 5), (U.S. CLS. 1, 4, 6, 18, 44, 46, 50, 51 AND 52). SN 85-073,226. PUB. 2-15-2011. FILED 6-28-2010.
- 3,953,937 ( *See Class 1 for this trademark*).
- 3,953,950. **ARIMINO AND DESIGN**. ARIMINO CO., LTD., (U.S. CLS. 1, 4, 6, 50, 51 AND 52). SN 85-085,129. PUB. 2-15-2011. FILED 7-15-2010.
- 3,953,975. **DANCOLY DANCOLY ANGEL PROFESSIONAL PARIS THE POWER OF THE OCEAN DEPTHS AND DESIGN**. LE SECRET INC, AND MAHMOOD JAMAL, (U.S. CLS. 1, 4, 6, 50, 51 AND 52). SN 85-091,884. PUB. 2-15-2011. FILED 7-23-2010.
- 3,954,043. **GOOD FORTUNE WASH YOUR TROUBLES AWAY AND DESIGN**. GOOD FORTUNE, LLC, (U.S. CLS. 1, 4, 6, 50, 51 AND 52). SN 85-104,899. PUB. 2-15-2011. FILED 8-11-2010.
- 3,954,061. **MORGANE LE FAY (STANDARD CHARACTER)**. MORGANE LE FAY, INC., (U.S. CLS. 1, 4, 6, 50, 51 AND 52). SN 85-106,230. PUB. 2-15-2011. FILED 8-12-2010.
- 3,954,114. **FANCY NIGHTS JESSICA SIMPSON (STANDARD CHARACTER)**. WITH YOU, INC., (U.S. CLS. 1, 4, 6, 50, 51 AND 52). SN 85-110,292. PUB. 2-15-2011. FILED 8-18-2010.
- 3,954,133. **MISCELLANEOUS DESIGN**. S & N ENTERPRISES, INC., (U.S. CLS. 1, 4, 6, 50, 51 AND 52). SN 85-111,213. PUB. 2-15-2011. FILED 8-19-2010.
- 3,954,136. **LUXE LAYERS (STANDARD CHARACTER)**. SALLY HERSHBERGER PROFESSIONAL HAIR CARE LLC, (U.S. CLS. 1, 4, 6, 50, 51 AND 52). SN 85-111,342. PUB. 2-15-2011. FILED 8-19-2010.
- 3,954,137. **SMOOTH FIX (STANDARD CHARACTER)**. SALLY HERSHBERGER PROFESSIONAL HAIR CARE LLC, (U.S. CLS. 1, 4, 6, 50, 51 AND 52). SN 85-111,366. PUB. 2-15-2011. FILED 8-19-2010.
- 3,954,183. **DANCE! AND DESIGN**. SCHARFF, EDITH, (U.S. CLS. 1, 4, 6, 50, 51 AND 52). SN 85-113,472. PUB. 2-15-2011. FILED 8-23-2010.

3,954,198. **JUST BRUSH & WHITEN (STANDARD CHARACTER)**. ROBELL RESEARCH, INC., (U.S. CLS. 1, 4, 6, 50, 51 AND 52). SN 85-114,094. PUB. 2-15-2011. FILED 8-23-2010.

3,954,266. **MISCELLANEOUS DESIGN**. VDERA INCORPORATED, (U.S. CLS. 1, 4, 6, 50, 51 AND 52). SN 85-115,528. PUB. 2-15-2011. FILED 8-25-2010.

3,954,274. **IT WORKS! (STANDARD CHARACTER)**. WILLIAM M. YARBROUGH FOUNDATION, (U.S. CLS. 1, 4, 6, 50, 51 AND 52). SN 85-115,781. PUB. 2-15-2011. FILED 8-25-2010.

3,954,287. **TRUE BODY AND DESIGN**. ORANGE MOUNTAIN, INC., DBA TRUE BODY PRODUCTS, (U.S. CLS. 1, 4, 6, 50, 51 AND 52). SN 85-116,009. PUB. 2-15-2011. FILED 8-25-2010.

3,954,288. **CURRENCY (STANDARD CHARACTER)**. NAHOUNOU, MIKE-CHARLES, (U.S. CLS. 1, 4, 6, 50, 51 AND 52). SN 85-116,037. PUB. 2-15-2011. FILED 8-25-2010.

3,954,408. **ROMANTICAL (STANDARD CHARACTER)**. KELLAR, CASEY, (U.S. CLS. 1, 4, 6, 50, 51 AND 52). SN 85-117,882. PUB. 2-15-2011. FILED 8-27-2010.

3,954,427. **S3FUSION POLISH (STANDARD CHARACTER)**. LEO J. SCANSAROLI, (U.S. CLS. 1, 4, 6, 50, 51 AND 52). SN 85-118,239. PUB. 2-15-2011. FILED 8-29-2010.

3,954,496. **BROWNBERRY (STANDARD CHARACTER)**. BROWNBERRY LLC, MULTIPLE CLASS, (INT. CLS. 3 AND 44), (U.S. CLS. 1, 4, 6, 50, 51, 52, 100 AND 101). SN 85-118,843. PUB. 2-15-2011. FILED 8-30-2010.

3,954,532. **VICHINARI (STANDARD CHARACTER)**. KIM, YONG S., (U.S. CLS. 1, 4, 6, 50, 51 AND 52). SN 85-119,228. PUB. 2-15-2011. FILED 8-30-2010.

3,954,580. **LIGHTS OUT (STANDARD CHARACTER)**. AFT DISTRIBUTING, (U.S. CLS. 1, 4, 6, 50, 51 AND 52). SN 85-119,790. PUB. 2-15-2011. FILED 8-31-2010.

3,954,639. **HOO-AHHS (STANDARD CHARACTER)**. HOO-AHHS, LLC, (U.S. CLS. 1, 4, 6, 50, 51 AND 52). SN 85-120,461. PUB. 2-15-2011. FILED 9-1-2010.

3,954,641. **EXTRA CLAIR (STANDARD CHARACTER)**. NOUVELLE PARFUMERIE GANDOUR, (U.S. CLS. 1, 4, 6, 50, 51 AND 52). SN 85-120,499. PUB. 2-15-2011. FILED 9-1-2010.

3,954,750. **DERMISA AND DESIGN**. MONTANI COSMETICS, INC., (U.S. CLS. 1, 4, 6, 50, 51 AND 52). SN 85-121,683. PUB. 2-15-2011. FILED 9-2-2010.

3,954,891. **VAMPIRE REPELLENT (STANDARD CHARACTER)**. WILLIAMS, ERIC B., (U.S. CLS. 1, 4, 6, 50, 51 AND 52). SN 85-123,333. PUB. 2-15-2011. FILED 9-4-2010.

3,954,940. **NEOCALM (STANDARD CHARACTER)**. LANCOME PARFUMS ET BEAUTE & CIE, (U.S. CLS. 1, 4, 6, 50, 51 AND 52). SN 85-124,718. PUB. 2-15-2011. FILED 9-8-2010.

3,954,945. **GLAMOUR TO GO (STANDARD CHARACTER)**. TOO FACED COSMETICS, INC., (U.S. CLS. 1, 4, 6, 50, 51 AND 52). SN 85-125,323. PUB. 2-15-2011. FILED 9-8-2010.

3,955,038. **RESULTS RINSE (STANDARD CHARACTER)**. SHOWSEASON ANIMAL PRODUCTS, LLC, (U.S. CLS. 1, 4, 6, 50, 51 AND 52). SN 85-138,077. PUB. 2-15-2011. FILED 9-24-2010.

3,955,039. **SPEED DRY (STANDARD CHARACTER)**. SHOWSEASON ANIMAL PRODUCTS, LLC, (U.S. CLS. 1, 4, 6, 50, 51 AND 52). SN 85-138,083. PUB. 2-15-2011. FILED 9-24-2010.

3,955,058. **BORDERLINE (STANDARD CHARACTER)**. TOO FACED COSMETICS, INC., (U.S. CLS. 1, 4, 6, 50, 51 AND 52). SN 85-141,386. PUB. 2-15-2011. FILED 9-29-2010.

3,955,074. **ENVIRO-VAC (STANDARD CHARACTER)**. COMPLIANT HEALTHCARE TECHNOLOGIES, LLC, (U.S. CLS. 1, 4, 6, 50, 51 AND 52). SN 85-146,568. PUB. 2-15-2011. FILED 10-6-2010.

3,955,138. **ETERNAL GRACE (STANDARD CHARACTER)**. PHILOSOPHY, INC., (U.S. CLS. 1, 4, 6, 50, 51 AND 52). SN 85-173,773. PUB. 2-15-2011. FILED 11-10-2010.

#### CLASS 4—LUBRICANTS AND FUELS

3,952,997. **WTH-MV (STANDARD CHARACTER)**. ADVANTAGE DIST. LLC, (U.S. CLS. 1, 6 AND 15). SN 76-704,360. PUB. 2-15-2011. FILED 9-3-2010.

3,953,083 ( *See Class 1 for this trademark*).

3,953,116. **ELEMENT POWER (STANDARD CHARACTER)**.

**ELEMENT POWER HOLDINGS, LP, MULTIPLE CLASS**, (INT. CLS. 4, 36, 37, 39, 40 AND 42), (U.S. CLS. 1, 6, 15, 100, 101, 102, 103, 105 AND 106). SN 77-808,787. PUB. 1-25-2011. FILED 8-20-2009.

3,953,193. **COSMIC CANDLES (STANDARD CHARACTER)**. JASON ALLEN DYMENT, AND JAN SARA DYMENT, (U.S. CLS. 1, 6 AND 15). SN 77-859,281. PUB. 2-15-2011. FILED 10-28-2009.

3,953,513 ( *See Class 1 for this trademark*).

3,953,578. **POLSKIE LNG AND DESIGN**. OPERATOR GAZO-CIAGÓW PRZESYLOWYCH; GAZ-SYSTEM S.A., MULTIPLE CLASS, (INT. CLS. 4, 35, 37, 39 AND 42), (U.S. CLS. 1, 6, 15, 100, 101, 102, 103, 105 AND 106). SN 79-081,977. PUB. 2-15-2011. FILED 10-29-2009.

3,953,579. **GAZ SYSTEM AND DESIGN**. OPERATOR GAZO-CIAGÓW PRZESYLOWYCH; GAZ-SYSTEM S.A., MULTIPLE CLASS, (INT. CLS. 4, 35, 37, 39 AND 42), (U.S. CLS. 1, 6, 15, 100, 101, 102, 103, 105 AND 106). SN 79-081,978. PUB. 2-15-2011. FILED 10-29-2009.

3,953,616. **LUBRITREAT (STANDARD CHARACTER)**. THYSENKRUPP STEEL EUROPE AG, MULTIPLE CLASS, (INT. CLS. 4 AND 6), (U.S. CLS. 1, 2, 6, 12, 13, 14, 15, 23, 25 AND 50). SN 79-084,165. PUB. 2-15-2011. FILED 4-30-2010.

3,953,920. **LUBRIX TECHNOLOGIES AND DESIGN**. CLINE, RODNEY, (U.S. CLS. 1, 6 AND 15). SN 85-076,017. PUB. 2-15-2011. FILED 7-1-2010.

3,954,223. **IGNITE (STANDARD CHARACTER)**. NATIONAL BIOFUELS DISTRIBUTION, LLC, (U.S. CLS. 1, 6 AND 15). SN 85-114,681. PUB. 2-15-2011. FILED 8-24-2010.

3,954,304. **MISCELLANEOUS DESIGN**. FORESTAR GROUP INC., MULTIPLE CLASS, (INT. CLS. 4, 19, 35, 37, 40 AND 45), (U.S. CLS. 1, 6, 12, 15, 33, 50, 100, 101, 102, 103 AND 106). SN 85-116,323. PUB. 2-15-2011. FILED 8-26-2010.

3,954,614. **DIKEN (STANDARD CHARACTER)**. DIKEN INTERNATIONAL, (U.S. CLS. 1, 6 AND 15). SN 85-120,173. PUB. 2-15-2011. FILED 8-31-2010.

3,954,952. **WILLIAMS & SPENCE (STANDARD CHARACTER)**. NEDBOY, ROBIN L., (U.S. CLS. 1, 6 AND 15). SN 85-125,850. PUB. 2-15-2011. FILED 9-9-2010.

3,955,088. **POLY-XTREME (STANDARD CHARACTER)**. CHS INC., (U.S. CLS. 1, 6 AND 15). SN 85-149,514. PUB. 2-15-2011. FILED 10-11-2010.

#### CLASS 5—PHARMACEUTICALS

3,952,985. **HEALTHMAX (STANDARD CHARACTER)**. VITAMIN CLASSICS., (U.S. CLS. 6, 18, 44, 46, 51 AND 52). SN 76-704,199. PUB. 2-15-2011. FILED 8-19-2010.

3,952,989. **LIVER WELL (STANDARD CHARACTER)**. GET WELL NATURAL LLC, (U.S. CLS. 6, 18, 44, 46, 51 AND 52). SN 76-704,303. PUB. 2-15-2011. FILED 8-30-2010.

3,952,990. **BLOOD WELL (STANDARD CHARACTER)**. GET WELL NATURAL LLC, (U.S. CLS. 6, 18, 44, 46, 51 AND 52). SN 76-704,304. PUB. 2-15-2011. FILED 8-30-2010.

3,952,991. **GOUT WELL (STANDARD CHARACTER)**. GET WELL NATURAL LLC, (U.S. CLS. 6, 18, 44, 46, 51 AND 52). SN 76-704,305. PUB. 2-15-2011. FILED 8-30-2010.

3,953,000 ( *See Class 3 for this trademark*).

3,953,064. **S'LITE (STANDARD CHARACTER)**. AMOREPACIFIC CORPORATION, (U.S. CLS. 6, 18, 44, 46, 51 AND 52). SN 77-723,515. PUB. 2-15-2011. FILED 4-27-2009.

3,953,073 ( *See Class 3 for this trademark*).

3,953,075 ( *See Class 3 for this trademark*).

3,953,078. **STRIVE AND DESIGN**. PIVOTAL BRANDS INC., MULTIPLE CLASS, (INT. CLS. 5, 29 AND 32), (U.S. CLS. 6, 18, 44, 45, 46, 48, 51 AND 52). SN 77-752,377. PUB. 2-15-2011. FILED 6-4-2009.

3,953,086. **FLUAD AND DESIGN**. NOVARTIS VACCINES AND DIAGNOSTICS S.R.L., (U.S. CLS. 6, 18, 44, 46, 51 AND 52). SN 77-767,895. PUB. 2-15-2011. FILED 6-25-2009.

3,953,099 ( *See Class 3 for this trademark*).

3,953,148. **CORE METHOD (STANDARD CHARACTER)**. RENNELL, COREY MARTIN, (U.S. CLS. 6, 18, 44, 46, 51 AND 52). SN 77-824,332. PUB. 2-15-2011. FILED 9-10-2009.

3,953,241. **ASPER AND DESIGN**. ASPER BIOTECH AS, MULTIPLE CLASS, (INT. CLS. 5, 42 AND 44), (U.S. CLS.

- 6, 18, 44, 46, 51, 52, 100 AND 101). SN 77-916,433. PUB. 2-15-2011. FILED 1-21-2010.
- 3,953,247. **DOUBLE VERIFIED GLUTEN FREE AND DESIGN.** NEXGEN PHARMA, INC., (U.S. CLS. 6, 18, 44, 46, 51 AND 52). SN 77-920,678. PUB. 2-15-2011. FILED 1-26-2010.
- 3,953,264. **LCT LIVING CELL TECHNOLOGIES AND DESIGN.** LIVING CELL TECHNOLOGIES LIMITED, MULTIPLE CLASS, (INT. CLS. 5, 42 AND 44), (U.S. CLS. 6, 18, 44, 46, 51, 52, 100 AND 101). SN 77-931,999. PUB. 2-15-2011. FILED 2-9-2010.
- 3,953,337. **BIEBER (STANDARD CHARACTER).** BIEBER, CRAIG J., (U.S. CLS. 6, 18, 44, 46, 51 AND 52). SN 77-949,670. PUB. 2-15-2011. FILED 3-3-2010.
- 3,953,348. **LUCY'S (STANDARD CHARACTER).** DR. LUCY'S LLC, MULTIPLE CLASS, (INT. CLS. 5 AND 30), (U.S. CLS. 6, 18, 44, 46, 51 AND 52). SN 77-950,499. PUB. 2-15-2011. FILED 3-4-2010.
- 3,953,357. **PROGESTOPATCH (STANDARD CHARACTER).** PIERRE FABRE MEDICAMENT, (U.S. CLS. 6, 18, 44, 46, 51 AND 52). SN 77-952,031. PUB. 2-15-2011. FILED 3-5-2010.
- 3,953,394 ( *See Class 1 for this trademark*).
- 3,953,409. **VAPOROOTER (STANDARD CHARACTER).** DOUGLAS PRODUCTS AND PACKAGING COMPANY LLC, (U.S. CLS. 6, 18, 44, 46, 51 AND 52). SN 77-959,217. PUB. 2-15-2011. FILED 3-15-2010.
- 3,953,452. **CONFORXY (STANDARD CHARACTER).** ACTELION PHARMACEUTICALS LTD, (U.S. CLS. 6, 18, 44, 46, 51 AND 52). SN 77-965,564. PUB. 2-15-2011. FILED 3-23-2010.
- 3,953,476. **LIGHTER LIFE LIFE IN BALANCE AND DESIGN.** LIGHTERLIFE UK LIMITED, MULTIPLE CLASS, (INT. CLS. 5, 16, 29, 30, 31, 32, 41, 42 AND 44), (U.S. CLS. 1, 2, 5, 6, 18, 22, 23, 29, 37, 38, 44, 45, 46, 48, 50, 51, 52, 100, 101 AND 107). SN 78-816,226. PUB. 4-27-2010. FILED 2-16-2006.
- 3,953,496 ( *See Class 3 for this trademark*).
- 3,953,499 ( *See Class 3 for this trademark*).
- 3,953,509. **BREDENT (STANDARD CHARACTER).** BREDENT DENTALGERÄTE UND; MATERIALIEN, FACH- UND; ORGANISATIONSBERATUNG PETER BREHM, MULTIPLE CLASS, (INT. CLS. 5, 10 AND 42), (U.S. CLS. 6, 18, 26, 39, 44, 46, 51, 52, 100 AND 101). SN 79-072,650. PUB. 2-15-2011. FILED 6-17-2009.
- 3,953,513 ( *See Class 1 for this trademark*).
- 3,953,517. **OCTAIN BRAIN BAR AND DESIGN.** OCTAIN GMBH, MULTIPLE CLASS, (INT. CLS. 5, 30 AND 35), (U.S. CLS. 6, 18, 44, 46, 51, 52, 100, 101 AND 102). SN 79-075,064. PUB. 2-15-2011. FILED 8-14-2009.
- 3,953,541 ( *See Class 1 for this trademark*).
- 3,953,565. **OLEVINE (STANDARD CHARACTER).** GREG JARDINE, MULTIPLE CLASS, (INT. CLS. 5, 30 AND 32), (U.S. CLS. 6, 18, 44, 45, 46, 48, 51 AND 52). SN 79-081,400. PUB. 2-15-2011. FILED 2-18-2010.
- 3,953,589. **MELORIUM (STANDARD CHARACTER).** BIOFARMA, (U.S. CLS. 6, 18, 44, 46, 51 AND 52). SN 79-082,304. PUB. 2-15-2011. FILED 3-30-2010.
- 3,953,590. **EVERTIM (STANDARD CHARACTER).** BIOFARMA, (U.S. CLS. 6, 18, 44, 46, 51 AND 52). SN 79-082,305. PUB. 2-15-2011. FILED 3-20-2010.
- 3,953,599. **OMNICAST (STANDARD CHARACTER).** ONBONE OY, MULTIPLE CLASS, (INT. CLS. 5 AND 10), (U.S. CLS. 6, 18, 26, 39, 44, 46, 51 AND 52). SN 79-082,609. PUB. 2-15-2011. FILED 4-27-2010.
- 3,953,649. **4 AND DESIGN.** ITOGHA AS, MULTIPLE CLASS, (INT. CLS. 5, 10 AND 29), (U.S. CLS. 6, 18, 26, 39, 44, 46, 51 AND 52). SN 79-087,325. PUB. 2-15-2011. FILED 4-28-2010.
- 3,953,669. **B/S SPANGE AND DESIGN.** BERND STOLZ GMBH, MULTIPLE CLASS, (INT. CLS. 5 AND 10), (U.S. CLS. 6, 18, 26, 39, 44, 46, 51 AND 52). SN 79-088,339. PUB. 2-15-2011. FILED 7-21-2010.
- 3,953,672. **FLUDEMIC (STANDARD CHARACTER).** NOVARTIS AG, (U.S. CLS. 6, 18, 44, 46, 51 AND 52). SN 79-089,149. PUB. 2-15-2011. FILED 10-12-2010.
- 3,953,726 ( *See Class 3 for this trademark*).
- 3,953,759. **IDEAL BOWEL SUPPORT (STANDARD CHARACTER).** JARROW FORMULAS, INC., (U.S. CLS. 6, 18, 44, 46, 51 AND 52). SN 85-025,679. PUB. 2-15-2011. FILED 4-28-2010.
- 3,953,777. **HYPERGENETIC LABS (STANDARD CHARACTER).** JRM NUTRASCIENTES LLC, (U.S. CLS. 6, 18, 44, 46, 51 AND 52). SN 85-032,861. PUB. 2-15-2011. FILED 5-7-2010.
- 3,953,825. **ATKINS (STANDARD CHARACTER).** ATKINS NUTRITIONALS, INC., MULTIPLE CLASS, (INT. CLS. 5, 30 AND 32), (U.S. CLS. 6, 18, 44, 45, 46, 48, 51 AND 52). SN 85-043,652. PUB. 2-15-2011. FILED 5-20-2010.
- 3,953,865. **ABRAZIL (STANDARD CHARACTER).** ABRAZIL LLC, DBA NATURAL HEALTH PRODUCTS AND NUTRACEUTICALS, (U.S. CLS. 6, 18, 44, 46, 51 AND 52). SN 85-059,311. PUB. 2-15-2011. FILED 6-10-2010.
- 3,953,867. **LICKITY STIFF (STANDARD CHARACTER).** PURE ROMANCE, INC., (U.S. CLS. 6, 18, 44, 46, 51 AND 52). SN 85-059,626. PUB. 2-15-2011. FILED 6-10-2010.
- 3,953,874 ( *See Class 3 for this trademark*).
- 3,953,876. **PROSTAKE AND DESIGN.** MALABAR PRODUCTS NATURALES, LLC, (U.S. CLS. 6, 18, 44, 46, 51 AND 52). SN 85-062,613. PUB. 11-9-2010. FILED 6-14-2010.
- 3,953,914 ( *See Class 3 for this trademark*).
- 3,953,937 ( *See Class 1 for this trademark*).
- 3,953,946. **AFTER GLOW POST WORKOUT EUPHORIA (STANDARD CHARACTER).** EXCLUSIVE SUPPLEMENTS, INC., DBA BIORYTHM - ADVANCED DIETARY SUPPLEMENTS, (U.S. CLS. 6, 18, 44, 46, 51 AND 52). SN 85-083,367. PUB. 2-15-2011. FILED 7-13-2010.
- 3,954,025. **HOODIA ACTION (STANDARD CHARACTER).** PRIMARY INVESTMENTS GROUP LIMITED, (U.S. CLS. 6, 18, 44, 46, 51 AND 52). SN 85-101,378. PUB. 2-15-2011. FILED 8-5-2010.
- 3,954,098. **AXAPHEN X AND DESIGN.** VAN BEEK NATURAL SCIENCE, LLC, (U.S. CLS. 6, 18, 44, 46, 51 AND 52). SN 85-109,112. PUB. 2-15-2011. FILED 8-17-2010.
- 3,954,104. **ESTROCOMFORT (STANDARD CHARACTER).** FUTUREBIOTICS, LLC, (U.S. CLS. 6, 18, 44, 46, 51 AND 52). SN 85-109,716. PUB. 2-15-2011. FILED 8-17-2010.
- 3,954,105. **VITOMEGAWOMEN (STANDARD CHARACTER).** FUTUREBIOTICS, LLC, (U.S. CLS. 6, 18, 44, 46, 51 AND 52). SN 85-109,728. PUB. 2-15-2011. FILED 8-17-2010.
- 3,954,118. **MISCELLANEOUS DESIGN.** NUVONYX INC, (U.S. CLS. 6, 18, 44, 46, 51 AND 52). SN 85-110,648. PUB. 2-15-2011. FILED 8-18-2010.
- 3,954,160. **FUTUREBIOTICS HEALTH. NATURE. LIFE. AND DESIGN.** FUTUREBIOTICS, LLC, (U.S. CLS. 6, 18, 44, 46, 51 AND 52). SN 85-112,276. PUB. 2-15-2011. FILED 8-20-2010.
- 3,954,168. **FINAL STOP (STANDARD CHARACTER).** SHAMMAS, MILO, (U.S. CLS. 6, 18, 44, 46, 51 AND 52). SN 85-112,756. PUB. 2-15-2011. FILED 8-20-2010.
- 3,954,224. **LIQUISOLV (STANDARD CHARACTER).** TISHCON CORP, (U.S. CLS. 6, 18, 44, 46, 51 AND 52). SN 85-114,707. PUB. 2-15-2011. FILED 8-24-2010.
- 3,954,229. **ADVANCING THE NEW VISION (STANDARD CHARACTER).** AKORN, INC., (U.S. CLS. 6, 18, 44, 46, 51 AND 52). SN 85-114,820. PUB. 2-15-2011. FILED 8-24-2010.
- 3,954,233. **TEN YEARS YOUNGER (STANDARD CHARACTER).** MASLEY, STEVEN, MULTIPLE CLASS, (INT. CLS. 5 AND 44), (U.S. CLS. 6, 18, 44, 46, 51, 52, 100 AND 101). SN 85-114,875. PUB. 2-15-2011. FILED 8-24-2010.
- 3,954,246. **FLANDERS BUTTOCKS OINTMENT AND DESIGN.** FLANDERS INC., (U.S. CLS. 6, 18, 44, 46, 51 AND 52). SN 85-115,148. PUB. 2-15-2011. FILED 8-25-2010.
- 3,954,326. **ZERO ODOR THE END OF ODOR. (STANDARD CHARACTER).** ZERO ODOR LLC, (U.S. CLS. 6, 18, 44, 46, 51 AND 52). SN 85-116,732. PUB. 2-15-2011. FILED 8-26-2010.
- 3,954,338. **ACHIEVING PHYSIOLOGICAL BALANCE (STANDARD CHARACTER).** NUMERICA, L.L.C., FORMERLY XYMOGEN NUMERICA, (U.S. CLS. 6, 18, 44, 46, 51 AND 52). SN 85-116,955. PUB. 2-15-2011. FILED 8-26-2010.
- 3,954,347. **BREASTELIXIR IMPROVE BREAST HEALTH (STANDARD CHARACTER).** CHAO, TED, (U.S. CLS. 6, 18, 44, 46, 51 AND 52). SN 85-117,120. PUB. 2-15-2011. FILED 8-27-2010.
- 3,954,351. **VITA-CORDY (STANDARD CHARACTER).** CONCORD INTERNATIONAL TRADING PTY LTD, (U.S. CLS. 6, 18, 44, 46, 51 AND 52). SN 85-117,130. PUB. 2-15-2011. FILED 8-27-2010.
- 3,954,357. **A3R LABS AND DESIGN.** A3R LABS, LLC, (U.S. CLS. 6, 18, 44, 46, 51 AND 52). SN 85-117,224. PUB. 2-15-2011. FILED 8-27-2010.
- 3,954,462. **THE NEW DEFINITION OF CLEAN (STANDARD CHARACTER).** TILE MEDIA PROPERTIES, INC., (U.S.

- CLS. 6, 18, 44, 46, 51 AND 52). SN 85-118,579. PUB. 2-15-2011. FILED 8-30-2010.
- 3,954,485. **DIVA TRIM (STANDARD CHARACTER)**. TWUSA INC., DBA BFF LABS, (U.S. CLS. 6, 18, 44, 46, 51 AND 52). SN 85-118,745. PUB. 2-15-2011. FILED 8-30-2010.
- 3,954,505. **L2 EXTREME (STANDARD CHARACTER)**. WOODBOLT DISTRIBUTION, (U.S. CLS. 6, 18, 44, 46, 51 AND 52). SN 85-118,922. PUB. 2-15-2011. FILED 8-30-2010.
- 3,954,510. **PLUVIMIN (STANDARD CHARACTER)**. MOHAMED JAVED, (U.S. CLS. 6, 18, 44, 46, 51 AND 52). SN 85-118,974. PUB. 2-15-2011. FILED 8-30-2010.
- 3,954,592. **USPLABS (STANDARD CHARACTER)**. USPLABS, LLC, (U.S. CLS. 6, 18, 44, 46, 51 AND 52). SN 85-119,922. PUB. 2-15-2011. FILED 8-31-2010.
- 3,954,597. **ACETADOTE EF (STANDARD CHARACTER)**. CUMBERLAND PHARMACEUTICALS INC., (U.S. CLS. 6, 18, 44, 46, 51 AND 52). SN 85-119,983. PUB. 2-15-2011. FILED 8-31-2010.
- 3,954,601. **ALLODERM (STANDARD CHARACTER)**. LIFECELL CORPORATION, (U.S. CLS. 6, 18, 44, 46, 51 AND 52). SN 85-120,035. PUB. 2-15-2011. FILED 8-31-2010.
- 3,954,636. **LIFE NUTRITION (STANDARD CHARACTER)**. LIFE NUTRITION COMPANY (U.S.A.), INC., (U.S. CLS. 6, 18, 44, 46, 51 AND 52). SN 85-120,445. PUB. 2-15-2011. FILED 9-1-2010.
- 3,954,658. **MAGNIFUSE AND DESIGN**. OSTEOTECH, INC., (U.S. CLS. 6, 18, 44, 46, 51 AND 52). SN 85-120,666. PUB. 2-15-2011. FILED 9-1-2010.
- 3,954,805. **GREEN2O (STANDARD CHARACTER)**. NUWORLD, INC., (U.S. CLS. 6, 18, 44, 46, 51 AND 52). SN 85-122,302. PUB. 2-15-2011. FILED 9-2-2010.
- 3,954,820. **CETHRIN (STANDARD CHARACTER)**. BIOAXONE THERAPEUTIQUE INC., MULTIPLE CLASS, (INT. CLS. 5 AND 10), (U.S. CLS. 6, 18, 26, 39, 44, 46, 51 AND 52). SN 85-122,459. PUB. 2-15-2011. FILED 9-3-2010.
- 3,954,856. **HYDROFUSION (STANDARD CHARACTER)**. ICUREDMYSELF.COM LLC, (U.S. CLS. 6, 18, 44, 46, 51 AND 52). SN 85-122,901. PUB. 2-15-2011. FILED 9-3-2010.
- 3,954,931. **REALW8 (STANDARD CHARACTER)**. LLUNDELL, DWIGHT, DBA REAL W8, (U.S. CLS. 6, 18, 44, 46, 51 AND 52). SN 85-124,317. PUB. 2-15-2011. FILED 9-7-2010.
- 3,954,948. **PULMOTOL (STANDARD CHARACTER)**. PEREZ DISTRIBUTING FRESNO INC., (U.S. CLS. 6, 18, 44, 46, 51 AND 52). SN 85-125,476. PUB. 2-15-2011. FILED 9-8-2010.
- 3,955,041. **THERALAC (STANDARD CHARACTER)**. MASTER SUPPLEMENTS, INC., (U.S. CLS. 6, 18, 44, 46, 51 AND 52). SN 85-138,542. PUB. 2-15-2011. FILED 9-27-2010.
- 3,955,059. **COLON HELPER (STANDARD CHARACTER)**. HEALTH CENTER FOR BETTER LIVING, INC, (U.S. CLS. 6, 18, 44, 46, 51 AND 52). SN 85-141,666. PUB. 2-15-2011. FILED 9-30-2010.
- 3,955,068. **USPLABS POWERFULL (STANDARD CHARACTER)**. USP LABS, LLC, (U.S. CLS. 6, 18, 44, 46, 51 AND 52). SN 85-144,217. PUB. 2-15-2011. FILED 10-4-2010.
- 3,955,069. **USPLABS JACK3D (STANDARD CHARACTER)**. USP LABS, LLC, (U.S. CLS. 6, 18, 44, 46, 51 AND 52). SN 85-144,236. PUB. 2-15-2011. FILED 10-4-2010.
- 3,955,070. **USPLABS RECREATE (STANDARD CHARACTER)**. USP LABS, LLC, (U.S. CLS. 6, 18, 44, 46, 51 AND 52). SN 85-144,290. PUB. 2-15-2011. FILED 10-4-2010.
- 3,955,071. **SUPERCISSUS (STANDARD CHARACTER)**. USP LABS, LLC, (U.S. CLS. 6, 18, 44, 46, 51 AND 52). SN 85-144,540. PUB. 2-15-2011. FILED 10-4-2010.
- 3,955,073. **TOMAHAWK 5 (STANDARD CHARACTER)**. UNITED SUPPLIERS, INC., (U.S. CLS. 6, 18, 44, 46, 51 AND 52). SN 85-145,925. PUB. 2-15-2011. FILED 10-6-2010.
- 3,955,081. **REVYTE WAKE UP REFRESHED AND DESIGN**. PILLAR ROCK USA CORP., (U.S. CLS. 6, 18, 44, 46, 51 AND 52). SN 85-148,599. PUB. 2-15-2011. FILED 10-8-2010.
- 3,955,083. **VELUM (STANDARD CHARACTER)**. BAYER AKTIENGESELLSCHAFT, (U.S. CLS. 6, 18, 44, 46, 51 AND 52). SN 85-148,744. PUB. 2-15-2011. FILED 10-8-2010.
- 3,955,084. **WET SYNERGY (STANDARD CHARACTER)**. TRIGG LABORATORIES, INC., (U.S. CLS. 6, 18, 44, 46, 51 AND 52). SN 85-148,831. PUB. 2-15-2011. FILED 10-8-2010.
- 3,955,100. **MAXN FUZE AND DESIGN**. MAX INTERNATIONAL, LLC, (U.S. CLS. 6, 18, 44, 46, 51 AND 52). SN 85-155,790. PUB. 2-15-2011. FILED 10-19-2010.
- 3,955,103. **SYNACORE (STYLIZED)**. VAN BEEK NATURAL SCIENCE, LLC, (U.S. CLS. 6, 18, 44, 46, 51 AND 52). SN 85-157,300. PUB. 2-15-2011. FILED 10-20-2010.
- 3,955,110. **CO-OP QUALITY FEEDS (STANDARD CHARACTER)**. KALMBACH FEEDS, INC., MULTIPLE CLASS, (INT. CLS. 5 AND 31), (U.S. CLS. 1, 6, 18, 44, 46, 51 AND 52). SN 85-162,698. PUB. 2-15-2011. FILED 10-27-2010.
- 3,955,116. **THERALAC TRUFLOA BIO-CLEANSING FORMULA (STANDARD CHARACTER)**. MASTER SUPPLEMENTS, INC., (U.S. CLS. 6, 18, 44, 46, 51 AND 52). SN 85-166,432. PUB. 2-15-2011. FILED 11-1-2010.

---

## CLASS 6—METAL GOODS

- 3,953,049. **AKER (STANDARD CHARACTER)**. INTELLECTUAL PROPERTY HOLDINGS AS, MULTIPLE CLASS, (INT. CLS. 6, 7, 9, 11, 12, 19, 20, 29, 35, 37, 40 AND 42), (U.S. CLS. 1, 2, 12, 13, 14, 19, 21, 22, 23, 25, 26, 31, 32, 33, 34, 35, 36, 38, 44, 46, 50, 100, 101, 102, 103 AND 106). SN 77-671,218. PUB. 1-12-2010. FILED 2-16-2009.
- 3,953,082. **BEERENBERG (STANDARD CHARACTER)**. BEERENBERG CORP. AS, MULTIPLE CLASS, (INT. CLS. 6, 17, 19, 37, 40, 42 AND 43), (U.S. CLS. 1, 2, 5, 12, 13, 14, 23, 25, 33, 35, 50, 100, 101, 103 AND 106). SN 77-755,968. PUB. 2-15-2011. FILED 6-10-2009.
- 3,953,141. **RICHARDS (STANDARD CHARACTER)**. RICHARDS HOMEWARES, INC., MULTIPLE CLASS, (INT. CLS. 6, 9, 12, 14, 18, 20, 21 AND 22), (U.S. CLS. 1, 2, 3, 7, 12, 13, 14, 19, 21, 22, 23, 25, 26, 27, 28, 29, 30, 31, 32, 33, 35, 36, 38, 40, 41, 42, 44 AND 50). SN 77-819,515. PUB. 2-15-2011. FILED 9-3-2009.
- 3,953,163. **SPRINKFLEX AND DESIGN**. SPRINKFLEX, LLC, MULTIPLE CLASS, (INT. CLS. 6 AND 9), (U.S. CLS. 2, 12, 13, 14, 21, 23, 25, 26, 36, 38 AND 50). SN 77-843,135. PUB. 2-15-2011. FILED 10-7-2009.
- 3,953,194. **DOORLAND GROUP YOUR ANSWER TO DOORS (STANDARD CHARACTER)**. DOORLAND 2000 INC., MULTIPLE CLASS, (INT. CLS. 6, 19 AND 20), (U.S. CLS. 1, 2, 12, 13, 14, 22, 23, 25, 32, 33 AND 50). SN 77-859,568. PUB. 2-15-2011. FILED 10-28-2009.
- 3,953,204. **BLUOMETALS AND DESIGN**. LEEDEN LIMITED, (U.S. CLS. 2, 12, 13, 14, 23, 25 AND 50). SN 77-878,503. PUB. 2-15-2011. FILED 11-23-2009.
- 3,953,208. **I C INTEGRA CASTINGS AND DESIGN**. INTEGRA CASTINGS INC., (U.S. CLS. 2, 12, 13, 14, 23, 25 AND 50). SN 77-879,847. PUB. 1-18-2011. FILED 11-24-2009.
- 3,953,418. **VAULT 360 (STANDARD CHARACTER)**. BARTEL, DAVID, MULTIPLE CLASS, (INT. CLS. 6 AND 20), (U.S. CLS. 2, 12, 13, 14, 22, 23, 25, 32 AND 50). SN 77-960,152. PUB. 2-15-2011. FILED 3-16-2010.
- 3,953,449. **LUGARNO (STANDARD CHARACTER)**. RESTORATION HARDWARE, INC., MULTIPLE CLASS, (INT. CLS. 6, 11, 20 AND 21), (U.S. CLS. 2, 12, 13, 14, 21, 22, 23, 25, 29, 30, 31, 32, 33, 34, 40 AND 50). SN 77-964,794. PUB. 2-15-2011. FILED 3-22-2010.
- 3,953,450. **DILLON (STANDARD CHARACTER)**. RESTORATION HARDWARE, INC., MULTIPLE CLASS, (INT. CLS. 6, 11, 20 AND 21), (U.S. CLS. 2, 12, 13, 14, 21, 22, 23, 25, 29, 30, 31, 32, 33, 34, 40 AND 50). SN 77-964,894. PUB. 2-15-2011. FILED 3-22-2010.
- 3,953,497. **G.MAGYAR (STANDARD CHARACTER)**. ETABLISSEMENTS MAGYAR, MULTIPLE CLASS, (INT. CLS. 6, 7, 9, 11, 12, 37, 39 AND 40), (U.S. CLS. 2, 12, 13, 14, 19, 21, 23, 25, 26, 31, 34, 35, 36, 38, 44, 50, 100, 103, 105 AND 106). SN 79-067,932. PUB. 2-15-2011. FILED 7-16-2008.
- 3,953,513 ( *See Class 1 for this trademark*).
- 3,953,529. **FIRE-FENCE (STANDARD CHARACTER)**. STRAUB WERKE AG, MULTIPLE CLASS, (INT. CLS. 6, 7 AND 17), (U.S. CLS. 1, 2, 5, 12, 13, 14, 19, 21, 23, 25, 31, 34, 35 AND 50). SN 79-077,567. PUB. 2-15-2011. FILED 8-19-2009.
- 3,953,554. **DALLMER (STYLIZED)**. DALLMER GMBH & CO. KG, MULTIPLE CLASS, (INT. CLS. 6, 7, 11 AND 20), (U.S. CLS. 2, 12, 13, 14, 19, 21, 22, 23, 25, 31, 32, 34, 35 AND 50). SN 79-081,103. PUB. 2-15-2011. FILED 3-8-2010.
- 3,953,555. **SANDVIK 14C28N (STANDARD CHARACTER)**. SANDVIK INTELLECTUAL PROPERTY AB, MULTIPLE

- CLASS. (INT. CLS. 6, 8 AND 10), (U.S. CLS. 2, 12, 13, 14, 23, 25, 26, 28, 39, 44 AND 50). SN 79-081,122. PUB. 2-15-2011. FILED 3-11-2010.
- 3,953,569. **SWISSLOG (STYLIZED)**. SWISSLOG AG, MULTIPLE CLASS, (INT. CLS. 6, 7, 9, 12, 20, 35, 37, 39, 41 AND 42), (U.S. CLS. 2, 12, 13, 14, 19, 21, 22, 23, 25, 26, 31, 32, 34, 35, 36, 38, 44, 50, 100, 101, 102, 103, 105, 106 AND 107). SN 79-081,688. PUB. 2-15-2011. FILED 2-17-2010.
- 3,953,570. **SWISSLOG (STANDARD CHARACTER)**. SWISSLOG AG, MULTIPLE CLASS, (INT. CLS. 6, 7, 9, 12, 20, 35, 37, 39, 41 AND 42), (U.S. CLS. 2, 12, 13, 14, 19, 21, 22, 23, 25, 26, 31, 32, 34, 35, 36, 38, 44, 50, 100, 101, 102, 103, 105, 106 AND 107). SN 79-081,689. PUB. 2-15-2011. FILED 2-17-2010.
- 3,953,582. **TOPRAN (STANDARD CHARACTER)**. HANS PRIES GMBH & CO. KG, MULTIPLE CLASS, (INT. CLS. 6, 7, 9, 11, 12 AND 17), (U.S. CLS. 1, 2, 5, 12, 13, 14, 19, 21, 23, 25, 26, 31, 34, 35, 36, 38, 44 AND 50). SN 79-082,066. PUB. 2-15-2011. FILED 3-23-2010.
- 3,953,593. **PROFILES AND MORE AND DESIGN**. NEUHOFFER HOLZ GMBH, MULTIPLE CLASS, (INT. CLS. 6 AND 19), (U.S. CLS. 1, 2, 12, 13, 14, 23, 25, 33 AND 50). SN 79-082,451. PUB. 2-15-2011. FILED 3-29-2010.
- 3,953,601. **PYRODUR (STANDARD CHARACTER)**. DEUTSCHE EDELSTAHLWERKE GMBH, (U.S. CLS. 2, 12, 13, 14, 23, 25 AND 50). SN 79-082,861. PUB. 2-15-2011. FILED 4-23-2010.
- 3,953,616 ( *See Class 4 for this trademark*).
- 3,953,626. **LI FU AND DESIGN**. TIANJIN HUAYUAN INDUSTRY CO., (U.S. CLS. 2, 12, 13, 14, 23, 25 AND 50). SN 79-085,103. PUB. 2-15-2011. FILED 6-14-2010.
- 3,953,697. **SAF (STYLIZED)**. SAFETY SOCKET LLC, (U.S. CLS. 2, 12, 13, 14, 23, 25 AND 50). SN 85-002,799. PUB. 2-15-2011. FILED 3-31-2010.
- 3,953,938. **JIN LONG AND DESIGN**. JIAXING JINLONG STANDARD PARTS CO., LTD, (U.S. CLS. 2, 12, 13, 14, 23, 25 AND 50). SN 85-080,882. PUB. 2-15-2011. FILED 7-8-2010.
- 3,954,038. **L V C AND DESIGN**. LINED VALVE COMPANY, INC., (U.S. CLS. 2, 12, 13, 14, 23, 25 AND 50). SN 85-104,239. PUB. 2-15-2011. FILED 8-10-2010.
- 3,954,046. **SNOW BREAKER REMOVABLE MAILBOX PROTECTOR AND DESIGN**. INTERCOUNTY CONTRACTING, LLC, (U.S. CLS. 2, 12, 13, 14, 23, 25 AND 50). SN 85-104,988. PUB. 2-15-2011. FILED 8-11-2010.
- 3,954,467. **ECLIPSE (STANDARD CHARACTER)**. NITE IZE, INC., (U.S. CLS. 2, 12, 13, 14, 23, 25 AND 50). SN 85-118,615. PUB. 2-15-2011. FILED 8-30-2010.
- 3,954,498. **TRU CATCH AND DESIGN**. MANUFACTURING SYSTEMS, INC., (U.S. CLS. 2, 12, 13, 14, 23, 25 AND 50). SN 85-118,855. PUB. 2-15-2011. FILED 8-30-2010.
- 3,954,530. **W&W STEEL (STANDARD CHARACTER)**. W&W STEEL, LLC, MULTIPLE CLASS, (INT. CLS. 6, 37, 40 AND 42), (U.S. CLS. 2, 12, 13, 14, 23, 25, 50, 100, 101, 103 AND 106). SN 85-119,191. PUB. 2-15-2011. FILED 8-30-2010.
- 3,954,705 ( *See Class 1 for this trademark*).
- 3,954,874. **RHINO WRAP (STANDARD CHARACTER)**. LA CORUÑA, INC., (U.S. CLS. 2, 12, 13, 14, 23, 25 AND 50). SN 85-123,111. PUB. 2-15-2011. FILED 9-3-2010.
- 3,955,049. **MASTRI (STANDARD CHARACTER)**. MILGARD MANUFACTURING INCORPORATED, (U.S. CLS. 2, 12, 13, 14, 23, 25 AND 50). SN 85-139,501. PUB. 2-15-2011. FILED 9-28-2010.
- 3,955,052. **MADRONA (STANDARD CHARACTER)**. MILGARD MANUFACTURING INCORPORATED, (U.S. CLS. 2, 12, 13, 14, 23, 25 AND 50). SN 85-139,513. PUB. 2-15-2011. FILED 9-28-2010.
- 3,955,140. **FVSU (STANDARD CHARACTER)**. BOARD OF REGENTS OF THE UNIVERSITY SYSTEM OF GEORGIA, MULTIPLE CLASS, (INT. CLS. 6, 16, 25 AND 41), (U.S. CLS. 2, 5, 12, 13, 14, 22, 23, 25, 29, 37, 38, 39, 50, 100, 101 AND 107). SN 85-174,494. PUB. 2-15-2011. FILED 11-11-2010.
- 3,952,969. **STEP N CUBE (STANDARD CHARACTER)**. DEJANA TRUCK & UTILITY EQUIPMENT CO. (U.S. CLS. 13, 19, 21, 23, 31, 34 AND 35). SN 76-701,766. PUB. 2-15-2011. FILED 2-23-2010.
- 3,953,009. **MISCELLANEOUS DESIGN**. PANASONIC ELECTRIC WORKS CO., LTD., MULTIPLE CLASS, (INT. CLS. 7, 10, 11 AND 12), (U.S. CLS. 13, 19, 21, 23, 26, 31, 34, 35, 39 AND 44). SN 77-179,143. PUB. 2-15-2011. FILED 5-11-2007.
- 3,953,049 ( *See Class 6 for this trademark*).
- 3,953,062. **NORTON CLIPPER AND DESIGN**. SAINT-GOBAIN ABRASIVES, INC., (U.S. CLS. 13, 19, 21, 23, 31, 34 AND 35). SN 77-719,428. PUB. 7-27-2010. FILED 4-22-2009.
- 3,953,067. **TRUEMOTIONCARE (STANDARD CHARACTER)**. LG ELECTRONICS INC., (U.S. CLS. 13, 19, 21, 23, 31, 34 AND 35). SN 77-734,639. PUB. 2-15-2011. FILED 5-12-2009.
- 3,953,083 ( *See Class 1 for this trademark*).
- 3,953,136. **COLORPROTECT (STANDARD CHARACTER)**. LG ELECTRONICS INC., MULTIPLE CLASS, (INT. CLS. 7 AND 11), (U.S. CLS. 13, 19, 21, 23, 31, 34 AND 35). SN 77-817,640. PUB. 2-15-2011. FILED 9-1-2009.
- 3,953,184. **ENVIROSYS AND DESIGN**. S.T.L. LUBRIFIANTS INC., MULTIPLE CLASS, (INT. CLS. 7 AND 42), (U.S. CLS. 13, 19, 21, 23, 31, 34, 35, 100 AND 101). SN 77-853,556. PUB. 9-14-2010. FILED 10-21-2009.
- 3,953,187. **MISCELLANEOUS DESIGN**. WERA-WERK HERMANN WERNER GMBH & CO. KG, MULTIPLE CLASS, (INT. CLS. 7 AND 8), (U.S. CLS. 13, 19, 21, 23, 28, 31, 34, 35 AND 44). SN 77-854,833. PUB. 2-15-2011. FILED 10-22-2009.
- 3,953,219. **RINGSAW AND DESIGN**. REIKA GMBH & CO. KG, (U.S. CLS. 13, 19, 21, 23, 31, 34 AND 35). SN 77-896,563. PUB. 2-15-2011. FILED 12-18-2009.
- 3,953,296. **E-ROK (STYLIZED)**. FLEET LINE MARKERS, LTD., MULTIPLE CLASS, (INT. CLS. 7 AND 12), (U.S. CLS. 13, 19, 21, 23, 31, 34, 35 AND 44). SN 77-942,087. PUB. 2-15-2011. FILED 2-23-2010.
- 3,953,395. **KWS (STANDARD CHARACTER)**. KWS SAAT AG, MULTIPLE CLASS, (INT. CLS. 7, 31 AND 42), (U.S. CLS. 1, 13, 19, 21, 23, 31, 34, 35, 46, 100 AND 101). SN 77-956,984. PUB. 2-15-2011. FILED 3-11-2010.
- 3,953,497 ( *See Class 6 for this trademark*).
- 3,953,505. **ZYAFOAM (STYLIZED)**. VESUVIUS FRANCE SA, MULTIPLE CLASS, (INT. CLS. 7, 9, 17, 19 AND 21), (U.S. CLS. 1, 2, 5, 12, 13, 19, 21, 23, 26, 29, 30, 31, 33, 34, 35, 36, 38, 40 AND 50). SN 79-071,978. PUB. 2-15-2011. FILED 12-19-2008.
- 3,953,513 ( *See Class 1 for this trademark*).
- 3,953,515. **QUICKE (STYLIZED)**. ÄLÖ AB, MULTIPLE CLASS, (INT. CLS. 7 AND 12), (U.S. CLS. 13, 19, 21, 23, 31, 34, 35 AND 44). SN 79-073,974. PUB. 2-15-2011. FILED 6-10-2009.
- 3,953,522. **TOSCA AND DESIGN**. CANGZHOU HUIYIN KENENG CO., LTD, MULTIPLE CLASS, (INT. CLS. 7 AND 11), (U.S. CLS. 13, 19, 21, 23, 31, 34 AND 35). SN 79-076,459. PUB. 2-15-2011. FILED 11-23-2009.
- 3,953,526. **FURUKAWA ROCK DRILL (STYLIZED)**. FURUKAWA ROCK DRILL CO., LTD., MULTIPLE CLASS, (INT. CLS. 7 AND 37), (U.S. CLS. 13, 19, 21, 23, 31, 34, 35, 100, 103 AND 106). SN 79-077,238. PUB. 2-15-2011. FILED 12-2-2009.
- 3,953,529 ( *See Class 6 for this trademark*).
- 3,953,549. **WINDRO (STYLIZED)**. TAE CHANG N.E.T. CO., LTD., (U.S. CLS. 13, 19, 21, 23, 31, 34 AND 35). SN 79-080,593. PUB. 2-15-2011. FILED 2-2-2010.
- 3,953,550. **BRÜCKNER AND DESIGN**. BRÜCKNER TROCKENTECHNIK; GMBH & CO. KG, (U.S. CLS. 13, 19, 21, 23, 31, 34 AND 35). SN 79-080,943. PUB. 2-15-2011. FILED 2-25-2010.
- 3,953,554 ( *See Class 6 for this trademark*).
- 3,953,568. **INDEX RIPPLE (STANDARD CHARACTER)**. BROSE FAHRZEUGTEILE GMBH & CO.; KOMMANDITGESELLSCHAFT, COBURG, MULTIPLE CLASS, (INT. CLS. 7, 9 AND 12), (U.S. CLS. 13, 19, 21, 23, 26, 31, 34, 35, 36, 38 AND 44). SN 79-081,522. PUB. 2-15-2011. FILED 1-21-2010.
- 3,953,569 ( *See Class 6 for this trademark*).
- 3,953,570 ( *See Class 6 for this trademark*).
- 3,953,574. **BLUEBIRD AND DESIGN**. NEDERLANDSE ORGANISATIE VOOR; TOEGEPAST- NATUUR-WE-TENSCHAPPELIJK; ONDERZOEK TNO, MULTIPLE CLASS, (INT. CLS. 7, 9 AND 42), (U.S. CLS. 13, 19, 21, 23,

---

## CLASS 7—MACHINERY

- 3,952,961. **PTI AND DESIGN**. PROCESSING TECHNOLOGIES, LLC, (U.S. CLS. 13, 19, 21, 23, 31, 34 AND 35). SN 76-698,078. PUB. 2-15-2011. FILED 6-25-2009.



- 26, 31, 34, 35, 36, 38, 100 AND 101). SN 79-081,800. PUB. 2-15-2011. FILED 2-24-2010.
- 3,953,582 ( *See Class 6 for this trademark*).
- 3,953,607. **BRC FUELMAKER AND DESIGN**. M.T.M. S.R.L. CON UNICO SOCIO, MULTIPLE CLASS, (INT. CLS. 7 AND 9), (U.S. CLS. 13, 19, 21, 23, 26, 31, 34, 35, 36 AND 38). SN 79-083,116. PUB. 2-15-2011. FILED 2-10-2010.
- 3,953,610. **TEBS (STANDARD CHARACTER)**. ELECTROENGINE IN SWEDEN AB, MULTIPLE CLASS, (INT. CLS. 7, 9, 12, 37, 40 AND 42), (U.S. CLS. 13, 19, 21, 23, 26, 31, 34, 35, 36, 38, 44, 100, 101, 103 AND 106). SN 79-083,456. PUB. 2-15-2011. FILED 2-10-2010.
- 3,953,628. **MISCELLANEOUS DESIGN**. MEBNER GMBH & CO. KG INDUSTRIEBEDARF, MULTIPLE CLASS, (INT. CLS. 7, 11 AND 17), (U.S. CLS. 1, 5, 12, 13, 19, 21, 23, 31, 34, 35 AND 50). SN 79-085,380. PUB. 2-15-2011. FILED 6-10-2010.
- 3,953,629. **POLICAP (STYLIZED)**. AUGUST RÜGGERBERG GMBH & CO. KG, (U.S. CLS. 13, 19, 21, 23, 31, 34 AND 35). SN 79-085,642. PUB. 2-15-2011. FILED 6-9-2010.
- 3,953,630. **POLIVLIES (STANDARD CHARACTER)**. AUGUST RÜGGERBERG GMBH & CO. KG, MULTIPLE CLASS, (INT. CLS. 7 AND 8), (U.S. CLS. 13, 19, 21, 23, 28, 31, 34, 35 AND 44). SN 79-085,671. PUB. 2-15-2011. FILED 6-9-2010.
- 3,953,652. **CTC (STYLIZED)**. JIAZHOU (CHANGZHOU) MACHINERY CO., LTD., (U.S. CLS. 13, 19, 21, 23, 31, 34 AND 35). SN 79-087,513. PUB. 2-15-2011. FILED 7-14-2010.
- 3,953,656. **DYECOO (STANDARD CHARACTER)**. DYECOO TEXTILE SYSTEMS B.V., (U.S. CLS. 13, 19, 21, 23, 31, 34 AND 35). SN 79-087,675. PUB. 2-15-2011. FILED 8-31-2010.
- 3,953,663. **Q.BO BY THECORPORA (STYLIZED)**. THECORPORA, S.L., (U.S. CLS. 13, 19, 21, 23, 31, 34 AND 35). SN 79-087,941. PUB. 2-15-2011. FILED 8-19-2010.
- 3,953,675. **EVERUS (STYLIZED)**. GUANGQI HONDA AUTOMOBILE CO., LTD., MULTIPLE CLASS, (INT. CLS. 7, 12 AND 37), (U.S. CLS. 13, 19, 21, 23, 31, 34, 35, 44, 100, 103 AND 106). SN 79-089,768. PUB. 2-15-2011. FILED 4-5-2010.
- 3,953,678. **SNK (STANDARD CHARACTER)**. SANKO TEKSTIL ISLETMELERI SANAYI VE TICARET ANONIM SIRKETI, MULTIPLE CLASS, (INT. CLS. 7 AND 12), (U.S. CLS. 13, 19, 21, 23, 31, 34, 35 AND 44). SN 79-089,845. PUB. 2-15-2011. FILED 8-6-2010.
- 3,953,692. **POWERMELA (STANDARD CHARACTER)**. STW TECHNIC, LP, MULTIPLE CLASS, (INT. CLS. 7 AND 9), (U.S. CLS. 13, 19, 21, 23, 26, 31, 34, 35, 36 AND 38). SN 85-001,873. PUB. 2-15-2011. FILED 3-30-2010.
- 3,953,764. **AEROFORTIS AND DESIGN**. AEROFORTIS ENERGY SOLUTIONS, INC., (U.S. CLS. 13, 19, 21, 23, 31, 34 AND 35). SN 85-027,239. PUB. 2-15-2011. FILED 4-30-2010.
- 3,953,799. **WIRE SAFEGUARD GROUP (STANDARD CHARACTER)**. CARON COMPACTOR COMPANY, (U.S. CLS. 13, 19, 21, 23, 31, 34 AND 35). SN 85-037,216. PUB. 2-15-2011. FILED 5-13-2010.
- 3,953,893. **EMBRACO DUO SERIES (STANDARD CHARACTER)**. WHIRLPOOL S.A., (U.S. CLS. 13, 19, 21, 23, 31, 34 AND 35). SN 85-068,900. PUB. 2-15-2011. FILED 6-22-2010.
- 3,953,940. **REVERSAROLLER (STANDARD CHARACTER)**. REVERSAROLLER, LLC, (U.S. CLS. 13, 19, 21, 23, 31, 34 AND 35). SN 85-081,364. PUB. 2-15-2011. FILED 7-9-2010.
- 3,954,162. **INTERCHANGE BRANDS, LLC AND DESIGN**. INTERCHANGE BRANDS, LLC, (U.S. CLS. 13, 19, 21, 23, 31, 34 AND 35). SN 85-112,424. PUB. 2-15-2011. FILED 8-20-2010.
- 3,954,320. **ULTRA PRO (STANDARD CHARACTER)**. SHOP VAC CORPORATION, (U.S. CLS. 13, 19, 21, 23, 31, 34 AND 35). SN 85-116,600. PUB. 2-15-2011. FILED 8-26-2010.
- 3,954,328. **AIR SWEEP (STANDARD CHARACTER)**. HEAT AND CONTROL, INC., (U.S. CLS. 13, 19, 21, 23, 31, 34 AND 35). SN 85-116,779. PUB. 2-15-2011. FILED 8-26-2010.
- 3,954,329. **HTO (STANDARD CHARACTER)**. HONSA ERGONOMIC TECHNOLOGIES, INC., (U.S. CLS. 13, 19, 21, 23, 31, 34 AND 35). SN 85-116,786. PUB. 2-15-2011. FILED 8-26-2010.
- 3,954,455. **BPM BAY PLASTICS MACHINERY AND DESIGN**. BAY HOLDINGS, INC., (U.S. CLS. 13, 19, 21, 23, 31, 34 AND 35). SN 85-118,527. PUB. 2-15-2011. FILED 8-30-2010.
- 3,954,465. **PAVEMOR (STANDARD CHARACTER)**. GRO MOR, INC., (U.S. CLS. 13, 19, 21, 23, 31, 34 AND 35). SN 85-118,590. PUB. 2-15-2011. FILED 8-30-2010.
- 3,954,472. **BAY PLASTICS MACHINERY (STANDARD CHARACTER)**. BAY HOLDINGS, INC., (U.S. CLS. 13, 19, 21, 23, 31, 34 AND 35). SN 85-118,663. PUB. 2-15-2011. FILED 8-30-2010.
- 3,954,486. **TRU20 (STANDARD CHARACTER)**. TRU20, INC., (U.S. CLS. 13, 19, 21, 23, 31, 34 AND 35). SN 85-118,761. PUB. 2-15-2011. FILED 8-30-2010.
- 3,954,564. **RED BAG SOLUTIONS (STANDARD CHARACTER)**. RED BAG SOLUTIONS, INC., MULTIPLE CLASS, (INT. CLS. 7 AND 40), (U.S. CLS. 13, 19, 21, 23, 31, 34, 35, 100, 103 AND 106). SN 85-119,643. PUB. 2-15-2011. FILED 8-31-2010.
- 3,954,646. **PRO-TECH (STYLIZED)**. P & F BROTHER INDUSTRIAL CORPORATION, (U.S. CLS. 13, 19, 21, 23, 31, 34 AND 35). SN 85-120,538. PUB. 2-15-2011. FILED 9-1-2010.
- 3,954,650. **PRO-TECH CONTRACTOR SERIES AND DESIGN**. P & F BROTHER INDUSTRIAL CORPORATION, (U.S. CLS. 13, 19, 21, 23, 31, 34 AND 35). SN 85-120,595. PUB. 2-15-2011. FILED 9-1-2010.
- 3,954,788. **LVCLP (STANDARD CHARACTER)**. AMERICAN TURBINE LLC, (U.S. CLS. 13, 19, 21, 23, 31, 34 AND 35). SN 85-122,083. PUB. 2-15-2011. FILED 9-2-2010.
- 3,954,792. **HVCLP (STANDARD CHARACTER)**. AMERICAN TURBINE LLC, (U.S. CLS. 13, 19, 21, 23, 31, 34 AND 35). SN 85-122,121. PUB. 2-15-2011. FILED 9-2-2010.
- 3,954,882. **WIND FLYER (STANDARD CHARACTER)**. ABUNDANT ENERGY, LLC, (U.S. CLS. 13, 19, 21, 23, 31, 34 AND 35). SN 85-123,274. PUB. 2-15-2011. FILED 9-3-2010.
- 3,954,901. **RPM AND DESIGN**. RPM INTERNATIONAL INC., (U.S. CLS. 13, 19, 21, 23, 31, 34 AND 35). SN 85-123,646. PUB. 2-15-2011. FILED 9-6-2010.
- 3,954,958. **HTP (STANDARD CHARACTER)**. HONSA ERGONOMIC TECHNOLOGIES, INC., (U.S. CLS. 13, 19, 21, 23, 31, 34 AND 35). SN 85-126,177. PUB. 2-15-2011. FILED 9-9-2010.
- 3,954,983. **TEE + CROSS (STANDARD CHARACTER)**. EAZY-POWER CORPORATION, MULTIPLE CLASS, (INT. CLS. 7 AND 8), (U.S. CLS. 13, 19, 21, 23, 28, 31, 34, 35 AND 44). SN 85-129,102. PUB. 2-15-2011. FILED 9-14-2010.
- 3,954,989. **TRIPLE-Y (STANDARD CHARACTER)**. EAZY-POWER CORPORATION, MULTIPLE CLASS, (INT. CLS. 7 AND 8), (U.S. CLS. 13, 19, 21, 23, 28, 31, 34, 35 AND 44). SN 85-130,056. PUB. 2-15-2011. FILED 9-15-2010.

---

## CLASS 8—HAND TOOLS

- 3,953,187 ( *See Class 7 for this trademark*).
- 3,953,326. **TIE-NOT (STANDARD CHARACTER)**. WAYNE SIKORCIN, (U.S. CLS. 23, 28 AND 44). SN 77-948,261. PUB. 2-15-2011. FILED 3-2-2010.
- 3,953,492. **HEPP 1863 AND DESIGN**. PROHEQ GMBH, MULTIPLE CLASS, (INT. CLS. 8, 11, 14 AND 21), (U.S. CLS. 2, 13, 21, 23, 27, 28, 29, 30, 31, 33, 34, 40, 44 AND 50). SN 79-063,873. PUB. 2-15-2011. FILED 5-26-2008.
- 3,953,502. **DAIWA AND DESIGN**. GLOBERIDE, INC., MULTIPLE CLASS, (INT. CLS. 8, 9, 18, 21, 25 AND 28), (U.S. CLS. 1, 2, 3, 13, 21, 22, 23, 26, 28, 29, 30, 33, 36, 38, 39, 40, 41, 44 AND 50). SN 79-069,849. PUB. 2-15-2011. FILED 1-27-2009.
- 3,953,555 ( *See Class 6 for this trademark*).
- 3,953,603. **AQUATEC (STANDARD CHARACTER)**. KONINKLIJKE PHILIPS ELECTRONICS N.V., (U.S. CLS. 23, 28 AND 44). SN 79-082,875. PUB. 2-15-2011. FILED 5-7-2010.
- 3,953,615. **PODORAPE AND DESIGN**. GUEUNOUN JACQUES, AND GUEUNOUN MICHÈLE, (U.S. CLS. 23, 28 AND 44). SN 79-084,091. PUB. 2-15-2011. FILED 5-14-2010.
- 3,953,630 ( *See Class 7 for this trademark*).
- 3,953,724. **R M ROYAL MASTER AND DESIGN**. ROYAL MASTER CISSORS CO., LTD., (U.S. CLS. 23, 28 AND 44). SN 85-011,689. PUB. 9-14-2010. FILED 4-12-2010.
- 3,954,473. **HAND - TECH - MADE (STANDARD CHARACTER)**. B & F MEYERCO., LLC, (U.S. CLS. 23, 28 AND 44). SN 85-118,674. PUB. 2-15-2011. FILED 8-30-2010.
- 3,954,477. **HAND - TECH - MADE HTM AND DESIGN**. B & F MEYERCO., LLC, (U.S. CLS. 23, 28 AND 44). SN 85-118,684. PUB. 2-15-2011. FILED 8-30-2010.
- 3,954,478. **HTM (STANDARD CHARACTER)**. B & F MEYERCO., LLC, (U.S. CLS. 23, 28 AND 44). SN 85-118,689. PUB. 2-15-2011. FILED 8-30-2010.

- 3,954,576. **ONLY WAY TO GO (STANDARD CHARACTER)**. SOUTHARD, JAMES L., DBA SOUTHARD'S RENTALS, (U.S. CLS. 23, 28 AND 44). SN 85-119,722. PUB. 2-15-2011. FILED 8-31-2010.
- 3,954,813. **SPABLADE (STANDARD CHARACTER)**. CIPRIANI, PAUL, (U.S. CLS. 23, 28 AND 44). SN 85-122,406. PUB. 2-15-2011. FILED 9-2-2010.
- 3,954,983 ( *See Class 7 for this trademark*).
- 3,954,989 ( *See Class 7 for this trademark*).

### CLASS 9—ELECTRICAL AND SCIENTIFIC APPARATUS

- 3,952,952. **QUANTUM (STANDARD CHARACTER)**. TANNAS COMPANY, (U.S. CLS. 21, 23, 26, 36 AND 38). SN 76-643,655. PUB. 12-12-2006. FILED 7-27-2005.
- 3,952,956. **SMARTESTING AND DESIGN**. SMARTESTING, MULTIPLE CLASS, (INT. CLS. 9, 35, 38 AND 42), (U.S. CLS. 21, 23, 26, 36, 38, 100, 101, 102 AND 104). SN 76-690,356. PUB. 2-15-2011. FILED 6-6-2008.
- 3,952,957. **CHAD VALLEY (STANDARD CHARACTER)**. ARGOS LIMITED, MULTIPLE CLASS, (INT. CLS. 9 AND 28), (U.S. CLS. 21, 22, 23, 26, 36, 38 AND 50). SN 76-690,829. PUB. 8-24-2010. FILED 6-24-2008.
- 3,952,984. **"DIVIDED BY 13...JUST CHECK WHO'S USING THEM" (STANDARD CHARACTER)**. TACCONI, FREDERIC ROCCO, (U.S. CLS. 21, 23, 26, 36 AND 38). SN 76-704,154. PUB. 2-15-2011. FILED 8-16-2010.
- 3,952,986. **INFORMATION THAT MATTERS (STANDARD CHARACTER)**. HEAT AND CONTROL, INC., (U.S. CLS. 21, 23, 26, 36 AND 38). SN 76-704,240. PUB. 2-15-2011. FILED 8-25-2010.
- 3,953,000 ( *See Class 3 for this trademark*).
- 3,953,001. **CELL DEVELOPER FORUM (STANDARD CHARACTER)**. SONY KABUSHIKI KAISHA, TA SONY CORPORATION, MULTIPLE CLASS, (INT. CLS. 9, 28, 38 AND 42), (U.S. CLS. 21, 22, 23, 26, 36, 38, 50, 100, 101 AND 104). SN 77-034,785. PUB. 2-15-2011. FILED 11-2-2006.
- 3,953,008. **ROH AND DESIGN**. SILKIN, CARY, MULTIPLE CLASS, (INT. CLS. 9, 16, 25 AND 41), (U.S. CLS. 2, 5, 21, 22, 23, 26, 29, 36, 37, 38, 39, 50, 100, 101 AND 107). SN 77-169,284. PUB. 4-15-2008. FILED 4-30-2007.
- 3,953,011. **PERSONAL LEARNING SOLUTIONS (STANDARD CHARACTER)**. UCENTRIK INC., (U.S. CLS. 21, 23, 26, 36 AND 38). SN 77-198,162. PUB. 2-15-2011. FILED 6-5-2007.
- 3,953,014. **HYGROMATOR (STANDARD CHARACTER)**. GABO QUALIMETER TESTANLAGEN GMBH, (U.S. CLS. 21, 23, 26, 36 AND 38). SN 77-230,515. PUB. 2-15-2011. FILED 7-16-2007.
- 3,953,025. **PLS-TREE (STANDARD CHARACTER)**. MKS UMETRICS AB, MULTIPLE CLASS, (INT. CLS. 9 AND 41), (U.S. CLS. 21, 23, 26, 36, 38, 100, 101 AND 107). SN 77-425,908. PUB. 2-15-2011. FILED 3-19-2008.
- 3,953,026. **TEXECOM DESIGNED TO PERFORM (STANDARD CHARACTER)**. TEXECOM LIMITED, (U.S. CLS. 21, 23, 26, 36 AND 38). SN 77-478,165. PUB. 2-15-2011. FILED 5-19-2008.
- 3,953,028. **INTELLIACT SOFT MINUTES BOOK (ISMB) (STANDARD CHARACTER)**. CORPORATEK INC., (U.S. CLS. 21, 23, 26, 36 AND 38). SN 77-513,368. PUB. 2-15-2011. FILED 7-2-2008.
- 3,953,029. **THE SOFT MINUTES BOOK (TSMB) (STANDARD CHARACTER)**. CORPORATEK INC., (U.S. CLS. 21, 23, 26, 36 AND 38). SN 77-513,383. PUB. 2-15-2011. FILED 7-2-2008.
- 3,953,035. **ROAMFORCE (STANDARD CHARACTER)**. IR-OAM MOBILE SOLUTIONS INC., MULTIPLE CLASS, (INT. CLS. 9, 35 AND 38), (U.S. CLS. 21, 23, 26, 36, 38, 100, 101, 102 AND 104). SN 77-615,744. PUB. 2-15-2011. FILED 11-17-2008.
- 3,953,036. **HEADRUSH (STANDARD CHARACTER)**. THE SOURCE (BELL) ELECTRONICS INC., (U.S. CLS. 21, 23, 26, 36 AND 38). SN 77-622,157. PUB. 1-12-2010. FILED 11-26-2008.
- 3,953,039. **BLUE GENIUS (STANDARD CHARACTER)**. BLUE GIANT EQUIPMENT CORPORATION, (U.S. CLS. 21, 23, 26, 36 AND 38). SN 77-631,704. PUB. 11-23-2010. FILED 12-11-2008.
- 3,953,040. **BIOS O.C. PROFILE AND DESIGN**. ASUSTEK COMPUTER INCORPORATION, (U.S. CLS. 21, 23, 26, 36 AND 38). SN 77-635,621. PUB. 2-15-2011. FILED 12-18-2008.
- 3,953,041. **GB/S AI DIRECT LINK AND DESIGN**. ASUSTEK COMPUTER INCORPORATION, (U.S. CLS. 21, 23, 26, 36 AND 38). SN 77-635,629. PUB. 2-15-2011. FILED 12-18-2008.
- 3,953,044. **CENDIO (STANDARD CHARACTER)**. CENDIO AB, (U.S. CLS. 21, 23, 26, 36 AND 38). SN 77-654,403. PUB. 2-15-2011. FILED 1-22-2009.
- 3,953,046. **\*RDS(ON) FET AND DESIGN**. PICOR CORPORATION, (U.S. CLS. 21, 23, 26, 36 AND 38). SN 77-664,492. PUB. 2-15-2011. FILED 2-5-2009.
- 3,953,049 ( *See Class 6 for this trademark*).
- 3,953,051. **KOSHERSWITCH (STANDARD CHARACTER)**. KALATIZADEH, ANDREH, AKA ANDY KALATI / ANDY KALATIZADEH, (U.S. CLS. 21, 23, 26, 36 AND 38). SN 77-679,250. PUB. 7-6-2010. FILED 2-26-2009.
- 3,953,055. **INTELLIGENT SHOT (STANDARD CHARACTER)**. LG ELECTRONICS INC., (U.S. CLS. 21, 23, 26, 36 AND 38). SN 77-687,276. PUB. 2-15-2011. FILED 3-10-2009.
- 3,953,077. **THE NOISY LION RAA RAA (STANDARD CHARACTER)**. CHAPMAN ENTERTAINMENT LIMITED, MULTIPLE CLASS, (INT. CLS. 9, 28 AND 41), (U.S. CLS. 21, 22, 23, 26, 36, 38, 50, 100, 101 AND 107). SN 77-751,347. PUB. 2-15-2011. FILED 6-3-2009.
- 3,953,083 ( *See Class 1 for this trademark*).
- 3,953,085. **GOL MANIA AND DESIGN**. INTERNATIONAL GAMING PROJECTS LIMITED, MULTIPLE CLASS, (INT. CLS. 9 AND 28), (U.S. CLS. 21, 22, 23, 26, 36, 38 AND 50). SN 77-763,214. PUB. 2-15-2011. FILED 6-18-2009.
- 3,953,087. **CRF HEALTH (STANDARD CHARACTER)**. CRF, INC., (U.S. CLS. 21, 23, 26, 36 AND 38). SN 77-768,877. PUB. 2-15-2011. FILED 6-26-2009.
- 3,953,090. **FLIGHT EXPERIENCE AND DESIGN**. PACIFIC SIMULATORS IP LIMITED, MULTIPLE CLASS, (INT. CLS. 9 AND 41), (U.S. CLS. 21, 23, 26, 36, 38, 100, 101 AND 107). SN 77-773,458. PUB. 2-15-2011. FILED 7-2-2009.
- 3,953,094. **NATHAN AND DESIGN**. PENGUIN BRANDS, INC., MULTIPLE CLASS, (INT. CLS. 9, 18, 21 AND 25), (U.S. CLS. 1, 2, 3, 13, 21, 22, 23, 26, 29, 30, 33, 36, 38, 39, 40, 41 AND 50). SN 77-780,331. PUB. 2-15-2011. FILED 7-14-2009.
- 3,953,095. **LEAK-GUARDIAN AND DESIGN**. PETRO-METER CORPORATION, (U.S. CLS. 21, 23, 26, 36 AND 38). SN 77-780,880. PUB. 2-15-2011. FILED 7-14-2009.
- 3,953,111. **TV DESI AND DESIGN**. TV-DESI INC., MULTIPLE CLASS, (INT. CLS. 9 AND 38), (U.S. CLS. 21, 23, 26, 36, 38, 100, 101 AND 104). SN 77-805,188. PUB. 2-15-2011. FILED 8-14-2009.
- 3,953,112. **LANDTECH (STYLIZED)**. LANDTECH INC., (U.S. CLS. 21, 23, 26, 36 AND 38). SN 77-805,619. PUB. 2-15-2011. FILED 8-17-2009.
- 3,953,113. **AP TECH (STANDARD CHARACTER)**. ADVANCED PRESSURE TECHNOLOGY, (U.S. CLS. 21, 23, 26, 36 AND 38). SN 77-806,286. PUB. 2-15-2011. FILED 8-17-2009.
- 3,953,115. **SKYWAVE ANTENNAS AND DESIGN**. SKYWAVE ANTENNAS, INC., MULTIPLE CLASS, (INT. CLS. 9 AND 42), (U.S. CLS. 21, 23, 26, 36, 38, 100 AND 101). SN 77-808,433. PUB. 2-15-2011. FILED 8-19-2009.
- 3,953,125. **MYSHARE (STANDARD CHARACTER)**. PKF HOSPITALITY RESEARCH, INC., MULTIPLE CLASS, (INT. CLS. 9 AND 42), (U.S. CLS. 21, 23, 26, 36, 38, 100 AND 101). SN 77-813,306. PUB. 2-15-2011. FILED 8-26-2009.
- 3,953,129. **ARMADA TECHNOLOGIES (STANDARD CHARACTER)**. ARMADA TECHNOLOGIES LLC, (U.S. CLS. 21, 23, 26, 36 AND 38). SN 77-815,257. PUB. 2-15-2011. FILED 8-28-2009.
- 3,953,131. **TEXAS T (STANDARD CHARACTER)**. HITECH RIBBON LLC, (U.S. CLS. 21, 23, 26, 36 AND 38). SN 77-815,992. PUB. 2-15-2011. FILED 8-30-2009.
- 3,953,133. **TOEFL IBT (STANDARD CHARACTER)**. EDUCATIONAL TESTING SERVICE, MULTIPLE CLASS, (INT. CLS. 9 AND 16), (U.S. CLS. 2, 5, 21, 22, 23, 26, 29, 36, 37, 38 AND 50). SN 77-816,457. PUB. 2-15-2011. FILED 8-31-2009.
- 3,953,140. **ORIA (STANDARD CHARACTER)**. ELBIT SYSTEMS LTD., (U.S. CLS. 21, 23, 26, 36 AND 38). SN 77-819,139. PUB. 2-15-2011. FILED 9-3-2009.

- 3,953,141 ( *See Class 6 for this trademark* ).
- 3,953,144 ( *See Class 3 for this trademark* ).
- 3,953,154. **EYE PAL (STANDARD CHARACTER)**. RESIDENT ARTIST STUDIO, LLC, (U.S. CLS. 21, 23, 26, 36 AND 38). SN 77-829,909. PUB. 3-30-2010. FILED 9-18-2009.
- 3,953,160. **COMPOVISION (STANDARD CHARACTER)**. SUMITOMO ELECTRIC INDUSTRIES, LTD., (U.S. CLS. 21, 23, 26, 36 AND 38). SN 77-839,890. PUB. 2-15-2011. FILED 10-2-2009.
- 3,953,163 ( *See Class 6 for this trademark* ).
- 3,953,169. **DMC (STANDARD CHARACTER)**. Z/I IMAGING CORPORATION, (U.S. CLS. 21, 23, 26, 36 AND 38). SN 77-845,195. PUB. 2-15-2011. FILED 10-9-2009.
- 3,953,171. **ADVANCED PROJECTS AND DESIGN**. SOFT-ENIGMA INC, DBA ADEACA CORP., (U.S. CLS. 21, 23, 26, 36 AND 38). SN 77-846,076. PUB. 2-15-2011. FILED 10-10-2009.
- 3,953,175. **YNGWIE MALMSTEEN (STANDARD CHARACTER)**. YNGWIE MALMSTEEN, AND APRIL MALMSTEEN, (U.S. CLS. 21, 23, 26, 36 AND 38). SN 77-846,731. PUB. 2-15-2011. FILED 10-12-2009.
- 3,953,176. **KANZI (STANDARD CHARACTER)**. RIGHTWARE OY, MULTIPLE CLASS, (INT. CLS. 9 AND 42), (U.S. CLS. 21, 23, 26, 36, 38, 100 AND 101). SN 77-847,197. PUB. 2-15-2011. FILED 10-13-2009.
- 3,953,180. **FLEXERA SOFTWARE (STANDARD CHARACTER)**. FLEXERA SOFTWARE, INC., MULTIPLE CLASS, (INT. CLS. 9 AND 42), (U.S. CLS. 21, 23, 26, 36, 38, 100 AND 101). SN 77-850,916. PUB. 2-15-2011. FILED 10-16-2009.
- 3,953,213. **LIBERTYCOMMAND (STANDARD CHARACTER)**. SOLACOM TECHNOLOGIES INC., (U.S. CLS. 21, 23, 26, 36 AND 38). SN 77-891,267. PUB. 2-15-2011. FILED 12-11-2009.
- 3,953,214. **LIBERTYSHIELD (STANDARD CHARACTER)**. SOLACOM TECHNOLOGIES INC., (U.S. CLS. 21, 23, 26, 36 AND 38). SN 77-891,288. PUB. 2-15-2011. FILED 12-11-2009.
- 3,953,221. **PAYLINE POKER! (STANDARD CHARACTER)**. GAMETECH INTERNATIONAL, INC., (U.S. CLS. 21, 23, 26, 36 AND 38). SN 77-900,226. PUB. 2-15-2011. FILED 12-23-2009.
- 3,953,232. **CONDUIT (STANDARD CHARACTER)**. CONDUIT LTD, (U.S. CLS. 21, 23, 26, 36 AND 38). SN 77-911,604. PUB. 11-9-2010. FILED 1-14-2010.
- 3,953,235. **GEELY (STANDARD CHARACTER)**. DELSON GROUP INC, MULTIPLE CLASS, (INT. CLS. 9 AND 42), (U.S. CLS. 21, 23, 26, 36, 38, 100 AND 101). SN 77-913,608. PUB. 2-15-2011. FILED 1-17-2010.
- 3,953,237. **EDOCWIZ (STANDARD CHARACTER)**. ECOMPEX, INC., (U.S. CLS. 21, 23, 26, 36 AND 38). SN 77-914,047. PUB. 2-15-2011. FILED 1-18-2010.
- 3,953,239. **DRAGON FLY AND DESIGN**. GLOBAL CELLULAR, INC., (U.S. CLS. 21, 23, 26, 36 AND 38). SN 77-915,129. PUB. 2-15-2011. FILED 1-19-2010.
- 3,953,246. **OLDHAM LION BATTERY AND DESIGN**. EH EUROPE GMBH, (U.S. CLS. 21, 23, 26, 36 AND 38). SN 77-920,500. PUB. 2-15-2011. FILED 1-26-2010.
- 3,953,248. **FIMAC SOLUTIONS (STANDARD CHARACTER)**. FIMAC SOLUTIONS, LLC., MULTIPLE CLASS, (INT. CLS. 9, 36 AND 42), (U.S. CLS. 21, 23, 26, 36, 38, 100, 101 AND 102). SN 77-921,417. PUB. 2-15-2011. FILED 1-27-2010.
- 3,953,250. **MARKETNET (STANDARD CHARACTER)**. UMEDEX, INC., (U.S. CLS. 21, 23, 26, 36 AND 38). SN 77-924,093. PUB. 2-15-2011. FILED 1-29-2010.
- 3,953,251. **ACCESSNET (STANDARD CHARACTER)**. UMEDEX, INC., (U.S. CLS. 21, 23, 26, 36 AND 38). SN 77-924,123. PUB. 2-15-2011. FILED 1-29-2010.
- 3,953,263. **THE LEMONATOR (STANDARD CHARACTER)**. GURUZ 3 LLC, (U.S. CLS. 21, 23, 26, 36 AND 38). SN 77-931,729. PUB. 2-15-2011. FILED 2-9-2010.
- 3,953,277. **CARDIACNET (STANDARD CHARACTER)**. UMEDEX, INC., (U.S. CLS. 21, 23, 26, 36 AND 38). SN 77-937,047. PUB. 2-15-2011. FILED 2-16-2010.
- 3,953,281. **JAEGER AND DESIGN**. MAGNETI MARELLI FRANCE, MULTIPLE CLASS, (INT. CLS. 9 AND 12), (U.S. CLS. 19, 21, 23, 26, 31, 35, 36, 38 AND 44). SN 77-937,899. PUB. 2-15-2011. FILED 2-17-2010.
- 3,953,283. **V-STUDIO (STANDARD CHARACTER)**. ROLAND CORPORATION, MULTIPLE CLASS, (INT. CLS. 9 AND 15), (U.S. CLS. 2, 21, 23, 26, 36 AND 38). SN 77-938,188. PUB. 2-15-2011. FILED 2-17-2010.
- 3,953,288. **VRAS (STANDARD CHARACTER)**. KABUSHIKI KAISHA TOSHIBA, DBA TOSHIBA CORPORATION, (U.S. CLS. 21, 23, 26, 36 AND 38). SN 77-939,815. PUB. 10-12-2010. FILED 2-19-2010.
- 3,953,291. **HYPERSHOW (STANDARD CHARACTER)**. HYPERSHOW LTD., TA HYPERSHOW, MULTIPLE CLASS, (INT. CLS. 9, 41 AND 42), (U.S. CLS. 21, 23, 26, 36, 38, 100, 101 AND 107). SN 77-940,707. PUB. 2-15-2011. FILED 2-20-2010.
- 3,953,298. **PROSOFT TECHNOLOGY AND DESIGN**. PROSOFT TECHNOLOGY, INC., MULTIPLE CLASS, (INT. CLS. 9, 35 AND 42), (U.S. CLS. 21, 23, 26, 36, 38, 100, 101 AND 102). SN 77-942,209. PUB. 11-9-2010. FILED 2-23-2010.
- 3,953,299. **SCANASYST (STANDARD CHARACTER)**. VEECO METROLOGY INC., (U.S. CLS. 21, 23, 26, 36 AND 38). SN 77-942,622. PUB. 2-15-2011. FILED 2-23-2010.
- 3,953,320. **SHIELD OF NANU (STANDARD CHARACTER)**. ARISTOCRAT TECHNOLOGIES AUSTRALIA PTY LTD., (U.S. CLS. 21, 23, 26, 36 AND 38). SN 77-947,172. PUB. 2-15-2011. FILED 3-1-2010.
- 3,953,322. **EAST SEA EMPIRE (STANDARD CHARACTER)**. ARISTOCRAT TECHNOLOGIES AUSTRALIA PTY LTD., (U.S. CLS. 21, 23, 26, 36 AND 38). SN 77-947,205. PUB. 2-15-2011. FILED 3-1-2010.
- 3,953,323. **TROPHIES OF OLYMPUS (STANDARD CHARACTER)**. ARISTOCRAT TECHNOLOGIES AUSTRALIA PTY LTD., (U.S. CLS. 21, 23, 26, 36 AND 38). SN 77-947,234. PUB. 2-15-2011. FILED 3-1-2010.
- 3,953,339. **COMFORTGILITY (STANDARD CHARACTER)**. DAIMLER AG, MULTIPLE CLASS, (INT. CLS. 9, 11 AND 12), (U.S. CLS. 13, 19, 21, 23, 26, 31, 34, 35, 36, 38 AND 44). SN 77-949,748. PUB. 2-15-2011. FILED 3-3-2010.
- 3,953,340. **IP COMPLETE AND DESIGN**. CRIME POINT INC, DBA CRIME POINT, (U.S. CLS. 21, 23, 26, 36 AND 38). SN 77-949,795. PUB. 2-15-2011. FILED 3-3-2010.
- 3,953,342. **TACTICELL (STANDARD CHARACTER)**. WESTERN DATACOM CO., INC., AKA WESTERN DATACOM, (U.S. CLS. 21, 23, 26, 36 AND 38). SN 77-949,949. PUB. 2-15-2011. FILED 3-3-2010.
- 3,953,353. **MERS MUNICIPAL EMPLOYEES' RETIREMENT SYSTEM AND DESIGN**. MUNICIPAL EMPLOYEES' RETIREMENT SYSTEM OF MICHIGAN, MULTIPLE CLASS, (INT. CLS. 9, 16, 36 AND 41), (U.S. CLS. 2, 5, 21, 22, 23, 26, 29, 36, 37, 38, 50, 100, 101, 102 AND 107). SN 77-951,618. PUB. 2-15-2011. FILED 3-5-2010.
- 3,953,361. **KLICKFILE (STANDARD CHARACTER)**. MSC IMAGING SOLUTIONS LLC, (U.S. CLS. 21, 23, 26, 36 AND 38). SN 77-952,711. PUB. 2-15-2011. FILED 3-8-2010.
- 3,953,367. **CASH CATAPULT (STANDARD CHARACTER)**. ARISTOCRAT TECHNOLOGIES AUSTRALIA PTY LTD., (U.S. CLS. 21, 23, 26, 36 AND 38). SN 77-953,186. PUB. 2-15-2011. FILED 3-8-2010.
- 3,953,372. **ICESTATION TITAN BY ITSENCLUSURES (STYLIZED)**. INTEGRATION TECHNOLOGY SYSTEMS, INC., (U.S. CLS. 21, 23, 26, 36 AND 38). SN 77-953,876. PUB. 2-15-2011. FILED 3-9-2010.
- 3,953,379. **MISCELLANEOUS DESIGN**. SMARTPLUG SYSTEMS LLC, (U.S. CLS. 21, 23, 26, 36 AND 38). SN 77-954,767. PUB. 2-15-2011. FILED 3-9-2010.
- 3,953,388. **FISHDOM (STANDARD CHARACTER)**. PLAYRIX ENTERTAINMENT LLC, MULTIPLE CLASS, (INT. CLS. 9 AND 41), (U.S. CLS. 21, 23, 26, 36, 38, 100, 101 AND 107). SN 77-956,301. PUB. 2-15-2011. FILED 3-11-2010.
- 3,953,394 ( *See Class 1 for this trademark* ).
- 3,953,398. **SCIENCEINSIDER (STANDARD CHARACTER)**. AMERICAN ASSOCIATION FOR THE ADVANCEMENT OF SCIENCE, MULTIPLE CLASS, (INT. CLS. 9, 41 AND 42), (U.S. CLS. 21, 23, 26, 36, 38, 100, 101 AND 107). SN 77-957,749. PUB. 2-15-2011. FILED 3-12-2010.
- 3,953,420. **JUSTBRAINS (STANDARD CHARACTER)**. DAVID SEABERG, (U.S. CLS. 21, 23, 26, 36 AND 38). SN 77-960,713. PUB. 2-15-2011. FILED 3-17-2010.
- 3,953,429. **ELECTRIC MIRROR (STANDARD CHARACTER)**. ELECTRIC MIRROR, LLC, (U.S. CLS. 21, 23, 26, 36 AND 38). SN 77-961,663. PUB. 2-15-2011. FILED 3-17-2010.
- 3,953,435. **FUNFAIR FORTUNE (STANDARD CHARACTER)**. ARISTOCRAT TECHNOLOGIES AUSTRALIA PTY LTD.,

- (U.S. CLS. 21, 23, 26, 36 AND 38). SN 77-961,994. PUB. 2-15-2011. FILED 3-18-2010.
- 3,953,437. **THROUGH THE LOOKING GLASS (STANDARD CHARACTER)**. ARISTOCRAT TECHNOLOGIES AUSTRALIA PTY LTD., (U.S. CLS. 21, 23, 26, 36 AND 38). SN 77-962,135. PUB. 2-15-2011. FILED 3-18-2010.
- 3,953,448. **BILCARE NONCLONABLE (STANDARD CHARACTER)**. BILCARE LIMITED, (U.S. CLS. 21, 23, 26, 36 AND 38). SN 77-964,503. PUB. 2-15-2011. FILED 3-22-2010.
- 3,953,454. **ABIL (STANDARD CHARACTER)**. BANCO BILBAO VIZCAYA ARGENTARIA, S.A., MULTIPLE CLASS, (INT. CLS. 9 AND 36), (U.S. CLS. 21, 23, 26, 36, 38, 100, 101 AND 102). SN 77-966,183. PUB. 2-15-2011. FILED 3-23-2010.
- 3,953,471 ( *See Class 3 for this trademark*).
- 3,953,484. **EYEQ (STANDARD CHARACTER)**. MOBILEYE TECHNOLOGIES LIMITED, (U.S. CLS. 21, 23, 26, 36 AND 38). SN 78-972,957. PUB. 2-15-2011. FILED 9-13-2006.
- 3,953,485 ( *See Class 3 for this trademark*).
- 3,953,488. **UNITED MOBILE (STANDARD CHARACTER)**. SPARK CONSULT GMBH, MULTIPLE CLASS, (INT. CLS. 9, 38 AND 42), (U.S. CLS. 21, 23, 26, 36, 38, 100, 101 AND 104). SN 79-031,616. PUB. 2-15-2011. FILED 6-12-2006.
- 3,953,489. **ADORE AND DESIGN**. EYEMED TECHNOLOGIES S.R.L., (U.S. CLS. 21, 23, 26, 36 AND 38). SN 79-057,274. PUB. 2-15-2011. FILED 6-11-2008.
- 3,953,490. **BALDESSARINI (STANDARD CHARACTER)**. BALDESSARINI GMBH, MULTIPLE CLASS, (INT. CLS. 9, 14, 18 AND 25), (U.S. CLS. 1, 2, 3, 21, 22, 23, 26, 27, 28, 36, 38, 39, 41 AND 50). SN 79-061,369. PUB. 2-15-2011. FILED 9-18-2008.
- 3,953,493. **FUGRO AND DESIGN**. FUGRO N.V., MULTIPLE CLASS, (INT. CLS. 9, 37, 41 AND 42), (U.S. CLS. 21, 23, 26, 36, 38, 100, 101, 103, 106 AND 107). SN 79-066,521. PUB. 2-15-2011. FILED 1-2-2009.
- 3,953,495. **MENTUM (STANDARD CHARACTER)**. MENTUM, MULTIPLE CLASS, (INT. CLS. 9, 35, 38 AND 42), (U.S. CLS. 21, 23, 26, 36, 38, 100, 101, 102 AND 104). SN 79-067,643. PUB. 2-15-2011. FILED 7-18-2008.
- 3,953,497 ( *See Class 6 for this trademark*).
- 3,953,498. **UPCLICK (STANDARD CHARACTER)**. UPCLICK MALTA LIMITED, MULTIPLE CLASS, (INT. CLS. 9, 16, 35 AND 42), (U.S. CLS. 2, 5, 21, 22, 23, 26, 29, 36, 37, 38, 50, 100, 101 AND 102). SN 79-068,150. PUB. 2-15-2011. FILED 4-17-2009.
- 3,953,502 ( *See Class 8 for this trademark*).
- 3,953,504. **TECHNOLIVE (STANDARD CHARACTER)**. KIEBACK & PETER GMBH & CO. KG, MULTIPLE CLASS, (INT. CLS. 9, 11, 37 AND 42), (U.S. CLS. 13, 21, 23, 26, 31, 34, 36, 38, 100, 101, 103 AND 106). SN 79-070,789. PUB. 2-15-2011. FILED 11-12-2008.
- 3,953,505 ( *See Class 7 for this trademark*).
- 3,953,506. **MAVIG AND DESIGN**. MAVIG GMBH, MULTIPLE CLASS, (INT. CLS. 9 AND 10), (U.S. CLS. 21, 23, 26, 36, 38, 39 AND 44). SN 79-072,019. PUB. 2-15-2011. FILED 7-27-2009.
- 3,953,511. **MANAGING THE WORLD'S INFRASTRUCTURE (STANDARD CHARACTER)**. INTERNATIONAL BUSINESS MACHINES CORPORATION, MULTIPLE CLASS, (INT. CLS. 9, 16, 35 AND 42), (U.S. CLS. 2, 5, 21, 22, 23, 26, 29, 36, 37, 38, 50, 100, 101 AND 102). SN 79-072,694. PUB. 2-15-2011. FILED 6-22-2009.
- 3,953,512. **ALU-TV (STANDARD CHARACTER)**. SABEMO SA, MULTIPLE CLASS, (INT. CLS. 9, 38 AND 41), (U.S. CLS. 21, 23, 26, 36, 38, 100, 101, 104 AND 107). SN 79-073,619. PUB. 2-15-2011. FILED 5-13-2009.
- 3,953,513 ( *See Class 1 for this trademark*).
- 3,953,514. **GREEN HOME AND DESIGN**. GIGASET COMMUNICATIONS GMBH, (U.S. CLS. 21, 23, 26, 36 AND 38). SN 79-073,936. PUB. 2-15-2011. FILED 7-31-2009.
- 3,953,516. **BELL-FRUIT GAMES AND DESIGN**. BELL-FRUIT GAMES LIMITED, MULTIPLE CLASS, (INT. CLS. 9, 28, 41 AND 42), (U.S. CLS. 21, 22, 23, 26, 36, 38, 50, 100, 101 AND 107). SN 79-074,141. PUB. 2-15-2011. FILED 6-18-2009.
- 3,953,518. **RETMARKER AND DESIGN**. CRITICAL HEALTH, S.A., MULTIPLE CLASS, (INT. CLS. 9 AND 42), (U.S. CLS. 21, 23, 26, 36, 38, 100 AND 101). SN 79-075,349. PUB. 2-15-2011. FILED 9-24-2009.
- 3,953,520. **DIGISENDER (STANDARD CHARACTER)**. AEI SECURITY & COMMUNICATIONS LIMITED, MULTIPLE CLASS, (INT. CLS. 9, 16 AND 41), (U.S. CLS. 2, 5, 21, 22, 23, 26, 29, 36, 37, 38, 50, 100, 101 AND 107). SN 79-075,521. PUB. 11-9-2010. FILED 8-25-2009.
- 3,953,521. **JOOP! (STANDARD CHARACTER)**. JOOP! GMBH, MULTIPLE CLASS, (INT. CLS. 9, 16 AND 25), (U.S. CLS. 2, 5, 21, 22, 23, 26, 29, 36, 37, 38, 39 AND 50). SN 79-075,953. PUB. 9-14-2010. FILED 9-3-2009.
- 3,953,531. **ICONNECT ONLINE APPLYING KNOWLEDGE TO DEVELOPMENT AND DESIGN**. STICHTING INTERNATIONAL INSTITUTE FOR: COMMUNICATION AND DEVELOPMENT, MULTIPLE CLASS, (INT. CLS. 9, 41 AND 42), (U.S. CLS. 21, 23, 26, 36, 38, 100, 101 AND 107). SN 79-077,882. PUB. 2-15-2011. FILED 11-16-2009.
- 3,953,532. **WAPI (STYLIZED)**. CHINA IWNCOMM CO., LTD., (U.S. CLS. 21, 23, 26, 36 AND 38). SN 79-078,159. PUB. 2-15-2011. FILED 1-4-2010.
- 3,953,545. **VELLUX (STYLIZED)**. DUNAN CO., LTD. (U.S. CLS. 21, 23, 26, 36 AND 38). SN 79-080,113. PUB. 2-15-2011. FILED 1-29-2010.
- 3,953,551. **ERRIDE (STANDARD CHARACTER)**. FLUDICON GMBH, MULTIPLE CLASS, (INT. CLS. 9 AND 12), (U.S. CLS. 19, 21, 23, 26, 31, 35, 36, 38 AND 44). SN 79-080,980. PUB. 1-11-2011. FILED 2-9-2010.
- 3,953,552. **CIM-LPCS (STANDARD CHARACTER)**. CIMPROGETTI S.P.A., MULTIPLE CLASS, (INT. CLS. 9 AND 42), (U.S. CLS. 21, 23, 26, 36, 38, 100 AND 101). SN 79-081,043. PUB. 2-15-2011. FILED 2-18-2010.
- 3,953,557. **NICESTUFF (STANDARD CHARACTER)**. LUFTHANSA TECHNIK AG, MULTIPLE CLASS, (INT. CLS. 9, 37 AND 42), (U.S. CLS. 21, 23, 26, 36, 38, 100, 101, 103 AND 106). SN 79-081,159. PUB. 2-15-2011. FILED 3-4-2010.
- 3,953,558. **CM NAVIGO AND DESIGN**. CRITICAL MANUFACTURING, S.A., MULTIPLE CLASS, (INT. CLS. 9 AND 42), (U.S. CLS. 21, 23, 26, 36, 38, 100 AND 101). SN 79-081,161. PUB. 2-15-2011. FILED 3-4-2010.
- 3,953,566. **SR-NLT (STYLIZED)**. NEC LCD TECHNOLOGIES, LTD., (U.S. CLS. 21, 23, 26, 36 AND 38). SN 79-081,440. PUB. 2-15-2011. FILED 3-18-2010.
- 3,953,568 ( *See Class 7 for this trademark*).
- 3,953,569 ( *See Class 6 for this trademark*).
- 3,953,570 ( *See Class 6 for this trademark*).
- 3,953,571. **METO (STANDARD CHARACTER)**. CHECKPOINT SYSTEMS INTERNATIONAL GMBH, MULTIPLE CLASS, (INT. CLS. 9, 16, 24 AND 35), (U.S. CLS. 2, 5, 21, 22, 23, 26, 29, 36, 37, 38, 42, 50, 100, 101 AND 102). SN 79-081,731. PUB. 2-15-2011. FILED 1-14-2010.
- 3,953,572. **BRÄNNSTROM (STANDARD CHARACTER)**. BRÄNNSTRÖM I GÖTEBORG AB, MULTIPLE CLASS, (INT. CLS. 9 AND 11), (U.S. CLS. 13, 21, 23, 26, 31, 34, 36 AND 38). SN 79-081,755. PUB. 2-15-2011. FILED 3-25-2010.
- 3,953,574 ( *See Class 7 for this trademark*).
- 3,953,575. **LOTUS KNOWS (STANDARD CHARACTER)**. INTERNATIONAL BUSINESS MACHINES CORPORATION, MULTIPLE CLASS, (INT. CLS. 9, 16, 38 AND 42), (U.S. CLS. 2, 5, 21, 22, 23, 26, 29, 36, 37, 38, 50, 100, 101 AND 104). SN 79-081,801. PUB. 2-15-2011. FILED 3-3-2010.
- 3,953,576. **FAROLAB AND DESIGN**. FAROLAB GMBH, (U.S. CLS. 21, 23, 26, 36 AND 38). SN 79-081,895. PUB. 2-15-2011. FILED 3-25-2010.
- 3,953,577. **DIDON (STANDARD CHARACTER)**. RP SAFE SPA, (U.S. CLS. 21, 23, 26, 36 AND 38). SN 79-081,896. PUB. 2-15-2011. FILED 3-5-2010.
- 3,953,582 ( *See Class 6 for this trademark*).
- 3,953,587. **PURESCALE (STANDARD CHARACTER)**. INTERNATIONAL BUSINESS MACHINES CORPORATION, MULTIPLE CLASS, (INT. CLS. 9, 16 AND 42), (U.S. CLS. 2, 5, 21, 22, 23, 26, 29, 36, 37, 38, 50, 100 AND 101). SN 79-082,265. PUB. 2-15-2011. FILED 3-8-2010.
- 3,953,594. **H SILVIAN HEACH KIDS (STYLIZED)**. ARAV HOLDING S.R.L. A SOCIO UNICO, MULTIPLE CLASS, (INT. CLS. 9, 14, 18, 25 AND 35), (U.S. CLS. 1, 2, 3, 21, 22, 23, 26, 27, 28, 36, 38, 39, 41, 50, 100, 101 AND 102). SN 79-082,461. PUB. 2-15-2011. FILED 3-5-2010.
- 3,953,607 ( *See Class 7 for this trademark*).
- 3,953,610 ( *See Class 7 for this trademark*).
- 3,953,612. **SILCA (STANDARD CHARACTER)**. SILCA S.P.A., (U.S. CLS. 21, 23, 26, 36 AND 38). SN 79-083,523. PUB. 2-15-2011. FILED 3-5-2010.
- 3,953,625. **OKM (STANDARD CHARACTER)**. OKM OR-

- TUNGSTECHNIK KRAUB & MÜLLER GMBH, (U.S. CLS. 21, 23, 26, 36 AND 38). SN 79-085,041. PUB. 2-15-2011. FILED 5-31-2010.
- 3,953,631. **ADFRONT (STYLIZED)**. SOCIÉTÉ FIVIA, (U.S. CLS. 21, 23, 26, 36 AND 38). SN 79-085,836. PUB. 1-18-2011. FILED 3-16-2010.
- 3,953,635. **VALUEPRO (STANDARD CHARACTER)**. VALUEPRO SOFTWARE PTY LTD, (U.S. CLS. 21, 23, 26, 36 AND 38). SN 79-086,189. PUB. 2-15-2011. FILED 6-9-2010.
- 3,953,640. **CHROMASTER (STANDARD CHARACTER)**. HITACHI HIGH-TECHNOLOGIES CORPORATION, (U.S. CLS. 21, 23, 26, 36 AND 38). SN 79-086,819. PUB. 2-15-2011. FILED 7-29-2010.
- 3,953,643 ( *See Class 3 for this trademark*).
- 3,953,657. **LIGHTING AND DESIGN**. GUANGZHOU TIGER HEAD BATTERY GROUP CO., LTD., (U.S. CLS. 21, 23, 26, 36 AND 38). SN 79-087,682. PUB. 2-15-2011. FILED 5-20-2010.
- 3,953,667. **ACTISCI (STANDARD CHARACTER)**. ACTITRAC SOFTWARE LIMITED, (U.S. CLS. 21, 23, 26, 36 AND 38). SN 79-088,113. PUB. 2-15-2011. FILED 8-5-2010.
- 3,953,691. **BLACK & WHITE (STANDARD CHARACTER)**. LEVITON MANUFACTURING CO., INC., (U.S. CLS. 21, 23, 26, 36 AND 38). SN 85-001,666. PUB. 2-15-2011. FILED 3-30-2010.
- 3,953,692 ( *See Class 7 for this trademark*).
- 3,953,696. **LAKEMASTER (STANDARD CHARACTER)**. WAYPOINT TECHNOLOGIES, INC., DBA LAKEMASTER LAKE MAPS, MULTIPLE CLASS, (INT. CLS. 9 AND 16), (U.S. CLS. 2, 5, 21, 22, 23, 26, 29, 36, 37, 38 AND 50). SN 85-002,724. PUB. 2-15-2011. FILED 3-31-2010.
- 3,953,700. **MISCELLANEOUS DESIGN**. CHAKRA ENERGETICS, INC., (U.S. CLS. 21, 23, 26, 36 AND 38). SN 85-003,226. PUB. 2-15-2011. FILED 3-31-2010.
- 3,953,704. **LEADING IN ACCURACY, FOLLOWING WITH SUCCESS (STANDARD CHARACTER)**. WAYPOINT TECHNOLOGIES, INC., DBA LAKEMASTER LAKE MAPS, MULTIPLE CLASS, (INT. CLS. 9 AND 16), (U.S. CLS. 2, 5, 21, 22, 23, 26, 29, 36, 37, 38 AND 50). SN 85-004,351. PUB. 2-15-2011. FILED 4-1-2010.
- 3,953,711. **COJK CHRISTENSEN O'CONNOR JOHNSON KINDNESS AND DESIGN**. CHRISTENSEN O'CONNOR JOHNSON KINDNESS PLLC, MULTIPLE CLASS, (INT. CLS. 9 AND 45), (U.S. CLS. 21, 23, 26, 36, 38, 100 AND 101). SN 85-006,798. PUB. 2-15-2011. FILED 4-5-2010.
- 3,953,715. **DJESSA (STANDARD CHARACTER)**. CARRIEJESSA, MULTIPLE CLASS, (INT. CLS. 9, 25 AND 41), (U.S. CLS. 21, 22, 23, 26, 36, 38, 39, 100, 101 AND 107). SN 85-007,978. PUB. 2-15-2011. FILED 4-7-2010.
- 3,953,718. **THINE (STANDARD CHARACTER)**. THINE ELECTRONICS KABUSHIKI KAISHA A/T/A THINE ELECTRONICS, INC., (U.S. CLS. 21, 23, 26, 36 AND 38). SN 85-008,407. PUB. 2-15-2011. FILED 4-7-2010.
- 3,953,720. **QSCRIPT (STANDARD CHARACTER)**. WAVE59 TECHNOLOGIES INT'L, INC., (U.S. CLS. 21, 23, 26, 36 AND 38). SN 85-009,749. PUB. 2-15-2011. FILED 4-8-2010.
- 3,953,723. **LEARN GREEK THE EASY WAY (STANDARD CHARACTER)**. THEODORE C. PAPALOIZOS PUBLICATIONS, INC., MULTIPLE CLASS, (INT. CLS. 9 AND 16), (U.S. CLS. 2, 5, 21, 22, 23, 26, 29, 36, 37, 38 AND 50). SN 85-011,194. PUB. 2-15-2011. FILED 4-10-2010.
- 3,953,727. **VOLTRONIX (STANDARD CHARACTER)**. GLOBAL FLUID POWER SOLUTIONS, LLC, AKA GLOBAL FPS, LLC, AND MAHOMANN CORP., (U.S. CLS. 21, 23, 26, 36 AND 38). SN 85-012,135. PUB. 2-15-2011. FILED 4-12-2010.
- 3,953,746. **X XTREME AND DESIGN**. YEN SUN TECHNOLOGY CORP., MULTIPLE CLASS, (INT. CLS. 9 AND 11), (U.S. CLS. 13, 21, 23, 26, 31, 34, 36 AND 38). SN 85-020,331. PUB. 2-15-2011. FILED 4-22-2010.
- 3,953,747. **IQUBE (STANDARD CHARACTER)**. DELCAM PLC., MULTIPLE CLASS, (INT. CLS. 9 AND 10), (U.S. CLS. 21, 23, 26, 36, 38, 39 AND 44). SN 85-020,359. PUB. 2-15-2011. FILED 4-22-2010.
- 3,953,749. **CONTOUR PRO (STYLIZED)**. WAYPOINT TECHNOLOGIES, INC., DBA LAKEMASTER LAKE MAPS, (U.S. CLS. 21, 23, 26, 36 AND 38). SN 85-022,918. PUB. 2-15-2011. FILED 4-26-2010.
- 3,953,765. **SUPERVISION SYSTEMS (STANDARD CHARACTER)**. SMITH, MICHAEL, DBA SUPERVISION SYSTEMS INC., (U.S. CLS. 21, 23, 26, 36 AND 38). SN 85-027,659. PUB. 2-15-2011. FILED 4-30-2010.
- 3,953,769. **MEDEA (STANDARD CHARACTER)**. MATERIALS DESIGN, INC., (U.S. CLS. 21, 23, 26, 36 AND 38). SN 85-029,619. PUB. 2-15-2011. FILED 5-4-2010.
- 3,953,776. **[VOI] (STANDARD CHARACTER)**. DATUM LLC, MULTIPLE CLASS, (INT. CLS. 9 AND 42), (U.S. CLS. 21, 23, 26, 36, 38, 100 AND 101). SN 85-030,567. PUB. 2-15-2011. FILED 5-5-2010.
- 3,953,789. **APMASPHERE (STANDARD CHARACTER)**. ARC-LIGHT INVESTMENTS PTY LTD, MULTIPLE CLASS, (INT. CLS. 9, 36, 38 AND 42), (U.S. CLS. 21, 23, 26, 36, 38, 100, 101, 102 AND 104). SN 85-035,486. PUB. 2-15-2011. FILED 5-11-2010.
- 3,953,813. **BIG CROC (STANDARD CHARACTER)**. ARISTOCRAT TECHNOLOGIES AUSTRALIA PTY LTD, (U.S. CLS. 21, 23, 26, 36 AND 38). SN 85-040,003. PUB. 2-15-2011. FILED 5-17-2010.
- 3,953,814. **STREETPARTY (STANDARD CHARACTER)**. DISRUPTIVE LIMITED, (U.S. CLS. 21, 23, 26, 36 AND 38). SN 85-040,150. PUB. 1-25-2011. FILED 5-17-2010.
- 3,953,818. **EATINGWELL WHERE GOOD TASTE MEETS GOOD HEALTH (STANDARD CHARACTER)**. EATING WELL, INC., MULTIPLE CLASS, (INT. CLS. 9, 16 AND 41), (U.S. CLS. 2, 5, 21, 22, 23, 26, 29, 36, 37, 38, 50, 100, 101 AND 107). SN 85-040,842. PUB. 2-15-2011. FILED 5-17-2010.
- 3,953,824. **STEEL PROJECTS AND DESIGN**. STEEL PROJECTS, MULTIPLE CLASS, (INT. CLS. 9 AND 42), (U.S. CLS. 21, 23, 26, 36, 38, 100 AND 101). SN 85-043,142. PUB. 2-15-2011. FILED 5-19-2010.
- 3,953,828. **MT AND DESIGN**. MAHAN TECHNICAL DESIGN, DBA MTEK WEAPON SYSTEMS, (U.S. CLS. 21, 23, 26, 36 AND 38). SN 85-045,624. PUB. 2-15-2011. FILED 5-22-2010.
- 3,953,837. **POPULAR SCIENCE+ (STANDARD CHARACTER)**. BONNIER ACTIVE MEDIA, INC., (U.S. CLS. 21, 23, 26, 36 AND 38). SN 85-048,951. PUB. 2-15-2011. FILED 5-27-2010.
- 3,953,844. **OUT OF SIGHT PEACE OF MIND (STANDARD CHARACTER)**. REVO AMERICA, (U.S. CLS. 21, 23, 26, 36 AND 38). SN 85-053,084. PUB. 2-15-2011. FILED 6-2-2010.
- 3,953,845. **MA SNAPSHOTS (STANDARD CHARACTER)**. THE ALLIANCE OF COMMUNITY HEALTH PLANS, (U.S. CLS. 21, 23, 26, 36 AND 38). SN 85-053,533. PUB. 2-15-2011. FILED 6-3-2010.
- 3,953,846. **MEDICARE ADVANTAGE SNAPSHOTS (STANDARD CHARACTER)**. THE ALLIANCE OF COMMUNITY HEALTH PLANS, (U.S. CLS. 21, 23, 26, 36 AND 38). SN 85-053,546. PUB. 2-15-2011. FILED 6-3-2010.
- 3,953,856. **DHR (STANDARD CHARACTER)**. DRÄGER SAFETY AG & CO. KGAA, (U.S. CLS. 21, 23, 26, 36 AND 38). SN 85-057,236. PUB. 2-15-2011. FILED 6-8-2010.
- 3,953,888. **TREASURE MAP (STANDARD CHARACTER)**. RETAIL BRANDS PTY LTD, MULTIPLE CLASS, (INT. CLS. 9 AND 41), (U.S. CLS. 21, 23, 26, 36, 38, 100, 101 AND 107). SN 85-068,213. PUB. 2-15-2011. FILED 6-22-2010.
- 3,953,907. **THE NEW HOUSEHOLD NAME IN READING INSTRUCTION (STANDARD CHARACTER)**. CLICKN' KIDS, INC., (U.S. CLS. 21, 23, 26, 36 AND 38). SN 85-072,283. PUB. 2-15-2011. FILED 6-26-2010.
- 3,953,911. **EPICDATA (STANDARD CHARACTER)**. EPIC DATA INTERNATIONAL, INC., MULTIPLE CLASS, (INT. CLS. 9 AND 16), (U.S. CLS. 2, 5, 21, 22, 23, 26, 29, 36, 37, 38 AND 50). SN 85-072,877. PUB. 2-15-2011. FILED 6-28-2010.
- 3,953,912. **THERAPIST HELPER (STANDARD CHARACTER)**. NETSMART TECHNOLOGIES, INC., (U.S. CLS. 21, 23, 26, 36 AND 38). SN 85-073,096. PUB. 2-15-2011. FILED 6-28-2010.
- 3,953,930. **WALLSTREET TO MAINSTREET (STANDARD CHARACTER)**. PETTINGILL, BERNARD, (U.S. CLS. 21, 23, 26, 36 AND 38). SN 85-077,892. PUB. 2-15-2011. FILED 7-5-2010.
- 3,953,932. **HEALTHFLASH AND DESIGN**. FLATFLASH GROUP, LLC, (U.S. CLS. 21, 23, 26, 36 AND 38). SN 85-078,317. PUB. 2-15-2011. FILED 7-6-2010.
- 3,953,941. **ADOLESCENT'S ORQUESTA (STANDARD CHARACTER)**. KORTA RECORDS, C.A., (U.S. CLS. 21, 23, 26, 36 AND 38). SN 85-081,786. PUB. 2-15-2011. FILED 7-9-2010.
- 3,953,957. **DURA TRAILER (STANDARD CHARACTER)**. IN-

- FORMATION DISPLAY COMPANY, (U.S. CLS. 21, 23, 26, 36 AND 38). SN 85-086,941. PUB. 2-15-2011. FILED 7-16-2010.
- 3,953,961. **RUNWAY SDK (STANDARD CHARACTER)**. TERRAFRAME, INC., (U.S. CLS. 21, 23, 26, 36 AND 38). SN 85-087,602. PUB. 2-15-2011. FILED 7-19-2010.
- 3,953,978. **OWLSTONE (STANDARD CHARACTER)**. OWLSTONE NANOTECH INC., (U.S. CLS. 21, 23, 26, 36 AND 38). SN 85-092,732. PUB. 2-15-2011. FILED 7-26-2010.
- 3,953,980. **MISCELLANEOUS DESIGN**. OWLSTONE NANOTECH INC., (U.S. CLS. 21, 23, 26, 36 AND 38). SN 85-092,784. PUB. 2-15-2011. FILED 7-26-2010.
- 3,953,982. **GIVE YOUR CELL PHONE A HOME (STANDARD CHARACTER)**. BURNS, DAVID ANTHONY, (U.S. CLS. 21, 23, 26, 36 AND 38). SN 85-093,299. PUB. 2-15-2011. FILED 7-26-2010.
- 3,953,986. **SOAPBOX MELODICS (STANDARD CHARACTER)**. BARBACCIA, NATHAN, MULTIPLE CLASS, (INT. CLS. 9, 25 AND 41), (U.S. CLS. 21, 22, 23, 26, 36, 38, 39, 100, 101 AND 107). SN 85-094,369. PUB. 2-15-2011. FILED 7-28-2010.
- 3,953,987. **FLY-N-HOG (STANDARD CHARACTER)**. FLY-N-HOG MEDIA GROUP, INC., MULTIPLE CLASS, (INT. CLS. 9 AND 35), (U.S. CLS. 21, 23, 26, 36, 38, 100, 101 AND 102). SN 85-094,713. PUB. 2-15-2011. FILED 7-28-2010.
- 3,953,988. **ASSURED BATTERIES (STANDARD CHARACTER)**. LITHIA MOTORS, INC., (U.S. CLS. 21, 23, 26, 36 AND 38). SN 85-095,269. PUB. 2-15-2011. FILED 7-28-2010.
- 3,953,989. **MENTAL WORKOUT (STANDARD CHARACTER)**. MENTAL WORKOUT, INC., MULTIPLE CLASS, (INT. CLS. 9, 42 AND 44), (U.S. CLS. 21, 23, 26, 36, 38, 100 AND 101). SN 85-095,335. PUB. 2-15-2011. FILED 7-28-2010.
- 3,953,997. **JORGE MORENO (STANDARD CHARACTER)**. MORENO, JORGE, (U.S. CLS. 21, 23, 26, 36 AND 38). SN 85-096,339. PUB. 2-15-2011. FILED 7-29-2010.
- 3,954,004. **MOBIGAME (STYLIZED)**. MOBIGAME, (U.S. CLS. 21, 23, 26, 36 AND 38). SN 85-097,846. PUB. 2-15-2011. FILED 8-2-2010.
- 3,954,020. **N2Y AND DESIGN**. DJC HOLDINGS LLC, MULTIPLE CLASS, (INT. CLS. 9 AND 41), (U.S. CLS. 21, 23, 26, 36, 38, 100, 101 AND 107). SN 85-100,159. PUB. 2-15-2011. FILED 8-4-2010.
- 3,954,029. **PRIMSAVERS (STANDARD CHARACTER)**. FLORIN URSU, (U.S. CLS. 21, 23, 26, 36 AND 38). SN 85-101,859. PUB. 2-15-2011. FILED 8-6-2010.
- 3,954,086. **ARCTOUCH (STANDARD CHARACTER)**. ARCTOUCH INCORPORATED, (U.S. CLS. 21, 23, 26, 36 AND 38). SN 85-108,186. PUB. 2-15-2011. FILED 8-16-2010.
- 3,954,087. **OD OLIVE DORA (STYLIZED)**. TIME PLAZA, (U.S. CLS. 21, 23, 26, 36 AND 38). SN 85-108,330. PUB. 2-15-2011. FILED 8-16-2010.
- 3,954,088. **UNIVERSAL SUN-V ORIGINAL AND DESIGN**. TIME PLAZA, (U.S. CLS. 21, 23, 26, 36 AND 38). SN 85-108,391. PUB. 2-15-2011. FILED 8-16-2010.
- 3,954,109. **LITTLE THINGS (STANDARD CHARACTER)**. KLIKTOK PTY LTD, (U.S. CLS. 21, 23, 26, 36 AND 38). SN 85-109,911. PUB. 2-15-2011. FILED 8-18-2010.
- 3,954,174. **SONGS THAT MAKE YOU SMILE ! (STANDARD CHARACTER)**. NILES, SUZANNE, (U.S. CLS. 21, 23, 26, 36 AND 38). SN 85-112,953. PUB. 2-15-2011. FILED 8-21-2010.
- 3,954,187. **ZOOLY (STANDARD CHARACTER)**. ONLINE WIRELESS, INC., (U.S. CLS. 21, 23, 26, 36 AND 38). SN 85-113,759. PUB. 2-15-2011. FILED 8-23-2010.
- 3,954,195. **GRAVITY HOOK HD AND DESIGN**. SEMI SECRET SOFTWARE, (U.S. CLS. 21, 23, 26, 36 AND 38). SN 85-114,030. PUB. 2-15-2011. FILED 8-23-2010.
- 3,954,197. **GSYNCIT (STANDARD CHARACTER)**. OMNIMIND, INC., (U.S. CLS. 21, 23, 26, 36 AND 38). SN 85-114,090. PUB. 2-15-2011. FILED 8-23-2010.
- 3,954,216. **B AND DESIGN**. BLOCKSTAR LLC, AKA BSTAR CLOTHING, MULTIPLE CLASS, (INT. CLS. 9 AND 25), (U.S. CLS. 21, 22, 23, 26, 36, 38 AND 39). SN 85-114,461. PUB. 2-15-2011. FILED 8-24-2010.
- 3,954,232. **AUNTIE SNOW'S (STANDARD CHARACTER)**. FILMICFLOY CORPORATION, (U.S. CLS. 21, 23, 26, 36 AND 38). SN 85-114,860. PUB. 2-15-2011. FILED 8-24-2010.
- 3,954,240. **+2 TECHNOLOGIES AND DESIGN**. PLUS2 TECHNOLOGIES, LLC, (U.S. CLS. 21, 23, 26, 36 AND 38). SN 85-115,018. PUB. 2-15-2011. FILED 8-24-2010.
- 3,954,241. **J ROSS PARRELLI AND DESIGN**. J ROSS PARRELLI, (U.S. CLS. 21, 23, 26, 36 AND 38). SN 85-115,019. PUB. 2-15-2011. FILED 8-24-2010.
- 3,954,289. **PEE MONKEY (STANDARD CHARACTER)**. EXOWEB LIMITED, (U.S. CLS. 21, 23, 26, 36 AND 38). SN 85-116,079. PUB. 2-15-2011. FILED 8-26-2010.
- 3,954,290. **NAFFCO AND DESIGN**. NATIONAL FIRE FIGHTING MANUFACTURING FZCO, AKA NAFFCO, (U.S. CLS. 21, 23, 26, 36 AND 38). SN 85-116,103. PUB. 2-15-2011. FILED 8-26-2010.
- 3,954,309. **MYHD (STANDARD CHARACTER)**. MINCRON SBC CORPORATION, (U.S. CLS. 21, 23, 26, 36 AND 38). SN 85-116,424. PUB. 2-15-2011. FILED 8-26-2010.
- 3,954,311. **CARUTEST (STANDARD CHARACTER)**. CARUS CORPORATION, (U.S. CLS. 21, 23, 26, 36 AND 38). SN 85-116,456. PUB. 2-15-2011. FILED 8-26-2010.
- 3,954,339. **NYS ELITE EYEWEAR (STANDARD CHARACTER)**. MARSALLE, INC., (U.S. CLS. 21, 23, 26, 36 AND 38). SN 85-116,971. PUB. 2-15-2011. FILED 8-26-2010.
- 3,954,381. **HINDSIGHT RECORDS AND DESIGN**. HINDSIGHT RECORDS, (U.S. CLS. 21, 23, 26, 36 AND 38). SN 85-117,459. PUB. 2-15-2011. FILED 8-27-2010.
- 3,954,410. **STARS 100% UV PROTECTION AND DESIGN**. TSAI, NIECO MING HUAN, (U.S. CLS. 21, 23, 26, 36 AND 38). SN 85-117,912. PUB. 2-15-2011. FILED 8-27-2010.
- 3,954,444. **SKATEWOMAN (STANDARD CHARACTER)**. JENNIFER GOLDSTEIN, (U.S. CLS. 21, 23, 26, 36 AND 38). SN 85-118,426. PUB. 2-15-2011. FILED 8-30-2010.
- 3,954,449. **STREET & STEEL (STYLIZED)**. CYCLE GEAR, INC., MULTIPLE CLASS, (INT. CLS. 9 AND 25), (U.S. CLS. 21, 22, 23, 26, 36, 38 AND 39). SN 85-118,474. PUB. 2-15-2011. FILED 8-30-2010.
- 3,954,468. **I (STYLIZED)**. IRONCLAD PERFORMANCE WEAR CORP., (U.S. CLS. 21, 23, 26, 36 AND 38). SN 85-118,617. PUB. 2-15-2011. FILED 8-30-2010.
- 3,954,471. **HOTSAUCE ON WHAAAT?!...EVERYTHAAANG!!! (STANDARD CHARACTER)**. GLOVER, BRANDON M., (U.S. CLS. 21, 23, 26, 36 AND 38). SN 85-118,634. PUB. 2-15-2011. FILED 8-30-2010.
- 3,954,476. **DOCK-IN-CASE (STANDARD CHARACTER)**. SA, SHUANG, (U.S. CLS. 21, 23, 26, 36 AND 38). SN 85-118,683. PUB. 2-15-2011. FILED 8-30-2010.
- 3,954,480. **UNIFIED POWER SOLUTION (STANDARD CHARACTER)**. SA, SHUANG, (U.S. CLS. 21, 23, 26, 36 AND 38). SN 85-118,702. PUB. 2-15-2011. FILED 8-30-2010.
- 3,954,491. **FLOCAT (STANDARD CHARACTER)**. TOTAL TEMPERATURE INSTRUMENTATION, INC., DBA INSTRUMART, (U.S. CLS. 21, 23, 26, 36 AND 38). SN 85-118,807. PUB. 2-15-2011. FILED 8-30-2010.
- 3,954,509. **WISELITE (STANDARD CHARACTER)**. BARBER, JACK A., (U.S. CLS. 21, 23, 26, 36 AND 38). SN 85-118,962. PUB. 2-15-2011. FILED 8-30-2010.
- 3,954,519. **ZOOM CMS AND DESIGN**. ZOOM WEB SOFTWARE LLC, (U.S. CLS. 21, 23, 26, 36 AND 38). SN 85-119,128. PUB. 2-15-2011. FILED 8-30-2010.
- 3,954,525. **ALLOY (STANDARD CHARACTER)**. IZOTOPE INC., (U.S. CLS. 21, 23, 26, 36 AND 38). SN 85-119,156. PUB. 2-15-2011. FILED 8-30-2010.
- 3,954,534. **WE TRAIN THE BRAIN (STANDARD CHARACTER)**. BRAIN POWER DIRECT, INC., (U.S. CLS. 21, 23, 26, 36 AND 38). SN 85-119,232. PUB. 2-15-2011. FILED 8-30-2010.
- 3,954,537. **HYDRO II (STANDARD CHARACTER)**. NICHOLS, JIM QUENTIN, (U.S. CLS. 21, 23, 26, 36 AND 38). SN 85-119,286. PUB. 2-15-2011. FILED 8-30-2010.
- 3,954,545. **HAT GRABBER (STANDARD CHARACTER)**. RENAISSANCE CONCRETE WORKS INC, (U.S. CLS. 21, 23, 26, 36 AND 38). SN 85-119,346. PUB. 2-15-2011. FILED 8-31-2010.
- 3,954,554. **SOFTTILT (STANDARD CHARACTER)**. REVERB NETWORKS, INC., (U.S. CLS. 21, 23, 26, 36 AND 38). SN 85-119,483. PUB. 2-15-2011. FILED 8-31-2010.
- 3,954,562. **TELOGIS (STANDARD CHARACTER)**. TELOGIS, INC., (U.S. CLS. 21, 23, 26, 36 AND 38). SN 85-119,608. PUB. 2-15-2011. FILED 8-31-2010.
- 3,954,569. **MISCELLANEOUS DESIGN**. TELOGIS, INC., MULTIPLE CLASS, (INT. CLS. 9 AND 42), (U.S. CLS. 21, 23, 26, 36, 38, 100 AND 101). SN 85-119,678. PUB. 2-15-2011. FILED 8-31-2010.

- 3,954,571. **HIGHTECHESSENTIALS (STANDARD CHARACTER)**. BLUE CENTER, INC., (U.S. CLS. 21, 23, 26, 36 AND 38). SN 85-119,681. PUB. 2-15-2011. FILED 8-31-2010.
- 3,954,607. **OH CROP! (STANDARD CHARACTER)**. PHOENIX APPS, (U.S. CLS. 21, 23, 26, 36 AND 38). SN 85-120,118. PUB. 2-15-2011. FILED 8-31-2010.
- 3,954,621. **FIELDRECON (STANDARD CHARACTER)**. AGRE-NAISSANCE SOFTWARE LLC, (U.S. CLS. 21, 23, 26, 36 AND 38). SN 85-120,268. PUB. 2-15-2011. FILED 8-31-2010.
- 3,954,625. **FOWL BOYS AND DESIGN**. FOWL BOYS, MULTIPLE CLASS, (INT. CLS. 9 AND 25), (U.S. CLS. 21, 22, 23, 26, 36, 38 AND 39). SN 85-120,283. PUB. 2-15-2011. FILED 8-31-2010.
- 3,954,631. **IDA (STANDARD CHARACTER)**. INTERNATIONAL DESALINATION ASSOCIATION, (U.S. CLS. 21, 23, 26, 36 AND 38). SN 85-120,368. PUB. 2-15-2011. FILED 8-31-2010.
- 3,954,635. **AEROGO (STYLIZED)**. LUCKY BELL PLASTIC FACTORY LIMITED, (U.S. CLS. 21, 23, 26, 36 AND 38). SN 85-120,423. PUB. 2-15-2011. FILED 9-1-2010.
- 3,954,644. **POGO (STANDARD CHARACTER)**. ALPAQUA ENGINEERING, LLC, (U.S. CLS. 21, 23, 26, 36 AND 38). SN 85-120,528. PUB. 2-15-2011. FILED 9-1-2010.
- 3,954,657. **AAVID THERMALLOY AND DESIGN**. AAVID THERMALLOY, LLC, (U.S. CLS. 21, 23, 26, 36 AND 38). SN 85-120,664. PUB. 2-15-2011. FILED 9-1-2010.
- 3,954,659. **SOUL WATER (STANDARD CHARACTER)**. SOUL WATER MUSIC, LLC, (U.S. CLS. 21, 23, 26, 36 AND 38). SN 85-120,683. PUB. 2-15-2011. FILED 9-1-2010.
- 3,954,675. **MED X MOBILE (STANDARD CHARACTER)**. MED X CHANGE, INC., (U.S. CLS. 21, 23, 26, 36 AND 38). SN 85-120,780. PUB. 2-15-2011. FILED 9-1-2010.
- 3,954,711. **SEED (STANDARD CHARACTER)**. CANTALOUPE SYSTEMS, INC., MULTIPLE CLASS, (INT. CLS. 9 AND 35), (U.S. CLS. 21, 23, 26, 36, 38, 100, 101 AND 102). SN 85-121,089. PUB. 2-15-2011. FILED 9-1-2010.
- 3,954,723. **TRUE-SPEAK (STANDARD CHARACTER)**. MCGRATH, MARY JO, MULTIPLE CLASS, (INT. CLS. 9, 16 AND 41), (U.S. CLS. 2, 5, 21, 22, 23, 26, 29, 36, 37, 38, 50, 100, 101 AND 107). SN 85-121,291. PUB. 2-15-2011. FILED 9-1-2010.
- 3,954,726. **TOASTER (STANDARD CHARACTER)**. RICKENBACKER INTERNATIONAL CORPORATION, (U.S. CLS. 21, 23, 26, 36 AND 38). SN 85-121,359. PUB. 2-15-2011. FILED 9-1-2010.
- 3,954,729. **GENTOUCH (STANDARD CHARACTER)**. AUGEN ELECTRONICS CORP., (U.S. CLS. 21, 23, 26, 36 AND 38). SN 85-121,430. PUB. 2-15-2011. FILED 9-2-2010.
- 3,954,734. **SIM-2GO (STANDARD CHARACTER)**. STARGATE MOBILE, INC., MULTIPLE CLASS, (INT. CLS. 9 AND 38), (U.S. CLS. 21, 23, 26, 36, 38, 100, 101 AND 104). SN 85-121,499. PUB. 2-15-2011. FILED 9-2-2010.
- 3,954,776. **GRIDARM (STANDARD CHARACTER)**. GRID CONNECT INC, (U.S. CLS. 21, 23, 26, 36 AND 38). SN 85-121,925. PUB. 2-15-2011. FILED 9-2-2010.
- 3,954,781. **COLOR MAX (STANDARD CHARACTER)**. JOHN M PATTERSON, (U.S. CLS. 21, 23, 26, 36 AND 38). SN 85-121,989. PUB. 2-15-2011. FILED 9-2-2010.
- 3,954,796. **MISCELLANEOUS DESIGN**. POSTUP, INC., (U.S. CLS. 21, 23, 26, 36 AND 38). SN 85-122,165. PUB. 2-15-2011. FILED 9-2-2010.
- 3,954,797. **TWIDROYD (STANDARD CHARACTER)**. POSTUP, INC., (U.S. CLS. 21, 23, 26, 36 AND 38). SN 85-122,172. PUB. 2-15-2011. FILED 9-2-2010.
- 3,954,799. **BRIDGELINE DIGITAL (STANDARD CHARACTER)**. BRIDGELINE DIGITAL, INC., (U.S. CLS. 21, 23, 26, 36 AND 38). SN 85-122,193. PUB. 2-15-2011. FILED 9-2-2010.
- 3,954,812. **WRISTALK (STANDARD CHARACTER)**. SCHERER, PATRICK, LEONARD, (U.S. CLS. 21, 23, 26, 36 AND 38). SN 85-122,400. PUB. 2-15-2011. FILED 9-2-2010.
- 3,954,821. **ELEMENTAL MONSTER (STANDARD CHARACTER)**. HUDSON SOFT CO., LTD., (U.S. CLS. 21, 23, 26, 36 AND 38). SN 85-122,461. PUB. 2-15-2011. FILED 9-3-2010.
- 3,954,822. **IDRINKSMARTER AND DESIGN**. BACZONE, LTD., (U.S. CLS. 21, 23, 26, 36 AND 38). SN 85-122,485. PUB. 2-15-2011. FILED 9-3-2010.
- 3,954,854. **CLOUDFUZION (STANDARD CHARACTER)**. AXCELEON, INC., (U.S. CLS. 21, 23, 26, 36 AND 38). SN 85-122,889. PUB. 2-15-2011. FILED 9-3-2010.
- 3,954,864. **SMOKENDERS LEARN HOW TO QUIT KIT AND DESIGN**. PETER N. ROGERS, DBA SMOKENDERS USA, (U.S. CLS. 21, 23, 26, 36 AND 38). SN 85-122,971. PUB. 2-15-2011. FILED 9-3-2010.
- 3,954,887. **F.D.R. (STANDARD CHARACTER)**. TART OPTICAL ENTERPRISES LLC, (U.S. CLS. 21, 23, 26, 36 AND 38). SN 85-123,314. PUB. 2-15-2011. FILED 9-3-2010.
- 3,954,894. **JEFIT (STANDARD CHARACTER)**. JEFIT INC., (U.S. CLS. 21, 23, 26, 36 AND 38). SN 85-123,413. PUB. 2-15-2011. FILED 9-5-2010.
- 3,954,902. **BALANCD (STANDARD CHARACTER)**. PORTER, BRENDAN ANDREW, DBA BALANCD.COM, (U.S. CLS. 21, 23, 26, 36 AND 38). SN 85-123,666. PUB. 2-15-2011. FILED 9-7-2010.
- 3,954,903. **MISCELLANEOUS DESIGN**. LEXIA LEARNING SYSTEMS, INC., (U.S. CLS. 21, 23, 26, 36 AND 38). SN 85-123,716. PUB. 2-15-2011. FILED 9-7-2010.
- 3,954,907. **PERSON TO PERSON (STANDARD CHARACTER)**. CPL SYSTEMS LIMITED, (U.S. CLS. 21, 23, 26, 36 AND 38). SN 85-123,743. PUB. 2-15-2011. FILED 9-7-2010.
- 3,954,915. **VONAGE SUENA MUY BIEN (STANDARD CHARACTER)**. VONAGE MARKETING LLC, MULTIPLE CLASS, (INT. CLS. 9 AND 38), (U.S. CLS. 21, 23, 26, 36, 38, 100, 101 AND 104). SN 85-123,941. PUB. 2-15-2011. FILED 9-7-2010.
- 3,954,922. **THUMB LITE AND DESIGN**. LARSEN, JERAMIAH, DBA THUMB LITE, (U.S. CLS. 21, 23, 26, 36 AND 38). SN 85-124,124. PUB. 2-15-2011. FILED 9-7-2010.
- 3,954,930. **STATYS (STANDARD CHARACTER)**. BIOMEDICAL DEVICE CONSULTANTS & LABORATORIES OF COLORADO, LLC, DBA BIOMEDICAL DEVICE CONSULTANTS & LABORATORIES, (U.S. CLS. 21, 23, 26, 36 AND 38). SN 85-124,281. PUB. 2-15-2011. FILED 9-7-2010.
- 3,954,936. **E AND DESIGN**. MICROSOFT CORPORATION, (U.S. CLS. 21, 23, 26, 36 AND 38). SN 85-124,465. PUB. 2-15-2011. FILED 9-7-2010.
- 3,954,938. **FIELDGENIUS (STANDARD CHARACTER)**. MICROSURVEY SOFTWARE INC., (U.S. CLS. 21, 23, 26, 36 AND 38). SN 85-124,512. PUB. 2-15-2011. FILED 9-7-2010.
- 3,954,951. **VISIONMASTER (STANDARD CHARACTER)**. KIRMANI, SHAHZAD FAROOQ, DBA DELTA INDUS SYSTEMS, (U.S. CLS. 21, 23, 26, 36 AND 38). SN 85-125,507. PUB. 2-15-2011. FILED 9-8-2010.
- 3,954,956. **CAV (STANDARD CHARACTER)**. CANNON INSTRUMENT COMPANY, (U.S. CLS. 21, 23, 26, 36 AND 38). SN 85-126,088. PUB. 2-15-2011. FILED 9-9-2010.
- 3,954,962. **PROTECTION IN ACTION CAMERA ARMOR AND DESIGN**. DAYMEN CANADA ACQUISITION ULC, (U.S. CLS. 21, 23, 26, 36 AND 38). SN 85-126,460. PUB. 2-15-2011. FILED 9-9-2010.
- 3,954,977. **901 ENTERTAINMENT, INC. AND DESIGN**. REGINALD GENE CHERRY, (U.S. CLS. 21, 23, 26, 36 AND 38). SN 85-128,461. PUB. 2-15-2011. FILED 9-13-2010.
- 3,954,991. **MISCELLANEOUS DESIGN**. I GROUP, LLC, (U.S. CLS. 21, 23, 26, 36 AND 38). SN 85-130,645. PUB. 2-15-2011. FILED 9-15-2010.
- 3,954,992. **MISCELLANEOUS DESIGN**. I GROUP, LLC, (U.S. CLS. 21, 23, 26, 36 AND 38). SN 85-130,658. PUB. 2-15-2011. FILED 9-15-2010.
- 3,954,996. **HALO REACH (STANDARD CHARACTER)**. MICROSOFT CORPORATION, (U.S. CLS. 21, 23, 26, 36 AND 38). SN 85-131,499. PUB. 2-15-2011. FILED 9-16-2010.
- 3,954,997. **PE (STYLIZED)**. PEI LICENSING, INC., (U.S. CLS. 21, 23, 26, 36 AND 38). SN 85-132,245. PUB. 2-15-2011. FILED 9-17-2010.
- 3,955,007. **TT T VISION AND DESIGN**. TIME PLAZA, (U.S. CLS. 21, 23, 26, 36 AND 38). SN 85-132,877. PUB. 2-15-2011. FILED 9-18-2010.
- 3,955,018. **XLR8 YOUR WORLD. (STANDARD CHARACTER)**. PNY TECHNOLOGIES, INC., (U.S. CLS. 21, 23, 26, 36 AND 38). SN 85-136,179. PUB. 2-15-2011. FILED 9-23-2010.
- 3,955,022. **ULTIMATE FAN (STANDARD CHARACTER)**. NEW YORK JETS LLC, MULTIPLE CLASS, (INT. CLS. 9 AND 41), (U.S. CLS. 21, 23, 26, 36, 38, 100, 101 AND 107). SN 85-136,612. PUB. 2-15-2011. FILED 9-23-2010.
- 3,955,033. **SYMMETRIX (STANDARD CHARACTER)**. EMC CORPORATION, (U.S. CLS. 21, 23, 26, 36 AND 38). SN 85-

- 137,589. PUB. 2-15-2011. FILED 9-24-2010.  
 3,955,045. **BI-SCOPE (STANDARD CHARACTER)**. PAN, LING-LING, (U.S. CLS. 21, 23, 26, 36 AND 38). SN 85-139,467. PUB. 2-15-2011. FILED 9-28-2010.  
 3,955,046. **VARYJACK (STANDARD CHARACTER)**. PAN, LING-LING, (U.S. CLS. 21, 23, 26, 36 AND 38). SN 85-139,472. PUB. 2-15-2011. FILED 9-28-2010.  
 3,955,057. **SANATOMY (STANDARD CHARACTER)**. SANPULSE TECHNOLOGIES INC., (U.S. CLS. 21, 23, 26, 36 AND 38). SN 85-141,332. PUB. 2-15-2011. FILED 9-29-2010.  
 3,955,061. **LIFEWORLD MEDIA MINISTRIES AND DESIGN**. LIFEWORLD BROADCAST MINISTRIES, INC., MULTIPLE CLASS, (INT. CLS. 9, 16, 38, 41 AND 45), (U.S. CLS. 2, 5, 21, 22, 23, 26, 29, 36, 37, 38, 50, 100, 101, 104 AND 107). SN 85-143,378. PUB. 2-15-2011. FILED 10-1-2010.  
 3,955,063. **LIFEWORLD (STANDARD CHARACTER)**. LIFEWORLD BROADCAST MINISTRIES, INC., MULTIPLE CLASS, (INT. CLS. 9, 16, 38, 41 AND 45), (U.S. CLS. 2, 5, 21, 22, 23, 26, 29, 36, 37, 38, 50, 100, 101, 104 AND 107). SN 85-143,430. PUB. 2-15-2011. FILED 10-1-2010.  
 3,955,067. **FA FA FA FORTUNE KING (STANDARD CHARACTER)**. ARISTOCRAT TECHNOLOGIES AUSTRALIA PTY LTD., (U.S. CLS. 21, 23, 26, 36 AND 38). SN 85-144,191. PUB. 2-15-2011. FILED 10-4-2010.  
 3,955,106. **NOTAFIT (STANDARD CHARACTER)**. GIESECKE & DEVRIENT GMBH, (U.S. CLS. 21, 23, 26, 36 AND 38). SN 85-161,233. PUB. 2-15-2011. FILED 10-26-2010.  
 3,955,117. **YBY (STANDARD CHARACTER)**. MILITTI SALES & PROMOTIONS, (U.S. CLS. 21, 23, 26, 36 AND 38). SN 85-167,225. PUB. 2-15-2011. FILED 11-2-2010.  
 3,955,122. **SALSA FREAK (STANDARD CHARACTER)**. SCHARFF, EDITH, (U.S. CLS. 21, 23, 26, 36 AND 38). SN 85-169,409. PUB. 2-15-2011. FILED 11-4-2010.

---

#### CLASS 10—MEDICAL APPARATUS

- 3,953,000 ( *See Class 3 for this trademark* ).  
 3,953,009 ( *See Class 7 for this trademark* ).  
 3,953,197. **RTI BIOLOGICS (STANDARD CHARACTER)**. RTI BIOLOGICS, INC., (U.S. CLS. 26, 39 AND 44). SN 77-864,004. PUB. 11-9-2010. FILED 11-3-2009.  
 3,953,269. **TWIN GRASPER (STANDARD CHARACTER)**. OVESCO ENDOSCOPY AG, (U.S. CLS. 26, 39 AND 44). SN 77-934,934. PUB. 2-15-2011. FILED 2-12-2010.  
 3,953,273. **X - GUIDE (STYLIZED)**. SUNMEDICA, INC., (U.S. CLS. 26, 39 AND 44). SN 77-936,489. PUB. 2-15-2011. FILED 2-16-2010.  
 3,953,292. **POCH (STANDARD CHARACTER)**. SYSMEX CORPORATION, (U.S. CLS. 26, 39 AND 44). SN 77-941,263. PUB. 2-15-2011. FILED 2-22-2010.  
 3,953,422. **SURESTEPPRO (STANDARD CHARACTER)**. JOHNSON & JOHNSON, (U.S. CLS. 26, 39 AND 44). SN 77-960,810. PUB. 2-15-2011. FILED 3-17-2010.  
 3,953,506 ( *See Class 9 for this trademark* ).  
 3,953,509 ( *See Class 5 for this trademark* ).  
 3,953,519. **FIBROSPRAY (STANDARD CHARACTER)**. PROFIBRIX B.V., (U.S. CLS. 26, 39 AND 44). SN 79-075,475. PUB. 2-15-2011. FILED 10-15-2009.  
 3,953,555 ( *See Class 6 for this trademark* ).  
 3,953,584. **NUK AIR SYSTEM AND DESIGN**. MAPA GMBH GUMMI- UND PLASTIKWERKE, (U.S. CLS. 26, 39 AND 44). SN 79-082,078. PUB. 2-15-2011. FILED 3-9-2010.  
 3,953,596. **AESTHETICA AND DESIGN**. EUROTEKNIKA, (U.S. CLS. 26, 39 AND 44). SN 79-082,552. PUB. 2-15-2011. FILED 4-20-2010.  
 3,953,597. **NATEA AND DESIGN**. EUROTEKNIKA, (U.S. CLS. 26, 39 AND 44). SN 79-082,574. PUB. 2-15-2011. FILED 4-20-2010.  
 3,953,598. **OBI AND DESIGN**. EUROTEKNIKA, (U.S. CLS. 26, 39 AND 44). SN 79-082,575. PUB. 2-15-2011. FILED 4-20-2010.  
 3,953,599 ( *See Class 5 for this trademark* ).  
 3,953,600. **UNEVA AND DESIGN**. EUROTEKNIKA, (U.S. CLS. 26, 39 AND 44). SN 79-082,662. PUB. 2-15-2011. FILED 4-20-2010.  
 3,953,648. **VARIMED (STYLIZED)**. VARIMED MEDIKAL SANAYI VE TICARET LIMITED SIRKETI, (U.S. CLS. 26, 39 AND 44). SN 79-087,321. PUB. 2-15-2011. FILED 6-3-2010.  
 3,953,649 ( *See Class 5 for this trademark* ).  
 3,953,664. **NEURODUO (STANDARD CHARACTER)**. RAUMEDIC AG, (U.S. CLS. 26, 39 AND 44). SN 79-087,952. PUB. 2-15-2011. FILED 9-1-2010.  
 3,953,665. **REKTOBAR (STANDARD CHARACTER)**. RAUMEDIC AG, (U.S. CLS. 26, 39 AND 44). SN 79-087,953. PUB. 2-15-2011. FILED 9-1-2010.  
 3,953,669 ( *See Class 5 for this trademark* ).  
 3,953,679. **MULTIPLE-X (STANDARD CHARACTER)**. SIEMENS AKTIENGESELLSCHAFT, (U.S. CLS. 26, 39 AND 44). SN 79-089,881. PUB. 2-15-2011. FILED 10-6-2010.  
 3,953,694 ( *See Class 3 for this trademark* ).  
 3,953,747 ( *See Class 9 for this trademark* ).  
 3,953,866. **JELLY TOOL BELT (STANDARD CHARACTER)**. PURE ROMANCE, INC., (U.S. CLS. 26, 39 AND 44). SN 85-059,465. PUB. 2-15-2011. FILED 6-10-2010.  
 3,953,966. **AGIL (STANDARD CHARACTER)**. OTICON A/S, (U.S. CLS. 26, 39 AND 44). SN 85-089,263. PUB. 2-15-2011. FILED 7-21-2010.  
 3,954,005. **OTICON CHILI (STANDARD CHARACTER)**. OTICON A/S, (U.S. CLS. 26, 39 AND 44). SN 85-097,852. PUB. 2-15-2011. FILED 8-2-2010.  
 3,954,074. **COMFORTEAR (STANDARD CHARACTER)**. DELTA LIFE SCIENCE, INC., (U.S. CLS. 26, 39 AND 44). SN 85-107,088. PUB. 2-15-2011. FILED 8-13-2010.  
 3,954,147. **APNEX MEDICAL (STANDARD CHARACTER)**. APNEX MEDICAL, INC., (U.S. CLS. 26, 39 AND 44). SN 85-111,739. PUB. 2-15-2011. FILED 8-19-2010.  
 3,954,269. **QS QUICK SLEEVE (STYLIZED)**. BENCO ENTERPRISES LLC, (U.S. CLS. 26, 39 AND 44). SN 85-115,654. PUB. 2-15-2011. FILED 8-25-2010.  
 3,954,394. **LIPTOR (STANDARD CHARACTER)**. SUPRAMEDICAL, LLC, (U.S. CLS. 26, 39 AND 44). SN 85-117,743. PUB. 2-15-2011. FILED 8-27-2010.  
 3,954,398. **ADVANTO (STANDARD CHARACTER)**. SUPRAMEDICAL, LLC, (U.S. CLS. 26, 39 AND 44). SN 85-117,786. PUB. 2-15-2011. FILED 8-27-2010.  
 3,954,504. **C-STEM (STANDARD CHARACTER)**. DEPUY, INC., (U.S. CLS. 26, 39 AND 44). SN 85-118,916. PUB. 2-15-2011. FILED 8-30-2010.  
 3,954,611. **NEURO-TRACE (STANDARD CHARACTER)**. NEO MEDICAL INC, (U.S. CLS. 26, 39 AND 44). SN 85-120,152. PUB. 2-15-2011. FILED 8-31-2010.  
 3,954,724. **ACUTEK (STANDARD CHARACTER)**. UPC MEDICAL SUPPLIES, INC, DBA UNITED PACIFIC COMPANY, (U.S. CLS. 26, 39 AND 44). SN 85-121,294. PUB. 2-15-2011. FILED 9-1-2010.  
 3,954,808. **SMARTGRIP (STANDARD CHARACTER)**. ASCEND EAGLE INC., (U.S. CLS. 26, 39 AND 44). SN 85-122,333. PUB. 2-15-2011. FILED 9-2-2010.  
 3,954,820 ( *See Class 5 for this trademark* ).  
 3,954,844. **CRYOSPHERE (STANDARD CHARACTER)**. CRYOSPHERE TECHNOLOGIES, LLC, (U.S. CLS. 26, 39 AND 44). SN 85-122,758. PUB. 2-15-2011. FILED 9-3-2010.  
 3,954,871. **OSTO-EZ-VENT (STANDARD CHARACTER)**. KEM ENTERPRISES, INC., (U.S. CLS. 26, 39 AND 44). SN 85-123,054. PUB. 2-15-2011. FILED 9-3-2010.  
 3,954,880. **BLACK GOLD (STANDARD CHARACTER)**. GOLDEN PROTECTIVE SERVICES, (U.S. CLS. 26, 39 AND 44). SN 85-123,228. PUB. 2-15-2011. FILED 9-3-2010.  
 3,954,883. **BLACK DIESEL (STANDARD CHARACTER)**. GOLDEN PROTECTIVE SERVICES, (U.S. CLS. 26, 39 AND 44). SN 85-123,284. PUB. 2-15-2011. FILED 9-3-2010.  
 3,954,994. **NANOKNIFE (STANDARD CHARACTER)**. ANGIODYNAMICS, INC., (U.S. CLS. 26, 39 AND 44). SN 85-130,851. PUB. 2-15-2011. FILED 9-16-2010.  
 3,955,011. **VEROSTAR TK (STANDARD CHARACTER)**. TEMCARE MEDICAL DESIGN AND MANUFACTURING, INC., (U.S. CLS. 26, 39 AND 44). SN 85-133,447. PUB. 2-15-2011. FILED 9-20-2010.  
 3,955,053. **FREEZIE WRAP AND DESIGN**. IN.GENU DESIGN GROUP INC., DBA MENDMESHOP, (U.S. CLS. 26, 39 AND 44). SN 85-140,018. PUB. 2-15-2011. FILED 9-28-2010.



**CLASS 11—ENVIRONMENTAL CONTROL APPARATUS**

3,953,009 ( *See Class 7 for this trademark.*)  
 3,953,049 ( *See Class 6 for this trademark.*)  
 3,953,074. **GREEN CONTRACTING COMPANY (STANDARD CHARACTER)**. GREEN CONTRACTING COMPANY, INC., MULTIPLE CLASS, (INT. CLS. 11, 37, 40, 41 AND 42), (U.S. CLS. 13, 21, 23, 31, 34, 100, 101, 103, 106 AND 107). SN 77-747,631. PUB. 2-15-2011. FILED 5-29-2009.  
 3,953,083 ( *See Class 1 for this trademark.*)  
 3,953,106. **THE NO-PAIN DRAIN (STANDARD CHARACTER)**. PF WATERWORKS LP, (U.S. CLS. 13, 21, 23, 31 AND 34). SN 77-798,152. PUB. 2-15-2011. FILED 8-5-2009.  
 3,953,136 ( *See Class 7 for this trademark.*)  
 3,953,137. **PRECISIONTEMP (STANDARD CHARACTER)**. LG ELECTRONICS INC., (U.S. CLS. 13, 21, 23, 31 AND 34). SN 77-817,693. PUB. 2-15-2011. FILED 9-1-2009.  
 3,953,139. **PRECISETEMP (STANDARD CHARACTER)**. LG ELECTRONICS INC., (U.S. CLS. 13, 21, 23, 31 AND 34). SN 77-817,754. PUB. 2-15-2011. FILED 9-1-2009.  
 3,953,152. **DIOS AUGERLESS ICE BIN (STANDARD CHARACTER)**. LG ELECTRONICS INC., (U.S. CLS. 13, 21, 23, 31 AND 34). SN 77-827,606. PUB. 2-15-2011. FILED 9-16-2009.  
 3,953,157. **HEATCO AND DESIGN**. HEATCO, INC., MULTIPLE CLASS, (INT. CLS. 11 AND 40), (U.S. CLS. 13, 21, 23, 31, 34, 100, 103 AND 106). SN 77-834,380. PUB. 2-15-2011. FILED 9-24-2009.  
 3,953,172. **DIFFRIENT (STANDARD CHARACTER)**. DIFFRIENT, NIELS, (U.S. CLS. 13, 21, 23, 31 AND 34). SN 77-846,469. PUB. 2-15-2011. FILED 10-12-2009.  
 3,953,324. **COOL SHOT (STANDARD CHARACTER)**. AERO MIST, INC., (U.S. CLS. 13, 21, 23, 31 AND 34). SN 77-947,616. PUB. 2-15-2011. FILED 3-1-2010.  
 3,953,329. **WILDCAT (STANDARD CHARACTER)**. NOVATAC, INC., (U.S. CLS. 13, 21, 23, 31 AND 34). SN 77-948,797. PUB. 2-15-2011. FILED 3-2-2010.  
 3,953,339 ( *See Class 9 for this trademark.*)  
 3,953,394 ( *See Class 1 for this trademark.*)  
 3,953,431. **ELECTRIC MIRROR (STANDARD CHARACTER)**. ELECTRIC MIRROR, LLC, (U.S. CLS. 13, 21, 23, 31 AND 34). SN 77-961,686. PUB. 2-15-2011. FILED 3-17-2010.  
 3,953,449 ( *See Class 6 for this trademark.*)  
 3,953,450 ( *See Class 6 for this trademark.*)  
 3,953,492 ( *See Class 8 for this trademark.*)  
 3,953,497 ( *See Class 6 for this trademark.*)  
 3,953,504 ( *See Class 9 for this trademark.*)  
 3,953,522 ( *See Class 7 for this trademark.*)  
 3,953,554 ( *See Class 6 for this trademark.*)  
 3,953,556. **1000ESPRESSOS AND DESIGN**. 1000ESPRESSOS, S.L.U., MULTIPLE CLASS, (INT. CLS. 11, 30 AND 35), (U.S. CLS. 13, 21, 23, 31, 34, 46, 100, 101 AND 102). SN 79-081,132. PUB. 2-15-2011. FILED 2-25-2010.  
 3,953,561. **@X AXIS (STYLIZED)**. KORDON TIP SAGLIK ARAC VE GERECLERI MUHENDISLIK PROJE ITHALAT SANAYI VE TICARET LIMITED SIRKETI, (U.S. CLS. 13, 21, 23, 31 AND 34). SN 79-081,191. PUB. 2-15-2011. FILED 2-15-2010.  
 3,953,564. **COMPAKBLUE (STANDARD CHARACTER)**. DEGREMONT, MULTIPLE CLASS, (INT. CLS. 11 AND 40), (U.S. CLS. 13, 21, 23, 31, 34, 100, 103 AND 106). SN 79-081,387. PUB. 2-15-2011. FILED 12-15-2009.  
 3,953,572 ( *See Class 9 for this trademark.*)  
 3,953,582 ( *See Class 6 for this trademark.*)  
 3,953,592. **PROBATONE (STANDARD CHARACTER)**. PROBATWERKE VON GIMBORN; MASCHINENFABRIK GMBH, MULTIPLE CLASS, (INT. CLS. 11, 37 AND 42), (U.S. CLS. 13, 21, 23, 31, 34, 100, 101, 103 AND 106). SN 79-082,429. PUB. 2-15-2011. FILED 12-1-2009.  
 3,953,623. **KRION AND DESIGN**. SYSTEM-POOL, S.A., MULTIPLE CLASS, (INT. CLS. 11 AND 19), (U.S. CLS. 1, 12, 13, 21, 23, 31, 33, 34 AND 50). SN 79-084,684. PUB. 2-15-2011. FILED 6-15-2010.  
 3,953,628 ( *See Class 7 for this trademark.*)  
 3,953,642. **ONOSI AND DESIGN**. HAINING OUPAI RINENG SOLAR WATER HEATER CO., LTD, (U.S. CLS. 13, 21, 23, 31 AND 34). SN 79-087,125. PUB. 2-15-2011. FILED 7-20-2010.  
 3,953,689. **VOLCANIC (STANDARD CHARACTER)**. FULTON MANAGEMENT SERVICES, INC., MULTIPLE CLASS,

(INT. CLS. 11 AND 37), (U.S. CLS. 13, 21, 23, 31, 34, 100, 103 AND 106). SN 85-001,625. PUB. 2-15-2011. FILED 3-30-2010.

3,953,746 ( *See Class 9 for this trademark.*)  
 3,953,892. **FX-AA EFFECTS/AUTOMOTIVE ACCESSORIES AND DESIGN**. DUNNO INTERNATIONAL, INC., (U.S. CLS. 13, 21, 23, 31 AND 34). SN 85-068,716. PUB. 2-15-2011. FILED 6-22-2010.  
 3,954,006. **ATR AND DESIGN**. ATR LIGHTING ENTERPRISES, INC., (U.S. CLS. 13, 21, 23, 31 AND 34). SN 85-098,140. PUB. 2-15-2011. FILED 8-2-2010.  
 3,954,033. **MAID-O'-MIST (STANDARD CHARACTER)**. MAID-O'-MIST LLC, (U.S. CLS. 13, 21, 23, 31 AND 34). SN 85-102,806. PUB. 2-15-2011. FILED 8-9-2010.  
 3,954,056. **JACOBUS (STANDARD CHARACTER)**. MAID-O'-MIST LLC, (U.S. CLS. 13, 21, 23, 31 AND 34). SN 85-105,724. PUB. 2-15-2011. FILED 8-12-2010.  
 3,954,096. **CHILL ZONE LLC.COM AND DESIGN**. CHILL ZONE LLC, (U.S. CLS. 13, 21, 23, 31 AND 34). SN 85-108,920. PUB. 2-15-2011. FILED 8-17-2010.  
 3,954,150. **DOG SHAMMY (STANDARD CHARACTER)**. CARELLI, LLC, (U.S. CLS. 13, 21, 23, 31 AND 34). SN 85-111,805. PUB. 2-15-2011. FILED 8-19-2010.  
 3,954,189. **E E (STYLIZED)**. Y.S. HARDWARE CO., LTD., (U.S. CLS. 13, 21, 23, 31 AND 34). SN 85-113,774. PUB. 2-15-2011. FILED 8-23-2010.  
 3,954,331. **AIRFORCE (STANDARD CHARACTER)**. HEAT AND CONTROL, INC., (U.S. CLS. 13, 21, 23, 31 AND 34). SN 85-116,853. PUB. 2-15-2011. FILED 8-26-2010.  
 3,954,363. **P PROSELECT AND DESIGN**. FERGUSON ENTERPRISES, INC., (U.S. CLS. 13, 21, 23, 31 AND 34). SN 85-117,263. PUB. 2-15-2011. FILED 8-27-2010.  
 3,954,738. **DRYCOOLCLEAN (STANDARD CHARACTER)**. COCOON, INC., (U.S. CLS. 13, 21, 23, 31 AND 34). SN 85-121,565. PUB. 2-15-2011. FILED 9-2-2010.  
 3,954,919. **SRS (STANDARD CHARACTER)**. ZOELLER PUMP COMPANY, LLC, (U.S. CLS. 13, 21, 23, 31 AND 34). SN 85-124,020. PUB. 2-15-2011. FILED 9-7-2010.  
 3,955,034. **LA-Z-BOY (STANDARD CHARACTER)**. LA-Z-BOY INCORPORATED, (U.S. CLS. 13, 21, 23, 31 AND 34). SN 85-137,752. PUB. 2-15-2011. FILED 9-24-2010.  
 3,955,079. **SOLO (STANDARD CHARACTER)**. SUREFIRE, LLC, (U.S. CLS. 13, 21, 23, 31 AND 34). SN 85-148,428. PUB. 2-15-2011. FILED 10-8-2010.  
 3,955,127. **ECOSERIES AND DESIGN**. WATER PIK, INC., (U.S. CLS. 13, 21, 23, 31 AND 34). SN 85-170,415. PUB. 2-15-2011. FILED 11-5-2010.

**CLASS 12—VEHICLES**

3,952,954. **POLLIZENI (STANDARD CHARACTER)**. CABRERA, ENRIQUE ZEPEDA, (U.S. CLS. 19, 21, 23, 31, 35 AND 44). SN 76-663,043. PUB. 2-15-2011. FILED 7-13-2006.  
 3,953,009 ( *See Class 7 for this trademark.*)  
 3,953,027. **SMOOTH LINK (STANDARD CHARACTER)**. GROUPE PROCYCLE INC./PROCYCLE GROUP INC., DBA ROCKY MOUNTAIN BICYCLES, (U.S. CLS. 19, 21, 23, 31, 35 AND 44). SN 77-511,979. PUB. 2-15-2011. FILED 7-1-2008.  
 3,953,031. **VERITAS-G-LINER (STANDARD CHARACTER)**. VERITAS AG, MULTIPLE CLASS, (INT. CLS. 12 AND 17), (U.S. CLS. 1, 5, 12, 13, 19, 21, 23, 31, 35, 44 AND 50). SN 77-549,186. PUB. 2-15-2011. FILED 8-18-2008.  
 3,953,049 ( *See Class 6 for this trademark.*)  
 3,953,141 ( *See Class 6 for this trademark.*)  
 3,953,281 ( *See Class 9 for this trademark.*)  
 3,953,296 ( *See Class 7 for this trademark.*)  
 3,953,339 ( *See Class 9 for this trademark.*)  
 3,953,364. **JET STREAM (STANDARD CHARACTER)**. GOLD-SHIELD FIBERGLASS, INC., (U.S. CLS. 19, 21, 23, 31, 35 AND 44). SN 77-952,991. PUB. 2-15-2011. FILED 3-8-2010.  
 3,953,402. **ROYALTY ROTORS (STANDARD CHARACTER)**. ROYALTY ROTORS, INC., (U.S. CLS. 19, 21, 23, 31, 35 AND 44). SN 77-958,304. PUB. 2-15-2011. FILED 3-13-2010.  
 3,953,473. **THE CANADIAN ELECTRIC BOAT CO. AND DESIGN**. BUSCH MARINE INC., MULTIPLE CLASS,

- (INT. CLS. 12, 35, 37 AND 42), (U.S. CLS. 19, 21, 23, 31, 35, 44, 100, 101, 102, 103 AND 106). SN 78-676,616. PUB. 9-28-2010. FILED 7-22-2005.
- 3,953,497 ( *See Class 6 for this trademark*).
- 3,953,515 ( *See Class 7 for this trademark*).
- 3,953,551 ( *See Class 9 for this trademark*).
- 3,953,568 ( *See Class 7 for this trademark*).
- 3,953,569 ( *See Class 6 for this trademark*).
- 3,953,570 ( *See Class 6 for this trademark*).
- 3,953,582 ( *See Class 6 for this trademark*).
- 3,953,610 ( *See Class 7 for this trademark*).
- 3,953,618. **LAILA CLEVER LAILA FITTINGS AND DESIGN.** ZHEJIANG SANMEN VIAIR; INDUSTRY CO., LTD., MULTIPLE CLASS, (INT. CLS. 12 AND 27), (U.S. CLS. 19, 20, 21, 23, 31, 35, 37, 42, 44 AND 50). SN 79-084,204. PUB. 2-15-2011. FILED 6-1-2010.
- 3,953,651. **TIMEMACHINE (STANDARD CHARACTER).** ISH INTERNATIONAL SPORT HOLDING AG, (U.S. CLS. 19, 21, 23, 31, 35 AND 44). SN 79-087,486. PUB. 2-15-2011. FILED 9-13-2010.
- 3,953,654. **PROMACHINE (STANDARD CHARACTER).** ISH INTERNATIONAL SPORT HOLDING AG, (U.S. CLS. 19, 21, 23, 31, 35 AND 44). SN 79-087,664. PUB. 2-15-2011. FILED 9-14-2010.
- 3,953,655. **CROSSMACHINE (STANDARD CHARACTER).** ISH INTERNATIONAL SPORT HOLDING AG, (U.S. CLS. 19, 21, 23, 31, 35 AND 44). SN 79-087,665. PUB. 2-15-2011. FILED 9-14-2010.
- 3,953,666. **HAMPTON (STANDARD CHARACTER).** BAYERISCHE MOTOREN WERKE AKTIENGESELLSCHAFT, (U.S. CLS. 19, 21, 23, 31, 35 AND 44). SN 79-088,092. PUB. 2-15-2011. FILED 9-8-2010.
- 3,953,673. **GC (STANDARD CHARACTER).** BAYERISCHE MOTOREN WERKE AKTIENGESELLSCHAFT, MULTIPLE CLASS, (INT. CLS. 12 AND 28), (U.S. CLS. 19, 21, 22, 23, 31, 35, 38, 44 AND 50). SN 79-089,200. PUB. 2-15-2011. FILED 9-28-2010.
- 3,953,675 ( *See Class 7 for this trademark*).
- 3,953,678 ( *See Class 7 for this trademark*).
- 3,953,710. **ONIT CHASSIS (STANDARD CHARACTER).** POUNDS, BRADLEY S., DBA BRAD POUNDS RACING, (U.S. CLS. 19, 21, 23, 31, 35 AND 44). SN 85-006,704. PUB. 2-15-2011. FILED 4-5-2010.
- 3,953,947. **V VIKRANT AND DESIGN.** JK TYRE & INDUSTRIES LIMITED, (U.S. CLS. 19, 21, 23, 31, 35 AND 44). SN 85-083,575. PUB. 2-15-2011. FILED 7-13-2010.
- 3,954,000. **BABY TREND CONVENIENCE THROUGH INNOVATION AND THOUGHTFUL DESIGN AND DESIGN.** BABY TREND, INC., (U.S. CLS. 19, 21, 23, 31, 35 AND 44). SN 85-097,354. PUB. 2-15-2011. FILED 7-30-2010.
- 3,954,355. **BUBBLE BUM (STANDARD CHARACTER).** KELLY, GRAINNE, MULTIPLE CLASS, (INT. CLS. 12 AND 20), (U.S. CLS. 2, 13, 19, 21, 22, 23, 25, 31, 32, 35, 44 AND 50). SN 85-117,188. PUB. 2-15-2011. FILED 8-27-2010.
- 3,954,380. **EXPRESS STRUT (STANDARD CHARACTER).** SERAPHINI TRADING INC., (U.S. CLS. 19, 21, 23, 31, 35 AND 44). SN 85-117,456. PUB. 2-15-2011. FILED 8-27-2010.
- 3,954,595. **BARBARI (STANDARD CHARACTER).** INTERNATIONAL INTERNET VENTURES, LLC, (U.S. CLS. 19, 21, 23, 31, 35 AND 44). SN 85-119,975. PUB. 2-15-2011. FILED 8-31-2010.
- 3,954,703. **P2-XL (STANDARD CHARACTER).** FREIGHTLINER SPECIALTY VEHICLES, INC., (U.S. CLS. 19, 21, 23, 31, 35 AND 44). SN 85-120,983. PUB. 2-15-2011. FILED 9-1-2010.
- 3,954,708. **PURSANG AND DESIGN.** GUBERT CERT, ROGER, AND ROGER, JAUME PALAU-RIBES, MULTIPLE CLASS, (INT. CLS. 12 AND 25), (U.S. CLS. 19, 21, 22, 23, 31, 35, 39 AND 44). SN 85-121,037. PUB. 2-15-2011. FILED 9-1-2010.
- 3,954,978. **MA MEGA AUTOMOTIVE AND DESIGN.** SERAPHINI TRADING INC., (U.S. CLS. 19, 21, 23, 31, 35 AND 44). SN 85-128,675. PUB. 2-15-2011. FILED 9-13-2010.
- BAL BATTLEFIELD AND DESIGN.** MAKO SECURITY, INC., (U.S. CLS. 2 AND 9). SN 76-702,064. PUB. 2-15-2011. FILED 3-15-2010.
- 3,953,100. **INTEGRATED AUTOMATIC BIPOD SYSTEM (STANDARD CHARACTER).** GRIP POD SYSTEMS, LLC, (U.S. CLS. 2 AND 9). SN 77-794,125. PUB. 2-15-2011. FILED 7-31-2009.
- 3,953,206. **GOLDEN TIGER AND DESIGN.** STAR VECTOR CORPORATION, (U.S. CLS. 2 AND 9). SN 77-879,351. PUB. 10-12-2010. FILED 11-23-2009.
- 3,953,734. **STRUT (STANDARD CHARACTER).** HUNTER'S SPECIALTIES, INC., MULTIPLE CLASS, (INT. CLS. 13, 20 AND 28), (U.S. CLS. 2, 9, 13, 22, 23, 25, 32, 38 AND 50). SN 85-016,213. PUB. 2-15-2011. FILED 4-16-2010.
- 3,954,352. **GOLDENBALL (STANDARD CHARACTER).** NEWPORT DYNAMICS, INC., (U.S. CLS. 2 AND 9). SN 85-117,152. PUB. 2-15-2011. FILED 8-27-2010.
- 3,954,373. **TEAM MATCH (STANDARD CHARACTER).** KIMBER IP, LLC, (U.S. CLS. 2 AND 9). SN 85-117,392. PUB. 2-15-2011. FILED 8-27-2010.
- 3,954,382. **FLATHEAD AMMUNITION (STANDARD CHARACTER).** CENTER CONSULTING LLC, DBA FLATHEAD AMMUNITION CO., (U.S. CLS. 2 AND 9). SN 85-117,460. PUB. 2-15-2011. FILED 8-27-2010.
- 3,954,433. **TI-RANT (STANDARD CHARACTER).** ADVANCED ARMAMENT CORP., LLC, (U.S. CLS. 2 AND 9). SN 85-118,329. PUB. 2-15-2011. FILED 8-30-2010.
- 3,954,435. **BRAKEOUT (STANDARD CHARACTER).** ADVANCED ARMAMENT CORP., LLC, (U.S. CLS. 2 AND 9). SN 85-118,343. PUB. 2-15-2011. FILED 8-30-2010.
- 3,954,437. **MISCELLANEOUS DESIGN.** ADVANCED ARMAMENT CORP., LLC, (U.S. CLS. 2 AND 9). SN 85-118,355. PUB. 2-15-2011. FILED 8-30-2010.
- 3,954,438. **AAC (STYLIZED).** ADVANCED ARMAMENT CORP., LLC, (U.S. CLS. 2 AND 9). SN 85-118,377. PUB. 2-15-2011. FILED 8-30-2010.
- 3,954,508. **H1000 (STANDARD CHARACTER).** HODGDON POWDER COMPANY, INC., (U.S. CLS. 2 AND 9). SN 85-118,957. PUB. 2-15-2011. FILED 8-30-2010.
- 3,955,002. **H4198 (STANDARD CHARACTER).** HODGDON POWDER COMPANY, INC., (U.S. CLS. 2 AND 9). SN 85-132,787. PUB. 2-15-2011. FILED 9-18-2010.
- 3,955,003. **H4350 (STANDARD CHARACTER).** HODGDON POWDER COMPANY, INC., (U.S. CLS. 2 AND 9). SN 85-132,789. PUB. 2-15-2011. FILED 9-18-2010.
- 3,955,004. **7828 SSC (STANDARD CHARACTER).** HODGDON POWDER COMPANY, INC., (U.S. CLS. 2 AND 9). SN 85-132,791. PUB. 2-15-2011. FILED 9-18-2010.
- 3,955,005. **8208 XBR (STANDARD CHARACTER).** HODGDON POWDER COMPANY, INC., (U.S. CLS. 2 AND 9). SN 85-132,792. PUB. 2-15-2011. FILED 9-18-2010.
- 3,955,006. **RETUMBO (STANDARD CHARACTER).** HODGDON POWDER COMPANY, INC., (U.S. CLS. 2 AND 9). SN 85-132,793. PUB. 2-15-2011. FILED 9-18-2010.

---

#### CLASS 14—JEWELRY

- 3,952,981. **SC SALLY C (STYLIZED).** CHANARATSOPON, SIRIWONG, (U.S. CLS. 2, 27, 28 AND 50). SN 76-704,002. PUB. 2-15-2011. FILED 8-3-2010.
- 3,952,998. **PICKS FOR PEACE AND DESIGN.** MIZRAHI, MARIEL, (U.S. CLS. 2, 27, 28 AND 50). SN 76-704,393. PUB. 2-15-2011. FILED 9-7-2010.
- 3,953,000 ( *See Class 3 for this trademark*).
- 3,953,068. **AOTC CREATED DIAMONDS COLOUR. OUR PASSION. (STANDARD CHARACTER).** ADVANCED OPTICAL TECHNOLOGIES CORPORATION, (U.S. CLS. 2, 27, 28 AND 50). SN 77-737,202. PUB. 2-15-2011. FILED 5-14-2009.
- 3,953,098. **A ADD'A TOUCH THINK COLOR; THINK STYLE; THINK YOU! AND DESIGN.** ADD'A TOUCH, DBA ADD'A TOUCH, (U.S. CLS. 2, 27, 28 AND 50). SN 77-793,017. PUB. 2-15-2011. FILED 7-30-2009.
- 3,953,141 ( *See Class 6 for this trademark*).
- 3,953,149. **THREE STEPS FROM GOLD (STANDARD CHARACTER).** THREE STEPS FROM GOLD, (U.S. CLS. 2, 27, 28 AND 50). SN 77-824,902. PUB. 2-15-2011. FILED 9-11-2009.

---

#### CLASS 13—FIREARMS

- 3,952,973. **GMG A TACTICAL ADVANTAGE ON THE GLO-**

3,953,233. **CORRUPTED IN LONDON (STANDARD CHARACTER)**. BROUWER, DERK, MULTIPLE CLASS, (INT. CLS. 14, 24 AND 25), (U.S. CLS. 2, 22, 27, 28, 39, 42 AND 50). SN 77-912,356. PUB. 12-21-2010. FILED 1-14-2010.

3,953,287. **YOU & ME GIVING A HELPING HAND AND DESIGN**. GITTENS, OLIVIA, (U.S. CLS. 2, 27, 28 AND 50). SN 77-939,402. PUB. 2-15-2011. FILED 2-18-2010.

3,953,373. **SIENA SILVER (STANDARD CHARACTER)**. ELMASSIAN, DIKRAN A., DBA SIENA SILVER, AND ANTONIS DEVES, DBA SIENA SILVER, (U.S. CLS. 2, 27, 28 AND 50). SN 77-954,064. PUB. 2-15-2011. FILED 3-9-2010.

3,953,471 ( *See Class 3 for this trademark*).

3,953,485 ( *See Class 3 for this trademark*).

3,953,490 ( *See Class 9 for this trademark*).

3,953,492 ( *See Class 8 for this trademark*).

3,953,538. **JOHN C TAYLOR (STANDARD CHARACTER)**. FROMANTEEL LIMITED, (U.S. CLS. 2, 27, 28 AND 50). SN 79-078,911. PUB. 2-15-2011. FILED 1-18-2010.

3,953,567. **ASTROTOURBILLON (STANDARD CHARACTER)**. CARTIER INTERNATIONAL AG, (U.S. CLS. 2, 27, 28 AND 50). SN 79-081,468. PUB. 2-15-2011. FILED 3-2-2010.

3,953,594 ( *See Class 9 for this trademark*).

3,953,620. **FASTER AND DESIGN**. FASTER INSIDE, S.L., MULTIPLE CLASS, (INT. CLS. 14 AND 32), (U.S. CLS. 2, 27, 28, 45, 46, 48 AND 50). SN 79-084,608. PUB. 2-15-2011. FILED 5-31-2010.

3,953,670. **ACREDO (STANDARD CHARACTER)**. ACREDO GMBH, (U.S. CLS. 2, 27, 28 AND 50). SN 79-088,407. PUB. 2-15-2011. FILED 8-28-2010.

3,953,703. **IMAZINE (STANDARD CHARACTER)**. JD DISTRIBUTORS, (U.S. CLS. 2, 27, 28 AND 50). SN 85-003,801. PUB. 2-15-2011. FILED 4-1-2010.

3,953,781. **MAGNET HOUSE JEWELRY CHANGE YOUR MAGNET, CHANGE YOUR LOOK! AND DESIGN**. RICHMOND, MARIANNE, (U.S. CLS. 2, 27, 28 AND 50). SN 85-033,534. PUB. 2-15-2011. FILED 5-7-2010.

3,953,782. **FIRE STAR (STANDARD CHARACTER)**. BEN HAKMAN & COMPANY LLC, (U.S. CLS. 2, 27, 28 AND 50). SN 85-033,613. PUB. 2-15-2011. FILED 5-8-2010.

3,954,030. **SIMPLY THE BEST (STANDARD CHARACTER)**. BEST OF EVERYTHING OF SOUTHWEST FLORIDA, INC., MULTIPLE CLASS, (INT. CLS. 14 AND 35), (U.S. CLS. 2, 27, 28, 50, 100, 101 AND 102). SN 85-102,003. PUB. 2-15-2011. FILED 8-6-2010.

3,954,107. **NAUTICAL CODE (STANDARD CHARACTER)**. MICHEL "MICKY" JOHNSON, DBA NICHOLAS LANDON JEWELRY, (U.S. CLS. 2, 27, 28 AND 50). SN 85-109,754. PUB. 2-15-2011. FILED 8-17-2010.

3,954,191. **MINOR OBSESSIONS BY FINN (STYLIZED)**. FINN NEW YORK, LLC, DBA MINOR OBSESSIONS, (U.S. CLS. 2, 27, 28 AND 50). SN 85-113,883. PUB. 2-15-2011. FILED 8-23-2010.

3,954,242. **BAND 2GETHER (STANDARD CHARACTER)**. BAND2GETHER, LLC, (U.S. CLS. 2, 27, 28 AND 50). SN 85-115,020. PUB. 2-15-2011. FILED 8-24-2010.

3,954,250. **LUCKY BUCK CLUB AND DESIGN**. BEETS, ED, (U.S. CLS. 2, 27, 28 AND 50). SN 85-115,206. PUB. 2-15-2011. FILED 8-25-2010.

3,954,313. **IT'S NOT ORIGINAL UNLESS IT'S A TIMEX (STANDARD CHARACTER)**. TIMEX GROUP USA, INC., (U.S. CLS. 2, 27, 28 AND 50). SN 85-116,482. PUB. 2-15-2011. FILED 8-26-2010.

3,954,337. **MISCELLANEOUS DESIGN**. BASEBALL IRELAND DEVELOPMENT LIMITED, MULTIPLE CLASS, (INT. CLS. 14 AND 25), (U.S. CLS. 2, 22, 27, 28, 39 AND 50). SN 85-116,943. PUB. 2-15-2011. FILED 8-26-2010.

3,954,349. **THE MILLSTONE AND DESIGN**. GRAY SR., KERRY BRAD, (U.S. CLS. 2, 27, 28 AND 50). SN 85-117,127. PUB. 2-15-2011. FILED 8-27-2010.

3,954,624. **VANTANI (STANDARD CHARACTER)**. VANTANI, INC., (U.S. CLS. 2, 27, 28 AND 50). SN 85-120,276. PUB. 2-15-2011. FILED 8-31-2010.

3,954,654. **TOE-LASSO (STANDARD CHARACTER)**. RUSHMORE INVESTMENTS, INC., (U.S. CLS. 2, 27, 28 AND 50). SN 85-120,634. PUB. 2-15-2011. FILED 9-1-2010.

3,954,692. **MORESS AND DESIGN**. FEMININE JEWELRY CO., LTD, (U.S. CLS. 2, 27, 28 AND 50). SN 85-120,889. PUB. 2-15-2011. FILED 9-1-2010.

3,954,760. **CP5 (STYLIZED)**. PUBLICITAT I IMATGE AGGIE, S.L., (U.S. CLS. 2, 27, 28 AND 50). SN 85-121,800. PUB. 2-15-2011. FILED 9-2-2010.

3,954,846. **NAYARI (STANDARD CHARACTER)**. CARMEN CARTER, (U.S. CLS. 2, 27, 28 AND 50). SN 85-122,777. PUB. 2-15-2011. FILED 9-3-2010.

3,954,913. **NAKEDWATCH (STANDARD CHARACTER)**. EDWARD B. OLSZEWSKI, (U.S. CLS. 2, 27, 28 AND 50). SN 85-123,919. PUB. 2-15-2011. FILED 9-7-2010.

3,954,999. **PE (STYLIZED)**. PEI LICENSING, INC., (U.S. CLS. 2, 27, 28 AND 50). SN 85-132,277. PUB. 2-15-2011. FILED 9-17-2010.

3,955,066. **DENOVA (STANDARD CHARACTER)**. RICHLINE GROUP, INC., (U.S. CLS. 2, 27, 28 AND 50). SN 85-144,140. PUB. 2-15-2011. FILED 10-4-2010.

---

## CLASS 15—MUSICAL INSTRUMENTS

3,953,283 ( *See Class 9 for this trademark*).

3,953,638. **2LOUD (STANDARD CHARACTER)**. RT-DISTRIBUTION, PETER WOLFLAST E.K., MULTIPLE CLASS, (INT. CLS. 15, 35 AND 41), (U.S. CLS. 2, 21, 36, 100, 101, 102 AND 107). SN 79-086,305. PUB. 2-15-2011. FILED 7-21-2010.

3,954,249. **G & B (STYLIZED)**. GWINN, RAYMOND, (U.S. CLS. 2, 21 AND 36). SN 85-115,174. PUB. 2-15-2011. FILED 8-25-2010.

3,954,254. **ROLLACASTER (STYLIZED)**. GWINN, RAYMOND, (U.S. CLS. 2, 21 AND 36). SN 85-115,220. PUB. 2-15-2011. FILED 8-25-2010.

3,954,436. **PATHMAKER (STANDARD CHARACTER)**. WECHTER GUITARS, INC., DBA WECHTER GUITARS USA, (U.S. CLS. 2, 21 AND 36). SN 85-118,354. PUB. 2-15-2011. FILED 8-30-2010.

---

## CLASS 16—PAPER GOODS AND PRINTED MATTER

3,952,947. **SHEENA, QUEEN OF THE JUNGLE (STANDARD CHARACTER)**. GALAXY PUBLISHING, INC., MULTIPLE CLASS, (INT. CLS. 16, 25 AND 28), (U.S. CLS. 2, 5, 22, 23, 29, 37, 38, 39 AND 50). SN 75-890,572. PUB. 2-15-2011. FILED 1-11-2000.

3,952,949. **INTERNATIONAL STAR REGISTRY NAME A STAR AND DESIGN**. INTERNATIONAL STAR REGISTRY OF ILLINOIS, LTD., MULTIPLE CLASS, (INT. CLS. 16 AND 35), (U.S. CLS. 2, 5, 22, 23, 29, 37, 38, 50, 100, 101 AND 102). SN 76-415,083. PUB. 11-2-2004. FILED 6-6-2002.

3,953,000 ( *See Class 3 for this trademark*).

3,953,003. **SPIN DIRECT AND DESIGN**. SPIN MASTER LTD., MULTIPLE CLASS, (INT. CLS. 16, 28 AND 35), (U.S. CLS. 2, 5, 22, 23, 29, 37, 38, 50, 100, 101 AND 102). SN 77-057,382. PUB. 2-15-2011. FILED 12-5-2006.

3,953,008 ( *See Class 9 for this trademark*).

3,953,038. **HOW THE WEST WAS ONCE (STANDARD CHARACTER)**. HERITAGE PARK SOCIETY, MULTIPLE CLASS, (INT. CLS. 16, 25 AND 35), (U.S. CLS. 2, 5, 22, 23, 29, 37, 38, 39, 50, 100, 101 AND 102). SN 77-629,409. PUB. 2-15-2011. FILED 12-9-2008.

3,953,060. **FAT TO SKINNY FAST AND EASY! (STANDARD CHARACTER)**. VARRIEUR, DOUGLAS, B, (U.S. CLS. 2, 5, 22, 23, 29, 37, 38 AND 50). SN 77-711,982. PUB. 2-15-2011. FILED 4-11-2009.

3,953,133 ( *See Class 9 for this trademark*).

3,953,167. **MOO (STANDARD CHARACTER)**. CHOI, HYOUNG KYOO, (U.S. CLS. 2, 5, 22, 23, 29, 37, 38 AND 50). SN 77-844,008. PUB. 2-15-2011. FILED 10-7-2009.

3,953,191. **US RE VIEWS AND DESIGN**. U.S. RE COMPANIES, INC., (U.S. CLS. 2, 5, 22, 23, 29, 37, 38 AND 50). SN 77-858,446. PUB. 2-15-2011. FILED 10-27-2009.

3,953,224. **TWISTED TAIL PRODUCTIONS AND DESIGN**. STRADLEY, ROBERT C., (U.S. CLS. 2, 5, 22, 23, 29, 37, 38 AND 50). SN 77-903,645. PUB. 2-15-2011. FILED 12-31-2009.

3,953,231. **LOCAL FLAIR (STANDARD CHARACTER)**. LO-

- CAL FLAIR MAGAZINE LTD, MULTIPLE CLASS, (INT. CLS. 16 AND 41), (U.S. CLS. 2, 5, 22, 23, 29, 37, 38, 50, 100, 101 AND 107). SN 77-911,149. PUB. 2-15-2011. FILED 1-13-2010.
- 3,953,249. **ALTEREGOS A POEMS COMPANY (STYLIZED)**. POEMS ART PUBLISHING LLC, (U.S. CLS. 2, 5, 22, 23, 29, 37, 38 AND 50). SN 77-923,552. PUB. 2-15-2011. FILED 1-29-2010.
- 3,953,260. **MOHINI INDIAN FUSIONS AND DESIGN**. MOHINI INDIAN FUSIONS, LLC, DBA MOHINI INDIAN FUSIONS, MULTIPLE CLASS, (INT. CLS. 16 AND 30), (U.S. CLS. 2, 5, 22, 23, 29, 37, 38, 46 AND 50). SN 77-929,989. PUB. 2-15-2011. FILED 2-7-2010.
- 3,953,270. **P.A.T.R.I.O.T. TRAINING SYSTEM (STANDARD CHARACTER)**. PROTECTING THE HOMELAND INNOVATIONS, LLC, MULTIPLE CLASS, (INT. CLS. 16 AND 41), (U.S. CLS. 2, 5, 22, 23, 29, 37, 38, 50, 100, 101 AND 107). SN 77-935,169. PUB. 2-15-2011. FILED 2-12-2010.
- 3,953,271. **P.A.T.R.I.O.T. TRAINING: PROACTIVE TERRORIST RECOGNITION AND INTERDICTION OPERATIONS AND TACTICS (STANDARD CHARACTER)**. PROTECTING THE HOMELAND INNOVATIONS, LLC, MULTIPLE CLASS, (INT. CLS. 16 AND 41), (U.S. CLS. 2, 5, 22, 23, 29, 37, 38, 50, 100, 101 AND 107). SN 77-935,172. PUB. 2-15-2011. FILED 2-12-2010.
- 3,953,297. **F.Y.EYE (STANDARD CHARACTER)**. NEWVIEW LASER EYE, INC., (U.S. CLS. 2, 5, 22, 23, 29, 37, 38 AND 50). SN 77-942,177. PUB. 2-15-2011. FILED 2-23-2010.
- 3,953,306. **IP INCIDENT PREVENTION (STANDARD CHARACTER)**. INCIDENT PREVENTION, INC., MULTIPLE CLASS, (INT. CLS. 16 AND 45), (U.S. CLS. 2, 5, 22, 23, 29, 37, 38, 50, 100 AND 101). SN 77-944,353. PUB. 2-15-2011. FILED 2-24-2010.
- 3,953,312. **PAINT QUALITY INSTITUTE AND DESIGN**. ROHM AND HAAS COMPANY, MULTIPLE CLASS, (INT. CLS. 16, 37 AND 42), (U.S. CLS. 2, 5, 22, 23, 29, 37, 38, 50, 100, 101, 103 AND 106). SN 77-944,839. PUB. 2-15-2011. FILED 2-25-2010.
- 3,953,353 ( *See Class 9 for this trademark*).
- 3,953,355. **THE JUDICIAL WATCH VERDICT (STANDARD CHARACTER)**. JUDICIAL WATCH, INC., (U.S. CLS. 2, 5, 22, 23, 29, 37, 38 AND 50). SN 77-951,982. PUB. 2-15-2011. FILED 3-5-2010.
- 3,953,370. **ADVANCED STUDIES IN NURSING (STANDARD CHARACTER)**. THE HEALTHCARE MEDIA GROUP, LLC, (U.S. CLS. 2, 5, 22, 23, 29, 37, 38 AND 50). SN 77-953,684. PUB. 2-15-2011. FILED 3-8-2010.
- 3,953,443. **EFCELT (STANDARD CHARACTER)**. SIGNUM INTERNATIONAL S.A.R.L., MULTIPLE CLASS, (INT. CLS. 16, 41 AND 42), (U.S. CLS. 2, 5, 22, 23, 29, 37, 38, 50, 100, 101 AND 107). SN 77-963,089. PUB. 2-15-2011. FILED 3-19-2010.
- 3,953,476 ( *See Class 5 for this trademark*).
- 3,953,479. **CARTEL (STANDARD CHARACTER)**. CARTEL MUSIC, LLC, (U.S. CLS. 2, 5, 22, 23, 29, 37, 38 AND 50). SN 78-915,974. PUB. 2-15-2011. FILED 6-23-2006.
- 3,953,494. **FASHIONSHOPPING (STANDARD CHARACTER)**. STRAUSS FRÉDÉRIC, MULTIPLE CLASS, (INT. CLS. 16 AND 25), (U.S. CLS. 2, 5, 22, 23, 29, 37, 38, 39 AND 50). SN 79-067,223. PUB. 2-15-2011. FILED 8-7-2008.
- 3,953,498 ( *See Class 9 for this trademark*).
- 3,953,510. **VINLINER AND DESIGN**. J.F. HILLEBRAND GROUP AG, MULTIPLE CLASS, (INT. CLS. 16 AND 17), (U.S. CLS. 1, 2, 5, 12, 13, 22, 23, 29, 35, 37, 38 AND 50). SN 79-072,689. PUB. 2-15-2011. FILED 6-24-2009.
- 3,953,511 ( *See Class 9 for this trademark*).
- 3,953,520 ( *See Class 9 for this trademark*).
- 3,953,521 ( *See Class 9 for this trademark*).
- 3,953,553. **KANGARILA (STANDARD CHARACTER)**. DAVID EDISON, MULTIPLE CLASS, (INT. CLS. 16, 25, 28 AND 41), (U.S. CLS. 2, 5, 22, 23, 29, 37, 38, 39, 50, 100, 101 AND 107). SN 79-081,085. PUB. 2-15-2011. FILED 2-24-2010.
- 3,953,571 ( *See Class 9 for this trademark*).
- 3,953,575 ( *See Class 9 for this trademark*).
- 3,953,583. **HEADWEB (STANDARD CHARACTER)**. HEADWEB AB, MULTIPLE CLASS, (INT. CLS. 16, 38 AND 41), (U.S. CLS. 2, 5, 22, 23, 29, 37, 38, 50, 100, 101, 104 AND 107). SN 79-082,069. PUB. 2-15-2011. FILED 3-19-2010.
- 3,953,587 ( *See Class 9 for this trademark*).
- 3,953,595. **JSTART (STANDARD CHARACTER)**. INTERNATIONAL BUSINESS MACHINES CORPORATION, MULTIPLE CLASS, (INT. CLS. 16, 41 AND 42), (U.S. CLS. 2, 5, 22, 23, 29, 37, 38, 50, 100, 101 AND 107). SN 79-082,480. PUB. 2-15-2011. FILED 4-6-2010.
- 3,953,609. **ECOROX (STANDARD CHARACTER)**. ROXCEL HANDELSGES.M.B.H., MULTIPLE CLASS, (INT. CLS. 16, 35 AND 39), (U.S. CLS. 2, 5, 22, 23, 29, 37, 38, 50, 100, 101, 102 AND 105). SN 79-083,451. PUB. 2-15-2011. FILED 11-18-2009.
- 3,953,662. **O'LIVE (STANDARD CHARACTER)**. SOVENA PORTUGAL - CONSUMER GOODS, S.A., (U.S. CLS. 2, 5, 22, 23, 29, 37, 38 AND 50). SN 79-087,919. PUB. 2-15-2011. FILED 9-3-2010.
- 3,953,684. **MISCELLANEOUS DESIGN**. BLACKSTAR VENTURES, LLC, MULTIPLE CLASS, (INT. CLS. 16, 25, 42 AND 45), (U.S. CLS. 2, 5, 22, 23, 29, 37, 38, 39, 50, 100 AND 101). SN 85-000,400. PUB. 2-15-2011. FILED 3-29-2010.
- 3,953,696 ( *See Class 9 for this trademark*).
- 3,953,704 ( *See Class 9 for this trademark*).
- 3,953,707. **PRECIOUS OILS UP ON THE HILL (STANDARD CHARACTER)**. HILLSON, CYNTHIA, (U.S. CLS. 2, 5, 22, 23, 29, 37, 38 AND 50). SN 85-005,785. PUB. 2-15-2011. FILED 4-3-2010.
- 3,953,722. **SUCCEED IN LIFE CENTER (STANDARD CHARACTER)**. THE UNIVERSAL CHURCH, INC., MULTIPLE CLASS, (INT. CLS. 16, 25 AND 45), (U.S. CLS. 2, 5, 22, 23, 29, 37, 38, 39, 50, 100 AND 101). SN 85-011,136. PUB. 2-15-2011. FILED 4-10-2010.
- 3,953,723 ( *See Class 9 for this trademark*).
- 3,953,744. **MOMTRA (STANDARD CHARACTER)**. JESSICA ICLISOY, (U.S. CLS. 2, 5, 22, 23, 29, 37, 38 AND 50). SN 85-018,789. PUB. 2-15-2011. FILED 4-20-2010.
- 3,953,783. **ROCK SCHOOL (STANDARD CHARACTER)**. WOOD, CRISPIN, (U.S. CLS. 2, 5, 22, 23, 29, 37, 38 AND 50). SN 85-033,937. PUB. 2-15-2011. FILED 5-10-2010.
- 3,953,818 ( *See Class 9 for this trademark*).
- 3,953,831. **EATINGWELL (STANDARD CHARACTER)**. EATING WELL, INC., (U.S. CLS. 2, 5, 22, 23, 29, 37, 38 AND 50). SN 85-047,006. PUB. 2-15-2011. FILED 5-25-2010.
- 3,953,857. **COOL KIDS CONNECTION (STANDARD CHARACTER)**. COOL KIDS CAMPAIGN, (U.S. CLS. 2, 5, 22, 23, 29, 37, 38 AND 50). SN 85-057,404. PUB. 2-15-2011. FILED 6-8-2010.
- 3,953,858 ( *See Class 1 for this trademark*).
- 3,953,879. **OSMOSIS IS NOT A STRATEGY (STANDARD CHARACTER)**. CONNELL, MARGARETANN G. (U.S. CLS. 2, 5, 22, 23, 29, 37, 38 AND 50). SN 85-064,176. PUB. 2-15-2011. FILED 6-16-2010.
- 3,953,889. **FAMILY FOCUS (STANDARD CHARACTER)**. FOCUS ON THE FAMILY, (U.S. CLS. 2, 5, 22, 23, 29, 37, 38 AND 50). SN 85-068,403. PUB. 2-15-2011. FILED 6-22-2010.
- 3,953,895. **EDGEWATER (STANDARD CHARACTER)**. EDGEWATER TECHNOLOGY, INC., MULTIPLE CLASS, (INT. CLS. 16, 35, 41 AND 42), (U.S. CLS. 2, 5, 22, 23, 29, 37, 38, 50, 100, 101, 102 AND 107). SN 85-069,947. PUB. 2-15-2011. FILED 6-23-2010.
- 3,953,910. **SAFARI GREETINGS (STANDARD CHARACTER)**. SAFARI GREETINGS, LLC, (U.S. CLS. 2, 5, 22, 23, 29, 37, 38 AND 50). SN 85-072,742. PUB. 2-15-2011. FILED 6-28-2010.
- 3,953,911 ( *See Class 9 for this trademark*).
- 3,953,971. **ZIP STICK (STANDARD CHARACTER)**. PAPER-CONE CORPORATION, (U.S. CLS. 2, 5, 22, 23, 29, 37, 38 AND 50). SN 85-090,638. PUB. 2-15-2011. FILED 7-22-2010.
- 3,953,983. **HIP ON HEALTH (STANDARD CHARACTER)**. HENDRICKS, CHARLOTTE M, (U.S. CLS. 2, 5, 22, 23, 29, 37, 38 AND 50). SN 85-093,474. PUB. 2-15-2011. FILED 7-27-2010.
- 3,954,011. **THE FIGHTING LAWYER (STANDARD CHARACTER)**. YANCEY, GREGORY, DAVID, (U.S. CLS. 2, 5, 22, 23, 29, 37, 38 AND 50). SN 85-098,635. PUB. 2-15-2011. FILED 8-3-2010.
- 3,954,028. **PRO TRUCKER (STANDARD CHARACTER)**. RANDALL-REILLY PUBLISHING COMPANY, LLC, (U.S. CLS. 2, 5, 22, 23, 29, 37, 38 AND 50). SN 85-101,666. PUB. 2-15-2011. FILED 8-6-2010.
- 3,954,037. **THE ULTIMATE CHECKLIST AND DESIGN**. VAUGHN, MARK, (U.S. CLS. 2, 5, 22, 23, 29, 37, 38 AND 50). SN 85-104,080. PUB. 2-15-2011. FILED 8-10-2010.

- 3,954,062. **THE SCIENCE OF PERSONALITY (STANDARD CHARACTER)**. HOGAN ASSESSMENT SYSTEMS, INC., (U.S. CLS. 2, 5, 22, 23, 29, 37, 38 AND 50). SN 85-106,428. PUB. 2-15-2011. FILED 8-12-2010.
- 3,954,119. **SEA (STANDARD CHARACTER)**. DUNCAN MCINTOSH COMPANY, INC., (U.S. CLS. 2, 5, 22, 23, 29, 37, 38 AND 50). SN 85-110,695. PUB. 2-15-2011. FILED 8-18-2010.
- 3,954,128. **KING OF POP ART (STANDARD CHARACTER)**. ART JUXTAPOSED, MULTIPLE CLASS, (INT. CLS. 16 AND 42), (U.S. CLS. 2, 5, 22, 23, 29, 37, 38, 50, 100 AND 101). SN 85-111,097. PUB. 2-15-2011. FILED 8-19-2010.
- 3,954,134. **STRATEGIES: A JOURNAL FOR PHYSICAL AND SPORT EDUCATORS (STANDARD CHARACTER)**. AMERICAN ALLIANCE FOR HEALTH, PHYSICAL EDUCATION, RECREATION AND DANCE, THE, MULTIPLE CLASS, (INT. CLS. 16 AND 41), (U.S. CLS. 2, 5, 22, 23, 29, 37, 38, 50, 100, 101 AND 107). SN 85-111,235. PUB. 2-15-2011. FILED 8-19-2010.
- 3,954,140. **THE 99 AND DESIGN**. TERRY HENSHAW MINISTRIES, INC., MULTIPLE CLASS, (INT. CLS. 16 AND 41), (U.S. CLS. 2, 5, 22, 23, 29, 37, 38, 50, 100, 101 AND 107). SN 85-111,553. PUB. 2-15-2011. FILED 8-19-2010.
- 3,954,177. **BRINGING SOLUTIONS TO THE POINT OF CARE (STANDARD CHARACTER)**. DE NOVO LABS, LLC, (U.S. CLS. 2, 5, 22, 23, 29, 37, 38 AND 50). SN 85-113,242. PUB. 2-15-2011. FILED 8-23-2010.
- 3,954,200. **LACIGAM (STANDARD CHARACTER)**. KANDON UNLIMITED, INC., (U.S. CLS. 2, 5, 22, 23, 29, 37, 38 AND 50). SN 85-114,126. PUB. 2-15-2011. FILED 8-24-2010.
- 3,954,217. **ATLANTIC 10 CONFERENCE AND DESIGN**. ATLANTIC 10 CONFERENCE, MULTIPLE CLASS, (INT. CLS. 16, 25 AND 41), (U.S. CLS. 2, 5, 22, 23, 29, 37, 38, 39, 50, 100, 101 AND 107). SN 85-114,519. PUB. 2-15-2011. FILED 8-24-2010.
- 3,954,258. **MEETINGS FOCUS (STANDARD CHARACTER)**. STAMATS MEETINGS MEDIA, INC., (U.S. CLS. 2, 5, 22, 23, 29, 37, 38 AND 50). SN 85-115,235. PUB. 2-15-2011. FILED 8-25-2010.
- 3,954,262. **WALL WRITTEN (STYLIZED)**. WALL WRITTEN, L.L.C., (U.S. CLS. 2, 5, 22, 23, 29, 37, 38 AND 50). SN 85-115,379. PUB. 2-15-2011. FILED 8-25-2010.
- 3,954,268. **WAVE AND DESIGN**. STENOGRAPH, L.L.C., (U.S. CLS. 2, 5, 22, 23, 29, 37, 38 AND 50). SN 85-115,604. PUB. 2-15-2011. FILED 8-25-2010.
- 3,954,273. **RAKE "N" SWEEP GARDENBAG & DUSTPAN AND DESIGN**. TRI-VALLEY PROPAC, INC., (U.S. CLS. 2, 5, 22, 23, 29, 37, 38 AND 50). SN 85-115,759. PUB. 2-15-2011. FILED 8-25-2010.
- 3,954,297. **JIT THE PACKAGING WHOLESALEERS (STANDARD CHARACTER)**. JIT PACKAGING, INC., MULTIPLE CLASS, (INT. CLS. 16 AND 35), (U.S. CLS. 2, 5, 22, 23, 29, 37, 38, 50, 100, 101 AND 102). SN 85-116,231. PUB. 2-15-2011. FILED 8-26-2010.
- 3,954,298. **HIS BREATH NOW PUBLICATIONS (STANDARD CHARACTER)**. HIS BREATH NOW PUBLICATIONS, LLC, (U.S. CLS. 2, 5, 22, 23, 29, 37, 38 AND 50). SN 85-116,236. PUB. 2-15-2011. FILED 8-26-2010.
- 3,954,300. **SIGNAL (STANDARD CHARACTER)**. ARMED FORCES COMMUNICATIONS AND ELECTRONICS ASSOCIATION INTERNATIONAL, AKA AFCEA, MULTIPLE CLASS, (INT. CLS. 16 AND 41), (U.S. CLS. 2, 5, 22, 23, 29, 37, 38, 50, 100, 101 AND 107). SN 85-116,282. PUB. 2-15-2011. FILED 8-26-2010.
- 3,954,392. **FILL IN THE FUN (STANDARD CHARACTER)**. WRITE-ON RIOT, LLC, (U.S. CLS. 2, 5, 22, 23, 29, 37, 38 AND 50). SN 85-117,717. PUB. 2-15-2011. FILED 8-27-2010.
- 3,954,409. **TECHLINES (STYLIZED)**. GHC SPECIALTY BRANDS, LLC, (U.S. CLS. 2, 5, 22, 23, 29, 37, 38 AND 50). SN 85-117,901. PUB. 2-15-2011. FILED 8-27-2010.
- 3,954,459. **HISTORIC INALAHAN . AND GEF PA'GO PARK . AND DESIGN**. HISTORIC INALAHAN FOUNDATION, INC., (U.S. CLS. 2, 5, 22, 23, 29, 37, 38 AND 50). SN 85-118,564. PUB. 2-15-2011. FILED 8-30-2010.
- 3,954,514. **LIFEWORDS AND DESIGN**. LIFEWORD BROADCAST MINISTRIES, INC., (U.S. CLS. 2, 5, 22, 23, 29, 37, 38 AND 50). SN 85-119,010. PUB. 2-15-2011. FILED 8-30-2010.
- 3,954,539. **COSMETOLOGY STYLE (STANDARD CHARACTER)**. CUNNINGHAM, KEITH A, DBA KEITH CUNNINGHAM & COMPANY, (U.S. CLS. 2, 5, 22, 23, 29, 37, 38 AND 50). SN 85-119,308. PUB. 2-15-2011. FILED 8-31-2010.
- 3,954,549. **G GRGICH GRAPHICS (STYLIZED)**. GRGICH, PETER, (U.S. CLS. 2, 5, 22, 23, 29, 37, 38 AND 50). SN 85-119,401. PUB. 2-15-2011. FILED 8-31-2010.
- 3,954,556. **R AND DESIGN**. MITCHELL, STEVEN, DBA HANDYREF, (U.S. CLS. 2, 5, 22, 23, 29, 37, 38 AND 50). SN 85-119,518. PUB. 2-15-2011. FILED 8-31-2010.
- 3,954,570. **ORGANIZED WITH ELEGANCE (STANDARD CHARACTER)**. HOLZ, M. KAREN, (U.S. CLS. 2, 5, 22, 23, 29, 37, 38 AND 50). SN 85-119,680. PUB. 2-15-2011. FILED 8-31-2010.
- 3,954,579. **HQ TRADE MAGAZINE (STANDARD CHARACTER)**. HEADQUEST, INC., (U.S. CLS. 2, 5, 22, 23, 29, 37, 38 AND 50). SN 85-119,766. PUB. 2-15-2011. FILED 8-31-2010.
- 3,954,586. **AGRIVISIONS (STANDARD CHARACTER)**. FIRST DAKOTA FINANCIAL CORPORATION, (U.S. CLS. 2, 5, 22, 23, 29, 37, 38 AND 50). SN 85-119,864. PUB. 2-15-2011. FILED 8-31-2010.
- 3,954,602. **S AND DESIGN**. SHANNON WALKER, (U.S. CLS. 2, 5, 22, 23, 29, 37, 38 AND 50). SN 85-120,043. PUB. 2-15-2011. FILED 8-31-2010.
- 3,954,666. **RAVEN HOUSE PUBLISHING AND DESIGN**. RAVEN HOUSE PUBLISHING, LLC, (U.S. CLS. 2, 5, 22, 23, 29, 37, 38 AND 50). SN 85-120,706. PUB. 2-15-2011. FILED 9-1-2010.
- 3,954,687. **SOUTHERN FRIED PAPER (STANDARD CHARACTER)**. C3 CREATIVE, LLC, DBA SOUTHERN FRIED PAPER, (U.S. CLS. 2, 5, 22, 23, 29, 37, 38 AND 50). SN 85-120,846. PUB. 2-15-2011. FILED 9-1-2010.
- 3,954,719. **MIND (STANDARD CHARACTER)**. MAIMONIDES MEDICAL CENTER, MULTIPLE CLASS, (INT. CLS. 16 AND 44), (U.S. CLS. 2, 5, 22, 23, 29, 37, 38, 50, 100 AND 101). SN 85-121,246. PUB. 2-15-2011. FILED 9-1-2010.
- 3,954,720 ( *See Class 1 for this trademark*).
- 3,954,723 ( *See Class 9 for this trademark*).
- 3,954,728. **REFINED LIVING (STANDARD CHARACTER)**. 1 TO 1 MEDIA GROUP, LLC, (U.S. CLS. 2, 5, 22, 23, 29, 37, 38 AND 50). SN 85-121,425. PUB. 2-15-2011. FILED 9-2-2010.
- 3,954,763. **ARISTOCRAT (STANDARD CHARACTER)**. INDUSTRIES OF THE BLIND, INCORPORATED, (U.S. CLS. 2, 5, 22, 23, 29, 37, 38 AND 50). SN 85-121,823. PUB. 2-15-2011. FILED 9-2-2010.
- 3,954,779. **OKLAHOMA SENIOR JOURNAL (STANDARD CHARACTER)**. ATHENA PUBLISHING COMPANY, INC., MULTIPLE CLASS, (INT. CLS. 16 AND 41), (U.S. CLS. 2, 5, 22, 23, 29, 37, 38, 50, 100, 101 AND 107). SN 85-121,957. PUB. 2-15-2011. FILED 9-2-2010.
- 3,954,939. **PAPER SQUID (STANDARD CHARACTER)**. PAPER SQUID INC., (U.S. CLS. 2, 5, 22, 23, 29, 37, 38 AND 50). SN 85-124,676. PUB. 2-15-2011. FILED 9-8-2010.
- 3,955,061 ( *See Class 9 for this trademark*).
- 3,955,063 ( *See Class 9 for this trademark*).
- 3,955,064. **HOT BIKE BAGGERS (STANDARD CHARACTER)**. SOURCE INTERLINK MAGAZINES, LLC, (U.S. CLS. 2, 5, 22, 23, 29, 37, 38 AND 50). SN 85-143,432. PUB. 2-15-2011. FILED 10-1-2010.
- 3,955,113. **100% YOU. (STANDARD CHARACTER)**. T-MOBILE USA, INC., (U.S. CLS. 2, 5, 22, 23, 29, 37, 38 AND 50). SN 85-164,006. PUB. 2-15-2011. FILED 10-28-2010.
- 3,955,128. **RUNNER'S WORLD (STANDARD CHARACTER)**. RODALE, INC., (U.S. CLS. 2, 5, 22, 23, 29, 37, 38 AND 50). SN 85-170,475. PUB. 2-15-2011. FILED 11-5-2010.
- 3,955,136. **IT'S ALL ABOUT THE A AND DESIGN**. COLORADO AVALANCHE, LLC, (U.S. CLS. 2, 5, 22, 23, 29, 37, 38 AND 50). SN 85-172,357. PUB. 2-15-2011. FILED 11-9-2010.
- 3,955,140 ( *See Class 6 for this trademark*).
- 3,955,150. **12 AND DESIGN**. BOARD OF TRUSTEES OF THE UNIVERSITY OF ALABAMA, (U.S. CLS. 2, 5, 22, 23, 29, 37, 38 AND 50). SN 85-975,048. PUB. 2-15-2011. FILED 5-19-2010.

---

**CLASS 17—RUBBER GOODS**

- 3,953,031 ( *See Class 12 for this trademark*).
- 3,953,065 ( *See Class 2 for this trademark*).
- 3,953,082 ( *See Class 6 for this trademark*).

3,953,083 ( *See Class 1 for this trademark.* )  
 3,953,394 ( *See Class 1 for this trademark.* )  
 3,953,505 ( *See Class 7 for this trademark.* )  
 3,953,510 ( *See Class 16 for this trademark.* )  
 3,953,513 ( *See Class 1 for this trademark.* )  
 3,953,529 ( *See Class 6 for this trademark.* )  
 3,953,559. **DRAGA (STANDARD CHARACTER)**. TUBI THOR S.P.A., (U.S. CLS. 1, 5, 12, 13, 35 AND 50). SN 79-081,168. PUB. 2-15-2011. FILED 2-17-2010.  
 3,953,560. **SUPERIOR AND DESIGN**. TUBI THOR S.P.A., (U.S. CLS. 1, 5, 12, 13, 35 AND 50). SN 79-081,169. PUB. 2-15-2011. FILED 2-17-2010.  
 3,953,582 ( *See Class 6 for this trademark.* )  
 3,953,617 ( *See Class 1 for this trademark.* )  
 3,953,628 ( *See Class 7 for this trademark.* )  
 3,953,650. **SUNSTELLAR (STANDARD CHARACTER)**. ASAH KASEI E-MATERIALS CORPORATION, (U.S. CLS. 1, 5, 12, 13, 35 AND 50). SN 79-087,407. PUB. 2-15-2011. FILED 9-1-2010.  
 3,953,801. **GEOCHEM (STANDARD CHARACTER)**. ENTEC POLYMERS, LLC, (U.S. CLS. 1, 5, 12, 13, 35 AND 50). SN 85-037,913. PUB. 2-15-2011. FILED 5-13-2010.  
 3,954,188. **E-Z PULL (STANDARD CHARACTER)**. SCHREIBER FOODS, INC., (U.S. CLS. 1, 5, 12, 13, 35 AND 50). SN 85-113,770. PUB. 2-15-2011. FILED 8-23-2010.  
 3,954,207. **WINLITE (STANDARD CHARACTER)**. CHANG CHUN PETROCHEMICAL CO., LTD, (U.S. CLS. 1, 5, 12, 13, 35 AND 50). SN 85-114,296. PUB. 2-15-2011. FILED 8-24-2010.  
 3,954,365. **ADSTEP (STANDARD CHARACTER)**. NELSON LEMMOND, MULTIPLE CLASS, (INT. CLS. 17 AND 37), (U.S. CLS. 1, 5, 12, 13, 35, 50, 100, 103 AND 106). SN 85-117,285. PUB. 2-15-2011. FILED 8-27-2010.  
 3,954,411. **OILUP SORBENT AND DESIGN**. GHC SPECIALTY BRANDS, LLC, (U.S. CLS. 1, 5, 12, 13, 35 AND 50). SN 85-117,941. PUB. 2-15-2011. FILED 8-27-2010.  
 3,954,720 ( *See Class 1 for this trademark.* )

### CLASS 18—LEATHER GOODS

3,953,000 ( *See Class 3 for this trademark.* )  
 3,953,094 ( *See Class 9 for this trademark.* )  
 3,953,141 ( *See Class 6 for this trademark.* )  
 3,953,245. **T-BAGS AND DESIGN**. LOVETT, TERRY, MULTIPLE CLASS, (INT. CLS. 18 AND 25), (U.S. CLS. 1, 2, 3, 22, 39 AND 41). SN 77-918,449. PUB. 2-15-2011. FILED 1-22-2010.  
 3,953,305. **MISCELLANEOUS DESIGN**. TIMBUK2 DESIGNS, INC., (U.S. CLS. 1, 2, 3, 22 AND 41). SN 77-943,682. PUB. 2-15-2011. FILED 2-24-2010.  
 3,953,424. **DOG THE ORANGE DOG (STYLIZED)**. THE ORANGE DOG INC., MULTIPLE CLASS, (INT. CLS. 18 AND 21), (U.S. CLS. 1, 2, 3, 13, 22, 23, 29, 30, 33, 40, 41 AND 50). SN 77-961,036. PUB. 2-15-2011. FILED 3-17-2010.  
 3,953,425. **THE ORANGE DOG (STANDARD CHARACTER)**. THE ORANGE DOG INC., MULTIPLE CLASS, (INT. CLS. 18 AND 21), (U.S. CLS. 1, 2, 3, 13, 22, 23, 29, 30, 33, 40, 41 AND 50). SN 77-961,053. PUB. 2-15-2011. FILED 3-17-2010.  
 3,953,464. **MISCELLANEOUS DESIGN**. EXPRESS, LLC, MULTIPLE CLASS, (INT. CLS. 18 AND 25), (U.S. CLS. 1, 2, 3, 22, 39 AND 41). SN 77-981,036. PUB. 2-15-2011. FILED 5-26-2009.  
 3,953,471 ( *See Class 3 for this trademark.* )  
 3,953,485 ( *See Class 3 for this trademark.* )  
 3,953,490 ( *See Class 9 for this trademark.* )  
 3,953,502 ( *See Class 8 for this trademark.* )  
 3,953,594 ( *See Class 9 for this trademark.* )  
 3,953,614. **TERGAN (STYLIZED)**. TERGAN DERI ÜRÜNLERİ; SANAYİ VE TİCARET ANONİM ŞİRKETİ, MULTIPLE CLASS, (INT. CLS. 18, 25 AND 35), (U.S. CLS. 1, 2, 3, 22, 39, 41, 100, 101 AND 102). SN 79-084,049. PUB. 2-15-2011. FILED 12-8-2009.  
 3,953,702. **POVERTY (STANDARD CHARACTER)**. XP INNOVATION, LLC, DBA DAN'S COMP, MULTIPLE CLASS, (INT. CLS. 18 AND 25), (U.S. CLS. 1, 2, 3, 22, 39 AND 41). SN 85-003,251. PUB. 2-15-2011. FILED 3-31-2010.  
 3,953,728. **EE (STYLIZED)**. LI JIANGUO, (U.S. CLS. 1, 2, 3, 22

AND 41). SN 85-012,176. PUB. 2-15-2011. FILED 4-12-2010.  
 3,954,424. **MISCELLANEOUS DESIGN**. DERMAN, YAEL, EMILY, (U.S. CLS. 1, 2, 3, 22 AND 41). SN 85-118,183. PUB. 2-15-2011. FILED 8-29-2010.  
 3,954,453. **REECO (STANDARD CHARACTER)**. FOURSTAR GROUP INC., MULTIPLE CLASS, (INT. CLS. 18 AND 21), (U.S. CLS. 1, 2, 3, 13, 22, 23, 29, 30, 33, 40, 41 AND 50). SN 85-118,507. PUB. 2-15-2011. FILED 8-30-2010.  
 3,954,528. **RR RACHEL RACHEL AND DESIGN**. PACPRO INC., (U.S. CLS. 1, 2, 3, 22 AND 41). SN 85-119,172. PUB. 2-15-2011. FILED 8-30-2010.  
 3,954,605. **TUMI VAPOR (STANDARD CHARACTER)**. TUMI, INC., (U.S. CLS. 1, 2, 3, 22 AND 41). SN 85-120,079. PUB. 2-15-2011. FILED 8-31-2010.  
 3,954,744. **BIRDSBESAFE (STANDARD CHARACTER)**. BIRDS BE SAFE LLC, AKA BIRDSBESAFE LLC, (U.S. CLS. 1, 2, 3, 22 AND 41). SN 85-121,605. PUB. 2-15-2011. FILED 9-2-2010.  
 3,954,911. **LIFT-N-AID (STANDARD CHARACTER)**. OURPET'S COMPANY, (U.S. CLS. 1, 2, 3, 22 AND 41). SN 85-123,829. PUB. 2-15-2011. FILED 9-7-2010.  
 3,954,916. **LEASHLINK AND DESIGN**. POOCHIE-PETS, LLC, (U.S. CLS. 1, 2, 3, 22 AND 41). SN 85-123,952. PUB. 2-15-2011. FILED 9-7-2010.

### CLASS 19—NON-METALLIC BUILDING MATERIALS

3,953,049 ( *See Class 6 for this trademark.* )  
 3,953,082 ( *See Class 6 for this trademark.* )  
 3,953,194 ( *See Class 6 for this trademark.* )  
 3,953,238. **AURANOX (STANDARD CHARACTER)**. MONIER GROUP GMBH, (U.S. CLS. 1, 12, 33 AND 50). SN 77-914,554. PUB. 1-4-2011. FILED 1-19-2010.  
 3,953,394 ( *See Class 1 for this trademark.* )  
 3,953,441. **EZ-PLUG (STANDARD CHARACTER)**. ETUNK SOLUTIONS, LLC, DBA ETUNK SOLUTIONS, LLC, (U.S. CLS. 1, 12, 33 AND 50). SN 77-962,640. PUB. 2-15-2011. FILED 3-18-2010.  
 3,953,459. **EZ-PLUG AND DESIGN**. ETUNK SOLUTIONS, LLC, DBA ETUNK SOLUTIONS, LLC, (U.S. CLS. 1, 12, 33 AND 50). SN 77-966,923. PUB. 2-15-2011. FILED 3-24-2010.  
 3,953,505 ( *See Class 7 for this trademark.* )  
 3,953,508. **MONINA BY TAGINA (STANDARD CHARACTER)**. TAGINA CERAMICHE D'ARTE S.P.A., (U.S. CLS. 1, 12, 33 AND 50). SN 79-072,259. PUB. 2-15-2011. FILED 6-10-2009.  
 3,953,513 ( *See Class 1 for this trademark.* )  
 3,953,586. **XXL GLASS (STYLIZED)**. SAINT-GOBAIN GLASS FRANCE, MULTIPLE CLASS, (INT. CLS. 19, 21, 37, 39, 40 AND 42), (U.S. CLS. 1, 2, 12, 13, 23, 29, 30, 33, 40, 50, 100, 101, 103, 105 AND 106). SN 79-082,174. PUB. 2-15-2011. FILED 4-7-2010.  
 3,953,593 ( *See Class 6 for this trademark.* )  
 3,953,617 ( *See Class 1 for this trademark.* )  
 3,953,622. **KARELIA HARDWOOD FLOORS (STYLIZED)**. KARELIA-UPOFLOOR OY, (U.S. CLS. 1, 12, 33 AND 50). SN 79-084,640. PUB. 2-15-2011. FILED 6-22-2010.  
 3,953,623 ( *See Class 11 for this trademark.* )  
 3,953,659. **PRIMUSS (STANDARD CHARACTER)**. GEORG PRINZING GMBH & CO. KG BETONFORMEN- U. MASCHINENFABRIK, (U.S. CLS. 1, 12, 33 AND 50). SN 79-087,745. PUB. 2-15-2011. FILED 9-2-2010.  
 3,954,023. **PRO-SHIELD (STANDARD CHARACTER)**. DALEN PRODUCTS, INC., (U.S. CLS. 1, 12, 33 AND 50). SN 85-101,125. PUB. 2-15-2011. FILED 8-5-2010.  
 3,954,206. **CORNERFLEX (STANDARD CHARACTER)**. GREGORY AMUNDSON, (U.S. CLS. 1, 12, 33 AND 50). SN 85-114,274. PUB. 2-15-2011. FILED 8-24-2010.  
 3,954,222. **HORSERAIL (STANDARD CHARACTER)**. JOHN WALL, INC., (U.S. CLS. 1, 12, 33 AND 50). SN 85-114,676. PUB. 2-15-2011. FILED 8-24-2010.  
 3,954,228. **GREEN CHOICE (STANDARD CHARACTER)**. GREEN CHOICE FLOORING INTERNATIONAL, INC., (U.S. CLS. 1, 12, 33 AND 50). SN 85-114,785. PUB. 2-15-2011. FILED 8-24-2010.  
 3,954,304 ( *See Class 4 for this trademark.* )  
 3,954,325. **RAINGUARD AND DESIGN**. SPC RESOURCES,

- INC., (U.S. CLS. 1, 12, 33 AND 50). SN 85-116,703. PUB. 2-15-2011. FILED 8-26-2010.
- 3,954,400. **SEAL-LOCK (STANDARD CHARACTER)**. HOME LEGEND, LLC., (U.S. CLS. 1, 12, 33 AND 50). SN 85-117,795. PUB. 2-15-2011. FILED 8-27-2010.
- 3,954,434. **MISCELLANEOUS DESIGN**. NORTHLAND CORPORATION, (U.S. CLS. 1, 12, 33 AND 50). SN 85-118,338. PUB. 2-15-2011. FILED 8-30-2010.
- 3,954,518. **ARIDUS (STANDARD CHARACTER)**. U.S. CONCRETE, INC., MULTIPLE CLASS, (INT. CLS. 19 AND 40), (U.S. CLS. 1, 12, 33, 50, 100, 103 AND 106). SN 85-119,125. PUB. 2-15-2011. FILED 8-30-2010.
- 3,954,752. **WE BUILD SMARTER AND DESIGN**. SPC RESOURCES, INC., (U.S. CLS. 1, 12, 33 AND 50). SN 85-121,696. PUB. 2-15-2011. FILED 9-2-2010.
- 3,954,756. **SEALPANES (STANDARD CHARACTER)**. SEALPANES, LLC, (U.S. CLS. 1, 12, 33 AND 50). SN 85-121,770. PUB. 2-15-2011. FILED 9-2-2010.
- 3,954,759. **WHITE RIVER ADORNMENTS FOR CABINETS & FURNITURE (STANDARD CHARACTER)**. WHITE RIVER HARDWOODS-WOODWORKS, INC., (U.S. CLS. 1, 12, 33 AND 50). SN 85-121,796. PUB. 2-15-2011. FILED 9-2-2010.
- 3,954,959. **EARTH MINDED (STANDARD CHARACTER)**. HOME LEGEND, LLC., (U.S. CLS. 1, 12, 33 AND 50). SN 85-126,286. PUB. 2-15-2011. FILED 9-9-2010.
- 3,955,042. **TUFF-N-RUGGED (STANDARD CHARACTER)**. OURPET'S COMPANY, (U.S. CLS. 1, 12, 33 AND 50). SN 85-138,554. PUB. 2-15-2011. FILED 9-27-2010.
- 
- CLASS 20—FURNITURE AND ARTICLES NOT OTHERWISE CLASSIFIED**
- 3,953,000 ( *See Class 3 for this trademark*).
- 3,953,022. **SWMSAFE (STANDARD CHARACTER)**. RSV POOLS, INC., (U.S. CLS. 2, 13, 22, 25, 32 AND 50). SN 77-383,649. PUB. 2-15-2011. FILED 1-29-2008.
- 3,953,049 ( *See Class 6 for this trademark*).
- 3,953,102. **ITOKIDESIGN AND DESIGN**. ITOKI CORPORATION, MULTIPLE CLASS, (INT. CLS. 20, 35 AND 42), (U.S. CLS. 2, 13, 22, 25, 32, 50, 100, 101 AND 102). SN 77-795,190. PUB. 2-15-2011. FILED 8-3-2009.
- 3,953,107. **BASCO (STANDARD CHARACTER)**. BASCO INCORPORATED, MULTIPLE CLASS, (INT. CLS. 20 AND 21), (U.S. CLS. 2, 13, 22, 23, 25, 29, 30, 32, 33, 40 AND 50). SN 77-798,802. PUB. 2-15-2011. FILED 8-6-2009.
- 3,953,141 ( *See Class 6 for this trademark*).
- 3,953,155. **THREE STAR (STANDARD CHARACTER)**. PACIFIC COAST FEATHER COMPANY, MULTIPLE CLASS, (INT. CLS. 20 AND 24), (U.S. CLS. 2, 13, 22, 25, 32, 42 AND 50). SN 77-830,207. PUB. 2-15-2011. FILED 9-18-2009.
- 3,953,183. **MFA BOSTON AND DESIGN**. MUSEUM OF FINE ARTS, BOSTON, (U.S. CLS. 2, 13, 22, 25, 32 AND 50). SN 77-852,783. PUB. 2-15-2011. FILED 10-20-2009.
- 3,953,194 ( *See Class 6 for this trademark*).
- 3,953,317. **KINEMA (STANDARD CHARACTER)**. ZOELL, STEFAN, MULTIPLE CLASS, (INT. CLS. 20, 35 AND 42), (U.S. CLS. 2, 13, 22, 25, 32, 50, 100, 101 AND 102). SN 77-946,578. PUB. 2-15-2011. FILED 2-27-2010.
- 3,953,418 ( *See Class 6 for this trademark*).
- 3,953,432. **ELECTRIC MIRROR (STANDARD CHARACTER)**. ELECTRIC MIRROR, LLC, (U.S. CLS. 2, 13, 22, 25, 32 AND 50). SN 77-961,694. PUB. 2-15-2011. FILED 3-17-2010.
- 3,953,449 ( *See Class 6 for this trademark*).
- 3,953,450 ( *See Class 6 for this trademark*).
- 3,953,554 ( *See Class 6 for this trademark*).
- 3,953,569 ( *See Class 6 for this trademark*).
- 3,953,570 ( *See Class 6 for this trademark*).
- 3,953,627. **DX RACER AND DESIGN**. WU QING, (U.S. CLS. 2, 13, 22, 25, 32 AND 50). SN 79-085,297. PUB. 2-15-2011. FILED 6-14-2010.
- 3,953,643 ( *See Class 3 for this trademark*).
- 3,953,690. **COPELAND FURNITURE (STANDARD CHARACTER)**. T. COPELAND AND SONS, INC., (U.S. CLS. 2, 13, 22, 25, 32 AND 50). SN 85-001,641. PUB. 2-15-2011. FILED 3-30-2010.
- 3,953,734 ( *See Class 13 for this trademark*).
- 3,953,743. **SEA-URN AND DESIGN**. SEA-URN, LTD., (U.S. CLS. 2, 13, 22, 25, 32 AND 50). SN 85-018,609. PUB. 2-15-2011. FILED 4-20-2010.
- 3,953,748. **JUST LOCK AND GO (STANDARD CHARACTER)**. BULMER, DONALD L., (U.S. CLS. 2, 13, 22, 25, 32 AND 50). SN 85-020,574. PUB. 2-15-2011. FILED 4-22-2010.
- 3,953,928. **I (STYLIZED)**. ABRAHAM, THOMAS G., MULTIPLE CLASS, (INT. CLS. 20 AND 28), (U.S. CLS. 2, 13, 22, 23, 25, 32, 38 AND 50). SN 85-077,081. PUB. 2-15-2011. FILED 7-2-2010.
- 3,953,972. **PHOS-BIN (STANDARD CHARACTER)**. ICL PERFORMANCE PRODUCTS, LP, (U.S. CLS. 2, 13, 22, 25, 32 AND 50). SN 85-090,653. PUB. 2-15-2011. FILED 7-22-2010.
- 3,954,125. **BATTER-ON-DECK ON DECK CHAIRS ADIRON-DACK AND DESIGN**. ON DECK CHAIRS, LLC, (U.S. CLS. 2, 13, 22, 25, 32 AND 50). SN 85-110,913. PUB. 2-15-2011. FILED 8-19-2010.
- 3,954,275. **BIRD-IN-HAND (STANDARD CHARACTER)**. CHILDCRAFT EDUCATION CORP., (U.S. CLS. 2, 13, 22, 25, 32 AND 50). SN 85-115,820. PUB. 2-15-2011. FILED 8-25-2010.
- 3,954,276. **BIRD-IN-HAND WOODWORKS AND DESIGN**. CHILDCRAFT EDUCATION CORP., (U.S. CLS. 2, 13, 22, 25, 32 AND 50). SN 85-115,823. PUB. 2-15-2011. FILED 8-25-2010.
- 3,954,292. **REFURBEST (STANDARD CHARACTER)**. DADCO, INC., (U.S. CLS. 2, 13, 22, 25, 32 AND 50). SN 85-116,126. PUB. 2-15-2011. FILED 8-26-2010.
- 3,954,293. **DURAGREEN (STANDARD CHARACTER)**. DADCO, INC., (U.S. CLS. 2, 13, 22, 25, 32 AND 50). SN 85-116,155. PUB. 2-15-2011. FILED 8-26-2010.
- 3,954,355 ( *See Class 12 for this trademark*).
- 3,954,375. **STATESMAN (STANDARD CHARACTER)**. AMERICAN LOCKER SECURITY SYSTEMS, INC., (U.S. CLS. 2, 13, 22, 25, 32 AND 50). SN 85-117,406. PUB. 2-15-2011. FILED 8-27-2010.
- 3,954,391. **TAYLOR (STANDARD CHARACTER)**. THE TAYLOR CHAIR COMPANY, (U.S. CLS. 2, 13, 22, 25, 32 AND 50). SN 85-117,714. PUB. 2-15-2011. FILED 8-27-2010.
- 3,954,456. **DR. MARVIN'S (STANDARD CHARACTER)**. ASSOCIATED BEDDING COMPANY, INC., (U.S. CLS. 2, 13, 22, 25, 32 AND 50). SN 85-118,553. PUB. 2-15-2011. FILED 8-30-2010.
- 3,954,552. **ENVOY (STANDARD CHARACTER)**. AMERICAN LOCKER SECURITY SYSTEMS, INC., (U.S. CLS. 2, 13, 22, 25, 32 AND 50). SN 85-119,460. PUB. 2-15-2011. FILED 8-31-2010.
- 3,954,553. **AMBASSADOR (STANDARD CHARACTER)**. AMERICAN LOCKER SECURITY SYSTEMS, INC., (U.S. CLS. 2, 13, 22, 25, 32 AND 50). SN 85-119,466. PUB. 2-15-2011. FILED 8-31-2010.
- 3,954,615. **PATIOSLINGEXPRESS (STANDARD CHARACTER)**. ADVANCED REFINISHING, INC., MULTIPLE CLASS, (INT. CLS. 20, 24 AND 35), (U.S. CLS. 2, 13, 22, 25, 32, 42, 50, 100, 101 AND 102). SN 85-120,184. PUB. 2-15-2011. FILED 8-31-2010.
- 3,954,616. **CHAIRCAREPATIO (STANDARD CHARACTER)**. ADVANCED REFINISHING, INC., MULTIPLE CLASS, (INT. CLS. 20, 24, 35 AND 37), (U.S. CLS. 2, 13, 22, 25, 32, 42, 50, 100, 101, 102, 103 AND 106). SN 85-120,199. PUB. 2-15-2011. FILED 8-31-2010.
- 3,954,715. **SOFT-TEX (STANDARD CHARACTER)**. PERRY TEXTILES INC, DBA SOFT-TEX MANUFACTURING, (U.S. CLS. 2, 13, 22, 25, 32 AND 50). SN 85-121,202. PUB. 2-15-2011. FILED 9-1-2010.
- 3,954,717. **INFINIFLEX (STANDARD CHARACTER)**. PERRY TEXTILES, INC., DBA SOFT-TEX MANUFACTURING, (U.S. CLS. 2, 13, 22, 25, 32 AND 50). SN 85-121,226. PUB. 2-15-2011. FILED 9-1-2010.
- 3,954,731. **SLING PAC (STANDARD CHARACTER)**. BICAST, INC., (U.S. CLS. 2, 13, 22, 25, 32 AND 50). SN 85-121,462. PUB. 2-15-2011. FILED 9-2-2010.
- 3,954,766. **CLEARLY CLASSIC (STANDARD CHARACTER)**. WHITE WEBB, LLC, (U.S. CLS. 2, 13, 22, 25, 32 AND 50). SN 85-121,845. PUB. 2-15-2011. FILED 9-2-2010.
- 3,955,027. **B-O-F CORPORATION AND DESIGN**. B-O-F CORPORATION, (U.S. CLS. 2, 13, 22, 25, 32 AND 50). SN 85-136,867. PUB. 2-15-2011. FILED 9-23-2010.

- 3,955,146. **OWL (STANDARD CHARACTER)**. WARNER, GEOFFREY, (U.S. CLS. 2, 13, 22, 25, 32 AND 50). SN 85-183,611. PUB. 2-15-2011. FILED 11-23-2010.
- 3,955,147. **OWL OWL FURNITURE AND DESIGN**. WARNER, GEOFFREY, (U.S. CLS. 2, 13, 22, 25, 32 AND 50). SN 85-183,618. PUB. 2-15-2011. FILED 11-23-2010.

---

### CLASS 21—HOUSEWARES AND GLASS

- 3,952,960. **WISHES INC. YOUR HOME. YOUR WAY. AND DESIGN**. WISHES INCORPORATED, (U.S. CLS. 2, 13, 23, 29, 30, 33, 40 AND 50). SN 76-696,337. PUB. 2-15-2011. FILED 3-16-2009.
- 3,952,971. **IZZIT (STANDARD CHARACTER)**. PHELPS, JULIE, AND PHELPS, ANDREW, (U.S. CLS. 2, 13, 23, 29, 30, 33, 40 AND 50). SN 76-701,957. PUB. 2-15-2011. FILED 3-8-2010.
- 3,953,000 ( *See Class 3 for this trademark*).
- 3,953,030. **BB'S BEST MUFFIN SPLITTER AND DESIGN**. BARTON, JAMES N, (U.S. CLS. 2, 13, 23, 29, 30, 33, 40 AND 50). SN 77-517,101. PUB. 2-15-2011. FILED 7-8-2008.
- 3,953,094 ( *See Class 9 for this trademark*).
- 3,953,105 ( *See Class 3 for this trademark*).
- 3,953,107 ( *See Class 20 for this trademark*).
- 3,953,141 ( *See Class 6 for this trademark*).
- 3,953,181. **COOKVILLE AND DESIGN**. HYUNDUK COMPANY LTD., (U.S. CLS. 2, 13, 23, 29, 30, 33, 40 AND 50). SN 77-852,568. PUB. 2-15-2011. FILED 10-20-2009.
- 3,953,182. **MFA BOSTON AND DESIGN**. MUSEUM OF FINE ARTS, BOSTON, (U.S. CLS. 2, 13, 23, 29, 30, 33, 40 AND 50). SN 77-852,778. PUB. 2-15-2011. FILED 10-20-2009.
- 3,953,222. **WINTERLAND (STANDARD CHARACTER)**. EPIC PRODUCTS INC., (U.S. CLS. 2, 13, 23, 29, 30, 33, 40 AND 50). SN 77-902,887. PUB. 11-9-2010. FILED 12-30-2009.
- 3,953,278. **BABY DIEGO (STANDARD CHARACTER)**. VENTANAZUL, LLC, DBA BABY DIEGO, (U.S. CLS. 2, 13, 23, 29, 30, 33, 40 AND 50). SN 77-937,694. PUB. 2-15-2011. FILED 2-17-2010.
- 3,953,328. **CRITTER NATION THE WORLD'S BEST SMALL ANIMAL HABITAT AND DESIGN**. MID-WEST METAL PRODUCTS CO., INC., (U.S. CLS. 2, 13, 23, 29, 30, 33, 40 AND 50). SN 77-948,721. PUB. 2-15-2011. FILED 3-2-2010.
- 3,953,392. **H HYDRATHON AND DESIGN**. HYDRATHON, LLC, (U.S. CLS. 2, 13, 23, 29, 30, 33, 40 AND 50). SN 77-956,653. PUB. 2-15-2011. FILED 3-11-2010.
- 3,953,394 ( *See Class 1 for this trademark*).
- 3,953,424 ( *See Class 18 for this trademark*).
- 3,953,425 ( *See Class 18 for this trademark*).
- 3,953,449 ( *See Class 6 for this trademark*).
- 3,953,450 ( *See Class 6 for this trademark*).
- 3,953,492 ( *See Class 8 for this trademark*).
- 3,953,502 ( *See Class 8 for this trademark*).
- 3,953,505 ( *See Class 7 for this trademark*).
- 3,953,581. **BAR-BLADES.COM HOME TO THE WORLD'S COOLEST BARBLADES AND DESIGN**. DYNAMIC DESIGN PTY LTD, (U.S. CLS. 2, 13, 23, 29, 30, 33, 40 AND 50). SN 79-082,021. PUB. 2-15-2011. FILED 3-10-2010.
- 3,953,586 ( *See Class 19 for this trademark*).
- 3,953,621 ( *See Class 3 for this trademark*).
- 3,953,643 ( *See Class 3 for this trademark*).
- 3,953,725. **BRUSH NAKED (STANDARD CHARACTER)**. WILMOTH, PATTI, (U.S. CLS. 2, 13, 23, 29, 30, 33, 40 AND 50). SN 85-011,789. PUB. 2-15-2011. FILED 4-12-2010.
- 3,953,836. **INCHBUG (STANDARD CHARACTER)**. INCHBUG, LLC, (U.S. CLS. 2, 13, 23, 29, 30, 33, 40 AND 50). SN 85-048,808. PUB. 2-15-2011. FILED 5-26-2010.
- 3,954,141. **ROSSETO (STANDARD CHARACTER)**. GOLD & LEVY, INC., DBA ROSSETO, (U.S. CLS. 2, 13, 23, 29, 30, 33, 40 AND 50). SN 85-111,562. PUB. 2-15-2011. FILED 8-19-2010.
- 3,954,453 ( *See Class 18 for this trademark*).
- 3,954,492. **TIPSY STIXS (STANDARD CHARACTER)**. TIPSY STIXS, LLC, (U.S. CLS. 2, 13, 23, 29, 30, 33, 40 AND 50). SN 85-118,808. PUB. 2-15-2011. FILED 8-30-2010.
- 3,954,541. **EPIC (STANDARD CHARACTER)**. FOODHANDLER, INC., (U.S. CLS. 2, 13, 23, 29, 30, 33, 40 AND 50). SN 85-119,324. PUB. 2-15-2011. FILED 8-31-2010.

- 3,954,542. **CONTACT (STANDARD CHARACTER)**. FOODHANDLER, INC., (U.S. CLS. 2, 13, 23, 29, 30, 33, 40 AND 50). SN 85-119,326. PUB. 2-15-2011. FILED 8-31-2010.
- 3,954,543. **SILKY (STANDARD CHARACTER)**. FOODHANDLER, INC., (U.S. CLS. 2, 13, 23, 29, 30, 33, 40 AND 50). SN 85-119,328. PUB. 2-15-2011. FILED 8-31-2010.
- 3,954,590. **OYSTERIA (STANDARD CHARACTER)**. MONIQUE CHAUVIN, (U.S. CLS. 2, 13, 23, 29, 30, 33, 40 AND 50). SN 85-119,887. PUB. 2-15-2011. FILED 8-31-2010.
- 3,954,889. **MISCELLANEOUS DESIGN**. SHELLBACK, LLC, DBA EIGHT BELLS WINERY, MULTIPLE CLASS, (INT. CLS. 21 AND 33), (U.S. CLS. 2, 13, 23, 29, 30, 33, 40, 47, 49 AND 50). SN 85-123,318. PUB. 2-15-2011. FILED 9-4-2010.
- 3,954,910. **AUNT CHICK'S (STANDARD CHARACTER)**. GRENO, CARRIE PLYMPTON, (U.S. CLS. 2, 13, 23, 29, 30, 33, 40 AND 50). SN 85-123,824. PUB. 2-15-2011. FILED 9-7-2010.
- 3,954,920. **BAG SOLUTIONS (STANDARD CHARACTER)**. SCHAFFER, DAVID, (U.S. CLS. 2, 13, 23, 29, 30, 33, 40 AND 50). SN 85-124,056. PUB. 2-15-2011. FILED 9-7-2010.

---

### CLASS 22—CORDAGE AND FIBERS

- 3,953,141 ( *See Class 6 for this trademark*).
- 3,953,394 ( *See Class 1 for this trademark*).
- 3,953,513 ( *See Class 1 for this trademark*).
- 3,953,977. **HOOKS (STANDARD CHARACTER)**. HOOKS TOWING AND RECOVERY SUPPLY, LLC, (U.S. CLS. 1, 2, 7, 19, 22, 42 AND 50). SN 85-092,602. PUB. 2-15-2011. FILED 7-26-2010.
- 3,954,364. **P PROSELECT AND DESIGN**. FERGUSON ENTERPRISES, INC., (U.S. CLS. 1, 2, 7, 19, 22, 42 AND 50). SN 85-117,278. PUB. 2-15-2011. FILED 8-27-2010.
- 3,954,577. **TRASCASH (STANDARD CHARACTER)**. UNIFLEX HOLDINGS, INC., (U.S. CLS. 1, 2, 7, 19, 22, 42 AND 50). SN 85-119,729. PUB. 2-15-2011. FILED 8-31-2010.
- 3,954,578. **TRASCASH/CHECK (STANDARD CHARACTER)**. UNIFLEX HOLDINGS, INC., (U.S. CLS. 1, 2, 7, 19, 22, 42 AND 50). SN 85-119,734. PUB. 2-15-2011. FILED 8-31-2010.

---

### CLASS 23—YARNS AND THREADS

- 3,953,146. **MONOSUISSE (STANDARD CHARACTER)**. SEFAR HOLDING AG, (U.S. CL. 43). SN 77-823,917. PUB. 7-27-2010. FILED 9-10-2009.

---

### CLASS 24—FABRICS

- 3,953,000 ( *See Class 3 for this trademark*).
- 3,953,020. **O2 ORGANIC ORIGINALS AND DESIGN**. COMMONWEALTH HOME FASHIONS INC., (U.S. CLS. 42 AND 50). SN 77-371,673. PUB. 1-19-2010. FILED 1-15-2008.
- 3,953,138. **THE STICKLERS (STANDARD CHARACTER)**. DOUG C. SMITH, DBA THE STICKLER FAMILY, (U.S. CLS. 42 AND 50). SN 77-817,718. PUB. 7-27-2010. FILED 9-1-2009.
- 3,953,155 ( *See Class 20 for this trademark*).
- 3,953,207. **CROSCILL WHITE LABEL (STANDARD CHARACTER)**. CROSCILL HOME LLC, (U.S. CLS. 42 AND 50). SN 77-879,534. PUB. 2-15-2011. FILED 11-24-2009.
- 3,953,233 ( *See Class 14 for this trademark*).
- 3,953,243. **UA (STANDARD CHARACTER)**. UNDER ARMOUR, INC., (U.S. CLS. 42 AND 50). SN 77-918,131. PUB. 2-15-2011. FILED 1-22-2010.
- 3,953,471 ( *See Class 3 for this trademark*).
- 3,953,485 ( *See Class 3 for this trademark*).
- 3,953,571 ( *See Class 9 for this trademark*).
- 3,953,643 ( *See Class 3 for this trademark*).
- 3,953,802. **HOUSE OF MONARCH LOS ANGELES AND DESIGN**. PHILOSOPHIA DESIGNS, DBA HOUSE OF MONARCH, (U.S. CLS. 42 AND 50). SN 85-037,994. PUB. 2-15-2011. FILED 5-13-2010.



- 3,954,083. **NAPPYLICIOUS (STANDARD CHARACTER)**. HUNT, YOLANDA S., MULTIPLE CLASS, (INT. CLS. 24 AND 25), (U.S. CLS. 22, 39, 42 AND 50). SN 85-107,831. PUB. 2-15-2011. FILED 8-15-2010.
- 3,954,130. **PLAY ACTION AND DESIGN**. SPORTS COVERAGE, INC., (U.S. CLS. 42 AND 50). SN 85-111,110. PUB. 2-15-2011. FILED 8-19-2010.
- 3,954,615 ( *See Class 20 for this trademark*).
- 3,954,616 ( *See Class 20 for this trademark*).
- 3,954,848. **"YOUR SOURCE FOR TOWELS" (STANDARD CHARACTER)**. ASHFORD TEXTILES, LLC, (U.S. CLS. 42 AND 50). SN 85-122,793. PUB. 2-15-2011. FILED 9-3-2010.

## CLASS 25—CLOTHING

- 3,952,947 ( *See Class 16 for this trademark*).
- 3,952,970. **GET HIGHER EDUCATION TO TEACH OTHERS (STANDARD CHARACTER)**. YOUNGER, CLINT R., (U.S. CLS. 22 AND 39). SN 76-701,937. PUB. 2-15-2011. FILED 3-5-2010.
- 3,952,974. **MUSIC CLUB (STANDARD CHARACTER)**. JONES, MICHAEL W., (U.S. CLS. 22 AND 39). SN 76-702,717. PUB. 2-15-2011. FILED 4-29-2010.
- 3,952,994. **KEAULANA'S AND DESIGN**. MAKAHA OCEAN PRODUCTION LLC, DBA KEAULANA'S SURF SHOP, (U.S. CLS. 22 AND 39). SN 76-704,324. PUB. 2-15-2011. FILED 9-1-2010.
- 3,953,000 ( *See Class 3 for this trademark*).
- 3,953,007. **TUMMY SHAPER (STANDARD CHARACTER)**. NORTHERN REFLECTIONS LTD., (U.S. CLS. 22 AND 39). SN 77-168,966. PUB. 8-10-2010. FILED 4-30-2007.
- 3,953,008 ( *See Class 9 for this trademark*).
- 3,953,016. **HEIRWEAR (STANDARD CHARACTER)**. ZNA P. HOUSTON, DBA HEIR, (U.S. CLS. 22 AND 39). SN 77-253,269. PUB. 3-10-2009. FILED 8-13-2007.
- 3,953,017. **MX MEXART (STANDARD CHARACTER)**. LUIS ERNESTO HERNÁNDEZ GUARDADO, (U.S. CLS. 22 AND 39). SN 77-278,424. PUB. 2-15-2011. FILED 9-13-2007.
- 3,953,024. **BI BRUNO IERULLO (STYLIZED)**. IERULLO INTERNATIONAL, INC., (U.S. CLS. 22 AND 39). SN 77-400,672. PUB. 2-15-2011. FILED 2-19-2008.
- 3,953,034. **MISCELLANEOUS DESIGN**. AMERICAN SPORTING GOODS CORPORATION, (U.S. CLS. 22 AND 39). SN 77-607,063. PUB. 2-15-2011. FILED 11-4-2008.
- 3,953,038 ( *See Class 16 for this trademark*).
- 3,953,042. **LIFESTYLE INNOVATOR K F M BY KOLON AND DESIGN**. KOLON FASHION MATERIAL, INC., (U.S. CLS. 22 AND 39). SN 77-640,826. PUB. 1-25-2011. FILED 12-29-2008.
- 3,953,047. **HOUND DOG (STANDARD CHARACTER)**. ELVIS PRESLEY ENTERPRISES, INC., (U.S. CLS. 22 AND 39). SN 77-666,234. PUB. 2-15-2011. FILED 2-9-2009.
- 3,953,050. **GEARUP AND DESIGN**. BITCHIN GEAR AND ACCESSORIES, (U.S. CLS. 22 AND 39). SN 77-675,280. PUB. 2-15-2011. FILED 2-20-2009.
- 3,953,084. **MISCELLANEOUS DESIGN**. LUCASFILM ENTERTAINMENT COMPANY LTD., MULTIPLE CLASS, (INT. CLS. 25 AND 28), (U.S. CLS. 22, 23, 38, 39 AND 50). SN 77-762,410. PUB. 2-15-2011. FILED 6-17-2009.
- 3,953,094 ( *See Class 9 for this trademark*).
- 3,953,108. **POWER-LITES (STANDARD CHARACTER)**. GOLDTOEMORETZ, LLC, (U.S. CLS. 22 AND 39). SN 77-801,601. PUB. 2-15-2011. FILED 8-11-2009.
- 3,953,119. **MISCELLANEOUS DESIGN**. GREGG, STEPHEN, (U.S. CLS. 22 AND 39). SN 77-809,093. PUB. 2-15-2011. FILED 8-20-2009.
- 3,953,135. **STONE-AGE (STANDARD CHARACTER)**. VOLCOM, INC., (U.S. CLS. 22 AND 39). SN 77-817,567. PUB. 2-15-2011. FILED 9-1-2009.
- 3,953,145. **CHIEF INK D L INK AND DESIGN**. MENDOZA, DAVID, (U.S. CLS. 22 AND 39). SN 77-823,749. PUB. 2-15-2011. FILED 9-10-2009.
- 3,953,153. **MISCELLANEOUS DESIGN**. LEISURE SOCIETY, LLC, DBA EL DORADO, (U.S. CLS. 22 AND 39). SN 77-828,373. PUB. 8-3-2010. FILED 9-17-2009.
- 3,953,164. **SHOE BACHS, INC. AN AFFORDABLE SYMPHONY OF STYLE, QUALITY & COMFORT AND DESIGN**. SHOE BACHS, INC., (U.S. CLS. 22 AND 39). SN 77-843,180. PUB. 2-15-2011. FILED 10-7-2009.
- 3,953,170. **GUNDIES NEW YORK CITY AND DESIGN**. GUNDIES LLC, (U.S. CLS. 22 AND 39). SN 77-845,368. PUB. 2-15-2011. FILED 10-9-2009.
- 3,953,200. **BIG COCKE (STANDARD CHARACTER)**. COCKE, JAMES E., (U.S. CLS. 22 AND 39). SN 77-870,338. PUB. 2-15-2011. FILED 11-11-2009.
- 3,953,216. **WELLEN (STYLIZED)**. WELLEN, LLC, (U.S. CLS. 22 AND 39). SN 77-894,116. PUB. 2-15-2011. FILED 12-15-2009.
- 3,953,226. **KNOW FUN (STANDARD CHARACTER)**. LYNETTE ZOROYA, DBA KNOW FUN STUFF, MULTIPLE CLASS, (INT. CLS. 25 AND 41), (U.S. CLS. 22, 39, 100, 101 AND 107). SN 77-906,031. PUB. 2-15-2011. FILED 1-6-2010.
- 3,953,227. **SECRET FIT (STANDARD CHARACTER)**. CAVE SPRINGS, INC., (U.S. CLS. 22 AND 39). SN 77-907,995. PUB. 7-27-2010. FILED 1-8-2010.
- 3,953,233 ( *See Class 14 for this trademark*).
- 3,953,240. **WARPAINT CLOTHING COMPANY (STANDARD CHARACTER)**. WARPAINT CLOTHING COMPANY, (U.S. CLS. 22 AND 39). SN 77-916,410. PUB. 2-15-2011. FILED 1-21-2010.
- 3,953,245 ( *See Class 18 for this trademark*).
- 3,953,257. **CREATE AND BOUNCE (STANDARD CHARACTER)**. BU HOLDINGS, LLC, DBA BOUNCEU, MULTIPLE CLASS, (INT. CLS. 25 AND 41), (U.S. CLS. 22, 39, 100, 101 AND 107). SN 77-928,476. PUB. 6-22-2010. FILED 2-4-2010.
- 3,953,358. **M MONTICELLI AND DESIGN**. KOTNI TRADING, INC., (U.S. CLS. 22 AND 39). SN 77-952,270. PUB. 2-15-2011. FILED 3-5-2010.
- 3,953,371. **POVERTY (STANDARD CHARACTER)**. XP INNOVATION, LLC, DBA DAN'S COMP, (U.S. CLS. 22 AND 39). SN 77-953,864. PUB. 2-15-2011. FILED 3-9-2010.
- 3,953,390. **PLUMP BABY WEAR AND DESIGN**. 56 STAR, LLC, (U.S. CLS. 22 AND 39). SN 77-956,348. PUB. 2-15-2011. FILED 3-11-2010.
- 3,953,404. **BMG AND DESIGN**. BRITISH MOTORCYCLE GEAR, (U.S. CLS. 22 AND 39). SN 77-958,842. PUB. 2-15-2011. FILED 3-15-2010.
- 3,953,445. **BROKEN CHERRY (STANDARD CHARACTER)**. REMEY ROZIN, (U.S. CLS. 22 AND 39). SN 77-963,620. PUB. 2-15-2011. FILED 3-19-2010.
- 3,953,464 ( *See Class 18 for this trademark*).
- 3,953,467. **CANALI (STANDARD CHARACTER)**. CANALI IRELAND LIMITED, MULTIPLE CLASS, (INT. CLS. 25 AND 35), (U.S. CLS. 22, 39, 100, 101 AND 102). SN 78-330,147. PUB. 6-21-2005. FILED 11-19-2003.
- 3,953,468. **CANALI SPORTSWEAR AND DESIGN**. CANALI IRELAND LIMITED, (U.S. CLS. 22 AND 39). SN 78-330,168. PUB. 6-21-2005. FILED 11-19-2003.
- 3,953,471 ( *See Class 3 for this trademark*).
- 3,953,485 ( *See Class 3 for this trademark*).
- 3,953,486. **HOT SECRET BY WOMEN'S SECRET (STYLIZED)**. CORTEFIEL, S.A., (U.S. CLS. 22 AND 39). SN 79-008,770. PUB. 2-15-2011. FILED 11-19-2004.
- 3,953,490 ( *See Class 9 for this trademark*).
- 3,953,494 ( *See Class 16 for this trademark*).
- 3,953,500. **WTF (STYLIZED)**. WORLD TAEKWONDO FEDERATION, MULTIPLE CLASS, (INT. CLS. 25, 28 AND 41), (U.S. CLS. 22, 23, 38, 39, 50, 100, 101 AND 107). SN 79-068,529. PUB. 9-14-2010. FILED 3-2-2009.
- 3,953,502 ( *See Class 8 for this trademark*).
- 3,953,521 ( *See Class 9 for this trademark*).
- 3,953,525. **MISCELLANEOUS DESIGN**. LONGBIN CHEN, (U.S. CLS. 22 AND 39). SN 79-077,218. PUB. 2-15-2011. FILED 11-16-2009.
- 3,953,553 ( *See Class 16 for this trademark*).
- 3,953,594 ( *See Class 9 for this trademark*).
- 3,953,606. **VORGE (STYLIZED)**. MENG FANTAO, (U.S. CLS. 22 AND 39). SN 79-083,061. PUB. 2-15-2011. FILED 3-15-2010.
- 3,953,608. **HEARTSONG (STANDARD CHARACTER)**. MELINDA CHIEW, (U.S. CLS. 22 AND 39). SN 79-083,422. PUB. 2-15-2011. FILED 4-28-2010.
- 3,953,614 ( *See Class 18 for this trademark*).
- 3,953,632 ( *See Class 3 for this trademark*).
- 3,953,641. **ONEOFEX AND DESIGN**. SVYATOSLAV MORO-

- ZOV, MULTIPLE CLASS, (INT. CLS. 25 AND 39), (U.S. CLS. 22, 39, 100 AND 105). SN 79-086,959. PUB. 2-15-2011. FILED 7-26-2010.
- 3,953,658. **MISCELLANEOUS DESIGN**. ZHEJIANG BAILIAN INDUSTRY AND TRADE GROUP CO., LTD., (U.S. CLS. 22 AND 39). SN 79-087,699. PUB. 2-15-2011. FILED 8-11-2010.
- 3,953,677. **SUNSPICE (STYLIZED)**. LOU GUOPING, (U.S. CLS. 22 AND 39). SN 79-089,777. PUB. 2-15-2011. FILED 8-17-2010.
- 3,953,680. **MYGIRLFUND (STANDARD CHARACTER)**. BLACKSTAR VENTURES, LLC, MULTIPLE CLASS, (INT. CLS. 25, 42 AND 45), (U.S. CLS. 22, 39, 100 AND 101). SN 85-000,385. PUB. 2-15-2011. FILED 3-29-2010.
- 3,953,681. **MYGIRLFUND AND DESIGN**. BLACKSTAR VENTURES, LLC, MULTIPLE CLASS, (INT. CLS. 25, 42 AND 45), (U.S. CLS. 22, 39, 100 AND 101). SN 85-000,390. PUB. 2-15-2011. FILED 3-29-2010.
- 3,953,684 ( *See Class 16 for this trademark*).
- 3,953,688. **LUNANOVIAS (STANDARD CHARACTER)**. NO-UIEURO, S.L., (U.S. CLS. 22 AND 39). SN 85-001,097. PUB. 2-15-2011. FILED 3-29-2010.
- 3,953,699. **SWAMISZ (STANDARD CHARACTER)**. I.H.W. MANAGEMENT LIMITED, DBA THE FINCHLEY GROUP, (U.S. CLS. 22 AND 39). SN 85-003,176. PUB. 2-15-2011. FILED 3-31-2010.
- 3,953,702 ( *See Class 18 for this trademark*).
- 3,953,706. **BEAUTIFUL FEET WORLDWIDE (STANDARD CHARACTER)**. JASPER RYAN C, DBA BEAUTIFUL FEET WORLDWIDE, (U.S. CLS. 22 AND 39). SN 85-005,014. PUB. 2-15-2011. FILED 4-2-2010.
- 3,953,708. **ZUTANO (STANDARD CHARACTER)**. ZUTANO, INC., (U.S. CLS. 22 AND 39). SN 85-006,059. PUB. 2-15-2011. FILED 4-5-2010.
- 3,953,715 ( *See Class 9 for this trademark*).
- 3,953,722 ( *See Class 16 for this trademark*).
- 3,953,730. **DROP CITY (STANDARD CHARACTER)**. SEKSES DISTRIBUTION LLC, (U.S. CLS. 22 AND 39). SN 85-014,223. PUB. 2-15-2011. FILED 4-14-2010.
- 3,953,752. **MISCELLANEOUS DESIGN**. I.H.W. MANAGEMENT LIMITED, DBA THE FINCHLEY GROUP, (U.S. CLS. 22 AND 39). SN 85-023,969. PUB. 2-15-2011. FILED 4-27-2010.
- 3,953,753. **SWAMISZ (STYLIZED)**. I.H.W. MANAGEMENT LIMITED, DBA THE FINCHLEY GROUP, (U.S. CLS. 22 AND 39). SN 85-024,054. PUB. 2-15-2011. FILED 4-27-2010.
- 3,953,767. **MISCELLANEOUS DESIGN**. I.H.W. MANAGEMENT LIMITED, DBA THE FINCHLEY GROUP, (U.S. CLS. 22 AND 39). SN 85-028,451. PUB. 2-15-2011. FILED 5-3-2010.
- 3,953,798. **GEL-FITWALK LYTE (STANDARD CHARACTER)**. ASICS CORPORATION, (U.S. CLS. 22 AND 39). SN 85-037,190. PUB. 2-15-2011. FILED 5-13-2010.
- 3,953,800. **WORMSER (STANDARD CHARACTER)**. SARAMAX APPAREL GROUP, INC., (U.S. CLS. 22 AND 39). SN 85-037,700. PUB. 2-15-2011. FILED 5-13-2010.
- 3,953,806. **ROYALE AND DESIGN**. ROYALE MONTE CARLO LIMITED, MULTIPLE CLASS, (INT. CLS. 25, 41 AND 43), (U.S. CLS. 22, 39, 100, 101 AND 107). SN 85-038,857. PUB. 2-15-2011. FILED 5-14-2010.
- 3,953,843. **BALD HEADED GEAR (STANDARD CHARACTER)**. BLUE, JOSEPH C., DBA BALD HEADED GEAR, (U.S. CLS. 22 AND 39). SN 85-051,383. PUB. 2-15-2011. FILED 6-1-2010.
- 3,953,868. **ISLANDER (STANDARD CHARACTER)**. FBC WORLDWIDE LLC, (U.S. CLS. 22 AND 39). SN 85-059,945. PUB. 2-15-2011. FILED 6-10-2010.
- 3,953,870. **LOVE MY BUBBLES (STANDARD CHARACTER)**. SWEET AND VICIOUS LLC, (U.S. CLS. 22 AND 39). SN 85-060,617. PUB. 2-15-2011. FILED 6-11-2010.
- 3,953,872. **OMAHA NIGHTHAWKS AND DESIGN**. UNITED FOOTBALL LEAGUE, LLC, MULTIPLE CLASS, (INT. CLS. 25 AND 41), (U.S. CLS. 22, 39, 100, 101 AND 107). SN 85-061,412. PUB. 11-9-2010. FILED 6-12-2010.
- 3,953,886. **BOARDPASS (STANDARD CHARACTER)**. RAIF, RONALD, (U.S. CLS. 22 AND 39). SN 85-067,236. PUB. 2-15-2011. FILED 6-21-2010.
- 3,953,899. **MARATHON MAN (STANDARD CHARACTER)**. JOHN GROAT, DBA HOLY SHIRT!, (U.S. CLS. 22 AND 39). SN 85-070,773. PUB. 2-15-2011. FILED 6-24-2010.
- 3,953,925. **WHAT KATIE DID (STANDARD CHARACTER)**. WHAT KATIE DID, LTD., MULTIPLE CLASS, (INT. CLS. 25 AND 35), (U.S. CLS. 22, 39, 100, 101 AND 102). SN 85-076,680. PUB. 2-15-2011. FILED 7-2-2010.
- 3,953,944. **LIME CORAL AND DESIGN**. BRIAN SCHOENHOLTZ, (U.S. CLS. 22 AND 39). SN 85-082,820. PUB. 2-15-2011. FILED 7-12-2010.
- 3,953,970. **DANNY SHANE (STANDARD CHARACTER)**. GOLF ETC. OF AMERICA, INC., (U.S. CLS. 22 AND 39). SN 85-090,603. PUB. 2-15-2011. FILED 7-22-2010.
- 3,953,986 ( *See Class 9 for this trademark*).
- 3,954,047. **STRICT LEATHER (STANDARD CHARACTER)**. XR, LLC, (U.S. CLS. 22 AND 39). SN 85-105,021. PUB. 2-15-2011. FILED 8-11-2010.
- 3,954,049. **DIVE LIFE DAVID DUNLEAVY (STYLIZED)**. DUNLEAVY, DAVID, (U.S. CLS. 22 AND 39). SN 85-105,187. PUB. 2-15-2011. FILED 8-11-2010.
- 3,954,058. **DENIM LONGEVITY (STANDARD CHARACTER)**. THE BCL GROUP, (U.S. CLS. 22 AND 39). SN 85-105,926. PUB. 2-15-2011. FILED 8-12-2010.
- 3,954,065. **STILETTO HARDWARE (STANDARD CHARACTER)**. KELLINA BRANDS INC., (U.S. CLS. 22 AND 39). SN 85-106,737. PUB. 2-15-2011. FILED 8-13-2010.
- 3,954,083 ( *See Class 24 for this trademark*).
- 3,954,097. **CONGRESSIONAL CUP AND DESIGN**. THE LONG BEACH YACHT CLUB, MULTIPLE CLASS, (INT. CLS. 25 AND 41), (U.S. CLS. 22, 39, 100, 101 AND 107). SN 85-109,074. PUB. 2-15-2011. FILED 8-17-2010.
- 3,954,124. **GN THERAPY (STANDARD CHARACTER)**. WILLY MONTANEZ, (U.S. CLS. 22 AND 39). SN 85-110,874. PUB. 2-15-2011. FILED 8-19-2010.
- 3,954,126. **BEACH WEDDING HUT (STANDARD CHARACTER)**. BEACH WEDDING HUT, (U.S. CLS. 22 AND 39). SN 85-110,955. PUB. 2-15-2011. FILED 8-19-2010.
- 3,954,216 ( *See Class 9 for this trademark*).
- 3,954,217 ( *See Class 16 for this trademark*).
- 3,954,238. **COUNTRY COUTURE AND DESIGN**. REGENT GLOBAL SOURCING INC., (U.S. CLS. 22 AND 39). SN 85-114,978. PUB. 2-15-2011. FILED 8-24-2010.
- 3,954,271. **MISCELLANEOUS DESIGN**. STUSSY, INC., (U.S. CLS. 22 AND 39). SN 85-115,691. PUB. 2-15-2011. FILED 8-25-2010.
- 3,954,315. **MYETIES.COM (STANDARD CHARACTER)**. MYETIES.COM, (U.S. CLS. 22 AND 39). SN 85-116,486. PUB. 2-15-2011. FILED 8-26-2010.
- 3,954,337 ( *See Class 14 for this trademark*).
- 3,954,346. **BOOTMATE (STANDARD CHARACTER)**. THE MAGIC BUS, LLC, DBA SKADI NORDIC, (U.S. CLS. 22 AND 39). SN 85-117,118. PUB. 2-15-2011. FILED 8-27-2010.
- 3,954,366. **BIBBY WRAP (STANDARD CHARACTER)**. DADDIN CORP, (U.S. CLS. 22 AND 39). SN 85-117,290. PUB. 2-15-2011. FILED 8-27-2010.
- 3,954,367. **BIBBY WRAP AND DESIGN**. DADDIN CORP, (U.S. CLS. 22 AND 39). SN 85-117,297. PUB. 2-15-2011. FILED 8-27-2010.
- 3,954,368. **BLACK WHITE AND DESIGN**. CHOICE CAP, INC., (U.S. CLS. 22 AND 39). SN 85-117,332. PUB. 2-15-2011. FILED 8-27-2010.
- 3,954,390. **ACRYLICANA (STANDARD CHARACTER)**. WINKLER, MARY, (U.S. CLS. 22 AND 39). SN 85-117,707. PUB. 2-15-2011. FILED 8-27-2010.
- 3,954,431. **KRAZY KAT (STANDARD CHARACTER)**. KRAZY KAT SPORTSWEAR LLC, (U.S. CLS. 22 AND 39). SN 85-118,297. PUB. 2-15-2011. FILED 8-30-2010.
- 3,954,432. **SILENT ARMY (STANDARD CHARACTER)**. ADVANCED ARMAMENT CORP., LLC, (U.S. CLS. 22 AND 39). SN 85-118,313. PUB. 2-15-2011. FILED 8-30-2010.
- 3,954,441. **CORINTHIANS (STANDARD CHARACTER)**. KATHERINE BISHOP II, LTD., DBA KB STUDIO, (U.S. CLS. 22 AND 39). SN 85-118,409. PUB. 2-15-2011. FILED 8-30-2010.
- 3,954,442. **PEERESS (STANDARD CHARACTER)**. KATHERINE BISHOP II, LTD., DBA KB STUDIO, (U.S. CLS. 22 AND 39). SN 85-118,419. PUB. 2-15-2011. FILED 8-30-2010.
- 3,954,449 ( *See Class 9 for this trademark*).
- 3,954,451. **IMPERIAL TOWN (STANDARD CHARACTER)**. IMPERIAL S.P.A., (U.S. CLS. 22 AND 39). SN 85-118,500.

PUB. 2-15-2011. FILED 8-30-2010.  
 3,954,461. **GOODSPARK (STANDARD CHARACTER)**. MOHAMMADI, ARASH, MULTIPLE CLASS, (INT. CLS. 25 AND 35), (U.S. CLS. 22, 39, 100, 101 AND 102). SN 85-118,574. PUB. 2-15-2011. FILED 8-30-2010.  
 3,954,515. **MAHALO (STANDARD CHARACTER)**. MCADAM, DANIEL PATRICK, (U.S. CLS. 22 AND 39). SN 85-119,046. PUB. 2-15-2011. FILED 8-30-2010.  
 3,954,575. **JOE BALLS (STANDARD CHARACTER)**. BONVENTRE, JOSEPH, (U.S. CLS. 22 AND 39). SN 85-119,720. PUB. 2-15-2011. FILED 8-31-2010.  
 3,954,618. **MISCELLANEOUS DESIGN**. LAQADASIC, (U.S. CLS. 22 AND 39). SN 85-120,219. PUB. 2-15-2011. FILED 8-31-2010.  
 3,954,625 ( *See Class 9 for this trademark*).  
 3,954,662. **IRONSKIN (STANDARD CHARACTER)**. RED STEER GLOVE COMPANY, (U.S. CLS. 22 AND 39). SN 85-120,694. PUB. 2-15-2011. FILED 9-1-2010.  
 3,954,708 ( *See Class 12 for this trademark*).  
 3,954,709. **TUMMY-UPS (STANDARD CHARACTER)**. THE HOLD-UP SUSPENDER COMPANY, (U.S. CLS. 22 AND 39). SN 85-121,065. PUB. 2-15-2011. FILED 9-1-2010.  
 3,954,735. **FALL OUT (STANDARD CHARACTER)**. CELESTE FOOTWEAR, TA CELESTEFootwear, (U.S. CLS. 22 AND 39). SN 85-121,527. PUB. 2-15-2011. FILED 9-2-2010.  
 3,954,737. **TRUE REPUBLIC (STANDARD CHARACTER)**. CELESTE FOOTWEAR, DBA CELESTE FOOTWEAR, (U.S. CLS. 22 AND 39). SN 85-121,547. PUB. 2-15-2011. FILED 9-2-2010.  
 3,954,751. **UNDUN (STYLIZED)**. GREEN JEANS, LLC, DBA UNDUN DENIM, (U.S. CLS. 22 AND 39). SN 85-121,686. PUB. 2-15-2011. FILED 9-2-2010.  
 3,954,758. **3 FOOT RULE (STANDARD CHARACTER)**. LUCKY MEDIA GROUP, INC., (U.S. CLS. 22 AND 39). SN 85-121,781. PUB. 2-15-2011. FILED 9-2-2010.  
 3,954,764. **PODIUMWEAR AND DESIGN**. PODIUMWEAR CUSTOM SPORTS APPAREL COMPANY, (U.S. CLS. 22 AND 39). SN 85-121,834. PUB. 2-15-2011. FILED 9-2-2010.  
 3,954,765. **AFL AND DESIGN**. ARENA FOOTBALL ONE, LLC, AKA AFL, MULTIPLE CLASS, (INT. CLS. 25 AND 41), (U.S. CLS. 22, 39, 100, 101 AND 107). SN 85-121,839. PUB. 2-15-2011. FILED 9-2-2010.  
 3,954,768. **MISCELLANEOUS DESIGN**. PODIUMWEAR CUSTOM SPORTS APPAREL COMPANY, (U.S. CLS. 22 AND 39). SN 85-121,851. PUB. 2-15-2011. FILED 9-2-2010.  
 3,954,806 ( *See Class 2 for this trademark*).  
 3,954,823. **GUIDO LOMBARDI (STANDARD CHARACTER)**. SICIM, (U.S. CLS. 22 AND 39). SN 85-122,489. PUB. 2-15-2011. FILED 9-3-2010.  
 3,954,825. **OMNI-DRY (STANDARD CHARACTER)**. COLUMBIA SPORTSWEAR NORTH AMERICA, INC., (U.S. CLS. 22 AND 39). SN 85-122,525. PUB. 2-15-2011. FILED 9-3-2010.  
 3,954,830. **HOKED AND DESIGN**. HOKED INDUSTRIES, LLC, (U.S. CLS. 22 AND 39). SN 85-122,634. PUB. 2-15-2011. FILED 9-3-2010.  
 3,954,833. **MISCELLANEOUS DESIGN**. STONE, JEREMIAH, (U.S. CLS. 22 AND 39). SN 85-122,689. PUB. 2-15-2011. FILED 9-3-2010.  
 3,954,867. **GLOBAL TRACKER (STANDARD CHARACTER)**. LIPSEY'S DISTRIBUTION, LLC, (U.S. CLS. 22 AND 39). SN 85-122,998. PUB. 2-15-2011. FILED 9-3-2010.  
 3,954,875. **FIVE STAR VINTAGE AND DESIGN**. NEWBLUE HOLDINGS LLC, (U.S. CLS. 22 AND 39). SN 85-123,116. PUB. 2-15-2011. FILED 9-3-2010.  
 3,954,890. **US AND DESIGN**. GARY L. PIFER, (U.S. CLS. 22 AND 39). SN 85-123,331. PUB. 2-15-2011. FILED 9-4-2010.  
 3,954,898. **BLUBOY (STANDARD CHARACTER)**. MARTIN, RYAN T, DBA BLUBOY BRAND, (U.S. CLS. 22 AND 39). SN 85-123,468. PUB. 2-15-2011. FILED 9-5-2010.  
 3,954,904. **HOKED (STANDARD CHARACTER)**. HOKED INDUSTRIES, LLC, (U.S. CLS. 22 AND 39). SN 85-123,726. PUB. 2-15-2011. FILED 9-7-2010.  
 3,954,924. **SEIZE THE DAY (STANDARD CHARACTER)**. HOKED NATION, INC., (U.S. CLS. 22 AND 39). SN 85-124,197. PUB. 2-15-2011. FILED 9-7-2010.  
 3,954,928. **MATA HARI (STANDARD CHARACTER)**. MATA HARI COLLECTION, LLC, (U.S. CLS. 22 AND 39). SN 85-124,254. PUB. 2-15-2011. FILED 9-7-2010.

3,954,941. **LAQADASIC (STANDARD CHARACTER)**. LAQADASIC, (U.S. CLS. 22 AND 39). SN 85-124,968. PUB. 2-15-2011. FILED 9-8-2010.  
 3,954,950. **BRANDISH (STANDARD CHARACTER)**. CIPRIANI, PAUL, DBA BRANDISH, (U.S. CLS. 22 AND 39). SN 85-125,503. PUB. 2-15-2011. FILED 9-8-2010.  
 3,954,984. **VINCE. (STYLIZED)**. KELLWOOD COMPANY, (U.S. CLS. 22 AND 39). SN 85-129,380. PUB. 2-15-2011. FILED 9-14-2010.  
 3,954,998. **PE (STYLIZED)**. PEI LICENSING, INC., (U.S. CLS. 22 AND 39). SN 85-132,270. PUB. 2-15-2011. FILED 9-17-2010.  
 3,955,026. **E (STYLIZED)**. DONOVAN ENGLAND, LLC, (U.S. CLS. 22 AND 39). SN 85-136,843. PUB. 2-15-2011. FILED 9-23-2010.  
 3,955,036. **SKYLER AND DESIGN**. REGENT GLOBAL SOURCING INC., (U.S. CLS. 22 AND 39). SN 85-137,987. PUB. 2-15-2011. FILED 9-24-2010.  
 3,955,050. **HERITAGE CROSS (STANDARD CHARACTER)**. ADDED TOUCH EMBROIDERY, LTD., DBA HERITAGE CROSS A, (U.S. CLS. 22 AND 39). SN 85-139,505. PUB. 2-15-2011. FILED 9-28-2010.  
 3,955,072. **FB (STANDARD CHARACTER)**. GTFM, INC., (U.S. CLS. 22 AND 39). SN 85-145,302. PUB. 2-15-2011. FILED 10-5-2010.  
 3,955,099. **BREEZEWAY (STANDARD CHARACTER)**. TALESE, MATTHEW, (U.S. CLS. 22 AND 39). SN 85-155,082. PUB. 2-15-2011. FILED 10-18-2010.  
 3,955,101. **CARPE DIEM (STANDARD CHARACTER)**. HOOKED NATION, INC., (U.S. CLS. 22 AND 39). SN 85-156,169. PUB. 2-15-2011. FILED 10-19-2010.  
 3,955,135. **IT'S ALL ABOUT THE A AND DESIGN**. COLORADO AVALANCHE, LLC, (U.S. CLS. 22 AND 39). SN 85-172,308. PUB. 2-15-2011. FILED 11-9-2010.  
 3,955,137. **MISCELLANEOUS DESIGN**. NBA PROPERTIES, INC., (U.S. CLS. 22 AND 39). SN 85-172,539. PUB. 2-15-2011. FILED 11-9-2010.  
 3,955,140 ( *See Class 6 for this trademark*).

---

## CLASS 26—FANCY GOODS

3,953,900. **SWIRLYDO (STANDARD CHARACTER)**. GRACE HARVEST & ASSOC. LLC, (U.S. CLS. 37, 39, 40, 42 AND 50). SN 85-071,199. PUB. 2-15-2011. FILED 6-24-2010.  
 3,953,985. **HAIR LINGERIE (STYLIZED)**. KIARA L. BAILEY, (U.S. CLS. 37, 39, 40, 42 AND 50). SN 85-094,263. PUB. 2-15-2011. FILED 7-27-2010.

---

## CLASS 27—FLOOR COVERINGS

3,953,618 ( *See Class 12 for this trademark*).  
 3,953,754. **PITMAT USA AND DESIGN**. PITMAT USA, (U.S. CLS. 19, 20, 37, 42 AND 50). SN 85-024,226. PUB. 2-15-2011. FILED 4-27-2010.  
 3,954,324. **ALTURASHOME (STANDARD CHARACTER)**. PICTURE GALLERIES, INC., (U.S. CLS. 19, 20, 37, 42 AND 50). SN 85-116,672. PUB. 2-15-2011. FILED 8-26-2010.  
 3,954,407. **DUAL-GRIP (STANDARD CHARACTER)**. SOFA MART, LLC, (U.S. CLS. 19, 20, 37, 42 AND 50). SN 85-117,881. PUB. 2-15-2011. FILED 8-27-2010.  
 3,954,785. **CONSTANTINE (STANDARD CHARACTER)**. MILLIKEN & COMPANY, (U.S. CLS. 19, 20, 37, 42 AND 50). SN 85-122,063. PUB. 2-15-2011. FILED 9-2-2010.

---

## CLASS 28—TOYS AND SPORTING GOODS

3,952,947 ( *See Class 16 for this trademark*).  
 3,952,957 ( *See Class 9 for this trademark*).  
 3,953,000 ( *See Class 3 for this trademark*).  
 3,953,001 ( *See Class 9 for this trademark*).  
 3,953,003 ( *See Class 16 for this trademark*).  
 3,953,019. **BLUE SKY (STANDARD CHARACTER)**. SPIN

- MASTER LTD., (U.S. CLS. 22, 23, 38 AND 50). SN 77-299,553. PUB. 11-9-2010. FILED 10-9-2007.  
 3,953,077 ( See Class 9 for this trademark).  
 3,953,084 ( See Class 25 for this trademark).  
 3,953,085 ( See Class 9 for this trademark).  
 3,953,256. **POWERSILK (STANDARD CHARACTER)**. ADVANCIUM TECHNOLOGIES, (U.S. CLS. 22, 23, 38 AND 50). SN 77-927,261. PUB. 2-15-2011. FILED 2-3-2010.  
 3,953,272. **PUSHER (STANDARD CHARACTER)**. REVOLUTION CLIMBING, INC., (U.S. CLS. 22, 23, 38 AND 50). SN 77-935,853. PUB. 2-15-2011. FILED 2-15-2010.  
 3,953,294. **AIRFIELD (STANDARD CHARACTER)**. RAIDEN TECHNOLOGY, INC., (U.S. CLS. 22, 23, 38 AND 50). SN 77-941,953. PUB. 2-15-2011. FILED 2-22-2010.  
 3,953,485 ( See Class 3 for this trademark).  
 3,953,500 ( See Class 25 for this trademark).  
 3,953,502 ( See Class 8 for this trademark).  
 3,953,516 ( See Class 9 for this trademark).  
 3,953,547. **BEATBELLY (STANDARD CHARACTER)**. STRAKSSTRAK B.V., (U.S. CLS. 22, 23, 38 AND 50). SN 79-080,449. PUB. 2-15-2011. FILED 2-9-2010.  
 3,953,553 ( See Class 16 for this trademark).  
 3,953,602. **TRIQO (STANDARD CHARACTER)**. NICO HEIMANS H.O.D.N. NICO HEIMANS VORMGEVING, (U.S. CLS. 22, 23, 38 AND 50). SN 79-082,873. PUB. 2-15-2011. FILED 4-6-2010.  
 3,953,673 ( See Class 12 for this trademark).  
 3,953,674. **BOOBAM AND DESIGN**. IDIS SÄRL, (U.S. CLS. 22, 23, 38 AND 50). SN 79-089,558. PUB. 2-15-2011. FILED 9-29-2010.  
 3,953,693. **DON'T LOSE YOUR MARBLES! A GAME FOR THE WHOLE FAMILY AGES 3-100 AND DESIGN**. LAROBARDIER CONTRACT AND DESIGN LLC, (U.S. CLS. 22, 23, 38 AND 50). SN 85-002,425. PUB. 2-15-2011. FILED 3-30-2010.  
 3,953,734 ( See Class 13 for this trademark).  
 3,953,791. **SOLEIRO (STANDARD CHARACTER)**. ALDRETEVERGARA, GENARO, (U.S. CLS. 22, 23, 38 AND 50). SN 85-035,763. PUB. 2-15-2011. FILED 5-11-2010.  
 3,953,913. **SPETSNAZ (STANDARD CHARACTER)**. LEE, SHANYAO, (U.S. CLS. 22, 23, 38 AND 50). SN 85-073,114. PUB. 2-15-2011. FILED 6-28-2010.  
 3,953,926. **THE EXTRA 20 YARDS (STYLIZED)**. THE EXTRA 20 YARDS LTD, TA THE EXTRA 20 YARDS, (U.S. CLS. 22, 23, 38 AND 50). SN 85-076,734. PUB. 2-15-2011. FILED 7-2-2010.  
 3,953,928 ( See Class 20 for this trademark).  
 3,954,132. **CHAKRA DIVINATION (STYLIZED)**. ALVAREZ, MELISSA, (U.S. CLS. 22, 23, 38 AND 50). SN 85-111,134. PUB. 2-15-2011. FILED 8-19-2010.  
 3,954,148. **HIC (STANDARD CHARACTER)**. MITCHELL BO R, DBA HIC SKATEBOARDS, (U.S. CLS. 22, 23, 38 AND 50). SN 85-111,743. PUB. 2-15-2011. FILED 8-19-2010.  
 3,954,155. **BOLLINGER (STANDARD CHARACTER)**. ROYAL QUEST, LLC, (U.S. CLS. 22, 23, 38 AND 50). SN 85-112,121. PUB. 2-15-2011. FILED 8-20-2010.  
 3,954,176. **VO-TOYS AND DESIGN**. VO-TOYS, INC., (U.S. CLS. 22, 23, 38 AND 50). SN 85-113,193. PUB. 2-15-2011. FILED 8-23-2010.  
 3,954,180. **WHITE MOUNTAIN PUZZLES INC. AND DESIGN**. WHITE MOUNTIAN PUZZLES INC., (U.S. CLS. 22, 23, 38 AND 50). SN 85-113,353. PUB. 2-15-2011. FILED 8-23-2010.  
 3,954,202. **TURNS & TOPICS (STANDARD CHARACTER)**. SUPER DUPER INC., DBA SUPER DUPER PUBLICATIONS, (U.S. CLS. 22, 23, 38 AND 50). SN 85-114,236. PUB. 2-15-2011. FILED 8-24-2010.  
 3,954,445. **MUTINY (STANDARD CHARACTER)**. EASTMAN OUTDOORS, INC., (U.S. CLS. 22, 23, 38 AND 50). SN 85-118,427. PUB. 2-15-2011. FILED 8-30-2010.  
 3,954,466. **MUSCLE CAR MONEY (STANDARD CHARACTER)**. SCIENTIFIC GAMES INTERNATIONAL, INC., (U.S. CLS. 22, 23, 38 AND 50). SN 85-118,603. PUB. 2-15-2011. FILED 8-30-2010.  
 3,954,493. **HELLA COOL COPTERS AND DESIGN**. US JESCO INTERNATIONAL LTD. INC., (U.S. CLS. 22, 23, 38 AND 50). SN 85-118,821. PUB. 2-15-2011. FILED 8-30-2010.  
 3,954,497. **HELLA COOL COPTERS (STANDARD CHARACTER)**. US JESCO INTERNATIONAL LTD., INC., (U.S. CLS. 22, 23, 38 AND 50). SN 85-118,844. PUB. 2-15-2011. FILED 8-30-2010.  
 3,954,594. **OFF THE WALL BALL (STANDARD CHARACTER)**. OZWEST, INC., AKA OZWEST IMPORTS, INC., (U.S. CLS. 22, 23, 38 AND 50). SN 85-119,967. PUB. 2-15-2011. FILED 8-31-2010.  
 3,954,599. **BUNGLE BUNGLE (STANDARD CHARACTER)**. OZWEST, INC., AKA OZWEST IMPORTS, INC., (U.S. CLS. 22, 23, 38 AND 50). SN 85-119,988. PUB. 2-15-2011. FILED 8-31-2010.  
 3,954,642. **BAG-O-LOOT AND DESIGN**. SHELLEY, JOHN, (U.S. CLS. 22, 23, 38 AND 50). SN 85-120,512. PUB. 2-15-2011. FILED 9-1-2010.  
 3,954,647. **MAYHEM (STANDARD CHARACTER)**. EASTMAN OUTDOORS, INC., (U.S. CLS. 22, 23, 38 AND 50). SN 85-120,577. PUB. 2-15-2011. FILED 9-1-2010.  
 3,954,667. **EKSTRÖM AND DESIGN**. EKSTRÖM, CARL, (U.S. CLS. 22, 23, 38 AND 50). SN 85-120,709. PUB. 2-15-2011. FILED 9-1-2010.  
 3,954,782. **DURATRED (STANDARD CHARACTER)**. PRINCE SPORTS, INC., (U.S. CLS. 22, 23, 38 AND 50). SN 85-121,990. PUB. 2-15-2011. FILED 9-2-2010.  
 3,954,791. **DELILAH NOIR (STANDARD CHARACTER)**. THE ASHTON-DRAKE GALLERIES, LTD., (U.S. CLS. 22, 23, 38 AND 50). SN 85-122,109. PUB. 2-15-2011. FILED 9-2-2010.  
 3,954,908. **LIFELINEUSA POWER WHEEL (STANDARD CHARACTER)**. LIFELINE INTERNATIONAL, INC., (U.S. CLS. 22, 23, 38 AND 50). SN 85-123,791. PUB. 2-15-2011. FILED 9-7-2010.  
 3,954,926. **BALDEEZ (STANDARD CHARACTER)**. ZING TOYS, INC., (U.S. CLS. 22, 23, 38 AND 50). SN 85-124,209. PUB. 2-15-2011. FILED 9-7-2010.  
 3,954,969. **CHIP SHOTZ (STANDARD CHARACTER)**. ZING TOYS, INC., (U.S. CLS. 22, 23, 38 AND 50). SN 85-127,710. PUB. 2-15-2011. FILED 9-12-2010.  
 3,954,972. **HOT WINGZ (STANDARD CHARACTER)**. OZWEST, INC., AKA OZWEST IMPORTS, INC., (U.S. CLS. 22, 23, 38 AND 50). SN 85-128,085. PUB. 2-15-2011. FILED 9-13-2010.  
 3,954,974. **AIRBOW SHOTZ (STANDARD CHARACTER)**. OZWEST, INC., AKA OZWEST IMPORTS, INC., (U.S. CLS. 22, 23, 38 AND 50). SN 85-128,113. PUB. 2-15-2011. FILED 9-13-2010.  
 3,954,975. **ITTY BITTY FROG (STANDARD CHARACTER)**. JOHNSON, KIMBERLY P., (U.S. CLS. 22, 23, 38 AND 50). SN 85-128,257. PUB. 2-15-2011. FILED 9-13-2010.  
 3,954,980. **HOT ROCKETZ (STANDARD CHARACTER)**. OZWEST, INC., AKA OZWEST IMPORTS, INC., (U.S. CLS. 22, 23, 38 AND 50). SN 85-129,056. PUB. 2-15-2011. FILED 9-14-2010.  
 3,954,982. **LITTLE RIPPERZ (STANDARD CHARACTER)**. OZWEST, INC., AKA OZWEST IMPORTS, INC., (U.S. CLS. 22, 23, 38 AND 50). SN 85-129,085. PUB. 2-15-2011. FILED 9-14-2010.  
 3,955,032. **MOUSEHUNTER (STANDARD CHARACTER)**. OURPET'S COMPANY, (U.S. CLS. 22, 23, 38 AND 50). SN 85-137,582. PUB. 2-15-2011. FILED 9-24-2010.  
 3,955,104. **THERMALLY FUSED STRONG, THIN, SMOOTH AND DESIGN**. PURE FISHING, INC., (U.S. CLS. 22, 23, 38 AND 50). SN 85-157,993. PUB. 2-15-2011. FILED 10-21-2010.  
 3,955,109. **CARBRA-MAX (STANDARD CHARACTER)**. EASTMAN OUTDOORS, INC., (U.S. CLS. 22, 23, 38 AND 50). SN 85-162,208. PUB. 2-15-2011. FILED 10-27-2010.  
 3,955,139. **ICKEE (STANDARD CHARACTER)**. ZING TOYS, INC., (U.S. CLS. 22, 23, 38 AND 50). SN 85-173,783. PUB. 2-15-2011. FILED 11-10-2010.  
 3,955,149. **MANE EVENTS (STANDARD CHARACTER)**. MULTIPET INTERNATIONAL, INC., (U.S. CLS. 22, 23, 38 AND 50). SN 85-192,428. PUB. 2-15-2011. FILED 12-7-2010.
- 
- CLASS 29—MEATS AND PROCESSED FOODS**  
 3,953,005. **GRAN PREMIO (STANDARD CHARACTER)**. DANIELE INTERNATIONAL, INC., (U.S. CL. 46). SN 77-163,396. PUB. 4-15-2008. FILED 4-23-2007.  
 3,953,006. **RISERVA (STANDARD CHARACTER)**. DANIELE

- INTERNATIONAL, INC., (U.S. CL. 46). SN 77-163,450. PUB. 4-1-2008. FILED 4-23-2007.
- 3,953,049 ( *See Class 6 for this trademark.*).
- 3,953,078 ( *See Class 5 for this trademark.*).
- 3,953,083 ( *See Class 1 for this trademark.*).
- 3,953,120. **DIXIE LILY AND DESIGN.** CHINA DOLL RICE AND BEANS, INC., MULTIPLE CLASS, (INT. CLS. 29 AND 30), (U.S. CL. 46). SN 77-811,933. PUB. 2-15-2011. FILED 8-25-2009.
- 3,953,198. **PROVOCATEUR DE GOUT (STANDARD CHARACTER).** CENTRE NATIONAL INTERPROFESSIONNEL DE L'ECONOMIE LAITIÈRE - CNIEL, MULTIPLE CLASS, (INT. CLS. 29, 30, 35, 41 AND 43), (U.S. CLS. 46, 100, 101, 102 AND 107). SN 77-866,082. PUB. 2-15-2011. FILED 11-5-2009.
- 3,953,457. **ARZ AND DESIGN.** KAROUN DAIRIES, INC., (U.S. CL. 46). SN 77-966,501. PUB. 2-15-2011. FILED 3-23-2010.
- 3,953,458. **GOPI AND DESIGN.** KAROUN DAIRIES, INC., (U.S. CL. 46). SN 77-966,535. PUB. 2-15-2011. FILED 3-23-2010.
- 3,953,465. **MARIE'S (STYLIZED).** VENTURA FOODS, LLC, MULTIPLE CLASS, (INT. CLS. 29, 30 AND 43), (U.S. CLS. 46, 100 AND 101). SN 77-981,694. PUB. 12-9-2008. FILED 5-9-2008.
- 3,953,475. **NOEL (STANDARD CHARACTER).** ARCOR S.A.I.C., MULTIPLE CLASS, (INT. CLS. 29 AND 30), (U.S. CL. 46). SN 78-791,105. PUB. 2-15-2011. FILED 1-13-2006.
- 3,953,476 ( *See Class 5 for this trademark.*).
- 3,953,482. **LA TERRA FINA (STANDARD CHARACTER).** LA TERRA FINA USA, INC., MULTIPLE CLASS, (INT. CLS. 29 AND 30), (U.S. CL. 46). SN 78-958,194. PUB. 2-15-2011. FILED 8-23-2006.
- 3,953,562. **MISCELLANEOUS DESIGN.** CIE EXPLOITATION DES SERVICES; AUXILIAIRES AERIENS SERVAIR, MULTIPLE CLASS, (INT. CLS. 29, 30, 31, 32, 33, 35, 37, 38, 39, 42, 43 AND 45), (U.S. CLS. 1, 45, 46, 47, 48, 49, 100, 101, 102, 103, 104, 105 AND 106). SN 79-081,271. PUB. 2-15-2011. FILED 2-8-2010.
- 3,953,563. **RAINERI (STANDARD CHARACTER).** RAINERI S.P.A., MULTIPLE CLASS, (INT. CLS. 29 AND 30), (U.S. CL. 46). SN 79-081,290. PUB. 2-15-2011. FILED 3-18-2010.
- 3,953,611. **SEEBERGER AND DESIGN.** SEEBERGER KG, MULTIPLE CLASS, (INT. CLS. 29, 30 AND 31), (U.S. CLS. 1 AND 46). SN 79-083,466. PUB. 2-15-2011. FILED 4-1-2010.
- 3,953,649 ( *See Class 5 for this trademark.*).
- 3,953,687. **FOUNTAIN OF HEALTH AND DESIGN.** ALIMENTS FONTAINE SANTÉ INC., (U.S. CL. 46). SN 85-000,522. PUB. 2-15-2011. FILED 3-29-2010.
- 3,953,712. **DENMAR (STANDARD CHARACTER).** KAROUN DAIRIES, INC., (U.S. CL. 46). SN 85-006,819. PUB. 2-15-2011. FILED 4-6-2010.
- 3,953,714. **GULFISH FRESH GULF SEAFOOD AND DESIGN.** GALLE, JAMES S., (U.S. CL. 46). SN 85-007,346. PUB. 2-15-2011. FILED 4-6-2010.
- 3,953,808. **BIOSTIME AND DESIGN.** BIOSTIME, INC. (- GUANGZHOU), (U.S. CL. 46). SN 85-039,519. PUB. 2-15-2011. FILED 5-15-2010.
- 3,953,854. **THE BEAN EXPERT (STANDARD CHARACTER).** SABORMEX EUROPA, S.L., (U.S. CL. 46). SN 85-057,032. PUB. 2-15-2011. FILED 6-8-2010.
- 3,953,869. **BIG JOHN'S BUFFALO JERKY (STANDARD CHARACTER).** MOUNTAIN MEATS, INC., (U.S. CL. 46). SN 85-060,379. PUB. 11-9-2010. FILED 6-11-2010.
- 3,953,878. **THE FRUIT PALETTE AND DESIGN.** THE FRUIT KINGDOM LLC, MULTIPLE CLASS, (INT. CLS. 29, 30 AND 32), (U.S. CLS. 45, 46 AND 48). SN 85-063,117. PUB. 2-15-2011. FILED 6-15-2010.
- 3,953,973. **SARA'S SPRING CHICKEN (STANDARD CHARACTER).** DAVID ELLIOT POULTRY FARM, INC., (U.S. CL. 46). SN 85-090,966. PUB. 2-15-2011. FILED 7-22-2010.
- 3,954,076. **OPE'S (STANDARD CHARACTER).** EXPORT OPE'S, L.L.C., MULTIPLE CLASS, (INT. CLS. 29 AND 30), (U.S. CL. 46). SN 85-107,159. PUB. 2-15-2011. FILED 8-13-2010.
- 3,954,079. **COFFEE LOVERS (STANDARD CHARACTER).** WISSAM AMOUDI, MULTIPLE CLASS, (INT. CLS. 29 AND 30), (U.S. CL. 46). SN 85-107,308. PUB. 2-15-2011. FILED 8-13-2010.
- 3,954,227. **LĀRĀBAR AND DESIGN.** GENERAL MILLS SPECIALTY PRODUCTS, LLC, (U.S. CL. 46). SN 85-114,763. PUB. 2-15-2011. FILED 8-24-2010.
- 3,954,369. **CHICKEN FAIS DO DO (STANDARD CHARACTER).** COPELAND'S OF NEW ORLEANS, INC., (U.S. CL. 46). SN 85-117,336. PUB. 2-15-2011. FILED 8-27-2010.
- 3,954,371. **RUPARI AND DESIGN.** RUPARI FOOD SERVICES, INC., (U.S. CL. 46). SN 85-117,349. PUB. 2-15-2011. FILED 8-27-2010.
- 3,954,612. **FOOTBALLIDAY (STANDARD CHARACTER).** FRITO-LAY NORTH AMERICA, INC., MULTIPLE CLASS, (INT. CLS. 29 AND 30), (U.S. CL. 46). SN 85-120,161. PUB. 2-15-2011. FILED 8-31-2010.
- 3,954,613. **FOGGY MORNING (STANDARD CHARACTER).** NICASIO VALLEY CHEESE CO., INC., DBA NICASIO VALLEY CHEESE COMPANY, (U.S. CL. 46). SN 85-120,164. PUB. 2-15-2011. FILED 8-31-2010.
- 3,954,633. **MUD (STANDARD CHARACTER).** KITSMUD, LLC, (U.S. CL. 46). SN 85-120,390. PUB. 2-15-2011. FILED 8-31-2010.
- 3,954,748. **PAELEON (STANDARD CHARACTER).** VASILEIOS STAMATAKOS, DBA PAELEON, (U.S. CL. 46). SN 85-121,665. PUB. 2-15-2011. FILED 9-2-2010.
- 3,954,877. **OROLIQUIDO (STANDARD CHARACTER).** FOREVER CHEESE INC., (U.S. CL. 46). SN 85-123,131. PUB. 2-15-2011. FILED 9-3-2010.
- 3,954,968. **JUNI (STANDARD CHARACTER).** FOREVER CHEESE INC., (U.S. CL. 46). SN 85-127,227. PUB. 2-15-2011. FILED 9-10-2010.
- 3,954,979. **INSPIRED SOLUTIONS. BETTER RESULTS. (STANDARD CHARACTER).** JTM PROVISIONS COMPANY, INC., MULTIPLE CLASS, (INT. CLS. 29 AND 30), (U.S. CL. 46). SN 85-128,997. PUB. 2-15-2011. FILED 9-14-2010.
- 3,955,077. **WE'VE TURNED UP THE HEAT ON HOT. (STANDARD CHARACTER).** FRANK BRUNCKHORST CO., L.L.C., (U.S. CL. 46). SN 85-147,503. PUB. 2-15-2011. FILED 10-7-2010.
- 3,955,093. **NERITOS (STANDARD CHARACTER).** SEÑOR SNACKS, INC., (U.S. CL. 46). SN 85-152,120. PUB. 2-15-2011. FILED 10-13-2010.
- 3,955,094. **PEÑITOS (STANDARD CHARACTER).** SEÑOR SNACKS, INC., (U.S. CL. 46). SN 85-152,128. PUB. 2-15-2011. FILED 10-13-2010.

---

### CLASS 30—STAPLE FOODS

- 3,952,966. **TINO'S ITALIAN SPECIALTIES - CIRCA 1989 - AND DESIGN.** BIANCA'S FOODS, INC., (U.S. CL. 46). SN 76-701,379. PUB. 2-15-2011. FILED 1-25-2010.
- 3,953,000 ( *See Class 3 for this trademark.*).
- 3,953,083 ( *See Class 1 for this trademark.*).
- 3,953,120 ( *See Class 29 for this trademark.*).
- 3,953,198 ( *See Class 29 for this trademark.*).
- 3,953,203. **SPRAY ON SHINE (STANDARD CHARACTER).** LAWRENCE FOODS, INC., (U.S. CL. 46). SN 77-877,567. PUB. 2-15-2011. FILED 11-20-2009.
- 3,953,260 ( *See Class 16 for this trademark.*).
- 3,953,321. **MISCELLANEOUS DESIGN.** HDN DEVELOPMENT CORPORATION, (U.S. CL. 46). SN 77-947,174. PUB. 2-15-2011. FILED 3-1-2010.
- 3,953,347. **%100 ORIGINAL CALIFORNIA CALROSE AND DESIGN.** CALIFORNIA RICE COMMISSION, (U.S. CL. 46). SN 77-950,384. PUB. 2-15-2011. FILED 3-4-2010.
- 3,953,348 ( *See Class 5 for this trademark.*).
- 3,953,352. **MICRO-READY (STANDARD CHARACTER).** BRIDGFORD FOODS CORPORATION, (U.S. CL. 46). SN 77-950,994. PUB. 2-15-2011. FILED 3-4-2010.
- 3,953,393. **C AND DESIGN.** THE CONNELL COMPANY, MULTIPLE CLASS, (INT. CLS. 30, 35, 36, 37 AND 39), (U.S. CLS. 46, 100, 101, 102, 103, 105 AND 106). SN 77-956,706. PUB. 2-15-2011. FILED 3-11-2010.
- 3,953,427. **WF REWARDS AND DESIGN.** WORLD'S FINEST CHOCOLATE, INC., MULTIPLE CLASS, (INT. CLS. 30 AND 36), (U.S. CLS. 46, 100, 101 AND 102). SN 77-961,223. PUB. 2-15-2011. FILED 3-17-2010.

- 3,953,461. **FRUTIGOMAS (STANDARD CHARACTER)**. GRUPO BIMBO, S.A.B. DE C.V., (U.S. CL. 46). SN 77-968,769. PUB. 2-15-2011. FILED 3-25-2010.
- 3,953,463. **GUARANTEED VALUE (STANDARD CHARACTER)**. AHOLD LICENSING SARL, (U.S. CL. 46). SN 77-979,417. PUB. 2-15-2011. FILED 2-18-2009.
- 3,953,465 ( *See Class 29 for this trademark*).
- 3,953,469. **VILLAGE HEARTH CARB CONTROL AND DESIGN**. PAN-O-GOLD BAKING CO., (U.S. CL. 46). SN 78-386,879. PUB. 2-15-2011. FILED 3-18-2004.
- 3,953,475 ( *See Class 29 for this trademark*).
- 3,953,476 ( *See Class 5 for this trademark*).
- 3,953,478. **SUNNYMOON (STANDARD CHARACTER)**. SUNNYMOON INC., (U.S. CL. 46). SN 78-864,676. PUB. 1-4-2011. FILED 4-19-2006.
- 3,953,482 ( *See Class 29 for this trademark*).
- 3,953,517 ( *See Class 5 for this trademark*).
- 3,953,539. **SLIM INDULGENCE (STANDARD CHARACTER)**. HI-PERFORMANCE HEALTH PTY LTD, MULTIPLE CLASS, (INT. CLS. 30 AND 32), (U.S. CLS. 45, 46 AND 48). SN 79-078,952. PUB. 2-15-2011. FILED 1-28-2010.
- 3,953,543. **MISCELLANEOUS DESIGN**. SAKAMOTO KUROZU, INC., (U.S. CL. 46). SN 79-079,651. PUB. 2-15-2011. FILED 12-25-2009.
- 3,953,556 ( *See Class 11 for this trademark*).
- 3,953,562 ( *See Class 29 for this trademark*).
- 3,953,563 ( *See Class 29 for this trademark*).
- 3,953,565 ( *See Class 5 for this trademark*).
- 3,953,580. **MISCELLANEOUS DESIGN**. KARL STEFAN RIENER, AND STRITTL, HANS JÜRGEN, MULTIPLE CLASS, (INT. CLS. 30, 32 AND 33), (U.S. CLS. 45, 46, 47, 48 AND 49). SN 79-081,993. PUB. 2-15-2011. FILED 3-16-2010.
- 3,953,604. **CERTOSSA (STANDARD CHARACTER)**. LIDL STIFTUNG & CO. KG, (U.S. CL. 46). SN 79-082,969. PUB. 2-15-2011. FILED 4-30-2010.
- 3,953,611 ( *See Class 29 for this trademark*).
- 3,953,745. **EUROCREM (STANDARD CHARACTER)**. A. GANDOLA & C. S.P.A., (U.S. CL. 46). SN 85-019,916. PUB. 2-15-2011. FILED 4-21-2010.
- 3,953,771. **CHARRAS "THE REAL MEXICAN FLAVOR" SALSA VERDE AND DESIGN**. PALACIOS & SONS, L.L.C., (U.S. CL. 46). SN 85-030,094. PUB. 2-15-2011. FILED 5-4-2010.
- 3,953,772. **CHARRAS "THE REAL MEXICAN FLAVOR" SALSA ROJA AND DESIGN**. PALACIOS & SONS, L.L.C., (U.S. CL. 46). SN 85-030,109. PUB. 2-15-2011. FILED 5-4-2010.
- 3,953,773. **CHARRAS "THE REAL MEXICAN FLAVOR" SALSA RANCHERA AND DESIGN**. PALACIOS & SONS, L.L.C., (U.S. CL. 46). SN 85-030,117. PUB. 2-15-2011. FILED 5-4-2010.
- 3,953,774. **CHARRAS "THE REAL MEXICAN FLAVOR" SALSA HABANERA AND DESIGN**. PALACIOS & SONS, L.L.C., (U.S. CL. 46). SN 85-030,130. PUB. 2-15-2011. FILED 5-4-2010.
- 3,953,809. **BIOSTIME AND DESIGN**. BIOSTIME, INC. (-GUANGZHOU), (U.S. CL. 46). SN 85-039,523. PUB. 2-15-2011. FILED 5-15-2010.
- 3,953,815. **CHIKO ECLAIRS CARAMEL WITH A CHOCOLATE CENTRE BIGGER CHOCOLATE CENTRE! AND DESIGN**. SWEETS OF OMAN SAOG, (U.S. CL. 46). SN 85-040,675. PUB. 2-15-2011. FILED 5-17-2010.
- 3,953,816. **CHIKO MILK ECLAIRS CARAMELS WITH MILKY MIDDLES MILK RICH CENTRES! AND DESIGN**. SWEETS OF OMAN SAOG, (U.S. CL. 46). SN 85-040,701. PUB. 2-15-2011. FILED 5-17-2010.
- 3,953,825 ( *See Class 5 for this trademark*).
- 3,953,859. **MAGIC SEASONING BLENDS (STANDARD CHARACTER)**. MAGIC SEASONING BLENDS, INC., MULTIPLE CLASS, (INT. CLS. 30, 35, 39, 40 AND 42), (U.S. CLS. 46, 100, 101, 102, 103, 105 AND 106). SN 85-057,749. PUB. 2-15-2011. FILED 6-8-2010.
- 3,953,878 ( *See Class 29 for this trademark*).
- 3,953,880. **NAPA CAFÉ AND DESIGN**. NAPA VALLEY FOODS INC, MULTIPLE CLASS, (INT. CLS. 30 AND 32), (U.S. CLS. 45, 46 AND 48). SN 85-064,191. PUB. 2-15-2011. FILED 6-16-2010.
- 3,953,934. **ABBOTT'S FROZEN CUSTARD SINCE 1902 AND DESIGN**. ABBOTT'S FROZEN CUSTARD, INC., MULTIPLE CLASS, (INT. CLS. 30 AND 35), (U.S. CLS. 46, 100, 101 AND 102). SN 85-078,404. PUB. 2-15-2011. FILED 7-6-2010.
- 3,953,965. **BELLAGIO AND DESIGN**. E & H DISTRIBUTING, LLC, (U.S. CL. 46). SN 85-088,877. PUB. 2-15-2011. FILED 7-20-2010.
- 3,953,969. **BELLAGIO (STANDARD CHARACTER)**. E & H DISTRIBUTING, LLC, (U.S. CL. 46). SN 85-090,581. PUB. 2-15-2011. FILED 7-22-2010.
- 3,954,057. **OXFORD (STANDARD CHARACTER)**. CAINS FOODS, L.P., (U.S. CL. 46). SN 85-105,740. PUB. 2-15-2011. FILED 8-12-2010.
- 3,954,076 ( *See Class 29 for this trademark*).
- 3,954,078. **FAR OUT FLYING SAUCER TEAS (STANDARD CHARACTER)**. MCELROY, SHAUNEEN, (U.S. CL. 46). SN 85-107,284. PUB. 2-15-2011. FILED 8-13-2010.
- 3,954,079 ( *See Class 29 for this trademark*).
- 3,954,082. **TONY BOFFA'S (STANDARD CHARACTER)**. TONY BOFFA'S SPECIALTY FOODS, INC., (U.S. CL. 46). SN 85-107,781. PUB. 2-15-2011. FILED 8-15-2010.
- 3,954,091. **802 (STANDARD CHARACTER)**. KIM SENG COMPANY, (U.S. CL. 46). SN 85-108,662. PUB. 2-15-2011. FILED 8-16-2010.
- 3,954,094. **ZOYO NEIGHBORHOOD YOGURT (STANDARD CHARACTER)**. ZOYO!, LLC, MULTIPLE CLASS, (INT. CLS. 30 AND 35), (U.S. CLS. 46, 100, 101 AND 102). SN 85-108,695. PUB. 2-15-2011. FILED 8-16-2010.
- 3,954,101. **SVENHARD'S AND DESIGN**. SVENHARD'S SWEDISH BAKERY CORPORATION, (U.S. CL. 46). SN 85-109,373. PUB. 2-15-2011. FILED 8-17-2010.
- 3,954,166. **NIRMAL AND DESIGN**. RAJ KUMAR JAWA, DBA SONA SPICES U.S.A., INC., (U.S. CL. 46). SN 85-112,667. PUB. 2-15-2011. FILED 8-20-2010.
- 3,954,230. **CREATORS OF SPECIALTY FOODS (STANDARD CHARACTER)**. STONEWALL KITCHEN , LLC, MULTIPLE CLASS, (INT. CLS. 30 AND 32), (U.S. CLS. 45, 46 AND 48). SN 85-114,843. PUB. 2-15-2011. FILED 8-24-2010.
- 3,954,257. **SPLASHPOPS AND DESIGN**. CHOO CHOO R SNACKS, INC., TA BUFFALO BILL'S PREMIUM SNACKS, (U.S. CL. 46). SN 85-115,233. PUB. 2-15-2011. FILED 8-25-2010.
- 3,954,308. **MINSA AND DESIGN**. GRUPO MINSA, S.A.B. DE C.V., MULTIPLE CLASS, (INT. CLS. 30 AND 31), (U.S. CLS. 1 AND 46). SN 85-116,385. PUB. 2-15-2011. FILED 8-26-2010.
- 3,954,310. **MAIZESOLUTION (STANDARD CHARACTER)**. GRUPO MINSA, S.A.B. DE C.V., MULTIPLE CLASS, (INT. CLS. 30 AND 31), (U.S. CLS. 1 AND 46). SN 85-116,441. PUB. 2-15-2011. FILED 8-26-2010.
- 3,954,314. **MAIZEXPERIENCE (STANDARD CHARACTER)**. GRUPO MINSA, S.A.B. DE C.V., MULTIPLE CLASS, (INT. CLS. 30 AND 31), (U.S. CLS. 1 AND 46). SN 85-116,483. PUB. 2-15-2011. FILED 8-26-2010.
- 3,954,319. **OPTIMAIZE (STANDARD CHARACTER)**. GRUPO MINSA, S.A.B. DE C.V., MULTIPLE CLASS, (INT. CLS. 30 AND 31), (U.S. CLS. 1 AND 46). SN 85-116,530. PUB. 2-15-2011. FILED 8-26-2010.
- 3,954,334. **MAIZENSATION (STANDARD CHARACTER)**. GRUPO MINSA, S.A.B. DE C.V., MULTIPLE CLASS, (INT. CLS. 30 AND 31), (U.S. CLS. 1 AND 46). SN 85-116,884. PUB. 2-15-2011. FILED 8-26-2010.
- 3,954,335. **DELIMAIZE (STANDARD CHARACTER)**. GRUPO MINSA, S.A.B. DE C.V., MULTIPLE CLASS, (INT. CLS. 30 AND 31), (U.S. CLS. 1 AND 46). SN 85-116,910. PUB. 2-15-2011. FILED 8-26-2010.
- 3,954,340. **THINK TWICE, THINKMAIZE (STANDARD CHARACTER)**. GRUPO MINSA, S.A.B. DE C.V., MULTIPLE CLASS, (INT. CLS. 30 AND 31), (U.S. CLS. 1 AND 46). SN 85-116,983. PUB. 2-15-2011. FILED 8-26-2010.
- 3,954,341. **HEALTHY EXPERIENCE (STANDARD CHARACTER)**. GRUPO MINSA, S.A.B. DE C.V., MULTIPLE CLASS, (INT. CLS. 30 AND 31), (U.S. CLS. 1 AND 46). SN 85-117,005. PUB. 2-15-2011. FILED 8-26-2010.
- 3,954,343. **OLD FRIENDS, NEW FLAVORS (STANDARD CHARACTER)**. GRUPO MINSA, S.A.B. DE C.V., MULTIPLE CLASS, (INT. CLS. 30 AND 31), (U.S. CLS. 1 AND 46). SN 85-117,019. PUB. 2-15-2011. FILED 8-26-2010.
- 3,954,344. **SOULMAIZE (STANDARD CHARACTER)**. GRUPO MINSA, S.A.B. DE C.V., MULTIPLE CLASS, (INT. CLS. 30 AND 31), (U.S. CLS. 1 AND 46). SN 85-117,032. PUB. 2-15-

2011. FILED 8-26-2010.  
 3,954,460. **BEACHPOPS AND DESIGN**. 3DOGEARTH CORPORATION, DBA BEACHPOPS, (U.S. CL. 46). SN 85-118,570. PUB. 2-15-2011. FILED 8-30-2010.  
 3,954,516. **ALABAMA SLAMA (STANDARD CHARACTER)**. BUBBAQUE'S, LLC, (U.S. CL. 46). SN 85-119,100. PUB. 2-15-2011. FILED 8-30-2010.  
 3,954,517. **MISSISSIPPI MUD (STANDARD CHARACTER)**. BUBBAQUE'S, LLC, (U.S. CL. 46). SN 85-119,122. PUB. 2-15-2011. FILED 8-30-2010.  
 3,954,521. **OLE YELLER (STANDARD CHARACTER)**. BUBBAQUE'S, LLC, (U.S. CL. 46). SN 85-119,139. PUB. 2-15-2011. FILED 8-30-2010.  
 3,954,522. **PINE TAR (STANDARD CHARACTER)**. BUBBAQUE'S, LLC, (U.S. CL. 46). SN 85-119,147. PUB. 2-15-2011. FILED 8-30-2010.  
 3,954,524. **RUMP ROASTER (STANDARD CHARACTER)**. BUBBAQUE'S, LLC, (U.S. CL. 46). SN 85-119,154. PUB. 2-15-2011. FILED 8-30-2010.  
 3,954,526. **SUGAR SHACK (STANDARD CHARACTER)**. BUBBAQUE'S, LLC, (U.S. CL. 46). SN 85-119,163. PUB. 2-15-2011. FILED 8-30-2010.  
 3,954,529. **TRACTOR GREASE (STANDARD CHARACTER)**. BUBBAQUE'S, LLC, (U.S. CL. 46). SN 85-119,177. PUB. 2-15-2011. FILED 8-30-2010.  
 3,954,547. **NOTHIN' BETTER THAN THAT (STANDARD CHARACTER)**. HERSHEY CHOCOLATE & CONFECTIONERY CORPORATION, (U.S. CL. 46). SN 85-119,374. PUB. 2-15-2011. FILED 8-31-2010.  
 3,954,560. **WAFFLEWICH (STANDARD CHARACTER)**. COLUMBUS BRANDS, (U.S. CL. 46). SN 85-119,565. PUB. 2-15-2011. FILED 8-31-2010.  
 3,954,581. **THE ALL DAY COOKIE (STANDARD CHARACTER)**. MRS WILLIAMS COUNTRY KITCHEN INC, (U.S. CL. 46). SN 85-119,800. PUB. 2-15-2011. FILED 8-31-2010.  
 3,954,604. **PIGGY BACK (STANDARD CHARACTER)**. HAMMOND'S CANDIES SINCE 1920 II, LLC, (U.S. CL. 46). SN 85-120,078. PUB. 2-15-2011. FILED 8-31-2010.  
 3,954,612 ( *See Class 29 for this trademark* ).  
 3,954,655. **JUST BAKED AND DESIGN**. MOTOR CITY CUPCAKES, LLC, MULTIPLE CLASS, (INT. CLS. 30 AND 35), (U.S. CLS. 46, 100, 101 AND 102). SN 85-120,639. PUB. 2-15-2011. FILED 9-1-2010.  
 3,954,663. **POWERCAFE (STANDARD CHARACTER)**. ASHLOCK, HOWARD K, (U.S. CL. 46). SN 85-120,700. PUB. 2-15-2011. FILED 9-1-2010.  
 3,954,664. **SPRING TREE (STANDARD CHARACTER)**. SPECIALTY BRANDS OF AMERICA, INC., (U.S. CL. 46). SN 85-120,702. PUB. 2-15-2011. FILED 9-1-2010.  
 3,954,702. **ICE BREAKERS FROST AND DESIGN**. HERSHEY CHOCOLATE & CONFECTIONERY CORPORATION, (U.S. CL. 46). SN 85-120,979. PUB. 2-15-2011. FILED 9-1-2010.  
 3,954,706. **ICE BREAKERS FROST AND DESIGN**. HERSHEY CHOCOLATE & CONFECTIONERY CORPORATION, (U.S. CL. 46). SN 85-121,013. PUB. 2-15-2011. FILED 9-1-2010.  
 3,954,869. **MI HUERTA AND DESIGN**. NORA FOODS INC, (U.S. CL. 46). SN 85-123,029. PUB. 2-15-2011. FILED 9-3-2010.  
 3,954,944. **HERO BAR (STANDARD CHARACTER)**. SWEET VALOR LLC, (U.S. CL. 46). SN 85-125,266. PUB. 2-15-2011. FILED 9-8-2010.  
 3,954,954. **RIB LUBE (STANDARD CHARACTER)**. BUBBAQUE'S, LLC, (U.S. CL. 46). SN 85-126,042. PUB. 2-15-2011. FILED 9-9-2010.  
 3,954,960. **PEANUT BUTTER BLISS (STANDARD CHARACTER)**. COLUMBUS BRANDS, (U.S. CL. 46). SN 85-126,393. PUB. 2-15-2011. FILED 9-9-2010.  
 3,954,979 ( *See Class 29 for this trademark* ).  
 3,955,014. **MAW 'N PAW KETTLEKORN (STANDARD CHARACTER)**. HOLMES, SHAWN, DBA MAW 'N PAW KETTLEKORN, (U.S. CL. 46). SN 85-133,870. PUB. 2-15-2011. FILED 9-20-2010.  
 3,955,078. **SO GOOD IT SPEAKS FOR ITSELF (STANDARD CHARACTER)**. WELLS' DAIRY, INC., (U.S. CL. 46). SN 85-148,127. PUB. 2-15-2011. FILED 10-8-2010.  
 3,955,096. **JOLLY SHOTS (STANDARD CHARACTER)**. HOLCOMB, KELLY, (U.S. CL. 46). SN 85-154,078. PUB. 2-15-2011. FILED 10-15-2010.  
 3,955,142. **"YOU WON'T BELIEVE IT'S THAT GOOD"**

(**STANDARD CHARACTER**). THE QUAKER OATS COMPANY, (U.S. CL. 46). SN 85-176,433. PUB. 2-15-2011. FILED 11-15-2010.

---

## CLASS 31—NATURAL AGRICULTURAL PRODUCTS

3,953,083 ( *See Class 1 for this trademark* ).  
 3,953,302. **ORGANIX (STANDARD CHARACTER)**. PET APPEAL, INC., (U.S. CLS. 1 AND 46). SN 77-942,953. PUB. 2-15-2011. FILED 2-23-2010.  
 3,953,332. **BIEBER (STANDARD CHARACTER)**. BIEBER, CRAIG J., (U.S. CLS. 1 AND 46). SN 77-949,184. PUB. 2-15-2011. FILED 3-3-2010.  
 3,953,394 ( *See Class 1 for this trademark* ).  
 3,953,395 ( *See Class 7 for this trademark* ).  
 3,953,419. **SEPTEMBER SONG (STANDARD CHARACTER)**. LACEBARK, INC., (U.S. CLS. 1 AND 46). SN 77-960,167. PUB. 2-15-2011. FILED 3-16-2010.  
 3,953,476 ( *See Class 5 for this trademark* ).  
 3,953,562 ( *See Class 29 for this trademark* ).  
 3,953,611 ( *See Class 29 for this trademark* ).  
 3,953,613. **MCHAWI (STANDARD CHARACTER)**. JUNGFANZEN GRÜNEWALD GMBH, (U.S. CLS. 1 AND 46). SN 79-083,654. PUB. 2-15-2011. FILED 5-17-2010.  
 3,953,671. **INDIAN RIVER (STANDARD CHARACTER)**. AVIAGEN LIMITED, (U.S. CLS. 1 AND 46). SN 79-088,854. PUB. 2-15-2011. FILED 8-19-2010.  
 3,953,974. **GROWER PETE'S HOME HARVEST ORGANIC LIVING LETTUCE MIX (STANDARD CHARACTER)**. GREEN GROWTH CONSULTING, (U.S. CLS. 1 AND 46). SN 85-091,112. PUB. 2-15-2011. FILED 7-22-2010.  
 3,954,181. **CRIMSON TREASURE (STANDARD CHARACTER)**. GREENHEART FARMS, INC, (U.S. CLS. 1 AND 46). SN 85-113,442. PUB. 2-15-2011. FILED 8-23-2010.  
 3,954,253. **VIRGINIA PRIME GOLD AND DESIGN**. OMEGA PROTEIN, INC., (U.S. CLS. 1 AND 46). SN 85-115,219. PUB. 2-15-2011. FILED 8-25-2010.  
 3,954,255. **VIRGINIA PRIME PLATINUM AND DESIGN**. OMEGA PROTEIN, INC., (U.S. CLS. 1 AND 46). SN 85-115,222. PUB. 2-15-2011. FILED 8-25-2010.  
 3,954,302. **CARMELINI (STANDARD CHARACTER)**. THE CHEF'S GARDEN, INC., (U.S. CLS. 1 AND 46). SN 85-116,307. PUB. 2-15-2011. FILED 8-26-2010.  
 3,954,308 ( *See Class 30 for this trademark* ).  
 3,954,310 ( *See Class 30 for this trademark* ).  
 3,954,314 ( *See Class 30 for this trademark* ).  
 3,954,319 ( *See Class 30 for this trademark* ).  
 3,954,334 ( *See Class 30 for this trademark* ).  
 3,954,335 ( *See Class 30 for this trademark* ).  
 3,954,340 ( *See Class 30 for this trademark* ).  
 3,954,341 ( *See Class 30 for this trademark* ).  
 3,954,343 ( *See Class 30 for this trademark* ).  
 3,954,344 ( *See Class 30 for this trademark* ).  
 3,954,416. **TENANTS HARBOR MAINE LOBSTER AND DESIGN**. LB BRANDS, LLC, (U.S. CLS. 1 AND 46). SN 85-118,079. PUB. 2-15-2011. FILED 8-28-2010.  
 3,954,458. **CUPCAKE IN BLOOM (STANDARD CHARACTER)**. 1-800-FLOWERS.COM, INC., (U.S. CLS. 1 AND 46). SN 85-118,562. PUB. 2-15-2011. FILED 8-30-2010.  
 3,954,583. **PURE PACIFIC (STANDARD CHARACTER)**. PACIFIC INTERNATIONAL MARKETING, (U.S. CLS. 1 AND 46). SN 85-119,828. PUB. 2-15-2011. FILED 8-31-2010.  
 3,954,668. **OMEGA 3 DRY AND DESIGN**. OMEGA PROTEIN, INC., (U.S. CLS. 1 AND 46). SN 85-120,736. PUB. 2-15-2011. FILED 9-1-2010.  
 3,954,697. **OMEGA 3 DRY THE OMEGA-3 SOLUTION FOR DRY APPLICATION AND DESIGN**. OMEGA PROTEIN, INC., (U.S. CLS. 1 AND 46). SN 85-120,933. PUB. 2-15-2011. FILED 9-1-2010.  
 3,955,110 ( *See Class 5 for this trademark* ).

**CLASS 32—LIGHT BEVERAGES**

3,952,953. "OBOLON LAGER" (STANDARD CHARACTER). CLOSED JOINT STOCK COMPANY "OBOLON", (U.S. CLS. 45, 46 AND 48). SN 76-658,461. PUB. 2-15-2011. FILED 4-12-2006.

3,953,000 ( See Class 3 for this trademark).

3,953,010. **TOTALLY NAKED (STYLIZED)**. NEW GLARUS BREWING COMPANY, (U.S. CLS. 45, 46 AND 48). SN 77-196,554. PUB. 2-15-2011. FILED 6-4-2007.

3,953,059. **LUMEN (STANDARD CHARACTER)**. LUMEN WATER, INC., (U.S. CLS. 45, 46 AND 48). SN 77-702,676. PUB. 2-15-2011. FILED 3-30-2009.

3,953,078 ( See Class 5 for this trademark).

3,953,168. **MICROCARBONATED (STANDARD CHARACTER)**. MOLSON CANADA 2005, (U.S. CLS. 45, 46 AND 48). SN 77-845,025. PUB. 2-15-2011. FILED 10-9-2009.

3,953,385. **CAPTAIN COOKER (STANDARD CHARACTER)**. DIXON, ANDREW, AND DIXON, JANE, AND WHALLEY, ROBIN, (U.S. CLS. 45, 46 AND 48). SN 77-955,779. PUB. 2-15-2011. FILED 3-10-2010.

3,953,411. **HOP RISING (STANDARD CHARACTER)**. SALT LAKE BREWING CO., L.C., (U.S. CLS. 45, 46 AND 48). SN 77-959,493. PUB. 2-15-2011. FILED 3-15-2010.

3,953,423. **O2 ALIVE AND DESIGN**. BIONIC VERTRIEBS GMBH, (U.S. CLS. 45, 46 AND 48). SN 77-960,928. PUB. 2-15-2011. FILED 3-17-2010.

3,953,430. **VILLAGE PURE (STANDARD CHARACTER)**. C.H.I.C. LLC, DBA VILLAGE PUB BAR & GRILL, (U.S. CLS. 45, 46 AND 48). SN 77-961,665. PUB. 2-15-2011. FILED 3-17-2010.

3,953,476 ( See Class 5 for this trademark).

3,953,503. **ISOLA BIO AND DESIGN**. ABAFOODS SRL, (U.S. CLS. 45, 46 AND 48). SN 79-069,965. PUB. 2-15-2011. FILED 3-25-2009.

3,953,539 ( See Class 30 for this trademark).

3,953,562 ( See Class 29 for this trademark).

3,953,565 ( See Class 5 for this trademark).

3,953,580 ( See Class 30 for this trademark).

3,953,585. **EXTRAOMNES LICET INSANIRE AND DESIGN**. EL MUNDO SPA, MULTIPLE CLASS, (INT. CLS. 32 AND 43), (U.S. CLS. 45, 46, 48, 100 AND 101). SN 79-082,167. PUB. 2-15-2011. FILED 3-1-2010.

3,953,619. **GOLDEN CUPOLAS (STANDARD CHARACTER)**. DOMAINE DES BROIX S.A.S., MULTIPLE CLASS, (INT. CLS. 32 AND 33), (U.S. CLS. 45, 46, 47, 48 AND 49). SN 79-084,578. PUB. 2-15-2011. FILED 5-3-2010.

3,953,620 ( See Class 14 for this trademark).

3,953,821. **IRON FIST BREWING COMPANY (STANDARD CHARACTER)**. IRON FIST BREWING COMPANY INCORPORATED, (U.S. CLS. 45, 46 AND 48). SN 85-042,501. PUB. 2-15-2011. FILED 5-19-2010.

3,953,825 ( See Class 5 for this trademark).

3,953,878 ( See Class 29 for this trademark).

3,953,880 ( See Class 30 for this trademark).

3,954,090. **HOGWASH (STANDARD CHARACTER)**. FULL-STEAM BREWERY LLC, (U.S. CLS. 45, 46 AND 48). SN 85-108,625. PUB. 2-15-2011. FILED 8-16-2010.

3,954,230 ( See Class 30 for this trademark).

3,954,286. **A HEALTHY THIRST QUENCHER A UNIQUE BEVERAGE NARDA'S GINGER PUNCH FOR ALL PEOPLE AND ALL OCCASIONS AND DESIGN**. NARDA'S GINGER PUNCH, L.L.C., (U.S. CLS. 45, 46 AND 48). SN 85-116,006. PUB. 2-15-2011. FILED 8-25-2010.

3,954,426. **CHAMP CHERRY (STANDARD CHARACTER)**. AMAZING BEVERAGES, INC., (U.S. CLS. 45, 46 AND 48). SN 85-118,194. PUB. 2-15-2011. FILED 8-29-2010.

3,954,544. **BULLETPROOF ENERGY (STANDARD CHARACTER)**. BLOCH, JEFF, (U.S. CLS. 45, 46 AND 48). SN 85-119,330. PUB. 2-15-2011. FILED 8-31-2010.

3,954,645. **GOOD EVENING AMERICA (STANDARD CHARACTER)**. SHENGLONG INTERNATIONAL GROUP CORPORATION, (U.S. CLS. 45, 46 AND 48). SN 85-120,532. PUB. 2-15-2011. FILED 9-1-2010.

3,954,769. **WAVE (STANDARD CHARACTER)**. HEALTH FUSION BRANDS, INC., (U.S. CLS. 45, 46 AND 48). SN 85-121,854. PUB. 2-15-2011. FILED 9-2-2010.

3,954,829. **HOPPYUM (STANDARD CHARACTER)**. 638 BREWING COMPANY, INC., DBA FOOTHILLS BREW-

ING, (U.S. CLS. 45, 46 AND 48). SN 85-122,632. PUB. 2-15-2011. FILED 9-3-2010.

3,954,838. **ROCKHOPPER (STANDARD CHARACTER)**. R.J. ROCKERS, INC., (U.S. CLS. 45, 46 AND 48). SN 85-122,721. PUB. 2-15-2011. FILED 9-3-2010.

3,954,970. **SEEING DOUBLE (STANDARD CHARACTER)**. 638 BREWING COMPANY, INC., DBA FOOTHILLS BREWING, (U.S. CLS. 45, 46 AND 48). SN 85-127,818. PUB. 2-15-2011. FILED 9-13-2010.

3,955,051. **FRUITABLES (STANDARD CHARACTER)**. APPLE & EVE, LLC, (U.S. CLS. 45, 46 AND 48). SN 85-139,506. PUB. 2-15-2011. FILED 9-28-2010.

3,955,097. **HOP CRISIS (STANDARD CHARACTER)**. FRECCIA/O'SULLIVAN, INC., (U.S. CLS. 45, 46 AND 48). SN 85-154,139. PUB. 2-15-2011. FILED 10-15-2010.

**CLASS 33—WINES AND SPIRITS**

3,953,032. **MISCELLANEOUS DESIGN**. NAKANO SHUZOU KABUSHIKI KAISHA, DBA NAKANO SAKE BREWERY CO., LTD., (U.S. CLS. 47 AND 49). SN 77-558,033. PUB. 6-29-2010. FILED 8-28-2008.

3,953,056. **SALVADOR'S (STANDARD CHARACTER)**. LUXCO, INC., (U.S. CLS. 47 AND 49). SN 77-688,811. PUB. 2-15-2011. FILED 3-11-2009.

3,953,185. **MESSICANO ALTEÑO (STANDARD CHARACTER)**. PRODUCTOS FINOS DE AGAVE, S.A. DE C.V., (U.S. CLS. 47 AND 49). SN 77-854,212. PUB. 9-28-2010. FILED 10-21-2009.

3,953,199. **REVELACION AND DESIGN**. VIDAURRI NUÑEZ, MARITZA, (U.S. CLS. 47 AND 49). SN 77-868,753. PUB. 2-15-2011. FILED 11-9-2009.

3,953,254. **ORANGE THE SECRET INGREDIENT BEHIND THE TOP COCKTAILS TORRES AND DESIGN**. MIGUEL TORRES, S.A., (U.S. CLS. 47 AND 49). SN 77-926,288. PUB. 2-15-2011. FILED 2-2-2010.

3,953,284. **HYOKETSU (STANDARD CHARACTER)**. KIRIN HOLDINGS KABUSHIKI KAISHA, TA KIRIN HOLDINGS CO., LTD., (U.S. CLS. 47 AND 49). SN 77-938,548. PUB. 2-15-2011. FILED 2-18-2010.

3,953,338. **TARARA WINERY LONG-BOMB AND DESIGN**. TARARA WINERY, DBA TARARA WINERY, (U.S. CLS. 47 AND 49). SN 77-949,686. PUB. 2-15-2011. FILED 3-3-2010.

3,953,359. **GHOST HORSE OUTLAW (STANDARD CHARACTER)**. ANDERSON, TODD, (U.S. CLS. 47 AND 49). SN 77-952,356. PUB. 2-15-2011. FILED 3-6-2010.

3,953,403. **TURN 4 FOUR (STYLIZED)**. BENNETT LANE WINERY, (U.S. CLS. 47 AND 49). SN 77-958,698. PUB. 2-15-2011. FILED 3-15-2010.

3,953,426. **MOMO COSMO (STANDARD CHARACTER)**. MIYAZATO KATS, DBA M & M ENTERPRISE, (U.S. CLS. 47 AND 49). SN 77-961,178. PUB. 2-15-2011. FILED 3-17-2010.

3,953,446. **VERACUBA (STANDARD CHARACTER)**. HAVANA CLUB HOLDING, S.A., (U.S. CLS. 47 AND 49). SN 77-963,677. PUB. 2-15-2011. FILED 3-19-2010.

3,953,507. **CIGOGNE NOIRE (STANDARD CHARACTER)**. A. DE FUSSIGNY, (U.S. CLS. 47 AND 49). SN 79-072,251. PUB. 2-15-2011. FILED 6-26-2009.

3,953,523. **BRUNO PAILLARD AND DESIGN**. BRUNO PAILLARD, (U.S. CLS. 47 AND 49). SN 79-076,526. PUB. 2-15-2011. FILED 7-9-2009.

3,953,524. **SAMUEL SMITH'S ORGANIC CIDER PRODUCED FROM ORGANICALLY GROWN APPLES AND DESIGN**. SAMUEL SMITH OLD BREWERY; (TADCASTER), (U.S. CLS. 47 AND 49). SN 79-076,614. PUB. 2-15-2011. FILED 11-13-2009.

3,953,548. **SILVER BARLEY (STANDARD CHARACTER)**. SPECIALITY DRINKS LIMITED, (U.S. CLS. 47 AND 49). SN 79-080,451. PUB. 2-15-2011. FILED 2-10-2010.

3,953,562 ( See Class 29 for this trademark).

3,953,573. **PUNCTUM (STANDARD CHARACTER)**. DOMINIO DE PUNCTUM, S.L., (U.S. CLS. 47 AND 49). SN 79-081,781. PUB. 2-15-2011. FILED 3-9-2010.

3,953,580 ( See Class 30 for this trademark).

3,953,619 ( See Class 32 for this trademark).



3,953,624. **SELIGO (STANDARD CHARACTER)**. CANTINE SETTESOLI S.C.A., AND ENOTRIA WINECELLARS LTD, (U.S. CLS. 47 AND 49). SN 79-084,825. PUB. 2-15-2011. FILED 6-4-2010.

3,953,639. **ARINE AND DESIGN**. ARARAT COGNAC FACTORY 'A.K.Z.' LTD, (U.S. CLS. 47 AND 49). SN 79-086,459. PUB. 2-15-2011. FILED 6-23-2010.

3,953,660. **ABRIKON (STANDARD CHARACTER)**. NAIRE POGHOSYAN, (U.S. CLS. 47 AND 49). SN 79-087,750. PUB. 2-15-2011. FILED 8-20-2010.

3,953,668. **DR H RIESLING DR. HERMANN AND DESIGN**. DR. THOMAS THEES, (U.S. CLS. 47 AND 49). SN 79-088,336. PUB. 2-15-2011. FILED 7-8-2010.

3,953,740. **A. DE FUSSIGNY (STANDARD CHARACTER)**. A. DE FUSSIGNY, (U.S. CLS. 47 AND 49). SN 85-018,244. PUB. 2-15-2011. FILED 4-20-2010.

3,953,775. **VINEYARD STATION RANCH (STANDARD CHARACTER)**. ARTHUR FICHTENBERG AND ASSOCIATES, (U.S. CLS. 47 AND 49). SN 85-030,224. PUB. 2-15-2011. FILED 5-4-2010.

3,953,819. **VIVACIOUS (STANDARD CHARACTER)**. 3 HORSE RANCH VINEYARDS, (U.S. CLS. 47 AND 49). SN 85-041,318. PUB. 2-15-2011. FILED 5-18-2010.

3,953,848. **TRIPLEBANK (STANDARD CHARACTER)**. PERIOD RICARD NEW ZEALAND LIMITED, (U.S. CLS. 47 AND 49). SN 85-053,911. PUB. 2-15-2011. FILED 6-3-2010.

3,953,942. **8 VINES AND DESIGN**. 8-VINES, (U.S. CLS. 47 AND 49). SN 85-082,110. PUB. 2-15-2011. FILED 7-11-2010.

3,953,967. **AVIATION GIN (STANDARD CHARACTER)**. HOUSE SPIRITS LLC, (U.S. CLS. 47 AND 49). SN 85-089,518. PUB. 2-15-2011. FILED 7-21-2010.

3,954,010. **NO BS TEMPRANILLO 2008 AND DESIGN**. BEAR 399, LLC, (U.S. CLS. 47 AND 49). SN 85-098,506. PUB. 2-15-2011. FILED 8-2-2010.

3,954,054. **LIVE LAUGH LOVE (STANDARD CHARACTER)**. D-GENERATION, INC., (U.S. CLS. 47 AND 49). SN 85-105,535. PUB. 2-15-2011. FILED 8-11-2010.

3,954,059. **CHEMISTRY FIG. 10 WILLAMETTE VALLEY AND DESIGN**. CHEHALEM, INC., (U.S. CLS. 47 AND 49). SN 85-106,003. PUB. 2-15-2011. FILED 8-12-2010.

3,954,280. **JOEL AIKEN (STANDARD CHARACTER)**. JOEL AIKEN, (U.S. CLS. 47 AND 49). SN 85-115,898. PUB. 2-15-2011. FILED 8-25-2010.

3,954,299. **SAL Y MIEL (STANDARD CHARACTER)**. FAVIA ERICKSON WINEGROWERS, LLC, (U.S. CLS. 47 AND 49). SN 85-116,272. PUB. 2-15-2011. FILED 8-26-2010.

3,954,402. **Z ZIGUNO AND DESIGN**. CORPORACIÓN DE LOS ANGELES, S.A. DE C.V., (U.S. CLS. 47 AND 49). SN 85-117,841. PUB. 2-15-2011. FILED 8-27-2010.

3,954,548. **MEJORTAGE (STANDARD CHARACTER)**. MEDITERRANEAN CELLARS, LLC, (U.S. CLS. 47 AND 49). SN 85-119,388. PUB. 2-15-2011. FILED 8-31-2010.

3,954,606. **ROUTESTOCK (STANDARD CHARACTER)**. WILSON DANIELS LTD., (U.S. CLS. 47 AND 49). SN 85-120,081. PUB. 2-15-2011. FILED 8-31-2010.

3,954,629. **SACHEM (STANDARD CHARACTER)**. FORTUNATUS, (U.S. CLS. 47 AND 49). SN 85-120,319. PUB. 2-15-2011. FILED 8-31-2010.

3,954,665. **SWEET SUNSET (STANDARD CHARACTER)**. ONE PLUS TWO INC., (U.S. CLS. 47 AND 49). SN 85-120,705. PUB. 2-15-2011. FILED 9-1-2010.

3,954,685. **AO AND DESIGN**. MOHOLT-SIEBERT, MELISSA J., (U.S. CLS. 47 AND 49). SN 85-120,838. PUB. 2-15-2011. FILED 9-1-2010.

3,954,690. **PIECE OF CAKE (STANDARD CHARACTER)**. PIECE OF CAKE, LLC, (U.S. CLS. 47 AND 49). SN 85-120,878. PUB. 2-15-2011. FILED 9-1-2010.

3,954,691. **FORTY-SEVEN FRIENDS (STANDARD CHARACTER)**. MOHOLT-SIEBERT, MELISSA J., (U.S. CLS. 47 AND 49). SN 85-120,885. PUB. 2-15-2011. FILED 9-1-2010.

3,954,694. **47 AND DESIGN**. MOHOLT-SIEBERT, MELISSA J., (U.S. CLS. 47 AND 49). SN 85-120,910. PUB. 2-15-2011. FILED 9-1-2010.

3,954,696. **47 AND DESIGN**. MOHOLT-SIEBERT, MELISSA J., (U.S. CLS. 47 AND 49). SN 85-120,930. PUB. 2-15-2011. FILED 9-1-2010.

3,954,801. **NELLIGAN ROAD (STANDARD CHARACTER)**. DEERING WINE USA, LLC, (U.S. CLS. 47 AND 49). SN

85-122,216. PUB. 2-15-2011. FILED 9-2-2010.

3,954,868. **LEATHERHEAD (STANDARD CHARACTER)**. HEY JOE WINE CO., LLC, (U.S. CLS. 47 AND 49). SN 85-123,028. PUB. 2-15-2011. FILED 9-3-2010.

3,954,889 ( *See Class 21 for this trademark*).

3,954,909. **PLUM CREEK (STANDARD CHARACTER)**. PLUM CREEK CELLARS, LTD., (U.S. CLS. 47 AND 49). SN 85-123,793. PUB. 2-15-2011. FILED 9-7-2010.

3,954,912. **OLD SMUGGLER (STANDARD CHARACTER)**. DAVIDE CAMPARI-MILANO S.P.A., (U.S. CLS. 47 AND 49). SN 85-123,900. PUB. 2-15-2011. FILED 9-7-2010.

3,954,932. **JETS UNCORKED (STANDARD CHARACTER)**. NEW YORK JETS LLC, (U.S. CLS. 47 AND 49). SN 85-124,326. PUB. 2-15-2011. FILED 9-7-2010.

3,955,023. **BEYOND VODKA (STANDARD CHARACTER)**. FRANK-LIN DISTILLERS PRODUCTS, LTD., (U.S. CLS. 47 AND 49). SN 85-136,676. PUB. 2-15-2011. FILED 9-23-2010.

3,955,044. **ALL THAT JAZZ (STANDARD CHARACTER)**. EATON, JOANNE MAREE, AND EATON, MICHAEL DOUGLAS, (U.S. CLS. 47 AND 49). SN 85-138,899. PUB. 2-15-2011. FILED 9-27-2010.

3,955,090. **WILD OAK (STANDARD CHARACTER)**. ST. FRANCIS WINERY AND VINEYARDS, L.P., (U.S. CLS. 47 AND 49). SN 85-151,312. PUB. 2-15-2011. FILED 10-13-2010.

3,955,141. **WENTE VINEYARDS FAMILY OWNED. ESTATE GROWN. SUSTAINABLY FARMED. (STANDARD CHARACTER)**. WENTE BROS., (U.S. CLS. 47 AND 49). SN 85-175,935. PUB. 2-15-2011. FILED 11-12-2010.

---

## CLASS 34—SMOKERS' ARTICLES

3,953,768. **21ST CENTURY SMOKE (STANDARD CHARACTER)**. DR DISTRIBUTORS, LLC, (U.S. CLS. 2, 8, 9 AND 17). SN 85-029,071. PUB. 2-15-2011. FILED 5-3-2010.

3,953,929. **COSTA LINDA HECHO A MANO NICARAGUA INSPIRADO POR LA COSTA DE ESPAÑA AND DESIGN**. FRIEDMAN & KLINGE CIGAR COMPANY, (U.S. CLS. 2, 8, 9 AND 17). SN 85-077,548. PUB. 2-15-2011. FILED 7-2-2010.

3,954,589. **CORONIDOR (STANDARD CHARACTER)**. SFH CONCEPTS, LLC, DBA KLONDIKE ROD COMPANY, (U.S. CLS. 2, 8, 9 AND 17). SN 85-119,886. PUB. 2-15-2011. FILED 8-31-2010.

3,955,031. **UNBLEACHED . CHLORINE FREE AND DESIGN**. MIQUEL Y COSTAS & MIQUEL S.A., (U.S. CLS. 2, 8, 9 AND 17). SN 85-137,361. PUB. 2-15-2011. FILED 9-24-2010.

---

## SERVICE MARKS

### CLASS 35—ADVERTISING AND BUSINESS

3,952,949 ( *See Class 16 for this trademark*).

3,952,956 ( *See Class 9 for this trademark*).

3,952,958. **2DIALOG (STANDARD CHARACTER)**. 2DIALOG, LTD., MULTIPLE CLASS, (INT. CLS. 35 AND 42), (U.S. CLS. 100, 101 AND 102). SN 76-694,204. PUB. 2-15-2011. FILED 11-13-2008.

3,952,959. **CO-OP REVELATION (STANDARD CHARACTER)**. CU COOPERATIVE SYSTEMS, INC., MULTIPLE CLASS, (INT. CLS. 35, 36 AND 45), (U.S. CLS. 100, 101 AND 102). SN 76-695,690. PUB. 2-15-2011. FILED 2-9-2009.

3,952,967. **DO GOOD PLANET AND DESIGN**. DO GOOD PLANET LLC, (U.S. CLS. 100, 101 AND 102). SN 76-701,447. PUB. 2-15-2011. FILED 2-1-2010.

3,952,968. **DO GOOD PLANET (STANDARD CHARACTER)**. DO GOOD PLANET LLC, (U.S. CLS. 100, 101 AND 102). SN 76-701,448. PUB. 2-15-2011. FILED 2-1-2010.

3,952,975. **LOG CABIN DAYS (STANDARD CHARACTER)**. HOCHSTETLER MILLING, LTD, MULTIPLE CLASS, (INT. CLS. 35 AND 41), (U.S. CLS. 100, 101, 102 AND 107). SN 76-702,831. PUB. 2-15-2011. FILED 5-6-2010.

3,952,976. **CITY OF WIXOM (STYLIZED)**. CITY OF WIXOM,

- (U.S. CLS. 100, 101 AND 102). SN 76-702,888. PUB. 2-15-2011. FILED 5-10-2010.
- 3,952,977. **PCAP-PROBE (STANDARD CHARACTER)**. YR20 US LLC, (U.S. CLS. 100, 101 AND 102). SN 76-703,266. PUB. 2-15-2011. FILED 6-7-2010.
- 3,952,978. **YR20 (STANDARD CHARACTER)**. YR20 US LLC, (U.S. CLS. 100, 101 AND 102). SN 76-703,267. PUB. 2-15-2011. FILED 6-7-2010.
- 3,952,979. **MISKELLY FURNITURE (STANDARD CHARACTER)**. MISKELLY FURNITURE WAREHOUSE, INC., (U.S. CLS. 100, 101 AND 102). SN 76-703,444. PUB. 2-15-2011. FILED 6-21-2010.
- 3,952,980. **ECO EARTH CITY GUIDE (STANDARD CHARACTER)**. RODRIGUEZ, ANGELA, (U.S. CLS. 100, 101 AND 102). SN 76-703,892. PUB. 2-15-2011. FILED 7-26-2010.
- 3,952,982. **RESTAURANTOWNER.COM (STANDARD CHARACTER)**. CENTER FOR FOODSERVICE EDUCATION, INC., (U.S. CLS. 100, 101 AND 102). SN 76-704,091. PUB. 2-15-2011. FILED 8-12-2010.
- 3,952,995. **PLANT BROTHERS (STANDARD CHARACTER)**. PLANT BROTHERS INC., (U.S. CLS. 100, 101 AND 102). SN 76-704,327. PUB. 2-15-2011. FILED 9-2-2010.
- 3,952,999. **KIDSBURGH (STANDARD CHARACTER)**. GREATER PITTSBURGH CONVENTION AND VISITORS BUREAU, INC., DBA VISITPITTSBURGH, (U.S. CLS. 100, 101 AND 102). SN 76-704,756. PUB. 2-15-2011. FILED 10-4-2010.
- 3,953,003 ( *See Class 16 for this trademark*).
- 3,953,012. **STAY (STANDARD CHARACTER)**. BELLSTAR HOTEL AND RESORTS LTD., MULTIPLE CLASS, (INT. CLS. 35, 36 AND 37), (U.S. CLS. 100, 101, 102, 103 AND 106). SN 77-213,101. PUB. 1-25-2011. FILED 6-22-2007.
- 3,953,013. **MYSTYLE. (STANDARD CHARACTER)**. E! ENTERTAINMENT TELEVISION, INC., (U.S. CLS. 100, 101 AND 102). SN 77-215,610. PUB. 2-15-2011. FILED 6-26-2007.
- 3,953,018. **ONE CLICK AND YOU'RE HOME (STANDARD CHARACTER)**. COUNSELOR REALTY, INC., (U.S. CLS. 100, 101 AND 102). SN 77-297,028. PUB. 8-31-2010. FILED 10-5-2007.
- 3,953,021. **HEALTHPOINTS (STANDARD CHARACTER)**. THE BILL SIMS COMPANY, (U.S. CLS. 100, 101 AND 102). SN 77-372,748. PUB. 2-15-2011. FILED 1-16-2008.
- 3,953,023. **ZIPTUNES (STANDARD CHARACTER)**. ZIP.CA INC., MULTIPLE CLASS, (INT. CLS. 35, 38, 41 AND 42), (U.S. CLS. 100, 101, 102, 104 AND 107). SN 77-389,126. PUB. 2-15-2011. FILED 2-5-2008.
- 3,953,035 ( *See Class 9 for this trademark*).
- 3,953,038 ( *See Class 16 for this trademark*).
- 3,953,045. **HOPELESS ROMANTIC (STANDARD CHARACTER)**. VICTORIAN PAPER COMPANY, (U.S. CLS. 100, 101 AND 102). SN 77-662,155. PUB. 2-15-2011. FILED 2-3-2009.
- 3,953,049 ( *See Class 6 for this trademark*).
- 3,953,054. **ENGAGED COMMUNITY CITIZENSHIP (STANDARD CHARACTER)**. VANCOUVER BOARD OF TRADE, MULTIPLE CLASS, (INT. CLS. 35 AND 41), (U.S. CLS. 100, 101, 102 AND 107). SN 77-687,223. PUB. 1-18-2011. FILED 3-10-2009.
- 3,953,069. **FUTURES LAB (STANDARD CHARACTER)**. APPLIED MINDS, INC., MULTIPLE CLASS, (INT. CLS. 35 AND 42), (U.S. CLS. 100, 101 AND 102). SN 77-738,095. PUB. 2-15-2011. FILED 5-15-2009.
- 3,953,083 ( *See Class 1 for this trademark*).
- 3,953,091. **ASTRO (STANDARD CHARACTER)**. ASTRO STUDIOS, INC., (U.S. CLS. 100, 101 AND 102). SN 77-775,708. PUB. 2-15-2011. FILED 7-7-2009.
- 3,953,092. **DOTTIE DONOR DOT AND DESIGN**. UNIVERSITY OF WISCONSIN HOSPITALS AND CLINICS AUTHORITY, DBA UW HEALTH, (U.S. CLS. 100, 101 AND 102). SN 77-776,120. PUB. 2-15-2011. FILED 7-7-2009.
- 3,953,096. **GOLF PIMP (STANDARD CHARACTER)**. BROWNSTONE MARKETING, LLC, DBA GOLF PIMP, (U.S. CLS. 100, 101 AND 102). SN 77-786,759. PUB. 2-15-2011. FILED 7-22-2009.
- 3,953,102 ( *See Class 20 for this trademark*).
- 3,953,127. **WHOLESALE SPORTS OUTDOOR OUTFITTERS AND DESIGN**. UNITED FARMERS OF ALBERTA CO-OPERATIVE LIMITED, (U.S. CLS. 100, 101 AND 102). SN 77-814,426. PUB. 2-15-2011. FILED 8-27-2009.
- 3,953,130. **MAN-O-GRAMS (STANDARD CHARACTER)**. RICCIO, TODD M, AND HWANG, SARA, (U.S. CLS. 100, 101 AND 102). SN 77-815,801. PUB. 2-15-2011. FILED 8-28-2009.
- 3,953,134. **GOLF TOWN AND DESIGN**. GOLF TOWN OPERATING LIMITED PARTNERSHIP, MULTIPLE CLASS, (INT. CLS. 35, 37 AND 41), (U.S. CLS. 100, 101, 102, 103, 106 AND 107). SN 77-817,562. PUB. 8-3-2010. FILED 9-1-2009.
- 3,953,142. **SUNTERRA MARKET (STANDARD CHARACTER)**. SUNTERRA FOOD CORPORATION, MULTIPLE CLASS, (INT. CLS. 35, 39, 43 AND 44), (U.S. CLS. 100, 101, 102 AND 105). SN 77-819,532. PUB. 2-15-2011. FILED 9-3-2009.
- 3,953,143. **SUNTERRA MARKET AND DESIGN**. SUNTERRA FOOD CORPORATION, MULTIPLE CLASS, (INT. CLS. 35, 39, 43 AND 44), (U.S. CLS. 100, 101, 102 AND 105). SN 77-819,559. PUB. 2-15-2011. FILED 9-3-2009.
- 3,953,150. **TAC AIR (STANDARD CHARACTER)**. TRUMAN ARNOLD COMPANIES, MULTIPLE CLASS, (INT. CLS. 35 AND 39), (U.S. CLS. 100, 101, 102 AND 105). SN 77-826,781. PUB. 2-15-2011. FILED 9-15-2009.
- 3,953,151. **TAC AIR AND DESIGN**. TRUMAN ARNOLD COMPANIES, MULTIPLE CLASS, (INT. CLS. 35 AND 39), (U.S. CLS. 100, 101, 102 AND 105). SN 77-826,796. PUB. 2-15-2011. FILED 9-15-2009.
- 3,953,161. **WOLF CAMERA & IMAGE (STANDARD CHARACTER)**. RITZ CAMERA & IMAGE, L.L.C., MULTIPLE CLASS, (INT. CLS. 35, 40 AND 42), (U.S. CLS. 100, 101, 102, 103 AND 106). SN 77-841,249. PUB. 2-15-2011. FILED 10-5-2009.
- 3,953,165. **GHA (STANDARD CHARACTER)**. GHA SERVICES SA, MULTIPLE CLASS, (INT. CLS. 35 AND 43), (U.S. CLS. 100, 101 AND 102). SN 77-843,223. PUB. 7-27-2010. FILED 10-7-2009.
- 3,953,166. **FLINT AND DESIGN**. FLINT ENERGY SERVICES LTD., MULTIPLE CLASS, (INT. CLS. 35, 37, 39 AND 40), (U.S. CLS. 100, 101, 102, 103, 105 AND 106). SN 77-843,592. PUB. 2-15-2011. FILED 10-7-2009.
- 3,953,188. **OXORA (STANDARD CHARACTER)**. OXORA NORTH AMERICA, INC., (U.S. CLS. 100, 101 AND 102). SN 77-856,756. PUB. 2-15-2011. FILED 10-24-2009.
- 3,953,190. **US RE AND DESIGN**. U.S. RE COMPANIES, INC., MULTIPLE CLASS, (INT. CLS. 35 AND 36), (U.S. CLS. 100, 101 AND 102). SN 77-857,557. PUB. 2-15-2011. FILED 10-26-2009.
- 3,953,192. **SELECT + SAVE NOT YOUR TYPICAL EMPLOYEE BENEFITS AND DESIGN**. ASTONISH RESULTS, LP, (U.S. CLS. 100, 101 AND 102). SN 77-859,179. PUB. 9-14-2010. FILED 10-28-2009.
- 3,953,198 ( *See Class 29 for this trademark*).
- 3,953,215. **I AND DESIGN**. IPAY TECHNOLOGIES, LLC, MULTIPLE CLASS, (INT. CLS. 35, 36, 38, 39, 42 AND 45), (U.S. CLS. 100, 101, 102, 104 AND 105). SN 77-893,727. PUB. 2-15-2011. FILED 12-15-2009.
- 3,953,223. **POWEROPTIONS (STANDARD CHARACTER)**. POWEROPTIONS, INC., (U.S. CLS. 100, 101 AND 102). SN 77-903,037. PUB. 2-15-2011. FILED 12-30-2009.
- 3,953,252. **GNOMEFRENZY (STANDARD CHARACTER)**. FORWARD MOMENTUM LLC, (U.S. CLS. 100, 101 AND 102). SN 77-925,424. PUB. 2-15-2011. FILED 2-1-2010.
- 3,953,267. **ALL ABOUT JAZZ AND DESIGN**. MICHAEL RICCI, DBA ALL ABOUT JAZZ, (U.S. CLS. 100, 101 AND 102). SN 77-933,585. PUB. 6-29-2010. FILED 2-11-2010.
- 3,953,268. **DVR (STANDARD CHARACTER)**. DEDICATED MARKETING SOLUTIONS, INC., DBA DEDICATED MEDIA, (U.S. CLS. 100, 101 AND 102). SN 77-934,851. PUB. 2-15-2011. FILED 2-12-2010.
- 3,953,275. **(IQ)2 (STYLIZED)**. THE BLACKSTONE GROUP INC., (U.S. CLS. 100, 101 AND 102). SN 77-936,592. PUB. 2-15-2011. FILED 2-16-2010.
- 3,953,280. **COMPARE FOODS (STANDARD CHARACTER)**. ASSOCIATED FOOD STORES, INC., (U.S. CLS. 100, 101 AND 102). SN 77-937,875. PUB. 2-15-2011. FILED 2-17-2010.
- 3,953,286. **FS FORENSIC SOLUTIONS LLC FORENSIC AND INVESTIGATIVE ACCOUNTANTS AND DESIGN**. FORENSIC SOLUTIONS, LLC, MULTIPLE CLASS, (INT. CLS. 35 AND 45), (U.S. CLS. 100, 101 AND 102). SN 77-939,050. PUB. 2-15-2011. FILED 2-18-2010.
- 3,953,289. **AMERICAN CRAFT BEER WEEK AND DESIGN**. BREWERS ASSOCIATION, INC., (U.S. CLS. 100, 101 AND 102). SN 77-940,255. PUB. 2-15-2011. FILED 2-19-2010.

- 3,953,295. **CETERA FINANCIAL GROUP (STANDARD CHARACTER)**. CETERA FINANCIAL HOLDINGS, INC., MULTIPLE CLASS, (INT. CLS. 35 AND 36), (U.S. CLS. 100, 101 AND 102). SN 77-942,067. PUB. 11-9-2010. FILED 2-23-2010.
- 3,953,298 ( *See Class 9 for this trademark*).
- 3,953,301. **GREEN HAT (STANDARD CHARACTER)**. GREEN HAT CONSULTANTS INC., (U.S. CLS. 100, 101 AND 102). SN 77-942,824. PUB. 2-15-2011. FILED 2-23-2010.
- 3,953,303. **4WAYFLYER.COM (STANDARD CHARACTER)**. ROSARIO, BRYAN, (U.S. CLS. 100, 101 AND 102). SN 77-943,178. PUB. 2-15-2011. FILED 2-24-2010.
- 3,953,309. **ARCHI EXPO AND DESIGN**. THIERCELIN, CORENTIN, MULTIPLE CLASS, (INT. CLS. 35 AND 41), (U.S. CLS. 100, 101, 102 AND 107). SN 77-944,677. PUB. 2-15-2011. FILED 2-25-2010.
- 3,953,310. **MEDICAL EXPO AND DESIGN**. THIERCELIN, CORENTIN, MULTIPLE CLASS, (INT. CLS. 35 AND 41), (U.S. CLS. 100, 101, 102 AND 107). SN 77-944,722. PUB. 2-15-2011. FILED 2-25-2010.
- 3,953,311. **SPONSUME (STANDARD CHARACTER)**. SPONSUME.COM LIMITED, MULTIPLE CLASS, (INT. CLS. 35, 38 AND 42), (U.S. CLS. 100, 101, 102 AND 104). SN 77-944,766. PUB. 2-15-2011. FILED 2-25-2010.
- 3,953,314. **ELITE FITNESS (STANDARD CHARACTER)**. ELITE INVESTMENT PORTFOLIO, LLC, MULTIPLE CLASS, (INT. CLS. 35 AND 38), (U.S. CLS. 100, 101, 102 AND 104). SN 77-944,920. PUB. 2-15-2011. FILED 2-25-2010.
- 3,953,317 ( *See Class 20 for this trademark*).
- 3,953,325. **STAR SHOW AND DESIGN**. GREENTIDE FT CORPORATION, (U.S. CLS. 100, 101 AND 102). SN 77-947,657. PUB. 2-15-2011. FILED 3-1-2010.
- 3,953,327. **WEBUYTEXTBOOKS.COM (STANDARD CHARACTER)**. SE BOOK COMPANY, LLC, (U.S. CLS. 100, 101 AND 102). SN 77-948,503. PUB. 2-15-2011. FILED 3-2-2010.
- 3,953,331. **NASTY GAL (STANDARD CHARACTER)**. NASTY GAL, INC., (U.S. CLS. 100, 101 AND 102). SN 77-949,164. PUB. 2-15-2011. FILED 3-3-2010.
- 3,953,336. **IOWA CORN PROMOTION BOARD (STANDARD CHARACTER)**. IOWA CORN PROMOTION BOARD, MULTIPLE CLASS, (INT. CLS. 35 AND 42), (U.S. CLS. 100, 101 AND 102). SN 77-949,604. PUB. 2-15-2011. FILED 3-3-2010.
- 3,953,341. **TRUSTED GROWERS. QUALITY DRIVEN. (STANDARD CHARACTER)**. CALIFORNIA ARTICHOKE AND VEGETABLE GROWERS CORPORATION, DBA OCEAN MIST FARMS, (U.S. CLS. 100, 101 AND 102). SN 77-949,932. PUB. 2-15-2011. FILED 3-3-2010.
- 3,953,349. **MEMORABLE EXPRESSIONS (STANDARD CHARACTER)**. HALLMARK BUSINESS CONNECTIONS, INC., (U.S. CLS. 100, 101 AND 102). SN 77-950,616. PUB. 2-15-2011. FILED 3-4-2010.
- 3,953,369 ( *See Class 2 for this trademark*).
- 3,953,374. **THE HUMAN SOLUTION (STANDARD CHARACTER)**. SQUARE GROVE, LLC, (U.S. CLS. 100, 101 AND 102). SN 77-954,123. PUB. 2-15-2011. FILED 3-9-2010.
- 3,953,378. **CROSSROADS (STANDARD CHARACTER)**. IGA, INC., (U.S. CLS. 100, 101 AND 102). SN 77-954,748. PUB. 2-15-2011. FILED 3-9-2010.
- 3,953,380. **US SOLAR & WIND SYNERGIES (STANDARD CHARACTER)**. US SOLAR & WIND SYNERGIES LLC, (U.S. CLS. 100, 101 AND 102). SN 77-954,914. PUB. 2-15-2011. FILED 3-9-2010.
- 3,953,387. **AUTO LOAN RECAPTURE (STANDARD CHARACTER)**. SER TECHNOLOGY CORPORATION, (U.S. CLS. 100, 101 AND 102). SN 77-956,011. PUB. 2-15-2011. FILED 3-10-2010.
- 3,953,391. **VM VENTUREMOM.COM AND DESIGN**. HILL FINANCIAL GROUP, LTD, (U.S. CLS. 100, 101 AND 102). SN 77-956,596. PUB. 2-15-2011. FILED 3-11-2010.
- 3,953,393 ( *See Class 30 for this trademark*).
- 3,953,397. **MARBLES THE BRAIN STORE (STANDARD CHARACTER)**. MARBLES LLC, (U.S. CLS. 100, 101 AND 102). SN 77-957,696. PUB. 2-15-2011. FILED 3-12-2010.
- 3,953,406. **MONSTER ROCKFISH TOURNAMENT (STYLIZED)**. BAMB ENTERPRISES, LLC, AKA JEFFERY D. TOMCSIK, DAVID J. COOPER, MICHAEL W. OWENS, MULTIPLE CLASS, (INT. CLS. 35 AND 41), (U.S. CLS. 100, 101, 102 AND 107). SN 77-959,044. PUB. 2-15-2011. FILED 3-15-2010.
- 3,953,412. **ADFUNKY (STANDARD CHARACTER)**. ADFUNKY LLC, (U.S. CLS. 100, 101 AND 102). SN 77-959,602. PUB. 2-15-2011. FILED 3-16-2010.
- 3,953,413. **EVMS CONSULTING GROUP, LLC (STANDARD CHARACTER)**. EVMS CONSULTING GROUP, LLC, (U.S. CLS. 100, 101 AND 102). SN 77-959,607. PUB. 2-15-2011. FILED 3-16-2010.
- 3,953,414. **ADFUNKY AND DESIGN**. ADFUNKY LLC, (U.S. CLS. 100, 101 AND 102). SN 77-959,609. PUB. 2-15-2011. FILED 3-16-2010.
- 3,953,415. **OFFICENATION (STANDARD CHARACTER)**. DAYAN, MEDWIN, (U.S. CLS. 100, 101 AND 102). SN 77-959,818. PUB. 2-15-2011. FILED 3-16-2010.
- 3,953,436. **FIND 'EM FIRST (STANDARD CHARACTER)**. BBY SOLUTIONS, INC., MULTIPLE CLASS, (INT. CLS. 35 AND 42), (U.S. CLS. 100, 101 AND 102). SN 77-962,025. PUB. 2-15-2011. FILED 3-18-2010.
- 3,953,451. **MAKE ADVENTURE YOUR BUSINESS (STANDARD CHARACTER)**. ADVENTURE HOLDINGS LLC, (U.S. CLS. 100, 101 AND 102). SN 77-965,332. PUB. 2-15-2011. FILED 3-22-2010.
- 3,953,455. **NATIONWIDE GRAPHICS PREMIER PRINT ORGANIZATION (STANDARD CHARACTER)**. NATIONWIDE GRAPHICS, INC., MULTIPLE CLASS, (INT. CLS. 35, 40, 41 AND 42), (U.S. CLS. 100, 101, 102, 103, 106 AND 107). SN 77-966,306. PUB. 2-15-2011. FILED 3-23-2010.
- 3,953,456. **NATIONWIDE GRAPHICS (STANDARD CHARACTER)**. NATIONWIDE GRAPHICS, INC., MULTIPLE CLASS, (INT. CLS. 35, 40, 41 AND 42), (U.S. CLS. 100, 101, 102, 103, 106 AND 107). SN 77-966,319. PUB. 2-15-2011. FILED 3-23-2010.
- 3,953,460. **HAYES (STANDARD CHARACTER)**. HAYES JEWELERS INC., (U.S. CLS. 100, 101 AND 102). SN 77-967,243. PUB. 2-15-2011. FILED 3-24-2010.
- 3,953,466. **AFAXYS (STANDARD CHARACTER)**. AFAXYS, INC., (U.S. CLS. 100, 101 AND 102). SN 77-981,741. PUB. 6-16-2009. FILED 9-10-2008.
- 3,953,467 ( *See Class 25 for this trademark*).
- 3,953,471 ( *See Class 3 for this trademark*).
- 3,953,473 ( *See Class 12 for this trademark*).
- 3,953,481. **CSI (STANDARD CHARACTER)**. FISERV, INC., (U.S. CLS. 100, 101 AND 102). SN 78-950,366. PUB. 2-15-2011. FILED 8-11-2006.
- 3,953,495 ( *See Class 9 for this trademark*).
- 3,953,498 ( *See Class 9 for this trademark*).
- 3,953,511 ( *See Class 9 for this trademark*).
- 3,953,513 ( *See Class 1 for this trademark*).
- 3,953,517 ( *See Class 5 for this trademark*).
- 3,953,528. **INDAZOO (STYLIZED)**. JM ROSES PTY LTD, AND DAVID JORDAN PTY LTD, MULTIPLE CLASS, (INT. CLS. 35, 38 AND 45), (U.S. CLS. 100, 101, 102 AND 104). SN 79-077,377. PUB. 2-15-2011. FILED 11-13-2009.
- 3,953,542. **NOTSODAFT (STYLIZED)**. NSD MEDIA LTD., MULTIPLE CLASS, (INT. CLS. 35, 38 AND 41), (U.S. CLS. 100, 101, 102, 104 AND 107). SN 79-079,574. PUB. 2-15-2011. FILED 1-21-2010.
- 3,953,544. **NAAWT NORTH AMERICAN ACADEMY OF WOUND TECHNOLOGY AND DESIGN**. CONGRES MF, MULTIPLE CLASS, (INT. CLS. 35, 41 AND 44), (U.S. CLS. 100, 101, 102 AND 107). SN 79-079,908. PUB. 2-15-2011. FILED 12-11-2009.
- 3,953,556 ( *See Class 11 for this trademark*).
- 3,953,562 ( *See Class 29 for this trademark*).
- 3,953,569 ( *See Class 6 for this trademark*).
- 3,953,570 ( *See Class 6 for this trademark*).
- 3,953,571 ( *See Class 9 for this trademark*).
- 3,953,578 ( *See Class 4 for this trademark*).
- 3,953,579 ( *See Class 4 for this trademark*).
- 3,953,594 ( *See Class 9 for this trademark*).
- 3,953,609 ( *See Class 16 for this trademark*).
- 3,953,614 ( *See Class 18 for this trademark*).
- 3,953,632 ( *See Class 3 for this trademark*).
- 3,953,636. **INNOTRIBE (STANDARD CHARACTER)**. SOCIETY FOR WORLDWIDE INTERBANK FINANCIAL TELECOMMUNICATION SCRL, MULTIPLE CLASS, (INT. CLS. 35, 41 AND 42), (U.S. CLS. 100, 101, 102 AND 107). SN 79-086,214. PUB. 2-15-2011. FILED 5-11-2010.
- 3,953,638 ( *See Class 15 for this trademark*).

- 3,953,686. **CLUBMILES (STANDARD CHARACTER)**. FARE-PORTAL, INC., MULTIPLE CLASS, (INT. CLS. 35, 39 AND 43), (U.S. CLS. 100, 101, 102 AND 105). SN 85-000,467. PUB. 2-15-2011. FILED 3-29-2010.
- 3,953,713. **CONSILIUM (STANDARD CHARACTER)**. DEVON HEALTH SERVICES, INC., (U.S. CLS. 100, 101 AND 102). SN 85-007,191. PUB. 2-15-2011. FILED 4-6-2010.
- 3,953,716. **TEMPUR-PEDIC SLEEP EXPERIENCE CENTER (STANDARD CHARACTER)**. DAN-FOAM APS, (U.S. CLS. 100, 101 AND 102). SN 85-007,990. PUB. 2-15-2011. FILED 4-7-2010.
- 3,953,721. **3 ROADS MEDIA (STANDARD CHARACTER)**. 3 ROADS MEDIA, (U.S. CLS. 100, 101 AND 102). SN 85-010,209. PUB. 2-15-2011. FILED 4-9-2010.
- 3,953,729. **HUMANEWATCH (STANDARD CHARACTER)**. CENTER FOR CONSUMER FREEDOM, (U.S. CLS. 100, 101 AND 102). SN 85-013,916. PUB. 2-15-2011. FILED 4-14-2010.
- 3,953,735. **MINNESOTA WEST AG SERVICES AND DESIGN**. MINNESOTA WEST AG SERVICES, LLC, (U.S. CLS. 100, 101 AND 102). SN 85-016,670. PUB. 2-15-2011. FILED 4-18-2010.
- 3,953,736. **C CETERA FINANCIAL GROUP AND DESIGN**. CETERA FINANCIAL HOLDINGS, INC., MULTIPLE CLASS, (INT. CLS. 35 AND 36), (U.S. CLS. 100, 101 AND 102). SN 85-016,918. PUB. 11-9-2010. FILED 4-19-2010.
- 3,953,737. **ESALONSPACE AND DESIGN**. ESALONSPACE, LLC, (U.S. CLS. 100, 101 AND 102). SN 85-016,968. PUB. 2-15-2011. FILED 4-19-2010.
- 3,953,738. **FABILOUS LIVING (STANDARD CHARACTER)**. EVA-MARIA FABI, (U.S. CLS. 100, 101 AND 102). SN 85-017,562. PUB. 2-15-2011. FILED 4-19-2010.
- 3,953,756. **AUTISM ANSWERS AND DESIGN**. HAYNES-PEDRAZA, LINDA, (U.S. CLS. 100, 101 AND 102). SN 85-024,727. PUB. 2-15-2011. FILED 4-27-2010.
- 3,953,761. **SHOPPERSCAPE (STANDARD CHARACTER)**. WPP PROPERTIES, (U.S. CLS. 100, 101 AND 102). SN 85-025,950. PUB. 2-15-2011. FILED 4-29-2010.
- 3,953,766. **AGREN (STANDARD CHARACTER)**. AGREN, INC., MULTIPLE CLASS, (INT. CLS. 35 AND 42), (U.S. CLS. 100, 101 AND 102). SN 85-028,365. PUB. 2-15-2011. FILED 5-3-2010.
- 3,953,770. **CLEAN AND SAFE ENERGY COALITION (STANDARD CHARACTER)**. NUCLEAR ENERGY INSTITUTE, INC., MULTIPLE CLASS, (INT. CLS. 35 AND 41), (U.S. CLS. 100, 101, 102 AND 107). SN 85-030,068. PUB. 2-15-2011. FILED 5-4-2010.
- 3,953,778. **U-SCOOT (STANDARD CHARACTER)**. MRB ACQUISITION CORP., DBA U-SCOOT, (U.S. CLS. 100, 101 AND 102). SN 85-033,080. PUB. 2-15-2011. FILED 5-7-2010.
- 3,953,779. **OPEN-AIRE (STANDARD CHARACTER)**. MRB ACQUISITION CORP., DBA OPEN-AIRE, (U.S. CLS. 100, 101 AND 102). SN 85-033,082. PUB. 2-15-2011. FILED 5-7-2010.
- 3,953,780. **EX HEALTHCARE EXCHANGE EXCHANGING IDEAS. FINDING SOLUTIONS (STYLIZED)**. CENTERSTONE INSURANCE AND FINANCIAL SERVICES, INC., DBA BENEFITMALL, MULTIPLE CLASS, (INT. CLS. 35, 36 AND 42), (U.S. CLS. 100, 101 AND 102). SN 85-033,204. PUB. 2-15-2011. FILED 5-7-2010.
- 3,953,784. **TALLIENCE (STANDARD CHARACTER)**. TALLIENCE LLC, (U.S. CLS. 100, 101 AND 102). SN 85-033,991. PUB. 2-15-2011. FILED 5-10-2010.
- 3,953,785. **ACTIVE AND DESIGN**. ACTIVE SPORTS LIFESTYLE USA, (U.S. CLS. 100, 101 AND 102). SN 85-034,254. PUB. 2-15-2011. FILED 5-10-2010.
- 3,953,786. **FACTORY DIRECT FURNITURE AND BEDS (STANDARD CHARACTER)**. MATHIS HOLDING, INC., (U.S. CLS. 100, 101 AND 102). SN 85-034,434. PUB. 2-15-2011. FILED 5-10-2010.
- 3,953,793. **SHOP THE BOSS.COM BARGAIN OUTLET SUPER STORE BUDDY AND DESIGN**. RICHARD BELL, (U.S. CLS. 100, 101 AND 102). SN 85-036,255. PUB. 2-15-2011. FILED 5-12-2010.
- 3,953,795. **CLICK . EAT . SAVE (STANDARD CHARACTER)**. LINEAR LIME INCORPORATED, DBA ONE BLOCK DOWN, (U.S. CLS. 100, 101 AND 102). SN 85-036,393. PUB. 2-15-2011. FILED 5-12-2010.
- 3,953,796. **JOSHUA VENTURE GROUP (STANDARD CHARACTER)**. JOSHUA VENTURE PHILANTHROPIES, (U.S. CLS. 100, 101 AND 102). SN 85-036,519. PUB. 2-15-2011. FILED 5-12-2010.
- 3,953,797. **SISTEMA AND DESIGN**. SISTEMA PLASTICS LIMITED, (U.S. CLS. 100, 101 AND 102). SN 85-036,628. PUB. 2-15-2011. FILED 5-12-2010.
- 3,953,804. **PAINT FOR FREEDOM (STANDARD CHARACTER)**. NATIONAL SOCIETY OF TOLE AND DECORATIVE PAINTERS, INC., (U.S. CLS. 100, 101 AND 102). SN 85-038,409. PUB. 2-15-2011. FILED 5-14-2010.
- 3,953,812. **IMPRESSIONS PER CONNECTION (STANDARD CHARACTER)**. PERFORMANCE PRICING, LLC, MULTIPLE CLASS, (INT. CLS. 35 AND 41), (U.S. CLS. 100, 101, 102 AND 107). SN 85-039,905. PUB. 2-15-2011. FILED 5-17-2010.
- 3,953,823. **SELLING MORE HOMES MEDIA (STANDARD CHARACTER)**. SELLING MORE HOMES MEDIA, (U.S. CLS. 100, 101 AND 102). SN 85-043,010. PUB. 2-15-2011. FILED 5-19-2010.
- 3,953,829. **PRIVATE EQUITY CFO ASSOCIATION (STANDARD CHARACTER)**. CITIZENS FINANCIAL GROUP, INC., DBA CITIZENS BANK, (U.S. CLS. 100, 101 AND 102). SN 85-046,575. PUB. 2-15-2011. FILED 5-24-2010.
- 3,953,832. **THE FASHION CENTER SIDEWALK CATWALK (STANDARD CHARACTER)**. FASHION CENTER DISTRICT MANAGEMENT ASSOCIATION, INC., (U.S. CLS. 100, 101 AND 102). SN 85-047,443. PUB. 2-15-2011. FILED 5-25-2010.
- 3,953,835. **SUPPLEMENTCLINIC.COM AND DESIGN**. DAREN LAM, (U.S. CLS. 100, 101 AND 102). SN 85-048,683. PUB. 2-15-2011. FILED 5-26-2010.
- 3,953,838. **SMASHER SALE (STANDARD CHARACTER)**. ROBERT RUIZ, DBA SPECTRUM BUSINESS SOLUTIONS, (U.S. CLS. 100, 101 AND 102). SN 85-048,991. PUB. 2-15-2011. FILED 5-27-2010.
- 3,953,842. **"THE MANAGEMENT COMPANY YOU DON'T HAVE TO MANAGE" (STANDARD CHARACTER)**. LELAND MANAGEMENT, INC, (U.S. CLS. 100, 101 AND 102). SN 85-051,343. PUB. 2-15-2011. FILED 6-1-2010.
- 3,953,849. **CUSTOM EDUCATION SOLUTIONS INC AND DESIGN**. CUSTOM EDUCATION SOLUTIONS INC., MULTIPLE CLASS, (INT. CLS. 35 AND 41), (U.S. CLS. 100, 101, 102 AND 107). SN 85-055,292. PUB. 2-15-2011. FILED 6-4-2010.
- 3,953,859 ( *See Class 30 for this trademark*).
- 3,953,862. **FORTRESS SOLUTIONS (STANDARD CHARACTER)**. FORTRESS SOLUTIONS, LTD., MULTIPLE CLASS, (INT. CLS. 35, 37 AND 42), (U.S. CLS. 100, 101, 102, 103 AND 106). SN 85-058,687. PUB. 2-15-2011. FILED 6-9-2010.
- 3,953,863. **FORTRESS SOLUTIONS AND DESIGN**. FORTRESS SOLUTIONS, LTD., MULTIPLE CLASS, (INT. CLS. 35, 37 AND 42), (U.S. CLS. 100, 101, 102, 103 AND 106). SN 85-058,695. PUB. 2-15-2011. FILED 6-9-2010.
- 3,953,875. **N CONFERENCE CONFERENCES . SEMINARS . WORKSHOPS A SERVICE OF THE NELROD COMPANY AND DESIGN**. THE NELROD COMPANY, (U.S. CLS. 100, 101 AND 102). SN 85-062,564. PUB. 2-15-2011. FILED 6-14-2010.
- 3,953,881. **AGATE HEALTHCARE (STANDARD CHARACTER)**. AGATE RESOURCES, INC., (U.S. CLS. 100, 101 AND 102). SN 85-064,422. PUB. 2-15-2011. FILED 6-16-2010.
- 3,953,884. **SMALL TOWN CHARM (STANDARD CHARACTER)**. MAURICES INCORPORATED, (U.S. CLS. 100, 101 AND 102). SN 85-065,282. PUB. 2-15-2011. FILED 6-17-2010.
- 3,953,885. **MAURICES SMALL TOWN CHARM (STANDARD CHARACTER)**. MAURICES INCORPORATED, (U.S. CLS. 100, 101 AND 102). SN 85-065,292. PUB. 2-15-2011. FILED 6-17-2010.
- 3,953,891. **SADDLEBACK GOLF CARS (STANDARD CHARACTER)**. SADDLEBACK GOLF CARS, MULTIPLE CLASS, (INT. CLS. 35 AND 39), (U.S. CLS. 100, 101, 102 AND 105). SN 85-068,710. PUB. 2-15-2011. FILED 6-22-2010.
- 3,953,895 ( *See Class 16 for this trademark*).
- 3,953,896. **X H PHI FOUNDED 1932 AND DESIGN**. CHI ETA PHI SORORITY INCORPORATED, (U.S. CLS. 100, 101 AND 102). SN 85-070,166. PUB. 2-15-2011. FILED 6-23-2010.
- 3,953,904. **FABRIC ON DEMAND AND DESIGN**. DO IT HAPPY, LLC, (U.S. CLS. 100, 101 AND 102). SN 85-071,605.

- PUB. 2-15-2011. FILED 6-25-2010.
- 3,953,917. **REFERRAL EXCHANGE NETWORK (STANDARD CHARACTER)**. SALEM, RAIED E., AND PEREZ, VICENTE ERNESTO, (U.S. CLS. 100, 101 AND 102). SN 85-074,629. PUB. 2-15-2011. FILED 6-30-2010.
- 3,953,918. **DORON OFIR CASTING (STANDARD CHARACTER)**. OFIR, DORON, (U.S. CLS. 100, 101 AND 102). SN 85-075,456. PUB. 2-15-2011. FILED 6-30-2010.
- 3,953,919. **BOOKBROWSE (STANDARD CHARACTER)**. BOOKBROWSE, MULTIPLE CLASS, (INT. CLS. 35 AND 41), (U.S. CLS. 100, 101, 102 AND 107). SN 85-075,534. PUB. 2-15-2011. FILED 6-30-2010.
- 3,953,922. **CHICAGO DENTAL SUPPLY (STANDARD CHARACTER)**. MY VIP ENTERPRISES INC, (U.S. CLS. 100, 101 AND 102). SN 85-076,101. PUB. 2-15-2011. FILED 7-1-2010.
- 3,953,923. **CALIFORNIA DENTAL SUPPLY (STANDARD CHARACTER)**. MY VIP ENTERPRISES INC, (U.S. CLS. 100, 101 AND 102). SN 85-076,242. PUB. 2-15-2011. FILED 7-1-2010.
- 3,953,925 ( *See Class 25 for this trademark*).
- 3,953,934 ( *See Class 30 for this trademark*).
- 3,953,939. **GREEN GUESTBOOK (STANDARD CHARACTER)**. ELIZABETH CARLSON, (U.S. CLS. 100, 101 AND 102). SN 85-081,302. PUB. 2-15-2011. FILED 7-9-2010.
- 3,953,943. **BIZZSHOUT! SOCIALLY PROMOTE YOUR BUSINESS (STYLIZED)**. BIZZSHOUT, LLC, (U.S. CLS. 100, 101 AND 102). SN 85-082,382. PUB. 2-15-2011. FILED 7-12-2010.
- 3,953,954. **PHILLY HOMEGROWN AND DESIGN**. GREATER PHILADELPHIA TOURISM MARKETING CORPORATION, (U.S. CLS. 100, 101 AND 102). SN 85-086,537. PUB. 2-15-2011. FILED 7-16-2010.
- 3,953,955. **RIGHTSGENIE AND DESIGN**. RIGHTSCUBE, INC., (U.S. CLS. 100, 101 AND 102). SN 85-086,647. PUB. 2-15-2011. FILED 7-16-2010.
- 3,953,956. **OUR HEROES' TREE AND DESIGN**. OUR HEROES' TREE, LLC, MULTIPLE CLASS, (INT. CLS. 35 AND 41), (U.S. CLS. 100, 101, 102 AND 107). SN 85-086,686. PUB. 2-15-2011. FILED 7-16-2010.
- 3,953,959. **BRINGING TOGETHER QUALITY ALLIANCES (STANDARD CHARACTER)**. ALLIED INTRADE, INC., (U.S. CLS. 100, 101 AND 102). SN 85-087,521. PUB. 2-15-2011. FILED 7-19-2010.
- 3,953,962. **RA RACEAUCTION.COM AND DESIGN**. RACEAUCTION.COM, INC., (U.S. CLS. 100, 101 AND 102). SN 85-087,717. PUB. 2-15-2011. FILED 7-19-2010.
- 3,953,963. **3S3P (STANDARD CHARACTER)**. ONEPARTNER, LLC, (U.S. CLS. 100, 101 AND 102). SN 85-087,725. PUB. 2-15-2011. FILED 7-19-2010.
- 3,953,976. **MANGELSEN (STANDARD CHARACTER)**. THOMAS D. MANGELSEN, INC., (U.S. CLS. 100, 101 AND 102). SN 85-092,515. PUB. 2-15-2011. FILED 7-26-2010.
- 3,953,987 ( *See Class 9 for this trademark*).
- 3,953,993. **RASTA EMPIRE (STANDARD CHARACTER)**. IRON DONUT, INC., DBA RASTAEMPIRE.COM, (U.S. CLS. 100, 101 AND 102). SN 85-096,042. PUB. 2-15-2011. FILED 7-29-2010.
- 3,953,994. **HIPPIE HERO (STANDARD CHARACTER)**. IRON DONUT, INC., DBA HIPPIEHERO.COM, (U.S. CLS. 100, 101 AND 102). SN 85-096,048. PUB. 2-15-2011. FILED 7-29-2010.
- 3,953,995. **WHITEBOARD CHALLENGE (STANDARD CHARACTER)**. NATIONAL BLACK MBA ASSOCIATION, INC., (U.S. CLS. 100, 101 AND 102). SN 85-096,101. PUB. 2-15-2011. FILED 7-29-2010.
- 3,954,001. **THEGIFTPOOL.COM AND DESIGN**. 42 NORTH GROUP INC., (U.S. CLS. 100, 101 AND 102). SN 85-097,384. PUB. 2-15-2011. FILED 7-30-2010.
- 3,954,002. **SOMEDIA SOLUTIONS (STANDARD CHARACTER)**. SOMEDIA SOLUTIONS, INC., (U.S. CLS. 100, 101 AND 102). SN 85-097,535. PUB. 2-15-2011. FILED 7-31-2010.
- 3,954,007. **FIRST LEGAL NETWORK (STANDARD CHARACTER)**. US LEGAL MANAGEMENT SERVICES, INC., MULTIPLE CLASS, (INT. CLS. 35 AND 45), (U.S. CLS. 100, 101 AND 102). SN 85-098,186. PUB. 2-15-2011. FILED 8-2-2010.
- 3,954,009. **INSIGHTSMUNDO (STANDARD CHARACTER)**. INSIGHTS MUNDO MARKETING AND ANALYTICS PVT. LTD., (U.S. CLS. 100, 101 AND 102). SN 85-098,475. PUB. 2-15-2011. FILED 8-2-2010.
- 3,954,027. **MISCELLANEOUS DESIGN**. INSIGHTS MUNDO MARKETING AND ANALYTICS PVT. LTD., (U.S. CLS. 100, 101 AND 102). SN 85-101,556. PUB. 2-15-2011. FILED 8-5-2010.
- 3,954,030 ( *See Class 14 for this trademark*).
- 3,954,032. **QUOTE WIZARD YOU DESERVE BETTER RATES! AND DESIGN**. QUOTEWIZARD.COM, LLC, (U.S. CLS. 100, 101 AND 102). SN 85-102,567. PUB. 2-15-2011. FILED 8-7-2010.
- 3,954,034. **M MECHANIX WEAR MVPC MECHANIX GLOVES MOST VALUABLE PIT CREW AND DESIGN**. MECHANIX WEAR, INC., (U.S. CLS. 100, 101 AND 102). SN 85-103,412. PUB. 2-15-2011. FILED 8-9-2010.
- 3,954,036. **LIVING SPACES FURNITURE AND DESIGN**. LIVING SPACES FURNITURE, LLC, (U.S. CLS. 100, 101 AND 102). SN 85-103,983. PUB. 2-15-2011. FILED 8-10-2010.
- 3,954,039. **CAROUSEL DESIGNS (STANDARD CHARACTER)**. CAROUSEL DESIGNS, (U.S. CLS. 100, 101 AND 102). SN 85-104,546. PUB. 2-15-2011. FILED 8-10-2010.
- 3,954,040. **UNDERSTAND TARGET ACQUIRE STIMULATE GROW RETAIN (STANDARD CHARACTER)**. INSIGHTS MUNDO MARKETING AND ANALYTICS PVT. LTD., (U.S. CLS. 100, 101 AND 102). SN 85-104,586. PUB. 2-15-2011. FILED 8-10-2010.
- 3,954,048. **STILETTO JUNGLE (STANDARD CHARACTER)**. RAHLFS, STEPHANIE, (U.S. CLS. 100, 101 AND 102). SN 85-105,046. PUB. 2-15-2011. FILED 8-11-2010.
- 3,954,060. **DISTRIBUTOR PARTNERS OF AMERICA (STANDARD CHARACTER)**. DISTRIBUTOR PARTNERS OF AMERICA, (U.S. CLS. 100, 101 AND 102). SN 85-106,168. PUB. 2-15-2011. FILED 8-12-2010.
- 3,954,069. **JOBSPOT (STANDARD CHARACTER)**. ROBINSON, MARY ALYCE, DBA JOBSPOT, (U.S. CLS. 100, 101 AND 102). SN 85-106,885. PUB. 2-15-2011. FILED 8-13-2010.
- 3,954,071. **MISCELLANEOUS DESIGN**. CLEAN AIR COUNCIL, (U.S. CLS. 100, 101 AND 102). SN 85-106,957. PUB. 2-15-2011. FILED 8-13-2010.
- 3,954,072. **ENERGY RX FOR YOUR HOME (STANDARD CHARACTER)**. TROY, EUGENE F, DBA ENERGY PENGUIN LLC, (U.S. CLS. 100, 101 AND 102). SN 85-106,980. PUB. 2-15-2011. FILED 8-13-2010.
- 3,954,073. **MISCELLANEOUS DESIGN**. TROY, EUGENE F, DBA ENERGY PENGUIN LLC, (U.S. CLS. 100, 101 AND 102). SN 85-106,989. PUB. 2-15-2011. FILED 8-13-2010.
- 3,954,084. **INTERNATIONAL FENG SHUI GUILD (STANDARD CHARACTER)**. INTERNATIONAL FENG SHUI GUILD, (U.S. CLS. 100, 101 AND 102). SN 85-108,032. PUB. 2-15-2011. FILED 8-16-2010.
- 3,954,085. **VACUUM-DIRECT.COM: THE #1 ON-LINE SOURCE FOR VACUUMS AND DESIGN**. BUY DIRECT, LLC, (U.S. CLS. 100, 101 AND 102). SN 85-108,064. PUB. 2-15-2011. FILED 8-16-2010.
- 3,954,092. **JOHN REID AWARD (STANDARD CHARACTER)**. SAINT PATRICK'S HOME, (U.S. CLS. 100, 101 AND 102). SN 85-108,689. PUB. 2-15-2011. FILED 8-16-2010.
- 3,954,094 ( *See Class 30 for this trademark*).
- 3,954,095. **CEDAR PARK JEWELRY (STANDARD CHARACTER)**. GEORGE POE, DBA CEDAR PARK JEWELRY, MULTIPLE CLASS, (INT. CLS. 35 AND 36), (U.S. CLS. 100, 101 AND 102). SN 85-108,819. PUB. 2-15-2011. FILED 8-17-2010.
- 3,954,099. **ALMONDTREE MARKETING FOR GROWTH AND DESIGN**. ALMOND TREE MARKETING, LLC, (U.S. CLS. 100, 101 AND 102). SN 85-109,153. PUB. 2-15-2011. FILED 8-17-2010.
- 3,954,102. **CUTLERYANDMORE.COM AND DESIGN**. CUTLERY AND MORE, LLC, (U.S. CLS. 100, 101 AND 102). SN 85-109,459. PUB. 2-15-2011. FILED 8-17-2010.
- 3,954,111. **AMERICA'S MOST EUROPEAN SUPERMARKET (STANDARD CHARACTER)**. TREASURE ISLAND FOODS, INC., (U.S. CLS. 100, 101 AND 102). SN 85-110,116. PUB. 2-15-2011. FILED 8-18-2010.
- 3,954,113. **YOUR HOMETOWN HEALTHCARE PROFESSIONALS (STANDARD CHARACTER)**. BEACON FALLS PHARMACY, LLC, DBA BEACON FALLS PHARMACY, (U.S. CLS. 100, 101 AND 102). SN 85-110,231. PUB. 2-15-2011. FILED 8-18-2010.

- 3,954,123. **MY DRINK ON (STANDARD CHARACTER)**. SOCIAL SCENE LLC, TA MY DRINK ON, (U.S. CLS. 100, 101 AND 102). SN 85-110,819. PUB. 2-15-2011. FILED 8-18-2010.
- 3,954,131. **D3 SYSTEMS (STYLIZED)**. D 3 SYSTEMS, INC., (U.S. CLS. 100, 101 AND 102). SN 85-111,114. PUB. 2-15-2011. FILED 8-19-2010.
- 3,954,135. **EWI WORLDWIDE AND DESIGN**. EXHIBIT WORKS, INC., DBA EWI WORLDWIDE, (U.S. CLS. 100, 101 AND 102). SN 85-111,341. PUB. 2-15-2011. FILED 8-19-2010.
- 3,954,138. **STUDIO CREATIVE (STANDARD CHARACTER)**. EXHIBIT WORKS, INC., DBA EWI WORLDWIDE, (U.S. CLS. 100, 101 AND 102). SN 85-111,413. PUB. 2-15-2011. FILED 8-19-2010.
- 3,954,143. **80 DSM 35 AND DESIGN**. GREATER DES MOINES MUSIC COALITION, INC., (U.S. CLS. 100, 101 AND 102). SN 85-111,573. PUB. 2-15-2011. FILED 8-19-2010.
- 3,954,144. **BLEND INTERIORS (STANDARD CHARACTER)**. THEVENOT, ERIC, (U.S. CLS. 100, 101 AND 102). SN 85-111,597. PUB. 2-15-2011. FILED 8-19-2010.
- 3,954,145. **80/35 (STANDARD CHARACTER)**. GREATER DES MOINES MUSIC COALITION, INC., (U.S. CLS. 100, 101 AND 102). SN 85-111,600. PUB. 2-15-2011. FILED 8-19-2010.
- 3,954,164. **P PROTOCOL PROFESSIONAL STAFFING AND DESIGN**. PROTOCOL AGENCY, INC., (U.S. CLS. 100, 101 AND 102). SN 85-112,488. PUB. 2-15-2011. FILED 8-20-2010.
- 3,954,169. **MVPA MILITARY VEHICLE PRESERVATION ASSOCIATION HISTORY IN MOTION AND DESIGN**. MILITARY VEHICLE PRESERVATION ASSOCIATION, (U.S. CLS. 100, 101 AND 102). SN 85-112,781. PUB. 2-15-2011. FILED 8-20-2010.
- 3,954,172. **9 AND DESIGN**. NINE LITTLE MONTHS LLC, (U.S. CLS. 100, 101 AND 102). SN 85-112,826. PUB. 2-15-2011. FILED 8-20-2010.
- 3,954,192. **ECCO (STANDARD CHARACTER)**. ELECTRONIC CONNECTOR CORPORATION OF ILLINOIS, DBA ELECTRONIC CONNECTOR CORP., (U.S. CLS. 100, 101 AND 102). SN 85-113,892. PUB. 2-15-2011. FILED 8-23-2010.
- 3,954,199. **YOUR ROADMAP TO PEACE OF MIND (STANDARD CHARACTER)**. GENESIS ENGINEERING & RE-DEVELOPMENT, MULTIPLE CLASS, (INT. CLS. 35 AND 42), (U.S. CLS. 100, 101 AND 102). SN 85-114,108. PUB. 2-15-2011. FILED 8-23-2010.
- 3,954,204. **INTERNATIONAL WOMEN'S FRIENDSHIP MONTH AND DESIGN**. KAPPA DELTA SORORITY, INC., (U.S. CLS. 100, 101 AND 102). SN 85-114,256. PUB. 2-15-2011. FILED 8-24-2010.
- 3,954,205. **INTERNATIONAL GIRLS DAY AND DESIGN**. KAPPA DELTA SORORITY, INC., (U.S. CLS. 100, 101 AND 102). SN 85-114,269. PUB. 2-15-2011. FILED 8-24-2010.
- 3,954,212. **HASTINGS-TO-GO (STANDARD CHARACTER)**. H.G. HASTINGS CO., (U.S. CLS. 100, 101 AND 102). SN 85-114,381. PUB. 2-15-2011. FILED 8-24-2010.
- 3,954,218. **ATLANTIC 10 CONFERENCE (STANDARD CHARACTER)**. ATLANTIC 10 CONFERENCE, (U.S. CLS. 100, 101 AND 102). SN 85-114,536. PUB. 2-15-2011. FILED 8-24-2010.
- 3,954,219. **PRINT CUT PARTY (STANDARD CHARACTER)**. ABIGAIL BARNES, (U.S. CLS. 100, 101 AND 102). SN 85-114,543. PUB. 2-15-2011. FILED 8-24-2010.
- 3,954,220. **SKYSHOP LOGISTICS AND DESIGN**. SKYSHOP LOGISTICS, INC., MULTIPLE CLASS, (INT. CLS. 35 AND 39), (U.S. CLS. 100, 101, 102 AND 105). SN 85-114,595. PUB. 2-15-2011. FILED 8-24-2010.
- 3,954,221. **"WHY BUY ANYWHERE ELSE?" (STANDARD CHARACTER)**. P.C. RICHARD & SON LONG ISLAND CORP., (U.S. CLS. 100, 101 AND 102). SN 85-114,609. PUB. 2-15-2011. FILED 8-24-2010.
- 3,954,231. **BLAIR CANDY (STANDARD CHARACTER)**. BLAIR CANDY COMPANY INC, (U.S. CLS. 100, 101 AND 102). SN 85-114,848. PUB. 2-15-2011. FILED 8-24-2010.
- 3,954,235. **APROMEX AND DESIGN**. APROMEX - ASOCIACION DE PROFESIONISTAS MEXICANOS EN MICHIGAN, (U.S. CLS. 100, 101 AND 102). SN 85-114,962. PUB. 2-15-2011. FILED 8-24-2010.
- 3,954,236. **APROMEX ASOCIACION DE PROFESIONISTAS MEXICANOS EN MICHIGAN AND DESIGN**. APROMEX - ASOCIACION DE PROFESIONISTAS MEXICANOS EN MICHIGAN, (U.S. CLS. 100, 101 AND 102). SN 85-114,963. PUB. 2-15-2011. FILED 8-24-2010.
- 3,954,237. **ALPHACARD (STANDARD CHARACTER)**. ALPHA CARD SYSTEMS, LLC, DBA ALPHACARD, (U.S. CLS. 100, 101 AND 102). SN 85-114,970. PUB. 2-15-2011. FILED 8-24-2010.
- 3,954,243. **CAREFINDING (STANDARD CHARACTER)**. COOPER, RANDY R., (U.S. CLS. 100, 101 AND 102). SN 85-115,036. PUB. 2-15-2011. FILED 8-24-2010.
- 3,954,244. **TEXT NO MORE AND DESIGN**. TEXTNOMORE LLC, MULTIPLE CLASS, (INT. CLS. 35 AND 38), (U.S. CLS. 100, 101, 102 AND 104). SN 85-115,075. PUB. 2-15-2011. FILED 8-24-2010.
- 3,954,245. **BARGAINBEE.COM (STANDARD CHARACTER)**. BARGAIN BEE.COM LLC, (U.S. CLS. 100, 101 AND 102). SN 85-115,129. PUB. 2-15-2011. FILED 8-25-2010.
- 3,954,247. **MEDSMEX (STANDARD CHARACTER)**. MEDICINE MEXICO, SA DE CV, (U.S. CLS. 100, 101 AND 102). SN 85-115,160. PUB. 2-15-2011. FILED 8-25-2010.
- 3,954,251. **TRELIANT RISK ADVISORS (STANDARD CHARACTER)**. TRELIANT RISK ADVISORS, LLC, (U.S. CLS. 100, 101 AND 102). SN 85-115,211. PUB. 2-15-2011. FILED 8-25-2010.
- 3,954,282. **REAL PEOPLE REEL STORIES (STANDARD CHARACTER)**. THE REEL PEOPLE COMPANY, LLC, (U.S. CLS. 100, 101 AND 102). SN 85-115,947. PUB. 2-15-2011. FILED 8-25-2010.
- 3,954,283. **THE REEL PEOPLE COMPANY (STANDARD CHARACTER)**. THE REEL PEOPLE COMPANY, LLC, (U.S. CLS. 100, 101 AND 102). SN 85-115,950. PUB. 2-15-2011. FILED 8-25-2010.
- 3,954,285. **APOLLO OPHTHALMICS (STANDARD CHARACTER)**. WEEDN, STUART, (U.S. CLS. 100, 101 AND 102). SN 85-115,982. PUB. 2-15-2011. FILED 8-25-2010.
- 3,954,291. **MATRIX WE'RE HOW YOU GET THERE. (STYLIZED)**. MATRIX RESOURCES, INC., MULTIPLE CLASS, (INT. CLS. 35 AND 42), (U.S. CLS. 100, 101 AND 102). SN 85-116,115. PUB. 2-15-2011. FILED 8-26-2010.
- 3,954,295. **AEQUOR (STANDARD CHARACTER)**. AEQUOR, (U.S. CLS. 100, 101 AND 102). SN 85-116,200. PUB. 2-15-2011. FILED 8-26-2010.
- 3,954,297 ( *See Class 16 for this trademark.*).
- 3,954,304 ( *See Class 4 for this trademark.*).
- 3,954,307. **PEACOCK PLUME AND DESIGN**. PEACOCK PLUME LLC, (U.S. CLS. 100, 101 AND 102). SN 85-116,377. PUB. 2-15-2011. FILED 8-26-2010.
- 3,954,312. **CHEDDARTREE AND DESIGN**. NARGES NADJEM, (U.S. CLS. 100, 101 AND 102). SN 85-116,462. PUB. 2-15-2011. FILED 8-26-2010.
- 3,954,316. **TASTE THE COFFEE, EXPERIENCE THE DIFFERENCE (STANDARD CHARACTER)**. THE FRESH MARKET, INC., (U.S. CLS. 100, 101 AND 102). SN 85-116,496. PUB. 2-15-2011. FILED 8-26-2010.
- 3,954,317. **BILLION POUND BLITZ AND DESIGN**. JABEZ COMMUNICATION LLC, (U.S. CLS. 100, 101 AND 102). SN 85-116,525. PUB. 2-15-2011. FILED 8-26-2010.
- 3,954,321. **FREEDOM-TO-TEXT (STANDARD CHARACTER)**. FREEDOM MERCHANTS CORPORATION, (U.S. CLS. 100, 101 AND 102). SN 85-116,605. PUB. 2-15-2011. FILED 8-26-2010.
- 3,954,322. **GO-DOME (STANDARD CHARACTER)**. YOUNG, GARY, DBA AVELA CORPORATION, (U.S. CLS. 100, 101 AND 102). SN 85-116,622. PUB. 2-15-2011. FILED 8-26-2010.
- 3,954,348. **BRIDECLICK (STANDARD CHARACTER)**. BRIDECLICK, INC, (U.S. CLS. 100, 101 AND 102). SN 85-117,125. PUB. 2-15-2011. FILED 8-27-2010.
- 3,954,359. **LANDMARK EARTH SOLUTIONS BY LEGGETT & PLATT (STANDARD CHARACTER)**. L & P PROPERTY MANAGEMENT COMPANY, (U.S. CLS. 100, 101 AND 102). SN 85-117,245. PUB. 2-15-2011. FILED 8-27-2010.
- 3,954,360. **LANDMARK EARTH SOLUTIONS (STANDARD CHARACTER)**. L & P PROPERTY MANAGEMENT COMPANY, (U.S. CLS. 100, 101 AND 102). SN 85-117,246. PUB. 2-15-2011. FILED 8-27-2010.
- 3,954,362. **MAXPRO (STANDARD CHARACTER)**. MAXPRO TECHNOLOGIES, INC., (U.S. CLS. 100, 101 AND 102). SN 85-117,257. PUB. 2-15-2011. FILED 8-27-2010.
- 3,954,379. **YSC TOUR DE PINK AND DESIGN**. YOUNG SURVIVAL COALITION, INC., MULTIPLE CLASS, (INT.

- CLS. 35 AND 36), (U.S. CLS. 100, 101 AND 102). SN 85-117,433. PUB. 2-15-2011. FILED 8-27-2010.
- 3,954,384. **LOOPBACK COMMUNICATIONS (STANDARD CHARACTER)**. LOOPBACK, LLC, DBA LOOPBACK COMMUNICATIONS, (U.S. CLS. 100, 101 AND 102). SN 85-117,495. PUB. 2-15-2011. FILED 8-27-2010.
- 3,954,395. **JISEA JOINT INSTITUTE FOR STRATEGIC ENERGY ANALYSIS AND DESIGN**. ALLIANCE FOR SUSTAINABLE ENERGY, LLC, MULTIPLE CLASS, (INT. CLS. 35, 36 AND 42), (U.S. CLS. 100, 101 AND 102). SN 85-117,756. PUB. 2-15-2011. FILED 8-27-2010.
- 3,954,399. **LESS WE CAN (STANDARD CHARACTER)**. MARK A. GRANNIS, (U.S. CLS. 100, 101 AND 102). SN 85-117,790. PUB. 2-15-2011. FILED 8-27-2010.
- 3,954,401. **LIFELINCANESTHESIA AND DESIGN**. LIFELINC ANESTHESIA CORP., (U.S. CLS. 100, 101 AND 102). SN 85-117,835. PUB. 2-15-2011. FILED 8-27-2010.
- 3,954,412. **TESTCO (STANDARD CHARACTER)**. TESTCO, (U.S. CLS. 100, 101 AND 102). SN 85-117,946. PUB. 2-15-2011. FILED 8-27-2010.
- 3,954,419. **CVM COMPLIANCE VALUE MEASURES (STANDARD CHARACTER)**. RNG TECHNOLOGY, (U.S. CLS. 100, 101 AND 102). SN 85-118,132. PUB. 2-15-2011. FILED 8-28-2010.
- 3,954,421. **WEBFOR (STANDARD CHARACTER)**. EVOLVE 24/7, LLC, DBA WEBFOR, (U.S. CLS. 100, 101 AND 102). SN 85-118,154. PUB. 2-15-2011. FILED 8-28-2010.
- 3,954,422. **WEABOT AND DESIGN**. SANDHILLS SOFTWARE, (U.S. CLS. 100, 101 AND 102). SN 85-118,155. PUB. 2-15-2011. FILED 8-28-2010.
- 3,954,425. **SPOTSMAP (STANDARD CHARACTER)**. RODRIGUEZ-LAUREANO, RICARDO J., (U.S. CLS. 100, 101 AND 102). SN 85-118,186. PUB. 2-15-2011. FILED 8-29-2010.
- 3,954,448. **ALL GOLF, ALL THE TIME (STANDARD CHARACTER)**. GOLF GALAXY, LLC, (U.S. CLS. 100, 101 AND 102). SN 85-118,454. PUB. 2-15-2011. FILED 8-30-2010.
- 3,954,452. **SSA SUNSHINE, SACHS & ASSOCIATES (STYLIZED)**. SS KS LLC, DBA SUNSHINE, SACHS & ASSOCIATES, (U.S. CLS. 100, 101 AND 102). SN 85-118,504. PUB. 2-15-2011. FILED 8-30-2010.
- 3,954,457. **BRANDWORKERS (STANDARD CHARACTER)**. BRANDWORKERS INTERNATIONAL, INC., (U.S. CLS. 100, 101 AND 102). SN 85-118,560. PUB. 2-15-2011. FILED 8-30-2010.
- 3,954,461 ( *See Class 25 for this trademark*).
- 3,954,469. **WHATS UP AND WHERE WHAT'S IN YOUR AREA? N W E S AND DESIGN**. WHATS UP AND WHERE-COM INC., (U.S. CLS. 100, 101 AND 102). SN 85-118,626. PUB. 2-15-2011. FILED 8-30-2010.
- 3,954,470. **SALES WISDOM (STANDARD CHARACTER)**. SYNTUITY LLC, DBA SYNTUITY, (U.S. CLS. 100, 101 AND 102). SN 85-118,633. PUB. 2-15-2011. FILED 8-30-2010.
- 3,954,483. **SUPPLEMENTBODY.COM ACHIEVE EVERY GOAL (STANDARD CHARACTER)**. CARSON BROTHERS LLC, (U.S. CLS. 100, 101 AND 102). SN 85-118,707. PUB. 2-15-2011. FILED 8-30-2010.
- 3,954,490. **NEA (STANDARD CHARACTER)**. NEA'S MEMBER BENEFITS CORPORATION, MULTIPLE CLASS, (INT. CLS. 35, 36, 39 AND 41), (U.S. CLS. 100, 101, 102, 105 AND 107). SN 85-118,805. PUB. 2-15-2011. FILED 8-30-2010.
- 3,954,502. **PEXUNIVERSE.COM (STANDARD CHARACTER)**. NORTFORT INC, (U.S. CLS. 100, 101 AND 102). SN 85-118,898. PUB. 2-15-2011. FILED 8-30-2010.
- 3,954,503. **Z .W ZENERGY WORKS AND DESIGN**. NEW GENERATION MEDIA LLC, (U.S. CLS. 100, 101 AND 102). SN 85-118,912. PUB. 2-15-2011. FILED 8-30-2010.
- 3,954,511. **SOLNÉ AND DESIGN**. SOL NÉ COLLECTIONS, INC., (U.S. CLS. 100, 101 AND 102). SN 85-118,982. PUB. 2-15-2011. FILED 8-30-2010.
- 3,954,512. **VINLOGIX (STANDARD CHARACTER)**. VINLOGIX, INC., (U.S. CLS. 100, 101 AND 102). SN 85-118,984. PUB. 2-15-2011. FILED 8-30-2010.
- 3,954,513. **VINLOGIX AND DESIGN**. VINLOGIX, INC., (U.S. CLS. 100, 101 AND 102). SN 85-119,005. PUB. 2-15-2011. FILED 8-30-2010.
- 3,954,527. **GRAPHICTHERAPY (STANDARD CHARACTER)**. GRAPHICTHERAPY, (U.S. CLS. 100, 101 AND 102). SN 85-119,171. PUB. 2-15-2011. FILED 8-30-2010.
- 3,954,531. **T TONE AND DESIGN**. TONE BRAND GROUP, INC, (U.S. CLS. 100, 101 AND 102). SN 85-119,227. PUB. 2-15-2011. FILED 8-30-2010.
- 3,954,533. **PINZOO AND DESIGN**. EXELON, INC., (U.S. CLS. 100, 101 AND 102). SN 85-119,230. PUB. 2-15-2011. FILED 8-30-2010.
- 3,954,536. **RALLY (STANDARD CHARACTER)**. RALLY MARKETING GROUP, INC., (U.S. CLS. 100, 101 AND 102). SN 85-119,255. PUB. 2-15-2011. FILED 8-30-2010.
- 3,954,540. **PEACH BUCKS AND DESIGN**. CUNNINGHAM, KEITH A, DBA KEITH CUNNINGHAM & COMPANY, (U.S. CLS. 100, 101 AND 102). SN 85-119,318. PUB. 2-15-2011. FILED 8-31-2010.
- 3,954,546. **GOLD SILVER JEWELRY COINS TREASURE HUNT PITTSBURGH'S TRUSTED EXPERTS SINCE 1963 AND DESIGN**. COINS, INC., (U.S. CLS. 100, 101 AND 102). SN 85-119,352. PUB. 2-15-2011. FILED 8-31-2010.
- 3,954,550. **DESIGNER BATHS AT IRRESISTIBLE PRICES (STANDARD CHARACTER)**. G.M. ROTH DESIGN REMODELING, INC., (U.S. CLS. 100, 101 AND 102). SN 85-119,410. PUB. 2-15-2011. FILED 8-31-2010.
- 3,954,558. **GARDEN TECH (STANDARD CHARACTER)**. GARDEN TECH, (U.S. CLS. 100, 101 AND 102). SN 85-119,544. PUB. 2-15-2011. FILED 8-31-2010.
- 3,954,565. **DOING GOOD AROUND THE WORLD (STANDARD CHARACTER)**. HUNT GLOBAL PARTNERSHIPS, (U.S. CLS. 100, 101 AND 102). SN 85-119,644. PUB. 2-15-2011. FILED 8-31-2010.
- 3,954,568. **MORPHOLOGIC (STANDARD CHARACTER)**. CORAL MORPHOLOGIC LLC, (U.S. CLS. 100, 101 AND 102). SN 85-119,671. PUB. 2-15-2011. FILED 8-31-2010.
- 3,954,572. **GROUPGOLFER (STANDARD CHARACTER)**. GROUP GOLFER LLC, (U.S. CLS. 100, 101 AND 102). SN 85-119,682. PUB. 2-15-2011. FILED 8-31-2010.
- 3,954,593. **KINDER JOCKS SPORTS (STANDARD CHARACTER)**. KINDER JOCKS SPORTS, INC., (U.S. CLS. 100, 101 AND 102). SN 85-119,932. PUB. 2-15-2011. FILED 8-31-2010.
- 3,954,615 ( *See Class 20 for this trademark*).
- 3,954,616 ( *See Class 20 for this trademark*).
- 3,954,617. **EVERYONE CAN LEAD -BECAUSE- EVERYONE CAN SERVE (STANDARD CHARACTER)**. JAMES STROCK & CO., MULTIPLE CLASS, (INT. CLS. 35 AND 41), (U.S. CLS. 100, 101, 102 AND 107). SN 85-120,204. PUB. 2-15-2011. FILED 8-31-2010.
- 3,954,620. **PADDLE WITH ALOHA AND DESIGN**. COOK, SHANNON, (U.S. CLS. 100, 101 AND 102). SN 85-120,228. PUB. 2-15-2011. FILED 8-31-2010.
- 3,954,627. **ZCREATIVE.COM (STANDARD CHARACTER)**. ZEE CREATIVE, INC., MULTIPLE CLASS, (INT. CLS. 35, 38, 39, 41 AND 42), (U.S. CLS. 100, 101, 102, 104, 105 AND 107). SN 85-120,306. PUB. 2-15-2011. FILED 8-31-2010.
- 3,954,634. **MYTIMETOVOTE (STANDARD CHARACTER)**. HUTCHINS, LUCIE N, AKA MYTIME2VOTE, (U.S. CLS. 100, 101 AND 102). SN 85-120,419. PUB. 2-15-2011. FILED 9-1-2010.
- 3,954,637. **ADVANCINA (STANDARD CHARACTER)**. ADVANCINA LLC, (U.S. CLS. 100, 101 AND 102). SN 85-120,447. PUB. 2-15-2011. FILED 9-1-2010.
- 3,954,649. **EVENTGRABBER (STANDARD CHARACTER)**. EVENTGRABBER IP, LLC, (U.S. CLS. 100, 101 AND 102). SN 85-120,592. PUB. 2-15-2011. FILED 9-1-2010.
- 3,954,651. **ONE IN THREE WOMEN AND DESIGN**. AXTELL, CHEYLA MCCORNACK, AND BROM, EVELYN, (U.S. CLS. 100, 101 AND 102). SN 85-120,597. PUB. 2-15-2011. FILED 9-1-2010.
- 3,954,655 ( *See Class 30 for this trademark*).
- 3,954,670. **BIG TOP (STANDARD CHARACTER)**. AKT & IWDT, INC., (U.S. CLS. 100, 101 AND 102). SN 85-120,741. PUB. 2-15-2011. FILED 9-1-2010.
- 3,954,673. **IMPACT ADVISORS (STANDARD CHARACTER)**. IMPACT ADVISORS, LLC, (U.S. CLS. 100, 101 AND 102). SN 85-120,767. PUB. 2-15-2011. FILED 9-1-2010.
- 3,954,678. **LIVE NATION ENTERTAINMENT (STANDARD CHARACTER)**. LIVE NATION ENTERTAINMENT, INC., (U.S. CLS. 100, 101 AND 102). SN 85-120,786. PUB. 2-15-2011. FILED 9-1-2010.
- 3,954,704. **LOCALDINES (STANDARD CHARACTER)**. LOCAL DINES L.L.C, DBA LOCALDINES, (U.S. CLS. 100,

- 101 AND 102). SN 85-120,985. PUB. 2-15-2011. FILED 9-1-2010.
- 3,954,707. **ATE GROUP AND DESIGN**. AIR TIGER EXPRESS COMPANIES, INC., MULTIPLE CLASS, (INT. CLS. 35, 36 AND 39), (U.S. CLS. 100, 101, 102 AND 105). SN 85-121,022. PUB. 2-15-2011. FILED 9-1-2010.
- 3,954,710. **STOP 'N' SWAP (STANDARD CHARACTER)**. COUNCIL ON THE ENVIRONMENT, INC., (U.S. CLS. 100, 101 AND 102). SN 85-121,070. PUB. 2-15-2011. FILED 9-1-2010.
- 3,954,711 ( *See Class 9 for this trademark*).
- 3,954,716. **WSP (STANDARD CHARACTER)**. EXPERT ADVOCATES IN SELECTION INTERNATIONAL, LLC, (U.S. CLS. 100, 101 AND 102). SN 85-121,225. PUB. 2-15-2011. FILED 9-1-2010.
- 3,954,718. **THE UNWIND.COMPANY AND DESIGN**. UNWIND.COM LLC, AKA THE UNWIND COMPANY, (U.S. CLS. 100, 101 AND 102). SN 85-121,242. PUB. 2-15-2011. FILED 9-1-2010.
- 3,954,720 ( *See Class 1 for this trademark*).
- 3,954,721. **MEETINGSIN (STANDARD CHARACTER)**. MEETINGSIN, LLC, (U.S. CLS. 100, 101 AND 102). SN 85-121,264. PUB. 2-15-2011. FILED 9-1-2010.
- 3,954,733. **CPS (STANDARD CHARACTER)**. COMPUTERIZED PAYROLL SOLUTIONS, INC., (U.S. CLS. 100, 101 AND 102). SN 85-121,470. PUB. 2-15-2011. FILED 9-2-2010.
- 3,954,736. **THE PROGRESSIVE EDGE (STANDARD CHARACTER)**. PROGRESSIVE LOGISTICS SERVICES, LLC, (U.S. CLS. 100, 101 AND 102). SN 85-121,534. PUB. 2-15-2011. FILED 9-2-2010.
- 3,954,743. **I AM WATERS (STANDARD CHARACTER)**. I AM WATERS FOUNDATION, INC., MULTIPLE CLASS, (INT. CLS. 35, 36 AND 43), (U.S. CLS. 100, 101 AND 102). SN 85-121,603. PUB. 2-15-2011. FILED 9-2-2010.
- 3,954,754. **LVPS (STANDARD CHARACTER)**. LVP SOLUTIONS, LLC, (U.S. CLS. 100, 101 AND 102). SN 85-121,724. PUB. 2-15-2011. FILED 9-2-2010.
- 3,954,755. **HEAR OUR VOICES SHEMA KOLAINU (STANDARD CHARACTER)**. SHEMA KOLAINU - HEAR OUR VOICES, (U.S. CLS. 100, 101 AND 102). SN 85-121,767. PUB. 2-15-2011. FILED 9-2-2010.
- 3,954,757. **30 DEEDS 30 DAYS AND DESIGN**. RANDY MORGAN, AKA TREY MORGAN, AND BROOKE MORGAN, (U.S. CLS. 100, 101 AND 102). SN 85-121,774. PUB. 2-15-2011. FILED 9-2-2010.
- 3,954,770. **BRINGING AIRSOFT TO THE MASSES (STANDARD CHARACTER)**. NEWPORT DYNAMICS, INC., (U.S. CLS. 100, 101 AND 102). SN 85-121,874. PUB. 2-15-2011. FILED 9-2-2010.
- 3,954,772. **TANGIBLE CREATIVITY (STANDARD CHARACTER)**. VUJA DE STUDIOS, (U.S. CLS. 100, 101 AND 102). SN 85-121,912. PUB. 2-15-2011. FILED 9-2-2010.
- 3,954,783. **ENGAGER (STANDARD CHARACTER)**. HALL & PARTNERS USA LLC, (U.S. CLS. 100, 101 AND 102). SN 85-122,029. PUB. 2-15-2011. FILED 9-2-2010.
- 3,954,810. **ALPINEGEAR AND DESIGN**. LB MARKETING INC, (U.S. CLS. 100, 101 AND 102). SN 85-122,355. PUB. 2-15-2011. FILED 9-2-2010.
- 3,954,811. **BARK HOP (STANDARD CHARACTER)**. MORRISTOWN AREA RESPONSIBLE DOG OWNERS GROUP, INC., (U.S. CLS. 100, 101 AND 102). SN 85-122,380. PUB. 2-15-2011. FILED 9-2-2010.
- 3,954,814. **PHARMA RESUME BLASTER (STANDARD CHARACTER)**. RECRUITER SOLUTIONS, INC., (U.S. CLS. 100, 101 AND 102). SN 85-122,417. PUB. 2-15-2011. FILED 9-3-2010.
- 3,954,815. **WORKING TOGETHER FOR A BETTER SOLUTION (STANDARD CHARACTER)**. VP TECHNOLOGIES LLC, (U.S. CLS. 100, 101 AND 102). SN 85-122,424. PUB. 2-15-2011. FILED 9-3-2010.
- 3,954,828. **EQUALSURANCE (STANDARD CHARACTER)**. EQUALSURANCE HOLDINGS, LLC, MULTIPLE CLASS, (INT. CLS. 35 AND 36), (U.S. CLS. 100, 101 AND 102). SN 85-122,611. PUB. 2-15-2011. FILED 9-3-2010.
- 3,954,832. **WE'RE THE AGENCY FOR THAT (STANDARD CHARACTER)**. PERKETTPT, (U.S. CLS. 100, 101 AND 102). SN 85-122,684. PUB. 2-15-2011. FILED 9-3-2010.
- 3,954,852. **REGAL CROWN CLUB AND DESIGN**. REGAL ENTERTAINMENT GROUP, (U.S. CLS. 100, 101 AND 102). SN 85-122,858. PUB. 2-15-2011. FILED 9-3-2010.
- 3,954,858. **TACIZZA (STANDARD CHARACTER)**. LA BAUM, JOHN, (U.S. CLS. 100, 101 AND 102). SN 85-122,905. PUB. 2-15-2011. FILED 9-3-2010.
- 3,954,859. **PRODIGY RESOURCES (STANDARD CHARACTER)**. PRODIGY RESOURCES LLC, (U.S. CLS. 100, 101 AND 102). SN 85-122,915. PUB. 2-15-2011. FILED 9-3-2010.
- 3,954,861. **CAPITAS SOLUTIONS (STANDARD CHARACTER)**. CAPITAS SOLUTIONS, LLC, (U.S. CLS. 100, 101 AND 102). SN 85-122,933. PUB. 2-15-2011. FILED 9-3-2010.
- 3,954,888. **DATAGEN (STANDARD CHARACTER)**. DATAGEN.COM, INC., (U.S. CLS. 100, 101 AND 102). SN 85-123,315. PUB. 2-15-2011. FILED 9-4-2010.
- 3,954,905. **RAVENSWOOD (STANDARD CHARACTER)**. FRANCISCAN VINEYARDS INC., (U.S. CLS. 100, 101 AND 102). SN 85-123,735. PUB. 2-15-2011. FILED 9-7-2010.
- 3,954,917. **ADVISORDIRECT (STANDARD CHARACTER)**. TD AMERITRADE IP COMPANY, INC., (U.S. CLS. 100, 101 AND 102). SN 85-124,008. PUB. 2-15-2011. FILED 9-7-2010.
- 3,954,929. **SPINSHARK (STANDARD CHARACTER)**. PARADYSZ MATERA CO., INC., MULTIPLE CLASS, (INT. CLS. 35 AND 42), (U.S. CLS. 100, 101 AND 102). SN 85-124,267. PUB. 2-15-2011. FILED 9-7-2010.
- 3,954,935. **CASI AND DESIGN**. CERTIFIED ACCESS SPECIALIST INSTITUTE, (U.S. CLS. 100, 101 AND 102). SN 85-124,456. PUB. 2-15-2011. FILED 9-7-2010.
- 3,954,943. **MISCELLANEOUS DESIGN**. EXPLORE GREEN, LLC, MULTIPLE CLASS, (INT. CLS. 35 AND 41), (U.S. CLS. 100, 101, 102 AND 107). SN 85-125,183. PUB. 2-15-2011. FILED 9-8-2010.
- 3,954,946. **DAILYSINGLE (STANDARD CHARACTER)**. DAILYSINGLE INC., AKA DAILYSINGLE, MULTIPLE CLASS, (INT. CLS. 35 AND 42), (U.S. CLS. 100, 101 AND 102). SN 85-125,336. PUB. 2-15-2011. FILED 9-8-2010.
- 3,954,957. **LEGACY FARMING (STANDARD CHARACTER)**. C.H. ROBINSON WORLDWIDE, INC., (U.S. CLS. 100, 101 AND 102). SN 85-126,152. PUB. 2-15-2011. FILED 9-9-2010.
- 3,954,963. **RSC SOLUTIONS (STANDARD CHARACTER)**. AKITA, INC., MULTIPLE CLASS, (INT. CLS. 35 AND 36), (U.S. CLS. 100, 101 AND 102). SN 85-126,602. PUB. 2-15-2011. FILED 9-10-2010.
- 3,954,971. **BEEN THERE, BOUGHT THAT (STANDARD CHARACTER)**. ALL ENTHUSIAST, INC., (U.S. CLS. 100, 101 AND 102). SN 85-128,061. PUB. 2-15-2011. FILED 9-13-2010.
- 3,954,973. **CUZZINS YOGURT 'CUZ IT'S GOOD AND DESIGN**. FIRST COUSINS, LLC, (U.S. CLS. 100, 101 AND 102). SN 85-128,112. PUB. 2-15-2011. FILED 9-13-2010.
- 3,954,985. **VINCE. (STYLIZED)**. KELLWOOD COMPANY, (U.S. CLS. 100, 101 AND 102). SN 85-129,401. PUB. 2-15-2011. FILED 9-14-2010.
- 3,955,019. **ALL YOU CRAVE. PRICED TO SAVE. (STANDARD CHARACTER)**. TARGET BRANDS, INC., (U.S. CLS. 100, 101 AND 102). SN 85-136,209. PUB. 2-15-2011. FILED 9-23-2010.
- 3,955,021. **WATERCAMPWS (STANDARD CHARACTER)**. THE BOARD OF TRUSTEES OF THE UNIVERSITY OF ILLINOIS, MULTIPLE CLASS, (INT. CLS. 35, 41 AND 42), (U.S. CLS. 100, 101, 102 AND 107). SN 85-136,479. PUB. 2-15-2011. FILED 9-23-2010.
- 3,955,024. **ZIFF DAVIS BUYERBASE (STANDARD CHARACTER)**. ZIFF DAVIS, INC., (U.S. CLS. 100, 101 AND 102). SN 85-136,706. PUB. 2-15-2011. FILED 9-23-2010.
- 3,955,025. **BUYERBASE (STANDARD CHARACTER)**. ZIFF DAVIS, INC., (U.S. CLS. 100, 101 AND 102). SN 85-136,718. PUB. 2-15-2011. FILED 9-23-2010.
- 3,955,029. **GUEST RESERVE AND DESIGN**. DELAWARE NORTH COMPANIES SPORTSERVICE, INC., MULTIPLE CLASS, (INT. CLS. 35 AND 43), (U.S. CLS. 100, 101 AND 102). SN 85-137,288. PUB. 2-15-2011. FILED 9-24-2010.
- 3,955,030. **GUEST RESERVE (STANDARD CHARACTER)**. DELAWARE NORTH COMPANIES SPORTSERVICE, INC., MULTIPLE CLASS, (INT. CLS. 35 AND 43), (U.S. CLS. 100, 101 AND 102). SN 85-137,310. PUB. 2-15-2011. FILED 9-24-2010.
- 3,955,043. **E INTERNATIONAL E-CART AND DESIGN**. SKY-SHOP LOGISTICS, INC., MULTIPLE CLASS, (INT. CLS. 35,



- 36 AND 39), (U.S. CLS. 100, 101, 102 AND 105), SN 85-138,586. PUB. 2-15-2011. FILED 9-27-2010.
- 3,955,055. **PLS PROFESSIONAL LABOR SUPPORT, LLC CONSULTING & NETWORKING AND DESIGN, PROFESSIONAL LABOR SUPPORT LLC**, (U.S. CLS. 100, 101 AND 102). SN 85-140,297. PUB. 2-15-2011. FILED 9-28-2010.
- 3,955,076. **RUTH EDELMAN INTEGRATED MARKETING (STYLIZED), EDELMAN, INC.**, (U.S. CLS. 100, 101 AND 102). SN 85-147,099. PUB. 2-15-2011. FILED 10-7-2010.
- 3,955,085. **CELLAIRIS (STANDARD CHARACTER), GLOBAL CELLULAR, INC.**, (U.S. CLS. 100, 101 AND 102). SN 85-148,846. PUB. 2-15-2011. FILED 10-8-2010.
- 3,955,086. **CELLAIRIS.COM (STANDARD CHARACTER), GLOBAL CELLULAR, INC.**, (U.S. CLS. 100, 101 AND 102). SN 85-148,865. PUB. 2-15-2011. FILED 10-8-2010.
- 3,955,102. **BIG COOL DEAL (STANDARD CHARACTER), GUITAR CENTER, INC.**, (U.S. CLS. 100, 101 AND 102). SN 85-157,113. PUB. 2-15-2011. FILED 10-20-2010.
- 3,955,121. **RSC SOLUTIONS MAKES THE CONNECTION (STANDARD CHARACTER), AKITA, INC.**, MULTIPLE CLASS, (INT. CLS. 35 AND 36), (U.S. CLS. 100, 101 AND 102). SN 85-169,106. PUB. 2-15-2011. FILED 11-4-2010.
- 3,955,126. **EMPOWERME CONVERSATIONS ABOUT ENERGY IN YOUR LIFE (STYLIZED), RELIANT ENERGY RETAIL HOLDINGS, LLC**, (U.S. CLS. 100, 101 AND 102). SN 85-170,298. PUB. 2-15-2011. FILED 11-5-2010.
- 3,955,148. **TOYWIZ.COM (STANDARD CHARACTER), TOYWIZ, INC.**, (U.S. CLS. 100, 101 AND 102). SN 85-190,879. PUB. 2-15-2011. FILED 12-5-2010.
- CHARACTER), SECONDMARKET HOLDINGS, INC.**, (U.S. CLS. 100, 101 AND 102). SN 77-796,160. PUB. 2-15-2011. FILED 8-4-2009.
- 3,953,104. **ECOSYSTEM (STANDARD CHARACTER), SECONDMARKET HOLDINGS, INC.**, (U.S. CLS. 100, 101 AND 102). SN 77-796,165. PUB. 2-15-2011. FILED 8-4-2009.
- 3,953,109. **AMERICAN GENERAL PREMIER PPVUL (STANDARD CHARACTER), AMERICAN INTERNATIONAL GROUP, INC.**, (U.S. CLS. 100, 101 AND 102). SN 77-801,884. PUB. 2-15-2011. FILED 8-11-2009.
- 3,953,110. **AMERICAN GENERAL PREMIER PPVA (STANDARD CHARACTER), AMERICAN INTERNATIONAL GROUP, INC.**, (U.S. CLS. 100, 101 AND 102). SN 77-801,897. PUB. 2-15-2011. FILED 8-11-2009.
- 3,953,116 ( *See Class 4 for this trademark*).
- 3,953,117. **ALL FUNDS BANK AND DESIGN, ALLFUNDS BANK, S.A.**, (U.S. CLS. 100, 101 AND 102). SN 77-808,828. PUB. 2-15-2011. FILED 8-20-2009.
- 3,953,118. **S SECURITY BENEFIT TO AND THROUGH RETIREMENT (STYLIZED), SECURITY BENEFIT CORPORATION**, (U.S. CLS. 100, 101 AND 102). SN 77-808,978. PUB. 2-15-2011. FILED 8-20-2009.
- 3,953,179. **AMERI-TECH REALTY, INC. LIVING YOUR DREAM AND DESIGN, AMERI-TECH REALTY, INC.**, (U.S. CLS. 100, 101 AND 102). SN 77-850,217. PUB. 2-15-2011. FILED 10-16-2009.
- 3,953,190 ( *See Class 35 for this trademark*).
- 3,953,215 ( *See Class 35 for this trademark*).
- 3,953,225. **A.S.A.P. AUTOMOBILE SERVICES ADVANTAGE PROGRAM PLUS UTICA NATIONAL INSURANCE GROUP AND DESIGN, UTICA MUTUAL INSURANCE COMPANY, DBA UTICA NATIONAL INSURANCE GROUP**, (U.S. CLS. 100, 101 AND 102). SN 77-905,208. PUB. 2-15-2011. FILED 1-5-2010.
- 3,953,244. **AIDS LIFECYCLE RIDE TO END AIDS AND DESIGN, THE SAN FRANCISCO AIDS FOUNDATION, AND THE LOS ANGELES GAY AND LESBIAN COMMUNITY SERVICES CENTER**, (U.S. CLS. 100, 101 AND 102). SN 77-918,176. PUB. 2-15-2011. FILED 1-22-2010.
- 3,953,248 ( *See Class 9 for this trademark*).
- 3,953,253. **CLEAR SKIES SOLAR (STANDARD CHARACTER), CLEAR SKIES SOLAR, INC.**, MULTIPLE CLASS, (INT. CLS. 36, 37 AND 42), (U.S. CLS. 100, 101, 102, 103 AND 106). SN 77-925,538. PUB. 2-15-2011. FILED 2-2-2010.
- 3,953,285. **ISHOP TO GIVE (STANDARD CHARACTER), ISHOP TO GIVE, INC.**, (U.S. CLS. 100, 101 AND 102). SN 77-938,778. PUB. 2-15-2011. FILED 2-18-2010.
- 3,953,295 ( *See Class 35 for this trademark*).
- 3,953,304. **DAVID'S VACATION CLUB RENTALS (STANDARD CHARACTER), MULLETT, DAVID**, (U.S. CLS. 100, 101 AND 102). SN 77-943,219. PUB. 2-15-2011. FILED 2-24-2010.
- 3,953,316. **PAYCONNECT (STANDARD CHARACTER), EDI HEALTH GROUP, INC., DBA DENTALXCHANGE**, (U.S. CLS. 100, 101 AND 102). SN 77-946,095. PUB. 2-15-2011. FILED 2-26-2010.
- 3,953,344. **ONE FLAT RATE, IT'S THAT SIMPLE. (STANDARD CHARACTER), SINGULAR PAYMENTS, LLC**, (U.S. CLS. 100, 101 AND 102). SN 77-950,197. PUB. 2-15-2011. FILED 3-4-2010.
- 3,953,353 ( *See Class 9 for this trademark*).
- 3,953,368. **FABRICARE INSURANCE PROGRAM (STANDARD CHARACTER), IRVING WEBER ASSOCIATES, INC.**, (U.S. CLS. 100, 101 AND 102). SN 77-953,219. PUB. 2-15-2011. FILED 3-8-2010.
- 3,953,376. **PRIVATE COLLEGE 529 PLAN TOMORROW'S TUITION AT TODAY'S PRICES-GUARANTEED AND DESIGN, TUITION PLAN CONSORTIUM, LLC**, (U.S. CLS. 100, 101 AND 102). SN 77-954,341. PUB. 2-15-2011. FILED 3-9-2010.
- 3,953,386. **CALIFORNIA LAW ENFORCEMENT ASSOCIATION CLEA EST. 1985 AND DESIGN, CALIFORNIA LAW ENFORCEMENT ASSOCIATION**, (U.S. CLS. 100, 101 AND 102). SN 77-955,922. PUB. 2-15-2011. FILED 3-10-2010.
- 3,953,393 ( *See Class 30 for this trademark*).
- 3,953,399. **AFRICARE (STANDARD CHARACTER), AFRICARE**, (U.S. CLS. 100, 101 AND 102). SN 77-957,785. PUB. 2-15-2011. FILED 3-12-2010.

### CLASS 36—INSURANCE AND FINANCIAL

- 3,952,948. **GUARANTY BANK, GUARANTY BANK, FSB**, (U.S. CLS. 100, 101 AND 102). SN 76-155,200. PUB. 10-8-2002. FILED 10-27-2000.
- 3,952,950. **SILVERLEAF PLANTATION (STANDARD CHARACTER), SJP, LLC, MULTIPLE CLASS, (INT. CLS. 36 AND 37), (U.S. CLS. 100, 101, 102, 103 AND 106)**. SN 76-620,345. PUB. 1-15-2008. FILED 11-12-2004.
- 3,952,951. **SILVERLEAF PLANTATION AND DESIGN, SJP, LLC, MULTIPLE CLASS, (INT. CLS. 36 AND 37), (U.S. CLS. 100, 101, 102, 103 AND 106)**. SN 76-623,091. PUB. 2-20-2007. FILED 11-29-2004.
- 3,952,959 ( *See Class 35 for this trademark*).
- 3,952,987. **HELPING YOU MAKE IT HOME (STANDARD CHARACTER), US MORTGAGE CORPORATION, DBA MORTGAGE CONCEPTS**, (U.S. CLS. 100, 101 AND 102). SN 76-704,259. PUB. 2-15-2011. FILED 8-26-2010.
- 3,952,993. **CEFCU, NOT A BANK, BETTER. (STANDARD CHARACTER), CITIZENS EQUITY FIRST CREDIT UNION**, (U.S. CLS. 100, 101 AND 102). SN 76-704,318. PUB. 2-15-2011. FILED 9-1-2010.
- 3,953,012 ( *See Class 35 for this trademark*).
- 3,953,052. **PB PITNEYBOWES (STYLIZED), PITNEY BOWES INC.**, (U.S. CLS. 100, 101 AND 102). SN 77-682,323. PUB. 2-15-2011. FILED 3-3-2009.
- 3,953,070. **CSH SUPPORTIVE HOUSING IT WORKS AND DESIGN, CORPORATION FOR SUPPORTIVE HOUSING, MULTIPLE CLASS, (INT. CLS. 36 AND 41), (U.S. CLS. 100, 101, 102 AND 107)**. SN 77-741,088. PUB. 2-15-2011. FILED 5-20-2009.
- 3,953,071. **CORPORATION FOR SUPPORTIVE HOUSING (STANDARD CHARACTER), CORPORATION FOR SUPPORTIVE HOUSING, MULTIPLE CLASS, (INT. CLS. 36 AND 41), (U.S. CLS. 100, 101, 102 AND 107)**. SN 77-741,392. PUB. 2-15-2011. FILED 5-20-2009.
- 3,953,083 ( *See Class 1 for this trademark*).
- 3,953,088. **RECOVERY ...PLUS AND DESIGN, CASCADES RECOVERY INC.**, MULTIPLE CLASS, (INT. CLS. 36, 37, 39 AND 40), (U.S. CLS. 100, 101, 102, 103, 105 AND 106). SN 77-769,143. PUB. 2-15-2011. FILED 6-26-2009.
- 3,953,097. **MISCELLANEOUS DESIGN, SHIFT4 CORPORATION, MULTIPLE CLASS, (INT. CLS. 36 AND 42), (U.S. CLS. 100, 101 AND 102)**. SN 77-792,690. PUB. 6-29-2010. FILED 7-29-2009.
- 3,953,103. **SECONDMARKET ECOSYSTEM (STANDARD**

- 3,953,405. **G AND DESIGN**. THE GRAHAM GROUP, INC., MULTIPLE CLASS, (INT. CLS. 36 AND 37), (U.S. CLS. 100, 101, 102, 103 AND 106). SN 77-959,040. PUB. 2-15-2011. FILED 3-15-2010.
- 3,953,408. **MULTI-DIMENSIONAL REAL ESTATE SOLUTIONS (STANDARD CHARACTER)**. THE GRAHAM GROUP, INC., MULTIPLE CLASS, (INT. CLS. 36 AND 37), (U.S. CLS. 100, 101, 102, 103 AND 106). SN 77-959,079. PUB. 2-15-2011. FILED 3-15-2010.
- 3,953,427 ( *See Class 30 for this trademark*).
- 3,953,454 ( *See Class 9 for this trademark*).
- 3,953,462. **"WHAT IF" FINANCIAL FORECASTING LLC (STANDARD CHARACTER)**. HAMEL, SCOTT W, DBA "WHAT IF" FINANCIAL FORECASTING, (U.S. CLS. 100, 101 AND 102). SN 77-969,234. PUB. 2-15-2011. FILED 3-26-2010.
- 3,953,487. **SPOTLIGHT AND DESIGN**. SPOTLIGHT PTY LTD, MULTIPLE CLASS, (INT. CLS. 36, 37, 41 AND 42), (U.S. CLS. 100, 101, 102, 103, 106 AND 107). SN 79-022,819. PUB. 2-15-2011. FILED 1-13-2006.
- 3,953,501. **INDEPENDENT FRANCHISE PARTNERS (STANDARD CHARACTER)**. INDEPENDENT FRANCHISE PARTNERS, LLP, (U.S. CLS. 100, 101 AND 102). SN 79-069,717. PUB. 2-15-2011. FILED 5-21-2009.
- 3,953,513 ( *See Class 1 for this trademark*).
- 3,953,530. **IICD PEOPLE- ICT DEVELOPMENT AND DESIGN**. STICHTING INTERNATIONAL INSTITUTE FOR; COMMUNICATION AND DEVELOPMENT, MULTIPLE CLASS, (INT. CLS. 36, 41 AND 42), (U.S. CLS. 100, 101, 102 AND 107). SN 79-077,655. PUB. 2-15-2011. FILED 11-16-2009.
- 3,953,533. **SINO GUARANTEE (STYLIZED)**. CHINA NATIONAL; INVESTMENT & GUARANTY CO., LTD., MULTIPLE CLASS, (INT. CLS. 36, 38 AND 42), (U.S. CLS. 100, 101, 102 AND 104). SN 79-078,165. PUB. 2-15-2011. FILED 1-4-2010.
- 3,953,534. **CNIG (STYLIZED)**. CHINA NATIONAL; INVESTMENT & GUARANTY CO., LTD., MULTIPLE CLASS, (INT. CLS. 36, 38 AND 42), (U.S. CLS. 100, 101, 102 AND 104). SN 79-078,264. PUB. 2-15-2011. FILED 1-4-2010.
- 3,953,537. **CNSURE (STYLIZED)**. CHINA NATIONAL; INVESTMENT & GUARANTY CO., LTD., MULTIPLE CLASS, (INT. CLS. 36, 38 AND 42), (U.S. CLS. 100, 101, 102 AND 104). SN 79-078,583. PUB. 2-15-2011. FILED 1-21-2010.
- 3,953,540. **I & G AND DESIGN**. CHINA NATIONAL; INVESTMENT & GUARANTY CO., LTD., MULTIPLE CLASS, (INT. CLS. 36, 38 AND 42), (U.S. CLS. 100, 101, 102 AND 104). SN 79-079,009. PUB. 2-15-2011. FILED 1-21-2010.
- 3,953,695. **VEO FINANCIAL COUNSEL, LLC BRINGING CLARITY TO YOUR FINANCIAL CHOICES AND DESIGN**. VEO FINANCIAL COUNSEL, LLC, (U.S. CLS. 100, 101 AND 102). SN 85-002,445. PUB. 2-15-2011. FILED 3-30-2010.
- 3,953,732. **FIRST CHOICE LOANS AND DESIGN**. QC HOLDINGS, INC., (U.S. CLS. 100, 101 AND 102). SN 85-015,306. PUB. 11-9-2010. FILED 4-15-2010.
- 3,953,733. **THE INSIDE SOURCE IN LOCAL REAL ESTATE (STANDARD CHARACTER)**. CLEANOFFER, INC., (U.S. CLS. 100, 101 AND 102). SN 85-015,768. PUB. 2-15-2011. FILED 4-16-2010.
- 3,953,736 ( *See Class 35 for this trademark*).
- 3,953,780 ( *See Class 35 for this trademark*).
- 3,953,788. **MOBIUS PAYMENTS (STANDARD CHARACTER)**. MOBIUS PAYMENTS LLC, DBA MOBIUS PAYMENTS, (U.S. CLS. 100, 101 AND 102). SN 85-034,873. PUB. 2-15-2011. FILED 5-11-2010.
- 3,953,789 ( *See Class 9 for this trademark*).
- 3,953,790. **PACIFIC FUNDING GROUP AND DESIGN**. AGV GROUPE INC., (U.S. CLS. 100, 101 AND 102). SN 85-035,567. PUB. 2-15-2011. FILED 5-11-2010.
- 3,953,803. **THE CFO DASHBOARD (STANDARD CHARACTER)**. FENTON & ROSS, AN ACCOUNTANCY CORPORATION, (U.S. CLS. 100, 101 AND 102). SN 85-038,285. PUB. 2-15-2011. FILED S.R. 5-13-2010; AM. P.R. 1-12-2011.
- 3,953,807. **OPEN-AIRE (STANDARD CHARACTER)**. MRB ACQUISITION CORP., DBA OPEN-AIRE, (U.S. CLS. 100, 101 AND 102). SN 85-039,001. PUB. 2-15-2011. FILED 5-14-2010.
- 3,953,817. **MEDCARE AMERICA (STANDARD CHARACTER)**. MEDCARE AMERICA, LLC, MULTIPLE CLASS, (INT. CLS. 36 AND 37), (U.S. CLS. 100, 101, 102, 103 AND 106). SN 85-040,796. PUB. 10-19-2010. FILED 5-17-2010.
- 3,953,852. **COOL KIDS CAMPAIGN (STANDARD CHARACTER)**. COOL KIDS CAMPAIGN, (U.S. CLS. 100, 101 AND 102). SN 85-056,936. PUB. 2-15-2011. FILED 6-8-2010.
- 3,953,855. **IRA ADVISOR GROUP ED SLOTT'S ELITE AND DESIGN**. SLOTT, EDWARD, MULTIPLE CLASS, (INT. CLS. 36 AND 41), (U.S. CLS. 100, 101, 102 AND 107). SN 85-057,062. PUB. 2-15-2011. FILED 6-8-2010.
- 3,953,860. **FICOHSA (STANDARD CHARACTER)**. BANCO FINANCIERA COMERCIAL HONDURENA, S.A., DBA BANCO FICOHSA, (U.S. CLS. 100, 101 AND 102). SN 85-057,840. PUB. 2-15-2011. FILED 6-8-2010.
- 3,953,877. **WIRELESS ZONE (STANDARD CHARACTER)**. AUTOMOTIVE TECHNOLOGIES, INC., (U.S. CLS. 100, 101 AND 102). SN 85-062,875. PUB. 2-15-2011. FILED 6-15-2010.
- 3,953,882. **FPI MANAGEMENT, INC. (STANDARD CHARACTER)**. FPI MANAGEMENT, INC., (U.S. CLS. 100, 101 AND 102). SN 85-065,130. PUB. 2-15-2011. FILED 6-17-2010.
- 3,953,890. **MARTIAL ARTS SCHOLARSHIP FUND AND DESIGN**. MARTIAL ARTS SCHOLARSHIP FUND, INC., (U.S. CLS. 100, 101 AND 102). SN 85-068,652. PUB. 2-15-2011. FILED 6-22-2010.
- 3,953,964. **SWR SMALL WORLD REALTY AND DESIGN**. SMALL WORLD REALTY, LLC, (U.S. CLS. 100, 101 AND 102). SN 85-088,368. PUB. 2-15-2011. FILED 7-20-2010.
- 3,953,981. **ETHICAL DENTAL LABORATORY ALLIANCE OF AMERICA (STANDARD CHARACTER)**. ETHICAL DENTAL LABORATORY ALLIANCE OF AMERICA, LTD., (U.S. CLS. 100, 101 AND 102). SN 85-093,269. PUB. 2-15-2011. FILED 7-26-2010.
- 3,953,990. **PAY GOVERNANCE ADVISORY SERVICES TO COMPENSATION COMMITTEES AND DESIGN**. PAY GOVERNANCE, LLC, (U.S. CLS. 100, 101 AND 102). SN 85-095,514. PUB. 2-15-2011. FILED 7-29-2010.
- 3,953,996. **CLEARBRIDGE (STANDARD CHARACTER)**. CLEARBRIDGE ADVISORS, LLC, (U.S. CLS. 100, 101 AND 102). SN 85-096,121. PUB. 2-15-2011. FILED 7-29-2010.
- 3,954,008. **THE GRAPEHOUND WINE TOUR (STANDARD CHARACTER)**. LARRY E. BOWERSOX, (U.S. CLS. 100, 101 AND 102). SN 85-098,440. PUB. 2-15-2011. FILED 8-2-2010.
- 3,954,095 ( *See Class 35 for this trademark*).
- 3,954,106. **MARKETACTION.COM ACTION SPEAKS LOUDER AND DESIGN**. MARKETACTION, INC., (U.S. CLS. 100, 101 AND 102). SN 85-109,731. PUB. 2-15-2011. FILED 8-17-2010.
- 3,954,115. **DEBT CENTER AMERICA AMERICA'S LEADING DEBT SOLUTION COMPANY AND DESIGN**. LGF-FTW CORP, (U.S. CLS. 100, 101 AND 102). SN 85-110,320. PUB. 2-15-2011. FILED 8-18-2010.
- 3,954,149. **CEDAR PARK GOLD (STANDARD CHARACTER)**. GEORGE POE, DBA CEDAR PARK JEWELRY, (U.S. CLS. 100, 101 AND 102). SN 85-111,777. PUB. 2-15-2011. FILED 8-19-2010.
- 3,954,157. **THE S.O.L.D. TEAM SELLING OUTSTANDING LIFETIME DREAMS (STANDARD CHARACTER)**. RICHARD LINTHICUM, (U.S. CLS. 100, 101 AND 102). SN 85-112,170. PUB. 2-15-2011. FILED 8-20-2010.
- 3,954,165. **FINANCIAL CARE PROVIDERS (STANDARD CHARACTER)**. ANGELA R. REHKOP, DBA FINANCIAL CARE PROVIDERS, (U.S. CLS. 100, 101 AND 102). SN 85-112,568. PUB. 2-15-2011. FILED 8-20-2010.
- 3,954,210. **EQUITY MORTGAGE BANKERS LLC LICENSED MORTGAGE LENDER AND DESIGN**. EQUITY MORTGAGE BANKERS LLC, (U.S. CLS. 100, 101 AND 102). SN 85-114,358. PUB. 2-15-2011. FILED 8-24-2010.
- 3,954,248. **BAREWOOD PROPERTIES (STANDARD CHARACTER)**. BAREWOOD, INC., (U.S. CLS. 100, 101 AND 102). SN 85-115,173. PUB. 2-15-2011. FILED 8-25-2010.
- 3,954,263. **SPENDOMETER (STANDARD CHARACTER)**. THE PNC FINANCIAL SERVICES GROUP, INC., (U.S. CLS. 100, 101 AND 102). SN 85-115,466. PUB. 2-15-2011. FILED 8-25-2010.
- 3,954,279. **OUR WORLD BENEFITS YOUR WORLD (STYLIZED)**. FBMC BENEFITS MANAGEMENT, INC., (U.S. CLS. 100, 101 AND 102). SN 85-115,858. PUB. 2-15-2011. FILED 8-25-2010.

- 3,954,376. **INTELLIGENCE AND CRITICAL DATA (STANDARD CHARACTER)**. CREDIT SUISSE SECURITIES (USA) LLC, (U.S. CLS. 100, 101 AND 102). SN 85-117,414. PUB. 2-15-2011. FILED 8-27-2010.
- 3,954,379 ( *See Class 35 for this trademark*).
- 3,954,393. **KEEP LA RUNNING (STANDARD CHARACTER)**. STEPHENS, ALEJANDRO, (U.S. CLS. 100, 101 AND 102). SN 85-117,727. PUB. 2-15-2011. FILED 8-27-2010.
- 3,954,395 ( *See Class 35 for this trademark*).
- 3,954,430. **DISCOVERING INEFFICIENCY IN AN EFFICIENT MARKET (STANDARD CHARACTER)**. BEATING WALL STREET, INC., (U.S. CLS. 100, 101 AND 102). SN 85-118,277. PUB. 2-15-2011. FILED 8-30-2010.
- 3,954,454. **FISHER BROWN (STANDARD CHARACTER)**. FISHER BROWN BOTTRELL INSURANCE, INC., (U.S. CLS. 100, 101 AND 102). SN 85-118,523. PUB. 2-15-2011. FILED 8-30-2010.
- 3,954,490 ( *See Class 35 for this trademark*).
- 3,954,499. **BRIGHT START (STANDARD CHARACTER)**. OFFICE OF THE ILLINOIS STATE TREASURER, (U.S. CLS. 100, 101 AND 102). SN 85-118,863. PUB. 2-15-2011. FILED 8-30-2010.
- 3,954,506. **YOU'RE IN BUSINESS WITH FLAGSTAR (STANDARD CHARACTER)**. FLAGSTAR BANK, FSB, (U.S. CLS. 100, 101 AND 102). SN 85-118,925. PUB. 2-15-2011. FILED 8-30-2010.
- 3,954,523. **TENCO (STANDARD CHARACTER)**. TENCO, INC., (U.S. CLS. 100, 101 AND 102). SN 85-119,148. PUB. 2-15-2011. FILED 8-30-2010.
- 3,954,555. **FOSTER THE AMERICAN DREAM (STANDARD CHARACTER)**. SHANNON FOSTER, (U.S. CLS. 100, 101 AND 102). SN 85-119,507. PUB. 2-15-2011. FILED 8-31-2010.
- 3,954,582. **CIATTI (STANDARD CHARACTER)**. CIATTI COMPANY, LLC, (U.S. CLS. 100, 101 AND 102). SN 85-119,812. PUB. 2-15-2011. FILED 8-31-2010.
- 3,954,591. **O'SHAUGHNESSY (STYLIZED)**. O'SHAUGHNESSY ASSET MANAGEMENT, L.L.C., (U.S. CLS. 100, 101 AND 102). SN 85-119,892. PUB. 2-15-2011. FILED 8-31-2010.
- 3,954,608. **A MEMBER OF THE POWER FINANCIAL CORPORATION GROUP OF COMPANIES (STANDARD CHARACTER)**. POWER CORPORATION OF CANADA, (U.S. CLS. 100, 101 AND 102). SN 85-120,142. PUB. 2-15-2011. FILED 8-31-2010.
- 3,954,638. **BODIES AS A WORK OF ART (STANDARD CHARACTER)**. THE PAUL AND DEBBIE CHELKO FOUNDATION, INC., (U.S. CLS. 100, 101 AND 102). SN 85-120,460. PUB. 2-15-2011. FILED 9-1-2010.
- 3,954,660. **NAVIGATORS AND DESIGN**. THE NAVIGATORS GROUP, INC., (U.S. CLS. 100, 101 AND 102). SN 85-120,687. PUB. 2-15-2011. FILED 9-1-2010.
- 3,954,707 ( *See Class 35 for this trademark*).
- 3,954,712. **BELO HERITAGE SOCIETY AND DESIGN**. DALLAS BAR FOUNDATION, (U.S. CLS. 100, 101 AND 102). SN 85-121,104. PUB. 2-15-2011. FILED 9-1-2010.
- 3,954,727. **QUOTECLIX (STANDARD CHARACTER)**. BLUNT, DAVID R., (U.S. CLS. 100, 101 AND 102). SN 85-121,424. PUB. 2-15-2011. FILED 9-2-2010.
- 3,954,730. **CALIFORNIADENTALINSURANCE.COM AND DESIGN**. BLUNT, DAVID R., (U.S. CLS. 100, 101 AND 102). SN 85-121,438. PUB. 2-15-2011. FILED 9-2-2010.
- 3,954,743 ( *See Class 35 for this trademark*).
- 3,954,745. **MISSION PINK (STANDARD CHARACTER)**. THE SUSAN G. KOMEN BREAST CANCER FOUNDATION, INC., (U.S. CLS. 100, 101 AND 102). SN 85-121,615. PUB. 2-15-2011. FILED 9-2-2010.
- 3,954,767. **DARE TO HOPE (STANDARD CHARACTER)**. HIGGINS, LISA, (U.S. CLS. 100, 101 AND 102). SN 85-121,847. PUB. 2-15-2011. FILED 9-2-2010.
- 3,954,774. **MISCELLANEOUS DESIGN**. GREAT LAKES APPRAISAL COMPANY OF GRAND RAPIDS, P.C., (U.S. CLS. 100, 101 AND 102). SN 85-121,919. PUB. 2-15-2011. FILED 9-2-2010.
- 3,954,793. **THE TRUCK INSURANCE STORE (STANDARD CHARACTER)**. STASSEN INSURANCE AGENCY, INC., (U.S. CLS. 100, 101 AND 102). SN 85-122,127. PUB. 2-15-2011. FILED 9-2-2010.
- 3,954,828 ( *See Class 35 for this trademark*).
- 3,954,842. **GOLDFARB PROPERTIES (STANDARD CHARACTER)**. GOLDFARB PROPERTIES, INC., (U.S. CLS. 100, 101 AND 102). SN 85-122,742. PUB. 2-15-2011. FILED 9-3-2010.
- 3,954,843. **G AND DESIGN**. GOLDFARB PROPERTIES, INC., (U.S. CLS. 100, 101 AND 102). SN 85-122,756. PUB. 2-15-2011. FILED 9-3-2010.
- 3,954,860. **COMPETING SO OUR CHILDREN WIN (STANDARD CHARACTER)**. KIDS CENTRAL, INC., (U.S. CLS. 100, 101 AND 102). SN 85-122,931. PUB. 2-15-2011. FILED 9-3-2010.
- 3,954,863. **S SRS AND DESIGN**. SRS REAL ESTATE PARTNERS, LLC, (U.S. CLS. 100, 101 AND 102). SN 85-122,968. PUB. 2-15-2011. FILED 9-3-2010.
- 3,954,865. **SRS (STANDARD CHARACTER)**. SRS REAL ESTATE PARTNERS, LLC, (U.S. CLS. 100, 101 AND 102). SN 85-122,976. PUB. 2-15-2011. FILED 9-3-2010.
- 3,954,870. **GLOBALCURE (STANDARD CHARACTER)**. TRANSLATIONAL GENOMICS RESEARCH INSTITUTE FOUNDATION, AKA TGEN FOUNDATION, (U.S. CLS. 100, 101 AND 102). SN 85-123,049. PUB. 2-15-2011. FILED 9-3-2010.
- 3,954,933. **CCCC AND DESIGN**. GREGORY E. SHERMAN AND ASSOCIATES, (U.S. CLS. 100, 101 AND 102). SN 85-124,367. PUB. 2-15-2011. FILED 9-7-2010.
- 3,954,963 ( *See Class 35 for this trademark*).
- 3,954,965. **MISCELLANEOUS DESIGN**. CARSAFE LLC, (U.S. CLS. 100, 101 AND 102). SN 85-126,874. PUB. 2-15-2011. FILED 9-10-2010.
- 3,954,966. **G GOLDFARB PROPERTIES UPGRADE YOUR SPACE (STANDARD CHARACTER)**. GOLDFARB PROPERTIES, INC., (U.S. CLS. 100, 101 AND 102). SN 85-126,878. PUB. 2-15-2011. FILED 9-10-2010.
- 3,955,017. **WOMEN IN RED (STANDARD CHARACTER)**. MICROSOFT CORPORATION, (U.S. CLS. 100, 101 AND 102). SN 85-135,974. PUB. 2-15-2011. FILED 9-22-2010.
- 3,955,028. **MARKETLOCK FOR LIFE (STANDARD CHARACTER)**. AMERICAN INTERNATIONAL GROUP, INC., (U.S. CLS. 100, 101 AND 102). SN 85-137,259. PUB. 2-15-2011. FILED 9-24-2010.
- 3,955,043 ( *See Class 35 for this trademark*).
- 3,955,047. **THIRD RAIL STRATEGY (STANDARD CHARACTER)**. EICHEN, MITCHELL D., (U.S. CLS. 100, 101 AND 102). SN 85-139,485. PUB. 2-15-2011. FILED 9-28-2010.
- 3,955,048. **RISK FIRST (STANDARD CHARACTER)**. EICHEN, MITCHELL D., (U.S. CLS. 100, 101 AND 102). SN 85-139,487. PUB. 2-15-2011. FILED 9-28-2010.
- 3,955,054. **FIRST BANKCARD (STANDARD CHARACTER)**. FIRST NATIONAL OF NEBRASKA, INC., (U.S. CLS. 100, 101 AND 102). SN 85-140,088. PUB. 2-15-2011. FILED 9-28-2010.
- 3,955,062. **MISCELLANEOUS DESIGN**. RAINBOW COAST ENTERPRISES PTY LTD, (U.S. CLS. 100, 101 AND 102). SN 85-143,427. PUB. 2-15-2011. FILED 10-1-2010.
- 3,955,111. **PLL MUNIPROTECT (STANDARD CHARACTER)**. AKITA, INC., (U.S. CLS. 100, 101 AND 102). SN 85-163,454. PUB. 2-15-2011. FILED 10-28-2010.
- 3,955,112. **AG BENEFIT SOLUTIONS CONNECTICUT CLAIM CENTER (STANDARD CHARACTER)**. AMERICAN INTERNATIONAL GROUP, INC., (U.S. CLS. 100, 101 AND 102). SN 85-163,691. PUB. 2-15-2011. FILED 10-28-2010.
- 3,955,115. **TAKE CONTROL BACK AND DESIGN**. FBMC BENEFITS MANAGEMENT, INC., (U.S. CLS. 100, 101 AND 102). SN 85-165,690. PUB. 2-15-2011. FILED 10-31-2010.
- 3,955,120. **RSC SOLUTIONS PROPERTY COMPLETE (STANDARD CHARACTER)**. AKITA, INC., (U.S. CLS. 100, 101 AND 102). SN 85-168,850. PUB. 2-15-2011. FILED 11-4-2010.
- 3,955,121 ( *See Class 35 for this trademark*).
- 3,955,144. **PLL REAL PROTECT (STANDARD CHARACTER)**. AKITA, INC., (U.S. CLS. 100, 101 AND 102). SN 85-180,080. PUB. 2-15-2011. FILED 11-18-2010.

---

**CLASS 37—CONSTRUCTION AND REPAIR**

- 3,952,950 ( *See Class 36 for this trademark*).
- 3,952,951 ( *See Class 36 for this trademark*).
- 3,953,004. **MAGIC SUNROOMS (STANDARD CHARACTER)**.

- COHEN, JAMES D., (U.S. CLS. 100, 103 AND 106). SN 77-121,414. PUB. 1-15-2008. FILED 3-2-2007.  
 3,953,012 ( *See Class 35 for this trademark*).  
 3,953,049 ( *See Class 6 for this trademark*).  
 3,953,053. **PB PITNEYBOWES (STYLIZED)**, PITNEY BOWES INC., (U.S. CLS. 100, 103 AND 106). SN 77-682,886. PUB. 2-15-2011. FILED 3-4-2009.  
 3,953,074 ( *See Class 11 for this trademark*).  
 3,953,082 ( *See Class 6 for this trademark*).  
 3,953,083 ( *See Class 1 for this trademark*).  
 3,953,088 ( *See Class 36 for this trademark*).  
 3,953,116 ( *See Class 4 for this trademark*).  
 3,953,134 ( *See Class 35 for this trademark*).  
 3,953,166 ( *See Class 35 for this trademark*).  
 3,953,201. **STANDARD ENERGY SOLUTIONS (STANDARD CHARACTER)**, STANDARD SOLAR, INC., (U.S. CLS. 100, 103 AND 106). SN 77-871,235. PUB. 2-15-2011. FILED S.R. 11-12-2009; AM. P.R. 1-6-2011.  
 3,953,210. **GREEN ANALYTICS (STANDARD CHARACTER)**, GREEN ANALYTICS, LLC, (U.S. CLS. 100, 103 AND 106). SN 77-887,218. PUB. 2-15-2011. FILED 12-7-2009.  
 3,953,236. **SILVER-CORR (STANDARD CHARACTER)**, MARCH COATINGS, INC., (U.S. CLS. 100, 103 AND 106). SN 77-913,974. PUB. 2-15-2011. FILED 1-18-2010.  
 3,953,242. **GOTRONICS (STANDARD CHARACTER)**, GOTRONICS LLC, FORMERLY IREPAIR TEAM LLC, (U.S. CLS. 100, 103 AND 106). SN 77-916,459. PUB. 2-15-2011. FILED 1-21-2010.  
 3,953,253 ( *See Class 36 for this trademark*).  
 3,953,307. **THE GRANDMASTERS OF DISASTER (STANDARD CHARACTER)**, CLEAN CARE OF NEW ENGLAND INC, (U.S. CLS. 100, 103 AND 106). SN 77-944,391. PUB. 2-15-2011. FILED 2-25-2010.  
 3,953,312 ( *See Class 16 for this trademark*).  
 3,953,393 ( *See Class 30 for this trademark*).  
 3,953,405 ( *See Class 36 for this trademark*).  
 3,953,408 ( *See Class 36 for this trademark*).  
 3,953,470. **SILVERLEAF (STANDARD CHARACTER)**, DC RANCH, LLC, (U.S. CLS. 100, 103 AND 106). SN 78-554,028. PUB. 10-21-2008. FILED 1-26-2005.  
 3,953,472. **FREEDOM FIRE PROTECTION (STANDARD CHARACTER)**, FREEDOM FIRE PROTECTION, LLC, MULTIPLE CLASS, (INT. CLS. 37 AND 42), (U.S. CLS. 100, 101, 103 AND 106). SN 78-666,334. PUB. 12-5-2006. FILED 7-8-2005.  
 3,953,473 ( *See Class 12 for this trademark*).  
 3,953,483. **NA NEW AGE ELECTRONICS AND DESIGN**, NEW AGE ELECTRONICS, INC., (U.S. CLS. 100, 103 AND 106). SN 78-967,542. PUB. 4-24-2007. FILED 9-5-2006.  
 3,953,487 ( *See Class 36 for this trademark*).  
 3,953,493 ( *See Class 9 for this trademark*).  
 3,953,497 ( *See Class 6 for this trademark*).  
 3,953,504 ( *See Class 9 for this trademark*).  
 3,953,526 ( *See Class 7 for this trademark*).  
 3,953,557 ( *See Class 9 for this trademark*).  
 3,953,562 ( *See Class 29 for this trademark*).  
 3,953,569 ( *See Class 6 for this trademark*).  
 3,953,570 ( *See Class 6 for this trademark*).  
 3,953,578 ( *See Class 4 for this trademark*).  
 3,953,579 ( *See Class 4 for this trademark*).  
 3,953,586 ( *See Class 19 for this trademark*).  
 3,953,592 ( *See Class 11 for this trademark*).  
 3,953,605. **MISCELLANEOUS DESIGN**, MICHAEL KARPINSKI, MULTIPLE CLASS, (INT. CLS. 37 AND 42), (U.S. CLS. 100, 101, 103 AND 106). SN 79-083,047. PUB. 2-15-2011. FILED 3-10-2010.  
 3,953,610 ( *See Class 7 for this trademark*).  
 3,953,675 ( *See Class 7 for this trademark*).  
 3,953,689 ( *See Class 11 for this trademark*).  
 3,953,701. **CHERRY DEMOLITION AND DESIGN**, CHERRY MOVING COMPANY, INC., DBA CHERRY DEMOLITION, (U.S. CLS. 100, 103 AND 106). SN 85-003,232. PUB. 2-15-2011. FILED 3-31-2010.  
 3,953,741. **RELIABLE PAVING (STANDARD CHARACTER)**, RELIABLE PAVING, INC., (U.S. CLS. 100, 103 AND 106). SN 85-018,507. PUB. 9-21-2010. FILED 4-20-2010.  
 3,953,742. **RELIABLE CONCRETE (STANDARD CHARACTER)**, RELIABLE PAVING, INC., (U.S. CLS. 100, 103 AND 106). SN 85-018,574. PUB. 9-21-2010. FILED 4-20-2010.  
 3,953,817 ( *See Class 36 for this trademark*).  
 3,953,862 ( *See Class 35 for this trademark*).  
 3,953,863 ( *See Class 35 for this trademark*).  
 3,954,103 ( *See Class 1 for this trademark*).  
 3,954,120. **COTEMAR CT AND DESIGN**, COTEMAR, S.A. DE C.V., MULTIPLE CLASS, (INT. CLS. 37 AND 43), (U.S. CLS. 100, 101, 103 AND 106). SN 85-110,706. PUB. 2-15-2011. FILED 8-18-2010.  
 3,954,211. **VYPERBYTE (STANDARD CHARACTER)**, VYPERBYTE, LLC, (U.S. CLS. 100, 103 AND 106). SN 85-114,364. PUB. 2-15-2011. FILED 8-24-2010.  
 3,954,296. **AUTOLAVISH (STYLIZED)**, AUTOLAVISH, LLC, (U.S. CLS. 100, 103 AND 106). SN 85-116,210. PUB. 2-15-2011. FILED 8-26-2010.  
 3,954,304 ( *See Class 4 for this trademark*).  
 3,954,365 ( *See Class 17 for this trademark*).  
 3,954,370. **WOW! DENT & SCRATCH REPAIR SMOOTHING OUT LIFE'S LITTLE DINGS! AND DESIGN**, WOW! DENT AND SCRATCH REPAIR, LLC, (U.S. CLS. 100, 103 AND 106). SN 85-117,340. PUB. 2-15-2011. FILED 8-27-2010.  
 3,954,372. **ICRACKED (STANDARD CHARACTER)**, ICRACKED HOLDINGS, LLC, DBA ICRACKED, (U.S. CLS. 100, 103 AND 106). SN 85-117,365. PUB. 2-15-2011. FILED 8-27-2010.  
 3,954,374. **IMS RENEW (STANDARD CHARACTER)**, INTEGRATED MEDICAL SYSTEMS INTERNATIONAL, INC., (U.S. CLS. 100, 103 AND 106). SN 85-117,400. PUB. 2-15-2011. FILED 8-27-2010.  
 3,954,385. **DANCO ROOFING SERVICES (STANDARD CHARACTER)**, DANCO ROOFING SERVICES, INC., (U.S. CLS. 100, 103 AND 106). SN 85-117,510. PUB. 2-15-2011. FILED 8-27-2010.  
 3,954,413. **G GRENADIER HOMES CLASSIC & SMART AND DESIGN**, GRENADIER HOMES, INC., (U.S. CLS. 100, 103 AND 106). SN 85-117,983. PUB. 2-15-2011. FILED 8-27-2010.  
 3,954,440. **AADISASTER RESTORATION24/7 (STANDARD CHARACTER)**, AADISASTER RESTORATION24/7, INC., MULTIPLE CLASS, (INT. CLS. 37 AND 40), (U.S. CLS. 100, 103 AND 106). SN 85-118,397. PUB. 2-15-2011. FILED 8-30-2010.  
 3,954,447. **AADISASTER RESTORATION24/7 AND DESIGN**, AADISASTER RESTORATION24/7, INC., MULTIPLE CLASS, (INT. CLS. 37 AND 40), (U.S. CLS. 100, 103 AND 106). SN 85-118,445. PUB. 2-15-2011. FILED 8-30-2010.  
 3,954,479. **ARTSPACE (STYLIZED)**, ARTSPACE PROJECTS, INC., (U.S. CLS. 100, 103 AND 106). SN 85-118,700. PUB. 2-15-2011. FILED 8-30-2010.  
 3,954,482. **BUILDING BETTER COMMUNITIES THROUGH THE ARTS (STANDARD CHARACTER)**, ARTSPACE PROJECTS, INC., (U.S. CLS. 100, 103 AND 106). SN 85-118,706. PUB. 2-15-2011. FILED 8-30-2010.  
 3,954,530 ( *See Class 6 for this trademark*).  
 3,954,557. **OLAF ANDERSON GENERAL CONTRACTORS AND DESIGN**, OLAF ANDERSON AND SON CONSTRUCTION COMPANY, (U.S. CLS. 100, 103 AND 106). SN 85-119,537. PUB. 2-15-2011. FILED 8-31-2010.  
 3,954,610. **DEH, L.L.C. CONSTRUCTION MANAGEMENT SERVICES (STANDARD CHARACTER)**, DEH, L.L.C., (U.S. CLS. 100, 103 AND 106). SN 85-120,148. PUB. 2-15-2011. FILED 8-31-2010.  
 3,954,616 ( *See Class 20 for this trademark*).  
 3,954,742. **EUTECHIC SERVICES LLC AND DESIGN**, EUTECHIC SERVICES, (U.S. CLS. 100, 103 AND 106). SN 85-121,600. PUB. 2-15-2011. FILED 9-2-2010.  
 3,954,800. **ECO-RID (STANDARD CHARACTER)**, B&J ENTERPRISES, INC., (U.S. CLS. 100, 103 AND 106). SN 85-122,196. PUB. 2-15-2011. FILED 9-2-2010.  
 3,954,807. **CONTRACTORS YOU CAN TRUST (STANDARD CHARACTER)**, FIREMANS CONTRACTORS, INC., (U.S. CLS. 100, 103 AND 106). SN 85-122,328. PUB. 2-15-2011. FILED 9-2-2010.  
 3,954,841. **ALL KANDY AND DESIGN**, ALL KANDY, (U.S. CLS. 100, 103 AND 106). SN 85-122,738. PUB. 2-15-2011. FILED 9-3-2010.  
 3,954,851. **CLEANING BUTLERS AND DESIGN**, CLEANING BUTLERS INTERNATIONAL, INC., (U.S. CLS. 100, 103 AND 106). SN 85-122,844. PUB. 2-15-2011. FILED 9-3-2010.

3,955,012. **TYPHOON HEATING & COOLING AND DESIGN.** STORM INVESTMENTS, LLC, (U.S. CLS. 100, 103 AND 106). SN 85-133,469. PUB. 2-15-2011. FILED 9-20-2010.

3,955,056. **CHE RENOVATIONS (STANDARD CHARACTER).** CUSTOM HOME EXTERIORS, INC., (U.S. CLS. 100, 103 AND 106). SN 85-141,226. PUB. 2-15-2011. FILED 9-29-2010.

3,955,152. **INTEGRATED LEAN PROJECT DELIVERY (STANDARD CHARACTER).** THE BOLDT GROUP, INC., (U.S. CLS. 100, 103 AND 106). SN 85-975,067. PUB. 2-15-2011. FILED 8-4-2010.

---

### CLASS 38—COMMUNICATION

3,952,956 ( *See Class 9 for this trademark.* )  
 3,953,001 ( *See Class 9 for this trademark.* )  
 3,953,023 ( *See Class 35 for this trademark.* )  
 3,953,035 ( *See Class 9 for this trademark.* )  
 3,953,101. **WOMEN'S RADIO (STANDARD CHARACTER).** WOMEN'S ONLINE MEDIA AND EDUCATION NETWORK, (U.S. CLS. 100, 101 AND 104). SN 77-795,135. PUB. 2-15-2011. FILED 8-2-2009.  
 3,953,111 ( *See Class 9 for this trademark.* )  
 3,953,114. **WOMEN'S RADIO NETWORK (STANDARD CHARACTER).** WOMEN'S ONLINE MEDIA AND EDUCATION NETWORK, (U.S. CLS. 100, 101 AND 104). SN 77-807,411. PUB. 2-15-2011. FILED 8-18-2009.  
 3,953,215 ( *See Class 35 for this trademark.* )  
 3,953,311 ( *See Class 35 for this trademark.* )  
 3,953,314 ( *See Class 35 for this trademark.* )  
 3,953,433. **SUPERNEWS (STANDARD CHARACTER).** SUPERNEWS, INC., (U.S. CLS. 100, 101 AND 104). SN 77-961,749. PUB. 2-15-2011. FILED 3-17-2010.  
 3,953,488 ( *See Class 9 for this trademark.* )  
 3,953,495 ( *See Class 9 for this trademark.* )  
 3,953,512 ( *See Class 9 for this trademark.* )  
 3,953,528 ( *See Class 35 for this trademark.* )  
 3,953,533 ( *See Class 36 for this trademark.* )  
 3,953,534 ( *See Class 36 for this trademark.* )  
 3,953,537 ( *See Class 36 for this trademark.* )  
 3,953,540 ( *See Class 36 for this trademark.* )  
 3,953,542 ( *See Class 35 for this trademark.* )  
 3,953,562 ( *See Class 29 for this trademark.* )  
 3,953,575 ( *See Class 9 for this trademark.* )  
 3,953,583 ( *See Class 16 for this trademark.* )  
 3,953,789 ( *See Class 9 for this trademark.* )  
 3,953,992. **ICN AND DESIGN.** INTERNATIONAL CHINESE NETWORK, INC., MULTIPLE CLASS, (INT. CLS. 38 AND 41), (U.S. CLS. 100, 101, 104 AND 107). SN 85-095,853. PUB. 2-15-2011. FILED 7-29-2010.  
 3,954,003. **HATE 2 WAIT (STANDARD CHARACTER).** BRYTE LIGHT ENTERPRISES LLC, (U.S. CLS. 100, 101 AND 104). SN 85-097,670. PUB. 2-15-2011. FILED 8-1-2010.  
 3,954,112. **PERFECTPAK (STANDARD CHARACTER).** NATIONAL PRINT GROUP, INC., (U.S. CLS. 100, 101 AND 104). SN 85-110,166. PUB. 2-15-2011. FILED 8-18-2010.  
 3,954,152. **SAILING A ANARCHY AND DESIGN.** TEMPESTA, SCOT, MULTIPLE CLASS, (INT. CLS. 38 AND 41), (U.S. CLS. 100, 101, 104 AND 107). SN 85-111,900. PUB. 2-15-2011. FILED 8-20-2010.  
 3,954,244 ( *See Class 35 for this trademark.* )  
 3,954,332. **BUSINESS BLACK BELT (STANDARD CHARACTER).** BURKE FRANKLIN, (U.S. CLS. 100, 101 AND 104). SN 85-116,864. PUB. 2-15-2011. FILED 8-26-2010.  
 3,954,627 ( *See Class 35 for this trademark.* )  
 3,954,734 ( *See Class 9 for this trademark.* )  
 3,954,787. **FANTASY 411 (STANDARD CHARACTER).** MLB ADVANCED MEDIA, L.P., (U.S. CLS. 100, 101 AND 104). SN 85-122,075. PUB. 2-15-2011. FILED 9-2-2010.  
 3,954,819. **RADMAIL (STANDARD CHARACTER).** MUSCULOSKELETAL IMAGING CONSULTANTS LLC, (U.S. CLS. 100, 101 AND 104). SN 85-122,442. PUB. 2-15-2011. FILED 9-3-2010.  
 3,954,915 ( *See Class 9 for this trademark.* )  
 3,954,921. **FLOODSTREAM (STANDARD CHARACTER).** PASHLEY CREATIVE, LLC, (U.S. CLS. 100, 101 AND 104). SN 85-124,075. PUB. 2-15-2011. FILED 9-7-2010.

3,954,947. **ORGULLO (STANDARD CHARACTER).** TOTAL CALL INTERNATIONAL, INC., (U.S. CLS. 100, 101 AND 104). SN 85-125,420. PUB. 2-15-2011. FILED 9-8-2010.  
 3,955,020. **ALERTMD BEING ON-CALL JUST GOT EASIER AND DESIGN.** RULESTER LLC, (U.S. CLS. 100, 101 AND 104). SN 85-136,311. PUB. 2-15-2011. FILED 9-23-2010.  
 3,955,060. **BELLERUD COMMUNICATIONS AND DESIGN.** BELLERUD COMMUNICATIONS, LLC, (U.S. CLS. 100, 101 AND 104). SN 85-142,788. PUB. 2-15-2011. FILED 10-1-2010.  
 3,955,061 ( *See Class 9 for this trademark.* )  
 3,955,063 ( *See Class 9 for this trademark.* )  
 3,955,098. **GOTORAD (STANDARD CHARACTER).** MUSCULOSKELETAL IMAGING CONSULTANTS LLC, (U.S. CLS. 100, 101 AND 104). SN 85-154,574. PUB. 2-15-2011. FILED 10-18-2010.

---

### CLASS 39—TRANSPORTATION AND STORAGE

3,953,083 ( *See Class 1 for this trademark.* )  
 3,953,088 ( *See Class 36 for this trademark.* )  
 3,953,116 ( *See Class 4 for this trademark.* )  
 3,953,142 ( *See Class 35 for this trademark.* )  
 3,953,143 ( *See Class 35 for this trademark.* )  
 3,953,150 ( *See Class 35 for this trademark.* )  
 3,953,151 ( *See Class 35 for this trademark.* )  
 3,953,166 ( *See Class 35 for this trademark.* )  
 3,953,195. **INTREPID URBAN ADVENTURES AND DESIGN.** INTREPID TRAVEL PTY LTD, MULTIPLE CLASS, (INT. CLS. 39 AND 41), (U.S. CLS. 100, 101, 105 AND 107). SN 77-861,743. PUB. 2-15-2011. FILED 10-30-2009.  
 3,953,215 ( *See Class 35 for this trademark.* )  
 3,953,220. **DRIVERS RENT A CAR AND DESIGN.** DRIVERS S.A., (U.S. CLS. 100 AND 105). SN 77-898,323. PUB. 11-9-2010. FILED 12-21-2009.  
 3,953,229. **JETVIZOR (STANDARD CHARACTER).** DUKE-JETS LLC, DBA JETVIZOR, (U.S. CLS. 100 AND 105). SN 77-909,625. PUB. 2-15-2011. FILED 1-12-2010.  
 3,953,261. **ONESTOP RECYCLING (STANDARD CHARACTER).** THE INSTITUTION RECYCLING NETWORK, INC., AKA IRN, (U.S. CLS. 100 AND 105). SN 77-931,111. PUB. 2-15-2011. FILED 2-9-2010.  
 3,953,265. **SWOOP MIAMI AND DESIGN.** ALEXANDER T. SMITH, (U.S. CLS. 100 AND 105). SN 77-933,419. PUB. 2-15-2011. FILED 2-11-2010.  
 3,953,384. **WE MOVE IT (STANDARD CHARACTER).** THOMPSON, JEFFREY S., DBA WE MOVE IT, (U.S. CLS. 100 AND 105). SN 77-955,669. PUB. 2-15-2011. FILED 3-10-2010.  
 3,953,393 ( *See Class 30 for this trademark.* )  
 3,953,497 ( *See Class 6 for this trademark.* )  
 3,953,562 ( *See Class 29 for this trademark.* )  
 3,953,569 ( *See Class 6 for this trademark.* )  
 3,953,570 ( *See Class 6 for this trademark.* )  
 3,953,578 ( *See Class 4 for this trademark.* )  
 3,953,579 ( *See Class 4 for this trademark.* )  
 3,953,586 ( *See Class 19 for this trademark.* )  
 3,953,609 ( *See Class 16 for this trademark.* )  
 3,953,641 ( *See Class 25 for this trademark.* )  
 3,953,686 ( *See Class 35 for this trademark.* )  
 3,953,705. **MISCELLANEOUS DESIGN.** WOODLANDS WILDLIFE REFUGE, (U.S. CLS. 100 AND 105). SN 85-004,634. PUB. 2-15-2011. FILED 4-1-2010.  
 3,953,859 ( *See Class 30 for this trademark.* )  
 3,953,891 ( *See Class 35 for this trademark.* )  
 3,953,935. **GLOBAL BAGGAGE EXPEDITER REUNITING TRAVELERS WITH THEIR LUGGAGE AND DESIGN.** GLOBAL BAGGAGE EXPEDITER INC, (U.S. CLS. 100 AND 105). SN 85-078,602. PUB. 2-15-2011. FILED 7-6-2010.  
 3,953,960. **SADDLE LIGHTS (STANDARD CHARACTER).** SADDLE LIGHTS, INC., DBA SADDLE LIGHTS, (U.S. CLS. 100 AND 105). SN 85-087,559. PUB. 2-15-2011. FILED 7-19-2010.  
 3,954,093. **SNA AUTO RENTAL (STANDARD CHARACTER).** SASH MANAGEMENT INCORPORATED, DBA SNA AUTO RENTAL, (U.S. CLS. 100 AND 105). SN 85-108,692.

PUB. 2-15-2011. FILED 8-16-2010.  
 3,954,139. **FREGGIES (STANDARD CHARACTER)**. HOME-TASK, INC., DBA FREGGIES, (U.S. CLS. 100 AND 105). SN 85-111,532. PUB. 2-15-2011. FILED 8-19-2010.  
 3,954,170. **GOLD STAR AMBULANCE AND DESIGN**. GOLD STAR EMS LLC, (U.S. CLS. 100 AND 105). SN 85-112,814. PUB. 2-15-2011. FILED 8-20-2010.  
 3,954,185. **LOCAL HOST (STANDARD CHARACTER)**. GROUP VOYAGERS, INC., (U.S. CLS. 100 AND 105). SN 85-113,661. PUB. 2-15-2011. FILED 8-23-2010.  
 3,954,186. **FLEXIDAY.COM AND DESIGN**. FLEXI-VAN LEASING, INC., (U.S. CLS. 100 AND 105). SN 85-113,666. PUB. 2-15-2011. FILED 8-23-2010.  
 3,954,213. **R AND DESIGN**. RYT-WAY INDUSTRIES, LLC, (U.S. CLS. 100 AND 105). SN 85-114,430. PUB. 2-15-2011. FILED 8-24-2010.  
 3,954,214. **THE RYT-WAY TO PACKAGE FOOD (STANDARD CHARACTER)**. RYT-WAY INDUSTRIES, LLC, (U.S. CLS. 100 AND 105). SN 85-114,441. PUB. 2-15-2011. FILED 8-24-2010.  
 3,954,215. **RYT-WAY (STANDARD CHARACTER)**. RYT-WAY INDUSTRIES, LLC, (U.S. CLS. 100 AND 105). SN 85-114,443. PUB. 2-15-2011. FILED 8-24-2010.  
 3,954,220 ( *See Class 35 for this trademark*).  
 3,954,490 ( *See Class 35 for this trademark*).  
 3,954,627 ( *See Class 35 for this trademark*).  
 3,954,707 ( *See Class 35 for this trademark*).  
 3,954,804. **CANAVERAL STAR (STANDARD CHARACTER)**. MARINE MAMMAL TOURS, INC., (U.S. CLS. 100 AND 105). SN 85-122,267. PUB. 2-15-2011. FILED 9-2-2010.  
 3,954,925. **511 AND DESIGN**. LOS ANGELES COUNTY SERVICE AUTHORITY FOR FREEWAY EMERGENCIES, (U.S. CLS. 100 AND 105). SN 85-124,203. PUB. 2-15-2011. FILED 9-7-2010.  
 3,954,942. **RELIANT FILTERS MADE EASY (STANDARD CHARACTER)**. RELIANT ENERGY RETAIL HOLDINGS, LLC, (U.S. CLS. 100 AND 105). SN 85-125,037. PUB. 2-15-2011. FILED 9-8-2010.  
 3,955,043 ( *See Class 35 for this trademark*).  
 3,955,114. **MISCELLANEOUS DESIGN**. MICROSOFT CORPORATION, MULTIPLE CLASS, (INT. CLS. 39 AND 42), (U.S. CLS. 100, 101 AND 105). SN 85-164,175. PUB. 2-15-2011. FILED 10-28-2010.

#### CLASS 40—MATERIAL TREATMENT

3,953,049 ( *See Class 6 for this trademark*).  
 3,953,074 ( *See Class 11 for this trademark*).  
 3,953,082 ( *See Class 6 for this trademark*).  
 3,953,083 ( *See Class 1 for this trademark*).  
 3,953,088 ( *See Class 36 for this trademark*).  
 3,953,116 ( *See Class 4 for this trademark*).  
 3,953,157 ( *See Class 11 for this trademark*).  
 3,953,161 ( *See Class 35 for this trademark*).  
 3,953,166 ( *See Class 35 for this trademark*).  
 3,953,396. **CDR (STANDARD CHARACTER)**. PERC WATER CORPORATION, MULTIPLE CLASS, (INT. CLS. 40 AND 42), (U.S. CLS. 100, 101, 103 AND 106). SN 77-957,183. PUB. 2-15-2011. FILED 3-11-2010.  
 3,953,455 ( *See Class 35 for this trademark*).  
 3,953,456 ( *See Class 35 for this trademark*).  
 3,953,497 ( *See Class 6 for this trademark*).  
 3,953,564 ( *See Class 11 for this trademark*).  
 3,953,586 ( *See Class 19 for this trademark*).  
 3,953,610 ( *See Class 7 for this trademark*).  
 3,953,762. **LITTLE LADY FOODS (STANDARD CHARACTER)**. LITTLE LADY FOODS, INC., MULTIPLE CLASS, (INT. CLS. 40, 42 AND 43), (U.S. CLS. 100, 101, 103 AND 106). SN 85-027,155. PUB. 2-15-2011. FILED 4-30-2010.  
 3,953,763. **LITTLE LADY FOODS AND DESIGN**. LITTLE LADY FOODS, INC., MULTIPLE CLASS, (INT. CLS. 40, 42 AND 43), (U.S. CLS. 100, 101, 103 AND 106). SN 85-027,180. PUB. 2-15-2011. FILED 4-30-2010.  
 3,953,859 ( *See Class 30 for this trademark*).  
 3,954,042. **S STRIDE TOOL AND DESIGN**. STRIDE TOOL INC., (U.S. CLS. 100, 103 AND 106). SN 85-104,731. PUB. 2-

15-2011. FILED 8-11-2010.  
 3,954,080. **A WEDDING RING EXPERIENCE (STANDARD CHARACTER)**. WEDDING RING WORKSHOP-USA, LLC, (U.S. CLS. 100, 103 AND 106). SN 85-107,590. PUB. 2-15-2011. FILED 8-13-2010.  
 3,954,103 ( *See Class 1 for this trademark*).  
 3,954,304 ( *See Class 4 for this trademark*).  
 3,954,440 ( *See Class 37 for this trademark*).  
 3,954,447 ( *See Class 37 for this trademark*).  
 3,954,518 ( *See Class 19 for this trademark*).  
 3,954,530 ( *See Class 6 for this trademark*).  
 3,954,564 ( *See Class 7 for this trademark*).  
 3,954,640. **NATIONS PHOTO LAB (STANDARD CHARACTER)**. NATIONS PHOTO LAB LLC, (U.S. CLS. 100, 103 AND 106). SN 85-120,490. PUB. 2-15-2011. FILED 9-1-2010.  
 3,954,689. **BUILD THE EXTRAORDINARY (STANDARD CHARACTER)**. EVENTScape INC., (U.S. CLS. 100, 103 AND 106). SN 85-120,866. PUB. 2-15-2011. FILED 9-1-2010.  
 3,954,884 ( *See Class 2 for this trademark*).  
 3,955,123. **AKT (STANDARD CHARACTER)**. AKT & IWDT, INC., (U.S. CLS. 100, 103 AND 106). SN 85-169,732. PUB. 2-15-2011. FILED 11-4-2010.  
 3,955,124. **BIG TOP (STANDARD CHARACTER)**. AKT & IWDT, INC., (U.S. CLS. 100, 103 AND 106). SN 85-169,745. PUB. 2-15-2011. FILED 11-4-2010.

#### CLASS 41—EDUCATION AND ENTERTAINMENT

3,952,965. **DEJA VU EROTIC ULTRALOUNGE AND DESIGN**. DEJA VU CONSULTING, INC., (U.S. CLS. 100, 101 AND 107). SN 76-701,198. PUB. 2-15-2011. FILED 1-14-2010.  
 3,952,975 ( *See Class 35 for this trademark*).  
 3,952,983. **HIGH ACHIEVERS (STANDARD CHARACTER)**. HIGH ACHIEVERS INC, (U.S. CLS. 100, 101 AND 107). SN 76-704,109. PUB. 2-15-2011. FILED 8-13-2010.  
 3,952,988. **PARENTING WITH LOVE AND LOGIC (STANDARD CHARACTER)**. INSTITUTE FOR PROFESSIONAL DEVELOPMENT, LTD., DBA THE LOVE AND LOGIC INSTITUTE, INC., (U.S. CLS. 100, 101 AND 107). SN 76-704,296. PUB. 2-15-2011. FILED 8-30-2010.  
 3,953,008 ( *See Class 9 for this trademark*).  
 3,953,023 ( *See Class 35 for this trademark*).  
 3,953,025 ( *See Class 9 for this trademark*).  
 3,953,033. **USA TODAY PULSE OF AMERICA SERIES (STANDARD CHARACTER)**. GANNETT SATELLITE INFORMATION NETWORK, INC., (U.S. CLS. 100, 101 AND 107). SN 77-605,800. PUB. 2-15-2011. FILED 11-3-2008.  
 3,953,037. **LATIN GOSPEL MAGAZINE (STANDARD CHARACTER)**. J. CASTRO, INC., (U.S. CLS. 100, 101 AND 107). SN 77-627,910. PUB. 2-15-2011. FILED 12-5-2008.  
 3,953,054 ( *See Class 35 for this trademark*).  
 3,953,057. **NATIONAL FLIGHT ACADEMY (STANDARD CHARACTER)**. NAVAL AVIATION MUSEUM FOUNDATION, INC., (U.S. CLS. 100, 101 AND 107). SN 77-690,802. PUB. 2-15-2011. FILED 3-13-2009.  
 3,953,066. **VERMINATORS (STANDARD CHARACTER)**. ORIGINAL PRODUCTIONS LLC, (U.S. CLS. 100, 101 AND 107). SN 77-731,343. PUB. 12-29-2009. FILED 5-7-2009.  
 3,953,070 ( *See Class 36 for this trademark*).  
 3,953,071 ( *See Class 36 for this trademark*).  
 3,953,074 ( *See Class 11 for this trademark*).  
 3,953,077 ( *See Class 9 for this trademark*).  
 3,953,079. **THE WOMEN'S SELF DEFENSE INSTITUTE (STANDARD CHARACTER)**. KARDIAN, STEPHEN F., AND PARKER, BRAD, (U.S. CLS. 100, 101 AND 107). SN 77-753,740. PUB. 2-15-2011. FILED 6-5-2009.  
 3,953,080. **DEFEND UNIVERSITY (STANDARD CHARACTER)**. KARDIAN, STEPHEN F., AND PARKER, BRAD, (U.S. CLS. 100, 101 AND 107). SN 77-753,743. PUB. 2-15-2011. FILED 6-5-2009.  
 3,953,081. **CONSEQUENCE OF SOUND (STANDARD CHARACTER)**. YOUNG, ALEXANDER P., (U.S. CLS. 100, 101 AND 107). SN 77-753,947. PUB. 2-15-2011. FILED 6-7-2009.  
 3,953,083 ( *See Class 1 for this trademark*).  
 3,953,090 ( *See Class 9 for this trademark*).

- 3,953,093. **GHOST ROBOT AND DESIGN**. GHOST ROBOT, INC. (U.S. CLS. 100, 101 AND 107). SN 77-778,255. PUB. 2-15-2011. FILED 7-10-2009.
- 3,953,121. **AUDIOMOXIE AND DESIGN**. BAKER, JAMES LAURANCE, DBA AUDIOMOXIE, (U.S. CLS. 100, 101 AND 107). SN 77-812,545. PUB. 2-15-2011. FILED 8-25-2009.
- 3,953,126. **KINETIC CITY (STANDARD CHARACTER)**. AMERICAN ASSOCIATION FOR THE ADVANCEMENT OF SCIENCE, (U.S. CLS. 100, 101 AND 107). SN 77-814,051. PUB. 2-15-2011. FILED 8-27-2009.
- 3,953,128. **UPF ULTIMATE PERFORMANCE & FITNESS INC. AND DESIGN**. ULTIMATE PERFORMANCE & FITNESS, INC., (U.S. CLS. 100, 101 AND 107). SN 77-815,064. PUB. 2-15-2011. FILED 8-28-2009.
- 3,953,134 ( *See Class 35 for this trademark*).
- 3,953,156. **THE MEDICAL MANAGEMENT INSTITUTE (STANDARD CHARACTER)**. KEENE, ROBERT D., (U.S. CLS. 100, 101 AND 107). SN 77-833,466. PUB. 2-15-2011. FILED 9-23-2009.
- 3,953,158. **RAPIDREPORTS (STANDARD CHARACTER)**. CBS INTERACTIVE INC., (U.S. CLS. 100, 101 AND 107). SN 77-835,481. PUB. 2-15-2011. FILED 9-25-2009.
- 3,953,159. **MOBILELEARN (STANDARD CHARACTER)**. LAUREATE EDUCATION, INC., (U.S. CLS. 100, 101 AND 107). SN 77-838,362. PUB. 2-15-2011. FILED 9-30-2009.
- 3,953,162. **GOSSIP COP AND DESIGN**. MICHAEL LEWITTES, (U.S. CLS. 100, 101 AND 107). SN 77-843,093. PUB. 2-15-2011. FILED 10-7-2009.
- 3,953,178. **WU KUI TANG 64TH CHIEN - LIANG HUANG TAI JI QUAN XING YI QUAN BAGUAZHANG NEI GONG MEDITATION POWER TRAINING SHUAI JIAO WEAPONS QIN NA TIEN SHAN PAI AND DESIGN**. WEE HUANG, DBA HUANG'S INC., (U.S. CLS. 100, 101 AND 107). SN 77-848,360. PUB. 2-15-2011. FILED 10-14-2009.
- 3,953,195 ( *See Class 39 for this trademark*).
- 3,953,198 ( *See Class 29 for this trademark*).
- 3,953,202. **BARTENDERS ASSOCIATION INTERNATIONALE (STANDARD CHARACTER)**. BOWMAN, ERIK, (U.S. CLS. 100, 101 AND 107). SN 77-874,796. PUB. 2-15-2011. FILED 11-17-2009.
- 3,953,212. **CAFFE LENA (STANDARD CHARACTER)**. CAFFE LENA, INC., MULTIPLE CLASS, (INT. CLS. 41 AND 43), (U.S. CLS. 100, 101 AND 107). SN 77-890,646. PUB. 2-15-2011. FILED 12-10-2009.
- 3,953,226 ( *See Class 25 for this trademark*).
- 3,953,228. **AIRWAYSIM (STANDARD CHARACTER)**. AVIA-DESIGN KY, DBA AIRWAYSIM, (U.S. CLS. 100, 101 AND 107). SN 77-908,308. PUB. 2-15-2011. FILED 1-8-2010.
- 3,953,231 ( *See Class 16 for this trademark*).
- 3,953,234. **MINYANVILLE (STANDARD CHARACTER)**. MINYANVILLE PUBLISHING & MULTIMEDIA LLC, MULTIPLE CLASS, (INT. CLS. 41 AND 45), (U.S. CLS. 100, 101 AND 107). SN 77-912,671. PUB. 11-9-2010. FILED 1-15-2010.
- 3,953,257 ( *See Class 25 for this trademark*).
- 3,953,262. **HELPME AND DESIGN**. DUSHAN WEGNER, (U.S. CLS. 100, 101 AND 107). SN 77-931,155. PUB. 2-15-2011. FILED 2-9-2010.
- 3,953,270 ( *See Class 16 for this trademark*).
- 3,953,271 ( *See Class 16 for this trademark*).
- 3,953,274. **COACH ACROSS AMERICA (STANDARD CHARACTER)**. UP2US, INC., (U.S. CLS. 100, 101 AND 107). SN 77-936,552. PUB. 2-15-2011. FILED 2-16-2010.
- 3,953,279. **JOLT AND DESIGN**. JOLT, INC., (U.S. CLS. 100, 101 AND 107). SN 77-937,726. PUB. 2-15-2011. FILED 2-17-2010.
- 3,953,290. **DJ THEORY (STANDARD CHARACTER)**. WIENNER, JONATHAN L, DBA DJ THEORY, (U.S. CLS. 100, 101 AND 107). SN 77-940,642. PUB. 2-15-2011. FILED 2-20-2010.
- 3,953,291 ( *See Class 9 for this trademark*).
- 3,953,293. **SBN (STANDARD CHARACTER)**. SPORTSBLOGS, INC., AKA SB NATION, (U.S. CLS. 100, 101 AND 107). SN 77-941,749. PUB. 2-15-2011. FILED 2-22-2010.
- 3,953,309 ( *See Class 35 for this trademark*).
- 3,953,310 ( *See Class 35 for this trademark*).
- 3,953,313. **LEE'S LIEUTENANTS HEADQUARTERS ARMY OF NORTHERN VIRGINIA KEEPING HISTORY ALIVE AND DESIGN**. LEE'S LIEUTENANTS - ARMY OF NORTHERN VIRGINIA, INC., (U.S. CLS. 100, 101 AND 107). SN 77-944,858. PUB. 2-15-2011. FILED 2-25-2010.
- 3,953,315. **SOUTHERN PARADISE BALL (STANDARD CHARACTER)**. SOUTHERN PARADISE, INC., (U.S. CLS. 100, 101 AND 107). SN 77-945,901. PUB. 2-15-2011. FILED 2-26-2010.
- 3,953,346. **MOJO MOOD CLOUD (STANDARD CHARACTER)**. BODIMOJO, INC., (U.S. CLS. 100, 101 AND 107). SN 77-950,298. PUB. 2-15-2011. FILED 3-4-2010.
- 3,953,350. **CPAE SPEAKER HALL OF FAME (STANDARD CHARACTER)**. NATIONAL SPEAKERS ASSOCIATION, (U.S. CLS. 100, 101 AND 107). SN 77-950,908. PUB. 2-15-2011. FILED 3-4-2010.
- 3,953,353 ( *See Class 9 for this trademark*).
- 3,953,360. **YOUR LIFE. YOUR FUTURE. (STANDARD CHARACTER)**. CHANCELLOR UNIVERSITY, (U.S. CLS. 100, 101 AND 107). SN 77-952,710. PUB. 2-15-2011. FILED 3-8-2010.
- 3,953,362. **CODING METRIX (STANDARD CHARACTER)**. CODING METRIX, INC., (U.S. CLS. 100, 101 AND 107). SN 77-952,818. PUB. 2-15-2011. FILED 3-8-2010.
- 3,953,365. **RELATIONSHIP GIFTING (STANDARD CHARACTER)**. THE RELATIONSHIP GIFTING SEMINARS & PRESENTATIONS LLC, (U.S. CLS. 100, 101 AND 107). SN 77-952,999. PUB. 2-15-2011. FILED 3-8-2010.
- 3,953,366. **SHUTTLE LAUNCH EXPERIENCE AND DESIGN**. DNC PARKS & RESORTS AT KSC, INC., (U.S. CLS. 100, 101 AND 107). SN 77-953,099. PUB. 2-15-2011. FILED 3-8-2010.
- 3,953,369 ( *See Class 2 for this trademark*).
- 3,953,375. **BOCA RATON MUSEUM OF ART (STANDARD CHARACTER)**. BOCA RATON MUSEUM OF ART, INC., (U.S. CLS. 100, 101 AND 107). SN 77-954,327. PUB. 2-15-2011. FILED 3-9-2010.
- 3,953,377. **SARASWATI FILMS FILM IS THE NEW PEN (STANDARD CHARACTER)**. SARASWATI FILMS, (U.S. CLS. 100, 101 AND 107). SN 77-954,599. PUB. 2-15-2011. FILED 3-9-2010.
- 3,953,381. **D2 DREAM2 INTERNATIONAL MUSIC GROUP AND DESIGN**. HARRISON, RANDY, (U.S. CLS. 100, 101 AND 107). SN 77-954,967. PUB. 2-15-2011. FILED 3-9-2010.
- 3,953,388 ( *See Class 9 for this trademark*).
- 3,953,398 ( *See Class 9 for this trademark*).
- 3,953,400. **SI5S AND DESIGN**. ARNOLD, ROBERT, (U.S. CLS. 100, 101 AND 107). SN 77-958,084. PUB. 2-15-2011. FILED 3-12-2010.
- 3,953,406 ( *See Class 35 for this trademark*).
- 3,953,407. **POPPED COLLAR AND TEARS PRODUCTIONS (STANDARD CHARACTER)**. DOHENY, JAMES, (U.S. CLS. 100, 101 AND 107). SN 77-959,058. PUB. 2-15-2011. FILED 3-15-2010.
- 3,953,440. **UTAH'S PREMIERE FAMILY THEATRE (STANDARD CHARACTER)**. HALE CENTRE THEATRE, DBA HALE CENTRE THEATRE, (U.S. CLS. 100, 101 AND 107). SN 77-962,545. PUB. 2-15-2011. FILED 3-18-2010.
- 3,953,442. **THE DR. OZ SHOW (STYLIZED)**. ZOCO 1, LLC, (U.S. CLS. 100, 101 AND 107). SN 77-962,674. PUB. 2-15-2011. FILED 3-18-2010.
- 3,953,443 ( *See Class 16 for this trademark*).
- 3,953,444. **HUMANITAS PRODUCTIONS (STANDARD CHARACTER)**. THE HUMANITAS PRIZE, (U.S. CLS. 100, 101 AND 107). SN 77-963,566. PUB. 2-15-2011. FILED 3-19-2010.
- 3,953,455 ( *See Class 35 for this trademark*).
- 3,953,456 ( *See Class 35 for this trademark*).
- 3,953,476 ( *See Class 5 for this trademark*).
- 3,953,477. **CRANKY GEEKS (STANDARD CHARACTER)**. ZIFF DAVIS, INC., (U.S. CLS. 100, 101 AND 107). SN 78-833,398. PUB. 2-15-2011. FILED 3-9-2006.
- 3,953,487 ( *See Class 36 for this trademark*).
- 3,953,493 ( *See Class 9 for this trademark*).
- 3,953,496 ( *See Class 3 for this trademark*).
- 3,953,500 ( *See Class 25 for this trademark*).
- 3,953,512 ( *See Class 9 for this trademark*).
- 3,953,516 ( *See Class 9 for this trademark*).
- 3,953,520 ( *See Class 9 for this trademark*).
- 3,953,527. **ETC.VENUES (STANDARD CHARACTER)**. ETC VENUES LIMITED, MULTIPLE CLASS, (INT. CLS. 41 AND 43), (U.S. CLS. 100, 101 AND 107). SN 79-077,252. PUB. 2-15-2011. FILED 8-28-2009.
- 3,953,530 ( *See Class 36 for this trademark*).
- 3,953,531 ( *See Class 9 for this trademark*).

- 3,953,542 ( *See Class 35 for this trademark.*)  
 3,953,544 ( *See Class 35 for this trademark.*)  
 3,953,553 ( *See Class 16 for this trademark.*)  
 3,953,569 ( *See Class 6 for this trademark.*)  
 3,953,570 ( *See Class 6 for this trademark.*)  
 3,953,583 ( *See Class 16 for this trademark.*)  
 3,953,595 ( *See Class 16 for this trademark.*)  
 3,953,636 ( *See Class 35 for this trademark.*)  
 3,953,638 ( *See Class 15 for this trademark.*)  
 3,953,685. **MAKING CHILDREN YOUR EXPERTISE (STANDARD CHARACTER)**. TERESA ALONSO LANDEROS, DBA A+ PARENTING, (U.S. CLS. 100, 101 AND 107). SN 85-000,437. PUB. 2-15-2011. FILED 3-29-2010.  
 3,953,698. **LEWELLYN TECHNOLOGY WE IMPROVE WORKPLACE SAFETY & PERFORMANCE (STYLIZED)**. LEWELLYN TECHNOLOGY, INC., (U.S. CLS. 100, 101 AND 107). SN 85-003,028. PUB. 2-15-2011. FILED 3-31-2010.  
 3,953,709. **MIBS (STANDARD CHARACTER)**. MAKE IT BETTER LLC, (U.S. CLS. 100, 101 AND 107). SN 85-006,097. PUB. 2-15-2011. FILED 4-5-2010.  
 3,953,715 ( *See Class 9 for this trademark.*)  
 3,953,739. **MARKET STREET SALOON AND DESIGN**. SLAMMIN SAM, LLC, DBA MARKET STREET SALOON, MULTIPLE CLASS, (INT. CLS. 41 AND 43), (U.S. CLS. 100, 101 AND 107). SN 85-017,941. PUB. 2-15-2011. FILED 4-20-2010.  
 3,953,751. **HIDING BEHIND THE LIPSTICK (STANDARD CHARACTER)**. CHANEY, MYESHA T, (U.S. CLS. 100, 101 AND 107). SN 85-023,752. PUB. 2-15-2011. FILED 4-27-2010.  
 3,953,755. **NEW HAMPSHIRE WOMEN'S GOLF ASSOCIATION AND DESIGN**. NEW HAMPSHIRE WOMEN'S GOLF ASSOCIATION, (U.S. CLS. 100, 101 AND 107). SN 85-024,662. PUB. 2-15-2011. FILED 4-27-2010.  
 3,953,770 ( *See Class 35 for this trademark.*)  
 3,953,794. **SATTVA YOGA AND DESIGN**. MEHROTRA, ANAND, (U.S. CLS. 100, 101 AND 107). SN 85-036,376. PUB. 2-15-2011. FILED 5-12-2010.  
 3,953,805. **FREE TO BE ME! A YOUTH PROGRAM (STANDARD CHARACTER)**. ELYCE MONET, (U.S. CLS. 100, 101 AND 107). SN 85-038,823. PUB. 2-15-2011. FILED 5-14-2010.  
 3,953,806 ( *See Class 25 for this trademark.*)  
 3,953,810. **BIOSTIME AND DESIGN**. BIOSTIME, INC. (-GUANGZHOU), (U.S. CLS. 100, 101 AND 107). SN 85-039,531. PUB. 2-15-2011. FILED 5-15-2010.  
 3,953,812 ( *See Class 35 for this trademark.*)  
 3,953,818 ( *See Class 9 for this trademark.*)  
 3,953,830. **FRANKLIN FRANKLIN EDUCATIONAL SERVICES AND DESIGN**. FRANKLIN EDUCATIONAL SERVICES, INC., (U.S. CLS. 100, 101 AND 107). SN 85-046,661. PUB. 2-15-2011. FILED 5-24-2010.  
 3,953,839. **TRUST THE PHYSICS (STANDARD CHARACTER)**. MCCAUGHEY-RIVAS, MARIA, (U.S. CLS. 100, 101 AND 107). SN 85-050,161. PUB. 2-15-2011. FILED 5-28-2010.  
 3,953,849 ( *See Class 35 for this trademark.*)  
 3,953,853. **ED SLOTT'S MASTER ELITE IRA ADVISOR GROUP AND DESIGN**. SLOTT, EDWARD, (U.S. CLS. 100, 101 AND 107). SN 85-056,993. PUB. 2-15-2011. FILED 6-8-2010.  
 3,953,855 ( *See Class 36 for this trademark.*)  
 3,953,871. **NETERAL (STANDARD CHARACTER)**. NVP/UM, DBA NVP/UM, (U.S. CLS. 100, 101 AND 107). SN 85-061,083. PUB. 2-15-2011. FILED 6-11-2010.  
 3,953,872 ( *See Class 25 for this trademark.*)  
 3,953,883. **RIVER EAST CLUB (STANDARD CHARACTER)**. BALLY TOTAL FITNESS HOLDING CORPORATION, (U.S. CLS. 100, 101 AND 107). SN 85-065,193. PUB. 2-15-2011. FILED 6-17-2010.  
 3,953,888 ( *See Class 9 for this trademark.*)  
 3,953,894. **CLEAR PONG (STANDARD CHARACTER)**. CLEAR PONG, LLC, (U.S. CLS. 100, 101 AND 107). SN 85-069,081. PUB. 2-15-2011. FILED 6-22-2010.  
 3,953,895 ( *See Class 16 for this trademark.*)  
 3,953,901. **X-PLOSIVE FITNESS SPEED STRENGTH TRAINING (STYLIZED)**. LONNON, DARREN, (U.S. CLS. 100, 101 AND 107). SN 85-071,242. PUB. 2-15-2011. FILED 6-24-2010.  
 3,953,908. **LAUNCH ME (STANDARD CHARACTER)**. MARSHAWN EVANS UNLIMITED LLC (ME UNLIMITED), DBA ME UNLIMITED, (U.S. CLS. 100, 101 AND 107). SN 85-072,498. PUB. 2-15-2011. FILED 6-27-2010.  
 3,953,909. **REINVENT ME (STANDARD CHARACTER)**. MARSHAWN EVANS UNLIMITED LLC (ME UNLIMITED), DBA ME UNLIMITED, (U.S. CLS. 100, 101 AND 107). SN 85-072,507. PUB. 2-15-2011. FILED 6-27-2010.  
 3,953,916. **TO PROTECT AND SERVE (STANDARD CHARACTER)**. THE HEALTH & WELLNESS INSTITUTE, LLC, MULTIPLE CLASS, (INT. CLS. 41 AND 44), (U.S. CLS. 100, 101 AND 107). SN 85-073,775. PUB. 2-15-2011. FILED 6-29-2010.  
 3,953,919 ( *See Class 35 for this trademark.*)  
 3,953,924. **OUR CHANCE ENTERPRISE AND DESIGN**. OUR CHANCE ENTERPRISE INC., (U.S. CLS. 100, 101 AND 107). SN 85-076,639. PUB. 2-15-2011. FILED 7-2-2010.  
 3,953,933. **RUNWAY GAMES AND DESIGN**. LOYALTY PLAY HOLDINGS, (U.S. CLS. 100, 101 AND 107). SN 85-078,331. PUB. 2-15-2011. FILED 7-6-2010.  
 3,953,936. **BLUE COAT (STANDARD CHARACTER)**. BLUE COAT SYSTEMS, INC., MULTIPLE CLASS, (INT. CLS. 41 AND 42), (U.S. CLS. 100, 101 AND 107). SN 85-079,904. PUB. 11-9-2010. FILED 7-7-2010.  
 3,953,953. **FOCUSED EYE FILMS (STANDARD CHARACTER)**. FOCUSED EYE FILMS, LLC, (U.S. CLS. 100, 101 AND 107). SN 85-086,045. PUB. 2-15-2011. FILED 7-15-2010.  
 3,953,956 ( *See Class 35 for this trademark.*)  
 3,953,958. **RADIORADIO RR AND DESIGN**. RADIORADIO, LLC, (U.S. CLS. 100, 101 AND 107). SN 85-087,206. PUB. 2-15-2011. FILED 7-18-2010.  
 3,953,968. **THE NATIONAL HISPANIC UNIVERSITY (STANDARD CHARACTER)**. NATIONAL HISPANIC UNIVERSITY LLC, (U.S. CLS. 100, 101 AND 107). SN 85-090,533. PUB. 2-15-2011. FILED 7-22-2010.  
 3,953,979. **SIRIUS | XM FANTASY SPORTS RADIO AND DESIGN**. SIRIUS XM RADIO INC., (U.S. CLS. 100, 101 AND 107). SN 85-092,782. PUB. 2-15-2011. FILED 7-26-2010.  
 3,953,986 ( *See Class 9 for this trademark.*)  
 3,953,992 ( *See Class 38 for this trademark.*)  
 3,954,014. **CALIFORNIA HEARTLAND AND DESIGN**. KVIE, INC., (U.S. CLS. 100, 101 AND 107). SN 85-099,043. PUB. 2-15-2011. FILED 8-3-2010.  
 3,954,017. **SEPCON SPORT & EVENT PHOTOGRAPHERS CONFERENCE AND DESIGN**. ALLIANCE OF VISUAL ARTIST, DBA SOCIETY OF SPORT AND EVENT PHOTOGRAPHERS, (U.S. CLS. 100, 101 AND 107). SN 85-099,257. PUB. 2-15-2011. FILED 8-3-2010.  
 3,954,019. **...EVERYBODY WANTS TOBEADORED X (STANDARD CHARACTER)**. TOBEADORED LLC, (U.S. CLS. 100, 101 AND 107). SN 85-100,121. PUB. 2-15-2011. FILED 8-4-2010.  
 3,954,020 ( *See Class 9 for this trademark.*)  
 3,954,024. **PRESCHOOLGEMS (STANDARD CHARACTER)**. MCCOLLOM, LESLIE ALLISON, (U.S. CLS. 100, 101 AND 107). SN 85-101,361. PUB. 2-15-2011. FILED 8-5-2010.  
 3,954,026. **HONEST ENGINE FILMS (STANDARD CHARACTER)**. HONEST ENGINE FILMS, INC., (U.S. CLS. 100, 101 AND 107). SN 85-101,537. PUB. 2-15-2011. FILED 8-5-2010.  
 3,954,031. **THE DOG MENTOR (STANDARD CHARACTER)**. MACDONALD, REBECCA A, DBA THE DOG MENTOR, (U.S. CLS. 100, 101 AND 107). SN 85-102,401. PUB. 2-15-2011. FILED 8-6-2010.  
 3,954,035. **WHAT IT TAKES TO BE GREAT (STANDARD CHARACTER)**. MIA MATISSE, (U.S. CLS. 100, 101 AND 107). SN 85-103,638. PUB. 2-15-2011. FILED 8-9-2010.  
 3,954,045. **SHAPING THE FUTURE (STANDARD CHARACTER)**. CITY OF MANASSAS DEPARTMENT OF PARKS AND RECREATION, (U.S. CLS. 100, 101 AND 107). SN 85-104,968. PUB. 2-15-2011. FILED 8-11-2010.  
 3,954,052. **ACHIEVE BEYOND (STANDARD CHARACTER)**. BILINGUALS INC., MULTIPLE CLASS, (INT. CLS. 41 AND 44), (U.S. CLS. 100, 101 AND 107). SN 85-105,374. PUB. 2-15-2011. FILED 8-11-2010.  
 3,954,053. **THIS WEEK IN THOROUGHBRED RACING (TWITR) (STANDARD CHARACTER)**. RICHARDSON, CORNELL N., (U.S. CLS. 100, 101 AND 107). SN 85-105,428. PUB. 2-15-2011. FILED 8-11-2010.  
 3,954,055. **MB/MARCONI (STANDARD CHARACTER)**. MARCONI, BARRETTO, DBA MBMARCONI, (U.S. CLS. 100, 101 AND 107). SN 85-105,551. PUB. 2-15-2011. FILED 8-11-



- 2010.
- 3,954,063. **ESTRELLAS DE TUZANTLA (STANDARD CHARACTER)**. HERNANDEZ MORA, HECTOR, (U.S. CLS. 100, 101 AND 107). SN 85-106,522. PUB. 2-15-2011. FILED 8-12-2010.
- 3,954,064. **LONGEVITY NOW (STANDARD CHARACTER)**. NEW HORIZON HEALTH, INC., (U.S. CLS. 100, 101 AND 107). SN 85-106,721. PUB. 2-15-2011. FILED 8-13-2010.
- 3,954,070. **MANAGER'S MINDSET (STANDARD CHARACTER)**. GLOBAL NOVATIONS, LLC, (U.S. CLS. 100, 101 AND 107). SN 85-106,889. PUB. 2-15-2011. FILED 8-13-2010.
- 3,954,075. **NATIONAL COLLEGE FOR DUI DEFENSE (STANDARD CHARACTER)**. THE NATIONAL COLLEGE FOR DUI DEFENSE, INC., (U.S. CLS. 100, 101 AND 107). SN 85-107,154. PUB. 2-15-2011. FILED 8-13-2010.
- 3,954,077. **NATIONAL COLLEGE FOR DUI DEFENSE; MCMXCV AND DESIGN**. THE NATIONAL COLLEGE FOR DUI DEFENSE, INC., (U.S. CLS. 100, 101 AND 107). SN 85-107,196. PUB. 2-15-2011. FILED 8-13-2010.
- 3,954,089. **A PFENNIG FOR YOUR THOUGHTS (STANDARD CHARACTER)**. EVERBANK, (U.S. CLS. 100, 101 AND 107). SN 85-108,578. PUB. 2-15-2011. FILED 8-16-2010.
- 3,954,097 ( *See Class 25 for this trademark*).
- 3,954,100. **WONDER OF THE DAY (STANDARD CHARACTER)**. NATIONAL CENTER FOR FAMILY LITERACY, INC., (U.S. CLS. 100, 101 AND 107). SN 85-109,220. PUB. 2-15-2011. FILED 8-17-2010.
- 3,954,110. **HIGHERGLYPH (STANDARD CHARACTER)**. HILL, ARMANDO D., (U.S. CLS. 100, 101 AND 107). SN 85-109,931. PUB. 2-15-2011. FILED 8-18-2010.
- 3,954,116. **TOTAL ANIMAL TRAINING (STANDARD CHARACTER)**. FORENCICH, FRANK, (U.S. CLS. 100, 101 AND 107). SN 85-110,505. PUB. 2-15-2011. FILED 8-18-2010.
- 3,954,122. **ATTORNEY CREDITS CLE YOUR WAY AND DESIGN**. ONLINE EDUCATION, INC., (U.S. CLS. 100, 101 AND 107). SN 85-110,751. PUB. 2-15-2011. FILED 8-18-2010.
- 3,954,129. **MIXEMWELL PRODUCTIONS AND DESIGN**. MIXEMWELL PRODUCTION, (U.S. CLS. 100, 101 AND 107). SN 85-111,109. PUB. 2-15-2011. FILED 8-19-2010.
- 3,954,134 ( *See Class 16 for this trademark*).
- 3,954,140 ( *See Class 16 for this trademark*).
- 3,954,142. **CUTTING EDGE LAW (STANDARD CHARACTER)**. J. KIM WRIGHT, (U.S. CLS. 100, 101 AND 107). SN 85-111,568. PUB. 2-15-2011. FILED 8-19-2010.
- 3,954,151. **ART 2 RIDE AND DESIGN**. LOSHBAUGH, KAREN E, DBA ART2RIDE, ART 2 RIDE, (U.S. CLS. 100, 101 AND 107). SN 85-111,837. PUB. 2-15-2011. FILED 8-19-2010.
- 3,954,152 ( *See Class 38 for this trademark*).
- 3,954,161. **NAEMT (STANDARD CHARACTER)**. NATIONAL ASSOCIATION OF EMERGENCY MEDICAL TECHNICIANS, AKA NAEMT, (U.S. CLS. 100, 101 AND 107). SN 85-112,364. PUB. 2-15-2011. FILED 8-20-2010.
- 3,954,163. **NATIONAL BOARD FOR COLON HYDROTHERAPY NBCHT AND DESIGN**. INTERNATIONAL ASSOCIATION FOR COLON HYDROTHERAPY, MULTIPLE CLASS, (INT. CLS. 41 AND 44), (U.S. CLS. 100, 101 AND 107). SN 85-112,474. PUB. 2-15-2011. FILED 8-20-2010.
- 3,954,184. **THE HOLE IN THE WALL GANG CAMP AND DESIGN**. THE HOLE IN THE WALL GANG FUND, INC., AKA THE HOLE IN THE WALL GANG CAMP, (U.S. CLS. 100, 101 AND 107). SN 85-113,627. PUB. 2-15-2011. FILED 8-23-2010.
- 3,954,190. **ACT SOLUTIONS (STYLIZED)**. AUTO CREDIT TRAINING SOLUTIONS, LLC, (U.S. CLS. 100, 101 AND 107). SN 85-113,852. PUB. 2-15-2011. FILED 8-23-2010.
- 3,954,194. **THE LUMINARY SHEDS LIGHT AND DESIGN**. SENATOR PUBLISHING, (U.S. CLS. 100, 101 AND 107). SN 85-114,009. PUB. 2-15-2011. FILED 8-23-2010.
- 3,954,203. **KINKYGFS (STANDARD CHARACTER)**. NARAJOA, LTD., (U.S. CLS. 100, 101 AND 107). SN 85-114,241. PUB. 2-15-2011. FILED 8-24-2010.
- 3,954,217 ( *See Class 16 for this trademark*).
- 3,954,225. **THE STANHOPE HOUSE THE LAST GREAT AMERICAN ROADHOUSE AND DESIGN**. JMK HOSPITALITY GROUP, LLC, MULTIPLE CLASS, (INT. CLS. 41 AND 43), (U.S. CLS. 100, 101 AND 107). SN 85-114,727. PUB. 2-15-2011. FILED 8-24-2010.
- 3,954,226. **TCHAD (STANDARD CHARACTER)**. TCHAD, (U.S. CLS. 100, 101 AND 107). SN 85-114,757. PUB. 2-15-2011. FILED 8-24-2010.
- 3,954,234. **OUT IN PUBLIC (STANDARD CHARACTER)**. GRHK IP, LLC, (U.S. CLS. 100, 101 AND 107). SN 85-114,894. PUB. 2-15-2011. FILED 8-24-2010.
- 3,954,239. **DESIGNS BY JK PHOTOGRAPHY (STYLIZED)**. KEITT, JONATHAN L., (U.S. CLS. 100, 101 AND 107). SN 85-115,000. PUB. 2-15-2011. FILED 8-24-2010.
- 3,954,252. **NLDC (STANDARD CHARACTER)**. JAMES R. BOWES, JR., (U.S. CLS. 100, 101 AND 107). SN 85-115,216. PUB. 2-15-2011. FILED 8-25-2010.
- 3,954,256. **HIP HOP MUSIC BUZZ AND DESIGN**. MUSIC BIZ BUZZ, MULTIPLE CLASS, (INT. CLS. 41 AND 45), (U.S. CLS. 100, 101 AND 107). SN 85-115,229. PUB. 2-15-2011. FILED 8-25-2010.
- 3,954,259. **REACHING THE WORLD FOR CHRIST . . . ONE CHILD AT A TIME (STANDARD CHARACTER)**. ACCELERATED CHRISTIAN EDUCATION, INC., (U.S. CLS. 100, 101 AND 107). SN 85-115,333. PUB. 2-15-2011. FILED 8-25-2010.
- 3,954,260. **MISCELLANEOUS DESIGN**. LEADERSHIP FAIR-FAX, INC., (U.S. CLS. 100, 101 AND 107). SN 85-115,335. PUB. 2-15-2011. FILED 8-25-2010.
- 3,954,264. **MMI MASTER MALE ILLUSIONIST AND DESIGN**. MASTER MALE ILLUSIONIST, LLC, (U.S. CLS. 100, 101 AND 107). SN 85-115,485. PUB. 2-15-2011. FILED 8-25-2010.
- 3,954,265. **TERPSIXORIANS HELLENIC DANCE GROUP OF NEW JERSEY 1994 AND DESIGN**. TERPSIXORIANS - HELLENIC DANCE GROUP OF NEW JERSEY, (U.S. CLS. 100, 101 AND 107). SN 85-115,522. PUB. 2-15-2011. FILED 8-25-2010.
- 3,954,267. **WONDER JAM (STANDARD CHARACTER)**. PREMIER PRODUCTIONS, INC., (U.S. CLS. 100, 101 AND 107). SN 85-115,568. PUB. 2-15-2011. FILED 8-25-2010.
- 3,954,270. **ED GURUKUL (STANDARD CHARACTER)**. TRISRI GLOBAL, INC., DBA ED GURUKUL, (U.S. CLS. 100, 101 AND 107). SN 85-115,657. PUB. 2-15-2011. FILED 8-25-2010.
- 3,954,277. **BOYD GAMING'S DELTA PRINCESS (STANDARD CHARACTER)**. BOYD GAMING CORPORATION, (U.S. CLS. 100, 101 AND 107). SN 85-115,833. PUB. 2-15-2011. FILED 8-25-2010.
- 3,954,281. **BOYD GAMING'S DELTA JACKPOT (STANDARD CHARACTER)**. BOYD GAMING CORPORATION, (U.S. CLS. 100, 101 AND 107). SN 85-115,919. PUB. 2-15-2011. FILED 8-25-2010.
- 3,954,294. **THREE CHIMNEYS (STANDARD CHARACTER)**. THREE CHIMNEYS FARM, LLC, MULTIPLE CLASS, (INT. CLS. 41 AND 44), (U.S. CLS. 100, 101 AND 107). SN 85-116,196. PUB. 2-15-2011. FILED 8-26-2010.
- 3,954,300 ( *See Class 16 for this trademark*).
- 3,954,303. **SMART WOMEN AND THEIR MONEY (STANDARD CHARACTER)**. TERESA JALBERT, (U.S. CLS. 100, 101 AND 107). SN 85-116,312. PUB. 2-15-2011. FILED 8-26-2010.
- 3,954,306. **NATIONAL HARD CRAB DERBY (STANDARD CHARACTER)**. CRISFIELD AREA CHAMBER OF COMMERCE, INC., (U.S. CLS. 100, 101 AND 107). SN 85-116,348. PUB. 2-15-2011. FILED 8-26-2010.
- 3,954,318. **CHACHERSIZE! AND DESIGN**. JABEZ COMMUNICATIONS, LLC, (U.S. CLS. 100, 101 AND 107). SN 85-116,529. PUB. 2-15-2011. FILED 8-26-2010.
- 3,954,323. **NFW (STANDARD CHARACTER)**. GIGLIO, EVERETT JR., (U.S. CLS. 100, 101 AND 107). SN 85-116,647. PUB. 2-15-2011. FILED 8-26-2010.
- 3,954,333. **BUSINESS BLACK BELT (STANDARD CHARACTER)**. BURKE FRANKLIN, (U.S. CLS. 100, 101 AND 107). SN 85-116,878. PUB. 2-15-2011. FILED 8-26-2010.
- 3,954,342. **CREATIVE LEARNING INSTITUTE (STANDARD CHARACTER)**. CRYSTAL CRUISES, INC., (U.S. CLS. 100, 101 AND 107). SN 85-117,012. PUB. 2-15-2011. FILED 8-26-2010.
- 3,954,350. **PROJECT MANAGEMENT THAT WORKS! (STANDARD CHARACTER)**. MORRIS, RICK, (U.S. CLS. 100, 101 AND 107). SN 85-117,128. PUB. 2-15-2011. FILED 8-27-2010.
- 3,954,354. **LOS TERRIBLES DEL NORTE (STANDARD CHARACTER)**. MENDEZ, BENEDICTO, (U.S. CLS. 100, 101 AND 107). SN 85-117,164. PUB. 2-15-2011. FILED 8-27-2010.
- 3,954,356. **EVERY MINUTE OF EVERYDAY YOU HAVE A**

- CHOICE BETWEEN THE (I) OR THE (A) YOU CAN BE FIT OR YOU CAN BE FAT (STANDARD CHARACTER).** TUCKER, ALFRED J., (U.S. CLS. 100, 101 AND 107). SN 85-117,204. PUB. 2-15-2011. FILED 8-27-2010.
- 3,954,361. **INDIANAPOLIS RACERS (STANDARD CHARACTER).** INDIANAPOLIS YOUTH HOCKEY ASSOCIATION, (U.S. CLS. 100, 101 AND 107). SN 85-117,254. PUB. 2-15-2011. FILED 8-27-2010.
- 3,954,383. **GAITS OF CHANGE AND DESIGN.** GAITS OF CHANGE, (U.S. CLS. 100, 101 AND 107). SN 85-117,491. PUB. 2-15-2011. FILED 8-27-2010.
- 3,954,388. **ADVENTUROUS AGING (STANDARD CHARACTER).** KELLEY, E.S., DBA ADVENTUROUS AGING, (U.S. CLS. 100, 101 AND 107). SN 85-117,612. PUB. 2-15-2011. FILED 8-27-2010.
- 3,954,397. **LIGHTNING MEDIA (STANDARD CHARACTER).** MRG ENTERTAINMENT, INC., (U.S. CLS. 100, 101 AND 107). SN 85-117,783. PUB. 2-15-2011. FILED 8-27-2010.
- 3,954,403. **GO! ST. LOUIS (STANDARD CHARACTER).** GO! ST. LOUIS, (U.S. CLS. 100, 101 AND 107). SN 85-117,872. PUB. 2-15-2011. FILED 8-27-2010.
- 3,954,404. **ONE LIFE JUVENILE DIVERSION PROGRAM AND DESIGN.** ONE LIFE (JUVENILE DIVERSION PROGRAM), (U.S. CLS. 100, 101 AND 107). SN 85-117,873. PUB. 2-15-2011. FILED 8-27-2010.
- 3,954,405. **ONE LIFE JUVENILE DIVERSION PROGRAM (STANDARD CHARACTER).** ONE LIFE (JUVENILE DIVERSION PROGRAM), (U.S. CLS. 100, 101 AND 107). SN 85-117,874. PUB. 2-15-2011. FILED 8-27-2010.
- 3,954,406. **TO INFORM TO EDUCATE TO ENCOURAGE (STANDARD CHARACTER).** ONE LIFE (JUVENILE DIVERSION PROGRAM), (U.S. CLS. 100, 101 AND 107). SN 85-117,876. PUB. 2-15-2011. FILED 8-27-2010.
- 3,954,418. **EMPOWERED DESTINATIONS (STANDARD CHARACTER).** THE SLATER GROUP, LLC, (U.S. CLS. 100, 101 AND 107). SN 85-118,118. PUB. 2-15-2011. FILED 8-28-2010.
- 3,954,420. **TECHNICAL JESUS (STANDARD CHARACTER).** LEDFORD, JAMES MCLEAN, (U.S. CLS. 100, 101 AND 107). SN 85-118,138. PUB. 2-15-2011. FILED 8-28-2010.
- 3,954,423. **THE IMPROV EFFECT AND DESIGN.** SHTERNSHUS, JESSICA C., DBA THE IMPROV EFFECT, (U.S. CLS. 100, 101 AND 107). SN 85-118,165. PUB. 2-15-2011. FILED 8-28-2010.
- 3,954,439. **HAUTE HOSTESS (STANDARD CHARACTER).** HAUTE HOSTESS LLC, (U.S. CLS. 100, 101 AND 107). SN 85-118,386. PUB. 2-15-2011. FILED 8-30-2010.
- 3,954,446. **LAUGHLETICS (STANDARD CHARACTER).** SORREL, JAMES P., (U.S. CLS. 100, 101 AND 107). SN 85-118,442. PUB. 2-15-2011. FILED 8-30-2010.
- 3,954,463. **BLACKWATER REFUGEES (STYLIZED).** NATHAN KELLENBENZ, (U.S. CLS. 100, 101 AND 107). SN 85-118,580. PUB. 2-15-2011. FILED 8-30-2010.
- 3,954,464. **TEMPTING FATE (STANDARD CHARACTER).** BEECHER, CORY, (U.S. CLS. 100, 101 AND 107). SN 85-118,583. PUB. 2-15-2011. FILED 8-30-2010.
- 3,954,475. **INSTANT INVESTOR (STANDARD CHARACTER).** INSTANT INVESTOR, LLC, (U.S. CLS. 100, 101 AND 107). SN 85-118,679. PUB. 2-15-2011. FILED 8-30-2010.
- 3,954,481. **PURPLE RAIN (STANDARD CHARACTER).** PURPLE RAIN, LLC, MULTIPLE CLASS, (INT. CLS. 41 AND 43), (U.S. CLS. 100, 101 AND 107). SN 85-118,704. PUB. 2-15-2011. FILED 8-30-2010.
- 3,954,487. **HANABI PHOTOGRAPHY AND DESIGN.** BAVAR, JANNA W., DBA HANABI PHOTOGRAPHY, (U.S. CLS. 100, 101 AND 107). SN 85-118,774. PUB. 2-15-2011. FILED 8-30-2010.
- 3,954,488. **P R AND DESIGN.** PURPLE RAIN, LLC, MULTIPLE CLASS, (INT. CLS. 41 AND 43), (U.S. CLS. 100, 101 AND 107). SN 85-118,799. PUB. 2-15-2011. FILED 8-30-2010.
- 3,954,490 ( *See Class 35 for this trademark*).
- 3,954,494. **ROCKSTAR CHEER (STANDARD CHARACTER).** ROCKSTAR CHEER & DANCE, INC., (U.S. CLS. 100, 101 AND 107). SN 85-118,829. PUB. 2-15-2011. FILED 8-30-2010.
- 3,954,495. **NEA ACADEMY (STANDARD CHARACTER).** NEA'S MEMBER BENEFITS CORPORATION, (U.S. CLS. 100, 101 AND 107). SN 85-118,842. PUB. 2-15-2011. FILED 8-30-2010.
- 3,954,501. **DELTA DIVERSE EDUCATIONAL LEADERSHIP TRAINING ACADEMY AND DESIGN.** MELISSA MAHAN, (U.S. CLS. 100, 101 AND 107). SN 85-118,891. PUB. 2-15-2011. FILED 8-30-2010.
- 3,954,520. **EXPERIENCE 9 TO 5 (STANDARD CHARACTER).** ADAMS COUNTY EDUCATION CONSORTIUM, (U.S. CLS. 100, 101 AND 107). SN 85-119,129. PUB. 2-15-2011. FILED 8-30-2010.
- 3,954,538. **THE LABORING OAR (STANDARD CHARACTER).** RUTTER HOBBS & DAVIDOFF INCORPORATED, (U.S. CLS. 100, 101 AND 107). SN 85-119,299. PUB. 2-15-2011. FILED 8-30-2010.
- 3,954,551. **COLOR WHEEL (STANDARD CHARACTER).** CATHERINE SPENCER, (U.S. CLS. 100, 101 AND 107). SN 85-119,422. PUB. 2-15-2011. FILED 8-31-2010.
- 3,954,559. **FORUM 2.0 (STANDARD CHARACTER).** FORUM-SHERPA, INC., (U.S. CLS. 100, 101 AND 107). SN 85-119,556. PUB. 2-15-2011. FILED 8-31-2010.
- 3,954,566. **COME BACK TO WILDLIFE. (STANDARD CHARACTER).** WILDLIFE CONSERVATION SOCIETY, (U.S. CLS. 100, 101 AND 107). SN 85-119,656. PUB. 2-15-2011. FILED 8-31-2010.
- 3,954,567. **VASHON ISLAND STRAWBERRY FESTIVAL (STANDARD CHARACTER).** VASHON-MAURY ISLAND CHAMBER OF COMMERCE, (U.S. CLS. 100, 101 AND 107). SN 85-119,668. PUB. 2-15-2011. FILED 8-31-2010.
- 3,954,574. **MINDFULNESS AT WORK (STANDARD CHARACTER).** EMINDFUL INC., (U.S. CLS. 100, 101 AND 107). SN 85-119,716. PUB. 2-15-2011. FILED 8-31-2010.
- 3,954,587. **H + SUMMIT (STANDARD CHARACTER).** WORLD TRANSHUMANIST ASSOCIATION, INC., DBA HUMANITY+, (U.S. CLS. 100, 101 AND 107). SN 85-119,869. PUB. 2-15-2011. FILED 8-31-2010.
- 3,954,600. **SOAR + EXPLORE (STANDARD CHARACTER).** ATTRACTIONS MANAGEMENT, INC., (U.S. CLS. 100, 101 AND 107). SN 85-119,992. PUB. 2-15-2011. FILED 8-31-2010.
- 3,954,603. **JEN AND BARB MOM LIFE (STANDARD CHARACTER).** BROADBAND ENTERPRISES, INC., (U.S. CLS. 100, 101 AND 107). SN 85-120,074. PUB. 2-15-2011. FILED 8-31-2010.
- 3,954,617 ( *See Class 35 for this trademark*).
- 3,954,619. **GAYROOM (STANDARD CHARACTER).** SSC GROUP, LLC, (U.S. CLS. 100, 101 AND 107). SN 85-120,222. PUB. 2-15-2011. FILED 8-31-2010.
- 3,954,627 ( *See Class 35 for this trademark*).
- 3,954,628. **SPARK & HUSTLE (STANDARD CHARACTER).** TORY JOHNSON PRODUCTIONS, (U.S. CLS. 100, 101 AND 107). SN 85-120,318. PUB. 2-15-2011. FILED 8-31-2010.
- 3,954,630. **CAMBY ROAD (STANDARD CHARACTER).** CASIDY, JENNIFER LYNN, (U.S. CLS. 100, 101 AND 107). SN 85-120,362. PUB. 2-15-2011. FILED 8-31-2010.
- 3,954,643. **GREEK YEARBOOK (STANDARD CHARACTER).** GREEK YEARBOOK LLC, (U.S. CLS. 100, 101 AND 107). SN 85-120,527. PUB. 2-15-2011. FILED 9-1-2010.
- 3,954,648. **MAKE MUSIC WITH DADDY'S (STANDARD CHARACTER).** DADDY'S JUNKY MUSIC STORES, INC., (U.S. CLS. 100, 101 AND 107). SN 85-120,591. PUB. 2-15-2011. FILED 9-1-2010.
- 3,954,661. **DP MRL (STANDARD CHARACTER).** MUNRO & ASSOCIATES, INC., (U.S. CLS. 100, 101 AND 107). SN 85-120,690. PUB. 2-15-2011. FILED 9-1-2010.
- 3,954,669. **B & B THEATRES (STANDARD CHARACTER).** B & B THEATRES OPERATING COMPANY, INC., (U.S. CLS. 100, 101 AND 107). SN 85-120,739. PUB. 2-15-2011. FILED 9-1-2010.
- 3,954,672. **STEAKBYTES (STANDARD CHARACTER).** OMAHA STEAKS INTERNATIONAL, INC., (U.S. CLS. 100, 101 AND 107). SN 85-120,764. PUB. 2-15-2011. FILED 9-1-2010.
- 3,954,676. **ROCK CHEER AND DESIGN.** ROCKSTAR CHEER & DANCE, INC., (U.S. CLS. 100, 101 AND 107). SN 85-120,782. PUB. 2-15-2011. FILED 9-1-2010.
- 3,954,677. **RAILTRENDS (STANDARD CHARACTER).** TRADE PRESS MEDIA GROUP, INC., (U.S. CLS. 100, 101 AND 107). SN 85-120,784. PUB. 2-15-2011. FILED 9-1-2010.
- 3,954,680. **LIVE NATION ENTERTAINMENT (STANDARD CHARACTER).** LIVE NATION ENTERTAINMENT, INC., (U.S. CLS. 100, 101 AND 107). SN 85-120,799. PUB. 2-15-2011. FILED 9-1-2010.

- 3,954,693. **TICKETWEB (STYLIZED)**. LIVE NATION ENTERTAINMENT, INC., (U.S. CLS. 100, 101 AND 107). SN 85-120,904. PUB. 2-15-2011. FILED 9-1-2010.
- 3,954,699. **CAPITOL VIEW (STANDARD CHARACTER)**. MINNESOTA PUBLIC RADIO, (U.S. CLS. 100, 101 AND 107). SN 85-120,944. PUB. 2-15-2011. FILED 9-1-2010.
- 3,954,700. **AURA & VANITY (STANDARD CHARACTER)**. JOSHUA CHAVEZ, (U.S. CLS. 100, 101 AND 107). SN 85-120,955. PUB. 2-15-2011. FILED 9-1-2010.
- 3,954,722. **FAITHFUL WITH FINANCES (STANDARD CHARACTER)**. SPM MARKETING, INC., (U.S. CLS. 100, 101 AND 107). SN 85-121,270. PUB. 2-15-2011. FILED 9-1-2010.
- 3,954,723 ( *See Class 9 for this trademark*).
- 3,954,732. **DO YOU HA (STANDARD CHARACTER)**. WORLD OF HA, LLC, (U.S. CLS. 100, 101 AND 107). SN 85-121,469. PUB. 2-15-2011. FILED 9-2-2010.
- 3,954,739. **TFO TAKEN FLIGHT OUTDOORS 2009-3-16 AND DESIGN**. TAKEN FLIGHT OUTDOORS, INC., (U.S. CLS. 100, 101 AND 107). SN 85-121,587. PUB. 2-15-2011. FILED 9-2-2010.
- 3,954,740. **KOMPUTROL (STANDARD CHARACTER)**. A E BOYCE COMPANY, INC., (U.S. CLS. 100, 101 AND 107). SN 85-121,593. PUB. 2-15-2011. FILED 9-2-2010.
- 3,954,746. **TREVIAN ACADEMY (STANDARD CHARACTER)**. TREVIAN SOCCER CLUB, (U.S. CLS. 100, 101 AND 107). SN 85-121,641. PUB. 2-15-2011. FILED 9-2-2010.
- 3,954,747. **TREVIAN SOCCER CLUB (STANDARD CHARACTER)**. TREVIAN SOCCER CLUB, (U.S. CLS. 100, 101 AND 107). SN 85-121,650. PUB. 2-15-2011. FILED 9-2-2010.
- 3,954,761. **SMART FISH SWIM IN SCHOOLS (STANDARD CHARACTER)**. SWIMTASTIC SWIM SCHOOL, INC., (U.S. CLS. 100, 101 AND 107). SN 85-121,817. PUB. 2-15-2011. FILED 9-2-2010.
- 3,954,765 ( *See Class 25 for this trademark*).
- 3,954,771. **IT'S ALL ABOUT THE A AND DESIGN**. COLORADO AVALANCHE, LLC, (U.S. CLS. 100, 101 AND 107). SN 85-121,904. PUB. 2-15-2011. FILED 9-2-2010.
- 3,954,773. **AQUABELLY (STANDARD CHARACTER)**. AQUABELLY, INC., (U.S. CLS. 100, 101 AND 107). SN 85-121,916. PUB. 2-15-2011. FILED 9-2-2010.
- 3,954,777. **CRAZY ASS (STANDARD CHARACTER)**. REAL PLANET ENTERTAINMENT, INC., (U.S. CLS. 100, 101 AND 107). SN 85-121,930. PUB. 2-15-2011. FILED 9-2-2010.
- 3,954,778. **CARROTS 'N' CAKE (STANDARD CHARACTER)**. HAUPERT, CHRISTINA, (U.S. CLS. 100, 101 AND 107). SN 85-121,943. PUB. 2-15-2011. FILED 9-2-2010.
- 3,954,779 ( *See Class 16 for this trademark*).
- 3,954,780. **THINKPODIUM (STANDARD CHARACTER)**. GRAHAM & ASSOCIATES, INC., (U.S. CLS. 100, 101 AND 107). SN 85-121,981. PUB. 2-15-2011. FILED 9-2-2010.
- 3,954,784. **ISTE LEARNING (STANDARD CHARACTER)**. INTERNATIONAL SOCIETY FOR TECHNOLOGY IN EDUCATION, INC., (U.S. CLS. 100, 101 AND 107). SN 85-122,043. PUB. 2-15-2011. FILED 9-2-2010.
- 3,954,786. **90 ACRE FARM (STANDARD CHARACTER)**. WHITE, WILLIAM T., (U.S. CLS. 100, 101 AND 107). SN 85-122,064. PUB. 2-15-2011. FILED 9-2-2010.
- 3,954,794. **SEED SURVIVOR (STANDARD CHARACTER)**. AGRIMUM INC., (U.S. CLS. 100, 101 AND 107). SN 85-122,157. PUB. 2-15-2011. FILED 9-2-2010.
- 3,954,795. **FREAKONOMICS (STANDARD CHARACTER)**. FREAKONOMICS, LLC, (U.S. CLS. 100, 101 AND 107). SN 85-122,160. PUB. 2-15-2011. FILED 9-2-2010.
- 3,954,802. **METMAX MOVEMENTS (STANDARD CHARACTER)**. BODY SOLUTIONS, INC., (U.S. CLS. 100, 101 AND 107). SN 85-122,238. PUB. 2-15-2011. FILED 9-2-2010.
- 3,954,803. **TICKET TO RIDE (STANDARD CHARACTER)**. JEFF TOCZYNSKI, (U.S. CLS. 100, 101 AND 107). SN 85-122,239. PUB. 2-15-2011. FILED 9-2-2010.
- 3,954,816. **HYPERACTIVISTS (STANDARD CHARACTER)**. CITYLAB, LLC, (U.S. CLS. 100, 101 AND 107). SN 85-122,428. PUB. 2-15-2011. FILED 9-3-2010.
- 3,954,827. **CRAZY, NUTS, YOU BETCHA! (STANDARD CHARACTER)**. PFIP, LLC, (U.S. CLS. 100, 101 AND 107). SN 85-122,593. PUB. 2-15-2011. FILED 9-3-2010.
- 3,954,831. **POLISHED PRODUCTIONS (STANDARD CHARACTER)**. BEALS, JOHANNES, (U.S. CLS. 100, 101 AND 107). SN 85-122,653. PUB. 2-15-2011. FILED 9-3-2010.
- 3,954,834. **BELIEVE IT! (STANDARD CHARACTER)**. PFIP, LLC, (U.S. CLS. 100, 101 AND 107). SN 85-122,696. PUB. 2-15-2011. FILED 9-3-2010.
- 3,954,836. **BELIEVE THE HYPE! (STANDARD CHARACTER)**. PFIP, LLC, (U.S. CLS. 100, 101 AND 107). SN 85-122,715. PUB. 2-15-2011. FILED 9-3-2010.
- 3,954,837. **NO COMMITMENT! (STANDARD CHARACTER)**. PFIP, LLC, (U.S. CLS. 100, 101 AND 107). SN 85-122,720. PUB. 2-15-2011. FILED 9-3-2010.
- 3,954,839. **REVERSE ORDER (STANDARD CHARACTER)**. CINDY RUSSO, DBA REVERSE ORDER, (U.S. CLS. 100, 101 AND 107). SN 85-122,729. PUB. 2-15-2011. FILED 9-3-2010.
- 3,954,840. **NO COMMITMENT! NO KIDDING! (STANDARD CHARACTER)**. PFIP, LLC, (U.S. CLS. 100, 101 AND 107). SN 85-122,736. PUB. 2-15-2011. FILED 9-3-2010.
- 3,954,845. **WHO CARES ABOUT STATUS? (STANDARD CHARACTER)**. PFIP, LLC, (U.S. CLS. 100, 101 AND 107). SN 85-122,761. PUB. 2-15-2011. FILED 9-3-2010.
- 3,954,847. **NEW NAME - NEW ATMOSPHERE - NO ATTITUDE (STANDARD CHARACTER)**. PFIP, LLC, (U.S. CLS. 100, 101 AND 107). SN 85-122,788. PUB. 2-15-2011. FILED 9-3-2010.
- 3,954,849. **ZERO - ZIP - ZILCH (STANDARD CHARACTER)**. PFIP, LLC, (U.S. CLS. 100, 101 AND 107). SN 85-122,804. PUB. 2-15-2011. FILED 9-3-2010.
- 3,954,850. **NO SALESMEN - NO COMMITMENT - NO KIDDING (STANDARD CHARACTER)**. PFIP, LLC, (U.S. CLS. 100, 101 AND 107). SN 85-122,811. PUB. 2-15-2011. FILED 9-3-2010.
- 3,954,862. **STRENGTHENING THE CORE (STANDARD CHARACTER)**. CHAYES, MICHAEL M., (U.S. CLS. 100, 101 AND 107). SN 85-122,967. PUB. 2-15-2011. FILED 9-3-2010.
- 3,954,866. **LIFEFLOW (STANDARD CHARACTER)**. MIND & BODY RESEARCH LTD., (U.S. CLS. 100, 101 AND 107). SN 85-122,984. PUB. 2-15-2011. FILED 9-3-2010.
- 3,954,879. **REMEMBER WHO YOU ARE (STANDARD CHARACTER)**. RODGER, KATE, (U.S. CLS. 100, 101 AND 107). SN 85-123,179. PUB. 2-15-2011. FILED 9-3-2010.
- 3,954,881. **SIMFEST (STANDARD CHARACTER)**. ST. LUKE'S REGIONAL MEDICAL CENTER, LTD., AKA ST. LUKE'S, (U.S. CLS. 100, 101 AND 107). SN 85-123,268. PUB. 2-15-2011. FILED 9-3-2010.
- 3,954,885. **ADAPTIVE INQUIRY (STANDARD CHARACTER)**. STRATEGIC LEADERSHIP RESOURCES, LLC, AKA SLR, (U.S. CLS. 100, 101 AND 107). SN 85-123,301. PUB. 2-15-2011. FILED 9-3-2010.
- 3,954,892. **INSURE YOUR STORY (STANDARD CHARACTER)**. THE FINAL DRAFT WRITING SERVICES, (U.S. CLS. 100, 101 AND 107). SN 85-123,341. PUB. 2-15-2011. FILED 9-4-2010.
- 3,954,896. **THEKIDSAREONFIRE (STANDARD CHARACTER)**. GAVILLET, ELIZABETH, (U.S. CLS. 100, 101 AND 107). SN 85-123,432. PUB. 2-15-2011. FILED 9-5-2010.
- 3,954,899. **OH MY GOODNESS (STANDARD CHARACTER)**. WORKMAN, TANYA THERESE, (U.S. CLS. 100, 101 AND 107). SN 85-123,476. PUB. 2-15-2011. FILED 9-5-2010.
- 3,954,900. **PLANET NUTSHELL (STANDARD CHARACTER)**. GUNN, JOSHUA R, DBA PLANET NUTSHELL, (U.S. CLS. 100, 101 AND 107). SN 85-123,546. PUB. 2-15-2011. FILED 9-6-2010.
- 3,954,923. **FREE YOUR SOUL (STANDARD CHARACTER)**. ZIMMER, PAMELA, (U.S. CLS. 100, 101 AND 107). SN 85-124,148. PUB. 2-15-2011. FILED 9-7-2010.
- 3,954,927. **BIOCITIZEN (STANDARD CHARACTER)**. HEIDINGER, KURT, (U.S. CLS. 100, 101 AND 107). SN 85-124,225. PUB. 2-15-2011. FILED 9-7-2010.
- 3,954,934. **STRIKECITY AND DESIGN**. TMTD, LLC, MULTIPLE CLASS, (INT. CLS. 41 AND 43), (U.S. CLS. 100, 101 AND 107). SN 85-124,390. PUB. 2-15-2011. FILED 9-7-2010.
- 3,954,937. **SOMATIC CONSENSUS (STANDARD CHARACTER)**. WEINSTOCK, DAVID KERRY, DBA LIMINAL SOMATICS, (U.S. CLS. 100, 101 AND 107). SN 85-124,476. PUB. 2-15-2011. FILED 9-7-2010.
- 3,954,943 ( *See Class 35 for this trademark*).
- 3,954,961. **WEDD NG REPUB C II (STYLIZED)**. REPUBLIC INC., DBA WEDDING REPUBLIC, (U.S. CLS. 100, 101 AND

107). SN 85-126,438. PUB. 2-15-2011. FILED 9-9-2010.

3,954,987. **THE GREAT FACE RACE (STANDARD CHARACTER)**. JANI BRYSON STUDIOS, INC., (U.S. CLS. 100, 101 AND 107). SN 85-129,714. PUB. 2-15-2011. FILED 9-14-2010.

3,954,988. **ATW'S SKYPATHS (STANDARD CHARACTER)**. PENTON MEDIA, INC., (U.S. CLS. 100, 101 AND 107). SN 85-129,822. PUB. 2-15-2011. FILED 9-15-2010.

3,954,990. **WORDSRU WE EDIT - YOU TAKE THE CREDIT (STANDARD CHARACTER)**. WORDSRU PTY LTD, (U.S. CLS. 100, 101 AND 107). SN 85-130,474. PUB. 2-15-2011. FILED 9-15-2010.

3,954,993. **SHILOH COUNTRY (STANDARD CHARACTER)**. MITCHELL, REX, (U.S. CLS. 100, 101 AND 107). SN 85-130,711. PUB. 2-15-2011. FILED 9-15-2010.

3,954,995. **SAN JOSE SABERCATS (STANDARD CHARACTER)**. ARENA FOOTBALL ONE, LLC, AKA AFL, (U.S. CLS. 100, 101 AND 107). SN 85-131,155. PUB. 2-15-2011. FILED 9-16-2010.

3,955,009. **SOLO FITNESS (STANDARD CHARACTER)**. HOFFMAN, LISA, DBA SOLO FITNESS, MULTIPLE CLASS, (INT. CLS. 41 AND 44), (U.S. CLS. 100, 101 AND 107). SN 85-133,235. PUB. 2-15-2011. FILED 9-20-2010.

3,955,013. **NICK 13 (STANDARD CHARACTER)**. JONES, K. NICK, AKA NICK 13, (U.S. CLS. 100, 101 AND 107). SN 85-133,742. PUB. 2-15-2011. FILED 9-20-2010.

3,955,021 ( *See Class 35 for this trademark*).

3,955,022 ( *See Class 9 for this trademark*).

3,955,035. **NCIS (STANDARD CHARACTER)**. CBS STUDIOS INC., (U.S. CLS. 100, 101 AND 107). SN 85-137,915. PUB. 2-15-2011. FILED 9-24-2010.

3,955,037. **TEACHING 21ST CENTURY KIDS (STANDARD CHARACTER)**. O'SULLIVAN, PATRICIA A., (U.S. CLS. 100, 101 AND 107). SN 85-138,071. PUB. 2-15-2011. FILED 9-24-2010.

3,955,061 ( *See Class 9 for this trademark*).

3,955,063 ( *See Class 9 for this trademark*).

3,955,065. **HOT BIKE BAGGERS (STANDARD CHARACTER)**. SOURCE INTERLINK MAGAZINES, LLC, (U.S. CLS. 100, 101 AND 107). SN 85-143,436. PUB. 2-15-2011. FILED 10-1-2010.

3,955,075. **ALPHA KING CHALLENGE (STANDARD CHARACTER)**. THREE FLOYDS BREWING LLC, (U.S. CLS. 100, 101 AND 107). SN 85-146,873. PUB. 2-15-2011. FILED 10-6-2010.

3,955,082. **EVERBANK FIELD (STANDARD CHARACTER)**. EVERBANK, (U.S. CLS. 100, 101 AND 107). SN 85-148,730. PUB. 2-15-2011. FILED 10-8-2010.

3,955,087. **TRANSFORMATIONS (STANDARD CHARACTER)**. MINNESOTA PUBLIC RADIO, (U.S. CLS. 100, 101 AND 107). SN 85-149,311. PUB. 2-15-2011. FILED 10-11-2010.

3,955,089. **PARTNERS IN CARE (STANDARD CHARACTER)**. VISITING NURSE SERVICE OF NEW YORK, MULTIPLE CLASS, (INT. CLS. 41, 44 AND 45), (U.S. CLS. 100, 101 AND 107). SN 85-151,309. PUB. 2-15-2011. FILED 10-13-2010.

3,955,091. **PARTNERS IN CARE PRIVATE, PROFESSIONAL HOME CARE AND DESIGN**. VISITING NURSE SERVICE OF NEW YORK, MULTIPLE CLASS, (INT. CLS. 41, 44 AND 45), (U.S. CLS. 100, 101 AND 107). SN 85-151,342. PUB. 2-15-2011. FILED 10-13-2010.

3,955,119. **THE AUTHORITY GROUP AND DESIGN**. CORTELL, NEAL P., (U.S. CLS. 100, 101 AND 107). SN 85-167,849. PUB. 2-15-2011. FILED 11-3-2010.

3,955,125. **HAZE HIM (STANDARD CHARACTER)**. GRHK IP, LLC, (U.S. CLS. 100, 101 AND 107). SN 85-170,033. PUB. 2-15-2011. FILED 11-5-2010.

3,955,129. **B&B GRAND SCREEN (STANDARD CHARACTER)**. B & B THEATRES OPERATING COMPANY, INC., (U.S. CLS. 100, 101 AND 107). SN 85-170,511. PUB. 2-15-2011. FILED 11-5-2010.

3,955,130. **MARQUEE SUITES (STANDARD CHARACTER)**. B & B THEATRES OPERATING COMPANY, INC., (U.S. CLS. 100, 101 AND 107). SN 85-170,551. PUB. 2-15-2011. FILED 11-5-2010.

3,955,131. **BRINGING HOLLYWOOD TO YOUR HOMETOWN SINCE 1924 (STANDARD CHARACTER)**. B & B THEATRES OPERATING COMPANY, INC., (U.S. CLS. 100, 101 AND 107). SN 85-170,585. PUB. 2-15-2011. FILED 11-5-2010.

3,955,140 ( *See Class 6 for this trademark*).

3,955,151. **DUMBDUMB (STANDARD CHARACTER)**. DUMB-DUMB ENTERPRISES LLC, (U.S. CLS. 100, 101 AND 107). SN 85-975,056. PUB. 2-15-2011. FILED 6-15-2010.

---

## CLASS 42—SCIENTIFIC AND COMPUTER SERVICES

3,952,956 ( *See Class 9 for this trademark*).

3,952,958 ( *See Class 35 for this trademark*).

3,952,962. **MACP CERTIFIED SOFTWARE NASSCO'S MANHOLE ASSESSMENT & CERTIFICATION PROGRAM AND DESIGN**. NASSCO, INC., (U.S. CLS. 100 AND 101). SN 76-700,586. PUB. 2-15-2011. FILED 11-27-2009.

3,952,963. **PACP CERTIFIED SOFTWARE NASSCO'S PIPELINE ASSESSMENT & CERTIFICATION PROGRAM AND DESIGN**. NASSCO, INC., (U.S. CLS. 100 AND 101). SN 76-700,587. PUB. 2-15-2011. FILED 11-27-2009.

3,952,964. **NASSCO'S LATERAL ASSESSMENT & CERTIFICATION PROGRAM LACP CERTIFIED SOFTWARE AND DESIGN**. NASSCO, INC., (U.S. CLS. 100 AND 101). SN 76-700,925. PUB. 2-15-2011. FILED 12-22-2009.

3,952,996. **DOCUFILL (STANDARD CHARACTER)**. AMERICAN STERLING DENTAL PLAN, LLC., (U.S. CLS. 100 AND 101). SN 76-704,350. PUB. 2-15-2011. FILED 9-2-2010.

3,953,001 ( *See Class 9 for this trademark*).

3,953,023 ( *See Class 35 for this trademark*).

3,953,049 ( *See Class 6 for this trademark*).

3,953,069 ( *See Class 35 for this trademark*).

3,953,074 ( *See Class 11 for this trademark*).

3,953,082 ( *See Class 6 for this trademark*).

3,953,083 ( *See Class 1 for this trademark*).

3,953,097 ( *See Class 36 for this trademark*).

3,953,102 ( *See Class 20 for this trademark*).

3,953,115 ( *See Class 9 for this trademark*).

3,953,116 ( *See Class 4 for this trademark*).

3,953,125 ( *See Class 9 for this trademark*).

3,953,161 ( *See Class 35 for this trademark*).

3,953,176 ( *See Class 9 for this trademark*).

3,953,177. **COLLABORATE DESIGN STUDIO (STANDARD CHARACTER)**. COLLABORATE DESIGN STUDIO, LTD., AKA COLLABORATE DESIGN, (U.S. CLS. 100 AND 101). SN 77-847,781. PUB. 2-15-2011. FILED 10-13-2009.

3,953,180 ( *See Class 9 for this trademark*).

3,953,184 ( *See Class 7 for this trademark*).

3,953,215 ( *See Class 35 for this trademark*).

3,953,217. **THOUGHT ROCK (STANDARD CHARACTER)**. B WYZE HOLDINGS INC., (U.S. CLS. 100 AND 101). SN 77-895,080. PUB. 2-15-2011. FILED 12-16-2009.

3,953,218. **SHIFT (STANDARD CHARACTER)**. B WYZE HOLDINGS INC., (U.S. CLS. 100 AND 101). SN 77-895,083. PUB. 2-15-2011. FILED 12-16-2009.

3,953,235 ( *See Class 9 for this trademark*).

3,953,241 ( *See Class 5 for this trademark*).

3,953,248 ( *See Class 9 for this trademark*).

3,953,253 ( *See Class 36 for this trademark*).

3,953,258. **G (STANDARD CHARACTER)**. GIMPLE ROOF ENGINEERS, INC., AND GIMPLE, JOHN L., (U.S. CLS. 100 AND 101). SN 77-928,934. PUB. 2-15-2011. FILED 2-5-2010.

3,953,264 ( *See Class 5 for this trademark*).

3,953,276. **WHEELHOUSE (STANDARD CHARACTER)**. WHEELHOUSE INVESTMENT REAL ESTATE BROKERAGE, INC., (U.S. CLS. 100 AND 101). SN 77-936,981. PUB. 2-15-2011. FILED 2-16-2010.

3,953,291 ( *See Class 9 for this trademark*).

3,953,298 ( *See Class 9 for this trademark*).

3,953,308. **NATIONAL SPORTS M.A.P. (STANDARD CHARACTER)**. KEENE, BRIAN J., (U.S. CLS. 100 AND 101). SN 77-944,421. PUB. 2-15-2011. FILED 2-25-2010.

3,953,311 ( *See Class 35 for this trademark*).

3,953,312 ( *See Class 16 for this trademark*).

3,953,317 ( *See Class 20 for this trademark*).

3,953,336 ( *See Class 35 for this trademark*).

3,953,369 ( *See Class 2 for this trademark*).

3,953,395 ( *See Class 7 for this trademark*).

- 3,953,396 ( See Class 40 for this trademark).  
 3,953,398 ( See Class 9 for this trademark).  
 3,953,401. **BLUE CARBON LEARNING (STANDARD CHARACTER)**. D'ABOY CAREER HORIZONS, DBA BLUE CARBON LEARNING, (U.S. CLS. 100 AND 101). SN 77-958,260. PUB. 2-15-2011. FILED 3-12-2010.  
 3,953,416. **RESOUNDING HEALTH (STANDARD CHARACTER)**. RESOUNDING HEALTH, INC., MULTIPLE CLASS, (INT. CLS. 42 AND 44), (U.S. CLS. 100 AND 101). SN 77-959,821. PUB. 2-15-2011. FILED 3-16-2010.  
 3,953,417. **PATENT CALLS (STANDARD CHARACTER)**. PATENT CALLS, INC., (U.S. CLS. 100 AND 101). SN 77-959,904. PUB. 2-15-2011. FILED 3-16-2010.  
 3,953,434. **SUPERNEWS (STANDARD CHARACTER)**. SUPERNEWS, INC., (U.S. CLS. 100 AND 101). SN 77-961,750. PUB. 2-15-2011. FILED 3-17-2010.  
 3,953,436 ( See Class 35 for this trademark).  
 3,953,439. **CROHNOLOGY (STANDARD CHARACTER)**. AHRENS, SEAN C., (U.S. CLS. 100 AND 101). SN 77-962,531. PUB. 2-15-2011. FILED 3-18-2010.  
 3,953,443 ( See Class 16 for this trademark).  
 3,953,455 ( See Class 35 for this trademark).  
 3,953,456 ( See Class 35 for this trademark).  
 3,953,472 ( See Class 37 for this trademark).  
 3,953,473 ( See Class 12 for this trademark).  
 3,953,476 ( See Class 5 for this trademark).  
 3,953,487 ( See Class 36 for this trademark).  
 3,953,488 ( See Class 9 for this trademark).  
 3,953,493 ( See Class 9 for this trademark).  
 3,953,495 ( See Class 9 for this trademark).  
 3,953,498 ( See Class 9 for this trademark).  
 3,953,504 ( See Class 9 for this trademark).  
 3,953,509 ( See Class 5 for this trademark).  
 3,953,511 ( See Class 9 for this trademark).  
 3,953,516 ( See Class 9 for this trademark).  
 3,953,518 ( See Class 9 for this trademark).  
 3,953,530 ( See Class 36 for this trademark).  
 3,953,531 ( See Class 9 for this trademark).  
 3,953,533 ( See Class 36 for this trademark).  
 3,953,534 ( See Class 36 for this trademark).  
 3,953,535 ( See Class 3 for this trademark).  
 3,953,537 ( See Class 36 for this trademark).  
 3,953,540 ( See Class 36 for this trademark).  
 3,953,541 ( See Class 1 for this trademark).  
 3,953,552 ( See Class 9 for this trademark).  
 3,953,557 ( See Class 9 for this trademark).  
 3,953,558 ( See Class 9 for this trademark).  
 3,953,562 ( See Class 29 for this trademark).  
 3,953,569 ( See Class 6 for this trademark).  
 3,953,570 ( See Class 6 for this trademark).  
 3,953,574 ( See Class 7 for this trademark).  
 3,953,575 ( See Class 9 for this trademark).  
 3,953,578 ( See Class 4 for this trademark).  
 3,953,579 ( See Class 4 for this trademark).  
 3,953,586 ( See Class 19 for this trademark).  
 3,953,587 ( See Class 9 for this trademark).  
 3,953,592 ( See Class 11 for this trademark).  
 3,953,595 ( See Class 16 for this trademark).  
 3,953,605 ( See Class 37 for this trademark).  
 3,953,610 ( See Class 7 for this trademark).  
 3,953,636 ( See Class 35 for this trademark).  
 3,953,680 ( See Class 25 for this trademark).  
 3,953,681 ( See Class 25 for this trademark).  
 3,953,682. **MYBOYFUND (STANDARD CHARACTER)**. BLACKSTAR VENTURES, LLC, MULTIPLE CLASS, (INT. CLS. 42 AND 45), (U.S. CLS. 100 AND 101). SN 85-000,392. PUB. 2-15-2011. FILED 3-29-2010.  
 3,953,683. **MYBOYFUND (STYLIZED)**. BLACKSTAR VENTURES, LLC, MULTIPLE CLASS, (INT. CLS. 42 AND 45), (U.S. CLS. 100 AND 101). SN 85-000,397. PUB. 2-15-2011. FILED 3-29-2010.  
 3,953,684 ( See Class 16 for this trademark).  
 3,953,719. **THINK BANK (STANDARD CHARACTER)**. TORRES, LUIS POIRE, (U.S. CLS. 100 AND 101). SN 85-009,042. PUB. 2-15-2011. FILED 4-8-2010.  
 3,953,750. **ROCKET SCIENCE, SIMPLIFIED (STANDARD CHARACTER)**. CORE COMPUTING TECHNOLOGIES, INC., (U.S. CLS. 100 AND 101). SN 85-023,099. PUB. 2-15-2011. FILED 4-26-2010.  
 3,953,758. **BAJARO METHOD (STANDARD CHARACTER)**. DESIGN DIMENSIONS, LLC, (U.S. CLS. 100 AND 101). SN 85-024,956. PUB. 2-15-2011. FILED 4-28-2010.  
 3,953,760. **BANDWITH (STANDARD CHARACTER)**. BANDWITHRADIO, LLC, (U.S. CLS. 100 AND 101). SN 85-025,850. PUB. 2-15-2011. FILED 4-28-2010.  
 3,953,762 ( See Class 40 for this trademark).  
 3,953,763 ( See Class 40 for this trademark).  
 3,953,766 ( See Class 35 for this trademark).  
 3,953,776 ( See Class 9 for this trademark).  
 3,953,780 ( See Class 35 for this trademark).  
 3,953,789 ( See Class 9 for this trademark).  
 3,953,792. **VECNA MEDICAL (STANDARD CHARACTER)**. VECNA TECHNOLOGIES, INC., (U.S. CLS. 100 AND 101). SN 85-036,098. PUB. 2-15-2011. FILED 5-12-2010.  
 3,953,811. **BIOSTIME AND DESIGN**. BIOSTIME, INC. (-GUANGZHOU), (U.S. CLS. 100 AND 101). SN 85-039,534. PUB. 2-15-2011. FILED 5-15-2010.  
 3,953,820. **HIGHWIRE (STANDARD CHARACTER)**. BUYIT-SELLIT, LLC, (U.S. CLS. 100 AND 101). SN 85-041,686. PUB. 2-15-2011. FILED 5-18-2010.  
 3,953,824 ( See Class 9 for this trademark).  
 3,953,859 ( See Class 30 for this trademark).  
 3,953,862 ( See Class 35 for this trademark).  
 3,953,863 ( See Class 35 for this trademark).  
 3,953,887. **PERFACTO (STANDARD CHARACTER)**. PRO-MARK SOLUTIONS, LLC, (U.S. CLS. 100 AND 101). SN 85-067,900. PUB. 2-15-2011. FILED 6-21-2010.  
 3,953,895 ( See Class 16 for this trademark).  
 3,953,898. **FUSIONAPPS AND DESIGN**. FUSIONAPPS, LLC., (U.S. CLS. 100 AND 101). SN 85-070,762. PUB. 2-15-2011. FILED 6-24-2010.  
 3,953,905. **BARRIERI (STANDARD CHARACTER)**. BARRIERI, LLC, FORMERLY THE BARRIER GROUP, LLC, (U.S. CLS. 100 AND 101). SN 85-071,740. PUB. 2-15-2011. FILED 6-25-2010.  
 3,953,915. **ALASKA HEALTHCARE ADVOCATES AND DESIGN**. ALASKA HEALTHCARE ADVOCATES, LLC, (U.S. CLS. 100 AND 101). SN 85-073,570. PUB. 2-15-2011. FILED 6-29-2010.  
 3,953,936 ( See Class 41 for this trademark).  
 3,953,989 ( See Class 9 for this trademark).  
 3,953,998. **GPCM VIEWPOINTS (STANDARD CHARACTER)**. RT7K, LLC, (U.S. CLS. 100 AND 101). SN 85-096,741. PUB. 2-15-2011. FILED 7-30-2010.  
 3,953,999. **GPCM VIEWPOINTS ON NATURAL GAS (STANDARD CHARACTER)**. RT7K, LLC, (U.S. CLS. 100 AND 101). SN 85-096,755. PUB. 2-15-2011. FILED 7-30-2010.  
 3,954,015. **MAILLISTCLEANER AND DESIGN**. TEC SOFTWARE, LLC, (U.S. CLS. 100 AND 101). SN 85-099,105. PUB. 2-15-2011. FILED 8-3-2010.  
 3,954,016. **TECAGORA (STANDARD CHARACTER)**. TEC SOFTWARE, LLC, (U.S. CLS. 100 AND 101). SN 85-099,126. PUB. 2-15-2011. FILED 8-3-2010.  
 3,954,018. **SELECT SOLAR & GENERATOR AND DESIGN**. POWERSOURCE INC, (U.S. CLS. 100 AND 101). SN 85-099,492. PUB. 2-15-2011. FILED 8-3-2010.  
 3,954,044. **FISHERS RESEARCH AND TECHNOLOGY CENTER AND DESIGN**. FISHERS ECONOMIC AND COMMUNITY DEVELOPMENT COMMISSION, INC., (U.S. CLS. 100 AND 101). SN 85-104,946. PUB. 2-15-2011. FILED 8-11-2010.  
 3,954,050. **DOMAINBOX (STANDARD CHARACTER)**. MESH DIGITAL LIMITED, DBA DOMAINBOX, MULTIPLE CLASS, (INT. CLS. 42 AND 45), (U.S. CLS. 100 AND 101). SN 85-105,234. PUB. 2-15-2011. FILED 8-11-2010.  
 3,954,051. **COMPANIONTREE MEET PEOPLE. MAKE FRIENDS. AND DESIGN**. COMPANION TREE, DBA COMPANION TREE LLC LIMITED LIABILITY COMPANY WASHINGTON, (U.S. CLS. 100 AND 101). SN 85-105,285. PUB. 2-15-2011. FILED 8-11-2010.  
 3,954,117. **IMFORZA (STANDARD CHARACTER)**. IMFORZA, LLC, (U.S. CLS. 100 AND 101). SN 85-110,641. PUB. 2-15-2011. FILED 8-18-2010.  
 3,954,121. **APPSNMIND (STANDARD CHARACTER)**. APPSNMIND, (U.S. CLS. 100 AND 101). SN 85-110,730. PUB. 2-15-2011. FILED 8-18-2010.

- 3,954,128 ( *See Class 16 for this trademark*).
- 3,954,146. **BASIC GURU AND DESIGN**. BENEFIT ADMINISTRATIVE SERVICES INTERNATIONAL CORPORATION, DBA BASIC, (U.S. CLS. 100 AND 101). SN 85-111,640. PUB. 2-15-2011. FILED 8-19-2010.
- 3,954,153. **CSDP (STANDARD CHARACTER)**. ASSOCIATION OF ENERGY ENGINEERS, (U.S. CLS. 100 AND 101). SN 85-112,034. PUB. 2-15-2011. FILED 8-20-2010.
- 3,954,154. **GBE (STANDARD CHARACTER)**. ASSOCIATION OF ENERGY ENGINEERS, (U.S. CLS. 100 AND 101). SN 85-112,073. PUB. 2-15-2011. FILED 8-20-2010.
- 3,954,156. **CBCP (STANDARD CHARACTER)**. ASSOCIATION OF ENERGY ENGINEERS, (U.S. CLS. 100 AND 101). SN 85-112,163. PUB. 2-15-2011. FILED 8-20-2010.
- 3,954,158. **CMVP (STANDARD CHARACTER)**. ASSOCIATION OF ENERGY ENGINEERS, (U.S. CLS. 100 AND 101). SN 85-112,199. PUB. 2-15-2011. FILED 8-20-2010.
- 3,954,159. **BEP (STANDARD CHARACTER)**. ASSOCIATION OF ENERGY ENGINEERS, (U.S. CLS. 100 AND 101). SN 85-112,254. PUB. 2-15-2011. FILED 8-20-2010.
- 3,954,171. **A X AND DESIGN**. ALPHA TEN TECHNOLOGIES, INC., MULTIPLE CLASS, (INT. CLS. 42 AND 45), (U.S. CLS. 100 AND 101). SN 85-112,825. PUB. 2-15-2011. FILED 8-20-2010.
- 3,954,175. **CONSTANT EMAILS (STANDARD CHARACTER)**. CONSTANT EMAILS INC., (U.S. CLS. 100 AND 101). SN 85-113,150. PUB. 2-15-2011. FILED 8-23-2010.
- 3,954,178. **MISCELLANEOUS DESIGN**. CONSTANT EMAILS INC., (U.S. CLS. 100 AND 101). SN 85-113,276. PUB. 2-15-2011. FILED 8-23-2010.
- 3,954,199 ( *See Class 35 for this trademark*).
- 3,954,209. **NEXXTEP TECHNOLOGY SERVICES INC. PROVEN TECHNOLOGY LEADERSHIP AND DESIGN**. NEXXTEP TECHNOLOGY SERVICES, INC., (U.S. CLS. 100 AND 101). SN 85-114,320. PUB. 2-15-2011. FILED 8-24-2010.
- 3,954,291 ( *See Class 35 for this trademark*).
- 3,954,305. **ISC INDUSTRIAL SOLAR CONSULTING AND DESIGN**. ISC-INDUSTRIAL SOLAR CONSULTING, (U.S. CLS. 100 AND 101). SN 85-116,326. PUB. 2-15-2011. FILED 8-26-2010.
- 3,954,330. **BUSINESS BULLPEN (STANDARD CHARACTER)**. BUSINESS BULLPEN, LLC, (U.S. CLS. 100 AND 101). SN 85-116,793. PUB. 2-15-2011. FILED 8-26-2010.
- 3,954,336. **SUMMITTEK AND DESIGN**. SUMMIT TECHNOLOGIC, INC., (U.S. CLS. 100 AND 101). SN 85-116,919. PUB. 2-15-2011. FILED 8-26-2010.
- 3,954,353. **RADIOLOGY IN THE PALM OF YOUR HAND (STANDARD CHARACTER)**. SMITH, DOUGLAS, (U.S. CLS. 100 AND 101). SN 85-117,156. PUB. 2-15-2011. FILED 8-27-2010.
- 3,954,358. **HOTFILE (STANDARD CHARACTER)**. HOTFILE CORP., (U.S. CLS. 100 AND 101). SN 85-117,237. PUB. 2-15-2011. FILED 8-27-2010.
- 3,954,386. **A C AND DESIGN**. CHINA, AISHA, (U.S. CLS. 100 AND 101). SN 85-117,553. PUB. 2-15-2011. FILED 8-27-2010.
- 3,954,387. **SINGER VEHICLE DESIGN RESTORED REIMAGINED REBORN AND DESIGN**. SINGER VEHICLE DESIGN, (U.S. CLS. 100 AND 101). SN 85-117,592. PUB. 2-15-2011. FILED 8-27-2010.
- 3,954,389. **PELTON LAND SOLUTIONS (STYLIZED)**. PELTON LAND SOLUTIONS, LLLP, (U.S. CLS. 100 AND 101). SN 85-117,680. PUB. 2-15-2011. FILED 8-27-2010.
- 3,954,395 ( *See Class 35 for this trademark*).
- 3,954,396. **CRAL AND DESIGN**. CRAL CONTRACTING, INC., (U.S. CLS. 100 AND 101). SN 85-117,780. PUB. 2-15-2011. FILED 8-27-2010.
- 3,954,414. **AVRS (STANDARD CHARACTER)**. CA-AVRS, INC., (U.S. CLS. 100 AND 101). SN 85-117,988. PUB. 2-15-2011. FILED 8-27-2010.
- 3,954,484. **CONNANCE AGENCY MANAGER (STANDARD CHARACTER)**. CONNANCE, INC., (U.S. CLS. 100 AND 101). SN 85-118,712. PUB. 2-15-2011. FILED 8-30-2010.
- 3,954,530 ( *See Class 6 for this trademark*).
- 3,954,569 ( *See Class 9 for this trademark*).
- 3,954,584. **ENVIEW (STANDARD CHARACTER)**. ENVIEW TECHNOLOGIES, LLC, (U.S. CLS. 100 AND 101). SN 85-119,830. PUB. 2-15-2011. FILED 8-31-2010.
- 3,954,585. **INTEGRAL BIOSYSTEMS (STANDARD CHARACTER)**. INTEGRAL BIOSYSTEMS, LLC, (U.S. CLS. 100 AND 101). SN 85-119,863. PUB. 2-15-2011. FILED 8-31-2010.
- 3,954,622. **G GISTCLOUD AND DESIGN**. GISTCLOUD, (U.S. CLS. 100 AND 101). SN 85-120,269. PUB. 2-15-2011. FILED 8-31-2010.
- 3,954,627 ( *See Class 35 for this trademark*).
- 3,954,652. **EDUTALK (STANDARD CHARACTER)**. WATERMOOR GROUP LIMITED, (U.S. CLS. 100 AND 101). SN 85-120,603. PUB. 2-15-2011. FILED 9-1-2010.
- 3,954,653. **PLANITSAFE AND DESIGN**. PROTECH FIRE, INC., (U.S. CLS. 100 AND 101). SN 85-120,621. PUB. 2-15-2011. FILED 9-1-2010.
- 3,954,656. **PASSIONATE SUPPORT (STANDARD CHARACTER)**. PHOTOBIZ, LLC, (U.S. CLS. 100 AND 101). SN 85-120,651. PUB. 2-15-2011. FILED 9-1-2010.
- 3,954,671. **BIG TOP (STANDARD CHARACTER)**. AKT & IWDT, INC., (U.S. CLS. 100 AND 101). SN 85-120,752. PUB. 2-15-2011. FILED 9-1-2010.
- 3,954,683. **AUDIT INTEGRITY TRUSTED CORPORATION 2010 AND DESIGN**. AUDIT INTEGRITY, INC., (U.S. CLS. 100 AND 101). SN 85-120,820. PUB. 2-15-2011. FILED 9-1-2010.
- 3,954,701. **FASO (STANDARD CHARACTER)**. BOLDBRUSH TECHNOLOGY, L.L.C., (U.S. CLS. 100 AND 101). SN 85-120,975. PUB. 2-15-2011. FILED 9-1-2010.
- 3,954,753. **SMARTCART (STANDARD CHARACTER)**. BIZCOM INTERNATIONAL, LLC, (U.S. CLS. 100 AND 101). SN 85-121,703. PUB. 2-15-2011. FILED 9-2-2010.
- 3,954,762. **SOCIAL GROCERY (STANDARD CHARACTER)**. MYWEBGROCER, INC., (U.S. CLS. 100 AND 101). SN 85-121,822. PUB. 2-15-2011. FILED 9-2-2010.
- 3,954,789. **NGUARD (STANDARD CHARACTER)**. NGUARD, INC., (U.S. CLS. 100 AND 101). SN 85-122,087. PUB. 2-15-2011. FILED 9-2-2010.
- 3,954,798. **BRIDGELINE DIGITAL (STANDARD CHARACTER)**. BRIDGELINE DIGITAL, INC., (U.S. CLS. 100 AND 101). SN 85-122,174. PUB. 2-15-2011. FILED 9-2-2010.
- 3,954,835. **NETROCKET (STANDARD CHARACTER)**. ISEND-COM, LLC, (U.S. CLS. 100 AND 101). SN 85-122,700. PUB. 2-15-2011. FILED 9-3-2010.
- 3,954,876. **GIS OASIS (STANDARD CHARACTER)**. GRINNELL MUTUAL REINSURANCE COMPANY, (U.S. CLS. 100 AND 101). SN 85-123,117. PUB. 2-15-2011. FILED 9-3-2010.
- 3,954,878. **GIS OASIS AND DESIGN**. GRINNELL MUTUAL REINSURANCE COMPANY, (U.S. CLS. 100 AND 101). SN 85-123,154. PUB. 2-15-2011. FILED 9-3-2010.
- 3,954,893. **REMMETRIK (STANDARD CHARACTER)**. PANTER, STEVEN, E, (U.S. CLS. 100 AND 101). SN 85-123,357. PUB. 2-15-2011. FILED 9-4-2010.
- 3,954,914. **SHAREM (STANDARD CHARACTER)**. SHAREM PARTNERSHIP, (U.S. CLS. 100 AND 101). SN 85-123,932. PUB. 2-15-2011. FILED 9-7-2010.
- 3,954,929 ( *See Class 35 for this trademark*).
- 3,954,946 ( *See Class 35 for this trademark*).
- 3,954,949. **LEGACY TREE (STANDARD CHARACTER)**. LEGACY TREE GENEALOGY, LLC, (U.S. CLS. 100 AND 101). SN 85-125,497. PUB. 2-15-2011. FILED 9-8-2010.
- 3,954,967. **BAY BRIDGE DECISION TECHNOLOGIES AND DESIGN**. BAY BRIDGE DECISION TECHNOLOGIES, INC., (U.S. CLS. 100 AND 101). SN 85-127,201. PUB. 2-15-2011. FILED 9-10-2010.
- 3,955,008. **MISCELLANEOUS DESIGN**. BOLDBRUSH TECHNOLOGY, L.L.C., (U.S. CLS. 100 AND 101). SN 85-132,990. PUB. 2-15-2011. FILED 9-19-2010.
- 3,955,021 ( *See Class 35 for this trademark*).
- 3,955,095. **CLOROXCONNECTS (STANDARD CHARACTER)**. THE CLOROX COMPANY, (U.S. CLS. 100 AND 101). SN 85-152,628. PUB. 2-15-2011. FILED 10-14-2010.
- 3,955,114 ( *See Class 39 for this trademark*).
- 3,955,118. **IMMVIEW (STANDARD CHARACTER)**. PARAGON RELOCATION HOLDINGS, (U.S. CLS. 100 AND 101). SN 85-167,235. PUB. 2-15-2011. FILED 11-2-2010.
- 3,955,133. **EMARF (STANDARD CHARACTER)**. EMERGENCY MEDICAL ASSOCIATES OF NEW JERSEY, (U.S. CLS. 100 AND 101). SN 85-170,886. PUB. 2-15-2011. FILED 11-6-2010.

**CLASS 43—HOTEL AND RESTAURANT SERVICES**

- 3,952,992. **I FRATELLI (STANDARD CHARACTER)**. STORY GLEN, INC., (U.S. CLS. 100 AND 101). SN 76-704,317. PUB. 2-15-2011. FILED 8-31-2010.
- 3,953,015. **THE MATADOR AND DESIGN**. MOCORE, LLC, (U.S. CLS. 100 AND 101). SN 77-232,571. PUB. 2-15-2011. FILED 7-18-2007.
- 3,953,061. **LIFT SOUTHWEST AIRLINES' SIGNATURE COFFEE A CUP ABOVE THE REST AND DESIGN**. SOUTHWEST AIRLINES CO., (U.S. CLS. 100 AND 101). SN 77-713,596. PUB. 2-15-2011. FILED 4-14-2009.
- 3,953,072. **CHINA BISTRO GLATT KOSHER AND DESIGN**. CHINA BISTRO LLC, (U.S. CLS. 100 AND 101). SN 77-742,350. PUB. 2-15-2011. FILED 5-21-2009.
- 3,953,082 ( *See Class 6 for this trademark*).
- 3,953,083 ( *See Class 1 for this trademark*).
- 3,953,142 ( *See Class 35 for this trademark*).
- 3,953,143 ( *See Class 35 for this trademark*).
- 3,953,165 ( *See Class 35 for this trademark*).
- 3,953,173. **LIVE AQUA (STANDARD CHARACTER)**. GRUPO POSADAS, S.A.B. DE C.V., (U.S. CLS. 100 AND 101). SN 77-846,587. PUB. 8-3-2010. FILED 10-12-2009.
- 3,953,174. **LIVE AQUA (STYLIZED)**. GRUPO POSADAS, S.A.B. DE C.V., (U.S. CLS. 100 AND 101). SN 77-846,693. PUB. 8-3-2010. FILED 10-12-2009.
- 3,953,186. **YO! SUSHI (STANDARD CHARACTER)**. YO! SUSHI LIMITED, (U.S. CLS. 100 AND 101). SN 77-854,632. PUB. 1-18-2011. FILED 10-22-2009.
- 3,953,189. **MICHELE'S (STANDARD CHARACTER)**. DOVER DOWNS GAMING & ENTERTAINMENT, INC., (U.S. CLS. 100 AND 101). SN 77-857,192. PUB. 2-15-2011. FILED 10-26-2009.
- 3,953,198 ( *See Class 29 for this trademark*).
- 3,953,209. **GROOVY LINEN (STANDARD CHARACTER)**. THE GROOVY LINEN CORPORATION, (U.S. CLS. 100 AND 101). SN 77-886,222. PUB. 2-15-2011. FILED 12-4-2009.
- 3,953,211. **SA-BAI THONG (STANDARD CHARACTER)**. SA-BAI THONG, LLC, (U.S. CLS. 100 AND 101). SN 77-890,564. PUB. 2-15-2011. FILED 12-10-2009.
- 3,953,212 ( *See Class 41 for this trademark*).
- 3,953,266. **CURRAGH (STANDARD CHARACTER)**. LEONGAS, PAUL, (U.S. CLS. 100 AND 101). SN 77-933,473. PUB. 2-15-2011. FILED 2-11-2010.
- 3,953,282. **AIR BAR (STANDARD CHARACTER)**. W2007 STRATOSPHERE PROPCO, L.P., (U.S. CLS. 100 AND 101). SN 77-938,035. PUB. 2-15-2011. FILED 2-17-2010.
- 3,953,356. **THE BIG WRAP AND DESIGN**. THE BIG WRAP, INC., (U.S. CLS. 100 AND 101). SN 77-951,995. PUB. 2-15-2011. FILED 3-5-2010.
- 3,953,447. **CIOFFI'S ORIGINAL SUBS-STEAKS AND MORE AND DESIGN**. CIOFFI'S, LLC, (U.S. CLS. 100 AND 101). SN 77-964,012. PUB. 2-15-2011. FILED 3-19-2010.
- 3,953,465 ( *See Class 29 for this trademark*).
- 3,953,491. **MYINDIGO (STANDARD CHARACTER)**. HEINER RASCHHOFER, (U.S. CLS. 100 AND 101). SN 79-063,000. PUB. 2-15-2011. FILED 11-25-2008.
- 3,953,527 ( *See Class 41 for this trademark*).
- 3,953,562 ( *See Class 29 for this trademark*).
- 3,953,585 ( *See Class 32 for this trademark*).
- 3,953,644. **UOTAMI (STANDARD CHARACTER)**. KABUSHIKI KAISHA MONTEROZA, (U.S. CLS. 100 AND 101). SN 79-087,290. PUB. 2-15-2011. FILED 8-26-2010.
- 3,953,645. **MISCELLANEOUS DESIGN**. KABUSHIKI KAISHA MONTEROZA, (U.S. CLS. 100 AND 101). SN 79-087,291. PUB. 2-15-2011. FILED 8-26-2010.
- 3,953,646. **SHIROKIYA (STANDARD CHARACTER)**. KABUSHIKI KAISHA MONTEROZA, (U.S. CLS. 100 AND 101). SN 79-087,292. PUB. 2-15-2011. FILED 8-26-2010.
- 3,953,647. **MISCELLANEOUS DESIGN**. KABUSHIKI KAISHA MONTEROZA, (U.S. CLS. 100 AND 101). SN 79-087,293. PUB. 2-15-2011. FILED 8-26-2010.
- 3,953,686 ( *See Class 35 for this trademark*).
- 3,953,739 ( *See Class 41 for this trademark*).
- 3,953,762 ( *See Class 40 for this trademark*).
- 3,953,763 ( *See Class 40 for this trademark*).
- 3,953,806 ( *See Class 25 for this trademark*).
- 3,953,822. **TRAVELING CULINARY CARNIVAL (STANDARD CHARACTER)**. VITARELLO, JUSTIN, (U.S. CLS. 100 AND 101). SN 85-042,752. PUB. 2-15-2011. FILED 5-19-2010.
- 3,953,864. **HAWAIIAN VILLAGE (STANDARD CHARACTER)**. HLT DOMESTIC IP LLC, (U.S. CLS. 100 AND 101). SN 85-058,722. PUB. 2-15-2011. FILED 6-9-2010.
- 3,953,873. **ORGANICLIFE (STANDARD CHARACTER)**. ORGANICLIFE, LLC, (U.S. CLS. 100 AND 101). SN 85-061,984. PUB. 2-15-2011. FILED 6-14-2010.
- 3,953,951. **THE ALLEGRO SENIOR LIFESTYLE (STANDARD CHARACTER)**. ALLEGRO SENIOR LIVING, LLC, (U.S. CLS. 100 AND 101). SN 85-085,340. PUB. 11-9-2010. FILED 7-15-2010.
- 3,954,041. **SINGAS FAMOUS PIZZA EST. 1967 AND DESIGN**. SINGAS FAMOUS PIZZA BRANDS CORP., (U.S. CLS. 100 AND 101). SN 85-104,616. PUB. 2-15-2011. FILED 8-10-2010.
- 3,954,081. **TONY BOFFA'S (STANDARD CHARACTER)**. TONY BOFFA'S RESTAURANT, INC., (U.S. CLS. 100 AND 101). SN 85-107,780. PUB. 2-15-2011. FILED 8-15-2010.
- 3,954,120 ( *See Class 37 for this trademark*).
- 3,954,167. **JIMMY'S FAMOUS AMERICAN TAVERN (STANDARD CHARACTER)**. JFAT, LLC, DBA JIMMY'S FAMOUS AMERICAN TAVERN, (U.S. CLS. 100 AND 101). SN 85-112,670. PUB. 2-15-2011. FILED 8-20-2010.
- 3,954,179. **RANUCCI'S BIG BUTT BBQ AND DESIGN**. RANUCCI, ALEX, (U.S. CLS. 100 AND 101). SN 85-113,343. PUB. 2-15-2011. FILED 8-23-2010.
- 3,954,225 ( *See Class 41 for this trademark*).
- 3,954,272. **Q4U HICKORY-SMOKED BAR-B-QUE AND DESIGN**. Q4U FRANCHISE DEVELOPMENT LLC, (U.S. CLS. 100 AND 101). SN 85-115,704. PUB. 2-15-2011. FILED 8-25-2010.
- 3,954,284. **DOGGIE DISTRICT PET RESORT VACANCY AND DESIGN**. PUPPY PLAYHOUSE 1, LLC, (U.S. CLS. 100 AND 101). SN 85-115,951. PUB. 2-15-2011. FILED 8-25-2010.
- 3,954,327. **CATER TOTS (STANDARD CHARACTER)**. CATER TOTS, INC., (U.S. CLS. 100 AND 101). SN 85-116,744. PUB. 2-15-2011. FILED 8-26-2010.
- 3,954,377. **PIZZERIA QUALITY AT SUPERMARKET PRICES (STANDARD CHARACTER)**. WHAT A PIZZA WHAT A PRICE FRANCHISING, LLC, (U.S. CLS. 100 AND 101). SN 85-117,415. PUB. 2-15-2011. FILED 8-27-2010.
- 3,954,481 ( *See Class 41 for this trademark*).
- 3,954,488 ( *See Class 41 for this trademark*).
- 3,954,563. **BURGERS ON THE SIDE (STYLIZED)**. BOISE FRY COMPANY, LLC, (U.S. CLS. 100 AND 101). SN 85-119,628. PUB. 2-15-2011. FILED 8-31-2010.
- 3,954,573. **ABC KITCHEN (STANDARD CHARACTER)**. ABC HOME FURNISHINGS, INC., (U.S. CLS. 100 AND 101). SN 85-119,707. PUB. 2-15-2011. FILED 8-31-2010.
- 3,954,596. **MISCELLANEOUS DESIGN**. WOLFIES RESTAURANTS & SPORTS BARS, INC., (U.S. CLS. 100 AND 101). SN 85-119,980. PUB. 2-15-2011. FILED 8-31-2010.
- 3,954,674. **BEST WESTERN PLUS AND DESIGN**. BEST WESTERN INTERNATIONAL, INC., (U.S. CLS. 100 AND 101). SN 85-120,774. PUB. 2-15-2011. FILED 9-1-2010.
- 3,954,679. **BEST WESTERN PLUS AND DESIGN**. BEST WESTERN INTERNATIONAL, INC., (U.S. CLS. 100 AND 101). SN 85-120,792. PUB. 2-15-2011. FILED 9-1-2010.
- 3,954,681. **BEST WESTERN PREMIER AND DESIGN**. BEST WESTERN INTERNATIONAL, INC., (U.S. CLS. 100 AND 101). SN 85-120,805. PUB. 2-15-2011. FILED 9-1-2010.
- 3,954,682. **BEST WESTERN PREMIER AND DESIGN**. BEST WESTERN INTERNATIONAL, INC., (U.S. CLS. 100 AND 101). SN 85-120,819. PUB. 2-15-2011. FILED 9-1-2010.
- 3,954,686. **CHEFDANCE (STANDARD CHARACTER)**. GRISWOLD, KENNETH, AND KIM, MIMI, AKA GRISWOLD, MIMI, (U.S. CLS. 100 AND 101). SN 85-120,845. PUB. 2-15-2011. FILED 9-1-2010.
- 3,954,698. **LSI LUNCHTIME SOLUTIONS, INC. AND DESIGN**. LUNCHTIME SOLUTIONS, INC., (U.S. CLS. 100 AND 101). SN 85-120,936. PUB. 2-15-2011. FILED 9-1-2010.
- 3,954,741. **RAW CAN ROLL CAFE AND DESIGN**. RAW CAN ROLL CAFE, LLC, (U.S. CLS. 100 AND 101). SN 85-121,594. PUB. 2-15-2011. FILED 9-2-2010.
- 3,954,743 ( *See Class 35 for this trademark*).
- 3,954,790. **GOODCENTS (STANDARD CHARACTER)**. MR. GOODCENTS FRANCHISE SYSTEMS, INC., (U.S. CLS. 100 AND 101). SN 85-122,104. PUB. 2-15-2011. FILED 9-2-2010.

3,954,918. **THE SPORTING HOUSE BAR AND GRILL (STANDARD CHARACTER)**, NEW YORK - NEW YORK HOTEL & CASINO, LLC, (U.S. CLS. 100 AND 101), SN 85-124,012. PUB. 2-15-2011. FILED 9-7-2010.  
 3,954,934 ( *See Class 41 for this trademark* ).  
 3,954,953. **COME KAMP & CARE WITH US WEEKEND AND DESIGN**, KAMPGROUNDS OF AMERICA, INC., (U.S. CLS. 100 AND 101), SN 85-125,915. PUB. 2-15-2011. FILED 9-9-2010.  
 3,954,955. **MAKING SWEET MEMORIES ONE CUP AT A TIME (STANDARD CHARACTER)**, SWEET CECE'S FRANCHISING, LLC, (U.S. CLS. 100 AND 101), SN 85-126,047. PUB. 2-15-2011. FILED 9-9-2010.  
 3,955,000. **15 NORTH ROADSIDE KITCHEN AND DESIGN**, MCKEE, BRETT, AKA CHEF BRETT MCKEE, (U.S. CLS. 100 AND 101), SN 85-132,372. PUB. 2-15-2011. FILED 9-17-2010.  
 3,955,001. **17 NORTH ROADSIDE KITCHEN AND DESIGN**, MCKEE, BRETT, AKA CHEF BRETT MCKEE, (U.S. CLS. 100 AND 101), SN 85-132,385. PUB. 2-15-2011. FILED 9-17-2010.  
 3,955,029 ( *See Class 35 for this trademark* ).  
 3,955,030 ( *See Class 35 for this trademark* ).

#### CLASS 44—MEDICAL, BEAUTY AND AGRICULTURAL SERVICES

3,952,972. **MOUNT NITTANY (STANDARD CHARACTER)**, MOUNT NITTANY MEDICAL CENTER, (U.S. CLS. 100 AND 101), SN 76-701,974. PUB. 2-15-2011. FILED 3-9-2010.  
 3,953,048. **CREATING FAMILIES (STANDARD CHARACTER)**, CENTER FOR SURROGATE PARENTING, INC., (U.S. CLS. 100 AND 101), SN 77-670,611. PUB. 2-15-2011. FILED 2-13-2009.  
 3,953,058. **BODYNEW MEDSPA (STANDARD CHARACTER)**, BODYNEW, INC., (U.S. CLS. 100 AND 101), SN 77-696,178. PUB. 2-15-2011. FILED 3-20-2009.  
 3,953,132. **AMERICAN TOTAL ORTHOPEDICS AND DESIGN**, MG BROWN INVESTMENT GROUP, LLC, (U.S. CLS. 100 AND 101), SN 77-816,381. PUB. 2-15-2011. FILED 8-31-2009.  
 3,953,142 ( *See Class 35 for this trademark* ).  
 3,953,143 ( *See Class 35 for this trademark* ).  
 3,953,241 ( *See Class 5 for this trademark* ).  
 3,953,259. **HEALTH PROMOTION SPECIALISTS (STANDARD CHARACTER)**, HEALTH PROMOTION SPECIALISTS, LLC, (U.S. CLS. 100 AND 101), SN 77-929,311. PUB. 2-15-2011. FILED 2-5-2010.  
 3,953,264 ( *See Class 5 for this trademark* ).  
 3,953,300. **PASSAGES (STANDARD CHARACTER)**, GRASSHOPPER HOUSE, LLC, MULTIPLE CLASS, (INT. CLS. 44 AND 45), (U.S. CLS. 100 AND 101), SN 77-942,696. PUB. 7-20-2010. FILED 2-23-2010.  
 3,953,330. **MASSACHUSETTS EYE AND EAR (STANDARD CHARACTER)**, MASSACHUSETTS EYE AND EAR INFIRMARY, (U.S. CLS. 100 AND 101), SN 77-949,023. PUB. 2-15-2011. FILED 3-3-2010.  
 3,953,343. **STEADMAN CLINIC (STANDARD CHARACTER)**, THE STEADMAN CLINIC, PROFESSIONAL LLC, (U.S. CLS. 100 AND 101), SN 77-950,074. PUB. 2-15-2011. FILED 3-3-2010.  
 3,953,345. **TEENS IN BALANCE (STANDARD CHARACTER)**, BODIMOJO, INC., (U.S. CLS. 100 AND 101), SN 77-950,239. PUB. 2-15-2011. FILED 3-4-2010.  
 3,953,351. **BIEBER (STANDARD CHARACTER)**, BIEBER, CRAIG J., (U.S. CLS. 100 AND 101), SN 77-950,929. PUB. 2-15-2011. FILED 3-4-2010.  
 3,953,416 ( *See Class 42 for this trademark* ).  
 3,953,421. **BEELOGICS (STANDARD CHARACTER)**, BEELOGICS INC., (U.S. CLS. 100 AND 101), SN 77-960,717. PUB. 2-15-2011. FILED 3-17-2010.  
 3,953,476 ( *See Class 5 for this trademark* ).  
 3,953,496 ( *See Class 3 for this trademark* ).  
 3,953,544 ( *See Class 35 for this trademark* ).  
 3,953,731. **THE WIZ QUIZ (STANDARD CHARACTER)**, THE WIZ QUIZ, LLC, (U.S. CLS. 100 AND 101), SN 85-014,547. PUB. 2-15-2011. FILED 4-15-2010.  
 3,953,851. **FITINCENTIVE AND DESIGN**, C3D PRODUCTIONS, INC., (U.S. CLS. 100 AND 101), SN 85-056,210. PUB. 2-15-2011. FILED 6-7-2010.  
 3,953,902. **PHARMACIST ON YOUR SIDE (STANDARD CHARACTER)**, SUN DRUG VILLAGE SQUARE, LTD., (U.S. CLS. 100 AND 101), SN 85-071,407. PUB. 1-11-2011. FILED 6-25-2010.  
 3,953,916 ( *See Class 41 for this trademark* ).  
 3,953,949. **EYECYCLOPEDIA (STANDARD CHARACTER)**, JOHN B. RUSH, (U.S. CLS. 100 AND 101), SN 85-083,868. PUB. 2-15-2011. FILED 7-13-2010.  
 3,953,952. **THE SLEEP MOM (STANDARD CHARACTER)**, BABYTIME, LLC, (U.S. CLS. 100 AND 101), SN 85-085,569. PUB. 2-15-2011. FILED 7-15-2010.  
 3,953,989 ( *See Class 9 for this trademark* ).  
 3,953,991. **CC CORNERSTONE CARES (STYLIZED)**, CORNERSTONE THERAPEUTICS INC., (U.S. CLS. 100 AND 101), SN 85-095,532. PUB. 2-15-2011. FILED 7-29-2010.  
 3,954,012. **THE SURROGACY & EGG DONATION CENTER PARTNERING FOR PARENTHOOD AND DESIGN**, CONCEPTUAL OPTIONS, LLC, (U.S. CLS. 100 AND 101), SN 85-098,936. PUB. 2-15-2011. FILED 8-3-2010.  
 3,954,021. **BODY EXOTIC AND DESIGN**, BIL BRIERLEY, (U.S. CLS. 100 AND 101), SN 85-100,592. PUB. 2-15-2011. FILED 8-5-2010.  
 3,954,022. **BC AND DESIGN**, BAUMAN CHIROPRACTIC CLINIC, P.L.L.C., AKA BAUMAN CHIROPRACTIC, (U.S. CLS. 100 AND 101), SN 85-100,927. PUB. 2-15-2011. FILED 8-5-2010.  
 3,954,052 ( *See Class 41 for this trademark* ).  
 3,954,067. **SOLEIL TANS SECOND TO THE SUN! AND DESIGN**, SOLEIL TANS, INC., (U.S. CLS. 100 AND 101), SN 85-106,814. PUB. 2-15-2011. FILED 8-13-2010.  
 3,954,163 ( *See Class 41 for this trademark* ).  
 3,954,173. **HOMEVET AND DESIGN**, JEFFREY FEINMAN, DBA HOMEVET, (U.S. CLS. 100 AND 101), SN 85-112,831. PUB. 2-15-2011. FILED 8-20-2010.  
 3,954,182. **COME SPA WITH US! (STANDARD CHARACTER)**, ZEN SPA ENTERPRISES INC., (U.S. CLS. 100 AND 101), SN 85-113,466. PUB. 2-15-2011. FILED 8-23-2010.  
 3,954,196. **TRUTH & TRIUMPH TATTOO TT AND DESIGN**, BRIAN'S SHOP LLC, (U.S. CLS. 100 AND 101), SN 85-114,045. PUB. 2-15-2011. FILED 8-23-2010.  
 3,954,208. **MOWJOBS AND DESIGN**, LEE, WILLIAM, (U.S. CLS. 100 AND 101), SN 85-114,318. PUB. 2-15-2011. FILED 8-24-2010.  
 3,954,233 ( *See Class 5 for this trademark* ).  
 3,954,261. **PINKALICIOUS SPARKLE SPA SALON CELEBRATIONS FF FF AND DESIGN**, PARTY BOUTIQUE, INC, DBA PINKALICIOUS DAY SPA AND SALON, (U.S. CLS. 100 AND 101), SN 85-115,371. PUB. 2-15-2011. FILED 8-25-2010.  
 3,954,294 ( *See Class 41 for this trademark* ).  
 3,954,378. **BEAUTY ADDIX MED SPA FOR MEN AND WOMEN AND DESIGN**, BEAUTY ADDIX LLC, (U.S. CLS. 100 AND 101), SN 85-117,421. PUB. 2-15-2011. FILED 8-27-2010.  
 3,954,415. **FACNJ (STANDARD CHARACTER)**, FOOT AND ANKLE CENTER OF NEW JERSEY, LLC, (U.S. CLS. 100 AND 101), SN 85-117,994. PUB. 2-15-2011. FILED 8-27-2010.  
 3,954,417. **I AND DESIGN**, EMERGENCY MEDICAL ASSOCIATES OF NEW JERSEY, (U.S. CLS. 100 AND 101), SN 85-118,095. PUB. 2-15-2011. FILED 8-28-2010.  
 3,954,428. **ENVIROMOW (STANDARD CHARACTER)**, ULRICH, PATRICK T., AND ULRICH, JOANNE V., (U.S. CLS. 100 AND 101), SN 85-118,240. PUB. 2-15-2011. FILED 8-29-2010.  
 3,954,443. **B@PEACE (STANDARD CHARACTER)**, SILVAN, JUDY, (U.S. CLS. 100 AND 101), SN 85-118,421. PUB. 2-15-2011. FILED 8-30-2010.  
 3,954,474. **MISCELLANEOUS DESIGN**, EATSTRONG, LLC, (U.S. CLS. 100 AND 101), SN 85-118,677. PUB. 2-15-2011. FILED 8-30-2010.  
 3,954,496 ( *See Class 3 for this trademark* ).  
 3,954,507. **VIRTIGO (STANDARD CHARACTER)**, LAMSON, RALPH J., (U.S. CLS. 100 AND 101), SN 85-118,938. PUB. 2-15-2011. FILED 8-30-2010.



- 3,954,561. **WE LIGHT THE WAY (STANDARD CHARACTER)**. HOSPICE OF HUNTINGTON, INC., (U.S. CLS. 100 AND 101). SN 85-119,576. PUB. 2-15-2011. FILED 8-31-2010.
- 3,954,609. **YOUR HOME OUR CARE (STANDARD CHARACTER)**. ASSISTING HANDS HOME CARE, LLC, (U.S. CLS. 100 AND 101). SN 85-120,145. PUB. 2-15-2011. FILED 8-31-2010.
- 3,954,626. **MOBILE PET VET (STANDARD CHARACTER)**. DENA D. BAKER, D.V.M., P.A., (U.S. CLS. 100 AND 101). SN 85-120,297. PUB. 2-15-2011. FILED 8-31-2010.
- 3,954,632. **A AND DESIGN**. AZUMI NAIL LLC, (U.S. CLS. 100 AND 101). SN 85-120,385. PUB. 2-15-2011. FILED 8-31-2010.
- 3,954,713. **SMOKENDERS AND DESIGN**. PETER N. ROGERS, DBA SMOKENDERS USA, (U.S. CLS. 100 AND 101). SN 85-121,153. PUB. 2-15-2011. FILED 9-1-2010.
- 3,954,714. **SMOKENDERS (STANDARD CHARACTER)**. PETER N. ROGERS, DBA SMOKENDERS USA, (U.S. CLS. 100 AND 101). SN 85-121,157. PUB. 2-15-2011. FILED 9-1-2010.
- 3,954,719 ( *See Class 16 for this trademark*).
- 3,954,725. **POINT OF ORIGIN HEALING (STANDARD CHARACTER)**. THE GROWTH CORPORATION, (U.S. CLS. 100 AND 101). SN 85-121,338. PUB. 2-15-2011. FILED 9-1-2010.
- 3,954,817. **CHIROCHI (STANDARD CHARACTER)**. MIGDAL, DR. LYNN, (U.S. CLS. 100 AND 101). SN 85-122,432. PUB. 2-15-2011. FILED 9-3-2010.
- 3,954,818. **RAD TO THE BONE (STANDARD CHARACTER)**. MUSCULOSKELETAL IMAGING CONSULTANTS LLC, (U.S. CLS. 100 AND 101). SN 85-122,438. PUB. 2-15-2011. FILED 9-3-2010.
- 3,954,826. **CPAM (STANDARD CHARACTER)**. THE METHODIST HOSPITAL, (U.S. CLS. 100 AND 101). SN 85-122,554. PUB. 2-15-2011. FILED 9-3-2010.
- 3,954,886. **SCRUBANTHROPY (STANDARD CHARACTER)**. GREGORY LILIE, (U.S. CLS. 100 AND 101). SN 85-123,308. PUB. 2-15-2011. FILED 9-3-2010.
- 3,954,895. **GWENEVANS.COM (STANDARD CHARACTER)**. EVANS, GWENDOLYN LENORA W, MULTIPLE CLASS, (INT. CLS. 44 AND 45), (U.S. CLS. 100 AND 101). SN 85-123,414. PUB. 2-15-2011. FILED 9-5-2010.
- 3,954,986. **SMARTBOMB TATTOO AND DESIGN**. BRIAN'S SHOP LLC, (U.S. CLS. 100 AND 101). SN 85-129,596. PUB. 2-15-2011. FILED 9-14-2010.
- 3,955,009 ( *See Class 41 for this trademark*).
- 3,955,015. **V AND DESIGN**. THE VANDERBILT UNIVERSITY, (U.S. CLS. 100 AND 101). SN 85-134,427. PUB. 2-15-2011. FILED 9-21-2010.
- 3,955,089 ( *See Class 41 for this trademark*).
- 3,955,091 ( *See Class 41 for this trademark*).
- 3,955,132. **A (STANDARD CHARACTER)**. EMERGENCY MEDICAL ASSOCIATES OF NEW JERSEY, (U.S. CLS. 100 AND 101). SN 85-170,883. PUB. 2-15-2011. FILED 11-6-2010.
- 3,955,134. **R AND DESIGN**. EMERGENCY MEDICAL ASSOCIATES OF NEW JERSEY, (U.S. CLS. 100 AND 101). SN 85-170,893. PUB. 2-15-2011. FILED 11-6-2010.
- 3,955,143. **SOUNDFOREST AND DESIGN**. SOUNDFOREST, INC., (U.S. CLS. 100 AND 101). SN 85-179,651. PUB. 2-15-2011. FILED 11-18-2010.
- 3,955,145. **MISCELLANEOUS DESIGN**. HOLISTIC PHYSICAL THERAPY SERVICES INC., (U.S. CLS. 100 AND 101). SN 85-183,564. PUB. 2-15-2011. FILED 11-23-2010.
- 3,953,562 ( *See Class 29 for this trademark*).
- 3,953,680 ( *See Class 25 for this trademark*).
- 3,953,681 ( *See Class 25 for this trademark*).
- 3,953,682 ( *See Class 42 for this trademark*).
- 3,953,683 ( *See Class 42 for this trademark*).
- 3,953,684 ( *See Class 16 for this trademark*).
- 3,953,711 ( *See Class 9 for this trademark*).
- 3,953,717. **OPERATION ENDURING CARE (STANDARD CHARACTER)**. UNITED SERVICE ORGANIZATIONS, INC., (U.S. CLS. 100 AND 101). SN 85-008,041. PUB. 2-15-2011. FILED 4-7-2010.
- 3,953,722 ( *See Class 16 for this trademark*).
- 3,953,787. **TRUNK CLUB (STANDARD CHARACTER)**. TRUNK CLUB, INC., (U.S. CLS. 100 AND 101). SN 85-034,671. PUB. 2-15-2011. FILED 5-10-2010.
- 3,953,861. **VIRTUALWAY (STANDARD CHARACTER)**. VIRTUALWAY, LLC, (U.S. CLS. 100 AND 101). SN 85-058,608. PUB. 2-15-2011. FILED 6-9-2010.
- 3,953,897. **COOKING UNDER PRESSURE (STANDARD CHARACTER)**. HOME INSTEAD, INC., (U.S. CLS. 100 AND 101). SN 85-070,375. PUB. 2-15-2011. FILED 6-24-2010.
- 3,953,927. **FCI INVESTIGATIONS WHERE VIDEO AND INFORMATION ARE KING AND DESIGN**. ANLEU, SALLY A, DBA F.C.I. FRAUDULENT CLAIMS INVESTIGATIONS, (U.S. CLS. 100 AND 101). SN 85-076,968. PUB. 2-15-2011. FILED 7-2-2010.
- 3,953,984. **WHERE'S SINGLES ARE (STANDARD CHARACTER)**. KENNEDY DATA CENTER INC, (U.S. CLS. 100 AND 101). SN 85-093,511. PUB. 2-15-2011. FILED 7-27-2010.
- 3,954,007 ( *See Class 35 for this trademark*).
- 3,954,050 ( *See Class 42 for this trademark*).
- 3,954,066. **BIBLE METHODIST CONNECTION OF CHURCHES (STANDARD CHARACTER)**. TWELVE STONES GROUP LLC, (U.S. CLS. 100 AND 101). SN 85-106,777. PUB. 2-15-2011. FILED 8-13-2010.
- 3,954,068. **HELPING YOUR BUSINESS WORK FOR YOU (STANDARD CHARACTER)**. MERGING ADMINISTRATIVE SOLUTIONS, INC., (U.S. CLS. 100 AND 101). SN 85-106,837. PUB. 2-15-2011. FILED 8-13-2010.
- 3,954,108. **PROCARE HOME AND PET SERVICES AND DESIGN**. PROCARE HOME AND PET SERVICES LLC, (U.S. CLS. 100 AND 101). SN 85-109,906. PUB. 2-15-2011. FILED 8-18-2010.
- 3,954,171 ( *See Class 42 for this trademark*).
- 3,954,193. **EQUITES PROTECTION SERVICES AND DESIGN**. JOSE MARRERO, DBA EQUITES PROTECTION SERVICES, (U.S. CLS. 100 AND 101). SN 85-113,947. PUB. 2-15-2011. FILED 8-23-2010.
- 3,954,201. **MISCELLANEOUS DESIGN**. IAN R MOISE, DBA REUSE CONNECTION, (U.S. CLS. 100 AND 101). SN 85-114,128. PUB. 2-15-2011. FILED 8-24-2010.
- 3,954,256 ( *See Class 41 for this trademark*).
- 3,954,301. **PROTECTOR (STANDARD CHARACTER)**. CSI-IDENTITY CORPORATION, (U.S. CLS. 100 AND 101). SN 85-116,284. PUB. 2-15-2011. FILED 8-26-2010.
- 3,954,304 ( *See Class 4 for this trademark*).
- 3,954,429. **LEGAFI (STANDARD CHARACTER)**. TOP CLASS ACTIONS LLC, (U.S. CLS. 100 AND 101). SN 85-118,243. PUB. 2-15-2011. FILED 8-29-2010.
- 3,954,489. **MPD AND DESIGN**. MILLS PASKERT DIVERS, P.A., (U.S. CLS. 100 AND 101). SN 85-118,802. PUB. 2-15-2011. FILED 8-30-2010.
- 3,954,500. **JUNTOS HACEMOS LA DIFERENCIA (STANDARD CHARACTER)**. FADDIS & FADDIS, P.A., (U.S. CLS. 100 AND 101). SN 85-118,867. PUB. 2-15-2011. FILED 8-30-2010.
- 3,954,623. **RAINMAKER RESOLUTION ALONG INTERNATIONAL NEGOTIATION MEDIATION ARBITRATION KINDLES ENRICHED RELATIONSHIPS (STANDARD CHARACTER)**. AGENCY FOR DISPUTE RESOLUTION, INC., (U.S. CLS. 100 AND 101). SN 85-120,271. PUB. 2-15-2011. FILED 8-31-2010.
- 3,954,684. **TRIP TROT TING (STANDARD CHARACTER)**. TRIP TROT TING INC., (U.S. CLS. 100 AND 101). SN 85-120,822. PUB. 2-15-2011. FILED 9-1-2010.
- 3,954,688. **MISCELLANEOUS DESIGN**. LILENFELD PC, (U.S. CLS. 100 AND 101). SN 85-120,856. PUB. 2-15-2011. FILED 9-1-2010.

#### CLASS 45—PERSONAL AND LEGAL SERVICES

- 3,952,959 ( *See Class 35 for this trademark*).
- 3,953,215 ( *See Class 35 for this trademark*).
- 3,953,234 ( *See Class 41 for this trademark*).
- 3,953,286 ( *See Class 35 for this trademark*).
- 3,953,300 ( *See Class 44 for this trademark*).
- 3,953,306 ( *See Class 16 for this trademark*).
- 3,953,428. **ALUMNICLASS (STANDARD CHARACTER)**. ALUMNICLASS.COM INC, (U.S. CLS. 100 AND 101). SN 77-961,474. PUB. 2-15-2011. FILED 3-17-2010.
- 3,953,528 ( *See Class 35 for this trademark*).

- 3,954,695. **CREATIVELY PROTECTING IDEAS (STANDARD CHARACTER)**. RYLANDER & ASSOCIATES PC, (U.S. CLS. 100 AND 101), SN 85-120,921. PUB. 2-15-2011. FILED 9-1-2010.
- 3,954,749. **AVANTI LAW GROUP (STANDARD CHARACTER)**. AVANTI LAW GROUP, PLLC, (U.S. CLS. 100 AND 101), SN 85-121,670. PUB. 2-15-2011. FILED 9-2-2010.
- 3,954,809. **CW (STYLIZED)**. CONNER & WINTERS, LLP, (U.S. CLS. 100 AND 101), SN 85-122,347. PUB. 2-15-2011. FILED 9-2-2010.
- 3,954,853. **MISCELLANEOUS DESIGN**. KIDS CENTRAL, INC., (U.S. CLS. 100 AND 101), SN 85-122,859. PUB. 2-15-2011. FILED 9-3-2010.
- 3,954,855. **MISCELLANEOUS DESIGN**. KIDS CENTRAL, INC., (U.S. CLS. 100 AND 101), SN 85-122,892. PUB. 2-15-2011. FILED 9-3-2010.
- 3,954,857. **BUILDING BETTER LIVES (STANDARD CHARACTER)**. KIDS CENTRAL, INC., (U.S. CLS. 100 AND 101), SN 85-122,903. PUB. 2-15-2011. FILED 9-3-2010.
- 3,954,895 ( *See Class 44 for this trademark*).
- 3,954,897. **MANNA FOR MOMS (STANDARD CHARACTER)**. BREEDLOVE, MEGAN SUZANNE, (U.S. CLS. 100 AND 101), SN 85-123,450. PUB. 2-15-2011. FILED 9-5-2010.
- 3,955,010. **AURM (STANDARD CHARACTER)**. THE UPPER ROOM, (U.S. CLS. 100 AND 101), SN 85-133,438. PUB. 2-15-2011. FILED 9-20-2010.
- 3,955,061 ( *See Class 9 for this trademark*).
- 3,955,063 ( *See Class 9 for this trademark*).
- 3,955,089 ( *See Class 41 for this trademark*).
- 3,955,091 ( *See Class 41 for this trademark*).

\* \* \* \* \*

## SECTION 2.—PRIOR UNITED STATES CLASSIFICATION

### CERTIFICATION MARKS

GREEN BUILDING COUNCIL, SN 77-949,485. PUB. 2-15-2011. FILED 3-3-2010.

### CLASS B—SERVICES

3,953,333. **LEED PLATINUM (STANDARD CHARACTER)**. U.S. GREEN BUILDING COUNCIL, SN 77-949,480. PUB. 2-15-2011. FILED 3-3-2010.

3,953,335. **LEED SILVER (STANDARD CHARACTER)**. U.S. GREEN BUILDING COUNCIL, SN 77-949,490. PUB. 2-15-2011. FILED 3-3-2010.

3,953,334. **LEED GOLD (STANDARD CHARACTER)**. U.S.

\* \* \* \* \*

# TRADEMARK REGISTRATIONS ISSUED UNDER SECTION 1(d)

The following marks have registered on the Principal Register pursuant to the intent-to-use provisions of Section 1(d) of the Trademark Act of 1946, as amended.

## SECTION 1.— INTERNATIONAL CLASSIFICATION

The short titles associated below with the international class numbers are terms designed merely for quick identification and are not an official part of the international classification. The full names of international classes are given in section 6.1 of the trademark rules of practice.

The designation "U.S. Cl." appearing in this section refers to the U.S. class in effect prior to Sep. 1, 1973 rather than the international class which applies to applications filed on or after that date. For adoption of international classification see notice in the OFFICIAL GAZETTE of Jun. 26, 1973 (911 O.G. TM 210).

### Application in more than one class

3,955,153. SJP, LLC, JACKSONVILLE, FL. SN 76-620,346.  
PUB. 7-25-2006, FILED 11-12-2004.

USE "INTERNATIONAL", APART FROM THE MARK AS SHOWN.

## SILVERLEAF

THE MARK CONSISTS OF STANDARD CHARACTERS WITHOUT CLAIM TO ANY PARTICULAR FONT, STYLE, SIZE, OR COLOR.

REGISTRATION LIMITED TO THE AREA COMPRISING THE UNITED STATES EAST OF THE MISSISSIPPI RIVER PURSUANT TO CONCURRENT USE PROCEEDING NO. 94002310. CONCURRENT USE WITH DC RANCH, LLC, APPLICATION SERIAL NO. 78554028.

### CLASS 19—NON-METALLIC BUILDING MATERIALS

FOR WOODEN FLOORING (U.S. CLS. 1, 12, 33 AND 50).  
FIRST USE 2-0-2010; IN COMMERCE 2-0-2010.

### CLASS 20—FURNITURE AND ARTICLES NOT OTHERWISE CLASSIFIED

FOR FURNITURE, NAMELY, VANITIES (U.S. CLS. 2, 13, 22, 25, 32 AND 50).  
FIRST USE 2-0-2010; IN COMMERCE 2-0-2010.

### CLASS 36—INSURANCE AND FINANCIAL

FOR REAL ESTATE MANAGEMENT SERVICES, NAMELY, THE OPERATION OF A PLANNED COMMUNITY (U.S. CLS. 100, 101 AND 102).  
FIRST USE 9-30-2004; IN COMMERCE 9-30-2004.

3,955,155. FLEMING, JOSEPH, NEW YORK, NY. SN 76-676,051. PUB. 3-18-2008, FILED 4-26-2007.

### CLASS 37—CONSTRUCTION AND REPAIR

FOR LAND DEVELOPMENT SERVICES, NAMELY, CONSTRUCTION OF A PLANNED COMMUNITY DEVELOPMENT OF MIXED USE, GATED AND UNGATED RESIDENTIAL, OFFICE, RETAIL, AND INDUSTRIAL PROPERTIES (U.S. CLS. 100, 103 AND 106).  
FIRST USE 9-30-2004; IN COMMERCE 9-30-2004.



We Make Music With a Conscious Message

3,955,154. FLOORCO INTERNATIONAL (NORTH AMERICA) INC., SHEPHERDSVILLE, KY. SN 76-673,311. PUB. 10-9-2007, FILED 2-28-2007.

### HERITAGE HOUSE INTERNATIONAL

THE MARK CONSISTS OF STANDARD CHARACTERS WITHOUT CLAIM TO ANY PARTICULAR FONT, STYLE, SIZE, OR COLOR.  
NO CLAIM IS MADE TO THE EXCLUSIVE RIGHT TO

### CLASS 9—ELECTRICAL AND SCIENTIFIC APPARATUS

FOR CD AND ALBUM COVERS, NAMELY, CD CASES; MUSICAL SOUND RECORDINGS, MUSICAL VIDEO RECORDINGS VIDEO RECORDINGS FEATURING MUSIC (U.S. CLS. 21, 23, 26, 36 AND 38).  
FIRST USE 5-24-2005; IN COMMERCE 5-24-2005.

**CLASS 16—PAPER GOODS AND PRINTED MATTER**

FOR POSTERS (U.S. CLS. 2, 5, 22, 23, 29, 37, 38 AND 50).  
FIRST USE 5-24-2005; IN COMMERCE 5-24-2005.

3,955,159. S/L LIFEHOPE TRADEMARK, LLC, ATLANTA, GA. SN 76-694,651. PUB. 1-12-2010, FILED 12-4-2008.

**Life & Wellness**

THE MARK CONSISTS OF STANDARD CHARACTERS WITHOUT CLAIM TO ANY PARTICULAR FONT, STYLE, SIZE, OR COLOR.

NO CLAIM IS MADE TO THE EXCLUSIVE RIGHT TO USE "WELLNESS", APART FROM THE MARK AS SHOWN.

**CLASS 3—COSMETICS AND CLEANING PREPARATIONS**

FOR LIP BALM (U.S. CLS. 1, 4, 6, 50, 51 AND 52).  
FIRST USE 10-15-2010; IN COMMERCE 10-15-2010.

**CLASS 5—PHARMACEUTICALS**

FOR FOOD FOR DIABETICS; FOOD FOR MEDICALLY RESTRICTED DIETS; NUTRITIONAL ENERGY BARS FOR USE AS A MEAL SUBSTITUTE (U.S. CLS. 6, 18, 44, 46, 51 AND 52).  
FIRST USE 10-15-2010; IN COMMERCE 10-15-2010.

**CLASS 25—CLOTHING**

FOR BASEBALL CAPS; HEADWEAR (U.S. CLS. 22 AND 39).  
FIRST USE 10-15-2010; IN COMMERCE 10-15-2010.

**CLASS 28—TOYS AND SPORTING GOODS**

FOR ATHLETIC SPORTING GOODS, NAMELY, ATHLETIC WRIST AND JOINT SUPPORTS (U.S. CLS. 22, 23, 38 AND 50).  
FIRST USE 10-15-2010; IN COMMERCE 10-15-2010.

**CLASS 29—MEATS AND PROCESSED FOODS**

FOR FRUIT AND SOY BASED SNACK FOOD (U.S. CL. 46).  
FIRST USE 10-15-2010; IN COMMERCE 10-15-2010.

**CLASS 32—LIGHT BEVERAGES**

FOR AERATED FRUIT JUICES; AERATED WATER; BOTTLED WATER; DISTILLED DRINKING WATER; ENERGY DRINKS; FLAVORED BOTTLED WATER; FRUIT DRINKS AND JUICES; MINERAL WATER; QUININE WATER; SOFT DRINKS; SPORTS DRINKS (U.S. CLS. 45, 46 AND 48).  
FIRST USE 5-26-2010; IN COMMERCE 5-26-2010.

**CLASS 35—ADVERTISING AND BUSINESS**

FOR BUSINESS MANAGEMENT CONSULTING WITH RELATION TO STRATEGY, MARKETING, PRODUCTION, PERSONNEL AND RETAIL SALE MATTERS; MANAGEMENT OF HEALTH CARE CLINICS FOR OTHERS (U.S. CLS. 100, 101 AND 102).  
FIRST USE 10-15-2010; IN COMMERCE 10-15-2010.

**CLASS 43—HOTEL AND RESTAURANT SERVICES**

FOR PREPARATION OF FOOD AND BEVERAGES (U.S. CLS. 100 AND 101).  
FIRST USE 6-11-2008; IN COMMERCE 6-11-2008.

3,955,170. STURGIS MOTORCYCLE RALLY, INC., STURGIS, SD. SN 76-979,109. PUB. 9-3-2002, FILED 1-30-2001.

**BLACK HILLS**

OWNER OF U.S. REG. NO. 1,948,097.  
SEC. 2(F).

**CLASS 6—METAL GOODS**

FOR METAL KEY RINGS, ALL OF THE AFOREMENTIONED GOODS RELATING TO THE STURGIS MOTORCYCLE RALLY (U.S. CLS. 2, 12, 13, 14, 23, 25 AND 50).  
FIRST USE 8-31-2006; IN COMMERCE 8-31-2006.

**CLASS 9—ELECTRICAL AND SCIENTIFIC APPARATUS**

FOR SUNGLASSES, MAGNETS AND PROTECTIVE HELMETS, ALL OF THE AFOREMENTIONED GOODS RELATING TO THE STURGIS MOTORCYCLE RALLY (U.S. CLS. 21, 23, 26, 36 AND 38).  
FIRST USE 8-31-1995; IN COMMERCE 8-31-1995.

**CLASS 13—FIREARMS**

FOR FIREARMS, ALL OF THE AFOREMENTIONED GOODS RELATING TO THE STURGIS MOTORCYCLE RALLY (U.S. CLS. 2 AND 9).  
FIRST USE 6-30-1998; IN COMMERCE 6-30-1998.

**CLASS 14—JEWELRY**

FOR JEWELRY AND CLOCKS, ALL OF THE AFOREMENTIONED GOODS RELATING TO THE STURGIS MOTORCYCLE RALLY (U.S. CLS. 2, 27, 28 AND 50).  
FIRST USE 6-30-2010; IN COMMERCE 6-30-2010.

**CLASS 16—PAPER GOODS AND PRINTED MATTER**

FOR PENS; AND PAPER GOODS AND PRINTED MATTER, NAMELY, POSTERS; BUMPER STICKERS; DECALS; IRON-ON AND PLASTIC TRANSFERS; WINDOW STICKERS; NOTE PADS; MOUNTED PHOTOGRAPHS; UNMOUNTED PHOTOGRAPHS; PRINTS, NAMELY, COLOR PRINTS, PHOTOGRAPHIC PRINTS, AND PICTORIAL PRINTS; PAPER AND PLASTIC BAGS FOR PACKAGING; AND POSTCARDS; ALL OF THE AFOREMENTIONED GOODS RELATING TO THE STURGIS MOTORCYCLE RALLY (U.S. CLS. 2, 5, 22, 23, 29, 37, 38 AND 50).  
FIRST USE 8-31-1987; IN COMMERCE 8-31-1987.

**CLASS 20—FURNITURE AND ARTICLES NOT OTHERWISE CLASSIFIED**

FOR NON-METAL KEY RINGS AND JEWELRY BOXES NOT OF METAL, ALL OF THE AFOREMENTIONED GOODS RELATING TO THE STURGIS MOTORCYCLE RALLY (U.S. CLS. 2, 13, 22, 25, 32 AND 50).  
FIRST USE 8-31-2002; IN COMMERCE 8-31-2002.

**CLASS 21—HOUSEWARES AND GLASS**

FOR GLASSWARE, NAMELY, SHOT GLASSES, DRINKING GLASSES, DRINKING CUPS, AND DRINKING MUGS; INSULATING SLEEVE HOLDERS MADE OF RUBBER, PLASTIC OR FOAM FOR BEVERAGE CANS; INSULATING SLEEVE HOLDERS MADE OF RUBBER, PLASTIC OR FOAM FOR BEVERAGE BOTTLES; COASTERS NOT OF PAPER AND NOT BEING TABLE LINEN; BOTTLE OPENERS; AND BEER STEINS; ALL OF THE AFOREMENTIONED GOODS RELATING TO THE STURGIS MOTORCYCLE RALLY (U.S. CLS. 2, 13, 23, 29, 30, 33, 40 AND 50).

FIRST USE 8-31-1995; IN COMMERCE 8-31-1995.

**CLASS 24—FABRICS**

FOR CLOTH FLAGS AND QUILTS, ALL OF THE AFOREMENTIONED GOODS RELATING TO THE STURGIS MOTORCYCLE RALLY (U.S. CLS. 42 AND 50).

FIRST USE 8-30-2004; IN COMMERCE 8-30-2004.

**CLASS 25—CLOTHING**

FOR CLOTHING, NAMELY, SHIRTS, T-SHIRTS, LONG SLEEVE T-SHIRTS, SLEEVELESS T-SHIRTS, DENIM SHIRTS, HENLEY SHIRTS, KNIT SHIRTS, SPORT SHIRTS, GOLF SHIRTS, JACKETS, COATS, TANK TOPS, POLO SHIRTS, SWEATSHIRTS, PULL-OVERS, WOMEN'S TOPS, CHEMISES, CLOTH WRAPS, HEAD WEAR, BANDANNAS, CAPS, CLOTH HEADWRAPS, HATS, SCARVES, BELTS, CHAPS, GLOVES, AND SUN VISORS, ALL OF THE AFOREMENTIONED GOODS RELATING TO THE STURGIS MOTORCYCLE RALLY (U.S. CLS. 22 AND 39).

FIRST USE 8-31-1986; IN COMMERCE 8-31-1986.

**CLASS 26—FANCY GOODS**

FOR CLOTH AND EMBROIDERED PATCHES FOR CLOTHING, ORNAMENTAL CLOTH PATCHES, HAT PINS FOR SECURING HATS, BELT BUCKLES NOT OF PRECIOUS METAL, AND NOVELTY PINS, ALL OF THE AFOREMENTIONED GOODS RELATING TO THE STURGIS MOTORCYCLE RALLY (U.S. CLS. 37, 39, 40, 42 AND 50).

FIRST USE 8-31-1986; IN COMMERCE 8-31-1986.

**CLASS 28—TOYS AND SPORTING GOODS**

FOR CHRISTMAS TREE ORNAMENTS AND GAMING CHIPS, ALL OF THE AFOREMENTIONED GOODS RELATING TO THE STURGIS MOTORCYCLE RALLY (U.S. CLS. 22, 23, 38 AND 50).

FIRST USE 6-30-2001; IN COMMERCE 6-30-2001.

**CLASS 32—LIGHT BEVERAGES**

FOR BOTTLED WATER AND BEER, ALL OF THE AFOREMENTIONED GOODS RELATING TO THE STURGIS MOTORCYCLE RALLY (U.S. CLS. 45, 46 AND 48).

FIRST USE 6-30-2005; IN COMMERCE 6-30-2005.

**CLASS 33—WINES AND SPIRITS**

FOR DISTILLED LIQUOR, ALL OF THE AFOREMENTIONED GOODS RELATING TO THE STURGIS MOTORCYCLE RALLY (U.S. CLS. 47 AND 49).

FIRST USE 6-30-2002; IN COMMERCE 6-30-2002.

**CLASS 34—SMOKERS' ARTICLES**

FOR ASHTRAYS NOT OF PRECIOUS METAL AND CIGARETTE LIGHTERS NOT OF PRECIOUS METAL, ALL OF THE AFOREMENTIONED GOODS RELATING TO THE STURGIS MOTORCYCLE RALLY (U.S. CLS. 2, 8, 9 AND 17).

FIRST USE 6-30-2007; IN COMMERCE 6-30-2007.

**CLASS 35—ADVERTISING AND BUSINESS**

FOR PROMOTING SPORTS COMPETITIONS AND CONDUCTING EVENTS OF OTHERS, NAMELY, MOTORCYCLE AND VEHICLE RALLIES, EXHIBITS, AND COMPETITIONS; PROMOTING ECONOMIC DEVELOPMENT IN THE CITY OF STURGIS AND THE BLACK HILLS AREA OF SOUTH DAKOTA AND WYOMING; AND ON-LINE RETAIL STORE SERVICES (U.S. CLS. 100, 101 AND 102).

FIRST USE 6-30-2002; IN COMMERCE 6-30-2002.

**CLASS 41—EDUCATION AND ENTERTAINMENT**

FOR ENTERTAINMENT SERVICES IN THE NATURE OF ORGANIZING, SPONSORING, AND CONDUCTING A MOTORCYCLE AND VEHICLE EXHIBITIONS AND RALLIES; AND ENTERTAINMENT SERVICES IN THE NATURE OF ORGANIZING, SPONSORING AND CONDUCTING CIVIC PRODUCTIONS AND LIVE MUSIC CONCERTS (U.S. CLS. 100, 101 AND 107).

FIRST USE 6-30-2002; IN COMMERCE 6-30-2002.

---

3,955,175. ITALIA FOODS, INC., SCHAUMBURG, IL. SN 77-055,388. PUB. 9-11-2007, FILED 12-1-2006.

VALLO DIANO

THE MARK CONSISTS OF STANDARD CHARACTERS WITHOUT CLAIM TO ANY PARTICULAR FONT, STYLE, SIZE, OR COLOR.

THE NAME(S), PORTRAIT(S), AND/OR SIGNATURE(S) SHOWN IN THE MARK DOES NOT IDENTIFY A PARTICULAR LIVING INDIVIDUAL.

THE FOREIGN WORDING IN THE MARK TRANSLATES INTO ENGLISH AS FOLLOWS; "VALLO": BANK, PARAPET, RAMPART OR RAMPARTS; AND "DIANO" IS THE SAME IN ENGLISH AS IN ITALIAN.

**CLASS 29—MEATS AND PROCESSED FOODS**

FOR FRESH, CURED OR FROZEN ENTREES CONSISTING PRIMARILY OF MEAT, CHICKEN AND EGG-PLANT WITH AND WITHOUT CHEESE (U.S. CL. 46).

FIRST USE 7-30-2007; IN COMMERCE 7-30-2007.

**CLASS 30—STAPLE FOODS**

FOR FRESH OR FROZEN ENTREES, CONSISTING PRIMARILY OF PASTA, ALSO CONTAINING MEAT, CHEESE AND/OR VEGETABLES; FRESH AND FROZEN PASTA, BUT SPECIFICALLY EXCLUDING PIZZAS, STROMBOLIS AND/OR CALZONES (U.S. CL. 46).

FIRST USE 7-30-2007; IN COMMERCE 7-30-2007.

3,955,178. A&R CARTON AB, LUND, SWEDEN. SN 77-070,125. PUB. 4-29-2008, FILED 12-22-2006.

3,955,179. AZUNA, LLC, JENKINTOWN, PA. SN 77-075,082. PUB. 12-25-2007, FILED 1-3-2007.



THE MARK CONSISTS OF THE LETTERS "AR" IN STYLIZED FORM.

#### CLASS 7—MACHINERY

FOR MACHINES FOR PRODUCING PACKAGES AND CLOSING DEVICES FOR PACKAGES; MACHINES FOR FILLING, CLOSING OR SEALING CONTAINERS AND PACKAGES; MACHINES FOR CUTTING CARDBOARD, PAPER ARTICLES, CARDBOARD ARTICLES AND CARDBOARD AND PAPER LAMINATES; MACHINES FOR FOLDING; MACHINES FOR PRODUCING PACKAGING CONTAINERS; PARTS AND FITTINGS FOR ALL THE AFORESAID GOODS NOT INCLUDED IN OTHER CLASSES (U.S. CLS. 13, 19, 21, 23, 31, 34 AND 35).  
FIRST USE 12-0-2000; IN COMMERCE 12-0-2000.

#### CLASS 16—PAPER GOODS AND PRINTED MATTER

FOR PAPER, CARDBOARD; PAPER ARTICLES AND CARDBOARD ARTICLES, ALL FOR PACKAGING PURPOSES; CARDBOARD PACKAGING; CONTAINERS OF CARDBOARD AND PAPER; PRINTED INSTRUCTIONAL AND TEACHING MATERIALS IN THE FIELD OF PACKAGING, BROCHURES IN THE FIELD OF PACKAGING PRODUCTS; PAPER CLOSURES FOR CONTAINERS (U.S. CLS. 2, 5, 22, 23, 29, 37, 38 AND 50).  
FIRST USE 12-0-2000; IN COMMERCE 12-0-2000.

#### CLASS 17—RUBBER GOODS

FOR LAMINATES OF PLASTIC WITH PAPER OR WITH CARDBOARD FOR USE IN THE MANUFACTURE OF CONTAINERS AND PACKAGES; PLASTIC IN THE FORM OF FOILS AND OF LAMINATE SHEETS ALL FOR USE IN THE MANUFACTURE OF CONTAINERS AND PACKAGES; BLANKS IN THE FORM OF FOILS AND OF LAMINATES FOR FORMING CONTAINERS AND PACKAGES MADE OF LAMINATED PLASTIC (U.S. CLS. 1, 5, 12, 13, 35 AND 50).  
FIRST USE 12-0-2000; IN COMMERCE 12-0-2000.

#### CLASS 20—FURNITURE AND ARTICLES NOT OTHERWISE CLASSIFIED

FOR ARTICLES MADE OF PLASTIC OR OF LAMINATED PLASTIC MATERIALS FOR PACKAGING PURPOSES, NAMELY, BOXES AND CONTAINERS; CONTAINERS MADE OF PLASTIC OR OF LAMINATED PLASTIC MATERIALS FOR PACKAGING PURPOSES; PLASTIC CAPS FOR CONTAINERS; PLASTIC CLOSURES FOR CONTAINERS AND PACKAGES (U.S. CLS. 2, 13, 22, 25, 32 AND 50).  
FIRST USE 12-0-2000; IN COMMERCE 12-0-2000.

# AZUNA

THE MARK CONSISTS OF STANDARD CHARACTERS WITHOUT CLAIM TO ANY PARTICULAR FONT, STYLE, SIZE, OR COLOR.

THE WORDING "AZUNA" HAS NO MEANING OTHER THAN TRADEMARK SIGNIFICANCE.

#### CLASS 16—PAPER GOODS AND PRINTED MATTER

FOR DECALS, PRINTED INSERTS FEATURING PROMOTIONS, PRODUCT INTRODUCTIONS AND CORPORATE BRANDING; DIRECT MAILING PROMOTIONAL CARDS WITHOUT MAGNETIC ENCODING, FOLDERS, STATIONERY-TYPE PORTFOLIOS, NOTEBOOK COVERS, POSTCARDS, CHRISTMAS CARDS, AND GREETING CARDS (U.S. CLS. 2, 5, 22, 23, 29, 37, 38 AND 50).  
FIRST USE 6-0-2009; IN COMMERCE 6-0-2009.

#### CLASS 35—ADVERTISING AND BUSINESS

FOR 3D MEDIA SERVICES, NAMELY, PROVIDING ADVERTISING SERVICES USING 3D DESIGNS; PREPARATION OF CUSTOM 3D ADVERTISEMENTS FOR OTHERS (U.S. CLS. 100, 101 AND 102).  
FIRST USE 0-0-2006; IN COMMERCE 0-0-2006.

3,955,183. CHEMISCHE FABRIK KREUSSLER & CO. GMBH, WIESBADEN, FED REP GERMANY. SN 77-103,372. PUB. 12-18-2007, FILED 2-9-2007.

# EasyFoam

THE MARK CONSISTS OF STANDARD CHARACTERS WITHOUT CLAIM TO ANY PARTICULAR FONT, STYLE, SIZE, OR COLOR.

#### CLASS 5—PHARMACEUTICALS

FOR MEDICAL DRUGS, NAMELY, FOAMING OR FOAMABLE MEDICATIONS FOR SCLEROTHERAPY (U.S. CLS. 6, 18, 44, 46, 51 AND 52).  
FIRST USE 6-0-2005; IN COMMERCE 3-2-2011.

#### CLASS 10—MEDICAL APPARATUS

FOR MEDICAL INSTRUMENTS AND DEVICES, NAMELY, DEVICES FOR THE GENERATION AND APPLICATION OF FOAM FOR THE TREATMENT OF SCLEROSIS (U.S. CLS. 26, 39 AND 44).  
FIRST USE 6-0-2005; IN COMMERCE 3-2-2011.

3,955,185. TRAVELHOST, INC., DALLAS, TX. SN 77-126,455.  
PUB. 2-19-2008, FILED 3-9-2007.

## MY TRAVELHOST

THE MARK CONSISTS OF STANDARD CHARACTERS WITHOUT CLAIM TO ANY PARTICULAR FONT, STYLE, SIZE, OR COLOR.

OWNER OF U.S. REG. NOS. 1,092,284, 2,047,517, AND OTHERS.

### CLASS 35—ADVERTISING AND BUSINESS

FOR PROVIDING HOTEL RATE COMPARISON INFORMATION; COMPUTERIZED ON-LINE RETAIL STORE SERVICES IN THE FIELD OF TRAVEL-RELATED GOODS AND SERVICES; PROVIDING ONLINE INFORMATION FEATURING INFORMATION REGARDING GIFT REGISTRIES; ADVERTISING, NAMELY, PROVIDING ADVERTISING SPACE VIA THE GLOBAL COMPUTER NETWORK; PROMOTING THE GOODS AND SERVICES OF OTHERS BY LINKS TO THE RETAIL WEB SITES OF OTHERS; ONLINE SHOPPING INFORMATION, NAMELY, SHOPPERS' GUIDE INFORMATION; PROVIDING PRICE COMPARISON SHOPPING INFORMATION VIA THE INTERNET; PRICE COMPARISON SERVICES FEATURING PROVIDING HOTEL, RESORT, AND OTHER LODGING RATE COMPARISON INFORMATION; PROVIDING ON-LINE DIRECTORY INFORMATION SERVICES ALSO FEATURING HYPERLINKS TO OTHER WEB SITES; PROVIDING AN INTERACTIVE COMPUTER DATABASE FEATURING INFORMATION ON SHOPPING (U.S. CLS. 100, 101 AND 102).

FIRST USE 12-15-2006; IN COMMERCE 7-30-2010.

### CLASS 39—TRANSPORTATION AND STORAGE

FOR PROVIDING AN INTERACTIVE WEBSITE AND ON-LINE COMPUTER DATABASE IN THE FIELDS OF TRAVEL INFORMATION, TRAVEL GUIDES AND TRAVEL AGENCY SERVICES THAT ALLOWS USERS TO MAKE RESERVATIONS AND BOOKINGS FOR AIRLINE TRAVEL, CAR RENTALS, LIMOUSINE SERVICE, BUS SERVICE, CRUISES, HELICOPTER AND AIRPLANE RIDES, RAILWAY AND SUBWAY TRAVEL, AND TOUR PACKAGES; PROVIDING INFORMATION AND TRAVEL ADVICE CONCERNING TRAVEL, DESTINATIONS, TRAVEL TOURS AND TRANSPORTATION; PROVIDING ON-LINE INDIVIDUAL AND GROUP TRAVEL AGENDAS AND ITINERARIES; PROVIDING ONLINE TRAVEL INFORMATION FEATURING INFORMATION IN THE FIELDS OF TRAVEL, TRAVEL LOCATIONS, TRAVEL ACTIVITIES, TRIP ROUTES, MAPS, TRAVEL TIPS, AND TRAVELERS' EXPERIENCES; TRAVEL INFORMATION; PROVIDING AN INTERACTIVE COMPUTER DATABASE FEATURING INFORMATION ABOUT TRAVEL INFORMATION, TRANSPORTATION BY AIR, TRAIN, BUS AND BOAT; PROVIDING AN INTERACTIVE COMPUTER DATABASE FEATURING INFORMATION ABOUT GROUND TRAFFIC AND PARKING (U.S. CLS. 100 AND 105).

FIRST USE 12-15-2006; IN COMMERCE 7-30-2010.

### CLASS 42—SCIENTIFIC AND COMPUTER SERVICES

FOR PROVIDING WEATHER INFORMATION (U.S. CLS. 100 AND 101).

FIRST USE 12-15-2006; IN COMMERCE 7-30-2010.

### CLASS 43—HOTEL AND RESTAURANT SERVICES

FOR PROVIDING INFORMATION AND ADVICE CONCERNING HOTEL SERVICES AND RESTAURANTS; PROVIDING LODGING AND RESTAURANT INFORMATION, NAMELY, PROVIDING INFORMATION CONCERNING HOTELS, RESORTS, INNS, TEMPORARY LODGINGS, HOSPITALITY SERVICES, DINING AND RESTAURANT SERVICES; PROVIDING RESERVATION SERVICES VIA A GLOBAL COMPUTER NETWORK, NAMELY, MAKING RESERVATIONS AND BOOKINGS FOR TEMPORARY LODGING AND RESTAURANTS; PROVIDING ONLINE INFORMATION IN THE FIELD OF HOSPITALITY SERVICES; PROVIDING ONLINE BOOKINGS OF RESERVATIONS FOR HOTELS, RESTAURANTS AND TEMPORARY LODGING; PROVIDING INFORMATION AND TRAVEL ADVICE CONCERNING LODGING; PROVIDING ADVICE TO TOURISTS AND BUSINESS TRAVELERS ON HOTEL AND RESTAURANT DESTINATIONS; PROVIDING AN INTERACTIVE COMPUTER DATABASE FEATURING INFORMATION ABOUT DINING (U.S. CLS. 100 AND 101).

FIRST USE 12-15-2006; IN COMMERCE 7-30-2010.

3,955,186. GOURMET SETTINGS INC., RICHMOND HILL, ONTARIO, CANADA. SN 77-126,463. PUB. 8-24-2010, FILED 3-9-2007.

PRIORITY CLAIMED UNDER SEC. 44(D) ON CANADA APPLICATION NO. 1329125, FILED 12-13-2006, REG. NO. TMA770276, DATED 6-21-2010, EXPIRES 6-21-2025.

### CLASS 8—HAND TOOLS

FOR FLATWARE, NAMELY, FORKS, SALAD FORKS, KNIVES, TEASPOONS AND SOUP SPOONS; CUTLERY, NAMELY, STEAK KNIVES, BUTTER KNIVES, FISH KNIVES, COCKTAIL FORKS, ICED TEA SPOONS, SUGAR SPOONS, CAKE KNIVES, SPREADER KNIVES FOR HORS D'OEUVRES (U.S. CLS. 23, 28 AND 44).

FIRST USE 0-0-2005; IN COMMERCE 0-0-2006.

### CLASS 21—HOUSEWARES AND GLASS

FOR SERVING FORKS, SERVING SPOONS, NAPKIN RINGS, PASTA SERVING FORKS, GRAVY SERVING LADLES, CAKE SERVERS, SOUP SERVING LADLES, ICE SCOOPS, SERVING TONGS (U.S. CLS. 2, 13, 23, 29, 30, 33, 40 AND 50).

FIRST USE 0-0-2005; IN COMMERCE 0-0-2006.



3,955,194. AIR ADVANTAGE INTELLECTUAL PROPERTY, LLC, FRANKENMUTH, MI. SN 77-224,753. PUB. 12-9-2008, FILED 7-9-2007.



#### CLASS 38—COMMUNICATION

FOR TELECOMMUNICATIONS SERVICES AND INTERNET SERVICES, NAMELY, WIRELESS INTERNET ACCESS SERVICES, DIGITAL SUBSCRIBER INTERNET ACCESS SERVICES, DIAL-UP INTERNET ACCESS SERVICES, EMAIL SERVICES, ELECTRONIC MAIL AND MESSAGING SERVICES, AND FIBER OPTIC NETWORK SERVICES (U.S. CLS. 100, 101 AND 104).

FIRST USE 7-0-2002; IN COMMERCE 7-0-2002.

#### CLASS 42—SCIENTIFIC AND COMPUTER SERVICES

FOR WEB SITE HOSTING (U.S. CLS. 100 AND 101).  
FIRST USE 7-0-2002; IN COMMERCE 7-0-2002.

#### CLASS 45—PERSONAL AND LEGAL SERVICES

FOR REGISTRATION OF DOMAIN NAMES (U.S. CLS. 100 AND 101).  
FIRST USE 7-0-2002; IN COMMERCE 7-0-2002.

3,955,195. AIR ADVANTAGE INTELLECTUAL PROPERTY, LLC, FRANKENMUTH, MI. SN 77-224,757. PUB. 12-2-2008, FILED 7-9-2007.

AIR ADVANTAGE

THE MARK CONSISTS OF STANDARD CHARACTERS WITHOUT CLAIM TO ANY PARTICULAR FONT, STYLE, SIZE, OR COLOR.

#### CLASS 38—COMMUNICATION

FOR TELECOMMUNICATIONS SERVICES AND INTERNET SERVICES, NAMELY, WIRELESS INTERNET ACCESS SERVICES, DIGITAL SUBSCRIBER INTERNET ACCESS SERVICES, DIAL-UP INTERNET ACCESS SERVICES, EMAIL SERVICES, ELECTRONIC MAIL AND MESSAGING SERVICES, AND FIBER OPTIC NETWORK SERVICES (U.S. CLS. 100, 101 AND 104).

FIRST USE 7-0-2002; IN COMMERCE 7-0-2002.

#### CLASS 42—SCIENTIFIC AND COMPUTER SERVICES

FOR WEB SITE HOSTING (U.S. CLS. 100 AND 101).  
FIRST USE 7-0-2002; IN COMMERCE 7-0-2002.

#### CLASS 45—PERSONAL AND LEGAL SERVICES

FOR REGISTRATION OF DOMAIN NAMES (U.S. CLS. 100 AND 101).  
FIRST USE 7-0-2002; IN COMMERCE 7-0-2002.

3,955,208. LINWOOD HOMES, LTD., DELTA, CANADA. SN 77-365,881. PUB. 7-8-2008, FILED 1-7-2008.

CUSTOM BUILDING MADE EASY

THE MARK CONSISTS OF STANDARD CHARACTERS WITHOUT CLAIM TO ANY PARTICULAR FONT, STYLE, SIZE, OR COLOR.

NO CLAIM IS MADE TO THE EXCLUSIVE RIGHT TO USE "CUSTOM BUILDING", APART FROM THE MARK AS SHOWN.

#### CLASS 36—INSURANCE AND FINANCIAL

FOR REAL ESTATE SERVICES, NAMELY, SELLING CUSTOM PREPACKAGED HOMES (U.S. CLS. 100, 101 AND 102).

FIRST USE 3-10-2005; IN COMMERCE 3-10-2005.

#### CLASS 37—CONSTRUCTION AND REPAIR

FOR CONSTRUCTION SERVICES, NAMELY, PLANNING AND CUSTOM CONSTRUCTION OF RESIDENTIAL HOUSES (U.S. CLS. 100, 103 AND 106).

FIRST USE 3-10-2005; IN COMMERCE 3-10-2005.

3,955,215. TRINCI, JEFFREY DANIEL, PORTLAND, OR. SN 77-420,443. PUB. 7-6-2010, FILED 3-12-2008.

the groom's list  
FROM PROPOSAL TO HONEYMOON

NO CLAIM IS MADE TO THE EXCLUSIVE RIGHT TO USE "GROOM'S", "PROPOSAL" AND "HONEYMOON", APART FROM THE MARK AS SHOWN.

THE MARK CONSISTS OF "THE GROOM'S LIST" IS IN LOWERCASE FONT (INSIGNIA TYPEFACE), AND "FROM PROPOSAL TO HONEYMOON" IS IN ALL CAPS. THE "CHECK MARK" IS USED IN PLACE OF AN APOSTROPHE FOR "GROOM'S".

#### CLASS 35—ADVERTISING AND BUSINESS

FOR ADVERTISING AND COMMERCIAL INFORMATION SERVICES, VIA THE INTERNET (U.S. CLS. 100, 101 AND 102).

FIRST USE 2-6-2008; IN COMMERCE 12-11-2010.

#### CLASS 38—COMMUNICATION

FOR INFORMATION TRANSMISSION VIA AN ONLINE CHAT ROOM THAT CONCERNS MARRIAGE PROPOSALS, WEDDINGS, HONEYMOON PLANNING, AND MARRIAGE ADVICE (U.S. CLS. 100, 101 AND 104).

FIRST USE 2-6-2008; IN COMMERCE 12-11-2010.

**CLASS 41—EDUCATION AND ENTERTAINMENT**

FOR PROVIDING INFORMATION IN THE FIELD OF WEDDING AND SPECIAL EVENT CONSULTATION, PLANNING AND COORDINATION SERVICES FOR SOCIAL ENTERTAINMENT PURPOSES VIA THE INTERNET (U.S. CLS. 100, 101 AND 107).

FIRST USE 2-6-2008; IN COMMERCE 2-2-2011.

**CLASS 45—PERSONAL AND LEGAL SERVICES**

FOR PROVIDING A WEBSITE FEATURING INFORMATION ON LOVE, ROMANCE, AND INTERPERSONAL RELATIONSHIPS VIA THE INTERNET; PROVIDING A WEBSITE FEATURING INFORMATION ON MARRIAGE PROPOSAL CONSULTATION IN THE NATURE OF ASSISTING OTHERS IN THE CREATION, PLANNING, PREPARATION, AND EXECUTION OF MARRIAGE PROPOSALS (U.S. CLS. 100 AND 101).

FIRST USE 2-6-2008; IN COMMERCE 12-11-2010.

3,955,218. RUCKUS ENTERPRISES LLC, LIBERTYVILLE, IL. SN 77-433,386. PUB. 8-25-2009, FILED 3-27-2008.

R.U.X.S. RUCKUS UNDERGROUND  
X-TREME SPORTS

THE MARK CONSISTS OF STANDARD CHARACTERS WITHOUT CLAIM TO ANY PARTICULAR FONT, STYLE, SIZE, OR COLOR.

NO CLAIM IS MADE TO THE EXCLUSIVE RIGHT TO USE "EXTREME SPORTS", APART FROM THE MARK AS SHOWN.

**CLASS 16—PAPER GOODS AND PRINTED MATTER**

FOR PUBLICATIONS AND PRINTED MATTER, NAMELY, NON-FICTION BOOKS IN THE FIELDS OF SPORTS, EXTREME SPORTS, RISK ACTIVITIES, STUNTS, ADVENTURES, AND COMPETITIONS; GUIDE BOOKS AND REFERENCE BOOKS FOR SPORTS, EXTREME SPORTS, RISK ACTIVITIES, STUNTS, ADVENTURES, AND COMPETITIONS; MAGAZINES IN THE FIELDS OF SPORTS, EXTREME SPORTS, RISK ACTIVITIES, STUNTS, ADVENTURES AND COMPETITIONS; CATALOGUES FEATURING, APPAREL, EQUIPMENT, COLLECTIBLES, AND MEMORABILIA IN THE FIELDS OF SPORTS, EXTREME SPORTS, RISK ACTIVITIES, STUNTS, ADVENTURES AND COMPETITIONS; NEWSLETTERS, PAMPHLETS, BOOKLETS, AND INFORMATIONAL BROCHURES IN THE FIELDS OF SPORTS, EXTREME SPORTS, RISK ACTIVITIES, STUNTS, ADVENTURES AND COMPETITIONS; POST CARDS; COMMEMORATIVE STAMPS; DECALS; IRON-ON DECALS; APPLIQUES IN THE FORM OF DECALS; STICKERS; BUMPER STICKERS; PRINTED PAPER; POSTERS; PICTURES; PHOTOGRAPHS; ADHESIVE BACKED SHEETS OF NOTE PAPER (U.S. CLS. 2, 5, 22, 23, 29, 37, 38 AND 50).

FIRST USE 2-23-2011; IN COMMERCE 2-23-2011.

**CLASS 24—FABRICS**

FOR TOWELS; AND CLOTH AND FABRIC FLAGS, BANNERS, AND PENNANTS (U.S. CLS. 42 AND 50).

FIRST USE 2-23-2011; IN COMMERCE 2-23-2011.

**CLASS 25—CLOTHING**

FOR CLOTHING FOR MEN, WOMEN, AND CHILDREN, NAMELY, SHIRTS, T-SHIRTS, BELTS, JACKETS, COATS, TOPS, VESTS, BLOUSES, JERSEYS, BOTTOMS, SHORTS, PANTS, TROUSERS, BOXER SHORTS, DRESSES, SKIRTS, NECKTIES, SCARVES, BANDANNAS, NIGHT GOWNS, LINGERIE, NIGHT SHIRTS, PAJAMAS, SLIPPERS, LOUNGEWEAR, SOCKS, SWEATERS, SWEAT SHIRTS, SWEAT PANTS, RASH GUARDS, SWIM WEAR, WET SUITS, CUMMERBUNDS, APRONS, GLOVES, HEADWEAR, HATS, CAPS; SUN VISORS (U.S. CLS. 22 AND 39).

FIRST USE 2-23-2011; IN COMMERCE 2-23-2011.

**CLASS 35—ADVERTISING AND BUSINESS**

FOR ADVERTISING AND INFORMATION DISTRIBUTION SERVICES, NAMELY, PROVIDING ADVERTISING SPACE VIA THE GLOBAL COMPUTER NETWORK; PROMOTING THE GOODS AND SERVICES OF OTHERS OVER THE INTERNET; PROVIDING AN ONLINE DIRECTORY INFORMATION SERVICE FEATURING INFORMATION IN THE FIELDS OF SPORTS, SPORTING ACTIVITIES, SPORTING EVENTS AND COMPETITIONS, EXTREME SPORTS, EXTREME SPORTING ACTIVITIES, EXTREME SPORTING EVENTS AND COMPETITIONS, RISK-TAKING VENTURES, STUNTS, STUNT-RELATED TRAINING, PRACTICE AND ACTIVITIES, MILITARY SERVICE, RISKY CIVILIAN ACTIVITIES, DANGEROUS ACTIVITIES AND PREVENTATIVE SAFETY MEASURES WITH RESPECT THERETO, EXTREME ACTIVITY EVENTS AND VENTURES, UNDERGROUND CULTURES, TATTOOING AND EXTREME FASHIONS, CLASSIFIEDS, VIRTUAL COMMUNITIES, SOCIAL NETWORKING, PHOTO SHARING, VIDEO SHARING, AND TRANSMISSION OF PHOTOGRAPHIC IMAGES (U.S. CLS. 100, 101 AND 102).

FIRST USE 2-23-2011; IN COMMERCE 2-23-2011.

**CLASS 41—EDUCATION AND ENTERTAINMENT**

FOR ELECTRONIC PUBLISHING SERVICES, NAMELY, PUBLISHING OF ONLINE WORKS OF OTHERS FEATURING USER-CREATED TEXT, AUDIO, VIDEO, AND GRAPHICS; PROVIDING ON-LINE JOURNALS AND WEB LOGS FEATURING USER-CREATED CONTENT IN THE FIELDS OF SPORTS, SPORTING ACTIVITIES, SPORTING EVENTS AND COMPETITIONS, EXTREME SPORTS, EXTREME SPORTING ACTIVITIES, EXTREME SPORTING EVENTS AND COMPETITIONS, AND ENTERTAINMENT ACTIVITIES, NAMELY, RISK-TAKING VENTURES, STUNTS, STUNT-RELATED TRAINING, PRACTICE AND ACTIVITIES, RISKY CIVILIAN ACTIVITIES, DANGEROUS ACTIVITIES AND PREVENTATIVE SAFETY MEASURES WITH RESPECT THERETO, EXTREME ACTIVITY EVENTS AND VENTURES, AND UNDERGROUND CULTURES; PROVIDING ON-LINE COMPUTER DATABASES AND ON-LINE SEARCHABLE DATABASES IN THE FIELDS OF SPORTS, SPORTING ACTIVITIES, SPORTING EVENTS AND COMPETITIONS, EXTREME SPORTS, EXTREME SPORTING ACTIVITIES, EXTREME SPORTING EVENTS AND COMPETITIONS, AND ENTERTAINMENT ACTIVITIES, NAMELY, RISK-TAKING VENTURES, STUNTS, STUNT-RELATED TRAINING, PRACTICE AND ACTIVITIES, RISKY CIVILIAN ACTIVITIES, DANGEROUS ACTIVITIES AND PREVENTATIVE SAFETY MEASURES WITH RESPECT THERETO, EXTREME ACTIVITY EVENTS AND VENTURES, AND UNDERGROUND CULTURES (U.S. CLS. 100, 101 AND 107).

FIRST USE 2-23-2011; IN COMMERCE 2-23-2011.

3,955,221. VOXER IP LLC, SAN FRANCISCO, CA. SN 77-464,199. PUB. 12-8-2009, FILED 5-2-2008.

# REBELVOX

THE MARK CONSISTS OF STANDARD CHARACTERS WITHOUT CLAIM TO ANY PARTICULAR FONT, STYLE, SIZE, OR COLOR.

## CLASS 9—ELECTRICAL AND SCIENTIFIC APPARATUS

FOR COMPUTER SOFTWARE FOR LIVE VOICE CALLS, VOICE MESSAGING, TEXT, TELECONFERENCING, FILE SHARING, AND MEDIA DISTRIBUTION; COMPUTER SOFTWARE CONFIGURED TO WORK IN COOPERATION WITH TRANSMITTERS, RECEIVERS, MICROPHONES, SPEAKERS, TRANSCODERS, MEDIA PROCESSORS, MEDIA MANAGEMENT SOFTWARE, AND GPS SYSTEMS; INSTRUCTIONAL MANUALS DISTRIBUTED WITH ALL OF THE AFOREMENTIONED SOFTWARE (U.S. CLS. 21, 23, 26, 36 AND 38).  
FIRST USE 6-30-2010; IN COMMERCE 6-30-2010.

## CLASS 38—COMMUNICATION

FOR COMMUNICATION SERVICES, NAMELY, TRANSMISSION OF VOICE, AUDIO, TEXT, AND DATA OVER TELECOMMUNICATIONS NETWORKS, WIRELESS COMMUNICATION NETWORKS, THE INTERNET, INFORMATION SERVICES NETWORKS AND DATA NETWORKS; TELECOMMUNICATION SERVICES, NAMELY, LOCAL AND LONG DISTANCE TRANSMISSION OF VOICE, TEXT, DATA, AND MULTIMEDIA CONTENT BY MEANS OF TELECOMMUNICATIONS NETWORKS AND WIRELESS NETWORKS; TELECOMMUNICATIONS SERVICES, NAMELY, CO-LOCATION SERVICES FOR VOICE, TEXT, AND DATA COMMUNICATIONS APPLICATIONS AND MEDIA STORAGE; TELECONFERENCING, WEB CONFERENCING AND NETWORK CONFERENCING SERVICES; TELECOMMUNICATIONS CONSULTATION; COMPUTER SERVICES, NAMELY, ELECTRONIC DELIVERY OF DIGITAL CONTENT VIA THE INTERNET, VOICE OVER INTERNET PROTOCOL (VOIP) SERVICES (U.S. CLS. 100, 101 AND 104).

FIRST USE 6-30-2010; IN COMMERCE 6-30-2010.

3,955,225. AVID MEDICAL, INC., TOANO, VA. SN 77-490,514. PUB. 4-28-2009, FILED 6-4-2008.

# AVID

THE MARK CONSISTS OF STANDARD CHARACTERS WITHOUT CLAIM TO ANY PARTICULAR FONT, STYLE, SIZE, OR COLOR.

OWNER OF U.S. REG. NO. 2,766,180.

## CLASS 10—MEDICAL APPARATUS

FOR SURGICAL AND MEDICAL PROCEDURE TRAYS (U.S. CLS. 26, 39 AND 44).

FIRST USE 5-15-1998; IN COMMERCE 10-20-1998.

## CLASS 42—SCIENTIFIC AND COMPUTER SERVICES

FOR CUSTOM DESIGN OF SURGICAL AND MEDICAL PROCEDURE TRAYS TO THE ORDER AND SPECIFICATION OF OTHERS (U.S. CLS. 100 AND 101).  
FIRST USE 5-15-1998; IN COMMERCE 10-20-1998.

3,955,227. AMPACET CORPORATION, TARRYTOWN, NY. SN 77-494,593. PUB. 5-5-2009, FILED 6-9-2008.

# NATURBLEND

THE MARK CONSISTS OF STANDARD CHARACTERS WITHOUT CLAIM TO ANY PARTICULAR FONT, STYLE, SIZE, OR COLOR.

## CLASS 1—CHEMICALS

FOR CHEMICALS IN THE NATURE OF CHEMICAL MULTI-FUNCTIONAL COMPOUNDS, ADDITIVES, AND CONCENTRATES FOR USE IN A WIDE VARIETY OF POLYMER GOODS AND DERIVED FROM SYNTHETIC AND NATURAL SOURCES; CHEMICALS IN THE NATURE OF ADDITIVE CONCENTRATES AND MASTERBATCHES; CHEMICALS IN THE NATURE OF CHEMICAL MULTI-FUNCTIONAL COMPOUNDS, ADDITIVES, AND CONCENTRATES FOR USE IN CONVENTIONAL AND NON-CONVENTIONAL POLYMERS AND DERIVED FROM SYNTHETIC AND NATURAL SOURCES (U.S. CLS. 1, 5, 6, 10, 26 AND 46).  
FIRST USE 4-9-2009; IN COMMERCE 4-9-2009.

## CLASS 2—PAINTS

FOR COLORANTS, NAMELY, COLOR COMPOUNDS, CONCENTRATES AND MASTERBATCHES FOR USE IN THE MANUFACTURE OF A WIDE VARIETY OF POLYMER GOODS AND DERIVED FROM SYNTHETIC AND NATURAL SOURCES; MULTI-FUNCTIONAL COLOR COMPOUNDS, CONCENTRATES AND MASTERBATCHES FOR USE IN THE MANUFACTURE OF CONVENTIONAL AND NON-CONVENTIONAL POLYMERIC GOODS (U.S. CLS. 6, 11 AND 16).

FIRST USE 4-9-2009; IN COMMERCE 4-9-2009.

3,955,230. DELOS LIVING, LLC, NEW YORK, NY. SN 77-502,579. PUB. 11-11-2008, FILED 6-19-2008.

# DELOS

THE MARK CONSISTS OF STANDARD CHARACTERS WITHOUT CLAIM TO ANY PARTICULAR FONT, STYLE, SIZE, OR COLOR.

## CLASS 36—INSURANCE AND FINANCIAL

FOR REAL ESTATE INVESTMENT; REAL ESTATE MANAGEMENT; REAL ESTATE RENTAL SERVICES, NAMELY, RENTAL OF RESIDENTIAL HOUSING; RENTAL OF APARTMENTS (U.S. CLS. 100, 101 AND 102).

FIRST USE 8-0-2008; IN COMMERCE 9-23-2010.

**CLASS 37—CONSTRUCTION AND REPAIR**

FOR REAL ESTATE DEVELOPMENT (U.S. CLS. 100, 103 AND 106).  
FIRST USE 8-0-2008; IN COMMERCE 9-23-2010.

3,955,233. FOOFQUEENS, INC., JOHNSTON, IA. SN 77-511,392. PUB. 5-26-2009, FILED 6-30-2008.

FOOFQUEENS

THE MARK CONSISTS OF STANDARD CHARACTERS WITHOUT CLAIM TO ANY PARTICULAR FONT, STYLE, SIZE, OR COLOR.

**CLASS 16—PAPER GOODS AND PRINTED MATTER**

FOR NATURAL AND SYNTHETIC MATERIALS FOR WRAPPING AND PACKAGING, NAMELY, TISSUE PAPER, CELLOPHANE PAPER, METALLIC PAPER, PAPER RIBBONS, GIFT WRAP PAPER; GIFT WRAP PAPER BOWS; GIFT ENCLOSURE CARDS, TAGS AND ENVELOPES (U.S. CLS. 2, 5, 22, 23, 29, 37, 38 AND 50).  
FIRST USE 8-10-2009; IN COMMERCE 8-10-2009.

**CLASS 35—ADVERTISING AND BUSINESS**

FOR PROVIDING HOME SHOPPING SERVICES AND RETAIL STORE SERVICES IN THE FIELD OF GIFT WRAPPING PRODUCTS BY MEANS OF CABLE AND DIGITAL TELEVISION AND WEBCASTS (U.S. CLS. 100, 101 AND 102).  
FIRST USE 8-10-2009; IN COMMERCE 8-10-2009.

3,955,236. ALGORITHMICS TRADEMARKS LLC, WILMINGTON, DE. SN 77-514,021. PUB. 12-15-2009, FILED 7-2-2008.

ALGO OPVAR

THE MARK CONSISTS OF STANDARD CHARACTERS WITHOUT CLAIM TO ANY PARTICULAR FONT, STYLE, SIZE, OR COLOR.

OWNER OF U.S. REG. NOS. 3,214,047 AND 3,311,666.  
THE FOREIGN WORDING "ALGO" IN THE MARK TRANSLATES INTO ENGLISH AS SOMETHING. THE WORDING "OPVAR" HAS NO MEANING IN A FOREIGN LANGUAGE.

**CLASS 9—ELECTRICAL AND SCIENTIFIC APPARATUS**

FOR COMPUTER SOFTWARE FOR CREDIT RISK MANAGEMENT AND MEASUREMENT COVERING CLIENT-SPECIFIC OPERATIONAL RISK MANAGEMENT SOLUTIONS, INTERNAL LOSS EVENT DATA COLLECTION, RISK AND CONTROL SELF-ASSESSMENTS, KEY RISK INDICATORS MEASUREMENTS, FINANCIAL RISK AND MEASUREMENT SCENARIOS, OPERATIONAL CAPITAL MODELING AND FINANCIAL RISK REGULATORY COMPLIANCE; COMPUTER SOFTWARE FOR FINANCIAL RISK MANAGEMENT AND MEASUREMENT; COMPUTER SOFTWARE FOR ORGANIZING AND CONSOLIDATING FINANCIAL INFORMATION REGARDING RATINGS OF SECURITIES AND RATING THE CREDIT WORTHINESS OF BONDS AND OTHER SECURITIES; COMPUTER SOFTWARE FOR USE IN FINANCIAL ANALYSIS, CREDIT-RISK ASSESSMENT FOR COMMERCIAL LENDING AND COMMERCIAL CREDIT RISK MANAGEMENT AND MEASUREMENT; COMPUTER SOFTWARE FOR DATA WAREHOUSING IN THE FINANCIAL FIELD, NAMELY, SOFTWARE FOR ORGANIZING AND OPERATING A SYSTEM FOR STORING, RETRIEVING AND MANAGING LARGE AMOUNTS OF ANY TYPE OF DATA IN THE FINANCIAL FIELD (U.S. CLS. 21, 23, 26, 36 AND 38).

FIRST USE 0-0-2006; IN COMMERCE 0-0-2006.

**CLASS 36—INSURANCE AND FINANCIAL**

FOR CONSULTING SERVICES RELATING TO CREDIT RISK MANAGEMENT AND MEASUREMENT COVERING CLIENT-SPECIFIC OPERATIONAL RISK MANAGEMENT SOLUTIONS, INTERNAL LOSS EVENT DATA COLLECTION, RISK AND CONTROL SELF-ASSESSMENTS, KEY RISK INDICATORS MEASUREMENTS, FINANCIAL RISK AND MEASUREMENT SCENARIOS, AND OPERATIONAL CAPITAL MODELING; CONSULTING SERVICES RELATING TO FINANCIAL RISK MANAGEMENT AND MEASUREMENT; CONSULTING SERVICES RELATING TO ORGANIZING AND CONSOLIDATING FINANCIAL INFORMATION REGARDING RATINGS OF SECURITIES AND RATING THE CREDIT WORTHINESS OF BONDS AND OTHER SECURITIES; CONSULTING SERVICES RELATING TO FINANCIAL ANALYSIS, CREDIT-RISK ASSESSMENT FOR COMMERCIAL LENDING AND COMMERCIAL CREDIT RISK MANAGEMENT AND MEASUREMENT; FINANCIAL SERVICES, NAMELY, CREDIT RISK MANAGEMENT AND MEASUREMENT COVERING CLIENT-SPECIFIC OPERATIONAL RISK MANAGEMENT SOLUTIONS, INTERNAL LOSS EVENT DATA COLLECTION, RISK AND CONTROL SELF-ASSESSMENTS, KEY RISK INDICATORS MEASUREMENTS, FINANCIAL RISK AND MEASUREMENT SCENARIOS, OPERATIONAL CAPITAL MODELING AND FINANCIAL RISK REGULATORY COMPLIANCE; FINANCIAL SERVICES, NAMELY, STRATEGIC FINANCIAL RISK MANAGEMENT AND MEASUREMENT; FINANCIAL CONSULTING; FINANCIAL CONSULTING CONCERNING FINANCIAL RISK MANAGEMENT AND MEASUREMENT; FINANCIAL SERVICES, NAMELY, ORGANIZING AND CONSOLIDATING FINANCIAL INFORMATION REGARDING RATINGS OF SECURITIES AND RATING THE CREDIT WORTHINESS OF BONDS AND OTHER SECURITIES; FINANCIAL SERVICES, NAMELY, FINANCIAL ANALYSIS, CREDIT-RISK ASSESSMENT FOR COMMERCIAL LENDING AND COMMERCIAL CREDIT RISK MANAGEMENT AND MEASUREMENT (U.S. CLS. 100, 101 AND 102).  
FIRST USE 0-0-2006; IN COMMERCE 0-0-2006.

**CLASS 39—TRANSPORTATION AND STORAGE**

FOR CONSULTING SERVICES RELATING TO ELECTRONIC STORAGE OF LARGE AMOUNTS OF ANY TYPE OF DATA IN THE FINANCIAL FIELD (U.S. CLS. 100 AND 105).

FIRST USE 0-0-2006; IN COMMERCE 0-0-2006.

**CLASS 42—SCIENTIFIC AND COMPUTER SERVICES**

FOR COMPUTER SOFTWARE IMPLEMENTATION AND MAINTENANCE SERVICES; CONSULTING SERVICES RELATING TO DATA WAREHOUSING IN THE FINANCIAL FIELD (U.S. CLS. 100 AND 101).  
FIRST USE 0-0-2006; IN COMMERCE 0-0-2006.

#### **CLASS 45—PERSONAL AND LEGAL SERVICES**

FOR CONSULTING SERVICES RELATING TO FINANCIAL RISK REGULATORY COMPLIANCE (U.S. CLS. 100 AND 101).  
FIRST USE 0-0-2006; IN COMMERCE 0-0-2006.

3,955,239. MOTOWN HISTORICAL MUSEUM, DETROIT, MI. SN 77-523,865. PUB. 12-1-2009, FILED 7-16-2008.

## LIVE IT AGAIN

THE MARK CONSISTS OF STANDARD CHARACTERS WITHOUT CLAIM TO ANY PARTICULAR FONT, STYLE, SIZE, OR COLOR.

#### **CLASS 6—METAL GOODS**

FOR METAL KEY RINGS AND METAL KEY CHAINS (U.S. CLS. 2, 12, 13, 14, 23, 25 AND 50).  
FIRST USE 6-1-2009; IN COMMERCE 6-1-2009.

#### **CLASS 9—ELECTRICAL AND SCIENTIFIC APPARATUS**

FOR MUSICAL SOUND RECORDINGS; MUSICAL VIDEO RECORDINGS; CINEMATOGRAPHIC FILMS FEATURING MUSIC ARTISTS; PRE-RECORDED RECORD DISCS AND AUDIO TAPES FEATURING MUSIC; PRE-RECORDED VIDEO CASSETTES FEATURING MUSIC ARTISTS; LASER DISCS FEATURING MUSIC ARTISTS; MAGNETIC-READABLE DISCS FEATURING MUSIC ARTISTS; OPTICAL DISCS FEATURING MUSIC ARTISTS; PRE-RECORDED COMPACT DISCS FEATURING MUSIC; PRE-RECORDED VIDEO TAPES, LASER DISCS AND DVD'S FEATURING MUSIC ARTISTS; BLANK CD-ROMS FOR SOUND OR VIDEO RECORDING; BLANK COMPUTER MINI-DISCS; PRE-RECORDED DIGITAL AUDIO TAPES, CASSETTES, AND COMPACT DISCS FEATURING MUSIC ARTISTS; MAGNETS FOR REFRIGERATORS (U.S. CLS. 21, 23, 26, 36 AND 38).  
FIRST USE 6-1-2010; IN COMMERCE 6-1-2010.

#### **CLASS 21—HOUSEWARES AND GLASS**

FOR MUGS, COFFEE MUGS, CUPS, DRINKING GLASSES, PLASTIC WATER BOTTLES SOLD EMPTY (U.S. CLS. 2, 13, 23, 29, 30, 33, 40 AND 50).  
FIRST USE 6-1-2010; IN COMMERCE 6-1-2010.

#### **CLASS 25—CLOTHING**

FOR CLOTHING, NAMELY, SHIRTS, T-SHIRTS, SWEATSHIRTS, TANK TOPS, POLO SHIRTS, SHORTS, JACKETS, BLOUSES, SKIRTS, PANTS, VESTS, PULL-OVERS, SWIMWEAR, BEACHWEAR; FOOTWEAR; TIES, HATS, CAPS AND HEADBANDS (U.S. CLS. 22 AND 39).  
FIRST USE 6-1-2009; IN COMMERCE 6-1-2009.

3,955,244. GENE ORACLE INCORPORATED, MOUNTAIN VIEW, CA. SN 77-547,673. PUB. 8-25-2009, FILED 8-14-2008.

## GENEIOS

THE MARK CONSISTS OF STANDARD CHARACTERS WITHOUT CLAIM TO ANY PARTICULAR FONT, STYLE, SIZE, OR COLOR.

#### **CLASS 1—CHEMICALS**

FOR BIOCHEMICAL LABORATORY KITS CONTAINING CATALYSTS AND REAGENTS NOT FOR MEDICAL USE FOR GENE SYNTHESIS AND GENE CLONING FOR LABORATORY OR RESEARCH USE (U.S. CLS. 1, 5, 6, 10, 26 AND 46).  
FIRST USE 6-22-2007; IN COMMERCE 1-10-2008.

#### **CLASS 9—ELECTRICAL AND SCIENTIFIC APPARATUS**

FOR COMPUTER SOFTWARE FOR USE IN RESEARCH, DEVELOPMENT, AND COMMERCIALIZATION IN THE FIELD OF MOLECULAR BIOLOGY, INCLUDING GENE, POLYNUCLEOTIDE, AND PROTEIN SYNTHESIS; COMPUTER SOFTWARE FOR USE IN SELECTING REAGENTS AND PROCESS CONDITIONS FOR GENE, POLYNUCLEOTIDE AND PROTEIN SYNTHESIS, AND FOR USE IN PRODUCING GENE SYNTHESIS KITS (U.S. CLS. 21, 23, 26, 36 AND 38).  
FIRST USE 6-22-2007; IN COMMERCE 6-22-2007.

3,955,245. COLLEN IP CONSULTING, LLC, OSSINING, NY. SN 77-549,670. PUB. 1-6-2009, FILED 8-18-2008.

## THE NOMINATOR

THE MARK CONSISTS OF STANDARD CHARACTERS WITHOUT CLAIM TO ANY PARTICULAR FONT, STYLE, SIZE, OR COLOR.

#### **CLASS 35—ADVERTISING AND BUSINESS**

FOR BUSINESS CONSULTATION SERVICES, NAMELY, BRAND EVALUATION AND CREATING TRADEMARKS FOR OTHERS (U.S. CLS. 100, 101 AND 102).  
FIRST USE 9-22-2009; IN COMMERCE 9-22-2009.

#### **CLASS 45—PERSONAL AND LEGAL SERVICES**

FOR LEGAL CONSULTING SERVICES; CONSULTING AND PROVIDING REPORTS IN THE FIELD OF INTELLECTUAL PROPERTY LAW; LEGAL RESEARCH SERVICES, NAMELY, TRADEMARK AND COMPANY NAME RESEARCH SERVICES (U.S. CLS. 100 AND 101).  
FIRST USE 9-22-2009; IN COMMERCE 9-22-2009.

3,955,246. GARY ROY GOODEN, COLUMBIA, SC. SN 77-549,953. PUB. 6-16-2009, FILED 8-18-2008.



NO CLAIM IS MADE TO THE EXCLUSIVE RIGHT TO USE "BARBER OR STYLIST", APART FROM THE MARK AS SHOWN.

THE MARK CONSISTS OF A CLIPPER WITH THE CORD EXTENDING IN A SPHERICAL OVAL SHAPE. THE PLUG ON THE CLIPPER CORD FACES THE BLADE OF THE CLIPPER AT THE TOP OF THE OVAL BUT NOT TOUCHING EACH OTHER. AN OPEN SCISSOR IS CENTERED IN THE SPHERE HORIZONTALLY. THE WORDING "BARBER OR STYLIST" APPEARS BENEATH THE OVAL.

#### CLASS 16—PAPER GOODS AND PRINTED MATTER

FOR GENERAL PURPOSE PLASTIC BAGS; MERCHANDISE BAGS; PAPER BAGS; PAPER BAGS FOR PACKAGING; PAPER GIFT BAGS; PAPER PARTY BAGS; PARTY GOODIE BAGS OF PAPER OR PLASTIC; PLASTIC BAGS FOR PACKAGING; PLASTIC BAGS FOR PACKING; PLASTIC OR PAPER BAGS FOR MERCHANDISE PACKAGING; PLASTIC SHOPPING BAGS (U.S. CLS. 2, 5, 22, 23, 29, 37, 38 AND 50).

FIRST USE 10-1-2009; IN COMMERCE 10-1-2009.

#### CLASS 21—HOUSEWARES AND GLASS

FOR BEER MUGS; COFFEE CUPS, TEA CUPS AND MUGS; CUPS AND MUGS; GLASS MUGS; MUGS; MUGS, NOT OF PRECIOUS METAL; PORCELAIN MUGS (U.S. CLS. 2, 13, 23, 29, 30, 33, 40 AND 50).

FIRST USE 10-1-2009; IN COMMERCE 10-1-2009.

#### CLASS 25—CLOTHING

FOR ATHLETIC APPAREL, NAMELY, SHIRTS, PANTS, JACKETS, FOOTWEAR, HATS AND CAPS, ATHLETIC UNIFORMS; CAPE; SCHOOL UNIFORMS; SHAMPOO CAPE; UNIFORMS (U.S. CLS. 22 AND 39).

FIRST USE 10-1-2009; IN COMMERCE 10-1-2009.

3,955,250. STEREN BRANDS, S. DE R.L. DE C.V., COL. OBRERO POPULAR CALZ. MEXICO CITY, MEXICO. SN 77-563,758. PUB. 8-11-2009, FILED 9-5-2008.

# STEREN

THE MARK CONSISTS OF STANDARD CHARACTERS WITHOUT CLAIM TO ANY PARTICULAR FONT, STYLE, SIZE, OR COLOR.

THE WORDING "STEREN" HAS NO MEANING IN A FOREIGN LANGUAGE.

#### CLASS 35—ADVERTISING AND BUSINESS

FOR RETAIL STORE SERVICES FEATURING ELECTRONICS AND ELECTRONIC PARTS (U.S. CLS. 100, 101 AND 102).

FIRST USE 1-17-1979; IN COMMERCE 1-17-1979.

#### CLASS 36—INSURANCE AND FINANCIAL

FOR PROVIDING EXTENDED WARRANTIES ON ELECTRONICS AND ELECTRONIC PARTS (U.S. CLS. 100, 101 AND 102).

FIRST USE 1-17-1979; IN COMMERCE 1-17-1979.

3,955,251. BIANCAMED LTD., BELFIELD, DUBLIN 4, IRELAND. SN 77-564,854. PUB. 6-16-2009, FILED 9-8-2008.

# SLEEPMINDER

THE MARK CONSISTS OF STANDARD CHARACTERS WITHOUT CLAIM TO ANY PARTICULAR FONT, STYLE, SIZE, OR COLOR.

#### CLASS 9—ELECTRICAL AND SCIENTIFIC APPARATUS

FOR BABY MONITORS; BABY SLEEP MONITORS; ELECTRONIC SENSORS AND SOFTWARE FOR MEASURING, MONITORING, AND ANALYZING SLEEP AND BREATHING (U.S. CLS. 21, 23, 26, 36 AND 38).

FIRST USE 6-0-2008; IN COMMERCE 6-0-2008.

#### CLASS 10—MEDICAL APPARATUS

FOR MEDICAL APPARATUS USED FOR SLEEP MONITORING AND DIAGNOSIS, NAMELY, HEART MONITORS, RESPIRATION MONITORS, AND PATIENT MONITORING SENSORS (U.S. CLS. 26, 39 AND 44).

FIRST USE 8-0-2010; IN COMMERCE 8-0-2010.

3,955,253. S. C. JOHNSON & SON, INC., RACINE, WI. SN 77-568,707. PUB. 12-30-2008, FILED 9-12-2008.

# GARDEN RETREAT

THE MARK CONSISTS OF STANDARD CHARACTERS WITHOUT CLAIM TO ANY PARTICULAR FONT, STYLE, SIZE, OR COLOR.

#### CLASS 4—LUBRICANTS AND FUELS

FOR CANDLES (U.S. CLS. 1, 6 AND 15).

FIRST USE 1-18-2011; IN COMMERCE 1-18-2011.

#### CLASS 5—PHARMACEUTICALS

FOR AIR FRESHENERS (U.S. CLS. 6, 18, 44, 46, 51 AND 52).

FIRST USE 1-20-2011; IN COMMERCE 1-20-2011.

3,955,255. BOSLEY, INC., BEVERLY HILLS, CA. SN 77-579,865. PUB. 4-21-2009, FILED 9-26-2008.

## TRUE SOLUTIONS

THE MARK CONSISTS OF STANDARD CHARACTERS WITHOUT CLAIM TO ANY PARTICULAR FONT, STYLE, SIZE, OR COLOR.

NO CLAIM IS MADE TO THE EXCLUSIVE RIGHT TO USE "SOLUTIONS", APART FROM THE MARK AS SHOWN.

### CLASS 3—COSMETICS AND CLEANING PREPARATIONS

FOR HAIR CARE PREPARATIONS, NAMELY, SHAMPOOS, CONDITIONERS, HAIR GELS AND HAIR SPRAYS (U.S. CLS. 1, 4, 6, 50, 51 AND 52).

FIRST USE 11-10-2008; IN COMMERCE 11-10-2008.

### CLASS 5—PHARMACEUTICALS

FOR MEDICATED HAIR PREPARATIONS, NAMELY, MEDICATED HAIR SHAMPOO, MEDICATED HAIR CONDITIONER, MEDICATED HAIR GEL, MEDICATED HAIR MOUSSE, MEDICATED POMADES, MEDICATED HAIR LOTIONS FOR HAIR REGENERATIONS, MEDICINAL PREPARATIONS FOR STIMULATING HAIR GROWTH, AND HAIR GROWTH STIMULANTS (U.S. CLS. 6, 18, 44, 46, 51 AND 52).

FIRST USE 11-10-2008; IN COMMERCE 11-10-2008.

### CLASS 44—MEDICAL, BEAUTY AND AGRICULTURAL SERVICES

FOR HYGIENIC AND BEAUTY CARE FOR HUMAN BEINGS, NAMELY, HAIR IMPLANTATION AND HAIR REPLACEMENT SERVICES (U.S. CLS. 100 AND 101).

FIRST USE 11-10-2008; IN COMMERCE 11-10-2008.

3,955,256. MAKE HIM STOP, LLC, NEW YORK, NY. SN 77-584,330. PUB. 12-8-2009, FILED 10-2-2008.

## FOOD, DRINKS AND ROCK 'N ROLL

THE MARK CONSISTS OF STANDARD CHARACTERS WITHOUT CLAIM TO ANY PARTICULAR FONT, STYLE, SIZE, OR COLOR.

NO CLAIM IS MADE TO THE EXCLUSIVE RIGHT TO USE "FOOD, DRINKS", APART FROM THE MARK AS SHOWN.

### CLASS 41—EDUCATION AND ENTERTAINMENT

FOR ENTERTAINMENT SERVICES IN THE NATURE OF AN ONGOING SERIES IN THE FIELD OF FOOD, COOKING AND CULINARY ARTS PROVIDED VIA TELEVISION, RADIO, INTERNET, MOBILE PHONES, PERSONAL DIGITAL ASSISTANTS, HANDHELD DIGITAL ELECTRONIC DEVICES, AND OTHER PERSONAL MEDIA DEVICES (U.S. CLS. 100, 101 AND 107).

FIRST USE 9-12-2008; IN COMMERCE 2-1-2011.

### CLASS 43—HOTEL AND RESTAURANT SERVICES

FOR ONLINE SERVICES, NAMELY, PROVIDING A WEBSITE FEATURING A DATABASE OF INFORMATION IN THE FIELD OF FOOD, NAMELY, RECIPES, COOKING INFORMATION AND CULINARY ARTS (U.S. CLS. 100 AND 101).

FIRST USE 9-12-2008; IN COMMERCE 10-1-2010.

3,955,262. BLOOD CELL STORAGE, INC., SEATTLE, WA. SN 77-607,727. PUB. 10-27-2009, FILED 11-5-2008.

## PURE NUCLEIC ACIDS, HASSLE FREE

THE MARK CONSISTS OF STANDARD CHARACTERS WITHOUT CLAIM TO ANY PARTICULAR FONT, STYLE, SIZE, OR COLOR.

### CLASS 1—CHEMICALS

FOR REAGENTS FOR PURIFYING AND DETECTING NUCLEIC ACIDS FOR SCIENTIFIC RESEARCH PURPOSES, NAMELY, SOLUTIONS FOR THE CAPTURE OF NUCLEIC ACIDS, SOLUTIONS FOR THE WASHING OF NUCLEIC ACIDS, SOLUTIONS FOR THE ELUTION OF NUCLEIC ACIDS, AND SOLUTIONS FOR DETECTION OF NUCLEIC ACIDS (U.S. CLS. 1, 5, 6, 10, 26 AND 46).

FIRST USE 11-30-2010; IN COMMERCE 11-30-2010.

### CLASS 5—PHARMACEUTICALS

FOR REAGENTS FOR PURIFYING AND DETECTING NUCLEIC ACIDS FOR MEDICAL DIAGNOSTIC PURPOSES, NAMELY, SOLUTIONS FOR THE CAPTURE OF NUCLEIC ACIDS, SOLUTIONS FOR THE WASHING OF NUCLEIC ACIDS, SOLUTIONS FOR THE ELUTION OF NUCLEIC ACIDS, AND SOLUTIONS FOR DETECTION OF NUCLEIC ACIDS (U.S. CLS. 6, 18, 44, 46, 51 AND 52).

FIRST USE 11-30-2010; IN COMMERCE 11-30-2010.

### CLASS 9—ELECTRICAL AND SCIENTIFIC APPARATUS

FOR LABORATORY INSTRUMENTS, NAMELY, FLUIDIC CARDS FOR EXTRACTING AND CAPTURING NUCLEIC ACIDS FOR DIAGNOSTIC AND SCIENTIFIC RESEARCH PURPOSES; INSTRUMENTS FOR MEASURING THE QUANTITY OF NUCLEIC ACIDS, NAMELY, FLUORIMETERS (U.S. CLS. 21, 23, 26, 36 AND 38).

FIRST USE 11-30-2010; IN COMMERCE 11-30-2010.

3,955,263. SHIONOGI & CO., LTD., OSAKA, JAPAN. SN 77-614,606. PUB. 5-26-2009, FILED 11-14-2008.



THE MARK CONSISTS OF A GEOMETRIC CIRCLE DESIGN.

**CLASS 5—PHARMACEUTICALS**

FOR HOUSE MARK FOR A FULL LINE OF PHARMACEUTICAL PREPARATIONS, DIETETIC AND NUTRITIONAL SUBSTANCES; VITAMINS; MEDICATIONS FOR PAIN RELIEF (U.S. CLS. 6, 18, 44, 46, 51 AND 52).  
FIRST USE 10-0-2008; IN COMMERCE 2-0-2009.

**CLASS 35—ADVERTISING AND BUSINESS**

FOR WHOLESALE DISTRIBUTORSHIP SERVICES OF PHARMACEUTICAL PREPARATIONS, DIETETIC AND NUTRITIONAL SUBSTANCES, VITAMINS, AND MEDICATIONS FOR PAIN RELIEF (U.S. CLS. 100, 101 AND 102).  
FIRST USE 10-0-2008; IN COMMERCE 10-0-2008.

3,955,264. LEFFEW, ROB, MARKLEVILLE, IN. SN 77-615,633. PUB. 3-31-2009, FILED 11-17-2008.

---

## After the Flowers

THE MARK CONSISTS OF STANDARD CHARACTERS WITHOUT CLAIM TO ANY PARTICULAR FONT, STYLE, SIZE, OR COLOR.

**CLASS 36—INSURANCE AND FINANCIAL**

FOR CHARITABLE FUNDRAISING SERVICES, NAMELY, BY PROVIDING INDIVIDUALS WITH THE INFORMATION AND OPPORTUNITY TO MAKE MONETARY DONATIONS TO THEIR FAVORITE CHARITY (U.S. CLS. 100, 101 AND 102).  
FIRST USE 11-23-2010; IN COMMERCE 11-23-2010.

**CLASS 42—SCIENTIFIC AND COMPUTER SERVICES**

FOR HOSTING AN ONLINE WEBSITE FEATURING CHARITABLE FUND RAISING SERVICES AND INFORMATION (U.S. CLS. 100 AND 101).  
FIRST USE 11-23-2010; IN COMMERCE 11-23-2010.

3,955,270. BIOTRONIK SE & CO. KG, BERLIN, FED REP GERMANY. SN 77-622,321. PUB. 9-29-2009, FILED 11-26-2008.

---

## EVIA

OWNER OF FED REP GERMANY REG. NO. 302008053704, DATED 3-16-2009, EXPIRES 8-31-2018.

**CLASS 10—MEDICAL APPARATUS**

FOR SURGICAL AND MEDICAL INSTRUMENTS AND APPARATUS, NAMELY, PACEMAKERS (U.S. CLS. 26, 39 AND 44).  
FIRST USE 5-20-2010; IN COMMERCE 5-20-2010.

**CLASS 38—COMMUNICATION**

FOR TELECOMMUNICATIONS SERVICES, NAMELY, ELECTRONIC TRANSMISSION OF DATA; REMOTE DATA TRANSMISSION FROM AND TO MEDICAL APPARATUS AND APPARATUS FOR COLLECTING, FORWARDING, STORING, EDITING OR PROCESSING MEDICAL DATA; WIRELESS TRANSMISSION OF ELECTRICAL SIGNALS TO AND FROM MEDICAL IMPLANTS (U.S. CLS. 100, 101 AND 104).  
FIRST USE 5-20-2010; IN COMMERCE 5-20-2010.

**CLASS 44—MEDICAL, BEAUTY AND AGRICULTURAL SERVICES**

FOR MEDICAL SERVICES, NAMELY, REMOTE MONITORING AND REMOTE DIAGNOSIS OF CIRCULATORY AND CARDIOLOGICAL DATA FOR MEDICAL CARE; TELEMETRIC AND DIRECT RECORDING OF PATIENT- AND IMPLANT-RELATED DATA FOR DIAGNOSTIC AND THERAPEUTIC PURPOSES; INTERNET SERVICES, NAMELY, PROVIDING MEDICAL DATA ABOUT PATIENTS AND MEDICAL IMPLANTS VIA THE INTERNET; RENTING OUT MEDICAL APPARATUS; PERFORMING MEDICAL AND CLINICAL EXAMINATIONS; MEDICAL CARE BY TELEMETRIC MEANS, INCLUDING LOCALIZATION, OF PATIENTS AND MEDICAL IMPLANTS (U.S. CLS. 100 AND 101).  
FIRST USE 5-20-2010; IN COMMERCE 5-20-2010.

3,955,271. REFERRED U CONCEPTS, LLC, PALM HARBOR, FL. SN 77-623,818. PUB. 11-3-2009, FILED 12-1-2008.

---

## REFERREDU

THE MARK CONSISTS OF STANDARD CHARACTERS WITHOUT CLAIM TO ANY PARTICULAR FONT, STYLE, SIZE, OR COLOR.

**CLASS 35—ADVERTISING AND BUSINESS**

FOR BUSINESS NETWORKING SERVICES; PROVIDING AN ONLINE DIRECTORY INFORMATION SERVICE FEATURING INFORMATION REGARDING EMPLOYMENT AND CAREERS; PROMOTING THE GOODS AND SERVICES OF OTHERS OVER THE INTERNET (U.S. CLS. 100, 101 AND 102).  
FIRST USE 12-1-2009; IN COMMERCE 12-1-2009.

**CLASS 42—SCIENTIFIC AND COMPUTER SERVICES**

FOR COMPUTER SERVICES, NAMELY, CREATING AN ONLINE COMMUNITY FOR REGISTERED USERS TO PARTICIPATE IN DISCUSSIONS REGARDING EMPLOYMENT AND CAREERS, ENGAGE IN CAREER NETWORKING ACTIVITIES AND FORM VIRTUAL COMMUNITIES (U.S. CLS. 100 AND 101).  
FIRST USE 12-1-2009; IN COMMERCE 12-1-2009.



3,955,272. HARVEY BALL SMILE LIMITED, SHINAGAWA-KU, JAPAN. SN 77-626,905. PUB. 11-10-2009, FILED 12-4-2008.



OWNER OF U.S. REG. NOS. 3,066,172, 3,242,722, AND OTHERS.

NO CLAIM IS MADE TO THE EXCLUSIVE RIGHT TO USE "DESIGNED BY" AND "USA 1963", APART FROM THE MARK AS SHOWN.

THE MARK DOES NOT IDENTIFY A LIVING INDIVIDUAL.

THE MARK CONSISTS OF THE WORDING "DESIGNED BY HARVEY R. BALL USA 1963", WHICH SURROUNDS A SMILEY FACE DESIGN.

#### CLASS 9—ELECTRICAL AND SCIENTIFIC APPARATUS

FOR EYEGLASSES (U.S. CLS. 21, 23, 26, 36 AND 38).  
FIRST USE 2-27-2009; IN COMMERCE 2-27-2009.

#### CLASS 14—JEWELRY

FOR ALARM CLOCKS; BRACELETS; BRACELETS OF PRECIOUS METAL; BROOCHES; CHRONOMETERS; CLOCKS; CUFF-LINKS; EARRINGS; FIGURES OF PRECIOUS METAL; FIGURINES OF PRECIOUS METAL; INSIGNIAS OF PRECIOUS METAL; KEY HOLDERS OF PRECIOUS METALS; KEY RINGS OF PRECIOUS METAL; NECKLACES; PRECIOUS GEMSTONES; TIE CLIPS; TIE PINS; WATCH BANDS; WATCHES; WRIST WATCHES (U.S. CLS. 2, 27, 28 AND 50).  
FIRST USE 2-27-2009; IN COMMERCE 2-27-2009.

#### CLASS 21—HOUSEWARES AND GLASS

FOR BATH SPONGES; COMBS; CUPS; DRINKING GLASSES; HAIR BRUSHES; PET BRUSHES; PLATES; SERVING PLATTERS; SERVING PLATTERS NOT OF PRECIOUS METAL; SERVING PLATTERS OF PRECIOUS METAL (U.S. CLS. 2, 13, 23, 29, 30, 33, 40 AND 50).  
FIRST USE 2-27-2009; IN COMMERCE 2-27-2009.

#### CLASS 24—FABRICS

FOR BATH LINEN; BED LINEN; CANVAS FOR TAPESTRY OR EMBROIDERY; CLOTH LABELS; CURTAIN FABRIC; CURTAINS MADE OF TEXTILE FABRICS; HOUSEHOLD LINEN; TABLE LINEN; TEXTILE FABRICS FOR LINGERIE; TOWELS (U.S. CLS. 42 AND 50).  
FIRST USE 2-27-2009; IN COMMERCE 2-27-2009.

#### CLASS 28—TOYS AND SPORTING GOODS

FOR ACTION SKILL GAMES; CHILDREN'S MULTIPLE ACTIVITY TOYS; DOLLS; PARLOR GAMES; PLAY FIGURES; PLAY HOUSES; STUFFED TOYS (U.S. CLS. 22, 23, 38 AND 50).  
FIRST USE 2-27-2009; IN COMMERCE 2-27-2009.

#### CLASS 30—STAPLE FOODS

FOR BEVERAGES MADE OF COFFEE; BISCUITS; BREAD; CANDIES; CANDY; CARAMELS; CHEWING GUM; CHOCOLATE; CHOCOLATE FOOD BEVERAGES NOT BEING DAIRY-BASED OR VEGETABLE BASED; CONES FOR ICECREAM; COOKIES; CRACKERS; CREAM PUFFS; DOUGHNUTS; HONEY; ICE CANDIES; ICE CREAM; PANCAKES; PASTA; PIES; SAUCES; SEASONINGS; SHERBET; SPONGE CAKES; SUGAR; WAFERS (U.S. CL. 46).

FIRST USE 2-27-2009; IN COMMERCE 2-27-2009.

3,955,275. FRANK, HOSEA, LOS ANGELES, CA. SN 77-631,925. PUB. 7-6-2010, FILED 12-12-2008.

# ZE FRANK

THE MARK CONSISTS OF STANDARD CHARACTERS WITHOUT CLAIM TO ANY PARTICULAR FONT, STYLE, SIZE, OR COLOR.

THE NAME "ZE FRANK" IDENTIFIES THE NICKNAME OF THE APPLICANT HOSEA "FRANK", A LIVING INDIVIDUAL WHOSE CONSENT IS OF RECORD.

#### CLASS 35—ADVERTISING AND BUSINESS

FOR BUSINESS CONSULTING SERVICES (U.S. CLS. 100, 101 AND 102).  
FIRST USE 3-31-2001; IN COMMERCE 3-31-2001.

#### CLASS 41—EDUCATION AND ENTERTAINMENT

FOR ONLINE ENTERTAINMENT SERVICES FOR CHILDREN AND ADULTS, FEATURING HUMOR, MUSIC, ART AND ANIMATION, VIRTUAL GAMES AND TOYS, NAMELY, INTERACTIVE MULTIMEDIA SINGLE- AND MULTI-PLAYER COMPUTER GAMES, AND ONLINE INTERACTIVE STORIES AND NON-DOWNLOADABLE INTERNET VIDEOS PERTAINING TO ONLINE CULTURE, SOCIAL COMMENTARY IN THE FIELD OF CURRENT EVENTS AND NEWS IN THE FIELD OF CURRENT EVENTS; EDUCATIONAL SERVICES, NAMELY, PRODUCTION OF INSTRUCTIONAL ONLINE GAMES AND VIDEOS FOR CHILDREN AND ADULTS RELATED TO ONLINE CULTURE, SOCIAL COMMENTARY AND NEWS IN THE FIELD OF CURRENT EVENTS (U.S. CLS. 100, 101 AND 107).  
FIRST USE 3-31-2001; IN COMMERCE 3-31-2001.

#### CLASS 45—PERSONAL AND LEGAL SERVICES

FOR ONLINE SOCIAL NETWORKING SERVICES (U.S. CLS. 100 AND 101).  
FIRST USE 3-31-2001; IN COMMERCE 3-31-2001.

3,955,279. WORKFORCE ENGINE, LLC, NEW YORK, NY.  
SN 77-635,000. PUB. 6-22-2010, FILED 12-17-2008.

## WORKFORCE ENGINE

THE MARK CONSISTS OF STANDARD CHARACTERS WITHOUT CLAIM TO ANY PARTICULAR FONT, STYLE, SIZE, OR COLOR.

NO CLAIM IS MADE TO THE EXCLUSIVE RIGHT TO USE "WORKFORCE", APART FROM THE MARK AS SHOWN.

### CLASS 16—PAPER GOODS AND PRINTED MATTER

FOR PRINTED MATERIALS, NAMELY, MANUALS, CONTRACTS AND FORMS IN THE FIELDS OF PERSONNEL MANAGEMENT AND EMPLOYMENT LAW (U.S. CLS. 2, 5, 22, 23, 29, 37, 38 AND 50).

FIRST USE 11-0-2010; IN COMMERCE 11-0-2010.

### CLASS 35—ADVERTISING AND BUSINESS

FOR DEVELOPMENT OF CUSTOM PERSONNEL MANAGEMENT MATERIALS FOR OTHERS, NAMELY, DEVELOPMENT OF CUSTOM EMPLOYEE MANUALS AND HANDBOOKS (U.S. CLS. 100, 101 AND 102).

FIRST USE 11-0-2010; IN COMMERCE 11-0-2010.

### CLASS 41—EDUCATION AND ENTERTAINMENT

FOR CONDUCTING EDUCATIONAL AND TRAINING SEMINARS AND TUTORIAL SESSIONS IN THE FIELDS OF PERSONNEL MANAGEMENT AND EMPLOYMENT LAW (U.S. CLS. 100, 101 AND 107).

FIRST USE 11-0-2010; IN COMMERCE 11-0-2010.

---

3,955,285. HEALTHBANKS BIOTECH USA, INC., DBA PACIFICORD, IRVINE, CA. SN 77-645,275. PUB. 11-17-2009, FILED 1-7-2009.

## Cord Blood Concierge

THE MARK CONSISTS OF STANDARD CHARACTERS WITHOUT CLAIM TO ANY PARTICULAR FONT, STYLE, SIZE, OR COLOR.

NO CLAIM IS MADE TO THE EXCLUSIVE RIGHT TO USE "CORD BLOOD", APART FROM THE MARK AS SHOWN.

### CLASS 35—ADVERTISING AND BUSINESS

FOR CUSTOMER SERVICE MANAGEMENT FOR OTHERS FOR CORD BLOOD BANKS, NAMELY, ENROLLMENT OF CUSTOMERS AND FOLLOW UP COMMUNICATIONS WITH THE CUSTOMER REGARDING CUSTOMER SATISFACTION (U.S. CLS. 100, 101 AND 102).

FIRST USE 11-21-2008; IN COMMERCE 2-0-2009.

### CLASS 39—TRANSPORTATION AND STORAGE

FOR TRANSPORTATION OF BLOOD FOR OTHERS (U.S. CLS. 100 AND 105).

FIRST USE 11-21-2008; IN COMMERCE 2-0-2009.

### CLASS 44—MEDICAL, BEAUTY AND AGRICULTURAL SERVICES

FOR CORD BLOOD BANKS (U.S. CLS. 100 AND 101).

FIRST USE 11-21-2008; IN COMMERCE 2-0-2009.

---

3,955,286. CHARLES J. FARRELL JR., GOLDEN, CO. SN 77-647,112. PUB. 3-2-2010, FILED 1-10-2009.

## Money Mass Index

THE MARK CONSISTS OF STANDARD CHARACTERS WITHOUT CLAIM TO ANY PARTICULAR FONT, STYLE, SIZE, OR COLOR.

NO CLAIM IS MADE TO THE EXCLUSIVE RIGHT TO USE "MONEY" AND "INDEX", APART FROM THE MARK AS SHOWN.

### CLASS 35—ADVERTISING AND BUSINESS

FOR FINANCIAL INFORMATION, NAMELY, PROVIDING A FINANCIAL INDEX IN THE NATURE OF QUANTITATIVE MEASUREMENTS FOR ANALYZING PROGRESS TOWARD RETIREMENT GOALS (U.S. CLS. 100, 101 AND 102).

FIRST USE 7-24-2010; IN COMMERCE 7-24-2010.

### CLASS 36—INSURANCE AND FINANCIAL

FOR FINANCIAL CONSULTING, NAMELY, FINANCIAL PLANNING FOR RETIREMENT; PROVIDING AN ON-LINE FINANCIAL CALCULATOR FOR GAUGING PROGRESS TOWARD RETIREMENT GOALS (U.S. CLS. 100, 101 AND 102).

FIRST USE 8-24-2010; IN COMMERCE 8-24-2010.

---

3,955,290. RECOLOGY INC., SAN FRANCISCO, CA. SN 77-651,556. PUB. 6-30-2009, FILED 1-16-2009.

## RECOLOGY

THE MARK CONSISTS OF STANDARD CHARACTERS WITHOUT CLAIM TO ANY PARTICULAR FONT, STYLE, SIZE, OR COLOR.

### CLASS 37—CONSTRUCTION AND REPAIR

FOR SOLID WASTE MANAGEMENT, NAMELY, WASTE DISPOSAL; WASTE DISPOSAL FOR OTHERS; CONSULTING SERVICES RELATED TO WASTE DISPOSAL; COLLECTION OF TRASH; TRASH COLLECTION, REFUSE CLEAN-UP (U.S. CLS. 100, 103 AND 106).

FIRST USE 10-27-2010; IN COMMERCE 10-27-2010.

**CLASS 39—TRANSPORTATION AND STORAGE**

FOR SOLID WASTE MANAGEMENT, NAMELY, WASTE COLLECTION IN THE NATURE OF TRANSPORTING WASTE; CONSULTING SERVICES RELATED TO WASTE COLLECTION IN THE NATURE OF TRANSPORTING WASTE; GARBAGE COLLECTION AND TRANSPORT BY TRUCK; RENTAL OF DUMPSTERS (U.S. CLS. 100 AND 105).

FIRST USE 10-27-2010; IN COMMERCE 10-27-2010.

**CLASS 40—MATERIAL TREATMENT**

FOR WASTE MANAGEMENT; SOLID WASTE MANAGEMENT INCLUDING COMPOSTING AND RECYCLING; RECYCLING, AND WASTE TREATMENT; CONSULTATION IN THE FIELD OF WASTE TREATMENT; CONSULTATION IN THE FIELD OF RECYCLING; RECYCLING AND WASTE TREATMENT SERVICES; SORTING OF WASTE AND RECYCLABLE MATERIAL; TREATMENT OF WASTE MATERIALS TO CONVERT THEM INTO PLANT FOOD PRODUCTS; CONSULTATION WITH REGARD TO TREATMENT OF WASTE MATERIALS; WASTE TREATMENT SERVICES AND PROVIDING TECHNICAL CONSULTATION IN CONNECTION THEREWITH; RECYCLING; WASTE-TO-ENERGY GENERATION SERVICES; RESOURCE RECOVERY AND RECLAMATION SERVICES, NAMELY, SORTING PLASTICS, PAPER, CARDBOARD, GLASS AND METAL; RECYCLING OF WASTE AND TRASH; CONSULTING SERVICES RELATED TO WASTE TREATMENT (U.S. CLS. 100, 103 AND 106).

FIRST USE 10-27-2010; IN COMMERCE 10-27-2010.

**CLASS 41—EDUCATION AND ENTERTAINMENT**

FOR DEVELOPING AND CONDUCTING EDUCATIONAL PROGRAMS FOR USE BY OTHERS IN PROMOTING ENVIRONMENTAL AWARENESS AND RECYCLING ISSUES DIRECTED TO THE COMMUNITY, BUSINESS AND SCHOOLS (U.S. CLS. 100, 101 AND 107).

FIRST USE 10-27-2010; IN COMMERCE 10-27-2010.

**CLASS 42—SCIENTIFIC AND COMPUTER SERVICES**

FOR ENGINEERING SERVICES RELATED TO THE PLANNING, DESIGN, REPAIR, RENOVATION AND CONSTRUCTION OF WASTE COLLECTION, TREATMENT AND DISPOSAL PLANTS, FACILITIES AND SYSTEMS (U.S. CLS. 100 AND 101).

FIRST USE 10-27-2010; IN COMMERCE 10-27-2010.

**CLASS 44—MEDICAL, BEAUTY AND AGRICULTURAL SERVICES**

FOR CONSULTING WITH REGARD TO USE OF FERTILIZERS (U.S. CLS. 100 AND 101).

FIRST USE 10-27-2010; IN COMMERCE 10-27-2010.

3,955,292. CML MEDIA CORP., AKA INTHEMO.COM, CULVER CITY, CA. SN 77-653,346. PUB. 5-5-2009, FILED 1-21-2009.



THE MARK CONSISTS OF THE LETTERS "M" AND "O" WITH THE SILHOUETTE OF THE HEAD AND SHOULDERS OF A PERSON IN THE "O".

**CLASS 35—ADVERTISING AND BUSINESS**

FOR ADVERTISING AND COMMERCIAL INFORMATION SERVICES, VIA THE INTERNET; ADVERTISING AND PUBLICITY SERVICES, NAMELY, PROMOTING THE GOODS, SERVICES, BRAND IDENTITY AND COMMERCIAL INFORMATION AND NEWS OF THIRD PARTIES THROUGH PRINT, AUDIO, VIDEO, DIGITAL AND ON-LINE MEDIUM; PRODUCING AUDIO OR VIDEO INFOMERCIALS; PROVIDING A WEB SITE AT WHICH USERS CAN OFFER GOODS FOR SALE AND BUY GOODS OFFERED BY OTHERS; PROVIDING A WEB SITE WHERE USERS CAN POST RATINGS, REVIEWS AND RECOMMENDATIONS ON PRODUCTS AND SERVICES; PROVIDING A WEB SITE WHICH FEATURES ADVERTISEMENTS FOR THE GOODS AND SERVICES OF OTHERS ON A GLOBAL COMPUTER NETWORK; PROVIDING AN ONLINE VIDEO BUSINESS DIRECTORY (U.S. CLS. 100, 101 AND 102).

FIRST USE 4-27-2007; IN COMMERCE 4-27-2007.

**CLASS 41—EDUCATION AND ENTERTAINMENT**

FOR ENTERTAINMENT SERVICES, NAMELY, PROVIDING A WEB SITE FEATURING PHOTOGRAPHIC, AUDIO, VIDEO AND PROSE PRESENTATIONS FEATURING RESTAURANTS, NIGHTLIFE VENUES, ARTISTS, CHEFS, LOCAL TASTEMAKERS, STORES, HOTELS AND PLACES OF PUBLIC INTEREST; ENTERTAINMENT SERVICES, NAMELY, PROVIDING A WEB SITE FEATURING USER-GENERATED VIDEOS ON A WIDE VARIETY OF TOPICS AND SUBJECTS; FILM AND VIDEO PRODUCTION (U.S. CLS. 100, 101 AND 107).

FIRST USE 4-27-2007; IN COMMERCE 4-27-2007.

**CLASS 45—PERSONAL AND LEGAL SERVICES**

FOR INTERNET BASED SOCIAL NETWORKING, INTRODUCTION SERVICES (U.S. CLS. 100 AND 101).

FIRST USE 4-27-2007; IN COMMERCE 4-27-2007.

3,955,301. BELIEVE IN ME THERAPY, LLC, NORTH ARLINGTON, NJ. SN 77-674,795. PUB. 6-16-2009, FILED 2-20-2009.

# JUNGANEW

THE MARK CONSISTS OF STANDARD CHARACTERS WITHOUT CLAIM TO ANY PARTICULAR FONT, STYLE, SIZE, OR COLOR.

**CLASS 9—ELECTRICAL AND SCIENTIFIC APPARATUS**

FOR PRERECORDED CDS, VIDEO TAPES AND DVDS FEATURING SPEECH LANGUAGE THERAPY PROGRAMS (U.S. CLS. 21, 23, 26, 36 AND 38).

FIRST USE 2-25-2011; IN COMMERCE 2-25-2011.

**CLASS 16—PAPER GOODS AND PRINTED MATTER**

FOR PRINTED PUBLICATIONS AND BOOKS, NAMELY, CHILDREN'S INTERACTIVE BOOKS FOR USE WITH SPEECH LANGUAGE THERAPY PROGRAMS (U.S. CLS. 2, 5, 22, 23, 29, 37, 38 AND 50).

FIRST USE 2-25-2011; IN COMMERCE 2-25-2011.

3,955,322. EVOLVE GUEST CONTROLS, INC., NEW HYDE PARK, NY. SN 77-711,324. PUB. 8-3-2010, FILED 4-10-2009.

# EVOLVE

THE MARK CONSISTS OF STANDARD CHARACTERS WITHOUT CLAIM TO ANY PARTICULAR FONT, STYLE, SIZE, OR COLOR.

## CLASS 9—ELECTRICAL AND SCIENTIFIC APPARATUS

FOR ELECTRIC CONTROL DEVICES FOR HEATING AND ENERGY MANAGEMENT; CARD READING EQUIPMENT; ELECTRONIC DEVICES WHICH CONTROL OR REGULATE LIGHTING, TEMPERATURE, BLINDS, UPON INSERTION OR REMOVAL OF A CARD (U.S. CLS. 21, 23, 26, 36 AND 38).

FIRST USE 10-1-2009; IN COMMERCE 10-1-2009.

## CLASS 37—CONSTRUCTION AND REPAIR

FOR INSTALLATION, MAINTENANCE AND REPAIR OF ELECTRIC CONTROL DEVICES FOR HEATING AND ENERGY MANAGEMENT (U.S. CLS. 100, 103 AND 106).

FIRST USE 10-1-2009; IN COMMERCE 10-1-2009.

---

3,955,326. NIKE, INC., BEAVERTON, OR. SN 77-718,270. PUB. 12-22-2009, FILED 4-21-2009.

# CONSIDERED DESIGN

THE MARK CONSISTS OF STANDARD CHARACTERS WITHOUT CLAIM TO ANY PARTICULAR FONT, STYLE, SIZE, OR COLOR.

NO CLAIM IS MADE TO THE EXCLUSIVE RIGHT TO USE "DESIGN", APART FROM THE MARK AS SHOWN.

## CLASS 18—LEATHER GOODS

FOR ATHLETIC SPORT BAGS (U.S. CLS. 1, 2, 3, 22 AND 41).

FIRST USE 4-1-2009; IN COMMERCE 4-1-2009.

## CLASS 25—CLOTHING

FOR FOOTWEAR; APPAREL, NAMELY, PANTS, SHORTS, SHIRTS, T-SHIRTS, PULLOVERS, SWEAT SHIRTS, SWEAT PANTS, UNDERWEAR, SPORTS BRAS, DRESSES, VESTS, SKIRTS, SWEATERS, JACKETS, COATS, SOCKS, HEADWEAR, HATS, CAPS, SWEATBANDS, GLOVES, BELTS, HOSIERY (U.S. CLS. 22 AND 39).

FIRST USE 4-1-2009; IN COMMERCE 4-1-2009.

3,955,332. USAUS LLC, LOVELAND, CO. SN 77-733,551. PUB. 6-8-2010, FILED 5-11-2009.



THE MARK CONSISTS OF A STYLIZED DESIGN THAT INCORPORATES THE BORDERS OF THE WEST COAST OF THE UNITED STATES OF AMERICA AND THE EAST COAST OF AUSTRALIA. THE LITERAL ELEMENT OF THE MARK "USAUS" IS LOCATED INSIDE THE DESIGN.

## CLASS 9—ELECTRICAL AND SCIENTIFIC APPARATUS

FOR QUILTING ACCESSORIES, NAMELY, GRADUATED RULERS OF VARIOUS SIZES AND SHAPES; ELECTRONIC MEDIA, NAMELY, PRE-RECORDED CDS AND DVDS FEATURING SUBJECTS IN THE FIELDS OF QUILTING AND COOKING (U.S. CLS. 21, 23, 26, 36 AND 38).

FIRST USE 3-10-2010; IN COMMERCE 3-10-2010.

## CLASS 20—FURNITURE AND ARTICLES NOT OTHERWISE CLASSIFIED

FOR TABLES; FURNITURE; PLASTIC TEMPLATES FOR GUIDING FABRIC CUTTING (U.S. CLS. 2, 13, 22, 25, 32 AND 50).

FIRST USE 3-25-2010; IN COMMERCE 3-25-2010.

---

3,955,333. TWO FOR THE ROAD, INC., EVANSTON, IL. SN 77-734,139. PUB. 12-15-2009, FILED 5-11-2009.

# RELATIONTRIPS

THE MARK CONSISTS OF STANDARD CHARACTERS WITHOUT CLAIM TO ANY PARTICULAR FONT, STYLE, SIZE, OR COLOR.

## CLASS 16—PAPER GOODS AND PRINTED MATTER

FOR PRINTED MATTER, NAMELY, BOOKS, BROCHURES, ARTICLES AND NEWSLETTERS ABOUT HOW TO DEVELOP, PLAN, EXECUTE AND DOCUMENT VACATION TRAVEL DESIGNED TO BUILD AND FOSTER STRONG BONDS BETWEEN PARENTS AND CHILDREN (U.S. CLS. 2, 5, 22, 23, 29, 37, 38 AND 50).

FIRST USE 12-31-2008; IN COMMERCE 2-10-2009.

**CLASS 39—TRANSPORTATION AND STORAGE**

FOR PROVIDING A WEBSITE FEATURING TRAVEL INFORMATION, NAMELY, DEVELOP, PLAN, EXECUTE AND DOCUMENT VACATION TRAVEL FOR BUILDING AND FOSTERING STRONG BONDS BETWEEN PARENTS AND CHILDREN (U.S. CLS. 100 AND 105).

FIRST USE 3-15-2009; IN COMMERCE 4-28-2009.

**CLASS 41—EDUCATION AND ENTERTAINMENT**

FOR EDUCATIONAL SERVICES, NAMELY, CONDUCTING SEMINARS ABOUT HOW TO DEVELOP, PLAN, EXECUTE AND DOCUMENT VACATION TRAVEL DESIGNED TO BUILD AND FOSTER STRONG BONDS BETWEEN PARENTS AND CHILDREN (U.S. CLS. 100, 101 AND 107).

FIRST USE 1-31-2009; IN COMMERCE 10-15-2009.

**CLASS 41—EDUCATION AND ENTERTAINMENT**

FOR EDUCATION AND ENTERTAINMENT, NAMELY, EDUCATIONAL SERVICES, NAMELY, DEVELOPING AND CONDUCTING TRAINING COURSES, WORKSHOPS, CONFERENCES AND DISTRIBUTION OF TRAINING MATERIALS IN CONNECTION THEREWITH FOR SUBJECT MATTERS AS REQUESTED BY EDUCATIONAL STAKEHOLDERS; ANALYZING EDUCATIONAL TESTS SCORES AND DATA FOR OTHERS; ARRANGING CONTESTS AND INCENTIVE AWARD PROGRAMS TO ENCOURAGE STUDENTS AND ORGANIZATION MEMBERS TO SET UP AND ACHIEVE GOALS IN ACADEMICS, ATTENDANCE, CITIZENSHIP AND CONDUCT; DISTRIBUTION OF TELEVISION PROGRAMS FOR OTHERS, EDUCATION SERVICES, NAMELY, PROVIDING KINDERGARTEN THROUGH 12TH GRADE CLASSROOM INSTRUCTION AND INCENTIVES IN CONNECTION WITH DEVELOPING READING SKILLS AND LANGUAGE COMPREHENSION (U.S. CLS. 100, 101 AND 107).

FIRST USE 5-1-2006; IN COMMERCE 5-1-2006.

3,955,348. HAEMONETICS CORPORATION, BRAINTREE, MA. SN 77-763,892. PUB. 12-15-2009, FILED 6-19-2009.

3,955,345. SPRINGBOARDS TO EDUCATION, INC., EDINBURG, TX. SN 77-761,990. PUB. 6-15-2010, FILED 6-17-2009.

**LIFE, UNINTERRUPTED**

THE MARK CONSISTS OF STANDARD CHARACTERS WITHOUT CLAIM TO ANY PARTICULAR FONT, STYLE, SIZE, OR COLOR.

**READ A MILLION WORDS**

THE MARK CONSISTS OF STANDARD CHARACTERS WITHOUT CLAIM TO ANY PARTICULAR FONT, STYLE, SIZE, OR COLOR.

**CLASS 16—PAPER GOODS AND PRINTED MATTER**

FOR PAPER GOODS AND PRINTED MATTER, NAMELY, PRINTED INSTRUCTIONAL, EDUCATIONAL, TEACHING MATERIALS AND INCENTIVES IN THE FORM OF STATIONERY, POSTCARDS, STORY BOOKS, BOOKMARKS, POSTERS, CALENDARS, CERTIFICATES, CHARTS, STICKERS AND TRANSFERS, ADVERTISING SIGNS OF PAPER OR CARDBOARD, ANNOUNCEMENT CARDS, ART PRINTS ON PAPER OR CANVAS, INSTRUCTION SHEETS, VINYL LETTERS AND NUMBERS FOR USE IN MAKING SIGNS OR POSTERS, NOTEBOOKS, NOTEPAPER, CATALOGS AND PAMPHLETS IN THE FIELD OF EDUCATION, COLORING BOOKS, PRINTS; PUBLICATIONS, NAMELY, BROCHURES, BOOKLETS, CERTIFICATES AND PRINTED INCENTIVE MATERIALS TO PROMOTE READING AND LANGUAGE COMPREHENSION FOR KINDERGARTEN THROUGH HIGH SCHOOL STUDENTS; REMOVABLE TATTOOS DECALS, SEALS, STUDY GUIDES (U.S. CLS. 2, 5, 22, 23, 29, 37, 38 AND 50).

FIRST USE 5-1-2006; IN COMMERCE 5-1-2006.

**CLASS 35—ADVERTISING AND BUSINESS**

FOR BLOOD SUPPLY CHAIN MANAGEMENT, NAMELY, LOGISTICS AND INVENTORY MANAGEMENT IN THE FIELD OF BLOOD AND BLOOD PRODUCTS (U.S. CLS. 100, 101 AND 102).

FIRST USE 3-7-2011; IN COMMERCE 3-7-2011.

**CLASS 44—MEDICAL, BEAUTY AND AGRICULTURAL SERVICES**

FOR PROVIDING SOLUTIONS FOR BLOOD SUPPLY CHAIN MANAGEMENT, NAMELY, PROVIDING INFORMATION IN THE FIELD OF COLLECTION AND PRESERVATION OF HUMAN BLOOD FOR BLOOD BANKS AND HOSPITALS (U.S. CLS. 100 AND 101).

FIRST USE 3-7-2011; IN COMMERCE 3-7-2011.

3,955,362. MOUNTAIN STONE ASSOCIATES LLC, WESTPORT, CT. SN 77-774,348. PUB. 12-1-2009, FILED 7-4-2009.

**Scribblitt**

THE MARK CONSISTS OF STANDARD CHARACTERS WITHOUT CLAIM TO ANY PARTICULAR FONT, STYLE, SIZE, OR COLOR.

**CLASS 16—PAPER GOODS AND PRINTED MATTER**

FOR BOOK COVERS; CHILDREN'S ACTIVITY BOOKS; CHILDREN'S BOOKS; CHILDREN'S INTERACTIVE EDUCATIONAL BOOKS; COMIC BOOKS; COMIC STRIPS; COMICS; COMPOSITION BOOKS; ILLUSTRATIONS; MANUSCRIPT BOOKS; NON-FICTION BOOKS ON A VARIETY OF TOPICS; NON-FICTION BOOKS ON A VARIETY OF TOPICS; NOTE BOOKS; PICTURE BOOKS; SCHOOL WRITING BOOKS; SERIES OF FICTION AND NON-FICTION BOOKS ON A VARIETY OF TOPICS; SERIES OF FICTION AND NON-FICTION BOOKS ON A VARIETY OF TOPICS; SERIES OF FICTION BOOKS; SERIES OF FICTION WORKS, NAMELY, NOVELS AND BOOKS; SKETCH BOOKS; STORIES IN ILLUSTRATED FORM; STORY BOOKS (U.S. CLS. 2, 5, 22, 23, 29, 37, 38 AND 50).

FIRST USE 2-21-2011; IN COMMERCE 2-21-2011.

**CLASS 40—MATERIAL TREATMENT**

FOR DIGITAL ON-DEMAND PRINTING SERVICES OF BOOKS AND OTHER DOCUMENTS; PRINTING OF BOOKS (U.S. CLS. 100, 103 AND 106).

FIRST USE 2-21-2011; IN COMMERCE 2-21-2011.

**CLASS 41—EDUCATION AND ENTERTAINMENT**

FOR BOOK AND REVIEW PUBLISHING; BOOK PUBLISHING; CUSTOM WRITING SERVICES; DESKTOP PUBLISHING FOR OTHERS; DIGITAL VIDEO, AUDIO, AND MULTIMEDIA PUBLISHING SERVICES; ELECTRONIC PUBLISHING SERVICES, NAMELY, PUBLICATION OF TEXT AND GRAPHIC WORKS OF OTHERS ON ONLINE FEATURING VARIOUS TOPICS; ENTERTAINMENT AND EDUCATIONAL SERVICES, NAMELY, PROVIDING A WEBSITE THAT DISPLAYS VARIOUS REQUESTS, REVIEWS, RECOMMENDATIONS, RANKINGS, TRACKINGS, VOTES, AND INFORMATION RELATING TO UNCREATED, UNRELEASED, NEW, SPECIAL, POPULAR, AND RARE PRODUCTS, SERVICES, AND EVENTS IN THE FIELDS OF POP CULTURE, ENTERTAINMENT, EDUCATION, LIFESTYLE, AND SPORTS, ALL EXCLUSIVELY FOR NON-BUSINESS AND NON-COMMERCIAL TRANSACTIONS AND PURPOSES; MAGAZINE PUBLISHING; MULTIMEDIA PUBLISHING OF BOOKS, MAGAZINES, JOURNALS, SOFTWARE, GAMES, MUSIC, AND ELECTRONIC PUBLICATIONS; MUSIC PUBLISHING SERVICES; ONLINE ELECTRONIC PUBLISHING OF BOOKS AND PERIODICALS; PROVIDING A WEBSITE FEATURING EDUCATION AND ENTERTAINMENT FOR CHILDREN; PROVIDING AN INTERNET WEBSITE PORTAL IN THE FIELD OF MUSIC; PUBLICATION OF BOOKS; PUBLICATION OF BOOKS, MAGAZINES, ALMANACS AND JOURNALS; PUBLICATION OF BOOKS, OF MAGAZINES, OF JOURNALS, OF NEWSPAPERS, OF PERIODICALS, OF CATALOGS, OF BROCHURES; PUBLICATION OF BOOKS, REVIEWS; PUBLISHING OF BOOKS AND REVIEWS; PUBLISHING OF BOOKS, MAGAZINES; PUBLISHING OF ELECTRONIC PUBLICATIONS; PUBLISHING OF REVIEWS; PUBLISHING OF WEB MAGAZINES (U.S. CLS. 100, 101 AND 107).

FIRST USE 2-21-2011; IN COMMERCE 2-21-2011.

**CLASS 42—SCIENTIFIC AND COMPUTER SERVICES**

FOR CHARITABLE SERVICES, NAMELY, PROVIDING A WEBSITE THAT ENABLES CHILDREN OF A SCHOOL DISTRICT TO COMMUNICATE WITH A CHARITY OF THEIR CHOICE; COMPUTER SERVICES, NAMELY, INTERACTIVE HOSTING SERVICES WHICH ALLOW THE USER TO PUBLISH AND SHARE THEIR OWN CONTENT AND IMAGES ON-LINE; COMPUTER SERVICES, NAMELY, PROVIDING AN INTERACTIVE WEB SITE THAT ALLOWS USERS TO CREATE THEIR OWN BOOKS; CUSTOM DESIGN OF BOOKS AND COMICS BASED ON PERSONAL SELECTIONS MADE BY THE CUSTOMER; DESIGN OF CUSTOMIZED BOOKS; GRAPHIC ILLUSTRATION SERVICES FOR OTHERS; HOSTING AN ONLINE WEBSITE FEATURING WRITING AND ILLUSTRATION AND PUBLISHING; PROVIDING A SECURED-ACCESS WEBSITE THAT

GIVES REGISTERED INTERNET NETWORKED INSTITUTIONS THE ABILITY TO UPLOAD, VIEW, COPY, PRINT, DOWNLOAD AND SHARE DOCUMENTS AND IMAGES FOR THE PURPOSES OF CONDUCTING CONSUMER-DRIVEN TRANSACTIONS; PROVIDING A WEBSITE FEATURING ON-LINE NON-DOWNLOADABLE SOFTWARE THAT ENABLES USERS TO CREATE AUDIO DRAMA SERIES AND EPISODES, WRITE SCRIPTS, AUDITION AND ASSIGN TALENT, RECORD AND MIX AUDIO, PUBLISH PRODUCED AUDIO DRAMAS, TRACK AND ANALYZE AUDIO DRAMA STATISTICS, ADVERTISE AND MARKET AUDIO DRAMAS, AND STREAM AND/OR DOWNLOAD AUDIO DRAMAS (U.S. CLS. 100 AND 101).

FIRST USE 2-21-2011; IN COMMERCE 2-21-2011.

3,955,365. BITTER BRILLIANCE, LLC, SMYRNA, GA. SN 77-778,178. PUB. 6-22-2010, FILED 7-10-2009.



THE COLOR(S) RED AND BLACK IS/ARE CLAIMED AS A FEATURE OF THE MARK.

THE MARK CONSISTS OF THE WORD "THAT'S" IN THE COLOR RED. THE WORD "TORN" IS UNDERNEATH IT IN BLACK WITH A RED EXCLAMATION POINT AFTER IT.

**CLASS 25—CLOTHING**

FOR CLOTHING, NAMELY, T-SHIRTS (U.S. CLS. 22 AND 39).

FIRST USE 2-1-2011; IN COMMERCE 2-1-2011.

**CLASS 41—EDUCATION AND ENTERTAINMENT**

FOR ENTERTAINMENT SERVICES, NAMELY, PROVIDING A WEBSITE FEATURING PHOTOGRAPHIC, AUDIO, VIDEO AND PROSE PRESENTATIONS ON CURRENT EVENTS, CELEBRITY GOSSIP, POLITICS, AND SOCIAL ISSUES; ONLINE JOURNALS, NAMELY, BLOGS FEATURING COMMENTARY AND ADVICE ON CURRENT EVENTS, CELEBRITY GOSSIP, POLITICS, AND SOCIAL ISSUES; PROVIDING A WEBSITE PORTAL IN THE FIELD OF ENTERTAINMENT, CULTURAL AND SPORTING EVENTS (U.S. CLS. 100, 101 AND 107).

FIRST USE 2-1-2011; IN COMMERCE 2-1-2011.

3,955,366. BITTER BRILLIANCE, LLC, SMYRNA, GA. SN 77-778,196. PUB. 6-22-2010, FILED 7-10-2009.



THE NAME(S), PORTRAIT(S), AND/OR SIGNATURE(S) SHOWN IN THE MARK DOES NOT IDENTIFY A PARTICULAR LIVING INDIVIDUAL.

THE MARK CONSISTS OF A PICTURE OF A MAN'S FACE WEARING GLASSES WITH THE WORDS "FRANK LEE" UNDERNEATH IT.

#### CLASS 25—CLOTHING

FOR CLOTHING, NAMELY, T-SHIRTS (U.S. CLS. 22 AND 39).  
FIRST USE 2-1-2011; IN COMMERCE 2-1-2011.

#### CLASS 41—EDUCATION AND ENTERTAINMENT

FOR ENTERTAINMENT SERVICES, NAMELY, PROVIDING A WEBSITE FEATURING PHOTOGRAPHIC, AUDIO, VIDEO AND PROSE PRESENTATIONS ON CURRENT EVENTS, CELEBRITY GOSSIP, POLITICS, AND SOCIAL ISSUES; ONLINE JOURNALS, NAMELY, BLOGS FEATURING COMMENTARY AND ADVICE ON CURRENT EVENTS, CELEBRITY GOSSIP, POLITICS, AND SOCIAL ISSUES; PROVIDING A WEBSITE PORTAL IN THE FIELD OF ENTERTAINMENT, CULTURAL AND SPORTING EVENTS (U.S. CLS. 100, 101 AND 107).  
FIRST USE 2-1-2011; IN COMMERCE 2-1-2011.

3,955,367. NUNOVA, LLC, HORSHAM, PA. SN 77-778,604. PUB. 6-8-2010, FILED 7-10-2009.

# NUNOVA

THE MARK CONSISTS OF STANDARD CHARACTERS WITHOUT CLAIM TO ANY PARTICULAR FONT, STYLE, SIZE, OR COLOR.

#### CLASS 39—TRANSPORTATION AND STORAGE

FOR ELECTRONIC STORAGE OF PATIENT MEDICAL RECORDS AND INFORMATION (U.S. CLS. 100 AND 105).  
FIRST USE 3-0-2010; IN COMMERCE 3-0-2010.

#### CLASS 42—SCIENTIFIC AND COMPUTER SERVICES

FOR PROVIDING ONLINE NON-DOWNLOADABLE SOFTWARE FOR USE IN THE MANAGEMENT, MAINTENANCE AND STORAGE OF PATIENT MEDICAL RECORDS AND INFORMATION; PROVIDING A WEBSITE FEATURING TECHNOLOGY THAT ENABLES USERS TO MANAGE, MAINTAIN AND STORE PATIENT MEDICAL RECORDS AND INFORMATION (U.S. CLS. 100 AND 101).  
FIRST USE 3-0-2010; IN COMMERCE 3-0-2010.

#### CLASS 44—MEDICAL, BEAUTY AND AGRICULTURAL SERVICES

FOR ELECTRONIC MAINTENANCE OF PATIENT MEDICAL RECORDS AND INFORMATION (U.S. CLS. 100 AND 101).  
FIRST USE 3-0-2010; IN COMMERCE 3-0-2010.

3,955,371. CMC ENERGY SERVICES, INC., BETHESDA, MD. SN 77-783,437. PUB. 1-12-2010, FILED 7-17-2009.

## CMC ENERGY SERVICES

THE MARK CONSISTS OF STANDARD CHARACTERS WITHOUT CLAIM TO ANY PARTICULAR FONT, STYLE, SIZE, OR COLOR.

OWNER OF U.S. REG. NOS. 2,362,796 AND 3,214,960.  
NO CLAIM IS MADE TO THE EXCLUSIVE RIGHT TO USE "ENERGY SERVICES", APART FROM THE MARK AS SHOWN.

#### CLASS 16—PAPER GOODS AND PRINTED MATTER

FOR PRINTED MATERIALS, NAMELY, BOOKS, WORKBOOKS, PRESENTATIONS, HANDOUTS, TESTS, AND BROCHURES IN THE FIELD OF ENERGY EFFICIENCY (U.S. CLS. 2, 5, 22, 23, 29, 37, 38 AND 50).  
FIRST USE 1-1-1999; IN COMMERCE 1-1-1999.

#### CLASS 35—ADVERTISING AND BUSINESS

FOR PROVIDING ADMINISTRATIVE SERVICES IN THE FIELD OF ENERGY EFFICIENCY FOR PROGRAMS SPONSORED BY GOVERNMENT AGENCIES OR DEPARTMENTS, GOVERNMENT SPONSORED ENTERPRISES, UTILITY COMPANIES, OR NON-GOVERNMENTAL GROUPS, NAMELY, EMPLOYMENT RECRUITING OF ENERGY AUDITORS, WEATHERIZATION SPECIALISTS, AND POST-INSTALLATION INSPECTORS FOR HIRE AS INDEPENDENT CONTRACTORS BY OTHER PARTIES; ENERGY AUDITING; PROVIDING REFERRALS IN THE FIELD OF ENERGY EFFICIENCY VIA THE INTERNET; CONSULTATION IN THE FIELD OF ENERGY EFFICIENCY; CUSTOM WRITING SERVICES COMPRISING MARKETING MATERIALS FOR OTHERS IN THE ENERGY EFFICIENCY INDUSTRY (U.S. CLS. 100, 101 AND 102).  
FIRST USE 10-21-2001; IN COMMERCE 10-21-2001.

**CLASS 41—EDUCATION AND ENTERTAINMENT**

FOR WRITING OF ARTICLES FOR PERIODICALS OTHER THAN FOR ADVERTISING OR PUBLICITY, IN THE FIELD OF ENERGY EFFICIENCY; TRAINING SERVICES IN THE FIELD OF ENERGY EFFICIENCY FOR ENERGY AUDITORS, WEATHERIZATION SPECIALISTS, AND POST-INSTALLATION INSPECTORS (U.S. CLS. 100, 101 AND 107).

FIRST USE 10-21-2001; IN COMMERCE 10-21-2001.

3,955,381. SMILE BRANDS INC., SANTA ANA, CA. SN 77-789,436. PUB. 12-8-2009, FILED 7-24-2009.

**SMILE BRANDS**

THE MARK CONSISTS OF STANDARD CHARACTERS WITHOUT CLAIM TO ANY PARTICULAR FONT, STYLE, SIZE, OR COLOR.

NO CLAIM IS MADE TO THE EXCLUSIVE RIGHT TO USE "BRANDS", APART FROM THE MARK AS SHOWN.

3,955,378. B.C.D. REALTY LLC, DBA BCD, BROOKLYN, NY. SN 77-789,138. PUB. 4-27-2010, FILED 7-24-2009.

**BCD**

THE MARK CONSISTS OF STANDARD CHARACTERS WITHOUT CLAIM TO ANY PARTICULAR FONT, STYLE, SIZE, OR COLOR.

**CLASS 5—PHARMACEUTICALS**

FOR DIETARY FOOD SUPPLEMENTS, MEDICINAL HERB EXTRACTS, GINSENG FOR MEDICINAL USE AND OINTMENTS, NAMELY, ANTI-INFLAMMATORY OINTMENTS, ANTI-ITCH OINTMENTS, HEMORRHOIDAL OINTMENTS (U.S. CLS. 6, 18, 44, 46, 51 AND 52).

FIRST USE 11-22-2010; IN COMMERCE 11-22-2010.

**CLASS 30—STAPLE FOODS**

FOR PROCESSED HERBS; HERBAL EXTRACTS FOR FOOD, NAMELY, HERBAL TEA EXTRACTS; PROCESSED GINSENG USED AS AN HERB; HERBAL TEA AND FOOD BEVERAGES, NAMELY, HERBAL TEA-BASED BEVERAGES; ROYAL JELLY FOR FOOD PURPOSE AND FOR USE WITH TEA (U.S. CL. 46).

FIRST USE 11-22-2010; IN COMMERCE 11-22-2010.

**CLASS 33—WINES AND SPIRITS**

FOR WINE, DISTILLED SPIRITS AND LIQUEURS (U.S. CLS. 47 AND 49).

FIRST USE 11-22-2010; IN COMMERCE 11-22-2010.

**CLASS 35—ADVERTISING AND BUSINESS**

FOR IMPORT AND EXPORT AGENCY SERVICES IN FIELDS OF WINE, LIQUEURS, DIETARY FOOD SUPPLEMENTS AND GENERAL MERCHANDISE; AND DISTRIBUTORSHIP SERVICES IN THE FIELDS OF WINE, LIQUEURS, DIETARY FOOD SUPPLEMENTS AND GENERAL MERCHANDISE; AND WHOLESALE STORE SERVICES IN THE FIELDS OF WINE, LIQUEURS, DIETARY FOOD SUPPLEMENTS AND GENERAL MERCHANDISE (U.S. CLS. 100, 101 AND 102).

FIRST USE 11-22-2010; IN COMMERCE 11-22-2010.

**CLASS 35—ADVERTISING AND BUSINESS**

FOR DENTAL PRACTICE MANAGEMENT FOR OTHERS (U.S. CLS. 100, 101 AND 102).

FIRST USE 6-26-2010; IN COMMERCE 6-26-2010.

**CLASS 44—MEDICAL, BEAUTY AND AGRICULTURAL SERVICES**

FOR DENTAL HYGIENIST SERVICES; DENTISTRY (U.S. CLS. 100 AND 101).

FIRST USE 6-26-2010; IN COMMERCE 6-26-2010.

3,955,387. CITARETX MANAGEMENT, LLC, LEAGUE CITY, TX. SN 77-793,710. PUB. 12-29-2009, FILED 7-30-2009.



THE MARK CONSISTS OF A SHADED PARTIAL RECTANGLE WITH A CURVED SIDE, WITH UNSHADED SLANTED LINES AND DIAMOND SHAPES, WHICH CONTAIN AN UNSHADED SUPERIMPOSED 5-POINT STAR IN THE RIGHT CORNER OF THE PARTIAL RECTANGLE, ABOVE THE TERM, "CITARETX".

**CLASS 35—ADVERTISING AND BUSINESS**

FOR NEW BUSINESS VENTURE DEVELOPMENT AND FORMATION CONSULTING SERVICES (U.S. CLS. 100, 101 AND 102).

FIRST USE 5-29-2009; IN COMMERCE 5-29-2009.

**CLASS 36—INSURANCE AND FINANCIAL**

FOR FUND INVESTMENT CONSULTATION; FUNDS INVESTMENT; INVESTMENT OF FUNDS FOR OTHERS; MANAGEMENT OF A CAPITAL INVESTMENT FUND; PRIVATE EQUITY FUND INVESTMENT SERVICES; VENTURE CAPITAL FUNDING SERVICES TO EMERGING AND START-UP COMPANIES (U.S. CLS. 100, 101 AND 102).

FIRST USE 5-29-2009; IN COMMERCE 5-29-2009.



3,955,409. BISON DESIGNS, LLC, LONGMONT, CO. SN 77-809,459. PUB. 7-20-2010, FILED 8-20-2009.

3,955,422. STEM CELL SCIENCES HOLDINGS LIMITED, EDINBURGH, LOTHIAN, UNITED KINGDOM. SN 77-818,195. PUB. 7-20-2010, FILED 9-2-2009.

# HOOKM

THE MARK CONSISTS OF STANDARD CHARACTERS WITHOUT CLAIM TO ANY PARTICULAR FONT, STYLE, SIZE, OR COLOR.

## CLASS 6—METAL GOODS

FOR CARABINERS OF METAL (U.S. CLS. 2, 12, 13, 14, 23, 25 AND 50).  
FIRST USE 4-30-2010; IN COMMERCE 4-30-2010.

## CLASS 20—FURNITURE AND ARTICLES NOT OTHERWISE CLASSIFIED

FOR CARABINERS OF PLASTIC (U.S. CLS. 2, 13, 22, 25, 32 AND 50).  
FIRST USE 7-30-2009; IN COMMERCE 7-30-2009.

3,955,412. ZINI'S INC., DBA LITTLE SHEBA'S RESTAURANT, RICHMOND, IN. SN 77-812,050. PUB. 9-28-2010, FILED 8-25-2009.



NO CLAIM IS MADE TO THE EXCLUSIVE RIGHT TO USE "RESTAURANT", APART FROM THE MARK AS SHOWN.

THE MARK CONSISTS OF THE STYLIZED WORDS "LITTLE SHEBA'S RESTAURANT" LOCATED WITHIN A HOUSE, BELOW THE TRIANGULAR ROOF OF THE HOUSE AND ABOVE THE RECTANGULAR FRONT DOOR OF THE HOUSE. THE WORDS "BETTER THAN BEING HOME" ARE LOCATED BELOW THE HOUSE.

## CLASS 25—CLOTHING

FOR BASEBALL CAPS; GOLF SHIRTS; SHIRTS; T-SHIRTS; TANK TOPS; GOLF CAPS (U.S. CLS. 22 AND 39).  
FIRST USE 2-1-2003; IN COMMERCE 9-1-2009.

## CLASS 43—HOTEL AND RESTAURANT SERVICES

FOR RESTAURANT, BAR, BANQUET AND CATERING SERVICES (U.S. CLS. 100 AND 101).  
FIRST USE 2-1-2003; IN COMMERCE 2-1-2003.



OWNER OF U.S. REG. NO. 3,242,637.  
NO CLAIM IS MADE TO THE EXCLUSIVE RIGHT TO USE "SC", APART FROM THE MARK AS SHOWN.

THE COLOR(S) BLACK, WHITE AND RED IS/ARE CLAIMED AS A FEATURE OF THE MARK.

THE MARK CONSISTS OF CONCENTRIC CIRCLES, A BLACK INNER CIRCLE AND A WHITE OUTER CIRCLE HAVING A BLACK PERIMETER. A RED CHECK MARK ORIGINATES WITHIN THE BLACK INNER CIRCLE AND EXTENDS OUTWARD THROUGH THE WHITE OUTER CIRCLE AND THE WHITE OUTER CIRCLE'S PERIMETER. THE LETTERS AND WORDING "SC PROVEN" ARE BLACK AND APPEAR WITHIN THE WHITE OUTER CIRCLE.

## CLASS 1—CHEMICALS

FOR REAGENTS FOR SCIENTIFIC USE IN BIOLOGICAL PROCESSING OTHER THAN FOR MEDICAL OR VETERINARY PURPOSES; BIOLOGICAL PREPARATIONS FOR SCIENTIFIC USE IN CELL CULTURES, OTHER THAN MEDICAL USE; CULTURES OF CELL MEDIA FOR SCIENTIFIC USE, OTHER THAN FOR MEDICAL OR VETERINARY USE; MEDIA IN THE NATURE OF BUFFER AND STANDARD SOLUTIONS USED IN ANALYTICAL CHEMISTRY FOR CELL CULTURE FOR USE IN SCIENTIFIC, NON-MEDICAL, RESEARCH LABORATORIES; MEDIA IN THE NATURE OF BUFFER AND STANDARD SOLUTIONS USED IN ANALYTICAL CHEMISTRY FOR CELL CULTURE USE IN SCIENTIFIC, NON-MEDICAL, RESEARCH LABORATORIES; MEDIA IN THE NATURE OF BUFFER AND STANDARD SOLUTIONS USED IN ANALYTICAL CHEMISTRY FOR CELL CULTURE FOR USE IN THE BIOTECHNOLOGICAL INDUSTRY; SERA, NAMELY, HUMAN SERUM ALBUMIN DERIVED FROM GRAINS FOR USE IN CELL CULTURE MEDIA FOR LIFE SCIENCE RESEARCH AND BIOPROCESSING FOR NON-MEDICAL RESEARCH PURPOSES; CHEMICAL AND BIOLOGICAL REAGENT FOR NON-MEDICAL USE, NAMELY, ANTIBODIES FOR SCIENTIFIC USE; DIAGNOSTIC PREPARATIONS FOR SCIENTIFIC USE, NAMELY, ANTIBODIES FOR DIAGNOSTIC USE; ELISA TEST KITS, NAMELY, BIOLOGICAL REAGENTS FOR USE IN SCIENTIFIC APPARATUS FOR CHEMICAL OR BIOLOGICAL ANALYSIS, FOR USE IN ENZYME LINKED IMMUNO-SORBENT ASSAYS FOR BIOCHEMICAL DETECTION OF SUBSTANCES; PRODUCTS, NAMELY, KITS CONTAINING ANTIBODIES FOR USE IN SCIENCE; TISSUE CULTURE REAGENTS FOR SCIENTIFIC AND MEDICAL LABORATORY RESEARCH USE; CELL CULTURE REAGENTS FOR SCIENTIFIC USE; CELL CULTURE MEDIA, NAMELY, REAGENTS FOR SCIENTIFIC OR RESEARCH USE; BIOLOGICAL TEST KITS COMPRISED OF BUFFER AND STANDARD SOLUTIONS USED IN ANALYTICAL CHEMISTRY, VECTORS, CELLS AND REAGENTS FOR RESEARCH USE (U.S. CLS. 1, 5, 6, 10, 26 AND 46).  
FIRST USE 5-14-2004; IN COMMERCE 11-12-2004.

**CLASS 5—PHARMACEUTICALS**

FOR BIOLOGICAL REAGENTS FOR MEDICAL USE IN EMBRYOLOGY; BIOLOGICAL REAGENTS FOR MEDICAL USE IN MOLECULAR BIOLOGY; REAGENTS FOR USE IN BIOLOGICAL PROCESSING FOR MEDICAL PURPOSES; REAGENTS FOR USE IN BIOLOGICAL PROCESSING FOR VETERINARY PURPOSES; AGENTS IN THE NATURE OF HORMONES, CYTOKINES, ANTIGENS, AND IMMUNOGLOBULINS FOR ACTIVATING CELLULAR FUNCTIONS ALL FOR MEDICAL USE; BIOLOGICAL PREPARATIONS FOR USE IN CELL CULTURES FOR MEDICAL PURPOSES; CELL CULTURE MEDIA, NAMELY, CELL CULTURE REAGENTS FOR MEDICAL USE; ANTITOXIC SERA; ANTITOXIC SERA FOR IN-VIVO USE; ANTIBODIES, NAMELY, ANTIBACTERIAL SUBSTANCES FOR MEDICAL PURPOSES; ANTIBODIES FOR IMMUNODIAGNOSTIC MEDICAL PURPOSES; ANTIBODIES FOR IN-VIVO USE IN DETECTING DISEASES IN LIVESTOCK; IMMUNOLOGICAL ANTIBODIES FOR MEDICAL USE (U.S. CLS. 6, 18, 44, 46, 51 AND 52).

FIRST USE 5-14-2004; IN COMMERCE 11-12-2004.

3,955,424. STONERIVER, INC., BROOKFIELD, WI. SN 77-819,254. PUB. 6-22-2010, FILED 9-3-2009.

# STREAM

THE MARK CONSISTS OF STANDARD CHARACTERS WITHOUT CLAIM TO ANY PARTICULAR FONT, STYLE, SIZE, OR COLOR.

**CLASS 9—ELECTRICAL AND SCIENTIFIC APPARATUS**

FOR COMPUTER SOFTWARE FOR ACCOUNTING, REPORTING, PROCESSING AND MANAGEMENT OF REINSURANCE CONTRACTS AND CLAIMS; COMPUTER SOFTWARE TO ENABLE INSURANCE COMPANIES TO MANAGE CLAIMS FOR THEIR LIFECYCLE, NAMELY, NOTICE OF LOSS THROUGH SALVAGE, SUBROGATION, AND LITIGATION; COMPUTER SOFTWARE TO TRACK POLICY HOLDER INFORMATION IN THE INSURANCE FIELD FOR USE BY THE INSURANCE INDUSTRY TO PROVIDE INFORMATION ABOUT INSURANCE POLICIES AND POLICY HOLDERS AND THEIR RELATIONSHIP WITH AN INSURANCE COMPANY; COMPUTER SOFTWARE USED BY THE INSURANCE INDUSTRY TO FACILITATE POLICY ENTRY AND QUOTATION, POLICY RATING AND UNDERWRITING, POLICY ISSUE AND ENDORSEMENT, POLICY ILLUSTRATION, POLICY CANCELLATION AND RENEWAL, CLAIMS ADMINISTRATION AND ASSIGNMENT, CLAIMS RESERVE MANAGEMENT, BILLING, COLLECTIONS, PAYMENTS, BUSINESS INTELLIGENCE, DOCUMENT PRINT, CUSTOMER RELATIONSHIP MANAGEMENT, REINSURANCE CONTRACT MANAGEMENT, CESSION, AND ASSUMPTION, ELECTRIC FUNDS TRANSFER, PREPARATION OF BILLING NOTICES, MANAGEMENT OF MEDICAL CLAIMS AND WORKERS COMPENSATION CLAIMS, BILLING, AND PAYMENT PROCESSING; COMPUTER SOFTWARE USED BY INSURANCE ADMINISTRATION FOR BILLING, CLAIMS ADMINISTRATION, UNDERWRITING, AND MANAGEMENT OF INSURANCE POLICIES AND APPLICATIONS; COMPUTER SOFTWARE USED BY INSURANCE COMPANIES, STATE WORKERS COMPENSATION INSURANCE FUNDS, AND THIRD PARTY ADMINISTRATORS FOR USE IN MANAGING AND ADMINISTERING WORKERS COMPENSATION INSURANCE POLICIES, BILLING, AND CLAIMS; COMPUTER SOFTWARE FOR FACILITATING THE ELECTRONIC SUBMISSION OF BILLS (U.S. CLS. 21, 23, 26, 36 AND 38).

FIRST USE 3-4-2010; IN COMMERCE 3-4-2010.

**CLASS 36—INSURANCE AND FINANCIAL**

FOR INSURANCE ADMINISTRATION SERVICES, NAMELY, MANAGING THE ADMINISTRATION OF INSURANCE POLICIES AND APPLICATIONS; PROVIDING ONLINE INFORMATION IN THE FIELD OF INSURANCE MATTERS, NAMELY, FINANCIAL COMPENSATION UNDER AN INSURANCE POLICY, WORKERS COMPENSATION AND MOTOR VEHICLE INSURANCE; INSURANCE CLAIM PROCESSING INFORMATION FOR EMPLOYERS WITH NOTIFICATION OF POTENTIAL WORKER'S COMPENSATION CLAIMS VIA FACSIMILE OR ELECTRONIC MAIL (U.S. CLS. 100, 101 AND 102).

FIRST USE 3-4-2010; IN COMMERCE 3-4-2010.

**CLASS 42—SCIENTIFIC AND COMPUTER SERVICES**

FOR APPLICATION SERVICE PROVIDER (ASP) FEATURING SOFTWARE FOR USE BY INSURANCE COMPANIES, STATE WORKERS COMPENSATION INSURANCE FUNDS, AND THIRD PARTY ADMINISTRATORS FOR USE IN MANAGING AND ADMINISTERING WORKERS COMPENSATION INSURANCE POLICIES, BILLING, AND CLAIMS; APPLICATION SERVICE PROVIDER (ASP), NAMELY, HOSTING COMPUTER SOFTWARE APPLICATIONS OF OTHERS; COMPUTER SOFTWARE DEVELOPMENT SERVICES IN THE FIELD OF INSURANCE MARKETING; DOCUMENT DATA TRANSFER FROM ONE COMPUTER MEDIA FORMAT TO ANOTHER MEDIA FORMAT (U.S. CLS. 100 AND 101).

FIRST USE 3-4-2010; IN COMMERCE 3-4-2010.

3,955,429. VOXEO CORPORATION, ORLANDO, FL. SN 77-820,144. PUB. 6-29-2010, FILED 9-4-2009.

## UNLOCKED COMMUNICATIONS

THE MARK CONSISTS OF STANDARD CHARACTERS WITHOUT CLAIM TO ANY PARTICULAR FONT, STYLE, SIZE, OR COLOR.

NO CLAIM IS MADE TO THE EXCLUSIVE RIGHT TO USE "COMMUNICATIONS", APART FROM THE MARK AS SHOWN.

**CLASS 9—ELECTRICAL AND SCIENTIFIC APPARATUS**

FOR COMPUTER TELEPHONY SOFTWARE; DOWNLOADABLE COMPUTER SOFTWARE FOR DEVELOPING OTHER COMPUTER PROGRAMS; DOWNLOADABLE COMPUTER SOFTWARE FOR ASSISTING DEVELOPERS IN CREATING PROGRAM CODE FOR COMMUNICATIONS APPLICATIONS, TELECOMMUNICATIONS SERVICES, INSTANT MESSAGING APPLICATIONS AND SMS APPLICATIONS; DOWNLOADABLE COMPUTER TELEPHONY SOFTWARE FOR THE CREATION, DEVELOPMENT AND DEPLOYMENT OF COMPUTER TELEPHONY APPLICATIONS, FOR INTEGRATION OF COMPUTER COMMUNICATIONS NETWORKS AND TELECOMMUNICATIONS NETWORKS, AND FOR ROUTING, MANAGEMENT, ENHANCEMENT, AND CONFIGURATION OF COMMUNICATIONS OVER TELECOMMUNICATIONS AND COMPUTER COMMUNICATIONS NETWORKS; COMPUTER TELEPHONY SOFTWARE FOR THE CREATION, DEVELOPMENT AND DEPLOYMENT OF COMPUTER TELEPHONY APPLICATIONS, FOR INTEGRATION OF COMPUTER COMMUNICATIONS NETWORKS AND TELECOMMUNICATIONS NETWORKS, AND FOR ROUTING, MANAGEMENT, ENHANCEMENT, AND CONFIGURATION OF COMMUNICATIONS OVER TELECOMMUNICATIONS AND COMPUTER COMMUNICATIONS NETWORKS (U.S. CLS. 21, 23, 26, 36 AND 38).

FIRST USE 10-1-2009; IN COMMERCE 10-1-2009.

**CLASS 38—COMMUNICATION**

FOR COMPUTER TELEPHONE COMMUNICATION SERVICES; INTERNET TELEPHONE COMMUNICATION SERVICES; TELECOMMUNICATION SERVICES, NAMELY, LOCAL AND LONG DISTANCE TRANSMISSION OF VOICE, DATA, GRAPHICS BY MEANS OF TELEPHONE, TELEGRAPHIC, CABLE, AND SATELLITE TRANSMISSIONS; VOICE OVER INTERNET PROTOCOL SERVICES; PROVIDING CO-LOCATION SERVICES FOR VOICE AND DATA COMMUNICATIONS APPLICATIONS; TELECOMMUNICATIONS RESELLER SERVICES, NAMELY, PROVIDING VALUE ADDED INTERACTIVE VOICE RESPONSE TELECOMMUNICATION SERVICES; PROVIDING TELEPHONE CONFERENCING SERVICES AND PROVIDING TELEPHONE AUTO ATTENDANT SERVICES; COMMUNICATIONS AND TELECOMMUNICATIONS SERVICES IN THE AREA OF AUTOMATED VOICE APPLICATIONS AND COMMUNICATIONS SYSTEMS, NAMELY, PROVIDING TELEPHONE CALL ROUTING, INTERACTIVE VOICE RESPONSE, AND TELECONFERENCING; TELEPHONE CALL MANAGEMENT SERVICES FOR OTHERS, NAMELY, TELEPHONE CALL BRIDGING, TELEPHONE CALL TRANSFERRING, AND TELEPHONE CALL CONFERENCING; ELECTRONIC TRANSMISSION OF DATA, DOCUMENTS AND VOICE MAIL VIA COMPUTER TERMINALS; COMMUNICATIONS AND TELECOMMUNICATIONS SERVICES IN THE AREA OF AUTOMATED VOICE APPLICATIONS AND COMMUNICATIONS SYSTEMS, NAMELY, PROVIDING TELEPHONE CALL ROUTING, INTERACTIVE VOICE RESPONSE, AND TELECONFERENCING (U.S. CLS. 100, 101 AND 104).

FIRST USE 10-1-2009; IN COMMERCE 10-1-2009.

**CLASS 42—SCIENTIFIC AND COMPUTER SERVICES**

FOR APPLICATION SERVICE PROVIDER FEATURING SOFTWARE IN THE FIELD OF INTERACTIVE VOICE RESPONSE; APPLICATION SERVICE PROVIDER, NAMELY, HOSTING COMPUTER SOFTWARE APPLICATIONS FOR THE USE OF OTHERS AND APPLICATIONS FEATURING SOFTWARE IN THE FIELD OF INTERACTIVE VOICE RESPONSE; PROVIDING ON-LINE NON-DOWNLOADABLE SOFTWARE FOR DEVELOPING OTHER COMPUTER PROGRAMS; PROVIDING ON-LINE NON-DOWNLOADABLE SOFTWARE FOR ASSISTING DEVELOPERS IN CREATING PROGRAM CODE FOR COMMUNICATIONS APPLICATIONS, TELECOMMUNICATIONS SERVICES, INSTANT MESSAGING APPLICATIONS AND SMS APPLICATIONS; HOSTING COMPUTER TELEPHONY APPLICATIONS OVER A NETWORK FOR OTHERS; HOSTING COMPUTER TELEPHONY APPLICATIONS AND AUTO-

MATED VOICE APPLICATIONS OVER COMMUNICATIONS NETWORK FOR OTHERS; CONSULTING SERVICES IN THE AREA OF AUTOMATED VOICE APPLICATIONS AND COMMUNICATION SYSTEMS; INTEGRATION OF TELECOMMUNICATION AND COMPUTER SYSTEMS; INTEGRATION OF TELEPHONE CALL CENTER SERVICES WITH COMPUTER AND COMMUNICATIONS SYSTEMS FOR OTHERS; INTEGRATION OF TELECOMMUNICATION AND COMPUTER SYSTEMS; INTEGRATION OF TELEPHONE CALL CENTER SERVICES WITH COMPUTERS AND COMMUNICATIONS SYSTEMS FOR OTHERS (U.S. CLS. 100 AND 101).

FIRST USE 10-1-2009; IN COMMERCE 10-1-2009.

3,955,432. EIKO ELECTRIC PRODUCTS CORP., TAIPEI 114, TAIWAN. SN 77-821,022. PUB. 7-6-2010, FILED 9-5-2009.



THE MARK CONSISTS OF THE STYLIZED WORD "EIKO" WITH THE DOT ABOVE THE LETTER "I" REPLACED WITH A PLUS LIKE DESIGN ALL ENCLOSED WITHIN AN OVAL CARRIER.

THE WORDING "EIKO" HAS NO MEANING IN A FOREIGN LANGUAGE.

**CLASS 7—MACHINERY**

FOR AQUARIUM PUMPS, AQUARIUM WATER PUMPS, ELECTRIC PUMPS FOR AQUARIA, AERATING PUMPS FOR AQUARIA, WATER PUMPS FOR WATER FILTERING UNITS, SUBMERSIBLE PUMPS, THERMOSTATIC CONTROL VALVES FOR MACHINES, COMPRESSED AIR PUMPS LOCATED IN AQUARIUMS, CLEANING MACHINES FOR PONDS (U.S. CLS. 13, 19, 21, 23, 31, 34 AND 35).

FIRST USE 2-18-2011; IN COMMERCE 2-18-2011.

**CLASS 21—HOUSEWARES AND GLASS**

FOR AQUARIUM, WATER TANKS FOR LIVE FISH, AQUARIUM HOODS, AQUARIUM COVERS, AQUARIUM AIR STONES, AQUARIUM ORNAMENT, ARTIFICIAL AQUARIUM LANDSCAPES, INDOOR AQUARIA (U.S. CLS. 2, 13, 23, 29, 30, 33, 40 AND 50).

FIRST USE 2-18-2011; IN COMMERCE 2-18-2011.

3,955,436. BOOM BOOM! REVOLUTION, INC., SANTA CRUZ, CA. SN 77-823,078. PUB. 10-5-2010, FILED 9-9-2009.

## BOOM BOOM! REVOLUTION

THE MARK CONSISTS OF STANDARD CHARACTERS WITHOUT CLAIM TO ANY PARTICULAR FONT, STYLE, SIZE, OR COLOR.

### CLASS 35—ADVERTISING AND BUSINESS

FOR PROMOTING PUBLIC AWARENESS OF THE NEED OF SOCIALLY BENEFICIAL ACTS AND BEHAVIOR (U.S. CLS. 100, 101 AND 102).  
FIRST USE 3-1-2007; IN COMMERCE 3-1-2007.

### CLASS 45—PERSONAL AND LEGAL SERVICES

FOR PROVIDING A WEBSITE FEATURING MOTIVATIONAL TOPICS ABOUT SOCIALLY BENEFICIAL ACTS AND BEHAVIOR (U.S. CLS. 100 AND 101).  
FIRST USE 3-1-2007; IN COMMERCE 3-1-2007.

3,955,454. VERINT SYSTEMS INC., MELVILLE, NY. SN 77-837,073. PUB. 9-7-2010, FILED 9-29-2009.

## INTELLIGENCE IN ACTION

THE MARK CONSISTS OF STANDARD CHARACTERS WITHOUT CLAIM TO ANY PARTICULAR FONT, STYLE, SIZE, OR COLOR.

OWNER OF U.S. REG. NOS. 2,913,705 AND 3,140,122.

NO CLAIM IS MADE TO THE EXCLUSIVE RIGHT TO USE "INTELLIGENCE", APART FROM THE MARK AS SHOWN.

### CLASS 9—ELECTRICAL AND SCIENTIFIC APPARATUS

FOR COMPUTER HARDWARE AND SOFTWARE FOR USE IN THE FIELDS OF COMMUNICATIONS INTERCEPTION, TELECOMMUNICATIONS, DIGITAL SECURITY, SURVEILLANCE, WORKFORCE OPTIMIZATION, CALL-CENTERS AND ENTERPRISE BUSINESS INTELLIGENCE FOR USE IN THE COLLECTION, RETENTION AND STORAGE, ANALYSIS, DISSEMINATION AND DISTRIBUTION OF VOICE, FAX, VIDEO, INTERNET, DATA AND DESK-TOP SCREEN IMAGERY TRANSMISSIONS, COMPUTER SOFTWARE FOR MONITORING, RECORDING AND ANALYZING CUSTOMER INTERACTIONS THROUGH VARIOUS MEANS AND MECHANISMS OF COMMUNICATION FOR THE PURPOSE OF WORKFORCE OPTIMIZATION; COMPUTER SOFTWARE FOR SCHEDULING, PERFORMANCE MANAGEMENT, TRAINING AND REPORTING ON EMPLOYEES, AND INSTRUCTION MANUALS AND DOCUMENTATION, SOLD AS A UNIT (U.S. CLS. 21, 23, 26, 36 AND 38).  
FIRST USE 12-9-2009; IN COMMERCE 12-9-2009.

### CLASS 42—SCIENTIFIC AND COMPUTER SERVICES

FOR COMPUTER CONSULTING SERVICES IN THE FIELDS OF COMMUNICATIONS INTERCEPTION, TELECOMMUNICATIONS, DIGITAL SECURITY, SURVEILLANCE, ENTERPRISE BUSINESS INTELLIGENCE, CALL-CENTERS AND WORKFORCE OPTIMIZATION (U.S. CLS. 100 AND 101).  
FIRST USE 12-9-2009; IN COMMERCE 12-9-2009.

3,955,468. SANCHEZ, DANIKA L, SANTA CLARITA, CA. SN 77-846,135. PUB. 3-9-2010, FILED 10-10-2009.



NO CLAIM IS MADE TO THE EXCLUSIVE RIGHT TO USE "UNITED STATES OF AMERICA", APART FROM THE MARK AS SHOWN.

THE COLOR(S) BROWN, ORANGE, GOLD, WHITE AND BURGUNDY IS/ARE CLAIMED AS A FEATURE OF THE MARK.

THE MARK CONSISTS OF A WHITE SILHOUETTE OF A WOMAN WITH GOLDEN HAIR ON A STYLIZED BROWN AND BURGUNDY PENNY WITH LIGHT RADIATING OUT FROM BEHIND HER. THE STYLIZED WORDS "CENT OF A WOMAN" APPEAR IN GOLD AND ORANGE LETTERS AROUND THE STYLIZED PENNY DESIGN.

### CLASS 35—ADVERTISING AND BUSINESS

FOR PROVIDING CONSUMER INFORMATION AND RELATED NEWS IN THE FIELD OF FINANCIAL PLANNING (U.S. CLS. 100, 101 AND 102).

FIRST USE 8-15-2009; IN COMMERCE 8-15-2009.

### CLASS 41—EDUCATION AND ENTERTAINMENT

FOR EDUCATIONAL SERVICES, NAMELY, CONDUCTING CLASSES, SEMINARS, CONFERENCES, WORKSHOPS IN THE FIELD OF FINANCIAL PLANNING FOR WOMEN AND DISTRIBUTION OF COURSE MATERIAL IN CONNECTION THEREWITH (U.S. CLS. 100, 101 AND 107).

FIRST USE 9-1-2009; IN COMMERCE 9-1-2009.

3,955,469. TWO FINE DOGS, OJAI, CA. SN 77-846,142. PUB. 3-30-2010, FILED 10-10-2009.

"We Put the  in Hospawtality"

THE COLOR(S) BLACK AND GREEN IS/ARE CLAIMED AS A FEATURE OF THE MARK.

THE MARK CONSISTS OF THE WORDS "WE PUT THE

IN HOSPITALITY" WRITTEN IN BLACK. THE IMAGE OF THE PAW IS OUTLINED IN BLACK AND FILLED IN WITH GREEN.

**CLASS 16—PAPER GOODS AND PRINTED MATTER**

FOR PLASTIC BAGS FOR DISPOSING OF PET WASTE (U.S. CLS. 2, 5, 22, 23, 29, 37, 38 AND 50).  
FIRST USE 8-1-2008; IN COMMERCE 10-1-2009.

**CLASS 20—FURNITURE AND ARTICLES NOT OTHERWISE CLASSIFIED**

FOR BEDS FOR HOUSEHOLD PETS; NON-METAL PET TAGS (U.S. CLS. 2, 13, 22, 25, 32 AND 50).  
FIRST USE 8-1-2008; IN COMMERCE 10-1-2010.

3,955,483. RESINCO CAPITAL PARTNERS INC., VANCOUVER, BC, CANADA. SN 77-853,811. PUB. 11-16-2010, FILED 10-21-2009.

RESINCO

THE MARK CONSISTS OF STANDARD CHARACTERS WITHOUT CLAIM TO ANY PARTICULAR FONT, STYLE, SIZE, OR COLOR.

PRIORITY CLAIMED UNDER SEC. 44(D) ON CANADA APPLICATION NO. 1,455,749, FILED 10-16-2009.

OWNER OF CANADA REG. NO. TMA776,155, DATED 9-1-2010, EXPIRES 9-1-2025.

**CLASS 36—INSURANCE AND FINANCIAL**

FOR (BASED ON USE IN COMMERCE) (BASED ON 44(E)) CAPITAL MARKET INVESTMENT SERVICES, NAMELY, PROVIDING FINANCING TO PRIVATE AND PUBLIC NATURAL RESOURCE COMPANIES IN THE HARD ROCK, RARE EARTH, OIL, GAS, RENEWABLE ENERGY, AND WATER SECTORS (U.S. CLS. 100, 101 AND 102).

FIRST USE 6-0-2010; IN COMMERCE 6-0-2010.

**CLASS 37—CONSTRUCTION AND REPAIR**

FOR (BASED ON 44(E)) MINING EXTRACTION SERVICES (U.S. CLS. 100, 103 AND 106).

**CLASS 42—SCIENTIFIC AND COMPUTER SERVICES**

FOR (BASED ON USE IN COMMERCE) (BASED ON 44(E)) NATURAL RESOURCES EXPLORATION AND MINERAL EXPLORATION SERVICES (U.S. CLS. 100 AND 101).

FIRST USE 6-0-2010; IN COMMERCE 6-0-2010.

3,955,492. PLASTI-KOTE CO., INC., MEDINA, OH. SN 77-859,493. PUB. 6-22-2010, FILED 10-28-2009.

**PlastiKote**

OWNER OF U.S. REG. NO. 856,353.  
THE MARK CONSISTS OF THE WORDS "PLASTI-KOTE" AND AN UNDERScore.

**CLASS 2—PAINTS**

FOR PAINTS, ENAMEL PAINTS, PRIMERS, PAINT SEALERS, LACQUERS, BATTERY TERMINAL COATINGS, AND VINYL COATINGS (U.S. CLS. 6, 11 AND 16).

FIRST USE 4-1-2010, THE MARK WAS FIRST USED ANYWHERE IN A DIFFERENT FORM OTHER THAN THAT SOUGHT TO BE REGISTERED AT LEAST AS EARLY AS 02/01/1941.; IN COMMERCE 4-1-2010, THE MARK WAS FIRST USED IN COMMERCE IN A DIFFERENT FORM OTHER THAN THAT SOUGHT TO BE REGISTERED AT LEAST AS EARLY AS 02/01/1941..

**CLASS 3—COSMETICS AND CLEANING PREPARATIONS**

FOR BATTERY CLEANER (U.S. CLS. 1, 4, 6, 50, 51 AND 52).

FIRST USE 4-1-2010, THE MARK WAS FIRST USED ANYWHERE IN A DIFFERENT FORM OTHER THAN THAT SOUGHT TO BE REGISTERED AT LEAST AS EARLY AS 02/01/1941.; IN COMMERCE 4-1-2010, THE MARK WAS FIRST USED IN COMMERCE IN A DIFFERENT FORM OTHER THAN THAT SOUGHT TO BE REGISTERED AT LEAST AS EARLY AS 02/01/1941..

**CLASS 4—LUBRICANTS AND FUELS**

FOR ALL PURPOSE LUBRICANTS, SPRAY SILICONE (U.S. CLS. 1, 6 AND 15).

FIRST USE 4-1-2010, THE MARK WAS FIRST USED ANYWHERE IN A DIFFERENT FORM OTHER THAN THAT SOUGHT TO BE REGISTERED AT LEAST AS EARLY AS 02/01/1941.; IN COMMERCE 4-1-2010, THE MARK WAS FIRST USED IN COMMERCE IN A DIFFERENT FORM OTHER THAN THAT SOUGHT TO BE REGISTERED AT LEAST AS EARLY AS 02/01/1941. .

3,955,493. PLASTI-KOTE CO., INC., MEDINA, OH. SN 77-859,532. PUB. 6-22-2010, FILED 10-28-2009.

**PlastiKote**

THE PERFECT FINISH

OWNER OF U.S. REG. NO. 856,353.  
NO CLAIM IS MADE TO THE EXCLUSIVE RIGHT TO USE "FINISH", APART FROM THE MARK AS SHOWN.  
THE MARK CONSISTS OF THE WORDS "PLASTI-KOTE" AND AN UNDERScore AND BELOW THAT THE WORDS "THE PERFECT FINISH".

**CLASS 2—PAINTS**

FOR PAINTS, ENAMEL PAINTS, PRIMERS, PAINT SEALERS, LACQUERS, BATTERY TERMINAL COATINGS, AND VINYL COATINGS (U.S. CLS. 6, 11 AND 16).

FIRST USE 4-1-2010, THE MARK WAS FIRST USED ANYWHERE IN A DIFFERENT FORM OTHER THAN THAT SOUGHT TO BE REGISTERED AT LEAST AS EARLY AS 02/01/1941.; IN COMMERCE 4-1-2010, THE MARK WAS FIRST USED IN COMMERCE IN A DIFFERENT FORM OTHER THAN THAT SOUGHT TO BE REGISTERED AT LEAST AS EARLY AS 02/01/1941..

**CLASS 3—COSMETICS AND CLEANING PREPARATIONS**

FOR BATTERY CLEANER (U.S. CLS. 1, 4, 6, 50, 51 AND 52).

FIRST USE 4-1-2010, THE MARK WAS FIRST USED ANYWHERE IN A DIFFERENT FORM OTHER THAN THAT SOUGHT TO BE REGISTERED AT LEAST AS EARLY AS 02/01/1941.; IN COMMERCE 4-1-2010, THE MARK WAS FIRST USED IN COMMERCE IN A DIFFERENT FORM OTHER THAN THAT SOUGHT TO BE REGISTERED AT LEAST AS EARLY AS 02/01/1941..

**CLASS 4—LUBRICANTS AND FUELS**

FOR ALL PURPOSE LUBRICANTS, SPRAY SILICONE (U.S. CLS. 1, 6 AND 15).

FIRST USE 4-1-2010, THE MARK WAS FIRST USED ANYWHERE IN A DIFFERENT FORM OTHER THAN THAT SOUGHT TO BE REGISTERED AT LEAST AS EARLY AS 02/01/1941. ; IN COMMERCE 4-1-2010, THE MARK WAS FIRST USED IN COMMERCE IN A DIFFERENT FORM OTHER THAN THAT SOUGHT TO BE REGISTERED AT LEAST AS EARLY AS 02/01/1941..

---

3,955,494. BUSH INDUSTRIES, INC., JAMESTOWN, NY. SN 77-860,449. PUB. 6-15-2010, FILED 10-29-2009.

**STABILIBAR**

THE MARK CONSISTS OF STANDARD CHARACTERS WITHOUT CLAIM TO ANY PARTICULAR FONT, STYLE, SIZE, OR COLOR.

**CLASS 6—METAL GOODS**

FOR ANTI-TIP DEVICES, NAMELY, METAL SUPPORTS FOR PREVENTING FURNITURE AND TELEVISIONS FROM OVERTURNING (U.S. CLS. 2, 12, 13, 14, 23, 25 AND 50).

FIRST USE 7-9-2010; IN COMMERCE 7-9-2010.

**CLASS 9—ELECTRICAL AND SCIENTIFIC APPARATUS**

FOR ANTI-TIP DEVICES, NAMELY, SUPPORTS SPECIALLY ADAPTED FOR PREVENTING MONITORS AND TELEVISIONS FROM OVERTURNING (U.S. CLS. 21, 23, 26, 36 AND 38).

FIRST USE 7-9-2010; IN COMMERCE 7-9-2010.

3,955,496. GONZALEZ, SAUL, LOS ANGELES, CA. AND MIZRAHI, ISAAC, LOS ANGELES, CA. SN 77-861,348. PUB. 4-13-2010, FILED 10-30-2009.

**THE L.A. USER'S GUIDE**

THE MARK CONSISTS OF STANDARD CHARACTERS WITHOUT CLAIM TO ANY PARTICULAR FONT, STYLE, SIZE, OR COLOR.

NO CLAIM IS MADE TO THE EXCLUSIVE RIGHT TO USE "L.A.", APART FROM THE MARK AS SHOWN.

**CLASS 38—COMMUNICATION**

FOR BROADCASTING AND STREAMING OF AUDIO-VISUAL MEDIA CONTENT IN THE FIELD OF NEWS AND ENTERTAINMENT VIA A GLOBAL COMPUTER NETWORK; TRANSMISSION OF DOWNLOADABLE AUDIO-VISUAL MEDIA CONTENT IN THE NATURE OF TELEVISION PROGRAMS AND VIDEOS VIA A GLOBAL COMPUTER NETWORK; TRANSMISSION OF VIDEO (U.S. CLS. 100, 101 AND 104).

FIRST USE 11-17-2010; IN COMMERCE 11-17-2010.

**CLASS 41—EDUCATION AND ENTERTAINMENT**

FOR EDUCATION AND ENTERTAINMENT SERVICES, NAMELY, PROVIDING A WEB SITE FEATURING AUDIO AND VIDEO PRESENTATIONS IN THE FIELDS OF CURRENT EVENT NEWS REPORTING AND ENTERTAINMENT; PROVIDING ONLINE INFORMATION VIA A GLOBAL COMPUTER NETWORK ON THE SUBJECTS OF CURRENT EVENT NEWS REPORTING AND ENTERTAINMENT; PROVIDING A WEBSITE FEATURING AUDIO-VISUAL CONTENT, NAMELY, TELEVISION PROGRAMS AND VIDEOS IN THE FIELDS OF CURRENT EVENT NEWS REPORTING AND ENTERTAINMENT; PROVIDING ENTERTAINMENT SERVICES IN THE MEDIUM OF TELEVISION IN THE NATURE OF ON-GOING TELEVISION PROGRAMS IN THE FIELD OF NEWS AND CURRENT EVENTS (U.S. CLS. 100, 101 AND 107).

FIRST USE 11-17-2010; IN COMMERCE 11-17-2010.

---

3,955,500. WATSON WYATT & COMPANY, ARLINGTON, VA. SN 77-863,612. PUB. 10-5-2010, FILED 11-3-2009.

**PEAK PERFORMER MODEL**

THE MARK CONSISTS OF STANDARD CHARACTERS WITHOUT CLAIM TO ANY PARTICULAR FONT, STYLE, SIZE, OR COLOR.

NO CLAIM IS MADE TO THE EXCLUSIVE RIGHT TO USE "MODEL", APART FROM THE MARK AS SHOWN.

**CLASS 35—ADVERTISING AND BUSINESS**

FOR HUMAN RESOURCE ANALYSIS AND CONSULTING SERVICES, NAMELY, EVALUATING PERFORMANCE OF SALES REPRESENTATIVES (U.S. CLS. 100, 101 AND 102).

FIRST USE 12-0-2009; IN COMMERCE 12-0-2009.

**CLASS 41—EDUCATION AND ENTERTAINMENT**

FOR TRAINING SALES REPRESENTATIVES IN THE FIELD OF SALES TECHNIQUES (U.S. CLS. 100, 101 AND 107).

FIRST USE 12-0-2009; IN COMMERCE 12-0-2009.

---

3,955,502. MICROTASK OY, HELSINKI, FINLAND. SN 77-864,498. PUB. 6-29-2010, FILED 11-4-2009.

# MICROTASK

THE MARK CONSISTS OF STANDARD CHARACTERS WITHOUT CLAIM TO ANY PARTICULAR FONT, STYLE, SIZE, OR COLOR.

**CLASS 9—ELECTRICAL AND SCIENTIFIC APPARATUS**

FOR COMPUTER SEARCH ENGINE SOFTWARE; COMPUTER SOFTWARE AND HARDWARE FOR THE USE OF CONNECTING SUPPLY AND DEMAND IN THE FIELD OF DIGITAL LABOUR; COMPUTER SOFTWARE PLATFORMS FOR COMPUTER PROGRAMS TO USE IN UTILIZATION OF HUMAN AND MACHINE INTELLIGENCE ON-DEMAND IN THE FIELD OF OUTSOURCING TASK BASED WORK; COMPUTER SOFTWARE THAT PROVIDES WEB-BASED ACCESS TO APPLICATIONS AND SERVICES THROUGH A WEB OPERATING SYSTEM OR PORTAL INTERFACE; COMPUTER SOFTWARE TO MAINTAIN AND OPERATE COMPUTER SYSTEM (U.S. CLS. 21, 23, 26, 36 AND 38).

FIRST USE 4-6-2009; IN COMMERCE 12-5-2009.

**CLASS 35—ADVERTISING AND BUSINESS**

FOR BUSINESS CONSULTATION SERVICES IN ORDER TO OPTIMIZE TASK BASED WORK REQUIRING HUMAN OR MACHINE INTELLIGENCE; DATA PROCESSING SERVICES; LOGISTICS MANAGEMENT IN THE FIELD OF COGNITIVE WORK (U.S. CLS. 100, 101 AND 102).

FIRST USE 4-6-2009; IN COMMERCE 12-5-2009.

**CLASS 42—SCIENTIFIC AND COMPUTER SERVICES**

FOR COMPUTER PROGRAMMING SERVICES; COMPUTER SOFTWARE CONSULTATION; COMPUTER SOFTWARE DESIGN, COMPUTER PROGRAMMING, OR MAINTENANCE OF COMPUTER SOFTWARE; DESIGN AND DEVELOPMENT OF COMPUTER SOFTWARE; DESIGN AND DEVELOPMENT OF ON-LINE COMPUTER SOFTWARE SYSTEMS (U.S. CLS. 100 AND 101).

FIRST USE 4-6-2009; IN COMMERCE 12-5-2009.

3,955,504. DAVEY WATER PRODUCTS PTY LTD, SCORSEBY, AUSTRALIA. SN 77-864,677. PUB. 3-23-2010, FILED 11-4-2009.



NO CLAIM IS MADE TO THE EXCLUSIVE RIGHT TO USE "WATER PRODUCTS", APART FROM THE MARK AS SHOWN.

THE COLOR(S) WHITE, YELLOW AND BLACK IS/ARE CLAIMED AS A FEATURE OF THE MARK.

THE MARK CONSISTS OF THE MARK CONSISTS OF THE BLACK WORDING "DEPEND ON DAVEY" IN A YELLOW BOX OVER THE WHITE WORDING "WATER PRODUCTS" IN A BLACK BOX.

**CLASS 7—MACHINERY**

FOR WATER PUMPS WITH FLUID FLOW OR PRESSURE CONTROL FOR DOMESTIC, INDUSTRIAL AND COMMERCIAL USE; AND PARTS AND FITTINGS THEREFOR (U.S. CLS. 13, 19, 21, 23, 31, 34 AND 35).

FIRST USE 4-0-2005; IN COMMERCE 5-0-2005.

**CLASS 11—ENVIRONMENTAL CONTROL APPARATUS**

FOR WATER SUPPLY APPARATUS AND INSTALLATIONS, NAMELY, PUMPS, HEATERS, CHLORINATORS AND FILTERS FOR SPAS, SWIMMING POOLS, HOT TUBS, WATER SLIDES, FOUNTAINS; AND PARTS AND FITTINGS THEREFOR (U.S. CLS. 13, 21, 23, 31 AND 34).

FIRST USE 4-0-2005; IN COMMERCE 5-0-2005.

---

3,955,510. RISC, LLC, PHOENIX, AZ. SN 77-871,321. PUB. 6-15-2010, FILED 11-12-2009.



THE COLOR(S) BLUE AND WHITE IS/ARE CLAIMED AS A FEATURE OF THE MARK.

THE MARK CONSISTS OF A BLUE SHADED GLOBE WITH WHITE GRIDLINES. THE GLOBE APPEARS TO THE LEFT OF AND CONNECTED THROUGH SHADING TO THE WORD "RISC", WHICH APPEARS IN A STYLIZED FONT. THE LEFT SIDE OF THE LETTER "R" APPEARS IN A SLIGHTLY DARKER SHADE OF BLUE THAN THE RIGHT SIDE OF THE LETTER "R". THE LETTERS "ISC" APPEAR IN A DARKER SHADE OF BLUE THAN THE LETTER "R".

**CLASS 35—ADVERTISING AND BUSINESS**

FOR INVESTIGATION OF ASSETS, CREDIT REPORTS, FISCAL ASSESSMENTS, BUSINESS RECORDS, AND COLLECTION REPORTS, FOR BUSINESS TRANSACTIONS; BUSINESS SERVICES, NAMELY, BACKGROUND SCREENING FOR THE PURPOSES OF MERGERS, ACQUISITIONS AND INVESTMENT TRANSACTIONS ON BEHALF OF OTHERS (U.S. CLS. 100, 101 AND 102).

FIRST USE 1-27-2010; IN COMMERCE 2-19-2010.

**CLASS 45—PERSONAL AND LEGAL SERVICES**

FOR PRIVATE INVESTIGATION AND CONSULTATION SERVICES; PRE-EMPLOYMENT BACKGROUND SCREENING; ALTERNATIVE DISPUTE RESOLUTION AND LITIGATION SUPPORT; INVESTIGATION OF ASSETS, CREDIT REPORTS, FISCAL ASSESSMENTS, BUSINESS RECORDS, AND COLLECTION REPORTS FOR SECURITY OR AUTHENTICATION PURPOSES; AND EXPERT WITNESS SERVICES IN LEGAL MATTERS IN THE FIELD OF BUSINESS DUE DILIGENCE (U.S. CLS. 100 AND 101).

FIRST USE 1-27-2010; IN COMMERCE 2-19-2010.

**CLASS 41—EDUCATION AND ENTERTAINMENT**

FOR DIGITAL VIDEO, AUDIO, AND MULTIMEDIA PUBLISHING SERVICES; ENTERTAINMENT SERVICES, NAMELY, PROVIDING VIRTUAL ENVIRONMENTS IN WHICH USERS CAN INTERACT FOR RECREATIONAL, LEISURE OR ENTERTAINMENT PURPOSES; ENTERTAINMENT SERVICES, NAMELY, PROVIDING ON-LINE, VIRTUAL DIGITAL VIDEOS FOR USE IN VIRTUAL ENVIRONMENTS CREATED FOR ENTERTAINMENT PURPOSES; EDUCATIONAL SERVICES, NAMELY, PROVIDING EDUCATIONAL COURSES AND INSTRUCTION VIA ON-LINE, VIRTUAL DIGITAL VIDEOS FOR USE IN VIRTUAL ENVIRONMENTS IN THE FIELD OF VISUAL PRESENTATIONS (U.S. CLS. 100, 101 AND 107).

FIRST USE 3-16-2009; IN COMMERCE 3-16-2009.

**CLASS 42—SCIENTIFIC AND COMPUTER SERVICES**

FOR PROVIDING TEMPORARY USE OF NON-DOWNLOADABLE SOFTWARE TO ENABLE UPLOADING, CAPTURING, POSTING, ENCODING, EDITING, PLAYING, STREAMING, VIEWING, PREVIEWING, DISPLAYING, TAGGING, BLOGGING, SHARING, MANIPULATING, DISTRIBUTING, PUBLISHING, REPRODUCING, SELLING OR OTHERWISE PROVIDING ELECTRONIC MEDIA, MULTIMEDIA CONTENT, VIDEOS, MOVIES, PICTURES, IMAGES, TEXT, PHOTOS, USER-GENERATED CONTENT, AUDIO CONTENT, AND INFORMATION VIA THE INTERNET AND OTHER COMMUNICATIONS NETWORKS; PROVIDING TEMPORARY USE OF NON-DOWNLOADABLE SOFTWARE TO ENABLE SHARING OF MULTIMEDIA CONTENT AND COMMENTS AMONG USERS; PROVIDING TEMPORARY USE OF NON-DOWNLOADABLE SOFTWARE TO ENABLE CONTENT PROVIDERS TO TRACK MULTIMEDIA CONTENT; PROVIDING TEMPORARY USE OF NON-DOWNLOADABLE ANALYTICS SOFTWARE, NAMELY, SOFTWARE THAT PROVIDES STATISTICS ABOUT THE BEHAVIOR OF VIEWERS OF ONLINE VIDEOS, MOVIES, PICTURES, IMAGES, TEXT, PHOTOS, GAMES, AND OTHER USER-GENERATED CONTENT; HOSTING DIGITAL MULTIMEDIA CONTENT ON THE INTERNET FOR OTHERS; HOSTING DIGITAL MULTIMEDIA ENTERTAINMENT AND EDUCATIONAL CONTENT ON THE INTERNET FOR OTHERS; PROVIDING APPLICATION SERVICE PROVIDER (ASP) FEATURING SOFTWARE TO ENABLE UPLOADING, POSTING, SHOWING, DISPLAYING, TAGGING, BLOGGING, SHARING OR OTHERWISE PROVIDING ELECTRONIC MEDIA OR INFORMATION OVER THE INTERNET OR OTHER COMMUNICATIONS NETWORKS; COMPUTER SERVICES, NAMELY, INTERACTIVE HOSTING SERVICES WHICH ALLOW THE USER, NAMELY, ADVERTISERS, MARKETERS, PARTNERS AND CONTENT PROVIDERS TO PUBLISH AND SHARE THEIR OWN CONTENT AND IMAGES ON-LINE IN ORDER TO REACH, ENGAGE, SELL TO AND INTERACT WITH ONLINE USERS FOR THE PURPOSE OF THE SALE OF THEIR GOODS AND SERVICES OVER THE INTERNET OR VIA OTHER COMMUNICATIONS NETWORKS; COMPUTER SERVICES, NAMELY, PROVIDING A WEBSITE THAT GIVES USERS THE ABILITY TO CREATE CUSTOMIZED WEB PAGES FEATURING USER-DEFINED INFORMATION, AUDIO CLIPS, VIDEO CLIPS, ARTISTIC PERFORMANCES, PERSONAL PERFORMANCES, MUSICAL PERFORMANCES, MUSIC VIDEOS, FILM CLIPS, PHOTOGRAPHS, AND OTHER MULTIMEDIA MATERIALS AND INFORMATION; PROVIDING SECURITY SERVICES FOR THE PROTECTION OF PROPERTY IN THE NATURE OF CONDUCTING DATA RECOVERY AND SECURITY ASSESSMENT FOR COMPUTERIZED DATA (U.S. CLS. 100 AND 101).

FIRST USE 3-16-2009; IN COMMERCE 3-16-2009.

3,955,513. MEDIA DELIVERY TECHNOLOGY, LLC, AKA MEDDELTECH, ASPEN, CO. SN 77-872,359. PUB. 6-1-2010, FILED 11-13-2009.

# VidCano

THE MARK CONSISTS OF STANDARD CHARACTERS WITHOUT CLAIM TO ANY PARTICULAR FONT, STYLE, SIZE, OR COLOR.

THE WORDING "VIDCANO" HAS NO MEANING IN A FOREIGN LANGUAGE.

**CLASS 35—ADVERTISING AND BUSINESS**

FOR PROVIDING ADVERTISING, ADVERTISEMENT AND PROMOTIONAL, MARKETING AND SALES PROMOTION SERVICES ON BEHALF OF OTHERS; PROVIDING CONSUMER INFORMATION IN THE FIELD OF DIGITAL VIDEO VIA ELECTRONIC MEDIA, OVER THE INTERNET OR OTHER COMMUNICATIONS NETWORKS; PROVIDING PROMOTIONAL SERVICES, NAMELY, PROMOTING THE GOODS AND SERVICES OF OTHERS THROUGH ONLINE ADVERTISING AND PROMOTION; PROMOTIONAL SERVICES IN THE FORM OF SHARING OF MULTIMEDIA ADVERTISING AND PROMOTIONAL CONTENT VIA THE INTERNET AND OTHER COMMUNICATIONS NETWORKS FOR THE PURPOSE OF PROMOTING THE GOODS AND SERVICES OF OTHERS; DEVELOPING AND PROVIDING MARKETING AND SALES PROGRAMS FOR ADVERTISERS, MARKETERS, PARTNERS AND CONTENT PROVIDERS, ALL TO FOSTER THE SALE OF GOODS AND SERVICES OF OTHERS; PROVIDING A WEBSITE FOR CONNECTING SELLERS WITH BUYERS, NAMELY, PROVIDING A WEBSITE WHERE ADVERTISERS, MARKETERS, PARTNERS AND CONTENT PROVIDERS CAN REACH, ENGAGE, SELL TO AND INTERACT WITH ONLINE USERS; PROVIDING ONLINE ADVERTISING AND MARKETING SERVICES VIA A WEBSITE FOR CONNECTING SELLERS AND BUYERS (U.S. CLS. 100, 101 AND 102).

FIRST USE 3-16-2009; IN COMMERCE 3-16-2009.

**CLASS 45—PERSONAL AND LEGAL SERVICES**



FOR PROVIDING PERSONAL AND SOCIAL NETWORKING SERVICES RENDERED BY OTHERS TO MEET THE NEEDS OF INDIVIDUALS, NAMELY, ON-LINE SOCIAL NETWORKING AND INTRODUCTION SERVICES; PROVIDING INTERNET BASED INTRODUCTION AND SOCIAL NETWORKING SERVICES; PROVIDING ON-LINE COMPUTER DATABASES AND ON-LINE SEARCHABLE DATABASES IN THE FIELD OF SOCIAL NETWORKING (U.S. CLS. 100 AND 101).  
FIRST USE 3-16-2009; IN COMMERCE 3-16-2009.

3,955,518. JESSIE STEELE, INC., BERKELEY, CA. SN 77-873,363. PUB. 6-1-2010, FILED 11-16-2009.

## Candy Baker

THE MARK CONSISTS OF STANDARD CHARACTERS WITHOUT CLAIM TO ANY PARTICULAR FONT, STYLE, SIZE, OR COLOR.

THE LIKENESS (OR, "PORTRAIT") IN THE MARK DOES NOT IDENTIFY A LIVING INDIVIDUAL.

### CLASS 24—FABRICS

FOR KITCHEN TOWELS; OVEN MITTS (U.S. CLS. 42 AND 50).  
FIRST USE 10-0-2009; IN COMMERCE 2-0-2010.

### CLASS 25—CLOTHING

FOR APRONS (U.S. CLS. 22 AND 39).  
FIRST USE 10-0-2009; IN COMMERCE 2-0-2010.

3,955,527. FOREVER 21, INC., LOS ANGELES, CA. SN 77-876,968. PUB. 11-23-2010, FILED 11-19-2009.

## 21 MEN

THE MARK CONSISTS OF STANDARD CHARACTERS WITHOUT CLAIM TO ANY PARTICULAR FONT, STYLE, SIZE, OR COLOR.

NO CLAIM IS MADE TO THE EXCLUSIVE RIGHT TO USE "MEN", APART FROM THE MARK AS SHOWN.

### CLASS 9—ELECTRICAL AND SCIENTIFIC APPARATUS

FOR SUNGLASSES DISTRIBUTED THROUGH PROPRIETOR'S RETAIL STORES (U.S. CLS. 21, 23, 26, 36 AND 38).  
FIRST USE 4-2-2010; IN COMMERCE 4-2-2010.

### CLASS 18—LEATHER GOODS

FOR ATHLETIC BAGS, MESSENGER BAGS, ALL DISTRIBUTED THROUGH PROPRIETOR'S RETAIL STORES (U.S. CLS. 1, 2, 3, 22 AND 41).  
FIRST USE 4-2-2010; IN COMMERCE 4-2-2010.

### CLASS 25—CLOTHING

FOR BELTS FOR CLOTHING, HATS, JACKETS, JEANS, PANTS, SCARVES, SHIRTS, SHOES, SHORTS, T-SHIRTS, ALL DISTRIBUTED THROUGH PROPRIETOR'S RETAIL STORES (U.S. CLS. 22 AND 39).  
FIRST USE 4-2-2010; IN COMMERCE 4-2-2010.

3,955,531. METROPOLITAN TRANSPORTATION COMMISSION, OAKLAND, CA. SN 77-877,909. PUB. 11-9-2010, FILED 11-20-2009.

## CLIPPER

THE MARK CONSISTS OF STANDARD CHARACTERS WITHOUT CLAIM TO ANY PARTICULAR FONT, STYLE, SIZE, OR COLOR.

### CLASS 9—ELECTRICAL AND SCIENTIFIC APPARATUS

FOR ENCODED CONTACTLESS SMART CARD FOR USE WITH PUBLIC TRANSPORTATION, ELECTRONIC FARE COLLECTION, ELECTRONIC TOLL COLLECTION, AND ELECTRONIC COLLECTION OF PARKING FEES; ELECTRONIC SYSTEMS FOR USE WITH PUBLIC TRANSPORTATION, ELECTRONIC FARE COLLECTION, ELECTRONIC TOLL COLLECTION, AND ELECTRONIC COLLECTION OF PARKING FEES, NAMELY, SMART CARD READERS, AUTOMATED TRANSIT SYSTEM ENTRY BARRIERS, AND OTHER AUXILIARY EQUIPMENT NAMELY, ON-BOARD SUBSYSTEMS, TICKET OFFICE TERMINALS, ADD VALUE MACHINES, TICKET VENDING MACHINES, AND DATA SERVERS (U.S. CLS. 21, 23, 26, 36 AND 38).  
FIRST USE 6-16-2010; IN COMMERCE 6-16-2010.

### CLASS 39—TRANSPORTATION AND STORAGE

FOR PUBLIC TRANSIT SERVICES FEATURING AN ELECTRONIC PAYMENT SYSTEM THAT CAN BE USED WITH BUS, RAIL, FERRY, AND OTHER PUBLIC-TRANSIT SYSTEMS AND ASSOCIATED PARKING (U.S. CLS. 100 AND 105).  
FIRST USE 6-16-2010; IN COMMERCE 6-16-2010.

3,955,532. HUMANIT SOFTWARE GMBH, D-53119 BONN, FED REP GERMANY. SN 77-878,483. PUB. 7-6-2010, FILED 11-23-2009.

## INFOZOOM

THE MARK CONSISTS OF STANDARD CHARACTERS WITHOUT CLAIM TO ANY PARTICULAR FONT, STYLE, SIZE, OR COLOR.

**CLASS 9—ELECTRICAL AND SCIENTIFIC APPARATUS**

FOR COMPUTER SOFTWARE, ASSOCIATED DOCUMENTATION, INSTRUCTIONS AND MANUALS SOLD AS A UNIT, FOR INFORMATION VISUALIZATION WITH AUTOMATICALLY CUSTOMIZED DISPLAY, DATA ANALYSIS, DATA COMPILATION, DIAGNOSIS OF DATA AND IMPORTING OF DATA, DATA PROFILING, AD-HOC ANALYSIS AND REPORTING WITH INTUITIVE OPERATION, SEARCH ENGINE AND MONITORING, GRAPHICAL USER INTERFACE FOR DATA FROM DATABASES, SPREADSHEETS AND COMPUTER PROGRAMS TO CONVERT AND DISPLAY FROM NUMBER AND TEXT STRINGS IN THE FORM OF GRAPHS, BARS, CHARTS, DISTINGUISHING COLORS AND SHAPES, IMAGES AND MULTIMEDIA (U.S. CLS. 21, 23, 26, 36 AND 38).

FIRST USE 3-16-1998; IN COMMERCE 6-1-1999.

**CLASS 41—EDUCATION AND ENTERTAINMENT**

FOR EDUCATIONAL AND TRAINING SERVICES IN THE FORM OF SEMINARS IN THE USE OF COMPUTER PROGRAMS USED FOR INFORMATION VISUALIZATION; EDUCATIONAL AND TRAINING SERVICES IN THE FORM OF SEMINARS FOR CERTIFICATION OF PARTNERS IN THE USE OF COMPUTER PROGRAMS USED FOR INFORMATION VISUALIZATION (U.S. CLS. 100, 101 AND 107).

FIRST USE 3-16-1998; IN COMMERCE 6-1-1999.

**CLASS 42—SCIENTIFIC AND COMPUTER SERVICES**

FOR COMPUTER SOFTWARE DEVELOPMENT FOR USE IN INFORMATION VISUALIZATION; CUSTOM DESIGN OF COMPUTER SOFTWARE FOR USE IN INFORMATION VISUALIZATION; INSTALLATION, MAINTENANCE AND UPDATING OF COMPUTER SOFTWARE FOR INFORMATION VISUALIZATION, LOCAL AND REMOTE (U.S. CLS. 100 AND 101).

FIRST USE 3-16-1998; IN COMMERCE 6-1-1999.

3,955,547. WANG, GRACE H., SEOUL, REPUBLIC OF KOREA. SN 77-884,980. PUB. 9-14-2010, FILED 12-3-2009.

---

iEnglish

THE MARK CONSISTS OF STANDARD CHARACTERS WITHOUT CLAIM TO ANY PARTICULAR FONT, STYLE, SIZE, OR COLOR.

**CLASS 9—ELECTRICAL AND SCIENTIFIC APPARATUS**

FOR ELECTRONIC PUBLICATIONS, NAMELY, BOOKS FEATURING INSTRUCTION IN THE FIELD OF ENGLISH LANGUAGE RECORDED ON COMPUTER MEDIA (U.S. CLS. 21, 23, 26, 36 AND 38).

FIRST USE 2-1-2011; IN COMMERCE 3-1-2011.

**CLASS 16—PAPER GOODS AND PRINTED MATTER**

FOR A SERIES OF BOOKS, WRITTEN ARTICLES, HANDOUTS AND WORKSHEETS IN INSTRUCTION IN THE FIELD OF ENGLISH LANGUAGE (U.S. CLS. 2, 5, 22, 23, 29, 37, 38 AND 50).

FIRST USE 9-1-2008; IN COMMERCE 9-1-2009.

3,955,566. ASSOCIATED OCEANS, LLC, MIAMI, FL. SN 77-897,969. PUB. 5-4-2010, FILED 12-21-2009.

ERIS EMERGENCY RESPONSE  
INFORMATION SYSTEM

THE MARK CONSISTS OF STANDARD CHARACTERS WITHOUT CLAIM TO ANY PARTICULAR FONT, STYLE, SIZE, OR COLOR.

NO CLAIM IS MADE TO THE EXCLUSIVE RIGHT TO USE "EMERGENCY RESPONSE INFORMATION SYSTEM", APART FROM THE MARK AS SHOWN.

**CLASS 9—ELECTRICAL AND SCIENTIFIC APPARATUS**

FOR DOWNLOADABLE COMPUTER SOFTWARE FOR THE DELIVERY OF MEDICAL AND INSURANCE INFORMATION FOR USE IN THE FIELD OF SCUBA DIVING (U.S. CLS. 21, 23, 26, 36 AND 38).

FIRST USE 10-1-2010; IN COMMERCE 10-1-2010.

**CLASS 42—SCIENTIFIC AND COMPUTER SERVICES**

FOR PROVIDING TEMPORARY USE OF ON-LINE NON-DOWNLOADABLE COMPUTER SOFTWARE FOR THE DELIVERY OF MEDICAL AND INSURANCE INFORMATION FOR USE IN THE FIELD OF SCUBA DIVING (U.S. CLS. 100 AND 101).

FIRST USE 10-1-2010; IN COMMERCE 10-1-2010.

---

3,955,568. SUPER YACHT BUILDERS ASSOCIATION, MC-98000 MONACO, MONACO. SN 77-899,065. PUB. 9-28-2010, FILED 12-22-2009.

SYBAss

THE MARK CONSISTS OF STANDARD CHARACTERS WITHOUT CLAIM TO ANY PARTICULAR FONT, STYLE, SIZE, OR COLOR.

**CLASS 35—ADVERTISING AND BUSINESS**

FOR ADVERTISING; BUSINESS MANAGEMENT; BUSINESS ADMINISTRATION; OFFICE FUNCTIONS; PERSONNEL MANAGEMENT CONSULTANCY SERVICES; BUSINESS ADVISORY AND CONSULTING SERVICES; BUSINESS MANAGEMENT AND BUSINESS ORGANIZATIONAL SERVICES; SERVICES OF TRADE ORGANIZATION IN THE NATURE OF ORGANIZING TRADE SHOWS FOR COMPANIES INVOLVED WITH DEVELOPING AND BUILDING SUPER YACHTS; PROMOTION IN THE NATURE OF ADVERTISING AND MARKETING RELATING TO YACHTS AND YACHT BUILDERS, ALSO THROUGH THE INTERNET; DATABASE MANAGEMENT SERVICES; MARKET RESEARCH AND MARKET ANALYSIS; PUBLIC OPINION POLLING; PUBLIC RELATIONS; ORGANIZATION OF EXHIBITIONS AND EVENTS FOR ADVERTISING OR COMMERCIAL PURPOSES; LEASING OF ADVERTISING SPACE, ALSO ON THE INTERNET; LOBBYING FOR COMMERCIAL USES; SERVICES PROVIDED BY INTEREST OR TRADE ORGANIZATION, NAMELY, THE PROMOTION OF INDIVIDUAL AND COLLECTIVE INTERESTS OF YACHT OWNERS AND BUILDERS IN THE FIELD OF LEGISLATION AND REGULATION; THE PROVISION FOR COMMON ADVERTISEMENT AND PUBLICITY IN THE NATURE OF THE DISTRIBUTION OF PUBLICITY MATERIALS FOR OTHERS INCLUDING ADVERTISING BROCHURES, ADVERTISING AND ADVERTISING MAGAZINES; ARRANGING OF MARKETING PROMOTIONAL EVENTS AND ACTIVITIES; AFORESAID SERVICES ALSO PROVIDED THROUGH ONLINE CHANNELS LIKE THE INTERNET; ALL OF THE FOREGOING SERVICES LIMITED TO THE YACHT AND YACHT BUILDER INDUSTRIES; ECONOMIC AND ORGANIZATIONAL CONSULTANCY FOR THE INTRODUCTION, OPTIMIZATION AND APPLICATION OF PROCESS MANAGEMENT, NAMELY, BUSINESS MANAGEMENT CONSULTATION IN THE NATURE OF DEVELOPMENT OF PROCESSES FOR THE ANALYSIS AND THE IMPLEMENTATION OF STRATEGY PLANS AND MANAGEMENT PROJECTS, ALL IN THE FIELD OF YACHTS AND YACHT BUILDING; INFORMATION AND ADVISORY SERVICES RELATING TO MARINE REGULATORY AFFAIRS IN THE NATURE OF PROVIDING BUSINESS INFORMATION AND CONSULTATION IN THE FIELD OF MARINE TRANSPORTATION AND YACHTING BY PROVIDING INFORMATION AND NEWS ON CURRENT EVENTS AND ON REGULATORY DEVELOPMENTS AS THEY RELATE TO AND CAN IMPACT BUSINESS (U.S. CLS. 100, 101 AND 102).

FIRST USE 10-25-2007; IN COMMERCE 10-25-2007.

**CLASS 41—EDUCATION AND ENTERTAINMENT**

FOR ARRANGING AND CONDUCTING ENTERTAINMENT EVENTS IN THE NATURE OF YACHT SHOWS; PROVIDING COURSES, TRAINING AND CLASSES IN THE FIELD OF YACHT BUILDING, HOW TO SAIL YACHTS AND IN THE FINANCIAL MANAGEMENT OF YACHTS; THE ORGANIZATION OF EDUCATIONAL CONGRESSES, CONFERENCES, TALKS IN THE NATURE OF PANEL DISCUSSIONS, SYMPOSIUMS, SEMINARS AND ALL TYPES OF MEETINGS FOR EDUCATIONAL PURPOSES IN THE FIELDS OF YACHTS AND YACHT BUILDING; ORGANIZING ENTERTAINMENT EVENTS IN THE FIELDS OF YACHTS AND YACHT BUILDERS IN THE NATURE OF YACHT RACES AND YACHT SHOWS; PUBLISHING AND LOANING OF PRINTED SCIENTIFIC PAPERS, ONLINE PUBLICATIONS IN THE NATURE OF MAGAZINES IN THE FIELD OF YACHTS AND YACHT BUILDERS; ELECTRONIC PUBLICATION OF TEXT AND GRAPHIC WORKS OF OTHERS ON CDS, CD-ROM'S AND DVDS IN THE FIELDS OF YACHTS AND YACHT BUILDERS; BUSINESS MANAGEMENT INFORMATION AND BUSINESS CONSULTANCY RELATING TO OPERATING YACHTS, ALSO PROVIDED ONLINE THROUGH THE INTERNET; ALL OF THE FOREGOING SERVICES LIMITED TO THE YACHT AND YACHT BUILDER INDUSTRIES (U.S. CLS. 100, 101 AND 107).

FIRST USE 10-25-2007; IN COMMERCE 10-25-2007.

**CLASS 42—SCIENTIFIC AND COMPUTER SERVICES**

FOR DEVELOPING AND MAINTAINING DATABASES IN THE NATURE OF DESIGN AND MAINTENANCE OF DATABASES CONTAINING INFORMATION REGARDING YACHTS AND YACHT BUILDERS; SCIENTIFIC RESEARCH AND TECHNOLOGICAL DESIGN SERVICES RELATING TO YACHTS AND BUILDING OF YACHTS; RESEARCH AND DEVELOPMENT IN THE FIELD OF YACHT BUILDING; INSPECTIONS IN THE FIELD OF YACHTS; DRAFTING EXPERTISE REPORTS IN THE NATURE OF DRAFTING OF CONSTRUCTION PLANS FOR YACHTS; QUALITY ASSURANCE IN THE FIELD OF THE CONSTRUCTION AND SAFETY OF YACHTS; TECHNICAL QUALITY ASSURANCE CONSULTANCY WITH REGARD TO THE DEVELOPMENT, INTRODUCTION, OPTIMIZATION AND APPLICATION OF QUALITY ASSURANCE SERVICES IN THE FIELD OF YACHTS AND YACHT BUILDING (U.S. CLS. 100 AND 101).

FIRST USE 10-27-2007; IN COMMERCE 10-27-2007.

3,955,575. KEYUP LLC, BLOOMINGTON, MN. SN 77-902,673. PUB. 11-23-2010, FILED 12-30-2009.

KeyUP

THE MARK CONSISTS OF STANDARD CHARACTERS WITHOUT CLAIM TO ANY PARTICULAR FONT, STYLE, SIZE, OR COLOR.

**CLASS 16—PAPER GOODS AND PRINTED MATTER**

FOR PRINTED EDUCATIONAL AND INSTRUCTIONAL MATERIALS EMPLOYING TEXTUAL, GRAPHICAL AND SYMBOLIC ELEMENTS AS VISUALS TO TEACH AND APPLY PRINCIPLES RELATED TO ASTROLOGY AND PSYCHOLOGY, EDUCATIONAL AND INSTRUCTIONAL DEVICES CONSISTING OF PRINTED BOARDS, CHARTS, CALENDARS AND CARDS WITH TEXTUAL, GRAPHICAL AND SYMBOLIC ELEMENTS, AND PRINTED WHEELS WITH LAYERS OR TIERS COUPLED FOR RELATIVE ROTATION TO VISUALLY ASSOCIATE SELECTED TEXTUAL, GRAPHICAL AND SYMBOLIC ELEMENTS TO TEACH AND APPLY PRINCIPLES RELATED TO ASTROLOGY AND PSYCHOLOGY (U.S. CLS. 2, 5, 22, 23, 29, 37, 38 AND 50).

FIRST USE 11-2-2010; IN COMMERCE 11-2-2010.

**CLASS 41—EDUCATION AND ENTERTAINMENT**

FOR EDUCATIONAL SERVICES, NAMELY, MAINTAINING A WEBSITE TO PROVIDE ONLINE EDUCATIONAL AND INSTRUCTIONAL CONTENT IN THE FIELDS OF PSYCHOLOGY AND ASTROLOGY (U.S. CLS. 100, 101 AND 107).

FIRST USE 5-31-2010; IN COMMERCE 5-31-2010.

3,955,582. SMITH SEAN R, MRKET WEIGHTON, YORK, UNITED KINGDOM. SN 77-907,521. PUB. 6-1-2010, FILED 1-8-2010.



THE COLOR(S) RED, BLACK, BLUE AND DARK BLUE IS/ARE CLAIMED AS A FEATURE OF THE MARK.

THE MARK CONSISTS OF THE WORDING "DETECTA-MET" WITH A STYLIZED MAGNET AND PEN FORMING THE LETTER "A". THE LETTERS "DETECT" AND "MET" ARE BLUE WITH DARK BLUE OUTLINES. THE STYLIZED MAGNET IS RED AND BLACK. THE PEN IS BLUE.

#### CLASS 1—CHEMICALS

FOR PLASTIC MOLDING COMPOUNDS FOR USE IN THE MANUFACTURE OF MOLDED PLASTIC ARTICLES; PLASTIC MOLDING COMPOUNDS FOR USE IN THE MANUFACTURE OF PLASTIC SHEETS AND FILMS (U.S. CLS. 1, 5, 6, 10, 26 AND 46).

FIRST USE 1-24-2005; IN COMMERCE 1-24-2005.

#### CLASS 9—ELECTRICAL AND SCIENTIFIC APPARATUS

FOR MAGNETIC PENS (U.S. CLS. 21, 23, 26, 36 AND 38).

FIRST USE 1-24-2005; IN COMMERCE 1-25-2005.

#### CLASS 16—PAPER GOODS AND PRINTED MATTER

FOR WRITING IMPLEMENTS (U.S. CLS. 2, 5, 22, 23, 29, 37, 38 AND 50).

FIRST USE 1-24-2005; IN COMMERCE 1-24-2005.

3,955,589. ARTIST SERVICES LTD., CAMDEN, LONDON, UNITED KINGDOM. SN 77-910,462. PUB. 6-29-2010, FILED 1-12-2010.

METALARMYAMERICA

THE MARK CONSISTS OF STANDARD CHARACTERS WITHOUT CLAIM TO ANY PARTICULAR FONT, STYLE, SIZE, OR COLOR.

#### CLASS 35—ADVERTISING AND BUSINESS

FOR ONLINE RETAIL STORE SERVICES FEATURING PRERECORDED MUSIC (U.S. CLS. 100, 101 AND 102).

FIRST USE 11-1-2009; IN COMMERCE 1-2-2011.

#### CLASS 41—EDUCATION AND ENTERTAINMENT

FOR PROVISION OF ONLINE INFORMATION CONCERNING MUSIC; ONLINE ENTERTAINMENT SERVICES, NAMELY, WEBCASTS IN THE FIELD OF MUSIC CONCERTS; ONLINE FAN CLUB SERVICES (U.S. CLS. 100, 101 AND 107).

FIRST USE 11-1-2009; IN COMMERCE 2-1-2010.

3,955,596. FIRECRAFT, INC., WEST CHESTER, PA. SN 77-914,037. PUB. 8-3-2010, FILED 1-18-2010.

THE MARK CONSISTS OF THE WORD "FIRECRAFT" WITH THE DOT OF THE LOWERCASE "I" IN "FIRE" RESEMBLING THE HEAD OF A SPATULA AND THE TOP OF THE LOWERCASE "T" IN "CRAFT" RESEMBLING A FLAME.

#### CLASS 35—ADVERTISING AND BUSINESS

FOR RETAIL STORE SERVICES AND CATALOG ORDERING SERVICES FEATURING OUTDOOR COOKING SUPPLIES AND EQUIPMENT, SPICE RUBS, READY-MADE SAUCES, MARINADES, COOKBOOKS, AND TAILGATING SUPPLIES (U.S. CLS. 100, 101 AND 102).

FIRST USE 4-15-2010; IN COMMERCE 4-15-2010.

#### CLASS 43—HOTEL AND RESTAURANT SERVICES

FOR PROVIDING AN ONLINE COMPUTER DATABASE TO CONSUMERS CONCERNING RECIPES, INGREDIENTS, AND COOKING INFORMATION, TIPS, AND TECHNIQUES RELATING TO OUTDOOR COOKING (U.S. CLS. 100 AND 101).

FIRST USE 4-15-2010; IN COMMERCE 4-15-2010.

3,955,597. FIRECRAFT, INC., WEST CHESTER, PA. SN 77-914,045. PUB. 8-3-2010, FILED 1-18-2010.

THE MARK CONSISTS OF STANDARD CHARACTERS WITHOUT CLAIM TO ANY PARTICULAR FONT, STYLE, SIZE, OR COLOR.

#### CLASS 35—ADVERTISING AND BUSINESS

FOR RETAIL STORE SERVICES AND CATALOG ORDERING SERVICES FEATURING OUTDOOR COOKING SUPPLIES AND EQUIPMENT, SPICE RUBS, READY-MADE SAUCES, MARINADES, COOKBOOKS, AND TAILGATING SUPPLIES (U.S. CLS. 100, 101 AND 102).

FIRST USE 4-15-2010; IN COMMERCE 4-15-2010.

**CLASS 43—HOTEL AND RESTAURANT SERVICES**

FOR PROVIDING AN ONLINE COMPUTER DATABASE TO CONSUMERS CONCERNING RECIPES, INGREDIENTS, AND COOKING INFORMATION, TIPS, AND TECHNIQUES RELATING TO OUTDOOR COOKING (U.S. CLS. 100 AND 101).

FIRST USE 4-15-2010; IN COMMERCE 4-15-2010.

**CLASS 29—MEATS AND PROCESSED FOODS**

FOR GARDEN SALADS; FRUIT SALADS; PREPARED POTATO ENTREES, NAMELY, AU GRATIN POTATOES, ROASTED POTATOES, MASHED POTATOES; POTATO SALAD; PREPARED FOOD ENTREES, NAMELY, MEXICAN TORTILLA CHICKEN CASSEROLE; PREPARED FOOD, NAMELY, VEGETABLE CASSEROLE; GRILLED VEGETABLES; PREPARE ENTREES CONSISTING PRIMARILY OF CHICKEN; AND FOOD DIPS (U.S. CL. 46).  
FIRST USE 2-3-2010; IN COMMERCE 2-3-2010.

**CLASS 30—STAPLE FOODS**

FOR SHORTCAKE; NACHOS SOLD ON TRAY SKITS FOR MAKING FAJITAS; SALAD DRESSINGS; STUFFING MIX CONTAINING BREAD; BREAD PUDDING; LASAGNA; CRANBERRY AND FRUIT RELISHES; QUICHE; PASTA SALADS; SANDWICHES; SALSAS; AND FOOD SAUCES (U.S. CL. 46).  
FIRST USE 2-3-2010; IN COMMERCE 2-3-2010.

**CLASS 31—NATURAL AGRICULTURAL PRODUCTS**

FOR FRESH FRUIT SOLD ON TRAYS; FRESH FRUIT SOLD IN CUPS; GIFT BASKETS OF FRESH FRUITS; FRESH VEGETABLES; AND FRESH VEGETABLES SOLD ON TRAYS (U.S. CLS. 1 AND 46).  
FIRST USE 2-3-2010; IN COMMERCE 2-3-2010.

3,955,606. MARTIN SURFACE TECHNOLOGIES, LLC, PARRISH, FL. SN 77-916,494. PUB. 7-13-2010, FILED 1-21-2010.

**INVISABLOCK**

THE MARK CONSISTS OF STANDARD CHARACTERS WITHOUT CLAIM TO ANY PARTICULAR FONT, STYLE, SIZE, OR COLOR.

**CLASS 1—CHEMICALS**

FOR WATERPROOFING CHEMICAL COMPOSITIONS BASED UPON SILICONE AND POLYMERS FOR POROUS SURFACES INCLUDING TEXTILES (U.S. CLS. 1, 5, 6, 10, 26 AND 46).

FIRST USE 4-21-2010; IN COMMERCE 4-21-2010.

**CLASS 2—PAINTS**

FOR COATINGS IN THE NATURE OF INDUSTRIAL SEALANTS FOR WATERPROOFING POROUS SURFACES (U.S. CLS. 6, 11 AND 16).

FIRST USE 4-21-2010; IN COMMERCE 4-21-2010.

3,955,632. NEWTEK BUSINESS SERVICES, INC., NEW YORK, NY. SN 77-924,688. PUB. 5-25-2010, FILED 2-1-2010.

**CLASS 17—RUBBER GOODS**

FOR SILICONE AND POLYMER BASED SEALANT FOR WATERPROOFING MATERIALS WITH POROUS SURFACES AT A NANO LEVEL (U.S. CLS. 1, 5, 12, 13, 35 AND 50).

FIRST USE 4-21-2010; IN COMMERCE 4-21-2010.

3,955,607. SPOKANE PRODUCE, INC., SPOKANE, WA. SN 77-916,605. PUB. 9-28-2010, FILED 1-21-2010.

**THE SMALL BUSINESS AUTHORITY**

**NORTHWEST CUISINE CREATIONS**

THE MARK CONSISTS OF STANDARD CHARACTERS WITHOUT CLAIM TO ANY PARTICULAR FONT, STYLE, SIZE, OR COLOR.

NO CLAIM IS MADE TO THE EXCLUSIVE RIGHT TO USE "NORTHWEST CUISINE", APART FROM THE MARK AS SHOWN.

THE MARK CONSISTS OF STANDARD CHARACTERS WITHOUT CLAIM TO ANY PARTICULAR FONT, STYLE, SIZE, OR COLOR.

NO CLAIM IS MADE TO THE EXCLUSIVE RIGHT TO USE "SMALL BUSINESS", APART FROM THE MARK AS SHOWN.

**CLASS 35—ADVERTISING AND BUSINESS**

FOR ACCOUNTING SERVICES; ONLINE ACCOUNTING SERVICES; COMPUTERIZED ACCOUNTING SERVICES; ACCOUNTING SERVICES FOR ELECTRONIC FUNDS SERVICES; ADMINISTRATION OF BUSINESS PAYROLL FOR OTHERS; PAYROLL PREPARATION; FINANCIAL STATEMENT PREPARATION AND ANALYSIS FOR BUSINESS; INTEGRATED TRACKING AND MANAGEMENT OF COMMERCIAL TRANSACTIONS ON A GLOBAL COMPUTER NETWORK; NOTIFICATION SERVICES TO BUSINESSES IN THE NATURE OF PROVIDING INFORMATION REGARDING BUSINESS FILING REQUIREMENTS AND FILING DATES VIA THE INTERNET AND EMAIL; INCOME TAX CONSULTATION AND PREPARATION SERVICES; BUSINESS CONSULTATION; BUSINESS DEVELOPMENT SERVICES, NAMELY, PROVIDING START-UP SUPPORT FOR BUSINESSES OF OTHERS; BUSINESS INVOICING SERVICES; CONDUCTING BUSINESS AND MARKET RESEARCH SURVEYS; BUSINESS MANAGEMENT PLANNING; BUSINESS MANAGEMENT INFORMATION ON A WIDE VARIETY OF TOPICS TO BUSINESS PROFESSIONALS; BUSINESS MARKETING; BUSINESS MARKETING CONSULTING SERVICES; BUSINESS ORGANIZATIONAL CONSULTATION; BUSINESS PLANNING; BUSINESS RESEARCH AND SURVEYS; PREPARING BUSINESS REPORTS; PROVIDING STATISTICAL INFORMATION FOR BUSINESSES; BUSINESS MANAGEMENT CONSULTATION AND MANAGEMENT CONSULTATION SERVICES (U.S. CLS. 100, 101 AND 102).

FIRST USE 1-10-2011; IN COMMERCE 1-10-2011.

**CLASS 36—INSURANCE AND FINANCIAL**

FOR FINANCIAL ANALYSIS AND CONSULTATION SERVICES; BUSINESS FINANCE PROCUREMENT SERVICES; LOAN FINANCING AND LOAN PROGRAMS IN THE NATURE OF PROVIDING BUSINESS LOANS AND TEMPORARY LOANS; PROVIDING FINANCIAL INFORMATION BY THE INTERNET; PROVIDING ONLINE FINANCIAL SERVICES IN THE NATURE OF BANKING AND BANKING SERVICES; BILL PAYMENT SERVICES; ELECTRONIC PAYMENT, NAMELY, ELECTRONIC PROCESSING AND TRANSMISSION OF BILL PAYMENT DATA; FINANCIAL INFORMATION PROVIDED BY ELECTRONIC MEANS; FINANCIAL ANALYSIS FOR BUSINESS (U.S. CLS. 100, 101 AND 102).

FIRST USE 1-10-2011; IN COMMERCE 1-10-2011.

**CLASS 38—COMMUNICATION**

FOR PROVIDING HIGH SPEED ACCESS TO AREA NETWORKS AND A GLOBAL COMPUTER INFORMATION NETWORKS (U.S. CLS. 100, 101 AND 104).

FIRST USE 1-10-2011; IN COMMERCE 1-10-2011.

**CLASS 42—SCIENTIFIC AND COMPUTER SERVICES**

FOR PROVIDING TEMPORARY USE OF ON-LINE NON-DOWNLOADABLE SOFTWARE FOR USE PROVIDING REFERRAL, FINANCIAL, SALES, MODULES; PROVIDING TEMPORARY USE OF ON-LINE NON-DOWNLOADABLE SOFTWARE TO ALLOW CUSTOMERS TO ACCESS ACCOUNT INFORMATION, REVIEW REFERRAL INFORMATION, AND INITIATE CONTACT REQUESTS (U.S. CLS. 100 AND 101).

FIRST USE 1-10-2011; IN COMMERCE 1-10-2011.

3,955,635. AMERICAN CHILDHOOD CANCER ORGANIZATION, KENSINGTON, MD. SN 77-925,425. PUB. 7-13-2010, FILED 2-1-2010.



NO CLAIM IS MADE TO THE EXCLUSIVE RIGHT TO USE "AMERICAN CHILDHOOD CANCER ORGANIZATION", APART FROM THE MARK AS SHOWN.

THE MARK CONSISTS OF THE WORDS "AMERICAN CHILDHOOD CANCER ORGANIZATION" WITH "AMERICAN", "CANCER" AND "ORGANIZATION" IN UPPER-CASE LETTERS AND THE WORD "CHILDHOOD" IN LOWER-CASE LETTERS; FLUSH LEFT OF THE WORDS IS A DESIGN DEPICTING A MOTHER HOLDING HER CHILD, CONSISTING OF TWO CIRCULAR OBJECTS, THE LARGER OF THE TWO DIRECTLY ABOVE THE SMALLER CIRCULAR OBJECT; OFF THE LARGER CIRCULAR OBJECT IS A HALF-SICKLE POSITIONED TO DEPICT THE MOTHER'S ARM; OFF THE SMALLER CIRCULAR OBJECT IS A QUARTER-SICKLE POSITIONED TO DEPICT THE CHILD'S BODY.

**CLASS 9—ELECTRICAL AND SCIENTIFIC APPARATUS**

FOR PRE-RECORDED DVDS AND ONLINE DOWNLOADABLE VIDEOS FEATURING TREATMENT INFORMATION ON CHILDHOOD CANCER FOR PATIENTS, PARENTS, SCHOOL TEACHERS AND HEALTHCARE PROFESSIONALS (U.S. CLS. 21, 23, 26, 36 AND 38).

FIRST USE 10-14-2010; IN COMMERCE 12-9-2010.

**CLASS 14—JEWELRY**

FOR LAPEL PINS AND MEDALLIONS (U.S. CLS. 2, 27, 28 AND 50).

FIRST USE 2-3-2010; IN COMMERCE 2-3-2010.

**CLASS 16—PAPER GOODS AND PRINTED MATTER**

FOR BOOKS, NEWSLETTERS, BROCHURES, AND BOOKLETS FEATURING TREATMENT INFORMATION ON CHILDHOOD CANCER FOR PATIENTS, PARENTS, SCHOOL TEACHERS AND HEALTHCARE PROFESSIONALS (U.S. CLS. 2, 5, 22, 23, 29, 37, 38 AND 50).

FIRST USE 3-4-2010; IN COMMERCE 3-4-2010.

**CLASS 35—ADVERTISING AND BUSINESS**

FOR PUBLIC ADVOCACY TO PROMOTE AWARENESS OF CHILDHOOD CANCER; PROMOTING PUBLIC AWARENESS OF THE NEED FOR A CURE FOR CHILDHOOD CANCER (U.S. CLS. 100, 101 AND 102).

FIRST USE 6-21-2010; IN COMMERCE 6-21-2010.

**CLASS 36—INSURANCE AND FINANCIAL**

FOR CHARITABLE FUNDRAISING SERVICES, NAMELY, ORGANIZING AND CONDUCTING FUNDRAISING EVENTS TO RAISE MONEY FOR CHILDHOOD CANCER RESEARCH, INFORMATION AND SUPPORT SERVICES (U.S. CLS. 100, 101 AND 102).

FIRST USE 2-4-2010; IN COMMERCE 2-4-2010.

**CLASS 44—MEDICAL, BEAUTY AND AGRICULTURAL SERVICES**

FOR PROVIDING A WEB SITE FEATURING TREATMENT INFORMATION ON CHILDHOOD CANCER FOR PATIENTS, PARENTS, SCHOOL TEACHERS AND HEALTHCARE PROFESSIONALS (U.S. CLS. 100 AND 101).

FIRST USE 3-2-2010; IN COMMERCE 3-2-2010.

**CLASS 45—PERSONAL AND LEGAL SERVICES**

FOR PROVIDING PERSONAL SUPPORT SERVICES FOR PATIENTS AND FAMILIES OF PATIENTS WITH CANCER, NAMELY, EMOTIONAL COUNSELING AND EMOTIONAL SUPPORT (U.S. CLS. 100 AND 101).

FIRST USE 3-2-2010; IN COMMERCE 3-2-2010.

3,955,640. NATURALLY SLIM, INC., GARLAND, TX. SN 77-926,026. PUB. 10-19-2010, FILED 2-2-2010.

**REAL FOOD, RIGHT PORTIONS**

THE MARK CONSISTS OF STANDARD CHARACTERS WITHOUT CLAIM TO ANY PARTICULAR FONT, STYLE, SIZE, OR COLOR.

**CLASS 29—MEATS AND PROCESSED FOODS**

FOR PACKAGED PROCESSED NUTS (U.S. CL. 46).  
FIRST USE 1-10-2011; IN COMMERCE 1-10-2011.

**CLASS 30—STAPLE FOODS**

FOR POPCORN (U.S. CL. 46).  
FIRST USE 1-10-2011; IN COMMERCE 1-10-2010.

**CLASS 32—LIGHT BEVERAGES**

FOR BOTTLED SPRING WATER (U.S. CLS. 45, 46 AND 48).  
FIRST USE 1-12-2011; IN COMMERCE 1-12-2011.

3,955,645. CORPNET, INCORPORATED, WESTLAKE VILLAGE, CA. SN 77-927,457. PUB. 6-22-2010, FILED 2-3-2010.



OWNER OF U.S. REG. NO. 3,776,034.  
THE COLOR(S) BLACK AND ORANGE IS/ARE CLAIMED AS A FEATURE OF THE MARK.  
THE MARK CONSISTS OF THE STYLIZED WORD "CORPNET" IN BLACK IN UPPER AND LOWER CASE, INCORPORATING A CAPITAL "C" AND A CAPITAL "N" TO THE LEFT OF AN ORANGE COLORED ARROW THAT ARCHES TO THE RIGHT OVER BLACK HORIZONTAL

AND VERTICAL BARS DEPICTING A STYLIZED STACK OF DOCUMENTS IN A BOX.

**CLASS 9—ELECTRICAL AND SCIENTIFIC APPARATUS**

FOR DOWNLOADABLE ELECTRONIC PUBLICATIONS IN THE NATURE OF NEWSLETTERS, TEMPLATES AND FORMS, MAGAZINES, BROCHURES, PAMPHLETS AND REPORTS IN THE FIELD OF BUSINESS RESEARCH, INCORPORATION AND ORGANIZATION OF LEGAL ENTITIES, MAINTENANCE AND COMPLIANCE OF LEGAL ENTITIES, AND INTELLECTUAL PROPERTY SEARCHING AND CLEARANCE (U.S. CLS. 21, 23, 26, 36 AND 38).

FIRST USE 4-20-2010; IN COMMERCE 4-20-2010.

**CLASS 16—PAPER GOODS AND PRINTED MATTER**

FOR PRINTED MATTER, NAMELY, NEWSLETTERS, TEMPLATES AND FORMS, MAGAZINES, BROCHURES, PAMPHLETS AND REPORTS IN THE FIELD OF BUSINESS RESEARCH, INCORPORATION AND ORGANIZATION OF LEGAL ENTITIES, MAINTENANCE AND COMPLIANCE OF LEGAL ENTITIES, AND INTELLECTUAL PROPERTY SEARCHING AND CLEARANCE (U.S. CLS. 2, 5, 22, 23, 29, 37, 38 AND 50).

FIRST USE 4-20-2010; IN COMMERCE 4-20-2010.

**CLASS 35—ADVERTISING AND BUSINESS**

FOR BUSINESS SERVICES, NAMELY, NEW BUSINESS VENTURE DEVELOPMENT AND FORMATION CONSULTING SERVICES; SECRETARIAL AND DOCUMENT FILING SERVICES FOR BUSINESS ENTITIES; BUSINESS RESEARCH; COMMERCIAL REGISTERED AGENT SERVICES FOR OTHERS; PROVIDING A WEBSITE AND DATABASE FEATURING ARTICLES AND INFORMATION ON ESTABLISHING AND MAINTAINING A BUSINESS; BUSINESS TO BUSINESS REFERRAL AND NETWORKING PROGRAMS (U.S. CLS. 100, 101 AND 102).

FIRST USE 4-20-2010; IN COMMERCE 4-20-2010.

**CLASS 42—SCIENTIFIC AND COMPUTER SERVICES**

FOR PROVIDING TEMPORARY USE OF NON-DOWNLOADABLE COMPUTER SOFTWARE FOR CORPORATE FILING INFORMATION AND CORPORATE RECORDS MANAGEMENT; PUBLIC CORPORATE DOCUMENT RETRIEVAL SERVICES (U.S. CLS. 100 AND 101).

FIRST USE 4-20-2010; IN COMMERCE 4-20-2010.

**CLASS 45—PERSONAL AND LEGAL SERVICES**

FOR PREPARING AND FILING INCORPORATION PAPERS; PUBLIC CORPORATE DOCUMENT FILING SERVICES; PROVIDING PUBLIC DOCUMENT FILING INFORMATION TO CONSUMERS SEEKING TO CHANGE THEIR NAME; CORPORATE NAME AVAILABILITY SEARCHES (U.S. CLS. 100 AND 101).

FIRST USE 4-20-2010; IN COMMERCE 4-20-2010.

3,955,686. ONLINE ADVISORS, INC., CARSON CITY, NV. SN 77-933,973. PUB. 7-13-2010, FILED 2-11-2010.

**Online Advisors**

THE MARK CONSISTS OF STANDARD CHARACTERS

WITHOUT CLAIM TO ANY PARTICULAR FONT, STYLE, SIZE, OR COLOR.

NO CLAIM IS MADE TO THE EXCLUSIVE RIGHT TO USE "ONLINE", APART FROM THE MARK AS SHOWN.

#### **CLASS 9—ELECTRICAL AND SCIENTIFIC APPARATUS**

FOR DOWNLOADABLE SOFTWARE FOR INVESTORS, FINANCIAL ADVISORS AND MONEY MANAGERS RELATING TO THE FUNCTIONALITY OF ACCOUNT INFORMATION, PERFORMANCE, BILLING AND TRADING FUNCTIONS (U.S. CLS. 21, 23, 26, 36 AND 38).

FIRST USE 2-1-2011; IN COMMERCE 2-1-2011.

#### **CLASS 42—SCIENTIFIC AND COMPUTER SERVICES**

FOR COMPUTER SOFTWARE DEVELOPMENT (U.S. CLS. 100 AND 101).

FIRST USE 2-1-2011; IN COMMERCE 2-1-2011.

3,955,691. GUNTER, BARBARA, MONROE TOWNSHIP, NJ. SN 77-934,079. PUB. 6-29-2010, FILED 2-11-2010.

# Kibibi

THE MARK CONSISTS OF STANDARD CHARACTERS WITHOUT CLAIM TO ANY PARTICULAR FONT, STYLE, SIZE, OR COLOR.

THE WORDING "KIBIBI" HAS NO MEANING IN A FOREIGN LANGUAGE.

#### **CLASS 16—PAPER GOODS AND PRINTED MATTER**

FOR BLANK WRITING JOURNALS; CALENDARS; CHILDREN'S BOOKS; GREETING CARDS; MAGAZINES IN THE FIELD OF RELIGION; NEWSLETTERS IN THE FIELD OF RELIGION; NEWSPAPERS IN THE FIELD OF RELIGION (U.S. CLS. 2, 5, 22, 23, 29, 37, 38 AND 50).

FIRST USE 2-24-2010; IN COMMERCE 2-24-2010.

#### **CLASS 28—TOYS AND SPORTING GOODS**

FOR BOARD GAMES; DOLLS; TEDDY BEARS (U.S. CLS. 22, 23, 38 AND 50).

FIRST USE 2-24-2010; IN COMMERCE 2-24-2010.

3,955,696. NOBLE WAR PRIZE, INC., SOUTHAMPTON, NY. SN 77-935,267. PUB. 7-13-2010, FILED 2-13-2010.

## WASHINGTON DC GLOBAL WARMING

THE MARK CONSISTS OF STANDARD CHARACTERS WITHOUT CLAIM TO ANY PARTICULAR FONT, STYLE, SIZE, OR COLOR.

#### **CLASS 25—CLOTHING**

FOR T-SHIRTS (U.S. CLS. 22 AND 39).  
FIRST USE 2-13-2010; IN COMMERCE 7-23-2010.

#### **CLASS 28—TOYS AND SPORTING GOODS**

FOR TOY SNOW GLOBES (U.S. CLS. 22, 23, 38 AND 50).

FIRST USE 2-13-2010; IN COMMERCE 7-23-2010.

3,955,710. KING, KAREEN, OSAGE, KS. SN 77-938,045. PUB. 7-13-2010, FILED 2-17-2010.

### THE GOLDEN EXPERIENCE

THE MARK CONSISTS OF STANDARD CHARACTERS WITHOUT CLAIM TO ANY PARTICULAR FONT, STYLE, SIZE, OR COLOR.

#### **CLASS 16—PAPER GOODS AND PRINTED MATTER**

FOR PAPER AND PRINTED MATTER, NAMELY, A SERIES OF ARTICLES FOR PUBLICATION IN BOOKLETS, BROCHURES, CATALOGS, GUIDES, HANDOUTS, MAGAZINES, MANUALS AND NEWSLETTERS ALL IN THE FIELD OF ISSUES RELATING TO LONG-TERM CARE AND AGING, ELDERCARE, AND MATURE OR RETIRED LIFESTYLES; POSTERS; POSTCARDS; PRINTED GREETING CARDS; PRINTED EDUCATIONAL, INSTRUCTIONAL AND TEACHING MATERIALS ALL IN THE FIELD OF ISSUES RELATING TO LONG-TERM CARE AND AGING, ELDERCARE, AND MATURE OR RETIRED LIFESTYLES; SERIES OF NON-FICTION BOOKS ALL IN THE FIELD OF ISSUES RELATING TO LONG-TERM CARE AND AGING, ELDERCARE, AND MATURE OR RETIRED LIFESTYLES (U.S. CLS. 2, 5, 22, 23, 29, 37, 38 AND 50).

FIRST USE 1-1-2010; IN COMMERCE 1-1-2010.

#### **CLASS 41—EDUCATION AND ENTERTAINMENT**

FOR EDUCATIONAL AND INSTRUCTIONAL SERVICES, NAMELY, CONDUCTING EDUCATIONAL CLASSES, CONFERENCES, RETREATS, SEMINARS AND WORKSHOPS ALL IN THE FIELD OF ISSUES RELATING TO LONG-TERM CARE AND AGING, ELDERCARE, AND MATURE OR RETIRED LIFESTYLES AND DISTRIBUTING INSTRUCTIONAL MATERIALS IN CONNECTION THEREWITH; ENTERTAINMENT SERVICES, NAMELY, LIVE SPEAKING PERFORMANCES AND SPEAKING ENGAGEMENTS ALL IN THE FIELD OF ISSUES RELATING TO LONG-TERM CARE AND AGING, ELDERCARE, AND MATURE OR RETIRED LIFESTYLES (U.S. CLS. 100, 101 AND 107).

FIRST USE 10-20-2010; IN COMMERCE 10-20-2010.



3,955,715. ELKAMET KUNSTSTOFFTECHNIK GMBH, BIEDENKOPF, FED REP GERMANY. SN 77-939,937. PUB. 7-13-2010, FILED 2-19-2010.

# Plasco

THE MARK CONSISTS OF STANDARD CHARACTERS WITHOUT CLAIM TO ANY PARTICULAR FONT, STYLE, SIZE, OR COLOR.

## CLASS 17—RUBBER GOODS

FOR PROFILES, AND TRIMS MADE OF PLASTICS, WITH OR WITHOUT METAL INLAYS FOR USE IN MANUFACTURING; PROFILES, AND TRIMS MADE OF PLASTICS, WITH OR WITHOUT DECORATIVE FOIL INSERTS FOR USE IN MANUFACTURING (U.S. CLS. 1, 5, 12, 13, 35 AND 50).

FIRST USE 1-1-2011; IN COMMERCE 1-1-2011.

## CLASS 20—FURNITURE AND ARTICLES NOT OTHERWISE CLASSIFIED

FOR DECORATIVE PROFILES, AND TRIMS MADE OF PLASTICS, WITH OR WITHOUT METAL INLAYS FOR ILLUMINATED LETTERS AND ADVERTISING LETTERING; DECORATIVE PROFILES, AND TRIMS MADE OF PLASTICS, WITH OR WITHOUT DECORATIVE FOIL INSERTS FOR ILLUMINATED LETTERS AND ADVERTISING LETTERING (U.S. CLS. 2, 13, 22, 25, 32 AND 50).

FIRST USE 1-1-2011; IN COMMERCE 1-1-2011.

3,955,729. PLAYCORE IP SUB, INC., CHATTANOOGA, TN. SN 77-942,215. PUB. 12-21-2010, FILED 2-23-2010.

# PATHWAYS FOR PLAY

THE MARK CONSISTS OF STANDARD CHARACTERS WITHOUT CLAIM TO ANY PARTICULAR FONT, STYLE, SIZE, OR COLOR.

## CLASS 16—PAPER GOODS AND PRINTED MATTER

FOR BROCHURES AND PAMPHLETS ABOUT THE DESIGN, CONSTRUCTION AND INSTALLATION OF PLAY, FITNESS AND ADVENTURE TRAILS (U.S. CLS. 2, 5, 22, 23, 29, 37, 38 AND 50).

FIRST USE 11-0-2010; IN COMMERCE 11-0-2010.

## CLASS 35—ADVERTISING AND BUSINESS

FOR PROMOTING PUBLIC AWARENESS OF THE UTILITY OF PLAY, FITNESS AND ADVENTURE TRAILS (U.S. CLS. 100, 101 AND 102).

FIRST USE 11-0-2010; IN COMMERCE 11-0-2010.

## CLASS 41—EDUCATION AND ENTERTAINMENT

FOR EDUCATIONAL SERVICES, NAMELY, CONDUCTING SEMINARS AND LECTURES IN THE FIELD OF THE DESIGN, CONSTRUCTION AND INSTALLATION OF PLAY, FITNESS AND ADVENTURE TRAILS (U.S. CLS. 100, 101 AND 107).

FIRST USE 11-0-2010; IN COMMERCE 11-10-2010.

3,955,735. JOHN B. SANFILIPPO & SON, INC., ELGIN, IL. SN 77-943,284. PUB. 6-29-2010, FILED 2-24-2010.

# SABOR Y TRADICIÓN

THE MARK CONSISTS OF STANDARD CHARACTERS WITHOUT CLAIM TO ANY PARTICULAR FONT, STYLE, SIZE, OR COLOR.

NO CLAIM IS MADE TO THE EXCLUSIVE RIGHT TO USE "SABOR", APART FROM THE MARK AS SHOWN.

THE ENGLISH TRANSLATION OF "SABOR Y TRADICIÓN" IN THE MARK IS "FLAVOR AND TRADITION".

## CLASS 29—MEATS AND PROCESSED FOODS

FOR SHELLED AND ROASTED NUTS; PROCESSED NUTS; PROCESSED FLAVORED NUTS; CANDIED NUTS; SNACK MIX CONSISTING PRIMARILY OF PROCESSED FRUITS AND PROCESSED NUTS (U.S. CL. 46).

FIRST USE 9-23-2010; IN COMMERCE 9-23-2010.

## CLASS 30—STAPLE FOODS

FOR SNACK MIXES CONSISTING PRIMARILY OF WHEAT-BASED OR RICE-BASED SNACK FOODS AND ALSO CONTAINING PROCESSED NUTS (U.S. CL. 46).

FIRST USE 9-23-2010; IN COMMERCE 9-23-2010.

3,955,737. SKOR MANAGEMENT LLC, BIRMINGHAM, MI. SN 77-943,640. PUB. 7-20-2010, FILED 2-24-2010.

# PURPLE SPOON

THE MARK CONSISTS OF STANDARD CHARACTERS WITHOUT CLAIM TO ANY PARTICULAR FONT, STYLE, SIZE, OR COLOR.

## CLASS 30—STAPLE FOODS

FOR FROZEN YOGURT IN VARIOUS FLAVORS (U.S. CL. 46).

FIRST USE 5-31-2010; IN COMMERCE 5-31-2010.

## CLASS 43—HOTEL AND RESTAURANT SERVICES

FOR FROZEN YOGURT SHOP SERVICES IN THE NATURE OF A RESTAURANT OR CAFE (U.S. CLS. 100 AND 101).

FIRST USE 5-31-2010; IN COMMERCE 5-31-2010.

3,955,739. NOMURA SECURITIES INTERNATIONAL, INC., NEW YORK, NY. SN 77-944,134. PUB. 7-20-2010, FILED 2-24-2010.

3,955,748. NOBLE WAR PRIZE, INC., SOUTHAMPTON, NY. SN 77-945,713. PUB. 7-13-2010, FILED 2-26-2010.

## SMARTSEEK

THE MARK CONSISTS OF STANDARD CHARACTERS WITHOUT CLAIM TO ANY PARTICULAR FONT, STYLE, SIZE, OR COLOR.

### CLASS 9—ELECTRICAL AND SCIENTIFIC APPARATUS

FOR COMPUTER PROGRAMS AND COMPUTER SOFTWARE FOR ELECTRONICALLY TRADING SECURITIES; COMPUTER SOFTWARE FOR USE IN EXECUTING TRADES AND IMPLEMENTING AN ALGORITHMIC TRADING STRATEGY (U.S. CLS. 21, 23, 26, 36 AND 38).

FIRST USE 4-21-2010; IN COMMERCE 4-21-2010.

### CLASS 35—ADVERTISING AND BUSINESS

FOR DIRECTING ORDERS FOR SECURITIES TRADES BY MEANS OF COMPUTER SOFTWARE WHICH AUTOMATICALLY DIRECTS TRADES TO THE BEST LOCATION FOR EXECUTING SUCH ORDERS (U.S. CLS. 100, 101 AND 102).

FIRST USE 4-21-2010; IN COMMERCE 4-21-2010.

3,955,745. HOME HEALTHCARE PARTNERS, LLC, DALLAS, TX. SN 77-944,978. PUB. 7-20-2010, FILED 2-25-2010.

## VP365

THE MARK CONSISTS OF STANDARD CHARACTERS WITHOUT CLAIM TO ANY PARTICULAR FONT, STYLE, SIZE, OR COLOR.

### CLASS 44—MEDICAL, BEAUTY AND AGRICULTURAL SERVICES

FOR HOME HEALTH CARE SERVICES; REMOTE MONITORING OF DATA INDICATIVE OF THE HEALTH OR CONDITION OF AN INDIVIDUAL OR GROUP OF INDIVIDUALS (U.S. CLS. 100 AND 101).

FIRST USE 9-1-2010; IN COMMERCE 9-1-2010.

### CLASS 45—PERSONAL AND LEGAL SERVICES

FOR MONITORING TELEPHONE CALLS AND COMMUNICATIONS FROM SUBSCRIBERS DURING MEDICAL EMERGENCIES AND NOTIFYING EMERGENCY FACILITIES AND EMERGENCY PERSONNEL (U.S. CLS. 100 AND 101).

FIRST USE 9-1-2010; IN COMMERCE 9-1-2010.

### CONGRESSIONAL TRANSPARENCY

THE MARK CONSISTS OF STANDARD CHARACTERS WITHOUT CLAIM TO ANY PARTICULAR FONT, STYLE, SIZE, OR COLOR.

### CLASS 25—CLOTHING

FOR T-SHIRTS (U.S. CLS. 22 AND 39).  
FIRST USE 2-26-2010; IN COMMERCE 7-23-2010.

### CLASS 28—TOYS AND SPORTING GOODS

FOR TOY SNOW GLOBES (U.S. CLS. 22, 23, 38 AND 50).  
FIRST USE 2-26-2010; IN COMMERCE 7-23-2010.

3,955,749. NOBLE WAR PRIZE, INC., SOUTHAMPTON, NY. SN 77-945,719. PUB. 7-13-2010, FILED 2-26-2010.

### WHITE HOUSE TRANSPARENCY

THE MARK CONSISTS OF STANDARD CHARACTERS WITHOUT CLAIM TO ANY PARTICULAR FONT, STYLE, SIZE, OR COLOR.

### CLASS 25—CLOTHING

FOR T-SHIRTS (U.S. CLS. 22 AND 39).  
FIRST USE 2-26-2010; IN COMMERCE 7-23-2010.

### CLASS 28—TOYS AND SPORTING GOODS

FOR TOY SNOW GLOBES (U.S. CLS. 22, 23, 38 AND 50).  
FIRST USE 2-26-2010; IN COMMERCE 7-23-2010.

3,955,750. M2P2, LLC, AMES, IA. SN 77-946,132. PUB. 10-5-2010, FILED 2-26-2010.

### REDEFINING WORLD CLASS

THE MARK CONSISTS OF STANDARD CHARACTERS WITHOUT CLAIM TO ANY PARTICULAR FONT, STYLE, SIZE, OR COLOR.

**CLASS 35—ADVERTISING AND BUSINESS**

FOR BUSINESS MANAGEMENT OF SWINE BREEDING AND SWINE FARMING FACILITIES (U.S. CLS. 100, 101 AND 102).  
FIRST USE 10-0-2009; IN COMMERCE 10-0-2009.

**CLASS 42—SCIENTIFIC AND COMPUTER SERVICES**

FOR SCIENTIFIC RESEARCH IN THE FIELD OF SWINE BREEDING AND SWINE FARMING (U.S. CLS. 100 AND 101).  
FIRST USE 10-0-2009; IN COMMERCE 10-0-2009.

**CLASS 44—MEDICAL, BEAUTY AND AGRICULTURAL SERVICES**

FOR SWINE BREEDING AND SWINE FARMING; CONSULTING IN THE FIELD OF SWINE BREEDING AND SWINE FARMING (U.S. CLS. 100 AND 101).  
FIRST USE 10-0-2009; IN COMMERCE 10-0-2009.

3,955,791. RECKITT BENCKISER LLC, PARSIPPANY, NJ.  
SN 77-956,540. PUB. 6-29-2010, FILED 3-11-2010.

RELEASE THE FRESHNESS OF  
NATURE

THE MARK CONSISTS OF STANDARD CHARACTERS WITHOUT CLAIM TO ANY PARTICULAR FONT, STYLE, SIZE, OR COLOR.

**CLASS 3—COSMETICS AND CLEANING PREPARATIONS**

FOR PERFUMING PREPARATIONS FOR THE AIR, NAMELY, ROOM FRAGRANCES, ROOM PERFUME SPRAYS (U.S. CLS. 1, 4, 6, 50, 51 AND 52).  
FIRST USE 12-0-2009; IN COMMERCE 12-0-2009.

**CLASS 5—PHARMACEUTICALS**

FOR AIR FRESHENERS AND AIR FRESHENING PREPARATIONS; PREPARATIONS FOR PERFUMING OR FRAGRANCING THE AIR, NAMELY, ROOM AIR FRESHENERS (U.S. CLS. 6, 18, 44, 46, 51 AND 52).  
FIRST USE 12-0-2009; IN COMMERCE 12-0-2009.

3,955,805. MARGALIT, JON, SAN DIEGO, CA. SN 77-959,423.  
PUB. 8-3-2010, FILED 3-15-2010.

TOWELMATE

THE MARK CONSISTS OF STANDARD CHARACTERS WITHOUT CLAIM TO ANY PARTICULAR FONT, STYLE, SIZE, OR COLOR.

**CLASS 18—LEATHER GOODS**

FOR SPORTS BAGS (U.S. CLS. 1, 2, 3, 22 AND 41).  
FIRST USE 8-4-2010; IN COMMERCE 8-4-2010.

**CLASS 24—FABRICS**

FOR GOLF TOWELS; TOWELS (U.S. CLS. 42 AND 50).  
FIRST USE 8-4-2010; IN COMMERCE 8-4-2010.

3,955,807. DOREL JUVENILE GROUP, INC., FOXBORO, MA. SN 77-960,022. PUB. 6-22-2010, FILED 3-16-2010.



THE MARK CONSISTS OF A DIAMOND OUTLINE WITHIN WHICH THE LETTER AND NUMBER "S1" APPEARS IN THE CENTER.

**CLASS 12—VEHICLES**

FOR STROLLERS; JUVENILE CAR SEATS; COMBINATION JUVENILE CAR SEATS AND STROLLERS (U.S. CLS. 19, 21, 23, 31, 35 AND 44).  
FIRST USE 12-1-2010; IN COMMERCE 12-1-2010.

**CLASS 20—FURNITURE AND ARTICLES NOT OTHERWISE CLASSIFIED**

FOR PLAY YARDS; HIGH CHAIRS (U.S. CLS. 2, 13, 22, 25, 32 AND 50).  
FIRST USE 12-1-2010; IN COMMERCE 12-1-2010.

3,955,831. NISSAN JIDOSHA KABUSHIKI KAISHA, DBA NISSAN MOTOR CO., LTD., YOKOHAMA-SHI, KANAGAWA, JAPAN. SN 77-980,240. PUB. 6-9-2009, FILED 10-29-2008.



THE MARK CONSISTS OF STYLIZED LETTER "Z".

**CLASS 6—METAL GOODS**

FOR METAL KEY RINGS (U.S. CLS. 2, 12, 13, 14, 23, 25 AND 50).  
FIRST USE 3-15-2010; IN COMMERCE 3-15-2010.

**CLASS 25—CLOTHING**

FOR SHIRTS, T-SHIRTS, JACKETS, NECKTIES, MUFFLERS, CAPS, HATS, COATS, SWEATERS, POLO-SHIRTS, WORKING CLOTHING, NAMELY, PANTS, JACKETS, SHIRTS AND COATS, SCARVES (U.S. CLS. 22 AND 39).

FIRST USE 7-30-2009; IN COMMERCE 7-30-2009.

---

3,955,836. NISSAN JIDOSHA KABUSHIKI KAISHA, DBA NISSAN MOTOR CO., LTD., YOKOHAMA-SHI, KANAGAWA, JAPAN. SN 77-981,327. PUB. 6-9-2009, FILED 10-29-2008.



THE MARK CONSISTS OF STYLIZED LETTER "Z".

**CLASS 14—JEWELRY**

FOR TIE TACKS, CUFF LINKS, LAPEL PINS, WATCHES, CLOCKS, WALL CLOCKS, KEY RINGS OF PRECIOUS METAL, ORNAMENTAL BADGES OF PRECIOUS METAL (U.S. CLS. 2, 27, 28 AND 50).

FIRST USE 8-31-2010; IN COMMERCE 8-31-2010.

**CLASS 16—PAPER GOODS AND PRINTED MATTER**

FOR GRAPHIC ART REPRODUCTIONS, STICKERS, PENS, PENCILS, STANDS FOR PENS AND PENCILS, CALENDARS, STATIONERY-TYPE WRITING PORTFOLIOS, POSTERS, PHOTO ALBUMS, POCKET DIARIES (U.S. CLS. 2, 5, 22, 23, 29, 37, 38 AND 50).

FIRST USE 8-31-2010; IN COMMERCE 8-31-2010.

---

3,955,839. LAVIN, RICHARD, NEW YORK, NY. SN 77-981,371. PUB. 6-15-2010, FILED 10-14-2009.

LeveragedWisdom

THE MARK CONSISTS OF STANDARD CHARACTERS WITHOUT CLAIM TO ANY PARTICULAR FONT, STYLE, SIZE, OR COLOR.

**CLASS 16—PAPER GOODS AND PRINTED MATTER**

FOR PUBLICATIONS, NAMELY, NEWSLETTERS AND WHITE PAPERS IN THE FIELDS OF OWNERSHIP, LEADERSHIP AND MANAGEMENT OF PRIVATELY HELD BUSINESSES (U.S. CLS. 2, 5, 22, 23, 29, 37, 38 AND 50).

FIRST USE 6-10-2010; IN COMMERCE 6-10-2010.

**CLASS 35—ADVERTISING AND BUSINESS**

FOR ARRANGING AND CONDUCTING BUSINESS CONFERENCES; MEMBERSHIP CLUB SERVICES, NAMELY, PROVIDING BUSINESS INFORMATION TO MEMBERS IN THE FIELDS OF OWNERSHIP, LEADERSHIP AND MANAGEMENT OF PRIVATELY HELD BUSINESSES; PROVIDING AN INTERNET WEBSITE FEATURING BUSINESS INFORMATION IN THE FIELD OF OWNERSHIP, LEADERSHIP AND MANAGEMENT OF PRIVATELY HELD BUSINESSES (U.S. CLS. 100, 101 AND 102).

FIRST USE 11-0-2009; IN COMMERCE 11-0-2009.

**CLASS 36—INSURANCE AND FINANCIAL**

FOR PROVIDING AN INTERNET WEBSITE FEATURING INFORMATION IN THE FIELD OF FINANCIAL MANAGEMENT OF PRIVATELY HELD BUSINESSES (U.S. CLS. 100, 101 AND 102).

FIRST USE 11-0-2009; IN COMMERCE 11-0-2009.

**CLASS 41—EDUCATION AND ENTERTAINMENT**

FOR PROVIDING ON-LINE PUBLICATIONS IN THE NATURE OF BOOKS, NEWSLETTERS, WHITE PAPERS AND BLOGS IN THE FIELD OF OWNERSHIP, LEADERSHIP AND MANAGEMENT OF PRIVATELY HELD BUSINESSES; PROFESSIONAL COACHING SERVICES IN THE FIELD OF OWNERSHIP, LEADERSHIP AND MANAGEMENT OF PRIVATELY HELD BUSINESSES; PROVIDING GROUP COACHING AND LEARNING FORUMS IN THE FIELD OF LEADERSHIP DEVELOPMENT; ARRANGING PEER-TO-PEER LEARNING GROUPS FOR CEO'S (SENIOR EXECUTIVES); WORKSHOPS AND SEMINARS IN THE FIELD OF OWNERSHIP, LEADERSHIP AND MANAGEMENT OF PRIVATELY HELD BUSINESSES; ON-LINE JOURNALS, NAMELY, BLOGS FEATURING INFORMATION ON OWNERSHIP, LEADERSHIP AND MANAGEMENT OF PRIVATELY HELD BUSINESSES; ARRANGING AND CONDUCTING EDUCATIONAL CONFERENCES (U.S. CLS. 100, 101 AND 107).

FIRST USE 11-0-2009; IN COMMERCE 11-0-2009.

---

3,955,841. KANN, VICTORIA, WESTPORT, CT. SN 77-981,408. PUB. 4-20-2010, FILED 4-17-2009.

PINKALICIOUS

THE MARK CONSISTS OF STANDARD CHARACTERS WITHOUT CLAIM TO ANY PARTICULAR FONT, STYLE, SIZE, OR COLOR.

**CLASS 9—ELECTRICAL AND SCIENTIFIC APPARATUS**

FOR PRE-RECORDED AUDIO RECORDING FEATURING NARRATION OF A CHILDREN'S BOOK IN MP3 FORMAT; MUSICAL SOUND RECORDINGS; PRE-RECORDED COMPACT DISCS FEATURING MUSIC; PRE-RECORDED COMPACT DISCS FEATURING NARRATION OF A CHILDREN'S BOOK; PRERECORDED MUSICAL SOUND RECORDINGS IN DIGITAL FORMAT; DOWNLOADABLE WORD GAMES AND DOWNLOADABLE COLORING PAGES (U.S. CLS. 21, 23, 26, 36 AND 38).

FIRST USE 8-31-2008; IN COMMERCE 8-31-2008.

**CLASS 16—PAPER GOODS AND PRINTED MATTER**

FOR PRINTED MATTER, NAMELY, STICKERS, STICKER BOOKS, DIARIES, PENCILS, AND MARKERS; BOOKS, NAMELY, A PERSONALIZED CHILDREN'S BOOK (U.S. CLS. 2, 5, 22, 23, 29, 37, 38 AND 50).  
FIRST USE 9-30-2008; IN COMMERCE 9-30-2008.

**CLASS 25—CLOTHING**

FOR CLOTHING, NAMELY, T-SHIRTS, DRESSES, PAJAMAS, AND PAJAMA AND BOOK SETS SOLD AS A UNIT; DRESS UP CLOTHES FOR CHILDREN, PLAY COSTUMES FOR CHILDREN, AND FANCY DRESS COSTUMES FOR CHILDREN; TUTUS; ALL IN CONNECTION WITH THE FICTIONAL CHARACTER KNOWN AS "PINKALICIOUS" (U.S. CLS. 22 AND 39).  
FIRST USE 3-3-2007; IN COMMERCE 3-3-2007.

**CLASS 26—FANCY GOODS**

FOR HAIR ACCESSORIES, NAMELY, HAIR CLIPS (U.S. CLS. 37, 39, 40, 42 AND 50).  
FIRST USE 3-1-2010; IN COMMERCE 3-1-2010.

**CLASS 28—TOYS AND SPORTING GOODS**

FOR TOYS, NAMELY, DOLLS, TOY ACTION FIGURES, PLAY WANDS; PLAY TIARAS (U.S. CLS. 22, 23, 38 AND 50).  
FIRST USE 3-1-2010; IN COMMERCE 3-1-2010.

**CLASS 41—EDUCATION AND ENTERTAINMENT**

FOR ENTERTAINMENT AND EDUCATIONAL SERVICES, NAMELY, PROVIDING A WEBSITE FEATURING CHILDREN'S PARTY IDEAS AND CLASSROOM ACTIVITY IDEAS; ENTERTAINMENT IN THE NATURE OF THEATER PRODUCTIONS, NAMELY, A LIVE THEATER PRODUCTION (U.S. CLS. 100, 101 AND 107).  
FIRST USE 1-13-2007; IN COMMERCE 1-13-2007.

**CLASS 30—STAPLE FOODS**

FOR STEAK SAUCE (U.S. CL. 46).  
FIRST USE 5-1-2010; IN COMMERCE 5-1-2010.

3,955,843. PACTIV CORPORATION, LAKE FOREST, IL. SN 77-981,425. PUB. 4-28-2009, FILED 12-2-2008.



THE MARK CONSISTS OF A TREE SURROUNDED BY TWO ARROWS.

**CLASS 20—FURNITURE AND ARTICLES NOT OTHERWISE CLASSIFIED**

FOR COMMERCIAL FOOD PACKAGING MATERIALS, NAMELY, PLASTIC TRAYS FOR FOOD; NON-METAL CONTAINERS FOR COMMERCIAL USE (U.S. CLS. 2, 13, 22, 25, 32 AND 50).  
FIRST USE 8-31-2009; IN COMMERCE 8-31-2009.

**CLASS 21—HOUSEWARES AND GLASS**

FOR DISPOSABLE DINNERWARE AND TABLEWARE, NAMELY, PLATES (U.S. CLS. 2, 13, 23, 29, 30, 33, 40 AND 50).  
FIRST USE 6-30-2008; IN COMMERCE 6-30-2008.

3,955,842. YGE STEAKHOUSES LLC, TAMPA, FL. SN 77-981,412. PUB. 12-16-2008, FILED 7-3-2008.

# NYE STEAK

THE MARK CONSISTS OF STANDARD CHARACTERS WITHOUT CLAIM TO ANY PARTICULAR FONT, STYLE, SIZE, OR COLOR.

NO CLAIM IS MADE TO THE EXCLUSIVE RIGHT TO USE "STEAK" AS TO CLASSES 8, 30 AND 43, APART FROM THE MARK AS SHOWN.

**CLASS 8—HAND TOOLS**

FOR STEAK KNIVES (U.S. CLS. 23, 28 AND 44).  
FIRST USE 5-1-2010; IN COMMERCE 5-1-2010.

**CLASS 21—HOUSEWARES AND GLASS**

FOR DRINKING GLASSES AND BEVERAGE GLASSWARE (U.S. CLS. 2, 13, 23, 29, 30, 33, 40 AND 50).  
FIRST USE 5-1-2010; IN COMMERCE 5-1-2010.

3,955,844. THE WILLIAM CARTER COMPANY, ATLANTA, GA. SN 77-981,437. PUB. 6-8-2010, FILED 12-10-2009.

# PRECIOUS FIRSTS

THE MARK CONSISTS OF STANDARD CHARACTERS WITHOUT CLAIM TO ANY PARTICULAR FONT, STYLE, SIZE, OR COLOR.

**CLASS 25—CLOTHING**

FOR INFANTS' AND CHILDREN'S CLOTHING, NAMELY, TOPS, BOTTOMS, UNDERWEAR, BLOOMERS, UNDERSHIRTS, CREEPERS, ROMPERS, OVERALLS, COVERALLS, TWO-PIECE SHIRT AND PANT SETS, KNIT-TOPS, SHIRTS, T-SHIRTS, TANKTOPS, SWEATERS, SWEATSHIRTS, SWEATPANTS, DRESSES, SHORTS, SHORTALLS, BATHROBES, SOCKS, BOOTIES, LEGGINGS, BONNETS, CAPS, SCARVES, MITTENS, SNOW SUITS, COATS, JACKETS, VESTS, BABY BUNTING, CLOTH BIBS; SLEEPWEAR, NAMELY, NIGHT-GOWNS, PAJAMAS, FOOTED PAJAMAS, INFANT SLEEPING PAJAMAS WITH ENCLOSED FOOT AREA (U.S. CLS. 22 AND 39).

FIRST USE 1-31-2010; IN COMMERCE 1-31-2010.

**CLASS 28—TOYS AND SPORTING GOODS**

FOR TOYS FOR INFANTS AND CHILDREN, NAMELY, BABY RATTLES, BATH TOYS, CRIB MOBILES, CRIB TOYS, STUFFED TOYS, WIND-UP TOYS, MULTIPLE ACTIVITY TOYS, TOY BUILDING BLOCKS, MUSICAL TOYS, HAND AND FINGER PUPPETS, PLAY MATS CONTAINING INFANT TOYS (U.S. CLS. 22, 23, 38 AND 50).

FIRST USE 1-31-2010; IN COMMERCE 1-31-2010.

**CLASS 41—EDUCATION AND ENTERTAINMENT**

FOR EDUCATIONAL AND ENTERTAINMENT SERVICES, NAMELY, A CONTINUING PROGRAM ABOUT ANIMAL AWARENESS, RELATIONSHIPS, HISTORY, LIFE, LITERATURE, PHILOSOPHY, POLITICS, PSYCHOLOGY, SCIENCE AND TECHNOLOGY, HUMOR, AND POLITICAL AND SOCIAL SATIRE ACCESSIBLE BY SATELLITE AND COMPUTER NETWORKS; EDUCATIONAL SERVICES, NAMELY, PROVIDING AN ON-LINE WEBSITE FEATURING INFORMAL ONLINE PROGRAMS IN THE FIELDS OF ANIMAL AWARENESS, RELATIONSHIPS, HISTORY, LIFE, LITERATURE, PHILOSOPHY, POLITICS, PSYCHOLOGY, SCIENCE AND TECHNOLOGY, HUMOR, AND SATIRE; ENTERTAINMENT SERVICES, NAMELY, CONDUCTING CONTESTS; PROVIDING ON-LINE PUBLICATIONS IN THE NATURE OF COMIC STRIPS, BLOGS IN THE FIELDS OF ANIMAL AWARENESS, RELATIONSHIPS, HISTORY, LIFE, LITERATURE, PHILOSOPHY, POLITICS, PSYCHOLOGY, SCIENCE AND TECHNOLOGY, HUMOR, AND POLITICAL AND SOCIAL SATIRE (U.S. CLS. 100, 101 AND 107).

FIRST USE 8-19-2008; IN COMMERCE 8-19-2008.

3,955,845. ENDGAME ENTERPRISES, LLC, WESTMINSTER, CO. SN 77-981,450. PUB. 6-15-2010, FILED 7-22-2009.

3,955,850. SEARCH INSTITUTE, MINNEAPOLIS, MN. SN 77-981,511. PUB. 6-29-2010, FILED 2-8-2010.

**LETTERS FROM US**

THE MARK CONSISTS OF STANDARD CHARACTERS WITHOUT CLAIM TO ANY PARTICULAR FONT, STYLE, SIZE, OR COLOR.

OWNER OF U.S. REG. NOS. 3,568,518, 3,605,724, AND 3,644,482.

**CLASS 6—METAL GOODS**

FOR METAL KEY CHAINS (U.S. CLS. 2, 12, 13, 14, 23, 25 AND 50).

FIRST USE 8-19-2008; IN COMMERCE 8-19-2008.

**CLASS 21—HOUSEWARES AND GLASS**

FOR CUPS AND MUGS (U.S. CLS. 2, 13, 23, 29, 30, 33, 40 AND 50).

FIRST USE 8-19-2008; IN COMMERCE 8-19-2008.

**CLASS 25—CLOTHING**

FOR JACKETS; SHIRTS (U.S. CLS. 22 AND 39).

FIRST USE 8-19-2008; IN COMMERCE 8-19-2008.

**CLASS 26—FANCY GOODS**

FOR NOVELTY BUTTONS (U.S. CLS. 37, 39, 40, 42 AND 50).

FIRST USE 8-19-2008; IN COMMERCE 8-19-2008.

**CLASS 35—ADVERTISING AND BUSINESS**

FOR PROMOTING PUBLIC AWARENESS OF ANIMALS (U.S. CLS. 100, 101 AND 102).

FIRST USE 8-19-2008; IN COMMERCE 8-19-2008.

**PARENT FURTHER**

THE MARK CONSISTS OF STANDARD CHARACTERS WITHOUT CLAIM TO ANY PARTICULAR FONT, STYLE, SIZE, OR COLOR.

NO CLAIM IS MADE TO THE EXCLUSIVE RIGHT TO USE "PARENT", APART FROM THE MARK AS SHOWN.

**CLASS 36—INSURANCE AND FINANCIAL**

FOR EDUCATION SERVICES, NAMELY, PROVIDING INFORMATION ON PARENTING TOPICS, NAMELY, PERSONAL FINANCES DESIGNED TO IDENTIFY AND IMPROVE PARENT-CHILD RELATIONSHIPS (U.S. CLS. 100, 101 AND 102).

FIRST USE 3-31-2010; IN COMMERCE 3-31-2010.

**CLASS 41—EDUCATION AND ENTERTAINMENT**

FOR EDUCATION SERVICES, NAMELY, PROVIDING INFORMATION ON PARENTING TOPICS, NAMELY, STUDENT EDUCATION DESIGNED TO IDENTIFY AND IMPROVE PARENT-CHILD RELATIONSHIPS (U.S. CLS. 100, 101 AND 107).

FIRST USE 3-31-2010; IN COMMERCE 3-31-2010.

**CLASS 44—MEDICAL, BEAUTY AND AGRICULTURAL SERVICES**

FOR EDUCATION SERVICES, NAMELY, PROVIDING INFORMATION ON PARENTING TOPICS, NAMELY, HEALTH AND WELLNESS AND DRUG AND ALCOHOL AWARENESS, DESIGNED TO IDENTIFY AND IMPROVE PARENT-CHILD RELATIONSHIPS (U.S. CLS. 100 AND 101).

FIRST USE 3-31-2010; IN COMMERCE 3-31-2010.

**CLASS 45—PERSONAL AND LEGAL SERVICES**

FOR EDUCATION SERVICES, NAMELY, PROVIDING INFORMATION ON PARENTING TOPICS, NAMELY, DATING AND SPIRITUALITY, DESIGNED TO IDENTIFY AND IMPROVE PARENT-CHILD RELATIONSHIPS; EDUCATION SERVICES, NAMELY, PROVIDING INFORMATION ON PARENTING TOPICS, NAMELY, DIVORCE AS IT RELATES TO FAMILY RELATIONSHIPS DURING AND AFTER DIVORCE, DESIGNED TO IDENTIFY AND IMPROVE PARENT-CHILD RELATIONSHIPS (U.S. CLS. 100 AND 101).

FIRST USE 3-31-2010; IN COMMERCE 3-31-2010.

3,955,851. SEARCH INSTITUTE, MINNEAPOLIS, MN. SN 77-981,512. PUB. 6-29-2010, FILED 2-8-2010.

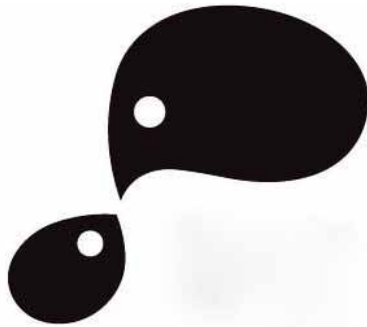

THE MARK CONSISTS OF TWO STYLIZED BIRDLIKE FIGURES, WITH THE LARGER ONE DENOTING A PARENT ATTENDING TO ITS CHILD, WHICH IS DENOTED BY THE SMALLER FIGURE.

**CLASS 36—INSURANCE AND FINANCIAL**

FOR EDUCATION SERVICES, NAMELY, PROVIDING INFORMATION ON PARENTING TOPICS, NAMELY, PERSONAL FINANCES DESIGNED TO IDENTIFY AND IMPROVE PARENT-CHILD RELATIONSHIPS (U.S. CLS. 100, 101 AND 102).

FIRST USE 3-31-2010; IN COMMERCE 3-31-2010.

**CLASS 41—EDUCATION AND ENTERTAINMENT**

FOR EDUCATION SERVICES, NAMELY, PROVIDING INFORMATION ON PARENTING TOPICS, NAMELY, STUDENT EDUCATION DESIGNED TO IDENTIFY AND IMPROVE PARENT-CHILD RELATIONSHIPS (U.S. CLS. 100, 101 AND 107).

FIRST USE 3-31-2010; IN COMMERCE 3-31-2010.

**CLASS 44—MEDICAL, BEAUTY AND AGRICULTURAL SERVICES**

FOR EDUCATION SERVICES, NAMELY, PROVIDING INFORMATION ON PARENTING TOPICS, NAMELY, HEALTH AND WELLNESS AND DRUG AND ALCOHOL AWARENESS, DESIGNED TO IDENTIFY AND IMPROVE PARENT-CHILD RELATIONSHIPS (U.S. CLS. 100 AND 101).

FIRST USE 3-31-2010; IN COMMERCE 3-31-2010.

**CLASS 45—PERSONAL AND LEGAL SERVICES**

FOR EDUCATION SERVICES, NAMELY, PROVIDING INFORMATION ON PARENTING TOPICS, NAMELY, DATING AND SPIRITUALITY, DESIGNED TO IDENTIFY AND IMPROVE PARENT-CHILD RELATIONSHIPS; EDUCATION SERVICES, NAMELY, PROVIDING INFORMATION ON PARENTING TOPICS, NAMELY, DIVORCE AS IT RELATES TO FAMILY RELATIONSHIPS DURING AND AFTER DIVORCE, DESIGNED TO IDENTIFY AND IMPROVE PARENT-CHILD RELATIONSHIPS (U.S. CLS. 100 AND 101).

FIRST USE 3-31-2010; IN COMMERCE 3-31-2010.

3,955,854. WALTON & POST, INC., MIAMI, FL. SN 77-981,529. PUB. 4-13-2010, FILED 7-30-2009.

**COUNTRY BARN**

THE MARK CONSISTS OF STANDARD CHARACTERS WITHOUT CLAIM TO ANY PARTICULAR FONT, STYLE, SIZE, OR COLOR.

OWNER OF U.S. REG. NOS. 2,936,483, 2,999,828, AND 3,348,961.

**CLASS 29—MEATS AND PROCESSED FOODS**

FOR CONDENSED MILK, EVAPORATED MILK (U.S. CL. 46).

FIRST USE 1-0-2009; IN COMMERCE 1-0-2009.

**CLASS 30—STAPLE FOODS**

FOR BAKING SODA, PROCESSED OATS, NAMELY, QUICK OATS, OLD FASHIONED OATS; PROCESSED UN-POPPED POPCORN (U.S. CL. 46).

FIRST USE 1-0-2009; IN COMMERCE 1-0-2009.

3,955,863. TARGET BRANDS, INC., MINNEAPOLIS, MN. SN 77-981,610. PUB. 6-23-2009, FILED 1-31-2008.

**RE**  
**ROOM ESSENTIALS**

OWNER OF U.S. REG. NO. 3,251,676.

NO CLAIM IS MADE TO THE EXCLUSIVE RIGHT TO USE "ROOM", APART FROM THE MARK AS SHOWN.

THE MARK CONSISTS OF UPPER CASE WIDE BOLD LETTERS "RE" STACKED ON TOP OF THE TWO WORDS "ROOM ESSENTIALS" IN UPPER CASE LETTERS.

**CLASS 20—FURNITURE AND ARTICLES NOT OTHERWISE CLASSIFIED**

FOR HOME AND OFFICE FURNITURE; GARDEN AND PATIO FURNITURE; MIRRORS; DECORATIVE WINDOW FINIALS; DRAPERY HARDWARE, NAMELY, TENSION RODS, ROD SETS, RODS OF WOOD, RODS OF STEEL, POLES, RINGS, TIE BACKS, BRACKETS, DRAPERY RINGS NOT OF METAL; STORAGE AND ORGANIZATION PRODUCTS AND ACCESSORIES, NAMELY, STORAGE SHELVES, STORAGE DRAWERS, STORAGE CARTS, STORAGE RACKS; WOOD AND PLASTIC STORAGE BOXES; TABLES; CHAIRS; SHELVES; BOOKCASES; BOOK STANDS; DESKS; CHAISE LOUNGES; CABINETS; CHESTS OF DRAWERS; DRESSERS; ENTERTAINMENT CENTERS; FILING CABINETS; MAGAZINE RACKS; MEDICINE CABINETS; NIGHTSTANDS; OTTOMANS; HAMPERS; PICTURE FRAMES; HANGERS FOR CLOTHES; PILLOWS; DECORATIVE PILLOWS; STOOLS; SHOWER CURTAIN RINGS; SHOWER CURTAIN RODS; CLOTHES HANGERS; FIGURINES OF STONE, WOOD, NON-PRECIOUS METAL, PLASTIC, CERAMIC, FOAM; PLANT STANDS; PLASTIC TISSUE BOX COVERS; SEAT CUSHIONS (U.S. CLS. 2, 13, 22, 25, 32 AND 50).

FIRST USE 5-9-2009; IN COMMERCE 5-9-2009.

**CLASS 21—HOUSEWARES AND GLASS**

FOR BEVERAGE WARE; DRINKING GLASSES AND MUGS; MIXING BOWLS; PAPER TOWEL HOLDERS; SOAP DISPENSERS; SOAP DISHES; SHOWER CADDIES; COTTON BALL DISPENSERS; TISSUE HOLDERS; TOILET BRUSHES; TOILET BRUSH HOLDERS; TOOTH-BRUSH HOLDERS; CONTAINERS FOR HOUSEHOLD OR KITCHEN USE; CLOTHES DRYING RACKS; CLOTHES PEGS; GARBAGE CANS; WASTE BASKETS; BOWLS (U.S. CLS. 2, 13, 23, 29, 30, 33, 40 AND 50).

FIRST USE 5-9-2009; IN COMMERCE 5-9-2009.

3,955,864. C/O HOTELS, LLC, NEW YORK, NY. SN 77-981,622. PUB. 7-6-2010, FILED 5-6-2009.

**C/O THE MAIDSTONE**

THE MARK CONSISTS OF STANDARD CHARACTERS WITHOUT CLAIM TO ANY PARTICULAR FONT, STYLE, SIZE, OR COLOR.

**CLASS 35—ADVERTISING AND BUSINESS**

FOR ART GALLERY SERVICES; WINE CLUB SERVICES, NAMELY, PROMOTING THE INTERESTS OF WINE ENTHUSIASTS (U.S. CLS. 100, 101 AND 102).

FIRST USE 5-9-2009; IN COMMERCE 5-9-2009.

**CLASS 41—EDUCATION AND ENTERTAINMENT**

FOR WINE AND FOOD TASTINGS; YOGA INSTRUCTION (U.S. CLS. 100, 101 AND 107).

FIRST USE 5-9-2009; IN COMMERCE 5-9-2009.

**CLASS 43—HOTEL AND RESTAURANT SERVICES**

FOR HOTEL, RESTAURANT, BAR, LOUNGE, AND CATERING SERVICES; SOMMELIER SERVICES, NAMELY, PROVIDING ADVICE ON WINE AND WINE AND FOOD PAIRING (U.S. CLS. 100 AND 101).

FIRST USE 5-9-2009; IN COMMERCE 5-9-2009.

**CLASS 45—PERSONAL AND LEGAL SERVICES**

FOR HOTEL CONCIERGE SERVICES (U.S. CLS. 100 AND 101).

FIRST USE 5-9-2009; IN COMMERCE 5-9-2009.

3,955,870. MARS, INCORPORATED, MCLEAN, VA. SN 77-981,703. PUB. 5-11-2010, FILED 8-7-2009.

**GOODNESSKNOWS**

THE MARK CONSISTS OF STANDARD CHARACTERS WITHOUT CLAIM TO ANY PARTICULAR FONT, STYLE, SIZE, OR COLOR.

**CLASS 29—MEATS AND PROCESSED FOODS**

FOR FRUIT BASED SNACK FOODS; NUT-BASED SNACK FOODS, NAMELY, NUT CRISPS; NUT-BASED SNACK FOODS, NAMELY, CLUSTERS; NUT-BASED SNACK FOODS (U.S. CL. 46).

FIRST USE 2-19-2010; IN COMMERCE 2-19-2010.

**CLASS 30—STAPLE FOODS**

FOR GRAIN BASED FOOD BARS ALSO CONTAINING DARK CHOCOLATE, NUTS, FRUIT AND SEEDS; GRAIN BASED SNACK FOODS; GRANOLA; GRANOLA SNACKS; GRANOLA BASED SNACK BARS (U.S. CL. 46).

FIRST USE 2-19-2010; IN COMMERCE 2-19-2010.

3,955,875. PAXTON AUTOMOTIVE CORP., OXNARD, CA. SN 78-617,363. PUB. 1-24-2006, FILED 4-26-2005.



THE COLOR(S) THE COLORS RED, ORANGE, YELLOW, BLACK, WHITE AND GRAY ARE CLAIMED AS A FEATURE OF THE MARK. IS/ARE CLAIMED AS A FEATURE OF THE MARK.

THE MARK CONSISTS OF THE COLORS RED, ORANGE AND YELLOW APPEAR IN THE FLAME HEAD. THE FLAME HEAD IS OUTLINED IN BLACK. THE COLOR BLACK APPEARS IN THE SUNGLASSES AND CONTAINS A WHITE STAR ON THE LEFT LENS. THE COLOR BLACK APPEARS IN THE NOSE, DIMPLE AND IN THE OUTLINE OF THE MOUTH AND WHITE TEETH. THE FLAME HEAD HAS GRAY SMOKE AND GRAY WHEELS.

**CLASS 7—MACHINERY**

FOR INTERNAL COMBUSTION LAND VEHICLE ENGINE PARTS, NAMELY, SUPERCHARGERS (U.S. CLS. 13, 19, 21, 23, 31, 34 AND 35).

FIRST USE 2-1-2010; IN COMMERCE 2-1-2010.



**CLASS 16—PAPER GOODS AND PRINTED MATTER**

FOR DECALS (U.S. CLS. 2, 5, 22, 23, 29, 37, 38 AND 50).  
FIRST USE 0-0-1995; IN COMMERCE 0-0-1995.

**CLASS 25—CLOTHING**

FOR CLOTHING, NAMELY, T-SHIRTS AND HATS  
(U.S. CLS. 22 AND 39).  
FIRST USE 0-0-1995; IN COMMERCE 0-0-1995.

3,955,876. CHEMTURA CORPORATION, MIDDLEBURY,  
CT. SN 78-656,421. PUB. 5-20-2008, FILED 6-22-2005.

**CLASS 1—CHEMICALS**

FOR HOUSE MARK FOR A FULL LINE OF CHEMICALS, CHEMICAL BLENDS AND CHEMICAL PREPARATIONS FOR USE IN THE AGRICULTURAL, HORTICULTURAL AND MANUFACTURING INDUSTRIES, NAMELY, SULFONATES, URETHANE CHEMICALS, URETHANE PREPOLYMERS, POLYESTER POLYOLS, SURFACTANTS, CHEMICAL STABILIZERS FOR USE IN MANUFACTURING, INTERMEDIATES, ANTIOXIDANTS, CURATIVES, HARDENERS, LIQUID POLYMERS, PRE-POLYMERS, ADDITIVES, NAMELY, PLASTIC ADDITIVES, RUBBER ADDITIVES, POLYMER ADDITIVES, AND PETROLEUM ADDITIVES, OLEFINS, POLYURETHANE DISPERSIONS AND ADDITIVES, BROMINE-BASED INTERMEDIATES, LIGHT STABILIZERS, ULTRAVIOLET LIGHT ABSORBERS, NICKEL QUENCHERS, CROSS-LINKING INHIBITORS, ANTIOXIDANTS, ANTIOZONANTS, VULCANIZATION ACCELERATORS, ORGANOMETALLIC COMPOUNDS FOR INDUSTRIAL AND MANUFACTURING USES IN PAINTS, VARNISHES, CLEANERS, SOLUTIONS, DETERGENTS, INDUSTRIAL DYES, PERSONAL CARE COMPOSITIONS, PRINTED CIRCUIT BOARDS, COATINGS FOR GLASS BOTTLES AND FLAT SHEET GLASS APPLICATIONS, POLYMER MANUFACTURING, AUTOMOTIVE, MARINE AND PHARMACEUTICAL PRODUCTS, AND FOR USE IN MANUFACTURING BUILDING MATERIALS, MANUFACTURE OF FIBERS, FILMS, EXTRUSIONS, CO-EXTRUSIONS, MOLDED ARTICLES, THERMO-FORMED ARTICLES, AND SIMILAR TANGIBLE ARTICLES, OR THE RAW MATERIALS FROM WHICH SUCH ARTICLES ARE MADE; BROMINE-BASED CHEMICALS AND CHEMICAL BLENDS FOR USE IN INDUSTRIAL, PHARMACEUTICAL, POLYMER, AND ELECTRONIC APPLICATIONS; CHEMICAL AGENTS FOR FLAME AND SMOKE RETARDANTS AND EXTINGUISHING COMPOSITIONS AND PRODUCTS, INCLUDING, FLAME RETARDANTS AND FIRE EXTINGUISHANTS; CHEMICAL AGENTS FOR FOAMING RUBBER AND PLASTIC FOR USE IN THE AUTOMOBILE, CONSTRUCTION, THERMOPLASTIC VULCANIZATES, THERMOPLASTIC POLYOLEFINS, TELECOMMUNICATIONS, APPLIANCE WIRE INSTALLATION AND INDUSTRIAL INDUSTRIES; CHEMICALS, NAMELY, ANTIMONY BASED CATALYSTS AND INHIBITORS FOR USE IN THE MANUFACTURE OF AIRCRAFT WINDOWS, WINDOWS AND GLASS WINDOWS OF CIVIL AND INDUSTRIAL IMMOVABLES, AND TRANSPARENT SURFACES, ADDITIVES, UNPROCESSED PLASTICS, AND ADHESIVES FOR USE IN THE INDUSTRIAL AND MANUFACTURING INDUSTRIES (U.S. CLS. 1, 5, 6, 10, 26 AND 46).  
FIRST USE 5-31-2010; IN COMMERCE 5-31-2010.

**CLASS 4—LUBRICANTS AND FUELS**

FOR GREASES AND LUBRICANTS FOR INDUSTRIAL USES (U.S. CLS. 1, 6 AND 15).  
FIRST USE 12-31-2007; IN COMMERCE 12-31-2007.

3,955,877. DAWN FOODS, INC., JACKSON, MI. SN 78-728,133. PUB. 5-22-2007, FILED 10-6-2005.

# ADORE

THE MARK CONSISTS OF STANDARD CHARACTERS WITHOUT CLAIM TO ANY PARTICULAR FONT, STYLE, SIZE, OR COLOR.

**CLASS 29—MEATS AND PROCESSED FOODS**

FOR FILLINGS, NAMELY, FRUIT-BASED FILLING FOR CAKES AND PIES; TOPPINGS, NAMELY, FRUIT TOPPING, NUT TOPPING, PEANUT BUTTER TOPPING, WHIPPED DAIRY AND NON-DAIRY TOPPING, ALL FOR BAKERY PRODUCTS (U.S. CL. 46).  
FIRST USE 8-12-2010; IN COMMERCE 8-12-2010.

**CLASS 30—STAPLE FOODS**

FOR BAKERY PRODUCTS; PREPARATION FOR MAKING BAKERY PRODUCTS, NAMELY, BREAD MIXES, CAKE MIXES, MUFFIN MIXES; MIXES FOR BAKERY PRODUCTS; FLOUR AND PREPARATIONS MADE FROM CEREALS, NAMELY, PROCESSED WHEAT, PROCESSED OATS, AND PROCESSED CORN; DOUGH; PASTRY; DOUGH PRODUCTS, NAMELY, CINNAMON ROLLS, CROISSANTS, BROWNIES, CAKES, CUPCAKES, COOKIES, DONUTS, MUFFINS, CREAM CAKES, POUND CAKES, SNACK CAKES, PUFF PASTRY DOUGH, STRUDELS, TURNOVERS, FRUIT STICKS, NAMELY, ELONGATED FRUIT PIES, DANISH; PASTRY PRODUCTS, NAMELY, CREAM PUFFS, DANISH, TURNOVERS, CINNAMON ROLLS, CROISSANTS, FRUIT STICKS, NAMELY, ELONGATED FRUIT PIES; MEXICAN PASTRIES, NAMELY, CONCHAS, EMPANADAS, BOLILLOS; PASTRIES; CAKES; DONUTS; BISCUITS; COOKIES; MUFFINS; DOUGH MIXES, NAMELY, DOUGH FOR MAKING BREAD, BROWNIES, CAKES, COOKIES, DONUTS, BISCUITS, SCONES, DANISH, ECLAIRS, PANCAKES, WAFFLES, PIZZA, PRETZELS, MUFFINS, SWEET DOUGH; CAKE MIXES; DONUT MIXES; BISCUIT MIXES; COOKIE MIXES; MUFFIN MIXES; BATTER, NAMELY, PANCAKE BATTER, MUFFIN BATTER; BAKERY INGREDIENTS, NAMELY, CHOCOLATE-BASED FILLINGS FOR CAKES AND PIES, CUSTARD-BASED FILLINGS FOR CAKES AND PIES; ICINGS, NAMELY, GANACHE, CHOCOLATE TRUFFLE ICING, BUTTER CREAM ICING, FLAT ICINGS, GLAZES; TOPPINGS AND EDIBLE DECORATIONS FOR BAKERY PRODUCTS, NAMELY, CHOCOLATE TOPPING, MARSHMALLOW TOPPING, TOPPING SYRUPS; EDIBLE DECORATIONS FOR BAKERY PRODUCTS (U.S. CL. 46).  
FIRST USE 8-12-2010; IN COMMERCE 8-12-2010.

3,955,881. PANASONIC CORPORATION OF NORTH AMERICA, SECAUCUS, NJ. SN 78-885,832. PUB. 12-18-2007, FILED 5-17-2006.

3,955,897. CONSTRUCTION RISK SOLUTIONS, LLC, HUNT VALLEY, MD. SN 85-004,499. PUB. 8-24-2010, FILED 4-1-2010.

## IDEAS FOR LIFE

THE MARK CONSISTS OF STANDARD CHARACTERS WITHOUT CLAIM TO ANY PARTICULAR FONT, STYLE, SIZE, OR COLOR.

OWNER OF U.S. REG. NOS. 2,882,770, 3,117,492, AND OTHERS.

### CLASS 7—MACHINERY

FOR COMPONENTS FOR ORIGINAL EQUIPMENT MANUFACTURERS, NAMELY, ELECTRIC MOTORS FOR MACHINES (U.S. CLS. 13, 19, 21, 23, 31, 34 AND 35). FIRST USE 3-31-2002; IN COMMERCE 3-31-2002.

### CLASS 9—ELECTRICAL AND SCIENTIFIC APPARATUS

FOR HAND REMOTE CONTROL UNITS FOR TELEVISION SETS; TELEPHONE ANSWERING MACHINES (U.S. CLS. 21, 23, 26, 36 AND 38).

FIRST USE 3-31-2002; IN COMMERCE 3-31-2002.

3,955,882. TECHNOLOGY ADVANCEMENT GROUP, INC., DULLES, VA. SN 78-892,993. PUB. 5-26-2009, FILED 5-25-2006.

RUGGED. RELIABLE. READY.

THE MARK CONSISTS OF STANDARD CHARACTERS WITHOUT CLAIM TO ANY PARTICULAR FONT, STYLE, SIZE, OR COLOR.

### CLASS 35—ADVERTISING AND BUSINESS

FOR MANAGING TELECOMMUNICATIONS NETWORKS FOR OTHERS; OPERATION AND ADMINISTRATION OF TELECOMMUNICATION SYSTEMS AND NETWORKS FOR OTHERS (U.S. CLS. 100, 101 AND 102). FIRST USE 1-0-2006; IN COMMERCE 1-0-2006.

### CLASS 41—EDUCATION AND ENTERTAINMENT

FOR PROVIDING ONLINE NON-DOWNLOADABLE NEWS BULLETINS (U.S. CLS. 100, 101 AND 107). FIRST USE 1-0-2006; IN COMMERCE 1-0-2006.

### CLASS 45—PERSONAL AND LEGAL SERVICES

FOR CONSULTING SERVICES IN THE FIELD OF MAINTAINING THE SECURITY AND INTEGRITY OF DATABASES (U.S. CLS. 100 AND 101). FIRST USE 1-0-2006; IN COMMERCE 1-0-2006.

## CRS

THE MARK CONSISTS OF STANDARD CHARACTERS WITHOUT CLAIM TO ANY PARTICULAR FONT, STYLE, SIZE, OR COLOR.

### CLASS 35—ADVERTISING AND BUSINESS

FOR BUSINESS CONSULTING SERVICES, NAMELY, MANAGEMENT CONSULTING AND RISK MANAGEMENT IN THE FIELD OF CONSTRUCTION (U.S. CLS. 100, 101 AND 102).

FIRST USE 12-15-2006; IN COMMERCE 12-15-2006.

### CLASS 36—INSURANCE AND FINANCIAL

FOR INSURANCE SERVICES, NAMELY, PROVIDING ADVICE IN CONNECTION WITH RISK MANAGEMENT, SAFETY, LOSS CONTROL, CLAIMS MANAGEMENT AND SURETY IN THE FIELD OF CONSTRUCTION; INSURANCE BROKERAGE SERVICES IN THE FIELD OF CONSTRUCTION (U.S. CLS. 100, 101 AND 102).

FIRST USE 12-15-2006; IN COMMERCE 12-15-2006.

3,955,902. REHABILITATION SERVICES, INC., DBA MYOFASCIAL RELEASE TREATMENT CENTERS AND SEMINARS, PAOLI, PA. SN 85-006,959. PUB. 8-31-2010, FILED 4-6-2010.

## Barnes' Myofascial Release Approach

THE MARK CONSISTS OF STANDARD CHARACTERS WITHOUT CLAIM TO ANY PARTICULAR FONT, STYLE, SIZE, OR COLOR.

OWNER OF U.S. REG. NO. 1,557,279.

NO CLAIM IS MADE TO THE EXCLUSIVE RIGHT TO USE "MYOFASCIAL RELEASE APPROACH", APART FROM THE MARK AS SHOWN.

### CLASS 41—EDUCATION AND ENTERTAINMENT

FOR WORKSHOPS AND SEMINARS IN THE FIELD OF MYOFASCIAL RELEASE THERAPY (U.S. CLS. 100, 101 AND 107).

FIRST USE 7-1-2010; IN COMMERCE 7-1-2010.

### CLASS 44—MEDICAL, BEAUTY AND AGRICULTURAL SERVICES

FOR PHYSICAL REHABILITATION AND MYOFASCIAL RELEASE THERAPY (U.S. CLS. 100 AND 101). FIRST USE 7-1-2010; IN COMMERCE 7-1-2010.

3,955,904. INTERNATIONAL GROUP, INC., TITUSVILLE, PA. SN 85-008,034. PUB. 9-7-2010, FILED 4-7-2010.

# SEBAPET

THE MARK CONSISTS OF STANDARD CHARACTERS WITHOUT CLAIM TO ANY PARTICULAR FONT, STYLE, SIZE, OR COLOR.

## CLASS 1—CHEMICALS

FOR CHEMICAL ADDITIVES FOR USE IN THE MANUFACTURE OF FOOD, COSMETICS, PERSONAL GOODS AND PHARMACEUTICALS (U.S. CLS. 1, 5, 6, 10, 26 AND 46).

FIRST USE 6-1-2010; IN COMMERCE 9-1-2010.

## CLASS 4—LUBRICANTS AND FUELS

FOR PETROLATUMS, OILS AND WAXES FOR USE IN THE MANUFACTURE OF FOOD, COSMETICS, PERSONAL GOODS AND PHARMACEUTICALS (U.S. CLS. 1, 6 AND 15).

FIRST USE 6-1-2010; IN COMMERCE 9-1-2010.

3,955,924. POINT B CAPITAL, LLC, SEATTLE, WA. SN 85-014,144. PUB. 9-7-2010, FILED 4-14-2010.

# POINT B CAPITAL

THE MARK CONSISTS OF STANDARD CHARACTERS WITHOUT CLAIM TO ANY PARTICULAR FONT, STYLE, SIZE, OR COLOR.

NO CLAIM IS MADE TO THE EXCLUSIVE RIGHT TO USE "CAPITAL", APART FROM THE MARK AS SHOWN.

## CLASS 35—ADVERTISING AND BUSINESS

FOR BUSINESS DEVELOPMENT, MANAGEMENT, AND INCUBATION SERVICES, NAMELY, PROVIDING BUSINESS CONSULTING AND START-UP SUPPORT FOR BUSINESSES OF OTHERS; MERGER AND ACQUISITION CONSULTATION (U.S. CLS. 100, 101 AND 102).

FIRST USE 3-31-2010; IN COMMERCE 3-31-2010.

## CLASS 36—INSURANCE AND FINANCIAL

FOR VENTURE CAPITAL AND INCUBATION SERVICES, NAMELY, PROVIDING FINANCING TO EXISTING BUSINESSES AND EMERGING AND START-UP COMPANIES (U.S. CLS. 100, 101 AND 102).

FIRST USE 3-31-2010; IN COMMERCE 3-31-2010.

3,955,942. JOHN B. SANFILIPPO & SON, INC., ELGIN, IL. SN 85-020,800. PUB. 6-22-2010, FILED 4-22-2010.



**SABOR Y TRADICIÓN**

NO CLAIM IS MADE TO THE EXCLUSIVE RIGHT TO USE "SABOR", APART FROM THE MARK AS SHOWN.

THE MARK CONSISTS OF AN IMAGE OF A SUN EMBODYING HUMAN FACIAL FEATURES WITH RAYS RADIATING OUTWARDLY FROM ITS PERIMETER AND CENTERED ABOVE THE WORDS "SABOR Y TRADICIÓN".

THE ENGLISH TRANSLATION OF "SABOR Y TRADICIÓN" IN THE MARK IS FLAVOR AND TRADITION.

## CLASS 29—MEATS AND PROCESSED FOODS

FOR SHELLED AND ROASTED NUTS; PROCESSED NUTS; PROCESSED FLAVORED NUTS; CANDIED NUTS; SNACK MIX CONSISTING PRIMARILY OF PROCESSED FRUITS AND PROCESSED NUTS (U.S. CL. 46).

FIRST USE 9-23-2010; IN COMMERCE 9-23-2010.

## CLASS 30—STAPLE FOODS

FOR SNACK MIXES CONSISTING PRIMARILY OF WHEAT-BASED OR RICE-BASED SNACK FOODS AND ALSO CONTAINING PROCESSED NUTS (U.S. CL. 46).

FIRST USE 9-23-2010; IN COMMERCE 9-23-2010.

3,955,943. WILLS GROUP, INC., THE, LA PLATA, MD. SN 85-020,975. PUB. 9-21-2010, FILED 4-22-2010.



THE MARK CONSISTS OF A HIGHLY STYLIZED REPRESENTATION OF A SUNBURST.

## CLASS 37—CONSTRUCTION AND REPAIR

FOR HVAC CONTRACTOR SERVICES; INSTALLATION AND REPLACEMENT SERVICE FOR HEATING, VENTILATING AND AIR CONDITIONING SYSTEMS; HEATING EQUIPMENT INSTALLATION AND REPAIR; FURNACE INSTALLATION AND REPAIR (U.S. CLS. 100, 103 AND 106).

FIRST USE 11-8-2010; IN COMMERCE 11-8-2010.

**CLASS 39—TRANSPORTATION AND STORAGE**

FOR DISTRIBUTION OF ENERGY; PUBLIC UTILITY SERVICES; HEAT SUPPLYING; TRANSMISSION OF OIL THROUGH PIPELINES (U.S. CLS. 100 AND 105).  
FIRST USE 11-8-2010; IN COMMERCE 11-8-2010.

3,955,944. WILLS GROUP, INC., THE, LA PLATA, MD. SN 85-020,990. PUB. 9-21-2010, FILED 4-22-2010.



THE MARK CONSISTS OF A HIGHLY STYLIZED REPRESENTATION OF A SUNBURST AND THE LETTERING "DMO".

**CLASS 37—CONSTRUCTION AND REPAIR**

FOR HVAC CONTRACTOR SERVICES; INSTALLATION AND REPLACEMENT SERVICE FOR HEATING, VENTILATING AND AIR CONDITIONING SYSTEMS; HEATING EQUIPMENT INSTALLATION AND REPAIR; FURNACE INSTALLATION AND REPAIR (U.S. CLS. 100, 103 AND 106).  
FIRST USE 11-8-2010; IN COMMERCE 11-8-2010.

**CLASS 39—TRANSPORTATION AND STORAGE**

FOR DISTRIBUTION OF ENERGY; PUBLIC UTILITY SERVICES; HEAT SUPPLYING; TRANSMISSION OF OIL THROUGH PIPELINES (U.S. CLS. 100 AND 105).  
FIRST USE 11-8-2010; IN COMMERCE 11-8-2010.

3,955,951. INNOVATIVE SEATING SOLUTIONS, LLC, SAN FRANCISCO, CA. SN 85-023,493. PUB. 9-28-2010, FILED 4-26-2010.

# InnoSeat

THE MARK CONSISTS OF STANDARD CHARACTERS WITHOUT CLAIM TO ANY PARTICULAR FONT, STYLE, SIZE, OR COLOR.

**CLASS 10—MEDICAL APPARATUS**

FOR ORTHOTICS FOR BACK OR BUTTOCKS (U.S. CLS. 26, 39 AND 44).  
FIRST USE 1-1-2011; IN COMMERCE 1-1-2011.

**CLASS 12—VEHICLES**

FOR AUTOMOBILE SEAT CUSHIONS; VEHICLE SEATS; WHEELCHAIR CUSHIONS (U.S. CLS. 19, 21, 23, 31, 35 AND 44).  
FIRST USE 1-1-2011; IN COMMERCE 1-1-2011.

**CLASS 20—FURNITURE AND ARTICLES NOT OTHERWISE CLASSIFIED**

FOR CHAIR CUSHIONS; CHAIRS; OFFICE CHAIRS; OFFICE SEATS; PORTABLE BACK SUPPORT FOR USE WITH CHAIRS; RECLINING CHAIRS; SEAT CUSHIONS; SEATS (U.S. CLS. 2, 13, 22, 25, 32 AND 50).  
FIRST USE 1-1-2011; IN COMMERCE 1-1-2011.

3,955,969. NOBLE WAR PRIZE, INC., SOUTHAMPTON, NY. SN 85-032,875. PUB. 7-13-2010, FILED 5-7-2010.

**PRESIDENTIAL TRANSPARENCY**

THE MARK CONSISTS OF STANDARD CHARACTERS WITHOUT CLAIM TO ANY PARTICULAR FONT, STYLE, SIZE, OR COLOR.

**CLASS 16—PAPER GOODS AND PRINTED MATTER**

FOR BUMPER STICKERS (U.S. CLS. 2, 5, 22, 23, 29, 37, 38 AND 50).  
FIRST USE 5-7-2010; IN COMMERCE 7-23-2010.

**CLASS 21—HOUSEWARES AND GLASS**

FOR CUPS AND MUGS (U.S. CLS. 2, 13, 23, 29, 30, 33, 40 AND 50).  
FIRST USE 5-7-2010; IN COMMERCE 7-23-2010.

**CLASS 25—CLOTHING**

FOR CAPS; T-SHIRTS (U.S. CLS. 22 AND 39).  
FIRST USE 5-7-2010; IN COMMERCE 7-23-2010.

**CLASS 28—TOYS AND SPORTING GOODS**

FOR SNOW GLOBES; TOY SNOW GLOBES (U.S. CLS. 22, 23, 38 AND 50).  
FIRST USE 5-7-2010; IN COMMERCE 7-23-2010.

3,955,974. RCI TM CORP., LAS VEGAS, NV. SN 85-036,217. PUB. 9-7-2010, FILED 5-12-2010.

# RCI PLATINUM

THE MARK CONSISTS OF STANDARD CHARACTERS WITHOUT CLAIM TO ANY PARTICULAR FONT, STYLE, SIZE, OR COLOR.

OWNER OF U.S. REG. NOS. 1,386,274, 2,259,563, AND OTHERS.

NO CLAIM IS MADE TO THE EXCLUSIVE RIGHT TO USE "PLATINUM", APART FROM THE MARK AS SHOWN.

**CLASS 35—ADVERTISING AND BUSINESS**

FOR ADMINISTRATION OF A PROGRAM FOR ENABLING PARTICIPANTS TO OBTAIN DISCOUNTS ON PRODUCTS AND SERVICES (U.S. CLS. 100, 101 AND 102).

FIRST USE 7-0-2010; IN COMMERCE 7-0-2010.

**CLASS 36—INSURANCE AND FINANCIAL**

FOR VACATION REAL ESTATE TIME SHARE EXCHANGE SERVICES (U.S. CLS. 100, 101 AND 102).

FIRST USE 7-0-2010; IN COMMERCE 7-0-2010.

---

3,955,995. LBW INSURANCE & FINANCIAL SERVICES, INC., VALENCIA, CA. SN 85-048,694. PUB. 11-30-2010, FILED 5-26-2010.

## TECH SECURE

THE MARK CONSISTS OF STANDARD CHARACTERS WITHOUT CLAIM TO ANY PARTICULAR FONT, STYLE, SIZE, OR COLOR.

NO CLAIM IS MADE TO THE EXCLUSIVE RIGHT TO USE "TECH", APART FROM THE MARK AS SHOWN.

**CLASS 35—ADVERTISING AND BUSINESS**

FOR BUSINESS RISK MANAGEMENT AND ASSESSMENT SERVICES (U.S. CLS. 100, 101 AND 102).

FIRST USE 10-12-2010; IN COMMERCE 10-12-2010.

**CLASS 36—INSURANCE AND FINANCIAL**

FOR INSURANCE AGENCY AND BROKERAGE; INSURANCE SERVICES IN THE NATURE OF LOSS CONTROL MANAGEMENT FOR OTHERS; INSURANCE SERVICES, NAMELY, WRITING PROPERTY AND CASUALTY INSURANCE, LIFE INSURANCE, DISABILITY INSURANCE, HEALTH INSURANCE, AND LONG TERM CARE POLICIES; ADMINISTRATION, PLACEMENT AND IMPLEMENTATION OF EMPLOYEE BENEFIT PLANS CONCERNING INSURANCE AND FINANCE AND CONSULTATION RELATED THERETO; INSURANCE CONSULTING SERVICES; FINANCIAL RISK MANAGEMENT AND ASSESSMENT SERVICES; FINANCIAL ADVICE, ASSET MANAGEMENT, INVESTMENT PLANNING AND CONSULTANCY SERVICES; FINANCIAL SERVICES, NAMELY, QUALIFIED RETIREMENT PLANNING AND CONSULTATION; FINANCIAL AND INSURANCE SERVICES, NAMELY, ESTATE AND SUCCESSION PLANNING SERVICES (U.S. CLS. 100, 101 AND 102).

FIRST USE 10-12-2010; IN COMMERCE 10-12-2010.

---

3,956,023. CHARLENE WANG, FOUNTAIN VALLEY, CA. SN 85-060,256. PUB. 11-9-2010, FILED 6-11-2010.

## Pure Releaf

THE MARK CONSISTS OF STANDARD CHARACTERS WITHOUT CLAIM TO ANY PARTICULAR FONT, STYLE,

SIZE, OR COLOR.

**CLASS 21—HOUSEWARES AND GLASS**

FOR COFFEE CUPS, TEA CUPS AND MUGS; DECANTERS; JAPANESE STYLE TEA-SERVING POTS (KYUSU); SAUCERS; TEA POTS; TEA SERVICES (U.S. CLS. 2, 13, 23, 29, 30, 33, 40 AND 50).

FIRST USE 7-21-2010; IN COMMERCE 10-30-2010.

**CLASS 30—STAPLE FOODS**

FOR GREEN TEA; MIXES IN THE NATURE OF CONCENTRATES, SYRUPS OR POWDERS USED IN THE PREPARATION OF TEA BASED BEVERAGES; OOLONG TEA; TEA BAGS; TEA FOR INFUSIONS (U.S. CL. 46).

FIRST USE 7-21-2010; IN COMMERCE 10-30-2010.

---

3,956,029. STOTELMYER, SCOTT, REDONDO BEACH, CA. SN 85-065,318. PUB. 11-16-2010, FILED 6-17-2010.



NO CLAIM IS MADE TO THE EXCLUSIVE RIGHT TO USE "SCOOTERS", APART FROM THE MARK AS SHOWN.

THE MARK CONSISTS OF THE STYLIZED WORDS "SCOTTY'S SCOOTERS" WHERE THE "S" IS LARGE AND SHARED BY BOTH WORDS AND IS A STYLIZED ROAD.

**CLASS 35—ADVERTISING AND BUSINESS**

FOR RETAIL STORES FEATURING MOTORIZED SCOOTERS (U.S. CLS. 100, 101 AND 102).

FIRST USE 6-0-2009; IN COMMERCE 5-1-2010.

**CLASS 39—TRANSPORTATION AND STORAGE**

FOR RENTAL OF MOTORIZED SCOOTERS FOR TRANSPORTATION PURPOSES (U.S. CLS. 100 AND 105).

FIRST USE 6-0-2009; IN COMMERCE 5-1-2010.

---

3,956,043. BILLY BOB TEETH, INC., HARDIN, IL. SN 85-077,493. PUB. 12-7-2010, FILED 7-2-2010.

## RUSSIAN ROULETTE

THE MARK CONSISTS OF STANDARD CHARACTERS WITHOUT CLAIM TO ANY PARTICULAR FONT, STYLE, SIZE, OR COLOR.

**CLASS 21—HOUSEWARES AND GLASS**

FOR PORTABLE BEVERAGE DISPENSERS (U.S. CLS. 2, 13, 23, 29, 30, 33, 40 AND 50).

FIRST USE 3-0-2009; IN COMMERCE 3-12-2010.

**CLASS 28—TOYS AND SPORTING GOODS**

FOR PARLOR GAMES; PARTY GAMES; GAME EQUIPMENT, NAMELY, NOVELTY BEVERAGE DISPENSERS FOR PLAYING PARLOR GAMES, PARTY GAMES AND DRINKING GAMES (U.S. CLS. 22, 23, 38 AND 50).

FIRST USE 3-0-2009; IN COMMERCE 3-10-2010.

3,956,057. CLUB REAL RESORT S.A. DE C.V., CANCUN, MEXICO. SN 85-081,233. PUB. 12-7-2010, FILED 7-9-2010.

PLUS ONE TRAVEL

THE MARK CONSISTS OF STANDARD CHARACTERS WITHOUT CLAIM TO ANY PARTICULAR FONT, STYLE, SIZE, OR COLOR.

NO CLAIM IS MADE TO THE EXCLUSIVE RIGHT TO USE "TRAVEL", APART FROM THE MARK AS SHOWN.

**CLASS 35—ADVERTISING AND BUSINESS**

FOR ADVERTISING SERVICES, NAMELY, PROMOTING AND MARKETING THE GOODS AND SERVICES OF OTHERS IN THE FIELD OF UPSCALE CHOICES SUCH AS CULTURAL EVENTS, RESTAURANTS, SHOPPING, AND TRAVEL VIA PRINT AND ELECTRONIC MEDIA; MARKETING, ADVERTISING AND PROMOTING THE GOODS AND SERVICES OF OTHERS IN THE FIELD OF TRAVEL AND TOURISM, NAMELY, PROVIDING INFORMATION VIA MAIL AND ELECTRONIC MAIL; TRAVEL MANAGEMENT (U.S. CLS. 100, 101 AND 102).

FIRST USE 7-28-2010; IN COMMERCE 7-28-2010.

**CLASS 39—TRANSPORTATION AND STORAGE**

FOR ARRANGING TRAVEL TOURS; BOOKING OF SEATS FOR TRAVEL; COORDINATING TRAVEL ARRANGEMENTS FOR INDIVIDUALS AND FOR GROUPS; ONLINE TRIP AND TRAVEL RESERVATION SERVICES; ORGANISATION OF TRAVEL; PROVIDING A WEBSITE FEATURING INFORMATION ON TRAVEL; PROVIDING AN ON-LINE SEARCHABLE COMPUTER DATABASE FEATURING INFORMATION ON TRAVEL; TRAVEL AGENCY SERVICES, NAMELY, MAKING RESERVATIONS AND BOOKINGS FOR TRANSPORTATION; TRAVEL INFORMATION; TRAVEL INFORMATION SERVICES (U.S. CLS. 100 AND 105).

FIRST USE 7-28-2010; IN COMMERCE 7-28-2010.

**CLASS 42—SCIENTIFIC AND COMPUTER SERVICES**

FOR PROVIDING A WEB SITE FEATURING TECHNOLOGY THAT ENABLES INTERNET USERS TO BOOK TRAVEL (U.S. CLS. 100 AND 101).

FIRST USE 7-28-2010; IN COMMERCE 7-28-2010.

**CLASS 43—HOTEL AND RESTAURANT SERVICES**

FOR PROVIDING PERSONALIZED INFORMATION ABOUT HOTELS AND TEMPORARY ACCOMMODATIONS FOR TRAVEL VIA THE INTERNET; PROVIDING TRAVEL LODGING INFORMATION SERVICES AND TRAVEL LODGING BOOKING AGENCY SERVICES FOR TRAVELERS; TRAVEL AGENCY SERVICES, NAMELY, MAKING RESERVATIONS AND BOOKING FOR TEMPORARY LODGING; TRAVEL AGENCY SERVICES, NAMELY, MAKING RESERVATIONS AND BOOKING FOR TEMPORARY LODGING FOR OTHER TRAVEL AGENCIES, TRAVEL SUPPLIERS, AND CORPORATIONS, VIA ON-LINE COMPUTER NETWORKS (U.S. CLS. 100 AND 101).

FIRST USE 7-8-2010; IN COMMERCE 7-28-2010.

3,956,058. LAZOO WORLDWIDE LLC, NEW YORK, NY. SN 85-081,525. PUB. 12-7-2010, FILED 7-9-2010.

LAZOO

THE MARK CONSISTS OF STANDARD CHARACTERS WITHOUT CLAIM TO ANY PARTICULAR FONT, STYLE, SIZE, OR COLOR.

**CLASS 16—PAPER GOODS AND PRINTED MATTER**

FOR CHILDREN'S ACTIVITY BOOKS; CHILDREN'S BOOKS; COLORING BOOKS; PICTURE BOOKS (U.S. CLS. 2, 5, 22, 23, 29, 37, 38 AND 50).

FIRST USE 4-0-2009; IN COMMERCE 4-0-2009.

**CLASS 25—CLOTHING**

FOR DRESSES; HATS FOR INFANTS, BABIES, TODDLERS AND CHILDREN; INFANT WEAR; PANTS; SHIRTS; SHIRTS FOR INFANTS, BABIES, TODDLERS AND CHILDREN; SKIRTS; SOCKS; SWEAT SHIRTS (U.S. CLS. 22 AND 39).

FIRST USE 9-24-2010; IN COMMERCE 9-24-2010.

**CLASS 28—TOYS AND SPORTING GOODS**

FOR INFANT TOYS; PLUSH DOLLS; PLUSH TOYS; SOFT SCULPTURE PLUSH TOYS; STUFFED AND PLUSH TOYS; STUFFED DOLLS AND ANIMALS; STUFFED TOYS (U.S. CLS. 22, 23, 38 AND 50).

FIRST USE 10-13-2010; IN COMMERCE 10-13-2010.

3,956,068. INNOVATION VENTURES, LLC, FARMINGTON HILLS, MI. SN 85-085,504. PUB. 12-21-2010, FILED 7-15-2010.

2:30 FEELING

THE MARK CONSISTS OF STANDARD CHARACTERS WITHOUT CLAIM TO ANY PARTICULAR FONT, STYLE, SIZE, OR COLOR.

**CLASS 5—PHARMACEUTICALS**

FOR DIETARY SUPPLEMENTS (U.S. CLS. 6, 18, 44, 46, 51 AND 52).  
FIRST USE 1-0-2010; IN COMMERCE 1-0-2010.

**CLASS 32—LIGHT BEVERAGES**

FOR NON-ALCOHOLIC DRINKS, NAMELY, ENERGY SHOTS (U.S. CLS. 45, 46 AND 48).  
FIRST USE 1-0-2010; IN COMMERCE 1-0-2010.

---

3,956,080. HOAG MEMORIAL HOSPITAL PRESBYTERIAN, NEWPORT BEACH, CA. SN 85-095,354. PUB. 12-14-2010, FILED 7-28-2010.

**HOAG FOR LIFE**

THE MARK CONSISTS OF STANDARD CHARACTERS WITHOUT CLAIM TO ANY PARTICULAR FONT, STYLE, SIZE, OR COLOR.

OWNER OF U.S. REG. NO. 1,977,913.

**CLASS 41—EDUCATION AND ENTERTAINMENT**

FOR COMMUNITY HEALTH EDUCATION SERVICES, NAMELY, CONDUCTING SEMINARS, LECTURES AND EDUCATIONAL MEETINGS IN THE FIELDS OF MEDICINE AND RESEARCH AND DISTRIBUTING EDUCATIONAL MATERIALS IN CONNECTION THEREWITH; DEVELOPMENT AND DISSEMINATION OF EDUCATIONAL MATERIALS FOR OTHERS IN THE FIELD OF MEDICINE (U.S. CLS. 100, 101 AND 107).  
FIRST USE 8-16-2010; IN COMMERCE 8-16-2010.

**CLASS 44—MEDICAL, BEAUTY AND AGRICULTURAL SERVICES**

FOR HOSPITAL AND MEDICAL SERVICES PROVIDING INPATIENT AND OUTPATIENT TREATMENT IN THE AREAS OF CANCER, HEART AND VASCULAR, NEUROSCIENCES, ORTHOPEDICS, WOMEN'S HEALTH AND MATERNAL CHILD SERVICES, EMERGENCY MEDICINE, DIABETES, PULMONARY, CHEMICAL DEPENDENCY INCLUDING TREATMENT AND RECOVERY, MEDICAL RADIOLOGY AND MEDICAL IMAGING (U.S. CLS. 100 AND 101).

FIRST USE 8-16-2010; IN COMMERCE 8-16-2010.

---

3,956,084. GALLERYTOPIA LLC, NASHVILLE, TN. SN 85-099,266. PUB. 1-11-2011, FILED 8-3-2010.

**GALLERYTOPIA**

THE MARK CONSISTS OF STANDARD CHARACTERS WITHOUT CLAIM TO ANY PARTICULAR FONT, STYLE, SIZE, OR COLOR.

**CLASS 39—TRANSPORTATION AND STORAGE**

FOR PROVIDING A WEB SITE FOR THE ELECTRONIC STORAGE OF DIGITAL IMAGES (U.S. CLS. 100 AND 105).  
FIRST USE 9-18-2010; IN COMMERCE 9-18-2010.

**CLASS 42—SCIENTIFIC AND COMPUTER SERVICES**

FOR COMPUTER SERVICES, NAMELY, HOSTING AND MAINTAINING AN ONLINE WEB SITE FOR OTHERS TO PROVIDE ACCESS TO USERS' WEB SITES THAT ARE OPTIMIZED FOR VIEWING BY MOBILE DEVICE USERS (U.S. CLS. 100 AND 101).  
FIRST USE 9-18-2010; IN COMMERCE 9-18-2010.

---

3,956,096. PICO PLATA AVV, LIMITED, CORAL GABLES, FL. SN 85-975,128. PUB. 10-19-2010, FILED 4-27-2010.

**YOGURFIT**

THE MARK CONSISTS OF STANDARD CHARACTERS WITHOUT CLAIM TO ANY PARTICULAR FONT, STYLE, SIZE, OR COLOR.

**CLASS 30—STAPLE FOODS**

FOR FROZEN DAIRY DESSERTS, NAMELY, ICE CREAMS; FROZEN YOGURT AND SORBET COMBINED WITH FRUITS, NUTS, CEREALS, SHAVED ICE, RICE CAKES AND CONFECTIONARIES, NAMELY, CANDIES (U.S. CL. 46).  
FIRST USE 1-14-2011; IN COMMERCE 1-14-2011.

**CLASS 35—ADVERTISING AND BUSINESS**

FOR RETAIL BAKERY SHOPS; TAKE-OUT BAKERY SERVICES; RETAIL STORE SERVICES FEATURING YOGURT; RETAIL STORE SERVICES FEATURING ICE CREAM (U.S. CLS. 100, 101 AND 102).  
FIRST USE 1-14-2011; IN COMMERCE 1-14-2011.

**CLASS 43—HOTEL AND RESTAURANT SERVICES**

FOR RESTAURANT SERVICES; RESTAURANTS; TAKE-OUT RESTAURANT SERVICES; CAFES; CAFE-RESTAURANTS; FAST-FOOD RESTAURANTS (U.S. CLS. 100 AND 101).  
FIRST USE 1-14-2011; IN COMMERCE 1-14-2011.

---

3,956,098. DSW SHOE WAREHOUSE, INC., COLUMBUS, OH. SN 85-975,144. PUB. 7-27-2010, FILED 4-14-2010.

**LEVITY**

THE MARK CONSISTS OF STANDARD CHARACTERS WITHOUT CLAIM TO ANY PARTICULAR FONT, STYLE, SIZE, OR COLOR.

**CLASS 25—CLOTHING**

FOR ATHLETIC SHOES; BOOTS; CLOGS; FOOTWEAR;  
OVERSHOES; SANDALS; SHOES; SLIPPERS (U.S. CLS.  
22 AND 39).  
FIRST USE 2-1-2011; IN COMMERCE 2-1-2011.

**CLASS 35—ADVERTISING AND BUSINESS**

FOR RETAIL STORE SERVICES FEATURING SHOES  
(U.S. CLS. 100, 101 AND 102).  
FIRST USE 2-1-2011; IN COMMERCE 2-1-2011.

\* \* \* \* \*



## SECTION 2.— INTERNATIONAL CLASSIFICATION

The short titles associated below with the international class numbers are terms designed merely for quick identification and are not an official part of the international classification. The full names of international classes are given in section 6.1 of the trademark rules of practice.

The designation "U.S. Cl." appearing in this section refers to the U.S. class in effect prior to Sep. 1, 1973 rather than the international class which applies to applications filed on or after that date. For adoption of international classification see notice in the OFFICIAL GAZETTE of Jun. 26, 1973 (911 O.G. TM 210).

### Application in one class

#### CLASS 1—CHEMICALS

3,955,160. MILLER CHEMICAL & FERTILIZER CORPORATION, HANOVER, PA. SN 76-695,481. PUB. 5-19-2009, FILED 1-28-2009.

#### CLASS 1—(Continued).

3,955,192. GOGO GREEN, LLC, MEMPHIS, TN. SN 77-219,653. PUB. 12-11-2007, FILED 6-29-2007.

# CAL-XPRESS

THE MARK CONSISTS OF STANDARD CHARACTERS WITHOUT CLAIM TO ANY PARTICULAR FONT, STYLE, SIZE, OR COLOR.

OWNER OF U.S. REG. NO. 3,048,352.  
FOR FERTILIZERS CONTAINING MICRONUTRIENTS (U.S. CLS. 1, 5, 6, 10, 26 AND 46).  
FIRST USE 1-9-2009; IN COMMERCE 1-9-2009.

# Poopular Products

THE MARK CONSISTS OF STANDARD CHARACTERS WITHOUT CLAIM TO ANY PARTICULAR FONT, STYLE, SIZE, OR COLOR.

NO CLAIM IS MADE TO THE EXCLUSIVE RIGHT TO USE "PRODUCTS", APART FROM THE MARK AS SHOWN.  
FOR MANURE; FERTILIZERS (U.S. CLS. 1, 5, 6, 10, 26 AND 46).  
FIRST USE 8-30-2010; IN COMMERCE 8-30-2010.

3,955,169. BLUEWATER CHEMGROUP, INC., BRADENTON BEACH, FL. SN 76-703,811. PUB. 12-21-2010, FILED 7-16-2010.

# MUCK DOCTOR

THE MARK CONSISTS OF STANDARD CHARACTERS WITHOUT CLAIM TO ANY PARTICULAR FONT, STYLE, SIZE, OR COLOR.

FOR BIOLOGICALLY ACTIVE ENZYMES AND MICROORGANISMS FOR TREATING ORGANIC MATTER IN LAKES AND PONDS (U.S. CLS. 1, 5, 6, 10, 26 AND 46).  
FIRST USE 8-1-2010; IN COMMERCE 8-1-2010.

3,955,249. FRANTZ COMPANY, INC., BUTLER, WI. SN 77-560,075. PUB. 7-14-2009, FILED 9-2-2008.

# ICE-TRAX

THE MARK CONSISTS OF STANDARD CHARACTERS WITHOUT CLAIM TO ANY PARTICULAR FONT, STYLE, SIZE, OR COLOR.

NO CLAIM IS MADE TO THE EXCLUSIVE RIGHT TO USE "ICE", APART FROM THE MARK AS SHOWN.  
FOR CHEMICAL PREPARATIONS FOR MELTING SNOW AND ICE; ROCK SALT (U.S. CLS. 1, 5, 6, 10, 26 AND 46).  
FIRST USE 11-1-2008; IN COMMERCE 11-1-2008.

**CLASS 1—(Continued).**

3,955,297. HENKEL CORPORATION, ROCKY HILL, CT. SN 77-669,360. PUB. 1-19-2010, FILED 2-12-2009.

**PRODUCER-PLUS**

THE MARK CONSISTS OF STANDARD CHARACTERS WITHOUT CLAIM TO ANY PARTICULAR FONT, STYLE, SIZE, OR COLOR.

OWNER OF U.S. REG. NO. 1,222,238.  
FOR ADHESIVES FOR INDUSTRIAL USE (U.S. CLS. 1, 5, 6, 10, 26 AND 46).  
FIRST USE 6-3-2010; IN COMMERCE 6-3-2010.

**CLASS 1—(Continued).**

3,955,634. TNEMEC COMPANY, INC., KANSAS CITY, MO. SN 77-924,959. PUB. 6-22-2010, FILED 2-1-2010.

**HYDROLINK**

THE MARK CONSISTS OF STANDARD CHARACTERS WITHOUT CLAIM TO ANY PARTICULAR FONT, STYLE, SIZE, OR COLOR.

OWNER OF U.S. REG. NO. 2,972,259.  
FOR CHEMICAL COMPOUNDS USED AS AN INGREDIENT OF PAINT FOR CURING PAINT (U.S. CLS. 1, 5, 6, 10, 26 AND 46).  
FIRST USE 9-30-2003; IN COMMERCE 9-30-2003.

3,955,341. AMERICAN BILTRITE INC., WELLESLEY HILLS, MA. SN 77-752,193. PUB. 12-8-2009, FILED 6-4-2009.

**LASERRITE**

THE MARK CONSISTS OF STANDARD CHARACTERS WITHOUT CLAIM TO ANY PARTICULAR FONT, STYLE, SIZE, OR COLOR.

FOR PROTECTIVE FILMS, IN THE NATURE OF COATINGS, USED IN THE MANUFACTURE OF STAINLESS STEEL (U.S. CLS. 1, 5, 6, 10, 26 AND 46).  
FIRST USE 5-3-2010; IN COMMERCE 5-3-2010.

3,955,747. CARL FREUDENBERG KG, D-69469 WEINHEIM, FED REP GERMANY. SN 77-945,361. PUB. 7-27-2010, FILED 2-25-2010.

**PURTEX**

THE MARK CONSISTS OF STANDARD CHARACTERS WITHOUT CLAIM TO ANY PARTICULAR FONT, STYLE, SIZE, OR COLOR.

FOR CHEMICAL AGENTS IN LIQUID OR PASTY CONSISTENCY FOR IMPREGNATING, BINDING, OR COATING OF TEXTILES (U.S. CLS. 1, 5, 6, 10, 26 AND 46).  
FIRST USE 2-14-2011; IN COMMERCE 2-14-2011.

3,955,435. TAKARA BIO INC., OTSU CITY, SHIGA, JAPAN. SN 77-822,366. PUB. 2-2-2010, FILED 9-9-2009.

**EPISCOPE**

THE MARK CONSISTS OF STANDARD CHARACTERS WITHOUT CLAIM TO ANY PARTICULAR FONT, STYLE, SIZE, OR COLOR.

FOR REAGENTS FOR SCIENTIFIC RESEARCH USE (U.S. CLS. 1, 5, 6, 10, 26 AND 46).  
FIRST USE 1-25-2010; IN COMMERCE 2-15-2011.

3,955,919. CHEMENCE, INC., ALPHARETTA, GA. SN 85-012,643. PUB. 9-14-2010, FILED 4-13-2010.

**Perma-Lock**

THE MARK CONSISTS OF STANDARD CHARACTERS WITHOUT CLAIM TO ANY PARTICULAR FONT, STYLE, SIZE, OR COLOR.

FOR ADHESIVES FOR AUTOMOTIVE AFTERMARKET (U.S. CLS. 1, 5, 6, 10, 26 AND 46).  
FIRST USE 1-14-2011; IN COMMERCE 1-14-2011.

**CLASS 1—(Continued).**

3,955,935. INNOVATIVE SURFACE TECHNOLOGIES, INC., ST. PAUL, MN. SN 85-017,749. PUB. 11-30-2010, FILED 4-19-2010.

---

# ISURLITE

THE MARK CONSISTS OF STANDARD CHARACTERS WITHOUT CLAIM TO ANY PARTICULAR FONT, STYLE, SIZE, OR COLOR.

OWNER OF U.S. REG. NOS. 3,083,846 AND 3,473,200.  
FOR PHOTOREACTIVE CHEMICAL REAGENTS FOR SCIENTIFIC AND MEDICAL RESEARCH USE; PHOTOREACTIVE CHEMICAL REAGENTS FOR USE IN THE MANUFACTURE OF MEDICAL DEVICES, NAMELY, PHOTOREACTIVE CHEMICAL REAGENTS FOR USE IN COATING MEDICAL DEVICES, SOLD SEPARATELY FROM THE MEDICAL DEVICES (U.S. CLS. 1, 5, 6, 10, 26 AND 46).

FIRST USE 10-4-2010; IN COMMERCE 10-4-2010.

---

3,955,979. EUROMED USA INC, PRESTO, PA. SN 85-037,738. PUB. 11-2-2010, FILED 5-13-2010.

---

# SPET-085

THE MARK CONSISTS OF STANDARD CHARACTERS WITHOUT CLAIM TO ANY PARTICULAR FONT, STYLE, SIZE, OR COLOR.

FOR BOTANICAL EXTRACT USED AS AN INGREDIENT IN THE MANUFACTURE OF FOODS, PHARMACEUTICALS, NUTRITIONAL SUPPLEMENTS AND COSMETICS (U.S. CLS. 1, 5, 6, 10, 26 AND 46).

FIRST USE 10-1-2010; IN COMMERCE 10-1-2010.

**CLASS 2—PAINTS**

3,955,433. DUNN-EDWARDS CORPORATION, LOS ANGELES, CA. SN 77-821,511. PUB. 7-27-2010, FILED 9-8-2009.

---

# SPARTAWALL

THE MARK CONSISTS OF STANDARD CHARACTERS WITHOUT CLAIM TO ANY PARTICULAR FONT, STYLE, SIZE, OR COLOR.

**CLASS 2—(Continued).**

OWNER OF U.S. REG. NOS. 2,562,410, 2,568,222, AND OTHERS.

FOR INTERIOR PAINTS; ARCHITECTURAL PROTECTIVE AND DECORATIVE COATINGS (U.S. CLS. 6, 11 AND 16).

FIRST USE 9-8-2009; IN COMMERCE 12-8-2010.

---

3,955,571. EVERLAST CLIMBING INDUSTRIES, INC., CHATTANOOGA, TN. SN 77-900,319. PUB. 6-22-2010, FILED 12-23-2009.

---

# SPECTRA SHIELD

THE MARK CONSISTS OF STANDARD CHARACTERS WITHOUT CLAIM TO ANY PARTICULAR FONT, STYLE, SIZE, OR COLOR.

FOR CORROSION INHIBITANTS IN THE NATURE OF A COATING FOR USE ON STAINLESS STEEL IN OR NEAR A POOL ENVIRONMENT (U.S. CLS. 6, 11 AND 16).

FIRST USE 1-1-2010; IN COMMERCE 1-1-2010.

---

3,955,586. MEGOLA INC., POINT EDWARD, ONTARIO, CANADA. SN 77-908,851. PUB. 11-30-2010, FILED 1-11-2010.

---

# HARTINDO ANTI-FIRE

THE MARK CONSISTS OF STANDARD CHARACTERS WITHOUT CLAIM TO ANY PARTICULAR FONT, STYLE, SIZE, OR COLOR.

NO CLAIM IS MADE TO THE EXCLUSIVE RIGHT TO USE "ANTI-FIRE", APART FROM THE MARK AS SHOWN. FOR FIRE RETARDANT CHEMICAL FORMULATIONS APPLIED AS COATINGS TO MANUFACTURED GOODS (U.S. CLS. 6, 11 AND 16).

FIRST USE 1-1-2011; IN COMMERCE 1-1-2011.

**CLASS 3—COSMETICS AND CLEANING PREPARATIONS**

**CLASS 3—(Continued).**

3,955,173. SUN PRODUCTS CORPORATION, THE, WILTON, CT. SN 77-039,847. PUB. 12-4-2007, FILED 11-8-2006.

**SUNSATIONAL SCENTS**

THE MARK CONSISTS OF STANDARD CHARACTERS WITHOUT CLAIM TO ANY PARTICULAR FONT, STYLE, SIZE, OR COLOR.

OWNER OF U.S. REG. NO. 2,714,500.

NO CLAIM IS MADE TO THE EXCLUSIVE RIGHT TO USE "SCENTS", APART FROM THE MARK AS SHOWN.

FOR LAUNDRY DETERGENTS, LIQUID LAUNDRY DETERGENTS, POWDERED LAUNDRY DETERGENTS, DISH DETERGENTS, LIQUID DISH DETERGENTS, POWDERED DISH DETERGENTS, LIQUID AUTOMATIC DISH DETERGENTS, POWDERED AUTOMATIC DISH DETERGENTS, FABRIC SOFTENERS, LIQUID FABRIC SOFTENERS (U.S. CLS. 1, 4, 6, 50, 51 AND 52).  
FIRST USE 4-0-2007; IN COMMERCE 4-0-2007.

3,955,174. ADVANCED BEAUTY SYSTEMS, INC, DALLAS, TX. SN 77-054,733. PUB. 12-25-2007, FILED 12-1-2006.

**AQUATION**

THE MARK CONSISTS OF STANDARD CHARACTERS WITHOUT CLAIM TO ANY PARTICULAR FONT, STYLE, SIZE, OR COLOR.

FOR SKIN MOISTURIZING LOTIONS AND BATH SOAP (U.S. CLS. 1, 4, 6, 50, 51 AND 52).

FIRST USE 1-0-2011; IN COMMERCE 1-0-2011.

3,955,191. FRESH PURE DELICIOUS L.L.C., PLYMOUTH, MI. SN 77-203,532. PUB. 11-13-2007, FILED 6-12-2007.



NO CLAIM IS MADE TO THE EXCLUSIVE RIGHT TO USE "PURE", APART FROM THE MARK AS SHOWN.

THE MARK CONSISTS OF THE WORD "PURE" WITH A HORIZONTAL HALO DIRECTLY ABOVE THE "U".

FOR COSMETICS (U.S. CLS. 1, 4, 6, 50, 51 AND 52).  
FIRST USE 8-31-2008; IN COMMERCE 3-27-2009.

**CLASS 3—(Continued).**

3,955,205. WEST CONSULTING INC., MEMPHIS, TN. SN 77-338,558. PUB. 4-29-2008, FILED 11-28-2007.

**OCEANICALS**

THE MARK CONSISTS OF STANDARD CHARACTERS WITHOUT CLAIM TO ANY PARTICULAR FONT, STYLE, SIZE, OR COLOR.

FOR BODY AND BEAUTY CARE COSMETICS; COSMETIC PREPARATIONS; COSMETIC PREPARATIONS FOR SKIN RENEWAL; COSMETICS AND COSMETIC PREPARATIONS; FACE CREAMS FOR COSMETIC USE; LOTIONS FOR COSMETIC PURPOSES; LOTIONS FOR FACE AND BODY CARE; NON-MEDICATED PREPARATIONS ALL FOR THE CARE OF SKIN, HAIR AND SCALP; NON-MEDICATED SKIN CARE PREPARATIONS, NAMELY, CREAMS, LOTIONS, GELS, TONERS, CLEANERS AND PEELS; NON-MEDICATED SKIN CREAMS; SKIN CONDITIONERS; SKIN CREAM; SKIN CREAMS; SKIN CREAMS IN LIQUID AND IN SOLID FORM; SKIN CREAMS IN LIQUID AND SOLID; SKIN CREAMS IN LIQUID AND SOLID FORM; SKIN EMOLLIENTS; SKIN LOTION; SKIN LOTIONS; SKIN MOISTURIZER; SKIN SOAP; SKIN TONERS; SOAPS FOR BODY CARE; SOAPS FOR PERSONAL USE; HAIR SHAMPOO (U.S. CLS. 1, 4, 6, 50, 51 AND 52).  
FIRST USE 11-28-2007; IN COMMERCE 12-15-2007.

3,955,219. MARC JACOBS TRADEMARKS LLC, NEW YORK, NY. SN 77-451,882. PUB. 9-9-2008, FILED 4-18-2008.



THE MARK CONSISTS OF STANDARD CHARACTERS WITHOUT CLAIM TO ANY PARTICULAR FONT, STYLE, SIZE, OR COLOR.

FOR HAIR CARE PREPARATIONS; NON-MEDICATED TOILETRIES (U.S. CLS. 1, 4, 6, 50, 51 AND 52).

FIRST USE 7-20-2010; IN COMMERCE 7-20-2010.

3,955,228. MANA PRODUCTS, INC., LONG ISLAND CITY, NY. SN 77-495,848. PUB. 5-5-2009, FILED 6-10-2008.

**BIO-BOOST COMPLEX**

THE MARK CONSISTS OF STANDARD CHARACTERS WITHOUT CLAIM TO ANY PARTICULAR FONT, STYLE, SIZE, OR COLOR.

**CLASS 3—(Continued).**

NO CLAIM IS MADE TO THE EXCLUSIVE RIGHT TO USE "COMPLEX", APART FROM THE MARK AS SHOWN.

FOR INGREDIENT COMPLEX SOLD AS AN INTEGRAL INGREDIENT OF COSMETICS, NON-MEDICATED SKIN CARE PREPARATIONS, AND NON-MEDICATED HAIR CARE PREPARATIONS; INGREDIENT COMPLEX SOLD AS AN INTEGRAL INGREDIENT OF NON-MEDICATED BODY CARE PREPARATIONS, NAMELY, COSMETIC PREPARATIONS FOR BODY CARE (U.S. CLS. 1, 4, 6, 50, 51 AND 52).

FIRST USE 9-30-2008; IN COMMERCE 9-30-2008.

**CLASS 3—(Continued).**

3,955,261. ALTICOR INC., ADA, MI. SN 77-606,235. PUB. 1-20-2009, FILED 11-3-2008.



THE MARK CONSISTS OF A LARGE OVAL SHAPE ON THE LEFT NEXT TO A SMALLER OVAL SHAPE ON THE RIGHT.

FOR ALL-PURPOSE CLEANING CONCENTRATE; HOUSEHOLD ENVIRONMENTAL CLEANING, BLEACHING, POLISHING, AIR FRESHENING COMPOSITIONS AND COMPOUNDS, NAMELY, CLEANING CONCENTRATES AND CLEANERS FOR GLASS, WINDOWS, COUNTERTOPS, BATHROOM SURFACES, SHOWER SURFACES, FLOORS; SOAPS IN LIQUID FORM FOR GLASS, COUNTERTOPS, BATHROOM SURFACES, SHOWER SURFACES; ABRASIVES AND POLISHING CLEANERS; LAUNDRY CARE PREPARATIONS, NAMELY, LAUNDRY DETERGENTS, LAUNDRY PRESOAK AND PREWASH AGENTS; FABRIC SOFTENERS AND BRIGHTENER, LAUNDRY BLEACHES, STAIN REMOVERS; DISH WASHING DETERGENTS; DISHWASHER DETERGENTS (U.S. CLS. 1, 4, 6, 50, 51 AND 52).

FIRST USE 9-1-2009; IN COMMERCE 9-1-2009.

3,955,229. BIOTANIKA USA, LLC, FT. LAUDERDALE, FL. SN 77-499,934. PUB. 4-7-2009, FILED 6-16-2008.



**COOLSENS**

THE MARK CONSISTS OF STANDARD CHARACTERS WITHOUT CLAIM TO ANY PARTICULAR FONT, STYLE, SIZE, OR COLOR.

FOR NON-MEDICATED SKIN CARE PREPARATIONS, NAMELY, HERBAL-BASED PREPARATIONS IN THE FORM OF GELS, CREAMS, OINTMENTS, LIQUIDS FOR HUMAN USE (U.S. CLS. 1, 4, 6, 50, 51 AND 52).

FIRST USE 5-4-2009; IN COMMERCE 5-4-2009.

3,955,298. SUMMIT ENTERTAINMENT, LLC, SANTA MONICA, CA. SN 77-671,086. PUB. 9-14-2010, FILED 2-16-2009.

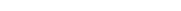

**TEAM JACOB**

THE MARK CONSISTS OF STANDARD CHARACTERS WITHOUT CLAIM TO ANY PARTICULAR FONT, STYLE, SIZE, OR COLOR.

FOR COSMETICS, NAMELY, EYE SHADOW, LIP GLOSS, MASCARA AND BLUSH (U.S. CLS. 1, 4, 6, 50, 51 AND 52).

FIRST USE 3-10-2010; IN COMMERCE 3-10-2010.

**CLASS 3—(Continued).**

3,955,309. DENA KARLIN, DEERFIELD BEACH, FL. AND VICKI KARLIN, DEERFIELD BEACH, FL. SN 77-686,254. PUB. 7-7-2009, FILED 3-9-2009.



NO CLAIM IS MADE TO THE EXCLUSIVE RIGHT TO USE "BOTANICALS", APART FROM THE MARK AS SHOWN.

THE COLOR(S) GREEN AND BROWN IS/ARE CLAIMED AS A FEATURE OF THE MARK.

THE MARK CONSISTS OF THE WORDING "NAYKED BOTANICALS", WITH "NAYKED" IN GREEN AND "BOTANICALS" IN BROWN. BETWEEN THE WORDS ARE A GREEN PROFILE OF A WOMAN WITH BROWN WAVY HAIR AND A GREEN PROFILE OF A MAN. THE WHITE IN THE MARK IS BACKGROUND AREA WHICH IS NOT A PART OF THE MARK.

FOR 3-IN-1 HAIR CONDITIONERS; 3-IN-1 HAIR SHAMPOOS; ANTIBACTERIAL SKIN SOAPS; AROMATHERAPY BODY CARE PRODUCTS, NAMELY, BODY LOTION, SHOWER GEL, CUTICLE CREAM, SHAMPOO, CONDITIONER, NON-MEDICATED LIP BALM, SOAP, BODY POLISH, BODY AND FOOT SCRUB AND NON-MEDICATED FOOT CREAM; AROMATHERAPY PILLOWS THAT MAY BE USED TO FRESHEN CLOTHING OR LAY OVER THE EYES; BABY HAIR CONDITIONER; BEAUTY CREAMS FOR BODY CARE; BODY AND BEAUTY CARE COSMETICS; CONCEALERS FOR FACE, BODY; CONDITIONERS; COSMETIC CREAMS FOR SKIN CARE; COSMETIC FACIAL BLOT-TING PAPERS; COSMETIC HAIR REGROWTH INHIBITING PREPARATIONS; COSMETIC OLIVE OIL FOR THE FACE AND BODY; COSMETIC PREPARATIONS FOR BODY CARE; COSMETIC PREPARATIONS FOR EYE LASHES; COSMETIC PREPARATIONS FOR SKIN RENEWAL; CREAMY FACE POWDER; DEODORANTS FOR BODY CARE; EXFOLIANT CREAMS; EXFOLIANTS FOR SKIN, FACE, BODY, HAIR, HANDS, FEET; EYE COMPRESSES FOR COSMETIC PURPOSES; EYE CREAM; EYE GELS; EYE LOTIONS; EYE MAKE-UP; FACE AND BODY BEAUTY CREAMS; FACE AND BODY CREAMS; FACE AND BODY GLITTER; FACE AND BODY LOTIONS; FACE AND BODY MILK; FACE CREAMS; FACE CREAMS AND CLEANSERS CONTAINING BENZOYL PEROXIDE FOR COSMETIC PURPOSES; FACE CREAMS FOR COSMETIC USE; FACE GLITTER; FACE MILK AND LOTIONS; FACE POWDER; FACIAL BEAUTY MASKS; FACIAL CLEANSERS; FACIAL CLEANSING GRAINS; FACIAL CLEANSING MILK; FACIAL CONCEALER; FACIAL CREAM; FACIAL CREAMS; FACIAL EMULSIONS; FACIAL LOTION; FACIAL MAKE-UP; FACIAL MASKS; FACIAL SCRUBS; FACIAL WASHES; FOOT SCRUBS; GEL EYE MASKS; HAIR CARE LOTIONS; HAIR CARE PREPARATIONS; HAIR CARE PREPARATIONS CONSISTING OF ORGANIC COCONUT VIRGIN OIL AND COCONUT VIRGIN OIL; HAIR CONDITIONER; HAIR CONDITIONERS; HAIR CONDITIONERS FOR BABIES; HAIR GEL; HAIR GEL AND HAIR MOUSSE; HAIR GELS; HAIR MOUSSE; HAIR NOURISHERS; HAIR OILS; HAIR RINSES; HAIR SHAMPOO; HAIR SHAMPOOS AND CONDITIONERS; HAIR SPRAYS AND HAIR GELS; HAND CLEANERS; HAND CLEANING PREPARATIONS; HAND CREAM; HAND CREAMS; HAND LOTIONS; HAND SCRUBS; HAND SOAPS; LIQUID SOAP USED IN FOOT BATH; LIQUID SOAPS FOR HANDS AND FACE; LIQUID SOAPS FOR HANDS, FACE AND BODY; LOOSE FACE POWDER; LOTIONS FOR FACE AND BODY CARE; LOTIONS FOR SKIN, FACE, BODY, HAIR, HANDS,

**CLASS 3—(Continued).**

FEET; MAKE-UP FOR THE FACE AND BODY; MOUSSE FOR HAND FOOT CREAMS, LOTION, EXFOLIATION; NON-MEDICATED COSMETIC SKIN CARE PREPARATIONS CONSISTING OF ORGANIC COCONUT VIRGIN OIL AND COCONUT VIRGIN OIL; NON-MEDICATED FOOT CREAM; NON-MEDICATED FOOT LOTIONS; NON-MEDICATED FOOT SOAKS; NON-MEDICATED HAIR RESTORATION LOTIONS; NON-MEDICATED HAIR TREATMENT PREPARATIONS FOR COSMETIC PURPOSES; NON-MEDICATED LIP CARE PREPARATIONS; NON-MEDICATED PREPARATIONS ALL FOR THE CARE OF SKIN, HAIR AND SCALP; NON-MEDICATED SKIN CARE PREPARATION, NAMELY, BODY MIST; NON-MEDICATED SKIN CARE PREPARATIONS; NON-MEDICATED SKIN CARE PREPARATIONS, NAMELY, CREAMS, LOTIONS, GELS, TONERS, CLEANSERS AND PEELS; NON-MEDICATED SKIN CREAMS; NON-MEDICATED STIMULATING LOTIONS FOR THE SKIN; NON-MEDICATED SUN CARE PREPARATIONS; OIL BATHS FOR HAIR CARE; OILS FOR HAIR CONDITIONING; SKIN ABRASIVE PREPARATIONS; SKIN AND BODY TOPICAL LOTIONS, CREAMS AND OILS FOR COSMETIC USE; SKIN BRONZING CREAMS; SKIN CARE PREPARATION, NAMELY, BODY POLISH; SKIN CARE PREPARATIONS, NAMELY, CHEMICAL PEELS FOR SKIN; SKIN CARE PREPARATIONS, NAMELY, FRUIT ACID PEELS FOR SKIN; SKIN CARE PREPARATIONS, NAMELY, BODY BALM; SKIN CARE PRODUCTS, NAMELY, NON-MEDICATED SKIN SERUM; SKIN CLARIFIERS; SKIN CLEANSERS; SKIN CLEANSING CREAM; SKIN CLEANSING LOTION; SKIN CONDITIONERS; SKIN CONDITIONING CREAMS FOR COSMETIC PURPOSES; SKIN CREAM; SKIN CREAMS; SKIN CREAMS IN LIQUID AND IN SOLID FORM; SKIN CREAMS IN LIQUID AND SOLID; SKIN CREAMS IN LIQUID AND SOLID FORM; SKIN EMOLLIENTS; SKIN FRESHENERS; SKIN GELS FOR ACCELERATING, ENHANCING OR EXTENDING TANS; SKIN LIGHTENERS; SKIN LIGHTENING CREAMS; SKIN LOTION; SKIN LOTIONS; SKIN MASKS; SKIN MOISTURIZER; SKIN MOISTURIZER MASKS; SKIN POLISHING RICE BRAN (ARAI-NUKA); SKIN SOAP; SKIN TEXTURIZERS; SKIN TONERS; SKIN WHITENING CREAMS; SOAPS FOR BODY CARE; SUN CARE LOTIONS; TONING LOTION, FOR THE FACE, BODY AND HANDS; TOPICAL SKIN SPRAYS FOR COSMETIC PURPOSES; UNDER-EYE ENHANCERS; WIPES IMPREGNATED WITH A SKIN CLEANSER; WRINKLE REMOVING SKIN CARE PREPARATIONS; WRINKLE-MINIMIZING COSMETIC PREPARATIONS FOR TOPICAL FACIAL USE (U.S. CLS. 1, 4, 6, 50, 51 AND 52).

FIRST USE 10-1-2009; IN COMMERCE 10-1-2009.

3,955,324. AUSTRALIAN GOLD, LLC, INDIANAPOLIS, IN. SN 77-713,099. PUB. 6-22-2010, FILED 4-14-2009.

**SIENNA SUNSET**

THE MARK CONSISTS OF STANDARD CHARACTERS WITHOUT CLAIM TO ANY PARTICULAR FONT, STYLE, SIZE, OR COLOR.

FOR SKIN CARE PREPARATIONS, NAMELY, NON-MEDICATED INDOOR AND OUTDOOR SKIN TANNING PREPARATIONS (U.S. CLS. 1, 4, 6, 50, 51 AND 52). FIRST USE 11-1-2010; IN COMMERCE 11-1-2010.

**CLASS 3—(Continued).**

3,955,340. BGK TRADEMARK HOLDINGS, LLC, NEW YORK, NY. SN 77-751,292. PUB. 6-22-2010, FILED 6-3-2009.

# BEYONCÉ HEAT

THE MARK CONSISTS OF STANDARD CHARACTERS WITHOUT CLAIM TO ANY PARTICULAR FONT, STYLE, SIZE, OR COLOR.

THE NAME(S), PORTRAIT(S), AND/OR SIGNATURE(S) SHOWN IN THE MARK IDENTIFIES BEYONCÉ KNOWLES, WHOSE CONSENT(S) TO REGISTER IS MADE OF RECORD.

FOR PERFUMERY, ESSENTIAL OILS, SOAPS, COSMETICS, AND HAIR LOTIONS (U.S. CLS. 1, 4, 6, 50, 51 AND 52).

FIRST USE 1-31-2010; IN COMMERCE 1-31-2010.

3,955,347. ISHKARA LLC, SANTA MONICA, CA. SN 77-763,435. PUB. 12-8-2009, FILED 6-18-2009.

# NEFER

THE MARK CONSISTS OF STANDARD CHARACTERS WITHOUT CLAIM TO ANY PARTICULAR FONT, STYLE, SIZE, OR COLOR.

THE ENGLISH TRANSLATION OF THE WORD "NEFER" IN THE MARK IS TO CONVEY GOODNESS AND BEAUTY AS WELL AS THE SENSE OF HAPPINESS, GOOD FORTUNE, AND YOUTH.

FOR BODY AND BEAUTY CARE COSMETICS; COSMETIC OILS; COSMETIC OILS FOR THE EPIDERMIS; COSMETIC PREPARATIONS; COSMETIC PREPARATIONS FOR BODY CARE; COSMETIC PREPARATIONS FOR SKIN RENEWAL; COSMETICS; COSMETICS AND COSMETIC PREPARATIONS, COSMETICS IN GENERAL, INCLUDING PERFUMES; OILS FOR COSMETIC PURPOSES; PRIVATE LABEL COSMETICS; ROSE OIL FOR COSMETIC PURPOSES; WRINKLE-MINIMIZING COSMETIC PREPARATIONS FOR TOPICAL FACIAL USE (U.S. CLS. 1, 4, 6, 50, 51 AND 52).

FIRST USE 3-1-2011; IN COMMERCE 3-1-2011.

3,955,420. REGIS INC., MINNEAPOLIS, MN. SN 77-817,389. PUB. 7-20-2010, FILED 9-1-2009.

# TEXTURE TOUSLE

THE MARK CONSISTS OF STANDARD CHARACTERS WITHOUT CLAIM TO ANY PARTICULAR FONT, STYLE, SIZE, OR COLOR.

**CLASS 3—(Continued).**

NO CLAIM IS MADE TO THE EXCLUSIVE RIGHT TO USE "TEXTURE", APART FROM THE MARK AS SHOWN.

FOR HAIR STYLING SPRAY (U.S. CLS. 1, 4, 6, 50, 51 AND 52).

FIRST USE 3-0-2010; IN COMMERCE 3-0-2010.

3,955,423. TERI AMATO, BAYSIDE, NY. SN 77-818,530. PUB. 8-17-2010, FILED 9-2-2009.

# BODY DESSERT

THE MARK CONSISTS OF STANDARD CHARACTERS WITHOUT CLAIM TO ANY PARTICULAR FONT, STYLE, SIZE, OR COLOR.

FOR EDIBLE SEXUAL ENHANCEMENT PREPARATIONS, NAMELY, MASSAGE LOTIONS (U.S. CLS. 1, 4, 6, 50, 51 AND 52).

FIRST USE 2-28-2010; IN COMMERCE 2-28-2010.

3,955,471. L'OREAL USA CREATIVE, INC., NEW YORK, NY. SN 77-847,248. PUB. 12-8-2009, FILED 10-13-2009.

# SHINE FLASH

THE MARK CONSISTS OF STANDARD CHARACTERS WITHOUT CLAIM TO ANY PARTICULAR FONT, STYLE, SIZE, OR COLOR.

OWNER OF U.S. REG. NO. 3,102,097.

NO CLAIM IS MADE TO THE EXCLUSIVE RIGHT TO USE "SHINE", APART FROM THE MARK AS SHOWN.

FOR HAIR STYLING PREPARATION (U.S. CLS. 1, 4, 6, 50, 51 AND 52).

FIRST USE 2-0-2011; IN COMMERCE 2-0-2011.

3,955,479. EGLOBAL BEAUTE, INC., INDUSTRY, CA. SN 77-852,174. PUB. 7-13-2010, FILED 10-19-2009.

# KARÉNE PARIS

THE MARK CONSISTS OF STANDARD CHARACTERS WITHOUT CLAIM TO ANY PARTICULAR FONT, STYLE, SIZE, OR COLOR.

NO CLAIM IS MADE TO THE EXCLUSIVE RIGHT TO USE "PARIS", APART FROM THE MARK AS SHOWN.

**CLASS 3—(Continued).**

THE NAME(S), PORTRAIT(S), AND/OR SIGNATURE(S) SHOWN IN THE MARK DOES NOT IDENTIFY A PARTICULAR LIVING INDIVIDUAL.

FOR NON-MEDICATED SKIN CARE PRODUCTS, NAMELY, LOTIONS, CLEANERS AND CREAMS; AROMATHERAPY OILS; ESSENTIAL OILS; NON-MEDICATED BODY CARE PRODUCTS, NAMELY, LOTIONS, CLEANERS AND CREAMS; HAIR SHAMPOO; COSMETICS (U.S. CLS. 1, 4, 6, 50, 51 AND 52).

FIRST USE 9-1-2010; IN COMMERCE 9-1-2010.

---

3,955,481. NICOLE MULDER, INC., DBA EPITOME SKINCARE, EDEN PRAIRIE, MN. SN 77-852,894. PUB. 5-18-2010, FILED 10-20-2009.

# Epitome

THE MARK CONSISTS OF STANDARD CHARACTERS WITHOUT CLAIM TO ANY PARTICULAR FONT, STYLE, SIZE, OR COLOR.

FOR COSMETICS, NAMELY, LIP GLOSS, LIP BALM, MASCARA; AND SKINCARE PRODUCTS, NAMELY, MOISTURIZING CREAMS, LOTIONS, AND BALMS, EXFOLIANTS, CLEANSING CREAMS, AND NON-MEDICATED FACIAL TREATMENT SERUMS (U.S. CLS. 1, 4, 6, 50, 51 AND 52).

FIRST USE 3-5-2010; IN COMMERCE 2-15-2011.

---

3,955,537. YZY INC, MIAMI, FL. SN 77-880,633. PUB. 4-13-2010, FILED 11-25-2009.

# ROSALINDA

THE MARK CONSISTS OF STANDARD CHARACTERS WITHOUT CLAIM TO ANY PARTICULAR FONT, STYLE, SIZE, OR COLOR.

FOR COLOGNES, PERFUMES AND COSMETICS; EAU DE TOILETTE AND EAU DE COLOGNE; PERFUMES, AFTERSHAVES AND COLOGNES; PERFUMES, EAU DE COLOGNES AND AFTERSHAVES (U.S. CLS. 1, 4, 6, 50, 51 AND 52).

FIRST USE 8-31-2010; IN COMMERCE 8-31-2010.

**CLASS 3—(Continued).**

3,955,556. YZY INC, MIAMI, FL. SN 77-889,265. PUB. 4-13-2010, FILED 12-9-2009.

# TENDER MOOD

THE MARK CONSISTS OF STANDARD CHARACTERS WITHOUT CLAIM TO ANY PARTICULAR FONT, STYLE, SIZE, OR COLOR.

FOR EAU DE PERFUME; EAU DE TOILETTE AND EAU DE COLOGNE; PERFUMES, EAU DE COLOGNES AND AFTERSHAVES (U.S. CLS. 1, 4, 6, 50, 51 AND 52).

FIRST USE 8-20-2009; IN COMMERCE 8-20-2009.

---

3,955,557. YZY INC, MIAMI, FL. SN 77-889,273. PUB. 4-13-2010, FILED 12-9-2009.

# SKIPPER

THE MARK CONSISTS OF STANDARD CHARACTERS WITHOUT CLAIM TO ANY PARTICULAR FONT, STYLE, SIZE, OR COLOR.

FOR EAU DE PERFUME; EAU DE TOILETTE AND EAU DE COLOGNE; PERFUMES, EAU DE COLOGNES AND AFTERSHAVES (U.S. CLS. 1, 4, 6, 50, 51 AND 52).

FIRST USE 8-20-2009; IN COMMERCE 8-20-2009.

---

3,955,608. AVON PRODUCTS, INC., NEW YORK, NY. SN 77-916,726. PUB. 6-15-2010, FILED 1-21-2010.



super extend

THE MARK CONSISTS OF THE WORDING "SUPER-EXTEND" WRITTEN IN A STYLIZED FONT WITH A WAVY LINE CROSSING THE LETTER "X".

FOR MASCARA (U.S. CLS. 1, 4, 6, 50, 51 AND 52).

FIRST USE 2-4-2010; IN COMMERCE 2-4-2010.



**CLASS 3—(Continued).**

3,955,611. PURE & NATURAL COMPANY, SCOTTSDALE, AZ. SN 77-917,664. PUB. 4-27-2010, FILED 1-22-2010.

**FRESH SNOW**

THE MARK CONSISTS OF STANDARD CHARACTERS WITHOUT CLAIM TO ANY PARTICULAR FONT, STYLE, SIZE, OR COLOR.

FOR ANTIBACTERIAL SOAP; HAND SOAPS; LIQUID SOAPS; SOAPS FOR PERSONAL USE (U.S. CLS. 1, 4, 6, 50, 51 AND 52).

FIRST USE 10-1-2010; IN COMMERCE 10-1-2010.

---

3,955,615. DERAMUS, GINA LYNN, EUCLID, OH. SN 77-918,722. PUB. 6-8-2010, FILED 1-23-2010.



THE MARK CONSISTS OF A STYLIZED SILHOUETTE OF THE PROFILE OF A WOMAN'S HEAD AND NECK.

FOR PERFUMES AND COLOGNES (U.S. CLS. 1, 4, 6, 50, 51 AND 52).

FIRST USE 6-1-2010; IN COMMERCE 6-1-2010.

---

3,955,616. SHISEIDO COMPANY, LIMITED, TOKYO 104-8010, JAPAN. SN 77-919,176. PUB. 8-3-2010, FILED 1-25-2010.

**SHIMMERING ROUGE**

THE MARK CONSISTS OF STANDARD CHARACTERS WITHOUT CLAIM TO ANY PARTICULAR FONT, STYLE, SIZE, OR COLOR.

NO CLAIM IS MADE TO THE EXCLUSIVE RIGHT TO USE "ROUGE", APART FROM THE MARK AS SHOWN.

FOR MAKE-UP PRODUCTS, NAMELY, COSMETICS (U.S. CLS. 1, 4, 6, 50, 51 AND 52).

FIRST USE 2-1-2011; IN COMMERCE 2-1-2011.

**CLASS 3—(Continued).**

3,955,624. UNILEVER PLC, MERSEYSIDE, ENGLAND. SN 77-921,717. PUB. 6-29-2010, FILED 1-27-2010.

**SLEEK MYSTIQUE**

THE MARK CONSISTS OF STANDARD CHARACTERS WITHOUT CLAIM TO ANY PARTICULAR FONT, STYLE, SIZE, OR COLOR.

FOR HAIR CARE PRODUCTS, NAMELY, SHAMPOOS, CONDITIONERS, HAIR SPRAYS, HAIR LACQUERS, HAIR GLAZES, HAIR LIQUID (U.S. CLS. 1, 4, 6, 50, 51 AND 52).

FIRST USE 9-0-2010; IN COMMERCE 9-0-2010.

---

3,955,697. BALLERINA FARMER, LLC, KALAMAZOO, MI. SN 77-935,525. PUB. 7-20-2010, FILED 2-14-2010.

**Ballerina Farmer**

THE MARK CONSISTS OF STANDARD CHARACTERS WITHOUT CLAIM TO ANY PARTICULAR FONT, STYLE, SIZE, OR COLOR.

FOR AROMATHERAPY BODY CARE PRODUCTS, NAMELY, PERFUME, ESSENTIAL OILS, BODY SPRAYS, FACE AND BODY LOTION, FACIAL AND BODY CLEANSERS, FACIAL AND BODY SCRUBS, FACIAL AND BODY MASKS, MASSAGE OILS, BATH OILS, BATH BOMBS IN THE NATURE OF BATH SALTS, BATH SALTS, BATH MELTS IN THE NATURE OF SOLID BATH OILS, LOTION BARS FOR BATH USE, HYDROSOLS IN THE NATURE OF SCENTED LINEN WATERS AND TOILET WATERS, DEODORANTS FOR PERSONAL USE, DEODORANTS FOR ANIMALS, SHOWER GEL, SHAMPOO, HAIR AND SKIN CONDITIONER, NON-MEDICATED LIP BALM, SOAPS, BODY BUTTER, FOOT SCRUBS, NON-MEDICATED FOOT CREAM, NON-MEDICATED FACE AND BODY SKIN CARE SERUMS, NON-MEDICATED SCALP AND HAIR CARE SERUMS, NON-MEDICATED HERBAL BODY CARE PRODUCTS, NAMELY, BODY OILS, SALVES, AND LIP BALMS; AROMATHERAPY INHALERS FILLED WITH ESSENTIAL OILS; NATURAL HOUSEHOLD FRAGRANCES AND CLEANING PREPARATIONS; BREATH FRESHENERS AND MOUTHWASHES FOR HUMANS AND PETS (U.S. CLS. 1, 4, 6, 50, 51 AND 52).

FIRST USE 10-20-2010; IN COMMERCE 10-20-2010.

**CLASS 3—(Continued).**

3,955,720. BALLERINA FARMER, LLC, KALAMAZOO, MI. SN 77-940,917. PUB. 7-20-2010, FILED 2-21-2010.



THE MARK CONSISTS OF A SILHOUETTE OF A DANCING BALLERINA OVERLAYING THE SILHOUETTE OF A BUTTERFLY.

FOR AROMATHERAPY BODY CARE PRODUCTS, NAMELY, PERFUME, ESSENTIAL OILS, BODY SPRAYS, FACE AND BODY LOTION, FACIAL AND BODY CLEANSERS, FACIAL AND BODY SCRUBS, FACIAL AND BODY MASKS, MASSAGE OILS, BATH OILS, BATH BOMBS IN THE NATURE OF BATH SALTS, BATH SALTS, BATH MELTS IN THE NATURE OF SOLID BATH OILS, LOTION BARS FOR BATH USE, HYDROSOLS IN THE NATURE OF SCENTED LINEN WATERS AND TOILET WATERS, DEODORANTS FOR PERSONAL USE, DEODORANTS FOR ANIMALS, SHOWER GEL, SHAMPOO, HAIR AND SKIN CONDITIONER, NON-MEDICATED LIP BALM, SOAPS, BODY BUTTER, FOOT SCRUBS, NON-MEDICATED FOOT CREAM, NON-MEDICATED FACE AND BODY SKIN CARE SERUMS, NON-MEDICATED SCALP AND HAIR CARE SERUMS, NON-MEDICATED HERBAL BODY CARE PRODUCTS, NAMELY, BODY OILS, SALVES, AND LIP BALMS; AROMATHERAPY INHALERS FILLED WITH ESSENTIAL OILS; NATURAL HOUSEHOLD FRAGRANCES AND CLEANING PREPARATIONS; BREATH FRESHENERS AND MOUTHWASHES FOR HUMANS AND PETS (U.S. CLS. 1, 4, 6, 50, 51 AND 52).

FIRST USE 10-20-2010; IN COMMERCE 10-20-2010.

3,955,740. AUSTRALIAN GOLD, LLC, INDIANAPOLIS, IN. SN 77-944,328. PUB. 12-7-2010, FILED 2-24-2010.

**SOL SEARCH**

THE MARK CONSISTS OF STANDARD CHARACTERS WITHOUT CLAIM TO ANY PARTICULAR FONT, STYLE, SIZE, OR COLOR.

FOR NON-MEDICATED INDOOR SKIN TANNING PREPARATIONS DISTRIBUTED AND MARKETED FOR SALE AND USE IN INDOOR TANNING SALONS (U.S. CLS. 1, 4, 6, 50, 51 AND 52).

FIRST USE 11-1-2010; IN COMMERCE 11-1-2010.

**CLASS 3—(Continued).**

3,955,742. IM CO., LTD., TAKAMATSU-CITY, KAGAWA, JAPAN. SN 77-944,775. PUB. 12-21-2010, FILED 2-25-2010.

**RICE FORCE**

THE MARK CONSISTS OF STANDARD CHARACTERS WITHOUT CLAIM TO ANY PARTICULAR FONT, STYLE, SIZE, OR COLOR.

OWNER OF U.S. REG. NOS. 2,668,615 AND 2,847,294.

NO CLAIM IS MADE TO THE EXCLUSIVE RIGHT TO USE "RICE", APART FROM THE MARK AS SHOWN.

FOR COSMETICS; NON-MEDICATED TOILETRIES (U.S. CLS. 1, 4, 6, 50, 51 AND 52).

FIRST USE 9-0-2000; IN COMMERCE 10-2-2010.

3,955,780. FUSION BRANDS INTERNATIONAL SRL, CHRIST CHURCH, BARBADOS. SN 77-952,044. PUB. 7-27-2010, FILED 3-5-2010.

**ILLUMIFILL**

THE MARK CONSISTS OF STANDARD CHARACTERS WITHOUT CLAIM TO ANY PARTICULAR FONT, STYLE, SIZE, OR COLOR.

FOR COSMETICS (U.S. CLS. 1, 4, 6, 50, 51 AND 52).

FIRST USE 1-31-2010; IN COMMERCE 5-1-2010.

3,955,795. SHUBIN, STEVE, DRIPPING SPRINGS, TX. SN 77-957,476. PUB. 7-13-2010, FILED 3-12-2010.

**FLESHWASH**

THE MARK CONSISTS OF STANDARD CHARACTERS WITHOUT CLAIM TO ANY PARTICULAR FONT, STYLE, SIZE, OR COLOR.

FOR LIQUID SOAP; ADULT TOY CLEANER (U.S. CLS. 1, 4, 6, 50, 51 AND 52).

FIRST USE 6-17-2010; IN COMMERCE 6-17-2010.

**CLASS 3—(Continued).**

3,955,827. KATE SPADE, LLC, NEW YORK, NY. SN 77-969,578. PUB. 8-17-2010, FILED 3-26-2010.

KATE SPADE NEW YORK

THE MARK CONSISTS OF STANDARD CHARACTERS WITHOUT CLAIM TO ANY PARTICULAR FONT, STYLE, SIZE, OR COLOR.

OWNER OF U.S. REG. NOS. 2,064,708, 2,073,406, AND OTHERS.

NO CLAIM IS MADE TO THE EXCLUSIVE RIGHT TO USE "NEW YORK", APART FROM THE MARK AS SHOWN. THE NAME "KATE SPADE" IDENTIFIES A LIVING INDIVIDUAL WHOSE CONSENT IS OF RECORD.

FOR BODY CREAM; BODY LOTION; FRAGRANCES AND PERFUMERY; SHOWER GEL (U.S. CLS. 1, 4, 6, 50, 51 AND 52).

FIRST USE 8-0-2010; IN COMMERCE 8-0-2010.

3,955,837. HEALTH20 PRODUCTS, LLC, DALLAS, TX. SN 77-981,329. PUB. 4-20-2010, FILED 7-23-2008.



OWNER OF U.S. REG. NO. 2,962,547. THE COLOR(S) BLACK, BLUE, AND WHITE IS/ARE CLAIMED AS A FEATURE OF THE MARK.

THE MARK CONSISTS OF "HEALTH" IN LOWERCASE BLACK FONT, A CAPITAL "H" IN BLUE FONT, A SUBSCRIPT "2" IN BLUE FONT, AND A SPHERE THAT IS SHADED BLUE AND WHITE, ALL IN A ROW.

FOR NON-MEDICATED GELS FOR THE SKIN, NAMELY, FACIAL WASH GEL, FACIAL SCRUB GEL, SKIN SERUM GEL, EYE GEL, FACIAL LOTION GEL, BODY LOTION GEL, GELS FOR FACE, AND GELS FOR BODY (U.S. CLS. 1, 4, 6, 50, 51 AND 52).

FIRST USE 11-4-2010; IN COMMERCE 11-4-2010.

**CLASS 3—(Continued).**

3,955,855. DISNEY ENTERPRISES, INC., BURBANK, CA. SN 77-981,542. PUB. 6-29-2010, FILED 2-11-2010.

TANGLED

THE MARK CONSISTS OF STANDARD CHARACTERS WITHOUT CLAIM TO ANY PARTICULAR FONT, STYLE, SIZE, OR COLOR.

FOR COSMETICS; NON-MEDICATED TOILETRIES (U.S. CLS. 1, 4, 6, 50, 51 AND 52).

FIRST USE 12-31-2010; IN COMMERCE 12-31-2010.

3,955,895. CHURCH & DWIGHT CO., INC., PRINCETON, NJ. SN 85-003,988. PUB. 7-13-2010, FILED 4-1-2010.

ESCAPE

THE MARK CONSISTS OF STANDARD CHARACTERS WITHOUT CLAIM TO ANY PARTICULAR FONT, STYLE, SIZE, OR COLOR.

OWNER OF U.S. REG. NO. 3,262,951. FOR LAUNDRY DETERGENTS AND LAUNDRY DETERGENTS CONTAINING FABRIC SOFTENERS (U.S. CLS. 1, 4, 6, 50, 51 AND 52).

FIRST USE 10-31-2007; IN COMMERCE 10-31-2007.

3,955,896. CHURCH & DWIGHT CO., INC., PRINCETON, NJ. SN 85-003,989. PUB. 7-13-2010, FILED 4-1-2010.



OWNER OF U.S. REG. NO. 3,262,951. THE MARK CONSISTS OF THE STYLIZED WORD "ESCAPE". THE LETTER "E" EXTENDS UNDERNEATH THE ENTIRE WORD.

FOR LAUNDRY DETERGENTS AND LAUNDRY DETERGENTS CONTAINING FABRIC SOFTENERS (U.S. CLS. 1, 4, 6, 50, 51 AND 52).

FIRST USE 10-31-2007; IN COMMERCE 10-31-2007.

**CLASS 3—(Continued).**

3,955,909. E.T. BROWNE DRUG CO., INC., ENGLEWOOD CLIFFS, NJ. SN 85-009,057. PUB. 6-29-2010, FILED 4-8-2010.

**CETESOMATE-E**

THE MARK CONSISTS OF STANDARD CHARACTERS WITHOUT CLAIM TO ANY PARTICULAR FONT, STYLE, SIZE, OR COLOR.

FOR SKIN MOISTURIZING LOTION (U.S. CLS. 1, 4, 6, 50, 51 AND 52).

FIRST USE 6-1-2010; IN COMMERCE 6-1-2010.

3,955,918. PHARMACEUTICAL SPECIALTIES, INC., ROCHESTER, MN. SN 85-012,420. PUB. 9-28-2010, FILED 4-13-2010.

**VANIPLY**

THE MARK CONSISTS OF STANDARD CHARACTERS WITHOUT CLAIM TO ANY PARTICULAR FONT, STYLE, SIZE, OR COLOR.

FOR SKIN MOISTURIZER FOR THE FACE AND BODY; GENERAL PURPOSE MENTHOLATED OINTMENT NOT FOR MEDICAL USE (U.S. CLS. 1, 4, 6, 50, 51 AND 52).

FIRST USE 2-24-2011; IN COMMERCE 2-24-2011.

3,955,980. SCHERING-PLOUGH HEALTHCARE PRODUCTS, INC., MEMPHIS, TN. SN 85-037,745. PUB. 9-14-2010, FILED 5-13-2010.

**COPPERTONE OUTSHINES**

THE MARK CONSISTS OF STANDARD CHARACTERS WITHOUT CLAIM TO ANY PARTICULAR FONT, STYLE, SIZE, OR COLOR.

OWNER OF U.S. REG. NOS. 917,825, 1,490,740, AND OTHERS.

FOR SUNTANNING AND SUN CARE PREPARATIONS, NAMELY, SUNSCREENS, SUN BLOCKS, AND PREPARATIONS TO ASSIST IN TANNING THE SKIN (U.S. CLS. 1, 4, 6, 50, 51 AND 52).

FIRST USE 6-0-2010; IN COMMERCE 6-0-2010.

**CLASS 3—(Continued).**

3,955,989. L'OREAL USA CREATIVE, INC., NEW YORK, NY. SN 85-043,713. PUB. 8-10-2010, FILED 5-20-2010.

**STRENGTH BUILDER**

THE MARK CONSISTS OF STANDARD CHARACTERS WITHOUT CLAIM TO ANY PARTICULAR FONT, STYLE, SIZE, OR COLOR.

NO CLAIM IS MADE TO THE EXCLUSIVE RIGHT TO USE "STRENGTH", APART FROM THE MARK AS SHOWN.

FOR NON-MEDICATED HAIR TREATMENT PREPARATIONS (U.S. CLS. 1, 4, 6, 50, 51 AND 52).

FIRST USE 2-0-2011; IN COMMERCE 2-0-2011.

3,956,010. AUSTRALIAN GOLD, LLC, INDIANAPOLIS, IN. SN 85-056,347. PUB. 11-9-2010, FILED 6-7-2010.

**SUN LUVIN'**

THE MARK CONSISTS OF STANDARD CHARACTERS WITHOUT CLAIM TO ANY PARTICULAR FONT, STYLE, SIZE, OR COLOR.

NO CLAIM IS MADE TO THE EXCLUSIVE RIGHT TO USE "SUN", APART FROM THE MARK AS SHOWN.

FOR NON-MEDICATED INDOOR AND OUTDOOR SKIN TANNING PREPARATIONS (U.S. CLS. 1, 4, 6, 50, 51 AND 52).

FIRST USE 11-1-2010; IN COMMERCE 11-1-2010.

3,956,025. BLACKSMITH BRANDS, INC., IRVINGTON, NY. SN 85-060,939. PUB. 11-9-2010, FILED 6-11-2010.

**Efferdent PM**

THE MARK CONSISTS OF STANDARD CHARACTERS WITHOUT CLAIM TO ANY PARTICULAR FONT, STYLE, SIZE, OR COLOR.

OWNER OF U.S. REG. NOS. 728,959, 3,555,227, AND OTHERS.

NO CLAIM IS MADE TO THE EXCLUSIVE RIGHT TO USE "PM", APART FROM THE MARK AS SHOWN.

FOR DENTURE CLEANERS; DENTURE CLEANING PREPARATIONS (U.S. CLS. 1, 4, 6, 50, 51 AND 52).

FIRST USE 2-4-2011; IN COMMERCE 2-4-2011.

**CLASS 4—LUBRICANTS AND FUELS**

**CLASS 4—(Continued).**

3,955,520. ALEX C. FERGUSSON, LLC, CHAMBERSBURG, PA. SN 77-874,162. PUB. 4-20-2010, FILED 11-17-2009.

**Smart Track Advanced**

THE MARK CONSISTS OF STANDARD CHARACTERS WITHOUT CLAIM TO ANY PARTICULAR FONT, STYLE, SIZE, OR COLOR.

FOR LUBRICANTS FOR INDUSTRIAL MACHINERY, NAMELY, CONVEYOR LUBRICANT (U.S. CLS. 1, 6 AND 15).

FIRST USE 11-0-2009; IN COMMERCE 11-0-2009.

**CLASS 5—(Continued).**

3,955,190. BABY GOURMET FOODS INC., EDMONTON ALBERTA T6E 5Z8, CANADA. SN 77-201,166. PUB. 1-8-2008, FILED 6-8-2007.

**BABY GOURMET**

THE MARK CONSISTS OF STANDARD CHARACTERS WITHOUT CLAIM TO ANY PARTICULAR FONT, STYLE, SIZE, OR COLOR.

NO CLAIM IS MADE TO THE EXCLUSIVE RIGHT TO USE "BABY", APART FROM THE MARK AS SHOWN.

FOR BABY FOOD (U.S. CLS. 6, 18, 44, 46, 51 AND 52). FIRST USE 2-18-2011; IN COMMERCE 2-18-2011.

3,955,706. SOLAZYME, INC., SOUTH SAN FRANCISCO, CA. SN 77-937,690. PUB. 7-13-2010, FILED 2-17-2010.

**SOLAJET**

THE MARK CONSISTS OF STANDARD CHARACTERS WITHOUT CLAIM TO ANY PARTICULAR FONT, STYLE, SIZE, OR COLOR.

FOR FOSSIL FUEL SUBSTITUTES, NAMELY, BIO-FUELS; FUELS, NAMELY, AVIATION FUEL AND JET-FUEL (U.S. CLS. 1, 6 AND 15).

FIRST USE 2-14-2011; IN COMMERCE 2-14-2011.

3,955,206. CORNETTA ENTERPRISES, INC., ATLANTA, GA. SN 77-347,699. PUB. 5-12-2009, FILED 12-10-2007.

**Hard**

THE MARK CONSISTS OF STANDARD CHARACTERS WITHOUT CLAIM TO ANY PARTICULAR FONT, STYLE, SIZE, OR COLOR.

FOR HERBAL SUPPLEMENTS; PHARMACEUTICALS, NAMELY, INDUCERS OF ERECTIONS (U.S. CLS. 6, 18, 44, 46, 51 AND 52).

FIRST USE 6-27-2007; IN COMMERCE 9-18-2007.

**CLASS 5—PHARMACEUTICALS**

3,955,171. ESSEN NUTRITION CORPORATION, ROMEOVILLE, IL. SN 77-001,976. PUB. 12-8-2009, FILED 9-19-2006.

**SIMPL**

THE MARK CONSISTS OF STANDARD CHARACTERS WITHOUT CLAIM TO ANY PARTICULAR FONT, STYLE, SIZE, OR COLOR.

OWNER OF U.S. REG. NO. 2,097,042.

FOR DIETARY DRINK MIX FOR USE AS A MEAL REPLACEMENT; DIETARY SUPPLEMENTAL DRINKS (U.S. CLS. 6, 18, 44, 46, 51 AND 52).

FIRST USE 1-0-2011; IN COMMERCE 1-0-2011.

3,955,212. WN PHARMACEUTICALS LTD., COQUITLAM, BC, CANADA. SN 77-396,430. PUB. 5-18-2010, FILED 2-13-2008.

**CHIANUTRA**

THE MARK CONSISTS OF STANDARD CHARACTERS WITHOUT CLAIM TO ANY PARTICULAR FONT, STYLE, SIZE, OR COLOR.

PRIORITY CLAIMED UNDER SEC. 44(D) ON CANADA APPLICATION NO. 1383347, FILED 2-13-2008.

FOR DIETARY AND NUTRITIONAL SUPPLEMENTS; DIETARY FOOD SUPPLEMENTS (U.S. CLS. 6, 18, 44, 46, 51 AND 52).

FIRST USE 3-4-2008; IN COMMERCE 5-28-2008.

**CLASS 5—(Continued).**

3,955,330. LANG NATURALS, INC., MIDDLETOWN, RI. SN 77-728,164. PUB. 11-10-2009, FILED 5-4-2009.



NO CLAIM IS MADE TO THE EXCLUSIVE RIGHT TO USE "OMEGA-3", APART FROM THE MARK AS SHOWN.

THE COLOR(S) SKY BLUE, LIGHT CYAN, DARK CYAN, HUNTER GREEN AND WHITE IS/ARE CLAIMED AS A FEATURE OF THE MARK.

THE MARK CONSISTS OF A GRADATION OF THE COLORS SKY BLUE, LIGHT CYAN AND DARK CYAN APPEARING WITHIN THE WATER DROP PORTION OF THE MARK. THE COLOR HUNTER GREEN APPEARS WITHIN THE LEAF PORTION OF THE MARK. THE COLOR WHITE APPEARS WITHIN THE LITERAL ELEMENT OF THE MARK, "PLANT PURE OMEGA-3", WHICH IS IN MINION PRO BOLDCOND FONT.

FOR DIETARY AND NUTRITIONAL SUPPLEMENTS CONTAINING OMEGA-3 (U.S. CLS. 6, 18, 44, 46, 51 AND 52).

FIRST USE 2-2-2010; IN COMMERCE 2-2-2010.

3,955,335. MERCK SHARP & DOHME CORP., WHITEHOUSE STATION, NJ. SN 77-737,096. PUB. 8-4-2009, FILED 5-14-2009.

**ODACTRA**

THE MARK CONSISTS OF STANDARD CHARACTERS WITHOUT CLAIM TO ANY PARTICULAR FONT, STYLE, SIZE, OR COLOR.

FOR PHARMACEUTICAL PREPARATIONS FOR THE TREATMENT OF CANCER (U.S. CLS. 6, 18, 44, 46, 51 AND 52).

FIRST USE 3-1-2011; IN COMMERCE 3-1-2011.

**CLASS 5—(Continued).**

3,955,337. KELLY, EDUARDO E., HINGHAM, MA. SN 77-739,595. PUB. 12-22-2009, FILED S.R. 5-18-2009; AM. P.R. 8-19-2009.



NO CLAIM IS MADE TO THE EXCLUSIVE RIGHT TO USE "THERAPEUTICS, INC.", APART FROM THE MARK AS SHOWN.

THE COLOR(S) MAGENTA AND WHITE IS/ARE CLAIMED AS A FEATURE OF THE MARK.

THE MARK CONSISTS OF THE INITIALS "STI" AND THE WORDING "STEPTOE THERAPEUTICS, INC.". THE LETTERS "S" AND "I" APPEAR IN THE COLOR WHITE, THE LETTER "T" AND THE WORDING "STEPTOE THERAPEUTICS, INC." APPEAR IN THE COLOR MAGENTA. THE DESIGN OF A CIRCLE DEPICTS A SIDE VIEW OF A PREGNANT WOMAN IN THE COLOR WHITE WITHIN THE CIRCLE AND THE SIDE PORTIONS OF THE CIRCLE APPEAR IN COLOR MAGENTA.

FOR PHARMACEUTICAL PREPARATIONS AND SUBSTANCES FOR THE TREATMENT OF VIRAL, METABOLIC, ENDOCRINE, MUSCULOSKELETAL, CARDIOVASCULAR, CARDIOPULMONARY, GENITOURINARY, SEXUAL DYSFUNCTION, ONCOLOGICAL, HEPATOLOGICAL, OPHTHALMIC, RESPIRATORY, NEUROLOGICAL, GASTROINTESTINAL, HORMONAL, DERMATOLOGICAL, PSYCHIATRIC AND IMMUNE SYSTEM RELATED DISEASES AND DISORDERS; THERAPEUTIC PHARMACEUTICAL FOR THE TREATMENT OF INFERTILITY (U.S. CLS. 6, 18, 44, 46, 51 AND 52).

FIRST USE 10-20-2010; IN COMMERCE 3-15-2011.

3,955,386. BAUSCH & LOMB INCORPORATED, ROCHESTER, NY. SN 77-793,552. PUB. 12-1-2009, FILED 7-30-2009.

**re.  
nu**

OWNER OF U.S. REG. NOS. 1,450,287, 1,537,182, AND OTHERS.

THE MARK CONSISTS OF STYLIZED STACKED RENU WITH DROP DESIGN AFTER THE "E".

FOR CONTACT LENS CLEANING SOLUTIONS; CONTACT LENS DISINFECTANTS; CONTACT LENS SOLUTIONS; CONTACT LENS WETTING SOLUTIONS; CONTACT LENS REWETTING DROPS (U.S. CLS. 6, 18, 44, 46, 51 AND 52).

FIRST USE 11-12-2009; IN COMMERCE 11-12-2009.

**CLASS 5—(Continued).**

3,955,388. SUN INDUSTRIES, INC., RAYTOWN, MO. SN 77-794,478. PUB. 7-20-2010, FILED 7-31-2009.

**PRANAJEEWA**

THE MARK CONSISTS OF STANDARD CHARACTERS WITHOUT CLAIM TO ANY PARTICULAR FONT, STYLE, SIZE, OR COLOR.

THE ENGLISH TRANSLATION OF "PRANAJEEWA" IN THE MARK IS "GIVING LIFE", FOR DIETARY SUPPLEMENTS (U.S. CLS. 6, 18, 44, 46, 51 AND 52).  
FIRST USE 3-24-2010; IN COMMERCE 3-24-2010.

3,955,414. DAVID PLATT, NEWTON, MA. AND KENNETH ALAN TASSEY JR., MANCHESTER, NH. SN 77-812,748. PUB. 7-20-2010, FILED 8-26-2009.

**SUGARDOWN**

THE MARK CONSISTS OF STANDARD CHARACTERS WITHOUT CLAIM TO ANY PARTICULAR FONT, STYLE, SIZE, OR COLOR.

FOR PHARMACEUTICAL PREPARATIONS AND OVER-THE-COUNTER MEDICATIONS FOR THE TREATMENT OF MEDICAL CONDITIONS ASSOCIATED WITH ISCHEMIA, CARDIOVASCULAR DISEASE, HYPERGLYCEMIA, IMPAIRED GLUCOSE TOLERANCE, IMPAIRED FASTING GLUCOSE, OBESITY AND OTHER DIABETIC AND PRE-DIABETIC CONDITIONS AND INDICATIONS (U.S. CLS. 6, 18, 44, 46, 51 AND 52).  
FIRST USE 4-15-2010; IN COMMERCE 5-15-2010.

3,955,416. ROMO, JOSE ISMAEL, TONALA CITY, JALISCO, MEXICO. SN 77-814,388. PUB. 7-27-2010, FILED 8-27-2009.

**SALICXA**

THE MARK CONSISTS OF STANDARD CHARACTERS WITHOUT CLAIM TO ANY PARTICULAR FONT, STYLE, SIZE, OR COLOR.

THE WORDING "SALICXA" HAS NO MEANING IN A FOREIGN LANGUAGE.

FOR MEDICATED SHAMPOO, MEDICATED SHAMPOO FOR DANDRUFF, ANTI DANDRUFF SHAMPOO (U.S. CLS. 6, 18, 44, 46, 51 AND 52).  
FIRST USE 7-1-2010; IN COMMERCE 7-1-2010.

**CLASS 5—(Continued).**

3,955,425. BISCO, INC., SCHAUMBURG, IL. SN 77-819,438. PUB. 7-27-2010, FILED 9-3-2009.



THE MARK CONSISTS OF "Z-PRIME PLUS" WITHIN RECTANGLE AND PLUS SIGN AFTER THE WORD "PLUS".

FOR DENTAL ADHESIVES (U.S. CLS. 6, 18, 44, 46, 51 AND 52).  
FIRST USE 11-11-2009; IN COMMERCE 11-11-2009.

3,955,489. CADENCE PHARMACEUTICALS, INC., SAN DIEGO, CA. SN 77-857,487. PUB. 3-30-2010, FILED 10-26-2009.

**OFIRMEV**

THE MARK CONSISTS OF STANDARD CHARACTERS WITHOUT CLAIM TO ANY PARTICULAR FONT, STYLE, SIZE, OR COLOR.

FOR PHARMACEUTICAL PREPARATIONS, NAMELY, INTRAVENOUS ANALGESICS AND ANTI-PYRETICS PREPARATIONS (U.S. CLS. 6, 18, 44, 46, 51 AND 52).

FIRST USE 10-26-2009; IN COMMERCE 1-10-2011.

3,955,521. RAINBOW LIGHT NUTRITIONAL SYSTEMS, INC., SANTA CRUZ, FL. SN 77-874,548. PUB. 8-3-2010, FILED 11-17-2009.

**Allergen SafeGuard**

THE MARK CONSISTS OF STANDARD CHARACTERS WITHOUT CLAIM TO ANY PARTICULAR FONT, STYLE, SIZE, OR COLOR.

NO CLAIM IS MADE TO THE EXCLUSIVE RIGHT TO USE "ALLERGEN", APART FROM THE MARK AS SHOWN.

FOR DIETARY AND NUTRITIONAL SUPPLEMENTS; VITAMINS (U.S. CLS. 6, 18, 44, 46, 51 AND 52).  
FIRST USE 12-23-2009; IN COMMERCE 12-23-2009.

**CLASS 5—(Continued).**

3,955,574. EL-GEN LLC, DBA ALIMENTAL SCIENCE, BOHEMIA, NY. SN 77-902,578. PUB. 5-18-2010, FILED 12-30-2009.

# Sufoxen

THE MARK CONSISTS OF STANDARD CHARACTERS WITHOUT CLAIM TO ANY PARTICULAR FONT, STYLE, SIZE, OR COLOR.

FOR DIETARY AND NUTRITIONAL SUPPLEMENTS (U.S. CLS. 6, 18, 44, 46, 51 AND 52).

FIRST USE 9-10-2010; IN COMMERCE 9-10-2010.

---

3,955,579. ALKERMES, INC., WALTHAM, MA. SN 77-906,658. PUB. 11-9-2010, FILED 1-7-2010.

# LINKERX

THE MARK CONSISTS OF STANDARD CHARACTERS WITHOUT CLAIM TO ANY PARTICULAR FONT, STYLE, SIZE, OR COLOR.

FOR PHARMACEUTICALS, NAMELY, PRODRUGS AND CHEMICAL DERIVATIVES OF PHARMACEUTICALLY ACTIVE INGREDIENTS FOR THE TREATMENT OF CENTRAL NERVOUS SYSTEM DISEASES AND DISORDERS, PSYCHIATRIC AND NEURODEGENERATIVE DISEASES, CARDIOVASCULAR DISEASES AND METABOLIC DISEASES; PHARMACEUTICAL COMPOUNDS, NAMELY, PRODRUGS AND CHEMICAL DERIVATIVES OF PHARMACEUTICALLY ACTIVE INGREDIENTS FOR THE TREATMENT OF THE AFORESAID DISEASES (U.S. CLS. 6, 18, 44, 46, 51 AND 52).

FIRST USE 4-8-2010; IN COMMERCE 4-8-2010.

---

3,955,595. NATURAL ORGANICS, INC., MELVILLE, NY. SN 77-913,236. PUB. 10-5-2010, FILED 1-15-2010.

## RECHARGE YOUR LIFE - STEP UP TO THE GOLD!

THE MARK CONSISTS OF STANDARD CHARACTERS WITHOUT CLAIM TO ANY PARTICULAR FONT, STYLE, SIZE, OR COLOR.

FOR NUTRITIONAL AND DIETARY SUPPLEMENTS; FRUIT AND VEGETABLE BASED POWDERS AND LIQUIDS FOR MAKING DIETARY AND NUTRITIONAL SUPPLEMENTAL BEVERAGES AND SHAKES (U.S. CLS. 6, 18, 44, 46, 51 AND 52).

FIRST USE 2-28-2010; IN COMMERCE 2-28-2010.

**CLASS 5—(Continued).**

3,955,600. BIO-ENGINEERED SUPPLEMENTS & NUTRITION, INC., EVANSTON, IL. SN 77-914,602. PUB. 5-4-2010, FILED 1-19-2010.

# ENDO BURN

THE MARK CONSISTS OF STANDARD CHARACTERS WITHOUT CLAIM TO ANY PARTICULAR FONT, STYLE, SIZE, OR COLOR.

FOR DIETARY SUPPLEMENT PRODUCTS SOLD OVER THE COUNTER ONLY, WITHOUT THE NEED FOR A PHYSICIAN'S PRESCRIPTION (U.S. CLS. 6, 18, 44, 46, 51 AND 52).

FIRST USE 5-26-2010; IN COMMERCE 5-26-2010.

---

3,955,672. ABBOTT LABORATORIES, ABBOTT PARK, IL. SN 77-930,835. PUB. 6-15-2010, FILED 2-8-2010.



THE COLOR(S) GREEN AND LIGHT GREEN IS/ARE CLAIMED AS A FEATURE OF THE MARK.

THE MARK CONSISTS OF AN UPSIDE DOWN TRIANGULAR SHIELD WITH A HORIZONTAL BAR GOING ACROSS THE INSIDE, ALL IN GREEN, WITH LIGHT GREEN SHADING ON THE RIGHT AND LEFT OF THE SHIELD. THE WHITE AND GRAY IN THE MARK REPRESENT BACKGROUND AND SHADING AREAS AND ARE NOT A PART OF THE MARK.

FOR INFANT FORMULA (U.S. CLS. 6, 18, 44, 46, 51 AND 52).

FIRST USE 1-19-2011; IN COMMERCE 1-19-2011.



**CLASS 5—(Continued).**

3,955,721. INLIFE, LLC, IRVINE, CA. SN 77-940,992. PUB. 7-13-2010, FILED 2-22-2010.

inFocus

THE MARK CONSISTS OF STANDARD CHARACTERS WITHOUT CLAIM TO ANY PARTICULAR FONT, STYLE, SIZE, OR COLOR.

FOR NICOTINE REPLACEMENT BEVERAGE TO ASSIST SMOKING CESSATION (U.S. CLS. 6, 18, 44, 46, 51 AND 52).

FIRST USE 2-1-2010; IN COMMERCE 2-1-2010.

3,955,788. QLT, INC., VANCOUVER, BC, CANADA. SN 77-954,799. PUB. 7-27-2010, FILED 3-9-2010.



THE MARK CONSISTS OF A STYLIZED DESIGN OF THE LETTER "Q".

FOR PHARMACEUTICAL PREPARATIONS FOR OCULAR DISEASES AND DISORDERS AND DISORDERS CHARACTERIZED BY UNWANTED ANGIOGENESIS (U.S. CLS. 6, 18, 44, 46, 51 AND 52).

FIRST USE 7-1-2010; IN COMMERCE 7-1-2010.

3,955,789. QLT, INC., VANCOUVER, BC, CANADA. SN 77-954,808. PUB. 7-27-2010, FILED 3-9-2010.



OWNER OF U.S. REG. NO. 2,046,175.

NO CLAIM IS MADE TO THE EXCLUSIVE RIGHT TO USE "OPHTHALMICS", APART FROM THE MARK AS SHOWN.

**CLASS 5—(Continued).**

THE MARK CONSISTS OF A STYLIZED DESIGN OF THE LETTER "Q" TO THE LEFT OF THE WORDS "QLT OPTHALMICS".

FOR PHARMACEUTICAL PREPARATIONS FOR OCULAR DISEASES AND DISORDERS AND DISORDERS CHARACTERIZED BY UNWANTED ANGIOGENESIS (U.S. CLS. 6, 18, 44, 46, 51 AND 52).

FIRST USE 7-1-2010; IN COMMERCE 7-1-2010.

3,955,796. DIAMOND, KLEIDEN, NORTHRIDGE, CA. SN 77-957,734. PUB. 12-7-2010, FILED 3-12-2010.



NO CLAIM IS MADE TO THE EXCLUSIVE RIGHT TO USE "DERMA BAR", APART FROM THE MARK AS SHOWN.

THE COLOR(S) AQUA BLUE, GREEN, WHITE, BLACK AND TAN IS/ARE CLAIMED AS A FEATURE OF THE MARK.

THE MARK CONSISTS OF AN AQUA BLUE RECTANGLE WITH WHITE HIGHLIGHTS INSIDE A GREEN RECTANGLE WITH AQUA BLUE AND WHITE ACCENTS SWIRLED THROUGHOUT. INSIDE THE INNER RECTANGLE APPEARS THE TERM "DERMA BAR" IN WHITE WITH BLACK HIGHLIGHTING ABOVE A TAN HORIZONTAL LINE. BENEATH THE LINE APPEARS THE TERM "LOVE YOUR SKIN" IN WHITE.

FOR SKIN NUTRIENTS BAR, NAMELY, NUTRITIONAL AND DIETARY SUPPLEMENTS FORMED AND PACKAGED AS BARS (U.S. CLS. 6, 18, 44, 46, 51 AND 52).

FIRST USE 3-1-2009; IN COMMERCE 4-1-2009.

3,955,813. WESTERN RESEARCH 3000, INC., THOUSAND OAKS, CA. SN 77-962,770. PUB. 8-3-2010, FILED 3-18-2010.

REZÓLV TO LIVE YOUNG

THE MARK CONSISTS OF STANDARD CHARACTERS WITHOUT CLAIM TO ANY PARTICULAR FONT, STYLE, SIZE, OR COLOR.

FOR DIETARY AND NUTRITIONAL SUPPLEMENTS (U.S. CLS. 6, 18, 44, 46, 51 AND 52).

FIRST USE 5-31-2010; IN COMMERCE 5-31-2010.

**CLASS 5—(Continued).**

3,955,955. UPSTATE DREAM INSTITUTE, LLC, ITHACA, NY. SN 85-026,260. PUB. 9-28-2010, FILED 4-29-2010.

## THE BEDTIME DELIGHT THAT HELPS YOU SLEEP THROUGH THE NIGHT!

THE MARK CONSISTS OF STANDARD CHARACTERS WITHOUT CLAIM TO ANY PARTICULAR FONT, STYLE, SIZE, OR COLOR.

FOR CHOCOLATE BASED DIETARY SUPPLEMENT USED TO AID IN SLEEP AND RELAXATION (U.S. CLS. 6, 18, 44, 46, 51 AND 52).

FIRST USE 10-27-2010; IN COMMERCE 10-27-2010.

---

3,956,047. ETHAN NUTRACEUTICAL LIMITED TAIWAN BRANCH, TAIPEI, TAIWAN. SN 85-078,776. PUB. 12-7-2010, FILED 7-6-2010.

## ETHANZYME

THE MARK CONSISTS OF STANDARD CHARACTERS WITHOUT CLAIM TO ANY PARTICULAR FONT, STYLE, SIZE, OR COLOR.

OWNER OF U.S. REG. NO. 3,354,323.

FOR POWDERED NUTRITIONAL SUPPLEMENT DRINK MIX; MEAL REPLACEMENT AND DIETARY SUPPLEMENT DRINK MIXES; VITAMIN AND MINERAL SUPPLEMENTS; HERBAL SUPPLEMENTS; DIETARY SUPPLEMENTS; AND NUTRITIONAL SUPPLEMENTS (U.S. CLS. 6, 18, 44, 46, 51 AND 52).

FIRST USE 10-16-2006; IN COMMERCE 2-21-2011.

---

3,956,093. L'OREAL USA CREATIVE, INC., NEW YORK, NY. SN 85-156,138. PUB. 12-14-2010, FILED 10-19-2010.

## BLEMISH + AGE DEFENSE

THE MARK CONSISTS OF STANDARD CHARACTERS WITHOUT CLAIM TO ANY PARTICULAR FONT, STYLE, SIZE, OR COLOR.

NO CLAIM IS MADE TO THE EXCLUSIVE RIGHT TO USE "BLEMISH", APART FROM THE MARK AS SHOWN.

FOR ACNE TREATMENT PREPARATION (U.S. CLS. 6, 18, 44, 46, 51 AND 52).

FIRST USE 2-7-2011; IN COMMERCE 2-7-2011.

**CLASS 5—(Continued).**

3,956,094. L'OREAL USA CREATIVE, INC., NEW YORK, NY. SN 85-156,163. PUB. 12-14-2010, FILED 10-19-2010.

## BLEMISH + AGE

THE MARK CONSISTS OF STANDARD CHARACTERS WITHOUT CLAIM TO ANY PARTICULAR FONT, STYLE, SIZE, OR COLOR.

NO CLAIM IS MADE TO THE EXCLUSIVE RIGHT TO USE "BLEMISH", APART FROM THE MARK AS SHOWN.

FOR ACNE TREATMENT PREPARATION (U.S. CLS. 6, 18, 44, 46, 51 AND 52).

FIRST USE 2-7-2011; IN COMMERCE 2-7-2011.

**CLASS 6—METAL GOODS**

---

3,955,210. HUNTING ENERGY SERVICES I, INC., DBA HUNTING ENERGY SERVICES, INC., HOUSTON, TX. SN 77-381,970. PUB. 7-8-2008, FILED 1-28-2008.

## WEDGE-LOCK

THE MARK CONSISTS OF STANDARD CHARACTERS WITHOUT CLAIM TO ANY PARTICULAR FONT, STYLE, SIZE, OR COLOR.

OWNER OF U.S. REG. NO. 1,456,097.

FOR CASINGS OF METAL AND METAL TUBING FOR USE IN THE OIL AND GAS INDUSTRY (U.S. CLS. 2, 12, 13, 14, 23, 25 AND 50).

FIRST USE 3-15-2011; IN COMMERCE 3-15-2011.

---

3,955,418. MESTEK, INC., WESTFIELD, MA. SN 77-816,668. PUB. 8-24-2010, FILED 8-31-2009.

## WOODPRO

THE MARK CONSISTS OF STANDARD CHARACTERS WITHOUT CLAIM TO ANY PARTICULAR FONT, STYLE, SIZE, OR COLOR.

FOR DOOR FRAMES, NAMELY, METALLIC DOOR FRAMES; METAL WINDOW FRAMES FOR VISION WINDOWS IN WOOD AND METAL DOORS (U.S. CLS. 2, 12, 13, 14, 23, 25 AND 50).

FIRST USE 9-0-2009; IN COMMERCE 9-0-2009.

**CLASS 6—(Continued).**

3,955,458. PORTEOUS FASTENER COMPANY, CARSON, CA. SN 77-841,927. PUB. 7-13-2010, FILED 10-5-2009.

**PROFERRED DRYWALLERZ**

THE MARK CONSISTS OF STANDARD CHARACTERS WITHOUT CLAIM TO ANY PARTICULAR FONT, STYLE, SIZE, OR COLOR.

NO CLAIM IS MADE TO THE EXCLUSIVE RIGHT TO USE "DRYWALLERS", APART FROM THE MARK AS SHOWN.

FOR METAL FASTENERS, NAMELY, SCREWS (U.S. CLS. 2, 12, 13, 14, 23, 25 AND 50).  
FIRST USE 6-24-2010; IN COMMERCE 6-24-2010.

3,955,459. PORTEOUS FASTENER COMPANY, CARSON, CA. SN 77-841,929. PUB. 7-13-2010, FILED 10-5-2009.

**PROFERRED DRILLERZ**

THE MARK CONSISTS OF STANDARD CHARACTERS WITHOUT CLAIM TO ANY PARTICULAR FONT, STYLE, SIZE, OR COLOR.

NO CLAIM IS MADE TO THE EXCLUSIVE RIGHT TO USE "DRILLERS", APART FROM THE MARK AS SHOWN.

FOR METAL FASTENERS, NAMELY, SCREWS (U.S. CLS. 2, 12, 13, 14, 23, 25 AND 50).  
FIRST USE 6-18-2010; IN COMMERCE 6-18-2010.

3,955,460. PORTEOUS FASTENER COMPANY, CARSON, CA. SN 77-841,930. PUB. 7-13-2010, FILED 10-5-2009.

**Proffered Drywallorz**

NO CLAIM IS MADE TO THE EXCLUSIVE RIGHT TO USE "DRYWALLERS", APART FROM THE MARK AS SHOWN.

**CLASS 6—(Continued).**

THE MARK CONSISTS OF THE WORDS "PROFERRED DRYWALLERZ" IN AN OUTLINED FONT WITH TWO SCREWS IN PLACE OF THE TWO LETTER "L"'S.

FOR METAL FASTENERS, NAMELY, SCREWS (U.S. CLS. 2, 12, 13, 14, 23, 25 AND 50).  
FIRST USE 6-24-2010; IN COMMERCE 6-24-2010.

3,955,461. PORTEOUS FASTENER COMPANY, CARSON, CA. SN 77-841,937. PUB. 7-13-2010, FILED 10-5-2009.

**Proffered Drillerz**

NO CLAIM IS MADE TO THE EXCLUSIVE RIGHT TO USE "DRILLERS", APART FROM THE MARK AS SHOWN.

THE MARK CONSISTS OF THE WORDS "PROFERRED DRILLERZ" IN AN OUTLINED FONT WITH TWO SCREWS IN PLACE OF THE TWO LETTER "L"'S.

FOR METAL FASTENERS, NAMELY, SCREWS (U.S. CLS. 2, 12, 13, 14, 23, 25 AND 50).  
FIRST USE 6-18-2010; IN COMMERCE 6-18-2010.

3,955,623. DIEBOLD, INCORPORATED, NORTH CANTON, OH. SN 77-921,669. PUB. 6-15-2010, FILED 1-27-2010.

**CENTURY**

THE MARK CONSISTS OF STANDARD CHARACTERS WITHOUT CLAIM TO ANY PARTICULAR FONT, STYLE, SIZE, OR COLOR.

OWNER OF U.S. REG. NOS. 595,921 AND 1,422,566.  
FOR METALLIC VAULT DOORS (U.S. CLS. 2, 12, 13, 14, 23, 25 AND 50).  
FIRST USE 1-24-2011; IN COMMERCE 1-24-2011.

**CLASS 6—(Continued).**

3,955,701. CLIPSY, LLC, SAN FRANCISCO, CA. SN 77-936,037. PUB. 7-6-2010, FILED 2-15-2010.



THE MARK CONSISTS OF THE WORD "PETAL" WITH THE "A" REPRESENTED AS A STYLIZED LEAF. FOR METAL DECORATIVE CLIPS FOR SUSPENDING PERSONAL OBJECTS FROM VARIOUS SURFACES (U.S. CLS. 2, 12, 13, 14, 23, 25 AND 50). FIRST USE 4-1-2010; IN COMMERCE 4-1-2010.

**CLASS 6—(Continued).**

3,955,888. THREE FORKS RANCH CORP., ST. LOUIS, MO. SN 78-981,390. PUB. 11-21-2006, FILED 4-12-2006.



THE MARK CONSISTS OF STYLIZED NUMBER "3" WITH A HORIZONTAL, THREE-PRONGED FORK JUTTING OUT TO THE RIGHT FROM THE MIDDLE OF THE NUMBER "3". FOR METAL GUN VAULTS (U.S. CLS. 2, 12, 13, 14, 23, 25 AND 50). FIRST USE 2-0-2010; IN COMMERCE 2-0-2010.

3,955,889. THREE FORKS RANCH CORP., ST. LOUIS, MO. SN 78-981,454. PUB. 11-21-2006, FILED 4-12-2006.



THE MARK CONSISTS OF A STYLIZED NUMBER "3" WITH A HORIZONTAL, THREE-PRONGED FORK JUTTING OUT TO THE RIGHT FROM THE MIDDLE OF THE NUMBER "3"; BENEATH THAT IS THE PHRASE "THREE FORKS", WHICH IS OVER LINED AND UNDERLINED WITH HORIZONTAL LINES; THE OVER LINE ALSO HAS A HORSE-SHOE SHAPED SEMI-CIRCLE THAT ARCS AROUND THE STYLIZED NUMBER "3"; THE TOPS OF THE LETTERS "T" AND "H" IN "THREE" AND "K" IN "FORKS" FUNCTION AS THE OVER LINE ABOVE THE PHRASE "THREE FORKS"; BENEATH THE UNDERLINE IS THE WORD "RANCH", WITH A BREAK IN THE UNDERLINE FOR THE TOP OF THE LETTERS "R" AND "H" IN "RANCH". FOR METAL GUN VAULTS (U.S. CLS. 2, 12, 13, 14, 23, 25 AND 50). FIRST USE 2-0-2010; IN COMMERCE 2-0-2010.

3,955,708. ALCOA INC., PITTSBURGH, PA. SN 77-937,853. PUB. 7-13-2010, FILED 2-17-2010.

**FLITE-TITE**

THE MARK CONSISTS OF STANDARD CHARACTERS WITHOUT CLAIM TO ANY PARTICULAR FONT, STYLE, SIZE, OR COLOR. FOR METAL FASTENERS, NAMELY, BLIND FASTENERS, CAPTIVE FASTENERS, THREADED FASTENERS, NUTS, BOLTS, LOCK BOLTS AND RIVETS (U.S. CLS. 2, 12, 13, 14, 23, 25 AND 50). FIRST USE 3-4-2011; IN COMMERCE 3-4-2011.

**CLASS 6—(Continued).**

3,956,009. GRAY METAL SOUTH, INC., DUNN, NC. SN 85-055,841. PUB. 11-16-2010, FILED 6-7-2010.

# PRE-SEAL

THE MARK CONSISTS OF STANDARD CHARACTERS WITHOUT CLAIM TO ANY PARTICULAR FONT, STYLE, SIZE, OR COLOR.

FOR VENTILATING DUCTS OF METAL (U.S. CLS. 2, 12, 13, 14, 23, 25 AND 50).

FIRST USE 3-10-2011; IN COMMERCE 3-10-2011.

**CLASS 7—MACHINERY**

3,955,157. WILSON, JACK H., SR., RIDGELAND, MS. SN 76-678,931. PUB. 12-4-2007, FILED 6-29-2007.

# SKIDMASTER

THE MARK CONSISTS OF STANDARD CHARACTERS WITHOUT CLAIM TO ANY PARTICULAR FONT, STYLE, SIZE, OR COLOR.

FOR PNEUMATICALLY OPERATED SPRAYING EQUIPMENT (U.S. CLS. 13, 19, 21, 23, 31, 34 AND 35).

FIRST USE 11-30-2008; IN COMMERCE 11-30-2008.

**CLASS 7—(Continued).**

THE MARK CONSISTS OF A PINK AND WHITE WINE GLASS, A PINK AND WHITE MARTINI GLASS AND A PINK AND WHITE COFFEE CUP AND SAUCER ALL OUTLINED IN BLACK. THE COLOR BLACK IS USED TO OUTLINE THE DESIGN ELEMENTS AND IS NOT CLAIMED AS A FEATURE OF THE MARK.

FOR COMPONENT FEATURE OF DISHWASHING MACHINES, NAMELY, A GENTLE WASH CYCLE (U.S. CLS. 13, 19, 21, 23, 31, 34 AND 35).

FIRST USE 8-0-2010; IN COMMERCE 8-0-2010.

3,955,356. SEARS BRANDS, LLC, HOFFMAN ESTATES, IL. SN 77-769,057. PUB. 6-8-2010, FILED 6-26-2009.



THE COLOR(S) WHITE AND GRAY IS/ARE CLAIMED AS A FEATURE OF THE MARK.

THE MARK CONSISTS OF A GRAY AND WHITE POT AND A GRAY AND WHITE FRYING PAN.

FOR COMPONENT FEATURE OF DISHWASHING MACHINES, NAMELY, A HEAVY WASH CYCLE FOR POTS AND PANS (U.S. CLS. 13, 19, 21, 23, 31, 34 AND 35).

FIRST USE 8-0-2010; IN COMMERCE 8-0-2010.

3,955,355. SEARS BRANDS, LLC, HOFFMAN ESTATES, IL. SN 77-769,030. PUB. 6-15-2010, FILED 6-26-2009.



THE COLOR(S) WHITE AND PINK IS/ARE CLAIMED AS A FEATURE OF THE MARK.

3,955,357. SEARS BRANDS, LLC, HOFFMAN ESTATES, IL. SN 77-769,228. PUB. 6-15-2010, FILED 6-26-2009.



THE COLOR(S) WHITE AND ORANGE IS/ARE CLAIMED AS A FEATURE OF THE MARK.

**CLASS 7—(Continued).**

THE MARK CONSISTS OF AN ORANGE AND WHITE CLOCK AND WATER DROP OUTLINED IN BLACK. A WHITE "1" APPEARS INSIDE THE WATER DROP. THE COLOR BLACK IN THE DRAWING ONLY REPRESENTS OUTLINING AND IS NOT PART OF THE MARK.

FOR COMPONENT FEATURE OF DISHWASHING MACHINES, NAMELY, A TIMED WASH CYCLE (U.S. CLS. 13, 19, 21, 23, 31, 34 AND 35).

FIRST USE 8-0-2010; IN COMMERCE 8-0-2010.

3,955,358. SEARS BRANDS, LLC, HOFFMAN ESTATES, IL. SN 77-769,235. PUB. 6-15-2010, FILED 6-26-2009.



THE COLOR(S) WHITE AND BLUE IS/ARE CLAIMED AS A FEATURE OF THE MARK.

THE MARK CONSISTS OF THREE BLUE AND WHITE WATER DROPS OUTLINED IN BLACK, WITH THREE HORIZONTAL WHITE LINES POSITIONED ADJACENT TO ONE OF THE DROPS AND OUTLINED IN BLACK. THE COLOR BLACK IN THE DRAWING ONLY REPRESENTS OUTLINING AND IS NOT PART OF THE MARK.

FOR COMPONENT FEATURE OF DISHWASHING MACHINES, NAMELY, A QUICK RINSE CYCLE (U.S. CLS. 13, 19, 21, 23, 31, 34 AND 35).

FIRST USE 8-0-2010; IN COMMERCE 8-0-2010.

3,955,359. SEARS BRANDS, LLC, HOFFMAN ESTATES, IL. SN 77-769,341. PUB. 7-13-2010, FILED 6-26-2009.



THE COLOR(S) WHITE AND BLUE IS/ARE CLAIMED AS A FEATURE OF THE MARK.

**CLASS 7—(Continued).**

THE MARK CONSISTS OF A BLUE AND WHITE PLATE, A BLUE AND WHITE MUG AND A WHITE FORK. THE COLOR BLACK REPRESENTS AN OUTLINE AND IS NOT CLAIMED AS A FEATURE OF THE MARK.

FOR COMPONENT FEATURE OF DISHWASHING MACHINES, NAMELY, A WASH CYCLE (U.S. CLS. 13, 19, 21, 23, 31, 34 AND 35).

FIRST USE 8-0-2010; IN COMMERCE 8-0-2010.

3,955,404. HSM GMBH & CO. KG, FRICKINGEN, FED REP GERMANY. SN 77-806,778. PUB. 7-13-2010, FILED 8-18-2009.

**HSM**

THE MARK CONSISTS OF STANDARD CHARACTERS WITHOUT CLAIM TO ANY PARTICULAR FONT, STYLE, SIZE, OR COLOR.

FOR MACHINES, APPARATUS AND TOOLS FOR INDUSTRIAL PURPOSES, WHICH ARE MOTOR-DRIVEN, EITHER ELECTRICALLY, MECHANICALLY, PNEUMATICALLY, HYDRAULICALLY OR BY A COMBINED DRIVE SYSTEM AS WELL AS PARTS, SUBASSEMBLIES AND ACCESSORIES THEREOF, NAMELY, SHREDDING MACHINES FOR INDUSTRIAL, COMMERCIAL, PROFESSIONAL, OR PERSONAL PURPOSES, DOCUMENT SHREDDING MACHINES, DOCUMENT SHREDDERS FOR INDUSTRIAL USE, DOCUMENT SHREDDERS FOR INDUSTRIAL USE WITH COMPACT-DISC AND CREDIT-CARD DESTRUCTORS, COMPACT-DISC SHREDDERS FOR INDUSTRIAL USE, CUTTING MACHINES AND STRUCTURAL PARTS FOR DOCUMENT SHREDDING MACHINES, NAMELY, STANDS FOR DOCUMENT SHREDDING MACHINES, MACHINE PARTS FOR DOCUMENT SHREDDERS AND DOCUMENT SHREDDING MACHINES, NAMELY, COLLECTING CONTAINERS, COLLECTING POUCHES AND COLLECTING BAGS AS MACHINE PARTS; MACHINES, NAMELY, MACHINES PRIMARILY COMPRISED OF DOCUMENT SHREDDERS AND DOCUMENT SHREDDING MACHINES; DATA-CARRIER SHREDDING MACHINES FOR INDUSTRIAL USE, NAMELY, SHREDDERS FOR INDUSTRIAL PURPOSES FOR PAPER, CARDBOARD AND MATERIALS PARTLY CONTAINING PAPER AND/OR CARDBOARD, FILM MATERIALS AS WELL AS FOR DATA CARRIERS IN THE FORM OF MICROFILMS, TAPES, FILM MATERIALS, COMPACT-DISCS AND DISKETTES; CUTTING MACHINES, NAMELY, CUTTING MACHINES FOR CUTTING PAPER, CARDBOARD AND CARTONBOARD. LEVER CUTTING MACHINES, ROLLER CUTTING MACHINES; INDUSTRIAL MACHINE PRESSES FOR THE PRODUCING OF BALES OF WASTE MATERIALS, NAMELY, FULLY AUTOMATIC INDUSTRIAL MACHINE PRESSES, NAMELY, BALING PRESSES WITH ELECTROHYDRAULIC DRIVE SYSTEMS; MACHINE PARTS FOR SHREDDING MACHINES AND INDUSTRIAL BALING MACHINE PRESSES, NAMELY, WASTE PAPER BASKETS AS PARTS OF SHREDDING MACHINES; SHREDDING MACHINES FOR INDUSTRIAL PURPOSES; CUTTING MACHINES AND MACHINE PARTS FOR SHREDDING MACHINES, NAMELY, STANDS FOR SHREDDING MACHINES FOR INDUSTRIAL, COMMERCIAL, PROFESSIONAL OR PERSONAL PURPOSES AS WELL AS MACHINES, NAMELY, MACHINES PRIMARILY COMPRISED OF SHREDDING MACHINES AND INDUSTRIAL MACHINE PRESSES, NAMELY, BALING PRESSES FOR INDUSTRIAL, COMMERCIAL, PROFESSIONAL OR PERSONAL PURPOSES (U.S. CLS. 13, 19, 21, 23, 31, 34 AND 35).

FIRST USE 0-0-2009; IN COMMERCE 0-0-2009.

**CLASS 7—(Continued).**

3,955,581. POET, LLC, SIOUX FALLS, SD. SN 77-907,312. PUB. 5-25-2010, FILED 1-7-2010.



THE MARK CONSISTS OF A STYLIZED DRAWING OF A TOAD HEAD WITHIN A HEXAGON SHAPED CUPPED WITHIN A HALF HEXAGON.

FOR LOADING MACHINES FOR DISPENSING AND LOADING GRAIN AND OTHER PARTICULATE MATTER INTO RAIL CARS, TRACTOR TRAILERS, AND OTHER VEHICLES AND CONTAINERS FOR TRANSPORTATION AND STORAGE (U.S. CLS. 13, 19, 21, 23, 31, 34 AND 35).

FIRST USE 3-9-2010; IN COMMERCE 3-9-2010.

3,955,583. MOTEURS LEROY-SOMER, 16000 ANGOULEME, FRANCE. SN 77-907,542. PUB. 7-13-2010, FILED 1-8-2010.



OWNER OF U.S. REG. NOS. 2,638,652 AND 2,731,549. THE STIPPLING IS A FEATURE OF THE MARK AND DOES NOT INDICATE COLOR.

THE MARK CONSISTS OF THE STYLIZED LETTERS "H", "P", "M" WITH A CIRCULAR DESIGN COMPRISED OF AN ARROW, AND A SQUARE ABOVE THE LETTER "P" IN "H", "P", "M".

FOR ELECTRIC GENERATORS; ELECTRIC MOTORS FOR MACHINES; ELECTRIC VARIATORS FOR ELECTRIC MOTORS AND ELECTRIC GENERATORS; ALTERNATORS FOR LAND VEHICLES; STARTERS FOR MOTORS AND ENGINES; GENERATORS FOR LAND VEHICLES (U.S. CLS. 13, 19, 21, 23, 31, 34 AND 35).

FIRST USE 3-29-2010; IN COMMERCE 3-29-2010.

**CLASS 7—(Continued).**

3,955,591. BARNES DE MEXICO, S.A. DE C.V., MONTERREY, NUEVO LEON, MEXICO. SN 77-911,104. PUB. 6-1-2010, FILED 1-13-2010.



THE MARK CONSISTS OF CIRCLE DESIGN WITH TWO HORIZONTAL LINES AT THE BOTTOM AND UNDERNEATH THE DESIGN IS THE WORDING "BARMESA".

THE WORDING "BARMESA" HAS NO MEANING IN A FOREIGN LANGUAGE.

FOR PUMPS, SPECIFICALLY FLUID PUMPS, CENTRIFUGAL PUMPS, SELF PRIMING PUMPS, GRINDER PUMPS, SUBMERSIBLE PUMPS AND EFFLUENT PUMPS (U.S. CLS. 13, 19, 21, 23, 31, 34 AND 35).

FIRST USE 1-24-2011; IN COMMERCE 1-24-2011.

3,955,612. BISSELL HOMECARE, INC., GRAND RAPIDS, MI. SN 77-918,110. PUB. 6-8-2010, FILED 1-22-2010.

## VAC&SHINE

THE MARK CONSISTS OF STANDARD CHARACTERS WITHOUT CLAIM TO ANY PARTICULAR FONT, STYLE, SIZE, OR COLOR.

FOR VACUUM CLEANERS AND PARTS THEREFOR (U.S. CLS. 13, 19, 21, 23, 31, 34 AND 35).

FIRST USE 9-20-2010; IN COMMERCE 9-20-2010.

3,955,790. JURA CAPRESSO, INC., CLOSTER, NJ. SN 77-955,152. PUB. 8-3-2010, FILED 3-10-2010.

## froth PRO

THE MARK CONSISTS OF STANDARD CHARACTERS WITHOUT CLAIM TO ANY PARTICULAR FONT, STYLE, SIZE, OR COLOR.

NO CLAIM IS MADE TO THE EXCLUSIVE RIGHT TO USE "FROTH", APART FROM THE MARK AS SHOWN.

FOR ELECTRIC MILK FROTHERS (U.S. CLS. 13, 19, 21, 23, 31, 34 AND 35).

FIRST USE 5-1-2010; IN COMMERCE 5-1-2010.

**CLASS 7—(Continued).**

3,955,814. MARK VII EQUIPMENT INC., ARVADA, CO. SN 77-963,404. PUB. 11-9-2010, FILED 3-19-2010.

**JETWASH**

THE MARK CONSISTS OF STANDARD CHARACTERS WITHOUT CLAIM TO ANY PARTICULAR FONT, STYLE, SIZE, OR COLOR.

FOR CAR WASHING EQUIPMENT, NAMELY, MACHINES FOR WASHING THE EXTERIOR SURFACE OF AN AUTOMOTIVE VEHICLE, WHERE THE EQUIPMENT IS TO BE MANUALLY OPERATED BY THE USER (U.S. CLS. 13, 19, 21, 23, 31, 34 AND 35).

FIRST USE 12-22-2010; IN COMMERCE 12-22-2010.

3,955,932. SMART PROCUREMENT SERVICES USA, LLC, DBA SIRRUSH MUFFLERS, RAINIER, WA. SN 85-016,541. PUB. 9-21-2010, FILED 4-17-2010.



THE MARK CONSISTS OF THE WORD "SIRRUSH" STYLIZED, WHERE THE "S" IS REPRESENTED BY A DRAGON IN THAT FORM.

FOR CATALYTIC CONVERTER UNITS FOR VEHICLE EXHAUSTS; CATALYTIC CONVERTERS; CATALYTIC CONVERTERS FOR MOTORS AND ENGINES; EMISSION REDUCTION UNITS FOR MOTORS AND ENGINES, NAMELY, CATALYTIC CONVERTERS; ENGINE EXHAUST SYSTEMS COMPRISED OF PIPES, COLLECTOR AND MUFFLER; ENGINE EXHAUST TIPS; ENGINE MUFFLERS; ENGINE OR MOTOR MUFFLERS; MOTOR MUFFLERS; MUFFLERS FOR MOTORS AND ENGINES (U.S. CLS. 13, 19, 21, 23, 31, 34 AND 35).

FIRST USE 11-1-2009; IN COMMERCE 11-1-2009.

**CLASS 7—(Continued).**

3,955,952. PETRUKHIN, EVGENY, LIMASSOL, CYPRUS. SN 85-024,346. PUB. 7-27-2010, FILED 4-27-2010.

**HIJECTOR**

THE MARK CONSISTS OF STANDARD CHARACTERS WITHOUT CLAIM TO ANY PARTICULAR FONT, STYLE, SIZE, OR COLOR.

FOR LIQUID JET EJECTORS FOR USE IN COMPRESSION AND VACUUM SYSTEMS (U.S. CLS. 13, 19, 21, 23, 31, 34 AND 35).

FIRST USE 12-1-2010; IN COMMERCE 12-1-2010.

3,955,972. COHERENT, INC., SANTA CLARA, CA. SN 85-034,771. PUB. 8-31-2010, FILED 5-10-2010.

**METABEAM**

THE MARK CONSISTS OF STANDARD CHARACTERS WITHOUT CLAIM TO ANY PARTICULAR FONT, STYLE, SIZE, OR COLOR.

FOR MACHINES AND MACHINE TOOLS FOR THE CUTTING, ETCHING, ENGRAVING AND FORMING OF MATERIALS; LASER MACHINES FOR CUTTING, ETCHING, ENGRAVING AND FORMING OF MATERIALS (U.S. CLS. 13, 19, 21, 23, 31, 34 AND 35).

FIRST USE 3-11-2011; IN COMMERCE 3-11-2011.

3,956,045. GREENLEE TEXTRON INC., ROCKFORD, IL. SN 85-078,454. PUB. 11-16-2010, FILED 7-6-2010.

**INTELLI-BENDER**

THE MARK CONSISTS OF STANDARD CHARACTERS WITHOUT CLAIM TO ANY PARTICULAR FONT, STYLE, SIZE, OR COLOR.

FOR CONDUIT, PIPE AND TUBE BENDING MACHINES (U.S. CLS. 13, 19, 21, 23, 31, 34 AND 35).

FIRST USE 11-30-2010; IN COMMERCE 11-30-2010.

**CLASS 8—HAND TOOLS**



**CLASS 8—(Continued).**

3,955,282. KIEPE DI TODESCHINI BRUNO, CODEGA GIOVANNA E C. S.N.C., PREMANA (LC), ITALY. SN 77-638,420. PUB. 11-17-2009, FILED 12-22-2008.



THE MARK CONSISTS OF AN IMAGE OF A GLOBE WITH THE WORDING "KIEPE" OVER THE GLOBE AND THE WORDING "KIEPE" UNDER THE GLOBE.

THE ENGLISH TRANSLATION OF "KIEPE" IN THE MARK IS PANNIER.

FOR HAND TOOLS AND HAND-OPERATED IMPLEMENTS, NAMELY, SCISSORS, PLIERS, PINNERS, CUTLERY; RAZORS; PEDICURE IMPLEMENTS, NAMELY, NAIL FILES, NAIL CLIPPERS, CUTICLE PUSHERS, TWEEZERS, NAIL AND CUTICLE SCISSORS, PEDICURE SETS; KNIVES; SCISSORS; NAIL SCISSORS; DEPILATORY APPLIANCES, ELECTRIC AND NON-ELECTRIC; HAIR CLIPPERS FOR PERSONAL USE, ELECTRIC AND NON-ELECTRIC; HAIR-REMOVING TWEEZERS; NAIL EXTRACTORS IN THE NATURE OF MANICURE IMPLEMENTS, PLIERS; RAZORS, ELECTRIC OR NON-ELECTRIC (U.S. CLS. 23, 28 AND 44).

FIRST USE 11-23-1981; IN COMMERCE 7-7-2004.

**CLASS 8—(Continued).**

3,955,389. DH EMPRESAS S.A., SANTIAGO, CHILE. SN 77-795,162. PUB. 4-6-2010, FILED 8-3-2009.

**CASAIDEAS**

THE MARK CONSISTS OF STANDARD CHARACTERS WITHOUT CLAIM TO ANY PARTICULAR FONT, STYLE, SIZE, OR COLOR.

THE ENGLISH TRANSLATION OF "CASAIDEAS" IN THE MARK IS "IDEASHOUSE".

FOR NON-ELECTRIC CAN OPENERS; HAND-OPERATED SHARPENING TOOLS AND INSTRUMENTS; KNIFE SHARPENERS; MANUALLY OPERATED SHARPENERS; NON-ELECTRIC CURLING IRONS; GARDENING SHEARS AND SCISSORS; PRUNING SCISSORS; HAND TOOLS, NAMELY, PINNERS; PLIERS; PRUNING KNIVES; PRUNING SHEARS; KNIVES, FORKS AND SPOONS; TWEEZERS; SHOVELS; HAND TOOLS, NAMELY, HAMMERS; MANICURE SETS; PEDICURE SETS; SCISSORS; SCISSORS FOR HOUSEHOLD USE; SCREWDRIVERS; DEPILATORY APPLIANCES; HAND TOOLS, NAMELY, NAIL SETS; NAIL CLIPPERS; NAIL SCISSORS; HAIR TRIMMERS; HAIR CLIPPERS; HAND-OPERATED HAIR CLIPPERS; HAND-OPERATED LAWN EDGERS; LAWN MAINTENANCE EQUIPMENT, NAMELY, LAWN ROLLERS; LAWN RAKES; ELECTRIC AND BATTERY-POWERED HAIR TRIMMERS; MEAT TENDERIZER, NAMELY, A KITCHEN Mallet; MEAT TENDERIZER, NAMELY, A PRONGED INSTRUMENT FOR POUNDING MEAT; HAND TOOLS, NAMELY, HAND-OPERATED PUMPS; VEGETABLE KNIVES; VEGETABLE SLICERS (U.S. CLS. 23, 28 AND 44).

FIRST USE 11-18-2010; IN COMMERCE 11-18-2010.

3,955,308. TOMLINSON, WILLIAM J., GREENVILLE, VA. SN 77-685,701. PUB. 7-7-2009, FILED 3-6-2009.

**HOOF ESSENTIALS**

THE MARK CONSISTS OF STANDARD CHARACTERS WITHOUT CLAIM TO ANY PARTICULAR FONT, STYLE, SIZE, OR COLOR.

NO CLAIM IS MADE TO THE EXCLUSIVE RIGHT TO USE "HOOF", APART FROM THE MARK AS SHOWN.

FOR ABRADING TOOLS; FILES; FOOT CARE IMPLEMENTS, NAMELY, FOOT FILES; HAND TOOLS, NAMELY, FILES; HAND TOOLS, NAMELY, RASPS; HAND TOOLS, NAMELY, SANDERS; HAND TOOLS, NAMELY, SCRAPERS (U.S. CLS. 23, 28 AND 44).

FIRST USE 1-1-2011; IN COMMERCE 1-1-2011.

3,955,765. CAMBRIDGE SILVERSMITHS LTD., INC., FAIRFIELD, NJ. SN 77-949,045. PUB. 7-27-2010, FILED 3-3-2010.

**UNFORGETTABLE STYLE,  
UNBELIEVABLE VALUE**

THE MARK CONSISTS OF STANDARD CHARACTERS WITHOUT CLAIM TO ANY PARTICULAR FONT, STYLE, SIZE, OR COLOR.

OWNER OF U.S. REG. NO. 3,152,016.  
FOR FLATWARE, NAMELY, FORKS, KNIVES, AND SPOONS (U.S. CLS. 23, 28 AND 44).

FIRST USE 12-1-2010; IN COMMERCE 12-1-2010.

**CLASS 8—(Continued).**

3,955,830. RAYMOND SMITH, DBA FREEWIRE, OHSWEN, ONTARIO, CANADA. SN 77-969,837. PUB. 10-5-2010, FILED 3-26-2010.

# FREEWIRE

THE MARK CONSISTS OF STANDARD CHARACTERS WITHOUT CLAIM TO ANY PARTICULAR FONT, STYLE, SIZE, OR COLOR.

FOR TATTOO MACHINES, NAMELY, WIRELESS TATTOO MACHINES, AND WIRELESS TATTOO MACHINE PARTS, NAMELY, BATTERIES, WIRELESS CONTROL-SIGNAL COMMUNICATION TRANSMITTERS, AND WIRELESS CONTROL-SIGNAL COMMUNICATION RECEIVERS, ALL SOLD AS A UNIT THEREWITH (U.S. CLS. 23, 28 AND 44).

FIRST USE 8-22-2010; IN COMMERCE 8-22-2010.

**CLASS 9—ELECTRICAL AND SCIENTIFIC APPARATUS**

3,955,162. BADAWAL INVESTMENTS, INC., DBA CERTIS IMAGING, WARREN, MI. SN 76-698,042. PUB. 7-6-2010, FILED 6-23-2009.

# MARS

THE MARK CONSISTS OF STANDARD CHARACTERS WITHOUT CLAIM TO ANY PARTICULAR FONT, STYLE, SIZE, OR COLOR.

FOR COMPUTER ARCHIVAL RETRIEVAL SYSTEM COMPRISED PRIMARILY OF SOFTWARE FOR SCANNING, WORKFLOW MANAGEMENT AND DOCUMENT IMAGING FOR USE IN THE FIELD OF DEFAULT AND DISTRESSED PROPERTY MANAGEMENT; COMPUTER SOFTWARE FOR SCANNING, MANAGING WORKFLOW, DOCUMENT IMAGING AND ARCHIVAL RETRIEVAL OF SCANNED DOCUMENTS FOR USE IN THE FIELD OF DEFAULT AND DISTRESSED PROPERTY MANAGEMENT (U.S. CLS. 21, 23, 26, 36 AND 38).

FIRST USE 1-12-2007; IN COMMERCE 1-12-2007.

**CLASS 9—(Continued).**

3,955,165. AMX LLC, RICHARDSON, TX. SN 76-700,920. PUB. 5-18-2010, FILED 12-18-2009.

# INSTAGATE

THE MARK CONSISTS OF STANDARD CHARACTERS WITHOUT CLAIM TO ANY PARTICULAR FONT, STYLE, SIZE, OR COLOR.

FOR FEATURE OF HDMJ (HIGH-DEFINITION MULTIMEDIA INTERFACE) APPARATUS AND COMPONENT CABLES SOLD AS A UNIT, NAMELY, AN HDMI SWITCH THAT ELIMINATES LATENCY ON ALL DISPLAYS BY PREAUTHORIZING ALL CONNECTED SOURCE AND DESTINATION DEVICES TO SATISFY HDCP AUTHORIZATION THEREBY ALLOWING INTERRUPTION FREE DELIVERY OF ALL HDMI CONTENT (U.S. CLS. 21, 23, 26, 36 AND 38).

FIRST USE 9-20-2009; IN COMMERCE 8-17-2010.

3,955,180. BALTIMORE GAS AND ELECTRIC COMPANY, BALTIMORE, MD. SN 77-083,471. PUB. 12-18-2007, FILED 1-16-2007.

# A BGE SMART ENERGY SAVERS PROGRAM

THE MARK CONSISTS OF STANDARD CHARACTERS WITHOUT CLAIM TO ANY PARTICULAR FONT, STYLE, SIZE, OR COLOR.

OWNER OF U.S. REG. NOS. 1,964,556, 2,596,900, AND OTHERS.

NO CLAIM IS MADE TO THE EXCLUSIVE RIGHT TO USE "SMART ENERGY SAVERS", APART FROM THE MARK AS SHOWN.

FOR SMART AIR CONDITIONER SWITCHES THAT CONTROL ENERGY SYSTEM LOADS IN HOMES (U.S. CLS. 21, 23, 26, 36 AND 38).

FIRST USE 3-4-2011; IN COMMERCE 3-4-2011.

3,955,193. IGT, RENO, NV. SN 77-220,747. PUB. 8-24-2010, FILED 7-2-2007.

# ULTIMATE X POKER

THE MARK CONSISTS OF STANDARD CHARACTERS WITHOUT CLAIM TO ANY PARTICULAR FONT, STYLE, SIZE, OR COLOR.

NO CLAIM IS MADE TO THE EXCLUSIVE RIGHT TO USE "POKER", APART FROM THE MARK AS SHOWN.

FOR GAMING MACHINES, NAMELY, DEVICES WHICH ACCEPT A WAGER (U.S. CLS. 21, 23, 26, 36 AND 38).

FIRST USE 10-16-2008; IN COMMERCE 1-13-2009.

**CLASS 9—(Continued).**

3,955,196. A QUANTUM MOMENT, LLC, RANCHO SANTA FE, CA. SN 77-227,300. PUB. 1-1-2008, FILED 7-11-2007.

**A QUANTUM MOMENT**

THE MARK CONSISTS OF STANDARD CHARACTERS WITHOUT CLAIM TO ANY PARTICULAR FONT, STYLE, SIZE, OR COLOR.

NO CLAIM IS MADE TO THE EXCLUSIVE RIGHT TO USE "QUANTUM", APART FROM THE MARK AS SHOWN.

FOR PRE-RECORDED CDS FEATURING INFORMATION IN THE FIELDS OF PARAPSYCHOLOGY, QUANTUM PHYSICS, QUANTUM ENERGY, ALTERNATIVE HEALING PRACTICES, SPONTANEOUS REMISSION, CONSCIOUSNESS, MIND, PSI AND PSYCHIC PHENOMENA; DOWNLOADABLE MP3 FILES, MP3 RECORDINGS, AND POD CASTS IN THE FIELDS OF PARAPSYCHOLOGY, QUANTUM PHYSICS, QUANTUM ENERGY, ALTERNATIVE HEALING PRACTICES, SPONTANEOUS REMISSION, CONSCIOUSNESS, MIND, PSI AND PSYCHIC PHENOMENA (U.S. CLS. 21, 23, 26, 36 AND 38).

FIRST USE 6-0-2008; IN COMMERCE 6-0-2008.

3,955,217. COMPUTER TECHNOLOGY LINK CORP., PORTLAND, OR. SN 77-431,254. PUB. 11-9-2010, FILED 3-25-2008.

**2GO PC**

THE MARK CONSISTS OF STANDARD CHARACTERS WITHOUT CLAIM TO ANY PARTICULAR FONT, STYLE, SIZE, OR COLOR.

NO CLAIM IS MADE TO THE EXCLUSIVE RIGHT TO USE "PC", APART FROM THE MARK AS SHOWN.

FOR LAPTOP COMPUTERS (U.S. CLS. 21, 23, 26, 36 AND 38).

FIRST USE 5-1-2008; IN COMMERCE 5-1-2008.

3,955,235. HUBBELL INCORPORATED, SHELTON, CT. SN 77-513,465. PUB. 10-28-2008, FILED 7-2-2008.

**RED ALERT**

THE MARK CONSISTS OF STANDARD CHARACTERS WITHOUT CLAIM TO ANY PARTICULAR FONT, STYLE, SIZE, OR COLOR.

**CLASS 9—(Continued).**

OWNER OF U.S. REG. NO. 2,565,052.

FOR EMERGENCY TELEPHONE AND INTERCOM SYSTEMS, COMPRISED OF TELEPHONES, INTERCOMS, KEYPADS, SPEAKERS, TELEPHONE RECEIVERS, LIGHTS FOR PUBLIC, INSTITUTIONAL AND INDUSTRIAL USE (U.S. CLS. 21, 23, 26, 36 AND 38).

FIRST USE 2-28-2011; IN COMMERCE 2-28-2011.

3,955,252. GIANT INTERNATIONAL (USA), LTD, ATLANTA, GA. SN 77-566,831. PUB. 8-4-2009, FILED 9-10-2008.



THE MARK CONSISTS OF THE MARK "INTOUCH" WITH THE LETTERS "IN" ENCASED IN A SHADED POLYGONAL GRAPHIC.

FOR DIGITAL PHOTO FRAMES FOR DISPLAYING PICTURES, VIDEO CLIPS, OR PLAYING MUSIC; CORDLESS TELEPHONES (U.S. CLS. 21, 23, 26, 36 AND 38).

FIRST USE 12-15-2008; IN COMMERCE 12-15-2008.

3,955,283. JURNEY, FORREST, PALM BEACH GARDENS, FL. SN 77-643,207. PUB. 7-7-2009, FILED 1-5-2009.

**AGAPE FOOTBALL**

THE MARK CONSISTS OF STANDARD CHARACTERS WITHOUT CLAIM TO ANY PARTICULAR FONT, STYLE, SIZE, OR COLOR.

NO CLAIM IS MADE TO THE EXCLUSIVE RIGHT TO USE "FOOTBALL", APART FROM THE MARK AS SHOWN.

FOR DIGITAL MATERIALS, NAMELY, CDS, DVDS FEATURING MARRIAGE/RELATIONSHIP ADVICE WITH A FOOTBALL THEME (U.S. CLS. 21, 23, 26, 36 AND 38).

FIRST USE 8-30-2010; IN COMMERCE 8-30-2010.

**CLASS 9—(Continued).**

3,955,291. MATTHEWS RESOURCES, INC., WILMINGTON, DE. SN 77-651,969. PUB. 12-29-2009, FILED 1-19-2009.

# CHROMOS

THE MARK CONSISTS OF STANDARD CHARACTERS WITHOUT CLAIM TO ANY PARTICULAR FONT, STYLE, SIZE, OR COLOR.

FOR WEB BASED COMPUTER SOFTWARE, NAMELY, DOWNLOADABLE SOFTWARE FOR WORKFLOW AUTOMATION OF GRAPHICS DEVELOPMENT FOR PACKAGING AND DISPLAYS, COLOR DEVELOPMENT, COLOR MONITORING, AND PRINT PROJECT, PROJECT CALENDARING, EVENT AND DEADLINE TRACKING, ALERTING AND REPORTING; WEB BASED COMPUTER SOFTWARE, NAMELY, DOWNLOADABLE SOFTWARE FOR ENSURING PRINT PROJECT ADHERENCE TO COLOR AND TIMELINE REQUIREMENTS, DATA COLLECTION, DATA ANALYSIS, AND CUSTOMIZED REPORTS BY ACCEPTING CUSTOMER INPUT ON REQUIREMENTS, ACCEPTING DATA INPUTS RELATIVE TO SPECTRAL MEASUREMENTS, TIMELINE REQUIREMENTS, AND ACTUAL MILESTONE COMPLETION DATES; WEB BASED COMPUTER SOFTWARE, NAMELY, DOWNLOADABLE SOFTWARE FOR MONITORING, STORING, SEARCHING AND RETRIEVING HIGH AND LOW RESOLUTION GRAPHIC FILES, PROJECT HISTORY, TARGET SPECTRAL VALUES AND PRINTED MATERIAL TESTING RECORDS; WEB BASED COMPUTER SOFTWARE, NAMELY, DOWNLOADABLE SOFTWARE FOR REVIEWING, APPROVING, ANNOTATING, DOCUMENTING CHANGES TO, AND REJECTING HIGH AND LOW RESOLUTION GRAPHICS FILES; WEB BASED COMPUTER SOFTWARE, NAMELY, DOWNLOADABLE SOFTWARE FOR DESIGN AND PACKAGING GRAPHICS PROJECT ORDER INQUIRY, ORDER PROCUREMENT, AND TRACKING OF ONLINE ORDERS OF SERVICES, SUPPLIES AND EQUIPMENT; WEB BASED COMPUTER SOFTWARE, NAMELY, DOWNLOADABLE SOFTWARE FOR THE CREATION AND SUBMISSION OF REQUIRED PROJECT SPECIFICATIONS SO THAT A PROPOSAL MAY BE DEVELOPED; WEB BASED COMPUTER SOFTWARE, NAMELY, DOWNLOADABLE SOFTWARE FOR THE CREATION, APPROVAL, AND STORAGE OF PROJECT BRIEFS; WEB BASED COMPUTER SOFTWARE, NAMELY, DOWNLOADABLE SOFTWARE FOR STORING AND REPORTING INFORMATION CONCERNING ONLINE PURCHASES, IN THE FIELDS OF PRINT MEDIA, BRAND MANAGEMENT, PACKAGING DEVELOPMENT, GRAPHICS DEVELOPMENT, AND PRINTING OF ALL FORMS OF PACKAGING (U.S. CLS. 21, 23, 26, 36 AND 38).

FIRST USE 1-31-2009; IN COMMERCE 1-31-2009.

3,955,312. DRESSER, INC., ADDISON, TX. SN 77-692,455. PUB. 7-7-2009, FILED 3-17-2009.

# WAUKESHA

THE MARK CONSISTS OF STANDARD CHARACTERS WITHOUT CLAIM TO ANY PARTICULAR FONT, STYLE, SIZE, OR COLOR.

**CLASS 9—(Continued).**

OWNER OF U.S. REG. NOS. 571,534, 1,161,639, AND OTHERS.  
SEC. 2(F).

FOR ELECTRIC POWER CONTROL SYSTEMS FOR USE IN CONJUNCTION WITH LARGE INTERNAL COMBUSTION ENGINES FOR INDUSTRIAL SERVICE; AND ELECTRIC POWER CONTROL SYSTEMS FOR PACKAGED UNITS CONSISTING OF LARGE INTERNAL COMBUSTION ENGINES AND GENERATORS (U.S. CLS. 21, 23, 26, 36 AND 38).

FIRST USE 3-30-2004; IN COMMERCE 3-30-2004.

3,955,313. GADLER, DIEGO, TRENTO 38100, ITALY. SN 77-692,892. PUB. 7-14-2009, FILED 3-17-2009.



THE MARK CONSISTS OF THE WORD "ANIMA" WITH THE LETTER "I" REPLACED BY A HUMAN FIGURE.

FOR 3D MODELLING SOFTWARE FOR ARCHITECTS, ANIMATORS AND DESIGNERS (U.S. CLS. 21, 23, 26, 36 AND 38).

FIRST USE 3-7-2011; IN COMMERCE 3-7-2011.

3,955,314. JW ELECTRONICS CO., LTD., TAIPEI, TAIWAN. SN 77-696,120. PUB. 9-28-2010, FILED 3-20-2009.



NO CLAIM IS MADE TO THE EXCLUSIVE RIGHT TO USE "AOE ENABLER", APART FROM THE MARK AS SHOWN.

THE MARK CONSISTS OF THE LETTERS "AOE" ABOVE A SET OF THREE INCLINED DISKS, EACH HAVING A NOTCH FORMING A STYLIZED INCLINED "E" ADJACENT TO THE LETTERS "NABLER". THE LETTERS "AOE" APPEAR MOSTLY IN FRONT OF AN INCOMPLETE BACKGROUND SQUARE, BUT WITH THE "E" PARTIALLY DISPLAYED OVER THE DISKS DESIGN.

FOR INTEGRATED CIRCUITS; COMPUTER MEMORIES; COMPUTER PERIPHERAL DEVICES; RECORDED COMPUTER PROGRAMS, DOWNLOADABLE COMPUTER PROGRAMS AND RECORDED COMPUTER SOFTWARE, ALL FOR CONTROLLING PROCESS OR OPERATION IN THE CONNECTION OF A REMOTE DATA STORAGE DEVICE TO A COMPUTER NETWORK; BLANK MAGNETIC DATA CARRIERS; BLANK OPTICAL DATA CARRIERS; DATA PROCESSING EQUIPMENT; DISK DRIVES FOR COMPUTERS; BLANK MAGNETIC DISCS; NOTEBOOK COMPUTERS; COMPUTER GAME PROGRAMS; RECORDED COMPUTER OPERATING PROGRAMS; COMPUTERS; INTERFACES FOR COMPUTERS (U.S. CLS. 21, 23, 26, 36 AND 38).

FIRST USE 7-24-2009; IN COMMERCE 7-24-2009.

**CLASS 9—(Continued).**

3,955,316. THE LINCOLN ELECTRIC COMPANY, CLEVELAND, OH. SN 77-698,008. PUB. 7-6-2010, FILED 3-24-2009.



OWNER OF U.S. REG. NOS. 2,350,082, 3,097,708, AND OTHERS.

NO CLAIM IS MADE TO THE EXCLUSIVE RIGHT TO USE "ELECTRIC GREEN INITIATIVE", APART FROM THE MARK AS SHOWN.

THE COLOR(S) GREEN, YELLOW, WHITE, GRAY AND BLACK IS/ARE CLAIMED AS A FEATURE OF THE MARK.

THE MARK CONSISTS OF THE RECTANGULAR CARRIER OUTLINED IN GRAY WITH BLACK BORDERS; THE CARRIER HAS A CIRCULAR END ON THE LEFT SIDE OUTLINED IN GRAY; WITHIN THE RECTANGULAR PORTION IS THE WORDING "THE LINCOLN ELECTRIC GREEN INITIATIVE" IN WHITE ON A GREEN BACKGROUND; BELOW THE WORDING IS AN OPEN WHITE SPACE; WITHIN THE CIRCULAR END IS A GREEN LEAF DESIGN WITH WHITE VEINS ON A WHITE BACKGROUND WITH YELLOW SHADING BELOW THE DESIGN.

FOR ENERGY-SAVING INVERTERS (U.S. CLS. 21, 23, 26, 36 AND 38).

FIRST USE 3-1-2009; IN COMMERCE 3-1-2009.

3,955,318. QUALCOMM SERVICES LABS, INC., SAN DIEGO, CA. SN 77-702,618. PUB. 7-28-2009, FILED 3-30-2009.

# VIVE

THE MARK CONSISTS OF STANDARD CHARACTERS WITHOUT CLAIM TO ANY PARTICULAR FONT, STYLE, SIZE, OR COLOR.

FOR COMPUTER SOFTWARE, NAMELY, COMPUTER SOFTWARE DEVELOPMENT TOOLS; COMPUTER SOFTWARE USED TO FACILITATE INTERFACES BETWEEN COMPUTER SOFTWARE AND/OR COMPUTER HARDWARE USED IN WIRELESS COMMUNICATION DEVICES, OR WITHIN MIXED NETWORKS EMPLOYING WIRELESS AND NON-WIRELESS COMMUNICATION DEVICES; COMPUTER SOFTWARE APPLICATIONS FOR CERTIFYING THAT OTHER COMPUTER SOFTWARE APPLICATIONS MEET CERTAIN STANDARDS; COMPUTER SOFTWARE USED TO INTERPRET INFORMATION, AND TO INTEGRATE, INTERPRET AND ORGANIZE DATA BETWEEN DIFFERENT WIRELESS AND/OR NON-WIRELESS DEVICES AND COMPUTER SOFTWARE APPLICATIONS; COMPUTER SOFTWARE FOR DEVELOPING AND MANAGING DISTRIBUTED APPLICATION COMPUTER SOFTWARE IN A WIRELESS OR MIXED NETWORK EMPLOYING WIRELESS AND NON-WIRELESS COMMUNICATION INTERFACES; COMPUTER SOFTWARE FOR USE IN ADVERTISING AND MARKETING, NAMELY, PROMOTING THE GOODS AND SERVICES OF OTHERS; COMPUTER SOFTWARE FOR DISSEMINATION OF ADVERTISING FOR OTHERS VIA AN ON-LINE COMMUNICATIONS NETWORK ON THE INTER-

**CLASS 9—(Continued).**

NET; COMPUTER SOFTWARE FOR MARKETING, ADVERTISING AND PROMOTING THE RETAIL GOODS AND SERVICES OF OTHERS TO WIRELESS COMMUNICATION DEVICES AND/OR COMPUTERS; COMPUTER SOFTWARE FOR SHOPPING GOODS AND SERVICES OF OTHERS USED IN WIRELESS COMMUNICATION DEVICES AND/OR COMPUTERS, NON-WIRELESS COMMUNICATION DEVICES AND/OR COMPUTERS, OR MIXED NETWORKS EMPLOYING WIRELESS AND NON-WIRELESS COMMUNICATION DEVICES AND/OR COMPUTERS; COMPUTER SOFTWARE FOR SHOPPING RETAIL GOODS AND SERVICES OF OTHERS USED IN WIRELESS COMMUNICATION DEVICES AND/OR COMPUTERS, NON-WIRELESS COMMUNICATION DEVICES AND/OR COMPUTERS, OR MIXED NETWORKS EMPLOYING WIRELESS AND NON-WIRELESS COMMUNICATION DEVICES AND/OR COMPUTERS; COMPUTER SOFTWARE FOR COMMUNICATIONS BETWEEN MEMBERS OF AN ON-LINE COMMUNITY (U.S. CLS. 21, 23, 26, 36 AND 38).

FIRST USE 6-30-2010; IN COMMERCE 6-30-2010.

3,955,321. CBS STUDIOS INC., STUDIO CITY, NY. SN 77-710,079. PUB. 6-23-2009, FILED 4-8-2009.

**ACCIDENTALLY ON PURPOSE**

THE MARK CONSISTS OF STANDARD CHARACTERS WITHOUT CLAIM TO ANY PARTICULAR FONT, STYLE, SIZE, OR COLOR.

FOR VIDEOCASSETTES, LASER DISCS, AND DIGITAL VIDEO DISCS/DIGITAL VERSATILE DISCS DVD, FEATURING PRE-RECORDED ENTERTAINMENT IN THE NATURE OF TELEVISION SERIES EPISODES (U.S. CLS. 21, 23, 26, 36 AND 38).

FIRST USE 10-19-2010; IN COMMERCE 10-19-2010.

3,955,334. EA INTERNATIONAL (STUDIO AND PUBLISHING) LTD., HAMILTON, BERMUDA. SN 77-735,885. PUB. 12-22-2009, FILED 5-13-2009.

# DRAGON AGE

THE MARK CONSISTS OF STANDARD CHARACTERS WITHOUT CLAIM TO ANY PARTICULAR FONT, STYLE, SIZE, OR COLOR.

OWNER OF U.S. REG. NOS. 3,298,603 AND 3,366,351.

**CLASS 9—(Continued).**

NO CLAIM IS MADE TO THE EXCLUSIVE RIGHT TO USE "DRAGON", APART FROM THE MARK AS SHOWN.

FOR COMPUTER GAME SOFTWARE; COMPUTER GAME SOFTWARE AND MANUALS SOLD AS A UNIT; COMPUTER VIDEO GAME SOFTWARE; COMPUTER VIDEO GAME SOFTWARE AND MANUALS SOLD AS A UNIT; INTERACTIVE VIDEO GAME PROGRAMS; INTERACTIVE COMPUTER GAME PROGRAMS; DOWNLOADABLE COMPUTER GAME SOFTWARE VIA A GLOBAL COMPUTER NETWORK; DOWNLOADABLE INTERACTIVE ENTERTAINMENT SOFTWARE FOR PLAYING COMPUTER GAMES; DOWNLOADABLE INTERACTIVE ENTERTAINMENT SOFTWARE FOR PLAYING VIDEO GAMES (U.S. CLS. 21, 23, 26, 36 AND 38).

FIRST USE 11-3-2009; IN COMMERCE 11-3-2009.

---

3,955,342. MINDSPEED TECHNOLOGIES, INC., NEWPORT BEACH, CA. SN 77-753,638. PUB. 10-20-2009, FILED 6-5-2009.

# Transcede

THE MARK CONSISTS OF STANDARD CHARACTERS WITHOUT CLAIM TO ANY PARTICULAR FONT, STYLE, SIZE, OR COLOR.

FOR SEMICONDUCTORS (U.S. CLS. 21, 23, 26, 36 AND 38).

FIRST USE 1-25-2010; IN COMMERCE 1-25-2010.

---

3,955,344. REVLON CONSUMER PRODUCTS CORPORATION, NEW YORK, NY. SN 77-761,598. PUB. 5-4-2010, FILED 6-17-2009.

# CURLSTAY

THE MARK CONSISTS OF STANDARD CHARACTERS WITHOUT CLAIM TO ANY PARTICULAR FONT, STYLE, SIZE, OR COLOR.

FOR ELECTRIC HAIR CURLING IRONS (U.S. CLS. 21, 23, 26, 36 AND 38).

FIRST USE 2-28-2010; IN COMMERCE 2-28-2010.

**CLASS 9—(Continued).**

3,955,353. EFFRON, MARVIN TANNER, ORLANDO, FL. SN 77-767,089. PUB. 12-15-2009, FILED 6-24-2009.

# AVERAGE JOE

THE MARK CONSISTS OF STANDARD CHARACTERS WITHOUT CLAIM TO ANY PARTICULAR FONT, STYLE, SIZE, OR COLOR.

FOR DOWNLOADABLE ELECTRONIC PUBLICATIONS IN THE NATURE OF COMIC STRIPS (U.S. CLS. 21, 23, 26, 36 AND 38).

FIRST USE 3-9-2011; IN COMMERCE 3-9-2011.

---

3,955,354. FUJINON CORPORATION, SAITAMA-KEN, JAPAN. SN 77-767,598. PUB. 11-3-2009, FILED 6-24-2009.

# HAE

THE MARK CONSISTS OF STANDARD CHARACTERS WITHOUT CLAIM TO ANY PARTICULAR FONT, STYLE, SIZE, OR COLOR.

FOR LENSES FOR CINEMATOGRAPHIC CAMERAS (U.S. CLS. 21, 23, 26, 36 AND 38).

FIRST USE 4-8-2002; IN COMMERCE 4-8-2002.

---

3,955,364. MARLIN MANUFACTURING CORPORATION, CLEVELAND, OH. SN 77-777,311. PUB. 12-1-2009, FILED 7-9-2009.

# MARLOC

THE MARK CONSISTS OF STANDARD CHARACTERS WITHOUT CLAIM TO ANY PARTICULAR FONT, STYLE, SIZE, OR COLOR.

FOR ELECTRICAL AND ELECTRONIC CONNECTORS (U.S. CLS. 21, 23, 26, 36 AND 38).

FIRST USE 6-30-2009; IN COMMERCE 1-31-2011.

**CLASS 9—(Continued).**

3,955,368. TRS QUALITY, INC., FT. WORTH, TX. SN 77-779,297. PUB. 11-24-2009, FILED 7-13-2009.



THE MARK CONSISTS OF THE LETTER "M" WITH A DOT IN ITS CENTER.

FOR POWER SUPPLY CONNECTORS AND ADAPTORS FOR USE WITH PORTABLE ELECTRONIC DEVICES (U.S. CLS. 21, 23, 26, 36 AND 38).  
FIRST USE 8-1-2010; IN COMMERCE 8-1-2010.

3,955,379. POWERTECH INDUSTRIAL CO., LTD., TAIPEI HSIEN, TAIWAN. SN 77-789,153. PUB. 6-29-2010, FILED 7-24-2009.



NO CLAIM IS MADE TO THE EXCLUSIVE RIGHT TO USE "FIREPROOF WITH BEST SURGE PROTECTION", APART FROM THE MARK AS SHOWN.

THE MARK CONSISTS OF THE WORDING "FIREPROOF WITH BEST SURGE PROTECTION" WITHIN A CONCENTRIC CIRCULAR DESIGN AND THE WORDING "X 3 INSIDE" SUPERIMPOSED OVER THE DESIGN OF A FIRE WITHIN THE CENTER CIRCLE.

FOR POWER SUPPLIES; MOBILE PHONE BATTERY CHARGERS; MOBILE PHONE BATTERY CHARGER STATIONS; BATTERY CHARGERS; UNIVERSAL POWER SUPPLIES; POWER SAVING ADAPTORS; ELECTRIC STORAGE BATTERIES; UNINTERRUPTIBLE POWER SUPPLIES; AC/DC CONVERTERS; POWER SOURCE STABLE ADAPTORS; ELECTRIC WIRES; REMOTE CONTROLLER FOR ELECTRICAL OUTLET; AUTOMATIC TIME SWITCHES; ELECTRIC PLUGS; ELECTRIC SOCKETS; POWER WIRES; SURGE ABSORBERS; RAILWAY TRAFFIC SAFETY DEVICES, NAMELY, TRACK SIGNALS AND SWITCHES; STARTER CABLES FOR MOTORS; VOLTAGE SURGE PROTECTORS (U.S. CLS. 21, 23, 26, 36 AND 38).  
FIRST USE 1-7-2010; IN COMMERCE 1-7-2010.

**CLASS 9—(Continued).**

3,955,382. SHINING UNION LIMITED, TSUEN WAN, NT, HONG KONG. SN 77-789,825. PUB. 11-23-2010, FILED 7-27-2009.

# QuickCrypt

THE MARK CONSISTS OF STANDARD CHARACTERS WITHOUT CLAIM TO ANY PARTICULAR FONT, STYLE, SIZE, OR COLOR.

FOR CALCULATING MACHINES; DATA PROCESSING EQUIPMENT AND COMPUTERS (U.S. CLS. 21, 23, 26, 36 AND 38).

FIRST USE 4-9-2009; IN COMMERCE 1-7-2010.

3,955,384. PASSIVSYSTEMS LIMITED, NEWBURY, UNITED KINGDOM. SN 77-790,801. PUB. 3-9-2010, FILED 7-28-2009.

# PassivLiving

THE MARK CONSISTS OF STANDARD CHARACTERS WITHOUT CLAIM TO ANY PARTICULAR FONT, STYLE, SIZE, OR COLOR.

FOR COMPUTERS; COMPUTER HARDWARE AND SOFTWARE FOR PROCESSING SIGNALS FROM SENSORS AND ACTUATORS; FIRMWARE FOR SWITCHING OR CONTROLLING THE FLOW OF ELECTRICITY TO ELECTRICAL DEVICES; COMPUTER HARDWARE AND SOFTWARE SYSTEM FOR REMOTELY MONITORING ENVIRONMENTAL CONDITIONS AND CONTROLLING DEVICES WITHIN A BUILDING, FACILITY, GROUNDS, OR DESIGNATED SPATIAL AREA; SOFTWARE FOR MANAGING ENERGY CONSUMPTION AND FOR PROVIDING ASSISTED LIVING AND SECURITY MONITORING SERVICES WHICH IS DOWNLOADABLE FROM THE INTERNET (U.S. CLS. 21, 23, 26, 36 AND 38).

FIRST USE 10-1-2010; IN COMMERCE 10-1-2010.

3,955,395. GLOBEXPRESS CO. LIMITED, HONG KONG, HONG KONG. SN 77-800,203. PUB. 2-23-2010, FILED 8-7-2009.



THE COLOR(S) WHITE, YELLOW, AND BLACK IS/ARE CLAIMED AS A FEATURE OF THE MARK.

**CLASS 9—(Continued).**

THE MARK CONSISTS OF A WHITE RECTANGULAR BACKGROUND, THE LETTERS "PG" IN YELLOW FORMING THE NUMBER "8", AND WORD "POWERGEN" IN BLACK.

FOR BATTERIES; BATTERIES AND BATTERY CHARGERS; CELL PHONE BATTERY CHARGERS FOR USE IN VEHICLES; CELL PHONE COVERS; HANDS FREE DEVICES FOR MOBILE-PHONES; KEYBOARDS FOR MOBILE PHONES; LAPTOP CARRYING CASES; MOBILE TELEPHONE BATTERIES; MP3 PLAYERS (U.S. CLS. 21, 23, 26, 36 AND 38).

FIRST USE 5-20-2010; IN COMMERCE 5-20-2010.

3,955,406. ACTIVEMAP LLC, BROOKLYN, NY. SN 77-807,506. PUB. 1-19-2010, FILED 8-18-2009.

# Mappo

THE MARK CONSISTS OF STANDARD CHARACTERS WITHOUT CLAIM TO ANY PARTICULAR FONT, STYLE, SIZE, OR COLOR.

FOR DOWNLOADABLE MAPS PROVIDED VIA THE INTERNET (U.S. CLS. 21, 23, 26, 36 AND 38).

FIRST USE 5-1-2010; IN COMMERCE 5-1-2010.

3,955,419. GLOBEXPRESS CO. LIMITED, HONG KONG, HONG KONG. SN 77-817,079. PUB. 1-19-2010, FILED 9-1-2009.



NO CLAIM IS MADE TO THE EXCLUSIVE RIGHT TO USE "MOBIMAN", APART FROM THE MARK AS SHOWN. THE COLOR(S) GREEN, BLUE, WHITE, BLACK IS/ARE CLAIMED AS A FEATURE OF THE MARK.

THE MARK CONSISTS OF A CIRCLE CONTAINING A GREEN BACKGROUND OVERLAPPED BY A BLUE WAVE, A WHITE LIGHTNING BOLT, CONCENTRIC INCOMPLETE CIRCLES AND CONCENTRIC INCOMPLETE BANDS IN WHITE, AND THE WORD "MOBIMAN" WITH "MOBI" IN SHADES OF GREEN AND BLUE AND WORD "MAN" IN BLACK.

FOR BATTERIES; BATTERIES AND BATTERY CHARGERS; CASES FOR MOBILE PHONES; CELL PHONE BATTERY CHARGERS; CELL PHONE COVERS; CELL PHONES; HANDS FREE DEVICES FOR MOBILE-PHONES; LAPTOP CARRYING CASES; LITHIUM IRON PHOSPHATE BATTERIES; MOBILE PHONES; MOBILE TELEPHONE BATTERIES; MP3 PLAYERS (U.S. CLS. 21, 23, 26, 36 AND 38).

FIRST USE 9-20-2009; IN COMMERCE 9-20-2009.

**CLASS 9—(Continued).**

3,955,430. ROCHE DIAGNOSTICS GMBH, 68305 MANNHEIM, FED REP GERMANY. SN 77-820,269. PUB. 7-13-2010, FILED 9-4-2009.

# REM

THE MARK CONSISTS OF STANDARD CHARACTERS WITHOUT CLAIM TO ANY PARTICULAR FONT, STYLE, SIZE, OR COLOR.

FOR LABORATORY APPARATUS FOR BIOTECHNOLOGY, NAMELY, INSTRUMENTS FOR DNA AND RNA SEQUENCING ANALYSIS AND COMPARISON; HARDWARE AND SOFTWARE FOR USE IN BIOTECHNOLOGY FOR COMPUTATIONAL ANALYSIS AND STORAGE OF DATA FROM DNA AND RNA SEQUENCING INSTRUMENTS (U.S. CLS. 21, 23, 26, 36 AND 38).

FIRST USE 8-17-2010; IN COMMERCE 8-17-2010.

3,955,445. U.S. VISION, INC., GLENDORA, NJ. SN 77-828,529. PUB. 9-14-2010, FILED 9-17-2009.

# WISEEYES

THE MARK CONSISTS OF STANDARD CHARACTERS WITHOUT CLAIM TO ANY PARTICULAR FONT, STYLE, SIZE, OR COLOR.

FOR EYEGLASS FRAMES; EYEGLASSES; EYEWEAR ACCESSORIES, NAMELY, STRAPS, NECK CORDS AND HEAD STRAPS WHICH RESTRAIN EYEWEAR FROM MOVEMENT ON A WEARER; EYEWEAR CASES; FRAMES FOR SPECTACLES AND SUNGLASSES; SUNGLASSES (U.S. CLS. 21, 23, 26, 36 AND 38).

FIRST USE 3-1-2010; IN COMMERCE 3-1-2010.

3,955,453. MONTGOMERY MOTOR SPORTS, INC., CLAYTON, OH. SN 77-835,185. PUB. 6-15-2010, FILED 9-25-2009.

# MOTOTAINMENT

THE MARK CONSISTS OF STANDARD CHARACTERS WITHOUT CLAIM TO ANY PARTICULAR FONT, STYLE, SIZE, OR COLOR.

FOR VIDEO RECORDINGS FEATURING RACING, MOTOR SPORTS, AND RELATED ACTIVITIES (U.S. CLS. 21, 23, 26, 36 AND 38).

FIRST USE 3-30-2010; IN COMMERCE 3-30-2010.



**CLASS 9—(Continued).**

3,955,465. WMS GAMING INC., WAUKEGAN, IL. SN 77-844,537. PUB. 2-2-2010, FILED 10-8-2009.

**MORE MORE MORE**

THE MARK CONSISTS OF STANDARD CHARACTERS WITHOUT CLAIM TO ANY PARTICULAR FONT, STYLE, SIZE, OR COLOR.

FOR COMPONENTS FOR GAMING MACHINES THAT GENERATE OR DISPLAY WAGER OUTCOMES, NAMELY, CONTROLLERS, DISPLAYS, BUTTON PANELS, BOLSTERS, ELECTRICAL WIRING, AND COMPUTER HARDWARE AND SOFTWARE ASSOCIATED THEREWITH; GAMING MACHINES, NAMELY, DEVICES WHICH ACCEPT A WAGER; GAMING SOFTWARE THAT GENERATES OR DISPLAYS WAGER OUTCOMES OF GAMING MACHINES (U.S. CLS. 21, 23, 26, 36 AND 38).

FIRST USE 11-16-2010; IN COMMERCE 11-16-2010.

---

3,955,467. INTELLIBRAND, INC., WAUKESHA, WI. SN 77-846,093. PUB. 7-6-2010, FILED 10-10-2009.

**IMONEY**

THE MARK CONSISTS OF STANDARD CHARACTERS WITHOUT CLAIM TO ANY PARTICULAR FONT, STYLE, SIZE, OR COLOR.

FOR ENCODED CARDS, NAMELY, MAGNETICALLY ENCODED CREDIT CARDS, MAGNETICALLY ENCODED DEBIT CARDS, MAGNETICALLY ENCODED PAYMENT CARDS, AND ENCODED SMART CARDS CONTAINING DATA AND PROGRAMMING, NAMELY, USED FOR FINANCIAL APPLICATIONS (U.S. CLS. 21, 23, 26, 36 AND 38).

FIRST USE 11-1-2010; IN COMMERCE 11-1-2010.

---

3,955,515. DAMANTRO, LLC, WALNUT CREEK, CA. SN 77-872,623. PUB. 4-13-2010, FILED 11-13-2009.

**ReviverSoft**

THE MARK CONSISTS OF STANDARD CHARACTERS WITHOUT CLAIM TO ANY PARTICULAR FONT, STYLE, SIZE, OR COLOR.

FOR COMPUTER UTILITY PROGRAMS TO IMPROVE THE PERFORMANCE OF A PC (U.S. CLS. 21, 23, 26, 36 AND 38).

FIRST USE 9-0-2009; IN COMMERCE 9-0-2009.

**CLASS 9—(Continued).**

3,955,517. IMPINJ, INC., SEATTLE, WA. SN 77-872,826. PUB. 9-21-2010, FILED 11-14-2009.

**QT**

THE MARK CONSISTS OF STANDARD CHARACTERS WITHOUT CLAIM TO ANY PARTICULAR FONT, STYLE, SIZE, OR COLOR.

FOR SYSTEMS FOR RADIO FREQUENCY IDENTIFICATION (RFID) COMMUNICATION CONSISTING OF RFID READERS, RFID TAG FOR GOODS, TAG AND READER ANTENNAS, TAG INLAYS, SOFTWARE FOR USE IN CONTROLLING RFID SYSTEMS, USER MANUALS, DATA SHEETS, INSTRUCTIONAL BROCHURES AND FLYERS IN PAPER OR ELECTRONIC FORMAT, ALL OF THE AFOREMENTIONED GOODS SOLD AS A UNIT (U.S. CLS. 21, 23, 26, 36 AND 38).

FIRST USE 2-23-2011; IN COMMERCE 2-23-2011.

---

3,955,525. TOURNAMENT ONE CORP, AKA T1 GAMING, T1, TOC, STAMFORD, CT. SN 77-875,440. PUB. 4-20-2010, FILED 11-18-2009.

**HOG'S HEAVEN**

THE MARK CONSISTS OF STANDARD CHARACTERS WITHOUT CLAIM TO ANY PARTICULAR FONT, STYLE, SIZE, OR COLOR.

FOR COMPUTER GAME SOFTWARE FOR GAMING MACHINES INCLUDING SLOT MACHINES OR VIDEO LOTTERY TERMINALS; COMPUTER GAME SOFTWARE FOR GAMING MACHINES, NAMELY, SLOT MACHINES AND VIDEO LOTTERY TERMINALS (U.S. CLS. 21, 23, 26, 36 AND 38).

FIRST USE 11-18-2009; IN COMMERCE 11-20-2010.

**CLASS 9—(Continued).**

3,955,526. TOURNAMENT ONE CORP, AKA T1 GAMING, T1, TOC, STAMFORD, CT. SN 77-875,512. PUB. 4-20-2010, FILED 11-18-2009.

**MAMBO MONEY**

THE MARK CONSISTS OF STANDARD CHARACTERS WITHOUT CLAIM TO ANY PARTICULAR FONT, STYLE, SIZE, OR COLOR.

FOR COMPUTER GAME SOFTWARE FOR GAMING MACHINES INCLUDING SLOT MACHINES OR VIDEO LOTTERY TERMINALS; COMPUTER GAME SOFTWARE FOR GAMING MACHINES, NAMELY, SLOT MACHINES AND VIDEO LOTTERY TERMINALS; COMPUTER SOFTWARE AND FIRMWARE FOR GAMES OF CHANCE ON ANY COMPUTERIZED PLATFORM, INCLUDING DEDICATED GAMING CONSOLES, VIDEO BASED SLOT MACHINES, REEL BASED SLOT MACHINES, AND VIDEO LOTTERY TERMINALS (U.S. CLS. 21, 23, 26, 36 AND 38).

FIRST USE 11-18-2009; IN COMMERCE 11-20-2010.

3,955,538. CELLOMICS INC., PITTSBURGH, PA. SN 77-881,037. PUB. 5-4-2010, FILED 11-25-2009.

**CELLINSIGHT**

THE MARK CONSISTS OF STANDARD CHARACTERS WITHOUT CLAIM TO ANY PARTICULAR FONT, STYLE, SIZE, OR COLOR.

FOR COMPUTERIZED SYSTEM FOR ANALYZING ARRAYS OF CELLS BY LIGHT OPTICAL METHODS COMPRISING LIGHT MICROSCOPE OPTICS, SCANNING HARDWARE, COMPUTER HARDWARE, COMPUTER SOFTWARE (U.S. CLS. 21, 23, 26, 36 AND 38).

FIRST USE 12-29-2010; IN COMMERCE 12-29-2010.

3,955,548. HDKARAOKE, LLC, ST. LOUIS, MO. SN 77-886,356. PUB. 11-9-2010, FILED 12-4-2009.



NO CLAIM IS MADE TO THE EXCLUSIVE RIGHT TO USE "KARAOKE", APART FROM THE MARK AS SHOWN. THE COLOR(S) BLACK, YELLOW, PURPLE, AND PINK IS/ARE CLAIMED AS A FEATURE OF THE MARK.

**CLASS 9—(Continued).**

THE MARK CONSISTS OF THE STYLIZED LETTERS "H" AND "D" AND THE WORD "KARAOKE" IN STYLIZED LETTERING ALL APPEARING IN THE COLOR BLACK, WITH TWO OVERLAPPING ELONGATED QUADRILATERALS, WITH ONE QUADRILATERAL APPEARING IN THE COLOR YELLOW, ONE QUADRILATERAL APPEARING IN THE COLOR PINK, AND THE OVERLAPPING PORTION APPEARING IN THE COLOR PURPLE, POSITIONED ABOVE AND TO THE RIGHT OF THE WORDING "HDKARAOKE".

FOR DIGITAL ELECTRONIC DEVICES FOR THE TRANSMISSION, STORAGE, PLAYBACK, ORGANIZING, AND STREAMING OF KARAOKE IMAGES, KARAOKE VIDEOS, KARAOKE MELODIES, KARAOKE LYRICS AND MULTIMEDIA CONTENT; TELEVISION SET TOP BOXES, PERIPHERALS, NAMELY, COMPUTER PERIPHERALS, AND SOFTWARE FOR USE IN THE TRANSMISSION, STORAGE, PLAYBACK, ORGANIZING, AND STREAMING OF KARAOKE IMAGES, KARAOKE VIDEOS, KARAOKE MELODIES, KARAOKE LYRICS AND MULTIMEDIA CONTENT (U.S. CLS. 21, 23, 26, 36 AND 38).

FIRST USE 1-15-2011; IN COMMERCE 1-15-2011.

3,955,554. CENTRAL LAKE ARMOR EXPRESS, INC., CENTRAL LAKE, MI. SN 77-888,285. PUB. 5-4-2010, FILED 12-8-2009.

**REVOLUTION**

THE MARK CONSISTS OF STANDARD CHARACTERS WITHOUT CLAIM TO ANY PARTICULAR FONT, STYLE, SIZE, OR COLOR.

FOR VESTS FOR HOLDING BODY ARMOR INSERTS (U.S. CLS. 21, 23, 26, 36 AND 38).

FIRST USE 3-26-2010; IN COMMERCE 3-26-2010.

3,955,563. COBY ELECTRONICS CORPORATION, LAKE SUCCESS, NY. SN 77-895,383. PUB. 6-15-2010, FILED 12-17-2009.

**JAMMERZ PLATINUM**

THE MARK CONSISTS OF STANDARD CHARACTERS WITHOUT CLAIM TO ANY PARTICULAR FONT, STYLE, SIZE, OR COLOR.

OWNER OF U.S. REG. NO. 3,636,192.

**CLASS 9—(Continued).**

NO CLAIM IS MADE TO THE EXCLUSIVE RIGHT TO USE "PLATINUM", APART FROM THE MARK AS SHOWN.

FOR AUDIO HEADPHONES; EAR PHONES; EARPHONE ACCESSORIES, NAMELY, EARPHONE CUSHIONS, EARPHONE PADS, CORD MANAGEMENT SYSTEMS, EARPHONE CASES, AND EARPHONE EXTENSION CORDS; EARPHONES; EARPHONES AND HEADPHONES; HEADPHONES; HEADPHONES INCLUDING ATTACHED LANYARD; PERSONAL HEADPHONES FOR SOUND TRANSMITTING APPARATUSES; PERSONAL HEADPHONES FOR USE WITH SOUND TRANSMITTING SYSTEMS; STEREO HEADPHONES (U.S. CLS. 21, 23, 26, 36 AND 38).

FIRST USE 2-19-2010; IN COMMERCE 2-19-2010.

---

3,955,573. A123 SYSTEMS, INC., WATERTOWN, MA. SN 77-902,492. PUB. 11-23-2010, FILED 12-29-2009.

**SGSS**

THE MARK CONSISTS OF STANDARD CHARACTERS WITHOUT CLAIM TO ANY PARTICULAR FONT, STYLE, SIZE, OR COLOR.

FOR ELECTRIC POWER GRID STABILIZATION SYSTEM COMPRISING POWER CELLS, TEMPERATURE CONTROL AND MANAGEMENT ELEMENTS, INVERTERS AND COMPUTER OPERATING PROGRAMS AND HARDWARE FOR USE IN OPERATING THE AFOREMENTIONED SYSTEM (U.S. CLS. 21, 23, 26, 36 AND 38).

FIRST USE 3-26-2010; IN COMMERCE 3-26-2010.

---

3,955,629. DIAMOND GAME ENTERPRISES, CHATSWORTH, CA. SN 77-922,774. PUB. 7-13-2010, FILED 1-28-2010.

**BURNING LOVE**

THE MARK CONSISTS OF STANDARD CHARACTERS WITHOUT CLAIM TO ANY PARTICULAR FONT, STYLE, SIZE, OR COLOR.

FOR GAMING EQUIPMENT, NAMELY, ELECTRONIC GAMING MACHINES AND GAMING MACHINES WITH VIDEO OUTPUT (U.S. CLS. 21, 23, 26, 36 AND 38).

FIRST USE 7-1-2010; IN COMMERCE 2-1-2011.

**CLASS 9—(Continued).**

3,955,637. DIAMOND GAME ENTERPRISES, CHATSWORTH, CA. SN 77-925,881. PUB. 7-13-2010, FILED 2-2-2010.

**Girls Just Want to Have Fun**

THE MARK CONSISTS OF STANDARD CHARACTERS WITHOUT CLAIM TO ANY PARTICULAR FONT, STYLE, SIZE, OR COLOR.

FOR GAMING EQUIPMENT, NAMELY, ELECTRONIC GAMING MACHINES AND GAMING MACHINES WITH VIDEO OUTPUT (U.S. CLS. 21, 23, 26, 36 AND 38).

FIRST USE 9-20-2010; IN COMMERCE 11-1-2010.

---

3,955,638. DIAMOND GAME ENTERPRISES, CHATSWORTH, CA. SN 77-925,924. PUB. 6-29-2010, FILED 2-2-2010.

**Hit Me With Your Best Shot**

THE MARK CONSISTS OF STANDARD CHARACTERS WITHOUT CLAIM TO ANY PARTICULAR FONT, STYLE, SIZE, OR COLOR.

FOR GAMING EQUIPMENT, NAMELY, ELECTRONIC GAMING MACHINES AND GAMING MACHINES WITH VIDEO OUTPUT (U.S. CLS. 21, 23, 26, 36 AND 38).

FIRST USE 4-30-2010; IN COMMERCE 1-4-2011.

---

3,955,649. SHELBY GROUP INTERNATIONAL, INC., MEMPHIS, TN. SN 77-928,450. PUB. 5-11-2010, FILED 2-4-2010.

**SAFEWAVES**

THE MARK CONSISTS OF STANDARD CHARACTERS WITHOUT CLAIM TO ANY PARTICULAR FONT, STYLE, SIZE, OR COLOR.

FOR HEARING PROTECTION HEADSETS, NOT FOR MEDICAL USE (U.S. CLS. 21, 23, 26, 36 AND 38).

FIRST USE 4-27-2010; IN COMMERCE 4-27-2010.

**CLASS 9—(Continued).**

3,955,653. UV TECHNOLOGIES, LLC, FORT MYERS, FL. SN 77-928,825. PUB. 11-2-2010, FILED 2-5-2010.

## iTanSmart

THE MARK CONSISTS OF STANDARD CHARACTERS WITHOUT CLAIM TO ANY PARTICULAR FONT, STYLE, SIZE, OR COLOR.

FOR COMPUTER SOFTWARE PROGRAM AND MOBILE PHONE SOFTWARE APPLICATION PROGRAM ALL FOR MONITORING AND DETERMINING LEVELS OF EXPOSURE TO THE SUN AND SUN LAMPS (U.S. CLS. 21, 23, 26, 36 AND 38).

FIRST USE 1-12-2010; IN COMMERCE 11-21-2010.

---

3,955,663. DMF CONSULTING, TROY, MI. SN 77-930,116. PUB. 7-27-2010, FILED 2-8-2010.

## MARY-ON-BOARD

THE MARK CONSISTS OF STANDARD CHARACTERS WITHOUT CLAIM TO ANY PARTICULAR FONT, STYLE, SIZE, OR COLOR.

FOR NOVELTY ITEM, NAMELY, A DEVICE FOR RECORDING, TRANSMISSION, PROCESSING AND REPRODUCTION OF SOUND AND IMAGE ON WHICH A PHOTOGRAPH CAN BE UPLOADED OR DISPLAYED, WHICH GENERATES PRE-RECORDED QUIPS WHEN A BUTTON/SENSOR IS ACTIVATED (U.S. CLS. 21, 23, 26, 36 AND 38).

FIRST USE 1-28-2011; IN COMMERCE 1-28-2011.

---

3,955,674. ICON EYEWEAR, INC., SECAUCUS, NJ. SN 77-931,374. PUB. 6-22-2010, FILED 2-9-2010.

## SUN REACTOR

THE MARK CONSISTS OF STANDARD CHARACTERS WITHOUT CLAIM TO ANY PARTICULAR FONT, STYLE, SIZE, OR COLOR.

FOR EYEWEAR: READING GLASSES; SUNGLASSES (U.S. CLS. 21, 23, 26, 36 AND 38).

FIRST USE 6-1-2010; IN COMMERCE 6-1-2010.

**CLASS 9—(Continued).**

3,955,675. AUTOMATED FINANCIAL SYSTEMS, INC., EX-  
TON, PA. SN 77-931,427. PUB. 6-22-2010, FILED 2-9-2010.

## AFSVision

THE MARK CONSISTS OF STANDARD CHARACTERS WITHOUT CLAIM TO ANY PARTICULAR FONT, STYLE, SIZE, OR COLOR.

OWNER OF U.S. REG. NOS. 2,997,541, 3,436,026, AND OTHERS.

FOR COMPUTER SOFTWARE FOR PROCESSING AND REPORTING LOAN INFORMATION; COMPUTER SOFTWARE AND INSTRUCTION MANUALS SOLD AS A UNIT FOR PROCESSING AND REPORTING LOAN INFORMATION; COMPUTER SOFTWARE FOR PROCESSING AND REPORTING LOAN INFORMATION IN MULTIPLE CURRENCIES AND LANGUAGES; COMPUTER SOFTWARE AND INSTRUCTION MANUALS SOLD AS A UNIT FOR PROCESSING AND REPORTING LOAN INFORMATION IN MULTIPLE CURRENCIES AND LANGUAGES (U.S. CLS. 21, 23, 26, 36 AND 38).

FIRST USE 12-23-2010; IN COMMERCE 12-23-2010.

---

3,955,683. INTELLISIST, INC., BELLEVUE, WA. SN 77-932,902. PUB. 6-29-2010, FILED 2-10-2010.

## GOTSEARCH

THE MARK CONSISTS OF STANDARD CHARACTERS WITHOUT CLAIM TO ANY PARTICULAR FONT, STYLE, SIZE, OR COLOR.

FOR COMPUTER SOFTWARE FOR RECEIVING REQUESTS FOR INFORMATION AND PROVIDING INFORMATION VIA TELEPHONE, VIA COMPUTER TERMINAL, OR OVER THE INTERNET (U.S. CLS. 21, 23, 26, 36 AND 38).

FIRST USE 2-13-2010; IN COMMERCE 2-13-2010.

---

3,955,684. ICON EYEWEAR, INC., SECAUCUS, NJ. SN 77-933,571. PUB. 6-22-2010, FILED 2-11-2010.

## FLYPAPER

THE MARK CONSISTS OF STANDARD CHARACTERS WITHOUT CLAIM TO ANY PARTICULAR FONT, STYLE, SIZE, OR COLOR.

FOR READING GLASSES; SUNGLASSES (U.S. CLS. 21, 23, 26, 36 AND 38).

FIRST USE 1-1-2010; IN COMMERCE 1-1-2010.

**CLASS 9—(Continued).**

3,955,688. SOILMOISTURE EQUIPMENT CORP., GOLETA, CA. SN 77-934,001. PUB. 4-27-2010, FILED 2-11-2010.

Record it in a Flash

THE MARK CONSISTS OF STANDARD CHARACTERS WITHOUT CLAIM TO ANY PARTICULAR FONT, STYLE, SIZE, OR COLOR.

FOR ELECTRONIC DATABASE IN THE FIELD OF AGRONOMIC INSTRUMENTATION RECORDED ON COMPUTER MEDIA (U.S. CLS. 21, 23, 26, 36 AND 38).  
FIRST USE 3-1-2010; IN COMMERCE 6-15-2010.

**CLASS 9—(Continued).**

3,955,698. AMBIVO, INC., REDWOOD CITY, CA. SN 77-935,773. PUB. 7-13-2010, FILED 2-15-2010.



THE MARK CONSISTS OF THE LETTERS "AM" IN STYLIZED FONT WITH TWO ARCS PLACED ABOVE THE LETTER "M".

FOR COMPUTER SOFTWARE SYSTEM FOR VIDEO AND MEDIA BASED NETWORKS COMPRISED OF GRAPHICAL USER INTERFACE SOFTWARE, VIDEO CREATION SOFTWARE, VIDEO EDITING SOFTWARE, SPEECH TO TEXT SOFTWARE AND VIDEO OPTICAL CHARACTER RECOGNITION SOFTWARE FOR USE IN CUSTOMER SERVICE, KNOWLEDGE MANAGEMENT AND E-COMMERCE SYSTEMS (U.S. CLS. 21, 23, 26, 36 AND 38).

FIRST USE 12-1-2010; IN COMMERCE 12-1-2010.

3,955,694. CLEARONE COMMUNICATIONS, SALT LAKE CITY, UT. SN 77-934,751. PUB. 6-29-2010, FILED 2-12-2010.

CLEARROOM

THE MARK CONSISTS OF STANDARD CHARACTERS WITHOUT CLAIM TO ANY PARTICULAR FONT, STYLE, SIZE, OR COLOR.

FOR AUDIO CONFERENCING EQUIPMENT AND SOFTWARE, NAMELY, TELEPHONES, AUDIOMIXERS, MICROPHONES, AMPLIFIERS, SPEAKERS AND CONFIGURATION AND MANAGEMENT SOFTWARE FOR AUDIO CONFERENCING (U.S. CLS. 21, 23, 26, 36 AND 38).  
FIRST USE 1-12-2011; IN COMMERCE 1-12-2011.

3,955,704. GATEWAY GAMING, PIEDMONT, SC. SN 77-937,439. PUB. 7-13-2010, FILED 2-17-2010.



THE MARK CONSISTS OF THE WORDS "HOTTER THAN" ABOVE AN IMAGE OF A DEVIL HOLDING A PITCHFORK. FLAMES APPEAR IN A HORIZONTAL FASHION ALONG THE TOP AND BOTTOM OF THE MARK, AND FLAMES ALSO PROTRUDE FROM THE PITCHFORK.

FOR GAMING EQUIPMENT, NAMELY, GAMING MACHINES (U.S. CLS. 21, 23, 26, 36 AND 38).  
FIRST USE 3-30-2010; IN COMMERCE 3-30-2010.

**CLASS 9—(Continued).**

3,955,717. ADVANCED BALLOT SOLUTIONS, LLC, CHANDLER, AZ. SN 77-940,322. PUB. 7-13-2010, FILED 2-19-2010.

**INTEGRA-VOTE**

THE MARK CONSISTS OF STANDARD CHARACTERS WITHOUT CLAIM TO ANY PARTICULAR FONT, STYLE, SIZE, OR COLOR.

FOR COMPUTER HARDWARE AND SOFTWARE FOR BALLOT PRINTING, PROCESSING, TRACKING AND VERIFICATION (U.S. CLS. 21, 23, 26, 36 AND 38).

FIRST USE 7-0-2010; IN COMMERCE 7-0-2010.

3,955,727. KNOCKAROUND, LLC, SAN DIEGO, CA. SN 77-941,965. PUB. 8-3-2010, FILED 2-22-2010.

**KNOCKAROUND**

THE MARK CONSISTS OF STANDARD CHARACTERS WITHOUT CLAIM TO ANY PARTICULAR FONT, STYLE, SIZE, OR COLOR.

OWNER OF U.S. REG. NO. 3,605,671.  
FOR CASES FOR EYEGLASSES AND SUNGLASSES (U.S. CLS. 21, 23, 26, 36 AND 38).

FIRST USE 11-16-2010; IN COMMERCE 11-16-2010.

3,955,768. DIAMOND GAME ENTERPRISES, CHATSWORTH, CA. SN 77-949,488. PUB. 7-13-2010, FILED 3-3-2010.

**Pretty Woman**

THE MARK CONSISTS OF STANDARD CHARACTERS WITHOUT CLAIM TO ANY PARTICULAR FONT, STYLE, SIZE, OR COLOR.

FOR GAMING EQUIPMENT, NAMELY, ELECTRONIC GAMING MACHINES AND GAMING MACHINES WITH VIDEO OUTPUT (U.S. CLS. 21, 23, 26, 36 AND 38).

FIRST USE 9-20-2010; IN COMMERCE 11-1-2010.

**CLASS 9—(Continued).**

3,955,770. DIAMOND GAME ENTERPRISES, CHATSWORTH, CA. SN 77-949,944. PUB. 7-13-2010, FILED 3-3-2010.

**I Want Candy**

THE MARK CONSISTS OF STANDARD CHARACTERS WITHOUT CLAIM TO ANY PARTICULAR FONT, STYLE, SIZE, OR COLOR.

FOR GAMING EQUIPMENT, NAMELY, ELECTRONIC GAMING MACHINES AND GAMING MACHINES WITH VIDEO OUTPUT (U.S. CLS. 21, 23, 26, 36 AND 38).

FIRST USE 9-20-2010; IN COMMERCE 11-1-2010.

3,955,778. WGI INNOVATIONS, LTD., GRAND PRAIRIE, TX. SN 77-951,500. PUB. 7-27-2010, FILED 3-5-2010.

**RAPIDX**

THE MARK CONSISTS OF STANDARD CHARACTERS WITHOUT CLAIM TO ANY PARTICULAR FONT, STYLE, SIZE, OR COLOR.

FOR ACTION CAMERAS (U.S. CLS. 21, 23, 26, 36 AND 38).

FIRST USE 9-1-2010; IN COMMERCE 9-1-2010.

3,955,785. POWERHOUSE TWO, INC., WINTER GARDEN, FL. SN 77-954,037. PUB. 8-3-2010, FILED 3-9-2010.



NO CLAIM IS MADE TO THE EXCLUSIVE RIGHT TO USE "POWER" AND "ALKALINE", APART FROM THE MARK AS SHOWN.

THE COLOR(S) BLACK, WHITE, GREY AND RED IS/ARE CLAIMED AS A FEATURE OF THE MARK.

THE MARK CONSISTS OF THE WORD "POWER" IN WHITE AND OUTLINED IN GREY WITH "XP" IN WHITE OUTLINED IN GREY ABOVE AND TO THE RIGHT OF THE "R" IN "POWER" ABOVE A RED UPSIDE DOWN CHECK MARK APPEARING AS A CURVED LINE, AND THE WORDS "ALKALINE XP" IN WHITE ARE UNDER THE WORD "POWER" AND WITHIN THE CHECK MARK, ALL APPEARING ON A BLACK BACKGROUND.

FOR BATTERIES, NAMELY, ALKALINE AND RECHARGEABLE (U.S. CLS. 21, 23, 26, 36 AND 38).

FIRST USE 4-1-2010; IN COMMERCE 7-7-2010.

**CLASS 9—(Continued).**

3,955,786. MICROPIER, LLC, SARASOTA, FL. SN 77-954,055.  
PUB. 8-3-2010, FILED 3-9-2010.

# MICROPIER

THE MARK CONSISTS OF STANDARD CHARACTERS WITHOUT CLAIM TO ANY PARTICULAR FONT, STYLE, SIZE, OR COLOR.

FOR COMPUTER SOFTWARE FOR USE IN THE CREATION AND USE OF EMBEDDED APPLICATIONS FOR ELECTRONIC DEVICES (U.S. CLS. 21, 23, 26, 36 AND 38).

FIRST USE 12-16-2010; IN COMMERCE 12-16-2010.

3,955,787. ASSESSMENT TECHNOLOGIES INSTITUTE, L.L.C., STILWELL, KS. SN 77-954,703. PUB. 7-27-2010, FILED 3-9-2010.

# MOBILEMENTOR

THE MARK CONSISTS OF STANDARD CHARACTERS WITHOUT CLAIM TO ANY PARTICULAR FONT, STYLE, SIZE, OR COLOR.

FOR COMPUTER SOFTWARE, NAMELY, AN APPLICATION ALLOWING USERS OF HANDHELD COMPUTERS, PERSONAL DIGITAL ASSISTANTS, ELECTRONIC ORGANIZERS, ELECTRONIC NOTE-PADS, TELEPHONES, AND VIDEOPHONES TO RECEIVE PRACTICE QUESTIONS FOR TESTS AND EXAMS IN THE FIELDS OF NURSING AND ALLIED HEALTH (U.S. CLS. 21, 23, 26, 36 AND 38).

FIRST USE 5-4-2010; IN COMMERCE 12-16-2010.

3,955,820. WMS GAMING INC., WAUKEGAN, IL. SN 77-964,609. PUB. 8-10-2010, FILED 3-22-2010.

# THE GREAT CASHINI

THE MARK CONSISTS OF STANDARD CHARACTERS WITHOUT CLAIM TO ANY PARTICULAR FONT, STYLE, SIZE, OR COLOR.

**CLASS 9—(Continued).**

"THE GREAT CASHINI" IN THE MARK DOES NOT IDENTIFY A LIVING INDIVIDUAL.

FOR COMPONENTS FOR GAMING MACHINES THAT GENERATE OR DISPLAY WAGER OUTCOMES, NAMELY, CONTROLLERS, DISPLAYS, BUTTON PANELS, BOLSTERS, ELECTRICAL WIRING, AND COMPUTER HARDWARE AND SOFTWARE ASSOCIATED THEREWITH; GAMING MACHINES, NAMELY, DEVICES WHICH ACCEPT A WAGER; GAMING SOFTWARE THAT GENERATES OR DISPLAYS WAGER OUTCOMES OF GAMING MACHINES (U.S. CLS. 21, 23, 26, 36 AND 38).

FIRST USE 11-16-2010; IN COMMERCE 11-16-2010.

3,955,829. WMS GAMING INC., WAUKEGAN, IL. SN 77-969,825. PUB. 8-10-2010, FILED 3-26-2010.

# VEGAS SHINDIG

THE MARK CONSISTS OF STANDARD CHARACTERS WITHOUT CLAIM TO ANY PARTICULAR FONT, STYLE, SIZE, OR COLOR.

NO CLAIM IS MADE TO THE EXCLUSIVE RIGHT TO USE "VEGAS", APART FROM THE MARK AS SHOWN.

FOR COMPONENTS FOR GAMING MACHINES THAT GENERATE OR DISPLAY WAGER OUTCOMES, NAMELY, CONTROLLERS, DISPLAYS, BUTTON PANELS, BOLSTERS, ELECTRICAL WIRING, AND COMPUTER HARDWARE AND SOFTWARE ASSOCIATED THEREWITH; GAMING MACHINES, NAMELY, DEVICES WHICH ACCEPT A WAGER; GAMING SOFTWARE THAT GENERATES OR DISPLAYS WAGER OUTCOMES OF GAMING MACHINES (U.S. CLS. 21, 23, 26, 36 AND 38).

FIRST USE 11-16-2010; IN COMMERCE 11-16-2010.

3,955,846. REVLOX CONSUMER PRODUCTS CORPORATION, NEW YORK, NY. SN 77-981,458. PUB. 11-10-2009, FILED 1-16-2009.

# REVLOX RADIANCE

THE MARK CONSISTS OF STANDARD CHARACTERS WITHOUT CLAIM TO ANY PARTICULAR FONT, STYLE, SIZE, OR COLOR.

FOR ELECTRIC HAIR APPLIANCES, NAMELY, CURLING IRONS (U.S. CLS. 21, 23, 26, 36 AND 38).

FIRST USE 4-30-2009; IN COMMERCE 4-30-2009.

**CLASS 9—(Continued).**

3,955,856. ORIGINAL POWER, INC., DULUTH, GA. SN 77-981,550. PUB. 6-15-2010, FILED 1-26-2010.

**POWER YOUR LIFESTYLE**

THE MARK CONSISTS OF STANDARD CHARACTERS WITHOUT CLAIM TO ANY PARTICULAR FONT, STYLE, SIZE, OR COLOR.

FOR ELECTRONIC PRODUCT ACCESSORIES, NAMELY, AC POWER ADAPTERS, DC POWER ADAPTERS, AUTOMOTIVE VOLTAGE ADAPTERS, TRANSFORMERS AND POWER SUPPLIES, OUTLET STRIPS, SURGE PROTECTORS, DC-TO-AC INVERTERS FOR PROVIDING AC POWER TO PORTABLE ELECTRONIC DEVICES FROM A DC SOURCE, BATTERY CHARGERS, BATTERY PACKS; AND PORTABLE TELEVISION SET/RADIO COMBINATION DEVICE, ELECTRONIC SOCKET, USB ELECTRONIC POWER SOCKET, JUMPER CABLES (U.S. CLS. 21, 23, 26, 36 AND 38).

FIRST USE 9-1-2010; IN COMMERCE 9-1-2010.

---

3,955,893. APPLIAN TECHNOLOGIES INC., SAN ANSELMO, CA. SN 85-003,723. PUB. 10-5-2010, FILED 3-31-2010.

**REPLAY TELERECORDER**

THE MARK CONSISTS OF STANDARD CHARACTERS WITHOUT CLAIM TO ANY PARTICULAR FONT, STYLE, SIZE, OR COLOR.

OWNER OF U.S. REG. NOS. 3,312,298, 3,738,736, AND OTHERS.

FOR COMPUTER SOFTWARE FOR RECORDING, CONVERTING AND PLAYING INTERNET AUDIO AND VIDEO (U.S. CLS. 21, 23, 26, 36 AND 38).

FIRST USE 2-28-2005; IN COMMERCE 2-28-2005.

**CLASS 9—(Continued).**

3,955,894. TU YONGFENG, GUANGDONG PROVINCE, CHINA. SN 85-003,820. PUB. 8-24-2010, FILED 4-1-2010.

**CARSON**

THE MARK CONSISTS OF STANDARD CHARACTERS WITHOUT CLAIM TO ANY PARTICULAR FONT, STYLE, SIZE, OR COLOR.

FOR AMUSEMENT APPARATUS ADAPTED FOR USE WITH TELEVISION RECEIVERS ONLY; AUDIO-RECEIVERS AND VIDEO-RECEIVERS; CAR TELEVISIONS; CD PLAYERS; COMPUTERS; DVD PLAYERS; GLOBAL POSITIONING SYSTEM (GPS); MP3 PLAYERS; MP4 PLAYERS; VCD MACHINES; VIDEO GAME MACHINES FOR USE WITH TELEVISIONS; VIDEO MONITORS (U.S. CLS. 21, 23, 26, 36 AND 38).

FIRST USE 1-3-2010; IN COMMERCE 1-3-2010.

---

3,955,898. HUDSON-ALPHA INSTITUTE FOR BIOTECHNOLOGY, HUNTSVILLE, AL. SN 85-004,514. PUB. 9-21-2010, FILED 4-1-2010.

**ICELL**

THE MARK CONSISTS OF STANDARD CHARACTERS WITHOUT CLAIM TO ANY PARTICULAR FONT, STYLE, SIZE, OR COLOR.

FOR EDUCATIONAL SOFTWARE APPLICATION FEATURING INSTRUCTION IN BIOLOGICAL SCIENCE THROUGH INTERACTIVE GRAPHICAL SIMULATION OF A CELL (U.S. CLS. 21, 23, 26, 36 AND 38).

FIRST USE 4-1-2010; IN COMMERCE 4-1-2010.

---

3,955,915. DIAMOND GAME ENTERPRISES, CHATSWORTH, CA. SN 85-010,911. PUB. 8-31-2010, FILED 4-9-2010.

**SO WILD**

THE MARK CONSISTS OF STANDARD CHARACTERS WITHOUT CLAIM TO ANY PARTICULAR FONT, STYLE, SIZE, OR COLOR.

FOR GAMING EQUIPMENT, NAMELY, ELECTRONIC GAMING MACHINES AND GAMING MACHINES WITH VIDEO OUTPUT (U.S. CLS. 21, 23, 26, 36 AND 38).

FIRST USE 9-20-2010; IN COMMERCE 11-1-2010.



**CLASS 9—(Continued).**

3,955,922. COMPAÑÍA DE MEDIOS DIGITALES (CMD) S.A., BUENOS AIRES, ARGENTINA. SN 85-013,158. PUB. 10-5-2010, FILED 4-13-2010.

## RACING GLORY

THE MARK CONSISTS OF STANDARD CHARACTERS WITHOUT CLAIM TO ANY PARTICULAR FONT, STYLE, SIZE, OR COLOR.

NO CLAIM IS MADE TO THE EXCLUSIVE RIGHT TO USE "RACING", APART FROM THE MARK AS SHOWN.

FOR COMPUTER GAMING SOFTWARE; MOBILE AND CELLULAR TELEPHONE APPLICATIONS IN THE NATURE OF COMPUTER GAME SOFTWARE (U.S. CLS. 21, 23, 26, 36 AND 38).

FIRST USE 10-15-2010; IN COMMERCE 10-15-2010.

**CLASS 9—(Continued).**

NO CLAIM IS MADE TO THE EXCLUSIVE RIGHT TO USE "FUTURE" OR "PERFECT", APART FROM THE MARK AS SHOWN.

FOR SOUND, VIDEO AND DATA RECORDINGS IN THE FIELD OF COMPUTER AND VIDEO GAMES, NAMELY, CARTRIDGES, CD ROMS, DVDS (DIGITAL VERSATILE DISCS), DVD-RWS (DIGITAL VERSATILE DISCS WITH READ/WRITE CAPABILITY), AUDIO, PICTURE AND VIDEO COMPRESSION FILES, INTERACTIVE COMPACT DISCS; DOWNLOADABLE ELECTRONIC PUBLICATIONS IN THE NATURE OF COMPUTER AND VIDEO GAMES IN THE FIELD OF COMPUTER AND VIDEO GAMES; COMPUTER SOFTWARE IN THE FIELD OF COMPUTER AND VIDEO GAMES; COMPUTER GAMES SOFTWARE; VIDEO GAMES SOFTWARE; ELECTRONIC GAME PROGRAMS; AND PRINTED MATTER IN THE NATURE OF INSTRUCTIONAL BOOKS, MANUALS, BROCHURES, FLY SHEETS AND LEAFLETS, ALL SOLD TOGETHER WITH THE AFORESAID GOODS (U.S. CLS. 21, 23, 26, 36 AND 38).

FIRST USE 3-31-2005; IN COMMERCE 3-31-2005.

3,955,940. FUJIMOTO, KEN, LOS ANGELES, CA. SN 85-020,182. PUB. 1-4-2011, FILED 4-22-2010.

## Machine Control

THE MARK CONSISTS OF STANDARD CHARACTERS WITHOUT CLAIM TO ANY PARTICULAR FONT, STYLE, SIZE, OR COLOR.

FOR AUDIO RECORDINGS FEATURING MUSIC; DIGITAL MUSIC DOWNLOADABLE FROM THE INTERNET; DOWNLOADABLE MP3 FILES, MP3 RECORDINGS, ON-LINE DISCUSSION BOARDS, WEBCASTS, WEBINARS AND PODCASTS FEATURING MUSIC, DOWNLOADABLE MUSICAL SOUND RECORDINGS; MUSICAL SOUND RECORDINGS; SOUND RECORDINGS FEATURING MUSIC (U.S. CLS. 21, 23, 26, 36 AND 38).

FIRST USE 7-18-2007; IN COMMERCE 11-1-2010.

3,955,973. MUSIC VIDEO DISTRIBUTORS, INC., OAKS, PA. SN 85-036,183. PUB. 10-12-2010, FILED 5-12-2010.

## IN THE HANDS OF THE FANS

THE MARK CONSISTS OF STANDARD CHARACTERS WITHOUT CLAIM TO ANY PARTICULAR FONT, STYLE, SIZE, OR COLOR.

FOR COMPACT DISCS FEATURING MUSIC; DIGITAL MEDIA, NAMELY, PRE-RECORDED VIDEO CASSETTES, DIGITAL VIDEO DISCS, DIGITAL VERSATILE DISCS, DOWNLOADABLE AUDIO AND VIDEO RECORDINGS, DVDS, AND HIGH DEFINITION DIGITAL DISCS FEATURING MUSIC AND MUSICAL PERFORMANCES; DOWNLOADABLE MP3 FILES AND MP3 RECORDINGS FEATURING MUSIC; DOWNLOADABLE MP3 FILES, MP3 RECORDINGS, ON-LINE DISCUSSION BOARDS, WEBCASTS, WEBINARS AND PODCASTS FEATURING MUSIC, AUDIO BOOKS AND NEWS BROADCASTS; DOWNLOADABLE MULTIMEDIA FILE CONTAINING ARTWORK, TEXT, AUDIO, VIDEO, GAMES, AND INTERNET WEB LINKS RELATING TO MUSIC AND MUSICAL PERFORMANCES; DVDS FEATURING MUSIC, LIVE MUSICAL PERFORMANCES, INTERVIEWS; PRERECORDED VIDEO TAPES FEATURING MUSIC AND MUSICAL PERFORMANCES; VIDEO RECORDINGS FEATURING MUSIC AND MUSICAL PERFORMANCES (U.S. CLS. 21, 23, 26, 36 AND 38).

FIRST USE 1-19-2011; IN COMMERCE 1-19-2011.

3,955,949. CRYTEK UK LTD, SANDIACRE, NOTTINGHAM, UNITED KINGDOM. SN 85-023,019. PUB. 10-26-2010, FILED 4-26-2010.

## TIMESPLITTERS FUTURE PERFECT

THE MARK CONSISTS OF STANDARD CHARACTERS WITHOUT CLAIM TO ANY PARTICULAR FONT, STYLE, SIZE, OR COLOR.

**CLASS 9—(Continued).**

3,955,983. ACCELERATED CARE PLUS CORP., RENO, NV.  
SN 85-042,426. PUB. 11-16-2010, FILED 5-19-2010.

# OMNIVR

THE MARK CONSISTS OF STANDARD CHARACTERS WITHOUT CLAIM TO ANY PARTICULAR FONT, STYLE, SIZE, OR COLOR.

OWNER OF U.S. REG. NOS. 1,450,593, 3,804,259, AND OTHERS.

FOR COMPUTER-BASED PHYSICAL THERAPY AND REHABILITATION EQUIPMENT, NAMELY, A VIDEO GAME CONSOLE, CAMERA AND APPLICATION SOFTWARE THAT TRACKS THE MOVEMENTS OF A USER AND INTEGRATES SUCH MOVEMENTS INTO A VIDEO GAME DEPICTED ON A DISPLAY DEVICE, AND INSTRUCTION MANUALS SOLD AS A UNIT THEREWITH (U.S. CLS. 21, 23, 26, 36 AND 38).

FIRST USE 3-0-2010; IN COMMERCE 3-0-2010.

---

3,955,985. WOVEN ELECTRONICS LLC, GREENVILLE, SC.  
SN 85-042,614. PUB. 10-26-2010, FILED 5-19-2010.

# SMARTGRATE - PLUS

THE MARK CONSISTS OF STANDARD CHARACTERS WITHOUT CLAIM TO ANY PARTICULAR FONT, STYLE, SIZE, OR COLOR.

OWNER OF U.S. REG. NO. 3,266,494.

FOR ALARM MONITORING SYSTEMS (U.S. CLS. 21, 23, 26, 36 AND 38).

FIRST USE 6-25-2010; IN COMMERCE 6-25-2010.

---

3,955,992. PANTECH CO., LTD., SEOUL, REPUBLIC OF KOREA. SN 85-046,030. PUB. 10-26-2010, FILED 5-24-2010.

# Link

THE MARK CONSISTS OF STANDARD CHARACTERS WITHOUT CLAIM TO ANY PARTICULAR FONT, STYLE, SIZE, OR COLOR.

FOR BATTERIES, BATTERY CHARGERS, CELLULAR TELEPHONES, MOBILE TELEPHONE BATTERIES, MOBILE TELEPHONES (U.S. CLS. 21, 23, 26, 36 AND 38).

FIRST USE 5-1-2010; IN COMMERCE 5-1-2010.

**CLASS 9—(Continued).**

3,955,993. KINGFIELD CORPORATION LIMITED, CHAI WAN, HONG KONG. SN 85-047,169. PUB. 11-23-2010, FILED 5-25-2010.

# CPS

THE MARK CONSISTS OF STANDARD CHARACTERS WITHOUT CLAIM TO ANY PARTICULAR FONT, STYLE, SIZE, OR COLOR.

FOR BATTERIES AND BATTERY CHARGERS; CARRYING CASES FOR CELL PHONES; CELL PHONE BACKPLATES; CELL PHONE CASES; CELL PHONE COVERS; CELL PHONE FACEPLATES; CELL PHONES (U.S. CLS. 21, 23, 26, 36 AND 38).

FIRST USE 6-1-2010; IN COMMERCE 6-1-2010.

---

3,955,996. FABIAN COLUSSI SILVA, BUENOS AIRES, ARGENTINA. SN 85-049,021. PUB. 11-30-2010, FILED 5-27-2010.

# VIUTECH THE WORLD IN YOUR HANDS

THE MARK CONSISTS OF STANDARD CHARACTERS WITHOUT CLAIM TO ANY PARTICULAR FONT, STYLE, SIZE, OR COLOR.

FOR PORTABLE AND HANDHELD DIGITAL ELECTRONIC DEVICES FOR RECORDING, ORGANIZING, TRANSMITTING, MANIPULATING, AND REVIEWING TEXT, DATA, AND AUDIO FILES; DIGITAL CAMERAS; AUDIO EQUIPMENT FOR VEHICLES, NAMELY, STEREO AND MULTIMEDIA PLAYERS; AUDIO SPEAKERS; COMPUTERS AND COMPUTER PERIPHERALS, NAMELY, MONITORS, KEYBOARDS, MICE; NOTEBOOK COMPUTERS; COMPUTERS, NAMELY, NETBOOKS; DIGITAL PHOTO FRAMES FOR DISPLAYING DIGITAL PICTURES, VIDEO CLIPS AND MUSIC; GLOBAL POSITIONING SYSTEM (GPS); EARPHONES AND HEADPHONES (U.S. CLS. 21, 23, 26, 36 AND 38).

FIRST USE 1-31-2010; IN COMMERCE 5-31-2010.

**CLASS 9—(Continued).**

3,955,998. AV TECH CORPORATION, TAIPEI CITY, TAIWAN. SN 85-049,351. PUB. 11-2-2010, FILED 5-27-2010.



THE MARK CONSISTS OF A CLOSE UP VIEW OF THE EYES AND BEAK OF AN EAGLE, WITH THE WORDING "EAGLEEYES" BELOW THE BEAK.

FOR MOBILE PHONE SOFTWARE ALLOWING USERS TO ACCESS TO DVRS, IP CAMERAS AND/OR NETWORK CAMERAS VIA MOBILE PHONES WITH INTERNET FOR MOBILE SURVEILLANCE, NAMELY, REMOTE REAL-TIME VIDEO AND AUDIO TRANSMITTING, FOOTAGE VIEWING, EVENT SEARCH, AND VIDEO PLAYBACK; SOFTWARE FOR MOBILE PHONE APPLICATIONS, NAMELY, MOBILE PHONE SOFTWARE FOR DVRS, IP CAMERAS AND/OR NETWORK CAMERAS TO ACHIEVE REAL-TIME REMOTE SURVEILLANCE VIA MOBILE PHONES WITH INTERNET (U.S. CLS. 21, 23, 26, 36 AND 38).

FIRST USE 2-9-2010; IN COMMERCE 6-10-2010.

3,956,036. THE TIFFEN COMPANY, LLC, HAUPPAUGE, NY. SN 85-070,827. PUB. 11-16-2010, FILED 6-24-2010.

**STEADICAM ZEPHYR**

THE MARK CONSISTS OF STANDARD CHARACTERS WITHOUT CLAIM TO ANY PARTICULAR FONT, STYLE, SIZE, OR COLOR.

OWNER OF U.S. REG. NOS. 1,706,335, 1,992,950, AND OTHERS.

FOR OPERATOR-SUPPORTED FILM AND VIDEO CAMERA STABILIZERS AND COMPONENTS THEREOF, NAMELY, VEST, MONITOR, POWER SUPPLY, ARTICULATED ARM, BOOM, POST, LIFT, GIMBAL, SPEAKER, INFRARED REMOTE, CONNECTOR AND CASE SOLD AS A UNIT (U.S. CLS. 21, 23, 26, 36 AND 38).

FIRST USE 12-29-2010; IN COMMERCE 12-31-2010.

**CLASS 9—(Continued).**

3,956,040. THE MAN MADE SOFTWARE COMPANY, LLC, AUSTIN, TX. SN 85-073,464. PUB. 11-30-2010, FILED 6-29-2010.

**MINDMANGO**

THE MARK CONSISTS OF STANDARD CHARACTERS WITHOUT CLAIM TO ANY PARTICULAR FONT, STYLE, SIZE, OR COLOR.

FOR COMPUTER SOFTWARE AND COMPUTER PROGRAMS FOR PERSONAL PRODUCTIVITY AND TASK MANAGEMENT USING IDEAS AND CONCEPTS IN THE FIELD OF MIND MAPPING (U.S. CLS. 21, 23, 26, 36 AND 38).

FIRST USE 8-1-2010; IN COMMERCE 8-1-2010.

3,956,044. SALES SUCCESS CONSULTING, LLC, PEABODY, MA. SN 85-078,078. PUB. 12-7-2010, FILED 7-6-2010.

**SUNSAFETY**

THE MARK CONSISTS OF STANDARD CHARACTERS WITHOUT CLAIM TO ANY PARTICULAR FONT, STYLE, SIZE, OR COLOR.

FOR COMPUTER APPLICATION SOFTWARE FOR MOBILE PHONES, NAMELY, SOFTWARE FOR DETERMINING THE UV INDEX FOR A GEOGRAPHICAL LOCATION (U.S. CLS. 21, 23, 26, 36 AND 38).

FIRST USE 3-8-2011; IN COMMERCE 3-8-2011.

3,956,082. INCIPIO TECHNOLOGIES, INC., IRVINE, CA. SN 85-096,354. PUB. 12-7-2010, FILED 7-29-2010.

**DESTROYER**

THE MARK CONSISTS OF STANDARD CHARACTERS WITHOUT CLAIM TO ANY PARTICULAR FONT, STYLE, SIZE, OR COLOR.

FOR CARRYING CASES FOR PORTABLE DEVICES, NAMELY, MOBILE PHONES, MOBILE COMPUTERS AND ELECTRONIC BOOK READERS (U.S. CLS. 21, 23, 26, 36 AND 38).

FIRST USE 10-5-2010; IN COMMERCE 10-5-2010.

**CLASS 10—MEDICAL APPARATUS**

**CLASS 10—(Continued).**

3,955,181. ILLUMINOSS MEDICAL, INC., EAST PROVIDENCE, RI. SN 77-097,756. PUB. 1-22-2008, FILED 2-2-2007.

## IlluminOss Medical

THE MARK CONSISTS OF STANDARD CHARACTERS WITHOUT CLAIM TO ANY PARTICULAR FONT, STYLE, SIZE, OR COLOR.

NO CLAIM IS MADE TO THE EXCLUSIVE RIGHT TO USE "MEDICAL", APART FROM THE MARK AS SHOWN, FOR MEDICAL DEVICES AND INSTRUMENTS, NAMELY, MEDICAL DEVICES AND SURGICAL INSTRUMENTS FOR USE IN ORTHOPEDIC AND TRAUMA SURGICAL PROCEDURES (U.S. CLS. 26, 39 AND 44).

FIRST USE 12-10-2008; IN COMMERCE 2-10-2011.

3,955,242. THERMOGENESIS CORPORATION, RANCHO CORDOVA, CA. SN 77-535,316. PUB. 11-11-2008, FILED 7-30-2008.

## RES-Q

THE MARK CONSISTS OF STANDARD CHARACTERS WITHOUT CLAIM TO ANY PARTICULAR FONT, STYLE, SIZE, OR COLOR.

FOR MEDICAL DEVICE THAT IS USED FOR ISOLATION AND CAPTURING OF BIOLOGICAL CELLS FROM FLUIDS AND ASPIRATES FROM HUMANS (U.S. CLS. 26, 39 AND 44).

FIRST USE 7-0-2009; IN COMMERCE 7-0-2009.

3,955,254. NOVOSTENT CORPORATION, MOUNTAIN VIEW, CA. SN 77-578,064. PUB. 6-22-2010, FILED 9-24-2008.

## SAMBA

THE MARK CONSISTS OF STANDARD CHARACTERS WITHOUT CLAIM TO ANY PARTICULAR FONT, STYLE, SIZE, OR COLOR.

FOR VASCULAR PROSTHESES AND VASCULAR PROSTHESES DELIVERY SYSTEMS CONSISTING PRIMARILY OF STENTS, BALLOONS, GUIDE WIRES AND CATHETERS (U.S. CLS. 26, 39 AND 44).

FIRST USE 2-22-2009; IN COMMERCE 4-16-2009.

**CLASS 10—(Continued).**

3,955,370. HARTALEGA SDN. BHD., KUALA LUMPUR, MALAYSIA. SN 77-783,285. PUB. 6-8-2010, FILED 7-17-2009.



THE MARK CONSISTS OF THE TERM "PHARMATEX" IN INVERSE WITHIN A RECTANGULAR BOX.

FOR GLOVES FOR MASSAGE; GLOVES FOR MEDICAL PURPOSES; SURGICAL APPARATUS AND INSTRUMENTS (U.S. CLS. 26, 39 AND 44).

FIRST USE 3-5-2003; IN COMMERCE 3-5-2003.

3,955,413. DUNHAM, PHILLIP, ARVADA, CO. SN 77-812,702. PUB. 3-23-2010, FILED 8-25-2009.



THE MARK CONSISTS OF THE IMAGE OF A CROSS CONTAINED WITHIN A SQUARE, WITH THE WORDING "HOSPIVENT" LOCATED TO THE RIGHT. A LINE SIMULATING A HEARTBEAT BISECTS THE CROSS AND CONTINUES ON THROUGH THE WORDING.

FOR MEDICAL APPARATUS, NAMELY, RESPIRATORY EQUIPMENT AND MONITORS THEREFOR; MEDICAL INSTRUMENTS FOR USE IN MEDICAL TREATMENT AND MONITORING, NAMELY, RESPIRATORY EQUIPMENT COMPRISED PRIMARILY OF MONITORS, OXYGEN SENSORS, FLOW SENSORS, EXTENSION CABLES, TRANSDUCERS, PATIENT ELECTRODES AND FILTERS; MEDICAL PRODUCTS, NAMELY, RESPIRATORY SENSORS (U.S. CLS. 26, 39 AND 44).

FIRST USE 1-0-2011; IN COMMERCE 1-0-2011.

3,955,440. LIFE SPINE, INC., HOFFMAN ESTATES, IL. SN 77-825,844. PUB. 7-6-2010, FILED 9-14-2009.

## CENTRIC

THE MARK CONSISTS OF STANDARD CHARACTERS WITHOUT CLAIM TO ANY PARTICULAR FONT, STYLE, SIZE, OR COLOR.

FOR SPINAL IMPLANTS MADE OF ARTIFICIAL MATERIALS FOR USE IN CERVICAL SPINAL SURGERY AND LUMBAR SPINAL SURGERY, NAMELY, PLATES, SCREWS, SCREW SYSTEMS, INTERBODY DEVICES, INTRABODY DEVICES, RODS, ROD CONNECTORS, CROSS-CONNECTORS, SPINOUS PROCESS SPACERS, SCREWDRIVERS, AND IMPLANT DRIVERS (U.S. CLS. 26, 39 AND 44).

FIRST USE 10-1-2009; IN COMMERCE 10-1-2009.

**CLASS 10—(Continued).**

3,955,442. ENCOMPASS GROUP, LLC, MCDONOUGH, GA.  
SN 77-826,640. PUB. 8-31-2010, FILED 9-15-2009.

# WS GEAR

THE MARK CONSISTS OF STANDARD CHARACTERS WITHOUT CLAIM TO ANY PARTICULAR FONT, STYLE, SIZE, OR COLOR.

NO CLAIM IS MADE TO THE EXCLUSIVE RIGHT TO USE "GEAR", APART FROM THE MARK AS SHOWN.

FOR HEALTHCARE APPAREL WORN BY PROFESSIONAL MEDICAL PERSONNEL, NAMELY, SCRUB TOPS, SCRUB PANTS, SCRUB JACKETS, AND SCRUB SHIRTS (U.S. CLS. 26, 39 AND 44).

FIRST USE 3-20-2010; IN COMMERCE 3-20-2010.

3,955,728. PARADIGM SPINE, LLC, NEW YORK, NY. SN 77-942,097. PUB. 7-20-2010, FILED 2-23-2010.

# COFLEX-F

THE MARK CONSISTS OF STANDARD CHARACTERS WITHOUT CLAIM TO ANY PARTICULAR FONT, STYLE, SIZE, OR COLOR.

OWNER OF U.S. REG. NO. 3,190,053.

FOR SURGICAL IMPLANTS COMPRISING ARTIFICIAL MATERIAL, SURGICAL INSTRUMENTS FOR SPINAL STABILIZATION (U.S. CLS. 26, 39 AND 44).

FIRST USE 11-10-2010; IN COMMERCE 11-10-2010.

3,955,755. ELI LILLY AND COMPANY, INDIANAPOLIS, IN.  
SN 77-947,615. PUB. 7-27-2010, FILED 3-1-2010.

# TEAMMATE

THE MARK CONSISTS OF STANDARD CHARACTERS WITHOUT CLAIM TO ANY PARTICULAR FONT, STYLE, SIZE, OR COLOR.

FOR MEDICAL DEVICES FOR SUBCUTANEOUS DISPENSING OF A DRUG, NAMELY, A DRUG DOSING AND DISPENSING DEVICE, A DISPOSABLE NEEDLE CASSETTE AND A DISPOSABLE DRUG CARTRIDGE; ELECTRONIC MEDICAL DEVICES FOR DOSING AND SUBCUTANEOUS DISPENSING OF A DRUG; NEEDLE CASSETTES FOR USE WITH DRUG DELIVERY DEVICES; MEDICAL DELIVERY DEVICES IN THE FORM OF A SYRINGE, INJECTOR DEVICE, OR PEN FOR INJECTING A PHARMACEUTICAL PREPARATION (U.S. CLS. 26, 39 AND 44).

FIRST USE 11-30-2010; IN COMMERCE 11-30-2010.

**CLASS 10—(Continued).**

3,955,761. ARTHREX, INC., NAPLES, FL. SN 77-948,905. PUB. 7-27-2010, FILED 3-2-2010.

# VISCOGEL

THE MARK CONSISTS OF STANDARD CHARACTERS WITHOUT CLAIM TO ANY PARTICULAR FONT, STYLE, SIZE, OR COLOR.

FOR MEDICAL DEVICE, NAMELY, APPLICATOR TIP TO ALLOW MIXTURE OF FLUIDS FOR USE IN SURGICAL PROCEDURES (U.S. CLS. 26, 39 AND 44).

FIRST USE 1-31-2011; IN COMMERCE 1-31-2011.

3,955,762. ARTHREX, INC., NAPLES, FL. SN 77-948,906. PUB. 7-27-2010, FILED 3-2-2010.

# VISCOSPRAY

THE MARK CONSISTS OF STANDARD CHARACTERS WITHOUT CLAIM TO ANY PARTICULAR FONT, STYLE, SIZE, OR COLOR.

FOR MEDICAL DEVICE, NAMELY, APPLICATOR TIP TO ALLOW MIXTURE OF FLUIDS FOR USE IN SURGICAL PROCEDURES (U.S. CLS. 26, 39 AND 44).

FIRST USE 1-31-2011; IN COMMERCE 1-31-2011.

3,955,803. RONALD J. FRENCH, NEW ORLEANS, LA. SN 77-958,786. PUB. 8-10-2010, FILED 3-15-2010.

# AWACS

THE MARK CONSISTS OF STANDARD CHARACTERS WITHOUT CLAIM TO ANY PARTICULAR FONT, STYLE, SIZE, OR COLOR.

FOR EAR CANAL IRRIGATION DEVICE (U.S. CLS. 26, 39 AND 44).

FIRST USE 1-1-2011; IN COMMERCE 1-1-2011.

**CLASS 10—(Continued).**

3,955,804. INSTRUMENT SPECIALISTS, INC., BOERNE, TX.  
SN 77-958,798. PUB. 8-10-2010, FILED 3-15-2010.

# STAT

THE MARK CONSISTS OF STANDARD CHARACTERS WITHOUT CLAIM TO ANY PARTICULAR FONT, STYLE, SIZE, OR COLOR.

FOR PORTABLE, SUPPORT PLATFORM THAT CAN BE PLACED UNDER THE PAD OF A STRETCHER OR AN OPERATING ROOM TABLE AND HELD IN PLACE BY THE WEIGHT OF THE PATIENT TO PROVIDE A STABLE SURFACE FOR TREATMENT OF AND MINOR SURGICAL PROCEDURES ON UPPER EXTREMITIES (U.S. CLS. 26, 39 AND 44).

FIRST USE 1-13-2011; IN COMMERCE 1-13-2011.

3,955,858. BONOVO ORTHOPEDICS, INC., SCOTTSDALE, AZ. SN 77-981,564. PUB. 6-3-2008, FILED 10-15-2007.

# BONOVO

THE MARK CONSISTS OF STANDARD CHARACTERS WITHOUT CLAIM TO ANY PARTICULAR FONT, STYLE, SIZE, OR COLOR.

THE WORDING "BONOVO" HAS NO MEANING IN A FOREIGN LANGUAGE.

FOR MEDICAL DEVICES AND MEDICAL APPARATUS, NAMELY, ARTIFICIAL ORTHOPEDIC IMPLANTS, ORTHOPEDIC INSTRUMENTS, AND ORTHOPEDIC DEVICES FOR USE IN ORTHOPEDIC THERAPY (U.S. CLS. 26, 39 AND 44).

FIRST USE 5-15-2010; IN COMMERCE 5-15-2010.

3,955,884. HANSEN MEDICAL, INC., MOUNTAIN VIEW, CA. SN 78-920,363. PUB. 6-22-2010, FILED 6-29-2006.

# ARTISAN

THE MARK CONSISTS OF STANDARD CHARACTERS WITHOUT CLAIM TO ANY PARTICULAR FONT, STYLE, SIZE, OR COLOR.

FOR MEDICAL DEVICES, NAMELY, CATHETERS, GUIDE CATHETERS AND PARTS AND FITTINGS THEREFOR, NONE OF THE AFORESAID FOR USE ON OR IN CONNECTION WITH ORTHOPEDICS PRODUCTS (U.S. CLS. 26, 39 AND 44).

FIRST USE 6-25-2007; IN COMMERCE 6-25-2007.

**CLASS 10—(Continued).**

3,955,908. BRONCUS TECHNOLOGIES, INC, MOUNTAIN VIEW, CA. SN 85-008,914. PUB. 9-7-2010, FILED 4-7-2010.

# FlexNeedle

THE MARK CONSISTS OF THE WORDING "FLEXNEEDLE" IN STYLIZED LETTERS.

FOR TRANSBRONCHIAL MEDICAL CATHETER (U.S. CLS. 26, 39 AND 44).

FIRST USE 2-2-2011; IN COMMERCE 2-2-2011.

3,955,984. CROSSTEX INTERNATIONAL, INC., HAUPPAUGE, NY. SN 85-042,542. PUB. 8-17-2010, FILED 5-19-2010.

# DUO-CHECK

THE MARK CONSISTS OF STANDARD CHARACTERS WITHOUT CLAIM TO ANY PARTICULAR FONT, STYLE, SIZE, OR COLOR.

FOR STERILIZATION POUCHES FOR MEDICAL AND DENTAL USE (U.S. CLS. 26, 39 AND 44).

FIRST USE 8-4-2010; IN COMMERCE 8-4-2010.

3,956,038. OCULAR SYSTEMS, INC., WINSTON-SALEM, NC. SN 85-071,577. PUB. 11-23-2010, FILED 6-25-2010.

# EndoSerter

THE MARK CONSISTS OF STANDARD CHARACTERS WITHOUT CLAIM TO ANY PARTICULAR FONT, STYLE, SIZE, OR COLOR.

FOR SURGICAL APPARATUS AND INSTRUMENTS FOR USE IN OPHTHALMIC SURGERY (U.S. CLS. 26, 39 AND 44).

FIRST USE 6-1-2010; IN COMMERCE 2-10-2011.

**CLASS 10—(Continued).**

3,956,066. NUVASIVE, INC., SAN DIEGO, CA. SN 85-084,494.  
PUB. 12-14-2010, FILED 7-14-2010.

**RADIAN**

THE MARK CONSISTS OF STANDARD CHARACTERS WITHOUT CLAIM TO ANY PARTICULAR FONT, STYLE, SIZE, OR COLOR.

FOR SPINAL IMPLANTS COMPOSED OF ARTIFICIAL MATERIAL AND SURGICAL INSTRUMENTATION FOR IMPLANTING THE SAME (U.S. CLS. 26, 39 AND 44).  
FIRST USE 11-1-2010; IN COMMERCE 11-1-2010.

3,956,071. MINDFRAME, INC., IRVINE, CA. SN 85-086,967.  
PUB. 1-4-2011, FILED 7-16-2010.

**MINDFRAME OPTICELL**

THE MARK CONSISTS OF STANDARD CHARACTERS WITHOUT CLAIM TO ANY PARTICULAR FONT, STYLE, SIZE, OR COLOR.

OWNER OF U.S. REG. NO. 3,506,171.  
FOR MINIMALLY INVASIVE VASCULAR DEVICES, NAMELY, NEUROVASCULAR DEVICES FOR THE TREATMENT OF NEUROLOGICAL DISEASES (U.S. CLS. 26, 39 AND 44).  
FIRST USE 10-15-2010; IN COMMERCE 10-15-2010.

**CLASS 11—ENVIRONMENTAL CONTROL APPARATUS**

3,955,177. AVIVE TECHNOLOGIES, LLC, ALBERTSON, NY.  
SN 77-063,588. PUB. 11-27-2007, FILED 12-13-2006.

**CIRCLEFRESH**

THE MARK CONSISTS OF STANDARD CHARACTERS WITHOUT CLAIM TO ANY PARTICULAR FONT, STYLE, SIZE, OR COLOR.

FOR REFRIGERATION EQUIPMENT, NAMELY, PANELS COMPOSED OF A NATURAL OCCURRING MINERAL THAT ABSORBS EXCESS HUMIDITY AND ETHYLENE GAS PRODUCED BY FRUITS AND VEGETABLES, THEREBY INCREASING PRODUCE LONGEVITY AND SAVING ELECTRICITY BY REDUCING COMPRESSOR RUN RATES (U.S. CLS. 13, 21, 23, 31 AND 34).  
FIRST USE 10-0-2006; IN COMMERCE 10-0-2006.

**CLASS 11—(Continued).**

3,955,267. BEACHCOMBER HOT TUBS INC., SURREY, BRITISH COLUMBIA, CANADA. SN 77-618,033. PUB. 10-19-2010, FILED 11-19-2008.

**BEACHCOMBER THE GREEN HOT TUB COMPANY**

THE MARK CONSISTS OF STANDARD CHARACTERS WITHOUT CLAIM TO ANY PARTICULAR FONT, STYLE, SIZE, OR COLOR.

PRIORITY CLAIMED UNDER SEC. 44(D) ON CANADA APPLICATION NO. 1416720, FILED 10-31-2008, REG. NO. TMA775802, DATED 8-30-2010, EXPIRES 8-30-2025.  
OWNER OF U.S. REG. NOS. 2,375,488, 2,798,583, AND 3,310,827.

NO CLAIM IS MADE TO THE EXCLUSIVE RIGHT TO USE "THE GREEN HOT TUB COMPANY", APART FROM THE MARK AS SHOWN.

FOR HOT TUBS (U.S. CLS. 13, 21, 23, 31 AND 34).  
FIRST USE 8-30-2010; IN COMMERCE 8-30-2010.

3,955,284. GILES, RICHARD, PARK CITY, UT. SN 77-644,638.  
PUB. 12-1-2009, FILED 1-7-2009.

**HEATWURX**

THE MARK CONSISTS OF STANDARD CHARACTERS WITHOUT CLAIM TO ANY PARTICULAR FONT, STYLE, SIZE, OR COLOR.

FOR ELECTRIC INFRARED HEATING SYSTEMS FOR MELTING SNOW AND ICE; ELECTRIC INFRARED HEATING SYSTEMS FOR USE IN ASPHALT ROAD REPAIRS (U.S. CLS. 13, 21, 23, 31 AND 34).

FIRST USE 4-1-2009; IN COMMERCE 4-1-2009.

3,955,287. SANVIK, CHARLES W., ST. MICHAEL, MN. SN 77-648,375. PUB. 12-8-2009, FILED 1-13-2009.

**FAILSAFE POWER**

THE MARK CONSISTS OF STANDARD CHARACTERS WITHOUT CLAIM TO ANY PARTICULAR FONT, STYLE, SIZE, OR COLOR.

FOR PORTABLE HEATING DEVICES FOR USE IN THE CONSTRUCTION INDUSTRY; PORTABLE HEATING DEVICES FOR GROUND THAWING AND CONCRETE CURING APPLICATIONS (U.S. CLS. 13, 21, 23, 31 AND 34).

FIRST USE 2-28-2009; IN COMMERCE 12-20-2009.

**CLASS 11—(Continued).**

3,955,466. COINAMATIC CANADA INC., MISSISSAUGA, ONTARIO, CANADA. SN 77-845,125. PUB. 9-7-2010, FILED 10-9-2009.

**enviro<sub>3</sub>matic**  
advanced laundry oxidation system

PRIORITY CLAIMED UNDER SEC. 44(D) ON CANADA APPLICATION NO. 1441218, FILED 6-11-2009, REG. NO. TMA771890, DATED 7-13-2010, EXPIRES 7-13-2025.

NO CLAIM IS MADE TO THE EXCLUSIVE RIGHT TO USE "ADVANCED LAUNDRY OXIDATION SYSTEM", APART FROM THE MARK AS SHOWN.

THE MARK CONSISTS OF THE WORDS "ENVIRO3-MATIC ADVANCED LAUNDRY OXIDATION SYSTEM" WITH A STYLIZED "O" AND SUBSCRIPT "3".

FOR OZONE GENERATOR AND DIFFUSER FOR WATER TREATMENT, NAMELY, TO DISINFECT THE WATER AND LAUNDRY LOADS FOR USE WITH COMMERCIAL LAUNDRY WASHERS AND WATER SUPPLY SYSTEMS (U.S. CLS. 13, 21, 23, 31 AND 34).  
FIRST USE 2-7-2011; IN COMMERCE 2-7-2011.

3,955,541. IDEA LATIN AMERICA LLC, MIAMI, FL. SN 77-881,263. PUB. 4-6-2010, FILED 11-25-2009.

**AirOn**

THE MARK CONSISTS OF STANDARD CHARACTERS WITHOUT CLAIM TO ANY PARTICULAR FONT, STYLE, SIZE, OR COLOR.

FOR APPLIANCES FOR DOMESTIC USE, NAMELY, TEMPERATURE CONTROLLED WINE CELLARS; BAKING OVENS; COMBINATION MICROWAVE/CONVECTION OVEN; COMBINATION STEAMERS AND OVENS; COOKING OVENS; DOMESTIC COOKING OVENS; ELECTRIC COOKING OVENS; ELECTRIC COOKING OVENS; ELECTRIC COOKTOPS; ELECTRIC REFRIGERATORS; EXHAUST HOODS FOR KITCHENS; FREEZERS; GAS COOKTOPS; GAS REFRIGERATORS; HOODS FOR RANGES; ICE-COOLING REFRIGERATORS; MICROWAVE OVENS; RANGE HOODS; REFRIGERATING APPLIANCES AND INSTALLATIONS; REFRIGERATING CABINETS; VENTILATION HOODS; VENTILATION HOODS FOR STOVES; WINE COOLERS, NAMELY, REFRIGERATED CABINETS CONTAINING RACKS FOR WINE BOTTLES AND STORAGE SHELVES (U.S. CLS. 13, 21, 23, 31 AND 34).  
FIRST USE 4-15-2010; IN COMMERCE 6-7-2010.

**CLASS 11—(Continued).**

3,955,651. CHAFFEE, KEVIN R., BATESVILLE, IN. SN 77-928,751. PUB. 6-22-2010, FILED 2-5-2010.

**ENVIROAER**

THE MARK CONSISTS OF STANDARD CHARACTERS WITHOUT CLAIM TO ANY PARTICULAR FONT, STYLE, SIZE, OR COLOR.

FOR WASTE WATER PURIFICATION UNITS (U.S. CLS. 13, 21, 23, 31 AND 34).

FIRST USE 8-10-2010; IN COMMERCE 12-15-2010.

3,955,652. CHAFFEE, KEVIN R., BATESVILLE, IN. SN 77-928,759. PUB. 6-22-2010, FILED 2-5-2010.

**ENVIROMBR**

THE MARK CONSISTS OF STANDARD CHARACTERS WITHOUT CLAIM TO ANY PARTICULAR FONT, STYLE, SIZE, OR COLOR.

FOR WASTE WATER PURIFICATION UNITS (U.S. CLS. 13, 21, 23, 31 AND 34).

FIRST USE 6-15-2010; IN COMMERCE 2-11-2011.

3,955,687. KOHLER CO., KOHLER, WI. SN 77-933,979. PUB. 11-23-2010, FILED 2-11-2010.

**CANVAS**

THE MARK CONSISTS OF STANDARD CHARACTERS WITHOUT CLAIM TO ANY PARTICULAR FONT, STYLE, SIZE, OR COLOR.

FOR LAVATORIES (U.S. CLS. 13, 21, 23, 31 AND 34).  
FIRST USE 2-1-2011; IN COMMERCE 2-1-2011.



**CLASS 11—(Continued).**

3,955,862. SOY BASICS, LLC, NEW HAMPTON, IA. SN 77-981,591. PUB. 7-13-2010, FILED 12-3-2009.

# HINT

THE MARK CONSISTS OF STANDARD CHARACTERS WITHOUT CLAIM TO ANY PARTICULAR FONT, STYLE, SIZE, OR COLOR.

FOR LUMINARY (U.S. CLS. 13, 21, 23, 31 AND 34).  
FIRST USE 6-0-2010; IN COMMERCE 6-0-2010.

---

3,955,947. BRIGHT ROSE, LLC, SAN DIEGO, CA. SN 85-021,748. PUB. 9-28-2010, FILED 4-23-2010.

# SNAPPY HEAT

THE MARK CONSISTS OF STANDARD CHARACTERS WITHOUT CLAIM TO ANY PARTICULAR FONT, STYLE, SIZE, OR COLOR.

NO CLAIM IS MADE TO THE EXCLUSIVE RIGHT TO USE "HEAT", APART FROM THE MARK AS SHOWN.

FOR CHEMICALLY-ACTIVATED COLD PACKS FOR COOLING THE BODY AND NOT FOR MEDICAL PURPOSES; CHEMICALLY-ACTIVATED HEATING PACKS FOR PROVIDING WARMTH TO THE BODY NOT FOR MEDICAL PURPOSES; COLD PACKS FOR COOLING THE BODY AND NOT FOR MEDICAL PURPOSES; HEATING AND COOLING PACKS FILLED WITH CHEMICAL SUBSTANCES THAT REACT WHEN REQUIRED TO WARM OR COOL THE BODY; HEATING CUSHIONS NOT FOR MEDICAL PURPOSES; HEATING PADS NOT FOR MEDICAL PURPOSES (U.S. CLS. 13, 21, 23, 31 AND 34).  
FIRST USE 5-31-2010; IN COMMERCE 5-31-2010.

---

3,956,039. INTELUX, S.A. DE C.V., NUEVO LEON, MEXICO. SN 85-072,711. PUB. 11-23-2010, FILED 6-28-2010.

THE MARK CONSISTS OF THE WORDING "INTELUX" WITH AN INTERLINE THROUGH THE LETTERS "T" AND "E". WITH THE LETTERS "I" AND "N" IN SMALL LETTERS AND "T", "E", "L", "U" AND "X" IN CAPITAL LETTERS, AND THE LETTER "X" AS A CURVED LETTER.

FOR LAMPS (U.S. CLS. 13, 21, 23, 31 AND 34).  
FIRST USE 2-25-2002; IN COMMERCE 5-17-2010.

**CLASS 11—(Continued).**

3,956,042. VICTORY LIGHT USA LLC, FRANKLIN PARK, IL. SN 85-076,347. PUB. 11-30-2010, FILED 7-1-2010.

# VISION EASE

THE MARK CONSISTS OF STANDARD CHARACTERS WITHOUT CLAIM TO ANY PARTICULAR FONT, STYLE, SIZE, OR COLOR.

FOR LAMPS (U.S. CLS. 13, 21, 23, 31 AND 34).  
FIRST USE 6-30-2010; IN COMMERCE 6-30-2010.

---

3,956,065. CLARCOR AIR FILTRATION PRODUCTS, INC., JEFFERSONVILLE, IN. SN 85-083,650. PUB. 12-21-2010, FILED 7-13-2010.

# KEY PLEAT

THE MARK CONSISTS OF STANDARD CHARACTERS WITHOUT CLAIM TO ANY PARTICULAR FONT, STYLE, SIZE, OR COLOR.

NO CLAIM IS MADE TO THE EXCLUSIVE RIGHT TO USE "PLEAT", APART FROM THE MARK AS SHOWN.

FOR COMMERCIAL AND INDUSTRIAL AIR FILTERS FOR HVAC SYSTEMS (U.S. CLS. 13, 21, 23, 31 AND 34).  
FIRST USE 8-31-2010; IN COMMERCE 8-31-2010.

---

3,956,086. EVERHII ILLUMINATION LLC, RANDOLPH, MA. SN 85-099,550. PUB. 12-28-2010, FILED 8-4-2010.

THE COLOR(S) GREEN, RED, AND BLUE IS/ARE CLAIMED AS A FEATURE OF THE MARK.

**CLASS 11—(Continued).**

THE MARK CONSISTS OF "EVERHII". "EVERHII" IS ONE WORD IN CAPITAL, ALSO IN BOLD FACE AND ITALICS FONT STYLE. THE PART OF THE MARK "EVERH" IS IN GREEN COLOR, BY FOLLOWING TWO "I"'S, WHICH ONE "I" IS IN RED COLOR AND THE OTHER "I" IS IN BLUE COLOR.

FOR CEILING LIGHTS; ELECTRIC HOLIDAY LIGHTS; ELECTRIC LIGHT BULBS; ELECTRIC LIGHTING FIXTURES; ELECTRIC LIGHTS FOR CHRISTMAS TREES; ELECTRIC NIGHT LIGHTS; FIBER OPTIC LIGHTING FIXTURES USED IN CONJUNCTION WITH ELECTRICAL ILLUMINATORS; FILTERS FOR PHOTOGRAPHIC, CINEMATOGRAPHIC, VIDEO AND PERFORMING ARTS LIGHTING; LAMP WHOSE LIGHT CAN BE TURNED IN ALL DIRECTIONS; LANDSCAPE LIGHTING INSTALLATIONS; LED (LIGHT EMITTING DIODES) LIGHTING FIXTURES FOR USE IN DISPLAY, COMMERCIAL, INDUSTRIAL, RESIDENTIAL, AND ARCHITECTURAL ACCENT LIGHTING APPLICATIONS; LED LIGHT ASSEMBLIES FOR STREET LIGHTS, SIGNS, COMMERCIAL LIGHTING, AUTOMOBILES, BUILDINGS, AND OTHER ARCHITECTURAL USES; LED LIGHT BULBS; LED LIGHTING FIXTURES FOR INDOOR AND OUTDOOR LIGHTING APPLICATIONS; LIGHT BULBS; LIGHT DIFFUSERS; LIGHT POST LUMINAIRES; LIGHTED PARTY-THEMED DECORATIONS, ELECTRIC LIGHT DECORATIVE STRINGS; LIGHTING APPARATUS FOR THEATRES, CLUBS AND DISCOTHEQUES; LIGHTING DEVICES FOR SHOWCASES; LIGHTING TUBES; LIGHTS FOR ILLUMINATING STAIRS, DOORS AND OTHER PORTIONS OF BUILDINGS; LIGHTS FOR USE IN ILLUMINATING SIGNS AND DISPLAYS; WALL LIGHTS (U.S. CLS. 13, 21, 23, 31 AND 34).  
FIRST USE 11-28-2010; IN COMMERCE 11-28-2010.

3,956,090. COLUMBIA LIGHTING PROPERTIES, INC., WILMINGTON, DE. SN 85-120,935. PUB. 11-30-2010, FILED 9-1-2010.

**TRANSITION**

THE MARK CONSISTS OF STANDARD CHARACTERS WITHOUT CLAIM TO ANY PARTICULAR FONT, STYLE, SIZE, OR COLOR.

FOR LIGHTING FIXTURES (U.S. CLS. 13, 21, 23, 31 AND 34).  
FIRST USE 11-10-2010; IN COMMERCE 11-10-2010.

**CLASS 12—VEHICLES**

3,955,226. HARBOR DUCK ADVENTURES CO., SAUGATUCK, MI. SN 77-493,854. PUB. 10-6-2009, FILED 6-9-2008.

**HARBOR DUCK**

THE MARK CONSISTS OF STANDARD CHARACTERS WITHOUT CLAIM TO ANY PARTICULAR FONT, STYLE, SIZE, OR COLOR.

**CLASS 12—(Continued).**

NO CLAIM IS MADE TO THE EXCLUSIVE RIGHT TO USE "DUCK", APART FROM THE MARK AS SHOWN.

FOR VEHICLES, NAMELY, AMPHIBIOUS VEHICLES FOR CONDUCTING SIGHTSEEING TOURS ON BOTH LAND AND WATER (U.S. CLS. 19, 21, 23, 31, 35 AND 44).  
FIRST USE 6-29-2010; IN COMMERCE 6-29-2010.

3,955,302. STARCRAFT MARK HOLDING COMPANY, LLC, GOSHEN, IN. SN 77-678,235. PUB. 12-22-2009, FILED 2-25-2009.

**EVER-LITE**

THE MARK CONSISTS OF STANDARD CHARACTERS WITHOUT CLAIM TO ANY PARTICULAR FONT, STYLE, SIZE, OR COLOR.

FOR RECREATIONAL VEHICLES, NAMELY, TRAVEL TRAILERS AND FIFTH WHEEL TRAILERS (U.S. CLS. 19, 21, 23, 31, 35 AND 44).  
FIRST USE 3-16-2011; IN COMMERCE 3-16-2011.

3,955,444. NINGBO JINHUI PRECISION CASTING CO., LTD., ZHEJIANG PROVINCE, CHINA. SN 77-827,536. PUB. 7-20-2010, FILED 9-16-2009.



THE MARK CONSISTS OF THE STYLIZED LETTERS OF "JINHUI", THREE PARALLEL ARCS AND ONE VERTICAL ARC INCLUDED IN A RECTANGLE DEVICE AGAINST A BLACK BACKGROUND ON TOP OF THE WORD "JINHUI".

FOR BUFFERS FOR RAILWAY ROLLING STOCK; VEHICLE SUSPENSION PARTS, NAMELY, SPRING SEAT FOR BUFFERS FOR RAILWAY ROLLING STOCK; BRAKE DISCS FOR RAILWAY VEHICLES; STRUCTURAL PARTS OF VEHICLES, NAMELY, SUPPORTING BRACKETS FOR AUTOMOBILE'S REAR AXLE; STRUCTURAL PARTS OF VEHICLES, NAMELY, BASE PLATE FOR LORRIES' REAR AXLE (U.S. CLS. 19, 21, 23, 31, 35 AND 44).

FIRST USE 2-20-2011; IN COMMERCE 2-20-2011.

**CLASS 12—(Continued).**

3,955,474. MACNEIL IP LLC, BOLINGBROOK, IL. SN 77-847,753. PUB. 7-20-2010, FILED 10-13-2009.

**TechShade**

OWNER OF U.S. REG. NOS. 1,891,121, 3,534,011, AND OTHERS.

THE COLOR(S) RED AND BLACK IS/ARE CLAIMED AS A FEATURE OF THE MARK.

THE MARK CONSISTS OF THE WORD "TECHSHADE" IN A SANS-SERIF FONT, WITH THE "T" AND THE "S" BEING CAPITALIZED AND THE REST OF THE WORD BEING IN LOWER CASE. THE FORMATIVE "TECH" IS IN RED WHILE THE FORMATIVE "SHADE" IS IN BLACK.

FOR WINDSHIELD SUN SHADES FOR LAND VEHICLES (U.S. CLS. 19, 21, 23, 31, 35 AND 44).

FIRST USE 3-10-2011; IN COMMERCE 3-10-2011.

3,955,497. DONALD SORANNO, DBA AERO HAMMOCK, ALEXANDRIA, VA. SN 77-861,708. PUB. 4-20-2010, FILED 10-30-2009.

**Aero Hammock**

THE MARK CONSISTS OF STANDARD CHARACTERS WITHOUT CLAIM TO ANY PARTICULAR FONT, STYLE, SIZE, OR COLOR.

NO CLAIM IS MADE TO THE EXCLUSIVE RIGHT TO USE "AERO", APART FROM THE MARK AS SHOWN.

FOR BICYCLE PARTS, NAMELY, AERO BAR NET (U.S. CLS. 19, 21, 23, 31, 35 AND 44).

FIRST USE 1-10-2010; IN COMMERCE 1-10-2010.

3,955,506. BRIDGESTONE BRANDS, LLC, NASHVILLE, TN. SN 77-867,006. PUB. 10-26-2010, FILED 11-6-2009.

**REGENCY**

THE MARK CONSISTS OF STANDARD CHARACTERS WITHOUT CLAIM TO ANY PARTICULAR FONT, STYLE, SIZE, OR COLOR.

FOR TIRES FOR AGRICULTURAL AND OFF-THE-ROAD VEHICLES (U.S. CLS. 19, 21, 23, 31, 35 AND 44).

FIRST USE 1-3-2011; IN COMMERCE 1-3-2011.

**CLASS 12—(Continued).**

3,955,562. SHIMANO INC., SAKAI CITY, OSAKA, JAPAN. SN 77-893,010. PUB. 7-20-2010, FILED 12-14-2009.

**DYNA·SYS**

THE MARK CONSISTS OF STANDARD CHARACTERS WITHOUT CLAIM TO ANY PARTICULAR FONT, STYLE, SIZE, OR COLOR.

FOR BICYCLE PARTS AND FITTINGS, NAMELY, GEAR RELEASE LEVERS, GEAR SHIFT LEVERS, FRONT DERAILLEURS, REAR DERAILLEURS, CHAIN GUIDES, FREEWHEELS, SPROCKETS, PULLEYS, CHAINS FOR BICYCLES, SHIFT CABLES, CRANKS, CRANK SETS, FRONT CHAIN WHEELS, BOTTOM BRACKETS (U.S. CLS. 19, 21, 23, 31, 35 AND 44).

FIRST USE 10-19-2009; IN COMMERCE 2-26-2010.

3,955,598. CHARLES STEVEN POWERS, DBA PROPULSION TECHNOLOGIES, INC., SHREVEPORT, LA. SN 77-914,051. PUB. 6-1-2010, FILED 1-18-2010.

**Rule the Water**

THE MARK CONSISTS OF STANDARD CHARACTERS WITHOUT CLAIM TO ANY PARTICULAR FONT, STYLE, SIZE, OR COLOR.

FOR SCREW PROPELLERS (U.S. CLS. 19, 21, 23, 31, 35 AND 44).

FIRST USE 8-1-2010; IN COMMERCE 8-1-2010.

3,955,646. SHENZHEN GREENWHEEL ELECTRIC VEHICLE CO., LTD., SHENZHEN CITY, CHINA. SN 77-927,654. PUB. 7-13-2010, FILED 2-4-2010.

**Jummer**

THE MARK CONSISTS OF STANDARD CHARACTERS WITHOUT CLAIM TO ANY PARTICULAR FONT, STYLE, SIZE, OR COLOR.

FOR CARS; WAGGONS; ELECTRIC VEHICLES, NAMELY, CARS; FORK LIFT TRUCKS; VEHICLES FOR LOCOMOTION BY LAND, AIR, AND WATER, NAMELY, LAND VEHICLES, BOATS, AND AIRPLANES; CONCRETE MIXING TRUCKS; CHASSIS FOR MOTOR VEHICLES; PROPULSION MECHANISMS FOR LAND VEHICLES, NAMELY, VEHICLE PROPELLERS, ENGINES FOR LAND VEHICLES; TROLLEYS; AUTOMOBILE BODIES; MILITARY VEHICLES FOR TRANSPORT PURPOSES, NAMELY, BOATS, AUTOMOBILES (U.S. CLS. 19, 21, 23, 31, 35 AND 44).

FIRST USE 11-11-2009; IN COMMERCE 6-27-2010.

**CLASS 12—(Continued).**

3,955,647. AERODYNAMIC TRAILER SYSTEMS, LLC, AUBURN TOWNSHIP, OH. SN 77-928,317. PUB. 6-22-2010, FILED 2-4-2010.

## SmartTail

THE MARK CONSISTS OF STANDARD CHARACTERS WITHOUT CLAIM TO ANY PARTICULAR FONT, STYLE, SIZE, OR COLOR.

FOR PRODUCTS TO IMPROVE FUEL ECONOMY BY REDUCING AERODYNAMIC DRAG, NAMELY, INFLATABLE BLADDERS INSTALLED ON THE REAR FACE OF A VEHICLE (U.S. CLS. 19, 21, 23, 31, 35 AND 44).  
FIRST USE 3-1-2010; IN COMMERCE 2-1-2011.

3,955,648. AERODYNAMIC TRAILER SYSTEMS, LLC, AUBURN TOWNSHIP, OH. SN 77-928,340. PUB. 6-22-2010, FILED 2-4-2010.

## WindTamer

THE MARK CONSISTS OF STANDARD CHARACTERS WITHOUT CLAIM TO ANY PARTICULAR FONT, STYLE, SIZE, OR COLOR.

FOR PRODUCTS TO IMPROVE FUEL ECONOMY BY REDUCING AERODYNAMIC DRAG, NAMELY, A CONTOURED AIR DEFLECTOR MOUNTED ON THE UNDERCARRIAGE OF A VEHICLE (U.S. CLS. 19, 21, 23, 31, 35 AND 44).

FIRST USE 3-1-2010; IN COMMERCE 2-1-2011.

3,955,702. JAYCO, INC., MIDDLEBURY, IN. SN 77-936,400. PUB. 12-7-2010, FILED 2-16-2010.

## PINNACLE

THE MARK CONSISTS OF STANDARD CHARACTERS WITHOUT CLAIM TO ANY PARTICULAR FONT, STYLE, SIZE, OR COLOR.

FOR RECREATIONAL VEHICLES, NAMELY, FIFTH WHEEL TRAVEL TRAILERS (U.S. CLS. 19, 21, 23, 31, 35 AND 44).

FIRST USE 6-20-2010; IN COMMERCE 6-20-2010.

**CLASS 12—(Continued).**

3,955,777. POLARIS INDUSTRIES, INC., MEDINA, MN. SN 77-951,499. PUB. 9-21-2010, FILED 3-5-2010.

## RANGER RZR XP

THE MARK CONSISTS OF STANDARD CHARACTERS WITHOUT CLAIM TO ANY PARTICULAR FONT, STYLE, SIZE, OR COLOR.

OWNER OF U.S. REG. NOS. 3,458,736, 3,509,238, AND OTHERS.

FOR ALL-TERRAIN UTILITY VEHICLES AND STRUCTURAL PARTS THEREFOR (U.S. CLS. 19, 21, 23, 31, 35 AND 44).

FIRST USE 1-14-2011; IN COMMERCE 1-14-2011.

3,955,945. LEXANI INTERNATIONAL, INC., CORONA, CA. SN 85-021,090. PUB. 11-23-2010, FILED 4-22-2010.

## ASANTI

THE MARK CONSISTS OF STANDARD CHARACTERS WITHOUT CLAIM TO ANY PARTICULAR FONT, STYLE, SIZE, OR COLOR.

OWNER OF U.S. REG. NO. 3,231,710.

FOR LAND VEHICLES AND STRUCTURAL PARTS THEREFOR; SHIPS, BOATS, AND STRUCTURAL PARTS THEREFOR; PERSONAL WATERCRAFT, NAMELY, SMALL POWERBOATS, SINGLE AND MULTIPLE PASSENGER RECREATIONAL JET BOATS, WATER SCOOTERS, AND STRUCTURAL PARTS THEREFOR (U.S. CLS. 19, 21, 23, 31, 35 AND 44).

FIRST USE 1-1-2009; IN COMMERCE 1-1-2009.

3,956,011. BRAKE PARTS INC., MCHENRY, IL. SN 85-056,478. PUB. 11-9-2010, FILED 6-7-2010.

## THE TECHNICIAN'S CHOICE SINCE 1902

THE MARK CONSISTS OF STANDARD CHARACTERS WITHOUT CLAIM TO ANY PARTICULAR FONT, STYLE, SIZE, OR COLOR.

NO CLAIM IS MADE TO THE EXCLUSIVE RIGHT TO USE "TECHNICIAN'S" AND "SINCE 1902", APART FROM THE MARK AS SHOWN.

FOR BRAKE PADS (U.S. CLS. 19, 21, 23, 31, 35 AND 44).

FIRST USE 11-1-2010; IN COMMERCE 11-1-2010.

**CLASS 12—(Continued).**

3,956,019. UTILIMASTER CORPORATION, WAKARUSA, IN.  
SN 85-058,321. PUB. 11-16-2010, FILED 6-9-2010.

**SAFE LOAD**

THE MARK CONSISTS OF STANDARD CHARACTERS WITHOUT CLAIM TO ANY PARTICULAR FONT, STYLE, SIZE, OR COLOR.

NO CLAIM IS MADE TO THE EXCLUSIVE RIGHT TO USE "LOAD", APART FROM THE MARK AS SHOWN.

FOR VEHICLE LAUNDRY BAGGING AND ORGANIZING SYSTEM COMPRISED PRIMARILY OF CARGO STORAGE CONTAINERS SPECIALLY ADAPTED FOR USE IN LAND VEHICLES (U.S. CLS. 19, 21, 23, 31, 35 AND 44).

FIRST USE 12-8-2010; IN COMMERCE 12-8-2010.

3,956,020. UTILIMASTER CORPORATION, WAKARUSA, IN.  
SN 85-058,327. PUB. 11-16-2010, FILED 6-9-2010.

**ENERGYWISE**

THE MARK CONSISTS OF STANDARD CHARACTERS WITHOUT CLAIM TO ANY PARTICULAR FONT, STYLE, SIZE, OR COLOR.

FOR CARGO LAND VEHICLE (U.S. CLS. 19, 21, 23, 31, 35 AND 44).

FIRST USE 3-11-2009; IN COMMERCE 3-11-2009.

3,956,022. PRIMO DESIGN IMPORTERS LTD., ROLLING HILLS ESTATES, CA. SN 85-059,763. PUB. 11-9-2010, FILED 6-10-2010.

**DRAKO**

THE MARK CONSISTS OF STANDARD CHARACTERS WITHOUT CLAIM TO ANY PARTICULAR FONT, STYLE, SIZE, OR COLOR.

FOR BICYCLE FRAMES; BICYCLES (U.S. CLS. 19, 21, 23, 31, 35 AND 44).

FIRST USE 3-24-2010; IN COMMERCE 3-24-2010.

**CLASS 12—(Continued).**

3,956,048. LIFENG GROUP CO., LTD., ZHEJIANG, CHINA.  
SN 85-079,141. PUB. 11-23-2010, FILED 7-7-2010.



THE MARK CONSISTS OF A QUADRANGLE STAR STANDING IN FRONT OF A CIRCLE WITH TWO WINGS. FOR MOTORCYCLES; ELECTRIC CARS (U.S. CLS. 19, 21, 23, 31, 35 AND 44).

FIRST USE 1-27-2010; IN COMMERCE 2-12-2011.

**CLASS 14—JEWELRY**

3,955,305. ASHLEY J. BERMAN, DBA ASHLEY MORGAN DESIGNS, SAN FRANCISCO, CA. SN 77-684,622. PUB. 7-13-2010, FILED 3-5-2009.

**Ashley Morgan Designs**

THE MARK CONSISTS OF STANDARD CHARACTERS WITHOUT CLAIM TO ANY PARTICULAR FONT, STYLE, SIZE, OR COLOR.

NO CLAIM IS MADE TO THE EXCLUSIVE RIGHT TO USE "DESIGNS", APART FROM THE MARK AS SHOWN.

THE NAME "ASHLEY MORGAN" DOES NOT IDENTIFY A LIVING INDIVIDUAL.

FOR JEWELRY (U.S. CLS. 2, 27, 28 AND 50).

FIRST USE 3-7-2011; IN COMMERCE 3-7-2011.

3,955,398. COMPAGNIE DES MONTRES LONGINES, FRANCILLON S.A. (LONGINES WATCH CO., FRANCILLON LTD.), 2610 SAINT-IMIER, SWITZERLAND. SN 77-801,466. PUB. 7-27-2010, FILED 8-11-2009.

**LONGINES SILVER ARROW**

THE MARK CONSISTS OF STANDARD CHARACTERS WITHOUT CLAIM TO ANY PARTICULAR FONT, STYLE, SIZE, OR COLOR.

OWNER OF SWITZERLAND REG. NO. 583468, DATED 2-24-2009, EXPIRES 2-24-2019.

OWNER OF U.S. REG. NOS. 65,109, 685,905, AND OTHERS.

**CLASS 14—(Continued).**

NO CLAIM IS MADE TO THE EXCLUSIVE RIGHT TO USE "SILVER", APART FROM THE MARK AS SHOWN.

FOR PRECIOUS METALS AND THEIR ALLOYS, JEWELRY, PRECIOUS STONES, HOROLOGICAL AND CHRONOMETRIC INSTRUMENTS (U.S. CLS. 2, 27, 28 AND 50).

FIRST USE 8-1-2009; IN COMMERCE 1-7-2010.

**CLASS 14—(Continued).**

3,955,723. M. Z. BERGER & CO., INC., LONG ISLAND CITY, NY. SN 77-941,120. PUB. 7-13-2010, FILED 2-22-2010.

---

## Jack of Hearts

THE MARK CONSISTS OF STANDARD CHARACTERS WITHOUT CLAIM TO ANY PARTICULAR FONT, STYLE, SIZE, OR COLOR.

FOR JEWELRY; WATCHES (U.S. CLS. 2, 27, 28 AND 50).

FIRST USE 3-24-2010; IN COMMERCE 3-24-2010.

3,955,543. JEWISH ROSARIES LLC, BROOKLYN, NY. SN 77-882,288. PUB. 4-27-2010, FILED 11-30-2009.

---

## jew la ree

THE MARK CONSISTS OF STANDARD CHARACTERS WITHOUT CLAIM TO ANY PARTICULAR FONT, STYLE, SIZE, OR COLOR.

FOR COSTUME JEWELRY; JEWELRY (U.S. CLS. 2, 27, 28 AND 50).

FIRST USE 11-15-2009; IN COMMERCE 2-24-2010.

3,955,726. OUTRCO, INC., WILMINGTON, DE. SN 77-941,683. PUB. 7-27-2010, FILED 2-22-2010.

---

## AVA & GRACE

THE MARK CONSISTS OF STANDARD CHARACTERS WITHOUT CLAIM TO ANY PARTICULAR FONT, STYLE, SIZE, OR COLOR.

FOR JEWELRY; WATCHES (U.S. CLS. 2, 27, 28 AND 50).

FIRST USE 4-1-2010; IN COMMERCE 4-1-2010.

3,955,613. SANDBERG & SIKORSKI CORPORATION, NEW YORK, NY. SN 77-918,318. PUB. 6-8-2010, FILED 1-22-2010.

---

## A. JAFFE HERITAGE COLLECTION

THE MARK CONSISTS OF STANDARD CHARACTERS WITHOUT CLAIM TO ANY PARTICULAR FONT, STYLE, SIZE, OR COLOR.

OWNER OF U.S. REG. NOS. 1,858,530 AND 2,262,297.

NO CLAIM IS MADE TO THE EXCLUSIVE RIGHT TO USE "COLLECTION", APART FROM THE MARK AS SHOWN.

THE NAME(S), PORTRAIT(S), AND/OR SIGNATURE(S) SHOWN IN THE MARK DOES NOT IDENTIFY A PARTICULAR LIVING INDIVIDUAL.

FOR JEWELRY (U.S. CLS. 2, 27, 28 AND 50).  
FIRST USE 12-1-2010; IN COMMERCE 12-1-2010.

3,955,794. RONEY, NEDRA DEE, DRAPER, UT. SN 77-956,962. PUB. 8-3-2010, FILED 3-11-2010.

---

## NORMA JEANE

THE MARK CONSISTS OF STANDARD CHARACTERS WITHOUT CLAIM TO ANY PARTICULAR FONT, STYLE, SIZE, OR COLOR.

OWNER OF U.S. REG. NO. 3,773,519.

FOR JEWELRY (U.S. CLS. 2, 27, 28 AND 50).  
FIRST USE 9-1-2010; IN COMMERCE 9-1-2010.

**CLASS 14—(Continued).**

3,955,966. NATIONAL ACADEMY OF RECORDING ARTS & SCIENCES, INC., SANTA MONICA, CA. SN 85-030,457. PUB. 8-3-2010, FILED 5-5-2010.



OWNER OF U.S. REG. NOS. 1,018,537, 1,704,527, AND OTHERS.

THE MARK CONSISTS OF A SILHOUETTE IMAGE OF A GRAMOPHONE FACING LEFT.

FOR JEWELRY AND WATCHES (U.S. CLS. 2, 27, 28 AND 50).

FIRST USE 11-1-2010; IN COMMERCE 11-1-2010.

3,955,977. QUALITY GOLD, INC., FAIRFIELD, OH. SN 85-037,278. PUB. 10-12-2010, FILED 5-13-2010.

**AMORE LA VITA CHARMS**

THE MARK CONSISTS OF STANDARD CHARACTERS WITHOUT CLAIM TO ANY PARTICULAR FONT, STYLE, SIZE, OR COLOR.

NO CLAIM IS MADE TO THE EXCLUSIVE RIGHT TO USE "CHARMS", APART FROM THE MARK AS SHOWN.

THE ENGLISH TRANSLATION OF "AMORE LA VITA" IN THE MARK IS "LOVE LIFE".

FOR JEWELRY INCLUDING CHARMS (U.S. CLS. 2, 27, 28 AND 50).

FIRST USE 5-0-2010; IN COMMERCE 5-0-2010.

**CLASS 15—MUSICAL INSTRUMENTS****CLASS 15—(Continued).**

3,955,176. HPF CORPORATION, SANTEE, CA. SN 77-056,363. PUB. 5-11-2010, FILED 12-4-2006.

**MASTER CLASS SERIES**

THE MARK CONSISTS OF STANDARD CHARACTERS WITHOUT CLAIM TO ANY PARTICULAR FONT, STYLE, SIZE, OR COLOR.

NO CLAIM IS MADE TO THE EXCLUSIVE RIGHT TO USE "SERIES", APART FROM THE MARK AS SHOWN.

FOR MUSICAL INSTRUMENTS (U.S. CLS. 2, 21 AND 36).

FIRST USE 8-0-2004; IN COMMERCE 8-0-2004.

**CLASS 16—PAPER GOODS AND PRINTED MATTER**

3,955,188. QUIDDITY, INC., SALEM, OR. SN 77-177,887. PUB. 12-11-2007, FILED 5-10-2007.

**LET YOURSELF HAPPEN**

THE MARK CONSISTS OF STANDARD CHARACTERS WITHOUT CLAIM TO ANY PARTICULAR FONT, STYLE, SIZE, OR COLOR.

FOR A SERIES OF BOOKS, HANDOUTS AND WORKSHEETS IN THE FIELD OF PERSONAL DEVELOPMENT, PARENTING, ABUSE PREVENTION (U.S. CLS. 2, 5, 22, 23, 29, 37, 38 AND 50).

FIRST USE 2-28-2011; IN COMMERCE 2-28-2011.

3,955,197. A QUANTUM MOMENT, LLC, RANCHO SANTA FE, CA. SN 77-227,305. PUB. 1-1-2008, FILED 7-11-2007.

**A QUANTUM MOMENT**

THE MARK CONSISTS OF STANDARD CHARACTERS WITHOUT CLAIM TO ANY PARTICULAR FONT, STYLE, SIZE, OR COLOR.

NO CLAIM IS MADE TO THE EXCLUSIVE RIGHT TO USE "QUANTUM", APART FROM THE MARK AS SHOWN.

FOR PRINTED GOODS, NAMELY, POSTERS, BROCHURES, PAMPHLETS, AND NEWSLETTERS CONCERNING PARAPSYCHOLOGY, QUANTUM PHYSICS, QUANTUM ENERGY, ALTERNATIVE HEALING PRACTICES, SPONTANEOUS REMISSION, CONSCIOUSNESS, MIND, PSI AND PSYCHIC PHENOMENA (U.S. CLS. 2, 5, 22, 23, 29, 37, 38 AND 50).

FIRST USE 6-0-2007; IN COMMERCE 6-0-2007.

**CLASS 16—(Continued).**

3,955,201. BISON CAPITAL LLC, VENICE, FL. SN 77-245,702.  
PUB. 1-1-2008, FILED 8-2-2007.

**WHITETAIL BUCKS**

THE MARK CONSISTS OF STANDARD CHARACTERS WITHOUT CLAIM TO ANY PARTICULAR FONT, STYLE, SIZE, OR COLOR.

FOR COUPONS USED FOR DISCOUNTS, PRIZE DRAWING, SWEEPSTAKES ENTRY (U.S. CLS. 2, 5, 22, 23, 29, 37, 38 AND 50).

FIRST USE 11-8-2010; IN COMMERCE 11-8-2010.

3,955,203. DUNNIGAN, TIMOTHY P., MIDLAND, GA. SN 77-275,064. PUB. 3-4-2008, FILED 9-9-2007.

**I'm a Hero Too**

THE MARK CONSISTS OF STANDARD CHARACTERS WITHOUT CLAIM TO ANY PARTICULAR FONT, STYLE, SIZE, OR COLOR.

FOR CHILDREN'S BOOKS (U.S. CLS. 2, 5, 22, 23, 29, 37, 38 AND 50).

FIRST USE 6-1-1997; IN COMMERCE 6-1-2007.

3,955,224. MUTASIAN MEDIA, LLC, PALM BEACH GARDENS, FL. SN 77-482,105. PUB. 4-14-2009, FILED 5-23-2008.

**PUKINI**

THE MARK CONSISTS OF STANDARD CHARACTERS WITHOUT CLAIM TO ANY PARTICULAR FONT, STYLE, SIZE, OR COLOR.

FOR PRINTED MATTER AND PUBLICATIONS, NAMELY, ADDRESS BOOKS, BOOK COVERS, BOOKMARKS, BOOKPLATES; CALENDARS; CHILDREN'S BOOKS; COLORING BOOKS; COMIC BOOKS; MAGAZINES REGARDING VIDEO GAMES OR ONLINE GAMES; MEMO BOARDS, MEMO PADS, NEWSPAPER CARTOONS, NOTE PADS, NOTEBOOKS, PAPER BANNERS, PAPER NAPKINS, PAPER PARTY FAVORS, PAPER PLACE MATS, PAPER TABLE COVERS, GIFT WRAPPING PAPER, GREETING CARDS, INVITATION CARDS, IRON-ON TRANSFERS; PICTURE STORYBOOKS, POSTCARDS, TRADING CARDS, POSTERS, RING BINDERS, RUBBER STAMPS, SCOREBOOKS, SCRAPBOOKS AND STAMP COLLECTOR BOOKS, SCRATCH PADS, STATIONARY, STATIONARY-TYPE PORTFOLIOS, STICKER ALBUMS, STICKERS; PENCIL BOXES, PENCIL SHARPENERS, PENCILS, PENS; STA-

**CLASS 16—(Continued).**

PLERS; ARTIST BRUSHES, ARTISTS PASTELS, PAINT SETS FOR CHILDREN, PAINT SETS FOR ARTISTS, ART AND CRAFT PAINT KITS, CRAYONS; DECORATIVE FIGURES ATTACHABLE TO PENCILS; DRAWING RULERS; ERASERS, FELT-TIP MARKERS; AND GIFT BOXES; BOOKS, NAMELY, PICTURE BOOKS; PICTURE BOOKS FEATURING WHIMSICAL CARTOON CHARACTERS; INSTRUCTIONAL MANUALS, NAMELY, PLAYER'S GUIDE BOOKS FOR USE WITH AN ON-LINE COMPUTER GAME AND A MULTI-USER COMPUTER GAME FEATURING CHILDREN'S CARTOON CHARACTERS, ACCESSED VIA LOCAL COMPUTER NETWORKS, GLOBAL COMPUTER NETWORKS OR THE INTERNET; PAPER INSTRUCTIONAL AND TEACHING MATERIALS, PRINTED PUBLICATIONS, NAMELY, LEAFLETS, BROCHURES AND POSTERS, ALL FEATURING CHILDREN'S CARTOON CHARACTERS AND FOR USE WITH AN ON-LINE COMPUTER GAME AND A MULTI-USER COMPUTER GAME AVAILABLE VIA LOCAL COMPUTER NETWORKS, GLOBAL COMPUTER NETWORKS OR THE INTERNET; CHILDREN'S ACTIVITY BOOKS; MAGNETIC SLATE BOARDS; PAPER PARTY DECORATIONS MOUNTABLE ON DOORS; PAPERBACK BOOKS FOR CHILDREN (U.S. CLS. 2, 5, 22, 23, 29, 37, 38 AND 50).

FIRST USE 3-17-2009; IN COMMERCE 9-10-2009.

3,955,269. EXECUTIVE MACHINES, INC., BROOKLYN, NY. SN 77-618,561. PUB. 3-31-2009, FILED 11-20-2008.

**MILITARY CUT**

THE MARK CONSISTS OF STANDARD CHARACTERS WITHOUT CLAIM TO ANY PARTICULAR FONT, STYLE, SIZE, OR COLOR.

FOR PAPER SHREDDERS FOR OFFICE USE (U.S. CLS. 2, 5, 22, 23, 29, 37, 38 AND 50).

FIRST USE 3-3-2011; IN COMMERCE 3-3-2011.

3,955,311. IDEASTREAM CONSUMER PRODUCTS, LLC, CLEVELAND, OH. SN 77-689,254. PUB. 7-27-2010, FILED 3-12-2009.

**EARTH RULES**

THE MARK CONSISTS OF STANDARD CHARACTERS WITHOUT CLAIM TO ANY PARTICULAR FONT, STYLE, SIZE, OR COLOR.

FOR PAPER PADS, NAMELY, PAPER WRITING PADS, LEGAL PADS (U.S. CLS. 2, 5, 22, 23, 29, 37, 38 AND 50).

FIRST USE 2-28-2010; IN COMMERCE 2-28-2010.



**CLASS 16—(Continued).**

3,955,319. CLOVERLEAF CORPORATION, RUSKIN, FL. SN 77-705,278. PUB. 2-23-2010, FILED 4-2-2009.

# MONTOOTH

THE MARK CONSISTS OF STANDARD CHARACTERS WITHOUT CLAIM TO ANY PARTICULAR FONT, STYLE, SIZE, OR COLOR.

FOR PRINTED MATTER, NAMELY, A SERIES OF FICTION BOOKS, FANTASY AND ADVENTURE BOOKS (U.S. CLS. 2, 5, 22, 23, 29, 37, 38 AND 50).

FIRST USE 7-29-2009; IN COMMERCE 7-29-2009.

3,955,369. CORKY'S PEST CONTROL, INC., SAN MARCOS, CA. SN 77-781,017. PUB. 12-1-2009, FILED 7-14-2009.

# CORKY'S PEST CONTROL

THE MARK CONSISTS OF STANDARD CHARACTERS WITHOUT CLAIM TO ANY PARTICULAR FONT, STYLE, SIZE, OR COLOR.

OWNER OF U.S. REG. NOS. 2,360,215, 3,669,306, AND 3,669,309.

NO CLAIM IS MADE TO THE EXCLUSIVE RIGHT TO USE "PEST CONTROL", APART FROM THE MARK AS SHOWN.

FOR PRINTED TEACHING MATERIALS IN THE FIELD OF TERMITE AND PEST CONTROL SERVICES (U.S. CLS. 2, 5, 22, 23, 29, 37, 38 AND 50).

FIRST USE 11-1-2010; IN COMMERCE 11-1-2010.

3,955,377. WINESTYLES, INC., MARGATE, FL. SN 77-788,144. PUB. 7-27-2010, FILED 7-23-2009.



OWNER OF U.S. REG. NOS. 3,126,917, 3,208,983, AND OTHERS.

NO CLAIM IS MADE TO THE EXCLUSIVE RIGHT TO USE "WINE CLUB", APART FROM THE MARK AS SHOWN.

**CLASS 16—(Continued).**

THE MARK CONSISTS OF THE STYLIZED WORDING "WINESTYLES" WITH THE STYLIZED WORDS "WINE CLUB" UNDERNEATH ON A CORK, AND THE STYLIZED WORDING "CLUBHOUSE UNCORKED" NEXT TO THE CORK WITH THE LETTER "D" IN THE FORM OF A CORKSCREW.

FOR MAGAZINES FEATURING ARTICLES AND COMMENTARY RELATING TO CULTURE, ARTS, ENTERTAINMENT, LEISURE, RECREATION, SHOPPING, TRAVELING, SPORTS, FINE FOOD AND WINE, SOCIETY, AND GENERAL CIVIC AND BUSINESS INTERESTS (U.S. CLS. 2, 5, 22, 23, 29, 37, 38 AND 50).

FIRST USE 3-1-2011; IN COMMERCE 3-1-2011.

3,955,431. TEK INDUSTRIES, INC., FREMONT, NE. SN 77-820,704. PUB. 2-2-2010, FILED 9-4-2009.

# ACQUILT GO!

THE MARK CONSISTS OF STANDARD CHARACTERS WITHOUT CLAIM TO ANY PARTICULAR FONT, STYLE, SIZE, OR COLOR.

FOR PRINTED PATTERNS FOR QUILTING, SEWING AND CRAFTS USE (U.S. CLS. 2, 5, 22, 23, 29, 37, 38 AND 50).

FIRST USE 12-1-2008; IN COMMERCE 12-1-2008.

3,955,439. SERVICE COMPANY SOLUTIONS, LLC, BEDFORD, NH. SN 77-825,685. PUB. 12-28-2010, FILED 9-14-2009.



NO CLAIM IS MADE TO THE EXCLUSIVE RIGHT TO USE "THE ORIGINAL BLUE BOOK MAJOR APPLIANCE JOB RATE GUIDE", APART FROM THE MARK AS SHOWN.

THE MARK CONSISTS A SHADED CIRCLE CONTAINING THE LETTERS "BB" WITH A DARKENED BORDER OF THE CIRCLE. TO THE RIGHT OF THE CIRCLE IS THE WORD "THE" WITH THE WORDS "ORIGINAL BLUE BOOK" BELOW. UNDERNEATH IS A SHADED RECTANGLE WITH THE WORDS "MAJOR APPLIANCE" AND BELOW THAT IS THE WORDS "JOB RATE GUIDE".

FOR BOOKS IN THE FIELD OF APPLIANCE REPAIR (U.S. CLS. 2, 5, 22, 23, 29, 37, 38 AND 50).

FIRST USE 1-1-2010; IN COMMERCE 1-1-2010.

**CLASS 16—(Continued).**

3,955,477. AVERY DENNISON CORPORATION, PASADENA, CA. SN 77-850,941. PUB. 6-29-2010, FILED 10-16-2009.

**RE-HESIVE**

THE MARK CONSISTS OF STANDARD CHARACTERS WITHOUT CLAIM TO ANY PARTICULAR FONT, STYLE, SIZE, OR COLOR.

FOR PAPER LABELS, NAMELY, ADDRESS LABELS, ADHESIVE LABELS, ADHESIVES STICKERS, BLANK LABELS, IMAGE-BEARING LABELS, LABELS AND STICKERS FOR INFORMATION AND DECORATION PURPOSES MADE FROM PAPER, LABELS, ADHESIVE IDENTIFICATION LABELS BEARING ALPHANUMERIC SYMBOLS, PRESSURE-SENSITIVE-PRINTING PAPERS FOR LABELS AND DISPLAYS, PRINTED LABELS, RETURN ADDRESS LABELS, SELF-ADHESIVE LABELS, FACESTOCK AND LABELS IN SHEET FORM AND SHIPPING LABELS (U.S. CLS. 2, 5, 22, 23, 29, 37, 38 AND 50).

FIRST USE 10-1-2008; IN COMMERCE 10-1-2008.

3,955,487. LYNN CROWLEY, HARVARD, MA. SN 77-857,048. PUB. 4-6-2010, FILED 10-26-2009.

**SPACE PAUSE**

THE MARK CONSISTS OF STANDARD CHARACTERS WITHOUT CLAIM TO ANY PARTICULAR FONT, STYLE, SIZE, OR COLOR.

FOR PRINTED INSTRUCTIONAL, EDUCATIONAL, AND TEACHING MATERIALS IN THE FIELD OF SPEECH, LANGUAGE AND COMMUNICATION (U.S. CLS. 2, 5, 22, 23, 29, 37, 38 AND 50).

FIRST USE 1-31-2009; IN COMMERCE 7-13-2009.

3,955,519. THE GYNECOLOGIC ONCOLOGY GROUP, CROFTON, MD. SN 77-874,006. PUB. 5-11-2010, FILED 11-17-2009.



OWNER OF U.S. REG. NO. 3,244,265.

**CLASS 16—(Continued).**

NO CLAIM IS MADE TO THE EXCLUSIVE RIGHT TO USE "GYNECOLOGIC ONCOLOGY GROUP" OR "GYN CANCER RESEARCH FUND", APART FROM THE MARK AS SHOWN.

THE COLOR(S) BLUE, RED, ORANGE, YELLOW, GREEN, INDIGO, VIOLET, BLACK, WHITE, GRAY AND TEAL IS/ARE CLAIMED AS A FEATURE OF THE MARK.

THE MARK CONSISTS OF MOUNTAIN SCENERY, WHERE THE MOUNTAINS ARE SHOWN IN GREEN AGAINST A BLUE SKY, WITH A SETTING SUN SHOWN IN YELLOW AT THE END OF A RAINBOW SHOWN IN RED, ORANGE, YELLOW, GREEN, BLUE, INDIGO AND VIOLET. THE WORDS "NEW HORIZONS GYN CANCER RESEARCH FUND" ARE SHOWN IN BLACK LETTERS AGAINST THE SKY; THE PHRASE "CHASING THE CURE FOR OVARIAN & UTERINE CANCER" IS SHOWN IN BLACK LETTERS AGAINST THE MOUNTAINS. ON THE LOWER LEFT CORNER OF THE MOUNTAINS IS A TEAL OVAL WITH THE TERM "GOG GYNECOLOGIC ONCOLOGY GROUP" IN BLACK LETTERS. BENEATH THE MOUNTAINS, A TEAL AWARENESS RIBBON WITH A CIRCLE FOR A HEAD IS SHOWN WITH GRAY SHOES AGAINST A WHITE BACKGROUND. THE WORDS "ONE STEP AT A TIME" ARE SHOWN IN BLACK LETTERS ON THE WHITE BACKGROUND.

FOR ART PRINTS; BLANK OR PARTIALLY PRINTED PAPER LABELS; BLANK OR PARTIALLY PRINTED POSTCARDS; GRAPHIC PRINTS AND REPRESENTATIONS; LASER PRINTING PAPER; PRINT ENGRAVINGS; PRINT SUBSTRATE, NAMELY, TRANSPARENT, OPAQUE AND TRANSLUCENT FILMS FOR USE WITH INK JET PRINTERS; PRINTED ADVERTISING BOARDS OF PAPER OR CARDBOARD; PRINTED AWARD CERTIFICATES; PRINTED AWARDS; PRINTED CERTIFICATES; PRINTED CHARTS; PRINTED CONSUMER REPORTS FEATURING INFORMATION ON GYN CANCER; PRINTED CORRESPONDENCE COURSE MATERIALS IN THE FIELD OF GYN CANCER; PRINTED EDUCATIONAL MATERIALS IN THE FIELD OF GYN CANCER; PRINTED EMBLEMS; PRINTED INSTRUCTIONAL, EDUCATIONAL, AND TEACHING MATERIALS IN THE FIELD OF GYN CANCER; PRINTED INVITATIONS; PRINTED MAIL RESPONSE CARDS RELATING TO GYN CANCER; PRINTED MATERIAL IN THE NATURE OF DECALS FOR MAINTENANCE SERVICE AND APPOINTMENT REMINDERS; PRINTED MATERIAL, NAMELY, SURVEYS AND ASSESSMENTS IN THE FIELD OF EDUCATOR TRAINING AND PERFORMANCE; PRINTED MATERIALS, NAMELY, CURRICULA IN THE FIELD OF GYN CANCER; PRINTED MATTER, NAMELY, NEWSPAPERS, PHOTOGRAPHS, MAGAZINES, BOOKS, PRINTED PERIODICALS, NEWSLETTERS, AND BROCHURES ALL IN THE FIELDS OF SECURITIES, OPTIONS AND OTHER FINANCIAL INSTRUMENTS; PRINTED PAPER LABELS; PRINTED PAPER SIGNS; PRINTED PAPER SIGNS, NAMELY, TABLE TENTS; PRINTED PERIODICALS IN THE FIELD OF DANCE; PRINTED PERIODICALS IN THE FIELD OF GYN CANCER; PRINTED SURVEY ANSWER SHEETS; PRINTING PAPER; PUBLICATIONS, NAMELY, BROCHURES, BOOKLETS, AND TEACHING MATERIALS IN THE FIELD OF GYN CANCER (U.S. CLS. 2, 5, 22, 23, 29, 37, 38 AND 50).

FIRST USE 3-23-2010; IN COMMERCE 9-17-2010.

**CLASS 16—(Continued).**

3,955,552. CARMICHAEL TRAINING SYSTEMS, INC., COLORADO SPRINGS, CO. SN 77-887,530. PUB. 5-4-2010, FILED 12-7-2009.

**THE TIME-CRUNCHED ATHLETE**

THE MARK CONSISTS OF STANDARD CHARACTERS WITHOUT CLAIM TO ANY PARTICULAR FONT, STYLE, SIZE, OR COLOR.

NO CLAIM IS MADE TO THE EXCLUSIVE RIGHT TO USE "ATHLETE", APART FROM THE MARK AS SHOWN. FOR PRINTED MATERIALS, NAMELY, A SERIES OF BOOKS AND PAMPHLETS FEATURING INFORMATION ABOUT ENDURANCE AND AEROBIC TRAINING, NUTRITION, PHYSICAL FITNESS, HEALTH AND WELLNESS (U.S. CLS. 2, 5, 22, 23, 29, 37, 38 AND 50). FIRST USE 11-1-2010; IN COMMERCE 11-1-2010.

3,955,558. IPS INDUSTRIES, INC., DBA SPECTRUM BAGS, UMATILLA, FL. SN 77-889,818. PUB. 4-27-2010, FILED 12-9-2009.

**FreshPic**

THE MARK CONSISTS OF STANDARD CHARACTERS WITHOUT CLAIM TO ANY PARTICULAR FONT, STYLE, SIZE, OR COLOR.

FOR PLASTIC FOOD STORAGE BAGS FOR HOUSEHOLD USE; PLASTIC SHOPPING BAGS (U.S. CLS. 2, 5, 22, 23, 29, 37, 38 AND 50). FIRST USE 11-30-2010; IN COMMERCE 11-30-2010.

3,955,564. FISCAL TIMES MEDIA GROUP, LLC, THE, NEW YORK, NY. SN 77-897,351. PUB. 10-5-2010, FILED 12-18-2009.

**FISCAL TIMES**

THE MARK CONSISTS OF STANDARD CHARACTERS WITHOUT CLAIM TO ANY PARTICULAR FONT, STYLE, SIZE, OR COLOR.

NO CLAIM IS MADE TO THE EXCLUSIVE RIGHT TO USE "FISCAL", APART FROM THE MARK AS SHOWN. FOR PUBLICATIONS, NAMELY, NEWSPAPERS, MAGAZINES, JOURNALS, BOOKS, PERIODICALS, AND NEWSLETTERS IN THE FIELDS OF BUSINESS, ECONOMICS, HEALTH CARE, GOVERNMENT POLICY AND FINANCE (U.S. CLS. 2, 5, 22, 23, 29, 37, 38 AND 50). FIRST USE 2-11-2010; IN COMMERCE 2-11-2010.

**CLASS 16—(Continued).**

3,955,584. IPS INDUSTRIES, INC., UMATILLA, FL. SN 77-907,705. PUB. 4-20-2010, FILED 1-8-2010.

**WaveStar**

THE MARK CONSISTS OF STANDARD CHARACTERS WITHOUT CLAIM TO ANY PARTICULAR FONT, STYLE, SIZE, OR COLOR.

FOR PLASTIC TRASH BAGS (U.S. CLS. 2, 5, 22, 23, 29, 37, 38 AND 50). FIRST USE 6-5-2010; IN COMMERCE 6-5-2010.

3,955,599. GRUHN, KATHRYN THORSON, CHARLOTTE, NC. SN 77-914,339. PUB. 6-29-2010, FILED 1-19-2010.

**MY BABY COMPASS**

THE MARK CONSISTS OF STANDARD CHARACTERS WITHOUT CLAIM TO ANY PARTICULAR FONT, STYLE, SIZE, OR COLOR.

NO CLAIM IS MADE TO THE EXCLUSIVE RIGHT TO USE "BABY", APART FROM THE MARK AS SHOWN. FOR A KIT SOLD AS A UNIT FOR A CHILD DEVELOPMENT PROGRAM WITH SPEECH AND LANGUAGE EMPHASIS WITH THE KIT CONSISTING PRIMARILY OF A BOOK, FLASH CARDS, CD-ROM, AND CD (U.S. CLS. 2, 5, 22, 23, 29, 37, 38 AND 50). FIRST USE 8-1-2010; IN COMMERCE 8-1-2010.

3,955,626. PENNY-FARTHING PRESS, INC., HOUSTON, TX. SN 77-922,420. PUB. 1-4-2011, FILED 1-28-2010.

**LUCI PHURR'S IMPS**

THE MARK CONSISTS OF STANDARD CHARACTERS WITHOUT CLAIM TO ANY PARTICULAR FONT, STYLE, SIZE, OR COLOR.

FOR COMICS (U.S. CLS. 2, 5, 22, 23, 29, 37, 38 AND 50). FIRST USE 12-21-2009; IN COMMERCE 12-21-2009.

**CLASS 16—(Continued).**

3,955,631. ECOMPANYSTORE, INC., ALPHARETTA, GA. SN 77-924,410. PUB. 9-7-2010, FILED 1-31-2010.

# BIGSHOOZ

THE MARK CONSISTS OF STANDARD CHARACTERS WITHOUT CLAIM TO ANY PARTICULAR FONT, STYLE, SIZE, OR COLOR.

FOR WRITING INSTRUMENTS, NAMELY, PENS; DESK ACCESSORIES, NAMELY, DESK SETS, PEN AND PENCIL HOLDERS, AND PAPERWEIGHTS; WRITING INSTRUMENTS, NAMELY, PENCILS AND MARKERS; DESK ACCESSORIES, NAMELY, DESK PADS AND PAPER CLIP HOLDERS; STATIONERY AND PRINTED PAPER GOODS (U.S. CLS. 2, 5, 22, 23, 29, 37, 38 AND 50).

FIRST USE 1-19-2010; IN COMMERCE 1-19-2010.

**CLASS 16—(Continued).**

3,955,668. PITTSBURGH ASSOCIATES, PITTSBURGH, PA. SN 77-930,237. PUB. 6-15-2010, FILED 2-8-2010.



THE MARK CONSISTS OF THE LETTER "B" STYLIZED. FOR PAPER GOODS AND PRINTED MATTER, NAMELY, GAME PROGRAMS, MAGAZINES AND BOOKS FEATURING BASEBALL, NOTE PAPER, PENS, PENCILS (U.S. CLS. 2, 5, 22, 23, 29, 37, 38 AND 50).

FIRST USE 4-8-2010; IN COMMERCE 4-8-2010.

3,955,678. TWENTIETH CENTURY FOX FILM CORPORATION, LOS ANGELES, CA. SN 77-932,110. PUB. 6-15-2010, FILED 2-9-2010.

## PERCY JACKSON AND THE OLYMPIANS

THE MARK CONSISTS OF STANDARD CHARACTERS WITHOUT CLAIM TO ANY PARTICULAR FONT, STYLE, SIZE, OR COLOR.

THE NAME "PERCY JACKSON" DOES NOT IDENTIFY A PARTICULAR LIVING INDIVIDUAL. FOR BOOKMARKS; POSTERS (U.S. CLS. 2, 5, 22, 23, 29, 37, 38 AND 50).

FIRST USE 1-15-2010; IN COMMERCE 1-15-2010.

3,955,810. LUCKY PAWS, LLC, COVINGTON, KY. SN 77-962,707. PUB. 6-22-2010, FILED 3-18-2010.

## PARTY 2 GO

THE MARK CONSISTS OF THE LETTER "B" STYLIZED. FOR PAPER GOODS AND PRINTED MATTER, NAMELY, PAPER SCHEDULES, GAME PROGRAMS, MAGAZINES AND BOOKS FEATURING BASEBALL, NOTE PAPER, PENS, PENCILS (U.S. CLS. 2, 5, 22, 23, 29, 37, 38 AND 50).

FIRST USE 4-8-2010; IN COMMERCE 4-8-2010.

THE MARK CONSISTS OF STANDARD CHARACTERS WITHOUT CLAIM TO ANY PARTICULAR FONT, STYLE, SIZE, OR COLOR.

**CLASS 16—(Continued).**

NO CLAIM IS MADE TO THE EXCLUSIVE RIGHT TO USE "PARTY", APART FROM THE MARK AS SHOWN.

FOR PREPACKAGED PET KIT COMPRISING INVITATIONS, PARTY HAT, MICROWAVE PAN, AND PET TREATS IN THE FORM OF ORGANIC MATERIAL TO BE MIXED WITH OTHER MATERIAL AND MICROWAVED IN THE MICROWAVE PAN (U.S. CLS. 2, 5, 22, 23, 29, 37, 38 AND 50).

FIRST USE 7-1-2010; IN COMMERCE 7-1-2010.

3,955,826. MORIARTY, GERALDINE M., SOUTH HADLEY, MA. SN 77-969,485. PUB. 8-24-2010, FILED 3-26-2010.

**FUNHUNTERS**

THE MARK CONSISTS OF STANDARD CHARACTERS WITHOUT CLAIM TO ANY PARTICULAR FONT, STYLE, SIZE, OR COLOR.

FOR PRINTED MATTER, NAMELY, BROCHURES IN THE FIELD OF SCAVENGER HUNTS FOR TOURISTS (U.S. CLS. 2, 5, 22, 23, 29, 37, 38 AND 50).

FIRST USE 5-1-2010; IN COMMERCE 5-1-2010.

3,955,865. SUMMIT ENTERTAINMENT, LLC, SANTA MONICA, CA. SN 77-981,667. PUB. 12-8-2009, FILED 2-16-2009.

**TEAM EDWARD**

THE MARK CONSISTS OF STANDARD CHARACTERS WITHOUT CLAIM TO ANY PARTICULAR FONT, STYLE, SIZE, OR COLOR.

FOR STICKERS, CALENDARS, PENS, STATIONERY, POSTERS, PENCILS, GREETING CARDS, GIFT WRAPPING PAPER, PAPER PARTY DECORATIONS, MAGAZINES IN THE FIELD OF ENTERTAINMENT, TRADING CARDS, POSTER BOOKS, PHOTOGRAPH ALBUMS, PAPER BAGS, PAPER BANNERS, PENCIL CASES, BOOK COVERS, DECALS, POSTCARDS, NOTE CARDS, BOOKMARKS, AND TEMPORARY TATTOOS (U.S. CLS. 2, 5, 22, 23, 29, 37, 38 AND 50).

FIRST USE 10-1-2009; IN COMMERCE 10-1-2009.

**CLASS 16—(Continued).**

3,955,866. SUMMIT ENTERTAINMENT, LLC, SANTA MONICA, CA. SN 77-981,668. PUB. 12-8-2009, FILED 2-16-2009.

**TEAM JACOB**

THE MARK CONSISTS OF STANDARD CHARACTERS WITHOUT CLAIM TO ANY PARTICULAR FONT, STYLE, SIZE, OR COLOR.

FOR STICKERS, CALENDARS, PENS, STATIONERY, POSTERS, PENCILS, GREETING CARDS, GIFT WRAPPING PAPER, PAPER PARTY DECORATIONS, MAGAZINES IN THE FIELD OF ENTERTAINMENT, TRADING CARDS, POSTER BOOKS, PHOTOGRAPH ALBUMS, PAPER BAGS, PAPER BANNERS, PENCIL CASES, BOOK COVERS, DECALS, POSTCARDS, NOTE CARDS, BOOKMARKS, AND TEMPORARY TATTOOS (U.S. CLS. 2, 5, 22, 23, 29, 37, 38 AND 50).

FIRST USE 10-1-2009; IN COMMERCE 10-1-2009.

3,955,869. OMX, INC., NAPERVILLE, IL. SN 77-981,701. PUB. 4-27-2010, FILED 12-15-2009.

**JUST BASICS**

THE MARK CONSISTS OF STANDARD CHARACTERS WITHOUT CLAIM TO ANY PARTICULAR FONT, STYLE, SIZE, OR COLOR.

FOR OFFICE AND ORGANIZATIONAL SUPPLIES, NAMELY, BINDERS, CLIP BOARDS, CORRECTION TAPE, ERASERS, FILE FOLDERS, MARKERS, PENCILS, AND PENS, EXCLUDING PAPER FOR USE BY ARTISTS OR FOR USE IN HANDICRAFT, EASELS FOR USE BY ARTISTS, PLASTIC AND CARDBOARD PAINT STORAGE BOXES FOR ARTISTS' USE, ARTISTS' PAINT BRUSHES, ARTISTS' CANVASES, ARTISTS' PALETTES, ARTISTS' SAUCERS FOR HOLDING PAINT, ARTISTS' PAPER DRAWING BOOKS, MODELING COMPOUND, AND PASTE FOR STATIONERY OR HOUSEHOLD PURPOSE (U.S. CLS. 2, 5, 22, 23, 29, 37, 38 AND 50).

FIRST USE 2-19-2009; IN COMMERCE 2-19-2009.

3,955,872. GEORGIA-PACIFIC CONSUMER PRODUCTS LP, ATLANTA, GA. SN 78-296,056. PUB. 7-13-2010, FILED 9-4-2003.

**BIGFOLD Z**

OWNER OF U.S. REG. NO. 2,257,154.  
FOR PAPER TOWELS (U.S. CLS. 2, 5, 22, 23, 29, 37, 38 AND 50).

FIRST USE 9-30-2003; IN COMMERCE 9-30-2003.

**CLASS 16—(Continued).**

3,955,878. LITERACY WEST NY, INC., BELMONT, NY. SN 78-808,876. PUB. 11-20-2007, FILED 2-7-2006.

**PEER WORX**

THE MARK CONSISTS OF STANDARD CHARACTERS WITHOUT CLAIM TO ANY PARTICULAR FONT, STYLE, SIZE, OR COLOR.

FOR PRINTED INSTRUCTIONAL, TEACHING, AND EDUCATIONAL MATERIALS, NAMELY, WRITTEN COURSE MATERIALS, NAMELY, DIAGRAMS, WRITTEN TRAINING AND INSTRUCTIONAL GUIDES, PRINTED LECTURES, STUDY GUIDES, AND COLUMNS, ALL IN THE FIELD OF TUTORING AND YOUTH DEVELOPMENT (U.S. CLS. 2, 5, 22, 23, 29, 37, 38 AND 50).

FIRST USE 11-30-2010; IN COMMERCE 11-30-2010.

3,955,885. UNITED STATES POSTAL SERVICE, WASHINGTON, DC. SN 78-922,003. PUB. 4-17-2007, FILED 7-3-2006.



OWNER OF U.S. REG. NOS. 2,963,878, 3,113,972, AND OTHERS.

NO CLAIM IS MADE TO THE EXCLUSIVE RIGHT TO USE "EST. 1775" AND "OFFICIAL LICENSED PRODUCT", APART FROM THE MARK AS SHOWN.

THE MARK CONSISTS OF WORDING "UNITED STATES POSTAL SERVICE EST. 1775 OFFICIAL LICENSED PRODUCT" AND THE DESIGN OF A STYLIZED STANDING EAGLE WITH OUTSTRETCHED WINGS ON A STAMP-LIKE BACKGROUND.

SEC. 2(F) AS TO "UNITED STATES POSTAL SERVICE".

FOR BOOKS IN THE FIELDS OF PHILATELICS, AND WORLD AND AMERICAN HISTORY; BOOKS CONTAINING COMMEMORATIVE STAMPS AND NARRATIVE TEXT REGARDING SUCH STAMPS; POSTCARDS (U.S. CLS. 2, 5, 22, 23, 29, 37, 38 AND 50).

FIRST USE 12-0-2007; IN COMMERCE 12-0-2007.

**CLASS 16—(Continued).**

3,955,887. NL WILLIAMS MEDIA INC., NORTH VANCOUVER, CANADA. SN 78-954,422. PUB. 11-27-2007, FILED 8-17-2006.

**WILDLY SOPHISTICATED**

THE MARK CONSISTS OF STANDARD CHARACTERS WITHOUT CLAIM TO ANY PARTICULAR FONT, STYLE, SIZE, OR COLOR.

FOR PRINTED PUBLICATIONS, NAMELY, SERIES OF BOOKS IN THE FIELD OF CAREER COUNSELING AND ADVICE (U.S. CLS. 2, 5, 22, 23, 29, 37, 38 AND 50).

FIRST USE 2-0-2004; IN COMMERCE 2-0-2004.

3,955,957. ARAUZ, CASEY, M, DBA CATASTROPHUNK, MIAMI, FL. SN 85-027,020. PUB. 10-5-2010, FILED 4-30-2010.



THE COLOR(S) WHITE, PINK, AND BLACK IS/ARE CLAIMED AS A FEATURE OF THE MARK.

THE MARK CONSISTS OF A SMILING FACE WITH TWO BLACK LINES IN THE CENTER THAT MAKE UP THE EYES AND A BLACK CURVING LINE THAT REPRESENTS THE MOUTH. TWO WHITE AND PINK BOWS ARE ON TOP OF THE FACE AND TWO BLACK ARCHES ARE SHOWN TO REPRESENT HAIR. THE WORD "CATASTROPHUNK" APPEARS BELOW THE FACE IN THE COLORS PINK AND WHITE.

FOR POSTERS MADE OF PAPER; STICKERS (U.S. CLS. 2, 5, 22, 23, 29, 37, 38 AND 50).

FIRST USE 1-8-2008; IN COMMERCE 4-10-2010.

3,956,016. BROWN-FORMAN CORPORATION, LOUISVILLE, KY. SN 85-058,063. PUB. 11-16-2010, FILED 6-9-2010.

**WOODFORD RESERVE**

THE MARK CONSISTS OF STANDARD CHARACTERS WITHOUT CLAIM TO ANY PARTICULAR FONT, STYLE, SIZE, OR COLOR.

**CLASS 16—(Continued).**

OWNER OF U.S. REG. NOS. 2,078,403, 2,453,285, AND OTHERS.

FOR PENS (U.S. CLS. 2, 5, 22, 23, 29, 37, 38 AND 50).  
FIRST USE 11-30-2010; IN COMMERCE 11-30-2010.

3,956,072. FEIST, LAUREN, RYE BROOK, NY. SN 85-087,414.  
PUB. 12-28-2010, FILED 7-19-2010.

## the puzzle pod

THE MARK CONSISTS OF STANDARD CHARACTERS WITHOUT CLAIM TO ANY PARTICULAR FONT, STYLE, SIZE, OR COLOR.

NO CLAIM IS MADE TO THE EXCLUSIVE RIGHT TO USE "PUZZLE", APART FROM THE MARK AS SHOWN.

FOR CARDBOARD PACKAGING; CARDBOARD PACKAGING BOXES IN COLLAPSIBLE FORM; CARDBOARD PACKAGING BOXES IN MADE-UP FORM; INDUSTRIAL PACKAGING CONTAINERS OF PAPER; PACKAGING AND CONTAINERS COMPRISED OF STARCH-BASED MATERIALS IN THE NATURE OF A PAPER SUBSTITUTE FOR FOOD, BEVERAGES AND CONSUMER PRODUCTS; PACKAGING CONTAINERS OF PAPER; PACKAGING MATERIALS MADE FROM MINERAL-BASED PAPER SUBSTITUTES; PACKAGING MATERIALS MADE OF RECYCLED PAPER; PAPER BAGS FOR PACKAGING; PAPER ENVELOPES FOR PACKAGING; PAPER FOR WRAPPING AND PACKAGING; PAPER POUCHES FOR PACKAGING; PAPERBOARD BOXES; PLASTIC OR PAPER BAGS FOR MERCHANDISE PACKAGING (U.S. CLS. 2, 5, 22, 23, 29, 37, 38 AND 50).

FIRST USE 2-14-2011; IN COMMERCE 2-14-2011.

**CLASS 17—RUBBER GOODS**

3,955,167. RUBIN, JODI, LAQUINTA, CA. SN 76-702,875. PUB. 11-16-2010, FILED 5-10-2010.

## WINDOW WONDERS

THE MARK CONSISTS OF STANDARD CHARACTERS WITHOUT CLAIM TO ANY PARTICULAR FONT, STYLE, SIZE, OR COLOR.

NO CLAIM IS MADE TO THE EXCLUSIVE RIGHT TO USE "WINDOW", APART FROM THE MARK AS SHOWN.

FOR TINTED, REFLECTIVE, AND LAMINATED PLASTIC FILMS FOR USE ON WINDOWS, NAMELY, INSULATED PLASTIC FILM PANELS TO BE PLACED IN WINDOWS TO BLOCK OUT SUN AND HEAT (U.S. CLS. 1, 5, 12, 13, 35 AND 50).

FIRST USE 7-9-2009; IN COMMERCE 1-4-2011.

**CLASS 17—(Continued).**

3,955,503. DAVLYN MANUFACTURING CO., INC., SPRING CITY, PA. SN 77-864,507. PUB. 7-6-2010, FILED 11-4-2009.



NO CLAIM IS MADE TO THE EXCLUSIVE RIGHT TO USE "WEAR", APART FROM THE MARK AS SHOWN.

THE MARK CONSISTS OF THE TERM "WEARGARD" PRESENTED IN ALL UPPER-CASE LETTERS, THE SEGMENT "WEAR" DEPICTED IN NOTCHED TYPEFACE AND THE SEGMENT "GARD" CONTAINED WITHIN TWO GRADUATED CONCENTRIC CIRCLES.

FOR PROTECTIVE SLEEVES FOR INDUSTRIAL APPLICATIONS, NAMELY, FIBERGLASS SLEEVES TO PROTECT POLYMER TUBES, HYDRAULIC TUBES, HYDRAULIC HOSES, COATED WIRES AND CABLES AGAINST ABRASION (U.S. CLS. 1, 5, 12, 13, 35 AND 50).

FIRST USE 12-31-2009; IN COMMERCE 12-31-2009.

3,955,661. NEPTUNE RESEARCH, INC., LAKE PARK, FL. SN 77-930,079. PUB. 6-29-2010, FILED 2-8-2010.

## TRIDENT SEAL

OWNER OF U.S. REG. NO. 3,396,478.

THE MARK CONSISTS OF THE WORDS "TRIDENT SEAL" WITH A DIAMOND SEPARATING THE TWO WORDS.

FOR KITS FOR THE REPAIR OF NATURAL GAS PIPES AND CONVEYANCES CONSISTING PRIMARILY OF RESIN-IMPREGNATED FIBERGLASS TAPE AND ALSO CONSISTING OF PUTTY AND RUBBER TAPE (U.S. CLS. 1, 5, 12, 13, 35 AND 50).

FIRST USE 1-11-2010; IN COMMERCE 1-11-2010.

3,955,662. NEPTUNE RESEARCH, INC., LAKE PARK, FL. SN 77-930,082. PUB. 6-29-2010, FILED 2-8-2010.

## TRIDENT WRAP

OWNER OF U.S. REG. NO. 3,649,972.

**CLASS 17—(Continued).**

THE MARK CONSISTS OF THE WORDS "TRIDENT WRAP" WITH A DIAMOND SEPARATING THE TWO WORDS.

FOR KITS FOR THE REPAIR OR REINFORCEMENT OF DAMAGED PIPES COMPRISING RESIN IMPREGNATED FIBERGLASS TAPE AND EPOXY RESIN (U.S. CLS. 1, 5, 12, 13, 35 AND 50).

FIRST USE 1-11-2010; IN COMMERCE 1-11-2010.

3,955,676. NEPTUNE RESEARCH, INC., LAKE PARK, FL. SN 77-931,523. PUB. 6-22-2010, FILED 2-9-2010.

**SYNTHO◆GLASS XT**

OWNER OF U.S. REG. NO. 1,287,083.  
FOR RESIN IMPREGNATED FIBERGLASS TAPE (U.S. CLS. 1, 5, 12, 13, 35 AND 50).  
FIRST USE 1-6-2010; IN COMMERCE 1-6-2010.

**CLASS 18—LEATHER GOODS**

3,955,216. TRUE VALUE COMPANY, CHICAGO, IL. SN 77-424,148. PUB. 12-2-2008, FILED 3-17-2008.



OWNER OF U.S. REG. NOS. 1,249,555 AND 1,561,687.  
FOR TOOL POUCHES SOLD EMPTY (U.S. CLS. 1, 2, 3, 22 AND 41).  
FIRST USE 0-0-2010; IN COMMERCE 0-0-2010.

**CLASS 18—(Continued).**

3,955,544. THE PETTING ZOO, INC., GLEN BURNIE, MD. SN 77-882,329. PUB. 4-27-2010, FILED 11-30-2009.

**ZOOTIQUE**

THE MARK CONSISTS OF STANDARD CHARACTERS WITHOUT CLAIM TO ANY PARTICULAR FONT, STYLE, SIZE, OR COLOR.

FOR BACKPACKS; DUFFLE BAGS; OVERNIGHT BAGS; PURSES; TOTE BAGS; WHEELED BAGS (U.S. CLS. 1, 2, 3, 22 AND 41).

FIRST USE 11-1-2010; IN COMMERCE 11-1-2010.

3,955,576. SHANGHAI CREATOR APPAREL & ACCESSORIES CO., LTD., SHANGHAI, CHINA. SN 77-903,262. PUB. 5-25-2010, FILED 12-31-2009.

**Autason**

THE MARK CONSISTS OF THE WORDING "AUTASON". THE WORDING "AUTASON" HAS NO MEANING IN A FOREIGN LANGUAGE.

FOR SKINS AND HIDES; ANIMAL SKINS; PURSES; LEATHER SHOPPING BAGS; MESH SHOPPING BAGS; WHEELED SHOPPING BAGS; REUSABLE SHOPPING BAGS; HANDBAGS; VALISES; LEATHER KEY CASES; LEATHER CASES; DOG COLLARS AND LEADS; HORSE TACK, NAMELY, BRIDLES, REINS, LEADS, BITS, STIRRUP LEATHERS, GIRTH STRAPS, LUNGE LINES AND HALTERS; FUR; UMBRELLAS; CANES; HARNESS STRAPS; REINS; GUT FOR MAKING SAUSAGE CASINGS; LEATHER FOR FURNITURE; UNFITTED FURNITURE COVERS OF LEATHER (U.S. CLS. 1, 2, 3, 22 AND 41).

FIRST USE 9-20-1997; IN COMMERCE 3-1-2010.

3,955,766. COLUMBIA INSURANCE COMPANY, OMAHA, NE. SN 77-949,166. PUB. 6-29-2010, FILED 3-3-2010.

**I AM LOVED**

THE MARK CONSISTS OF STANDARD CHARACTERS WITHOUT CLAIM TO ANY PARTICULAR FONT, STYLE, SIZE, OR COLOR.



**CLASS 18—(Continued).**

OWNER OF U.S. REG. NOS. 856,626, 1,195,267, AND OTHERS.  
FOR PET CLOTHING (U.S. CLS. 1, 2, 3, 22 AND 41).  
FIRST USE 9-24-2010; IN COMMERCE 9-24-2010.

---

3,955,825. DSW SHOE WAREHOUSE, INC., COLUMBUS, OH.  
SN 77-969,359. PUB. 7-27-2010, FILED 3-26-2010.

**CROWN VINTAGE**

THE MARK CONSISTS OF STANDARD CHARACTERS WITHOUT CLAIM TO ANY PARTICULAR FONT, STYLE, SIZE, OR COLOR.

OWNER OF U.S. REG. NOS. 3,757,925 AND 3,763,627.  
NO CLAIM IS MADE TO THE EXCLUSIVE RIGHT TO USE "VINTAGE", APART FROM THE MARK AS SHOWN.  
FOR BACKPACKS; HANDBAGS; LUGGAGE; PURSES; SHOULDER BAGS; SPORT BAGS; WAIST PACKS; WALLETS (U.S. CLS. 1, 2, 3, 22 AND 41).  
FIRST USE 8-1-2010; IN COMMERCE 8-1-2010.

---

3,955,997. HL OPERATING CORPORATION, LEBANON, TN.  
SN 85-049,255. PUB. 11-2-2010, FILED 5-27-2010.

**ZOOM**

THE MARK CONSISTS OF STANDARD CHARACTERS WITHOUT CLAIM TO ANY PARTICULAR FONT, STYLE, SIZE, OR COLOR.

FOR TOTE BAGS; BACKPACKS; DUFFEL BAGS; LUGGAGE (U.S. CLS. 1, 2, 3, 22 AND 41).  
FIRST USE 6-0-2010; IN COMMERCE 6-0-2010.

---

3,956,000. GLASSER, ROBIN PREISS, IRVINE, CA. AND O'CONNOR, JANE, NEW YORK, NY. SN 85-050,015. PUB. 10-26-2010, FILED 5-28-2010.

**FANCY NANCY**

THE MARK CONSISTS OF STANDARD CHARACTERS WITHOUT CLAIM TO ANY PARTICULAR FONT, STYLE, SIZE, OR COLOR.

**CLASS 18—(Continued).**

OWNER OF U.S. REG. NO. 3,516,168.  
FOR ALL PURPOSE CARRYING BAGS, SHOULDER BAGS, BACKPACKS, SCHOOL BAGS, CHANGE PURSES, HANDBAGS, UMBRELLAS, LUGGAGE TAGS (U.S. CLS. 1, 2, 3, 22 AND 41).  
FIRST USE 6-0-2009; IN COMMERCE 6-0-2009.

---

3,956,017. BROWN-FORMAN CORPORATION, LOUISVILLE, KY. SN 85-058,084. PUB. 11-16-2010, FILED 6-9-2010.

**WOODFORD RESERVE**

THE MARK CONSISTS OF STANDARD CHARACTERS WITHOUT CLAIM TO ANY PARTICULAR FONT, STYLE, SIZE, OR COLOR.

OWNER OF U.S. REG. NOS. 2,078,403, 2,453,285, AND OTHERS.  
FOR BUSINESS CARD CASES; WALLETS (U.S. CLS. 1, 2, 3, 22 AND 41).  
FIRST USE 10-2-2009; IN COMMERCE 10-2-2009.

---

3,956,089. TELEBRANDS CORP., FAIRFIELD, NJ. SN 85-111,042. PUB. 11-16-2010, FILED 8-19-2010.

**COMFY CONTROL**

THE MARK CONSISTS OF STANDARD CHARACTERS WITHOUT CLAIM TO ANY PARTICULAR FONT, STYLE, SIZE, OR COLOR.

NO CLAIM IS MADE TO THE EXCLUSIVE RIGHT TO USE "CONTROL", APART FROM THE MARK AS SHOWN.  
FOR DOG HARNESS (U.S. CLS. 1, 2, 3, 22 AND 41).  
FIRST USE 9-21-2010; IN COMMERCE 9-21-2010.

**CLASS 19—NON-METALLIC BUILDING MATERIALS**

---

3,955,306. PRIMESOURCE BUILDING PRODUCTS, INC., IRVING, TX. SN 77-684,962. PUB. 6-9-2009, FILED 3-6-2009.

**GRIP-RITE**

THE MARK CONSISTS OF STANDARD CHARACTERS WITHOUT CLAIM TO ANY PARTICULAR FONT, STYLE, SIZE, OR COLOR.

**CLASS 19—(Continued).**

OWNER OF U.S. REG. NOS. 907,843, 2,995,884, AND OTHERS.

FOR BUILDING MATERIALS, NAMELY, ADHESIVE GLASS FIBER MESH SOLD IN ROLLS (U.S. CLS. 1, 12, 33 AND 50).

FIRST USE 6-22-2010; IN COMMERCE 6-22-2010.

---

3,955,307. PRIMESOURCE BUILDING PRODUCTS, INC., IRVING, TX. SN 77-684,965. PUB. 6-9-2009, FILED 3-6-2009.



OWNER OF U.S. REG. NOS. 2,953,644, 3,298,813, AND OTHERS.

THE MARK CONSISTS OF THE WORDS "GRIP RITE" INSIDE A QUADRILATERAL.

FOR BUILDING MATERIALS, NAMELY, ADHESIVE GLASS FIBER MESH SOLD IN ROLLS (U.S. CLS. 1, 12, 33 AND 50).

FIRST USE 6-22-2010; IN COMMERCE 6-22-2010.

---

3,955,402. KENTWOOD FLOORS INC., DELTA, BC, CANADA. SN 77-804,086. PUB. 1-4-2011, FILED 8-13-2009.

# EVOKE

THE MARK CONSISTS OF STANDARD CHARACTERS WITHOUT CLAIM TO ANY PARTICULAR FONT, STYLE, SIZE, OR COLOR.

PRIORITY CLAIMED UNDER SEC. 44(D) ON CANADA APPLICATION NO. 1,448,022, FILED 8-12-2009, REG. NO. TMA783,546, DATED 11-26-2010, EXPIRES 11-26-2025.

FOR LAMINATE FLOORING (U.S. CLS. 1, 12, 33 AND 50).

FIRST USE 12-16-2009; IN COMMERCE 12-16-2009.

**CLASS 19—(Continued).**

3,955,421. MESTEK, INC., WESTFIELD, MA. SN 77-817,642. PUB. 8-24-2010, FILED 9-1-2009.



NO CLAIM IS MADE TO THE EXCLUSIVE RIGHT TO USE "STORM", APART FROM THE MARK AS SHOWN.

THE MARK CONSISTS OF THE WORDS "STORM PRO -HR" WHEREIN THE "S" IN STORM CONTAINS A HURRICANE DESIGN ELEMENT.

FOR WINDOW GLASS AND FRAME ASSEMBLY, NAMELY, A GLASS, FRAME AND TAPING SYSTEM FOR WINDOWS IN DOORS COMPRISED OF WINDOW PANES, METAL FRAMES AND TAPE (U.S. CLS. 1, 12, 33 AND 50).

FIRST USE 9-0-2009; IN COMMERCE 9-0-2009.

---

3,955,783. MANNINGTON MILLS, INC., SALEM, NJ. SN 77-953,985. PUB. 7-20-2010, FILED 3-9-2010.

**LOCKSSOLID TECHNOLOGY**

THE MARK CONSISTS OF STANDARD CHARACTERS WITHOUT CLAIM TO ANY PARTICULAR FONT, STYLE, SIZE, OR COLOR.

NO CLAIM IS MADE TO THE EXCLUSIVE RIGHT TO USE "TECHNOLOGY", APART FROM THE MARK AS SHOWN.

FOR VINYL FLOORING (U.S. CLS. 1, 12, 33 AND 50).

FIRST USE 9-1-2010; IN COMMERCE 9-1-2010.

---

3,955,905. JKA, INC., DBA JKA HOME, PORT ST. JOE, FL. SN 85-008,082. PUB. 8-24-2010, FILED 4-7-2010.

# SuperFast

THE MARK CONSISTS OF STANDARD CHARACTERS WITHOUT CLAIM TO ANY PARTICULAR FONT, STYLE, SIZE, OR COLOR.

FOR WOODEN FLOORING (U.S. CLS. 1, 12, 33 AND 50).

FIRST USE 11-1-2010; IN COMMERCE 11-1-2010.

**CLASS 19—(Continued).**

3,955,986. NORTHWEST MAINTENANCE MANAGEMENT, LLC, TACOMA, WA. SN 85-043,215. PUB. 10-19-2010, FILED 5-19-2010.

**CATCH-ALL**

THE MARK CONSISTS OF STANDARD CHARACTERS WITHOUT CLAIM TO ANY PARTICULAR FONT, STYLE, SIZE, OR COLOR.

FOR NON-METAL INSERTS SPECIALLY ADAPTED FOR USE WITH CATCH BASINS FOR COLLECTION AND REMOVAL OF DEBRIS AND SEDIMENT FROM STORM WATER RUNOFF (U.S. CLS. 1, 12, 33 AND 50). FIRST USE 6-1-2010; IN COMMERCE 10-8-2010.

3,956,081. BUILDING MATERIALS INVESTMENT CORP., DALLAS, TX. SN 85-095,531. PUB. 1-11-2011, FILED 7-29-2010.

**EVERGUARD EXTREME**

THE MARK CONSISTS OF STANDARD CHARACTERS WITHOUT CLAIM TO ANY PARTICULAR FONT, STYLE, SIZE, OR COLOR.

FOR THERMOPLASTIC OLEFIN ROOFING MEMBRANES (U.S. CLS. 1, 12, 33 AND 50). FIRST USE 8-31-2010; IN COMMERCE 8-31-2010.

3,956,091. BUILDING MATERIALS INVESTMENT CORP., DALLAS, TX. SN 85-132,243. PUB. 1-11-2011, FILED 9-17-2010.

**MajorSeal**

THE MARK CONSISTS OF STANDARD CHARACTERS WITHOUT CLAIM TO ANY PARTICULAR FONT, STYLE, SIZE, OR COLOR.

FOR NON-METAL BUILDING AND ROOF FLASHING (U.S. CLS. 1, 12, 33 AND 50). FIRST USE 2-28-2011; IN COMMERCE 2-28-2011.

**CLASS 20—FURNITURE AND ARTICLES NOT OTHERWISE CLASSIFIED**

**CLASS 20—(Continued).**

3,955,232. JOHNSON, NORTH, CHICAGO, IL. SN 77-506,438. PUB. 6-16-2009, FILED 6-24-2008.

**FOO FOO FABZ**

THE MARK CONSISTS OF STANDARD CHARACTERS WITHOUT CLAIM TO ANY PARTICULAR FONT, STYLE, SIZE, OR COLOR.

FOR IMITATION FOODS FOR DISPLAY MADE OF PLASTIC, FOAM AND CLAY MATERIALS, NAMELY, IMITATION CONFECTIONERY, NAMELY, IMITATION CHOCOLATE, IMITATION CANDY, IMITATION GUM, IMITATION COTTON CANDY, AND IMITATION CARAMEL; IMITATION FOODS FOR DISPLAY MADE OF PLASTIC, FOAM AND CLAY MATERIALS, NAMELY, IMITATION PUDDING, IMITATION CUSTARD, IMITATION GELATIN, IMITATION ICE CREAM, IMITATION SANDWICHES AND IMITATION SNACK FOOD ITEMS (U.S. CLS. 2, 13, 22, 25, 32 AND 50). FIRST USE 5-27-2009; IN COMMERCE 6-22-2009.

3,955,241. PLASTIPAK PACKAGING, INC., PLYMOUTH, MI. SN 77-530,103. PUB. 12-23-2008, FILED 7-24-2008.

**PLASTI-GRIP**

THE MARK CONSISTS OF STANDARD CHARACTERS WITHOUT CLAIM TO ANY PARTICULAR FONT, STYLE, SIZE, OR COLOR.

FOR PLASTIC HANDLES FOR ATTACHMENT TO PLASTIC CONTAINERS; UNFILLED MOLDED PLASTIC CONTAINERS FOR COMMERCIAL USE (U.S. CLS. 2, 13, 22, 25, 32 AND 50).

FIRST USE 3-11-2011; IN COMMERCE 3-11-2011.

3,955,266. HUBBARD, DICK, DBA AMISH FURNITURE GALLERY, INC., CRYSTAL LAKE, IL. SN 77-616,906. PUB. 10-20-2009, FILED 11-18-2008.

**UNPLUGGEDFURNITURE**

THE MARK CONSISTS OF STANDARD CHARACTERS WITHOUT CLAIM TO ANY PARTICULAR FONT, STYLE, SIZE, OR COLOR.

FOR FURNITURE (U.S. CLS. 2, 13, 22, 25, 32 AND 50). FIRST USE 11-1-2008; IN COMMERCE 11-1-2008.

**CLASS 20—(Continued).**

3,955,380. WENCO, LLC, DBA SILVERMARK, NEW YORK, NY. SN 77-789,274. PUB. 6-15-2010, FILED 7-24-2009.

**INFLATE & TAKE**

THE MARK CONSISTS OF STANDARD CHARACTERS WITHOUT CLAIM TO ANY PARTICULAR FONT, STYLE, SIZE, OR COLOR.

NO CLAIM IS MADE TO THE EXCLUSIVE RIGHT TO USE "INFLATE", APART FROM THE MARK AS SHOWN.

FOR INFLATABLE FOOD STORAGE AND TRANSPORTATION DEVICES, NAMELY, REUSABLE PLASTIC INFLATABLE CONTAINERS FOR TRANSPORTATION OF MERCHANDISE OR MATERIALS (U.S. CLS. 2, 13, 22, 25, 32 AND 50).

FIRST USE 10-27-2010; IN COMMERCE 10-27-2010.

3,955,411. HUMAN TOUCH, LLC, LONG BEACH, CA. SN 77-811,642. PUB. 7-27-2010, FILED 8-24-2009.

**EASY SLEEVES**

THE MARK CONSISTS OF STANDARD CHARACTERS WITHOUT CLAIM TO ANY PARTICULAR FONT, STYLE, SIZE, OR COLOR.

NO CLAIM IS MADE TO THE EXCLUSIVE RIGHT TO USE "SLEEVES", APART FROM THE MARK AS SHOWN.

FOR FITTED FABRIC COVERS FOR ELECTROMECHANICAL MASSAGERS AND CHAIRS FEATURING ELECTROMECHANICAL MASSAGE MECHANISMS (U.S. CLS. 2, 13, 22, 25, 32 AND 50).

FIRST USE 5-1-2010; IN COMMERCE 5-1-2010.

3,955,437. DAN-FOAM APS, AARUP, DENMARK. SN 77-824,506. PUB. 2-2-2010, FILED 9-11-2009.

**TEMPUR-ES**

THE MARK CONSISTS OF STANDARD CHARACTERS WITHOUT CLAIM TO ANY PARTICULAR FONT, STYLE, SIZE, OR COLOR.

OWNER OF U.S. REG. NOS. 1,926,469 AND 3,451,045.

FOR SEATING AND COUCHING MATS IN THE NATURE OF A PILLOW OR SEAT LINER, PILLOWS, CUSHIONS, MATTRESSES, TOP MATTRESSES, BOLSTERS AND CHAIR PADS (U.S. CLS. 2, 13, 22, 25, 32 AND 50).

FIRST USE 9-14-2009; IN COMMERCE 1-1-2010.

**CLASS 20—(Continued).**

3,955,484. HDM FURNITURE INDUSTRIES, INC., HIGH POINT, NC. SN 77-854,600. PUB. 4-20-2010, FILED 10-22-2009.

**SALEM RODS**

THE MARK CONSISTS OF STANDARD CHARACTERS WITHOUT CLAIM TO ANY PARTICULAR FONT, STYLE, SIZE, OR COLOR.

NO CLAIM IS MADE TO THE EXCLUSIVE RIGHT TO USE "RODS", APART FROM THE MARK AS SHOWN.

FOR FURNITURE PARTS (U.S. CLS. 2, 13, 22, 25, 32 AND 50).

FIRST USE 0-0-1970; IN COMMERCE 0-0-1970.

3,955,621. KURT LING, DBA CUSTOMER KINETICS, ALPHARETTA, GA. SN 77-920,846. PUB. 6-22-2010, FILED 1-26-2010.

**PURE LATEXBLISS THE WORLD'S BEST BEDS**

THE MARK CONSISTS OF STANDARD CHARACTERS WITHOUT CLAIM TO ANY PARTICULAR FONT, STYLE, SIZE, OR COLOR.

NO CLAIM IS MADE TO THE EXCLUSIVE RIGHT TO USE "THE WORLD'S BEST BEDS", APART FROM THE MARK AS SHOWN.

FOR MATTRESSES AND PILLOWS (U.S. CLS. 2, 13, 22, 25, 32 AND 50).

FIRST USE 1-24-2011; IN COMMERCE 1-24-2011.

**CLASS 21—HOUSEWARES AND GLASS**

3,955,346. MONOFLO INTERNATIONAL, INC., WINCHESTER, VA. SN 77-762,064. PUB. 5-25-2010, FILED 6-17-2009.

**WORK-TOTE**

THE MARK CONSISTS OF STANDARD CHARACTERS WITHOUT CLAIM TO ANY PARTICULAR FONT, STYLE, SIZE, OR COLOR.

FOR HEAVY DUTY, PLASTIC CONTAINER SOLD AT RETAIL FOR HOUSEHOLD OR DOMESTIC USE (U.S. CLS. 2, 13, 23, 29, 30, 33, 40 AND 50).

FIRST USE 8-24-2009; IN COMMERCE 8-24-2009.

**CLASS 21—(Continued).**

3,955,349. BOOLABOX, LLC, DOYLESTOWN, PA. SN 77-764,516. PUB. 11-10-2009, FILED 6-20-2009.

# YumBox

THE MARK CONSISTS OF STANDARD CHARACTERS WITHOUT CLAIM TO ANY PARTICULAR FONT, STYLE, SIZE, OR COLOR.

FOR LUNCHBOXES (U.S. CLS. 2, 13, 23, 29, 30, 33, 40 AND 50).

FIRST USE 4-21-2010; IN COMMERCE 10-29-2010.

3,955,428. DOBI & ASSOCIATES, INC., SAN DIEGO, CA. SN 77-820,035. PUB. 6-1-2010, FILED 9-3-2009.

# TRUEFIRE GOURMET

THE MARK CONSISTS OF STANDARD CHARACTERS WITHOUT CLAIM TO ANY PARTICULAR FONT, STYLE, SIZE, OR COLOR.

NO CLAIM IS MADE TO THE EXCLUSIVE RIGHT TO USE "GOURMET", APART FROM THE MARK AS SHOWN.

FOR WOOD COOKING PLANKS FOR USE IN GRILLING; SERVING PLATTERS; HOUSEHOLD UTENSILS, NAMELY, SPATULAS; WOOD COOKING WRAPS FOR USE IN GRILLING, NAMELY, CEDAR WRAPS; OVEN TO TABLE RACKS; AND SERVING TONGS (U.S. CLS. 2, 13, 23, 29, 30, 33, 40 AND 50).

FIRST USE 1-1-2009; IN COMMERCE 4-1-2009.

3,955,485. RAY MARKS CO. LLC, NEW YORK, NY. SN 77-854,602. PUB. 2-16-2010, FILED 10-22-2009.

# EGG HUGGER

THE MARK CONSISTS OF STANDARD CHARACTERS WITHOUT CLAIM TO ANY PARTICULAR FONT, STYLE, SIZE, OR COLOR.

NO CLAIM IS MADE TO THE EXCLUSIVE RIGHT TO USE "EGG", APART FROM THE MARK AS SHOWN.

FOR A HOUSEHOLD CONTAINER FOR TRANSPORTING AND SERVING HORS D'OEUVRES (U.S. CLS. 2, 13, 23, 29, 30, 33, 40 AND 50).

FIRST USE 4-24-2010; IN COMMERCE 4-24-2010.

**CLASS 21—(Continued).**

3,955,551. ALSCO INDUSTRIES, INC., STURBRIDGE, MA. SN 77-887,156. PUB. 7-6-2010, FILED 12-6-2009.

# FLEXIFLOSS

THE MARK CONSISTS OF STANDARD CHARACTERS WITHOUT CLAIM TO ANY PARTICULAR FONT, STYLE, SIZE, OR COLOR.

OWNER OF U.S. REG. NO. 3,595,723.

FOR DENTAL HYGIENE PRODUCTS, NAMELY, INTERDENTAL CLEANERS; DENTAL FLOSSING PRODUCTS, NAMELY, DENTAL FLOSSER DISPENSERS AND SINGLE-USE, DISPOSABLE DENTAL FLOSSERS (U.S. CLS. 2, 13, 23, 29, 30, 33, 40 AND 50).

FIRST USE 7-31-2010; IN COMMERCE 7-31-2010.

3,955,630. GLOBAL CONCEPTS LIMITED, INC., DBA GLOBAL TV CONCEPTS, LTD., DEERFIELD BEACH, FL. SN 77-923,586. PUB. 6-22-2010, FILED 1-29-2010.

# BIG TOP COOKIE

THE MARK CONSISTS OF STANDARD CHARACTERS WITHOUT CLAIM TO ANY PARTICULAR FONT, STYLE, SIZE, OR COLOR.

OWNER OF U.S. REG. NO. 3,724,761.

NO CLAIM IS MADE TO THE EXCLUSIVE RIGHT TO USE "COOKIE", APART FROM THE MARK AS SHOWN.

FOR SILICONE BAKING MOLDS (U.S. CLS. 2, 13, 23, 29, 30, 33, 40 AND 50).

FIRST USE 9-1-2010; IN COMMERCE 9-1-2010.

3,955,641. ECOPARADISE CO., LTD., SUGINAME-KU, TOKYO, JAPAN. SN 77-926,111. PUB. 6-22-2010, FILED 2-2-2010.

# ECOPARADISE

THE MARK CONSISTS OF STANDARD CHARACTERS WITHOUT CLAIM TO ANY PARTICULAR FONT, STYLE, SIZE, OR COLOR.

**CLASS 21—(Continued).**

OWNER OF U.S. REG. NOS. 3,454,214 AND 3,502,103.

FOR CASES OF PLASTIC IN THE NATURE OF PLASTIC CONTAINERS USED TO KEEP FOOD GOODS AND COSMETIC GOODS FRESH FOR HOUSEHOLD USE; CASES OF PLASTIC IN THE NATURE OF PLASTIC CONTAINERS USED TO ACCELERATE THE FERMENTATION PROCESS IN FOOD GOODS AND COSMETIC GOODS FOR HOUSEHOLD USE (U.S. CLS. 2, 13, 23, 29, 30, 33, 40 AND 50).

FIRST USE 4-1-2004; IN COMMERCE 5-4-2010.

3,955,655. INNOGATION, INC., EAGLE, ID. SN 77-929,045. PUB. 6-15-2010, FILED 2-5-2010.

**INNOGATION**

THE MARK CONSISTS OF STANDARD CHARACTERS WITHOUT CLAIM TO ANY PARTICULAR FONT, STYLE, SIZE, OR COLOR.

FOR LAWN SPRINKLERS (U.S. CLS. 2, 13, 23, 29, 30, 33, 40 AND 50).

FIRST USE 11-15-2010; IN COMMERCE 11-15-2010.

3,955,724. JOHNSON & JOHNSON, NEW BRUNSWICK, NJ. SN 77-941,397. PUB. 7-20-2010, FILED 2-22-2010.

**MICRAWHITENING**

THE MARK CONSISTS OF STANDARD CHARACTERS WITHOUT CLAIM TO ANY PARTICULAR FONT, STYLE, SIZE, OR COLOR.

FOR TOOTHBRUSHES (U.S. CLS. 2, 13, 23, 29, 30, 33, 40 AND 50).

FIRST USE 8-4-2010; IN COMMERCE 8-4-2010.

3,955,746. MEYER INTELLECTUAL PROPERTIES LIMITED, KOWLOON, HONGKONG, CHINA. SN 77-945,175. PUB. 5-4-2010, FILED 2-25-2010.

**Ami-Matin**

THE MARK CONSISTS OF STANDARD CHARACTERS WITHOUT CLAIM TO ANY PARTICULAR FONT, STYLE, SIZE, OR COLOR.

**CLASS 21—(Continued).**

THE ENGLISH TRANSLATION OF "AMI-MATIN" IN THE MARK IS "MORNING FRIEND".

FOR NON-ELECTRIC COFFEE MAKERS (U.S. CLS. 2, 13, 23, 29, 30, 33, 40 AND 50).

FIRST USE 3-1-2010; IN COMMERCE 6-20-2010.

3,955,792. PACIFIC MARKET INTERNATIONAL, LLC, SEATTLE, WA. SN 77-956,633. PUB. 8-3-2010, FILED 3-11-2010.

**STANLEY ADVENTURE SERIES**

THE MARK CONSISTS OF STANDARD CHARACTERS WITHOUT CLAIM TO ANY PARTICULAR FONT, STYLE, SIZE, OR COLOR.

OWNER OF U.S. REG. NOS. 643,096 AND 3,725,445. NO CLAIM IS MADE TO THE EXCLUSIVE RIGHT TO USE "SERIES", APART FROM THE MARK AS SHOWN.

FOR THERMAL INSULATED CONTAINERS FOR FOOD OR BEVERAGES (U.S. CLS. 2, 13, 23, 29, 30, 33, 40 AND 50).

FIRST USE 1-20-2011; IN COMMERCE 1-20-2011.

3,955,828. BAGHDASARYAN, HOVHANNES HOVIK, GLENDALE, CA. SN 77-969,698. PUB. 8-17-2010, FILED 3-26-2010.

**POOPUP**

THE MARK CONSISTS OF STANDARD CHARACTERS WITHOUT CLAIM TO ANY PARTICULAR FONT, STYLE, SIZE, OR COLOR.

FOR SCOOPS FOR THE DISPOSAL OF PET WASTE (U.S. CLS. 2, 13, 23, 29, 30, 33, 40 AND 50).

FIRST USE 2-2-2011; IN COMMERCE 2-2-2011.

**CLASS 21—(Continued).**

3,955,840. BERKSHIRE CORPORATION, GREAT BARRINGTON, MA. SN 77-981,383. PUB. 2-2-2010, FILED 8-21-2009.

# CAPSURE

THE MARK CONSISTS OF STANDARD CHARACTERS WITHOUT CLAIM TO ANY PARTICULAR FONT, STYLE, SIZE, OR COLOR.

FOR NATURAL SYNTHETIC AND BLENDED NON-WOVEN, WOVEN AND KNITTED DRY WIPES FOR USE IN LABORATORIES AND SIMILAR CLEAN ROOM ENVIRONMENTS (U.S. CLS. 2, 13, 23, 29, 30, 33, 40 AND 50).

FIRST USE 11-13-2009; IN COMMERCE 1-11-2010.

3,955,976. BROCKMAN, ROBERT, PALM BEACH GARDENS, FL. SN 85-037,073. PUB. 10-12-2010, FILED 5-12-2010.

# Cabinet Keeper

NO CLAIM IS MADE TO THE EXCLUSIVE RIGHT TO USE "CABINET", APART FROM THE MARK AS SHOWN.

THE MARK CONSISTS OF THE STYLIZED TEXT "CABINET KEEPER" WITH A FANCIFUL UNDERLINING DESIGN ELEMENT WHICH INCORPORATES THE "R" IN "KEEPER".

FOR PLASTIC TRAYS FOR KITCHEN CABINETS (U.S. CLS. 2, 13, 23, 29, 30, 33, 40 AND 50).

FIRST USE 10-1-2010; IN COMMERCE 10-1-2010.

3,955,978. VICKIE K. WEBER, WELCOME, MN. SN 85-037,648. PUB. 10-12-2010, FILED 5-13-2010.

# IceHuggy

THE MARK CONSISTS OF STANDARD CHARACTERS WITHOUT CLAIM TO ANY PARTICULAR FONT, STYLE, SIZE, OR COLOR.

FOR INSULATING SLEEVE HOLDERS FOR AN ICE CONFECTIONERY, NAMELY, FREEZER BARS (U.S. CLS. 2, 13, 23, 29, 30, 33, 40 AND 50).

FIRST USE 2-18-2011; IN COMMERCE 2-18-2011.

**CLASS 21—(Continued).**

3,956,002. EVRIHOLDER PRODUCTS LLC, ANAHEIM, CA. SN 85-050,261. PUB. 10-26-2010, FILED 5-28-2010.

# SNACK-TAINER

THE MARK CONSISTS OF STANDARD CHARACTERS WITHOUT CLAIM TO ANY PARTICULAR FONT, STYLE, SIZE, OR COLOR.

FOR CUP CAKE HOLDER WITH LID, NAMELY, HOUSEHOLD CONTAINER WITH LID FOR CUP CAKES (U.S. CLS. 2, 13, 23, 29, 30, 33, 40 AND 50).

FIRST USE 5-10-2010; IN COMMERCE 6-9-2010.

3,956,014. BROWN-FORMAN CORPORATION, LOUISVILLE, KY. SN 85-058,046. PUB. 11-16-2010, FILED 6-9-2010.

# WOODFORD RESERVE

THE MARK CONSISTS OF STANDARD CHARACTERS WITHOUT CLAIM TO ANY PARTICULAR FONT, STYLE, SIZE, OR COLOR.

OWNER OF U.S. REG. NOS. 2,078,403, 2,453,285, AND OTHERS.

FOR MUGS, NOT OF PRECIOUS METAL (U.S. CLS. 2, 13, 23, 29, 30, 33, 40 AND 50).

FIRST USE 8-10-2010; IN COMMERCE 8-10-2010.

**CLASS 22—CORDAGE AND FIBERS**

3,955,374. LEAF TACO COMPANY, LLC, MORRISON, CO. SN 77-785,461. PUB. 6-1-2010, FILED 7-21-2009.

# Leaf Taco

THE MARK CONSISTS OF STANDARD CHARACTERS WITHOUT CLAIM TO ANY PARTICULAR FONT, STYLE, SIZE, OR COLOR.

NO CLAIM IS MADE TO THE EXCLUSIVE RIGHT TO USE "LEAF", APART FROM THE MARK AS SHOWN.

FOR LAWN AND LEAF DISPOSAL SYSTEM, COMPRISED OF AN UNFITTED TARP WITH SUPPORTS, HANDLES AND SPECIALIZED HOOKS FOR ATTACHING TRASH BAGS (U.S. CLS. 1, 2, 7, 19, 22, 42 AND 50).

FIRST USE 6-1-2009; IN COMMERCE 6-1-2009.

**CLASS 23—YARNS AND THREADS**

**CLASS 23—(Continued).**

3,955,659. AMERICAN & EFIRD ENTERPRISES, INC., MOUNT HOLLY, NC. SN 77-929,201. PUB. 6-29-2010, FILED 2-5-2010.

**MAXI-LOCK STRETCH**

THE MARK CONSISTS OF STANDARD CHARACTERS WITHOUT CLAIM TO ANY PARTICULAR FONT, STYLE, SIZE, OR COLOR.

OWNER OF U.S. REG. NOS. 1,703,350 AND 3,311,698. NO CLAIM IS MADE TO THE EXCLUSIVE RIGHT TO USE "STRETCH", APART FROM THE MARK AS SHOWN. FOR SEWING THREAD AND YARN (U.S. CL. 43). FIRST USE 4-7-2010; IN COMMERCE 4-7-2010.

**CLASS 24—FABRICS**

3,955,202. WHISTLE & WINK, INC., NEW YORK, NY. SN 77-249,761. PUB. 6-17-2008, FILED 8-8-2007.

**WHISTLE & WINK**

THE MARK CONSISTS OF STANDARD CHARACTERS WITHOUT CLAIM TO ANY PARTICULAR FONT, STYLE, SIZE, OR COLOR.

FOR BEDDING, NAMELY, BED SHEETS, BED COMFORTERS, BED BLANKETS, QUILTS, DUST RUFFLES, DUVET COVERS, PILLOW CASES, PILLOW SHAMS, BED SHAMS, BED SPREADS; COTTON, LINEN AND SATEEN FABRICS (U.S. CLS. 42 AND 50). FIRST USE 2-0-2008; IN COMMERCE 2-0-2008.

3,955,451. KIM STEIN, INC., AGOURA HILLS, CA. SN 77-833,068. PUB. 2-16-2010, FILED 9-23-2009.

**k.I.M.**

THE MARK CONSISTS OF STANDARD CHARACTERS WITHOUT CLAIM TO ANY PARTICULAR FONT, STYLE, SIZE, OR COLOR.

FOR BLANKET THROWS; CHILDREN'S BLANKETS; PET BLANKETS (U.S. CLS. 42 AND 50). FIRST USE 12-0-2010; IN COMMERCE 12-0-2010.

**CLASS 24—(Continued).**

3,955,550. DIGNITY MATTERS, INC, DAWSONVILLE, GA. SN 77-886,546. PUB. 6-15-2010, FILED 12-4-2009.



THE MARK CONSISTS OF THE WORDING, "DIGNITY MATTERS", INSIDE AN INCOMPLETE RECTANGLE DESIGN AND FEATURED ABOVE ARE THE LETTERS, "DM" IN STYLIZED FONT.

FOR DECORATIVE FABRIC SLIP COVERS FOR PORTABLE BEDSIDE TOILET COMMODES (U.S. CLS. 42 AND 50).

FIRST USE 9-1-2009; IN COMMERCE 12-1-2010.

3,955,713. UNDER ARMOUR, INC., BALTIMORE, MD. SN 77-938,185. PUB. 5-25-2010, FILED 2-17-2010.

**ARMOUR**

THE MARK CONSISTS OF STANDARD CHARACTERS WITHOUT CLAIM TO ANY PARTICULAR FONT, STYLE, SIZE, OR COLOR.

OWNER OF U.S. REG. NOS. 3,052,160, 3,722,377, AND OTHERS.

FOR TOWELS; SPORTS TOWELS; FOOTBALL TOWELS (U.S. CLS. 42 AND 50).

FIRST USE 5-0-2010; IN COMMERCE 5-0-2010.

3,955,927. THIN MAN PRODUCTIONS, INC., NEW YORK, NY. SN 85-015,233. PUB. 9-21-2010, FILED 4-15-2010.

**BOLLY HOME**

THE MARK CONSISTS OF STANDARD CHARACTERS WITHOUT CLAIM TO ANY PARTICULAR FONT, STYLE, SIZE, OR COLOR.



**CLASS 24—(Continued).**

NO CLAIM IS MADE TO THE EXCLUSIVE RIGHT TO USE "HOME", APART FROM THE MARK AS SHOWN.

FOR BATH TOWELS; BED BLANKETS; BED LINEN AND TABLE LINEN; BED SHEETS; BED SKIRTS; BED SPREADS; CASHMERE BLANKETS; COMFORTERS; DUVET COVERS; DUVETS; PILLOW CASES; SHAMS; THROWS (U.S. CLS. 42 AND 50).

FIRST USE 11-11-2010; IN COMMERCE 2-1-2011.

**CLASS 24—(Continued).**

3,956,097. FABRICTECH 2000, LLC, CEDAR GROVE, NJ. SN 85-975,133. PUB. 12-14-2010, FILED 6-4-2010.

PURECARE ANTIBACTERIAL  
SILVER

3,956,018. BROWN-FORMAN CORPORATION, LOUISVILLE, KY. SN 85-058,101. PUB. 11-16-2010, FILED 6-9-2010.

WOODFORD RESERVE

THE MARK CONSISTS OF STANDARD CHARACTERS WITHOUT CLAIM TO ANY PARTICULAR FONT, STYLE, SIZE, OR COLOR.

NO CLAIM IS MADE TO THE EXCLUSIVE RIGHT TO USE "ANTIBACTERIAL SILVER", APART FROM THE MARK AS SHOWN.

FOR MATTRESS COVERS AND PILLOW COVERS ALL CONTAINING SILVER NANOPARTICLES (U.S. CLS. 42 AND 50).

FIRST USE 7-0-2010; IN COMMERCE 10-0-2010.

THE MARK CONSISTS OF STANDARD CHARACTERS WITHOUT CLAIM TO ANY PARTICULAR FONT, STYLE, SIZE, OR COLOR.

OWNER OF U.S. REG. NOS. 2,078,403, 2,453,285, AND OTHERS.

FOR THROWS (U.S. CLS. 42 AND 50).

FIRST USE 4-23-2009; IN COMMERCE 4-23-2009.

**CLASS 25—CLOTHING**

3,955,156. JAH INNOVATIONS INC., ATLANTA, GA. SN 76-678,371. PUB. 5-6-2008, FILED 6-18-2007.

3,956,075. VESTIGES, INC., MINNEAPOLIS, MN. SN 85-090,249. PUB. 1-4-2011, FILED 7-22-2010.



NO CLAIM IS MADE TO THE EXCLUSIVE RIGHT TO USE "INC", APART FROM THE MARK AS SHOWN.

THE MARK CONSISTS OF THE LETTER "V" INSIDE A GENERALLY CIRCULAR BACKGROUND DESIGN WITH SCALLOPED EDGES. THE WORD "VESTIGES" APPEARS BELOW THE DESIGN CONTAINING THE "V". THE TERM "INC" APPEARS BELOW THE WORD "VESTIGES", WITH A HORIZONTAL LINE APPEARING ON EACH SIDE OF "INC".

FOR SOUVENIR TEA TOWELS (U.S. CLS. 42 AND 50). FIRST USE 11-2-2010; IN COMMERCE 11-2-2010.



THE COLOR(S) WHITE, YELLOW, GRAY, RED AND BLUE IS/ARE CLAIMED AS A FEATURE OF THE MARK.

THE MARK CONSISTS OF THE COLORS WHITE, YELLOW AND RED IN THE DESIGN OF THE HUMAN FIGURES; THE COLORS WHITE, GRAY AND YELLOW APPEAR IN THE DESIGN OF THE ROLLER COASTER TRACKS; THE COLOR WHITE APPEARS IN THE WORDING "ROLLER COASTER" AND IN THE DESIGN OF THE TIGER; THE COLOR YELLOW APPEARS IN THE RIBBON DESIGN; AND THE COLOR BLUE APPEARS IN THE DESIGN OF THE ROLLER COASTER CARS.

FOR CLOTHING AND HEADGEAR, NAMELY, JEANS, T-SHIRTS AND HATS (U.S. CLS. 22 AND 39).

FIRST USE 1-4-2010; IN COMMERCE 1-4-2010.

**CLASS 25—(Continued).**

3,955,166. C.D.B. APPAREL, INC., NEW YORK, NY. SN 76-701,029. PUB. 6-8-2010, FILED 12-28-2009.

**SACRED CROWN**

THE MARK CONSISTS OF STANDARD CHARACTERS WITHOUT CLAIM TO ANY PARTICULAR FONT, STYLE, SIZE, OR COLOR.

FOR CLOTHING, NAMELY, JEANS, SHORTS, SHIRTS, TOPS, SWEATSHIRTS, SWIMWEAR, JACKETS, HATS, SCARVES, GLOVES, BELTS AND UNDERWEAR (U.S. CLS. 22 AND 39).

FIRST USE 5-0-2010; IN COMMERCE 5-0-2010.

3,955,187. GUETTA THIERRY, LOS ANGELES, CA. SN 77-164,785. PUB. 9-11-2007, FILED 4-24-2007.

**Mr Brainwash**

THE MARK CONSISTS OF STANDARD CHARACTERS WITHOUT CLAIM TO ANY PARTICULAR FONT, STYLE, SIZE, OR COLOR.

FOR SHOES; SOCKS; SOCKS AND STOCKINGS; SNEAKERS; UNDERWEAR; WOMEN'S UNDERWEAR; JEANS; PANTS; SHORT SETS; SHORT TROUSERS; SHORTS; SWEAT SHORTS; FABRIC BELTS; LEATHER BELTS; WAIST BELTS; SHORT-SLEEVED OR LONG-SLEEVED T-SHIRTS; T-SHIRTS; SWEATERS; TURTLE-NECK SWEATERS; V-NECK SWEATERS; POLO SHIRTS; SHIRTS; SHIRTS FOR SUITS; HATS; HEADGEAR, NAMELY, CAPS; BEANIES; COATS; COATS FOR MEN AND WOMEN; COATS MADE OF COTTON; COATS OF DENIM; JACKETS; LEATHER JACKETS; SCARVES (U.S. CLS. 22 AND 39).

FIRST USE 5-28-1996; IN COMMERCE 5-28-1996.

3,955,189. ALTICOR INC., ADA, MI. SN 77-199,545. PUB. 11-20-2007, FILED 6-6-2007.

**AMWAY**

THE MARK CONSISTS OF STANDARD CHARACTERS WITHOUT CLAIM TO ANY PARTICULAR FONT, STYLE, SIZE, OR COLOR.

FOR CLOTHING, NAMELY, T-SHIRTS, JACKETS (U.S. CLS. 22 AND 39).

FIRST USE 2-1-2011; IN COMMERCE 2-1-2011.

**CLASS 25—(Continued).**

3,955,199. KNOG PTY LTD, RICHMOND, AUSTRALIA. SN 77-227,619. PUB. 12-11-2007, FILED 7-12-2007.

**KNOG**

THE MARK CONSISTS OF STANDARD CHARACTERS WITHOUT CLAIM TO ANY PARTICULAR FONT, STYLE, SIZE, OR COLOR.

FOR BICYCLE GLOVES (U.S. CLS. 22 AND 39).

FIRST USE 3-1-2004; IN COMMERCE 3-1-2004.

3,955,213. GREEN LAYER LLC, PORTLAND, OR. SN 77-398,454. PUB. 11-18-2008, FILED 2-15-2008.

**GREENLAYER**

THE MARK CONSISTS OF STANDARD CHARACTERS WITHOUT CLAIM TO ANY PARTICULAR FONT, STYLE, SIZE, OR COLOR.

FOR BASEBALL CAPS; CAP VISORS; CYCLISTS' JERSEYS; FLEECE PULLOVERS; JACKETS; JERSEYS; JOGGING OUTFITS; JOGGING PANTS; JOGGING SUITS; LONG-SLEEVED SHIRTS; OPEN-NECKED SHIRTS; POLO SHIRTS; RAIN JACKETS; RAINPROOF JACKETS; SHIRTS; SHORTS; SINGLETS; SLEEVED OR SLEEVELESS JACKETS; SLEEVELESS JERSEYS; SOCKS; SPORT SHIRTS; SPORTS JACKETS; SPORTS SHIRTS; SWEAT SHIRTS; T-SHIRTS; TEE SHIRTS; WIND-JACKETS; TOPS; BOTTOMS (U.S. CLS. 22 AND 39).

FIRST USE 3-22-2008; IN COMMERCE 3-22-2008.

**CLASS 25—(Continued).**

3,955,222. BYRNE, WENDY SUSAN, AMSTERDAM, NETHERLANDS. SN 77-471,578. PUB. 10-14-2008, FILED 5-12-2008.



THE MARK CONSISTS OF STYLIZED STACKED LETTERS SPELLING THE WORD "POODLE" TOGETHER WITH A SYMBOL OF FOUR STACKED FILLED-IN CIRCLES, WHICH VISUALLY REPEAT THE SHAPE OF THE FIRST FOUR STACKED LETTERS.

FOR BOARD SHORTS; SHORTS; SPORTS SHIRTS WITH SHORT SLEEVES; GOLF SHIRTS; MOISTURE-WICKING SPORTS SHIRTS; SHIRTS; SHORT-SLEEVED SHIRTS; SPORT SHIRTS; SPORTS SHIRTS; CAPRI PANTS; CARGO PANTS; MOISTURE-WICKING SPORTS PANTS; PANTS; SPORTS PANTS; HALTER TOPS; TANK TOPS; TANK-TOPS; TOPS (U.S. CLS. 22 AND 39).  
FIRST USE 6-22-2007; IN COMMERCE 6-22-2007.

3,955,234. BENMOSHE, OREN, LOS ANGELES, CA. SN 77-511,691. PUB. 3-30-2010, FILED 6-30-2008.

**LORDZ & LEGENDZ**

THE MARK CONSISTS OF STANDARD CHARACTERS WITHOUT CLAIM TO ANY PARTICULAR FONT, STYLE, SIZE, OR COLOR.

FOR HATS; JACKETS; JEANS; PANTS; SHIRTS; SHORTS; T-SHIRTS; UNDERWEAR (U.S. CLS. 22 AND 39).  
FIRST USE 11-0-2008; IN COMMERCE 6-0-2009.

**CLASS 25—(Continued).**

3,955,243. E.S. ORIGINALS, INC., NEW YORK, NY. SN 77-541,695. PUB. 11-11-2008, FILED 8-7-2008.

**FLEX-TONE**

THE MARK CONSISTS OF STANDARD CHARACTERS WITHOUT CLAIM TO ANY PARTICULAR FONT, STYLE, SIZE, OR COLOR.

FOR FOOTWEAR (U.S. CLS. 22 AND 39).  
FIRST USE 1-17-2011; IN COMMERCE 1-17-2011.

3,955,248. RED ONION INVESTORS, LLC, ASPEN, CO. SN 77-555,085. PUB. 7-7-2009, FILED 8-25-2008.

**RED ONION**

THE MARK CONSISTS OF STANDARD CHARACTERS WITHOUT CLAIM TO ANY PARTICULAR FONT, STYLE, SIZE, OR COLOR.

FOR CLOTHING, NAMELY, SHIRTS, T-SHIRTS, LONG SLEEVE T-SHIRTS; HEADGEAR, NAMELY, HATS AND CAPS (U.S. CLS. 22 AND 39).  
FIRST USE 5-17-2010; IN COMMERCE 5-17-2010.

3,955,259. AMERICAL CORPORATION, HENDERSON, NC. SN 77-592,239. PUB. 10-12-2010, FILED 10-14-2008.

**REVIVE**

THE MARK CONSISTS OF STANDARD CHARACTERS WITHOUT CLAIM TO ANY PARTICULAR FONT, STYLE, SIZE, OR COLOR.

OWNER OF U.S. REG. NOS. 1,265,807 AND 2,502,637.  
FOR MEN'S, WOMEN'S AND CHILDREN'S CLOTHING AND ACTIVE AND BODYWEAR, NAMELY, TANK TOPS, CAMISOLES, T-SHIRTS, BIKE SHORTS, CAPRIS, LEGGINGS; UNDERWEAR, NAMELY, T-SHIRTS, TANK SHIRTS, BRIEFS AND BOXER BRIEFS; SHAPEWEAR, NAMELY, SHAPER PANTY AND SHAPER CAPRI; FOOTWEAR, NAMELY, SHOES, SLIPPERS; FOOTWEAR, NAMELY, SHOE INSERTS, INSOLES AND INSERTS IN THE NATURE OF FOOT PADS ALL FOR NON-ORTHOPEDIC PURPOSES; AND SOCKS AND HOSIERY, NAMELY, PANTYHOSE, THIGH HIGHS, KNEE HIGHS, ANKLE HIGHS, FOOTIES, TIGHTS, TROUSER SOCKS, SOCKS IN ALL LENGTHS, AND STOCKINGS (U.S. CLS. 22 AND 39).  
FIRST USE 10-7-2010; IN COMMERCE 10-7-2010.

**CLASS 25—(Continued).**

3,955,265. RUFF MAGIC ENTERTAINMENT, LLC, NEWARK, NJ. SN 77-616,438. PUB. 6-22-2010, FILED 11-18-2008.

## World Freerunning & Parkour Federation

THE MARK CONSISTS OF STANDARD CHARACTERS WITHOUT CLAIM TO ANY PARTICULAR FONT, STYLE, SIZE, OR COLOR.

NO CLAIM IS MADE TO THE EXCLUSIVE RIGHT TO USE "FREERUNNING & PARKOUR FEDERATION", APART FROM THE MARK AS SHOWN.

FOR CLOTHING, NAMELY, T-SHIRTS, HATS, SWEATSHIRTS, SWEATPANTS AND WRISTBANDS (U.S. CLS. 22 AND 39).

FIRST USE 12-1-2010; IN COMMERCE 12-1-2010.

3,955,280. DOMINGO, RAEMAR, IRVINE, CA. SN 77-635,470. PUB. 7-27-2010, FILED 12-17-2008.



## TurtleScarf

OWNER OF U.S. REG. NO. 3,123,186.

THE MARK CONSISTS OF THE WORDING "TURTLE-SCARF" BELOW A STYLIZED TURTLE SHAPED LIKE THE LETTER "A".

FOR MEN'S, WOMEN'S, CHILDREN'S CLOTHING AND ACCESSORIES; NAMELY, BLOUSES; DRESSES; JACKETS; PANTS; SHIRTS; SHORTS; SWEATPANTS; TEE-SHIRTS; SWEATSHIRTS; SKIRTS; VESTS; COATS; RAINWEAR; LINGERIE; SLEEPWEAR; UNDERWEAR; LOUNGE WEAR; BUSINESS SUITS; BEACHWEAR; SWIMWEAR; INFANT WEAR; GLOVES; SOCKS; HOSIERY; BELTS; SCARVES; HATS; HEADWEAR; UNDERWEAR; TIES; FOOTWEAR; SHOES; SLIPPERS; TURTLE NECKS; SCARVES; TURTLE NECKS WITH OR WITHOUT A HOOD (U.S. CLS. 22 AND 39).

FIRST USE 1-1-2009; IN COMMERCE 4-1-2010.

**CLASS 25—(Continued).**

3,955,304. NAUTICA APPAREL, INC., NEW YORK, NY. SN 77-684,212. PUB. 6-9-2009, FILED 3-5-2009.

## REAL DENIM. REAL FIT

THE MARK CONSISTS OF STANDARD CHARACTERS WITHOUT CLAIM TO ANY PARTICULAR FONT, STYLE, SIZE, OR COLOR.

NO CLAIM IS MADE TO THE EXCLUSIVE RIGHT TO USE "REAL DENIM", APART FROM THE MARK AS SHOWN.

FOR DENIM CLOTHING, NAMELY, JACKETS, JEANS, SHIRTS AND SHORTS (U.S. CLS. 22 AND 39).

FIRST USE 9-0-2009; IN COMMERCE 9-0-2009.

3,955,310. PACIFIC SUNWEAR OF CALIFORNIA, INC., ANAHEIM, CA. SN 77-687,728. PUB. 8-17-2010, FILED 3-10-2009.

## 44 mm

THE MARK CONSISTS OF STANDARD CHARACTERS WITHOUT CLAIM TO ANY PARTICULAR FONT, STYLE, SIZE, OR COLOR.

FOR SHIRTS, INCLUDING FLANNEL SHIRTS, LONG-SLEEVED SHIRTS, SHORT-SLEEVED SHIRTS, SHORT-SLEEVED FLANNEL SHIRTS, AND LONG-SLEEVED FLANNEL SHIRTS (U.S. CLS. 22 AND 39).

FIRST USE 6-1-2009; IN COMMERCE 6-1-2009.

3,955,317. MAYNARD, MICHAEL, BIRMINGHAM, MI. SN 77-698,672. PUB. 6-8-2010, FILED 3-25-2009.

## Plain Clothes Runner

THE MARK CONSISTS OF STANDARD CHARACTERS WITHOUT CLAIM TO ANY PARTICULAR FONT, STYLE, SIZE, OR COLOR.

NO CLAIM IS MADE TO THE EXCLUSIVE RIGHT TO USE "RUNNER", APART FROM THE MARK AS SHOWN.

FOR ATHLETIC APPAREL, NAMELY, SHIRTS, PANTS, JACKETS, FOOTWEAR, HATS AND CAPS, ATHLETIC UNIFORMS (U.S. CLS. 22 AND 39).

FIRST USE 6-1-2009; IN COMMERCE 7-5-2009.

**CLASS 25—(Continued).**

3,955,329. KENNETH COLE PRODUCTIONS (LIC), LLC, NEW YORK, NY. SN 77-725,686. PUB. 8-3-2010, FILED 4-30-2009.

EXCLUSIVE 9 2 5 TECHNOLOGY

THE MARK CONSISTS OF STANDARD CHARACTERS WITHOUT CLAIM TO ANY PARTICULAR FONT, STYLE, SIZE, OR COLOR.

NO CLAIM IS MADE TO THE EXCLUSIVE RIGHT TO USE "EXCLUSIVE" AND "TECHNOLOGY", APART FROM THE MARK AS SHOWN.

FOR FOOTWEAR (U.S. CLS. 22 AND 39).  
FIRST USE 8-7-2009; IN COMMERCE 8-7-2009.

3,955,331. ACROSS THE SKYY, GLENDALE, AZ. SN 77-728,537. PUB. 2-23-2010, FILED S.R. 5-4-2009; AM. P.R. 12-30-2009.



THE MARK CONSISTS OF THE MARK IN THE FORM OF A CROSS CONSIST OF: TOP CROWN OF THORNS, 1ST WORD: "LOVE" IN REVERSE WITH BLEEDING HEART BEING THE "O" AND THE CENTER "L"'S WITH CHAIN LINK THROUGH IT 2ND WORD: "LINK" WITH NAIL BEING THE "I" 3RD WORD: "LORD" IN CAPITAL LETTERS WITH BLOOD DRIPPING FROM THE BOTTOM THEN SCRIPTURE VERSE NEAR THAT "COL. 3:14".

FOR T-SHIRTS AND HATS (U.S. CLS. 22 AND 39).  
FIRST USE 5-15-2010; IN COMMERCE 5-15-2010.

**CLASS 25—(Continued).**

3,955,339. ZUMIEZ INC., EVERETT, WA. SN 77-749,372. PUB. 9-28-2010, FILED 6-1-2009.

TRILLIUM

THE MARK CONSISTS OF STANDARD CHARACTERS WITHOUT CLAIM TO ANY PARTICULAR FONT, STYLE, SIZE, OR COLOR.

FOR CLOTHING, NAMELY, DRESSES, SHORTS, TANK TOPS, HALTER TOPS, AND PANTS (U.S. CLS. 22 AND 39).

FIRST USE 1-20-2010; IN COMMERCE 1-20-2010.

3,955,350. SOFTSPIKES, LLC, BRENTWOOD, TN. SN 77-765,331. PUB. 11-23-2010, FILED 6-22-2009.

PINS

THE MARK CONSISTS OF STANDARD CHARACTERS WITHOUT CLAIM TO ANY PARTICULAR FONT, STYLE, SIZE, OR COLOR.

FOR GOLF CLEATS AND CLEAT RECEPTACLES FOR SECURING CLEATS TO THE SOLES OF GOLF SHOES (U.S. CLS. 22 AND 39).

FIRST USE 10-0-2009; IN COMMERCE 10-0-2009.

**CLASS 25—(Continued).**

3,955,360. NBA DEVELOPMENT LEAGUE, LLC, SECAUCUS, NJ. SN 77-769,985. PUB. 11-17-2009, FILED 6-29-2009.



THE MARK CONSISTS OF THE DEPICTION OF AN ARMORED HELMET IN FRONT OF A SHIELD.

FOR CLOTHING, NAMELY, HOSIERY, FOOTWEAR, BASKETBALL SHOES, BASKETBALL SNEAKERS, T-SHIRTS, SHIRTS, POLO SHIRTS, SWEATSHIRTS, SWEATPANTS, PANTS, TANK TOPS, JERSEYS, SHORTS, PAJAMAS, SPORT SHIRTS, RUGBY SHIRTS, SWEATERS, BELTS, TIES, NIGHTSHIRTS, HATS, CAPS, VISORS, WARM-UP SUITS, WARM-UP PANTS, WARM-UP TOPS/SHOOTING SHIRTS, JACKETS, WIND RESISTANT JACKETS, PARKAS, COATS, BABY BIBS NOT OF PAPER, HEAD BANDS, WRIST BANDS, APRONS, UNDERGARMENTS, BOXER SHORTS, SLACKS, EAR MUFFS, GLOVES, MITTENS, SCARVES, WOVEN AND KNIT SHIRTS, JERSEY DRESSES, DRESSES, CHEERLEADING DRESSES AND UNIFORMS, SWIM WEAR, BATHING SUITS, SWIMSUITS, BIKINIS, TANKINIS, SWIM TRUNKS, BATHING TRUNKS, BOARD SHORTS, WET SUITS, BEACH COVER-UPS, BATHING SUIT COVER-UPS, BATHING SUIT WRAPS, SANDALS, BEACH SANDALS, BEACH HATS, SUN VISORS, SWIM CAPS, BATHING CAPS, NOVELTY HEADWEAR WITH ATTACHED WIGS (U.S. CLS. 22 AND 39).

FIRST USE 1-1-2010; IN COMMERCE 1-1-2010.

3,955,376. YICHUN XU, FRESH MEADOWS, NY. SN 77-787,227. PUB. 1-5-2010, FILED 7-22-2009.

# Youya

THE MARK CONSISTS OF STANDARD CHARACTERS WITHOUT CLAIM TO ANY PARTICULAR FONT, STYLE, SIZE, OR COLOR.

THE WORDING "YOUYA" HAS NO MEANING IN A FOREIGN LANGUAGE.

FOR CAPRI PANTS; CARGO PANTS; CLOTHING FOR ATHLETIC USE, NAMELY, PADDED PANTS; DENIMS; PANTS; SKIRTS; SKIRTS AND DRESSES; SPORTS PANTS; TRAVEL CLOTHING CONTAINED IN A PACKAGE COMPRISING REVERSIBLE JACKETS, PANTS, SKIRTS, TOPS AND A BELT OR SCARF (U.S. CLS. 22 AND 39).

FIRST USE 10-19-2010; IN COMMERCE 10-19-2010.

**CLASS 25—(Continued).**

3,955,385. TRILLIONAIRE TYCOON, INC., CHICAGO, IL. SN 77-790,888. PUB. 7-27-2010, FILED 7-28-2009.

# Trillionaire Tycoon

THE MARK CONSISTS OF STANDARD CHARACTERS WITHOUT CLAIM TO ANY PARTICULAR FONT, STYLE, SIZE, OR COLOR.

FOR TOPS (U.S. CLS. 22 AND 39).

FIRST USE 7-17-2009; IN COMMERCE 5-3-2010.

3,955,403. TAIZHOU J&F HEADWEAR CO., LTD., JIANGSU PROVINCE, CHINA. SN 77-806,674. PUB. 7-13-2010, FILED 8-18-2009.



OWNER OF U.S. REG. NO. 3,340,372.

THE MARK CONSISTS OF THE HEAD OF A LEOPARD ABOVE THE STYLIZED WORD "LACKPARD".

THE WORDING "LACKPARD" HAS NO MEANING IN A FOREIGN LANGUAGE.

FOR HATS; GLOVES; CLOTHING, NAMELY, JACKETS, JERSEYS AND PANTS; HOSIERY; SOCKS; SHOES; SCARVES (U.S. CLS. 22 AND 39).

FIRST USE 10-0-2008; IN COMMERCE 12-0-2009.

3,955,441. CAERUS & MUSE, INC., WEST COVINA, CA. SN 77-826,269. PUB. 4-27-2010, FILED 9-14-2009.

# Bilancia

THE MARK CONSISTS OF STANDARD CHARACTERS WITHOUT CLAIM TO ANY PARTICULAR FONT, STYLE, SIZE, OR COLOR.

THE ENGLISH TRANSLATION OF "BILANCIA" IS SCALES, BALANCE OR LIBRA, THE SEVENTH SIGN OF THE ZODIAC IN ASTROLOGY.

FOR BATHROBES; CAPES; CAPS; CARDIGANS; CLOAKS; GLOVES; HATS; HEADWEAR; JACKETS; PAJAMAS; PETTICOATS; PULLOVERS; SCARVES; SOCKS; SWEAT SHIRTS; SWEATERS; VESTS (U.S. CLS. 22 AND 39).

FIRST USE 10-1-2010; IN COMMERCE 10-1-2010.

**CLASS 25—(Continued).**

3,955,463. BROWN SHOE COMPANY, INC., ST. LOUIS, MO.  
SN 77-843,970. PUB. 1-12-2010, FILED 10-7-2009.

**POWERWALK BY NATURALSPO**

THE MARK CONSISTS OF STANDARD CHARACTERS WITHOUT CLAIM TO ANY PARTICULAR FONT, STYLE, SIZE, OR COLOR.

OWNER OF U.S. REG. NOS. 1,504,936 AND 3,349,128.  
FOR FOOTWEAR (U.S. CLS. 22 AND 39).  
FIRST USE 12-8-2009; IN COMMERCE 12-8-2009.

3,955,505. LEAVE ME B, CARLSBAD, CA. SN 77-865,257. PUB.  
4-13-2010, FILED 11-4-2009.

**NOT MINE**

THE MARK CONSISTS OF STANDARD CHARACTERS WITHOUT CLAIM TO ANY PARTICULAR FONT, STYLE, SIZE, OR COLOR.

FOR CLOTHING, NAMELY, SHIRTS, T-SHIRTS, UNDER SHIRTS, NIGHT SHIRTS, RUGBY SHIRTS, POLO SHIRTS, CARDIGANS, JERSEYS, UNIFORMS, ATHLETIC UNIFORMS, PANTS, TROUSERS, SLACKS, JEANS, DENIM JEANS, CULOTTES, CARGO PANTS, OVERALLS, COVERALLS, JUMPERS, JUMP SUITS, SHORTS, BOXER SHORTS, TOPS, CROP TOPS, TANK TOPS, HALTER TOPS, SWEAT SHIRTS, SWEAT SHORTS, SWEAT PANTS, WRAPS, WARM-UP SUITS, JOGGING SUITS, TRACK SUITS, BLOUSES, SKIRTS, DRESSES, GOWNS, SWEATERS, VESTS, FLEECE VESTS, PULLOVERS, SNOW SUITS, PARKAS, CAPES, ANORAKS, PONCHOS, JACKETS, REVERSIBLE JACKETS, COATS, BLAZERS, SUITS, TURTLENECKS, CLOTH SKI BIBS, SWIMWEAR, BEACHWEAR, TENNIS WEAR, SURF WEAR, SKI WEAR, INFANT WEAR, BABY BIBS NOT OF PAPER, CLOTH DIAPERS, CAPS, SWIM CAPS, BERETS, BEANIES, HATS, VISORS, HEADBANDS, WRIST BANDS, SWEAT BANDS, HEADWEAR, EAR MUFFS, APRONS, SCARVES, BANDANAS, BELTS, SUSPENDERS, NECKWEAR, NECKTIES, TIES, NECKERCHIEFS, ASCOTS, UNDERWEAR, BRIEFS, SWIM AND BATHING TRUNKS, BRAS, SPORTS BRAS, BRASIERES, BUSTIERS, CORSETS, PANTIES, GARTERS AND GARTER BELTS, TEDDIES, GIRDLES, FOUNDATION GARMENTS, SINGLET, SOCKS, LOUNGEWEAR, ROBES, BATHROBES, UNDERCLOTHES, PAJAMAS, SLEEPWEAR, NIGHT GOWNS, LINGERIE, CAMISOLES, NEGLIGEEES, CHEMISES, CHEMISETTES, SLIPS, SARONGS, LEG WARMERS, HOSIERY, PANTYHOSE, BODY STOCKINGS, KNEE HIGHS, LEGGINGS, TIGHTS, LEOTARDS, BODY SUITS, UNITARDS, BODY SHAPERS, GLOVES, MITTENS, FOOTWEAR, SHOES, SNEAKERS, BOOTS, GALOSHES, SANDALS, FLIP-FLOPS, ZORI, SLIPPERS AND RAINWEAR (U.S. CLS. 22 AND 39).  
FIRST USE 3-0-2004; IN COMMERCE 3-12-2007.

**CLASS 25—(Continued).**

3,955,509. HUMBLE FASHION, LLC, GOLDEN VALLEY,  
MN. SN 77-870,659. PUB. 9-7-2010, FILED 11-11-2009.

**HAMMERMADE**

THE MARK CONSISTS OF THE WORD "HAMMER" FOLLOWED BY THE IMAGE OF A HAMMER IN A CIRCLE FOLLOWED BY THE WORD "MADE".

FOR MEN'S CLOTHING, NAMELY, SHIRTS, SUITS, VESTS, SPORT COATS, NECK TIES, POCKET SQUARES, SOCKS, PANTS, AND KNITWEAR IN THE NATURE OF SHIRTS (U.S. CLS. 22 AND 39).

FIRST USE 11-27-2009; IN COMMERCE 11-27-2009.

3,955,528. HAMMERHOUSE DESIGNS LLC, GAMBRILLS,  
MD. SN 77-877,429. PUB. 4-20-2010, FILED 11-20-2009.



THE MARK CONSISTS OF STYLIZED WORD "HAMMERJACKS" WITH A HAMMER AND TWO LIGHTNING BOLTS ABOVE THE LETTER "J".

FOR BANDANAS; BASEBALL CAPS; BASELAYER TOPS; CAP VISORS; CAPS; CAPS WITH VISORS; CROP TOPS; HALTER TOPS; HATS; HEADBANDS; HEADGEAR, NAMELY, HEADBANDS, BANDANAS; JACKETS; KNITTED CAPS; LONG-SLEEVED SHIRTS; MUSCLE TOPS; SHORT-SLEEVED OR LONG-SLEEVED T-SHIRTS; SHORT-SLEEVED SHIRTS; SKULL CAPS; SWEAT SHIRTS; T-SHIRTS; TANK TOPS; TANK-TOPS; TEE SHIRTS; TOPS; TUBE TOPS (U.S. CLS. 22 AND 39).  
FIRST USE 6-1-2010; IN COMMERCE 6-1-2010.

3,955,534. PIERRE, ROGER, NEW YORK, NY. SN 77-879,562.  
PUB. 7-6-2010, FILED 11-24-2009.

**PIERRE LEROCK**

THE MARK CONSISTS OF STANDARD CHARACTERS WITHOUT CLAIM TO ANY PARTICULAR FONT, STYLE, SIZE, OR COLOR.

THE NAME(S), PORTRAIT(S), AND/OR SIGNATURE(S) SHOWN IN THE MARK IDENTIFIES THE NICKNAME OF ROGER "PIERRE", WHOSE CONSENT(S) TO REGISTER IS MADE OF RECORD.

FOR FOOTWEAR; HATS; HOODED PULLOVERS; HOODS; JACKETS; JEANS; JOGGING SUITS; MEN'S SUITS; SHIRTS; SPORT SHIRTS; SPORTS JACKETS; SPORTS PANTS; SWEAT PANTS; SWEATERS (U.S. CLS. 22 AND 39).

FIRST USE 2-25-2011; IN COMMERCE 2-25-2011.

**CLASS 25—(Continued).**

3,955,545. THE PETTING ZOO, INC., GLEN BURNIE, MD. SN 77-882,363. PUB. 4-27-2010, FILED 11-30-2009.

## ZOOTIQUE

THE MARK CONSISTS OF STANDARD CHARACTERS WITHOUT CLAIM TO ANY PARTICULAR FONT, STYLE, SIZE, OR COLOR.

FOR BATHROBES; BELTS; HATS; JACKETS; SHIRTS; SLIPPERS; SWEAT SHIRTS; T-SHIRTS; VESTS; ALL OF THE FOREGOING EXCLUDING SPORTS CLOTHING, SPORTS FOOTWEAR, AND SPORTS HATS (U.S. CLS. 22 AND 39).

FIRST USE 11-1-2010; IN COMMERCE 11-1-2010.

3,955,546. DUNN, DENISE, M, FORMERLY DUNN PAINTING, SPANAWAY, WA. SN 77-882,742. PUB. 4-27-2010, FILED 11-30-2009.

## BNME

THE MARK CONSISTS OF STANDARD CHARACTERS WITHOUT CLAIM TO ANY PARTICULAR FONT, STYLE, SIZE, OR COLOR.

FOR ATHLETIC APPAREL, NAMELY, SHIRTS, PANTS, JACKETS, FOOTWEAR, HATS AND CAPS, ATHLETIC UNIFORMS; BODY SHIRTS; FISHING SHIRTS; GOLF PANTS, SHIRTS AND SKIRTS; GOLF SHIRTS; HOODED SWEAT SHIRTS; KNIT SHIRTS; LONG-SLEEVED SHIRTS (U.S. CLS. 22 AND 39).

FIRST USE 7-2-2010; IN COMMERCE 8-21-2010.

3,955,549. GRUNDENS USA, LTD., POULSBO, WA. SN 77-886,494. PUB. 4-13-2010, FILED 12-4-2009.



THE MARK CONSISTS OF SKELETAL DESIGN OF FISH WITH LETTER "G" FORMING PART OF THE BODY AND THE WORD "GAGE" SITUATED WITHIN THE LETTER "G".

FOR BIB OVERALLS; BOOTS; COATS; FISHERMEN'S JACKETS; FLEECE VESTS; GLOVES; HATS; JACKETS; PANTS; RAIN BOOTS; RAIN COATS; RAIN HATS; RAINPROOF JACKETS; SHIRTS; SWEAT PANTS; SWEAT SHIRTS; VESTS (U.S. CLS. 22 AND 39).

FIRST USE 1-15-2011; IN COMMERCE 1-15-2011.

**CLASS 25—(Continued).**

3,955,553. WISECRACKER LLC, PETALUMA, CA. SN 77-887,933. PUB. 5-4-2010, FILED 12-7-2009.

## WISECRACKER

THE MARK CONSISTS OF STANDARD CHARACTERS WITHOUT CLAIM TO ANY PARTICULAR FONT, STYLE, SIZE, OR COLOR.

FOR CLOTHING, NAMELY, JACKETS, COATS AND VESTS (U.S. CLS. 22 AND 39).

FIRST USE 1-31-2008; IN COMMERCE 1-31-2008.

3,955,572. CHILSON ENTERPRISES, INC., IRVING, TX. SN 77-900,908. PUB. 5-4-2010, FILED 12-24-2009.

## WWS2012 WE WILL SURVIVE 2012

THE MARK CONSISTS OF STANDARD CHARACTERS WITHOUT CLAIM TO ANY PARTICULAR FONT, STYLE, SIZE, OR COLOR.

FOR CLOTHING, NAMELY, HATS, BALL CAPS, KNIT CAPS, SHIRTS, TOPS, VESTS, BLOUSES, SWEATERS, SWEATSHIRTS, SHORTS, SKIRTS, PANTS, TROUSERS, SLACKS, OVERALLS, JEANS, SWEATPANTS, DRESSES, FOOTWEAR, SOCKS, STOCKINGS, TIGHTS, PANTY-HOSE, SCARVES, TIES, SUSPENDERS, GLOVES, BELTS, SLIPPERS, COATS, JACKETS, PARKAS, WIND RESISTANT JACKETS, UNDERWEAR, LOUNGING PANTS AND TOPS, PAJAMAS, LONG UNDERWEAR, ROBES, MENS BRIEFS AND BOXERS, LEATHER PANTS, LEATHER COATS, LEATHER TOPS, LEATHER SKIRTS, LEATHER DRESSES, LEATHER VESTS, AND UNIFORMS, NAMELY, UNIFORM SLACKS, UNIFORM SHIRTS, UNIFORM JACKETS, AND UNIFORM SWEATERS (U.S. CLS. 22 AND 39).

FIRST USE 1-1-2010; IN COMMERCE 4-1-2010.

3,955,577. THARANCO LIFESTYLES LLC, BAYONNE, NJ. SN 77-904,199. PUB. 6-15-2010, FILED 1-4-2010.

## PERFORMANCE BY DESIGN

THE MARK CONSISTS OF STANDARD CHARACTERS WITHOUT CLAIM TO ANY PARTICULAR FONT, STYLE, SIZE, OR COLOR.

FOR CLOTHING FOR MEN AND WOMEN, NAMELY, SHIRTS, PANTS, SHORTS, SKIRTS, SWEATERS, PULL-OVERS, WIND-RESISTANT JACKETS, VESTS, CAPS AND SHOES (U.S. CLS. 22 AND 39).

FIRST USE 1-0-2010; IN COMMERCE 1-0-2010.



**CLASS 25—(Continued).**

3,955,594. DOLOR, ALBERT, MONTEREY, CA. SN 77-912,341.  
PUB. 10-26-2010, FILED 1-14-2010.

**DOLOR MODA**

THE MARK CONSISTS OF STANDARD CHARACTERS WITHOUT CLAIM TO ANY PARTICULAR FONT, STYLE, SIZE, OR COLOR.

NO CLAIM IS MADE TO THE EXCLUSIVE RIGHT TO USE "MODA", APART FROM THE MARK AS SHOWN.

THE ENGLISH TRANSLATION OF "DOLOR MODA" IN THE MARK IS "PAIN FASHION."

FOR CLOTHING, NAMELY, TOPS, BOTTOMS, HOSIERY, T-SHIRTS, SHIRTS, HOODED SWEATSHIRTS, VESTS, SHORTS, AND HEADWEAR (U.S. CLS. 22 AND 39).

FIRST USE 8-15-2010; IN COMMERCE 8-15-2010.

3,955,614. HARPER, BOBBY, LA MARQUE, TX. SN 77-918,420. PUB. 6-8-2010, FILED 1-22-2010.

**bobby joe harper apparels**

THE MARK CONSISTS OF STANDARD CHARACTERS WITHOUT CLAIM TO ANY PARTICULAR FONT, STYLE, SIZE, OR COLOR.

NO CLAIM IS MADE TO THE EXCLUSIVE RIGHT TO USE "APPARELS", APART FROM THE MARK AS SHOWN.

THE NAME "BOBBY JOE HARPER" IDENTIFIES A LIVING INDIVIDUAL WHOSE CONSENT IS OF RECORD.

FOR CAPS; CHAPS; GLOVES; HEADWEAR; JACKETS; PANTS; SHIRTS; SHOES; VESTS (U.S. CLS. 22 AND 39).

FIRST USE 7-5-2009; IN COMMERCE 7-5-2009.

3,955,625. VANTERPOOL, DIRK, DEJOINE, AKA DIRK DEJOINE, ROSWELL, GA. SN 77-921,948. PUB. 6-15-2010, FILED 1-27-2010.

**Dirk Dejoine**

THE MARK CONSISTS OF STANDARD CHARACTERS WITHOUT CLAIM TO ANY PARTICULAR FONT, STYLE, SIZE, OR COLOR.

**CLASS 25—(Continued).**

THE NAME "DIRK DEJOINE" IDENTIFIES A LIVING INDIVIDUAL WHOSE CONSENT IS OF RECORD.

FOR APPAREL FOR DANCERS, NAMELY, TEE SHIRTS, SWEATSHIRTS, PANTS, LEGGINGS, SHORTS AND JACKETS; ATHLETIC APPAREL, NAMELY, SHIRTS, PANTS, JACKETS, FOOTWEAR, HATS AND CAPS, ATHLETIC UNIFORMS; ATHLETIC SHOES; BODY SHIRTS; BRIEFS; CAMOUFLAGE PANTS; CAMOUFLAGE SHIRTS; CANVAS SHOES; CAPRI PANTS; CARGO PANTS; DANCE SHOES; DECK-SHOES; DENIMS; DRESS SHIRTS; GOLF PANTS, SHIRTS AND SKIRTS; GOLF SHIRTS; GOLF SHOES; HOODED SWEAT SHIRTS; INFANTS' SHOES AND BOOTS; JOGGING PANTS; KNIT SHIRTS; KNITTED UNDERWEAR; LADIES' UNDERWEAR; LEATHER PANTS; LEATHER SHOES; LEISURE SHOES; LONG UNDERWEAR; LONG-SLEEVED SHIRTS; LOUNGE PANTS; MEN'S UNDERWEAR; NIGHT SHIRTS; OPEN-NECKED SHIRTS; OVER SHIRTS; PANTIES; PANTIES, SHORTS AND BRIEFS; PANTS; PETTI-PANTS; PIQUE SHIRTS; POLO SHIRTS; RUGBY SHIRTS; RUNNING SHOES; SANDALS AND BEACH SHOES; SHIRT FRONTS; SHIRTS; SHIRTS AND SHORT-SLEEVED SHIRTS; SHIRTS FOR INFANTS, BABIES, TODDLERS AND CHILDREN; SHIRTS FOR SUITS; SHOES; SHORT-SLEEVED OR LONG-SLEEVED T-SHIRTS; SHORT-SLEEVED SHIRTS; SKI PANTS; SLEEP PANTS; SLEEP SHIRTS; SPORT SHIRTS; SPORTS PANTS; SPORTS SHIRTS; SPORTS SHIRTS WITH SHORT SLEEVES; STRETCH PANTS; SWEAT PANTS; SWEAT SHIRTS; T-SHIRTS; TEE SHIRTS; TENNIS SHOES; THERMAL UNDERWEAR; THONGS; TOBOGGAN HATS, PANTS AND CAPS; TRACK AND FIELD SHOES; TRACK PANTS; TURTLE NECK SHIRTS; UNDERWEAR; UNDERWEAR, NAMELY, BOY SHORTS; WATERPROOF JACKETS AND PANTS; WEARABLE GARMENTS AND CLOTHING, NAMELY, SHIRTS; WIND PANTS; WIND SHIRTS; WOMEN'S SHOES; WOMEN'S UNDERWEAR; WORK SHOES AND BOOTS; WOVEN OR KNITTED UNDERWEAR; YOGA PANTS; YOGA SHIRTS (U.S. CLS. 22 AND 39).

FIRST USE 2-10-2011; IN COMMERCE 2-10-2011.

3,955,657. MAMIYE BROTHERS, INC., NEW YORK, NY. SN 77-929,083. PUB. 12-21-2010, FILED 2-5-2010.

**LITTLE ME BLUES**

THE MARK CONSISTS OF STANDARD CHARACTERS WITHOUT CLAIM TO ANY PARTICULAR FONT, STYLE, SIZE, OR COLOR.

OWNER OF U.S. REG. NOS. 2,690,470, 3,540,112, AND OTHERS.

NO CLAIM IS MADE TO THE EXCLUSIVE RIGHT TO USE "BLUES", APART FROM THE MARK AS SHOWN.

FOR CHILDREN'S CLOTHING, NAMELY, CREEPERS, COVERALLS, JACKETS, OVERALLS, HATS AND COVERALLS AND JACKET SOLD TOGETHER, SWEATERS, SUN ROMPERS, SWIMSUITS, JUMP SUITS, SHIRTS, PANTS AND DRESSES (U.S. CLS. 22 AND 39).

FIRST USE 11-0-2010; IN COMMERCE 11-0-2010.

**CLASS 25—(Continued).**

3,955,667. PITTSBURGH ASSOCIATES, PITTSBURGH, PA. SN 77-930,226. PUB. 6-15-2010, FILED 2-8-2010.



THE MARK CONSISTS OF THE LETTER "B" STYLIZED. FOR CLOTHING, NAMELY, CAPS, HATS, SHIRTS, T-SHIRTS (U.S. CLS. 22 AND 39).  
FIRST USE 2-25-2010; IN COMMERCE 2-25-2010.

3,955,673. KRZEMIEN, KELLY C., MIDLOTHIAN, VA. SN 77-931,040. PUB. 6-22-2010, FILED 2-8-2010.

**GET YOUR WINGS ON**

THE MARK CONSISTS OF STANDARD CHARACTERS WITHOUT CLAIM TO ANY PARTICULAR FONT, STYLE, SIZE, OR COLOR.

FOR CAPS; HATS; SHORT-SLEEVED OR LONG-SLEEVED T-SHIRTS; SHORTS; SWEAT PANTS; SWEAT SHIRTS; SWEAT SHORTS; SWEAT SUITS; TOPS; COATS; JACKETS (U.S. CLS. 22 AND 39).

FIRST USE 5-23-2009; IN COMMERCE 5-23-2009.

3,955,679. TWENTIETH CENTURY FOX FILM CORPORATION, LOS ANGELES, CA. SN 77-932,113. PUB. 6-15-2010, FILED 2-9-2010.

**PERCY JACKSON AND THE OLYMPIANS**

THE MARK CONSISTS OF STANDARD CHARACTERS WITHOUT CLAIM TO ANY PARTICULAR FONT, STYLE, SIZE, OR COLOR.

THE NAME "PERCY JACKSON" DOES NOT IDENTIFY A PARTICULAR LIVING INDIVIDUAL.

FOR SHIRTS (U.S. CLS. 22 AND 39).

FIRST USE 12-31-2009; IN COMMERCE 12-31-2009.

**CLASS 25—(Continued).**

3,955,738. CAR TATTOOS DECALS AND SPORTSWEAR LTD., YONKERS, NY. SN 77-943,710. PUB. 7-20-2010, FILED 2-24-2010.

**HIGHWAY OUTLAW**

THE MARK CONSISTS OF STANDARD CHARACTERS WITHOUT CLAIM TO ANY PARTICULAR FONT, STYLE, SIZE, OR COLOR.

FOR CLOTHING, NAMELY, T-SHIRTS, SHIRTS, SWEATSHIRTS, JACKETS, BANDANAS, HEADWEAR (U.S. CLS. 22 AND 39).

FIRST USE 3-11-2011; IN COMMERCE 3-11-2011.

3,955,756. THE WORD OF TRUTH CHURCH, DETROIT, MI. SN 77-947,943. PUB. 7-27-2010, FILED 3-2-2010.



THE COLOR(S) BLUE, YELLOW, RED AND BLACK IS/ ARE CLAIMED AS A FEATURE OF THE MARK.

THE MARK CONSISTS OF A CIRCLE DIVIDED INTO FOUR QUARTERS. THE OUTLINE OF THE CIRCLE IS IN DARK BLUE, AS WELL AS, THE HORIZONTAL AND VERTICAL LINES DIRECTLY IN THE CENTER OF THE CIRCLE. THE UPPER LEFT QUARTER IS IN BLUE WITH A YELLOW "T". THE UPPER RIGHT QUARTER IS IN YELLOW WITH A BLACK "W". THE LOWER LEFT QUARTER IS IN RED WITH A BLACK "O". THE LOWER RIGHT QUARTER IS IN BLUE WITH A YELLOW "T".

FOR UNIFORMS (U.S. CLS. 22 AND 39).

FIRST USE 3-1-2010; IN COMMERCE 3-1-2010.

**CLASS 25—(Continued).**

3,955,757. FOOT CANDI, LLC, CHARLOTTE, NC. SN 77-948,439. PUB. 7-27-2010, FILED 3-2-2010.

**SWEETSLIPS**

THE MARK CONSISTS OF STANDARD CHARACTERS WITHOUT CLAIM TO ANY PARTICULAR FONT, STYLE, SIZE, OR COLOR.

FOR FOOTWEAR (U.S. CLS. 22 AND 39).  
FIRST USE 11-26-2010; IN COMMERCE 11-26-2010.

3,955,772. CHARLES KOMAR & SONS, INC., NEW YORK, NY. SN 77-950,755. PUB. 7-27-2010, FILED 3-4-2010.

**KOMAR KIDS**

THE MARK CONSISTS OF STANDARD CHARACTERS WITHOUT CLAIM TO ANY PARTICULAR FONT, STYLE, SIZE, OR COLOR.

OWNER OF U.S. REG. NO. 1,687,931.

NO CLAIM IS MADE TO THE EXCLUSIVE RIGHT TO USE "KIDS", APART FROM THE MARK AS SHOWN.

SEC. 2(F) AS TO "KOMAR".

FOR BABY LAYETTES FOR CLOTHING; BOOTIES; BOTTOMS; CHILDREN'S AND INFANT'S APPAREL, NAMELY, JUMPERS, OVERALL SLEEPWEAR, PAJAMAS, ROMPERS AND ONE-PIECE GARMENTS; LAYETTES; ONE PIECE GARMENT FOR INFANTS AND TODDLERS; PANTS; ROBES; SHIRTS; SHORTS; SLEEPWEAR; TOPS; UNDERWEAR (U.S. CLS. 22 AND 39).  
FIRST USE 12-31-2009; IN COMMERCE 12-13-2009.

3,955,782. WILDER, ERNEST T, FERNANDINA BEACH, FL. SN 77-952,387. PUB. 7-27-2010, FILED 3-6-2010.



NO CLAIM IS MADE TO THE EXCLUSIVE RIGHT TO USE "FISHING", APART FROM THE MARK AS SHOWN.

THE MARK CONSISTS OF "3QUARTER FISHING" AND AN IMAGE OF A FISHING HOOK.

FOR HATS; SHORT-SLEEVED OR LONG-SLEEVED T-SHIRTS (U.S. CLS. 22 AND 39).  
FIRST USE 3-2-2010; IN COMMERCE 3-2-2010.

**CLASS 25—(Continued).**

3,955,802. SHELTER-PRO, LLC, STEARNS, KY. SN 77-958,771. PUB. 8-3-2010, FILED 3-15-2010.

**OVERFLAGE**

THE MARK CONSISTS OF STANDARD CHARACTERS WITHOUT CLAIM TO ANY PARTICULAR FONT, STYLE, SIZE, OR COLOR.

FOR CAMOUFLAGE CLOTHING, NAMELY, HOODS, PANTS AND TOPS (U.S. CLS. 22 AND 39).  
FIRST USE 3-1-2011; IN COMMERCE 3-1-2011.

3,955,806. RETAIL CONCEPTS, INC., HOUSTON, TX. SN 77-959,641. PUB. 8-3-2010, FILED 3-16-2010.

**B360**

THE MARK CONSISTS OF STANDARD CHARACTERS WITHOUT CLAIM TO ANY PARTICULAR FONT, STYLE, SIZE, OR COLOR.

OWNER OF U.S. REG. NO. 2,584,844.

FOR CLOTHING FOR SKIING AND SNOWBOARDING, NAMELY, SOCKS AND GLOVES (U.S. CLS. 22 AND 39).

FIRST USE 2-25-2011; IN COMMERCE 2-25-2011.

3,955,816. BREWSTER, MARCUS W, DBA VICTORY EVERYWEAR, CENTREVILLE, VA. SN 77-963,897. PUB. 8-10-2010, FILED 3-19-2010.



THE COLOR(S) RED, WHITE, AND BLACK IS/ARE CLAIMED AS A FEATURE OF THE MARK.

**CLASS 25—(Continued).**

THE MARK CONSISTS OF THE WORD "VICTORY" ON TOP, WITH THE LETTER "T" AS A CROSS, WITH THE WORDS "EVERYWEAR" UNDER IT. THE CROSS (LETTER T) IS COMPLETELY RED, BOTH WORDS ARE WHITE WITH A BLACK OUTLINE, AS WELL AS A RED OUTLINE AROUND IT.

FOR A-SHIRTS; ATHLETIC APPAREL, NAMELY, SHIRTS, PANTS, JACKETS, FOOTWEAR, HATS AND CAPS, ATHLETIC UNIFORMS; BASEBALL CAPS; BASEBALL CAPS AND HATS; BELTS; BELTS FOR CLOTHING; BELTS MADE OF LEATHER; BOMBER JACKETS; COATS; COATS FOR MEN AND WOMEN; COATS MADE OF COTTON; DOWN JACKETS; DRESS SHIRTS; HEADBANDS AGAINST SWEATING; HEAVY COATS; HEAVY JACKETS; HOODED SWEAT SHIRTS; JACKETS; JACKETS AND SOCKS; JEANS; JOGGING PANTS; LEATHER BELTS; LEATHER COATS; LIGHT-REFLECTING JACKETS; LONG JACKETS; LONG-SLEEVED SHIRTS; MEN'S AND WOMEN'S JACKETS, COATS, TROUSERS, VESTS; OUTER JACKETS; PANTS; POLO SHIRTS; RAIN JACKETS; RAINPROOF JACKETS; SCIENTIFIC AND TECHNOLOGICAL APPAREL, NAMELY, SHIRTS, PANTS, JACKETS, FOOTWEAR, HATS AND CAPS, UNIFORMS; SHIRTS; SHIRTS AND SHORT-SLEEVED SHIRTS; SHORT-SLEEVED OR LONG-SLEEVED T-SHIRTS; SHORT-SLEEVED SHIRTS; SPORT COATS; SPORTS CAPS AND HATS; SPORTS JACKETS; SPORTS SHIRTS WITH SHORT SLEEVES; SWEAT BANDS; SWEAT JACKETS; SWEAT SHIRTS; T-SHIRTS; TURTLE NECK SHIRTS; WATERPROOF JACKETS AND PANTS; WEARABLE GARMENTS AND CLOTHING, NAMELY, SHIRTS; WIND RESISTANT JACKETS; WIND-JACKETS (U.S. CLS. 22 AND 39).

FIRST USE 12-31-2009; IN COMMERCE 12-31-2010.

3,955,822. MERLIN, AVROM, PHILADELPHIA, PA. SN 77-965,540. PUB. 8-10-2010, FILED 3-23-2010.

**SO FETCH**

THE MARK CONSISTS OF STANDARD CHARACTERS WITHOUT CLAIM TO ANY PARTICULAR FONT, STYLE, SIZE, OR COLOR.

FOR FOOTWEAR, HEADWEAR, AND MEN'S, WOMEN'S AND CHILDREN'S WEARING APPAREL, NAMELY, JEANS, SHIRTS; OUTERWEAR, NAMELY, JACKETS, COATS, VESTS, SCARVES, SHELLS, SPORTS JACKETS; PANTS, TROUSERS, SWEATERS, SWEAT-PANTS, SWEATSHIRTS, SWEAT SUITS, JUMPSUITS, SHORTS, OVERALLS, SHORTALLS, DRESSES, SKIRTS, BLOUSES, T-SHIRTS, KNIT SHIRTS, RAINWEAR, RAINCOATS, TANK TOPS, BATHING SUITS, SUITS, ROBES, PAJAMAS, LOUNGEWEAR, BELTS, BRIEFS, LEOTARDS, TIGHTS, HOSIERY, SOCKS, GLOVES, ARM WARMERS, PANTYHOSE, SCARVES, AND SHAWLS FOR CONSUMERS OF ALL AGES (U.S. CLS. 22 AND 39).

FIRST USE 1-1-2010; IN COMMERCE 12-1-2010.

**CLASS 25—(Continued).**

3,955,823. TRACY HEALY, PROVIDENCE, RI. SN 77-969,222. PUB. 7-20-2010, FILED 3-26-2010.

**WHAT IS YOUR MOMENT?**

THE MARK CONSISTS OF STANDARD CHARACTERS WITHOUT CLAIM TO ANY PARTICULAR FONT, STYLE, SIZE, OR COLOR.

OWNER OF U.S. REG. NO. 3,755,223.  
FOR LOUNGEWEAR; PAJAMAS; ROBES (U.S. CLS. 22 AND 39).

FIRST USE 1-1-2010; IN COMMERCE 1-1-2010.

3,955,824. SMITH, RUSSELL JAMES, LONGWOOD, FL. SN 77-969,256. PUB. 8-17-2010, FILED 3-26-2010.

**KnuckleNap**

THE MARK CONSISTS OF STANDARD CHARACTERS WITHOUT CLAIM TO ANY PARTICULAR FONT, STYLE, SIZE, OR COLOR.

FOR CLOTHING, NAMELY, T-SHIRTS, CAPS, AND SHORTS (U.S. CLS. 22 AND 39).

FIRST USE 3-26-2010; IN COMMERCE 2-18-2011.

3,955,838. LANE INTERNATIONAL, INC., HAYWARD, CA. SN 77-981,334. PUB. 12-22-2009, FILED 5-29-2007.



THE MARK CONSISTS OF THE LETTERS "RJ" IN STYLIZED FORM.

FOR BEACH FOOTWEAR; BEACH SHOES (U.S. CLS. 22 AND 39).

FIRST USE 12-26-2009; IN COMMERCE 12-26-2009.

**CLASS 25—(Continued).**

3,955,857. SUSAN, KIWAN, OTTAWA, ONTARIO, CANADA.  
SN 77-981,557. PUB. 9-7-2010, FILED 1-18-2010.

# SHLICK

THE MARK CONSISTS OF STANDARD CHARACTERS WITHOUT CLAIM TO ANY PARTICULAR FONT, STYLE, SIZE, OR COLOR.

FOR CLOTHING PRODUCTS, NAMELY, CLOTHING, NAMELY, SHIRTS, T-SHIRTS, HOODED SHIRTS, SWEAT SHIRTS, SHORTS, TROUSERS, FOOTWEAR, HEADGEAR, NAMELY, HATS, CAPS FOR CONSUMERS (U.S. CLS. 22 AND 39).

FIRST USE 1-1-2010; IN COMMERCE 1-1-2010.

**CLASS 25—(Continued).**

3,955,873. O & K, INC., LOS ANGELES, CA. SN 78-410,208.  
PUB. 7-13-2010, FILED 4-29-2004.



OWNER OF U.S. REG. NOS. 2,523,863 AND 2,584,784.  
NO CLAIM IS MADE TO THE EXCLUSIVE RIGHT TO USE "CLOTHING", APART FROM THE MARK AS SHOWN. THE COLOR(S) BLACK, WHITE AND RED IS/ARE CLAIMED AS A FEATURE OF THE MARK.

THE MARK CONSISTS OF THE FOLLOWING: RED STIPPLING SURROUNDING A RED HEART WITH THE WORDING "ONE CLOTHING" IN WHITE WITH SHADING FOR THE WORDING IN THE COLOR BLACK.

FOR JUNIORS AND WOMEN'S CLOTHING, NAMELY, SKIRTS, TOPS, BLOUSES, T-SHIRTS, PANTS, SHORTS, SUITS, DRESSES, JACKETS AND JEANS; GIRLS AND INFANT/TODDLER CLOTHING, NAMELY, SKIRTS, TOPS, BLOUSES, T-SHIRTS, PANTS, SHORTS, JUMPERS, DRESSES, JACKETS AND JEANS (U.S. CLS. 22 AND 39).

FIRST USE 9-21-1998; IN COMMERCE 9-21-1998.

3,955,860. TB ACQUISITIONS, LLC, HULETT, WY. SN 77-981,574. PUB. 5-27-2008, FILED 1-14-2008.

# THIS AIN'T NO PICNIC

THE MARK CONSISTS OF STANDARD CHARACTERS WITHOUT CLAIM TO ANY PARTICULAR FONT, STYLE, SIZE, OR COLOR.

FOR T-SHIRTS; HATS (U.S. CLS. 22 AND 39).  
FIRST USE 5-0-2007; IN COMMERCE 5-0-2007.

3,955,891. SAITEX INTERNATIONAL INC., NEW YORK, NY. SN 85-001,879. PUB. 6-22-2010, FILED 3-30-2010.

# SAITEX

3,955,871. KASWIT, INC., LA QUINTA, CA. SN 77-981,716.  
PUB. 7-27-2010, FILED 3-8-2010.

# STASH 'N DASH

THE MARK CONSISTS OF STANDARD CHARACTERS WITHOUT CLAIM TO ANY PARTICULAR FONT, STYLE, SIZE, OR COLOR.

FOR SCARVES (U.S. CLS. 22 AND 39).  
FIRST USE 11-1-2010; IN COMMERCE 11-1-2010.

THE MARK CONSISTS OF STANDARD CHARACTERS WITHOUT CLAIM TO ANY PARTICULAR FONT, STYLE, SIZE, OR COLOR.

FOR CAPS; FOOTWEAR; HATS; JACKETS; JEANS; JOGGING SUITS; PANTS; SHIRTS; T-SHIRTS; TOPS; TROUSERS; UNDERWEAR (U.S. CLS. 22 AND 39).  
FIRST USE 1-31-2010; IN COMMERCE 1-31-2010.

**CLASS 25—(Continued).**

3,955,903. KING'S SHADOW CAMO, LLC, SOUTH JORDAN, UT. SN 85-007,738. PUB. 7-13-2010, FILED 4-6-2010.

ANYTAG ANYTIME

THE MARK CONSISTS OF STANDARD CHARACTERS WITHOUT CLAIM TO ANY PARTICULAR FONT, STYLE, SIZE, OR COLOR.

FOR CLOTHING, NAMELY, HATS AND T-SHIRTS (U.S. CLS. 22 AND 39).  
FIRST USE 11-30-2010; IN COMMERCE 11-30-2010.

---

3,955,907. MALIBU DREAM GIRL, INC., COMMERCE, CA. SN 85-008,664. PUB. 6-29-2010, FILED 4-7-2010.

SHAPETEX

THE MARK CONSISTS OF STANDARD CHARACTERS WITHOUT CLAIM TO ANY PARTICULAR FONT, STYLE, SIZE, OR COLOR.

FOR SWIMWEAR (U.S. CLS. 22 AND 39).  
FIRST USE 6-10-2010; IN COMMERCE 6-10-2010.

---

3,955,920. HBI BRANDED APPAREL ENTERPRISES, LLC, WINSTON-SALEM, NC. SN 85-012,715. PUB. 7-27-2010, FILED 4-13-2010.

FIT FOR ALL

THE MARK CONSISTS OF STANDARD CHARACTERS WITHOUT CLAIM TO ANY PARTICULAR FONT, STYLE, SIZE, OR COLOR.

FOR PANTS; SHORTS (U.S. CLS. 22 AND 39).  
FIRST USE 7-31-2010; IN COMMERCE 7-31-2010.

**CLASS 25—(Continued).**

3,955,923. LIMON, JOHN B., LAS VEGAS, NV. SN 85-014,005. PUB. 9-7-2010, FILED 4-14-2010.

Ut@ng

THE MARK CONSISTS OF STANDARD CHARACTERS WITHOUT CLAIM TO ANY PARTICULAR FONT, STYLE, SIZE, OR COLOR.

FOR APPAREL FOR DANCERS, NAMELY, TEE SHIRTS, SWEATSHIRTS, PANTS, LEGGINGS, SHORTS AND JACKETS; ATHLETIC APPAREL, NAMELY, SHIRTS, PANTS, JACKETS, FOOTWEAR, HATS AND CAPS, ATHLETIC UNIFORMS; DRESS SHIRTS; HOODED SWEAT SHIRTS; LONG-SLEEVED SHIRTS; POLO SHIRTS; SHIRTS AND SHORT-SLEEVED SHIRTS; SHIRTS FOR INFANTS, BABIES, TODDLERS AND CHILDREN (U.S. CLS. 22 AND 39).  
FIRST USE 12-1-2010; IN COMMERCE 2-1-2011.

---

3,955,941. MEYNARD DESIGNS, INC., WALTHAM, MA. SN 85-020,417. PUB. 11-23-2010, FILED 4-22-2010.

€arthies

OWNER OF U.S. REG. NO. 3,366,425.

THE MARK CONSISTS OF A STYLIZED CAPITAL LETTER "E" FOLLOWED BY FOLLOWED BY LOWERCASE SCRIPT OF THE LETTERS "ARTHIES."

FOR FOOTWEAR (U.S. CLS. 22 AND 39).  
FIRST USE 1-0-2011; IN COMMERCE 1-0-2011.

**CLASS 25—(Continued).**

3,955,953. C. & J. CLARK INTERNATIONAL LIMITED, STREET, SOMERSET, UNITED KINGDOM. SN 85-025,963. PUB. 7-20-2010, FILED 4-29-2010.

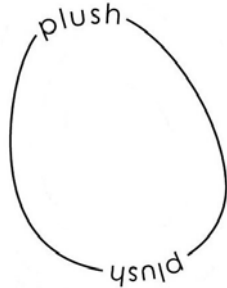

NO CLAIM IS MADE TO THE EXCLUSIVE RIGHT TO USE "PLUSH", APART FROM THE MARK AS SHOWN. FOR FOOTWEAR (U.S. CLS. 22 AND 39). FIRST USE 1-1-2011; IN COMMERCE 1-1-2011.

**CLASS 25—(Continued).**

3,955,963. EXCLAIM HOLDINGS, LLC, DALLAS, TX. SN 85-029,502. PUB. 7-27-2010, FILED 5-4-2010.



THE MARK CONSISTS OF TWO SMILEY FACES THAT ARE TILTED TO THE RIGHT WITH THE SMALLER SMILEY FACE OVERLAPPING THE LOWER RIGHT PORTION OF THE LARGER SMILEY FACE AND AN EXCLAMATION MARK TO THE RIGHT.

FOR MEN'S, WOMEN'S, AND CHILDREN'S APPAREL, NAMELY, TOPS, PANTS, SHORTS, JACKETS, HEADWEAR, AND DRESSES (U.S. CLS. 22 AND 39). FIRST USE 3-1-2011; IN COMMERCE 3-1-2011.

3,955,954. MEYNARD DESIGNS, INC., WALTHAM, MA. SN 85-026,105. PUB. 11-23-2010, FILED 4-29-2010.

**EARTHIES**

THE MARK CONSISTS OF STANDARD CHARACTERS WITHOUT CLAIM TO ANY PARTICULAR FONT, STYLE, SIZE, OR COLOR. OWNER OF U.S. REG. NO. 3,366,425. FOR FOOTWEAR (U.S. CLS. 22 AND 39). FIRST USE 1-0-2011; IN COMMERCE 1-0-2011.

3,955,987. FIGHTERS FIRE INC., WINTER SPRINGS, FL. SN 85-043,261. PUB. 10-19-2010, FILED 5-19-2010.

**Fighter By Day**

THE MARK CONSISTS OF STANDARD CHARACTERS WITHOUT CLAIM TO ANY PARTICULAR FONT, STYLE, SIZE, OR COLOR.

FOR ATHLETIC APPAREL, NAMELY, SHIRTS, PANTS, JACKETS, FOOTWEAR, HATS AND CAPS, ATHLETIC UNIFORMS; BABY TOPS; BOARD SHORTS; CAPS; CLOTHING FOR WEAR IN JUDO PRACTICES; CLOTHING FOR WEAR IN WRESTLING GAMES; EYE-SHADES; FLIP FLOPS; FOOTWEAR; HATS; HOODED SWEAT SHIRTS; HOODS; JACKETS; JERSEYS; KNITTED CAPS; MUSCLE TOPS; PANTS; POLO KNIT TOPS; SHORT-SLEEVED SHIRTS; SHORTS; SKULL CAPS; SWEAT PANTS; T-SHIRTS; TANK TOPS; TIES; TRAVEL CLOTHING CONTAINED IN A PACKAGE COMPRISING REVERSIBLE JACKETS, PANTS, SKIRTS, TOPS AND A BELT OR SCARF; TRIATHLON CLOTHING, NAMELY, TRIATHLON TIGHTS, TRIATHLON SHORTS, TRIATHLON SINGLETS, TRIATHLON SHIRTS, TRIATHLON SUITS; UNDERWEAR, NAMELY, BOY SHORTS (U.S. CLS. 22 AND 39). FIRST USE 7-15-2010; IN COMMERCE 11-1-2010.

**CLASS 25—(Continued).**

3,956,001. SKINNYSHIRT LLC, GLEN HEAD, NY. SN 85-050,213. PUB. 8-24-2010, FILED 5-28-2010.



NO CLAIM IS MADE TO THE EXCLUSIVE RIGHT TO USE "SKINNY SHIRT", APART FROM THE MARK AS SHOWN.

THE MARK CONSISTS OF AN IMAGE OF A WOMAN HOLDING A BAG, WITH "SKINNYSHIRT" APPEARING ON THE BAG.

FOR FOUNDATION GARMENTS; UNDERGARMENTS; GIRDLES; CLOTHING, NAMELY, SHIRTS, BODY SHAPERS, CAMISOLES, AND LINGERIE; SHAPEWEAR, NAMELY, FOUNDATION GARMENTS INTEGRATED WITH SHIRT ELEMENTS, DESIGNED TO BE WORN UNDER CLOTHING WITH SHIRT ELEMENTS EXPOSED TO SIMULATE AN ENTIRE SHIRT; FOUNDATION GARMENTS WORN AROUND THE TORSO TO SUPPORT AND COMPRESS BODY TO CREATE A SLIMMING EFFECT (U.S. CLS. 22 AND 39).  
FIRST USE 11-28-2010; IN COMMERCE 11-28-2010.

3,956,003. SKINNYSHIRT LLC, GLEN HEAD, NY. SN 85-050,273. PUB. 8-24-2010, FILED 5-28-2010.



NO CLAIM IS MADE TO THE EXCLUSIVE RIGHT TO USE "SKINNY SHIRT", APART FROM THE MARK AS SHOWN.

**CLASS 25—(Continued).**

THE MARK CONSISTS OF AN IMAGE OF A PREGNANT WOMAN HOLDING A BAG, WITH "SKINNYSHIRT MAMA" APPEARING ON THE BAG.

FOR MATERNITY FOUNDATION GARMENTS; MATERNITY UNDERGARMENTS; MATERNITY GIRDLES; MATERNITY CLOTHING, NAMELY, SHIRTS, BODY SHAPERS, CAMISOLES, AND LINGERIE; MATERNITY SHAPEWEAR, NAMELY, FOUNDATION GARMENTS INTEGRATED WITH SHIRT ELEMENTS, DESIGNED TO BE WORN UNDER CLOTHING WITH SHIRT ELEMENTS EXPOSED TO SIMULATE AN ENTIRE SHIRT; MATERNITY FOUNDATION GARMENTS WORN AROUND THE TORSO TO SUPPORT AND COMPRESS BODY TO CREATE A SLIMMING EFFECT (U.S. CLS. 22 AND 39).

FIRST USE 11-28-2010; IN COMMERCE 11-28-2010.

3,956,021. PETERSEN, DENNIS, VENICE, FL. SN 85-059,032. PUB. 11-9-2010, FILED 6-10-2010.

**GET'N AFTER IT!**

THE MARK CONSISTS OF STANDARD CHARACTERS WITHOUT CLAIM TO ANY PARTICULAR FONT, STYLE, SIZE, OR COLOR.

FOR CLOTHING PRODUCTS, NAMELY, SHIRTS, FOOTWEAR AND HEADWEAR FOR CONSUMERS (U.S. CLS. 22 AND 39).

FIRST USE 9-1-2010; IN COMMERCE 9-1-2010.

3,956,052. HEARD DESIGN LLC, DBA HOWLER BROTHERS, AUSTIN, TX. SN 85-080,091. PUB. 12-7-2010, FILED 7-8-2010.

The logo for "Howler Bros" features the word "Howler" in a large, bold, black, cursive-style font. Below it, the word "BROS" is written in a smaller, bold, black, sans-serif font. The "H" in "Howler" has a lightning bolt shape extending from its top right corner.

THE MARK CONSISTS OF THE STYLIZED PRESENTATION OF THE WORDS "HOWLER BROS". "HOWLER" IS LOCATED ABOVE "BROS" AND IS LARGER AND SLOPING UPWARDS FROM LEFT TO RIGHT. THE HORIZONTAL MARK OF THE "H" OF "HOWLER" EXTENDS INTO A LIGHTNING BOLT WHICH FALLS BEHIND THE "L" OF "HOWLER". "BROS" IS LOCATED BELOW AND RIGHT OF THE WORD "HOWLER". "BROS" IS IN ALL CAPS AND BOLD TYPEFACE.

FOR ATHLETIC APPAREL, NAMELY, SHIRTS, PANTS, JACKETS, FOOTWEAR, HATS AND CAPS, ATHLETIC UNIFORMS; BOARD SHORTS; FABRIC BELTS; HATS; LEATHER BELTS; WEARABLE GARMENTS AND CLOTHING, NAMELY, SHIRTS (U.S. CLS. 22 AND 39).

FIRST USE 8-1-2009; IN COMMERCE 1-1-2010.



**CLASS 25—(Continued).**

3,956,053. HEARD DESIGN LLC, DBA HOWLER BROTHERS, AUSTIN, TX. SN 85-080,128. PUB. 12-7-2010, FILED 7-8-2010.



THE MARK CONSISTS OF A BOLD LETTER "H" WITH A VERTICAL LIGHTNING BOLT INTERSECTING THE HORIZONTAL STROKE OF THE "H".

FOR ATHLETIC APPAREL, NAMELY, SHIRTS, PANTS, JACKETS, FOOTWEAR, HATS AND CAPS, ATHLETIC UNIFORMS; BOARD SHORTS; FABRIC BELTS; HATS; LEATHER BELTS; WEARABLE GARMENTS AND CLOTHING, NAMELY, SHIRTS (U.S. CLS. 22 AND 39).

FIRST USE 8-1-2009; IN COMMERCE 1-1-2010.

3,956,054. HEARD DESIGN LLC, DBA HOWLER BROTHERS, AUSTIN, TX. SN 85-080,158. PUB. 12-7-2010, FILED 7-8-2010.



THE MARK CONSISTS OF A STYLIZED MONKEY FACE WITH GEOMETRIC FEATURES AND LIGHTNING BOLT SHAPED SIDEBURNS. THE OUTER PORTION OF THE DRAWING COMPRISES THE ANGULAR SHAPE OF THE HEAD AND EARS, AND CREATES THE JAGGED EDGES OF THE FACE. TRIANGULAR EYES, ELLIPTICAL NOSE HOLES, AND A LINE REPRESENTING THE MOUTH ARE LOCATED IN THE SPACE CREATED BY THE OUTER PORTION OF THE DRAWING.

FOR ATHLETIC APPAREL, NAMELY, SHIRTS, PANTS, JACKETS, FOOTWEAR, HATS AND CAPS, ATHLETIC UNIFORMS; BOARD SHORTS; FABRIC BELTS; HATS; LEATHER BELTS; WEARABLE GARMENTS AND CLOTHING, NAMELY, SHIRTS (U.S. CLS. 22 AND 39).

FIRST USE 8-1-2009; IN COMMERCE 1-1-2010.

**CLASS 25—(Continued).**

3,956,060. IMMEDIATE GOODS INC., LOS ANGELES, CA. SN 85-082,220. PUB. 12-14-2010, FILED 7-12-2010.

# Jolene

THE MARK CONSISTS OF STANDARD CHARACTERS WITHOUT CLAIM TO ANY PARTICULAR FONT, STYLE, SIZE, OR COLOR.

FOR DRESSES (U.S. CLS. 22 AND 39).

FIRST USE 1-1-2011; IN COMMERCE 1-1-2011.

3,956,083. BIFLEX INTIMATES GROUP, LTD., NEW YORK, NY. SN 85-098,780. PUB. 11-16-2010, FILED 8-3-2010.

## The Naughty behind the Nice!

THE MARK CONSISTS OF STANDARD CHARACTERS WITHOUT CLAIM TO ANY PARTICULAR FONT, STYLE, SIZE, OR COLOR.

FOR LINGERIE, NAMELY, BRAS AND PANTIES (U.S. CLS. 22 AND 39).

FIRST USE 1-19-2011; IN COMMERCE 1-19-2011.

3,956,085. DILLARD'S, INC., LITTLE ROCK, AR. SN 85-099,391. PUB. 11-16-2010, FILED 8-3-2010.

## TRAVEL SMART

THE MARK CONSISTS OF STANDARD CHARACTERS WITHOUT CLAIM TO ANY PARTICULAR FONT, STYLE, SIZE, OR COLOR.

FOR WOMEN'S CLOTHING, NAMELY, PANTS, CROPS, SHORTS, SKIRTS, JACKETS, DRESSES AND TOPS (U.S. CLS. 22 AND 39).

FIRST USE 7-1-2010; IN COMMERCE 7-1-2010.

**CLASS 26—FANCY GOODS**

**CLASS 26—(Continued).**

3,955,299. MICHAEL LAPLANTE, LOWELL, MA. SN 77-671,199. PUB. 12-15-2009, FILED 2-16-2009.

**TOE TAGZ**

THE MARK CONSISTS OF STANDARD CHARACTERS WITHOUT CLAIM TO ANY PARTICULAR FONT, STYLE, SIZE, OR COLOR.

FOR SHOE ORNAMENTS NOT OF PRECIOUS METAL (U.S. CLS. 37, 39, 40, 42 AND 50).

FIRST USE 2-1-2011; IN COMMERCE 2-1-2011.

**CLASS 27—FLOOR COVERINGS**

3,955,390. COLOUR & DESIGN, INC., NORTH LITTLE ROCK, AR. SN 77-796,795. PUB. 6-22-2010, FILED 8-4-2009.

**KADEN**

THE MARK CONSISTS OF STANDARD CHARACTERS WITHOUT CLAIM TO ANY PARTICULAR FONT, STYLE, SIZE, OR COLOR.

FOR WALLPAPER; WALLPAPER IN THE NATURE OF ROOMSIZE DECORATIVE ADHESIVE WALL COVERINGS; NON-TEXTILE WALL COVERINGS; VINYL WALLCOVERINGS (U.S. CLS. 19, 20, 37, 42 AND 50).

FIRST USE 1-1-2009; IN COMMERCE 1-1-2009.

3,955,391. COLOUR & DESIGN, INC., NORTH LITTLE ROCK, AR. SN 77-796,799. PUB. 6-22-2010, FILED 8-4-2009.

**TOBA**

THE MARK CONSISTS OF STANDARD CHARACTERS WITHOUT CLAIM TO ANY PARTICULAR FONT, STYLE, SIZE, OR COLOR.

FOR WALLPAPER; WALLPAPER IN THE NATURE OF ROOMSIZE DECORATIVE ADHESIVE WALL COVERINGS; NON-TEXTILE WALL COVERINGS; VINYL WALLCOVERINGS (U.S. CLS. 19, 20, 37, 42 AND 50).

FIRST USE 1-1-2009; IN COMMERCE 1-1-2009.

**CLASS 27—(Continued).**

3,955,392. DH EMPRESAS S.A., SANTIAGO, CHILE. SN 77-798,225. PUB. 12-29-2009, FILED 8-6-2009.

**CASAIDEAS**

THE MARK CONSISTS OF STANDARD CHARACTERS WITHOUT CLAIM TO ANY PARTICULAR FONT, STYLE, SIZE, OR COLOR.

THE ENGLISH TRANSLATION OF "CASAIDEAS" IN THE MARK IS "IDEASHOUSE".

FOR CARPET BACKING; CARPET PADDING; CARPET UNDERLAYS; CARPET UNDERLINING; CARPETS AND RUGS; CARPETS FOR AUTOMOBILES; CARPETS, RUGS, MATS AND MATTING, LINOLEUM FOR COVERING EXISTING FLOORS; FLOOR MATS; FLOOR MATS FOR VEHICLES; FLOOR MATS IN THE NATURE OF NON-SLIP PADS FOR USE UNDER APPARATUS TO PREVENT SLIPPAGE; GOZA RUSH MATS; GYMNASIUM EXERCISE MATS; GYMNASIUM MATS; NON-SLIP BATH TUB MATS; PAPER BATH MATS; ADHESIVE COATED CONTAMINATION CONTROL FLOOR MAT MADE OF POLYPROPYLENE THAT CAPTURES PARTICULATES; SYNTHETIC LAWN; LINOLEUM FOR USE ON FLOORS; TAPESTRY-STYLE WALL HANGINGS, NOT OF TEXTILE; WALL PAPER; WALLPAPER IN THE NATURE OF ROOMSIZE DECORATIVE ADHESIVE WALL COVERINGS (U.S. CLS. 19, 20, 37, 42 AND 50).

FIRST USE 11-18-2010; IN COMMERCE 11-18-2010.

3,956,059. BEAULIEU GROUP, LLC, DALTON, GA. SN 85-081,566. PUB. 11-23-2010, FILED 7-9-2010.

**IT'S DOGGONE AMAZING**

THE MARK CONSISTS OF STANDARD CHARACTERS WITHOUT CLAIM TO ANY PARTICULAR FONT, STYLE, SIZE, OR COLOR.

FOR SELF-RENEWING, ODOR-DESTROYING CARPET TREATMENT SOLD AS A COMPONENT OF CARPETING (U.S. CLS. 19, 20, 37, 42 AND 50).

FIRST USE 2-0-2010; IN COMMERCE 2-0-2010.

**CLASS 28—TOYS AND SPORTING GOODS**

**CLASS 28—(Continued).**

3,955,200. CITY OF CARLSBAD, CARLSBAD, CA. SN 77-235,270. PUB. 5-18-2010, FILED 7-20-2007.

# TCAC

THE MARK CONSISTS OF STANDARD CHARACTERS WITHOUT CLAIM TO ANY PARTICULAR FONT, STYLE, SIZE, OR COLOR.

FOR COVERS FOR GOLF CLUBS; GOLF BALL MARKERS (U.S. CLS. 22, 23, 38 AND 50).

FIRST USE 3-8-2011; IN COMMERCE 3-8-2011.

3,955,204. PURE GLOBAL BRANDS, INC., WEST PALM BEACH, FL. SN 77-322,852. PUB. 6-16-2009, FILED 11-6-2007.



NO CLAIM IS MADE TO THE EXCLUSIVE RIGHT TO USE "BODY FITNESS", APART FROM THE MARK AS SHOWN.

THE COLOR(S) BLACK, WHITE AND RED IS/ARE CLAIMED AS A FEATURE OF THE MARK.

THE MARK CONSISTS OF A BLACK HORIZONTAL OVAL WITH THE WORD "PURE" IN LARGE LOWER CASE WHITE LETTERS CONSUMING THE GREATER PORTION OF THE UPPER QUADRANT OF THE BLACK OVAL. A RED HORIZONTAL OVAL IS SUPERIMPOSED ONTO THE LOWER QUADRANT OF THE BLACK OVAL WHICH CONTAINS THE WORDS "BODY FITNESS" IN WHITE LETTERS.

FOR EXERCISE AND FITNESS EQUIPMENT, NAMELY, MANUALLY OPERATED EXERCISE EQUIPMENT; EXERCISE MACHINES; GYMNASIUM-TYPE BODY BUILDING EXERCISE EQUIPMENT, NAMELY, WEIGHT LIFTING MACHINES, STATIONARY BIKES, WEIGHT LIFTING MACHINES, EXERCISE BENCHES AND WEIGHTS FOR USE WITH EXERCISE BENCHES, DUMBBELL SETS, FITNESS WEIGHTED BALLS, WEIGHT PLATES, NAMELY, EXERCISE WEIGHTS, BARBELLS, AND DUMBBELL HANDLES (U.S. CLS. 22, 23, 38 AND 50).

FIRST USE 11-6-2007; IN COMMERCE 6-1-2010.

**CLASS 28—(Continued).**

3,955,278. PBC INTERNATIONAL, INC., OXNARD, CA. SN 77-634,014. PUB. 8-24-2010, FILED 12-16-2008.

# BRITE SPOTS

THE MARK CONSISTS OF STANDARD CHARACTERS WITHOUT CLAIM TO ANY PARTICULAR FONT, STYLE, SIZE, OR COLOR.

FOR STUFFED AND PLUSH TOYS; STUFFED TOY ANIMALS (U.S. CLS. 22, 23, 38 AND 50).

FIRST USE 6-26-2008; IN COMMERCE 6-26-2008.

3,955,288. LITTLE KIDS, INC., SEEKONK, MA. SN 77-649,887. PUB. 8-10-2010, FILED 1-15-2009.

# Press Dough!

THE MARK CONSISTS OF STANDARD CHARACTERS WITHOUT CLAIM TO ANY PARTICULAR FONT, STYLE, SIZE, OR COLOR.

FOR TOY BAKEWARE AND COOKWARE; CHILDREN'S MULTIPLE ACTIVITY TOY SETS CONTAINING ONE OR MORE EXTRUDERS, PRESSES, TEMPLATES AND MOLDS, ALL TO EXTRUDE OR SHAPE COOKIE DOUGH, SPATULAS, ROLLING PINS, PIZZA CUTTERS AND FLOUR SHAKERS (U.S. CLS. 22, 23, 38 AND 50).

FIRST USE 9-1-2009; IN COMMERCE 9-1-2009.

3,955,336. EA INTERNATIONAL (STUDIO AND PUBLISHING) LTD., HAMILTON, BERMUDA. SN 77-737,991. PUB. 12-22-2009, FILED 5-15-2009.

# DRAGON AGE

THE MARK CONSISTS OF STANDARD CHARACTERS WITHOUT CLAIM TO ANY PARTICULAR FONT, STYLE, SIZE, OR COLOR.

OWNER OF U.S. REG. NOS. 3,298,603 AND 3,366,351.

NO CLAIM IS MADE TO THE EXCLUSIVE RIGHT TO USE "DRAGON", APART FROM THE MARK AS SHOWN.

FOR BOARD GAMES; TABLETOP GAMES (U.S. CLS. 22, 23, 38 AND 50).

FIRST USE 12-9-2009; IN COMMERCE 12-9-2009.

**CLASS 28—(Continued).**

3,955,338. RUDELL DESIGN LLC, TORRANCE, CA. SN 77-741,679. PUB. 12-22-2009, FILED 5-20-2009.

**CHINESE REVOLUTION**

THE MARK CONSISTS OF STANDARD CHARACTERS WITHOUT CLAIM TO ANY PARTICULAR FONT, STYLE, SIZE, OR COLOR.

NO CLAIM IS MADE TO THE EXCLUSIVE RIGHT TO USE "CHINESE", APART FROM THE MARK AS SHOWN.

FOR BOARD GAME WHEREIN PLAYERS MOVE GAME TOKENS ALONG A PATH ON A GAME BOARD (U.S. CLS. 22, 23, 38 AND 50).

FIRST USE 10-7-2010; IN COMMERCE 10-7-2010.

3,955,401. CLARENCE J. VENNE, LLC, BRISTOL, PA. SN 77-802,487. PUB. 6-29-2010, FILED 8-12-2009.

**DABBY**

THE MARK CONSISTS OF STANDARD CHARACTERS WITHOUT CLAIM TO ANY PARTICULAR FONT, STYLE, SIZE, OR COLOR.

FOR BINGO CARD MARKERS; AND BINGO CARD MARKERS IN THE FORM OF INK SOLD IN BOTTLES (U.S. CLS. 22, 23, 38 AND 50).

FIRST USE 3-0-2010; IN COMMERCE 3-0-2010.

3,955,427. MATTEL, INC., EL SEGUNDO, CA. SN 77-819,973. PUB. 7-13-2010, FILED 9-3-2009.

**DOUBLE DEMON DELIVERY**

THE MARK CONSISTS OF STANDARD CHARACTERS WITHOUT CLAIM TO ANY PARTICULAR FONT, STYLE, SIZE, OR COLOR.

OWNER OF U.S. REG. NO. 1,374,048.

FOR TOYS, GAMES AND PLAYTHINGS, NAMELY, TOY VEHICLES AND ACCESSORIES THEREFOR (U.S. CLS. 22, 23, 38 AND 50).

FIRST USE 2-8-2011; IN COMMERCE 2-8-2011.

**CLASS 28—(Continued).**

3,955,450. MATTEL, INC., EL SEGUNDO, CA. SN 77-832,875. PUB. 7-20-2010, FILED 9-23-2009.



NO CLAIM IS MADE TO THE EXCLUSIVE RIGHT TO USE "GAMES", APART FROM THE MARK AS SHOWN.

THE MARK CONSISTS OF A PERSON JUGGLING BLOCKS WITH THE LETTERS "G", "A", "M", "E" AND "S" STANDING OVER THE WORD "iMAGiNATION" ALL WITHIN A SEMI-CIRCLE CONNECTED TO A MISSHAPEN RECTANGLE CARRIER.

FOR TOYS, GAMES AND PLAYTHINGS, NAMELY, ACTION SKILL GAMES (U.S. CLS. 22, 23, 38 AND 50).

FIRST USE 2-16-2010; IN COMMERCE 2-16-2010.

3,955,455. MATTEL, INC., EL SEGUNDO, CA. SN 77-837,610. PUB. 8-3-2010, FILED 9-29-2009.

**PALM BEACH CORAL**

THE MARK CONSISTS OF STANDARD CHARACTERS WITHOUT CLAIM TO ANY PARTICULAR FONT, STYLE, SIZE, OR COLOR.

FOR TOYS, GAMES AND PLAYTHINGS, NAMELY, DOLLS, DOLL CLOTHING AND DOLL ACCESSORIES (U.S. CLS. 22, 23, 38 AND 50).

FIRST USE 2-8-2011; IN COMMERCE 2-8-2011.

**CLASS 28—(Continued).**

3,955,456. MATTEL, INC., EL SEGUNDO, CA. SN 77-841,282.  
PUB. 3-2-2010, FILED 10-5-2009.

**TOMB UP**

THE MARK CONSISTS OF STANDARD CHARACTERS WITHOUT CLAIM TO ANY PARTICULAR FONT, STYLE, SIZE, OR COLOR.

FOR TOYS, GAMES AND PLAYTHINGS, NAMELY, TOY VEHICLES AND ACCESSORIES THEREFOR (U.S. CLS. 22, 23, 38 AND 50).

FIRST USE 1-24-2011; IN COMMERCE 1-24-2011.

**CLASS 28—(Continued).**

3,955,670. SHURE PRODUCTS, INC., CHICAGO, IL. SN 77-930,624. PUB. 6-22-2010, FILED 2-8-2010.

**Stable Pals**

THE MARK CONSISTS OF STANDARD CHARACTERS WITHOUT CLAIM TO ANY PARTICULAR FONT, STYLE, SIZE, OR COLOR.

NO CLAIM IS MADE TO THE EXCLUSIVE RIGHT TO USE "STABLE", APART FROM THE MARK AS SHOWN.

FOR DOLLS (U.S. CLS. 22, 23, 38 AND 50).

FIRST USE 7-15-2010; IN COMMERCE 8-1-2010.

3,955,490. WATERWHEEL LICENSING LLC, LOS ANGELES, CA. SN 77-857,755. PUB. 8-10-2010, FILED 10-26-2009.

**PRINCE OF PERSIA: THE SANDS OF TIME**

THE MARK CONSISTS OF STANDARD CHARACTERS WITHOUT CLAIM TO ANY PARTICULAR FONT, STYLE, SIZE, OR COLOR.

OWNER OF U.S. REG. NOS. 1,646,934, 3,074,103, AND OTHERS.

FOR ACTION FIGURES AND ACCESSORIES THEREFOR; TOY BUILDING BLOCKS; COLLECTABLE TOY FIGURES; DOLL PLAYSETS; TOY WEAPONS (U.S. CLS. 22, 23, 38 AND 50).

FIRST USE 2-28-2010; IN COMMERCE 2-28-2010.

3,955,677. TWENTIETH CENTURY FOX FILM CORPORATION, LOS ANGELES, CA. SN 77-932,100. PUB. 6-15-2010, FILED 2-9-2010.

**PERCY JACKSON AND THE OLYMPIANS**

THE MARK CONSISTS OF STANDARD CHARACTERS WITHOUT CLAIM TO ANY PARTICULAR FONT, STYLE, SIZE, OR COLOR.

THE NAME "PERCY JACKSON" DOES NOT IDENTIFY A PARTICULAR LIVING INDIVIDUAL.

FOR TOY FIGURES; TOY ACTION FIGURES AND ACCESSORIES THEREFOR (U.S. CLS. 22, 23, 38 AND 50).

FIRST USE 1-31-2010; IN COMMERCE 1-31-2010.

3,955,650. TOYNAMI, INC, VAN NUYS, CA. SN 77-928,681. PUB. 6-22-2010, FILED 2-5-2010.

**COLD-BLOODED COLLECTIBLES**

THE MARK CONSISTS OF STANDARD CHARACTERS WITHOUT CLAIM TO ANY PARTICULAR FONT, STYLE, SIZE, OR COLOR.

NO CLAIM IS MADE TO THE EXCLUSIVE RIGHT TO USE "COLLECTIBLES", APART FROM THE MARK AS SHOWN.

FOR PLAYTHINGS, NAMELY, TOY FIGURES, MOLDDED PLASTIC TOY FIGURES, MOLDED TOY FIGURES, TOY MODEL PLASTIC FIGURINES, PLASTIC CHARACTER TOYS, TOY ACTION FIGURES (U.S. CLS. 22, 23, 38 AND 50).

FIRST USE 2-1-2010; IN COMMERCE 2-1-2010.

3,955,682. LIFELINE INTERNATIONAL, INC., MADISON, WI. SN 77-932,413. PUB. 6-29-2010, FILED 2-10-2010.

**PULLUP REVOLUTION**

THE MARK CONSISTS OF STANDARD CHARACTERS WITHOUT CLAIM TO ANY PARTICULAR FONT, STYLE, SIZE, OR COLOR.

NO CLAIM IS MADE TO THE EXCLUSIVE RIGHT TO USE "PULL UP", APART FROM THE MARK AS SHOWN.

FOR EXERCISE EQUIPMENT, NAMELY, RESISTANCE CABLES, STRETCHABLE CORDS, AND STRAPS AND BANDS FOR ATTACHMENT TO CABLES AND CORDS; EXERCISE DEVICE WITH STRAPS AND ELASTIC CABLES AND CORDS FOR ASSISTING A USER IN THE PERFORMANCE OF PULL-UPS (U.S. CLS. 22, 23, 38 AND 50).

FIRST USE 0-0-2010; IN COMMERCE 0-0-2010.

**CLASS 28—(Continued).**

3,955,692. MATTEL, INC., EL SEGUNDO, CA. SN 77-934,346.  
PUB. 7-6-2010, FILED 2-12-2010.

**BOW**

THE MARK CONSISTS OF STANDARD CHARACTERS WITHOUT CLAIM TO ANY PARTICULAR FONT, STYLE, SIZE, OR COLOR.

OWNER OF U.S. REG. NO. 3,293,977.  
FOR TOYS, GAMES AND PLAYTHINGS, NAMELY, TOY ACTION FIGURES AND ACCESSORIES THEREFOR (U.S. CLS. 22, 23, 38 AND 50).  
FIRST USE 2-15-2011; IN COMMERCE 2-15-2011.

3,955,695. SMITH, SUSAN MARIA, LONDON, ONTARIO, CANADA. SN 77-935,069. PUB. 6-29-2010, FILED 2-12-2010.

**NIGHTMARE NIBBLER**

THE MARK CONSISTS OF STANDARD CHARACTERS WITHOUT CLAIM TO ANY PARTICULAR FONT, STYLE, SIZE, OR COLOR.

FOR PLUSH TOYS (U.S. CLS. 22, 23, 38 AND 50).  
FIRST USE 9-21-2010; IN COMMERCE 1-31-2011.

3,955,709. TONY CRUZE, WILLMAR, MN. AND SHARON CURZE, WILLMAR, MN. SN 77-938,031. PUB. 7-13-2010, FILED 2-17-2010.

**FISHING JUST GOT BETTER**

THE MARK CONSISTS OF STANDARD CHARACTERS WITHOUT CLAIM TO ANY PARTICULAR FONT, STYLE, SIZE, OR COLOR.

NO CLAIM IS MADE TO THE EXCLUSIVE RIGHT TO USE "FISHING", APART FROM THE MARK AS SHOWN.  
FOR FISHING LURES; FISHING TACKLE; FISHING TACKLE CONTAINERS (U.S. CLS. 22, 23, 38 AND 50).  
FIRST USE 5-27-2010; IN COMMERCE 5-27-2010.

**CLASS 28—(Continued).**

3,955,892. KOLCRAFT ENTERPRISES, INC., CHICAGO, IL. SN 85-003,423. PUB. 8-24-2010, FILED 3-31-2010.

**WONDERBUG**

THE MARK CONSISTS OF STANDARD CHARACTERS WITHOUT CLAIM TO ANY PARTICULAR FONT, STYLE, SIZE, OR COLOR.

FOR BABY MULTIPLE ACTIVITY TOYS (U.S. CLS. 22, 23, 38 AND 50).  
FIRST USE 1-1-2011; IN COMMERCE 1-1-2011.

3,955,899. ENGINEERING FITNESS INTERNATIONAL CORP., DBA TOTAL GYM, EFI, EFI MEDICAL SYSTEMS, SAN DIEGO, CA. SN 85-005,497. PUB. 8-24-2010, FILED 4-2-2010.

**TOTAL GYM GTS**

THE MARK CONSISTS OF STANDARD CHARACTERS WITHOUT CLAIM TO ANY PARTICULAR FONT, STYLE, SIZE, OR COLOR.

OWNER OF U.S. REG. NOS. 2,174,671, 2,876,377, AND OTHERS.

NO CLAIM IS MADE TO THE EXCLUSIVE RIGHT TO USE "GYM", APART FROM THE MARK AS SHOWN.  
FOR EXERCISE MACHINES (U.S. CLS. 22, 23, 38 AND 50).

FIRST USE 10-28-2010; IN COMMERCE 10-28-2010.

3,955,900. ENGINEERING FITNESS INTERNATIONAL CORP., DBA TOTAL GYM, EFI, EFI MEDICAL SYSTEMS, SAN DIEGO, CA. SN 85-005,508. PUB. 8-24-2010, FILED 4-2-2010.

**TOTAL GYM SPORT**

THE MARK CONSISTS OF STANDARD CHARACTERS WITHOUT CLAIM TO ANY PARTICULAR FONT, STYLE, SIZE, OR COLOR.

OWNER OF U.S. REG. NOS. 2,174,671, 3,082,481, AND OTHERS.

NO CLAIM IS MADE TO THE EXCLUSIVE RIGHT TO USE "GYM" AND "SPORT", APART FROM THE MARK AS SHOWN.

FOR EXERCISE MACHINES; EXERCISE EQUIPMENT (U.S. CLS. 22, 23, 38 AND 50).  
FIRST USE 10-28-2010; IN COMMERCE 10-28-2010.

**CLASS 28—(Continued).**

3,955,906. 3BB LLC, ATLANTA, GA. SN 85-008,224. PUB. 9-28-2010, FILED 4-7-2010.

## Swing Advantage

THE MARK CONSISTS OF STANDARD CHARACTERS WITHOUT CLAIM TO ANY PARTICULAR FONT, STYLE, SIZE, OR COLOR.

NO CLAIM IS MADE TO THE EXCLUSIVE RIGHT TO USE "SWING", APART FROM THE MARK AS SHOWN.

FOR ATHLETIC EQUIPMENT, NAMELY, TRAINING DEVICES TO BE WORN ON THE BODY FOR SUPPORT; BODY-TRAINING APPARATUS; GOLF CLUB SWING AIDS, NAMELY, MECHANICAL SWING TRAINING DEVICES UTILIZING RESISTANCE TRAINING (U.S. CLS. 22, 23, 38 AND 50).

FIRST USE 2-1-2011; IN COMMERCE 2-1-2011.

3,955,925. RICHARD JOHN BUCHNER, III, SNELLVILLE, GA. SN 85-015,001. PUB. 9-21-2010, FILED 4-15-2010.

## ALBERT'S INSOMNIA

THE MARK CONSISTS OF STANDARD CHARACTERS WITHOUT CLAIM TO ANY PARTICULAR FONT, STYLE, SIZE, OR COLOR.

FOR CARD GAMES; EDUCATIONAL CARD GAMES; ELECTRONIC GAMES FOR THE TEACHING OF CHILDREN (U.S. CLS. 22, 23, 38 AND 50).

FIRST USE 10-1-2010; IN COMMERCE 10-1-2010.

3,955,964. LITE & E-Z, LLC, BYRON, GA. SN 85-029,650. PUB. 10-26-2010, FILED 5-4-2010.



NO CLAIM IS MADE TO THE EXCLUSIVE RIGHT TO USE "HUNTER.COM", APART FROM THE MARK AS SHOWN.

**CLASS 28—(Continued).**

THE MARK CONSISTS OF THE STYLIZED WORDING "THE LONE HUNTER.COM" WITH A STYLIZED SILHOUETTE INSIDE THE LETTER "O" IN "LONE" OF A HUNTER HOLDING A BOW AND CARRYING A HUNTING STAND ON HIS BACK.

FOR METAL FOLDING LADDER STAND IN THE NATURE OF A HUNTING STAND FOR ATTACHMENT TO A TREE OR OTHER UPRIGHT STRUCTURES (U.S. CLS. 22, 23, 38 AND 50).

FIRST USE 4-4-2010; IN COMMERCE 4-4-2010.

3,955,965. LITE & E-Z, LLC, BYRON, GA. SN 85-029,672. PUB. 10-26-2010, FILED 5-4-2010.

## LONE HUNTER

THE MARK CONSISTS OF STANDARD CHARACTERS WITHOUT CLAIM TO ANY PARTICULAR FONT, STYLE, SIZE, OR COLOR.

NO CLAIM IS MADE TO THE EXCLUSIVE RIGHT TO USE "HUNTER", APART FROM THE MARK AS SHOWN.

FOR METAL FOLDING LADDER STAND IN THE NATURE OF A HUNTING STAND FOR ATTACHMENT TO A TREE OR OTHER UPRIGHT STRUCTURES (U.S. CLS. 22, 23, 38 AND 50).

FIRST USE 4-4-2010; IN COMMERCE 4-4-2010.

3,955,970. SPORTS CONNECTION INTERNATIONAL LLC, MIAMI, FL. SN 85-033,682. PUB. 11-30-2010, FILED 5-8-2010.



NO CLAIM IS MADE TO THE EXCLUSIVE RIGHT TO USE "LACROSSE", APART FROM THE MARK AS SHOWN.

THE MARK CONSISTS OF THE WORDING "RIP LACROSSE" WHERE THE STYLIZED AND CONNECTED LETTERS "R", "I", AND "P" INCLUDE A BACKWARDS "R" SUCH THAT THE TOPS OF THE LETTERS CONNOTE A BASKET OR SCOOP. THE STEMS OF THE LETTERS CROSSED WITH THE CONNECTION FEATURE INDICATE A NET OR WEAVE, AND THE ENTIRE LOGO IS SLANTED FORWARD TO IMPLY RAPID MOTION. THE WORDING "LACROSSE" IS UNDERLINED.

FOR ATHLETIC PROTECTIVE PADS FOR LACROSSE; LACROSSE GLOVES; LACROSSE STICK BAGS; LACROSSE STICK HEADS; LACROSSE STICK STRINGS; LACROSSE STICKS; NETS FOR SPORTS (U.S. CLS. 22, 23, 38 AND 50).

FIRST USE 6-20-2010; IN COMMERCE 6-20-2010.

**CLASS 28—(Continued).**

3,956,015. BROWN-FORMAN CORPORATION, LOUISVILLE, KY. SN 85-058,051. PUB. 11-16-2010, FILED 6-9-2010.

**WOODFORD RESERVE**

THE MARK CONSISTS OF STANDARD CHARACTERS WITHOUT CLAIM TO ANY PARTICULAR FONT, STYLE, SIZE, OR COLOR.

OWNER OF U.S. REG. NOS. 2,078,403, 2,453,285, AND OTHERS.

FOR COPPER HOLIDAY TREE ORNAMENTS (U.S. CLS. 22, 23, 38 AND 50).

FIRST USE 10-31-2006; IN COMMERCE 10-31-2006.

3,956,035. BRANTINGHAM, DAVID E., TAIPEI, TAIWAN. SN 85-069,970. PUB. 11-16-2010, FILED 6-23-2010.

**STRAIGHT SHOT**

THE MARK CONSISTS OF STANDARD CHARACTERS WITHOUT CLAIM TO ANY PARTICULAR FONT, STYLE, SIZE, OR COLOR.

FOR GOLF CLUB SWING AIDS, NAMELY, GOLF SIMULATORS AND GOLF SWING ANALYZERS (U.S. CLS. 22, 23, 38 AND 50).

FIRST USE 3-2-2011; IN COMMERCE 3-2-2011.

3,956,063. ADAMS GOLF IP, LP., PLANO, TX. SN 85-083,220. PUB. 12-14-2010, FILED 7-13-2010.

**skyhawk**

THE MARK CONSISTS OF STANDARD CHARACTERS WITHOUT CLAIM TO ANY PARTICULAR FONT, STYLE, SIZE, OR COLOR.

FOR GOLF BAGS (U.S. CLS. 22, 23, 38 AND 50). FIRST USE 1-15-2011; IN COMMERCE 1-15-2011.

**CLASS 28—(Continued).**

3,956,064. ADAMS GOLF IP, LP, PLANO, TX. SN 85-083,230. PUB. 12-14-2010, FILED 7-13-2010.

**harrier**

THE MARK CONSISTS OF STANDARD CHARACTERS WITHOUT CLAIM TO ANY PARTICULAR FONT, STYLE, SIZE, OR COLOR.

FOR GOLF BAGS (U.S. CLS. 22, 23, 38 AND 50).

FIRST USE 1-15-2011; IN COMMERCE 1-15-2011.

**CLASS 29—MEATS AND PROCESSED FOODS**

3,955,300. RESTREPO GUTIERREZ, SANTIAGO, BOGOTÁ, COLOMBIA. SN 77-674,265. PUB. 6-16-2009, FILED 2-19-2009.

**POWER FRUITS**

THE MARK CONSISTS OF STANDARD CHARACTERS WITHOUT CLAIM TO ANY PARTICULAR FONT, STYLE, SIZE, OR COLOR.

NO CLAIM IS MADE TO THE EXCLUSIVE RIGHT TO USE "FRUITS", APART FROM THE MARK AS SHOWN.

FOR DEHYDRATED FRUIT SNACKS; DRIED FRUITS (U.S. CL. 46).

FIRST USE 12-20-2005; IN COMMERCE 12-31-2008.

3,955,394. COVEMEX CORP., FOREST VIEW, IL. SN 77-799,701. PUB. 11-9-2010, FILED 8-7-2009.

**La Alteñita**

THE COLOR(S) GREEN, WHITE, RED, BLUE, BROWN, BLACK, YELLOW AND PEACH IS/ARE CLAIMED AS A FEATURE OF THE MARK.



**CLASS 29—(Continued).**

THE MARK CONSISTS OF THE WORDING "LA ALTEÑITA" IN RED WITH BLACK OUTLINE APPEARING ABOVE THE DESIGN OF AN HISPANIC WOMAN IN PEACH, BLACK, RED, BROWN, AND YELLOW, WITH A YELLOW AND BROWN BASKET ON HER HEAD. THERE IS A GREEN, WHITE, AND RED FABRIC IN THE BASKET. THE WOMAN IS WEARING A WHITE TOP AND BLUE PANTS.

THE ENGLISH TRANSLATION OF "LA ALTEÑITA" IN THE MARK IS A YOUNG LADY FROM A REGION LOCATED IN MEXICO.

FOR CHEESE; CREAM; DAIRY PRODUCTS EXCLUDING ICE CREAM, ICE MILK AND FROZEN YOGURT; DAIRY-BASED SNACK FOODS EXCLUDING ICE CREAM, ICE MILK AND FROZEN YOGURT; EDIBLE OILS AND FATS, PRESERVES AND PICKLES; PICKLED FISH; PICKLED FRUITS; PICKLED VEGETABLES; SAUSAGES; YOGURT (U.S. CL. 46).

FIRST USE 4-23-2010; IN COMMERCE 4-23-2010.

---

3,955,464. PROMARK BRANDS INC., MERIDIAN, ID. SN 77-844,488. PUB. 2-2-2010, FILED 10-8-2009.

## ORE IDA

THE MARK CONSISTS OF STANDARD CHARACTERS WITHOUT CLAIM TO ANY PARTICULAR FONT, STYLE, SIZE, OR COLOR.

OWNER OF U.S. REG. NOS. 739,456, 2,366,711, AND OTHERS.

FOR PROCESSED POTATOES AND VEGETABLES (U.S. CL. 46).

FIRST USE 9-30-1970; IN COMMERCE 9-30-1970.

---

3,955,482. FRITO-LAY NORTH AMERICA, INC., PLANO, TX. SN 77-852,954. PUB. 3-30-2010, FILED 10-20-2009.

## A LOUDER KIND OF CRUNCH

THE MARK CONSISTS OF STANDARD CHARACTERS WITHOUT CLAIM TO ANY PARTICULAR FONT, STYLE, SIZE, OR COLOR.

FOR POTATO-BASED SNACK FOODS (U.S. CL. 46).  
FIRST USE 2-13-2010; IN COMMERCE 2-13-2010.

**CLASS 29—(Continued).**

3,955,587. NEW CENTURY SNACKS, LLC, COMMERCE, CA. SN 77-910,078. PUB. 6-1-2010, FILED 1-12-2010.

## POWER TO GO

THE MARK CONSISTS OF STANDARD CHARACTERS WITHOUT CLAIM TO ANY PARTICULAR FONT, STYLE, SIZE, OR COLOR.

FOR SNACK MIX CONSISTING PRIMARILY OF PROCESSED FRUITS, PROCESSED NUTS AND/OR RAISINS (U.S. CL. 46).

FIRST USE 11-30-2010; IN COMMERCE 11-30-2010.

---

3,955,725. STARKIST CO., PITTSBURGH, PA. SN 77-941,453. PUB. 7-20-2010, FILED 2-22-2010.

## StarKist Selects

THE MARK CONSISTS OF STANDARD CHARACTERS WITHOUT CLAIM TO ANY PARTICULAR FONT, STYLE, SIZE, OR COLOR.

OWNER OF U.S. REG. NOS. 381,518, 678,978, AND OTHERS.

NO CLAIM IS MADE TO THE EXCLUSIVE RIGHT TO USE "SELECTS", APART FROM THE MARK AS SHOWN.

FOR SEAFOOD (U.S. CL. 46).

FIRST USE 11-3-2010; IN COMMERCE 11-3-2010.

---

3,955,834. REVOLUTION FOODS, INC., OAKLAND, CA. SN 77-981,173. PUB. 2-3-2009, FILED 5-30-2008.

## REVOLUTION FOODS

THE MARK CONSISTS OF STANDARD CHARACTERS WITHOUT CLAIM TO ANY PARTICULAR FONT, STYLE, SIZE, OR COLOR.

OWNER OF U.S. REG. NO. 3,473,564.

NO CLAIM IS MADE TO THE EXCLUSIVE RIGHT TO USE "FOODS", APART FROM THE MARK AS SHOWN.

FOR DRIED FRUITS, FRUIT-BASED ORGANIC FOOD BARS, FRUIT PUREES (U.S. CL. 46).

FIRST USE 10-0-2008; IN COMMERCE 10-0-2008.

**CLASS 29—(Continued).**

3,955,859. DEAN INTELLECTUAL PROPERTY SERVICES, INC., DALLAS, TX. SN 77-981,571. PUB. 7-13-2010, FILED 3-25-2010.

**FIVE POINT PURITY CHECKLIST**

THE MARK CONSISTS OF STANDARD CHARACTERS WITHOUT CLAIM TO ANY PARTICULAR FONT, STYLE, SIZE, OR COLOR.

FOR DAIRY PRODUCTS EXCLUDING ICE CREAM, ICE MILK AND FROZEN YOGURT (U.S. CL. 46).  
FIRST USE 3-0-2010; IN COMMERCE 3-0-2010.

---

3,956,055. VITAL CHOICE SEAFOOD, INC., BELLINGHAM, WA. SN 85-080,320. PUB. 12-14-2010, FILED 7-8-2010.

**VITAL RED**

THE MARK CONSISTS OF STANDARD CHARACTERS WITHOUT CLAIM TO ANY PARTICULAR FONT, STYLE, SIZE, OR COLOR.

OWNER OF U.S. REG. NOS. 2,914,492 AND 3,169,567.  
NO CLAIM IS MADE TO THE EXCLUSIVE RIGHT TO USE "RED", APART FROM THE MARK AS SHOWN.  
FOR FISH OIL, NAMELY, KRILL OIL (U.S. CL. 46).  
FIRST USE 9-17-2010; IN COMMERCE 9-17-2010.

---

3,956,087. STEWART & BROWN, LLC, KENEDY, TX. SN 85-100,345. PUB. 1-4-2011, FILED 8-4-2010.

**ORGANIC HARVEST**

THE MARK CONSISTS OF STANDARD CHARACTERS WITHOUT CLAIM TO ANY PARTICULAR FONT, STYLE, SIZE, OR COLOR.

NO CLAIM IS MADE TO THE EXCLUSIVE RIGHT TO USE "ORGANIC", APART FROM THE MARK AS SHOWN.  
FOR FRESH AND PROCESSED ORGANIC MEAT, NAMELY, BEEF (U.S. CL. 46).  
FIRST USE 8-17-2010; IN COMMERCE 8-17-2010.

**CLASS 30—STAPLE FOODS****CLASS 30—(Continued).**

3,955,220. AMERICAN ITALIAN PASTA COMPANY, KANSAS CITY, MO. SN 77-460,883. PUB. 1-6-2009, FILED 4-29-2008.

**PASTA FOR A HEALTHY LIFESTYLE**

THE MARK CONSISTS OF STANDARD CHARACTERS WITHOUT CLAIM TO ANY PARTICULAR FONT, STYLE, SIZE, OR COLOR.

NO CLAIM IS MADE TO THE EXCLUSIVE RIGHT TO USE "PASTA", APART FROM THE MARK AS SHOWN.  
FOR PASTA (U.S. CL. 46).  
FIRST USE 7-0-2010; IN COMMERCE 7-0-2010.

---

3,955,247. ORION CORPORATION, SEOUL, REPUBLIC OF KOREA. SN 77-550,475. PUB. 7-20-2010, FILED 8-19-2008.

**DR. YOU PROJECT**

THE MARK CONSISTS OF STANDARD CHARACTERS WITHOUT CLAIM TO ANY PARTICULAR FONT, STYLE, SIZE, OR COLOR.

FOR CHOCOLATES; BISCUITS; COOKIES; CRACKERS; EDIBLE WAFERS; CORN CHIPS; BREAD; PASTRIES; CAKES; PIES; DESSERT PUDDINGS; SHERBETS; ICE CREAMS; CANDY; CARAMELS; AND CHEWING GUM, NOT FOR MEDICAL PURPOSES (U.S. CL. 46).  
FIRST USE 1-3-2008; IN COMMERCE 7-2-2008.

---

3,955,258. RECKITT BENCKISER INC., PARSIPPANY, NJ. SN 77-591,398. PUB. 3-10-2009, FILED 10-13-2008.

**I PUT THAT S\*\*\*\* ON EVERYTHING.**

THE MARK CONSISTS OF STANDARD CHARACTERS WITHOUT CLAIM TO ANY PARTICULAR FONT, STYLE, SIZE, OR COLOR.

FOR FOOD FLAVORINGS, MARINADES, SAUCES, SEASONINGS, AND SPICES FOR FOOD OR FOOD PRODUCTS; CONDIMENTS IN THE NATURE OF HOT SAUCES AND CAYENNE PEPPER SAUCES; COATINGS AND SEASONINGS FOR FOOD, NAMELY, SEASONED COATING FOR MEAT, FISH AND POULTRY (U.S. CL. 46).

FIRST USE 1-1-2009; IN COMMERCE 1-1-2009.

**CLASS 30—(Continued).**

3,955,396. FLAVOR AND FOOD INGREDIENTS, INC., DBA SUMMIT HILL FLAVORS, MIDDLESEX, NJ. SN 77-800,929. PUB. 1-5-2010, FILED 8-10-2009.

# LO-SO

THE MARK CONSISTS OF STANDARD CHARACTERS WITHOUT CLAIM TO ANY PARTICULAR FONT, STYLE, SIZE, OR COLOR.

FOR EXTRACTS USED AS FLAVORING; FLAVORING ADDITIVES FOR NON-NUTRITIONAL PURPOSES; FOOD ADDITIVES FOR NON-NUTRITIONAL PURPOSES FOR USE AS A FLAVORING; FOOD FLAVORINGS; SEASONINGS AND FLAVORINGS FOR DOG FOODS AND CATTLE FEED (U.S. CL. 46).

FIRST USE 6-1-2009; IN COMMERCE 6-1-2009.

3,955,397. FLAVOR AND FOOD INGREDIENTS, INC., DBA SUMMIT HILL FLAVORS, MIDDLESEX, NJ. SN 77-800,941. PUB. 1-5-2010, FILED 8-10-2009.

# FLAVXTRA

THE MARK CONSISTS OF STANDARD CHARACTERS WITHOUT CLAIM TO ANY PARTICULAR FONT, STYLE, SIZE, OR COLOR.

FOR EXTRACTS USED AS FLAVORING; FLAVORING ADDITIVES FOR NON-NUTRITIONAL PURPOSES; FOOD ADDITIVES FOR NON-NUTRITIONAL PURPOSES FOR USE AS A FLAVORING; FOOD FLAVORINGS; SEASONINGS AND FLAVORINGS FOR DOG FOODS AND CATTLE FEED (U.S. CL. 46).

FIRST USE 6-1-2009; IN COMMERCE 6-1-2009.

3,955,446. VANTAGE BRANDS, LLC, DALLAS, TX. SN 77-828,650. PUB. 7-27-2010, FILED 9-17-2009.



NO CLAIM IS MADE TO THE EXCLUSIVE RIGHT TO USE "GOURMET SYRUPS", APART FROM THE MARK AS SHOWN.

**CLASS 30—(Continued).**

THE MARK CONSISTS OF STYLIZED WORD "CAFELLA" IN LOWER CASE AND THE STYLIZED WORDS "GOURMET SYRUPS" APPEARING BELOW THE LETTERS "ELLA".

FOR SYRUPS FOR FLAVORING COFFEE BEVERAGES (U.S. CL. 46).

FIRST USE 12-11-2009; IN COMMERCE 12-11-2009.

3,955,447. VANTAGE BRANDS, LLC, DALLAS, TX. SN 77-828,653. PUB. 7-27-2010, FILED 9-17-2009.

# CAFELLA

THE MARK CONSISTS OF STANDARD CHARACTERS WITHOUT CLAIM TO ANY PARTICULAR FONT, STYLE, SIZE, OR COLOR.

FOR SYRUPS FOR FLAVORING COFFEE BEVERAGES (U.S. CL. 46).

FIRST USE 12-11-2009; IN COMMERCE 12-11-2009.

3,955,448. CODY KRAMER IMPORTS, LLC, ORANGEBURG, NY. SN 77-829,824. PUB. 8-10-2010, FILED 9-18-2009.

# 100% GOODNESS

THE MARK CONSISTS OF STANDARD CHARACTERS WITHOUT CLAIM TO ANY PARTICULAR FONT, STYLE, SIZE, OR COLOR.

FOR BISCUITS, COOKIES, CRACKERS AND CONFECTIONERY, NAMELY, CHOCOLATE-BASED AND SUGAR-BASED CONFECTIONERY (U.S. CL. 46).

FIRST USE 12-14-2009; IN COMMERCE 12-14-2009.

**CLASS 30—(Continued).**

3,955,449. CODY KRAMER IMPORTS, LLC, ORANGEBURG, NY. SN 77-829,833. PUB. 8-10-2010, FILED 9-18-2009.



THE MARK CONSISTS OF THE WORDS "100%" POSITIONED ABOVE THE WORD "GOODNESS", IN A STYLIZED FONT. ADDITIONALLY, A HALO DESIGN IS PLACED ABOVE THE WORDS "100% GOODNESS". THE HALO, NUMERICAL AND WORD ELEMENTS ARE CONTAINED IN RECTANGULAR CARRIER WITH AN SEMICIRCLE ON THE TOP CENTER, THE CARRIER IS OUTLINED WITH A SINGLE LINE

FOR BISCUITS, COOKIES, CRACKERS AND CONFECTIONERY, NAMELY, CHOCOLATE-BASED AND SUGAR-BASED CONFECTIONERY (U.S. CL. 46).  
FIRST USE 12-14-2009; IN COMMERCE 12-14-2009.

3,955,501. J & J PROCESSING, INC., SANTA FE SPRINGS, CA. SN 77-864,022. PUB. 4-13-2010, FILED 11-3-2009.



NO CLAIM IS MADE TO THE EXCLUSIVE RIGHT TO USE "KITCHEN", APART FROM THE MARK AS SHOWN.

THE MARK CONSISTS OF THE WORDS "AUNT CYNDI'S" INSIDE A BANNER SUPERIMPOSED OVER THE WORD "KITCHEN" INSIDE A BANNER.

FOR MIXES FOR BAKERY GOODS (U.S. CL. 46).  
FIRST USE 1-5-2011; IN COMMERCE 1-5-2011.

**CLASS 30—(Continued).**

3,955,530. RICH PRODUCTS CORPORATION, BUFFALO, NY. SN 77-877,817. PUB. 9-28-2010, FILED 11-20-2009.

**COOKIE CRUNCH**

THE MARK CONSISTS OF STANDARD CHARACTERS WITHOUT CLAIM TO ANY PARTICULAR FONT, STYLE, SIZE, OR COLOR.

NO CLAIM IS MADE TO THE EXCLUSIVE RIGHT TO USE "COOKIE", APART FROM THE MARK AS SHOWN.

FOR NON-DAIRY WHIPPED ICINGS AND FROSTINGS (U.S. CL. 46).

FIRST USE 1-29-2010; IN COMMERCE 1-29-2010.

3,955,743. HAN, GINA, BEVERLY HILLS, CA. SN 77-944,899. PUB. 7-20-2010, FILED 2-25-2010.

**Madame Woo of Beverly Hills**

THE MARK CONSISTS OF STANDARD CHARACTERS WITHOUT CLAIM TO ANY PARTICULAR FONT, STYLE, SIZE, OR COLOR.

NO CLAIM IS MADE TO THE EXCLUSIVE RIGHT TO USE "BEVERLY HILLS", APART FROM THE MARK AS SHOWN.

"MADAM WOO" DOES NOT IDENTIFY A LIVING INDIVIDUAL.

FOR PACKAGED FOODS, NAMELY, BBQ SAUCE, DIPPING SAUCES, AND SALAD DRESSING (U.S. CL. 46).

FIRST USE 11-25-2010; IN COMMERCE 11-25-2010.

3,955,767. KRAFT FOODS GLOBAL BRANDS LLC, NORTHFIELD, IL. SN 77-949,295. PUB. 6-22-2010, FILED 3-3-2010.



OWNER OF U.S. REG. NOS. 93,009, 1,928,734, AND OTHERS.

THE COLOR(S) BLUE AND WHITE IS/ARE CLAIMED AS A FEATURE OF THE MARK.

THE MARK CONSISTS OF THE WORD "OREO" WRITTEN ON A SLIGHT DIAGONAL WITH THE FIRST LETTER BEING ON THE LOWER LEFT AND THE LAST LETTER BEING ON THE UPPER RIGHT. THE LETTERS ARE WHITE AND ARE WRITTEN ON A BLUE BACKGROUND.

FOR BAKERY GOODS; BISCUITS; COOKIES (U.S. CL. 46).

FIRST USE 5-0-2002; IN COMMERCE 5-0-2002.

**CLASS 30—(Continued).**

3,955,798. BUSH FOODS OVERSEAS PRIVATE LIMITED, NEW DELHI, INDIA. SN 77-958,306. PUB. 8-3-2010, FILED 3-13-2010.

# SONARGAON

THE MARK CONSISTS OF STANDARD CHARACTERS WITHOUT CLAIM TO ANY PARTICULAR FONT, STYLE, SIZE, OR COLOR.

FOR RICE (U.S. CL. 46).  
FIRST USE 7-27-2010; IN COMMERCE 7-27-2010.

3,955,835. REVOLUTION FOODS, INC., OAKLAND, CA. SN 77-981,174. PUB. 3-24-2009, FILED 5-30-2008.

# REVOLUTION FOODS

THE MARK CONSISTS OF STANDARD CHARACTERS WITHOUT CLAIM TO ANY PARTICULAR FONT, STYLE, SIZE, OR COLOR.

OWNER OF U.S. REG. NO. 3,473,564.  
NO CLAIM IS MADE TO THE EXCLUSIVE RIGHT TO USE "FOODS", APART FROM THE MARK AS SHOWN.  
FOR GRAIN-BASED FOOD BARS CONTAINING FRUITS (U.S. CL. 46).  
FIRST USE 10-0-2008; IN COMMERCE 10-0-2008.

3,955,852. E S ROBBINS CORPORATION, MUSCLE SHOALS, AL. SN 77-981,516. PUB. 7-20-2010, FILED 2-25-2010.



OWNER OF U.S. REG. NO. 3,777,831.  
NO CLAIM IS MADE TO THE EXCLUSIVE RIGHT TO USE "GRILL & FISH MARKET", APART FROM THE MARK AS SHOWN.  
THE NAME IN THE MARK DOES NOT REFER TO ANY PARTICULAR LIVING INDIVIDUAL.

**CLASS 30—(Continued).**

THE MARK CONSISTS OF THE RIGHT SIDE VIEW OF A CROCODILE HEAD ENCIRCLED BY A DOUBLE RING CONTAINING "CROCODILE ED'S" ABOVE THE CROCODILE HEAD AND "GRILL & FISH MARKET" BELOW THE CROCODILE HEAD.

FOR COFFEE; COFFEE BEANS; CONDIMENT, NAMELY, PEPPER SAUCE; DRY SPICE RUB FOR MEATS AND FISH; EDIBLE SPICES; GROUND COFFEE BEANS; PEPPER SPICE; ROASTED COFFEE BEANS; SALAD DRESSINGS; SPICE BLENDS; SPICE RUBS; SPICES (U.S. CL. 46).

FIRST USE 10-30-2010; IN COMMERCE 10-30-2010.

3,955,913. THE ITALIAN COOKIE JAR, INC., DBA ICJ COOKIES, SYRACUSE, NY. SN 85-010,490. PUB. 9-7-2010, FILED 4-9-2010.

# ICJ Cookies

THE MARK CONSISTS OF STANDARD CHARACTERS WITHOUT CLAIM TO ANY PARTICULAR FONT, STYLE, SIZE, OR COLOR.

NO CLAIM IS MADE TO THE EXCLUSIVE RIGHT TO USE "COOKIES", APART FROM THE MARK AS SHOWN.  
FOR COOKIE DOUGH; COOKIE MIXES; COOKIES; COOKIES AND CRACKERS; FOOD PACKAGE COMBINATIONS CONSISTING PRIMARILY OF BREAD, CRACKERS AND/OR COOKIES; FRIED DOUGH COOKIES (KARINTOH); FROZEN COOKIE DOUGH; VEGAN COOKIES (U.S. CL. 46).  
FIRST USE 8-1-2010; IN COMMERCE 8-1-2010.

3,955,914. THE ITALIAN COOKIE JAR, INC., DBA ICJ COOKIES, SYRACUSE, NY. SN 85-010,521. PUB. 9-7-2010, FILED 4-9-2010.

## Let Us Fill Your Cookie Jar

THE MARK CONSISTS OF STANDARD CHARACTERS WITHOUT CLAIM TO ANY PARTICULAR FONT, STYLE, SIZE, OR COLOR.

FOR COOKIE DOUGH; COOKIE MIXES; COOKIES; COOKIES AND CRACKERS; FOOD PACKAGE COMBINATIONS CONSISTING PRIMARILY OF BREAD, CRACKERS AND/OR COOKIES; FRIED DOUGH COOKIES (KARINTOH); FROZEN COOKIE DOUGH; VEGAN COOKIES (U.S. CL. 46).  
FIRST USE 7-1-2010; IN COMMERCE 7-1-2010.

**CLASS 30—(Continued).**

3,955,934. PRO JOE, INC, GREENVILLE, WI. SN 85-017,561.  
PUB. 10-12-2010, FILED 4-19-2010.

## Pro Joe

THE MARK CONSISTS OF STANDARD CHARACTERS WITHOUT CLAIM TO ANY PARTICULAR FONT, STYLE, SIZE, OR COLOR.

NO CLAIM IS MADE TO THE EXCLUSIVE RIGHT TO USE "JOE", APART FROM THE MARK AS SHOWN.

FOR PREPARED COFFEE AND COFFEE-BASED BEVERAGES (U.S. CL. 46).

FIRST USE 1-1-2011; IN COMMERCE 1-1-2011.

3,955,959. MIKE DEAMICIS-ROBERTS, HOLLISTER, CA. SN 85-028,100. PUB. 10-5-2010, FILED 5-1-2010.

## STONER FOOD

THE MARK CONSISTS OF STANDARD CHARACTERS WITHOUT CLAIM TO ANY PARTICULAR FONT, STYLE, SIZE, OR COLOR.

NO CLAIM IS MADE TO THE EXCLUSIVE RIGHT TO USE "FOOD", APART FROM THE MARK AS SHOWN.

FOR CANDY; COFFEE AND TEA (U.S. CL. 46).

FIRST USE 1-21-2011; IN COMMERCE 1-21-2011.

3,956,008. CONTINENTAL MILLS, INC., SEATTLE, WA. SN 85-054,407. PUB. 10-26-2010, FILED 6-3-2010.

## EAGLE MILLS

THE MARK CONSISTS OF STANDARD CHARACTERS WITHOUT CLAIM TO ANY PARTICULAR FONT, STYLE, SIZE, OR COLOR.

OWNER OF U.S. REG. NO. 2,014,163.

FOR PANCAKE AND WAFFLE MIXES (U.S. CL. 46).

FIRST USE 1-10-2011; IN COMMERCE 1-10-2011.

**CLASS 30—(Continued).**

3,956,024. R.A.B. FOOD GROUP, LLC, SECAUCUS, NJ. SN 85-060,528. PUB. 11-9-2010, FILED 6-11-2010.

## TAM TAMS

THE MARK CONSISTS OF STANDARD CHARACTERS WITHOUT CLAIM TO ANY PARTICULAR FONT, STYLE, SIZE, OR COLOR.

OWNER OF U.S. REG. NO. 394,250.

FOR CRACKERS (U.S. CL. 46).

FIRST USE 10-1-2010; IN COMMERCE 10-1-2010.

3,956,033. CORPORATIVO INTERNACIONAL MEXICANO, S. DE R.L. DE C.V., MEXICO CITY, MEXICO. SN 85-067,683. PUB. 11-16-2010, FILED 6-21-2010.



THE MARK CONSISTS OF THE WORD "GIRO" IN A STYLIZED FORMAT AND THE LETTER "O" HAVING A SWIRL DESIGN.

THE ENGLISH TRANSLATION OF THE WORD "GIRO" IN THE MARK IS TURN.

FOR COOKIES (U.S. CL. 46).

FIRST USE 11-30-2010; IN COMMERCE 11-30-2010.

**CLASS 31—NATURAL AGRICULTURAL PRODUCTS**

3,955,276. JIFFY PRODUCTS OF AMERICA, INC., NORWALK, OH. SN 77-633,163. PUB. 4-21-2009, FILED 12-15-2008.



THE MARK CONSISTS OF A CIRCULAR SHAPE CONTAINING A LEAF DESIGN IN THE COLOR WHITE WITH A SHADED BACKGROUND.

FOR GIFT BOXES CONTAINING SEEDS, NAMELY, FLOWER, VEGETABLE AND HERBS (U.S. CLS. 1 AND 46).

FIRST USE 8-1-2009; IN COMMERCE 8-1-2009.

**CLASS 31—(Continued).**

3,955,328. SEASONS PET FOOD CO., INC., NORCO, CA. SN 77-724,952. PUB. 10-13-2009, FILED 4-29-2009.

SEASONS CHANGE - SO SHOULD  
YOUR PET'S FOOD

THE MARK CONSISTS OF STANDARD CHARACTERS WITHOUT CLAIM TO ANY PARTICULAR FONT, STYLE, SIZE, OR COLOR.

OWNER OF U.S. REG. NO. 2,633,044.  
FOR PET FOOD (U.S. CLS. 1 AND 46).  
FIRST USE 9-23-2010; IN COMMERCE 9-23-2010.

---

3,955,533. ISADORO SEED INC., EAGAN, MN. SN 77-878,867.  
PUB. 9-21-2010, FILED 11-23-2009.

CROIXDALE FARMS

THE MARK CONSISTS OF STANDARD CHARACTERS WITHOUT CLAIM TO ANY PARTICULAR FONT, STYLE, SIZE, OR COLOR.

FOR ANIMAL FEED; BIRD FEED (U.S. CLS. 1 AND 46).  
FIRST USE 9-15-2010; IN COMMERCE 9-15-2010.

---

3,955,578. GLOBAL FRESH, LLC, SAN ANTONIO, TX. SN 77-905,018. PUB. 7-13-2010, FILED 1-5-2010.

GREEN LITE FARMS

THE MARK CONSISTS OF STANDARD CHARACTERS WITHOUT CLAIM TO ANY PARTICULAR FONT, STYLE, SIZE, OR COLOR.

NO CLAIM IS MADE TO THE EXCLUSIVE RIGHT TO USE "GREEN" AND "FARMS", APART FROM THE MARK AS SHOWN.

FOR FRESH FRUITS AND VEGETABLES (U.S. CLS. 1 AND 46).  
FIRST USE 6-0-2010; IN COMMERCE 6-0-2010.

**CLASS 31—(Continued).**

3,955,699. CYNTHIA SUKUT, DBA AZARIAH ACRES AVONS, NORTH BEND, NE. AND KELVIN SUKUT, DBA AZARIAH ACRES AVONS, NORTH BEND, NE. SN 77-935,848. PUB. 7-13-2010, FILED 2-15-2010.



NO CLAIM IS MADE TO THE EXCLUSIVE RIGHT TO USE "AVON TERRIERS", APART FROM THE MARK AS SHOWN.

THE MARK CONSISTS OF THE STYLIZED OUTLINE OF A TERRIER, THE WORDING "AVON TERRIERS", AND THE LETTERS "A" AND "T" INTERTWINED IN A PINE TREE SHAPED DESIGN WITH A CROSS.

FOR DOGS, NAMELY, TERRIERS (U.S. CLS. 1 AND 46).

FIRST USE 4-15-2010; IN COMMERCE 5-26-2010.

---

3,955,819. SOCIETE DES PRODUITS NESTLE S.A., VEVEY, SWITZERLAND. SN 77-964,584. PUB. 8-10-2010, FILED 3-22-2010.

TASTY TREASURES

THE MARK CONSISTS OF STANDARD CHARACTERS WITHOUT CLAIM TO ANY PARTICULAR FONT, STYLE, SIZE, OR COLOR.

FOR PET FOOD (U.S. CLS. 1 AND 46).  
FIRST USE 1-25-2011; IN COMMERCE 1-25-2011.

**CLASS 31—(Continued).**

3,955,821. FRUTOS DE HUERTA REAL S.P.R. DE R.L., PUEBLA, MEXICO. SN 77-964,714. PUB. 8-10-2010, FILED 3-22-2010.

# TOMEIKO

THE MARK CONSISTS OF STANDARD CHARACTERS WITHOUT CLAIM TO ANY PARTICULAR FONT, STYLE, SIZE, OR COLOR.

FOR FRESH TOMATOES; RAW TOMATOES; UNPROCESSED TOMATOES (U.S. CLS. 1 AND 46).  
FIRST USE 2-11-2011; IN COMMERCE 2-11-2011.

---

3,955,916. SPECTRUM PET CARE, INC., MONTGOMERY CITY, MO. SN 85-011,539. PUB. 8-31-2010, FILED 4-12-2010.

# NIPS FOR CATS

THE MARK CONSISTS OF STANDARD CHARACTERS WITHOUT CLAIM TO ANY PARTICULAR FONT, STYLE, SIZE, OR COLOR.

NO CLAIM IS MADE TO THE EXCLUSIVE RIGHT TO USE "FOR CATS", APART FROM THE MARK AS SHOWN. FOR CAT TREATS (U.S. CLS. 1 AND 46).  
FIRST USE 1-1-2011; IN COMMERCE 1-1-2011.

---

3,955,917. SPECTRUM PET CARE, INC., MONTGOMERY CITY, MO. SN 85-011,693. PUB. 8-31-2010, FILED 4-12-2010.

# NIPS FOR DOGS

THE MARK CONSISTS OF STANDARD CHARACTERS WITHOUT CLAIM TO ANY PARTICULAR FONT, STYLE, SIZE, OR COLOR.

NO CLAIM IS MADE TO THE EXCLUSIVE RIGHT TO USE "FOR DOGS", APART FROM THE MARK AS SHOWN. FOR DOG TREATS (U.S. CLS. 1 AND 46).  
FIRST USE 1-1-2011; IN COMMERCE 1-1-2011.

---

**CLASS 32—LIGHT BEVERAGES**
**CLASS 32—(Continued).**

3,955,231. LIVSMART BRANDS, PANAMA, PANAMA. SN 77-506,066. PUB. 11-23-2010, FILED 6-24-2008.



THE COLOR(S) GREEN, BLUE, ORANGE AND YELLOW IS/ARE CLAIMED AS A FEATURE OF THE MARK.

THE MARK CONSISTS OF THE WORD "LIVSMART" IN STYLIZED LOWER CASE LETTERS, THE LETTERS "LIV" APPEARING IN COLOR GREEN AND THE LETTERS "SMART" APPEARING IN COLOR BLUE. TO THE LEFT OF THE LETTER "L" THERE IS A FIGURATIVE DESIGN OF A PERSON WITH HIS ARMS OPEN. THE HEAD, THE RIGHT ARM AND THE CHEST APPEAR IN COLOR BLUE WHEREAS THE LEFT ARM APPEARS IN COLOR GREEN. THERE IS A LEAF ABOVE THE LETTER "I". BELOW THE LETTER "M" THERE IS A CURVED LINE CONTAINING FOUR COLORS. THE FIRST QUARTER IS YELLOW, THE SECOND IS ORANGE, THE THIRD IS GREEN AND THE FOURTH IS BLUE.

FOR AERATED WATER; BEER; CONCENTRATES, SYRUPS OR POWDERS USED IN THE PREPARATION OF SOFT DRINKS; FRUIT DRINKS AND JUICES; MINERAL AND CARBONATED WATERS; NON-ALCOHOLIC BEVERAGES CONTAINING FRUIT JUICES; NON-ALCOHOLIC FRUIT JUICE BEVERAGES; SYRUPS FOR MAKING BEVERAGES (U.S. CLS. 45, 46 AND 48).  
FIRST USE 3-31-2008; IN COMMERCE 6-30-2009.

---

3,955,417. THE COCA-COLA COMPANY, ATLANTA, GA. SN 77-816,268. PUB. 6-15-2010, FILED 8-31-2009.

# NO-CHOKE MIXTURE

THE MARK CONSISTS OF STANDARD CHARACTERS WITHOUT CLAIM TO ANY PARTICULAR FONT, STYLE, SIZE, OR COLOR.

NO CLAIM IS MADE TO THE EXCLUSIVE RIGHT TO USE "MIXTURE", APART FROM THE MARK AS SHOWN. FOR ENERGY DRINKS (U.S. CLS. 45, 46 AND 48).  
FIRST USE 11-1-2009; IN COMMERCE 11-1-2009.



**CLASS 32—(Continued).**

3,955,472. SUPER BAKERY, INCORPORATED, PITTSBURGH, PA. SN 77-847,606. PUB. 9-14-2010, FILED 10-13-2009.

**CAROLINA ADE**

THE MARK CONSISTS OF STANDARD CHARACTERS WITHOUT CLAIM TO ANY PARTICULAR FONT, STYLE, SIZE, OR COLOR.

FOR SPORTS DRINKS AND PERFORMANCE DRINKS IN THE NATURE OF FRUIT DRINKS (U.S. CLS. 45, 46 AND 48).

FIRST USE 12-3-2010; IN COMMERCE 12-3-2010.

---

3,955,473. SUPER BAKERY, INCORPORATED, PITTSBURGH, PA. SN 77-847,617. PUB. 9-14-2010, FILED 10-13-2009.

**MICHIGANA ADE**

THE MARK CONSISTS OF STANDARD CHARACTERS WITHOUT CLAIM TO ANY PARTICULAR FONT, STYLE, SIZE, OR COLOR.

FOR SPORTS DRINKS AND PERFORMANCE DRINKS IN THE NATURE OF FRUIT DRINKS (U.S. CLS. 45, 46 AND 48).

FIRST USE 12-3-2010; IN COMMERCE 12-3-2010.

---

3,955,535. SUPER BAKERY INC., PITTSBURGH, PA. SN 77-879,901. PUB. 4-13-2010, FILED 11-24-2009.

**HoustonAde**

THE MARK CONSISTS OF STANDARD CHARACTERS WITHOUT CLAIM TO ANY PARTICULAR FONT, STYLE, SIZE, OR COLOR.

FOR FRUIT DRINKS; SPORTS DRINKS (U.S. CLS. 45, 46 AND 48).

FIRST USE 12-3-2010; IN COMMERCE 12-3-2010.

**CLASS 32—(Continued).**

3,955,580. MAAYAN LLC, IRVINE, CA. SN 77-906,871. PUB. 5-18-2010, FILED 1-7-2010.

**ME Confidence Water**

THE MARK CONSISTS OF STANDARD CHARACTERS WITHOUT CLAIM TO ANY PARTICULAR FONT, STYLE, SIZE, OR COLOR.

NO CLAIM IS MADE TO THE EXCLUSIVE RIGHT TO USE "WATER", APART FROM THE MARK AS SHOWN.

FOR NON-ALCOHOLIC BEVERAGES, NAMELY, FLAVORED WATER, DRINKING WATER, VEGETABLE JUICE AND FRUIT JUICE, ALL CONTAINING FLOWER ESSENCES (U.S. CLS. 45, 46 AND 48).

FIRST USE 1-10-2010; IN COMMERCE 6-1-2010.

---

3,955,799. LOHRING, CHRISTOPHER, SALEM, MA. SN 77-958,348. PUB. 8-3-2010, FILED 3-13-2010.

**Notch**

THE MARK CONSISTS OF STANDARD CHARACTERS WITHOUT CLAIM TO ANY PARTICULAR FONT, STYLE, SIZE, OR COLOR.

FOR BEER, ALE, LAGER, STOUT AND PORTER; DE-ALCOHOLISED BEER (U.S. CLS. 45, 46 AND 48).

FIRST USE 5-1-2010; IN COMMERCE 5-1-2010.

**CLASS 32—(Continued).**

3,955,948. GRUPO OMNILIFE, S.A. DE C.V., DBA GOM940311LF7, GUADALAJARA, JALISCO, MEXICO. SN 85-022,861. PUB. 10-12-2010, FILED 4-26-2010.



THE MARK CONSISTS OF A CAPITAL LETTER "E" IN STYLIZED FONT, WITH THE LOWER PORTION OF THE LETTER INCORPORATING A DESIGN RESEMBLING LIQUID.

FOR COLAS; ENERGY DRINKS; FRUIT FLAVORED DRINKS; FRUIT-FLAVORED BEVERAGES; ISOTONIC BEVERAGES; NON-ALCOHOLIC BEVERAGES, NAMELY, CARBONATED BEVERAGES; PREPARATIONS FOR MAKING BEVERAGES, NAMELY, FRUIT-FLAVORED BEVERAGES, ISOTONIC DRINKS, ENERGY DRINKS AND OTHER NON-ALCOHOLIC BEVERAGES, NAMELY, HYPOTONIC SPORT DRINKS AND HYPOTONIC SPORT BEVERAGES (U.S. CLS. 45, 46 AND 48).

FIRST USE 3-1-2010; IN COMMERCE 10-21-2010.

**CLASS 33—WINES AND SPIRITS**

3,955,158. ARKENSTONE VINEYARDS, LLC, ST. HELENA, CA. SN 76-679,444. PUB. 12-25-2007, FILED 7-12-2007.

**PETROGLYPH**

THE MARK CONSISTS OF STANDARD CHARACTERS WITHOUT CLAIM TO ANY PARTICULAR FONT, STYLE, SIZE, OR COLOR.

FOR WINE (U.S. CLS. 47 AND 49).  
FIRST USE 3-1-2011; IN COMMERCE 3-1-2011.

**CLASS 33—(Continued).**

3,955,184. COURVOISIER S.A.S., JARNAC, FRANCE. SN 77-120,990. PUB. 1-26-2010, FILED 3-2-2007.

**COURVOISIER EXCLUSIF**

THE MARK CONSISTS OF STANDARD CHARACTERS WITHOUT CLAIM TO ANY PARTICULAR FONT, STYLE, SIZE, OR COLOR.

OWNER OF U.S. REG. NOS. 311,352 AND 656,570.

NO CLAIM IS MADE TO THE EXCLUSIVE RIGHT TO USE "EXCLUSIF", APART FROM THE MARK AS SHOWN.

THE ENGLISH TRANSLATION OF THE WORD "EXCLUSIF" IS "EXCLUSIVE".

FOR ALCOHOLIC BEVERAGES, NAMELY, COGNAC (U.S. CLS. 47 AND 49).

FIRST USE 7-27-2007; IN COMMERCE 7-27-2007.

3,955,274. MUSH, INC., DBA IGLOO'S FROZEN DRINKS, FT. WORTH, TX. SN 77-629,561. PUB. 4-14-2009, FILED 12-9-2008.

**ISLE HAVARITA**

THE MARK CONSISTS OF STANDARD CHARACTERS WITHOUT CLAIM TO ANY PARTICULAR FONT, STYLE, SIZE, OR COLOR.

FOR FROZEN ALCOHOLIC BEVERAGES, NAMELY, PREPARED COCKTAILS; NON-ALCOHOLIC COCKTAIL MIX; NON-ALCOHOLIC MIX INTENDED FOR MIXING WITH ALCOHOL TO MAKE A FROZEN COCKTAIL (U.S. CLS. 47 AND 49).

FIRST USE 8-12-2010; IN COMMERCE 8-12-2010.

**CLASS 33—(Continued).**

3,955,277. SCHERRER, FREDERICK WILLIAM, APTOS, CA. SN 77-633,440. PUB. 4-14-2009, FILED 12-15-2008.

**Frederick William**

THE MARK CONSISTS OF STANDARD CHARACTERS WITHOUT CLAIM TO ANY PARTICULAR FONT, STYLE, SIZE, OR COLOR.

FOR APERITIF WINES; APERITIFS WITH A WINE BASE; COOKING WINE; FRUIT WINE; SPARKLING FRUIT WINE; GRAPE WINE; SPARKLING GRAPE WINE; HONEY WINE; KITS FOR MAKING WINE; SPARKLING WINES; NATURAL SPARKLING WINES; PORT WINES; PREPARED WINE COCKTAILS; RED WINES; STRAWBERRY WINE; SWEET WINES; TABLE WINES; TONIC SWEET GRAPE WINE CONTAINING EXTRACTS FROM GINSENG AND CONCHONA BARK (NINJIN-KINATETSU WINE); WHITE WINE; WINE COOLERS; WINE PUNCHES; WINES; FORTIFIED WINES; LIQUEURS (U.S. CLS. 47 AND 49).

FIRST USE 2-11-2011; IN COMMERCE 2-11-2011.

3,955,383. SOCETA' AGRICOLA DEGLI DEI S.R.L., GREVE IN CHIANTI (FI), ITALY. SN 77-790,555. PUB. 6-22-2010, FILED 7-27-2009.

**DEGLI DEI**

THE MARK CONSISTS OF STANDARD CHARACTERS WITHOUT CLAIM TO ANY PARTICULAR FONT, STYLE, SIZE, OR COLOR.

PRIORITY CLAIMED UNDER SEC. 44(D) ON ITALY APPLICATION NO. MI2009C00092, FILED 1-30-2009, REG. NO. 0001221988, DATED 10-16-2009, EXPIRES 10-16-2019.

THE ENGLISH TRANSLATION OF "DEGLI DEI" IS OF THE GODS.

FOR WINE (U.S. CLS. 47 AND 49).  
FIRST USE 9-0-2008; IN COMMERCE 7-0-2010.

3,955,470. F L NAVARRO LTD, DBA THE ARTISAN COLLECTION, BROOKLYN, NY. SN 77-846,164. PUB. 3-9-2010, FILED 10-11-2009.

**LOLITA**

THE MARK CONSISTS OF STANDARD CHARACTERS WITHOUT CLAIM TO ANY PARTICULAR FONT, STYLE, SIZE, OR COLOR.

FOR WINE (U.S. CLS. 47 AND 49).  
FIRST USE 11-9-2009; IN COMMERCE 11-9-2009.

**CLASS 33—(Continued).**

3,955,565. DESTILERIA LEYROS SA DE CV, TEQUILA, MEXICO. SN 77-897,683. PUB. 9-28-2010, FILED 12-20-2009.

**Los Azules**

THE MARK CONSISTS OF STANDARD CHARACTERS WITHOUT CLAIM TO ANY PARTICULAR FONT, STYLE, SIZE, OR COLOR.

THE ENGLISH TRANSLATION OF "LOS AZULES" IN THE MARK IS "THE BLUES".

FOR DISTILLED LIQUOR CONTAINING AGAVE (U.S. CLS. 47 AND 49).

FIRST USE 3-1-2011; IN COMMERCE 3-1-2011.

3,955,585. DREAM WELL WINES, INC., BROOKLYN, NY. SN 77-907,715. PUB. 6-8-2010, FILED 1-8-2010.

**PASSA TEMPO**

THE MARK CONSISTS OF STANDARD CHARACTERS WITHOUT CLAIM TO ANY PARTICULAR FONT, STYLE, SIZE, OR COLOR.

THE ENGLISH TRANSLATION OF "PASSA TEMPO" IN THE MARK IS "PLEASANT TIMES".

FOR WINE (U.S. CLS. 47 AND 49).

FIRST USE 3-1-2010; IN COMMERCE 1-15-2011.

3,955,590. BROWN-FORMAN CORPORATION, LOUISVILLE, KY. SN 77-910,940. PUB. 5-18-2010, FILED 1-13-2010.

**RAISE THE BAR ON HOME ENTERTAINMENT**

THE MARK CONSISTS OF STANDARD CHARACTERS WITHOUT CLAIM TO ANY PARTICULAR FONT, STYLE, SIZE, OR COLOR.

FOR DISTILLED SPIRITS (U.S. CLS. 47 AND 49).  
FIRST USE 2-1-2010; IN COMMERCE 2-1-2010.

**CLASS 33—(Continued).**

3,955,603. KAHUNAVILLE INTERNATIONAL LICENSING LLC, WILMINGTON, DE. SN 77-915,541. PUB. 6-1-2010, FILED 1-20-2010.

**KAHUNAVILLE PARTY RUM**

THE MARK CONSISTS OF STANDARD CHARACTERS WITHOUT CLAIM TO ANY PARTICULAR FONT, STYLE, SIZE, OR COLOR.

OWNER OF U.S. REG. NO. 2,158,165.

NO CLAIM IS MADE TO THE EXCLUSIVE RIGHT TO USE "RUM", APART FROM THE MARK AS SHOWN.

FOR LIQUOR (U.S. CLS. 47 AND 49).

FIRST USE 2-25-2011; IN COMMERCE 2-25-2011.

3,955,604. KAHUNAVILLE INTERNATIONAL LICENSING LLC, WILMINGTON, DE. SN 77-915,550. PUB. 6-1-2010, FILED 1-20-2010.

**KAHUNAVILLE**

THE MARK CONSISTS OF STANDARD CHARACTERS WITHOUT CLAIM TO ANY PARTICULAR FONT, STYLE, SIZE, OR COLOR.

OWNER OF U.S. REG. NO. 2,158,165.

FOR LIQUOR (U.S. CLS. 47 AND 49).

FIRST USE 2-25-2011; IN COMMERCE 2-25-2011.

3,955,660. WILLIAM ALLEN WOOTEN, COVINGTON, TN. SN 77-929,753. PUB. 6-22-2010, FILED 2-6-2010.

**Dragon Kiss**

THE MARK CONSISTS OF STANDARD CHARACTERS WITHOUT CLAIM TO ANY PARTICULAR FONT, STYLE, SIZE, OR COLOR.

FOR ALCOHOLIC BEVERAGES CONTAINING FRUIT; CREAM LIQUEURS; DISTILLED SPIRITS; SPIRITS AND LIQUEURS; WINES AND LIQUEURS (U.S. CLS. 47 AND 49).

FIRST USE 11-3-2008; IN COMMERCE 10-21-2010.

**CLASS 33—(Continued).**

3,955,714. MOËT HENNESSY USA, INC., NEW YORK, NY. SN 77-939,072. PUB. 7-13-2010, FILED 2-18-2010.



OWNER OF U.S. REG. NOS. 854,800, 2,124,249, AND OTHERS.

THE MARK CONSISTS OF A LABEL DESIGN WITH THE WORDS "MOËT & CHANDON ICE IMPÉRIAL" IN THE CENTER. ABOVE THE WORDS "MOËT & CHANDON ICE IMPÉRIAL" IS A CROWN DESIGN, AND UNDERNEATH THE WORDS IS A STAR. THERE IS A THIN BAND AT THE TOP OF THE LABEL, AND THERE IS A THICK BAND AT THE BOTTOM OF THE LABEL. THE GRAY TONES ARE INTENDED FOR SHADING PURPOSES ONLY.

FOR SPARKLING WINES, CHAMPAGNE WINES (U.S. CLS. 47 AND 49).

FIRST USE 5-1-2010; IN COMMERCE 5-1-2010.

3,955,741. DESTILADORA SAN NICOLAS, S.A. DE C.V., ARANDAS, JALISCO, MEXICO. SN 77-944,654. PUB. 7-27-2010, FILED 2-25-2010.

**ESPOLON**

THE MARK CONSISTS OF STANDARD CHARACTERS WITHOUT CLAIM TO ANY PARTICULAR FONT, STYLE, SIZE, OR COLOR.

OWNER OF MEXICO REG. NO. 980774, DATED 4-19-2007, EXPIRES 3-1-2017.

OWNER OF U.S. REG. NO. 2,513,724.

THE ENGLISH TRANSLATION OF "ESPOLON" IN THE MARK IS "SPUR".

FOR ALCOHOLIC BEVERAGES EXCEPT BEERS (U.S. CLS. 47 AND 49).

FIRST USE 4-23-2010; IN COMMERCE 4-28-2010.

**CLASS 33—(Continued).**

3,955,764. FERRI, CHARLES, NEW YORK, NY. SN 77-949,038. PUB. 1-4-2011, FILED 3-3-2010.

**STAR BY CHARLES FERRI**

THE MARK CONSISTS OF STANDARD CHARACTERS WITHOUT CLAIM TO ANY PARTICULAR FONT, STYLE, SIZE, OR COLOR.

THE NAME "CHARLES FERRI" IDENTIFIES A LIVING INDIVIDUAL WHOSE CONSENT IS OF RECORD.

FOR ALCOHOLIC BEVERAGES, NAMELY, DISTILLED SPIRITS (U.S. CLS. 47 AND 49).

FIRST USE 8-31-2010; IN COMMERCE 8-31-2010.

3,955,874. MURILLO, ADOLFO, OXNARD, CA. SN 78-609,325. PUB. 2-20-2007, FILED 4-14-2005.

**TEQUILA DON ADOLFO**

THE MARK CONSISTS OF STANDARD CHARACTERS WITHOUT CLAIM TO ANY PARTICULAR FONT, STYLE, SIZE, OR COLOR.

NO CLAIM IS MADE TO THE EXCLUSIVE RIGHT TO USE "TEQUILA", APART FROM THE MARK AS SHOWN.

THE NAME(S), PORTRAIT(S), AND/OR SIGNATURE(S) SHOWN IN THE MARK DOES NOT IDENTIFY A PARTICULAR LIVING INDIVIDUAL.

THE FOREIGN WORDING IN THE MARK TRANSLATES INTO ENGLISH AS "DON" = SIR, OR MISTER.

FOR TEQUILA (U.S. CLS. 47 AND 49).  
FIRST USE 8-16-2010; IN COMMERCE 8-16-2010.

3,955,931. INTERCONTINENTAL PACKAGING CO., ST. PAUL, MN. SN 85-016,078. PUB. 8-3-2010, FILED 4-16-2010.

**MARK ONE**

THE MARK CONSISTS OF STANDARD CHARACTERS WITHOUT CLAIM TO ANY PARTICULAR FONT, STYLE, SIZE, OR COLOR.

FOR DISTILLED SPIRITS (U.S. CLS. 47 AND 49).  
FIRST USE 12-1-2010; IN COMMERCE 12-1-2010.

**CLASS 33—(Continued).**

3,955,999. POLACCO ITALO RINO, 37047 SAN BONIFACIO-VR, ITALY. SN 85-049,744. PUB. 10-26-2010, FILED 5-27-2010.



*La Pria*

THE MARK CONSISTS OF THE WORD "LA PRIA" IN STYLIZED FONT ABOVE WHICH THERE IS A STYLIZED DESIGN OF SIX CIRCLES THAT ARE TOTALLY SHADED.

THE WORDING "LA PRIA" HAS NO MEANING IN A FOREIGN LANGUAGE.

FOR WINES AND SPARKLING WINES (U.S. CLS. 47 AND 49).

FIRST USE 12-1-2003; IN COMMERCE 2-14-2011.

3,956,028. SOQUE RIVER ENTERPRISE, LLC, CLARKSVILLE, GA. SN 85-063,342. PUB. 11-16-2010, FILED 6-15-2010.

**FLYLINE**

THE MARK CONSISTS OF STANDARD CHARACTERS WITHOUT CLAIM TO ANY PARTICULAR FONT, STYLE, SIZE, OR COLOR.

FOR WINES (U.S. CLS. 47 AND 49).

FIRST USE 11-10-2010; IN COMMERCE 11-10-2010.

3,956,067. RED ISLAND INDUSTRIES, MERIDIAN, ID. SN 85-084,517. PUB. 12-14-2010, FILED 7-14-2010.



THE COLOR(S) RED IS/ARE CLAIMED AS A FEATURE OF THE MARK.

**CLASS 33—(Continued).**

THE MARK CONSISTS OF THREE RED BRUSH STROKES THAT REPRESENT THE IMAGE OF A KANGAROO.  
FOR RUM (U.S. CLS. 47 AND 49).  
FIRST USE 1-15-2011; IN COMMERCE 1-15-2011.

---

3,956,077. BROWN-FORMAN CORPORATION, LOUISVILLE, KY. SN 85-091,766. PUB. 11-2-2010, FILED 7-23-2010.

**NEVER COMPROMISE**

THE MARK CONSISTS OF STANDARD CHARACTERS WITHOUT CLAIM TO ANY PARTICULAR FONT, STYLE, SIZE, OR COLOR.  
FOR DISTILLED SPIRITS (U.S. CLS. 47 AND 49).  
FIRST USE 9-1-2010; IN COMMERCE 9-1-2010.

---

3,956,088. K & G IMPORTS LLC, EL PRADO, NM. SN 85-109,221. PUB. 11-16-2010, FILED 8-17-2010.

**Cosmic Charlie**

THE MARK CONSISTS OF STANDARD CHARACTERS WITHOUT CLAIM TO ANY PARTICULAR FONT, STYLE, SIZE, OR COLOR.  
FOR LIQUOR; WINE (U.S. CLS. 47 AND 49).  
FIRST USE 1-1-2011; IN COMMERCE 1-1-2011.

**CLASS 34—SMOKERS' ARTICLES**

3,955,320. MANGIAMELI, DANIELE. MIAMI, FL. SN 77-709,220. PUB. 7-27-2010, FILED 4-8-2009.



THE NAME(S), PORTRAIT(S), AND/OR SIGNATURE(S) SHOWN IN THE MARK DOES NOT IDENTIFY A PARTICULAR LIVING INDIVIDUAL.

THE COLOR(S) GOLD, TAN, SILVER, BLUE, RED, BLACK, AND WHITE IS/ARE CLAIMED AS A FEATURE OF THE MARK.

THE MARK CONSIST OF THE COLOR GOLD APPEARS IN THE TEXT OF THE WORDING "CARLOS V", IN THE STITCHING OF THE JACKET APPEARING ON THE PORTRAIT, AND AS THE OUTLINE OF THE OVAL, THE

**CLASS 34—(Continued).**

OUTLINE OF THE RECTANGLE ON WHICH APPEARS THE WORDING "CARLOS V", IN THE OUTLINE OF THE AROUND THE PORTRAITS OF THE MEN ON HORSES, AND AS THE BACKGROUND TO THE REPETITIVE DIAMOND DESIGN ON EITHER SIDE OF THE RECTANGLE ON WHICH APPEARS THE WORDING "CARLOS V". THE COLOR RED APPEARS AS THE BACKGROUND SHADING OF THE PORTRAIT DESIGN, AND AS THE SHADING FOR COVERINGS ON THE HORSES, AND AS THE SHADING FOR THE GROUND BENEATH THE HORSES. THE COLOR SILVER APPEARS IN THE ARMOR FOR THE MEN ON THE HORSES. THE COLOR TAN APPEARS AS THE SHADING FOR THE SKIN IN THE PORTRAIT, AND AS THE SHADING IN THE RECTANGULAR DESIGNS ON THE FAR LEFT AND RIGHT SIDES OF THE OVERALL DESIGN. THE COLOR WHITE APPEARS IN THE COLLAR OF THE MAN IN THE PORTRAIT. THE COLOR BLUE APPEARS AS THE BACKGROUND SHADING IN THE RECTANGLE DESIGN ON WHICH APPEARS THE TEXT "CARLOS V", AS THE BORDER FOR THE DIAMOND DESIGNS ON EITHER SIDE OF THE AFOREMENTIONED RECTANGLE DESIGN, AS THE SHADING FOR THE SKY ABOVE THE HORSE DESIGNS, AND IN THE OUTLINE OF THE ENTIRE DESIGN. THE COLOR BLACK APPEARS AS THE SHADING FOR THE HORSES, AS THE SHADING IN THE JACKET DESIGN IN THE PORTRAIT, AND AS THE SHADING IN THE HAIR ON THE INDIVIDUAL IN THE PORTRAIT.

FOR CIGAR BOXES; CIGARS (U.S. CLS. 2, 8, 9 AND 17).  
FIRST USE 7-10-2008; IN COMMERCE 7-10-2008.

---

3,955,363. NICARAGUA TOBACCO IMPORTS, INC., DBA CUBAN CRAFTERS, MIAMI, FL. SN 77-774,349. PUB. 11-24-2009, FILED 7-4-2009.

**CALIXTO LOPEZ**

THE MARK CONSISTS OF STANDARD CHARACTERS WITHOUT CLAIM TO ANY PARTICULAR FONT, STYLE, SIZE, OR COLOR.

THE NAME(S), PORTRAIT(S), AND/OR SIGNATURE(S) SHOWN IN THE MARK DOES NOT IDENTIFY A PARTICULAR LIVING INDIVIDUAL.

FOR CIGAR AND CIGARETTE BOXES; CIGAR AND CIGARETTE BOXES NOT OF PRECIOUS METAL; CIGAR BOXES; CIGARS; TOBACCO, CIGARS AND CIGARETTES (U.S. CLS. 2, 8, 9 AND 17).

FIRST USE 11-17-2010; IN COMMERCE 2-9-2011.

---

3,955,512. VENDETTA, INC., SAN FRANCISCO, CA. SN 77-871,677. PUB. 4-13-2010, FILED 11-12-2009.

**BAYONET**

THE MARK CONSISTS OF STANDARD CHARACTERS WITHOUT CLAIM TO ANY PARTICULAR FONT, STYLE, SIZE, OR COLOR.

FOR CIGAR HOLDERS (U.S. CLS. 2, 8, 9 AND 17).  
FIRST USE 12-23-2010; IN COMMERCE 1-28-2011.

**CLASS 34—(Continued).**

3,955,990. AROMA DE VUELTA ABAJO, INC., MIAMI, FL. SN 85-044,299. PUB. 10-19-2010, FILED 5-20-2010.

# EL GALAN

THE MARK CONSISTS OF STANDARD CHARACTERS WITHOUT CLAIM TO ANY PARTICULAR FONT, STYLE, SIZE, OR COLOR.

THE ENGLISH TRANSLATION OF "EL GALAN" IN THE MARK IS THE HANDSOME FELLOW.

FOR CIGAR BOXES; CIGARS (U.S. CLS. 2, 8, 9 AND 17).

FIRST USE 3-1-2011; IN COMMERCE 3-1-2011.

**CLASS 35—(Continued).**

3,955,163. D.C., INC., FENTON, MO. SN 76-699,539. PUB. 2-16-2010, FILED 9-21-2009.

# LIVING LIFE ON THE CHEAP, DIRT CHEAP

THE MARK CONSISTS OF STANDARD CHARACTERS WITHOUT CLAIM TO ANY PARTICULAR FONT, STYLE, SIZE, OR COLOR.

OWNER OF U.S. REG. NOS. 2,048,425, 2,613,728, AND 3,047,335.

FOR WHOLESALE DISTRIBUTORSHIP AND RETAIL STORE SERVICES FEATURING BEER, LIQUOR AND WINE (U.S. CLS. 100, 101 AND 102).

FIRST USE 3-0-2009; IN COMMERCE 3-0-2009.

3,956,013. DRL ENTERPRISES, INC., GLENVIEW, IL. SN 85-057,681. PUB. 11-9-2010, FILED 6-8-2010.



OWNER OF U.S. REG. NO. 174,501.  
THE MARK CONSISTS OF A STYLIZED DISPLAY OF THE MARK "OCB".

FOR CIGARETTE PAPER (U.S. CLS. 2, 8, 9 AND 17).

FIRST USE 9-1-2010; IN COMMERCE 9-1-2010.

**SERVICE MARKS****CLASS 35—ADVERTISING AND BUSINESS**

3,955,161. PRIZEBITE, INC., MOON TOWNSHIP, PA. SN 76-697,220. PUB. 12-8-2009, FILED 5-4-2009.

# American Artemis

NO CLAIM IS MADE TO THE EXCLUSIVE RIGHT TO USE "AMERICAN", APART FROM THE MARK AS SHOWN. THE MARK CONSISTS OF THE WORDING "AMERICAN ARTEMIS" IN STYLIZED FONT.

FOR ONLINE RETAIL MARKETING, NAMELY, ONLINE RETAIL STORE SERVICES FEATURING GIFT BASKETS OF APPAREL, HOUSEWARES, ARTS AND CRAFTS, GIFT CERTIFICATES, AND FOODS FOR PURCHASERS (U.S. CLS. 100, 101 AND 102).

FIRST USE 11-26-2010; IN COMMERCE 11-26-2010.

3,955,207. JUNE BUG ENTERPRISES, INC., BEVERLY HILLS, CA. SN 77-350,062. PUB. 6-29-2010, FILED 12-12-2007.



OWNER OF U.S. REG. NOS. 3,257,581 AND 3,273,417.  
NO CLAIM IS MADE TO THE EXCLUSIVE RIGHT TO USE "WORKFORCE SOLUTIONS", APART FROM THE MARK AS SHOWN.

THE COLOR(S) RED AND WHITE IS/ARE CLAIMED AS A FEATURE OF THE MARK.

THE MARK CONSISTS OF THE WORDS "MAGIC WORKFORCE SOLUTIONS", WITH THE WORDS "MAGIC WORKFORCE" IN RED COLORED LETTERS STACKED OVER A DESIGN CONSISTING OF A RED COLORED BALL HAVING A WHITE COLORED "M" SUPERIMPOSED OVER THE BALL'S UPPER HEMISPHERE, AND A WHITE COLORED LETTER "W" SUPERIMPOSED OVER THE BALL'S LOWER HEMISPHERE, AND A RED COLORED RECTANGLE BANNER JUTTING OUT FROM THE RIGHT OF THE BALL HAVING THE WORD "SOLUTIONS" IN WHITE COLORED LETTERS ENCLOSED WITHIN THE BANNER.

FOR EMPLOYMENT AGENCY SERVICES; EMPLOYEE LEASING; EMPLOYMENT RELATED SERVICES, NAMELY, PROVIDING JOB PLACEMENT, CAREER DEVELOPMENT, EMPLOYMENT RECRUITMENT, AND GENERAL EMPLOYMENT INFORMATION TO OTHERS; CAREER DEVELOPMENT SERVICES; PROVIDING INFORMATION AND CONSULTANCY SERVICES ON THE PROCUREMENT OF TEMPORARY, CONTRACT, AND PERMANENT PERSONNEL; EMPLOYMENT COUNSELING; WORKFORCE DEVELOPMENT SERVICES; PROVIDING CAREER INFORMATION VIA A WEBSITE ON A GLOBAL INFORMATION NETWORK; PROVIDING INFORMATION ON JOBS VIA A WEBSITE ON A GLOBAL INFORMATION NETWORK (U.S. CLS. 100, 101 AND 102).

FIRST USE 5-1-2008; IN COMMERCE 5-1-2008.

**CLASS 35—(Continued).**

3,955,240. JOHNSON & JOHNSON, NEW BRUNSWICK, NJ. SN 77-526,867. PUB. 12-9-2008, FILED 7-21-2008.

## WORKSENSE

THE MARK CONSISTS OF STANDARD CHARACTERS WITHOUT CLAIM TO ANY PARTICULAR FONT, STYLE, SIZE, OR COLOR.

FOR EMPLOYMENT HIRING, RECRUITING, PLACEMENT, STAFFING AND CAREER NETWORKING SERVICES (U.S. CLS. 100, 101 AND 102).

FIRST USE 7-23-2008; IN COMMERCE 7-23-2008.

3,955,260. THETABIZ S.A., MIAMI, FL. SN 77-605,817. PUB. 5-26-2009, FILED 11-3-2008.

## Thetabiz

THE MARK CONSISTS OF STANDARD CHARACTERS WITHOUT CLAIM TO ANY PARTICULAR FONT, STYLE, SIZE, OR COLOR.

FOR ADVISORY SERVICES RELATING TO BUSINESS MANAGEMENT AND BUSINESS OPERATIONS (U.S. CLS. 100, 101 AND 102).

FIRST USE 5-21-2008; IN COMMERCE 5-21-2009.

3,955,273. INSTRIDE CORP., ROCKY RIVER, OH. SN 77-628,729. PUB. 6-9-2009, FILED 12-8-2008.



THE MARK CONSISTS OF STYLIZED RENDITION OF A FOOTPRINT.

FOR RETAIL STORE SERVICES FEATURING CLOTHING, FOOTWEAR, ACCESSORIES FOR RUNNING, WATCHES, HYDRATION AND NUTRITIONAL PRODUCTS (U.S. CLS. 100, 101 AND 102).

FIRST USE 7-0-2010; IN COMMERCE 7-0-2010.

**CLASS 35—(Continued).**

3,955,294. TOFASCO OF AMERICA, INC., LA VERNE, CA. SN 77-662,447. PUB. 1-5-2010, FILED 2-3-2009.

## *Be Bold • Be For Everyone*

THE MARK CONSISTS OF THE WORDS "BE BOLD BE FOR EVERYONE" WITH A DARK CIRCLE IN BETWEEN THE WORDS "BOLD" AND "BE" AND A BRUSH STROKE UNDERNEATH THE WORDS "BE BOLD BE FOR EVERYONE".

FOR ON-LINE RETAIL AND WHOLESALE STORE, WHOLESALE DISTRIBUTORSHIP SERVICES, CATALOGUE ORDERING SERVICES, MAIL ORDER SERVICES, COMPUTERIZED ONLINE ORDERING SERVICES, ALL FEATURING TELEVISIONS; PORTABLE TELEVISIONS; DIGITAL TELEVISIONS; PLASMA TELEVISIONS; LIQUID CRYSTAL DISPLAY (LCD) TELEVISIONS; GLOBAL POSITIONING SYSTEM (GPS) NAVIGATION UNITS; DIGITAL PHOTO FRAMES FOR DISPLAYING DIGITAL PICTURES, VIDEO CLIPS AND MUSIC; DIGITAL PHOTO DISPLAYS FOR DISPLAYING PICTURES, VIDEO CLIPS AND MUSIC WHICH INCLUDES A KEY-CHAIN; DIGITAL PHOTO DISPLAYS FOR DISPLAYING PICTURES, VIDEO CLIPS AND MUSIC WHICH INCLUDES A CLOCK; DIGITAL PHOTO DISPLAYS FOR DISPLAYING PICTURES, VIDEO CLIPS AND MUSIC WHICH INCLUDES AN ALARM CLOCK; DIGITAL PHOTO MAGNETS FOR DISPLAYING TIME, DIGITAL PICTURES, VIDEO CLIPS AND MUSIC; DIGITAL PHOTO DISPLAYS FOR DISPLAYING PICTURES, VIDEO CLIPS AND MUSIC WHICH INCLUDES A CHRISTMAS ORNAMENT; DIGITAL PHOTO DISPLAYS FOR DISPLAYING PICTURES, VIDEO CLIPS AND MUSIC WHICH INCLUDES A WALLET; PORTABLE DIGITAL PHOTO FRAMES FOR DISPLAYING DIGITAL PICTURES, VIDEO CLIPS AND MUSIC; MUSIC PLAYERS; MUSIC PLAYERS WITH REMOVABLE FLASH MEMORY DRIVE; MUSIC PLAYERS WITH RADIO RECEIVER AND RECORDER; MUSIC PLAYERS WITH VOICE RECORDER; MUSIC PLAYERS WITH MULTIMEDIA PLAYERS; DIGITAL, WIRELESS, HAND-HELD, AND PORTABLE MP3 AND MP4 PLAYERS FOR PLAYING AUDIO, VIDEO, AUDIO-VIDEO AND MULTIMEDIA FILES; MULTIMEDIA PLAYERS; PORTABLE MULTIMEDIA PLAYERS; HEADPHONES; MULTIMEDIA PROJECTORS; DVD PLAYERS, PORTABLE DVD PLAYERS, DVD PLAYERS FOR VEHICLES; RADIOS; RADIOS FOR VEHICLES; BROADBAND RADIOS; SPEAKERS FOR VEHICLES; SPEAKERS; PORTABLE SPEAKERS; WATERPROOF SPEAKERS; WIRELESS SPEAKERS; ACCESSORIES FOR TELEVISIONS, NAMELY, AC AND CAR ADAPTERS, REMOTE CONTROLS, AND PROTECTIVE CARRYING POUCHES; ACCESSORIES FOR GPS NAVIGATION UNITS, NAMELY, VEHICLE ADAPTERS, POWER ADAPTERS, CARRYING CASES AND POUCHES, DASHBOARD MOUNT DISKS, USB CABLES, BATTERIES, MEMORY CARDS WITH MAPS, DVD-ROM WITH MAPS; ACCESSORIES FOR DIGITAL PHOTO FRAMES, NAMELY, USB CABLES, POWER ADAPTERS, REMOTE CONTROLS, FRAME STANDS; ACCESSORIES FOR MUSIC PLAYERS, NAMELY, ARMBANDS, USB CABLES, HEADPHONES, DC POWERED FM MODULATOR; ACCESSORIES FOR DVD PLAYERS, NAMELY, BATTERIES, AV CABLES, AC CORDS, FITTED CARRYING CASES, VEHICLE ADAPTERS, POWER ADAPTERS, REMOTE CONTROLS, HEADPHONES; AND DISSEMINATION OF ADVERTISEMENTS AND OF ADVERTISING MATERIAL FEATURING ALL OF THE AFOREMENTIONED GOODS (U.S. CLS. 100, 101 AND 102).

FIRST USE 1-1-2011; IN COMMERCE 1-1-2011.



**CLASS 35—(Continued).**

3,955,295. BATTERIES PLUS, LLC, HARTLAND, WI. SN 77-663,192. PUB. 6-9-2009, FILED 2-4-2009.



OWNER OF U.S. REG. NOS. 1,697,440, 2,725,695, AND 3,322,549.

NO CLAIM IS MADE TO THE EXCLUSIVE RIGHT TO USE "BATTERIES" AND "BULBS", APART FROM THE MARK AS SHOWN.

THE COLOR(S) GREEN AND ORANGE IS/ARE CLAIMED AS A FEATURE OF THE MARK.

THE MARK CONSISTS OF THE WORD "BATTERIES" IN GREEN, A GREEN AND ORANGE PLUS SYMBOL IN THE SHAPE OF A PERSON, AND THE WORD "BULBS" IN ORANGE.

FOR RETAIL STORE SERVICES FEATURING BATTERIES AND LIGHT BULBS (U.S. CLS. 100, 101 AND 102).

FIRST USE 5-0-2009; IN COMMERCE 5-0-2009.

3,955,315. QUIN, MARK, ATLANTA, GA. SN 77-696,556. PUB. 7-21-2009, FILED 3-23-2009.



THE MARK CONSISTS OF STANDARD CHARACTERS WITHOUT CLAIM TO ANY PARTICULAR FONT, STYLE, SIZE, OR COLOR.

NO CLAIM IS MADE TO THE EXCLUSIVE RIGHT TO USE "AGENCY", APART FROM THE MARK AS SHOWN.

FOR ADVERTISING AGENCIES (U.S. CLS. 100, 101 AND 102).

FIRST USE 6-14-2010; IN COMMERCE 6-14-2010.

3,955,325. YOUR BRIDAL FLOWERS LLC, ELMHURST, IL. SN 77-714,273. PUB. 3-2-2010, FILED 4-15-2009.



THE MARK CONSISTS OF STANDARD CHARACTERS WITHOUT CLAIM TO ANY PARTICULAR FONT, STYLE, SIZE, OR COLOR.

NO CLAIM IS MADE TO THE EXCLUSIVE RIGHT TO USE "WHOLESALE FLOWERS", APART FROM THE MARK AS SHOWN.

**CLASS 35—(Continued).**

"RUSS" IDENTIFIES A LIVING INDIVIDUAL WHOSE CONSENT IS OF RECORD.

FOR ELECTRONIC CATALOG AND WHOLESALE DISTRIBUTORSHIP IN THE FIELD OF FLOWERS, FLORAL ARRANGEMENTS, BOUQUETS, PLANTS, AND FLORAL RELATED GIFTS AND ACCESSORIES (U.S. CLS. 100, 101 AND 102).

FIRST USE 7-15-2009; IN COMMERCE 7-15-2009.

3,955,327. COLLABORENT GROUP, LTD., CLEVELAND, OH. SN 77-723,602. PUB. 9-14-2010, FILED 4-28-2009.



THE MARK CONSISTS OF STANDARD CHARACTERS WITHOUT CLAIM TO ANY PARTICULAR FONT, STYLE, SIZE, OR COLOR.

NO CLAIM IS MADE TO THE EXCLUSIVE RIGHT TO USE "SOURCING", APART FROM THE MARK AS SHOWN.

FOR BUSINESS MANAGEMENT CONSULTANCY IN THE FIELD OF PURCHASES, NAMELY, ASSISTING LOCAL GOVERNMENTS, ORGANIZATIONS, AND OTHER BUSINESSES IN THE DEVELOPMENT, IMPLEMENTATION, AND IMPROVEMENT OF GROUP PURCHASING PROGRAMS (U.S. CLS. 100, 101 AND 102).

FIRST USE 9-0-2009; IN COMMERCE 9-0-2009.

3,955,372. SENIOR SHIFT LLC, OMAHA, NE. SN 77-784,310. PUB. 12-8-2009, FILED 7-18-2009.



THE MARK CONSISTS OF STANDARD CHARACTERS WITHOUT CLAIM TO ANY PARTICULAR FONT, STYLE, SIZE, OR COLOR.

FOR MOVING AND RELOCATION SERVICES, NAMELY, PLANNING AND IMPLEMENTING MOVES OF HOMES FOR OTHERS (U.S. CLS. 100, 101 AND 102).

FIRST USE 5-13-2010; IN COMMERCE 10-29-2010.

**CLASS 35—(Continued).**

3,955,400. PEER SQUARED LLC, HOLLYWOOD, CA. SN 77-802,275. PUB. 7-27-2010, FILED 8-11-2009.



THE MARK CONSISTS OF THE WORD "PEER" IN STYLIZED FONT FOLLOWED BY A RAISED NUMERAL "2" IN A SHADED SQUARE.

FOR PROMOTIONAL SERVICES, NAMELY, PROMOTING THE GOODS OF OTHERS BY MEANS OF AN INTERACTIVE WEB SITE UTILIZING A REWARD INCENTIVE PROGRAM (U.S. CLS. 100, 101 AND 102).

FIRST USE 8-31-2010; IN COMMERCE 8-31-2010.

3,955,407. TRICO PRODUCTS CORPORATION, ROCHESTER HILLS, MI. SN 77-808,749. PUB. 6-15-2010, FILED 8-20-2009.

**WIPE THE WIN-SHIELD**

THE MARK CONSISTS OF STANDARD CHARACTERS WITHOUT CLAIM TO ANY PARTICULAR FONT, STYLE, SIZE, OR COLOR.

FOR ADMINISTRATION OF AN INCENTIVE REWARD PROGRAM COMPRISED OF REBATES FOR WINDSHIELD WIPER BLADES; ADMINISTRATION OF A REBATE PROGRAM, NAMELY, PROVIDING REBATES AS INCENTIVES FOR PURCHASING WINDSHIELD WIPER BLADES (U.S. CLS. 100, 101 AND 102).

FIRST USE 10-1-2009; IN COMMERCE 10-1-2009.

3,955,434. VENTURA FOODS, LLC, BREA, CA. SN 77-822,183. PUB. 6-29-2010, FILED 9-8-2009.

**PURE PRODUCING USEFUL  
RENEWABLE ENERGY**

THE MARK CONSISTS OF STANDARD CHARACTERS WITHOUT CLAIM TO ANY PARTICULAR FONT, STYLE, SIZE, OR COLOR.

NO CLAIM IS MADE TO THE EXCLUSIVE RIGHT TO USE "PRODUCING USEFUL RENEWABLE ENERGY", APART FROM THE MARK AS SHOWN.

FOR PROMOTING PUBLIC AWARENESS OF THE IMPORTANCE OF RECYCLING OF WASTE VEGETABLE OIL INTO RENEWABLE FUEL (U.S. CLS. 100, 101 AND 102).

FIRST USE 9-3-2009; IN COMMERCE 9-3-2009.

**CLASS 35—(Continued).**

3,955,438. SEARS BRANDS, LLC, HOFFMAN ESTATES, IL. SN 77-824,819. PUB. 7-27-2010, FILED 9-11-2009.

**GIVE MORE BY SHARING THE  
LOVE AND SPLITTING THE COST**

THE MARK CONSISTS OF STANDARD CHARACTERS WITHOUT CLAIM TO ANY PARTICULAR FONT, STYLE, SIZE, OR COLOR.

FOR GIFT REGISTRY SERVICES AND ONLINE GIFT REGISTRY SERVICES, NAMELY, PROVIDING AN INTERNET WEBSITE WHICH ENABLES INDIVIDUALS TO CONTRIBUTE TOWARD THE PURCHASE OF GIFTS FOR OTHERS (U.S. CLS. 100, 101 AND 102).

FIRST USE 10-0-2009; IN COMMERCE 10-0-2009.

3,955,443. SCHOOLHOUSE PARTNERS LLC, SUGARLAND, TX. SN 77-827,068. PUB. 6-22-2010, FILED 9-15-2009.

**SCHOOLHOUSE PARTNERS**

THE MARK CONSISTS OF STANDARD CHARACTERS WITHOUT CLAIM TO ANY PARTICULAR FONT, STYLE, SIZE, OR COLOR.

NO CLAIM IS MADE TO THE EXCLUSIVE RIGHT TO USE "PARTNERS", APART FROM THE MARK AS SHOWN.

FOR CONNECTING QUALIFIED SERVICE PROVIDERS WITH CONSUMERS; PROVIDING RECOMMENDATIONS ON SERVICE PROVIDERS TO CONSUMERS FOR COMMERCIAL PURPOSES (U.S. CLS. 100, 101 AND 102).

FIRST USE 6-1-2009; IN COMMERCE 8-1-2009.

3,955,457. BIONDI, ELENA, PHILADELPHIA, PA. SN 77-841,390. PUB. 3-23-2010, FILED 10-5-2009.



NO CLAIM IS MADE TO THE EXCLUSIVE RIGHT TO USE "LLC", APART FROM THE MARK AS SHOWN.

THE COLOR(S) BLUE IS/ARE CLAIMED AS A FEATURE OF THE MARK.

**CLASS 35—(Continued).**

THE MARK CONSISTS OF THE NAME OF THE ENTITY, I.E. "RECOUPERS, LLC" PLUS A LOGO OF THREE PARTIAL RINGS, VIEWED PARTIALLY FROM THE SIDE. THE RINGS ARE PLACED OVER THE NAME OF THE ENTITY. EVERYTHING IS BLUE, INCLUDING THE ENTITY NAME AND THE LOGO.

FOR ADVICE AND INFORMATION CONCERNING COMMERCIAL BUSINESS MANAGEMENT; ASSISTANCE, ADVISORY SERVICES AND CONSULTANCY WITH REGARD TO BUSINESS PLANNING, BUSINESS ANALYSIS, BUSINESS MANAGEMENT, BUSINESS ORGANIZATION, MARKETING AND CUSTOMER ANALYSIS; BUSINESS CONSULTATION; BUSINESS CONSULTATION IN THE FIELD OF TELECOMMUNICATIONS EXPENSE MANAGEMENT; ADVISORY SERVICE FOR ORGANIZATIONAL ISSUES AND BUSINESS ADMINISTRATION, WITH AND WITHOUT THE HELP OF ELECTRONIC DATA BASES; ADVISORY SERVICES RELATING TO BUSINESS MANAGEMENT AND BUSINESS OPERATIONS; ARRANGING AND CONDUCTING OF FAIRS AND EXHIBITIONS FOR BUSINESS AND ADVERTISING PURPOSES; ASSISTANCE AND ADVICE REGARDING BUSINESS ORGANIZATION AND MANAGEMENT; ASSISTANCE IN MANAGEMENT OF BUSINESS ACTIVITIES; ASSISTANCE, ADVISORY SERVICES AND CONSULTANCY WITH REGARD TO BUSINESS PLANNING, BUSINESS ANALYSIS, BUSINESS MANAGEMENT, AND BUSINESS ORGANIZATION; BUSINESS CONSULTATION AND MANAGEMENT REGARDING MARKETING ACTIVITIES AND LAUNCHING OF NEW PRODUCTS; THE BRINGING TOGETHER, FOR THE BENEFIT OF OTHERS, OF A VARIETY OF GOODS AND SERVICES, ENABLING CUSTOMERS TO CONVENIENTLY VIEW AND PURCHASE THOSE GOODS AND SERVICES FROM AN INTERNET WEB SITE PARTICULARLY SPECIALIZING IN THE MARKETING OF THE SALE OF GOODS AND SERVICES OF OTHERS (U.S. CLS. 100, 101 AND 102).

FIRST USE 6-15-2007; IN COMMERCE 6-15-2007.

3,955,476. 3 STEP PAYROLL, LLC, ALBUQUERQUE, NM. SN 77-849,933. PUB. 5-25-2010, FILED 10-15-2009.



NO CLAIM IS MADE TO THE EXCLUSIVE RIGHT TO USE "PAYROLL", APART FROM THE MARK AS SHOWN. THE MARK CONSISTS OF THREE SQUARES UPWARDLY OVERLAPPING SUGGESTING 3 STEPS OF STAIRS WITH THE NUMBER "3" ABOVE THE FIRST SQUARE AND THE WORDS "STEP" AND "PAYROLL" UNDER THE SECOND ASCENDING SQUARE.

FOR ADMINISTRATION OF BUSINESS PAYROLL FOR OTHERS; PAYROLL PREPARATION; PAYROLL PROCESSING SERVICES (U.S. CLS. 100, 101 AND 102). FIRST USE 2-19-2010; IN COMMERCE 2-19-2010.

**CLASS 35—(Continued).**

3,955,486. NORTHWEST FEED BARN ONE, LLC, HERMISTON, OR. SN 77-855,360. PUB. 4-6-2010, FILED 10-22-2009.

**Northwest Feed Barn One**

THE MARK CONSISTS OF STANDARD CHARACTERS WITHOUT CLAIM TO ANY PARTICULAR FONT, STYLE, SIZE, OR COLOR.

NO CLAIM IS MADE TO THE EXCLUSIVE RIGHT TO USE "NORTHWEST FEED", APART FROM THE MARK AS SHOWN.

FOR RETAIL STORE SERVICES FEATURING HAY (U.S. CLS. 100, 101 AND 102).

FIRST USE 12-31-2010; IN COMMERCE 12-31-2010.

3,955,491. LOVIN' SCOOPFUL, LLC, SEATTLE, WA. SN 77-859,278. PUB. 2-16-2010, FILED 10-28-2009.

**Shoppin' With Lovin'**

THE MARK CONSISTS OF STANDARD CHARACTERS WITHOUT CLAIM TO ANY PARTICULAR FONT, STYLE, SIZE, OR COLOR.

NO CLAIM IS MADE TO THE EXCLUSIVE RIGHT TO USE "SHOPPING", APART FROM THE MARK AS SHOWN.

FOR MARKETING CAMPAIGN TARGETED TOWARD ENCOURAGING THE PURCHASE OF PRODUCTS AND SERVICES FROM COMPANIES MAKING SIGNIFICANT CHARITABLE CONTRIBUTIONS TO SPECIFIC CAUSES (U.S. CLS. 100, 101 AND 102).

FIRST USE 6-13-2010; IN COMMERCE 6-13-2010.

3,955,495. BINDO, LLC, WILMINGTON, DE. SN 77-861,027. PUB. 7-27-2010, FILED 10-30-2009.

**bindo**

THE MARK CONSISTS OF STANDARD CHARACTERS WITHOUT CLAIM TO ANY PARTICULAR FONT, STYLE, SIZE, OR COLOR.

**CLASS 35—(Continued).**

THE WORD "BINDO" HAS NO MEANING IN A FOREIGN LANGUAGE.

FOR ADVERTISING AND BUSINESS SERVICES, NAMELY, PROVIDING AN ONLINE WEBSITES WHERE ADVERTISERS, MARKETERS, AND CONTENT PROVIDERS CAN INTERACT WITH USERS FOR ADVERTISING, BRANDING, AND PROMOTING KNOWLEDGE, PRODUCTS, AND SERVICES, AND TRADESHOWS, ON BEHALF OF THEMSELVES AND OTHERS, AND FOR EVALUATING AND RATING THE SAME, ALL THE FOREGOING RELEVANT TO HUMAN ACTIVITIES AFFECTING CLIMATE CHANGE AND RELATED FIELDS; ADVERTISING AND COMMERCIAL INFORMATION SERVICES, VIA THE INTERNET; ADVERTISING SERVICES, NAMELY, COST-PER-ACTION ON-LINE ADVERTISING; ADVERTISING SERVICES, NAMELY, PROMOTING PROPERTIES FOR SALE BY OWNER VIA THE INTERNET; ADVERTISING VIA ELECTRONIC MEDIA AND SPECIFICALLY THE INTERNET; ADVICE AND INFORMATION ABOUT CUSTOMER SERVICES AND PRODUCT MANAGEMENT AND PRICES ON INTERNET SITES IN CONNECTION WITH PURCHASES MADE OVER THE INTERNET; AN INTERACTIVE WEB SITE FOR USERS TO REVIEW AND RATE INTERNET CONTENT, PEOPLE, COMPANIES, PRODUCTS AND/OR SERVICES UTILIZING A SOFTWARE APPLICATION TO AWARD POINTS WHEREBY WEB SITE USERS ARE ELIGIBLE TO EXCHANGE POINTS EARNED FOR PROMOTIONAL ITEMS CONSISTING OF COUPONS, REBATES, DISCOUNTS OR SPECIAL OFFERINGS ON GOODS AND/OR SERVICE PROVIDED BY WEB SITE SPONSORS; ARRANGING SUBSCRIPTIONS OF THE ONLINE PUBLICATIONS OF OTHERS; COMPUTERIZED ON-LINE ORDERING FEATURING GENERAL MERCHANDISE AND GENERAL CONSUMER GOODS; DESIGN OF INTERNET ADVERTISING; DISSEMINATION OF ADVERTISING FOR OTHERS VIA THE INTERNET; ELECTRONIC COMMERCE SERVICES, NAMELY, PROVIDING INFORMATION ABOUT PRODUCTS VIA TELECOMMUNICATION NETWORKS FOR ADVERTISING AND SALES PURPOSES; FACILITATING THE EXCHANGE OF NEEDED INFORMATION FOR FINANCIAL COMPENSATION VIA THE INTERNET; INFORMATION MANAGEMENT SERVICES, NAMELY, SHIPMENT PROCESSING, PREPARING SHIPPING DOCUMENTS AND INVOICES, TRACKING DOCUMENTS, PACKAGES AND FREIGHT OVER COMPUTER NETWORKS, INTRANETS AND INTERNETS; INTERNET ADVERTISING SERVICES; MARKET MANIPULATION, RESEARCH AND ANALYSIS, WHETHER OR NOT VIA THE INTERNET; ON-LINE BUSINESS RESEARCH SERVICE THAT ALLOWS THE USER TO ANALYZE OPINION TRENDS CONTAINED IN DOCUMENTS ON THE INTERNET; ON-LINE RETAIL STORE SERVICES FEATURING PHYSICAL AND VIRTUAL MERCHANDISE FOR USE BY MEMBERS OF AN ON-LINE COMMUNITY IN CONNECTION WITH A DESIGNATED WEBSITE FEATURING FICTIONAL CHARACTERS; ONLINE ADVERTISING VIA A COMPUTER COMMUNICATIONS NETWORK; PROVIDING A SEARCHABLE ONLINE ADVERTISING GUIDE FEATURING THE GOODS AND SERVICES OF ONLINE VENDORS; PROVIDING A SEARCHABLE ONLINE ADVERTISING GUIDE FEATURING THE GOODS AND SERVICES OF OTHER ON-LINE VENDORS ON THE INTERNET; PROVIDING A WEB-BASED SYSTEM AND ONLINE PORTALS IN THE FIELD OF CONSUMER-TO-

**CLASS 35—(Continued).**

BUSINESS COMMERCE FOR CONSUMERS TO ENTER, MANAGE AND MODIFY THEIR CONSUMER PREFERENCE INFORMATION FOR USE BY MERCHANTS TO CREATE AND MANAGE OFFERS FOR DELIVERY TO CONSUMERS; PROVIDING AN ON-LINE COMMERCIAL INFORMATION DIRECTORY ON THE INTERNET; PROVIDING AND RENTAL OF ADVERTISING SPACE ON THE INTERNET; PROVIDING CONSUMER PRODUCT INFORMATION VIA THE INTERNET; PROVIDING INFORMATION ABOUT AUTOMOBILES FOR SALE BY MEANS OF THE INTERNET; PROVIDING INFORMATION IN THE FIELD OF MARKETING AND ON-LINE MARKETING MEDIA VIA THE INTERNET; THE BRINGING TOGETHER, FOR THE BENEFIT OF OTHERS, OF A VARIETY OF GOODS AND SERVICES, ENABLING CUSTOMERS TO CONVENIENTLY VIEW AND PURCHASE THOSE GOODS AND SERVICES FROM AN INTERNET WEB SITE PARTICULARLY SPECIALIZING IN THE MARKETING OF THE SALE OF GOODS AND SERVICES OF OTHERS (U.S. CLS. 100, 101 AND 102).

FIRST USE 1-22-2011; IN COMMERCE 2-1-2011.

---

3,955,498. BARON, ALEXANDER C. DBA RISKOVATION, HOUSTON, TX. SN 77-863,216. PUB. 4-6-2010, FILED 11-2-2009.

## Riskovation

THE MARK CONSISTS OF STANDARD CHARACTERS WITHOUT CLAIM TO ANY PARTICULAR FONT, STYLE, SIZE, OR COLOR.

FOR BUSINESS RISK MANAGEMENT; BUSINESS RISK MANAGEMENT CONSULTATION (U.S. CLS. 100, 101 AND 102).

FIRST USE 3-1-2004; IN COMMERCE 6-30-2007.

---

3,955,514. H.B. FULLER COMPANY, SAINT PAUL, MN. SN 77-872,450. PUB. 6-29-2010, FILED 11-13-2009.

## FULL VALU

THE MARK CONSISTS OF STANDARD CHARACTERS WITHOUT CLAIM TO ANY PARTICULAR FONT, STYLE, SIZE, OR COLOR.

OWNER OF U.S. REG. NOS. 964,939, 2,571,893, AND OTHERS.

NO CLAIM IS MADE TO THE EXCLUSIVE RIGHT TO USE "VALUE", APART FROM THE MARK AS SHOWN.

FOR BUSINESS CONSULTATION FOR OTHERS IN THE FIELD OF INDUSTRIAL ADHESIVES, SEALANTS AND COATINGS (U.S. CLS. 100, 101 AND 102).

FIRST USE 7-13-2010; IN COMMERCE 7-13-2010.

**CLASS 35—(Continued).**

3,955,522. SHUBIN, STEVE, DRIPPING SPRINGS, TX. SN 77-874,976. PUB. 8-3-2010, FILED 11-18-2009.

# FLESHJACK

THE MARK CONSISTS OF STANDARD CHARACTERS WITHOUT CLAIM TO ANY PARTICULAR FONT, STYLE, SIZE, OR COLOR.

OWNER OF U.S. REG. NOS. 3,497,865 AND 3,497,866. FOR ONLINE RETAIL STORE SERVICES FEATURING ADULT-ORIENTED PRODUCTS (U.S. CLS. 100, 101 AND 102).

FIRST USE 4-30-2007; IN COMMERCE 4-30-2007.

---

3,955,523. SHUBIN, STEVE, DRIPPING SPRINGS, TX. SN 77-874,982. PUB. 8-3-2010, FILED 11-18-2009.

# FLESHJACK

THE MARK CONSISTS OF STANDARD CHARACTERS WITHOUT CLAIM TO ANY PARTICULAR FONT, STYLE, SIZE, OR COLOR.

OWNER OF U.S. REG. NOS. 3,497,865 AND 3,497,866. FOR PROVIDING CONSUMER INFORMATION ABOUT ADULT PRODUCTS AND SERVICES BY MEANS OF THE INTERNET (U.S. CLS. 100, 101 AND 102).

FIRST USE 4-30-2007; IN COMMERCE 4-30-2007.

---

3,955,529. OGGI, LLC, MINNETRISTA, MN. SN 77-877,768. PUB. 9-21-2010, FILED 11-20-2009.

# OGGI

THE MARK CONSISTS OF STANDARD CHARACTERS WITHOUT CLAIM TO ANY PARTICULAR FONT, STYLE, SIZE, OR COLOR.

THE ENGLISH TRANSLATION OF THE WORD "OGGI" IN THE MARK IS TODAY.

FOR EMPLOYMENT AGENCY AND PERSONNEL RECRUITMENT SERVICES; EXECUTIVE SEARCH AND PLACEMENT SERVICES; EXECUTIVE EMPLOYMENT STAFFING CONSULTATION SERVICES (U.S. CLS. 100, 101 AND 102).

FIRST USE 11-0-2009; IN COMMERCE 2-0-2010.

**CLASS 35—(Continued).**

3,955,555. A. B. CLOSING CORPORATION, DBA KAVALIRO INC., ORLANDO, FL. SN 77-888,820. PUB. 5-4-2010, FILED 12-8-2009.

# Kavaliro

THE MARK CONSISTS OF STANDARD CHARACTERS WITHOUT CLAIM TO ANY PARTICULAR FONT, STYLE, SIZE, OR COLOR.

FOR BUSINESS CONSULTING SERVICES RELATING TO THE INTEGRATION OF THE AREAS OF BUSINESS PROCESS TECHNOLOGY, ORGANIZATIONAL LEARNING, CHANGE MANAGEMENT, AND OPERATIONAL SUSTAINABILITY; BUSINESS MANAGEMENT CONSULTING WITH RELATION TO STRATEGY, FINANCING, MARKETING, PRODUCTION, PERSONNEL AND SALE MATTERS FOR COMPANIES INVOLVED WITH THIN FILM AND NANO TECHNOLOGIES AND PLASMA PROCESSES; EMPLOYMENT AGENCY SERVICES, NAMELY, FILLING THE TEMPORARY AND PERMANENT STAFFING NEEDS OF BUSINESSES; EMPLOYMENT HIRING, RECRUITING, PLACEMENT, STAFFING AND CAREER NETWORKING SERVICES; EMPLOYMENT STAFFING CONSULTATION SERVICES; EMPLOYMENT STAFFING IN THE FIELD OF TECHNOLOGY; PROFESSIONAL STAFFING AND RECRUITING SERVICES; STRATEGIC SOURCING, NAMELY, STAFFING IN THE FIELD OF ENGINEERING (U.S. CLS. 100, 101 AND 102).

FIRST USE 12-8-2009; IN COMMERCE 12-8-2009.

---

3,955,592. AHALIFE IP HOLDINGS LLC, NEW YORK, NY. SN 77-911,426. PUB. 7-13-2010, FILED 1-13-2010.

# AHALIFE

THE MARK CONSISTS OF STANDARD CHARACTERS WITHOUT CLAIM TO ANY PARTICULAR FONT, STYLE, SIZE, OR COLOR.

FOR ON-LINE RETAIL STORE SERVICES FEATURING CLOTHING, APPAREL, BELTS, FOOTWEAR, CLOTHING ACCESSORIES, LUGGAGE, BAGS, HANDBAGS, WALLETS, SMALL LEATHER GOODS, SUNGLASSES, JEWELRY, WATCHES, PERFUMES, COLOGNES, COSMETICS, BATH AND BEAUTY PRODUCTS, HOME FURNISHINGS, LINENS, APPLIANCES, COOKWARE, ELECTRONICS, ARTWORK, MUSIC, BOOKS, STATIONERY, HEALTH, WELLNESS AND LIFESTYLE PRODUCTS AND FOODS (U.S. CLS. 100, 101 AND 102).

FIRST USE 9-13-2010; IN COMMERCE 9-13-2010.

**CLASS 35—(Continued).**

3,955,605. ZAMZUU, INC., WOOD RIVER, IL. SN 77-915,914.  
PUB. 6-1-2010, FILED 1-20-2010.



THE MARK CONSISTS OF THE STYLIZED WORD "ZAMZUU" WITH THE SECOND "Z" BEING LARGER THAN THE OTHER LETTERS.

THE MARK HAS NO MEANING IN A FOREIGN LANGUAGE.

FOR ON-LINE WHOLESALE AND RETAIL STORE SERVICES FEATURING GENERAL CONSUMER MERCHANDISE; PROMOTION OF OPPORTUNITIES FOR ON-LINE BUSINESSES IN THE FIELDS OF TRAVEL AND GENERAL CONSUMER MERCHANDISE; MULTI-LEVEL MARKETING BUSINESS SERVICES (U.S. CLS. 100, 101 AND 102).

FIRST USE 1-0-2010; IN COMMERCE 1-0-2010.

3,955,618. NEVADA PROPERTY 1 LLC, LAS VEGAS, NV. SN 77-920,747. PUB. 5-25-2010, FILED 1-26-2010.



OWNER OF U.S. REG. NOS. 3,337,476 AND 3,337,479.  
NO CLAIM IS MADE TO THE EXCLUSIVE RIGHT TO USE "LAS VEGAS", APART FROM THE MARK AS SHOWN.

THE MARK CONSISTS OF THREE OVERLAPPING AND STYLIZED LETTER "C"'S TO THE LEFT OF THE WORDS "THE COSMOPOLITAN OF LAS VEGAS".

FOR RETAIL STORE SERVICES FEATURING A WIDE VARIETY OF CONSUMER GOODS OF OTHERS (U.S. CLS. 100, 101 AND 102).

FIRST USE 12-15-2010; IN COMMERCE 12-15-2010.

3,955,622. THE FENNIMORE GROUP, LLC, ARLINGTON HEIGHTS, IL. SN 77-921,233. PUB. 12-7-2010, FILED 1-27-2010.



OWNER OF U.S. REG. NO. 3,031,669.  
NO CLAIM IS MADE TO THE EXCLUSIVE RIGHT TO USE "SOLUTIONS", APART FROM THE MARK AS SHOWN.

**CLASS 35—(Continued).**

THE MARK CONSISTS OF A FEATHER AND A CIRCLE WITH A STYLIZED "F", ACCOMPANIED BY "FENNIMORE SOLUTIONS".

FOR BUSINESS CONSULTING SERVICES RELATING TO OPERATIONS AND SUPPLY CHAIN STAFFING (U.S. CLS. 100, 101 AND 102).

FIRST USE 1-18-2011; IN COMMERCE 1-18-2011.

3,955,627. STELO ENTERPRISES, INC., CARLISLE, PA. SN 77-922,544. PUB. 6-15-2010, FILED 1-28-2010.

# JULABUG

THE MARK CONSISTS OF STANDARD CHARACTERS WITHOUT CLAIM TO ANY PARTICULAR FONT, STYLE, SIZE, OR COLOR.

FOR MAIL ORDER CATALOG SERVICES FEATURING TOYS; ON-LINE RETAIL STORE SERVICES FEATURING TOYS (U.S. CLS. 100, 101 AND 102).

FIRST USE 10-1-2010; IN COMMERCE 10-1-2010.

3,955,639. ONECBIZ, INC., CLEVELAND, OH. SN 77-925,977.  
PUB. 8-10-2010, FILED 2-2-2010.

# MMPact

OWNER OF U.S. REG. NO. 3,621,656.

THE MARK CONSISTS OF THE LETTERS "MMP" IN UPPER CASE LETTERS FOLLOWED BY THE LETTERS "ACT" IN LOWER CASE LETTERS, ALL IN A STYLIZED FONT.

FOR BUSINESS INFORMATION REPORTING SERVICES AND DATA MANAGEMENT SERVICES ALL IN THE FIELD OF PRACTICE MANAGEMENT FOR HEALTHCARE PROVIDERS; BILLING AND BUSINESS PRACTICE MANAGEMENT SERVICES FOR HEALTHCARE PROVIDERS (U.S. CLS. 100, 101 AND 102).

FIRST USE 3-23-2010; IN COMMERCE 3-23-2010.

3,955,671. TRACY BENDER, DBA THE CENTER FOR MASTERPIECE LIVING, GILROY, CA. SN 77-930,813.  
PUB. 6-22-2010, FILED 2-8-2010.

# MLIVING

THE MARK CONSISTS OF STANDARD CHARACTERS WITHOUT CLAIM TO ANY PARTICULAR FONT, STYLE, SIZE, OR COLOR.

**CLASS 35—(Continued).**

OWNER OF U.S. REG. NOS. 2,810,382, 3,101,176, AND 3,281,947.

FOR ON-LINE RETAIL STORE SERVICES IN THE FIELD OF LIFESTYLE ACCESSORIES AND GIFTS, FEATURING APPAREL, HOUSEHOLD ITEMS, GIFTS AND GIFTWARE, ISSUING GIFT CERTIFICATES, AND DIGITAL PRODUCTS, NAMELY, DIGITAL MAGAZINES, BOOKS AND NEWSPAPERS, E-CARDS, MOBILE GREETINGS, DOWNLOADABLE MUSIC, MOVIES, PHOTOGRAPHS, PODCASTS, GAMES, AND APPLICATIONS, PROVIDED VIA THE INTERNET AND OTHER COMPUTER AND ELECTRONIC COMMUNICATION NETWORKS (U.S. CLS. 100, 101 AND 102).

FIRST USE 2-9-2011; IN COMMERCE 2-9-2011.

3,955,681. WELLESLEY SYSTEMS, INC., WELLESLEY, MA. SN 77-932,151. PUB. 12-21-2010, FILED 2-9-2010.

# WELLSYS

THE MARK CONSISTS OF STANDARD CHARACTERS WITHOUT CLAIM TO ANY PARTICULAR FONT, STYLE, SIZE, OR COLOR.

FOR BUSINESS SERVICES, NAMELY, FACILITIES MANAGEMENT OF TECHNICAL OPERATIONS; OPERATIONAL BUSINESS ASSISTANCE TO ENTERPRISES; BUSINESS CONSULTATION SERVICES, NAMELY, BUSINESS PROCESS IMPROVEMENT AND ENTERPRISE ARCHITECTURE DESIGN; BUSINESS SERVICES, NAMELY, REGISTERING, SCREENING, CREDENTIALING AND ORGANIZING THIRD PARTY VENDORS, SUPPLIERS AND CONTRACTORS AND DOCUMENTATION AND REGISTRATION ON BEHALF OF OTHERS; BUSINESS CONSULTATION IN THE FIELD OF PROGRAM AND PROJECT MANAGEMENT, OPERATIONS MANAGEMENT AND MASTER DATA AND INFORMATION GOVERNANCE (U.S. CLS. 100, 101 AND 102).

FIRST USE 11-6-2008; IN COMMERCE 11-6-2008.

3,955,693. LEARNING MANAGEMENT INSTITUTE, WINCHESTER, MA. SN 77-934,503. PUB. 11-30-2010, FILED 2-12-2010.

# CLMO

THE MARK CONSISTS OF STANDARD CHARACTERS WITHOUT CLAIM TO ANY PARTICULAR FONT, STYLE, SIZE, OR COLOR.

FOR ORGANIZATIONAL DEVELOPMENT SERVICES, NAMELY, ASSISTANCE AND ADVICE REGARDING BUSINESS ORGANIZATION AND MANAGEMENT IN THE FIELD OF LEARNING MANAGEMENT (U.S. CLS. 100, 101 AND 102).

FIRST USE 6-1-2010; IN COMMERCE 6-1-2010.

**CLASS 35—(Continued).**

3,955,703. JIFFY LUBE INTERNATIONAL, INC., HOUSTON, TX. SN 77-936,840. PUB. 7-13-2010, FILED 2-16-2010.

# Jiffy Lube Rewards

THE MARK CONSISTS OF STANDARD CHARACTERS WITHOUT CLAIM TO ANY PARTICULAR FONT, STYLE, SIZE, OR COLOR.

OWNER OF U.S. REG. NOS. 1,326,317, 2,368,103, AND OTHERS.

NO CLAIM IS MADE TO THE EXCLUSIVE RIGHT TO USE "REWARDS", APART FROM THE MARK AS SHOWN.

FOR ARRANGING AND CONDUCTING INCENTIVE REWARD PROGRAMS TO PROMOTE THE SALE OF VEHICLE PREVENTATIVE MAINTENANCE SERVICES, NAMELY, LUBRICATING CHASSIS, CHANGING MOTOR OIL, CHANGING OIL AND AIR FILTERS, REFILLING TRANSMISSION, DIFFERENTIAL, BRAKE, POWER STEERING, RADIATOR, WINDSHIELD WASHER AND BATTERY RESERVOIRS TO PROPER FLUID LEVELS, CHANGING WINDSHIELD WIPER BLADES, INFLATING TIRES TO PROPER PRESSURE, VACUUMING INTERIORS, AND WASHING WINDOWS (U.S. CLS. 100, 101 AND 102).

FIRST USE 2-16-2010; IN COMMERCE 2-16-2010.

3,955,711. NOVARTIS AG, BASEL, SWITZERLAND. SN 77-938,074. PUB. 6-22-2010, FILED 2-17-2010.



OWNER OF U.S. REG. NOS. 3,608,891, 3,638,838, AND OTHERS.

THE MARK CONSISTS OF THE WORD "MEET" ABOVE THE WORD "MENVEO". TO THE LEFT OF THE WORDS "MEET MENVEO" ARE TWO STYLIZED FIGURES FACING EACH OTHER TO FORM THE LETTER "M". THE WORDS "MEET MENVEO" AND THE STYLIZED LETTER "M" ARE ENCLOSED WITHIN A RECTANGULAR BORDER.

THE WORDING "MENVEO" HAS NO MEANING IN A FOREIGN LANGUAGE.

FOR ONLINE ORDERING SERVICES IN THE FIELD OF VACCINES; DISTRIBUTORSHIP SERVICES IN THE FIELD OF VACCINES; SUPPLY CHAIN MANAGEMENT SERVICES; INVENTORY MANAGEMENT; MANAGEMENT SERVICES PROVIDED TO HEALTHCARE PROVIDERS FOR CONTROLLING VACCINE INVENTORIES (U.S. CLS. 100, 101 AND 102).

FIRST USE 3-1-2010; IN COMMERCE 3-1-2010.

**CLASS 35—(Continued).**

3,955,734. DIGITAL PLACE BASED ADVERTISING ASSOCIATION, INC., NEW YORK, NY. SN 77-943,240. PUB. 7-20-2010, FILED 2-24-2010.

# DPAA

THE MARK CONSISTS OF STANDARD CHARACTERS WITHOUT CLAIM TO ANY PARTICULAR FONT, STYLE, SIZE, OR COLOR.

FOR ASSOCIATION SERVICES, NAMELY, PROMOTING THE INTEREST OF THE ADVERTISING AND MARKETING COMMUNITY IN THE FIELD OF IN-STORE TV, OUT-OF-HOME VIDEO NETWORKS AND OTHER FORMS OF DIGITAL MEDIA; PROVIDING INFORMATION FOR BUSINESSES REGARDING USE OF IN-STORE TV, OUT-OF-HOME VIDEO NETWORKS AND OTHER FORMS OF DIGITAL MEDIA FOR ADVERTISING AND MARKETING PURPOSES; PROMOTING PUBLIC AWARENESS IN THE BUSINESS COMMUNITY ABOUT THE USE OF IN-STORE TV, OUT-OF-HOME VIDEO NETWORKS AND OTHER FORMS OF DIGITAL MEDIA FOR ADVERTISING AND MARKETING PURPOSES; CONDUCTING MARKETING STUDIES ON THE EFFECTIVENESS OF IN-STORE TV, OUT-OF-HOME VIDEO NETWORKS AND OTHER FORMS OF DIGITAL MEDIA; PROVIDING INFORMATION FOR BUSINESSES VIA AN INTERNET WEBSITE REGARDING USE OF IN-STORE TV, OUT-OF-HOME VIDEO NETWORK AND OTHER FORMS OF DIGITAL MEDIA FOR ADVERTISING AND MARKETING PURPOSES; MEDIA CLEARINGHOUSE SERVICES FOR MAJOR MEDIA BROKERS (U.S. CLS. 100, 101 AND 102).

FIRST USE 3-23-2010; IN COMMERCE 3-23-2010.

3,955,744. MJS I.P. HOLDING CO. LLC, FRISCO, TX. SN 77-944,950. PUB. 7-20-2010, FILED 2-25-2010.

# KLOSEOUT KLOSET

THE MARK CONSISTS OF STANDARD CHARACTERS WITHOUT CLAIM TO ANY PARTICULAR FONT, STYLE, SIZE, OR COLOR.

NO CLAIM IS MADE TO THE EXCLUSIVE RIGHT TO USE "KLOSEOUT", APART FROM THE MARK AS SHOWN.

FOR RETAIL AND ONLINE DEPARTMENT STORE SERVICES FEATURING ITEMS FOR BABIES AND CHILDREN (U.S. CLS. 100, 101 AND 102).

FIRST USE 4-1-2010; IN COMMERCE 4-1-2010.

**CLASS 35—(Continued).**

3,955,751. DD IP HOLDER LLC, CANTON, MA. SN 77-946,175. PUB. 8-10-2010, FILED 2-26-2010.

# THERE'S NO DUNKIN' WITHOUT U

THE MARK CONSISTS OF STANDARD CHARACTERS WITHOUT CLAIM TO ANY PARTICULAR FONT, STYLE, SIZE, OR COLOR.

OWNER OF U.S. REG. NOS. 3,094,260 AND 3,134,998. FOR BUSINESS MANAGEMENT SERVICES, NAMELY, PROVIDING ADVICE AND ASSISTANCE IN THE FIELDS OF EMPLOYEE RECRUITMENT, EMPLOYEE RECOGNITION, EMPLOYEE DEVELOPMENT, EMPLOYEE MORALE (U.S. CLS. 100, 101 AND 102).

FIRST USE 3-23-2010; IN COMMERCE 3-24-2010.

3,955,758. CONNECTICUT TECHNOLOGY COUNCIL, INC., EAST HARTFORD, CT. SN 77-948,677. PUB. 8-10-2010, FILED 3-2-2010.

# WOMEN OF INNOVATION

THE MARK CONSISTS OF STANDARD CHARACTERS WITHOUT CLAIM TO ANY PARTICULAR FONT, STYLE, SIZE, OR COLOR.

NO CLAIM IS MADE TO THE EXCLUSIVE RIGHT TO USE "WOMEN", APART FROM THE MARK AS SHOWN.

FOR ARRANGING AND CONDUCTING BUSINESS CONFERENCES THAT SHOWCASE THE ACHIEVEMENTS OF WOMEN AND PROVIDE NETWORKING OPPORTUNITIES FOR WOMEN IN THE BUSINESS, PROFESSIONAL, GOVERNMENT AND PHILANTHROPIC COMMUNITIES; PROVIDING AN INTERNET WEBSITE FEATURING NEWS AND INFORMATION REGARDING BUSINESS CONFERENCES AND INFORMATION IN BUSINESS MATTERS OF INTEREST TO WOMEN IN THE BUSINESS, PROFESSIONAL, GOVERNMENT AND PHILANTHROPIC COMMUNITIES (U.S. CLS. 100, 101 AND 102).

FIRST USE 11-16-2004; IN COMMERCE 11-16-2004.

3,955,760. TURTLE MARKET LLC, MURRELLS INLET, SC. SN 77-948,781. PUB. 7-27-2010, FILED 3-2-2010.

# TURTLE MARKET

THE MARK CONSISTS OF STANDARD CHARACTERS WITHOUT CLAIM TO ANY PARTICULAR FONT, STYLE, SIZE, OR COLOR.



**CLASS 35—(Continued).**

NO CLAIM IS MADE TO THE EXCLUSIVE RIGHT TO USE "MARKET", APART FROM THE MARK AS SHOWN.

FOR RETAIL STORE SERVICES FEATURING CONVENIENCE STORE ITEMS AND GASOLINE (U.S. CLS. 100, 101 AND 102).

FIRST USE 11-8-2010; IN COMMERCE 11-8-2010.

---

3,955,771. THEDACARE, INC., APPLETON, WI. SN 77-950,181. PUB. 7-27-2010, FILED 3-4-2010.

**WALLY POLYP**

THE MARK CONSISTS OF STANDARD CHARACTERS WITHOUT CLAIM TO ANY PARTICULAR FONT, STYLE, SIZE, OR COLOR.

NO CLAIM IS MADE TO THE EXCLUSIVE RIGHT TO USE "POLYP", APART FROM THE MARK AS SHOWN.

FOR PROMOTING PUBLIC AWARENESS OF THE BENEFITS OF COLON CANCER SCREENING PROCEDURES; DISTRIBUTING PROMOTIONAL MATERIALS PROMOTING PUBLIC AWARENESS OF THE BENEFITS OF COLON CANCER SCREENING PROCEDURES (U.S. CLS. 100, 101 AND 102).

FIRST USE 3-11-2010; IN COMMERCE 3-11-2010.

---

3,955,811. ROMAN STOICA, SORIN, THORNHILL, ONTARIO, CANADA. SN 77-962,745. PUB. 7-27-2010, FILED 3-18-2010.

**XPERANK**

THE COLOR(S) GRAY, RED AND NAVY BLUE IS/ARE CLAIMED AS A FEATURE OF THE MARK.

**CLASS 35—(Continued).**

THE MARK CONSISTS OF THE STYLIZED TERM "XPERANK", WITH THE LETTERS "XPE" IN GRAY WITH NAVY BLUE OUTLINING AND THE LETTERS "RANK" IN RED WITH NAVY BLUE OUTLINING, WHERE THE LETTERS ARE ALL CAPITALIZED EXCEPT FOR THE LETTER "E". THE BACKGROUND OF THE ENTIRE MARK IS TRANSLUCENT.

FOR BUSINESS ADMINISTRATION CONSULTANCY; BUSINESS ADVISORY SERVICES, CONSULTANCY AND INFORMATION; BUSINESS CONSULTATION; BUSINESS CONSULTATION IN THE FIELD OF DATA-DRIVEN DECISION-MAKING, OPERATIONAL TRANSFORMATION, AND CHANGE MANAGEMENT; BUSINESS CONSULTATION SERVICES; BUSINESS CONSULTATION SERVICES, NAMELY, BUSINESS PROCESS IMPROVEMENT AND ENTERPRISE ARCHITECTURE DESIGN; BUSINESS CONSULTING AND BUSINESS INFORMATION FOR ENTERPRISES; BUSINESS CONSULTING SERVICES IN THE FIELD OF ORGANIZATIONAL CHANGE MANAGEMENT; BUSINESS CONSULTING SERVICES RELATING TO THE INTEGRATION OF THE AREAS OF BUSINESS PROCESS TECHNOLOGY, ORGANIZATIONAL LEARNING, CHANGE MANAGEMENT, AND OPERATIONAL SUSTAINABILITY; BUSINESS CONSULTING SERVICES, NAMELY, PROVIDING ASSISTANCE IN DEVELOPMENT OF BUSINESS STRATEGIES AND CREATIVE IDEATION; BUSINESS CONSULTING, MANAGEMENT, PLANNING AND SUPERVISION; BUSINESS MANAGEMENT AND CONSULTATION; BUSINESS MANAGEMENT AND ENTERPRISE ORGANIZATION CONSULTANCY; BUSINESS MANAGEMENT CONSULTANCY AND ADVISORY SERVICES; BUSINESS MANAGEMENT CONSULTANCY AS WELL AS DEVELOPMENT OF PROCESSES FOR THE ANALYSIS AND THE IMPLEMENTATION OF STRATEGY PLANS AND MANAGEMENT PROJECTS; BUSINESS MANAGEMENT CONSULTANCY SERVICES; BUSINESS MANAGEMENT CONSULTANCY, ALSO VIA THE INTERNET; BUSINESS MANAGEMENT CONSULTATION; BUSINESS MANAGEMENT CONSULTING; BUSINESS MANAGEMENT CONSULTING AND ADVISORY SERVICES; BUSINESS MANAGEMENT CONSULTING IN THE FIELD OF TEAM DEVELOPMENT; BUSINESS MANAGEMENT CONSULTING WITH RELATION TO STRATEGY, MARKETING, PRODUCTION, PERSONNEL AND RETAIL SALE MATTERS; BUSINESS MANAGEMENT CONSULTING WITH RELATION TO STRATEGY, MARKETING, SALES, OPERATION, PRODUCT DESIGN PARTICULARLY SPECIALIZING IN THE USE OF ANALYTIC AND STATISTIC MODELS FOR THE UNDERSTANDING AND PREDICTING OF CONSUMERS, BUSINESSES, AND MARKET TRENDS AND ACTIONS; BUSINESS ORGANISATION AND MANAGEMENT CONSULTING SERVICES; BUSINESS ORGANISATION CONSULTING; BUSINESS ORGANIZATION AND MANAGEMENT CONSULTING; BUSINESS ORGANIZATION AND OPERATION CONSULTANCY; BUSINESS ORGANIZATION CONSULTING; BUSINESS ORGANIZATIONAL CONSULTATION; BUSINESS RELOCATION CONSULTING; BUSINESS RESEARCH CONSULTATION; BUSINESS SUPPORT SERVICES, NAMELY, BUSINESS CONSULTING TO FREELANCERS, START-UPS, EXISTING BUSINESSES AND NON-PROFIT ORGANIZATIONS; CONSULTANCY AND ADVISORY SERVICES IN THE FIELD OF BUSINESS STRATEGY; CONSULTANCY OF PERSONNEL RECRUITMENT; CONSULTING SERVICES IN BUSINESS LEADERSHIP DEVELOPMENT AND BUSINESS MANAGEMENT; CONSULTING SERVICES IN BUSINESS ORGANIZATION AND MANAGEMENT; CONSULTING SERVICES IN THE AREA OF SUSTAINABLE BUSINESS SOLUTIONS; CONSULTING SERVICES IN THE FIELD OF HUMAN RESOURCES DEVELOPMENT, NAMELY, FOR THE PROMOTION OF EMPLOYEE RETENTION, CAREER GROWTH, AND INCREASED PRODUCTIVITY

**CLASS 35—(Continued).**

FOR EMPLOYEES AND EMPLOYERS; CONSULTING SERVICES IN THE FIELD OF HUMAN RESOURCES DEVELOPMENT, NAMELY, UTILIZING TECHNOLOGY FOR THE PROMOTION OF EMPLOYEE RETENTION, CAREER GROWTH AND INCREASED PRODUCTIVITY FOR EMPLOYEES AND EMPLOYERS; CONSULTING SERVICES IN THE FIELDS OF BUSINESS MANAGEMENT, HUMAN RESOURCES, AND BUSINESS ORGANIZATIONAL DESIGN; HUMAN RESOURCES CONSULTANCY; HUMAN RESOURCES CONSULTATION; MANAGEMENT AND BUSINESS CONSULTING SERVICES IN THE FIELD OF DATA-DRIVEN DECISION-MAKING, OPERATIONAL TRANSFORMATION, AND CHANGE MANAGEMENT; MANAGEMENT CONSULTING AND ADVISORY SERVICES IN THE AREAS OF CORPORATE GROWTH STRATEGY, INNOVATION AND GROWTH PROCESSES, ORGANIZATIONAL TRANSFORMATION, AND TALENT MANAGEMENT AND DEVELOPMENT STRATEGIES; PERSONNEL MANAGEMENT CONSULTATION; PERSONNEL MANAGEMENT CONSULTING (U.S. CLS. 100, 101 AND 102).  
FIRST USE 7-1-2010; IN COMMERCE 7-1-2010.

---

3,955,812. ROMAN STOICA, SORIN, THORNHILL, ONTARIO, CANADA. SN 77-962,756. PUB. 7-27-2010, FILED 3-18-2010.



The logo for XPETTRACK features the word "XPETTRACK" in a stylized, blocky font. The letters "XP" are in a light blue color, while "ETTRACK" is in a bright green color. The letters have a slight 3D effect with a darker shade on the bottom and right sides.

THE COLOR(S) GRAY, NAVY BLUE AND GREEN IS/ARE CLAIMED AS A FEATURE OF THE MARK.

THE MARK CONSISTS OF THE STYLIZED TERM "XPETTRACK", WITH THE LETTERS "XPE" IN GRAY WITH NAVY BLUE OUTLINING, AND THE LETTERS "TRACK" IN GREEN WITH NAVY BLUE OUTLINING, WHERE THE LETTERS ARE ALL CAPITALIZED EXCEPT FOR THE LETTER "E". THE BACKGROUND OF THE ENTIRE MARK IS TRANSLUCENT.

FOR BUSINESS ADMINISTRATION CONSULTANCY; BUSINESS CONSULTATION; BUSINESS CONSULTATION IN THE FIELD OF BUSINESS LEADERSHIP DEVELOPMENT; BUSINESS CONSULTATION IN THE FIELD OF PERFORMANCE MANAGEMENT FOR BUSINESS UNITS, TEAMS, AND INDIVIDUALS; BUSINESS CONSULTATION SERVICES; BUSINESS CONSULTATION SERVICES, NAMELY, BUSINESS PROCESS IMPROVEMENT AND ENTERPRISE ARCHITECTURE DESIGN; BUSINESS CONSULTING AND BUSINESS INFORMATION FOR ENTERPRISES; BUSINESS CONSULTING AND INFORMATION SERVICES; BUSINESS CONSULTING SERVICES IN THE FIELD OF ORGANIZATIONAL CHANGE MANAGEMENT; BUSINESS MANAGEMENT AND CONSULTATION; BUSINESS MANAGEMENT AND ENTERPRISE ORGANIZATION CONSULTANCY; BUSINESS MANAGEMENT CONSULTANCY AND ADVISORY SERVICES; BUSINESS MANAGEMENT CONSULTANCY SERVICES; BUSINESS MANAGEMENT CONSULTANCY, ALSO VIA THE INTERNET; BUSINESS MANAGEMENT CONSULTATION; BUSINESS MANAGEMENT CONSULTATION IN THE FIELD OF EXECUTIVE AND LEADERSHIP DEVELOPMENT; BUSINESS MANAGEMENT CONSULTING; BUSINESS MANAGEMENT CONSULTING AND ADVISORY SERVICES; BUSINESS MANAGEMENT CONSULTING IN THE FIELD OF TEAM DEVELOPMENT; BUSINESS ORGANISATION AND MANAGEMENT CON-

**CLASS 35—(Continued).**

SULTING SERVICES; BUSINESS ORGANISATION CONSULTING; BUSINESS ORGANIZATION AND MANAGEMENT CONSULTING; BUSINESS ORGANIZATION AND OPERATION CONSULTANCY; BUSINESS ORGANIZATION CONSULTING; BUSINESS ORGANIZATIONAL CONSULTATION; BUSINESS SUPPORT SERVICES, NAMELY, BUSINESS CONSULTING TO FREELANCERS, START-UPS, EXISTING BUSINESSES AND NON-PROFIT ORGANIZATIONS; CONSULTANCY AND ADVISORY SERVICES IN THE FIELD OF BUSINESS STRATEGY; CONSULTANCY OF PERSONNEL RECRUITMENT; CONSULTING SERVICES IN BUSINESS LEADERSHIP DEVELOPMENT AND BUSINESS MANAGEMENT; CONSULTING SERVICES IN BUSINESS ORGANIZATION AND MANAGEMENT; CONSULTING SERVICES IN THE AREA OF SUSTAINABLE BUSINESS SOLUTIONS; CONSULTING SERVICES IN THE FIELD OF HUMAN RESOURCES DEVELOPMENT, NAMELY, FOR THE PROMOTION OF EMPLOYEE RETENTION, CAREER GROWTH, AND INCREASED PRODUCTIVITY FOR EMPLOYEES AND EMPLOYERS; CONSULTING SERVICES IN THE FIELD OF HUMAN RESOURCES DEVELOPMENT, NAMELY, UTILIZING TECHNOLOGY FOR THE PROMOTION OF EMPLOYEE RETENTION, CAREER GROWTH AND INCREASED PRODUCTIVITY FOR EMPLOYEES AND EMPLOYERS; EMPLOYMENT STAFFING CONSULTATION SERVICES; HUMAN RESOURCE ANALYSIS AND CONSULTING SERVICES; HUMAN RESOURCES CONSULTANCY; HUMAN RESOURCES CONSULTATION; MANAGEMENT AND BUSINESS CONSULTING SERVICES IN THE FIELD OF PERFORMANCE MANAGEMENT FOR BUSINESS UNITS, TEAMS, AND INDIVIDUALS; PERSONNEL MANAGEMENT CONSULTATION; PERSONNEL MANAGEMENT CONSULTING; PROFESSIONAL BUSINESS CONSULTATION; PROFESSIONAL BUSINESS CONSULTING (U.S. CLS. 100, 101 AND 102).  
FIRST USE 7-1-2010; IN COMMERCE 7-1-2010.

---

3,955,849. MANUCHAR NV, B-2170 ANTWERP, BELGIUM. SN 77-981,509. PUB. 8-17-2010, FILED 9-30-2009.



The logo for MANUCHAR consists of the word "MANUCHAR" in a bold, serif, all-caps font. The letters are black and have a classic, slightly condensed appearance.

THE MARK CONSISTS OF STANDARD CHARACTERS WITHOUT CLAIM TO ANY PARTICULAR FONT, STYLE, SIZE, OR COLOR.

FOR BUSINESS MANAGEMENT SERVICES, NAMELY, MANAGING LOGISTICS, REVERSE LOGISTICS, AND SUPPLY CHAIN SERVICES; TRANSPORTATION LOGISTICS SERVICES, NAMELY, ARRANGING THE TRANSPORTATION OF GOODS FOR OTHERS; PROVIDING TRACKING SERVICES CONCERNING TRACKING OF ASSETS IN TRANSIT, NAMELY, DELIVERY CONTAINERS (U.S. CLS. 100, 101 AND 102).  
FIRST USE 8-0-2009; IN COMMERCE 2-0-2010.

**CLASS 35—(Continued).**

3,955,912. SURRY COUNTY ECONOMIC DEVELOPMENT AND TOURISM, DOBSON, NC. SN 85-010,358. PUB. 9-7-2010, FILED 4-9-2010.



NO CLAIM IS MADE TO THE EXCLUSIVE RIGHT TO USE "SURRY", APART FROM THE MARK AS SHOWN. THE COLOR(S) GRAY AND MAROON IS/ARE CLAIMED AS A FEATURE OF THE MARK.

THE MARK CONSISTS OF "VERY SURRY". THE "VERY" IS LOCATED ABOVE "SURRY" WITHIN THE FIRST CURVE OF THE "S" IN "SURRY". "VERY" IS WRITTEN IN GRAY BLOCK LETTERS AND "SURRY" IS WRITTEN IN MAROON CURSIVE LETTERS.

FOR PROMOTING RECREATION AND TOURISM IN SURRY COUNTY, NORTH CAROLINA (U.S. CLS. 100, 101 AND 102).

FIRST USE 7-1-2009; IN COMMERCE 7-1-2009.

3,955,928. UNDER ARMOUR, INC., BALTIMORE, MD. SN 85-015,703. PUB. 7-13-2010, FILED 4-16-2010.

MOTHER NATURE MADE IT. WE  
MADE IT BETTER.

THE MARK CONSISTS OF STANDARD CHARACTERS WITHOUT CLAIM TO ANY PARTICULAR FONT, STYLE, SIZE, OR COLOR.

FOR ONLINE RETAIL STORE SERVICES FEATURING APPAREL, FOOTWEAR, HEADWEAR, AND SPORTING GOODS; MOBILE RETAIL STORE SERVICES FEATURING APPAREL, FOOTWEAR, HEADWEAR, AND SPORTING GOODS (U.S. CLS. 100, 101 AND 102).  
FIRST USE 2-5-2011; IN COMMERCE 2-5-2011.

3,955,929. UNDER ARMOUR, INC., BALTIMORE, MD. SN 85-015,981. PUB. 7-13-2010, FILED 4-16-2010.

MOTHER NATURE MADE IT.  
UNDER ARMOUR MADE IT  
BETTER.

THE MARK CONSISTS OF STANDARD CHARACTERS WITHOUT CLAIM TO ANY PARTICULAR FONT, STYLE, SIZE, OR COLOR.

**CLASS 35—(Continued).**

OWNER OF U.S. REG. NOS. 2,279,668, 3,638,277, AND OTHERS.

FOR RETAIL STORE SERVICES FEATURING APPAREL, FOOTWEAR, HEADWEAR, AND SPORTING GOODS (U.S. CLS. 100, 101 AND 102).

FIRST USE 3-1-2011; IN COMMERCE 3-1-2011.

3,955,930. KARMALOOP, INC., BOSTON, MA. SN 85-016,075. PUB. 9-14-2010, FILED 4-16-2010.

PLNDR

THE MARK CONSISTS OF STANDARD CHARACTERS WITHOUT CLAIM TO ANY PARTICULAR FONT, STYLE, SIZE, OR COLOR.

FOR ON-LINE RETAIL STORE SERVICES FEATURING CLOTHING, FOOTWEAR, BELTS, HATS, BAGS, EYEWEAR, ACCESSORIES, GIFT ITEMS, JEWELRY, WALLETS, TOYS, AND GENERAL MERCHANDISE (U.S. CLS. 100, 101 AND 102).  
FIRST USE 4-28-2010; IN COMMERCE 4-28-2010.

3,955,937. CALLED TO SURF, LLC, PROVO, UT. SN 85-018,796. PUB. 9-21-2010, FILED 4-20-2010.

CALLED TO SURF

THE MARK CONSISTS OF STANDARD CHARACTERS WITHOUT CLAIM TO ANY PARTICULAR FONT, STYLE, SIZE, OR COLOR.

FOR RETAIL CLOTHING STORES; RETAIL SPORTING GOODS STORES (U.S. CLS. 100, 101 AND 102).  
FIRST USE 6-2-2010; IN COMMERCE 6-2-2010.

**CLASS 35—(Continued).**

3,955,938. DUTZ TECHNOLOGIES LLC, DBA APPICKER, SAN FRANCISCO, CA. SN 85-019,143. PUB. 9-28-2010, FILED 4-21-2010.

**How Do You Like Them Apps?**

THE MARK CONSISTS OF STANDARD CHARACTERS WITHOUT CLAIM TO ANY PARTICULAR FONT, STYLE, SIZE, OR COLOR.

FOR PROVIDING A SEARCHABLE WEBSITE FEATURING THE GOODS AND SERVICES OF OTHER VENDORS; PROVIDING CONSUMER PRODUCT INFORMATION VIA THE INTERNET (U.S. CLS. 100, 101 AND 102).

FIRST USE 4-22-2010; IN COMMERCE 4-22-2010.

---

3,955,961. U.S. FOODSERVICE, INC., ROSEMONT, IL. SN 85-029,019. PUB. 8-24-2010, FILED 5-3-2010.



NO CLAIM IS MADE TO THE EXCLUSIVE RIGHT TO USE "SPECIALTY FOODS", APART FROM THE MARK AS SHOWN.

THE MARK CONSISTS OF THE WORD "CONNOISSEUR" IN BOLD WITH THE WORDS "SPECIALTY FOODS" UNDERNEATH WITHIN A RECTANGULAR BOX.

FOR WHOLESALE DISTRIBUTORSHIPS FEATURING SPECIALTY FOODS (U.S. CLS. 100, 101 AND 102).

FIRST USE 6-1-2010; IN COMMERCE 6-1-2010.

---

3,955,968. POWE, ANTHONY, NEW YORK, NY. SN 85-032,278. PUB. 10-26-2010, FILED 5-6-2010.

**ZIPCARD**

THE MARK CONSISTS OF STANDARD CHARACTERS WITHOUT CLAIM TO ANY PARTICULAR FONT, STYLE, SIZE, OR COLOR.

FOR PROMOTING THE GOODS AND SERVICES OF OTHERS IN A SPECIFIC ZIP CODE BY MEANS OF THE ISSUANCE OF LOYALTY REWARDS CARDS TO PEOPLE LIVING OR WORKING IN THE SAME ZIP CODED AREA (U.S. CLS. 100, 101 AND 102).

FIRST USE 6-1-2010; IN COMMERCE 11-5-2010.

**CLASS 35—(Continued).**

3,955,971. TEXAS ONE VOICE: A COLLABORATIVE FOR HEALTH AND HUMAN SERVICES, HOUSTON, TX. SN 85-034,672. PUB. 11-23-2010, FILED 5-10-2010.

**ONE VOICE TEXAS**

THE MARK CONSISTS OF STANDARD CHARACTERS WITHOUT CLAIM TO ANY PARTICULAR FONT, STYLE, SIZE, OR COLOR.

NO CLAIM IS MADE TO THE EXCLUSIVE RIGHT TO USE "TEXAS", APART FROM THE MARK AS SHOWN.

FOR ASSOCIATION SERVICES, NAMELY, PROMOTING THE PUBLIC INTEREST AND AWARENESS IN THE FIELDS OF HEALTH AND HUMAN SERVICES, AND PUBLIC POLICY ISSUES RELATED TO HEALTH AND HUMAN SERVICES; CHARITABLE SERVICES, NAMELY, PROMOTING PUBLIC AWARENESS ABOUT THE NEED FOR HEALTH AND HUMAN SERVICES BY CONDUCTING WORK GROUPS TO RESEARCH AND DEVELOP SOLUTIONS TO HEALTH AND HUMAN SERVICE ISSUES; PROMOTING PUBLIC AWARENESS OF HEALTH AND HUMAN SERVICE ISSUES, AND PUBLIC POLICY ISSUES RELATED TO HEALTH AND HUMAN SERVICES; AND PUBLIC ADVOCACY TO PROMOTE AWARENESS OF HEALTH AND HUMAN SERVICE ISSUES (U.S. CLS. 100, 101 AND 102).

FIRST USE 6-9-2009; IN COMMERCE 6-9-2009.

---

3,955,982. CUPCAKE HOLDINGS LLC, BROOKLYN, NY. SN 85-038,862. PUB. 10-19-2010, FILED 5-14-2010.



NO CLAIM IS MADE TO THE EXCLUSIVE RIGHT TO USE "CUPCAKE", APART FROM THE MARK AS SHOWN.

THE MARK CONSISTS OF A DRAWING OF A CUPCAKE TO THE RIGHT OF WHICH APPEAR THE WORDS "CUPCAKE CREW" IN STYLIZED FONTS, WITH THE WORD "CUPCAKE" POSITIONED ABOVE THE WORD "CREW".

FOR MOBILE STREET VENDOR SERVICES FEATURING FOOD AND DRINK (U.S. CLS. 100, 101 AND 102).

FIRST USE 10-29-2010; IN COMMERCE 10-29-2010.

**CLASS 35—(Continued).**

3,956,007. RAFTELIS FINANCIAL CONSULTANTS, INC., CHARLOTTE, NC. SN 85-053,551. PUB. 11-2-2010, FILED 6-3-2010.

# SUNESIS

THE MARK CONSISTS OF STANDARD CHARACTERS WITHOUT CLAIM TO ANY PARTICULAR FONT, STYLE, SIZE, OR COLOR.

THE ENGLISH TRANSLATION OF "SUNESIS" IN THE MARK IS "KNOWLEDGE".

FOR BUSINESS MANAGEMENT CONSULTING SERVICES FOR REGULATED AND NON-REGULATED UTILITY COMPANIES WITH REGARD TO EFFECTIVE UTILITY MANAGEMENT, STRATEGIC PLANNING, CHANGE MANAGEMENT, ORGANIZATIONAL IMPROVEMENT, PERFORMANCE BENCHMARKING, INFRASTRUCTURE PLANNING, AND PROCESS IMPROVEMENT (U.S. CLS. 100, 101 AND 102).

FIRST USE 7-25-2010; IN COMMERCE 7-25-2010.

3,956,031. BUILD.COM, INC., CHICO, CA. SN 85-066,293. PUB. 12-7-2010, FILED 6-18-2010.

## SMARTER HOME IMPROVEMENT

THE MARK CONSISTS OF STANDARD CHARACTERS WITHOUT CLAIM TO ANY PARTICULAR FONT, STYLE, SIZE, OR COLOR.

NO CLAIM IS MADE TO THE EXCLUSIVE RIGHT TO USE "HOME", APART FROM THE MARK AS SHOWN.

FOR ON-LINE RETAIL STORE SERVICES FEATURING DECORATIVE PLUMBING PRODUCTS, LIGHTING, DOOR HARDWARE, AND HOME DECOR PRODUCTS (U.S. CLS. 100, 101 AND 102).

FIRST USE 5-31-2010; IN COMMERCE 5-31-2010.

3,956,034. CITIGROUP INC., NEW YORK, NY. SN 85-068,362. PUB. 9-28-2010, FILED 6-22-2010.

## CITI THANKYOU

THE MARK CONSISTS OF STANDARD CHARACTERS WITHOUT CLAIM TO ANY PARTICULAR FONT, STYLE, SIZE, OR COLOR.

**CLASS 35—(Continued).**

OWNER OF U.S. REG. NOS. 2,923,492, 2,926,291, AND OTHERS.

FOR PROMOTING THE GOODS AND SERVICES OF OTHERS THROUGH ADMINISTRATION OF INCENTIVE REWARD AND REDEMPTION PROGRAMS BY DISTRIBUTING REWARDS FOR CREDIT AND DEBIT CARD USE, AND FOR BANKING AND WEALTH MANAGEMENT CUSTOMER LOYALTY (U.S. CLS. 100, 101 AND 102).

FIRST USE 6-0-2010; IN COMMERCE 6-0-2010.

3,956,041. PROJECT ARTISAN LLC, NEWPORT BEACH, CA. SN 85-075,940. PUB. 11-30-2010, FILED 7-1-2010.

## PROJECT ARTISAN

THE MARK CONSISTS OF STANDARD CHARACTERS WITHOUT CLAIM TO ANY PARTICULAR FONT, STYLE, SIZE, OR COLOR.

FOR COMPUTERIZED ON-LINE ORDERING FEATURING GENERAL MERCHANDISE AND GENERAL CONSUMER GOODS; PROVIDING AN ON-LINE COMMERCIAL INFORMATION DIRECTORY; PROVIDING A SEARCHABLE ON-LINE ADVERTISING GUIDE FEATURING THE GOODS AND SERVICES OF OTHER ON-LINE VENDORS; DATABASE MANAGEMENT SERVICES; ADVERTISING SERVICES, NAMELY, PROVIDING ADVERTISING IN THE NATURE OF ON-LINE AND ELECTRONIC CLASSIFIED DIRECTORIES; PROVIDING A WEBSITE FEATURING EVALUATIVE FEEDBACK AND PRODUCT RATINGS OF CONSUMER SERVICES OF OTHERS IN THE FIELD OF RATING SELLERS' GOODS AND SERVICES, THE VALUE AND PRICES OF SELLERS' GOODS AND SERVICES, BUYERS' AND SELLERS' PERFORMANCE, DELIVERY, AND OVERALL EXPERIENCE IN CONNECTION THEREWITH (U.S. CLS. 100, 101 AND 102).

FIRST USE 8-0-2010; IN COMMERCE 8-0-2010.

3,956,051. IRVIN KAHN & SONS, INC., LOUISVILLE, KY. SN 85-080,063. PUB. 12-7-2010, FILED 7-8-2010.



NO CLAIM IS MADE TO THE EXCLUSIVE RIGHT TO USE "FLOORS", APART FROM THE MARK AS SHOWN.

THE MARK CONSISTS OF A STYLIZED IMAGE OF A HOME'S SIDE WALL, PARTIAL ROOF AND CHIMNEY, WITH THE WORDS "FLOORS TO YOUR HOME" WITHIN THE STYLIZED HOME, AND WITH THE "L" IN "FLOORS" HAVING THE APPEARANCE OF BEING CONSTRUCTED FROM A FLOOR COVERING.

FOR ON-LINE RETAIL STORE SERVICES FEATURING FLOOR COVERINGS (U.S. CLS. 100, 101 AND 102).

FIRST USE 6-1-2010; IN COMMERCE 6-1-2010.

**CLASS 35—(Continued).**

3,956,061. MEDI IP LLC, TAMPA, FL. SN 85-082,717. PUB. 12-14-2010, FILED 7-12-2010.

**POWERPLAY**

THE MARK CONSISTS OF STANDARD CHARACTERS WITHOUT CLAIM TO ANY PARTICULAR FONT, STYLE, SIZE, OR COLOR.

FOR FRANCHISING, NAMELY, OFFERING BUSINESS MANAGEMENT ASSISTANCE IN THE ESTABLISHMENT AND/OR OPERATION OF PHYSICIAN SUPERVISED PEDIATRIC WEIGHT LOSS PROGRAMS (U.S. CLS. 100, 101 AND 102).

FIRST USE 2-4-2011; IN COMMERCE 2-4-2011.

---

3,956,062. RX GEAR, LLC, QUINCY, MA. SN 85-083,174. PUB. 12-14-2010, FILED 7-13-2010.

**SCRUBOLOGY**

THE MARK CONSISTS OF STANDARD CHARACTERS WITHOUT CLAIM TO ANY PARTICULAR FONT, STYLE, SIZE, OR COLOR.

FOR RETAIL AND ONLINE STORE SERVICES FEATURING CLOTHING AND MEDICAL AND HEALTH-CARE APPAREL AND RELATED ACCESSORIES (U.S. CLS. 100, 101 AND 102).

FIRST USE 11-3-2010; IN COMMERCE 11-3-2010.

---

3,956,078. THE RED FLAG GROUP LIMITED, SHEUNG WAN, HONG KONG. SN 85-092,419. PUB. 12-14-2010, FILED 7-26-2010.

**INTEGRASURE**

THE MARK CONSISTS OF STANDARD CHARACTERS WITHOUT CLAIM TO ANY PARTICULAR FONT, STYLE, SIZE, OR COLOR.

FOR BUSINESS AUDITING (U.S. CLS. 100, 101 AND 102).

FIRST USE 1-1-2011; IN COMMERCE 1-1-2011.

**CLASS 35—(Continued).**

3,956,092. TRENEGY INCORPORATED, HOUSTON, TX. SN 85-145,269. PUB. 12-28-2010, FILED 10-5-2010.



THE MARK CONSISTS OF THREE HALF-RINGS THAT ARE ALIGNED IN AN IRREGULAR CIRCLE TO THE LEFT OF THE STYLIZED WORD "TRENEGY" WITH THE LETTERS "T" AND "R" TOUCHING AT THE TOP.

FOR BUSINESS CONSULTING SERVICES RELATING TO THE INTEGRATION OF THE AREAS OF BUSINESS PROCESS TECHNOLOGY, ORGANIZATIONAL LEARNING, CHANGE MANAGEMENT, AND OPERATIONAL SUSTAINABILITY (U.S. CLS. 100, 101 AND 102).

FIRST USE 10-1-2010; IN COMMERCE 10-1-2010.

**CLASS 36—INSURANCE AND FINANCIAL**

3,955,296. WORLD CARES CENTER, INC., NEW YORK, NY. SN 77-666,975. PUB. 10-6-2009, FILED 2-10-2009.



OWNER OF U.S. REG. NO. 2,873,423.

NO CLAIM IS MADE TO THE EXCLUSIVE RIGHT TO USE "COOK OFF", APART FROM THE MARK AS SHOWN.

THE MARK CONSISTS OF THE WORDS "IRON SKILLET COOK OFF JR." SUPERIMPOSED OVER THE OUTLINE OF A FRYING PAN.

FOR CHARITABLE FUND RAISING IN VIEW OF DISASTER PRECAUTIONS AND PREVENTION; CHARITABLE FUND RAISING SERVICES (U.S. CLS. 100, 101 AND 102).

FIRST USE 3-6-2009; IN COMMERCE 3-6-2009.

**CLASS 36—(Continued).**

3,955,426. HCA-HEALTHONE LLC, DENVER, CO. SN 77-819,887. PUB. 2-2-2010, FILED 9-3-2009.



THE MARK CONSISTS OF THE FANCIFUL DESIGN OF TWO CHILDREN SITUATED OVER A MOUNTAIN RANGE AND UNDERNEATH A STAR.

FOR CHARITABLE FUND RAISING; CHARITABLE SERVICES, NAMELY, PROVIDING FINANCIAL ASSISTANCE TO FAMILIES WITH CHILDREN REQUIRING HEALTH CARE; CHARITABLE SERVICES, NAMELY, PROVIDING FINANCIAL ASSISTANCE TO COMMUNITY ORGANIZATIONS WHICH PROVIDE ASSISTANCE TO PEDIATRIC PATIENTS AND THEIR FAMILIES; CHARITABLE SERVICES, NAMELY, PROVIDING FINANCIAL ASSISTANCE TO COMMUNITY-BASED MEDICAL RESEARCH AND HEALTH CARE PROGRAMS DIRECTED TO CHILDREN 18 YEARS OF AGE AND YOUNGER; CHARITABLE SERVICES, NAMELY, PROVIDING FINANCIAL ASSISTANCE TO FUND EDUCATION PROGRAMS DIRECTED TO ISSUES INVOLVING CHILDREN, PARENTS AND HEALTH-CARE PROVIDERS (U.S. CLS. 100, 101 AND 102).

FIRST USE 8-0-2009; IN COMMERCE 8-0-2009.

3,955,588. ALPINE INVESTMENT MANAGEMENT, LLC. ST. LOUIS, MO. SN 77-910,242. PUB. 8-24-2010, FILED 1-12-2010.

**ACR**

THE MARK CONSISTS OF STANDARD CHARACTERS WITHOUT CLAIM TO ANY PARTICULAR FONT, STYLE, SIZE, OR COLOR.

FOR FINANCIAL SERVICES, NAMELY, INVESTMENT MANAGEMENT AND INVESTMENT ADVICE; FINANCIAL INVESTMENT IN THE FIELD OF SECURITIES FOR INDIVIDUALS AND INSTITUTIONS; FINANCIAL AFFAIRS, NAMELY, PRIVATE EQUITY FUND MANAGEMENT AND INVESTMENT; SECURITIES BROKERAGE; FINANCIAL ANALYSIS AND CONSULTATION; FINANCIAL AND INVESTMENT SERVICES, NAMELY, MANAGEMENT AND BROKERAGE IN THE FIELDS OF STOCKS, BONDS, OPTIONS, COMMODITIES, FUTURES AND OTHER SECURITIES, AND THE INVESTMENT OF FUNDS OF OTHERS (U.S. CLS. 100, 101 AND 102).

FIRST USE 3-1-2009; IN COMMERCE 3-1-2009.

**CLASS 36—(Continued).**

3,955,593. BRICKS REALTORS INC, SUWANEE, GA. SN 77-911,988. PUB. 4-6-2010, FILED 1-14-2010.



THE COLOR(S) YELLOW AND BLACK IS/ARE CLAIMED AS A FEATURE OF THE MARK.

THE MARK CONSISTS OF THE TERM "BRICKS" APPEARING IN BLACK NEXT TO STYLIZED DEPICTION OF A YELLOW BRICK WALL APPEARING OVER A BLACK RECTANGLE. THE ADDITIONAL WHITE THAT APPEARS REPRESENTS THE BACKGROUND AND IS NOT PART OF THE MARK.

FOR REAL ESTATE AGENCIES; REAL ESTATE BROKERAGE (U.S. CLS. 100, 101 AND 102).

FIRST USE 2-1-2010; IN COMMERCE 2-1-2010.

3,955,636. LIBERTY NATIONAL LIFE INSURANCE COMPANY, MCKINNEY, TX. SN 77-925,665. PUB. 7-20-2010, FILED 2-2-2010.

**PLATINUM PLUS**

THE MARK CONSISTS OF STANDARD CHARACTERS WITHOUT CLAIM TO ANY PARTICULAR FONT, STYLE, SIZE, OR COLOR.

NO CLAIM IS MADE TO THE EXCLUSIVE RIGHT TO USE "PLUS", APART FROM THE MARK AS SHOWN.

FOR INSURANCE UNDERWRITING SERVICES, NAMELY, MEDICARE SUPPLEMENT INSURANCE UNDERWRITING (U.S. CLS. 100, 101 AND 102).

FIRST USE 2-26-2010; IN COMMERCE 2-26-2010.

3,955,643. METROPOLITAN LIFE INSURANCE COMPANY, NEW YORK, NY. SN 77-926,828. PUB. 6-15-2010, FILED 2-3-2010.

**METLIFE DISABILITY INCOME INSURANCE SELECTOR**

THE MARK CONSISTS OF STANDARD CHARACTERS WITHOUT CLAIM TO ANY PARTICULAR FONT, STYLE, SIZE, OR COLOR.

OWNER OF U.S. REG. NOS. 1,541,862, 3,763,825, AND OTHERS.

NO CLAIM IS MADE TO THE EXCLUSIVE RIGHT TO USE "DISABILITY INCOME INSURANCE", APART FROM THE MARK AS SHOWN.

FOR INSURANCE ADMINISTRATION IN THE FIELD OF DISABILITY INCOME (U.S. CLS. 100, 101 AND 102).

FIRST USE 12-29-2009; IN COMMERCE 12-29-2009.

**CLASS 36—(Continued).**

3,955,707. FULTON FINANCIAL CORPORATION, LANCASTER, PA. SN 77-937,843. PUB. 7-20-2010, FILED 2-17-2010.

## Listening Post

THE MARK CONSISTS OF STANDARD CHARACTERS WITHOUT CLAIM TO ANY PARTICULAR FONT, STYLE, SIZE, OR COLOR.

FOR FINANCIAL SERVICES, NAMELY, BANKING SERVICES, INSURANCE CONSULTATION AND BROKERAGE SERVICES AND INVESTMENT MANAGEMENT, CONSULTATION AND BROKERAGE SERVICES (U.S. CLS. 100, 101 AND 102).

FIRST USE 9-10-2009; IN COMMERCE 9-10-2009.

---

3,955,722. HEAD & ASSOCIATES, PORTLAND, ME. SN 77-941,098. PUB. 7-13-2010, FILED 2-22-2010.

## HEADINVEST

THE MARK CONSISTS OF STANDARD CHARACTERS WITHOUT CLAIM TO ANY PARTICULAR FONT, STYLE, SIZE, OR COLOR.

FOR FINANCIAL ADVISORY AND CONSULTANCY SERVICES (U.S. CLS. 100, 101 AND 102).

FIRST USE 2-3-2011; IN COMMERCE 2-3-2011.

---

3,955,736. ASPEN RE AMERICA, INC., ROCKY HILL, CT. SN 77-943,524. PUB. 7-27-2010, FILED 2-24-2010.

## EZ FAC

THE MARK CONSISTS OF STANDARD CHARACTERS WITHOUT CLAIM TO ANY PARTICULAR FONT, STYLE, SIZE, OR COLOR.

NO CLAIM IS MADE TO THE EXCLUSIVE RIGHT TO USE "FAC", APART FROM THE MARK AS SHOWN.

FOR INSURANCE AND REINSURANCE SERVICES, NAMELY, UNDERWRITING, ISSUANCE AND ADMINISTRATION OF INSURANCE POLICIES IN THE FIELD OF FACULTATIVE CASUALTY AND PROPERTY REINSURANCE; CONSULTING AND INFORMATION CONCERNING INSURANCE (U.S. CLS. 100, 101 AND 102).

FIRST USE 3-24-2010; IN COMMERCE 5-20-2010.

**CLASS 36—(Continued).**

3,955,759. INTRUST FINANCIAL CORPORATION, WICHITA, KS. SN 77-948,714. PUB. 5-18-2010, FILED 3-2-2010.



NO CLAIM IS MADE TO THE EXCLUSIVE RIGHT TO USE "CARD SOLUTIONS", APART FROM THE MARK AS SHOWN.

THE COLOR(S) GOLD AND BLUE IS/ARE CLAIMED AS A FEATURE OF THE MARK.

THE MARK CONSISTS OF A STYLIZED HEAD OF WHEAT AND THE WORDS "WHEATLAND CARD SOLUTIONS", WITH THE STYLIZED HEAD OF WHEAT HAVING A GOLD LOWER PORTION AND A BLUE UPPER PORTION, THE WORD "WHEATLAND" IN BLUE LETTERS PLACED NEXT TO THE STYLIZED HEAD OF WHEAT AND THE WORDS "CARD SOLUTIONS" IS IN A SMALLER FONT PLACED BELOW THE WORD "WHEATLAND" IN GOLD.

FOR CREDIT CARD SERVICES (U.S. CLS. 100, 101 AND 102).

FIRST USE 2-9-2010; IN COMMERCE 2-9-2010.

---

3,955,809. KEPOS CAPITAL LP, NEW YORK, NY. SN 77-962,523. PUB. 8-10-2010, FILED 3-18-2010.

## KEPOS

THE MARK CONSISTS OF STANDARD CHARACTERS WITHOUT CLAIM TO ANY PARTICULAR FONT, STYLE, SIZE, OR COLOR.

FOR FINANCIAL SERVICES, NAMELY, INVESTMENT ADVISORY SERVICES, INVESTMENT MANAGEMENT SERVICES AND ASSET MANAGEMENT SERVICES (U.S. CLS. 100, 101 AND 102).

FIRST USE 2-1-2011; IN COMMERCE 2-1-2011.

---

3,955,880. NATIONAL CONSUMER COOPERATIVE BANK, DBA NATIONAL COOPERATIVE BANK, ARLINGTON, VA. SN 78-866,006. PUB. 1-11-2011, FILED 4-20-2006.



FOR BANKING SERVICES (U.S. CLS. 100, 101 AND 102).

FIRST USE 10-2-2006; IN COMMERCE 10-2-2006.



**CLASS 36—(Continued).**

3,955,901. BANK OF AMERICA CORPORATION, CHARLOTTE, NC. SN 85-006,527. PUB. 7-20-2010, FILED 4-5-2010.

**BOFAML OPEN MINDS**

THE MARK CONSISTS OF STANDARD CHARACTERS WITHOUT CLAIM TO ANY PARTICULAR FONT, STYLE, SIZE, OR COLOR.

OWNER OF U.S. REG. NO. 3,644,389.  
FOR FINANCIAL INVESTMENT RESEARCH SERVICES, NAMELY, ELECTRONICALLY PROVIDING INSTITUTIONAL INVESTORS THIRD-PARTY RESEARCH SURROUNDING CLIENT'S INVESTMENT PORTFOLIOS (U.S. CLS. 100, 101 AND 102).  
FIRST USE 12-31-2009; IN COMMERCE 12-31-2009.

**CLASS 36—(Continued).**

3,955,950. BANK OF AMERICA CORPORATION, CHARLOTTE, NC. SN 85-023,173. PUB. 7-20-2010, FILED 4-26-2010.

**MEDP**

THE MARK CONSISTS OF STANDARD CHARACTERS WITHOUT CLAIM TO ANY PARTICULAR FONT, STYLE, SIZE, OR COLOR.

FOR FINANCIAL PLANNING AND INVESTMENT ADVISORY SERVICES (U.S. CLS. 100, 101 AND 102).  
FIRST USE 6-30-2010; IN COMMERCE 6-30-2010.

3,955,910. KEPOS CAPITAL LP, NEW YORK, NY. SN 85-009,471. PUB. 8-10-2010, FILED 4-8-2010.

**KEPOS CAPITAL LP**

THE MARK CONSISTS OF STANDARD CHARACTERS WITHOUT CLAIM TO ANY PARTICULAR FONT, STYLE, SIZE, OR COLOR.

NO CLAIM IS MADE TO THE EXCLUSIVE RIGHT TO USE "CAPITAL LP", APART FROM THE MARK AS SHOWN.

FOR FINANCIAL SERVICES, NAMELY, INVESTMENT ADVISORY SERVICES, INVESTMENT MANAGEMENT SERVICES AND ASSET MANAGEMENT SERVICES (U.S. CLS. 100, 101 AND 102).  
FIRST USE 2-1-2011; IN COMMERCE 2-1-2011.

3,955,962. ZELKOVA ACQUISITION LLC, LAS VEGAS, NV. SN 85-029,383. PUB. 10-5-2010, FILED 5-4-2010.

**ZELKOVA**

THE MARK CONSISTS OF STANDARD CHARACTERS WITHOUT CLAIM TO ANY PARTICULAR FONT, STYLE, SIZE, OR COLOR.

FOR FINANCIAL SERVICES, NAMELY, RESTRUCTURING EXISTING LOANS AND ACQUIRING AND COLLECTING RECEIVABLES FOR SECURED AND UNSECURED, NON-PERFORMING AND SUB-PERFORMING, CONSUMER AND COMMERCIAL DEBT; FINANCIAL PORTFOLIO MANAGEMENT IN THE FIELD OF NON-PERFORMING AND DISTRESSED CONSUMER DEBT, NAMELY, ACQUISITION AND LIQUIDATION OF CHARGED-OFF CONSUMER ACCOUNTS RECEIVABLES (U.S. CLS. 100, 101 AND 102).  
FIRST USE 7-27-2010; IN COMMERCE 7-27-2010.

3,955,936. CNA FINANCIAL CORPORATION, CHICAGO, IL. SN 85-018,637. PUB. 9-21-2010, FILED 4-20-2010.

**TechComplete**

THE MARK CONSISTS OF STANDARD CHARACTERS WITHOUT CLAIM TO ANY PARTICULAR FONT, STYLE, SIZE, OR COLOR.

FOR INSURANCE UNDERWRITING IN THE FIELD OF BUSINESS PROPERTY AND BUSINESS LIABILITY (U.S. CLS. 100, 101 AND 102).  
FIRST USE 8-31-2010; IN COMMERCE 8-31-2010.

3,955,981. GOVERNMENT PAYMENT SERVICE, INC., INDIANAPOLIS, IN. SN 85-038,341. PUB. 10-19-2010, FILED 5-13-2010.



THE MARK CONSISTS OF FOUR SMALL SQUARES

**CLASS 36—(Continued).**

ALIGNED TO FORM A LARGER SINGLE SQUARE, WHICH SINGLE SQUARE IS CIRCUMSCRIBED ABOVE BY A PARTIAL ELLIPSE, AND FOLLOWED BY THE TERM "GOVPAYNET" IN LARGE TYPE, BELOW WHICH TERM APPEARS IN SMALL TYPE THE TERMS "THE SIMPLE WAY TO PAY". THE FOUR SMALL SQUARES FEATURE, MOVING CLOCKWISE STARTING WITH THE UPPER LEFT SMALL SQUARE, A DESIGN OF A COURTHOUSE, A DESIGN OF A GAVEL, A DESIGN OF AN ELECTRONIC PAYMENT CARD, AND A DESIGN OF HANDCUFFS.

FOR PROVIDING ELECTRONIC TRANSMISSION AND PROCESSING OF FINANCIAL TRANSACTIONS BETWEEN INDIVIDUALS AND LAW ENFORCEMENT AGENCIES TO FACILITATE POSTING BAIL (U.S. CLS. 100, 101 AND 102).

FIRST USE 6-1-2010; IN COMMERCE 6-1-2010.

---

3,956,049. THE NEJ AND MASCOLO FAMILY FOUNDATION, INC., BEACON FALLS, CT. SN 85-079,617. PUB. 12-7-2010, FILED 7-7-2010.

THE MARK CONSISTS OF "KI2S" IN STYLIZED LETTERING.

FOR CHARITABLE FUNDRAISING SERVICES (U.S. CLS. 100, 101 AND 102).

FIRST USE 12-2-2010; IN COMMERCE 12-2-2010.

---

3,956,050. THE NEJ AND MASCOLO FAMILY FOUNDATION, INC., BEACON FALLS, CT. SN 85-079,619. PUB. 12-7-2010, FILED 7-7-2010.

**KIDS INSPIRED 2 SUCCEED**

THE MARK CONSISTS OF STANDARD CHARACTERS WITHOUT CLAIM TO ANY PARTICULAR FONT, STYLE, SIZE, OR COLOR.

FOR CHARITABLE FUNDRAISING SERVICES (U.S. CLS. 100, 101 AND 102).

FIRST USE 12-2-2010; IN COMMERCE 12-2-2010.

**CLASS 36—(Continued).**

3,956,073. BANCORPSOUTH BANK, TUPELO, MS. SN 85-088,580. PUB. 12-7-2010, FILED 7-20-2010.

**BXS BANK**

THE MARK CONSISTS OF STANDARD CHARACTERS WITHOUT CLAIM TO ANY PARTICULAR FONT, STYLE, SIZE, OR COLOR.

NO CLAIM IS MADE TO THE EXCLUSIVE RIGHT TO USE "BANK", APART FROM THE MARK AS SHOWN.

FOR BANKING SERVICES (U.S. CLS. 100, 101 AND 102).

FIRST USE 2-0-2010; IN COMMERCE 2-0-2010.

**CLASS 37—CONSTRUCTION AND REPAIR**

3,955,361. SHIP EQUIP AS, N-6022 AALESUND, NORWAY. SN 77-771,484. PUB. 6-22-2010, FILED 6-30-2009.

**SEVEN SEAS. ONE  
COMMUNICATION PROVIDER.**

THE MARK CONSISTS OF STANDARD CHARACTERS WITHOUT CLAIM TO ANY PARTICULAR FONT, STYLE, SIZE, OR COLOR.

FOR INSTALLATION OF TELECOMMUNICATION EQUIPMENT, NAMELY, VSATS (VERY SMALL APERTURE TERMINALS) (U.S. CLS. 100, 103 AND 106).

FIRST USE 7-0-2003; IN COMMERCE 11-0-2005.

---

3,955,664. HERSHEY, JACOB, BUTLER, PA. SN 77-930,175. PUB. 7-20-2010, FILED 2-8-2010.

**BUTLER PC**

THE MARK CONSISTS OF STANDARD CHARACTERS WITHOUT CLAIM TO ANY PARTICULAR FONT, STYLE, SIZE, OR COLOR.

NO CLAIM IS MADE TO THE EXCLUSIVE RIGHT TO USE "PC", APART FROM THE MARK AS SHOWN.

FOR MAINTENANCE AND/OR REPAIR OF COMPUTERS (U.S. CLS. 100, 103 AND 106).

FIRST USE 9-2-2004; IN COMMERCE 9-2-2004.

**CLASS 37—(Continued).**

3,955,666. CRAIG COLUZZI, DBA CORTEX HOOD CLEANING, GREAT NECK, NY. SN 77-930,225. PUB. 6-22-2010, FILED 2-8-2010.

# CORTEX

THE MARK CONSISTS OF STANDARD CHARACTERS WITHOUT CLAIM TO ANY PARTICULAR FONT, STYLE, SIZE, OR COLOR.

FOR CLEANING SERVICES FOR COMMERCIAL ROOFTOP GREASE CONTAINMENT SYSTEM COMPRISING AN EXHAUST FAN, GREASE DEFLECTOR, AND FILTER FOR TRAPPING GREASE VENTED FROM ROOFTOP EXHAUST FANS FOR COOKING AREAS WITHIN THE BUILDING (U.S. CLS. 100, 103 AND 106).  
FIRST USE 10-6-2010; IN COMMERCE 10-6-2010.

---

3,955,718. SUSTAINABLE PROPERTIES, CARRBORO, NC. SN 77-940,620. PUB. 7-13-2010, FILED 2-19-2010.

# Veridia

THE MARK CONSISTS OF STANDARD CHARACTERS WITHOUT CLAIM TO ANY PARTICULAR FONT, STYLE, SIZE, OR COLOR.

SEC. 2(F).  
FOR REAL ESTATE DEVELOPMENT (U.S. CLS. 100, 103 AND 106).  
FIRST USE 4-30-2008; IN COMMERCE 12-4-2008.

---

3,955,800. MAXWELL JON H., BREVARD, NC. SN 77-958,440. PUB. 8-3-2010, FILED 3-13-2010.

# Energy Efficiency NOW

THE MARK CONSISTS OF STANDARD CHARACTERS WITHOUT CLAIM TO ANY PARTICULAR FONT, STYLE, SIZE, OR COLOR.

NO CLAIM IS MADE TO THE EXCLUSIVE RIGHT TO USE "ENERGY EFFICIENCY", APART FROM THE MARK AS SHOWN.

FOR HOME ENERGY ASSESSMENT SERVICES FOR THE PURPOSE OF DETERMINING HOME IMPROVEMENTS NEEDED TO IMPROVE ENERGY USE AND EFFICIENCY (U.S. CLS. 100, 103 AND 106).  
FIRST USE 8-1-2010; IN COMMERCE 8-1-2010.

**CLASS 37—(Continued).**

3,955,861. SILVER OAK INVESTMENTS, LLC, MINNEAPOLIS, MN. SN 77-981,590. PUB. 8-3-2010, FILED 3-11-2010.

# SKYLARK

THE MARK CONSISTS OF STANDARD CHARACTERS WITHOUT CLAIM TO ANY PARTICULAR FONT, STYLE, SIZE, OR COLOR.

FOR DRY CLEANING; LAUNDRY SERVICES; RUG CLEANING; TEXTILE CLEANING (U.S. CLS. 100, 103 AND 106).  
FIRST USE 1-10-2011; IN COMMERCE 2-11-2011.

---

3,955,911. CON AM MANAGEMENT CORPORATION, SAN DIEGO, CA. SN 85-009,605. PUB. 8-31-2010, FILED 4-8-2010.

# HAVE A NICE PLACE

THE MARK CONSISTS OF STANDARD CHARACTERS WITHOUT CLAIM TO ANY PARTICULAR FONT, STYLE, SIZE, OR COLOR.

FOR REAL ESTATE DEVELOPMENT SERVICES; RESIDENTIAL AND COMMERCIAL BUILDING CONSTRUCTION SERVICES (U.S. CLS. 100, 103 AND 106).  
FIRST USE 2-7-2011; IN COMMERCE 2-7-2011.

---

3,955,933. WATTERS PLUMBING, INC. MENASHA, WI. SN 85-017,442. PUB. 9-21-2010, FILED 4-19-2010.

# The Leak Squad

THE MARK CONSISTS OF STANDARD CHARACTERS WITHOUT CLAIM TO ANY PARTICULAR FONT, STYLE, SIZE, OR COLOR.

NO CLAIM IS MADE TO THE EXCLUSIVE RIGHT TO USE "LEAK", APART FROM THE MARK AS SHOWN.  
FOR PLUMBING SERVICES; PLUMBING CONTRACTOR SERVICES (U.S. CLS. 100, 103 AND 106).  
FIRST USE 8-1-2010; IN COMMERCE 8-1-2010.

**CLASS 37—(Continued).**

3,956,026. AERONAUTICAL SYSTEMS, INCORPORATED, STERLING, VA. SN 85-061,316. PUB. 11-16-2010, FILED 6-12-2010.

**OPERATE WITH CONFIDENCE**

THE MARK CONSISTS OF STANDARD CHARACTERS WITHOUT CLAIM TO ANY PARTICULAR FONT, STYLE, SIZE, OR COLOR.

FOR REPAIR AND MAINTENANCE OF AIRCRAFT (U.S. CLS. 100, 103 AND 106).  
FIRST USE 3-14-2010; IN COMMERCE 3-14-2010.

3,956,027. AERONAUTICAL SYSTEMS, INCORPORATED, STERLING, VA. SN 85-061,321. PUB. 11-16-2010, FILED 6-12-2010.

**AVAILABILITY DELIVERED**

THE MARK CONSISTS OF STANDARD CHARACTERS WITHOUT CLAIM TO ANY PARTICULAR FONT, STYLE, SIZE, OR COLOR.

FOR REPAIR AND MAINTENANCE OF AIRCRAFT (U.S. CLS. 100, 103 AND 106).  
FIRST USE 3-14-2010; IN COMMERCE 3-14-2010.

3,956,074. PIONEER LINING TECHNOLOGY LIMITED, GLASGOW, UNITED KINGDOM. SN 85-089,676. PUB. 1-4-2011, FILED 7-21-2010.



OWNER OF U.S. REG. NOS. 1,578,635 AND 1,834,904.  
THE MARK CONSISTS OF THE WORD "SWAGELINING", WITH LINES AT THE TOP AND BOTTOM OF THE WORD. THE LINES ARE MADE TO APPEAR AS IF THEY ARE A PIPE WITH THE TERM BEING INSERTED THEREIN. THE LETTER "E" APPEARS TO FORM A COLUMN IN BETWEEN THE LETTERS "SWAG" AND "LINING".

FOR PIPELINE CONSTRUCTION AND MAINTENANCE, NAMELY, PIPELINE LAYING AND LINING OF PIPES (U.S. CLS. 100, 103 AND 106).  
FIRST USE 4-30-2010; IN COMMERCE 4-30-2010.

**CLASS 38—COMMUNICATION**

3,955,508. MCDONALD'S CORPORATION, OAK BROOK, IL. SN 77-869,489. PUB. 10-26-2010, FILED 11-10-2009.



OWNER OF U.S. REG. NOS. 893,440 AND 2,772,543.  
THE COLOR(S) RED, AND YELLOW IS/ARE CLAIMED AS A FEATURE OF THE MARK.

THE MARK CONSISTS OF THE LOGO KNOWN AS THE GOLDEN ARCHES IN YELLOW WITH YELLOW CURVED LINES ON EITHER SIDE, IN A RED OVAL SHAPED DESIGN.

FOR PROVIDING MULTIPLE-USER ACCESS TO A GLOBAL COMPUTER INFORMATION NETWORK; PROVIDING ACCESS TO ON-LINE SERVICES, GAMES, WEB SITES, PRIVATE OR GLOBAL COMMUNICATION NETWORKS (U.S. CLS. 100, 101 AND 104).  
FIRST USE 1-1-2011; IN COMMERCE 1-1-2011.

3,955,516. VIZ MEDIA, LLC, SAN FRANCISCO, CA. SN 77-872,637. PUB. 5-25-2010, FILED 11-13-2009.

**VIZANIME**

THE MARK CONSISTS OF STANDARD CHARACTERS WITHOUT CLAIM TO ANY PARTICULAR FONT, STYLE, SIZE, OR COLOR.

OWNER OF U.S. REG. NO. 3,720,085.  
FOR STREAMING OF AUDIO, VISUAL AND AUDIO-VISUAL MATERIAL VIA A GLOBAL COMPUTER NETWORK, NAMELY, DIGITAL MUSIC, MOTION PICTURES, FILMS, TELEVISION PROGRAMS, VIDEOS AND INTERACTIVE TELEVISION PROGRAMS (U.S. CLS. 100, 101 AND 104).

FIRST USE 12-21-2009; IN COMMERCE 12-21-2009.

**CLASS 38—(Continued).**

3,955,731. EVERLOOP, INC., DANVILLE, CA. SN 77-942,404. PUB. 7-13-2010, FILED 2-23-2010.

**EVERLOOP**

THE MARK CONSISTS OF STANDARD CHARACTERS WITHOUT CLAIM TO ANY PARTICULAR FONT, STYLE, SIZE, OR COLOR.

FOR COMMUNICATION SERVICES, NAMELY, ELECTRONIC TRANSMISSION OF AUDIO, MESSAGES, VIDEO AND OTHER DATA; PROVIDING ON-LINE CHAT ROOMS AND ELECTRONIC BULLETIN BOARDS FOR TRANSMISSION OF MESSAGES AMONG USERS IN THE FIELD OF GENERAL INTEREST (U.S. CLS. 100, 101 AND 104).

FIRST USE 10-1-2010; IN COMMERCE 10-1-2010.

3,955,883. DELMARVA BROADCASTING COMPANY, WILMINGTON, DE. SN 78-902,381. PUB. 4-28-2009, FILED 6-7-2006.

**GRAFFITI RADIO**

THE MARK CONSISTS OF STANDARD CHARACTERS WITHOUT CLAIM TO ANY PARTICULAR FONT, STYLE, SIZE, OR COLOR.

NO CLAIM IS MADE TO THE EXCLUSIVE RIGHT TO USE "RADIO", APART FROM THE MARK AS SHOWN.

FOR HYBRID DIGITAL RADIO BROADCASTING INCLUDING DIGITAL RADIO BROADCASTING AND ANALOG RADIO BROADCASTING; AND DIGITAL AUDIO STREAMING ON THE INTERNET (U.S. CLS. 100, 101 AND 104).

FIRST USE 10-31-2006; IN COMMERCE 10-31-2006.

3,955,946. FOUR RIVERS COMMUNITY BROADCASTING CORPORATION, SOUDERTON, PA. SN 85-021,234. PUB. 12-7-2010, FILED 4-22-2010.

**POSITIVE & UPLIFTING**

THE MARK CONSISTS OF STANDARD CHARACTERS WITHOUT CLAIM TO ANY PARTICULAR FONT, STYLE, SIZE, OR COLOR.

FOR RADIO PROGRAM BROADCASTING (U.S. CLS. 100, 101 AND 104).

FIRST USE 3-1-2010; IN COMMERCE 3-1-2010.

**CLASS 39—TRANSPORTATION AND STORAGE**

3,955,182. METROPOLITAN HEALTHCARE SERVICES, INC., VIENNA, VA. SN 77-099,061. PUB. 6-16-2009, FILED 2-5-2007.



NO CLAIM IS MADE TO THE EXCLUSIVE RIGHT TO USE "SERVICES GROUP", APART FROM THE MARK AS SHOWN.

THE COLOR(S) BLUE, LIGHT BLUE, YELLOW AND WHITE IS/ARE CLAIMED AS A FEATURE OF THE MARK.

THE MARK CONSISTS OF THE COLOR BLUE LOCATED ON THE LARGE "N" AT THE TOP OF THE MARK, IN THE STYLIZED WORDING "NAT" AND "ONWIDE SERVICES" AND "GROUP", AS WELL AS ON THE HAT, SHIRT AND SHOES OF THE HUMAN FIGURE BETWEEN "NAT" AND "ONWIDE". THE COLOR LIGHT BLUE APPEARS IN THE SHADOWING OF THE LETTER "N". THE COLOR YELLOW APPEARS IN THE IN THE TRIANGULAR DESIGN IN THE UPPER SECTION OF THE LETTER "N". THE COLOR WHITE APPEARS IN THE FACE, HAND AND PANTS OF THE HUMAN FIGURE BETWEEN "NAT" AND "ONWIDE" AND IN THE SMALL RECTANGULAR DESIGN AT THE TOP OF THE YELLOW TRIANGLE.

FOR CAR PARKING; VALET PARKING; VEHICLE PARKING (U.S. CLS. 100 AND 105).

FIRST USE 7-7-2008; IN COMMERCE 7-7-2008.

3,955,281. LAN AIRLINES S.A., SANTIAGO, CHILE. SN 77-636,106. PUB. 11-17-2009, FILED 12-18-2008.

**LANCO**

THE MARK CONSISTS OF STANDARD CHARACTERS WITHOUT CLAIM TO ANY PARTICULAR FONT, STYLE, SIZE, OR COLOR.

FOR FREIGHT TRANSPORTATION BY LAND VEHICLES, SHIPS AND AIRCRAFT OF GOODS, DOCUMENTS AND ARTICLES; TRANSPORTATION OF PEOPLE BY LAND VEHICLES, SHIPS AND AIRCRAFT; STORAGE, WAREHOUSING, DEPOSIT, CUSTODY, PACKAGING, PACKING, LOADING, UNLOADING, SHIPPING AND DISTRIBUTION OF GOODS, DOCUMENTS AND ARTICLES, BY LAND VEHICLES, SHIPS AND AIRCRAFT; COURIER SERVICES BY AIR, LAND AND SEA (U.S. CLS. 100 AND 105).

FIRST USE 3-28-2009; IN COMMERCE 3-28-2009.

**CLASS 39—(Continued).**

3,955,567. GOFISH-IT, LLC, CHARLOTTE, NC. SN 77-898,414.  
PUB. 5-25-2010, FILED 12-21-2009.



NO CLAIM IS MADE TO THE EXCLUSIVE RIGHT TO USE ".COM", APART FROM THE MARK AS SHOWN.

THE MARK CONSISTS OF THE WORDING "GOFISH-IT" IN STYLIZED FONT WITH A TRIANGLE DESIGN FORMING THE HYPHEN. ALL APPEARING ABOVE THE WORDING "FIND IT. BOOK IT. FISH IT." AND ".COM" WITH ".COM" APPEARING LARGER THAN THE WORDING PRECEDING IT ON THE SAME LINE. ALL OF THE ABOVE IS CONTAINED IN A STYLIZED OVAL THAT IS SURROUNDED BY THREE STYLIZED FISH.

FOR ARRANGING AND BOOKING GUIDED AND CHARTERED FISHING TRIPS (U.S. CLS. 100 AND 105).  
FIRST USE 8-9-2010; IN COMMERCE 8-9-2010.

3,955,808. AMBIT ENERGY, L.P., DALLAS, TX. SN 77-961,301. PUB. 8-3-2010, FILED 3-17-2010.

## SMARTPLAN

THE MARK CONSISTS OF STANDARD CHARACTERS WITHOUT CLAIM TO ANY PARTICULAR FONT, STYLE, SIZE, OR COLOR.

FOR DISTRIBUTION OF ENERGY, NAMELY, PROVIDING ELECTRICAL ENERGY TO RESIDENTIAL AND COMMERCIAL USERS (U.S. CLS. 100 AND 105).  
FIRST USE 5-0-2010; IN COMMERCE 5-0-2010.

**CLASS 40—MATERIAL TREATMENT****CLASS 40—(Continued).**

3,955,214. PHOENIX PERFORMANCE PRODUCTS INC., MISSISSAUGA, ONTARIO, CANADA. SN 77-407,431.  
PUB. 4-13-2010, FILED 2-27-2008.

## MyPhoenix

THE MARK CONSISTS OF STANDARD CHARACTERS WITHOUT CLAIM TO ANY PARTICULAR FONT, STYLE, SIZE, OR COLOR.

OWNER OF U.S. REG. NO. 2,911,897.

FOR CUSTOM MANUFACTURE OF RODEO PRODUCTS, NAMELY, RODEO PROTECTIVE VESTS AND RELATED PROTECTIVE EQUIPMENT, BULL RIDING VESTS, SADDLE BRONC VESTS, BARE BACK VESTS, CALF COLLARS, STEER WRESTLING VESTS, SADDLE BRONC COLLARS, SADDLE PADS, ROUGH STOCK RODEO SHIRTS, BULL RIDING HELMETS, SPORTS PROTECTIVE VESTS, HARNESS RACING HELMETS, HARNESS RACING VESTS, HORSE RIDING PROTECTIVE VESTS (U.S. CLS. 100, 103 AND 106).

FIRST USE 12-3-2010; IN COMMERCE 12-3-2010.

**CLASS 41—EDUCATION AND ENTERTAINMENT**

3,955,168. SHAPPELL, SCOTT B., DALLAS, TX. SN 76-703,203.  
PUB. 10-26-2010, FILED 6-1-2010.

## HEKASA

THE MARK CONSISTS OF STANDARD CHARACTERS WITHOUT CLAIM TO ANY PARTICULAR FONT, STYLE, SIZE, OR COLOR.

FOR PUBLISHER'S SERVICES, NAMELY, WRITTEN TEXT EDITING AND PUBLICATION OF BOOKS (U.S. CLS. 100, 101 AND 107).

FIRST USE 1-21-2011; IN COMMERCE 1-21-2011.

3,955,198. A QUANTUM MOMENT, LLC, RANCHO SANTA FE, CA. SN 77-227,316. PUB. 1-1-2008, FILED 7-11-2007.

## A QUANTUM MOMENT

THE MARK CONSISTS OF STANDARD CHARACTERS WITHOUT CLAIM TO ANY PARTICULAR FONT, STYLE, SIZE, OR COLOR.

**CLASS 41—(Continued).**

NO CLAIM IS MADE TO THE EXCLUSIVE RIGHT TO USE "QUANTUM", APART FROM THE MARK AS SHOWN.

FOR EDUCATIONAL SERVICES, NAMELY, WORKSHOPS IN THE FIELDS OF PARAPSYCHOLOGY, QUANTUM PHYSICS, QUANTUM ENERGY, ALTERNATIVE HEALING PRACTICES, SPONTANEOUS REMISSION, CONSCIOUSNESS, MIND, PSI AND PSYCHIC PHENOMENA RENDERED LIVE AND THROUGH WEBSITES AND PODCASTS; EDUCATIONAL SERVICES, NAMELY, PROVIDING LIVE CLASSES, SEMINARS AND WORKSHOPS IN THE FIELDS OF PARAPSYCHOLOGY, QUANTUM PHYSICS, QUANTUM ENERGY, ALTERNATIVE HEALING PRACTICES, SPONTANEOUS REMISSION, CONSCIOUSNESS, MIND, PSI AND PSYCHIC PHENOMENA (U.S. CLS. 100, 101 AND 107).

FIRST USE 4-0-2008; IN COMMERCE 4-0-2008.

---

3,955,209. ROTH BROS., INC., YOUNGSTOWN, OH. SN 77-371,060. PUB. 6-23-2009, FILED 1-14-2008.

**GREEN POWERED BY ROTH**

THE MARK CONSISTS OF STANDARD CHARACTERS WITHOUT CLAIM TO ANY PARTICULAR FONT, STYLE, SIZE, OR COLOR.

NO CLAIM IS MADE TO THE EXCLUSIVE RIGHT TO USE "GREEN", APART FROM THE MARK AS SHOWN.

FOR EDUCATION SERVICES, NAMELY, SEMINARS FEATURING INFORMATION ABOUT RENEWABLE ENERGY OPTIONS, SOURCE AND USAGE (U.S. CLS. 100, 101 AND 107).

FIRST USE 10-7-2008; IN COMMERCE 10-7-2008.

---

3,955,223. UNITED STATES OLYMPIC COMMITTEE, COLORADO SPRINGS, CO. SN 77-472,496. PUB. 12-30-2008, FILED 5-12-2008.

**WHERE OLYMPIC JOURNEYS  
BEGIN**

THE MARK CONSISTS OF STANDARD CHARACTERS WITHOUT CLAIM TO ANY PARTICULAR FONT, STYLE, SIZE, OR COLOR.

OWNER OF U.S. REG. NOS. 968,566, 2,777,890, AND OTHERS.

FOR ORGANIZING AND CONDUCTING ATHLETIC COMPETITIONS AND DEMONSTRATIONS; PROVIDING INSTRUCTION IN THE FIELD OF SPORTS; PROVIDING INFORMATION IN THE FIELD OF SPORTS VIA WEB SITES (U.S. CLS. 100, 101 AND 107).

FIRST USE 11-30-2010; IN COMMERCE 11-30-2010.

**CLASS 41—(Continued).**

3,955,238. LOGICAL KINETICS LLC, NEW YORK, NY. SN 77-523,564. PUB. 6-22-2010, FILED 7-16-2008.

**LOGIC**

THE MARK CONSISTS OF STANDARD CHARACTERS WITHOUT CLAIM TO ANY PARTICULAR FONT, STYLE, SIZE, OR COLOR.

FOR PROVIDING ASSISTANCE, PERSONAL TRAINING AND PHYSICAL FITNESS CONSULTATION TO INDIVIDUALS TO HELP THEM MAKE PHYSICAL FITNESS, STRENGTH, CONDITIONING, AND EXERCISE IMPROVEMENT IN THEIR DAILY LIVING (U.S. CLS. 100, 101 AND 107).

FIRST USE 2-0-2008; IN COMMERCE 2-0-2008.

---

3,955,257. IRVING, MARILYN, M., GREENBELT, MD. SN 77-587,957. PUB. 5-19-2009, FILED 10-7-2008.

**Irving and Associates  
Character Education  
Services, Inc.**

THE MARK CONSISTS OF STANDARD CHARACTERS WITHOUT CLAIM TO ANY PARTICULAR FONT, STYLE, SIZE, OR COLOR.

NO CLAIM IS MADE TO THE EXCLUSIVE RIGHT TO USE "ASSOCIATES CHARACTER EDUCATION SERVICES, INC.", APART FROM THE MARK AS SHOWN.

FOR EDUCATIONAL SERVICES, NAMELY, PROVIDING PROFESSIONAL DEVELOPMENT AND TRAINING IN THE AREA OF CHARACTER EDUCATION (U.S. CLS. 100, 101 AND 107).

FIRST USE 4-1-2009; IN COMMERCE 4-1-2009.

---

3,955,289. TURNER NETWORK TELEVISION, INC., ATLANTA, GA. SN 77-651,266. PUB. 6-15-2010, FILED 1-16-2009.

**MEN OF A CERTAIN AGE**

THE MARK CONSISTS OF STANDARD CHARACTERS WITHOUT CLAIM TO ANY PARTICULAR FONT, STYLE, SIZE, OR COLOR.

FOR ENTERTAINMENT SERVICES, NAMELY, A MULTIMEDIA PROGRAM SERIES FEATURING COMEDY, ACTION, ADVENTURE AND DRAMA DISTRIBUTED VIA VARIOUS PLATFORMS ACROSS MULTIPLE FORMS OF TRANSMISSION MEDIA (U.S. CLS. 100, 101 AND 107).

FIRST USE 12-7-2009; IN COMMERCE 12-7-2009.

**CLASS 41—(Continued).**

3,955,293. DREAMS FOR KIDS INC., CHICAGO, IL. SN 77-655,393. PUB. 12-29-2009, FILED 1-23-2009.

**WE ARE THE CHANGE**

THE MARK CONSISTS OF STANDARD CHARACTERS WITHOUT CLAIM TO ANY PARTICULAR FONT, STYLE, SIZE, OR COLOR.

FOR YOUTH LEADERSHIP DEVELOPMENT PROGRAM, NAMELY, ORGANIZING AND CONDUCTING WORKSHOPS AND SEMINARS IN PERSONAL AND SOCIAL AWARENESS (U.S. CLS. 100, 101 AND 107).

FIRST USE 4-14-2010; IN COMMERCE 4-14-2010.

---

3,955,303. JAMES VOIGHT, DBA CHIP TAYLOR, NEW YORK, NY. SN 77-678,328. PUB. 6-23-2009, FILED 2-25-2009.

**ROCK AND ROLL JOE**

THE MARK CONSISTS OF STANDARD CHARACTERS WITHOUT CLAIM TO ANY PARTICULAR FONT, STYLE, SIZE, OR COLOR.

FOR ENTERTAINMENT SERVICES, NAMELY, PROVIDING A WEBSITE FEATURING MUSIC, MUSIC EVENTS, MUSICIANS, BANDS, AUDIO CLIPS, VIDEO CLIPS, MUSICAL PERFORMANCES, MUSICAL VIDEOS, FILM CLIPS, PHOTOGRAPHS AND OTHER MULTIMEDIA MATERIALS, INFORMATION AND COMMENTARY IN CONNECTION WITH THE FIELD OF MUSIC (U.S. CLS. 100, 101 AND 107).

FIRST USE 3-15-2011; IN COMMERCE 3-15-2011.

---

3,955,405. ROBIN, MICHELLE, SHAWNEE, KS. SN 77-807,292. PUB. 6-22-2010, FILED 8-18-2009.

**WELLNESS ON A SHOESTRING**

THE MARK CONSISTS OF STANDARD CHARACTERS WITHOUT CLAIM TO ANY PARTICULAR FONT, STYLE, SIZE, OR COLOR.

FOR TRAINING, COACHING AND EDUCATION SERVICES, NAMELY, CONDUCTING CLASSES, SEMINARS, WORKSHOPS, COURSES, CONFERENCES, AND FOCUS GROUPS, IN PERSON AND ONLINE, ALL IN THE FIELDS OF HEALTH AND WELLNESS; PROVIDING INFORMATION ON-LINE IN THE NATURE OF ONLINE BLOGS FEATURING INFORMATION ABOUT HEALTH AND WELLNESS (U.S. CLS. 100, 101 AND 107).

FIRST USE 3-1-2009; IN COMMERCE 1-7-2010.

**CLASS 41—(Continued).**

3,955,408. THE CARTOON NETWORK, INC., ATLANTA, GA. SN 77-809,351. PUB. 1-19-2010, FILED 8-20-2009.

**EAGLEHEART**

THE MARK CONSISTS OF STANDARD CHARACTERS WITHOUT CLAIM TO ANY PARTICULAR FONT, STYLE, SIZE, OR COLOR.

FOR ENTERTAINMENT SERVICES, NAMELY, PROVISION OF ONGOING MULTIMEDIA PROGRAMS IN THE FIELD OF COMEDY, ACTION AND ADVENTURE DISTRIBUTED VIA VARIOUS PLATFORMS ACROSS MULTIPLE FORMS OF TRANSMISSION MEDIA (U.S. CLS. 100, 101 AND 107).

FIRST USE 2-3-2011; IN COMMERCE 2-3-2011.

---

3,955,415. ST. LOUIS SCIENCE CENTER, ST. LOUIS, MO. SN 77-813,311. PUB. 7-13-2010, FILED 8-26-2009.



NO CLAIM IS MADE TO THE EXCLUSIVE RIGHT TO USE "CENTER FOR SCIENCE", APART FROM THE MARK AS SHOWN.

THE MARK CONSISTS OF TWO INTERLOCKING SPHERES WHICH FORM A CIRCLE TO THE LEFT OF THE WORD "CENTERFORSCIENCE".

FOR EDUCATIONAL SERVICES, NAMELY, CONDUCTING EDUCATIONAL DEMONSTRATIONS, COURSES OF INSTRUCTION, SEMINARS AND EDUCATIONAL EXHIBITIONS ALL IN THE FIELDS OF ARTS AND SCIENCES; AND ORGANIZING AND ARRANGING EXHIBITIONS FOR ENTERTAINMENT PURPOSES IN THE FIELDS OF SCIENCE AND TECHNOLOGY (U.S. CLS. 100, 101 AND 107).

FIRST USE 6-1-2009; IN COMMERCE 6-1-2009.



**CLASS 41—(Continued).**

3,955,452. PENSKE RACING SOUTH, INC., MOORESVILLE, NC. SN 77-833,179. PUB. 8-3-2010, FILED 9-23-2009.



THE MARK CONSISTS OF NUMBER "22" IN A STYLIZED FORMAT.

FOR ENTERTAINMENT SERVICES IN THE NATURE OF AUTOMOBILE RACING AND EXHIBITIONS (U.S. CLS. 100, 101 AND 107).

FIRST USE 2-7-2010; IN COMMERCE 2-7-2010.

**CLASS 41—(Continued).**

3,955,480. HOPE 360, INC, ATLANTA, GA. SN 77-852,567. PUB. 3-30-2010, FILED 10-20-2009.



THE MARK CONSISTS OF THREE PEOPLE SYMBOLS WITH THE STYLIZED TEXT "HOPE 360 HELPING OTHER PEOPLE EXCEL".

FOR EDUCATION SERVICES, NAMELY, PROVIDING LIVE AND ON-LINE CLASSES, SEMINARS, WORKSHOPS IN THE FIELD OF EFFECTIVE LEADERSHIP; EDUCATIONAL AND ENTERTAINMENT SERVICES, NAMELY, PROVIDING MOTIVATIONAL SPEAKING SERVICES IN THE FIELD OF EFFECTIVE LEADERSHIP; LIFE COACHING SERVICES IN THE FIELD OF EFFECTIVE LEADERSHIP (U.S. CLS. 100, 101 AND 107). FIRST USE 5-1-2009; IN COMMERCE 11-1-2009.

3,955,475. RCN TELEVISION S.A., BOGOTÁ D.C., COLOMBIA. SN 77-848,829. PUB. 6-15-2010, FILED 10-14-2009.

**CAZANOTICIAS**

THE MARK CONSISTS OF STANDARD CHARACTERS WITHOUT CLAIM TO ANY PARTICULAR FONT, STYLE, SIZE, OR COLOR.

THE ENGLISH TRANSLATION OF "CAZANOTICIAS" IN THE MARK IS "NEWSHUNTER".

FOR ENTERTAINMENT AND RECREATION SERVICES, NAMELY, ON-GOING TELEVISION PROGRAMS IN THE FIELDS OF VARIETY, COMEDY, NEWS, SPORTS, DRAMA, SPECIAL INTEREST (U.S. CLS. 100, 101 AND 107).

FIRST USE 9-11-2009; IN COMMERCE 9-11-2009.

3,955,488. BE YOUR OWN BOSS ENTERTAINMENT, FORT WORTH, TX. SN 77-857,193. PUB. 3-30-2010, FILED 10-26-2009.

**Be Your Own Boss  
Entertainment**

THE MARK CONSISTS OF STANDARD CHARACTERS WITHOUT CLAIM TO ANY PARTICULAR FONT, STYLE, SIZE, OR COLOR.

NO CLAIM IS MADE TO THE EXCLUSIVE RIGHT TO USE "ENTERTAINMENT", APART FROM THE MARK AS SHOWN.

FOR MULTIMEDIA ENTERTAINMENT SERVICES IN THE NATURE OF RECORDING, PRODUCTION AND POST-PRODUCTION SERVICES IN THE FIELDS OF MUSIC, VIDEO, AND FILMS (U.S. CLS. 100, 101 AND 107).

FIRST USE 8-1-2008; IN COMMERCE 8-1-2008.

**CLASS 41—(Continued).**

3,955,507. BURGER KING CORPORATION, MIAMI, FL. SN 77-867,948. PUB. 3-30-2010, FILED 11-9-2009.

GO PLAY YOUR WAY AT BK

THE MARK CONSISTS OF STANDARD CHARACTERS WITHOUT CLAIM TO ANY PARTICULAR FONT, STYLE, SIZE, OR COLOR.

FOR PROVIDING CHILDREN'S PLAY GROUND FACILITIES FOR RECREATION ACTIVITIES (U.S. CLS. 100, 101 AND 107).

FIRST USE 3-2-2011; IN COMMERCE 3-2-2011.

3,955,524. SHUBIN, STEVE, DRIPPING SPRINGS, TX. SN 77-874,984. PUB. 8-3-2010, FILED 11-18-2009.

FLESHJACK

THE MARK CONSISTS OF STANDARD CHARACTERS WITHOUT CLAIM TO ANY PARTICULAR FONT, STYLE, SIZE, OR COLOR.

OWNER OF U.S. REG. NOS. 3,497,865 AND 3,497,866. FOR ONLINE ENTERTAINMENT AND INFORMATION SERVICES, NAMELY, PROVIDING A WEBSITE FEATURING ADULT-ORIENTED ENTERTAINMENT AND INFORMATION SERVICES IN THE NATURE OF ADULT-ORIENTED IMAGES AND PROVIDING INFORMATION ABOUT ADULT-ORIENTED TOPICS FOR ENTERTAINMENT PURPOSES (U.S. CLS. 100, 101 AND 107).

FIRST USE 4-30-2007; IN COMMERCE 4-30-2007.

3,955,559. MICHAEL O'NEILL, INC., AKA MICHAEL O'NEILL PHOTOGRAPHY, BROOKLYN, NY. SN 77-890,264. PUB. 6-15-2010, FILED 12-10-2009.

Why Yoga

THE MARK CONSISTS OF STANDARD CHARACTERS WITHOUT CLAIM TO ANY PARTICULAR FONT, STYLE, SIZE, OR COLOR.

NO CLAIM IS MADE TO THE EXCLUSIVE RIGHT TO USE "YOGA", APART FROM THE MARK AS SHOWN.

FOR PHOTOGRAPHY SERVICES; PORTRAIT PHOTOGRAPHY; PROVIDING FACILITIES FOR PRODUCING VIDEO, CINEMA AND PHOTOGRAPHY PRODUCTIONS; YOGA INSTRUCTION (U.S. CLS. 100, 101 AND 107).

FIRST USE 3-24-2010; IN COMMERCE 3-24-2010.

**CLASS 41—(Continued).**

3,955,560. LANOIS, DANIEL, TORONTO, ONTARIO, CANADA. SN 77-892,253. PUB. 6-8-2010, FILED 12-13-2009.

BLACK DUB

THE MARK CONSISTS OF STANDARD CHARACTERS WITHOUT CLAIM TO ANY PARTICULAR FONT, STYLE, SIZE, OR COLOR.

FOR ENTERTAINMENT SERVICES IN THE NATURE OF LIVE MUSICAL PERFORMANCES; RECORD PRODUCTION SERVICES; PRODUCTION OF MUSIC VIDEOS; PROVIDING ONLINE NONDOWNLOADABLE MUSICAL SOUND RECORDINGS; ENTERTAINMENT SERVICES IN THE NATURE OF PROVIDING INFORMATION REGARDING MUSICAL GROUPS, MUSICIANS, MUSICAL SOUND RECORDINGS, MUSIC VIDEOS, MUSIC AND LICENSED MERCHANDISE VIA A WEBSITE; ENTERTAINMENT, NAMELY, PERSONAL APPEARANCES BY A MUSICIAN, MUSICAL GROUP OR MUSICAL BAND; MUSIC PUBLISHING SERVICES; PRODUCING MUSICAL AUDIO AND VIDEO RECORDINGS; ORGANIZATION AND PRODUCTION OF ENTERTAINMENT FESTIVALS; FAN CLUB SERVICES; AND BLOGS FOR DISCUSSING MUSIC, MUSICIANS, FILMS, TELEVISION PROGRAMS, AND ENTERTAINMENT EVENTS (U.S. CLS. 100, 101 AND 107).

FIRST USE 10-15-2009; IN COMMERCE 10-15-2009.

3,955,602. TIKI BASH, LLC., WEST PALM BEACH, FL. SN 77-915,454. PUB. 6-1-2010, FILED 1-20-2010.

TIKI BASH

NO CLAIM IS MADE TO THE EXCLUSIVE RIGHT TO USE "BASH", APART FROM THE MARK AS SHOWN.

THE MARK CONSISTS OF THE STYLIZED WORDING "TIKI BASH".

FOR ARRANGING, ORGANIZING, CONDUCTING, AND HOSTING SOCIAL ENTERTAINMENT EVENTS (U.S. CLS. 100, 101 AND 107).

FIRST USE 5-20-2005; IN COMMERCE 6-1-2006.

**CLASS 41—(Continued).**

3,955,610. WARNER BROS. ENTERTAINMENT INC., BURBANK, CA. SN 77-917,399. PUB. 10-19-2010, FILED 1-21-2010.

## SCHOOL PRIDE

THE MARK CONSISTS OF STANDARD CHARACTERS WITHOUT CLAIM TO ANY PARTICULAR FONT, STYLE, SIZE, OR COLOR.

NO CLAIM IS MADE TO THE EXCLUSIVE RIGHT TO USE "SCHOOL", APART FROM THE MARK AS SHOWN.

FOR ENTERTAINMENT SERVICES IN THE NATURE OF LIVE-ACTION, COMEDY, DRAMA, ANIMATED, AND REALITY TELEVISION SERIES; AND PROVIDING INFORMATION FOR AND ACTUAL ENTERTAINMENT VIA AN ELECTRONIC GLOBAL COMMUNICATIONS NETWORK IN THE NATURE OF LIVE-ACTION, COMEDY, DRAMA AND ANIMATED PROGRAMS AND PRODUCTION OF LIVE-ACTION, COMEDY, DRAMA AND ANIMATED MOTION PICTURE FILMS FOR DISTRIBUTION VIA A GLOBAL COMPUTER NETWORK (U.S. CLS. 100, 101 AND 107).

FIRST USE 10-15-2010; IN COMMERCE 10-15-2010.

3,955,619. NEVADA PROPERTY 1 LLC, LAS VEGAS, NV. SN 77-920,748. PUB. 5-25-2010, FILED 1-26-2010.



OWNER OF U.S. REG. NOS. 3,337,476 AND 3,337,479. NO CLAIM IS MADE TO THE EXCLUSIVE RIGHT TO USE "LAS VEGAS", APART FROM THE MARK AS SHOWN.

THE MARK CONSISTS OF THREE OVERLAPPING AND STYLIZED LETTER "C"'S TO THE LEFT OF THE WORDS "THE COSMOPOLITAN OF LAS VEGAS".

FOR CASINOS (U.S. CLS. 100, 101 AND 107). FIRST USE 12-15-2010; IN COMMERCE 12-15-2010.

3,955,628. ALBION COLLEGE, ALBION, MI. SN 77-922,658. PUB. 6-29-2010, FILED 1-28-2010.

## Albion Advantage

THE MARK CONSISTS OF STANDARD CHARACTERS WITHOUT CLAIM TO ANY PARTICULAR FONT, STYLE, SIZE, OR COLOR.

**CLASS 41—(Continued).**

NO CLAIM IS MADE TO THE EXCLUSIVE RIGHT TO USE "ALBION", APART FROM THE MARK AS SHOWN.

FOR EDUCATIONAL SERVICES, NAMELY, PROVIDING CURRICULAR AND CO-CURRICULAR COURSES OF INSTRUCTION AT THE COLLEGE LEVEL; EDUCATIONAL SERVICES, NAMELY, PROVIDING COURSES OF INSTRUCTION AT THE COLLEGE LEVEL IN THE FIELD OF INTERDISCIPLINARY LEARNING, THE FIELD OF NETWORKING OPPORTUNITIES TO SECURE POST-GRADUATE STUDY OR EMPLOYMENT AND IN THE FIELD OF PROMOTING CAREER ADVANCEMENT (U.S. CLS. 100, 101 AND 107).

FIRST USE 3-12-2010; IN COMMERCE 3-19-2010.

3,955,642. SCOREBIG, INC., BOSTON, MA. SN 77-926,499. PUB. 6-22-2010, FILED 2-3-2010.



THE COLOR(S) BLACK, WHITE AND RED IS/ARE CLAIMED AS A FEATURE OF THE MARK.

THE MARK CONSISTS OF THE STYLIZED TERM "SCOREBIG", WITH THE WORD "SCORE" IN BLACK, AND THE WORD "BIG" IN WHITE LOCATED OVER THE IMAGE OF A RED TICKET.

FOR ENTERTAINMENT TICKET AGENCY SERVICES; ON-LINE ENTERTAINMENT TICKET AGENCY SERVICES; TICKET AGENCY SERVICES FOR ENTERTAINMENT EVENTS (U.S. CLS. 100, 101 AND 107).

FIRST USE 8-0-2010; IN COMMERCE 8-0-2010.

3,955,644. POWELL, MARSHA L, MARINA DEL REY, CA. SN 77-926,869. PUB. 6-22-2010, FILED 2-3-2010.

## migigs

THE MARK CONSISTS OF STANDARD CHARACTERS WITHOUT CLAIM TO ANY PARTICULAR FONT, STYLE, SIZE, OR COLOR.

FOR PROVIDING AN INTERNET WEBSITE PORTAL IN THE FIELD OF ENTERTAINMENT, CULTURAL AND SPORTING EVENTS (U.S. CLS. 100, 101 AND 107).

FIRST USE 8-17-2010; IN COMMERCE 8-17-2010.

**CLASS 41—(Continued).**

3,955,654. NEW VISIONS FOR PUBLIC SCHOOLS, NEW YORK, NY. SN 77-928,996. PUB. 6-29-2010, FILED 2-5-2010.

GOOD TO GO

THE MARK CONSISTS OF STANDARD CHARACTERS WITHOUT CLAIM TO ANY PARTICULAR FONT, STYLE, SIZE, OR COLOR.

FOR EDUCATIONAL CONSULTING SERVICES, NAMELY, WORKING WITH PUBLIC SCHOOLS, THE PRIVATE SECTOR AND LOCAL COMMUNITIES TO DEVELOP PROGRAMS AND POLICIES TO IMPROVE THE QUALITY OF EDUCATION FOR CHILDREN (U.S. CLS. 100, 101 AND 107).

FIRST USE 12-0-2009; IN COMMERCE 12-0-2009.

3,955,656. NEW VISIONS FOR PUBLIC SCHOOLS, NEW YORK, NY. SN 77-929,049. PUB. 6-29-2010, FILED 2-5-2010.

(G2G)  
Good to Go

THE MARK CONSISTS OF THE WORDS "G2G GOOD TO GO" WITHIN PARENTHESES.

FOR EDUCATIONAL CONSULTING SERVICES, NAMELY, WORKING WITH PUBLIC SCHOOLS, THE PRIVATE SECTOR AND LOCAL COMMUNITIES TO DEVELOP PROGRAMS AND POLICIES TO IMPROVE THE QUALITY OF EDUCATION FOR CHILDREN (U.S. CLS. 100, 101 AND 107).

FIRST USE 12-0-2009; IN COMMERCE 12-0-2009.

**CLASS 41—(Continued).**

3,955,669. PITTSBURGH ASSOCIATES, PITTSBURGH, PA. SN 77-930,239. PUB. 6-15-2010, FILED 2-8-2010.



THE MARK CONSISTS OF THE LETTER "B" STYLIZED FOR ENTERTAINMENT SERVICES IN THE NATURE OF BASEBALL EXHIBITIONS (U.S. CLS. 100, 101 AND 107).

FIRST USE 2-25-2010; IN COMMERCE 2-25-2010.

3,955,680. TWENTIETH CENTURY FOX FILM CORPORATION, LOS ANGELES, CA. SN 77-932,147. PUB. 6-22-2010, FILED 2-9-2010.

BREAKOUT KINGS

THE MARK CONSISTS OF STANDARD CHARACTERS WITHOUT CLAIM TO ANY PARTICULAR FONT, STYLE, SIZE, OR COLOR.

FOR ENTERTAINMENT SERVICES IN THE NATURE OF A TELEVISION SERIES FEATURING DRAMA; PROVIDING ON-LINE INFORMATION IN THE FIELD OF TELEVISION AND VIDEO ENTERTAINMENT FEATURING DRAMA VIA THE INTERNET; ENTERTAINMENT SERVICES IN THE NATURE OF NON-DOWNLOADABLE VIDEOS AND IMAGES FEATURING TELEVISION SHOWS AND ENTERTAINMENT TRANSMITTED VIA THE INTERNET AND WIRELESS COMMUNICATION NETWORKS; ON-LINE JOURNALS, NAMELY, BLOGS FEATURING PERSONAL OPINIONS IN THE FIELD OF GENERAL INTEREST AND DRAMA (U.S. CLS. 100, 101 AND 107).

FIRST USE 3-6-2011; IN COMMERCE 3-6-2011.

**CLASS 41—(Continued).**

3,955,690. HIRATA, DEBBE, SEATTLE, WA. SN 77-934,074.  
PUB. 6-29-2010, FILED 2-11-2010.

**THE POWER TO INSTILL TRUST**

THE MARK CONSISTS OF STANDARD CHARACTERS WITHOUT CLAIM TO ANY PARTICULAR FONT, STYLE, SIZE, OR COLOR.

FOR VOICE SERVICES, NAMELY, PROVIDING VOICE SERVICES FOR ENTERTAINMENT AND EDUCATION PURPOSES; VOICE OVER SERVICES, NAMELY, PROVIDING VOICE OVER SERVICES FOR ENTERTAINMENT AND EDUCATION PURPOSES; NARRATION SERVICES, NAMELY, ACTING AS A NARRATOR FOR ENTERTAINMENT AND EDUCATION PURPOSES; SPOKESPERSON SERVICES, NAMELY, ACTING AS A SPOKESPERSON FOR ENTERTAINMENT AND EDUCATION PURPOSES; STORYTELLING SERVICES, NAMELY, ACTING AS A STORYTELLER FOR ENTERTAINMENT AND EDUCATION PURPOSES; ACTING SERVICES, NAMELY, PROVIDING ACTING SERVICES FOR ENTERTAINMENT AND EDUCATION PURPOSES (U.S. CLS. 100, 101 AND 107).

FIRST USE 2-23-2011; IN COMMERCE 2-23-2011.

3,955,700. NANOINK, INC., SKOKIE, IL. SN 77-935,902. PUB.  
7-13-2010, FILED 2-15-2010.

**NANOPROFESSOR**

THE MARK CONSISTS OF STANDARD CHARACTERS WITHOUT CLAIM TO ANY PARTICULAR FONT, STYLE, SIZE, OR COLOR.

FOR INFORMATIONAL AND EDUCATIONAL SERVICES, NAMELY, CURRICULUM DEVELOPMENT FOR OTHERS AND INSTRUCTOR TRAINING SERVICES IN THE FIELD OF NANOTECHNOLOGY (U.S. CLS. 100, 101 AND 107).

FIRST USE 1-4-2011; IN COMMERCE 1-4-2011.

**CLASS 41—(Continued).**

3,955,719. FOREVER INTERACTIVE, LLC, CHICAGO, IL. SN  
77-940,898. PUB. 7-13-2010, FILED 2-21-2010.

**VISIONS OF ZOSIMOS**

THE MARK CONSISTS OF STANDARD CHARACTERS WITHOUT CLAIM TO ANY PARTICULAR FONT, STYLE, SIZE, OR COLOR.

FOR ENTERTAINMENT SERVICES, NAMELY, PROVIDING TEMPORARY USE OF NON-DOWNLOADABLE COMPUTER GAME SOFTWARE WHICH PROVIDES MULTI-PLAYER ACCESS TO AN ONLINE COMPUTER GAMING ENVIRONMENT; ENTERTAINMENT SERVICES, NAMELY, PROVIDING TEMPORARY USE OF NON-DOWNLOADABLE COMPUTER GAME SOFTWARE PLATFORMS WHICH PROVIDE MULTI-PLAYER ACCESS TO AN ONLINE COMPUTER GAMING ENVIRONMENT (U.S. CLS. 100, 101 AND 107).

FIRST USE 6-1-2009; IN COMMERCE 3-1-2010.

3,955,732. EVERLOOP, INC., DANVILLE, CA. SN 77-943,046.  
PUB. 7-13-2010, FILED 2-23-2010.

**EVERLOOP**

THE MARK CONSISTS OF STANDARD CHARACTERS WITHOUT CLAIM TO ANY PARTICULAR FONT, STYLE, SIZE, OR COLOR.

FOR ENTERTAINMENT SERVICES, NAMELY, PROVIDING TEMPORARY USE OF NON-DOWNLOADABLE VIDEO GAMES (U.S. CLS. 100, 101 AND 107).

FIRST USE 10-1-2010; IN COMMERCE 10-1-2010.

3,955,763. RANDOLPH, CHRISTOPHER, WATERBURY, CT.  
SN 77-948,969. PUB. 8-3-2010, FILED 3-3-2010.

**SNEEZE GAZETTE**

THE MARK CONSISTS OF STANDARD CHARACTERS WITHOUT CLAIM TO ANY PARTICULAR FONT, STYLE, SIZE, OR COLOR.

NO CLAIM IS MADE TO THE EXCLUSIVE RIGHT TO USE "GAZETTE", APART FROM THE MARK AS SHOWN.

FOR PROVIDING ONLINE NEWSLETTERS FEATURING INFORMATION ABOUT ALLERGIES AND ASTHMA (U.S. CLS. 100, 101 AND 107).

FIRST USE 4-1-2010; IN COMMERCE 4-1-2010.

**CLASS 41—(Continued).**

3,955,773. DE LUCA, ALEX, SUNNYVALE, CA. SN 77-951,156. PUB. 7-27-2010, FILED 3-4-2010.

## The Raytones

THE MARK CONSISTS OF STANDARD CHARACTERS WITHOUT CLAIM TO ANY PARTICULAR FONT, STYLE, SIZE, OR COLOR.

FOR ENTERTAINMENT IN THE NATURE OF LIVE PERFORMANCES BY MUSICAL GROUP (U.S. CLS. 100, 101 AND 107).

FIRST USE 2-8-2008; IN COMMERCE 2-8-2008.

---

3,955,774. LANGUAGE BLISS, LLC, ENCINO, CA. SN 77-951,176. PUB. 8-3-2010, FILED 3-4-2010.

## Learning languages will never be the same again.

THE MARK CONSISTS OF STANDARD CHARACTERS WITHOUT CLAIM TO ANY PARTICULAR FONT, STYLE, SIZE, OR COLOR.

NO CLAIM IS MADE TO THE EXCLUSIVE RIGHT TO USE "LEARNING LANGUAGES", APART FROM THE MARK AS SHOWN.

FOR PROVIDING SUBSCRIPTION-BASED ONLINE FOREIGN LANGUAGE COURSES (U.S. CLS. 100, 101 AND 107).

FIRST USE 4-1-2010; IN COMMERCE 12-7-2010.

---

3,955,775. LANGUAGE BLISS, LLC, ENCINO, CA. SN 77-951,178. PUB. 8-3-2010, FILED 3-4-2010.

## Language Bliss

THE MARK CONSISTS OF STANDARD CHARACTERS WITHOUT CLAIM TO ANY PARTICULAR FONT, STYLE, SIZE, OR COLOR.

NO CLAIM IS MADE TO THE EXCLUSIVE RIGHT TO USE "LANGUAGE", APART FROM THE MARK AS SHOWN.

FOR PROVIDING SUBSCRIPTION-BASED ONLINE FOREIGN LANGUAGE COURSES (U.S. CLS. 100, 101 AND 107).

FIRST USE 4-1-2010; IN COMMERCE 12-7-2010.

**CLASS 41—(Continued).**

3,955,781. DISNEY ENTERPRISES, INC., BURBANK, CA. SN 77-952,233. PUB. 7-20-2010, FILED 3-5-2010.

## SILLY SYMPHONY SWINGS

THE MARK CONSISTS OF STANDARD CHARACTERS WITHOUT CLAIM TO ANY PARTICULAR FONT, STYLE, SIZE, OR COLOR.

NO CLAIM IS MADE TO THE EXCLUSIVE RIGHT TO USE "SWINGS", APART FROM THE MARK AS SHOWN.

FOR ENTERTAINMENT SERVICES IN THE NATURE OF AN AMUSEMENT PARK ATTRACTION, NAMELY, AN AMUSEMENT PARK RIDE (U.S. CLS. 100, 101 AND 107).

FIRST USE 6-11-2010; IN COMMERCE 6-11-2010.

---

3,955,793. COURTROOM TELEVISION NETWORK LLC, NEW YORK, NY. SN 77-956,768. PUB. 8-24-2010, FILED 3-11-2010.

## MA'S ROADHOUSE

THE MARK CONSISTS OF STANDARD CHARACTERS WITHOUT CLAIM TO ANY PARTICULAR FONT, STYLE, SIZE, OR COLOR.

NO CLAIM IS MADE TO THE EXCLUSIVE RIGHT TO USE "ROADHOUSE", APART FROM THE MARK AS SHOWN.

FOR ENTERTAINMENT SERVICES, NAMELY, CONTINUING SCRIPTED AND UNSCRIPTED TELEVISION PROGRAM SERIES IN THE FIELD OF COMEDY, DRAMA, ACTION, ADVENTURE AND/OR REALITY PROVIDED THROUGH CABLE TELEVISION, BROADCAST TELEVISION, INTERNET, VIDEO-ON-DEMAND, AND THROUGH OTHER DISTRIBUTION PLATFORMS; PROVIDING INFORMATION, NAMELY, ENTERTAINMENT INFORMATION, OVER THE INTERNET (U.S. CLS. 100, 101 AND 107).

FIRST USE 9-15-2010; IN COMMERCE 9-15-2010.

**CLASS 41—(Continued).**

3,955,801. ERIC J. HERBIG, SEATTLE, WA. SN 77-958,612. PUB. 8-10-2010, FILED 3-15-2010.

## Pocket Panda

THE MARK CONSISTS OF STANDARD CHARACTERS WITHOUT CLAIM TO ANY PARTICULAR FONT, STYLE, SIZE, OR COLOR.

FOR ENTERTAINMENT IN THE NATURE OF VISUAL AND AUDIO PERFORMANCES, NAMELY, MUSICAL BAND, ROCK GROUP; ENTERTAINMENT, NAMELY, LIVE PERFORMANCES BY A MUSICAL BAND; ENTERTAINMENT, NAMELY, LIVE PERFORMANCES BY MUSICAL BANDS (U.S. CLS. 100, 101 AND 107).

FIRST USE 2-10-2010; IN COMMERCE 4-18-2010.

3,955,833. SERVICE COMPANY SOLUTIONS, LLC, BEDFORD, NH. SN 77-980,716. PUB. 1-4-2011, FILED 9-14-2009.



NO CLAIM IS MADE TO THE EXCLUSIVE RIGHT TO USE "THE ORIGINAL BLUE BOOK MAJOR APPLIANCE JOB RATE GUIDE", APART FROM THE MARK AS SHOWN.

THE MARK CONSISTS OF A SHADED CIRCLE CONTAINING THE LETTERS "BB" WITH A DARKENED BORDER OF THE CIRCLE. TO THE RIGHT OF THE CIRCLE IS THE WORD "THE" WITH THE WORDS "ORIGINAL BLUE BOOK" BELOW. UNDERNEATH IS A SHADED RECTANGLE WITH THE WORDS "MAJOR APPLIANCE" AND BELOW THAT IS THE WORDS "JOB RATE GUIDE".

FOR PUBLICATION OF BOOKS AND PROVIDING ON-LINE PUBLICATIONS IN THE NATURE OF AN E-BOOK, NAMELY, IN THE FIELD OF APPLIANCE REPAIR (U.S. CLS. 100, 101 AND 107).

FIRST USE 1-1-2010; IN COMMERCE 1-1-2010.

**CLASS 41—(Continued).**

3,955,847. NOODLE HEAD, INC., SANTA BARBARA, CA. SN 77-981,462. PUB. 6-24-2008, FILED 4-3-2008.

## PAWPARAZZI

THE MARK CONSISTS OF STANDARD CHARACTERS WITHOUT CLAIM TO ANY PARTICULAR FONT, STYLE, SIZE, OR COLOR.

FOR PROVIDING INFORMATION IN THE FIELD OF ENTERTAINMENT, FEATURING ANIMATION RENDERED BY MEANS OF A GLOBAL COMPUTER NETWORK, EDUCATIONAL AND ENTERTAINMENT SERVICES, NAMELY, A CONTINUING PROGRAM ABOUT ANIMATED ANIMALS ACCESSIBLE BY COMPUTER NETWORK, INFORMATION RELATING TO ENTERTAINMENT AND EDUCATION, PROVIDED ON-LINE FROM A COMPUTER DATABASE OR INTERNET (U.S. CLS. 100, 101 AND 107).

FIRST USE 11-30-2010; IN COMMERCE 11-30-2010.

3,955,848. XANTHUS COMMUNICATIONS LLC, SEATTLE, WA. SN 77-981,475. PUB. 6-22-2010, FILED 8-6-2009.

## PR FOR PEOPLE

THE MARK CONSISTS OF STANDARD CHARACTERS WITHOUT CLAIM TO ANY PARTICULAR FONT, STYLE, SIZE, OR COLOR.

NO CLAIM IS MADE TO THE EXCLUSIVE RIGHT TO USE "PR", APART FROM THE MARK AS SHOWN.

FOR EDUCATIONAL AND ENTERTAINMENT SERVICES, NAMELY, A CONTINUING PROGRAM ABOUT ADVERTISING SERVICES, MARKETING SERVICES AND PUBLIC RELATIONS ACCESSIBLE BY RADIO, TELEVISION, SATELLITE, AUDIO, VIDEO AND COMPUTER NETWORKS (U.S. CLS. 100, 101 AND 107).

FIRST USE 12-21-2010; IN COMMERCE 12-21-2010.

3,955,853. WORTSMAN, MICHAEL, PALOS VERDES ESTATES, CA. SN 77-981,518. PUB. 7-1-2008, FILED 10-31-2007.

## QUEEN FOR A DAY

THE MARK CONSISTS OF STANDARD CHARACTERS WITHOUT CLAIM TO ANY PARTICULAR FONT, STYLE, SIZE, OR COLOR.

**CLASS 41—(Continued).**

OWNER OF U.S. REG. NO. 1,163,128.

FOR ENTERTAINMENT SERVICES, NAMELY, PROVIDING TELEVISION GAME SHOWS AND REALITY SHOWS OVER THE INTERNET; PRODUCTION AND DISTRIBUTION OF TELEVISION PROGRAMS; ENTERTAINMENT SERVICES, NAMELY, AN ONGOING TELEVISION GAME SHOW; WEB SITES FEATURING INFORMATION ABOUT ENTERTAINMENT; ONLINE COMPUTER GAMES; PRODUCTION AND DISTRIBUTION OF MOTION PICTURES (U.S. CLS. 100, 101 AND 107).

FIRST USE 2-7-2011; IN COMMERCE 2-7-2011.

---

3,955,868. CLAYPOOL, LES, SAN RAFAEL, CA. SN 77-981,672. PUB. 12-1-2009, FILED 1-28-2009.

**THE ODDITY FAIRE**

THE MARK CONSISTS OF STANDARD CHARACTERS WITHOUT CLAIM TO ANY PARTICULAR FONT, STYLE, SIZE, OR COLOR.

NO CLAIM IS MADE TO THE EXCLUSIVE RIGHT TO USE "FAIR", APART FROM THE MARK AS SHOWN.

FOR ENTERTAINMENT SERVICES, NAMELY, ORGANIZING AND CONDUCTING TRAVELING EXHIBITIONS, TOURS, CONCERTS, FESTIVALS AND EXHIBITIONS, ALL FEATURING LIVE PERFORMANCES, MUSIC, THEATRE AND ARTS; PROVISION OF INFORMATION RELATING TO A MUSICAL GROUP; PROVIDING AN INTERNET WEB SITE FEATURING INFORMATION IN THE FIELD OF MUSIC AND ENTERTAINMENT; SONG WRITING SERVICE, MUSIC COMPOSITION AND TRANSCRIPTION FOR OTHERS; AUDIO AND VIDEO RECORDING AND PRODUCTION SERVICES, MUSIC PRODUCTION AND RECORD PRODUCTION SERVICES; MOTION PICTURE SONG PRODUCTION; PRODUCTION OF INTERACTIVE ENTERTAINMENT IN THE FIELD OF MUSIC AND THEATRE; CIRCUS EXHIBITIONS (U.S. CLS. 100, 101 AND 107).

FIRST USE 9-14-2010; IN COMMERCE 9-14-2010.

---

3,955,879. BRATTER, BERNICE, LOS ANGELES, CA. AND DENNIS, HELEN, REDONDO BEACH, CA. SN 78-836,673. PUB. 6-19-2007, FILED 3-14-2006.

**PROJECT RENEWMENT**

THE MARK CONSISTS OF STANDARD CHARACTERS WITHOUT CLAIM TO ANY PARTICULAR FONT, STYLE, SIZE, OR COLOR.

NO CLAIM IS MADE TO THE EXCLUSIVE RIGHT TO USE "PROJECT", APART FROM THE MARK AS SHOWN.

FOR EDUCATIONAL SERVICES, NAMELY, LEADING DISCUSSION GROUPS AND WORKSHOPS ON THE SUBJECT OF THE DEVELOPMENT OF HUMAN POTENTIAL AND THE TRANSITION OF CAREER WOMEN INTO RETIREMENT (U.S. CLS. 100, 101 AND 107).

FIRST USE 8-27-2010; IN COMMERCE 8-27-2010.

**CLASS 41—(Continued).**

3,955,886. TV GUIDE ENTERTAINMENT GROUP, LLC, LOS ANGELES, CA. SN 78-952,538. PUB. 11-13-2007, FILED 8-15-2006.

**MY TVGUIDE**

THE MARK CONSISTS OF STANDARD CHARACTERS WITHOUT CLAIM TO ANY PARTICULAR FONT, STYLE, SIZE, OR COLOR.

OWNER OF U.S. REG. NOS. 650,942, 3,007,648, AND OTHERS.

SEC. 2(F) AS TO "TV GUIDE".

FOR ENTERTAINMENT SERVICES, NAMELY, PROVIDING PROMOTIONAL, INFORMATIONAL, AND INTERACTIVE TELEVISION AND VIDEO PROGRAMMING SERVICES VIA MOBILE AND ONLINE ELECTRONIC COMMUNICATIONS NETWORKS (U.S. CLS. 100, 101 AND 107).

FIRST USE 10-31-2009; IN COMMERCE 10-31-2009.

---

3,955,890. LANGUAGE BLISS, LLC, ENCINO, CA. SN 85-000,618. PUB. 8-3-2010, FILED 3-29-2010.



THE MARK CONSISTS OF THE STYLIZED TEXT ENCLOSED IN A CIRCLE.

FOR PROVIDING A WEBSITE FOR USERS TO LEARN DIFFERENT LANGUAGES (U.S. CLS. 100, 101 AND 107).

FIRST USE 4-1-2010; IN COMMERCE 12-7-2010.

---

3,955,939. DUARTE, ALEXANDRE, SANTA FE, NM. SN 85-020,130. PUB. 9-28-2010, FILED 4-21-2010.

**RUNNING 2.0**

THE MARK CONSISTS OF STANDARD CHARACTERS WITHOUT CLAIM TO ANY PARTICULAR FONT, STYLE, SIZE, OR COLOR.



**CLASS 41—(Continued).**

NO CLAIM IS MADE TO THE EXCLUSIVE RIGHT TO USE "RUNNING", APART FROM THE MARK AS SHOWN.

FOR PROVIDING CLASSES TO IMPROVE RUNNING TECHNIQUE; INDIVIDUAL AND GROUP CLASSES IN THE FIELD OF RUNNING AND RUNNING TECHNIQUE IMPROVEMENT; PROVIDING TRAINING AND CLASSES TO ENHANCE SPORTS PERFORMANCE; SPORTS CONSULTING IN THE AREA OF THE ORGANIZATION OF SPORTING EVENTS; TREADMILL CLASSES; PROVIDING TRAINING IN THE FIELD OF THERAPEUTIC APPROACHES FOR RUNNERS; PROVIDING TRAINING IN THE FIELD OF INJURY-FREE APPROACHES TO RUNNERS; TRAINING FOR STUDENTS IN THE FIELD OF RUNNING; TRAINING FOR TEACHERS IN THE FIELD OF RUNNING; PROVIDING SCHOOLS IN THE FIELD OF RUNNING; TEAM CONSULTING IN THE AREA OF RUNNER FITNESS; PERSONAL TRAINERS CONSULTING; PROVIDING ONLINE CLASSES IN THE FIELD OF RUNNER FITNESS PERFORMANCE; MEDITATION FOR RUNNERS; PROVIDING CLASSES TO IMPROVE RUNNING EFFICIENCY (U.S. CLS. 100, 101 AND 107).

FIRST USE 2-1-2011; IN COMMERCE 2-1-2011.

3,955,975. UNIVISION COMMUNICATIONS INC., LOS ANGELES, CA. SN 85-036,930. PUB. 9-21-2010, FILED 5-12-2010.

**EL GRAN SHOW**

THE MARK CONSISTS OF STANDARD CHARACTERS WITHOUT CLAIM TO ANY PARTICULAR FONT, STYLE, SIZE, OR COLOR.

NO CLAIM IS MADE TO THE EXCLUSIVE RIGHT TO USE "SHOW", APART FROM THE MARK AS SHOWN.

THE ENGLISH TRANSLATION OF "EL GRAN SHOW" IN THE MARK IS THE GRAND SHOW.

FOR ENTERTAINMENT SERVICES, NAMELY, AN ONGOING TELEVISION VARIETY PROGRAM (U.S. CLS. 100, 101 AND 107).

FIRST USE 12-5-2010; IN COMMERCE 12-5-2010.

3,955,988. THE OSS SOCIETY, INC., MCLEAN, VA. SN 85-043,702. PUB. 10-26-2010, FILED 5-20-2010.

**Hugh Montgomery Award**

THE MARK CONSISTS OF STANDARD CHARACTERS WITHOUT CLAIM TO ANY PARTICULAR FONT, STYLE, SIZE, OR COLOR.

NO CLAIM IS MADE TO THE EXCLUSIVE RIGHT TO USE "AWARD", APART FROM THE MARK AS SHOWN.

THE NAME "HUGH MONTGOMERY" IDENTIFIES A LIVING INDIVIDUAL WHOSE CONSENT IS OF RECORD.

FOR PROVIDING RECOGNITION AND INCENTIVES BY THE WAY OF AWARDS TO DEMONSTRATE EXCELLENCE IN THE FIELD OF STRATEGIC INTELLIGENCE AND PUBLIC SERVICE (U.S. CLS. 100, 101 AND 107).

FIRST USE 2-9-2011; IN COMMERCE 2-9-2011.

**CLASS 41—(Continued).**

3,955,991. TRACK 180, LLC, NEW HAVEN, CT. SN 85-044,597. PUB. 10-19-2010, FILED 5-21-2010.

**TrackLine**

THE MARK CONSISTS OF STANDARD CHARACTERS WITHOUT CLAIM TO ANY PARTICULAR FONT, STYLE, SIZE, OR COLOR.

FOR PROVIDING CURRENT EVENT NEWS AND INFORMATION VIA A GLOBAL COMPUTER NETWORK (U.S. CLS. 100, 101 AND 107).

FIRST USE 9-27-2010; IN COMMERCE 11-5-2010.

3,956,004. ILLINOIS INSTITUTE OF TECHNOLOGY, CHICAGO, IL. SN 85-050,483. PUB. 11-2-2010, FILED 5-28-2010.



THE COLOR(S) BLACK AND RED IS/ARE CLAIMED AS A FEATURE OF THE MARK.

THE MARK CONSISTS OF THE WORDING "IDEASHOP", WITH THE WORDING "IDEA" IN BLACK, AND "SHOP" IN RED. THE LETTERING "IDE" IS LOWERCASE, THE "A" IS UPPERCASE, AND "SHOP" IS LOWER CASE. THE MARK INCLUDES A GRAPHIC, WHICH APPEARS ABOVE THE "A". THE GRAPHIC IS A RED CIRCLE OUTLINED IN BLACK FOLLOWED BY THREE CONCENTRIC RINGS OF COLOR, 1 BLACK, 1 RED WITH BLACK OUTLINE AND 1 BLACK.

FOR EDUCATING AT UNIVERSITY OR COLLEGES (U.S. CLS. 100, 101 AND 107).

FIRST USE 5-1-2010; IN COMMERCE 5-1-2010.

3,956,032. TROON GOLF, L.L.C., SCOTTSDALE, AZ. SN 85-066,325. PUB. 12-7-2010, FILED 6-18-2010.

**TROON PRIVÉ CONNECT**

THE MARK CONSISTS OF STANDARD CHARACTERS WITHOUT CLAIM TO ANY PARTICULAR FONT, STYLE, SIZE, OR COLOR.

OWNER OF U.S. REG. NOS. 2,299,833, 3,372,598, AND OTHERS.

**CLASS 41—(Continued).**

THE ENGLISH TRANSLATION OF THE WORD "PRIVÉ" IN THE MARK IS PRIVATE.  
FOR PUBLICATION OF ELECTRONIC MAGAZINES (U.S. CLS. 100, 101 AND 107).  
FIRST USE 8-1-2010; IN COMMERCE 8-1-2010.

3,956,056. SCHOLASTIC INC., NEW YORK, NY. SN 85-080,971. PUB. 11-23-2010, FILED 7-9-2010.

## LISTEN INN

THE MARK CONSISTS OF STANDARD CHARACTERS WITHOUT CLAIM TO ANY PARTICULAR FONT, STYLE, SIZE, OR COLOR.

FOR AUDIO AND VIDEO PRODUCTION SERVICES, NAMELY, CREATING AND PRODUCING AMBIENT SOUNDSCAPES, AND SOUND STORIES AND VISUALS FOR PODCASTS, AUDIO BOOKS, BROADCASTS, WEBSITES AND GAMES (U.S. CLS. 100, 101 AND 107).  
FIRST USE 9-20-2010; IN COMMERCE 9-20-2010.

3,956,076. SLAVICK, DAVID, EASTLAKE, OH. SN 85-090,509. PUB. 1-4-2011, FILED 7-22-2010.

## THE TRACKMEET

THE MARK CONSISTS OF STANDARD CHARACTERS WITHOUT CLAIM TO ANY PARTICULAR FONT, STYLE, SIZE, OR COLOR.

FOR ARRANGING, ORGANIZING AND CONDUCTING MUSIC COMPETITIONS (U.S. CLS. 100, 101 AND 107).  
FIRST USE 2-1-2011; IN COMMERCE 2-1-2011.

3,956,079. ANTON, ANTHONY, CHICAGO, IL. SN 85-094,398. PUB. 1-11-2011, FILED 7-28-2010.

## FUZE

THE MARK CONSISTS OF STANDARD CHARACTERS WITHOUT CLAIM TO ANY PARTICULAR FONT, STYLE, SIZE, OR COLOR.

FOR ENTERTAINMENT SERVICES, NAMELY, NIGHT CLUBS FOR CONSUMERS OF 21 YEARS AGE AND ABOVE (U.S. CLS. 100, 101 AND 107).  
FIRST USE 7-1-2010; IN COMMERCE 7-1-2010.

**CLASS 42—SCIENTIFIC AND COMPUTER SERVICES**

3,955,211. SONY COMPUTER ENTERTAINMENT INC., TOKYO, JAPAN. SN 77-386,341. PUB. 6-24-2008, FILED 2-1-2008.



OWNER OF U.S. REG. NO. 2,964,761.

THE MARK CONSISTS OF A STYLIZED LETTER P.  
FOR DEVELOPMENT OF VIDEO-GAME SOFTWARE AND COMPUTER GRAPHICS FOR COMPUTER GAMES, COMPUTER SOFTWARE DESIGN, MAINTENANCE OF VIDEO GAME SOFTWARE, AND RECOVERY OF COMPUTER DATA (U.S. CLS. 100 AND 101).  
FIRST USE 3-9-2011; IN COMMERCE 3-9-2011.

3,955,268. TRANSZAP, INC., DENVER, CO. SN 77-618,120. PUB. 6-29-2010, FILED 11-19-2008.

## AFEWORKS

THE MARK CONSISTS OF STANDARD CHARACTERS WITHOUT CLAIM TO ANY PARTICULAR FONT, STYLE, SIZE, OR COLOR.

FOR COMPUTER SERVICES, NAMELY, PROVIDING A WEB SITE THAT FEATURES A STANDARDIZED FORMAT THAT ENABLES USERS TO PERFORM BUSINESS MANAGEMENT TASKS BY MONITORING, COMPILING AND DELIVERING BUSINESS, STATISTICAL AND ADMINISTRATION DATA, AND THAT AUTOMATES ACCOUNTING FOR ELECTRONIC REVENUE AND EXPENSE PROCESSING (U.S. CLS. 100 AND 101).  
FIRST USE 2-1-2009; IN COMMERCE 2-1-2009.

**CLASS 42—(Continued).**

3,955,323. HIP DESIGN, MOUNT VERNON, WA. SN 77-711,352. PUB. 8-11-2009, FILED 4-10-2009.

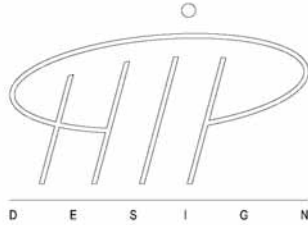

NO CLAIM IS MADE TO THE EXCLUSIVE RIGHT TO USE "DESIGN", APART FROM THE MARK AS SHOWN. THE MARK CONSISTS OF THE STYLIZED TEXT "HIP DESIGN", WITH THE LETTERS "H" AND "P" EXTENDING UPWARDS TO FORM A PARTIAL OVAL. FOR DESIGN AND DEVELOPMENT OF NEW PRODUCTS (U.S. CLS. 100 AND 101). FIRST USE 5-1-2009; IN COMMERCE 5-22-2009.

3,955,351. CFAM, INC., DBA CONSUMER FINANCE ASSET MANAGEMENT, DALLAS, TX. SN 77-766,354. PUB. 6-8-2010, FILED 6-23-2009.



THE MARK CONSISTS OF TWO UPWARD REACHING DIAGONAL LINES, ONE LEANING TO THE LEFT AND ONE TO THE RIGHT, WITH AN ITALICIZED LOWER CASE "I" IN THE MIDDLE. THE WORD "WINDICIUM" APPEARS BELOW THE LINES AND LETTER "I" WITH AN UPSIDE DOWN REFLECTION OF THE WORD DIRECTLY BELOW IT.

FOR PROVIDING TEMPORARY USE OF A WEB-BASED SOFTWARE APPLICATION USED TO PROVIDE A LEGAL DEBT RECOVERY SYSTEM TO CREDIT ORIGINATORS IN THE FIELD OF LEGAL SERVICES MANAGEMENT (U.S. CLS. 100 AND 101). FIRST USE 1-0-2005; IN COMMERCE 1-0-2005.

**CLASS 42—(Continued).**

3,955,352. CFAM, INC., DBA CONSUMER FINANCE ASSET MANAGEMENT, DALLAS, TX. SN 77-766,366. PUB. 5-11-2010, FILED 6-23-2009.

# WINDICIUM

THE MARK CONSISTS OF STANDARD CHARACTERS WITHOUT CLAIM TO ANY PARTICULAR FONT, STYLE, SIZE, OR COLOR.

FOR PROVIDING TEMPORARY USE OF ONLINE SOFTWARE IN THE FIELD OF LEGAL SERVICES MANAGEMENT USED TO PROVIDE A LEGAL DEBT RECOVERY SYSTEM TO CREDIT ORIGINATORS (U.S. CLS. 100 AND 101).

FIRST USE 1-0-2005; IN COMMERCE 1-0-2005.

3,955,373. BRITETAB, INC., CHICAGO, IL. SN 77-785,021. PUB. 12-29-2009, FILED 7-20-2009.

# IMPRESSION LAB

THE MARK CONSISTS OF STANDARD CHARACTERS WITHOUT CLAIM TO ANY PARTICULAR FONT, STYLE, SIZE, OR COLOR.

FOR PROVIDING TEMPORARY USE OF ON-LINE NON-DOWNLOADABLE SOFTWARE FOR CREATING RESUMES AND MANAGING SUPPORTING MEDIA SUCH AS VIDEOS, GRAPHICS, PHOTOS, AND OTHER FORMS OF DIGITAL MEDIA (U.S. CLS. 100 AND 101).

FIRST USE 3-1-2010; IN COMMERCE 3-1-2010.

3,955,393. HUMANA INC., LOUISVILLE, KY. SN 77-798,766. PUB. 7-6-2010, FILED 8-6-2009.

# HUMANA GAMES FOR HEALTH

THE MARK CONSISTS OF STANDARD CHARACTERS WITHOUT CLAIM TO ANY PARTICULAR FONT, STYLE, SIZE, OR COLOR.

**CLASS 42—(Continued).**

NO CLAIM IS MADE TO THE EXCLUSIVE RIGHT TO USE "GAMES", APART FROM THE MARK AS SHOWN.

FOR COMPUTER SERVICES, NAMELY, CREATING AN ONLINE COMMUNITY FOR REGISTERED USERS TO CREATE AND SHARE MULTIMEDIA CONTENT AND ENGAGE IN SOCIAL NETWORKING; ON-LINE NONDOWNLOADABLE COMPUTER SOFTWARE FOR USE IN PERSONALIZING CONTENT, GAMES AND MULTIMEDIA ADVERTISEMENTS TO PLAY, DOWNLOAD, SHARE AND EXCHANGE; COMPUTER SERVICES, NAMELY, CREATING AN ONLINE COMMUNITY FOR REGISTERED USERS TO PARTICIPATE IN COMPETITIONS, PARTICIPATE IN VIRTUAL REALITY GAMES AND SOCIAL EVENTS, AND ENGAGE IN SOCIAL NETWORKING; CREATING AND HOSTING MOBILE TELEPHONE-BASED AND INTERNET-BASED WEBSITES WHERE USERS MAY LOCATE AND COMMUNICATE WITH OTHER USERS IN THE FIELD OF WEIGHT LOSS, DIETING, HEALTH, WELLNESS, NUTRITION, AND PHYSICAL FITNESS (U.S. CLS. 100 AND 101).

FIRST USE 5-31-2008; IN COMMERCE 5-31-2008.

---

3,955,399. ATE, LLC, NIXA, MO. SN 77-801,871. PUB. 7-13-2010, FILED 8-11-2009.

**CULTIVATORS**

THE MARK CONSISTS OF STANDARD CHARACTERS WITHOUT CLAIM TO ANY PARTICULAR FONT, STYLE, SIZE, OR COLOR.

FOR PRODUCT DEVELOPMENT SERVICES IN THE FIELD OF CULINARY ARTS AND INFORMATION RELATED THERETO; THINK TANK SERVICES, NAMELY, PROVIDING NEW IDEAS AND CONCEPTS FOR OTHERS IN THE CULINARY FIELD, NAMELY, CHEFS, FOOD GROWERS, FARMERS, FOOD SERVICE MANUFACTURERS, AND CONSUMERS (U.S. CLS. 100 AND 101).

FIRST USE 6-12-2010; IN COMMERCE 6-12-2010.

---

3,955,410. TOTALPAAS, INC., PALO ALTO, CA. SN 77-810,892. PUB. 7-13-2010, FILED 8-24-2009.

**TOTALPAAS**

THE MARK CONSISTS OF STANDARD CHARACTERS WITHOUT CLAIM TO ANY PARTICULAR FONT, STYLE, SIZE, OR COLOR.

FOR PROVIDING A WEBSITE FEATURING A MEDIA AGGREGATOR AND SEARCH ENGINE FOR INTERNET CONTENT; APPLICATION SERVICE PROVIDER, NAMELY, PROVIDING, HOSTING, MANAGING, DEVELOPING, AND MAINTAINING APPLICATIONS, SOFTWARE, WEB SITES, AND DATABASES IN THE FIELDS OF PERSONAL PRODUCTIVITY, WIRELESS COMMUNICATION, MOBILE INFORMATION ACCESS, AND REMOTE DATA MANAGEMENT (U.S. CLS. 100 AND 101).

FIRST USE 7-0-2009; IN COMMERCE 7-0-2009.

**CLASS 42—(Continued).**

3,955,499. ENGQUEST CONSULTING INC, NORCROSS, GA. SN 77-863,300. PUB. 4-6-2010, FILED 11-2-2009.

**ENGQUEST**

THE MARK CONSISTS OF STANDARD CHARACTERS WITHOUT CLAIM TO ANY PARTICULAR FONT, STYLE, SIZE, OR COLOR.

FOR ENGINEERING CONSULTING SERVICES (U.S. CLS. 100 AND 101).

FIRST USE 3-3-2011; IN COMMERCE 3-3-2011.

---

3,955,511. IMMIGRATION AND CUSTOMS SOLUTIONS, LLC, AKA ICS, LLC, EVANSTON, IL. SN 77-871,590. PUB. 11-2-2010, FILED 11-12-2009.

**SecureID**

THE MARK CONSISTS OF STANDARD CHARACTERS WITHOUT CLAIM TO ANY PARTICULAR FONT, STYLE, SIZE, OR COLOR.

FOR PROVIDING TEMPORARY USE OF ON-LINE NON-DOWNLOADABLE COMPUTER SOFTWARE PROGRAMS FOR IDENTITY AND EMPLOYMENT ELIGIBILITY VERIFICATION FOR EMPLOYERS (U.S. CLS. 100 AND 101).

FIRST USE 6-1-2010; IN COMMERCE 6-1-2010.

---

3,955,540. CUSTOM DATA PROCESSING, INC, LA GRANGE, IL. SN 77-881,175. PUB. 6-1-2010, FILED 11-25-2009.



NO CLAIM IS MADE TO THE EXCLUSIVE RIGHT TO USE "EBT", APART FROM THE MARK AS SHOWN.

**CLASS 42—(Continued).**

THE MARK CONSISTS OF 4 ARROWS FORMING A SQUARE IN THE BACKGROUND AND A RIGHT-POINTING HORIZONTAL ARROW SEPARATING THE TEXT "WIC DIRECT" AND "THE EBT SOLUTION".

FOR APPLICATION SERVICE PROVIDER (ASP) FEATURING SOFTWARE FOR USE SOFTWARE FOR USE IN ELECTRONIC TRANSACTION PROCESSING; COMPUTER PROJECT MANAGEMENT SERVICES; CONSULTATION SERVICES IN THE FIELDS OF SELECTION, IMPLEMENTATION AND USE OF COMPUTER HARDWARE AND SOFTWARE SYSTEMS FOR OTHERS; MAINTENANCE OF COMPUTER SOFTWARE (U.S. CLS. 100 AND 101).

FIRST USE 11-7-2009; IN COMMERCE 11-7-2009.

---

3,955,569. TAYLOR PUBLISHING COMPANY, DALLAS, TX. SN 77-899,172. PUB. 6-15-2010, FILED 12-22-2009.

**GROUP SUPPLEMENTS**

THE MARK CONSISTS OF STANDARD CHARACTERS WITHOUT CLAIM TO ANY PARTICULAR FONT, STYLE, SIZE, OR COLOR.

NO CLAIM IS MADE TO THE EXCLUSIVE RIGHT TO USE "SUPPLEMENTS", APART FROM THE MARK AS SHOWN.

FOR PROVIDING TEMPORARY USE OF NON-DOWNLOADABLE SOFTWARE FOR PLANNING, CREATING, SUBMITTING, AND CHECKING YEARBOOK CONTENT (U.S. CLS. 100 AND 101).

FIRST USE 1-31-2010; IN COMMERCE 1-31-2010.

---

3,955,570. VIBIO INC., SAN FRANCISCO, CA. SN 77-900,212. PUB. 7-27-2010, FILED 12-23-2009.



THE MARK CONSISTS OF THE OUTLINED WORD "VIBIO" IN LOWERCASE LETTERS WITH THE TWO LETTER "I"'S DOTTED WITH SOLID CIRCLES.

THE WORDING "VIBIO" HAS NO MEANING IN A FOREIGN LANGUAGE.

FOR PROVIDING A SOCIAL NETWORKING WEBSITE FEATURING TECHNOLOGY ENABLING A BUYER OR SELLER TO USE HIS SOCIAL NETWORK TO SEE WHAT GOODS AND SERVICES MEMBERS OF THE NETWORK ARE BUYING AND SELLING, AND TO SEE HOW THEY ARE CONNECTED TO THE BUYER OR SELLER OF GOODS OR SERVICES AND TO PROVIDE EVALUATIVE FEEDBACK BY WAY OF HIS SOCIAL NETWORK (U.S. CLS. 100 AND 101).

FIRST USE 1-11-2011; IN COMMERCE 1-11-2011.

**CLASS 42—(Continued).**

3,955,601. MAKERS INTERACTIVE CORP, SANTA CLARA, CA. SN 77-915,329. PUB. 6-8-2010, FILED 1-19-2010.

**Makers Interactive**

THE MARK CONSISTS OF STANDARD CHARACTERS WITHOUT CLAIM TO ANY PARTICULAR FONT, STYLE, SIZE, OR COLOR.

NO CLAIM IS MADE TO THE EXCLUSIVE RIGHT TO USE "INTERACTIVE", APART FROM THE MARK AS SHOWN.

FOR VIDEO GAME DEVELOPMENT SERVICES; AND COMPUTER SERVICES, NAMELY, THE DESIGN AND DEVELOPMENT OF COMPUTER SOFTWARE APPLICATIONS (U.S. CLS. 100 AND 101).

FIRST USE 3-8-2011; IN COMMERCE 3-8-2011.

---

3,955,633. DATAJOOP LLC, CHESTER, VA. SN 77-924,948. PUB. 6-22-2010, FILED 2-1-2010.

**DataJoop**

THE MARK CONSISTS OF STANDARD CHARACTERS WITHOUT CLAIM TO ANY PARTICULAR FONT, STYLE, SIZE, OR COLOR.

FOR HOSTING AN ONLINE COMMUNITY WEBSITE FEATURING SHARED COMMUNICATIONS BETWEEN COMMUNITY MEMBERS FOR SHARING, TRANSFERRING, STORING AND ACCESSING INFORMATION AND DATA OF VARIOUS KINDS AND FORMATS (U.S. CLS. 100 AND 101).

FIRST USE 2-1-2010; IN COMMERCE 11-1-2010.

---

3,955,658. QUALITY INNOVATIVE SYSTEMS, INC., PARAGOULD, AR. SN 77-929,109. PUB. 6-22-2010, FILED 2-5-2010.

**UBSREADY**

THE MARK CONSISTS OF STANDARD CHARACTERS WITHOUT CLAIM TO ANY PARTICULAR FONT, STYLE, SIZE, OR COLOR.

FOR CONSULTING SERVICES IN THE FIELD OF INTEGRATION, IMPLEMENTATION AND SUPPORT OF COMPUTER-BASED SOFTWARE SYSTEMS FOR UTILITY BILLING COMPANIES (U.S. CLS. 100 AND 101).

FIRST USE 8-15-2009; IN COMMERCE 8-15-2009.

**CLASS 42—(Continued).**

3,955,685. TWORKZ.COM, LLC, NAPLES, FL. SN 77-933,871.  
PUB. 6-29-2010, FILED 2-11-2010.

# TWORKZ

THE MARK CONSISTS OF STANDARD CHARACTERS WITHOUT CLAIM TO ANY PARTICULAR FONT, STYLE, SIZE, OR COLOR.

FOR PROVISION OF SEARCH ENGINES FOR THE INTERNET (U.S. CLS. 100 AND 101).

FIRST USE 11-30-2010; IN COMMERCE 11-30-2010.

---

3,955,689. D4 MEDIA, INC., IRVINE, CA. SN 77-934,035. PUB.  
6-29-2010, FILED 2-11-2010.

# LEANBACK

THE MARK CONSISTS OF STANDARD CHARACTERS WITHOUT CLAIM TO ANY PARTICULAR FONT, STYLE, SIZE, OR COLOR.

FOR COMPUTER SERVICES, NAMELY, PROVIDING SEARCH ENGINES FOR OBTAINING DATA ON A GLOBAL COMPUTER NETWORK; COMPUTER SERVICES, NAMELY, PROVIDING SEARCH PLATFORMS TO ALLOW USERS TO REQUEST CONTENT FROM AND RECEIVE CONTENT TO A MOBILE DEVICE; DEVELOPMENT, MAINTENANCE AND UPDATING OF A TELECOMMUNICATION NETWORK SEARCH ENGINE; PROVIDING A WEBSITE FEATURING A MEDIA AGGREGATOR AND SEARCH ENGINE FOR INTERNET CONTENT; PROVIDING INFORMATION AT THE SPECIFIC REQUEST OF END-USERS BY MEANS OF TELEPHONE OR GLOBAL COMPUTER NETWORKS; PROVIDING SPECIFIC INFORMATION AS REQUESTED BY CUSTOMERS VIA THE INTERNET; PROVISION OF INTERNET SEARCH ENGINES; PROVISION OF SEARCH ENGINES FOR THE INTERNET; SEARCHING AND RETRIEVING INFORMATION, SITES, AND OTHER RESOURCES AVAILABLE ON COMPUTER NETWORKS FOR OTHERS (U.S. CLS. 100 AND 101).

FIRST USE 3-1-2010; IN COMMERCE 3-1-2010.

**CLASS 42—(Continued).**

3,955,769. NEARVERSE INC., HUNTINGDON VALLEY, PA.  
SN 77-949,771. PUB. 6-22-2010, FILED 3-3-2010.

# LOKAST

THE MARK CONSISTS OF STANDARD CHARACTERS WITHOUT CLAIM TO ANY PARTICULAR FONT, STYLE, SIZE, OR COLOR.

FOR COMPUTER SERVICES, NAMELY, CREATING AN ON-LINE COMMUNITY FOR REGISTERED USERS TO PARTICIPATE IN DISCUSSIONS, GET FEEDBACK FROM THEIR PEERS, FORM VIRTUAL COMMUNITIES, TRANSFER MEDIA, CONSUME MEDIA, AND ENGAGE IN SOCIAL NETWORKING FEATURING GAMES, GROUPS, VIDEO, PHOTOS, BLOGS, FORUMS, AND POLLS (U.S. CLS. 100 AND 101).

FIRST USE 2-15-2010; IN COMMERCE 3-15-2010.

---

3,955,832. ACHATES POWER, INC., SAN DIEGO, CA. SN 77-980,591. PUB. 1-19-2010, FILED 9-8-2009.

# FUNDAMENTALLY BETTER ENGINES

THE MARK CONSISTS OF STANDARD CHARACTERS WITHOUT CLAIM TO ANY PARTICULAR FONT, STYLE, SIZE, OR COLOR.

NO CLAIM IS MADE TO THE EXCLUSIVE RIGHT TO USE "BETTER ENGINES", APART FROM THE MARK AS SHOWN.

FOR CONSULTING IN THE FIELD OF ENGINEERING (U.S. CLS. 100 AND 101).

FIRST USE 8-5-2010; IN COMMERCE 8-5-2010.

**CLASS 42—(Continued).**

3,955,921. MICHAEL L. BROWN, WAXAHACHIE, TX. SN 85-013,110. PUB. 7-20-2010, FILED 4-13-2010.

# IntelliKNOW

THE MARK CONSISTS OF STANDARD CHARACTERS WITHOUT CLAIM TO ANY PARTICULAR FONT, STYLE, SIZE, OR COLOR.

FOR SOFTWARE AS A SERVICE (SAAS) SERVICES FEATURING SOFTWARE IN THE FIELD OF HUMAN, NETWORK AND APPLICATION CONTENT ANALYSIS, FOR USE IN THE MONITORING AND ANALYSIS OF NETWORK AND APPLICATION DATA FOR USE IN NETWORK BEHAVIOR ANALYSIS, SOCIAL NETWORK ANALYSIS, TACIT KNOWLEDGE ANALYSIS, AND ORGANIZATIONAL NETWORK ANALYSIS; DIAGNOSTIC ANALYSIS FOR USE IN ORGANIZATIONAL PROCESS AND PROCEDURE COMPLIANCE MONITORING, DATA SECURITY, HUMAN CAPITAL MANAGEMENT, WORKFORCE MANAGEMENT, AND TALENT OPTIMIZATION (U.S. CLS. 100 AND 101).

FIRST USE 1-0-2008; IN COMMERCE 7-0-2009.

3,955,926. GREATAMERICA LEASING CORPORATION, CEDAR RAPIDS, IA. SN 85-015,127. PUB. 9-14-2010, FILED 4-15-2010.

# COLLABRANCE

THE MARK CONSISTS OF STANDARD CHARACTERS WITHOUT CLAIM TO ANY PARTICULAR FONT, STYLE, SIZE, OR COLOR.

FOR COMPUTER SERVICES, NAMELY, ON-LINE SCANNING, DETECTING, QUARANTINING AND ELIMINATING VIRUSES, WORMS, TROJANS, SPYWARE, ADWARE, MALWARE AND UNAUTHORIZED DATA AND PROGRAMS ON COMPUTERS AND ELECTRONIC DEVICES; BACK-UP SERVICES FOR COMPUTER HARD DRIVE DATA; MONITORING THE COMPUTER SYSTEMS OF OTHERS FOR TECHNICAL PURPOSES AND PROVIDING BACK-UP COMPUTER PROGRAMS AND FACILITIES; TECHNICAL SUPPORT, NAMELY, PROVIDING BACK-UP COMPUTER PROGRAMS AND FACILITIES; TECHNICAL SUPPORT SERVICES, NAMELY, TROUBLESHOOTING IN THE NATURE OF DIAGNOSING COMPUTER HARDWARE AND SOFTWARE PROBLEMS; TECHNICAL SUPPORT SERVICES, NAMELY, TROUBLESHOOTING OF COMPUTER SOFTWARE PROBLEMS; REMOTE COMPUTER NETWORK TECHNICAL MONITORING AND SOFTWARE MAINTENANCE SERVICES; COMPUTER TECHNOLOGY SUPPORT SERVICES, NAMELY, HELP DESK SERVICES; MONITORING AND FILTERING THE EMAIL OF OTHERS FOR SPAM, VIRUSES, WORMS, TROJANS, SPYWARE, ADWARE, MALWARE AND UNAUTHORIZED DATA AND PROGRAMS ON COMPUTERS AND ELECTRONIC DEVICES (U.S. CLS. 100 AND 101).

FIRST USE 6-1-2010; IN COMMERCE 6-1-2010.

**CLASS 42—(Continued).**

3,955,958. RAQMAND ENTERPRISES, INC., PLANTATION, FL. SN 85-028,051. PUB. 9-28-2010, FILED 5-1-2010.

NO CLAIM IS MADE TO THE EXCLUSIVE RIGHT TO USE "DNA SERVICES", APART FROM THE MARK AS SHOWN.

THE COLOR(S) BURGUNDY AND GOLD IS/ARE CLAIMED AS A FEATURE OF THE MARK.

THE MARK CONSISTS OF THE WORDING "ALL ABOUT TRUTH DNA SERVICES" TO THE RIGHT OF A DOUBLE HELIX DESIGN. THE WORDS "ALL ABOUT TRUTH" ARE STACKED ON TOP OF EACH OTHER AND APPEAR IN GOLD WITH A BURGUNDY OUTLINE. THE WORD "DNA" IS TO THE RIGHT IN LARGER FONT AND APPEARS IN BURGUNDY WITH A GOLD OUTLINE. THE TERM "SERVICES" IS TO THE RIGHT OF "DNA" AND APPEARS IN GOLD WITH A BURGUNDY OUTLINE. ALL OF THE WORDING APPEARS TO THE RIGHT OF THE DOUBLE HELIX DESIGN WHICH IS BURGUNDY.

FOR DNA ANALYSIS SERVICES (U.S. CLS. 100 AND 101).

FIRST USE 5-1-2010; IN COMMERCE 5-1-2010.

3,956,005. KUKLA, FRANK, JEFFERSON CITY, MO. SN 85-052,328. PUB. 12-7-2010, FILED 6-2-2010.

# PADGUY.COM

THE MARK CONSISTS OF STANDARD CHARACTERS WITHOUT CLAIM TO ANY PARTICULAR FONT, STYLE, SIZE, OR COLOR.

FOR PROVIDING COMPUTER AND COMPUTER SOFTWARE INFORMATION IN THE FIELD OF MOBILE COMPUTING VIA AN ONLINE WEBSITE FOR CONSUMERS (U.S. CLS. 100 AND 101).

FIRST USE 4-1-2010; IN COMMERCE 4-1-2010.

3,956,006. KUKLA, FRANK, JEFFERSON CITY, MO. SN 85-052,356. PUB. 12-7-2010, FILED 6-2-2010.

# A MAGICAL AND REVOLUTIONARY BLOG.

THE MARK CONSISTS OF STANDARD CHARACTERS WITHOUT CLAIM TO ANY PARTICULAR FONT, STYLE, SIZE, OR COLOR.

**CLASS 42—(Continued).**

NO CLAIM IS MADE TO THE EXCLUSIVE RIGHT TO USE "BLOG", APART FROM THE MARK AS SHOWN.

FOR PROVIDING COMPUTER AND COMPUTER SOFTWARE INFORMATION IN THE FIELD OF MOBILE COMPUTING VIA AN ONLINE WEBSITE FOR CONSUMERS (U.S. CLS. 100 AND 101).

FIRST USE 4-1-2010; IN COMMERCE 4-1-2010.

---

3,956,030. AON CORPORATION, CHICAGO, IL. SN 85-065,671. PUB. 12-7-2010, FILED 6-17-2010.

## Aon Client Exchange

THE MARK CONSISTS OF STANDARD CHARACTERS WITHOUT CLAIM TO ANY PARTICULAR FONT, STYLE, SIZE, OR COLOR.

OWNER OF U.S. REG. NOS. 1,496,123, 3,254,615, AND OTHERS.

NO CLAIM IS MADE TO THE EXCLUSIVE RIGHT TO USE "CLIENT EXCHANGE", APART FROM THE MARK AS SHOWN.

FOR PROVIDING A WEB SITE FEATURING TECHNOLOGY THAT ENABLES USERS TO ACCESS, EDIT, SUBMIT, REQUEST AND REVIEW DOCUMENTATION AND INFORMATION IN THE FIELD OF INSURANCE AND RISK MANAGEMENT (U.S. CLS. 100 AND 101).

FIRST USE 10-31-2010; IN COMMERCE 10-31-2010.

---

3,956,037. INSURANCE TECHNOLOGIES, LLC, COLORADO SPRINGS, CO. SN 85-071,225. PUB. 11-23-2010, FILED 6-24-2010.

## FireLight

THE MARK CONSISTS OF STANDARD CHARACTERS WITHOUT CLAIM TO ANY PARTICULAR FONT, STYLE, SIZE, OR COLOR.

FOR PROVIDING ONLINE NON-DOWNLOADABLE SOFTWARE APPLICATION FOR USE IN THE INSURANCE INDUSTRY TO FACILITATE THE COMPLETION AND SUBMISSION OF ELECTRONIC INSURANCE APPLICATIONS (U.S. CLS. 100 AND 101).

FIRST USE 2-7-2011; IN COMMERCE 2-7-2011.

**CLASS 42—(Continued).**

3,956,046. MYWORKSHIFT, INC., LITTLE ROCK, AR. SN 85-078,676. PUB. 12-7-2010, FILED 7-6-2010.



NO CLAIM IS MADE TO THE EXCLUSIVE RIGHT TO USE "SCHEDULING", APART FROM THE MARK AS SHOWN.

THE MARK CONSISTS OF THE WORDING "MY WORK SHIFT SCHEDULING MADE SIMPLE" IN A STYLIZED FONT, WITH THE WORDING "MY WORK SHIFT" DEPICTED IN A CURSIVE FONT THAT IS ALL TIED TOGETHER AS ONE CONNECTED PHRASE WITH NO SPACES BETWEEN THEM.

FOR PROVIDING CUSTOMER-DEFINED GENERATED CONTENT AND CONTENT OF OTHERS AUTOMATICALLY SELECTED AND CUSTOMIZED BASED ON THE KNOWN OR ESTIMATED GEOGRAPHICAL LOCATION OF AN INTERNET, MOBILE TELEPHONE OR OTHER WIRED OR WIRELESS DIGITAL NETWORK BASED CUSTOMER; PROVIDING ON-LINE NON-DOWNLOADABLE SOFTWARE FOR USE IN SCHEDULING EMPLOYEES EXCLUDING PROVIDING ON-LINE GAMES; PROVIDING TEMPORARY USE OF A WEB-BASED SOFTWARE APPLICATION FOR USE IN SCHEDULING EMPLOYEES EXCLUDING PROVIDING ON-LINE GAMES (U.S. CLS. 100 AND 101).

FIRST USE 6-22-2010; IN COMMERCE 7-20-2010.

---

3,956,069. ALL ONLINE, INC., MIDDLEVILLE, MI. SN 85-085,545. PUB. 12-21-2010, FILED 7-15-2010.

## FILE CHEETAH

THE MARK CONSISTS OF STANDARD CHARACTERS WITHOUT CLAIM TO ANY PARTICULAR FONT, STYLE, SIZE, OR COLOR.

NO CLAIM IS MADE TO THE EXCLUSIVE RIGHT TO USE "FILE", APART FROM THE MARK AS SHOWN.

FOR FILE SHARING SERVICES, NAMELY, PROVIDING A WEBSITE FEATURING TECHNOLOGY ENABLING USERS TO UPLOAD AND DOWNLOAD ELECTRONIC FILES (U.S. CLS. 100 AND 101).

FIRST USE 3-1-2011; IN COMMERCE 3-1-2011.

**CLASS 43—HOTEL AND RESTAURANT SERVICES**



**CLASS 43—(Continued).**

3,955,164. MOTH MANAGEMENT, INC., DALLAS, TX. SN 76-699,793. PUB. 5-18-2010, FILED 10-9-2009.

**THE MEDDLESOME MOTH**

THE MARK CONSISTS OF STANDARD CHARACTERS WITHOUT CLAIM TO ANY PARTICULAR FONT, STYLE, SIZE, OR COLOR.

FOR BAR AND RESTAURANT SERVICES; BEER ESTABLISHMENT, NAMELY, A PUB; FOOD AND EATING ESTABLISHMENT, NAMELY, RESTAURANT (U.S. CLS. 100 AND 101).

FIRST USE 2-24-2011; IN COMMERCE 2-24-2011.

3,955,172. CHEWFO, LLC, NEW YORK, NY. SN 77-007,065. PUB. 12-4-2007, FILED 9-25-2006.

**CHEWFO**

THE MARK CONSISTS OF STANDARD CHARACTERS WITHOUT CLAIM TO ANY PARTICULAR FONT, STYLE, SIZE, OR COLOR.

FOR PROVIDING AN INTERACTIVE WEB SITE FEATURING NEWS AND INFORMATION IN THE FIELDS OF CULINARY ARTS, COOKING, BAKING, RECIPES, DINING AND RESTAURANT INFORMATION (U.S. CLS. 100 AND 101).

FIRST USE 9-2-2010; IN COMMERCE 1-23-2011.

3,955,462. CASTLE MANOR, LLC, HYDE PARK, UT. SN 77-842,502. PUB. 9-21-2010, FILED 10-6-2009.

**Castle Manor  
Reception and Event Center**

THE MARK CONSISTS OF STANDARD CHARACTERS WITHOUT CLAIM TO ANY PARTICULAR FONT, STYLE, SIZE, OR COLOR.

NO CLAIM IS MADE TO THE EXCLUSIVE RIGHT TO USE "RECEPTION AND EVENT CENTER", APART FROM THE MARK AS SHOWN.

FOR PROVIDING BANQUET AND SOCIAL FUNCTION FACILITIES FOR SPECIAL OCCASIONS (U.S. CLS. 100 AND 101).

FIRST USE 6-1-2009; IN COMMERCE 11-1-2009.

**CLASS 43—(Continued).**

3,955,617. RSB RESTAURANT GROUP LLC, FLAGSTAFF, AZ. SN 77-920,182. PUB. 11-9-2010, FILED 1-26-2010.



NO CLAIM IS MADE TO THE EXCLUSIVE RIGHT TO USE "TAVERNA GREEK GRILL", APART FROM THE MARK AS SHOWN.

THE COLOR(S) TAN, DARK RED, BLUE, BROWN, YELLOW AND WHITE IS/ARE CLAIMED AS A FEATURE OF THE MARK.

THE MARK CONSISTS OF THE WORD "TAVERNA" IN WHITE LETTERS ON A DARK RED RECTANGLE BACKGROUND WITH BLUE AND WHITE RECTANGLES INSIDE OF EACH OTHER BORDERING THE DARK RED RECTANGLE. THE STYLIZED WORDING "GREEK GRILL" APPEARS IN BROWN LETTERS WITH GREEK CHARACTERS FORMING THE LETTER "E" IN THE TERM "GREEK". AN ORNAMENTAL BROWN ARCH DESIGN IS LOCATED ABOVE RECTANGLE DESIGN. THE WORDING AND DESIGN ELEMENTS IN THE MARK APPEAR OVER A RECTANGULAR YELLOW AND TAN PATTERNED BACKGROUND.

FOR RESTAURANT SERVICES, INCLUDING SIT-DOWN SERVICE OF FOOD AND TAKE-OUT RESTAURANT SERVICES (U.S. CLS. 100 AND 101).

FIRST USE 9-0-2010; IN COMMERCE 9-0-2010.

3,955,620. NEVADA PROPERTY 1 LLC, LAS VEGAS, NV. SN 77-920,749. PUB. 5-25-2010, FILED 1-26-2010.



OWNER OF U.S. REG. NOS. 3,337,476 AND 3,337,479. NO CLAIM IS MADE TO THE EXCLUSIVE RIGHT TO USE "LAS VEGAS", APART FROM THE MARK AS SHOWN.

THE MARK CONSISTS OF THREE OVERLAPPING AND STYLIZED LETTER "C"S TO THE LEFT OF THE WORDS "THE COSMOPOLITAN OF LAS VEGAS".

FOR RESORT HOTELS; PROVIDING TEMPORARY HOUSING ACCOMMODATIONS IN CONDOMINIUMS (U.S. CLS. 100 AND 101).

FIRST USE 12-15-2010; IN COMMERCE 12-15-2010.

**CLASS 43—(Continued).**

3,955,712. GATTEN SUSHI USA, INC., CERRITOS, CA. SN 77-938,184. PUB. 7-13-2010, FILED 2-17-2010.



NO CLAIM IS MADE TO THE EXCLUSIVE RIGHT TO USE "REVOLVING SUSHI BAR", APART FROM THE MARK AS SHOWN.

THE MARK CONSISTS OF A STANDING CARTOON CHEF CHARACTER WEARING A HEADBAND AND GETA SLIPPERS WITH UPRAISED ARMS; THE WORD "REVOLVING" IS WRITTEN ABOVE THE CHEF'S HEAD AND THE WORDS "SUSHI BAR" ARE WRITTEN BELOW THE CHEF'S FEET, ALL CONTAINED WITHIN A CIRCLE.

FOR RESTAURANT SERVICES (U.S. CLS. 100 AND 101).

FIRST USE 9-1-2010; IN COMMERCE 9-1-2010.

3,955,797. RESTAURANTS UNLIMITED, INC., SEATTLE, WA. SN 77-958,230. PUB. 8-3-2010, FILED 3-12-2010.



OWNER OF U.S. REG. NOS. 1,626,442 AND 2,008,261. NO CLAIM IS MADE TO THE EXCLUSIVE RIGHT TO USE "RESTAURANT & BAR EST. 1988", APART FROM THE MARK AS SHOWN.

THE MARK CONSISTS OF A HORSE DESIGN. THE WORD "PALOMINO" APPEARS BELOW THE HORSE. THE WORDS "RESTAURANT & BAR" APPEAR BELOW THE WORD "PALOMINO". THE WORDS "EST. 1988" APPEAR BELOW THE WORDS "RESTAURANT & BAR".

FOR RESTAURANT, BAR, AND CATERING SERVICES (U.S. CLS. 100 AND 101).

FIRST USE 2-22-2010; IN COMMERCE 2-22-2010.

**CLASS 43—(Continued).**

3,955,867. SARDELLA, LLC, ANNAPOLIS, MD. SN 77-981,671. PUB. 7-20-2010, FILED 8-27-2009.

**HELL POINT SEAFOOD**

THE MARK CONSISTS OF STANDARD CHARACTERS WITHOUT CLAIM TO ANY PARTICULAR FONT, STYLE, SIZE, OR COLOR.

NO CLAIM IS MADE TO THE EXCLUSIVE RIGHT TO USE "SEAFOOD", APART FROM THE MARK AS SHOWN.

FOR RESTAURANT, CAFE, COCKTAIL LOUNGE AND CATERING SERVICES; RESTAURANT, CAFE, COCKTAIL LOUNGE AND CATERING SERVICES FEATURING SEAFOOD, FISH AND SHELLFISH (U.S. CLS. 100 AND 101).

FIRST USE 6-27-2009; IN COMMERCE 6-27-2009.

3,955,994. DAVID WU INVESTMENTS, INC., TAMPA, FL. SN 85-047,356. PUB. 9-28-2010, FILED 5-25-2010.

**THAI MAX**

THE MARK CONSISTS OF STANDARD CHARACTERS WITHOUT CLAIM TO ANY PARTICULAR FONT, STYLE, SIZE, OR COLOR.

OWNER OF U.S. REG. NO. 2,456,834.

NO CLAIM IS MADE TO THE EXCLUSIVE RIGHT TO USE "THAI", APART FROM THE MARK AS SHOWN.

THE NAME(S), PORTRAIT(S), AND/OR SIGNATURE(S) SHOWN IN THE MARK DOES NOT IDENTIFY A PARTICULAR LIVING INDIVIDUAL.

FOR FAST-FOOD RESTAURANTS; RESTAURANT SERVICES; SERVING OF FOOD AND DRINK/BEVERAGES; TAKE-OUT RESTAURANT SERVICES (U.S. CLS. 100 AND 101).

FIRST USE 3-4-2011; IN COMMERCE 3-4-2011.

3,956,095. LOWER SIOUX INDIAN COMMUNITY, MOR-TON, MN. SN 85-172,302. PUB. 1-18-2011, FILED 11-9-2010.

**JACKPOT! PLAYZONE**

THE MARK CONSISTS OF STANDARD CHARACTERS WITHOUT CLAIM TO ANY PARTICULAR FONT, STYLE, SIZE, OR COLOR.

NO CLAIM IS MADE TO THE EXCLUSIVE RIGHT TO USE "PLAYZONE", APART FROM THE MARK AS SHOWN.

FOR CHILD DAY CARE SERVICES (U.S. CLS. 100 AND 101).

FIRST USE 12-1-2010; IN COMMERCE 12-1-2010.

**CLASS 44—MEDICAL, BEAUTY AND AGRICULTURAL SERVICES**

3,955,343. ASSIOUN, PATRICK, CAMBRIDGE, MA. SN 77-761,573. PUB. 11-10-2009, FILED 6-17-2009.



THE MARK CONSISTS OF FIVE STARS WITH SMILES AND TEETH, THE STARS ARE ARRANGED IN A LINE WITH THE CENTER STAR BEING THE LARGEST AND THE STARS DESCENDING IN HEIGHT FROM THE CENTER STAR.

FOR ORTHODONTIC SERVICES (U.S. CLS. 100 AND 101).

FIRST USE 6-1-2009; IN COMMERCE 6-1-2009.

---

3,955,536. OMS INVESTMENTS, INC., LOS ANGELES, CA. SN 77-880,022. PUB. 4-27-2010, FILED 11-24-2009.

**GRO YOUR OWN**

THE MARK CONSISTS OF STANDARD CHARACTERS WITHOUT CLAIM TO ANY PARTICULAR FONT, STYLE, SIZE, OR COLOR.

FOR PROVIDING ADVICE AND INFORMATION ON THE SUBJECTS OF GARDENING AND LAWN CARE AND THE USE OF PRODUCTS RELATING TO GARDENING AND LAWN CARE, NAMELY, PLANT FOODS, FERTILIZERS, PESTICIDES, HERBICIDES, GRASS SEED, POTTING MIXES, SOIL, SOIL CONDITIONERS AND AMENDMENTS, MULCHES, AND LAWN AND GARDEN EQUIPMENT; PROVIDING ADVICE AND INFORMATION ON THE SUBJECTS OF GARDENING AND LAWN CARE AND THE USE OF PRODUCTS RELATING TO GARDENING AND LAWN CARE, NAMELY, PLANT FOODS, FERTILIZERS, PESTICIDES, HERBICIDES, GRASS SEED, POTTING MIXES, SOIL, SOIL CONDITIONERS AND AMENDMENTS, MULCHES, AND LAWN AND GARDEN EQUIPMENT VIA PRINT AND ELECTRONIC MEANS; PROVIDING IN-STORE CONSULTING SERVICES ON THE SUBJECTS OF GARDENING AND LAWN CARE AND THE USE OF RELATED PRODUCTS, NAMELY, PLANT FOODS, FERTILIZERS, PESTICIDES, GRASS SEED, POTTING MIXES, SOIL, SOIL CONDITIONERS AND AMENDMENTS, MULCHES, AND LAWN AND GARDEN EQUIPMENT; LAWN, TREE, AND SHRUB CARE SERVICES; LANDSCAPE GARDENING SERVICES; CONSULTING SERVICES IN THE FIELD OF LAWN, TREE, AND SHRUB CARE AND LANDSCAPE GARDENING (U.S. CLS. 100 AND 101).

FIRST USE 3-0-2010; IN COMMERCE 3-0-2010.

**CLASS 44—(Continued).**

3,955,542. QUATTRA VIA, INC., SAN DIEGO, CA. SN 77-881,755. PUB. 9-28-2010, FILED 11-29-2009.

**QUATTRA VIA**

THE MARK CONSISTS OF STANDARD CHARACTERS WITHOUT CLAIM TO ANY PARTICULAR FONT, STYLE, SIZE, OR COLOR.

THE WORDING "QUATTRA VIA" HAS NO MEANING IN A FOREIGN LANGUAGE.

FOR BEAUTY SALON SERVICES; BEAUTY SPA SERVICES, NAMELY, COSMETIC BODY CARE SERVICES, COSMETIC SKIN CARE AND BODY CARE SERVICES, NAIL CARE SERVICES, HAIR CUTTING, COLORING, STYLING AND REMOVAL SERVICES; FACIAL AND MAKE-UP SERVICES (U.S. CLS. 100 AND 101).

FIRST USE 11-26-2010; IN COMMERCE 11-26-2010.

---

3,955,609. APOLLO PET CARE, INC., DBA APOLLO PET CARE, MANTON, CA. SN 77-917,181. PUB. 6-1-2010, FILED 1-21-2010.

**APOLLO PET CARE**

THE MARK CONSISTS OF STANDARD CHARACTERS WITHOUT CLAIM TO ANY PARTICULAR FONT, STYLE, SIZE, OR COLOR.

NO CLAIM IS MADE TO THE EXCLUSIVE RIGHT TO USE "PET CARE", APART FROM THE MARK AS SHOWN.

FOR PET GROOMING SERVICES, NAMELY, HYGIENIC AND BEAUTY DENTAL CARE FOR PETS WITHOUT USING ANESTHESIA (U.S. CLS. 100 AND 101).

FIRST USE 1-1-1988; IN COMMERCE 1-1-2009.

**CLASS 44—(Continued).**

3,955,705. TI, RONALD DR., QUEENSLAND, AUSTRALIA.  
SN 77-937,679. PUB. 8-24-2010, FILED 2-17-2010.

# ASA

THE MARK CONSISTS OF STANDARD CHARACTERS WITHOUT CLAIM TO ANY PARTICULAR FONT, STYLE, SIZE, OR COLOR.

FOR CONSULTANCY AND ADVISORY SERVICES IN RELATION TO MEDICAL SERVICES; MEDICAL ADVISORY SERVICES; MEDICAL ASSISTANCE; MEDICAL SERVICES; PROVISION OF MEDICAL INFORMATION; EMERGENCY MEDICAL RESPONSE AND RESUSCITATION SERVICES; PROVISION OF MEDICAL SERVICES IN REMOTE AREAS; PROVISION OF MOBILE SURGICAL SERVICES; CONSULTING SERVICES IN THE FIELD OF HEALTH; MEDICAL SERVICES, NAMELY, PREVENTATIVE MEDICAL SERVICES; MEDICAL SERVICES, NAMELY, ADMINISTERING PROTECTIVE VACCINES (U.S. CLS. 100 AND 101).

FIRST USE 12-1-2005; IN COMMERCE 5-3-2010.

---

3,955,716. ABS GLOBAL, INC., DEFOREST, WI. SN 77-940,086. PUB. 7-20-2010, FILED 2-19-2010.

# CMS

THE MARK CONSISTS OF STANDARD CHARACTERS WITHOUT CLAIM TO ANY PARTICULAR FONT, STYLE, SIZE, OR COLOR.

FOR ANIMAL BREEDING SERVICES (U.S. CLS. 100 AND 101).

FIRST USE 12-2-2009; IN COMMERCE 12-2-2009.

---

3,955,730. JOHNSON & JOHNSON, NEW BRUNSWICK, NJ.  
SN 77-942,218. PUB. 7-20-2010, FILED 2-23-2010.

# RA VOICES

THE MARK CONSISTS OF STANDARD CHARACTERS WITHOUT CLAIM TO ANY PARTICULAR FONT, STYLE, SIZE, OR COLOR.

NO CLAIM IS MADE TO THE EXCLUSIVE RIGHT TO USE "RA", APART FROM THE MARK AS SHOWN.

FOR PROVIDING INFORMATION RELATED TO RHEUMATOID ARTHRITIS TO PATIENTS (U.S. CLS. 100 AND 101).

FIRST USE 4-12-2010; IN COMMERCE 4-12-2010.

**CLASS 44—(Continued).**

3,955,752. HEFTER, EUGENE, AKA EUGENIUSZ HEFTER, CHICAGO, IL. SN 77-946,185. PUB. 7-27-2010, FILED 2-26-2010.



NO CLAIM IS MADE TO THE EXCLUSIVE RIGHT TO USE "MINISTRY", APART FROM THE MARK AS SHOWN.

THE MARK CONSISTS OF AN OVAL SHAPE CONTAINING THE WORDS "GOD IS ONE FOR ALL" AT THE TOP OF THE OVAL AND "ALL RELIGIONS UNITED" AT THE BOTTOM OF THE OVAL. THE WORD "MINISTRY" APPEARS JUST OUTSIDE THE OVAL AT THE LOWER RIGHT CORNER OF THE MARK. THE INTERIOR OF THE OVAL HAS A CIRCLE WHICH CONTAINS A CROSS DESIGN WITH STYLIZED LIGHT RAYS AND AN INTERTWINED HEART AND TRIANGLE AT THE TOP OF THE CROSS. THE INTERIOR OF THE HEART AND TRIANGLE PORTION OF THE MARK CONTAINS TWO HUMAN HANDS WITH THEIR THUMBS CROSSED.

FOR PROVIDING SPIRITUAL HEALING SERVICES, NAMELY, PROVIDING MEDICAL SERVICES BASED ON SPIRITUAL PRINCIPLES (U.S. CLS. 100 AND 101).

FIRST USE 5-18-2003; IN COMMERCE 5-18-2003.

---

3,955,779. CIECAL RC, INC., CHULA VISTA, CA. SN 77-951,640. PUB. 7-27-2010, FILED 3-5-2010.

"IMPROVING HEALTHCARE, ONE  
PATIENT AT A TIME"

THE MARK CONSISTS OF STANDARD CHARACTERS WITHOUT CLAIM TO ANY PARTICULAR FONT, STYLE, SIZE, OR COLOR.

FOR MEDICAL CLINICS; MEDICAL CONSULTATIONS (U.S. CLS. 100 AND 101).

FIRST USE 3-5-2010; IN COMMERCE 3-5-2010.

**CLASS 44—(Continued).**

3,955,815. BULLOCK, ERICA S., PORT ORANGE, FL. SN 77-963,420. PUB. 8-10-2010, FILED 3-19-2010.



NO CLAIM IS MADE TO THE EXCLUSIVE RIGHT TO USE "PEDIATRIC" AND "CHIROPRACTIC", APART FROM THE MARK AS SHOWN.

THE MARK CONSISTS OF AN ANGELIC MALE HOLDING A BABY WRAPPED IN A SASH CONTAINING THE WORDS "PEDIATRIC CHIROPRACTIC".

FOR CHIROPRACTIC SERVICES (U.S. CLS. 100 AND 101).

FIRST USE 11-1-2009; IN COMMERCE 11-1-2009.

**CLASS 44—(Continued).**

3,955,818. HARMAN M.D., DEBRA, BRISTOL, VA. SN 77-963,960. PUB. 8-10-2010, FILED 3-19-2010.

**emDee Clinica**



NO CLAIM IS MADE TO THE EXCLUSIVE RIGHT TO USE "CLINICA" AND "HEALTH", APART FROM THE MARK AS SHOWN.

THE MARK CONSISTS OF A CADUCEUS MADE OF THE BODY OF A MAN WITH ARMS OUTSTRETCHED WITH WINGS AND A SINGLE WRAP GOING AROUND THE LOWER HALF OF THE BODY WITH THE STYLIZED TEXT "EMDEE CLINICA" ON THE WRAP AND THE WORD "HEALTH" OVER THE HEAD OF THE FIGURE. ON THE TOP THERE IS THE STYLIZED TEXT "EMDEE CLINICA".

FOR MEDICAL CLINICS (U.S. CLS. 100 AND 101).  
FIRST USE 11-24-2010; IN COMMERCE 11-24-2010.

3,955,956. PHARMAPACKS, LLC, WHITESTONE, NC. SN 85-026,733. PUB. 8-10-2010, FILED 4-29-2010.

**Pharmapacks.com**

THE MARK CONSISTS OF STANDARD CHARACTERS WITHOUT CLAIM TO ANY PARTICULAR FONT, STYLE, SIZE, OR COLOR.

FOR PROVIDING A WEBSITE FEATURING CONTENT REGARDING HEALTHY LIVING AND LIFESTYLE WELLNESS (U.S. CLS. 100 AND 101).

FIRST USE 2-7-2011; IN COMMERCE 2-7-2011.

3,955,817. RETAILFOODRX, INC., CAMBRIDGE, MA. SN 77-963,902. PUB. 8-10-2010, FILED 3-19-2010.

**RetailFoodRx**

THE MARK CONSISTS OF STANDARD CHARACTERS WITHOUT CLAIM TO ANY PARTICULAR FONT, STYLE, SIZE, OR COLOR.

FOR FOOD NUTRITION CONSULTATION (U.S. CLS. 100 AND 101).

FIRST USE 6-1-2010; IN COMMERCE 6-1-2010.

3,955,960. HALDANKAR, SHAMIM, NEWBURY PARK, CA. SN 85-028,632. PUB. 10-19-2010, FILED 5-3-2010.

**shamim slp**  
a voice for every child

NO CLAIM IS MADE TO THE EXCLUSIVE RIGHT TO USE "SLP", APART FROM THE MARK AS SHOWN.

**CLASS 44—(Continued).**

THE MARK CONSISTS OF A DESIGN OF FOUR HEARTS TOUCHING EACH OTHER AT THE BOTTOM BETWEEN THE WORDING "SHAMIM" AND "SLP" AND WITH THE WORDING "A VOICE FOR EVERY CHILD" BELOW THE HEART DESIGN AND "SHAMIM SLP" WORDING.

FOR SPEECH PATHOLOGY THERAPY SERVICES (U.S. CLS. 100 AND 101).

FIRST USE 5-28-2010; IN COMMERCE 5-28-2010.

---

3,955,967. MILLER, ERIC L., DBA THE LAWN ACADEMY, FRISCO, TX. SN 85-031,357. PUB. 10-5-2010, FILED 5-6-2010.



NO CLAIM IS MADE TO THE EXCLUSIVE RIGHT TO USE "LAWN", APART FROM THE MARK AS SHOWN.

THE COLOR(S) BLACK, WHITE, GRAY, GREEN, LIGHT GREEN AND DARK GREEN IS/ARE CLAIMED AS A FEATURE OF THE MARK.

THE MARK CONSISTS OF THE WORDING "THE LAWN ACADEMY" WHERE THE WORD "THE" IS BLACK, THE WORD "LAWN" IS GREEN INSIDE A WHITE RECTANGLE OUTLINED IN GREEN AND THE WORD "ACADEMY" IS WHITE INSIDE A GREEN RECTANGLE OUTLINED IN LIGHT GREEN. THE RECTANGLES CONTAINING THE WORDS "LAWN" AND "ACADEMY" APPEAR AGAINST A BACKGROUND DESIGN OF LIGHT GREEN AND DARK GREEN GRASS AND THE WORD "THE" APPEARS AGAINST A WHITE BACKGROUND ABOVE THE GRASS DESIGN. ALL OF THE FOREGOING ELEMENTS APPEAR INSIDE A RECTANGLE OUTLINED IN GREEN AND WHITE WITH GRAY SHADING.

FOR LAWN CARE SERVICES PROVIDED BY YOUTH FOR ELDERLY AND DISABLED PERSONS (U.S. CLS. 100 AND 101).

FIRST USE 6-10-2010; IN COMMERCE 6-10-2010.

---

3,956,070. L T PARKER & ASSOCIATES, INC., NORTH CANTON, OH. SN 85-086,475. PUB. 12-28-2010, FILED 7-16-2010.

**EMS SENTRY, INC.**

THE MARK CONSISTS OF STANDARD CHARACTERS WITHOUT CLAIM TO ANY PARTICULAR FONT, STYLE, SIZE, OR COLOR.

**CLASS 44—(Continued).**

NO CLAIM IS MADE TO THE EXCLUSIVE RIGHT TO USE "EMS" AND "INC.", APART FROM THE MARK AS SHOWN.

FOR MEDICAL ASSISTANCE SERVICES PROVIDED VIA TELECOMMUNICATION AND GLOBAL COMPUTER NETWORKS FOR INDIVIDUALS WITH HEALTH PROBLEMS THROUGH THE USE OF WEARABLE MEDICAL DEVICES WITH AUTOMATED ALERT AND MONITORING CAPACITY; INTERACTIVE MEDICAL MONITORING AND ALERT SERVICE FOR REMINDING CLIENTS OF MEDICAL INFORMATION, NAMELY, MEDICINAL DOSAGE, ALLERGIC SENSITIVITY, AND PRESCRIPTION REFILLS (U.S. CLS. 100 AND 101).

FIRST USE 7-0-2010; IN COMMERCE 1-1-2011.

**CLASS 45—PERSONAL AND LEGAL SERVICES**

---

3,955,237. ARI MEYERS, NEW YORK, NY. SN 77-520,224. PUB. 12-2-2008, FILED 7-11-2008.

**MY PURPOSE PARTY**

THE MARK CONSISTS OF STANDARD CHARACTERS WITHOUT CLAIM TO ANY PARTICULAR FONT, STYLE, SIZE, OR COLOR.

FOR ON-LINE SOCIAL NETWORKING SERVICES (U.S. CLS. 100 AND 101).

FIRST USE 5-30-2010; IN COMMERCE 5-30-2010.

---

3,955,375. BAYLES, SHAUN L, WAIPAHU, HI. AND HER, XEE, KAPOLEI, HI. SN 77-786,225. PUB. 12-8-2009, FILED 7-21-2009.

**FēVA**

THE MARK CONSISTS OF "FEVA" - THE WORD "FEVA" HAS A CAPITAL "F" AND LOWER CASE "E" WITH THE "LONG FORM" LINE ABOVE IT AND FINISHES WITH A CAPITAL "V" AND "A".

FOR COMPUTER DATING SERVICES; DATING SERVICES; DATING SERVICES, NAMELY, PROVIDING AN ON-LINE COMPUTER DATABASE FEATURING SINGLE PEOPLE INTERESTED IN MEETING OTHER SINGLE PEOPLE; INTERNET BASED SOCIAL NETWORKING, INTRODUCTION, AND DATING SERVICES; INTERNET-BASED DATING, SOCIAL INTRODUCTION AND SOCIAL NETWORKING SERVICES; MARRIAGE PARTNER INTRODUCTION OR DATING SERVICES; ON-LINE IDENTITY RELIABILITY INVESTIGATION IN THE FIELD OF ON-LINE DATING AND CLAIMS MADE ABOUT AGE, GENDER; PROVIDING A WEB SITE FEATURING INFORMATION AND CONTENT IN THE FIELDS OF PERSONAL RELATIONSHIPS, DATING AND FASHION; VIDEO DATING SERVICES; WEB SITE SERVICES FEATURING ON-LINE DATING CLUB (U.S. CLS. 100 AND 101).

FIRST USE 8-28-2009; IN COMMERCE 12-4-2009.

**CLASS 45—(Continued).**

3,955,539. HEALTHDATAINSIGHTS, INC., LAS VEGAS, NV.  
SN 77-881,040. PUB. 6-15-2010, FILED 11-25-2009.

## Claims Integrity Matters.

THE MARK CONSISTS OF THE STYLIZED WORDS "CLAIMS INTEGRITY MATTERS" FOLLOWED BY A LARGE PERIOD.

FOR COMPILING AND ANALYZING HEALTHCARE CLAIMS AND DATA IN ORDER TO UNCOVER AND IDENTIFY HEALTH CARE FRAUD, ABUSE, CLAIMS ERRORS AND RECOVERY AS WELL AS MEDICAL NECESSITY / UTILIZATION REVIEW SERVICES FOR HEALTHCARE PURCHASERS AND PAYORS IN ORDER TO UNCOVER AND IDENTIFY HEALTH CARE FRAUD, ABUSE, CLAIMS ERRORS AND RECOVERY (U.S. CLS. 100 AND 101).

FIRST USE 10-25-2010; IN COMMERCE 10-25-2010.

3,955,561. BUZUB, INC., HOPKINTON, MA. SN 77-892,464.  
PUB. 11-2-2010, FILED 12-14-2009.

# BUZUB

THE MARK CONSISTS OF STANDARD CHARACTERS WITHOUT CLAIM TO ANY PARTICULAR FONT, STYLE, SIZE, OR COLOR.

FOR PROVIDING SOCIAL NETWORKING SERVICES VIA ON-LINE WEBSITES (U.S. CLS. 100 AND 101).

FIRST USE 9-17-2010; IN COMMERCE 9-17-2010.

3,955,733. EVERLOOP, INC., DANVILLE, CA. SN 77-943,061.  
PUB. 7-13-2010, FILED 2-23-2010.

# EVERLOOP

THE MARK CONSISTS OF STANDARD CHARACTERS WITHOUT CLAIM TO ANY PARTICULAR FONT, STYLE, SIZE, OR COLOR.

FOR PROVIDING INTERNET-BASED SOCIAL NETWORKING SERVICES (U.S. CLS. 100 AND 101).

FIRST USE 10-1-2010; IN COMMERCE 10-1-2010.

**CLASS 45—(Continued).**

3,955,753. STAR LAW NETWORK, LLC, RIDGELAND, MS.  
SN 77-947,304. PUB. 8-3-2010, FILED 3-1-2010.



NO CLAIM IS MADE TO THE EXCLUSIVE RIGHT TO USE "LAW NETWORK", APART FROM THE MARK AS SHOWN.

THE MARK CONSISTS OF AN ARC OR SWOOP, THE POINTS OF WHICH FACE LEFT, WITH FOUR (4) DESCENDING STARS POSITIONED ALONG THE CURVE OF THE SWOOP. INSIDE EACH CONSECUTIVE STAR, TOP TO BOTTOM, A SINGLE LETTER IS FOUND: "S", "T", "A", "R", RESPECTIVELY. POSITIONED ALONG THE SWOOP, FROM TOP TO BOTTOM, ARE THE FOLLOWING WORDS: "SMART", "TIMELY", "ASSERTIVE" AND "REASONABLE" WITH THE FIRST LETTER OF EACH SUCH WORD BEING LOCATED INSIDE EACH OF THE DESCENDING STARS. BENEATH THE SWOOP AND STARS IS THE PHRASE "STAR LAW NETWORK" WHICH IS LOCATED BETWEEN TWO (2) HORIZONTAL LINES.

FOR LEGAL SERVICES (U.S. CLS. 100 AND 101).

FIRST USE 12-1-2009; IN COMMERCE 12-1-2009.

3,955,754. STAR LAW NETWORK, LLC, RIDGELAND, MS.  
SN 77-947,348. PUB. 8-3-2010, FILED 3-1-2010.



NO CLAIM IS MADE TO THE EXCLUSIVE RIGHT TO USE "LAW NETWORK", APART FROM THE MARK AS SHOWN.

**CLASS 45—(Continued).**

THE MARK CONSISTS OF AN ARC OR SWOOP, THE POINTS OF WHICH FACE LEFT, WITH FOUR (4) DESCENDING STARS POSITIONED ALONG THE CURVE OF THE SWOOP. INSIDE EACH CONSECUTIVE STAR, TOP TO BOTTOM, A SINGLE LETTER IS FOUND: "S", "T", "A", "R", RESPECTIVELY. BENEATH THE SWOOP AND STARS IS THE PHRASE "STAR LAW NETWORK" WHICH IS LOCATED BETWEEN TWO (2) HORIZONTAL LINES.

FOR LEGAL SERVICES (U.S. CLS. 100 AND 101).  
FIRST USE 12-1-2009; IN COMMERCE 12-1-2009.



3,955,776. BODY OF ART, LTD., DBA PURETHREAD, MOUNT KISCO, NY. SN 77-951,353. PUB. 7-27-2010, FILED 3-5-2010.

**PURETHREAD**

THE MARK CONSISTS OF STANDARD CHARACTERS WITHOUT CLAIM TO ANY PARTICULAR FONT, STYLE, SIZE, OR COLOR.

FOR FASHION STYLING SERVICES, PERSONAL SHOPPING FOR OTHERS, PROVIDING NEWS AND INFORMATION IN THE FIELD OF FASHION AND FASHION STYLING, PROVISION OF A WEBSITE FEATURING INFORMATION ON FASHION AND FASHION STYLING (U.S. CLS. 100 AND 101).

FIRST USE 9-1-2010; IN COMMERCE 9-1-2010.

**CLASS 45—(Continued).**

3,955,784. SAN DIEGO ROCK CHURCH, SAN DIEGO, CA. SN 77-954,035. PUB. 8-3-2010, FILED 3-9-2010.



THE MARK CONSISTS OF AN EXCLAMATION MARK DESIGN AND THE WORDS "DO SOMETHING WORLD".

FOR CHRISTIAN MINISTERIAL AND EVANGELICAL SERVICES (U.S. CLS. 100 AND 101).

FIRST USE 11-4-2009; IN COMMERCE 11-4-2009.



3,956,012. ZEMA ENTERPRISES, INC., GLENDALE, CA. SN 85-057,176. PUB. 11-2-2010, FILED 6-8-2010.

**Leadership as a Service  
(LaaS)**

THE MARK CONSISTS OF STANDARD CHARACTERS WITHOUT CLAIM TO ANY PARTICULAR FONT, STYLE, SIZE, OR COLOR.

FOR BUSINESS MANAGEMENT CONSULTATION IN THE FIELD OF EXECUTIVE AND LEADERSHIP DEVELOPMENT FOR TECHNOLOGY COMPANIES (U.S. CLS. 100 AND 101).

FIRST USE 9-1-2010; IN COMMERCE 9-1-2010.

\* \* \* \* \*



PRIOR UNITED STATES CLASSIFICATION

APPLICATION IN ONE CLASS

CERTIFICATION MARKS

**CLASS A—GOODS**

3,955,478. VILLAGE PRESS, INC., TRAVERSE CITY, MI. SN  
77-851,347. PUB. 3-30-2010, FILED 10-19-2009.

THE MARK CONSISTS OF THE WORDS "ENVIRO-SMART MARKETING" AND A SOLID SILHOUETTE OF A LEAFY TREE.

THE CERTIFICATION MARK, AS INTENDED TO BE USED BY AUTHORIZED PERSONS, IS INTENDED TO CERTIFY THAT THE PRINTED MATERIALS TO WHICH THE MARK IS APPLIED MEET THE CERTIFIER'S SPECIFICATIONS FOR PAPER USE, CARBON FOOTPRINT, MATERIAL SELECTION AND RECYCLING APPLICABILITY.

FOR PRINTED PROMOTIONAL, ADVERTISING AND SHIPPING MATERIALS (U.S. CL. A).

FIRST USE 12-13-2010; IN COMMERCE 12-13-2010.



NO CLAIM IS MADE TO THE EXCLUSIVE RIGHT TO USE "MARKETING", APART FROM THE MARK AS SHOWN.

\* \* \* \* \*

# SUPPLEMENTAL REGISTER

These registrations are not subject to opposition.

## SECTION 1.— INTERNATIONAL CLASSIFICATION

The short titles associated below with the international class numbers are terms designed merely for quick identification and are not an official part of the international classification. The full names of international classes are given in section 6.1 of the trademark rules of practice.

The designation "U.S. Cl." appearing in this section refers to the U.S. class in effect prior to Sep. 1, 1973 rather than the international class which applies to applications filed on or after that date. For adoption of international classification see notice in the OFFICIAL GAZETTE of Jun. 26, 1973 (911 O.G. TM 210).

### Application in more than one class

3,956,102. GEORGETOWN CUPCAKE, LLC, WASHINGTON, DC. SN 76-705,991. FILED P.R. 1-14-2011; AM. S.R. 1-14-2011.

3,956,109. NORTH SHORE ANIMAL LEAGUE AMERICA, INC., PORT WASHINGTON, NY. SN 77-824,761. FILED P.R. 9-11-2009; AM. S.R. 1-10-2011.



THE COLORS WHITE, BLACK, AND PINK ARE CLAIMED AS FEATURES OF THE MARK.

THE MARK CONSISTS OF THREE-DIMENSIONAL TRADE DRESS FOR THE APPEARANCE OF A RETAIL BAKERY SHOP OFFERING CAFE SERVICES, PRODUCED BY A COMBINATION OF A BUILDING WITH A WHITE EXTERIOR, BLACK AWNINGS AND SIGNIFICANT GLASS STOREFRONT, HAVING VISIBLE, THROUGH THE GLASS, PINK BOXES AND CUPCAKES DISPLAYED ON ELEVATED TRAYS. THE DASHED LINES, SUCH AS SHOWING THE CONTOURS OF THE BUILDING, ARE NOT PART OF THE MARK AND ARE USED TO INDICATE THE POSITION OF SUCH FEATURES. OWNER MAKES NO CLAIM TO THE COLOR OF THE INTERIOR OF THE SHOP AS VISIBLE THROUGH STOREFRONT WINDOWS AND DOOR OTHER THAN FOR PINK BOXES AS SHOWN. OWNER MAKES NO CLAIM TO COLOR FOR THE SIDEWALK OR UPPER STORIES OF THE BUILDING OR THE BUILDINGS TO THE LEFT OR RIGHT OF THE ESTABLISHMENT. OWNER MAKES NO CLAIM TO THE "GEORGETOWN CUPCAKE" MARK AND LOGO (WORDS AND DESIGN) AS A FEATURE OF THE MARK, SHOWN DASHED IN THE DRAWING.

#### CLASS 35—ADVERTISING AND BUSINESS

FOR RETAIL BAKERY SHOP (U.S. CLS. 100, 101 AND 102).  
FIRST USE 3-1-2008; IN COMMERCE 3-1-2008.

#### CLASS 43—HOTEL AND RESTAURANT SERVICES

FOR CAFE SERVICES (U.S. CLS. 100 AND 101).  
FIRST USE 3-1-2008; IN COMMERCE 3-1-2008.

## ANIMAL LEAGUE

THE MARK CONSISTS OF STANDARD CHARACTERS WITHOUT CLAIM TO ANY PARTICULAR FONT, STYLE, SIZE, OR COLOR.

OWNER OF U.S. REG. NOS. 2,590,858 AND 3,457,123.

NO CLAIM IS MADE TO THE EXCLUSIVE RIGHT TO USE "LEAGUE", APART FROM THE MARK AS SHOWN.

#### CLASS 35—ADVERTISING AND BUSINESS

FOR PROMOTING PUBLIC AWARENESS ABOUT THE NEED FOR ADOPTING ANIMALS, FOR ANIMAL ADOPTION PLACEMENT, FOR ANIMAL ADOPTION AGENCIES, FOR SPAYING, FOR NEUTERING AND FOR OTHER VETERINARY SERVICES RELATED TO ANIMAL ADOPTION; PROMOTING THE SERVICES OF ANIMAL SHELTERS THROUGH DISTRIBUTION OF PRINTED MATERIAL AND DISSEMINATION OF INFORMATION IN THE FORM OF ADVERTISING MATTER VIA THE INTERNET; PROMOTING THE SERVICES OF ANIMAL ADOPTION ORGANIZATIONS THROUGH PROMOTIONAL CONTESTS (U.S. CLS. 100, 101 AND 102).

FIRST USE 0-0-2008; IN COMMERCE 0-0-2008.

#### CLASS 36—INSURANCE AND FINANCIAL

FOR CHARITABLE FUND RAISING SERVICES TO RAISE MONEY FOR ANIMAL ADOPTION (U.S. CLS. 100, 101 AND 102).

FIRST USE 0-0-2008; IN COMMERCE 0-0-2008.

#### CLASS 44—MEDICAL, BEAUTY AND AGRICULTURAL SERVICES

FOR PROVIDING VETERINARY SERVICES, NAMELY, ANIMAL SPAYING AND NEUTERING SERVICES; PROVIDING AN INTERACTIVE WEBSITE FEATURING INFORMATION ABOUT PET SPAYING AND NEUTERING (U.S. CLS. 100 AND 101).

FIRST USE 0-0-2008; IN COMMERCE 0-0-2008.

3,956,116. MILUX HOLDING S.A., LUXEMBOURG, LUXEMBOURG. SN 77-859,165. FILED P.R. 10-28-2009; AM. S.R. 3-2-2011.

## POTENCYCONTROL

THE MARK CONSISTS OF STANDARD CHARACTERS WITHOUT CLAIM TO ANY PARTICULAR FONT, STYLE, SIZE, OR COLOR.

PRIORITY CLAIMED UNDER SEC. 44(D) ON ERP CMNTY TM OFC APPLICATION NO. 008255473, FILED 4-29-2009, REG. NO. 008255473, DATED 1-28-2010, EXPIRES 4-29-2019.

### CLASS 9—ELECTRICAL AND SCIENTIFIC APPARATUS

FOR APPARATUS, DEVICES AND INSTRUMENTS, ALL NOT USED IN DIRECT ASSOCIATION WITH ACTIVE IMPLANTS, FOR MEASURING, RECEIVING, SENDING, CHECKING, CONTROLLING, DRIVING, TRANSFERRING, TRANSMITTING, PROCESSING, ANALYZING, CONDUCTING, SWITCHING, TRANSFORMING, ACCUMULATING, AND REGULATING ELECTRICITY, ENERGY AND/OR DATA, INCLUDING PHYSICAL PARAMETERS, NAMELY, ELECTRONIC STORAGE DEVICES IN THE NATURE OF BLANK MEMORY DISCS, MEMORY CARDS AND DATA STORAGE MEDIA, NAMELY, PACKAGED SEMICONDUCTORS, ELECTRONIC CONTROL UNIT AND PROGRAMMER WHICH CONTROLS THE WORKING PARAMETERS OF WIRELESS COMMUNICATION SYSTEMS AND WIRELESS POWERING SYSTEMS, CHARGERS IN THE NATURE OF BATTERY CHARGERS, DIGITAL CHARGERS AND ELECTRONIC CHARGERS, ELECTRONIC TRANSMITTERS AND ELECTRONIC RECEIVERS OF ELECTRONIC SIGNALS, AND ELECTRONIC CIRCUITS; REMOTE CONTROLS FOR WIRELESS CONTROLLING, AND PROGRAMMING WIRELESS CHARGER APPARATUS FOR WIRELESS ENERGIZING AND CONTROL STATIONS FOR WIRELESS CONTROLLING, PROGRAMMING AND ENERGIZING OF ACTIVE IMPLANTS; SOFTWARE, IN PARTICULAR FOR ACTIVE MEDICAL IMPLANTS, FOR MEASURING, RECEIVING, SENDING, CHECKING, TRANSFERRING, CALCULATING, PROCESSING, CONTROLLING, PRESENTING AND ANALYZING OF DATA, NAMELY, DATA ABOUT ELECTRICITY, ENERGY, PHYSICAL PARAMETERS, AND COMMUNICATION AND PROGRAMMING DATA IN MEDICAL IMPLANTS; SOFTWARE, IN PARTICULAR FOR MEASURING, RECEIVING, SENDING, CHECKING, TRANSFERRING, CALCULATING, PROCESSING, CONTROLLING, PRESENTING AND ANALYZING OF DATA, NAMELY, DATA ABOUT ELECTRICITY, ENERGY, PHYSICAL PARAMETERS, COMMUNICATION AND PROGRAMMING DATA IN APPARATUS, DEVICES AND INSTRUMENTS FOR COMMUNICATING WITH, ENERGIZING AND PROGRAMMING OF MEDICAL IMPLANTS; AND DATA PROCESSING EQUIPMENT AND COMPUTERS (U.S. CLS. 21, 23, 26, 36 AND 38).

### CLASS 10—MEDICAL APPARATUS

FOR MEDICAL AND SURGICAL APPARATUS, INSTRUMENTS AND DEVICES, INCLUDING ACTIVE AND NON-ACTIVE MEDICAL IMPLANTS, NAMELY, MEDICAL IMPLANTS COMPRISED OF ARTIFICIAL MATERIAL; MEDICAL AND SURGICAL APPARATUS, INSTRUMENTS AND DEVICES INTENDED FOR USE INSIDE THE MAMMAL OR HUMAN BODY, IN PARTICULAR MANUAL, ELECTRICAL OR A COMBINATION OF MANUAL AND ELECTRICAL APPARATUS, DEVICES AND INSTRUMENTS, IN ALL GOODS INCLUDING MEDICAL HYDRAULIC, MECHANICAL, AND PNEUMATIC APPARATUS, DEVICES AND INSTRUMENTS, NAMELY, MEDICAL IMPLANTS COMPRISED OF ARTIFICIAL MATERIAL; MEDICAL AND SURGICAL APPARATUS, INSTRUMENTS AND DEVICES FOR REPLACING AND ADDING ONE OR MORE BODILY FUNCTIONS AND PARTS INSIDE THE BODY, NAMELY, MEDICAL IMPLANTS COMPRISED OF ARTIFICIAL MATERIAL; MEDICAL AND SURGICAL APPARATUS, INSTRUMENTS AND DEVICES DESIGNED FOR WIRELESS PROGRAMMING, WIRELESS CONTROLLING, WIRELESS COMMUNICATING AND WIRELESS ENERGIZING, NAMELY, ACTIVE IMPLANTS IN THE NATURE OF IMPLANTS CONSISTING OF ARTIFICIAL MATERIALS, AND A WIRELESS TRANSMITTER AND A RECEIVER AS AN INTEGRAL COMPONENT OF A SURGICAL IMPLANT; WIRELESS COMMUNICATION SYSTEMS, APPARATUS, DEVICES, AND INSTRUMENTS AND WIRELESS ENERGIZING SYSTEMS, APPARATUS, DEVICES, AND INSTRUMENTS FOR MEASURING, RECEIVING, SENDING, SWITCHING, TRANSFORMING, ACCUMULATING, REGULATING, STORING, CHECKING, CONTROLLING, DRIVING, TRANSFERRING, TRANSMITTING, PROCESSING AND ANALYZING, IN ALL THE APPLICABLE AFOREMENTIONED GOODS, OF DATA INCLUDING PHYSICAL PARAMETERS, ELECTRICITY, ENERGY AND DATA, NAMELY, ELECTRONIC TRANSMITTERS FOR COMMUNICATING WITH, AND ENERGIZING OF, AND USED IN DIRECT ASSOCIATION WITH, ACTIVE MEDICAL IMPLANTS CONSISTING OF ARTIFICIAL MATERIALS; SURGICAL INSTRUMENTS IN PARTICULAR TO BE USED DURING OPERATIONS OF ACTIVE OR NON-ACTIVE MEDICAL IMPLANTS; VETERINARY MEDICAL AND SURGICAL APPARATUS, INSTRUMENTS AND DEVICES, FOR USE IN IMPLANT SURGERIES; MEDICAL AND SURGICAL APPARATUS, INSTRUMENTS AND DEVICES FOR ORTHOPAEDIC JOINT IMPLANTS; AND MEDICAL IMPLANTS FOR COLLECTING, RECEIVING, SENDING, STORING, PREPARING, CONTROLLING, ANALYZING AND PROCESSING OF DATA AND ENERGY TO AND FROM SAID MEDICAL IMPLANTS (U.S. CLS. 26, 39 AND 44).

### CLASS 44—MEDICAL, BEAUTY AND AGRICULTURAL SERVICES

FOR MEDICAL SERVICES IN RELATION TO MEDICAL IMPLANTS FOR COLLECTING, SENDING, RECEIVING, STORING, PREPARING, CONTROLLING, PRESENTING, CALCULATING, ANALYZING AND PROCESSING OF DATA TO AND FROM PATIENTS AND TO AND FROM MEDICAL IMPLANTS AND TO AND FROM REMOTE CONTROLS, WIRELESS CHARGER APPARATUS AND CONTROL STATIONS FOR ACTIVE IMPLANTS; SURGICAL AND HEALTH SERVICES, NAMELY, IMPLANTATION OF ARTIFICIAL IMPLANTS TO ALLOW THE IMPLANTS TO COLLECT, SEND, RECEIVE, STORE, PREPARE, CONTROL, PRESENT, CALCULATE, ANALYZE, AND PROCESS OF DATA TO AND FROM PATIENTS AND TO AND FROM MEDICAL IMPLANTS AND TO AND FROM MEDICAL IMPLANTS AND TO AND FROM REMOTE CONTROLS, WIRELESS CHARGER APPARATUS AND CONTROL STATIONS FOR ACTIVE IMPLANTS; PROVIDING A

MEDICAL, SURGICAL AND HEALTH DATABASE FEATURING MEDICAL, SURGICAL AND HEALTH INFORMATION RELATING TO MEDICAL IMPLANTS THAT HAS BEEN INPUT, COLLECTED, RECEIVED, PREPARED, CONTROLLED, PROGRAMMED, CALCULATED, AND ANALYZED, FROM MEDICAL IMPLANTS, REMOTE CONTROLS OR CONTROL STATIONS FOR USE BY MEDICAL, SURGICAL AND HEALTH PROFESSIONALS FOR THE PURPOSES OF MONITORING AND DIAGNOSING MEDICAL CONDITIONS; MEDICAL AND SURGICAL SERVICES, NAMELY, IMPLANTATION OF ARTIFICIAL IMPLANTS IN RELATION TO MEDICAL IMPLANTS FOR PROGRAMMING, CONTROLLING, COMMUNICATING WITH, AND ENERGIZING OF, ACTIVE IMPLANTS; AND MEDICAL AND SURGICAL SERVICES, NAMELY, ARTIFICIAL IMPLANTATION SERVICES FOR PERSONS HAVING A MEDICAL RELATED CONDITION AND BEING CANDIDATES FOR OR BEING OPERATED ON WITH AN ACTIVE OR A NON-ACTIVE IMPLANT (U.S. CLS. 100 AND 101).

AND CONTROL STATIONS FOR WIRELESS CONTROLLING, PROGRAMMING AND ENERGIZING OF ACTIVE IMPLANTS; SOFTWARE, IN PARTICULAR FOR ACTIVE MEDICAL IMPLANTS, FOR MEASURING, RECEIVING, SENDING, CHECKING, TRANSFERRING, CALCULATING, PROCESSING, CONTROLLING, PRESENTING AND ANALYZING OF DATA, NAMELY, DATA ABOUT ELECTRICITY, ENERGY, PHYSICAL PARAMETERS, AND COMMUNICATION AND PROGRAMMING DATA IN MEDICAL IMPLANTS; SOFTWARE, IN PARTICULAR FOR MEASURING, RECEIVING, SENDING, CHECKING, TRANSFERRING, CALCULATING, PROCESSING, CONTROLLING, PRESENTING AND ANALYZING OF DATA, NAMELY, DATA ABOUT ELECTRICITY, ENERGY, PHYSICAL PARAMETERS, COMMUNICATION AND PROGRAMMING DATA IN APPARATUS, DEVICES AND INSTRUMENTS FOR COMMUNICATING WITH, ENERGIZING AND PROGRAMMING OF MEDICAL IMPLANTS; AND DATA PROCESSING EQUIPMENT AND COMPUTERS (U.S. CLS. 21, 23, 26, 36 AND 38).

3,956,117. MILUX HOLDING S.A., LUXEMBOURG, LUXEMBOURG. SN 77-860,218. FILED P.R. 10-29-2009; AM. S.R. 3-8-2011.

## IMPLANTENERGY

THE MARK CONSISTS OF STANDARD CHARACTERS WITHOUT CLAIM TO ANY PARTICULAR FONT, STYLE, SIZE, OR COLOR.

PRIORITY CLAIMED UNDER SEC. 44(D) ON ERPN CMNTY TM OFC APPLICATION NO. 008256125, FILED 4-29-2009, REG. NO. 008256125, DATED 1-31-2010, EXPIRES 4-29-2019.

### CLASS 9—ELECTRICAL AND SCIENTIFIC APPARATUS

FOR APPARATUS, DEVICES AND INSTRUMENTS, ALL NOT USED IN DIRECT ASSOCIATION WITH ACTIVE IMPLANTS, FOR MEASURING, RECEIVING, SENDING, CHECKING, CONTROLLING, DRIVING, TRANSFERRING, TRANSMITTING, PROCESSING, ANALYZING, CONDUCTING, SWITCHING, TRANSFORMING, ACCUMULATING, AND REGULATING ELECTRICITY, ENERGY AND/OR DATA, INCLUDING PHYSICAL PARAMETERS, NAMELY, ELECTRONIC STORAGE DEVICES IN THE NATURE OF BLANK MEMORY DISCS, MEMORY CARDS AND DATA STORAGE MEDIA, NAMELY, PACKAGED SEMICONDUCTORS, ELECTRONIC CONTROL UNIT AND PROGRAMMER WHICH CONTROLS THE WORKING PARAMETERS OF WIRELESS COMMUNICATION SYSTEMS AND WIRELESS POWERING SYSTEMS, CHARGERS IN THE NATURE OF BATTERY CHARGERS, DIGITAL CHARGERS AND ELECTRONIC CHARGERS, ELECTRONIC TRANSMITTERS AND ELECTRONIC RECEIVERS OF ELECTRONIC SIGNALS, AND ELECTRONIC CIRCUITS; REMOTE CONTROLS FOR WIRELESS CONTROLLING, AND PROGRAMMING WIRELESS CHARGER APPARATUS FOR WIRELESS ENERGIZING

### CLASS 10—MEDICAL APPARATUS

FOR MEDICAL AND SURGICAL APPARATUS, INSTRUMENTS AND DEVICES, INCLUDING ACTIVE AND NON-ACTIVE MEDICAL IMPLANTS, NAMELY, MEDICAL IMPLANTS COMPRISED OF ARTIFICIAL MATERIAL; MEDICAL AND SURGICAL APPARATUS, INSTRUMENTS AND DEVICES INTENDED FOR USE INSIDE THE MAMMAL OR HUMAN BODY, IN PARTICULAR MANUAL, ELECTRICAL OR A COMBINATION OF MANUAL AND ELECTRICAL APPARATUS, DEVICES AND INSTRUMENTS, IN ALL GOODS INCLUDING MEDICAL HYDRAULIC, MECHANICAL, AND PNEUMATIC APPARATUS, DEVICES AND INSTRUMENTS, NAMELY, MEDICAL IMPLANTS COMPRISED OF ARTIFICIAL MATERIAL; MEDICAL AND SURGICAL APPARATUS, INSTRUMENTS AND DEVICES FOR REPLACING AND ADDING ONE OR MORE BODILY FUNCTIONS AND PARTS INSIDE THE BODY, NAMELY, MEDICAL IMPLANTS COMPRISED OF ARTIFICIAL MATERIAL; MEDICAL AND SURGICAL APPARATUS, INSTRUMENTS AND DEVICES DESIGNED FOR WIRELESS PROGRAMMING, WIRELESS CONTROLLING, WIRELESS COMMUNICATING AND WIRELESS ENERGIZING, NAMELY, ACTIVE IMPLANTS IN THE NATURE OF IMPLANTS CONSISTING OF ARTIFICIAL MATERIALS, AND A WIRELESS TRANSMITTER AND A RECEIVER AS AN INTEGRAL COMPONENT OF A SURGICAL IMPLANT; WIRELESS COMMUNICATION SYSTEMS, APPARATUS, DEVICES, AND INSTRUMENTS AND WIRELESS ENERGIZING SYSTEMS, APPARATUS, DEVICES, AND INSTRUMENTS FOR MEASURING, RECEIVING, SENDING, SWITCHING, TRANSFORMING, ACCUMULATING, REGULATING, STORING, CHECKING, CONTROLLING, DRIVING, TRANSFERRING, TRANSMITTING, PROCESSING AND ANALYZING, IN ALL THE APPLICABLE AFOREMENTIONED GOODS, OF DATA INCLUDING PHYSICAL PARAMETERS, ELECTRICITY, ENERGY AND DATA, NAMELY, ELECTRONIC TRANSMITTERS FOR COMMUNICATING WITH, AND ENERGIZING OF, AND USED IN DIRECT ASSOCIATION WITH, ACTIVE MEDICAL IMPLANTS CONSISTING OF ARTIFICIAL MATERIALS; SURGICAL INSTRUMENTS IN PARTICULAR TO BE USED DURING OPERATIONS OF ACTIVE OR NON-ACTIVE MEDICAL IMPLANTS; VETERINARY MEDICAL AND SURGICAL APPARATUS, INSTRUMENTS AND DEVICES, FOR USE IN IMPLANT SURGERIES; MEDICAL AND SURGICAL APPARATUS, INSTRUMENTS AND DEVICES FOR ORTHOPAEDIC JOINT IMPLANTS; AND MEDICAL IMPLANTS FOR COLLECTING, RECEIVING, SENDING, STORING, PREPARING, CONTROLLING, ANALYZING AND PROCESSING OF DATA AND ENERGY TO AND FROM SAID MEDICAL IMPLANTS (U.S. CLS. 26, 39 AND 44).

**CLASS 44—MEDICAL, BEAUTY AND AGRICULTURAL SERVICES**

FOR MEDICAL SERVICES IN RELATION TO MEDICAL IMPLANTS FOR COLLECTING, SENDING, RECEIVING, STORING, PREPARING, CONTROLLING, PRESENTING, CALCULATING, ANALYZING AND PROCESSING OF DATA TO AND FROM PATIENTS AND TO AND FROM MEDICAL IMPLANTS AND TO AND FROM REMOTE CONTROLS, WIRELESS CHARGER APPARATUS AND CONTROL STATIONS FOR ACTIVE IMPLANTS; SURGICAL AND HEALTH SERVICES, NAMELY, IMPLANTATION OF ARTIFICIAL IMPLANTS TO ALLOW THE IMPLANTS TO COLLECT, SEND, RECEIVE, STORE, PREPARE, CONTROL, PRESENT, CALCULATE, ANALYZE, AND PROCESS OF DATA TO AND FROM PATIENTS AND TO AND FROM MEDICAL IMPLANTS AND TO AND FROM MEDICAL IMPLANTS AND TO AND FROM REMOTE CONTROLS, WIRELESS CHARGER APPARATUS AND CONTROL STATIONS FOR ACTIVE IMPLANTS; PROVIDING A MEDICAL, SURGICAL AND HEALTH DATABASE FEATURING MEDICAL, SURGICAL AND HEALTH INFORMATION RELATING TO MEDICAL IMPLANTS THAT HAS BEEN INPUT, COLLECTED, RECEIVED, PREPARED, CONTROLLED, PROGRAMMED, CALCULATED, AND ANALYZED, FROM MEDICAL IMPLANTS, REMOTE CONTROLS OR CONTROL STATIONS FOR USE BY MEDICAL, SURGICAL AND HEALTH PROFESSIONALS FOR THE PURPOSES OF MONITORING AND DIAGNOSING MEDICAL CONDITIONS; MEDICAL AND SURGICAL SERVICES, NAMELY, IMPLANTATION OF ARTIFICIAL IMPLANTS IN RELATION TO MEDICAL IMPLANTS FOR PROGRAMMING, CONTROLLING, COMMUNICATING WITH, AND ENERGIZING OF, ACTIVE IMPLANTS; AND MEDICAL AND SURGICAL SERVICES, NAMELY, ARTIFICIAL IMPLANTATION SERVICES FOR PERSONS HAVING A MEDICAL RELATED CONDITION AND BEING CANDIDATES FOR OR BEING OPERATED ON WITH AN ACTIVE OR A NON-ACTIVE IMPLANT (U.S. CLS. 100 AND 101).

**CLASS 41—EDUCATION AND ENTERTAINMENT**

FOR CONDUCTING EDUCATIONAL EXHIBITIONS IN THE NATURE OF PLANNING ARRANGEMENT OF SHOWING BRITISH MOVIES, PROVIDING RECOGNITION BY WAY OF AWARDS TO DEMONSTRATE EXCELLENCE IN THE FIELD OF BRITISH CULTURE, LIVE MUSIC CONCERTS, BRITISH ART EXHIBITIONS, SPORTING EVENTS, NAMELY, SOCCER GAMES, LECTURES BY PROMINENT BRITISH INDIVIDUALS IN THE FIELD OF BRITISH CULTURE, COMEDY SHOWS, PROVIDING RECOGNITION BY WAY OF AWARDS TO DEMONSTRATE EXCELLENCE IN THE FIELD OF BUSINESS INNOVATION AND OTHER EVENTS FOR THE PURPOSE OF EDUCATING THE PUBLIC ABOUT BRITISH CONTRIBUTIONS IN SOUTHERN CALIFORNIA, NAMELY, HOSTING AND PUBLICLY SUPPORTING EVENTS OPEN TO THE PUBLIC THAT FOCUS ON BRITISH CONTRIBUTION TO FILM, FASHION, MUSIC, THE AUTOMOTIVE INDUSTRY AND SCIENCE THROUGH VARIOUS ENTERTAINMENT EVENTS, NAMELY, GALA DINNERS, CONFERENCES, LIVE MUSIC PERFORMANCES, ART EXHIBITIONS, SPORTING EVENTS AND FASHION SHOWS (U.S. CLS. 100, 101 AND 107).

FIRST USE 3-31-2008; IN COMMERCE 3-31-2008.

3,956,122. VOITH PATENT GMBH, HEIDENHEIM, FED REP GERMANY. SN 77-893,139. FILED 12-14-2009.

3,956,121. BRITWEEK, INC., LOS ANGELES, CA. SN 77-888,659. FILED P.R. 12-8-2009; AM. S.R. 3-22-2011.

# BritWeek

THE MARK CONSISTS OF THE WORD "BRITWEEK". THE LETTERS "B" AND "W" ARE CAPITALIZED. THE REMAINING LETTERS ARE LOWERCASE.

**CLASS 36—INSURANCE AND FINANCIAL**

FOR CHARITABLE FUNDRAISING SERVICES BY MEANS OF ENTERTAINMENT EVENTS, NAMELY, GALA DINNERS, CONFERENCES, MUSIC EVENTS, ART EVENTS, SPORTING EVENTS AND FASHION EVENTS (U.S. CLS. 100, 101 AND 102).

FIRST USE 3-31-2008; IN COMMERCE 3-31-2008.

# Küsel

THE MARK CONSISTS OF STANDARD CHARACTERS WITHOUT CLAIM TO ANY PARTICULAR FONT, STYLE, SIZE, OR COLOR.

OWNER OF ERPN CMNTY TM OFC REG. NO. 007278245, DATED 5-14-2009, EXPIRES 10-1-2018.

**CLASS 7—MACHINERY**

FOR ELECTRIC DRIVES, ELECTRIC MOTORS, ENGINES NOT FOR LAND VEHICLES, COUPLINGS, BRAKES AND TRANSMISSION COMPONENTS, ALL FOR MACHINES; APPARATUS FOR LOCOMOTION BY AIR OR WATER, NAMELY, ENGINES AND MOTORS FOR AIRCRAFT AND SHIPS; TRANSMISSION COMPONENTS FOR AIRCRAFT AND SHIPS, NAMELY, MACHINE COUPLINGS AND TRANSMISSIONS, EXCEPT FOR LAND VEHICLES (U.S. CLS. 13, 19, 21, 23, 31, 34 AND 35).

**CLASS 12—VEHICLES**

FOR APPARATUS FOR LOCOMOTION BY LAND, NAMELY, ELECTRIC DRIVES, MOTORS, ENGINES, COUPLINGS, BRAKES AND TRANSMISSIONS, ALL FOR LAND VEHICLES; BRAKES FOR VEHICLES IN THE NATURE OF AIRCRAFT AND SHIPS; ELECTRIC DRIVES FOR VEHICLES IN THE NATURE OF AIRCRAFT AND SHIPS (U.S. CLS. 19, 21, 23, 31, 35 AND 44).

3,956,131. THE AMERICAN ARCHITECTURAL FOUNDATION, INC., WASHINGTON, DC. SN 77-950,656. FILED P.R. 3-4-2010; AM. S.R. 3-4-2011.

### SUSTAINABLE CITIES DESIGN ACADEMY

THE MARK CONSISTS OF STANDARD CHARACTERS WITHOUT CLAIM TO ANY PARTICULAR FONT, STYLE, SIZE, OR COLOR.

NO CLAIM IS MADE TO THE EXCLUSIVE RIGHT TO USE "ACADEMY", APART FROM THE MARK AS SHOWN.

#### CLASS 35—ADVERTISING AND BUSINESS

FOR BUSINESS SERVICES, NAMELY, FORMATION OF BEST PRACTICES FOR THE DESIGN OF ENVIRONMENTALLY FRIENDLY BUILDINGS (U.S. CLS. 100, 101 AND 102).

FIRST USE 0-0-2008; IN COMMERCE 0-0-2008.

#### CLASS 42—SCIENTIFIC AND COMPUTER SERVICES

FOR DEVELOPMENT OF VOLUNTARY STANDARDS FOR THE DESIGN OF ENVIRONMENTALLY FRIENDLY BUILDINGS; RESIDENTIAL AND COMMERCIAL BUILDING DESIGN CONSULTING SERVICES, NAMELY, PROVIDING TECHNICAL ASSISTANCE TO LOCAL COMMUNITY LEADERS IN THE FIELD OF THE DESIGN OF ENVIRONMENTALLY FRIENDLY BUILDINGS AND SUSTAINABLE BUILDING PROJECTS (U.S. CLS. 100 AND 101).

FIRST USE 0-0-2008; IN COMMERCE 0-0-2008.

3,956,138. SANOFI-AVENTIS, PARIS, FRANCE. SN 85-015,694. FILED P.R. 4-16-2010; AM. S.R. 3-4-2011.

## DISCUSS DIABETES

THE MARK CONSISTS OF STANDARD CHARACTERS WITHOUT CLAIM TO ANY PARTICULAR FONT, STYLE, SIZE, OR COLOR.

#### CLASS 38—COMMUNICATION

FOR PROVIDING ELECTRONIC BULLETIN BOARDS FOR TRANSMISSION OF MESSAGES AMONG USERS IN THE FIELD OF DIABETES (U.S. CLS. 100, 101 AND 104).

FIRST USE 1-14-2011; IN COMMERCE 1-14-2011.

#### CLASS 41—EDUCATION AND ENTERTAINMENT

FOR ON-LINE JOURNALS, NAMELY, BLOGS FEATURING INFORMATION IN THE FIELD OF DIABETES (U.S. CLS. 100, 101 AND 107).

FIRST USE 1-14-2011; IN COMMERCE 1-14-2011.

#### CLASS 44—MEDICAL, BEAUTY AND AGRICULTURAL SERVICES

FOR PROVIDING INFORMATION IN THE FIELD OF DIABETES; PROVIDING A WEBSITE FEATURING CONTENT AND INFORMATION IN THE FIELD OF DIABETES, FOR USE BY PATIENTS, CAREGIVERS, AND HOSPITAL PERSONNEL (U.S. CLS. 100 AND 101).

FIRST USE 1-14-2011; IN COMMERCE 1-14-2011.

3,956,141. ACROSS THE STREET PRODUCTIONS INC., PHOENIX, AZ. SN 85-023,974. FILED P.R. 4-27-2010; AM. S.R. 3-22-2011.

### FIRE COMMAND SEMINARS

THE MARK CONSISTS OF STANDARD CHARACTERS WITHOUT CLAIM TO ANY PARTICULAR FONT, STYLE, SIZE, OR COLOR.

NO CLAIM IS MADE TO THE EXCLUSIVE RIGHT TO USE "SEMINARS", APART FROM THE MARK AS SHOWN.

#### CLASS 41—EDUCATION AND ENTERTAINMENT

FOR EDUCATIONAL SERVICES, NAMELY, CONDUCTING COURSES AND SEMINARS IN THE FIELD OF HAZARD ZONE MANAGEMENT AND DISTRIBUTION OF COURSE MATERIAL IN CONNECTION THEREWITH (U.S. CLS. 100, 101 AND 107).

FIRST USE 8-0-2009; IN COMMERCE 8-0-2009.

#### CLASS 42—SCIENTIFIC AND COMPUTER SERVICES

FOR TESTING, ANALYSIS, AND EVALUATION OF THE KNOWLEDGE, SKILLS AND ABILITIES OF OTHERS FOR THE PURPOSE OF CERTIFICATION IN THE FIELD OF HAZARD ZONE MANAGEMENT (U.S. CLS. 100 AND 101).

FIRST USE 8-0-2009; IN COMMERCE 8-0-2009.

3,956,145. GIE MEDIA, INC., RICHFIELD, OH. SN 85-026,338. FILED P.R. 4-29-2010; AM. S.R. 2-10-2011.

### NURSERY MANAGEMENT

THE MARK CONSISTS OF STANDARD CHARACTERS WITHOUT CLAIM TO ANY PARTICULAR FONT, STYLE, SIZE, OR COLOR.

#### CLASS 16—PAPER GOODS AND PRINTED MATTER

FOR MAGAZINES IN THE FIELD OF THE COMMERCIAL PLANT NURSERY INDUSTRY (U.S. CLS. 2, 5, 22, 23, 29, 37, 38 AND 50).

FIRST USE 1-0-2011; IN COMMERCE 1-0-2011.

**CLASS 41—EDUCATION AND ENTERTAINMENT**

FOR ONLINE MAGAZINES IN THE FIELD OF THE COMMERCIAL PLANT NURSERY INDUSTRY (U.S. CLS. 100, 101 AND 107).

FIRST USE 1-0-2011; IN COMMERCE 1-0-2011.

---

3,956,149. AWARENESS, INC., BURLINGTON, MA. SN 85-031,960. FILED P.R. 5-6-2010; AM. S.R. 2-23-2011.

**SOCIAL MARKETING HUB**

THE MARK CONSISTS OF STANDARD CHARACTERS WITHOUT CLAIM TO ANY PARTICULAR FONT, STYLE, SIZE, OR COLOR.

NO CLAIM IS MADE TO THE EXCLUSIVE RIGHT TO USE "HUB", APART FROM THE MARK AS SHOWN.

**CLASS 35—ADVERTISING AND BUSINESS**

FOR ADVERTISING AND MARKETING SERVICES, NAMELY, THE DISSEMINATING, PLACEMENT, AND MANAGING OF ADVERTISING AND MARKETING CONTENT FOR OTHERS OVER SOCIAL MEDIA NETWORKS, AND ANALYSIS OF THE EFFECTIVENESS THEREOF (U.S. CLS. 100, 101 AND 102).

FIRST USE 3-15-2010; IN COMMERCE 3-15-2010.

**CLASS 42—SCIENTIFIC AND COMPUTER SERVICES**

FOR APPLICATION SERVICE PROVIDER FEATURING NON-DOWNLOADABLE SOFTWARE FOR USE COLLECTING, ANALYZING, DEVELOPING, PUBLISHING, REPORTING, AND MANAGING ADVERTISING AND MARKETING CONTENT DELIVERED OVER SOCIAL MEDIA NETWORKS (U.S. CLS. 100 AND 101).

FIRST USE 3-15-2010; IN COMMERCE 3-15-2010.

---

3,956,153. RESTORZ LLC, WESTLAKE, OH. SN 85-039,951. FILED P.R. 5-17-2010; AM. S.R. 3-4-2011.

**RESTORZ**

THE MARK CONSISTS OF STANDARD CHARACTERS WITHOUT CLAIM TO ANY PARTICULAR FONT, STYLE, SIZE, OR COLOR.

**CLASS 37—CONSTRUCTION AND REPAIR**

FOR FIRE AND WATER DAMAGE RESTORATION OF BUILDINGS AND BUILDING SURFACES AND DISASTER RECOVERY SERVICES FOR BUILDINGS AND BUILDING SURFACES, NAMELY, WATER EXTRACTION, STRUCTURAL DRYING, INTERIOR SURFACE STAIN REMOVAL, AND APPLICATION OF PAINT; APPLYING SEALERS TO BUILDING INTERIORS FOR PREVENTION OF ABSORPTION OF MOISTURE, WATER, STAIN, AND SUCCEEDING COATINGS (U.S. CLS. 100, 103 AND 106).

FIRST USE 8-9-2005; IN COMMERCE 8-9-2005.

**CLASS 40—MATERIAL TREATMENT**

FOR MOLD PREVENTION TREATMENT OF BUILDING WALLS AND BUILDING INTERIORS; MOLD REMEDIATION SERVICES; ODOR NEUTRALIZATION SERVICES, NAMELY, ODOR REMEDIATION AND REMOVAL; DRY ICE BLASTING CLEANING SERVICES; APPLICATION OF ANTIMICROBIALS AND SEALERS, NAMELY, TREATMENT OF BUILDING INTERIORS WITH ANTIMICROBIAL AGENTS AND APPLYING SEALERS TO BUILDING INTERIORS FOR MILDEW PROOFING (U.S. CLS. 100, 103 AND 106).

FIRST USE 8-9-2005; IN COMMERCE 8-9-2005.

---

3,956,157. TRAGESER, MARK, WOODLAND HILLS, CA. SN 85-046,879. FILED P.R. 5-25-2010; AM. S.R. 3-7-2011.

**Tip Bin**

THE MARK CONSISTS OF STANDARD CHARACTERS WITHOUT CLAIM TO ANY PARTICULAR FONT, STYLE, SIZE, OR COLOR.

NO CLAIM IS MADE TO THE EXCLUSIVE RIGHT TO USE "BIN", APART FROM THE MARK AS SHOWN.

**CLASS 20—FURNITURE AND ARTICLES NOT OTHERWISE CLASSIFIED**

FOR PLASTIC STORAGE CONTAINERS FOR COMMERCIAL OR INDUSTRIAL USE (U.S. CLS. 2, 13, 22, 25, 32 AND 50).

FIRST USE 5-27-2010; IN COMMERCE 6-15-2010.

**CLASS 21—HOUSEWARES AND GLASS**

FOR PLASTIC STORAGE CONTAINERS FOR HOUSEHOLD OR DOMESTIC USE (U.S. CLS. 2, 13, 23, 29, 30, 33, 40 AND 50).

FIRST USE 5-27-2010; IN COMMERCE 6-15-2010.

3,956,216. JOHN B. SANFILIPPO & SON, INC., ELGIN, IL. SN 85-157,302. FILED P.R. 10-20-2010; AM. S.R. 2-16-2011.

3,956,218. THE REVENUE GROUP, INC., CLEVELAND, OH. SN 85-159,198. FILED P.R. 10-22-2010; AM. S.R. 3-9-2011.

## ENERGY SNX

THE MARK CONSISTS OF STANDARD CHARACTERS WITHOUT CLAIM TO ANY PARTICULAR FONT, STYLE, SIZE, OR COLOR.

### CLASS 29—MEATS AND PROCESSED FOODS

FOR SHELLED, PROCESSED NUTS AND FLAVORED NUTS; NUTS INFUSED WITH VITAMINS; NUTS INFUSED WITH MINERALS; NUTS INFUSED WITH CAFFEINE; DRIED FRUITS; DRIED FRUITS INFUSED WITH VITAMINS; DRIED FRUITS INFUSED WITH MINERALS; DRIED FRUITS INFUSED WITH CAFFEINE; SNACK MIXES CONSISTING OF COMBINATIONS OF PROCESSED NUTS AND FLAVORED NUTS AND DRIED FRUITS; CANDIED FRUITS, NAMELY, RAISINS; CANDIED FLAVORED NUTS; CANDIED FLAVORED NUTS INFUSED WITH VITAMINS, MINERALS AND/OR CAFFEINE; PRESERVED SOYA BEANS FOR FOOD INFUSED WITH VITAMINS, MINERALS AND/OR CAFFEINE; FOODSTUFFS IN THE FORM OF POTATO STICKS, ALL MADE PRINCIPALLY OF FLOUR AND ALL BEING FLAVORED ALL PREPARED AND INFUSED WITH VITAMINS, MINERALS AND/OR CAFFEINE (U.S. CL. 46).

FIRST USE 7-28-2010; IN COMMERCE 8-19-2010.

### CLASS 30—STAPLE FOODS

FOR SNACK MIXES CONSISTING PRIMARILY OF CRACKERS AND PRETZELS AND ALSO CONTAINING PROCESSED NUTS WITHOUT SHELLS AND NUTS THAT ARE PROCESSED, ROASTED, SALTED, FLAVORED AND CANDY-COVERED OR CHOCOLATE COVERED, AS WELL AS CANDIED FRUIT AND MARSHMALLOWS, THE SNACK MIXES BEING INFUSED WITH VITAMINS, MINERALS AND/OR CAFFEINE; SWEETENED YOGURT COVERED RAISINS INFUSED WITH VITAMINS, MINERALS AND/OR CAFFEINE; CANDIES INFUSED WITH VITAMINS, MINERALS AND/OR CAFFEINE; CHOCOLATE COVERED NUTS INFUSED WITH VITAMINS, MINERALS AND/OR CAFFEINE; CHOCOLATE COVERED FRUITS INFUSED WITH VITAMINS, MINERALS AND/OR CAFFEINE; RAISINS DIPPED IN YOGURT AND INFUSED WITH VITAMINS, MINERALS AND/OR CAFFEINE; MARSHMALLOWS; CHEESE FLAVORED PUFFED CORN SNACKS; PUFFED CORN SNACKS; POPPED POPCORN; POPCORN GLAZED, CARAMEL OR CANDY-COATED AND MIXTURES THEREOF; COOKIES; PRETZELS; GRANOLA-BASED SNACK CLUSTERS AND BARS INFUSED WITH VITAMINS, MINERALS AND/OR CAFFEINE; FOODSTUFFS IN THE FORM OF BREAD STICKS, SESAME STICKS, CORN CHIPS, AND FLOUR-BASED CHIPS, ALL MADE PRINCIPALLY OF FLOUR AND ALL BEING FLAVORED ALL PREPARED AND INFUSED WITH VITAMINS, MINERALS AND/OR CAFFEINE; SESAME FLAVORED SNACKS IN STICK FORM CONTAINING WHEAT FLOUR AND INFUSED WITH VITAMINS, MINERALS AND/OR CAFFEINE; AND BREAD STICKS MADE PRIMARILY FROM WHEAT FLOUR, VEGETABLE OIL, SESAME SEEDS, AND OTHER FLAVORINGS AND COLORING INGREDIENTS AND INFUSED WITH VITAMINS, MINERALS AND/OR CAFFEINE (U.S. CL. 46).

FIRST USE 7-28-2010; IN COMMERCE 8-19-2010.

## REVENUE GROUP

THE MARK CONSISTS OF STANDARD CHARACTERS WITHOUT CLAIM TO ANY PARTICULAR FONT, STYLE, SIZE, OR COLOR.

NO CLAIM IS MADE TO THE EXCLUSIVE RIGHT TO USE "GROUP", APART FROM THE MARK AS SHOWN.

### CLASS 35—ADVERTISING AND BUSINESS

FOR ACCOUNTS RECEIVABLE SERVICES (U.S. CLS. 100, 101 AND 102).

FIRST USE 12-31-1999; IN COMMERCE 12-31-1999.

### CLASS 36—INSURANCE AND FINANCIAL

FOR DEBT COLLECTION (U.S. CLS. 100, 101 AND 102).

FIRST USE 12-31-1999; IN COMMERCE 12-31-1999.

3,956,234. SITE BASED ENERGY, HAILEY, ID. SN 85-177,080. FILED P.R. 11-15-2010; AM. S.R. 3-14-2011.

## site based energy

THE MARK CONSISTS OF STANDARD CHARACTERS WITHOUT CLAIM TO ANY PARTICULAR FONT, STYLE, SIZE, OR COLOR.

NO CLAIM IS MADE TO THE EXCLUSIVE RIGHT TO USE "ENERGY", APART FROM THE MARK AS SHOWN.

### CLASS 7—MACHINERY

FOR SOLAR-POWERED ELECTRICITY GENERATORS; WIND-POWERED ELECTRICITY GENERATORS (U.S. CLS. 13, 19, 21, 23, 31, 34 AND 35).

FIRST USE 6-26-2010; IN COMMERCE 6-26-2010.

### CLASS 37—CONSTRUCTION AND REPAIR

FOR INSTALLATION OF RENEWABLE ENERGY GENERATION EQUIPMENT; INSTALLATION, MAINTENANCE AND REPAIR OF RENEWABLE ENERGY GENERATION EQUIPMENT (U.S. CLS. 100, 103 AND 106).

FIRST USE 6-26-2010; IN COMMERCE 6-26-2010.



3,956,237. CBT SPORTS, LLC, BRENTWOOD, TN. SN 85-179,378. FILED P.R. 11-17-2010; AM. S.R. 3-14-2011.

# 247SPORTS

THE MARK CONSISTS OF STANDARD CHARACTERS WITHOUT CLAIM TO ANY PARTICULAR FONT, STYLE, SIZE, OR COLOR.

OWNER OF U.S. REG. NO. 3,912,575.

### CLASS 38—COMMUNICATION

FOR PROVIDING ONLINE ELECTRONIC BULLETIN BOARDS FOR TRANSMISSION OF MESSAGES AMONG COMPUTER USERS IN THE FIELD OF AMATEUR SPORTS (U.S. CLS. 100, 101 AND 104).

FIRST USE 9-1-2010; IN COMMERCE 9-1-2010.

### CLASS 41—EDUCATION AND ENTERTAINMENT

FOR PROVIDING ONLINE INFORMATION IN THE FIELD OF ATHLETICS (U.S. CLS. 100, 101 AND 107).

FIRST USE 9-1-2010; IN COMMERCE 9-1-2010.

### CLASS 41—EDUCATION AND ENTERTAINMENT

FOR EDUCATIONAL SERVICES, NAMELY, PROVIDING ON-LINE TRAINING, COURSES, SEMINARS AND WORKSHOPS IN THE FIELD OF THE BONDS, FIXED INCOME MARKETS, BOND MARKETS, AND THE ECONOMY (U.S. CLS. 100, 101 AND 107).

FIRST USE 11-20-2009; IN COMMERCE 7-15-2010.

### CLASS 42—SCIENTIFIC AND COMPUTER SERVICES

FOR COMPUTER SERVICES, NAMELY, CREATING AN ON-LINE COMMUNITY FOR REGISTERED USERS TO PARTICIPATE IN DISCUSSIONS, GET FEEDBACK FROM THEIR PEERS, FORM VIRTUAL COMMUNITIES, AND ENGAGE IN SOCIAL NETWORKING (U.S. CLS. 100 AND 101).

FIRST USE 11-20-2009; IN COMMERCE 7-15-2010.

3,956,251. YUMMYEARTH, INC., RIDGEWOOD, NJ. SN 85-189,435. FILED P.R. 12-2-2010; AM. S.R. 3-9-2011.

# FRUITFRUIT

THE MARK CONSISTS OF STANDARD CHARACTERS WITHOUT CLAIM TO ANY PARTICULAR FONT, STYLE, SIZE, OR COLOR.

### CLASS 5—PHARMACEUTICALS

FOR VITAMIN PREPARATIONS; NUTRITIONAL AND DIETARY SUPPLEMENTS (U.S. CLS. 6, 18, 44, 46, 51 AND 52).

FIRST USE 12-2-2010; IN COMMERCE 12-2-2010.

### CLASS 30—STAPLE FOODS

FOR CANDY; VITAMIN-FORTIFIED CANDY; CHOCOLATE CANDIES (U.S. CL. 46).

FIRST USE 12-2-2010; IN COMMERCE 12-2-2010.

3,956,249. FIXED INCOME LIVE, LP, ORANGE, CA. SN 85-188,568. FILED P.R. 12-1-2010; AM. S.R. 3-9-2011.



THE MARK CONSISTS OF THE WORDS "FIXED INCOME" SINGLE SPACED AND THE WORD "LIVE" SLANTED ON THE TOP LEFT CORNER.

### CLASS 36—INSURANCE AND FINANCIAL

FOR PROVIDING A WEBSITE FEATURING FINANCIAL NEWS AND INFORMATION IN THE FORM OF NON-DOWNLOADABLE VIDEOS REGARDING FIXED INCOME, THE FIXED INCOME MARKETS, BONDS, THE BOND MARKETS, AND THE ECONOMY (U.S. CLS. 100, 101 AND 102).

FIRST USE 11-20-2009; IN COMMERCE 7-15-2010.

\* \* \* \* \*

## SECTION 2.— INTERNATIONAL CLASSIFICATION

The short titles associated below with the international class numbers are terms designed merely for quick identification and are not an official part of the international classification. The full names of international classes are given in section 6.1 of the trademark rules of practice.

The designation "U.S. Cl." appearing in this section refers to the U.S. class in effect prior to Sep. 1, 1973 rather than the international class which applies to applications filed on or after that date. For adoption of international classification see notice in the OFFICIAL GAZETTE of Jun. 26, 1973 (911 O.G. TM 210).

### Application in one class

#### CLASS 3—COSMETICS AND CLEANING PREPARATIONS

3,956,124. FAROUK SYSTEMS, INC., HOUSTON, TX. SN 77-902,415. FILED P.R. 12-29-2009; AM. S.R. 3-8-2011.

#### PEARL COMPLEX

THE MARK CONSISTS OF STANDARD CHARACTERS WITHOUT CLAIM TO ANY PARTICULAR FONT, STYLE, SIZE, OR COLOR.

NO CLAIM IS MADE TO THE EXCLUSIVE RIGHT TO USE "PEARL", APART FROM THE MARK AS SHOWN.

FOR HAIR CARE AND SKIN PREPARATIONS, NAMELY, HAIR CONDITIONERS, SKIN MOISTURIZERS, AND SKIN LOTIONS, ALL CONTAINING PEARL (U.S. CLS. 1, 4, 6, 50, 51 AND 52).

FIRST USE 3-8-2011; IN COMMERCE 3-8-2011.

3,956,190. BREMENN IP HOLDINGS, LLC, CARSON CITY, NV. SN 85-102,938. FILED P.R. 8-9-2010; AM. S.R. 3-10-2011.

#### TUMMY FIRING EMULSION

THE MARK CONSISTS OF STANDARD CHARACTERS WITHOUT CLAIM TO ANY PARTICULAR FONT, STYLE, SIZE, OR COLOR.

FOR COSMETICS (U.S. CLS. 1, 4, 6, 50, 51 AND 52).  
FIRST USE 11-3-2010; IN COMMERCE 11-3-2010.

#### CLASS 3—(Continued).

3,956,203. HAIR SALONS, INC., DBA SPORTSMANS HAIRCUT, BENNET, NE. SN 85-129,995. FILED P.R. 9-15-2010; AM. S.R. 3-7-2011.



OWNER OF U.S. REG. NO. 3,239,018.  
NO CLAIM IS MADE TO THE EXCLUSIVE RIGHT TO USE "HAIR CARE SYSTEM", APART FROM THE MARK AS SHOWN.

THE COLOR(S) RED AND BLACK IS/ARE CLAIMED AS A FEATURE OF THE MARK.

THE MARK CONSISTS OF THE COLOR RED APPEARS IN THE WORD "SPORTSMAN'S" AND "SYSTEM"; AND THE COLOR BLACK APPEARS IN THE WORD "HAIR CARE".

FOR HAIR SHAMPOOS AND CONDITIONERS; HAIR SPRAYS AND HAIR GELS; POMADES FOR HAIR (U.S. CLS. 1, 4, 6, 50, 51 AND 52).

FIRST USE 9-1-2010; IN COMMERCE 9-1-2010.

3,956,206. CHURCH & DWIGHT CO., INC., PRINCETON, NJ. SN 85-135,621. FILED 9-22-2010.



OWNER OF U.S. REG. NO. 2,990,778.  
THE COLOR(S) PURPLE AND GREEN IS/ARE CLAIMED AS A FEATURE OF THE MARK.

**CLASS 3—(Continued).**

THE MARK CONSISTS OF THE COLOR PURPLE APPLIED TO THE ENTIRE SURFACE OF THE BOTTLE CONTAINING THE GOODS AND THE COLOR GREEN APPLIED TO THE ENTIRE SURFACE OF THE TRIGGER SPRAY. THE DOTTED LINES ARE INTENDED TO SHOW THE POSITION OF THE MARK AND ARE NOT PART OF THE MARK AS SHOWN.

FOR SHOWER, TUB AND TILE CLEANERS (U.S. CLS. 1, 4, 6, 50, 51 AND 52).  
FIRST USE 3-31-2005; IN COMMERCE 3-31-2005.

**CLASS 5—(Continued).**

3,956,148. AMERICAN BOTANICAL PHARMACY, MARINA DEL REY, CA. SN 85-029,777. FILED P.R. 5-4-2010; AM. S.R. 3-28-2011.

**FEMALE "SHOT"**

THE MARK CONSISTS OF STANDARD CHARACTERS WITHOUT CLAIM TO ANY PARTICULAR FONT, STYLE, SIZE, OR COLOR.

NO CLAIM IS MADE TO THE EXCLUSIVE RIGHT TO USE "FEMALE", APART FROM THE MARK AS SHOWN.

FOR HERBAL SUPPLEMENTS (U.S. CLS. 6, 18, 44, 46, 51 AND 52).  
FIRST USE 7-15-2010; IN COMMERCE 7-15-2010.

3,956,238. ABDUL AZIZ, DBA LA CASH AND CARRY, LOS ANGELES, CA. SN 85-180,294. FILED P.R. 11-18-2010; AM. S.R. 3-3-2011.

**LA INCENSE**

THE MARK CONSISTS OF STANDARD CHARACTERS WITHOUT CLAIM TO ANY PARTICULAR FONT, STYLE, SIZE, OR COLOR.

NO CLAIM IS MADE TO THE EXCLUSIVE RIGHT TO USE "INCENSE", APART FROM THE MARK AS SHOWN.

FOR INCENSE; INCENSE STICKS (U.S. CLS. 1, 4, 6, 50, 51 AND 52).  
FIRST USE 3-1-2011; IN COMMERCE 3-1-2011.

3,956,178. NANO-VIBRONIX, INC., CEDARHURST, NY. SN 85-067,374. FILED P.R. 6-21-2010; AM. S.R. 3-28-2011.

**WOUNDSHIELD**

THE MARK CONSISTS OF STANDARD CHARACTERS WITHOUT CLAIM TO ANY PARTICULAR FONT, STYLE, SIZE, OR COLOR.

FOR PATCH TO PROTECT WOUND (U.S. CLS. 6, 18, 44, 46, 51 AND 52).  
FIRST USE 7-28-2009; IN COMMERCE 7-28-2009.

**CLASS 5—PHARMACEUTICALS**

3,956,147. AMERICAN BOTANICAL PHARMACY, MARINA DEL REY, CA. SN 85-029,708. FILED P.R. 5-4-2010; AM. S.R. 3-23-2011.

3,956,192. ORMUS GOLD LLC, AKA NANO-GOLD, SANTA MONICA, CA. SN 85-114,719. FILED P.R. 8-24-2010; AM. S.R. 2-15-2011.

**MALE "SHOT"**

THE MARK CONSISTS OF STANDARD CHARACTERS WITHOUT CLAIM TO ANY PARTICULAR FONT, STYLE, SIZE, OR COLOR.

NO CLAIM IS MADE TO THE EXCLUSIVE RIGHT TO USE "MALE", APART FROM THE MARK AS SHOWN.

FOR HERBAL SUPPLEMENTS (U.S. CLS. 6, 18, 44, 46, 51 AND 52).  
FIRST USE 7-0-2009; IN COMMERCE 8-0-2009.

**Ormus Gold**

THE MARK CONSISTS OF STANDARD CHARACTERS WITHOUT CLAIM TO ANY PARTICULAR FONT, STYLE, SIZE, OR COLOR.

FOR MINERAL SUPPLEMENTS CONTAINING ORMUS GOLD (U.S. CLS. 6, 18, 44, 46, 51 AND 52).  
FIRST USE 6-4-2000; IN COMMERCE 10-0-2009.

**CLASS 5—(Continued).**

3,956,259. PRIMARY INVESTMENTS GROUP LIMITED, TORTOLA, BR.VIRGIN ISLANDS. SN 85-200,049. FILED 12-16-2010.

RED WINE EXTRACT  
RESVERATROL RAPID CALORIE  
BURN

THE MARK CONSISTS OF STANDARD CHARACTERS WITHOUT CLAIM TO ANY PARTICULAR FONT, STYLE, SIZE, OR COLOR.

OWNER OF U.S. REG. NO. 3,861,889.

FOR DIETARY SUPPLEMENTS; FOOD SUPPLEMENTS; HERBAL SUPPLEMENTS; MINERAL SUPPLEMENTS; NUTRITIONAL SUPPLEMENTS; VITAMIN SUPPLEMENTS; MULTI-VITAMIN MINERAL SUPPLEMENTS; DIETARY SUPPLEMENTS AND NUTRITIONAL SUPPLEMENTS IN THE FORM OF LIQUID (U.S. CLS. 6, 18, 44, 46, 51 AND 52).

FIRST USE 11-30-2009; IN COMMERCE 11-30-2009.

3,956,260. PRIMARY INVESTMENTS GROUP LIMITED, ROAD TOWN, TORTOLA, BR.VIRGIN ISLANDS. SN 85-200,065. FILED 12-16-2010.

RESVERATROL + CALORIE BURN  
& FAT METABOLIZER

THE MARK CONSISTS OF STANDARD CHARACTERS WITHOUT CLAIM TO ANY PARTICULAR FONT, STYLE, SIZE, OR COLOR.

OWNER OF U.S. REG. NO. 3,115,553.

FOR DIETARY SUPPLEMENTS; FOOD SUPPLEMENTS; HERBAL SUPPLEMENTS; MINERAL SUPPLEMENTS; NUTRITIONAL SUPPLEMENTS; VITAMIN SUPPLEMENTS; MULTI-VITAMIN MINERAL SUPPLEMENTS (U.S. CLS. 6, 18, 44, 46, 51 AND 52).

FIRST USE 11-30-2009; IN COMMERCE 11-30-2009.

3,956,264. MAXIMUM LIVING, INC., SOULSBYVILLE, CA. SN 85-207,584. FILED 12-29-2010.

HYSSOP CLEANSE

THE MARK CONSISTS OF STANDARD CHARACTERS WITHOUT CLAIM TO ANY PARTICULAR FONT, STYLE, SIZE, OR COLOR.

NO CLAIM IS MADE TO THE EXCLUSIVE RIGHT TO USE "HYSSOP", APART FROM THE MARK AS SHOWN.

FOR A DIETARY SUPPLEMENT CONTAINING HYSOP (U.S. CLS. 6, 18, 44, 46, 51 AND 52).

FIRST USE 4-15-1993; IN COMMERCE 4-15-1993.

**CLASS 6—METAL GOODS**

3,956,132. ADVANCED ARCHITECTURAL GRILLES, VALLEY STREAM, NY. SN 77-963,967. FILED P.R. 3-19-2010; AM. S.R. 2-15-2011.

Advanced Architectural  
Grilles

THE MARK CONSISTS OF STANDARD CHARACTERS WITHOUT CLAIM TO ANY PARTICULAR FONT, STYLE, SIZE, OR COLOR.

NO CLAIM IS MADE TO THE EXCLUSIVE RIGHT TO USE "ARCHITECTURAL GRILLES", APART FROM THE MARK AS SHOWN.

FOR PERFORATED SHEET METAL GRILLES AND LINEAR BAR GRILLES, NAMELY GRILLES FOR FAN VENTILATION SYSTEMS (U.S. CLS. 2, 12, 13, 14, 23, 25 AND 50).

FIRST USE 12-1-2004; IN COMMERCE 12-1-2004.

3,956,263. BHP, LLC, WEST ALLIS, WI. SN 85-205,764. FILED P.R. 12-27-2010; AM. S.R. 3-15-2011.

RAIN RUNOFF

THE MARK CONSISTS OF STANDARD CHARACTERS WITHOUT CLAIM TO ANY PARTICULAR FONT, STYLE, SIZE, OR COLOR.

FOR ANGLED METAL COVERINGS SOLD AS AN INTEGRAL COMPONENT OF METAL FLUID STORAGE TANKS FOR USE WITH GENERATORS; ANGLED METAL COVERINGS SOLD AS AN INTEGRAL COMPONENT OF METAL ENCLOSURE TANKS FOR CONTAINING POWER-GENERATING EQUIPMENT (U.S. CLS. 2, 12, 13, 14, 23, 25 AND 50).

FIRST USE 6-5-2005; IN COMMERCE 6-10-2005.

**CLASS 7—MACHINERY**

**CLASS 7—(Continued).**

3,956,106. GRANITE CITY TOOL COMPANY, WAITE PARK, MN. SN 77-714,636. FILED P.R. 4-15-2009; AM. S.R. 3-17-2011.



THE COLOR(S) BLACK AND YELLOW IS/ARE CLAIMED AS A FEATURE OF THE MARK.

THE MARK CONSISTS OF TWO CONCENTRIC, OVERLAPPING 4-POINTED VORTEX DESIGNS ROTATIONALLY ALIGNED SEVERAL DEGREES SO THE UNDERLYING YELLOW VORTEX DESIGN IS VISIBLE IN BETWEEN THE SPOKES OF THE OVERLAPPING BLACK VORTEX DESIGN.

FOR BLADES FOR POWER SAWS; CORE DRILLING BITS; POWER DRILL BITS; POWER SAW BLADES (U.S. CLS. 13, 19, 21, 23, 31, 34 AND 35).

FIRST USE 4-20-2009; IN COMMERCE 4-20-2009.

3,956,235. SITE BASED ENERGY, HAILEY, ID. SN 85-177,086. FILED P.R. 11-15-2010; AM. S.R. 3-14-2011.

**Mobile Renewable Generator**

THE MARK CONSISTS OF STANDARD CHARACTERS WITHOUT CLAIM TO ANY PARTICULAR FONT, STYLE, SIZE, OR COLOR.

NO CLAIM IS MADE TO THE EXCLUSIVE RIGHT TO USE "RENEWABLE GENERATOR", APART FROM THE MARK AS SHOWN.

FOR SOLAR-POWERED ELECTRICITY GENERATORS; WIND-POWERED ELECTRICITY GENERATORS (U.S. CLS. 13, 19, 21, 23, 31, 34 AND 35).

FIRST USE 6-26-2010; IN COMMERCE 6-26-2010.

**CLASS 8—HAND TOOLS****CLASS 8—(Continued).**

3,956,177. HOWI INC, YORKTOWN HEIGHTS, NY. SN 85-066,143. FILED P.R. 6-18-2010; AM. S.R. 3-1-2011.

**Parke Safety Razor**

THE MARK CONSISTS OF STANDARD CHARACTERS WITHOUT CLAIM TO ANY PARTICULAR FONT, STYLE, SIZE, OR COLOR.

NO CLAIM IS MADE TO THE EXCLUSIVE RIGHT TO USE "SAFETY RAZOR", APART FROM THE MARK AS SHOWN.

FOR SAFETY RAZORS (U.S. CLS. 23, 28 AND 44).  
FIRST USE 2-25-2011; IN COMMERCE 2-25-2011.

**CLASS 9—ELECTRICAL AND SCIENTIFIC APPARATUS**

3,956,111. FTEN, INC., NEW YORK, NY. SN 77-833,530. FILED P.R. 9-23-2009; AM. S.R. 2-28-2011.

**Distributed RiskXposure**

THE MARK CONSISTS OF STANDARD CHARACTERS WITHOUT CLAIM TO ANY PARTICULAR FONT, STYLE, SIZE, OR COLOR.

FOR SOFTWARE FOR USE IN HIGH SPEED, LOW LATENCY FINANCIAL SECURITIES TRADING (U.S. CLS. 21, 23, 26, 36 AND 38).

FIRST USE 6-1-2010; IN COMMERCE 6-1-2010.

3,956,118. COGENT REAL-TIME SYSTEMS INC., GEORGETOWN, ONTARIO, CANADA. SN 77-864,283. FILED P.R. 11-3-2009; AM. S.R. 2-3-2009.

**DATAHUB**

THE MARK CONSISTS OF STANDARD CHARACTERS WITHOUT CLAIM TO ANY PARTICULAR FONT, STYLE, SIZE, OR COLOR.

**CLASS 9—(Continued).**

PRIORITY CLAIMED UNDER SEC. 44(D) ON CANADA APPLICATION NO. 1443867, FILED 6-25-2009, REG. NO. TMA774161, DATED 8-10-2010, EXPIRES 8-10-2025.

FOR COMPUTER SOFTWARE, NAMELY, FOR USE IN THE DISTRIBUTION AND SHARING OF DATA, AND USER MANUALS PROVIDED IN CONNECTION THEREWITH; COMPUTER SOFTWARE, NAMELY, FOR ACTING AS MIDDLEWARE TO ALLOW DISPARATE SOFTWARE SYSTEMS TO COMMUNICATE AMONG ONE ANOTHER, AND USER MANUALS PROVIDED IN CONNECTION THEREWITH; COMPUTER SOFTWARE, NAMELY, FOR PROTOCOL CONVERSION, NETWORK TRANSMISSION AND COMMUNICATION AMONG MULTIPLE PROTOCOLS, AND USER MANUALS PROVIDED IN CONNECTION THEREWITH (U.S. CLS. 21, 23, 26, 36 AND 38).

FIRST USE 8-17-2003; IN COMMERCE 8-17-2003.

**CLASS 9—(Continued).**

3,956,159. HIPAA SOLUTIONS, LC, SUGAR LAND, TX. SN 85-052,996. FILED P.R. 6-2-2010; AM. S.R. 3-14-2011.

**PHI LOCATOR**

3,956,120. SAMHAIN PUBLISHING, LTD., MACON, GA. SN 77-880,625. FILED P.R. 11-25-2009; AM. S.R. 3-11-2011.

**RETRO ROMANCE**

THE MARK CONSISTS OF STANDARD CHARACTERS WITHOUT CLAIM TO ANY PARTICULAR FONT, STYLE, SIZE, OR COLOR.

NO CLAIM IS MADE TO THE EXCLUSIVE RIGHT TO USE "ROMANCE", APART FROM THE MARK AS SHOWN, FOR DOWNLOADABLE ELECTRONIC BOOKS IN THE NATURE OF A SERIES OF ROMANCE (U.S. CLS. 21, 23, 26, 36 AND 38).

FIRST USE 3-10-2011; IN COMMERCE 3-10-2011.

THE MARK CONSISTS OF STANDARD CHARACTERS WITHOUT CLAIM TO ANY PARTICULAR FONT, STYLE, SIZE, OR COLOR.

FOR COMPUTER SOFTWARE THAT AUTOMATES COMPLIANCE WITH PRIVACY AND SECURITY RULES REGARDING HEALTH INFORMATION (U.S. CLS. 21, 23, 26, 36 AND 38).

FIRST USE 1-1-2007; IN COMMERCE 1-1-2007.

3,956,135. BEYONDTRUST SOFTWARE, INC., AGOURA HILLS, CA. SN 85-008,232. FILED P.R. 4-7-2010; AM. S.R. 3-16-2011.

**DIRECTORY INTEGRATOR**

THE MARK CONSISTS OF STANDARD CHARACTERS WITHOUT CLAIM TO ANY PARTICULAR FONT, STYLE, SIZE, OR COLOR.

FOR COMPUTER SOFTWARE PROGRAMS THAT PROVIDE ACCESS TO MULTIPLE APPLICATIONS IN DIFFERENT OPERATING SYSTEMS (U.S. CLS. 21, 23, 26, 36 AND 38).

FIRST USE 6-8-2010; IN COMMERCE 6-8-2010.

3,956,172. SUZANNE BESSE, BOCA RATON, FL. SN 85-061,996. FILED P.R. 6-14-2010; AM. S.R. 3-23-2011.

**Rx Reader**

THE MARK CONSISTS OF STANDARD CHARACTERS WITHOUT CLAIM TO ANY PARTICULAR FONT, STYLE, SIZE, OR COLOR.

FOR MAGNIFICATION DEVICE, NAMELY, MAGNIFYING LENSES FOR READING PRESCRIPTION AND MEDICINE BOTTLE LABELS (U.S. CLS. 21, 23, 26, 36 AND 38).

FIRST USE 12-20-2010; IN COMMERCE 3-10-2011.

**CLASS 9—(Continued).**

3,956,196. JING LIN, NEW YORK, NY. SN 85-119,231. FILED P.R. 8-30-2010; AM. S.R. 3-7-2011.

# Sorrentino

THE MARK CONSISTS OF STANDARD CHARACTERS WITHOUT CLAIM TO ANY PARTICULAR FONT, STYLE, SIZE, OR COLOR.

FOR ANTIREFLECTION COATED EYEGLASSES; CASES FOR EYEGLASSES AND SUNGLASSES; CASES FOR SPECTACLES AND SUNGLASSES; CHAINS FOR EYEGLASSES; CHAINS FOR SPECTACLES AND FOR SUNGLASSES; EYEGLASS CASES; EYEGLASS CHAINS; EYEGLASS CHAINS AND CORDS; EYEGLASS CORDS; EYEGLASS FRAMES; EYEGLASS LENSES; EYEGLASS RETAINING CORDS; EYEGLASSES; EYEWEAR; EYEWEAR ACCESSORIES, NAMELY, STRAPS, NECK CORDS AND HEAD STRAPS WHICH RESTRAIN EYEWEAR FROM MOVEMENT ON A WEARER; EYEWEAR CASES; EYEWEAR RETAINERS; EYEWEAR, NAMELY, SUNGLASSES, EYEGLASSES AND OPHTHALMIC FRAMES AND CASES THEREFOR; FRAMES FOR EYEGLASSES AND PINCE-NEZ; FRAMES FOR GLASSES AND PINCE-NEZ; FRAMES FOR SPECTACLES; FRAMES FOR SPECTACLES AND PINCE-NEZ; FRAMES FOR SPECTACLES AND SUNGLASSES; GLACIER EYEGLASSES; LENSES FOR SUNGLASSES; MAGNIFYING GLASSES THAT FIT ON THE USER'S FACE IN THE MANNER OF EYEGLASSES; NOSE GUARDS WHICH CAN BE WORN BY ATTACHMENT TO EYEWEAR SUCH AS SUNGLASSES AND SKI GOGGLES; OPTICAL FRAMES; PROTECTIVE EYEGLASSES; PROTECTIVE EYEWEAR; PROTECTIVE EYEWEAR AND COMPONENT PARTS THEREOF; READING EYEGLASSES; SAFETY EYEWEAR; SIDE GUARDS FOR EYEGLASSES; SPECTACLE FRAMES; SPECTACLE FRAMES MADE OF METAL AND OF SYNTHETIC MATERIAL; SPECTACLE FRAMES MADE OF METAL OR A COMBINATION OF METAL AND PLASTICS; SPECTACLE FRAMES MADE OF METAL OR OF A COMBINATION OF METAL AND PLASTIC; SPECTACLES; SPECTACLES AND SUNGLASSES; SPECTACLES, FRAMES AND CASES; SPORTS EYEWEAR; SPORTS TRAINING EYEGLASSES; SUNGLASS CHAINS AND CORDS; SUNGLASS LENSES; SUNGLASSES; SUNGLASSES AND SPECTACLES; VIDEO DISPLAYS MOUNTED IN EYEGLASSES (U.S. CLS. 21, 23, 26, 36 AND 38).

FIRST USE 6-1-2008; IN COMMERCE 6-1-2008.

3,956,207. REALTIMEPT, LLC, ROCKWALL, TX. SN 85-136,991. FILED P.R. 9-23-2010; AM. S.R. 3-9-2011.

# RealTimePT

THE MARK CONSISTS OF STANDARD CHARACTERS WITHOUT CLAIM TO ANY PARTICULAR FONT, STYLE, SIZE, OR COLOR.

FOR COMPUTER SOFTWARE FOR PROJECT TRACKING, PROJECT MANAGEMENT, AND PROJECT COORDINATION (U.S. CLS. 21, 23, 26, 36 AND 38).  
FIRST USE 11-0-2009; IN COMMERCE 1-0-2010.

**CLASS 9—(Continued).**

3,956,212. AWR CORPORATION, EL SEGUNDO, CA. SN 85-145,828. FILED P.R. 10-5-2010; AM. S.R. 3-15-2011.

# TX-LINE

THE MARK CONSISTS OF STANDARD CHARACTERS WITHOUT CLAIM TO ANY PARTICULAR FONT, STYLE, SIZE, OR COLOR.

FOR DOWNLOADABLE SOFTWARE FOR ANALYSIS AND SYNTHESIS OF TRANSMISSION LINE STRUCTURES (U.S. CLS. 21, 23, 26, 36 AND 38).

FIRST USE 12-31-1996; IN COMMERCE 12-31-1996.

3,956,217. SOUTH BAY TRADING INC., ONTARIO, CA. SN 85-157,583. FILED P.R. 10-20-2010; AM. S.R. 3-14-2011.



THE MARK CONSISTS OF A REPETITION OF FLEURS-DE-LIS: ONE STANDING ALONE, ONE IN A CIRCLE, FOUR CONNECTED AT THEIR BASES WITH A CIRCLE FORMING A FANCIFUL DIAMOND, AND FOUR UNCONNECTED WITH THEIR BASES FACING ONE ANOTHER FORMING A FANCIFUL DIAMOND IN A DIAMOND BACKGROUND.

FOR EYEWEAR (U.S. CLS. 21, 23, 26, 36 AND 38).  
FIRST USE 10-4-2010; IN COMMERCE 10-4-2010.

3,956,222. SAGE PUBLICATIONS, INC., THOUSAND OAKS, CA. SN 85-160,649. FILED P.R. 10-25-2010; AM. S.R. 3-14-2011.

# AMERICAN JOURNAL OF HOSPICE & PALLIATIVE MEDICINE

THE MARK CONSISTS OF STANDARD CHARACTERS WITHOUT CLAIM TO ANY PARTICULAR FONT, STYLE, SIZE, OR COLOR.

OWNER OF U.S. REG. NO. 2,982,375.

**CLASS 9—(Continued).**

NO CLAIM IS MADE TO THE EXCLUSIVE RIGHT TO USE "JOURNAL", APART FROM THE MARK AS SHOWN.

FOR DOWNLOADABLE ELECTRONIC PUBLICATIONS, NAMELY, JOURNALS FEATURING MEDICAL INFORMATION, ACADEMIC INFORMATION, PSYCHOLOGICAL INFORMATION, SPIRITUAL INFORMATION, AND TECHNICAL RESEARCH INCLUDING TRAINING AND EDUCATIONAL INFORMATION IN THE FIELDS OF MEDICINE, ACADEMICS, PSYCHOLOGY, BUSINESS AND SCIENCE (U.S. CLS. 21, 23, 26, 36 AND 38).  
FIRST USE 3-0-2004; IN COMMERCE 5-11-2006.

3,956,223. SAGE PUBLICATIONS, INC., THOUSAND OAKS, CA. SN 85-160,666. FILED P.R. 10-25-2010; AM. S.R. 3-14-2011.

---

**AMERICAN JOURNAL OF  
ALZHEIMER'S DISEASE &  
OTHER DEMENTIAS**

THE MARK CONSISTS OF STANDARD CHARACTERS WITHOUT CLAIM TO ANY PARTICULAR FONT, STYLE, SIZE, OR COLOR.

OWNER OF U.S. REG. NO. 2,982,377.

NO CLAIM IS MADE TO THE EXCLUSIVE RIGHT TO USE "JOURNAL", APART FROM THE MARK AS SHOWN.

FOR DOWNLOADABLE ELECTRONIC PUBLICATIONS, NAMELY, JOURNALS FEATURING MEDICAL INFORMATION, ACADEMIC INFORMATION, PSYCHOLOGICAL INFORMATION AND TECHNICAL RESEARCH INCLUDING TRAINING AND EDUCATIONAL INFORMATION IN THE FIELDS OF MEDICINE, ACADEMICS, PSYCHOLOGY AND SCIENCE (U.S. CLS. 21, 23, 26, 36 AND 38).  
FIRST USE 9-0-2000; IN COMMERCE 5-11-2006.

3,956,226. BRAEBURN SYSTEMS LLC, MONTGOMERY, IL. SN 85-171,371. FILED P.R. 11-8-2010; AM. S.R. 2-25-2011.

---

**TOUCHSCREEN HYBRID**

THE MARK CONSISTS OF STANDARD CHARACTERS WITHOUT CLAIM TO ANY PARTICULAR FONT, STYLE, SIZE, OR COLOR.

FOR THERMOSTATS (U.S. CLS. 21, 23, 26, 36 AND 38).  
FIRST USE 1-31-2011; IN COMMERCE 1-31-2011.

**CLASS 9—(Continued).**

3,956,229. THE CONTEMPORARY YOUTH ORCHESTRA, CLEVELAND HEIGHTS, OH. SN 85-173,181. FILED P.R. 11-10-2010; AM. S.R. 3-10-2011.

**CONTEMPORARY YOUTH  
ORCHESTRA**

THE MARK CONSISTS OF STANDARD CHARACTERS WITHOUT CLAIM TO ANY PARTICULAR FONT, STYLE, SIZE, OR COLOR.

FOR DIGITAL MEDIA, NAMELY, PRE-RECORDED VIDEO CASSETTES, DIGITAL VIDEO DISCS, DIGITAL VERSATILE DISCS, DOWNLOADABLE AUDIO AND VIDEO RECORDINGS, DVDS, AND HIGH DEFINITION DIGITAL DISCS FEATURING ORCHESTRAL PERFORMANCES (U.S. CLS. 21, 23, 26, 36 AND 38).  
FIRST USE 11-7-2006; IN COMMERCE 11-7-2006.

3,956,231. WINDMAX GREEN ENERGY CORPORATION, PLANO, TX. SN 85-174,034. FILED P.R. 11-10-2010; AM. S.R. 2-21-2011.

---

**APPLIED MAGNETS**

THE MARK CONSISTS OF STANDARD CHARACTERS WITHOUT CLAIM TO ANY PARTICULAR FONT, STYLE, SIZE, OR COLOR.

NO CLAIM IS MADE TO THE EXCLUSIVE RIGHT TO USE "MAGNETS", APART FROM THE MARK AS SHOWN. FOR MAGNETS; MAGNETS FOR INDUSTRIAL PURPOSES (U.S. CLS. 21, 23, 26, 36 AND 38).  
FIRST USE 6-30-2005; IN COMMERCE 6-30-2005.

**CLASS 10—MEDICAL APPARATUS**

3,956,143. MGD INNOVATIONS, LLC, TAMPA, FL. SN 85-025,350. FILED P.R. 4-28-2010; AM. S.R. 2-8-2011.

---

**MASKIN**

THE MARK CONSISTS OF STANDARD CHARACTERS WITHOUT CLAIM TO ANY PARTICULAR FONT, STYLE, SIZE, OR COLOR.

FOR MEDICAL AND OPHTHALMOLOGICAL DEVICES, NAMELY, INTRADUCTAL PROBES AND TUBES (U.S. CLS. 26, 39 AND 44).  
FIRST USE 7-0-2009; IN COMMERCE 7-0-2009.



**CLASS 10—(Continued).**

3,956,152. LAKE REGION MANUFACTURING, INC., DBA LAKE REGION MEDICAL, INC., CHASKA, MN. SN 85-036,798. FILED P.R. 5-12-2010; AM. S.R. 2-16-2011.

# WEDGE

THE MARK CONSISTS OF STANDARD CHARACTERS WITHOUT CLAIM TO ANY PARTICULAR FONT, STYLE, SIZE, OR COLOR.

FOR TIPS FOR MEDICAL GUIDEWIRES (U.S. CLS. 26, 39 AND 44).

FIRST USE 9-16-2010; IN COMMERCE 9-16-2010.

3,956,244. MEDTRONIC, INC., MINNEAPOLIS, MN. SN 85-183,744. FILED P.R. 11-23-2010; AM. S.R. 2-28-2011.

## MULTI-LEAD TRIALING CABLE

THE MARK CONSISTS OF STANDARD CHARACTERS WITHOUT CLAIM TO ANY PARTICULAR FONT, STYLE, SIZE, OR COLOR.

FOR MEDICAL APPARATUS, NAMELY, A HOUSING FOR EXTERNAL LEADS USED IN SPINAL CORD STIMULATION (U.S. CLS. 26, 39 AND 44).

FIRST USE 11-12-2010; IN COMMERCE 11-12-2010.

**CLASS 11—ENVIRONMENTAL CONTROL APPARATUS**

3,956,167. STYLE CREST ENTERPRISES, INC., FREMONT, OH. SN 85-059,871. FILED P.R. 6-10-2010; AM. S.R. 3-14-2011.

## SMART COMPONENTS

THE MARK CONSISTS OF STANDARD CHARACTERS WITHOUT CLAIM TO ANY PARTICULAR FONT, STYLE, SIZE, OR COLOR.

FOR HEATING, VENTING AND AIR CONDITIONER (HVAC) EQUIPMENT AND ACCESSORIES, NAMELY, GAS, ELECTRIC AND OIL FURNACES, HEAT PUMPS, CONDENSERS AS PARTS OF HVAC UNITS, PRE-CHARGED LINE SETS AS PARTS OF HVAC UNITS, AND COILS AS PARTS OF HVAC UNITS (U.S. CLS. 13, 21, 23, 31 AND 34).

FIRST USE 10-4-2007; IN COMMERCE 10-4-2007.

**CLASS 12—VEHICLES**

3,956,123. LI-ION MOTORS CORP, MOORESVILLE, NC. SN 77-902,109. FILED P.R. 12-29-2009; AM. S.R. 2-16-2011.

# Li-ion Motors Corp

THE MARK CONSISTS OF STANDARD CHARACTERS WITHOUT CLAIM TO ANY PARTICULAR FONT, STYLE, SIZE, OR COLOR.

NO CLAIM IS MADE TO THE EXCLUSIVE RIGHT TO USE "MOTORS CORP", APART FROM THE MARK AS SHOWN.

FOR ELECTRIC VEHICLES, NAMELY, CARS (U.S. CLS. 19, 21, 23, 31, 35 AND 44).

FIRST USE 2-1-2010; IN COMMERCE 2-1-2010.

3,956,125. RADIO FLYER, INC., CHICAGO, IL. SN 77-914,527. FILED P.R. 1-19-2010; AM. S.R. 3-15-2011.

## ULTIMATE CLASSIC TRIKE

THE MARK CONSISTS OF STANDARD CHARACTERS WITHOUT CLAIM TO ANY PARTICULAR FONT, STYLE, SIZE, OR COLOR.

NO CLAIM IS MADE TO THE EXCLUSIVE RIGHT TO USE "CLASSIC TRIKE", APART FROM THE MARK AS SHOWN.

FOR TRICYCLES (U.S. CLS. 19, 21, 23, 31, 35 AND 44).

FIRST USE 6-30-2009; IN COMMERCE 6-30-2009.

3,956,166. BRAKE PARTS INC., MCHENRY, IL. SN 85-056,484. FILED P.R. 6-7-2010; AM. S.R. 3-7-2011.

## CERAMIC MAXIMUM STOPPING POWER AND SAFETY

THE MARK CONSISTS OF STANDARD CHARACTERS WITHOUT CLAIM TO ANY PARTICULAR FONT, STYLE, SIZE, OR COLOR.

NO CLAIM IS MADE TO THE EXCLUSIVE RIGHT TO USE "CERAMIC", APART FROM THE MARK AS SHOWN.

FOR LAND VEHICLE PARTS AND COMPONENTS, NAMELY, BRAKE PADS (U.S. CLS. 19, 21, 23, 31, 35 AND 44).

FIRST USE 11-1-2010; IN COMMERCE 11-1-2010.

**CLASS 13—FIREARMS**

**CLASS 13—(Continued).**

3,956,139. UNITED STATES FIRE ARMS MANUFACTURING CO., INC., HARTFORD, CT. SN 85-019,935. FILED P.R. 4-21-2010; AM. S.R. 1-28-2011.

# 12/22

THE MARK CONSISTS OF STANDARD CHARACTERS WITHOUT CLAIM TO ANY PARTICULAR FONT, STYLE, SIZE, OR COLOR.

FOR FIREARMS (U.S. CLS. 2 AND 9).  
FIRST USE 10-25-2008; IN COMMERCE 10-25-2008.

**CLASS 14—JEWELRY**

3,956,197. LIN, JING, NEW YORK, NY. SN 85-119,246. FILED P.R. 8-30-2010; AM. S.R. 3-7-2011.

# Sorrentino

THE MARK CONSISTS OF STANDARD CHARACTERS WITHOUT CLAIM TO ANY PARTICULAR FONT, STYLE, SIZE, OR COLOR.

FOR ALARM CLOCKS; ANKLE BRACELETS; BADGES OF PRECIOUS METAL; BANGLE BRACELETS; BASKETS OF PRECIOUS METAL; BEADS FOR USE IN THE MANUFACTURE OF JEWELRY; BODY JEWELRY; BOLO TIES WITH PRECIOUS METAL TIPS; BOTTLE CAPS OF PRECIOUS METALS; BOXES FOR TIMEPIECES; BOXES OF PRECIOUS METAL; BRACELETS; BRACELETS; BRACELETS AND JEWELRY FEATURING ELECTRONIC CHIPS FOR ATTRACTING ENERGY TO THE BODY WHEREIN THE ELECTRONIC CHIPS INCREASE IN POWER IN THE PRESENCE OF ELECTROMAGNETIC FIELDS, FOR THE PURPOSE OF REBALANCING THE HUMAN ENERGY FIELD; BRACELETS OF PRECIOUS METAL; BROACHES; BRONZE JEWELRY; BROOCHES; CASES FOR WATCHES AND CLOCKS; CHARMS FOR COLLAR JEWELRY AND BRACELET; CLOCKS; COSTUME JEWELRY; CUT DIAMONDS; DIAMOND; DIAMOND BELTS; DIAMOND JEWELRY; DIAMONDS; EARRINGS; EMERALD; EMERALDS; GEMS; GEMSTONE JEWELRY; GEMSTONES; GOLD; GOLD THREAD JEWELRY; GOLD, UNWORKED OR SEMI-WORKED; IDENTIFICATION BRACELETS; INEXPENSIVE NON-JEWELRY WATCHES; JADE; JEWELRY; JEWELRY AND IMITATION JEWELRY; JEWELRY AND WATCHES; JEWELRY; JEWELRY AND IMITATION JEWELRY; JEWELRY ARMOIRES; JEWELRY BOXES; JEWELRY BOXES NOT OF METAL; JEWELRY BOXES OF METAL; JEWELRY BOXES OF PRECIOUS METAL; JEWELRY BROOCHES; JEWELRY CASES; JEWELRY CASES NOT OF PRECIOUS METAL; JEWELRY CASES OF PRECIOUS METAL; JEWELRY CASKETS; JEWELRY CASKETS OF PRECIOUS METAL; JEWELRY CHAINS; JEWELRY FINDINGS; JEWELRY FOR ATTACHMENT TO CLOTHING; JEWELRY FOR THE HEAD; JEWELRY IN THE NATURE OF ARMBANDS; JEWELRY INCORPORATING A COMPUTER STORAGE DEVICE CONTAINING MEDICAL INFORMATION FOR MEDICAL ALERT PURPOSES; JEWELRY MAKING KITS; JEWELRY ORGANIZERS; JEWELRY PINS FOR USE ON HATS; JEWELRY RING HOLDERS; JEWELRY TO BE AFFIXED TO BIKINIS; JEWELRY

**CLASS 14—(Continued).**

WATCHES; JEWELRY, NAMELY, AMULETS; JEWELRY, NAMELY, ANKLETS; JEWELRY, NAMELY, ARM CUFFS; JEWELRY, NAMELY, BRACELETS, WRISTBANDS AND NECKLACES THAT ALSO PROVIDES NOTIFICATION TO THE WEARER OF A PENDING MEDICAL RELATED TASK; JEWELRY, NAMELY, CROSSES; JEWELRY, NAMELY, DOG TAGS FOR WEAR BY HUMANS FOR DECORATIVE PURPOSES; JEWELRY, NAMELY, MAGNETIC NECKLACES; JEWELRY, NAMELY, MAGNETIC PENDANTS; JEWELRY, NAMELY, PRECIOUS METAL PLATED REAL LEAVES AND FLOWERS; JEWELRY, NAMELY, STONE PENDANTS; JEWELS; LAPEL PINS; METAL WIRE FOR USE IN THE MAKING OF JEWELRY, NAMELY, JEWELRY CABLE; NECKLACES; ORNAMENTS OF PRECIOUS METAL; PENDANTS; PINS BEING JEWELRY; PLASTIC BRACELETS IN THE NATURE OF JEWELRY; PLATINUM; PRECIOUS AND SEMI-PRECIOUS CRYSTAL STONES AND BEADS FOR USE IN JEWELRY; PRECIOUS AND SEMI-PRECIOUS GEMS; PRECIOUS AND SEMI-PRECIOUS MINERALS; PRECIOUS AND SEMI-PRECIOUS STONES; PRECIOUS GEMSTONES; PRECIOUS JEWELS; PRECIOUS METAL ALLOYS; PRECIOUS METAL TROPHIES; PRECIOUS METAL TROPHY COLUMNS; PRECIOUS METALS; PRECIOUS METALS AND ALLOYS THEREOF; PRECIOUS STONES; PRECIOUS STONES AND WATCHES; PROCESSED OR SEMI-PROCESSED PRECIOUS METALS; REAL AND IMITATION JEWELRY; RINGS; RINGS BEING JEWELRY; RUBY; SAPPHIRE; SEMI-PRECIOUS STONES; SILVER; SINTERED DIAMONDS; SMALL CLOCKS; SOUVENIR PRESSED COINS; SPORTS WATCHES; STAINLESS STEEL JEWELRY BRACELETS; STATUES OF PRECIOUS METAL; STATUES OF PRECIOUS METAL AND THEIR ALLOYS; STOP WATCHES; SYNTHETIC DIAMONDS; TIMEPIECES; TIMEPIECES AND CHRONOMETRIC INSTRUMENTS; TOMBSTONES OF PRECIOUS METAL; TRAVEL CLOCKS; WALL CLOCKS; WATCH AND CLOCK SPRINGS; WATCH BOXES; WATCH BRACELETS; WATCH CASES; WATCH CHAINS; WATCH FACES; WATCHES; WATCHES AND JEWELRY; WATCHES, CLOCKS; WATCHES, CLOCKS, JEWELRY AND IMITATION JEWELRY; WATCHSTRAPS; WEDDING BANDS; WOMEN'S JEWELRY; WOMEN'S WATCHES; WORKS OF ART OF PRECIOUS METAL (U.S. CLS. 2, 27, 28 AND 50).  
FIRST USE 6-1-2010; IN COMMERCE 6-1-2010.

3,956,243. REICHERT, TERRY R., DBA PRO ICE, SCOTTSBLUFF, NE. SN 85-183,389. FILED P.R. 11-23-2010; AM. S.R. 3-15-2011.

# Sand Hills Gold

THE MARK CONSISTS OF STANDARD CHARACTERS WITHOUT CLAIM TO ANY PARTICULAR FONT, STYLE, SIZE, OR COLOR.

NO CLAIM IS MADE TO THE EXCLUSIVE RIGHT TO USE "GOLD", APART FROM THE MARK AS SHOWN.

FOR GOLD, UNWORKED OR SEMI-WORKED; PRECIOUS METALS AND THEIR ALLOYS, NAMELY, GOLD, SILVER, AND PLATINUM; PRECIOUS METALS AND THEIR ALLOYS IN THE FORM OF RINGS, PENDANTS, EARRINGS, BRACELETS, AND ALL OTHER TYPES OF JEWELRY (U.S. CLS. 2, 27, 28 AND 50).

FIRST USE 6-1-2010; IN COMMERCE 6-1-2010.

**CLASS 15—MUSICAL INSTRUMENTS**

**CLASS 15—(Continued).**

3,956,115. WD MUSIC PRODUCTS, INC., NORTH FORT MYERS, FL. SN 77-855,457. FILED 10-22-2009.

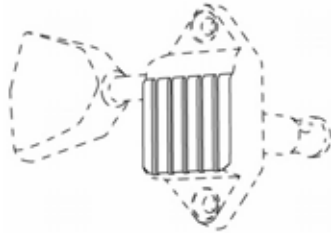

THE MARK CONSISTS OF A UNIQUE THREE-DIMENSIONAL CONFIGURATION OF A TUNING APPARATUS FOR MUSICAL INSTRUMENTS. THE CLAIMED FEATURES ARE SHOWN IN SOLID LINES AND THE PORTIONS THAT ARE IN DOTTED LINES ARE NOT CLAIMED AS FEATURES OF THE MARK.

FOR TUNING APPARATUS FOR MUSICAL INSTRUMENTS (U.S. CLS. 2, 21 AND 36).

FIRST USE 2-6-2008; IN COMMERCE 2-6-2008.

**CLASS 16—(Continued).**

3,956,113. MOS ENTERPRISES, INC., SANTA MONICA, CA. SN 77-843,789. FILED P.R. 10-7-2009; AM. S.R. 1-20-2011.

**THE SHRIVER REPORT**

THE MARK CONSISTS OF STANDARD CHARACTERS WITHOUT CLAIM TO ANY PARTICULAR FONT, STYLE, SIZE, OR COLOR.

NO CLAIM IS MADE TO THE EXCLUSIVE RIGHT TO USE "REPORT", APART FROM THE MARK AS SHOWN.

FOR PRINTED REPORTS FEATURING THE ROLE AND EFFECT OF WOMEN IN ECONOMY AND CULTURE (U.S. CLS. 2, 5, 22, 23, 29, 37, 38 AND 50).

FIRST USE 4-13-2009; IN COMMERCE 4-13-2009.

3,956,134. LICEA, LLC, LONG ISLAND CITY, NY. SN 85-005,941. FILED P.R. 4-5-2010; AM. S.R. 3-14-2011.

THE MARK CONSISTS OF CURSIVE LETTERING OF THE WORD "LICEA".

FOR GUITARS (U.S. CLS. 2, 21 AND 36).

FIRST USE 2-21-2010; IN COMMERCE 2-21-2010.

3,956,129. DEQING SUNNY PLASTIC PRODUCTS CO. LTD., DEQING, ZHEJIANG, CHINA. SN 77-944,770. FILED P.R. 2-25-2010; AM. S.R. 1-19-2011.



THE COLOR(S) BLUE IS/ARE CLAIMED AS A FEATURE OF THE MARK.

THE MARK CONSISTS OF THE COLOR BLUE USED ON THE ENTIRE SURFACE OF PLASTIC FILM STORAGE BAGS. THE MATTER SHOWN IN BROKEN LINES ON THE DRAWING SHOWS POSITIONING OF THE MARK ON THE GOODS AND THE CONFIGURATION OF THE BAG IS NOT CLAIMED AS A FEATURE OF THE MARK.

FOR SEMI-TRANSPARENT PLASTIC FILM PRESERVING STORAGE BAGS FOR FRUIT, VEGETABLES AND FLOWERS, FOR HOUSEHOLD USE (U.S. CLS. 2, 5, 22, 23, 29, 37, 38 AND 50).

FIRST USE 9-17-2010; IN COMMERCE 9-17-2010.

**CLASS 16—PAPER GOODS AND PRINTED MATTER**

3,956,108. PRICE INTERNATIONAL, INC., VAUGHN, ONTARIO, CANADA. SN 77-786,134. FILED P.R. 7-21-2009; AM. S.R. 3-10-2011.

1600 PENNSYLVANIA AVENUE NW

THE MARK CONSISTS OF STANDARD CHARACTERS WITHOUT CLAIM TO ANY PARTICULAR FONT, STYLE, SIZE, OR COLOR.

FOR TRADING CARDS (U.S. CLS. 2, 5, 22, 23, 29, 37, 38 AND 50).

FIRST USE 6-1-2010; IN COMMERCE 6-1-2010.

**CLASS 16—(Continued).**

3,956,187. SLIMBOARD, LLC, CHESHIRE, CT. SN 85-092,142. FILED P.R. 7-23-2010; AM. S.R. 3-1-2011.



THE MARK CONSISTS OF THE TERM "SLIMBOARD" WITH A STYLIZED "S" AT THE BEGINNING WITH THE UPPER LEG PORTION EXTENDING ABOVE AND SUBSTANTIALLY OVER THE LETTERS "L", "I", "M" AND "B". FOR LAP BOARDS FOR READING AND WRITING WITH A POCKET FOR STORAGE (U.S. CLS. 2, 5, 22, 23, 29, 37, 38 AND 50).  
FIRST USE 10-1-2009; IN COMMERCE 9-1-2010.

3,956,198. FULL FREQUENCY TRANSFORMATION, LLC, MONTCLAIR, NJ. SN 85-120,015. FILED P.R. 8-31-2010; AM. S.R. 3-9-2011.

**Premie Parents**

THE MARK CONSISTS OF STANDARD CHARACTERS WITHOUT CLAIM TO ANY PARTICULAR FONT, STYLE, SIZE, OR COLOR.  
FOR SERIES OF NON-FICTION BOOKS IN THE FIELD OF PARENTING PREMATURE BABIES (U.S. CLS. 2, 5, 22, 23, 29, 37, 38 AND 50).  
FIRST USE 8-17-2006; IN COMMERCE 6-0-2007.

3,956,201. PAPERBOARD PACKAGING COUNCIL, SPRINGFIELD, MA. SN 85-125,813. FILED P.R. 9-9-2010; AM. S.R. 3-16-2011.



NO CLAIM IS MADE TO THE EXCLUSIVE RIGHT TO USE "PACKAGING", APART FROM THE MARK AS SHOWN.

**CLASS 16—(Continued).**

THE MARK CONSISTS OF THE THREE CHASING ARROWS RECYCLING SYMBOL WITH THE WORDS "PAPERBOARD PACKAGING", IN STYLIZED FORM ABOVE THE SYMBOL AND THE WORD "RECYCLABLE", IN STYLIZED FORM BELOW THE SYMBOL.  
FOR FIBER-BASED PACKAGING MATERIALS, NAMELY, FOLDING CARTONS MADE FROM RECYCLABLE PAPER OR CARDBOARD (U.S. CLS. 2, 5, 22, 23, 29, 37, 38 AND 50).  
FIRST USE 12-1-2010; IN COMMERCE 12-1-2010.

3,956,215. ROYAL PAPER CONVERTING, INC., PHOENIX, AZ. SN 85-156,181. FILED P.R. 10-19-2010; AM. S.R. 3-11-2011.



THE MARK CONSISTS OF A STYLIZED FLOWER AND BUTTERFLY WITH DOTTED CURVED LINES SEPARATING THE SAME.  
FOR PAPER NAPKINS, TOILET PAPER (U.S. CLS. 2, 5, 22, 23, 29, 37, 38 AND 50).  
FIRST USE 1-1-2002; IN COMMERCE 1-1-2002.

3,956,227. JONES, RICHARD D., DBA LIFE MINISTRIES, DALLAS, TX. AND JONES, DOROTHY H. E., DBA LIFE MINISTRIES, DALLAS, TX. SN 85-171,878. FILED P.R. 11-8-2010; AM. S.R. 3-23-2011.

**MONEY MAT**

THE MARK CONSISTS OF STANDARD CHARACTERS WITHOUT CLAIM TO ANY PARTICULAR FONT, STYLE, SIZE, OR COLOR.  
FOR PRINTED INSTRUCTIONAL, EDUCATIONAL, AND TEACHING MATERIALS FOR EDUCATIONAL ACTIVITIES IN THE FIELD OF TEACHING FAITH-BASED PERSONAL FINANCIAL MANAGEMENT TO CHILDREN (U.S. CLS. 2, 5, 22, 23, 29, 37, 38 AND 50).  
FIRST USE 7-7-2003; IN COMMERCE 1-31-2008.

**CLASS 16—(Continued).**

3,956,228. JONES, RICHARD D., DBA LIFE MINISTRIES, DALLAS, TX. AND JONES, DOROTHY H. E., DBA LIFE MINISTRIES, DALLAS, TX. SN 85-171,891. FILED P.R. 11-8-2010; AM. S.R. 3-23-2011.

**FAITH & FINANCES FOR KIDS**

THE MARK CONSISTS OF STANDARD CHARACTERS WITHOUT CLAIM TO ANY PARTICULAR FONT, STYLE, SIZE, OR COLOR.

FOR PACKAGED KITS COMPRISING PRINTED INSTRUCTIONAL, EDUCATIONAL, AND TEACHING MATERIALS AND TOOLS FOR EDUCATIONAL ACTIVITIES IN THE FIELD OF TEACHING FAITH-BASED PERSONAL FINANCIAL MANAGEMENT TO CHILDREN (U.S. CLS. 2, 5, 22, 23, 29, 37, 38 AND 50).

FIRST USE 10-8-2010; IN COMMERCE 10-21-2010.

**CLASS 18—LEATHER GOODS**

3,956,199. LIN, JING, NEW YORK, NY. SN 85-121,543. FILED P.R. 9-2-2010; AM. S.R. 3-7-2011.

**Sorrentino**

THE MARK CONSISTS OF STANDARD CHARACTERS WITHOUT CLAIM TO ANY PARTICULAR FONT, STYLE, SIZE, OR COLOR.

FOR ALL-PURPOSE REUSABLE CARRYING BAGS; ANIMAL LEASHES; ANIMAL SKINS AND HIDES; ATTACHE CASES; ATTACHE CASES MADE OF IMITATION LEATHER; ATTACHE CASES MADE OF LEATHER; BABY BACKPACKS; BABY CARRIERS WORN ON THE BODY; BABY CARRYING BAGS; BACK PACKS; BACKPACKS, BOOK BAGS, SPORTS BAGS, BUM BAGS, WALLETS AND HANDBAGS; BEACH BAGS; BEACHBAGS; BELT BAGS; BELT BAGS AND HIP BAGS; BOOK BAGS; BOSTON BAGS; BRIEFBAGS; BRIEFCASES; BUM BAGS; BUMBAGS; BUSINESS CARD CASES; BUSINESS CASES; CANTLE BAGS; CANVAS SHOPPING BAGS; CARRIERS FOR SUITS, SHIRTS AND DRESSES; CASES FOR KEYS; CATALOG CASES; CHALK BAGS; CLUTCH PURSES; COIN HOLDERS IN THE NATURE OF WALLETS; COIN PURSES; COSMETIC CARRYING CASES SOLD EMPTY; CREDIT CARD CASES; CREDIT CARD CASES AND HOLDERS; DIAPERS FOR DOGS; DOCUMENT CASES; DOCUMENT SUITCASES; EVENING HANDBAGS; FLIGHT BAGS; GARMENT BAGS FOR TRAVEL; GARMENTS FOR PETS; GENERAL PURPOSE BAGS FOR HOLDING DANCE EQUIPMENT; GENERAL PURPOSE SPORT TROLLEY BAGS; GENTLEMEN'S HANDBAGS; HANDBAGS; HANDBAGS, PURSES AND WALLETS; HOBO BAGS; JEWELRY ORGANIZERS FOR TRAVEL; JEWELRY POUCHES; KEY BAGS; KEY CASES; KEY WALLETS; KEYCASES; KIT BAGS; LEATHER BAGS AND WALLETS; LEATHER BAGS, SUITCASES AND WALLETS; LEATHER BRIEFCASES; LEATHER CASES FOR KEYS; LEATHER CREDIT CARD CASES; LEATHER CREDIT CARD HOLDER; LEATHER CREDIT CARD WALLETS; LEATHER PURSES; LEATHER SHOULDER BELTS; LUGGAGE; LUGGAGE LABEL HOLDERS; MEN'S CLUTCH BAGS; MESSENGER BAGS; MULTI-

**CLASS 18—(Continued).**

PURPOSE PURSES; NAME CARD CASES; OVERNIGHT CASES; OVERNIGHT SUITCASES; POUCHES AND BAGS SOLD EMPTY FOR ATTACHMENT TO BACKPACKS; POUCHES FOR HOLDING KEYS; POUCHES OF LEATHER; POUCHES OF TEXTILE; PURSES; PURSES AND WALLETS; ROLL BAGS; SADDLE BELTS; SADDLE HORN BAGS; SADDLEBAGS; SADDLES; SATCHELS; SCHOOL BAGS; SCHOOL BOOK BAGS; SCHOOL SATCHELS; SCHOOLBAGS; SCHOOLCHILDREN'S BACKPACKS; SHOE BAGS FOR TRAVEL; SHOULDER BAGS; SLING BAGS FOR CARRYING INFANTS; SMALL BACKPACKS; SMALL BAGS FOR MEN; SMALL CLUTCH PURSES; SMALL PURSES; SMALL SUITCASES; SOUVENIR BAGS; SUIT BAGS; SUIT CARRIERS; SUITCASES; TEXTILE SHOPPING BAGS; TOOL BAGS SOLD EMPTY; TOOL POUCHES, SOLD EMPTY; TRAIN CASES; TRAVEL BAGGAGE; TRAVEL CASES; UMBRELLAS; UNFITTED VANITY CASES; WAIST BAGS; WAIST PACKS; WALLETS; WHEELED MESSENGER BAGS; WINE CARRYING CASES; WRIST MOUNTED CARRYALL BAGS; WRIST MOUNTED PURSES (U.S. CLS. 1, 2, 3, 22 AND 41).

FIRST USE 6-1-2008; IN COMMERCE 6-1-2008.

**CLASS 20—FURNITURE AND ARTICLES NOT OTHERWISE CLASSIFIED**

3,956,160. DEDON GMBH, 21337 LÜNEBURG, FED REP GERMANY. SN 85-053,096. FILED P.R. 6-2-2010; AM. S.R. 2-8-2011.

**Leaf**

THE MARK CONSISTS OF STANDARD CHARACTERS WITHOUT CLAIM TO ANY PARTICULAR FONT, STYLE, SIZE, OR COLOR.

FOR OUTDOOR FURNITURE, NAMELY, SIDE TABLES AND BEACH CHAIRS (U.S. CLS. 2, 13, 22, 25, 32 AND 50).

FIRST USE 12-31-2006; IN COMMERCE 12-31-2006.

3,956,161. DEDON GMBH, 21337 LÜNEBURG, FED REP GERMANY. SN 85-053,125. FILED P.R. 6-2-2010; AM. S.R. 3-2-2011.

**Yin Yang**

THE MARK CONSISTS OF STANDARD CHARACTERS WITHOUT CLAIM TO ANY PARTICULAR FONT, STYLE, SIZE, OR COLOR.

FOR FURNITURE (U.S. CLS. 2, 13, 22, 25, 32 AND 50).

FIRST USE 12-31-2006; IN COMMERCE 12-31-2006.

**CLASS 21—HOUSEWARES AND GLASS**

**CLASS 21—(Continued).**

3,956,127. 3D-COOLIE, LLC, ORLANDO, FL. SN 77-918,802.  
FILED P.R. 1-23-2010; AM. S.R. 4-26-2010.

**3D Coolie**

THE MARK CONSISTS OF STANDARD CHARACTERS WITHOUT CLAIM TO ANY PARTICULAR FONT, STYLE, SIZE, OR COLOR.

NO CLAIM IS MADE TO THE EXCLUSIVE RIGHT TO USE "COOLIE", APART FROM THE MARK AS SHOWN.

FOR FOAM DRINK HOLDERS (U.S. CLS. 2, 13, 23, 29, 30, 33, 40 AND 50).

FIRST USE 11-1-2007; IN COMMERCE 2-10-2008.

**CLASS 22—CORDAGE AND FIBERS**

3,956,156. CHOCKSTRAP, LLC, HARLEYSVILLE, PA. SN 85-045,999. FILED P.R. 5-24-2010; AM. S.R. 3-4-2011.

**CHOCKSTRAP**

THE MARK CONSISTS OF STANDARD CHARACTERS WITHOUT CLAIM TO ANY PARTICULAR FONT, STYLE, SIZE, OR COLOR.

FOR STRAPS FOR HANDLING LOADS (U.S. CLS. 1, 2, 7, 19, 22, 42 AND 50).

FIRST USE 5-7-2010; IN COMMERCE 5-7-2010.

3,956,144. AMES TRUE TEMPER, INC., CAMP HILL, PA. SN 85-025,534. FILED P.R. 4-28-2010; AM. S.R. 3-7-2011.

**REINFORCED  
Fiber  
BOND**

THE MARK CONSISTS OF THE WORD "FIBER" OVER THE WORD "BOND" WITH THE WORD "REINFORCED" OVER THE "BER" OF "FIBER".

FOR FIBERGLASS REINFORCED PLASTIC MATERIAL FOR USE IN A POT OR PLANTER (U.S. CLS. 2, 13, 23, 29, 30, 33, 40 AND 50).

FIRST USE 12-1-2010; IN COMMERCE 12-1-2010.

3,956,169. EASY GARDENER PRODUCTS, INC., WACO, TX. SN 85-060,773. FILED P.R. 6-11-2010; AM. S.R. 3-11-2011.

**AQUAWRAP**

THE MARK CONSISTS OF STANDARD CHARACTERS WITHOUT CLAIM TO ANY PARTICULAR FONT, STYLE, SIZE, OR COLOR.

FOR TREE AND PLANT PROTECTION AND GROWTH ENHANCEMENT PRODUCTS IN THE NATURE OF GROWING BAGS FOR GROWING TREES AND PLANTS, NAMELY, FLUID-FILLED COVERINGS MADE OF PLASTIC TO BE PLACED AROUND TREES AND PLANTS (U.S. CLS. 1, 2, 7, 19, 22, 42 AND 50).

FIRST USE 4-30-2010; IN COMMERCE 12-31-2010.

3,956,252. ZOO MED LABORATORIES, INC., SAN LUIS OBISPO, CA. SN 85-191,776. FILED P.R. 12-6-2010; AM. S.R. 3-10-2011.

**NATURALISTIC TERRARIUM**

THE MARK CONSISTS OF STANDARD CHARACTERS WITHOUT CLAIM TO ANY PARTICULAR FONT, STYLE, SIZE, OR COLOR.

NO CLAIM IS MADE TO THE EXCLUSIVE RIGHT TO USE "TERRARIUM", APART FROM THE MARK AS SHOWN.

FOR TERRARIUMS FOR ANIMALS OR INSECTS (U.S. CLS. 2, 13, 23, 29, 30, 33, 40 AND 50).

FIRST USE 1-31-2009; IN COMMERCE 1-31-2009.

**CLASS 25—CLOTHING**

3,956,101. CLAUDIA A. AFXENTIOU, OAKLAND GARDENS, NY. SN 76-704,174. FILED P.R. 8-20-2010; AM. S.R. 3-16-2011.

**THE LIFT 'N SNAP BRA**

THE MARK CONSISTS OF STANDARD CHARACTERS WITHOUT CLAIM TO ANY PARTICULAR FONT, STYLE, SIZE, OR COLOR.

NO CLAIM IS MADE TO THE EXCLUSIVE RIGHT TO USE "BRA", APART FROM THE MARK AS SHOWN.

FOR BRASSIERE (U.S. CLS. 22 AND 39).

FIRST USE 2-22-2011; IN COMMERCE 2-22-2011.

**CLASS 25—(Continued).**

3,956,103. FUCHS, SVETLANA, LAS VEGAS, NV. SN 77-200,117. FILED P.R. 6-7-2007; AM. S.R. 2-21-2011.

## Neck-Lace

THE MARK CONSISTS OF STANDARD CHARACTERS WITHOUT CLAIM TO ANY PARTICULAR FONT, STYLE, SIZE, OR COLOR.

FOR CLOTHING TO BE WORN AROUND THE NECK, NAMELY, A COLLAR CONSISTING OF LAYERS OF LACE (U.S. CLS. 22 AND 39).

FIRST USE 1-1-2005; IN COMMERCE 1-1-2005.

3,956,126. BERNARD'S, DBA BERNARD'S CUSTOM LOGO, CORTLAND, NY. SN 77-918,231. FILED P.R. 1-22-2010; AM. S.R. 3-4-2011.

## CORTACA

THE MARK CONSISTS OF STANDARD CHARACTERS WITHOUT CLAIM TO ANY PARTICULAR FONT, STYLE, SIZE, OR COLOR.

FOR APPAREL, NAMELY, SHIRTS, T-SHIRTS, SWEATSHIRTS, JACKETS, HATS AND CAPS (U.S. CLS. 22 AND 39).

FIRST USE 10-0-1998; IN COMMERCE 10-0-1998.

3,956,158. THE OUTLAWS MOTORCYCLE CLUB INC., MILWAUKEE, WI. SN 85-049,548. FILED P.R. 5-27-2010; AM. S.R. 3-9-2011.

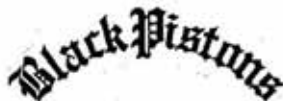

THE MARK CONSISTS OF "BLACK PISTONS". FOR T-SHIRTS (U.S. CLS. 22 AND 39). FIRST USE 1-1-2010; IN COMMERCE 1-1-2010.

**CLASS 25—(Continued).**

3,956,193. DAYS OF NOAH, LLC, BEDFORD, NH. SN 85-115,073. FILED P.R. 8-24-2010; AM. S.R. 3-8-2011.

## Days Of Noah

THE MARK CONSISTS OF STANDARD CHARACTERS WITHOUT CLAIM TO ANY PARTICULAR FONT, STYLE, SIZE, OR COLOR.

FOR CLOTHING, NAMELY, SHIRTS, SWEATSHIRTS, SWEATSHIRTS WITH HOODS, HATS, AND BANDANAS (U.S. CLS. 22 AND 39).

FIRST USE 7-25-2009; IN COMMERCE 7-25-2009.

3,956,195. DELLOSO, MICHELLE, IVINS, UT. SN 85-119,175. FILED P.R. 8-30-2010; AM. S.R. 3-10-2011.

## Rim to Rim

THE MARK CONSISTS OF STANDARD CHARACTERS WITHOUT CLAIM TO ANY PARTICULAR FONT, STYLE, SIZE, OR COLOR.

FOR ATHLETIC APPAREL, NAMELY, SHIRTS, PANTS, JACKETS, FOOTWEAR, HATS AND CAPS, ATHLETIC UNIFORMS (U.S. CLS. 22 AND 39).

FIRST USE 9-1-2010; IN COMMERCE 9-1-2010.

3,956,200. JING LIN, NEW YORK, NY. SN 85-122,529. FILED P.R. 9-3-2010; AM. S.R. 3-7-2011.

## Sorrentino

THE MARK CONSISTS OF STANDARD CHARACTERS WITHOUT CLAIM TO ANY PARTICULAR FONT, STYLE, SIZE, OR COLOR.

FOR A-SHIRTS; ANKLE SOCKS; ANORAK; APRONS; AQUA SHOES; ATHLETIC APPAREL, NAMELY, SHIRTS, PANTS, JACKETS, FOOTWEAR, HATS AND CAPS, ATHLETIC UNIFORMS; BATHING SUITS; BATHROBES; BEACH COVER-UPS; BELTS FOR CLOTHING; BELTS MADE OF LEATHER; BELTS MADE OUT OF CLOTH; BIKINIS; BLOUSES; BOARD SHORTS; BODY SHIRTS; BODY SUITS; BOOTS; BOW TIES; BRAS; BRIEFS; BRIEFS; CAPES; CAPS; COATS; COATS MADE OF COTTON; COATS OF DENIM; COSTUMES FOR USE IN CHILDREN'S DRESS UP PLAY; COSTUMES FOR USE IN ROLE-PLAYING GAMES; DANCE SHOES; DANCE SLIPPERS; DENIM JACKETS; DENIMS; DICKIES; DOWN JACKETS; DOWN SUITS; DRESS PANTS; DRESS SHIRTS; DRESS SUITS; DRESSES; DRY SUITS; EUROPEAN FOOTBALL BIBS; EVENING

**CLASS 25—(Continued).**

GOWNS; FOOTWEAR; FUR COATS; FUR COATS AND JACKETS; GLOVES; GOWNS; HATS; HEADWEAR; HOODS; INFANT WEAR; JACKETS; KNICKERS; LADIES' BOOTS; LADIES' SUITS; LADIES' UNDERWEAR; LEATHER BELTS; LEATHER COATS; LEATHER HATS; LEATHER HEADWEAR; LEATHER JACKETS; LEATHER PANTS; LEATHER SHIRTS; LEATHER SHOES; LEATHER SKIRTS; LEATHER SLIPPERS; LEATHER VESTS; LINGERIE; MARTIAL ARTS UNIFORMS; MEN'S AND WOMEN'S JACKETS, COATS, TROUSERS, VESTS; MEN'S DRESS SOCKS; MEN'S SOCKS; MEN'S SUITS, WOMEN'S SUITS; MEN'S UNDERWEAR; METAL FITTINGS FOR JAPANESE STYLE WOODEN CLOGS; MINISKIRTS; NECKWEAR; NIGHT GOWNS; NIGHT SHIRTS; NIGHTGOWNS; NIGHTWEAR; PANTIES; PANTS; POLO SHIRTS; PULLOVERS; RAIN BOOTS; RAIN COATS; RAIN HATS; RAIN JACKETS; RAIN SUITS; RAINWEAR; SANDALS; SASHES; SHIRTS; SHOES; SHORTS; SHOWER CAPS; SKIRTS; SKIWEAR; SLEEPWEAR; SLIPPERS; SNEAKERS; SNOW SUITS; SOCCER SHOES; SOCKS; SPORT COATS; SPORT SHIRTS; SPORTS BRA; SPORTS PANTS; SPORTS SHIRTS; SUITS; SUNDRÉSSES; SWEAT SUITS; SWEATERS; SWIM WEAR; SWIMMING TRUNKS; SWIMSUITS; T-SHIRTS; TANK TOPS; TENNIS WEAR; TROUSERS; TRUNKS; TUXEDOS; UNDERCLOTHES; UNDERSHIRTS; UNDERSKIRTS; UNDERWEAR; UNIFORMS; VESTS; WOMEN'S UNDERWEAR (U.S. CLS. 22 AND 39).

FIRST USE 6-1-2010; IN COMMERCE 6-1-2010.

3,956,239. RICARDO VIZCAINO, LOS ANGELES, CA. AND OROSMAN VIZCAINO, JR., LOS ANGELES, CA. SN 85-180,403. FILED P.R. 11-18-2010; AM. S.R. 3-15-2011.

# VIZCAINO

THE MARK CONSISTS OF STANDARD CHARACTERS WITHOUT CLAIM TO ANY PARTICULAR FONT, STYLE, SIZE, OR COLOR.

FOR CLOTHING, NAMELY, JEANS, SHIRTS, SHORTS, SKIRTS, DRESSES, PANTS, COATS, TOPS AND BOTTOMS (U.S. CLS. 22 AND 39).

FIRST USE 2-3-2011; IN COMMERCE 2-25-2011.

3,956,248. MITCHELL GROSS, NEW YORK, NY. SN 85-188,145. FILED 12-1-2010.

# Design Direct

THE MARK CONSISTS OF STANDARD CHARACTERS WITHOUT CLAIM TO ANY PARTICULAR FONT, STYLE, SIZE, OR COLOR.

FOR WOMEN'S APPAREL, NAMELY, JACKETS, PANTS, SKIRTS, BLOUSES, DRESSES, COATS AND SPORTS SHIRTS (U.S. CLS. 22 AND 39).

FIRST USE 4-15-2009; IN COMMERCE 4-15-2009.

**CLASS 25—(Continued).**

3,956,253. ELESAR HOLDINGS, LLC, TUCSON, AZ. SN 85-193,413. FILED P.R. 12-8-2010; AM. S.R. 3-14-2011.



THE MARK CONSISTS OF THE WORDS "TALK TO THE FIST" LOCATED OVER A PICTURE OF A FIST WITH THE WORDS "CUZ THE HAND IS PISSED" LOCATED UNDERNEATH THE PICTURE OF THE FIST.

FOR WEARABLE GARMENTS AND CLOTHING, NAMELY, SHIRTS (U.S. CLS. 22 AND 39).

FIRST USE 10-18-2010; IN COMMERCE 10-22-2010.

**CLASS 26—FANCY GOODS**

3,956,194. SHAKE-N-GO FASHION, INC., PORT WASHINGTON, NY. SN 85-116,232. FILED P.R. 8-26-2010; AM. S.R. 3-22-2011.

# FORTIFIED CUTICLES

THE MARK CONSISTS OF STANDARD CHARACTERS WITHOUT CLAIM TO ANY PARTICULAR FONT, STYLE, SIZE, OR COLOR.

FOR HAIR PRODUCTS, NAMELY, HAIR PIECES, WIGS, HAIR EXTENSIONS AND PONYTAIL HAIR PIECES (U.S. CLS. 37, 39, 40, 42 AND 50).

FIRST USE 8-16-2010; IN COMMERCE 8-16-2010.

**CLASS 28—TOYS AND SPORTING GOODS**

3,956,107. SPIN MASTER LTD., TORONTO, ONTARIO, CANADA. SN 77-773,050. FILED P.R. 7-2-2009; AM. S.R. 3-15-2011.

# WALL RACER

THE MARK CONSISTS OF STANDARD CHARACTERS WITHOUT CLAIM TO ANY PARTICULAR FONT, STYLE, SIZE, OR COLOR.



**CLASS 28—(Continued).**

PRIORITY CLAIMED UNDER SEC. 44(D) ON CANADA APPLICATION NO. 1,441,043, FILED 6-10-2009, REG. NO. TMA782575, DATED 11-16-2010, EXPIRES 11-16-2025.  
FOR TOY VEHICLES (U.S. CLS. 22, 23, 38 AND 50).

3,956,146. ROBERT S. JOHNSTON, MILWAUKEE, WI. SN 85-027,246. FILED P.R. 4-30-2010; AM. S.R. 3-25-2011.

# Paddler

THE MARK CONSISTS OF STANDARD CHARACTERS WITHOUT CLAIM TO ANY PARTICULAR FONT, STYLE, SIZE, OR COLOR.

FOR FLOATS FOR RECREATIONAL USE, NAMELY, SWIM FLOATS (U.S. CLS. 22, 23, 38 AND 50).  
FIRST USE 5-5-2010; IN COMMERCE 5-5-2010.

3,956,165. NORSEMEN OUTDOORS, INC., LAKE MILLS, IA. SN 85-055,914. FILED P.R. 6-7-2010; AM. S.R. 2-28-2011.

# FOLD-A-WAY

THE MARK CONSISTS OF STANDARD CHARACTERS WITHOUT CLAIM TO ANY PARTICULAR FONT, STYLE, SIZE, OR COLOR.

FOR HAND-HELD FISHING NETS (U.S. CLS. 22, 23, 38 AND 50).  
FIRST USE 1-1-2008; IN COMMERCE 1-1-2008.

**CLASS 29—MEATS AND PROCESSED FOODS**

3,956,128. PEAMEAL BACON OF CANADA LTD., STONEY CREEK, ONTARIO, CANADA. SN 77-934,844. FILED P.R. 2-12-2010; AM. S.R. 9-2-2010.

PEAMEAL BACON OF CANADA  
LTD.

THE MARK CONSISTS OF STANDARD CHARACTERS WITHOUT CLAIM TO ANY PARTICULAR FONT, STYLE, SIZE, OR COLOR.

PRIORITY CLAIMED UNDER SEC. 44(D) ON CANADA APPLICATION NO. 1,448,084, FILED 8-12-2009.

**CLASS 29—(Continued).**

NO CLAIM IS MADE TO THE EXCLUSIVE RIGHT TO USE "PEAMEAL BACON" AND "LTD.", APART FROM THE MARK AS SHOWN.

FOR PEAMEAL-STYLE BACON, NAMELY, CURED PORK LOIN ROLLED IN CORNMEAL (U.S. CL. 46).  
FIRST USE 12-31-1992; IN COMMERCE 1-31-1994.

3,956,261. CAVIAR PETROSSIAN, 75007 PARIS, FRANCE. SN 85-202,752. FILED 12-21-2010.

# CAVIARCUBE

THE MARK CONSISTS OF STANDARD CHARACTERS WITHOUT CLAIM TO ANY PARTICULAR FONT, STYLE, SIZE, OR COLOR.

OWNER OF FRANCE REG. NO. 093677039, DATED 3-26-2010, EXPIRES 9-17-2019.  
FOR CAVIAR; PREPARED AND PRESERVED FISH SPAWN (U.S. CL. 46).

**CLASS 30—STAPLE FOODS**

3,956,119. MALT-O-MEAL COMPANY, MINNEAPOLIS, MN. SN 77-870,021. FILED P.R. 11-11-2009; AM. S.R. 2-9-2011.

# FROSTED WHEAT BISCUITS

THE MARK CONSISTS OF STANDARD CHARACTERS WITHOUT CLAIM TO ANY PARTICULAR FONT, STYLE, SIZE, OR COLOR.

OWNER OF U.S. REG. NO. 2,116,741.  
NO CLAIM IS MADE TO THE EXCLUSIVE RIGHT TO USE "WHEAT", APART FROM THE MARK AS SHOWN.  
FOR BREAKFAST CEREAL (U.S. CL. 46).  
FIRST USE 11-15-2010; IN COMMERCE 11-15-2010.

**CLASS 30—(Continued).**

3,956,137. THE REALBEANZ CORPORATION, BROOKLYN, NY. SN 85-011,862. FILED P.R. 4-12-2010; AM. S.R. 12-9-2010.

# REALBEANZ

THE MARK CONSISTS OF STANDARD CHARACTERS WITHOUT CLAIM TO ANY PARTICULAR FONT, STYLE, SIZE, OR COLOR.

FOR COFFEE AND COFFEE BASED BEVERAGES (U.S. CL. 46).

FIRST USE 11-29-2010; IN COMMERCE 11-29-2010.

---

3,956,140. HERITAGE CANDY COMPANY, INC., VAN NUYS, CA. SN 85-020,054. FILED P.R. 4-21-2010; AM. S.R. 2-7-2011.

# BENSONS

THE MARK CONSISTS OF STANDARD CHARACTERS WITHOUT CLAIM TO ANY PARTICULAR FONT, STYLE, SIZE, OR COLOR.

THE NAME(S), PORTRAIT(S), AND/OR SIGNATURE(S) SHOWN IN THE MARK DOES NOT IDENTIFY A PARTICULAR LIVING INDIVIDUAL.

FOR CANDIES, CANDY; CHEWING GUM; CHEWY CANDY; CHOCOLATE CANDIES; CHOCOLATE CANDY; CHOCOLATE COVERED NUTS; CHOCOLATES AND CHOCOLATE BASED READY TO EAT CANDIES AND SNACKS; GUMMY CANDIES; CHEWY CANDIES; MILK CHOCOLATE COVERED RAISINS; PRETZELS; CANDY, NAMELY, SPICE DROPS, TOFFEE; YOGURT COVERED ALMONDS; YOGURT COVERED PRETZELS; AND YOGURT RAISINS (U.S. CL. 46).

FIRST USE 10-0-2009; IN COMMERCE 10-0-2009.

---

3,956,224. SUPER BAKERY INC, PITTSBURGH, PA. SN 85-170,090. FILED 11-5-2010.

# SUPER CRISPY

THE MARK CONSISTS OF STANDARD CHARACTERS WITHOUT CLAIM TO ANY PARTICULAR FONT, STYLE, SIZE, OR COLOR.

OWNER OF U.S. REG. NOS. 1,767,566, 3,836,272, AND OTHERS.

FOR READY TO EAT, FORTIFIED RICE CEREAL DERIVED FOOD BARS (U.S. CL. 46).

FIRST USE 8-16-2010; IN COMMERCE 8-16-2010.

**CLASS 31—NATURAL AGRICULTURAL PRODUCTS**

3,956,189. KAYTEE PRODUCTS INCORPORATED, CHILTON, WI. SN 85-101,456. FILED P.R. 8-5-2010; AM. S.R. 3-23-2011.

# ENERGY CHIPS

THE MARK CONSISTS OF STANDARD CHARACTERS WITHOUT CLAIM TO ANY PARTICULAR FONT, STYLE, SIZE, OR COLOR.

NO CLAIM IS MADE TO THE EXCLUSIVE RIGHT TO USE "CHIPS", APART FROM THE MARK AS SHOWN.

FOR WILD BIRD FOOD (U.S. CLS. 1 AND 46).

FIRST USE 11-1-2010; IN COMMERCE 11-1-2010.

**CLASS 33—WINES AND SPIRITS**

3,956,099. GEMTREE VINEYARDS PTY LTD., MCLAREN VALE SA 5171, AUSTRALIA. SN 76-699,193. FILED P.R. 9-17-2007; AM. S.R. 3-7-2011.

# White Lees

THE MARK CONSISTS OF STANDARD CHARACTERS WITHOUT CLAIM TO ANY PARTICULAR FONT, STYLE, SIZE, OR COLOR.

PRIORITY CLAIMED UNDER SEC. 44(D) ON AUSTRALIA APPLICATION NO. 1193379, FILED 8-16-2007.

NO CLAIM IS MADE TO THE EXCLUSIVE RIGHT TO USE "LEES", APART FROM THE MARK AS SHOWN.

FOR RED WINE (U.S. CLS. 47 AND 49).

FIRST USE 9-30-2006; IN COMMERCE 9-30-2009.

**CLASS 33—(Continued).**

3,956,104. TEQUILA CASA DE LOS GONZALEZ, S.A. DE C.V., GUADALAJARA, MEXICO. SN 77-605,816. FILED P.R. 11-3-2008; AM. S.R. 3-17-2011.



THE MARK CONSISTS OF AN UPRIGHT BOTTLE WITH AGAVE DESIGN. THE MATTER SHOWN IN BROKEN LINES IS NOT A PORTION OF THE MARK, BUT IS ONLY INCLUDED TO SHOW THE POSITION OF THE MARK.

FOR TEQUILA (U.S. CLS. 47 AND 49).  
FIRST USE 6-30-2009; IN COMMERCE 6-30-2009.

3,956,105. TEQUILA CASA DE LOS GONZALEZ, S.A. DE C.V., GUADALAJARA, MEXICO. SN 77-605,819. FILED P.R. 11-3-2008; AM. S.R. 3-17-2011.

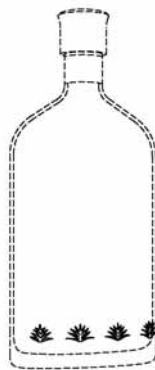

THE MARK CONSISTS OF A FLAT BOTTLE WITH FOUR STYLIZED AGAVES. THE MATTER SHOWN IN BROKEN LINES IS NOT A PORTION OF THE MARK, BUT IS ONLY INCLUDED TO SHOW THE POSITION OF THE MARK.

FOR TEQUILA (U.S. CLS. 47 AND 49).  
FIRST USE 6-30-2009; IN COMMERCE 6-30-2009.

**SERVICE MARKS****CLASS 35—ADVERTISING AND BUSINESS****CLASS 35—(Continued).**

3,956,110. CENTINELA CAPITAL PARTNERS LLC, LOS ANGELES, CA. SN 77-826,156. FILED P.R. 9-14-2009; AM. S.R. 3-22-2011.

**FUNDAMENTAL PRIVATE EQUITY INVESTOR**

THE MARK CONSISTS OF STANDARD CHARACTERS WITHOUT CLAIM TO ANY PARTICULAR FONT, STYLE, SIZE, OR COLOR.

NO CLAIM IS MADE TO THE EXCLUSIVE RIGHT TO USE "PRIVATE EQUITY INVESTOR", APART FROM THE MARK AS SHOWN.

FOR BUSINESS DATA ANALYSIS; ECONOMIC FORECASTING AND ANALYSIS; MARKET ANALYSIS (U.S. CLS. 100, 101 AND 102).

FIRST USE 1-1-2011; IN COMMERCE 1-1-2011.

3,956,133. WALCHLE, JONATHAN, DBA LABOR STAFFING, INC., ALPHARETTA, GA. SN 85-004,775. FILED P.R. 4-1-2010; AM. S.R. 2-4-2011.

**Labor Staffing**

THE MARK CONSISTS OF STANDARD CHARACTERS WITHOUT CLAIM TO ANY PARTICULAR FONT, STYLE, SIZE, OR COLOR.

NO CLAIM IS MADE TO THE EXCLUSIVE RIGHT TO USE "STAFFING", APART FROM THE MARK AS SHOWN.

FOR EMPLOYMENT AGENCY SERVICES, NAMELY, FILLING THE TEMPORARY AND PERMANENT STAFFING NEEDS OF BUSINESSES; EMPLOYMENT AGENCY SERVICES, NAMELY, TEMPORARY AND PERMANENT PLACEMENT OF HEALTH CARE PROFESSIONALS; EMPLOYMENT AGENCY SERVICES, NAMELY, TEMPORARY PLACEMENT OF CHILD CARE PROVIDERS; EMPLOYMENT HIRING, RECRUITING, PLACEMENT, STAFFING AND CAREER NETWORKING SERVICES; EMPLOYMENT RECRUITING AND STAFFING SERVICES PROVIDED VIA TEXT MESSAGING; EMPLOYMENT STAFFING CONSULTATION SERVICES; EMPLOYMENT STAFFING IN THE FIELD OF, NAMELY, HOSPITALITY, WAREHOUSING, GENERAL LABOR, JANITORIAL CLEANING, HOSPITAL WORKERS AND ALL LIGHT INDUSTRIAL.; PROFESSIONAL STAFFING AND RECRUITING SERVICES; PROVIDING AN EMPLOYER WITH CANDIDATES OR POTENTIAL EMPLOYEES TO FILL TEMPORARY, CONTRACT AND PERMANENT POSITIONS; STRATEGIC SOURCING, NAMELY, STAFFING IN THE FIELD OF ENGINEERING; TEMPORARY EMPLOYMENT AGENCIES; TEMPORARY PERSONNEL SERVICES; TEMPORARY RETAIL STORES SET UP ON-SITE AT SCHOOLS TO PROVIDE SHOPPING FACILITIES FOR STUDENTS (U.S. CLS. 100, 101 AND 102).

FIRST USE 5-14-1999; IN COMMERCE 5-14-1999.

**CLASS 35—(Continued).**

3,956,136. DC BOCCE LEAGUE, WASHINGTON, DC. SN 85-010,004. FILED P.R. 4-8-2010; AM. S.R. 2-28-2011.

**DC BOCCE LEAGUE**

THE MARK CONSISTS OF STANDARD CHARACTERS WITHOUT CLAIM TO ANY PARTICULAR FONT, STYLE, SIZE, OR COLOR.

NO CLAIM IS MADE TO THE EXCLUSIVE RIGHT TO USE "BOCCE LEAGUE", APART FROM THE MARK AS SHOWN.

FOR COORDINATION OF RECREATIONAL SPORTING OPPORTUNITIES FOR INDIVIDUALS WHO WISH TO PARTICIPATE IN TEAM LEAGUE SPORTS (U.S. CLS. 100, 101 AND 102).

FIRST USE 8-1-2005; IN COMMERCE 8-1-2005.

---

3,956,151. GLOBAL TALENT AGENCY, LLC, DBA GLOBAL TALENT AGENCY, BURBANK, CA. SN 85-033,317. FILED P.R. 5-7-2010; AM. S.R. 1-3-2011.

**Global Talent Agency**

THE MARK CONSISTS OF STANDARD CHARACTERS WITHOUT CLAIM TO ANY PARTICULAR FONT, STYLE, SIZE, OR COLOR.

NO CLAIM IS MADE TO THE EXCLUSIVE RIGHT TO USE "TALENT AGENCY", APART FROM THE MARK AS SHOWN.

FOR TALENT AGENCIES FOR WRITERS, PERFORMING ARTISTS, TECHNICAL ARTISTS (U.S. CLS. 100, 101 AND 102).

FIRST USE 11-1-2009; IN COMMERCE 11-1-2009.

---

3,956,171. DIVERSIFIED FREIGHT, INC., CORVALLIS, MT. SN 85-061,635. FILED P.R. 6-14-2010; AM. S.R. 3-24-2011.

**FASTFREIGHTQUOTES.COM**

THE MARK CONSISTS OF STANDARD CHARACTERS WITHOUT CLAIM TO ANY PARTICULAR FONT, STYLE, SIZE, OR COLOR.

FOR PURCHASING AGENT SERVICES, NAMELY, OBTAINING FAST PRICE QUOTES FROM MULTIPLE VENDORS; TRANSPORTATION LOGISTICS SERVICES, NAMELY, ARRANGING THE TRANSPORTATION OF GOODS OF OTHERS (U.S. CLS. 100, 101 AND 102).

FIRST USE 1-27-2009; IN COMMERCE 1-27-2009.

**CLASS 35—(Continued).**

3,956,175. CAESARS LICENSE COMPANY, LLC, LAS VEGAS, NV. SN 85-065,039. FILED P.R. 6-17-2010; AM. S.R. 2-14-2011.

**All Stage Pass**

THE MARK CONSISTS OF STANDARD CHARACTERS WITHOUT CLAIM TO ANY PARTICULAR FONT, STYLE, SIZE, OR COLOR.

FOR ADMINISTRATION OF A PROGRAM THAT ENABLES PARTICIPANTS TO ATTEND SHOWS AT PARTICIPATING THEATRES THROUGH THE ISSUANCE OF A PREPAID CARD, WRISTBAND OR COUPON DURING A PRESCRIBED PERIOD OF TIME FOR A DISCOUNTED PRICE; COOPERATIVE ADVERTISING AND MARKETING SERVICES, NAMELY, OFFERING DISCOUNTS TO CUSTOMERS THROUGH THE JOINT PARTICIPATION OF MEMBER THEATRES (U.S. CLS. 100, 101 AND 102).

FIRST USE 10-4-2010; IN COMMERCE 10-4-2010.

---

3,956,176. LIFE PURPOSE RESOURCES INC., FAIRFIELD, IA. SN 85-065,990. FILED P.R. 6-18-2010; AM. S.R. 3-11-2011.

**NATIONAL ASSOCIATION OF ENVIRONMENTAL CLUBS**

THE MARK CONSISTS OF STANDARD CHARACTERS WITHOUT CLAIM TO ANY PARTICULAR FONT, STYLE, SIZE, OR COLOR.

NO CLAIM IS MADE TO THE EXCLUSIVE RIGHT TO USE "ASSOCIATION OF ENVIRONMENTAL CLUBS", APART FROM THE MARK AS SHOWN.

FOR ASSOCIATION SERVICES, NAMELY, PROMOTING PUBLIC AWARENESS OF ENVIRONMENTAL ISSUES AND PROMOTING THE INTERESTS OF ENVIRONMENTAL CLUBS AND ORGANIZATIONS AND THOSE CONCERNED WITH FORMING SUCH GROUPS (U.S. CLS. 100, 101 AND 102).

FIRST USE 6-14-2010; IN COMMERCE 6-16-2010.

**CLASS 35—(Continued).**

3,956,191. SYX SERVICES INC., PORT WASHINGTON, NY. SN 85-104,350. FILED P.R. 8-10-2010; AM. S.R. 3-4-2011.

## LAPTOP WEEK

THE MARK CONSISTS OF STANDARD CHARACTERS WITHOUT CLAIM TO ANY PARTICULAR FONT, STYLE, SIZE, OR COLOR.

FOR PROMOTING THE SALE OF THE LAPTOPS OF OTHERS THROUGH DISTRIBUTION OF PROMOTIONAL MATERIALS VIA PRINTED PUBLICATIONS AND ON-LINE ELECTRONIC COMMUNICATIONS (U.S. CLS. 100, 101 AND 102).

FIRST USE 8-10-2010; IN COMMERCE 8-10-2010.

**CLASS 35—(Continued).**

3,956,209. DENTALSUBS.COM, LLC, BIRDSBORO, PA. SN 85-144,592. FILED P.R. 10-4-2010; AM. S.R. 3-3-2011.

## DentalSubs.com

THE MARK CONSISTS OF STANDARD CHARACTERS WITHOUT CLAIM TO ANY PARTICULAR FONT, STYLE, SIZE, OR COLOR.

FOR PROVIDING AN EMPLOYER WITH CANDIDATES OR POTENTIAL EMPLOYEES TO FILL TEMPORARY, CONTRACT AND PERMANENT POSITIONS; PROVIDING AN ON-LINE SEARCHABLE DATABASE FEATURING EMPLOYMENT OPPORTUNITIES AND CONTENT ABOUT EMPLOYMENT RELEVANT TO THE DENTAL HEALTH CARE INDUSTRY; PROVIDING ON-LINE EMPLOYMENT PLACEMENT SERVICES, NAMELY, MATCHING RESUMES AND POTENTIAL EMPLOYERS VIA A GLOBAL COMPUTER NETWORK; TEMPORARY EMPLOYMENT AGENCIES (U.S. CLS. 100, 101 AND 102).

FIRST USE 8-27-2010; IN COMMERCE 10-5-2010.

3,956,208. KOI CONCEPTS, LLC, DUARTE, CA. SN 85-137,632. FILED P.R. 9-24-2010; AM. S.R. 2-12-2011.

## HAMILTON

THE MARK CONSISTS OF STANDARD CHARACTERS WITHOUT CLAIM TO ANY PARTICULAR FONT, STYLE, SIZE, OR COLOR.

FOR ON-LINE RETAIL STORE SERVICES FEATURING ADULT SEXUAL AIDS, NAMELY, PENIS EXTENDERS, PENIS ENHANCEMENT SLEEVES, IMITATION SEXUAL ORGANS, NAMELY, PENISES, PENISES AND TESTICLES, AND ERECTION AND ORGASM-ENHANCING ARTICLES FOR IMMEDIATE APPLICATION TO THE HUMAN BODY (U.S. CLS. 100, 101 AND 102).

FIRST USE 8-31-2010; IN COMMERCE 8-31-2010.

3,956,211. COLORECTAL CANCER COALITION, INC., ALEXANDRIA, VA. SN 85-145,367. FILED P.R. 10-5-2010; AM. S.R. 3-8-2011.

## Fight Colorectal Cancer

THE MARK CONSISTS OF STANDARD CHARACTERS WITHOUT CLAIM TO ANY PARTICULAR FONT, STYLE, SIZE, OR COLOR.

OWNER OF U.S. REG. NO. 3,176,724.  
FOR PROMOTING PUBLIC AWARENESS OF PATIENT ISSUES RELATING TO COLORECTAL CANCER PREVENTION AND TREATMENT TO THE PUBLIC AND RESEARCHERS, PHYSICIANS AND POLICY MAKERS IN THE MEDICAL FIELD (U.S. CLS. 100, 101 AND 102).

FIRST USE 3-7-2011; IN COMMERCE 3-7-2011.

**CLASS 35—(Continued).**

3,956,232. WEBSHOZ, INC., DBA WEBSHOZ, KIRKLAND, WA. SN 85-174,663. FILED P.R. 11-11-2010; AM. S.R. 3-1-2011.

# Videobar

THE MARK CONSISTS OF THE WORDING "VIDEOBAR". FOR ADVERTISEMENT FOR OTHERS ON THE INTERNET; ADVERTISING AND PUBLICITY SERVICES, NAMELY, PROMOTING THE GOODS, SERVICES, BRAND IDENTITY AND COMMERCIAL INFORMATION AND NEWS OF THIRD PARTIES THROUGH PRINT, AUDIO, VIDEO, DIGITAL AND ON-LINE MEDIUM; ADVERTISING ON THE INTERNET FOR OTHERS; BANNER ADVERTISING; DISSEMINATION OF ADVERTISING FOR OTHERS VIA AN ON-LINE COMMUNICATIONS NETWORK ON THE INTERNET; DISSEMINATION OF ADVERTISING FOR OTHERS VIA THE INTERNET; PREPARING ADVERTISEMENTS FOR OTHERS, NAMELY, PREPARING VIDEO ADVERTISING AND PROMOTIONAL VIDEOS FOR COMMERCIAL USE VIA THE INTERNET AND TELEVISION, DIGITAL CABLE AND VIDEO-ON-DEMAND OR DOWNLOAD; PROMOTING THE GOODS AND SERVICES OF OTHERS BY MEANS OF DISTRIBUTING ADVERTISING ON THE INTERNET; PROVIDING ADVERTISING SERVICE TO DISTRIBUTE ADVERTISEMENTS FOR DISPLAY ON INTERNET, NAMELY, IN WEBSITES, SOCIAL CONVERSATIONS OVER THE INTERNET, E-MAILS, MICROBLOGS, BLOGS, ELECTRONIC MESSAGES, INSTANT MESSAGES, TEXT MESSAGES, MULTIMEDIA MESSAGES, SOCIAL NETWORKS, STATUS UPDATES, FORUMS, ELECTRONIC BULLETIN BOARDS (U.S. CLS. 100, 101 AND 102).  
FIRST USE 9-7-2006; IN COMMERCE 11-1-2010.

3,956,236. NATIONAL AUTOMATED CLEARING HOUSE ASSOCIATION, HERNDON, VA. SN 85-179,005. FILED P.R. 11-17-2010; AM. S.R. 3-3-2011.



NO CLAIM IS MADE TO THE EXCLUSIVE RIGHT TO USE "COUNCIL", APART FROM THE MARK AS SHOWN.  
THE MARK CONSISTS OF THE WORDING "INTERNET COUNCIL", WITH A SWIRL DESIGN.  
FOR ASSOCIATION SERVICES, NAMELY, PROMOTING THE INTERESTS OF THE ELECTRONIC AND MOBILE COMMERCE INDUSTRY (U.S. CLS. 100, 101 AND 102).  
FIRST USE 0-0-2001; IN COMMERCE 0-0-2001.

**CLASS 35—(Continued).**

3,956,240. FRYE, PATRICIA A, MONTESANO, WA. SN 85-181,637. FILED P.R. 11-19-2010; AM. S.R. 3-9-2011.

# COASTAL ATV

THE MARK CONSISTS OF STANDARD CHARACTERS WITHOUT CLAIM TO ANY PARTICULAR FONT, STYLE, SIZE, OR COLOR.

NO CLAIM IS MADE TO THE EXCLUSIVE RIGHT TO USE "ATV", APART FROM THE MARK AS SHOWN.

FOR RETAIL STORE SERVICES FEATURING ATV ALL TERRAIN VEHICLES, MOTORCYCLES, TRAILERS, TOYHAULERS, PERSONAL WATERCRAFT, SNOWMOBILES, AND ATV AND MOTORCYCLE PARTS AND ACCESSORIES (U.S. CLS. 100, 101 AND 102).

FIRST USE 11-8-2009; IN COMMERCE 11-8-2009.

3,956,254. SNEAKERCHANGE, CORONA, NY. SN 85-194,663. FILED P.R. 12-9-2010; AM. S.R. 3-12-2011.

# The Social Marketplace for Footwear

THE MARK CONSISTS OF STANDARD CHARACTERS WITHOUT CLAIM TO ANY PARTICULAR FONT, STYLE, SIZE, OR COLOR.

NO CLAIM IS MADE TO THE EXCLUSIVE RIGHT TO USE "SOCIAL MARKETPLACE", APART FROM THE MARK AS SHOWN.

FOR ON-LINE RETAIL STORE SERVICES FEATURING SHOES (U.S. CLS. 100, 101 AND 102).

FIRST USE 5-14-2010; IN COMMERCE 11-16-2010.

3,956,257. WHOLESALE STONE LLC, MIAMI BEACH, FL. SN 85-197,484. FILED P.R. 12-14-2010; AM. S.R. 3-16-2011.

# TRAVERTINE MART

THE MARK CONSISTS OF STANDARD CHARACTERS WITHOUT CLAIM TO ANY PARTICULAR FONT, STYLE, SIZE, OR COLOR.

NO CLAIM IS MADE TO THE EXCLUSIVE RIGHT TO USE "MART", APART FROM THE MARK AS SHOWN.

FOR ON-LINE WHOLESALE AND RETAIL STORE SERVICES FEATURING TRAVERTINE AND MARBLE NATURAL STONE PRODUCTS (U.S. CLS. 100, 101 AND 102).

FIRST USE 6-1-2007; IN COMMERCE 6-1-2007.

**CLASS 35—(Continued).**

3,956,265. CHEROKEE NATION ENTERTAINMENT, L.L.C., CATOOSA, OK. SN 85-215,791. FILED P.R. 1-12-2011; AM. S.R. 3-15-2011.

**FOR PLAYERS ONLY**

THE MARK CONSISTS OF STANDARD CHARACTERS WITHOUT CLAIM TO ANY PARTICULAR FONT, STYLE, SIZE, OR COLOR.

FOR ARRANGING AND CONDUCTING INCENTIVE REWARD PROGRAMS TO PROMOTE THE SALE OF CASINO, GAMING, HOTEL AND RESORT SERVICES; PROMOTING THE GOODS AND SERVICES OF OTHERS BY MEANS OF THE ISSUANCE OF LOYALTY REWARDS CARDS; PROVIDING INCENTIVE AWARD PROGRAMS FOR CUSTOMERS AND EMPLOYEES THROUGH THE DISTRIBUTION OF PREPAID STORED VALUE CARDS FOR THE PURPOSE OF PROMOTING AND REWARDING LOYALTY (U.S. CLS. 100, 101 AND 102).

FIRST USE 1-0-2011; IN COMMERCE 1-0-2011.

**CLASS 36—INSURANCE AND FINANCIAL**

3,956,154. CHODOSH, TERRY, RANCHO PALOS VERDES, CA. SN 85-043,992. FILED P.R. 5-20-2010; AM. S.R. 3-24-2011.

**LEOSA-HR218 SELF DEFENSE PROTECTION**

THE MARK CONSISTS OF STANDARD CHARACTERS WITHOUT CLAIM TO ANY PARTICULAR FONT, STYLE, SIZE, OR COLOR.

FOR INSURANCE SERVICES, NAMELY, INSURANCE CONSULTATION AND INSURANCE ADMINISTRATION IN THE FIELD OF SELF-DEFENSE INSURANCE (U.S. CLS. 100, 101 AND 102).

FIRST USE 12-20-2010; IN COMMERCE 12-20-2010.

**CLASS 36—(Continued).**

3,956,168. UNION TELECOM, INC., CHICAGO, IL. SN 85-060,189. FILED P.R. 6-10-2010; AM. S.R. 3-16-2011.

**TALK DIRECT**

THE MARK CONSISTS OF STANDARD CHARACTERS WITHOUT CLAIM TO ANY PARTICULAR FONT, STYLE, SIZE, OR COLOR.

FOR TELEPHONE CALLING CARD SERVICES (U.S. CLS. 100, 101 AND 102).

FIRST USE 1-1-2010; IN COMMERCE 1-1-2010.

3,956,188. SIMMONS MESOTHELIOMA FOUNDATION, EAST ALTON, IL. SN 85-100,813. FILED P.R. 8-5-2010; AM. S.R. 2-8-2011.

**SIMMONS MESOTHELIOMA FOUNDATION**

THE MARK CONSISTS OF STANDARD CHARACTERS WITHOUT CLAIM TO ANY PARTICULAR FONT, STYLE, SIZE, OR COLOR.

NO CLAIM IS MADE TO THE EXCLUSIVE RIGHT TO USE "MESOTHELIOMA FOUNDATION", APART FROM THE MARK AS SHOWN.

FOR CHARITABLE FUNDRAISING; CHARITABLE FUNDRAISING SERVICES BY MEANS OF ORGANIZING AND CONDUCTING SPECIAL EVENTS (U.S. CLS. 100, 101 AND 102).

FIRST USE 3-0-2010; IN COMMERCE 3-0-2010.

3,956,246. CALVERT GROUP, LTD., BETHESDA, MD. SN 85-185,922. FILED P.R. 11-29-2010; AM. S.R. 3-4-2011.

**Solution Strategies**

THE MARK CONSISTS OF STANDARD CHARACTERS WITHOUT CLAIM TO ANY PARTICULAR FONT, STYLE, SIZE, OR COLOR.

FOR INVESTMENT ADVISORY SERVICES (U.S. CLS. 100, 101 AND 102).

FIRST USE 7-15-2008; IN COMMERCE 7-15-2008.

**CLASS 37—CONSTRUCTION AND REPAIR**

**CLASS 37—(Continued).**

3,956,150. WORLDWIDE DEEPWATER SOLUTIONS, LLC, RICHMOND, TX. SN 85-032,789. FILED P.R. 5-7-2010; AM. S.R. 2-16-2011.

**WORLDWIDE DEEPWATER  
SOLUTIONS**

THE MARK CONSISTS OF STANDARD CHARACTERS WITHOUT CLAIM TO ANY PARTICULAR FONT, STYLE, SIZE, OR COLOR.

FOR OIL AND GAS DRILLING SERVICES; RENTAL OF OIL AND GAS WELL DRILLING TOOLS; CONSTRUCTION PROJECT MANAGEMENT SERVICES IN THE FIELD OF CONSTRUCTION OF OFFSHORE OIL AND GAS FACILITIES (U.S. CLS. 100, 103 AND 106).

FIRST USE 9-1-2009; IN COMMERCE 9-1-2009.

**CLASS 38—COMMUNICATION**

3,956,130. TRACFONE WIRELESS, INC., MIAMI, FL. SN 77-948,413. FILED P.R. 3-2-2010; AM. S.R. 3-28-2011.

**SVC**

THE MARK CONSISTS OF STANDARD CHARACTERS WITHOUT CLAIM TO ANY PARTICULAR FONT, STYLE, SIZE, OR COLOR.

FOR CELLULAR TELEPHONE COMMUNICATIONS SERVICES; CELLULAR TELEPHONE TELECOMMUNICATIONS SERVICES PROVIDED VIA PREPAID AIR TIME CELLULAR TELEPHONES AND PREPAID AIR TIME CELLULAR TELEPHONE CALLING CARD SERVICES (U.S. CLS. 100, 101 AND 104).

FIRST USE 8-31-2010; IN COMMERCE 8-31-2010.

**CLASS 39—TRANSPORTATION AND STORAGE****CLASS 39—(Continued).**

3,956,180. FLEISHER, YECHEZKEL, LAKEWOOD, NJ. SN 85-077,701. FILED P.R. 7-3-2010; AM. S.R. 3-29-2011.

**1-800-TOW-TRUCK**

THE MARK CONSISTS OF STANDARD CHARACTERS WITHOUT CLAIM TO ANY PARTICULAR FONT, STYLE, SIZE, OR COLOR.

FOR TRANSPORTATION AND STORAGE SERVICES, NAMELY, VEHICLE TOWING FOR CONSUMERS (U.S. CLS. 100 AND 105).

FIRST USE 8-26-2010; IN COMMERCE 8-26-2010.

3,956,181. PUBLIC PARKING ASSOCIATES INC., ROHNERT PARK, CA. SN 85-080,936. FILED P.R. 7-9-2010; AM. S.R. 3-7-2011.

**PUBLIC PARKING ASSOCIATES**

THE MARK CONSISTS OF STANDARD CHARACTERS WITHOUT CLAIM TO ANY PARTICULAR FONT, STYLE, SIZE, OR COLOR.

NO CLAIM IS MADE TO THE EXCLUSIVE RIGHT TO USE "ASSOCIATES", APART FROM THE MARK AS SHOWN.

FOR CONSULTING IN THE FIELD OF PARKING GARAGE SERVICES FOR PUBLIC ORGANIZATIONS, CITIES, AIRPORTS, HOSPITALS AND UNIVERSITIES (U.S. CLS. 100 AND 105).

FIRST USE 1-31-2010; IN COMMERCE 4-3-2010.

3,956,230. MAUI FUN COMPANY INC, LAHAINA, HI. SN 85-173,930. FILED P.R. 11-10-2010; AM. S.R. 3-7-2011.

**Activity Savers Maui**

THE MARK CONSISTS OF STANDARD CHARACTERS WITHOUT CLAIM TO ANY PARTICULAR FONT, STYLE, SIZE, OR COLOR.

FOR ARRANGING TRAVEL TOURS; CONDUCTING SIGHTSEEING TOURS FOR OTHERS (U.S. CLS. 100 AND 105).

FIRST USE 7-21-2002; IN COMMERCE 9-21-2002.



**CLASS 39—(Continued).**

3,956,247. 1-800-DECLUTTER, INC., DBA 1-800-DECLUTTER, HEBRON, KY. SN 85-186,714. FILED P.R. 11-29-2010; AM. S.R. 3-9-2011.

**1-800-DECLUTTER**

THE MARK CONSISTS OF STANDARD CHARACTERS WITHOUT CLAIM TO ANY PARTICULAR FONT, STYLE, SIZE, OR COLOR.

FOR JUNK, TRASH AND DEBRIS REMOVAL (U.S. CLS. 100 AND 105).

FIRST USE 11-27-2010; IN COMMERCE 11-27-2010.

---

3,956,255. ORO AZUL, LLC, DBA TRIPS4FUNDRAISING, SEATTLE, WA. SN 85-195,313. FILED P.R. 12-10-2010; AM. S.R. 3-21-2011.

**Trips4Fundraising**

THE MARK CONSISTS OF STANDARD CHARACTERS WITHOUT CLAIM TO ANY PARTICULAR FONT, STYLE, SIZE, OR COLOR.

FOR COORDINATING TRAVEL ARRANGEMENTS FOR INDIVIDUALS AND FOR GROUPS; ONLINE TRIP AND TRAVEL RESERVATION SERVICES; ORGANIZATION OF EXCURSIONS, SIGHTSEEING TOURS, HOLIDAYS, TOURS AND TRAVEL; PROVIDE A WEBSITE FOR THE ARRANGEMENT AND BOOKING OF ECOTRAVEL AND ECO-TOURS; PROVIDING A WEB SITE FEATURING TRAVEL INFORMATION AND COMMENTARY; PROVIDING INFORMATION, NEWS AND COMMENTARY IN THE FIELD OF TRAVEL; RESERVATION AND BOOKING OF SEATS FOR TRAVEL; TRAVEL AGENCY SERVICES, NAMELY, MAKING RESERVATIONS AND BOOKINGS FOR TRANSPORTATION; TRAVEL AND TOUR INFORMATION SERVICE; TRAVEL BOOKING AGENCIES (U.S. CLS. 100 AND 105).

FIRST USE 12-9-2008; IN COMMERCE 1-25-2009.

**CLASS 39—(Continued).**

3,956,258. MSM CANADIAN TRANSPORT, LLC., SANTA FE SPRINGS, CA. SN 85-198,464. FILED 12-15-2010.

**The VALUE Leader  
in Transportation**

THE MARK CONSISTS OF STANDARD CHARACTERS WITHOUT CLAIM TO ANY PARTICULAR FONT, STYLE, SIZE, OR COLOR.

FOR FREIGHT AND TRANSPORT BROKERAGE; FREIGHT BROKERAGE; FREIGHT FORWARDING; FREIGHT FORWARDING SERVICES; FREIGHT LOADING SERVICES; FREIGHT TRANSPORTATION BROKERAGE; FREIGHT TRANSPORTATION BY TRUCK; SUPPLY CHAIN LOGISTICS AND REVERSE LOGISTICS SERVICES, NAMELY, STORAGE, TRANSPORTATION AND DELIVERY OF DOCUMENTS, PACKAGES, RAW MATERIALS, AND OTHER FREIGHT FOR OTHERS BY AIR, RAIL, SHIP OR TRUCK (U.S. CLS. 100 AND 105).

FIRST USE 2-10-2010; IN COMMERCE 2-13-2010.

**CLASS 40—MATERIAL TREATMENT**

---

3,956,202. PISTACCHIO, TOM, FRESNO, CA. SN 85-129,601. FILED P.R. 9-14-2010; AM. S.R. 3-15-2011.

**"America's Trailer Company"**

THE MARK CONSISTS OF STANDARD CHARACTERS WITHOUT CLAIM TO ANY PARTICULAR FONT, STYLE, SIZE, OR COLOR.

NO CLAIM IS MADE TO THE EXCLUSIVE RIGHT TO USE "TRAILER COMPANY", APART FROM THE MARK AS SHOWN.

FOR MANUFACTURING FOR OTHERS IN THE FIELD OF HEAVY HAUL TRAILERS (U.S. CLS. 100, 103 AND 106).

FIRST USE 7-1-2010; IN COMMERCE 7-1-2010.

**CLASS 41—EDUCATION AND ENTERTAINMENT**

**CLASS 41—(Continued).**

3,956,114. ATTIAS, RICHARD, GREENWICH, CT. SN 77-849,693. FILED P.R. 10-15-2009; AM. S.R. 7-26-2010.

**THE NEW YORK FORUM**

THE MARK CONSISTS OF STANDARD CHARACTERS WITHOUT CLAIM TO ANY PARTICULAR FONT, STYLE, SIZE, OR COLOR.

NO CLAIM IS MADE TO THE EXCLUSIVE RIGHT TO USE "FORUM", APART FROM THE MARK AS SHOWN.

FOR ORGANIZATION AND HOSTING OF BUSINESS, PUBLIC POLICY AND INTERNATIONAL AFFAIRS SEMINARS, COURSES AND WORKSHOPS RELATING TO THE IMPROVEMENT OF BUSINESS SKILLS AND THE DEVELOPMENT OF POLICIES AND POSITIONS ON BUSINESS, GOVERNMENTAL, SOCIAL, LEGAL AND ECONOMIC DEVELOPMENTS AND ISSUES; PROVIDING EDUCATIONAL, BUSINESS AND GOVERNMENTAL SPEAKERS RELATED TO BUSINESS, GOVERNMENTAL, LEGAL AND ECONOMIC DEVELOPMENTS AND ISSUES; ORGANIZING SOCIAL EVENTS, NAMELY, PARTIES, CONFERENCES AND SPORTING TOURNAMENTS; PROVIDING ONLINE NON-DOWNLOADABLE PUBLICATIONS, NAMELY, MAGAZINES, BULLETINS, JOURNALS AND NEWSLETTERS IN THE FIELD OF BUSINESS, GOVERNMENTAL, SOCIAL, LEGAL AND ECONOMIC DEVELOPMENT AND ISSUES (U.S. CLS. 100, 101 AND 107).

FIRST USE 1-0-2010; IN COMMERCE 2-0-2010.

3,956,164. KCUSA.COM INC, MIAMI, FL. SN 85-055,815. FILED P.R. 6-7-2010; AM. S.R. 3-15-2011.

**GAMES4PARTY**

THE MARK CONSISTS OF STANDARD CHARACTERS WITHOUT CLAIM TO ANY PARTICULAR FONT, STYLE, SIZE, OR COLOR.

FOR ENTERTAINMENT SERVICES, NAMELY, PROVIDING RENTAL SERVICES OF MOBILE VIDEO GAMES THEATER FOR CONSUMERS (U.S. CLS. 100, 101 AND 107).

FIRST USE 3-1-2010; IN COMMERCE 5-1-2010.

**CLASS 41—(Continued).**

3,956,173. LIFE PURPOSE RESOURCES, FAIRFIELD, IA. SN 85-062,768. FILED P.R. 6-15-2010; AM. S.R. 3-11-2011.

**ENVIRONMENTAL SCIENCE FAIR**

THE MARK CONSISTS OF STANDARD CHARACTERS WITHOUT CLAIM TO ANY PARTICULAR FONT, STYLE, SIZE, OR COLOR.

NO CLAIM IS MADE TO THE EXCLUSIVE RIGHT TO USE "FAIR", APART FROM THE MARK AS SHOWN.

FOR ORGANIZING, PRODUCING AND PROMOTING A SCIENCE FAIR FEATURING THE ENVIRONMENTAL OR SUSTAINABILITY PROJECTS OF INDIVIDUALS OF ALL AGES, NAMELY, GRADE SCHOOL, HIGH SCHOOL, VOCATIONAL SCHOOL, COLLEGE OR UNIVERSITY STUDENTS IN EACH CITY OR STATE OVER THE INTERNET OR IN DISPLAYS IN A SCIENCE FAIR-TYPE SETTING (U.S. CLS. 100, 101 AND 107).

FIRST USE 5-2-2009; IN COMMERCE 5-2-2009.

3,956,174. LIFE PURPOSE RESOURCES INC., FAIRFIELD, IA. SN 85-063,893. FILED P.R. 6-16-2010; AM. S.R. 3-11-2011.

**NATIONAL ENVIRONMENTAL SCIENCE FAIR**

THE MARK CONSISTS OF STANDARD CHARACTERS WITHOUT CLAIM TO ANY PARTICULAR FONT, STYLE, SIZE, OR COLOR.

NO CLAIM IS MADE TO THE EXCLUSIVE RIGHT TO USE "FAIR", APART FROM THE MARK AS SHOWN.

FOR ORGANIZING, PRODUCING AND PROMOTING A SCIENCE FAIR FEATURING THE ENVIRONMENTAL OR SUSTAINABILITY PROJECTS OF INDIVIDUALS OF ALL AGES, NAMELY, GRADE SCHOOL, HIGH SCHOOL, VOCATIONAL SCHOOL, COLLEGE OR UNIVERSITY STUDENTS IN EACH STATE, COUNTRY OR NATION OVER THE INTERNET OR IN DISPLAYS IN A SCIENCE FAIR-TYPE SETTING (U.S. CLS. 100, 101 AND 107).

FIRST USE 5-2-2009; IN COMMERCE 5-2-2009.

**CLASS 41—(Continued).**

3,956,185. COLOMBINI, RICHARD V, SAINT LOUIS PARK, MS. SN 85-090,414. FILED P.R. 7-22-2010; AM. S.R. 2-11-2011.

**PRESCHOOL UNIVERSITY**

THE MARK CONSISTS OF STANDARD CHARACTERS WITHOUT CLAIM TO ANY PARTICULAR FONT, STYLE, SIZE, OR COLOR.

FOR EDUCATION SERVICES IN THE NATURE OF EARLY CHILDHOOD INSTRUCTION; EDUCATIONAL AND ENTERTAINMENT SERVICES, NAMELY, PROVIDING ON-LINE INTERACTIVE CHILDREN'S STORIES; EDUCATIONAL SERVICES, NAMELY, CONDUCTING INFORMAL ON-LINE PROGRAMS IN THE FIELDS OF EARLY CHILDHOOD EDUCATION, AND PRINTABLE MATERIALS DISTRIBUTED THEREWITH; EDUCATIONAL SERVICES, NAMELY, DEVELOPING CURRICULUM FOR EDUCATORS; ENTERTAINMENT SERVICES, NAMELY, PROVIDING ON-LINE COMPUTER GAMES; ON-LINE JOURNALS, NAMELY, BLOGS FEATURING EARLY CHILDHOOD EDUCATION; PROVIDING ON-LINE PUBLICATIONS IN THE NATURE OF AN E-BOOK IN THE FIELD OF EARLY CHILDHOOD EDUCATION; PROVIDING ON-LINE TRAINING INSTRUCTION AND LEARNING GAMES IN THE FIELD OF EARLY CHILDHOOD EDUCATION (U.S. CLS. 100, 101 AND 107).

FIRST USE 7-28-2010; IN COMMERCE 7-28-2010.

3,956,204. ROCKET TURTLE, LLC, SAN FRANCISCO, CA. SN 85-130,434. FILED P.R. 9-15-2010; AM. S.R. 3-14-2011.

**International Beer Day**

THE MARK CONSISTS OF STANDARD CHARACTERS WITHOUT CLAIM TO ANY PARTICULAR FONT, STYLE, SIZE, OR COLOR.

FOR ENTERTAINMENT IN THE NATURE OF ANNUAL BEER FESTIVALS AND BEER CELEBRATION EVENTS (U.S. CLS. 100, 101 AND 107).

FIRST USE 7-25-2010; IN COMMERCE 7-25-2010.

**CLASS 41—(Continued).**

3,956,205. COLUMBIA COUNTY PC INCORPORATED, LAKE CITY, FL. SN 85-135,388. FILED P.R. 9-22-2010; AM. S.R. 3-8-2011.

**Seminars@Sea**

THE MARK CONSISTS OF STANDARD CHARACTERS WITHOUT CLAIM TO ANY PARTICULAR FONT, STYLE, SIZE, OR COLOR.

FOR ARRANGING OF SEMINARS (U.S. CLS. 100, 101 AND 107).

FIRST USE 9-1-2010; IN COMMERCE 9-1-2010.

3,956,214. THE AMERICAN COLLEGE, BRYN MAWR, PA. SN 85-148,206. FILED P.R. 10-8-2010; AM. S.R. 2-8-2011.

**CHARTERED HEALTHCARE  
CONSULTANT**

THE MARK CONSISTS OF STANDARD CHARACTERS WITHOUT CLAIM TO ANY PARTICULAR FONT, STYLE, SIZE, OR COLOR.

OWNER OF U.S. REG. NOS. 2,928,388, 3,672,478, AND OTHERS.

FOR EDUCATIONAL SERVICES, NAMELY, CONDUCTING CLASSES, SEMINARS, AND CONFERENCES FOR PROFESSIONALS IN THE FIELDS OF HEALTHCARE INSURANCE AND OTHER FINANCIAL MATTERS RELATING TO HEALTHCARE; OFFERING AND ADMINISTERING EDUCATIONAL EXAMINATIONS FOR PROFESSIONALS IN THE FIELDS OF HEALTHCARE INSURANCE AND OTHER FINANCIAL MATTERS RELATING TO HEALTHCARE (U.S. CLS. 100, 101 AND 107).

FIRST USE 10-26-2010; IN COMMERCE 10-26-2010.

3,956,219. THE OUTDOOR CHANNEL, INC., TEMECULA, CA. SN 85-159,784. FILED P.R. 10-24-2010; AM. S.R. 3-14-2011.

**AMERICA'S LEADER IN  
OUTDOOR TV**

THE MARK CONSISTS OF STANDARD CHARACTERS WITHOUT CLAIM TO ANY PARTICULAR FONT, STYLE, SIZE, OR COLOR.

**CLASS 41—(Continued).**

OWNER OF U.S. REG. NOS. 2,053,733, 3,144,319, AND 3,398,087.

FOR PRODUCTION OF TELEVISION PROGRAMS; SCHEDULING OF TELEVISION PROGRAMS; ENTERTAINMENT SERVICES IN THE NATURE OF PRODUCING ONGOING TELEVISION PROGRAMS IN THE FIELD OF OUTDOOR LIFESTYLES, ADVENTURE, SPORTS, AND RECREATION ACTIVITIES; ENTERTAINMENT SERVICES, NAMELY, PROVIDING A WEBSITE FEATURING PHOTOGRAPHIC, AUDIO, VIDEO, AND PROSE PRESENTATIONS FEATURING OUTDOOR LIFESTYLES, ADVENTURE, SPORTS AND RECREATION ACTIVITIES (U.S. CLS. 100, 101 AND 107).

FIRST USE 7-2-2007; IN COMMERCE 7-2-2007.

**CLASS 41—(Continued).**

3,956,233. VISIONING HEALTHCARE INC., SARASOTA, FL. SN 85-175,533. FILED P.R. 11-12-2010; AM. S.R. 3-14-2011.



3,956,220. PATT JR., DOUGLAS C, DBA HOW TO ARCHITECT, ALLENTOWN, PA. SN 85-159,833. FILED P.R. 10-24-2010; AM. S.R. 2-17-2011.

## How To Architect

THE MARK CONSISTS OF STANDARD CHARACTERS WITHOUT CLAIM TO ANY PARTICULAR FONT, STYLE, SIZE, OR COLOR.

FOR PRODUCTION OF VIDEO AND CREATION OF VISUAL EFFECTS FOR OTHERS FOR USE ON WEBSITES FEATURING VIDEOS AND IN DVDS FOR TEACHING ARCHITECTURE; WRITING OF TEXTS ABOUT ARCHITECTURE (U.S. CLS. 100, 101 AND 107).

FIRST USE 9-11-2008; IN COMMERCE 9-11-2008.

THE MARK CONSISTS OF THE LETTERS "SPHM" IN A STYLIZED OVAL WITH THE WORD "CERTIFIED" INSIDE THE OVAL ABOVE THE "M" AND THE WORD "PROFESSIONAL" INSIDE THE OVAL BELOW THE "PH".

FOR EDUCATIONAL SERVICES, NAMELY, PROVIDING LIVE AND ONLINE SEMINARS, WORKSHOPS AND PRESENTATIONS IN THE FIELDS OF SAFE PATIENT HANDLING AND MOVEMENT FOR THE PURPOSE OF CERTIFICATION (U.S. CLS. 100, 101 AND 107).

FIRST USE 1-31-2011; IN COMMERCE 1-31-2011.

3,956,242. FLYNN, LISA D., SOUTH BERWICK, ME. SN 85-182,915. FILED P.R. 11-22-2010; AM. S.R. 3-9-2011.

3,956,225. K'HILLAH K'DOSHAH B'NAI YESHURUN, DBA ISAAC M. WISE TEMPLE, CINCINNATI, OH. SN 85-170,367. FILED P.R. 11-5-2010; AM. S.R. 3-11-2011.

## CINCINNATI CHOCOLATE FESTIVAL

THE MARK CONSISTS OF STANDARD CHARACTERS WITHOUT CLAIM TO ANY PARTICULAR FONT, STYLE, SIZE, OR COLOR.

NO CLAIM IS MADE TO THE EXCLUSIVE RIGHT TO USE "CHOCOLATE FESTIVAL", APART FROM THE MARK AS SHOWN.

FOR ENTERTAINMENT IN THE NATURE OF CHOCOLATE FESTIVALS (U.S. CLS. 100, 101 AND 107).

FIRST USE 4-30-2010; IN COMMERCE 4-30-2010.

## Yoga 4 Classrooms

THE MARK CONSISTS OF STANDARD CHARACTERS WITHOUT CLAIM TO ANY PARTICULAR FONT, STYLE, SIZE, OR COLOR.

NO CLAIM IS MADE TO THE EXCLUSIVE RIGHT TO USE "YOGA", APART FROM THE MARK AS SHOWN.

FOR YOGA INSTRUCTION (U.S. CLS. 100, 101 AND 107).

FIRST USE 6-1-2009; IN COMMERCE 10-1-2009.

**CLASS 41—(Continued).**

3,956,250. HARTZELL, M. LEONTINE, DBA EYE OF THE EAGLE CENTER FOR SPIRITUAL LIGHT, ANDOVER, MA. SN 85-188,811. FILED P.R. 12-1-2010; AM. S.R. 3-8-2011.

## Alignment for Ascension: For The 2012 Transition

THE MARK CONSISTS OF STANDARD CHARACTERS WITHOUT CLAIM TO ANY PARTICULAR FONT, STYLE, SIZE, OR COLOR.

FOR ARRANGING AND CONDUCTING BUSINESS SEMINARS IN THE FIELD OF SPIRITUAL TEACHINGS, MEDITATION, VISUALIZATION OF ALIGNMENT FOR ASCENSION FOR THE 2012 TRANSITION; EDUCATIONAL SERVICES, NAMELY, CONDUCTING SEMINARS, WORKSHOPS, AND LECTURES IN THE FIELD OF SPIRITUAL TEACHING, GUIDED MEDITATION AND DISTRIBUTION OF PRINTED MATERIALS IN CONNECTION THEREWITH IN HARD COPY OR ELECTRONIC FORMAT ON THE SAME TOPICS; EDUCATIONAL SERVICES, NAMELY, PROVIDING ON-LINE SEMINARS, WRITTEN MATERIALS IN THE FIELD OF SPIRITUAL TEACHING, GUIDED MEDITATION; WORKSHOPS AND SEMINARS IN THE FIELD OF ALIGNMENT FOR ASCENSION, PREPARATION FOR 2012 TRANSITION (U.S. CLS. 100, 101 AND 107).

FIRST USE 11-1-2009; IN COMMERCE 11-1-2009.

3,956,256. CORE FITNESS STUDIOS, UPPER ARLINGTON, OH. SN 85-196,914. FILED P.R. 12-13-2010; AM. S.R. 3-16-2011.

**CORE**  
FITNESS STUDIO

NO CLAIM IS MADE TO THE EXCLUSIVE RIGHT TO USE "FITNESS STUDIO", APART FROM THE MARK AS SHOWN.

THE MARK CONSISTS OF THE STYLIZED TEXT "CORE FITNESS STUDIO", WITH A FALSE "R" IN "CORE".

FOR EDUCATIONAL AND ENTERTAINMENT SERVICES, NAMELY, PROVIDING MOTIVATIONAL SPEAKING SERVICES IN THE FIELD OF EXERCISE AND FITNESS; PERSONAL TRAINING SERVICES, NAMELY, STRENGTH AND CONDITIONING TRAINING; PHYSICAL FITNESS CONDITIONING CLASSES; PROVIDING FITNESS AND EXERCISE FACILITIES (U.S. CLS. 100, 101 AND 107).

FIRST USE 1-1-2008; IN COMMERCE 1-1-2008.

**CLASS 41—(Continued).**

3,956,266. DANIEL KELLEY, HORSEHEADS, NY. SN 85-975,108. FILED P.R. 4-30-2010; AM. S.R. 2-11-2011.

## Great Dog Pros

THE MARK CONSISTS OF STANDARD CHARACTERS WITHOUT CLAIM TO ANY PARTICULAR FONT, STYLE, SIZE, OR COLOR.

FOR PET TRAINING SERVICES (U.S. CLS. 100, 101 AND 107).

FIRST USE 10-31-2010; IN COMMERCE 10-31-2010.

**CLASS 42—SCIENTIFIC AND COMPUTER SERVICES**

3,956,112. INTERNATIONAL DATA GROUP, INC., FRAMINGHAM, MA. SN 77-834,153. FILED P.R. 9-24-2009; AM. S.R. 3-4-2011.

## SALTED HASH

THE MARK CONSISTS OF STANDARD CHARACTERS WITHOUT CLAIM TO ANY PARTICULAR FONT, STYLE, SIZE, OR COLOR.

FOR PROVIDING A WEBSITE FEATURING INFORMATION IN THE FIELD OF COMPUTER SECURITY (U.S. CLS. 100 AND 101).

FIRST USE 12-6-2010; IN COMMERCE 12-6-2010.

3,956,155. ENTERPRISE HIVE, LLC, IRVINGTON, VA. SN 85-045,415. FILED P.R. 5-21-2010; AM. S.R. 3-6-2011.

EDUCATION INSTITUTION  
TECHNOLOGY PROFILE DATABASE

THE MARK CONSISTS OF STANDARD CHARACTERS WITHOUT CLAIM TO ANY PARTICULAR FONT, STYLE, SIZE, OR COLOR.

FOR APPLICATION SERVICE PROVIDER (ASP) FEATURING SOFTWARE FOR USE IN CONNECTION WITH RESOURCES AND TECHNOLOGY AVAILABLE TO THE EDUCATION AND HIGHER EDUCATION COMMUNITY; PROVIDING A WEBSITE FEATURING RESOURCES, NAMELY, NON-DOWNLOADABLE SOFTWARE FOR OPERATION OF AND ACCESS TO AN ONLINE COMPUTER DATABASE IN THE FIELD OF EDUCATION, HIGHER EDUCATION, RESEARCH AND TECHNOLOGY, AND RESOURCES AVAILABLE TO THESE FIELDS (U.S. CLS. 100 AND 101).

FIRST USE 2-1-2009; IN COMMERCE 2-1-2009.

**CLASS 42—(Continued).**

3,956,163. CENTRAL DYNAMICS CORP., AKA CENDYN, BOCA RATON, AZ. SN 85-055,760. FILED P.R. 6-6-2010; AM. S.R. 3-7-2011.

## Quick Quote

THE MARK CONSISTS OF STANDARD CHARACTERS WITHOUT CLAIM TO ANY PARTICULAR FONT, STYLE, SIZE, OR COLOR.

FOR PROVIDING TEMPORARY USE OF ON-LINE NON-DOWNLOADABLE SOFTWARE DEVELOPMENT TOOLS FOR GETTING AN INSTANT REQUEST FOR PROPOSAL FOR MEETING PLANNERS IN THE HOSPITALITY INDUSTRY AROUND THE WORLD - TO GET ESTIMATES FOR EVENTS (U.S. CLS. 100 AND 101).  
FIRST USE 5-13-2010; IN COMMERCE 5-13-2010.

---

3,956,179. LOCHRIDGE ENERGY SERVICES, LLC, DALLAS, TX. SN 85-067,767. FILED P.R. 6-21-2010; AM. S.R. 2-25-2011.

## LOCHRIDGE ENERGY SERVICES

THE MARK CONSISTS OF STANDARD CHARACTERS WITHOUT CLAIM TO ANY PARTICULAR FONT, STYLE, SIZE, OR COLOR.

NO CLAIM IS MADE TO THE EXCLUSIVE RIGHT TO USE "ENERGY SERVICES", APART FROM THE MARK AS SHOWN.

FOR ENGINEERING AND CONSULTING SERVICES IN THE FIELD OF OIL EXPLORATION (U.S. CLS. 100 AND 101).

FIRST USE 2-0-2010; IN COMMERCE 2-0-2010.

---

3,956,183. RAINWAVE, LLC, AUBURN, AL. SN 85-087,147. FILED P.R. 7-17-2010; AM. S.R. 2-18-2011.

## AMERICA'S RAIN GAUGE

THE MARK CONSISTS OF STANDARD CHARACTERS WITHOUT CLAIM TO ANY PARTICULAR FONT, STYLE, SIZE, OR COLOR.

FOR RAINFALL INFORMATION SERVICES, NAMELY, MEASURING AND RECORDING RAINFALL INFORMATION (U.S. CLS. 100 AND 101).

FIRST USE 7-16-2010; IN COMMERCE 7-16-2010.

**CLASS 42—(Continued).**

3,956,184. OSF GLOBAL SERVICES, INC., WOBURN, MA. SN 85-089,374. FILED P.R. 7-21-2010; AM. S.R. 3-1-2011.

## CODE MY IMAGE

THE MARK CONSISTS OF STANDARD CHARACTERS WITHOUT CLAIM TO ANY PARTICULAR FONT, STYLE, SIZE, OR COLOR.

FOR COMPUTER PROGRAMMING SERVICES, NAMELY, CONVERTING DIGITAL DESIGNS AND IMAGES TO ENABLE VIEWING WEB PAGES AND WEB APPLICATIONS ON COMPUTERS AND MOBILE DEVICES (U.S. CLS. 100 AND 101).

FIRST USE 11-30-2009; IN COMMERCE 11-30-2009.

---

3,956,213. CYBERSPACE INNOVATION CENTER, INC., DBA CYBER INNOVATION CENTER, BOSSIER CITY, LA. SN 85-147,541. FILED P.R. 10-7-2010; AM. S.R. 2-7-2011.

## NATIONAL CYBER RESEARCH PARK

THE MARK CONSISTS OF STANDARD CHARACTERS WITHOUT CLAIM TO ANY PARTICULAR FONT, STYLE, SIZE, OR COLOR.

NO CLAIM IS MADE TO THE EXCLUSIVE RIGHT TO USE "CYBER RESEARCH", APART FROM THE MARK AS SHOWN.

FOR RESEARCH AND DEVELOPMENT AND CONSULTATION RELATED THERETO IN THE FIELD OF CYBER TECHNOLOGY (U.S. CLS. 100 AND 101).

FIRST USE 3-1-2008; IN COMMERCE 3-1-2008.

---

3,956,245. LUNA GARDNER CONSULTING, LLC, PHOENIX, AZ. SN 85-185,519. FILED P.R. 11-26-2010; AM. S.R. 3-9-2011.

## animalprofessional.com

THE MARK CONSISTS OF STANDARD CHARACTERS WITHOUT CLAIM TO ANY PARTICULAR FONT, STYLE, SIZE, OR COLOR.

FOR PROVIDING A WEBSITE FEATURING TECHNOLOGY THAT ENABLES USERS TO SHARE FILES, COLLABORATE, DISCUSS TOPICS AND CONNECT WITH OTHERS ALL SPECIFIC TO THE ANIMAL PROFESSIONAL FIELD (U.S. CLS. 100 AND 101).

FIRST USE 8-14-2010; IN COMMERCE 8-14-2010.

**CLASS 42—(Continued).**

3,956,262. MMIS, INC., FORMERLY MILLENNIUM MEDICAL INFORMATION SERVICES, INC., PORTSMOUTH, NH. SN 85-204,669. FILED 12-23-2010.

# AcnePro

THE MARK CONSISTS OF STANDARD CHARACTERS WITHOUT CLAIM TO ANY PARTICULAR FONT, STYLE, SIZE, OR COLOR.

NO CLAIM IS MADE TO THE EXCLUSIVE RIGHT TO USE "ACNE", APART FROM THE MARK AS SHOWN.

FOR SOFTWARE AS A SERVICE (SAAS) SERVICES, NAMELY, HOSTING SOFTWARE FOR USE BY OTHERS FOR USE IN ESTABLISHING NETWORKS OF HEALTH CARE PROFESSIONALS TO FACILITATE COLLABORATION AND COMMUNICATION (U.S. CLS. 100 AND 101). FIRST USE 3-8-2010; IN COMMERCE 3-8-2010.

**CLASS 43—HOTEL AND RESTAURANT SERVICES**

3,956,100. BRAZILIAN BBQ LLC, KENNER, LA. SN 76-700,129. FILED P.R. 10-30-2009; AM. S.R. 3-2-2011.

# BRAZILIAN BBQ

THE MARK CONSISTS OF STANDARD CHARACTERS WITHOUT CLAIM TO ANY PARTICULAR FONT, STYLE, SIZE, OR COLOR.

NO CLAIM IS MADE TO THE EXCLUSIVE RIGHT TO USE "BBQ", APART FROM THE MARK AS SHOWN.

FOR FAST FOOD AND RESTAURANT SERVICES; CATERING (U.S. CLS. 100 AND 101). FIRST USE 11-26-2009; IN COMMERCE 11-26-2009.

3,956,182. BAUER, DEREK, OLATHE, KS. SN 85-085,220. FILED P.R. 7-15-2010; AM. S.R. 2-17-2011.

# BOLILLO FRESHMEXSUBS

THE MARK CONSISTS OF STANDARD CHARACTERS WITHOUT CLAIM TO ANY PARTICULAR FONT, STYLE, SIZE, OR COLOR.

THE ENGLISH TRANSLATION OF THE WORD "BOLILLO" IN THE MARK IS "ROLL".

FOR RESTAURANT SERVICES FEATURING MEXICAN SANDWICHES (U.S. CLS. 100 AND 101). FIRST USE 10-27-2010; IN COMMERCE 10-27-2010.

**CLASS 44—MEDICAL, BEAUTY AND AGRICULTURAL SERVICES**

3,956,162. INVIVOSCRIBE TECHNOLOGIES, INC., SAN DIEGO, CA. SN 85-054,867. FILED P.R. 6-4-2010; AM. S.R. 3-3-2011.

# AML ALLIANCE

THE MARK CONSISTS OF STANDARD CHARACTERS WITHOUT CLAIM TO ANY PARTICULAR FONT, STYLE, SIZE, OR COLOR.

FOR PROVIDING INFORMATION SERVICES REGARDING THE DIAGNOSIS, MONITORING AND OPTIONS IN THE TREATMENT OF LEUKEMIA (U.S. CLS. 100 AND 101).

FIRST USE 6-1-2010; IN COMMERCE 6-1-2010.

3,956,170. NEWMAN, RHONDA J., LUTHER, OK. SN 85-060,842. FILED P.R. 6-11-2010; AM. S.R. 2-20-2011.

# Equine Energetic Evaluations

THE MARK CONSISTS OF STANDARD CHARACTERS WITHOUT CLAIM TO ANY PARTICULAR FONT, STYLE, SIZE, OR COLOR.

FOR EQUINE MASSAGE AND KINESTHESIOLOGY SERVICES (U.S. CLS. 100 AND 101).

FIRST USE 4-1-2008; IN COMMERCE 4-1-2008.

3,956,186. JEFFREY E. FROMBERG, PALM SPRINGS, CA. SN 85-090,523. FILED P.R. 7-22-2010; AM. S.R. 2-22-2011.

# NATIONAL MALE MEDICAL CLINICS

THE MARK CONSISTS OF STANDARD CHARACTERS WITHOUT CLAIM TO ANY PARTICULAR FONT, STYLE, SIZE, OR COLOR.

NO CLAIM IS MADE TO THE EXCLUSIVE RIGHT TO USE "MEDICAL CLINICS", APART FROM THE MARK AS SHOWN.

FOR ONLINE WEBSITE FEATURING INFORMATION IN THE FIELD OF MEDICAL TREATMENT SERVICES RELATED TO SEXUAL PROBLEMS AND SEXUAL HEALTH (U.S. CLS. 100 AND 101).

FIRST USE 8-1-2010; IN COMMERCE 8-1-2010.

**CLASS 45—(Continued).**

3,956,221. URBAN LIFE SKILLS ACADEMY, NEPTUNE, NJ. SN 85-160,109. FILED P.R. 10-25-2010; AM. S.R. 3-13-2011.

**CLASS 45—PERSONAL AND LEGAL SERVICES**

3,956,142. ASSETS INTERNATIONAL LLC, SOUTHFIELD, MI. SN 85-025,107. FILED P.R. 4-28-2010; AM. S.R. 1-31-2011.

**Urban Life Skills Academy**

**Assets International**

THE MARK CONSISTS OF STANDARD CHARACTERS WITHOUT CLAIM TO ANY PARTICULAR FONT, STYLE, SIZE, OR COLOR.

NO CLAIM IS MADE TO THE EXCLUSIVE RIGHT TO USE "ACADEMY", APART FROM THE MARK AS SHOWN. FOR CHEMICAL DEPENDENCY AND SUBSTANCE ABUSE TREATMENT SERVICES; MENTAL HEALTH SERVICES (U.S. CLS. 100 AND 101).  
FIRST USE 1-1-2009; IN COMMERCE 1-1-2009.

THE MARK CONSISTS OF STANDARD CHARACTERS WITHOUT CLAIM TO ANY PARTICULAR FONT, STYLE, SIZE, OR COLOR.

FOR PRIVATE INVESTIGATION (U.S. CLS. 100 AND 101).  
FIRST USE 4-19-2001; IN COMMERCE 4-19-2001.

3,956,241. LICEDOCTORS, SHORT HILLS, NJ. SN 85-182,448. FILED P.R. 11-22-2010; AM. S.R. 3-3-2011.

3,956,210. GENERAL COUNSEL SOLUTIONS, LLC, NEW YORK, NY. SN 85-145,020. FILED P.R. 10-5-2010; AM. S.R. 3-3-2011.

**Licedoctors**

**MANAGED LEGAL SERVICES**

THE MARK CONSISTS OF STANDARD CHARACTERS WITHOUT CLAIM TO ANY PARTICULAR FONT, STYLE, SIZE, OR COLOR.

FOR LICE REMOVAL FROM HUMANS AND ANIMALS (U.S. CLS. 100 AND 101).  
FIRST USE 7-12-2010; IN COMMERCE 7-12-2010.

THE MARK CONSISTS OF STANDARD CHARACTERS WITHOUT CLAIM TO ANY PARTICULAR FONT, STYLE, SIZE, OR COLOR.

NO CLAIM IS MADE TO THE EXCLUSIVE RIGHT TO USE "LEGAL SERVICES", APART FROM THE MARK AS SHOWN.  
FOR LEGAL SERVICES (U.S. CLS. 100 AND 101).  
FIRST USE 9-3-2010; IN COMMERCE 9-3-2010.

\* \* \* \* \*



# TRADEMARK REGISTRATIONS RENEWED

The designation "U.S. Cl." appearing in this section refers to the U.S. class in effect prior to Sep. 1, 1973 rather than the international class which applies to applications filed on or after that date. For adoption of international classification see notice in the OFFICIAL GAZETTE of Jun. 26, 1973 (911 O.G. TM 210).

82,086.	BEACON. U.S. CL. 39. (INT. CL. 25). REG. 5-30-1911.	714,520.	REC AMERICAN SOCIETY REAL ESTATE COUNSELORS AND DESIGN. U.S. CL. 200. REG. 4-25-1961.
139,220.	TIFFANY & CO. (STYLIZED). U.S. CL. 32. (INT. CL. 20). REG. 1-25-1921.	715,303.	AIR-TIPS. U.S. CL. 17. (INT. CL. 34). REG. 5-16-1961.
140,996.	TIFFANY (STYLIZED). U.S. CL. 38. (INT. CLS. 9, 16 AND 28). REG. 3-29-1921.	715,546.	REGAL. U.S. CL. 50. (INT. CL. 19). REG. 5-16-1961.
143,162.	SANI-CAN (STYLIZED). U.S. CL. 13. (INT. CL. 6). REG. 5-24-1921.	717,196.	MISCELLANEOUS DESIGN. U.S. CL. 37. (INT. CL. 16). REG. 6-20-1961.
274,575.	DUKE (STYLIZED). U.S. CL. 13. (INT. CLS. 6, 7, 11, 17, 20 AND 21). REG. 9-2-1930.	718,527.	TITAN (STYLIZED). U.S. CL. 23. (INT. CL. 7). REG. 7-18-1961.
275,715.	DUKE (STYLIZED). U.S. CL. 32. (INT. CL. 20). REG. 9-30-1930.	718,705.	RAMADA INN. U.S. CL. 100. (INT. CL. 42). REG. 7-18-1961.
283,605.	TERRO (STYLIZED). U.S. CL. 6. (INT. CL. 5). REG. 6-2-1931.	719,316.	HEAT-A-VENT. U.S. CL. 34. (INT. CL. 11). REG. 8-1-1961.
285,774.	FERALOY (STYLIZED). U.S. CL. 21. (INT. CL. 9). REG. 8-4-1931.	719,827.	SCOTCH-WELD. U.S. CL. 5. (INT. CL. 1). REG. 8-15-1961.
290,222.	OILDAG (STYLIZED). U.S. CL. 6. (INT. CL. 1). REG. 12-22-1931.	720,480.	AVA. U.S. CL. 107. (INT. CL. 41). REG. 8-22-1961.
386,280.	AIRLOK (STYLIZED). U.S. CL. 8. (INT. CL. 34). REG. 4-1-1941.	720,959.	BOLEX. U.S. CL. 26. (INT. CL. 9). REG. 9-5-1961.
390,253.	GRACO. U.S. CL. 46. (INT. CLS. 1, 5, 29, 30, 31 AND 32). REG. 9-16-1941.	721,820.	K-LINE. U.S. CL. 21. (INT. CL. 9). REG. 9-26-1961.
515,517.	OSTER (STYLIZED). U.S. CL. 23 ONLY. (INT. CLS. 6, 7, 8, 9, 11, 12, 16, 21 AND 28). REG. 9-27-1949.	723,074.	MISCELLANEOUS DESIGN. U.S. CL. 23. (INT. CL. 7). REG. 10-24-1961.
530,092.	WEBSTER. U.S. CL. 23. (INT. CL. 7). REG. 9-5-1950.	728,072.	MRS. T'S. U.S. CL. 46. (INT. CLS. 1, 5, 29, 30, 31 AND 32). REG. 2-27-1962.
531,705.	PLYLE-NATIONAL. U.S. CL. 21. (INT. CLS. 7, 9, 11, 12 AND 15). REG. 10-10-1950.	728,247.	PINES. U.S. CL. 23. (INT. CL. 7). REG. 3-6-1962.
539,298.	GLASTIC STANDARD CHARACTER MARK. U.S. CL. 21. (INT. CL. 17). REG. 3-13-1951.	729,052.	GENESOLV. U.S. CL. 6. (INT. CL. 1). REG. 3-27-1962.
539,304.	MC GILL (STYLIZED). U.S. CL. 23. (INT. CL. 8). REG. 3-13-1951.	898,627.	REGAL (STYLIZED). U.S. CL. 19. (INT. CL. 12). REG. 9-15-1970.
539,346.	NORDIC (STYLIZED). U.S. CL. 46. (INT. CL. 29). REG. 3-13-1951.	899,524.	FINEWELD. U.S. CL. 13. (INT. CL. 6). REG. 9-29-1970.
539,836.	FULLER AND DESIGN. U.S. CL. 4. (INT. CL. 3). REG. 3-27-1951.	900,938.	PM. U.S. CL. 49. (INT. CL. 33). REG. 10-13-1970.
540,541.	L'OREAL (STYLIZED). U.S. CL. 51. (INT. CLS. 3 AND 5). REG. 4-3-1951.	904,150.	MISCELLANEOUS DESIGN. U.S. CL. 13. (INT. CL. 6). REG. 12-15-1970.
543,639.	DANLY AND DESIGN. U.S. CL. 13. (INT. CL. 6). REG. 6-12-1951.	906,742.	PERMA-LINE. U.S. CL. 37. (INT. CL. 16). REG. 1-26-1971.
548,357.	BUGWISER (STYLIZED). U.S. CL. 23. (INT. CL. 8). REG. 9-18-1951.	906,773.	DSM. U.S. CL. 38. (INT. CLS. 9, 16 AND 28). REG. 1-26-1971.
549,742.	BUSINESS WEEK. U.S. CL. 38. (INT. CL. 16). REG. 10-23-1951.	908,125.	E-Z-FLOSS. U.S. CL. 44. (INT. CL. 10). REG. 2-16-1971.
552,693.	MOTHER'S AND DESIGN. U.S. CL. 46. (INT. CLS. 1, 5, 29, 30, 31 AND 32). REG. 1-1-1952.	908,927.	CHEROKEE BRAND. U.S. CL. 14. (INT. CL. 6). REG. 3-2-1971.
554,957.	SPUN. U.S. CL. 46. (INT. CL. 30). REG. 2-19-1952.	909,047.	K1 (STYLIZED). U.S. CL. 23. (INT. CLS. 6, 7, 8, 9, 11, 12, 16, 21 AND 28). REG. 3-2-1971.
556,398.	PARACOL (STYLIZED). U.S. CL. 6. (INT. CL. 1). REG. 3-18-1952.	909,171.	HORIZON HOUSE. U.S. CL. 38. (INT. CL. 16). REG. 3-2-1971.
703,903.	AMPOWER (STYLIZED). U.S. CL. 23. (INT. CL. 8). REG. 9-6-1960.	909,424.	FOAMASTER. U.S. CL. 6. (INT. CL. 1). REG. 3-9-1971.
708,780.	HEMOSET. U.S. CL. 44. (INT. CL. 10). REG. 12-20-1960.	910,258.	MISCELLANEOUS DESIGN. U.S. CL. 101. (INT. CL. 35). REG. 3-16-1971.
712,007.	MISCELLANEOUS DESIGN. U.S. CL. 12. (INT. CL. 6). REG. 3-7-1961.	910,368.	ELTEX. U.S. CL. 21. (INT. CL. 9). REG. 3-23-1971.
713,017.	T-FAL. U.S. CL. 13. (INT. CL. 21). REG. 3-28-1961.	910,386.	HAROGATOR. U.S. CL. 23. (INT. CL. 7). REG. 3-23-1971.
713,110.	SU (STYLIZED). U.S. CL. 23. (INT. CL. 7). REG. 3-28-1961.	910,403.	KENNAMETAL (STYLIZED). U.S. CL. 23. (INT. CLS. 6, 7, 8, 9, 11, 12, 16, 21 AND 28). REG. 3-23-1971.
713,297.	INA AND DESIGN. U.S. CL. 102. (INT. CL. 36). REG. 3-28-1961.	910,452.	AMIGO. U.S. CL. 46. (INT. CL. 31). REG. 3-23-1971.
713,498.	MAJORICA. U.S. CL. 28. (INT. CL. 14). REG. 4-4-1961.	910,758.	BIG BOY AND DESIGN. U.S. CL. 100. (INT. CL. 42). REG. 3-30-1971.
713,626.	NUTRAMENT. U.S. CL. 46. (INT. CL. 29). REG. 4-4-1961.	910,809.	STAT-KON. INT. CL. 1. (U.S. CL. 1). REG. 4-6-1971.
714,104.	AMF. U.S. CL. 22. (INT. CL. 28). REG. 4-18-1961.	911,878.	GRILTEX (STYLIZED). INT. CL. 1. (U.S. CL. 1). REG. 6-8-1971.
714,156.	LAUREL. U.S. CL. 36. (INT. CLS. 9 AND 15). REG. 4-18-1961.	912,262.	DAIKIN. INT. CL. 7. (U.S. CLS. 13, 19, 21, 23, 31, 34 AND 35). REG. 6-8-1971.
		912,472.	HERPECIN-L. U.S. CL. 18. (INT. CL. 5). REG. 6-8-1971.
		912,948.	STANDUN. U.S. CL. 23. (INT. CL. 7). REG. 6-8-1971.

- 913,031. VERS-GRIP. U.S. CL. 23. (INT. CL. 7). REG. 6-8-1971.
- 914,107. BRACH'S. U.S. CL. 46. (INT. CL. 30). REG. 6-8-1971.
- 915,365. AURORA PINK. U.S. CL. 11. (INT. CL. 2). REG. 6-22-1971.
- 915,533. PRE-GAGED. U.S. CL. 44. (INT. CL. 10). REG. 6-22-1971.
- 916,740. QUAD. U.S. CL. 35. (INT. CL. 17). REG. 7-20-1971.
- 919,544. SPACE CENTER. U.S. CL. 100. (INT. CL. 42). REG. 8-31-1971.
- 920,102. FLOS. U.S. CL. 21. (INT. CL. 11). REG. 9-14-1971.
- 920,742. CAPE. U.S. CL. 38. (INT. CL. 9). REG. 9-21-1971.
- 921,506. SNAPTITE (STYLIZED). U.S. CL. 22. (INT. CL. 28). REG. 10-5-1971.
- 922,225. MALDROXAL. U.S. CL. 18. (INT. CL. 5). REG. 10-19-1971.
- 922,985. TUFFY. U.S. CL. 103. (INT. CL. 37). REG. 10-26-1971.
- 927,120. HI-DENSE. U.S. CL. 12. (INT. CL. 19). REG. 1-18-1972.
- 928,500. WATER PANEL. U.S. CL. 34. (INT. CL. 11). REG. 2-1-1972.
- 1,086,911. VOLTALIT. INT. CL. 17. (U.S. CL. 21). REG. 3-7-1978.
- 1,139,113. REGENT. INT. CL. 42. (U.S. CLS. 100 AND 101). REG. 8-26-1980.
- 1,139,698. PILLAR ROCK. INT. CL. 29. (U.S. CL. 46). REG. 9-16-1980.
- 1,141,006. MICROBAN. INT. CL. 1. (U.S. CL. 6). REG. 11-4-1980.
- 1,141,543. TA (STYLIZED). INT. CLS. 9 AND 11. (U.S. CLS. 13, 21, 23, 26 AND 34). REG. 11-18-1980.
- 1,144,179. LANCOME (STYLIZED). INT. CLS. 18 AND 42. (U.S. CLS. 3 AND 100). REG. 12-23-1980.
- 1,144,766. MICRO CUT. INT. CL. 7. (U.S. CL. 23). REG. 12-30-1980.
- 1,146,433. BOSTON TRADERS. INT. CL. 25. (U.S. CL. 39). REG. 1-27-1981.
- 1,147,589. SUPERFLUE. INT. CL. 11. (U.S. CL. 34). REG. 2-24-1981.
- 1,147,928. PEDINOL. INT. CL. 5. (U.S. CLS. 6, 18, 44, 46, 51 AND 52). REG. 3-3-1981.
- 1,148,394. LIFELINE. INT. CL. 9. (U.S. CL. 26). REG. 3-17-1981.
- 1,148,529. PERFECT ROLLER. INT. CL. 34. (U.S. CL. 8). REG. 3-17-1981.
- 1,148,595. PRICE CHOPPER. INT. CLS. 3, 5, 16, 22, 29, 30, 31, 32 AND 34. (U.S. CLS. 2, 6, 9, 18, 37, 45, 46, 51 AND 52). REG. 3-24-1981.
- 1,148,608. SUNLIGHT. INT. CL. 3. (U.S. CL. 52). REG. 3-24-1981.
- 1,148,645. TENORETIC. INT. CL. 5. (U.S. CL. 18). REG. 3-24-1981.
- 1,148,671. SEXAUER AND DESIGN. INT. CL. 6. (U.S. CL. 13). REG. 3-24-1981.
- 1,148,817. CONCENTRIX. INT. CL. 10. (U.S. CL. 44). REG. 3-24-1981.
- 1,148,818. UNI, TEX AND DESIGN. INT. CL. 10. (U.S. CL. 44). REG. 3-24-1981.
- 1,148,848. MISCELLANEOUS DESIGN. INT. CL. 12. (U.S. CL. 23). REG. 3-24-1981.
- 1,148,861. BOB ALLEN. INT. CLS. 13, 18 AND 25. (U.S. CLS. 3, 9 AND 39). REG. 3-24-1981.
- 1,148,870. MISCELLANEOUS DESIGN. INT. CL. 15. (U.S. CL. 36). REG. 3-24-1981.
- 1,148,945. SNAIDERO AND DESIGN. INT. CL. 20. (U.S. CL. 32). REG. 3-24-1981.
- 1,149,086. PERFECT DIAMOND. INT. CL. 30. (U.S. CL. 46). REG. 3-24-1981.
- 1,149,199. CIRCLE K. INT. CL. 42. (U.S. CL. 101). REG. 3-24-1981.
- 1,149,419. BIALETTI. INT. CL. 21. (U.S. CL. 13). REG. 3-24-1981.
- 1,149,572. PRIMATABS. INT. CL. 5. (U.S. CL. 18). REG. 3-31-1981.
- 1,149,811. AL-THERM. INT. CL. 17. (U.S. CL. 21). REG. 3-31-1981.
- 1,149,820. GAL GREAT AMERICAN LEATHERWORKS INC. AND DESIGN. INT. CL. 18. (U.S. CL. 3). REG. 3-31-1981.
- 1,149,872. DRALON. INT. CL. 24. (U.S. CL. 42). REG. 3-31-1981.
- 1,149,932. RAWLINGS (STYLIZED). INT. CL. 28. (U.S. CL. 22). REG. 3-31-1981.
- 1,150,217. MIDMARK. INT. CLS. 10 AND 20 ONLY. (U.S. CLS. 32 AND 44). REG. 4-7-1981.
- 1,150,227. ARROW. INT. CLS. 7 AND 8. (U.S. CL. 23). REG. 4-7-1981.
- 1,150,296. EPOXYN. INT. CL. 9. (U.S. CLS. 26 AND 32). REG. 4-7-1981.
- 1,150,303. SX-200. INT. CL. 9. (U.S. CL. 21). REG. 4-7-1981.
- 1,150,367. KIDSDAY. INT. CL. 16. (U.S. CL. 38). REG. 4-7-1981.
- 1,150,485. DEL RIO. INT. CL. 25. (U.S. CL. 39). REG. 4-7-1981.
- 1,150,766. LIPOSYN. INT. CL. 5. (U.S. CL. 18). REG. 4-14-1981.
- 1,150,809. BEAM BUG AND DESIGN. INT. CL. 7. (U.S. CLS. 23 AND 34). REG. 4-14-1981.
- 1,150,860. WATTS. INT. CLS. 9 AND 11. (U.S. CLS. 13, 21, 23, 26, 36 AND 38). REG. 4-14-1981.
- 1,150,965. KING KALIPERS. INT. CL. 12. (U.S. CLS. 19, 21, 23, 31, 35 AND 44). REG. 4-14-1981.
- 1,151,201. TARGETED SELECTION (STYLIZED). INT. CLS. 35 AND 41. (U.S. CLS. 101 AND 107). REG. 4-14-1981.
- 1,151,441. DILATRATE. INT. CL. 5. (U.S. CL. 18). REG. 4-21-1981.
- 1,151,836. BUTTERBALL AND DESIGN. INT. CL. 29. (U.S. CL. 46). REG. 4-21-1981.
- 1,151,942. UNITED STATES OPEN CHAMPIONSHIP. INT. CL. 41. (U.S. CL. 107). REG. 4-21-1981.
- 1,151,943. U.S. OPEN. INT. CL. 41. (U.S. CL. 107). REG. 4-21-1981.
- 1,151,944. U.S. OPEN CHAMPIONSHIP. INT. CL. 41. (U.S. CL. 107). REG. 4-21-1981.
- 1,151,945. U.S. WOMEN'S OPEN CHAMPIONSHIP. INT. CL. 41. (U.S. CL. 107). REG. 4-21-1981.
- 1,151,946. UNITED STATES OPEN. INT. CL. 41. (U.S. CL. 107). REG. 4-21-1981.
- 1,151,981. CABELA'S. INT. CL. 42. (U.S. CL. 101). REG. 4-21-1981.
- 1,152,057. MAKROLON. INT. CL. 1. (U.S. CL. 1). REG. 4-28-1981.
- 1,152,065. LIQUID CHISEL. INT. CL. 3. (U.S. CL. 52). REG. 4-28-1981.
- 1,152,225. FLEAKER. INT. CL. 9. (U.S. CL. 26). REG. 4-28-1981.
- 1,152,406. MAKROFOL. INT. CL. 17. (U.S. CL. 1). REG. 4-28-1981.
- 1,152,867. K-ZYME (STYLIZED). INT. CL. 5. (U.S. CL. 18). REG. 5-5-1981.
- 1,153,309. THE SODA POP CANDY (STYLIZED). INT. CL. 30. (U.S. CL. 46). REG. 5-5-1981.
- 1,153,553. MASLIP. INT. CL. 1. (U.S. CLS. 6 AND 15). REG. 5-12-1981.
- 1,153,729. CUFLON (STYLIZED). INT. CL. 9. (U.S. CL. 21). REG. 5-12-1981.
- 1,154,222. NATIONAL SELF STORAGE AND DESIGN. INT. CL. 39. (U.S. CL. 105). REG. 5-12-1981.
- 1,154,223. MISCELLANEOUS DESIGN. INT. CL. 39. (U.S. CL. 105). REG. 5-12-1981.
- 1,154,419. OUTPORE. INT. CL. 3. (U.S. CL. 51). REG. 5-19-1981.
- 1,154,526. DEFIANCE. INT. CL. 7. (U.S. CL. 23). REG. 5-19-1981.
- 1,154,576. HEATLESS. INT. CL. 7. (U.S. CL. 34). REG. 5-19-1981.
- 1,155,299. LENTON. INT. CL. 6. (U.S. CL. 13). REG. 5-26-1981.
- 1,155,910. CANVENTION. INT. CL. 41. (U.S. CL. 107). REG. 5-26-1981.
- 1,156,104. TUBINGSAVER. INT. CL. 7. (U.S. CL. 23). REG. 6-2-1981.
- 1,156,314. PYRAMID AND DESIGN. INT. CL. 15. (U.S. CL. 36). REG. 6-2-1981.
- 1,156,955. MITEX (STYLIZED). INT. CL. 5. (U.S. CL. 18). REG. 6-9-1981.
- 1,157,059. TOXI-LAB. INT. CL. 9. (U.S. CL. 26). REG. 6-9-1981.
- 1,157,294. BRADYTAG. INT. CLS. 16 AND 20. (U.S. CLS. 37 AND 50). REG. 6-9-1981.
- 1,158,080. NORVAL. INT. CL. 16. (U.S. CL. 37). REG. 6-23-1981.
- 1,159,092. PYRAMID. INT. CL. 15. (U.S. CL. 36). REG. 6-30-1981.
- 1,159,354. DUNKIN' DONUTS (STYLIZED). INT. CL. 30. (U.S. CL. 46). REG. 6-30-1981.
- 1,159,427. COLLEGE CRAFT. INT. CL. 37. (U.S. CL. 103). REG. 6-30-1981.

- 1,160,430. DAYS INN. INT. CL. 42. (U.S. CL. 100). REG. 7-7-1981.
- 1,160,631. IGNITOR. INT. CL. 7. (U.S. CL. 21). REG. 7-14-1981.
- 1,160,775. TEXTTOOL. INT. CL. 9. (U.S. CLS. 21 AND 26). REG. 7-14-1981.
- 1,161,003. RIG-RAG (STYLIZED). INT. CL. 21. (U.S. CL. 29). REG. 7-14-1981.
- 1,161,223. PERE PATRIARCHE (STYLIZED). INT. CL. 33. (U.S. CL. 47). REG. 7-14-1981.
- 1,161,507. THE ORIGINAL BUG GUN! (STYLIZED). INT. CL. 28. (U.S. CL. 22). REG. 7-14-1981.
- 1,161,639. WAUKESHA. INT. CL. 7. (U.S. CL. 23). REG. 7-21-1981.
- 1,162,060. PSE. INT. CL. 28. (U.S. CL. 22). REG. 7-21-1981.
- 1,163,128. QUEEN FOR A DAY. INT. CL. 41. (U.S. CL. 107). REG. 7-28-1981.
- 1,163,472. TT AND DESIGN. INT. CL. 9. (U.S. CLS. 21, 23, 26, 36 AND 38). REG. 8-4-1981.
- 1,163,487. BANNER. INT. CL. 9. (U.S. CL. 26). REG. 8-4-1981.
- 1,163,600. LUFRA. INT. CL. 11. (U.S. CL. 34). REG. 8-4-1981.
- 1,163,732. PLASTISEAM. INT. CL. 17. (U.S. CL. 12). REG. 8-4-1981.
- 1,163,990. MISCELLANEOUS DESIGN. INT. CL. 31. (U.S. CL. 46). REG. 8-4-1981.
- 1,165,231. OPTIMA. INT. CLS. 7 AND 9. (U.S. CLS. 23 AND 26). REG. 8-18-1981.
- 1,165,334. RLC AND DESIGN. INT. CL. 9. (U.S. CLS. 21, 23, 26, 36 AND 38). REG. 8-18-1981.
- 1,165,335. RLC ELECTRONICS. INT. CL. 9. (U.S. CLS. 21, 23, 26, 36 AND 38). REG. 8-18-1981.
- 1,166,202. CONVIRON. INT. CL. 9. (U.S. CL. 26). REG. 8-25-1981.
- 1,166,222. ULTIMATTE. INT. CL. 9. (U.S. CL. 21). REG. 8-25-1981.
- 1,166,670. DUNGEONS & DRAGONS. INT. CL. 28. (U.S. CL. 22). REG. 8-25-1981.
- 1,167,424. ONEX. INT. CL. 25. (U.S. CL. 39). REG. 9-1-1981.
- 1,168,249. POLYBED. INT. CL. 11. (U.S. CL. 34). REG. 9-8-1981.
- 1,168,584. PFEIFFER. INT. CL. 29. (U.S. CL. 46). REG. 9-8-1981.
- 1,168,613. IAMS MINI CHUNKS. INT. CL. 31. (U.S. CL. 46). REG. 9-8-1981.
- 1,168,616. OH BOY! AND DESIGN. INT. CL. 31. (U.S. CL. 46). REG. 9-8-1981.
- 1,169,284. SIGLA. INT. CL. 21 ONLY. (U.S. CL. 33). REG. 9-15-1981.
- 1,169,514. IAMS CHUNKS. INT. CL. 31. (U.S. CL. 46). REG. 9-15-1981.
- 1,170,009. VIBAR. INT. CL. 9. (U.S. CL. 21). REG. 9-22-1981.
- 1,170,277. DURUS I (STYLIZED). INT. CL. 21. (U.S. CL. 2). REG. 9-22-1981.
- 1,171,155. EASY READER. INT. CL. 14. (U.S. CLS. 2, 27, 28 AND 50). REG. 9-29-1981.
- 1,172,455. PENNANT. INT. CL. 29. (U.S. CL. 46). REG. 10-6-1981.
- 1,176,274. TREELOC. INT. CL. 22. (U.S. CL. 7). REG. 11-3-1981.
- 1,177,066. ASSI. INT. CL. 10. (U.S. CL. 44). REG. 11-10-1981.
- 1,177,931. WATER-JEL. INT. CL. 9. (U.S. CL. 42). REG. 11-17-1981.
- 1,181,438. THE FOODSERVICE GROUP. INT. CL. 35. (U.S. CL. 101). REG. 12-8-1981.
- 1,181,721. TURF MASTER. INT. CL. 1. (U.S. CL. 10). REG. 12-15-1981.
- 1,181,782. GARGOYLE ARCTIC SHC (STYLIZED). INT. CL. 4. (U.S. CL. 15). REG. 12-15-1981.
- 1,181,945. SIMELT. INT. CL. 9. (U.S. CLS. 21 AND 26). REG. 12-15-1981.
- 1,182,239. MISCELLANEOUS DESIGN. INT. CL. 25. (U.S. CL. 39). REG. 12-15-1981.
- 1,182,968. CUSTOM GARD. INT. CL. 19. (U.S. CL. 12). REG. 12-22-1981.
- 1,183,003. TECHNI-CLOTH. INT. CL. 21. (U.S. CL. 29). REG. 12-22-1981.
- 1,184,227. CHICKEN DELIGHT. INT. CL. 42. (U.S. CL. 100). REG. 12-29-1981.
- 1,185,872. BONE-DRY. INT. CL. 25. (U.S. CL. 39). REG. 1-12-1982.
- 1,186,027. CRAZY CRUSTS. INT. CL. 30. (U.S. CL. 46). REG. 1-12-1982.
- 1,188,282. PROTOZYME. INT. CL. 1. (U.S. CL. 6). REG. 2-2-1982.
- 1,190,425. BENZAC W. INT. CL. 5. (U.S. CL. 18). REG. 2-23-1982.
- 1,190,430. TRIGGER LOCK. INT. CL. 6. (U.S. CL. 13). REG. 2-23-1982.
- 1,192,301. LPC. INT. CL. 37. (U.S. CLS. 100 AND 103). REG. 3-16-1982.
- 1,192,541. CANVEX. INT. CL. 17. (U.S. CL. 50). REG. 3-23-1982.
- 1,367,907. RAMS HEAD. INT. CL. 29. (U.S. CL. 46). REG. 10-29-1985.
- 1,531,740. I-F/X. INT. CL. 9. (U.S. CL. 26). REG. 3-28-1989.
- 1,546,796. ESP EXTRA SENSORY PRODUCTIONS AND DESIGN. INT. CL. 41. (U.S. CLS. 100 AND 107). REG. 7-4-1989.
- 1,581,353. ENVIRO-TEC. INT. CL. 11. (U.S. CL. 34). REG. 2-6-1990.
- 1,593,508. MISCELLANEOUS DESIGN. INT. CL. 41. (U.S. CLS. 100, 101 AND 107). REG. 4-24-1990.
- 1,605,906. INSTITUTES OF QUALITY. INT. CLS. 36 AND 42. (U.S. CLS. 100 AND 102). REG. 7-10-1990.
- 1,607,576. TRINIDAD. INT. CL. 30. (U.S. CL. 46). REG. 7-24-1990.
- 1,611,189. HOT DOG. INT. CLS. 16 AND 28. (U.S. CLS. 22, 23, 38 AND 50). REG. 8-28-1990.
- 1,613,251. DOMO JUMP TO THE PUMP AND DESIGN. INT. CL. 37. (U.S. CL. 103). REG. 9-11-1990.
- 1,615,209. CODEMASTER. INT. CL. 41. (U.S. CL. 107). REG. 9-25-1990.
- 1,615,695. CHILDREN'S WORSHIP BULLETINS. INT. CL. 16. (U.S. CLS. 2, 5, 22, 23, 29, 37, 38 AND 50). REG. 10-2-1990.
- 1,616,436. RAYZIST PHOTOMASK. INT. CLS. 7 AND 42. (U.S. CLS. 23 AND 100). REG. 10-9-1990.
- 1,616,866. OUTNUMBERED!. INT. CL. 28. (U.S. CLS. 22 AND 38). REG. 10-9-1990.
- 1,616,887. FOOD CLUB AND DESIGN. INT. CL. 29. (U.S. CL. 46). REG. 10-9-1990.
- 1,617,359. SOUND RETRIEVAL SYSTEM. INT. CL. 9. (U.S. CL. 21). REG. 10-16-1990.
- 1,618,786. ECOPHON. INT. CLS. 17 AND 19. (U.S. CLS. 1, 5, 12, 13, 33, 35 AND 50). REG. 10-23-1990.
- 1,619,742. ROCKFORD POWERTRAIN (STYLIZED). INT. CL. 12. (U.S. CLS. 19, 21, 23, 31, 35 AND 44). REG. 10-30-1990.
- 1,619,849. LOGOS PRODUCTIONS INC. AND DESIGN. INT. CL. 16. (U.S. CL. 38). REG. 10-30-1990.
- 1,621,609. SMC. INT. CL. 37. (U.S. CLS. 103 AND 106). REG. 11-6-1990.
- 1,624,813. LASERTAB. INT. CL. 16. (U.S. CLS. 2, 5, 22, 23, 29, 37, 38 AND 50). REG. 11-27-1990.
- 1,625,632. ORION. INT. CLS. 7 AND 11. (U.S. CLS. 23 AND 34). REG. 12-4-1990.
- 1,626,209. COL D'ORCIA. INT. CL. 33. (U.S. CL. 47). REG. 12-4-1990.
- 1,633,524. SAM'S AND DESIGN. INT. CL. 42. (U.S. CL. 101). REG. 1-29-1991.
- 1,634,431. SIGILLUM UNIVERSITATIS VANDERBILTIAE. MDCCCLXXIII. AND DESIGN. INT. CL. 41. (U.S. CL. 107). REG. 2-5-1991.
- 1,634,793. RINCON DE SAN LAZARO (STYLIZED). INT. CLS. 16 AND 42. (U.S. CLS. 38 AND 100). REG. 2-12-1991.
- 1,636,070. GRANIFRIGOR. INT. CL. 11. (U.S. CL. 34). REG. 2-26-1991.
- 1,636,456. TOMMY CONDON'S AND DESIGN. INT. CL. 42. (U.S. CL. 100). REG. 2-26-1991.
- 1,636,639. WILLOWPRIN. INT. CL. 5. (U.S. CL. 18). REG. 3-5-1991.
- 1,636,889. A PROFESSIONAL IMPRESSION. INT. CL. 16. (U.S. CLS. 23 AND 37). REG. 3-5-1991.
- 1,637,364. SAT-FAT. INT. CL. 5. (U.S. CLS. 18 AND 46). REG. 3-12-1991.
- 1,637,511. SNORE GUARD. INT. CL. 10. (U.S. CLS. 26, 39 AND 44). REG. 3-12-1991.
- 1,637,817. GUARDIAN. INT. CL. 36. (U.S. CLS. 101 AND 102). REG. 3-12-1991.
- 1,637,974. PCAM. U.S. CL. 200. REG. 3-12-1991.
- 1,638,120. WIPE ON STRI-DEX . . . WIPE OUT PIMPLES. INT. CL. 5. (U.S. CL. 18). REG. 3-19-1991.
- 1,638,130. ORX AND DESIGN. INT. CL. 5. (U.S. CL. 18). REG. 3-19-1991.
- 1,638,298. DREAM RIDE. INT. CL. 12. (U.S. CL. 19). REG. 3-19-1991.

- 1,638,304. SWIV-EL. INT. CL. 12. (U.S. CL. 19). REG. 3-19-1991.
- 1,638,329. SOTHEBY'S. INT. CLS. 16, 25, 35, 36, 39, 41 AND 42 ONLY. (U.S. CLS. 38, 39, 100, 101, 102, 105 AND 107). REG. 3-19-1991.
- 1,638,353. ORANGE COUNTY BUSINESS JOURNAL. INT. CL. 16. (U.S. CL. 38). REG. 3-19-1991.
- 1,638,354. FUN PACK. INT. CL. 16. (U.S. CLS. 22 AND 37). REG. 3-19-1991.
- 1,638,508. MAKAPUU. INT. CL. 28. (U.S. CL. 22). REG. 3-19-1991.
- 1,638,519. BALLOONATIKS. INT. CL. 28. (U.S. CLS. 22 AND 50). REG. 3-19-1991.
- 1,638,570. ANTIQUE. INT. CL. 33. (U.S. CL. 49). REG. 3-19-1991.
- 1,638,705. THE BREAKERS. INT. CL. 42. (U.S. CL. 100). REG. 3-19-1991.
- 1,638,817. EAGLE ONE. INT. CL. 3. (U.S. CLS. 4 AND 52). REG. 3-26-1991.
- 1,638,824. ULTRA 23. INT. CL. 3. (U.S. CL. 4). REG. 3-26-1991.
- 1,638,843. SPACE-IT RED. INT. CL. 5. (U.S. CLS. 18 AND 44). REG. 3-26-1991.
- 1,638,885. ADDRESSOGRAPH. INT. CLS. 7 AND 8. (U.S. CLS. 21, 23, 28 AND 44). REG. 3-26-1991.
- 1,638,906. QUICK-GRIP. INT. CL. 8. (U.S. CL. 23). REG. 3-26-1991.
- 1,638,908. S AND DESIGN. INT. CLS. 9 AND 11. (U.S. CLS. 13, 21, 23, 26, 31, 34, 36 AND 38). REG. 3-26-1991.
- 1,638,934. HAUG AND DESIGN. INT. CLS. 9 AND 11. (U.S. CLS. 21, 26 AND 31). REG. 3-26-1991.
- 1,638,946. SMART "Y". INT. CL. 9. (U.S. CL. 21). REG. 3-26-1991.
- 1,638,978. EEA. INT. CL. 10. (U.S. CL. 44). REG. 3-26-1991.
- 1,639,035. ULTIMATE. INT. CL. 15. (U.S. CL. 36). REG. 3-26-1991.
- 1,639,036. SAN DIEGO. INT. CL. 16. (U.S. CL. 38). REG. 3-26-1991.
- 1,639,038. MAY PEACE PREVAIL ON EARTH. INT. CLS. 16 AND 25 ONLY. (U.S. CLS. 2, 5, 22, 23, 29, 37, 38, 39 AND 50). REG. 3-26-1991.
- 1,639,041. DATASEAL. INT. CL. 16. (U.S. CL. 37). REG. 3-26-1991.
- 1,639,044. PIERO GUIDI. INT. CLS. 16, 18, 25 AND 28. (U.S. CLS. 3, 22, 37, 39 AND 41). REG. 3-26-1991.
- 1,639,071. SAVE VENICE. INT. CLS. 16 AND 36. (U.S. CLS. 38 AND 102). REG. 3-26-1991.
- 1,639,201. YANKEE DOODLE DOLLY. INT. CL. 28. (U.S. CLS. 22 AND 50). REG. 3-26-1991.
- 1,639,202. MISCELLANEOUS DESIGN. INT. CL. 29. (U.S. CL. 46). REG. 3-26-1991.
- 1,639,207. MOUTARDE DE MEAUX POMMERY AROMATISEE AUVINAIGRE FIN HUIC CONDIMENTO EST IMPERARE OMNIBUS CIBIS MUSTAROA MELDENSIS A.D. 1632 AND DESIGN. INT. CL. 30. (U.S. CL. 46). REG. 3-26-1991.
- 1,639,228. BUD AND DESIGN. INT. CL. 31. (U.S. CLS. 1 AND 46). REG. 3-26-1991.
- 1,639,234. LIGHTSHIP. INT. CL. 32. (U.S. CL. 48). REG. 3-26-1991.
- 1,639,241. PLS. INT. CL. 35. (U.S. CL. 101). REG. 3-26-1991.
- 1,639,303. FITZ. INT. CL. 42. (U.S. CL. 100). REG. 3-26-1991.
- 1,639,317. PIKE NURSERIES. INT. CL. 42. (U.S. CL. 101). REG. 3-26-1991.
- 1,639,448. QUICK CLEAR. INT. CL. 1. (U.S. CL. 6). REG. 4-2-1991.
- 1,639,455. ULTRA-BROM. INT. CL. 1. (U.S. CL. 6). REG. 4-2-1991.
- 1,639,579. KOYO. INT. CL. 9. (U.S. CL. 21). REG. 4-2-1991.
- 1,639,613. FLEXIBAR. INT. CL. 9. (U.S. CL. 50). REG. 4-2-1991.
- 1,639,644. PROCARE. INT. CLS. 10 AND 28. (U.S. CLS. 22 AND 44). REG. 4-2-1991.
- 1,639,667. GOLD SEAL. INT. CL. 12. (U.S. CL. 19). REG. 4-2-1991.
- 1,639,684. TISSOT (STYLIZED). INT. CL. 14. (U.S. CL. 27). REG. 4-2-1991.
- 1,639,721. COLOR BOX. INT. CL. 16. (U.S. CL. 11). REG. 4-2-1991.
- 1,639,741. FOX. INT. CL. 16. (U.S. CL. 38). REG. 4-2-1991.
- 1,639,747. KYDEX 6565. INT. CL. 17. (U.S. CL. 12). REG. 4-2-1991.
- 1,639,760. NORTH AMERICAN PLYWOOD. INT. CL. 19. (U.S. CL. 12). REG. 4-2-1991.
- 1,639,763. STAGING CONCEPTS. INT. CL. 19. (U.S. CL. 12). REG. 4-2-1991.
- 1,639,903. NATURE'S SYMPHONY. INT. CL. 30. (U.S. CL. 46). REG. 4-2-1991.
- 1,640,002. CREATIVE EDUCATION FOUNDATION. INT. CLS. 41 AND 42. (U.S. CLS. 101 AND 107). REG. 4-2-1991.
- 1,640,057. EMBERS. INT. CL. 42. (U.S. CL. 100). REG. 4-2-1991.
- 1,640,081. DELICIOUS. INT. CL. 30. (U.S. CL. 46). REG. 4-2-1991.
- 1,640,123. SHALE-BOND. INT. CL. 1. (U.S. CL. 6). REG. 4-9-1991.
- 1,640,126. ARMEX. INT. CL. 1. (U.S. CLS. 6 AND 52). REG. 4-9-1991.
- 1,640,133. CHAPCOTE. INT. CL. 2. (U.S. CLS. 6 AND 16). REG. 4-9-1991.
- 1,640,201. OETIKER. INT. CL. 6. (U.S. CLS. 13 AND 14). REG. 4-9-1991.
- 1,640,202. SOUTHERN STEEL SS (STYLIZED). INT. CL. 6. (U.S. CLS. 2, 12, 13, 14, 23, 25 AND 50). REG. 4-9-1991.
- 1,640,219. WINDLEAVES. INT. CL. 6. (U.S. CLS. 12 AND 14). REG. 4-9-1991.
- 1,640,257. SPEEDY SHARP. INT. CL. 8. (U.S. CL. 23). REG. 4-9-1991.
- 1,640,548. TOUSSE AND DESIGN. INT. CL. 25. (U.S. CL. 39). REG. 4-9-1991.
- 1,640,549. AMERICAN TROUSER. INT. CL. 25. (U.S. CL. 39). REG. 4-9-1991.
- 1,640,627. MOR-GOLD PLUS. INT. CL. 29. (U.S. CL. 46). REG. 4-9-1991.
- 1,640,668. BAROWSKY'S. INT. CL. 30. (U.S. CL. 46). REG. 4-9-1991.
- 1,640,810. POWERSPEAKING. INT. CL. 41. (U.S. CL. 107). REG. 4-9-1991.
- 1,640,928. COLORWHEEL. INT. CL. 16. (U.S. CL. 23). REG. 4-9-1991.
- 1,641,037. WESTFIELD (STYLIZED). INT. CL. 7. (U.S. CL. 23). REG. 4-16-1991.
- 1,641,168. P.A.S. PORT. INT. CL. 10. (U.S. CLS. 26, 39 AND 44). REG. 4-16-1991.
- 1,641,427. VALENTINA. INT. CL. 30. (U.S. CL. 46). REG. 4-16-1991.
- 1,641,496. HR SOLUTIONS. INT. CLS. 35 AND 41. (U.S. CLS. 101 AND 107). REG. 4-16-1991.
- 1,641,661. VW AND DESIGN. INT. CL. 42. (U.S. CL. 101). REG. 4-16-1991.
- 1,641,769. MEMORYCALL. INT. CL. 38. (U.S. CL. 104). REG. 4-16-1991.
- 1,642,239. PRIZE PATROL (STYLIZED). INT. CL. 35. (U.S. CL. 100). REG. 4-23-1991.
- 1,642,253. KOZLAK'S ROYAL OAK RESTAURANT AND DESIGN. INT. CL. 35. (U.S. CL. 101). REG. 4-23-1991.
- 1,642,436. ROBOT/SAVE. INT. CL. 9. (U.S. CL. 38). REG. 4-23-1991.
- 1,642,524. LUMACEL. INT. CL. 2. (U.S. CLS. 6, 11 AND 16). REG. 4-30-1991.
- 1,642,596. QWIK CLEAN. INT. CL. 7. (U.S. CL. 23). REG. 4-30-1991.
- 1,642,735. JBD (STYLIZED). INT. CL. 14. (U.S. CL. 28). REG. 4-30-1991.
- 1,643,134. G GEORGIA ALWAYS IN GOOD TASTE AND DESIGN. U.S. CL. A. REG. 4-30-1991.
- 1,643,249. MAJANTOL. INT. CL. 1. (U.S. CL. 6). REG. 5-7-1991.
- 1,643,395. CROWN ROLL LEAF, INC.. INT. CL. 16 ONLY. (U.S. CLS. 37 AND 38). REG. 5-7-1991.
- 1,643,852. GENEVA AND DESIGN. INT. CL. 35. (U.S. CLS. 100 AND 101). REG. 5-7-1991.
- 1,644,070. SNUFFER'S. INT. CL. 42. (U.S. CL. 100). REG. 5-7-1991.
- 1,644,192. BRAHMANOL. INT. CL. 3. (U.S. CLS. 6 AND 51). REG. 5-14-1991.
- 1,644,215. HEALTHY 'N FIT AND DESIGN. INT. CL. 5. (U.S. CL. 18). REG. 5-14-1991.
- 1,644,228. MISCELLANEOUS DESIGN. INT. CL. 5. (U.S. CLS. 6 AND 18). REG. 5-14-1991.
- 1,644,395. GOLDEN SPOON AWARDS. INT. CL. 16. (U.S. CL. 38). REG. 5-14-1991.
- 1,644,410. HCP CONTOURED PLASTICS (STYLIZED). INT. CL. 17. (U.S. CL. 35). REG. 5-14-1991.

- 1,644,488. CLUE THE CLASSIC DETECTIVE GAME AND DESIGN. INT. CL. 28. (U.S. CL. 22). REG. 5-14-1991.
- 1,644,508. INSTA-GRIP. INT. CL. 28. (U.S. CL. 22). REG. 5-14-1991.
- 1,644,511. G. SENSAT AND DESIGN. INT. CL. 29. (U.S. CL. 46). REG. 5-14-1991.
- 1,644,947. CROWN BOLT. INT. CL. 6. (U.S. CL. 13). REG. 5-21-1991.
- 1,645,121. S (STYLIZED). INT. CL. 12. (U.S. CL. 19). REG. 5-21-1991.
- 1,645,378. MISCELLANEOUS DESIGN. INT. CL. 28. (U.S. CL. 22). REG. 5-21-1991.
- 1,645,426. FORBIDDEN CHOCOLATE. INT. CL. 30. (U.S. CL. 46). REG. 5-21-1991.
- 1,645,467. PROMPT CREATIVE COMPUTING RESOURCES. INT. CL. 35. (U.S. CL. 101). REG. 5-21-1991.
- 1,645,595. PERFORMANCE SELLING. INT. CL. 41. (U.S. CL. 107). REG. 5-21-1991.
- 1,645,688. REFLECTION CONTROL. INT. CL. 21. (U.S. CL. 33). REG. 5-21-1991.
- 1,645,766. CERETEC. INT. CL. 5. (U.S. CL. 18). REG. 5-28-1991.
- 1,645,897. CRYOSAFE. INT. CL. 10. (U.S. CL. 44). REG. 5-28-1991.
- 1,646,305. CUNARD (STYLIZED). INT. CLS. 39 AND 42. (U.S. CLS. 100, 105 AND 107). REG. 5-28-1991.
- 1,646,379. UNION SQUARE CAFE. INT. CL. 42. (U.S. CL. 100). REG. 5-28-1991.
- 1,646,431. MISCELLANEOUS DESIGN. INT. CL. 42. (U.S. CL. 100). REG. 5-28-1991.
- 1,646,569. SANDRANOL. INT. CL. 3. (U.S. CLS. 1 AND 51). REG. 6-4-1991.
- 1,647,191. INFORMS (STYLIZED). INT. CL. 6. (U.S. CL. 13). REG. 6-11-1991.
- 1,647,422. LOCKSMITH LEDGER INTERNATIONAL. INT. CL. 16. (U.S. CL. 38). REG. 6-11-1991.
- 1,647,550. ROYAL BALTIC. INT. CL. 29. (U.S. CL. 46). REG. 6-11-1991.
- 1,647,608. RELAXATION. INT. CL. 34. (U.S. CL. 17). REG. 6-11-1991.
- 1,648,431. TRANS-POWER. INT. CL. 42. (U.S. CL. 101). REG. 6-18-1991.
- 1,648,749. MAGIC LANTERN. INT. CL. 9. (U.S. CLS. 21 AND 26). REG. 6-25-1991.
- 1,648,772. M.R.L. INT. CL. 10. (U.S. CL. 44). REG. 6-25-1991.
- 1,649,193. THE CLUTCH PRO (STYLIZED). INT. CL. 37. (U.S. CL. 103). REG. 6-25-1991.
- 1,649,333. HOMESPUN VIDEO. INT. CL. 9. (U.S. CL. 21). REG. 7-2-1991.
- 1,649,952. NOISEKEN (STYLIZED). INT. CL. 9. (U.S. CLS. 21 AND 26). REG. 7-9-1991.
- 1,650,299. SAPPHIRE. INT. CL. 33. (U.S. CL. 49). REG. 7-9-1991.
- 1,650,434. PROFORMA. INT. CL. 42. (U.S. CLS. 100 AND 101). REG. 7-9-1991.
- 1,650,625. TACTICIAN. INT. CL. 9. (U.S. CL. 26). REG. 7-16-1991.
- 1,650,975. FARMING FOR FLAVORS. INT. CL. 33. (U.S. CL. 47). REG. 7-16-1991.
- 1,650,982. FACILITATIVE LEADERSHIP. INT. CL. 35. (U.S. CLS. 100, 101 AND 102). REG. 7-16-1991.
- 1,651,125. CHILI'S SOUTHWEST GRILL & BAR. INT. CL. 42. (U.S. CL. 100). REG. 7-16-1991.
- 1,651,687. HEARTCARE. INT. CL. 36. (U.S. CL. 102). REG. 7-23-1991.
- 1,651,696. NVA AND DESIGN. INT. CL. 36. (U.S. CLS. 101 AND 102). REG. 7-23-1991.
- 1,651,774. PEAK. INT. CL. 41. (U.S. CL. 107). REG. 7-23-1991.
- 1,652,405. STRATA GRID. INT. CL. 17. (U.S. CLS. 1 AND 12). REG. 7-30-1991.
- 1,652,449. POUR-FREE. INT. CL. 21. (U.S. CL. 50). REG. 7-30-1991.
- 1,652,889. STELLITE AND DESIGN. INT. CL. 6. (U.S. CL. 14). REG. 8-6-1991.
- 1,653,165. LGB. INT. CL. 28. (U.S. CL. 22). REG. 8-6-1991.
- 1,653,200. CENTRAL CASTING. INT. CL. 35. (U.S. CL. 101). REG. 8-6-1991.
- 1,654,388. MAC ATTACK. INT. CL. 25. (U.S. CL. 39). REG. 8-20-1991.
- 1,654,938. MISCELLANEOUS DESIGN. INT. CL. 24. (U.S. CL. 42). REG. 8-27-1991.
- 1,655,480. LIPOCLEAR. INT. CL. 10. (U.S. CL. 44). REG. 9-3-1991.
- 1,655,626. GEO BLOSSOM. INT. CL. 28. (U.S. CLS. 22, 23, 38 AND 50). REG. 9-3-1991.
- 1,656,162. SAFECRIT. INT. CL. 10. (U.S. CL. 44). REG. 9-10-1991.
- 1,656,387. MISCELLANEOUS DESIGN. INT. CL. 30. (U.S. CL. 46). REG. 9-10-1991.
- 1,656,404. VITTEL (STYLIZED). INT. CL. 32. (U.S. CLS. 45, 46 AND 48). REG. 9-10-1991.
- 1,656,944. R AND DESIGN. INT. CL. 29. (U.S. CL. 46). REG. 9-10-1991.
- 1,657,302. KINO AND DESIGN. INT. CL. 11. (U.S. CL. 21). REG. 9-17-1991.
- 1,657,835. DAYSTAR. INT. CL. 35. (U.S. CL. 101). REG. 9-17-1991.
- 1,657,962. MISCELLANEOUS DESIGN. INT. CLS. 4 AND 8 ONLY. (U.S. CLS. 15 AND 23). REG. 9-24-1991.
- 1,658,129. CLASSIC. INT. CL. 10. (U.S. CL. 44). REG. 9-24-1991.
- 1,658,134. X-TEN. INT. CL. 10. (U.S. CL. 44). REG. 9-24-1991.
- 1,658,342. V.F.D.. INT. CL. 29. (U.S. CL. 46). REG. 9-24-1991.
- 1,658,443. W AND DESIGN. INT. CL. 31. (U.S. CL. 46). REG. 9-24-1991.
- 1,658,705. GREAT GRAINS. INT. CL. 30. (U.S. CL. 46). REG. 9-24-1991.
- 1,658,959. ALL-STATE RECYCLED BOND. INT. CL. 16. (U.S. CL. 37). REG. 10-1-1991.
- 1,659,761. VOGUE. INT. CL. 18. (U.S. CL. 3). REG. 10-8-1991.
- 1,660,481. QUIKSTART AND DESIGN. INT. CL. 4. (U.S. CL. 1). REG. 10-15-1991.
- 1,662,732. BIG IRON (STYLIZED). INT. CL. 35. (U.S. CL. 101). REG. 10-29-1991.
- 1,662,756. NAVIGATOR. INT. CL. 36. (U.S. CL. 102). REG. 10-29-1991.
- 1,662,804. THE COMMONWEALTH CLUB OF CALIFORNIA. INT. CL. 41. (U.S. CL. 107). REG. 10-29-1991.
- 1,664,103. SPARC. INT. CL. 16. (U.S. CL. 38). REG. 11-12-1991.
- 1,664,349. SECRET SHOPPER. INT. CL. 35. (U.S. CL. 101). REG. 11-12-1991.
- 1,664,643. GRO-STAKES. INT. CL. 1. (U.S. CL. 10). REG. 11-19-1991.
- 1,668,361. TRANSEQUATOR. INT. CL. 9. (U.S. CL. 26). REG. 12-17-1991.
- 1,670,049. TWISTER SPEED LATHE. INT. CL. 7. (U.S. CL. 23). REG. 12-31-1991.
- 1,670,605. LARSEN DESIGN. INT. CL. 42. (U.S. CL. 100). REG. 12-31-1991.
- 1,670,822. DELIWARE. INT. CL. 21. (U.S. CLS. 2, 13 AND 33). REG. 12-31-1991.
- 1,670,870. SEAWORTHY. INT. CL. 36. (U.S. CL. 102). REG. 12-31-1991.
- 1,670,948. DEFACER ERASER. INT. CL. 3. (U.S. CL. 52). REG. 1-7-1992.
- 1,672,577. SCHOLASTIC. INT. CL. 16. (U.S. CLS. 37 AND 38). REG. 1-21-1992.
- 1,672,699. STRAUSS VEAL. INT. CL. 29. (U.S. CL. 46). REG. 1-21-1992.
- 1,674,656. TESSCO. INT. CL. 42. (U.S. CL. 101). REG. 2-4-1992.
- 1,674,927. TROJAN MAN. INT. CL. 10. (U.S. CL. 44). REG. 2-11-1992.
- 1,676,604. SNUGZ (STYLIZED). INT. CL. 9. (U.S. CLS. 21, 23, 26, 36 AND 38). REG. 2-25-1992.
- 1,677,101. DUKE ELLINGTON. INT. CL. 41. (U.S. CL. 107). REG. 2-25-1992.
- 1,677,306. EARTHRISE. INT. CL. 5. (U.S. CLS. 18 AND 46). REG. 3-3-1992.
- 1,677,745. SHARK ATTACK. INT. CL. 28. (U.S. CL. 22). REG. 3-3-1992.
- 1,677,924. SCHOLASTIC. INT. CL. 41. (U.S. CL. 107). REG. 3-3-1992.
- 1,677,988. SCHOLASTIC. INT. CL. 42. (U.S. CLS. 100 AND 101). REG. 3-3-1992.
- 1,678,457. INNOVATIONS EXPERIENCING LITERATURE IN THE CLASSROOM. INT. CL. 16. (U.S. CL. 38). REG. 3-10-1992.
- 1,678,518. BABY-SITTER'S LITTLE SISTER. INT. CL. 16. (U.S. CL. 38). REG. 3-10-1992.
- 1,678,889. MAX 10. INT. CL. 42. (U.S. CL. 101). REG. 3-10-1992.
- 1,679,002. PAI. INT. CL. 16. (U.S. CL. 38). REG. 3-10-1992.
- 1,679,277. PULSELITE. INT. CL. 9. (U.S. CL. 26). REG. 3-17-1992.

- 1,679,625. PEOPLE HELPING PEOPLE. INT. CL. 36. (U.S. CL. 102). REG. 3-17-1992.
- 1,679,884. INDICATOR. INT. CL. 21. (U.S. CLS. 21 AND 29). REG. 3-17-1992.
- 1,680,118. DELTA STAR INC. AND DESIGN. INT. CL. 9. (U.S. CLS. 21, 23, 26, 36 AND 38). REG. 3-24-1992.
- 1,727,357. MISCELLANEOUS DESIGN. INT. CL. 11. (U.S. CL. 34). REG. 10-27-1992.
- 1,732,853. CREATIVE ICE. INT. CL. 11. (U.S. CL. 31). REG. 11-17-1992.
- 2,091,489. ANGELO AND MAXIE'S. INT. CL. 42. (U.S. CLS. 100 AND 101). REG. 8-26-1997.
- 2,303,585. UNITY WORLDWEAR AND DESIGN. INT. CL. 25. (U.S. CLS. 22 AND 39). REG. 12-28-1999.
- 2,333,261. THRIFT SHAVE. INT. CL. 7. (U.S. CLS. 13, 19, 21, 23, 31, 34 AND 35). REG. 3-21-2000.
- 2,337,036. FRESH SPAN. INT. CL. 35. (U.S. CLS. 100, 101 AND 102). REG. 4-4-2000.
- 2,338,968. TECHNOGYM. INT. CLS. 35 AND 41. (U.S. CLS. 100, 101, 102 AND 107). REG. 4-4-2000.
- 2,371,527. FLEUR DE LIS. INT. CL. 41. (U.S. CLS. 100, 101 AND 107). REG. 7-25-2000.
- 2,372,248. THE ENSWORTH SCHOOL. INT. CLS. 16, 25 AND 41. (U.S. CLS. 2, 5, 22, 23, 29, 37, 38, 39, 50, 100, 101 AND 107). REG. 8-1-2000.
- 2,377,112. GENEXPRESS AND DESIGN. INT. CLS. 1 AND 5. (U.S. CLS. 1, 5, 6, 10, 18, 26, 44, 46, 51 AND 52). REG. 8-15-2000.
- 2,377,113. GENEXPRESS. INT. CLS. 1 AND 5. (U.S. CLS. 1, 5, 6, 10, 18, 26, 44, 46, 51 AND 52). REG. 8-15-2000.
- 2,377,814. PANE E VINO. INT. CL. 42. (U.S. CLS. 100 AND 101). REG. 8-15-2000.
- 2,382,524. CALVET MAISON FONDEE EN 1818 AND DESIGN. INT. CL. 33. (U.S. CLS. 47 AND 49). REG. 9-5-2000.
- 2,382,933. FIRE DYNAMICS. INT. CL. 42. (U.S. CLS. 100 AND 101). REG. 9-5-2000.
- 2,383,544. MISCELLANEOUS DESIGN. INT. CLS. 35, 37, 38, 41 AND 42. (U.S. CLS. 100, 101, 102, 103, 104, 106 AND 107). REG. 9-5-2000.
- 2,384,915. P AND DESIGN. INT. CLS. 16 AND 36. (U.S. CLS. 2, 5, 22, 23, 29, 37, 38, 50, 100, 101 AND 102). REG. 9-12-2000.
- 2,385,051. TIMET AND DESIGN. INT. CL. 6. (U.S. CLS. 2, 12, 13, 14, 23, 25 AND 50). REG. 9-12-2000.
- 2,386,629. OPTICAL VILLAGE. INT. CL. 36. (U.S. CLS. 100, 101 AND 102). REG. 9-12-2000.
- 2,386,706. TEC-SEM. INT. CLS. 7, 9, 37 AND 41. (U.S. CLS. 13, 19, 21, 23, 26, 31, 34, 35, 36, 38, 100, 101, 103, 106 AND 107). REG. 9-19-2000.
- 2,387,121. SOREN. INT. CLS. 9 AND 18. (U.S. CLS. 1, 2, 3, 21, 22, 23, 26, 36, 38 AND 41). REG. 9-19-2000.
- 2,387,168. CANYON GATE. INT. CL. 37. (U.S. CLS. 100, 103 AND 106). REG. 9-19-2000.
- 2,387,273. ETRAV. INT. CLS. 39 AND 42. (U.S. CLS. 100, 101 AND 105). REG. 9-19-2000.
- 2,387,394. WEBWASHER (STYLIZED). INT. CL. 9. (U.S. CLS. 21, 23, 26, 36 AND 38). REG. 9-19-2000.
- 2,387,471. A.B. LAMB DIN. INT. CLS. 25 AND 35. (U.S. CLS. 22, 39, 100, 101 AND 102). REG. 9-19-2000.
- 2,388,114. MEDIA CLUSTER. INT. CL. 9. (U.S. CLS. 21, 23, 26, 36 AND 38). REG. 9-19-2000.
- 2,388,137. EVE. INT. CLS. 35 AND 41. (U.S. CLS. 100, 101, 102 AND 107). REG. 9-19-2000.
- 2,388,209. KANGA. INT. CL. 7. (U.S. CLS. 13, 19, 21, 23, 31, 34 AND 35). REG. 9-19-2000.
- 2,389,010. QI AND DESIGN. INT. CL. 30 ONLY. (U.S. CL. 46). REG. 9-26-2000.
- 2,389,381. BREAK EVEN. INT. CL. 9. (U.S. CLS. 21, 23, 26, 36 AND 38). REG. 9-26-2000.
- 2,389,491. CATCH US IF YOU CAN!. INT. CL. 28. (U.S. CLS. 22, 23, 38 AND 50). REG. 9-26-2000.
- 2,389,630. SUAREZ NEW YORK. INT. CL. 25. (U.S. CLS. 22 AND 39). REG. 9-26-2000.
- 2,390,106. HEALING BOUQUET. INT. CL. 31. (U.S. CLS. 1 AND 46). REG. 9-26-2000.
- 2,390,143. BLAKE STREET BOMBERS. INT. CL. 25. (U.S. CLS. 22 AND 39). REG. 9-26-2000.
- 2,390,260. VITAMINS 4LESS AND DESIGN. INT. CL. 5. (U.S. CLS. 6, 18, 44, 46, 51 AND 52). REG. 9-26-2000.
- 2,390,520. THE SILENT MARSHAL. INT. CL. 9. (U.S. CLS. 21, 23, 26, 36 AND 38). REG. 9-26-2000.
- 2,390,533. BOZO. INT. CL. 28. (U.S. CLS. 22, 23, 38 AND 50). REG. 9-26-2000.
- 2,390,972. BECKER UNDERWOOD. INT. CLS. 1, 2 AND 3 ONLY. (U.S. CLS. 1, 4, 5, 6, 10, 11, 16, 26, 46, 50, 51 AND 52). REG. 10-3-2000.
- 2,391,349. SUAREZ NEW YORK. INT. CL. 18. (U.S. CLS. 1, 2, 3, 22 AND 41). REG. 10-3-2000.
- 2,391,465. BELLINO ITALIAN NOUGAT CANDY TORRONE TRADITIONALLY SOFT AND DESIGN. INT. CL. 30. (U.S. CL. 46). REG. 10-3-2000.
- 2,391,793. KATE & TOBY BEDTIME. INT. CLS. 20 AND 24. (U.S. CLS. 2, 13, 22, 25, 32, 42 AND 50). REG. 10-3-2000.
- 2,392,425. SEXUAL SOLUTIONS AND DESIGN. INT. CL. 9. (U.S. CLS. 21, 23, 26, 36 AND 38). REG. 10-3-2000.
- 2,393,314. GRAND LUX CAFE AND DESIGN. INT. CL. 42. (U.S. CLS. 100 AND 101). REG. 10-10-2000.
- 2,393,470. MONTEVERDE. INT. CL. 16. (U.S. CLS. 2, 5, 22, 23, 29, 37, 38 AND 50). REG. 10-10-2000.
- 2,394,009. FOREVERGREEN. INT. CL. 3. (U.S. CLS. 1, 4, 6, 50, 51 AND 52). REG. 10-10-2000.
- 2,394,020. TOTAL EXPERIENCE MANAGEMENT. INT. CL. 35. (U.S. CLS. 100, 101 AND 102). REG. 10-10-2000.
- 2,394,690. FORT VALE AND DESIGN. INT. CLS. 6, 9 AND 17. (U.S. CLS. 1, 2, 5, 12, 13, 14, 21, 23, 25, 26, 35, 36, 38 AND 50). REG. 10-17-2000.
- 2,395,095. NMRA. U.S. CL. 200. REG. 10-17-2000.
- 2,395,099. NMRA AND DESIGN. U.S. CL. 200. REG. 10-17-2000.
- 2,395,352. ORGULLOSAMENTE MEXICANA. INT. CL. 32. (U.S. CLS. 45, 46 AND 48). REG. 10-17-2000.
- 2,396,126. PEAKPLUS. INT. CL. 9. (U.S. CLS. 21, 23, 26, 36 AND 38). REG. 10-17-2000.
- 2,396,942. THERE'S A LOT TO BE SAID FOR SAYING IT RIGHT.. INT. CL. 35. (U.S. CLS. 100, 101 AND 102). REG. 10-24-2000.
- 2,397,000. RAPIDPOINT. INT. CL. 10. (U.S. CLS. 26, 39 AND 44). REG. 10-24-2000.
- 2,399,278. F5 NETWORKS. INT. CLS. 9 AND 42. (U.S. CLS. 21, 23, 26, 36, 38, 100 AND 101). REG. 10-31-2000.
- 2,401,216. TECNOFIRE. INT. CL. 17. (U.S. CLS. 1, 5, 12, 13, 35 AND 50). REG. 11-7-2000.
- 2,401,632. SERVO GUARD. INT. CL. 10. (U.S. CLS. 26, 39 AND 44). REG. 11-7-2000.
- 2,401,655. SMITHMICRO SOFTWARE. INT. CL. 9. (U.S. CLS. 21, 23, 26, 36 AND 38). REG. 11-7-2000.
- 2,402,063. NHSI. INT. CL. 35. (U.S. CLS. 100, 101 AND 102). REG. 11-7-2000.
- 2,402,837. HOLIDAY EXPRESSIONS. INT. CL. 16. (U.S. CLS. 2, 5, 22, 23, 29, 37, 38 AND 50). REG. 11-7-2000.
- 2,404,315. HEAVENLYTREASURES.COM. INT. CL. 35. (U.S. CLS. 100, 101 AND 102). REG. 11-14-2000.
- 2,405,326. DUNHAM'S. INT. CLS. 2 AND 17. (U.S. CLS. 1, 5, 6, 11, 12, 13, 16, 35 AND 50). REG. 11-21-2000.
- 2,405,847. MISCELLANEOUS DESIGN. INT. CL. 36. (U.S. CLS. 100, 101 AND 102). REG. 11-21-2000.
- 2,405,984. THE WOODMUPS. INT. CL. 16. (U.S. CLS. 2, 5, 22, 23, 29, 37, 38 AND 50). REG. 11-21-2000.
- 2,406,489. PEEK-A-BOO BABY. INT. CL. 28. (U.S. CLS. 22, 23, 38 AND 50). REG. 11-21-2000.
- 2,406,589. 180 NPS. INT. CL. 9. (U.S. CLS. 21, 23, 26, 36 AND 38). REG. 11-21-2000.
- 2,407,698. THE APOTHECARY AND DESIGN. INT. CL. 3. (U.S. CLS. 1, 4, 6, 50, 51 AND 52). REG. 11-28-2000.
- 2,408,103. SUAREZ. INT. CL. 18. (U.S. CLS. 1, 2, 3, 22 AND 41). REG. 11-28-2000.
- 2,408,770. NOIR. INT. CL. 14 ONLY. (U.S. CLS. 2, 27 AND 50). REG. 11-28-2000.
- 2,409,089. FLORASTOR. INT. CL. 5. (U.S. CLS. 6, 18, 44, 46, 51 AND 52). REG. 11-28-2000.
- 2,409,236. SF SCHAEFER FURNACES AND DESIGN. INT. CLS. 11, 37 AND 42. (U.S. CLS. 13, 21, 23, 31, 34, 100, 101, 103 AND 106). REG. 11-28-2000.
- 2,412,057. LACTALIS. INT. CL. 29. (U.S. CL. 46). REG. 12-12-2000.
- 2,413,656. MULTIBUCKET STANDARD CHARACTER MARK. INT. CL. 36. (U.S. CLS. 100, 101 AND 102). REG. 12-19-2000.
- 2,414,976. ENERMED. INT. CL. 10. (U.S. CLS. 26, 39 AND 44). REG. 12-26-2000.
- 2,416,253. BAKEMARK. INT. CLS. 29, 30 AND 35. (U.S. CLS. 46, 100, 101 AND 102). REG. 12-26-2000.
- 2,416,269. CHARLOTTE RUSSE. INT. CL. 14. (U.S. CLS. 2, 27, 28 AND 50). REG. 12-26-2000.

- 2,416,270. CHARLOTTE RUSSE. INT. CL. 26. (U.S. CLS. 37, 39, 40, 42 AND 50). REG. 12-26-2000.
- 2,416,273. CHARLOTTE RUSSE. INT. CL. 25. (U.S. CLS. 22 AND 39). REG. 12-26-2000.
- 2,416,283. LIGHT-LESS. INT. CL. 20. (U.S. CLS. 2, 13, 22, 25, 32 AND 50). REG. 12-26-2000.
- 2,416,843. KERUSSO. INT. CL. 25. (U.S. CLS. 22 AND 39). REG. 1-2-2001.
- 2,417,828. SERENADE. INT. CL. 5. (U.S. CLS. 6, 18, 44, 46, 51 AND 52). REG. 1-2-2001.
- 2,417,931. CHECKS UNLIMITED. INT. CLS. 16, 35 AND 42. (U.S. CLS. 2, 5, 22, 23, 29, 37, 38, 50, 100, 101 AND 102). REG. 1-2-2001.
- 2,417,971. FREEFORM. INT. CL. 7. (U.S. CLS. 13, 19, 21, 23, 31, 34 AND 35). REG. 1-2-2001.
- 2,418,621. JUST FOR KIDS. INT. CL. 35. (U.S. CLS. 100, 101 AND 102). REG. 1-9-2001.
- 2,418,644. ALS. INT. CL. 35. (U.S. CLS. 100, 101 AND 102). REG. 1-9-2001.
- 2,419,187. DW DIMENSIONAL WORLDWIDE AND DESIGN. INT. CL. 41. (U.S. CLS. 100, 101 AND 107). REG. 1-9-2001.
- 2,419,790. LITERACY COLLABORATIVE. INT. CL. 41. (U.S. CLS. 100, 101 AND 107). REG. 1-9-2001.
- 2,419,800. AIRFENCE AND DESIGN. INT. CL. 19. (U.S. CLS. 1, 12, 33 AND 50). REG. 1-9-2001.
- 2,420,792. FASHION GENTS (STYLIZED). INT. CL. 35. (U.S. CLS. 100, 101 AND 102). REG. 1-16-2001.
- 2,421,607. CAM BALANCER. INT. CL. 7. (U.S. CLS. 13, 19, 21, 23, 31, 34 AND 35). REG. 1-16-2001.
- 2,421,726. LOCK + LOAD. INT. CLS. 19 AND 37. (U.S. CLS. 1, 12, 33, 50, 100, 103 AND 106). REG. 1-16-2001.
- 2,422,572. GARY PLAYER COLLECTION. INT. CL. 25. (U.S. CLS. 22 AND 39). REG. 1-23-2001.
- 2,422,630. WOLFSON. INT. CL. 9. (U.S. CLS. 21, 23, 26, 36 AND 38). REG. 1-23-2001.
- 2,423,088. ECHL.COM. INT. CL. 41. (U.S. CLS. 100, 101 AND 107). REG. 1-23-2001.
- 2,423,370. COUNTRY BUNNY BATH & BODY. INT. CL. 3. (U.S. CLS. 1, 4, 6, 50, 51 AND 52). REG. 1-23-2001.
- 2,423,775. LONDON HARBOR. INT. CL. 25. (U.S. CLS. 22 AND 39). REG. 1-23-2001.
- 2,423,948. SPANISH 21. INT. CL. 41. (U.S. CLS. 100, 101 AND 107). REG. 1-23-2001.
- 2,424,088. CITI AND DESIGN. INT. CLS. 35 AND 36 ONLY. (U.S. CLS. 100, 101 AND 102). REG. 1-23-2001.
- 2,424,180. MOELLER (STYLIZED). INT. CLS. 9, 37, 41 AND 42. (U.S. CLS. 21, 23, 26, 36, 38, 100, 101, 103, 106 AND 107). REG. 1-23-2001.
- 2,424,250. MULTIGRADE. INT. CL. 9. (U.S. CLS. 21, 23, 26, 36 AND 38). REG. 1-23-2001.
- 2,424,471. HOODIES AND DESIGN. INT. CL. 25. (U.S. CLS. 22 AND 39). REG. 1-30-2001.
- 2,424,918. KOHINOOR. INT. CL. 30. (U.S. CL. 46). REG. 1-30-2001.
- 2,425,068. ROCKY BRANCH FARM. INT. CL. 29. (U.S. CL. 46). REG. 1-30-2001.
- 2,425,088. CULINARY CARE. INT. CL. 37. (U.S. CLS. 100, 103 AND 106). REG. 1-30-2001.
- 2,425,615. NUMERO. INT. CL. 28. (U.S. CLS. 22, 23, 38 AND 50). REG. 1-30-2001.
- 2,425,616. CALC!. INT. CL. 28. (U.S. CLS. 22, 23, 38 AND 50). REG. 1-30-2001.
- 2,426,026. PENNY GRAHAMS. INT. CL. 30. (U.S. CL. 46). REG. 2-6-2001.
- 2,426,061. NEBS. INT. CLS. 9, 16 AND 25. (U.S. CLS. 2, 5, 21, 22, 23, 26, 29, 36, 37, 38, 39 AND 50). REG. 2-6-2001.
- 2,426,200. MISCELLANEOUS DESIGN. INT. CL. 42. (U.S. CLS. 100 AND 101). REG. 2-6-2001.
- 2,426,406. SILENT SEAL. INT. CL. 17. (U.S. CLS. 1, 5, 12, 13, 35 AND 50). REG. 2-6-2001.
- 2,426,783. GOLDEN STATE AND DESIGN. INT. CL. 1 ONLY. (U.S. CLS. 1, 5, 6, 10, 26 AND 46). REG. 2-6-2001.
- 2,427,009. ULTIMUS. INT. CL. 9. (U.S. CLS. 21, 23, 26, 36 AND 38). REG. 2-6-2001.
- 2,427,196. KNOWLEDGE FROM DATA. INT. CLS. 9 AND 42. (U.S. CLS. 21, 23, 26, 36, 38, 100 AND 101). REG. 2-6-2001.
- 2,427,487. ULTRAXOL. INT. CL. 1. (U.S. CLS. 1, 5, 6, 10, 26 AND 46). REG. 2-6-2001.
- 2,427,558. JEWELRY FOR CARS. INT. CLS. 6 AND 12. (U.S. CLS. 2, 12, 13, 14, 19, 21, 23, 25, 31, 35, 44 AND 50). REG. 2-6-2001.
- 2,428,096. CYBERNASTICS. INT. CL. 9. (U.S. CLS. 21, 23, 26, 36 AND 38). REG. 2-13-2001.
- 2,428,721. QLAV (STYLIZED). INT. CL. 11. (U.S. CLS. 13, 21, 23, 31 AND 34). REG. 2-13-2001.
- 2,428,809. THRASHERS STREET DASHERS. INT. CL. 41. (U.S. CLS. 100, 101 AND 107). REG. 2-13-2001.
- 2,429,025. TEXAS REDS. INT. CL. 30. (U.S. CL. 46). REG. 2-20-2001.
- 2,429,150. MARKETSTAR. INT. CL. 35. (U.S. CLS. 100, 101 AND 102). REG. 2-20-2001.
- 2,429,299. HOOFF 'N HEEL. INT. CL. 5. (U.S. CLS. 6, 18, 44, 46, 51 AND 52). REG. 2-20-2001.
- 2,429,431. CYBERWEIGHTS. INT. CL. 9. (U.S. CLS. 21, 23, 26, 36 AND 38). REG. 2-20-2001.
- 2,429,432. MISCELLANEOUS DESIGN. INT. CL. 9. (U.S. CLS. 21, 23, 26, 36 AND 38). REG. 2-20-2001.
- 2,429,597. WORKOUT.COM AND DESIGN. INT. CL. 35. (U.S. CLS. 100, 101 AND 102). REG. 2-20-2001.
- 2,429,726. MO-SHEN. INT. CL. 25. (U.S. CLS. 22 AND 39). REG. 2-20-2001.
- 2,429,729. FIELDCENTRIX. INT. CL. 9. (U.S. CLS. 21, 23, 26, 36 AND 38). REG. 2-20-2001.
- 2,429,774. THE QUILTWORKS. INT. CL. 35. (U.S. CLS. 100, 101 AND 102). REG. 2-20-2001.
- 2,429,822. MANAGEMENT CONCEPTS AND DESIGN. INT. CLS. 9, 16, 35, 36, 41 AND 42. (U.S. CLS. 2, 5, 21, 22, 23, 26, 29, 36, 37, 38, 50, 100, 101, 102 AND 107). REG. 2-20-2001.
- 2,430,069. SOUTHERN STAR. INT. CL. 24. (U.S. CLS. 42 AND 50). REG. 2-20-2001.
- 2,430,227. MODEL 2002. INT. CL. 9. (U.S. CLS. 21, 23, 26, 36 AND 38). REG. 2-20-2001.
- 2,430,306. CABO. INT. CL. 28. (U.S. CLS. 22, 23, 38 AND 50). REG. 2-20-2001.
- 2,430,606. RED BULL INN AND DESIGN. INT. CLS. 29 AND 30. (U.S. CL. 46). REG. 2-27-2001.
- 2,430,846. MISCELLANEOUS DESIGN. INT. CL. 33. (U.S. CLS. 47 AND 49). REG. 2-27-2001.
- 2,431,160. CARBOTHERM. INT. CL. 11. (U.S. CLS. 13, 21, 23, 31 AND 34). REG. 2-27-2001.
- 2,431,279. GKE THE EDUCATIONAL EXCHANGE AND DESIGN. INT. CL. 41. (U.S. CLS. 100, 101 AND 107). REG. 2-27-2001.
- 2,431,340. INNOVATION-"PURE AND SIMPLE". INT. CL. 7. (U.S. CLS. 13, 19, 21, 23, 31, 34 AND 35). REG. 2-27-2001.
- 2,431,451. ROADBLOCK. INT. CL. 17. (U.S. CLS. 1, 5, 12, 13, 35 AND 50). REG. 2-27-2001.
- 2,431,493. EVENT 1. INT. CL. 35. (U.S. CLS. 100, 101 AND 102). REG. 2-27-2001.
- 2,431,802. FAIRWAYS TO FAITH. INT. CL. 41. (U.S. CLS. 100, 101 AND 107). REG. 2-27-2001.
- 2,432,615. FREIREMAR.SA AND DESIGN. INT. CL. 29. (U.S. CL. 46). REG. 3-6-2001.
- 2,432,652. HG (STYLIZED). INT. CL. 12. (U.S. CLS. 19, 21, 23, 31, 35 AND 44). REG. 3-6-2001.
- 2,432,851. SWAN CREEK CANDLE CO.. INT. CLS. 4 AND 21. (U.S. CLS. 1, 2, 6, 13, 15, 23, 29, 30, 33, 40 AND 50). REG. 3-6-2001.
- 2,432,910. IVILLAGE. INT. CL. 16. (U.S. CLS. 2, 5, 22, 23, 29, 37, 38 AND 50). REG. 3-6-2001.
- 2,433,058. ENCOMPASS. INT. CL. 35. (U.S. CLS. 100, 101 AND 102). REG. 3-6-2001.
- 2,433,094. KOSE (STYLIZED). INT. CLS. 11 AND 20. (U.S. CLS. 2, 13, 21, 22, 23, 25, 31, 32, 34 AND 50). REG. 3-6-2001.
- 2,433,166. MISCELLANEOUS DESIGN. INT. CLS. 37 AND 42. (U.S. CLS. 100, 101, 103 AND 106). REG. 3-6-2001.
- 2,433,261. BEAR TRAP DUNES AND DESIGN. INT. CLS. 35, 41 AND 42. (U.S. CLS. 100, 101, 102 AND 107). REG. 3-6-2001.
- 2,433,263. EUROPEAN SILKY WRAP SYSTEM. INT. CL. 3. (U.S. CLS. 1, 4, 6, 50, 51 AND 52). REG. 3-6-2001.
- 2,433,539. VAX-D (STYLIZED). INT. CL. 10. (U.S. CLS. 26, 39 AND 44). REG. 3-6-2001.
- 2,433,584. UOFL ALUMNI ASSOCIATION AND DESIGN. INT. CL. 42. (U.S. CLS. 100 AND 101). REG. 3-6-2001.
- 2,433,813. ICARUS. INT. CL. 16 ONLY. (U.S. CLS. 2, 5, 22, 23, 29, 37, 38 AND 50). REG. 3-6-2001.
- 2,433,855. DUCK CENTRAL. INT. CL. 39. (U.S. CLS. 100 AND 105). REG. 3-6-2001.
- 2,434,289. VISUAL GRAMMAR. INT. CL. 16. (U.S. CLS. 2, 5, 22, 23, 29, 37, 38 AND 50). REG. 3-6-2001.

- 2,434,435. CONICA. INT. CLS. 1, 2 AND 27. (U.S. CLS. 1, 5, 6, 10, 11, 16, 19, 20, 26, 37, 42, 46 AND 50). REG. 3-13-2001.
- 2,434,458. MXSTEN. INT. CL. 1. (U.S. CLS. 1, 5, 6, 10, 26 AND 46). REG. 3-13-2001.
- 2,434,679. CORPORATE BROTHERS. INT. CL. 36. (U.S. CLS. 100, 101 AND 102). REG. 3-13-2001.
- 2,434,687. SMARTER. INT. CL. 19. (U.S. CLS. 1, 12, 33 AND 50). REG. 3-13-2001.
- 2,434,937. SAN DIEGO STATE UNIVERSITY. INT. CLS. 12, 14, 16, 18, 20, 21 AND 25. (U.S. CLS. 1, 2, 3, 5, 13, 19, 21, 22, 23, 25, 27, 28, 29, 30, 31, 32, 33, 35, 37, 38, 39, 40, 41, 44 AND 50). REG. 3-13-2001.
- 2,435,100. M AND DESIGN. INT. CL. 21. (U.S. CLS. 2, 13, 23, 29, 30, 33, 40 AND 50). REG. 3-13-2001.
- 2,435,377. TRIAD. INT. CL. 27. (U.S. CLS. 19, 20, 37, 42 AND 50). REG. 3-13-2001.
- 2,435,579. OMEGA. INT. CL. 29. (U.S. CL. 46). REG. 3-13-2001.
- 2,435,742. ROKSOLID. INT. CL. 42. (U.S. CLS. 100 AND 101). REG. 3-13-2001.
- 2,435,794. LEVERENCH. INT. CL. 8. (U.S. CLS. 23, 28 AND 44). REG. 3-13-2001.
- 2,435,991. QR CODE (STYLIZED). INT. CL. 9. (U.S. CLS. 21, 23, 26, 36 AND 38). REG. 3-13-2001.
- 2,436,060. DREAM. INT. CL. 9. (U.S. CLS. 21, 23, 26, 36 AND 38). REG. 3-20-2001.
- 2,436,088. SUNCOR ENERGY AND DESIGN. INT. CLS. 35, 37, 39, 40 AND 42. (U.S. CLS. 100, 101, 102, 103, 105 AND 106). REG. 3-20-2001.
- 2,436,123. SUNBEAM AND DESIGN. INT. CLS. 4, 7, 8, 9, 10, 11, 20, 21 AND 37. (U.S. CLS. 1, 2, 6, 13, 15, 19, 21, 22, 23, 25, 26, 28, 29, 30, 31, 32, 33, 34, 35, 36, 38, 39, 40, 44, 50, 100, 103 AND 106). REG. 3-20-2001.
- 2,436,164. BLINDS TO GO AND DESIGN. INT. CL. 35. (U.S. CLS. 100, 101 AND 102). REG. 3-20-2001.
- 2,436,196. FFSC (STYLIZED). INT. CL. 42. (U.S. CLS. 100 AND 101). REG. 3-20-2001.
- 2,436,246. BEATSTOCK. INT. CLS. 9, 25, 38 AND 41. (U.S. CLS. 21, 22, 23, 26, 36, 38, 39, 100, 101, 104 AND 107). REG. 3-20-2001.
- 2,436,339. SCANNING FOR LIFE IDSI AND DESIGN. INT. CL. 10. (U.S. CLS. 26, 39 AND 44). REG. 3-20-2001.
- 2,436,357. EZREG. INT. CL. 11. (U.S. CLS. 13, 21, 23, 31 AND 34). REG. 3-20-2001.
- 2,436,368. THE PASADENA PLAYHOUSE. INT. CL. 41. (U.S. CLS. 100, 101 AND 107). REG. 3-20-2001.
- 2,436,387. DONA TOTA. INT. CL. 42. (U.S. CLS. 100 AND 101). REG. 3-20-2001.
- 2,436,400. O'HAGIN CLOAKED VENT TILE. INT. CL. 6. (U.S. CLS. 2, 12, 13, 14, 23, 25 AND 50). REG. 3-20-2001.
- 2,436,428. FLUIDKING AND DESIGN. INT. CL. 7. (U.S. CLS. 13, 19, 21, 23, 31, 34 AND 35). REG. 3-20-2001.
- 2,436,429. FLUIDKING. INT. CL. 7. (U.S. CLS. 13, 19, 21, 23, 31, 34 AND 35). REG. 3-20-2001.
- 2,436,476. CYBERBREAK. INT. CL. 9. (U.S. CLS. 21, 23, 26, 36 AND 38). REG. 3-20-2001.
- 2,436,511. UNIGLOBE INHOUSE TRAVEL AND DESIGN. INT. CLS. 39 AND 42. (U.S. CLS. 100, 101 AND 105). REG. 3-20-2001.
- 2,436,517. SOUTHWEST SILICON SWS AND DESIGN. INT. CLS. 1 AND 9. (U.S. CLS. 1, 5, 6, 10, 21, 23, 26, 36, 38 AND 46). REG. 3-20-2001.
- 2,436,557. MCNEILUS. INT. CLS. 7 AND 12. (U.S. CLS. 13, 19, 21, 23, 31, 34, 35 AND 44). REG. 3-20-2001.
- 2,436,560. GTSI.COM. INT. CLS. 35 AND 42. (U.S. CLS. 100, 101 AND 102). REG. 3-20-2001.
- 2,436,580. GREENHEAD GEAR. INT. CLS. 25 AND 28 ONLY. (U.S. CLS. 22, 23, 38, 39 AND 50). REG. 3-20-2001.
- 2,436,592. LCI. INT. CL. 41. (U.S. CLS. 100, 101 AND 107). REG. 3-20-2001.
- 2,436,640. MISTER MACHO. INT. CL. 5. (U.S. CLS. 6, 18, 44, 46, 51 AND 52). REG. 3-20-2001.
- 2,436,655. NEOCRETE. INT. CL. 2. (U.S. CLS. 6, 11 AND 16). REG. 3-20-2001.
- 2,436,700. NORTHSTAR. INT. CL. 2. (U.S. CLS. 6, 11 AND 16). REG. 3-20-2001.
- 2,436,723. AMERICATEL, SIEMPRE AL SERVICIO DE LOS HISPANOS. INT. CL. 38. (U.S. CLS. 100, 101 AND 104). REG. 3-20-2001.
- 2,436,745. MISCELLANEOUS DESIGN. INT. CL. 24. (U.S. CLS. 42 AND 50). REG. 3-20-2001.
- 2,436,746. THE BLACK DOG. INT. CL. 24. (U.S. CLS. 42 AND 50). REG. 3-20-2001.
- 2,436,756. DROID. INT. CL. 28. (U.S. CLS. 22, 23, 38 AND 50). REG. 3-20-2001.
- 2,436,827. LESPORTSAC AND DESIGN. INT. CLS. 18 AND 35. (U.S. CLS. 1, 2, 3, 22, 41, 100, 101 AND 102). REG. 3-20-2001.
- 2,436,828. MULTI ORO. INT. CLS. 3 AND 4. (U.S. CLS. 1, 4, 6, 15, 50, 51 AND 52). REG. 3-20-2001.
- 2,436,898. NEW YORK NEW YORK HOTEL & CASINO. INT. CL. 41. (U.S. CLS. 100, 101 AND 107). REG. 3-20-2001.
- 2,436,939. EGGLESTONWORKS. INT. CL. 9. (U.S. CLS. 21, 23, 26, 36 AND 38). REG. 3-20-2001.
- 2,436,944. THE SOCIAL GRACES. INT. CL. 35. (U.S. CLS. 100, 101 AND 102). REG. 3-20-2001.
- 2,437,063. LEWIS N. CLARK. INT. CL. 22. (U.S. CLS. 1, 2, 7, 19, 22, 42 AND 50). REG. 3-20-2001.
- 2,437,068. LEWIS N. CLARK. INT. CL. 10. (U.S. CLS. 26, 39 AND 44). REG. 3-20-2001.
- 2,437,086. PURATE. INT. CL. 1. (U.S. CLS. 1, 5, 6, 10, 26 AND 46). REG. 3-20-2001.
- 2,437,104. A-ZOOM. INT. CL. 13. (U.S. CLS. 2 AND 9). REG. 3-20-2001.
- 2,437,136. MISCELLANEOUS DESIGN. INT. CL. 42. (U.S. CLS. 100 AND 101). REG. 3-20-2001.
- 2,437,149. EZ-SPOT-UR. INT. CL. 7. (U.S. CLS. 13, 19, 21, 23, 31, 34 AND 35). REG. 3-20-2001.
- 2,437,203. STEELE (STYLIZED). INT. CL. 35. (U.S. CLS. 100, 101 AND 102). REG. 3-20-2001.
- 2,437,245. MISCELLANEOUS DESIGN. INT. CL. 42. (U.S. CLS. 100 AND 101). REG. 3-20-2001.
- 2,437,246. ULTRA-MAYD. INT. CL. 22. (U.S. CLS. 1, 2, 7, 19, 22, 42 AND 50). REG. 3-20-2001.
- 2,437,295. NORTHLAND AND DESIGN. INT. CLS. 36 AND 37. (U.S. CLS. 100, 101, 102, 103 AND 106). REG. 3-20-2001.
- 2,437,297. NORTHLAND. INT. CLS. 36 AND 37. (U.S. CLS. 100, 101, 102, 103 AND 106). REG. 3-20-2001.
- 2,437,338. RITE SURGE. INT. CL. 4. (U.S. CLS. 1, 6 AND 15). REG. 3-20-2001.
- 2,437,364. VAN BAERLE AND DESIGN. INT. CL. 1. (U.S. CLS. 1, 5, 6, 10, 26 AND 46). REG. 3-20-2001.
- 2,437,387. TRITECH. INT. CL. 9. (U.S. CLS. 21, 23, 26, 36 AND 38). REG. 3-20-2001.
- 2,437,421. VECTORWORKS. INT. CL. 9. (U.S. CLS. 21, 23, 26, 36 AND 38). REG. 3-20-2001.
- 2,437,487. BRITE SMILE. INT. CL. 42. (U.S. CLS. 100 AND 101). REG. 3-20-2001.
- 2,437,539. LITESPEED. INT. CL. 28. (U.S. CLS. 22, 23, 38 AND 50). REG. 3-20-2001.
- 2,437,576. WANTED2SELL. INT. CL. 35. (U.S. CLS. 100, 101 AND 102). REG. 3-20-2001.
- 2,437,652. PLUS P RATED FOR DUTY USE. INT. CL. 13. (U.S. CLS. 2 AND 9). REG. 3-20-2001.
- 2,437,684. DESIGN ASSESSMENT OF RELIABILITY WITH INSPECTION. INT. CL. 9. (U.S. CLS. 21, 23, 26, 36 AND 38). REG. 3-20-2001.
- 2,437,753. CELLGENIX. INT. CL. 5 ONLY. (U.S. CLS. 6, 18, 44, 46, 51 AND 52). REG. 3-27-2001.
- 2,437,794. PLAYER'S DESIGN. INT. CL. 25. (U.S. CLS. 22 AND 39). REG. 3-27-2001.
- 2,437,801. TRILOGY. INT. CLS. 9 AND 42 ONLY. (U.S. CLS. 21, 23, 26, 36, 38, 100 AND 101). REG. 3-27-2001.
- 2,437,812. UI AND DESIGN. INT. CLS. 14, 16, 25 AND 42 ONLY. (U.S. CLS. 2, 5, 22, 23, 27, 28, 29, 37, 38, 39, 50, 100 AND 101). REG. 3-27-2001.
- 2,437,825. TATEOSSIAN. INT. CLS. 6, 14, 18, 20 AND 25 ONLY. (U.S. CLS. 1, 2, 3, 12, 13, 14, 22, 23, 25, 27, 28, 32, 39, 41 AND 50). REG. 3-27-2001.
- 2,437,829. PDS. INT. CL. 12. (U.S. CLS. 19, 21, 23, 31, 35 AND 44). REG. 3-27-2001.
- 2,437,855. COTTO. INT. CL. 19. (U.S. CLS. 1, 12, 33 AND 50). REG. 3-27-2001.
- 2,437,866. THERMACELL. INT. CLS. 4 AND 9. (U.S. CLS. 1, 6, 15, 21, 23, 26, 36 AND 38). REG. 3-27-2001.
- 2,437,891. TOTALBANK. INT. CL. 36. (U.S. CLS. 100, 101 AND 102). REG. 3-27-2001.
- 2,437,930. FUGRO-SEASTAR. INT. CLS. 9 AND 39. (U.S. CLS. 21, 23, 26, 36, 38, 100 AND 105). REG. 3-27-2001.



- 2,437,931. B A D BEST AMERICAN DUFFEL. INT. CL. 18 ONLY. (U.S. CLS. 1, 2, 3, 22 AND 41). REG. 3-27-2001.
- 2,437,935. YAN CAN COOK. INT. CL. 8 ONLY. (U.S. CLS. 23, 28 AND 44). REG. 3-27-2001.
- 2,437,945. BEAUFORT BOOK COMPANY. INT. CLS. 16, 35 AND 41. (U.S. CLS. 2, 5, 22, 23, 29, 37, 38, 50, 100, 101, 102 AND 107). REG. 3-27-2001.
- 2,437,954. MISCELLANEOUS DESIGN. INT. CL. 16. (U.S. CLS. 2, 5, 22, 23, 29, 37, 38 AND 50). REG. 3-27-2001.
- 2,437,959. WICANDERS AND DESIGN. INT. CLS. 2 AND 3. (U.S. CLS. 1, 4, 6, 11, 16, 50, 51 AND 52). REG. 3-27-2001.
- 2,437,967. ZORB. INT. CL. 28 ONLY. (U.S. CLS. 22, 23, 38 AND 50). REG. 3-27-2001.
- 2,437,978. DURA-LAZ. INT. CL. 16. (U.S. CLS. 2, 5, 22, 23, 29, 37, 38 AND 50). REG. 3-27-2001.
- 2,438,003. OFFICECARE. INT. CL. 35. (U.S. CLS. 100, 101 AND 102). REG. 3-27-2001.
- 2,438,031. BRACLI. INT. CLS. 25 AND 35. (U.S. CLS. 22, 39, 100, 101 AND 102). REG. 3-27-2001.
- 2,438,034. SPIDERLINE. INT. CL. 9. (U.S. CLS. 21, 23, 26, 36 AND 38). REG. 3-27-2001.
- 2,438,039. CTI AND DESIGN. INT. CLS. 35, 37, 39 AND 42. (U.S. CLS. 100, 101, 102, 103, 105 AND 106). REG. 3-27-2001.
- 2,438,054. MEALSONWHEELS ASSOCIATION OF AMERICA AND DESIGN. INT. CLS. 41 AND 42. (U.S. CLS. 100, 101 AND 107). REG. 3-27-2001.
- 2,438,073. FLUORSHIELD. INT. CLS. 1 AND 5. (U.S. CLS. 1, 5, 6, 10, 18, 26, 44, 46, 51 AND 52). REG. 3-27-2001.
- 2,438,090. SHARKEE AND DESIGN. INT. CL. 8. (U.S. CLS. 23, 28 AND 44). REG. 3-27-2001.
- 2,438,096. SABL. INT. CL. 9. (U.S. CLS. 21, 23, 26, 36 AND 38). REG. 3-27-2001.
- 2,438,112. SECURE. INT. CL. 10. (U.S. CLS. 26, 39 AND 44). REG. 3-27-2001.
- 2,438,117. THERAGYM AND DESIGN. INT. CL. 10. (U.S. CLS. 26, 39 AND 44). REG. 3-27-2001.
- 2,438,138. EVERPLATE. INT. CL. 1. (U.S. CLS. 1, 5, 6, 10, 26 AND 46). REG. 3-27-2001.
- 2,438,162. REDLINE. INT. CL. 25. (U.S. CLS. 22 AND 39). REG. 3-27-2001.
- 2,438,174. B AND DESIGN. INT. CLS. 11 AND 21 ONLY. (U.S. CLS. 2, 13, 21, 23, 29, 30, 31, 33, 34, 40 AND 50). REG. 3-27-2001.
- 2,438,216. SELMER (STYLIZED). INT. CL. 16. (U.S. CLS. 2, 5, 22, 23, 29, 37, 38 AND 50). REG. 3-27-2001.
- 2,438,284. SCRAPBOOKS ETC.. INT. CL. 16. (U.S. CLS. 2, 5, 22, 23, 29, 37, 38 AND 50). REG. 3-27-2001.
- 2,438,309. QUESTIONMARKET.COM. INT. CL. 42. (U.S. CLS. 100 AND 101). REG. 3-27-2001.
- 2,438,323. JUST AND DESIGN. INT. CL. 3 ONLY. (U.S. CLS. 1, 4, 6, 50, 51 AND 52). REG. 3-27-2001.
- 2,438,333. ST. LUC (STYLIZED). INT. CL. 30. (U.S. CL. 46). REG. 3-27-2001.
- 2,438,343. GAR PRODUCTS. INT. CL. 20. (U.S. CLS. 2, 13, 22, 25, 32 AND 50). REG. 3-27-2001.
- 2,438,355. SWEET BLUE ONION. INT. CL. 30. (U.S. CL. 46). REG. 3-27-2001.
- 2,438,356. SWEET ORANGE POPPYSEED. INT. CL. 30. (U.S. CL. 46). REG. 3-27-2001.
- 2,438,405. AMERICAN CYCLE & FITNESS AND DESIGN. INT. CL. 35. (U.S. CLS. 100, 101 AND 102). REG. 3-27-2001.
- 2,438,462. TRIALMAX. INT. CL. 9. (U.S. CLS. 21, 23, 26, 36 AND 38). REG. 3-27-2001.
- 2,438,473. THE SILENCER. INT. CL. 7. (U.S. CLS. 13, 19, 21, 23, 31, 34 AND 35). REG. 3-27-2001.
- 2,438,485. NOTHING ESCAPES THE POWER OF A DIRT DEVIL. INT. CL. 7. (U.S. CLS. 13, 19, 21, 23, 31, 34 AND 35). REG. 3-27-2001.
- 2,438,517. LEWIS N. CLARK. INT. CL. 18. (U.S. CLS. 1, 2, 3, 22 AND 41). REG. 3-27-2001.
- 2,438,562. STARS. INT. CL. 9. (U.S. CLS. 21, 23, 26, 36 AND 38). REG. 3-27-2001.
- 2,438,570. FOR THE TAN OF YOUR LIFE ..... AND THE LIFE OF YOUR TAN!. INT. CL. 3. (U.S. CLS. 1, 4, 6, 50, 51 AND 52). REG. 3-27-2001.
- 2,438,577. TT 49V. INT. CL. 12. (U.S. CLS. 19, 21, 23, 31, 35 AND 44). REG. 3-27-2001.
- 2,438,592. T S RESTAURANTS. INT. CL. 42. (U.S. CLS. 100 AND 101). REG. 3-27-2001.
- 2,438,624. PROSERIES. INT. CL. 9. (U.S. CLS. 21, 23, 26, 36 AND 38). REG. 3-27-2001.
- 2,438,641. FRESH ATTRACTIONS. INT. CL. 42. (U.S. CLS. 100 AND 101). REG. 3-27-2001.
- 2,438,649. FAMILYCIRCLE. INT. CL. 42. (U.S. CLS. 100 AND 101). REG. 3-27-2001.
- 2,438,680. PIX. INT. CL. 9. (U.S. CLS. 21, 23, 26, 36 AND 38). REG. 3-27-2001.
- 2,438,686. WHISTLER WATER. INT. CL. 32. (U.S. CLS. 45, 46 AND 48). REG. 3-27-2001.
- 2,438,740. LOGIX5550. INT. CL. 9. (U.S. CLS. 21, 23, 26, 36 AND 38). REG. 3-27-2001.
- 2,438,763. S AND DESIGN. INT. CL. 1. (U.S. CLS. 1, 5, 6, 10, 26 AND 46). REG. 3-27-2001.
- 2,438,766. KATALCO. INT. CLS. 1, 40 AND 42. (U.S. CLS. 1, 5, 6, 10, 26, 46, 100, 101, 103 AND 106). REG. 3-27-2001.
- 2,438,857. HIGH SOLIDS. INT. CLS. 3 AND 5. (U.S. CLS. 1, 4, 6, 18, 44, 46, 50, 51 AND 52). REG. 3-27-2001.
- 2,438,882. SNB DIRECTBANKER. INT. CL. 36. (U.S. CLS. 100, 101 AND 102). REG. 3-27-2001.
- 2,438,888. HARBOR FREIGHT TOOLS USA. INT. CL. 35. (U.S. CLS. 100, 101 AND 102). REG. 3-27-2001.
- 2,438,893. AKAMAI. INT. CL. 9. (U.S. CLS. 21, 23, 26, 36 AND 38). REG. 3-27-2001.
- 2,438,928. HORIZON. INT. CL. 9. (U.S. CLS. 21, 23, 26, 36 AND 38). REG. 3-27-2001.
- 2,438,933. SHABBY CHIC. INT. CL. 27. (U.S. CLS. 19, 20, 37, 42 AND 50). REG. 3-27-2001.
- 2,438,984. CENTRON. INT. CL. 9 ONLY. (U.S. CLS. 21, 23, 26, 36 AND 38). REG. 3-27-2001.
- 2,439,005. LINEN-LIKE SUPREME AND DESIGN. INT. CL. 16. (U.S. CLS. 2, 5, 22, 23, 29, 37, 38 AND 50). REG. 3-27-2001.
- 2,439,016. YOGANETICS. INT. CLS. 9 AND 41. (U.S. CLS. 21, 23, 26, 36, 38, 100, 101 AND 107). REG. 3-27-2001.
- 2,439,063. ROOBEE. INT. CL. 16. (U.S. CLS. 2, 5, 22, 23, 29, 37, 38 AND 50). REG. 3-27-2001.
- 2,439,084. SHADOW HAWK. INT. CL. 42. (U.S. CLS. 100 AND 101). REG. 3-27-2001.
- 2,439,086. SHADOW HAWK. INT. CL. 25. (U.S. CLS. 22 AND 39). REG. 3-27-2001.
- 2,439,087. SHADOW HAWK. INT. CL. 24. (U.S. CLS. 42 AND 50). REG. 3-27-2001.
- 2,439,105. REALCHANGE. INT. CL. 41. (U.S. CLS. 100, 101 AND 107). REG. 3-27-2001.
- 2,439,145. MINI WAVE. INT. CL. 11. (U.S. CLS. 13, 21, 23, 31 AND 34). REG. 3-27-2001.
- 2,439,152. STALLEX. INT. CLS. 3 AND 5. (U.S. CLS. 1, 4, 6, 18, 44, 46, 50, 51 AND 52). REG. 3-27-2001.
- 2,439,173. PS PAUL SMITH (STYLIZED). INT. CL. 25. (U.S. CLS. 22 AND 39). REG. 3-27-2001.
- 2,439,226. TPS. INT. CLS. 16 AND 42. (U.S. CLS. 2, 5, 22, 23, 29, 37, 38, 50, 100 AND 101). REG. 3-27-2001.
- 2,439,232. AMERICAN TOURISTER AND DESIGN. INT. CL. 9 ONLY. (U.S. CLS. 21, 23, 26, 36 AND 38). REG. 3-27-2001.
- 2,439,279. NATURALLY BETTER. INT. CL. 35. (U.S. CLS. 100, 101 AND 102). REG. 3-27-2001.
- 2,439,376. FASTTRACK ABM. INT. CL. 9. (U.S. CLS. 21, 23, 26, 36 AND 38). REG. 3-27-2001.
- 2,439,460. TOURSTAGE. INT. CL. 28. (U.S. CLS. 22, 23, 38 AND 50). REG. 3-27-2001.
- 2,439,462. INSTAMORTGAGE.COM. INT. CL. 36. (U.S. CLS. 100, 101 AND 102). REG. 3-27-2001.
- 2,439,471. 350 BULL. INT. CL. 19. (U.S. CLS. 1, 12, 33 AND 50). REG. 3-27-2001.
- 2,439,504. THE BEST FOOD ON EARTH ANYWHERE ON THE PLANET. INT. CL. 42. (U.S. CLS. 100 AND 101). REG. 3-27-2001.
- 2,439,556. DESOTO APPEAL. INT. CL. 16. (U.S. CLS. 2, 5, 22, 23, 29, 37, 38 AND 50). REG. 3-27-2001.
- 2,439,576. RCC. INT. CLS. 38 AND 39 ONLY. (U.S. CLS. 100, 101, 104 AND 105). REG. 3-27-2001.
- 2,439,598. RAPID PARTS. INT. CL. 35. (U.S. CLS. 100, 101 AND 102). REG. 3-27-2001.
- 2,439,636. ULTRAPURE. INT. CL. 1. (U.S. CLS. 1, 5, 6, 10, 26 AND 46). REG. 3-27-2001.
- 2,439,693. SCRIPTURE STRIPS. INT. CL. 9. (U.S. CLS. 21, 23, 26, 36 AND 38). REG. 3-27-2001.
- 2,439,698. HIGASHI. INT. CL. 14. (U.S. CLS. 2, 27, 28 AND 50). REG. 3-27-2001.
- 2,439,733. DREVE. INT. CLS. 5, 10 AND 17. (U.S. CLS. 1, 5, 6, 12, 13, 18, 26, 35, 39, 44, 46, 50, 51 AND 52). REG. 4-3-2001.

- 2,439,751. MISCELLANEOUS DESIGN. INT. CL. 29. (U.S. CL. 46). REG. 4-3-2001.
- 2,439,778. MISCELLANEOUS DESIGN. INT. CL. 11. (U.S. CLS. 13, 21, 23, 31 AND 34). REG. 4-3-2001.
- 2,439,784. CAP. INT. CL. 36. (U.S. CLS. 100, 101 AND 102). REG. 4-3-2001.
- 2,439,810. ULTRA-VISION. INT. CL. 21. (U.S. CLS. 2, 13, 23, 29, 30, 33, 40 AND 50). REG. 4-3-2001.
- 2,439,811. POLICYLINK. INT. CL. 42. (U.S. CLS. 100 AND 101). REG. 4-3-2001.
- 2,439,812. EDP SCIENCES. INT. CLS. 9, 16 AND 41. (U.S. CLS. 2, 5, 21, 22, 23, 26, 29, 36, 37, 38, 50, 100, 101 AND 107). REG. 4-3-2001.
- 2,439,817. SERAPID. INT. CLS. 6 AND 7. (U.S. CLS. 2, 12, 13, 14, 19, 21, 23, 25, 31, 34, 35 AND 50). REG. 4-3-2001.
- 2,439,893. THE MAGNIFICENT MILE. INT. CLS. 35 AND 42. (U.S. CLS. 100, 101 AND 102). REG. 4-3-2001.
- 2,439,898. FLEX-LINK. INT. CL. 27. (U.S. CLS. 19, 20, 37, 42 AND 50). REG. 4-3-2001.
- 2,439,949. AMARA. INT. CL. 42. (U.S. CLS. 100 AND 101). REG. 4-3-2001.
- 2,439,968. COMMITTED TO OUR COMMUNITY NGA GROCERS CARE AND DESIGN. INT. CL. 42. (U.S. CLS. 100 AND 101). REG. 4-3-2001.
- 2,439,994. FREE LOTTO AND DESIGN. INT. CL. 41. (U.S. CLS. 100, 101 AND 107). REG. 4-3-2001.
- 2,440,016. SACRAMENTO SOUTHERN RAILROAD AND DESIGN. INT. CL. 39. (U.S. CLS. 100 AND 105). REG. 4-3-2001.
- 2,440,033. VARIOFAN. INT. CL. 9. (U.S. CLS. 21, 23, 26, 36 AND 38). REG. 4-3-2001.
- 2,440,068. TAPCO. INT. CLS. 6 AND 8. (U.S. CLS. 2, 12, 13, 14, 23, 25, 28, 44 AND 50). REG. 4-3-2001.
- 2,440,079. IRON SEARCH. INT. CL. 42. (U.S. CLS. 100 AND 101). REG. 4-3-2001.
- 2,440,099. CIRCULATIONPRO. INT. CL. 9. (U.S. CLS. 21, 23, 26, 36 AND 38). REG. 4-3-2001.
- 2,440,112. COOL. INT. CLS. 38 AND 41. (U.S. CLS. 100, 101, 104 AND 107). REG. 4-3-2001.
- 2,440,113. COOL AND DESIGN. INT. CLS. 38 AND 41. (U.S. CLS. 100, 101, 104 AND 107). REG. 4-3-2001.
- 2,440,124. SOLUS. INT. CL. 19. (U.S. CLS. 1, 12, 33 AND 50). REG. 4-3-2001.
- 2,440,135. MUFFIN TOWN. INT. CL. 30. (U.S. CL. 46). REG. 4-3-2001.
- 2,440,138. ROAD FORCE MEASUREMENT. INT. CL. 12. (U.S. CLS. 19, 21, 23, 31, 35 AND 44). REG. 4-3-2001.
- 2,440,141. PANDA CARES. INT. CL. 36. (U.S. CLS. 100, 101 AND 102). REG. 4-3-2001.
- 2,440,145. SCHOOL BOARD. INT. CL. 19. (U.S. CLS. 1, 12, 33 AND 50). REG. 4-3-2001.
- 2,440,149. ACDELCO AND DESIGN. INT. CL. 4. (U.S. CLS. 1, 6 AND 15). REG. 4-3-2001.
- 2,440,150. ACDELCO AND DESIGN. INT. CL. 1. (U.S. CLS. 1, 5, 6, 10, 26 AND 46). REG. 4-3-2001.
- 2,440,175. RELY PRODUCTS AND DESIGN. INT. CL. 5 ONLY. (U.S. CLS. 6, 18, 44, 46, 51 AND 52). REG. 4-3-2001.
- 2,440,181. HALO. INT. CL. 15. (U.S. CLS. 2, 21 AND 36). REG. 4-3-2001.
- 2,440,188. HOMELAND FOUNDATION. INT. CL. 41. (U.S. CLS. 100, 101 AND 107). REG. 4-3-2001.
- 2,440,197. REBEL. INT. CL. 9. (U.S. CLS. 21, 23, 26, 36 AND 38). REG. 4-3-2001.
- 2,440,262. CHEF TALK. INT. CL. 42. (U.S. CLS. 100 AND 101). REG. 4-3-2001.
- 2,440,268. GLOCK PERFECTION. INT. CLS. 6, 8, 9, 13 AND 16. (U.S. CLS. 2, 5, 9, 12, 13, 14, 21, 22, 23, 25, 26, 28, 29, 36, 37, 38, 44 AND 50). REG. 4-3-2001.
- 2,440,275. FOUR RIVERS LAYOUT BOAT. INT. CL. 12. (U.S. CLS. 19, 21, 23, 31, 35 AND 44). REG. 4-3-2001.
- 2,440,304. MISCELLANEOUS DESIGN. INT. CL. 28. (U.S. CLS. 22, 23, 38 AND 50). REG. 4-3-2001.
- 2,440,345. BELMARK. INT. CLS. 16, 35 AND 42. (U.S. CLS. 2, 5, 22, 23, 29, 37, 38, 50, 100, 101 AND 102). REG. 4-3-2001.
- 2,440,348. ESCIENCE AND DESIGN. INT. CL. 42. (U.S. CLS. 100 AND 101). REG. 4-3-2001.
- 2,440,358. MISCELLANEOUS DESIGN. INT. CL. 25. (U.S. CLS. 22 AND 39). REG. 4-3-2001.
- 2,440,374. JACKPOT JUNCTION. INT. CL. 41. (U.S. CLS. 100, 101 AND 107). REG. 4-3-2001.
- 2,440,388. MERCY HOME CARE. INT. CL. 42. (U.S. CLS. 100 AND 101). REG. 4-3-2001.
- 2,440,530. CREE. INT. CL. 9. (U.S. CLS. 21, 23, 26, 36 AND 38). REG. 4-3-2001.
- 2,440,541. VERSACE. INT. CLS. 8, 19, 20, 21 AND 24. (U.S. CLS. 1, 2, 12, 13, 22, 23, 25, 28, 29, 30, 32, 33, 40, 42, 44 AND 50). REG. 4-3-2001.
- 2,440,548. THE PALMETTO. INT. CL. 11. (U.S. CLS. 13, 21, 23, 31 AND 34). REG. 4-3-2001.
- 2,440,671. PRUDENTIAL PLAZA. INT. CL. 36. (U.S. CLS. 100, 101 AND 102). REG. 4-3-2001.
- 2,440,715. UTAH. INT. CL. 9. (U.S. CLS. 21, 23, 26, 36 AND 38). REG. 4-3-2001.
- 2,440,716. BIOJECT. INT. CL. 10. (U.S. CLS. 26, 39 AND 44). REG. 4-3-2001.
- 2,440,731. THE BUSINESS OF INNOVATION. INT. CL. 42. (U.S. CLS. 100 AND 101). REG. 4-3-2001.
- 2,440,790. SAFESHOPPING ORG AND DESIGN. INT. CL. 42. (U.S. CLS. 100 AND 101). REG. 4-3-2001.
- 2,440,827. EPI-DERM. INT. CL. 5. (U.S. CLS. 6, 18, 44, 46, 51 AND 52). REG. 4-3-2001.
- 2,440,879. PROCURI. INT. CL. 35. (U.S. CLS. 100, 101 AND 102). REG. 4-3-2001.
- 2,440,882. LEWIS N. CLARK. INT. CL. 6. (U.S. CLS. 2, 12, 13, 14, 23, 25 AND 50). REG. 4-3-2001.
- 2,440,884. LEWIS N. CLARK. INT. CL. 20. (U.S. CLS. 2, 13, 22, 25, 32 AND 50). REG. 4-3-2001.
- 2,440,890. LINCOLN TECH. INT. CL. 41. (U.S. CLS. 100, 101 AND 107). REG. 4-3-2001.
- 2,441,004. MISCELLANEOUS DESIGN. INT. CLS. 29 AND 30. (U.S. CL. 46). REG. 4-3-2001.
- 2,441,013. FIN-TECH. INT. CL. 28. (U.S. CLS. 22, 23, 38 AND 50). REG. 4-3-2001.
- 2,441,061. MIRACLE DREAMS. INT. CL. 16. (U.S. CLS. 2, 5, 22, 23, 29, 37, 38 AND 50). REG. 4-3-2001.
- 2,441,064. "M&M'S" (STYLIZED). INT. CL. 21. (U.S. CLS. 2, 13, 23, 29, 30, 33, 40 AND 50). REG. 4-3-2001.
- 2,441,088. KMSP. INT. CL. 38. (U.S. CLS. 100, 101 AND 104). REG. 4-3-2001.
- 2,441,167. FITBUY. INT. CL. 35. (U.S. CLS. 100, 101 AND 102). REG. 4-3-2001.
- 2,441,182. CENSAR. INT. CL. 9. (U.S. CLS. 21, 23, 26, 36 AND 38). REG. 4-3-2001.
- 2,441,205. ZINGA (STYLIZED). INT. CLS. 1 AND 2. (U.S. CLS. 1, 5, 6, 10, 11, 16, 26 AND 46). REG. 4-3-2001.
- 2,441,217. LOVE OASIS CHRISTIAN CENTER TAKING HIS WORD, TO HIS EARTH: THROUGH HIS LOVE, BY AND DESIGN. INT. CLS. 9 AND 35. (U.S. CLS. 21, 23, 26, 36, 38, 100, 101 AND 102). REG. 4-3-2001.
- 2,441,310. OFFICIAL ELECTION MAIL AND DESIGN. INT. CLS. 16, 35 AND 39. (U.S. CLS. 2, 5, 22, 23, 29, 37, 38, 50, 100, 101, 102 AND 105). REG. 4-3-2001.
- 2,441,328. VPN-1. INT. CL. 9. (U.S. CLS. 21, 23, 26, 36 AND 38). REG. 4-3-2001.
- 2,441,331. VIRTUAL EYE. INT. CL. 10. (U.S. CLS. 26, 39 AND 44). REG. 4-3-2001.
- 2,441,337. SAN FRANCISCO. INT. CL. 11. (U.S. CLS. 13, 21, 23, 31 AND 34). REG. 4-3-2001.
- 2,441,363. EXHIBIT EDGE. INT. CLS. 37, 39 AND 42. (U.S. CLS. 100, 101, 103, 105 AND 106). REG. 4-3-2001.
- 2,441,371. LYCOVIT (STYLIZED). INT. CL. 5 ONLY. (U.S. CLS. 6, 18, 44, 46, 51 AND 52). REG. 4-3-2001.
- 2,441,373. BRITETOP. INT. CL. 16. (U.S. CLS. 2, 5, 22, 23, 29, 37, 38 AND 50). REG. 4-3-2001.
- 2,441,462. AQUA COOLER. INT. CL. 11. (U.S. CLS. 13, 21, 23, 31 AND 34). REG. 4-3-2001.
- 2,441,465. GOLDEN TOUCH. INT. CL. 37. (U.S. CLS. 100, 103 AND 106). REG. 4-3-2001.
- 2,441,494. PENTASOL. INT. CL. 5. (U.S. CLS. 6, 18, 44, 46, 51 AND 52). REG. 4-3-2001.
- 2,441,524. CARDIOFIX. INT. CL. 10. (U.S. CLS. 26, 39 AND 44). REG. 4-3-2001.
- 2,441,545. SHOWTEC. INT. CLS. 5 AND 31. (U.S. CLS. 1, 6, 18, 44, 46, 51 AND 52). REG. 4-3-2001.
- 2,441,567. MASAI. INT. CL. 25. (U.S. CLS. 22 AND 39). REG. 4-3-2001.
- 2,441,624. RECONSERVE. INT. CL. 31. (U.S. CLS. 1 AND 46). REG. 4-3-2001.
- 2,441,653. THE GOURMET OUTLET. INT. CL. 42. (U.S. CLS. 100 AND 101). REG. 4-3-2001.
- 2,441,740. WORLD WIDE TECHNOLOGY, INC. AND DESIGN. INT. CL. 38. (U.S. CLS. 100, 101 AND 104). REG. 4-10-2001.

- 2,441,786. JET WEB AND DESIGN. INT. CL. 7. (U.S. CLS. 13, 19, 21, 23, 31, 34 AND 35). REG. 4-10-2001.
- 2,441,794. THE PALISADE. INT. CL. 11. (U.S. CLS. 13, 21, 23, 31 AND 34). REG. 4-10-2001.
- 2,441,830. BOLLORE AND DESIGN. INT. CL. 16 ONLY. (U.S. CLS. 2, 5, 22, 23, 29, 37, 38 AND 50). REG. 4-10-2001.
- 2,441,929. THAT '70S SHOW (STYLIZED). INT. CL. 41. (U.S. CLS. 100, 101 AND 107). REG. 4-10-2001.
- 2,441,992. NIGEN INTERNATIONAL (STYLIZED). INT. CLS. 35 AND 42. (U.S. CLS. 100, 101 AND 102). REG. 4-10-2001.
- 2,442,024. CAFE GAVINA (STYLIZED). INT. CL. 30. (U.S. CL. 46). REG. 4-10-2001.
- 2,442,042. IFINANCE. INT. CL. 36. (U.S. CLS. 100, 101 AND 102). REG. 4-10-2001.
- 2,442,045. B AND DESIGN. INT. CL. 5. (U.S. CLS. 6, 18, 44, 46, 51 AND 52). REG. 4-10-2001.
- 2,442,084. TAKE ACTION!. INT. CL. 41. (U.S. CLS. 100, 101 AND 107). REG. 4-10-2001.
- 2,442,090. GENO. INT. CLS. 5 AND 42 ONLY. (U.S. CLS. 6, 18, 44, 46, 51, 52, 100 AND 101). REG. 4-10-2001.
- 2,442,145. VITROGRIT. INT. CL. 3. (U.S. CLS. 1, 4, 6, 50, 51 AND 52). REG. 4-10-2001.
- 2,442,152. THE IVY LEAGUE. INT. CL. 41. (U.S. CLS. 100, 101 AND 107). REG. 4-10-2001.
- 2,442,175. ELECTRIC-AIRE AND DESIGN. INT. CL. 11. (U.S. CLS. 13, 21, 23, 31 AND 34). REG. 4-10-2001.
- 2,442,176. ELECTRIC-AIRE. INT. CL. 11. (U.S. CLS. 13, 21, 23, 31 AND 34). REG. 4-10-2001.
- 2,442,185. MISCELLANEOUS DESIGN. INT. CL. 36 ONLY. (U.S. CLS. 100, 101 AND 102). REG. 4-10-2001.
- 2,442,222. MICHIGAN WIRE PROCESSING COMPANY, INC.. INT. CL. 6. (U.S. CLS. 2, 12, 13, 14, 23, 25 AND 50). REG. 4-10-2001.
- 2,442,223. MICHIGAN WIRE PROCESSING COMPANY, INC.. INT. CL. 40. (U.S. CLS. 100, 103 AND 106). REG. 4-10-2001.
- 2,442,318. MISCELLANEOUS DESIGN. INT. CL. 7. (U.S. CLS. 13, 19, 21, 23, 31, 34 AND 35). REG. 4-10-2001.
- 2,442,355. TRLR-LOC AND DESIGN. INT. CL. 6. (U.S. CLS. 2, 12, 13, 14, 23, 25 AND 50). REG. 4-10-2001.
- 2,442,618. TIGER WOODS. INT. CL. 41. (U.S. CLS. 100, 101 AND 107). REG. 4-10-2001.
- 2,442,651. HOMEPUTER. INT. CL. 9. (U.S. CLS. 21, 23, 26, 36 AND 38). REG. 4-10-2001.
- 2,442,674. ORW. INT. CLS. 35 AND 37. (U.S. CLS. 100, 101, 102, 103 AND 106). REG. 4-10-2001.
- 2,442,790. WRBW. INT. CL. 38. (U.S. CLS. 100, 101 AND 104). REG. 4-10-2001.
- 2,442,861. PLANET OF THE APES (STYLIZED). INT. CL. 41. (U.S. CLS. 100, 101 AND 107). REG. 4-10-2001.
- 2,443,000. SWINGOLF. INT. CLS. 25 AND 28. (U.S. CLS. 22, 23, 38, 39 AND 50). REG. 4-10-2001.
- 2,443,049. SOOJI CHIM. INT. CL. 41. (U.S. CLS. 100, 101 AND 107). REG. 4-10-2001.
- 2,443,052. REAL QUIET. INT. CL. 9. (U.S. CLS. 21, 23, 26, 36 AND 38). REG. 4-10-2001.
- 2,443,279. PED F2. INT. CL. 10. (U.S. CLS. 26, 39 AND 44). REG. 4-10-2001.
- 2,443,370. HYDOL. INT. CL. 1. (U.S. CLS. 1, 5, 6, 10, 26 AND 46). REG. 4-10-2001.
- 2,443,386. CARNIVAL. INT. CL. 34. (U.S. CLS. 2, 8, 9 AND 17). REG. 4-10-2001.
- 2,443,430. C-TEK. INT. CL. 17. (U.S. CLS. 1, 5, 12, 13, 35 AND 50). REG. 4-10-2001.
- 2,443,463. DATAGYM. INT. CL. 9. (U.S. CLS. 21, 23, 26, 36 AND 38). REG. 4-10-2001.
- 2,443,464. DATAGYM. INT. CL. 35. (U.S. CLS. 100, 101 AND 102). REG. 4-10-2001.
- 2,443,473. POWERPROFILE. INT. CL. 9. (U.S. CLS. 21, 23, 26, 36 AND 38). REG. 4-10-2001.
- 2,443,474. STATEPROFILE. INT. CL. 9. (U.S. CLS. 21, 23, 26, 36 AND 38). REG. 4-10-2001.
- 2,443,510. BLUECAT. INT. CL. 9. (U.S. CLS. 21, 23, 26, 36 AND 38). REG. 4-10-2001.
- 2,443,586. FOOD CULTURE. INT. CL. 16. (U.S. CLS. 2, 5, 22, 23, 29, 37, 38 AND 50). REG. 4-10-2001.
- 2,443,595. SPICY THREE PEPPER. INT. CL. 30. (U.S. CL. 46). REG. 4-10-2001.
- 2,443,636. RAISING YOUR EXPECTATIONS. INT. CL. 9. (U.S. CLS. 21, 23, 26, 36 AND 38). REG. 4-17-2001.
- 2,443,691. MISCELLANEOUS DESIGN. INT. CLS. 16 AND 17. (U.S. CLS. 1, 2, 5, 12, 13, 22, 23, 29, 35, 37, 38 AND 50). REG. 4-17-2001.
- 2,443,721. RUBBEX. INT. CL. 7. (U.S. CLS. 13, 19, 21, 23, 31, 34 AND 35). REG. 4-17-2001.
- 2,443,819. BULL STEEL AND DESIGN. INT. CL. 6. (U.S. CLS. 2, 12, 13, 14, 23, 25 AND 50). REG. 4-17-2001.
- 2,444,008. THE MARRIAGE ENRICHMENT WEEKEND PROGRAM INC. AND DESIGN. INT. CLS. 16 AND 41. (U.S. CLS. 2, 5, 22, 23, 29, 37, 38, 50, 100, 101 AND 107). REG. 4-17-2001.
- 2,444,031. PERFORMANCE VINYL. INT. CL. 22. (U.S. CLS. 1, 2, 7, 19, 22, 42 AND 50). REG. 4-17-2001.
- 2,444,061. MARGINQUEST AND DESIGN. INT. CL. 36. (U.S. CLS. 100, 101 AND 102). REG. 4-17-2001.
- 2,444,072. BUSINESS EXTRA AND DESIGN. INT. CL. 35. (U.S. CLS. 100, 101 AND 102). REG. 4-17-2001.
- 2,444,085. PRIMALOFT. INT. CLS. 20 AND 24. (U.S. CLS. 2, 13, 22, 25, 32, 42 AND 50). REG. 4-17-2001.
- 2,444,092. MISCELLANEOUS DESIGN. INT. CL. 4. (U.S. CLS. 1, 6 AND 15). REG. 4-17-2001.
- 2,444,165. EXALTO. INT. CL. 12. (U.S. CLS. 19, 21, 23, 31, 35 AND 44). REG. 4-17-2001.
- 2,444,195. APPALACHIAN STATE UNIVERSITY. INT. CL. 41. (U.S. CLS. 100, 101 AND 107). REG. 4-17-2001.
- 2,444,242. C STOP. INT. CL. 35. (U.S. CLS. 100, 101 AND 102). REG. 4-17-2001.
- 2,444,246. TRAKMATES. INT. CL. 9. (U.S. CLS. 21, 23, 26, 36 AND 38). REG. 4-17-2001.
- 2,444,378. LET THE EXPERTS TAKE A LOOK. INT. CL. 35. (U.S. CLS. 100, 101 AND 102). REG. 4-17-2001.
- 2,444,384. AUCTION WIZARD. INT. CL. 9. (U.S. CLS. 21, 23, 26, 36 AND 38). REG. 4-17-2001.
- 2,444,528. HOW TO LIVE IN AMERICA. INT. CL. 41. (U.S. CLS. 100, 101 AND 107). REG. 4-17-2001.
- 2,444,632. RICO (STYLIZED). INT. CL. 30. (U.S. CL. 46). REG. 4-17-2001.
- 2,444,642. HYPERIPURE. INT. CL. 1. (U.S. CLS. 1, 5, 6, 10, 26 AND 46). REG. 4-17-2001.
- 2,444,682. CERAMO. INT. CL. 10. (U.S. CLS. 26, 39 AND 44). REG. 4-17-2001.
- 2,444,686. IPGPHOR. INT. CL. 9. (U.S. CLS. 21, 23, 26, 36 AND 38). REG. 4-17-2001.
- 2,444,767. CHEMGUARD. INT. CL. 9. (U.S. CLS. 21, 23, 26, 36 AND 38). REG. 4-17-2001.
- 2,444,885. ETOIMS. INT. CL. 42. (U.S. CLS. 100 AND 101). REG. 4-17-2001.
- 2,445,017. WEATHERALL COMPANY, INC. AND DESIGN. INT. CLS. 17 AND 19. (U.S. CLS. 1, 5, 12, 13, 33, 35 AND 50). REG. 4-17-2001.
- 2,445,075. ORANGE DIVINE. INT. CL. 32. (U.S. CLS. 45, 46 AND 48). REG. 4-17-2001.
- 2,445,076. BLACK CHERRY CHERISH. INT. CL. 32. (U.S. CLS. 45, 46 AND 48). REG. 4-17-2001.
- 2,445,078. HALLCOMAG. INT. CL. 1. (U.S. CLS. 1, 5, 6, 10, 26 AND 46). REG. 4-17-2001.
- 2,445,179. PLAYBOY. INT. CL. 15. (U.S. CLS. 2, 21 AND 36). REG. 4-17-2001.
- 2,445,192. COMFORT SNAFFLE. INT. CL. 18. (U.S. CLS. 1, 2, 3, 22 AND 41). REG. 4-17-2001.
- 2,445,249. WESTCLAY. INT. CL. 37. (U.S. CLS. 100, 103 AND 106). REG. 4-17-2001.
- 2,445,306. NEW ENGLAND HEARTH & SOAPSTONE LLC. INT. CLS. 37 AND 40. (U.S. CLS. 100, 103 AND 106). REG. 4-17-2001.
- 2,445,324. UNION COMMUNITY FUND. INT. CL. 36 ONLY. (U.S. CLS. 100, 101 AND 102). REG. 4-17-2001.
- 2,445,327. PETFOOODIRECT.COM. INT. CLS. 35 AND 39. (U.S. CLS. 100, 101, 102 AND 105). REG. 4-17-2001.
- 2,445,343. POCKET COOLIE. INT. CL. 21. (U.S. CLS. 2, 13, 23, 29, 30, 33, 40 AND 50). REG. 4-17-2001.
- 2,445,386. HEIMBACH AND DESIGN. INT. CL. 7. (U.S. CLS. 13, 19, 21, 23, 31, 34 AND 35). REG. 4-24-2001.
- 2,445,586. MORSE. INT. CLS. 6 AND 7. (U.S. CLS. 2, 12, 13, 14, 19, 21, 23, 25, 31, 34, 35 AND 50). REG. 4-24-2001.
- 2,445,606. HANDY AND DESIGN. INT. CL. 40. (U.S. CLS. 100, 103 AND 106). REG. 4-24-2001.
- 2,445,675. FOI AND DESIGN. INT. CL. 16. (U.S. CLS. 2, 5, 22, 23, 29, 37, 38 AND 50). REG. 4-24-2001.
- 2,445,737. ACDELCO AND DESIGN. INT. CL. 12. (U.S. CLS. 19, 21, 23, 31, 35 AND 44). REG. 4-24-2001.
- 2,445,738. ACDELCO AND DESIGN. INT. CL. 17. (U.S. CLS. 1, 5, 12, 13, 35 AND 50). REG. 4-24-2001.

- 2,445,739. ACDELCO AND DESIGN. INT. CL. 9. (U.S. CLS. 21, 23, 26, 36 AND 38). REG. 4-24-2001.
- 2,445,740. ACDELCO AND DESIGN. INT. CL. 7. (U.S. CLS. 13, 19, 21, 23, 31, 34 AND 35). REG. 4-24-2001.
- 2,445,794. BOOMERANG BOX. INT. CL. 41. (U.S. CLS. 100, 101 AND 107). REG. 4-24-2001.
- 2,445,799. TAMCO. INT. CL. 36. (U.S. CLS. 100, 101 AND 102). REG. 4-24-2001.
- 2,445,934. MARGINQUEST. INT. CL. 36. (U.S. CLS. 100, 101 AND 102). REG. 4-24-2001.
- 2,445,989. DI AND DESIGN. INT. CL. 39. (U.S. CLS. 100 AND 105). REG. 4-24-2001.
- 2,445,990. CO AND DESIGN. INT. CL. 39. (U.S. CLS. 100 AND 105). REG. 4-24-2001.
- 2,446,056. PIZZA HUT AND DESIGN. INT. CL. 42. (U.S. CLS. 100 AND 101). REG. 4-24-2001.
- 2,446,309. BL21-CODONPLUS. INT. CL. 1. (U.S. CLS. 1, 5, 6, 10, 26 AND 46). REG. 4-24-2001.
- 2,446,388. USGA FOUNDATION. INT. CL. 36. (U.S. CLS. 100, 101 AND 102). REG. 4-24-2001.
- 2,446,490. BREAST PETALS. INT. CL. 10. (U.S. CLS. 26, 39 AND 44). REG. 4-24-2001.
- 2,446,625. SYLVANIA. INT. CLS. 9 AND 37. (U.S. CLS. 21, 23, 26, 36, 38, 100, 103 AND 106). REG. 4-24-2001.
- 2,446,630. AIR-RANGEMENT. INT. CL. 28. (U.S. CLS. 22, 23, 38 AND 50). REG. 4-24-2001.
- 2,446,694. SB (STYLIZED). INT. CL. 6. (U.S. CLS. 2, 12, 13, 14, 23, 25 AND 50). REG. 4-24-2001.
- 2,446,704. PRETTY WOMAN. INT. CL. 25. (U.S. CLS. 22 AND 39). REG. 4-24-2001.
- 2,446,735. VEGETASE. INT. CL. 5. (U.S. CLS. 6, 18, 44, 46, 51 AND 52). REG. 4-24-2001.
- 2,446,756. INTEGRITEAM. INT. CL. 35. (U.S. CLS. 100, 101 AND 102). REG. 4-24-2001.
- 2,446,787. CFS. INT. CL. 7. (U.S. CLS. 13, 19, 21, 23, 31, 34 AND 35). REG. 4-24-2001.
- 2,447,145. BUCKEYE (STYLIZED). INT. CL. 1. (U.S. CLS. 1, 5, 6, 10, 26 AND 46). REG. 4-24-2001.
- 2,447,282. HUGO HUGO BOSS (STYLIZED). INT. CL. 25. (U.S. CLS. 22 AND 39). REG. 5-1-2001.
- 2,447,361. HARBORCHEM. INT. CL. 1. (U.S. CLS. 1, 5, 6, 10, 26 AND 46). REG. 5-1-2001.
- 2,447,366. SIKO. INT. CLS. 7 AND 9. (U.S. CLS. 13, 19, 21, 23, 26, 31, 34, 35, 36 AND 38). REG. 5-1-2001.
- 2,447,373. ACADEMY IMPRINTS. INT. CL. 16. (U.S. CLS. 2, 5, 22, 23, 29, 37, 38 AND 50). REG. 5-1-2001.
- 2,447,462. RENA DEE. INT. CL. 28. (U.S. CLS. 22, 23, 38 AND 50). REG. 5-1-2001.
- 2,447,575. GLOBALTEACH. INT. CL. 35. (U.S. CLS. 100, 101 AND 102). REG. 5-1-2001.
- 2,447,750. NON STOP LABEL. INT. CL. 16. (U.S. CLS. 2, 5, 22, 23, 29, 37, 38 AND 50). REG. 5-1-2001.
- 2,447,981. LATTICE. INT. CL. 36. (U.S. CLS. 100, 101 AND 102). REG. 5-1-2001.
- 2,448,053. DEVELOPER: YOUR ON-LINE MENTOR FOR PROFESSIONAL DEVELOPMENT. INT. CL. 35. (U.S. CLS. 100, 101 AND 102). REG. 5-1-2001.
- 2,448,216. TEEGO. INT. CL. 21. (U.S. CLS. 2, 13, 23, 29, 30, 33, 40 AND 50). REG. 5-1-2001.
- 2,448,314. RAPTOR ROOTER AND DESIGN. INT. CL. 37. (U.S. CLS. 100, 103 AND 106). REG. 5-1-2001.
- 2,448,328. R.H. VINTAGE (STYLIZED). INT. CL. 25. (U.S. CLS. 22 AND 39). REG. 5-1-2001.
- 2,448,635. U.S. WOMEN'S OPEN. INT. CLS. 25 AND 41. (U.S. CLS. 22, 39, 100, 101 AND 107). REG. 5-8-2001.
- 2,448,642. JJID (STYLIZED). INT. CLS. 19 AND 37. (U.S. CLS. 1, 12, 33, 50, 100, 103 AND 106). REG. 5-8-2001.
- 2,448,928. SALMI. INT. CL. 26. (U.S. CLS. 37, 39, 40, 42 AND 50). REG. 5-8-2001.
- 2,449,030. AMC FUNTOYZ. INT. CL. 28. (U.S. CLS. 22, 23, 38 AND 50). REG. 5-8-2001.
- 2,449,031. AMC PARTY PAX. INT. CL. 28. (U.S. CLS. 22, 23, 38 AND 50). REG. 5-8-2001.
- 2,449,269. WSAB. INT. CL. 42. (U.S. CLS. 100 AND 101). REG. 5-8-2001.
- 2,449,284. SOFTAP. INT. CLS. 3, 10 AND 42. (U.S. CLS. 1, 4, 6, 26, 39, 44, 50, 51, 52, 100 AND 101). REG. 5-8-2001.
- 2,449,289. LIMOXCHANGE. INT. CL. 16. (U.S. CLS. 2, 5, 22, 23, 29, 37, 38 AND 50). REG. 5-8-2001.
- 2,449,387. Y'S GUYS! AND DESIGN. INT. CL. 30. (U.S. CL. 46). REG. 5-8-2001.
- 2,449,508. LABORATOIRE DERMSCAN AND DESIGN. INT. CL. 42. (U.S. CLS. 100 AND 101). REG. 5-8-2001.
- 2,449,512. THE ROMANTIC HOURS. INT. CLS. 9 AND 41. (U.S. CLS. 21, 23, 26, 36, 38, 100, 101 AND 107). REG. 5-8-2001.
- 2,449,575. 1969. INT. CL. 25. (U.S. CLS. 22 AND 39). REG. 5-8-2001.
- 2,449,681. 1800 COLECCION. INT. CL. 33. (U.S. CLS. 47 AND 49). REG. 5-8-2001.
- 2,449,738. TIANMA. INT. CL. 9. (U.S. CLS. 21, 23, 26, 36 AND 38). REG. 5-8-2001.
- 2,449,898. UNITED STATES COLD SOLUTIONS AND DESIGN. INT. CL. 39. (U.S. CLS. 100 AND 105). REG. 5-8-2001.
- 2,449,977. ADHERIS. INT. CL. 42. (U.S. CLS. 100 AND 101). REG. 5-8-2001.
- 2,450,147. POLAR VISION. INT. CL. 9. (U.S. CLS. 21, 23, 26, 36 AND 38). REG. 5-8-2001.
- 2,450,149. MY BABY GIFT PACK. INT. CL. 28. (U.S. CLS. 22, 23, 38 AND 50). REG. 5-8-2001.
- 2,450,150. FIRST MOMENT OF LIFE. INT. CL. 28. (U.S. CLS. 22, 23, 38 AND 50). REG. 5-8-2001.
- 2,450,151. DOMINIQUE. INT. CL. 28. (U.S. CLS. 22, 23, 38 AND 50). REG. 5-8-2001.
- 2,450,152. BABY JOANNE. INT. CL. 28. (U.S. CLS. 22, 23, 38 AND 50). REG. 5-8-2001.
- 2,450,213. WX (STYLIZED). INT. CL. 9. (U.S. CLS. 21, 23, 26, 36 AND 38). REG. 5-8-2001.
- 2,450,250. VELOCITY. INT. CL. 3. (U.S. CLS. 1, 4, 6, 50, 51 AND 52). REG. 5-8-2001.
- 2,450,379. H&H BAGELS. INT. CL. 30. (U.S. CL. 46). REG. 5-15-2001.
- 2,450,537. PAC-TEN. INT. CL. 30. (U.S. CL. 46). REG. 5-15-2001.
- 2,450,656. DWI MEANS DEFEND WITH INGENUITY. INT. CL. 16. (U.S. CLS. 2, 5, 22, 23, 29, 37, 38 AND 50). REG. 5-15-2001.
- 2,450,982. KAMMPRO. INT. CL. 6. (U.S. CLS. 2, 12, 13, 14, 23, 25 AND 50). REG. 5-15-2001.
- 2,451,064. SAFECOACH PLUS. INT. CL. 16. (U.S. CLS. 2, 5, 22, 23, 29, 37, 38 AND 50). REG. 5-15-2001.
- 2,451,171. CONSULTWORKS. INT. CL. 9. (U.S. CLS. 21, 23, 26, 36 AND 38). REG. 5-15-2001.
- 2,451,241. UNIMATIC. INT. CL. 7. (U.S. CLS. 13, 19, 21, 23, 31, 34 AND 35). REG. 5-15-2001.
- 2,451,396. MOLTON. INT. CL. 2. (U.S. CLS. 6, 11 AND 16). REG. 5-15-2001.
- 2,451,472. MISCELLANEOUS DESIGN. INT. CL. 25. (U.S. CLS. 22 AND 39). REG. 5-15-2001.
- 2,451,635. MISCELLANEOUS DESIGN. INT. CL. 25. (U.S. CLS. 22 AND 39). REG. 5-15-2001.
- 2,451,791. BUDGET TANK. INT. CL. 37. (U.S. CLS. 100, 103 AND 106). REG. 5-15-2001.
- 2,451,814. UNITED STATES COLD SOLUTIONS. INT. CL. 39. (U.S. CLS. 100 AND 105). REG. 5-15-2001.
- 2,451,921. OFFICE PLAYGROUND. INT. CL. 35. (U.S. CLS. 100, 101 AND 102). REG. 5-15-2001.
- 2,451,968. BASIS. INT. CL. 10. (U.S. CLS. 26, 39 AND 44). REG. 5-15-2001.
- 2,452,064. MEGAPROFILE. INT. CL. 9. (U.S. CLS. 21, 23, 26, 36 AND 38). REG. 5-15-2001.
- 2,452,083. BRITBAK. INT. CL. 16. (U.S. CLS. 2, 5, 22, 23, 29, 37, 38 AND 50). REG. 5-15-2001.
- 2,452,411. MEMBER THE UNITED STATES JUNIOR CHAMBER OF COMMERCE OFFICIALLY RECOGNIZED JUNIOR CHAMBER OF COMMERCE AND DESIGN. U.S. CL. 200. REG. 5-22-2001.
- 2,452,543. SPOLETO. INT. CL. 29. (U.S. CL. 46). REG. 5-22-2001.
- 2,452,555. LEX-EFX LIGHT CONTROL FILM. INT. CL. 11. (U.S. CLS. 13, 21, 23, 31 AND 34). REG. 5-22-2001.
- 2,452,694. BELMONT COUNTRY CLUB. INT. CLS. 37 AND 41. (U.S. CLS. 100, 101, 103, 106 AND 107). REG. 5-22-2001.
- 2,452,855. NATURAL BALANCE. INT. CL. 31. (U.S. CLS. 1 AND 46). REG. 5-22-2001.
- 2,453,537. BASSCUBE. INT. CL. 9. (U.S. CLS. 21, 23, 26, 36 AND 38). REG. 5-22-2001.
- 2,453,710. TERANEX. INT. CL. 9. (U.S. CLS. 21, 23, 26, 36 AND 38). REG. 5-22-2001.
- 2,453,869. SANTA FE. INT. CL. 12. (U.S. CLS. 19, 21, 23, 31, 35 AND 44). REG. 5-22-2001.
- 2,453,925. CINN-A-SWIRL. INT. CL. 30. (U.S. CL. 46). REG. 5-22-2001.

- 2,454,059. AGQUEST FINANCIAL SERVICES, INC. INT. CL. 36. (U.S. CLS. 100, 101 AND 102). REG. 5-22-2001.
- 2,454,261. ONCOLOGY NET GUIDE. INT. CL. 16. (U.S. CLS. 2, 5, 22, 23, 29, 37, 38 AND 50). REG. 5-22-2001.
- 2,454,611. SAIL BOSTON. INT. CL. 16. (U.S. CLS. 2, 5, 22, 23, 29, 37, 38 AND 50). REG. 5-29-2001.
- 2,454,755. FLOWBAR AND DESIGN. INT. CL. 11. (U.S. CLS. 13, 21, 23, 31 AND 34). REG. 5-29-2001.
- 2,454,905. ARCHAEOLOGICAL TOURS AND DESIGN. INT. CL. 39. (U.S. CLS. 100 AND 105). REG. 5-29-2001.
- 2,455,005. BEKINS TRADESHOW SERVICES. INT. CL. 39. (U.S. CLS. 100 AND 105). REG. 5-29-2001.
- 2,455,110. THE RADIO CHICK. INT. CL. 41. (U.S. CLS. 100, 101 AND 107). REG. 5-29-2001.
- 2,455,163. RELO GUARD. INT. CL. 36. (U.S. CLS. 100, 101 AND 102). REG. 5-29-2001.
- 2,455,226. HUMMER. INT. CL. 7. (U.S. CLS. 13, 19, 21, 23, 31, 34 AND 35). REG. 5-29-2001.
- 2,455,395. P & N. INT. CL. 35. (U.S. CLS. 100, 101 AND 102). REG. 5-29-2001.
- 2,455,447. WEBEX. INT. CL. 40. (U.S. CLS. 100, 103 AND 106). REG. 5-29-2001.
- 2,455,658. XCELL. INT. CL. 5. (U.S. CLS. 6, 18, 44, 46, 51 AND 52). REG. 5-29-2001.
- 2,456,311. PM1D AND DESIGN. INT. CL. 9. (U.S. CLS. 21, 23, 26, 36 AND 38). REG. 5-29-2001.
- 2,456,322. MAX-ER. INT. CL. 7. (U.S. CLS. 13, 19, 21, 23, 31, 34 AND 35). REG. 5-29-2001.
- 2,456,689. ALMOST BARE. INT. CL. 25. (U.S. CLS. 22 AND 39). REG. 6-5-2001.
- 2,456,713. OUTDOOR RESEARCH. INT. CLS. 20, 21 AND 22. (U.S. CLS. 1, 2, 7, 13, 19, 22, 23, 25, 29, 30, 32, 33, 40, 42 AND 50). REG. 6-5-2001.
- 2,457,020. CRUCIANI. INT. CL. 25. (U.S. CLS. 22 AND 39). REG. 6-5-2001.
- 2,457,022. MISCELLANEOUS DESIGN. INT. CL. 9 ONLY. (U.S. CLS. 21, 23, 26, 36 AND 38). REG. 6-5-2001.
- 2,457,174. REGWEEK. INT. CL. 42. (U.S. CLS. 100 AND 101). REG. 6-5-2001.
- 2,457,176. POSI-SET. INT. CL. 6. (U.S. CLS. 2, 12, 13, 14, 23, 25 AND 50). REG. 6-5-2001.
- 2,457,186. DRC. INT. CL. 9. (U.S. CLS. 21, 23, 26, 36 AND 38). REG. 6-5-2001.
- 2,457,324. HOME OF THE HEARTY. INT. CL. 42. (U.S. CLS. 100 AND 101). REG. 6-5-2001.
- 2,457,732. POWER TRIP. INT. CL. 3. (U.S. CLS. 1, 4, 6, 50, 51 AND 52). REG. 6-5-2001.
- 2,457,750. FCRAM. INT. CL. 9. (U.S. CLS. 21, 23, 26, 36 AND 38). REG. 6-5-2001.
- 2,457,813. CAPTAIN CURT'S. INT. CLS. 30 AND 42. (U.S. CLS. 46, 100 AND 101). REG. 6-5-2001.
- 2,457,824. NAME PLATES. INT. CL. 16. (U.S. CLS. 2, 5, 22, 23, 29, 37, 38 AND 50). REG. 6-5-2001.
- 2,458,519. READY TO WIN. INT. CL. 28. (U.S. CLS. 22, 23, 38 AND 50). REG. 6-5-2001.
- 2,458,576. TOUCH OF NATURE. INT. CLS. 20 AND 31. (U.S. CLS. 1, 2, 13, 22, 25, 32, 46 AND 50). REG. 6-5-2001.
- 2,458,665. THE BREWMASTER. INT. CL. 11. (U.S. CLS. 13, 21, 23, 31 AND 34). REG. 6-5-2001.
- 2,458,846. HONEYMOONSHARE. INT. CL. 35. (U.S. CLS. 100, 101 AND 102). REG. 6-5-2001.
- 2,458,974. FAB PRIME. INT. CL. 2. (U.S. CLS. 6, 11 AND 16). REG. 6-12-2001.
- 2,458,994. LOOKS LIKE GRASS... FEELS LIKE GRASS... PLAYS LIKE GRASS!. INT. CL. 27. (U.S. CLS. 19, 20, 37, 42 AND 50). REG. 6-12-2001.
- 2,459,029. SUMMIT ACADEMY OIC. INT. CL. 41. (U.S. CLS. 100, 101 AND 107). REG. 6-12-2001.
- 2,459,053. DAYS BUSINESS PLACE. INT. CL. 42. (U.S. CLS. 100 AND 101). REG. 6-12-2001.
- 2,459,608. CLAUSEN MILLER PC (STYLIZED). INT. CL. 42. (U.S. CLS. 100 AND 101). REG. 6-12-2001.
- 2,459,640. LISTWARE. INT. CL. 9. (U.S. CLS. 21, 23, 26, 36 AND 38). REG. 6-12-2001.
- 2,460,001. ROCK SPRINGS. INT. CL. 12. (U.S. CLS. 19, 21, 23, 31, 35 AND 44). REG. 6-12-2001.
- 2,460,315. SDC THE SILENT MARSHAL AND DESIGN. INT. CL. 9. (U.S. CLS. 21, 23, 26, 36 AND 38). REG. 6-12-2001.
- 2,460,493. KSS. INT. CL. 12. (U.S. CLS. 19, 21, 23, 31, 35 AND 44). REG. 6-12-2001.
- 2,460,532. INOXIA. INT. CL. 21. (U.S. CLS. 2, 13, 23, 29, 30, 33, 40 AND 50). REG. 6-12-2001.
- 2,460,876. EQUATION. INT. CL. 39. (U.S. CLS. 100 AND 105). REG. 6-19-2001.
- 2,461,027. DIMENSION. INT. CL. 39. (U.S. CLS. 100 AND 105). REG. 6-19-2001.
- 2,461,183. OASIS MANAGEMENT. INT. CL. 36. (U.S. CLS. 100, 101 AND 102). REG. 6-19-2001.
- 2,461,299. INSTABOND. INT. CL. 1. (U.S. CLS. 1, 5, 6, 10, 26 AND 46). REG. 6-19-2001.
- 2,461,483. DIRECT DEGREE. INT. CL. 41. (U.S. CLS. 100, 101 AND 107). REG. 6-19-2001.
- 2,461,777. SEIU AND DESIGN. INT. CL. 42. (U.S. CLS. 100 AND 101). REG. 6-19-2001.
- 2,461,955. TRAVEL THE WORLD WITHOUT LEAVING HOME. INT. CL. 36. (U.S. CLS. 100, 101 AND 102). REG. 6-19-2001.
- 2,461,969. ENDO FAX. INT. CL. 16. (U.S. CLS. 2, 5, 22, 23, 29, 37, 38 AND 50). REG. 6-19-2001.
- 2,462,087. POS-I-LOCK. INT. CL. 7. (U.S. CLS. 13, 19, 21, 23, 31, 34 AND 35). REG. 6-19-2001.
- 2,462,200. GRASPIT. INT. CL. 10. (U.S. CLS. 26, 39 AND 44). REG. 6-19-2001.
- 2,462,243. NUTROL (STYLIZED). INT. CL. 5. (U.S. CLS. 6, 18, 44, 46, 51 AND 52). REG. 6-19-2001.
- 2,462,546. LAS VEGAS PAIUTE GOLF RESORT AND DESIGN. INT. CL. 21. (U.S. CLS. 2, 13, 23, 29, 30, 33, 40 AND 50). REG. 6-19-2001.
- 2,462,573. VETANIA AND DESIGN. INT. CL. 14. (U.S. CLS. 2, 27, 28 AND 50). REG. 6-19-2001.
- 2,462,712. TOPCAT. INT. CL. 1. (U.S. CLS. 1, 5, 6, 10, 26 AND 46). REG. 6-19-2001.
- 2,462,733. ZAOLLA. INT. CL. 9. (U.S. CLS. 21, 23, 26, 36 AND 38). REG. 6-19-2001.
- 2,463,229. BODEN. INT. CL. 25. (U.S. CLS. 22 AND 39). REG. 6-26-2001.
- 2,463,359. CCHA. U.S. CL. 200. REG. 6-26-2001.
- 2,463,460. DYNARIC, INC. AND DESIGN. INT. CL. 7. (U.S. CLS. 13, 19, 21, 23, 31, 34 AND 35). REG. 6-26-2001.
- 2,463,525. RX AND DESIGN. INT. CL. 36. (U.S. CLS. 100, 101 AND 102). REG. 6-26-2001.
- 2,463,722. SIDE BY SIDE. INT. CL. 35. (U.S. CLS. 100, 101 AND 102). REG. 6-26-2001.
- 2,463,758. SIMPLICD. INT. CL. 36. (U.S. CLS. 100, 101 AND 102). REG. 6-26-2001.
- 2,463,894. PORTER AND DESIGN. INT. CL. 2. (U.S. CLS. 6, 11 AND 16). REG. 6-26-2001.
- 2,464,139. MUSICNOTES. INT. CL. 42. (U.S. CLS. 100 AND 101). REG. 6-26-2001.
- 2,464,170. MONUMENTAL MOMENTS. INT. CL. 16. (U.S. CLS. 2, 5, 22, 23, 29, 37, 38 AND 50). REG. 6-26-2001.
- 2,464,409. XTRAVISION (STYLIZED). INT. CL. 11. (U.S. CLS. 13, 21, 23, 31 AND 34). REG. 6-26-2001.
- 2,464,430. SPANX. INT. CL. 25. (U.S. CLS. 22 AND 39). REG. 6-26-2001.
- 2,464,512. POLARISTAR PROTECTION PLUS. INT. CL. 36. (U.S. CLS. 100, 101 AND 102). REG. 6-26-2001.
- 2,464,536. ABILITYFIRST. INT. CL. 35. (U.S. CLS. 100, 101 AND 102). REG. 6-26-2001.
- 2,464,556. THE SAVAGE TRUTH ON MONEY. INT. CL. 9. (U.S. CLS. 21, 23, 26, 36 AND 38). REG. 6-26-2001.
- 2,464,627. PLAYMORE. INT. CL. 42. (U.S. CLS. 100 AND 101). REG. 6-26-2001.
- 2,465,012. BUMPERNETS. INT. CLS. 35 AND 41. (U.S. CLS. 100, 101, 102 AND 107). REG. 7-3-2001.
- 2,465,116. MYRATEPLAN.COM. INT. CL. 42. (U.S. CLS. 100 AND 101). REG. 7-3-2001.
- 2,465,534. NCA AND DESIGN. INT. CL. 42. (U.S. CLS. 100 AND 101). REG. 7-3-2001.
- 2,466,160. MIYABI. INT. CL. 31. (U.S. CLS. 1 AND 46). REG. 7-3-2001.
- 2,466,675. THE GAME OF INTERNATIONAL INTRIGUE. INT. CL. 28. (U.S. CLS. 22, 23, 38 AND 50). REG. 7-3-2001.
- 2,467,135. N AND DESIGN. INT. CL. 1. (U.S. CLS. 1, 5, 6, 10, 26 AND 46). REG. 7-10-2001.
- 2,467,335. RIDE BMX. INT. CL. 25. (U.S. CLS. 22 AND 39). REG. 7-10-2001.
- 2,467,544. CHECKSUM. INT. CL. 9. (U.S. CLS. 21, 23, 26, 36 AND 38). REG. 7-10-2001.
- 2,467,593. SIDE BY SIDE. INT. CL. 16. (U.S. CLS. 2, 5, 22, 23, 29, 37, 38 AND 50). REG. 7-10-2001.
- 2,468,187. A.F.G. ESTD. 1919 BORGIO TARO, ITALIA LA QUALITA NON HA TEMPO AND DESIGN. INT. CL. 30. (U.S. CL. 46). REG. 7-10-2001.

- 2,468,243. L.E.K. CONSULTING (STYLIZED). INT. CL. 35. (U.S. CLS. 100, 101 AND 102). REG. 7-10-2001.
- 2,468,436. FRESH INK. INT. CL. 16. (U.S. CLS. 2, 5, 22, 23, 29, 37, 38 AND 50). REG. 7-10-2001.
- 2,468,559. KITE BOARDING (STYLIZED). INT. CL. 16. (U.S. CLS. 2, 5, 22, 23, 29, 37, 38 AND 50). REG. 7-10-2001.
- 2,468,684. BOILER AGGREGATE. INT. CL. 19. (U.S. CLS. 1, 12, 33 AND 50). REG. 7-17-2001.
- 2,468,966. 24IP. INT. CLS. 35 AND 42. (U.S. CLS. 100, 101 AND 102). REG. 7-17-2001.
- 2,469,023. NATIONAL TATTOO SUPPLY. INT. CLS. 2 AND 7. (U.S. CLS. 6, 11, 13, 16, 19, 21, 23, 31, 34 AND 35). REG. 7-17-2001.
- 2,469,571. HOME COMFORT INSULATION AND DESIGN. INT. CL. 37. (U.S. CLS. 100, 103 AND 106). REG. 7-17-2001.
- 2,469,712. KOLDKISS. INT. CLS. 7, 30 AND 32. (U.S. CLS. 13, 19, 21, 23, 31, 34, 35, 45, 46 AND 48). REG. 7-17-2001.
- 2,469,828. WE HAVE YOU COVERED. INT. CL. 41. (U.S. CLS. 100, 101 AND 107). REG. 7-17-2001.
- 2,470,512. FEEL THE GAME. INT. CL. 16. (U.S. CLS. 2, 5, 22, 23, 29, 37, 38 AND 50). REG. 7-17-2001.
- 2,470,792. TRUMPER. INT. CLS. 3 AND 18. (U.S. CLS. 1, 2, 3, 4, 6, 22, 41, 50, 51 AND 52). REG. 7-24-2001.
- 2,470,887. SUMMIT ACADEMY S OIC AND DESIGN. INT. CL. 41. (U.S. CLS. 100, 101 AND 107). REG. 7-24-2001.
- 2,470,897. BOSSMAN. INT. CL. 12. (U.S. CLS. 19, 21, 23, 31, 35 AND 44). REG. 7-24-2001.
- 2,471,066. WFR AND DESIGN. INT. CL. 36. (U.S. CLS. 100, 101 AND 102). REG. 7-24-2001.
- 2,471,166. SUPERIOR SELF STORAGE AND DESIGN. INT. CL. 39. (U.S. CLS. 100 AND 105). REG. 7-24-2001.
- 2,471,181. AREA AND DESIGN. INT. CLS. 35, 37, 39 AND 40. (U.S. CLS. 100, 101, 102, 103, 105 AND 106). REG. 7-24-2001.
- 2,471,182. AREA. INT. CLS. 35, 37, 39 AND 40. (U.S. CLS. 100, 101, 102, 103, 105 AND 106). REG. 7-24-2001.
- 2,471,354. BEHLEN. INT. CLS. 6, 7 AND 20. (U.S. CLS. 2, 12, 13, 14, 19, 21, 22, 23, 25, 31, 32, 34, 35 AND 50). REG. 7-24-2001.
- 2,471,355. B AND DESIGN. INT. CLS. 6, 7 AND 20. (U.S. CLS. 2, 12, 13, 14, 19, 21, 22, 23, 25, 31, 32, 34, 35 AND 50). REG. 7-24-2001.
- 2,471,378. ARCHITECTURAL DIGEST AND DESIGN. INT. CL. 16. (U.S. CLS. 2, 5, 22, 23, 29, 37, 38 AND 50). REG. 7-24-2001.
- 2,471,696. DREAMLAND. INT. CL. 42. (U.S. CLS. 100 AND 101). REG. 7-24-2001.
- 2,471,873. UNITEDAUTO (STYLIZED). INT. CL. 40. (U.S. CLS. 100, 103 AND 106). REG. 7-24-2001.
- 2,472,057. MISCELLANEOUS DESIGN. INT. CL. 36. (U.S. CLS. 100, 101 AND 102). REG. 7-24-2001.
- 2,472,148. DAKOTA GROWERS PASTA CO. AND DESIGN. INT. CL. 30. (U.S. CL. 46). REG. 7-24-2001.
- 2,472,269. EXPEDITION FLORIDA. INT. CL. 41. (U.S. CLS. 100, 101 AND 107). REG. 7-24-2001.
- 2,472,431. NA AND DESIGN. INT. CLS. 14, 20 AND 25. (U.S. CLS. 2, 13, 22, 25, 27, 28, 32, 39 AND 50). REG. 7-24-2001.
- 2,473,138. MISCELLANEOUS DESIGN. INT. CLS. 14 AND 16. (U.S. CLS. 2, 5, 22, 23, 27, 28, 29, 37, 38 AND 50). REG. 7-31-2001.
- 2,473,175. LIFE ENGINEERING. INT. CL. 41. (U.S. CLS. 100, 101 AND 107). REG. 7-31-2001.
- 2,473,448. TRUTH FOR LIFE. INT. CL. 16. (U.S. CLS. 2, 5, 22, 23, 29, 37, 38 AND 50). REG. 7-31-2001.
- 2,473,450. SORBO. INT. CL. 21. (U.S. CLS. 2, 13, 23, 29, 30, 33, 40 AND 50). REG. 7-31-2001.
- 2,473,670. INSALA. INT. CL. 35. (U.S. CLS. 100, 101 AND 102). REG. 7-31-2001.
- 2,474,001. NOWLINE. INT. CL. 36. (U.S. CLS. 100, 101 AND 102). REG. 7-31-2001.
- 2,474,115. L.E.K. AND DESIGN. INT. CL. 35. (U.S. CLS. 100, 101 AND 102). REG. 7-31-2001.
- 2,474,275. REDENVELOPE. INT. CL. 42. (U.S. CLS. 100 AND 101). REG. 7-31-2001.
- 2,474,743. THAT PET PLACE A DIVISION OF THAT FISH PLACE AND DESIGN. INT. CL. 35. (U.S. CLS. 100, 101 AND 102). REG. 8-7-2001.
- 2,474,819. METAPOR. INT. CL. 1 ONLY. (U.S. CLS. 1, 5, 6, 10, 26 AND 46). REG. 8-7-2001.
- 2,474,886. QISS QUALITY INTEGRITY SAFETY SERVICE (STYLIZED). INT. CL. 42. (U.S. CLS. 100 AND 101). REG. 8-7-2001.
- 2,474,985. ADVANCED TECHNOLOGIES AND SERVICES, INC.. INT. CL. 42. (U.S. CLS. 100 AND 101). REG. 8-7-2001.
- 2,475,146. M W AND DESIGN. INT. CL. 40. (U.S. CLS. 100, 103 AND 106). REG. 8-7-2001.
- 2,475,182. XAVIX (STYLIZED). INT. CL. 9. (U.S. CLS. 21, 23, 26, 36 AND 38). REG. 8-7-2001.
- 2,475,230. H HELO AND DESIGN. INT. CL. 12. (U.S. CLS. 19, 21, 23, 31, 35 AND 44). REG. 8-7-2001.
- 2,475,353. REDPOINT VENTURES AND DESIGN. INT. CL. 36. (U.S. CLS. 100, 101 AND 102). REG. 8-7-2001.
- 2,476,034. THE EDUCATED PATIENT. INT. CL. 16. (U.S. CLS. 2, 5, 22, 23, 29, 37, 38 AND 50). REG. 8-7-2001.
- 2,476,037. SILIKON AND DESIGN. INT. CL. 5. (U.S. CLS. 6, 18, 44, 46, 51 AND 52). REG. 8-7-2001.
- 2,476,047. PROJECTEDGE. INT. CL. 9. (U.S. CLS. 21, 23, 26, 36 AND 38). REG. 8-7-2001.
- 2,477,542. LAS NINAS. INT. CL. 33. (U.S. CLS. 47 AND 49). REG. 8-14-2001.
- 2,477,683. CANOE RIDGE. INT. CL. 33. (U.S. CLS. 47 AND 49). REG. 8-14-2001.
- 2,477,784. MARRIAGE BUILDERS. INT. CLS. 35 AND 42. (U.S. CLS. 100, 101 AND 102). REG. 8-14-2001.
- 2,477,933. VIKING POOLS AND DESIGN. INT. CL. 37. (U.S. CLS. 100, 103 AND 106). REG. 8-14-2001.
- 2,478,187. GOLDEN COMPANION. INT. CL. 12. (U.S. CLS. 19, 21, 23, 31, 35 AND 44). REG. 8-14-2001.
- 2,478,748. GEMCOM. INT. CLS. 9 AND 42. (U.S. CLS. 21, 23, 26, 36, 38, 100 AND 101). REG. 8-21-2001.
- 2,479,265. BIO-FIGHTER. INT. CL. 11. (U.S. CLS. 13, 21, 23, 31 AND 34). REG. 8-21-2001.
- 2,479,314. ADCOM WORLDWIDE. INT. CL. 39. (U.S. CLS. 100 AND 105). REG. 8-21-2001.
- 2,479,560. OAK PARK. INT. CL. 42. (U.S. CLS. 100 AND 101). REG. 8-21-2001.
- 2,479,673. JAZBOX. INT. CL. 9. (U.S. CLS. 21, 23, 26, 36 AND 38). REG. 8-21-2001.
- 2,479,769. GIVE GOOD GIFT. INT. CL. 35. (U.S. CLS. 100, 101 AND 102). REG. 8-21-2001.
- 2,480,039. BASE 9. INT. CL. 9. (U.S. CLS. 21, 23, 26, 36 AND 38). REG. 8-21-2001.
- 2,480,243. ADPOWER. INT. CL. 9. (U.S. CLS. 21, 23, 26, 36 AND 38). REG. 8-21-2001.
- 2,480,486. THE CLINT STANDARD CHARACTER MARK. INT. CL. 25. (U.S. CLS. 22 AND 39). REG. 8-21-2001.
- 2,480,549. MISCELLANEOUS DESIGN. INT. CL. 3. (U.S. CLS. 1, 4, 6, 50, 51 AND 52). REG. 8-21-2001.
- 2,480,916. JUST FOR TONIGHT. INT. CL. 35. (U.S. CLS. 100, 101 AND 102). REG. 8-21-2001.
- 2,481,094. GEO F. TRUMPER. INT. CLS. 3 AND 18. (U.S. CLS. 1, 2, 3, 4, 6, 22, 41, 50, 51 AND 52). REG. 8-28-2001.
- 2,481,451. M (STYLIZED). INT. CLS. 3 AND 5. (U.S. CLS. 1, 4, 6, 18, 44, 46, 50, 51 AND 52). REG. 8-28-2001.
- 2,481,539. TRUCK TRACKER. INT. CL. 9. (U.S. CLS. 21, 23, 26, 36 AND 38). REG. 8-28-2001.
- 2,481,802. EMERALD HOME FURNISHINGS. INT. CL. 20. (U.S. CLS. 2, 13, 22, 25, 32 AND 50). REG. 8-28-2001.
- 2,481,826. SECUREWARE. INT. CLS. 6 AND 7. (U.S. CLS. 2, 12, 13, 14, 19, 21, 23, 25, 31, 34, 35 AND 50). REG. 8-28-2001.
- 2,482,024. TRENEV TRIO. INT. CL. 5. (U.S. CLS. 6, 18, 44, 46, 51 AND 52). REG. 8-28-2001.
- 2,482,210. VIKING POOLS. INT. CL. 37. (U.S. CLS. 100, 103 AND 106). REG. 8-28-2001.
- 2,482,558. WALDEN CHAMBER PLAYERS. INT. CL. 41. (U.S. CLS. 100, 101 AND 107). REG. 8-28-2001.
- 2,483,070. ZINTRO ALUM. INT. CL. 6. (U.S. CLS. 2, 12, 13, 14, 23, 25 AND 50). REG. 8-28-2001.
- 2,483,258. STUDIOLINE. INT. CL. 9. (U.S. CLS. 21, 23, 26, 36 AND 38). REG. 8-28-2001.
- 2,483,366. PURIFAN. INT. CL. 11. (U.S. CLS. 13, 21, 23, 31 AND 34). REG. 8-28-2001.
- 2,484,004. BRESSER. INT. CL. 9. (U.S. CLS. 21, 23, 26, 36 AND 38). REG. 8-28-2001.
- 2,484,106. WORLD'S STRONGEST MAN. INT. CL. 41. (U.S. CLS. 100, 101 AND 107). REG. 9-4-2001.
- 2,484,222. HACIENDA. INT. CL. 42. (U.S. CLS. 100 AND 101). REG. 9-4-2001.

- 2,484,480. PRIDE. INT. CL. 12. (U.S. CLS. 19, 21, 23, 31, 35 AND 44). REG. 9-4-2001.
- 2,484,511. MISCELLANEOUS DESIGN. INT. CLS. 16 AND 40 ONLY. (U.S. CLS. 2, 5, 22, 23, 29, 37, 38, 50, 100, 103 AND 106). REG. 9-4-2001.
- 2,484,548. CARAUSTAR. INT. CLS. 16 AND 40 ONLY. (U.S. CLS. 2, 5, 22, 23, 29, 37, 38, 50, 100, 103 AND 106). REG. 9-4-2001.
- 2,484,769. DYNAPEL. INT. CL. 9 ONLY. (U.S. CLS. 21, 23, 26, 36 AND 38). REG. 9-4-2001.
- 2,485,104. JAY-Z. INT. CL. 16. (U.S. CLS. 2, 5, 22, 23, 29, 37, 38 AND 50). REG. 9-4-2001.
- 2,485,193. LEFT BEHIND. INT. CL. 9. (U.S. CLS. 21, 23, 26, 36 AND 38). REG. 9-4-2001.
- 2,485,294. SEAMLESS ORS. INT. CL. 36. (U.S. CLS. 100, 101 AND 102). REG. 9-4-2001.
- 2,485,480. HARVEST MOON. INT. CL. 31. (U.S. CLS. 1 AND 46). REG. 9-4-2001.
- 2,485,525. BRANDFX. INT. CL. 9. (U.S. CLS. 21, 23, 26, 36 AND 38). REG. 9-4-2001.
- 2,485,639. SPIRIT OF HOCKEY. INT. CL. 35. (U.S. CLS. 100, 101 AND 102). REG. 9-4-2001.
- 2,485,816. LOADMATCH. INT. CL. 11. (U.S. CLS. 13, 21, 23, 31 AND 34). REG. 9-4-2001.
- 2,486,017. RUHRPUMPEN AND DESIGN. INT. CL. 7. (U.S. CLS. 13, 19, 21, 23, 31, 34 AND 35). REG. 9-4-2001.
- 2,486,205. HUMIDITROL. INT. CL. 11. (U.S. CLS. 13, 21, 23, 31 AND 34). REG. 9-4-2001.
- 2,486,206. HALF PINT 1/2 AND DESIGN. INT. CL. 11. (U.S. CLS. 13, 21, 23, 31 AND 34). REG. 9-4-2001.
- 2,486,599. EDUCATIONAL LEADERSHIP. INT. CL. 42. (U.S. CLS. 100 AND 101). REG. 9-11-2001.
- 2,486,900. EYE PRO. INT. CL. 9. (U.S. CLS. 21, 23, 26, 36 AND 38). REG. 9-11-2001.
- 2,487,139. NM AND DESIGN. INT. CL. 25. (U.S. CLS. 22 AND 39). REG. 9-11-2001.
- 2,487,164. VIBRA-JET. INT. CL. 7. (U.S. CLS. 13, 19, 21, 23, 31, 34 AND 35). REG. 9-11-2001.
- 2,487,268. WHERE GREAT BRANDS BEGIN. INT. CLS. 35 AND 42. (U.S. CLS. 100, 101 AND 102). REG. 9-11-2001.
- 2,487,442. AP AND DESIGN. INT. CL. 36. (U.S. CLS. 100, 101 AND 102). REG. 9-11-2001.
- 2,487,484. AG ATLANTA GRILL AND DESIGN. INT. CL. 42. (U.S. CLS. 100 AND 101). REG. 9-11-2001.
- 2,487,497. MINDTRIBE. INT. CL. 42. (U.S. CLS. 100 AND 101). REG. 9-11-2001.
- 2,487,510. ELIZABETH GLASER PEDIATRIC AIDS FOUNDATION. INT. CL. 42. (U.S. CLS. 100 AND 101). REG. 9-11-2001.
- 2,487,796. RELPAX. INT. CL. 5. (U.S. CLS. 6, 18, 44, 46, 51 AND 52). REG. 9-11-2001.
- 2,487,869. CAPSTONE. INT. CL. 37. (U.S. CLS. 100, 103 AND 106). REG. 9-11-2001.
- 2,488,600. SNOW-LITE. INT. CL. 9. (U.S. CLS. 21, 23, 26, 36 AND 38). REG. 9-11-2001.
- 2,488,890. CAMPMASTERS GOURMET POPCORN NSEW AND DESIGN. INT. CL. 30. (U.S. CL. 46). REG. 9-11-2001.
- 2,488,896. RUHRPUMPEN. INT. CL. 7. (U.S. CLS. 13, 19, 21, 23, 31, 34 AND 35). REG. 9-11-2001.
- 2,489,363. UOMO BRAVO. INT. CL. 25. (U.S. CLS. 22 AND 39). REG. 9-11-2001.
- 2,489,455. MISCELLANEOUS DESIGN. INT. CL. 3. (U.S. CLS. 1, 4, 6, 50, 51 AND 52). REG. 9-11-2001.
- 2,489,612. DATAPIPE. INT. CL. 9. (U.S. CLS. 21, 23, 26, 36 AND 38). REG. 9-11-2001.
- 2,489,866. MAGIC LIFT PLUS AND DESIGN. INT. CL. 25. (U.S. CLS. 22 AND 39). REG. 9-18-2001.
- 2,489,867. MAGIC LIFT AND DESIGN. INT. CL. 25. (U.S. CLS. 22 AND 39). REG. 9-18-2001.
- 2,490,025. CHAMPION MORTGAGE. INT. CL. 36. (U.S. CLS. 100, 101 AND 102). REG. 9-18-2001.
- 2,490,369. PAN AMERICAN. INT. CL. 7. (U.S. CLS. 13, 19, 21, 23, 31, 34 AND 35). REG. 9-18-2001.
- 2,490,370. MISCELLANEOUS DESIGN. INT. CL. 7. (U.S. CLS. 13, 19, 21, 23, 31, 34 AND 35). REG. 9-18-2001.
- 2,490,460. RIDING THE CREST. INT. CL. 35. (U.S. CLS. 100, 101 AND 102). REG. 9-18-2001.
- 2,490,510. MISCELLANEOUS DESIGN. INT. CL. 37. (U.S. CLS. 100, 103 AND 106). REG. 9-18-2001.
- 2,490,518. FISHERMAN'S PRIDE AND DESIGN. INT. CL. 29. (U.S. CL. 46). REG. 9-18-2001.
- 2,490,825. ALUMADOME. INT. CL. 6. (U.S. CLS. 2, 12, 13, 14, 23, 25 AND 50). REG. 9-18-2001.
- 2,490,826. ALUMAVault. INT. CL. 6. (U.S. CLS. 2, 12, 13, 14, 23, 25 AND 50). REG. 9-18-2001.
- 2,491,153. SYNARC. INT. CL. 42. (U.S. CLS. 100 AND 101). REG. 9-18-2001.
- 2,491,252. SMARTCRUISER. INT. CL. 39. (U.S. CLS. 100 AND 105). REG. 9-18-2001.
- 2,491,427. HOGWARTS. INT. CL. 9. (U.S. CLS. 21, 23, 26, 36 AND 38). REG. 9-18-2001.
- 2,491,537. DIGITAL CARTOGRAPHIC STUDIO. INT. CL. 9. (U.S. CLS. 21, 23, 26, 36 AND 38). REG. 9-18-2001.
- 2,491,684. E AND DESIGN. INT. CL. 9. (U.S. CLS. 21, 23, 26, 36 AND 38). REG. 9-25-2001.
- 2,491,701. DIPLOMAT. INT. CL. 42. (U.S. CLS. 100 AND 101). REG. 9-25-2001.
- 2,492,114. NATURE'S PATH AND DESIGN. INT. CL. 30. (U.S. CL. 46). REG. 9-25-2001.
- 2,492,282. E EMBASSY CARGO AND DESIGN. INT. CL. 39. (U.S. CLS. 100 AND 105). REG. 9-25-2001.
- 2,492,633. KEL-VISTA. INT. CL. 7. (U.S. CLS. 13, 19, 21, 23, 31, 34 AND 35). REG. 9-25-2001.
- 2,492,836. WISH RINGS. INT. CL. 14. (U.S. CLS. 2, 27, 28 AND 50). REG. 9-25-2001.
- 2,493,219. REDSTONE CAFE AND DESIGN. INT. CLS. 30 AND 42. (U.S. CLS. 46, 100 AND 101). REG. 9-25-2001.
- 2,493,340. TEPHA. INT. CL. 1. (U.S. CLS. 1, 5, 6, 10, 26 AND 46). REG. 9-25-2001.
- 2,493,407. GREENSTONE. INT. CLS. 35 AND 36. (U.S. CLS. 100, 101 AND 102). REG. 9-25-2001.
- 2,493,484. HARRY POTTER. INT. CL. 21. (U.S. CLS. 2, 13, 23, 29, 30, 33, 40 AND 50). REG. 9-25-2001.
- 2,495,217. SUPERTREE SEEDLINGS AND DESIGN. INT. CL. 31. (U.S. CLS. 1 AND 46). REG. 10-9-2001.
- 2,495,338. HEMAVISION. INT. CL. 5. (U.S. CLS. 6, 18, 44, 46, 51 AND 52). REG. 10-9-2001.
- 2,495,452. HOLLAND AMERICAN FOOD COMPANY. INT. CL. 35. (U.S. CLS. 100, 101 AND 102). REG. 10-9-2001.
- 2,495,631. AUTUMN MIST. INT. CL. 5. (U.S. CLS. 6, 18, 44, 46, 51 AND 52). REG. 10-9-2001.
- 2,495,632. ENCHANTED MIST. INT. CL. 5. (U.S. CLS. 6, 18, 44, 46, 51 AND 52). REG. 10-9-2001.
- 2,495,896. BENNETT LAWRENCE MANAGEMENT, LLC AND DESIGN. INT. CL. 36. (U.S. CLS. 100, 101 AND 102). REG. 10-9-2001.
- 2,495,998. OGLETREE DEAKINS. INT. CL. 42. (U.S. CLS. 100 AND 101). REG. 10-9-2001.
- 2,496,261. HAFCO. INT. CL. 35. (U.S. CLS. 100, 101 AND 102). REG. 10-9-2001.
- 2,496,626. BIKER'S CHOICE. INT. CL. 35. (U.S. CLS. 100, 101 AND 102). REG. 10-9-2001.
- 2,496,820. POWER MIS. INT. CL. 9. (U.S. CLS. 21, 23, 26, 36 AND 38). REG. 10-9-2001.
- 2,497,062. TOTAL WAR AND DESIGN. INT. CL. 9 ONLY. (U.S. CLS. 21, 23, 26, 36 AND 38). REG. 10-9-2001.
- 2,497,408. PRIMECODE. INT. CL. 9. (U.S. CLS. 21, 23, 26, 36 AND 38). REG. 10-16-2001.
- 2,497,430. MUCOPREN. INT. CL. 5. (U.S. CLS. 6, 18, 44, 46, 51 AND 52). REG. 10-16-2001.
- 2,497,763. MISCELLANEOUS DESIGN. INT. CL. 2. (U.S. CLS. 6, 11 AND 16). REG. 10-16-2001.
- 2,497,791. MISCELLANEOUS DESIGN. INT. CL. 31. (U.S. CLS. 1 AND 46). REG. 10-16-2001.
- 2,498,095. PHOCUSWRIGHT. INT. CL. 35. (U.S. CLS. 100, 101 AND 102). REG. 10-16-2001.
- 2,498,096. MISCELLANEOUS DESIGN. INT. CL. 35. (U.S. CLS. 100, 101 AND 102). REG. 10-16-2001.
- 2,498,520. AIESEC AND DESIGN. INT. CL. 42. (U.S. CLS. 100 AND 101). REG. 10-16-2001.
- 2,498,917. TRENDY TOES. INT. CL. 25. (U.S. CLS. 22 AND 39). REG. 10-16-2001.
- 2,499,428. QUESTRA. INT. CL. 42. (U.S. CLS. 100 AND 101). REG. 10-23-2001.
- 2,499,555. ONTRAC. INT. CL. 9. (U.S. CLS. 21, 23, 26, 36 AND 38). REG. 10-23-2001.
- 2,499,575. NATIONAL TATTOO ASSOCIATION. U.S. CL. 200. REG. 10-23-2001.
- 2,500,000. MISCELLANEOUS DESIGN. INT. CLS. 35 AND 42. (U.S. CLS. 100, 101 AND 102). REG. 10-23-2001.
- 2,500,196. 3 GUYS FROM BROOKLYN. INT. CL. 35. (U.S. CLS. 100, 101 AND 102). REG. 10-23-2001.

- 2,500,255. SPARTACUS MEDIA ENTERPRISES. INT. CL. 35. (U.S. CLS. 100, 101 AND 102). REG. 10-23-2001.
- 2,500,561. AIESEC. INT. CL. 42. (U.S. CLS. 100 AND 101). REG. 10-23-2001.
- 2,500,792. MISCELLANEOUS DESIGN. INT. CL. 41. (U.S. CLS. 100, 101 AND 107). REG. 10-23-2001.
- 2,500,948. PARADISE LANDING. INT. CL. 41. (U.S. CLS. 100, 101 AND 107). REG. 10-23-2001.
- 2,502,061. 800-BUY-A-CAR. INT. CL. 35. (U.S. CLS. 100, 101 AND 102). REG. 10-30-2001.
- 2,502,596. FRITOS CHILI PIE. INT. CLS. 29 AND 30. (U.S. CL. 46). REG. 10-30-2001.
- 2,504,256. CRAZEEMAIL. INT. CL. 38. (U.S. CLS. 100, 101 AND 104). REG. 11-6-2001.
- 2,505,052. BEADMAX. INT. CL. 3. (U.S. CLS. 1, 4, 6, 50, 51 AND 52). REG. 11-6-2001.
- 2,505,147. PDC PERSONAL DESIGN CHOICES AND DESIGN. INT. CL. 20. (U.S. CLS. 2, 13, 22, 25, 32 AND 50). REG. 11-6-2001.
- 2,505,869. THE MONEY PIT. INT. CLS. 37 AND 42. (U.S. CLS. 100, 101, 103 AND 106). REG. 11-13-2001.
- 2,506,249. NVE. INT. CL. 9. (U.S. CLS. 21, 23, 26, 36 AND 38). REG. 11-13-2001.
- 2,506,286. WE TAKE THE DENTS OUT OF ACCIDENTS. INT. CL. 37. (U.S. CLS. 100, 103 AND 106). REG. 11-13-2001.
- 2,506,318. ICON INTERNATIONAL. INT. CLS. 35 AND 36. (U.S. CLS. 100, 101 AND 102). REG. 11-13-2001.
- 2,506,745. M W AND DESIGN. INT. CL. 6. (U.S. CLS. 2, 12, 13, 14, 23, 25 AND 50). REG. 11-13-2001.
- 2,507,043. PERMASPRAY. INT. CL. 19. (U.S. CLS. 1, 12, 33 AND 50). REG. 11-13-2001.
- 2,507,526. MISCELLANEOUS DESIGN. INT. CL. 20. (U.S. CLS. 2, 13, 22, 25, 32 AND 50). REG. 11-13-2001.
- 2,507,764. EAGLE & ROSE AND DESIGN. INT. CL. 42. (U.S. CLS. 100 AND 101). REG. 11-13-2001.
- 2,508,311. FOOTLOOSE. INT. CL. 39. (U.S. CLS. 100 AND 105). REG. 11-20-2001.
- 2,509,326. ANGELINA PICTURES AND DESIGN. INT. CL. 41. (U.S. CLS. 100, 101 AND 107). REG. 11-20-2001.
- 2,509,433. BIG 6. INT. CL. 31. (U.S. CLS. 1 AND 46). REG. 11-20-2001.
- 2,509,459. CFT CENTER FOR FINANCIAL TRAINING AND DESIGN. INT. CL. 41. (U.S. CLS. 100, 101 AND 107). REG. 11-20-2001.
- 2,509,886. DIAL-A-PATTERN. INT. CL. 16. (U.S. CLS. 2, 5, 22, 23, 29, 37, 38 AND 50). REG. 11-20-2001.
- 2,509,888. DIAL-A-TRIAL. INT. CL. 16. (U.S. CLS. 2, 5, 22, 23, 29, 37, 38 AND 50). REG. 11-20-2001.
- 2,510,003. MISCELLANEOUS DESIGN. INT. CL. 9. (U.S. CLS. 21, 23, 26, 36 AND 38). REG. 11-20-2001.
- 2,510,010. MISCELLANEOUS DESIGN. INT. CL. 35. (U.S. CLS. 100, 101 AND 102). REG. 11-20-2001.
- 2,510,865. ASHWORTH AND DESIGN. INT. CL. 7. (U.S. CLS. 13, 19, 21, 23, 31, 34 AND 35). REG. 11-20-2001.
- 2,511,013. EAGLE & ROSE AND DESIGN. INT. CL. 33. (U.S. CLS. 47 AND 49). REG. 11-20-2001.
- 2,512,400. BLUEGRASS CLUB. INT. CL. 41. (U.S. CLS. 100, 101 AND 107). REG. 11-27-2001.
- 2,512,610. NUTRAVIEW. INT. CL. 5. (U.S. CLS. 6, 18, 44, 46, 51 AND 52). REG. 11-27-2001.
- 2,513,163. TUFF & TACKY. INT. CL. 16. (U.S. CLS. 2, 5, 22, 23, 29, 37, 38 AND 50). REG. 11-27-2001.
- 2,513,888. MISCELLANEOUS DESIGN. INT. CL. 16. (U.S. CLS. 2, 5, 22, 23, 29, 37, 38 AND 50). REG. 12-4-2001.
- 2,513,891. CLIFFTENT. INT. CL. 42. (U.S. CLS. 100 AND 101). REG. 12-4-2001.
- 2,514,178. TALISMA. INT. CLS. 35 AND 42. (U.S. CLS. 100, 101 AND 102). REG. 12-4-2001.
- 2,514,634. OLE RAY'S. INT. CL. 30. (U.S. CL. 46). REG. 12-4-2001.
- 2,514,852. BUILDING COLORADO'S FUTURE (STYLIZED). INT. CL. 37. (U.S. CLS. 100, 103 AND 106). REG. 12-4-2001.
- 2,515,335. TETRADATA. INT. CL. 9. (U.S. CLS. 21, 23, 26, 36 AND 38). REG. 12-4-2001.
- 2,515,357. BBH COMSET PLUS AND DESIGN. INT. CL. 36. (U.S. CLS. 100, 101 AND 102). REG. 12-4-2001.
- 2,515,540. CONTEXT SYSTEMS. INT. CL. 42. (U.S. CLS. 100 AND 101). REG. 12-4-2001.
- 2,517,367. HOMEWOOD SUITES HILTON AND DESIGN. INT. CL. 42. (U.S. CLS. 100 AND 101). REG. 12-11-2001.
- 2,517,368. PENTAGON PROTECTION. INT. CL. 9. (U.S. CLS. 21, 23, 26, 36 AND 38). REG. 12-11-2001.
- 2,517,509. BE ART-GET A TATTOO. INT. CL. 42. (U.S. CLS. 100 AND 101). REG. 12-11-2001.
- 2,517,511. MAXIMUM VELOCITY!. INT. CL. 16. (U.S. CLS. 2, 5, 22, 23, 29, 37, 38 AND 50). REG. 12-11-2001.
- 2,517,961. GRECIAN 5. INT. CL. 3. (U.S. CLS. 1, 4, 6, 50, 51 AND 52). REG. 12-11-2001.
- 2,518,635. GOLO. INT. CL. 28. (U.S. CLS. 22, 23, 38 AND 50). REG. 12-11-2001.
- 2,518,657. PRESIDENTE MARGARITA. INT. CL. 33. (U.S. CLS. 47 AND 49). REG. 12-11-2001.
- 2,518,659. PRESIDENTE MARGARITA AND DESIGN. INT. CL. 33. (U.S. CLS. 47 AND 49). REG. 12-11-2001.
- 2,518,853. PATCHAMP. INT. CL. 9. (U.S. CLS. 21, 23, 26, 36 AND 38). REG. 12-11-2001.
- 2,519,263. ODYSSEY INNOVATIVE DESIGNS AND DESIGN. INT. CLS. 9 AND 12. (U.S. CLS. 19, 21, 23, 26, 31, 35, 36, 38 AND 44). REG. 12-18-2001.
- 2,519,375. SPEVCO. INT. CLS. 35, 40 AND 42. (U.S. CLS. 100, 101, 102, 103 AND 106). REG. 12-18-2001.
- 2,519,898. SKY WHEEL. INT. CL. 28. (U.S. CLS. 22, 23, 38 AND 50). REG. 12-18-2001.
- 2,520,075. OPUS AND DESIGN. INT. CLS. 36, 37 AND 42. (U.S. CLS. 100, 101, 102, 103 AND 106). REG. 12-18-2001.
- 2,520,815. TITANIUM EXCLUSIVE. INT. CL. 21. (U.S. CLS. 2, 13, 23, 29, 30, 33, 40 AND 50). REG. 12-18-2001.
- 2,521,860. DRAMATIC IMPACT. INT. CL. 41. (U.S. CLS. 100, 101 AND 107). REG. 12-25-2001.
- 2,522,061. THE LATIN BROTHERS. INT. CL. 9. (U.S. CLS. 21, 23, 26, 36 AND 38). REG. 12-25-2001.
- 2,522,151. PROFITSTAR. INT. CL. 9. (U.S. CLS. 21, 23, 26, 36 AND 38). REG. 12-25-2001.
- 2,522,473. INNERPEACE "THE SHEET PEOPLE" (STYLIZED). INT. CL. 24. (U.S. CLS. 42 AND 50). REG. 12-25-2001.
- 2,522,535. T AND DESIGN. INT. CL. 25. (U.S. CLS. 22 AND 39). REG. 12-25-2001.
- 2,522,826. CRICKET. INT. CL. 36. (U.S. CLS. 100, 101 AND 102). REG. 12-25-2001.
- 2,524,246. TENNESSEE CROSSROADS. INT. CL. 9. (U.S. CLS. 21, 23, 26, 36 AND 38). REG. 1-1-2002.
- 2,524,426. DIGIVIEW. INT. CL. 9. (U.S. CLS. 21, 23, 26, 36 AND 38). REG. 1-1-2002.
- 2,525,242. BOATSAFE.COM. INT. CL. 41. (U.S. CLS. 100, 101 AND 107). REG. 1-1-2002.
- 2,525,292. WARM GLOW CANDLE CO.. INT. CL. 4. (U.S. CLS. 1, 6 AND 15). REG. 1-1-2002.
- 2,525,608. SPEEDBEAD. INT. CL. 3. (U.S. CLS. 1, 4, 6, 50, 51 AND 52). REG. 1-1-2002.
- 2,526,108. AVANTE. INT. CL. 42. (U.S. CLS. 100 AND 101). REG. 1-1-2002.
- 2,526,848. SCIENCE MINDS OVER BUSINESS MATTERS. INT. CLS. 35 AND 42. (U.S. CLS. 100, 101 AND 102). REG. 1-8-2002.
- 2,527,929. AWAKE AROMA SPOTS. INT. CL. 3. (U.S. CLS. 1, 4, 6, 50, 51 AND 52). REG. 1-8-2002.
- 2,528,430. PLUMB-JACK. INT. CL. 8. (U.S. CLS. 23, 28 AND 44). REG. 1-8-2002.
- 2,528,502. S2000. INT. CLS. 9 AND 28. (U.S. CLS. 21, 22, 23, 26, 36, 38 AND 50). REG. 1-8-2002.
- 2,528,623. WILD PALMS HOTEL. INT. CL. 42. (U.S. CLS. 100 AND 101). REG. 1-8-2002.
- 2,528,832. MISCELLANEOUS DESIGN. INT. CL. 5. (U.S. CLS. 6, 18, 44, 46, 51 AND 52). REG. 1-15-2002.
- 2,529,413. THE SANCTUARY AND DESIGN. INT. CL. 1. (U.S. CLS. 1, 5, 6, 10, 26 AND 46). REG. 1-15-2002.
- 2,529,656. MULTI-Q. INT. CL. 5. (U.S. CLS. 6, 18, 44, 46, 51 AND 52). REG. 1-15-2002.
- 2,529,957. MZAP. INT. CL. 2. (U.S. CLS. 6, 11 AND 16). REG. 1-15-2002.
- 2,531,109. G624. INT. CL. 4. (U.S. CLS. 1, 6 AND 15). REG. 1-22-2002.
- 2,531,110. G623. INT. CL. 4. (U.S. CLS. 1, 6 AND 15). REG. 1-22-2002.
- 2,531,626. TECH VEST. INT. CLS. 35 AND 36. (U.S. CLS. 100, 101 AND 102). REG. 1-22-2002.
- 2,531,747. THE ART OF FOOD. INT. CL. 35. (U.S. CLS. 100, 101 AND 102). REG. 1-22-2002.
- 2,531,765. SCHONBEK. INT. CL. 11. (U.S. CLS. 13, 21, 23, 31 AND 34). REG. 1-22-2002.



- 2,531,928. KASINA. INT. CL. 42. (U.S. CLS. 100 AND 101). REG. 1-22-2002.
- 2,531,952. MISCELLANEOUS DESIGN. INT. CL. 25. (U.S. CLS. 22 AND 39). REG. 1-22-2002.
- 2,532,218. ADVANCIS. INT. CL. 35. (U.S. CLS. 100, 101 AND 102). REG. 1-22-2002.
- 2,532,373. KIRKLAND SIGNATURE. INT. CL. 21. (U.S. CLS. 2, 13, 23, 29, 30, 33, 40 AND 50). REG. 1-22-2002.
- 2,532,447. ROUTERWARE. INT. CL. 9. (U.S. CLS. 21, 23, 26, 36 AND 38). REG. 1-22-2002.
- 2,533,130. MISCELLANEOUS DESIGN. INT. CL. 16. (U.S. CLS. 2, 5, 22, 23, 29, 37, 38 AND 50). REG. 1-22-2002.
- 2,533,131. MISCELLANEOUS DESIGN. INT. CL. 16. (U.S. CLS. 2, 5, 22, 23, 29, 37, 38 AND 50). REG. 1-22-2002.
- 2,533,724. QUICKSWITCH. INT. CL. 35. (U.S. CLS. 100, 101 AND 102). REG. 1-29-2002.
- 2,534,602. WASH-IT-KWIK. INT. CL. 37. (U.S. CLS. 100, 103 AND 106). REG. 1-29-2002.
- 2,535,060. DIGITAL CAMERA & PHOTO. INT. CL. 16. (U.S. CLS. 2, 5, 22, 23, 29, 37, 38 AND 50). REG. 1-29-2002.
- 2,535,505. COPPERBRITE. INT. CL. 6. (U.S. CLS. 2, 12, 13, 14, 23, 25 AND 50). REG. 2-5-2002.
- 2,535,583. MAMMOTH RECORDS. INT. CL. 9. (U.S. CLS. 21, 23, 26, 36 AND 38). REG. 2-5-2002.
- 2,535,922. MISCELLANEOUS DESIGN. INT. CLS. 29 AND 30. (U.S. CL. 46). REG. 2-5-2002.
- 2,535,982. DJ USA. INT. CL. 41. (U.S. CLS. 100, 101 AND 107). REG. 2-5-2002.
- 2,536,233. KRONOS VINEYARD. INT. CL. 33. (U.S. CLS. 47 AND 49). REG. 2-5-2002.
- 2,536,540. PROSPECTOR. INT. CL. 35. (U.S. CLS. 100, 101 AND 102). REG. 2-5-2002.
- 2,536,623. POSITRONIC INDUSTRIES, INC.. INT. CL. 9. (U.S. CLS. 21, 23, 26, 36 AND 38). REG. 2-5-2002.
- 2,536,871. MISCELLANEOUS DESIGN. INT. CL. 42. (U.S. CLS. 100 AND 101). REG. 2-5-2002.
- 2,537,667. CARLSON SYSTEMS. INT. CLS. 35 AND 41. (U.S. CLS. 100, 101, 102 AND 107). REG. 2-12-2002.
- 2,537,933. WATER TECHNOLOGY. INT. CL. 16. (U.S. CLS. 2, 5, 22, 23, 29, 37, 38 AND 50). REG. 2-12-2002.
- 2,537,958. STAGECOACH SPOKE. INT. CL. 31. (U.S. CLS. 1 AND 46). REG. 2-12-2002.
- 2,538,260. MICROLINE. INT. CL. 16. (U.S. CLS. 2, 5, 22, 23, 29, 37, 38 AND 50). REG. 2-12-2002.
- 2,538,934. COMMUNITY HOSPITAL FOUNDATION AND DESIGN. INT. CL. 36. (U.S. CLS. 100, 101 AND 102). REG. 2-19-2002.
- 2,539,086. CORP!. INT. CL. 16. (U.S. CLS. 2, 5, 22, 23, 29, 37, 38 AND 50). REG. 2-19-2002.
- 2,539,293. OUT THINK. OUT PERFORM.. INT. CL. 35. (U.S. CLS. 100, 101 AND 102). REG. 2-19-2002.
- 2,539,664. BORE-GEL. INT. CL. 1. (U.S. CLS. 1, 5, 6, 10, 26 AND 46). REG. 2-19-2002.
- 2,540,304. F AND DESIGN. INT. CL. 17. (U.S. CLS. 1, 5, 12, 13, 35 AND 50). REG. 2-19-2002.
- 2,540,534. SUSPS. INT. CL. 42. (U.S. CLS. 100 AND 101). REG. 2-19-2002.
- 2,540,720. SCENT OF A WOMAN. INT. CL. 3. (U.S. CLS. 1, 4, 6, 50, 51 AND 52). REG. 2-19-2002.
- 2,541,155. KINGSFORD. INT. CLS. 8, 11 AND 21. (U.S. CLS. 2, 13, 21, 23, 28, 29, 30, 31, 33, 34, 40, 44 AND 50). REG. 2-19-2002.
- 2,541,238. DIGILAZ. INT. CL. 9. (U.S. CLS. 21, 23, 26, 36 AND 38). REG. 2-19-2002.
- 2,541,619. DUJEL. INT. CL. 3. (U.S. CLS. 1, 4, 6, 50, 51 AND 52). REG. 2-19-2002.
- 2,542,172. TRANS GLOBAL. INT. CLS. 39 AND 42. (U.S. CLS. 100, 101 AND 105). REG. 2-26-2002.
- 2,542,790. QUICK CHEF. INT. CL. 42. (U.S. CLS. 100 AND 101). REG. 2-26-2002.
- 2,542,894. CORDY-CHI. INT. CL. 5. (U.S. CLS. 6, 18, 44, 46, 51 AND 52). REG. 2-26-2002.
- 2,542,964. ALLSTATE USTED ESTA' EN BUENAS MANOS. INT. CL. 36. (U.S. CLS. 100, 101 AND 102). REG. 2-26-2002.
- 2,543,468. NETCATERING. INT. CL. 9. (U.S. CLS. 21, 23, 26, 36 AND 38). REG. 2-26-2002.
- 2,543,487. NETNUTRITION. INT. CL. 9. (U.S. CLS. 21, 23, 26, 36 AND 38). REG. 2-26-2002.
- 2,543,490. OPTIVAR. INT. CL. 5. (U.S. CLS. 6, 18, 44, 46, 51 AND 52). REG. 2-26-2002.
- 2,543,549. THRUST. INT. CL. 1. (U.S. CLS. 1, 5, 6, 10, 26 AND 46). REG. 2-26-2002.
- 2,543,792. SIGNAL 369 AND DESIGN. INT. CL. 5. (U.S. CLS. 6, 18, 44, 46, 51 AND 52). REG. 3-5-2002.
- 2,543,864. PAN-WAY. INT. CL. 9. (U.S. CLS. 21, 23, 26, 36 AND 38). REG. 3-5-2002.
- 2,544,246. CASA DO PAO DE QUEIJO (STYLIZED). INT. CL. 35. (U.S. CLS. 100, 101 AND 102). REG. 3-5-2002.
- 2,544,254. BIOLOGICAL IMMUNITY ANALYSIS. INT. CL. 42. (U.S. CLS. 100 AND 101). REG. 3-5-2002.
- 2,544,320. CENTRAL WASHINGTON UNIVERSITY. INT. CLS. 16 AND 25. (U.S. CLS. 2, 5, 22, 23, 29, 37, 38, 39 AND 50). REG. 3-5-2002.
- 2,544,467. MISCELLANEOUS DESIGN. INT. CLS. 35, 36 AND 42. (U.S. CLS. 100, 101 AND 102). REG. 3-5-2002.
- 2,544,476. RAINFOREST DESIGNER. INT. CL. 9. (U.S. CLS. 21, 23, 26, 36 AND 38). REG. 3-5-2002.
- 2,544,589. YOURGOVSHOP AND DESIGN. INT. CL. 35. (U.S. CLS. 100, 101 AND 102). REG. 3-5-2002.
- 2,544,605. SECURE. INT. CL. 20. (U.S. CLS. 2, 13, 22, 25, 32 AND 50). REG. 3-5-2002.
- 2,544,676. RESTAURANT RADAR. INT. CL. 16. (U.S. CLS. 2, 5, 22, 23, 29, 37, 38 AND 50). REG. 3-5-2002.
- 2,544,859. MISCELLANEOUS DESIGN. INT. CL. 36. (U.S. CLS. 100, 101 AND 102). REG. 3-5-2002.
- 2,544,960. LEMONADE AND DESIGN. INT. CL. 21. (U.S. CLS. 2, 13, 23, 29, 30, 33, 40 AND 50). REG. 3-5-2002.
- 2,545,664. MAGIC RING. INT. CL. 20. (U.S. CLS. 2, 13, 22, 25, 32 AND 50). REG. 3-12-2002.
- 2,545,671. MALABAR PRODUCTOS NATURALES AND DESIGN. INT. CLS. 5 AND 30. (U.S. CLS. 6, 18, 44, 46, 51 AND 52). REG. 3-12-2002.
- 2,545,868. FISH-N-MATE. INT. CL. 12. (U.S. CLS. 19, 21, 23, 31, 35 AND 44). REG. 3-12-2002.
- 2,545,903. ACCU-TEC AND DESIGN. INT. CLS. 35, 39 AND 42. (U.S. CLS. 100, 101, 102 AND 105). REG. 3-12-2002.
- 2,546,037. FRESH & GO AND DESIGN. INT. CLS. 3 AND 21. (U.S. CLS. 1, 2, 4, 6, 13, 23, 29, 30, 33, 40, 50, 51 AND 52). REG. 3-12-2002.
- 2,546,548. COLORATIONS. INT. CL. 16. (U.S. CLS. 2, 5, 22, 23, 29, 37, 38 AND 50). REG. 3-12-2002.
- 2,546,619. THE BIG TIP. INT. CL. 25. (U.S. CLS. 22 AND 39). REG. 3-12-2002.
- 2,546,892. CLICKIQ. INT. CL. 35. (U.S. CLS. 100, 101 AND 102). REG. 3-12-2002.
- 2,546,930. FRAME CAP. INT. CL. 25. (U.S. CLS. 22 AND 39). REG. 3-12-2002.
- 2,547,016. TERRAZOS. INT. CL. 42. (U.S. CLS. 100 AND 101). REG. 3-12-2002.
- 2,547,257. PROLA. INT. CL. 42. (U.S. CLS. 100 AND 101). REG. 3-12-2002.
- 2,547,272. PW. INT. CL. 31. (U.S. CLS. 1 AND 46). REG. 3-12-2002.
- 2,548,341. HIGH-RAM. INT. CL. 7. (U.S. CLS. 13, 19, 21, 23, 31, 34 AND 35). REG. 3-12-2002.
- 2,548,528. ACTIVE MATURITY. INT. CL. 31. (U.S. CLS. 1 AND 46). REG. 3-12-2002.
- 2,548,656. ORIGINAL CRISTALL SIGNATURE SERIES MOSCOW AND DESIGN. INT. CL. 33. (U.S. CLS. 47 AND 49). REG. 3-19-2002.
- 2,548,786. REFLEX. INT. CL. 16. (U.S. CLS. 2, 5, 22, 23, 29, 37, 38 AND 50). REG. 3-19-2002.
- 2,548,843. WE KEEP GOOD COMPANY. INT. CL. 36. (U.S. CLS. 100, 101 AND 102). REG. 3-19-2002.
- 2,548,902. GIANT EAGLE AND DESIGN. INT. CL. 35. (U.S. CLS. 100, 101 AND 102). REG. 3-19-2002.
- 2,548,973. LOANOPTIMIZER.COM. INT. CL. 36. (U.S. CLS. 100, 101 AND 102). REG. 3-19-2002.
- 2,549,269. BERGEN INTERNATIONAL. INT. CL. 1. (U.S. CLS. 1, 5, 6, 10, 26 AND 46). REG. 3-19-2002.
- 2,549,270. BI (STYLIZED). INT. CL. 1. (U.S. CLS. 1, 5, 6, 10, 26 AND 46). REG. 3-19-2002.
- 2,549,356. MCCUTCHEON'S (STYLIZED). INT. CLS. 29, 30 AND 32. (U.S. CLS. 45, 46 AND 48). REG. 3-19-2002.
- 2,549,470. OPTIMA. INT. CL. 36. (U.S. CLS. 100, 101 AND 102). REG. 3-19-2002.
- 2,549,606. ALTERASSET MANAGEMENT (STYLIZED). INT. CL. 36. (U.S. CLS. 100, 101 AND 102). REG. 3-19-2002.
- 2,549,758. TIMELESS ROCK, TRUE VARIETY. INT. CL. 41. (U.S. CLS. 100, 101 AND 107). REG. 3-19-2002.

- 2,549,803. PREMERA LTC. INT. CL. 36. (U.S. CLS. 100, 101 AND 102). REG. 3-19-2002.
- 2,550,002. MISCELLANEOUS DESIGN. INT. CL. 42. (U.S. CLS. 100 AND 101). REG. 3-19-2002.
- 2,550,011. ALL GAR. INT. CL. 5. (U.S. CLS. 6, 18, 44, 46, 51 AND 52). REG. 3-19-2002.
- 2,550,084. COZEN O'CONNOR AND DESIGN. INT. CL. 42. (U.S. CLS. 100 AND 101). REG. 3-19-2002.
- 2,550,187. THE MIDNIGHT SPECIAL (STYLIZED). INT. CL. 9. (U.S. CLS. 21, 23, 26, 36 AND 38). REG. 3-19-2002.
- 2,550,329. MINNESOTA LYNX. INT. CL. 18. (U.S. CLS. 1, 2, 3, 22 AND 41). REG. 3-19-2002.
- 2,550,504. GENEWARE. INT. CL. 42. (U.S. CLS. 100 AND 101). REG. 3-19-2002.
- 2,550,630. TRAIL AMERICA. INT. CL. 12. (U.S. CLS. 19, 21, 23, 31, 35 AND 44). REG. 3-19-2002.
- 2,550,655. THE SAVAGE TRUTH. INT. CL. 16. (U.S. CLS. 2, 5, 22, 23, 29, 37, 38 AND 50). REG. 3-19-2002.
- 2,551,172. ECOREALTY. INT. CL. 36. (U.S. CLS. 100, 101 AND 102). REG. 3-19-2002.
- 2,551,198. ART-CARE. INT. CL. 35. (U.S. CLS. 100, 101 AND 102). REG. 3-19-2002.
- 2,551,251. SOAK-PROOF SHIELD AND DESIGN. INT. CL. 21. (U.S. CLS. 2, 13, 23, 29, 30, 33, 40 AND 50). REG. 3-19-2002.
- 2,551,457. LAPD AND DESIGN. INT. CL. 41. (U.S. CLS. 100, 101 AND 107). REG. 3-26-2002.
- 2,551,635. WALKERSWOOD. INT. CLS. 29 AND 30. (U.S. CL. 46). REG. 3-26-2002.
- 2,551,731. RCM. INT. CLS. 35, 41 AND 42. (U.S. CLS. 100, 101, 102 AND 107). REG. 3-26-2002.
- 2,552,287. SAND. INT. CL. 9. (U.S. CLS. 21, 23, 26, 36 AND 38). REG. 3-26-2002.
- 2,552,320. JOHNNY SUMATRA AND DESIGN. INT. CL. 30. (U.S. CL. 46). REG. 3-26-2002.
- 2,552,538. COMMUNITY IT INNOVATORS. INT. CLS. 37, 41 AND 42. (U.S. CLS. 100, 101, 103, 106 AND 107). REG. 3-26-2002.
- 2,552,773. SAWATDEE. INT. CL. 42. (U.S. CLS. 100 AND 101). REG. 3-26-2002.
- 2,554,134. ACTIGARD. INT. CL. 1. (U.S. CLS. 1, 5, 6, 10, 26 AND 46). REG. 3-26-2002.

\* \* \* \* \*

# TRADEMARK REGISTRATIONS CANCELED

The designation "U.S. Cl." appearing in this section refers to the U.S. class in effect prior to Sep. 1, 1973 rather than the international class which applies to applications filed on or after that date. For adoption of international classification see notice in the OFFICIAL GAZETTE of Jun. 26, 1973 (911 O.G. TM 210).

## SECTION 7(D)

- 2,422,256. DRY F-X. INT. CL. 25. REG. 1-16-2001.  
2,847,137. SURGI-VISION. INT. CL. 10. REG. 6-1-2004.  
2,890,183. FIBERTEX. INT. CL. 30. REG. 9-28-2004.  
2,895,348. P.O.W.E.R. PATIENT OUTCOME WITH BEXTRA REGIMEN AND DESIGN. INT. CL. 5. REG. 10-19-2004.  
3,093,737. LA MAS RICA STANDARD CHARACTER MARK. INT. CLS. 29 AND 32. REG. 5-16-2006.  
3,472,718. SUNDANCE. INT. CL. 40. REG. 7-22-2008.  
3,628,834. LA MAS RICA STANDARD CHARACTER MARK. INT. CL. 30. REG. 5-26-2009.  
3,633,301. GET THE 411 STANDARD CHARACTER MARK. INT. CL. 42. REG. 6-2-2009.  
3,759,003. BLIPCITY STANDARD CHARACTER MARK. INT. CLS. 41 AND 45. REG. 3-9-2010.  
3,811,600. SURGIVISION AND DESIGN. INT. CL. 10. REG. 6-29-2010.  
3,902,500. HDD HIGH DEFINITION DESIGN (STYLIZED). INT. CLS. 19 AND 27. REG. 1-11-2011.
- 1,424,489. RE-FRESH THE CHOICE OF PROFESSIONALS AND DESIGN. INT. CL. 1. REG. 1-13-1987.  
1,426,956. G GLADSTONE'S 4 FISH AND DESIGN. INT. CL. 42. REG. 1-27-1987.  
1,429,352. PINE STATE. INT. CL. 25. REG. 2-17-1987.  
1,431,380. WESTERN TRAIL MIX. INT. CL. 29. REG. 3-3-1987.  
1,434,389. EUROPEAN TRAVEL & LIFE. INT. CL. 16. REG. 3-24-1987.  
1,441,861. CORE. INT. CLS. 9 AND 42. REG. 6-9-1987.  
1,459,594. BROADWAY VIDEO AND DESIGN. INT. CL. 40. REG. 9-29-1987.  
1,459,755. CURLS. INT. CL. 18. REG. 9-29-1987.  
1,459,783. MOLD SHIELD. INT. CL. 2. REG. 10-6-1987.  
1,473,502. T.E.D.. INT. CL. 36. REG. 1-19-1988.  
1,500,829. THE DOLPHIN EXPERIENCE AND DESIGN. INT. CL. 41. REG. 8-16-1988.  
1,551,555. TASI YEN PING AND DESIGN. INT. CLS. 3 AND 41. REG. 8-15-1989.  
1,554,944. BUONA BEEF "BUONA" MEANS GOOD. INT. CL. 30. REG. 9-5-1989.  
1,562,518. HISPANOCARE. INT. CL. 35. REG. 10-24-1989.  
1,573,059. LEVEL ONE AND DESIGN. INT. CL. 9. REG. 12-26-1989.  
1,576,909. HUGO. INT. CL. 41. REG. 1-9-1990.  
1,577,371. REUNION. INT. CL. 9. REG. 1-16-1990.  
1,578,206. WORLD CHAMPIONSHIP BINGO TOURNAMENT 1989 BINGO BUGLE NEWSPAPERS AND DESIGN. INT. CL. 41. REG. 1-16-1990.  
1,591,647. MILDVAC-MA5 (STYLIZED). INT. CL. 5. REG. 4-17-1990.  
1,610,439. ADD-A-NAME. INT. CLS. 9 AND 42. REG. 8-21-1990.  
1,610,521. C DIOR (STYLIZED). INT. CLS. 14, 18, 21, 24 AND 25. REG. 8-21-1990.  
1,638,329. SOTHEBY'S. INT. CL. 37 ONLY. REG. 3-19-1991.  
1,639,038. MAY PEACE PREVAIL ON EARTH. INT. CLS. 18, 21, 24 AND 26 ONLY. REG. 3-26-1991.  
1,909,071. P AND DESIGN. INT. CLS. 10, 16, 17, 20 AND 40. REG. 8-1-1995.  
1,909,662. MSS-58. INT. CL. 3. REG. 8-8-1995.  
1,930,895. COMING ATTRACTIONS PARTIES AND DESIGN. INT. CL. 42. REG. 10-31-1995.  
1,966,018. VINEDOS LOS ALTOS DE TUNUYAN. INT. CL. 33. REG. 4-2-1996.  
1,976,820. DIVORCESOLUTIONS AND DESIGN. INT. CL. 42. REG. 5-28-1996.  
1,993,280. ESQ AND DESIGN. INT. CL. 9. REG. 8-13-1996.  
1,997,271. SUNSTAR (STYLIZED). INT. CL. 21. REG. 8-27-1996.  
2,055,830. SELECTIVES. INT. CL. 21. REG. 4-22-1997.  
2,060,552. THE REAL ITALIAN TOMATO COMPANY WITH THE POLISH NAME!. INT. CL. 42. REG. 5-13-1997.  
2,067,378. GEOBEE. INT. CL. 9. REG. 6-3-1997.  
2,067,948. KYOHO. INT. CL. 31. REG. 6-3-1997.  
2,069,994. MOONEYES. INT. CL. 26. REG. 6-10-1997.  
2,103,839. ISYS. INT. CL. 9. REG. 10-7-1997.  
2,106,652. MISCELLANEOUS DESIGN. INT. CL. 39. REG. 10-21-1997.  
2,135,382. DNTLWORKS AND DESIGN. INT. CL. 10. REG. 2-10-1998.  
2,140,388. SHARE WORLD AND DESIGN. INT. CL. 41. REG. 3-3-1998.

## SECTION 8

- 506,554. NEWPORT (STYLIZED). U.S. CL. 6. REG. 2-8-1949.  
507,028. NEWPORT (STYLIZED). U.S. CL. 1. REG. 2-22-1949.  
515,517. OSTER (STYLIZED). U.S. CLS. 21 AND 44 ONLY. REG. 9-27-1949.  
833,136. STA-TAC. U.S. CL. 1. REG. 8-8-1967.  
864,846. T GLO. U.S. CL. 16. REG. 2-18-1969.  
1,043,066. EL ARMINO (STYLIZED). INT. CL. 30. REG. 7-6-1976.  
1,046,953. MISS CHOCOLATE. INT. CL. 30. REG. 8-24-1976.  
1,048,839. PRO-ZONE. INT. CL. 5. REG. 9-28-1976.  
1,074,290. NATIONAL ASSOCIATION OF SCHOOL PSYCHOLOGISTS AND DESIGN. INT. CL. 42. REG. 9-27-1977.  
1,122,164. LOTEPRO. INT. CLS. 6 AND 11. REG. 7-17-1979.  
1,130,080. DIENER SEEDS AND DESIGN. INT. CL. 31. REG. 1-29-1980.  
1,313,264. THESIS. INT. CL. 9. REG. 1-8-1985.  
1,372,903. REDCORT. INT. CL. 31. REG. 11-26-1985.  
1,380,491. CHINA AND DESIGN. INT. CL. 21. REG. 1-28-1986.  
1,390,271. CAPTAIN BALLOON. INT. CLS. 39 AND 42. REG. 4-15-1986.  
1,390,504. HARVARD AND DESIGN. INT. CL. 11. REG. 4-22-1986.  
1,398,509. ELITE COLLECTION. INT. CL. 16. REG. 6-24-1986.  
1,398,890. MISCELLANEOUS DESIGN. INT. CL. 39. REG. 6-24-1986.  
1,422,972. JET PILOT AND DESIGN. INT. CL. 25. REG. 12-30-1986.

- 2,142,722. ELASTOBLEND. INT. CL. 17. REG. 3-10-1998.  
 2,144,630. MAGNABLEND. INT. CL. 17. REG. 3-17-1998.  
 2,149,280. E-Z FLUSH. INT. CL. 17. REG. 4-7-1998.  
 2,151,915. JOE BOXER. INT. CL. 18. REG. 4-21-1998.  
 2,154,355. CHEWY MIX. INT. CL. 30. REG. 4-28-1998.  
 2,159,931. FLEXSYSTEMS. INT. CL. 20. REG. 5-26-1998.  
 2,161,332. RUDE GIRL. INT. CL. 41. REG. 6-2-1998.  
 2,162,681. MAGNASWEEP. INT. CL. 7. REG. 6-2-1998.  
 2,167,340. CARNEGIE COACH. INT. CL. 9. REG. 6-23-1998.  
 2,186,889. ERA ECONOMICS RESEARCH ASSOCIATES AND DESIGN. INT. CLS. 35 AND 36. REG. 9-1-1998.  
 2,204,741. BUSH-WHACKER. INT. CL. 7. REG. 11-24-1998.  
 2,216,004. WELLNESS ADVERTISING. INT. CL. 35. REG. 1-5-1999.  
 2,220,508. STRATEGIC LAW PARTNERS. INT. CL. 42. REG. 1-26-1999.  
 2,224,051. CONTEX. INT. CL. 9. REG. 2-16-1999.  
 2,267,888. FRESH SEASONAL SEAFOOD FROM PORTS WORLDWIDE. INT. CL. 42. REG. 8-3-1999.  
 2,270,391. TEE TIME EXPRESS. INT. CL. 41. REG. 8-17-1999.  
 2,272,431. VILLA VERDE. INT. CL. 33. REG. 8-24-1999.  
 2,297,262. CERVINI'S. INT. CL. 12. REG. 12-7-1999.  
 2,308,859. BEANER'S. INT. CLS. 25, 30 AND 42. REG. 1-18-2000.  
 2,316,088. TIMESHARELINK. INT. CL. 35. REG. 2-8-2000.  
 2,327,309. BUFFALO SOLDIER ICE CREAM AND DESIGN. INT. CL. 30. REG. 3-7-2000.  
 2,336,608. SHOCK QUICK AND DESIGN. INT. CL. 1. REG. 3-28-2000.  
 2,343,194. FULL MOTION APPAREL. INT. CL. 25. REG. 4-18-2000.  
 2,348,106. JINGAROO. INT. CL. 9. REG. 5-9-2000.  
 2,350,821. ROCKFISH CATALOG CO. A CATALOG FOR WOMEN AND THE MEN WHO LOVE THEM AND DESIGN. INT. CL. 35. REG. 5-16-2000.  
 2,369,935. HUNTSMAN AND DESIGN. INT. CL. 1. REG. 7-25-2000.  
 2,376,182. EVERYDAY GREEN TEA. INT. CLS. 5 AND 30. REG. 8-8-2000.  
 2,378,321. INVESTOR'S ADVANTAGE. INT. CL. 36. REG. 8-22-2000.  
 2,378,326. ZEB-ROLLER (STYLIZED). INT. CL. 16. REG. 8-22-2000.  
 2,378,380. ANTICO SAPORE ITALIANO ITALPIZZA AND DESIGN. INT. CL. 30. REG. 8-22-2000.  
 2,378,397. SANTECH INDUSTRIES. INT. CL. 17. REG. 8-22-2000.  
 2,378,408. DESIGN, COPY, PRINT, MIRACLES.. INT. CLS. 35, 38, 40 AND 42. REG. 8-22-2000.  
 2,378,409. NO KIDS FOR SIDS!. INT. CLS. 35 AND 42. REG. 8-22-2000.  
 2,378,418. MUSKEGON FURY. INT. CL. 28. REG. 8-22-2000.  
 2,378,420. INNORES. INT. CL. 35. REG. 8-22-2000.  
 2,378,422. COWGIRLZ AUTHENTIC CLOTHING AND DESIGN. INT. CL. 25. REG. 8-22-2000.  
 2,378,427. KIL-N-DRI. INT. CL. 17. REG. 8-22-2000.  
 2,378,429. MISCELLANEOUS DESIGN. INT. CL. 20. REG. 8-22-2000.  
 2,378,434. POLESTAR. INT. CLS. 9 AND 38. REG. 8-22-2000.  
 2,378,441. YOUR PAYROLL & SOFTWARE SOLUTION. INT. CLS. 9 AND 35. REG. 8-22-2000.  
 2,378,444. OCEAN WATCH AND DESIGN. INT. CL. 42. REG. 8-22-2000.  
 2,378,447. TR. INT. CL. 6. REG. 8-22-2000.  
 2,378,452. TIMBRE TUNE. INT. CL. 15. REG. 8-22-2000.  
 2,378,455. TOPCORE. INT. CL. 6. REG. 8-22-2000.  
 2,378,456. AS PRO. INT. CL. 36. REG. 8-22-2000.  
 2,378,459. SOLAR QUEST. INT. CL. 35. REG. 8-22-2000.  
 2,378,460. TEAL TOWN USA. INT. CLS. 25 AND 41. REG. 8-22-2000.  
 2,378,466. HEALTHCOUNTS. INT. CLS. 40 AND 42. REG. 8-22-2000.  
 2,378,468. FILM FASHION. INT. CL. 42. REG. 8-22-2000.  
 2,378,472. STEVEN RAMBAM. INT. CL. 42. REG. 8-22-2000.  
 2,378,473. STAHL SAC. INT. CLS. 18 AND 28. REG. 8-22-2000.  
 2,378,477. CONFLANDEY C AND DESIGN. INT. CL. 6. REG. 8-22-2000.  
 2,378,483. M.A.P.S.. INT. CL. 41. REG. 8-22-2000.  
 2,378,484. MOST AMAZING PERSONAL SERVICE. INT. CL. 41. REG. 8-22-2000.  
 2,378,486. MANIERI AND DESIGN. INT. CL. 25. REG. 8-22-2000.  
 2,378,493. LENDER'S SERVICE, INC. INT. CLS. 35 AND 36. REG. 8-22-2000.  
 2,378,495. TRILOGY. INT. CL. 42. REG. 8-22-2000.  
 2,378,499. CROSS COUNTRY. INT. CL. 12. REG. 8-22-2000.  
 2,378,501. AVENUE [PERFECT SCENTS] (STYLIZED). INT. CLS. 3 AND 4. REG. 8-22-2000.  
 2,378,508. YOUTH FOR CHRIST INTERNATIONAL. INT. CL. 42. REG. 8-22-2000.  
 2,378,512. REGINA RUBENS (STYLIZED). INT. CLS. 3, 18 AND 25. REG. 8-22-2000.  
 2,378,516. EZEKIEL AND DESIGN. INT. CL. 25. REG. 8-22-2000.  
 2,378,522. REGENCY AND DESIGN. INT. CL. 42. REG. 8-22-2000.  
 2,378,525. WETLANDS. INT. CLS. 38 AND 41. REG. 8-22-2000.  
 2,378,528. MEGADOTS. INT. CL. 9. REG. 8-22-2000.  
 2,378,533. STAR SPANGLED CELEBRATION. INT. CL. 41. REG. 8-22-2000.  
 2,378,549. SYNSOR. INT. CL. 28. REG. 8-22-2000.  
 2,378,553. HOMEREWARDS. INT. CL. 36. REG. 8-22-2000.  
 2,378,556. PHUTURE. INT. CL. 9. REG. 8-22-2000.  
 2,378,571. PROFESSIONAL CLUBFITTER. INT. CL. 42. REG. 8-22-2000.  
 2,378,602. MISCELLANEOUS DESIGN. INT. CL. 41. REG. 8-22-2000.  
 2,378,607. GUIDE. INT. CL. 9. REG. 8-22-2000.  
 2,378,612. BRACCIO. INT. CL. 14. REG. 8-22-2000.  
 2,378,613. JET PRINT PHOTO. INT. CL. 16. REG. 8-22-2000.  
 2,378,614. RAPID AD DELIVERY AND DESIGN. INT. CL. 35. REG. 8-22-2000.  
 2,378,622. THE CONNECTION. INT. CL. 35. REG. 8-22-2000.  
 2,378,624. VISLUBE. INT. CL. 5. REG. 8-22-2000.  
 2,378,629. CO SPACE. INT. CLS. 38 AND 42. REG. 8-22-2000.  
 2,378,630. EAGLS ELECTRONIC ACCOUNT GOVERNMENT LEDGER SYSTEM. INT. CL. 36. REG. 8-22-2000.  
 2,378,641. UNIPLAS. INT. CL. 5. REG. 8-22-2000.  
 2,378,645. ACCESSORCASE. INT. CL. 9. REG. 8-22-2000.  
 2,378,650. 9000. INT. CL. 10. REG. 8-22-2000.  
 2,378,651. CORRIDOR AND DESIGN. INT. CL. 9. REG. 8-22-2000.  
 2,378,654. SUMX. INT. CL. 36. REG. 8-22-2000.  
 2,378,664. LAZERVEICE (STYLIZED). INT. CL. 9. REG. 8-22-2000.  
 2,378,667. CLIPPARD MINIMETRIC. INT. CLS. 7 AND 9. REG. 8-22-2000.  
 2,378,673. COMFORTSILK. INT. CL. 17. REG. 8-22-2000.  
 2,378,679. NEW DIMENSIONS AND DESIGN. INT. CL. 5. REG. 8-22-2000.  
 2,378,680. FLORIDA TRUCKING ASSOCIATION MEMBER AND DESIGN. INT. CL. 42. REG. 8-22-2000.  
 2,378,704. DYNAFLAIR. INT. CL. 6. REG. 8-22-2000.  
 2,378,710. CRISP. INT. CL. 35. REG. 8-22-2000.  
 2,378,720. SYSTRONIX. INT. CLS. 40 AND 42. REG. 8-22-2000.  
 2,378,723. GREAT PLAINS. INT. CL. 9. REG. 8-22-2000.  
 2,378,726. KROGH. INT. CL. 7. REG. 8-22-2000.  
 2,378,728. LYE AND DESIGN. INT. CL. 42. REG. 8-22-2000.  
 2,378,739. GEOPORTAL.COM. INT. CL. 42. REG. 8-22-2000.  
 2,378,755. BUILDING FINANCIAL BRIDGES (STYLIZED). INT. CL. 36. REG. 8-22-2000.  
 2,378,762. GIZBO AND DESIGN. INT. CL. 25. REG. 8-22-2000.  
 2,378,765. BLACKBATT. INT. CL. 22. REG. 8-22-2000.  
 2,378,766. IGNITIONGARD. INT. CL. 22. REG. 8-22-2000.  
 2,378,768. STAR SPANGLED 4TH. INT. CLS. 35 AND 41. REG. 8-22-2000.  
 2,378,780. RES. INT. CLS. 36 AND 39. REG. 8-22-2000.  
 2,378,785. WICKED. INT. CL. 9. REG. 8-22-2000.  
 2,378,787. SOMATOM STAR (STYLIZED). INT. CL. 10. REG. 8-22-2000.

- 2,378,796. THE ASH GROVE GROUP INC. AND DESIGN. INT. CL. 42. REG. 8-22-2000.
- 2,378,799. BOXIT. INT. CL. 9. REG. 8-22-2000.
- 2,378,801. AVANU INTERNET & NETWORKING PRODUCT SOLUTIONS DISTRIBUTOR AND DESIGN. INT. CL. 35. REG. 8-22-2000.
- 2,378,808. R203. INT. CL. 3. REG. 8-22-2000.
- 2,378,809. R145. INT. CL. 3. REG. 8-22-2000.
- 2,378,810. K35. INT. CL. 3. REG. 8-22-2000.
- 2,378,811. S181. INT. CL. 3. REG. 8-22-2000.
- 2,378,814. CORPORATEMIND. INT. CL. 42. REG. 8-22-2000.
- 2,378,817. HBO THE WORKS AND DESIGN. INT. CL. 41. REG. 8-22-2000.
- 2,378,821. XTENDER. INT. CL. 6. REG. 8-22-2000.
- 2,378,822. 5280. INT. CL. 16. REG. 8-22-2000.
- 2,378,827. PBM. INT. CLS. 35 AND 42. REG. 8-22-2000.
- 2,378,831. ENVIROSUPPLY & SERVICE, INC. AND DESIGN. INT. CL. 35. REG. 8-22-2000.
- 2,378,847. DIFFERENCE BY DESIGN CUSTOMIZED GROUP DEVELOPMENT CONSULTING AND DESIGN. INT. CL. 41. REG. 8-22-2000.
- 2,378,850. COLLECTION EXCELLENCE. INT. CL. 41. REG. 8-22-2000.
- 2,378,856. CAROLINA THUNDER. INT. CL. 36. REG. 8-22-2000.
- 2,378,860. DUEGI AND DESIGN. INT. CL. 25. REG. 8-22-2000.
- 2,378,862. ENTERPRISE ROLLUP. INT. CL. 9. REG. 8-22-2000.
- 2,378,863. CUISINE THE YEAR IN CREATIVE HOME COOKING. INT. CL. 16. REG. 8-22-2000.
- 2,378,885. MAXXUM. INT. CL. 7. REG. 8-22-2000.
- 2,378,887. AMPHION (STYLIZED). INT. CL. 35. REG. 8-22-2000.
- 2,378,912. MATURITY WORKS. INT. CL. 35. REG. 8-22-2000.
- 2,378,922. CENTURY 21 CONNECTIONS REAL CONVE-NIENCEREAL VALUE AND DESIGN. INT. CL. 35. REG. 8-22-2000.
- 2,378,934. MISCELLANEOUS DESIGN. INT. CL. 42. REG. 8-22-2000.
- 2,378,939. SPEED-CHUCK. INT. CL. 7. REG. 8-22-2000.
- 2,378,955. ACTIV8. INT. CL. 9. REG. 8-22-2000.
- 2,378,970. AXIS. INT. CL. 10. REG. 8-22-2000.
- 2,378,972. MOORHEAD AND COMPANY, INC. AGAR AND AGAR PRODUCTS A TRADITION OF QUAL-ITY SINCE AND DESIGN. INT. CL. 35. REG. 8-22-2000.
- 2,378,973. GUT SESSIONS. INT. CL. 35. REG. 8-22-2000.
- 2,378,974. THE GUT. INT. CL. 35. REG. 8-22-2000.
- 2,378,998. PUT POWERTECH AND DESIGN. INT. CL. 9. REG. 8-22-2000.
- 2,379,001. PRIVATE PRACTICE SUCCESS PROGRAM. INT. CL. 41. REG. 8-22-2000.
- 2,379,006. EMANON. INT. CL. 25. REG. 8-22-2000.
- 2,379,019. PORTO VITA AND DESIGN. INT. CLS. 36 AND 37. REG. 8-22-2000.
- 2,379,024. BIZRATE.COM. INT. CLS. 35 AND 42. REG. 8-22-2000.
- 2,379,028. SAFETY SEAL. INT. CL. 21. REG. 8-22-2000.
- 2,379,033. HC AND DESIGN. INT. CLS. 35 AND 42. REG. 8-22-2000.
- 2,379,034. FRONT PAGE NEWS (STYLIZED). INT. CL. 16. REG. 8-22-2000.
- 2,379,049. MITEK AND DESIGN. INT. CL. 9. REG. 8-22-2000.
- 2,379,052. VIVID MEDIA. INT. CL. 42. REG. 8-22-2000.
- 2,379,053. SIMPLY SOAP A CALIFORNIA HANDCRAFTED SOAP CO.. INT. CL. 3. REG. 8-22-2000.
- 2,379,064. IMAGENET. INT. CL. 35. REG. 8-22-2000.
- 2,379,066. OUTDOOR DESIGNS AND DESIGN. INT. CL. 42. REG. 8-22-2000.
- 2,379,078. MARS. INT. CLS. 5, 10 AND 42. REG. 8-22-2000.
- 2,379,101. CALENDAR LIVE!. INT. CL. 41. REG. 8-22-2000.
- 2,379,104. PLOW INTO PLEASURE. INT. CL. 30. REG. 8-22-2000.
- 2,379,105. FUDGE AKERS. INT. CL. 30. REG. 8-22-2000.
- 2,379,107. BIDFIND. INT. CL. 42. REG. 8-22-2000.
- 2,379,108. EL CABALLO AND DESIGN. INT. CL. 18. REG. 8-22-2000.
- 2,379,111. SOVEREIGN AND DESIGN. INT. CL. 10. REG. 8-22-2000.
- 2,379,127. PURE FUN. INT. CLS. 25 AND 28. REG. 8-22-2000.
- 2,379,138. INSTYLE THE LOOK. INT. CL. 16. REG. 8-22-2000.
- 2,379,146. F FLEMING'S PRIME STEAKHOUSE & WINE BAR AND DESIGN. INT. CL. 42. REG. 8-22-2000.
- 2,379,150. ZEBRA STRIPES AND DESIGN. INT. CL. 37. REG. 8-22-2000.
- 2,379,157. REACHING HIGHER. INT. CL. 41. REG. 8-22-2000.
- 2,379,162. HURRICANE. INT. CL. 7. REG. 8-22-2000.
- 2,379,167. IT'S DO + ABLE. INT. CL. 20. REG. 8-22-2000.
- 2,379,169. FRICTION FARM. INT. CL. 41. REG. 8-22-2000.
- 2,379,170. SEASHELL POETRY LISTEN... "THEY SAY YOU-CAN HEAR THE OCEAN" AND DESIGN. INT. CL. 41. REG. 8-22-2000.
- 2,379,186. J JOHNSON TRUST AND DESIGN. INT. CL. 36. REG. 8-22-2000.
- 2,379,188. SCOTTNET. INT. CL. 37. REG. 8-22-2000.
- 2,379,195. EFLIP. INT. CL. 9. REG. 8-22-2000.
- 2,379,199. TRIZIVIR. INT. CL. 5. REG. 8-22-2000.
- 2,379,204. SIMPLY HELPING THE WORLD SLEEP. INT. CL. 5. REG. 8-22-2000.
- 2,379,205. DUAL-THERM. INT. CL. 9. REG. 8-22-2000.
- 2,379,224. DR. EFFECT. INT. CLS. 16 AND 41. REG. 8-22-2000.
- 2,379,237. PROGUARD SYSTEMS. INT. CL. 37. REG. 8-22-2000.
- 2,379,265. LEADERSHIP FLORIDA INSTITUTE. INT. CL. 41. REG. 8-22-2000.
- 2,379,298. TELE-QUAL. INT. CL. 35. REG. 8-22-2000.
- 2,379,300. THE JEWELS OF HEAVEN (STYLIZED). INT. CL. 14. REG. 8-22-2000.
- 2,379,304. 911-STAT. INT. CL. 42. REG. 8-22-2000.
- 2,379,306. LA FRESH AND DESIGN. INT. CL. 3. REG. 8-22-2000.
- 2,379,309. MULTEX. INT. CL. 36. REG. 8-22-2000.
- 2,379,325. ANKER AND DESIGN. INT. CL. 12. REG. 8-22-2000.
- 2,379,326. PFM. INT. CL. 7. REG. 8-22-2000.
- 2,379,332. FRESH ICE. INT. CL. 11. REG. 8-22-2000.
- 2,379,338. FLOTEK. INT. CL. 9. REG. 8-22-2000.
- 2,379,347. TIRE CONTROL. INT. CL. 1. REG. 8-22-2000.
- 2,379,351. TOTAL FIT. INT. CL. 9. REG. 8-22-2000.
- 2,379,352. RESOLUTION PERFECT. INT. CL. 9. REG. 8-22-2000.
- 2,379,361. QUBX. INT. CL. 42. REG. 8-22-2000.
- 2,379,362. MADE IN HOCKEYTOWN. INT. CLS. 20, 24, 28 AND 34. REG. 8-22-2000.
- 2,379,363. COMPUHOME. INT. CL. 42. REG. 8-22-2000.
- 2,379,377. WIND DANCER. INT. CL. 20. REG. 8-22-2000.
- 2,379,382. B (STYLIZED). INT. CL. 37. REG. 8-22-2000.
- 2,379,384. ASHLEY ROBERTS. INT. CLS. 16 AND 20. REG. 8-22-2000.
- 2,379,385. SILIKUP. INT. CL. 1. REG. 8-22-2000.
- 2,379,386. TITANKUP. INT. CL. 1. REG. 8-22-2000.
- 2,379,406. LIVE IN LEGENDARY LUXURY. INT. CL. 36. REG. 8-22-2000.
- 2,379,407. OAK GROVE SCHOOL. INT. CL. 41. REG. 8-22-2000.
- 2,379,413. HEIRLOOM EDITION. INT. CL. 7. REG. 8-22-2000.
- 2,379,414. SILICON HEIGHTS COMPUTERS. INT. CL. 35. REG. 8-22-2000.
- 2,379,422. NEON MOON PRODUCTIONS. INT. CL. 41. REG. 8-22-2000.
- 2,379,423. ATLANTIS MUSIC CONFERENCE AND DE-SIGN. INT. CL. 41. REG. 8-22-2000.
- 2,379,424. OMNI FORGE. INT. CL. 40. REG. 8-22-2000.
- 2,379,427. EXOTIC TAN SUN CLUB AND DESIGN. INT. CL. 42. REG. 8-22-2000.
- 2,379,435. EPIER. INT. CL. 35. REG. 8-22-2000.
- 2,379,446. ALPHA II. INT. CL. 9. REG. 8-22-2000.
- 2,379,447. YOU SIT BEHIND THE WHEEL...WE STAND BEHIND THE TRUCK. INT. CL. 36. REG. 8-22-2000.

- 2,379,452. NET FORGE. INT. CL. 40. REG. 8-22-2000.  
2,379,462. MYGRADEBOOK.COM. INT. CL. 41. REG. 8-22-2000.  
2,379,468. VALVOLINE. INT. CL. 9. REG. 8-22-2000.  
2,379,476. HOMEWORK MANAGER. INT. CL. 16. REG. 8-22-2000.  
2,379,478. G GENERAL MILLS BOX TOPS FOR EDUCATION. INT. CLS. 29 AND 30. REG. 8-22-2000.  
2,379,479. KBEQ. INT. CL. 38. REG. 8-22-2000.  
2,379,485. DIVINITEA. INT. CL. 30. REG. 8-22-2000.  
2,379,497. THERMAL MASTER III. INT. CL. 19. REG. 8-22-2000.  
2,379,521. COLLEGE IS POSSIBLE. INT. CL. 41. REG. 8-22-2000.  
2,379,526. PERSONAL PLUMBER AND DESIGN. INT. CL. 37. REG. 8-22-2000.  
2,379,527. EWMORTGAGE.COM. INT. CL. 36. REG. 8-22-2000.  
2,379,534. FRANK THE NET FLORIDA KEYS AND DESIGN. INT. CL. 28. REG. 8-22-2000.  
2,379,537. SWEET-STICK. INT. CL. 8. REG. 8-22-2000.  
2,379,539. NU WAVE AUDIO. INT. CL. 37. REG. 8-22-2000.  
2,379,541. VEIN FREE. INT. CL. 5. REG. 8-22-2000.  
2,379,543. THE ULTIMATE IN HIGH ENERGY ENTERTAINMENT (STYLIZED). INT. CL. 41. REG. 8-22-2000.  
2,379,545. HURRICANENET. INT. CL. 37. REG. 8-22-2000.  
2,379,556. HEMOCYTE-F. INT. CL. 5. REG. 8-22-2000.  
2,379,580. QBB. INT. CL. 16. REG. 8-22-2000.  
2,379,583. STOPPER NETTING. INT. CL. 28. REG. 8-22-2000.  
2,379,585. DYNAMANAGE. INT. CL. 42. REG. 8-22-2000.  
2,379,587. BEYOND LAWYERING. INT. CL. 42. REG. 8-22-2000.  
2,379,590. FLORIDA' S CARIBBEAN ISLAND. INT. CL. 42. REG. 8-22-2000.  
2,379,596. D DELUXE (STYLIZED). INT. CL. 16. REG. 8-22-2000.  
2,379,621. HARPER'S TO GO GO. INT. CL. 42. REG. 8-22-2000.  
2,379,627. REFILL EASE. INT. CL. 42. REG. 8-22-2000.  
2,379,641. TURBOTUNE (STYLIZED). INT. CL. 8. REG. 8-22-2000.  
2,379,648. KEEP ME POSTED AND DESIGN. INT. CL. 41. REG. 8-22-2000.  
2,379,651. BUSTER ON A STICK. INT. CL. 9. REG. 8-22-2000.  
2,379,652. NIDR. INT. CL. 42. REG. 8-22-2000.  
2,379,659. DECKS, EFX & 909. INT. CL. 41. REG. 8-22-2000.  
2,379,663. DRIVER'S ROAD AND DESIGN. INT. CL. 25. REG. 8-22-2000.  
2,379,665. TURN ON THE POWER. INT. CL. 35. REG. 8-22-2000.  
2,379,676. SEDUCTION. INT. CL. 41. REG. 8-22-2000.  
2,379,681. PROFESSIONAL SERVICE DEALER NETWORK. INT. CL. 42. REG. 8-22-2000.  
2,379,686. TOP FIVE AND DESIGN. INT. CL. 35. REG. 8-22-2000.  
2,379,689. BATTERY STUDIOS (STYLIZED). INT. CL. 41. REG. 8-22-2000.  
2,379,692. ENJOY THE GAME. INT. CL. 41. REG. 8-22-2000.  
2,379,699. BEARCAT. INT. CL. 7. REG. 8-22-2000.  
2,379,711. RACKSPACE.COM AND DESIGN. INT. CL. 42. REG. 8-22-2000.  
2,379,716. TECH FORM AND DESIGN. INT. CL. 6. REG. 8-22-2000.  
2,379,727. PANA. INT. CL. 42. REG. 8-22-2000.  
2,379,741. TOPNOTCHDOG (STYLIZED). INT. CL. 41. REG. 8-22-2000.  
2,379,756. VANEER. INT. CL. 20. REG. 8-22-2000.  
2,379,757. TIME2VALUE. INT. CL. 9. REG. 8-22-2000.  
2,379,771. SONIC DVD CREATOR. INT. CL. 9. REG. 8-22-2000.  
2,379,772. M AUDIO (STYLIZED). INT. CL. 9. REG. 8-22-2000.  
2,379,782. MATHMATAZZ. INT. CL. 16. REG. 8-22-2000.  
2,379,789. AMERITAPE. INT. CL. 9. REG. 8-22-2000.  
2,379,791. APPLE FARM. INT. CL. 25. REG. 8-22-2000.  
2,379,793. FCL. INT. CL. 14. REG. 8-22-2000.  
2,379,796. CASINO ROYALE. INT. CL. 41. REG. 8-22-2000.  
2,379,822. YARD CRUISER. INT. CL. 7. REG. 8-22-2000.  
2,379,824. HARD BARGIN. INT. CL. 25. REG. 8-22-2000.  
2,379,828. IT SPRING WIRE. INT. CL. 12. REG. 8-22-2000.  
2,379,829. QUICK SHIP. INT. CL. 40. REG. 8-22-2000.  
2,379,834. THE SECRET STONE. INT. CL. 21. REG. 8-22-2000.  
2,379,846. COPPUS COLDFRONT. INT. CL. 11. REG. 8-22-2000.  
2,379,847. INTEGRAL ACCESS. INT. CL. 9. REG. 8-22-2000.  
2,379,848. GOODLINK. INT. CL. 9. REG. 8-22-2000.  
2,379,851. STARCRAFT. INT. CL. 12. REG. 8-22-2000.  
2,379,857. CADENCE. INT. CL. 39. REG. 8-22-2000.  
2,379,859. MD 2 DATA AND DESIGN. INT. CL. 9. REG. 8-22-2000.  
2,379,865. STATIFLOR. INT. CL. 27. REG. 8-22-2000.  
2,379,880. XC865. INT. CL. 9. REG. 8-22-2000.  
2,379,901. MATTHEWS & STEPHENS ASSOCIATES. INT. CL. 35. REG. 8-22-2000.  
2,379,908. NEXTNEXT. INT. CL. 9. REG. 8-22-2000.  
2,379,918. CASA DEL MAR. INT. CL. 42. REG. 8-22-2000.  
2,379,930. STRATOSPHERE. INT. CL. 9. REG. 8-22-2000.  
2,379,936. TFTC. INT. CL. 6. REG. 8-22-2000.  
2,379,943. XC23. INT. CL. 9. REG. 8-22-2000.  
2,379,944. XC33. INT. CL. 9. REG. 8-22-2000.  
2,379,946. ANY DAY NOW. INT. CL. 41. REG. 8-22-2000.  
2,379,948. GAM GEAR. INT. CL. 7. REG. 8-22-2000.  
2,379,951. TITANS TRENTON AND DESIGN. INT. CL. 25. REG. 8-22-2000.  
2,379,952. FROSTY FEET. INT. CL. 25. REG. 8-22-2000.  
2,379,956. BUSINESSIGHT. INT. CL. 35. REG. 8-22-2000.  
2,379,959. TANGO. INT. CL. 9. REG. 8-22-2000.  
2,379,961. TROPICAL LIGHTS AND DESIGN. INT. CL. 4. REG. 8-22-2000.  
2,379,986. AMBRODERM. INT. CL. 3. REG. 8-22-2000.  
2,379,996. ELEGANTE. INT. CL. 20. REG. 8-22-2000.  
2,380,000. AFTER DARK. INT. CL. 9. REG. 8-22-2000.  
2,380,005. THE WAY FUN STORE. INT. CL. 16. REG. 8-22-2000.  
2,380,012. OVERLOOK SOFTWARE. INT. CL. 9. REG. 8-22-2000.  
2,380,013. CALL HOME AMERICA SELECT. INT. CL. 38. REG. 8-22-2000.  
2,380,018. BEANDANCE. INT. CL. 35. REG. 8-22-2000.  
2,380,026. NATUREBED. INT. CL. 31. REG. 8-22-2000.  
2,380,030. ACCOUNTABLE RESOURCE MANAGEMENT AND DESIGN. INT. CLS. 35 AND 40. REG. 8-22-2000.  
2,380,032. SUGARBUSH HOLLOW. INT. CL. 30. REG. 8-22-2000.  
2,380,037. MISCELLANEOUS DESIGN. INT. CL. 20. REG. 8-22-2000.  
2,380,053. V FAST (STYLIZED). INT. CL. 9. REG. 8-22-2000.  
2,380,055. PENOFFICE. INT. CL. 9. REG. 8-22-2000.  
2,380,075. ZINERA. INT. CL. 5. REG. 8-22-2000.  
2,380,078. MISCELLANEOUS DESIGN. INT. CL. 10. REG. 8-22-2000.  
2,380,080. YOUR SATISFACTION IS 200% GUARANTEED WITH THE ERIE 2 FOR 1 GUARANTEE. INT. CL. 21. REG. 8-22-2000.  
2,380,087. MISCELLANEOUS DESIGN. INT. CL. 2. REG. 8-22-2000.  
2,380,098. HR-WARE. INT. CL. 9. REG. 8-22-2000.  
2,380,106. SAX TRAX. INT. CL. 42. REG. 8-22-2000.  
2,380,109. CITY STAGE. INT. CL. 41. REG. 8-22-2000.  
2,380,110. AWARD. INT. CL. 9. REG. 8-22-2000.  
2,380,112. FRACTIONAL JET OWNERSHIP. INT. CL. 42. REG. 8-22-2000.  
2,380,122. SELECT FIBER BARLEY. INT. CL. 30. REG. 8-22-2000.  
2,380,125. AMERICAN LUMPING ASSOCIATION. INT. CL. 35. REG. 8-22-2000.  
2,380,133. BUY-CYCLE. INT. CL. 35. REG. 8-22-2000.  
2,380,135. STEAM FAST. INT. CL. 9. REG. 8-22-2000.  
2,380,141. MARK-A-TEXT. INT. CL. 9. REG. 8-22-2000.  
2,380,144. DTC PREVIEW DIRECT-TO-CONSUMER AND DESIGN. INT. CL. 41. REG. 8-22-2000.  
2,380,148. THE NATIONAL EDUCATORS' HALL OF FAME. INT. CL. 41. REG. 8-22-2000.

- 2,380,153. FLEXIBLE ADMINISTRATION SYSTEM TECHNOLOGY. INT. CL. 9. REG. 8-22-2000.
- 2,381,264. T POST COVERS AND DESIGN. INT. CL. 19. REG. 8-29-2000.
- 2,387,212. BIG ORANGE CONE. INT. CL. 41. REG. 9-19-2000.
- 2,389,449. NETREACH (STYLIZED). INT. CLS. 38 AND 42. REG. 9-26-2000.
- 2,390,972. BECKER UNDERWOOD. INT. CL. 7 ONLY. REG. 10-3-2000.
- 2,395,104. IO VISION. INT. CL. 42. REG. 10-17-2000.
- 2,396,130. AFTER HOURS. INT. CL. 25 ONLY. REG. 10-17-2000.
- 2,396,800. Y AND DESIGN. INT. CLS. 6, 18 AND 26. REG. 10-24-2000.
- 2,408,770. NOIR. INT. CLS. 18 AND 26 ONLY. REG. 11-28-2000.
- 2,417,165. CAMP GRANDMA AND DESIGN. INT. CLS. 18, 24 AND 25. REG. 1-2-2001.
- 2,422,197. "ALL THE QUALITY, HALF THE PRICE". INT. CL. 16. REG. 1-16-2001.
- 2,422,198. "CARING SO MUCH NEVER COSTS SO LITTLE". INT. CL. 16. REG. 1-16-2001.
- 2,424,088. CITI AND DESIGN. INT. CL. 9 ONLY. REG. 1-23-2001.
- 2,426,704. COWBOY JOE. INT. CL. 42. REG. 2-6-2001.
- 2,436,580. GREENHEAD GEAR. INT. CLS. 13, 18 AND 21 ONLY. REG. 3-20-2001.
- 2,436,995. STRATOS. INT. CL. 12. REG. 3-20-2001.
- 2,437,753. CELLGENIX. INT. CL. 42 ONLY. REG. 3-27-2001.
- 2,437,825. TATEOSSIAN. INT. CLS. 3, 21 AND 24 ONLY. REG. 3-27-2001.
- 2,437,931. B A D BEST AMERICAN DUFFEL. INT. CL. 28 ONLY. REG. 3-27-2001.
- 2,437,935. YAN CAN COOK. INT. CL. 21 ONLY. REG. 3-27-2001.
- 2,438,323. JUST AND DESIGN. INT. CL. 21 ONLY. REG. 3-27-2001.
- 2,439,010. MISCELLANEOUS DESIGN. INT. CL. 9. REG. 3-27-2001.
- 2,439,232. AMERICAN TOURISTER AND DESIGN. INT. CL. 11 ONLY. REG. 3-27-2001.
- 2,439,576. RCC. INT. CLS. 35, 36 AND 37 ONLY. REG. 3-27-2001.
- 2,440,175. RELY PRODUCTS AND DESIGN. INT. CL. 3 ONLY. REG. 4-3-2001.
- 2,442,225. SUITES OF CALIFORNIA AND DESIGN. INT. CL. 42. REG. 4-10-2001.
- 2,444,519. MAGIC MORTGAGE. INT. CL. 36. REG. 4-17-2001.
- 2,445,309. CONSOLIDATED VENDORS. INT. CLS. 35 AND 42. REG. 4-17-2001.
- 2,452,306. TOPAQ AND DESIGN. INT. CL. 9. REG. 5-22-2001.
- 2,457,022. MISCELLANEOUS DESIGN. INT. CLS. 14 AND 25 ONLY. REG. 6-5-2001.
- 2,461,433. TOTEM TATTOO. INT. CL. 42. REG. 6-19-2001.
- 2,468,301. NOW AND AGAIN. INT. CL. 41. REG. 7-10-2001.
- 2,476,816. PRIORITY LOAN. INT. CL. 36. REG. 8-7-2001.
- 2,477,779. MOUNTAIN MADE.COM GENERATIONS IN THE MAKING AND DESIGN. INT. CL. 35. REG. 8-14-2001.
- 2,478,720. B2D. INT. CLS. 35, 41 AND 42. REG. 8-14-2001.
- 2,479,951. SOCK AND ROLL. INT. CL. 41. REG. 8-21-2001.
- 2,481,609. VITAL-LEARNING.COM. INT. CL. 41. REG. 8-28-2001.
- 2,482,933. WATER BETTY'S. INT. CL. 25. REG. 8-28-2001.
- 2,484,511. MISCELLANEOUS DESIGN. INT. CL. 17 ONLY. REG. 9-4-2001.
- 2,484,548. CARAUSTAR. INT. CL. 17 ONLY. REG. 9-4-2001.
- 2,484,769. DYNAPEL. INT. CLS. 38 AND 42 ONLY. REG. 9-4-2001.
- 2,497,062. TOTAL WAR AND DESIGN. INT. CL. 41 ONLY. REG. 10-9-2001.
- 2,505,088. FLUOROTHANE. INT. CL. 1. REG. 11-6-2001.
- 2,510,791. EARTH MOTHER ESSENCES AND DESIGN. INT. CL. 3. REG. 11-20-2001.
- 2,530,743. LATILLA. INT. CL. 9. REG. 1-15-2002.
- 2,533,307. CHRISTY'S COUNTRY CANDLES. INT. CLS. 4 AND 35. REG. 1-29-2002.
- 2,548,977. SHADE SHACK. INT. CL. 9. REG. 3-19-2002.
- 2,554,992. LOS ANGELES TIMES TRAVEL SHOW AND DESIGN. INT. CL. 35. REG. 4-2-2002.
- 2,556,585. THE TANNING PALACE. INT. CL. 42. REG. 4-2-2002.
- 2,560,985. FUZZY BRUSH AND DESIGN. INT. CLS. 9 AND 21. REG. 4-16-2002.
- 2,562,902. THE HEARING RESEARCH INSTITUTE AND DESIGN. INT. CLS. 16 AND 41. REG. 4-23-2002.
- 2,571,955. FIRE & LIGHT. INT. CL. 41. REG. 5-21-2002.
- 2,572,462. CARDIO TONE AND DESIGN. INT. CL. 5. REG. 5-28-2002.
- 2,582,298. SMITHSOLUTIONS. INT. CL. 42. REG. 6-18-2002.
- 2,587,285. V AND DESIGN. INT. CL. 6. REG. 7-2-2002.
- 2,588,792. WOCKHARDT AND DESIGN. INT. CL. 5. REG. 7-2-2002.
- 2,594,651. NO WIRES. NO WORRIES.. INT. CL. 9. REG. 7-16-2002.
- 2,596,777. EDUBOT (STYLIZED). INT. CLS. 9 AND 28. REG. 7-23-2002.
- 2,623,052. FINFOAM. INT. CL. 37. REG. 9-24-2002.
- 2,628,838. THE VOICE IN MANUFACTURING. INT. CLS. 9 AND 35. REG. 10-1-2002.
- 2,630,163. R.V.I.P. AND DESIGN. INT. CL. 42. REG. 10-8-2002.
- 2,643,732. INTRALASE. INT. CL. 10. REG. 10-29-2002.
- 2,645,783. X-MEN: EVOLUTION. INT. CL. 28. REG. 11-5-2002.
- 2,667,300. X-MEN: EVOLUTION. INT. CL. 16. REG. 12-24-2002.
- 2,672,434. EVERY DAY WITH JESUS. INT. CL. 16. REG. 1-7-2003.
- 2,688,702. REMERIGUARD. INT. CL. 36. REG. 2-18-2003.
- 2,730,606. COMPASS - LEARN TO NAVIGATE YOUR LIFE. INT. CL. 16. REG. 6-24-2003.
- 2,758,121. MEDIFAST DIRECT. INT. CL. 44. REG. 9-2-2003.
- 2,768,502. PAGEMAN (STYLIZED). INT. CL. 9. REG. 9-30-2003.
- 2,830,565. STUFFITS. INT. CL. 43. REG. 4-6-2004.
- 2,838,319. MALBER. INT. CL. 7. REG. 5-4-2004.
- 2,849,995. BRASSELER USA DENTAL ROTARY INSTRUMENTS AND DESIGN. INT. CLS. 7, 8 AND 9 ONLY. REG. 6-8-2004.
- 2,868,958. MISCELLANEOUS DESIGN. INT. CL. 41. REG. 8-3-2004.
- 2,869,363. THE PROGRESSION OF WEALTH PROCESS. INT. CL. 36. REG. 8-3-2004.
- 2,870,483. THE NARRATIVE HOUSE. INT. CL. 16. REG. 8-3-2004.
- 2,873,090. AFP AND DESIGN. INT. CLS. 9, 20 AND 40 ONLY. REG. 8-17-2004.
- 2,875,837. LET YOUR FINGERS DO THE RUNNING..... AND DESIGN. INT. CL. 35. REG. 8-24-2004.
- 2,875,843. TECHMEDIA. INT. CL. 9. REG. 8-24-2004.
- 2,875,846. CARECOMPASS. INT. CL. 9. REG. 8-24-2004.
- 2,875,847. MAKE YOURSELF HEARD. INT. CL. 9. REG. 8-24-2004.
- 2,875,848. FRIDAY HARBOR USA AND DESIGN. INT. CL. 25. REG. 8-24-2004.
- 2,875,849. Q NAILS AND DESIGN. INT. CL. 3. REG. 8-24-2004.
- 2,875,850. DIGILINK (STYLIZED). INT. CL. 9. REG. 8-24-2004.
- 2,875,851. DO-IT DRILLING OPERATIONS INTERACTIVE TECHNOLOGIES. INT. CLS. 9 AND 42. REG. 8-24-2004.
- 2,875,855. E-CRUITER. INT. CL. 35. REG. 8-24-2004.
- 2,875,856. BLUMBERG. INT. CL. 16. REG. 8-24-2004.
- 2,875,857. LUNASOL AND DESIGN. INT. CLS. 3 AND 5. REG. 8-24-2004.
- 2,875,860. CHENEGA. INT. CLS. 35, 37, 39, 40, 41 AND 42. REG. 8-24-2004.
- 2,875,861. PIMEX. INT. CL. 1. REG. 8-24-2004.
- 2,875,864. MISCELLANEOUS DESIGN. INT. CLS. 9 AND 42. REG. 8-24-2004.
- 2,875,866. CKT'S POMMES FOR PRESIDENT AND DESIGN. INT. CLS. 21, 29, 30 AND 42. REG. 8-24-2004.

- 2,875,872. REPRONET PICKING PACK AND DESIGN. INT. CLS. 35, 38, 39 AND 42. REG. 8-24-2004.
- 2,875,875. WE DO IT RIGHT! (STYLIZED). INT. CL. 42. REG. 8-24-2004.
- 2,875,877. SECUREPROX. INT. CL. 9. REG. 8-24-2004.
- 2,875,879. ETERRA. INT. CL. 42. REG. 8-24-2004.
- 2,875,881. DOUBLE BARREL DASH FOR CASH. INT. CL. 41. REG. 8-24-2004.
- 2,875,884. STEP. INT. CLS. 41 AND 42. REG. 8-24-2004.
- 2,875,887. SPACE. INT. CL. 14. REG. 8-24-2004.
- 2,875,888. 123 INSTRUCTIONS 4. INT. CL. 16. REG. 8-24-2004.
- 2,875,890. TECHHEALTH. INT. CLS. 9 AND 36. REG. 8-24-2004.
- 2,875,894. STREETSIDE. INT. CL. 35. REG. 8-24-2004.
- 2,875,896. THE ART OF PERFORMANCE. INT. CL. 42. REG. 8-24-2004.
- 2,875,898. OPTIMUM LOGISTICS AND DESIGN. INT. CLS. 9 AND 42. REG. 8-24-2004.
- 2,875,899. OPTIMUM LOGISTICS. INT. CLS. 9 AND 42. REG. 8-24-2004.
- 2,875,910. AUTOSSET CS. INT. CLS. 37 AND 42. REG. 8-24-2004.
- 2,875,911. SCHOBBER INFORMATION GROUP AND DESIGN. INT. CLS. 9, 16, 35, 38 AND 42. REG. 8-24-2004.
- 2,875,913. ROWENA'S AND DESIGN. INT. CL. 30. REG. 8-24-2004.
- 2,875,914. MICKEY JONES. INT. CL. 9. REG. 8-24-2004.
- 2,875,916. MISCELLANEOUS DESIGN. INT. CL. 28. REG. 8-24-2004.
- 2,875,921. BENEFIT. INT. CL. 25. REG. 8-24-2004.
- 2,875,922. TRADEX. INT. CLS. 8, 9 AND 21. REG. 8-24-2004.
- 2,875,924. MATISS. INT. CLS. 7 AND 42. REG. 8-24-2004.
- 2,875,925. RÉMY ATTITUDE (STYLIZED). INT. CLS. 16, 38, 41 AND 42. REG. 8-24-2004.
- 2,875,926. QUIZID. INT. CLS. 9, 35, 36, 37, 42 AND 45. REG. 8-24-2004.
- 2,875,928. WOTCH.COM. INT. CLS. 41 AND 42. REG. 8-24-2004.
- 2,875,931. MBIDEAS. INT. CL. 35. REG. 8-24-2004.
- 2,875,932. LIPIBURSTER. INT. CL. 5. REG. 8-24-2004.
- 2,875,936. SENTINEL. INT. CL. 9. REG. 8-24-2004.
- 2,875,937. ENMANAGE AND DESIGN. INT. CLS. 9, 40 AND 42. REG. 8-24-2004.
- 2,875,939. PROCALIBRATOR. INT. CLS. 9 AND 10. REG. 8-24-2004.
- 2,875,941. PLANO. INT. CL. 20. REG. 8-24-2004.
- 2,875,947. MYCLOUD9. INT. CL. 35. REG. 8-24-2004.
- 2,875,950. NEXT 150 INDEX. INT. CLS. 35, 36 AND 41. REG. 8-24-2004.
- 2,875,951. EURONEXT 100 INDEX. INT. CLS. 35, 36 AND 41. REG. 8-24-2004.
- 2,875,952. WORLD LOTTERY ASSOCIATION WLA AND DESIGN. INT. CLS. 16, 35 AND 41. REG. 8-24-2004.
- 2,875,953. DREAM ROSE AND DESIGN. INT. CL. 31. REG. 8-24-2004.
- 2,875,954. CO-SOURCING. INT. CL. 35. REG. 8-24-2004.
- 2,875,956. FDR FRANKLYN D. RESORT. INT. CL. 42. REG. 8-24-2004.
- 2,875,957. BRAIN WORKS BUZZ AND DESIGN. INT. CL. 35. REG. 8-24-2004.
- 2,875,959. B.E.S.T.. INT. CL. 9. REG. 8-24-2004.
- 2,875,960. ATHLETES@RISK. INT. CL. 25. REG. 8-24-2004.
- 2,875,961. OVALUTE. INT. CL. 5. REG. 8-24-2004.
- 2,875,962. CONREL. INT. CLS. 1, 5 AND 42. REG. 8-24-2004.
- 2,875,967. HARPAPHYT. INT. CL. 5. REG. 8-24-2004.
- 2,875,969. OMNIPOINT. INT. CL. 10. REG. 8-24-2004.
- 2,875,971. CONSENSURE. INT. CLS. 9 AND 35. REG. 8-24-2004.
- 2,875,972. NETWORKS. INT. CL. 35. REG. 8-24-2004.
- 2,875,973. NETWORKS. INT. CL. 35. REG. 8-24-2004.
- 2,875,974. TO BEER OR NOT TO BEER ROYAL SHAKES BEER TRADITIONALLY BREWED BREWERS OF DISTINCTION AND DESIGN. INT. CL. 32. REG. 8-24-2004.
- 2,875,975. TWO NUCLEAR SERVICES AND DESIGN. INT. CLS. 37, 41 AND 42. REG. 8-24-2004.
- 2,875,976. ANNOTIS. INT. CLS. 9 AND 38. REG. 8-24-2004.
- 2,875,977. AIMSPRESS. INT. CL. 35. REG. 8-24-2004.
- 2,875,978. TABULA. INT. CL. 9. REG. 8-24-2004.
- 2,875,979. AECON CONSTRUCTION GROUP. INT. CLS. 35, 36, 37, 40 AND 42. REG. 8-24-2004.
- 2,875,984. CYTOMATRIX. INT. CL. 5. REG. 8-24-2004.
- 2,875,987. SHOOFLY DESIGN. INT. CL. 25. REG. 8-24-2004.
- 2,875,988. SILMO SALON INTERNATIONAL DE L'OPTIQUE LUNETTERIE (STYLIZED). INT. CLS. 35 AND 41. REG. 8-24-2004.
- 2,875,989. ECO INFO AND DESIGN. INT. CLS. 9 AND 28. REG. 8-24-2004.
- 2,875,991. BIRKOFASHION (STYLIZED). INT. CLS. 10 AND 25. REG. 8-24-2004.
- 2,875,992. ROPALISTA TINTORERIA 24 HORAS AND DESIGN. INT. CL. 37. REG. 8-24-2004.
- 2,875,996. PREVENTON. INT. CL. 9. REG. 8-24-2004.
- 2,875,997. WARRIOR KINGS. INT. CLS. 9, 16, 25, 28 AND 41. REG. 8-24-2004.
- 2,875,998. HARVESTOR. INT. CL. 25. REG. 8-24-2004.
- 2,876,000. MOBIPAY. INT. CLS. 9, 36 AND 38. REG. 8-24-2004.
- 2,876,001. CONVEXX AND DESIGN. INT. CL. 35. REG. 8-24-2004.
- 2,876,002. OMNIPOR. INT. CL. 5. REG. 8-24-2004.
- 2,876,005. OSCAR. INT. CLS. 37, 40 AND 42. REG. 8-24-2004.
- 2,876,006. AMI AND DESIGN. INT. CLS. 16 AND 41. REG. 8-24-2004.
- 2,876,007. OPRANO. INT. CL. 38. REG. 8-24-2004.
- 2,876,008. COOLSA.COM AND DESIGN. INT. CL. 35. REG. 8-24-2004.
- 2,876,010. STI SIERRA TEL INTERNET AND DESIGN. INT. CLS. 9, 35, 38 AND 42. REG. 8-24-2004.
- 2,876,012. SOLCORP / PRODUCTXPRESS. INT. CLS. 9, 35 AND 42. REG. 8-24-2004.
- 2,876,015. FAST KLEEN. INT. CLS. 3 AND 21. REG. 8-24-2004.
- 2,876,017. POLYINK. INT. CLS. 2, 7, 9, 37, 40 AND 42. REG. 8-24-2004.
- 2,876,019. PLASSEIN INTERNATIONAL. INT. CLS. 16 AND 22. REG. 8-24-2004.
- 2,876,021. RANGER. INT. CL. 12. REG. 8-24-2004.
- 2,876,023. THE COMPETENCY CONNECTION STRATEGIC HIRING FOR A CHANGING WORKPLACE. INT. CLS. 16 AND 41. REG. 8-24-2004.
- 2,876,024. CHAHTA ENTERPRISE. INT. CL. 40. REG. 8-24-2004.
- 2,876,025. LMD PHARMACOGNOSIE AND DESIGN. INT. CLS. 3 AND 5. REG. 8-24-2004.
- 2,876,027. APPLE EYEWEAR AND DESIGN. INT. CL. 9. REG. 8-24-2004.
- 2,876,029. MISCELLANEOUS DESIGN. INT. CL. 25. REG. 8-24-2004.
- 2,876,033. 20 ESO EUROPEAN SCHOOL OF ONCOLOGY LEARNING TO CARE AND DESIGN. INT. CL. 41. REG. 8-24-2004.
- 2,876,036. MANY WISHES. INT. CL. 3. REG. 8-24-2004.
- 2,876,038. EL MONTEREY QUALITY SINCE 1964 AND DESIGN. INT. CL. 30. REG. 8-24-2004.
- 2,876,043. ASTEROP. INT. CLS. 9, 41 AND 42. REG. 8-24-2004.
- 2,876,044. HONEYGRILLED CHICKEN. INT. CL. 30. REG. 8-24-2004.
- 2,876,045. FLIGHT2GROUND. INT. CL. 39. REG. 8-24-2004.
- 2,876,046. MISCELLANEOUS DESIGN. INT. CL. 9. REG. 8-24-2004.
- 2,876,048. SHARK AND DESIGN. INT. CL. 9. REG. 8-24-2004.
- 2,876,050. UPM ECO (STYLIZED). INT. CLS. 16 AND 17. REG. 8-24-2004.
- 2,876,051. UPM MATT (STYLIZED). INT. CLS. 16 AND 17. REG. 8-24-2004.
- 2,876,052. JESSE JAMES. INT. CL. 25. REG. 8-24-2004.
- 2,876,053. LUDOWICI SILENT KNIGHT. INT. CL. 7. REG. 8-24-2004.



- 2,876,054. PENDRAGON. INT. CLS. 10, 35, 38 AND 42. REG. 8-24-2004.
- 2,876,055. ROOTS HOME. INT. CL. 27. REG. 8-24-2004.
- 2,876,060. MISCELLANEOUS DESIGN. INT. CLS. 29 AND 35. REG. 8-24-2004.
- 2,876,064. MAGICQ (STYLIZED). INT. CL. 9. REG. 8-24-2004.
- 2,876,065. THRIFTY AUTO GLASS. INT. CL. 35. REG. 8-24-2004.
- 2,876,066. KOHL'S FROZEN CUSTARD & JUMBO BURGERS AND DESIGN. INT. CL. 43. REG. 8-24-2004.
- 2,876,067. THEORY OF HOSPITALITY. INT. CLS. 39, 41 AND 43. REG. 8-24-2004.
- 2,876,072. MISCELLANEOUS DESIGN. INT. CLS. 9, 10, 25 AND 38. REG. 8-24-2004.
- 2,876,073. M AND DESIGN. INT. CL. 9. REG. 8-24-2004.
- 2,876,074. SWEETWATER. INT. CLS. 16 AND 27. REG. 8-24-2004.
- 2,876,076. DIAMOND PEAK. INT. CL. 22. REG. 8-24-2004.
- 2,876,078. GOODBYE CHAIN. INT. CLS. 35 AND 42. REG. 8-24-2004.
- 2,876,079. TIME TAG. INT. CL. 28. REG. 8-24-2004.
- 2,876,080. BRACCO. INT. CLS. 9 AND 10. REG. 8-24-2004.
- 2,876,082. EUROFENG (STYLIZED). INT. CL. 42. REG. 8-24-2004.
- 2,876,084. PUSHPIN. INT. CLS. 7 AND 12. REG. 8-24-2004.
- 2,876,085. LAPTOP LANDING PAD. INT. CL. 9. REG. 8-24-2004.
- 2,876,086. SIG PRO. INT. CLS. 8, 9, 13, 18, 25, 28, 34 AND 42. REG. 8-24-2004.
- 2,876,087. X-CAPE. INT. CL. 25. REG. 8-24-2004.
- 2,876,088. NAVIGATOR. INT. CL. 4. REG. 8-24-2004.
- 2,876,089. DWL AND DESIGN. INT. CLS. 9 AND 35. REG. 8-24-2004.
- 2,876,090. PIZZA PRODIGY. INT. CL. 43. REG. 8-24-2004.
- 2,876,092. THE SUPER FLORAL SHOW. INT. CL. 35. REG. 8-24-2004.
- 2,876,094. FEEL THE ROAR. INT. CL. 41. REG. 8-24-2004.
- 2,876,096. REVOLUCION AND DESIGN. INT. CL. 41. REG. 8-24-2004.
- 2,876,097. ULTRA PERFORMANCE CONCRETE. INT. CL. 19. REG. 8-24-2004.
- 2,876,103. REBEL. INT. CL. 11. REG. 8-24-2004.
- 2,876,106. XP ONLINE EDI INNOVATIONS FROM QUADAX. INT. CL. 42. REG. 8-24-2004.
- 2,876,108. MISCELLANEOUS DESIGN. INT. CLS. 3, 5 AND 44. REG. 8-24-2004.
- 2,876,111. FIDEURAM AND DESIGN. INT. CLS. 9, 16, 35 AND 36. REG. 8-24-2004.
- 2,876,115. ALGATRON. INT. CL. 7. REG. 8-24-2004.
- 2,876,118. SWEET CHOCOLATE SWEET AND DESIGN. INT. CL. 30. REG. 8-24-2004.
- 2,876,120. SUPREME. INT. CL. 24. REG. 8-24-2004.
- 2,876,121. GLAZA. INT. CL. 25. REG. 8-24-2004.
- 2,876,122. LEPORELLO. INT. CLS. 3, 9, 14 AND 16. REG. 8-24-2004.
- 2,876,124. THE AMERICAN COMPANIES. INT. CLS. 35 AND 39. REG. 8-24-2004.
- 2,876,125. CARDSWELL AND DESIGN. INT. CL. 16. REG. 8-24-2004.
- 2,876,127. HEALTH FAIRS PLUS AND DESIGN. INT. CL. 35. REG. 8-24-2004.
- 2,876,128. CLUB-TIX. INT. CL. 41. REG. 8-24-2004.
- 2,876,129. BOSS BOB O'LEARY SPORTS SCIENCE (STYLIZED). INT. CL. 35. REG. 8-24-2004.
- 2,876,130. THE SAVVY TRAVELER. INT. CLS. 9, 14, 21 AND 25. REG. 8-24-2004.
- 2,876,131. ATERRA MEDIA. INT. CL. 9. REG. 8-24-2004.
- 2,876,133. ANCIENT ATLANTIS. INT. CLS. 9, 28 AND 41. REG. 8-24-2004.
- 2,876,135. HAWKEYE SYSTEMS. INT. CLS. 35, 42 AND 45. REG. 8-24-2004.
- 2,876,136. PULBROOK & GOULD. INT. CLS. 3, 24 AND 31. REG. 8-24-2004.
- 2,876,137. ART & REVOLUTION ORGANIZATION. INT. CL. 25. REG. 8-24-2004.
- 2,876,138. BOPIOCCA AND DESIGN. INT. CL. 30. REG. 8-24-2004.
- 2,876,140. CMSTUDIO. INT. CL. 9. REG. 8-24-2004.
- 2,876,142. STRAIGHT-UP. INT. CL. 3. REG. 8-24-2004.
- 2,876,144. SYBIAN WORLD (STYLIZED). INT. CL. 41. REG. 8-24-2004.
- 2,876,145. AMERICAN REAL ESTATE EXCHANGE. INT. CL. 36. REG. 8-24-2004.
- 2,876,147. TOTAL COCKTAILS. INT. CLS. 16 AND 35. REG. 8-24-2004.
- 2,876,149. ROYAL CREAMWARE. INT. CL. 21. REG. 8-24-2004.
- 2,876,150. HYBRASIL. INT. CLS. 1, 3 AND 4. REG. 8-24-2004.
- 2,876,151. DEVLIN AND DESIGN. INT. CLS. 9 AND 42. REG. 8-24-2004.
- 2,876,153. PARTY PANIC. INT. CLS. 35 AND 41. REG. 8-24-2004.
- 2,876,154. REGENTE, LA BAGUETTE MINCEUR. INT. CLS. 30, 35, 42 AND 43. REG. 8-24-2004.
- 2,876,156. DERMAREPAIR BY DERMALI. INT. CL. 3. REG. 8-24-2004.
- 2,876,158. TIP TOAD. INT. CL. 16. REG. 8-24-2004.
- 2,876,162. E RMA AND DESIGN. INT. CL. 37. REG. 8-24-2004.
- 2,876,163. PREMIER ELEVEN. INT. CLS. 9 AND 28. REG. 8-24-2004.
- 2,876,164. PREMIER ELEVEN AND DESIGN. INT. CLS. 9 AND 28. REG. 8-24-2004.
- 2,876,165. VIE FINANCIAL GROUP. INT. CL. 36. REG. 8-24-2004.
- 2,876,166. RIBOPHAGE. INT. CLS. 1 AND 42. REG. 8-24-2004.
- 2,876,171. CINCOM SMALLTALK AND DESIGN. INT. CL. 9. REG. 8-24-2004.
- 2,876,172. TAKE A HIKE!. INT. CL. 39. REG. 8-24-2004.
- 2,876,174. SAVAGE SOAPS GET WET WITH SAVAGE! AND DESIGN. INT. CL. 3. REG. 8-24-2004.
- 2,876,175. ERAPREVE. INT. CL. 5. REG. 8-24-2004.
- 2,876,176. WOOF WEAR N.Y.C. AND DESIGN. INT. CL. 18. REG. 8-24-2004.
- 2,876,177. YOUR FIRST TWO YEARS IN YOUTH MINISTRY. INT. CL. 16. REG. 8-24-2004.
- 2,876,178. CLAYS AND CLAY MINERALS. INT. CLS. 16 AND 41. REG. 8-24-2004.
- 2,876,179. HAPPY HEINY'S. INT. CL. 25. REG. 8-24-2004.
- 2,876,180. STIFF WHITE GUY YOGA. INT. CL. 41. REG. 8-24-2004.
- 2,876,181. CAPEASE (STYLIZED). INT. CL. 9. REG. 8-24-2004.
- 2,876,189. WASHINGTONPOST.NEWSWEEK INTERACTIVE. INT. CLS. 35, 41 AND 42. REG. 8-24-2004.
- 2,876,190. AMERICAN HOMES REALTY. INT. CL. 36. REG. 8-24-2004.
- 2,876,191. BURKE. INT. CL. 44. REG. 8-24-2004.
- 2,876,193. MISCELLANEOUS DESIGN. INT. CL. 9. REG. 8-24-2004.
- 2,876,194. WELLSPRING INTERNATIONAL. INT. CLS. 35, 37 AND 42. REG. 8-24-2004.
- 2,876,195. ESSI AND DESIGN. INT. CL. 9. REG. 8-24-2004.
- 2,876,196. GRADE-MAKER. INT. CLS. 16 AND 41. REG. 8-24-2004.
- 2,876,197. B AND DESIGN. INT. CLS. 11 AND 19. REG. 8-24-2004.
- 2,876,198. ENO. INT. CL. 33. REG. 8-24-2004.
- 2,876,200. MISCELLANEOUS DESIGN. INT. CLS. 9, 41 AND 42. REG. 8-24-2004.
- 2,876,201. SANDRO MOSCOLONI VINEYARD. INT. CL. 25. REG. 8-24-2004.
- 2,876,203. TOUT BEAU TOUT PROPRE TOTALLY GORGEOUS SQUEAKY CLEAN. INT. CL. 3. REG. 8-24-2004.
- 2,876,205. 24/7 REFERENCE AND DESIGN. INT. CL. 41. REG. 8-24-2004.
- 2,876,206. JOHN MORRELL GERMAN BRAND WIENERS AND DESIGN. INT. CL. 29. REG. 8-24-2004.
- 2,876,208. MEDICAL EDUCATION INITIATIVES. INT. CL. 41. REG. 8-24-2004.
- 2,876,210. ROSA FINA. INT. CL. 3. REG. 8-24-2004.
- 2,876,212. NATUPRO. INT. CL. 31. REG. 8-24-2004.

- 2,876,214. OMNI 2000 (STYLIZED). INT. CL. 3. REG. 8-24-2004.
- 2,876,215. PHM PLAYER HATER MAKER AND DESIGN. INT. CL. 25. REG. 8-24-2004.
- 2,876,218. WILL' TEK (STYLIZED). INT. CL. 9. REG. 8-24-2004.
- 2,876,219. MISCELLANEOUS DESIGN. INT. CL. 43. REG. 8-24-2004.
- 2,876,223. PB PHUTURISTIC BLUEZ AND DESIGN. INT. CL. 9. REG. 8-24-2004.
- 2,876,225. HYDROCOMPLEX STANDARD CHARACTER MARK. INT. CL. 1. REG. 8-24-2004.
- 2,876,226. THE HONEST FITNESS SITE. INT. CLS. 35 AND 44. REG. 8-24-2004.
- 2,876,227. IRVINE WEB WORKS AND DESIGN. INT. CL. 42. REG. 8-24-2004.
- 2,876,230. THE MAGIC ROUNDABOUT. INT. CL. 9. REG. 8-24-2004.
- 2,876,231. GREENVILLE FEDERAL CREDIT UNION JOIN AND PROSPER. AND DESIGN. INT. CL. 36. REG. 8-24-2004.
- 2,876,232. PROVIDERCV. INT. CL. 9. REG. 8-24-2004.
- 2,876,234. ROTO GRADER. INT. CL. 7. REG. 8-24-2004.
- 2,876,236. MISCELLANEOUS DESIGN. INT. CLS. 16 AND 41. REG. 8-24-2004.
- 2,876,237. VLAD AND DESIGN. INT. CL. 43. REG. 8-24-2004.
- 2,876,239. MISCELLANEOUS DESIGN. INT. CLS. 9 AND 38. REG. 8-24-2004.
- 2,876,241. DCC CLOTHING. INT. CL. 25. REG. 8-24-2004.
- 2,876,245. COLDSAFE MINUS (STYLIZED). INT. CL. 16. REG. 8-24-2004.
- 2,876,246. MARIEHAVEZ. INT. CL. 14. REG. 8-24-2004.
- 2,876,248. DONKEE PRODUCTS AND DESIGN. INT. CL. 35. REG. 8-24-2004.
- 2,876,249. TRITON'S BANANA BITS. INT. CL. 30. REG. 8-24-2004.
- 2,876,250. MMD (STYLIZED). INT. CL. 40. REG. 8-24-2004.
- 2,876,252. ON TIME STEEL MANAGEMENT AND DESIGN. INT. CL. 37. REG. 8-24-2004.
- 2,876,253. ON TIME STEEL MANAGEMENT AND DESIGN. INT. CL. 40. REG. 8-24-2004.
- 2,876,255. BWIA WEST INDIES AIRWAYS AND DESIGN. INT. CL. 18. REG. 8-24-2004.
- 2,876,256. BWIA WEST INDIES AIRWAYS AND DESIGN. INT. CL. 25. REG. 8-24-2004.
- 2,876,257. BWIA WEST INDIES AIRWAYS AND DESIGN. INT. CL. 39. REG. 8-24-2004.
- 2,876,258. BWIA WEST INDIES AIRWAYS AND DESIGN. INT. CL. 43. REG. 8-24-2004.
- 2,876,259. BOMBER GIRL. INT. CL. 16. REG. 8-24-2004.
- 2,876,261. ELITE LINE OF CREDIT. INT. CL. 36. REG. 8-24-2004.
- 2,876,262. W AND DESIGN. INT. CL. 14. REG. 8-24-2004.
- 2,876,263. SKY-EYE TRIBUNE. INT. CL. 9. REG. 8-24-2004.
- 2,876,264. ENTITY RESOLUTION. INT. CL. 42. REG. 8-24-2004.
- 2,876,265. ENTITY RESOLUTION. INT. CL. 35. REG. 8-24-2004.
- 2,876,266. SI WAREHOUSE AND DESIGN. INT. CL. 35. REG. 8-24-2004.
- 2,876,269. MISCELLANEOUS DESIGN. INT. CL. 32. REG. 8-24-2004.
- 2,876,270. SHAKING HANDS ON THE INTERNET. INT. CL. 41. REG. 8-24-2004.
- 2,876,271. BEAUTYGUARD. INT. CL. 6. REG. 8-24-2004.
- 2,876,275. CRYPTOCARD SECURE PASSWORD TECHNOLOGY. INT. CL. 9. REG. 8-24-2004.
- 2,876,277. MMD EQUIPMENT AND DESIGN. INT. CL. 9. REG. 8-24-2004.
- 2,876,278. MISCELLANEOUS DESIGN. INT. CL. 3. REG. 8-24-2004.
- 2,876,280. ALT-NETWORKING THE ALTERNATIVE CHOICE IN NETWORKING AND DESIGN. INT. CL. 42. REG. 8-24-2004.
- 2,876,281. THE NEW BARBERING EXPERIENCE. INT. CL. 44. REG. 8-24-2004.
- 2,876,284. SPRINT BUSINESS CONNECTION. INT. CL. 38. REG. 8-24-2004.
- 2,876,285. LIC. INT. CLS. 16, 35 AND 41. REG. 8-24-2004.
- 2,876,286. LIFE INSURERS COUNCIL. INT. CLS. 16, 35 AND 41. REG. 8-24-2004.
- 2,876,287. TARAWA. INT. CL. 14. REG. 8-24-2004.
- 2,876,289. WWW.STUDIODISTRIBUTION.COM AND DESIGN. INT. CL. 35. REG. 8-24-2004.
- 2,876,290. PRINT, INC. AND DESIGN. INT. CLS. 35, 37 AND 40. REG. 8-24-2004.
- 2,876,293. TORAH LAB. INT. CLS. 9 AND 16. REG. 8-24-2004.
- 2,876,294. EN VIE (STYLIZED). INT. CLS. 16, 18 AND 25. REG. 8-24-2004.
- 2,876,296. SEAMENT. INT. CLS. 37 AND 42. REG. 8-24-2004.
- 2,876,297. THINK ON. INT. CLS. 16 AND 41. REG. 8-24-2004.
- 2,876,299. DELHOMME FUNERAL HOME. INT. CL. 36. REG. 8-24-2004.
- 2,876,300. TART-O-CREAM. INT. CL. 30. REG. 8-24-2004.
- 2,876,302. POLKA. INT. CL. 29. REG. 8-24-2004.
- 2,876,304. NU ALPHA PHI. INT. CL. 35. REG. 8-24-2004.
- 2,876,305. CERAESTE. INT. CLS. 5 AND 10. REG. 8-24-2004.
- 2,876,311. COMPLIANCE MADE EASY. INT. CL. 16. REG. 8-24-2004.
- 2,876,312. TURNING THE SUNDAY STUFF INTO MONDAY STUFF FOR BETTER LIVES AND BETTER BUSINESSES. INT. CLS. 16 AND 41. REG. 8-24-2004.
- 2,876,318. MISCELLANEOUS DESIGN. INT. CL. 37. REG. 8-24-2004.
- 2,876,319. CHECK UP. INT. CL. 16. REG. 8-24-2004.
- 2,876,322. LAST FITTING. INT. CL. 3. REG. 8-24-2004.
- 2,876,323. ADVANCED ARCHITECTURAL FRAMES. INT. CL. 6. REG. 8-24-2004.
- 2,876,324. MISCELLANEOUS DESIGN. INT. CL. 6. REG. 8-24-2004.
- 2,876,325. BRAZANITE. INT. CL. 14. REG. 8-24-2004.
- 2,876,326. EGGSELLENT. INT. CL. 16. REG. 8-24-2004.
- 2,876,327. MISCELLANEOUS DESIGN. INT. CL. 30. REG. 8-24-2004.
- 2,876,329. EL NINO TROPICAL FREEZE. INT. CL. 32. REG. 8-24-2004.
- 2,876,331. LGB EXTRA AND DESIGN. INT. CLS. 28 AND 35. REG. 8-24-2004.
- 2,876,332. LGB EXTRA AND DESIGN. INT. CLS. 28 AND 35. REG. 8-24-2004.
- 2,876,333. EXTRA (STYLIZED). INT. CLS. 28 AND 35. REG. 8-24-2004.
- 2,876,334. FLEXWALL. INT. CL. 19. REG. 8-24-2004.
- 2,876,335. ONE MAN & A VAN AND DESIGN. INT. CL. 37. REG. 8-24-2004.
- 2,876,338. MISCELLANEOUS DESIGN. INT. CL. 36. REG. 8-24-2004.
- 2,876,342. OHIO BUSINESS GATEWAY @ ELECTRONIC FILING AND DESIGN. INT. CLS. 35 AND 36. REG. 8-24-2004.
- 2,876,343. OTTO BOCK ORTHOBIONIC. INT. CLS. 1, 10, 12, 17, 24 AND 25. REG. 8-24-2004.
- 2,876,355. MISCELLANEOUS DESIGN. INT. CL. 1. REG. 8-24-2004.
- 2,876,360. GHOST BOARD. INT. CL. 28. REG. 8-24-2004.
- 2,876,364. STRIPE BY RAYURE (STYLIZED). INT. CL. 25. REG. 8-24-2004.
- 2,876,365. THE VOICE OF PACKET COMMUNICATIONS. INT. CL. 35. REG. 8-24-2004.
- 2,876,366. HEVI-DUTY. INT. CL. 11. REG. 8-24-2004.
- 2,876,368. CCLEAR (STYLIZED). INT. CL. 9. REG. 8-24-2004.
- 2,876,369. TARAMET STERLING. INT. CL. 3. REG. 8-24-2004.
- 2,876,370. TARAMET STERLING. INT. CL. 1. REG. 8-24-2004.
- 2,876,371. VALUE FIRST. INT. CL. 16. REG. 8-24-2004.
- 2,876,372. DON'T STOP AT SEARCH. INT. CL. 9. REG. 8-24-2004.
- 2,876,373. ONE2CONNECT. INT. CL. 38. REG. 8-24-2004.
- 2,876,374. ZURICH BANK. INT. CL. 36. REG. 8-24-2004.
- 2,876,375. IFS AND DESIGN. INT. CL. 42. REG. 8-24-2004.
- 2,876,379. ONEZIG. INT. CL. 9. REG. 8-24-2004.
- 2,876,380. BTGPS. INT. CL. 9. REG. 8-24-2004.
- 2,876,382. GREAT DECK! DECK SYSTEM AND DESIGN. INT. CLS. 17 AND 19. REG. 8-24-2004.

- 2,876,383. IEDX STANDARD CHARACTER MARK. INT. CL. 41. REG. 8-24-2004.
- 2,876,385. NJTP TURNPIKE 1951 2001 50 YEARS OF SERVICE AND DESIGN. INT. CLS. 14, 18, 20, 25, 36 AND 39. REG. 8-24-2004.
- 2,876,387. JAVA 2 U. INT. CL. 39. REG. 8-24-2004.
- 2,876,388. MOMFIA. INT. CL. 25. REG. 8-24-2004.
- 2,876,389. EFTLOGIX. INT. CLS. 35, 36 AND 42. REG. 8-24-2004.
- 2,876,393. LADDER WORKS. INT. CL. 17. REG. 8-24-2004.
- 2,876,394. AIR FLORA. INT. CLS. 20 AND 21. REG. 8-24-2004.
- 2,876,398. BEHAVIOR PATH MARKETING. INT. CL. 35. REG. 8-24-2004.
- 2,876,399. BP BARBARA PALACIOS JEWELRY COLLECTION AND DESIGN. INT. CL. 14. REG. 8-24-2004.
- 2,876,400. TURBOPIER. INT. CL. 7. REG. 8-24-2004.
- 2,876,403. REVEALING ROOMS. INT. CL. 16. REG. 8-24-2004.
- 2,876,406. MEMBERS BUSINESS SERVICES AND DESIGN. INT. CL. 36. REG. 8-24-2004.
- 2,876,408. PSYCEXTRA (STYLIZED). INT. CL. 44. REG. 8-24-2004.
- 2,876,412. MESSAGE OF HOPE. INT. CL. 9. REG. 8-24-2004.
- 2,876,414. GIF. INT. CLS. 41 AND 42. REG. 8-24-2004.
- 2,876,416. FINGER LAKES AND DESIGN. INT. CLS. 36 AND 41. REG. 8-24-2004.
- 2,876,419. CHRIS BY CHRIS MESTDAGH. INT. CLS. 20, 24 AND 27. REG. 8-24-2004.
- 2,876,421. CONCOURSE. INT. CL. 9. REG. 8-24-2004.
- 2,876,422. BASS MOUNTAIN MUSIC PARK. INT. CL. 41. REG. 8-24-2004.
- 2,876,424. ACL. INT. CLS. 6, 22, 37 AND 39. REG. 8-24-2004.
- 2,876,425. MISCELLANEOUS DESIGN. INT. CL. 35. REG. 8-24-2004.
- 2,876,426. LAEL LAEL PRODUCTS. INT. CL. 3. REG. 8-24-2004.
- 2,876,427. VERSATOUCH (STYLIZED). INT. CL. 11. REG. 8-24-2004.
- 2,876,428. THE TOWER PAN PIZZA. INT. CL. 30. REG. 8-24-2004.
- 2,876,429. HBA HEALTH & BEAUTY AMERICA AND DESIGN. INT. CL. 35. REG. 8-24-2004.
- 2,876,430. HBA HEALTH & BEAUTY AMERICA. INT. CL. 35. REG. 8-24-2004.
- 2,876,435. PROTERM. INT. CL. 5. REG. 8-24-2004.
- 2,876,437. INTREPID. INT. CL. 7. REG. 8-24-2004.
- 2,876,440. VINO È BUONO (STYLIZED). INT. CL. 33. REG. 8-24-2004.
- 2,876,441. BCOOL. INT. CL. 9. REG. 8-24-2004.
- 2,876,443. SCENTZONE. INT. CL. 9. REG. 8-24-2004.
- 2,876,445. GE ACCESS OPENLINK. INT. CL. 36. REG. 8-24-2004.
- 2,876,446. TILANO FRESCO. INT. CL. 19. REG. 8-24-2004.
- 2,876,447. RUTH ANN'S GARDEN STYLE BEEF. INT. CL. 29. REG. 8-24-2004.
- 2,876,450. BLUE DAY. INT. CLS. 9 AND 16. REG. 8-24-2004.
- 2,876,451. LANE HOME MEDICAL. INT. CL. 35. REG. 8-24-2004.
- 2,876,452. WHEEE AND DESIGN. INT. CL. 30. REG. 8-24-2004.
- 2,876,453. XHAIL AUTO HAIL DAMAGE REPAIR. INT. CL. 37. REG. 8-24-2004.
- 2,876,457. WEDDING & EVENT VIDEOGRAPHY. INT. CL. 16. REG. 8-24-2004.
- 2,876,458. LANE HOME MEDICAL AND DESIGN. INT. CL. 35. REG. 8-24-2004.
- 2,876,461. T THOMPSON AND DESIGN. INT. CLS. 16 AND 20. REG. 8-24-2004.
- 2,876,463. BENSON'S CANINE COOKIES. INT. CL. 31. REG. 8-24-2004.
- 2,876,465. VIEWCATCHER. INT. CL. 9. REG. 8-24-2004.
- 2,876,467. AMHERST TECHNOLOGIES. INT. CL. 35. REG. 8-24-2004.
- 2,876,469. CHEERLYTE. INT. CL. 11. REG. 8-24-2004.
- 2,876,470. WHERE MEMORIES BEGIN. INT. CL. 35. REG. 8-24-2004.
- 2,876,472. STAND OUT. INT. CL. 41. REG. 8-24-2004.
- 2,876,474. TRUMANCARE HOME HEALTH SERVICES AND DESIGN. INT. CLS. 44 AND 45. REG. 8-24-2004.
- 2,876,483. PEPPER STINGERS. INT. CL. 29. REG. 8-24-2004.
- 2,876,485. OSAKI AND DESIGN. INT. CL. 9. REG. 8-24-2004.
- 2,876,486. SAFFTEX. INT. CL. 1. REG. 8-24-2004.
- 2,876,490. TMNG OPA (OPERATIONAL PERFORMANCE APPRAISAL). INT. CL. 35. REG. 8-24-2004.
- 2,876,497. GLOBAL INVENTORY LEVELING. INT. CLS. 35 AND 36. REG. 8-24-2004.
- 2,876,499. D&D AND DESIGN. INT. CL. 41. REG. 8-24-2004.
- 2,876,501. EZ PNP AND DESIGN. INT. CL. 9. REG. 8-24-2004.
- 2,876,503. X-FLY AND DESIGN. INT. CL. 9. REG. 8-24-2004.
- 2,876,504. TODOFUT. INT. CL. 35. REG. 8-24-2004.
- 2,876,506. SHACKPACK. INT. CL. 9. REG. 8-24-2004.
- 2,876,507. ACCELERATE YOUR INNOVATION (STYLIZED). INT. CL. 42. REG. 8-24-2004.
- 2,876,508. BBRIGHT. INT. CL. 9. REG. 8-24-2004.
- 2,876,510. CARECOAT. INT. CLS. 5 AND 10. REG. 8-24-2004.
- 2,876,512. GIANT HOUSING. INT. CL. 11. REG. 8-24-2004.
- 2,876,513. SURLY GIRL STUDIOS. INT. CL. 18. REG. 8-24-2004.
- 2,876,514. WORLD SAVINGS. INT. CL. 36. REG. 8-24-2004.
- 2,876,516. MISCELLANEOUS DESIGN. INT. CL. 16. REG. 8-24-2004.
- 2,876,520. PUNK ROCK TIMES (STYLIZED). INT. CLS. 16 AND 35. REG. 8-24-2004.
- 2,876,525. MANNING ESTATES AND DESIGN. INT. CL. 33. REG. 8-24-2004.
- 2,876,528. LIFELITE. INT. CL. 12. REG. 8-24-2004.
- 2,876,532. DALWORTH CARPET CLEANING. INT. CL. 37. REG. 8-24-2004.
- 2,876,533. THE UNIVERSITY OF TOLEDO AND DESIGN. INT. CLS. 16, 21, 25 AND 41. REG. 8-24-2004.
- 2,876,534. MISCELLANEOUS DESIGN. INT. CLS. 16, 21, 25 AND 41. REG. 8-24-2004.
- 2,876,538. SILVER LINING. INT. CL. 43. REG. 8-24-2004.
- 2,876,539. ABINGTON LIGHTHOUSE. INT. CL. 6. REG. 8-24-2004.
- 2,876,540. CARS CHAMPIONSHIP AUTO RACING SERIES. INT. CL. 41. REG. 8-24-2004.
- 2,876,541. BORING IS BEAUTIFUL. BUILD WEALTH OVER TIME. INT. CL. 36. REG. 8-24-2004.
- 2,876,542. Z-FORCE. INT. CL. 18. REG. 8-24-2004.
- 2,876,543. MISCELLANEOUS DESIGN. INT. CL. 5. REG. 8-24-2004.
- 2,876,544. MISCELLANEOUS DESIGN. INT. CL. 5. REG. 8-24-2004.
- 2,876,545. ORPHAN SUNDAY. INT. CL. 36. REG. 8-24-2004.
- 2,876,546. LENTRIVEL. INT. CL. 5. REG. 8-24-2004.
- 2,876,549. HUMMERHANGER (STYLIZED). INT. CL. 21. REG. 8-24-2004.
- 2,876,550. INNER HARBOUR FOR CHILDREN & FAMILIES HEALING THROUGH EXPERIENCE AND DESIGN. INT. CLS. 41 AND 44. REG. 8-24-2004.
- 2,876,551. DLVFD TOURNEY. INT. CL. 41. REG. 8-24-2004.
- 2,876,553. CRE8TE. INT. CL. 16. REG. 8-24-2004.
- 2,876,554. PATIO DRESSING AND DESIGN. INT. CL. 24. REG. 8-24-2004.
- 2,876,556. UNCLE SKIPPY'S (INTERNATIONALLY PATENTED) BODY JEWELRY (STYLIZED). INT. CL. 14. REG. 8-24-2004.
- 2,876,558. WHITE & CASE UNIVERSE. INT. CLS. 39 AND 42. REG. 8-24-2004.
- 2,876,559. MISCELLANEOUS DESIGN. INT. CL. 9. REG. 8-24-2004.
- 2,876,561. BUZET (STYLIZED). INT. CL. 33. REG. 8-24-2004.
- 2,876,563. THE RELEVANT CHURCH. INT. CLS. 9 AND 16. REG. 8-24-2004.
- 2,876,564. THE SAFEST PLACE FOR YOUR DATA. INT. CL. 9. REG. 8-24-2004.
- 2,876,566. COMPLETEPACKAGEENT. INT. CL. 9. REG. 8-24-2004.
- 2,876,569. MICHA. INT. CL. 3. REG. 8-24-2004.
- 2,876,570. MOVAL MA AND DESIGN. INT. CL. 20. REG. 8-24-2004.

- 2,876,571. FLAVIOLIVERA ACCESSORIES AND DESIGN. INT. CLS. 18 AND 25. REG. 8-24-2004.
- 2,876,572. DYNA SLIM. INT. CL. 5. REG. 8-24-2004.
- 2,876,573. SCINATURE. INT. CL. 3. REG. 8-24-2004.
- 2,876,574. INTOHOMES. INT. CL. 36. REG. 8-24-2004.
- 2,876,577. FOOT SWEATERS. INT. CL. 25. REG. 8-24-2004.
- 2,876,578. AUTHENTIC LOST WAGES. INT. CL. 21. REG. 8-24-2004.
- 2,876,579. THE OASIS EXPERIENCE. INT. CL. 45. REG. 8-24-2004.
- 2,876,580. SMOOTH CAP. INT. CL. 25. REG. 8-24-2004.
- 2,876,581. PETRO-PLUG. INT. CLS. 1 AND 37. REG. 8-24-2004.
- 2,876,582. CREATIVE LINENS AND DESIGN. INT. CL. 24. REG. 8-24-2004.
- 2,876,585. SILVER LINING RANCH. INT. CL. 25. REG. 8-24-2004.
- 2,876,586. THE SILVER LINING FOUNDATION AND DESIGN. INT. CL. 43. REG. 8-24-2004.
- 2,876,587. PLOCK AND DESIGN. INT. CL. 9. REG. 8-24-2004.
- 2,876,591. FAIR LOAN AND DESIGN. INT. CL. 36. REG. 8-24-2004.
- 2,876,592. ICEBRAND. INT. CL. 29. REG. 8-24-2004.
- 2,876,594. RASAGE VELOURS. INT. CL. 3. REG. 8-24-2004.
- 2,876,596. THE SOURCE FOR HEALTHCARE PROFESSIONAL LIABILITY. INT. CL. 36. REG. 8-24-2004.
- 2,876,602. BALANCING ACT (STYLIZED). INT. CL. 45. REG. 8-24-2004.
- 2,876,604. CUP FOR GRABS. INT. CL. 30. REG. 8-24-2004.
- 2,876,605. YO-BAG AND DESIGN. INT. CLS. 5, 18 AND 25. REG. 8-24-2004.
- 2,876,606. GEMELLE'S AND DESIGN. INT. CL. 30. REG. 8-24-2004.
- 2,876,607. UNIQUE GOLD PHONE CARD. INT. CL. 16. REG. 8-24-2004.
- 2,876,608. THQ WIRELESS AND DESIGN. INT. CL. 9. REG. 8-24-2004.
- 2,876,611. CARE COUNSELING ADVICE RELATIONSHIP EXPERTISE AND DESIGN. INT. CL. 44. REG. 8-24-2004.
- 2,876,612. ETHERBAND. INT. CL. 9. REG. 8-24-2004.
- 2,876,613. HUGS. INT. CL. 16. REG. 8-24-2004.
- 2,876,614. JUDGMENTWEB.COM. INT. CL. 36. REG. 8-24-2004.
- 2,876,615. RECRUITFORCE. INT. CL. 35. REG. 8-24-2004.
- 2,876,616. FITNESS PROS PLUS, LLC FITNESS TRAINING AND HEALTH EDUCATION SERVICES AND DESIGN. INT. CL. 41. REG. 8-24-2004.
- 2,876,617. SCORPION SERIES. INT. CL. 28. REG. 8-24-2004.
- 2,876,618. FEEL THE STING. INT. CL. 28. REG. 8-24-2004.
- 2,876,619. SENOR HOG'S AND DESIGN. INT. CL. 43. REG. 8-24-2004.
- 2,876,623. ORIGINAL COMMON SENSE NON-SCORE DRIVEN PROGRAM. INT. CL. 36. REG. 8-24-2004.
- 2,876,627. TUSCANY EXPRESSIONS. INT. CL. 2. REG. 8-24-2004.
- 2,876,631. IBEX HEALTHDATA SYSTEMS. INT. CLS. 9 AND 42. REG. 8-24-2004.
- 2,876,640. SLK 63. INT. CLS. 12 AND 28. REG. 8-24-2004.
- 2,876,641. R 63. INT. CLS. 12 AND 28. REG. 8-24-2004.
- 2,876,642. MR SQUID AND DESIGN. INT. CL. 29. REG. 8-24-2004.
- 2,876,646. WINDOWVATION. INT. CL. 35. REG. 8-24-2004.
- 2,876,652. PROSPECTING TO THE TOP. INT. CL. 41. REG. 8-24-2004.
- 2,876,654. CREATE-A-LINK. INT. CL. 14. REG. 8-24-2004.
- 2,876,656. HANDS OF GRACE. INT. CL. 45. REG. 8-24-2004.
- 2,876,663. SIMONIS ON TOP. INT. CL. 24. REG. 8-24-2004.
- 2,876,666. B BERTOLUCCI DOPPIA (STYLIZED). INT. CL. 14. REG. 8-24-2004.
- 2,876,673. MISCELLANEOUS DESIGN. INT. CL. 7. REG. 8-24-2004.
- 2,876,674. DOCTOR Z & C. INT. CL. 3. REG. 8-24-2004.
- 2,876,677. LA QUE PONE EL AMBIENTE. INT. CL. 38. REG. 8-24-2004.
- 2,876,678. NETWORKIO. INT. CL. 35. REG. 8-24-2004.
- 2,876,681. FEDSOURCE. INT. CL. 35. REG. 8-24-2004.
- 2,876,682. ONYXPAK. INT. CL. 37. REG. 8-24-2004.
- 2,876,684. DIAMOND TEAM FANTASY BASEBALL. INT. CL. 42. REG. 8-24-2004.
- 2,876,688. MUSIC BUSINESS MADE SIMPLE. INT. CL. 16. REG. 8-24-2004.
- 2,876,689. HEAR DIRECT. INT. CL. 35. REG. 8-24-2004.
- 2,876,690. HEAR FOR LIFE. INT. CL. 35. REG. 8-24-2004.
- 2,876,692. ITCARD. INT. CL. 35. REG. 8-24-2004.
- 2,876,696. QUIOTE. INT. CL. 33. REG. 8-24-2004.
- 2,876,698. VISUAL INFINITY. INT. CL. 9. REG. 8-24-2004.
- 2,876,707. REGAL DYNASTY. INT. CL. 30. REG. 8-24-2004.
- 2,876,708. XPC TARGETBOX. INT. CL. 9. REG. 8-24-2004.
- 2,876,710. H20MASSAGE SYSTEMS. INT. CL. 10. REG. 8-24-2004.
- 2,876,712. DOIN' BIG THANGZ RECORDS. INT. CL. 9. REG. 8-24-2004.
- 2,876,714. ENGINEERED TO LAST A LIFETIME. INT. CL. 8. REG. 8-24-2004.
- 2,876,717. E! ONLINE INSIDER. INT. CL. 41. REG. 8-24-2004.
- 2,876,718. ACDB. INT. CL. 9. REG. 8-24-2004.
- 2,876,719. DG THE DEVLIN GROUP AND DESIGN. INT. CLS. 36 AND 37. REG. 8-24-2004.
- 2,876,724. MISCELLANEOUS DESIGN. INT. CL. 7. REG. 8-24-2004.
- 2,876,725. MODYDETX. INT. CL. 42. REG. 8-24-2004.
- 2,876,726. DMIA DOCUMENT MANAGEMENT INDUSTRIES ASSOCIATION AND DESIGN. INT. CLS. 16 AND 35. REG. 8-24-2004.
- 2,876,728. FLAT STANLEY'S, INC.. INT. CL. 43. REG. 8-24-2004.
- 2,876,733. DISTRIBUTIONOPTIMIZER. INT. CL. 39. REG. 8-24-2004.
- 2,876,736. TEKSING TOWARD TAKS. INT. CL. 16. REG. 8-24-2004.
- 2,876,739. DHC. INT. CL. 20. REG. 8-24-2004.
- 2,876,741. ENHANCER. INT. CL. 35. REG. 8-24-2004.
- 2,876,748. REVIEWSCAN. INT. CL. 9. REG. 8-24-2004.
- 2,876,750. G (STYLIZED). INT. CL. 32. REG. 8-24-2004.
- 2,876,756. FROSTY-FREEZE AND DESIGN. INT. CL. 37. REG. 8-24-2004.
- 2,876,758. BELWOOD FRENCH BAKERY & CAFÉ. INT. CL. 43. REG. 8-24-2004.
- 2,876,759. HELLION. INT. CL. 15. REG. 8-24-2004.
- 2,876,760. IMMUNIZATION PASSPORT. INT. CL. 16. REG. 8-24-2004.
- 2,876,762. FLUSHFREE. INT. CL. 5. REG. 8-24-2004.
- 2,876,763. PROTECTION PERSONNELLE AJUSTEE. INT. CL. 5. REG. 8-24-2004.
- 2,876,765. DHEC. INT. CLS. 9, 16 AND 41. REG. 8-24-2004.
- 2,876,766. BUTTERNUT FARMS ORGANIC CO-OP, INC. AND DESIGN. INT. CL. 29. REG. 8-24-2004.
- 2,876,767. COOL CAR CARE. INT. CL. 37. REG. 8-24-2004.
- 2,876,768. SCENT TRIFIC AND DESIGN. INT. CL. 1. REG. 8-24-2004.
- 2,876,770. STUBBIES. INT. CL. 17. REG. 8-24-2004.
- 2,876,773. FIREFLY. INT. CL. 10. REG. 8-24-2004.
- 2,876,775. POSH PALS. INT. CL. 24. REG. 8-24-2004.
- 2,876,776. EDAT AND DESIGN. INT. CL. 42. REG. 8-24-2004.
- 2,876,777. FIELDHAND AND DESIGN. INT. CL. 9. REG. 8-24-2004.
- 2,876,778. LA MOLINA AND DESIGN. INT. CL. 5. REG. 8-24-2004.
- 2,876,779. CAPTURING THE MOMENTS THAT CAPTURE OUR HEARTS. INT. CL. 41. REG. 8-24-2004.
- 2,876,780. LIVING MOMENTS. INT. CL. 41. REG. 8-24-2004.
- 2,876,782. SEE THRU PAPER WINDOW. INT. CL. 16. REG. 8-24-2004.
- 2,876,786. FROZINI. INT. CL. 33. REG. 8-24-2004.
- 2,876,787. TANJA AND DESIGN. INT. CL. 20. REG. 8-24-2004.
- 2,876,790. LIGHTNIN' BUGZ. INT. CL. 41. REG. 8-24-2004.
- 2,876,791. EL REGRESO DE LAS CURVAS PELIGROSAS. INT. CL. 41. REG. 8-24-2004.
- 2,876,792. TARGETMATRIX. INT. CL. 16. REG. 8-24-2004.
- 2,876,793. PRINT-A-TOOTH. INT. CL. 35. REG. 8-24-2004.
- 2,876,795. THUNDER DOG. INT. CL. 31. REG. 8-24-2004.
- 2,876,796. WTAPYONFR. INT. CL. 25. REG. 8-24-2004.
- 2,876,798. HUNT'EM HIGH. INT. CL. 25. REG. 8-24-2004.

- 2,876,800. LEYLAND. INT. CLS. 25 AND 28. REG. 8-24-2004.  
 2,876,803. STOA. INT. CL. 43. REG. 8-24-2004.  
 2,876,805. PIANO LOGIC. INT. CL. 9. REG. 8-24-2004.  
 2,876,810. WESTERN DESIGN CONFERENCE. INT. CL. 35. REG. 8-24-2004.  
 2,876,813. JUSTRIGHTLIGHT AND DESIGN. INT. CL. 9. REG. 8-24-2004.  
 2,876,819. HOPPER TOPPER GET UP & GO! AND DESIGN. INT. CL. 12. REG. 8-24-2004.  
 2,876,821. ESTAR NETWORK AND DESIGN. INT. CL. 35. REG. 8-24-2004.  
 2,876,822. ESTAR. INT. CL. 35. REG. 8-24-2004.  
 2,876,823. ESTARNETWORK. INT. CL. 35. REG. 8-24-2004.  
 2,876,824. MISCELLANEOUS DESIGN. INT. CL. 35. REG. 8-24-2004.  
 2,876,825. LIYA INC AND DESIGN. INT. CL. 18. REG. 8-24-2004.  
 2,876,829. DURAVENT. INT. CL. 27. REG. 8-24-2004.  
 2,876,830. NEXT GENERATION EDUCATION. INT. CL. 41. REG. 8-24-2004.  
 2,876,831. NYC & COMPANY CULTUREFEST AND DESIGN. INT. CL. 35. REG. 8-24-2004.  
 2,876,833. OCEANSIDE. INT. CLS. 36 AND 45. REG. 8-24-2004.  
 2,876,835. CARING CANINE REHABILITATION CENTER AND DESIGN. INT. CL. 44. REG. 8-24-2004.  
 2,876,838. APPLYING EASTERN WISDOM AND WESTERN PRACTICALITY. INT. CL. 41. REG. 8-24-2004.  
 2,876,841. QUIKSAND. INT. CL. 11. REG. 8-24-2004.  
 2,876,842. DORSAN SUITES. INT. CL. 43. REG. 8-24-2004.  
 2,876,843. PLAY IT INDOORS!. INT. CL. 41. REG. 8-24-2004.  
 2,876,846. THE REAL FLAVOR OF BAJA. INT. CL. 43. REG. 8-24-2004.  
 2,876,851. STICKERLAND. INT. CL. 9. REG. 8-24-2004.  
 2,876,852. TOY-O-MAT. INT. CL. 9. REG. 8-24-2004.  
 2,876,853. JANA CURCIO PHOTOGRAPHY WWW.JANA-PHOTO.COM. INT. CL. 41. REG. 8-24-2004.  
 2,876,854. LOTSA. INT. CL. 1. REG. 8-24-2004.  
 2,876,855. GRAND MARK AND DESIGN. INT. CL. 11. REG. 8-24-2004.  
 2,876,856. GRAND CHEF (STYLIZED). INT. CL. 11. REG. 8-24-2004.  
 2,876,857. TRAVEL WISE. INT. CL. 18. REG. 8-24-2004.  
 2,876,859. WEST COAST CHOPPERS. INT. CL. 16. REG. 8-24-2004.  
 2,876,860. DIGEST "C". INT. CL. 31. REG. 8-24-2004.  
 2,876,861. TRACVIEW. INT. CL. 9. REG. 8-24-2004.  
 2,876,864. AIROPEEK. INT. CL. 9. REG. 8-24-2004.  
 2,876,865. MAT WITH MUSCLE!. INT. CL. 27. REG. 8-24-2004.  
 2,876,866. MISCELLANEOUS DESIGN. INT. CL. 9. REG. 8-24-2004.  
 2,876,868. OPWATCH STANDARD CHARACTER MARK. INT. CL. 35. REG. 8-24-2004.  
 2,876,869. MISCELLANEOUS DESIGN. INT. CL. 35. REG. 8-24-2004.  
 2,876,870. POPULAR CHECK PROTECT. INT. CL. 36. REG. 8-24-2004.  
 2,876,873. LOCATION STRATEGIES. INT. CL. 16. REG. 8-24-2004.  
 2,876,874. SANDEI AND DESIGN. INT. CL. 7. REG. 8-24-2004.  
 2,876,876. THE RIDING RINGMASTERS INC. AND DESIGN. INT. CL. 37. REG. 8-24-2004.  
 2,876,878. ORIENTAL MASCOT. INT. CLS. 29 AND 30. REG. 8-24-2004.  
 2,876,879. KIDS AND COMPANY TOGETHER FOR SAFETY. INT. CLS. 9, 16 AND 41. REG. 8-24-2004.  
 2,876,880. KIDS AND COMPANY TOGETHER FOR SAFETY AND DESIGN. INT. CLS. 16 AND 41. REG. 8-24-2004.  
 2,876,881. SPPKIDS.COM. INT. CL. 35. REG. 8-24-2004.  
 2,876,882. SELECTIRA. INT. CL. 36. REG. 8-24-2004.  
 2,876,886. UDM. INT. CL. 16. REG. 8-24-2004.  
 2,876,887. ALLIANCEBERNSTEIN INVESTMENT SOLUTIONS. INT. CL. 36. REG. 8-24-2004.  
 2,876,888. STRATA CUBE. INT. CL. 6. REG. 8-24-2004.  
 2,876,890. CURVACEOUS COURSES. INT. CL. 16. REG. 8-24-2004.  
 2,876,891. BELFORD SPRINGS. INT. CL. 33. REG. 8-24-2004.  
 2,876,893. CUTLER CREEK. INT. CL. 33. REG. 8-24-2004.  
 2,876,894. ANGEL DUST. INT. CL. 3. REG. 8-24-2004.  
 2,876,895. BLACK MAGIC. INT. CL. 28. REG. 8-24-2004.  
 2,876,897. COUNTRY GOLD. INT. CL. 31. REG. 8-24-2004.  
 2,876,904. GLOBALPLATEAU. INT. CL. 16. REG. 8-24-2004.  
 2,876,905. WELCOME!. INT. CL. 16. REG. 8-24-2004.  
 2,876,906. BECAUSE EATING ALONE IS BORING. INT. CL. 45. REG. 8-24-2004.  
 2,876,907. SAIZEN AND DESIGN. INT. CL. 5. REG. 8-24-2004.  
 2,876,911. GO! FIGHT! WIN!. INT. CL. 41. REG. 8-24-2004.  
 2,876,912. FOLD-IT CONCEPTS. INT. CL. 12. REG. 8-24-2004.  
 2,876,914. QUILL PRODUCTIONS INCORPORATED AND DESIGN. INT. CL. 42. REG. 8-24-2004.  
 2,876,916. LOVE MY ONLINE PARTY. INT. CL. 35. REG. 8-24-2004.  
 2,876,920. FIT AND DESIGN. INT. CL. 12. REG. 8-24-2004.  
 2,876,921. TAKE CHARGE OF YOUR FUTURE. INT. CL. 41. REG. 8-24-2004.  
 2,876,929. TADPOLE. INT. CL. 31. REG. 8-24-2004.  
 2,876,930. ALLIEDSTEEL STRUCTURES AND DESIGN. INT. CL. 6. REG. 8-24-2004.  
 2,876,931. HEAVY METAL AND DESIGN. INT. CL. 3. REG. 8-24-2004.  
 2,876,932. MID TOWN SOUND AND DESIGN. INT. CL. 41. REG. 8-24-2004.  
 2,876,933. HUMITEK. INT. CL. 19. REG. 8-24-2004.  
 2,876,937. DOT WORKS AND DESIGN. INT. CLS. 1, 7 AND 16. REG. 8-24-2004.  
 2,876,939. FAST TOYS AREN'T JUST FOR BOYS. INT. CL. 25. REG. 8-24-2004.  
 2,876,944. MICKEN (STYLIZED). INT. CL. 41. REG. 8-24-2004.  
 2,876,946. WELENDNOW. INT. CL. 36. REG. 8-24-2004.  
 2,876,954. GO 365. INT. CL. 3. REG. 8-24-2004.  
 2,876,955. COOKIES BY DESIGN AND DESIGN. INT. CLS. 30 AND 35. REG. 8-24-2004.  
 2,876,958. NUTRILEUM STANDARD CHARACTER MARK. INT. CL. 3. REG. 8-24-2004.  
 2,876,960. GRAND ELK. INT. CLS. 25, 28 AND 37. REG. 8-24-2004.  
 2,876,962. BRANDLINKING. INT. CLS. 38, 41 AND 42. REG. 8-24-2004.  
 2,876,963. TITAN AIR. INT. CL. 39. REG. 8-24-2004.  
 2,876,964. SPEED RACER X. INT. CL. 41. REG. 8-24-2004.  
 2,876,967. LEGACY. INT. CL. 30. REG. 8-24-2004.  
 2,876,971. SERIOUS MUSIC AND DESIGN. INT. CL. 35. REG. 8-24-2004.  
 2,876,972. AIDSRIX. INT. CL. 5. REG. 8-24-2004.  
 2,876,973. TIME OFF. INT. CL. 25. REG. 8-24-2004.  
 2,876,974. AMERSHAM HEALTH AND DESIGN. INT. CLS. 1, 5, 9, 10, 41 AND 42. REG. 8-24-2004.  
 2,876,975. INFOWORLD KNOWLEDGELINK. INT. CL. 42. REG. 8-24-2004.  
 2,876,978. MICRATOR. INT. CL. 14. REG. 8-24-2004.  
 2,876,980. TEACHER'S DESK. INT. CL. 9. REG. 8-24-2004.  
 2,876,981. MISCELLANEOUS DESIGN. INT. CLS. 9, 16, 41 AND 42. REG. 8-24-2004.  
 2,876,982. VIKING TAKE A LIKING TO A VIKING VIKING LIFE - SAVNG EQUIPMENT AND DESIGN. INT. CL. 9. REG. 8-24-2004.  
 2,876,984. THE FREEMOUNT CORPORATION BUILDING COMMUNITY INSTITUTE AND DESIGN. INT. CL. 41. REG. 8-24-2004.  
 2,876,986. VICTORY OVER SELF. INT. CL. 41. REG. 8-24-2004.  
 2,876,987. REGIONAL PHYSICIAN NETWORK AND DESIGN. INT. CL. 44. REG. 8-24-2004.  
 2,876,988. RXELITE AND DESIGN. INT. CL. 5. REG. 8-24-2004.  
 2,876,990. THE DEERBERG COMPLETE GREEN SHIP PHILOSOPHY 21. INT. CL. 40. REG. 8-24-2004.  
 2,876,991. JUST ONE PARK. INT. CL. 35. REG. 8-24-2004.  
 2,876,992. ALERA THE IT PERFORMANCE COMPANY AND DESIGN. INT. CL. 42. REG. 8-24-2004.

- 2,876,993. HUSKY HARDCORES. INT. CL. 41. REG. 8-24-2004.
- 2,876,994. MELLERT AND DESIGN. INT. CL. 11. REG. 8-24-2004.
- 2,876,995. SHAMWARI. INT. CL. 33. REG. 8-24-2004.
- 2,876,996. INZOLO. INT. CL. 33. REG. 8-24-2004.
- 2,876,997. KHOSAM. INT. CL. 33. REG. 8-24-2004.
- 2,876,998. SYAQUA. INT. CL. 31. REG. 8-24-2004.
- 2,876,999. REGBROWSER AND DESIGN. INT. CL. 35. REG. 8-24-2004.
- 2,877,000. VENTACUTE. INT. CL. 5. REG. 8-24-2004.
- 2,877,001. SANDONLINE. INT. CLS. 9 AND 42. REG. 8-24-2004.
- 2,877,002. POLYCRYSTAL. INT. CL. 11. REG. 8-24-2004.
- 2,877,003. DOGLEGS.COM AND DESIGN. INT. CLS. 38 AND 42. REG. 8-24-2004.
- 2,877,005. CAPITALIA. INT. CLS. 9, 16, 35, 36 AND 38. REG. 8-24-2004.
- 2,877,007. ARTURO BRACHETTI AND DESIGN. INT. CLS. 9, 16, 18, 25, 28, 41 AND 43. REG. 8-24-2004.
- 2,877,008. VISIONAEL. INT. CL. 9. REG. 8-24-2004.
- 2,877,011. DECHAMPS. INT. CL. 24. REG. 8-24-2004.
- 2,877,014. USMED. INT. CL. 36. REG. 8-24-2004.
- 2,877,016. PIEDRA DE APAGUÍZ (STYLIZED). INT. CL. 34. REG. 8-24-2004.
- 2,877,017. AMERICAN MASCOT CLOCKS. INT. CL. 14. REG. 8-24-2004.
- 2,877,018. IM-AGE. INT. CL. 9. REG. 8-24-2004.
- 2,877,019. IT'S THE RIDE!. INT. CL. 12. REG. 8-24-2004.
- 2,877,021. DEMPSEY DOO ORIGINALS AND DESIGN. INT. CL. 16. REG. 8-24-2004.
- 2,877,022. NEXIT. INT. CL. 9. REG. 8-24-2004.
- 2,877,025. ANTARCTIC SEA. INT. CL. 30. REG. 8-24-2004.
- 2,877,026. THE POWER OF CHOICE. INT. CL. 44. REG. 8-24-2004.
- 2,877,029. CAPITAL. INT. CL. 34. REG. 8-24-2004.
- 2,877,031. DEPDIDO. INT. CL. 35. REG. 8-24-2004.
- 2,877,033. PACIFIC CHAI AND DESIGN. INT. CL. 30. REG. 8-24-2004.
- 2,877,034. NOVABLAST. INT. CLS. 1 AND 3. REG. 8-24-2004.
- 2,877,038. AVENT BABY CASE. INT. CL. 18. REG. 8-24-2004.
- 2,877,039. XTRASPACE. INT. CL. 11. REG. 8-24-2004.
- 2,877,041. SGP FIM SPEEDWAY GRAND PRIX AND DESIGN. INT. CLS. 9, 16, 18, 25, 28, 38 AND 41. REG. 8-24-2004.
- 2,877,042. MARITIQUE NAUTICAL COLLECTIONS AND DESIGN. INT. CL. 9. REG. 8-24-2004.
- 2,877,043. THE HIPPO HIPPOPRESSMANCHESTER (STYLIZED). INT. CL. 16. REG. 8-24-2004.
- 2,877,044. AMERICA'S LENDING LEADER. INT. CL. 36. REG. 8-24-2004.
- 2,877,048. SMART BAND (STYLIZED). INT. CL. 20. REG. 8-24-2004.
- 2,877,050. K2. INT. CL. 20. REG. 8-24-2004.
- 2,877,053. SECRET SOCIETY. INT. CL. 42. REG. 8-24-2004.
- 2,877,056. VECAFIX. INT. CL. 5. REG. 8-24-2004.
- 2,877,057. VECA-C. INT. CL. 5. REG. 8-24-2004.
- 2,877,058. ABIANT HOME HEALTH CARE AND DESIGN. INT. CL. 44. REG. 8-24-2004.
- 2,877,059. PETERSEN (STYLIZED). INT. CLS. 6, 7, 9, 11 AND 17. REG. 8-24-2004.
- 2,877,063. MILA SCHÖN (STYLIZED). INT. CL. 34. REG. 8-24-2004.
- 2,877,064. INCREDIBLE TOUCH. INT. CL. 3. REG. 8-24-2004.
- 2,877,065. SPEAK WITH A GEEK. INT. CL. 42. REG. 8-24-2004.
- 2,877,070. CAMATTA CANYON. INT. CL. 33. REG. 8-24-2004.
- 2,877,071. BLAZE THE WORLD RECORDS. INT. CLS. 9 AND 41. REG. 8-24-2004.
- 2,877,072. INITIATION CHOCOLAT. INT. CL. 30. REG. 8-24-2004.
- 2,877,074. PAY FOR PERFORMANCE. INT. CL. 35. REG. 8-24-2004.
- 2,877,076. EQUI-GRIP. INT. CL. 25. REG. 8-24-2004.
- 2,877,078. DIPLOM-IS AND DESIGN. INT. CL. 30. REG. 8-24-2004.
- 2,877,079. MAMA. INT. CL. 41. REG. 8-24-2004.
- 2,877,080. S TEK.. INT. CL. 27. REG. 8-24-2004.
- 2,877,083. EXCLUSIVE WASHINGTON D.C. MARYLAND-VIRGINIA. INT. CL. 36. REG. 8-24-2004.
- 2,877,084. URBAN LEATHER. INT. CLS. 20 AND 35. REG. 8-24-2004.
- 2,877,086. NEXCITE. INT. CL. 3. REG. 8-24-2004.
- 2,877,087. GOOHOO. INT. CL. 25. REG. 8-24-2004.
- 2,877,088. GOODNESS FROM THE HIVE. INT. CL. 30. REG. 8-24-2004.
- 2,877,091. THE DVD COLLECTION AND DESIGN. INT. CLS. 9 AND 41. REG. 8-24-2004.
- 2,877,092. TOUCAN TAN. INT. CL. 44. REG. 8-24-2004.
- 2,877,094. MEGAN MCCAULEY. INT. CL. 41. REG. 8-24-2004.
- 2,877,095. MISCELLANEOUS DESIGN. INT. CL. 35. REG. 8-24-2004.
- 2,877,097. IDM SERVICES, INC. AND DESIGN. INT. CLS. 39, 40 AND 42. REG. 8-24-2004.
- 2,877,098. PLEISTOSCENE. INT. CL. 41. REG. 8-24-2004.
- 2,877,109. GOLD LEAF VINEYARDS AND DESIGN. INT. CL. 41. REG. 8-24-2004.
- 2,877,110. FXKJ. INT. CL. 6. REG. 8-24-2004.
- 2,877,111. FARALLOY. INT. CL. 17. REG. 8-24-2004.
- 2,877,114. WORLD CUP STACKING ASSOCIATION WCSA AND DESIGN. INT. CL. 35. REG. 8-24-2004.
- 2,877,115. EYEZING. INT. CL. 3. REG. 8-24-2004.
- 2,877,116. LIFE CASE BULLET RESISTANT ATTACHES AND DESIGN. INT. CL. 18. REG. 8-24-2004.
- 2,877,119. EXPRESS HOME HELP. INT. CLS. 37, 39, 41 AND 45. REG. 8-24-2004.
- 2,877,120. ICHTHUS AND DESIGN. INT. CL. 41. REG. 8-24-2004.
- 2,877,124. MISCELLANEOUS DESIGN. INT. CLS. 32, 33, 35 AND 43. REG. 8-24-2004.
- 2,877,126. GEOJP2. INT. CL. 9. REG. 8-24-2004.
- 2,877,127. PARVOPAK (STYLIZED). INT. CLS. 5, 29 AND 31. REG. 8-24-2004.
- 2,877,131. CREME CARAMEL DREAM (STYLIZED). INT. CL. 30. REG. 8-24-2004.
- 2,877,132. THE INTELLIGENT CHOICE NUTECH LIGHTING AND DESIGN. INT. CL. 11. REG. 8-24-2004.
- 2,877,136. MELON BURST. INT. CL. 5. REG. 8-24-2004.
- 2,877,137. RESOURCE TRADING GROUP. INT. CL. 36. REG. 8-24-2004.
- 2,877,138. SAFETY & SECURITY INTERNATIONAL AND DESIGN. INT. CL. 35. REG. 8-24-2004.
- 2,877,139. RED BULL BIKE BATTLE. INT. CLS. 25 AND 41. REG. 8-24-2004.
- 2,877,141. RED BULL HEAVY METAL. INT. CLS. 25 AND 41. REG. 8-24-2004.
- 2,877,142. POSTCARDBUILDER. INT. CL. 9. REG. 8-24-2004.
- 2,877,143. PART OF THE SOLUTION. INT. CL. 42. REG. 8-24-2004.
- 2,877,144. WEBDECK. INT. CL. 41. REG. 8-24-2004.
- 2,877,145. VALENTINE GIRLS. INT. CL. 45. REG. 8-24-2004.
- 2,877,147. MISCELLANEOUS DESIGN. INT. CLS. 9, 38 AND 42. REG. 8-24-2004.
- 2,877,150. MTR-I AND DESIGN. INT. CLS. 16, 41 AND 44. REG. 8-24-2004.
- 2,877,151. TMC AND DESIGN. INT. CL. 41. REG. 8-24-2004.
- 2,877,157. DORIS DE PONT MADE IN NEW ZEALAND AND DESIGN. INT. CL. 25. REG. 8-24-2004.
- 2,877,158. ONE PURPOSE. INFINITE PERKS.. INT. CL. 35. REG. 8-24-2004.
- 2,877,159. IN\*SIGHT. INT. CL. 9. REG. 8-24-2004.
- 2,877,161. BELLVALE. INT. CL. 33. REG. 8-24-2004.
- 2,877,163. COMMUNICATION SERVICE FOR THE DEAF. INT. CLS. 35, 38, 41 AND 44. REG. 8-24-2004.
- 2,877,164. GUTKNECHT STANDARD CHARACTER MARK. INT. CLS. 29 AND 30. REG. 8-24-2004.
- 2,877,171. DURAHUM. INT. CL. 5. REG. 8-24-2004.
- 2,877,173. DIAMOND PLUS. INT. CL. 36. REG. 8-24-2004.
- 2,877,177. UPTOWN BILL. INT. CL. 20. REG. 8-24-2004.
- 2,877,178. !NPULSE. INT. CL. 35. REG. 8-24-2004.
- 2,877,179. INSTAREAD. INT. CL. 5. REG. 8-24-2004.
- 2,877,180. BELIZEAN BREEZE. INT. CL. 19. REG. 8-24-2004.
- 2,877,181. TOPTHIS!. INT. CL. 41. REG. 8-24-2004.

- 2,877,182. ACOUSTIC DISC 100% HANDMADE MUSIC AND DESIGN. INT. CLS. 9 AND 41. REG. 8-24-2004.
- 2,877,184. AIRPORT MECHANICAL SERVICES, INC. AIRCRAFT DOOR DETECTOR / WARNING DEVICE WWW.AIRPORTMECHANICAL.COM AND DESIGN. INT. CL. 9. REG. 8-24-2004.
- 2,877,186. GREAT NORTHERN WHOLEAVES NO CUT AND DESIGN. INT. CL. 31. REG. 8-24-2004.
- 2,877,188. CRB 27 CANYON RIVER BLUES AND DESIGN. INT. CL. 25. REG. 8-24-2004.
- 2,877,189. BK (STYLIZED). INT. CL. 28. REG. 8-24-2004.
- 2,877,190. RELATIONSHIPS THAT CLICK. INT. CL. 45. REG. 8-24-2004.
- 2,877,191. INCP. INT. CL. 9. REG. 8-24-2004.
- 2,877,198. AIVA DESIGN AND DESIGN. INT. CL. 42. REG. 8-24-2004.
- 2,877,203. COSTOURICA. INT. CL. 39. REG. 8-24-2004.
- 2,877,205. CORNERSTONE STERLING (STYLIZED). INT. CL. 14. REG. 8-24-2004.
- 2,877,207. CENET AND DESIGN. INT. CLS. 9 AND 42. REG. 8-24-2004.
- 2,877,208. C COSTA DEL MAR AMERICA'S #1 POLARIZED SUNGLASSES AND DESIGN. INT. CL. 9. REG. 8-24-2004.
- 2,877,209. RAPS. INT. CL. 36. REG. 8-24-2004.
- 2,877,211. WORLD TRAVELER. INT. CL. 30. REG. 8-24-2004.
- 2,877,212. ABSOLUTELY FABULOUS!. INT. CL. 30. REG. 8-24-2004.
- 2,877,213. MADISON & 29TH. INT. CLS. 35 AND 45. REG. 8-24-2004.
- 2,877,214. KIWILOAN QUALITY PEOPLE QUALITY MORTGAGES AND DESIGN. INT. CL. 36. REG. 8-24-2004.
- 2,877,215. MAGGIE SOTTERO RUNWAY COLLECTION. INT. CL. 25. REG. 8-24-2004.
- 2,877,220. MEA CULPA. INT. CL. 25. REG. 8-24-2004.
- 2,877,222. TRITON. INT. CL. 9. REG. 8-24-2004.
- 2,877,223. SIMPLIRIX. INT. CL. 5. REG. 8-24-2004.
- 2,877,225. AU PAIR EXTRAORDINAIRE AND DESIGN. INT. CL. 43. REG. 8-24-2004.
- 2,877,229. FRUITANGO. INT. CL. 32. REG. 8-24-2004.
- 2,877,230. EDIEDGE. INT. CL. 10. REG. 8-24-2004.
- 2,877,231. SPLIT-SHOT. INT. CL. 7. REG. 8-24-2004.
- 2,877,232. ECOTECH. INT. CL. 11. REG. 8-24-2004.
- 2,877,235. THE DENTURE SOLUTION. INT. CL. 44. REG. 8-24-2004.
- 2,877,236. INVOQ. INT. CL. 42. REG. 8-24-2004.
- 2,877,238. SHOOTINGOLF AND DESIGN. INT. CLS. 13, 25, 28 AND 41. REG. 8-24-2004.
- 2,877,240. ATREUS XAUTHORITY. INT. CLS. 9 AND 42. REG. 8-24-2004.
- 2,877,244. SISTINA. INT. CLS. 9 AND 16. REG. 8-24-2004.
- 2,877,245. CAST. INT. CL. 36. REG. 8-24-2004.
- 2,877,247. LANDJUNKER. INT. CLS. 29 AND 31. REG. 8-24-2004.
- 2,877,252. ANTARES. INT. CLS. 35 AND 36. REG. 8-24-2004.
- 2,877,253. MAZDA RX-8. INT. CLS. 9, 14, 16, 18, 25, 27 AND 28. REG. 8-24-2004.
- 2,877,254. GET SCHOOLED TOUR. INT. CL. 41. REG. 8-24-2004.
- 2,877,255. HALL OF LAME. INT. CL. 41. REG. 8-24-2004.
- 2,877,257. GO GO GRAHAMS. INT. CL. 30. REG. 8-24-2004.
- 2,877,259. ARRANON. INT. CL. 5. REG. 8-24-2004.
- 2,877,260. DOING IT RIGHT. INT. CL. 35. REG. 8-24-2004.
- 2,877,261. EXPRESS SUPERMARKET AND DESIGN. INT. CL. 39. REG. 8-24-2004.
- 2,877,264. NANCY'S AND DESIGN. INT. CLS. 29 AND 30. REG. 8-24-2004.
- 2,877,266. POSITIVE CABLE. INT. CL. 9. REG. 8-24-2004.
- 2,877,269. XXX TRIPLE X (STYLIZED). INT. CL. 28. REG. 8-24-2004.
- 2,877,270. XPORT MANAGER. INT. CL. 42. REG. 8-24-2004.
- 2,877,272. POWERPROGRAM. INT. CL. 35. REG. 8-24-2004.
- 2,877,273. SX1. INT. CL. 9. REG. 8-24-2004.
- 2,877,274. PSILIAMOS. INT. CL. 18. REG. 8-24-2004.
- 2,877,281. RAINBOW SPORTS NETWORKS. INT. CLS. 38 AND 41. REG. 8-24-2004.
- 2,877,282. NLK AND DESIGN. INT. CL. 5. REG. 8-24-2004.
- 2,877,285. SUNDOG. INT. CL. 3. REG. 8-24-2004.
- 2,877,288. WEB CONTENT WITH A SPINE. INT. CL. 41. REG. 8-24-2004.
- 2,877,289. ZURIBOOKS. INT. CL. 16. REG. 8-24-2004.
- 2,877,290. ZURIMEDIA. INT. CL. 41. REG. 8-24-2004.
- 2,877,297. BIG SKY BOTANICALS. INT. CL. 40. REG. 8-24-2004.
- 2,877,298. B BOOTIE ONLINE AND DESIGN. INT. CL. 35. REG. 8-24-2004.
- 2,877,299. AXELER. INT. CL. 25. REG. 8-24-2004.
- 2,877,302. SAND DUNE. INT. CL. 14. REG. 8-24-2004.
- 2,877,305. SPLASH C. INT. CL. 32. REG. 8-24-2004.
- 2,877,306. TWINNER. INT. CLS. 29 AND 30. REG. 8-24-2004.
- 2,877,307. TOPPO. INT. CLS. 29 AND 30. REG. 8-24-2004.
- 2,877,308. CREAM OF THE CROP BAND SEARCH. INT. CL. 41. REG. 8-24-2004.
- 2,877,310. MYBIZ. INT. CL. 9. REG. 8-24-2004.
- 2,877,311. WALKIMET. INT. CL. 16. REG. 8-24-2004.
- 2,877,314. ABEL RECORDS. INT. CL. 41. REG. 8-24-2004.
- 2,877,315. EPICSEARCH. INT. CL. 35. REG. 8-24-2004.
- 2,877,318. PARTY GIRLS GET LOOSE. INT. CL. 9. REG. 8-24-2004.
- 2,877,320. S.E.A. BAG. INT. CL. 16. REG. 8-24-2004.
- 2,877,321. INKJETS.COM AND DESIGN. INT. CL. 35. REG. 8-24-2004.
- 2,877,323. ENVALIGHT. INT. CLS. 17 AND 20. REG. 8-24-2004.
- 2,877,325. MIPANADA OVEN-BAKED EMPANADAS AUTENTICAS DE ARGENTINA AND DESIGN. INT. CL. 43. REG. 8-24-2004.
- 2,877,327. IDRESPONSE POWERED BY ETALINC.COM AND DESIGN. INT. CL. 45. REG. 8-24-2004.
- 2,877,329. POP FLOWER. INT. CL. 25. REG. 8-24-2004.
- 2,877,330. ESPHION. INT. CL. 9. REG. 8-24-2004.
- 2,877,331. THE POSSIBILITIES ARE SO SWEET. INT. CL. 42. REG. 8-24-2004.
- 2,877,332. SHAPE-AMINO (STYLIZED). INT. CL. 5. REG. 8-24-2004.
- 2,877,333. GET REAL MAGAZINE YOUR WORLD, YOUR WAY ... WWW.GETREALMAGAZINE.COM AND DESIGN. INT. CL. 41. REG. 8-24-2004.
- 2,877,334. SYNCRIA. INT. CL. 5. REG. 8-24-2004.
- 2,877,336. BAY (STYLIZED). INT. CLS. 1 AND 9. REG. 8-24-2004.
- 2,877,339. GLENRIDDLE AND DESIGN. INT. CLS. 37 AND 41. REG. 8-24-2004.
- 2,877,340. MISCELLANEOUS DESIGN. INT. CL. 35. REG. 8-24-2004.
- 2,877,342. PROJECTDESIGNSTUDIO. INT. CL. 42. REG. 8-24-2004.
- 2,877,343. QUIET ENTREPRENEURS. INT. CL. 35. REG. 8-24-2004.
- 2,877,344. QE QUIET ENTREPRENEURS AND DESIGN. INT. CL. 35. REG. 8-24-2004.
- 2,877,345. DELIGHTFUL DELIVERIES.COM AND DESIGN. INT. CL. 35. REG. 8-24-2004.
- 2,877,347. VERITA. INT. CL. 11. REG. 8-24-2004.
- 2,877,348. LANDING TECHNOLOGY GROUP AND DESIGN. INT. CL. 38. REG. 8-24-2004.
- 2,877,351. OPTIMIZATION MATTERS. INT. CL. 35. REG. 8-24-2004.
- 2,877,352. CGL. INT. CL. 19. REG. 8-24-2004.
- 2,877,353. DATAHIDING. INT. CLS. 40 AND 42. REG. 8-24-2004.
- 2,877,354. DO WE THINK ALIKE OR WHAT?. INT. CL. 38. REG. 8-24-2004.
- 2,877,355. WRITER RESCUE. INT. CL. 41. REG. 8-24-2004.
- 2,877,356. \*FOTO NITRO HEADSHOTS. INT. CL. 41. REG. 8-24-2004.
- 2,877,368. LITTLE BIRDY BAGS AND DESIGN. INT. CL. 18. REG. 8-24-2004.
- 2,877,369. ENVISIONING BUSINESS (STYLIZED). INT. CL. 35. REG. 8-24-2004.
- 2,877,370. PET SHED. INT. CL. 35. REG. 8-24-2004.
- 2,877,375. YELLOW STEEL. INT. CL. 35. REG. 8-24-2004.
- 2,877,382. GLOBAL OUTREACH. INT. CL. 35. REG. 8-24-2004.

- 2,877,388. NATURCLEAN. INT. CL. 1. REG. 8-24-2004.  
 2,877,390. ZANYVREZ. INT. CL. 5. REG. 8-24-2004.  
 2,877,392. ÜBERDOG YOUR OTHER BEST FRIEND. AND DESIGN. INT. CL. 18. REG. 8-24-2004.  
 2,877,394. ALPINE COACH. INT. CL. 12. REG. 8-24-2004.  
 2,877,395. PEAK CHASSIS. INT. CL. 12. REG. 8-24-2004.  
 2,877,398. DVF (STYLIZED). INT. CL. 3. REG. 8-24-2004.  
 2,877,400. HPS EXCHANGE AND DESIGN. INT. CL. 36. REG. 8-24-2004.  
 2,877,403. NOVA X. INT. CL. 16. REG. 8-24-2004.  
 2,877,404. FUNHOUSEPARTY.COM. INT. CL. 41. REG. 8-24-2004.  
 2,877,405. GUS ATTITUDE WEAR GET-U-SOME AND DESIGN. INT. CL. 25. REG. 8-24-2004.  
 2,877,407. TROPICAL BLENDS AND DESIGN. INT. CL. 28. REG. 8-24-2004.  
 2,877,408. LIFE IS A JOURNEY. WOK WITH FRIENDS.. INT. CLS. 39 AND 43. REG. 8-24-2004.  
 2,877,412. GRINGO LINGO. INT. CL. 16. REG. 8-24-2004.  
 2,877,417. MNOTES. INT. CL. 9. REG. 8-24-2004.  
 2,877,418. COMMONTIME. INT. CL. 42. REG. 8-24-2004.  
 2,877,420. MENTALITY AND DESIGN. INT. CLS. 16 AND 28. REG. 8-24-2004.  
 2,877,422. SOILSERV. INT. CLS. 1 AND 5. REG. 8-24-2004.  
 2,877,424. AV-GRAM. INT. CL. 38. REG. 8-24-2004.  
 2,877,425. MISCELLANEOUS DESIGN. INT. CL. 43. REG. 8-24-2004.  
 2,877,426. ONSCHEDULE BASIC AND DESIGN. INT. CL. 9. REG. 8-24-2004.  
 2,877,427. ONSCHEDULE CLASS AND DESIGN. INT. CL. 9. REG. 8-24-2004.  
 2,877,428. ONSCHEDULE FLIGHT AND DESIGN. INT. CL. 9. REG. 8-24-2004.  
 2,877,433. SYNTHESIS DESIGNS AND DESIGN. INT. CL. 42. REG. 8-24-2004.  
 2,877,434. GRANESI. INT. CL. 30. REG. 8-24-2004.  
 2,877,435. AÑORANZAS. INT. CLS. 16 AND 38. REG. 8-24-2004.  
 2,877,436. AÑORANZAS LATINA (STYLIZED). INT. CLS. 16 AND 38. REG. 8-24-2004.  
 2,877,437. MISCELLANEOUS DESIGN. INT. CLS. 16 AND 35. REG. 8-24-2004.  
 2,877,438. INNER DEVELOPMENT IMAGE. INT. CL. 16. REG. 8-24-2004.  
 2,877,440. VENDOR PASSPORT. INT. CL. 9. REG. 8-24-2004.  
 2,877,442. TROPICAL DELIGHT. INT. CL. 29. REG. 8-24-2004.  
 2,877,443. OPTIONSOFT. INT. CL. 9. REG. 8-24-2004.  
 2,877,445. PEOPLE DO BUSINESS WITH PEOPLE. INT. CL. 36. REG. 8-24-2004.  
 2,877,446. SNELGROVE (STYLIZED). INT. CL. 30. REG. 8-24-2004.  
 2,877,448. CAPITAL ONE CHALLENGE 1-877-680-0373 AND DESIGN. INT. CL. 36. REG. 8-24-2004.  
 2,877,449. SECUREWEALTH SOLUTIONS HIGH RISK INCOME HIGH RISK GROWTH HIGH RISK ESTATE MEDIUM RISK INCOME MEDIUM RISK GROWTH MEDIUM RISK ESTATE LOW RISK INCOME LOW RISK GROWTH LOW RISK ESTATE AND DESIGN. INT. CL. 36. REG. 8-24-2004.  
 2,877,450. ACCEPTANCE CAPITAL MORTGAGE CORPORATION. INT. CL. 36. REG. 8-24-2004.  
 2,877,451. NANNIES AND MORE.... INT. CL. 35. REG. 8-24-2004.  
 2,877,453. LA DEL PUEBLO. INT. CL. 16. REG. 8-24-2004.  
 2,877,456. POP 'EM ORIGINAL AND DESIGN. INT. CL. 29. REG. 8-24-2004.  
 2,877,458. HOT TRADES. INT. CL. 36. REG. 8-24-2004.  
 2,877,459. CRITICAL FUSE. INT. CL. 41. REG. 8-24-2004.  
 2,877,462. ANTIQUITY STONE. INT. CL. 35. REG. 8-24-2004.  
 2,877,465. WAREHOUSE CONNECTION. INT. CL. 36. REG. 8-24-2004.  
 2,877,466. DRNA DENTAL RECYCLING NORTH AMERICA, INC. AND DESIGN. INT. CL. 40. REG. 8-24-2004.  
 2,877,469. DON LUCAS. INT. CLS. 14 AND 25. REG. 8-24-2004.  
 2,877,470. INTEGRATED (STYLIZED). INT. CL. 6. REG. 8-24-2004.  
 2,877,471. THE SHERPA SHOP. INT. CL. 35. REG. 8-24-2004.  
 2,877,472. SECURE MS SPECIAL. INT. CL. 6. REG. 8-24-2004.  
 2,877,479. MISCELLANEOUS DESIGN. INT. CL. 35. REG. 8-24-2004.  
 2,877,482. WEBVENTURI. INT. CL. 35. REG. 8-24-2004.  
 2,877,484. LEROS TECHNOLOGIES CORPORATION AND DESIGN. INT. CLS. 9 AND 42. REG. 8-24-2004.  
 2,877,485. YAUSET. INT. CL. 9. REG. 8-24-2004.  
 2,877,487. THE STING THING. INT. CL. 5. REG. 8-24-2004.  
 2,877,493. FURÉE (STYLIZED). INT. CL. 32. REG. 8-24-2004.  
 2,877,495. VBALLS. INT. CL. 28. REG. 8-24-2004.  
 2,877,498. IDEAL FOR YOUR BUSINESS, YOUR FAMILY, YOUR LIFE.. INT. CL. 35. REG. 8-24-2004.  
 2,877,499. ELUMINATIONS AT LIFETIME.ORG AND DESIGN. INT. CL. 41. REG. 8-24-2004.  
 2,877,501. ORIGINAL TABLE HOCKEY AND DESIGN. INT. CL. 28. REG. 8-24-2004.  
 2,877,502. THE VACCINE FUND EVERY CHILD. EVERYWHERE.. INT. CL. 36. REG. 8-24-2004.  
 2,877,503. THE VACCINE FUND EVERY CHILD. EVERYWHERE. AND DESIGN. INT. CL. 36. REG. 8-24-2004.  
 2,877,512. ASSET HORIZON CORPORATION AND DESIGN. INT. CL. 35. REG. 8-24-2004.  
 2,877,514. CHARTMINE. INT. CL. 9. REG. 8-24-2004.  
 2,877,515. TYCERB. INT. CL. 5. REG. 8-24-2004.  
 2,877,516. KATREMA. INT. CL. 5. REG. 8-24-2004.  
 2,877,518. BRAXX. INT. CL. 19. REG. 8-24-2004.  
 2,877,519. NICO WATER. INT. CL. 5. REG. 8-24-2004.  
 2,877,526. SERAH (STYLIZED). INT. CLS. 9 AND 16. REG. 8-24-2004.  
 2,877,532. SPECTRA. INT. CL. 7. REG. 8-24-2004.  
 2,877,534. SOCIETYWEST. INT. CLS. 41 AND 45. REG. 8-24-2004.  
 2,877,536. AXESSION. INT. CL. 9. REG. 8-24-2004.  
 2,877,537. THE AMERICAN COLLEGE OF PSYCHIATRISTS MAY 8 1963 AND DESIGN. INT. CLS. 35 AND 41. REG. 8-24-2004.  
 2,877,539. NEW ENGLAND ECONOMIC ADVENTURE. INT. CL. 41. REG. 8-24-2004.  
 2,877,547. BLACK GOLD. INT. CLS. 16 AND 38. REG. 8-24-2004.  
 2,877,548. SOS STRATEGIC ORGANIZATION SOLUTIONS AND DESIGN. INT. CL. 35. REG. 8-24-2004.  
 2,877,549. H HANWHA AND DESIGN. INT. CL. 7. REG. 8-24-2004.  
 2,877,555. TRES MONKEY. INT. CL. 25. REG. 8-24-2004.  
 2,877,557. SNAPS STUDIOS AND DESIGN. INT. CL. 41. REG. 8-24-2004.  
 2,877,561. THE PROS IN AMATEUR SPORTS. INT. CL. 41. REG. 8-24-2004.  
 2,877,562. SUICIDE CLOTHING.COM AND DESIGN. INT. CL. 25. REG. 8-24-2004.  
 2,877,563. SISTERS ITALIAN CHARM . . . A CHARMED LIFE!. INT. CL. 35. REG. 8-24-2004.  
 2,877,565. SUNSHOWER. INT. CL. 3. REG. 8-24-2004.  
 2,877,566. SECRET SOURCES. INT. CL. 16. REG. 8-24-2004.  
 2,877,570. JENZ. INT. CLS. 16 AND 41. REG. 8-24-2004.  
 2,877,571. PROSTACK. INT. CL. 9. REG. 8-24-2004.  
 2,877,572. THE SANDWICH OF CHOICE ACROSS AMERICA. INT. CL. 43. REG. 8-24-2004.  
 2,877,573. CAPITALINTELLIGENCEIX. INT. CL. 36. REG. 8-24-2004.  
 2,877,580. MORE THAN SEATING AND EATING. INT. CL. 35. REG. 8-24-2004.  
 2,877,581. BRAND, NOT BLAND. INT. CL. 35. REG. 8-24-2004.  
 2,877,582. JUST AROUND THE CORNER GIFT SALE. INT. CL. 35. REG. 8-24-2004.  
 2,877,585. SAVVY DATING. INT. CL. 16. REG. 8-24-2004.  
 2,877,587. VAVAMOJO. INT. CL. 14. REG. 8-24-2004.  
 2,877,588. LOOK. INT. CL. 11. REG. 8-24-2004.  
 2,877,590. AVENAVIN. INT. CL. 5. REG. 8-24-2004.  
 2,877,593. CABINET ARCHITECT. INT. CL. 9. REG. 8-24-2004.



- 2,877,595. TOTAL LOGO CREATIONS. INT. CL. 40. REG. 8-24-2004.
- 2,877,597. MISCELLANEOUS DESIGN. INT. CL. 37. REG. 8-24-2004.
- 2,877,600. DORRIT. INT. CL. 42. REG. 8-24-2004.
- 2,877,602. DAVIS PAUL. INT. CL. 35. REG. 8-24-2004.
- 2,877,604. BRIDGING THE PACIFIC. INT. CL. 39. REG. 8-24-2004.
- 2,877,605. HIDDEN TALENTS. INT. CL. 28. REG. 8-24-2004.
- 2,877,606. SMART ADJUST. INT. CL. 9. REG. 8-24-2004.
- 2,877,612. PHARMOTIF. INT. CL. 42. REG. 8-24-2004.
- 2,877,613. POWERING LEAD ADVANCEMENT. INT. CL. 42. REG. 8-24-2004.
- 2,877,614. MXADDICT AND DESIGN. INT. CLS. 16 AND 25. REG. 8-24-2004.
- 2,877,615. Q CHIROPRACTIC. INT. CL. 44. REG. 8-24-2004.
- 2,877,616. EXTREME FREEZE. INT. CLS. 10 AND 21. REG. 8-24-2004.
- 2,877,618. WEB ONLY AND DESIGN. INT. CL. 35. REG. 8-24-2004.
- 2,877,620. BLIZZARD. INT. CL. 18. REG. 8-24-2004.
- 2,877,621. SUN SOLVER. INT. CL. 35. REG. 8-24-2004.
- 2,877,625. PHENOTECH. INT. CL. 28. REG. 8-24-2004.
- 2,877,626. THE CAPRICCIO ENSEMBLE AND DESIGN. INT. CL. 41. REG. 8-24-2004.
- 2,877,627. SHEER VOLUME. INT. CL. 3. REG. 8-24-2004.
- 2,877,628. NOSY. INT. CL. 10. REG. 8-24-2004.
- 2,877,629. ACAPULCO. INT. CL. 9. REG. 8-24-2004.
- 2,877,630. AUSTIN. INT. CL. 9. REG. 8-24-2004.
- 2,877,631. NEW ORLEANS. INT. CL. 9. REG. 8-24-2004.
- 2,877,634. SOFABILITIES. INT. CL. 35. REG. 8-24-2004.
- 2,877,638. BE THE SIZE TO TANTALIZE. INT. CL. 5. REG. 8-24-2004.
- 2,877,639. BUILDING COMMUNITIES THROUGH FAITH AND HOUSING PARTNERSHIPS. INT. CL. 36. REG. 8-24-2004.
- 2,877,641. NO SECRET. INT. CL. 25. REG. 8-24-2004.
- 2,877,643. WHIMFLY AND DESIGN. INT. CL. 16. REG. 8-24-2004.
- 2,877,644. GEMETRICS. INT. CL. 14. REG. 8-24-2004.
- 2,877,646. BABY DREAMS. INT. CL. 25. REG. 8-24-2004.
- 2,877,650. STUDIO. INT. CL. 34. REG. 8-24-2004.
- 2,877,651. CLEARFOCUS. INT. CL. 35. REG. 8-24-2004.
- 2,877,652. FUN STUFF (STYLIZED). INT. CL. 27. REG. 8-24-2004.
- 2,877,654. PROPRIORING A+. INT. CL. 36. REG. 8-24-2004.
- 2,877,655. TWINKLE TOOF (STYLIZED). INT. CL. 28. REG. 8-24-2004.
- 2,877,656. SWING BY LOU. INT. CL. 41. REG. 8-24-2004.
- 2,877,657. MIND BODY SPIRIT AND DESIGN. INT. CL. 9. REG. 8-24-2004.
- 2,877,658. CWARDFS. INT. CL. 35. REG. 8-24-2004.
- 2,877,659. THE POWER OF SHARED KNOWLEDGE AND EXPERIENCE. INT. CL. 42. REG. 8-24-2004.
- 2,877,660. SKYBOX. INT. CL. 20. REG. 8-24-2004.
- 2,877,661. ISLAND DISPLAY. INT. CL. 35. REG. 8-24-2004.
- 2,877,671. WILDSIDE. INT. CL. 28. REG. 8-24-2004.
- 2,877,676. SUITS TO YOU. INT. CL. 35. REG. 8-24-2004.
- 2,877,677. COLLEGE AUTHENTICS. INT. CL. 25. REG. 8-24-2004.
- 2,877,680. ROCKIN' ROADIES. INT. CL. 41. REG. 8-24-2004.
- 2,877,681. MISCELLANEOUS DESIGN. INT. CL. 41. REG. 8-24-2004.
- 2,877,682. STAND-OUTS. INT. CL. 16. REG. 8-24-2004.
- 2,877,691. PATRONUS. INT. CL. 42. REG. 8-24-2004.
- 2,877,692. PATRONUS CONSULTING. INT. CL. 42. REG. 8-24-2004.
- 2,877,693. FERRIMET. INT. CL. 11. REG. 8-24-2004.
- 2,877,694. ZEROMET. INT. CL. 11. REG. 8-24-2004.
- 2,877,695. LUCKY CROWN EXTRA FANCY LONG GRAIN RICE. INT. CL. 30. REG. 8-24-2004.
- 2,877,697. SOPHISTICATED LADIES. INT. CLS. 14 AND 21. REG. 8-24-2004.
- 2,877,698. GOT NUTS?. INT. CL. 25. REG. 8-24-2004.
- 2,877,700. PULL-TOGGLE. INT. CL. 6. REG. 8-24-2004.
- 2,877,702. RHYTHMS INTERNATIONAL. INT. CL. 41. REG. 8-24-2004.
- 2,877,705. PAC-RATADS. INT. CL. 35. REG. 8-24-2004.
- 2,877,706. GRIZZLY RANCH. INT. CLS. 36, 37 AND 41. REG. 8-24-2004.
- 2,877,707. 42ND STREET TOURS AND DESIGN. INT. CL. 39. REG. 8-24-2004.
- 2,877,708. UBU TV. INT. CL. 38. REG. 8-24-2004.
- 2,877,709. EZSKINS. INT. CL. 35. REG. 8-24-2004.
- 2,877,710. BULL STAR. INT. CL. 25. REG. 8-24-2004.
- 2,877,711. CALIFORNIA CRISP. INT. CL. 29. REG. 8-24-2004.
- 2,877,712. ITW SAFE ZONE. INT. CL. 7. REG. 8-24-2004.
- 2,877,713. ITW SAFE ZONE AND DESIGN. INT. CL. 7. REG. 8-24-2004.
- 2,877,715. CAPTAIN CAR WASH GREEN LANTERN AND DESIGN. INT. CL. 21. REG. 8-24-2004.
- 2,877,718. GERMANIA. INT. CL. 9. REG. 8-24-2004.
- 2,877,720. ODORZONE. INT. CL. 5. REG. 8-24-2004.
- 2,877,721. HRX PRESCRIPTION FOR SMALL BUSINESS. INT. CL. 9. REG. 8-24-2004.
- 2,877,723. FREEZER BOAT. INT. CL. 29. REG. 8-24-2004.
- 2,877,726. XPRESSBILL AND DESIGN. INT. CLS. 35 AND 36. REG. 8-24-2004.
- 2,877,734. ACE BOAT HOIST. INT. CL. 7. REG. 8-24-2004.
- 2,877,735. ACE AND DESIGN. INT. CL. 7. REG. 8-24-2004.
- 2,877,736. BE MORE DIGITAL. INT. CL. 42. REG. 8-24-2004.
- 2,877,739. MPTIA BMP MEDICAL TRANSCRIPTION INDUSTRY ALLIANCE BILLING METHOD PRINCIPLES DEFINABILITY INTEGRITY CONSISTENCY MEASURABILITY VERIFIABILITY AND DESIGN. INT. CL. 35. REG. 8-24-2004.
- 2,877,741. THE BANGSTER. INT. CL. 28. REG. 8-24-2004.
- 2,877,742. BANGENSTEIN. INT. CL. 28. REG. 8-24-2004.
- 2,877,743. MEDIUM CONTROL AND DESIGN. INT. CL. 25. REG. 8-24-2004.
- 2,877,746. TROPIC BAY. INT. CL. 29. REG. 8-24-2004.
- 2,877,759. WIRED WORLD. INT. CL. 36. REG. 8-24-2004.
- 2,877,761. GEOMINION. INT. CL. 9. REG. 8-24-2004.
- 2,877,762. FILIBUSTER AND DESIGN. INT. CL. 32. REG. 8-24-2004.
- 2,877,763. TEAM MVP. INT. CL. 35. REG. 8-24-2004.
- 2,877,765. MISCELLANEOUS DESIGN. INT. CL. 9. REG. 8-24-2004.
- 2,877,770. QUIK PRESS. INT. CL. 1. REG. 8-24-2004.
- 2,877,771. REINVENTING THE WAY BUSINESS COMMUNICATES. INT. CLS. 38 AND 42. REG. 8-24-2004.
- 2,877,772. FOR THE LOVE OF KIDS, A CONFERENCE ON PRACTICAL PARENTING. INT. CL. 41. REG. 8-24-2004.
- 2,877,773. DENTACHOICE. INT. CLS. 18 AND 31. REG. 8-24-2004.
- 2,877,774. RAPIDDOC. INT. CL. 36. REG. 8-24-2004.
- 2,877,775. HR POWERHOUSE. INT. CL. 36. REG. 8-24-2004.
- 2,877,776. MISCELLANEOUS DESIGN. INT. CLS. 18 AND 28. REG. 8-24-2004.
- 2,877,777. SIMPLE BUSINESS. INT. CL. 38. REG. 8-24-2004.
- 2,877,779. SELENETIX. INT. CL. 42. REG. 8-24-2004.
- 2,877,783. NOVAJET. INT. CL. 17. REG. 8-24-2004.
- 2,877,784. ACQUA E SALE. INT. CL. 42. REG. 8-24-2004.
- 2,877,786. TUMMY TOPPER (STYLIZED). INT. CL. 16. REG. 8-24-2004.
- 2,877,787. HR POWERHOUSE. INT. CL. 35. REG. 8-24-2004.
- 2,877,788. POLICYPARTNER. INT. CL. 42. REG. 8-24-2004.
- 2,877,791. SURE THING. INT. CLS. 35, 36 AND 37. REG. 8-24-2004.
- 2,877,792. LOCTITE AND DESIGN. INT. CL. 16. REG. 8-24-2004.
- 2,877,793. COOLS YOUR BREATH TWICE. INT. CL. 30. REG. 8-24-2004.
- 2,877,795. COLUMBITECH. INT. CLS. 9 AND 42. REG. 8-24-2004.
- 2,877,796. CUBE IT AND DESIGN. INT. CL. 20. REG. 8-24-2004.
- 2,877,803. SURFACE LOGIX AND DESIGN. INT. CLS. 40 AND 42. REG. 8-24-2004.
- 2,877,804. IBIS AND DESIGN. INT. CL. 42. REG. 8-24-2004.
- 2,877,806. COOL COW SOFT SERVE ICE CREAM AND DESIGN. INT. CL. 35. REG. 8-24-2004.
- 2,877,807. IDICTATE. INT. CL. 9. REG. 8-24-2004.

- 2,877,809. AMERICAN MOUNTAIN GUIDES ASSOCIATION AND DESIGN. INT. CLS. 25 AND 35. REG. 8-24-2004.
- 2,877,811. MERIDIAN MEASURING ADVERTISING FOR PROFIT PERFORMANCE. INT. CLS. 35, 40 AND 42. REG. 8-24-2004.
- 2,877,812. MERIDIAN MAPP. INT. CLS. 35, 40 AND 42. REG. 8-24-2004.
- 2,877,813. D F-M P AND DESIGN. INT. CL. 42. REG. 8-24-2004.
- 2,877,815. HAPPINESS HAPPENS THROUGH MY SENSES. INT. CL. 16. REG. 8-24-2004.
- 2,877,816. COLORCOTE. INT. CL. 1. REG. 8-24-2004.
- 2,877,817. WE DELIVER PERFORMANCE!. INT. CL. 12. REG. 8-24-2004.
- 2,877,818. DECOPRINT. INT. CL. 16. REG. 8-24-2004.
- 2,877,821. TECHORA RESOURCES. INT. CL. 39. REG. 8-24-2004.
- 2,877,822. LEGG MASON VALUE PLUS. INT. CL. 36. REG. 8-24-2004.
- 2,877,827. SALUTE TO NONPROFITS CALENDAR. INT. CL. 16. REG. 8-24-2004.
- 2,877,828. THE SPIRIT OF AMERICA IS STRONGER THAN ITS TALLEST BUILDINGS. THE SPIRIT OF AMERICA IS LIBERTY, COMPASSION, AND COURAGE.. INT. CL. 16. REG. 8-24-2004.
- 2,877,830. STRETCH POWER. INT. CL. 25. REG. 8-24-2004.
- 2,877,831. STRATIFY DISCOVERY SYSTEM. INT. CLS. 35 AND 42. REG. 8-24-2004.
- 2,877,833. BRITISH MORTGAGES ABROAD AND DESIGN. INT. CL. 36. REG. 8-24-2004.
- 2,877,834. RELATIONWARE. INT. CLS. 9, 37, 41 AND 42. REG. 8-24-2004.
- 2,877,835. MICASATUCASA. INT. CLS. 16 AND 41. REG. 8-24-2004.
- 2,877,838. PRIMO PATISSERIE AND DESIGN. INT. CL. 30. REG. 8-24-2004.
- 2,877,840. MY ENERGYINFO AND DESIGN. INT. CLS. 35, 38 AND 42. REG. 8-24-2004.
- 2,877,841. KOSMOS PHARMA. INT. CL. 5. REG. 8-24-2004.
- 2,877,845. SHEEPLE. INT. CL. 28. REG. 8-24-2004.
- 2,877,846. LA LA OFFICE PLAZA I-II AND DESIGN. INT. CL. 36. REG. 8-24-2004.
- 2,877,848. BIG IDEA'S JONAH A VEGGIETALES MOVIE AND DESIGN. INT. CLS. 9 AND 16. REG. 8-24-2004.
- 2,877,851. FULL BLAST. INT. CL. 3. REG. 8-24-2004.
- 2,877,852. CINNA MUNCHIES. INT. CL. 30. REG. 8-24-2004.
- 2,877,853. CINNA MUNCH. INT. CL. 30. REG. 8-24-2004.
- 2,877,855. TSL (USA) INC.. INT. CL. 36. REG. 8-24-2004.
- 2,877,856. MERITON. INT. CL. 9. REG. 8-24-2004.
- 2,877,859. FOOD PHARMACY. INT. CLS. 9, 41 AND 42. REG. 8-24-2004.
- 2,877,860. BARRIERPRO POLYMER. INT. CL. 1. REG. 8-24-2004.
- 2,877,863. PURE CUSHION. INT. CL. 25. REG. 8-24-2004.
- 2,877,864. COOL BLUE BOOKS AND DESIGN. INT. CL. 41. REG. 8-24-2004.
- 2,877,865. THE POWER OF MEMBERSHIP. INT. CL. 42. REG. 8-24-2004.
- 2,877,868. SCCO TECHNOLOGY. INT. CL. 7. REG. 8-24-2004.
- 2,877,869. NEGAMI. INT. CL. 9. REG. 8-24-2004.
- 2,877,871. CELEBRATING THE CHEF IN YOU. INT. CL. 35. REG. 8-24-2004.
- 2,877,875. MISCELLANEOUS DESIGN. INT. CL. 9. REG. 8-24-2004.
- 2,877,876. MISCELLANEOUS DESIGN. INT. CL. 9. REG. 8-24-2004.
- 2,877,877. WETTRIX. INT. CL. 3. REG. 8-24-2004.
- 2,877,882. LEADERSHIP SCORECARD. INT. CL. 38. REG. 8-24-2004.
- 2,877,885. WILD ROCKS. INT. CL. 19. REG. 8-24-2004.
- 2,877,887. METAMAG AND DESIGN. INT. CLS. 9 AND 11. REG. 8-24-2004.
- 2,877,888. WEBEEZ AND DESIGN. INT. CL. 29. REG. 8-24-2004.
- 2,877,891. IOT SYSTEMS, LLC AND DESIGN. INT. CLS. 38 AND 42. REG. 8-24-2004.
- 2,877,892. IOT SYSTEMS, LLC. INT. CLS. 38 AND 42. REG. 8-24-2004.
- 2,877,894. IQ IDEAL QUALITY AND DESIGN. INT. CL. 16. REG. 8-24-2004.
- 2,877,899. SHARPCO. INT. CL. 6. REG. 8-24-2004.
- 2,877,903. POPWAR. INT. CLS. 25 AND 28. REG. 8-24-2004.
- 2,877,904. PARISIAN. INT. CL. 11. REG. 8-24-2004.
- 2,877,905. REPUBLIC CONDUIT. INT. CL. 40. REG. 8-24-2004.
- 2,877,906. SKI ELGUIDE. INT. CL. 35. REG. 8-24-2004.
- 2,877,909. THE HOUSE @ ANCHORSOUL FORK AND DESIGN. INT. CL. 41. REG. 8-24-2004.
- 2,877,912. MISCELLANEOUS DESIGN. INT. CL. 41. REG. 8-24-2004.
- 2,877,913. BERMUDA TRIANGLE. INT. CL. 11. REG. 8-24-2004.
- 2,877,916. ANGIOFLOW. INT. CL. 10. REG. 8-24-2004.
- 2,877,917. FUEL. INT. CL. 16. REG. 8-24-2004.
- 2,877,918. MOMENTUM. INT. CL. 27. REG. 8-24-2004.
- 2,877,920. TOMMY JEANS. INT. CL. 3. REG. 8-24-2004.
- 2,877,921. CUTIE MARK. INT. CL. 28. REG. 8-24-2004.
- 2,877,924. EMMA EMERSON. INT. CL. 28. REG. 8-24-2004.
- 2,877,926. TRISEC COMPUTER SERVICES AND DESIGN. INT. CL. 37. REG. 8-24-2004.
- 2,877,932. XCLAIM. INT. CL. 20. REG. 8-24-2004.
- 2,877,933. EXPLORE AND DESIGN. INT. CL. 28. REG. 8-24-2004.
- 2,877,936. MAXIMUM SPORT FORMULE. INT. CL. 3. REG. 8-24-2004.
- 2,877,937. IVILLAGE SOLUTIONS. INT. CL. 16. REG. 8-24-2004.
- 2,877,939. CREATIVE LIFESTYLES. INT. CLS. 4, 11, 19, 20 AND 21. REG. 8-24-2004.
- 2,877,941. MENDON TECHNOLOGIES. INT. CL. 42. REG. 8-24-2004.
- 2,877,943. ZARNESTRA. INT. CL. 5. REG. 8-24-2004.
- 2,877,944. AM PULS (STYLIZED). INT. CLS. 9, 16, 35, 38 AND 42. REG. 8-24-2004.
- 2,877,948. CLICKWRAP. INT. CL. 35. REG. 8-24-2004.
- 2,877,950. SENTONICS AND DESIGN. INT. CL. 9. REG. 8-24-2004.
- 2,877,951. CHITO- SEAL STANDARD CHARACTER MARK. INT. CL. 10. REG. 8-24-2004.
- 2,877,955. ECHOCAST. INT. CL. 9. REG. 8-24-2004.
- 2,877,957. AHT MASTER. INT. CL. 19. REG. 8-24-2004.
- 2,877,958. LIFESTAGES FIXED ADVANTAGE ANNUITY. INT. CL. 36. REG. 8-24-2004.
- 2,877,959. R-O-S. INT. CLS. 35 AND 41. REG. 8-24-2004.
- 2,877,960. XIPHERX IPHONEBOOK. INT. CLS. 9 AND 16. REG. 8-24-2004.
- 2,877,961. VAP. INT. CL. 6. REG. 8-24-2004.
- 2,877,962. ROLL & LATCH. INT. CL. 27. REG. 8-24-2004.
- 2,877,965. CAPTIVE ADVISORY SERVICES AND DESIGN. INT. CL. 36. REG. 8-24-2004.
- 2,877,967. CNBC - MAKE IT YOUR BUSINESS. INT. CL. 41. REG. 8-24-2004.
- 2,877,972. AMERITAN. INT. CL. 44. REG. 8-24-2004.
- 2,877,973. NOODLE YOGA. INT. CL. 41. REG. 8-24-2004.
- 2,877,975. EASYTWIST SUN. INT. CL. 9. REG. 8-24-2004.
- 2,877,977. USUL. INT. CL. 28. REG. 8-24-2004.
- 2,877,978. BRAINWEDGIE. INT. CL. 28. REG. 8-24-2004.
- 2,877,979. THINK OUTSIDE THE TOUR. INT. CL. 39. REG. 8-24-2004.
- 2,877,980. THE WORLD UNDER YOUR THUMB. INT. CL. 9. REG. 8-24-2004.
- 2,877,981. POWER BLEACH EXCEL 3. INT. CL. 3. REG. 8-24-2004.
- 2,877,983. FEEL THE IMPACT. INT. CL. 7. REG. 8-24-2004.
- 2,877,986. HEAT BUDDY. INT. CL. 11. REG. 8-24-2004.
- 2,877,987. FOOT BUDDY. INT. CL. 11. REG. 8-24-2004.
- 2,877,988. IMS CHARACTERGENERATOR STUDIO. INT. CL. 9. REG. 8-24-2004.
- 2,877,989. REMINISCENCE. INT. CL. 19. REG. 8-24-2004.
- 2,877,990. AMERICAN BAD ASS. INT. CL. 41. REG. 8-24-2004.
- 2,877,992. PINNACLE DATACOM. INT. CL. 35. REG. 8-24-2004.
- 2,877,994. XY-TV. INT. CLS. 38 AND 41. REG. 8-24-2004.

- 2,877,995. INBOUND ADVANTAGE. INT. CL. 38. REG. 8-24-2004.
- 2,877,998. MDSPEAKIT. INT. CL. 35. REG. 8-24-2004.
- 2,877,999. THE STRESS STOPPER. INT. CL. 10. REG. 8-24-2004.
- 2,878,005. METRO NIGHTS. INT. CL. 41. REG. 8-24-2004.
- 2,878,007. PLASTICPEOPLE. INT. CL. 25. REG. 8-24-2004.
- 2,878,009. 12 HOUR D-HUMIDIFIER. INT. CL. 3. REG. 8-24-2004.
- 2,878,011. CEYLON. INT. CL. 11. REG. 8-24-2004.
- 2,878,019. AQUA LIFE. INT. CL. 9. REG. 8-24-2004.
- 2,878,020. MISCELLANEOUS DESIGN. INT. CL. 33. REG. 8-24-2004.
- 2,878,021. FINANCEFILEMANAGER. INT. CL. 9. REG. 8-24-2004.
- 2,878,026. THE OPEN LUNG CONCEPT. INT. CLS. 16 AND 41. REG. 8-24-2004.
- 2,878,027. AMERICAN TAI CHI ASSOCIATION. INT. CL. 41. REG. 8-24-2004.
- 2,878,028. MONITORING ON DEMAND. INT. CL. 9. REG. 8-24-2004.
- 2,878,029. SPORTSMAN'S XTREME OUTDOORS. INT. CL. 41. REG. 8-24-2004.
- 2,878,031. INTELLIGENT INTEGRATION SYSTEMS. INT. CL. 41. REG. 8-24-2004.
- 2,878,033. ASPEN LIVING. INT. CL. 16. REG. 8-24-2004.
- 2,878,034. EZ SPRAY. INT. CL. 8. REG. 8-24-2004.
- 2,878,035. FLEECE PANELS. INT. CL. 24. REG. 8-24-2004.
- 2,878,036. REALTY RESOURCE CAFE. INT. CLS. 36 AND 43. REG. 8-24-2004.
- 2,878,039. GALLAHER'S. INT. CL. 30. REG. 8-24-2004.
- 2,878,041. BEAD NABBERS. INT. CL. 8. REG. 8-24-2004.
- 2,878,043. DOUBLE-UP. INT. CL. 36. REG. 8-24-2004.
- 2,878,045. TRIPNAV. INT. CL. 9. REG. 8-24-2004.
- 2,878,047. CLINICIAN'S BRIEF (STYLIZED). INT. CL. 16. REG. 8-24-2004.
- 2,878,048. SLOVENIAN GAMING INDUSTRY. INT. CL. 9. REG. 8-24-2004.
- 2,878,049. REBATES REALTY. INT. CL. 36. REG. 8-24-2004.
- 2,878,051. COMFORT SUITING. INT. CL. 25. REG. 8-24-2004.
- 2,878,052. EMBRYOBOND (STYLIZED). INT. CL. 5. REG. 8-24-2004.
- 2,878,053. BIG MEN'S MORE SELECTION MORE STYLE MORE SAVINGS AND DESIGN. INT. CL. 35. REG. 8-24-2004.
- 2,878,054. IBUSXCHANGE. INT. CL. 35. REG. 8-24-2004.
- 2,878,055. ROI ONLINE. INT. CL. 35. REG. 8-24-2004.
- 2,878,057. CELSIUS CONTROL CONSOLE. INT. CL. 10. REG. 8-24-2004.
- 2,878,059. CABLEGUIDE. INT. CL. 17. REG. 8-24-2004.
- 2,878,063. MEADOR ESTATE. INT. CL. 33. REG. 8-24-2004.
- 2,878,065. SINBORON. INT. CL. 1. REG. 8-24-2004.
- 2,878,066. THOUGHT LEADERSHIP CENTER. INT. CL. 35. REG. 8-24-2004.
- 2,878,067. TXT-411. INT. CL. 38. REG. 8-24-2004.
- 2,878,068. THOMASSEN TURBINE SYSTEMS. INT. CLS. 7, 37 AND 42. REG. 8-24-2004.
- 2,878,070. TRAFFICBUILDER. INT. CL. 35. REG. 8-24-2004.
- 2,878,073. NO MORE LINE BORING. INT. CL. 6. REG. 8-24-2004.
- 2,878,074. CARMELLINI. INT. CL. 31. REG. 8-24-2004.
- 2,878,078. NEW YORK CITY HALL OF FAME. INT. CL. 41. REG. 8-24-2004.
- 2,878,080. G GARMENTGUIDE.COM (STYLIZED). INT. CL. 35. REG. 8-24-2004.
- 2,878,081. MIDWEST BUILDERS SHOW STANDARD CHARACTER MARK. INT. CL. 35. REG. 8-24-2004.
- 2,878,082. A TOTAL FUNDS MANAGEMENT SOLUTION FOR FINANCIAL INSTITUTIONS STANDARD CHARACTER MARK. INT. CL. 36. REG. 8-24-2004.
- 2,878,794. MISCELLANEOUS DESIGN. INT. CL. 35. REG. 8-31-2004.
- 2,880,420. "HOME IS WHERE THE ART IS". INT. CL. 35. REG. 8-31-2004.
- 2,884,183. INGENIOUS AND DESIGN. INT. CLS. 37 AND 41 ONLY. REG. 9-14-2004.
- 2,885,647. MISCELLANEOUS DESIGN. INT. CL. 28 ONLY. REG. 9-21-2004.
- 2,889,446. NEXT LEVEL OF CARE. INT. CL. 5 ONLY. REG. 9-28-2004.
- 2,890,756. CABM CONSORZIO ACETO BALSAMICO DI MODENA AND DESIGN. INT. CLS. 35 AND 42 ONLY. REG. 10-5-2004.
- 2,892,648. CLUBPLANET. INT. CL. 38 ONLY. REG. 10-12-2004.
- 2,893,105. KINETOFOAM. INT. CL. 25 ONLY. REG. 10-12-2004.
- 2,893,616. DISCOVER THE CHAMPION IN YOU. INT. CL. 16 ONLY. REG. 10-12-2004.
- 2,912,063. GEZE AND DESIGN. INT. CLS. 11, 12, 19 AND 37 ONLY. REG. 12-21-2004.
- 2,932,664. FIBOTEC. INT. CL. 38 ONLY. REG. 3-15-2005.
- 2,932,731. TN. INT. CLS. 17 AND 20 ONLY. REG. 3-15-2005.
- 2,933,418. H HEIDI KLUM (STYLIZED). INT. CLS. 3, 5, 18, 20, 21, 24, 25, 28, 35, 43 AND 44 ONLY. REG. 3-15-2005.
- 2,934,386. CARNEGIE-MELLON UNIVERSITY PITTSBURGH PENNSYLVANIA 1900 AND DESIGN. INT. CLS. 18, 25 AND 36 ONLY. REG. 3-22-2005.
- 2,934,455. USPS EPM STANDARD CHARACTER MARK. INT. CL. 35 ONLY. REG. 3-22-2005.
- 2,935,748. MONK. INT. CL. 16 ONLY. REG. 3-29-2005.
- 2,935,803. AMERICAN TRUCKING ASSOCIATIONS. INT. CL. 25 ONLY. REG. 3-29-2005.
- 2,936,205. APEX AND DESIGN. INT. CL. 9 ONLY. REG. 3-29-2005.
- 2,936,323. KALLE STANDARD CHARACTER MARK. INT. CL. 1 ONLY. REG. 3-29-2005.
- 2,937,090. NANOLEUCITE. INT. CL. 10 ONLY. REG. 3-29-2005.
- 2,937,918. BOON EDAM STANDARD CHARACTER MARK. INT. CLS. 11 AND 19 ONLY. REG. 4-5-2005.
- 2,938,540. SEW EURODRIVE (STYLIZED). INT. CL. 42 ONLY. REG. 4-5-2005.
- 2,941,551. TRUDI AND DESIGN. INT. CLS. 16, 18, 24 AND 25 ONLY. REG. 4-19-2005.
- 2,941,792. GO MENTAL STANDARD CHARACTER MARK. INT. CLS. 9 AND 16 ONLY. REG. 4-19-2005.
- 2,943,332. INTERLOCKEN. INT. CL. 21 ONLY. REG. 4-26-2005.
- 2,943,653. THERAGENICS. INT. CL. 42 ONLY. REG. 4-26-2005.
- 2,943,676. GENTLE SOULS. INT. CL. 18 ONLY. REG. 4-26-2005.
- 2,956,504. UBS GLOBAL ASSET MANAGEMENT. INT. CL. 35 ONLY. REG. 5-31-2005.
- 2,957,630. KOI SPA. INT. CLS. 41 AND 44 ONLY. REG. 5-31-2005.
- 2,961,970. ALMIRALL. INT. CL. 35 ONLY. REG. 6-14-2005.
- 2,966,140. DIMENSION AND DESIGN. INT. CL. 9 ONLY. REG. 7-12-2005.
- 2,966,235. ESS SUPPORT SERVICES WORLDWIDE AND DESIGN. INT. CLS. 42 AND 45 ONLY. REG. 7-12-2005.
- 2,967,986. JASPER THE MULE. INT. CL. 41 ONLY. REG. 7-12-2005.
- 2,971,175. EBIND (STYLIZED). INT. CL. 1 ONLY. REG. 7-19-2005.
- 2,980,805. PROJECT ORANGE THUMB. INT. CL. 21 ONLY. REG. 8-2-2005.
- 2,991,158. STAR ALLOYS AND DESIGN. INT. CL. 2 ONLY. REG. 9-6-2005.
- 2,993,886. BIKER'S CHOICE AND DESIGN. INT. CL. 9 ONLY. REG. 9-13-2005.
- 3,019,033. MISCELLANEOUS DESIGN. INT. CL. 28 ONLY. REG. 11-29-2005.
- 3,026,209. CUSTOM CAPITAL TAILORED FOR GROWTH. STANDARD CHARACTER MARK. INT. CL. 16 ONLY. REG. 12-13-2005.
- 3,029,546. THE PINEHILLS. INT. CLS. 3, 9 AND 28 ONLY. REG. 12-13-2005.
- 3,056,706. HONDA RIDER'S CLUB OF AMERICA. INT. CLS. 37 AND 39 ONLY. REG. 2-7-2006.

TM 1860

OFFICIAL GAZETTE

MAY 3, 2011

3,062,391. CASCADE MEDICAL ENTERPRISES STANDARD CHARACTER MARK. INT. CL. 42 ONLY. REG. 2-28-2006.

3,070,229. LEADFUSION STANDARD CHARACTER MARK. INT. CL. 9 ONLY. REG. 3-21-2006.

\* \* \* \* \*

# TRADEMARK REGISTRATIONS AMENDED, CORRECTED, ETC.

The designation "U.S. Cl." appearing in this section refers to the U.S. class in effect prior to Sep. 1, 1973 rather than the international class which applies to applications filed on or after that date. For adoption of international classification see notice in the OFFICIAL GAZETTE of Jun. 26, 1973 (911 O.G. TM 210).

Any change to the registration will be indicated at the bottom of each entry under ELEMENTS AMENDED, CORRECTED OR RESTRICTED. With the exception of changes to the goods and services, additions to the registration will appear in asterisks and deletions of the registration will appear in brackets. Elements which are only changed will be listed with no punctuation. As to the goods/services statement, amendments to the goods/services will appear in asterisks and deletions will appear in brackets. In addition if any change to the goods/services occurs, the element "Goods/Services" will be listed under ELEMENTS AMENDED, CORRECTED OR RESTRICTED.

143,048. REG. 5-24-1921. SPEEDBALL ART PRODUCTS CO., L.L.C. (VIRGINIA LIMITED LIABILITY COMPANY) 2301 SPEEDBALL ROAD, STATESVILLE, NC. 28677. SN 71-138,907. FILED 10-28-1920. PRINCIPAL REGISTER.

1,603,366. REG. 6-26-1990. MITSUI CHEMICALS AGRO, INC. (JAPAN CORPORATION) 5-2, HIGASHI-SHIMBASHI 1-CHOME, MINATO-KU, TOKYO, JAPAN., SN 73-792,281. FILED 4-10-1989. PRINCIPAL REGISTER.

**"SPEEDBALL"**

**TREBON**

INT. CL. 16/U.S. CL. 11  
FOR DRAWING AND LETTERING INK.  
FIRST USE 6-9-1920; IN COMMERCE 6-9-1920.

OWNER OF JAPAN REG. NO. 2108987, DATED 1-23-1989,  
EXPIRES 1-23-1999.

INT. CL. 5/U.S. CL. 6  
FOR PREPARATIONS FOR DESTROYING VERMIN  
SUCH AS MOSQUITOES, FLIES, CATERPILLARS,  
GRUBS, FLEAS, LICE AND THE LIKE, FOR AGRICUL-  
TURAL AND DOMESTIC USE.

ELEMENTS CORRECTED  
\*ASSIGNMENT/NAME CHANGE\*  
OWNER NAME

ELEMENTS CORRECTED  
\*ASSIGNMENT/NAME CHANGE\*  
OWNER NAME

1,159,588. REG. 6-30-1981. AMERICAN SOCIETY OF CIVIL ENGINEERS, THE (NEW YORK NON-PROFIT CORPORATION) 1801 ALEXANDER BELL DRIVE, RESTON, VA. 201914400. SN 73-196,430. FILED 12-11-1978. PRINCIPAL REGISTER.

1,616,887. REG. 10-9-1990. TOPCO HOLDINGS, INC. (WISCONSIN CORPORATION) 7711 GROSS POINT ROAD, SKOKIE, IL, 60077. SN 73-833,954. FILED 10-26-1989. PRINCIPAL REGISTER.



INT. CL. 200/U.S. CL. 200  
FOR INDICATING MEMBERSHIP IN AN ASSOCIATION OF CIVIL ENGINEERS AND FOR PERIODICALS AND PRINTED MATTER SUCH AS MANUALS AND REPORTS.  
FIRST USE 0-0-1895; IN COMMERCE 10-0-1930.

OWNER OF U.S. REG. NOS. 588,433, 650,608 AND OTHERS.  
NO CLAIM IS MADE TO THE EXCLUSIVE RIGHT TO USE "FOOD", APART FROM THE MARK AS SHOWN.  
INT. CL. 29/U.S. CL. 46

ELEMENTS AMENDED  
MARK

FOR FROZEN VEGETABLES, FRUITS, MEATS, FISH, NON-DAIRY WHIPPED TOPPING, AND NON-DAIRY CREAMERS; MARGARINES; CHEESE; SOUR CREAM; COTTAGE CHEESE; YOGURT; BUTTER; DAIRY-BASED OR VEGETABLE-BASED DIPS, MILK; EGGS; MEATS; POULTRY; APPLESAUCE; CANNED FRUITS, VEGETABLES, FISH, AND SOUP; INSTANT MASHED POTATOES; PROCESSED BEANS AND PEAS; RAISINS; PRUNES; DRIED FRUITS; SANDWICH SPREAD; MAYONNAISE; SALAD DRESSING; CORN AND VEGETABLE OILS; SHORTENING; MARASCHINO CHERRIES; CHILI; PICKLES; PEPPERS; OLIVES; JELLIES AND PRESERVES; PEANUT BUTTER; PROCESSED NUTS; EVAPORATED AND INSTANT MILK; AND NON-DAIRY COFFEE CREAMER.

FIRST USE 11-0-1987; IN COMMERCE 11-0-1987.

ELEMENTS AMENDED  
MARK

1,967,755. REG. 4-16-1996. STEEL AND PIPE SUPPLY COMPANY, INC. (KANSAS CORPORATION) 555 POYNTZ AVENUE, P.O. BOX 1688, MANHATTAN, KS, 66502, SN 74-545,029. FILED 6-30-1994. PRINCIPAL REGISTER.



INT. CL. 6/U.S. CLS. 2, 12, 13, 14, 23, 25 AND 50

FOR RAW MILL-ROLLED STEEL IN VARIOUS FORMS, PRIMARILY FOR FURTHER MANUFACTURING, NAMELY CARBON STEEL IN ELONGATED FORM, TUBULAR FORM, AND SHEET FORM.

FIRST USE 12-15-1992; IN COMMERCE 12-15-1992.

ELEMENTS CORRECTED  
OWNER NAME

2,336,948. REG. 4-4-2000. MOLSON CANADA 2005 (CANADA PARTNERSHIP) 33 CARLINGVIEW DRIVE, TORONTO, ONTARIO, M9W 5E4, SN 75-033,328. FILED 12-15-1995. PRINCIPAL REGISTER.

## MOLSON

PRIORITY CLAIMED UNDER SEC. 44(D) ON CANADA APPLICATION NO. 792980, FILED 9-13-1995, REG. NO. TMA497995, DATED 7-29-1998, EXPIRES 7-29-2013.

OWNER OF U.S. REG. NOS. 672,613, 1,840,785 AND OTHERS.

INT. CL. 9/U.S. CLS. 21, 23, 26, 36 AND 38

FOR [ SUNGLASSES; ] ELECTRIC SIGNS; LUMINOUS SIGNS; NEON SIGNS; [ NOTE MAGNETS ].

FIRST USE ; IN COMMERCE .

INT. CL. 18/U.S. CLS. 1, 2, 3, 22 AND 41

FOR ALL PURPOSE SPORTS BAGS; [ WALLETS; ] UMBRELLAS; [ HIP PACKS; ] TOTE BAGS; SUITCASES; BRIEFCASES; [ BACK PACKS; BUSINESS CARD CASES ].

FIRST USE ; IN COMMERCE .

INT. CL. 21/U.S. CLS. 2, 13, 23, 29, 30, 33, 40 AND 50

FOR THERMAL INSULATED BEVERAGE HOLDERS; PORTABLE ICE CHESTS FOR FOOD AND BEVERAGE; BOTTLE OPENERS; [STEINS; MUGS; ] BEVERAGE GLASSWARE AND RELATED ACCESSORIES, NAMELY, DRINKING GLASSES, CUPS, [SPORTS WATER BOTTLES,] AND COASTERS; ICE BUCKETS; [ BEER TUBS; TAP HANDLES ].

FIRST USE ; IN COMMERCE .

INT. CL. 25/U.S. CLS. 22 AND 39

FOR [ PANTS; ] APRONS; CAPS; T-SHIRTS; SWEAT-SHIRTS; JACKETS; SHIRTS; [ SUSPENDERS; ] SWEATERS; VESTS; [ RAIN SUITS; ROBES; ] TOPS; [BUSTIERS; SHORTS; BATHING SUITS; ] CLOTHING ACCESSORIES, NAMELY, [ HEADBANDS, ] HATS, [ TIES, ] VISORS, [ BELTS, SOCKS ].

FIRST USE ; IN COMMERCE .

INT. CL. 29/U.S. CL. 46

FOR [ FOOD, NAMELY, PACKAGED NUTS ].

FIRST USE ; IN COMMERCE .

ELEMENTS CORRECTED  
GOODS/SERVICES

2,399,278. REG. 10-31-2000. F5 NETWORKS, INC. (WASHINGTON CORPORATION) 401 ELLIOTT AVENUE WEST, SEATTLE, WA, 98119, SN 75-659,052. FILED 3-12-1999. PRINCIPAL REGISTER.

## F5 NETWORKS

OWNER OF U.S. REG. NO. 2,094,918.

NO CLAIM IS MADE TO THE EXCLUSIVE RIGHT TO USE "NETWORKS", APART FROM THE MARK AS SHOWN.

INT. CL. 9/U.S. CLS. 21, 23, 26, 36 AND 38

FOR COMPUTER HARDWARE AND SOFTWARE FOR ENHANCING THE PERFORMANCE OF A PLURALITY OF SERVERS CONNECTED TOGETHER BY A NETWORK.

FIRST USE 9-0-1999; IN COMMERCE 9-0-1999.

INT. CL. 42/U.S. CLS. 100 AND 101

FOR (( COMPUTER CONSULTING SERVICES )).

FIRST USE 4-0-1999; IN COMMERCE 4-0-1999.

ELEMENTS CORRECTED  
DATE OF FIRST USE  
DATE OF FIRST USE IN COMMERCE

2,413,656. REG. 12-19-2000. CDOC, INC. (DELAWARE CORPORATION) 11815 N. PENNSYLVANIA STREET, CARMEL, IN, 46082, SN 75-700,674. FILED 5-7-1999. PRINCIPAL REGISTER.

## MULTIBUCKET

THE MARK CONSISTS OF STANDARD CHARACTERS WITHOUT CLAIM TO ANY PARTICULAR FONT, STYLE, SIZE, OR COLOR.

INT. CL. 36/U.S. CLS. 100, 101 AND 102

FOR ANNUITY UNDERWRITING.

FIRST USE 4-1-1999; IN COMMERCE 4-1-1999.

ELEMENTS AMENDED  
MARK  
[DISCLAIMER]

2,422,179. REG. 1-16-2001. KATHRYN SHAFER (UNITED STATES INDIVIDUAL), DBA LIMITLESS POTENTIALS, 675 W. INDIANTOWN RD., JUPITER, FL, 33458, SN 75-701,765. FILED 5-10-1999. PRINCIPAL REGISTER.

## FUN

INT. CL. 42/U.S. CLS. 100 AND 101  
FOR CLINICAL PSYCHOTHERAPEUTIC SERVICES FOR THE TREATMENT OF ASTHMA, SUBSTANCE ABUSE, MENTAL HEALTH, AND OTHER PHYSICAL DISEASES.

FIRST USE 9-0-1997; IN COMMERCE 9-0-1997.

### ELEMENTS CORRECTED

\*DBA/AKA\*  
OWNER NAME  
OWNER ADDRESS  
CITIZENSHIP  
ENTITY

2,445,249. REG. 4-17-2001. BRENNICK TND COMMUNITIES, LLC (INDIANA LIMITED LIABILITY COMPANY) 12775 HORSEFERRY ROAD, CARMEL, IN, 460327258, SN 75-818,888. FILED 10-8-1999. PRINCIPAL REGISTER.

## WESTCLAY

INT. CL. 37/U.S. CLS. 100, 103 AND 106  
FOR REAL ESTATE DEVELOPMENT SERVICES.  
FIRST USE 12-18-1997; IN COMMERCE 7-0-1999.

ELEMENTS AMENDED  
OWNER ADDRESS

2,456,176. REG. 5-29-2001. LAS VEGAS PAIUTE TRIBE (UNITED STATES FEDERALLY RECOGNIZED INDIAN TRIBE) 1 PAIUTE DRIVE, LAS VEGAS, NV, 891063261, SN 75-731,532. FILED 6-17-1999. PRINCIPAL REGISTER.



NO CLAIM IS MADE TO THE EXCLUSIVE RIGHT TO USE "PAIUTE LAS VEGAS PAIUTE GOLF RESORT", APART FROM THE MARK AS SHOWN.

THE MARK CONSISTS OF STYLIZED DESIGN OF A TURTLE APPEARING ON THE LEFT SIDE OF THE WORD "PAIUTE" IN CAPITAL LETTERS, WITH THE WORDS "LAS VEGAS PAIUTE GOLF RESORT" APPEARING IN SMALLER CAPITAL LETTERS BELOW THE LARGER WORD "PAIUTE".

INT. CL. 42/U.S. CLS. 100 AND 101  
FOR RESTAURANT AND SNACK BAR SERVICES.  
FIRST USE 6-10-1999; IN COMMERCE 6-10-1999.

ELEMENTS AMENDED  
MARK  
DISCLAIMER

2,456,177. REG. 5-29-2001. LAS VEGAS PAIUTE TRIBE (UNITED STATES FEDERALLY RECOGNIZED INDIAN TRIBE) 1 PAIUTE DRIVE, LAS VEGAS, NV, 891063261, SN 75-732,219. FILED 6-17-1999. PRINCIPAL REGISTER.



NO CLAIM IS MADE TO THE EXCLUSIVE RIGHT TO USE "PAIUTE LAS VEGAS PAIUTE GOLF RESORT", APART FROM THE MARK AS SHOWN.

THE MARK CONSISTS OF STYLIZED DESIGN OF A TURTLE APPEARING ON THE LEFT SIDE OF THE WORD "PAIUTE" IN CAPITAL LETTERS, WITH THE WORDS "LAS VEGAS PAIUTE GOLF RESORT" APPEARING IN SMALLER CAPITAL LETTERS BELOW THE LARGER WORD "PAIUTE".

INT. CL. 41/U.S. CLS. 100, 101 AND 107  
FOR GOLF COURSE SERVICES.  
FIRST USE 6-10-1999; IN COMMERCE 6-10-1999.

ELEMENTS AMENDED  
MARK  
DISCLAIMER

2,487,369. REG. 9-11-2001. MARKETING DISPLAYS, INC. (MICHIGAN CORPORATION) 38271 W. TWELVE MILE ROAD, FARMINGTON HILLS, MI, 48331, SN 76-114,473. FILED 8-16-2000. PRINCIPAL REGISTER.

## CAMLOCK

INT. CL. 6/U.S. CLS. 2, 12, 13, 14, 23, 25 AND 50  
FOR METAL DISPLAY APPARATUS FOR USE IN HOLDING AND DISPLAYING SIGNS, POSTERS, METAL PANELS, ROLL-UP PANELS, AND ADVERTISING MESSAGES.  
FIRST USE 7-7-1999; IN COMMERCE 7-7-1999.

ELEMENTS CORRECTED  
OWNER NAME

2,493,601. REG. 9-25-2001. ARNOLD & ASSOCIATES OF WICHITA, INC. (KANSAS CORPORATION) 530 SOUTH TOPEKA, WICHITA, KS, 67202, SN 78-012,285. FILED 6-12-2000. PRINCIPAL REGISTER.

## THE ARNOLD GROUP

NO CLAIM IS MADE TO THE EXCLUSIVE RIGHT TO USE "GROUP", APART FROM THE MARK AS SHOWN.

INT. CL. 42/U.S. CLS. 100 AND 101  
FOR TEMPORARY EMPLOYMENT AGENCY.  
FIRST USE 8-1-2000; IN COMMERCE 8-1-2000.

ELEMENTS CORRECTED  
OWNER NAME

2,493,602. REG. 9-25-2001. ARNOLD & ASSOCIATES OF WICHITA, INC. (KANSAS CORPORATION) 530 SOUTH TOPEKA, WICHITA, KS, 67202, SN 78-012,288. FILED 6-12-2000. PRINCIPAL REGISTER.

## THE ARNOLD GROUP A HUMAN RESOURCE COMPANY

NO CLAIM IS MADE TO THE EXCLUSIVE RIGHT TO USE "GROUP" AND "HUMAN RESOURCE COMPANY", APART FROM THE MARK AS SHOWN.

INT. CL. 42/U.S. CLS. 100 AND 101  
FOR TEMPORARY EMPLOYMENT AGENCY.  
FIRST USE 8-1-2000; IN COMMERCE 8-1-2000.

ELEMENTS CORRECTED  
OWNER NAME

2,544,829. REG. 3-5-2002. MEDIACOM COMMUNICATIONS CORPORATION (DELAWARE CORPORATION) 100 CRYSTAL RUN ROAD, MIDDLETOWN, NY, 10941, SN 76-246,469. FILED 4-25-2001. PRINCIPAL REGISTER.

## MEDIACOM

INT. CL. 38/U.S. CLS. 100, 101 AND 104

FOR CABLE TELEVISION TRANSMISSION SERVICES; INTERNET AND TELEPHONY SERVICES, NAMELY, PROVIDING MULTIPLE USER ACCESS TO A GLOBAL COMPUTER NETWORK; INTERNET AND TELEPHONY SERVICES IN THE NATURE OF COMMUNICATIONS SERVICES, NAMELY, TRANSMITTING STREAMED SOUND AND AUDIO-VISUAL RECORDINGS VIA THE INTERNET; INTERNET AND TELEPHONY SERVICES, NAMELY, ELECTRONIC, ELECTRIC, AND DIGITAL TRANSMISSION OF VOICE, DATA, INFORMATION, IMAGES, SIGNALS, AND MESSAGES.  
FIRST USE 7-17-1995; IN COMMERCE 7-17-1995.

ELEMENTS CORRECTED  
CITIZENSHIP

2,694,988. REG. 3-11-2003. TIGERDIRECT, INC. (FLORIDA CORPORATION) SUITE 35, 7795 WEST FLAGLER STREET, MIAMI, FL, 33144, SN 76-337,345. FILED 11-14-2001. PRINCIPAL REGISTER.

# TigerDirect

OWNER OF U.S. REG. NO. 2,526,739.  
INT. CL. 35/U.S. CLS. 100, 101 AND 102  
FOR MAIL ORDER SERVICES FEATURING COMPUTER HARDWARE AND SOFTWARE.  
FIRST USE 1-31-1993; IN COMMERCE 1-31-1993.

ELEMENTS CORRECTED  
OWNER NAME  
OWNER ADDRESS

2,694,989. REG. 3-11-2003. TIGERDIRECT, INC (FLORIDA CORPORATION) STE. 35, 7795 WEST FLAGLER STREET, MIAMI, FL, 33144, SN 76-337,346. FILED 11-14-2001. PRINCIPAL REGISTER.

## TIGERDIRECT

OWNER OF U.S. REG. NO. 2,526,739.  
INT. CL. 35/U.S. CLS. 100, 101 AND 102  
FOR MAIL ORDER SERVICES FEATURING COMPUTER HARDWARE AND SOFTWARE.  
FIRST USE 1-31-1993; IN COMMERCE 1-31-1993.

ELEMENTS CORRECTED  
OWNER NAME  
OWNER ADDRESS

2,801,171. REG. 12-30-2003. PERRY EQUIPMENT CORPORATION (TEXAS CORPORATION) P.O. BOX 640, WOLTERS INDUSTRIAL PARK, MINERAL WELLS, TX, 76068, SN 76-428,949. FILED 7-10-2002. PRINCIPAL REGISTER.

## COMPLEAT

INT. CL. 7/U.S. CLS. 13, 19, 21, 23, 31, 34 AND 35  
FOR FILTRATION ELEMENTS MADE OF INORGANIC \*AND ORGANIC\* FIBER FOR USE WITH INDUSTRIAL EQUIPMENT FOR THE PURIFICATION OF AIR AND INDUSTRIAL FLUIDS.  
FIRST USE 6-28-2002; IN COMMERCE 6-28-2002.

ELEMENTS AMENDED  
GOODS/SERVICES

2,839,736. REG. 5-11-2004. CLUB DE FUTBOL AMERICA, S.A. DE C.V. (MEXICO CORPORATION) AV. DEL TORO NO. 100, COL. VILLA COAPA, MEXICO, 14390, SN 76-489,929. FILED 2-13-2003. PRINCIPAL REGISTER.



THE MARK CONSISTS OF THE LETTERS CA AND A CARTOGRAPHIC REPRESENTATION OF NORTH AMERICA AND SOUTH AMERICA DISPLAYED ON A STYLIZED REPRESENTATION OF A SOCCER BALL.

INT. CL. 41/U.S. CLS. 100, 101 AND 107  
FOR ENTERTAINMENT SERVICES, NAMELY, PROVIDING PROFESSIONAL SOCCER EXHIBITIONS; EDUCATIONAL SERVICES, NAMELY, PROVIDING SOCCER TRAINING FOR YOUTH.  
FIRST USE 10-15-1950; IN COMMERCE 10-15-1950.

ELEMENTS AMENDED  
\*DESCRIPTION OF MARK\*



MARK

2,839,934. REG. 5-11-2004. AMERICAN HEARING SYSTEMS, INC. (MINNESOTA CORPORATION), DBA INTERTON, 8001 BLOOMINGTON FWY., BLOOMINGTON, MN, 55420, SN 76-523,526. FILED 5-27-2003. PRINCIPAL REGISTER.

## COMPUFIT

INT. CL. 9/U.S. CLS. 21, 23, 26, 36 AND 38  
FOR COMPUTER SOFTWARE FOR USE WITH FACILITATING THE PROGRAMMING OF HEARING AIDS.  
FIRST USE 4-0-1996; IN COMMERCE 4-0-1996.

ELEMENTS CORRECTED  
\*DBA/AKA\*  
OWNER NAME

2,853,190. REG. 6-15-2004. MEDIACOM COMMUNICATIONS CORPORATION (DELAWARE CORPORATION) 100 CRYSTAL RUN ROAD, MIDDLETOWN, NY, 10941, SN 76-528,478. FILED 7-8-2003. PRINCIPAL REGISTER.



OWNER OF U.S. REG. NO. 2,544,829.  
INT. CL. 38/U.S. CLS. 100, 101 AND 104  
FOR CABLE TELEVISION TRANSMISSION SERVICES; INTERNET AND TELEPHONY SERVICES, NAMELY, PROVIDING MULTIPLE USER ACCESS TO A GLOBAL COMPUTER NETWORK; INTERNET AND TELEPHONY SERVICES IN THE NATURE OF COMMUNICATIONS SERVICES, NAMELY, TRANSMITTING STREAMED SOUND AND AUDIO-VISUAL RECORDINGS VIA THE INTERNET; INTERNET AND TELEPHONY SERVICES, NAMELY, ELECTRONIC, ELECTRIC, AND DIGITAL TRANSMISSION OF VOICE, DATA, INFORMATION, IMAGES, SIGNALS, AND MESSAGES.  
FIRST USE 10-1-1999; IN COMMERCE 10-1-1999.

ELEMENTS CORRECTED  
CITIZENSHIP

2,857,149. REG. 6-29-2004. BEE AND HERBAL NEW ZEALAND LIMITED (NEW ZEALAND CORPORATION) 11 CARTERS CRESCENT, CAMBRIDGE, NEW ZEALAND., SN 76-080,652. FILED 6-30-2000. PRINCIPAL REGISTER.

## MEDI-BEE

OWNER OF NEW ZEALAND REG. NO. 295081, DATED 12-23-1998.  
INT. CL. 5/U.S. CLS. 6, 18, 44, 46, 51 AND 52

FOR BEE PRODUCTS FOR MEDICINAL OR THERAPEUTIC PURPOSES, NAMELY, [ PROPOLIS FOR THE TREATMENT OF SORE THROATS, COLDS, FLU, SKIN TISSUE DAMAGE, DENTAL CARE, LIVER, DIGESTIVE DISORDERS, IMMUNE SYSTEM SUPPORT, AND CANCER, BEE POLLEN FOR USE AS A NUTRITIONAL SUPPLEMENT, ROYAL JELLY FOR THE TREATMENT OF FATIGUE, TIREDNESS AND WELL-BEING AND UMF ] MANUKA HONEY FOR THE TREATMENT OF STOMACH ULCERS, WOUND INFECTIONS, ULCERS, AND ORAL HYGIENE [ ; WOUND DRESSINGS; BURN DRESSINGS, PREPARATIONS FOR TREATING COLDS; DIETARY, VITAMIN AND MINERAL SUPPLEMENTS; LOTIONS, NAMELY, MEDICATED SKIN LOTIONS AND MEDICATED BODY LOTIONS; RUBBING COMPOUNDS FOR MEDICAL AND THERAPEUTIC USE; SUNBURN LOTIONS, NAMELY, MEDICATED SUNBURN LOTIONS; TOPICAL GELS FOR MEDICAL AND THERAPEUTIC USE ].

FIRST USE ; IN COMMERCE .  
INT. CL. 30/U.S. CL. 46  
FOR HONEY [ , PROPOLIS; CONFECTIONERY FOOD PRODUCTS MADE FROM OR INCLUDING BEE PRODUCTS ].  
FIRST USE ; IN COMMERCE .

ELEMENTS AMENDED  
GOODS/SERVICES

2,899,677. REG. 11-2-2004. VISIBLE LIGHT LLC (FLORIDA LIMITED LIABILITY COMPANY) 3365 SHADY RUN ROAD, MELBOURNE, FL, 32934, SN 78-268,623. FILED 6-30-2003. PRINCIPAL REGISTER.

## ONSTAGE

OWNER OF U.S. REG. NO. 2,230,093.  
INT. CL. 9/U.S. CLS. 21, 23, 26, 36 AND 38  
FOR COMPUTER SOFTWARE FOR CREATING, DEVELOPING AND MANAGING DIGITAL VIDEO AND MULTIMEDIA PRESENTATIONS FOR EDUCATION, ENTERTAINMENT, ADVERTISING, TRAINING, BRIEFINGS AND INFORMATION OF GOODS AND SERVICES AND BUSINESSES ON COMPACT DISCS, DIGITAL VERSATILE/VIDEO DISCS; COMPUTER SOFTWARE FOR CREATING, DEVELOPING AND MANAGING DIGITAL VIDEO AND MULTIMEDIA PRESENTATIONS FOR EDUCATION, ENTERTAINMENT, ADVERTISING, TRAINING, BRIEFINGS AND INFORMATION OF GOODS AND SERVICES AND BUSINESSES DISSEMINATED ONLINE; COMPUTER SOFTWARE FOR CREATING, DEVELOPING AND MANAGING DIGITAL VIDEO AND MULTIMEDIA PRESENTATIONS FOR EDUCATION, ENTERTAINMENT, ADVERTISING, TRAINING, BRIEFINGS AND INFORMATION OF GOODS AND SERVICES FOR BUSINESSES DISSEMINATED THROUGH KIOSKS, COMPUTERS, [ SET-TOP BOXES AND PDA DEVICES; ] COMPUTER SOFTWARE FOR CREATING, DEVELOPING AND MANAGING DIGITAL VIDEO AND MULTIMEDIA PRESENTATIONS FOR EDUCATION, ENTERTAINMENT, ADVERTISING, TRAINING, BRIEFINGS AND INFORMATION OF GOODS AND SERVICES FOR BUSINESSES FOR TRADESHOWS.  
FIRST USE 5-23-1996; IN COMMERCE 5-23-1996.

ELEMENTS CORRECTED  
OWNER NAME  
OWNER ADDRESS

2,907,303. REG. 11-30-2004. JAMES HOTEL MANAGEMENT COMPANY, LLC (DELAWARE LIMITED LIABILITY COMPANY) 10TH FLOOR, 551 FIFTH AVENUE, NEW YORK, NY, 10176, SN 78-234,199. FILED 4-4-2003. PRINCIPAL REGISTER.

# JBAR

THE MARK CONSISTS OF STANDARD CHARACTERS WITHOUT CLAIM TO ANY PARTICULAR FONT, STYLE, SIZE, OR COLOR.

NO CLAIM IS MADE TO THE EXCLUSIVE RIGHT TO USE "BAR", APART FROM THE MARK AS SHOWN.

INT. CL. 43/U.S. CLS. 100 AND 101

FOR RESTAURANT, BAR, AND CAFE SERVICES.

FIRST USE 1-23-2004; IN COMMERCE 1-23-2004.

ELEMENTS AMENDED  
MARK

2,925,168. REG. 2-8-2005. COUNTRY RADIO BROADCASTERS, INC. (TENNESSEE NON-PROFIT CORPORATION) 819 18TH AVENUE SOUTH, NASHVILLE, TN, 37203, SN 78-342,286. FILED 12-17-2003. PRINCIPAL REGISTER.

# NEW FACES OF COUNTRY MUSIC

THE MARK CONSISTS OF STANDARD CHARACTERS WITHOUT CLAIM TO ANY PARTICULAR FONT, STYLE, SIZE, OR COLOR.

NO CLAIM IS MADE TO THE EXCLUSIVE RIGHT TO USE "COUNTRY MUSIC", APART FROM THE MARK AS SHOWN.

INT. CL. 41/U.S. CLS. 100, 101 AND 107

FOR ENTERTAINMENT SERVICES, NAMELY, LIVE CONCERTS FEATURING PERFORMANCES BY MUSICAL ARTISTS; EDUCATIONAL SERVICES, NAMELY, CONDUCTING SEMINARS, CONFERENCES AND WORKSHOPS IN THE FIELD OF RADIO BROADCASTING THROUGHOUT THE COUNTRY.

FIRST USE 1-1-1970; IN COMMERCE 1-1-1970.

ELEMENTS CORRECTED  
OWNER NAME

2,931,143. REG. 3-8-2005. HEMOTEQ AG (FED REP GERMANY CORPORATION) ADENAUERSTRASSE 15, WUERSELEN, FED REP GERMANY, 52146, SN 76-326,915. FILED 10-18-2001. PRINCIPAL REGISTER.

# HEMOTEQ

PRIORITY CLAIMED UNDER SEC. 44(D) ON FED REP GERMANY APPLICATION NO. 30125293.9/1, FILED 4-20-2001, REG. NO. 30125293, DATED 6-18-2002.

INT. CL. 5/U.S. CLS. 6, 18, 44, 46, 51 AND 52

FOR [ HEPARIN PREPARATIONS AND HEPARIN DERIVATIVES COMBINED WITH ORGANIC MACROMOLECULAR SUBSTANCES WITH ANTI-THROMBOTIC AND/OR ANTI-COAGULATIVE PROPERTIES FOR USE IN COATING ARTIFICIAL AND NATURAL SURFACES FOR INTRACORPOREAL AND EXTRACORPOREAL CIRCULATION AND FOR USE IN COATING SURGICAL IMPLANTS; SURGICAL IMPLANTS COMPRISING LIVING TISSUE AND ORGANS, NAMELY, HEARTS, HEART PARTS, LUNGS, ARTERIES, VEINS, AORTAS OF MAMMALS, ESPECIALLY HEARTS OF PIGS, HEART VALVES OF PIGS AND CORPSE VEINS; SURGICAL IMPLANTS COMPRISING LIVING TISSUE AND ORGANS COATED WITH HEPARIN, HEPARIN DERIVATIVES AND MACROMOLECULAR AGENTS, NAMELY, HEARTS, HEART VALVES, LUNGS, ARTERIES, VEINS AND AORTAS OF MAMMALS \* ALL GOODS EXCLUSIVE OF THE USE OF ANTIBODIES \* ].

FIRST USE 2-0-2001; IN COMMERCE 2-0-2001.

INT. CL. 10/U.S. CLS. 26, 39 AND 44

FOR [ SURGICAL IMPLANTS COMPRISING ARTIFICIAL MATERIAL, NAMELY, ARTIFICIAL HEART VALVES, HEARTS, LUNGS, ARTERIES, VEINS AND AORTAS; MEDICAL INSTRUMENTS AND ACCESSORIES FOR USE WITH THE TRANSFER AND HANDLING OF BLOOD, NAMELY, TUBING, VALVES, CONTAINERS, PLASTIC BAGS, CANS, NEEDLES, CATHETERS AND FOR USE WITH ARTIFICIAL SURGICAL IMPLANTS FOR THE CARDIOVASCULAR SYSTEM AND FOR EXTRACORPOREAL CIRCULATION; SURGICAL IMPLANTS COMPRISING ARTIFICIAL MATERIAL; ANTI-THROMBOTIC AND/OR ANTI-COAGULATIVE SURGICAL IMPLANTS, ARTIFICIAL SURFACES, NAMELY, ARTIFICIAL SURFACES, NAMELY, ARTIFICIAL HEART VALVES, ARTIFICIAL HEARTS, ARTIFICIAL LUNGS, ARTIFICIAL ARTERIES, ARTIFICIAL VEINS, ARTIFICIAL AORTAS, TUBING, VALVES, CONTAINERS, PLASTIC BAGS, CANS, NEEDLES, CATHETERS, AND ACCESSORIES FOR USE WITH THE TRANSFER AND HANDLING OF BLOOD FOR MEDICAL PURPOSES, ESPECIALLY FOR INTRACORPOREAL AND EXTRACORPOREAL CIRCULATION; ARTIFICIAL SURGICAL IMPLANTS COATED WITH HEPARIN, HEPARIN DERIVATIVES AND MACROMOLECULAR AGENTS, NAMELY, ARTIFICIAL HEART VALVES, HEARTS, LUNGS, ARTERIES, VEINS AND AORTAS; MEDICAL INSTRUMENTS AND ACCESSORIES FOR USE WITH THE TRANSFER AND HANDLING OF BLOOD COATED WITH HEPARIN, HEPARIN DERIVATIVES AND MACROMOLECULAR AGENTS, NAMELY, TUBING, VALVES, CONTAINERS, PLASTIC BAGS, CANS, NEEDLES, CATHETERS AND FOR USE WITH ARTIFICIAL SURGICAL IMPLANTS FOR THE CARDIOVASCULAR SYSTEM AND FOR EXTRACORPOREAL CIRCULATION \* ALL GOODS EXCLUSIVE OF THE USE OF ANTIBODIES \* ].

FIRST USE 2-0-2001; IN COMMERCE 2-0-2001.

INT. CL. 40/U.S. CLS. 100, 103 AND 106

FOR COMMISSIONED COATING SERVICES OF ARTIFICIAL SURGICAL IMPLANTS AND OF SURGICAL IMPLANTS COMPRISED OF LIVING TISSUE AND ORGANS WITH BIOPOLYMERS, ESPECIALLY WITH HEPARIN, HEPARIN DERIVATIVES AND ANTI-THROMBOTIC AND/OR COAGULATIVE MACROMOLECULAR SUBSTANCES \* ALL COATING SERVICES EXCLUSIVE OF THE USE OF ANTIBODIES \*.

FIRST USE 2-0-2001; IN COMMERCE 2-0-2001.

INT. CL. 42/U.S. CLS. 100 AND 101

FOR COMMISSIONED RESEARCH AND DEVELOPMENT SERVICES IN THE FIELDS OF SURROGATES FOR BLOOD AND BLOOD SUBSTITUTES, BLOOD PRODUCTS, BLOOD-COMPATIBLE MATERIALS AND BLOOD-COMPATIBLE IMPLANTS; COMMISSIONED RESEARCH AND DEVELOPMENT AND CONSULTATION SERVICES IN THE FIELDS OF ARTIFICIAL SURGICAL IMPLANTS AND OF SURGICAL IMPLANTS COMPRISED OF LIVING TISSUE AND ORGANS FOR THE CARDIOVASCULAR SYSTEM AND FOR EXTRACORPOREAL CIRCULATION, ESPECIALLY COATINGS WITH HEPARIN, HEPARIN DERIVATIVES AND ANTI-THROMBOTIC AND/OR ANTI-COAGULATIVE MACROMOLECULAR SUBSTANCES; BIOCHEMICAL, PHARMACEUTICAL, MEDICAL AND SCIENTIFIC RESEARCH SERVICES IN THE FIELDS OF SURROGATES FOR BLOOD, BLOOD SUBSTITUTES, BLOOD PRODUCTS, BLOOD-COMPATIBLE MATERIAL, BLOOD-COMPATIBLE IMPLANTS AND BLOOD-COMPATIBLE PARTS FOR THE CARDIOVASCULAR SYSTEM AND FOR EXTRACORPOREAL CIRCULATION \* ALL RESEARCH AND DEVELOPMENT SERVICES EXCLUSIVE OF THE USE OF ANTIBODIES \*

FIRST USE 2-0-2001; IN COMMERCE 2-0-2001.

ELEMENTS AMENDED  
GOODS/SERVICES

2,931,392. REG. 3-8-2005. DIVERSIFIED GLOBAL TECHNOLOGIES, LLC (DELAWARE LIMITED LIABILITY COMPANY) 128 SINGLETON STREET, WOONSOCKET, RI, 02895, SN 76-514,056. FILED 5-12-2003. PRINCIPAL REGISTER.

## FEATHER DOME

INT. CL. 21/U.S. CLS. 2, 13, 23, 29, 30, 33, 40 AND 50  
FOR [BATH SPONGES MADE OF FOAM AND MESH; EXFOLIATING BATH SPONGES MADE OF LOOFAH, SISAL AND RAMIE; BATH GLOVES AND MITTS FOR CLEANSING THE SKIN;] COSMETIC BRUSHES [, FOAM SPONGES, COSMETIC FOAM SPONGE WEDGES AND COSMETIC APPLICATOR STICKS, ALL FOR APPLYING MAKE-UP; HAIR COMBS AND BRUSHES; AND BATH AND NAIL BRUSHES].

FIRST USE 1-1-2003; IN COMMERCE 1-1-2003.

ELEMENTS AMENDED  
GOODS/SERVICES

2,934,616. REG. 3-22-2005. GREEN INDUSTRY INNOVATORS, LLC (OHIO LIMITED LIABILITY COMPANY) 9305 LOUISVILLE ST. NW, LOUISVILLE, OH, 44641, SN 76-583,021. FILED 3-25-2004. PRINCIPAL REGISTER.

## MULCH MULE

THE MARK CONSISTS OF STANDARD CHARACTERS WITHOUT CLAIM TO ANY PARTICULAR FONT, STYLE, SIZE, OR COLOR.

NO CLAIM IS MADE TO THE EXCLUSIVE RIGHT TO USE "MULCH", APART FROM THE MARK AS SHOWN.  
INT. CL. 12/U.S. CLS. 19, 21, 23, 31, 35 AND 44

FOR TRAILER FOR HAULING AND DISPENSING LANDSCAPING MULCH OR BULK MATERIALS.

FIRST USE 1-0-1999; IN COMMERCE 1-0-1999.

ELEMENTS AMENDED  
OWNER ADDRESS  
ENTITY  
MARK

2,937,326. REG. 4-5-2005. VENTURI WIRELESS, INC. (CALIFORNIA CORPORATION) 490 NORTH MCCARTHY BOULEVARD, MILPITAS, CA, 95035, SN 76-545,111. FILED 9-16-2003. PRINCIPAL REGISTER.



THE MARK CONSISTS OF A WAVE DESIGN TO THE LEFT OF THE WORDS VENTURI WIRELESS.

INT. CL. 9/U.S. CLS. 21, 23, 26, 36 AND 38

FOR COMPUTER HARDWARE AND COMPUTER SOFTWARE, AND MANUALS SUPPLIED THEREWITH, FOR ACCELERATING AND OPTIMIZING THE TRANSMISSION, SECURITY, DELIVERY AND STORAGE OF DATA OVER WIRED AND WIRELESS COMPUTER NETWORKS.

FIRST USE 3-24-2003; IN COMMERCE 3-24-2003.

ELEMENTS AMENDED  
\*DESCRIPTION OF MARK\*  
MARK

2,946,689. REG. 5-3-2005. FITMETRICS ASSOCIATES, LIMITED (OHIO LIMITED LIABILITY COMPANY) 213 BRENTWOOD DRIVE, HUDSON, OH, 44236, SN 78-227,798. FILED 3-19-2003. PRINCIPAL REGISTER.

## ISOCIZER

INT. CL. 28/U.S. CLS. 22, 23, 38 AND 50  
FOR EXERCISE EQUIPMENT, NAMELY INFLATABLE ISOMETRIC EXERCISE CUSHIONS.

FIRST USE 10-21-2003; IN COMMERCE 10-21-2003.

ELEMENTS CORRECTED  
ENTITY

2,949,737. REG. 5-10-2005. ECOLAB INC. (DELAWARE CORPORATION) 370 WABASHA STREET NORTH, ST. PAUL, MN, 55102, SN 78-175,340. FILED 10-17-2002. PRINCIPAL REGISTER.



THE MARK CONSISTS OF DESIGNATION "X-STATIC" WITH A LIGHTENING BOLT DESIGN INCORPORATED IN THE LETTER "X" OF THE MARK.

INT. CL. 3/U.S. CLS. 1, 4, 6, 50, 51 AND 52

FOR ANTI-STATIC LAUNDRY BLOCK AND FABRIC SOFTENER.

FIRST USE 11-1-2002; IN COMMERCE 11-1-2002.

ELEMENTS AMENDED  
\*DESCRIPTION OF MARK\*  
MARK

2,951,879. REG. 5-17-2005. PHILIPPE CHARRIOL INTERNATIONAL BV (NETHERLANDS CORPORATION) ZEE-MANSSTRAAT 13, NL-3016 CN ROTTERDAM, NETHERLANDS. SN 79-000,603. FILED 12-18-2003. PRINCIPAL REGISTER.

2,969,170. REG. 7-19-2005. INSIGHT STRATEGIC CONCEPTS INC. (INDIANA CORPORATION) 17595 COUNTY RD. 14, GOSHEN, IN, 46528, SN 76-493,522. FILED 2-27-2003. PRINCIPAL REGISTER.

# ACTOR



THE MARK CONSISTS OF STANDARD CHARACTERS WITHOUT CLAIM TO ANY PARTICULAR FONT, STYLE, SIZE, OR COLOR.

PRIORITY DATE OF 7-3-2003 IS CLAIMED.  
OWNER OF INTERNATIONAL REGISTRATION 0817400 DATED 12-18-2003, EXPIRES 12-18-2013.  
INT. CL. 14/U.S. CLS. 2, 27, 28 AND 50

FOR CUFFLINKS, [ TIE PINS, KEY RINGS OF PRECIOUS METAL, ] RINGS, [ NECKLACES, EARRINGS, ] BRACELETS, [ JEWELRY CHAINS, BROOCHES, MEDALLIONS, WATCH CHAINS; PRECIOUS STONES, CLOCKS, ] WATCHES, [ POCKET WATCHES, PENDULUM CLOCKS, PENDULETTES, ALARM CLOCKS, ] CHRONOMETERS, WATCHBANDS; [ CLOCK AND ] WATCH DIALS, WATCH CASES, [ CLOCK AND ] WATCH PRESENTATION CASES [, BUCKLES OF PRECIOUS METAL ].

FIRST USE ; IN COMMERCE .

ELEMENTS AMENDED  
GOODS/SERVICES

NO CLAIM IS MADE TO THE EXCLUSIVE RIGHT TO USE "STRATEGIC", APART FROM THE MARK AS SHOWN.

INT. CL. 35/U.S. CLS. 100, 101 AND 102

FOR CONSULTING IN THE FIELD OF MANAGEMENT, BUSINESS ORGANIZATIONAL DEVELOPMENT, HUMAN RESOURCE DEVELOPMENT, AND CORPORATE STRATEGY.

FIRST USE 12-1-2001; IN COMMERCE 12-1-2001.

INT. CL. 41/U.S. CLS. 100, 101 AND 107

FOR EDUCATIONAL SERVICES, NAMELY CONDUCTING WORKSHOPS AND SEMINARS FOR INDIVIDUALS AND ORGANIZATIONS RELATING TO ORGANIZATIONAL DEVELOPMENT, HUMAN RESOURCE DEVELOPMENT, EXECUTIVE COACHING, TRAINING, AND EDUCATION, AND CORPORATE STRATEGY.

FIRST USE 12-1-2001; IN COMMERCE 12-1-2001.

ELEMENTS CORRECTED  
OWNER NAME

2,963,323. REG. 6-21-2005. TIJON, LLC (GEORGIA LIMITED LIABILITY COMPANY) PO BOX 523882, MIAMI, FL, 331523882, SN 78-374,731. FILED 2-26-2004. PRINCIPAL REGISTER.

2,975,735. REG. 7-26-2005. BIO-REFERENCE LABORATORIES, INC. (NEW JERSEY CORPORATION) 481B EDWARD H. ROSS DRIVE, ELMWOOD PARK, NJ, 07407, SN 78-306,357. FILED 9-27-2003. PRINCIPAL REGISTER.

# TIJON

# GeneDz

THE MARK CONSISTS OF STYLIZED LETTERING WITH A STYLIZED BROKEN CIRCLE HELD TOGETHER BY A VERTICAL LINE.

INT. CL. 3/U.S. CLS. 1, 4, 6, 50, 51 AND 52

FOR COSMETICS.  
FIRST USE 11-1-2001; IN COMMERCE 11-1-2001.

ELEMENTS AMENDED  
MARK  
TRANSLITERATION STATEMENT

INT. CL. 44/U.S. CLS. 100 AND 101

FOR MEDICAL TESTING.  
FIRST USE 3-9-2000; IN COMMERCE 3-9-2000.

ELEMENTS AMENDED  
MARK  
[DISCLAIMER]

MAY 3, 2011

U.S. PATENT AND TRADEMARK OFFICE

TM 1869

2,979,713. REG. 7-26-2005. PROVO STEEL & SECURITY CO. (UTAH CORPORATION), DBA PROSTEEL, 1400 SOUTH STATE STREET, PROVO, UT, 846030977, SN 78-347,296. FILED 1-2-2004. PRINCIPAL REGISTER.

3,028,660. REG. 12-13-2005. DIMRS, INC (CALIFORNIA CORPORATION) 3460 INGRAHAM ST, SAN DIEGO, CA, 92109, SN 78-512,918. FILED 11-8-2004. PRINCIPAL REGISTER.

**THEFTGARD**

THE MARK CONSISTS OF STANDARD CHARACTERS WITHOUT CLAIM TO ANY PARTICULAR FONT, STYLE, SIZE, OR COLOR.  
INT. CL. 6/U.S. CLS. 2, 12, 13, 14, 23, 25 AND 50  
FOR METAL SAFES.  
FIRST USE 12-29-2003; IN COMMERCE 12-29-2003.

ELEMENTS CORRECTED  
\*DBA/AKA\*  
OWNER NAME

3,008,605. REG. 10-25-2005. SPINNER INDUSTRY, CO. LTD. (TAIWAN CORPORATION) #34 CHIA-HOU ROAD LIU FENG TSUEN WAIPU, TAICHUNG, TAIWAN., SN 78-369,340. FILED 2-17-2004. PRINCIPAL REGISTER.

**GRIND**

THE MARK CONSISTS OF STANDARD CHARACTERS WITHOUT CLAIM TO ANY PARTICULAR FONT, STYLE, SIZE, OR COLOR.  
INT. CL. 12/U.S. CLS. 19, 21, 23, 31, 35 AND 44  
FOR BICYCLE SUSPENSION SYSTEMS COMPOSED PRIMARILY OF FRONT FORKS, REAR FORKS AND SEAT POSTS.  
FIRST USE 4-0-2002; IN COMMERCE 4-0-2002.

ELEMENTS CORRECTED  
ENTITY

**DIMRS**

THE MARK CONSISTS OF STANDARD CHARACTERS WITHOUT CLAIM TO ANY PARTICULAR FONT, STYLE, SIZE, OR COLOR.  
INT. CL. 25/U.S. CLS. 22 AND 39  
FOR SELF-ADHESIVE NIPPLE COVERS FOR BREASTS.  
FIRST USE 12-22-2004; IN COMMERCE 12-22-2004.

ELEMENTS AMENDED  
MARK

3,040,600. REG. 1-10-2006. GREAT BOOKS SUMMER READING PROGRAM LLC (CONNECTICUT LIMITED LIABILITY COMPANY) 79 SANFORD STREET., FAIRFIELD, CT, 06824, SN 78-455,973. FILED 7-23-2004. PRINCIPAL REGISTER.

**GREAT BOOKS SUMMER PROGRAM**

THE MARK CONSISTS OF STANDARD CHARACTERS WITHOUT CLAIM TO ANY PARTICULAR FONT, STYLE, SIZE, OR COLOR.  
NO CLAIM IS MADE TO THE EXCLUSIVE RIGHT TO USE "SUMMER PROGRAM", APART FROM THE MARK AS SHOWN.  
INT. CL. 41/U.S. CLS. 100, 101 AND 107  
FOR EDUCATIONAL SERVICES, NAMELY READING CAMPS AND ONLINE AND AT HOME READING PROGRAMS IN LITERATURE AND HISTORY.  
FIRST USE 11-0-2001; IN COMMERCE 5-0-2002.

ELEMENTS AMENDED  
MARK  
DISCLAIMER

3,042,125. REG. 1-10-2006. BIRKO ORTHOPAEDIE GMBH (FED REP GERMANY CORPORATION) BURG OCKENFELS, 53545 LINZ, FED REP GERMANY., SN 76-262,924. FILED 5-23-2001. PRINCIPAL REGISTER.

**BirkoBasic**

PRIORITY CLAIMED UNDER SEC. 44(D) ON FED REP GERMANY APPLICATION NO. 30086307.1/1, FILED 11-23-2000, REG. NO. 30086307, DATED 9-5-2001, EXPIRES 11-30-2010.  
INT. CL. 10/U.S. CLS. 26, 39 AND 44

FOR ORTHOPEDIC FOOTBEDS, ORTHOPEDIC ARCH SUPPORTS; PREFORMED ORTHOPEDIC FOOTWEAR SHELLS [ AND HEEL INSERTS ] (BASED ON 44(E)) AND (BASED ON USE IN COMMERCE); [ ORTHOPEDIC FOOTWEAR; ] ORTHOPEDIC PADDINGS FOR FOOTWEAR AND ORTHOPEDIC LININGS FOR FOOTWEAR-(BASED ON 44(E)).

FIRST USE 2-14-1996; IN COMMERCE 2-14-1996.  
INT. CL. 25/U.S. CLS. 22 AND 39

FOR INSOLES [ AND HEEL INSERTS ] FOR FOOTWEAR, FOOTBEDS, PREFORMED SHELLS AND INSOLE SHELLS FOR FOOTWEAR (BASED ON 44(E)) AND (BASED ON USE IN COMMERCE) [ FOOTWEAR (BASED ON 44(E)) ].

FIRST USE 2-14-1996; IN COMMERCE 2-14-1996.

ELEMENTS CORRECTED  
GOODS/SERVICES

3,044,587. REG. 1-17-2006. SWC GRAPHICS, INC. (ARIZONA CORPORATION) 4318 E. UNIVERSITY, PHOENIX, AZ, 85034, SN 78-377,579. FILED 3-3-2004. PRINCIPAL REGISTER.

## MONSTER COLOR

THE MARK CONSISTS OF STANDARD CHARACTERS WITHOUT CLAIM TO ANY PARTICULAR FONT, STYLE, SIZE, OR COLOR.

INT. CL. 40/U.S. CLS. 100, 103 AND 106

FOR CUSTOM MANUFACTURE OF COLOR SIGNS FOR OTHERS.

FIRST USE 11-30-2002; IN COMMERCE 12-31-2002.

INT. CL. 42/U.S. CLS. 100 AND 101

FOR CUSTOM DESIGN OF COLOR SIGNS FOR OTHERS.

FIRST USE 11-30-2002; IN COMMERCE 11-30-2002.

ELEMENTS CORRECTED  
OWNER NAME

3,069,101. REG. 3-14-2006. PHITEN CO., LTD. (JAPAN CORPORATION) 678, TEARAIMIZU-CHO, KARASUMADORI, NISHIKIKOJIKADO., NAKAGYO-KU, KYOTO CITY, KYOTO PREF., JAPAN., SN 78-343,723. FILED 12-19-2003. PRINCIPAL REGISTER.

## REPAIR THROUGH

PRIORITY CLAIMED UNDER SEC. 44(D) ON JAPAN APPLICATION NO. 2003-082262, FILED 9-22-2003, REG. NO. 4769005, DATED 4-30-2004.

NO CLAIM IS MADE TO THE EXCLUSIVE RIGHT TO USE REPAIR, APART FROM THE MARK AS SHOWN.

INT. CL. 3/U.S. CLS. 1, 4, 6, 50, 51 AND 52

FOR COSMETICS.

FIRST USE 12-19-2003; IN COMMERCE 12-19-2003.

ELEMENTS AMENDED  
MARK

3,096,359. REG. 5-23-2006. MEDIACOM COMMUNICATIONS CORPORATION (DELAWARE CORPORATION) 100 CRYSTAL RUN ROAD, MIDDLETOWN, NY, 10941, SN 78-308,492. FILED 10-2-2003. PRINCIPAL REGISTER.

## MEDIACOM HDTV HIGH DEFINITION TELEVISION

OWNER OF U.S. REG. NO. 2,544,829.

NO CLAIM IS MADE TO THE EXCLUSIVE RIGHT TO USE "HDTV HIGH DEFINITION TELEVISION", APART FROM THE MARK AS SHOWN.

INT. CL. 38/U.S. CLS. 100, 101 AND 104

FOR TELECOMMUNICATION SERVICES, NAMELY, CABLE TELEVISION AND SATELLITE BROADCASTING AND TRANSMISSION SERVICES; PAY-PER-VIEW TELEVISION TRANSMISSION SERVICES; VIDEO ON DEMAND TELEVISION TRANSMISSION SERVICES; INTERACTIVE TELEVISION TRANSMISSION SERVICES; ELECTRONIC TRANSMISSION OF DATA, VOICE, MUSIC AND IMAGES, ALL OF THE FOREGOING SERVICES DELIVERED IN HIGH-DEFINITION FORMAT.

FIRST USE 4-15-2003; IN COMMERCE 4-15-2003.

ELEMENTS CORRECTED  
CITIZENSHIP

3,111,258. REG. 7-4-2006. PROVO STEEL & SUPPLY CO. (UTAH CORPORATION), DBA PROSTEEL, 1400 S. STATE ST., PROVO, UT, 84601, SN 78-492,849. FILED 10-1-2004. PRINCIPAL REGISTER.

## PROSTEEL

THE MARK CONSISTS OF STANDARD CHARACTERS WITHOUT CLAIM TO ANY PARTICULAR FONT, STYLE, SIZE, OR COLOR.

INT. CL. 6/U.S. CLS. 2, 12, 13, 14, 23, 25 AND 50

FOR METAL SAFES.

FIRST USE 6-15-1982; IN COMMERCE 6-15-1982.

ELEMENTS CORRECTED  
\*DBA/KA\*  
OWNER NAME

3,130,639. REG. 8-15-2006. EKin GROUP, LLC (TEXAS LIMITED LIABILITY CORPORATION) 2934 CHURCHILL WAY, GARLAND, TX, 75044, SN 78-381,032. FILED 3-9-2004. PRINCIPAL REGISTER.

3,135,192. REG. 8-29-2006. LFS, INC. (WASHINGTON CORPORATION) 5303 SHILSHOLE AVE., N.W., SEATTLE, WA, 98107, SN 78-578,090. FILED 3-2-2005. PRINCIPAL REGISTER.

## DURASCENT

THE MARK CONSISTS OF STANDARD CHARACTERS WITHOUT CLAIM TO ANY PARTICULAR FONT, STYLE, SIZE, OR COLOR.

INT. CL. 3/U.S. CLS. 1, 4, 6, 50, 51 AND 52

FOR SCENTED GELS FOR USE IN THE MANUFACTURE OF SCENTED [ PRODUCTS ]\*APPAREL AND SCENTED FLEXIBLE SUBSTRATES INCLUDING FABRICS, TEXTILES, LEATHER, PAPER, SYNTHETIC-BASED SUBSTRATES, RESIN-BASED SUBSTRATES AND RUBBER, AND LAMINATES COMBINING TWO OR MORE OF THE FOREGOING SUBSTRATES\*.

FIRST USE 2-0-2005; IN COMMERCE 2-0-2005.

ELEMENTS AMENDED  
GOODS/SERVICES

3,135,191. REG. 8-29-2006. LFS, INC. (WASHINGTON CORPORATION) 5303 SHILSHOLE AVE., N.W., SEATTLE, WA, 98107, SN 78-577,869. FILED 3-1-2005. PRINCIPAL REGISTER.

## NITRILE TOUCH

THE MARK CONSISTS OF STANDARD CHARACTERS WITHOUT CLAIM TO ANY PARTICULAR FONT, STYLE, SIZE, OR COLOR.

NO CLAIM IS MADE TO THE EXCLUSIVE RIGHT TO USE "NITRILE", APART FROM THE MARK AS SHOWN.

INT. CL. 9/U.S. CLS. 21, 23, 26, 36 AND 38  
FOR NON-DISPOSABLE NITRILE PALM-COATED PROTECTIVE GRIPPING GLOVES FOR INDUSTRIAL USE.

FIRST USE 11-4-2002; IN COMMERCE 11-4-2002.  
INT. CL. 21/U.S. CLS. 2, 13, 23, 29, 30, 33, 40 AND 50

FOR NON-DISPOSABLE NITRILE PALM-COATED PROTECTIVE GRIPPING GLOVES FOR GENERAL HOUSEHOLD USE.

FIRST USE 11-4-2002; IN COMMERCE 11-4-2002.

ELEMENTS CORRECTED  
OWNER NAME

## NITRILE TOUGH

THE MARK CONSISTS OF STANDARD CHARACTERS WITHOUT CLAIM TO ANY PARTICULAR FONT, STYLE, SIZE, OR COLOR.

NO CLAIM IS MADE TO THE EXCLUSIVE RIGHT TO USE "NITRILE", APART FROM THE MARK AS SHOWN.

INT. CL. 9/U.S. CLS. 21, 23, 26, 36 AND 38  
FOR NON-DISPOSABLE NITRILE PALM-COATED PROTECTIVE GRIPPING GLOVES FOR INDUSTRIAL USE.

FIRST USE 9-16-2003; IN COMMERCE 9-16-2003.

INT. CL. 21/U.S. CLS. 2, 13, 23, 29, 30, 33, 40 AND 50

FOR NON-DISPOSABLE NITRILE PALM-COATED PROTECTIVE GRIPPING GLOVES FOR GENERAL HOUSEHOLD USE.

FIRST USE 9-16-2003; IN COMMERCE 9-16-2003.

INT. CL. 28/U.S. CLS. 22, 23, 38 AND 50

FOR NON-DISPOSABLE NITRILE PALM-COATED PROTECTIVE GLOVES FOR SPORTS ACTIVITIES THAT REQUIRE SECURE GRIPPING, NAMELY, CANOEING, ROCK CLIMBING, FISHING, SCUBA DIVING, AND HAND GLIDING .

FIRST USE 9-16-2003; IN COMMERCE 9-16-2003.

ELEMENTS CORRECTED  
OWNER NAME

3,179,254. REG. 12-5-2006. ASIAINSPECTION (HONG KONG LIMITED COMPANY) RM 5, 19/F, NAM WO HONG BUILDING, 148 WING LOK STREET, SHUENG WAN, HONG KONG,, SN 78-477,592. FILED 9-2-2004. PRINCIPAL REGISTER.

## YOUR EYES IN THE FACTORY !

THE MARK CONSISTS OF STANDARD CHARACTERS WITHOUT CLAIM TO ANY PARTICULAR FONT, STYLE, SIZE, OR COLOR.

OWNER OF HONG KONG REG. NO. 300280340, DATED 9-4-2004.

INT. CL. 35/U.S. CLS. 100, 101 AND 102

FOR [ ADVERTISEMENT SERVICES; FRANCHISING, NAMELY, CONSULTATION AND ASSISTANCE IN BUSINESS MANAGEMENT, ORGANIZATION AND PROMOTION; ] COMMERCIAL INFORMATION IN THE FIELD OF PRODUCT ORDERS PROCESSING, MANUFACTURING PLACES, MANUFACTURING MEANS AND CONSEQUENCES OF THE PRODUCTS MANUFACTURING ON ECOLOGY; DATA PROCESSING SERVICES, NAMELY, DATA INPUT, FORMATTING, COMPILATION AND PROCESSING OF DATA RELATING TO PRODUCT ORDERS PROCESSING, MANUFACTURING PLACES, MANUFACTURING MEANS AND CONSEQUENCES OF THE PRODUCTS MANUFACTURING ON ECOLOGY; SUBSCRIPTION TO COMPUTER SERVICE, NAMELY, SUBSCRIPTION TO GLOBAL COMPUTER NETWORKS; CONDUCTING PUBLIC OPINION POLLS; BUSINESS INVESTIGATIONS; PERSONNEL RECRUITMENT, NAMELY, ONLINE RECRUITMENT OF STAFF AND INVESTIGATORS.

FIRST USE ; IN COMMERCE .  
INT. CL. 42/U.S. CLS. 100 AND 101

FOR HOSTING OF DIGITAL CONTENT ON THE INTERNET; [ LICENSING OF INTELLECTUAL PROPERTY; COPYRIGHT MANAGEMENT; ] DATABASE DEVELOPMENT SERVICES, NAMELY, CONSTRUCTION, DESIGN AND OPERATION OF TECHNICAL DATA BANKS AND DATABASES; PREPARING ENVIRONMENTAL COMPLIANCE REPORTS AND REVIEWING STANDARDS AND PRACTICES TO ASSURE COMPLIANCE WITH ENVIRONMENTAL LAWS AND REGULATIONS; PROVIDING QUALITY ASSURANCE SERVICES IN THE FIELD OF MANUFACTURING VIA PHOTOGRAPHS, CALIBRATION, MATCHING, COUNT AND BENCHMARKING.

FIRST USE ; IN COMMERCE .

ELEMENTS AMENDED  
GOODS/SERVICES

3,317,035. REG. 10-23-2007. KASHI COMPANY (CALIFORNIA CORPORATION) 4275 EXECUTIVE SQUARE, SUITE 500, LA JOLLA, CA. 92037, SN 77-148,114. FILED 4-4-2007. PRINCIPAL REGISTER.

**GOLEAN**  
*Crunch!*

OWNER OF U.S. REG. NOS. 2,650,531, 2,965,290 AND 2,994,759.

THE MARK CONSISTS OF STYLIZED LETTERING DEPICTING THE MARK "GOLEAN CRUNCH!" THE WORD GOLEAN IS IN CAPITAL LETTERS. THE PORTION OF THE MARK "GO" IS IN BLOCK THICK FILLED LETTERING. THE PORTION OF THE MARK "LEAN" IS IN BLOCK THIN FILLED LETTERING. "CRUNCH!" IS IN A STYLIZED LOWER CASE MEDIUM FILLED LETTERING WITH THE INITIAL CAPITAL "C" .

INT. CL. 30/U.S. CL. 46

FOR BREAKFAST CEREALS.

FIRST USE 12-31-2000; IN COMMERCE 12-31-2000.

ELEMENTS AMENDED  
MARK

3,204,239. REG. 1-30-2007. PRIVATE FORMULA CORPORATION (CALIFORNIA CORPORATION) 1 ENTERPRISE, ALISO VIEJO, CA, 92656, SN 76-324,164. FILED 10-11-2001. PRINCIPAL REGISTER.

**DR. LEWINN**

THE MARK CONSISTS OF STANDARD CHARACTERS WITHOUT CLAIM TO ANY PARTICULAR FONT, STYLE, SIZE, OR COLOR.

THE NAME "DR. LEWINN" DOES NOT IDENTIFY A PARTICULAR LIVING INDIVIDUAL

INT. CL. 3/U.S. CLS. 1, 4, 6, 50, 51 AND 52

FOR SKIN CARE PRODUCTS, NAMELY, NON-MEDICATED SKIN SERUM .

FIRST USE 11-0-2003; IN COMMERCE 11-11-2005.

ELEMENTS AMENDED  
OWNER ADDRESS  
MARK

3,339,156. REG. 11-20-2007. CLUB MONACO CORP. (CANADA CORPORATION) 430 KING STREET WEST, TORONTO, CANADA, M5V1L5, SN 77-154,239. FILED 4-11-2007. PRINCIPAL REGISTER.

**CLUB MONACO**

THE MARK CONSISTS OF STANDARD CHARACTERS WITHOUT CLAIM TO ANY PARTICULAR FONT, STYLE, SIZE, OR COLOR.

OWNER OF U.S. REG. NOS. 2,137,573, 2,568,196 AND OTHERS.

INT. CL. 35/U.S. CLS. 100, 101 AND 102

FOR RETAIL STORE SERVICES FEATURING WEARING APPAREL, FASHION ACCESSORIES, BAGS, EYEWEAR, JEWELRY, PERSONAL CARE PRODUCTS AND HOME FURNISHINGS.

FIRST USE 9-0-1989; IN COMMERCE 9-0-1989.

ELEMENTS CORRECTED  
OWNER NAME  
MARK



3,339,201. REG. 11-20-2007. CLUB MONACO CORP (CANADA CORPORATION) 430 KING STREET WEST, TORONTO, CANADA, M5V1L5, SN 77-178,957. FILED 5-11-2007. PRINCIPAL REGISTER.

3,421,742. REG. 5-6-2008. RVI DISTRIBUTION (CALIFORNIA CORPORATION) UNIT A1, 23482 PERALTA DR., LAGUNA HILLS, CA, 92653, SN 77-192,525. FILED 5-29-2007. PRINCIPAL REGISTER.

## CLUB MONACO

THE MARK CONSISTS OF STANDARD CHARACTERS WITHOUT CLAIM TO ANY PARTICULAR FONT, STYLE, SIZE, OR COLOR.

OWNER OF U.S. REG. NOS. 2,137,573, 2,568,196 AND OTHERS.

INT. CL. 14/U.S. CLS. 2, 27, 28 AND 50

FOR JEWELRY, NAMELY, BRACELETS, NECKLACES.

FIRST USE 9-1-1985; IN COMMERCE 9-0-1989.

ELEMENTS CORRECTED  
OWNER NAME  
MARK

## Phat Performance Parts

THE MARK CONSISTS OF STANDARD CHARACTERS WITHOUT CLAIM TO ANY PARTICULAR FONT, STYLE, SIZE, OR COLOR.

NO CLAIM IS MADE TO THE EXCLUSIVE RIGHT TO USE "PERFORMANCE PARTS", APART FROM THE MARK AS SHOWN.

INT. CL. 35/U.S. CLS. 100, 101 AND 102

FOR ON-LINE RETAIL STORE SERVICES IN THE POWER SPORTS INDUSTRY FEATURING MOTORCYCLES, ATV'S WATERSPORT PARTS AND ALL RELATED ITEMS; ON-LINE RETAIL STORE SERVICES IN THE POWER SPORTS INDUSTRY FEATURING MOTORCYCLES, ATVS, WATERSPORT PARTS AND ALL RELATED ITEMS.

FIRST USE 3-1-2003; IN COMMERCE 3-1-2003.

ELEMENTS AMENDED  
GOODS/SERVICES

3,409,871. REG. 4-8-2008. RIGHT NOW REDESIGN LLC (ILLINOIS LIMITED LIABILITY COMPANY) 4127 N. LAWLER AVENUE, CHICAGO, IL, 60641, SN 77-043,596. FILED 11-14-2006. PRINCIPAL REGISTER.

3,437,688. REG. 5-27-2008. MEDIACOM COMMUNICATIONS CORPORATION (DELAWARE CORPORATION) 100 CRYSTAL RUN ROAD, MIDDLETOWN, NY, 10941, SN 78-589,141. FILED 3-17-2005. PRINCIPAL REGISTER.



NO CLAIM IS MADE TO THE EXCLUSIVE RIGHT TO USE "REDESIGN", APART FROM THE MARK AS SHOWN.

THE MARK CONSISTS OF A DESIGN OF A STYLIZED CHAIR AND LAMP, WITH THE WORDING "RIGHT NOW REDESIGN" BELOW THE DESIGN PORTION OF THE COMPOSITE MARK.

INT. CL. 42/U.S. CLS. 100 AND 101

FOR INTERIOR DECORATING; INTERIOR DECORATION CONSULTATION.

FIRST USE 4-0-2007; IN COMMERCE 4-0-2007.

ELEMENTS AMENDED  
MARK  
DISCLAIMER

## MEDIACOM PHONE

THE MARK CONSISTS OF STANDARD CHARACTERS WITHOUT CLAIM TO ANY PARTICULAR FONT, STYLE, SIZE, OR COLOR.

OWNER OF U.S. REG. NOS. 2,544,829, 2,837,255 AND 2,882,896.

NO CLAIM IS MADE TO THE EXCLUSIVE RIGHT TO USE "PHONE", APART FROM THE MARK AS SHOWN.

INT. CL. 37/U.S. CLS. 100, 103 AND 106

FOR INSTALLATION, MAINTENANCE AND REPAIR OF EQUIPMENT AND WIRING USED FOR VOICE AND AUDIO TRANSMISSION.

FIRST USE 2-7-2005; IN COMMERCE 2-7-2005.

INT. CL. 38/U.S. CLS. 100, 101 AND 104

FOR VOICE COMMUNICATION SERVICES, NAMELY, ELECTRONIC TRANSMISSION OF VOICE AND AUDIO; TELEPHONE COMMUNICATION SERVICES.

FIRST USE 2-7-2005; IN COMMERCE 2-7-2005.

ELEMENTS CORRECTED  
CITIZENSHIP

3,437,689. REG. 5-27-2008. MEDIACOM COMMUNICATIONS CORPORATION (DELAWARE CORPORATION) 100 CRYSTAL RUN ROAD, MIDDLETOWN, NY, 10941, SN 78-589,183. FILED 3-17-2005. PRINCIPAL REGISTER.

3,493,871. REG. 8-26-2008. MEDIACOM COMMUNICATIONS CORPORATION (DELAWARE CORPORATION) 100 CRYSTAL RUN ROAD, MIDDLETOWN, NY, 10941, SN 78-589,201. FILED 3-17-2005. PRINCIPAL REGISTER.

**MEDIACOM PHONE SERVICE**



THE MARK CONSISTS OF STANDARD CHARACTERS WITHOUT CLAIM TO ANY PARTICULAR FONT, STYLE, SIZE, OR COLOR.

OWNER OF U.S. REG. NOS. 2,544,829, 2,837,255 AND 2,882,896.

NO CLAIM IS MADE TO THE EXCLUSIVE RIGHT TO USE "PHONE SERVICE", APART FROM THE MARK AS SHOWN.

INT. CL. 37/U.S. CLS. 100, 103 AND 106

FOR INSTALLATION, MAINTENANCE AND REPAIR OF EQUIPMENT AND WIRING USED FOR VOICE AND AUDIO TRANSMISSION.

FIRST USE 2-7-2005; IN COMMERCE 2-7-2005.

INT. CL. 38/U.S. CLS. 100, 101 AND 104

FOR VOICE COMMUNICATION SERVICES, NAMELY, ELECTRONIC TRANSMISSION OF VOICE AND AUDIO; TELEPHONE COMMUNICATION SERVICES.

FIRST USE 2-7-2005; IN COMMERCE 2-7-2005.

ELEMENTS CORRECTED  
CITIZENSHIP

OWNER OF U.S. REG. NOS. 2,544,829, 2,837,255 AND 2,882,896.

NO CLAIM IS MADE TO THE EXCLUSIVE RIGHT TO USE "PHONE SERVICE", APART FROM THE MARK AS SHOWN.

INT. CL. 37/U.S. CLS. 100, 103 AND 106

FOR INSTALLATION, MAINTENANCE AND REPAIR OF EQUIPMENT AND WIRING USED FOR VOICE AND AUDIO TRANSMISSION.

FIRST USE 2-7-2005; IN COMMERCE 2-7-2005.

INT. CL. 38/U.S. CLS. 100, 101 AND 104

FOR VOICE COMMUNICATION SERVICES, NAMELY, ELECTRONIC TRANSMISSION OF VOICE AND AUDIO; TELEPHONE COMMUNICATION SERVICES.

FIRST USE 2-7-2005; IN COMMERCE 2-7-2005.

ELEMENTS CORRECTED  
CITIZENSHIP

3,442,365. REG. 6-3-2008. MEDIACOM COMMUNICATIONS CORPORATION (DELAWARE CORPORATION) 100 CRYSTAL RUN ROAD, MIDDLETOWN, NY, 10941, SN 78-670,325. FILED 7-14-2005. PRINCIPAL REGISTER.

3,579,338. REG. 2-24-2009. INTEGRATED TELECOM MANAGEMENT SERVICES, INC. (GEORGIA CORPORATION), DBA DRIFEAT, 1237 RIVERSOUND COURT, MARIETTA, GA, 30068, SN 77-488,775. FILED 6-2-2008. PRINCIPAL REGISTER.

**FREE PASS**



THE MARK CONSISTS OF STANDARD CHARACTERS WITHOUT CLAIM TO ANY PARTICULAR FONT, STYLE, SIZE, OR COLOR.

INT. CL. 38/U.S. CLS. 100, 101 AND 104

FOR TELECOMMUNICATIONS SERVICES, NAMELY THE ELECTRONIC TRANSMISSION OF DATA, VOICE AND IMAGES; VIDEO ON DEMAND TELEVISION TRANSMISSION SERVICES.

FIRST USE 10-17-2005; IN COMMERCE 10-17-2005.

INT. CL. 41/U.S. CLS. 100, 101 AND 107

FOR TELEVISION PROGRAMMING; VIDEO ON DEMAND TELEVISION PROGRAMMING SERVICES.

FIRST USE 10-17-2005; IN COMMERCE 10-17-2005.

ELEMENTS CORRECTED  
CITIZENSHIP

THE COLOR(S) BLACK AND YELLOW IS/ARE CLAIMED AS A FEATURE OF THE MARK.

THE MARK CONSISTS OF THE BLACK LETTER "S" INSIDE A BLACK CIRCLE. BOTH ENDS OF THE "S" TOUCH THE CIRCLE. THE SPACE INSIDE THE CIRCLE BUT NOT THE "S" IS YELLOW.

INT. CL. 3/U.S. CLS. 1, 4, 6, 50, 51 AND 52

FOR SACHETS.

FIRST USE 11-8-2007; IN COMMERCE 11-8-2007.

ELEMENTS CORRECTED  
OWNER NAME

3,591,335. REG. 3-17-2009. ORASOLV AB (SWEDEN CORPORATION) MEDICINAREGATAN 8B, 5TH FLOOR, SE-413 46 GÖTEBORG, SWEDEN., SN 79-038,899. FILED 5-25-2007. PRINCIPAL REGISTER.

# MANO+

PRIORITY DATE OF 12-29-2006 IS CLAIMED.  
OWNER OF INTERNATIONAL REGISTRATION 0925204 DATED 5-25-2007, EXPIRES 5-25-2017.  
THE MARK CONSISTS OF THE TEXT MANO FOLLOWED BY A CROSS. THE PORTION OF THE MARK COMPRISED OF A CROSS DESIGN IS NOT DISPLAYED IN THE COLOR RED OR A COLORABLE IMITATION THEREOF; AND IS NOT USED AND WILL NOT BE USED IN A COLORABLE IMITATION THEREOF.  
THE ENGLISH TRANSLATION OF THE WORD "MANO" IN THE MARK IS "HAND".  
INT. CL. 5/U.S. CLS. 6, 18, 44, 46, 51 AND 52  
FOR DISINFECTANTS FOR HYGIENE PURPOSES.

ELEMENTS CORRECTED  
\*DESCRIPTION OF MARK\*

3,596,562. REG. 3-24-2009. MEDIACOM COMMUNICATIONS CORPORATION (DELAWARE CORPORATION) 100 CRYSTAL RUN ROAD, MIDDLETOWN, NY, 10941, SN 78-589,170. FILED 3-17-2005. PRINCIPAL REGISTER.

# Mediacom Phone

OWNER OF U.S. REG. NOS. 2,544,829, 2,837,255 AND 2,882,896.  
NO CLAIM IS MADE TO THE EXCLUSIVE RIGHT TO USE "PHONE", APART FROM THE MARK AS SHOWN.  
INT. CL. 37/U.S. CLS. 100, 103 AND 106  
FOR INSTALLATION, MAINTENANCE AND REPAIR OF EQUIPMENT AND WIRING USED FOR VOICE AND AUDIO TRANSMISSION.  
FIRST USE 2-7-2005; IN COMMERCE 2-7-2005.  
INT. CL. 38/U.S. CLS. 100, 101 AND 104  
FOR VOICE COMMUNICATION SERVICES, NAMELY, ELECTRONIC TRANSMISSION OF VOICE AND AUDIO; TELEPHONE COMMUNICATION SERVICES.  
FIRST USE 2-7-2005; IN COMMERCE 2-7-2005.

ELEMENTS CORRECTED  
CITIZENSHIP

3,641,709. REG. 6-23-2009. CLUB MONACO CORP. (CANADA CORPORATION) 430 KING STREET WEST, TORONTO, CANADA, M5V1L5, SN 77-178,984. FILED 5-11-2007. PRINCIPAL REGISTER.

# CLUB MONACO

THE MARK CONSISTS OF STANDARD CHARACTERS WITHOUT CLAIM TO ANY PARTICULAR FONT, STYLE, SIZE, OR COLOR.  
OWNER OF U.S. REG. NOS. 2,137,573, 2,568,196 AND OTHERS.  
INT. CL. 18/U.S. CLS. 1, 2, 3, 22 AND 41  
FOR HANDBAGS, LEATHER NOTEBOOKS, WALLET.  
FIRST USE 9-1-1985; IN COMMERCE 9-0-1989.

ELEMENTS CORRECTED  
OWNER NAME

3,649,191. REG. 7-7-2009. CERVANTES, ENRIQUE (UNITED STATES INDIVIDUAL) 6969A INDUSTRIAL, EL PASO, TX, 79915, AND LESTER, KURT FRED (UNITED STATES INDIVIDUAL) 610 CLINTON STREET, HOBOKEN, NJ, 07030, SN 76-696,102. FILED 3-4-2008. PRINCIPAL REGISTER.

# MAISON BIBLIOTHEQUE

THE MARK CONSISTS OF STANDARD CHARACTERS WITHOUT CLAIM TO ANY PARTICULAR FONT, STYLE, SIZE, OR COLOR.  
THE ENGLISH TRANSLATION OF THE PHRASE "MAISON BIBLIOTHEQUE" IS "LIBRARY HOUSE".  
INT. CL. 25/U.S. CLS. 22 AND 39  
FOR MEN'S, WOMEN'S AND CHILDREN'S CLOTHING, NAMELY, DENIM JEANS, T-SHIRTS, JACKETS.  
FIRST USE 11-15-2007; IN COMMERCE 11-15-2007.

ELEMENTS CORRECTED  
MARK

3,672,251. REG. 8-25-2009. SWYPE, INC. (WASHINGTON CORPORATION) 71 COLUMBIA STREET, SUITE 200, SEATTLE, WA, 98104, SN 77-647,699. FILED 1-12-2009. PRINCIPAL REGISTER.



THE MARK CONSISTS OF THE WORD "SWYPE" WITH A SILHOUETTE OF A HAND AT THE END OF THE "E".  
INT. CL. 9/U.S. CLS. 21, 23, 26, 36 AND 38  
FOR TEXT INPUT SOFTWARE.  
FIRST USE 9-8-2008; IN COMMERCE 9-8-2008.

ELEMENTS AMENDED  
OWNER ADDRESS  
MARK

3,676,420. REG. 9-1-2009. BOUNCE ENERGY, INC. (DELAWARE CORPORATION) 2802 ALBANY STREET, HOUSTON, TX, 77006, SN 77-677,837. FILED 2-25-2009. PRINCIPAL REGISTER.

3,746,874. REG. 2-9-2010. RAINER GMBH (FED REP GERMANY LIMITED LIABILITY COMPANY) FRANKFURTER STRABE 493, 51145 KÖLN, FED REP GERMANY., SN 79-032,565. FILED 6-19-2006. PRINCIPAL REGISTER.



NO CLAIM IS MADE TO THE EXCLUSIVE RIGHT TO USE "ENERGY", APART FROM THE MARK AS SHOWN.

THE COLOR(S) ORANGE, BLUE AND WHITE IS/ARE CLAIMED AS A FEATURE OF THE MARK.

THE MARK CONSISTS OF THE WORDS "BOUNCE" IN BLUE AND "ENERGY" IN ORANGE. THE WORD "ENERGY" IS LOCATED DIRECTLY BENEATH THE WORD "BOUNCE". TO THE LEFT OF THE WORDS THERE IS A STARBURST DESIGN, THE TOP OF WHICH IS ORANGE IN COLOR, THE BOTTOM IN BLUE, THE COLORS BEING SEPARATED BY A STARBURST DESIGN IN WHITE.

INT. CL. 39/U.S. CLS. 100 AND 105

FOR PUBLIC UTILITY SERVICES IN THE NATURE OF ELECTRICITY DISTRIBUTION.

FIRST USE 6-5-2008; IN COMMERCE 6-5-2008.

ELEMENTS AMENDED  
MARK



PRIORITY DATE OF 12-19-2005 IS CLAIMED.

OWNER OF INTERNATIONAL REGISTRATION 0907700 DATED 6-19-2006, EXPIRES 6-19-2016.

THE COLOR(S) RED, GRAY AND WHITE IS/ARE CLAIMED AS A FEATURE OF THE MARK.

THE MARK CONSISTS OF A FILLED-IN CIRCLE, WHICH IS SURROUNDED BY A SEMI-CIRCLE THAT DOES NOT MEET IN THE TOP OR BOTTOM MIDDLE OF THE SEMI-CIRCLE. THE COLOR RED REPRESENTS THE FILLED-IN MIDDLE CIRCLE, WHICH IS SURROUNDED BY A GRAY SEMI-CIRCLE THAT DOES NOT MEET IN THE TOP OR BOTTOM MIDDLE OF THE SEMI-CIRCLE AND A WHITE BACKGROUND.

INT. CL. 16/U.S. CLS. 2, 5, 22, 23, 29, 37, 38 AND 50

FOR PLASTIC PACKAGING MATERIAL, NAMELY, PLASTIC BAGS FOR PACKAGING, PLASTIC BUBBLE PACKS FOR WRAPPING OR PACKAGING; CARDBOARD CARTONS FOR PACKAGING; PACKAGING MATERIAL OF PAPER, NAMELY, PACKAGING PAPER, PAPER BAGS FOR PACKAGING; PACKAGING FILM OF PLASTIC NOT FOR COMMERCIAL OR INDUSTRIAL PURPOSES, USED TO WRAP FOOD FOR HOUSEHOLD USE; STRETCH FILM OF PLASTIC FOR PACKAGING NOT FOR COMMERCIAL OR INDUSTRIAL PURPOSES, USED TO WRAP FOOD FOR HOUSEHOLD USE.

FIRST USE ; IN COMMERCE .

INT. CL. 20/U.S. CLS. 2, 13, 22, 25, 32 AND 50

FOR AIRBAGS AND AIR CUSHIONS NOT FOR MEDICAL APPLICATIONS FOR SAFEGUARDING OF GOODS AND WARES.

FIRST USE ; IN COMMERCE .

INT. CL. 22/U.S. CLS. 1, 2, 7, 19, 22, 42 AND 50

FOR BELTS, NOT MADE OF METAL, FOR CLAMPING AND HANDLING LOADS; ROPES; STRETCHING BELTS, NOT MADE OF METAL, FOR HANDLING LOADS; TEXTILE PACKAGING MATERIAL, NAMELY, INDUSTRIAL PACKAGING CONTAINERS OF TEXTILE; PACKAGING BAGS OF TEXTILE MATERIAL; LASHING MATERIALS, NAMELY, BELTS, NOT MADE OF METAL, FOR CLAMPING AND STRAPS FOR ANGULAR CLAMPING OF LOADS, GOODS AND WARES.

FIRST USE ; IN COMMERCE .

INT. CL. 39/U.S. CLS. 100 AND 105

FOR TRANSPORT OF GOODS, NAMELY, CONTAINER TRANSPORT; PACKAGING ARTICLES FOR TRANSPORTATION, NAMELY, RESTRAINING OF CARGO DURING TRANSPORTATION; PACKAGING ARTICLES FOR TRANSPORTATION, NAMELY, RESTRAINING OF WARES AND GOODS IN CONNECTION WITH LOADING SERVICES DURING TRANSPORTATION; PACKAGING OF WARES AND GOODS, NAMELY, FLUIDS AND SOLIDS NOT FOR MEDICAL APPLICATIONS; PACKAGING OF ARTICLES FOR TRANSPORTATION, NAMELY, PACKAGING, BAGS, BARRELS, CASKS, BINS, BOXES AND CARTONS USED FOR RESTRAIN-

3,682,600. REG. 9-15-2009. ONE KINGS LANE, LLC (CALIFORNIA LIMITED LIABILITY COMPANY) 501 SECOND STREET, SUITE 114, SAN FRANCISCO, CA, 94107, SN 77-667,601. FILED 2-10-2009. PRINCIPAL REGISTER.



THE MARK CONSISTS OF THE DESIGN OF TWO ELEPHANTS FACING EACH OTHER WITH THE DESIGN OF A TOPIARY IN BETWEEN THE ELEPHANTS.

INT. CL. 35/U.S. CLS. 100, 101 AND 102

FOR ON-LINE RETAIL STORE SERVICES FEATURING A WIDE VARIETY OF CONSUMER GOODS INCLUDING HOUSEHOLD AND LIFESTYLE PRODUCTS.

FIRST USE 11-19-2008; IN COMMERCE 1-26-2009.

ELEMENTS CORRECTED  
OWNER NAME  
OWNER ADDRESS

ING OF WARES AND GOODS DURING TRANSPORTATION NOT FOR MEDICAL APPLICATIONS, \* ALL OF THE AFOREMENTIONED SERVICES NOT IN CONNECTION WITH THE REMOVAL AND STORAGE OF WASTE MATERIALS OCCURRING PARTICULARLY AT THE CLEANING OF BUILDINGS, EQUIPMENT, MACHINES AND TEXTILES, AT THE REMEDIATION OF FIRE AND WATER DAMAGE, AT DEMOLITION WORK, PLUMBING WORK AND REPAIRS OF BUILDINGS, AT THE DEHUMIDIFICATION OF BUILDINGS AND REMEDIATION OF DAMAGE CAUSED BY FIRE, SMOKE, WATER FOR FIREFIGHTING, TAP WATER AND FLOODING \*.  
FIRST USE ; IN COMMERCE .

ELEMENTS CORRECTED  
GOODS/SERVICES

---

3,760,563. REG. 3-16-2010. JOEL SULLIVAN (UNITED STATES INDIVIDUAL) 952 OLD FORT ROAD, FAIRVIEW, NC, 28730, SN 77-785,529. FILED 7-21-2009. PRINCIPAL REGISTER.

## SECRET AGENT 23 SKIDOO

THE MARK CONSISTS OF STANDARD CHARACTERS WITHOUT CLAIM TO ANY PARTICULAR FONT, STYLE, SIZE, OR COLOR.  
INT. CL. 41/U.S. CLS. 100, 101 AND 107  
FOR ENTERTAINMENT, NAMELY, LIVE PERFORMANCES BY A MUSICAL BAND.  
FIRST USE 10-1-2007; IN COMMERCE 10-1-2007.

ELEMENTS CORRECTED  
CITIZENSHIP

---

3,761,935. REG. 8-16-1983. BHS-SONTHOFEN GMBH (FED REP GERMANY GMBH) AN DER EISENSCHMELZE 47, SONTHOFEN, FED REP GERMANY, 87527, SN 75-983,683. FILED 3-21-1980. PRINCIPAL REGISTER.

## BHS

INT. CL. 7/U.S. CLS. 13, 19, 21, 23, 31, 34 AND 35  
FOR CONSTRUCTION EQUIPMENT—NAMELY, CONCRETE MIXING MACHINES, CRUSHING MACHINES, COMPULSORY MIXING MACHINES, SAND AND GRIT MILLING ROLLS; PRESSURE FILTERING MACHINES FOR SEPARATING LIQUIDS AND SOLIDS; PARTS FOR THE ABOVE GOODS .  
FIRST USE 0-0-1934; IN COMMERCE 7-0-1973.

ELEMENTS CORRECTED  
[FOREIGN REG. NO.]  
[FOREIGN REG. DATE]  
[FOREIGN REG. EXPIRATION DATE]

3,762,291. REG. 3-23-2010. TELEFONAKTIEBOLAGET LM ERICSSON (SWEDEN CORPORATION) TORSHAMNSGATAN 23, KISTA, STOCKHOLM, SWEDEN, SE-16483, SN 77-663,768. FILED 2-5-2009. PRINCIPAL REGISTER.

## MARCONI

THE MARK CONSISTS OF STANDARD CHARACTERS WITHOUT CLAIM TO ANY PARTICULAR FONT, STYLE, SIZE, OR COLOR.

THE NAME(S), PORTRAIT(S), AND/OR SIGNATURE(S) SHOWN IN THE MARK DOES NOT IDENTIFY A PARTICULAR LIVING INDIVIDUAL.

SEC. 2(F).  
INT. CL. 9/U.S. CLS. 21, 23, 26, 36 AND 38  
FOR COMMUNICATION AND TELECOMMUNICATION RADIOS, COMPUTER HARDWARE, EXCHANGES AND TELECOMMUNICATION SERVERS FOR THE TRANSMISSION AND RECEPTION OF VOICE, VIDEO AND DATA BY MEANS OF RADIO FREQUENCY AND OPTICAL SIGNALS; RADIO TELECOMMUNICATION TRANSMITTERS, RECEIVERS, AERIALS, MOBILE COMMUNICATION TERMINALS, TELECOMMUNICATIONS BASE STATION EQUIPMENT FOR CELLULAR COMMUNICATION NETWORKS, ELECTRIC SWITCHES, ELECTRIC RELAYS, AND ELECTRIC CONTROLLERS.  
FIRST USE 7-14-1961; IN COMMERCE 7-14-1961.

ELEMENTS CORRECTED  
OWNER NAME

---

3,786,607. REG. 5-11-2010. 4 LIFE, INC. (NORTH CAROLINA CORPORATION) 3009 PROPHET DR., HILLSBOROUGH, NC, 28806, SN 77-446,532. FILED 4-11-2008. PRINCIPAL REGISTER.

## 4LIFE

THE MARK CONSISTS OF STANDARD CHARACTERS WITHOUT CLAIM TO ANY PARTICULAR FONT, STYLE, SIZE, OR COLOR.

INT. CL. 41/U.S. CLS. 100, 101 AND 107  
FOR ENCOURAGING AMATEUR SPORTS AND PHYSICAL EDUCATION BY ORGANIZING, PROMOTING, SPONSORING, SANCTIONING, CONDUCTING, ADMINISTERING, REGULATING AND GOVERNING AMATEUR ATHLETIC PROGRAMS AND ACTIVITIES \* PRIMARILY AT CAMPS, COMMUNITY FACILITIES, AND SPORTING FIELDS \* SHOULD BE INSERTED.  
FIRST USE 4-8-2002; IN COMMERCE 4-8-2002.

ELEMENTS AMENDED  
GOODS/SERVICES

3,786,626. REG. 5-11-2010. MAESTRO CALABRESE INTERNATIONAL LTD (UNITED KINGDOM LIMITED COMPANY (LTD.)) 24 LEADALE AVENUE, CHINGFORD, LONDON, UNITED KINGDOM, E48AT, SN 77-504,488. FILED 6-20-2008. PRINCIPAL REGISTER.

## CALABRESE

THE MARK CONSISTS OF STANDARD CHARACTERS WITHOUT CLAIM TO ANY PARTICULAR FONT, STYLE, SIZE, OR COLOR.

PRIORITY CLAIMED UNDER SEC. 44(D) ON ERPN CMNTY TM OFC APPLICATION NO. 6942619, FILED 5-12-2008, REG. NO. 006942619, DATED 4-3-2009, EXPIRES 5-12-2018.

INT. CL. 7/U.S. CLS. 13, 19, 21, 23, 31, 34 AND 35

FOR WASTE DISPOSAL MACHINES; WASTE DISPOSAL UNITS AND APPARATUS, NAMELY, FOOD WASTE DISPOSALS AND FOOD WASTE DISPOSERS; RUBBISH COMPACTING MACHINES; MACHINE PARTS, NAMELY, CHUTES FOR WASTE DISPOSAL MACHINES AND RUBBISH COMPACTING MACHINES; KITCHEN MACHINES, NAMELY, MANUAL MIXERS.

FIRST USE ; IN COMMERCE .

INT. CL. 11/U.S. CLS. 13, 21, 23, 31 AND 34

FOR APPARATUS FOR LIGHTING, NAMELY, LIGHTING FIXTURES; APPARATUS FOR HEATING, NAMELY, ELECTRIC HEATING FANS AND CABINETS USED TO CONTROL TEMPERATURE AND HUMIDITY FOR HEATING AND PROOFING FOOD GOODS; APPARATUS FOR STEAM GENERATING, NAMELY, ELECTRIC FOOD STEAMERS; APPARATUS FOR COOKING, NAMELY, COOKTOPS; APPARATUS FOR REFRIGERATING, NAMELY, REFRIGERATORS AND REFRIGERATING MACHINES; APPARATUS FOR DRYING, NAMELY, ELECTRIC HOT AIR HAND DRYERS; APPARATUS FOR VENTILATING, NAMELY, VENTILATION HOODS, VENTILATING EXHAUST FANS AND VENTILATING LOUVERS; APPARATUS FOR WATER SUPPLY, NAMELY, WATER DISPENSERS; APPARATUS FOR SANITARY PURPOSES, NAMELY, AIR CLEANING UNITS; SINKS; SINK UNITS COMPRISED OF SINKS AND SINK PEDESTALS; COOLING APPARATUS, NAMELY, WATER COOLERS, WINE COOLERS AND WALK-IN COOLERS; BAKING OVENS FOR HOUSEHOLD PURPOSES; BARBEQUES AND GRILLS; BEVERAGE COOLING APPARATUS; ELECTRIC FOOD BOILERS; ELECTRIC BREAD TOASTERS; ELECTRIC COFFEE MACHINES; COOKERS, NAMELY, GAS COOKERS, ELECTRIC SLOW COOKERS, ELECTRIC RICE COOKERS, ELECTRIC BREAD COOKERS AND ELECTRIC EGG COOKERS; REFRIGERATING DISPLAY CABINETS; FILTERS FOR DRINKING WATER; ELECTRIC LAMPS; ELECTRIC FANS; FOUNTAINS, NAMELY, DRINKING FOUNTAINS, WATER FOUNTAINS AND DECORATIVE FOUNTAINS; GRILLS, NAMELY, GAS GRILLS, BARBEQUE GRILLS, ELECTRIC GRILLS AND CHARCOAL GRILLS; ICE BOXES; ICE MACHINES; KITCHEN RANGES, NAMELY, COOKING RANGES, GAS RANGES AND ELECTRIC RANGES; LAMP SHADES; LANTERNS; MICROWAVE OVENS; ELECTRIC PRESSURE COOKERS; HAND WASHING BOWLS AS PARTS OF SANITARY INSTALLATIONS; WASTE DISPOSAL INCINERATORS; APPARATUS FOR FILTERING WATER, NAMELY, WATER FILTERS AND WATER PURIFICATION AND FILTRATION APPARATUS; MACHINES FOR WATER FILTERING.

FIRST USE ; IN COMMERCE .

INT. CL. 20/U.S. CLS. 2, 13, 22, 25, 32 AND 50

FOR FURNITURE UNITS, NAMELY, WASHSTANDS, CABINETS AND CABINETS FOR KITCHEN SINKS AND BAR SINKS.

FIRST USE ; IN COMMERCE .

INT. CL. 21/U.S. CLS. 2, 13, 23, 29, 30, 33, 40 AND 50

FOR HOUSEHOLD OR KITCHEN UTENSILS AND CONTAINERS, NAMELY, BATTER DISPENSERS, WIRE BASKETS, GRATERS, SIEVES, STRAINERS, SKIMMERS, POT AND PAN SCRAPERS, ROLLING PINS, TURNERS, WHISKS, SPLATTER SCREENS AND UTENSILS FOR BARBECUES, NAMELY, FORKS, TONGS, TURNERS; ALL PURPOSE PORTABLE HOUSEHOLD CONTAINERS, CONTAINERS FOR HOUSEHOLD OR KITCHEN USE, CONTAINERS FOR ICE, SOAP CONTAINERS, HOUSEHOLD CONTAINERS FOR FOODS; COMBS; SPONGES FOR HOUSEHOLD PURPOSES; BRUSHES, NAMELY, HAIR BRUSHES, BATH BRUSHES, CAKE BRUSHES, CRUMB BRUSHES, DISHWASHING BRUSHES, DUSTING BRUSHES, MUSHROOM BRUSHES, SCRAPPING BRUSHES, SCRUBBING BRUSHES, WASHING BRUSHES, TOOTH BRUSHES; BRUSH MAKING MATERIALS; ARTICLES FOR CLEANING PURPOSES, NAMELY, CLEANING CLOTHS, CLEANING COTTON, CLEANING COMBS, CLEANING PADS, CLEANING RAGS, CLEANING SPONGES, CLEANING MITTS MADE OF FABRIC AND PRE-MOISTENED TOWELETTS FOR CLEANING; STEELWOOL; UNWORKED OR SEMI-WORKED GLASS, NOT FOR BUILDING; BEVERAGE GLASSWARE; PORCELAIN, NAMELY, EARTHENWARE JARS FOR JAMS AND JELLIES, EARTHENWARE MUGS; EARTHENWARE, NAMELY, EARTHENWARE JARS FOR JAMS AND JELLIES, EARTHENWARE MUGS, EARTHENWARE BASINS AND BOWLS, NOT PARTS OF SANITARY INSTALLATIONS; ICE BUCKETS; ICE CONTAINERS; ICE CREAM SCOOPS; ICE CUBE MOULDS; ICE CUBE TRAYS; ICEPACKS FOR KEEPING FOOD AND DRINKS COLD; ICE PAILS; ICE TRAYS; VESSELS OF METAL FOR MAKING ICES AND ICED DRINKS, NAMELY, COCKTAIL SHAKERS; COCKTAIL STIRRERS; DRINK STIRRERS; DRINKING GLASSES, BOWLS; RECEPTACLES, NAMELY, BASINS; LAUNDRY BASKETS FOR DOMESTIC USE; MUGS; NON-ELECTRIC FOOD BLENDERS; BOTTLE OPENERS; BOTTLES, SOLD EMPTY; BREAD BASKETS FOR DOMESTIC USE; BREAD BOARDS; BROOMS; BUCKETS; DISHES; CANDLESTICKS; CHINA ORNAMENTS; CHOP STICKS; CLOTHS FOR CLEANING; COASTERS NOT OF PAPER AND NOT BEING TABLE LINEN; NON-ELECTRIC COFFEE MACHINES; COFFEE POTS; COMBS; PASTRY BAGS; COOKERY MOULDS; COOKIE JARS; COOKING POTS; NON-ELECTRIC COOKIE UTENSILS, NAMELY, COOKIE CUTTERS AND COOKIE SHEETS; FOOD COOLING DEVICES, NAMELY, BUTTER COOLERS, COOLERS FOR WINE, COOLING RACKS FOR BAKED GOODS AND PORTABLE COOLERS; CORKSCREWS; COVERS FOR DISHES; CROCKERY, NAMELY, DINERWARE; CUPS; EGG CUPS; KITCHEN CUTTING BOARDS; DECANTERS; NON-ELECTRIC DOMESTIC GRINDERS; FLASKS; FRUIT CUPS; FRYING PANS; NON-ELECTRIC KITCHEN UTENSILS, NAMELY, GRILL SUPPORTS; JUGS; KITCHEN CONTAINERS; LUNCH BOXES; MANUAL MIXERS, NAMELY, MIXING SPOONS AND/OR MIXING CUPS; COCKTAIL SHAKERS; NAPKIN RINGS; ROLLING PINS; SAUCEPANS; SAUCERS; SOAP BOXES; HOUSEHOLD UTENSILS, NAMELY, SPATULAS; BASTING SPOONS; STEW PANS; SUGAR BOWLS; TABLE PLATES; TRAYS; NON-ELECTRIC WAFFLE IRONS; CHOPPING BOARDS FOR KITCHEN USE; WASTE DISPOSAL RECEPTACLES, NAMELY, WASTE BASKETS; BINS, NAMELY, REFUSE BINS AND DUST BINS; WASTE BINS; RUBBISH CONTAINERS FOR HOUSEHOLD USE; HAND WASHING BOWLS, NOT PARTS OF SANITARY INSTALLATIONS.

FIRST USE ; IN COMMERCE .

ELEMENTS CORRECTED

FOREIGN APPLICATION FILING DATE

3,787,740. REG. 5-11-2010. CPP GROUP LIMITED (UNITED KINGDOM LIMITED COMPANY) HOLGATE PARK, YORK, UNITED KINGDOM, YO264GA, SN 77-062,158. FILED 12-12-2006. PRINCIPAL REGISTER.

3,796,336. REG. 6-1-2010. MEDIACOM COMMUNICATIONS CORPORATION (DELAWARE CORPORATION) 100 CRYSTAL RUN ROAD, MIDDLETOWN, NY, 10941, SN 77-475,842. FILED 5-15-2008. PRINCIPAL REGISTER.

# CPP

THE MARK CONSISTS OF STANDARD CHARACTERS WITHOUT CLAIM TO ANY PARTICULAR FONT, STYLE, SIZE, OR COLOR.

INT. CL. 35/U.S. CLS. 100, 101 AND 102

FOR MANAGEMENT OF BUSINESS; BUSINESS TO BUSINESS OUTSOURCING SERVICES, NAMELY, OPERATION AND MANAGEMENT OF CALL CENTER FACILITIES RELATING TO CONSUMER ASSISTANCE SERVICE; MARKETING, AND ADVERTISING SERVICES; OPERATION AND MANAGEMENT OF CREDIT CARD RELATED SERVICES OF OTHERS, NAMELY, CREDIT CARD REGISTRATION SERVICES; OPERATION AND MANAGEMENT OF AWARD PROGRAM SERVICES OF OTHERS, NAMELY, PROMOTING THE SALE OF GOODS AND SERVICES OF OTHERS BY OFFERING CONSUMER DISCOUNTS FOR SERVICES, NAMELY, HOTEL, AIRLINE, CAR RENTAL, ENTERTAINMENT, RESTAURANT, AND SPORTS EVENTS SERVICES THROUGH USE OF A DISCOUNT MEMBERSHIP CARD; CREDIT BUREAU REPORT SERVICES IN THE NATURE OF FACILITATING CONSUMERS' PURCHASE OF CONSUMER CREDIT REPORTS, AND MONITORING CONSUMER CREDIT REPORTS AND PROVIDING AN ALERT AS TO ANY CHANGES.

FIRST USE 2-1-2004; IN COMMERCE 2-1-2004.

INT. CL. 39/U.S. CLS. 100 AND 105

FOR TRAVEL CLUB SERVICES, NAMELY, PROVIDING TRAVEL CLUBS FEATURING TRAVEL BOOKING SERVICES AND DISCOUNTS ON TRAVEL AND CAR RENTALS.

FIRST USE 2-1-2004; IN COMMERCE 2-1-2004.

INT. CL. 43/U.S. CLS. 100 AND 101

FOR RESTAURANT AND HOTEL RESERVATIONS.

FIRST USE 2-1-2004; IN COMMERCE 2-1-2004.

INT. CL. 45/U.S. CLS. 100 AND 101

FOR LOST PROPERTY RETURN SERVICES; SAFEGUARDING OF CREDIT CARDS, DEBIT CARDS, PAYMENT CARDS, CHARGE CARDS AND OTHER PLASTIC CARDS, NAMELY, FRAUD DETECTION AND RESOLUTION SERVICES; LOST PROPERTY RETURN SERVICES, NAMELY, PROPERTY RECOVERY AND RETRIEVAL; VALUABLE NUMBER REGISTRATION SERVICES, NAMELY, ASSIGNMENT OF MEMBERSHIP IDENTIFICATION NUMBERS TO AFFIX TO VALUABLES TO FACILITATE THEIR RECOVERY FOLLOWING LOSS OR THEFT; REMINDER SERVICES IN THE AREA OF UPCOMING IMPORTANT DATES AND EVENTS; IDENTITY THEFT SERVICES, NAMELY, FRAUD DETECTION SERVICES IN THE FIELD OF CREDIT CARDS; AND FRAUD RESOLUTION SERVICES, NAMELY, PROVIDING ADVICE AND CONSULTATION IN THE FIELD OF IDENTITY THEFT; IDENTITY AND FRAUD PREVENTION SERVICES, NAMELY, PROVIDING ADVICE AND CONSULTATION IN THE FIELD OF IDENTITY THEFT.

FIRST USE 2-1-2004; IN COMMERCE 2-1-2004.

ELEMENTS CORRECTED  
OWNER NAME  
ENTITY

# RAVVID

THE MARK CONSISTS OF STANDARD CHARACTERS WITHOUT CLAIM TO ANY PARTICULAR FONT, STYLE, SIZE, OR COLOR.

INT. CL. 35/U.S. CLS. 100, 101 AND 102

FOR ONLINE BUSINESS DIRECTORY SERVICES REGARDING THE PURCHASE AND SALE OF A WIDE VARIETY OF PRODUCTS AND SERVICES OF OTHERS; ADVERTISING AND MARKETING SERVICES.

FIRST USE 11-3-2009; IN COMMERCE 11-3-2009.

ELEMENTS CORRECTED  
CITIZENSHIP

3,799,829. REG. 6-8-2010. THE COMBS COMPANY (OREGON CORPORATION) 333 WEST ESTABROOK BLVD, GLENDALE, WI, 53212, SN 76-479,078. FILED 12-23-2002. PRINCIPAL REGISTER.

# BOGS

INT. CL. 25/U.S. CLS. 22 AND 39

FOR BOOTS AND SHOES.

FIRST USE 2-1-2003; IN COMMERCE 2-1-2003.

ELEMENTS CORRECTED  
OWNER NAME  
OWNER ADDRESS

3,805,583. REG. 6-22-2010. LOS ANGELES LAKERS, INC., THE (CALIFORNIA CORPORATION) SUITE 206, 555 NORTH NASH STREET, EL SEGUNDO, CA, 90245, SN 77-726,996. FILED 5-1-2009. PRINCIPAL REGISTER.



OWNER OF U.S. REG. NOS. 1,718,952, 3,101,429 AND OTHERS.

NO CLAIM IS MADE TO THE EXCLUSIVE RIGHT TO USE "LOS ANGELES" AND "GIRLS", APART FROM THE MARK AS SHOWN.

THE MARK CONSISTS OF A STYLIZED DESIGN OF A BASKETBALL AND LINES INDICATING SPEED OR MOTION.

INT. CL. 41/U.S. CLS. 100, 101 AND 107

FOR ENTERTAINMENT AND EDUCATIONAL SERVICES IN THE NATURE OF ONGOING TELEVISION AND RADIO PROGRAMS IN THE FIELD OF BASKETBALL AND RENDERING LIVE BASKETBALL GAMES AND BASKETBALL EXHIBITIONS; THE PRODUCTION AND DISTRIBUTION OF RADIO AND TELEVISION SHOWS FEATURING BASKETBALL GAMES, BASKETBALL EVENTS AND PROGRAMS IN THE FIELD OF BASKETBALL; CONDUCTING AND ARRANGING BASKETBALL CLINICS AND CAMPS, COACHES CLINICS AND CAMPS, DANCE TEAM CLINICS AND CAMPS AND BASKETBALL GAMES; ENTERTAINMENT SERVICES IN THE NATURE OF PERSONAL APPEARANCES BY A COSTUMED MASCOT, DANCE TEAM, CHEERLEADERS, OR PEP SQUAD AT BASKETBALL GAMES AND EXHIBITIONS, CLINICS, CAMPS, PROMOTIONS, AND OTHER BASKETBALL-RELATED EVENTS, SPECIAL EVENTS AND PARTIES; FAN CLUB SERVICES; ENTERTAINMENT SERVICES, NAMELY, PROVIDING A WEBSITE FEATURING MULTIMEDIA MATERIAL IN THE NATURE OF TELEVISION HIGHLIGHTS, INTERACTIVE TELEVISION HIGHLIGHTS, VIDEO RECORDINGS, VIDEO STREAM RECORDINGS, INTERACTIVE VIDEO HIGHLIGHT SELECTIONS, RADIO PROGRAMS, RADIO HIGHLIGHTS, AND AUDIO RECORDINGS IN THE FIELD OF BASKETBALL; PROVIDING NEWS AND INFORMATION IN THE NATURE OF STATISTICS AND TRIVIA IN THE FIELD OF BASKETBALL; ON-LINE NON-DOWNLOADABLE GAMES, NAMELY, COMPUTER GAMES, VIDEO GAMES, INTERACTIVE VIDEO GAMES, ACTION SKILL GAMES, ARCADE GAMES, ADULTS' AND CHILDREN'S PARTY GAMES, BOARD GAMES, PUZZLES, AND TRIVIA GAMES; ELECTRONIC PUBLISHING SERVICES, NAMELY, PUBLICATION OF MAGAZINES, GUIDES, NEWSLETTERS, COLORING BOOKS, AND GAME SCHEDULES OF OTHERS ON-LINE THROUGH THE INTERNET, ALL IN THE FIELD OF BASKETBALL; PROVIDING AN ONLINE COMPUTER DATABASE IN THE FIELD OF BASKETBALL.

FIRST USE 6-1-2008; IN COMMERCE 6-1-2008.

ELEMENTS CORRECTED  
OWNER NAME  
OWNER ADDRESS

---

3,809,934. REG. 6-29-2010. ARISTOTLE CIRCLE, INC. (DELAWARE CORPORATION) 2ND FLOOR, 419 LAFAYETTE STREET, NEW YORK, NY, 10003, SN 77-851,573. FILED 10-19-2009. PRINCIPAL REGISTER.

## ARISTOTLE CIRCLE

THE MARK CONSISTS OF STANDARD CHARACTERS WITHOUT CLAIM TO ANY PARTICULAR FONT, STYLE, SIZE, OR COLOR.

INT. CL. 41/U.S. CLS. 100, 101 AND 107

FOR ADMISSION CONSULTING SERVICES, NAMELY, CONSULTING IN THE FIELD OF COLLEGE AND PRIVATE SCHOOL ADMISSIONS, SPECIFICALLY, COLLEGE AND PRIVATE SCHOOLS SELECTION, COMPLETING ADMISSIONS APPLICATIONS, AND PREPARATION FOR COLLEGE AND PRIVATE SCHOOL ADMISSION INTERVIEWS.

FIRST USE 9-26-2008; IN COMMERCE 1-29-2009.

ELEMENTS CORRECTED  
OWNER NAME

3,811,067. REG. 6-29-2010. GIELEN KRIS ZULMA JOS (BELGIUM INDIVIDUAL) NEERSTRAAT 15, B-3560 LUMMEN, BELGIUM., AND HEIDEN, KENT RICHARD (UNITED STATES INDIVIDUAL) ARROYO VISTA DRIVE 28, GOLETA, CA 93117, UNITED STATES., SN 79-070,121. FILED 1-28-2009. PRINCIPAL REGISTER.



OWNER OF INTERNATIONAL REGISTRATION 1005760 DATED 1-28-2009, EXPIRES 1-28-2019.

THE COLOR(S) BLACK, GREY, WHITE IS/ARE CLAIMED AS A FEATURE OF THE MARK.

THE MARK CONSISTS OF THE WORDING "TIMEBEADS .... FOR THE TIME OF YOUR LIFE" AND THE DESIGN OF A CLOCK APPEARING TO THE RIGHT OF THE WORD "TIMEBEADS". THE COLOR BLACK APPEARS ON THE WORD "TIMEBEADS" AND ON THE CLOCK HANDS. THE COLOR GRAY APPEARS ON THE WORDING "FOR THE TIME OF YOUR LIFE", ON THE OUTLINE OF THE CLOCK, AND ON THE NUMBERS APPEARING ON THE CLOCK FACE. THE COLOR WHITE APPEARS ON THE CLOCK FACE.

INT. CL. 14/U.S. CLS. 2, 27, 28 AND 50

FOR WATCHES, TIMEPIECES AND CHRONOMETRIC INSTRUMENTS, JEWELLERY, COSTUME JEWELLERY AND PRECIOUS STONES; PRECIOUS METALS AND THEIR ALLOYS.

INT. CL. 35/U.S. CLS. 100, 101 AND 102

FOR ADVERTISING; BUSINESS MANAGEMENT; BUSINESS ADMINISTRATION; DISSEMINATION OF ADVERTISING MATERIAL; COMPILATION OF STATISTICS; ACCOUNTING; ARRANGING AUCTIONS AND CONDUCTING PUBLIC AUCTION SALES; BUSINESS INFORMATION FOR CONSUMERS; MARKET STUDIES AND RESEARCH AND ANALYSIS RELATED THERETO; SHOP-WINDOW DRESSING; ADVISORY SERVICES FOR BUSINESS ORGANIZATION AND MANAGEMENT; RETAIL STORE SERVICES FEATURING WATCHES, TIMEPIECES, CHRONOMETRIC INSTRUMENTS, JEWELLERY, COSTUME JEWELLERY, PRECIOUS STONES, PRECIOUS METALS AND THEIR ALLOYS; COMMERCIAL INTERMEDIARY SERVICES, NAMELY, WHOLESALE STORE SERVICES FEATURING WATCHES, TIMEPIECES, CHRONOMETRIC INSTRUMENTS, JEWELLERY, COSTUME JEWELLERY, PRECIOUS STONES, PRECIOUS METALS AND THEIR ALLOYS.

ELEMENTS CORRECTED  
CITIZENSHIP

---

3,819,670. REG. 7-13-2010. YOE ENTERPRISES OF NEVADA, INC. (NEVADA CORPORATION) 7823 STONEHEDGE DRIVE, CHATTANOOGA, TN, 37421, SN 77-796,223. FILED 8-4-2009. PRINCIPAL REGISTER.

The logo for FITS sock co. features the word "FITS" in a large, bold, black, sans-serif font. Below it, the words "sock co." are written in a smaller, lowercase, black, sans-serif font.

NO CLAIM IS MADE TO THE EXCLUSIVE RIGHT TO USE "SOCK CO.", APART FROM THE MARK AS SHOWN.

THE COLOR(S) BLACK IS/ARE CLAIMED AS A FEATURE OF THE MARK.



THE MARK CONSISTS OF THE WORDS "FITS SOCK CO." IN BLACK COLOR.  
INT. CL. 25/U.S. CLS. 22 AND 39  
FOR SOCKS .  
FIRST USE 11-12-2009; IN COMMERCE 11-17-2009.

FOR CHEMICAL ENGINE TREATMENTS AND ADDITIVES FOR ENGINE OILS, GASOLINE AND DIESEL FUELS, TRANSMISSION FLUIDS AND COOLING SYSTEMS .  
FIRST USE 1-10-2010; IN COMMERCE 1-10-2010.

ELEMENTS CORRECTED  
CITIZENSHIP

ELEMENTS CORRECTED  
OWNER NAME  
OWNER ADDRESS  
CITIZENSHIP  
ENTITY

3,828,755. REG. 8-3-2010. HOUSE FOODS CORPORATION (JAPAN CORPORATION) 1-5-7, MIKURIYA SAKAE-MACHI, HIGASHI-OSAKA, OSAKA, JAPAN., SN 77-359,613. FILED 12-26-2007. PRINCIPAL REGISTER.

3,855,110. REG. 9-28-2010. GREAT BASIN GOLD LIMITED (CANADA COMPANY) 1020 - 800 WEST PENDER STREET, VANCOUVER, CANADA, V6C2V6, SN 77-122,339. FILED P.R. 3-5-2007; AM. S.R. 8-5-2010. SUPPLEMENTAL REGISTER.

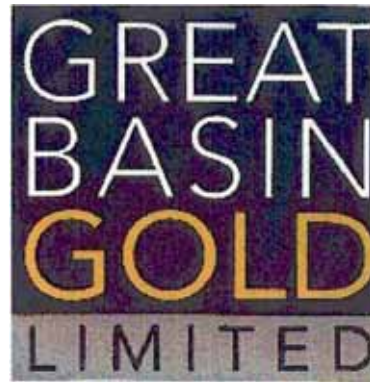

NO CLAIM IS MADE TO THE EXCLUSIVE RIGHT TO USE "UKON" AND THE REPRESENTATION OF TURMERIC, APART FROM THE MARK AS SHOWN.

THE MARK CONSISTS OF JAPANESE CHARACTERS ABOVE AND BELOW THE WORDS "UKON NO CHIKARA" IN A STYLIZED FONT, AND AN IMAGE OF A ROOT IN THE LOWER RIGHT CORNER.

THE NON-LATIN CHARACTERS IN THE MARK TRANSLITERATE TO "UKON NO CHIKARA", AND THIS MEANS THE POWER OF TURMERIC OR THE STRENGTH OF TURMERIC OR THE ENERGY OF TURMERIC IN ENGLISH.

INT. CL. 5/U.S. CLS. 6, 18, 44, 46, 51 AND 52  
FOR DIETARY SUPPLEMENTAL DRINKS.  
FIRST USE 5-17-2004; IN COMMERCE 3-15-2010.  
INT. CL. 32/U.S. CLS. 45, 46 AND 48  
FOR SOFT DRINKS.  
FIRST USE 5-17-2004; IN COMMERCE 3-15-2010.

OWNER OF SOUTH AFRICA REG. NO. 200703027, DATED 2-15-2007, EXPIRES 2-15-2017.

OWNER OF SOUTH AFRICA REG. NO. 200703026, DATED 2-15-2007, EXPIRES 2-15-2017.

NO CLAIM IS MADE TO THE EXCLUSIVE RIGHT TO USE "GOLD LIMITED", APART FROM THE MARK AS SHOWN.

THE COLOR(S) WHITE, GOLD, BLACK, GRAY IS/ARE CLAIMED AS A FEATURE OF THE MARK.

THE MARK CONSISTS OF THE WORDS "GREAT BASIN" IN WHITE AND "GOLD" IN GOLD AGAINST A BLACK BACKGROUND, AND "LIMITED" IN BLACK AGAINST A GRAY BACKGROUND.

INT. CL. 37/U.S. CLS. 100, 103 AND 106  
FOR REPAIR AND INSTALLATION OF MINING EXTRACTION MACHINES AND APPARATUS.

INT. CL. 42/U.S. CLS. 100 AND 101  
FOR SCIENTIFIC AND TECHNOLOGICAL SERVICES AND RESEARCH AND DESIGN RELATING THERETO IN THE FIELD OF MINING; INDUSTRIAL ANALYSIS AND RESEARCH SERVICES IN THE FIELD OF MINING; DESIGN AND DEVELOPMENT OF COMPUTER HARDWARE AND SOFTWARE.

ELEMENTS CORRECTED  
OWNER ADDRESS

ELEMENTS CORRECTED  
\*FOREIGN COUNTRY OF ORIGIN\*  
\*FOREIGN REG. NO.\*  
\*FOREIGN REG. DATE\*  
\*FOREIGN REG. EXPIRATION DATE\*

3,844,653. REG. 9-7-2010. SOLID START, LLC (DELAWARE LIMITED LIABILITY COMPANY) 3705 HIGHWAY 98 SOUTH, SUITE 8-12, LAKELAND, FL, 33812, SN 77-925,539. FILED 2-2-2010. PRINCIPAL REGISTER.

SS SOLID START

THE MARK CONSISTS OF STANDARD CHARACTERS WITHOUT CLAIM TO ANY PARTICULAR FONT, STYLE, SIZE, OR COLOR.  
INT. CL. 1/U.S. CLS. 1

3,862,463. REG. 10-19-2010. YANG ZIJUN (CHINA INDIVIDUAL) DASHI TOWN, PANYU CITY, 22-3-202 NANJIE JIXIANG BEIYUAN LUOCHENG, GUANGDONG PROVINCE. CHINA., SN 77-607,111. FILED 11-4-2008. PRINCIPAL REGISTER.

**DGMCON**

THE MARK CONSISTS OF STANDARD CHARACTERS WITHOUT CLAIM TO ANY PARTICULAR FONT, STYLE, SIZE, OR COLOR.

OWNER OF CHINA REG. NO. 370212, DATED 5-14-2005, EXPIRES 5-13-2015.

INT. CL. 9/U.S. CLS. 21, 23, 26, 36 AND 38

FOR TELEVISIONS, LOUDSPEAKER ENCLOSURES, VIDEO RECORDERS, AMPLIFIERS, ELECTRIC GRAMOPHONES, MICROPHONES, ACOUSTIC CONNECTORS, NAMELY, ELECTRIC CONNECTORS FOR USE WITH ACOUSTIC EQUIPMENT, VIDEO DISC PLAYERS, VIDEO CAMERAS, SOUND TRANSMITTING APPARATUS.

FIRST USE ; IN COMMERCE .

ELEMENTS CORRECTED  
OWNER NAME

---

3,862,840. REG. 10-19-2010. WINDMILLS MARKETING, LLC (CALIFORNIA LIMITED LIABILITY COMPANY) 1280 BISON AVE., B9-373, NEWPORT BEACH, CA, 92660, SN 77-830,348. FILED 9-18-2009. PRINCIPAL REGISTER.



NO CLAIM IS MADE TO THE EXCLUSIVE RIGHT TO USE "NETWORKING", APART FROM THE MARK AS SHOWN.

THE MARK CONSISTS OF A FANCIFUL GRAPHIC REPRESENTATION OF A WINDMILL INSIDE A PARTIALLY SHADED SQUARE WITH CURVED CORNERS, AND A SILHOUETTE OF A PERSON STANDING NEXT TO THE WINDMILL, WITH THE WORDING, "WINDMILL" TO THE RIGHT, WITH "NETWORKING" BELOW.

INT. CL. 35/U.S. CLS. 100, 101 AND 102

FOR BUSINESS CONSULTATION IN THE FIELD OF INTERNET-BASED SOCIAL MEDIA AND SOCIAL NETWORKING TECHNOLOGY.

FIRST USE 7-8-2009; IN COMMERCE 7-8-2009.

ELEMENTS CORRECTED  
\*OWNER NAME\*  
\*OWNER ADDRESS\*  
\*CITIZENSHIP\*  
\*ENTITY\*

3,863,120. REG. 10-19-2010. TRINITY COLON & RECTAL SURGERY CLINIC, PA (TEXAS PROFESSIONAL ASSOCIATION) 777 E. WHEATLAND RD., STE. 105, DUNCANVILLE, TX, 75116, SN 77-902,245. FILED 12-29-2009. PRINCIPAL REGISTER.

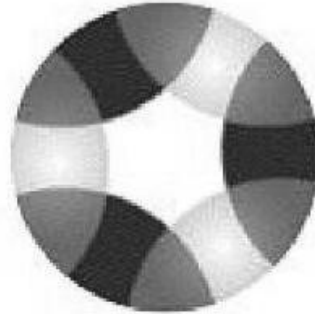

THE MARK CONSISTS OF A STYLIZED CIRCULAR DESIGN WHEREIN A TOTAL OF SIX OVERLAPPING SEMI CIRCULAR DESIGNS OVERLAP TO FORM APPLICANT'S OVERALL STYLIZED CIRCULAR LOGO CONFIGURATION.

INT. CL. 44/U.S. CLS. 100 AND 101

FOR MEDICAL SERVICES, NAMELY, CONSULTATION AND TREATMENT OF COLON AND RECTAL DISORDERS; PROVIDING MINIMALLY INVASIVE AND ENDOSCOPIC SURGICAL PROCEDURES IN THE FIELD OF COLON AND RECTAL DISORDERS.

FIRST USE 4-29-2009; IN COMMERCE 4-29-2009.

ELEMENTS AMENDED  
OWNER ADDRESS

---

3,866,221. REG. 10-26-2010. BBH PARTNERS LLP (UNITED KINGDOM LIMITED PARTNERSHIP) 60 KINGLY STREET, SOHO, LONDON, UNITED KINGDOM, W1B5DS, SN 77-088,803. FILED 1-23-2007. PRINCIPAL REGISTER.



PRIORITY CLAIMED UNDER SEC. 44(D) ON ERPNCMNTY TM OFC APPLICATION NO. 5625892, FILED 1-18-2007, REG. NO. 005625892, DATED 6-13-2008, EXPIRES 1-18-2017.

THE COLOR(S) BLACK AND RED IS/ARE CLAIMED AS A FEATURE OF THE MARK.

THE COLOR BLACK APPEARS IN THE DEPICTION OF A SHEEP. THE COLOR RED APPEARS IN THE DOTS UNDERNEATH THE DEPICTION OF A SHEEP.

INT. CL. 9/U.S. CLS. 21, 23, 26, 36 AND 38

FOR DOWNLOADABLE ELECTRONIC PUBLICATIONS IN THE NATURE OF BOOKS, MAGAZINES, MANUALS, BROCHURES, FLIERS, NEWSLETTERS, ONLINE JOURNALS, NAMELY, BLOGS IN THE FIELDS OF ADVERTISING, PUBLIC RELATIONS, MARKETING AND MARKET RESEARCH, ADVERTISING SALES, AND SALES PROMOTION; VIDEO DISCS, AUDIO DISCS, CASSETTES, DVDS, AND CD ROMS FEATURING MUSIC, ADVERTISEMENTS, COMPUTER GAMES AND MOTION PICTURE FILMS IN THE FIELDS OF ADVERTISING, PUBLIC RELATIONS, MARKETING, BRANDING, MARKET RESEARCH AND ADVERTISING INDUSTRY AWARDS; DIGITAL AUDIO TAPES FEATURING MUSIC AND SPOKEN WORD IN THE FIELDS OF ADVERTISING, PUBLIC RELATIONS, MARKETING, BRANDING, MARKET RESEARCH AND ADVERTISING INDUSTRY AWARDS; DIGITAL AUDIO RECORDINGS STORED IN DIGITAL OR ANALOGUE FORM IN THE FIELD OF ADVERTISING, PUBLIC RELATIONS, MARKETING, BRANDING, MARKET RESEARCH AND ADVERTISING INDUSTRY AWARDS; MOTION PICTURE FILMS ABOUT ADVERTISING, PUBLIC RELATIONS, MARKETING, BRANDING, MARKET RESEARCH AND ADVERTISING INDUSTRY AWARDS; AUDIO AND VISUAL RECORDINGS FEATURING ADVERTISEMENTS FOR OTHERS; PRE-RECORDED MAGNETIC DATA CARRIERS FEATURING EXAMPLES OF PROPOSED ADVERTISING, PUBLIC RELATIONS AND MARKETING CAMPAIGNS; BLANK MAGNETIC DATA CARRIERS; MAGNETIC DATA CARRIERS FEATURING PRE-RECORDED SOUNDS, IMAGES, FILMS AND INTERACTIVE PROGRAMS IN THE FIELD OF ADVERTISING, PUBLIC RELATIONS, MARKETING AND MARKET RESEARCH, ADVERTISING SALES, AND SALES PROMOTION; APPARATUS AND MEDIA FOR STORAGE OF SOUNDS AND IMAGES, NAMELY, DONGLES; MAGNETICALLY ENCODED CARDS CARRYING FILES AND IMAGES RELATING TO ADVERTISING, PUBLIC RELATIONS AND MARKETING; COMPUTER GAMES SOFTWARE; VIDEO OR DIGITAL RECORDINGS OF TELEVISION PROGRAMS USED FOR ADVERTISING, PUBLIC RELATIONS AND MARKETING PURPOSES.

FIRST USE ; IN COMMERCE .

INT. CL. 16/U.S. CLS. 2, 5, 22, 23, 29, 37, 38 AND 50

FOR PRINTED MATTER, NAMELY, BOOKS, MAGAZINES, MANUALS, BROCHURES, FLIERS, NEWSLETTERS, POSTERS, COASTERS, PERIODICALS AND CATALOGUES IN THE FIELD OF ADVERTISING, PUBLIC RELATIONS, MARKETING AND MARKET RESEARCH, ADVERTISING SALES, AND SALES PROMOTION; STATIONERY; CALENDARS; DIARIES; PRINTED GRAPHS; PRINTED ADVERTISING STORY BOARDS OF PAPER OR CARDBOARD; POSTERS; PICTURES; PRINTED INSTRUCTIONAL AND TEACHING MATERIALS IN THE FIELD OF ADVERTISING, PUBLIC RELATIONS, MARKETING AND MARKET RESEARCH, ADVERTISING SALES, AND SALES PROMOTION .

FIRST USE ; IN COMMERCE .

INT. CL. 35/U.S. CLS. 100, 101 AND 102

FOR ADVERTISING AND PROMOTIONAL SERVICES; MARKETING SERVICES; PUBLIC RELATIONS SERVICES; SALES PROMOTION SERVICES; MARKET RESEARCH; PRODUCTION OF TELEVISION, RADIO AND INTERNET COMMERCIALS; ADVERTISING AGENCIES, NAMELY, PLANNING, BUYING AND NEGOTIATING ADVERTISING SPACE FOR OTHERS; COMMERCIAL INFORMATION AGENCY SERVICES; ECONOMIC FORECASTING; BUSINESS ENQUIRY AND INVESTIGATIONS; CONDUCTING MARKETING STUDIES; PUBLIC OPINION POLLING; PUBLICATION OF PUBLICITY TEXTS; PROVIDING RADIO AND TELEVISION ADVERTISING FOR OTHERS; ORGANIZATION OF EXHIBITIONS FOR COMMERCIAL OR ADVERTISING PURPOSES; INFORMATION AND ADVISORY SERVICES ALL RELATED TO THE AFORESAID SERVICES.

FIRST USE ; IN COMMERCE .

ELEMENTS CORRECTED

\*OWNER NAME\*  
\*OWNER ADDRESS\*  
\*CITIZENSHIP\*  
\*ENTITY\*

3,871,286. REG. 11-2-2010. YOE ENTERPRISES OF NEVADA, INC (NEVADA CORPORATION) 7823 STONEHEDGE DRIVE, CHATTANOOGA, TN, 37421, SN 77-783,717. FILED 7-17-2009. PRINCIPAL REGISTER.

# FITS

THE MARK CONSISTS OF STANDARD CHARACTERS WITHOUT CLAIM TO ANY PARTICULAR FONT, STYLE, SIZE, OR COLOR.

INT. CL. 25/U.S. CLS. 22 AND 39

FOR SOCKS, EXCLUDING WOMEN'S PANTYHOSE, SHEER HOSIERY, AND WOMEN'S SHEER STOCKINGS. FIRST USE 11-12-2009; IN COMMERCE 11-17-2009.

ELEMENTS CORRECTED  
CITIZENSHIP

3,873,890. REG. 11-9-2010. STERLING NATIONAL BANK (UNITED STATES NATIONAL BANKING ASSOCIATION) 650 FIFTH AVENUE, NEW YORK, NY, 10019, SN 77-521,739. FILED 7-14-2008. PRINCIPAL REGISTER.

## STERLING RESOURCE FUNDING

THE MARK CONSISTS OF STANDARD CHARACTERS WITHOUT CLAIM TO ANY PARTICULAR FONT, STYLE, SIZE, OR COLOR.

OWNER OF U.S. REG. NOS. 3,024,420 AND 3,465,765.

NO CLAIM IS MADE TO THE EXCLUSIVE RIGHT TO USE "RESOURCE FUNDING", APART FROM THE MARK AS SHOWN.

INT. CL. 36/U.S. CLS. 100, 101 AND 102

FOR FINANCIAL SERVICES PROVIDED TO THE STAFFING INDUSTRY, NAMELY, ADVANCING CASH FUNDS TO PROCESS EMPLOYEE PAYROLL, TAX WITHHOLDING, NAMELY, PAYROLL TAX DEBITING SERVICES, AND ACCOUNTS RECEIVABLE FINANCING.

FIRST USE 4-18-2006; IN COMMERCE 4-18-2006.

ELEMENTS CORRECTED  
CITIZENSHIP

3,876,479. REG. 11-16-2010. FRUTAROM NETHERLANDS B.V. (NETHERLANDS A DUTCH LTD. COMPANY UNDER THE LAWS OF NETHERLANDS) LANDJUWEL 5, NL-3905 PE VEENENDAAL, NETHERLANDS., SN 79-077,938. FILED 9-15-2009. PRINCIPAL REGISTER.

# PORTUSANA

THE MARK CONSISTS OF STANDARD CHARACTERS WITHOUT CLAIM TO ANY PARTICULAR FONT, STYLE, SIZE, OR COLOR.

PRIORITY DATE OF 3-30-2009 IS CLAIMED.

OWNER OF INTERNATIONAL REGISTRATION 1026517 DATED 9-15-2009, EXPIRES 9-15-2019.

INT. CL. 5/U.S. CLS. 6, 18, 44, 46, 51 AND 52

FOR EXTRACTS, CONCENTRATES, PREPARATIONS AND SUPPLEMENTS MADE FROM PURSLANE SOLD AS INTEGRAL INGREDIENTS OF DIETARY SUPPLEMENTS AND FOR USE AS DIETARY SUPPLEMENTS FOR MEDICAL PURPOSES, NAMELY, FOR BLOOD GLUCOSE REGULATION AND WEIGHT MANAGEMENT.

FIRST USE ; IN COMMERCE .  
INT. CL. 30/U.S. CL. 46

FOR \* VEGETABLE EXTRACTS IN SOLID OR LIQUID FORM IN THE NATURE OF \* MEAL MADE OF EXTRACTS OF PURSLANE AND FLOUR MADE OF EXTRACTS OF PURSLANE; POWDER AND LIQUID EXTRACTS, CONCENTRATES, PREPARATIONS AND SUPPLEMENTS MADE OF PURSLANE FOR USE IN MANUFACTURE OF NUTRITIONAL AND FOOD SUPPLEMENTS.

FIRST USE ; IN COMMERCE .

ELEMENTS CORRECTED  
GOODS/SERVICES

3,878,161. REG. 11-16-2010. DR. SEUSS ENTERPRISES, L.P. (CALIFORNIA LIMITED PARTNERSHIP) 1200 PROSPECT STREET, SUITE 575, C/O KARL ZOBELL, ESQ. DLA PIPER LLP (US), LA JOLLA, CA. 920373610, SN 77-980,426. FILED 7-25-2008. PRINCIPAL REGISTER.

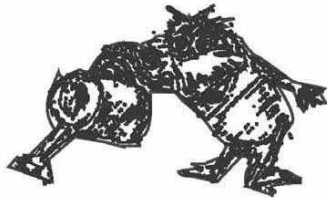

THE MARK CONSISTS OF A STYLIZED DRAWING OF A FURRY CREATURE HOLDING A WATERING CAN.

INT. CL. 16/U.S. CLS. 2, 5, 22, 23, 29, 37, 38 AND 50  
FOR PRINTED MATERIALS, NAMELY, CHILDREN'S BOOKS; PAPER PRODUCTS, NAMELY, PRINTER PAPER, COPY PAPER, LINED WRITING PAPER, ENVELOPES, PAPER BAGS, GIFT WRAPPING PAPER, NEWSLETTERS IN THE FIELD OF ENVIRONMENTAL ISSUES AND CONCERNS, STICKERS, CALENDARS; GREETING CARDS; NOTEBOOKS; STATIONERY.

FIRST USE 3-0-2009; IN COMMERCE 3-0-2009.

ELEMENTS CORRECTED  
MARK

3,878,472. REG. 11-23-2010. YONDER BERRIES LIMITED (UNITED KINGDOM COMPANY) LUSTLEIGH, NEWTON ABBOT, DEVON, UNITED KINGDOM, TQ139SQ, SN 77-651,257. FILED 1-16-2009. PRINCIPAL REGISTER.

## THE BLUEBERRY BROTHERS

THE MARK CONSISTS OF STANDARD CHARACTERS WITHOUT CLAIM TO ANY PARTICULAR FONT, STYLE, SIZE, OR COLOR.

OWNER OF UNITED KINGDOM REG. NO. 2437259, DATED 10-31-2006, EXPIRES 10-31-2016.

NO CLAIM IS MADE TO THE EXCLUSIVE RIGHT TO USE "BLUEBERRY", APART FROM THE MARK AS SHOWN.

INT. CL. 29/U.S. CL. 46

FOR PRESERVED, DRIED AND COOKED FRUITS AND VEGETABLES; JELLIES, JAMS, MARMALADES, FRUIT PRESERVES; FRUIT SAUCES, NAMELY, CRANBERRY SAUCES, BLUEBERRY SAUCES, APPLESAUCE, AND FRUIT TOPPINGS; FRUIT PUREES AND COMPOSTES; EXTRACTS OF FRUIT AND/OR VEGETABLES; MILK PRODUCTS EXCLUDING ICE CREAM, ICE MILK AND FROZEN YOGURT; YOGURTS, DRINKING YOGURTS, FRUIT AND VEGETABLE BASED SPREADS CONSISTING WHOLLY OR SUBSTANTIALLY OF FRUITS OR VEGETABLES; DESSERTS, NAMELY, FRUIT SALADS, FROSTED FRUITS, AND DAIRY-BASED SNACK FOODS EXCLUDING ICE CREAM, ICE MILK AND FROZEN YOGURT; FRUIT DESSERTS, NAMELY, CANDIED FRUITS, CANDIED FRUIT SNACKS, CRYSTALLIZED FRUITS AND GLAZED FRUITS.

FIRST USE ; IN COMMERCE .

INT. CL. 30/U.S. CL. 46

FOR FROZEN DESSERTS CONSISTING OF FRUIT AND CREAM OR CREAM SUBSTITUTES AND FROZEN SOY-BASED DESSERTS; SORBETS, SHERBETS; ICE CREAM; ICE CREAM PRODUCTS, NAMELY, ICE CREAM SANDWICHES AND ICE CREAM CAKES; ICE CREAM STICK BARS; ICES, NAMELY, FRUIT ICES, FRUIT ICE BARS, FRUIT-FLAVORED ICES, ICE FOR REFRESHMENT AND SHAVED ICE CONFECTIONS; SAUCES; TOPPINGS, NAMELY, CHOCOLATE TOPPINGS, MARSHMALLOW TOPPINGS, AND TOPPING SYRUPS; ESSENCES, NAMELY, EXTRACTS USED AS FLAVORING FOR FOODSTUFFS; FLAVORINGS OTHER THAN ESSENTIAL OILS; FROZEN YOGURTS; MOUSSES, NAMELY, CHOCOLATE MOUSSES, FRUIT MOUSSES AND DESSERT MOUSSES; SWEET SPREADS, NAMELY, COCOA SPREADS, SPREADS CONTAINING CHOCOLATE AND FRUITS, AND SPREADS CONTAINING CHOCOLATE AND NUTS; FRUIT JELLIES; PUDDINGS; NATURAL SWEETENERS AND VANILLA; PASTRY, BISCUITS, CAKES, COOKIES; PIES, TARTS; CONFECTIONERY, NAMELY, FONDANTS, FROZEN CONFECTIONERY, FRUIT PASTILLES, CHOCOLATE-COVERED FRUITS, AND PEPPERMINT FOR CONFECTIONERY; CANDY; DESSERTS, NAMELY, BAKERY DESSERTS, DESSERT MOUSSES, DESSERT PUDDINGS, AND DESSERT SOUFFLES.

FIRST USE ; IN COMMERCE .

INT. CL. 31/U.S. CLS. 1 AND 46

FOR FRESH FRUIT AND VEGETABLES; SEEDS, NAMELY, FRUIT SEEDS, GRASS SEEDS, HERB SEEDS FOR PLANTING, PLANT SEEDS, AND VEGETABLE SEEDS FOR PLANTING; NATURAL PLANTS AND LIVE BUSHES.

FIRST USE ; IN COMMERCE .

INT. CL. 32/U.S. CLS. 45, 46 AND 48

FOR DRINKING WATERS, FLAVORED WATERS, MINERAL AND AERATED WATERS; NON-ALCOHOLIC BEVERAGES, NAMELY, CARBONATED BEVERAGES, NON-ALCOHOLIC FRUIT JUICE BEVERAGES, NON-ALCOHOLIC BEVERAGES WITH FRUIT FLAVORS, NON-ALCOHOLIC BEVERAGES WITH TEA FLAVOR, AND NON-ALCOHOLIC MALT BEVERAGES; SOFT DRINKS; FRUIT DRINKS AND JUICES; SYRUPS FOR MAKING BEVERAGES; CONCENTRATES FOR MAKING FLAVORED WATERS, FRUIT DRINKS, SOFT DRINKS AND NON-ALCOHOLIC BEVERAGES.

FIRST USE ; IN COMMERCE .

INT. CL. 35/U.S. CLS. 100, 101 AND 102

FOR THE BRINGING TOGETHER, FOR THE BENEFIT OF OTHERS, OF A VARIETY OF FOODS AND FOOD PRODUCTS, FRUIT AND VEGETABLES AND NON-ALCOHOLIC DRINKS, WATERS AND BEVERAGES, ENABLING CUSTOMERS TO CONVENIENTLY VIEW AND PURCHASE THOSE GOODS FROM A MAIL ORDER CATALOG, BY MEANS OF TELECOMMUNICATIONS AND VIA AN INTERNET WEBSITE; ONLINE RETAIL STORE SERVICES, RETAIL KIOSK SERVICES, RETAIL STAND SERVICES AND RETAIL STORE SERVICES FEATURING FOOD AND FOOD PRODUCTS, FRUIT AND VEGETABLES, NATURAL PLANTS AND BUSHES, NON-ALCOHOLIC DRINKS, WATERS AND BEVERAGES; ADVISORY AND CONSULTANCY SERVICES IN THE FIELD OF MARKETING AND SUPPLY CHAIN MANAGEMENT SERVICES.

FIRST USE ; IN COMMERCE .

ELEMENTS CORRECTED  
FOREIGN REG. EXPIRATION DATE

3,884,805. REG. 12-7-2010. OVIBELL PFLANZEN, DEKO UND FREIZEIT GMBH & CO. KG (FED REP GERMANY CORPORATION) STEINSHOFFWEG 2, MULHEIM, FED REP GERMANY, 45479, SN 77-756,256. FILED 6-10-2009. PRINCIPAL REGISTER.

# OVIBELL

THE MARK CONSISTS OF STANDARD CHARACTERS WITHOUT CLAIM TO ANY PARTICULAR FONT, STYLE, SIZE, OR COLOR.

OWNER OF FED REP GERMANY REG. NO. 30641870, DATED 10-20-2006, EXPIRES 7-31-2016.

INT. CL. 6/U.S. CLS. 2, 12, 13, 14, 23, 25 AND 50

FOR GOODS OF METAL FOR KEEPING ANIMALS, NAMELY, ANIMAL ENCLOSURES, ANIMAL GATES FOR USE IN AUTOMOBILES; MAILBOXES OF METAL; METAL GUTTER GUARDS; ANIMAL ENCLOSURES, NAMELY, METAL ANIMAL CAGES FOR WILD ANIMALS FOR USE IN AUTOMOBILES.

FIRST USE ; IN COMMERCE .

INT. CL. 8/U.S. CLS. 23, 28 AND 44

FOR HAND TOOLS AND HAND OPERATED IMPLEMENTS FOR HOUSEHOLD AND GARDEN, NAMELY, SCISSORS, PIZZA CUTTERS, FILES AND RASPS SOLD INDIVIDUALLY OR AS A SET, DRILL BITS FOR HAND DRILLS, LOCK JAW PLIERS SOLD INDIVIDUALLY OR AS A SET, MAULS, HAND-POWERED STAPLE GUNS, HEX KEY WRENCHES SOLD INDIVIDUALLY OR AS A SET, CHISELS SOLD INDIVIDUALLY OR AS A SET, VICES, DRILLS AND BITS SOLD INDIVIDUALLY OR AS A SET, HAMMERS SOLD INDIVIDUALLY OR AS A SET, SCREWDRIVERS SOLD INDIVIDUALLY OR AS A SET, PLIERS, BOLT CUTTERS, HOLE SAWS SOLD INDIVIDUALLY OR AS A SET, PIPE CLEANERS, NAIL CLIPPERS, QUICK CLAMPS, SPRING CLAMPS, F-CLAMPS, G-CLAMPS, RIVETERS, SAWS SOLD INDIVIDUALLY OR AS A SET, SLEDGE HAMMERS, HAND OPERATED LIFTING JACKS, GARDENING SHEARS, TREE CUTTERS, PRUNING SHEARS, GARDENING TOOLS SOLD INDIVIDUALLY OR AS A SET, NAMELY, A SHOVEL, RAKE AND SHEARS; CUTLERY, FLATWARE.

FIRST USE ; IN COMMERCE .

INT. CL. 18/U.S. CLS. 1, 2, 3, 22 AND 41

FOR LEATHER AND IMITATIONS OF LEATHER AS WELL AS GOODS MADE OF THESE MATERIALS, ALSO FOR ANIMAL HUSBANDRY AND ANIMAL CARE, NAMELY, TOOL POUCHES SOLD EMPTY, PET RESTRAINING DEVICES CONSISTING OF LEASHES AND DOG COLLARS; TRUNKS AND TRAVELLING BAGS, VANITY CASES SOLD EMPTY; UMBRELLAS, PARASOLS AND WALKING STICKS; SADDLERY.

FIRST USE ; IN COMMERCE .

INT. CL. 20/U.S. CLS. 2, 13, 22, 25, 32 AND 50

FOR FURNITURE, MIRRORS, PICTURE FRAMES; FURNITURE FITTINGS NOT OF METAL; MATTRESSES NOT FOR MEDICAL USE; SLEEPING BAGS FOR CAMPING; MAILBOXES NOT OF METAL AND NOT OF BRICKWORK; GOODS OF PLASTICS, WOOD, CORK, REED, CANE, WICKER, HORN, BONE, IVORY, WHALEBONE, SHELL, AMBER, MOTHER-OF-PEARL, MEERSCHAUM AND SUBSTITUTES FOR ALL THESE MATERIALS, NAMELY, COAT RACKS, GARMENT HOOKS, MOLDED EASTER EGGS, CURTAIN RAILS, CLOTHES HANGERS, TISSUE BOX COVERS, TOWEL RACKS, STORAGE RACKS, CUPBOARDS, STORAGE RACKS WITH DRAWERS, DOOR STOPS AND WEDGES, FOLDING TABLES, SET OF UTILITY HOOKS, ROLLERS FOR SUPPORTING AND TRANSPORTING FURNITURE AND OTHER HEAVY ITEMS, CLAMPS AND STRAPS FOR ORGANIZING, HOLDING AND CONNECTING CABLE AND WIRING, HOSE CLIPS, FITTED COVERS FOR GARDEN CHAIRS, MATS FOR USE AS KNEELING PADS, KNEELERS FOR GARDENING, GOODS FOR DECORATION NOT OF TEXTILE MATERIAL, NAMELY, DECORATIVE FIGURES, DECORATIVE EGGS, OUTDOOR ORNAMENTS, DECORATIVE BALLS, HOLIDAY ORNAMENTS, ORNAMENTS OF STRAW; ANIMAL ENCLOSURES, NAMELY, DOG KENNELS; TABLE CLOTH HOLDERS, NAMELY, NON-METAL CLIPS FOR ATTACHING TABLE CLOTHS TO TABLES; CLOTHES HANGERS.

FIRST USE ; IN COMMERCE .

INT. CL. 21/U.S. CLS. 2, 13, 23, 29, 30, 33, 40 AND 50

FOR SMALL, NON-ELECTRIC HOUSEHOLD OR GARDEN UTENSILS AND ITEMS NOT OF PRECIOUS METAL OR COATED THEREWITH, NAMELY, CANDLE HOLDERS, POTPOURRI BURNER, SOAP DISPENSERS, TOILET ROLL HOLDERS, CAKE PANS, CAKE RINGS, NON-PAPER AND NON-TABLE LINEN COASTERS, TRIVETS, BREAKFAST BOARDS, CUTTING BOARDS, FOOD MILLS, SHOEHORNS, RAILS FOR STORAGE ESPECIALLY FOR USE IN KITCHENS, ROLLING PINS, SPATULAS, EGG WHISKS, SIEVES SOLD INDIVIDUALLY OR AS A SET, CHOPPING BOARDS, PLUNGERS FOR CLEARING BLOCKED DRAINS, SNAIL TRAPS, MOUSETRAPS, WASP TRAPS, HOLDERS FOR FLOWERS AND PLANTS, SPRAYERS ATTACHED TO GARDEN HOSES; HOUSEHOLD OR GARDEN CONTAINERS, NAMELY, DUSTBINS, SPICE CELLARS, THERMAL INSULATED CONTAINERS FOR FOOD AND BEVERAGES, TRASH CANS, PLANTERS FOR FLOWERS AND PLANTS; COMBS AND SPONGES, NAMELY, SQUEEGEES; BRUSHES EXCEPT PAINT BRUSHES, NAMELY, TOILET BRUSHES, BRUSHES FOR BASTING MEAT; GLASSWARE, PORCELAIN AND EARTHENWARE, NAMELY, ARTIFICIAL EGGS, DECORATIVE PUMPKINS, DECORATIVE FIGURES, TISSUE BOX COVERS, SHELVES, GLASS HOLDER AND GLASS SOLD AS A SET; COOKING POT SETS; HAND-OPERATED PEPPER MILLS; PEPPER POTS NOT OF PRECIOUS METAL, SALT SHAKERS AND SALT CELLARS NOT OF PRECIOUS METAL; KITCHEN CONTAINERS, IN PARTICULAR BOWLS NOT OF PRECIOUS METAL; CANDLESTICKS NOT OF PRECIOUS METAL; TOWEL HOLDERS NOT OF PRECIOUS METAL, NAMELY, DISPENSERS FOR PAPER TOWELS, TOWEL RAILS AND RINGS; GOODS OF METAL FOR KEEPING ANIMALS, NAMELY, FEED BOWLS AND DRINKING BOWLS; ANIMAL ENCLOSURES, NAMELY, ANIMAL CAGES FOR PETS FOR USE IN AUTOMOBILES.

FIRST USE ; IN COMMERCE .

INT. CL. 28/U.S. CLS. 22, 23, 38 AND 50

FOR GAMES AND PLAYTHINGS, NAMELY, TOY CARS, TOY MODEL KIT CARS, TOY TOOLS, INFANT TOYS, TOY MODEL MOTORCYCLES, TOY MODEL TRAIN SETS, PUZZLE MATS FOR CHILDREN WHICH MAY ALSO BE USED AS KNEELING MATS; GYMNAS-TIC AND SPORTING ARTICLES AND APPLIANCES AND PARTS THEREOF, NAMELY, DUMBBELLS SOLD AS A SET, BADMINTON SETS, BADMINTON RACKETS, TABLE TENNIS SETS, AND EXERCISE EQUIPMENT FOR DEVELOPING MUSCLE STRENGTH IN ARMS AND LEGS; PLAYTHINGS FOR ANIMALS, NAMELY, DOG TOYS, ESPECIALLY DOG CHEWS AND BALLS; ITEMS AND UTENSILS FOR TRAINING IN ANIMAL DRESSAGE AND ANIMAL SPORTS, ESPECIALLY ITEMS FOR CHEWING, ITEMS FOR THROWING, BALLS FOR ANIMALS, NAMELY, DOG TOYS; SEASO-NAL DECORATIONS, NAMELY, CHRISTMAS TREE ORNAMENTS AND DECORATIONS, ARTIFICIAL CHRISTMAS TREES, AND HANGERS FOR CHRISTMAS TREE ORNAMENTS.

FIRST USE ; IN COMMERCE .

ELEMENTS CORRECTED  
GOODS/SERVICES

3,884,807. REG. 12-7-2010. OVIBELL PFLANZEN, DEKO UND FREIZEIT GMBH & CO. KG (FED REP GERMANY CORPORATION) STEINESHOFWEG 2, MULHEIM, FED REP GERMANY, 45479, SN 77-756,522. FILED 6-10-2009. PRINCIPAL REGISTER.

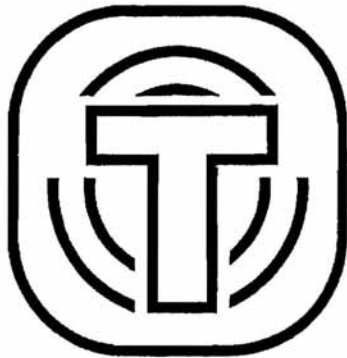

OWNER OF FED REP GERMANY REG. NO. 30755248, DATED 11-19-2007, EXPIRES 8-31-2017.

THE MARK CONSISTS OF THE LETTER "T" STYLIZED BY A PLURALITY OF CURVED LINES.

INT. CL. 6/U.S. CLS. 2, 12, 13, 14, 23, 25 AND 50

FOR GOODS OF METAL FOR KEEPING ANIMALS, NAMELY, ANIMAL ENCLOSURES, ANIMAL GATES FOR USE IN AUTOMOBILES; MAILBOXES OF METAL; METAL GUTTER GUARDS; ANIMAL ENCLOSURES, NAMELY, METAL ANIMAL CAGES FOR WILD ANIMALS FOR USE IN AUTOMOBILES.

FIRST USE ; IN COMMERCE .

INT. CL. 8/U.S. CLS. 23, 28 AND 44

FOR HAND TOOLS AND HAND OPERATED IMPLEMENTS FOR HOUSEHOLD AND GARDEN, NAMELY, SCISSORS, PIZZA CUTTERS, FILES AND RASPS SOLD INDIVIDUALLY OR AS A SET, DRILL BITS FOR HAND DRILLS, LOCK JAW PLIERS SOLD INDIVIDUALLY OR AS A SET, MAULS, HAND-POWERED STAPLE GUNS, HEX KEY WRENCHES SOLD INDIVIDUALLY OR AS A SET, CHISELS SOLD INDIVIDUALLY OR AS A SET, VICES, DRILLS AND BITS SOLD INDIVIDUALLY OR AS A SET, HAMMERS SOLD INDIVIDUALLY OR AS A SET, SCREWDRIVERS SOLD INDIVIDUALLY OR AS A SET, PLIERS, BOLT CUTTERS, HOLE SAWS SOLD INDIVIDUALLY OR AS A SET, PIPE CLEANERS, NAIL CLIPPERS, QUICK CLAMPS, SPRING CLAMPS, F-CLAMPS, G-CLAMPS, RIVETERS, SAWS SOLD INDIVIDUALLY OR AS A SET, SLEDGE HAMMERS, HAND OPERATED LIFTING JACKS, GARDENING SHEARS, TREE CUTTERS, PRUNING SHEARS, GARDENING TOOLS SOLD INDIVIDUALLY OR AS A SET, NAMELY, A SHOVEL, RAKE AND SHEARS; CUTLERY, FLAT-WARE.

FIRST USE ; IN COMMERCE .

INT. CL. 18/U.S. CLS. 1, 2, 3, 22 AND 41

FOR LEATHER AND IMITATIONS OF LEATHER AS WELL AS GOODS MADE OF THESE MATERIALS, ALSO FOR ANIMAL HUSBANDRY AND ANIMAL CARE, NAMELY, TOOL POUCHES SOLD EMPTY, PET RESTRAINING DEVICES CONSISTING OF LEASHES AND DOG COLLARS; TRUNKS AND TRAVELLING BAGS, VANITY CASES SOLD EMPTY; UMBRELLAS, PARASOLS AND WALKING STICKS; SADDLERY.

FIRST USE ; IN COMMERCE .

INT. CL. 20/U.S. CLS. 2, 13, 22, 25, 32 AND 50

FOR FURNITURE, MIRRORS, PICTURE FRAMES; FURNITURE FITTINGS NOT OF METAL; MATTRESSES NOT FOR MEDICAL USE; SLEEPING BAGS FOR CAMPING; MAILBOXES NOT OF METAL AND NOT OF BRICKWORK; GOODS OF PLASTICS, WOOD, CORK, REED, CANE, WICKER, HORN, BONE, IVORY, WHALEBONE, SHELL, AMBER, MOTHER-OF-PEARL, MEERSCHAUM AND SUBSTITUTES FOR ALL THESE MATERIALS, NAMELY, COAT RACKS, GARMENT HOOKS, MOLDED EASTER EGGS, CURTAIN RAILS, CLOTHES HANGERS, TISSUE BOX COVERS, TOWEL RACKS, STORAGE RACKS, CUPBOARDS, STORAGE RACKS WITH DRAWERS, DOOR STOPS AND WEDGES, FOLDING TABLES, SET OF UTILITY HOOKS, ROLLERS FOR SUPPORTING AND TRANSPORTING FURNITURE AND OTHER HEAVY ITEMS, CLAMPS AND STRAPS FOR ORGANIZING, HOLDING AND CONNECTING CABLE AND WIRING, HOSE CLIPS, FITTED COVERS FOR GARDEN CHAIRS, MATS FOR USE AS KNEELING PADS, KNEELERS FOR GARDENING, GOODS FOR DECORATION NOT OF TEXTILE MATERIAL, NAMELY, DECORATIVE FIGURES, DECORATIVE EGGS, OUTDOOR ORNAMENTS, DECORATIVE BALLS, HOLIDAY ORNAMENTS, ORNAMENTS OF STRAW; ANIMAL ENCLOSURES, NAMELY, DOG KENNELS; TABLE CLOTH HOLDERS, NAMELY, NON-METAL CLIPS FOR ATTACHING TABLE CLOTHS TO TABLES; CLOTHES HANGERS.

FIRST USE ; IN COMMERCE .

INT. CL. 21/U.S. CLS. 2, 13, 23, 29, 30, 33, 40 AND 50

FOR SMALL, NON-ELECTRIC HOUSEHOLD OR GARDEN UTENSILS AND ITEMS NOT OF PRECIOUS METAL OR COATED THEREWITH, NAMELY, CANDLE HOLDERS, POTPOURRI BURNER, SOAP DISPENSERS, TOILE TROLL HOLDERS, CAKE PANS, CAKE RINGS, NON-PAPER AND NON-TABLE LINEN COASTERS, TRIVETS, BREAKFAST BOARDS, CUTTING BOARDS, FOOD MILLS, SHOEHORNS, RAILS FOR STORAGE ESPECIALLY FOR USE IN KITCHENS, ROLLING PINS, SPATULAS, EGG WHISKS, SIEVES SOLD INDIVIDUALLY OR AS A SET, CHOPPING BOARDS, PLUNGERS FOR CLEARING BLOCKED DRAINS, SNAIL TRAPS, MOUSETRAPS, WASP TRAPS, HOLDERS FOR FLOWERS AND PLANTS, SPRAYERS ATTACHED TO GARDEN HOSES; HOUSEHOLD OR GARDEN CONTAINERS, NAMELY, DUSTBINS, SPICE CELLARS, THERMAL INSULATED CONTAINERS FOR FOOD AND BEVERAGES, TRASH CANS, PLANTERS FOR FLOWERS AND PLANTS; COMBS AND SPONGES, NAMELY, SQUEEGEES; BRUSHES EXCEPT PAINT BRUSHES, NAMELY, TOILET BRUSHES, BRUSHES FOR BASTING MEAT; GLASSWARE, PORCELAIN AND EARTH-ENWARE, NAMELY, ARTIFICIAL EGGS, DECORATIVE PUMPKINS, DECORATIVE FIGURES, TISSUE BOX COVERS, SHELVES, GLASS HOLDER AND GLASS

SOLD AS A SET; COOKING POT SETS; HAND-OPERATED PEPPER MILLS; PEPPER POTS NOT OF PRECIOUS METAL, SALT SHAKERS AND SALT CELLARS NOT OF PRECIOUS METAL; KITCHEN CONTAINERS, IN PARTICULAR BOWLS NOT OF PRECIOUS METAL; CANDLESTICKS NOT OF PRECIOUS METAL; TOWEL HOLDERS NOT OF PRECIOUS METAL, NAMELY, DISPENSERS FOR PAPER TOWELS, TOWEL RAILS AND RINGS; GOODS OF METAL FOR KEEPING ANIMALS, NAMELY, FEED BOWLS AND DRINKING BOWLS; ANIMAL ENCLOSURES, NAMELY, ANIMAL CAGES FOR PETS FOR USE IN AUTOMOBILES.

FIRST USE ; IN COMMERCE .

INT. CL. 28/U.S. CLS. 22, 23, 38 AND 50

FOR GAMES AND PLAYTHINGS, NAMELY, TOY CARS, TOY MODEL KIT CARS, TOY TOOLS, INFANT TOYS, TOY MODEL MOTORCYCLES, TOY MODEL TRAIN SETS, PUZZLE MATS FOR CHILDREN WHICH MAY ALSO BE USED AS KNEELING MATS; GYMNASIAC AND SPORTING ARTICLES AND APPLIANCES AND PARTS THEREOF, NAMELY, DUMBBELLS SOLD AS A SET, BADMINTON SETS, BADMINTON RACKETS, TABLE TENNIS SETS, AND EXERCISE EQUIPMENT FOR DEVELOPING MUSCLE STRENGTH IN ARMS AND LEGS; PLAYTHINGS FOR ANIMALS, NAMELY, DOG TOYS, ESPECIALLY DOG CHEWS AND BALLS; ITEMS AND UTENSILS FOR TRAINING IN ANIMAL DRESSAGE AND ANIMAL SPORTS, ESPECIALLY ITEMS FOR CHEWING, ITEMS FOR THROWING, BALLS FOR ANIMALS, NAMELY, DOG TOYS; SEASONAL DECORATIONS, NAMELY, CHRISTMAS TREE ORNAMENTS AND DECORATIONS, ARTIFICIAL CHRISTMAS TREES, AND HANGERS FOR CHRISTMAS TREE ORNAMENTS.

FIRST USE ; IN COMMERCE .

ELEMENTS CORRECTED  
GOODS/SERVICES

---

3,888,043, REG. 12-7-2010. NATURAL SWEET VENTURES, LLC (DELAWARE LIMITED LIABILITY COMPANY) 8016 HWY. 90A, P.O. BOX 9, SUGAR LAND, TX, 77478, SN 77-966,146. FILED 3-23-2010. PRINCIPAL REGISTER.



NO CLAIM IS MADE TO THE EXCLUSIVE RIGHT TO USE "NATURAL SWEET VENTURES", APART FROM THE MARK AS SHOWN.

THE COLOR(S) WHITE, BLUE, YELLOW AND GREEN IS/ARE CLAIMED AS A FEATURE OF THE MARK.

THE MARK CONSISTS OF THE WORDS "NATURAL SWEET VENTURES" IN A WHITE STYLIZED FONT ON A RECTANGLE WITH A DESIGN COMPRISED OF A BLUE SKY, YELLOW HORIZON AND GREEN EARTH.

INT. CL. 30/U.S. CL. 46

FOR NATURAL SWEETENER; FLAVOR ENHANCER USED IN FOOD AND BEVERAGE PRODUCTS.

FIRST USE 3-0-2010; IN COMMERCE 8-0-2010.

ELEMENTS CORRECTED  
CITIZENSHIP

3,890,384, REG. 12-14-2010. LOGIX INSULATED CONCRETE FORMS LTD. (CANADA CORPORATION) P.O. BOX 162, PORT HOPE, ONTARIO, CANADA, L1A 3W3, SN 76-695,775. FILED 2-12-2009. PRINCIPAL REGISTER.



OWNER OF U.S. REG. NOS. 2,960,156 AND 2,971,523.

NO CLAIM IS MADE TO THE EXCLUSIVE RIGHT TO USE "HYBRID TECHNOLOGY", APART FROM THE MARK AS SHOWN.

THE COLOR(S) BLACK AND RED IS/ARE CLAIMED AS A FEATURE OF THE MARK.

THE MARK CONSISTS OF THE COLOR BLACK IS USED IN THE LETTERS OF THE WORD "LOGIX" AND "HYBRID" AND AS A BLACK FIELD IN WHICH THE WORD "TECHNOLOGY" APPEARS. THE COLOR RED IS USED TO DOT THE LETTER "I" IN THE WORDS "LOGIX" AND "HYBRID" AND AS THE CENTER BAR OF THE LETTER "H" IN "HYBRID".

INT. CL. 19/U.S. CLS. 1, 12, 33 AND 50

FOR INSULATED CONCRETE FORMS, NAMELY, NON-METAL CASTING FORMS FOR USE IN CASTING CONCRETE AND TAPE; AND NON-METAL FORM CONNECTORS USED WITH SUCH CASTING FORMS; BRACING AND SCAFFOLDING MATERIALS, NAMELY, NON-METAL SCAFFOLDING .

FIRST USE 1-0-2009; IN COMMERCE 1-0-2009.

ELEMENTS CORRECTED  
[PRIOR U.S. REGS.]

---

3,892,341, REG. 12-21-2010. TRIPWIRE, INC. (DELAWARE CORPORATION) 101 SW MAIN STREET, SUITE 1500, PORTLAND, OR, 97204, SN 77-926,916. FILED 2-3-2010. PRINCIPAL REGISTER.

# LOGCENTER

THE MARK CONSISTS OF STANDARD CHARACTERS WITHOUT CLAIM TO ANY PARTICULAR FONT, STYLE, SIZE, OR COLOR.

INT. CL. 9/U.S. CLS. 21, 23, 26, 36 AND 38

FOR COMPUTER SOFTWARE, NAMELY, SOFTWARE THAT CAPTURES EVENT DATA FROM COMPUTER NETWORK AND SECURITY DEVICES, SOFTWARE APPLICATIONS, AND OTHER DATA SOURCES TO PROVIDE ACCESS TO HISTORICAL DATA FOR FORENSICS, COMPLIANCE REPORTING, AND POLICY EVALUATION.

FIRST USE 12-31-2008; IN COMMERCE 12-31-2008.

ELEMENTS CORRECTED  
OWNER NAME  
OWNER ADDRESS

3,892,442. REG. 12-21-2010. DAVID C. COOK (ILLINOIS NON-PROFIT CORPORATION) 4050 LEE VANCE VIEW, COLORADO SPRINGS, CO, 80918, SN 77-950,343. FILED 3-4-2010. PRINCIPAL REGISTER.



NO CLAIM IS MADE TO THE EXCLUSIVE RIGHT TO USE "WORSHIP", APART FROM THE MARK AS SHOWN. THE COLOR(S) BLACK, WHITE, YELLOW, AND GREY IS/ARE CLAIMED AS A FEATURE OF THE MARK.

THE MARK CONSISTS OF A BLACK CIRCLE WITH THE WHITE WORDING "TRU" CONTAINED WITHIN THE CIRCLE AND THE YELLOW SHAPE OF A ROOFLINE ABOVE THE LETTER "U". THE WORD "WORSHIP" IN GREY FOLLOWS THE CIRCLE, AND THE WORDS "INSPIRE. EQUIP. SUPPORT." IN GREY APPEAR UNDERNEATH THE WORD "WORSHIP".

INT. CL. 9/U.S. CLS. 21, 23, 26, 36 AND 38

FOR PRE-RECORDED CDS FEATURING CHILDREN'S CHRISTIAN EDUCATIONAL MUSIC. FIRST USE 1-1-2010; IN COMMERCE 1-1-2010.

ELEMENTS CORRECTED  
ENTITY

3,895,368. REG. 12-21-2010. BOYER, LLC (KANSAS LIMITED LIABILITY COMPANY) 3741 GREENWAY CIRCLE, LAWRENCE, KS, 66046, SN 77-933,759. FILED 2-11-2010. PRINCIPAL REGISTER.

## PROSOCO R-GUARD CAT 5

THE MARK CONSISTS OF STANDARD CHARACTERS WITHOUT CLAIM TO ANY PARTICULAR FONT, STYLE, SIZE, OR COLOR.

OWNER OF U.S. REG. NOS. 2,609,036, 2,811,532 AND 3,229,452.

INT. CL. 2/U.S. CLS. 6, 11 AND 16

FOR LIQUID SEALANT COATING FOR USE AS A WATER AND AIR BARRIER FOR USE ON BUILDINGS. FIRST USE 4-27-2010; IN COMMERCE 4-27-2010.

ELEMENTS AMENDED  
MARK

3,895,984. REG. 12-28-2010. NOVARTIS AG (SWITZERLAND CORPORATION) CH-4002, BASEL, SWITZERLAND., SN 77-783,544. FILED 7-17-2009. PRINCIPAL REGISTER.

## SATIXEO

THE MARK CONSISTS OF STANDARD CHARACTERS WITHOUT CLAIM TO ANY PARTICULAR FONT, STYLE, SIZE, OR COLOR.

OWNER OF SWITZERLAND REG. NO. 519655, DATED 3-9-2004, EXPIRES 3-9-2014.

OWNER OF U.S. REG. NO. 3,378,481.

INT. CL. 5/U.S. CLS. 6, 18, 44, 46, 51 AND 52

FOR VACCINES FOR HUMAN USE, NOT FOR USE IN ONCOLOGY, NOT IN SPRAY FORM AND NOT THROUGH SUBLINGUAL OR BUCCAL DELIVERY. FIRST USE ; IN COMMERCE .

ELEMENTS CORRECTED  
GOODS/SERVICES

3,904,614. REG. 1-11-2011. CLUB MONACO CORP. (CANADA CORPORATION) 430 KING STREET WEST, TORONTO, ONTARIO, CANADA, M5V1L5, SN 77-185,994. FILED 5-21-2007. PRINCIPAL REGISTER.

## CLUB MONACO

THE MARK CONSISTS OF STANDARD CHARACTERS WITHOUT CLAIM TO ANY PARTICULAR FONT, STYLE, SIZE, OR COLOR.

OWNER OF U.S. REG. NOS. 2,137,573, 2,568,196 AND OTHERS.

INT. CL. 24/U.S. CLS. 42 AND 50

FOR BLANKET THROWS, BED SHEETS, PILLOW CASES, DUVET COVERS, BED BLANKETS, TEXTILE TABLECLOTHS, FABRIC TABLE RUNNERS, FABRIC NAPKINS AND PLACEMATS.

FIRST USE 11-1-2010; IN COMMERCE 11-1-2010.

ELEMENTS CORRECTED  
OWNER NAME

3,908,222. REG. 1-18-2011. TRAVELLERS EXCHANGE CORPORATION LIMITED (UNITED KINGDOM CORPORATION) 65 KINGSWAY, LONDON WC2B 6TD, UNITED KINGDOM., SN 76-689,965. FILED 5-22-2008. PRINCIPAL REGISTER.



OWNER OF U.S. REG. NOS. 1,694,803 AND 2,807,801.

NO CLAIM IS MADE TO THE EXCLUSIVE RIGHT TO USE "ALLIANCE", APART FROM THE MARK AS SHOWN.

THE COLOR(S) RED, WHITE, BLUE AND GREY IS/ARE CLAIMED AS A FEATURE OF THE MARK.

THE MARK CONSISTS OF THE COLOR(S) RED, WHITE, BLUE AND GREY; THE COLOR BLUE APPEARS IN THE WORDING "TRAVELEX" AND "GLOBAL" AS WELL AS IN THE DEPICTION OF THE GLOBE THAT APPEARS IN THE LETTER "O" OF THE WORD "GLOBAL"; THE COLOR RED APPEARS IN THE WORDING "PAY"; THE COLOR WHITE APPEARS IN THE DEPICTION OF THE CONTINENTS AS WELL AS HIGHLIGHTING ON THE GLOBE THAT APPEARS IN THE LETTER "O" OF THE WORD "GLOBAL"; THE COLOR GREY APPEARS IN THE WORDING "ALLIANCE".

INT. CL. 35/U.S. CLS. 100, 101 AND 102



FOR MANAGING OF GLOBAL PAYMENT PROCESSES, NAMELY, PROVIDING AN ON-LINE COMPUTER DATABASE FOR THE REPORTING AND TRACKING OF DOMESTIC AND INTERNATIONAL FINANCIAL OR BILL PAYMENT DATA FOR BUSINESS PURPOSES; AUTOMATED PAYMENT TRACKING SERVICES, NAMELY, PROVIDING AN ON-LINE COMPUTER DATABASE FOR THE REPORTING AND TRACKING OF AUTOMATED DOMESTIC AND INTERNATIONAL FINANCIAL OR BILL PAYMENT DATA FOR BUSINESS PURPOSES; ONLINE FINANCIAL ACCOUNT MONITORING SERVICES, NAMELY, MONITORING CONSUMER CREDIT REPORTS AND PROVIDING AN ALERT AS TO ANY CHANGES THEREIN.

FIRST USE 5-2-2008; IN COMMERCE 5-2-2008.  
INT. CL. 36/U.S. CLS. 100, 101 AND 102

FOR FINANCIAL SERVICES FOR BANKS, NAMELY, CASH AND FOREIGN EXCHANGE TRANSACTIONS TO BUSINESSES; CASH AND FOREIGN EXCHANGE TRANSACTIONS, NAMELY, ISSUANCE OF BANK CHECKS; ELECTRONIC PAYMENT, NAMELY, ELECTRONIC PROCESSING AND TRANSMISSION OF BILL PAYMENT DATA; FOREIGN CURRENCY MARKET ANALYSIS, NAMELY, FINANCIAL ANALYSES AND RESEARCH SERVICES CONCERNING FOREIGN CURRENCY MARKETS; FOREIGN CURRENCY EXCHANGE TRANSACTIONS IN REAL-TIME.

FIRST USE 5-2-2008; IN COMMERCE 5-2-2008.  
INT. CL. 38/U.S. CLS. 100, 101 AND 104

FOR AUTOMATED PAYMENT NOTIFICATION SERVICES, NAMELY, PROVIDING E-MAIL NOTIFICATION ALERTS OF DOMESTIC AND INTERNATIONAL FINANCIAL OR BILL PAYMENTS.

FIRST USE 5-2-2008; IN COMMERCE 5-2-2008.  
INT. CL. 39/U.S. CLS. 100 AND 105

FOR MANAGING OF GLOBAL PAYMENT PROCESSES, NAMELY, ELECTRONIC STORAGE OF DOMESTIC AND INTERNATIONAL FINANCIAL OR BILL PAYMENT DATA .

FIRST USE 5-2-2008; IN COMMERCE 5-2-2008.  
INT. CL. 45/U.S. CLS. 100 AND 101

FOR ONLINE FINANCIAL ACCOUNT MONITORING AND INVESTIGATION SERVICES, NAMELY, INVESTIGATION OF ASSETS, CREDIT REPORTS, FISCAL ASSESSMENTS, AND COLLECTION REPORTS FOR SECURITY OR AUTHENTICATION PURPOSES; PROVIDING FRAUD DETECTION SERVICES FOR ELECTRONIC FUNDS TRANSFER, CREDIT AND DEBIT CARD AND ELECTRONIC CHECK TRANSACTIONS VIA A GLOBAL COMPUTER NETWORK; MONITORING OF CREDIT REPORTS, THE INTERNET, AND PUBLIC RECORDS TO FACILITATE THE DETECTION AND PREVENTION OF IDENTITY THEFT AND FRAUD.

FIRST USE 5-2-2008; IN COMMERCE 5-2-2008.

ELEMENTS CORRECTED  
DATE OF FIRST USE IN COMMERCE

3,910,258. REG. 1-25-2011. CORTES, AMELIA TORO (COLOMBIA INDIVIDUAL) CALLE 115, BIS NO. 58-04, APTO. 902, TORRE 2, BOGOTA D.C., COLOMBIA., SN 78-957,026. FILED 8-21-2006. PRINCIPAL REGISTER.

## AMELIA TORO

THE MARK CONSISTS OF STANDARD CHARACTERS WITHOUT CLAIM TO ANY PARTICULAR FONT, STYLE, SIZE, OR COLOR.

OWNER OF COLOMBIA REG. NO. 153895, DATED 2-28-1994, EXPIRES 2-28-2014.

THE NAME "AMELIA TORO" IDENTIFIES A LIVING INDIVIDUAL WHOSE CONSENT IS OF RECORD.

INT. CL. 6/U.S. CLS. 2, 12, 13, 14, 23, 25 AND 50

FOR (BASED ON 44(E)) KEY RINGS OF METAL.

FIRST USE ; IN COMMERCE .  
INT. CL. 14/U.S. CLS. 2, 27, 28 AND 50

FOR (BASED ON 44(E)) BRACELETS, EARRINGS, NECKLACES, AND RINGS; KEY RINGS OF PRECIOUS METAL.

FIRST USE ; IN COMMERCE .  
INT. CL. 18/U.S. CLS. 1, 2, 3, 22 AND 41

FOR (BASED ON COMMERCE IN USE) HANDBAGS.  
FIRST USE 0-0-1981; IN COMMERCE 0-0-1986.

INT. CL. 25/U.S. CLS. 22 AND 39

FOR (BASED ON USE IN COMMERCE) AND (BASED ON 44(E)) CLOTHING, NAMELY, DRESSES, T-SHIRTS, SHORTS, SWIM SUITS, JACKETS, SHIRTS, TOPS, SKIRTS, SWEATERS, SLEEPWEAR, UNDERGARMENTS, PAJAMAS, ROBES, SOCKS, BLOUSES, COATS, BELTS, FOOTWEAR.

FIRST USE 0-0-1981; IN COMMERCE 0-0-1986.

ELEMENTS CORRECTED  
OWNER NAME

3,912,639. REG. 2-1-2011. HOPKINS MEDICAL PRODUCTS (MARYLAND CORPORATION) 5 GREENWOOD PLACE, BALTIMORE, MD, 21208, SN 76-695,475. FILED 1-27-2009. PRINCIPAL REGISTER.

## HOPKINS MEDICAL PRODUCTS

THE MARK CONSISTS OF STANDARD CHARACTERS WITHOUT CLAIM TO ANY PARTICULAR FONT, STYLE, SIZE, OR COLOR.

NO CLAIM IS MADE TO THE EXCLUSIVE RIGHT TO USE "MEDICAL PRODUCTS", APART FROM THE MARK AS SHOWN.

SEC. 2(F).  
INT. CL. 5/U.S. CLS. 6, 18, 44, 46, 51 AND 52

FOR WATERLESS HAND SANITIZING PREPARATIONS; WOUND DRESSINGS; MEDICAL ADHESIVE TAPES; SURFACE DISINFECTANTS FOR SANITARY PURPOSES; DISINFECTING HAND WASH; COTTON SWABS FOR MEDICAL PURPOSES; TAPES FOR VARICOSE VEINS; STERILE SALINE WASH FOR MEDICAL PURPOSES; MEDICAL COTTON BALLS FOR USE IN APPLYING TOPICAL MEDICINE; COTTON TIPPED APPLICATORS FOR MEDICAL PURPOSES; DISINFECTANTS FOR MEDICAL INSTRUMENTS; ANTI-DIABETIC PHARMACEUTICALS; FIRST AID KIT.

FIRST USE 12-31-1995; IN COMMERCE 12-31-1995.  
INT. CL. 9/U.S. CLS. 21, 23, 26, 36 AND 38

FOR BABY SCALES, WEIGHING SCALES FOR HOME HEALTH CARE USE, FLOOR SCALES LASER DOPPLER FOR MEASURING PURPOSES; DISPOSABLE PAPER MEASURING TAPE; GUIDING DEVICES FOR USE WITH FIBERGLASS TAPE MEASURES; BASELINE CALIPER; STADIOMETERS; GONIOMETER; PROTECTIVE EYE WEAR.

FIRST USE 12-31-1995; IN COMMERCE 12-31-1995.  
INT. CL. 10/U.S. CLS. 26, 39 AND 44

FOR MEDICAL BAGS SOLD EMPTY; APPARATUS FOR TAKING BLOOD SAMPLES; SPHYGMOMANOMETERS; NURSING BAGS DESIGNED TO HOLD SPECIFIC MEDICAL APPARATUS; APPARATUS FOR CLINICAL DIAGNOSIS; CPR MASKS; PULSE MEASURING DEVICES; PULSE OXIMETER FOR USE ON THE FINGER; STETHOSCOPES; DIGITAL THERMOMETERS FOR MEDICAL PURPOSES; MEDICAL GLOVES; CONTAINERS ESPECIALLY ADAPTED FOR THE DISPOSAL OF MEDICAL INSTRUMENTS, SYRINGES, AND OTHER CONTAMINATED MEDICAL WASTE; DEVICES FOR MEASURING WOUNDS; SURGICAL SPONGES; SURGICAL MASKS; MEDICAL GOWNS; MEDICAL TEST KITS FOR MONITORING DIABETES AND ITS EFFECTS ON THE FOOT; [OTOSCOPES;] OPHTHALMOSCOPES; TRANSILLUMINATOR FOR HIGHLIGHTING THE VEINS WHICH ABSORB THE LIGHT; CLINICAL THERMOMETERS; HAND-HELD MEDICAL EXAMINATIONS TOOLS, NAMELY, PINWHEEL ROLLING DEVICES AND BODY HAMMERS FOR TESTING MUSCULAR AND NERVE REACTIONS; SURGICAL SCISSORS; FORCE AND MOTION TESTING APPARATUS FOR PHYSICAL TRAINING; RE-

SPIRATORY MASKS FOR MEDICAL PURPOSES; DISPOSABLE CONTAINERS FOR MEDICAL WASTE, SPECIFICALLY FOR NEEDLES AND SYRINGES; SMALL TRANSPORTABLE DISPOSABLE CONTAINERS FOR MEDICAL WASTE, SPECIFICALLY FOR NEEDLES AND SYRINGES; BRUSHES FOR CLEANING BODY CAVITIES; SUTURE REMOVAL TRAY; A WOUND GAUGE TO MONITOR ULCER OR WOUND SIZE; WOUND SUCTION APPARATUS; MEDICAL DEVICES IN THE NATURE OF HAND HELD LIGHTS FOR USE IN GAUGING AND STIMULATING THE PUPIL OF THE EYE; EYE CHARTS FOR MEDICAL EXAMINATION USE; CARDIOPULMONARY RESUSCITATION MASKS; SHIELDS FOR USE WITH CARDIOPULMONARY RESUSCITATION MASKS; MEDICAL DEVICES FOR PATIENT HYGIENE, NAMELY, STATIONS FOR PATIENT PERSONAL HYGIENE COMPOSED OF HAND PUMPED SHAMPOO BOTTLES SOLD EMPTY, INFLATABLE SINKS, SHAMPOO TRAYS, BATH THERMOMETERS, PATIENT COMMUNICATION BOARD, PRIVACY SCREEN, PORTABLE IV POLE, AND CARRYING CASE; LANCETS; MEDICAL DEVICES FOR INSTANT MONITORING BLOOD GLUCOSE FOR MEDICAL PURPOSES; BLOOD TESTING APPARATUS FOR TESTING BILIRUBIN; SUTURE REMOVAL KITS AND SUPPLIES, NAMELY, TWEEZERS, SCISSORS; STETHOSCOPES, SPECULAS; ROLLING LAB TRANSPORT SYSTEMS COMPRISING FOAM PADDED CONTAINER, FRONT ZIP COMPARTMENT, TWO SIDED MESH POCKETS, LEAK-PROOF NEEDLE DISPOSAL CONTAINER, REUSABLE ICE PACK, BIO-HAZARD LABELED CONTAINERS WITH FOAM TO SAFELY TRANSPORT FILLED BLOOD DRAW TUBES; FORCEPS; APPARATUS FOR CLINICAL DIAGNOSIS; BLOOD PRESSURE CUFFS; CONTAINERS IN THE NATURE OF CARRIERS FOR BIOHAZARDOUS MEDICAL WASTE; DISPOSAL BAGS FOR BIOHAZARDOUS MEDICAL WASTE; HAND HELD MEDICAL TOOLS, NAMELY, MEDICAL MANICURE STICKS FOR MEDICAL PURPOSES; TONGUE DEPRESSOR; MEDICAL HAND HELD MANUAL TOOLS IN THE NATURE OF ANEROID GAUGES; DISPOSABLE BAGS FOR BIO-HAZARDOUS MEDICAL WASTE; SKINFOLD CALIPERS \* ALL OF THE ABOVE EXCLUDING ENDOSCOPES OR MEDICAL IMAGING EQUIPMENT \*

FIRST USE 12-31-1987; IN COMMERCE 12-31-1987.

INT. CL. 11/U.S. CLS. 13, 21, 23, 31 AND 34  
FOR CEILING LIGHTS; PEN LIGHTS.  
FIRST USE 12-31-1995; IN COMMERCE 12-31-1995.

INT. CL. 18/U.S. CLS. 1, 2, 3, 22 AND 41  
FOR TOTE BAGS WITH A SIDE FOR HOLDING CLEAN ITEMS SUCH AS CLOTHING AND A SIDE FOR HOLDING DIRTY ITEMS SUCH AS CLOTHING; TOTE BAGS; HIP POUCHES; BACK PACKS.  
FIRST USE 12-31-1986; IN COMMERCE 12-31-1986.

INT. CL. 21/U.S. CLS. 2, 13, 23, 29, 30, 33, 40 AND 50  
FOR PILL BOXES FOR PERSONAL USE.  
FIRST USE 12-31-1995; IN COMMERCE 12-31-1995.

INT. CL. 40/U.S. CLS. 100, 103 AND 106  
FOR CUSTOM IMPRINTING OF THE LOGOS OF OTHERS ON MEDICAL SUPPLIES.  
FIRST USE 12-31-1995; IN COMMERCE 12-31-1995.

ELEMENTS AMENDED  
GOODS/SERVICES

3,914,964. REG. 2-1-2011. COFACO AÇORES - INDÚSTRIA DE CONSERVAS,S.A. (PORTUGAL CORPORATION) RUA DE LAPINHA, RABO DE PEIXE, RIBEIRA GRANDE, S. MIGUEL - AÇORES, PORTUGAL, 9600-115, SN 77-816,485. FILED 8-31-2009. PRINCIPAL REGISTER.

# PITÉU

THE MARK CONSISTS OF STANDARD CHARACTERS WITHOUT CLAIM TO ANY PARTICULAR FONT, STYLE, SIZE, OR COLOR.

THE ENGLISH TRANSLATION OF "PITÉU" IN THE MARK IS "GOOD TIDBIT".

INT. CL. 29/U.S. CL. 46  
FOR PRESERVED FISH, NAMELY, TUNA.  
FIRST USE 2-14-2008; IN COMMERCE 2-14-2008.

ELEMENTS CORRECTED  
OWNER ADDRESS

3,915,441. REG. 2-8-2011. VAN CLEEF & ARPELS S.A. (SWITZERLAND CORPORATION) 1752 8, ROUTE DE BICHES, VILLARS-SUR-GLANE, SWITZERLAND,, SN 77-522,663. FILED 7-15-2008. PRINCIPAL REGISTER.

# ALHAMBRA

THE MARK CONSISTS OF STANDARD CHARACTERS WITHOUT CLAIM TO ANY PARTICULAR FONT, STYLE, SIZE, OR COLOR.

PRIORITY CLAIMED UNDER SEC. 44(D) ON SWITZERLAND APPLICATION NO. 58181/2008, FILED 6-30-2008, REG. NO. 578849, DATED 11-4-2008, EXPIRES 6-30-2018.

OWNER OF U.S. REG. NO. 3,489,019.  
THE ENGLISH TRANSLATION OF "ALHAMBRA" IS "THE RED ONE".

INT. CL. 3/U.S. CLS. 1, 4, 6, 50, 51 AND 52  
FOR PERFUMERY, ESSENTIAL OILS, SOAPS, COSMETIC PREPARATIONS FOR SKIN CARE, DEODORANTS FOR PERSONAL USE.  
FIRST USE ; IN COMMERCE .

ELEMENTS CORRECTED  
OWNER ADDRESS  
TRANSLATION OF MARK

3,918,889. REG. 2-15-2011. AMICOR, INC. (NEVADA CORPORATION) 1350 AVENUE OF THE AMERICAS, 24TH FLOOR, NEW YORK, NY, 10019, SN 77-979,922. FILED 4-8-2009. PRINCIPAL REGISTER.

# Caffeine

INT. CL. 25/U.S. CLS. 22 AND 39

FOR MEN'S, WOMEN'S AND CHILDREN'S WEARING APPAREL AND CLOTHING, NAMELY, T'SHIRTS, DRESS AND CASUAL SHIRTS, TANK TOPS, SWEATERS, SWEATSHIRTS, SHORTS, PANTS, JEANS, DRESSES, SKIRTS, JACKETS, JOGGING SUITS, VESTS, RAINWEAR, SLEEPWEAR, HATS AND BELTS .  
FIRST USE 3-0-1992; IN COMMERCE 3-0-1992.

ELEMENTS CORRECTED  
OWNER NAME  
OWNER ADDRESS  
CITIZENSHIP

---

3,920,054. REG. 2-15-2011. VENTUS MEDICAL, INC. (DELAWARE CORPORATION) 1301 SHOREWAY ROAD, SUITE 425, BELMONT, CA, 94002, SN 77-268,760. FILED 8-30-2007. PRINCIPAL REGISTER.

## VENTUS MEDICAL

THE MARK CONSISTS OF STANDARD CHARACTERS WITHOUT CLAIM TO ANY PARTICULAR FONT, STYLE, SIZE, OR COLOR.

NO CLAIM IS MADE TO THE EXCLUSIVE RIGHT TO USE "MEDICAL", APART FROM THE MARK AS SHOWN.  
INT. CL. 10/U.S. CLS. 26, 39 AND 44

FOR MEDICAL RESPIRATORY APPARATUS FOR USE IN NON-INVASIVE VENTILATION, NAMELY, NASAL CANNULAE, NASAL SEALS, AND PARTS AND ACCESSORIES THEREFORE.

FIRST USE 5-0-2010; IN COMMERCE 5-0-2010.

ELEMENTS CORRECTED  
GOODS/SERVICES

---

3,920,154. REG. 2-15-2011. PENDLETON ESTATE PTY LTD. (AUSTRALIA CORPORATION) STEPNEY, 5069, 40 NELSON STREET, SOUTH AUSTRALIA, AUSTRALIA., SN 77-478,753. FILED 5-20-2008. PRINCIPAL REGISTER.

## PINNAROO HILL

THE MARK CONSISTS OF STANDARD CHARACTERS WITHOUT CLAIM TO ANY PARTICULAR FONT, STYLE, SIZE, OR COLOR.

INT. CL. 29/U.S. CL. 46

FOR OLIVE OILS.

FIRST USE 6-28-2009; IN COMMERCE 6-28-2009.

INT. CL. 30/U.S. CL. 46

FOR VINEGARS; FLAVOURED VINEGARS; SALAD DRESSINGS; SEASONINGS, NAMELY, DUKKAHS.

FIRST USE 6-22-2010; IN COMMERCE 6-22-2010.

ELEMENTS CORRECTED  
GOODS/SERVICES

3,927,025. REG. 3-1-2011. JACK BLACK, LLC (DELAWARE LIMITED LIABILITY COMPANY) 2155 CHENAULT DRIVE, SUITE 509, CARROLLTON, TX, 75006, SN 85-035,015. FILED 5-11-2010. PRINCIPAL REGISTER.

## DRY DOWN

THE MARK CONSISTS OF STANDARD CHARACTERS WITHOUT CLAIM TO ANY PARTICULAR FONT, STYLE, SIZE, OR COLOR.

INT. CL. 3/U.S. CLS. 1, 4, 6, 50, 51 AND 52

FOR BODY POWDER.

FIRST USE 8-15-2010; IN COMMERCE 8-15-2010.

ELEMENTS CORRECTED  
MARK

---

3,929,551. REG. 3-8-2011. EVEN WEIGHT BRUSH, LLC (WISCONSIN LIMITED LIABILITY COMPANY) P.O. BOX 241, GILLETT, WI, 54124, SN 77-842,314. FILED 10-6-2009. PRINCIPAL REGISTER.

## SMART BRISTLE

THE MARK CONSISTS OF STANDARD CHARACTERS WITHOUT CLAIM TO ANY PARTICULAR FONT, STYLE, SIZE, OR COLOR.

NO CLAIM IS MADE TO THE EXCLUSIVE RIGHT TO USE "BRISTLE", APART FROM THE MARK AS SHOWN.

INT. CL. 21/U.S. CLS. 2, 13, 23, 29, 30, 33, 40 AND 50

FOR FILAMENTS SOLD AS A FEATURE OF COTTON GINNING BRUSHES.

FIRST USE 10-1-2009; IN COMMERCE 10-1-2009.

ELEMENTS CORRECTED  
DATE OF FIRST USE

---

3,930,031. REG. 3-8-2011. DISNEY ENTERPRISES, INC. (DELAWARE CORPORATION) 500 SOUTH BUENA VISTA STREET, BURBANK, CA, 91521, SN 77-981,026. FILED 2-2-2007. PRINCIPAL REGISTER.

## WALT DISNEY

THE MARK CONSISTS OF STANDARD CHARACTERS WITHOUT CLAIM TO ANY PARTICULAR FONT, STYLE, SIZE, OR COLOR.

OWNER OF U.S. REG. NOS. 1,141,312, 3,268,689 AND OTHERS.

THE NAME "WALT DISNEY" DOES NOT IDENTIFY A LIVING INDIVIDUAL.

INT. CL. 3/U.S. CLS. 1, 4, 6, 50, 51 AND 52

FOR COSMETICS .

FIRST USE 1-21-2010; IN COMMERCE 1-21-2010.

INT. CL. 14/U.S. CLS. 2, 27, 28 AND 50

FOR JEWELRY, WATCHES, CLOCKS, JEWELRY BOXES NOT MADE OF PRECIOUS METALS.

FIRST USE 10-22-2009; IN COMMERCE 10-22-2009.

INT. CL. 18/U.S. CLS. 1, 2, 3, 22 AND 41

FOR ARTICLES MADE FROM LEATHER AND IMITATIONS OF LEATHER, NAMELY, LUGGAGE, LUGGAGE TAGS, SACHELS, WAIST PACKS; BAGS, NAMELY, BACKPACKS, BOOK BAGS, OVERNIGHT BAGS; SHOPPING BAGS OF TEXTILE; TOTE BAGS; PURSES; HANDBAGS; WALLETS; UMBRELLAS.  
 FIRST USE 10-22-2009; IN COMMERCE 10-22-2009.

INT. CL. 21/U.S. CLS. 2, 13, 23, 29, 30, 33, 40 AND 50  
 FOR HOUSEWARES, NAMELY, BOWLS, CANDLE HOLDERS NOT OF PRECIOUS METAL, COOKIE CUTTERS, CUPS, DISHES, FIGURINES MADE OF CRYSTAL, AND PORCELAIN, MUGS, PLATES, SPORTS BOTTLES SOLD EMPTY, TEA KETTLES, THERMAL INSULATED CONTAINERS FOR FOOD OR BEVERAGE, TRIVETS, AND CONTAINERS FOR HOUSEHOLD USE; DINNERWARE; BEVERAGeware; PLASTIC CUPS; COOKIE JARS.  
 FIRST USE 10-23-2009; IN COMMERCE 10-23-2009.

INT. CL. 24/U.S. CLS. 42 AND 50  
 FOR BATH TOWELS; BED SHEETS; BLANKET THROWS; CLOTH FLAGS; COMFORTERS; CURTAINS; FABRIC FLAGS; GOLF TOWELS; HOODED TOWELS; KITCHEN TOWELS; OVEN MITTS; PILLOW CASES; PILLOW COVERS; POT HOLDERS; THROWS; TOWELS; WASHCLOTHS; BED LINEN; BATH LINEN; HOUSEHOLD LINEN.  
 FIRST USE 10-22-2009; IN COMMERCE 10-22-2009.

INT. CL. 28/U.S. CLS. 22, 23, 38 AND 50  
 FOR TOYS, GAMES, AND PLAYTHINGS, NAMELY, TOY ACTION FIGURES AND ACCESSORIES THEREFOR; BOARD GAMES; CARD GAMES; CHILDREN'S MULTIPLE ACTIVITY TOYS; BATH TOYS; BEAN BAG DOLLS; TOY BUILDING BLOCKS; CHILDREN'S PLAY COSMETICS; CHRISTMAS TREE DECORATIONS EXCEPT CONFECTIONARY OR ILLUMINATION ARTICLES; CHRISTMAS TREE ORNAMENTS; COLLECTABLE TOY FIGURES; CRIB TOYS; DOLLS; DOLL CLOTHING; DOLL ACCESSORIES; DOLL PLAYSETS; ELECTRIC ACTION TOYS; MUSICAL TOYS; PARTY GAMES; PLUSH TOYS; SNOW GLOBES; SQUEEZE TOYS; STUFFED TOYS; TALKING TOYS; TEDDY BEARS; TOY VEHICLES; TOY CARS; TOY FIGURES; TOY BANKS; TOY TRUCKS.  
 FIRST USE 10-22-2009; IN COMMERCE 10-22-2009.

INT. CL. 30/U.S. CL. 46  
 FOR COFFEE; TEA.  
 FIRST USE 10-22-2009; IN COMMERCE 10-22-2009.

ELEMENTS CORRECTED  
 GOODS/SERVICES

3,932,919. REG. 3-15-2011. DATA CEDE LLC (NEW JERSEY LIMITED LIABILITY COMPANY) 301 N. HARRISON STREET, SUITE 459, PRINCETON, NJ, 08540, SN 77-748,449. FILED P.R. 5-31-2009; AM. S.R. 2-4-2011. SUPPLEMENTAL REGISTER.

# DataCede

THE MARK CONSISTS OF STANDARD CHARACTERS WITHOUT CLAIM TO ANY PARTICULAR FONT, STYLE, SIZE, OR COLOR.

INT. CL. 35/U.S. CLS. 100, 101 AND 102  
 FOR DATA COMPILING AND ANALYZING IN THE FIELD OF INSURANCE; INSURANCE CLAIMS AUDITING SERVICES; MANAGING THE OPERATIONS OF INSURANCE AGENCIES AND BROKERS ON AN OUTSOURCING BASIS; PROMOTION OF FINANCIAL AND INSURANCE SERVICES, ON BEHALF OF THIRD PARTIES; PROVIDING STATISTICAL EVALUATION OF INSURANCE CLAIMS PERFORMANCE MEASURES FOR OTHERS; TRACKING AND MONITORING INSURANCE COMPLIANCE; REINSURANCE BILLING SERVICES.  
 FIRST USE 5-15-2009; IN COMMERCE 5-15-2009.

INT. CL. 36/U.S. CLS. 100, 101 AND 102  
 FOR CONSULTING AND INFORMATION CONCERNING INSURANCE; FINANCIAL CONSULTANCY AND INSURANCE CONSULTANCY; INSURANCE ADMINISTRATION; INSURANCE ADMINISTRATION IN THE FIELD OF REINSURANCE, AND CONSULTATION PROVIDED IN CONNECTION THEREWITH; CONSULTATION IN THE FIELD OF REINSURANCE AND REINSURANCE ADMINISTRATION; INSURANCE AND FINANCIAL INFORMATION AND CONSULTANCY SERVICES; INSURANCE CONSULTANCY; INSURANCE CONSULTATION; INSURANCE INFORMATION; INSURANCE INFORMATION AND CONSULTANCY; PROVIDING INFORMATION IN INSURANCE MATTERS; INSURANCE ADMINISTRATION SERVICES, NAMELY, ASSISTING OTHERS WITH COLLECTION INSURANCE PREMIUMS.  
 FIRST USE 5-15-2009; IN COMMERCE 5-15-2009.

ELEMENTS CORRECTED  
 OWNER ADDRESS

\* \* \* \* \*

# TRADEMARK REGISTRATIONS—NEW CERTIFICATES

New Certificates issued under section 7(d) of the Trademark Act of 1946 for the unexpired term of the original registrations.

1,923,297. UNICATCH. INT. CL. 7. UNICATCH INTERNATIONAL, INC., WHITTIER, CA. REG. 10-3-1995. NEW CERT. SEC. 7(D) TO REGISTRANT.

3,441,211. ALPHAWORKS STANDARD CHARACTER MARK. INT. CL. 36. ALPHAWORKS, LLC, NEW YORK, NY. REG. 6-3-2008. NEW CERT. SEC. 7(D) TO REGISTRANT.

2,931,058. TOTIS. INT. CL. 30. TORRES, ABRAHAM MARCELO GONZALEZ, TIZAYUCA, HIDALGO, MEXICO. REG. 3-8-2005. NEW CERT. SEC. 7(D) TO REGISTRANT.

3,523,698. VALENTINS STANDARD CHARACTER MARK. INT. CL. 32. EICHBAUM-BRAUEREIEN AG, MANNHEIM, FED REP GERMANY. REG. 10-28-2008. NEW CERT. SEC. 7(D) TO REGISTRANT.

3,249,247. TUNECORE STANDARD CHARACTER MARK. INT. CLS. 35 AND 40. YOUR TUNES, INC. DBA TUNECORE, BROOKLYN, NY. REG. 6-5-2007. NEW CERT. SEC. 7(D) TO REGISTRANT.

3,628,166. GERMANIA PREMIUM AND DESIGN. INT. CL. 32. EICHBAUM-BRAUEREIEN AG, MANNHEIM, FED REP GERMANY. REG. 5-26-2009. NEW CERT. SEC. 7(D) TO REGISTRANT.

\* \* \* \* \*

This page is intentionally blank

# INDEX OF REGISTRANTS

MAY 3, 2011

(Registered; Renewed; Canceled; Amended, Corrected, etc.; New Certificates; 12c Publications.)

The designation "U.S. Cl." appearing in this section refers to the U.S. class in effect prior to Sep. 1, 1973 rather than the international class which applies to applications filed on or after that date. For adoption of international classification see notice in the OFFICIAL GAZETTE of Jun. 26, 1973 (911 O.G. TM 210).

- ÅLÖ AB, SWEDEN:  
3,953,515, PUB. 2-15-2011. MULTIPLE CLASS, INT. CLS. 7 AND 12.
- A & B JEWELRY DESIGNS, INC., NEW YORK, NY:  
2,876,325, CANC. INT. CL. 14.
- A CASA DO PAO DE QUEIJO INC., NEWARK, NJ:  
2,544,246, REN. 3-28-11. INT. CL. 35.
- A E BOYCE COMPANY, INC., DALEVILLE, IN:  
3,954,740, PUB. 2-15-2011. INT. CL. 41.
- A QUANTUM MOMENT, LLC, RANCHO SANTA FE, CA:  
3,955,196, INT. CL. 9.  
3,955,197, INT. CL. 16.  
3,955,198, INT. CL. 41.
- A. B. CLOSING CORPORATION, ORLANDO, FL, DBA KAVALIRO INC.:  
3,955,555, INT. CL. 35.
- A. DE FUSSIGNY, FRANCE:  
3,953,507, PUB. 2-15-2011. INT. CL. 33.
- A. DE FUSSIGNY, COGNAC, FRANCE:  
3,953,740, PUB. 2-15-2011. INT. CL. 33.
- A. GANDOLA & C. S.P.A., PONTE S. MARCO-BRESCIA, ITALY:  
3,953,745, PUB. 2-15-2011. INT. CL. 30.
- A. L. BAZZINI CO., INC., BRONX, NY:  
1,367,907, REN. 3-30-11. INT. CL. 29.
- A.G. FERRARI FOODS, SAN LEANDRO, CA:  
2,468,187, REN. 3-29-11. INT. CL. 30.
- A.I.J.J. ENTERPRISES, INC., BROOKLYN, NY:  
2,420,792, REN. 3-31-11. INT. CL. 35.
- A.N.P., INC., PHOENIX, AZ, DBA ARIZONA NATURAL PRODUCTS:  
2,550,011, REN. 3-26-11. INT. CL. 5.
- A&A HARRIS ENTERPRISES, ALAMEDA, CA:  
2,379,651, CANC. INT. CL. 9.
- A&R CARTON AB, LUND, SWEDEN:  
3,955,178, MULTIPLE CLASS, INT. CLS. 7, 16, 17 AND 20.
- AADISASTER RESTORATION24/7, INC., PUNTA GORDA, FL:  
3,954,440, PUB. 2-15-2011. MULTIPLE CLASS, INT. CLS. 37 AND 40.  
3,954,447, PUB. 2-15-2011. MULTIPLE CLASS, INT. CLS. 37 AND 40.
- AAVID THERMALLOY, LLC, CONCORD, NH:  
3,954,657, PUB. 2-15-2011. INT. CL. 9.
- ABAFODDS SRL, BADIA POLESINE (RO), ITALY:  
3,953,503, PUB. 2-15-2011. INT. CL. 32.
- ABB INC., CARY, NC, I-T-E CIRCUIT BREAKER COMPANY, PHILADELPHIA, PA:  
721,820, REN. 3-31-11. U.S. CL. 21 (INT. CL. 9).
- ABBOTT LABORATORIES, ABBOTT PARK, IL:  
2,877,951, CANC. INT. CL. 10.  
3,955,672, INT. CL. 5.
- ABBOTT MEDICAL OPTICS INC., SANTA ANA, CA:  
2,379,111, CANC. INT. CL. 10.
- ABBOTT'S FROZEN CUSTARD, INC., ROCHESTER, NY:  
3,953,934, PUB. 2-15-2011. MULTIPLE CLASS, INT. CLS. 30 AND 35.
- ABC HOME FURNISHINGS, INC., NEW YORK, NY:  
3,954,573, PUB. 2-15-2011. INT. CL. 43.
- ABDUL AZIZ, LOS ANGELES, CA, DBA LA CASH AND CARRY:  
3,956,238, INT. CL. 3.
- ABIGAIL BARNES, LONG BEACH, CA:  
3,954,219, PUB. 2-15-2011. INT. CL. 35.
- ABILITYFIRST, PASADENA, CA, ABILITYFIRST, PASADENA, CA:  
2,464,536, REN. 3-31-11. INT. CL. 35.
- ABN AMRO BANK N.V., 1082 PP AMSTERDAM, NETHERLANDS:  
2,878,043, CANC. INT. CL. 36.
- ABRAHAM, THOMAS G., MIAMI, FL:  
3,953,928, PUB. 2-15-2011. MULTIPLE CLASS, INT. CLS. 20 AND 28.
- ABRAZIL LLC, KENDALL PARK, NJ, DBA NATURAL HEALTH PRODUCTS AND NUTRACEUTICALS:  
3,953,865, PUB. 2-15-2011. INT. CL. 5.
- ABS GLOBAL, INC., DEFOREST, WI:  
3,955,716, INT. CL. 44.
- ABSOLUTE COLD GMBH, D-38106 BRAUNSCHWEIG, FED REP GERMANY:  
2,876,245, CANC. INT. CL. 16.
- ABUNDANT ENERGY, LLC, PLANO, TX:  
3,954,882, PUB. 2-15-2011. INT. CL. 7.
- ACADEMY OF MOLECULAR IMAGING, LOS ANGELES, CA:  
2,876,006, CANC. MULTIPLE CLASS, INT. CLS. 16 AND 41.
- ACADEMY OF MOTION PICTURE ARTS AND SCIENCES, BEVERLY HILLS, CA:  
2,447,373, REN. 3-31-11. INT. CL. 16.
- ACCELERATED CARE PLUS CORP., RENO, NV:  
3,955,983, INT. CL. 9.
- ACCELERATED CHRISTIAN EDUCATION, INC., NASHVILLE, TN:  
3,954,259, PUB. 2-15-2011. INT. CL. 41.
- ACCEPTANCE CAPITAL MORTGAGE CORPORATION, SPOKANE, WA:  
2,877,450, CANC. INT. CL. 36.
- ACCESS INTERNATIONAL, INC., CAMBRIDGE, MA:  
2,443,636, REN. 3-30-11. INT. CL. 9.
- ACCARBOND CORPORATION, OLIVE BRANCH, MS:  
2,461,299, REN. 3-31-11. INT. CL. 1.
- ACCU-TEC, INC., LOUISVILLE, KY:  
2,545,903, REN. 3-26-11. MULTIPLE CLASS, INT. CLS. 35, 39 AND 42.
- ACCURATE SURGICAL & SCIENTIFIC INSTRUMENTS CORPORATION, WESTBURY, NY:  
1,177,066, REN. 3-31-11. INT. CL. 10.
- ACE BOAT LIFTS, L.L.C., SARASOTA, FL:  
2,877,734, CANC. INT. CL. 7.  
2,877,735, CANC. INT. CL. 7.
- ACH FOO COMPANIES, INC., CORDOVA, TN:  
2,450,537, REN. 3-25-11. INT. CL. 30.
- ACHATES POWER, INC., SAN DIEGO, CA:  
3,955,832, INT. CL. 42.
- ACOLYTE TECHNOLOGIES CORPORATION, NEW YORK, NY:  
2,876,469, CANC. INT. CL. 11.
- ACOUSTIC DISC, SAN RAFAEL, CA:  
2,877,182, CANC. MULTIPLE CLASS, INT. CLS. 9 AND 41.
- ACREDO GMBH, SWITZERLAND:  
3,953,670, PUB. 2-15-2011. INT. CL. 14.

- ACROPRINT TIME RECORDER COMPANY, RALEIGH, NC:  
2,877,721, CANC. INT. CL. 9.
- ACROSS THE SKYY, GLENDALE, AZ:  
3,955,331, INT. CL. 25.
- ACROSS THE STREET PRODUCTIONS INC., PHOENIX, AZ:  
3,956,141, MULTIPLE CLASS, INT. CLS. 41 AND 42.
- ACRUXO TECHNOLOGY INC., TAIPEI, TAIWAN:  
2,876,587, CANC. INT. CL. 9.
- ACTELION PHARMACEUTICALS LTD, ALLSCHWIL, SWITZERLAND:  
3,953,452, PUB. 2-15-2011. INT. CL. 5.
- ACTITRAC SOFTWARE LIMITED, HADLEIGH, SUFFOLK IP7 5JF, UNITED KINGDOM:  
3,953,667, PUB. 2-15-2011. INT. CL. 9.
- ACTIVE CONCEPTS LLC, LINCOLNTON, NC:  
3,954,976, PUB. 2-15-2011. INT. CL. 1.
- ACTIVE PRODUCTS, INC., CORONA, CA:  
2,876,076, CANC. INT. CL. 22.
- ACTIVE SPORTS LIFESTYLE USA, MIRALOMA, CA:  
3,953,785, PUB. 2-15-2011. INT. CL. 35.
- ACTIVEMAP LLC, BROOKLYN, NY:  
3,955,406, INT. CL. 9.
- ACTIVSTYLE HOLDING COMPANY, MINNEAPOLIS, MN:  
2,440,175, REN. 3-31-11. INT. CL. 5.  
2,440,175, CANC. INT. CL. 3.
- AD-MAKER, INC., GARDENA, CA:  
2,876,741, CANC. INT. CL. 35.
- ADAMS APPLE DISTRIBUTING L.P., GLENVIEW, IL, ADAMS APPLE DISTRIBUTING CO., CHICAGO, IL:  
1,148,529, REN. 3-25-11. INT. CL. 34.
- ADAMS COUNTY EDUCATION CONSORTIUM, WESTMINSTER, CO:  
3,954,520, PUB. 2-15-2011. INT. CL. 41.
- ADAMS GOLF IP, LP, PLANO, TX:  
3,956,064, INT. CL. 28.
- ADAMS GOLF IP, LP., PLANO, TX:  
3,956,063, INT. CL. 28.
- ADCOM EXPRESS, INC., EDINA, MN:  
2,479,314, REN. 3-25-11. INT. CL. 39.
- ADD-A-NAME PARTNERS, TEMPE, AZ:  
1,610,439, CANC. MULTIPLE CLASS, INT. CLS. 9 AND 42.
- ADD'A TOUCH, ST. CROIX, US VIRGIN ISLANDS, DBA ADD'A TOUCH:  
3,953,098, PUB. 2-15-2011. INT. CL. 14.
- ADDED TOUCH EMBROIDERY, LTD., FOUNTAIN HILLS, AZ, DBA HERITAGE CROSS A:  
3,955,050, PUB. 2-15-2011. INT. CL. 25.
- ADDISON-WESLEY EDUCATIONAL PUBLISHERS INC., READING, MA AND ADDISON WESLEY LONGMAN, INC., READING, MA AND CHILDREN'S TELEVISION WORKSHOP, NEW YORK, NY:  
2,379,782, CANC. INT. CL. 16.
- ADFUNKY LLC, NEW YORK, NY:  
3,953,412, PUB. 2-15-2011. INT. CL. 35.  
3,953,414, PUB. 2-15-2011. INT. CL. 35.
- ADHERIS, INC., BURLINGTON, MA, ADHERIS, INC., BURLINGTON, MA:  
2,449,977, REN. 3-29-11. INT. CL. 42.
- ADHESIVES TECHNOLOGY CORPORATION, POMPANO BEACH, FL:  
3,953,382, PUB. 2-15-2011. INT. CL. 1.
- ADMINISTAFF, INC., KINGWOOD, TX:  
2,877,775, CANC. INT. CL. 36.  
2,877,787, CANC. INT. CL. 35.
- ADVANCE MAGAZINE PUBLISHERS INC., NEW YORK, NY:  
1,434,389, CANC. INT. CL. 16.  
1,659,761, REN. 3-28-11. INT. CL. 18.  
2,471,378, REN. 3-26-11. INT. CL. 16.  
2,876,692, CANC. INT. CL. 35.
- ADVANCED ARCHITECTURAL FRAMES, STANTON, CA:  
2,876,323, CANC. INT. CL. 6.  
2,876,324, CANC. INT. CL. 6.
- ADVANCED ARCHITECTURAL GRILLES, VALLEY STREAM, NY:  
3,956,132, INT. CL. 6.
- ADVANCED ARMAMENT CORP., LLC, MADISON, NC:  
3,954,432, PUB. 2-15-2011. INT. CL. 25.  
3,954,433, PUB. 2-15-2011. INT. CL. 13.  
3,954,435, PUB. 2-15-2011. INT. CL. 13.  
3,954,437, PUB. 2-15-2011. INT. CL. 13.  
3,954,438, PUB. 2-15-2011. INT. CL. 13.
- ADVANCED BALLOT SOLUTIONS, LLC, CHANDLER, AZ:  
3,955,717, INT. CL. 9.
- ADVANCED BEAUTY SYSTEMS, INC, DALLAS, TX:  
3,955,174, INT. CL. 3.
- ADVANCED CERAMICS RESEARCH, INC., TUCSON, AZ:  
2,878,065, CANC. INT. CL. 1.
- ADVANCED NAIL GROWTH SYSTEMS, INC., NEW YORK, NY:  
3,953,063, PUB. 12-1-2009. INT. CL. 3.
- ADVANCED OPTICAL TECHNOLOGIES CORPORATION, OTTAWA, ONTARIO, CANADA:  
3,953,068, PUB. 2-15-2011. INT. CL. 14.
- ADVANCED PRESSURE TECHNOLOGY, NAPA, CA:  
3,953,113, PUB. 2-15-2011. INT. CL. 9.
- ADVANCED REFINISHING, INC., DALLAS, TX:  
3,954,615, PUB. 2-15-2011. MULTIPLE CLASS, INT. CLS. 20, 24 AND 35.  
3,954,616, PUB. 2-15-2011. MULTIPLE CLASS, INT. CLS. 20, 24, 35 AND 37.
- ADVANCED SORTING TECHNOLOGIES LLC, NASHVILLE, TN:  
2,424,250, REN. 3-29-11. INT. CL. 9.
- ADVANCED SURGICAL CONCEPTS LIMITED, BRAY, COUNTY WICKLOW, IRELAND:  
2,875,969, CANC. INT. CL. 10.
- ADVANCED TECHNOLOGIES AND SERVICES, INC., WAYNE, NJ:  
2,474,985, REN. 3-26-11. INT. CL. 42.
- ADVANCINA LLC, HERNDON, VA:  
3,954,637, PUB. 2-15-2011. INT. CL. 35.
- ADVANCIS.COM, DALLAS, TX:  
2,532,218, REN. 3-26-11. INT. CL. 35.
- ADVANCIUM TECHNOLOGIES, 69008 LYON, FRANCE:  
3,953,256, PUB. 2-15-2011. INT. CL. 28.
- ADVANTAGE DIST. LLC, ROCHESTER, MN:  
3,952,997, PUB. 2-15-2011. INT. CL. 4.
- ADVENTURE HOLDINGS LLC, PUKALANI, HI:  
3,953,451, PUB. 2-15-2011. INT. CL. 35.
- ADVICEHERE.COM, INC., ARMONK, NY:  
2,876,614, CANC. INT. CL. 36.
- AECON GROUP INC., TORONTO, ONTARIO, CANADA:  
2,875,979, CANC. MULTIPLE CLASS, INT. CLS. 35, 36, 37, 40 AND 42.
- AEI SECURITY & COMMUNICATIONS LIMITED, HAILSHAM, EAST SUSSEX, UNITED KINGDOM:  
3,953,520, PUB. 11-9-2010. MULTIPLE CLASS, INT. CLS. 9, 16 AND 41.
- AEQUOR, ISELIN, NJ:  
3,954,295, PUB. 2-15-2011. INT. CL. 35.
- AERO MIST, INC., PHOENIX, AZ:  
3,953,324, PUB. 2-15-2011. INT. CL. 11.
- AERODYNAMIC TRAILER SYSTEMS, LLC, AUBURN TOWNSHIP, OH:  
3,955,647, INT. CL. 12.  
3,955,648, INT. CL. 12.
- AEROFORTIS ENERGY SOLUTIONS, INC., TAIPEI COUNTY, TAIWAN:  
3,953,764, PUB. 2-15-2011. INT. CL. 7.
- AERONAUTICAL SYSTEMS, INCORPORATED, STERLING, VA:  
3,956,026, INT. CL. 37.  
3,956,027, INT. CL. 37.
- AETNA, INC., HARTFORD, CT, PRUDENTIAL INSURANCE COMPANY OF AMERICA, THE, NEWARK, NJ:  
1,605,906, REN. 3-28-11. MULTIPLE CLASS, INT. CLS. 36 AND 42.
- AF CONCEPT HOLDINGS, LLC, SAN LUIS OBISPO, CA:  
2,379,791, CANC. INT. CL. 25.
- AFAXYS, INC., CHARLESTON, SC:  
3,953,466, PUB. 6-16-2009. INT. CL. 35.
- AFP IMAGING CORPORATION, ELMSFORD, NY:  
2,378,650, CANC. INT. CL. 10.



AFRICARE, WASHINGTON, DC:  
3,953,399, PUB. 2-15-2011. INT. CL. 36.

AFT DISTRIBUTING, ST. GEORGE, UT:  
3,954,580, PUB. 2-15-2011. INT. CL. 3.

AFX TECHNOLOGY GROUP INTERNATIONAL, INC.,  
DALLAS, TX:  
2,877,761, CANC. INT. CL. 9.

AG GROWTH INDUSTRIES PARTNERSHIP, WINNIPEG,  
MANITOBA, CANADA:  
1,641,037, REN. 3-29-11. INT. CL. 7.

AGATE RESOURCES, INC., EUGENE, OR:  
3,953,881, PUB. 2-15-2011. INT. CL. 35.

AGAVERA CAMACHINES, S.A. DE C.V., TLAQUEPAQUE,  
JALISCO, C.P., MEXICO:  
2,449,681, REN. 3-29-11. INT. CL. 33.

AGENCE FRANCE PRESSE, 75002 PARIS, FRANCE:  
2,873,090, CANC. MULTIPLE CLASS, INT. CLS. 9, 20  
AND 40.

AGENCY FOR DISPUTE RESOLUTION, INC., BEVERLY  
HILLS, CA:  
3,954,623, PUB. 2-15-2011. INT. CL. 45.

AGILENT TECHNOLOGIES, INC., SANTA CLARA, CA:  
1,157,059, REN. 3-26-11. INT. CL. 9.  
2,446,309, REN. 3-26-11. INT. CL. 1.

AGQUEST FINANCIAL SERVICES, INC., MORGAN, MN:  
2,454,059, REN. 3-30-11. INT. CL. 36.

AGRAQUEST, INC., DAVIS, CA:  
2,417,828, REN. 3-29-11. INT. CL. 5.

AGREN, INC., CARROLL, IA:  
3,953,766, PUB. 2-15-2011. MULTIPLE CLASS, INT. CLS.  
35 AND 42.

AGRENAISSANCE SOFTWARE LLC, RALEIGH, NC:  
3,954,621, PUB. 2-15-2011. INT. CL. 9.

AGRIUM INC., CALGARY, ALBERTA, CANADA:  
3,954,794, PUB. 2-15-2011. INT. CL. 41.

AGROTIKI VIOMICHANIA GALAKTOS IPIROU DODONI  
A.E. (AGRICULTURAL DAIRY INDUSTRY OF EPIRUS  
DODONI S.A.), ELEAUSA IOANNINON, GREECE:  
1,639,202, REN. 3-26-11. INT. CL. 29.

AGV GROUPE INC., BRENTWOOD, CA:  
3,953,790, PUB. 2-15-2011. INT. CL. 36.

AHALIFE IP HOLDINGS LLC, NEW YORK, NY:  
3,955,592, INT. CL. 35.

AHC PATENT CO., ANGLETON, TX:  
2,378,765, CANC. INT. CL. 22.  
2,378,766, CANC. INT. CL. 22.

AHMANN, RANDALL, LOS ANGELES, CA:  
2,379,796, CANC. INT. CL. 41.

AHOLD LICENSING SARL, GENEVA, SWITZERLAND:  
3,953,463, PUB. 2-15-2011. INT. CL. 30.

AHRENS, SEAN C., NEVADA CITY, CA:  
3,953,439, PUB. 2-15-2011. INT. CL. 42.

AIASEC - U.S., INC., NEW YORK, NY:  
2,498,520, REN. 3-26-11. INT. CL. 42.  
2,500,561, REN. 3-25-11. INT. CL. 42.

AIR ADVANTAGE INTELLECTUAL PROPERTY, LLC,  
FRANKENMUTH, MI:  
3,955,194, MULTIPLE CLASS, INT. CLS. 38, 42 AND 45.  
3,955,195, MULTIPLE CLASS, INT. CLS. 38, 42 AND 45.

AIR FLORA, INC., APOPKA, FL:  
2,876,394, CANC. MULTIPLE CLASS, INT. CLS. 20 AND  
21.

AIR PRODUCTS AND CHEMICALS, INC., ALLENTOWN,  
PA:  
2,444,767, REN. 3-26-11. INT. CL. 9.

AIR SYSTEM COMPONENTS, INC, RICHARDSON, TX:  
2,454,755, REN. 3-31-11. INT. CL. 11.

AIR TIGER EXPRESS COMPANIES, INC., SPRINGFIELD  
GARDENS, NY:  
3,954,707, PUB. 2-15-2011. MULTIPLE CLASS, INT. CLS.  
35, 36 AND 39.

AIRFENCE SAFETY SYSTEMS (AUSTRALIA) PTY LTD,  
HEIDELBERG, VICTORIA 3084, AUSTRALIA:  
2,419,800, REN. 3-27-11. INT. CL. 19.

AIRLINE CONTAINER LEASING, INC., OCEANSIDE, NY:  
2,876,424, CANC. MULTIPLE CLASS, INT. CLS. 6, 22, 37  
AND 39.

AIRPORT MECHANICAL SERVICE, ENUMCLAW, WA:  
2,877,184, CANC. INT. CL. 9.

AIWA CO., LTD., TOKYO, JAPAN:  
1,441,861, CANC. MULTIPLE CLASS, INT. CLS. 9 AND  
42.

AJ&B, INC., ALBERTVILLE, AL:  
2,877,888, CANC. INT. CL. 29.

AKAMAI TECHNOLOGIES, INC., CAMBRIDGE, MA, AKA-  
MAI TECHNOLOGIES, INC., CAMBRIDGE, MA:  
2,438,893, REN. 3-30-11. INT. CL. 9.

AKERS, C. MICHAEL, WESTERVILLE, OH:  
2,379,105, CANC. INT. CL. 30.

AKERS, MICHAEL C., WESTERVILLE, OH:  
2,379,104, CANC. INT. CL. 30.

AKITA, INC., WILMINGTON, DE:  
3,954,963, PUB. 2-15-2011. MULTIPLE CLASS, INT. CLS.  
35 AND 36.  
3,955,111, PUB. 2-15-2011. INT. CL. 36.  
3,955,120, PUB. 2-15-2011. INT. CL. 36.  
3,955,121, PUB. 2-15-2011. MULTIPLE CLASS, INT. CLS.  
35 AND 36.  
3,955,144, PUB. 2-15-2011. INT. CL. 36.

AKORN, INC., LAKE FOREST, IL:  
3,954,229, PUB. 2-15-2011. INT. CL. 5.

AKRON PRODUCTS COMPANY, THE, BATH, OH:  
2,440,068, REN. 3-26-11. MULTIPLE CLASS, INT. CLS. 6  
AND 8.

AKT & IWDT, INC., WINTER PARK, FL:  
3,954,670, PUB. 2-15-2011. INT. CL. 35.  
3,954,671, PUB. 2-15-2011. INT. CL. 42.  
3,955,123, PUB. 2-15-2011. INT. CL. 40.  
3,955,124, PUB. 2-15-2011. INT. CL. 40.

ALABAMA THRIFT STORES, INC., BIRMINGHAM, AL:  
1,646,431, REN. 3-30-11. INT. CL. 42.

ALANRNIC FOOD DISTRIBUTORS, INC., WEST DEPTFORD,  
NJ:  
2,391,465, REN. 3-26-11. INT. CL. 30.

ALASKA HEALTHCARE ADVOCATES, LLC, ANCHO-  
RAGE, AK:  
3,953,915, PUB. 2-15-2011. INT. CL. 42.

ALBANY INTERNATIONAL CORP., ALBANY, NY:  
2,444,085, REN. 3-26-11. MULTIPLE CLASS, INT. CLS. 20  
AND 24.

ALBION COLLEGE, ALBION, MI:  
3,955,628, INT. CL. 41.

ALCOA INC., PITTSBURGH, PA:  
3,955,708, INT. CL. 6.

ALCON, INC., HUNENBERG, SWITZERLAND:  
2,476,037, REN. 3-30-11. INT. CL. 5.

ALDERETTE, KIXX, HEMET, CA AND ALDERETTE, SILK,  
HEMET, CA:  
2,877,333, CANC. INT. CL. 41.

ALDI INC., BATAVIA, IL:  
3,093,737, CANC. MULTIPLE CLASS, INT. CLS. 29 AND  
32.  
3,628,834, CANC. INT. CL. 30.

ALDRETE-VERGARA, GENARO, GUADALAJARA, MEXI-  
CO:  
3,953,791, PUB. 2-15-2011. INT. CL. 28.

ALERA SOLUTIONS, LLC, GAITHERSBURG, MD:  
2,876,992, CANC. INT. CL. 42.

ALEX C. FERGUSSON, LLC, CHAMBERSBURG, PA:  
3,955,520, INT. CL. 4.

ALEXANDER T. SMITH, MIAMI, FL:  
3,953,265, PUB. 2-15-2011. INT. CL. 39.

ALGORITHMIC TRADEMARKS LLC, WILMINGTON, DE:  
3,955,236, MULTIPLE CLASS, INT. CLS. 9, 36, 39, 42 AND  
45.

ALIMENTS FONTAINE SANTÉ INC., MONTREAL QC H4M  
2N5, CANADA:  
3,953,687, PUB. 2-15-2011. INT. CL. 29.

ALKERMES, INC., WALTHAM, MA:  
3,955,579, INT. CL. 5.

ALL ENTHUSIAST, INC., WALNUT CREEK, CA:  
3,954,971, PUB. 2-15-2011. INT. CL. 35.

ALL KANDY, WEST MONROE, LA:  
3,954,841, PUB. 2-15-2011. INT. CL. 37.

- ALL ONLINE, INC., MIDDLEVILLE, MI:  
3,956,069, INT. CL. 42.
- ALL RING TECH CO., LTD., KAOHSIUNG HSIEN, TAIWAN:  
2,876,465, CANC. INT. CL. 9.
- ALL-STATE INTERNATIONAL, INC., CRANFORD, NJ:  
1,658,959, REN. 3-26-11, INT. CL. 16.
- ALLEGRO SENIOR LIVING, LLC, ST. LOUIS, MO:  
3,953,951, PUB. 11-9-2010, INT. CL. 43.
- ALLFUNDS BANK, S.A., MADRID, SPAIN:  
3,953,117, PUB. 2-15-2011, INT. CL. 36.
- ALLIANCE FOR SUSTAINABLE ENERGY, LLC, GOLDEN, CO:  
3,954,395, PUB. 2-15-2011, MULTIPLE CLASS, INT. CLS. 35, 36 AND 42.
- ALLIANCE OF VISUAL ARTIST, ATLANTA, GA, DBA SOCIETY OF SPORT AND EVENT PHOTOGRAPHERS:  
3,954,017, PUB. 2-15-2011, INT. CL. 41.
- ALLIANCE TIRE AMERICAS, INC., WAKEFIELD, MA:  
2,470,897, REN. 3-28-11, INT. CL. 12.
- ALLIANCEBERNSTEIN L.P., NEW YORK, NY:  
2,876,887, CANC. INT. CL. 36.
- ALLIED INTRADE, INC., CARLSBAD, CA:  
3,953,959, PUB. 2-15-2011, INT. CL. 35.
- ALLIED STEEL BUILDINGS INC., FT. LAUDERDALE, FL:  
2,876,930, CANC. INT. CL. 6.
- ALLSTATE INSURANCE COMPANY, NORTHBROOK, IL:  
2,542,964, REN. 3-29-11, INT. CL. 36.  
2,544,467, REN. 3-29-11, MULTIPLE CLASS, INT. CLS. 35, 36 AND 42.
- ALLSUP, INC, BELLEVILLE, IL:  
2,485,294, REN. 3-26-11, INT. CL. 36.
- ALLTEL COMMUNICATIONS, LLC, LITTLE ROCK, AR:  
2,877,354, CANC. INT. CL. 38.
- ALMIRALL, S.A., 08022 BARCELONA, SPAIN:  
2,961,970, CANC. INT. CL. 35.
- ALMO, STEVEN, ROWLAND HEIGHTS, CA AND FU, CHRISTOPHER, MONTEREY PARK, CA:  
2,877,741, CANC. INT. CL. 28.  
2,877,742, CANC. INT. CL. 28.
- ALMOND TREE MARKETING, LLC, PASSAIC, NJ:  
3,954,099, PUB. 2-15-2011, INT. CL. 35.
- ALP LIGHTING & CEILING PRODUCTS, INC., NILES, IL:  
2,452,555, REN. 3-25-11, INT. CL. 11.
- ALPAQUA ENGINEERING, LLC, GLOUCESTER, MA:  
3,954,644, PUB. 2-15-2011, INT. CL. 9.
- ALPHA AWNING PRODUCTS INC., SCOTTSDALE, AZ:  
2,877,621, CANC. INT. CL. 35.
- ALPHA CARD SYSTEMS, LLC, PORTLAND, OR, DBA ALPHACARD:  
3,954,237, PUB. 2-15-2011, INT. CL. 35.
- ALPHA LASER RECHARGE, INC., HOUSTON, TX:  
2,497,763, REN. 3-29-11, INT. CL. 2.
- ALPHA TEN TECHNOLOGIES, INC., SAN MARCOS, CA:  
3,954,171, PUB. 2-15-2011, MULTIPLE CLASS, INT. CLS. 42 AND 45.
- ALPHAGRAPHICS, INC., SALT LAKE CITY, UT:  
2,378,408, CANC. MULTIPLE CLASS, INT. CLS. 35, 38, 40 AND 42.
- ALPHIN BROTHERS, INC., DUNN, NC:  
2,877,723, CANC. INT. CL. 29.
- ALPINE INVESTMENT MANAGEMENT, LLC, ST. LOUIS, MO:  
3,955,588, INT. CL. 36.
- ALSCO INDUSTRIES, INC., STURBRIDGE, MA:  
3,955,551, INT. CL. 21.
- ALTANA AG, 61285 BAD HOMBURG, FED REP GERMANY:  
2,876,297, CANC. MULTIPLE CLASS, INT. CLS. 16 AND 41.
- ALTER GROUP, LTD., THE, SKOKIE, IL:  
2,549,606, REN. 3-31-11, INT. CL. 36.
- ALTERNATIVE CONTINUUM OF CARE OF IOWA, L.L.C., DAKOTA DUNES, SD:  
2,479,560, REN. 3-31-11, INT. CL. 42.
- ALTICOR INC., ADA, MI:  
3,955,189, INT. CL. 25.  
3,955,261, INT. CL. 3.
- ALUMBAUGH FAMILY CORPORATION, THE, MIDDLETOWN, CA, DBA EAGLE & ROSE ESTATE:  
2,507,764, REN. 3-31-11, INT. CL. 42.  
2,511,013, REN. 3-31-11, INT. CL. 33.
- ALUMNICLASS.COM INC, SPOKANE, WA:  
3,953,428, PUB. 2-15-2011, INT. CL. 45.
- ALVAREZ, MELISSA, JUNO BEACH, FL:  
3,954,132, PUB. 2-15-2011, INT. CL. 28.
- AM 0645, 9000 GENT, BELGIUM:  
2,876,419, CANC. MULTIPLE CLASS, INT. CLS. 20, 24 AND 27.
- AM:PM ENTERTAINMENT CONCEPTS, INC., BROOKLYN, NY:  
2,436,246, REN. 3-25-11, MULTIPLE CLASS, INT. CLS. 9, 25, 38 AND 41.
- AMALGAMATED SOFTWARE OF NORTH AMERICA, INC., SAN ANTONIO, TX:  
2,378,955, CANC. INT. CL. 9.
- AMARA INTERNATIONAL HOTELS & RESORTS PTE LTD, THE AMARA, SINGAPORE:  
2,439,949, REN. 3-31-11, INT. CL. 42.
- AMAZING BEVERAGES, INC., JENKINTOWN, PA:  
3,954,426, PUB. 2-15-2011, INT. CL. 32.
- AMBASSADOR SOUTHWEST, LLC, SCOTTSDALE, AZ, DBA SONORAN SUITES AND TEE TIME EXPRESS:  
2,270,391, CANC. INT. CL. 41.
- AMBIT ENERGY, L.P., DALLAS, TX:  
3,955,808, INT. CL. 39.
- AMBIVO, INC., REDWOOD CITY, CA:  
3,955,698, INT. CL. 9.
- AMBROSIA, INC., SWANTON, OH:  
2,432,851, REN. 3-30-11, MULTIPLE CLASS, INT. CLS. 4 AND 21.
- AMC SALES, INC., MINNEAPOLIS, MN:  
2,449,030, REN. 3-26-11, INT. CL. 28.  
2,449,031, REN. 3-26-11, INT. CL. 28.
- AMERI-TECH REALTY, INC., CLEARWATER, FL:  
3,953,179, PUB. 2-15-2011, INT. CL. 36.
- AMERICAN CORPORATION, HENDERSON, NC:  
3,955,259, INT. CL. 25.
- AMERICAN & EFIRD ENTERPRISES, INC., MOUNT HOLLY, NC:  
3,955,659, INT. CL. 23.
- AMERICAN AIRLINES, INC., FORT WORTH, TX:  
2,444,072, REN. 3-29-11, INT. CL. 35.
- AMERICAN ALLIANCE FOR HEALTH, PHYSICAL EDUCATION, RECREATION AND DANCE, THE, RESTON, VA:  
3,954,134, PUB. 2-15-2011, MULTIPLE CLASS, INT. CLS. 16 AND 41.
- AMERICAN ASSOCIATION FOR THE ADVANCEMENT OF SCIENCE, WASHINGTON, DC:  
3,953,126, PUB. 2-15-2011, INT. CL. 41.  
3,953,398, PUB. 2-15-2011, MULTIPLE CLASS, INT. CLS. 9, 41 AND 42.
- AMERICAN BAR ASSOCIATION, CHICAGO, IL:  
2,440,790, REN. 3-29-11, INT. CL. 42.
- AMERICAN BILTRITE INC., WELLESLEY HILLS, MA:  
3,955,341, INT. CL. 1.
- AMERICAN BOTANICAL PHARMACY, MARINA DEL REY, CA:  
3,956,147, INT. CL. 5.  
3,956,148, INT. CL. 5.
- AMERICAN CHEMICAL SOCIETY, WASHINGTON, DC:  
2,440,348, REN. 3-30-11, INT. CL. 42.
- AMERICAN CHILDHOOD CANCER ORGANIZATION, KENSINGTON, MD:  
3,955,635, MULTIPLE CLASS, INT. CLS. 9, 14, 16, 35, 36, 44 AND 45.
- AMERICAN COUNCIL ON EDUCATION, WASHINGTON, DC:  
2,379,521, CANC. INT. CL. 41.
- AMERICAN CYCLE & FITNESS, INC., WALLED LAKE, MI:  
2,438,405, REN. 3-28-11, INT. CL. 35.
- AMERICAN EDUCATION FOUNDATION, INC., SANTA ANA, CA:  
2,380,148, CANC. INT. CL. 41.

AMERICAN FEDERATION OF LABOR AND CONGRESS OF INDUSTRIAL ORGANIZATIONS, WASHINGTON, DC:  
2,445,324. REN. 3-28-11. INT. CL. 36.

AMERICAN GRANBY, INC., LIVERPOOL, NY:  
1,390,504. CANC. INT. CL. 11.

AMERICAN HEARING SYSTEMS, INC., PLYMOUTH, MN, DBA INTERTON:  
2,839,934. COR. INT. CL. 9.

AMERICAN HOMES REALTY, INC., JERSEY CITY, NJ:  
2,876,190. CANC. INT. CL. 36.

AMERICAN INSTITUTE FOR FOREIGN STUDY, INC., STAMFORD, CT:  
2,877,225. CANC. INT. CL. 43.

AMERICAN INTERNATIONAL GROUP, INC., NEW YORK, NY:  
3,953,109. PUB. 2-15-2011. INT. CL. 36.  
3,953,110. PUB. 2-15-2011. INT. CL. 36.  
3,955,028. PUB. 2-15-2011. INT. CL. 36.  
3,955,112. PUB. 2-15-2011. INT. CL. 36.

AMERICAN IRONHORSE MOTORCYCLE COMPANY, INC., FORT WORTH, TX:  
2,876,021. CANC. INT. CL. 12.

AMERICAN ITALIAN PASTA COMPANY, KANSAS CITY, MO:  
3,955,220. INT. CL. 30.

AMERICAN LABELMARK COMPANY, CHICAGO, IL:  
2,876,311. CANC. INT. CL. 16.

AMERICAN LOCKER SECURITY SYSTEMS, INC., GRAPEVINE, TX:  
3,954,375. PUB. 2-15-2011. INT. CL. 20.  
3,954,552. PUB. 2-15-2011. INT. CL. 20.  
3,954,553. PUB. 2-15-2011. INT. CL. 20.

AMERICAN LUMPING ASSOCIATION, AURORA, CO:  
2,380,125. CANC. INT. CL. 35.

AMERICAN MOUNTAIN GUIDES ASSOCIATION (AMGA), GOLDEN, CO:  
2,877,809. CANC. MULTIPLE CLASS, INT. CLS. 25 AND 35.

AMERICAN PHARMACISTS ASSOCIATION (APHA), WASHINGTON, DC:  
2,380,144. CANC. INT. CL. 41.

AMERICAN PHYSICAL SOCIETY, THE, COLLEGE PARK, MD:  
2,547,257. REN. 3-29-11. INT. CL. 42.

AMERICAN PSYCHOLOGICAL ASSOCIATION, WASHINGTON, DC:  
2,876,408. CANC. INT. CL. 44.

AMERICAN PUBLIC LIFE INSURANCE COMPANY, OKLAHOMA CITY, OK:  
2,487,442. REN. 3-30-11. INT. CL. 36.

AMERICAN SILK MILLS CORPORATION, NEW YORK, NY:  
1,654,938. REN. 3-25-11. INT. CL. 24.

AMERICAN SOCIETY OF CIVIL ENGINEERS, THE, RESTON, VA:  
1,159,588. AM. U.S. CL. 200.

AMERICAN SOCIETY OF COMPOSERS, AUTHORS & PUBLISHERS, NEW YORK, NY:  
2,877,865. CANC. INT. CL. 42.

AMERICAN SPORTING GOODS CORPORATION, ALISO VIEJO, CA:  
3,953,034. PUB. 2-15-2011. INT. CL. 25.

AMERICAN STERLING DENTAL PLAN, LLC., MAYFIELD HEIGHTS, OH:  
3,952,996. PUB. 2-15-2011. INT. CL. 42.

AMERICAN TAI CHI ASSOCIATION, A PENNSYLVANIA NON-PROFIT NON-STOCK ASSOCIATION, PHILADELPHIA, PA:  
2,878,027. CANC. INT. CL. 41.

AMERICAN TIME & SIGNAL CO., DASSEL, MN:  
2,877,017. CANC. INT. CL. 14.

AMERICAN TRUCKING ASSOCIATIONS, INC., ARLINGTON, VA:  
2,935,803. CANC. INT. CL. 25.

AMERICAN TURBINE LLC, NORTH ST. PAUL, MN:  
3,954,788. PUB. 2-15-2011. INT. CL. 7.  
3,954,792. PUB. 2-15-2011. INT. CL. 7.

AMERICAN WEST FURNITURE MANUFACTURERS, INC., SANTA FE SPRINGS, CA:  
2,378,429. CANC. INT. CL. 20.

AMERICATEL CORPORATION, IRVING, TX:  
2,436,723. REN. 3-26-11. INT. CL. 38.

AMERISURE MUTUAL INSURANCE COMPANY, FARMINGTON HILLS, MI:  
2,439,784. REN. 3-26-11. INT. CL. 36.  
2,442,185. REN. 3-26-11. INT. CL. 36.

AMES TRUE TEMPER, INC., CAMP HILL, PA:  
3,956,144. INT. CL. 21.

AMETEK PRECITECH, INC., KEENE, NH:  
2,417,971. REN. 3-29-11. INT. CL. 7.

AMF BOWLING WORLDWIDE, INC., MECHANICSVILLE, VA:  
714,104. REN. 3-29-11. U.S. CL. 22 (INT. CL. 28).

AMHERST, L.L.C., MERRIMACK, NH:  
2,876,467. CANC. INT. CL. 35.

AMK PRODUCTS INC., WINCHESTER, VA:  
2,378,447. CANC. INT. CL. 6.

AMO DEVELOPMENT, LLC, SANTA ANA, CA:  
2,643,732. CANC. INT. CL. 10.

AMOREPACIFIC CORPORATION, SEOUL, REPUBLIC OF KOREA:  
2,876,322. CANC. INT. CL. 3.  
3,953,043. PUB. 8-3-2010. INT. CL. 3.  
3,953,064. PUB. 2-15-2011. INT. CL. 5.  
3,953,122. PUB. 8-3-2010. INT. CL. 3.  
3,953,123. PUB. 8-3-2010. INT. CL. 3.  
3,953,124. PUB. 8-17-2010. INT. CL. 3.

AMORIM REVESTIMENTOS, S.A., 4535 S. PAIO DE OLEIROS, PORTUGAL:  
2,437,959. REN. 3-26-11. MULTIPLE CLASS, INT. CLS. 2 AND 3.

AMPACET CORPORATION, TARRYTOWN, NY:  
3,955,227. MULTIPLE CLASS, INT. CLS. 1 AND 2.

AMPHENOL CORPORATION, WALINGFORD, CT, PYLE-NATIONAL COMPANY, THE, CHICAGO, IL:  
531,705. REN. 3-26-11. U.S. CL. 21 (INT. CLS. 7, 9, 11, 12 AND 15).

AMPHIONS INNOVATIONS PLC, NEW YORK, NY:  
2,378,887. CANC. INT. CL. 35.

AMX LLC, RICHARDSON, TX:  
3,955,165. INT. CL. 9.

ANABOLIC LABORATORIES, LLC, IRVINE, CA:  
1,148,818. REN. 3-26-11. INT. CL. 10.

ANDERSON, TODD, ST. HELENA, CA:  
3,953,359. PUB. 2-15-2011. INT. CL. 33.

ANDRE, MARK WAYNE, SAN DIEGO, CA:  
2,380,005. CANC. INT. CL. 16.

ANDREW M. EDELSTEIN AND JESSICA S. EDELSTEIN PARTNERSHIP, THE, TORRANCE, CA, DBA PROJECT DESIGN STUDIO:  
2,877,342. CANC. INT. CL. 42.

ANDRZEJ J. OLEJNICZAK, NEW YORK, NY:  
2,877,369. CANC. INT. CL. 35.

ANGELA R. REHKOP, ATLANTA, GA, DBA FINANCIAL CARE PROVIDERS:  
3,954,165. PUB. 2-15-2011. INT. CL. 36.

ANGELO & MAXIE'S, LLC, NEW YORK, NY, DBA ANGELO & MAXIE'S:  
2,091,489. REN. 3-29-11. INT. CL. 42.

ANGIODYNAMICS, INC., QUEENSBURY, NY:  
2,877,916. CANC. INT. CL. 10.

ANGIODYNAMICS, INC., LATHAM, NY:  
3,954,994. PUB. 2-15-2011. INT. CL. 10.

ANIMAGIC ENTERTAINMENT GROUP, INC., CARPINTERIA, CA, BALLOONATIKS INTERNATIONAL, INC., NEW YORK, NY:  
1,638,519. REN. 3-31-11. INT. CL. 28.

ANIMAL FEED TECHNOLOGIES, LLC, GREELEY, CO:  
2,876,860. CANC. INT. CL. 31.

ANKER-TEPPICHBODEN GEBR. SCHOELLER GMBH & CO. KG, D-52319 DUREN, FED REP GERMANY:  
2,379,325. CANC. INT. CL. 12.

ANLEU, SALLY A, BROOKSVILLE, FL, DBA F.C.I. FRAUDULENT CLAIMS INVESTIGATIONS:  
3,953,927. PUB. 2-15-2011. INT. CL. 45.

- ANNE GIBBONS CARTOONING & ILLUSTRATION, NEW YORK, NY:  
2,877,697, CANC. MULTIPLE CLASS, INT. CLS. 14 AND 21.
- ANTARES INVESTMENT PARTNERS, ARMONK, NY:  
2,877,252, CANC. MULTIPLE CLASS, INT. CLS. 35 AND 36.
- ANTARIA LIMITED, AUSTRALIA:  
3,953,546, PUB. 2-15-2011. INT. CL. 1.
- ANTHONY TESSELAAR PLANTS PTY LTD, SILVAN, VICTORIA 3795, AUSTRALIA:  
2,875,953, CANC. INT. CL. 31.
- ANTON, ANTHONY, CHICAGO, IL:  
3,956,079, INT. CL. 41.
- ANYTHING GOES, INC., ALLENHURST, NJ:  
2,404,315, REN. 3-26-11. INT. CL. 35.
- AON CORPORATION, CHICAGO, IL:  
3,956,030, INT. CL. 42.
- APEX SECURITY HARDWARE CORP., BROOKLYN, NY:  
2,481,826, REN. 3-26-11. MULTIPLE CLASS, INT. CLS. 6 AND 7.
- APL LIMITED, SCOTTSDALE, AZ:  
2,445,794, REN. 3-31-11. INT. CL. 41.
- APNEX MEDICAL, INC., ST. PAUL, MN:  
3,954,147, PUB. 2-15-2011. INT. CL. 10.
- APOLLO PET CARE, INC., MANTON, CA, DBA APOLLO PET CARE:  
3,955,609, INT. CL. 44.
- APOTHECARY PRODUCTS, INC., BURNSVILLE, MN:  
2,443,052, REN. 3-31-11. INT. CL. 9.
- APPALACHIAN STATE UNIVERSITY, BOONE, NC:  
2,444,195, REN. 3-26-11. INT. CL. 41.
- APPLE & EVE, LLC, PORT WASHINGTON, NY:  
3,955,051, PUB. 2-15-2011. INT. CL. 32.
- APPLE INC., CUPERTINO, CA:  
2,876,046, CANC. INT. CL. 9.
- APPLE OPTICAL CO., MCLEAN, VA:  
2,876,027, CANC. INT. CL. 9.
- APPLIAN TECHNOLOGIES INC., SAN ANSELMO, CA:  
3,955,893, INT. CL. 9.
- APPLIED MINDS, INC., GLENDALE, CA:  
3,953,069, PUB. 2-15-2011. MULTIPLE CLASS, INT. CLS. 35 AND 42.
- APPSNMINDED, MALIBU, CA:  
3,954,121, PUB. 2-15-2011. INT. CL. 42.
- APROMEX - ASOCIACIÓN DE PROFESIONISTAS MEXICANOS EN MICHIGAN, DETROIT, MI:  
3,954,235, PUB. 2-15-2011. INT. CL. 35.  
3,954,236, PUB. 2-15-2011. INT. CL. 35.
- APTEC CORPORATION, ORMOND BEACH, FL:  
2,875,896, CANC. INT. CL. 42.
- AQUABELLY, INC., BOYNTON BEACH, FL:  
3,954,773, PUB. 2-15-2011. INT. CL. 41.
- AQUATROLS CORPORATION OF AMERICA, PAULSBORO, NJ:  
3,954,906, PUB. 2-15-2011. INT. CL. 1.
- ARARAT COGNAC FACTORY 'A.K.Z.' LTD, ARARAT, ARMENIA:  
3,953,639, PUB. 2-15-2011. INT. CL. 33.
- ARAUZ, CASEY, M. MIAMI, FL, DBA CATASTROPHUNK:  
3,955,957, INT. CL. 16.
- ARAV HOLDING S.R.L. A SOCIO UNICO, ITALY:  
3,953,594, PUB. 2-15-2011. MULTIPLE CLASS, INT. CLS. 9, 14, 18, 25 AND 35.
- ARBORGEN INC., SUMMERVILLE, SC:  
2,495,217, REN. 3-31-11. INT. CL. 31.
- ARBY'S IP HOLDER TRUST, ATLANTA, GA:  
2,443,595, REN. 3-26-11. INT. CL. 30.
- ARCHER DANIELS MIDLAND COMPANY, DECATUR, IL:  
2,441,545, REN. 3-31-11. MULTIPLE CLASS, INT. CLS. 5 AND 31.
- ARCHIE COMIC PUBLICATIONS, INC., MAMARONECK, NY:  
1,611,189, REN. 3-31-11. MULTIPLE CLASS, INT. CLS. 16 AND 28.
- ARCLIGHT INVESTMENTS PTY LTD, BRISBANE QLD, AUSTRALIA:  
3,953,789, PUB. 2-15-2011. MULTIPLE CLASS, INT. CLS. 9, 36, 38 AND 42.
- ARCOR S.A.I.C., BUENOS AIRES, ARGENTINA:  
3,953,475, PUB. 2-15-2011. MULTIPLE CLASS, INT. CLS. 29 AND 30.
- ARCTOUCH INCORPORATED, SAN FRANCISCO, CA:  
3,954,086, PUB. 2-15-2011. INT. CL. 9.
- AREA DISPOSAL SERVICE, INC., PEORIA, IL:  
2,471,181, REN. 3-31-11. MULTIPLE CLASS, INT. CLS. 35, 37, 39 AND 40.  
2,471,182, REN. 3-31-11. MULTIPLE CLASS, INT. CLS. 35, 37, 39 AND 40.
- ARENA FOOTBALL ONE, LLC, TULSA, OK, AKA AFL:  
3,954,765, PUB. 2-15-2011. MULTIPLE CLASS, INT. CLS. 25 AND 41.  
3,954,995, PUB. 2-15-2011. INT. CL. 41.
- ARES TRADING S.A., 2028 VAUMARCUS, SWITZERLAND:  
2,875,961, CANC. INT. CL. 5.  
2,876,907, CANC. INT. CL. 5.
- ARGO GROUP INTERNATIONAL HOLDINGS, LTD., PEMBROKE, BERMUDA:  
2,877,965, CANC. INT. CL. 36.
- ARGOS LIMITED, MILTON KEYNES, UNITED KINGDOM:  
3,952,957, PUB. 8-24-2010. MULTIPLE CLASS, INT. CLS. 9 AND 28.
- ARI MEYERS, NEW YORK, NY:  
3,955,237, INT. CL. 45.
- ARIBA, INC., SUNNYVALE, CA:  
2,440,879, REN. 3-29-11. INT. CL. 35.
- ARIMINO CO., LTD., TOKYO, JAPAN:  
3,953,950, PUB. 2-15-2011. INT. CL. 3.
- ARISTOCRAT TECHNOLOGIES AUSTRALIA PTY LTD., NORTH RYDE, NSW, AUSTRALIA:  
3,953,320, PUB. 2-15-2011. INT. CL. 9.  
3,953,322, PUB. 2-15-2011. INT. CL. 9.  
3,953,323, PUB. 2-15-2011. INT. CL. 9.
- ARISTOCRAT TECHNOLOGIES AUSTRALIA PTY LTD., NORTH RYSE, NSW, AUSTRALIA:  
3,953,367, PUB. 2-15-2011. INT. CL. 9.
- ARISTOCRAT TECHNOLOGIES AUSTRALIA PTY LTD., NORTH RYDE, NSW, AUSTRALIA:  
3,953,435, PUB. 2-15-2011. INT. CL. 9.  
3,953,437, PUB. 2-15-2011. INT. CL. 9.
- ARISTOCRAT TECHNOLOGIES AUSTRALIA PTY LTD., NORTH RYDE, NSW, AUSTRALIA:  
3,953,813, PUB. 2-15-2011. INT. CL. 9.
- ARISTOCRAT TECHNOLOGIES AUSTRALIA PTY LTD., NORTH RYDE, NSW, AUSTRALIA:  
3,955,067, PUB. 2-15-2011. INT. CL. 9.
- ARISTOTLE CIRCLE, INC., NEW YORK, NY:  
3,809,934, COR. INT. CL. 41.
- ARIZONA CHEMICAL COMPANY, PANAMA CITY, FL:  
833,136, CANC. U.S. CL. 1.
- ARKENSTONE VINEYARDS, LLC, ST. HELENA, CA:  
3,955,158, INT. CL. 33.
- ARMADA TECHNOLOGIES LLC, CALEDONIA, MI:  
3,953,129, PUB. 2-15-2011. INT. CL. 9.
- ARMED FORCES COMMUNICATIONS AND ELECTRONICS ASSOCIATION INTERNATIONAL, FAIRFAX, VA, AKA AFCEA:  
3,954,300, PUB. 2-15-2011. MULTIPLE CLASS, INT. CLS. 16 AND 41.
- ARNOLD & ASSOCIATES OF WICHITA, INC., WICHITA, KS:  
2,493,601, COR. INT. CL. 42.  
2,493,602, COR. INT. CL. 42.
- ARNOLD, ROBERT, TOLUCA WOODS, CA:  
3,953,400, PUB. 2-15-2011. INT. CL. 41.
- AROMA DE VUELTA ABAJO, INC., MIAMI, FL:  
3,955,990, INT. CL. 34.
- AROMAT CORPORATION, PROVIDENCE, NJ:  
2,876,073, CANC. INT. CL. 9.
- ARROW FASTENER CO., LLC, SADDLE BROOK, NJ:  
1,150,227, REN. 3-30-11. MULTIPLE CLASS, INT. CLS. 7 AND 8.
- ART JUXTAPOSED, SIMI VALLEY, CA:  
3,954,128, PUB. 2-15-2011. MULTIPLE CLASS, INT. CLS. 16 AND 42.

ART-CARE, LLC, WARRENTON, VA:  
2,551,198, REN. 3-31-11. INT. CL. 35.

ARTEO S.A.S. DI GIORGIO BRACHETTI, TORINO, ITALY:  
2,877,007, CANC. MULTIPLE CLASS, INT. CLS. 9, 16, 18,  
25, 28, 41 AND 43.

ARTFX, INC., NORFOLK, VA:  
2,451,635, REN. 3-28-11. INT. CL. 25.

ARTHREX, INC., NAPLES, FL:  
3,955,761, INT. CL. 10.  
3,955,762, INT. CL. 10.

ARTHUR FICHTENBERG AND ASSOCIATES, ROHNERT  
PARK, CA:  
3,953,775, PUB. 2-15-2011. INT. CL. 33.

ARTIST SERVICES LTD., CAMDEN, LONDON, UNITED  
KINGDOM:  
3,955,589, MULTIPLE CLASS, INT. CLS. 35 AND 41.

ARTSPACE PROJECTS, INC., MINNEAPOLIS, MN:  
3,954,479, PUB. 2-15-2011. INT. CL. 37.  
3,954,482, PUB. 2-15-2011. INT. CL. 37.

ASAH KASEI E-MATERIALS CORPORATION, JAPAN:  
3,953,650, PUB. 2-15-2011. INT. CL. 17.

ASCEND EAGLE INC., AMERICAN CANYON, CA:  
3,954,808, PUB. 2-15-2011. INT. CL. 10.

ASH GROVE GROUP, INC., THE, SANTA BARBARA, CA:  
2,378,796, CANC. INT. CL. 42.

ASHBROOK, SUSAN, SANTA MONICA, CA:  
2,378,468, CANC. INT. CL. 42.

ASHFORD TEXTILES, LLC, GARDENA, CA:  
3,954,848, PUB. 2-15-2011. INT. CL. 24.

ASHLAND LICENSING AND INTELLECTUAL PROPERTY  
LLC, DUBLIN, OH, EGL 1, INC., CARLSBAD, CA, DBA  
EAGLE ONE INDUSTRIES:  
1,638,817, REN. 3-26-11. INT. CL. 3.

ASHLAND LICENSING AND INTELLECTUAL PROPERTY  
LLC, DUBLIN, OH:  
2,379,468, CANC. INT. CL. 9.

ASHLEY J. BERMAN, SAN FRANCISCO, CA, DBA ASHLEY  
MORGAN DESIGNS:  
3,955,305, INT. CL. 14.

ASHLOCK, HOWARD K, SAN FRANCISCO, CA:  
3,954,663, PUB. 2-15-2011. INT. CL. 30.

ASHWORTH BROTHERS, INC., FALL RIVER, MA:  
2,510,865, REN. 3-29-11. INT. CL. 7.

ASIANSPECTION, SHUENG WAN, HONG KONG:  
3,179,254, AM. MULTIPLE CLASS, INT. CLS. 35 AND 42.

ASIANIC, INC., OAK PARK, IL:  
2,876,425, CANC. INT. CL. 35.

ASICS CORPORATION, CHUO-KU, KOBE, JAPAN:  
3,953,798, PUB. 2-15-2011. INT. CL. 25.

ASPEN RE AMERICA, INC., ROCKY HILL, CT:  
3,955,736, INT. CL. 36.

ASPER BIOTECH AS, TARTU, ESTONIA:  
3,953,241, PUB. 2-15-2011. MULTIPLE CLASS, INT. CLS.  
5, 42 AND 44.

ASPEX GROUP INC., TOWN OF MOUNT ROYAL, CANA-  
DA:  
2,877,975, CANC. INT. CL. 9.

ASSESSMENT TECHNOLOGIES INSTITUTE, L.L.C., STIL-  
WELL, KS:  
3,955,787, INT. CL. 9.

ASSET HORIZON CORP, AUSTIN, TX:  
2,877,512, CANC. INT. CL. 35.

ASSETS INTERNATIONAL LLC, SOUTHFIELD, MI:  
3,956,142, INT. CL. 45.

ASSIOUN, PATRICK, CAMBRIDGE, MA:  
3,955,343, INT. CL. 44.

ASSISTING HANDS HOME CARE, LLC, NAMPA, ID:  
3,954,609, PUB. 2-15-2011. INT. CL. 44.

ASSOCIATED BEDDING COMPANY, INC., LEXINGTON,  
OH:  
3,954,456, PUB. 2-15-2011. INT. CL. 20.

ASSOCIATED FOOD STORES, INC., HEWLETT, NY:  
3,953,280, PUB. 2-15-2011. INT. CL. 35.

ASSOCIATED MANUFACTURERS LIMITED, KINGSTON 5,  
JAMAICA:  
2,551,635, REN. 3-29-11. MULTIPLE CLASS, INT. CLS. 29  
AND 30.

ASSOCIATED OCEANS, LLC, MIAMI, FL:  
3,955,566, MULTIPLE CLASS, INT. CLS. 9 AND 42.

ASSOCIATION FOR SUPERVISION AND CURRICULUM  
DEVELOPMENT, ALEXANDRIA, VA:  
2,486,599, REN. 3-28-11. INT. CL. 42.

ASSOCIATION OF ENERGY ENGINEERS, ATLANTA, GA:  
3,954,153, PUB. 2-15-2011. INT. CL. 42.  
3,954,154, PUB. 2-15-2011. INT. CL. 42.  
3,954,156, PUB. 2-15-2011. INT. CL. 42.  
3,954,158, PUB. 2-15-2011. INT. CL. 42.  
3,954,159, PUB. 2-15-2011. INT. CL. 42.

ASTEN, INC., CHARLESTON, SC:  
2,378,885, CANC. INT. CL. 7.

ASTEROP SA, 75016 PARIS, FRANCE:  
2,876,043, CANC. MULTIPLE CLASS, INT. CLS. 9, 41  
AND 42.

ASTONISH RESULTS, LP, WARWICK, RI:  
3,953,192, PUB. 9-14-2010. INT. CL. 35.

ASTRAZENECA UK LIMITED, LONDON, W2 6BD, UNITED  
KINGDOM, IMPERIAL CHEMICAL INDUSTRIES LIM-  
ITED, MILLBANK, ENGLAND:  
1,148,645, REN. 3-30-11. INT. CL. 5.

ASTRO STUDIOS, INC., SAN FRANCISCO, CA:  
3,953,091, PUB. 2-15-2011. INT. CL. 35.

ASUSTEK COMPUTER INCORPORATION, PEI TOU, TAI-  
PEI, TAIWAN:  
3,953,040, PUB. 2-15-2011. INT. CL. 9.  
3,953,041, PUB. 2-15-2011. INT. CL. 9.

AT&T INTELLECTUAL PROPERTY II, L.P., RENO, NV:  
1,641,769, REN. 3-30-11. INT. CL. 38.  
2,875,837, CANC. INT. CL. 35.  
2,877,310, CANC. INT. CL. 9.  
2,878,067, CANC. INT. CL. 38.

ATE, LLC, NIXA, MO:  
3,955,399, INT. CL. 42.

ATECO, INCORPORATED, SHENANDOAH, PA:  
728,072, REN. 3-29-11. U.S. CL. 46 (INT. CLS. 1, 5, 29, 30, 31  
AND 32).

ATHENA PUBLISHING COMPANY, INC., OKLAHOMA  
CITY, OK:  
3,954,779, PUB. 2-15-2011. MULTIPLE CLASS, INT. CLS.  
16 AND 41.

ATHENA TREES, INC., MONROE, GA:  
2,485,480, REN. 3-25-11. INT. CL. 31.

ATICO INTERNATIONAL USA, INC., FORT LAUDER-  
DALE, FL:  
2,878,019, CANC. INT. CL. 9.

ATKINS NUTRITIONALS, INC., DENVER, CO:  
3,953,825, PUB. 2-15-2011. MULTIPLE CLASS, INT. CLS.  
5, 30 AND 32.

ATLANTA HOCKEY CLUB, LLC, ATLANTA, GA:  
2,451,472, REN. 3-29-11. INT. CL. 25.  
2,500,792, REN. 3-29-11. INT. CL. 41.

ATLANTA HOCKEY CLUB, LLC., ATLANTA, GA:  
2,428,809, REN. 3-29-11. INT. CL. 41.

ATLANTIC 10 CONFERENCE, NEWPORT NEWS, VA:  
3,954,217, PUB. 2-15-2011. MULTIPLE CLASS, INT. CLS.  
16, 25 AND 41.  
3,954,218, PUB. 2-15-2011. INT. CL. 35.

ATLANTICO SUL ADMINISTRACAO E PARTICIPACOES  
LTDA, CERA, BRAZIL, INDUSTRIA DEL RIO S.A.,  
FORTELEZA CEARA, BRAZIL:  
1,150,485, REN. 3-26-11. INT. CL. 25.

ATLANTIS ENTERPRISES, INC., MARIETTA, GA:  
2,379,423, CANC. INT. CL. 41.

ATOTECH DEUTSCHLAND GMBH, D-10507 BERLIN, FED  
REP GERMANY:  
2,438,138, REN. 3-25-11. INT. CL. 1.

ATR LIGHTING ENTERPRISES, INC., RICHLAND, MO:  
3,954,006, PUB. 2-15-2011. INT. CL. 11.

ATREUS SYSTEMS CORPORATION, OTTAWA, ONTARIO,  
CANADA:  
2,877,240, CANC. MULTIPLE CLASS, INT. CLS. 9 AND  
42.

ATRONIC INTERNATIONAL GMBH, LUBBECKE, FED  
REP GERMANY:  
2,875,914, CANC. INT. CL. 9.

- ATTIAS, RICHARD, GREENWICH, CT:  
3,956,114, INT. CL. 41.
- ATTRactions MANAGEMENT, INC., ROCKLEDGE, FL:  
3,954,600, PUB. 2-15-2011. INT. CL. 41.
- AUDIO MARKETING SERVICES S.A.S., LE BLANC-MES-  
NIL, FRANCE:  
2,877,266, CANC. INT. CL. 9.
- AUDIT INTEGRITY, INC., LOS ANGELES, CA:  
3,954,683, PUB. 2-15-2011. INT. CL. 42.
- AUGEN ELECTRONICS CORP., HOLLYWOOD, FL:  
3,954,729, PUB. 2-15-2011. INT. CL. 9.
- AUGUST HOME PUBLISHING COMPANY, DES MOINES,  
IA:  
2,378,863, CANC. INT. CL. 16.
- AUGUST RÜGGERBERG GMBH & CO. KG, FED REP  
GERMANY:  
3,953,629, PUB. 2-15-2011. INT. CL. 7.  
3,953,630, PUB. 2-15-2011. MULTIPLE CLASS, INT. CLS. 7  
AND 8.
- AUSTRALIAN GOLD, INC., INDIANAPOLIS, IN:  
2,438,570, REN. 3-31-11. INT. CL. 3.
- AUSTRALIAN GOLD, LLC, INDIANAPOLIS, IN:  
3,955,324, INT. CL. 3.  
3,955,740, INT. CL. 3.  
3,956,010, INT. CL. 3.
- AUTO CREDIT TRAINING SOLUTIONS, LLC, SURPRISE,  
AZ:  
3,954,190, PUB. 2-15-2011. INT. CL. 41.
- AUTO V GROOVING INC., WESTON, ONTARIO, CANADA:  
2,877,868, CANC. INT. CL. 7.
- AUTOLAVISH, LLC, ROCHESTER, MI:  
3,954,296, PUB. 2-15-2011. INT. CL. 37.
- AUTOMATED FINANCIAL SYSTEMS, INC., EXTON, PA:  
3,955,675, INT. CL. 9.
- AUTOMOTIVE MARKETING GROUP, LLC, KENT, WA:  
1,649,193, REN. 3-25-11. INT. CL. 37.
- AUTOMOTIVE PRODUCTS DRIVELINE TECHNOLOGY  
LIMITED, WARWICKSHIRE, CV31 3ER, UNITED KING-  
DOM:  
2,876,528, CANC. INT. CL. 12.
- AUTOMOTIVE TECHNOLOGIES, INC., MIDDLETOWN,  
CT:  
3,953,877, PUB. 2-15-2011. INT. CL. 36.
- AV TECH CORPORATION, TAIPEI CITY, TAIWAN:  
3,955,998, INT. CL. 9.
- AVANTI LAW GROUP, PLLC, WYOMING, MI:  
3,954,749, PUB. 2-15-2011. INT. CL. 45.
- AVCOR HEALTH CARE PRODUCTS, INC., FORT WORTH,  
TX:  
1,658,134, REN. 3-29-11. INT. CL. 10.
- AVENT LIMITED, NEW SOUTHGATE, LONDON, UNITED  
KINGDOM:  
2,877,038, CANC. INT. CL. 18.
- AVERY DENNISON CORPORATION, PASADENA, CA:  
2,437,978, REN. 3-26-11. INT. CL. 16.  
3,955,477, INT. CL. 16.
- AVERY OUTDOORS, INC., MEMPHIS, TN:  
2,436,580, REN. 3-25-11. MULTIPLE CLASS, INT. CLS. 25  
AND 28.  
2,436,580, CANC. MULTIPLE CLASS, INT. CLS. 13, 18  
AND 21.
- AVIADESIGN KY, VANTAA, FINLAND, DBA AIRWAYSIM:  
3,953,228, PUB. 2-15-2011. INT. CL. 41.
- AVIAGEN LIMITED, WARWICKSHIRE CV37 8BH, UNITED  
KINGDOM:  
3,953,671, PUB. 2-15-2011. INT. CL. 31.
- AVID MEDICAL, INC., TOANO, VA:  
3,955,225, MULTIPLE CLASS, INT. CLS. 10 AND 42.
- AVID TECHNOLOGY, INC., BURLINGTON, MA:  
2,379,772, CANC. INT. CL. 9.
- AVIVE TECHNOLOGIES, LLC, ALBERTSON, NY:  
3,955,177, INT. CL. 11.
- AVON PRODUCTS, INC., NEW YORK, NY:  
3,955,608, INT. CL. 3.
- AWARENESS, INC., BURLINGTON, MA:  
3,956,149, MULTIPLE CLASS, INT. CLS. 35 AND 42.
- AWI ACQUISITION COMPANY, SYLMAR, CA, AWI AC-  
QUISITION COMPANY, SYLMAR, CA:  
2,435,794, REN. 3-30-11. INT. CL. 8.
- AWR CORPORATION, EL SEGUNDO, CA:  
3,956,212, INT. CL. 9.
- AXCELEON, INC., HUNTINGTON BEACH, CA:  
3,954,854, PUB. 2-15-2011. INT. CL. 9.
- AXEDA ACQUISITION CORP., FOXBORO, MA:  
2,499,428, REN. 3-29-11. INT. CL. 42.
- AXELROD & STEELE, INC., CHICAGO, IL:  
2,437,203, REN. 3-26-11. INT. CL. 35.
- AXIUM INC., MONTREAL, QUEBEC, CANADA:  
2,426,200, REN. 3-31-11. INT. CL. 42.
- AXTELL, CHEYLA MCCORNACK, SEATTLE, WA AND  
BROM, EVELYN, SEATTLE, WA:  
3,954,651, PUB. 2-15-2011. INT. CL. 35.
- AZTEC SHOPS LTD. OF SAN DIEGO STATE UNIVERSITY,  
SAN DIEGO, CA:  
2,434,937, REN. 3-31-11. MULTIPLE CLASS, INT. CLS. 12,  
14, 16, 18, 20, 21 AND 25.
- AZUMI NAIL LLC, HONOLULU, HI:  
3,954,632, PUB. 2-15-2011. INT. CL. 44.
- AZUNA, LLC, JENKINTOWN, PA:  
3,955,179, MULTIPLE CLASS, INT. CLS. 16 AND 35.
- A123 SYSTEMS, INC., WATERTOWN, MA:  
3,955,573, INT. CL. 9.
- A3R LABS, LLC, EVANSVILLE, IN:  
3,954,357, PUB. 2-15-2011. INT. CL. 5.
- B & B THEATRES OPERATING COMPANY, INC., LIBERTY,  
MO:  
3,954,669, PUB. 2-15-2011. INT. CL. 41.  
3,955,129, PUB. 2-15-2011. INT. CL. 41.  
3,955,130, PUB. 2-15-2011. INT. CL. 41.  
3,955,131, PUB. 2-15-2011. INT. CL. 41.
- B & F MEYERCO., LLC, DALLAS, TX:  
3,954,473, PUB. 2-15-2011. INT. CL. 8.  
3,954,477, PUB. 2-15-2011. INT. CL. 8.  
3,954,478, PUB. 2-15-2011. INT. CL. 8.
- B WYZE HOLDINGS INC., MARKHAM, ONTARIO, CANA-  
DA:  
3,953,217, PUB. 2-15-2011. INT. CL. 42.  
3,953,218, PUB. 2-15-2011. INT. CL. 42.
- B.C.D. REALTY LLC, BROOKLYN, NY, DBA BCD:  
3,955,378, MULTIPLE CLASS, INT. CLS. 5, 30, 33 AND 35.
- B&J ENTERPRISES, INC., COLORADO SPRINGS, CO:  
3,954,800, PUB. 2-15-2011. INT. CL. 37.
- B-O-F CORPORATION, AURORA, IL:  
3,955,027, PUB. 2-15-2011. INT. CL. 20.
- BABY GOURMET FOODS INC., EDMONTON ALBERTA  
T6E 5Z8, CANADA:  
3,955,190, INT. CL. 5.
- BABY TREND, INC., ONTARIO, CA:  
3,954,000, PUB. 2-15-2011. INT. CL. 12.
- BABYTIME, LLC, TAMPA, FL:  
3,953,952, PUB. 2-15-2011. INT. CL. 44.
- BACARDI & COMPANY LIMITED, VADUZ, LIECHTEN-  
STEIN, BOMBAY SPIRITS COMPANY LIMITED, LON-  
DON NW1, ENGLAND:  
1,650,299, REN. 3-30-11. INT. CL. 33.
- BACZONE, LTD., DOYLESTOWN, PA:  
3,954,822, PUB. 2-15-2011. INT. CL. 9.
- BAD BAGS, INC., SEATTLE, WA:  
2,437,931, REN. 3-30-11. INT. CL. 18.  
2,437,931, CANC. INT. CL. 28.
- BADAWAL INVESTMENTS, INC., WARREN, MI, DBA  
CERTIS IMAGING:  
3,955,162, INT. CL. 9.
- BAE SYSTEMS TECHNOLOGY SOLUTIONS & SERVICES,  
INC., ROCKVILLE, MD:  
2,439,376, REN. 3-27-11. INT. CL. 9.
- BAER, ALLAN, CHELSEA, VT:  
2,378,459, CANC. INT. CL. 35.
- BAGHDASARYAN, HOVHANNES HOVIK, GLENDALE,  
CA:  
3,955,828, INT. CL. 21.
- BAKEAST COMPANY, AUBURN, ME:  
1,640,668, REN. 3-28-11. INT. CL. 30.

BAKER COMMODITIES, INC., LOS ANGELES, CA:  
1,637,364, REN. 3-31-11. INT. CL. 5.

BAKER HUGHES INCORPORATED, HOUSTON, TX:  
1,640,123, REN. 3-29-11. INT. CL. 1.

BAKER, JAMES LAURANCE, AUSTIN, TX, DBA AUDIO-MOXIE:  
3,953,121, PUB. 2-15-2011. INT. CL. 41.

BALANCING ACT, LLC, SAN FRANCISCO, CA:  
2,876,602, CANC. INT. CL. 45.

BALDERSON, KURT L., DOYLESTOWN, PA:  
2,830,565, CANC. INT. CL. 43.

BALDESSARINI GMBH, MÜNCHEN, FED REP GERMANY:  
3,953,490, PUB. 2-15-2011. MULTIPLE CLASS, INT. CLS. 9, 14, 18 AND 25.

BALLERINA FARMER, LLC, KALAMAZOO, MI:  
3,955,697, INT. CL. 3.  
3,955,720, INT. CL. 3.

BALLET MAKERS, INC., TOTOWA, NJ:  
2,546,619, REN. 3-28-11. INT. CL. 25.

BALLY TOTAL FITNESS HOLDING CORPORATION, CHICAGO, IL:  
3,953,883, PUB. 2-15-2011. INT. CL. 41.

BALTIMORE GAS AND ELECTRIC COMPANY, BALTIMORE, MD:  
3,955,180, INT. CL. 9.

BAMM ENTERPRISES, LLC, LEXINGTON PARK, MD, AKA JEFFERY D. TOMCSIK, DAVID J. COOPER, MICHAEL W. OWENS:  
3,953,406, PUB. 2-15-2011. MULTIPLE CLASS, INT. CLS. 35 AND 41.

BANCA FIDEURAM S.P.A. MILAN, ITALY:  
2,876,111, CANC. MULTIPLE CLASS, INT. CLS. 9, 16, 35 AND 36.

BANCO BILBAO VIZCAYA ARGENTARIA, S.A., BILBAO, VIZCAYA, SPAIN:  
3,953,454, PUB. 2-15-2011. MULTIPLE CLASS, INT. CLS. 9 AND 36.

BANCO FINANCIERA COMERCIAL HONDURENA, S.A., MIAMI, FL, DBA BANCO FICOHSA:  
3,953,860, PUB. 2-15-2011. INT. CL. 36.

BANCORPSOUTH BANK, TUPELO, MS:  
3,956,073, INT. CL. 36.

BANDWITHRADIO, LLC, EAU CLAIRE, WI:  
3,953,760, PUB. 2-15-2011. INT. CL. 42.

BAND2GETHER, LLC, CORAL SPRINGS, FL:  
3,954,242, PUB. 2-15-2011. INT. CL. 14.

BANK OF AMERICA CORPORATION, CHARLOTTE, NC:  
2,378,630, CANC. INT. CL. 36.  
3,955,901, INT. CL. 36.  
3,955,950, INT. CL. 36.

BARBACCIA, NATHAN, SAN JOSE, CA:  
3,953,986, PUB. 2-15-2011. MULTIPLE CLASS, INT. CLS. 9, 25 AND 41.

BARBARA'S BAKERY, INC., PETALUMA, CA:  
2,877,257, CANC. INT. CL. 30.

BARBER, JACK A, LEESBURG, FL:  
3,954,509, PUB. 2-15-2011. INT. CL. 9.

BAREFOOT BOTANICALS LIMITED, LONDON, N1 2LH, UNITED KINGDOM:  
2,876,210, CANC. INT. CL. 3.

BAREWOOD, INC., ATLANTA, GA:  
3,954,248, PUB. 2-15-2011. INT. CL. 36.

BARGAIN BEE.COM LLC, SULPHUR, LA:  
3,954,245, PUB. 2-15-2011. INT. CL. 35.

BARKLEY INTERNATIONAL, INC., BEDFORD, NY:  
2,461,183, REN. 3-26-11. INT. CL. 36.

BARNES DE MEXICO, S.A. DE C.V., MONTERREY, NUEVO LEON, MEXICO:  
3,955,591, INT. CL. 7.

BARNETT, WADE CHARLES, PENN VALLEY, PA:  
2,875,954, CANC. INT. CL. 35.

BARNEY'S, INC., NEW YORK, NY:  
2,479,769, REN. 3-26-11. INT. CL. 35.

BARNZ B, INC., NIXA, MO:  
2,423,370, REN. 3-28-11. INT. CL. 3.

BARON, ALEXANDER C, HOUSTON, TX, DBA RISKOVATION:  
3,955,498, INT. CL. 35.

BARRIER1, LLC, RAMSEY, MN, FORMERLY THE BARRIER GROUP, LLC:  
3,953,905, PUB. 2-15-2011. INT. CL. 42.

BARTEL, DAVID, WARSAW, MO:  
3,953,418, PUB. 2-15-2011. MULTIPLE CLASS, INT. CLS. 6 AND 20.

BARTLE BOGLE HEGARTY LIMITED, LONDON, UNITED KINGDOM:  
3,866,221, COR. MULTIPLE CLASS, INT. CLS. 9, 16 AND 35.

BARTON, JAMES N, NAPLES, FL:  
3,953,030, PUB. 2-15-2011. INT. CL. 21.

BASCO INCORPORATED, BOYNTON BEACH, FL:  
3,953,107, PUB. 2-15-2011. MULTIPLE CLASS, INT. CLS. 20 AND 21.

BASEBALL IRELAND DEVELOPMENT LIMITED, CABINETEELY, DUBLIN, IRELAND:  
3,954,337, PUB. 2-15-2011. MULTIPLE CLASS, INT. CLS. 14 AND 25.

BASF AKTIENGESELLSCHAFT, LUDWIGSHAFEN AM RHEIN, FED REP GERMANY:  
2,441,371, REN. 3-26-11. INT. CL. 5.

BASF CORPORATION, MT. OLIVE, NJ:  
1,153,553, REN. 3-31-11. INT. CL. 1.

BASILIUS TOOL COMPANY, TOLEDO, OH:  
2,379,382, CANC. INT. CL. 37.

BASS PRO INTELLECTUAL PROPERTY, LLC, SPRINGFIELD, MO, RED HEAD BRAND CORPORATION, DALLAS, TX:  
1,185,872, REN. 3-28-11. INT. CL. 25.

BATTELLE MEMORIAL INSTITUE, COLUMBUS, OH:  
2,440,731, REN. 3-30-11. INT. CL. 42.

BATTERIES PLUS, LLC, HARTLAND, WI:  
3,955,295, INT. CL. 35.

BAUER, DEREK, OLATHE, KS:  
3,956,182, INT. CL. 43.

BAUMAN CHIROPRACTIC CLINIC, P.L.L.C., VANCOUVER, WA, AKA BAUMAN CHIROPRACTIC:  
3,954,022, PUB. 2-15-2011. INT. CL. 44.

BAUSCH & LOMB INCORPORATED, ROCHESTER, NY:  
3,955,386, INT. CL. 5.

BAVAR, JANNA W, MOUNTAIN VIEW, CA, DBA HANABI PHOTOGRAPHY:  
3,954,487, PUB. 2-15-2011. INT. CL. 41.

BAY BRIDGE DECISION TECHNOLOGIES, INC., ANNAPOLIS, MD:  
3,954,967, PUB. 2-15-2011. INT. CL. 42.

BAY GENE, INC., SAN FRANCISCO, CA:  
2,877,336, CANC. MULTIPLE CLASS, INT. CLS. 1 AND 9.

BAY HOLDINGS, INC., BAY CITY, MI:  
3,954,455, PUB. 2-15-2011. INT. CL. 7.  
3,954,472, PUB. 2-15-2011. INT. CL. 7.

BAY STATE MILLING COMPANY, QUINCY, MA:  
1,149,086, REN. 3-25-11. INT. CL. 30.

BAYER AKTIENGESELLSCHAFT, 51373 LEVERKUSEN, FED REP GERMANY:  
1,152,057, REN. 3-29-11. INT. CL. 1.  
1,152,406, REN. 3-31-11. INT. CL. 17.  
3,955,083, PUB. 2-15-2011. INT. CL. 5.

BAYER HEALTHCARE LLC, PITTSBURGH, PA:  
2,442,045, REN. 3-29-11. INT. CL. 5.

BAYERISCHE MOTOREN WERKE AKTIENGESELLSCHAFT, FED REP GERMANY:  
3,953,666, PUB. 2-15-2011. INT. CL. 12.  
3,953,673, PUB. 2-15-2011. MULTIPLE CLASS, INT. CLS. 12 AND 28.

BAYLES, SHAUN L, WAIPAHU, HI AND HER, XEE, KAPOLEI, HI:  
3,955,375, INT. CL. 45.

BBL MINISTRIES, INC., RANCHO SANTA MARGARITA, CA:  
2,876,312, CANC. MULTIPLE CLASS, INT. CLS. 16 AND 41.

BBY SOLUTIONS, INC., RICHFIELD, MN:  
3,953,436, PUB. 2-15-2011. MULTIPLE CLASS, INT. CLS. 35 AND 42.

- BE YOUR OWN BOSS ENTERTAINMENT, FORT WORTH, TX:  
3,955,488, INT. CL. 41.
- BEACH WEDDING HUT, HONOLULU, HI:  
3,954,126, PUB. 2-15-2011. INT. CL. 25.
- BEACHCOMBER HOT TUBS INC., SURREY, BRITISH COLUMBIA, CANADA:  
3,955,267, INT. CL. 11.
- BEACON CHEMICAL COMPANY, INC., MT. VERNON, NY:  
2,513,163, REN. 3-25-11. INT. CL. 16.
- BEACON FALLS PHARMACY, LLC, BEACON FALLS, CT, DBA BEACON FALLS PHARMACY:  
3,954,113, PUB. 2-15-2011. INT. CL. 35.
- BEACON FOOTWEAR, INC., WILDWOOD, MO:  
82,086, REN. 3-31-11. U.S. CL. 39 (INT. CL. 25).
- BEALS, JOHANNES, PISMO BEACH, CA:  
3,954,831, PUB. 2-15-2011. INT. CL. 41.
- BEAR TRAP PARTNERS, LLC, OLNEY, MD:  
2,433,261, REN. 3-26-11. MULTIPLE CLASS, INT. CLS. 35, 41 AND 42.
- BEAR 399, LLC, COPPELL, TX:  
3,954,010, PUB. 2-15-2011. INT. CL. 33.
- BEATING WALL STREET, INC., GRANADA HILLS, CA:  
3,954,430, PUB. 2-15-2011. INT. CL. 36.
- BEAULIEU GROUP, LLC, DALTON, GA:  
3,956,059, INT. CL. 27.
- BEAUTE CREATEURS (SOCIETE ANONYME), PARIS, FRANCE:  
2,877,064, CANC. INT. CL. 3.
- BEAUTY ADDIX LLC, DRAPER, UT:  
3,954,378, PUB. 2-15-2011. INT. CL. 44.
- BECKER-UNDERWOOD, INC., AMES, IA:  
2,390,972, REN. 3-29-11. MULTIPLE CLASS, INT. CLS. 1, 2 AND 3.  
2,390,972, CANC. INT. CL. 7.
- BECKETT ENTERTAINMENT, INC., DALLAS, TX:  
2,348,106, CANC. INT. CL. 9.
- BEE AND HERBAL NEW ZEALAND LIMITED, CAMBRIDGE, NEW ZEALAND:  
2,857,149, AM. MULTIPLE CLASS, INT. CLS. 5 AND 30.
- BEECH ACRES, CINCINNATI, OH:  
2,877,772, CANC. INT. CL. 41.
- BEECHER, CORY, WOODSIDE, CA:  
3,954,464, PUB. 2-15-2011. INT. CL. 41.
- BEELOGICS INC., MIAMI, FL:  
3,953,421, PUB. 2-15-2011. INT. CL. 44.
- BEERENBERG CORP. AS, BERGEN, NORWAY:  
3,953,082, PUB. 2-15-2011. MULTIPLE CLASS, INT. CLS. 6, 17, 19, 37, 40, 42 AND 43.
- BEETS, ED, COLUMBIA, MS:  
3,954,250, PUB. 2-15-2011. INT. CL. 14.
- BEHLEN MFG. CO., COLUMBUS, NE:  
2,471,354, REN. 3-26-11. MULTIPLE CLASS, INT. CLS. 6, 7 AND 20.  
2,471,355, REN. 3-26-11. MULTIPLE CLASS, INT. CLS. 6, 7 AND 20.
- BEKINS HOLDING CORP., HILLSIDE, IL:  
2,455,005, REN. 3-26-11. INT. CL. 39.
- BEL CANTO FOODS LLC, BRONX, NY:  
2,438,333, REN. 3-26-11. INT. CL. 30.
- BELIEVE IN ME THERAPY, LLC, NORTH ARLINGTON, NJ:  
3,955,301, MULTIPLE CLASS, INT. CLS. 9 AND 16.
- BELL-FRUIT GAMES LIMITED, UNITED KINGDOM:  
3,953,516, PUB. 2-15-2011. MULTIPLE CLASS, INT. CLS. 9, 28, 41 AND 42.
- BELLERUD COMMUNICATIONS, LLC, MELBOURNE, FL:  
3,955,060, PUB. 2-15-2011. INT. CL. 38.
- BELLSTAR HOTEL AND RESORTS LTD., CALGARY, CANADA:  
3,953,012, PUB. 1-25-2011. MULTIPLE CLASS, INT. CLS. 35, 36 AND 37.
- BELMARK, INC., DE PERE, WI:  
2,440,345, REN. 3-26-11. MULTIPLE CLASS, INT. CLS. 16, 35 AND 42.
- BEOLOG, BARRY D., WINNIPEG, CANADA:  
2,877,495, CANC. INT. CL. 28.
- BELWOOD FRENCH BAKERY & CAFE', INC., CLIVE, IA:  
2,876,758, CANC. INT. CL. 43.
- BEN HAKMAN & COMPANY LLC, NEW YORK, NY:  
3,953,782, PUB. 2-15-2011. INT. CL. 14.
- BENCO ENTERPRISES LLC, BROADLANDS, VA:  
3,954,269, PUB. 2-15-2011. INT. CL. 10.
- BENEFIT ADMINISTRATIVE SERVICES INTERNATIONAL CORPORATION, PORTAGE, MI, DBA BASIC:  
3,954,146, PUB. 2-15-2011. INT. CL. 42.
- BENFIELD SPORTS INTERNATIONAL LIMITED, LONDON, UNITED KINGDOM:  
2,877,041, CANC. MULTIPLE CLASS, INT. CLS. 9, 16, 18, 25, 28, 38 AND 41.
- BENHAMOU, FABRICE, 75007 PARIS, FRANCE:  
2,876,364, CANC. INT. CL. 25.
- BENMOSHE, OREN, LOS ANGELES, CA:  
3,955,234, INT. CL. 25.
- BENNETT LANE WINERY, CALISTOGA, CA:  
3,953,403, PUB. 2-15-2011. INT. CL. 33.
- BENNETT LAWRENCE MANAGEMENT, LLC, NEW YORK, NY:  
2,495,896, REN. 3-26-11. INT. CL. 36.
- BENNETT MANUFACTURING COMPANY, INC., ALDEN, NY:  
143,162, REN. 3-28-11. U.S. CL. 13 (INT. CL. 6).
- BENNETT, WILLIAM AARON, HARVEY, LA:  
2,876,195, CANC. INT. CL. 9.
- BENSON'S CANINE COOKIES, INC., LAKELAND, FL:  
2,876,463, CANC. INT. CL. 31.
- BENTLEY, DORIS A., NORTH VANCOUVER, BRITISH COLUMBIA, CANADA, DBA CENTREPOINT CAREER CONSULTING:  
2,876,023, CANC. MULTIPLE CLASS, INT. CLS. 16 AND 41.
- BENZEL'S BRETZEL BAKERY, INC., ALTOONA, PA:  
2,426,026, REN. 3-30-11. INT. CL. 30.
- BENZIGER FAMILY WINERY LLC, GLEN ELLEN, CA:  
1,650,975, REN. 3-26-11. INT. CL. 33.
- BERGEN INTERNATIONAL, LLC, ROCHELLE PARK, NJ:  
2,549,269, REN. 3-26-11. INT. CL. 1.  
2,549,270, REN. 3-26-11. INT. CL. 1.
- BERK ENTERPRISES, INC., WARREN, OH, DBA BERK PAPER & SUPPLY:  
2,544,960, REN. 3-29-11. INT. CL. 21.
- BERKSHIRE CORPORATION, GREAT BARRINGTON, MA:  
3,955,840, INT. CL. 21.
- BERMO ENTERPRISES, INC., SCHOOLCRAFT, MI:  
1,678,889, REN. 3-26-11. INT. CL. 42.
- BERNARD'S, CORTLAND, NY, DBA BERNARD'S CUSTOM LOGO:  
3,956,126, INT. CL. 25.
- BERNARDI, PIETRO, SANTA BARBARA, CA:  
2,377,814, REN. 3-26-11. INT. CL. 42.
- BERND STOLZ GMBH, 92224 AMBERG, FED REP GERMANY:  
3,953,669, PUB. 2-15-2011. MULTIPLE CLASS, INT. CLS. 5 AND 10.
- BERNE FURNITURE COMPANY, BERNE, IN:  
2,379,829, CANC. INT. CL. 40.
- BERTOLUCCI SA, 1211 GENEVA 26, SWITZERLAND:  
2,876,666, CANC. INT. CL. 14.
- BESLOTEN VENNOOTSCHAP MET BEPERKTE AANSPRAKELIJKHEID ZINGAMETALL, 9810 EKE, BELGIUM:  
2,441,205, REN. 3-26-11. MULTIPLE CLASS, INT. CLS. 1 AND 2.
- BEST OF EVERYTHING OF SOUTHWEST FLORIDA, INC., NAPLES, FL:  
3,954,030, PUB. 2-15-2011. MULTIPLE CLASS, INT. CLS. 14 AND 35.
- BEST WESTERN INTERNATIONAL, INC., PHOENIX, AZ:  
3,954,674, PUB. 2-15-2011. INT. CL. 43.  
3,954,679, PUB. 2-15-2011. INT. CL. 43.  
3,954,681, PUB. 2-15-2011. INT. CL. 43.  
3,954,682, PUB. 2-15-2011. INT. CL. 43.
- BETCO CORPORATION, TOLEDO, OH:  
2,450,250, REN. 3-30-11. INT. CL. 3.
- BETCO CORPORATION, THE, TOLEDO, OH:  
1,152,065, REN. 3-31-11. INT. CL. 3.



- BETTS TACKLE, LTD., FUQUAY-VARINA, NC:  
2,379,534, CANC. INT. CL. 28.
- BEYONDTRUST SOFTWARE, INC., AGOURA HILLS, CA:  
3,956,135, INT. CL. 9.
- BGK TRADEMARK HOLDINGS, LLC, NEW YORK, NY:  
3,955,340, INT. CL. 3.
- BHP, LLC, WEST ALLIS, WI:  
3,956,263, INT. CL. 6.
- BHS-BAYERISCHE BERG-, HUTTEN- UND SALZWERKE  
AKTIENGESELLSCHAFT, MUNICH, FED REP GER-  
MANY:  
3,761,935, COR. INT. CL. 7.
- BIALETTI INDUSTRIE S.P.A., OMEGNA (VERBANIA),  
ITALY:  
1,149,419, REN. 3-26-11, INT. CL. 21.
- BIANCA'S FOODS, INC., SHOREWOOD, MN:  
3,952,966, PUB. 2-15-2011, INT. CL. 30.
- BIANCAMED LTD., BELFIELD, DUBLIN 4, IRELAND:  
3,955,251, MULTIPLE CLASS, INT. CLS. 9 AND 10.
- BIAS, RICHARD J., ALBUQUERQUE, NM:  
2,876,580, CANC. INT. CL. 25.
- BICAST, INC., WILLIAMSBURG, VA:  
3,954,731, PUB. 2-15-2011, INT. CL. 20.
- BIEBER, CRAIG J., LEOLA, SD:  
3,953,332, PUB. 2-15-2011, INT. CL. 31.  
3,953,337, PUB. 2-15-2011, INT. CL. 5.  
3,953,351, PUB. 2-15-2011, INT. CL. 44.
- BIESSE S.P.A., 61100 PESARO, ITALY:  
2,442,318, REN. 3-26-11, INT. CL. 7.
- BIFLEX INTIMATES GROUP, LTD., NEW YORK, NY:  
3,956,083, INT. CL. 25.
- BIG APPLE JEWELRY MANUFACTURING CORP., NEW  
YORK, NY:  
2,378,612, CANC. INT. CL. 14.
- BIG BOY RESTAURANTS INTERNATIONAL LLC, WAR-  
REN, MI, MARRIOTT CORPORATION, WASHINGTON,  
DC:  
910,758, REN. 3-30-11, U.S. CL. 100 (INT. CL. 42).
- BIG IDEA ENTERTAINMENT, LLC, NEW YORK, NY:  
2,877,848, CANC. MULTIPLE CLASS, INT. CLS. 9 AND  
16.
- BIG SQUIRT, INC., TORRANCE, CA:  
2,440,304, REN. 3-31-11, INT. CL. 28.
- BIG SUR WATERBEDS, INC., DENVER, CO:  
2,439,279, REN. 3-28-11, INT. CL. 35.
- BIL BRIERLEY, SAN JOSE, CA:  
3,954,021, PUB. 2-15-2011, INT. CL. 44.
- BILCARE LIMITED, PUNE, INDIA:  
3,953,448, PUB. 2-15-2011, INT. CL. 9.
- BILINGUALS INC., NEW YORK, NY:  
3,954,052, PUB. 2-15-2011, MULTIPLE CLASS, INT. CLS.  
41 AND 44.
- BILLY BOB TEETH, INC., HARDIN, IL:  
3,956,043, MULTIPLE CLASS, INT. CLS. 21 AND 28.
- BINDO, LLC, WILMINGTON, DE:  
3,955,495, INT. CL. 35.
- BIO-ENGINEERED SUPPLEMENTS & NUTRITION, INC.,  
EVANSTON, IL:  
3,955,600, INT. CL. 5.
- BIO-LAB, INC., MIDDLEBURY, CT, BIO-LAB, INC., DEC-  
ATUR, GA:  
1,639,448, REN. 3-31-11, INT. CL. 1.
- BIO-REFERENCE LABORATORIES, INC., ELMWOOD  
PARK, NJ:  
2,975,735, AM. INT. CL. 44.
- BIOAXONE THÉRAPEUTIQUE INC., MONTRÉAL, QUE-  
BEC, CANADA:  
3,954,820, PUB. 2-15-2011, MULTIPLE CLASS, INT. CLS. 5  
AND 10.
- BIOCYTE SARL, JUAN LES PINS, FRANCE:  
3,953,099, PUB. 1-4-2011, MULTIPLE CLASS, INT. CLS. 3  
AND 5.
- BIOFARMA, F-92200 NEUILLY-SUR-SEINE, FRANCE:  
3,953,589, PUB. 2-15-2011, INT. CL. 5.  
3,953,590, PUB. 2-15-2011, INT. CL. 5.
- BIOJECT INC., TUALATIN, OR:  
2,440,716, REN. 3-31-11, INT. CL. 10.
- BIOLOGICAL IMMUNITY RESEARCH INSTITUTE,  
SCOTTSDALE, AZ:  
2,544,254, REN. 3-29-11, INT. CL. 42.
- BIOMEDICAL DEVICE CONSULTANTS & LABORATORIES  
OF COLORADO, LLC, WHEAT RIDGE, CO, DBA BIOME-  
DICAL DEVICE CONSULTANTS & LABORATORIES:  
3,954,930, PUB. 2-15-2011, INT. CL. 9.
- BIONDI, ELENA, PHILADELPHIA, PA:  
3,955,457, INT. CL. 35.
- BIONIC VERTRIEBS GMBH, LINZ, AUSTRIA:  
3,953,423, PUB. 2-15-2011, INT. CL. 32.
- BIONUTRIGEN (BNG), LTD., SOUTH KOREA, REPUBLIC  
OF KOREA:  
2,875,932, CANC. INT. CL. 5.
- BIOPELLE, INC., FERNDALE, MI:  
3,953,438, PUB. 2-15-2011, INT. CL. 3.
- BIORGANON SA, GENEVE, SWITZERLAND:  
2,409,089, REN. 3-29-11, INT. CL. 5.
- BIOSTIME, INC. (GUANGZHOU), GUANGZHOU, GUANG-  
DONG, CHINA:  
3,953,808, PUB. 2-15-2011, INT. CL. 29.  
3,953,809, PUB. 2-15-2011, INT. CL. 30.  
3,953,810, PUB. 2-15-2011, INT. CL. 41.  
3,953,811, PUB. 2-15-2011, INT. CL. 42.
- BIOTANIKA USA, LLC, FT. LAUDERDALE, FL:  
3,955,229, INT. CL. 3.
- BIOTECH SYSTEMS, LLC, GAINESVILLE, FL:  
2,876,841, CANC. INT. CL. 11.
- BIOTRONIK SE & CO. KG, BERLIN, FED REP GERMANY:  
3,955,270, MULTIPLE CLASS, INT. CLS. 10, 38 AND 44.
- BIOZYME, INCORPORATED, ST. JOSEPH, MO, BIO-ZYME  
ENTERPRISES, INC., ST. JOSEPH, MO:  
1,152,867, REN. 3-25-11, INT. CL. 5.
- BIRDS BE SAFE LLC, DUXBURY, VT, AKA BIRDSBESAFE  
LLC:  
3,954,744, PUB. 2-15-2011, INT. CL. 18.
- BIRKO ORTHOPAEDIE GMBH, 53545 LINZ, FED REP  
GERMANY:  
2,875,991, CANC. MULTIPLE CLASS, INT. CLS. 10 AND  
25.  
3,042,125, COR. MULTIPLE CLASS, INT. CLS. 10 AND  
25.
- BISCO, INC., SCHAUMBURG, IL:  
3,955,425, INT. CL. 5.
- BISON CAPITAL LLC, VENICE, FL:  
3,955,201, INT. CL. 16.
- BISON DESIGNS, LLC, LONGMONT, CO:  
3,955,409, MULTIPLE CLASS, INT. CLS. 6 AND 20.
- BISSELL HOMECARE, INC., GRAND RAPIDS, MI:  
3,955,612, INT. CL. 7.
- BITCHIN GEAR AND ACCESSORIES, VANCOUVER, CA-  
NADA:  
3,953,050, PUB. 2-15-2011, INT. CL. 25.
- BITTER BRILLIANCE, LLC, SMYRNA, GA:  
3,955,365, MULTIPLE CLASS, INT. CLS. 25 AND 41.  
3,955,366, MULTIPLE CLASS, INT. CLS. 25 AND 41.
- BITUMENES ORINOCO, S.A., CARACAS, VENEZUELA:  
2,876,197, CANC. MULTIPLE CLASS, INT. CLS. 11 AND  
19.
- BIZCOM INTERNATIONAL, LLC, DRAPER, UT:  
3,954,753, PUB. 2-15-2011, INT. CL. 42.
- BIZET HUMAN ASSET MANAGEMENT, INC., MCMUR-  
RAY, PA, CLARKE, WALTER V., EAST PROVIDENCE, RI:  
720,480, REN. 3-25-11, U.S. CL. 107 (INT. CL. 41).
- BIZZSHOUT, LLC, CLOSTER, NJ:  
3,953,943, PUB. 2-15-2011, INT. CL. 35.
- BLACK & DECKER CORPORATION, THE, TOWSON, MD:  
2,877,983, CANC. INT. CL. 7.
- BLACK BEAUTY CUSTOM STICKS, L.L.C., BIRMINGHAM,  
MI:  
2,876,617, CANC. INT. CL. 28.  
2,876,618, CANC. INT. CL. 28.
- BLACK CACTUS (GAMES) LIMITED, MORDEN, SURREY  
SM4 5AZ, UNITED KINGDOM:  
2,875,997, CANC. MULTIPLE CLASS, INT. CLS. 9, 16, 25,  
28 AND 41.

- BLACK DOG TAVERN COMPANY, INC., THE, VINEYARD HAVEN, MA:  
2,436,745. REN. 3-26-11. INT. CL. 24.  
2,436,746. REN. 3-26-11. INT. CL. 24.
- BLACK KNIGHT TRUST, ST. PETER PORT, GUERNSEY:  
2,422,572. REN. 3-26-11. INT. CL. 25.
- BLACKSMITH BRANDS, INC., IRVINGTON, NY:  
3,956,025. INT. CL. 3.
- BLACKSTAR VENTURES, LLC, SAN DIEGO, CA:  
3,953,680. PUB. 2-15-2011. MULTIPLE CLASS, INT. CLS. 25, 42 AND 45.  
3,953,681. PUB. 2-15-2011. MULTIPLE CLASS, INT. CLS. 25, 42 AND 45.  
3,953,682. PUB. 2-15-2011. MULTIPLE CLASS, INT. CLS. 42 AND 45.  
3,953,683. PUB. 2-15-2011. MULTIPLE CLASS, INT. CLS. 42 AND 45.  
3,953,684. PUB. 2-15-2011. MULTIPLE CLASS, INT. CLS. 16, 25, 42 AND 45.
- BLAINE BROOKE PHOTOGRAPHY, INC., LOUISVILLE, KY:  
2,877,828. CANC. INT. CL. 16.
- BLAINE, PAUL EDWIN, HENDERSONVILLE, NC:  
2,876,549. CANC. INT. CL. 21.
- BLAIR CANDY COMPANY INC, ALTOONA, PA:  
3,954,231. PUB. 2-15-2011. INT. CL. 35.
- BLAZE ENTERTAINMENT INTERNATIONAL, INC., CONCORD, MA:  
2,877,071. CANC. MULTIPLE CLASS, INT. CLS. 9 AND 41.
- BLINDS TO GO INC., MONTREAL, QUEBEC, CANADA:  
2,436,164. REN. 3-26-11. INT. CL. 35.
- BLISS, STEVEN J., MARIETTA, GA:  
2,877,412. CANC. INT. CL. 16.
- BLISTEX INC., OAK BROOK, IL:  
1,638,120. REN. 3-31-11. INT. CL. 5.
- BLOCH, JEFF, STOCKTON, CA:  
3,954,544. PUB. 2-15-2011. INT. CL. 32.
- BLOCK, NADIA, BROOKLYN, NY:  
2,877,973. CANC. INT. CL. 41.
- BLOCKSTAR LLC, GLENDALE, AZ, AKA BSTAR CLOTHING:  
3,954,216. PUB. 2-15-2011. MULTIPLE CLASS, INT. CLS. 9 AND 25.
- BLOOD CELL STORAGE, INC., SEATTLE, WA:  
3,955,262. MULTIPLE CLASS, INT. CLS. 1, 5 AND 9.
- BLOOMBERG L.P., NEW YORK, NY:  
549,742. REN. 3-31-11. U.S. CL. 38 (INT. CL. 16).
- BLUE CENTER, INC., WILDWOOD, NJ:  
3,954,571. PUB. 2-15-2011. INT. CL. 9.
- BLUE COAT SYSTEMS, INC., SUNNYVALE, CA:  
3,953,936. PUB. 11-9-2010. MULTIPLE CLASS, INT. CLS. 41 AND 42.
- BLUE GIANT EQUIPMENT CORPORATION, BRAMPTON, CANADA:  
3,953,039. PUB. 11-23-2010. INT. CL. 9.
- BLUE MOUNTAIN WALLCOVERINGS CANADA INC., BOUCHERVILLE, QUEBEC, CANADA:  
2,877,652. CANC. INT. CL. 27.
- BLUE SKY NATURAL BEVERAGE CO., CORONA, CA:  
2,445,075. REN. 3-26-11. INT. CL. 32.
- BLUE SKY NATURAL BEVERAGE COMPANY, CORONA, CA:  
2,445,076. REN. 3-26-11. INT. CL. 32.
- BLUE SPRING INTERNATIONAL, L.L.C., OKLAHOMA CITY, OK:  
2,876,278. CANC. INT. CL. 3.
- BLUE, JOSEPH C., RALEIGH, NC, DBA BALD HEADED GEAR:  
3,953,843. PUB. 2-15-2011. INT. CL. 25.
- BLUESTONE TRADE GROUP, LTD., GEORGETOWN GRANDCAYMAN, CAYMAN ISLANDS:  
3,918,889. COR. INT. CL. 25.
- BLUEWATER CHEMGROUP, INC., BRADENTON BEACH, FL:  
3,955,169. INT. CL. 1.
- BLUMBERG GMBH & CO. KG, 40885 RATINGEN, FED REP GERMANY:  
2,875,856. CANC. INT. CL. 16.
- BLUNT, DAVID R., HARBOR CITY, CA:  
3,954,727. PUB. 2-15-2011. INT. CL. 36.  
3,954,730. PUB. 2-15-2011. INT. CL. 36.
- BOARD OF REGENTS OF THE UNIVERSITY SYSTEM OF GEORGIA, ATLANTA, GA:  
2,876,236. CANC. MULTIPLE CLASS, INT. CLS. 16 AND 41.  
3,955,140. PUB. 2-15-2011. MULTIPLE CLASS, INT. CLS. 6, 16, 25 AND 41.
- BOARD OF TRUSTEES OF THE UNIVERSITY OF ALABAMA, TUSCALOOSA, AL:  
3,955,150. PUB. 2-15-2011. INT. CL. 16.
- BOC GASES AUSTRALIA LIMITED, NEW SOUTH WALES, 2113, AUSTRALIA:  
2,876,005. CANC. MULTIPLE CLASS, INT. CLS. 37, 40 AND 42.
- BOCA RATON MUSEUM OF ART, INC., BOCA RATON, FL:  
3,953,375. PUB. 2-15-2011. INT. CL. 41.
- BODIMOJO, INC., MILTON, MA:  
3,953,345. PUB. 2-15-2011. INT. CL. 44.  
3,953,346. PUB. 2-15-2011. INT. CL. 41.
- BODY OF ART, LTD., MOUNT KISCO, NY, DBA PURE-THREAD:  
3,955,776. INT. CL. 45.
- BODY SOLUTIONS, INC., VOORHEES, NJ:  
3,954,802. PUB. 2-15-2011. INT. CL. 41.
- BODYNEW, INC., SCOTTSDALE, AZ:  
3,953,058. PUB. 2-15-2011. INT. CL. 44.
- BOEHMER, MELISSA M., ODESSA, MO:  
2,440,275. REN. 3-30-11. INT. CL. 12.
- BOISE FRY COMPANY, LLC, BOISE, ID:  
3,954,563. PUB. 2-15-2011. INT. CL. 43.
- BOLDBRUSH TECHNOLOGY, L.L.C., SAN ANTONIO, TX:  
3,954,701. PUB. 2-15-2011. INT. CL. 42.  
3,955,008. PUB. 2-15-2011. INT. CL. 42.
- BOLEX INTERNATIONAL S.A., YVERDON-LES-BAINS, SWITZERLAND:  
720,959. REN. 3-30-11. U.S. CL. 26 (INT. CL. 9).
- BOLLAND, LES, SARASOTA, FL:  
2,443,000. REN. 3-30-11. MULTIPLE CLASS, INT. CLS. 25 AND 28.
- BOLLORE, ERGUE GABERIC, FRANCE:  
2,441,830. REN. 3-31-11. INT. CL. 16.
- BONNEVILLE INTERNATIONAL CORPORATION, SALT LAKE CITY, UT:  
2,549,758. REN. 3-26-11. INT. CL. 41.
- BONNIER ACTIVE MEDIA, INC., WINTER PARK, FL:  
2,467,335. REN. 3-30-11. INT. CL. 25.  
3,953,837. PUB. 2-15-2011. INT. CL. 9.
- BONOVO ORTHOPEDICS, INC., SCOTTSDALE, AZ:  
3,955,858. INT. CL. 10.
- BONVENTRE, JOSEPH, MASSAPEQUA PARK, NY:  
3,954,575. PUB. 2-15-2011. INT. CL. 25.
- BOOKBROWSE, SARATOGA, CA:  
3,953,919. PUB. 2-15-2011. MULTIPLE CLASS, INT. CLS. 35 AND 41.
- BOOLABOX, LLC, DOYLESTOWN, PA:  
3,955,349. INT. CL. 21.
- BOOM BOOM! REVOLUTION, INC., SANTA CRUZ, CA:  
3,955,436. MULTIPLE CLASS, INT. CLS. 35 AND 45.
- BOON EDAM GROUP HOLDING B.V., EDAM, NETHERLANDS:  
2,937,918. CANC. MULTIPLE CLASS, INT. CLS. 11 AND 19.
- BOOTIE BREWING COMPANY, WINTER PARK, FL:  
2,877,298. CANC. INT. CL. 35.
- BORGWARNER INC., AUBURN HILLS, MI, BORGWARNER INC., AUBURN HILLS, MI:  
2,445,586. REN. 3-26-11. MULTIPLE CLASS, INT. CLS. 6 AND 7.
- BOSCH SECURITY SYSTEMS, INC., FAIRPORT, NY:  
2,437,387. REN. 3-26-11. INT. CL. 9.
- BOSLEY, INC., BEVERLY HILLS, CA:  
3,955,255. MULTIPLE CLASS, INT. CLS. 3, 5 AND 44.

BOST. ROBERT F., JR., NORTH HUNTINGDON, PA:  
2,876,767, CANC. INT. CL. 37.

BOSTON BEER CORPORATION, BOSTON, MA, BOSTON BEER COMPANY LIMITED PARTNERSHIP, BOSTON, MA, DBA THE BOSTON BEER COMPANY:  
1,639,234, REN. 3-31-11. INT. CL. 32.

BOSTON SCIENTIFIC CORPORATION, NATICK, MA:  
2,462,200, REN. 3-27-11. INT. CL. 10.

BOSTON TRADERS LICENSING INC., DOVER, DE, BOSTON TRADING LTD., INC., LYNN, MA:  
1,146,433, REN. 3-29-11. INT. CL. 25.

BOUNCE ENERGY, INC., HOUSTON, TX:  
3,676,420, AM. INT. CL. 39.

BOWMAN, ERIK, REDONDO BEACH, CA:  
3,953,202, PUB. 2-15-2011. INT. CL. 41.

BOXITECH- TECNOLOGIA DE EMBALAGEM, LDA., 3880-180 OVAR, PORTUGAL:  
2,378,799, CANC. INT. CL. 9.

BOY SCOUTS OF AMERICA, IRVING, TX:  
1,615,209, REN. 3-29-11. INT. CL. 41.

BOYD GAMING CORPORATION, LAS VEGAS, NV:  
3,954,277, PUB. 2-15-2011. INT. CL. 41.  
3,954,281, PUB. 2-15-2011. INT. CL. 41.

BOYER, LLC, LAWRENCE, KS:  
1,670,948, REN. 3-31-11. INT. CL. 3.  
3,895,368, AM. INT. CL. 2.

BOYT HARNESS COMPANY, L.L.C., OSCEOLA, IA:  
1,148,861, REN. 3-26-11. MULTIPLE CLASS, INT. CLS. 13, 18 AND 25.

BRÄNNSTRÖM I GÖTEBORG AB, SWEDEN:  
3,953,572, PUB. 2-15-2011. MULTIPLE CLASS, INT. CLS. 9 AND 11.

BRACCO SPA, 20134 MILANO, ITALY:  
2,876,080, CANC. MULTIPLE CLASS, INT. CLS. 9 AND 10.

BRACERAS, FERMIN, PEMBROKE PINES, FL:  
2,462,573, REN. 3-31-11. INT. CL. 14.

BRADY WORLDWIDE, INC., MILWAUKEE, WI:  
1,157,294, REN. 3-29-11. MULTIPLE CLASS, INT. CLS. 16 AND 20.  
1,624,813, REN. 3-26-11. INT. CL. 16.

BRAEBURN SYSTEMS LLC, MONTGOMERY, IL:  
3,956,226, INT. CL. 9.

BRAIN POWER DIRECT, INC., FRESNO, CA:  
3,954,534, PUB. 2-15-2011. INT. CL. 9.

BRAINWORKS ADVERTISING, L.L.C., EDMOND, OK:  
2,875,957, CANC. INT. CL. 35.

BRAKE PARTS INC., MCHENRY, IL:  
3,956,011, INT. CL. 12.  
3,956,166, INT. CL. 12.

BRAND INSTITUTE, MIAMI, FL:  
2,487,268, REN. 3-28-11. MULTIPLE CLASS, INT. CLS. 35 AND 42.

BRANDWORKERS INTERNATIONAL, INC., QUEENS, NY:  
3,954,457, PUB. 2-15-2011. INT. CL. 35.

BRANNEN, BARBARA, LITTLETON, CO:  
2,464,627, REN. 3-26-11. INT. CL. 42.

BRANTINGHAM, DAVID E., TAIPEI, TAIWAN:  
3,956,035, INT. CL. 28.

BRASS-CRAFT MANUFACTURING COMPANY, NOVI, MI:  
2,439,778, REN. 3-25-11. INT. CL. 11.

BRATTER, BERNICE, LOS ANGELES, CA AND DENNIS, HELEN, REDONDO BEACH, CA:  
3,955,879, INT. CL. 41.

BRAZILIAN BBQ LLC, KENNER, LA:  
3,956,100, INT. CL. 43.

BREAKERS PALM BEACH, INC., THE, PALM BEACH, FL:  
1,638,705, REN. 3-29-11. INT. CL. 42.

BREDENT DENTALGERÄTE UND; MATERIALIEN, FACH-UND; ORGANISATIONSBERATUNG PETER BREHM, 89250 SENDEN, FED REP GERMANY:  
3,953,509, PUB. 2-15-2011. MULTIPLE CLASS, INT. CLS. 5, 10 AND 42.

BREEDLOVE, MEGAN SUZANNE, FORT WORTH, TX:  
3,954,897, PUB. 2-15-2011. INT. CL. 45.

BREMENN IP HOLDINGS, LLC, CARSON CITY, NV:  
3,956,190, INT. CL. 3.

BRENOVA, INC., MANSFIELD, MA:  
2,431,451, REN. 3-31-11. INT. CL. 17.

BRENNWICK TND COMMUNITIES, LLC, CARMEL, IN:  
2,445,249, REN. 3-31-11. INT. CL. 37.  
2,445,249, AM. INT. CL. 37.

BREWERS ASSOCIATION, INC., BOULDER, CO:  
3,953,289, PUB. 2-15-2011. INT. CL. 35.

BREWERY COLLECTIBLES CLUB OF AMERICA, INC., FENTON, MO:  
1,155,910, REN. 3-30-11. INT. CL. 41.

BREWSTER, MARCUS W, CENTREVILLE, VA, DBA VICTORY EVERYWEAR:  
3,955,816, INT. CL. 25.

BRIAN SCHOENHOLTZ, REEDS SPRING, MO:  
3,953,944, PUB. 2-15-2011. INT. CL. 25.

BRIAN'S SHOP LLC, DAYTON, OH:  
3,954,196, PUB. 2-15-2011. INT. CL. 44.  
3,954,986, PUB. 2-15-2011. INT. CL. 44.

BRICK INCORPORATED, CHELTENHAM, PA, TA EXECUTIVE AUTO BODY:  
2,490,510, REN. 3-29-11. INT. CL. 37.

BRICK INCORPORATED, CHELTENHAM, PA, TA EXECUTIVE AUTO BODY:  
2,506,286, REN. 3-29-11. INT. CL. 37.

BRICKS REALTORS INC, SUWANEE, GA:  
3,955,593, INT. CL. 36.

BRIDECCLICK, INC, NEW YORK, NY:  
3,954,348, PUB. 2-15-2011. INT. CL. 35.

BRIDGELINE DIGITAL, INC., WOBURN, MA:  
3,954,798, PUB. 2-15-2011. INT. CL. 42.  
3,954,799, PUB. 2-15-2011. INT. CL. 9.

BRIDGESTONE BRANDS, LLC, NASHVILLE, TN:  
3,955,506, INT. CL. 12.

BRIDGESTONE SPORTS CO., LTD, TOKYO, JAPAN:  
2,439,460, REN. 3-25-11. INT. CL. 28.

BRIDGFORD FOODS CORPORATION, ANAHEIM, CA:  
3,953,352, PUB. 2-15-2011. INT. CL. 30.

BRIGGS & STRATTON CORPORATION, WAUWATOSA, WI, BRIGGS & STRATTON CORPORATION, WAUWATOSA, WI:  
1,148,848, REN. 3-25-11. INT. CL. 12.

BRIGHT ROSE, LLC, SAN DIEGO, CA:  
3,955,947, INT. CL. 11.

BRINKER INTERNATIONAL PAYROLL COMPANY, L.P., DALLAS, TX:  
1,651,125, REN. 3-29-11. INT. CL. 42.  
2,518,657, REN. 3-28-11. INT. CL. 33.  
2,518,659, REN. 3-31-11. INT. CL. 33.

BRITETAB, INC., CHICAGO, IL:  
3,955,373, INT. CL. 42.

BRITISH MOTORCYCLE GEAR, SAN DIEGO, CA:  
3,953,404, PUB. 2-15-2011. INT. CL. 25.

BRITWEEK, INC., LOS ANGELES, CA:  
3,956,121, MULTIPLE CLASS, INT. CLS. 36 AND 41.

BROADBAND ENTERPRISES, INC., NEW YORK, NY:  
3,954,603, PUB. 2-15-2011. INT. CL. 41.

BROADWAY ENTERPRISES, INC., CLEVELAND, OH:  
2,522,535, REN. 3-30-11. INT. CL. 25.

BROADWAY VIDEO ENTERTAINMENT, INC., NEW YORK, NY:  
1,459,594, CANC. INT. CL. 40.

BROAN-NUTONE LLC, HARTFORD, WI, NUTONE, INC., CINCINNATI, OH:  
719,316, REN. 3-31-11. U.S. CL. 34 (INT. CL. 11).

BROCK USA LLC, BOULDER, CO:  
2,877,776, CANC. MULTIPLE CLASS, INT. CLS. 18 AND 28.

BROCKMAN, ROBERT, PALM BEACH GARDENS, FL:  
3,955,976, INT. CL. 21.

BRODRENE HARTMANN A/S, DK-2800 LYNGBY, DENMARK:  
2,876,326, CANC. INT. CL. 16.

BRONCUS TECHNOLOGIES, INC, MOUNTAIN VIEW, CA:  
3,955,908, INT. CL. 10.

BROOKSHIRE, LISA ELIZABETH, MORGAN HILL, CA:  
2,877,565, CANC. INT. CL. 3.

- BROSE FAHRZEUGTEILE GMBH & CO.; KOMMANDIT-GESELLSCHAFT, COBURG, 96450 COBURG, FED REP GERMANY:  
3,953,568, PUB. 2-15-2011. MULTIPLE CLASS, INT. CLS. 7, 9 AND 12.
- BROTHERS SIGNAL COMPANY, THE, LEESBURG, VA, DBA SIGNAL DESIGN CORPORATION:  
2,390,520. REN. 3-31-11. INT. CL. 9.  
2,460,315. REN. 3-29-11. INT. CL. 9.
- BROUWER, DERK, 1075 HM, AMSTERDAM,, NETHERLANDS:  
3,953,233, PUB. 12-21-2010. MULTIPLE CLASS, INT. CLS. 14, 24 AND 25.
- BROWN BROTHERS HARRIMAN & CO., NEW YORK, NY:  
2,515,357. REN. 3-30-11. INT. CL. 36.
- BROWN SHOE COMPANY, INC., ST. LOUIS, MO:  
3,955,463, INT. CL. 25.
- BROWN-FORMAN CORPORATION, LOUISVILLE, KY:  
3,955,590, INT. CL. 33.  
3,956,014, INT. CL. 21.  
3,956,015, INT. CL. 28.  
3,956,016, INT. CL. 16.  
3,956,017, INT. CL. 18.  
3,956,018, INT. CL. 24.  
3,956,077, INT. CL. 33.
- BROWNBERRY LLC, NEW YORK, NY:  
3,954,496, PUB. 2-15-2011. MULTIPLE CLASS, INT. CLS. 3 AND 44.
- BROWNSTONE MARKETING, LLC, WATERLOO, IA, DBA GOLF PIMP:  
3,953,096, PUB. 2-15-2011. INT. CL. 35.
- BRUNO PAILLARD, FRANCE:  
3,953,523, PUB. 2-15-2011. INT. CL. 33.
- BRYTE LIGHT ENTERPRISES LLC, DEL MAR, CA:  
3,954,003, PUB. 2-15-2011. INT. CL. 38.
- BRÜCKNER TROCKENTECHNIK; GMBH & CO. KG, FED REP GERMANY:  
3,953,550, PUB. 2-15-2011. INT. CL. 7.
- BTG STUDIOS PTY LIMITED, WOOLLAHRA NSW, AUSTRALIA:  
2,876,450, CANC. MULTIPLE CLASS, INT. CLS. 9 AND 16.
- BU HOLDINGS, LLC, TEMPE, AZ, DBA BOUNCEU:  
3,953,257, PUB. 6-22-2010. MULTIPLE CLASS, INT. CLS. 25 AND 41.
- BUBBAQUE'S, LLC, BRANDON, FL:  
3,954,516, PUB. 2-15-2011. INT. CL. 30.  
3,954,517, PUB. 2-15-2011. INT. CL. 30.  
3,954,521, PUB. 2-15-2011. INT. CL. 30.  
3,954,522, PUB. 2-15-2011. INT. CL. 30.  
3,954,524, PUB. 2-15-2011. INT. CL. 30.  
3,954,526, PUB. 2-15-2011. INT. CL. 30.  
3,954,529, PUB. 2-15-2011. INT. CL. 30.  
3,954,954, PUB. 2-15-2011. INT. CL. 30.
- BUCKEYE TECHNOLOGIES INC., MEMPHIS, TN:  
2,447,145. REN. 3-29-11. INT. CL. 1.
- BUCKLEY, PETER T, PHOENIXVILLE, PA:  
2,389,381. REN. 3-25-11. INT. CL. 9.
- BUD ANTLE, INC., WESTLAKE VILLAGE, CA:  
1,639,228. REN. 3-25-11. INT. CL. 31.
- BUENO OF CALIFORNIA, INC., SANTA FE SPRINGS, CA, GREAT AMERICAN LEATHERWORKS, INC., ATLANTA, GA:  
1,149,820. REN. 3-29-11. INT. CL. 18.
- BUFFALO CHINA, INC., BUFFALO, NY:  
1,380,491, CANC. INT. CL. 21.
- BUILD.COM, INC., CHICO, CA:  
3,956,031, INT. CL. 35.
- BUILDING MATERIALS INVESTMENT CORP., DALLAS, TX:  
3,956,081, INT. CL. 19.  
3,956,091, INT. CL. 19.
- BUISSON, LAWRENCE DU, HOLLYWOOD, CA:  
2,371,527. REN. 3-28-11. INT. CL. 41.
- BULK LIFT INTERNATIONAL INCORPORATED, CARPENTERSVILLE, IL:  
2,877,320, CANC. INT. CL. 16.
- BULLOCK, ERICA S., PORT ORANGE, FL:  
3,955,815, INT. CL. 44.
- BULMER, DONALD L., KENMORE, WA:  
3,953,748, PUB. 2-15-2011. INT. CL. 20.
- BUMPERNETS, INC., BIRMINGHAM, AL:  
2,465,012. REN. 3-30-11. MULTIPLE CLASS, INT. CLS. 35 AND 41.
- BUNGE OILS, INC., ST. LOUIS, MO:  
1,658,342. REN. 3-26-11. INT. CL. 29.
- BUONA BEEF, INC., BERWYN, IL:  
1,554,944, CANC. INT. CL. 30.
- BURGER KING CORPORATION, MIAMI, FL:  
3,955,507, INT. CL. 41.
- BURKE FRANKLIN, CHICO, CA:  
3,954,332, PUB. 2-15-2011. INT. CL. 38.  
3,954,333, PUB. 2-15-2011. INT. CL. 41.
- BURNES HOME ACCENTS, LLC, ROUND ROCK, TX:  
1,398,509, CANC. INT. CL. 16.
- BURNS, DAVID ANTHONY, TIGARD, OR:  
3,953,982, PUB. 2-15-2011. INT. CL. 9.
- BURNS, GARY LEE, BOCA RATON, FL:  
2,429,726. REN. 3-29-11. INT. CL. 25.
- BURROUGHS & CHAPIN COMPANY, INC., MYRTLE BEACH, SC:  
2,876,790, CANC. INT. CL. 41.
- BURRUS, SWAN, IV, BRENTWOOD, TN:  
2,877,912, CANC. INT. CL. 41.
- BURT RICHARD TATE, SANTA ROSA, CA:  
2,877,597, CANC. INT. CL. 37.
- BURT SUGARMAN, INC., BEVERLY HILLS, CA:  
2,550,187. REN. 3-26-11. INT. CL. 9.
- BUSCH MARINE INC., OKA, QUEBEC PROVINCE, CANADA:  
3,953,473, PUB. 9-28-2010. MULTIPLE CLASS, INT. CLS. 12, 35, 37 AND 42.
- BUSH FOODS OVERSEAS PRIVATE LIMITED, NEW DELHI, INDIA:  
3,955,798, INT. CL. 30.
- BUSH INDUSTRIES, INC., JAMESTOWN, NY:  
3,955,494, MULTIPLE CLASS, INT. CLS. 6 AND 9.
- BUSHNELL CORPORATION, OVERLAND PARK, KS:  
1,163,487. REN. 3-29-11. INT. CL. 9.
- BUSHNELL INC., OVERLAND PARK, KS:  
2,457,022. REN. 3-29-11. INT. CL. 9.  
2,457,022, CANC. MULTIPLE CLASS, INT. CLS. 14 AND 25.
- BUSINESS BULLPEN, LLC, CHARLOTTESVILLE, VA:  
3,954,330, PUB. 2-15-2011. INT. CL. 42.
- BUTTERBALL, LLC, GARNER, NC:  
1,151,836. REN. 3-26-11. INT. CL. 29.
- BUTTERNUT FARMS ORGANIC CO-OP, INC., S. KORTRIGHT, NY:  
2,876,766, CANC. INT. CL. 29.
- BUY DIRECT, LLC, BAD AXE, MI:  
3,954,085, PUB. 2-15-2011. INT. CL. 35.
- BUYITSELLIT, LLC, HIGLEY, AZ:  
3,953,820, PUB. 2-15-2011. INT. CL. 42.
- BUZUB, INC., HOPKINTON, MA:  
3,955,561, INT. CL. 45.
- BWIA WEST INDIES AIRWAYS LIMITED, PIARCO, WEST INDIES, TRINIDAD/TOBAGO:  
2,876,255, CANC. INT. CL. 18.  
2,876,256, CANC. INT. CL. 25.  
2,876,257, CANC. INT. CL. 39.  
2,876,258, CANC. INT. CL. 43.
- BYERLINE, LINDA, LA MESA, CA:  
2,876,179, CANC. INT. CL. 25.
- BYRNE, WENDY SUSAN, AMSTERDAM, NETHERLANDS:  
3,955,222, INT. CL. 25.
- C. & J. CLARK INTERNATIONAL LIMITED, STREET, SOMERSET, UNITED KINGDOM:  
3,955,953, INT. CL. 25.
- C. HOWARD HUNT PEN COMPANY, CAMDEN, NJ TO C. HOWARD HUNT PEN COMPANY, CAMDEN, NJ:  
143,048, COR. U.S. CL. 11.
- C. R. BARD, INC., MURRAY HILL, NJ:  
1,648,772. REN. 3-31-11. INT. CL. 10.

C.D.B. APPAREL, INC., NEW YORK, NY:  
3,955,166, INT. CL. 25.

C.H. ROBINSON WORLDWIDE, INC., EDEN PRAIRIE, MN:  
3,954,957, PUB. 2-15-2011. INT. CL. 35.

C.H.I.C. LLC, PALM SPRINGS, CA, DBA VILLAGE PUB  
BAR & GRILL:  
3,953,430, PUB. 2-15-2011. INT. CL. 32.

C.L. INDUSTRIES, INC., ORLANDO, FL:  
2,507,043. REN. 3-25-11. INT. CL. 19.

C-TECH INDUSTRIES, INC., CAMAS, WA:  
2,876,103, CANC. INT. CL. 11.

C/O HOTELS, LLC, NEW YORK, NY:  
3,955,864, MULTIPLE CLASS, INT. CLS. 35, 41, 43 AND  
45.

CA-AVRS, INC., PETALUMA, CA:  
3,954,414, PUB. 2-15-2011. INT. CL. 42.

CABELA'S INC., SIDNEY, NE:  
1,151,981. REN. 3-31-11. INT. CL. 42.

CABRERA, ENRIQUE ZEPEDA, MEXICO, D.F., C.P. 06000,  
MEXICO:  
3,952,954, PUB. 2-15-2011. INT. CL. 12.

CABURY ADAMS USA LLC, PARSIPPANY, NY:  
2,877,793, CANC. INT. CL. 30.

CADENCE NETWORK LLC, CINCINNATI, OH TO CA-  
DENCE NETWORK, INC., CINCINNATI, OH:  
2,379,857, CANC. INT. CL. 39.

CADENCE PHARMACEUTICALS, INC., SAN DIEGO, CA:  
3,955,489, INT. CL. 5.

CAERUS & MUSE, INC., WEST COVINA, CA:  
3,955,441, INT. CL. 25.

CAESARS LICENSE COMPANY, LLC, LAS VEGAS, NV:  
3,956,175, INT. CL. 35.

CAFFE LENA, INC., SARATOGA SPRINGS, NY:  
3,953,212, PUB. 2-15-2011. MULTIPLE CLASS, INT. CLS.  
41 AND 43.

CAINS FOODS, L.P., AYER, MA:  
3,954,057, PUB. 2-15-2011. INT. CL. 30.

CALIFORNIA ARTICHOKE AND VEGETABLE GROWERS  
CORPORATION, CASTROVILLE, CA, DBA OCEAN MIST  
FARMS:  
3,953,341, PUB. 2-15-2011. INT. CL. 35.

CALIFORNIA LAW ENFORCEMENT ASSOCIATION, MAR-  
TELL, CA:  
3,953,386, PUB. 2-15-2011. INT. CL. 36.

CALIFORNIA RICE COMMISSION, SACRAMENTO, CA:  
3,953,347, PUB. 2-15-2011. INT. CL. 30.

CALIFORNIA STATE RAILROAD MUSEUM FOUNDA-  
TION, SACRAMENTO, CA:  
2,440,016. REN. 3-31-11. INT. CL. 39.

CALLED TO SURF, LLC, PROVO, UT:  
3,955,937, INT. CL. 35.

CALUMET ABRASIVES CO., INC., HAMMOND, IN:  
2,455,226. REN. 3-26-11. INT. CL. 7.

CALVERT GROUP, LTD., BETHESDA, MD:  
3,956,246, INT. CL. 36.

CALVERT SCHOOL, BALTIMORE, MD:  
1,593,508. REN. 3-31-11. INT. CL. 41.

CALVET S.A.S., 3370 LANDIRAS, FRANCE:  
2,382,524. REN. 3-31-11. INT. CL. 33.

CAMBRIDGE SILVERSMITHS LTD., INC., FAIRFIELD, NJ:  
3,955,765, INT. CL. 8.

CAMPUS MANAGEMENT CORP., BOCA RATON, FL,  
TALISMA CORP., BELLEVUE, WA:  
2,514,178. REN. 3-26-11. MULTIPLE CLASS, INT. CLS. 35  
AND 42.

CANALI IRELAND LIMITED, DUBLIN 12, IRELAND:  
3,953,467, PUB. 6-21-2005. MULTIPLE CLASS, INT. CLS.  
25 AND 35.  
3,953,468, PUB. 6-21-2005. INT. CL. 25.

CANALI IRELAND LIMITED, IRELAND:  
3,953,485, PUB. 2-21-2006. MULTIPLE CLASS, INT. CLS.  
3, 9, 14, 18, 24, 25 AND 28.

CANGZHOU HUIYIN KENENG CO., LTD, CANGZHOU  
CITY, HEBEI PROVINCE, CHINA:  
3,953,522, PUB. 2-15-2011. MULTIPLE CLASS, INT. CLS. 7  
AND 11.

CANNON INSTRUMENT COMPANY, STATE COLLEGE,  
PA:  
3,954,956, PUB. 2-15-2011. INT. CL. 9.

CANTALOUPE SYSTEMS, INC., SAN FRANCISCO, CA:  
3,954,711, PUB. 2-15-2011. MULTIPLE CLASS, INT. CLS. 9  
AND 35.

CANTEEN SERVICES, INC., BELMONT, MI:  
2,445,309, CANC. MULTIPLE CLASS, INT. CLS. 35 AND  
42.

CANTINE SETTESOLI S.C.A., ITALY AND ENOTRIA WINE-  
CELLARS LTD, UNITED KINGDOM:  
3,953,624, PUB. 2-15-2011. INT. CL. 33.

CAPE SYSTEMS, INC., ALLEN, TX:  
920,742. REN. 3-26-11. U.S. CL. 38 (INT. CL. 9).

CAPITAL CITY TOOL, INC., FRANKFORT, KY:  
530,092. REN. 3-31-11. U.S. CL. 23 (INT. CL. 7).

CAPITAL DISTRIBUTION, INC., IRVINE, CA:  
2,378,516, CANC. INT. CL. 25.

CAPITAL ONE FINANCIAL CORPORATION, GLEN AL-  
LEN, VA:  
2,877,448, CANC. INT. CL. 36.

CAPITAL TREND CORPORATION, LYNDBURST, NJ:  
2,877,434, CANC. INT. CL. 30.

CAPITALIA S.P.A., ROMA, ITALY:  
2,877,005, CANC. MULTIPLE CLASS, INT. CLS. 9, 16, 35,  
36 AND 38.

CAPITAS SOLUTIONS, LLC, OLD HICKORY, TN:  
3,954,861, PUB. 2-15-2011. INT. CL. 35.

CAPSTONE TURBINE CORPORATION, CHATSWORTH,  
CA:  
2,487,869. REN. 3-31-11. INT. CL. 37.

CAPSULE GROUP, L.L.C. GREENSBORO, NC:  
2,441,465. REN. 3-26-11. INT. CL. 37.

CAPTAIN BALLOON, INC., INDIANAPOLIS, IN:  
1,390,271, CANC. MULTIPLE CLASS, INT. CLS. 39 AND  
42.

CAPTAIN CURT'S CRAB & OYSTER BAR, INC., SIESTA  
KEY, FL:  
2,457,813. REN. 3-31-11. MULTIPLE CLASS, INT. CLS. 30  
AND 42.

CAR TATTOOS DECALS AND SPORTSWEAR LTD., YON-  
KERS, NY:  
3,955,738, INT. CL. 25.

CARAUSTAR, G.P., FORT MILL, SC, CARAUSTAR, G.P.,  
FORT MILL, SC:  
2,484,511. REN. 3-25-11. MULTIPLE CLASS, INT. CLS. 16  
AND 40.

CARAUSTAR, G.P., FORT MILL, SC TO CARAUSTAR, G.P.,  
FORT MILL, SC:  
2,484,511, CANC. INT. CL. 17.

CARAUSTAR, G.P., FORT MILL, SC, CARAUSTAR, G.P.,  
FORT MILL, SC:  
2,484,548. REN. 3-28-11. MULTIPLE CLASS, INT. CLS. 16  
AND 40.

CARAUSTAR, G.P., FORT MILL, SC TO CARAUSTAR, G.P.,  
FORT MILL, SC:  
2,484,548, CANC. INT. CL. 17.

CARAVAN INGREDIENTS INC., LENEXA, KS:  
2,876,300, CANC. INT. CL. 30.

CARDSMART INC., STATEN ISLAND, NY:  
2,422,197, CANC. INT. CL. 16.  
2,422,198, CANC. INT. CL. 16.

CARDSWELL, LTD., WEST BLOOMFIELD, MI:  
2,876,125, CANC. INT. CL. 16.

CARELLI, LLC, GEORGETOWN, KY:  
3,954,150, PUB. 2-15-2011. INT. CL. 11.

CARGILL, INCORPORATED, WAYZATA, MN:  
2,877,654, CANC. INT. CL. 36.

CARL FREUDENBERG KG, D-69469 WEINHEIM, FED REP  
GERMANY:  
3,955,747, INT. CL. 1.

CARLISLE FOODSERVICE PRODUCTS, INCORPORATED,  
OKLAHOMA CITY, OK, PLASTICS MANUFACTURING  
COMPANY, DALLAS, TX:  
1,170,277. REN. 3-31-11. INT. CL. 21.

- CARLISLE FOODSERVICE PRODUCTS, INCORPORATED, OKLAHOMA CITY, OK:  
1,652,449. REN. 3-26-11. INT. CL. 21.  
1,670,822. REN. 3-26-11. INT. CL. 21.
- CARLSON SYSTEMS HOLDINGS, INC., EVANSTON, IL:  
2,537,667. REN. 3-31-11. MULTIPLE CLASS, INT. CLS. 35 AND 41.
- CARMEN CARTER, THOUSAND OAKS, CA:  
3,954,846. PUB. 2-15-2011. INT. CL. 14.
- CARMICHAEL TRAINING SYSTEMS, INC., COLORADO SPRINGS, CO:  
3,955,552. INT. CL. 16.
- CARNEGIE MELLON UNIVERSITY, PITTSBURGH, PA:  
2,934,386. CANC. MULTIPLE CLASS, INT. CLS. 18, 25 AND 36.
- CARNINI FOOD (SUISSE) S.A., 32 - 6830 CHIASSO, SWITZERLAND:  
2,877,838. CANC. INT. CL. 30.
- CARNIVAL PLC, LONDON, UNITED KINGDOM:  
1,646,305. REN. 3-27-11. MULTIPLE CLASS, INT. CLS. 39 AND 42.
- CAROLINA THUNDER CHARITIES, INC., CHARLOTTE, NC:  
2,378,856. CANC. INT. CL. 36.
- CAROLINA TRADING COMPANY, LLC, PRIMOS, PA, SEMINOLE MANUFACTURING COMPANY, COLUMBUS, MS:  
1,640,549. REN. 3-28-11. INT. CL. 25.
- CARON COMPACTOR COMPANY, ESCALON, CA:  
3,953,799. PUB. 2-15-2011. INT. CL. 7.
- CAROUSEL DESIGNS, DOUGLASVILLE, GA:  
3,954,039. PUB. 2-15-2011. INT. CL. 35.
- CARRIE, JESSA, STAUNTON, VA:  
3,953,715. PUB. 2-15-2011. MULTIPLE CLASS, INT. CLS. 9, 25 AND 41.
- CARRIER CORPORATION, FARMINGTON, CT:  
2,441,462. REN. 3-30-11. INT. CL. 11.
- CARROLL COMPANY, GARLAND, TX:  
2,529,656. REN. 3-28-11. INT. CL. 5.
- CARROTS, PALO ALTO, CA:  
2,876,803. CANC. INT. CL. 43.
- CARSAFE LLC, ST. CHARLES, MO:  
3,954,965. PUB. 2-15-2011. INT. CL. 36.
- CARSEY-WERNER COMPANY, LLC, THE, ENCINO, CA:  
2,441,929. REN. 3-30-11. INT. CL. 41.
- CARSON BROTHERS LLC, LITTLETON, CO:  
3,954,483. PUB. 2-15-2011. INT. CL. 35.
- CARSON, JENNIFER L., WOODBRIDGE, VA:  
2,876,388. CANC. INT. CL. 25.
- CARTE BLANCHE GREETINGS LIMITED, WEST SUSSEX BN176BD, UNITED KINGDOM:  
2,885,647. CANC. INT. CL. 28.
- CARTEL MUSIC, LLC, AVONDALE ESTATES, GA:  
3,953,479. PUB. 2-15-2011. INT. CL. 16.
- CARTER, ADELA-MARIE, BROOKLYN, NY:  
2,877,433. CANC. INT. CL. 42.
- CARTER, SHAWN, BEVERLY HILLS, CA:  
2,485,104. REN. 3-30-11. INT. CL. 16.
- CARTIER INTERNATIONAL AG, SWITZERLAND:  
3,953,567. PUB. 2-15-2011. INT. CL. 14.  
3,953,588. PUB. 2-15-2011. INT. CL. 3.  
3,953,591. PUB. 2-15-2011. INT. CL. 3.
- CARUS CORPORATION, PERU, IL:  
3,954,311. PUB. 2-15-2011. INT. CL. 9.
- CASCADE MEDICAL ENTERPRISES, LLC, WAYNE, NJ:  
3,062,391. CANC. INT. CL. 42.
- CASCADES RECOVERY INC., TORONTO, ONTARIO, CANADA:  
3,953,088. PUB. 2-15-2011. MULTIPLE CLASS, INT. CLS. 36, 37, 39 AND 40.
- CASSIDY, JENNIFER LYNN, PLAINFIELD, IN:  
3,954,630. PUB. 2-15-2011. INT. CL. 41.
- CASTLE MANOR, LLC, HYDE PARK, UT:  
3,955,462. INT. CL. 43.
- CATER TOTS, INC., WILLIAMSVILLE, NY:  
3,954,327. PUB. 2-15-2011. INT. CL. 43.
- CATERPILLAR INC., PEORIA, IL:  
2,378,755. CANC. INT. CL. 36.
- CATHERINE SPENCER, DECATUR, GA:  
3,954,551. PUB. 2-15-2011. INT. CL. 41.
- CATHOLIC KNIGHTS, MILWAUKEE, WI:  
2,877,158. CANC. INT. CL. 35.
- CAVE SPRINGS, INC., WILMINGTON, DE:  
3,953,227. PUB. 7-27-2010. INT. CL. 25.
- CAVIAR PETROSSIAN, 75007 PARIS, FRANCE:  
3,956,261. INT. CL. 29.
- CBC KABUSHIKI KAISHA, CHUO-KU, TOKYO, JAPAN, DBA CBC CO., LTD.:  
2,876,072. CANC. MULTIPLE CLASS, INT. CLS. 9, 10, 25 AND 38.
- CBJ, L.P., OVERLAND PARK, KS:  
1,638,353. REN. 3-31-11. INT. CL. 16.
- CBORD GROUP, INC., THE, ITHACA, NY:  
2,543,468. REN. 3-31-11. INT. CL. 9.  
2,543,487. REN. 3-30-11. INT. CL. 9.
- CBS INTERACTIVE INC., NEW YORK, NY:  
3,953,158. PUB. 2-15-2011. INT. CL. 41.
- CBS RADIO STATIONS INC., NEW YORK, NY:  
2,877,308. CANC. INT. CL. 41.
- CBS STUDIOS INC., NEW YORK, NY:  
2,468,301. CANC. INT. CL. 41.
- CBS STUDIOS INC., STUDIO CITY, CA:  
3,955,035. PUB. 2-15-2011. INT. CL. 41.
- CBS STUDIOS INC., STUDIO CITY, NY:  
3,955,321. INT. CL. 9.
- CBT SPORTS, LLC, BRENTWOOD, TN:  
3,956,237. MULTIPLE CLASS, INT. CLS. 38 AND 41.
- CDG HOLDING COMPANY, CARROLLTON, TX, DBA CDG & ASSOCIATES:  
2,876,338. CANC. INT. CL. 36.
- CDOC, INC., CARMEL, IN, CAPITOL AMERICAN LIFE INSURANCE COMPANY, CLEVELAND, OH:  
1,651,687. REN. 3-25-11. INT. CL. 36.
- CDOC, INC., CARMEL, IN:  
2,413,656. REN. 3-30-11. INT. CL. 36.  
2,413,656. AM. INT. CL. 36.
- CE SOIR LINGERIE CO., INC., VENTURA, CA, DBA FASHION FORMS:  
2,446,490. REN. 3-29-11. INT. CL. 10.
- CEL CHEMICAL & SUPPLIES, INC., EASLEY, SC:  
3,953,826. PUB. 10-19-2010. INT. CL. 1.
- CELESTE FOOTWEAR, MIAMI, FL, TA CELESTEFOTWEAR:  
3,954,735. PUB. 2-15-2011. INT. CL. 25.
- CELESTE FOOTWEAR, MIAMI, FL, DBA CELESTE FOOTWEAR:  
3,954,737. PUB. 2-15-2011. INT. CL. 25.
- CELESTIAL SEASONINGS, INC., BOULDER, CO:  
2,877,131. CANC. INT. CL. 30.
- CELLGENIX TECHNOLOGIE TRANSFER AG, D 79106 FREIBURG, FED REP GERMANY:  
2,437,753. REN. 3-26-11. INT. CL. 5.  
2,437,753. CANC. INT. CL. 42.
- CELLNET INNOVATIONS, INC., ALPHARETTA, GA:  
2,877,840. CANC. MULTIPLE CLASS, INT. CLS. 35, 38 AND 42.
- CELLOMICS INC., PITTSBURGH, PA:  
3,955,538. INT. CL. 9.
- CELLTECH PHARMACEUTICALS LIMITED, SLOUGH, UNITED KINGDOM:  
2,877,171. CANC. INT. CL. 5.
- CENDIO AB, LINKOPING, SWEDEN:  
3,953,044. PUB. 2-15-2011. INT. CL. 9.
- CENET, S.A., BOGOTA, COLOMBIA:  
2,877,207. CANC. MULTIPLE CLASS, INT. CLS. 9 AND 42.
- CENSAR TECHNOLOGIES, INC., JACKSONVILLE, FL:  
2,441,182. REN. 3-31-11. INT. CL. 9.
- CENTER CONSULTING LLC, ROSEBURG, OR, DBA FLAT-HEAD AMMUNITION CO.:  
3,954,382. PUB. 2-15-2011. INT. CL. 13.
- CENTER FOR CONSUMER FREEDOM, WASHINGTON, DC:  
3,953,729. PUB. 2-15-2011. INT. CL. 35.

- CENTER FOR FOODSERVICE EDUCATION, INC., SUGAR LAND, TX:  
3,952,982, PUB. 2-15-2011. INT. CL. 35.
- CENTER FOR SURROGATE PARENTING, INC., ENCINO, CA:  
3,953,048, PUB. 2-15-2011. INT. CL. 44.
- CENTERSTONE INSURANCE AND FINANCIAL SERVICES, INC., DALLAS, TX, DBA BENEFITMALL:  
3,953,780, PUB. 2-15-2011. MULTIPLE CLASS, INT. CLS. 35, 36 AND 42.
- CENTEX/TAYLOR, LLC, CHANTILLY, VA:  
2,877,339, CANC. MULTIPLE CLASS, INT. CLS. 37 AND 41.
- CENTINELA CAPITAL PARTNERS LLC, LOS ANGELES, CA:  
3,956,110, INT. CL. 35.
- CENTRAL COLLEGIATE HOCKEY ASSOCIATION, FARMINGTON HILLS, MI:  
2,463,359, REN. 3-29-11. U.S. CL. 200.
- CENTRAL DYNAMICS CORP., BOCA RATON, AZ, AKA CENDYN:  
3,956,163, INT. CL. 42.
- CENTRAL LAKE ARMOR EXPRESS, INC., CENTRAL LAKE, MI:  
3,955,554, INT. CL. 9.
- CENTRAL WASHINGTON UNIVERSITY, ELLENSBURG, WA:  
2,544,320, REN. 3-26-11. MULTIPLE CLASS, INT. CLS. 16 AND 25.
- CENTRE NATIONAL INTERPROFESSIONNEL DE L'ECONOMIE LAITIÈRE - CNIEL, PARIS, FRANCE:  
3,953,198, PUB. 2-15-2011. MULTIPLE CLASS, INT. CLS. 29, 30, 35, 41 AND 43.
- CENTURY 21 REAL ESTATE LLC, PARSIPPANY, NJ:  
2,378,922, CANC. INT. CL. 35.
- CEREAL INGREDIENTS, INC., LEAVENWORTH, KS:  
2,453,925, REN. 3-31-11. INT. CL. 30.
- CERTAINTED CEILINGS CORPORATION, VALLEY FORGE, PA:  
2,440,145, REN. 3-31-11. INT. CL. 19.
- CERTIFIED ACCESS SPECIALIST INSTITUTE, FRESNO, CA:  
3,954,935, PUB. 2-15-2011. INT. CL. 35.
- CERVANTES, ENRIQUE, EL PASO, TX AND LESTER, KURT FRED, HOBOKEN, NJ:  
3,649,191, COR. INT. CL. 25.
- CERVECERIA MODELO, S.A. DE C.V., 11320 MEXICO, D.F., MEXICO:  
2,395,352, REN. 3-31-11. INT. CL. 32.
- CERVINI'S, INC., VINELAND, NJ:  
2,297,262, CANC. INT. CL. 12.
- CESSNA AIRCRAFT COMPANY, WICHITA, KS:  
2,877,791, CANC. MULTIPLE CLASS, INT. CLS. 35, 36 AND 37.
- CETERA FINANCIAL HOLDINGS, INC., EL SEGUNDO, CA:  
3,953,295, PUB. 11-9-2010. MULTIPLE CLASS, INT. CLS. 35 AND 36.  
3,953,736, PUB. 11-9-2010. MULTIPLE CLASS, INT. CLS. 35 AND 36.
- CFAM, INC., DALLAS, TX, DBA CONSUMER FINANCE ASSET MANAGEMENT:  
3,955,351, INT. CL. 42.  
3,955,352, INT. CL. 42.
- CFS INTERNATIONAL INC., IRVINE, CA:  
2,877,270, CANC. INT. CL. 42.
- CHAFFEE, KEVIN R., BATESVILLE, IN:  
3,955,651, INT. CL. 11.  
3,955,652, INT. CL. 11.
- CHAKRA ENERGETICS, INC., TAIPEI COUNTY, TAIWAN:  
3,953,700, PUB. 2-15-2011. INT. CL. 9.
- CHAMPION TECHNOLOGIES INC, HOUSTON, TX:  
1,156,104, REN. 3-31-11. INT. CL. 7.
- CHAMPIONSHIP AUTO RACING SERIES, INC., TERRE HAUTE, IN:  
2,876,540, CANC. INT. CL. 41.
- CHANARATSOPON, SIRIWONG, HOUSTON, TX:  
3,952,981, PUB. 2-15-2011. INT. CL. 14.
- CHANCELLOR UNIVERSITY, CLEVELAND, AZ:  
3,953,360, PUB. 2-15-2011. INT. CL. 41.
- CHANEY, MYESHA T, LONG BEACH, CA:  
3,953,751, PUB. 2-15-2011. INT. CL. 41.
- CHANG CHUN PETROCHEMICAL CO., LTD, TAIPEI, TAIWAN:  
3,954,207, PUB. 2-15-2011. INT. CL. 17.
- CHAO, TED, CLAREMONT, CA:  
3,954,347, PUB. 2-15-2011. INT. CL. 5.
- CHAPMAN ENTERTAINMENT LIMITED, LONDON, UNITED KINGDOM:  
3,953,077, PUB. 2-15-2011. MULTIPLE CLASS, INT. CLS. 9, 28 AND 41.
- CHARLENE WANG, FOUNTAIN VALLEY, CA:  
3,956,023, MULTIPLE CLASS, INT. CLS. 21 AND 30.
- CHARLES INDUSTRIES, LTD., ROLLING MEADOWS, IL:  
1,638,946, REN. 3-30-11. INT. CL. 9.
- CHARLES J. FARRELL JR., GOLDEN, CO:  
3,955,286, MULTIPLE CLASS, INT. CLS. 35 AND 36.
- CHARLES KOMAR & SONS, INC., NEW YORK, NY:  
3,955,772, INT. CL. 25.
- CHARLES STEVEN POWERS, SHREVEPORT, LA, DBA PROPULSION TECHNOLOGIES, INC.:  
3,955,598, INT. CL. 12.
- CHARLES V. GUARINO AND RYAN J.C. TURNER PARTNERSHIP, THE, OCEANPORT, NJ:  
2,878,007, CANC. INT. CL. 25.
- CHARLOTTE METRO FEDERAL CREDIT UNION, CHARLOTTE, NC:  
2,522,826, REN. 3-30-11. INT. CL. 36.
- CHARLOTTE NBA LIMITED PARTNERSHIP, CHARLOTTE, NC TO CHARLOTTE HORNETS NBA LIMITED PARTNERSHIP, CHARLOTTE, NC:  
1,576,909, CANC. INT. CL. 41.
- CHARLOTTE RUSSE MERCHANDISING, INC., SAN DIEGO, CA:  
2,416,269, REN. 3-31-11. INT. CL. 14.  
2,416,270, REN. 3-26-11. INT. CL. 26.  
2,416,273, REN. 3-26-11. INT. CL. 25.
- CHARTIER, TIFFANY, K, ALLEN, TX:  
2,877,643, CANC. INT. CL. 16.
- CHATEAU DIANA, LLC, HEALDSBURG, CA:  
2,876,525, CANC. INT. CL. 33.
- CHAYES, MICHAEL M., SCARSDALE, NY:  
3,954,862, PUB. 2-15-2011. INT. CL. 41.
- CHECK POINT SOFTWARE TECHNOLOGIES LTD., TEL AVIV 67897, ISRAEL:  
2,441,328, REN. 3-29-11. INT. CL. 9.
- CHECK UP MAGAZINE PUBLISHING INC., CALGARY, AB, CANADA:  
2,876,319, CANC. INT. CL. 16.
- CHECKERS DRIVE-IN RESTAURANTS, INC., TAMPA, FL:  
2,876,044, CANC. INT. CL. 30.
- CHECKPOINT SYSTEMS INTERNATIONAL GMBH, FED REP GERMANY:  
3,953,571, PUB. 2-15-2011. MULTIPLE CLASS, INT. CLS. 9, 16, 24 AND 35.
- CHECKSUM, INC., ARLINGTON, WA:  
2,467,544, REN. 3-27-11. INT. CL. 9.
- CHEETHAM SALT LIMITED, CORIO, VICTORIA, AUSTRALIA:  
2,877,025, CANC. INT. CL. 30.
- CHEHALEM, INC., NEWBERG, OR:  
3,954,059, PUB. 2-15-2011. INT. CL. 33.
- CHELSEA BUILDING PRODUCTS, INC., OAK MONT, PA:  
1,182,968, REN. 3-31-11. INT. CL. 19.
- CHEM LAB PRODUCTS, INC., ONTARIO, CA:  
2,336,608, CANC. INT. CL. 1.
- CHEMENCE, INC., ALPHARETTA, GA:  
3,955,919, INT. CL. 1.
- CHEMISCHE FABRIK KREUSSLER & CO. GMBH, WIESBADEN, FED REP GERMANY:  
3,955,183, MULTIPLE CLASS, INT. CLS. 5 AND 10.
- CHEMTURA CORPORATION, MIDDLEBURY, CT:  
3,955,876, MULTIPLE CLASS, INT. CLS. 1 AND 4.
- CHENG, MONICA WAI MAN, MS., KOWLOON, HONG KONG:  
2,441,061, REN. 3-29-11. INT. CL. 16.

- CHEROKEE NATION ENTERTAINMENT, L.L.C., CATOOSA, OK:  
3,956,265, INT. CL. 35.
- CHERRY MOVING COMPANY, INC., HOUSTON, TX, DBA CHERRY DEMOLITION:  
3,953,701, PUB. 2-15-2011. INT. CL. 37.
- CHESNIER, CLARISSE, 34800 CLERMONT L'HERAULT, FRANCE:  
2,876,154, CANC. MULTIPLE CLASS, INT. CLS. 30, 35, 42 AND 43.
- CHEWFO, LLC, NEW YORK, NY:  
3,955,172, INT. CL. 43.
- CHI ETA PHI SORORITY INCORPORATED, WASHINGTON, DC:  
3,953,896, PUB. 2-15-2011. INT. CL. 35.
- CHI MEI OPTOELECTRONICS CORP., INDUSTRIAL PARK, TAIWAN:  
2,876,162, CANC. INT. CL. 37.
- CHICKEN DELIGHT VENTURES INCORPORATED, WINNIPEG, MANITOBA, CANADA:  
1,184,227, REN. 3-29-11. INT. CL. 42.
- CHICO'S BRANDS INVESTMENTS, INC., FORT MYERS, FL:  
2,378,483, CANC. INT. CL. 41.  
2,378,484, CANC. INT. CL. 41.
- CHICOPEE, INC., BENSON, NC TO PGI POLYMER, INC., WILMINGTON, DE:  
2,378,673, CANC. INT. CL. 17.
- CHILDCRAFT EDUCATION CORP., MOUNT JOY, PA:  
3,954,275, PUB. 2-15-2011. INT. CL. 20.  
3,954,276, PUB. 2-15-2011. INT. CL. 20.
- CHILL ZONE LLC, PORT ORANGE, FL:  
3,954,096, PUB. 2-15-2011. INT. CL. 11.
- CHILSON ENTERPRISES, INC., IRVING, TX:  
3,955,572, INT. CL. 25.
- CHINA BISTRO LLC, AVENTURA, FL:  
3,953,072, PUB. 2-15-2011. INT. CL. 43.
- CHINA DOLL RICE AND BEANS, INC., SARALAND, AL:  
3,953,120, PUB. 2-15-2011. MULTIPLE CLASS, INT. CLS. 29 AND 30.
- CHINA IWNCOMM CO., LTD., CHINA:  
3,953,532, PUB. 2-15-2011. INT. CL. 9.
- CHINA NATIONAL INVESTMENT & GUARANTY CO., LTD., CHINA:  
3,953,533, PUB. 2-15-2011. MULTIPLE CLASS, INT. CLS. 36, 38 AND 42.  
3,953,534, PUB. 2-15-2011. MULTIPLE CLASS, INT. CLS. 36, 38 AND 42.  
3,953,537, PUB. 2-15-2011. MULTIPLE CLASS, INT. CLS. 36, 38 AND 42.  
3,953,540, PUB. 2-15-2011. MULTIPLE CLASS, INT. CLS. 36, 38 AND 42.
- CHINA, AISHA, PHILADELPHIA, PA:  
3,954,386, PUB. 2-15-2011. INT. CL. 42.
- CHIQUITA BRANDS, INC., CINCINNATI, OH:  
910,452, REN. 3-29-11. U.S. CL. 46 (INT. CL. 31).
- CHOCKSTRAP, LLC, HARLEYSVILLE, PA:  
3,956,156, INT. CL. 22.
- CHODOSH, TERRY, RANCHO PALOS VERDES, CA:  
3,956,154, INT. CL. 36.
- CHOI, HYOUNG KYOO, LOS ANGELES, CA:  
3,953,167, PUB. 2-15-2011. INT. CL. 16.
- CHOICE CAP, INC., DORAVILLE, GA:  
3,954,368, PUB. 2-15-2011. INT. CL. 25.
- CHONGQING FULING HOT PICKLED MUSTARD TUBER GROUP CO.,LTD., CHONGQING CITY, CHINA:  
2,439,751, REN. 3-28-11. INT. CL. 29.
- CHOO CHOO R SNACKS, INC., LEBANON, PA, TA BUFFALO BILL'S PREMIUM SNACKS:  
3,954,257, PUB. 2-15-2011. INT. CL. 30.
- CHRIST'S CHURCH OF THE VALLEY, INC., PEORIA, AZ:  
2,868,958, CANC. INT. CL. 41.
- CHRISTENSEN O'CONNOR JOHNSON KINDNESS PLLC, SEATTLE, WA:  
3,953,711, PUB. 2-15-2011. MULTIPLE CLASS, INT. CLS. 9 AND 45.
- CHRISTIAN DIOR COUTURE, S.A., PARIS, FRANCE:  
1,610,521, CANC. MULTIPLE CLASS, INT. CLS. 14, 18, 21, 24 AND 25.
- CHRISTIE, CHARLES V., PONTE VEDRA BEACH, FL, DBA THE CHRISTIE COMPANY:  
1,645,595, REN. 3-31-11. INT. CL. 41.
- CHRISTY'S COUNTRY CANDLES, INC., MADISON, IN:  
2,533,307, CANC. MULTIPLE CLASS, INT. CLS. 4 AND 35.
- CHS INC., INVER GROVE HEIGHTS, MN:  
3,955,088, PUB. 2-15-2011. INT. CL. 4.
- CHURCH & DWIGHT CO., INC., PRINCETON, NJ, CHURCH & DWIGHT CO., INC., PRINCETON, NJ:  
1,640,126, REN. 3-28-11. INT. CL. 1.
- CHURCH & DWIGHT CO., INC., PRINCETON, NJ, CARTER-WALLACE, INC., NEW YORK, NY:  
1,674,927, REN. 3-26-11. INT. CL. 10.
- CHURCH & DWIGHT CO., INC., PRINCETON, NJ:  
3,955,895, INT. CL. 3.  
3,955,896, INT. CL. 3.  
3,956,206, INT. CL. 3.
- CIANT CORPORATION, WHITE PLAINS, NY:  
2,443,463, REN. 3-31-11. INT. CL. 9.  
2,443,464, REN. 3-31-11. INT. CL. 35.
- CIATTI COMPANY, LLC, SAN RAFAEL, CA:  
3,954,582, PUB. 2-15-2011. INT. CL. 36.
- CIE EXPLOITATION DES SERVICES; AUXILIAIRES AERIENS SERVAIR, FRANCE:  
3,953,562, PUB. 2-15-2011. MULTIPLE CLASS, INT. CLS. 29, 30, 31, 32, 33, 35, 37, 38, 39, 42, 43 AND 45.
- CIECAL RC, INC., CHULA VISTA, CA:  
3,955,779, INT. CL. 44.
- CIGNA INTELLECTUAL PROPERTY, INC., CLAYMONT, DE, CIGNA INTELLECTUAL PROPERTY, INC., CLAYMONT, DE:  
2,533,724, REN. 3-31-11. INT. CL. 35.
- CIMPROGETTI S.P.A., ITALY:  
3,953,552, PUB. 2-15-2011. MULTIPLE CLASS, INT. CLS. 9 AND 42.
- CINCINNATI BELL TELEPHONE COMPANY LLC, CINCINNATI, OH:  
2,875,972, CANC. INT. CL. 35.  
2,875,973, CANC. INT. CL. 35.
- CINCOM SYSTEMS, INC., CINCINNATI, OH:  
2,876,171, CANC. INT. CL. 9.
- CINDY RUSSO, HACKETTSTOWN, NJ, DBA REVERSE ORDER:  
3,954,839, PUB. 2-15-2011. INT. CL. 41.
- CIOFFI'S, LLC, COLUMBIANA, OH:  
3,953,447, PUB. 2-15-2011. INT. CL. 43.
- CIPRIANI, PAUL, WESTLAKE VILLAGE, CA:  
3,954,813, PUB. 2-15-2011. INT. CL. 8.
- CIPRIANI, PAUL, WESTLAKE VILLAGE, CA, DBA BRANDISH:  
3,954,950, PUB. 2-15-2011. INT. CL. 25.
- CIRCLE K STORES INC., TEMPE, AZ, CIRCLE K CORPORATION, THE, PHOENIX, AZ:  
1,149,199, REN. 3-29-11. INT. CL. 42.
- CISCO TECHNOLOGY, INC., SAN JOSE, CA, CISCO SYSTEMS, INC., SAN JOSE, CA:  
2,438,680, REN. 3-30-11. INT. CL. 9.
- CITARETX MANAGEMENT, LLC, LEAGUE CITY, TX:  
3,955,387, MULTIPLE CLASS, INT. CLS. 35 AND 36.
- CITIGROUP GLOBAL MARKETS INC., NEW YORK, NY:  
2,877,245, CANC. INT. CL. 36.
- CITIGROUP INC., NEW YORK, NY:  
2,424,088, REN. 3-25-11. MULTIPLE CLASS, INT. CLS. 35 AND 36.  
2,424,088, CANC. INT. CL. 9.  
3,956,034, INT. CL. 35.
- CITIZENS EQUITY FIRST CREDIT UNION, PEORIA, IL:  
3,952,993, PUB. 2-15-2011. INT. CL. 36.
- CITIZENS FINANCIAL GROUP, INC., BOSTON, MA, DBA CITIZENS BANK:  
3,953,829, PUB. 2-15-2011. INT. CL. 35.
- CITY OF CARLSBAD, CARLSBAD, CA:  
3,955,200, INT. CL. 28.
- CITY OF EDMOND, OKLAHOMA, EDMOND, OK:  
2,544,589, REN. 3-28-11. INT. CL. 35.



CITY OF GARLAND, TX, GARLAND, TX:  
2,378,768, CANC. MULTIPLE CLASS, INT. CLS. 35 AND 41.

CITY OF MANASSAS DEPARTMENT OF PARKS AND RECREATION, MANASSAS PARK, VA:  
3,954,045, PUB. 2-15-2011. INT. CL. 41.

CITY OF WIXOM, WIXOM, MI:  
3,952,976, PUB. 2-15-2011. INT. CL. 35.

CITYLAB, LLC, MALIBU, CA:  
3,954,816, PUB. 2-15-2011. INT. CL. 41.

CJJ, INC., OMAHA, NE:  
2,877,926, CANC. INT. CL. 37.

CKT FOOD GMBH, 22761 HAMBURG, FED REP GERMANY:  
2,875,866, CANC. MULTIPLE CLASS, INT. CLS. 21, 29, 30 AND 42.

CLAIRSON, INC., NEWARK, DE:  
2,379,167, CANC. INT. CL. 20.

CLARCOR AIR FILTRATION PRODUCTS, INC., JEFFERSONVILLE, IN:  
3,956,065, INT. CL. 11.

CLARENCE J. VENNE, LLC, BRISTOL, PA:  
3,955,401, INT. CL. 28.

CLARK CAPITAL MANAGEMENT GROUP INC., THE, PHILADELPHIA, PA:  
1,662,756, REN. 3-31-11. INT. CL. 36.

CLAUDIA A. AFXENTIOU, OAKLAND GARDENS, NY:  
3,956,101, INT. CL. 25.

CLAUSEN MILLER, P.C., CHICAGO, IL:  
2,459,608, REN. 3-26-11. INT. CL. 42.

CLAWSON CUSTOM CUES, INC., JACKSONVILLE, FL:  
2,877,189, CANC. INT. CL. 28.

CLAYPOOL, LES, SAN RAFAEL, CA:  
3,955,868, INT. CL. 41.

CLAYTON, MYRNA, ATLANTA, GA:  
2,877,314, CANC. INT. CL. 41.

CLEAN AIR COUNCIL, PHILADELPHIA, PA:  
3,954,071, PUB. 2-15-2011. INT. CL. 35.

CLEAN CARE OF NEW ENGLAND INC, WARWICK, RI:  
3,953,307, PUB. 2-15-2011. INT. CL. 37.

CLEAN CONTROL CORPORATION, WARNER ROBINS, GA:  
2,379,347, CANC. INT. CL. 1.

CLEANING BUTLERS INTERNATIONAL, INC., SARASOTA, FL:  
3,954,851, PUB. 2-15-2011. INT. CL. 37.

CLEANOFFER, INC., SAN FRANCISCO, CA:  
3,953,733, PUB. 2-15-2011. INT. CL. 36.

CLEANUP, INC., SCOTTSDALE, AZ:  
2,445,606, REN. 3-31-11. INT. CL. 40.

CLEAR CHANNEL BROADCASTING, INC., SAN ANTONIO, TX:  
2,440,112, REN. 3-30-11. MULTIPLE CLASS, INT. CLS. 38 AND 41.  
2,440,113, REN. 3-30-11. MULTIPLE CLASS, INT. CLS. 38 AND 41.  
2,469,828, REN. 3-29-11. INT. CL. 41.

CLEAR PONG, LLC, LONGWOOD, FL:  
3,953,894, PUB. 2-15-2011. INT. CL. 41.

CLEAR SKIES SOLAR, INC., MINEOLA, NY:  
3,953,253, PUB. 2-15-2011. MULTIPLE CLASS, INT. CLS. 36, 37 AND 42.

CLEARBRIDGE ADVISORS, LLC, NEW YORK, NY:  
3,953,996, PUB. 2-15-2011. INT. CL. 36.

CLEARONE COMMUNICATIONS, SALT LAKE CITY, UT:  
3,955,694, INT. CL. 9.

CLEARSNAP HOLDING, INC., BURLINGTON, WA:  
1,639,721, REN. 3-26-11. INT. CL. 16.

CLEARY UNIVERSITY, ANN ARBOR, MI:  
2,461,483, REN. 3-31-11. INT. CL. 41.

CLEMENTI, WILLIAM A., BRYN MAWR, PA:  
2,877,190, CANC. INT. CL. 45.

CLICKIQ.COM, INC., BLOOMINGTON, MN:  
2,546,892, REN. 3-26-11. INT. CL. 35.

CLICKN' KIDS, INC., AGOURA HILLS, CA:  
3,953,907, PUB. 2-15-2011. INT. CL. 9.

CLIFFTENT, INC., HOUSTON, TX:  
2,513,891, REN. 3-26-11. INT. CL. 42.

CLINE, RODNEY, BUFORD, GA:  
3,953,920, PUB. 2-15-2011. INT. CL. 4.  
3,953,921, PUB. 2-15-2011. INT. CL. 1.

CLIPPARD INSTRUMENT LABORATORY, INC., CINCINNATI, OH:  
2,378,667, CANC. MULTIPLE CLASS, INT. CLS. 7 AND 9.

CLIPSY, LLC, SAN FRANCISCO, CA:  
3,955,701, INT. CL. 6.

CLOCKWORK ENTERTAINMENT, LLC, PLANO, TX:  
2,436,060, REN. 3-26-11. INT. CL. 9.

CLOSED JOINT STOCK COMPANY "OBOLON", KYIV, 04655, UKRAINE:  
3,952,953, PUB. 2-15-2011. INT. CL. 32.

CLOSER COMMUNICATIONS INCORPORATED, NATICK, MA:  
2,875,847, CANC. INT. CL. 9.

CLOVERLEAF CORPORATION, RUSKIN, FL:  
3,955,319, INT. CL. 16.

CLUB DE FUTBOL AMERICA, S.A. DE C.V., COL. VILLA COAPA, MEXICO:  
2,839,736, AM. INT. CL. 41.

CLUB MONACO CORP, TORONTO, CANADA:  
3,339,201, COR. INT. CL. 14.

CLUB MONACO CORP., TORONTO, CANADA:  
3,339,156, COR. INT. CL. 35.  
3,641,709, COR. INT. CL. 18.

CLUB MONACO CORP., TORONTO, ONTARIO, CANADA:  
3,904,614, COR. INT. CL. 24.

CLUB REAL RESORT S.A. DE C.V., CANCUN, MEXICO:  
3,956,057, MULTIPLE CLASS, INT. CLS. 35, 39, 42 AND 43.

CLUB-TIX, LLC, SAINT LOUIS PARK, MN:  
2,876,128, CANC. INT. CL. 41.

CLUBPLANET, INC., NEW YORK, NY:  
2,892,648, CANC. INT. CL. 38.

CMC ENERGY SERVICES, INC., BETHESDA, MD:  
3,955,371, MULTIPLE CLASS, INT. CLS. 16, 35 AND 41.

CML MEDIA CORP., CULVER CITY, CA, AKA INTHEMO-COM:  
3,955,292, MULTIPLE CLASS, INT. CLS. 35, 41 AND 45.

CNA FINANCIAL CORPORATION, CHICAGO, IL:  
3,955,936, INT. CL. 36.

CO SPACE, INC., BOSTON, MA:  
2,378,629, CANC. MULTIPLE CLASS, INT. CLS. 38 AND 42.

COACHELLA VALLEY CITRUS, THERMAL, CA:  
2,876,897, CANC. INT. CL. 31.

COACHMEN RECREATIONAL VEHICLE COMPANY, LLC, MIDDLEBURY, IN:  
2,378,499, CANC. INT. CL. 12.

COAMIX INC., MUSASHINO-SHI, TOKYO 180-0003, JAPAN:  
2,876,259, CANC. INT. CL. 16.

COBRA ELECTRONICS CORPORATION, CHICAGO, IL:  
2,517,368, REN. 3-28-11. INT. CL. 9.  
2,524,426, REN. 3-31-11. INT. CL. 9.

COBY ELECTRONICS CORPORATION, LAKE SUCCESS, NY:  
3,955,563, INT. CL. 9.

COCKE, JAMES E., VALDOSTA, GA:  
3,953,200, PUB. 2-15-2011. INT. CL. 25.

COCOON, INC., NORTH HAMPTON, NH:  
3,954,738, PUB. 2-15-2011. INT. CL. 11.

CODING METRIX, INC., POWDER SPRINGS, GA:  
3,953,362, PUB. 2-15-2011. INT. CL. 41.

CODONICS, INC., MIDDLEBURG HEIGHTS, OH:  
2,438,928, REN. 3-25-11. INT. CL. 9.

CODY KRAMER IMPORTS, LLC, ORANGEBURG, NY:  
3,955,448, INT. CL. 30.  
3,955,449, INT. CL. 30.

COFACO AÇORES - INDÚSTRIA DE CONSERVAS, S.A., S. MIGUEL - AÇORES, PORTUGAL:  
3,914,964, COR. INT. CL. 29.

COGENT REAL-TIME SYSTEMS INC., GEORGETOWN, ONTARIO, CANADA:  
3,956,118, INT. CL. 9.

- COGNIS IP MANAGEMENT GMBH, DUESSELDORF, FED REP GERMANY, DIAMOND SHAMROCK CORPORATION, CLEVELAND, OH:  
909,424. REN. 3-31-11. U.S. CL. 6 (INT. CL. 1).
- COHEN, JAMES D., WYCKOFF, NJ:  
3,953,004, PUB. 1-15-2008. INT. CL. 37.
- COHERENT, INC., SANTA CLARA, CA:  
3,955,972, INT. CL. 7.
- COINAMATIC CANADA INC., MISSISSAUGA, ONTARIO, CANADA:  
3,955,466, INT. CL. 11.
- COINS, INC., PITTSBURGH, PA:  
3,954,546, PUB. 2-15-2011. INT. CL. 35.
- COL D'ORCIA S.P.A. SOCIETA AGRICOLA, MONTALCINO, SIENA, ITALY:  
1,626,209. REN. 3-31-11. INT. CL. 33.
- COLLABORATE DESIGN STUDIO, LTD., DEERFIELD, IL, AKA COLLABORATE DESIGN:  
3,953,177, PUB. 2-15-2011. INT. CL. 42.
- COLLABORENT GROUP, LTD., CLEVELAND, OH:  
3,955,327, INT. CL. 35.
- COLLARD, WILLIAM, MANHASSET, NY:  
2,540,534. REN. 3-26-11. INT. CL. 42.
- COLLEGE CRAFT ENTERPRISES, LTD., WHEATON, IL:  
1,159,427. REN. 3-26-11. INT. CL. 37.
- COLLEN IP CONSULTING, LLC, OSSINING, NY:  
3,955,245, MULTIPLE CLASS, INT. CLS. 35 AND 45.
- COLOMBINI, RICHARD V, SAINT LOUIS PARK, MS:  
3,956,185, INT. CL. 41.
- COLORADO AVALANCHE, LLC, DENVER, CO:  
3,954,771, PUB. 2-15-2011. INT. CL. 41.  
3,955,135, PUB. 2-15-2011. INT. CL. 25.  
3,955,136, PUB. 2-15-2011. INT. CL. 16.
- COLORADO ROCKIES BASEBALL CLUB, LTD., DENVER, CO:  
2,390,143. REN. 3-30-11. INT. CL. 25.
- COLORECTAL CANCER COALITION, INC., ALEXANDRIA, VA:  
3,956,211, INT. CL. 35.
- COLOUR & DESIGN, INC., NORTH LITTLE ROCK, AR:  
3,955,390, INT. CL. 27.  
3,955,391, INT. CL. 27.
- COLUMBIA COUNTY PC INCORPORATED, LAKE CITY, FL:  
3,956,205, INT. CL. 41.
- COLUMBIA INSURANCE COMPANY, OMAHA, NE:  
2,877,080, CANC. INT. CL. 27.  
3,955,766, INT. CL. 18.
- COLUMBIA LIGHTING PROPERTIES, INC., WILMINGTON, DE:  
3,956,090, INT. CL. 11.
- COLUMBIA SPORTSWEAR NORTH AMERICA, INC., PORTLAND, OR:  
3,954,825, PUB. 2-15-2011. INT. CL. 25.
- COLUMBITECH AB, 100 64 STOCKHOLM, SWEDEN:  
2,877,795, CANC. MULTIPLE CLASS, INT. CLS. 9 AND 42.
- COLUMBUS BRANDS, NEW YORK, NY:  
3,954,560, PUB. 2-15-2011. INT. CL. 30.  
3,954,960, PUB. 2-15-2011. INT. CL. 30.
- COMBE INCORPORATED, WHITE PLAINS, NY:  
2,517,961. REN. 3-29-11. INT. CL. 3.
- COMING ATTRACTIONS PARTIES, INC., BRISBANE, CA:  
1,930,895, CANC. INT. CL. 42.
- COMMONTIME LIMITED, DERBY, UNITED KINGDOM:  
2,877,417, CANC. INT. CL. 9.  
2,877,418, CANC. INT. CL. 42.
- COMMONWEALTH CLUB OF CALIFORNIA, THE, SAN FRANCISCO, CA:  
1,662,804. REN. 3-25-11. INT. CL. 41.
- COMMONWEALTH HOME FASHIONS INC., MONTRÉAL, CANADA:  
3,953,020, PUB. 1-19-2010. INT. CL. 24.
- COMMUNICATION SERVICE FOR THE DEAF, INC., SIOUX FALLS, SD:  
2,877,163, CANC. MULTIPLE CLASS, INT. CLS. 35, 38, 41 AND 44.
- COMMUNITY ASSOCIATIONS INSTITUTE, FALLS CHURCH, VA:  
1,637,974. REN. 3-29-11. U.S. CL. 200.
- COMMUNITY COMMUNICATIONS, INC., SANTA BARBARA, CA:  
2,444,528. REN. 3-29-11. INT. CL. 41.
- COMMUNITY HOSPITAL OF THE MONTEREY PENINSULA, MONTEREY, CA:  
2,538,934. REN. 3-26-11. INT. CL. 36.
- COMMUNITY IT INNOVATORS, INC., WASHINGTON, DC:  
2,552,538. REN. 3-31-11. MULTIPLE CLASS, INT. CLS. 37, 41 AND 42.
- COMONCONSABLE INC., TORTOLA,, BR.VIRGIN ISLANDS:  
3,953,931, PUB. 2-15-2011. INT. CL. 2.
- COMPAGNIE DES GRANDS VINS GENEREUX DE FRANCE, CASES DE PENE, FRANCE:  
2,477,542. REN. 3-29-11. INT. CL. 33.
- COMPAGNIE DES MONTRES LONGINES, FRANCILLON S.A. (LONGINES WATCH CO., FRANCILLON LTD.), 2610 SAINT-IMIER, SWITZERLAND:  
3,955,398, INT. CL. 14.
- COMPANIA ESPANOLA DE PETROLEOS, S.A. (CEPSA), 28042 MADRID, SPAIN:  
2,875,992, CANC. INT. CL. 37.
- COMPANION TREE, SEATTLE, WA, DBA COMPANION TREE LLC LIMITED LIABILITY COMPANY WASHINGTON:  
3,954,051, PUB. 2-15-2011. INT. CL. 42.
- COMPANY OF ARTISTS, LLC, DENVER, CO:  
3,954,806, PUB. 2-15-2011. MULTIPLE CLASS, INT. CLS. 2 AND 25.
- COMPANÍA DE MEDIOS DIGITALES (CMD) S.A., BUENOS AIRES, ARGENTINA:  
3,955,922, INT. CL. 9.
- COMPASS GROUP NEDERLAND B.V., AMSTERDAM, NETHERLANDS:  
2,966,235, CANC. MULTIPLE CLASS, INT. CLS. 42 AND 45.
- COMPASS GROUP USA, INC., CHARLOTTE, NC:  
2,877,425, CANC. INT. CL. 43.
- COMPETITIVE EDGE DECISION SYSTEMS, THE WOODLANDS, TX:  
2,877,514, CANC. INT. CL. 9.
- COMPLIANT HEALTHCARE TECHNOLOGIES, LLC, RALEIGH, NC:  
3,955,074, PUB. 2-15-2011. INT. CL. 3.
- COMPOSITE TECHNOLOGY, INC., GRAND PRAIRIE, TX:  
2,438,039. REN. 3-26-11. MULTIPLE CLASS, INT. CLS. 35, 37, 39 AND 42.
- COMPUTER TECHNOLOGY LINK CORP., PORTLAND, OR:  
3,955,217, INT. CL. 9.
- COMPUTER WIZARDS.COM, SCOTTSDALE, AZ:  
2,877,424, CANC. INT. CL. 38.
- COMPUTERIZED PAYROLL SOLUTIONS, INC., CHATTANOOGA, TN:  
3,954,733, PUB. 2-15-2011. INT. CL. 35.
- CON AM MANAGEMENT CORPORATION, SAN DIEGO, CA:  
3,955,911, INT. CL. 37.
- CONAIR CORPORATION, STAMFORD, CT:  
2,438,473. REN. 3-30-11. INT. CL. 7.  
2,876,857, CANC. INT. CL. 18.
- CONCEPTUAL OPTIONS, LLC, POWAY, CA:  
3,954,012, PUB. 2-15-2011. INT. CL. 44.
- CONCORD INTERNATIONAL TRADING PTY LTD, SYDNEY, AUSTRALIA:  
3,954,351, PUB. 2-15-2011. INT. CL. 5.
- CONDO EXPRESS, INC., CONROE, TX:  
2,316,088, CANC. INT. CL. 35.
- CONDUIT LTD, NESS ZIONA, ISRAEL:  
3,953,232, PUB. 11-9-2010. INT. CL. 9.
- CONDUX INTERNATIONAL, INC., MANKATO, MN:  
1,657,962. REN. 3-28-11. MULTIPLE CLASS, INT. CLS. 4 AND 8.
- CONFLANDEY SA, NEW YORK, NY:  
2,378,477, CANC. INT. CL. 6.

CONGRES MF, FRANCE:  
 3,953,544, PUB. 2-15-2011. MULTIPLE CLASS, INT. CLS. 35, 41 AND 44.

CONN-SELMER, INC., ELKHART, IN, WILLIAM LEWIS AND SON, CHICAGO, IL:  
 714,156. REN. 3-29-11. U.S. CL. 36 (INT. CLS. 9 AND 15).

CONN-SELMER, INC., ELKHART, IN:  
 2,438,216. REN. 3-26-11. INT. CL. 16.

CONNANCE, INC., WALTHAM, MA:  
 3,954,484, PUB. 2-15-2011. INT. CL. 42.

CONNECTICUT TECHNOLOGY COUNCIL, INC., EAST HARTFORD, CT:  
 3,955,758, INT. CL. 35.

CONNELL, MARGARETANN G, CHICAGO, IL:  
 3,953,879, PUB. 2-15-2011. INT. CL. 16.

CONNER & WINTERS, LLP, TULSA, OK:  
 3,954,809, PUB. 2-15-2011. INT. CL. 45.

CONSENSURE, INC., REDDING, CT:  
 2,875,971, CANC. MULTIPLE CLASS, INT. CLS. 9 AND 35.

CONSERVATEK INDUSTRIES, INC., CONROE, TX:  
 2,490,825. REN. 3-30-11. INT. CL. 6.  
 2,490,826. REN. 3-30-11. INT. CL. 6.

CONSONA CORPORATION, INDIANAPOLIS, IN:  
 2,379,757, CANC. INT. CL. 9.

CONSORCIO COMEX, S.A. DE C.V., MEXICO, D.F., MEXICO:  
 2,875,861, CANC. INT. CL. 1.

CONSORZIO ACETO BALSAMICO DI MODENA SOC. CONS. A R.L., 41100 MODENA (MO), ITALY:  
 2,890,756, CANC. MULTIPLE CLASS, INT. CLS. 35 AND 42.

CONSORZIO COOP. RIUNITE D'ABRUZZO S.C.P.A., 66026 - ORTONA (CH), ITALY:  
 2,272,431, CANC. INT. CL. 33.

CONSTANT EMAILS INC., MILLTOWN, NJ:  
 3,954,175, PUB. 2-15-2011. INT. CL. 42.  
 3,954,178, PUB. 2-15-2011. INT. CL. 42.

CONSTELLATION AUSTRALIA LIMITED, REYNELLA, AUSTRALIA:  
 2,876,995, CANC. INT. CL. 33.  
 2,876,996, CANC. INT. CL. 33.  
 2,876,997, CANC. INT. CL. 33.

CONSTRUCTION RESEARCH & TECHNOLOGY GMBH, TROSTBERG, FED REP GERMANY:  
 2,434,435. REN. 3-27-11. MULTIPLE CLASS, INT. CLS. 1, 2 AND 27.

CONSTRUCTION RISK SOLUTIONS, LLC, HUNT VALLEY, MD:  
 3,955,897, MULTIPLE CLASS, INT. CLS. 35 AND 36.

CONTEX, INC., SHERMAN OAKS, CA:  
 2,224,051, CANC. INT. CL. 9.

CONTINENTAL AMERICAN CORPORATION, WICHITA, KS, DBA PIONEER BALLOON COMPANY:  
 1,655,626. REN. 3-27-11. INT. CL. 28.

CONTINENTAL MILLS, INC., SEATTLE, WA:  
 3,956,008, INT. CL. 30.

CONTINENTAL WESTERN CORPORATION, SAN LEANDRO, CA:  
 1,176,274. REN. 3-30-11. INT. CL. 22.

CONTROLLED ENVIRONMENTS LIMITED, WINNIPEG, MANITOBA, CANADA:  
 1,166,202. REN. 3-25-11. INT. CL. 9.

CONVENTURES, INC., BOSTON, MA:  
 2,454,611. REN. 3-26-11. INT. CL. 16.

CONVEXX, HENDERSON, NV:  
 2,876,001, CANC. INT. CL. 35.

COOK, SHANNON, FULLERTON, CA:  
 3,954,620, PUB. 2-15-2011. INT. CL. 35.

COOL KIDS CAMPAIGN, COCKEYSVILLE, MD:  
 3,953,852, PUB. 2-15-2011. INT. CL. 36.  
 3,953,857, PUB. 2-15-2011. INT. CL. 16.

COOPER TECHNOLOGIES COMPANY, HOUSTON, TX:  
 285,774. REN. 3-31-11. U.S. CL. 21 (INT. CL. 9).

COOPER, RANDY R., LOGANVILLE, GA:  
 3,954,243, PUB. 2-15-2011. INT. CL. 35.

COPELAND'S OF NEW ORLEANS, INC, METAIRIE, LA:  
 3,954,369, PUB. 2-15-2011. INT. CL. 29.

COPESAN SERVICES, INC., MENOMONEE FALLS, WI:  
 2,425,088. REN. 3-28-11. INT. CL. 37.

COPSIDAS, FRANK JR., WHITEFISH, MT:  
 2,876,963, CANC. INT. CL. 39.

CORAL MORPHOLOGIC LLC, MIAMI, FL:  
 3,954,568, PUB. 2-15-2011. INT. CL. 35.

CORE COMPUTING TECHNOLOGIES, INC., EVANSTON, IL:  
 3,953,750, PUB. 2-15-2011. INT. CL. 42.

CORE FITNESS STUDIOS, UPPER ARLINGTON, OH:  
 3,956,256, INT. CL. 41.

CORELOGIC INFORMATION SOLUTIONS, INC., SANTA ANA, CA:  
 2,378,780, CANC. MULTIPLE CLASS, INT. CLS. 36 AND 39.

CORISON WINES, INC., ST. HELENA, CA:  
 2,536,233. REN. 3-31-11. INT. CL. 33.

CORKY'S PEST CONTROL, INC., SAN MARCOS, CA:  
 3,955,369, INT. CL. 16.

CORNERSTONE STERLING, SPOKANE, WA:  
 2,877,205, CANC. INT. CL. 14.

CORNERSTONE THERAPEUTICS INC., CARY, NC:  
 3,953,991, PUB. 2-15-2011. INT. CL. 44.

CORNETTA ENTERPRISES, INC., ATLANTA, GA:  
 3,955,206, INT. CL. 5.

CORP PUBLISHING, LLC, WARREN, MI:  
 2,539,086. REN. 3-29-11. INT. CL. 16.

CORPNET, INCORPORATED, WESTLAKE VILLAGE, CA:  
 3,955,645, MULTIPLE CLASS, INT. CLS. 9, 16, 35, 42 AND 45.

CORPORACIÓN DE LOS ANGELES, S.A. DE C.V., CUERNEVACA, MORELOS, MEXICO:  
 3,954,402, PUB. 2-15-2011. INT. CL. 33.

CORPORATEK INC., MONTREAL, QUEBEC, CANADA:  
 3,953,028, PUB. 2-15-2011. INT. CL. 9.  
 3,953,029, PUB. 2-15-2011. INT. CL. 9.

CORPORATION FOR SUPPORTIVE HOUSING, NEW YORK, NY:  
 3,953,070, PUB. 2-15-2011. MULTIPLE CLASS, INT. CLS. 36 AND 41.  
 3,953,071, PUB. 2-15-2011. MULTIPLE CLASS, INT. CLS. 36 AND 41.

CORPORATIVO INTERNACIONAL MEXICANO, S. DE R.L. DE C.V., MEXICO CITY, MEXICO:  
 3,956,033, INT. CL. 30.

CORRIDOR RECORDS, L.L.C., OWOSSO, MI:  
 2,378,651, CANC. INT. CL. 9.

CORRTABLESPORTS, LLC, QUAKERTOWN, PA:  
 2,877,501, CANC. INT. CL. 28.

CORTEFIEL, S.A., E-28034 MADRID, SPAIN:  
 3,953,486, PUB. 2-15-2011. INT. CL. 25.

CORTELL, NEAL P., QUAKER HILL, CT:  
 3,955,119, PUB. 2-15-2011. INT. CL. 41.

CORTES, AMELIA TORO, BOGOTÁ D.C., COLOMBIA:  
 3,910,258, COR. MULTIPLE CLASS, INT. CLS. 6, 14, 18 AND 25.

COSCO MANAGEMENT INC, WILMINGTON, DE, COSCO, INC., COLUMBUS, IN:  
 1,638,298. REN. 3-31-11. INT. CL. 12.

COSMETICS BASED ON NATURE INC., RICHMOND HILL, ONTARIO, CANADA:  
 2,876,569, CANC. INT. CL. 3.

COSTA, T. JEFFERY, ROCKLIN, CA:  
 2,876,387, CANC. INT. CL. 39.

COSTCO WHOLESALE CORPORATION, ISSAQUAH, WA:  
 2,532,373. REN. 3-26-11. INT. CL. 21.

COTEMAR, S.A. DE C.V., MEXICO D.F., MEXICO:  
 3,954,120, PUB. 2-15-2011. MULTIPLE CLASS, INT. CLS. 37 AND 43.

COUNCIL OF IVY GROUP PRESIDENTS, PRINCETON, NJ:  
 2,442,152. REN. 3-26-11. INT. CL. 41.

COUNCIL ON THE ENVIRONMENT, INC., NEW YORK, NY:  
 3,954,710, PUB. 2-15-2011. INT. CL. 35.

COUNSELOR REALTY, INC., FRIDLEY, MN:  
 3,953,018, PUB. 8-31-2010. INT. CL. 35.

- COUNSELOS OF REAL ESTATE, THE, CHICAGO, IL,  
AMERICAN SOCIETY OF REAL ESTATE COUNSELORS,  
CHICAGO, IL:  
714,520. REN. 3-31-11. U.S. CL. 200.
- COUNTRY RADIO BROADCASTERS, INC., NASHVILLE,  
TN:  
2,925,168. COR. INT. CL. 41.
- COURTROOM TELEVISION NETWORK LLC, NEW YORK,  
NY:  
3,955,793. INT. CL. 41.
- COURVOISIER S.A.S., JARNAC, FRANCE:  
3,955,184. INT. CL. 33.
- COVEMEX CORP., FOREST VIEW, IL:  
3,955,394. INT. CL. 29.
- COVENTURES, INC., TEANECK, NJ:  
1,640,548. REN. 3-30-11. INT. CL. 25.
- COVERBIND CORPORATION, WILMINGTON, NC:  
1,636,889. REN. 3-26-11. INT. CL. 16.
- COZEN O'CONNOR, P.C., PHILADELPHIA, PA:  
2,550,084. REN. 3-28-11. INT. CL. 42.
- CPL SYSTEMS LIMITED, SHEFFIELD, UNITED KING-  
DOM:  
3,954,907. PUB. 2-15-2011. INT. CL. 9.
- CPP GROUP PLC, YORK, UNITED KINGDOM:  
3,787,740. COR. MULTIPLE CLASS, INT. CLS. 35, 39, 43  
AND 45.
- CRAB ASSOCIATES LLC, PINELLAS PARK, FL:  
2,877,746. CANC. INT. CL. 29.
- CRAFTMADE INTERNATIONAL INC., COPPELL, TX:  
2,878,011. CANC. INT. CL. 11.
- CRAIG COLUZZI, GREAT NECK, NY, DBA CORTEX  
HOOD CLEANING:  
3,955,666. INT. CL. 37.
- CRAL CONTRACTING, INC., EAST SYRACUSE, NY:  
3,954,396. PUB. 2-15-2011. INT. CL. 42.
- CRANE CO., STAMFORD, CT:  
1,153,729. REN. 3-26-11. INT. CL. 9.
- CRAYOLA PROPERTIES, INC., EASTON, PA:  
717,196. REN. 3-30-11. U.S. CL. 37 (INT. CL. 16).
- CREATIVE ASSEMBLY LIMITED, SOUTHWATER NR.  
HORSHAM, UNITED KINGDOM:  
2,497,062. REN. 3-31-11. INT. CL. 9.  
2,497,062. CANC. INT. CL. 41.
- CREATIVE CHARACTER LICENSING, CARMEL, CA:  
1,639,201. REN. 3-26-11. INT. CL. 28.
- CREATIVE EDUCATION FOUNDATION, INC., AMHERST,  
MA:  
1,640,002. REN. 3-26-11. MULTIPLE CLASS, INT. CLS. 41  
AND 42.
- CREATIVE GEMS & JEWELRY CO., LTD., BANGKOK  
10600, THAILAND:  
2,877,644. CANC. INT. CL. 14.
- CREATIVE LAB, INC., LAS VEGAS, NV AND THE FRED  
SILVERMAN COMPANY, LOS ANGELES, CA:  
3,759,003. CANC. MULTIPLE CLASS, INT. CLS. 41 AND  
45.
- CREATIVE LINENS, INC., WALNUT, CA:  
2,876,582. CANC. INT. CL. 24.
- CREATIVE TECHNOLOGY LTD., CREATIVE RESOURCE,  
SINGAPORE:  
2,453,537. REN. 3-28-11. INT. CL. 9.
- CREDIT SUISSE SECURITIES (USA) LLC, NEW YORK, NY:  
3,954,376. PUB. 2-15-2011. INT. CL. 36.
- CREDIT UNION NATIONAL ASSOCIATION, INC., MADI-  
SON, WI:  
1,679,625. REN. 3-30-11. INT. CL. 36.
- CREDIT UNION SERVICES, INC., DALLAS, TX:  
2,876,591. CANC. INT. CL. 36.
- CREE, INC., DURHAM, NC, CREE, INC., DURHAM, NC:  
2,440,530. REN. 3-29-11. INT. CL. 9.
- CRF, INC., PLYMOUTH MEETING, PA:  
3,953,087. PUB. 2-15-2011. INT. CL. 9.
- CRIME POINT INC, CAMARILLO, CA, DBA CRIME POINT:  
3,953,340. PUB. 2-15-2011. INT. CL. 9.
- CRISFIELD AREA CHAMBER OF COMMERCE, INC.,  
CRISFIELD, MD:  
3,954,306. PUB. 2-15-2011. INT. CL. 41.
- CRISTALL U.S.A., INC., BOCA RATON, FL:  
2,548,656. REN. 3-31-11. INT. CL. 33.
- CRITICAL HEALTH, S.A., PORTUGAL:  
3,953,518. PUB. 2-15-2011. MULTIPLE CLASS, INT. CLS. 9  
AND 42.
- CRITICAL MANUFACTURING, S.A., PORTUGAL:  
3,953,558. PUB. 2-15-2011. MULTIPLE CLASS, INT. CLS. 9  
AND 42.
- CROSCILL HOME LLC, NEW YORK, NY:  
3,953,207. PUB. 2-15-2011. INT. CL. 24.
- CROSS OPTICAL GROUP, INC., DAYTONA BEACH, FL:  
2,877,208. CANC. INT. CL. 9.
- CROSSTEX INTERNATIONAL, INC., HAUPPAUGE, NY:  
3,955,984. INT. CL. 10.
- CROWN ROLL LEAF, INC., PATERSON, NJ:  
1,643,395. REN. 3-26-11. INT. CL. 16.
- CRUMB CORPS. LLC, PLANO, TX:  
2,876,955. CANC. MULTIPLE CLASS, INT. CLS. 30 AND  
35.
- CRUSADE FOR WORLD REVIVAL, SURREY GU9 8EP,  
UNITED KINGDOM:  
2,672,434. CANC. INT. CL. 16.
- CRUZ BAY PUBLISHING, INC., EL SEGUNDO, CA:  
2,876,172. CANC. INT. CL. 39.
- CRYO-SPHERE TECHNOLOGIES, LLC, LAGRANGE, GA:  
3,954,844. PUB. 2-15-2011. INT. CL. 10.
- CRYOLIFE, INC., KENNESAW, GA, CRYOLIFE, INC.,  
MARIETTA, GA:  
1,645,897. REN. 3-29-11. INT. CL. 10.
- CRYPTOCARD CORPORATION, OTTAWA, K2K 2E2, ON-  
TARIO, CANADA:  
2,876,275. CANC. INT. CL. 9.
- CRYSTAL CRUISES, INC., LOS ANGELES, CA:  
3,954,342. PUB. 2-15-2011. INT. CL. 41.
- CRYTEK UK LTD, SANDIACRE, NOTTINGHAM, UNITED  
KINGDOM:  
3,955,949. INT. CL. 9.
- CSIDENTITY CORPORATION, AUSTIN, TX:  
3,954,301. PUB. 2-15-2011. INT. CL. 45.
- CSM BAKERY PRODUCTS NA, INC., TUCKER, GA:  
2,416,253. REN. 3-25-11. MULTIPLE CLASS, INT. CLS. 29,  
30 AND 35.
- CT ATLANTIC LTD., SWITZERLAND:  
3,953,541. PUB. 2-15-2011. MULTIPLE CLASS, INT. CLS.  
1, 5 AND 42.
- CU COOPERATIVE SYSTEMS, INC., RANCHO CUCAMON-  
GA, CA:  
3,952,959. PUB. 2-15-2011. MULTIPLE CLASS, INT. CLS.  
35, 36 AND 45.
- CUMBERLAND PHARMACEUTICALS INC., NASHVILLE,  
TN:  
3,954,597. PUB. 2-15-2011. INT. CL. 5.
- CUNNINGHAM, KEITH A, KENNESAW, GA, DBA KEITH  
CUNNINGHAM & COMPANY:  
3,954,539. PUB. 2-15-2011. INT. CL. 16.  
3,954,540. PUB. 2-15-2011. INT. CL. 35.
- CUPCAKE HOLDINGS LLC, BROOKLYN, NY:  
3,955,982. INT. CL. 35.
- CURBELL PLASTICS, INC., ORCHARD PARK, NY:  
2,443,430. REN. 3-26-11. INT. CL. 17.
- CUSTOM DATA PROCESSING, INC, LA GRANGE, IL:  
3,955,540. INT. CL. 42.
- CUSTOM EDUCATION SOLUTIONS INC., CHAMPLIN,  
MN:  
3,953,849. PUB. 2-15-2011. MULTIPLE CLASS, INT. CLS.  
35 AND 41.
- CUSTOM HOME EXTERIORS, INC., RALEIGH, NC:  
3,955,056. PUB. 2-15-2011. INT. CL. 37.
- CUTLERY AND MORE, LLC, EAST DUNDEE, IL:  
3,954,102. PUB. 2-15-2011. INT. CL. 35.
- CYBERSPACE INNOVATION CENTER, INC., BOSSIER  
CITY, LA, DBA CYBER INNOVATION CENTER:  
3,956,213. INT. CL. 42.
- CYCLE GEAR, INC., BENICIA, CA:  
3,954,449. PUB. 2-15-2011. MULTIPLE CLASS, INT. CLS. 9  
AND 25.

CYNTHIA SUKUT, NORTH BEND, NE, DBA AZARIAH ACRES AVONS AND KELVIN SUKUT, NORTH BEND, NE, DBA AZARIAH ACRES AVONS:  
3,955,699, INT. CL. 31.

CYTOMATRIX, LLC, CHELMSFORD, MA:  
2,875,984, CANC. INT. CL. 5.

CYTOSKELETON, INC., DENVER, CO:  
3,954,450, PUB. 2-15-2011. INT. CL. 1.

C1 DESIGN GROUP L.L.C., KETCHUM, ID:  
2,437,539. REN. 3-26-11. INT. CL. 28.

C3 CREATIVE, LLC, DALLAS, TX, DBA SOUTHERN FRIED PAPER:  
3,954,687, PUB. 2-15-2011. INT. CL. 16.

C3D PRODUCTIONS, INC., GREENWOOD, SC:  
3,953,851, PUB. 2-15-2011. INT. CL. 44.

D K SELECTIONS, LLC, PARK RIDGE, NJ:  
2,498,917. REN. 3-28-11. INT. CL. 25.

D 3 SYSTEMS, INC., VIENNA, VA:  
3,954,131, PUB. 2-15-2011. INT. CL. 35.

D.C., INC., FENTON, MO:  
3,955,163, INT. CL. 35.

D-GENERATION, INC., DAYTONA BEACH, FL:  
3,954,054, PUB. 2-15-2011. INT. CL. 33.

D'ABOY CAREER HORIZONS, OLYMPIA, WA, DBA BLUE CARBON LEARNING:  
3,953,401, PUB. 2-15-2011. INT. CL. 42.

DADCO, INC., CINCINNATI, OH:  
3,954,292, PUB. 2-15-2011. INT. CL. 20.  
3,954,293, PUB. 2-15-2011. INT. CL. 20.

DADDIN CORP, BLUE BELL, PA:  
3,954,366, PUB. 2-15-2011. INT. CL. 25.  
3,954,367, PUB. 2-15-2011. INT. CL. 25.

DADDY'S JUNKY MUSIC STORES, INC., MANCHESTER, NH:  
3,954,648, PUB. 2-15-2011. INT. CL. 41.

DAFFY'S INC., SECAUCUS, NJ:  
2,489,363. REN. 3-29-11. INT. CL. 25.

DAIKIN INDUSTRIES, LTD., OSAKA, JAPAN:  
912,262. REN. 3-26-11. U.S. CL. 7 (INT. CL. 7).

DAILYSINGLE INC., NEW YORK, NY, AKA DAILYSINGLE:  
3,954,946, PUB. 2-15-2011. MULTIPLE CLASS, INT. CLS. 35 AND 42.

DAIMLER AG, STUTTGART, FED REP GERMANY:  
2,876,640, CANC. MULTIPLE CLASS, INT. CLS. 12 AND 28.  
2,876,641, CANC. MULTIPLE CLASS, INT. CLS. 12 AND 28.  
3,953,339, PUB. 2-15-2011. MULTIPLE CLASS, INT. CLS. 9, 11 AND 12.

DAIRYLAND, U.S.A. CORPORATION, BRONX, NY:  
2,452,543. REN. 3-28-11. INT. CL. 29.

DAKOTA GROWERS PASTA COMPANY, INC., CARRINGTON, ND:  
2,472,148. REN. 3-29-11. INT. CL. 30.

DAKOTA WEST DESIGN, INC., ALBUQUERQUE, NM, SOUTH DAKOTA GOLD COMPANY, RAPID CITY, SD:  
2,492,836. REN. 3-29-11. INT. CL. 14.

DALE CARNEGIE & ASSOCIATES, INC., HAUPPAUGE, NY:  
2,167,340, CANC. INT. CL. 9.

DALE MILLER, INC., DACULA, GA:  
2,379,204, CANC. INT. CL. 5.

DALEN PRODUCTS, INC., KNOXVILLE, TN:  
3,954,023, PUB. 2-15-2011. INT. CL. 19.

DALLAS BAR FOUNDATION, DALLAS, TX:  
3,954,712, PUB. 2-15-2011. INT. CL. 36.

DALLMER GMBH & CO. KG, FED REP GERMANY:  
3,953,554, PUB. 2-15-2011. MULTIPLE CLASS, INT. CLS. 6, 7, 11 AND 20.

DALWORTH CARPET CLEANING, INC., EULESS, TX:  
2,876,532, CANC. INT. CL. 37.

DAMANTRO, LLC, WALNUT CREEK, CA:  
3,955,515, INT. CL. 9.

DAMIEN JEWELRY INC., NEW YORK, NY:  
2,876,654, CANC. INT. CL. 14.

DAN-FOAM APS, AARUP, DENMARK:  
3,953,716, PUB. 2-15-2011. INT. CL. 35.  
3,955,437, INT. CL. 20.

DANCO ROOFING SERVICES, INC., INDIANAPOLIS, IN:  
3,954,385, PUB. 2-15-2011. INT. CL. 37.

DANIEL KELLEY, HORSEHEADS, NY:  
3,956,266, INT. CL. 41.

DANIELE INTERNATIONAL, INC., PASCOAG, RI:  
3,953,005, PUB. 4-15-2008. INT. CL. 29.  
3,953,006, PUB. 4-1-2008. INT. CL. 29.

DANLY IEM, LLC, BOSTON, MA, C/O CONNELL LIMITED PARTNERSHIP, DANLY MACHINE SPECIALTIES, INC., CHICAGO, IL:  
543,639. REN. 3-31-11. U.S. CL. 13 (INT. CL. 6).

DARBY ENTERPRISES, LLC, CASTRO VALLEY, CA:  
2,878,005, CANC. INT. CL. 41.

DARBY O'BRIEN ADVERTISING, INC., SOUTH HADLEY, MA:  
2,378,973, CANC. INT. CL. 35.  
2,378,974, CANC. INT. CL. 35.

DAREN LAM, GLENDALE, CA:  
3,953,835, PUB. 2-15-2011. INT. CL. 35.

DASTMALCHI ENTERPRISES, INC., COSTA MESA, CA:  
2,877,479, CANC. INT. CL. 35.

DATA CEDE LLC, PRINCETON, NJ:  
3,932,919, COR. MULTIPLE CLASS, INT. CLS. 35 AND 36.

DATAGEN.COM, INC., SAN FRANCISCO, CA:  
3,954,888, PUB. 2-15-2011. INT. CL. 35.

DATAJOOP LLC, CHESTER, VA:  
3,955,633, INT. CL. 42.

DATCO INTERNATIONAL, INC., BIRMINGHAM, MI:  
2,379,028, CANC. INT. CL. 21.

DATUM LLC, RICHMOND, VA:  
3,953,776, PUB. 2-15-2011. MULTIPLE CLASS, INT. CLS. 9 AND 42.

DAVEY WATER PRODUCTS PTY LTD, SCORESBY, AUSTRALIA:  
3,955,504, MULTIPLE CLASS, INT. CLS. 7 AND 11.

DAVID C. COOK, COLORADO SPRINGS, CO:  
3,892,442, COR. INT. CL. 9.

DAVID EDISON, LONDON E17 9LG, UNITED KINGDOM:  
3,953,553, PUB. 2-15-2011. MULTIPLE CLASS, INT. CLS. 16, 25, 28 AND 41.

DAVID ELLIOT POULTRY FARM, INC., SCRANTON, PA:  
3,953,973, PUB. 2-15-2011. INT. CL. 29.

DAVID PLATT, NEWTON, MA AND KENNETH ALAN TASSEY JR., MANCHESTER, NH:  
3,955,414, INT. CL. 5.

DAVID SEABERG, COLLEGE STATION, TX:  
3,953,420, PUB. 2-15-2011. INT. CL. 9.

DAVID TEXTILES, INC., CITY OF COMMERCE, CA:  
2,878,035, CANC. INT. CL. 24.

DAVID WU INVESTMENTS, INC., TAMPA, FL:  
3,955,994, INT. CL. 43.

DAVIDE CAMPARI-MILANO S.P.A., SESTO SAN GIOVANNI (MI, ITALY):  
3,954,912, PUB. 2-15-2011. INT. CL. 33.

DAVIS PAUL COMPANY, ATLANTA, GA:  
2,877,602, CANC. INT. CL. 35.

DAVIS SELECTED ADVISERS, L.P., TUCSON, AZ:  
2,876,541, CANC. INT. CL. 36.

DAVIS-STANDARD, LLC, PAWCATUCK, CT:  
2,379,205, CANC. INT. CL. 9.

DAVIS, RANDALL LEE, PEORIA, AZ:  
2,517,511. REN. 3-25-11. INT. CL. 16.

DAVLYN MANUFACTURING CO., INC., SPRING CITY, PA:  
3,955,503, INT. CL. 17.

DAVOS LIFE SCIENCE PTE. LTD., SINGAPORE 138667, SINGAPORE:  
3,953,499, PUB. 2-15-2011. MULTIPLE CLASS, INT. CLS. 3 AND 5.

DAWN FOODS, INC., JACKSON, MI:  
3,955,877, MULTIPLE CLASS, INT. CLS. 29 AND 30.

DAY INTERNATIONAL, INC., DAYTON, OH:  
2,877,818, CANC. INT. CL. 16.

DAY-GLO COLOR CORP., CLEVELAND, OH:  
915,365. REN. 3-30-11. U.S. CL. 11 (INT. CL. 2).

DAYAN, MEDWIN, NORTHBROOK, IL:  
3,953,415, PUB. 2-15-2011. INT. CL. 35.

- DAYMEN CANADA ACQUISITION ULC, VANCOUVER, BRITISH COLUMBIA, CANADA:  
3,954,962, PUB. 2-15-2011. INT. CL. 9.
- DAYS OF NOAH, LLC, BEDFORD, NH:  
3,956,193, INT. CL. 25.
- DAYTON SUPERIOR DELAWARE CORPORATION, DAYTON, OH, DBA DAYTON SUPERIOR CORPORATION:  
2,877,957, CANC. INT. CL. 19.
- DBG GROUP INVESTMENTS, LLC, DALLAS, TX:  
2,877,232, CANC. INT. CL. 11.
- DC BOCCLE LEAGUE, WASHINGTON, DC:  
3,956,136, INT. CL. 35.
- DC RANCH, LLC, SCOTTSDALE, AZ:  
3,953,470, PUB. 10-21-2008. INT. CL. 37.
- DD IP HOLDER LLC, CANTON, MA, DUNKIN' DONUTS OF AMERICA, INC., RANDOLPH, MA, AKA DUNKIN' DONUTS:  
1,159,354, REN. 3-31-11. INT. CL. 30.
- DD IP HOLDER LLC, CANTON, MA:  
3,955,751, INT. CL. 35.
- DE BEERS LV LTD, LONDON, UNITED KINGDOM:  
2,877,302, CANC. INT. CL. 14.
- DE BENEDETTO, VINCENT C., PASSAIC, NJ:  
2,876,412, CANC. INT. CL. 9.
- DE LUCA, ALEX, SUNNYVALE, CA:  
3,955,773, INT. CL. 41.
- DE NOVO LABS, LLC, SANDWICH, MA:  
3,954,177, PUB. 2-15-2011. INT. CL. 16.
- DE PONT, DORIS, AUCKLAND, NEW ZEALAND:  
2,877,157, CANC. INT. CL. 25.
- DEAN INTELLECTUAL PROPERTY SERVICES, INC., DALLAS, TX:  
1,640,081, REN. 3-29-11. INT. CL. 30.  
3,955,859, INT. CL. 29.
- DECHAMPS TEXTIL AG, 52078 AACHEN, FED REP GERMANY:  
2,877,011, CANC. INT. CL. 24.
- DECISION RESEARCH CORPORATION, HONOLULU, HI:  
2,457,186, REN. 3-29-11. INT. CL. 9.
- DEDICATED MARKETING SOLUTIONS, INC., EL SEGUNDO, CA, DBA DEDICATED MEDIA:  
3,953,268, PUB. 2-15-2011. INT. CL. 35.
- DEDON GMBH, 21337 LÜNEBURG, FED REP GERMANY:  
3,956,160, INT. CL. 20.  
3,956,161, INT. CL. 20.
- DEER VALLEY, INC., CORTLAND, OH:  
2,343,194, CANC. INT. CL. 25.
- DEERING WINE USA, LLC, SANTA ROSA, CA:  
3,954,801, PUB. 2-15-2011. INT. CL. 33.
- DEFIANCE MACHINE & TOOL MANUFACTURING COMPANY, INC., EARTH CITY, MO, AKA DEFIANCE MACHINE & TOOL MFG. CO., AND DEFIANCE MACHINE & TOOL CO.:  
1,154,526, REN. 3-26-11. INT. CL. 7.
- DEGAYNOR, G. SCOTT, GRAND RAPIDS, MI, DBA CREATIVE ICE:  
1,732,853, REN. 3-31-11. INT. CL. 11.
- DEGREMONT, FRANCE:  
3,953,564, PUB. 2-15-2011. MULTIPLE CLASS, INT. CLS. 11 AND 40.
- DEH, L.L.C., GLENDALE, AZ:  
3,954,610, PUB. 2-15-2011. INT. CL. 37.
- DEISTER ELECTRONIC GMBH, D-30890 BARSINGHAUSEN, FED REP GERMANY:  
2,875,877, CANC. INT. CL. 9.
- DEJA VU CONSULTING, INC., LANSING, MI:  
3,952,965, PUB. 2-15-2011. INT. CL. 41.
- DEJANA TRUCK & UTILITY EQUIPMENT CO, KINGS PARK, NY:  
3,952,969, PUB. 2-15-2011. INT. CL. 7.
- DEL MAR COMMUNICATIONS, INC., SARASOTA, FL:  
2,876,457, CANC. INT. CL. 16.
- DELAWARE NORTH COMPANIES SPORTSERVICE, INC., BUFFALO, NY:  
3,955,029, PUB. 2-15-2011. MULTIPLE CLASS, INT. CLS. 35 AND 43.  
3,955,030, PUB. 2-15-2011. MULTIPLE CLASS, INT. CLS. 35 AND 43.
- DELCAM PLC., BIRMINGHAM, UNITED KINGDOM:  
3,953,747, PUB. 2-15-2011. MULTIPLE CLASS, INT. CLS. 9 AND 10.
- DELHOMME FUNERAL HOME, INCORPORATED, LA-FAYETTE, LA:  
2,876,299, CANC. INT. CL. 36.
- DELIGHTFUL DELIVERIES, INC., SYOSSET, NY:  
2,877,345, CANC. INT. CL. 35.
- DELLOSO, MICHELLE, IVINS, UT:  
3,956,195, INT. CL. 25.
- DELMARVA BROADCASTING COMPANY, WILMINGTON, DE:  
3,955,883, INT. CL. 38.
- DELORO STELLITE HOLDINGS CORPORATION, ST. LOUIS, MO:  
1,652,889, REN. 3-26-11. INT. CL. 6.
- DELOS LIVING, LLC, NEW YORK, NY:  
3,955,230, MULTIPLE CLASS, INT. CLS. 36 AND 37.
- DELSON GROUP INC, CUPERTINO, CA:  
3,953,235, PUB. 2-15-2011. MULTIPLE CLASS, INT. CLS. 9 AND 42.
- DELTA EDUCATION, INC., NASHUA, NH:  
2,509,888, REN. 3-31-11. INT. CL. 16.
- DELTA EDUCATION, LLC, NASHUA, NH:  
2,509,886, REN. 3-31-11. INT. CL. 16.
- DELTA LIFE SCIENCE, INC., MIDDLETOWN, CT:  
3,954,074, PUB. 2-15-2011. INT. CL. 10.
- DELTA SHOE GROUP, INC., MIAMI, FL:  
2,876,201, CANC. INT. CL. 25.
- DELTA STAR, INC., SAN CARLOS, CA:  
1,680,118, REN. 3-30-11. INT. CL. 9.
- DELUXE ENTERPRISE OPERATIONS, INC., SHOREVIEW, MN:  
2,379,596, CANC. INT. CL. 16.  
2,402,837, REN. 3-26-11. INT. CL. 16.  
2,417,931, REN. 3-28-11. MULTIPLE CLASS, INT. CLS. 16, 35 AND 42.
- DELUXE ENTERPRISE OPERATIONS, INC., SHOREVIEW, MN, RUSSELL & MILLER, INC., SANTA FE SPRINGS, DE:  
2,426,061, REN. 3-31-11. MULTIPLE CLASS, INT. CLS. 9, 16 AND 25.
- DEMOULIN, JOSEPH J., TAMPA, FL:  
2,876,426, CANC. INT. CL. 3.
- DEN-TAL-EZ, INC., MALVERN, PA, SYNTEX (U.S.A.) INC., PALO ALTO, CA:  
1,148,817, REN. 3-31-11. INT. CL. 10.
- DENA D. BAKER, D.V.M., P.A., NAPLES, FL:  
3,954,626, PUB. 2-15-2011. INT. CL. 44.
- DENA KARLIN, DEERFIELD BEACH, FL AND VICKI KARLIN, DEERFIELD BEACH, FL:  
3,955,309, INT. CL. 3.
- DENNEEN & CO., INC., BOSTON, MA:  
2,539,293, REN. 3-29-11. INT. CL. 35.
- DENSO WAVE INCORPORATED, TOKYO, JAPAN:  
2,435,991, REN. 3-26-11. INT. CL. 9.
- DENTAL RECYCLING NORTH AMERICA, INC., NEW YORK, NY:  
2,877,466, CANC. INT. CL. 40.
- DENTALSUBS.COM, LLC, BIRDSBORO, PA:  
3,956,209, INT. CL. 35.
- DENTSPLY INTERNATIONAL INC., YORK, PA:  
1,658,129, REN. 3-29-11. INT. CL. 10.
- DEPARTMENT OF THE TREASURY, BUREAU OF THE PUBLIC DEBT, PARKERSBURG, WV:  
2,876,681, CANC. INT. CL. 35.
- DEPINTO, CHRIS, PHILADELPHIA, PA:  
2,876,759, CANC. INT. CL. 15.
- DEPUY, INC., WARSAW, IN:  
3,954,504, PUB. 2-15-2011. INT. CL. 10.
- DEQING SUNNY PLASTIC PRODUCTS CO. LTD., DEQING, ZHEJIANG, CHINA:  
3,956,129, INT. CL. 16.
- DERAMUS, GINA LYNN, EUCLID, OH:  
3,955,615, INT. CL. 3.
- DERMALI, INC., MEDFORD, OR:  
2,876,156, CANC. INT. CL. 3.

DERMAN, YAEL, EMILY, HIGHLAND PARK, IL:  
3,954,424, PUB. 2-15-2011. INT. CL. 18.

DERRENBACHER, STEPHEN P., WOODSBORO, MD AND  
DERRENBACHER, RUTH ANN, WOODSBORO, MD, DBA  
RUTH ANN'S GARDEN STYLE BEEF:  
2,876,447, CANC. INT. CL. 29.

DESIGN DIMENSIONS, LLC, SCOTTSDALE, AZ:  
3,953,758, PUB. 2-15-2011. INT. CL. 42.

DESIGNER BRANDS, INC., SANTA MONICA, CA:  
2,877,995, CANC. INT. CL. 38.

DESTILADORA SAN NICOLAS, S.A. DE C.V., ARANDAS,  
JALISCO, MEXICO:  
3,955,741, INT. CL. 33.

DESTILERIA LEYROS SA DE CV, TEQUILA, MEXICO:  
3,955,565, INT. CL. 33.

DETROIT CITY DAIRY, INC., TAYLOR, MI, DBA DAIRY  
FRESH FOODS, INC.:  
2,876,302, CANC. INT. CL. 29.

DETROIT RED WINGS, INC., DETROIT, MI:  
2,379,362, CANC. MULTIPLE CLASS, INT. CLS. 20, 24, 28  
AND 34.

DEUTSCHE EDELSTAHLWERKE GMBH, 58452 WITTEN,  
FED REP GERMANY:  
3,953,601, PUB. 2-15-2011. INT. CL. 6.

DEVELOPMENT DIMENSIONS INTERNATIONAL, INC.,  
BRIDGEVILLE, PA, DEVELOPMENT DIMENSIONS IN-  
TERNATIONAL, INC., BRIDGEVILLE, PA:  
1,151,201. REN. 3-30-11. MULTIPLE CLASS, INT. CLS. 35  
AND 41.

DEVELOPMENT DIMENSIONS INTERNATIONAL, INC.,  
BRIDGEVILLE, PA:  
2,448,053. REN. 3-31-11. INT. CL. 35.

DEVENISH NUTRITION LIMITED, BELFAST BT3 9AR,  
UNITED KINGDOM:  
2,876,212, CANC. INT. CL. 31.

DEVILS LAKE VOLUNTEER FIRE DEPARTMENT, DEVILS  
LAKE, ND:  
2,876,551, CANC. INT. CL. 41.

DEVLIN EBUSINESS ARCHITECTS INC., TORONTO, ON-  
TARIO, CANADA:  
2,876,151, CANC. MULTIPLE CLASS, INT. CLS. 9 AND  
42.

DEVON HEALTH SERVICES, INC., KING OF PRUSSIA, PA:  
3,953,713, PUB. 2-15-2011. INT. CL. 35.

DEWITT, SARAH A., LA SELVA BEACH, CA:  
2,482,933, CANC. INT. CL. 25.

DH EMPRESAS S.A., SANTIAGO, CHILE:  
3,955,389, INT. CL. 8.  
3,955,392, INT. CL. 27.

DH, INC., RENO, NV:  
2,877,462, CANC. INT. CL. 35.

DHC ENTERPRISE INC., COMMERCE, CA:  
2,876,739, CANC. INT. CL. 20.

DIADORA SPORT S.R.L., CAERANO DI SAN MARCO  
(TREVISO), ITALY:  
2,877,299, CANC. INT. CL. 25.

DIAGEO BRANDS B.V., AMSTERDAM, NETHERLANDS:  
2,430,846, REN. 3-26-11. INT. CL. 33.

DIAGRAPH CORPORATION, ST. LOUIS, MO, DIAGRAPH-  
BRADLEY INDUSTRIES, INC., HERRIN, IL:  
906,742, REN. 3-29-11. U.S. CL. 37 (INT. CL. 16).

DIAMOND GAME ENTERPRISES, CHATSWORTH, CA:  
3,955,629, INT. CL. 9.  
3,955,637, INT. CL. 9.  
3,955,638, INT. CL. 9.  
3,955,768, INT. CL. 9.  
3,955,770, INT. CL. 9.  
3,955,915, INT. CL. 9.

DIAMOND, KLEIDEN, NORTHRIDGE, CA:  
3,955,796, INT. CL. 5.

DIANE VON FURSTENBERG STUDIO, NEW MILFORD,  
CT:  
2,877,398, CANC. INT. CL. 3.

DIAZ, DOSITEO CELA, 09007-BURGOS, SPAIN AND BAR-  
BERO, LUIS MA ARNAIZ, 09007-BURGOS, SPAIN:  
2,378,762, CANC. INT. CL. 25.

DIEBOLD, INCORPORATED, NORTH CANTON, OH:  
3,955,623, INT. CL. 6.

DIENER BROS. INCORPORATED, REYNOLDS, IN TO  
AMERICAN SEEDS, LLC, ST. LOUIS, MO:  
1,130,080, CANC. INT. CL. 31.

DIFFRIENT, NIELS, RIDGEFIELD, CT:  
3,953,172, PUB. 2-15-2011. INT. CL. 11.

DIGISPLICE PRODUCTIONS INC., SEATTLE, WA, DBA  
LIVING MOMENTS:  
2,876,779, CANC. INT. CL. 41.  
2,876,780, CANC. INT. CL. 41.

DIGITAL PLACE BASED ADVERTISING ASSOCIATION,  
INC., NEW YORK, NY:  
3,955,734, INT. CL. 35.

DIGNITY MATTERS, INC, DAWSONVILLE, GA:  
3,955,550, INT. CL. 24.

DIKEN INTERNATIONAL, RICHLAND HILLS, TX:  
3,954,614, PUB. 2-15-2011. INT. CL. 4.

DILLARD'S, INC., LITTLE ROCK, AR:  
3,956,085, INT. CL. 25.

DILLS, JIM, MONUMENT, CO AND STONE, HARVEY,  
TESUQUE, NM:  
2,876,078, CANC. MULTIPLE CLASS, INT. CLS. 35 AND  
42.

DIMENSION ONE SPAS, INC, VISTA, CA:  
2,876,427, CANC. INT. CL. 11.

DIMRS, INC, SAN DIEGO, CA:  
3,028,660, AM. INT. CL. 25.

DINOLA, JON BARRY, YARDLEY, PA, DBA YARDLEY  
JEWELERS - JBD STUDIO:  
1,642,735, REN. 3-26-11. INT. CL. 14.

DIPLOM-IS AS, SKYTITA, NORWAY:  
2,877,078, CANC. INT. CL. 30.

DIPLOMAT PROPERTIES LIMITED PARTNERSHIP, HOL-  
LYWOOD, FL:  
2,491,701, REN. 3-28-11. INT. CL. 42.

DIRECT SOURCE SPECIAL PRODUCTS INC., LASALLE,  
QUEBEC, CANADA:  
2,877,657, CANC. INT. CL. 9.

DISC INTELLECTUAL PROPERTIES, LLC, BURBANK, CA,  
IDC SERVICES, INC., CHICAGO, IL:  
1,653,200, REN. 3-25-11. INT. CL. 35.

DISCOS FUENTES EDIMUSICA, S.A., MEDELLIN, COLOM-  
BIA:  
2,522,061, REN. 3-30-11. INT. CL. 9.

DISCUS DENTAL, LLC, CULVER CITY, CA:  
2,437,487, REN. 3-26-11. INT. CL. 42.

DISNEY ENTERPRISES, INC., BURBANK, CA:  
3,930,031, COR. MULTIPLE CLASS, INT. CLS. 3, 14, 18,  
21, 24, 28 AND 30.  
3,955,781, INT. CL. 41.  
3,955,855, INT. CL. 3.

DISRUPTIVE LIMITED, BUCKINGHAMSHIRE, UNITED  
KINGDOM:  
3,953,814, PUB. 1-25-2011. INT. CL. 9.

DISTILLEERDERIJEN ERVEN LUCAS BOLS B.V., 2723 RB  
ZOETERMEER, NETHERLANDS:  
2,876,147, CANC. MULTIPLE CLASS, INT. CLS. 16 AND  
35.

DISTRIBUTOR PARTNERS OF AMERICA, NAPLES, FL:  
3,954,060, PUB. 2-15-2011. INT. CL. 35.

DISUCS DENTAL, LLC, CULVER CITY, CA:  
2,877,981, CANC. INT. CL. 3.

DIVERSIFIED BUSINESS COMMUNICATIONS, PORT-  
LAND, ME:  
2,876,092, CANC. INT. CL. 35.

DIVERSIFIED FREIGHT, INC., CORVALLIS, MT:  
3,956,171, INT. CL. 35.

DIVERSIFIED GLOBAL TECHNOLOGIES, LLC, WOON-  
SOCKET, RI:  
2,931,392, AM. INT. CL. 21.

DIVERSIFIED RESEARCH, INC., MERRITT ISLAND, FL:  
2,379,446, CANC. INT. CL. 9.

DIVERSIFIED WOOD RESOURCES, DRAIN, OR, DBA  
AMERICAN LAMINATORS AND DBA DUCO-LAM:  
2,877,352, CANC. INT. CL. 19.

DIXIE CONSUMER PRODUCTS LLC, ATLANTA, GA:  
2,551,251, REN. 3-26-11. INT. CL. 21.

- DIXON, ANDREW, TAKAKA, NEW ZEALAND AND DIXON, JANE, TAKAKA, NEW ZEALAND AND WHALLEY, ROBIN, TAKAKA, NEW ZEALAND:  
3,953,385, PUB. 2-15-2011. INT. CL. 32.
- DJC HOLDINGS LLC, HURON, OH:  
3,954,020, PUB. 2-15-2011. MULTIPLE CLASS, INT. CLS. 9 AND 41.
- DJO, LLC, VISTA, CA, PROFESSIONAL CARE PRODUCTS INCORPORATED, SAN MARCOS, CA:  
1,639,644, REN. 3-25-11. MULTIPLE CLASS, INT. CLS. 10 AND 28.
- DJO, LLC, VISTA, CA:  
2,438,003, REN. 3-29-11. INT. CL. 35.
- DMF CONSULTING, TROY, MI:  
3,955,663, INT. CL. 9.
- DML, MARKETING GROUP, LTD., SYLMAR, CA:  
2,379,952, CANC. INT. CL. 25.
- DNA TECHNOLOGY A/S, DK-8000 ARHUS C, DENMARK:  
2,495,338, REN. 3-25-11. INT. CL. 5.
- DNC PARKS & RESORTS AT KSC, INC., BUFFALO, NY:  
3,953,366, PUB. 2-15-2011. INT. CL. 41.
- DNTLWORKS EQUIPMENT CORPORATION, CENTENNIAL, CO:  
2,135,382, CANC. INT. CL. 10.
- DO GOOD PLANET LLC, NEW YORK, NY:  
3,952,967, PUB. 2-15-2011. INT. CL. 35.  
3,952,968, PUB. 2-15-2011. INT. CL. 35.
- DO IT HAPPY, LLC, RANCHO PALOS VERDES, CA:  
3,953,904, PUB. 2-15-2011. INT. CL. 35.
- DOBI & ASSOCIATES, INC., SAN DIEGO, CA:  
3,955,428, INT. CL. 21.
- DOGBAG OF AMERICA, SANTA BARBARA, CA:  
2,877,392, CANC. INT. CL. 18.
- DOHENY, JAMES, ASTORIA, NY:  
3,953,407, PUB. 2-15-2011. INT. CL. 41.
- DOLE FOOD COMPANY, INC., WESTLAKE VILLAGE, CA:  
2,877,229, CANC. INT. CL. 32.
- DOLISOS SANTE ANIMALE, 31500 TOULOUSE, FRANCE:  
2,875,967, CANC. INT. CL. 5.
- DOLOR, ALBERT, MONTEREY, CA:  
3,955,594, INT. CL. 25.
- DOMAINE DES BROIX S.A.S., FRANCE:  
3,953,619, PUB. 2-15-2011. MULTIPLE CLASS, INT. CLS. 32 AND 33.
- DOMINGO, RAEMAR, IRVINE, CA:  
3,955,280, INT. CL. 25.
- DOMINIO DE PUNCTUM, S.L., SPAIN:  
3,953,573, PUB. 2-15-2011. INT. CL. 33.
- DOMO GASOLINE CORPORATION LTD., WINNIPEG, MANITOBA, CANADA:  
1,613,251, REN. 3-30-11. INT. CL. 37.
- DONALD BYFORD & SONS SDN. BHD., KUALA LUMPUR, MALAYSIA:  
3,953,471, PUB. 2-15-2011. MULTIPLE CLASS, INT. CLS. 3, 9, 14, 18, 24, 25 AND 35.
- DONALD SORANNO, ALEXANDRIA, VA, DBA AERO HAMMOCK:  
3,955,497, INT. CL. 12.
- DONOVAN ENGLAND, LLC, ARLINGTON, VA:  
3,955,026, PUB. 2-15-2011. INT. CL. 25.
- DOORLAND 2000 INC., WOODBRIDGE, ONTARIO, CANADA:  
3,953,194, PUB. 2-15-2011. MULTIPLE CLASS, INT. CLS. 6, 19 AND 20.
- DOREL JUVENILE GROUP, INC., FOXBORO, MA:  
3,955,807, MULTIPLE CLASS, INT. CLS. 12 AND 20.
- DORRIES FRANK-MOLNIA & POHLMAN, 81669 MUNCHEN, FED REP GERMANY:  
2,877,813, CANC. INT. CL. 42.
- DOTY, PETER M., NEW PORT RICHEY, FL:  
2,876,499, CANC. INT. CL. 41.
- DOUG C. SMITH, DANA POINT, CA, DBA THE STICKLER FAMILY:  
3,953,138, PUB. 7-27-2010. INT. CL. 24.
- DOUGLAS PRODUCTS AND PACKAGING COMPANY LLC, LIBERTY, MO:  
3,953,409, PUB. 2-15-2011. INT. CL. 5.
- DOVER DOWNS GAMING & ENTERTAINMENT, INC., WILMINGTON, DE:  
3,953,189, PUB. 2-15-2011. INT. CL. 43.
- DOVER, TERENCE, BROOKLYN, NY AND PAPAMIHALIS, MICHAEL, FLUSHING, NY AND PAYSON, JON, BROOKLYN, NY AND PHILIPS, ERAN, NEW YORK, NY:  
2,877,459, CANC. INT. CL. 41.
- DR DISTRIBUTORS, LLC, ROCKFORD, IL:  
3,953,768, PUB. 2-15-2011. INT. CL. 34.
- DR. EFFECT COMMUNICATIONS, PITTSBURGH, PA:  
2,379,224, CANC. MULTIPLE CLASS, INT. CLS. 16 AND 41.
- DR. FRESH, INC., LA MIRADA, CA:  
2,876,762, CANC. INT. CL. 5.
- DR. LUCY'S LLC, NORFOLK, VA:  
3,953,348, PUB. 2-15-2011. MULTIPLE CLASS, INT. CLS. 5 AND 30.
- DR. SEUSS ENTERPRISES, L.P., LA JOLLA, CA:  
3,878,161, COR. INT. CL. 16.
- DR. THOMAS THEES, FED REP GERMANY:  
3,953,668, PUB. 2-15-2011. INT. CL. 33.
- DRÄGER SAFETY AG & CO. KGAA, LÜBECK, FED REP GERMANY:  
3,953,856, PUB. 2-15-2011. INT. CL. 9.
- DRAFT WORLDWIDE, INC., CHICAGO, IL:  
2,876,398, CANC. INT. CL. 35.
- DRAHTWARENFABRIK DRAHTZUG STEIN GMBH & CO. KG, ALTLEININGEN, FED REP GERMANY:  
2,378,455, CANC. INT. CL. 6.
- DRALON GMBH, DORMAGEN, FED REP GERMANY:  
1,149,872, REN. 3-26-11. INT. CL. 24.
- DRAPER'S & DAMON'S, INC., IRVINE, CA:  
2,877,618, CANC. INT. CL. 35.
- DREAM WELL WINES, INC., BROOKLYN, NY:  
3,955,585, INT. CL. 33.
- DREAMLAND HOLDING COMPANY, LLC, BIRMINGHAM, AL:  
2,471,696, REN. 3-25-11. INT. CL. 42.
- DREAMS FOR KIDS INC., CHICAGO, IL:  
3,955,293, INT. CL. 41.
- DRESSER-RAND COMPANY, OLEAN, NY:  
2,379,846, CANC. INT. CL. 11.
- DRESSER, INC., ADDISON, TX:  
1,161,639, REN. 3-29-11. INT. CL. 7.  
2,439,598, REN. 3-26-11. INT. CL. 35.  
3,955,312, INT. CL. 9.
- DREVE OTOPLASTIK GMBH, D-59423 UNNA, FED REP GERMANY:  
2,439,733, REN. 3-29-11. MULTIPLE CLASS, INT. CLS. 5, 10 AND 17.
- DRI-IT CORPORATION, CEDAR PARK, TX:  
3,953,948, PUB. 2-15-2011. INT. CL. 1.
- DRIVERS S.A., CORDOBA, ARGENTINA:  
3,953,220, PUB. 11-9-2010. INT. CL. 39.
- DRL ENTERPRISES, INC., GLENVIEW, IL:  
3,956,013, INT. CL. 34.
- DRUM WORKSHOP, INC., OXNARD, CA:  
2,378,452, CANC. INT. CL. 15.
- DSW SHOE WAREHOUSE, INC., COLUMBUS, OH:  
3,955,825, INT. CL. 18.  
3,956,098, MULTIPLE CLASS, INT. CLS. 25 AND 35.
- DUARTE, ALEXANDRE, SANTA FE, NM:  
3,955,939, INT. CL. 41.
- DUBOIS CHEMICALS, INC., SHARONVILLE, OH:  
2,541,619, REN. 3-26-11. INT. CL. 3.
- DUDLEY PRODUCTS, INC., KERNERSVILLE, NC:  
2,875,849, CANC. INT. CL. 3.
- DUKE MANUFACTURING CO., ST. LOUIS, MO:  
274,575, REN. 3-31-11. U.S. CL. 13 (INT. CLS. 6, 7, 11, 17, 20 AND 21).  
275,715, REN. 3-31-11. U.S. CL. 32 (INT. CL. 20).
- DUKEJETS LLC, GREENWOOD VILLAGE, CO, DBA JET-VIZOR:  
3,953,229, PUB. 2-15-2011. INT. CL. 39.
- DUMB DUMB ENTERPRISES LLC, BEVERLY HILLS, CA:  
3,955,151, PUB. 2-15-2011. INT. CL. 41.



DUNAN CO., LTD, GYEONGGI-DO, REPUBLIC OF KOREA:  
3,953,545, PUB. 2-15-2011. INT. CL. 9.

DUNCAN MCINTOSH COMPANY, INC., IRVINE, CA:  
3,954,119, PUB. 2-15-2011. INT. CL. 16.

DUNHAM, PHILLIP, ARVADA, CO:  
3,955,413, INT. CL. 10.

DUNLEAVY, DAVID, CAPE MAY, NJ:  
3,954,049, PUB. 2-15-2011. INT. CL. 25.

DUNN-EDWARDS CORPORATION, LOS ANGELES, CA:  
3,955,433, INT. CL. 2.

DUNN, DENISE, M. SPANAWAY, WA, FORMERLY DUNN PAINTING:  
3,955,546, INT. CL. 25.

DUNNIGAN, TIMOTHY P., MIDLAND, GA:  
3,955,203, INT. CL. 16.

DUNNO INTERNATIONAL, INC., HIALEAH, FL:  
3,953,892, PUB. 2-15-2011. INT. CL. 11.

DUPREE, CRAWFORD MICHAEL, PALMDALE, CA:  
2,877,614, CANC. MULTIPLE CLASS, INT. CLS. 16 AND 25.

DURABLE SURFACE PRODUCTS COMPANY, SANTA MONICA, CA:  
2,876,627, CANC. INT. CL. 2.

DURAFLEAME, INC., STOCKTON, CA:  
1,660,481, REN. 3-31-11. INT. CL. 4.

DUSHAN WEGNER, HÜRTH, FED REP GERMANY:  
3,953,262, PUB. 2-15-2011. INT. CL. 41.

DUST FREE, INC., ROYCE CITY, TX, DUST FREE, INC., ROYCE CITY, TX:  
2,479,265, REN. 3-30-11. INT. CL. 11.

DUTZ TECHNOLOGIES LLC, SAN FRANCISCO, CA, DBA APPICKER:  
3,955,938, INT. CL. 35.

DUXBURY SYSTEMS, INC., WESTFORD, MA TO DUXBURY SYSTEMS, INC., WESTFORD, MA:  
2,378,528, CANC. INT. CL. 9.

DWL INCORPORATED, TORONTO, ONTARIO, CANADA:  
2,876,089, CANC. MULTIPLE CLASS, INT. CLS. 9 AND 35.

DYECOO TEXTILE SYSTEMS B.V., NL-1382 KB WEESP, NETHERLANDS:  
3,953,656, PUB. 2-15-2011. INT. CL. 7.

DYNAFLAIR CORPORATION CANADA INC., QUEBEC, H9R 3Y2, CANADA:  
2,378,704, CANC. INT. CL. 6.

DYNAMIC AIR INC., ST. PAUL, MN:  
2,487,164, REN. 3-26-11. INT. CL. 7.

DYNAMIC DESIGN PTY LTD, AUSTRALIA:  
3,953,581, PUB. 2-15-2011. INT. CL. 21.

DYNAMICLOGIC, INC., NEW YORK, NY:  
2,438,309, REN. 3-26-11. INT. CL. 42.

DYNARIC, INC., VIRGINIA BEACH, VA:  
2,463,460, REN. 3-30-11. INT. CL. 7.

DYNASLIM LLC, BATAVIA, IL:  
2,876,572, CANC. INT. CL. 5.

D4 MEDIA, INC., IRVINE, CA:  
3,955,689, INT. CL. 42.

E & G FRANCHISE SYSTEMS, INC., EAU CLAIRE, WI:  
2,877,572, CANC. INT. CL. 43.

E & H DISTRIBUTING, LLC, ROSEMONT, IL:  
3,953,965, PUB. 2-15-2011. INT. CL. 30.  
3,953,969, PUB. 2-15-2011. INT. CL. 30.

E S ROBBINS CORPORATION, MUSCLE SHOALS, AL:  
3,955,852, INT. CL. 30.

E. LEAD ELECTRONIC CO., LTD., CHANGHUA, TAIWAN:  
2,491,684, REN. 3-28-11. INT. CL. 9.

E. REMY MARTIN & CO. S.A., 16100 COGNAC, FRANCE:  
2,875,925, CANC. MULTIPLE CLASS, INT. CLS. 16, 38, 41 AND 42.

E.S. ORIGINALS, INC., NEW YORK, NY:  
3,955,243, INT. CL. 25.

E.T. BROWNE DRUG CO., INC., ENGLEWOOD CLIFFS, NJ:  
3,955,909, INT. CL. 3.

E! ENTERTAINMENT TELEVISION, INC., LOS ANGELES, CA:  
2,876,717, CANC. INT. CL. 41.  
3,953,013, PUB. 2-15-2011. INT. CL. 35.

E-TERRA, LLC, ANCHORAGE, AK:  
2,875,879, CANC. INT. CL. 42.

E-Z FLOSS, SOLANA BEACH, CA, E-Z FLOSS, PALM SPRINGS, CA:  
908,125, REN. 3-31-11. U.S. CL. 44 (INT. CL. 10).

EA INTERNATIONAL (STUDIO AND PUBLISHING) LTD., HAMILTON, BERMUDA:  
3,955,334, INT. CL. 9.  
3,955,336, INT. CL. 28.

EARLY WARNING SERVICES, LLC, SCOTTSDALE, AZ:  
2,876,389, CANC. MULTIPLE CLASS, INT. CLS. 35, 36 AND 42.

EARLYCHILDHOOD, MONTEREY, CA, DBA DISCOUNT SCHOOL SUPPLY:  
2,546,548, REN. 3-29-11. INT. CL. 16.

EARTHRISE NUTRITIONALS, IRVINE, CA, EARTHRISE FARMS, SANTA FE SPRINGS, CA:  
1,677,306, REN. 3-31-11. INT. CL. 5.

EAST OF CHICAGO PIZZA COMPANY, WILLARD, OH:  
2,876,428, CANC. INT. CL. 30.

EAST WEST MORTGAGE CO., INC., MCLEAN, VA:  
2,379,527, CANC. INT. CL. 36.

EASTERN BEAUTY CO., LTD., TAIPEI, TAIWAN TO NATURAL BEAUTY COSMETICS CO., LTD., TAIPEI, TWX R.O.C., TAIWAN:  
1,551,555, CANC. MULTIPLE CLASS, INT. CLS. 3 AND 41.

EASTMAN OUTDOORS, INC., FLUSHING, MI:  
3,954,445, PUB. 2-15-2011. INT. CL. 28.  
3,954,647, PUB. 2-15-2011. INT. CL. 28.  
3,955,109, PUB. 2-15-2011. INT. CL. 28.

EASTON SPORTS, INC., VAN NUYS, CA:  
2,876,895, CANC. INT. CL. 28.

EASTWOOD, CLINT, LOS ANGELES, CA:  
2,480,486, REN. 3-26-11. INT. CL. 25.

EASY GARDENER PRODUCTS, INC., WACO, TX:  
3,956,169, INT. CL. 22.

EASY GARDENER PRODUCTS, LTD., WACO, TX:  
1,664,643, REN. 3-25-11. INT. CL. 1.

EASY TELECOMMUNICATIONS, PHOENIX, AZ:  
2,877,453, CANC. INT. CL. 16.

EATING WELL, INC., CHARLOTTE, VT:  
3,953,818, PUB. 2-15-2011. MULTIPLE CLASS, INT. CLS. 9, 16 AND 41.  
3,953,831, PUB. 2-15-2011. INT. CL. 16.

EATON INDUSTRIES GMBH, BONN, FED REP GERMANY:  
2,424,180, REN. 3-29-11. MULTIPLE CLASS, INT. CLS. 9, 37, 41 AND 42.

EATON, JOANNE MAREE, MARLBOROUGH, NEW ZEALAND AND EATON, MICHAEL DOUGLAS, MARLBOROUGH, NEW ZEALAND:  
3,955,044, PUB. 2-15-2011. INT. CL. 33.

EATSTRONG, LLC, NEW YORK, NY:  
3,954,474, PUB. 2-15-2011. INT. CL. 44.

EAZYPOWER CORPORATION, CHICAGO, IL:  
3,954,983, PUB. 2-15-2011. MULTIPLE CLASS, INT. CLS. 7 AND 8.  
3,954,989, PUB. 2-15-2011. MULTIPLE CLASS, INT. CLS. 7 AND 8.

EBM-PAPST ST. GEORGEN GMBH & CO. KG, ST. GEORGEN, FED REP GERMANY:  
2,440,033, REN. 3-28-11. INT. CL. 9.

EBSCO INDUSTRIES, INC., BIRMINGHAM, AL:  
2,537,933, REN. 3-29-11. INT. CL. 16.

ECHL, INC., PRINCETON, NJ:  
2,423,088, REN. 3-31-11. INT. CL. 41.

ECKERD CORPORATION, LARGO, FL:  
2,876,611, CANC. INT. CL. 44.

ECLAIRAGE CONTRASTE M.L. INC., ST. JEAN CHRYSOSOTOME, QUEBEC, CANADA:  
2,877,347, CANC. INT. CL. 11.

ECMD, INC., NORTH WILKESBORO, NC:  
2,876,646, CANC. INT. CL. 35.

ECOLAB INC., ST. PAUL, MN:  
2,949,737, AM. INT. CL. 3.

ECOMPANYSTORE, INC., ALPHARETTA, GA:  
3,955,631, INT. CL. 16.

- ECOMPEX, INC., MCLEAN, VA:  
3,953,237, PUB. 2-15-2011. INT. CL. 9.
- ECONOMICS RESEARCH ASSOCIATES, LOS ANGELES, CA:  
2,186,889, CANC. MULTIPLE CLASS, INT. CLS. 35 AND 36.
- ECOPARADISE CO., LTD., SUGINAME-KU, TOKYO, JAPAN:  
3,955,641, INT. CL. 21.
- EDC LICENSING, INC., WILMINGTON, DE:  
2,379,627, CANC. INT. CL. 42.
- EDDIE BAUER LICENSING SERVICES LLC, BELLEVUE, WA:  
2,875,848, CANC. INT. CL. 25.
- EDDY & MARTIN GOLDFARB AND ASSOCIATES, LLC, LOS ANGELES, CA:  
1,677,745, REN. 3-26-11. INT. CL. 28.
- EDELMAN, INC., CHICAGO, IL:  
3,955,076, PUB. 2-15-2011. INT. CL. 35.
- EDGEWATER TECHNOLOGY, INC., WAKEFIELD, MA:  
3,953,895, PUB. 2-15-2011. MULTIPLE CLASS, INT. CLS. 16, 35, 41 AND 42.
- EDI HEALTH GROUP, INC., IRVINE, CA, DBA DENTALX-CHANGE:  
3,953,316, PUB. 2-15-2011. INT. CL. 36.
- EDITION DIFFUSION PRESSE SCIENCES, LES ULIS, FRANCE:  
2,439,812, REN. 3-29-11. MULTIPLE CLASS, INT. CLS. 9, 16 AND 41.
- EDUCATIONAL CONCEPTS, LLC, TULSA, OK:  
2,878,047, CANC. INT. CL. 16.
- EDUCATIONAL TESTING SERVICE, PRINCETON, NJ:  
3,953,133, PUB. 2-15-2011. MULTIPLE CLASS, INT. CLS. 9 AND 16.
- EDWARD B. OLSZEWSKI, GLENWOOD SPRINGS, CO:  
3,954,913, PUB. 2-15-2011. INT. CL. 14.
- EF CULTURAL TOURS SARL, ZUG BRANCH, 6301 ZUG, SWITZERLAND:  
2,387,273, REN. 3-29-11. MULTIPLE CLASS, INT. CLS. 39 AND 42.
- EFFRON, MARVIN TANNER, ORLANDO, FL:  
3,955,353, INT. CL. 9.
- EGAMES, INC., LANGHORNE, PA:  
2,877,875, CANC. INT. CL. 9.  
2,877,876, CANC. INT. CL. 9.
- EGLOBAL BEAUTE, INC., INDUSTRY, CA:  
3,955,479, INT. CL. 3.
- EGS ELECTRICAL GROUP, LLC, ROSEMONT, IL, MCGILL MANUFACTURING COMPANY, INC., VALPARAISO, IN:  
539,304, REN. 3-31-11. U.S. CL. 23 (INT. CL. 8).
- EH EUROPE GMBH, ZURICH, SWITZERLAND:  
3,953,246, PUB. 2-15-2011. INT. CL. 9.
- EICHEN, MITCHELL D., MORRISTOWN, NJ:  
3,955,047, PUB. 2-15-2011. INT. CL. 36.  
3,955,048, PUB. 2-15-2011. INT. CL. 36.
- EID PASSPORT, INC., BEAVERTON, OR:  
2,877,440, CANC. INT. CL. 9.
- EIGES & EIGES PC, NEW YORK, NY:  
1,976,820, CANC. INT. CL. 42.
- EIKO ELECTRIC PRODUCTS CORP., TAIPEI 114, TAIWAN:  
3,955,432, MULTIPLE CLASS, INT. CLS. 7 AND 21.
- EKA CHEMICALS INC., MARIETTA, GA:  
2,437,086, REN. 3-28-11. INT. CL. 1.
- EKIN GROUP, LLC, GARLAND, TX:  
3,130,639, AM. INT. CL. 3.
- EKSTRÖM, CARL, RANCHO SANTA FE, CA:  
3,954,667, PUB. 2-15-2011. INT. CL. 28.
- EL DORADO FURNITURE CORPORATION, MIAMI, FL:  
2,405,984, REN. 3-31-11. INT. CL. 16.
- EL MUNDO SPA, ITALY:  
3,953,585, PUB. 2-15-2011. MULTIPLE CLASS, INT. CLS. 32 AND 43.
- EL-GEN LLC, BOHEMIA, NY, DBA ALIMENTAL SCIENCE:  
3,955,574, INT. CL. 5.
- ELBIT SYSTEMS LTD., HAIFA 31053, ISRAEL:  
3,953,140, PUB. 2-15-2011. INT. CL. 9.
- ELDERHOSTEL, INC., BOSTON, MA:  
2,877,979, CANC. INT. CL. 39.
- ELECTION SYSTEMS & SOFTWARE, INC., OMAHA, NE:  
2,443,473, REN. 3-31-11. INT. CL. 9.  
2,443,474, REN. 3-31-11. INT. CL. 9.  
2,452,064, REN. 3-25-11. INT. CL. 9.
- ELECTRIC MIRROR, LLC, EVERETT, WA:  
3,953,429, PUB. 2-15-2011. INT. CL. 9.  
3,953,431, PUB. 2-15-2011. INT. CL. 11.  
3,953,432, PUB. 2-15-2011. INT. CL. 20.
- ELECTROENGINE IN SWEDEN AB, SWEDEN:  
3,953,610, PUB. 2-15-2011. MULTIPLE CLASS, INT. CLS. 7, 9, 12, 37, 40 AND 42.
- ELECTRONIC ACCESS DATA TECHNOLOGIES, INC., EAST PRAIRIE, MO:  
2,876,777, CANC. INT. CL. 9.
- ELECTRONIC CONNECTOR CORPORATION OF ILLINOIS, CHICAGO, IL, DBA ELECTRONIC CONNECTOR CORP.:  
3,954,192, PUB. 2-15-2011. INT. CL. 35.
- ELECTRONIC DATA ACCESS TECHNOLOGIES, INC., EAST PRAIRIE, MO:  
2,876,776, CANC. INT. CL. 42.
- ELECTRONIC DATA SYSTEMS CORPORATION, PLANO, TX:  
2,876,012, CANC. MULTIPLE CLASS, INT. CLS. 9, 35 AND 42.
- ELEMATICS INC., BEAVERTON, OR:  
2,877,191, CANC. INT. CL. 9.
- ELEMENT POWER HOLDINGS, LP, EDINBURGH EH3 9WJ, UNITED KINGDOM:  
3,953,116, PUB. 1-25-2011. MULTIPLE CLASS, INT. CLS. 4, 36, 37, 39, 40 AND 42.
- ELEMICA, INC., WAYNE, PA:  
2,875,898, CANC. MULTIPLE CLASS, INT. CLS. 9 AND 42.  
2,875,899, CANC. MULTIPLE CLASS, INT. CLS. 9 AND 42.
- ELESAR HOLDINGS, LLC, TUCSON, AZ:  
3,956,253, INT. CL. 25.
- ELI LILLY AND COMPANY, INDIANAPOLIS, IN:  
3,955,755, INT. CL. 10.
- ELITE INVESTMENT PORTFOLIO, LLC, MIAMI BEACH, FL:  
3,953,314, PUB. 2-15-2011. MULTIPLE CLASS, INT. CLS. 35 AND 38.
- ELIZABETH CARLSON, CHICAGO, IL:  
3,953,939, PUB. 2-15-2011. INT. CL. 35.
- ELIZABETH GLASER PEDIATRIC AIDS FOUNDATION, WASHINGTON, DC:  
2,487,510, REN. 3-28-11. INT. CL. 42.
- ELKAMET KUNSTSTOFFTECHNIK GMBH, BIEDENKOPF, FED REP GERMANY:  
3,955,715, MULTIPLE CLASS, INT. CLS. 17 AND 20.
- ELLINGTON, MERCER K., NEW YORK, NY:  
1,677,101, REN. 3-25-11. INT. CL. 41.
- ELLIS, ATHENA, HAWTHORN, VICTORIA, AUSTRALIA AND ELLIS, JOHN, C., HAWTHORN, VICTORIA, AUSTRALIA:  
2,877,161, CANC. INT. CL. 33.
- ELMASSIAN, DIKRAN A., MONROVIA, CA, DBA SIENA SILVER AND ANTONIS DEVES, MONROVIA, CA, DBA SIENA SILVER:  
3,953,373, PUB. 2-15-2011. INT. CL. 14.
- ELMER'S PRODUCTS, INC., COLUMBUS, OH:  
3,953,858, PUB. 2-15-2011. MULTIPLE CLASS, INT. CLS. 1 AND 16.
- ELMHURST ECONOMIC DEVELOPMENT CORPORATION, ELMHURST, IL:  
2,877,498, CANC. INT. CL. 35.
- ELSTON, MICHAEL D, WARNER ROBINS, GA:  
2,877,203, CANC. INT. CL. 39.
- ELTEX U.S., INCORPORATED, GREER, SC, AB ALMHULTS ELTEX, S-343 00 ALMHULT, SWEDEN:  
910,368, REN. 3-26-11. U.S. CL. 21 (INT. CL. 9).
- ELVIS PRESLEY ENTERPRISES, INC., MEMPHIS, TN:  
3,953,047, PUB. 2-15-2011. INT. CL. 25.
- ELYCE MONET, ARCADIA, CA:  
3,953,805, PUB. 2-15-2011. INT. CL. 41.
- EMBASSY CARGO, INC., ROSEDALE, NY:  
2,492,282, REN. 3-31-11. INT. CL. 39.

EMBO-OPTICS, LLC, GLOUCESTER, MA:  
2,876,773, CANC. INT. CL. 10.

EMC CORPORATION, HOPKINTON, MA:  
3,955,033, PUB. 2-15-2011. INT. CL. 9.

EME ENTERPRISE, INC., UNION CITY, CA:  
2,876,778, CANC. INT. CL. 5.

EMERALD HOME FURNISHINGS, LLC, TACOMA, WA:  
2,481,802. REN. 3-26-11. INT. CL. 20.

EMERGENCY MEDICAL ASSOCIATES OF NEW JERSEY,  
LIVINGSTON, NJ:  
3,954,417, PUB. 2-15-2011. INT. CL. 44.  
3,955,132, PUB. 2-15-2011. INT. CL. 44.  
3,955,133, PUB. 2-15-2011. INT. CL. 42.  
3,955,134, PUB. 2-15-2011. INT. CL. 44.

EMERIS TECHNOLOGIES, 60160 MONTATAIRE, FRANCE:  
2,875,976, CANC. MULTIPLE CLASS, INT. CLS. 9 AND  
38.

EMERSON ELECTRIC CO., ST. LOUIS, MO:  
2,462,087. REN. 3-30-11. INT. CL. 7.

EMINDFUL INC., VERO BEACH, FL:  
3,954,574, PUB. 2-15-2011. INT. CL. 41.

EMPEREX CORPORATION, MISSISSAUGA, ONTARIO,  
CANADA:  
2,497,408. REN. 3-28-11. INT. CL. 9.

EMS-CHEMIE AG, CH-7013 DOMAT/EMS, SWITZERLAND,  
EMSER WERKE A.G., 7013 DOMAT/EMS, SWITZER-  
LAND:  
911,878. REN. 3-30-11. U.S. CL. 1 (INT. CLS. 1, 3, 4, 17, 18,  
19, 22 AND 31).

ENAP, INC., NEW WINDSOR, NY:  
2,434,687. REN. 3-26-11. INT. CL. 19.

ENCOMPASS GROUP, LLC, MCDONOUGH, GA:  
3,955,442, INT. CL. 10.

ENDECA TECHNOLOGIES, INC., CAMBRIDGE, MA:  
2,876,372, CANC. INT. CL. 9.

ENDGAME ENTERPRISES, LLC, WESTMINSTER, CO:  
3,955,845, MULTIPLE CLASS, INT. CLS. 6, 21, 25, 26, 35  
AND 41.

ENERGETIC NUTRITION, INC., AUBURN, CA:  
3,953,480, PUB. 2-15-2011. INT. CL. 3.

ENERGY ANSWERS INTERNATIONAL, INC., ALBANY,  
NY:  
2,468,684. REN. 3-26-11. INT. CL. 19.

ENERGY MEDICINE DEVELOPMENTS (NORTH AMERI-  
CA) INC., VANCOUVER, CANADA:  
2,414,976. REN. 3-28-11. INT. CL. 10.

ENGINEERING FITNESS INTERNATIONAL CORP., SAN  
DIEGO, CA, DBA TOTAL GYM, EFI, EFI MEDICAL  
SYSTEMS:  
3,955,899, INT. CL. 28.  
3,955,900, INT. CL. 28.

ENGQUEST CONSULTING INC, NORCROSS, GA:  
3,955,499, INT. CL. 42.

ENJOY THE GAME, INC., BLUE SPRINGS, MO:  
2,379,692, CANC. INT. CL. 41.

ENSWORTH SCHOOL, THE, NASHVILLE, TN:  
2,372,248. REN. 3-28-11. MULTIPLE CLASS, INT. CLS. 16,  
25 AND 41.

ENTEC POLYMERS, LLC, ORLANDO, FL:  
3,953,801, PUB. 2-15-2011. INT. CL. 17.

ENTELOS, INC., FOSTER CITY, CA:  
2,877,612, CANC. INT. CL. 42.  
2,877,613, CANC. INT. CL. 42.

ENTERPRISE HIVE, LLC, IRVINGTON, VA:  
3,956,155, INT. CL. 42.

ENTRAVISION COMMUNICATIONS CORPORATION,  
SANTA MONICA, CA:  
2,876,677, CANC. INT. CL. 38.  
2,876,791, CANC. INT. CL. 41.

ENVASES DEL VALLES, S.A., BARCELONA, SPAIN:  
2,877,323, CANC. MULTIPLE CLASS, INT. CLS. 17 AND  
20.

ENVIEW TECHNOLOGIES, LLC, MONTPELIER, OH:  
3,954,584, PUB. 2-15-2011. INT. CL. 42.

ENVIRONMENTS, INC., BEAUFORT, SC:  
2,437,945. REN. 3-25-11. MULTIPLE CLASS, INT. CLS. 16,  
35 AND 41.

ENVIROS CONSULTING LIMITED, WOLVERHAMPTON,  
UNITED KINGDOM:  
2,875,937, CANC. MULTIPLE CLASS, INT. CLS. 9, 40  
AND 42.

ENVIROSUPPLY & SERVICE, INC., IRVINE, CA:  
2,378,831, CANC. INT. CL. 35.

ENZO BIOCHEM, INC., FARMINGDALE, NY:  
2,438,073. REN. 3-28-11. MULTIPLE CLASS, INT. CLS. 1  
AND 5.

EP ACQUISITION, INC., CALEDONIA, MI:  
2,486,900. REN. 3-29-11. INT. CL. 9.

EPANA NETWORKS INC., NEW YORK, NY:  
2,877,435, CANC. MULTIPLE CLASS, INT. CLS. 16 AND  
38.  
2,877,436, CANC. MULTIPLE CLASS, INT. CLS. 16 AND  
38.  
2,877,547, CANC. MULTIPLE CLASS, INT. CLS. 16 AND  
38.

EPIC AVIATION, LLC, SALEM, OR:  
2,876,045, CANC. INT. CL. 39.

EPIC DATA INTERNATIONAL, INC., RICHMOND, BC,  
CANADA:  
3,953,911, PUB. 2-15-2011. MULTIPLE CLASS, INT. CLS. 9  
AND 16.

EPIC PRODUCTS INC., SANTA ANA, CA:  
3,953,222, PUB. 11-9-2010. INT. CL. 21.

EPIC SEARCH, LLC, NEW YORK, NY:  
2,877,315, CANC. INT. CL. 35.

EPROSTACK, BOULDER, CO:  
2,877,571, CANC. INT. CL. 9.

EQUALSURANCE HOLDINGS, LLC, RICHMOND  
HEIGHTS, OH:  
3,954,828, PUB. 2-15-2011. MULTIPLE CLASS, INT. CLS.  
35 AND 36.

EQUITACION Y CAZA, S.A., 7, SEVILLA, SPAIN:  
2,379,108, CANC. INT. CL. 18.

EQUITY MORTGAGE BANKERS LLC, CORAL GABLES,  
FL:  
3,954,210, PUB. 2-15-2011. INT. CL. 36.

ERIC J. HERBIG, SEATTLE, WA:  
3,955,801, INT. CL. 41.

ERICO INTERNATIONAL CORPORATION, SOLON, OH:  
1,155,299. REN. 3-26-11. INT. CL. 6.  
1,639,613. REN. 3-25-11. INT. CL. 9.

ERIE BRUSH & MANUFACTURING CORP., CHICAGO, IL:  
2,380,080, CANC. INT. CL. 21.

ERNST PAUL LEHMANN PATENTWERK, D-90475 NURN-  
BERG, FED REP GERMANY:  
2,876,331, CANC. MULTIPLE CLASS, INT. CLS. 28 AND  
35.

ERNST PAUL LEHMANN PATENTWERK, D-90475 NUM-  
BERG, FED REP GERMANY:  
2,876,332, CANC. MULTIPLE CLASS, INT. CLS. 28 AND  
35.

ERNST PAUL LEHMANN PATENTWERK, D-90475 NURN-  
BERG, FED REP GERMANY:  
2,876,333, CANC. MULTIPLE CLASS, INT. CLS. 28 AND  
35.

ESALONSPACE, LLC, SOUTHFIELD, MI:  
3,953,737, PUB. 2-15-2011. INT. CL. 35.

ESCO, LLC, IRVINE, CA:  
2,875,977, CANC. INT. CL. 35.

ESOTERIX, INC., AUSTIN, TX:  
2,876,725, CANC. INT. CL. 42.

ESPHION LIMITED, AUCKLAND, NEW ZEALAND:  
2,877,330, CANC. INT. CL. 9.

ESQ BUSINESS SERVICES, INC., CUPERTINO, CA:  
1,993,280, CANC. INT. CL. 9.

ESSEN NUTRITION CORPORATION, ROMEOVILLE, IL:  
3,955,171, INT. CL. 5.

ESTAR NETWORK, LLC, EVANSVILLE, IN:  
2,876,821, CANC. INT. CL. 35.  
2,876,822, CANC. INT. CL. 35.  
2,876,823, CANC. INT. CL. 35.  
2,876,824, CANC. INT. CL. 35.

ET AL, INC., OLEAN, NY, DBA IDRESPONSE:  
2,877,327, CANC. INT. CL. 45.

- ETABLISSEMENTS MAGYAR, DIJON, FRANCE:  
3,953,497, PUB. 2-15-2011. MULTIPLE CLASS, INT. CLS.  
6, 7, 9, 11, 12, 37, 39 AND 40.
- ETC VENUES LIMITED, UNITED KINGDOM:  
3,953,527, PUB. 2-15-2011. MULTIPLE CLASS, INT. CLS.  
41 AND 43.
- ETHAN NUTRACEUTICAL LIMITED TAIWAN BRANCH,  
TAIPEI, TAIWAN:  
3,956,047, INT. CL. 5.
- ETHERIDGE, DIANA C., MERRITT ISLAND, FL:  
2,428,096, REN. 3-26-11. INT. CL. 9.  
2,429,431, REN. 3-26-11. INT. CL. 9.  
2,429,432, REN. 3-26-11. INT. CL. 9.  
2,436,476, REN. 3-26-11. INT. CL. 9.
- ETHICAL DENTAL LABORATORY ALLIANCE OF AMER-  
ICA, LTD., WEST HEMPSTEAD, NY:  
3,953,981, PUB. 2-15-2011. INT. CL. 36.
- ETUNK SOLUTIONS, LLC, FITCHBURG, WI, DBA ETUNK  
SOLUTIONS, LLC:  
3,953,441, PUB. 2-15-2011. INT. CL. 19.  
3,953,459, PUB. 2-15-2011. INT. CL. 19.
- ETW CORP., CLEVELAND, OH:  
2,442,618, REN. 3-26-11. INT. CL. 41.
- EURO-PRO OPERATING LLC, NEWTON, MA:  
2,877,532, CANC. INT. CL. 7.
- EUROCHOC AMERICAS CORPORATION, CLEARWATER,  
FL:  
2,877,456, CANC. INT. CL. 29.
- EUROMED USA INC, PRESTO, PA:  
3,955,979, INT. CL. 1.
- EURONEXT INDICES B.V., 1012 JW AMSTERDAM, NETH-  
ERLANDS:  
2,875,950, CANC. MULTIPLE CLASS, INT. CLS. 35, 36  
AND 41.  
2,875,951, CANC. MULTIPLE CLASS, INT. CLS. 35, 36  
AND 41.
- EUROPEAN BEVERAGE COMPANY, INC., CHATSWORTH,  
CA TO DIDELOW, PATRICIA, CHATSWORTH, CA:  
1,966,018, CANC. INT. CL. 33.
- EUROPEAN COSMETIC GROUP, INC., NEW YORK, NY:  
2,876,674, CANC. INT. CL. 3.
- EUROPEAN SCHOOL OF ONCOLOGY, 20122 MILANO,  
ITALY:  
2,876,033, CANC. INT. CL. 41.
- EUROTEKNIKA, FRANCE:  
3,953,596, PUB. 2-15-2011. INT. CL. 10.  
3,953,597, PUB. 2-15-2011. INT. CL. 10.  
3,953,598, PUB. 2-15-2011. INT. CL. 10.  
3,953,600, PUB. 2-15-2011. INT. CL. 10.
- EUTECHIC SERVICES, ROUND ROCK, TX:  
3,954,742, PUB. 2-15-2011. INT. CL. 37.
- EVA-MARIA FABI, D - 81925, MUNICH, FED REP GER-  
MANY:  
3,953,738, PUB. 2-15-2011. INT. CL. 35.
- EVANGELICAL LUTHERAN CHURCH IN AMERICA, CHI-  
CAGO, IL:  
2,447,575, REN. 3-30-11. INT. CL. 35.
- EVANS NEWTON INCORPORATED, SCOTTSDALE, AZ:  
2,876,792, CANC. INT. CL. 16.
- EVANS, GWENDOLYN LENORA W, SAN MARCOS, CA:  
3,954,895, PUB. 2-15-2011. MULTIPLE CLASS, INT. CLS.  
44 AND 45.
- EVEN WEIGHT BRUSH, LLC, GILLETT, WI:  
3,929,551, COR. INT. CL. 21.
- EVENT 1, INC., LENEXA, KS:  
2,431,493, REN. 3-31-11. INT. CL. 35.
- EVENTGRABBER IP, LLC, ORLANDO, FL:  
3,954,649, PUB. 2-15-2011. INT. CL. 35.
- EVENTSCAPE INC., TORONTO, ONTARIO, CANADA:  
3,954,689, PUB. 2-15-2011. INT. CL. 40.
- EVENTSTYLE, INC., NEW YORK, NY:  
2,877,580, CANC. INT. CL. 35.  
2,877,581, CANC. INT. CL. 35.
- EVERBANK, JACKSONVILLE, FL:  
3,954,089, PUB. 2-15-2011. INT. CL. 41.  
3,955,082, PUB. 2-15-2011. INT. CL. 41.
- EVERHII ILLUMINATION LLC, RANDOLPH, MA:  
3,956,086, INT. CL. 11.
- EVERLAST CLIMBING INDUSTRIES, INC., CHATTANOO-  
GA, TN:  
3,955,571, INT. CL. 2.
- EVERLOOP, INC., DANVILLE, CA:  
3,955,731, INT. CL. 38.  
3,955,732, INT. CL. 41.  
3,955,733, INT. CL. 45.
- EVERY ORPHAN'S HOPE, FRISCO, TX:  
2,876,545, CANC. INT. CL. 36.
- EVMS CONSULTING GROUP, LLC, LEESBURG, VA:  
3,953,413, PUB. 2-15-2011. INT. CL. 35.
- EVOLVE GUEST CONTROLS, INC., NEW HYDE PARK, NY:  
3,955,322, MULTIPLE CLASS, INT. CLS. 9 AND 37.
- EVOLVE 24/7, LLC, VANCOUVER, WA, DBA WEBFOR:  
3,954,421, PUB. 2-15-2011. INT. CL. 35.
- EVONIK STOCKHAUSEN GMBH, KREFELD 47805, FED  
REP GERMANY:  
2,875,962, CANC. MULTIPLE CLASS, INT. CLS. 1, 5 AND  
42.
- EVRIHOLDER PRODUCTS LLC, ANAHEIM, CA:  
3,956,002, INT. CL. 21.
- EXCLAIM HOLDINGS, LLC, DALLAS, TX:  
3,955,963, INT. CL. 25.
- EXCLUSIVE SUPPLEMENTS, INC., CORAOPOLIS, PA, DBA  
BIORYTHM - ADVANCED DIETARY SUPPLEMENTS:  
3,953,946, PUB. 2-15-2011. INT. CL. 5.
- EXECUTIVE MACHINES, INC., BROOKLYN, NY:  
3,955,269, INT. CL. 16.
- EXECUTIVE SOFTWARE INTERNATIONAL, INC., BUR-  
BANK, CA:  
2,439,010, CANC. INT. CL. 9.
- EXEL, INC., WESTERVILLE, OH:  
2,386,629, REN. 3-31-11. INT. CL. 36.
- EXELON, INC., GLENDALE, CA:  
3,954,533, PUB. 2-15-2011. INT. CL. 35.
- EXHIBIT EDGE INC., CHANTILLY, VA:  
2,441,363, REN. 3-30-11. MULTIPLE CLASS, INT. CLS. 37,  
39 AND 42.
- EXHIBIT WORKS, INC., LIVONIA, MI, DBA EWI WORLD-  
WIDE:  
3,954,135, PUB. 2-15-2011. INT. CL. 35.  
3,954,138, PUB. 2-15-2011. INT. CL. 35.
- EXOTIC TANS INTERNATIONAL, INC., WARWICK, RI:  
2,379,427, CANC. INT. CL. 42.
- EXOWEB LIMITED, BEIJING, CHINA:  
3,954,289, PUB. 2-15-2011. INT. CL. 9.
- EXPANDER AMERICAS INC., SEDONA, AZ:  
2,878,073, CANC. INT. CL. 6.
- EXPERIENCEENGINEERING, INC., MINNEAPOLIS, MN:  
2,394,020, REN. 3-26-11. INT. CL. 35.
- EXPERT ADVOCATES IN SELECTION INTERNATIONAL,  
LLC, ST. LOUIS, MO:  
3,954,716, PUB. 2-15-2011. INT. CL. 35.
- EXPLORE GREEN, LLC, ST. LOUIS, MO:  
3,954,943, PUB. 2-15-2011. MULTIPLE CLASS, INT. CLS.  
35 AND 41.
- EXPORT OPE'S, L.L.C., PORTAGE, MI:  
3,954,076, PUB. 2-15-2011. MULTIPLE CLASS, INT. CLS.  
29 AND 30.
- EXPRESS FRANCHISE SERVICES, L.P., OKLAHOMA CITY,  
OK:  
2,877,119, CANC. MULTIPLE CLASS, INT. CLS. 37, 39, 41  
AND 45.
- EXPRESS, LLC, COLUMBUS, OH:  
3,953,464, PUB. 2-15-2011. MULTIPLE CLASS, INT. CLS.  
18 AND 25.
- EXTRA SENSORY PRODUCTIONS, DOSWELL, VA:  
1,546,796, REN. 3-30-11. INT. CL. 41.
- EXTREME PRODUCTS, INC., HUNTERSVILLE, NC:  
2,877,616, CANC. MULTIPLE CLASS, INT. CLS. 10 AND  
21.
- EXXON MOBIL CORPORATION, IRVING, TX:  
1,181,782, REN. 3-29-11. INT. CL. 4.
- EXXON MOBIL CORPORATION, IRVING, TX, MOBIL OIL  
CORPORATION, NEW YORK, NY:  
1,182,239, REN. 3-31-11. INT. CL. 25.
- EYEMED TECHNOLOGIES S.R.L., ITALY:  
3,953,489, PUB. 2-15-2011. INT. CL. 9.

EZ-SPOT-UR, INC., FARGO, ND:  
2,437,149. REN. 3-26-11. INT. CL. 7.

EZPNP TECHNOLOGIES CORP., TAIPEI, TAIWAN:  
2,876,501. CANC. INT. CL. 9.

F L NAVARRO LTD, BROOKLYN, NY, DBA THE ARTISAN COLLECTION:  
3,955,470. INT. CL. 33.

F. GAVINA & SONS, INC., VERNON, CA:  
2,442,024. REN. 3-30-11. INT. CL. 30.

FABASOFT AG, LINZ, AUSTRIA:  
2,877,834. CANC. MULTIPLE CLASS, INT. CLS. 9, 37, 41 AND 42.

FABIAN COLUSSI SILVA, BUENOS AIRES, ARGENTINA:  
3,955,996. INT. CL. 9.

FABRICAS DE BOTAS BULL RIDER, S.A. DE C.V., NUEVO LEON, MEXICO:  
2,877,710. CANC. INT. CL. 25.

FABRICTECH 2000, LLC, CEDAR GROVE, NJ:  
3,956,097. INT. CL. 24.

FADDIS & FADDIS, P.A., CASSELBERRY, FL:  
3,954,500. PUB. 2-15-2011. INT. CL. 45.

FAIRLY ODD TREASURES, LLC., HARRISBURG, NC, DBA ABSORBENT INDUSTRIES:  
3,954,013. PUB. 2-15-2011. INT. CL. 1.

FAITH BAPTIST CHURCH, YOUNGSVILLE, NC:  
2,877,909. CANC. INT. CL. 41.

FALCON SOLUTIONS, LLC, ROSWELL, GA:  
2,876,497. CANC. MULTIPLE CLASS, INT. CLS. 35 AND 36.

FANIMATION, INC., ZIONSVILLE, IN:  
2,440,548. REN. 3-31-11. INT. CL. 11.  
2,441,794. REN. 3-28-11. INT. CL. 11.  
2,458,665. REN. 3-31-11. INT. CL. 11.

FANNIE MAY CONFECTIONS, INC., CANTON, OH, FANNIE MAY CANDY SHOPS, INC., CHICAGO, IL:  
1,607,576. REN. 3-29-11. INT. CL. 30.

FANTASIA INDUSTRIES CORPORATION, PARAMUS, NJ:  
2,489,455. REN. 3-29-11. INT. CL. 3.

FAREPORTAL, INC., NEW YORK, NY:  
3,953,686. PUB. 2-15-2011. MULTIPLE CLASS, INT. CLS. 35, 39 AND 43.

FARLEY'S & SATHERS CANDY CO., INC., ROUND LAKE, MN:  
2,154,355. CANC. INT. CL. 30.

FARLEY'S & SATHERS CANDY COMPANY, INC., ROUND LAKE, MN:  
914,107. REN. 3-31-11. U.S. CL. 46 (INT. CL. 30).

FARM FINANCIAL STANDARDS COUNCIL, OMAHA, NE:  
2,436,196. REN. 3-26-11. INT. CL. 42.

FARMERS SUPPLY CO. OF DINUBA, INC., REEDLEY, CA:  
2,067,948. CANC. INT. CL. 31.

FAROLAB GMBH, SWITZERLAND:  
3,953,576. PUB. 2-15-2011. INT. CL. 9.

FAROUK SYSTEMS, INC., HOUSTON, TX:  
3,953,089. PUB. 2-15-2011. INT. CL. 3.  
3,956,124. INT. CL. 3.

FASHION CENTER DISTRICT MANAGEMENT ASSOCIATION, INC., NEW YORK, NY:  
3,953,832. PUB. 2-15-2011. INT. CL. 35.

FASSINO, ROBERT J., HUDSON, WI:  
2,571,955. CANC. INT. CL. 41.

FAST CHIX, SAN LUIS OBISPO, CA:  
2,876,939. CANC. INT. CL. 25.

FAST CLEAN LIMITED, NEW TERRITORIES, HONG KONG:  
2,876,015. CANC. MULTIPLE CLASS, INT. CLS. 3 AND 21.

FASTER INSIDE, S.L., E-28002 MADRID, SPAIN:  
3,953,620. PUB. 2-15-2011. MULTIPLE CLASS, INT. CLS. 14 AND 32.

FASTNET CORPORATION, BETHLEHEM, PA:  
2,389,449. CANC. MULTIPLE CLASS, INT. CLS. 38 AND 42.

FAVIA ERICKSON WINEGROWERS, LLC, NAPA, CA:  
3,954,299. PUB. 2-15-2011. INT. CL. 33.

FAYGENOV, AARON, BREA, CA:  
2,877,972. CANC. INT. CL. 44.

FBC WORLDWIDE LLC, HOUSTON, TX:  
3,953,868. PUB. 2-15-2011. INT. CL. 25.

FBMC BENEFITS MANAGEMENT, INC., TALLAHASSEE, FL:  
3,954,279. PUB. 2-15-2011. INT. CL. 36.  
3,955,115. PUB. 2-15-2011. INT. CL. 36.

FC ACQUISITION CORP., WILMINGTON, DE:  
2,429,729. REN. 3-31-11. INT. CL. 9.

FEDERAL NATIONAL MORTGAGE ASSOCIATION, WASHINGTON, DC, DBA FANNIE MAE:  
2,877,639. CANC. INT. CL. 36.

FEDERAL RESERVE BANK OF BOSTON, BOSTON, MA:  
2,877,539. CANC. INT. CL. 41.

FEHLING, GERALD, KARLSTEIN D-63791, FED REP GERMANY:  
2,444,682. REN. 3-26-11. INT. CL. 10.

FEIST, LAUREN, RYE BROOK, NY:  
3,956,072. INT. CL. 16.

FEMININE JEWELRY CO., LTD, BANGKOK, THAILAND:  
3,954,692. PUB. 2-15-2011. INT. CL. 14.

FENDER MUSICAL INSTRUMENTS CORPORATION, SCOTTSDALE, AZ:  
1,148,870. REN. 3-26-11. INT. CL. 15.

FENDI ADELE S.R.L., ITALY:  
3,953,621. PUB. 2-15-2011. MULTIPLE CLASS, INT. CLS. 3 AND 21.

FENSKE, DAVID J., PORTLAND, OR, AKA VINYLDOC:  
3,954,103. PUB. 2-15-2011. MULTIPLE CLASS, INT. CLS. 1, 37 AND 40.

FENTON & ROSS, AN ACCOUNTANCY CORPORATION, LOS ANGELES, CA:  
3,953,803. PUB. 2-15-2011. INT. CL. 36.

FERGO APPAREL, INC., MIAMI, FL:  
2,876,029. CANC. INT. CL. 25.

FERGUSON ENTERPRISES, INC., NEWPORT NEWS, VA:  
3,954,363. PUB. 2-15-2011. INT. CL. 11.  
3,954,364. PUB. 2-15-2011. INT. CL. 22.

FERNANDEZ, LUIS ALVAREZ, OVIEDO, SPAIN:  
2,438,031. REN. 3-29-11. MULTIPLE CLASS, INT. CLS. 25 AND 35.

FERRI, CHARLES, NEW YORK, NY:  
3,955,764. INT. CL. 33.

FERRILL, BRIAN W., TOPEKA, KS, DBA DOGLEGS.COM:  
2,877,003. CANC. MULTIPLE CLASS, INT. CLS. 38 AND 42.

FIA CARD SERVICES, NATIONAL ASSOCIATION, WILMINGTON, DE:  
2,876,261. CANC. INT. CL. 36.

FIBERMARK NORTH AMERICA, INC., BRATTLEBORO, VT, BOISE CASCADE CORPORATION, BOISE, ID:  
1,158,080. REN. 3-31-11. INT. CL. 16.

FIBERSPAR CORPORATION, NEW BEDFORD, MA:  
2,540,304. REN. 3-25-11. INT. CL. 17.

FIDESSA LATENTZERO LIMITED, LONDON, ENGLAND:  
2,875,936. CANC. INT. CL. 9.

FIELDPOINT BV, AMSTERDAM, NETHERLANDS:  
2,480,549. REN. 3-28-11. INT. CL. 3.

FIELDS, DOUG, LAKE FOREST, CA:  
2,876,177. CANC. INT. CL. 16.

FIELDTURF TARKETT INC., TMR-MONTREAL, QUEBEC, CANADA, FIELDTURF INC., MONTREAL, QUEBEC, CANADA:  
2,458,994. REN. 3-30-11. INT. CL. 27.

FIGARO'S ITALIAN PIZZA, INC., SALEM, OR:  
2,876,090. CANC. INT. CL. 43.

FIGHTERS FIRE INC., WINTER SPRINGS, FL:  
3,955,987. INT. CL. 25.

FIGI'S INC., MARSHFIELD, WI:  
2,877,213. CANC. MULTIPLE CLASS, INT. CLS. 35 AND 45.

FIKE CORPORATION, BLUE SPRINGS, MO:  
2,876,048. CANC. INT. CL. 9.

FILMICFLOY CORPORATION, CEDAR GLEN, CA:  
3,954,232. PUB. 2-15-2011. INT. CL. 9.

FIMAC SOLUTIONS, LLC., GREENWOOD VILLAGE, CO:  
3,953,248. PUB. 2-15-2011. MULTIPLE CLASS, INT. CLS. 9, 36 AND 42.

- FINGER LAKES RACING ASSOCIATION, INC., FARMINGTON, NY:  
2,876,416, CANC. MULTIPLE CLASS, INT. CLS. 36 AND 41.
- FINN NEW YORK, LLC, NEW YORK, NY, DBA MINOR OBSESSIONS:  
3,954,191, PUB. 2-15-2011. INT. CL. 14.
- FINNZYMES OY, FIN-02201 ESPOO, FINLAND:  
2,876,181, CANC. INT. CL. 9.
- FIRE DYNAMICS, LENEXA, KS, DBA FIRE DYNAMICS, A HENDERSON ENGINEER, INC., DIVISION:  
2,382,933. REN. 3-30-11. INT. CL. 42.
- FIRECRAFT, INC., WEST CHESTER, PA:  
3,955,596, MULTIPLE CLASS, INT. CLS. 35 AND 43.  
3,955,597, MULTIPLE CLASS, INT. CLS. 35 AND 43.
- FIREMANS CONTRACTORS, INC., NORTH RICHLAND HILLS, TX:  
3,954,807, PUB. 2-15-2011. INT. CL. 37.
- FIRST CLASS IMPORTS, INC., BROOKLYN, NY:  
2,379,793, CANC. INT. CL. 14.
- FIRST COUSINS, LLC, COLUMBUS, OH:  
3,954,973, PUB. 2-15-2011. INT. CL. 35.
- FIRST DAKOTA FINANCIAL CORPORATION, YANKTON, SD:  
3,954,586, PUB. 2-15-2011. INT. CL. 16.
- FIRST NATIONAL OF NEBRASKA, INC., OMAHA, NE:  
3,955,054, PUB. 2-15-2011. INT. CL. 36.
- FIRSTCALL HEALTHCARE, INC., WINTER PARK, FL:  
2,876,127, CANC. INT. CL. 35.
- FISCAL TIMES MEDIA GROUP, LLC, THE, NEW YORK, NY:  
3,955,564, INT. CL. 16.
- FISERV, INC., BROOKFIELD, WI:  
3,953,481, PUB. 2-15-2011. INT. CL. 35.
- FISH NET, INC., LANCASTER, PA:  
2,474,743. REN. 3-26-11. INT. CL. 35.
- FISHER BROWN BOTTRELL INSURANCE, INC., JACKSON, MS:  
3,954,454, PUB. 2-15-2011. INT. CL. 36.
- FISHER HAMILTON LLC, TWO RIVERS, WI, FISHER SCIENTIFIC COMPANY, PITTSBURGH, PA:  
1,150,296. REN. 3-28-11. INT. CL. 9.
- FISHERS ECONOMIC AND COMMUNITY DEVELOPMENT COMMISSION, INC., FISHERS, IN:  
3,954,044, PUB. 2-15-2011. INT. CL. 42.
- FISKARS BRANDS, INC., MADISON, WI:  
2,980,805, CANC. INT. CL. 21.
- FITMETRICS ASSOCIATES, LIMITED, HUDSON, OH:  
2,946,689, COR. INT. CL. 28.
- FITNESS PROS PLUS, LLC, PUYALLUP, WA:  
2,876,616, CANC. INT. CL. 41.
- FITNESS RENAISSANCE, LLC, HOBOKEN, NJ:  
2,876,226, CANC. MULTIPLE CLASS, INT. CLS. 35 AND 44.
- FIXED INCOME LIVE, LP, ORANGE, CA:  
3,956,249, MULTIPLE CLASS, INT. CLS. 36, 41 AND 42.
- FLAGHOUSE, INC., HASBROUCK HEIGHTS, NJ:  
2,438,117. REN. 3-26-11. INT. CL. 10.
- FLAGSTAR BANK, FSB, TROY, MI:  
3,954,506, PUB. 2-15-2011. INT. CL. 36.
- FLANDERS INC., CHARLESTON, SC:  
3,954,246, PUB. 2-15-2011. INT. CL. 5.
- FLAT STANLEY'S, INC., STUART, FL:  
2,876,728, CANC. INT. CL. 43.
- FLATFLASH GROUP, LLC, FAIRFIELD, CT:  
3,953,932, PUB. 2-15-2011. INT. CL. 9.
- FLAVOR AND FOOD INGREDIENTS, INC., MIDDLESEX, NJ, DBA SUMMIT HILL FLAVORS:  
3,955,396, INT. CL. 30.  
3,955,397, INT. CL. 30.
- FLAWA AG, 9230 FLAWIL, SWITZERLAND:  
3,953,105, PUB. 2-15-2011. MULTIPLE CLASS, INT. CLS. 3 AND 21.
- FLECK FOODS, INC., CARNEGIE, PA:  
2,430,606. REN. 3-31-11. MULTIPLE CLASS, INT. CLS. 29 AND 30.
- FLEET LINE MARKERS, LTD., WORCESTERSHIRE, UNITED KINGDOM:  
3,953,296, PUB. 2-15-2011. MULTIPLE CLASS, INT. CLS. 7 AND 12.
- FLEET STREET, LTD., AVENEL, NJ:  
2,423,775. REN. 3-26-11. INT. CL. 25.
- FLEETSOFIT, LLC, SOUTH ELGIN, IL:  
2,481,539. REN. 3-26-11. INT. CL. 9.
- FLEISHER, YECHZKEL, LAKEWOOD, NJ:  
3,956,180, INT. CL. 39.
- FLEMING, JOSEPH, NEW YORK, NY:  
3,955,155, MULTIPLE CLASS, INT. CLS. 9 AND 16.
- FLETCHER, KERRIE, PAWTUCKET, RI:  
2,876,916, CANC. INT. CL. 35.
- FLEXERA SOFTWARE, INC., SCHAUMBURG, IL:  
3,953,180, PUB. 2-15-2011. MULTIPLE CLASS, INT. CLS. 9 AND 42.
- FLEXI-VAN LEASING, INC., KENILWORTH, NJ:  
3,954,186, PUB. 2-15-2011. INT. CL. 39.
- FLEXSYSTEMS USA INCORPORATED, EL CAJON, CA:  
2,159,931, CANC. INT. CL. 20.
- FLINT ENERGY SERVICES LTD., CALGARY, ALBERTA, CANADA:  
3,953,166, PUB. 2-15-2011. MULTIPLE CLASS, INT. CLS. 35, 37, 39 AND 40.
- FLINT GROUP INCORPORATED, PLYMOUTH, MI:  
2,439,226. REN. 3-26-11. MULTIPLE CLASS, INT. CLS. 16 AND 42.
- FLOORCO INTERNATIONAL (NORTH AMERICA) INC., SHEPHERDSTOWN, KY:  
3,955,154, MULTIPLE CLASS, INT. CLS. 19 AND 20.
- FLORIDA CHAMBER OF COMMERCE, THE, TALLAHASSEE, FL:  
2,379,265, CANC. INT. CL. 41.
- FLORIDA TRUCKING ASSOCIATION, INC., TALLAHASSEE, FL:  
2,378,680, CANC. INT. CL. 42.
- FLORIN URSU, TORONTO, CANADA:  
3,954,029, PUB. 2-15-2011. INT. CL. 9.
- FLOS S.P.A., BOVEZZO, BRESCIA, ITALY:  
920,102. REN. 3-30-11. U.S. CL. 21 (INT. CL. 11).
- FLUDICON GMBH, FED REP GERMANY:  
3,953,551, PUB. 1-11-2011. MULTIPLE CLASS, INT. CLS. 9 AND 12.
- FLY-N-HOG MEDIA GROUP, INC., FORT SMITH, AR:  
3,953,987, PUB. 2-15-2011. MULTIPLE CLASS, INT. CLS. 9 AND 35.
- FLYNN, LISA D., SOUTH BERWICK, ME:  
3,956,242, INT. CL. 41.
- FMC TECHNOLOGIES ITALIA S.P.A., 1-43100 PARMA, ITALY:  
2,876,874, CANC. INT. CL. 7.
- FOCUS ON THE FAMILY, COLORADO SPRINGS, CO:  
3,953,889, PUB. 2-15-2011. INT. CL. 16.
- FOCUSED EYE FILMS, LLC, PHILADELPHIA, PA:  
3,953,953, PUB. 2-15-2011. INT. CL. 41.
- FOLD-IT CONCEPTS, LLC, ANNAPOLIS, MD:  
2,876,912, CANC. INT. CL. 12.  
2,876,920, CANC. INT. CL. 12.
- FOMO PRODUCTS INC., NORTON, OH:  
2,426,406. REN. 3-29-11. INT. CL. 17.
- FOODHANDLER, INC., RENO, NV:  
3,954,541, PUB. 2-15-2011. INT. CL. 21.  
3,954,542, PUB. 2-15-2011. INT. CL. 21.  
3,954,543, PUB. 2-15-2011. INT. CL. 21.
- FOODSERVICE GROUP, INC., THE, MARIETTA, GA:  
1,181,438. REN. 3-31-11. INT. CL. 35.
- FOOFQUEENS, INC., JOHNSTON, IA:  
3,955,233, MULTIPLE CLASS, INT. CLS. 16 AND 35.
- FOONBERG, JAY, BEVERLY HILLS, CA:  
2,380,112, CANC. INT. CL. 42.
- FOOT AND ANKLE CENTER OF NEW JERSEY, LLC, HILLSBOROUGH, NJ:  
3,954,415, PUB. 2-15-2011. INT. CL. 44.
- FOOT CANDI, LLC, CHARLOTTE, NC:  
3,955,757, INT. CL. 25.
- FOREMOST GROUPS, INC., EAST HANOVER, NJ:  
2,877,796, CANC. INT. CL. 20.

FORENCICH, FRANK, SEATTLE, WA:  
3,954,116, PUB. 2-15-2011. INT. CL. 41.

FORENSIC SOLUTIONS, LLC, SAN FRANCISCO, CA:  
3,953,286, PUB. 2-15-2011. MULTIPLE CLASS, INT. CLS.  
35 AND 45.

FORESTAR GROUP INC., AUSTIN, TX:  
3,954,304, PUB. 2-15-2011. MULTIPLE CLASS, INT. CLS.  
4, 19, 35, 37, 40 AND 45.

FOREVER CHEESE INC., L.I.C., NY:  
3,954,877, PUB. 2-15-2011. INT. CL. 29.  
3,954,968, PUB. 2-15-2011. INT. CL. 29.

FOREVER INTERACTIVE, LLC, CHICAGO, IL:  
3,955,719, INT. CL. 41.

FOREVER 21, INC., LOS ANGELES, CA:  
3,955,527, MULTIPLE CLASS, INT. CLS. 9, 18 AND 25.

FORNEX TECHNOLOGY CORP., FU-KUO, HSIN-CHU,  
TAIWAN:  
2,876,131, CANC. INT. CL. 9.

FORT VALE ENGINEERING LIMITED, BURNLEY, LAN-  
CASHIRE, ENGLAND:  
2,394,690, REN. 3-26-11. MULTIPLE CLASS, INT. CLS. 6,  
9 AND 17.

FORTRESS SOLUTIONS, LTD., PLANO, TX:  
3,953,862, PUB. 2-15-2011. MULTIPLE CLASS, INT. CLS.  
35, 37 AND 42.  
3,953,863, PUB. 2-15-2011. MULTIPLE CLASS, INT. CLS.  
35, 37 AND 42.

FORTUNATUS, REDWOOD CITY, CA:  
3,954,629, PUB. 2-15-2011. INT. CL. 33.

FORUMSHERPA, INC., ATLANTA, GA:  
3,954,559, PUB. 2-15-2011. INT. CL. 41.

FORWARD MOMENTUM LLC, GRAYSLAKE, IL:  
3,953,252, PUB. 2-15-2011. INT. CL. 35.

FORWARD STEP THE LEARNING COALITION, LOS AN-  
GELES, CA:  
2,730,606, CANC. INT. CL. 16.

FOTO-KEM INDUSTRIES, INC., BURBANK, CA:  
2,379,648, CANC. INT. CL. 41.

FOTOS, SUSAN ROSTER, MECHANICSBURG, PA:  
2,439,698, REN. 3-26-11. INT. CL. 14.

FOUGY, AL, BROOKLYN, NY:  
2,876,223, CANC. INT. CL. 9.

FOUR DOWN, INC., HUNTINGTON BEACH, CA:  
2,877,903, CANC. MULTIPLE CLASS, INT. CLS. 25 AND  
28.

FOUR PAWS PRODUCTS LTD., HAUPPAUGE, NY:  
2,380,026, CANC. INT. CL. 31.

FOUR RIVERS COMMUNITY BROADCASTING COR-  
PORATION, SOUDERTON, PA:  
3,955,946, INT. CL. 38.

FOURSTAR GROUP INC., TAIPEI, TAIWAN:  
3,954,453, PUB. 2-15-2011. MULTIPLE CLASS, INT. CLS.  
18 AND 21.

FOURTH TORO FAMILY LIMITED PARTNERSHIP, THE,  
NEW YORK, NY, DBA H&H BAGELS:  
2,450,379, REN. 3-25-11. INT. CL. 30.

FOWL BOYS, RENO, NV:  
3,954,625, PUB. 2-15-2011. MULTIPLE CLASS, INT. CLS. 9  
AND 25.

FOX/UTV HOLDINGS, INC., LOS ANGELES, CA:  
2,441,088, REN. 3-26-11. INT. CL. 38.

FPI MANAGEMENT, INC., FOLSOM, CA:  
3,953,882, PUB. 2-15-2011. INT. CL. 36.

FRANCIS, JUSTIN, NEW YORK, NY:  
2,877,680, CANC. INT. CL. 41.

FRANCISCAN VINEYARDS INC., ST. HELENA, CA:  
3,954,905, PUB. 2-15-2011. INT. CL. 35.

FRANCO, MADELEINE, LAS VEGAS, NV, DBA JORDAN  
RICHARD ASSOC., A SOLE PROPRIETORSHIP OF  
UTAH:  
2,396,942, REN. 3-31-11. INT. CL. 35.

FRANK BRUNCKHORST CO., L.L.C., BROOKLYN, NY:  
3,955,077, PUB. 2-15-2011. INT. CL. 29.

FRANK-LIN DISTILLERS PRODUCTS, LTD., SAN JOSE,  
CA:  
3,955,023, PUB. 2-15-2011. INT. CL. 33.

FRANK, HOSEA, LOS ANGELES, CA:  
3,955,275, MULTIPLE CLASS, INT. CLS. 35, 41 AND 45.

FRANKLIN EDUCATIONAL SERVICES, INC., LOS AN-  
GELES, CA:  
3,953,830, PUB. 2-15-2011. INT. CL. 41.

FRANKLYN D. RESORTS LTD., ST. ANN, JAMAICA:  
2,875,956, CANC. INT. CL. 42.

FRANTZ COMPANY, INC., BUTLER, WI:  
3,955,249, INT. CL. 1.

FRASCARELLI PAOLO & C. S.A.S, SAN SEVERINO  
MARCHE, MC, ITALY:  
2,378,486, CANC. INT. CL. 25.

FREAKONOMICS, LLC, NEW YORK, NY:  
3,954,795, PUB. 2-15-2011. INT. CL. 41.

FRECCIA/O'SULLIVAN, INC., SAN FRANCISCO, CA:  
3,955,097, PUB. 2-15-2011. INT. CL. 32.

FRED MEYER STORES, INC., PORTLAND, OR:  
2,531,747, REN. 3-31-11. INT. CL. 35.

FRED SONNENBERG AND CHRISTIAN FORTMANN, D-  
80331 MUNCHEN, FED REP GERMANY:  
2,468,966, REN. 3-26-11. MULTIPLE CLASS, INT. CLS. 35  
AND 42.

FREDERIQUE POINSIGNON, LIMONEST, FRANCE:  
2,449,508, REN. 3-26-11. INT. CL. 42.

FREEDOM FIRE PROTECTION, LLC, LONGMONT, CO:  
3,953,472, PUB. 12-5-2006. MULTIPLE CLASS, INT. CLS.  
37 AND 42.

FREEDOM MERCHANTS CORPORATION, PHILADEL-  
PHIA, PA:  
3,954,321, PUB. 2-15-2011. INT. CL. 35.

FREEPORT DEL PASO CORP., EL PASO, TX:  
2,877,718, CANC. INT. CL. 9.

FREIGHTLINER SPECIALTY VEHICLES, INC., CLINTON,  
OK:  
3,954,703, PUB. 2-15-2011. INT. CL. 12.

FREIREMAR, S.A., GRAN CANARIA (CANARY ISLANDS),  
SPAIN:  
2,432,615, REN. 3-26-11. INT. CL. 29.

FRESENIUS KABI AG, 60323 FRANKFURT, FED REP  
GERMANY:  
2,876,510, CANC. MULTIPLE CLASS, INT. CLS. 5 AND  
10.

FRESH AND GO LTD., KIRIAT ANAVIM, ISRAEL:  
2,546,037, REN. 3-26-11. MULTIPLE CLASS, INT. CLS. 3  
AND 21.

FRESH EXPRESS INCORPORATED, SALINAS, CA:  
2,877,711, CANC. INT. CL. 29.

FRESH PACIFIC FRUIT & VEGETABLES, INC., PINEDALE,  
CA:  
2,466,160, REN. 3-26-11. INT. CL. 31.

FRESH PURE DELICIOUS L.L.C., PLYMOUTH, MI:  
3,955,191, INT. CL. 3.

FRICTION FARM, PALM BEACH GARDENS, FL:  
2,379,169, CANC. INT. CL. 41.

FRIEDMAN & KLINGE CIGAR COMPANY, ST. LOUIS, MO:  
3,953,929, PUB. 2-15-2011. INT. CL. 34.

FRIENDLY FRUIT, INC., NEW BEDFORD, MA:  
2,441,653, REN. 3-29-11. INT. CL. 42.

FRIENDLY ICE CREAM CORPORATION, WILBRAHAM,  
MA:  
1,645,426, REN. 3-31-11. INT. CL. 30.

FRIENDS OF ISRAEL GOSPEL MINISTRY, INC., BELL-  
MAWR, NJ:  
2,445,675, REN. 3-28-11. INT. CL. 16.

FRIENDS OF THE NEW YORK CITY HALL OF FAME,  
FLUSHING, NY:  
2,878,078, CANC. INT. CL. 41.

FRIGOR TEC GMBH, 88279 AMTZELL, FED REP GER-  
MANY:  
1,636,070, REN. 3-31-11. INT. CL. 11.

FRITO-LAY NORTH AMERICA, INC., PLANO, TX:  
2,502,596, REN. 3-29-11. MULTIPLE CLASS, INT. CLS. 29  
AND 30.  
3,954,612, PUB. 2-15-2011. MULTIPLE CLASS, INT. CLS.  
29 AND 30.  
3,955,482, INT. CL. 29.

FRITOS TOTIS, S.A. DE C.V., TIZAYUCA, HIDALGO,  
MEXICO:  
2,931,058 NEW CERT. 5-3-2011. INT. CL. 30.

- FRITZ A. SEIDEL ELEKTRO-AUTOMATIK GMBH, 40489 DUSSELDORF, FED REP GERMANY:  
2,875,850, CANC. INT. CL. 9.
- FRITZ HANSEN A/S, ALLEROD, DENMARK:  
2,875,941, CANC. INT. CL. 20.
- FROMANTEEL LIMITED, UNITED KINGDOM:  
3,953,538, PUB. 2-15-2011. INT. CL. 14.
- FRONTIER PUBLICATIONS INC., VASHON ISLAND, WA:  
1,578,206, CANC. INT. CL. 41.
- FRUTAROM NETHERLANDS B.V., NETHERLANDS:  
3,876,479, COR. MULTIPLE CLASS, INT. CLS. 5 AND 30.
- FRUTOS DE HUERTA REAL S.P.R. DE R.L., PUEBLA, MEXICO:  
3,955,821, INT. CL. 31.
- FRYE, PATRICIA A, MONTESANO, WA:  
3,956,240, INT. CL. 35.
- FTEN, INC., NEW YORK, NY:  
3,956,111, INT. CL. 9.
- FTI CONSULTING, INC., ANNAPOLIS, MD:  
2,438,462, REN. 3-29-11. INT. CL. 9.
- FUCHS, SVETLANA, LAS VEGAS, NV:  
3,956,103, INT. CL. 25.
- FUEL PLUS TECHNOLOGY, INC., PORT MONMOUTH, NJ:  
3,954,598, PUB. 2-15-2011. INT. CL. 1.
- FUGRO N.V., LEIDSCHENDAM, NETHERLANDS:  
2,437,930, REN. 3-26-11. MULTIPLE CLASS, INT. CLS. 9 AND 39.
- FUGRO N.V., NETHERLANDS:  
3,953,493, PUB. 2-15-2011. MULTIPLE CLASS, INT. CLS. 9, 37, 41 AND 42.
- FUISZ, RICHARD C., MCLEAN, VA:  
2,877,841, CANC. INT. CL. 5.
- FUJIMOTO, KEN, LOS ANGELES, CA:  
3,955,940, INT. CL. 9.
- FUJINON CORPORATION, SAITAMA-KEN, JAPAN:  
3,955,354, INT. CL. 9.
- FUJITSU SEMICONDUCTOR LIMITED, KANAGAWA 222-0033, JAPAN:  
2,457,750, REN. 3-26-11. INT. CL. 9.
- FULL FREQUENCY TRANSFORMATION, LLC, MONTECLAIR, NJ:  
3,956,198, INT. CL. 16.
- FULLSTEAM BREWERY LLC, DURHAM, NC:  
3,954,090, PUB. 2-15-2011. INT. CL. 32.
- FULTON FINANCIAL CORPORATION, LANCASTER, PA:  
3,955,707, INT. CL. 36.
- FULTON MANAGEMENT SERVICES, INC., PULASKI, NY:  
3,953,689, PUB. 2-15-2011. MULTIPLE CLASS, INT. CLS. 11 AND 37.
- FURUKAWA ROCK DRILL CO., LTD., JAPAN:  
3,953,526, PUB. 2-15-2011. MULTIPLE CLASS, INT. CLS. 7 AND 37.
- FUSCO, CHRISTOPHER, JAY, LOS ANGELES, CA:  
2,877,053, CANC. INT. CL. 42.
- FUSION BRANDS INTERNATIONAL SRL, CHRIST CHURCH, BARBADOS:  
3,955,780, INT. CL. 3.
- FUSIONAPPS, LLC., SECAUCUS, NJ:  
3,953,898, PUB. 2-15-2011. INT. CL. 42.
- FUTABA CORPORATION OF AMERICA, SCHAUMBURG, IL:  
2,594,651, CANC. INT. CL. 9.
- FUTUREBIOTICS, LLC, HAUPPAGUE, NY:  
3,954,104, PUB. 2-15-2011. INT. CL. 5.  
3,954,105, PUB. 2-15-2011. INT. CL. 5.  
3,954,160, PUB. 2-15-2011. INT. CL. 5.
- FUZZY BRUSH LIMITED, LONDON NW6 4HY, ENGLAND:  
2,560,985, CANC. MULTIPLE CLASS, INT. CLS. 9 AND 21.
- F5 NETWORKS, INC., SEATTLE, WA:  
2,399,278, REN. 3-25-11. MULTIPLE CLASS, INT. CLS. 9 AND 42.  
2,399,278, COR. MULTIPLE CLASS, INT. CLS. 9 AND 42.
- G. J. DEERBERG-SYSTEMS GMBH, OLDENBURG (OLDENBURG), NIEDERSACHSEN, FED REP GERMANY:  
2,876,990, CANC. INT. CL. 40.
- G. NEIL DIRECT MAIL, INC., SUNRISE, FL TO EVERGLADES DIRECT, INC., NORTH MANKATO, MN:  
2,380,098, CANC. INT. CL. 9.
- G.A. BLUE CORPORATION SDN BHD., BAYAN LEPAS 11900, PENANG, MALAYSIA:  
2,531,952, REN. 3-31-11. INT. CL. 25.
- G.L. TURNER CO., NORTH LITTLE ROCK, AR:  
2,204,741, CANC. INT. CL. 7.
- G.M. ROTH DESIGN REMODELING, INC., NASHUA, NH:  
3,954,550, PUB. 2-15-2011. INT. CL. 35.
- GABO QUALIMETER TESTANLAGEN GMBH, AHLDEN, FED REP GERMANY:  
3,953,014, PUB. 2-15-2011. INT. CL. 9.
- GADGET FACTORY PTY LTD., THE, NEW SOUTH WALES, AUSTRALIA:  
2,875,928, CANC. MULTIPLE CLASS, INT. CLS. 41 AND 42.
- GADLER, DIEGO, TRENTO 38100, ITALY:  
3,955,313, INT. CL. 9.
- GAITS OF CHANGE, PETALUMA, CA:  
3,954,383, PUB. 2-15-2011. INT. CL. 41.
- GALAXY PUBLISHING, INC., STUDIO CITY, CA:  
3,952,947, PUB. 2-15-2011. MULTIPLE CLASS, INT. CLS. 16, 25 AND 28.
- GALDERMA LABORATORIES, L.P., FORT WORTH, TX, ALCON LABORATORIES, INC., FT. WORTH, TX:  
1,190,425, REN. 3-31-11. INT. CL. 5.
- GALE BANKS ENGINEERING, AZUSA, CA:  
2,548,341, REN. 3-26-11. INT. CL. 7.
- GALLE, JAMES S., SAUSALITO, CA:  
3,953,714, PUB. 2-15-2011. INT. CL. 29.
- GALLERYTOPIA LLC, NASHVILLE, TN:  
3,956,084, MULTIPLE CLASS, INT. CLS. 39 AND 42.
- GAM GEAR, LLC, HARWOOD HEIGHTS, IL:  
2,379,948, CANC. INT. CL. 7.
- GAMBRO LUNDIA AB, LUND, SWEDEN:  
2,379,078, CANC. MULTIPLE CLASS, INT. CLS. 5, 10 AND 42.
- GAME SHOW NETWORK, LLC, SANTA MONICA, CA:  
2,877,254, CANC. INT. CL. 41.  
2,877,255, CANC. INT. CL. 41.
- GAMETECH INTERNATIONAL, INC., RENO, NV:  
3,953,221, PUB. 2-15-2011. INT. CL. 9.
- GANNETT SATELLITE INFORMATION NETWORK, INC., MCLEAN, VA:  
3,953,033, PUB. 2-15-2011. INT. CL. 41.
- GAP (APPAREL), LLC, SAN FRANCISCO, CA:  
2,449,575, REN. 3-28-11. INT. CL. 25.
- GAR PRODUCTS, INC., LAKEWOOD, NJ:  
2,438,343, REN. 3-29-11. INT. CL. 20.
- GARCIA, THELMA R., COVINA, CA:  
2,876,846, CANC. INT. CL. 43.
- GARDEN TECH, COLORADO SPRINGS, CO:  
3,954,558, PUB. 2-15-2011. INT. CL. 35.
- GARRETT, JANICE L., WARREN, MI:  
2,390,106, REN. 3-31-11. INT. CL. 31.
- GARTNER STUDIOS, INC., STILLWATER, MN:  
2,439,063, REN. 3-31-11. INT. CL. 16.
- GARY L. PIFER, OCEANSIDE, CA:  
3,954,890, PUB. 2-15-2011. INT. CL. 25.
- GARY ROY GOODEN, COLUMBIA, SC:  
3,955,246, MULTIPLE CLASS, INT. CLS. 16, 21 AND 25.
- GASTON SYSTEMS, INC., STANLEY, NC:  
2,446,787, REN. 3-30-11. INT. CL. 7.
- GATEWAY GAMING, PIEDMONT, SC:  
3,955,704, INT. CL. 9.
- GATTEN SUSHI USA, INC., CERRITOS, CA:  
3,955,712, INT. CL. 43.
- GAUCAS, INC., SANTA ANA, CA:  
2,441,167, REN. 3-31-11. INT. CL. 35.
- GAULME S.A., 75012, PARIS, FRANCE:  
2,876,203, CANC. INT. CL. 3.
- GAVILLET, ELIZABETH, WINNETKA, IL:  
3,954,896, PUB. 2-15-2011. INT. CL. 41.
- GAYLE MARTZ, INC., NEW YORK, NY:  
2,877,471, CANC. INT. CL. 35.
- GBC METALS, LLC, EAST ALTON, IL:  
899,524, REN. 3-29-11. U.S. CL. 13 (INT. CL. 6).



- GDA TECHNOLOGIES INC., SAN JOSE, CA:  
2,876,507, CANC. INT. CL. 42.
- GDJ INC., MENTOR, OH:  
2,379,338, CANC. INT. CL. 9.
- GE HEALTHCARE BIO-SCIENCES AB, UPPSALA, SWEDEN, AMERSHAM PHARMACIA BIOTECH AB, SE-751 84 UPPSALA, SWEDEN:  
2,444,686, REN. 3-30-11, INT. CL. 9.
- GE HEALTHCARE LIMITED, BUCKINGHAMSHIRE, UNITED KINGDOM:  
1,645,766, REN. 3-31-11, INT. CL. 5.  
2,876,974, CANC. MULTIPLE CLASS, INT. CLS. 1, 5, 9, 10, 41 AND 42.
- GE MONEY SERVICING LIMITED, WATFORD, HERTFORDSHIRE, UNITED KINGDOM:  
2,877,833, CANC. INT. CL. 36.
- GEM ART JEWELLERY MFG., LTD., CENTRAL, HONG KONG:  
2,473,138, REN. 3-30-11, MULTIPLE CLASS, INT. CLS. 14 AND 16.
- GEMCOM SOFTWARE INTERNATIONAL INC., VANCOUVER, BC, CANADA, GEMCOM SOFTWARE INTERNATIONAL INC., VANCOUVER, BC, CANADA:  
2,478,748, REN. 3-30-11, MULTIPLE CLASS, INT. CLS. 9 AND 42.
- GEMMIKE FOODS, INC., BABYLON, NY:  
2,876,606, CANC. INT. CL. 30.
- GEMTREE VINEYARDS PTY LTD., MCLAREN VALE SA 5171, AUSTRALIA:  
3,956,099, INT. CL. 33.
- GENCO TRANSPORTATION MANAGEMENT LLC, PITTSBURGH, PA:  
2,876,678, CANC. INT. CL. 35.
- GENE ORACLE INCORPORATED, MOUNTAIN VIEW, CA:  
3,955,244, MULTIPLE CLASS, INT. CLS. 1 AND 9.
- GENERAL COUNSEL SOLUTIONS, LLC, NEW YORK, NY:  
3,956,210, INT. CL. 45.
- GENERAL ELECTRIC COMPANY, SCHENECTADY, NY:  
2,876,445, CANC. INT. CL. 36.
- GENERAL MILLS SPECIALTY PRODUCTS, LLC, MINNEAPOLIS, MN:  
3,954,227, PUB. 2-15-2011, INT. CL. 29.
- GENERAL MILLS, INC., MINNEAPOLIS, MN:  
2,379,478, CANC. MULTIPLE CLASS, INT. CLS. 29 AND 30.
- GENERAL MOTORS LLC, DETROIT, MI:  
2,440,149, REN. 3-26-11, INT. CL. 4.  
2,440,150, REN. 3-26-11, INT. CL. 1.  
2,445,737, REN. 3-25-11, INT. CL. 12.  
2,445,738, REN. 3-25-11, INT. CL. 17.  
2,445,739, REN. 3-31-11, INT. CL. 9.  
2,445,740, REN. 3-27-11, INT. CL. 7.
- GENERAL NUCLEAR SYSTEMS, INC., COLUMBIA, SC:  
1,398,890, CANC. INT. CL. 39.
- GENERAL TOOLS MANUFACTURING CO., INC., NEW YORK, NY:  
2,378,939, CANC. INT. CL. 7.
- GENESIS ENGINEERING & REDEVELOPMENT, RIPON, CA:  
3,954,199, PUB. 2-15-2011, MULTIPLE CLASS, INT. CLS. 35 AND 42.
- GENESIS PHARMACEUTICAL, INC., MORRISTOWN, NJ:  
2,478,720, CANC. MULTIPLE CLASS, INT. CLS. 35, 41 AND 42.
- GENEVA CHAMBER OF COMMERCE, GENEVA, IL:  
1,643,852, REN. 3-29-11, INT. CL. 35.
- GENO, N-2301 HAMAR, NORWAY, GENO, N-2301 HAMAR, NORWAY:  
2,442,090, REN. 3-29-11, MULTIPLE CLASS, INT. CLS. 5 AND 42.
- GENX INTERNATIONAL, INC., GUILFORD, CT:  
2,878,052, CANC. INT. CL. 5.
- GEO F. TRUMPER (PERFUMER & PRODUCTS) LTD, LONDON W1Y 7FL, ENGLAND:  
2,470,792, REN. 3-31-11, MULTIPLE CLASS, INT. CLS. 3 AND 18.
- GEO F. TRUMPER(PERFUMER & PRODUCTS) LTD., LONDON W1Y 7FL, ENGLAND:  
2,481,094, REN. 3-30-11, MULTIPLE CLASS, INT. CLS. 3 AND 18.
- GEOGLOBAL PARTNERS, LLC, SOUTH PLAINFIELD, NJ:  
3,953,394, PUB. 2-15-2011, MULTIPLE CLASS, INT. CLS. 1, 2, 5, 9, 11, 17, 19, 21, 22 AND 31.
- GEOPORTALS.COM, INC., NEW YORK, NY:  
2,378,739, CANC. INT. CL. 42.
- GEORG PRINZING GMBH & CO. KG BETONFORMEN- U. MASCHINENFABRIK, FED REP GERMANY:  
3,953,659, PUB. 2-15-2011, INT. CL. 19.
- GEORGE POE, CEDAR PARK, TX, DBA CEDAR PARK JEWELRY:  
3,954,095, PUB. 2-15-2011, MULTIPLE CLASS, INT. CLS. 35 AND 36.  
3,954,149, PUB. 2-15-2011, INT. CL. 36.
- GEORGE TAUB PRODUCTS AND FUSION COMPANY, INC., JERSEY CITY, NJ:  
1,638,843, REN. 3-31-11, INT. CL. 5.
- GEORGETOWN CUPCAKE, LLC, WASHINGTON, DC:  
3,956,102, MULTIPLE CLASS, INT. CLS. 35 AND 43.
- GEORGIA DEPARTMENT OF AGRICULTURE, ATLANTA, GA:  
1,643,134, REN. 3-31-11, U.S. CL. A.
- GEORGIA-PACIFIC CONSUMER PRODUCTS LP, ATLANTA, GA:  
3,955,872, INT. CL. 16.
- GEOSOFT INC., TORONTO, ONTARIO, CANADA:  
2,427,196, REN. 3-26-11, MULTIPLE CLASS, INT. CLS. 9 AND 42.
- GEO THERMAL HEAT PUMP CONSORTIUM, INC., WASHINGTON, DC:  
2,383,544, REN. 3-29-11, MULTIPLE CLASS, INT. CLS. 35, 37, 38, 41 AND 42.
- GET WELL NATURAL LLC, LAS VEGAS, NV:  
3,952,989, PUB. 2-15-2011, INT. CL. 5.  
3,952,990, PUB. 2-15-2011, INT. CL. 5.  
3,952,991, PUB. 2-15-2011, INT. CL. 5.
- GETTY IMAGES (US), INC., SEATTLE, WA:  
2,437,245, REN. 3-25-11, INT. CL. 42.
- GEZE GMBH, 71229 LEONBERG, FED REP GERMANY:  
2,912,063, CANC. MULTIPLE CLASS, INT. CLS. 11, 12, 19 AND 37.
- GHA SERVICES SA, GENEVA, SWITZERLAND:  
3,953,165, PUB. 7-27-2010, MULTIPLE CLASS, INT. CLS. 35 AND 43.
- GHC SPECIALTY BRANDS, LLC, JANESVILLE, WI:  
3,954,409, PUB. 2-15-2011, INT. CL. 16.  
3,954,411, PUB. 2-15-2011, INT. CL. 17.
- GHEN CORPORATION, GIFU-SHI, GIFU-KEN, JAPAN:  
2,877,127, CANC. MULTIPLE CLASS, INT. CLS. 5, 29 AND 31.
- GHOST ROBOT, INC, NEW YORK, NY:  
3,953,093, PUB. 2-15-2011, INT. CL. 41.
- GHOSTRIDERX SKATEBOARDS, LLC., RANCHO PALOS VERDES, CA:  
2,876,360, CANC. INT. CL. 28.
- GIACOBINO ALESSIA, VISERBA (RIMINI), ITALY:  
3,953,643, PUB. 2-15-2011, MULTIPLE CLASS, INT. CLS. 3, 9, 20, 21 AND 24.
- GIANNI VERSACE S.P.A., MILAN, ITALY:  
2,440,541, REN. 3-31-11, MULTIPLE CLASS, INT. CLS. 8, 19, 20, 21 AND 24.
- GIANT IMPACT, LLC, DULUTH, GA:  
2,876,563, CANC. MULTIPLE CLASS, INT. CLS. 9 AND 16.
- GIANT INTERNATIONAL (USA), LTD, ATLANTA, GA:  
3,955,252, INT. CL. 9.
- GIE MEDIA, INC., RICHFIELD, OH:  
3,956,145, MULTIPLE CLASS, INT. CLS. 16 AND 41.
- GIELEN KRIS ZULMA JOS, BELGIUM AND HEIDEN,; KENT RICHARD, UNITED STATES:  
3,811,067, COR. MULTIPLE CLASS, INT. CLS. 14 AND 35.
- GIESECKE & DEVRIENT GMBH, MUNICH, FED REP GERMANY:  
3,955,106, PUB. 2-15-2011, INT. CL. 9.

- GIGANTINO, JOE, MR., SAN JOSE, CA:  
2,429,597. REN. 3-31-11. INT. CL. 35.
- GIGASET COMMUNICATIONS GMBH, FED REP GER-  
MANY:  
3,953,514, PUB. 2-15-2011. INT. CL. 9.
- GIGLIO, EVERETT JR., PLANT CITY, FL:  
3,954,323, PUB. 2-15-2011. INT. CL. 41.
- GILDAY, JOHN, LAS VEGAS, NV:  
2,480,916. REN. 3-31-11. INT. CL. 35.
- GILES, RICHARD, PARK CITY, UT:  
3,955,284, INT. CL. 11.
- GILLUM, CYNTHIA J., LOXAHATCHEE, FL:  
2,448,314. REN. 3-28-11. INT. CL. 37.
- GIMPLE ROOF ENGINEERS, INC., ARVADA, CO AND  
GIMPLE, JOHN L., ARVADA, CO:  
3,953,258, PUB. 2-15-2011. INT. CL. 42.
- GISTCLOUD, SHERMAN OAKS, CA:  
3,954,622, PUB. 2-15-2011. INT. CL. 42.
- GITTENS, OLIVIA, THORNTON, CO:  
3,953,287, PUB. 2-15-2011. INT. CL. 14.
- GIVAUDAN SA, 1214 VERNIER, SWITZERLAND:  
2,876,443, CANC. INT. CL. 9.
- GLAMORISE FOUNDATIONS, INC., NEW YORK, NY:  
2,489,866. REN. 3-28-11. INT. CL. 25.  
2,489,867. REN. 3-30-11. INT. CL. 25.
- GLASSER, ROBIN PREISS, IRVINE, CA AND O' CONNOR,  
JANE, NEW YORK, NY:  
3,956,000, INT. CL. 18.
- GLAXO GROUP LIMITED, MIDDLESEX, UNITED KING-  
DOM:  
2,877,334, CANC. INT. CL. 5.
- GLAXO GROUP LIMITED, GREENFORD, MIDDLESEX,  
UNITED KINGDOM:  
2,877,390, CANC. INT. CL. 5.
- GLAXO GROUP LIMITED, GREENFORD MIDDLESEX  
UB6 0NN, UNITED KINGDOM:  
2,877,516, CANC. INT. CL. 5.
- GLAXOSMITHKLINE BIOLOGICALS S.A., RIXENSART,  
BELGIUM:  
2,877,223, CANC. INT. CL. 5.
- GLAXOSMITHKLINE LLC, WILMINGTON, DE:  
2,877,259, CANC. INT. CL. 5.
- GLAZA, TOLUCA LAKE, CA:  
2,876,121, CANC. INT. CL. 25.
- GLAZE, DOYLE P., BOLINGBROOK, IL:  
2,876,280, CANC. INT. CL. 42.
- GLEASON WORKS, THE, ROCHESTER, NY:  
913,031. REN. 3-26-11. U.S. CL. 23 (INT. CL. 7).
- GLEN RAVEN, INC., GLEN RAVEN, NC, LEUCADIA, INC.,  
NEW YORK, NY:  
1,652,405. REN. 3-29-11. INT. CL. 17.
- GLEYZER, MARINA, HUNTINGTON, NY:  
3,953,363, PUB. 2-15-2011. INT. CL. 3.
- GLOBAL CONCEPTS LIMITED, INC., DEERFIELD BEACH,  
FL, DBA GLOBAL TV CONCEPTS, LTD.:  
3,955,630, INT. CL. 21.
- GLOBAL BAGGAGE EXPEDITER INC, ARVERNE, NY:  
3,953,935, PUB. 2-15-2011. INT. CL. 39.
- GLOBAL CELLULAR, INC., ALPHARETTA, GA:  
3,953,239, PUB. 2-15-2011. INT. CL. 9.  
3,955,085, PUB. 2-15-2011. INT. CL. 35.  
3,955,086, PUB. 2-15-2011. INT. CL. 35.
- GLOBAL CROSSING NORTH AMERICA, INC., ROCHE-  
STER, NY:  
2,380,013, CANC. INT. CL. 38.
- GLOBAL ENTERTAINMENT MEDIA, INC., LOS ANGELES,  
CA:  
2,877,708, CANC. INT. CL. 38.
- GLOBAL FLUID POWER SOLUTIONS, LLC, LONG BEACH,  
CA, AKA GLOBAL FPS, LLC AND MAHOMANN CORP.,  
MIAO LI HSIEN, TAIWAN:  
3,953,727, PUB. 2-15-2011. INT. CL. 9.
- GLOBAL FRESH, LLC, SAN ANTONIO, TX:  
3,955,578, INT. CL. 31.
- GLOBAL KNOWLEDGE EXCHANGE, INC, TOTOWA, NJ:  
2,431,279. REN. 3-30-11. INT. CL. 41.
- GLOBAL NOVATIONS, LLC, BOSTON, MA:  
3,954,070, PUB. 2-15-2011. INT. CL. 41.
- GLOBAL ORANGE, L.L.C., LANSING, MI:  
2,308,859, CANC. MULTIPLE CLASS, INT. CLS. 25, 30  
AND 42.
- GLOBAL OUTREACH, INC., MINNEAPOLIS, MN:  
2,877,382, CANC. INT. CL. 35.
- GLOBAL PROCESS DIAGNOSTICS, INC., PRAIRIEVILLE,  
LA:  
2,623,052, CANC. INT. CL. 37.
- GLOBAL TALENT AGENCY, LLC, BURBANK, CA, DBA  
GLOBAL TALENT AGENCY:  
3,956,151, INT. CL. 35.
- GLOBAL TEL\*LINK CORPORATION, MOBILE, AL:  
2,378,664, CANC. INT. CL. 9.
- GLOBALPLATEAU LLC, CAMBRIDGE, MA:  
2,876,904, CANC. INT. CL. 16.  
2,876,905, CANC. INT. CL. 16.
- GLOBERIDE, INC., TOKYO 203-8511, JAPAN:  
3,953,502, PUB. 2-15-2011. MULTIPLE CLASS, INT. CLS.  
8, 9, 18, 21, 25 AND 28.
- GLOBEXPRESS CO. LIMITED, HONG KONG, HONG  
KONG:  
3,955,395, INT. CL. 9.  
3,955,419, INT. CL. 9.
- GLOCK, INC., SMYRNA, GA:  
2,440,268. REN. 3-31-11. MULTIPLE CLASS, INT. CLS. 6,  
8, 9, 13 AND 16.
- GLOVER, BRANDON M., COLUMBIA, SC:  
3,954,471, PUB. 2-15-2011. INT. CL. 9.
- GO! ST. LOUIS, ST. LOUIS, MO:  
3,954,403, PUB. 2-15-2011. INT. CL. 41.
- GOEN TECHNOLOGIES CORPORATION, CEDAR  
KNOLLS, NJ:  
2,877,638, CANC. INT. CL. 5.
- GOFISH-IT, LLC, CHARLOTTE, NC:  
3,955,567, INT. CL. 39.
- GOGO GREEN, LLC, MEMPHIS, TN:  
3,955,192, INT. CL. 1.
- GOLABEK, MONA, BEVERLY HILLS, CA:  
2,449,512. REN. 3-31-11. MULTIPLE CLASS, INT. CLS. 9  
AND 41.
- GOLD & LEVY, INC., SKOKIE, IL, DBA ROSSETO:  
3,954,141, PUB. 2-15-2011. INT. CL. 21.
- GOLD STANDARD ENTERPRISES, INC., SKOKIE, IL:  
1,633,524. REN. 3-31-11. INT. CL. 42.
- GOLD STAR EMS LLC, ALBANY, GA:  
3,954,170, PUB. 2-15-2011. INT. CL. 39.
- GOLDBERG, MATTHEW, AGOURA HILLS, CA:  
2,876,911, CANC. INT. CL. 41.
- GOLDEN CROWN PRODUCE, INC., MIAMI, FL:  
2,877,695, CANC. INT. CL. 30.
- GOLDEN GATE MICROSYSTEMS INCORPORATED, SAN  
RAFAEL, CA, GRAPHICS WEST MICRO SYSTEMS, SAN  
RAFAEL, CA:  
1,144,766. REN. 3-26-11. INT. CL. 7.
- GOLDEN PROTECTIVE SERVICES, SALEM, OR:  
3,954,880, PUB. 2-15-2011. INT. CL. 10.  
3,954,883, PUB. 2-15-2011. INT. CL. 10.
- GOLDEN TECHNOLOGIES, INC., OLD FORGE, PA:  
2,478,187. REN. 3-28-11. INT. CL. 12.
- GOLDEN VALLEY FARMS COMMODITY GROUP, INC.,  
WEST CHESTER, PA, AKA GOLDEN VALLEY FARMS:  
2,493,219. REN. 3-31-11. MULTIPLE CLASS, INT. CLS. 30  
AND 42.
- GOLDEN WEST FINANCIAL, OAKLAND, CA:  
2,876,514, CANC. INT. CL. 36.
- GOLDFARB PROPERTIES, INC., NEW ROCHELLE, NY:  
3,954,842, PUB. 2-15-2011. INT. CL. 36.  
3,954,843, PUB. 2-15-2011. INT. CL. 36.  
3,954,966, PUB. 2-15-2011. INT. CL. 36.
- GOLDSHIELD FIBERGLASS, INC., NEW YORK, NY:  
3,953,364, PUB. 2-15-2011. INT. CL. 12.
- GOLDTOEMORETZ, LLC, NEWTON, NC:  
3,953,108, PUB. 2-15-2011. INT. CL. 25.
- GOLF ETC. OF AMERICA, INC., GRANBURY, TX:  
3,953,970, PUB. 2-15-2011. INT. CL. 25.
- GOLF GALAXY, LLC, CORAOPOLIS, PA:  
3,954,448, PUB. 2-15-2011. INT. CL. 35.

GOLF TOWN OPERATING LIMITED PARTNERSHIP, MARKHAM, ONTARIO, CANADA:  
3,953,134, PUB. 8-3-2010. MULTIPLE CLASS, INT. CLS. 35, 37 AND 41.

GOLUB CORPORATION, SCHENECTADY, NY:  
1,148,595. REN. 3-26-11. MULTIPLE CLASS, INT. CLS. 3, 5, 16, 22, 29, 30, 31, 32 AND 34.

GONZALEZ, SAUL, LOS ANGELES, CA AND MIZRAHI, ISAAC, LOS ANGELES, CA:  
3,955,496, MULTIPLE CLASS, INT. CLS. 38 AND 41.

GOOD FORTUNE, LLC, CLEVELAND, TN:  
3,954,043, PUB. 2-15-2011. INT. CL. 3.

GORELL ENTERPRISES, INC., INDIANA, PA:  
2,379,497, CANC. INT. CL. 19.

GOT NUTS GEAR, SANTEE, CA:  
2,877,698, CANC. INT. CL. 25.

GOTRONICS LLC, SCOTTSDALE, AZ, FORMERLY IREPAIR TEAM LLC:  
3,953,242, PUB. 2-15-2011. INT. CL. 37.

GOURMET SETTINGS INC., RICHMOND HILL, ONTARIO, CANADA:  
3,955,186, MULTIPLE CLASS, INT. CLS. 8 AND 21.

GOVERNMENT PAYMENT SERVICE, INC., INDIANAPOLIS, IN:  
3,955,981, INT. CL. 36.

GPC ENTERPRISES INC., EUGENE, OR, DBA GLENN PLUMBING PRODUCTS:  
2,876,770, CANC. INT. CL. 17.

GRACE HARVEST & ASSOC. LLC, MERCER ISLAND, WA:  
3,953,900, PUB. 2-15-2011. INT. CL. 26.

GRAHAM & ASSOCIATES, INC., SAN FRANCISCO, CA:  
3,954,780, PUB. 2-15-2011. INT. CL. 41.

GRAND ELK, LLC, RADOR, PA:  
2,876,960, CANC. MULTIPLE CLASS, INT. CLS. 25, 28 AND 37.

GRAND HALL ENTERPRISE CO., LTD., TAIPEI, TAIWAN:  
2,876,855, CANC. INT. CL. 11.  
2,876,856, CANC. INT. CL. 11.

GRANITE CITY TOOL COMPANY, WAITE PARK, MN:  
3,956,106, INT. CL. 7.

GRAPHICTHERAPY, NEW YORK, NY:  
3,954,527, PUB. 2-15-2011. INT. CL. 35.

GRASSHOPPER HOUSE, LLC, MALIBU, CA:  
3,953,300, PUB. 7-20-2010. MULTIPLE CLASS, INT. CLS. 44 AND 45.

GRASSHOPPER PACKING COMPANY, LLC, PITTSBURG, KS:  
2,876,795, CANC. INT. CL. 31.

GRAVER TECHNOLOGIES, INC., GLASGOW, DE:  
2,877,693, CANC. INT. CL. 11.  
2,877,694, CANC. INT. CL. 11.

GRAY & COMPANY, FOREST GROVE, OR, GRAY & COMPANY, PORTLAND, OR:  
390,253. REN. 3-26-11. U.S. CL. 46 (INT. CLS. 1, 5, 29, 30, 31 AND 32).

GRAY & COMPANY, FOREST GROVE, OR, GRAY & COMPANY, FOREST GROVE, OR:  
1,172,455. REN. 3-30-11. INT. CL. 29.

GRAY METAL SOUTH, INC., DUNN, NC:  
3,956,009, INT. CL. 6.

GRAY SR., KERRY BRAD, HAMPTON, VA:  
3,954,349, PUB. 2-15-2011. INT. CL. 14.

GREAT BASIN GOLD LIMITED, VANCOUVER, CANADA:  
3,855,110, COR. MULTIPLE CLASS, INT. CLS. 37 AND 42.

GREAT BOOKS SUMMER READING PROGRAM LLC, FAIRFIELD, CT:  
3,040,600, AM. INT. CL. 41.

GREAT LAKES APPRAISAL COMPANY OF GRAND RAPIDS, P.C., GRAND RAPIDS, MI:  
3,954,774, PUB. 2-15-2011. INT. CL. 36.

GREAT NORTHERN ARTS, LTD, SANTA BARBARA, CA:  
2,877,526, CANC. MULTIPLE CLASS, INT. CLS. 9 AND 16.

GREAT PLAINS SOFTWARE, INC., FARGO, ND:  
2,378,723, CANC. INT. CL. 9.

GREATAMERICA LEASING CORPORATION, CEDAR RAPIDS, IA:  
3,955,926, INT. CL. 42.

GREATER DES MOINES MUSIC COALITION, INC., DES MOINES, IA:  
3,954,143, PUB. 2-15-2011. INT. CL. 35.  
3,954,145, PUB. 2-15-2011. INT. CL. 35.

GREATER NORTH MICHIGAN AVENUE ASSOCIATION, THE, CHICAGO, IL:  
2,439,893. REN. 3-30-11. MULTIPLE CLASS, INT. CLS. 35 AND 42.

GREATER PHILADELPHIA TOURISM MARKETING CORPORATION, PHILADELPHIA, PA:  
3,953,954, PUB. 2-15-2011. INT. CL. 35.

GREATER PITTSBURGH CONVENTION AND VISITORS BUREAU, INC., PITTSBURGH, PA, DBA VISITPITTSBURGH:  
3,952,999, PUB. 2-15-2011. INT. CL. 35.

GREEK YEARBOOK LLC, OWINGS MILLS, MD:  
3,954,643, PUB. 2-15-2011. INT. CL. 41.

GREEN ANALYTICS, LLC, BENTONVILLE, AR:  
3,953,210, PUB. 2-15-2011. INT. CL. 37.

GREEN CHOICE FLOORING INTERNATIONAL, INC., HOLLAND, MI:  
3,954,228, PUB. 2-15-2011. INT. CL. 19.

GREEN CONTRACTING COMPANY, INC., BALTIMORE, MD:  
3,953,074, PUB. 2-15-2011. MULTIPLE CLASS, INT. CLS. 11, 37, 40, 41 AND 42.

GREEN GROWTH CONSULTING, CARPINTERIA, CA:  
3,953,974, PUB. 2-15-2011. INT. CL. 31.

GREEN HAT CONSULTANTS INC., SURREY, BC, CANADA:  
3,953,301, PUB. 2-15-2011. INT. CL. 35.

GREEN INDUSTRY INNOVATORS, LLC, LOUISVILLE, OH:  
2,934,616, AM. INT. CL. 12.

GREEN JEANS, LLC, BRYN MAWR, PA, DBA UNDUN DENIM:  
3,954,751, PUB. 2-15-2011. INT. CL. 25.

GREEN LANTERN, INC., SALINA, KS:  
2,877,715, CANC. INT. CL. 21.

GREEN LAYER LLC, PORTLAND, OR:  
3,955,213, INT. CL. 25.

GREEN TURTLE BAY VITAMINS CO., INC., THE, SUMMIT, NJ:  
2,543,792. REN. 3-31-11. INT. CL. 5.

GREENE KING BREWING AND RETAILING LIMITED, SUFFOLK IP33 1QT, UNITED KINGDOM:  
2,876,269, CANC. INT. CL. 32.

GREENE, RAY, GOSHEN, OH:  
2,514,634. REN. 3-31-11. INT. CL. 30.

GREENHEART FARMS, INC, ARROYO GRANDE, CA:  
3,954,181, PUB. 2-15-2011. INT. CL. 31.

GREENLEE TEXTRON INC., ROCKFORD, IL:  
3,956,045, INT. CL. 7.

GREENSTONE FARM CREDIT SERVICES, ACA, EAST LANSING, MI, GREENSTONE FARM CREDIT SERVICES, ACA, EAST LANSING, MI:  
2,493,407. REN. 3-25-11. MULTIPLE CLASS, INT. CLS. 35 AND 36.

GREENTIDE FT CORPORATION, LOS ANGELES, CA:  
3,953,325, PUB. 2-15-2011. INT. CL. 35.

GREENVILLE FEDERAL CREDIT UNION, GREENVILLE, SC:  
2,876,231, CANC. INT. CL. 36.

GREG JARDINE, QLD 4520, AUSTRALIA:  
3,953,565, PUB. 2-15-2011. MULTIPLE CLASS, INT. CLS. 5, 30 AND 32.

GREGG, STEPHEN, LAKE FOREST, CA:  
3,953,119, PUB. 2-15-2011. INT. CL. 25.

GREGORIOUS PRODUCTIONS, INC., ERIN TOWNSHIP, WI:  
2,876,756, CANC. INT. CL. 37.

GREGORY AMUNDSON, SCANDIA, MN:  
3,954,206, PUB. 2-15-2011. INT. CL. 19.

GREGORY E. SHERMAN AND ASSOCIATES, ATLANTIC HIGHLANDS, NJ:  
3,954,933, PUB. 2-15-2011. INT. CL. 36.

- GREGORY LILIEN, CHICAGO, IL:  
3,954,886, PUB. 2-15-2011. INT. CL. 44.
- GRENADIER HOMES, INC., DALLAS, TX:  
3,954,413, PUB. 2-15-2011. INT. CL. 37.
- GRENO, CARRIE PLYMPTON, EAST ROCHESTER, NY:  
3,954,910, PUB. 2-15-2011. INT. CL. 21.
- GRGICH, PETER, LARKSPUR, CO:  
3,954,549, PUB. 2-15-2011. INT. CL. 16.
- GRHK IP, LLC, MIAMI, FL:  
3,954,234, PUB. 2-15-2011. INT. CL. 41.  
3,955,125, PUB. 2-15-2011. INT. CL. 41.
- GRID CONNECT INC, NAPERVILLE, IL:  
3,954,776, PUB. 2-15-2011. INT. CL. 9.
- GRIMWADES LIMITED, STAFFORDSHIRE, ST3 1PA, UNITED KINGDOM:  
2,876,149, CANC. INT. CL. 21.
- GRINNELL MUTUAL REINSURANCE COMPANY, GRINNELL, IA:  
3,954,876, PUB. 2-15-2011. INT. CL. 42.  
3,954,878, PUB. 2-15-2011. INT. CL. 42.
- GRIP POD SYSTEMS, LLC, JACKSONVILLE, FL:  
3,953,100, PUB. 2-15-2011. INT. CL. 13.
- GRISWOLD, KENNETH, LOS ANGELES, CA AND KIM, MIMI, LOS ANGELES, CA, AKA GRISWOLD, MIMI:  
3,954,686, PUB. 2-15-2011. INT. CL. 43.
- GRIZZLY CREEK DEVELOPMENT, LLC, LOS ANGELES, CA:  
2,877,706, CANC. MULTIPLE CLASS, INT. CLS. 36, 37 AND 41.
- GRO MOR, INC., ADAMS, MA:  
3,954,465, PUB. 2-15-2011. INT. CL. 7.
- GRODZKI, LYNN, SILVER SPRING, MD:  
2,379,001, CANC. INT. CL. 41.
- GROUP GOLFER LLC, GROSSE POINTE FARMS, MI:  
3,954,572, PUB. 2-15-2011. INT. CL. 35.
- GROUP VOYAGERS, INC, LITTLETON, CO:  
3,954,185, PUB. 2-15-2011. INT. CL. 39.
- GROUPE CONTROLE INC., PROVINCE OF QUEBEC, CANADA:  
2,875,924, CANC. MULTIPLE CLASS, INT. CLS. 7 AND 42.
- GROUPE LACTALIS, 5300 LAVAL, FRANCE:  
2,412,057, REN. 3-30-11. INT. CL. 29.
- GROUPE PROCYCLE INC./PROCYCLE GROUP INC., QUEBEC, CANADA, DBA ROCKY MOUNTAIN BICYCLES:  
3,953,027, PUB. 2-15-2011. INT. CL. 12.
- GRUEN-SELLS, LTD., CHICAGO, IL, DBA MARKETEDGE GROUP:  
2,378,553, CANC. INT. CL. 36.
- GRUHN, KATHRYN THORSON, CHARLOTTE, NC:  
3,955,599, INT. CL. 16.
- GRUNDENS USA, LTD, POULSBO, WA:  
2,875,998, CANC. INT. CL. 25.
- GRUNDENS USA, LTD., POULSBO, WA:  
3,955,549, INT. CL. 25.
- GRUPO BIMBO, S.A.B. DE C.V., MEXICO CITY, MEXICO:  
3,953,461, PUB. 2-15-2011. INT. CL. 30.
- GRUPO KALTEX, S.A. DE C.V., NAUCALPAN DE JUAREZ, MEXICO:  
2,391,793, REN. 3-29-11. MULTIPLE CLASS, INT. CLS. 20 AND 24.
- GRUPO MINSA, S.A.B. DE C.V., TLALNEPANTLA DE BAZ, MEXICO:  
3,954,308, PUB. 2-15-2011. MULTIPLE CLASS, INT. CLS. 30 AND 31.  
3,954,310, PUB. 2-15-2011. MULTIPLE CLASS, INT. CLS. 30 AND 31.  
3,954,314, PUB. 2-15-2011. MULTIPLE CLASS, INT. CLS. 30 AND 31.  
3,954,319, PUB. 2-15-2011. MULTIPLE CLASS, INT. CLS. 30 AND 31.  
3,954,334, PUB. 2-15-2011. MULTIPLE CLASS, INT. CLS. 30 AND 31.  
3,954,335, PUB. 2-15-2011. MULTIPLE CLASS, INT. CLS. 30 AND 31.  
3,954,340, PUB. 2-15-2011. MULTIPLE CLASS, INT. CLS. 30 AND 31.  
3,954,341, PUB. 2-15-2011. MULTIPLE CLASS, INT. CLS. 30 AND 31.
- 3,954,343, PUB. 2-15-2011. MULTIPLE CLASS, INT. CLS. 30 AND 31.
- 3,954,344, PUB. 2-15-2011. MULTIPLE CLASS, INT. CLS. 30 AND 31.
- GRUPO OMNILIFE, S.A. DE C.V., GUADALAJARA, JALISCO, MEXICO, DBA GOM940311LF7:  
3,955,948, INT. CL. 32.
- GRUPO POSADAS, S.A.B. DE C.V., MEXICO CITY, MEXICO:  
3,953,173, PUB. 8-3-2010. INT. CL. 43.  
3,953,174, PUB. 8-3-2010. INT. CL. 43.
- GSBS DEVELOPMENT CORPORATION, CHARLOTTE, NC:  
2,876,718, CANC. INT. CL. 9.
- GTECH CORPORATION, WEST GREENWICH, RI:  
2,103,839, CANC. INT. CL. 9.
- GTFM, INC., NEW YORK, NY:  
3,955,072, PUB. 2-15-2011. INT. CL. 25.
- GTSI CORP., HERNDON, VA:  
2,436,560, REN. 3-25-11. MULTIPLE CLASS, INT. CLS. 35 AND 42.
- GUANGQI HONDA AUTOMOBILE CO., LTD., CHINA:  
3,953,675, PUB. 2-15-2011. MULTIPLE CLASS, INT. CLS. 7, 12 AND 37.
- GUANGZHOU TIGER HEAD BATTERY GROUP CO., LTD., CHINA:  
3,953,657, PUB. 2-15-2011. INT. CL. 9.
- GUARANTY BANK, FSB, MILWAUKEE, WI FROM GUARANTY FEDERAL BANK, F.S.B., DALLAS, TX:  
3,952,948, PUB. 10-8-2002. INT. CL. 36.
- GUARANTY FEDERAL BANK, F.S.B.:  
*See—GUARANTY BANK, FSB.*
- GUARDIAN BUSINESS SOLUTIONS, INC., BROOKFIELD, WI:  
2,628,838, CANC. MULTIPLE CLASS, INT. CLS. 9 AND 35.
- GUARDIAN LIFE INSURANCE COMPANY OF AMERICA, THE, NEW YORK, NY:  
1,637,817, REN. 3-25-11. INT. CL. 36.
- GUBERT CERT, ROGER, BARCELONA, SPAIN AND ROGER, JAUME PALAU-RIBES, BARCELONA, SPAIN:  
3,954,708, PUB. 2-15-2011. MULTIPLE CLASS, INT. CLS. 12 AND 25.
- GUERLAIN S.A. (SOCIÉTÉ ANONYME), FRANCE:  
3,953,536, PUB. 2-15-2011. INT. CL. 3.
- GUERLAIN S.A., SOCIÉTÉ ANONYME, FRANCE:  
3,953,535, PUB. 2-15-2011. MULTIPLE CLASS, INT. CLS. 3 AND 42.
- GUERLAIN SOCIÉTÉ ANONYME, 75008 PARIS, FRANCE:  
3,953,827, PUB. 2-15-2011. INT. CL. 3.
- GUETTA THIERRY, LOS ANGELES, CA:  
3,955,187, INT. CL. 25.
- GUEUNOUN JACQUES, FRANCE AND GUEUNOUN MICHÈLE, FRANCE:  
3,953,615, PUB. 2-15-2011. INT. CL. 8.
- GUITAR CENTER, INC., WESTLAKE VILLAGE, CA:  
3,955,102, PUB. 2-15-2011. INT. CL. 35.
- GUNDIES LLC, NEW YORK, NY:  
3,953,170, PUB. 2-15-2011. INT. CL. 25.
- GUNN, JOSHUA R, CAMBRIDGE, MA, DBA PLANET NUTSHELL:  
3,954,900, PUB. 2-15-2011. INT. CL. 41.
- GUNTER, BARBARA, MONROE TOWNSHIP, NJ:  
3,955,691, MULTIPLE CLASS, INT. CLS. 16 AND 28.
- GURIT (UK) LTD, UNITED KINGDOM:  
3,953,617, PUB. 2-15-2011. MULTIPLE CLASS, INT. CLS. 1, 17 AND 19.
- GURUZ 3 LLC, SMYRNA, GA:  
3,953,263, PUB. 2-15-2011. INT. CL. 9.
- GWG GROUP, LLC, SANTA MONICA, CA:  
2,877,272, CANC. INT. CL. 35.
- GWINN, RAYMOND, BECKLEY, WV:  
3,954,249, PUB. 2-15-2011. INT. CL. 15.  
3,954,254, PUB. 2-15-2011. INT. CL. 15.
- H. LOEB CORPORATION, NEW BEDFORD, MA:  
1,149,811, REN. 3-31-11. INT. CL. 17.
- H.B. FULLER COMPANY, SAINT PAUL, MN:  
3,955,514, INT. CL. 35.

H.D. HUDSON MANUFACTURING COMPANY, CHICAGO, IL:  
548,357. REN. 3-29-11. U.S. CL. 23 (INT. CL. 8).

H.D.N. HOLDINGS CORPORATION, FITCHBURG, MA:  
2,877,770. CANC. INT. CL. 1.

H.G. HASTINGS CO., ATLANTA, GA:  
3,954,212. PUB. 2-15-2011. INT. CL. 35.

H.W. NAYLOR COMPANY, INC., MORRIS, NY:  
2,429,299. REN. 3-25-11. INT. CL. 5.

H&M SYSTEMS SOFTWARE, INC., UPP-ER SADDLE RIVER, NJ:  
2,483,258. REN. 3-25-11. INT. CL. 9.

HAEMONETICS CORPORATION, BRAintree, MA:  
3,955,348. MULTIPLE CLASS, INT. CLS. 35 AND 44.

HAHN, CATHY J., LONGMONT, CO:  
2,876,796. CANC. INT. CL. 25.

HAINING OUPAI RINENG SOLAR WATER HEATER CO., LTD, CHINA:  
3,953,642. PUB. 2-15-2011. INT. CL. 11.

HAIR SALONS, INC., BENNET, NE, DBA SPORTSMANS HAIRCUT:  
3,956,203. INT. CL. 3.

HALDANKAR, SHAMIM, NEWBURY PARK, CA:  
3,955,960. INT. CL. 44.

HALDEX BRAKE CORPORATION, KANSAS CITY, MO, ANCHORLOK CORP., MUSKEGON, MI:  
1,639,667. REN. 3-28-11. INT. CL. 12.

HALE CENTRE THEATRE, SALT LAKE CITY, UT, DBA HALE CENTRE THEATRE:  
3,953,440. PUB. 2-15-2011. INT. CL. 41.

HALL & PARTNERS USA LLC, NEW YORK, NY:  
3,954,783. PUB. 2-15-2011. INT. CL. 35.

HALLIBURTON ENERGY SERVICES, INC., CARROLLTON, TX, HALLIBURTON COMPANY, DUNCAN, OK, DBA HALLIBURTON SERVICES:  
927,120. REN. 3-31-11. U.S. CL. 12 (INT. CL. 19).

HALLIBURTON ENERGY SERVICES, INC., CARROLLTON, TX:  
2,539,664. REN. 3-28-11. INT. CL. 1.  
3,955,080. PUB. 2-15-2011. INT. CL. 1.

HALLMARK BUSINESS CONNECTIONS, INC., MINNEAPOLIS, MN:  
3,953,349. PUB. 2-15-2011. INT. CL. 35.

HALLSTAR INNOVATIONS CORP., CHICAGO, IL:  
2,445,078. REN. 3-30-11. INT. CL. 1.

HALSTEAD, RUSSELL, SHEFFIELD LAKE, OH:  
2,379,526. CANC. INT. CL. 37.

HAMCO, INC., GONZALES, LA:  
2,877,786. CANC. INT. CL. 16.

HAMEL, SCOTT W, ESTERO, FL, DBA "WHAT IF" FINANCIAL FORECASTING:  
3,953,462. PUB. 2-15-2011. INT. CL. 36.

HAMILTON SUNDSTRAND CORPORATION, WINDSOR LOCKS, CT:  
718,527. REN. 3-29-11. U.S. CL. 23 (INT. CL. 7).

HAMILTON, RODNEY, MANSFIELD, LA:  
2,876,712. CANC. INT. CL. 9.

HAMMER DIRECT LLC, PLYMOUTH, MN:  
2,877,142. CANC. INT. CL. 9.

HAMMERHOUSE DESIGNS LLC, GAMBRILLS, MD:  
3,955,528. INT. CL. 25.

HAMMOND, CRAIG M., SAN FRANCISCO, CA:  
2,876,991. CANC. INT. CL. 35.

HAMMOND'S CANDIES SINCE 1920 II, LLC, DENVER, CO:  
3,954,604. PUB. 2-15-2011. INT. CL. 30.

HAMMONDS TECHNICAL SERVICES, INC., HOUSTON, TX:  
2,431,340. REN. 3-26-11. INT. CL. 7.

HAN, GINA, BEVERLY HILLS, CA:  
3,955,743. INT. CL. 30.

HANS OETIKER AG MASCHINEN- UND APPARATEFABRIK, CH-8812 HORGEN 2, SWITZERLAND:  
1,640,201. REN. 3-29-11. INT. CL. 6.

HANS PRIES GMBH & CO. KG, 27777 GANDERKESEE, FED REP GERMANY:  
3,953,582. PUB. 2-15-2011. MULTIPLE CLASS, INT. CLS. 6, 7, 9, 11, 12 AND 17.

HANSEN MEDICAL, INC., MOUNTAIN VIEW, CA:  
3,955,884. INT. CL. 10.

HANSON, CARL RALPH, TUCSON, AZ:  
2,876,556. CANC. INT. CL. 14.

HANWHA MACHINERY CO., LTD., CHANGWON CITY, REPUBLIC OF KOREA:  
2,877,549. CANC. INT. CL. 7.

HAPPY JACK, INC., SNOW HILL, NC:  
1,156,955. REN. 3-25-11. INT. CL. 5.

HARBOR DUCK ADVENTURES CO., SAUGATUCK, MI:  
3,955,226. INT. CL. 12.

HARBOR FREIGHT TOOLS USA, INC., CALABASAS, CA:  
2,438,888. REN. 3-29-11. INT. CL. 35.

HARBORCHEM, CRANFORD, NJ:  
2,447,361. REN. 3-29-11. INT. CL. 1.

HARCOURT SUPPLEMENTAL PUBLISHERS INC., AUSTIN, TX:  
2,379,157. CANC. INT. CL. 41.

HARD BARGIN ENTERPRISES, JAMUL, CA:  
2,379,824. CANC. INT. CL. 25.

HARDINGE, INC., ELMIRA, NY:  
2,492,633. REN. 3-28-11. INT. CL. 7.

HARGER, PAUL, BINGHAMTON, NY:  
3,953,147. PUB. 2-15-2011. INT. CL. 1.

HARMAN M.D., DEBRA, BRISTOL, VA:  
3,955,818. INT. CL. 44.

HARMAN MUSIC GROUP, NORTHRIDGE, CA:  
2,396,126. REN. 3-31-11. INT. CL. 9.

HARPER, BOBBY, LA MARQUE, TX:  
3,955,614. INT. CL. 25.

HARPER'S RESTAURANTS, INCORPORATED, CHARLOTTE, NC:  
2,379,621. CANC. INT. CL. 42.

HARRIS BEACH PLLC, PITTSFORD, NY:  
2,379,587. CANC. INT. CL. 42.

HARRIS, APRIL, PATERSON, NJ:  
2,379,676. CANC. INT. CL. 41.

HARRIS, CURTIS JAMES, DARNESTOWN, MD:  
2,877,980. CANC. INT. CL. 9.

HARRISON, RANDY, NEW ROCHELLE, NY:  
3,953,381. PUB. 2-15-2011. INT. CL. 41.

HARTELEGA SDN. BHD., KUALA LUMPUR, MALAYSIA:  
3,955,370. INT. CL. 10.

HARTWELL CORPORATION, PLACENTIA, CA:  
1,190,430. REN. 3-31-11. INT. CL. 6.

HARTZELL, M. LEONTINE, ANDOVER, MA, DBA EYE OF THE EAGLE CENTER FOR SPIRITUAL LIGHT:  
3,956,250. INT. CL. 41.

HARVEY BALL SMILE LIMITED, SHINAGAWA-KU, JAPAN:  
3,955,272. MULTIPLE CLASS, INT. CLS. 9, 14, 21, 24, 28 AND 30.

HASBRO, INC., PAWTUCKET, RI, WADDINGTONS GAMES LIMITED, OULTON, LEEDS, ENGLAND:  
1,644,488. REN. 3-31-11. INT. CL. 28.

HASBRO, INC., PAWTUCKET, RI:  
2,466,675. REN. 3-31-11. INT. CL. 28.  
2,877,921. CANC. INT. CL. 28.  
2,877,924. CANC. INT. CL. 28.

HATTIE GRACE ELLIOT, NEW YORK, NY, DBA THE GRACE LIST:  
3,953,850. PUB. 2-15-2011. INT. CL. 41.

HAUG GMBH & CO. KG, LEINFELDEN-ECHTERDINGEN, FED REP GERMANY:  
1,638,934. REN. 3-30-11. MULTIPLE CLASS, INT. CLS. 9 AND 11.

HAUGHEY, LARRY, ADA, MI:  
2,877,677. CANC. INT. CL. 25.

HAUPERT, CHRISTINA, WEYMOUTH, MA:  
3,954,778. PUB. 2-15-2011. INT. CL. 41.

HAUTE HOSTESS LLC, PARK CITY, UT:  
3,954,439. PUB. 2-15-2011. INT. CL. 41.

HAVANA CLUB HOLDING, S.A., LUXEMBOURG, LUXEMBOURG:  
3,953,446. PUB. 2-15-2011. INT. CL. 33.

- HAVILAND CONSUMER PRODUCTS, INC., GRAND RAPIDS, MI:  
1,639,455. REN. 3-29-11. INT. CL. 1.  
1,644,410. REN. 3-29-11. INT. CL. 17.
- HAVUS ENTERPRISES, INC., OKLAHOMA CITY, OK:  
2,877,998, CANC. INT. CL. 35.
- HAWK'S CAY MANAGEMENT, INC., POMPANO BEACH, FL, DBA HAWK'S CAY RESORT AND MARINA:  
2,379,590, CANC. INT. CL. 42.
- HAWKEYE SYSTEMS, LLC, ALEXANDRIA, VA:  
2,876,135, CANC. MULTIPLE CLASS, INT. CLS. 35, 42 AND 45.
- HAYES JEWELERS INC., LEXINGTON, NC:  
3,953,460, PUB. 2-15-2011. INT. CL. 35.
- HAYES, JAMES, L., HONOLULU, HI:  
2,877,407, CANC. INT. CL. 28.
- HAYES, LAURA L. SMYRNA, TN:  
2,877,548, CANC. INT. CL. 35.
- HAYNES-PEDRAZA, LINDA, ALAMEDA, CA:  
3,953,756, PUB. 2-15-2011. INT. CL. 35.
- HBI BRANDED APPAREL ENTERPRISES, LLC, WINSTON-SALEM, NC:  
2,876,973, CANC. INT. CL. 25.  
2,877,329, CANC. INT. CL. 25.  
3,955,920, INT. CL. 25.
- HC CREATIVE COMMUNICATIONS, LLC, BETHESDA, MD:  
2,379,033, CANC. MULTIPLE CLASS, INT. CLS. 35 AND 42.
- HCA-HEALTHONE LLC, DENVER, CO:  
3,955,426, INT. CL. 36.
- HCL FASTENERS LIMITED, BATH, UNITED KINGDOM:  
2,877,048, CANC. INT. CL. 20.
- HDKARAOKE, LLC, ST. LOUIS, MO:  
3,955,548, INT. CL. 9.
- HDM FURNITURE INDUSTRIES, INC., HIGH POINT, NC:  
3,955,484, INT. CL. 20.
- HDN DEVELOPMENT CORPORATION, WINSTON-SALEM, NC:  
3,953,321, PUB. 2-15-2011. INT. CL. 30.
- HDS IP HOLDINGS, LLC, LAS VEGAS, NV:  
1,644,947. REN. 3-25-11. INT. CL. 6.
- HEAD & ASSOCIATES, PORTLAND, ME:  
3,955,722, INT. CL. 36.
- HEADQUEST, INC., ALBUQUERQUE, NM:  
3,954,579, PUB. 2-15-2011. INT. CL. 16.
- HEADWEB AB, SWEDEN:  
3,953,583, PUB. 2-15-2011. MULTIPLE CLASS, INT. CLS. 16, 38 AND 41.
- HEALTH & BEAUTY ASSOCIATION LLC, MANHASSET, NY:  
2,876,429, CANC. INT. CL. 35.  
2,876,430, CANC. INT. CL. 35.
- HEALTH CENTER FOR BETTER LIVING, INC, NAPLES, FL:  
3,955,059, PUB. 2-15-2011. INT. CL. 5.
- HEALTH FUSION BRANDS, INC., MARIETTA, GA:  
3,954,769, PUB. 2-15-2011. INT. CL. 32.
- HEALTH PROMOTION SPECIALISTS, LLC, COLUMBIA, SC:  
3,953,259, PUB. 2-15-2011. INT. CL. 44.
- HEALTHBANKS BIOTECH USA, INC., IRVINE, CA, DBA PACIFICORD:  
3,955,285, MULTIPLE CLASS, INT. CLS. 35, 39 AND 44.
- HEALTHCARE RISK SPECIALISTS, LLC, WEST HARTFORD, CT:  
2,876,596, CANC. INT. CL. 36.
- HEALTHDATAINSIGHTS, INC., LAS VEGAS, NV:  
3,955,539, INT. CL. 45.
- HEALTHMAGIC, DENVER, CO:  
2,875,846, CANC. INT. CL. 9.
- HEALTHY 'N FIT INTERNATIONAL, INC., CROTON-ON-HUDSON, NY:  
1,644,215. REN. 3-26-11. INT. CL. 5.
- HEALTH20 PRODUCTS, LLC, DALLAS, TX:  
3,955,837, INT. CL. 3.
- HEAR DIRECT, INC., MOORESVILLE, NC:  
2,876,689, CANC. INT. CL. 35.  
2,876,690, CANC. INT. CL. 35.
- HEARD DESIGN LLC, AUSTIN, TX, DBA HOWLER BROTHERS:  
3,956,052, INT. CL. 25.  
3,956,053, INT. CL. 25.  
3,956,054, INT. CL. 25.
- HEARING RESEARCH INSTITUTE, INC., THE, SUNRISE, FL:  
2,562,902, CANC. MULTIPLE CLASS, INT. CLS. 16 AND 41.
- HEARTLAND INTERNATIONAL TRADE SHOWS, INC., IOLA, WI:  
2,877,437, CANC. MULTIPLE CLASS, INT. CLS. 16 AND 35.
- HEARTLAND PAYMENT SYSTEMS, INC., PRINCETON, NJ:  
2,877,400, CANC. INT. CL. 36.
- HEAT AND CONTROL, INC., HAYWARD, CA:  
3,952,986, PUB. 2-15-2011. INT. CL. 9.  
3,954,331, PUB. 2-15-2011. INT. CL. 11.
- HEAT AND CONTROL, INC, HAYWARD, CA:  
3,954,328, PUB. 2-15-2011. INT. CL. 7.
- HEATCO, INC., CARTERSVILLE, GA:  
3,953,157, PUB. 2-15-2011. MULTIPLE CLASS, INT. CLS. 11 AND 40.
- HEBERT, TIM, AVON, CO:  
2,878,033, CANC. INT. CL. 16.
- HEFTER, EUGENE, CHICAGO, IL, AKA EUGENIUSZ HEFTER:  
3,955,752, INT. CL. 44.
- HEIDINGER, KURT, WESTHAMPTON, MA:  
3,954,927, PUB. 2-15-2011. INT. CL. 41.
- HEIMBACH GMBH & CO. KG, DUREN, FED REP GERMANY:  
2,445,386. REN. 3-26-11. INT. CL. 7.
- HEINER RASCHHOFFER, SALZBURG, AUSTRIA:  
3,953,491, PUB. 2-15-2011. INT. CL. 43.
- HELDOR INDUSTRIES, INC., MORRISTOWN, NJ TO ALLIANCE TRADING, INC., COVINGTON, LA:  
1,424,489, CANC. INT. CL. 1.
- HELP/SYSTEMS, LLC, EDAN PRAIRIE, MN:  
1,642,436. REN. 3-31-11. INT. CL. 9.
- HEMOTEQ AG, WUERSELEN, FED REP GERMANY:  
2,931,143, AM. MULTIPLE CLASS, INT. CLS. 40 AND 42.
- HENDRICKS, CHARLOTTE M, PELHAM, AL:  
3,953,983, PUB. 2-15-2011. INT. CL. 16.
- HENKEL CORPORATION, ROCKY HILL, CT:  
290,222. REN. 3-30-11. U.S. CL. 6 (INT. CL. 1).  
2,877,792, CANC. INT. CL. 16.  
3,955,297, INT. CL. 1.
- HENRY-GRIFFITTS, INC., HAYDEN LAKE, ID:  
2,378,571, CANC. INT. CL. 42.
- HERBAL HEALTH LIMITED, MAIDSTONE, KENT, GREAT BRITAIN:  
2,389,010. REN. 3-31-11. INT. CL. 30.
- HERCULES INCORPORATED, WILMINGTON, DE, HERCULES POWDER COMPANY, WILMINGTON, DE:  
556,398. REN. 3-28-11. U.S. CL. 6 (INT. CL. 1).
- HERITAGE CANDY COMPANY, INC., VAN NUYS, CA:  
3,956,140, INT. CL. 30.
- HERITAGE PARK SOCIETY, CALGARY, ALBERTA, CANADA:  
3,953,038, PUB. 2-15-2011. MULTIPLE CLASS, INT. CLS. 16, 25 AND 35.
- HERITAGE PRESERVATION CORPORATION, SPARTANBURG, SC:  
2,876,733, CANC. INT. CL. 39.
- HERMAN MILLER, INC., ZEELAND, MI:  
712,007. REN. 3-30-11. U.S. CL. 12 (INT. CL. 6).
- HERMANN MELLERT GMBH & CO. KG, BRETTEN, FED REP GERMANY:  
2,876,994, CANC. INT. CL. 11.
- HERMES INTERNATIONAL, PARIS, FRANCE:  
2,877,274, CANC. INT. CL. 18.
- HERNANDEZ MORA, HECTOR, BAKERSFIELD, CA:  
3,954,063, PUB. 2-15-2011. INT. CL. 41.

HERNANDEZ, ALFONSO, MEXICO CITY, DF 01000, MEXICO:  
2,876,096, CANC. INT. CL. 41.

HERNANDEZ, SHELLIE A., LAS VEGAS, NV, DBA IN-KJETS.COM:  
2,877,321, CANC. INT. CL. 35.

HERSHEY CHOCOLATE & CONFECTIONERY CORPORATION, WHEAT RIDGE, CO:  
3,954,547, PUB. 2-15-2011. INT. CL. 30.  
3,954,702, PUB. 2-15-2011. INT. CL. 30.  
3,954,706, PUB. 2-15-2011. INT. CL. 30.

HERSHEY, JACOB, BUTLER, PA:  
3,955,664, INT. CL. 37.

HEXION SPECIALTY CHEMICALS, INC., COLUMBUS, OH:  
3,955,107, PUB. 2-15-2011. INT. CL. 2.  
3,955,108, PUB. 2-15-2011. INT. CL. 2.

HEY JOE WINE CO., LLC, MINNEAPOLIS, MN:  
3,954,868, PUB. 2-15-2011. INT. CL. 33.

HI-PERFORMANCE HEALTH PTY LTD, AUSTRALIA:  
3,953,539, PUB. 2-15-2011. MULTIPLE CLASS, INT. CLS. 30 AND 32.

HIGGINS, LISA, DULUTH, GA:  
3,954,767, PUB. 2-15-2011. INT. CL. 36.

HIGH ACHIEVERS INC, BROOKLYN, NY:  
3,952,983, PUB. 2-15-2011. INT. CL. 41.

HIGH CO. SOCIETE ANONYME A DIRECTOIRE ET CONSEIL DE SURVEILLANCE, 13799 AIX-EN-PROVENCE CEDEX 3, FRANCE:  
2,876,962, CANC. MULTIPLE CLASS, INT. CLS. 38, 41 AND 42.

HILL FINANCIAL GROUP, LTD, DARIEN, CT:  
3,953,391, PUB. 2-15-2011. INT. CL. 35.

HILL, ARMANDO D., AVONDALE ESTATES, GA:  
3,954,110, PUB. 2-15-2011. INT. CL. 41.

HILLSON, CYNTHIA, CORNELIUS, NC:  
3,953,707, PUB. 2-15-2011. INT. CL. 16.

HINDSIGHT RECORDS, MASSENA, NY:  
3,954,381, PUB. 2-15-2011. INT. CL. 9.

HIP DESIGN, MOUNT VERNON, WA:  
3,955,323, INT. CL. 42.

HIPAA SOLUTIONS, LC, SUGAR LAND, TX:  
3,956,159, INT. CL. 9.

HIPPOPRESS LLC, MANCHESTER, NH:  
2,877,043, CANC. INT. CL. 16.

HIRATA, DEBBE, SEATTLE, WA:  
3,955,690, INT. CL. 41.

HIS BREATH NOW PUBLICATIONS, LLC, WHITE, GA:  
3,954,298, PUB. 2-15-2011. INT. CL. 16.

HISCOT CO., LTD., KYOUNGGI-DO, REPUBLIC OF KOREA:  
2,877,124, CANC. MULTIPLE CLASS, INT. CLS. 32, 33, 35 AND 43.

HISPANOCARE, INC., CHICAGO, IL, DBA HISPANOCARE:  
1,562,518, CANC. INT. CL. 35.

HISTORIC INALAHAN FOUNDATION, INC., INARAJAN, HI:  
3,954,459, PUB. 2-15-2011. INT. CL. 16.

HITACHI HIGH-TECHNOLOGIES CORPORATION, JAPAN:  
3,953,640, PUB. 2-15-2011. INT. CL. 9.

HITECH RIBBON LLC, RICHMOND, VA:  
3,953,131, PUB. 2-15-2011. INT. CL. 9.

HL GAMES LIMITED, BANBURY OXFORDSHIRE, UNITED KINGDOM:  
2,941,792, CANC. MULTIPLE CLASS, INT. CLS. 9 AND 16.

HL OPERATING CORPORATION, LEBANON, TN:  
3,955,997, INT. CL. 18.

HLT DOMESTIC IP LLC, MCLEAN, VA:  
2,517,367, REN. 3-29-11. INT. CL. 42.  
2,547,016, REN. 3-25-11. INT. CL. 42.  
3,953,864, PUB. 2-15-2011. INT. CL. 43.

HMH IP COMPANY, DUBLIN, IRELAND, LEARNING COMPANY, THE, FREMONT, CA:  
1,616,866, REN. 3-25-11. INT. CL. 28.

HMR ACQUISITION COMPANY, INC., SOUTH BEND, IN, DBA HACIENDA MEXICAN RESTAURANTS:  
2,484,222, REN. 3-26-11. INT. CL. 42.

HMSHOST CORPORATION, BETHESDA, MD:  
2,438,641, REN. 3-30-11. INT. CL. 42.

HO, LILI G. LEE, LOS ANGELES, CA:  
2,876,138, CANC. INT. CL. 30.

HOAG MEMORIAL HOSPITAL PRESBYTERIAN, NEWPORT BEACH, CA:  
3,956,080, MULTIPLE CLASS, INT. CLS. 41 AND 44.

HOBO INC, LAKEVILLE, MN:  
3,953,906, PUB. 2-15-2011. INT. CL. 3.

HOCHSTETLER MILLING, LTD, LOUDONVILLE, OH:  
3,952,975, PUB. 2-15-2011. MULTIPLE CLASS, INT. CLS. 35 AND 41.

HOCKEY HALL OF FAME AND MUSEUM, TORONTO, ONTARIO, M5E 1X8, CANADA:  
2,485,639, REN. 3-28-11. INT. CL. 35.

HODGDON POWDER COMPANY, INC., SHAWNEE MISSION, KS:  
3,954,508, PUB. 2-15-2011. INT. CL. 13.  
3,955,002, PUB. 2-15-2011. INT. CL. 13.  
3,955,003, PUB. 2-15-2011. INT. CL. 13.  
3,955,004, PUB. 2-15-2011. INT. CL. 13.  
3,955,005, PUB. 2-15-2011. INT. CL. 13.  
3,955,006, PUB. 2-15-2011. INT. CL. 13.

HOFFMAN, LISA, NEW YORK, NY, DBA SOLO FITNESS:  
3,955,009, PUB. 2-15-2011. MULTIPLE CLASS, INT. CLS. 41 AND 44.

HOFFMASTER GROUP, INC., OSHKOSH, WI:  
2,439,005, REN. 3-31-11. INT. CL. 16.

HOGAN ASSESSMENT SYSTEMS, INC., TULSA, OK:  
3,954,062, PUB. 2-15-2011. INT. CL. 16.

HOLCOMB, KELLY, HUNTINGTON BEACH, CA:  
3,955,096, PUB. 2-15-2011. INT. CL. 30.

HOLIDAY FOOD CENTER INC., ROYAL OAK, MI:  
2,877,871, CANC. INT. CL. 35.

HOLISTIC PHYSICAL THERAPY SERVICES INC., SOUTH PORTLAND, ME:  
3,955,145, PUB. 2-15-2011. INT. CL. 44.

HOLLAND AMERICAN FOOD CO., GRAND RAPIDS, MI:  
2,495,452, REN. 3-28-11. INT. CL. 35.  
2,496,261, REN. 3-25-11. INT. CL. 35.

HOLLEY, MARY F., ARAB, AL:  
2,877,079, CANC. INT. CL. 41.

HOLMES, SHAWN, LAGUNA HILLS, CA, DBA MAW 'N PAW KETTLEKORN:  
3,955,014, PUB. 2-15-2011. INT. CL. 30.

HOLTZMAN, SANDRA, NEW YORK, NY:  
2,216,004, CANC. INT. CL. 35.

HOLZ, M. KAREN, SUPERIOR, CO:  
3,954,570, PUB. 2-15-2011. INT. CL. 16.

HOME BOX OFFICE, INC., NEW YORK, NY:  
2,378,817, CANC. INT. CL. 41.

HOME BUILDERS ASSOCIATION OF GREATER CHICAGO, LOMBARD, IL:  
2,878,081, CANC. INT. CL. 35.

HOME COMFORT, INC., PEORIA, IL:  
2,469,571, REN. 3-26-11. INT. CL. 37.

HOME HEALTHCARE PARTNERS, LLC, DALLAS, TX:  
3,955,745, MULTIPLE CLASS, INT. CLS. 44 AND 45.

HOME INSTEAD, INC., OMAHA, NE:  
3,953,897, PUB. 2-15-2011. INT. CL. 45.

HOME LEGEND, LLC., CHINO, CA:  
3,954,400, PUB. 2-15-2011. INT. CL. 19.  
3,954,959, PUB. 2-15-2011. INT. CL. 19.

HOMELAND FOUNDATION, INCORPORATED, NEW YORK, NY:  
2,440,188, REN. 3-30-11. INT. CL. 41.

HOMESPUN TAPES, LTD., WOODSTOCK, NY:  
1,649,333, REN. 3-26-11. INT. CL. 9.

HOMETASK, INC., SEATTLE, WA, DBA FREGGIES:  
3,954,139, PUB. 2-15-2011. INT. CL. 39.

HONDA GIKEN KOGYO KABUSHIKI KAISHA (HONDA MOTOR CO., LTD.), MINATO-KU, TOKYO, JAPAN:  
2,528,502, REN. 3-31-11. MULTIPLE CLASS, INT. CLS. 9 AND 28.

HONDA GIKEN KOGYO KABUSHIKI KAISHA (HONDA MOTOR CO. LTD.), TOKYO, JAPAN:  
3,056,706, CANC. MULTIPLE CLASS, INT. CLS. 37 AND 39.

- HONEST ENGINE FILMS, INC., PEBBLE BEACH, CA:  
3,954,026, PUB. 2-15-2011. INT. CL. 41.
- HONEYWELL INTERNATIONAL INC., MORRISTOWN, NJ:  
729,052. REN. 3-29-11. U.S. CL. 6 (INT. CL. 1).  
2,552,287. REN. 3-29-11. INT. CL. 9.
- HONG KONG CITY TOYS FACTORY LIMITED, KOW-  
LOON, HONG KONG:  
2,450,149. REN. 3-26-11. INT. CL. 28.  
2,450,150. REN. 3-26-11. INT. CL. 28.  
2,450,151. REN. 3-26-11. INT. CL. 28.  
2,450,152. REN. 3-26-11. INT. CL. 28.
- HONSA ERGONOMIC TECHNOLOGIES, INC., MILAN, IL:  
3,954,329, PUB. 2-15-2011. INT. CL. 7.  
3,954,958, PUB. 2-15-2011. INT. CL. 7.
- HOO-AHHS, LLC, SAINT PAUL, MN:  
3,954,639, PUB. 2-15-2011. INT. CL. 3.
- HOOKED INDUSTRIES, LLC, POLSON, MT:  
3,954,830, PUB. 2-15-2011. INT. CL. 25.  
3,954,904, PUB. 2-15-2011. INT. CL. 25.
- HOOKED NATION, INC., VERO BEACH, FL:  
3,954,924, PUB. 2-15-2011. INT. CL. 25.  
3,955,101, PUB. 2-15-2011. INT. CL. 25.
- HOOKS TOWING AND RECOVERY SUPPLY, LLC,  
WYNNE, AR:  
3,953,977, PUB. 2-15-2011. INT. CL. 22.
- HOPE 360, INC, ATLANTA, GA:  
3,955,480, INT. CL. 41.
- HOPELESS RECORDS, INC., VAN NUYS, CA:  
2,442,084. REN. 3-25-11. INT. CL. 41.  
2,876,520, CANC. MULTIPLE CLASS, INT. CLS. 16 AND  
35.
- HOPKINS MEDICAL PRODUCTS, BALTIMORE, MD:  
3,912,639, AM. MULTIPLE CLASS, INT. CLS. 5, 9, 10, 11,  
18, 21 AND 40.
- HOPKINS, DAVID, AMHERST, MA:  
2,551,172. REN. 3-29-11. INT. CL. 36.
- HORIZON HOUSE PUBLICATIONS, INC., NORWOOD, MA:  
909,171. REN. 3-31-11. U.S. CL. 38 (INT. CL. 16).
- HOSA TECHNOLOGY, INC., BUENA PARK, CA:  
2,462,733. REN. 3-31-11. INT. CL. 9.
- HOSPICE OF HUNTINGTON, INC., HUNTINGTON, WV:  
3,954,561, PUB. 2-15-2011. INT. CL. 44.
- HOSPIRA, INC., LAKE FOREST, IL:  
708,780. REN. 3-26-11. U.S. CL. 44 (INT. CL. 10).  
1,150,766. REN. 3-26-11. INT. CL. 5.
- HOTFILE CORP., FORT LAUDERDALE, FL:  
3,954,358, PUB. 2-15-2011. INT. CL. 42.
- HOUGHTON MIFFLIN HARCOURT PUBLISHING COM-  
PANY, BOSTON, MA:  
2,434,289. REN. 3-31-11. INT. CL. 16.
- HOUSE FOODS CORPORATION, HIGASHI-OSAKA, OSA-  
KA, JAPAN:  
3,828,755, COR. MULTIPLE CLASS, INT. CLS. 5 AND 32.
- HOUSE OF PEARL FASHIONS (US) LTD., LODI, NJ:  
2,876,241, CANC. INT. CL. 25.
- HOUSE SPIRITS LLC, PORTLAND, OR:  
3,953,967, PUB. 2-15-2011. INT. CL. 33.
- HOUSTONIAN GOLF, LTD., HOUSTON, TX:  
2,439,084. REN. 3-28-11. INT. CL. 42.  
2,439,086. REN. 3-29-11. INT. CL. 25.  
2,439,087. REN. 3-28-11. INT. CL. 24.
- HOWI INC, YORKTOWN HEIGHTS, NY:  
3,956,177, INT. CL. 8.
- HPF CORPORATION, SANTEE, CA:  
3,955,176, INT. CL. 15.
- HSIAO AND MONTANO, INC., SAN GABRIEL, CA:  
2,519,263. REN. 3-28-11. MULTIPLE CLASS, INT. CLS. 9  
AND 12.
- HSIEH, VIET FAI TSE, ALHAMBRA, CA:  
2,876,008, CANC. INT. CL. 35.
- HSM GMBH & CO. KG, FRICKINGEN, FED REP GER-  
MANY:  
3,955,404, INT. CL. 7.
- HT PET PRODUCTS, LLC, EL PASO, TX:  
2,877,773, CANC. MULTIPLE CLASS, INT. CLS. 18 AND  
31.
- HUBBARD, DICK, CRYSTAL LAKE, IL, DBA AMISH  
FURNITURE GALLERY, INC.:  
3,955,266, INT. CL. 20.
- HUBBELL INCORPORATED, SHELTON, CT:  
3,955,235, INT. CL. 9.
- HUBEI FUXING SCIENCE AND TECHNOLOGY CO., LTD.,  
HANCHUAN CITY, HUBEI PROVINCE, CHINA:  
2,877,110, CANC. INT. CL. 6.
- HUBEI YIHUA CHEMICAL & INDUSTRY COMPANY LTD.,  
HUBEI, CHINA:  
2,876,355, CANC. INT. CL. 1.
- HUDSON SOFT CO., LTD., TOKYO, JAPAN:  
3,954,821, PUB. 2-15-2011. INT. CL. 9.
- HUDSON-ALPHA INSTITUTE FOR BIOTECHNOLOGY,  
HUNTSVILLE, AL:  
3,955,898, INT. CL. 9.
- HUGO BOSS TRADE MARKS MANAGEMENT GMBH &  
CO. KG, METZINGEN, FED REP GERMANY:  
2,447,282. REN. 3-29-11. INT. CL. 25.
- HUMAN TOUCH, LLC, LONG BEACH, CA:  
3,955,411, INT. CL. 20.
- HUMANA INC., LOUISVILLE, KY:  
3,955,393, INT. CL. 42.
- HUMANIT SOFTWARE GMBH, D-53119 BONN, FED REP  
GERMANY:  
3,955,532, MULTIPLE CLASS, INT. CLS. 9, 41 AND 42.
- HUMBLE FASHION, LLC, GOLDEN VALLEY, MN:  
3,955,509, INT. CL. 25.
- HUNT GLOBAL PARTNERSHIPS, DALLAS, TX:  
3,954,565, PUB. 2-15-2011. INT. CL. 35.
- HUNT MIDWEST ENTERPRISES, INC., KANSAS CITY, MO:  
2,474,886. REN. 3-28-11. INT. CL. 42.
- HUNT, YOLANDA S., CORDOVA, TN:  
3,954,083, PUB. 2-15-2011. MULTIPLE CLASS, INT. CLS.  
24 AND 25.
- HUNT'M HIGH VEST COMPANY, INC., HOT SPRINGS, AR:  
2,876,798, CANC. INT. CL. 25.
- HUNTER ENGINEERING COMPANY, BRIDGETON, MO:  
2,440,138. REN. 3-26-11. INT. CL. 12.
- HUNTER'S SPECIALTIES, INC., CEDAR RAPIDS, IA:  
3,953,734, PUB. 2-15-2011. MULTIPLE CLASS, INT. CLS.  
13, 20 AND 28.
- HUNTING ENERGY SERVICES I, INC., HOUSTON, TX,  
DBA HUNTING ENERGY SERVICES, INC.:  
3,955,210, INT. CL. 6.
- HUNTSMAN GROUP INTELLECTUAL PROPERTY HOLD-  
INGS CORPORATION, SALT LAKE CITY, UT:  
2,369,935, CANC. INT. CL. 1.
- HUNTSMAN PETROCHEMICAL CORPORATION, SALT  
LAKE CITY, UT:  
2,439,636. REN. 3-25-11. INT. CL. 1.
- HUPPERT, MIKEL, ELLSWORTH, WI, DBA FIN-TECH CO.:  
2,441,013. REN. 3-31-11. INT. CL. 28.
- HURON CONSULTING GROUP INC., CHICAGO, IL:  
2,499,555. REN. 3-31-11. INT. CL. 9.
- HURON CONSULTING GROUP LLC, CHICAGO, IL:  
2,878,066, CANC. INT. CL. 35.
- HUTCHINS, LUCIE N, LAMOINE, ME, AKA MYTIME2-  
VOTE:  
3,954,634, PUB. 2-15-2011. INT. CL. 35.
- HUTCHINSON, ROSEMARY, ELMHURST, IL:  
2,392,425. REN. 3-31-11. INT. CL. 9.
- HY-TEK, LTD., DAYTON, MD:  
2,379,304, CANC. INT. CL. 42.
- HYDRATHON, LLC, BOSTON, MA:  
3,953,392, PUB. 2-15-2011. INT. CL. 21.
- HYPERSHOW LTD., SEATTLE, WA, TA HYPERSHOW:  
3,953,291, PUB. 2-15-2011. MULTIPLE CLASS, INT. CLS.  
9, 41 AND 42.
- HYUNDAI MOTOR AMERICA, FOUNTAIN VALLEY, CA:  
2,453,869. REN. 3-31-11. INT. CL. 12.
- HYUNDUK COMPANY LTD., KYUNGKI-DO, REPUBLIC  
OF KOREA:  
3,953,181, PUB. 2-15-2011. INT. CL. 21.
- I AM WATERS FOUNDATION, INC., HOUSTON, TX:  
3,954,743, PUB. 2-15-2011. MULTIPLE CLASS, INT. CLS.  
35, 36 AND 43.



I GROUP, LLC, S. EL MONTE, CA:  
3,954,991, PUB. 2-15-2011. INT. CL. 9.  
3,954,992, PUB. 2-15-2011. INT. CL. 9.

I SALOTTI SU MISURA S.R.L., 29100 ALSENO (PC), ITALY:  
2,876,787, CANC. INT. CL. 20.

I.G. BAUERHIN GMBH, D-63584 GRUNDAU (ROTHENBERGEN), FED REP GERMANY:  
2,431,160. REN. 3-31-11. INT. CL. 11.

I.H.W. MANAGEMENT LIMITED, TORONTO, ONTARIO, CANADA, DBA THE FINCHLEY GROUP:  
3,953,699, PUB. 2-15-2011. INT. CL. 25.  
3,953,752, PUB. 2-15-2011. INT. CL. 25.  
3,953,753, PUB. 2-15-2011. INT. CL. 25.  
3,953,767, PUB. 2-15-2011. INT. CL. 25.

I-SLICES INNOVATIONS (PTY) LTD, GLEN AUSTIN, MID-RAND, SOUTH AFRICA:  
3,953,076, PUB. 7-27-2010. INT. CL. 3.

IAMS COMPANY, THE, CINCINNATI, OH:  
1,163,990. REN. 3-31-11. INT. CL. 31.  
1,168,613. REN. 3-28-11. INT. CL. 31.

IAMS COMPANY, THE, CINCINNATI, OH, IAMS FOOD COMPANY, LEWISBURG, OH:  
1,169,514. REN. 3-26-11. INT. CL. 31.

IAMS COMPANY, THE, CINCINNATI, OH:  
2,548,528. REN. 3-29-11. INT. CL. 31.

IAN R MOISE, HERNDON VIRGINIA 201, VA, DBA REUSE CONNECTION:  
3,954,201, PUB. 2-15-2011. INT. CL. 45.

IAN, JANIS, NASHVILLE, TN:  
2,161,332, CANC. INT. CL. 41.

IBC MANUFACTURING COMPANY, MEMPHIS, TN:  
1,640,133. REN. 3-31-11. INT. CL. 2.

IBEX HEALTHDATA SYSTEMS, INC., ROSEMONT, IL:  
2,876,631, CANC. MULTIPLE CLASS, INT. CLS. 9 AND 42.

IBIS BIOSCIENCES, INC., CARLSBAD, CA:  
2,877,804, CANC. INT. CL. 42.

ICE COLD S.R.L., 33 RTMINT 47900, ITALY:  
2,876,237, CANC. INT. CL. 43.

ICEBRAND FOODS, INC., PORTLAND, ME:  
2,876,592, CANC. INT. CL. 29.

ICHTHUS MINISTRIES, INC, WILMORE, KY:  
2,877,120, CANC. INT. CL. 41.

ICL PERFORMANCE PRODUCTS, LP, ST. LOUIS, MO:  
3,953,972, PUB. 2-15-2011. INT. CL. 20.

ICOBES B.V.B.A., 9940 EVERGEM, BELGIUM:  
2,877,762, CANC. INT. CL. 32.

ICON EYEWEAR, INC., SECAUCUS, NJ:  
3,955,674, INT. CL. 9.  
3,955,684, INT. CL. 9.

ICON INTERNATIONAL, INC., STAMFORD, CT:  
2,506,318. REN. 3-31-11. MULTIPLE CLASS, INT. CLS. 35 AND 36.

ICRACKED HOLDINGS, LLC, DALLAS, TX, DBA ICRACKED:  
3,954,372, PUB. 2-15-2011. INT. CL. 37.

ICUREDMYSELF.COM LLC, GLENSIDE, PA:  
3,954,856, PUB. 2-15-2011. INT. CL. 5.

IDEA LATIN AMERICA LLC, MIAMI, FL:  
3,955,541, INT. CL. 11.

IDEASTREAM CONSUMER PRODUCTS, LLC, CLEVELAND, OH:  
3,955,311, INT. CL. 16.

IDEATION UNLIMITED INC, NEW YORK, NY:  
1,638,130. REN. 3-28-11. INT. CL. 5.

IDEATION UNLIMITED, INC., NEW YORK, NY:  
1,154,419. REN. 3-31-11. INT. CL. 3.

IDIS SÀRL, CH-1618 CHÂTEL-ST-DENIS, SWITZERLAND:  
3,953,674, PUB. 2-15-2011. INT. CL. 28.

IDM SERVICES, INC., FEDERAL WAY, WA:  
2,877,097, CANC. MULTIPLE CLASS, INT. CLS. 39, 40 AND 42.

IDT NETHERLANDS, B.V. (PUERTO RICO BRANCH), SAN JUAN, PUERTO RICO:  
2,877,083, CANC. INT. CL. 36.

IERULLO INTERNATIONAL, INC., TORONTO, CANADA:  
3,953,024, PUB. 2-15-2011. INT. CL. 25.

IGA, INC., CHICAGO, IL:  
3,953,378, PUB. 2-15-2011. INT. CL. 35.

IGT, RENO, NV:  
3,955,193, INT. CL. 9.

ILLINOIS INSTITUTE OF TECHNOLOGY, CHICAGO, IL:  
3,956,004, INT. CL. 41.

ILLINOIS TOOL WORKS INC., GLENVIEW, IL:  
1,183,003. REN. 3-31-11. INT. CL. 21.  
2,876,854, CANC. INT. CL. 1.  
2,877,700, CANC. INT. CL. 6.  
2,877,712, CANC. INT. CL. 7.  
2,877,713, CANC. INT. CL. 7.

ILLUMINOSS MEDICAL, INC., EAST PROVIDENCE, RI:  
3,955,181, INT. CL. 10.

IM CO., LTD., TAKAMATSU-CITY, KAGAWA, JAPAN:  
3,955,742, INT. CL. 3.

IMAGENET ASSOCIATES, INC., LLC, DALLAS, TX:  
2,379,064, CANC. INT. CL. 35.

IMAGING DIAGNOSTIC SYSTEMS, INC., FORT LAUDERDALE, FL:  
2,436,339. REN. 3-29-11. INT. CL. 10.

IMFORZA, LLC, EL SEGUNDO, CA:  
3,954,117, PUB. 2-15-2011. INT. CL. 42.

IMMEDIATE GOODS INC., LOS ANGELES, CA:  
3,956,060, INT. CL. 25.

IMMIGRATION AND CUSTOMS SOLUTIONS, LLC, EVANSTON, IL, AKA ICS, LLC:  
3,955,511, INT. CL. 42.

IMPACT ADVISORS, LLC, NAPERVILLE, IL:  
3,954,673, PUB. 2-15-2011. INT. CL. 35.

IMPACT WHOLESALE, INC., FRIDLEY, MN:  
2,877,655, CANC. INT. CL. 28.

IMPERIAL S.P.A., FUNO DI ARGELATO (BO), ITALY:  
3,954,451, PUB. 2-15-2011. INT. CL. 25.

IMPINJ, INC., SEATTLE, WA:  
3,955,517, INT. CL. 9.

IMPORT COLLECTION, THE, PANORAMA CITY, CA:  
2,055,830, CANC. INT. CL. 21.

IMPRESSIVE REFLECTIONS, INC., TROUTDALE, OR:  
2,876,931, CANC. INT. CL. 3.

IN.GENU DESIGN GROUP INC., COLLINGWOOD, CANADA, DBA MENDMESHOP:  
3,955,053, PUB. 2-15-2011. INT. CL. 10.

INA CORPORATION, PHILADELPHIA, PA:  
713,297. REN. 3-29-11. U.S. CL. 102 (INT. CL. 36).  
1,473,502, CANC. INT. CL. 36.

INCHBUG, LLC, AUSTIN, TX:  
3,953,836, PUB. 2-15-2011. INT. CL. 21.

INCIDENT PREVENTION, INC., CARY, IL:  
3,953,306, PUB. 2-15-2011. MULTIPLE CLASS, INT. CLS. 16 AND 45.

INCIPIO TECHNOLOGIES, INC., IRVINE, CA:  
3,956,082, INT. CL. 9.

INCOR 3 S.R.L., 20050 RONCO BRIANTINO (MI), ITALY:  
2,876,087, CANC. INT. CL. 25.

INDEED LABORATORIES INC., MISSISSAUGA, ONTARIO, CANADA:  
3,953,318, PUB. 2-15-2011. INT. CL. 3.  
3,953,319, PUB. 2-15-2011. INT. CL. 3.

INDEPENDENT FRANCHISE PARTNERS, LLP, UNITED KINGDOM:  
3,953,501, PUB. 2-15-2011. INT. CL. 36.

INDEX POWERED FINANCIAL SERVICES, LLC, DENVER, CO:  
2,878,082, CANC. INT. CL. 36.

INDI-BEL, INC., INDIANOLA, MS, DBA DELTA WESTERN:  
1,658,443. REN. 3-26-11. INT. CL. 31.

INDIANA UNIVRSITY RESEARCH AND TECHNOLOGY CORPORATION, BLOOMINGTON, IA:  
2,876,921, CANC. INT. CL. 41.

INDIANAPOLIS YOUTH HOCKEY ASSOCIATION, CARMEL, IN:  
3,954,361, PUB. 2-15-2011. INT. CL. 41.

INDIO PRODUCTS, INC., LOS ANGELES, CA:  
2,436,828. REN. 3-26-11. MULTIPLE CLASS, INT. CLS. 3 AND 4.

- INDIUM CORPORATION OF AMERICA, UTICA, NY:  
1,647,191. REN. 3-26-11. INT. CL. 6.  
2,877,470. CANC. INT. CL. 6.
- INDUSTRIAL RIVET & FASTENER CO., NORTHVALE, NJ:  
2,379,716. CANC. INT. CL. 6.
- INDUSTRIES OF THE BLIND, INCORPORATED, GREENSBORO, NC:  
3,954,763. PUB. 2-15-2011. INT. CL. 16.
- INFORMA ECONOMICS, INC., MEMPHIS, TN:  
2,444,061. REN. 3-31-11. INT. CL. 36.  
2,445,934. REN. 3-31-11. INT. CL. 36.
- INFORMATION DISPLAY COMPANY, BEAVERTON, OR:  
3,953,957. PUB. 2-15-2011. INT. CL. 9.
- INGENIOUS GROUP, INC., NEW HARTFORD, CT:  
2,884,183. CANC. MULTIPLE CLASS, INT. CLS. 37 AND 41.
- INLIFE, LLC, IRVINE, CA:  
3,955,721. INT. CL. 5.
- INMON, WILLIAM H., CASTLE ROCK, CO:  
2,876,414. CANC. MULTIPLE CLASS, INT. CLS. 41 AND 42.
- INNER HARBOUR, LTD., DOUGLASVILLE, GA:  
2,876,550. CANC. MULTIPLE CLASS, INT. CLS. 41 AND 44.
- INNERPEACE, THE SHEET PEOPLE, LLC, WALPOLE, NH:  
2,522,473. REN. 3-31-11. INT. CL. 24.
- INNOGATION, INC., EAGLE, ID:  
3,955,655. INT. CL. 21.
- INNORES INCORPORATED, SMITHSBURG, MD:  
2,378,420. CANC. INT. CL. 35.
- INNOVATION VENTURES, LLC, FARMINGTON HILLS, MI:  
3,956,068. MULTIPLE CLASS, INT. CLS. 5 AND 32.
- INNOVATIVE SEATING SOLUTIONS, LLC, SAN FRANCISCO, CA:  
3,955,951. MULTIPLE CLASS, INT. CLS. 10, 12 AND 20.
- INNOVATIVE SURFACE TECHNOLOGIES, INC., ST. PAUL, MN:  
3,955,935. INT. CL. 1.
- INOXIA, S.R.L., VERBANIA, ITALY:  
2,460,532. REN. 3-25-11. INT. CL. 21.
- INSALA, LLC, EULESS, TX:  
2,473,670. REN. 3-31-11. INT. CL. 35.
- INSIGHT HEALTH CORP., LAKE FOREST, CA:  
2,378,934. CANC. INT. CL. 42.
- INSIGHT STRATEGIC CONCEPTS INC., GOSHEN, IN:  
2,969,170. COR. MULTIPLE CLASS, INT. CLS. 35 AND 41.
- INSIGHTS MUNDO MARKETING AND ANALYTICS PVT. LTD., VADODARA, GUJARAT, INDIA:  
3,954,009. PUB. 2-15-2011. INT. CL. 35.  
3,954,027. PUB. 2-15-2011. INT. CL. 35.  
3,954,040. PUB. 2-15-2011. INT. CL. 35.
- INSTANT INVESTOR, LLC, HUNTSVILLE, NC:  
3,954,475. PUB. 2-15-2011. INT. CL. 41.
- INSTANT MESSAGING AGE SOFTWARE, INC., HOUSTON, TX:  
2,877,018. CANC. INT. CL. 9.
- INSTITUT FRANCAIS DU PETROLE, 92852 RUEIL-MALMAISON, CEDEX, FRANCE:  
2,875,851. CANC. MULTIPLE CLASS, INT. CLS. 9 AND 42.
- INSTITUTE FOR PROFESSIONAL DEVELOPMENT, LTD., GOLDEN, CO, DBA THE LOVE AND LOGIC INSTITUTE, INC.:  
3,952,988. PUB. 2-15-2011. INT. CL. 41.
- INSTRIDE CORP., ROCKY RIVER, OH:  
3,955,273. INT. CL. 35.
- INSTRUMENT SPECIALISTS, INC., BOERNE, TX:  
3,955,804. INT. CL. 10.
- INSURANCE TECHNOLOGIES, LLC, COLORADO SPRINGS, CO:  
3,956,037. INT. CL. 42.
- INTEGRA CASTINGS INC., WINNIPEG MANITOBA, CANADA:  
3,953,208. PUB. 1-18-2011. INT. CL. 6.
- INTEGRAL BIOSYSTEMS, LLC, BEDFORD, MA:  
3,954,585. PUB. 2-15-2011. INT. CL. 42.
- INTEGRAL KNOWLEDGE UTILIZATION BV, AMSTERDAM, NETHERLANDS:  
2,378,814. CANC. INT. CL. 42.
- INTEGRATED MEDICAL SYSTEMS INTERNATIONAL, INC., BIRMINGHAM, AL:  
3,954,374. PUB. 2-15-2011. INT. CL. 37.
- INTEGRATED TELECOM MANAGEMENT SERVICES, INC., MARIETTA, GA, DBA DRIFEAT:  
3,579,338. COR. INT. CL. 3.
- INTEGRATION TECHNOLOGY SYSTEMS, INC., MOUNT PLEASANT, PA:  
3,953,372. PUB. 2-15-2011. INT. CL. 9.
- INTEGRITY SALES & MARKETING, INC., GREENVILLE, SC:  
2,446,756. REN. 3-31-11. INT. CL. 35.
- INTELSPEND PREPAID SOLUTIONS, L.L.C., FENTON, MO:  
2,433,058. REN. 3-26-11. INT. CL. 35.
- INTELLECTUAL PROPERTY HOLDINGS AS, OSLO, NORWAY:  
3,953,049. PUB. 1-12-2010. MULTIPLE CLASS, INT. CLS. 6, 7, 9, 11, 12, 19, 20, 29, 35, 37, 40 AND 42.
- INTELLIBRAND, INC., WAUKESHA, WI:  
3,955,467. INT. CL. 9.
- INTELLIGENT COMPUTER SOLUTIONS, LLC, AURORA, IL:  
2,379,585. CANC. INT. CL. 42.
- INTELLISIST, INC., BELLEVUE, WA:  
3,955,683. INT. CL. 9.
- INTELLISPHERE LLC, PLAINSBORO, NJ:  
2,454,261. REN. 3-25-11. INT. CL. 16.
- INTELLISPHERE, LLC, PLAINSBORO, NJ:  
2,476,034. REN. 3-26-11. INT. CL. 16.
- INTELUX, S.A. DE C.V., NUEVO LEON, MEXICO:  
3,956,039. INT. CL. 11.
- INTER HOLDING LLC, WEST PALM BEACH, FL:  
2,878,048. CANC. INT. CL. 9.
- INTER-PLANT PATENT MARKETING, INC., ST. CATHARINES, ONTARIO, CANADA:  
1,372,903. CANC. INT. CL. 31.
- INTERACTION ASSOCIATES, INC., BOSTON, MA:  
1,650,982. REN. 3-31-11. INT. CL. 35.
- INTERACTIVE MARKET SYSTEMS, INC., NEW YORK, NY:  
2,378,862. CANC. INT. CL. 9.
- INTERACTIVE MULTIMEDIA SOLUTIONS, INC., RALEIGH, NC:  
2,877,988. CANC. INT. CL. 9.
- INTERACTIVE NETWORK SYSTEMS, INC., BLACKWOOD, NJ:  
2,876,140. CANC. INT. CL. 9.
- INTERCHANGE BRANDS, LLC, OMAHA, NE:  
3,954,162. PUB. 2-15-2011. INT. CL. 7.
- INTERCHANGE DATA SYSTEMS, INC., SANTA ANA, CA:  
2,877,159. CANC. INT. CL. 9.
- INTERCONTINENTAL PACKAGING CO., ST. PAUL, MN:  
3,955,931. INT. CL. 33.
- INTERCOUNTY CONTRACTING, LLC, NEW HARTFORD, CT:  
3,954,046. PUB. 2-15-2011. INT. CL. 6.
- INTEREXEC, INC., CLEVELAND, OH:  
1,657,835. REN. 3-26-11. INT. CL. 35.
- INTERGRAPH CORPORATION, HUNTSVILLE, AL:  
2,489,612. REN. 3-26-11. INT. CL. 9.  
2,491,537. REN. 3-26-11. INT. CL. 9.
- INTERLINE BRANDS, INC., JACKSONVILLE, FL, J.A. SEXAUER, INC., WHITE PLAINS, NY:  
1,148,671. REN. 3-25-11. INT. CL. 6.
- INTERMEDIA COMMUNICATIONS INC., TAMPA, FL:  
2,877,771. CANC. MULTIPLE CLASS, INT. CLS. 38 AND 42.
- INTERNATIONAL ASSOCIATION FOR COLON HYDROTHERAPY, SAN ANTONIO, TX:  
3,954,163. PUB. 2-15-2011. MULTIPLE CLASS, INT. CLS. 41 AND 44.

- INTERNATIONAL BUSINESS MACHINES CORPORATION, ARMONK, NY, AKA IBM CORPORATION:  
2,876,264, CANC. INT. CL. 42.  
2,876,265, CANC. INT. CL. 35.  
2,876,266, CANC. INT. CL. 35.
- INTERNATIONAL BUSINESS MACHINES CORPORATION, ARMONK, NY:  
2,877,353, CANC. MULTIPLE CLASS, INT. CLS. 40 AND 42.
- INTERNATIONAL BUSINESS MACHINES CORPORATION, ARMONK, NY, AKA IBM CORPORATION:  
2,878,028, CANC. INT. CL. 9.
- INTERNATIONAL BUSINESS MACHINES CORPORATION, UNITED STATES:  
3,953,511, PUB. 2-15-2011. MULTIPLE CLASS, INT. CLS. 9, 16, 35 AND 42.  
3,953,575, PUB. 2-15-2011. MULTIPLE CLASS, INT. CLS. 9, 16, 38 AND 42.  
3,953,587, PUB. 2-15-2011. MULTIPLE CLASS, INT. CLS. 9, 16 AND 42.  
3,953,595, PUB. 2-15-2011. MULTIPLE CLASS, INT. CLS. 16, 41 AND 42.
- INTERNATIONAL CHINESE NETWORK, INC., EL MONTE, CA:  
3,953,992, PUB. 2-15-2011. MULTIPLE CLASS, INT. CLS. 38 AND 41.
- INTERNATIONAL DATA GROUP, INC., FRAMINGHAM, MA:  
2,876,975, CANC. INT. CL. 42.  
3,956,112, INT. CL. 42.
- INTERNATIONAL DESALINATION ASSOCIATION, TOPSFIELD, MA:  
3,954,631, PUB. 2-15-2011. INT. CL. 9.
- INTERNATIONAL FEDERATION OF THE PHONOGRAPHIC INDUSTRY (IFPI), CH-8024 ZURICH, SWITZERLAND:  
2,876,239, CANC. MULTIPLE CLASS, INT. CLS. 9 AND 38.
- INTERNATIONAL FENG SHUI GUILD, LEE'S SUMMIT, MO:  
3,954,084, PUB. 2-15-2011. INT. CL. 35.
- INTERNATIONAL FIRE SPRINKLER, INC., ST. LOUIS, MO:  
2,876,375, CANC. INT. CL. 42.
- INTERNATIONAL GAMING PROJECTS LIMITED, VALLETTA, MALTA:  
3,953,085, PUB. 2-15-2011. MULTIPLE CLASS, INT. CLS. 9 AND 28.
- INTERNATIONAL GROUP, INC., TITUSVILLE, PA:  
3,955,904, MULTIPLE CLASS, INT. CLS. 1 AND 4.
- INTERNATIONAL HYDROMASAGE INC., WINNIPEG, MANITOBA R3R 3S3, CANADA:  
2,876,710, CANC. INT. CL. 10.
- INTERNATIONAL INTERNET VENTURES, LLC, WOODS CROSS, UT:  
3,954,595, PUB. 2-15-2011. INT. CL. 12.
- INTERNATIONAL PACKET COMMUNICATIONS CONSORTIUM, CHICAGO, IL:  
2,876,365, CANC. INT. CL. 35.
- INTERNATIONAL PAPER COMPANY, MEMPHIS, TN:  
2,441,373, REN. 3-29-11. INT. CL. 16.
- INTERNATIONAL SOCIETY FOR TECHNOLOGY IN EDUCATION, INC., EUGENE, OR:  
3,954,784, PUB. 2-15-2011. INT. CL. 41.
- INTERNATIONAL STAR REGISTRY OF ILLINOIS, LTD., INGLESIDE, IL:  
3,952,949, PUB. 11-2-2004. MULTIPLE CLASS, INT. CLS. 16 AND 35.
- INTERNATIONAL TRUCK INTELLECTUAL PROPERTY COMPANY, LLC, WARRENVILLE, IL:  
2,877,173, CANC. INT. CL. 36.  
2,877,231, CANC. INT. CL. 7.
- INTERNATIONAL UNDERWATER EXPLORERS SOCIETY, LIMITED, THE, FREEPORT, GRAND BAHMA, ISLANDS, BAHAMAS, DBA UNEXSO AND DBA UNDERWATER EXPLORERS SOCIETY:  
1,500,829, CANC. INT. CL. 41.
- INTERNET EDUCATION EXCHANGE INC., SCOTTSDALE, AZ:  
2,876,383, CANC. INT. CL. 41.
- INTERVET AMERICA, INC., MILLSBORO, DE TO INTERVET, INC., MILLSBORO, DE:  
1,591,647, CANC. INT. CL. 5.
- INTOHOMES MORTGAGE SERVICES, INC., RENO, NV:  
2,876,574, CANC. INT. CL. 36.
- INTRADO SYSTEMS CORP., LONGMONT, CO:  
2,496,820, REN. 3-29-11. INT. CL. 9.
- INTREPID TRAVEL PTY LTD, FITZROY, VICTORIA 3065, AUSTRALIA:  
3,953,195, PUB. 2-15-2011. MULTIPLE CLASS, INT. CLS. 39 AND 41.
- INTRUST FINANCIAL CORPORATION, WICHITA, KS:  
3,955,759, INT. CL. 36.
- INVIVOSCRIBE TECHNOLOGIES, INC., SAN DIEGO, CA:  
3,956,162, INT. CL. 44.
- INVOQ, LLC, BALTIMORE, MD:  
2,877,236, CANC. INT. CL. 42.
- IOLCO PTY LTD, WEST PERTH, AUSTRALIA:  
2,877,222, CANC. INT. CL. 9.
- IOT SYSTEMS, LLC, WILLIAMSPORT, MD:  
2,877,891, CANC. MULTIPLE CLASS, INT. CLS. 38 AND 42.  
2,877,892, CANC. MULTIPLE CLASS, INT. CLS. 38 AND 42.
- IOWA CORN PROMOTION BOARD, JOHNSTON, IA:  
3,953,336, PUB. 2-15-2011. MULTIPLE CLASS, INT. CLS. 35 AND 42.
- IPAY TECHNOLOGIES, LLC, ELIZABETHTOWN, KY:  
3,953,215, PUB. 2-15-2011. MULTIPLE CLASS, INT. CLS. 35, 36, 38, 39, 42 AND 45.
- IPS INDUSTRIES, INC., UMATILLA, FL, DBA SPECTRUM BAGS:  
3,955,558, INT. CL. 16.
- IPS INDUSTRIES, INC., UMATILLA, FL:  
3,955,584, INT. CL. 16.
- IPSIL, INCORPORATED, BETHESDA, MD:  
2,876,612, CANC. INT. CL. 9.
- IRAIL, LLC, PARSIPPANY, NJ:  
2,878,054, CANC. INT. CL. 35.
- IRBY, JOSEPH A., LITTLE ROCK, AR, DBA BESTQUEST TEACHING SYSTEMS:  
2,876,830, CANC. INT. CL. 41.
- IROAM MOBILE SOLUTIONS INC., TORONTO, CANADA:  
3,953,035, PUB. 2-15-2011. MULTIPLE CLASS, INT. CLS. 9, 35 AND 38.
- IRON DONUT, INC., JACKSONVILLE, FL, DBA RASTAEMPIRE.COM:  
3,953,993, PUB. 2-15-2011. INT. CL. 35.
- IRON DONUT, INC., JACKSONVILLE, FL, DBA HIPPIEHERO.COM:  
3,953,994, PUB. 2-15-2011. INT. CL. 35.
- IRON FIST BREWING COMPANY INCORPORATED, SAN MARCOS, CA:  
3,953,821, PUB. 2-15-2011. INT. CL. 32.
- IRON SOLUTIONS, INC., FENTON, MO:  
2,440,079, REN. 3-28-11. INT. CL. 42.
- IRONCLAD PERFORMANCE WEAR CORP., EL SEGUNDO, CA:  
3,954,468, PUB. 2-15-2011. INT. CL. 9.
- IRVIN KAHN & SONS, INC., LOUISVILLE, KY:  
3,956,051, INT. CL. 35.
- IRVINWEBWORKS, INC., IRVINE, CA:  
2,876,227, CANC. INT. CL. 42.
- IRVING WEBER ASSOCIATES, INC., RONKONKOMA, NY:  
3,953,368, PUB. 2-15-2011. INT. CL. 36.
- IRVING, MARILYN, M., GREENBELT, MD:  
3,955,257, INT. CL. 41.
- IRWIN INDUSTRIAL TOOL COMPANY, ATLANTA, GA:  
1,638,906, REN. 3-29-11. INT. CL. 8.  
2,876,369, CANC. INT. CL. 3.  
2,876,370, CANC. INT. CL. 1.
- ISADORO SEED INC., EAGAN, MN:  
3,955,533, INT. CL. 31.
- ISC-INDUSTRIAL SOLAR CONSULTING, MESA, AZ:  
3,954,305, PUB. 2-15-2011. INT. CL. 42.

- ISEND.COM, LLC, BALTIMORE, MD:  
3,954,835, PUB. 2-15-2011. INT. CL. 42.
- ISERA GROUP, LLC, SANTA BARBARA, CA:  
2,877,426, CANC. INT. CL. 9.  
2,877,427, CANC. INT. CL. 9.
- ISH INTERNATIONAL SPORT HOLDING AG, SWITZERLAND:  
3,953,651, PUB. 2-15-2011. INT. CL. 12.  
3,953,654, PUB. 2-15-2011. INT. CL. 12.  
3,953,655, PUB. 2-15-2011. INT. CL. 12.
- ISHKARA LLC, SANTA MONICA, CA:  
3,955,347, INT. CL. 3.
- ISHOP TO GIVE, INC., PLOVER, WI:  
3,953,285, PUB. 2-15-2011. INT. CL. 36.
- ISI BRANDS INC., GRAND RAPIDS, MI:  
1,636,639, REN. 3-26-11. INT. CL. 5.
- ISLAND DISPLAY, INC, LEWISVILLE, TX:  
2,877,660, CANC. INT. CL. 20.  
2,877,661, CANC. INT. CL. 35.
- ISP INVESTMENTS INC., WILMINGTON, DE:  
3,955,016, PUB. 2-15-2011. INT. CL. 1.
- IT'S A LULU! INC., NEW YORK, NY:  
2,877,177, CANC. INT. CL. 20.
- ITALIA FOODS, INC., SCHAUMBURG, IL:  
3,955,175, MULTIPLE CLASS, INT. CLS. 29 AND 30.
- ITALPIZZA SPA, MODENA, ITALY:  
2,378,380, CANC. INT. CL. 30.
- ITOCHU SHOJI KABUSHIKI KAISHA (ITOCHU CORPORATION), OSAKA, JAPAN:  
2,877,063, CANC. INT. CL. 34.
- ITOGHA AS, NORWAY:  
3,953,649, PUB. 2-15-2011. MULTIPLE CLASS, INT. CLS. 5, 10 AND 29.
- ITOKI CORPORATION, OSAKA-SHI, OSAKA, JAPAN:  
3,953,102, PUB. 2-15-2011. MULTIPLE CLASS, INT. CLS. 20, 35 AND 42.
- ITRON, INC., LIBERTY LAKE, WA:  
2,438,984, REN. 3-29-11. INT. CL. 9.
- IVILLAGE INC., NEW YORK, NY:  
2,432,910, REN. 3-28-11. INT. CL. 16.  
2,877,937, CANC. INT. CL. 16.
- IWAN SIMONIS INCORPORATED, GURNEE, IL:  
2,876,663, CANC. INT. CL. 24.
- IZOTOPE INC., CAMBRIDGE, MA:  
3,954,525, PUB. 2-15-2011. INT. CL. 9.
- 19 SPORTS CORPORATION, BRANDON, FL:  
2,877,561, CANC. INT. CL. 41.
- J & J PROCESSING, INC., SANTA FE SPRINGS, CA:  
3,955,501, INT. CL. 30.
- J & L PEABERRY COFFEE & TEA, INC., EMERYVILLE, CA:  
2,448,216, REN. 3-29-11. INT. CL. 21.
- J ROSS PARRELLI, RED BANK, NJ:  
3,954,241, PUB. 2-15-2011. INT. CL. 9.
- J. C. PENNEY PRIVATE BRANDS, INC., PLANO, TX:  
2,878,051, CANC. INT. CL. 25.
- J. CASTRO, INC., NEW YORK, N.Y., NY:  
3,953,037, PUB. 2-15-2011. INT. CL. 41.
- J. GROSSMITH & SON LIMITED, LONDON, UNITED KINGDOM:  
3,953,453, PUB. 2-15-2011. INT. CL. 3.
- J. KIM WRIGHT, ASHEVILLE, NC:  
3,954,142, PUB. 2-15-2011. INT. CL. 41.
- J. LAMB, INC., ENGLEWOOD, NJ:  
2,877,646, CANC. INT. CL. 25.
- J. P. BODEN & CO. LIMITED, LONDON, ENGLAND:  
2,463,229, REN. 3-26-11. INT. CL. 25.
- J.C. PENNEY PRIVATE BRANDS, INC., PLANO, TX:  
2,876,120, CANC. INT. CL. 24.
- J.F. HILLEBRAND GROUP AG, FED REP GERMANY:  
3,953,510, PUB. 2-15-2011. MULTIPLE CLASS, INT. CLS. 16 AND 17.
- J.F. LABS, INC., CHICAGO, IL:  
2,433,263, REN. 3-26-11. INT. CL. 3.
- J.S. SUAREZ, INC., NEW YORK, NY:  
2,389,630, REN. 3-30-11. INT. CL. 25.  
2,391,349, REN. 3-29-11. INT. CL. 18.  
2,408,103, REN. 3-29-11. INT. CL. 18.
- J.S.B. INDUSTRIES, INC., CHELSEA, MA:  
2,440,135, REN. 3-31-11. INT. CL. 30.
- JABEZ COMMUNICATION LLC, LITHONIA, GA:  
3,954,317, PUB. 2-15-2011. INT. CL. 35.
- JABEZ COMMUNICATIONS, LLC, LITHONIA, GA:  
3,954,318, PUB. 2-15-2011. INT. CL. 41.
- JABIL CIRCUIT TAIWAN LIMITED, HSINCHU, TAIWAN:  
2,876,380, CANC. INT. CL. 9.
- JACK BLACK, LLC, CARROLLTON, TX:  
3,927,025, COR. INT. CL. 3.
- JACK HENRY SOFTWARE/COMMLINK, L.P., MONETT, MO:  
2,522,151, REN. 3-31-11. INT. CL. 9.
- JACKSON INTERNATIONAL TRADING COMPANY KURT D. BRUHL GESELLSCHAFT MBH & CO. KG, GRAZ, AUSTRIA:  
2,875,974, CANC. INT. CL. 32.
- JACKSON, C. LEE, HUTTO, TX:  
2,876,851, CANC. INT. CL. 9.  
2,876,852, CANC. INT. CL. 9.
- JACKSON, MICHAEL, SARASOTA, FL:  
2,379,545, CANC. INT. CL. 37.
- JACQUES MORET, INC., NEW YORK, NY:  
2,422,256, CANC. INT. CL. 25.
- JADEN CHARTERS PTY LTD., QUEENSLAND, AUSTRALIA, JADEN CHARTERS PTY LTD., QUEENSLAND, AUSTRALIA:  
2,388,209, REN. 3-29-11. INT. CL. 7.
- JAG MEDIA LLC, BOCA RATON, FL:  
2,875,894, CANC. INT. CL. 35.
- JAH INNOVATIONS INC., ATLANTA, GA:  
3,955,156, INT. CL. 25.
- JAMES HOTEL MANAGEMENT COMPANY, LLC, NEW YORK, NY:  
2,907,303, AM. INT. CL. 43.
- JAMES R. BOWES, JR., ROSWELL, GA:  
3,954,252, PUB. 2-15-2011. INT. CL. 41.
- JAMES STROCK & CO., SCOTTSDALE, AZ:  
3,954,617, PUB. 2-15-2011. MULTIPLE CLASS, INT. CLS. 35 AND 41.
- JAMES VOIGHT, NEW YORK, NY, DBA CHIP TAYLOR:  
3,955,303, INT. CL. 41.
- JANA CURCIO PHOTOGRAPHY, WASHINGTON, DC:  
2,876,853, CANC. INT. CL. 41.
- JANI BRYSON STUDIOS, INC., LEAWOOD, KS:  
3,954,987, PUB. 2-15-2011. INT. CL. 41.
- JARROW FORMULAS, INC., LOS ANGELES, CA:  
3,953,759, PUB. 2-15-2011. INT. CL. 5.
- JASON ALLEN DYMENT, WARNER, NH AND JAN SARA DYMENT, WARNER, NH:  
3,953,193, PUB. 2-15-2011. INT. CL. 4.
- JASON ENTERPRISES, INC., OWINGS, MD:  
2,758,121, CANC. INT. CL. 44.
- JASPER RYAN C, SARASOTA, FL, DBA BEAUTIFUL FEET WORLDWIDE:  
3,953,706, PUB. 2-15-2011. INT. CL. 25.
- JAYCO, INC., MIDDLEBURY, IN:  
2,379,851, CANC. INT. CL. 12.  
3,955,702, INT. CL. 12.
- JCA CORPORATION, FEDERAL WAY, WA, JC AUTO PART GROUP, LTD., FIFE, WA:  
2,550,630, REN. 3-26-11. INT. CL. 12.
- JD DISTRIBUTORS, PLANTATION, FL:  
3,953,703, PUB. 2-15-2011. INT. CL. 14.
- JEFF TOCZYNSKI, SIMI VALLEY, CA:  
3,954,803, PUB. 2-15-2011. INT. CL. 41.
- JEFFERSON WELLS INTERNATIONAL, INC., BROOKFIELD, WI:  
2,878,794, CANC. INT. CL. 35.
- JEFFREY E. FROMBERG, PALM SPRINGS, CA:  
3,956,186, INT. CL. 44.
- JEFFREY FEINMAN, WESTON, CT, DBA HOMEVET:  
3,954,173, PUB. 2-15-2011. INT. CL. 44.
- JEFIT INC., CARY, NC:  
3,954,894, PUB. 2-15-2011. INT. CL. 9.
- JENNIFER GOLDSTEIN, PHILADELPHIA, PA:  
3,954,444, PUB. 2-15-2011. INT. CL. 9.

JENZ PUBLICATIONS, INC., THOUSAND OAKS, CA:  
2,877,570, CANC. MULTIPLE CLASS, INT. CLS. 16 AND 41.

JEPPESEN SYSTEMS AB, GOTEBOURG, SWEDEN:  
2,877,351, CANC. INT. CL. 35.

JESSICA ICLISOY, BEVERLY HILLS, CA:  
3,953,744, PUB. 2-15-2011. INT. CL. 16.

JESSIE STEELE, INC., BERKELEY, CA:  
3,955,518, MULTIPLE CLASS, INT. CLS. 24 AND 25.

JEWISH CONTENT PROVIDERS, LLC, MONSEY, NY:  
2,876,293, CANC. MULTIPLE CLASS, INT. CLS. 9 AND 16.

JEWISH ROSARIES LLC, BROOKLYN, NY:  
3,955,543, INT. CL. 14.

JFAT, LLC, SAN DIEGO, CA, DBA JIMMY'S FAMOUS AMERICAN TAVERN:  
3,954,167, PUB. 2-15-2011. INT. CL. 43.

JHG TECHNOLOGIES, LLC, ATLANTA, GA:  
2,877,573, CANC. INT. CL. 36.

JHL CONSTRUCTORS, INC., ENGLEWOOD, CO:  
2,514,852, REN. 3-26-11. INT. CL. 37.

JIAXING JINLONG STANDARD PARTS CO., LTD, JIAXING, CHINA:  
3,953,938, PUB. 2-15-2011. INT. CL. 6.

JIAZHUO (CHANGZHOU) MACHINERY CO., LTD., CHANGZHOU JIANGSU PROVINCE, CHINA:  
3,953,652, PUB. 2-15-2011. INT. CL. 7.

JIFFY LUBE INTERNATIONAL, INC., HOUSTON, TX:  
3,955,703, INT. CL. 35.

JIFFY PRODUCTS OF AMERICA, INC., NORWALK, OH:  
3,955,276, INT. CL. 31.

JIM BEAM BRANDS CO., DEERFIELD, IL:  
900,938, REN. 3-30-11. U.S. CL. 49 (INT. CL. 33).

JIM COLEMAN COMPANY, HOUSTON, TX:  
2,876,673, CANC. INT. CL. 7.

JING LIN, NEW YORK, NY:  
3,956,196, INT. CL. 9.  
3,956,200, INT. CL. 25.

JIT PACKAGING, INC., SCHAUMBURG, IL:  
3,954,297, PUB. 2-15-2011. MULTIPLE CLASS, INT. CLS. 16 AND 35.

JJID, INC., BEAR, DE:  
2,448,642, REN. 3-29-11. MULTIPLE CLASS, INT. CLS. 19 AND 37.

JJJJW, LLC, MEMPHIS, TN:  
2,436,939, REN. 3-25-11. INT. CL. 9.

JK TYRE & INDUSTRIES LIMITED, CALCUTTA - 700 001, INDIA:  
3,953,947, PUB. 2-15-2011. INT. CL. 12.

JKA, INC., PORT ST. JOE, FL, DBA JKA HOME:  
3,955,905, INT. CL. 19.

JM ROSES PTY LTD, AUSTRALIA AND DAVID JORDAN PTY LTD, AUSTRALIA:  
3,953,528, PUB. 2-15-2011. MULTIPLE CLASS, INT. CLS. 35, 38 AND 45.

JME, INCORPORATED, PACOIMA, CA, DBA TMB ASSOCIATES:  
2,438,624, REN. 3-30-11. INT. CL. 9.

JMK HOSPITALITY GROUP, LLC, STANHOPE, NJ:  
3,954,225, PUB. 2-15-2011. MULTIPLE CLASS, INT. CLS. 41 AND 43.

JODEPA, INC., HAM LAKE, MN:  
2,379,834, CANC. INT. CL. 21.

JOE BOXER COMPANY, LLC, WILMINGTON, DE:  
2,151,915, CANC. INT. CL. 18.

JOEL AIKEN, ST. HELENA, CA:  
3,954,280, PUB. 2-15-2011. INT. CL. 33.

JOEL SULLIVAN, FAIRVIEW, NC:  
3,760,563, COR. INT. CL. 41.

JOHN B. RUSH, GOLD BEACH, OR:  
3,953,949, PUB. 2-15-2011. INT. CL. 44.

JOHN B. SANFILIPPO & SON, INC., ELGIN, IL:  
3,955,735, MULTIPLE CLASS, INT. CLS. 29 AND 30.  
3,955,942, MULTIPLE CLASS, INT. CLS. 29 AND 30.  
3,956,216, MULTIPLE CLASS, INT. CLS. 29 AND 30.

JOHN GROAT, SYRACUSE, NY, DBA HOLY SHIRT!:  
3,953,899, PUB. 2-15-2011. INT. CL. 25.

JOHN M PATTERSON, WOODSTOCK, GA:  
3,954,781, PUB. 2-15-2011. INT. CL. 9.

JOHN M. FLOYD & ASSOCIATES, INC., BAYTOWN, TX:  
2,548,973, REN. 3-30-11. INT. CL. 36.

JOHN OSTER MANUFACTURING CO., RACINE, WI TO SUNBEAM PRODUCTS, INC., BOCA RATON, FL:  
515,517, CANC. MULTIPLE CLASS, U.S. CLS. 21 AND 44.

JOHN WALL, INC., CARMICHAELS, PA:  
3,954,222, PUB. 2-15-2011. INT. CL. 19.

JOHNSON & JOHNSON, NEW BRUNSWICK, NJ:  
2,876,763, CANC. INT. CL. 5.  
2,877,943, CANC. INT. CL. 5.  
3,953,422, PUB. 2-15-2011. INT. CL. 10.  
3,955,240, INT. CL. 35.  
3,955,724, INT. CL. 21.  
3,955,730, INT. CL. 44.

JOHNSON CONTROLS TECHNOLOGY COMPANY, HOLLAND, MI:  
1,581,353, REN. 3-28-11. INT. CL. 11.

JOHNSON FINANCIAL GROUP, INC., RACINE, WI:  
2,379,186, CANC. INT. CL. 36.

JOHNSON MATTHEY PUBLIC LIMITED CO., LONDON, ENGLAND:  
2,438,766, REN. 3-28-11. MULTIPLE CLASS, INT. CLS. 1, 40 AND 42.

JOHNSON OUTDOORS INC., RACINE, WI:  
2,378,607, CANC. INT. CL. 9.

JOHNSON, KIMBERLY P., YORK, SC:  
3,954,975, PUB. 2-15-2011. INT. CL. 28.

JOHNSON, NORTH, CHICAGO, IL:  
3,955,232, INT. CL. 20.

JOHNSON, PHILLIP L., ENCINITAS, CA, DBA JET PILOT TO CHIYODA BUILDING CO., LTD., KANAGAWA 251-0025, JAPAN:  
1,422,972, CANC. INT. CL. 25.

JOLT, INC., TAMPA, FL:  
3,953,279, PUB. 2-15-2011. INT. CL. 41.

JONES-BLAIR COMPANY, DALLAS, TX:  
2,436,655, REN. 3-31-11. INT. CL. 2.

JONES, JERRY L., EL PASO, TX:  
2,327,309, CANC. INT. CL. 30.

JONES, K. NICK, UKIAH, CA, AKA NICK 13:  
3,955,013, PUB. 2-15-2011. INT. CL. 41.

JONES, KIM, KANSAS CITY, MO AND FLETCHER, BRYANT, KANSAS CITY, MO:  
2,876,214, CANC. INT. CL. 3.

JONES, MICHAEL W., WASHINGTON, DC:  
3,952,974, PUB. 2-15-2011. INT. CL. 25.

JONES, RICHARD D., DALLAS, TX, DBA LIFE MINISTRIES AND JONES, DOROTHY H. E., DALLAS, TX, DBA LIFE MINISTRIES:  
3,956,227, INT. CL. 16.  
3,956,228, INT. CL. 16.

JONMOR INVESTMENTS, INC., WILMINGTON, DE:  
2,876,206, CANC. INT. CL. 29.

JOOP! GMBH, 20149 HAMBURG, FED REP GERMANY:  
3,953,521, PUB. 9-14-2010. MULTIPLE CLASS, INT. CLS. 9, 16 AND 25.

JOSE MARRERO, NEWARK, NJ, DBA EQUITES PROTECTION SERVICES:  
3,954,193, PUB. 2-15-2011. INT. CL. 45.

JOSHUA CHAVEZ, PERRIS, CA:  
3,954,700, PUB. 2-15-2011. INT. CL. 41.

JOSHUA VENTURE PHILANTHROPIES, NEW YORK, NY:  
3,953,796, PUB. 2-15-2011. INT. CL. 35.

JOSIPOVICH, DOROTHY, LAKE FOREST, CA AND JOSIPOVICH, DANIEL E., LAKE FOREST, CA AND JOSIPOVICH, DANIEL T., LAKE FOREST, CA AND JOSIPOVICH, MARK, LAKE FOREST, CA AND JOSIPOVICH, MICHELA, LAKE FOREST, CA:  
2,875,959, CANC. INT. CL. 9.

JRM NUTRASCENCES LLC, BROOKLYN, NY:  
3,953,777, PUB. 2-15-2011. INT. CL. 5.

JT INTERNATIONAL DISTRIBUTORS, INC., INDIANAPOLIS, IN:  
2,877,076, CANC. INT. CL. 25.  
2,877,620, CANC. INT. CL. 18.

- JTEKT CORPORATION, OSAKA 542-8502, JAPAN:  
1,639,579, REN. 3-30-11. INT. CL. 9.
- JTI MACDONALD TM CORP., MONTREAL, QUEBEC, CANADA:  
2,877,650, CANC. INT. CL. 34.
- JTM PROVISIONS COMPANY, INC., HARRISON, OH:  
3,954,979, PUB. 2-15-2011. MULTIPLE CLASS, INT. CLS. 29 AND 30.
- JUDICIAL WATCH, INC., WASHINGTON, DC:  
3,953,355, PUB. 2-15-2011. INT. CL. 16.
- JULIE ANN TURNER & COMPANY, PLANO, TX:  
2,877,763, CANC. INT. CL. 35.
- JUNE BUG ENTERPRISES, INC., BEVERLY HILLS, CA:  
3,955,207, INT. CL. 35.
- JUNGPFLANZEN GRÜNEWALD GMBH, FED REP GERMANY:  
3,953,613, PUB. 2-15-2011. INT. CL. 31.
- JURA CAPRESSO, INC., CLOSTER, NJ:  
3,955,790, INT. CL. 7.
- JURNEY, FORREST, PALM BEACH GARDENS, FL:  
3,955,283, INT. CL. 9.
- JUS-JAS LLC, HAVERFORD, PA:  
2,444,885, REN. 3-26-11. INT. CL. 42.
- JW ELECTRONICS CO., LTD., TAIPEI, TAIWAN:  
3,955,314, INT. CL. 9.
- K & G IMPORTS LLC, EL PRADO, NM:  
3,956,088, INT. CL. 33.
- K.C. ELECTRONICS, INC., CHICAGO, IL:  
2,876,559, CANC. INT. CL. 9.
- K-2 CORPORATION, VASHON, WA:  
2,877,050, CANC. INT. CL. 20.
- K'HILLAH K'DOSHAH B'NAI YESHURUN, CINCINNATI, OH, DBA ISAAC M. WISE TEMPLE:  
3,956,225, INT. CL. 41.
- KABUSHIKI KAISHA BSP, TOKYO, JAPAN, AKA BSP INC.:  
2,876,263, CANC. INT. CL. 9.
- KABUSHIKI KAISHA MONTEROZA, JAPAN:  
3,953,644, PUB. 2-15-2011. INT. CL. 43.  
3,953,645, PUB. 2-15-2011. INT. CL. 43.  
3,953,646, PUB. 2-15-2011. INT. CL. 43.  
3,953,647, PUB. 2-15-2011. INT. CL. 43.
- KABUSHIKI KAISHA NICHIREI, CHUO-KU, TOKYO, JAPAN, DBA NICHIREI CORPORATION:  
2,467,135, REN. 3-31-11. INT. CL. 1.
- KABUSHIKI KAISHA SHUEISHA, TOKYO, JAPAN, DBA SHUEISHA INC.:  
2,875,916, CANC. INT. CL. 28.
- KABUSHIKI KAISHA SUN HEALTH, BUNKYO-KU, TOKYO, JAPAN, DBA SUN HEALTH CO., LTD.:  
2,877,332, CANC. INT. CL. 5.
- KABUSHIKI KAISHA TOSHIBA, MINATO-KU, TOKYO, JAPAN, DBA TOSHIBA CORPORATION:  
3,953,288, PUB. 10-12-2010. INT. CL. 9.
- KABUSHIKI KAISHA YOMIURI SHIMBUN TOKYO HONSHA, TOKYO, JAPAN:  
2,876,516, CANC. INT. CL. 16.
- KAHUNAVILLE INTERNATIONAL LICENSING LLC, WILMINGTON, DE:  
3,955,603, INT. CL. 33.  
3,955,604, INT. CL. 33.
- KALATIZADEH, ANDREH, KEW GARDENS, NY, AKA ANDY KALATI / ANDY KALATIZADEH:  
3,953,051, PUB. 7-6-2010. INT. CL. 9.
- KALLE GMBH & CO. KG, D-65203 WIESBADEN, FED REP GERMANY:  
2,936,323, CANC. INT. CL. 1.
- KALMBACH FEEDS, INC., UPPER SANDUSKY, OH:  
3,955,110, PUB. 2-15-2011. MULTIPLE CLASS, INT. CLS. 5 AND 31.
- KAMAN AEROSPACE CORPORATION, BLOOMFIELD, CT:  
1,648,749, REN. 3-26-11. INT. CL. 9.
- KAMAN INDUSTRIAL TECHNOLOGIES CORPORATION, WINDSOR, CT:  
1,648,431, REN. 3-29-11. INT. CL. 42.
- KAMPGROUNDS OF AMERICA, INC., BILLINGS, MT:  
3,954,953, PUB. 2-15-2011. INT. CL. 43.
- KANDON UNLIMITED, INC., SAN DIEGO, CA:  
3,954,200, PUB. 2-15-2011. INT. CL. 16.
- KANN, VICTORIA, WESTPORT, CT:  
3,955,841, MULTIPLE CLASS, INT. CLS. 9, 16, 25, 26, 28 AND 41.
- KAPPA DELTA SORORITY, INC., MEMPHIS, TN:  
3,954,204, PUB. 2-15-2011. INT. CL. 35.  
3,954,205, PUB. 2-15-2011. INT. CL. 35.
- KARDIAN, STEPHEN F., HAWTHORNE, NY AND PARKER, BRAD, HAWTHORNE, NY:  
3,953,079, PUB. 2-15-2011. INT. CL. 41.  
3,953,080, PUB. 2-15-2011. INT. CL. 41.
- KARELIA-UPOFLOOR OY, FINLAND:  
3,953,622, PUB. 2-15-2011. INT. CL. 19.
- KARL STEFAN RIENER, AUSTRIA AND STRITTL, HANS JURGEN, AUSTRIA:  
3,953,580, PUB. 2-15-2011. MULTIPLE CLASS, INT. CLS. 30, 32 AND 33.
- KARL STORZ GMBH & CO. KG, D-78532 TUTTLINGEN, FED REP GERMANY:  
2,461,969, REN. 3-26-11. INT. CL. 16.
- KARMALOOOP, INC., BOSTON, MA:  
3,955,930, INT. CL. 35.
- KAROUN DAIRIES, INC., SUN VALLEY, CA:  
3,953,457, PUB. 2-15-2011. INT. CL. 29.  
3,953,458, PUB. 2-15-2011. INT. CL. 29.  
3,953,712, PUB. 2-15-2011. INT. CL. 29.
- KASHI COMPANY, LA JOLLA, CA:  
3,317,035, AM. INT. CL. 30.
- KASINA, LLC, NEW YORK, NY:  
2,531,928, REN. 3-28-11. INT. CL. 42.
- KASTENSEN, SUE, WESTBY, WI, DBA SUE'S AMAZING LIP STUFF, INC.:  
2,877,285, CANC. INT. CL. 3.
- KASWIT, INC., LA QUINTA, CA:  
3,955,871, INT. CL. 25.
- KATE SPADE, LLC, NEW YORK, NY:  
3,955,827, INT. CL. 3.
- KATHERINE BISHOP II, LTD., HOLLIS, NY, DBA KB STUDIO:  
3,954,441, PUB. 2-15-2011. INT. CL. 25.  
3,954,442, PUB. 2-15-2011. INT. CL. 25.
- KATHRYN SHAFER, WEST PALM BEACH, FL, DBA LIMITLESS POTENTIALS:  
2,422,179, COR. INT. CL. 42.
- KATZENBERGER, JANET, ST. LOUIS, MO:  
2,378,847, CANC. INT. CL. 41.
- KAUFFMAN, MARC R., SAN FRANCISCO, CA:  
2,544,676, REN. 3-25-11. INT. CL. 16.
- KAUFMAN, JAMES L., SAN FRANCISCO, CA, DBA GOO-HOO:  
2,877,087, CANC. INT. CL. 25.
- KAYSER-ROTH CORPORATION, GREENSBORO, NC:  
2,456,689, REN. 3-30-11. INT. CL. 25.
- KAYTEE PRODUCTS INCORPORATED, CHILTON, WI:  
3,956,189, INT. CL. 31.
- KCUSA.COM INC, MIAMI, FL:  
3,956,164, INT. CL. 41.
- KEENE, BRIAN J., SHERMAN OAKS, CA:  
3,953,308, PUB. 2-15-2011. INT. CL. 42.
- KEENE, ROBERT D., MILTON, GA:  
3,953,156, PUB. 2-15-2011. INT. CL. 41.
- KEITT, JONATHAN L, CHARLOTTE, NC:  
3,954,239, PUB. 2-15-2011. INT. CL. 41.
- KELLAR, CASEY, PORTLAND, OR:  
3,954,408, PUB. 2-15-2011. INT. CL. 3.
- KELLEY, E.S., LA JOLLA, CA, DBA ADVENTUROUS AGING:  
3,954,388, PUB. 2-15-2011. INT. CL. 41.
- KELLINA BRANDS INC., VANCOUVER, CANADA:  
3,954,065, PUB. 2-15-2011. INT. CL. 25.
- KELLOGG NORTH AMERICA COMPANY, BATTLE CREEK, MI:  
2,877,852, CANC. INT. CL. 30.  
2,877,853, CANC. INT. CL. 30.
- KELLWOOD COMPANY, CHESTERFIELD, MO:  
3,954,984, PUB. 2-15-2011. INT. CL. 25.  
3,954,985, PUB. 2-15-2011. INT. CL. 35.

KELLY-MOORE PAINT COMPANY, INC., SAN CARLOS, CA:  
3,954,872, PUB. 2-15-2011. INT. CL. 2.

KELLY, EDUARDO E., HINGHAM, MA:  
3,955,337, INT. CL. 5.

KELLY, GRAINNE, DERRY, NORTHERN IRELAND:  
3,954,355, PUB. 2-15-2011. MULTIPLE CLASS, INT. CLS. 12 AND 20.

KELSCH, BRUCE J., LONGMONT, CO:  
2,877,088, CANC. INT. CL. 30.

KEM ENTERPRISES, INC., ADA, MI:  
3,954,871, PUB. 2-15-2011. INT. CL. 10.

KENNAMETAL INC., LATROBE, PA:  
909,047, REN. 3-31-11. U.S. CL. 23 (INT. CLS. 6, 7, 8, 9, 11, 12, 16, 21 AND 28).  
910,403, REN. 3-31-11. U.S. CL. 23 (INT. CLS. 6, 7, 8, 9, 11, 12, 16, 21 AND 28).

KENNEDY DATA CENTER INC, DOTHAN, AL:  
3,953,984, PUB. 2-15-2011. INT. CL. 45.

KENNETH COLE PRODUCTIONS (LIC), LLC, NEW YORK, NY:  
2,943,676, CANC. INT. CL. 18.  
3,955,329, INT. CL. 25.

KENT STATE UNIVERSITY, KENT, OH:  
2,436,592, REN. 3-26-11. INT. CL. 41.

KENTUCKY BIOPROCESSING, LLC, OWENSBORO, KY:  
2,550,504, REN. 3-28-11. INT. CL. 42.

KENTWOOD FLOORS INC., DELTA, BC, CANADA:  
3,955,402, INT. CL. 19.

KEPOS CAPITAL LP, NEW YORK, NY:  
3,955,809, INT. CL. 36.  
3,955,910, INT. CL. 36.

KERR CORPORATION, ORANGE, CA:  
2,378,970, CANC. INT. CL. 10.

KERUSSO ACTIVEWEAR, INC., BERRYVILLE, AR:  
2,416,843, REN. 3-28-11. INT. CL. 25.

KETTENBACH GMBH & CO. KG, ESCHENBURG, FED REP GERMANY:  
2,497,430, REN. 3-30-11. INT. CL. 5.

KEYSTONE ANILINE CORPORATION, CHICAGO, IL:  
3,954,824, PUB. 2-15-2011. INT. CL. 2.

KEYUP LLC, BLOOMINGTON, MN:  
3,955,575, MULTIPLE CLASS, INT. CLS. 16 AND 41.

KIARA L. BAILEY, BEVERLY HILLS, CA:  
3,953,985, PUB. 2-15-2011. INT. CL. 26.

KIDS CENTRAL, INC., OCALA, FL:  
3,954,853, PUB. 2-15-2011. INT. CL. 45.  
3,954,855, PUB. 2-15-2011. INT. CL. 45.  
3,954,857, PUB. 2-15-2011. INT. CL. 45.  
3,954,860, PUB. 2-15-2011. INT. CL. 36.

KIDS FOUNDATION, BEL AIR, CA:  
2,877,815, CANC. INT. CL. 16.

KIDS' STUFF FOUNDATION, ASPEN, CO:  
2,876,538, CANC. INT. CL. 43.  
2,876,585, CANC. INT. CL. 25.  
2,876,586, CANC. INT. CL. 43.

KIEBACK & PETER GMBH & CO. KG, BERLIN, FED REP GERMANY:  
3,953,504, PUB. 2-15-2011. MULTIPLE CLASS, INT. CLS. 9, 11, 37 AND 42.

KIEPE DI TODESCHINI BRUNO, CODEGA GIOVANNA E C. S.N.C., PREMANA (LC), ITALY:  
3,955,282, INT. CL. 8.

KIKKOMAN CORPORATION, CHIBA, JAPAN:  
2,443,586, REN. 3-26-11. INT. CL. 16.

KIKKOMAN SALES USA, INC., SAN FRANCISCO, CA:  
2,877,442, CANC. INT. CL. 29.

KIL-N-DRI VENTILATION SYSTEMS, LLC, MONTROSE, CO:  
2,378,427, CANC. INT. CL. 17.

KILCOYNE, TIMOTHY J., BOLTON, MA:  
2,431,802, REN. 3-25-11. INT. CL. 41.

KIM SENG COMPANY, COMMERCE, CA:  
3,954,091, PUB. 2-15-2011. INT. CL. 30.

KIM STEIN, INC., AGOURA HILLS, CA:  
3,955,451, INT. CL. 24.

KIM, JAMES, SPOKANE, WA:  
2,379,435, CANC. INT. CL. 35.

KIM, YONG S., BUENA PARK, CA:  
3,954,532, PUB. 2-15-2011. INT. CL. 3.

KIMBER IP, LLC, YONKERS, NY:  
3,954,373, PUB. 2-15-2011. INT. CL. 13.

KINDER JOCKS SPORTS, INC., BELLE HARBOR, NY:  
3,954,593, PUB. 2-15-2011. INT. CL. 35.

KING KALIPERS, INC., PEABODY, MA:  
1,150,965, REN. 3-31-11. INT. CL. 12.

KING SYSTEMS CORPORATION, NOBLESVILLE, IN:  
2,443,279, REN. 3-26-11. INT. CL. 10.

KING, KAREEN, OSAGE, KS:  
3,955,710, MULTIPLE CLASS, INT. CLS. 16 AND 41.

KING'S SHADOW CAMO, LLC, SOUTH JORDAN, UT:  
3,955,903, INT. CL. 25.

KINGFIELD CORPORATION LIMITED, CHAI WAN, HONG KONG:  
3,955,993, INT. CL. 9.

KINO FLO, INC., BURBANK, CA:  
1,657,302, REN. 3-25-11. INT. CL. 11.

KIRINO HOLDINGS KABUSHIKI KAISHA, CHUO-KU, TOKYO, JAPAN, TA KIRIN HOLDINGS CO., LTD.:  
3,953,284, PUB. 2-15-2011. INT. CL. 33.

KIRMANI, SHAHZAD FAROOQ, SCARBOROUGH, ME, DBA DELTA INDUS SYSTEMS:  
3,954,951, PUB. 2-15-2011. INT. CL. 9.

KISTER, BART, INDIANAPOLIS, IN:  
1,640,219, REN. 3-31-11. INT. CL. 6.

KITSMUD, LLC, GALESBURG, IL:  
3,954,633, PUB. 2-15-2011. INT. CL. 29.

KITTRICH CORPORATION, LA MIRADA, CA:  
2,379,384, CANC. MULTIPLE CLASS, INT. CLS. 16 AND 20.

KIWILOAN, INC., BURLINGAME, CA:  
2,877,214, CANC. INT. CL. 36.

KLICKTOCK PTY LTD, EDENHOPE, AUSTRALIA:  
3,954,109, PUB. 2-15-2011. INT. CL. 9.

KLUM, HEIDI, 51435 BERGISCH-GLADBACH, FED REP GERMANY:  
2,933,418, CANC. MULTIPLE CLASS, INT. CLS. 3, 5, 18, 20, 21, 24, 25, 28, 35, 43 AND 44.

KMT ROBOTIC SOLUTIONS, INC., AUBURN HILLS, MI:  
2,532,447, REN. 3-29-11. INT. CL. 9.

KNAPHEIDE MFG. CO., THE, QUINCY, IL:  
2,460,493, REN. 3-26-11. INT. CL. 12.

KNOCKAROUND, LLC, SAN DIEGO, CA:  
3,955,727, INT. CL. 9.

KNOG PTY LTD, RICHMOND, AUSTRALIA:  
3,955,199, INT. CL. 25.

KOBO PRODUCTS, INC., SOUTH PLAINFIELD, NJ:  
2,438,857, REN. 3-30-11. MULTIPLE CLASS, INT. CLS. 3 AND 5.

KOHL'S FROZEN CUSTARD, INC., WILMINGTON, NC:  
2,876,066, CANC. INT. CL. 43.

KOHLER CO., KOHLER, WI:  
3,955,687, INT. CL. 11.

KOHUTE, BRIAN, PLYMOUTH MEETING, PA AND HELLER, JAY, PLYMOUTH MEETING, PA:  
2,869,363, CANC. INT. CL. 36.

KOI CONCEPTS, LLC, DUARTE, CA:  
3,956,208, INT. CL. 35.

KOI SPA INTERNATIONAL, LLC, WAYNE, NJ:  
2,957,630, CANC. MULTIPLE CLASS, INT. CLS. 41 AND 44.

KOIKE CORPORACION, S.L., SAN SEBASTIAN, GUIPUZC, SPAIN, G. SENSAT HIJOS, S.A., MADRID, SPAIN:  
1,644,511, REN. 3-30-11. INT. CL. 29.

KOLCRAFT ENTERPRISES, INC., CHICAGO, IL:  
3,955,892, INT. CL. 28.

KOLDER, INC., EDINBURG, TX:  
2,445,343, REN. 3-25-11. INT. CL. 21.

KOLDKISS, LLC, BALTIMORE, MD:  
2,469,712, REN. 3-26-11. MULTIPLE CLASS, INT. CLS. 7, 30 AND 32.

KOLON FASHION MATERIAL, INC., GWACHEON-SI, GYEONGGI-DO 427-709, REPUBLIC OF KOREA:  
3,953,042, PUB. 1-25-2011. INT. CL. 25.

- KONINKLIJKE PHILIPS ELECTRONICS N.V., EINDHOVEN, NETHERLANDS:  
1,148,394. REN. 3-29-11. INT. CL. 9.  
2,876,368. CANC. INT. CL. 9.  
2,876,441. CANC. INT. CL. 9.  
2,876,508. CANC. INT. CL. 9.
- KONINKLIJKE PHILIPS ELECTRONICS N.V., NETHERLANDS:  
3,953,603. PUB. 2-15-2011. INT. CL. 8.
- KORDON TIP SAGLIK ARAC VE GERECLERI MUHENDISLIK PROJE ITHALAT SANAYI VE TICARET LIMITED SIRKETI, TURKEY:  
3,953,561. PUB. 2-15-2011. INT. CL. 11.
- KORTA RECORDS, C.A., CARACAS, VENEZUELA:  
3,953,941. PUB. 2-15-2011. INT. CL. 9.
- KORTE, ANDREAS, D-78267 AACH, FED REP GERMANY:  
2,510,791. CANC. INT. CL. 3.
- KOSE CORPORATION, CHUO-KU, TOKYO, JAPAN:  
2,527,929. REN. 3-26-11. INT. CL. 3.
- KOTNI TRADING, INC., PASADENA, CA:  
3,953,358. PUB. 2-15-2011. INT. CL. 25.
- KOZLAK'S ROYAL OAK RESTAURANT, INC., SHOREVIEW, MN:  
1,642,253. REN. 3-31-11. INT. CL. 35.
- KPCB HOLDINGS, INC., MENLO PARK, CA:  
2,878,057. CANC. INT. CL. 10.
- KRAFT FOODS GLOBAL BRANDS LLC, NORTHFIELD, IL:  
3,955,767. INT. CL. 30.
- KRAZY KAT SPORTSWEAR LLC, CARLSTADT, NJ:  
3,954,431. PUB. 2-15-2011. INT. CL. 25.
- KRIEGLER, NATALIE D., NEW YORK, NY:  
2,877,626. CANC. INT. CL. 41.
- KRISHNAMURTI FOUNDATION OF AMERICA, OJAI, CA:  
2,379,407. CANC. INT. CL. 41.
- KRITER BRUT DE BRUIT, 21200 BEAUNE, FRANCE, COMPTOIR D'ACHAT VINICOLE, BEAUNE (COTE D'OR), FRANCE:  
1,161,223. REN. 3-31-11. INT. CL. 33.
- KROEGER HERB PRODUCTS CO., INC., BOULDER, CO:  
2,378,679. CANC. INT. CL. 5.
- KROGH PUMP COMPANY, INC., BENICIA, CA:  
2,378,726. CANC. INT. CL. 7.
- KRONOPLUS TECHNICAL AG, NIEDERTEUFEN, SWITZERLAND:  
3,902,500. CANC. MULTIPLE CLASS, INT. CLS. 19 AND 27.
- KRUEGER INTERNATIONAL, INC., GREEN BAY, WI:  
2,877,932. CANC. INT. CL. 20.
- KRZEMIEN, KELLY C., MIDLOTHIAN, VA:  
3,955,673. INT. CL. 25.
- KT & G CORPORATION, TAEJON, REPUBLIC OF KOREA:  
2,443,386. REN. 3-25-11. INT. CL. 34.
- KTM SPORTMOTORCYCLE USA, INC., AMHERST, OH:  
2,437,829. REN. 3-30-11. INT. CL. 12.
- KUKLA, FRANK, JEFFERSON CITY, MO:  
3,956,005. INT. CL. 42.  
3,956,006. INT. CL. 42.
- KURT LING, ALPHARETTA, GA, DBA CUSTOMER KINETICS:  
3,955,621. INT. CL. 20.
- KVIE, INC., SACRAMENTO, CA:  
3,954,014. PUB. 2-15-2011. INT. CL. 41.
- KWIK INDUSTRIES, INC., DALLAS, TX:  
2,534,602. REN. 3-29-11. INT. CL. 37.
- KWS SAAT AG, EINBECK, FED REP GERMANY:  
3,953,395. PUB. 2-15-2011. MULTIPLE CLASS, INT. CLS. 7, 31 AND 42.
- KYDEX LLC, BLOOMSBURG, PA:  
1,639,747. REN. 3-29-11. INT. CL. 17.
- L & P PROPERTY MANAGEMENT COMPANY, SOUTH GATE, CA:  
3,954,359. PUB. 2-15-2011. INT. CL. 35.  
3,954,360. PUB. 2-15-2011. INT. CL. 35.
- L M D, 63963 VEYRE MONTON, FRANCE:  
2,876,025. CANC. MULTIPLE CLASS, INT. CLS. 3 AND 5.
- L T PARKER & ASSOCIATES, INC., NORTH CANTON, OH:  
3,956,070. INT. CL. 44.
- L. PERRIGO COMPANY, ALLEGAN, MI:  
922,225. REN. 3-30-11. U.S. CL. 18 (INT. CL. 5).
- L.A. T SPORTSWEAR, LLC, BALLGROUND, GA:  
2,878,080. CANC. INT. CL. 35.
- L.C. INDUSTRIES, INC., CHICAGO, IL:  
2,437,063. REN. 3-25-11. INT. CL. 22.  
2,437,068. REN. 3-25-11. INT. CL. 10.  
2,438,517. REN. 3-25-11. INT. CL. 18.  
2,440,882. REN. 3-25-11. INT. CL. 6.  
2,440,884. REN. 3-25-11. INT. CL. 20.
- L.E.K. CONSULTING LLC, BOSTON, MA:  
2,468,243. REN. 3-26-11. INT. CL. 35.  
2,474,115. REN. 3-26-11. INT. CL. 35.
- L.H. WILSON, INC., FOREST HILL, MD:  
2,443,819. REN. 3-29-11. INT. CL. 6.
- L.S. STARRETT COMPANY, THE, ATHOL, MA:  
2,379,699. CANC. INT. CL. 7.
- L'OREAL, PARIS CEDEX, FRANCE:  
540,541. REN. 3-31-11. U.S. CL. 51 (INT. CLS. 3 AND 5).
- L'OREAL, PARIS, FRANCE:  
2,876,142. CANC. INT. CL. 3.  
2,876,958. CANC. INT. CL. 3.
- L'OREAL USA CREATIVE, INC., NEW YORK, NY:  
2,877,851. CANC. INT. CL. 3.  
2,877,877. CANC. INT. CL. 3.  
3,955,471. INT. CL. 3.  
3,955,989. INT. CL. 3.  
3,956,093. INT. CL. 5.  
3,956,094. INT. CL. 5.
- LA BAUM, JOHN, HENDERSON, NV:  
3,954,858. PUB. 2-15-2011. INT. CL. 35.
- LA CORUÑA, INC., TOA BAJA, PUERTO RICO:  
3,954,874. PUB. 2-15-2011. INT. CL. 6.
- LA FRESH GROUP, INC., ONTARIO, CA:  
2,379,306. CANC. INT. CL. 3.
- LA OFFICE PLAZA, LLC, WESTLAKE, OH:  
2,877,846. CANC. INT. CL. 36.
- LA TERRA FINA USA, INC., SOUTH SAN FRANCISCO, CA:  
3,953,482. PUB. 2-15-2011. MULTIPLE CLASS, INT. CLS. 29 AND 30.
- LA-Z-BOY INCORPORATED, MONROE, MI:  
3,955,034. PUB. 2-15-2011. INT. CL. 11.
- LABORATOIRE M2 INC., SHERBROOKE, QUEBEC, CANADA:  
3,953,937. PUB. 2-15-2011. MULTIPLE CLASS, INT. CLS. 1, 3 AND 5.
- LABORATOIRES EXPANSCIENCE, F-92400 COURBEVOIE, FRANCE:  
3,953,634. PUB. 2-15-2011. INT. CL. 3.
- LACEBARK, INC., STILLWATER, OK:  
3,953,419. PUB. 2-15-2011. INT. CL. 31.
- LADDER PAD CO., INC., ST. LOUIS, MO:  
2,876,393. CANC. INT. CL. 17.
- LADUE, DONALD G., 60385 FRANKFURT, FED REP GERMANY:  
2,877,944. CANC. MULTIPLE CLASS, INT. CLS. 9, 16, 35, 38 AND 42.
- LAFARGE NORTH AMERICA INC., HERNDON, VA:  
2,876,097. CANC. INT. CL. 19.
- LAKE REGION MANUFACTURING, INC., CHASKA, MN, DBA LAKE REGION MEDICAL, INC.:  
3,956,152. INT. CL. 10.
- LAKEWOOD CHURCH, HOUSTON, TX:  
2,893,616. CANC. INT. CL. 16.
- LAMBTECH AUTOMATION, INC., LYNCHBURG, VA:  
2,877,593. CANC. INT. CL. 9.
- LAMONS GASKET COMPANY, HOUSTON, TX:  
2,450,982. REN. 3-28-11. INT. CL. 6.
- LAMSON, RALPH J., SAN RAFAEL, CA:  
3,954,507. PUB. 2-15-2011. INT. CL. 44.
- LAN AIRLINES S.A., SANTIAGO, CHILE:  
3,955,281. INT. CL. 39.
- LANCER INSURANCE COMPANY, LONG BEACH, NY:  
2,449,289. REN. 3-29-11. INT. CL. 16.  
2,451,064. REN. 3-29-11. INT. CL. 16.
- LANCOME PARFUMS ET BEAUTE & CIE, 75008 PARIS, FRANCE, LANCOME S.A., PARIS 8E, FRANCE:  
1,144,179. REN. 3-31-11. MULTIPLE CLASS, INT. CLS. 18



- AND 42.  
LANCÔME PARFUMS ET BEAUTE & CIE, PARIS, FRANCE:  
2,876,594, CANC. INT. CL. 3.  
3,954,940, PUB. 2-15-2011. INT. CL. 3.
- LAND MARK PRODUCTS, INC., MILFORD, IA:  
2,437,136. REN. 3-26-11. INT. CL. 42.
- LAND TEJAS DEVELOPMENT, HOUSTON, TX:  
2,387,168. REN. 3-26-11. INT. CL. 37.
- LANDING TECHNOLOGY GROUP, LLC, FRANKLIN LAKES, NJ:  
2,877,348, CANC. INT. CL. 38.
- LANDTECH INC., ALHAMBRA, CA:  
3,953,112, PUB. 2-15-2011. INT. CL. 9.
- LANE INDIVIDUAL PRACTICE ASSOCIATION, INC., EUGENE, OR:  
2,876,451, CANC. INT. CL. 35.  
2,876,458, CANC. INT. CL. 35.
- LANE INTERNATIONAL, INC., HAYWARD, CA:  
3,955,838, INT. CL. 25.
- LANE, MICHAEL E., LOS ANGELES, CA AND CROTTY, JAMES M., LOS ANGELES, CA:  
2,935,748, CANC. INT. CL. 16.
- LANE, RONALD S., SPRING VALLEY, NY:  
2,379,195, CANC. INT. CL. 9.
- LANG NATURALS, INC., MIDDLETOWN, RI:  
3,955,330, INT. CL. 5.
- LANGKAMP, CRAIG, MONTEREY, CA:  
2,442,225, CANC. INT. CL. 42.
- LANGUAGE BLISS, LLC, ENCINO, CA:  
3,955,774, INT. CL. 41.  
3,955,775, INT. CL. 41.  
3,955,890, INT. CL. 41.
- LANIAK, MAUREEN L., MATTHEWS, NC, DBA IMAGO DEI:  
3,953,903, PUB. 2-15-2011. INT. CL. 3.
- LANOIS, DANIEL, TORONTO, ONTARIO, CANADA:  
3,955,560, INT. CL. 41.
- LAQADASIC, NEW YORK, NY:  
3,954,618, PUB. 2-15-2011. INT. CL. 25.
- LAQADASIC, BRONX, NY:  
3,954,941, PUB. 2-15-2011. INT. CL. 25.
- LAROBARDIER CONTRACT AND DESIGN LLC, DOVER PLAINS, NY:  
3,953,693, PUB. 2-15-2011. INT. CL. 28.
- LARRY E. BOWERSOX, NARVON, PA:  
3,954,008, PUB. 2-15-2011. INT. CL. 36.
- LARRY ECKERLING AND HIS ORCHESTRA, INC., GLENVIEW, IL:  
2,379,543, CANC. INT. CL. 41.
- LARRY HARMON PICTURES CORPORATION, AGOURA HILLS, CA:  
2,390,533. REN. 3-26-11. INT. CL. 28.
- LARSEN DESIGN OFFICE, INC., EDINA, MN:  
1,670,605. REN. 3-30-11. INT. CL. 42.
- LARSEN, JERAMIAH, DENVER, CO, DBA THUMB LITE:  
3,954,922, PUB. 2-15-2011. INT. CL. 9.
- LAS VEGAS PAIUTE TRIBE, LAS VEGAS, NV:  
2,456,176, AM. INT. CL. 42.  
2,456,177, AM. INT. CL. 41.  
2,462,546. REN. 3-28-11. INT. CL. 21.
- LASER REGISTRATION, INC., WASHINGTON, DC:  
2,876,999, CANC. INT. CL. 35.
- LATHAM POOL PRODUCTS INC., LATHAM, NY:  
2,444,031. REN. 3-31-11. INT. CL. 22.
- LATILLA, LLC, CAMPBELL, CA:  
2,530,743, CANC. INT. CL. 9.
- LAUREATE EDUCATION, INC., BALTIMORE, MD:  
3,953,159, PUB. 2-15-2011. INT. CL. 41.
- LAURUS LLC, SEATTLE, WA:  
2,877,859, CANC. MULTIPLE CLASS, INT. CLS. 9, 41 AND 42.
- LAVALAIS, TRENT D., HOUSTON, TX:  
2,876,215, CANC. INT. CL. 25.
- LAVERN ALECCI, GALATIA, IL, DBA ALECCI CONSTRUCTION:  
2,528,430. REN. 3-31-11. INT. CL. 8.
- LAVIN, RICHARD, NEW YORK, NY:  
3,955,839, MULTIPLE CLASS, INT. CLS. 16, 35, 36 AND 41.
- LAWRENCE FOODS, INC., ELK GROVE VILLAGE, IL:  
3,953,203, PUB. 2-15-2011. INT. CL. 30.
- LAZOO WORLDWIDE LLC, NEW YORK, NY:  
3,956,058, MULTIPLE CLASS, INT. CLS. 16, 25 AND 28.
- LB BRANDS, LLC, PORT CLYDE, ME:  
3,954,416, PUB. 2-15-2011. INT. CL. 31.
- LB MARKETING INC, ALPHARETTA, GA:  
3,954,810, PUB. 2-15-2011. INT. CL. 35.
- LBW INSURANCE & FINANCIAL SERVICES, INC., VALENCIA, CA:  
3,955,995, MULTIPLE CLASS, INT. CLS. 35 AND 36.
- LC TRADEMARKS, INC., DETROIT, MI:  
1,186,027. REN. 3-31-11. INT. CL. 30.
- LE SAVON, INC., FREDERICK, MD:  
2,876,174, CANC. INT. CL. 3.
- LE SECRET INC, ORLANDO, FL AND MAHMOOD JAMAL, ORLANDO, FL:  
3,953,975, PUB. 2-15-2011. INT. CL. 3.
- LE SPORTSAC, INC., RENO, NV:  
2,436,827. REN. 3-26-11. MULTIPLE CLASS, INT. CLS. 18 AND 35.
- LEADER TECHNOLOGIES, LLC, WESTERVILLE, OH:  
2,877,882, CANC. INT. CL. 38.
- LEADERSHIP FAIRFAX, INC., VIENNA, VA:  
3,954,260, PUB. 2-15-2011. INT. CL. 41.
- LEADFUSION INCORPORATED, SAN DIEGO, CA:  
3,070,229, CANC. INT. CL. 9.
- LEAF TACO COMPANY, LLC, MORRISON, CO:  
3,955,374, INT. CL. 22.
- LEARNING MANAGEMENT INSTITUTE, WINCHESTER, MA:  
3,955,693, INT. CL. 35.
- LEAVE ME B, CARLSBAD, CA:  
3,955,505, INT. CL. 25.
- LEBANON SEABOARD CORPORATION, LEBANON, PA:  
1,181,721. REN. 3-29-11. INT. CL. 1.
- LEDFORD, JAMES MCLEAN, LITCHFIELD PARK, AZ:  
3,954,420, PUB. 2-15-2011. INT. CL. 41.
- LEE, SHANYAO, SANTA ANA, CA:  
3,953,913, PUB. 2-15-2011. INT. CL. 28.
- LEE, TZONG LONG, HUNTINGTON BEACH, CA:  
2,876,750, CANC. INT. CL. 32.
- LEE, WILLIAM, WOODSTOCK, GA:  
3,954,208, PUB. 2-15-2011. INT. CL. 44.
- LEE'S LIEUTENANTS - ARMY OF NORTHERN VIRGINIA, INC., GEORGETOWN, KY:  
3,953,313, PUB. 2-15-2011. INT. CL. 41.
- LEEANN CHIN, INC., BLOOMINGTON, MN:  
2,877,408, CANC. MULTIPLE CLASS, INT. CLS. 39 AND 43.
- LEEDEN LIMITED, SINGAPORE, SINGAPORE:  
3,953,204, PUB. 2-15-2011. INT. CL. 6.
- LEEPFROG TECHNOLOGIES, INC., IOWA CITY, IA:  
2,536,871. REN. 3-26-11. INT. CL. 42.
- LEFFEW, ROB, MARKLEVILLE, IN:  
3,955,264, MULTIPLE CLASS, INT. CLS. 36 AND 42.
- LEGACY TREE GENEALOGY, LLC, SALT LAKE CITY, UT:  
3,954,949, PUB. 2-15-2011. INT. CL. 42.
- LEGG MASON PROPERTIES, INC., CHARLOTTE, NC:  
2,877,822, CANC. INT. CL. 36.
- LEGO JURIS A/S, DK-7190 BILLUND, DENMARK:  
2,877,933, CANC. INT. CL. 28.
- LEHMAN, LEROY F., JETERSVILLE, VA:  
2,425,068. REN. 3-28-11. INT. CL. 29.
- LEIS POLYTECHNIK - POLYMERE WERKSTOFFE GMBH, FED REP GERMANY:  
3,953,661, PUB. 2-15-2011. INT. CL. 1.
- LEISURE SOCIETY, LLC, SAN DIEGO, CA, DBA EL DORADO:  
3,953,153, PUB. 8-3-2010. INT. CL. 25.
- LELAND MANAGEMENT, INC, ORLANDO, FL:  
3,953,842, PUB. 2-15-2011. INT. CL. 35.
- LENNOX INDUSTRIES INC., RICHARDSON, TX:  
2,486,205. REN. 3-29-11. INT. CL. 11.
- LEO J. SCANSAROLI, WARWICK, RI:  
3,954,427, PUB. 2-15-2011. INT. CL. 3.

- LEON, LOURDES DE, 87000 CD. VICTORIA, TAMAUlipAS, MEXICO:  
2,436,387. REN. 3-26-11. INT. CL. 42.
- LEONGAS, PAUL, CHICAGO, IL:  
3,953,266, PUB. 2-15-2011. INT. CL. 43.
- LEPORELLO GMBH, 90431 NURNBERG, FED REP GERMANY:  
2,876,122, CANC. MULTIPLE CLASS, INT. CLS. 3, 9, 14 AND 16.
- LEROS TECHNOLOGIES CORPORATION, FAIRFAX, VA:  
2,877,484, CANC. MULTIPLE CLASS, INT. CLS. 9 AND 42.
- LES ASSAISONNEMENTS BRIARDS, NANTEUIL-LES-MEAUX, FRANCE:  
1,639,207. REN. 3-31-11. INT. CL. 30.
- LES VIGNERONS DE BUZET, FRANCE:  
2,876,561, CANC. INT. CL. 33.
- LEVEL ONE COMMUNICATIONS, INCORPORATED, SACRAMENTO, CA:  
1,573,059, CANC. INT. CL. 9.
- LEVINGER COMPANY, DELRAY BEACH, FL:  
2,876,085, CANC. INT. CL. 9.
- LEVITON MANUFACTURING CO., INC., MELVILLE, NY:  
3,953,691, PUB. 2-15-2011. INT. CL. 9.
- LEVY WORLD LIMITED PARTNERSHIP, CHICAGO, IL:  
2,267,888, CANC. INT. CL. 42.
- LEVY, DAVID, W., CORONA, CA:  
2,877,676, CANC. INT. CL. 35.
- LEWELLYN TECHNOLOGY, INC., LINTON, IN:  
3,953,698, PUB. 2-15-2011. INT. CL. 41.
- LEXANI INTERNATIONAL, INC., CORONA, CA:  
3,955,945, INT. CL. 12.
- LEXIA LEARNING SYSTEMS, INC., CONCORD, MA:  
3,954,903, PUB. 2-15-2011. INT. CL. 9.
- LEYLAND SPORTS, INC., SPOKANE, WA:  
2,876,800, CANC. MULTIPLE CLASS, INT. CLS. 25 AND 28.
- LFS, INC., SEATTLE, WA:  
3,135,191, COR. MULTIPLE CLASS, INT. CLS. 9 AND 21.  
3,135,192, COR. MULTIPLE CLASS, INT. CLS. 9, 21 AND 28.
- LG ELECTRONICS INC., SEOUL, REPUBLIC OF KOREA:  
3,953,055, PUB. 2-15-2011. INT. CL. 9.  
3,953,067, PUB. 2-15-2011. INT. CL. 7.  
3,953,136, PUB. 2-15-2011. MULTIPLE CLASS, INT. CLS. 7 AND 11.  
3,953,137, PUB. 2-15-2011. INT. CL. 11.  
3,953,139, PUB. 2-15-2011. INT. CL. 11.  
3,953,152, PUB. 2-15-2011. INT. CL. 11.
- LGF-FTW CORP, FORT WASHINGTON, PA:  
3,954,115, PUB. 2-15-2011. INT. CL. 36.
- LI JIANGUO, WENZHOU, ZHEJIANG PROV, CHINA:  
3,953,728, PUB. 2-15-2011. INT. CL. 18.
- LI-ION MOTORS CORP, MOORESVILLE, NC:  
3,956,123, INT. CL. 12.
- LIBERTY NATIONAL LIFE INSURANCE COMPANY, MCKINNEY, TX:  
3,955,636, INT. CL. 36.
- LICEA, LLC, LONG ISLAND CITY, NY:  
3,956,134, INT. CL. 15.
- LICEDOCTORS, SHORT HILLS, NJ:  
3,956,241, INT. CL. 44.
- LICO BRANDS, INC., STOCKTON, CA:  
2,060,552, CANC. INT. CL. 42.
- LIDL STIFTUNG & CO. KG, NECKARSULM, FED REP GERMANY:  
2,877,164, CANC. MULTIPLE CLASS, INT. CLS. 29 AND 30.  
2,877,247, CANC. MULTIPLE CLASS, INT. CLS. 29 AND 31.  
2,877,306, CANC. MULTIPLE CLASS, INT. CLS. 29 AND 30.  
2,877,307, CANC. MULTIPLE CLASS, INT. CLS. 29 AND 30.
- LIDL STIFTUNG & CO. KG, FED REP GERMANY:  
3,953,604, PUB. 2-15-2011. INT. CL. 30.
- LIDOCHEM INC., HAZLET, NJ:  
2,462,243. REN. 3-31-11. INT. CL. 5.
- LIFE CASE LLC, TUCSON, AZ:  
2,877,116, CANC. INT. CL. 18.
- LIFE ENGINEERING FOUNDATION, BRIDGEWATER, IA:  
2,473,175. REN. 3-25-11. INT. CL. 41.
- LIFE NUTRITION COMPANY (U.S.A.), INC., BROOKLYN, NY:  
3,954,636, PUB. 2-15-2011. INT. CL. 5.
- LIFE PURPOSE RESOURCES, FAIRFIELD, IA:  
3,956,173, INT. CL. 41.
- LIFE PURPOSE RESOURCES INC., FAIRFIELD, IA:  
3,956,174, INT. CL. 41.  
3,956,176, INT. CL. 35.
- LIFE SPINE, INC., HOFFMAN ESTATES, IL:  
3,955,440, INT. CL. 10.
- LIFE-LINK INTERNATIONAL, INC., JACKSON, WY:  
2,548,977, CANC. INT. CL. 9.
- LIFECCELL CORPORATION, BRANCHBURG, NJ:  
3,954,601, PUB. 2-15-2011. INT. CL. 5.
- LIFELINC ANESTHESIA CORP., MEMPHIS, TN:  
3,954,401, PUB. 2-15-2011. INT. CL. 35.
- LIFELINE INTERNATIONAL, INC., MADISON, WI:  
3,954,908, PUB. 2-15-2011. INT. CL. 28.  
3,955,682, INT. CL. 28.
- LIFENG GROUP CO., LTD., ZHEJIANG, CHINA:  
3,956,048, INT. CL. 12.
- LIFETIME GUARANTEE, INC., FORT WORTH, TX:  
2,877,499, CANC. INT. CL. 41.
- LIFEWORD BROADCAST MINISTRIES, INC., CONWAY, AR:  
3,954,514, PUB. 2-15-2011. INT. CL. 16.  
3,955,061, PUB. 2-15-2011. MULTIPLE CLASS, INT. CLS. 9, 16, 38, 41 AND 45.  
3,955,063, PUB. 2-15-2011. MULTIPLE CLASS, INT. CLS. 9, 16, 38, 41 AND 45.
- LIGHTERLIFE UK LIMITED, HARLOW, UNITED KINGDOM:  
3,953,476, PUB. 4-27-2010. MULTIPLE CLASS, INT. CLS. 5, 16, 29, 30, 31, 32, 41, 42 AND 44.
- LILENFELD PC, ATLANTA, GA:  
3,954,688, PUB. 2-15-2011. INT. CL. 45.
- LIMON, JOHN B., LAS VEGAS, NV:  
3,955,923, INT. CL. 25.
- LIN, JING, NEW YORK, NY:  
3,956,197, INT. CL. 14.  
3,956,199, INT. CL. 18.
- LINCOLN TECHNICAL INSTITUTE, INC., WEST ORANGE, NJ:  
2,440,890. REN. 3-28-11. INT. CL. 41.
- LINCOLN, DARREN RICHARD, BOYNTON BEACH, FL:  
2,877,566, CANC. INT. CL. 16.
- LIND STONE TRAVEL, INC, NEW YORK, NY, DBA ARCHAEOLOGICAL TOURS COMPANY:  
2,454,905. REN. 3-26-11. INT. CL. 39.
- LINDA M. SMITH, SCHENECTADY, NY, DBA DIVINITEA:  
2,379,485, CANC. INT. CL. 30.
- LINDE AKTIENGESELLSCHAFT, MUNICH, FED REP GERMANY:  
3,954,705, PUB. 2-15-2011. MULTIPLE CLASS, INT. CLS. 1 AND 6.
- LINDE AKTIENGESELLSCHAFT, 80331 MÜNCHEN, FED REP GERMANY, AKA LINDE AG:  
3,955,105, PUB. 2-15-2011. INT. CL. 1.
- LINEAR LIME INCORPORATED, MOORESVILLE, NC, DBA ONE BLOCK DOWN:  
3,953,795, PUB. 2-15-2011. INT. CL. 35.
- LINED VALVE COMPANY, INC., WOODLAND, WA:  
3,954,038, PUB. 2-15-2011. INT. CL. 6.
- LINOTYPE GMBH, BAD HOMBURG V.D.H., FED REP GERMANY:  
2,877,244, CANC. MULTIPLE CLASS, INT. CLS. 9 AND 16.
- LINWOOD HOMES, LTD., DELTA, CANADA:  
3,955,208, MULTIPLE CLASS, INT. CLS. 36 AND 37.
- LIPSEY'S DISTRIBUTION, LLC, BATON ROUGE, LA:  
3,954,867, PUB. 2-15-2011. INT. CL. 25.
- LIQUID PHOENIX, LLC, LOS ANGELES, CA:  
2,877,438, CANC. INT. CL. 16.

LISA FRANK INC, TUCSON, AZ, DBA LISA FRANK COMPANY:  
1,638,354. REN. 3-28-11. INT. CL. 16.

LITE & E-Z, LLC, BYRON, GA:  
3,955,964, INT. CL. 28.  
3,955,965, INT. CL. 28.

LITERACY PARTNERS INC., NEW YORK, NY:  
2,378,602, CANC. INT. CL. 41.

LITERACY WEST NY, INC., BELMONT, NY:  
3,955,878, INT. CL. 16.

LITHIA MOTORS, INC., MEDFORD, OR:  
3,953,988, PUB. 2-15-2011. INT. CL. 9.

LITTLE KIDS, INC., SEEKONK, MA:  
3,955,288, INT. CL. 28.

LITTLE LADY FOODS, INC., ELK GROVE VILLAGE, IL:  
3,953,762, PUB. 2-15-2011. MULTIPLE CLASS, INT. CLS. 40, 42 AND 43.  
3,953,763, PUB. 2-15-2011. MULTIPLE CLASS, INT. CLS. 40, 42 AND 43.

LIVE NATION ENTERTAINMENT, INC., BEVERLY HILLS, CA:  
3,954,678, PUB. 2-15-2011. INT. CL. 35.  
3,954,680, PUB. 2-15-2011. INT. CL. 41.  
3,954,693, PUB. 2-15-2011. INT. CL. 41.

LIVING CELL TECHNOLOGIES LIMITED, SYDNEY, NSW 2000, AUSTRALIA:  
3,953,264, PUB. 2-15-2011. MULTIPLE CLASS, INT. CLS. 5, 42 AND 44.

LIVING SPACES FURNITURE, LLC, RANCHO CUCAMONGA, CA:  
3,954,036, PUB. 2-15-2011. INT. CL. 35.

LIVSMART BRANDS, PANAMA, PANAMA:  
3,955,231, INT. CL. 32.

LIYA INC., MIAMI, FL:  
2,876,825, CANC. INT. CL. 18.

LIZARDTECH, INC., SEATTLE, WA:  
2,877,126, CANC. INT. CL. 9.

LL GLOBAL, INC., WINDSOR, CT:  
2,876,285, CANC. MULTIPLE CLASS, INT. CLS. 16, 35 AND 41.  
2,876,286, CANC. MULTIPLE CLASS, INT. CLS. 16, 35 AND 41.

LL PARKS LIVESTOCK INC., OAKWOOD, IL:  
2,497,791. REN. 3-29-11. INT. CL. 31.

LLUNDELL, DWIGHT, GILBERT, AZ, DBA REAL W8:  
3,954,931, PUB. 2-15-2011. INT. CL. 5.

LOCAL DINES L.L.C, SCOTTSDALE, AZ, DBA LOCAL-DINES:  
3,954,704, PUB. 2-15-2011. INT. CL. 35.

LOCAL FLAIR MAGAZINE LTD, CRESCO, PA:  
3,953,231, PUB. 2-15-2011. MULTIPLE CLASS, INT. CLS. 16 AND 41.

LOCHRIDGE ENERGY SERVICES, LLC, DALLAS, TX:  
3,956,179, INT. CL. 42.

LOCKSMITH PUBLISHING CORP., THE, PARK RIDGE, IL:  
1,647,422. REN. 3-26-11. INT. CL. 16.

LOFO HIGH TECH FILM GMBH, D-79576 WEIL AM RHEIN, FED REP GERMANY, LOFO HIGH TECH FILM GMBH, D-79576 WEIL AM RHEIN, FED REP GERMANY:  
2,443,691. REN. 3-28-11. MULTIPLE CLASS, INT. CLS. 16 AND 17.

LOGICAL KINETICS LLC, NEW YORK, NY:  
3,955,238, INT. CL. 41.

LOGIX INSULATED CONCRETE FORMS LTD., PORT HOPE, ONTARIO, CANADA:  
3,890,384, COR. INT. CL. 19.

LOGOS PRODUCTIONS, INC., INVER GROVE HEIGHTS, MN:  
1,619,849. REN. 3-30-11. INT. CL. 16.

LOGOS PRODUCTIONS, INC., INVER GROVE HEIGHTS, MN, LOGOS ART PRODUCTIONS, INC., INVER GROVE HEIGHTS, MN:  
1,615,695. REN. 3-31-11. INT. CL. 16.

LOHMANN & RAUSCHER GMBH, 2525 SCHOENAU AN DER TRIESTING, AUSTRIA:  
2,455,658. REN. 3-30-11. INT. CL. 5.

LOHRING, CHRISTOPHER, SALEM, MA:  
3,955,799, INT. CL. 32.

LONGBIN CHEN, CHINA:  
3,953,525, PUB. 2-15-2011. INT. CL. 25.

LONNON, DARREN, WEED, CA:  
3,953,901, PUB. 2-15-2011. INT. CL. 41.

LOOPBACK, LLC, DALLAS, TX, DBA LOOPBACK COMMUNICATIONS:  
3,954,384, PUB. 2-15-2011. INT. CL. 35.

LORIN INDUSTRIES, INC., MUSKEGON, MI:  
2,535,505. REN. 3-31-11. INT. CL. 6.

LOS ANGELES COUNTY SERVICE AUTHORITY FOR FREEWAY EMERGENCIES, LOS ANGELES, CA:  
3,954,925, PUB. 2-15-2011. INT. CL. 39.

LOS ANGELES LAKERS, INC., THE, EL SEGUNDO, CA:  
3,805,583, COR. INT. CL. 41.

LOS ANGELES PARTY DESIGNS, INC., LOS ANGELES, CA:  
2,551,457. REN. 3-31-11. INT. CL. 41.

LOS ANGELES TIMES COMMUNICATIONS LLC, LOS ANGELES, CA:  
2,379,101, CANC. INT. CL. 41.

LOSHBAUGH, KAREN E, ENCINITAS, CA, DBA ART2RIDE, ART 2 RIDE:  
3,954,151, PUB. 2-15-2011. INT. CL. 41.

LOTEPRO CORPORATION, VALHALLA, NY:  
1,122,164, CANC. MULTIPLE CLASS, INT. CLS. 6 AND 11.

LOU GUOPING, CHINA:  
3,953,677, PUB. 2-15-2011. INT. CL. 25.

LOVE OASIS CHRISTIAN CENTER, MALVERNE, NY:  
2,441,217. REN. 3-26-11. MULTIPLE CLASS, INT. CLS. 9 AND 35.

LOVELAND PRODUCTS, INC., LOVELAND, CO:  
2,543,549. REN. 3-31-11. INT. CL. 1.

LOVETT, TERRY, COSTA MESA, CA:  
3,953,245, PUB. 2-15-2011. MULTIPLE CLASS, INT. CLS. 18 AND 25.

LOVIN' SCOOPFUL, LLC, SEATTLE, WA:  
3,955,491, INT. CL. 35.

LOVING TOUCH ANIMAL CENTER, P.C., STONE MOUNTAIN, GA:  
2,876,835, CANC. INT. CL. 44.

LOWER SIOUX INDIAN COMMUNITY, MORTON, MN:  
3,956,095, INT. CL. 43.

LOWER SIOUX INDIAN COMMUNITY IN MINNESOTA, MORTON, MN:  
2,440,374. REN. 3-30-11. INT. CL. 41.

LOYALTY PLAY HOLDINGS, GLENDALE, CA:  
3,953,933, PUB. 2-15-2011. INT. CL. 41.

LOZES, JOHN L., PASADENA, CA:  
2,379,422, CANC. INT. CL. 41.

LPS IP HOLDING COMPANY, LLC, JACKSONVILLE, FL:  
2,378,493, CANC. MULTIPLE CLASS, INT. CLS. 35 AND 36.

LUCAS WORLD, INC., CERRITOS, CA:  
2,876,327, CANC. INT. CL. 30.

LUCAS, DON DEHAN, BAKERSFIELD, CA:  
2,877,469, CANC. MULTIPLE CLASS, INT. CLS. 14 AND 25.

LUCASFILM ENTERTAINMENT COMPANY LTD., SAN FRANCISCO, CA:  
2,436,756. REN. 3-26-11. INT. CL. 28.  
3,953,084, PUB. 2-15-2011. MULTIPLE CLASS, INT. CLS. 25 AND 28.

LUCHT, RON J., SMYRNA, TN:  
2,877,405, CANC. INT. CL. 25.

LUCKY BELL PLASTIC FACTORY LIMITED, KOWLOON, HONG KONG, HONG KONG:  
3,954,635, PUB. 2-15-2011. INT. CL. 9.

LUCKY MEDIA GROUP, INC., WILMINGTON, DE:  
3,954,758, PUB. 2-15-2011. INT. CL. 25.

LUCKY PAWS, LLC, COVINGTON, KY:  
3,955,810, INT. CL. 16.

LUCKY THREE PRODUCTIONS, LLC, LOVELAND, CO:  
2,967,986, CANC. INT. CL. 41.

LUCKYFISH, INC., SANTA BARBARA, CA:  
2,517,509. REN. 3-28-11. INT. CL. 42.

LUDOWICI AUSTRALIA PTY LTD, QUEENSLAND, AUSTRALIA:  
2,876,053, CANC. INT. CL. 7.

- LUFTHANSA TECHNIK AG, 22335 HAMBURG, FED REP GERMANY:  
3,953,557, PUB. 2-15-2011. MULTIPLE CLASS, INT. CLS. 9, 37 AND 42.
- LUIS ERNESTO HERNÁNDEZ GUARDADO, LEÓN, MEXICO:  
3,953,017, PUB. 2-15-2011. INT. CL. 25.
- LUMEN WATER, INC., DALLAS, TX:  
3,953,059, PUB. 2-15-2011. INT. CL. 32.
- LUNA GARDNER CONSULTING, LLC, PHOENIX, AZ:  
3,956,245, INT. CL. 42.
- LUNASOL KOSMETIK VERTRIEBS GMBH, D-86609 DONAUWORTH, FED REP GERMANY:  
2,875,857, CANC. MULTIPLE CLASS, INT. CLS. 3 AND 5.
- LUNCHTIME SOLUTIONS, INC., N SIOUX CITY, SD:  
3,954,698, PUB. 2-15-2011. INT. CL. 43.
- LUSID TECHNOLOGIES, INC., KEARNS, UT:  
2,436,700, REN. 3-29-11. INT. CL. 2.
- LUXCO, INC., ST. LOUIS, MO:  
3,953,056, PUB. 2-15-2011. INT. CL. 33.
- LVP SOLUTIONS, LLC, WESTON, FL:  
3,954,754, PUB. 2-15-2011. INT. CL. 35.
- LYNETTE ZOROYA, SCOTTSDALE, AZ, DBA KNOW FUN STUFF:  
3,953,226, PUB. 2-15-2011. MULTIPLE CLASS, INT. CLS. 25 AND 41.
- LYNN CROWLEY, HARVARD, MA:  
3,955,487, INT. CL. 16.
- LYNUXWORKS, INCORPORATED, SAN JOSE, CA, LY-  
NUXWORKS, INCORPORATED, SAN JOSE, CA:  
2,443,510, REN. 3-30-11. INT. CL. 9.
- LYON COMPANY, THE, SALT LAKE CITY, UT:  
2,587,285, CANC. INT. CL. 6.
- M. DOHMEN KOREA LTD., SEOUL 158-050, REPUBLIC OF  
KOREA, LUCKY, LTD., YONGDUNGPO-KU, SEOUL,  
REPUBLIC OF KOREA:  
1,642,524, REN. 3-26-11. INT. CL. 2.
- M. Z. BERGER & CO., INC., LONG ISLAND CITY, NY:  
3,955,723, INT. CL. 14.
- M.F.H. FEJLESZTŐ KORLÁTOLT FELELŐSSÉGŰ TÁRSÁ-  
SÁG, HUNGARY:  
3,953,632, PUB. 2-15-2011. MULTIPLE CLASS, INT. CLS. 3, 25 AND 35.
- M.T.M. S.R.L. CON UNICO SOCIO, ITALY:  
3,953,607, PUB. 2-15-2011. MULTIPLE CLASS, INT. CLS. 7  
AND 9.
- M!PANADA, LLC, POMONA, CA:  
2,877,325, CANC. INT. CL. 43.
- M&FC HOLDING, LLC, RALEIGH, NC:  
2,446,694, REN. 3-26-11. INT. CL. 6.
- M-REAL CORPORATION, ESPOO, FINLAND:  
2,877,403, CANC. INT. CL. 16.
- MAAG PUMP SYSTEMS TEXTRON AG, OBERGLATT,  
SWITZERLAND:  
2,443,721, REN. 3-30-11. INT. CL. 7.
- MAAX INC., LACHINE, QUEBEC:  
2,877,002, CANC. INT. CL. 11.
- MAAYAN LLC, IRVINE, CA:  
3,955,580, INT. CL. 32.
- MACDONALD, REBECCA A, SAN JOSE, CA, DBA THE  
DOG MENTOR:  
3,954,031, PUB. 2-15-2011. INT. CL. 41.
- MACKAY, TIMOTHY K., COMMERCE TWP., MI:  
2,379,537, CANC. INT. CL. 8.
- MACNEIL IP LLC, BOLINGBROOK, IL:  
3,955,474, INT. CL. 12.
- MACSPEECH, INC., BEDFORD, NH:  
2,877,807, CANC. INT. CL. 9.
- MADDOCK INDUSTRIES, INC., BLOOMINGTON, IN:  
2,876,234, CANC. INT. CL. 7.
- MAESTRO CALABRESE INTERNATIONAL LTD, CHING-  
FORD, LONDON, UNITED KINGDOM:  
3,786,626, COR. MULTIPLE CLASS, INT. CLS. 7, 11, 20  
AND 21.
- MAFCOTE, INC., NORWALK, CT:  
2,378,613, CANC. INT. CL. 16.
- MAGGIE SOTTERO DESIGNS, LLC, SALT LAKE CITY, UT:  
2,877,215, CANC. INT. CL. 25.
- MAGIC RIGHTS LIMITED, LONDON W1W 8AR, UNITED  
KINGDOM:  
2,876,230, CANC. INT. CL. 9.
- MAGIC RING, INC., PROSPECT HEIGHTS, IL:  
2,545,664, REN. 3-28-11. INT. CL. 20.
- MAGIC SEASONING BLENDS, INC., NEW ORLEANS, LA:  
3,953,859, PUB. 2-15-2011. MULTIPLE CLASS, INT. CLS. 30, 35, 39, 40 AND 42.
- MAGIC SEASONINGS BLENDS, INC., NEW ORLEANS, LA:  
2,439,504, REN. 3-26-11. INT. CL. 42.
- MAGLITAL - S.R.L., VIA STRADA STATALE FLAMINIA  
KM. 145, ITALY:  
2,457,020, REN. 3-25-11. INT. CL. 25.
- MAGNETI MARELLI FRANCE, NANTERRE, FRANCE:  
3,953,281, PUB. 2-15-2011. MULTIPLE CLASS, INT. CLS. 9  
AND 12.
- MAGUIRE, WILLIAM E., PACIFIC PALISADES, CA:  
2,552,320, REN. 3-31-11. INT. CL. 30.
- MAHAN TECHNICAL DESIGN, MARTINSVILLE, IN, DBA  
MTEK WEAPON SYSTEMS:  
3,953,828, PUB. 2-15-2011. INT. CL. 9.
- MAID-O'-MIST LLC, CHICAGO, IL:  
3,954,033, PUB. 2-15-2011. INT. CL. 11.  
3,954,056, PUB. 2-15-2011. INT. CL. 11.
- MAIMONIDES MEDICAL CENTER, BROOKLYN, NY:  
3,954,719, PUB. 2-15-2011. MULTIPLE CLASS, INT. CLS. 16  
AND 44.
- MAJORICA, S.A., BARCELONA, SPAIN, INDUSTRIA ESPA-  
NOLA DE PERLAS IMITACION, S.A., BARCELONA,  
SPAIN:  
713,498, REN. 3-29-11. U.S. CL. 28 (INT. CL. 14).
- MAKAHA OCEAN PRODUCTION LLC, WAIANAE, HI,  
DBA KEAULANA'S SURF SHOP:  
3,952,994, PUB. 2-15-2011. INT. CL. 25.
- MAKE HIM STOP, LLC, NEW YORK, NY:  
3,955,256, MULTIPLE CLASS, INT. CLS. 41 AND 43.
- MAKE IT BETTER LLC, WILMETTE, IL:  
3,953,709, PUB. 2-15-2011. INT. CL. 41.
- MAKERS INTERACTIVE CORP, SANTA CLARA, CA:  
3,955,601, INT. CL. 42.
- MAKO SECURITY, INC., FOREST HILLS, NY:  
3,952,973, PUB. 2-15-2011. INT. CL. 13.
- MALABAR PRODUCTOS NATURALES, LLC, SAN ANTO-  
NIO, TX:  
2,545,671, REN. 3-29-11. MULTIPLE CLASS, INT. CLS. 5  
AND 30.  
3,953,876, PUB. 11-9-2010. INT. CL. 5.
- MALBER USA, INC., GARDEN CITY, NY:  
2,838,319, CANC. INT. CL. 7.
- MALIBU DREAM GIRL, INC., COMMERCE, CA:  
3,955,907, INT. CL. 25.
- MALLARD CREEK POLYMERS, INC., CHARLOTTE, NC:  
2,877,860, CANC. INT. CL. 1.
- MALT-O-MEAL COMPANY, MINNEAPOLIS, MN:  
3,956,119, INT. CL. 30.
- MALVENTANO SALES, INC., PHOENIX, AZ:  
2,877,784, CANC. INT. CL. 42.
- MALVERN MINERALS COMPANY, HOT SPRINGS, AR:  
2,379,385, CANC. INT. CL. 1.  
2,379,386, CANC. INT. CL. 1.
- MAM BABYARTIKEL GESELLSCHAFT M.B.H., A-1160  
WIEN, AUSTRIA:  
2,378,409, CANC. MULTIPLE CLASS, INT. CLS. 35 AND  
42.
- MAMIYE BROTHERS, INC., NEW YORK, NY:  
3,955,657, INT. CL. 25.
- MAMMOTH RECORDS, INC., CARRBORO, NC:  
2,535,583, REN. 3-26-11. INT. CL. 9.
- MANA PRODUCTS, INC., LONG ISLAND CITY, NY:  
3,955,228, INT. CL. 3.
- MANAGEMENT CONCEPTS, INC., VIENNA, VA:  
2,429,822, REN. 3-31-11. MULTIPLE CLASS, INT. CLS. 9,  
16, 35, 36, 41 AND 42.
- MANARD WARREN & ASSOCIATES, INC., FLOWER  
MOUND, TX:  
2,876,652, CANC. INT. CL. 41.
- MANGIAMELI, DANIELE, MIAMI, FL:  
3,955,320, INT. CL. 34.

MANITOWOC CRANE COMPANIES, LLC, MANITOWOC, WI:  
2,456,322. REN. 3-31-11. INT. CL. 7.

MANNATECH, INC., COPPELL, TX:  
2,379,986. CANC. INT. CL. 3.

MANNINGTON MILLS, INC., SALEM, NJ:  
2,877,918. CANC. INT. CL. 27.  
3,955,783. INT. CL. 19.

MANRIQUE, VICTOR, WESTON, FL:  
2,876,399. CANC. INT. CL. 14.

MANUCHAR NV, B-2170 ANTWERP, BELGIUM:  
3,955,849. INT. CL. 35.

MANUFACTURING SYSTEMS, INC., BELLE FOURCHE, SD:  
3,954,498. PUB. 2-15-2011. INT. CL. 6.

MANULI STRETCH USA, INC., SHELBYVILLE, TN:  
2,379,580. CANC. INT. CL. 16.

MAPA GMBH GUMMI- UND PLASTIKWERKE, FED REP GERMANY:  
3,953,584. PUB. 2-15-2011. INT. CL. 10.

MAPES PIANO STRING CO., THE, ELIZABETHTON, TN:  
908,927. REN. 3-29-11. U.S. CL. 14 (INT. CL. 6).

MAQUET CRITICAL CARE AB, SOLNA, SWEDEN:  
2,401,632. REN. 3-29-11. INT. CL. 10.  
2,878,026. CANC. MULTIPLE CLASS, INT. CLS. 16 AND 41.

MARATHON EQUIPMENT COMPANY, VERNON, AL:  
1,642,596. REN. 3-26-11. INT. CL. 7.

MARBLES LLC, CHICAGO, IL:  
3,953,397. PUB. 2-15-2011. INT. CL. 35.

MARC JACOBS TRADEMARKS LLC, NEW YORK, NY:  
3,955,219. INT. CL. 3.

MARCH COATINGS, INC., BRIGHTON, MI:  
3,953,236. PUB. 2-15-2011. INT. CL. 37.

MARCHON EYEWEAR, INC., MELVILLE, NY:  
1,531,740. REN. 3-30-11. INT. CL. 9.

MARCO POLO EXPLORERS, INC., CINCINNATI, OH:  
2,877,978. CANC. INT. CL. 28.

MARCONI, BARRETTO, LAS VEGAS, NV, DBA MBMARCONI:  
3,954,055. PUB. 2-15-2011. INT. CL. 41.

MARCUS CORPORATION, THE, MILWAUKEE, WI:  
2,500,948. REN. 3-26-11. INT. CL. 41.

MARCUS MICHAEL DESIGNS LLC, BETHLEHEM, PA:  
2,876,250. CANC. INT. CL. 40.

MARGALIT, JON, SAN DIEGO, CA:  
3,955,805. MULTIPLE CLASS, INT. CLS. 18 AND 24.

MARIEHAVEZ, INC., LOS ANGELES, CA:  
2,876,246. CANC. INT. CL. 14.

MARIN MOUNTAIN BIKES, INC., NOVATO, CA:  
2,460,001. REN. 3-25-11. INT. CL. 12.

MARINE MAMMAL TOURS, INC., CAPE CANAVERAL, FL:  
3,954,804. PUB. 2-15-2011. INT. CL. 39.

MARIUS MOREL FRANCE SAS, MORBIER 39400, FRANCE:  
2,440,197. REN. 3-26-11. INT. CL. 9.

MARK A. GRANNIS, WASHINGTON, DC:  
3,954,399. PUB. 2-15-2011. INT. CL. 35.

MARK VII EQUIPMENT INC., ARVADA, CO:  
3,955,814. INT. CL. 7.

MARKET AMERICA, INC., GREENSBORO, NC:  
3,953,833. PUB. 2-15-2011. INT. CL. 3.

MARKETACTION, INC., CHICAGO, IL:  
3,954,106. PUB. 2-15-2011. INT. CL. 36.

MARKETING DISPLAYS, INC., FARMINGTON HILLS, MI:  
2,487,369. COR. INT. CL. 6.

MARKETSTAR CORPORATION, OGDEN, UT:  
2,429,150. REN. 3-28-11. INT. CL. 35.

MARKLIN HUNGARIA KFT., GYOR, HUNGARY:  
1,653,165. REN. 3-31-11. INT. CL. 28.

MARLIN MANUFACTURING CORPORATION, CLEVELAND, OH:  
3,955,364. INT. CL. 9.

MARRIAGE BUILDERS, INC., WHITE BEAR LAKE, MN:  
2,477,784. REN. 3-26-11. MULTIPLE CLASS, INT. CLS. 35 AND 42.  
2,500,000. REN. 3-29-11. MULTIPLE CLASS, INT. CLS. 35 AND 42.

MARS, INCORPORATED, MCLEAN, VA:  
2,435,100. REN. 3-25-11. INT. CL. 21.  
2,441,064. REN. 3-28-11. INT. CL. 21.  
3,955,870. MULTIPLE CLASS, INT. CLS. 29 AND 30.

MARSALLE, INC., METUCHEN, NJ:  
3,954,339. PUB. 2-15-2011. INT. CL. 9.

MARSHAWN EVANS UNLIMITED LLC (ME UNLIMITED), ATLANTA, GA, DBA ME UNLIMITED:  
3,953,908. PUB. 2-15-2011. INT. CL. 41.  
3,953,909. PUB. 2-15-2011. INT. CL. 41.

MARTELL, MICHAEL D., POWAY, CA AND JOHNSON, RODNEY, BAKERSFIELD, CA:  
2,877,019. CANC. INT. CL. 12.

MARTIAL ARTS SCHOLARSHIP FUND, INC., ALLEN, TX:  
3,953,890. PUB. 2-15-2011. INT. CL. 36.

MARTIN PAUL, INC., DENTON, TX:  
1,161,507. REN. 3-26-11. INT. CL. 28.

MARTIN SURFACE TECHNOLOGIES, LLC, PARRISH, FL:  
3,955,606. MULTIPLE CLASS, INT. CLS. 1, 2 AND 17.

MARTIN, JASMIN, COOROY QUEENSLAND, AUSTRALIA:  
2,876,082. CANC. INT. CL. 42.

MARTIN, RYAN T, FRESNO, CA, DBA BLUBOY BRAND:  
3,954,898. PUB. 2-15-2011. INT. CL. 25.

MARTINDALE, DELORES, THORNTON, CO:  
2,876,929. CANC. INT. CL. 31.

MARVEL CHARACTERS, INC., BEVERLY HILLS, CA:  
2,645,783. CANC. INT. CL. 28.  
2,667,300. CANC. INT. CL. 16.

MASLEY, STEVEN, ST. PETERSBURG, FL:  
3,954,233. PUB. 2-15-2011. MULTIPLE CLASS, INT. CLS. 5 AND 44.

MASQUE PUBLISHING, INC., HIGHLANDS RANCH, CO:  
2,423,948. REN. 3-30-11. INT. CL. 41.

MASSACHUSETTS BIOMEDICAL INITIATIVES, WORCESTER, MA:  
2,875,931. CANC. INT. CL. 35.

MASSACHUSETTS EYE AND EAR INFIRMARY, BOSTON, MA:  
3,953,330. PUB. 2-15-2011. INT. CL. 44.

MASSENGILL, R. KEMP, LEUCADIA, CA:  
2,441,331. REN. 3-30-11. INT. CL. 10.

MAST, DAVID PAUL, RIVERSIDE, CA AND REDDING, ADAM PAUL, RIVERSIDE, CA:  
2,877,955. CANC. INT. CL. 9.

MASTER MALE ILLUSIONIST, LLC, DAYTON, OH:  
3,954,264. PUB. 2-15-2011. INT. CL. 41.

MASTER SUPPLEMENTS, INC., VICTORIA, MN:  
3,955,041. PUB. 2-15-2011. INT. CL. 5.  
3,955,116. PUB. 2-15-2011. INT. CL. 5.

MASTIS, DANIEL, ST. LOUIS, MO, DBA FRONT PAGE NEWS:  
2,379,034. CANC. INT. CL. 16.

MATA HARI COLLECTION, LLC, NEW YORK, NY:  
3,954,928. PUB. 2-15-2011. INT. CL. 25.

MATERIALS DESIGN, INC., ANGEL FIRE, NM:  
3,953,769. PUB. 2-15-2011. INT. CL. 9.

MATERIALS MODIFICATION INC., FAIRFAX, VA:  
2,437,338. REN. 3-31-11. INT. CL. 4.

MATHIS HOLDING, INC., OKLAOMA CITY, OK:  
3,953,786. PUB. 2-15-2011. INT. CL. 35.

MATRIX RESOURCES, INC., ATLANTA, GA:  
3,954,291. PUB. 2-15-2011. MULTIPLE CLASS, INT. CLS. 35 AND 42.

MATRIX TECHNOLOGIES LLC, HUDSON, NH:  
2,444,246. REN. 3-29-11. INT. CL. 9.

MATTEL, INC., EL SEGUNDO, CA:  
3,955,427. INT. CL. 28.  
3,955,450. INT. CL. 28.  
3,955,455. INT. CL. 28.  
3,955,456. INT. CL. 28.  
3,955,692. INT. CL. 28.

MATTHEWS & STEPHENS ASSOCIATES INC., ROCKY HILL, CT TO MATTHEWS & STEPHENS ASSOCIATES INC., ROCKY HILL, CT:  
2,379,901. CANC. INT. CL. 35.

MATTHEWS RESOURCES, INC., WILMINGTON, DE:  
3,955,291. INT. CL. 9.

- MAUI FUN COMPANY INC, LAHAINA, HI:  
3,956,230, INT. CL. 39.
- MAURICES INCORPORATED, DULUTH, MN:  
3,953,884, PUB. 2-15-2011. INT. CL. 35.  
3,953,885, PUB. 2-15-2011. INT. CL. 35.
- MAVERICK TUBE CORPORATION, CHESTERFIELD, MO:  
2,877,905, CANC. INT. CL. 40.
- MAVIG GMBH, FED REP GERMANY:  
3,953,506, PUB. 2-15-2011. MULTIPLE CLASS, INT. CLS. 9 AND 10.
- MAX ECO, LLC, OLD TAPAN, NJ:  
3,953,383, PUB. 2-15-2011. INT. CL. 3.
- MAX INTERNATIONAL, LLC, SALT LAKE CITY, UT:  
3,955,100, PUB. 2-15-2011. INT. CL. 5.
- MAX ROHR, INC., WILMINGTON, DE, ROGERS IMPORTS, INC., NEW YORK, NY:  
386,280. REN. 3-29-11. U.S. CL. 8 (INT. CL. 34).
- MAX ROHR, INC., WILMINGTON, DE:  
715,303. REN. 3-30-11. U.S. CL. 17 (INT. CL. 34).  
1,647,608. REN. 3-26-11. INT. CL. 34.
- MAXIMUM LIVING, INC., SOULSBYVILLE, CA:  
3,956,264, INT. CL. 5.
- MAXPRO TECHNOLOGIES, INC., FAIRVIEW, PA:  
3,954,362, PUB. 2-15-2011. INT. CL. 35.
- MAXWELL JON H., BREVARD, NC:  
3,955,800, INT. CL. 37.
- MAYNARD, MICHAEL, BIRMINGHAM, MI:  
3,955,317, INT. CL. 25.
- MAZDA MOTOR CORPORATION, HIROSHIMA, JAPAN:  
2,877,253, CANC. MULTIPLE CLASS, INT. CLS. 9, 14, 16, 18, 25, 27 AND 28.
- MBA MORTGAGE CORPORATION, BALTIMORE, MD:  
2,876,946, CANC. INT. CL. 36.
- MCADAM, DANIEL PATRICK, REDONDO BEACH, CA:  
3,954,515, PUB. 2-15-2011. INT. CL. 25.
- MCAFFEE, INC., PLANO, TX:  
2,387,394. REN. 3-31-11. INT. CL. 9.
- MCC EVENTS, LLC, AUGUSTA, GA:  
2,875,881, CANC. INT. CL. 41.
- MCCARTER & ENGLISH, LLP, NEWARK, NJ:  
2,877,143, CANC. INT. CL. 42.
- MCCAUGHEY-RIVAS, MARIA, BOCA RATON, FL:  
3,953,839, PUB. 2-15-2011. INT. CL. 41.
- MCCOLLOM, LESLIE ALLISON, PORTLAND, OR:  
3,954,024, PUB. 2-15-2011. INT. CL. 41.
- MCCULLUM, VICTOR, INDIAN HEAD PARK, IL:  
2,877,864, CANC. INT. CL. 41.
- MCCUTCHEON APPLE PRODUCTS, INC., FREDERICK, MD:  
2,535,922. REN. 3-26-11. MULTIPLE CLASS, INT. CLS. 29 AND 30.  
2,549,356. REN. 3-31-11. MULTIPLE CLASS, INT. CLS. 29, 30 AND 32.
- MCDONALD'S CORPORATION, OAK BROOK, IL:  
1,654,388. REN. 3-28-11. INT. CL. 25.  
3,955,508, INT. CL. 38.
- MCELROY, SHAUNEEN, SANTA CRUZ, CA:  
3,954,078, PUB. 2-15-2011. INT. CL. 30.
- MCG VENTURES, INC., BIG BEAR LAKE, CA:  
2,876,619, CANC. INT. CL. 43.
- MCGRATH, DYANNE, ROLLING HILLS, CA:  
2,350,821, CANC. INT. CL. 35.
- MCGRATH, MARY JO, SANTA BARBARA, CA:  
3,954,723, PUB. 2-15-2011. MULTIPLE CLASS, INT. CLS. 9, 16 AND 41.
- MCKEE, BRETT, CHARLESTON, SC, AKA CHEF BRETT MCKEE:  
3,955,000, PUB. 2-15-2011. INT. CL. 43.  
3,955,001, PUB. 2-15-2011. INT. CL. 43.
- MCMC, LLC, QUINCY, MA:  
2,444,378. REN. 3-30-11. INT. CL. 35.
- MCMURDO, JOHN B., NOVATO, CA:  
2,428,721. REN. 3-28-11. INT. CL. 11.
- MCNEILUS TRUCK AND MANUFACTURING, INC., DODGE CENTER, MN:  
2,436,557. REN. 3-26-11. MULTIPLE CLASS, INT. CLS. 7 AND 12.
- MCPHERSON, MATHEW A., NORWALK, WI:  
2,389,491. REN. 3-26-11. INT. CL. 28.
- MDR FITNESS CORP., SUNRISE, FL:  
2,572,462, CANC. INT. CL. 5.
- MEBNER GMBH & CO. KG INDUSTRIEBEDARF, FED REP GERMANY:  
3,953,628, PUB. 2-15-2011. MULTIPLE CLASS, INT. CLS. 7, 11 AND 17.
- MEADE INSTRUMENTS EUROPE GMBH & CO. KG, 46414 RHEDE, FED REP GERMANY:  
2,484,004. REN. 3-28-11. INT. CL. 9.
- MEADOR, LUANN, MONTEREY, CA AND MEADOR, J. DOUGLAS, MONTEREY, CA, DBA MEADOR ESTATE:  
2,878,063, CANC. INT. CL. 33.
- MEADWESTVACO CORPORATION, STAMFORD, CT:  
2,877,917, CANC. INT. CL. 16.
- MEALS ON WHEELS ASSOCIATION OF AMERICA, ALEXANDRIA, VA:  
2,438,054. REN. 3-30-11. MULTIPLE CLASS, INT. CLS. 41 AND 42.
- MECHANIX WEAR, INC., VALENCIA, CA:  
3,954,034, PUB. 2-15-2011. INT. CL. 35.
- MED X CHANGE, INC., BRADENTON, FL:  
3,954,675, PUB. 2-15-2011. INT. CL. 9.
- MEDA PHARMACEUTICALS INC., SOMERSET, NJ:  
2,543,490. REN. 3-31-11. INT. CL. 5.
- MEDCARE AMERICA, LLC, CHULA VISTA, CA:  
3,953,817, PUB. 10-19-2010. MULTIPLE CLASS, INT. CLS. 36 AND 37.
- MEDI IP LLC, TAMPA, FL:  
3,956,061, INT. CL. 35.
- MEDI PLUS TEC MEDIZINISCH-TECHNISCHE HANDELSGESELLSCHAFT MBH, MOERS, FED REP GERMANY:  
2,877,029, CANC. INT. CL. 34.
- MEDIA DELIVERY TECHNOLOGY, LLC, ASPEN, CO, AKA MEDDELTECH:  
3,955,513, MULTIPLE CLASS, INT. CLS. 35, 41, 42 AND 45.
- MEDIA-X SYSTEMS INC., OTTAWA, ONTARIO, CANADA:  
2,876,980, CANC. INT. CL. 9.
- MEDIACOM COMMUNICATIONS CORPORATION, MIDDLETOWN, NY:  
2,544,829, COR. INT. CL. 38.  
2,853,190, COR. INT. CL. 38.  
3,096,359, COR. INT. CL. 38.  
3,437,688, COR. MULTIPLE CLASS, INT. CLS. 37 AND 38.  
3,437,689, COR. MULTIPLE CLASS, INT. CLS. 37 AND 38.  
3,442,365, COR. MULTIPLE CLASS, INT. CLS. 38 AND 41.  
3,493,871, COR. MULTIPLE CLASS, INT. CLS. 37 AND 38.  
3,596,562, COR. MULTIPLE CLASS, INT. CLS. 37 AND 38.  
3,796,336, COR. INT. CL. 35.
- MEDIASPAN GROUP, INC., ANN ARBOR, MI:  
2,440,099. REN. 3-26-11. INT. CL. 9.  
2,479,673. REN. 3-26-11. INT. CL. 9.  
2,480,243. REN. 3-26-11. INT. CL. 9.
- MEDICAL TRANSCRIPTION INDUSTRY ASSOCIATION, CHICAGO, IL:  
2,877,739, CANC. INT. CL. 35.
- MEDICINE MEXICO, SA DE CV, MEXICO, DF, MEXICO:  
3,954,247, PUB. 2-15-2011. INT. CL. 35.
- MEDITERRANEAN CELLARS, LLC, WARRENTON, VA:  
3,954,548, PUB. 2-15-2011. INT. CL. 33.
- MEDIUM CONTROL, DULUTH, MN:  
2,877,743, CANC. INT. CL. 25.
- MEDTRONIC, INC., MINNEAPOLIS, MN:  
3,956,244, INT. CL. 10.
- MEDZONE CORPORATION OF ARIZONA, SUN CITY, AZ:  
2,877,720, CANC. INT. CL. 5.
- MEEKS, MARY GROSSMAN, CORONA, CA:  
2,495,631. REN. 3-25-11. INT. CL. 5.  
2,495,632. REN. 3-30-11. INT. CL. 5.

- MEETINGS & EVENTS INTERNATIONAL, INC., EVANSVILLE, IN:  
2,876,208, CANC. INT. CL. 41.
- MEETINGSIN, LLC, SCOTTSDALE, AZ:  
3,954,721, PUB. 2-15-2011. INT. CL. 35.
- MEGOLA INC., POINT EDWARD, ONTARIO, CANADA:  
3,955,586, INT. CL. 2.
- MEHROTRA, ANAND, TORRANCE, CA:  
3,953,794, PUB. 2-15-2011. INT. CL. 41.
- MEIJER, INC., GRAND RAPIDS, MI:  
2,444,242, REN. 3-31-11. INT. CL. 35.
- MELALEUCA, INC., IDAHO FALLS, ID:  
2,512,610, REN. 3-31-11. INT. CL. 5.
- MELINDA CHIEW, AUSTRALIA:  
3,953,608, PUB. 2-15-2011. INT. CL. 25.
- MELISSA DATA CORP., SANTA RANCHO MARGARITA, CA:  
2,459,640, REN. 3-25-11. INT. CL. 9.
- MELISSA MAHAN, BROKEN ARROW, OK:  
3,954,501, PUB. 2-15-2011. INT. CL. 41.
- MEMBERS BUSINESS SERVICES, LLC, SAN BERNARDINO, CA:  
2,876,406, CANC. INT. CL. 36.
- MEMPHIS PUBLISHING COMPANY, MEMPHIS, TN:  
2,439,556, REN. 3-28-11. INT. CL. 16.
- MENDEZ, BENEDICTO, PINEHURST, TX:  
3,954,354, PUB. 2-15-2011. INT. CL. 41.
- MENDOZA, DAVID, CARTERET, NJ:  
3,953,145, PUB. 2-15-2011. INT. CL. 25.
- MENG FANTAO, BEIJING, CHINA:  
3,953,606, PUB. 2-15-2011. INT. CL. 25.
- MENTAL WORKOUT, INC., SOUTHAMPTON, NY:  
3,953,989, PUB. 2-15-2011. MULTIPLE CLASS, INT. CLS. 9, 42 AND 44.
- MENTALITY SKATEBOARDING, INC., HOUSTON, TX:  
2,877,420, CANC. MULTIPLE CLASS, INT. CLS. 16 AND 28.
- MENTUM, FRANCE:  
3,953,495, PUB. 2-15-2011. MULTIPLE CLASS, INT. CLS. 9, 35, 38 AND 42.
- MERCK KGAA, DARMSTADT, FED REP GERMANY:  
3,953,065, PUB. 8-3-2010. MULTIPLE CLASS, INT. CLS. 2 AND 17.  
3,953,230, PUB. 11-2-2010. INT. CL. 1.
- MERCK SHARP & DOHME CORP., WHITEHOUSE STATION, NJ:  
3,955,335, INT. CL. 5.
- MERCY HEALTH SYSTEM - NORTHERN REGION, TOLEDO, OH:  
2,440,388, REN. 3-30-11. INT. CL. 42.
- MEREDITH CORPORATION, DES MOINES, IA:  
2,438,284, REN. 3-26-11. INT. CL. 16.  
2,438,649, REN. 3-26-11. INT. CL. 42.  
2,876,403, CANC. INT. CL. 16.
- MERGING ADMINISTRATIVE SOLUTIONS, INC., WALDORF, MD:  
3,954,068, PUB. 2-15-2011. INT. CL. 45.
- MERIAL LLC, DULUTH, GA:  
1,644,228, REN. 3-30-11. INT. CL. 5.
- MERIDIAN RETAIL, INC., TROY, MI:  
2,877,811, CANC. MULTIPLE CLASS, INT. CLS. 35, 40 AND 42.  
2,877,812, CANC. MULTIPLE CLASS, INT. CLS. 35, 40 AND 42.
- MERITON NETWORKS INC., KANATA, ONTARIO, K2K 2E1, CANADA:  
2,877,856, CANC. INT. CL. 9.
- MERLIN, AVROM, PHILADELPHIA, PA:  
3,955,822, INT. CL. 25.
- MESH DIGITAL LIMITED, GUILDFORD, UNITED KINGDOM, DBA DOMAINBOX:  
3,954,050, PUB. 2-15-2011. MULTIPLE CLASS, INT. CLS. 42 AND 45.
- MESOPHOTONICS LIMITED, SOUTHAMPTON, ENGLAND:  
2,877,147, CANC. MULTIPLE CLASS, INT. CLS. 9, 38 AND 42.
- MESTEK, INC., WESTFIELD, MA:  
3,955,418, INT. CL. 6.  
3,955,421, INT. CL. 19.
- MESYL LIMITED, CASTLETOWN, ISLE OF MAN:  
3,953,354, PUB. 2-15-2011. INT. CL. 3.
- METAMAG INC., STRATHROY ONTARIO, CANADA:  
2,877,887, CANC. MULTIPLE CLASS, INT. CLS. 9 AND 11.
- METECH INTERNATIONAL, LLC, WORCESTER, MA:  
2,380,030, CANC. MULTIPLE CLASS, INT. CLS. 35 AND 40.
- METROPOLITAN COOPERATIVE LIBRARY SYSTEM, PASADENA, CA:  
2,876,205, CANC. INT. CL. 41.
- METROPOLITAN HEALTHCARE SERVICES, INC., VIENNA, VA:  
3,955,182, INT. CL. 39.
- METROPOLITAN LIFE INSURANCE COMPANY, NEW YORK, NY:  
3,955,643, INT. CL. 36.
- METROPOLITAN TRANSPORTATION COMMISSION, OAKLAND, CA:  
3,955,531, MULTIPLE CLASS, INT. CLS. 9 AND 39.
- MEYER INTELLECTUAL PROPERTIES LIMITED, KOWLOON, HONGKONG, CHINA:  
3,955,746, INT. CL. 21.
- MEYNARD DESIGNS, INC., WALTHAM, MA:  
3,955,941, INT. CL. 25.  
3,955,954, INT. CL. 25.
- MG BROWN INVESTMENT GROUP, LLC, HOUSTON, TX:  
3,953,132, PUB. 2-15-2011. INT. CL. 44.
- MGD INNOVATIONS, LLC, TAMPA, FL:  
3,956,143, INT. CL. 10.
- MGI LUXURY GROUP SA, 2502 BIEL, SWITZERLAND:  
2,876,287, CANC. INT. CL. 14.
- MGM TECHNOLOGY, INC., GRETN, LA:  
2,876,007, CANC. INT. CL. 38.
- MIA MATISSE, LAS VEGAS, NV:  
3,954,035, PUB. 2-15-2011. INT. CL. 41.
- MICHAEL KARPINSKI, FED REP GERMANY:  
3,953,605, PUB. 2-15-2011. MULTIPLE CLASS, INT. CLS. 37 AND 42.
- MICHAEL L. BROWN, WAXAHACHIE, TX:  
3,955,921, INT. CL. 42.
- MICHAEL LAPLANTE, LOWELL, MA:  
3,955,299, INT. CL. 26.
- MICHAEL LEWITTES, WHITE PLAINS, NY:  
3,953,162, PUB. 2-15-2011. INT. CL. 41.
- MICHAEL O'NEILL, INC., BROOKLYN, NY, AKA MICHAEL O'NEILL PHOTOGRAPHY:  
3,955,559, INT. CL. 41.
- MICHAEL PIRETTI, ARCATA, CA:  
3,954,278, PUB. 2-15-2011. INT. CL. 1.
- MICHAEL RICCI, SPRINGFIELD, PA, DBA ALL ABOUT JAZZ:  
3,953,267, PUB. 6-29-2010. INT. CL. 35.
- MICHAEL, MARY JAYNE, FREMONT, OH:  
2,378,645, CANC. INT. CL. 9.
- MICHEL "MICKEY" JOHNSON, WASHINGTON, TX, DBA NICHOLAS LONDON JEWELRY:  
3,954,107, PUB. 2-15-2011. INT. CL. 14.
- MICHELIN NORTH AMERICA, INC., GREENVILLE, SC:  
2,444,165, REN. 3-25-11. INT. CL. 12.
- MICHIGAN WIRE PROCESSING CO., INC., LOWELL, MI:  
2,442,222, REN. 3-31-11. INT. CL. 6.
- MICHIGAN WIRE PROCESSING COMPANY, INC., LOWELL, MI:  
2,442,223, REN. 3-30-11. INT. CL. 40.  
2,475,146, REN. 3-31-11. INT. CL. 40.  
2,506,745, REN. 3-31-11. INT. CL. 6.
- MICKEN RECORDS, LAWTON, OK:  
2,876,944, CANC. INT. CL. 41.
- MICRO INDUSTRIES CORPORATION, WESTERVILLE, OH:  
2,877,331, CANC. INT. CL. 42.

- MICROBAN PRODUCTS COMPANY, HUNTERSVILLE, NC, CONVENIENT SYSTEMS, INC., WINSTON-SALEM, NC, AKA CONVENIENT SYSTEMS, DIVISION OF WASHINGTON GROUP:  
1,141,006, REN. 3-31-11. INT. CL. 1.
- MICROPIER, LLC, SARASOTA, FL:  
3,955,786, INT. CL. 9.
- MICROSOFT CORPORATION, REDMOND, WA:  
3,954,936, PUB. 2-15-2011. INT. CL. 9.  
3,954,996, PUB. 2-15-2011. INT. CL. 9.  
3,955,017, PUB. 2-15-2011. INT. CL. 36.  
3,955,114, PUB. 2-15-2011. MULTIPLE CLASS, INT. CLS. 39 AND 42.
- MICROSURVEY SOFTWARE INC., WESTBANK, BC, CANADA:  
3,954,938, PUB. 2-15-2011. INT. CL. 9.
- MICROTASK OY, HELSINKI, FINLAND:  
3,955,502, MULTIPLE CLASS, INT. CLS. 9, 35 AND 42.
- MID-WEST METAL PRODUCTS CO., INC., MUNCIE, IN:  
3,953,328, PUB. 2-15-2011. INT. CL. 21.
- MIDMARK CORPORATION, VERSAILLES, OH, MIDMARK CORPORATION, VERSAILLES, OH:  
1,150,217, REN. 3-31-11. MULTIPLE CLASS, INT. CLS. 10 AND 20.
- MIDTOWN SOUND, INC., MELVILLE, NY:  
2,876,932, CANC. INT. CL. 41.
- MIDWEST DESIGN IMPORTS, INC., OMAHA, NE:  
2,458,576, REN. 3-30-11. MULTIPLE CLASS, INT. CLS. 20 AND 31.
- MIGDAL, DR. LYNN, DELRAY BEACH, FL:  
3,954,817, PUB. 2-15-2011. INT. CL. 44.
- MIGUEL TORRES, S.A., (BARCELONA), SPAIN:  
3,953,254, PUB. 2-15-2011. INT. CL. 33.
- MIKE DEAMICIS-ROBERTS, HOLLISTER, CA:  
3,955,959, INT. CL. 30.
- MILGARD MANUFACTURING INCORPORATED, TACOMA, WA:  
3,955,049, PUB. 2-15-2011. INT. CL. 6.  
3,955,052, PUB. 2-15-2011. INT. CL. 6.
- MILITARY VEHICLE PRESERVATION ASSOCIATION, INDEPENDENCE, MO:  
3,954,169, PUB. 2-15-2011. INT. CL. 35.
- MILITTI SALES & PROMOTIONS, OMAHA, NE:  
3,955,117, PUB. 2-15-2011. INT. CL. 9.
- MILLENNIUM PARTNERS MANAGEMENT, LLC., NEW YORK, NY:  
2,379,406, CANC. INT. CL. 36.
- MILLER CHEMICAL & FERTILIZER CORPORATION, HANOVER, PA:  
3,955,160, INT. CL. 1.
- MILLER, ANTHONY ALAN, ACWORTH, GA:  
2,877,092, CANC. INT. CL. 44.
- MILLER, ERIC L., FRISCO, TX, DBA THE LAWN ACADEMY:  
3,955,967, INT. CL. 44.
- MILLIKEN & COMPANY, SPARTANBURG, SC:  
3,954,785, PUB. 2-15-2011. INT. CL. 27.
- MILLS PASKERT DIVERS, P.A., TAMPA, FL:  
3,954,489, PUB. 2-15-2011. INT. CL. 45.
- MILNER, DAVID, UKIAH, CA:  
2,877,388, CANC. INT. CL. 1.
- MILUX HOLDING S.A., LUXEMBOURG, LUXEMBOURG:  
3,956,116, MULTIPLE CLASS, INT. CLS. 9, 10 AND 44.  
3,956,117, MULTIPLE CLASS, INT. CLS. 9, 10 AND 44.
- MINCRON SBC CORPORATION, HOUSTON, TX:  
3,954,309, PUB. 2-15-2011. INT. CL. 9.
- MIND & BODY RESEARCH LTD., GIBRALTAR, GIBRALTAR:  
3,954,866, PUB. 2-15-2011. INT. CL. 41.
- MINDFRAME, INC., IRVINE, CA:  
3,956,071, INT. CL. 10.
- MINDSPEED TECHNOLOGIES, INC., NEWPORT BEACH, CA:  
3,955,342, INT. CL. 9.
- MINDTRIBE PRODUCT ENGINEERING, INC., PALO ALTO, CA:  
2,487,497, REN. 3-26-11. INT. CL. 42.
- MINKA LIGHTING, INC., CORONA, CA:  
2,441,337, REN. 3-31-11. INT. CL. 11.  
2,877,904, CANC. INT. CL. 11.
- MINNESOTA PUBLIC RADIO, ST. PAUL, MN:  
2,876,130, CANC. MULTIPLE CLASS, INT. CLS. 9, 14, 21 AND 25.  
3,954,699, PUB. 2-15-2011. INT. CL. 41.  
3,955,087, PUB. 2-15-2011. INT. CL. 41.
- MINNESOTA WEST AG SERVICES, LLC, BIRD ISLAND, MN:  
3,953,735, PUB. 2-15-2011. INT. CL. 35.
- MINUS, INC., WINDSOR, ONTARIO, CANADA:  
2,379,659, CANC. INT. CL. 41.
- MINYANVILLE PUBLISHING & MULTIMEDIA LLC, NEW YORK, NY:  
3,953,234, PUB. 11-9-2010. MULTIPLE CLASS, INT. CLS. 41 AND 45.
- MIQUEL Y COSTAS & MIQUEL S.A., BARCELONA, SPAIN:  
3,955,031, PUB. 2-15-2011. INT. CL. 34.
- MISKELLY FURNITURE WAREHOUSE, INC., JACKSON, MS:  
3,952,979, PUB. 2-15-2011. INT. CL. 35.
- MISS CHOCOLATE CO. INC., GARDEN CITY, NY:  
1,046,953, CANC. INT. CL. 30.
- MISS UNIVERSE L.P., LLLP, NEW YORK, NY:  
2,877,681, CANC. INT. CL. 41.
- MISSION KLEENSWEEP PRODUCTS, INC., LOS ANGELES, CA:  
1,638,824, REN. 3-30-11. INT. CL. 3.
- MISSION SUPPLY, INC., SAN ANTONIO, TX:  
2,877,016, CANC. INT. CL. 34.
- MISSISSIPPI BAND OF CHOCTAW INDIANS, PHILADELPHIA, MS:  
2,876,024, CANC. INT. CL. 40.
- MITCHELL BO R, AIKEN, SC, DBA HIC SKATEBOARDS:  
3,954,148, PUB. 2-15-2011. INT. CL. 28.
- MITCHELL GROSS, NEW YORK, NY:  
3,956,248, INT. CL. 25.
- MITCHELL, REX, MOUNT EVELYN, VICTORIA, AUSTRALIA:  
3,954,993, PUB. 2-15-2011. INT. CL. 41.
- MITCHELL, STEVEN, SUFFERN, NY, DBA HANDYREF:  
3,954,556, PUB. 2-15-2011. INT. CL. 16.
- MITEK CORPORATION, PHOENIX, AZ:  
2,379,351, CANC. INT. CL. 9.  
2,379,352, CANC. INT. CL. 9.
- MITEK SYSTEMS, INC., SAN DIEGO, CA:  
2,379,049, CANC. INT. CL. 9.
- MITEL NETWORKS CORPORATION, KANATA, ONTARIO, CANADA:  
1,150,303, REN. 3-30-11. INT. CL. 9.
- MITSUBISHI PHARMA CORPORATION, CHUO-KU, OSAKA, JAPAN:  
2,876,175, CANC. INT. CL. 5.
- MITSUI MACHINERY DISTRIBUTION, INC., SWEDENBORO, NJ:  
2,876,277, CANC. INT. CL. 9.
- MITSUI TOATSU CHEMICALS, INCORPORATED, CHIYODA-KU, TOKYO, JAPAN TO MITSUI TOATSU CHEMICALS, INCORPORATED, CHIYODA-KU, TOKYO, JAPAN:  
1,603,366, COR. INT. CL. 5.
- MIVA, INC., FT. MYERS, FL, AKA MIVA:  
2,878,070, CANC. INT. CL. 35.
- MIXEMWELL PRODUCTION, HYDE PARK, MA:  
3,954,129, PUB. 2-15-2011. INT. CL. 41.
- MIYAZATO KATS, TORRANCE, CA, DBA M & M ENTERPRISE:  
3,953,426, PUB. 2-15-2011. INT. CL. 33.
- MIZRAHI, MARIEL, ATLANTIC BEACH, NY:  
3,952,998, PUB. 2-15-2011. INT. CL. 14.
- MJS I.P. HOLDING CO. LLC, FRISCO, TX:  
3,955,744, INT. CL. 35.
- MKS UMETRICS AB, UMEÅ, SWEDEN:  
3,953,025, PUB. 2-15-2011. MULTIPLE CLASS, INT. CLS. 9 AND 41.
- MLB ADVANCED MEDIA, L.P., NEW YORK, NY:  
3,954,787, PUB. 2-15-2011. INT. CL. 38.



MMIS, INC., PORTSMOUTH, NH, FORMERLY MILLENIUM MEDICAL INFORMATION SERVICES, INC.:  
3,956,262, INT. CL. 42.

MMS USA HOLDINGS, INC., CHICAGO, IL:  
910,258, REN. 3-29-11. U.S. CL. 101 (INT. CL. 35).

MOBIGAME, PARIS, FRANCE:  
3,954,004, PUB. 2-15-2011. INT. CL. 9.

MOBILEYE TECHNOLOGIES LIMITED, NICOSIA, CYPRUS:  
3,953,484, PUB. 2-15-2011. INT. CL. 9.

MOBIPAY INTERNATIONAL, S.A., 28001 MADRID, SPAIN:  
2,876,000, CANC. MULTIPLE CLASS, INT. CLS. 9, 36 AND 38.

MOBIUS PAYMENTS LLC, LOS ANGELES, CA, DBA MOBIUS PAYMENTS:  
3,953,788, PUB. 2-15-2011. INT. CL. 36.

MOBSHOP, INC., SAN FRANCISCO, CA:  
2,380,133, CANC. INT. CL. 35.

MOCAL, INC., LAKE ORION, MI:  
2,378,710, CANC. INT. CL. 35.

MOCORE, LLC, SEATTLE, WA:  
3,953,015, PUB. 2-15-2011. INT. CL. 43.

MOET HENNESSY USA, INC., NEW YORK, NY:  
3,955,714, INT. CL. 33.

MOHAMED JAVED, YANGON, MYANMAR:  
3,954,510, PUB. 2-15-2011. INT. CL. 5.

MOHAMMADI, ARASH, IRVINE, CA:  
3,954,461, PUB. 2-15-2011. MULTIPLE CLASS, INT. CLS. 25 AND 35.

MOHINI INDIAN FUSIONS, LLC, TURLOCK, CA, DBA MOHINI INDIAN FUSIONS:  
3,953,260, PUB. 2-15-2011. MULTIPLE CLASS, INT. CLS. 16 AND 30.

MOHOLT-SIEBERT, MELISSA J., SANTA ROSA, CA:  
3,954,685, PUB. 2-15-2011. INT. CL. 33.  
3,954,691, PUB. 2-15-2011. INT. CL. 33.  
3,954,694, PUB. 2-15-2011. INT. CL. 33.  
3,954,696, PUB. 2-15-2011. INT. CL. 33.

MOLSON BREWERIES, TORONTO, ONTARIO, CANADA:  
2,336,948, COR. MULTIPLE CLASS, INT. CLS. 9, 18, 21 AND 25.

MOLSON CANADA 2005, TORONTO, ONTARIO, CANADA:  
3,953,168, PUB. 2-15-2011. INT. CL. 32.

MONDI UNCOATED FINE PAPER SALES GMBH, 1032 VIENNA, AUSTRIA:  
2,877,894, CANC. INT. CL. 16.

MONIER GROUP GMBH, OBERURSEL, FED REP GERMANY:  
3,953,238, PUB. 1-4-2011. INT. CL. 19.

MONIQUE CHAUVIN, NEW ORLEANS, LA:  
3,954,590, PUB. 2-15-2011. INT. CL. 21.

MONITOR COMPANY GROUP LIMITED PARTNERSHIP, CAMBRIDGE, MA:  
2,388,137, REN. 3-29-11. MULTIPLE CLASS, INT. CLS. 35 AND 41.

MONOFLO INTERNATIONAL, INC., WINCHESTER, VA:  
3,955,346, INT. CL. 21.

MONOTYPE IMAGING INC., WOBURN, MA:  
2,440,715, REN. 3-29-11. INT. CL. 9.

MONSANTO TECHNOLOGY, LLC, ST. LOUIS, MO:  
2,380,122, CANC. INT. CL. 30.

MONTANI COSMETICS, INC., CHICAGO, IL:  
3,954,750, PUB. 2-15-2011. INT. CL. 3.

MONTGOMERY MOTOR SPORTS, INC., CLAYTON, OH:  
3,955,453, INT. CL. 9.

MONTOLA GROWERS, INC., CULBERTSON, MT:  
2,877,297, CANC. INT. CL. 40.

MOONEYES USA, INC., SANTA FE SPRINGS, CA:  
2,069,994, CANC. INT. CL. 26.

MOORE, BRIAN C., MASON, OH:  
2,877,736, CANC. INT. CL. 42.

MOORHEAD AND COMPANY, INC, VAN NUYS, CA:  
2,378,972, CANC. INT. CL. 35.

MORENO, JORGE, PORTERVILLE, CA:  
3,953,997, PUB. 2-15-2011. INT. CL. 9.

MORENO, SANDRA, WEST ORANGE, NJ:  
2,379,170, CANC. INT. CL. 41.

MORESCO CORPORATION, KOBE-SHI, HYOGO-KEN, JAPAN:  
2,443,370, REN. 3-31-11. INT. CL. 1.

MORGAN, CHRISTINA, ELKO, NV AND MORGAN, KENNETH, ELKO, NV:  
2,426,704, CANC. INT. CL. 42.

MORGANE LE FAY, INC., NEW YORK, NY:  
3,954,061, PUB. 2-15-2011. INT. CL. 3.

MORIARTY, GERALDINE M., SOUTH HADLEY, MA:  
3,955,826, INT. CL. 16.

MORITZ, ROB, SHAWNEE, KS:  
2,521,860, REN. 3-28-11. INT. CL. 41.

MORRIS, RICK, HOOVER, AL:  
3,954,350, PUB. 2-15-2011. INT. CL. 41.

MORRISTOWN AREA RESPONSIBLE DOG OWNERS GROUP, INC., MORRISTOWN, NJ:  
3,954,811, PUB. 2-15-2011. INT. CL. 35.

MOS ENTERPRISES, INC., SANTA MONICA, CA:  
3,956,113, INT. CL. 16.

MOTEURS LEROY-SOMER, 16000 ANGOULEME, FRANCE:  
3,955,583, INT. CL. 7.

MOTH MANAGEMENT, INC., DALLAS, TX:  
3,955,164, INT. CL. 43.

MOTHERSHIP, LLC, SEATTLE, WA:  
2,876,137, CANC. INT. CL. 25.

MOTOR CITY CUPCAKES, LLC, LIVONIA, MI:  
3,954,655, PUB. 2-15-2011. MULTIPLE CLASS, INT. CLS. 30 AND 35.

MOTOWN HISTORICAL MUSEUM, DETROIT, MI:  
3,955,239, MULTIPLE CLASS, INT. CLS. 6, 9, 21 AND 25.

MOUNT NITTANY MEDICAL CENTER, STATE COLLEGE, PA:  
3,952,972, PUB. 2-15-2011. INT. CL. 44.

MOUNTAIN MEATS, INC., PAINT BANK, VA:  
3,953,869, PUB. 11-9-2010. INT. CL. 29.

MOUNTAIN STONE ASSOCIATES LLC, WESTPORT, CT:  
3,955,362, MULTIPLE CLASS, INT. CLS. 16, 40, 41 AND 42.

MOUNTAIN VIEW HOLDINGS, LP, SAN FRANCISCO, CA:  
2,526,108, REN. 3-25-11. INT. CL. 42.

MOVAL MOVEIS ARAPONGAS LTDA., CEP. 86703-000, PARANA, BRAZIL:  
2,876,570, CANC. INT. CL. 20.

MOY SAM CORPORATION, FLUSHING, NY:  
2,877,765, CANC. INT. CL. 9.

MPC INC., WILMINGTON, DE:  
2,876,512, CANC. INT. CL. 11.

MR. EMS SYSTEMS, INC., ST. PAUL, MN:  
1,640,057, REN. 3-30-11. INT. CL. 42.

MR. GOODCENTS FRANCHISE SYSTEMS, INC., DE SOTO, KS:  
3,954,790, PUB. 2-15-2011. INT. CL. 43.

MRB ACQUISITION CORP., PORT ORANGE, FL, DBA U-SCOOT:  
3,953,778, PUB. 2-15-2011. INT. CL. 35.

MRB ACQUISITION CORP., PORT ORANGE, FL, DBA OPEN-AIRE:  
3,953,779, PUB. 2-15-2011. INT. CL. 35.  
3,953,807, PUB. 2-15-2011. INT. CL. 36.

MRG ENTERTAINMENT, INC., SANTA MONICA, CA:  
3,954,397, PUB. 2-15-2011. INT. CL. 41.

MRO CORPORATION, KING OF PRUSSIA, PA:  
2,878,055, CANC. INT. CL. 35.

MRS WILLIAMS COUNTRY KITCHEN INC, WESTLAKE VILLAGE, CA:  
3,954,581, PUB. 2-15-2011. INT. CL. 30.

MSC IMAGING SOLUTIONS LLC, MURRAY, UT:  
3,953,361, PUB. 2-15-2011. INT. CL. 9.

MSC POLYMER AG, 35460 STAUFENBERG-MAINZLAR, FED REP GERMANY:  
3,953,653, PUB. 2-15-2011. INT. CL. 1.

MSM CANADIAN TRANSPORT, LLC., SANTA FE SPRINGS, CA:  
3,956,258, INT. CL. 39.

MT. VERNON ENTERPRISES, INC., CHATTANOOGA, TN:  
2,438,355, REN. 3-26-11. INT. CL. 30.  
2,438,356, REN. 3-28-11. INT. CL. 30.

- MTD PRODUCTS INC, VALLEY CITY, OH:  
2,943,332, CANC. INT. CL. 21.
- MULLETT, DAVID, LONDON, CANADA:  
3,953,304, PUB. 2-15-2011. INT. CL. 36.
- MULTINATIONAL BUSINESS SERVICES, INC., WASHINGTON, DC:  
2,457,174, REN. 3-31-11. INT. CL. 42.
- MULTIPET INTERNATIONAL, INC., MOONACHIE, NJ:  
3,955,149, PUB. 2-15-2011. INT. CL. 28.
- MUNCE, DON, LEE'S SUMMIT, MO:  
2,877,144, CANC. INT. CL. 41.
- MUNICIPAL EMPLOYEES' RETIREMENT SYSTEM OF MICHIGAN, LANSING, MI:  
3,953,353, PUB. 2-15-2011. MULTIPLE CLASS, INT. CLS. 9, 16, 36 AND 41.
- MUNRO & ASSOCIATES, INC., TROY, MI:  
3,954,661, PUB. 2-15-2011. INT. CL. 41.
- MURAD, INC., EL SEGUNDO, CA:  
2,481,451, REN. 3-26-11. MULTIPLE CLASS, INT. CLS. 3 AND 5.
- MURILLO, ADOLFO, OXNARD, CA:  
3,955,874, INT. CL. 33.
- MUSCULOSKELETAL IMAGING CONSULTANTS LLC, SAN ANTONIO, TX:  
3,954,818, PUB. 2-15-2011. INT. CL. 44.  
3,954,819, PUB. 2-15-2011. INT. CL. 38.  
3,955,098, PUB. 2-15-2011. INT. CL. 38.
- MUSEUM OF FINE ARTS, BOSTON, BOSTON, MA:  
3,953,182, PUB. 2-15-2011. INT. CL. 21.  
3,953,183, PUB. 2-15-2011. INT. CL. 20.
- MUSH, INC., FT. WORTH, TX, DBA IGLOO'S FROZEN DRINKS:  
3,955,274, INT. CL. 33.
- MUSIC BIZ BUZZ, ASTORIA, NY:  
3,954,256, PUB. 2-15-2011. MULTIPLE CLASS, INT. CLS. 41 AND 45.
- MUSIC VIDEO DISTRIBUTORS, INC., OAKS, PA:  
3,955,973, INT. CL. 9.
- MUSICNOTES, INC., MADISON, WI, MUSICNOTES, INC., MADISON, WI:  
2,464,139, REN. 3-30-11. INT. CL. 42.
- MUSKEGON HOCKEY CLUB, INC., MUSKEGON, MI:  
2,378,418, CANC. INT. CL. 28.
- MUTASIAN MEDIA, LLC, PALM BEACH GARDENS, FL:  
3,955,224, INT. CL. 16.
- MY GRADE BOOK.COM INC., CARSON CITY, NV:  
2,379,462, CANC. INT. CL. 41.
- MY VIP ENTERPRISES INC, CARMEL, IN:  
3,953,922, PUB. 2-15-2011. INT. CL. 35.  
3,953,923, PUB. 2-15-2011. INT. CL. 35.
- MYCONE DENTAL SUPPLY CO., INC., CHERRY HILL, NJ:  
1,154,576, REN. 3-29-11. INT. CL. 7.
- MYERS, STEPHEN, P., WEST KIRBY, UNITED KINGDOM:  
2,877,150, CANC. MULTIPLE CLASS, INT. CLS. 16, 41 AND 44.
- MYETIES.COM, CHICOPEE, MA:  
3,954,315, PUB. 2-15-2011. INT. CL. 25.
- MYLER BITS USA LLC, MARSHFIELD, MO:  
2,445,192, REN. 3-28-11. INT. CL. 18.
- MYRATEPLAN.COM, LLC, ATLANTA, GA:  
2,465,116, REN. 3-28-11. INT. CL. 42.
- MYWEBGROCER, INC., COLCHESTER, VT:  
3,954,762, PUB. 2-15-2011. INT. CL. 42.
- MYWORKSHIFT, INC., LITTLE ROCK, AR:  
3,956,046, INT. CL. 42.
- M2P2, LLC, AMES, IA:  
3,955,750, MULTIPLE CLASS, INT. CLS. 35, 42 AND 44.
- N.S.C.G., INC., CLEVELAND, OH:  
2,531,109, REN. 3-29-11. INT. CL. 4.  
2,531,110, REN. 3-29-11. INT. CL. 4.
- NADER ANGHA, FED REP GERMANY:  
3,953,496, PUB. 2-15-2011. MULTIPLE CLASS, INT. CLS. 3, 5, 41 AND 44.
- NAHOUNOU, MIKE-CHARLES, BLOOMFIELD, CT:  
3,954,288, PUB. 2-15-2011. INT. CL. 3.
- NAIBYS, INC., ENCINO, CA:  
2,876,144, CANC. INT. CL. 41.
- NAIRE POGHOSYAN, ARMENIA:  
3,953,660, PUB. 2-15-2011. INT. CL. 33.
- NAKANO SHUZOU KABUSHIKI KAISHA, AICHI-KEN, JAPAN, DBA NAKANO SAKE BREWERY CO., LTD.:  
3,953,032, PUB. 6-29-2010. INT. CL. 33.
- NALCO COMPANY, NAPERVILLE, IL:  
2,427,487, REN. 3-29-11. INT. CL. 1.
- NANDO MUZI- S.R.L., VIA FALERIENSE 2103, ITALY:  
2,487,139, REN. 3-25-11. INT. CL. 25.
- NANOINK, INC., SKOKIE, IL:  
3,955,700, INT. CL. 41.
- NANOVIBRONIX, INC., CEDARHURST, NY:  
3,956,178, INT. CL. 5.
- NAPA VALLEY FOODS INC, LONDON, UNITED KINGDOM:  
3,953,880, PUB. 2-15-2011. MULTIPLE CLASS, INT. CLS. 30 AND 32.
- NARAJOA, LTD., NICOSIA, PC, CYPRUS:  
3,954,203, PUB. 2-15-2011. INT. CL. 41.
- NARCOTICS ANONYMOUS WORLD SERVICES, INC., CHATSWORTH, CA:  
2,472,431, REN. 3-28-11. MULTIPLE CLASS, INT. CLS. 14, 20 AND 25.
- NARDA'S GINGER PUNCH, L.L.C., EAST ORANGE, NJ:  
3,954,286, PUB. 2-15-2011. INT. CL. 32.
- NARGES NADJEM, LOS ANGELES, CA:  
3,954,312, PUB. 2-15-2011. INT. CL. 35.
- NASHVILLE PUBLIC TELEVISION, INCORPORATED, NASHVILLE, TN:  
2,524,246, REN. 3-28-11. INT. CL. 9.
- NASSCO, INC, OWINGS MILLS, MD:  
3,952,963, PUB. 2-15-2011. INT. CL. 42.
- NASSCO, INC., OWINGS MILLS, MD:  
3,952,962, PUB. 2-15-2011. INT. CL. 42.  
3,952,964, PUB. 2-15-2011. INT. CL. 42.
- NASTY GAL, INC., EMERYVILLE, CA:  
3,953,331, PUB. 2-15-2011. INT. CL. 35.
- NATHAN KELLENBENZ, DENTON, MD:  
3,954,463, PUB. 2-15-2011. INT. CL. 41.
- NATIONAL ACADEMY OF RECORDING ARTS & SCIENCES, INC., SANTA MONICA, CA:  
3,955,966, INT. CL. 14.
- NATIONAL ARTIST COLORS & TATTOO SUPPLY, INC., ALLENTOWN, PA, DBA NATIONAL TATTOO SUPPLY:  
2,469,023, REN. 3-31-11. MULTIPLE CLASS, INT. CLS. 2 AND 7.  
2,499,575, REN. 3-31-11. U.S. CL. 200.
- NATIONAL ASSOCIATION OF EMERGENCY MEDICAL TECHNICIANS, CLINTON, MS, AKA NAEMT:  
3,954,161, PUB. 2-15-2011. INT. CL. 41.
- NATIONAL ASSOCIATION OF SCHOOL PSYCHOLOGISTS, BETHESDA, MD:  
1,074,290, CANC. INT. CL. 42.
- NATIONAL AUTOMATED CLEARING HOUSE ASSOCIATION, HERNDON, VA:  
3,956,236, INT. CL. 35.
- NATIONAL BIOFUELS DISTRIBUTION, LLC, CARMEL, IN:  
3,954,223, PUB. 2-15-2011. INT. CL. 4.
- NATIONAL BLACK MBA ASSOCIATION, INC., CHICAGO, IL:  
3,953,995, PUB. 2-15-2011. INT. CL. 35.
- NATIONAL CENTER FOR FAMILY LITERACY, INC., LOUISVILLE, KY:  
3,954,100, PUB. 2-15-2011. INT. CL. 41.
- NATIONAL CENTER FOR FINANCIAL TRAINING, INC., NORWICH, CT:  
2,509,459, REN. 3-31-11. INT. CL. 41.
- NATIONAL CENTER FOR MISSING & EXPLOITED CHILDREN, ALEXANDRIA, VA:  
2,876,879, CANC. MULTIPLE CLASS, INT. CLS. 9, 16 AND 41.  
2,876,880, CANC. MULTIPLE CLASS, INT. CLS. 16 AND 41.
- NATIONAL CONCIERGE ASSOCIATION, CRYSTAL, MN:  
2,465,534, REN. 3-31-11. INT. CL. 42.
- NATIONAL CONSUMER COOPERATIVE BANK, ARLINGTON, VA, DBA NATIONAL COOPERATIVE BANK:  
3,955,880, INT. CL. 36.

NATIONAL COUNCIL ON AGING, INC., WASHINGTON, DC:  
2,378,912, CANC. INT. CL. 35.

NATIONAL FIRE FIGHTING MANUFACTURING FZCO, DUBAI, UNITED ARAB EMIR., AKA NAFFCO:  
3,954,290, PUB. 2-15-2011. INT. CL. 9.

NATIONAL GEOGRAPHIC SOCIETY, WASHINGTON, DC:  
2,067,378, CANC. INT. CL. 9.

NATIONAL GROCERS ASSOCIATION, ARLINGTON, VA:  
2,439,968. REN. 3-31-11. INT. CL. 42.

NATIONAL HISPANIC UNIVERSITY LLC, SAN JOSE, CA:  
3,953,968, PUB. 2-15-2011. INT. CL. 41.

NATIONAL MODEL RAILROAD ASSOCIATION, INC., CHATTANOOGA, TN:  
2,395,095. REN. 3-25-11. U.S. CL. 200.  
2,395,099. REN. 3-25-11. U.S. CL. 200.

NATIONAL OILWELL VARCO, L.P., HOUSTON, TX:  
2,436,428. REN. 3-26-11. INT. CL. 7.  
2,436,429. REN. 3-26-11. INT. CL. 7.

NATIONAL PRINT GROUP, INC., CHATTANOOGA, TN:  
3,954,112, PUB. 2-15-2011. INT. CL. 38.

NATIONAL SELF STORAGE MANAGEMENT, INC., TUCSON, AZ:  
1,154,222. REN. 3-31-11. INT. CL. 39.

NATIONAL SELF STORAGE MANAGEMENT, INC., TUCSON, AZ, EXECUTIVE PROPERTY DEVELOPMENT, TUCSON, AZ:  
1,154,223. REN. 3-30-11. INT. CL. 39.

NATIONAL SOCIETY OF TOLE AND DECORATIVE PAINTERS, INC., WICHITA, KS:  
3,953,804, PUB. 2-15-2011. INT. CL. 35.

NATIONAL SPEAKERS ASSOCIATION, TEMPE, AZ:  
3,953,350, PUB. 2-15-2011. INT. CL. 41.

NATIONAL STARCH LLC, BRIDGEWATER, NJ:  
2,890,183, CANC. INT. CL. 30.

NATIONAL VISION ADMINISTRATORS, LLC, CLIFTON, NJ:  
1,651,696. REN. 3-31-11. INT. CL. 36.

NATIONS PHOTO LAB LLC, OWINGS MILLS, MD:  
3,954,640, PUB. 2-15-2011. INT. CL. 40.

NATIONSTAR MORTGAGE LLC, LEWISVILLE, TX:  
2,490,025. REN. 3-26-11. INT. CL. 36.

NATIONWIDE GRAPHICS, INC., HOUSTON, TX:  
3,953,455, PUB. 2-15-2011. MULTIPLE CLASS, INT. CLS. 35, 40, 41 AND 42.  
3,953,456, PUB. 2-15-2011. MULTIPLE CLASS, INT. CLS. 35, 40, 41 AND 42.

NATREN, INC., WESTLAKE VILLAGE, CA:  
2,482,024. REN. 3-29-11. INT. CL. 5.

NATURAL BALANCE PET FOODS, INC., PACOIMA, CA:  
2,452,855. REN. 3-30-11. INT. CL. 31.

NATURAL ORGANICS, INC., MELVILLE, NY:  
3,955,595, INT. CL. 5.

NATURAL SWEET VENTURES, LLC, SUGAR LAND, TX:  
3,888,043, COR. INT. CL. 30.

NATURALLY SLIM, INC., GARLAND, TX:  
3,955,640, MULTIPLE CLASS, INT. CLS. 29, 30 AND 32.

NATURE'S PATH FOODS INC., RICHMOND, BRITISH COLUMBIA, CANADA:  
2,492,114. REN. 3-29-11. INT. CL. 30.

NATUREX, INC., SOUTH HACKENSACK, NJ:  
2,444,642. REN. 3-26-11. INT. CL. 1.

NAUTICA APPAREL, INC., NEW YORK, NY:  
3,955,304, INT. CL. 25.

NAUTICAL KNOW HOW, INC., PHILADELPHIA, PA:  
2,525,242. REN. 3-29-11. INT. CL. 41.

NAVAL AVIATION MUSEUM FOUNDATION, INC., PENSACOLA, FL:  
3,953,057, PUB. 2-15-2011. INT. CL. 41.

NBA DEVELOPMENT LEAGUE, LLC, SECAUCUS, NJ:  
3,955,360, INT. CL. 25.

NBA PROPERTIES, INC., NEW YORK, NY:  
3,955,137, PUB. 2-15-2011. INT. CL. 25.

NBC UNIVERSAL, INC., NEW YORK, NY:  
2,877,967, CANC. INT. CL. 41.

NEA'S MEMBER BENEFITS CORPORATION, GAITHERSBURG, MD:  
3,954,490, PUB. 2-15-2011. MULTIPLE CLASS, INT. CLS. 35, 36, 39 AND 41.  
3,954,495, PUB. 2-15-2011. INT. CL. 41.

NEARVERSE INC., HUNTINGDON VALLEY, PA:  
3,955,769, INT. CL. 42.

NEBERGALL, ERIK, CINCINNATI, OH:  
2,379,298, CANC. INT. CL. 35.

NEC LCD TECHNOLOGIES, LTD., JAPAN:  
3,953,566, PUB. 2-15-2011. INT. CL. 9.

NEDBOY, ROBIN, NEW YORK, NY:  
2,407,698. REN. 3-26-11. INT. CL. 3.

NEDBOY, ROBIN L., NEW YORK, NY:  
3,954,952, PUB. 2-15-2011. INT. CL. 4.

NEDERLANDSE ORGANISATIE VOOR; TOEGEPAST-NATUUR-WETENSCHAPPELIJK; ONDERZOEK TNO, NETHERLANDS:  
3,953,574, PUB. 2-15-2011. MULTIPLE CLASS, INT. CLS. 7, 9 AND 42.

NEGORO, FUMIO, KAMAKURA-SHI, KANAGAWA-KEN, JAPAN:  
2,378,728, CANC. INT. CL. 42.

NEGRON, VALERIE, BRONX, NY:  
2,877,404, CANC. INT. CL. 41.

NELSON LEMMOND, CHARLOTTE, NC:  
3,954,365, PUB. 2-15-2011. MULTIPLE CLASS, INT. CLS. 17 AND 37.

NELSON, DARWIN J., EADS, CO:  
2,876,819, CANC. INT. CL. 12.

NEMETSCHKE VECTORWORKS, INC., COLUMBIA, MD:  
2,437,421. REN. 3-25-11. INT. CL. 9.

NEO MEDICAL INC, FREMONT, CA:  
3,954,611, PUB. 2-15-2011. INT. CL. 10.

NEOPETS, INC., GLENDALE, CA:  
2,877,977, CANC. INT. CL. 28.

NEPTUNE RESEARCH, INC., LAKE PARK, FL:  
3,955,661, INT. CL. 17.  
3,955,662, INT. CL. 17.  
3,955,676, INT. CL. 17.

NEPTUNE TECHNOLOGIES & BIORESOURCES INC., LAVAL, QUEBEC, CANADA:  
2,877,282, CANC. INT. CL. 5.

NESTLE WATERS FRANCE, 92130 ISSY LES MOULINEAUX, FRANCE, SOCIETE GENERALE DES EAUX MINERALES DE VITTEL, 88800 VITTEL, FRANCE:  
1,656,404. REN. 3-31-11. INT. CL. 32.

NETCOM, INC., TEANECK, NJ:  
2,518,853. REN. 3-26-11. INT. CL. 9.

NETSMART TECHNOLOGIES, INC., GREAT RIVER, NY:  
3,953,912, PUB. 2-15-2011. INT. CL. 9.

NETUREN CO., LTD., SHINAGAWA-KU, TOKYO, JAPAN:  
2,379,828, CANC. INT. CL. 12.

NEUHOFFER HOLZ GMBH, AUSTRIA:  
3,953,593, PUB. 2-15-2011. MULTIPLE CLASS, INT. CLS. 6 AND 19.

NEVADA PROPERTY 1 LLC, LAS VEGAS, NV:  
3,955,618, INT. CL. 35.  
3,955,619, INT. CL. 41.  
3,955,620, INT. CL. 43.

NEW AGE ELECTRONICS, INC., CARSON, CA:  
3,953,483, PUB. 4-24-2007. INT. CL. 37.

NEW CENTURY SNACKS, LLC, COMMERCE, CA:  
3,955,587, INT. CL. 29.

NEW ENGLAND HEARTH AND SOAPSTONE LLC, GOSHEN, CT:  
2,445,306. REN. 3-26-11. MULTIPLE CLASS, INT. CLS. 37 AND 40.

NEW GENERATION MEDIA LLC, SANTA ROSA, CA:  
3,954,503, PUB. 2-15-2011. INT. CL. 35.

NEW GLARUS BREWING COMPANY, NEW GLARUS, WI:  
3,953,010, PUB. 2-15-2011. INT. CL. 32.

NEW HAMPSHIRE WOMEN'S GOLF ASSOCIATION, MANCHESTER, NH:  
3,953,755, PUB. 2-15-2011. INT. CL. 41.

NEW HORIZON HEALTH, INC., WESTLAKE VILLAGE, CA:  
3,954,064, PUB. 2-15-2011. INT. CL. 41.

NEW JERSEY TURNPIKE AUTHORITY, NEW BRUNSWICK, NJ:  
2,876,385, CANC. MULTIPLE CLASS, INT. CLS. 14, 18, 20, 25, 36 AND 39.

- NEW PENDULUM CORP., WILMINGTON, DE:  
2,876,865, CANC. INT. CL. 27.
- NEW VISIONS FOR PUBLIC SCHOOLS, NEW YORK, NY:  
3,955,654, INT. CL. 41.  
3,955,656, INT. CL. 41.
- NEW WAVE ENVIRO PRODUCTS, INC., DENVER, CO:  
2,379,332, CANC. INT. CL. 11.
- NEW WAVE GROUP AB, HISINGS KARRA, SWEDEN:  
3,019,033, CANC. INT. CL. 28.
- NEW YORK - NEW YORK HOTEL & CASINO, LLC, LAS VEGAS, NV:  
3,954,918, PUB. 2-15-2011. INT. CL. 43.
- NEW YORK JETS LLC, FLORHAM PARK, NJ:  
3,954,932, PUB. 2-15-2011. INT. CL. 33.  
3,955,022, PUB. 2-15-2011. MULTIPLE CLASS, INT. CLS. 9 AND 41.
- NEW YORK LIFE INSURANCE COMPANY, NEW YORK, NY:  
2,877,958, CANC. INT. CL. 36.
- NEW YORK NEW YORK HOTEL & CASINO, L.L.C., LAS VEGAS, NV:  
2,436,898, REN. 3-25-11. INT. CL. 41.
- NEWBLUE HOLDINGS LLC, MORAGA, CA:  
3,954,875, PUB. 2-15-2011. INT. CL. 25.
- NEWBOLD CORPORATION, ROCKY MOUNTAIN, VA,  
DATACARD CORPORATION, MINNEAPOLIS, MN:  
1,638,885, REN. 3-31-11. MULTIPLE CLASS, INT. CLS. 7 AND 8.
- NEWMAN, RHONDA J., LUTHER, OK:  
3,956,170, INT. CL. 44.
- NEWPORT DYNAMICS, INC., BALDWIN PARK, CA:  
3,954,352, PUB. 2-15-2011. INT. CL. 13.  
3,954,770, PUB. 2-15-2011. INT. CL. 35.
- NEWPORT INDUSTRIES, INC., PENSACOLA, FL TO ARIZONA CHEMICAL COMPANY, PANAMA CITY, FL:  
506,554, CANC. U.S. CL. 6.  
507,028, CANC. U.S. CL. 1.
- NEWS-JOURNAL CORPORATION, DAYTONA BEACH, FL:  
2,378,614, CANC. INT. CL. 35.
- NEWSDAY LLC, MELVILLE, NY:  
1,150,367, REN. 3-31-11. INT. CL. 16.
- NEWTEK BUSINESS SERVICES, INC., NEW YORK, NY:  
3,955,632, MULTIPLE CLASS, INT. CLS. 35, 36, 38 AND 42.
- NEWVIEW LASER EYE, INC., RESTON, VA:  
3,953,297, PUB. 2-15-2011. INT. CL. 16.
- NEXCITE AB, STOCKHOLM, SWEDEN:  
2,877,086, CANC. INT. CL. 3.
- NEXGEN PHARMA, INC., IRVINE, CA:  
3,953,247, PUB. 2-15-2011. INT. CL. 5.
- NEXTANCE, INC., REDWOOD CITY, CA:  
2,877,022, CANC. INT. CL. 9.
- NEXTLIFE LICENSING, LLC, BOCA RATON, FL:  
3,953,369, PUB. 2-15-2011. MULTIPLE CLASS, INT. CLS. 2, 35, 41 AND 42.
- NEXXTEP TECHNOLOGY SERVICES, INC., VALDOSTA, GA:  
3,954,209, PUB. 2-15-2011. INT. CL. 42.
- NGUARD, INC., CHARLOTTE, NC:  
3,954,789, PUB. 2-15-2011. INT. CL. 42.
- NIC MANAGEMENT, INC., WHITTIER, CA:  
3,953,757, PUB. 2-15-2011. INT. CL. 3.
- NICARAGUA TOBACCO IMPORTS, INC., MIAMI, FL, DBA CUBAN CRAFTERS:  
3,955,363, INT. CL. 34.
- NICASIO VALLEY CHEESE CO., INC., SAN RAFAEL, CA,  
DBA NICASIO VALLEY CHEESE COMPANY:  
3,954,613, PUB. 2-15-2011. INT. CL. 29.
- NICHOLS, JIM QUENTIN, MANSFIELD, TX:  
3,954,537, PUB. 2-15-2011. INT. CL. 9.
- NICO HEIMANS H.O.D.N. NICO HEIMANS VORMGEVING, NETHERLANDS:  
3,953,602, PUB. 2-15-2011. INT. CL. 28.
- NICOLE MULDER, INC., EDEN PRAIRIE, MN, DBA EPITOME SKINCARE:  
3,955,481, INT. CL. 3.
- NIGEN INTERNATIONAL, LLC, HOUSTON, TX:  
2,441,992, REN. 3-25-11. MULTIPLE CLASS, INT. CLS. 35 AND 42.
- NII COMMUNICATIONS, LTD., SAN ANTONIO, TX:  
2,877,777, CANC. INT. CL. 38.
- NIKE, INC., BEAVERTON, OR:  
3,955,326, MULTIPLE CLASS, INT. CLS. 18 AND 25.
- NILES, SUZANNE, WESTFORD, MA:  
3,954,174, PUB. 2-15-2011. INT. CL. 9.
- NIMMO BAY RESORT LTD., PORT MCNEILL, BRITISH COLUMBIA, CANADA:  
2,876,067, CANC. MULTIPLE CLASS, INT. CLS. 39, 41 AND 43.
- NINE LITTLE MONTHS LLC, RANCHO SANTA MARGARITA, CA:  
3,954,172, PUB. 2-15-2011. INT. CL. 35.
- NINGBO JINHUI PRECISION CASTING CO., LTD., ZHEJIANG PROVINCE, CHINA:  
3,955,444, INT. CL. 12.
- NIO SECURITY, INC., BOKEELIA, FL:  
2,484,769, REN. 3-30-11. INT. CL. 9.  
2,484,769, CANC. MULTIPLE CLASS, INT. CLS. 38 AND 42.
- NISSAN CHEMICAL INDUSTRIES, LTD., TOKYO, JAPAN:  
3,953,002, PUB. 1-1-2008. INT. CL. 1.
- NISSAN JIDOSHA KABUSHIKI KAISHA, YOKOHAMA-SHI, KANAGAWA, JAPAN, DBA NISSAN MOTOR CO., LTD.:  
3,955,831, MULTIPLE CLASS, INT. CLS. 6 AND 25.  
3,955,836, MULTIPLE CLASS, INT. CLS. 14 AND 16.
- NISSIM, JARED, NEW YORK, NY:  
2,876,906, CANC. INT. CL. 45.
- NITE IZE, INC., BOULDER, CO:  
3,954,467, PUB. 2-15-2011. INT. CL. 6.
- NL WILLIAMS MEDIA INC., NORTH VANCOUVER, CANADA:  
3,955,887, INT. CL. 16.
- NOBLE WAR PRIZE, INC., SOUTHAMPTON, NY:  
3,955,696, MULTIPLE CLASS, INT. CLS. 25 AND 28.  
3,955,748, MULTIPLE CLASS, INT. CLS. 25 AND 28.  
3,955,749, MULTIPLE CLASS, INT. CLS. 25 AND 28.  
3,955,969, MULTIPLE CLASS, INT. CLS. 16, 21, 25 AND 28.
- NOIR NY, INC., NEW YORK, NY:  
2,408,770, REN. 3-31-11. INT. CL. 14.  
2,408,770, CANC. MULTIPLE CLASS, INT. CLS. 18 AND 26.
- NOISE LABORATORY CO., LTD., KANAGAWA, 252-0237, JAPAN:  
1,649,952, REN. 3-31-11. INT. CL. 9.
- NOMURA SECURITIES INTERNATIONAL, INC., NEW YORK, NY:  
3,955,739, MULTIPLE CLASS, INT. CLS. 9 AND 35.
- NON STOP LABEL CORPORATION, SANTA FE SPRINGS, CA:  
2,447,750, REN. 3-31-11. INT. CL. 16.
- NOODLE HEAD, INC., SANTA BARBARA, CA:  
3,955,847, INT. CL. 41.
- NORA FOODS INC, SUGAR LAND, TX:  
3,954,869, PUB. 2-15-2011. INT. CL. 30.
- NORANDEX BUILDING MATERIALS DISTRIBUTION, INC., HUDSON, OH:  
2,877,989, CANC. INT. CL. 19.
- NORCRAFT COMPANIES, L.P., EAGAN, MN:  
2,505,147, REN. 3-30-11. INT. CL. 20.
- NORSEMEN OUTDOORS, INC., LAKE MILLS, IA:  
3,956,165, INT. CL. 28.
- NORSK HYDRO ASA, N-0240 OSLO, NORWAY:  
2,876,225, CANC. INT. CL. 1.
- NORTFORT INC, HEMPSTEAD, NY:  
3,954,502, PUB. 2-15-2011. INT. CL. 35.
- NORTH AMERICAN JEWELERS, INC., CHICAGO, IL:  
2,875,887, CANC. INT. CL. 14.
- NORTH AMERICAN PLYWOOD CORPORATION, SANTA FE SPRINGS, CA:  
1,639,760, REN. 3-31-11. INT. CL. 19.
- NORTH AMERICAN SALT COMPANY, OVERLAND PARK, KS:  
2,509,433, REN. 3-30-11. INT. CL. 31.

NORTH SHORE ANIMAL LEAGUE AMERICA, INC., PORT WASHINGTON, NY:  
3,956,109, MULTIPLE CLASS, INT. CLS. 35, 36 AND 44.

NORTH STAR PHONE CARD INC., JERSEY CITY, NJ:  
2,876,607, CANC. INT. CL. 16.

NORTHERN PLAINS RESOURCE COUNCIL, BILLINGS, MT:  
2,877,260, CANC. INT. CL. 35.

NORTHERN REFLECTIONS LTD., MISSISSAUGA, ONTARIO, CANADA:  
3,953,007, PUB. 8-10-2010. INT. CL. 25.

NORTHERN STRESSWALL CANADA LTD., VANCOUVER, BRITISH COLUMBIA, CANADA:  
2,421,726, REN. 3-26-11. MULTIPLE CLASS, INT. CLS. 19 AND 37.

NORTHLAND CORPORATION, LAGRANGE, KY:  
3,954,434, PUB. 2-15-2011. INT. CL. 19.

NORTHLAND INVESTMENT CORPORATION, NEWTON, MA:  
2,437,295, REN. 3-26-11. MULTIPLE CLASS, INT. CLS. 36 AND 37.  
2,437,297, REN. 3-26-11. MULTIPLE CLASS, INT. CLS. 36 AND 37.

NORTHLAND PRODUCTS, INC., CHINO VALLEY, AZ:  
2,876,437, CANC. INT. CL. 7.

NORTHWEST FEED BARN ONE, LLC, HERMISTON, OR:  
3,955,486, INT. CL. 35.

NORTHWEST MAINTENANCE MANAGEMENT, LLC, TACOMA, WA:  
3,955,986, INT. CL. 19.

NOUVELLE PARFUMERIE GANDOUR, MIAMI, FL:  
3,954,641, PUB. 2-15-2011. INT. CL. 3.

NOVACARB, NANCY, FRANCE:  
2,877,034, CANC. MULTIPLE CLASS, INT. CLS. 1 AND 3.

NOVARTIS AG, BASEL, SWITZERLAND:  
2,877,230, CANC. INT. CL. 10.  
3,895,984, COR. INT. CL. 5.

NOVARTIS AG, SWITZERLAND:  
3,953,672, PUB. 2-15-2011. INT. CL. 5.

NOVARTIS AG, BASEL, SWITZERLAND:  
3,955,711, INT. CL. 35.

NOVARTIS VACCINES AND DIAGNOSTICS S.R.L., 53100 SIENA, ITALY:  
3,953,086, PUB. 2-15-2011. INT. CL. 5.

NOVATAC, INC., CARLSBAD, CA:  
3,953,329, PUB. 2-15-2011. INT. CL. 11.

NOVATECH PROCESS SOLUTIONS, LLC, PORTLAND, OR:  
2,438,096, REN. 3-29-11. INT. CL. 9.

NOVIEURO, S.L., BARCELONA, SPAIN:  
3,953,688, PUB. 2-15-2011. INT. CL. 25.

NOVOMATIC AG, A-2352 GUMPOLDSKIRCHEN, AUSTRIA:  
2,876,133, CANC. MULTIPLE CLASS, INT. CLS. 9, 28 AND 41.

NOVOSTENT CORPORATION, MOUNTAIN VIEW, CA:  
3,955,254, INT. CL. 10.

NOZAKI, RALPH, CHICAGO, IL:  
2,380,106, CANC. INT. CL. 42.

NSD MEDIA LTD., CASTLETROY, CO. LIMERICK, IRELAND:  
3,953,542, PUB. 2-15-2011. MULTIPLE CLASS, INT. CLS. 35, 38 AND 41.

NSE PRODUCTS, INC., PROVO, UT:  
2,877,305, CANC. INT. CL. 32.

NU ALPHA PHI FRATERNITY, INC., CLAREMONT, CA:  
2,876,304, CANC. INT. CL. 35.

NU WAVE ELECTRONICS, INC., LEWISBURG, TN:  
2,379,539, CANC. INT. CL. 37.

NUCLEAR ENERGY INSTITUTE, INC., WASHINGTON, DC:  
3,953,770, PUB. 2-15-2011. MULTIPLE CLASS, INT. CLS. 35 AND 41.

NUERNBERGER, EDWIN P., HONESDALE, PA:  
2,878,031, CANC. INT. CL. 41.

NUMEDICA, L.L.C., TULSA, OK, FORMERLY XYMOGEN NUMEDICA:  
3,954,338, PUB. 2-15-2011. INT. CL. 5.

NUNOVA, LLC, HORSHAM, PA:  
3,955,367, MULTIPLE CLASS, INT. CLS. 39, 42 AND 44.

NUOVA DUEGI S.R.L., 31030 ALTIVOLE, TREVISO, ITALY:  
2,378,860, CANC. INT. CL. 25.

NUTECH LIGHTING CORP., NEW YORK, NY:  
2,877,132, CANC. INT. CL. 11.

NUVASIVE, INC., SAN DIEGO, CA:  
3,956,066, INT. CL. 10.

NUVIDIA, LLC, OVERLAND PARK, KS:  
2,379,789, CANC. INT. CL. 9.

NUVONYX INC, CARLSBAD, CA:  
3,954,118, PUB. 2-15-2011. INT. CL. 5.

NUWORLD, INC., CENTERVILLE, UT:  
3,954,805, PUB. 2-15-2011. INT. CL. 5.

NV BIOMEDICAL, INC., LAS VEGAS, NV:  
2,440,827, REN. 3-25-11. INT. CL. 5.

NVE CORPORATION, EDEN PRAIRIE, MN, NVE CORPORATION, EDEN PRAIRIE, MN:  
2,506,249, REN. 3-30-11. INT. CL. 9.

NVP/UM, BROOKLYN, NY, DBA NVP/UM:  
3,953,871, PUB. 2-15-2011. INT. CL. 41.

NXP B.V., EINDHOVEN, NETHERLANDS:  
2,379,848, CANC. INT. CL. 9.  
2,876,379, CANC. INT. CL. 9.

NYC & COMPANY, INC., NEW YORK, NY:  
2,876,831, CANC. INT. CL. 35.

NYCOMED GMBH, KONSTANZ, FED REP GERMANY:  
2,877,000, CANC. INT. CL. 5.

O & K, INC., LOS ANGELES, CA:  
3,955,873, INT. CL. 25.

O'HAGIN'S INC., ROHNERT PARK, GA:  
2,436,400, REN. 3-29-11. INT. CL. 6.

O'NEIL COLOR AND COMPOUNDING CORP., JASPER, TN:  
2,877,111, CANC. INT. CL. 17.

O'SHAUGHNESSY ASSET MANAGEMENT, L.L.C., STAMFORD, CT:  
3,954,591, PUB. 2-15-2011. INT. CL. 36.

O'SULLIVAN, PATRICIA A., SANTA FE, NM:  
3,955,037, PUB. 2-15-2011. INT. CL. 41.

OBERMAN, STEVEN, KNOXVILLE, TN:  
2,450,656, REN. 3-29-11. INT. CL. 16.

OBERMAN, TIVOLI & PICKERT, INC., LOS ANGELES, CA:  
2,378,441, CANC. MULTIPLE CLASS, INT. CLS. 9 AND 35.

OCEAN BEAUTY SEAFOODS, LLC, SEATTLE, WA, NEW ENGLAND FISH COMPANY, SEATTLE, WA:  
1,139,698, REN. 3-25-11. INT. CL. 29.

OCEAN SOFTWARE PTY LTD, MELBOURNE, VICTORIA, AUSTRALIA:  
2,877,428, CANC. INT. CL. 9.

OCEAN WATCH FOUNDATION, INC., FORT LAUDERDALE, FL:  
2,378,444, CANC. INT. CL. 42.

OCHS, CAROL, SAN DIEGO, CA:  
2,379,053, CANC. INT. CL. 3.

OCI COMPANY LTD., REPUBLIC OF KOREA:  
3,953,513, PUB. 10-12-2010. MULTIPLE CLASS, INT. CLS. 1, 2, 3, 4, 5, 6, 7, 9, 17, 19, 22, 35 AND 36.

OCTAIN GMBH, AUSTRIA:  
3,953,517, PUB. 2-15-2011. MULTIPLE CLASS, INT. CLS. 5, 30 AND 35.

OCTAPHARMA AG, CH-8866 ZIEGELBRUCKE, SWITZERLAND:  
2,378,641, CANC. INT. CL. 5.

OCULAR SYSTEMS, INC., WINSTON-SALEM, NC:  
3,956,038, INT. CL. 10.

OFFICE OF THE ILLINOIS STATE TREASURER, CHICAGO, IL:  
3,954,499, PUB. 2-15-2011. INT. CL. 36.

OFIR, DORON, LOS ANGELES, CA:  
3,953,918, PUB. 2-15-2011. INT. CL. 35.

OGGI, LLC, MINNETRISTA, MN:  
3,955,529, INT. CL. 35.

OGLETREE, DEAKINS, NASH, SMOAK & STEWART, P.C., GREENVILLE, SC:  
2,495,998, REN. 3-29-11. INT. CL. 42.

OHAYON, MAURICE, PARIS, FRANCE:  
2,877,220, CANC. INT. CL. 25.

- OHIO DEPARTMENT OF TAXATION, COLUMBUS, OH:  
2,876,342, CANC. MULTIPLE CLASS, INT. CLS. 35 AND 36.
- OHIO STATE UNIVERSITY, THE, COLUMBUS, OH:  
2,419,790, REN. 3-28-11. INT. CL. 41.  
2,437,954, REN. 3-28-11. INT. CL. 16.
- OKI ELECTRIC INDUSTRY CO., LTD., MINATO-KU, TOKYO, JAPAN:  
2,538,260, REN. 3-29-11. INT. CL. 16.
- OKM ORTUNGSTECHNIK KRAUB & MÜLLER GMBH, 04603 WINDISCHLEUBA, FED REP GERMANY:  
3,953,625, PUB. 2-15-2011. INT. CL. 9.
- OLAF ANDERSON AND SON CONSTRUCTION COMPANY, FARGO, ND:  
3,954,557, PUB. 2-15-2011. INT. CL. 37.
- OLD WORLD INDUSTRIES, LLC, NORTHBROOK, IL, OLD WORLD TRADING COMPANY, INC., THE, DES PLAINES, IL:  
1,651,774, REN. 3-25-11. INT. CL. 41.
- OLI, INC., LOS ANGELES, CA:  
2,876,571, CANC. MULTIPLE CLASS, INT. CLS. 18 AND 25.
- OLIN CORPORATION, ST. LOUIS, MO:  
904,150, REN. 3-31-11. U.S. CL. 13 (INT. CL. 6).
- OLYMPIAN LABS, INC., SCOTTSDALE, AZ:  
2,876,573, CANC. INT. CL. 3.
- OMAHA STEAKS INTERNATIONAL, INC., OMAHA, NE:  
3,954,672, PUB. 2-15-2011. INT. CL. 41.
- OMEGA IMPORTS, INC., MIAMI, FL:  
2,435,579, REN. 3-30-11. INT. CL. 29.
- OMEGA NETWORK SERVICES, INC., FORT WORTH, TX:  
2,379,363, CANC. INT. CL. 42.
- OMEGA PROTEIN, INC., HOUSTON, TX:  
3,954,253, PUB. 2-15-2011. INT. CL. 31.  
3,954,255, PUB. 2-15-2011. INT. CL. 31.  
3,954,668, PUB. 2-15-2011. INT. CL. 31.  
3,954,697, PUB. 2-15-2011. INT. CL. 31.
- OMNI FORGE, INC., REMINGTON, IN:  
2,379,424, CANC. INT. CL. 40.
- OMNI FORGE, INC., COLUMBUS, IN:  
2,379,452, CANC. INT. CL. 40.
- OMNIMIND, INC., MONROE, NY:  
3,954,197, PUB. 2-15-2011. INT. CL. 9.
- OMNOVA SOLUTIONS INC., FAIRLAWN, OH:  
2,877,783, CANC. INT. CL. 17.
- OMS INVESTMENTS, INC., SANTA MONICA, CA:  
2,876,543, CANC. INT. CL. 5.  
2,876,544, CANC. INT. CL. 5.
- OMS INVESTMENTS, INC., LOS ANGELES, CA:  
3,955,536, INT. CL. 44.
- OMX, INC., NAPERVILLE, IL:  
3,955,869, INT. CL. 16.
- ON DECK CHAIRS, LLC, BOSTON, MA:  
3,954,125, PUB. 2-15-2011. INT. CL. 20.
- ON HAND PRESS, INC., CLEARWATER, FL:  
2,876,760, CANC. INT. CL. 16.
- ONBONE OY, FINLAND:  
3,953,599, PUB. 2-15-2011. MULTIPLE CLASS, INT. CLS. 5 AND 10.
- ONE KINGS LANE, LLC, LOS ANGELES, CA:  
3,682,600, COR. INT. CL. 35.
- ONE LIFE (JUVENILE DIVERSION PROGRAM), DETROIT, MI:  
3,954,404, PUB. 2-15-2011. INT. CL. 41.  
3,954,405, PUB. 2-15-2011. INT. CL. 41.  
3,954,406, PUB. 2-15-2011. INT. CL. 41.
- ONE PLUS TWO INC., CONCORD, CA:  
3,954,665, PUB. 2-15-2011. INT. CL. 33.
- ONECBIZ, INC., CLEVELAND, OH:  
3,955,639, INT. CL. 35.
- ONEPARTNER, LLC, DUFFIELD, VA:  
3,953,963, PUB. 2-15-2011. INT. CL. 35.
- ONEWORLD APPAREL LLC, SOUTH EL MONTE, CA:  
2,303,585, REN. 3-30-11. INT. CL. 25.
- ONEX IMPORTS, INCORPORATED, NORTH HOLLYWOOD, CA:  
1,167,424, REN. 3-30-11. INT. CL. 25.
- ONE2CONNECT, INC, ROSWELL, GA:  
2,876,373, CANC. INT. CL. 38.
- ONLINE ADVISORS, INC., CARSON CITY, NV:  
3,955,686, MULTIPLE CLASS, INT. CLS. 9 AND 42.
- ONLINE EDUCATION, INC., CARLSBAD, CA:  
3,954,122, PUB. 2-15-2011. INT. CL. 41.
- ONLINE WIRELESS, INC., TAMPA, FL:  
3,954,187, PUB. 2-15-2011. INT. CL. 9.
- ONSPORT LLC, SANTA BARBARA, CA:  
2,436,995, CANC. INT. CL. 12.
- ONTARIO PAINT & WALLPAPER LIMITED, CONCORD, ONTARIO L4K 3S8, CANADA:  
2,876,074, CANC. MULTIPLE CLASS, INT. CLS. 16 AND 27.
- ONYX ENVIRONMENTAL SERVICES, L.L.C., LOMBARD, IL:  
2,876,682, CANC. INT. CL. 37.
- OP II, INC., DELRAY BEACH, FL:  
2,436,123, REN. 3-26-11. MULTIPLE CLASS, INT. CLS. 4, 7, 8, 9, 10, 11, 20, 21 AND 37.
- OPERATOR GAZOCIAGÓW PRZESYŁOWYCH; GAZ-SYSTEM S.A., POLAND:  
3,953,578, PUB. 2-15-2011. MULTIPLE CLASS, INT. CLS. 4, 35, 37, 39 AND 42.  
3,953,579, PUB. 2-15-2011. MULTIPLE CLASS, INT. CLS. 4, 35, 37, 39 AND 42.
- OPTIDEP CORP., MAHWAH, NJ:  
2,877,031, CANC. INT. CL. 35.
- OPTIMA INVESTMENT RESEARCH, INC., WILMETTE, IL:  
2,549,470, REN. 3-31-11. INT. CL. 36.
- OPTIMA PACKAGING GROUP GMBH, 74523 SCHWABISCH HALL, FED REP GERMANY:  
1,165,231, REN. 3-30-11. MULTIPLE CLASS, INT. CLS. 7 AND 9.
- OPTION ONE MORTGAGE CORPORATION, IRVINE, CA:  
2,876,623, CANC. INT. CL. 36.
- OPTIONSOFT TECHNOLOGIES, INC., CLIFTON PARK, NY:  
2,877,443, CANC. INT. CL. 9.
- OPUS HERITAGE, L.L.C., MINNETONKA, MN:  
2,520,075, REN. 3-26-11. MULTIPLE CLASS, INT. CLS. 36, 37 AND 42.
- ORANGE MOUNTAIN, INC., RICHMOND, VT, DBA TRUE BODY PRODUCTS:  
3,954,287, PUB. 2-15-2011. INT. CL. 3.
- ORASOLV AB, SWEDEN:  
3,591,335, COR. INT. CL. 5.
- OREQ CORPORATION, TEMECULA, CA:  
2,876,768, CANC. INT. CL. 1.
- ORGANICLIFE, LLC, NORTHFIELD, IL:  
3,953,873, PUB. 2-15-2011. INT. CL. 43.
- ORIENT CHEMICAL INDUSTRIES CO., LTD., OSAKA-SHI, OSAKA, JAPAN:  
2,971,175, CANC. INT. CL. 1.
- ORIGEN FINANCIAL L.L.C., SOUTHFIELD, MI:  
2,544,859, REN. 3-27-11. INT. CL. 36.
- ORIGINAL POWER, INC., DULUTH, GA:  
3,955,856, INT. CL. 9.
- ORIGINAL PRODUCTIONS LLC, BURBANK, CA:  
3,953,066, PUB. 12-29-2009. INT. CL. 41.
- ORION CORPORATION, 02200 ESPOO, FINLAND:  
2,876,546, CANC. INT. CL. 5.
- ORION CORPORATION, SEOUL, REPUBLIC OF KOREA:  
3,955,247, INT. CL. 30.
- ORION MACHINERY CO., LTD., NAGANO-KEN, JAPAN:  
1,625,632, REN. 3-26-11. MULTIPLE CLASS, INT. CLS. 7 AND 11.
- ORMUS GOLD LLC, SANTA MONICA, CA, AKA NANO-GOLD:  
3,956,192, INT. CL. 5.
- ORO AZUL, LLC, SEATTLE, WA, DBA TRIPS4FUNDRAISING:  
3,956,255, INT. CL. 39.
- ORW IMPORT PARTS AND MACHINE, INC., SAN DIEGO, CA:  
2,442,674, REN. 3-25-11. MULTIPLE CLASS, INT. CLS. 35 AND 37.

OSAKI ELECTRIC CO., LTD., SHINAGAWA-KU, TOKYO, JAPAN:  
2,876,485, CANC. INT. CL. 9.

OSCAR FABER GROUP, LTD., HERTFORDSHIRE, UNITED KINGDOM:  
1,313,264, CANC. INT. CL. 9.

OSF GLOBAL SERVICES, INC., WOBURN, MA:  
3,956,184, INT. CL. 42.

OSRAM SYLVANIA INC., DANVERS, MA:  
2,446,625, REN. 3-30-11. MULTIPLE CLASS, INT. CLS. 9 AND 37.  
2,464,409, REN. 3-31-11. INT. CL. 11.

OSSIAN, INC., DAVENPORT, IA:  
3,954,127, PUB. 2-15-2011. INT. CL. 1.

OSTEOTECH, INC., EATONTOWN, NJ:  
3,954,658, PUB. 2-15-2011. INT. CL. 5.

OTICON A/S, SMORUM, DENMARK:  
3,953,966, PUB. 2-15-2011. INT. CL. 10.  
3,954,005, PUB. 2-15-2011. INT. CL. 10.

OTTO BOCK HEALTH CARE GMBH, 37115 DUDERSTADT, FED REP GERMANY:  
2,876,343, CANC. MULTIPLE CLASS, INT. CLS. 1, 10, 12, 17, 24 AND 25.

OTTO INTERNATIONAL, INC., FAIRBURN, GA:  
2,546,930, REN. 3-25-11. INT. CL. 25.

OUR CHANCE ENTERPRISE INC., MIAMI, FL:  
3,953,924, PUB. 2-15-2011. INT. CL. 41.

OUR HEROES' TREE, LLC, BOYDS, MD:  
3,953,956, PUB. 2-15-2011. MULTIPLE CLASS, INT. CLS. 35 AND 41.

OURPET'S COMPANY, FAIRPORT HARBOR, OH:  
3,954,911, PUB. 2-15-2011. INT. CL. 18.  
3,955,032, PUB. 2-15-2011. INT. CL. 28.  
3,955,042, PUB. 2-15-2011. INT. CL. 19.

OUT OF THE BOX PUBLISHING, INC., DODGEVILLE, WI:  
2,877,671, CANC. INT. CL. 28.

OUTBACK/FLEMING'S LLC, TAMPA, FL TO OSI/FLEMING'S, LLC, TAMPA, FL:  
2,379,146, CANC. INT. CL. 42.

OUTDOOR DESIGNS GROUP LLC, BLUFFTON, SC:  
2,379,066, CANC. INT. CL. 42.

OUTDOOR RESEARCH, INC., SEATTLE, WA:  
2,456,713, REN. 3-26-11. MULTIPLE CLASS, INT. CLS. 20, 21 AND 22.

OUTDOORS UNLIMITED, INC., ROSWELL, GA:  
2,378,821, CANC. INT. CL. 6.

OUTRCO, INC., WILMINGTON, DE:  
3,955,726, INT. CL. 14.

OVERBECK, WAYNE W., SANTA CRUZ, CA:  
1,670,049, REN. 3-25-11. INT. CL. 7.

OVERLOOK SOFTWARE, INC., GREENSBORO, NC:  
2,380,012, CANC. INT. CL. 9.

OVESCO ENDOSCOPY AG, TUBINGEN, FED REP GERMANY:  
3,953,269, PUB. 2-15-2011. INT. CL. 10.

OVBELL PFLANZEN, DEKO UND FREIZEIT GMBH & CO. KG, MULHEIM, FED REP GERMANY:  
3,884,805, COR. MULTIPLE CLASS, INT. CLS. 6, 8, 18, 20, 21 AND 28.  
3,884,807, COR. MULTIPLE CLASS, INT. CLS. 6, 8, 18, 20, 21 AND 28.

OWLSTONE NANOTECH INC., SUFFERN, NY:  
3,953,978, PUB. 2-15-2011. INT. CL. 9.  
3,953,980, PUB. 2-15-2011. INT. CL. 9.

OXORA NORTH AMERICA, INC., CHEYENNE, WY:  
3,953,188, PUB. 2-15-2011. INT. CL. 35.

OY ACOMARIN ENGINEERING LTD, NAANTALI, FINLAND:  
2,876,084, CANC. MULTIPLE CLASS, INT. CLS. 7 AND 12.

OYAMA, NOBUO, TOKYO, JAPAN:  
2,876,115, CANC. INT. CL. 7.

OZTURK, MAHMUT CEMAL, MR, GLASGOW, UNITED KINGDOM:  
2,596,777, CANC. MULTIPLE CLASS, INT. CLS. 9 AND 28.

OZWEST, INC., BANKS, OR, AKA OZWEST IMPORTS, INC.:  
3,954,594, PUB. 2-15-2011. INT. CL. 28.  
3,954,599, PUB. 2-15-2011. INT. CL. 28.  
3,954,972, PUB. 2-15-2011. INT. CL. 28.  
3,954,974, PUB. 2-15-2011. INT. CL. 28.  
3,954,980, PUB. 2-15-2011. INT. CL. 28.  
3,954,982, PUB. 2-15-2011. INT. CL. 28.

P & F BROTHER INDUSTRIAL CORPORATION, TAI-CHUNG, TAIWAN:  
3,954,646, PUB. 2-15-2011. INT. CL. 7.  
3,954,650, PUB. 2-15-2011. INT. CL. 7.

P. H. GLATFELTER COMPANY, YORK, PA:  
2,533,130, REN. 3-30-11. INT. CL. 16.  
2,533,131, REN. 3-30-11. INT. CL. 16.

P.B.P.C., INC., SUWANEE, GA:  
2,379,237, CANC. INT. CL. 37.

P.C. RICHARD & SON LONG ISLAND CORP., FARMING-DALE, NY:  
3,954,221, PUB. 2-15-2011. INT. CL. 35.

PAC-TEC, INC., HEATH, OH:  
2,488,600, REN. 3-31-11. INT. CL. 9.

PACIFIC COAST FEATHER COMPANY, SEATTLE, WA:  
3,953,155, PUB. 2-15-2011. MULTIPLE CLASS, INT. CLS. 20 AND 24.

PACIFIC INTERNATIONAL MARKETING, SALINAS, CA:  
3,954,583, PUB. 2-15-2011. INT. CL. 31.

PACIFIC MARKET INTERNATIONAL, LLC, SEATTLE, WA:  
3,955,792, INT. CL. 21.

PACIFIC SIMULATORS IP LIMITED, CHRISTCHURCH, NEW ZEALAND:  
3,953,090, PUB. 2-15-2011. MULTIPLE CLASS, INT. CLS. 9 AND 41.

PACIFIC SUNWEAR OF CALIFORNIA, INC., ANAHEIM, CA:  
3,955,310, INT. CL. 25.

PACPRO INC., EL MONTE, CA:  
3,954,528, PUB. 2-15-2011. INT. CL. 18.

PACTIV CORPORATION, LAKE FOREST, IL:  
3,955,843, MULTIPLE CLASS, INT. CLS. 20 AND 21.

PALACIOS & SONS, L.L.C., LAREDO, TX:  
3,953,771, PUB. 2-15-2011. INT. CL. 30.  
3,953,772, PUB. 2-15-2011. INT. CL. 30.  
3,953,773, PUB. 2-15-2011. INT. CL. 30.  
3,953,774, PUB. 2-15-2011. INT. CL. 30.

PALECKI, THOMAS L., PLEASANTON, CA AND JEFFERY, DAVID R., PLEASANTON, CA:  
2,379,641, CANC. INT. CL. 8.

PAN AMERICAN GRAIN MFG. CO. INC., GUAYNABO, PUERTO RICO:  
2,444,632, REN. 3-29-11. INT. CL. 30.

PAN AMERICAN NIKKEI ASSOCIATION OF U.S.A., LOS ANGELES, CA:  
2,379,727, CANC. INT. CL. 42.

PAN AMERICAN TOOL CORPORATION, FT. LAUDERDALE, FL:  
2,490,369, REN. 3-28-11. INT. CL. 7.  
2,490,370, REN. 3-28-11. INT. CL. 7.

PAN-O-GOLD BAKING CO., ST. CLOUD, MN:  
3,953,469, PUB. 2-15-2011. INT. CL. 30.

PAN, LING-LING, TAIPEI CITY, TAIWAN:  
3,955,045, PUB. 2-15-2011. INT. CL. 9.  
3,955,046, PUB. 2-15-2011. INT. CL. 9.

PANASONIC CORPORATION OF NORTH AMERICA, SECAUCUS, NJ:  
2,876,421, CANC. INT. CL. 9.  
3,955,881, MULTIPLE CLASS, INT. CLS. 7 AND 9.

PANASONIC ELECTRIC WORKS CO., LTD., KADOMA-SHI, OSAKA, JAPAN:  
3,953,009, PUB. 2-15-2011. MULTIPLE CLASS, INT. CLS. 7, 10, 11 AND 12.

PANDA RESTAURANT GROUP, INC., ROSEMEAD, CA:  
2,440,141, REN. 3-29-11. INT. CL. 36.

PANDUIT CORP., TINLEY PARK, IL:  
2,543,864, REN. 3-29-11. INT. CL. 9.

PANTECH CO., LTD., SEOUL, REPUBLIC OF KOREA:  
3,955,992, INT. CL. 9.

PANTER, STEVEN, E, LAWRENCEVILLE, NJ:  
3,954,893, PUB. 2-15-2011. INT. CL. 42.

- PAPER SQUID INC., MIAMI SPRINGS, FL:  
3,954,939, PUB. 2-15-2011. INT. CL. 16.
- PAPER-PAK EUROPE GMBH, ZUG, SWITZERLAND:  
2,877,057, CANC. INT. CL. 5.
- PAPER-PAK SWEDEN AB, SUNDBYBERG, SWEDEN:  
2,877,056, CANC. INT. CL. 5.
- PAPERBOARD PACKAGING COUNCIL, SPRINGFIELD, MA:  
3,956,201, INT. CL. 16.
- PAPERCON CORPORATION, LOUISVILLE, KY:  
3,953,971, PUB. 2-15-2011. INT. CL. 16.
- PARADIGM SOLUTIONS CORPORATION, ROCKVILLE, MD:  
2,876,868, CANC. INT. CL. 35.  
2,876,869, CANC. INT. CL. 35.
- PARADIGM SPINE, LLC, NEW YORK, NY:  
3,955,728, INT. CL. 10.
- PARADYSZ MATERA CO., INC., NEW YORK, NY:  
3,954,929, PUB. 2-15-2011. MULTIPLE CLASS, INT. CLS. 35 AND 42.
- PARAGON RELOCATION HOLDINGS, DUBLIN 15, IRELAND:  
3,955,118, PUB. 2-15-2011. INT. CL. 42.
- PARKER MARKETING RESEARCH, INC., MILFORD, OH:  
2,877,651, CANC. INT. CL. 35.
- PARTY BOUTIQUE, INC, GROVE CITY, OH, DBA PINKALICIOUS DAY SPA AND SALON:  
3,954,261, PUB. 2-15-2011. INT. CL. 44.
- PARTY PANIC, TORONTO, ONTARIO, CANADA:  
2,876,153, CANC. MULTIPLE CLASS, INT. CLS. 35 AND 41.
- PASADENA PLAYHOUSE STATE THEATRE OF CALIFORNIA, INC., THE, PASADENA, CA:  
2,436,368, REN. 3-31-11. INT. CL. 41.
- PASHLEY CREATIVE, LLC, GILBERT, AZ:  
3,954,921, PUB. 2-15-2011. INT. CL. 38.
- PASSIVSYSTEMS LIMITED, NEWBURY, UNITED KINGDOM:  
3,955,384, INT. CL. 9.
- PAT SHINGLETON PRODUCTIONS, INC., BATON ROUGE, LA:  
2,463,525, REN. 3-25-11. INT. CL. 36.
- PATENT CALLS, INC., AUSTIN, TX:  
3,953,417, PUB. 2-15-2011. INT. CL. 42.
- PATRICIA CARLSON ENTERPRISES, LLC, FRIENDSVILLE, TN:  
2,876,805, CANC. INT. CL. 9.
- PATRIOT COMMUNICATIONS LLC, LOS ANGELES, CA:  
2,504,256, REN. 3-29-11. INT. CL. 38.
- PATRONUS CONSULTING LLC, EVANSVILLE, IN:  
2,877,691, CANC. INT. CL. 42.  
2,877,692, CANC. INT. CL. 42.
- PATT JR., DOUGLAS C, ALLENTOWN, PA, DBA HOW TO ARCHITECT:  
3,956,220, INT. CL. 41.
- PAUL HARTMANN AG, HEIDENHEIM, FED REP GERMANY:  
2,876,002, CANC. INT. CL. 5.
- PAUL SMITH GROUP HOLDINGS LIMITED, NOTTINGHAM, UNITED KINGDOM:  
2,439,173, REN. 3-26-11. INT. CL. 25.
- PAVLOVIC PANCAKE HOUSE COUNTRY RESTAURANT, INC., RIDGEWOOD, NJ:  
2,457,324, REN. 3-28-11. INT. CL. 42.
- PAXTON AUTOMOTIVE CORP., OXNARD, CA:  
3,955,875, MULTIPLE CLASS, INT. CLS. 7, 16 AND 25.
- PAY GOVERNANCE, LLC, ATLANTA, GA:  
3,953,990, PUB. 2-15-2011. INT. CL. 36.
- PBC INTERNATIONAL, INC., OXNARD, CA:  
3,955,278, INT. CL. 28.
- PBM GRAPHICS, INC., DURHAM, NC:  
2,378,827, CANC. MULTIPLE CLASS, INT. CLS. 35 AND 42.
- PC CONNECTION SALES CORPORATION, MERRIMACK, NH, DBA PC CONNECTION, MACCONNECTION:  
2,378,622, CANC. INT. CL. 35.
- PE, ADELFO QUITON, CONROE, TX:  
2,876,838, CANC. INT. CL. 41.
- PEACOCK PLUME LLC, AUSTIN, TX:  
3,954,307, PUB. 2-15-2011. INT. CL. 35.
- PEAMEAL BACON OF CANADA LTD., STONEY CREEK, ONTARIO, CANADA:  
3,956,128, INT. CL. 29.
- PEDINOL PHARMACAL INC., FARMINGDALE, NY:  
1,147,928, REN. 3-30-11. INT. CL. 5.
- PEER SQUARED LLC, HOLLYWOOD, CA:  
3,955,400, INT. CL. 35.
- PEGASYSYSTEMS INC., CAMBRIDGE, MA:  
2,877,606, CANC. INT. CL. 9.
- PEI LICENSING, INC., MIAMI, FL:  
3,954,997, PUB. 2-15-2011. INT. CL. 9.  
3,954,998, PUB. 2-15-2011. INT. CL. 25.  
3,954,999, PUB. 2-15-2011. INT. CL. 14.
- PEIKER ACUSTIC GMBH & CO. KG, D-61381 FRIEDRICHSDORF, FED REP GERMANY:  
2,378,434, CANC. MULTIPLE CLASS, INT. CLS. 9 AND 38.
- PELTON LAND SOLUTIONS, LLLP, KELLER, TX:  
3,954,389, PUB. 2-15-2011. INT. CL. 42.
- PELUSO, MIA, GREENWICH, CT, DBA PARAPHERNALIA COSMETICS:  
2,876,894, CANC. INT. CL. 3.
- PENDARVIS, EDWARD T., MT. PLEASANT, SC:  
2,876,145, CANC. INT. CL. 36.
- PENDLETON ESTATE PTY LTD., SOUTH AUSTRALIA, AUSTRALIA:  
3,920,154, COR. MULTIPLE CLASS, INT. CLS. 29 AND 30.
- PENDRAGON MEDICAL AG, 8050 ZURICH, SWITZERLAND:  
2,876,054, CANC. MULTIPLE CLASS, INT. CLS. 10, 35, 38 AND 42.
- PENFORD PRODUCTS CO., CEDAR RAPIDS, IA:  
2,462,712, REN. 3-26-11. INT. CL. 1.
- PENGUIN BRANDS, INC., SHARON HILL, PA:  
3,953,094, PUB. 2-15-2011. MULTIPLE CLASS, INT. CLS. 9, 18, 21 AND 25.
- PENNY-FARTHING PRESS, INC., HOUSTON, TX:  
3,955,626, INT. CL. 16.
- PENSKE AUTOMOTIVE GROUP, INC., BLOOMFIELD HILLS, MI:  
2,471,873, REN. 3-26-11. INT. CL. 40.
- PENSKE RACING SOUTH, INC., MOORESVILLE, NC:  
3,955,452, INT. CL. 41.
- PENTON MEDIA, INC., NEW YORK, NY:  
3,954,988, PUB. 2-15-2011. INT. CL. 41.
- PENZIM PRODUCE CORP., BROOKLYN, NY:  
2,500,196, REN. 3-30-11. INT. CL. 35.
- PERC WATER CORPORATION, COSTA MESA, CA:  
3,953,396, PUB. 2-15-2011. MULTIPLE CLASS, INT. CLS. 40 AND 42.
- PERCY HARMS CORPORATION, WHEELING, IL:  
1,459,783, CANC. INT. CL. 2.
- PEREZ DISTRIBUTING FRESNO INC., SANGER, CA:  
3,954,948, PUB. 2-15-2011. INT. CL. 5.
- PERFORMANCE PRICING, LLC, CHATHAM, NJ:  
3,953,812, PUB. 2-15-2011. MULTIPLE CLASS, INT. CLS. 35 AND 41.
- PERIPOLE BERGERAULT INC., SALEM, OR:  
2,440,181, REN. 3-31-11. INT. CL. 15.
- PERKETTPR, MARSHFIELD, MA:  
3,954,832, PUB. 2-15-2011. INT. CL. 35.
- PERNOD RICARD, 75008 PARIS, FRANCE:  
2,878,020, CANC. INT. CL. 33.
- PERNOD RICARD NEW ZEALAND LIMITED, AUCKLAND 1010, NEW ZEALAND:  
3,953,848, PUB. 2-15-2011. INT. CL. 33.
- PERRY EQUIPMENT CORPORATION, MINERAL WELLS, TX:  
2,801,171, AM. INT. CL. 7.
- PERRY TEXTILES INC, WATERFORD, NY, DBA SOFT-TEX MANUFACTURING:  
3,954,715, PUB. 2-15-2011. INT. CL. 20.
- PERRY TEXTILES, INC., WATERFORD, NY, DBA SOFT-TEX MANUFACTURING:  
3,954,717, PUB. 2-15-2011. INT. CL. 20.



- PERSHING INVESTMENTS LLC, NEWARK, DE:  
2,384,915. REN. 3-30-11. MULTIPLE CLASS, INT. CLS. 16 AND 36.
- PERTRONIX, INC., SAN DIMAS, CA:  
1,160,631. REN. 3-27-11. INT. CL. 7.
- PET APPEAL, INC., CLACKAMAS, OR:  
3,953,302. PUB. 2-15-2011. INT. CL. 31.
- PET PRODUCTS, INC., YONKERS, NY TO HARTZ MOUNTAIN CORPORATION, THE, SEACAUCUS, NJ:  
1,459,755. CANC. INT. CL. 18.
- PETER BRASSELER HOLDINGS, LLC, SAVANNAH, GA:  
2,849,995. CANC. MULTIPLE CLASS, INT. CLS. 7, 8 AND 9.
- PETER N. ROGERS, CHICAGO, IL, DBA SMOKENDERS USA:  
3,954,713. PUB. 2-15-2011. INT. CL. 44.  
3,954,714. PUB. 2-15-2011. INT. CL. 44.  
3,954,864. PUB. 2-15-2011. INT. CL. 9.
- PETERSEN RESOURCES LLC, FREDONIA, WI:  
2,877,059. CANC. MULTIPLE CLASS, INT. CLS. 6, 7, 9, 11 AND 17.
- PETERSEN, DENNIS, VENICE, FL:  
3,956,021. INT. CL. 25.
- PETERSON MANUFACTURING COMPANY, GRANDVIEW, MO:  
1,170,009. REN. 3-29-11. INT. CL. 9.
- PETERSON TOOL COMPANY, NASHVILLE, TN:  
2,333,261. REN. 3-28-11. INT. CL. 7.
- PETFOODDIRECT, INC., HARLEYSVILLE, PA:  
2,445,327. REN. 3-26-11. MULTIPLE CLASS, INT. CLS. 35 AND 39.
- PETRO-METER CORPORATION, LINDENHURST, NY:  
3,953,095. PUB. 2-15-2011. INT. CL. 9.
- PETROSKY, STEVEN T., CINCINNATI, OH, DBA PAIN-TRIX:  
2,379,663. CANC. INT. CL. 25.
- PETRUKHIN, EVGENY, LIMASSOL, CYPRUS:  
3,955,952. INT. CL. 7.
- PETTINGILL, BERNARD, PALM BEACH GARDENS, FL:  
3,953,930. PUB. 2-15-2011. INT. CL. 9.
- PF WATERWORKS LP, HOUSTON, TX:  
3,953,106. PUB. 2-15-2011. INT. CL. 11.
- PFIP, LLC, NEWINGTON, NH:  
3,954,827. PUB. 2-15-2011. INT. CL. 41.  
3,954,834. PUB. 2-15-2011. INT. CL. 41.  
3,954,836. PUB. 2-15-2011. INT. CL. 41.  
3,954,837. PUB. 2-15-2011. INT. CL. 41.  
3,954,840. PUB. 2-15-2011. INT. CL. 41.  
3,954,845. PUB. 2-15-2011. INT. CL. 41.  
3,954,847. PUB. 2-15-2011. INT. CL. 41.  
3,954,849. PUB. 2-15-2011. INT. CL. 41.  
3,954,850. PUB. 2-15-2011. INT. CL. 41.
- PFIZER INC., NEW YORK, NY:  
2,487,796. REN. 3-26-11. INT. CL. 5.
- PGA SERVICE CORPORATION, NASHVILLE, TN:  
2,405,847. REN. 3-26-11. INT. CL. 36.
- PHARMACEUTICAL SPECIALTIES, INC., ROCHESTER, MN:  
3,955,918. INT. CL. 3.
- PHARMACIA & UPJOHN COMPANY, INC., NEW YORK, NY:  
2,895,348. CANC. INT. CL. 5.
- PHARMAPACKS, LLC, WHITESTONE, NC:  
3,955,956. INT. CL. 44.
- PHAT FASHIONS LLC, NEW YORK, NY:  
2,440,358. REN. 3-31-11. INT. CL. 25.
- PHATWARE CORPORATION, MOUNTAIN VIEW, CA:  
2,380,055. CANC. INT. CL. 9.
- PHEASANT, THOMAS, WASHINGTON, DC:  
2,507,526. REN. 3-30-11. INT. CL. 20.
- PHELPS, JULIE, MOLINE, IL AND PHELPS, ANDREW, MOLINE, IL:  
3,952,971. PUB. 2-15-2011. INT. CL. 21.
- PHH MORTGAGE CORPORATION, MT. LAUREL, NJ:  
2,439,462. REN. 3-30-11. INT. CL. 36.
- PHILIPPE CHARRIOL INTERNATIONAL BV, NETHERLANDS:  
2,951,879. AM. INT. CL. 14.
- PHILOSOPHIA DESIGNS, LOS ANGELES, CA, DBA HOUSE OF MONARCH:  
3,953,802. PUB. 2-15-2011. INT. CL. 24.
- PHILOSOPHY, INC., PHOENIX, AZ:  
3,955,138. PUB. 2-15-2011. INT. CL. 3.
- PHITEN CO., LTD., KYOTO CITY, KYOTO PREF., JAPAN:  
3,069,101. AM. INT. CL. 3.
- PHOCUSWRIGHT, INC., SHERMAN, CT:  
2,498,095. REN. 3-31-11. INT. CL. 35.  
2,498,096. REN. 3-31-11. INT. CL. 35.
- PHOENIX INTANGIBLES HOLDING COMPANY, GREENVILLE, DE:  
2,548,902. REN. 3-29-11. INT. CL. 35.
- PHOENIX PERFORMANCE PRODUCTS INC., MISSISSAUGA, ONTARIO, CANADA:  
3,955,214. INT. CL. 40.
- PHOENIX APPS, ROSS, CA:  
3,954,607. PUB. 2-15-2011. INT. CL. 9.
- PHOTOBIZ, LLC, GREENSBORO, NC:  
3,954,656. PUB. 2-15-2011. INT. CL. 42.
- PHR SYSTEMS LIMITED, A NEW ZEALAND CORPORATION, TAUPO, NEW ZEALAND:  
2,876,714. CANC. INT. CL. 8.
- PICO PLATA AVV, LIMITED, CORAL GABLES, FL:  
3,956,096. MULTIPLE CLASS, INT. CLS. 30, 35 AND 43.
- PICOR CORPORATION, NORTH SMITH, RI:  
3,953,046. PUB. 2-15-2011. INT. CL. 9.
- PICTURE GALLERIES, INC., MERIDIAN, ID:  
3,954,324. PUB. 2-15-2011. INT. CL. 27.
- PIECE OF CAKE, LLC, RIVERVIEW, MI:  
3,954,690. PUB. 2-15-2011. INT. CL. 33.
- PIERO GUIDI S.R.L., 61029 SCHIETI DI URBINO (PU), ITALY:  
1,639,044. REN. 3-29-11. MULTIPLE CLASS, INT. CLS. 16, 18, 25 AND 28.
- PIERRE FABRE DERMO-COSMETIQUE, BOULOGNE BILLANCOURT, FRANCE:  
3,953,075. PUB. 2-15-2011. MULTIPLE CLASS, INT. CLS. 3 AND 5.
- PIERRE FABRE MEDICAMENT, BOULOGNE BILLANCOURT, FRANCE:  
3,953,357. PUB. 2-15-2011. INT. CL. 5.  
3,953,726. PUB. 2-15-2011. MULTIPLE CLASS, INT. CLS. 3 AND 5.
- PIERRE, ROGER, NEW YORK, NY:  
3,955,534. INT. CL. 25.
- PIKE NURSERIES ACQUISITION, LLC, DULUTH, GA:  
1,639,317. REN. 3-28-11. INT. CL. 42.
- PILKINGTON DEUTSCHLAND AG, 45884 GELSENKIRCHEN, FED REP GERMANY, FLACHGLAS AKTIENGESELLSCHAFT, 8510 FURTH, BAYERN, FED REP GERMANY:  
1,169,284. REN. 3-28-11. INT. CL. 21.
- PILLAR ROCK USA CORP., FARMINGDALE, NY:  
3,955,081. PUB. 2-15-2011. INT. CL. 5.
- PINE STATE KNITWEAR COMPANY, INC., MOUNT AIRY, NC:  
1,429,352. CANC. INT. CL. 25.
- PINEHILLS LLC, PLYMOUTH, MA:  
3,029,546. CANC. MULTIPLE CLASS, INT. CLS. 3, 9 AND 28.
- PINES MANUFACTURING, INC., WESTLAKE, OH, PINES ENGINEERING CO., INC., AURORA, IL:  
728,247. REN. 3-30-11. U.S. CL. 23 (INT. CL. 7).
- PINNACLE FRAMES AND ACCENTS, INC, AUSTIN, TX:  
2,876,371. CANC. INT. CL. 16.  
2,876,461. CANC. MULTIPLE CLASS, INT. CLS. 16 AND 20.
- PINNACLE PRODUCTS INTERNATIONAL, INC., YARDELEY, PA:  
1,727,357. REN. 3-30-11. INT. CL. 11.
- PINNACLE TELEMARKETING INTERNATIONAL, INC., ADDISON, TX:  
2,877,992. CANC. INT. CL. 35.
- PIONEER LINING TECHNOLOGY LIMITED, GLASGOW, UNITED KINGDOM:  
3,956,074. INT. CL. 37.

- PISTACCHIO, TOM, FRESNO, CA:  
3,956,202, INT. CL. 40.
- PITMAT USA, FRANKTOWN, CO:  
3,953,754, PUB. 2-15-2011. INT. CL. 27.
- PITNEY BOWES INC., STAMFORD, CT:  
3,953,052, PUB. 2-15-2011. INT. CL. 36.  
3,953,053, PUB. 2-15-2011. INT. CL. 37.
- PITTSBURGH ASSOCIATES, PITTSBURGH, PA:  
3,955,665, INT. CL. 16.  
3,955,667, INT. CL. 25.  
3,955,668, INT. CL. 16.  
3,955,669, INT. CL. 41.
- PITTSBURGH SEAFOODS, INC., MONROEVILLE, PA,  
ATLANTIC COAST FISHERIES COMPANY, THE, BOS-  
TON, MA:  
539,346. REN. 3-29-11. U.S. CL. 46 (INT. CL. 29).
- PIVOTAL BRANDS INC., OAKVILLE, ONTARIO, CANADA:  
3,953,078, PUB. 2-15-2011. MULTIPLE CLASS, INT. CLS.  
5, 29 AND 32.
- PIZZA HUT, INC., DALLAS, TX:  
2,446,056. REN. 3-25-11. INT. CL. 42.
- PKF HOSPITALITY RESEARCH, INC., ATLANTA, GA:  
3,953,125, PUB. 2-15-2011. MULTIPLE CLASS, INT. CLS. 9  
AND 42.
- PLAID PANTRIES, INC., BEAVERTON, OR:  
2,510,010. REN. 3-26-11. INT. CL. 35.
- PLANET HORTICULTURE, SEABSTOPOL, CA:  
2,877,109, CANC. INT. CL. 41.
- PLANT BROTHERS INC., MIAMI, FL:  
3,952,995, PUB. 2-15-2011. INT. CL. 35.
- PLASMANET, INC., NEW YORK, NY:  
2,439,994. REN. 3-30-11. INT. CL. 41.
- PLASSEIN INTERNATIONAL CORP., WILLINGTON, CT:  
2,876,019, CANC. MULTIPLE CLASS, INT. CLS. 16 AND  
22.
- PLASTI DIP INTERNATIONAL, INC., BLAINE, MN:  
1,163,732. REN. 3-31-11. INT. CL. 17.
- PLASTI-KOTE CO., INC., MEDINA, OH:  
3,955,492, MULTIPLE CLASS, INT. CLS. 2, 3 AND 4.  
3,955,493, MULTIPLE CLASS, INT. CLS. 2, 3 AND 4.
- PLASTIMAYD LLC, OREGON CITY, OR:  
2,437,246. REN. 3-29-11. INT. CL. 22.
- PLASTIPAK PACKAGING, INC., PLYMOUTH, MI:  
3,955,241, INT. CL. 20.
- PLATINUM PRODUCTS LLC, LOS VEGAS, CA:  
2,877,519, CANC. INT. CL. 5.
- PLATTSBURGH - STATE UNIVERSITY OF NEW YORK,  
PLATTSBURGH, NY:  
2,876,472, CANC. INT. CL. 41.
- PLAYBOY ENTERPRISES INTERNATIONAL, INC., CHICA-  
GO, IL:  
2,445,179. REN. 3-29-11. INT. CL. 15.
- PLAYCORE IP SUB, INC., CHATTANOOGA, TN:  
2,519,898. REN. 3-31-11. INT. CL. 28.  
3,955,729, MULTIPLE CLASS, INT. CLS. 16, 35 AND 41.
- PLAYER'S DESIGN, INC., FORT MILL, SC:  
2,437,794. REN. 3-29-11. INT. CL. 25.
- PLAYRIX ENTERTAINMENT LLC, VOLOGDA, RUSSIAN  
FED.:  
3,953,388, PUB. 2-15-2011. MULTIPLE CLASS, INT. CLS. 9  
AND 41.
- PLEISTOSCENE, INC., CHICAGO, IL:  
2,877,098, CANC. INT. CL. 41.
- PLICON CORPORATION, COLUMBUS, GA:  
1,909,071, CANC. MULTIPLE CLASS, INT. CLS. 10, 16, 17,  
20 AND 40.
- PLS PETROLEUM LISTING SERVICE INC., HOUSTON, TX:  
1,639,241. REN. 3-31-11. INT. CL. 35.
- PLUM CREEK CELLARS, LTD., DENVER, CO:  
3,954,909, PUB. 2-15-2011. INT. CL. 33.
- PLUS2 TECHNOLOGIES, LLC, SCOTTSDALE, AZ:  
3,954,240, PUB. 2-15-2011. INT. CL. 9.
- PNY TECHNOLOGIES, INC., PARSIPPANY, NJ:  
3,955,018, PUB. 2-15-2011. INT. CL. 9.
- PODIUMWEAR CUSTOM SPORTS APPAREL COMPANY,  
ST. PAUL, MN:  
3,954,764, PUB. 2-15-2011. INT. CL. 25.  
3,954,768, PUB. 2-15-2011. INT. CL. 25.
- POEMS ART PUBLISHING LLC, SALT LAKE CITY, UT:  
3,953,249, PUB. 2-15-2011. INT. CL. 16.
- POET, LLC, SIOUX FALLS, SD:  
3,955,581, INT. CL. 7.
- POGUE, A. MACK, DALLAS, TX, LINCOLN PROPERTY  
COMPANY NO. 1, INC., DALLAS, TX:  
1,192,301. REN. 3-26-11. INT. CL. 37.
- POINT B CAPITAL, LLC, SEATTLE, WA:  
3,955,924, MULTIPLE CLASS, INT. CLS. 35 AND 36.
- POLACCO ITALO RINO, 37047 SAN BONIFACIO-VR,  
ITALY:  
3,955,999, INT. CL. 33.
- POLARIS INDUSTRIES INC., MEDINA, MN:  
2,464,512. REN. 3-31-11. INT. CL. 36.
- POLARIS INDUSTRIES, INC., MEDINA, MN:  
3,955,777, INT. CL. 12.
- POLICYLINK, OAKLAND, CA:  
2,439,811. REN. 3-30-11. INT. CL. 42.
- POLICYPARTNER LLC, WASHINGTON, DC:  
2,877,788, CANC. INT. CL. 42.
- POOCHIE-PETS, LLC, SIMSBURG, CT:  
3,954,916, PUB. 2-15-2011. INT. CL. 18.
- POPEJOY, JAMES E., SR., EUDORA, AR, DBA THE CAT-  
FISH PRODUCERS OF AMERICA:  
2,876,060, CANC. MULTIPLE CLASS, INT. CLS. 29 AND  
35.
- POPULAR, INC., SAN JUAN, PUERTO RICO:  
2,876,870, CANC. INT. CL. 36.
- PORTEC AG, AADORF, SWITZERLAND:  
2,474,819. REN. 3-29-11. INT. CL. 1.
- PORTEOUS FASTENER COMPANY, CARSON, CA:  
3,955,458, INT. CL. 6.  
3,955,459, INT. CL. 6.  
3,955,460, INT. CL. 6.  
3,955,461, INT. CL. 6.
- PORTER, BRENDAN ANDREW, MILFORD, IA, DBA BAL-  
ANCD.COM:  
3,954,902, PUB. 2-15-2011. INT. CL. 9.
- POSITRONIC INDUSTRIES, INC., SPRINGFIELD, MO:  
2,536,623. REN. 3-25-11. INT. CL. 9.
- POST FOODS, LLC, ST. LOUIS, MO, KRAFT GENERAL  
FOODS, INC., GLENVIEW, IL:  
1,658,705. REN. 3-29-11. INT. CL. 30.
- POSTLETHWAITE & NETTERVILLE, A.P.A.C., BATON  
ROUGE, LA:  
2,455,395. REN. 3-30-11. INT. CL. 35.
- POSTUP, INC., PASADENA, CA:  
3,954,796, PUB. 2-15-2011. INT. CL. 9.  
3,954,797, PUB. 2-15-2011. INT. CL. 9.
- POUNDS, BRADLEY S., BAKERSFIELD, CA, DBA BRAD  
POUNDS RACING:  
3,953,710, PUB. 2-15-2011. INT. CL. 12.
- POWDER MOUNTAIN PRESS (WY), LLC, JACKSON, WY,  
DBA, WESTERN DESIGN CONFERENCE:  
2,876,810, CANC. INT. CL. 35.
- POWE, ANTHONY, NEW YORK, NY:  
3,955,968, INT. CL. 35.
- POWELL, MARSHA L, MARINA DEL REY, CA:  
3,955,644, INT. CL. 41.
- POWER CORPORATION OF CANADA, MONTREAL, CA-  
NADA:  
3,954,608, PUB. 2-15-2011. INT. CL. 36.
- POWERHOUSE TWO, INC., WINTER GARDEN, FL:  
3,955,785, INT. CL. 9.
- POWEROPTIONS, INC., BOSTON, MA:  
3,953,223, PUB. 2-15-2011. INT. CL. 35.
- POWERS CANDY & NUT CO., SPOKANE, WA:  
1,431,380, CANC. INT. CL. 29.
- POWERSOURCE INC, SEVIERVILLE, TN:  
3,954,018, PUB. 2-15-2011. INT. CL. 42.
- POWERSPEAKING, INC., REDWOOD CITY, CA:  
1,640,810. REN. 3-31-11. INT. CL. 41.
- POWERTECH INDUSTRIAL CO., LTD., TAIPEI HSIEN,  
TAIWAN:  
3,955,379, INT. CL. 9.

PPG ARCHITECTURAL FINISHES INCORPORATED, PITTSBURGH, PA. PPG ARCHITECTURAL FINISHES INCORPORATED, PITTSBURGH, PA:  
2,458,974. REN. 3-26-11. INT. CL. 2.

PPG ARCHITECTURAL FINISHES, INC., PITTSBURGH, PA:  
2,463,894. REN. 3-28-11. INT. CL. 2.

PRAI BEAUTY GROUP, INC., NEW CANAAN, CT:  
2,540,720. REN. 3-26-11. INT. CL. 3.

PRE-CON INC., BRAMPTON, ONTARIO, CANADA:  
2,876,334. CANC. INT. CL. 19.

PRECEPT BRANDS LLC, SEATTLE, WA:  
2,477,683. REN. 3-29-11. INT. CL. 33.

PRECISE FLIGHT, INC., BEND, OR:  
1,679,277. REN. 3-28-11. INT. CL. 9.

PRECISION LIGHTING, INC., LINCOLN, NE:  
2,876,813. CANC. INT. CL. 9.

PRECISION PIER U.S.A. INC., MOSCOW, PA:  
2,876,400. CANC. INT. CL. 7.

PRECISION SHOOTING EQUIPMENT, INC., TUCSON, AZ:  
1,162,060. REN. 3-26-11. INT. CL. 28.

PREFERRED HOSPICE OF OKLAHOMA, INC., OKLAHOMA CITY, OK:  
2,877,026. CANC. INT. CL. 44.

PREMERA BLUE CROSS, SEATTLE, WA:  
2,549,803. REN. 3-30-11. INT. CL. 36.

PREMIER PRODUCTIONS, INC., HIGH POINT, NC:  
3,954,267. PUB. 2-15-2011. INT. CL. 41.

PREPAID VACATION INTERNATIONAL INC., MIAMI LAKES, FL:  
2,876,842. CANC. INT. CL. 43.

PRESS SMART PRINTING PRODUCTS LLC, PLAINFIELD, IL:  
3,953,205. PUB. 2-15-2011. INT. CL. 2.

PREVENTON TECHNOLOGIES LIMITED, READING RG30 3UN, BERKSHIRE, UNITED KINGDOM:  
2,875,996. CANC. INT. CL. 9.

PRICE INTERNATIONAL, INC., VAUGHN, ONTARIO, CANADA:  
3,956,108. INT. CL. 16.

PRIDE MOBILITY PRODUCTS CORPORATION, EXETER, PA:  
2,484,480. REN. 3-31-11. INT. CL. 12.

PRIMARY FINANCIAL COMPANY LLC, COLUMBUS, OH:  
2,463,758. REN. 3-26-11. INT. CL. 36.

PRIMARY INVESTMENTS GROUP LIMITED, ROAD TOWN, TORTOLA, BR.VIRGIN ISLANDS:  
3,954,025. PUB. 2-15-2011. INT. CL. 5.

PRIMARY INVESTMENTS GROUP LIMITED, TORTOLA, BR.VIRGIN ISLANDS:  
3,956,259. INT. CL. 5.

PRIMARY INVESTMENTS GROUP LIMITED, ROAD TOWN, TORTOLA, BR.VIRGIN ISLANDS:  
3,956,260. INT. CL. 5.

PRIMESOURCE BUILDING PRODUCTS, INC., IRVING, TX:  
3,955,306. INT. CL. 19.  
3,955,307. INT. CL. 19.

PRIMO DESIGN IMPORTERS LTD., ROLLING HILLS ESTATES, CA:  
3,956,022. INT. CL. 12.

PRINCE MINERALS, INC., QUINCY, IL:  
3,953,410. PUB. 2-15-2011. INT. CL. 1.

PRINCE SPORTS, INC., BORDENTOWN, NJ:  
3,954,782. PUB. 2-15-2011. INT. CL. 28.

PRINCETON TECTONICS, INC., BORDENTOWN, NJ:  
2,439,145. REN. 3-31-11. INT. CL. 11.

PRINT SERVICES & DISTRIBUTION ASSOCIATION, ALEXANDRIA, VA:  
2,876,726. CANC. MULTIPLE CLASS, INT. CLS. 16 AND 35.

PRINT-A-TOOTH, INC., FRAZER, PA:  
2,876,793. CANC. INT. CL. 35.

PRINT, INC., KIRKLAND, WA:  
2,876,290. CANC. MULTIPLE CLASS, INT. CLS. 35, 37 AND 40.

PRIVATBRAUEREI EICHBAUM GMBH & CO. KG, MANNHEIM, FED REP GERMANY:  
3,523,698 NEW CERT. 5-3-2011. INT. CL. 32.  
3,628,166 NEW CERT. 5-3-2011. INT. CL. 32.

PRIVATE FORMULA CORPORATION, ALISO VIEJO, CA:  
3,204,239. AM. INT. CL. 3.

PRIZEBITE, INC., MOON TOWNSHIP, PA:  
3,955,161. INT. CL. 35.

PRO JOE, INC, GREENVILLE, WI:  
3,955,934. INT. CL. 30.

PRO-CUT LICENSING, LLC, WEST LEBANON, NH:  
2,379,326. CANC. INT. CL. 7.

PROBAT-WERKE VON GIMBORN; MASCHINENFABRIK GMBH, EMMERICH, FED REP GERMANY:  
3,953,592. PUB. 2-15-2011. MULTIPLE CLASS, INT. CLS. 11, 37 AND 42.

PROCARE HOME AND PET SERVICES LLC, COLORADO SPRINGS, CO:  
3,954,108. PUB. 2-15-2011. INT. CL. 45.

PROCESSING TECHNOLOGIES, LLC, AURORA, IL:  
3,952,961. PUB. 2-15-2011. INT. CL. 7.

PROCTER & GAMBLE BUSINESS SERVICES CANADA COMPANY, HALIFAX, NOVA SCOTIA, CANADA:  
1,679,884. REN. 3-30-11. INT. CL. 21.

PROCTER & GAMBLE COMPANY, THE, CINCINNATI, OH:  
2,878,009. CANC. INT. CL. 3.

PRODIGY RESOURCES LLC, DENVER, CO:  
3,954,859. PUB. 2-15-2011. INT. CL. 35.

PRODUCTOS FINOS DE AGAVE, S.A. DE C.V., GUADALAJARA, JAL., MEXICO:  
3,953,185. PUB. 9-28-2010. INT. CL. 33.

PRODUCTOS SOBRINO INC., HATO REY, PUERTO RICO:  
2,876,118. CANC. INT. CL. 30.

PROFESSIONAL FARMERS OF AMERICA, INC., CEDAR FALLS, IA:  
2,877,458. CANC. INT. CL. 36.

PROFESSIONAL LABOR SUPPORT LLC, MAHOMET, IL:  
3,955,055. PUB. 2-15-2011. INT. CL. 35.

PROFESSIONAL SECURITY CORPORATION, HIAWATHA, IA, DBA PERSONAL SAFETY CORPORATION:  
2,438,112. REN. 3-26-11. INT. CL. 10.

PROFESSIONALS FOR NONPROFITS, INC., NEW YORK, NY:  
2,877,827. CANC. INT. CL. 16.

PROFIBRIX B.V., NETHERLANDS:  
3,953,519. PUB. 2-15-2011. INT. CL. 10.

PROFILE NETWORK, INC., SKOKIE, IL, DBA SPORTS PROFILES:  
2,876,881. CANC. INT. CL. 35.

PROFITFUEL, INC., AUSTIN, TX:  
2,877,074. CANC. INT. CL. 35.

PROFORMA INC., CLEVELAND, OH:  
1,650,434. REN. 3-26-11. INT. CL. 42.

PROGRAMMER'S PARADISE, INC., SHREWSBURY, NJ:  
2,490,460. REN. 3-29-11. INT. CL. 35.

PROGRESSIVE LOGISTICS SERVICES, LLC, ATLANTA, GA:  
3,954,736. PUB. 2-15-2011. INT. CL. 35.

PROHEQ GMBH, 75217 BIRKENFELD, FED REP GERMANY:  
3,953,492. PUB. 2-15-2011. MULTIPLE CLASS, INT. CLS. 8, 11, 14 AND 21.

PROJECT ARTISAN LLC, NEWPORT BEACH, CA:  
3,956,041. INT. CL. 35.

PROJECTEDGE.COM. INC., LIVERPOOL, NY:  
2,476,047. REN. 3-26-11. INT. CL. 9.

PROMARK BRANDS INC., MERIDIAN, ID:  
3,955,464. INT. CL. 29.

PROMARK BRANDS, INC., MERIDIAN, ID, DBA PROMARK BRANDS, INC.:  
2,877,264. CANC. MULTIPLE CLASS, INT. CLS. 29 AND 30.

PROMARK SOLUTIONS, LLC, LAS VEGAS, NV:  
3,953,887. PUB. 2-15-2011. INT. CL. 42.

PROMPT, INCORPORATED, ALBURG, VT:  
1,645,467. REN. 3-29-11. INT. CL. 35.

PROSOFT TECHNOLOGY, INC., BAKERSFIELD, CA:  
3,953,298. PUB. 11-9-2010. MULTIPLE CLASS, INT. CLS. 9, 35 AND 42.

PROSPECTOR DISCOUNT STORES LLC, EVERETT, WA:  
2,536,540. REN. 3-29-11. INT. CL. 35.

- PROTECH FIRE, INC., GAINESVILLE, GA:  
3,954,653, PUB. 2-15-2011. INT. CL. 42.
- PROTECTING THE HOMELAND INNOVATIONS, LLC,  
CHELSEA, MA:  
3,953,270, PUB. 2-15-2011. MULTIPLE CLASS, INT. CLS.  
16 AND 41.  
3,953,271, PUB. 2-15-2011. MULTIPLE CLASS, INT. CLS.  
16 AND 41.
- PROTEIN SCIENCES CORPORATION, MERIDEN, CT:  
2,377,112, REN. 3-28-11. MULTIPLE CLASS, INT. CLS. 1  
AND 5.  
2,377,113, REN. 3-28-11. MULTIPLE CLASS, INT. CLS. 1  
AND 5.
- PROTOCOL AGENCY, INC., WESTLAKE VILLAGE, CA:  
3,954,164, PUB. 2-15-2011. INT. CL. 35.
- PROVEN WINNERS NORTH AMERICA, L.L.C., CAMP-  
BELL, CA:  
2,547,272, REN. 3-25-11. INT. CL. 31.
- PROVENWEBSITES LLC, CHICAGO, IL:  
2,877,658, CANC. INT. CL. 35.
- PROVIDE GIFTS, INC. DBA REDENVELOPE, SAN DIEGO,  
CA, REDENVELOPE, INC., SAN FRANCISCO, CA:  
2,474,275, REN. 3-28-11. INT. CL. 42.
- PROVO CRAFT & NOVELTY, INC., SPANISH FORK, UT:  
2,877,682, CANC. INT. CL. 16.
- PROVO STEEL & SECURITY CO., PROVO, UT, DBA  
PROSTEEL:  
2,979,713, COR. INT. CL. 6.
- PROVO STEEL & SUPPLY CO., PROVO, UT, DBA PROS-  
TEEL:  
3,111,258, COR. INT. CL. 6.
- PRUDENTIAL INSURANCE COMPANY OF AMERICA,  
THE, NEWARK, NJ:  
2,440,671, REN. 3-30-11. INT. CL. 36.
- PRYSMIAN CAVI E SISTEMI ENERGIA SRL, MILAN,  
ITALY:  
1,086,911, REN. 3-29-11. INT. CL. 17.
- PSYCHOLOGICAL ASSESSMENT RESOURCES, INC.,  
LUTZ, FL:  
1,679,002, REN. 3-28-11. INT. CL. 16.
- PSYCHOLOGICAL ASSOCIATES, INC., ST. LOUIS, MO:  
906,773, REN. 3-31-11. U.S. CL. 38 (INT. CLS. 9, 16 AND  
28).  
2,419,187, REN. 3-29-11. INT. CL. 41.
- PUBLIC PARKING ASSOCIATES INC., ROHNERT PARK,  
CA:  
3,956,181, INT. CL. 39.
- PUBLICITAT I IMATGE AGGIE, S.L., BARCELONA, SPAIN:  
3,954,760, PUB. 2-15-2011. INT. CL. 14.
- PUBLISHERS CLEARING HOUSE LLC, PORT WASHING-  
TON, NY:  
1,642,239, REN. 3-30-11. INT. CL. 35.
- PULBROOK & GOULD LIMITED, LONDON SW1X 9AS,  
ENGLAND:  
2,876,136, CANC. MULTIPLE CLASS, INT. CLS. 3, 24  
AND 31.
- PULMUONE U.S.A., INC., SOUTH GATE, CA:  
2,877,493, CANC. INT. CL. 32.
- PUPPY PLAYHOUSE 1, LLC, LAS VEGAS, NV:  
3,954,284, PUB. 2-15-2011. INT. CL. 43.
- PURE & NATURAL COMPANY, SCOTTSDALE, AZ:  
3,955,611, INT. CL. 3.
- PURE FISHING, INC., SPIRIT LAKE, IA:  
3,955,104, PUB. 2-15-2011. INT. CL. 28.
- PURE FUN CUSTOM LONGBOARDS, CARLSBAD, CA:  
2,379,127, CANC. MULTIPLE CLASS, INT. CLS. 25 AND  
28.
- PURE GLOBAL BRANDS, INC., WEST PALM BEACH, FL:  
3,955,204, INT. CL. 28.
- PURE ROMANCE, INC., LOVELAND, OH:  
3,953,866, PUB. 2-15-2011. INT. CL. 10.  
3,953,867, PUB. 2-15-2011. INT. CL. 5.  
3,953,874, PUB. 2-15-2011. MULTIPLE CLASS, INT. CLS. 3  
AND 5.
- PURIFAN, INC., WICHITA, KS:  
2,483,366, REN. 3-26-11. INT. CL. 11.
- PURITAN'S PRIDE, INC., RONKONKOMA, NY:  
2,390,260, REN. 3-28-11. INT. CL. 5.
- PURPLE RAIN, LLC, DULUTH, GA:  
3,954,481, PUB. 2-15-2011. MULTIPLE CLASS, INT. CLS.  
41 AND 43.  
3,954,488, PUB. 2-15-2011. MULTIPLE CLASS, INT. CLS.  
41 AND 43.
- PUT POWERTECH, INC., TAIPEI HSIEN, TAIWAN:  
2,378,998, CANC. INT. CL. 9.
- PYRAMID SAITEN-UND STIMMPFEIFENFABRIK JUN-  
GER GMBH, BUBENREUTH, ERLANGEN D-8526, FED  
REP GERMANY:  
1,156,314, REN. 3-29-11. INT. CL. 15.
- PYRAMID SAITEN-UND STIMMPFEIFENFABRIK JUN-  
GER GMBH, D-8526 BUBENREUTH, ERLANGEN, FED  
REP GERMANY, JUNGER; NORBERT, BUBENREUTH,  
ERLANGEN, FED REP GERMANY, DBA KARL JUNGER:  
1,159,092, REN. 3-30-11. INT. CL. 15.
- Q CHIROPRACTIC, LLC, PHOENIX, AZ:  
2,877,615, CANC. INT. CL. 44.
- QC HOLDINGS, INC., OVERLAND PARK, KS:  
3,953,732, PUB. 11-9-2010. INT. CL. 36.
- QLT, INC., VANCOUVER, BC, CANADA:  
3,955,788, INT. CL. 5.  
3,955,789, INT. CL. 5.
- QUADAX, INC., CLEVELAND, OH:  
2,876,106, CANC. INT. CL. 42.
- QUADCO INC., BRIGHTON, CO:  
2,876,193, CANC. INT. CL. 9.
- QUADION CORPORATION, MINNEAPOLIS, MN:  
916,740, REN. 3-30-11. U.S. CL. 35 (INT. CL. 17).
- QUALCOMM SERVICES LABS, INC., SAN DIEGO, CA:  
3,955,318, INT. CL. 9.
- QUALITY GOLD, INC., FAIRFIELD, OH:  
3,955,977, INT. CL. 14.
- QUALITY INNOVATIVE SYSTEMS, INC., PARAGOULD,  
AR:  
3,955,658, INT. CL. 42.
- QUANTUM LEAP, LLC, MIDLOTHIAN, VA:  
2,877,033, CANC. INT. CL. 30.
- QUATTRA VIA, INC., SAN DIEGO, CA:  
3,955,542, INT. CL. 44.
- QUBX CONSULTING, INC., PALATINE, IL:  
2,379,361, CANC. INT. CL. 42.
- QUIDDITY, INC., SALEM, OR:  
3,955,188, INT. CL. 16.
- QUILL PRODUCTIONS, INC., HANOVER, PA:  
2,876,914, CANC. INT. CL. 42.
- QUIN, MARK, ATLANTA, GA:  
3,955,315, INT. CL. 35.
- QUIZID TECHNOLOGIES LIMITED, LONDON WC2B 4HP,  
ENGLAND:  
2,875,926, CANC. MULTIPLE CLASS, INT. CLS. 9, 35, 36,  
37, 42 AND 45.
- QUOTEWIZARD.COM, LLC, SEATTLE, WA:  
3,954,032, PUB. 2-15-2011. INT. CL. 35.
- Q4U FRANCHISE DEVELOPMENT LLC, TAYLORSVILLE,  
UT:  
3,954,272, PUB. 2-15-2011. INT. CL. 43.
- R.A.B. FOOD GROUP, LLC, SECAUCUS, NJ, MOTHER'S  
FOOD PRODUCTS, INC., NEWARK, NJ:  
552,693, REN. 3-31-11. U.S. CL. 46 (INT. CLS. 1, 5, 29, 30, 31  
AND 32).
- R.A.B. FOOD GROUP, LLC, SECAUCUS, NJ:  
3,956,024, INT. CL. 30.
- R.J. ROCKERS, INC., SPARTANBURG, SC:  
3,954,838, PUB. 2-15-2011. INT. CL. 32.
- R.L. VALLEE, INC., ST. ALBANS, VT:  
2,542,790, REN. 3-31-11. INT. CL. 42.
- RACEAUCTION.COM, INC., FORT WORTH, TX:  
3,953,962, PUB. 2-15-2011. INT. CL. 35.
- RACKSPACE US, INC., SAN ANTONIO, TX, DBA RACK-  
SPACE MANAGED HOSTING:  
2,379,711, CANC. INT. CL. 42.
- RADIO FLYER, INC., CHICAGO, IL:  
3,956,125, INT. CL. 12.
- RADIOCHICK, LLC, NEW YORK, NY:  
2,455,110, REN. 3-31-11. INT. CL. 41.
- RADIOCRAFT, INC., SOUTHBOROUGH, MA:  
2,877,994, CANC. MULTIPLE CLASS, INT. CLS. 38 AND

41.  
RADIORADIO, LLC, TULSA, OK:  
3,953,958, PUB. 2-15-2011. INT. CL. 41.
- RAFTELIS FINANCIAL CONSULTANTS, INC., CHARLOTTE, NC:  
3,956,007, INT. CL. 35.
- RAHLFS, STEPHANIE, SANTA CLARA, CA:  
3,954,048, PUB. 2-15-2011. INT. CL. 35.
- RAIDEN TECHNOLOGY, INC., CITY OF INDUSTRY, CA:  
3,953,294, PUB. 2-15-2011. INT. CL. 28.
- RAIF, RONALD, JACKSONVILLE, FL:  
3,953,886, PUB. 2-15-2011. INT. CL. 25.
- RAINBOW COAST ENTERPRISES PTY LTD, FLOREAT WA, AUSTRALIA:  
3,955,062, PUB. 2-15-2011. INT. CL. 36.
- RAINBOW LIGHT NUTRITIONAL SYSTEMS, INC., SANTA CRUZ, FL:  
3,955,521, INT. CL. 5.
- RAINBOW MEDIA HOLDINGS LLC, JERICHO, NY:  
2,877,281, CANC. MULTIPLE CLASS, INT. CLS. 38 AND 41.
- RAINER GMBH, FED REP GERMANY:  
3,746,874, COR. MULTIPLE CLASS, INT. CLS. 16, 20, 22 AND 39.
- RAINERI S.P.A., ITALY:  
3,953,563, PUB. 2-15-2011. MULTIPLE CLASS, INT. CLS. 29 AND 30.
- RAINMAKER RESTAURANTS, L.L.C., COLUMBIA, MD:  
2,877,806, CANC. INT. CL. 35.
- RAINWAVE, LLC, AUBURN, AL:  
3,956,183, INT. CL. 42.
- RAJ KUMAR JAWA, SANTA CLARITA, CA, DBA SONA SPICES U.S.A., INC.:  
3,954,166, PUB. 2-15-2011. INT. CL. 30.
- RALLY MARKETING GROUP, INC., SEATTLE, WA:  
3,954,536, PUB. 2-15-2011. INT. CL. 35.
- RAMSEY POPCORN CO., INC., RAMSEY, IN:  
2,488,890, REN. 3-25-11. INT. CL. 30.
- RAMSEY, WILLIAM AARON, HENDERSON, NC:  
2,545,868, REN. 3-29-11. INT. CL. 12.
- RANDALL-REILLY PUBLISHING COMPANY, LLC, TUSCALOOSA, AL:  
3,954,028, PUB. 2-15-2011. INT. CL. 16.
- RANDOLPH, CHRISTOPHER, WATERBURY, CT:  
3,955,763, INT. CL. 41.
- RANDOX LABORATORIES LIMITED, BT29 4QY NORTH-EARN IRELAND, UNITED KINGDOM:  
2,876,166, CANC. MULTIPLE CLASS, INT. CLS. 1 AND 42.
- RANDY MORGAN, JERSEY CITY, NJ, AKA TREY MORGAN AND BROOKE MORGAN, JERSEY CITY, NJ:  
3,954,757, PUB. 2-15-2011. INT. CL. 35.
- RANIR, LLC, GRAND RAPIDS, MI:  
1,637,511, REN. 3-31-11. INT. CL. 10.
- RANUCCI, ALEX, BELMONT, NC:  
3,954,179, PUB. 2-15-2011. INT. CL. 43.
- RAPPORT SHAFT TECHNOLOGIES, LLC, WESTFIELD, IN:  
2,378,549, CANC. INT. CL. 28.
- RAQMAM ENTERPRISES, INC., PLANTATION, FL:  
3,955,958, INT. CL. 42.
- RATTIN, MARIA ROSARIA, MILANO, ITALY:  
2,433,094, REN. 3-30-11. MULTIPLE CLASS, INT. CLS. 11 AND 20.
- RAUMEDIC AG, 95213 MÜNCHBERG, FED REP GERMANY:  
3,953,664, PUB. 2-15-2011. INT. CL. 10.  
3,953,665, PUB. 2-15-2011. INT. CL. 10.
- RAVEN HOUSE PUBLISHING, LLC, WESTBROOK, ME:  
3,954,666, PUB. 2-15-2011. INT. CL. 16.
- RAVEN INDUSTRIES, INC., SIOUX FALLS, SD:  
1,192,541, REN. 3-31-11. INT. CL. 17.
- RAW CAN ROLL CAFE, LLC, DOUGLASSVILLE, PA:  
3,954,741, PUB. 2-15-2011. INT. CL. 43.
- RAWLINGS SPORTING GOODS COMPANY, INC., ST. LOUIS, MO:  
1,149,932, REN. 3-26-11. INT. CL. 28.
- RAY MARKS CO. LLC, NEW YORK, NY:  
3,955,485, INT. CL. 21.
- RAYCOM AMERICA, INC., MONTGOMERY, AL:  
2,378,533, CANC. INT. CL. 41.
- RAYLON CORPORATION, READING, PA:  
2,876,281, CANC. INT. CL. 44.
- RAYMING CORPORATION, CITY OF INDUSTRY, CA:  
2,878,045, CANC. INT. CL. 9.
- RAYMOND SMITH, OHSWEKEN, ONTARIO, CANADA, DBA FREEWIRE:  
3,955,830, INT. CL. 8.
- RAYTHEON COMPANY, LEXINGTON, MA:  
2,876,861, CANC. INT. CL. 9.
- RAYZIST PHOTOMASK, INC., VISTA, CA:  
1,616,436, REN. 3-30-11. MULTIPLE CLASS, INT. CLS. 7 AND 42.
- RCI TM CORP., LAS VEGAS, NV:  
3,955,974, MULTIPLE CLASS, INT. CLS. 35 AND 36.
- RCM TECHNOLOGIES, INC., PENNSAUKEN, NJ:  
2,551,731, REN. 3-31-11. MULTIPLE CLASS, INT. CLS. 35, 41 AND 42.
- RCN TELEVISION S.A., BOGOTÁ D.C., COLOMBIA:  
3,955,475, INT. CL. 41.
- READY PRODUCTS CORPORATION, IRVINE, CA:  
2,437,104, REN. 3-25-11. INT. CL. 13.
- REAL CHANGE NETWORK, INC., APTOS, CA:  
2,439,105, REN. 3-26-11. INT. CL. 41.
- REAL INTELLECTUAL PROPERTIES LLC, NORTH MIAMI BEACH, FL:  
2,877,906, CANC. INT. CL. 35.
- REAL PLANET ENTERTAINMENT, INC, LOS ANGELES, CA:  
3,954,777, PUB. 2-15-2011. INT. CL. 41.
- REALTIMEPT, LLC, ROCKWALL, TX:  
3,956,207, INT. CL. 9.
- REALTY RESOURCE CAFE, INC., YONKERS, NY:  
2,878,036, CANC. MULTIPLE CLASS, INT. CLS. 36 AND 43.
- REBORN BEAUTY, LLC, BALTIMORE, MD:  
2,877,115, CANC. INT. CL. 3.
- RECKITT BENCKISER INC., PARSIPPANY, NJ:  
3,955,258, INT. CL. 30.
- RECKITT BENCKISER LLC, PARSIPPANY, NJ:  
3,955,791, MULTIPLE CLASS, INT. CLS. 3 AND 5.
- RECOGNITION SYSTEMS INC., PORT WASHINGTON, NY:  
2,876,937, CANC. MULTIPLE CLASS, INT. CLS. 1, 7 AND 16.
- RECOLOGY INC., SAN FRANCISCO, CA:  
3,955,290, MULTIPLE CLASS, INT. CLS. 37, 39, 40, 41, 42 AND 44.
- RECRUITER SOLUTIONS, INC., LAGUNA NIGUEL, CA:  
3,954,814, PUB. 2-15-2011. INT. CL. 35.
- RECRUITFORCE.COM, INC., SANTA CLARA, CA:  
2,876,615, CANC. INT. CL. 35.
- RED BAG SOLUTIONS, INC., BALTIMORE, MD:  
3,954,564, PUB. 2-15-2011. MULTIPLE CLASS, INT. CLS. 7 AND 40.
- RED BULL GMBH, FUSCHL AM SEE, 5330, AUSTRIA:  
2,877,139, CANC. MULTIPLE CLASS, INT. CLS. 25 AND 41.  
2,877,141, CANC. MULTIPLE CLASS, INT. CLS. 25 AND 41.
- RED ISLAND INDUSTRIES, MERIDIAN, ID:  
3,956,067, INT. CL. 33.
- RED ONION INVESTORS, LLC, ASPEN, CO:  
3,955,248, INT. CL. 25.
- RED RIVER VALLEY FAIR ASSOCIATION, WEST FARGO, ND:  
1,662,732, REN. 3-31-11. INT. CL. 35.
- RED STEER GLOVE COMPANY, SALEM, OR:  
3,954,662, PUB. 2-15-2011. INT. CL. 25.
- REDI-GRO CORPORATION, SACRAMENTO, CA:  
2,426,783, REN. 3-30-11. INT. CL. 1.
- REDMAN, JOHN B., JR., NASHUA, NH:  
2,434,679, REN. 3-25-11. INT. CL. 36.
- REDPOINT MANAGEMENT LLC, MENLO PARK, CA:  
2,475,353, REN. 3-26-11. INT. CL. 36.
- REED ELSEVIER INC., NEWTON, MA:  
2,876,873, CANC. INT. CL. 16.

- REFAELY, WANDA M., SAN DIEGO, CA AND REFAELY, RAPHAEL, SAN DIEGO, CA:  
2,875,921, CANC. INT. CL. 25.
- REFERRED U CONCEPTS, LLC, PALM HARBOR, FL:  
3,955,271, MULTIPLE CLASS, INT. CLS. 35 AND 42.
- REFINED TECHNOLOGIES, INC., SPRING, TX:  
3,953,945, PUB. 2-15-2011. INT. CL. 1.
- REGAL ENTERTAINMENT GROUP, KNOXVILLE, TN:  
3,954,852, PUB. 2-15-2011. INT. CL. 35.
- REGAL MARINE INDUSTRIES, INC., ORLANDO, FL:  
898,627. REN. 3-31-11. U.S. CL. 19 (INT. CL. 12).
- REGENT GLOBAL SOURCING INC., BURBANK, CA:  
3,954,238, PUB. 2-15-2011. INT. CL. 25.  
3,955,036, PUB. 2-15-2011. INT. CL. 25.
- REGENT HOSPITALITY WORLDWIDE, INC., CENTRAL, HONG KONG, REGENT INTERNATIONAL HOTELS LTD., NEW YORK, NY:  
1,139,113. REN. 3-31-11. INT. CL. 42.
- REGINA RUBENS S.A. (SOCIETE ANONYME), PARIS, FRANCE:  
2,378,512, CANC. MULTIPLE CLASS, INT. CLS. 3, 18 AND 25.
- REGINALD GENE CHERRY, MEMPHIS, TN:  
3,954,977, PUB. 2-15-2011. INT. CL. 9.
- REGIS INC., MINNEAPOLIS, MN:  
3,955,420, INT. CL. 3.
- REGNI, GERALD, JR., PHILADELPHIA, PA:  
2,889,446, CANC. INT. CL. 5.
- REHABILITATION SERVICES, INC., PAOLI, PA, DBA MYOFASCIAL RELEASE TREATMENT CENTERS AND SEMINARS:  
3,955,902, MULTIPLE CLASS, INT. CLS. 41 AND 44.
- REICHERT, TERRY R., SCOTTSBLUFF, NE, DBA PRO ICE:  
3,956,243, INT. CL. 14.
- REIKA GMBH & CO. KG, HAGEN, FED REP GERMANY:  
3,953,219, PUB. 2-15-2011. INT. CL. 7.
- RELIABLE PAVING, INC., ARLINGTON, TX:  
3,953,741, PUB. 9-21-2010. INT. CL. 37.  
3,953,742, PUB. 9-21-2010. INT. CL. 37.
- RELIALAB INC., BASKING RIDGE, NJ:  
2,877,179, CANC. INT. CL. 5.
- RELIANCE RELOCATION SERVICES, INC., CHICAGO, IL:  
2,455,163. REN. 3-30-11. INT. CL. 36.
- RELIANT ENERGY RETAIL HOLDINGS, LLC, HOUSTON, TX:  
3,954,942, PUB. 2-15-2011. INT. CL. 39.  
3,955,126, PUB. 2-15-2011. INT. CL. 35.
- REMEDY MARKETING, INC., CHARLESTON, SC:  
2,877,487, CANC. INT. CL. 5.
- REMERICA REAL ESTATE CORPORATION, PLYMOUTH, MI:  
2,688,702, CANC. INT. CL. 36.
- REMEY ROZIN, CHICAGO, IL:  
3,953,445, PUB. 2-15-2011. INT. CL. 25.
- RENAISSANCE CONCRETE WORKS INC, VAN BUREN, AR:  
3,954,545, PUB. 2-15-2011. INT. CL. 9.
- RENNELL, COREY MARTIN, ANCHORAGE, AK:  
3,953,148, PUB. 2-15-2011. INT. CL. 5.
- REPUBLIC INC., OTTAWA, CANADA, DBA WEDDING REPUBLIC:  
3,954,961, PUB. 2-15-2011. INT. CL. 41.
- REQUEST FOODS, INC., HOLLAND, MI:  
1,656,944. REN. 3-30-11. INT. CL. 29.
- RESEARCH PRODUCTS CORPORATION, MADISON, WI:  
928,500. REN. 3-30-11. U.S. CL. 34 (INT. CL. 11).
- RESIDENT ARTIST STUDIO, LLC, BOXBOROUGH, MA:  
3,953,154, PUB. 3-30-2010. INT. CL. 9.
- RESIDENTIAL CAPITAL MANAGEMENT LIMITED, LLC, BELLEVUE, WA:  
2,877,209, CANC. INT. CL. 36.
- RESIDENTIAL SERVICES, L.P., HOUSTON, TX:  
2,877,774, CANC. INT. CL. 36.
- RESINCO CAPITAL PARTNERS INC., VANCOUVER, BC, CANADA:  
3,955,483, MULTIPLE CLASS, INT. CLS. 36, 37 AND 42.
- RESMED LIMITED, NORTH RYDE NSW 2113, AUSTRALIA:  
2,875,910, CANC. MULTIPLE CLASS, INT. CLS. 37 AND 42.
- RESNICK, RONALD S., BEVERLY HILLS, CA:  
3,441,211 NEW CERT. 5-3-2011. INT. CL. 36.
- RESOUNDING HEALTH, INC., CHESTNUT HILL, MA:  
3,953,416, PUB. 2-15-2011. MULTIPLE CLASS, INT. CLS. 42 AND 44.
- RESOURCE TRADING GROUP, L.L.C., CHICAGO, IL:  
2,877,137, CANC. INT. CL. 36.
- RESTAURANTS UNLIMITED, INC., SEATTLE, WA:  
3,955,797, INT. CL. 43.
- RESTORATION HARDWARE, INC., CORTE MADERA, CA:  
3,953,449, PUB. 2-15-2011. MULTIPLE CLASS, INT. CLS. 6, 11, 20 AND 21.  
3,953,450, PUB. 2-15-2011. MULTIPLE CLASS, INT. CLS. 6, 11, 20 AND 21.
- RESTORATION INDUSTRY ASSOCIATION, INC., COLUMBIA, MD:  
2,379,652, CANC. INT. CL. 42.
- RESTORZ LLC, WESTLAKE, OH:  
3,956,153, MULTIPLE CLASS, INT. CLS. 37 AND 40.
- RESTREPO GUTIERREZ, SANTIAGO, BOGOTÁ, COLOMBIA:  
3,955,300, INT. CL. 29.
- RETAIL BRANDS PTY LTD, QUEENSLAND, AUSTRALIA:  
3,953,888, PUB. 2-15-2011. MULTIPLE CLASS, INT. CLS. 9 AND 41.
- RETAIL CONCEPTS, INC., HOUSTON, TX:  
3,955,806, INT. CL. 25.
- RETAILFOODRX, INC., CAMBRIDGE, MA:  
3,955,817, INT. CL. 44.
- REUNION RECORDS, INC., FRANKLIN, TN:  
1,577,371, CANC. INT. CL. 9.
- REUTERS SA, GENEVA, SWITZERLAND:  
2,379,309, CANC. INT. CL. 36.
- REVELL INC., ELK GROVE VILLAGE, IL:  
921,506. REN. 3-31-11. U.S. CL. 22 (INT. CL. 28).
- REVERB NETWORKS, INC., ASHBURN, VA:  
3,954,554, PUB. 2-15-2011. INT. CL. 9.
- REVERSAROLLER, LLC, LINDON, UT:  
3,953,940, PUB. 2-15-2011. INT. CL. 7.
- REVLON CONSUMER PRODUCTS CORPORATION, NEW YORK, NY:  
3,955,344, INT. CL. 9.  
3,955,846, INT. CL. 9.
- REVO AMERICA, POWAY, CA:  
3,953,844, PUB. 2-15-2011. INT. CL. 9.
- REVOLUTION CLIMBING, INC., SALT LAKE CITY, UT:  
3,953,272, PUB. 2-15-2011. INT. CL. 28.
- REVOLUTION FOODS, INC., OAKLAND, CA:  
3,955,834, INT. CL. 29.  
3,955,835, INT. CL. 30.
- REYMAN DRUG COMPANY, INC., BALTIMORE, MD:  
2,436,640. REN. 3-26-11. INT. CL. 5.
- RHEONIX, INC., ITHACA, NY:  
3,953,840, PUB. 2-15-2011. INT. CL. 1.  
3,953,841, PUB. 2-15-2011. INT. CL. 1.
- RHYTHMS INTERNATIONAL COMPANY, FT. LAUDERDALE, FL:  
2,877,702, CANC. INT. CL. 41.
- RICARDO VIZCAINO, LOS ANGELES, CA AND OROSMAN VIZCAINO, JR., LOS ANGELES, CA:  
3,956,239, INT. CL. 25.
- RICCIO, TODD M, THOUSAND OAKS, CA AND HWANG, SARA, THOUSAND OAKS, CA:  
3,953,130, PUB. 2-15-2011. INT. CL. 35.
- RICH PRODUCTS CORPORATION, BUFFALO, NY:  
3,955,530, INT. CL. 30.
- RICHARD BELL, EULESS, TX:  
3,953,793, PUB. 2-15-2011. INT. CL. 35.
- RICHARD JOHN BUCHNER, III, SNELLVILLE, GA:  
3,955,925, INT. CL. 28.
- RICHARD LINTHICUM, KEYSER, WV:  
3,954,157, PUB. 2-15-2011. INT. CL. 36.
- RICHARDS HOMEWARES, INC., PORTLAND, OR:  
3,953,141, PUB. 2-15-2011. MULTIPLE CLASS, INT. CLS. 6, 9, 12, 14, 18, 20, 21 AND 22.
- RICHARDSON, CORNELL N., NEW YORK, NY:  
3,954,053, PUB. 2-15-2011. INT. CL. 41.

RICHLINE GROUP, INC., MOUNT VERNON, NY:  
3,955,066, PUB. 2-15-2011. INT. CL. 14.

RICHMAN, DEBORAH K., HUNTINGTON, NY:  
2,876,036, CANC. INT. CL. 3.

RICHMOND, MARIANNE, SAINT ANTHONY, MN:  
3,953,781, PUB. 2-15-2011. INT. CL. 14.

RICKENBACKER INTERNATIONAL CORPORATION,  
SANTA ANA, CA:  
3,954,726, PUB. 2-15-2011. INT. CL. 9.

RIDE THE DUCKS INTERNATIONAL, LLC, BRANSON,  
MO:  
2,433,855, REN. 3-31-11. INT. CL. 39.

RIES, SHANE, DIAMOND BAR, CA:  
2,480,039, REN. 3-28-11. INT. CL. 9.

RIGHT NOW REDESIGN LLC, CHICAGO, IL:  
3,409,871, AM. INT. CL. 42.

RIGHTSCUBE, INC., NEW YORK, NY:  
3,953,955, PUB. 2-15-2011. INT. CL. 35.

RIGHTWARE OY, ESPOO, FINLAND:  
3,953,176, PUB. 2-15-2011. MULTIPLE CLASS, INT. CLS. 9  
AND 42.

RINCON DE SAN LAZARO, INC., HIALEAH, FL:  
1,634,793, REN. 3-31-11. MULTIPLE CLASS, INT. CLS. 16  
AND 42.

RISC, LLC, PHOENIX, AZ:  
3,955,510, MULTIPLE CLASS, INT. CLS. 35 AND 45.

RITCHIE, ROBERT, ORTONVILLE, MI:  
2,877,990, CANC. INT. CL. 41.

RITZ CAMERA & IMAGE, L.L.C., BELTSVILLE, MD:  
3,953,161, PUB. 2-15-2011. MULTIPLE CLASS, INT. CLS.  
35, 40 AND 42.

RITZ-CARLTON HOTEL COMPANY L.L.C., THE, BETHES-  
DA, MD:  
2,487,484, REN. 3-28-11. INT. CL. 42.

RLC ELECTRONICS, INC., MT. KISCO, NY:  
1,165,334, REN. 3-31-11. INT. CL. 9.  
1,165,335, REN. 3-31-11. INT. CL. 9.

RNG TECHNOLOGY, CHICAGO, IL:  
3,954,419, PUB. 2-15-2011. INT. CL. 35.

ROBELL RESEARCH, INC., NEW YORK, NY:  
3,954,198, PUB. 2-15-2011. INT. CL. 3.

ROBERT BOSCH LLC, BROADVIEW, IL:  
2,877,629, CANC. INT. CL. 9.  
2,877,630, CANC. INT. CL. 9.  
2,877,631, CANC. INT. CL. 9.

ROBERT RUIZ, IRVINE, CA, DBA SPECTRUM BUSINESS  
SOLUTIONS:  
3,953,838, PUB. 2-15-2011. INT. CL. 35.

ROBERT S. JOHNSTON, MILWAUKEE, WI:  
3,956,146, INT. CL. 28.

ROBERTS, FRANK, MICHAEL, TOLUCA LAKE, CA:  
2,877,356, CANC. INT. CL. 41.

ROBERTS, ROBERTA, GREAT FALLS, VA:  
2,877,368, CANC. INT. CL. 18.

ROBIN, MICHELLE, SHAWNEE, KS:  
3,955,405, INT. CL. 41.

ROBINSON, MARY ALYCE, LITTLE ROCK, AR, DBA  
JOBSPOT:  
3,954,069, PUB. 2-15-2011. INT. CL. 35.

ROCHE DIAGNOSTICS GMBH, 68305 MANNHEIM, FED  
REP GERMANY:  
3,955,430, INT. CL. 9.

ROCHLING GLASTIC COMPOSITES, L.P., CLEVELAND,  
OH:  
539,298, REN. 3-29-11. U.S. CL. 21 (INT. CL. 17).

ROCK OF AGES CORPORATION, GRANITEVILLE, VT:  
715,546, REN. 3-31-11. U.S. CL. 50 (INT. CL. 19).

ROCKET TURTLE, LLC, SAN FRANCISCO, CA:  
3,956,204, INT. CL. 41.

ROCKFORD POWERTRAIN, INC., ROCKFORD, IL:  
1,619,742, REN. 3-28-11. INT. CL. 12.

ROCKLAND TRUST CO., ROCKLAND, MA:  
2,877,445, CANC. INT. CL. 36.

ROCKSTAR CHEER & DANCE, INC., GREER, SC:  
3,954,494, PUB. 2-15-2011. INT. CL. 41.  
3,954,676, PUB. 2-15-2011. INT. CL. 41.

ROCKWELL AUTOMATION, INC., MILWAUKEE, WI:  
2,438,740, REN. 3-26-11. INT. CL. 9.

RODALE, INC., EMMAUS, PA:  
3,955,128, PUB. 2-15-2011. INT. CL. 16.

RODGER, KATE, VENICE, CA:  
3,954,879, PUB. 2-15-2011. INT. CL. 41.

RODRIGUEZ-LAUREANO, RICARDO J., TOA ALTA,  
PUERTO RICO:  
3,954,425, PUB. 2-15-2011. INT. CL. 35.

RODRIGUEZ, ANGELA, LOMPOC, CA:  
3,952,980, PUB. 2-15-2011. INT. CL. 35.

ROGER CUBICCIOTTI, MONTCLAIR, NJ, TA NANOME-  
DIA, INC.:  
3,954,535, PUB. 2-15-2011. INT. CL. 1.

ROHM AND HAAS COMPANY, PHILADELPHIA, PA:  
3,953,312, PUB. 2-15-2011. MULTIPLE CLASS, INT. CLS.  
16, 37 AND 42.

ROKSOLID AMERICAN PRODUCTS & SERVICES, INC.,  
EVERGREEN, CO:  
2,435,742, REN. 3-30-11. INT. CL. 42.

ROLAND CORPORATION, SHIZUOKA, JAPAN:  
3,953,283, PUB. 2-15-2011. MULTIPLE CLASS, INT. CLS. 9  
AND 15.

ROLLADEN, INC., HALLENDALE, FL:  
2,876,271, CANC. INT. CL. 6.

ROMAN CATHOLIC CHURCH OF THE ARCHDIOCESE OF  
SANTA FE, ALBUQUERQUE, NM:  
2,444,008, REN. 3-26-11. MULTIPLE CLASS, INT. CLS. 16  
AND 41.

ROMAN STOICA, SORIN, THORNHILL, ONTARIO, CANA-  
DA:  
3,955,811, INT. CL. 35.  
3,955,812, INT. CL. 35.

ROMANO APPRAISAL AGENCY, INC., RUTLAND, VT:  
2,442,651, REN. 3-31-11. INT. CL. 9.

ROMBOM, STEVEN P., BROOKLYN, NY:  
2,378,472, CANC. INT. CL. 42.

ROMO, JOSE ISMAEL, TONALA CITY, JALISCO, MEXICO:  
3,955,416, INT. CL. 5.

RONALD J. FRENCH, NEW ORLEANS, LA:  
3,955,803, INT. CL. 10.

RONEY, NEDRA DEE, DRAPER, UT:  
3,955,794, INT. CL. 14.

ROOT, DARLA, CANON CITY, OH:  
2,380,018, CANC. INT. CL. 35.

ROOTS CANADA LTD., TORONTO, ONTARIO M6A 2W5,  
CANADA:  
2,876,055, CANC. INT. CL. 27.

ROSARIO, BRYAN, RENO, NV:  
3,953,303, PUB. 2-15-2011. INT. CL. 35.

ROSS, GREG, FORT LAUDERDALE, FL:  
3,633,301, CANC. INT. CL. 42.

ROSS, WILLIAM H. III, SAN FRANCISCO, CA:  
2,451,921, REN. 3-25-11. INT. CL. 35.

ROTH BROS., INC., YOUNGSTOWN, OH:  
3,955,209, INT. CL. 41.

ROWEN, MICHAEL, CHAPEL HILL, NC:  
2,877,948, CANC. INT. CL. 35.

ROWENA'S, INC., NORFOLK, VA:  
2,875,913, CANC. INT. CL. 30.

ROXCEL HANDELSGES.M.B.H., AUSTRIA:  
3,953,609, PUB. 2-15-2011. MULTIPLE CLASS, INT. CLS.  
16, 35 AND 39.

ROY, CHRISTOPHER H.W., DRURY, MO:  
2,381,264, CANC. INT. CL. 19.

ROYAL BALTIC, LTD., BROOKLYN, NY:  
1,647,550, REN. 3-31-11. INT. CL. 29.

ROYAL MASTER CISSORS CO., LTD., CHUO-KU, OSAKA,  
JAPAN:  
3,953,724, PUB. 9-14-2010. INT. CL. 8.

ROYAL PAPER CONVERTING, INC., PHOENIX, AZ:  
3,956,215, INT. CL. 16.

ROYAL QUEST, LLC, BEDFORD, TX:  
3,954,155, PUB. 2-15-2011. INT. CL. 28.

ROYALE MONTE CARLO LIMITED, ST HELIER, JERSEY:  
3,953,806, PUB. 2-15-2011. MULTIPLE CLASS, INT. CLS.  
25, 41 AND 43.

ROYALTY ROTORS, INC., SANTA CLARITA, CA:  
3,953,402, PUB. 2-15-2011. INT. CL. 12.

- RP SAFE SPA, ITALY:  
3,953,577, PUB. 2-15-2011. INT. CL. 9.
- RPM INTERNATIONAL INC., CERRITOS, CA:  
3,954,901, PUB. 2-15-2011. INT. CL. 7.
- RPM WOOD FINISHES GROUP, INC, HICKORY, NC:  
3,953,474, PUB. 2-15-2011. INT. CL. 2.
- RS INVESTMENTS, LLC, EAGLE, ID, DBA REBATES REALTY:  
2,878,049, CANC. INT. CL. 36.
- RSB RESTAURANT GROUP LLC, FLAGSTAFF, AZ:  
3,955,617, INT. CL. 43.
- RSV POOLS, INC., GAITHERSBURG, MD:  
3,953,022, PUB. 2-15-2011. INT. CL. 20.
- RT-DISTRIBUTION, PETER WOLFSLAST E.K., FED REP GERMANY:  
3,953,638, PUB. 2-15-2011. MULTIPLE CLASS, INT. CLS. 15, 35 AND 41.
- RTI BIOLOGICS, INC., ALACHUA, FL:  
3,953,197, PUB. 11-9-2010. INT. CL. 10.
- RT7K, LLC, SHERMAN OAKS, CA:  
3,953,998, PUB. 2-15-2011. INT. CL. 42.  
3,953,999, PUB. 2-15-2011. INT. CL. 42.
- RUBENSTEIN & ZIFF, INC., MINNEAPOLIS, MN:  
2,429,774, REN. 3-31-11. INT. CL. 35.
- RUBICON WEST, INC., PORTLAND, OR:  
2,510,003, REN. 3-29-11. INT. CL. 9.
- RUBIN, GARY, BOSTON, MA:  
2,535,982, REN. 3-26-11. INT. CL. 41.
- RUBIN, JODI, LAQUINTA, CA:  
3,955,167, INT. CL. 17.
- RUCKUS ENTERPRISES LLC, LIBERTYVILLE, IL:  
3,955,218, MULTIPLE CLASS, INT. CLS. 16, 24, 25, 35 AND 41.
- RUDELL DESIGN LLC, TORRANCE, CA:  
3,955,338, INT. CL. 28.
- RUDSENSKE, J. SCOTT, HOUSTON, TX:  
2,876,688, CANC. INT. CL. 16.
- RUFF MAGIC ENTERTAINMENT, LLC, NEWARK, NJ:  
3,955,265, INT. CL. 25.
- RUGGIERO SEAFOODS, INC., NEWARK, NJ:  
2,490,518, REN. 3-26-11. INT. CL. 29.
- RUHOF CORPORATION, THE, MINEOLA, NY:  
1,188,282, REN. 3-29-11. INT. CL. 1.
- RUHRPUMPEN, S.A. DE C.V., NUEVA LEON C.P., MEXICO, RUHRPUMPEN, INC., TULSA, OK:  
2,486,017, REN. 3-26-11. INT. CL. 7.  
2,488,896, REN. 3-26-11. INT. CL. 7.
- RUIZ FOOD PRODUCTS, INC., DINUBA, CA:  
2,876,038, CANC. INT. CL. 30.
- RULESTER LLC, CHICAGO, IL:  
3,955,020, PUB. 2-15-2011. INT. CL. 38.
- RUPARI FOOD SERVICES, INC., DEERFIELD BEACH, FL:  
3,954,371, PUB. 2-15-2011. INT. CL. 29.
- RURAL CELLULAR CORPORATION, ALEXANDRIA, MN:  
2,439,576, REN. 3-30-11. MULTIPLE CLASS, INT. CLS. 38 AND 39.  
2,439,576, CANC. MULTIPLE CLASS, INT. CLS. 35, 36 AND 37.
- RUSHMORE INVESTMENTS, INC., CLEARWATER, FL:  
3,954,654, PUB. 2-15-2011. INT. CL. 14.
- RUSSELL BRANDS, LLC, ALEXANDER CITY, AL:  
1,048,839, CANC. INT. CL. 5.  
2,877,830, CANC. INT. CL. 25.
- RUSTIC AND WESTERN ENTERPRISES, INC., CLYDE, TX:  
2,378,422, CANC. INT. CL. 25.
- RUTTER COMMUNICATIONS NETWORK, L.L.C., MUNCIE, IN:  
2,379,665, CANC. INT. CL. 35.
- RUTTER HOBBS & DAVIDOFF INCORPORATED, LOS ANGELES, CA:  
3,954,538, PUB. 2-15-2011. INT. CL. 41.
- RVI DISTRIBUTION, LAGUNA HILLS, CA:  
3,421,742, AM. INT. CL. 35.
- RX GEAR, LLC, QUINCY, MA:  
3,956,062, INT. CL. 35.
- RXHOLDINGS, LLC, MERIDIAN, ID:  
2,876,988, CANC. INT. CL. 5.
- RYDER, KIRA, OJAI, CA AND RYDER, ERIC, OJAI, CA:  
2,876,180, CANC. INT. CL. 41.
- RYLANDER & ASSOCIATES PC, VANCOUVER, WA:  
3,954,695, PUB. 2-15-2011. INT. CL. 45.
- RYT-WAY INDUSTRIES, LLC, LAKEVILLE, MN:  
3,954,213, PUB. 2-15-2011. INT. CL. 39.  
3,954,214, PUB. 2-15-2011. INT. CL. 39.  
3,954,215, PUB. 2-15-2011. INT. CL. 39.
- RYU IL INTERNATIONAL, INC., LOS ANGELES, CA, DBA JR BEAUTY:  
3,953,255, PUB. 11-9-2010. INT. CL. 3.
- S & N ENTERPRISES, INC., RICHMOND, VA:  
3,954,133, PUB. 2-15-2011. INT. CL. 3.
- S. C. JOHNSON & SON, INC., RACINE, WI:  
2,877,136, CANC. INT. CL. 5.  
3,955,253, MULTIPLE CLASS, INT. CLS. 4 AND 5.
- S.T.L. LUBRIFIANTS INC., ROBERVAL (QUÉBEC), CANADA:  
3,953,184, PUB. 9-14-2010. MULTIPLE CLASS, INT. CLS. 7 AND 42.
- S&T BANK, INDIANA, PA:  
2,444,519, CANC. INT. CL. 36.
- S/L LIFEHOPE TRADEMARK, LLC, ATLANTA, GA:  
3,955,159, MULTIPLE CLASS, INT. CLS. 3, 5, 25, 28, 29, 32, 35 AND 43.
- SA-BAI THONG, LLC, MADISON, WI:  
3,953,211, PUB. 2-15-2011. INT. CL. 43.
- SA, SHUANG, RICHMOND, BC, CANADA:  
3,954,476, PUB. 2-15-2011. INT. CL. 9.  
3,954,480, PUB. 2-15-2011. INT. CL. 9.
- SABEMO SA, SWITZERLAND:  
3,953,512, PUB. 2-15-2011. MULTIPLE CLASS, INT. CLS. 9, 38 AND 41.
- SABIC INNOVATIVE PLASTICS IP B.V., BERGEN OP ZOOM, NETHERLANDS, LIQUID NITROGEN PROCESSING CORPORATION, MALVERN, PA:  
910,809, REN. 3-30-11. U.S. CL. 1 (INT. CL. 1).
- SABORMEX EUROPA, S.L., BILBAO, SPAIN:  
3,953,854, PUB. 2-15-2011. INT. CL. 29.
- SACHA WILBANKS, ATLANTA, GA:  
2,877,451, CANC. INT. CL. 35.
- SACRAMENTO KINGS LIMITED PARTNERSHIP, L.P., SACRAMENTO, CA:  
2,876,094, CANC. INT. CL. 41.
- SACRON INNOVATIONS PTY LIMITED, AUSTRALIA:  
3,953,676, PUB. 2-15-2011. INT. CL. 1.
- SADDLE LIGHTS, INC., FLAGSTAFF, AZ, DBA SADDLE LIGHTS:  
3,953,960, PUB. 2-15-2011. INT. CL. 39.
- SADDLEBACK GOLF CARS, LAGUNA WOODS, CA:  
3,953,891, PUB. 2-15-2011. MULTIPLE CLASS, INT. CLS. 35 AND 39.
- SAFARI GREETINGS, LLC, NEWARK, NJ:  
3,953,910, PUB. 2-15-2011. INT. CL. 16.
- SAFESPACE PRODUCTIONS LLC, NEW YORK, NY:  
2,379,908, CANC. INT. CL. 9.
- SAFETY AND SECURITY INTERNATIONAL, BRENTWOOD, TN:  
2,877,138, CANC. INT. CL. 35.
- SAFETY LOCK, INC., BARSTOW, CA:  
2,442,355, REN. 3-31-11. INT. CL. 6.
- SAFETY SOCKET LLC, CHICAGO, IL:  
3,953,697, PUB. 2-15-2011. INT. CL. 6.
- SAFEWORKS, LLC, TUKWILA, WA:  
2,438,034, REN. 3-31-11. INT. CL. 9.
- SAGE PUBLICATIONS, INC., THOUSAND OAKS, CA:  
3,956,222, INT. CL. 9.  
3,956,223, INT. CL. 9.
- SAHLAS, NICHOLAOS, NORTH RIVERSIDE, IL, SAHLAS, NICHOLAOS, NORTH RIVERSIDE, IL:  
2,440,262, REN. 3-31-11. INT. CL. 42.
- SAINT PATRICK'S HOME, BRONX, NY:  
3,954,092, PUB. 2-15-2011. INT. CL. 35.
- SAINT THOMAS HEALTH SERVICES, NASHVILLE, TN:  
2,876,656, CANC. INT. CL. 45.
- SAINT-GOBAIN ABRASIVES, INC., WORCESTER, MA:  
3,953,062, PUB. 7-27-2010. INT. CL. 7.



- SAINT-GOBAIN ECOPHON AB, HYLLINGE, SWEDEN:  
1,618,786. REN. 3-31-11. MULTIPLE CLASS, INT. CLS. 17 AND 19.
- SAINT-GOBAIN GLASS FRANCE, FRANCE:  
3,953,586. PUB. 2-15-2011. MULTIPLE CLASS, INT. CLS. 19, 21, 37, 39, 40 AND 42.
- SAINT-GOBAIN SOVIS, SAS, 02407 CHATEAU-THIERRY, FRANCE:  
2,439,810. REN. 3-28-11. INT. CL. 21.
- SAIRGROUP, 8001 ZURICH, SWITZERLAND:  
2,875,947. CANC. INT. CL. 35.
- SAITEX INTERNATIONAL INC., NEW YORK, NY:  
3,955,891. INT. CL. 25.
- SAKAMOTO KUROZU, INC., JAPAN:  
3,953,543. PUB. 2-15-2011. INT. CL. 30.
- SALEM, RAIED E., RANCHO CUCAMONGA, CA AND PEREZ, VICENTE ERNESTO, RANCHO CUCAMONGA, CA:  
3,953,917. PUB. 2-15-2011. INT. CL. 35.
- SALES SUCCESS CONSULTING, LLC, PEABODY, MA:  
3,956,044. INT. CL. 9.
- SALLY HERSHBERGER PROFESSIONAL HAIR CARE LLC, NEW YORK, NY:  
3,954,136. PUB. 2-15-2011. INT. CL. 3.  
3,954,137. PUB. 2-15-2011. INT. CL. 3.
- SALMI INTERNATIONAL LTD., KWAI CHUNG, NEW TERRITORIES, HONG KONG:  
2,448,928. REN. 3-30-11. INT. CL. 26.
- SALSA TAMAZULA, S.A. DE C.V., GUADALAJARA VALISCO, MEXICO, SALSA TAMAZULA, S. A., GUADALAJARA, JALISCO, MEXICO:  
1,641,427. REN. 3-28-11. INT. CL. 30.
- SALT LAKE BREWING CO., L.C., SALT LAKE CITY, UT:  
3,953,411. PUB. 2-15-2011. INT. CL. 32.
- SAMHAIN PUBLISHING, LTD., MACON, GA:  
3,956,120. INT. CL. 9.
- SAMMY CORPORATION, TOSHIMA-KU, TOKYO, JAPAN:  
2,876,163. CANC. MULTIPLE CLASS, INT. CLS. 9 AND 28.  
2,876,164. CANC. MULTIPLE CLASS, INT. CLS. 9 AND 28.
- SAMSONITE IP HOLDINGS S.A.R.L., LUXEMBOURG, LUXEMBOURG:  
2,439,232. REN. 3-29-11. INT. CL. 9.  
2,439,232. CANC. INT. CL. 11.
- SAMSUNG AMERICA, INC., RIDGEFIELD PARK, NJ:  
2,877,536. CANC. INT. CL. 9.
- SAMSUNG ELECTRONICS CO., LTD., KYUNGKI-DO, REPUBLIC OF KOREA:  
2,876,064. CANC. INT. CL. 9.
- SAMSUNG ELECTRONICS CO., LTD., SUWON-SI, GYEONGGI-DO, REPUBLIC OF KOREA:  
2,877,039. CANC. INT. CL. 11.
- SAMUEL SMITH OLD BREWERY; (TADCASTER), UNITED KINGDOM:  
3,953,524. PUB. 2-15-2011. INT. CL. 33.
- SAN DIEGO MAGAZINE, LLC, SAN DIEGO, CA:  
1,639,036. REN. 3-29-11. INT. CL. 16.
- SAN DIEGO ROCK CHURCH, SAN DIEGO, CA:  
3,955,784. INT. CL. 45.
- SAN JOSE SHARKS, LP, SAN JOSE, CA:  
2,378,460. CANC. MULTIPLE CLASS, INT. CLS. 25 AND 41.
- SANCHEZ, DANIKA L, SANTA CLARITA, CA:  
3,955,468. MULTIPLE CLASS, INT. CLS. 35 AND 41.
- SANCTUARY ENVIRONMENTAL PRODUCTS & SOLUTIONS, THE, WINTER PARK, CO:  
2,529,413. REN. 3-25-11. INT. CL. 1.
- SAND TECHNOLOGY INC., WESTMOUNT, QUEBEC, CANADA:  
2,877,001. CANC. MULTIPLE CLASS, INT. CLS. 9 AND 42.
- SANDBERG & SIKORSKI CORPORATION, NEW YORK, NY:  
3,955,613. INT. CL. 14.
- SANDHILLS SOFTWARE, LONE TREE, CO:  
3,954,422. PUB. 2-15-2011. INT. CL. 35.
- SANDVIK INTELLECTUAL PROPERTY AB, SWEDEN:  
3,953,555. PUB. 2-15-2011. MULTIPLE CLASS, INT. CLS. 6, 8 AND 10.
- SANKO TEKSTIL ISLETMELERI SANAYI VE TICARET ANONIM SIRKETI, GAZIANTEP, TURKEY:  
3,953,678. PUB. 2-15-2011. MULTIPLE CLASS, INT. CLS. 7 AND 12.
- SANKYO MANUFACTURING CO., LTD., KITA-KU, TOKYO, JAPAN:  
2,421,607. REN. 3-31-11. INT. CL. 7.
- SANOFI-AVENTIS, 75013 PARIS, FRANCE:  
2,876,981. CANC. MULTIPLE CLASS, INT. CLS. 9, 16, 41 AND 42.
- SANOFI-AVENTIS, PARIS, FRANCE:  
3,956,138. MULTIPLE CLASS, INT. CLS. 38, 41 AND 44.
- SANPULSE TECHNOLOGIES INC., JERSEY CITY, NJ:  
3,955,057. PUB. 2-15-2011. INT. CL. 9.
- SANSU LIMITED, LONDON SW10 0TH, UNITED KINGDOM:  
2,876,294. CANC. MULTIPLE CLASS, INT. CLS. 16, 18 AND 25.
- SANTECH INDUSTRIES, INC, FORT WORTH, TX:  
2,378,397. CANC. INT. CL. 17.
- SANTORO, MICHAEL, BUFFALO, NY:  
2,877,562. CANC. INT. CL. 25.
- SANVIK, CHARLES W., ST. MICHAEL, MN:  
3,955,287. INT. CL. 11.
- SARAMAR, L.L.C., DOWNERS GROVE, IL:  
2,876,967. CANC. INT. CL. 30.
- SARAMAX APPAREL GROUP, INC., NEW YORK, NY:  
3,953,800. PUB. 2-15-2011. INT. CL. 25.
- SARASWATI FILMS, SALE, UNITED KINGDOM:  
3,953,377. PUB. 2-15-2011. INT. CL. 41.
- SARDELLA, LLC, ANNAPOLIS, MD:  
3,955,867. INT. CL. 43.
- SASH MANAGEMENT INCORPORATED, NEWPORT BEACH, CA, DBA SNA AUTO RENTAL:  
3,954,093. PUB. 2-15-2011. INT. CL. 39.
- SATNAM OVERSEAS (EXPORTS), NEW DELHI 110 048, INDIA:  
2,424,918. REN. 3-31-11. INT. CL. 30.
- SAUER, LOUIS, LAKE BLUFF, IL:  
2,877,656. CANC. INT. CL. 41.
- SAVE VENICE INC., NEW YORK, NY:  
1,639,071. REN. 3-31-11. MULTIPLE CLASS, INT. CLS. 16 AND 36.
- SAWATDEE INC., MINNEAPOLIS, MN:  
2,552,773. REN. 3-31-11. INT. CL. 42.
- SBO PICTURES, INC., CANOGA PARK, CA:  
2,378,785. CANC. INT. CL. 9.
- SCHAEFER GROUP, INC., THE, DAYTON, OH, DBA SCHAEFER FURNACES:  
2,409,236. REN. 3-26-11. MULTIPLE CLASS, INT. CLS. 11, 37 AND 42.
- SCHAFER, DAVID, YORKVILLE, IL:  
3,954,920. PUB. 2-15-2011. INT. CL. 21.
- SCHAFFER, NEAL, NEWPORT BEACH, CA:  
3,862,840. COR. INT. CL. 35.
- SCHARFF, EDITH, SEDALIA, CO:  
3,954,183. PUB. 2-15-2011. INT. CL. 3.  
3,955,122. PUB. 2-15-2011. INT. CL. 9.
- SCHAWBEL CORPORATION, THE, BEDFORD, MA:  
2,437,866. REN. 3-25-11. MULTIPLE CLASS, INT. CLS. 4 AND 9.
- SCHERER, GORDON F., WORTHINGTON, OH:  
2,437,576. REN. 3-25-11. INT. CL. 35.
- SCHERER, PATRICK, LEONARD, NAPLES, FL:  
3,954,812. PUB. 2-15-2011. INT. CL. 9.
- SCHERING-PLOUGH HEALTHCARE PRODUCTS, INC., MEMPHIS, TN:  
3,955,980. INT. CL. 3.
- SCHERRER, FREDERICK WILLIAM, APTOS, CA:  
3,955,277. INT. CL. 33.
- SCHOBER HOLDING AG, D-71254 DITZINGEN, FED REP GERMANY:  
2,875,911. CANC. MULTIPLE CLASS, INT. CLS. 9, 16, 35, 38 AND 42.

- SCHOLASTIC INC., NEW YORK, NY:  
1,672,577. REN. 3-26-11. INT. CL. 16.  
1,677,924. REN. 3-26-11. INT. CL. 41.  
1,677,988. REN. 3-31-11. INT. CL. 42.  
1,678,457. REN. 3-31-11. INT. CL. 16.  
1,678,518. REN. 3-25-11. INT. CL. 16.  
3,956,056. INT. CL. 41.
- SCHONBEK WORLDWIDE LIGHTING INC., PLATTSBURGH, NY:  
2,531,765. REN. 3-31-11. INT. CL. 11.
- SCHOOLHOUSE PARTNERS LLC, SUGARLAND, TX:  
3,955,443. INT. CL. 35.
- SCHRAUGER, DEBORAH SUE, BRENTWOOD, TN:  
2,877,021. CANC. INT. CL. 16.
- SCHREIBER FOODS, INC., GREEN BAY, WI:  
3,954,188. PUB. 2-15-2011. INT. CL. 17.
- SCHUFF INTERNATIONAL, INC., PHOENIX, AZ:  
2,876,252. CANC. INT. CL. 37.  
2,876,253. CANC. INT. CL. 40.
- SCIENTIFIC GAMES INTERNATIONAL, INC., ALPHARETTA, GA:  
3,954,466. PUB. 2-15-2011. INT. CL. 28.
- SCIENTIFIC MOLDING CORPORATION, LTD., SOMERSET, WI:  
1,621,609. REN. 3-31-11. INT. CL. 37.
- SCIOPI, MICHAEL, NORTH HOLLYWOOD, CA:  
2,877,318. CANC. INT. CL. 9.
- SCOPE PRODUCTS, INC., SANTA MONICA, CA:  
2,441,624. REN. 3-31-11. INT. CL. 31.
- SCOREBIG, INC., BOSTON, MA:  
3,955,642. INT. CL. 41.
- SCORPIO MOON, INC., SHOREWOOD, WI:  
2,877,885. CANC. INT. CL. 19.
- SCOTT SUPPLY SERVICES INC., TUCSON, AZ:  
2,379,188. CANC. INT. CL. 37.
- SCRAGG, JOHN C., SEATTLE, WA, DBA MARITIQUE:  
2,877,042. CANC. INT. CL. 9.
- SD ACQUISITION INC., OMAHA, NE, SD ACQUISITION INC., OMAHA, NE:  
2,541,238. REN. 3-28-11. INT. CL. 9.
- SE BOOK COMPANY, LLC, MURRAY, KY:  
3,953,327. PUB. 2-15-2011. INT. CL. 35.
- SEA VIEW RESTAURANTS, INC.:  
1,426,956. CANC. INT. CL. 42.
- SEA-URN, LTD., DEER PARK, NY:  
3,953,743. PUB. 2-15-2011. INT. CL. 20.
- SEACHANGE INTERNATIONAL, INC., ACTON, MA:  
2,388,114. REN. 3-26-11. INT. CL. 9.
- SEALPANES, LLC, HARTFORD, WI:  
3,954,756. PUB. 2-15-2011. INT. CL. 19.
- SEAMENT SHORELINE SYSTEMS, INC., KING GEORGE, VA:  
2,876,296. CANC. MULTIPLE CLASS, INT. CLS. 37 AND 42.
- SEAR, DEXTER A, BOISE, ID:  
2,395,104. CANC. INT. CL. 42.
- SEARCH INSTITUTE, MINNEAPOLIS, MN:  
3,955,850. MULTIPLE CLASS, INT. CLS. 36, 41, 44 AND 45.  
3,955,851. MULTIPLE CLASS, INT. CLS. 36, 41, 44 AND 45.
- SEARS BRANDS, LLC, HOFFMAN ESTATES, IL:  
2,877,188. CANC. INT. CL. 25.  
3,955,355. INT. CL. 7.  
3,955,356. INT. CL. 7.  
3,955,357. INT. CL. 7.  
3,955,358. INT. CL. 7.  
3,955,359. INT. CL. 7.  
3,955,438. INT. CL. 35.
- SEASONS PET FOOD CO., INC., NORCO, CA:  
3,955,328. INT. CL. 31.
- SEATTLE BIKE SUPPLY, INC., KENT, WA:  
2,438,162. REN. 3-29-11. INT. CL. 25.
- SEATTLE CANCER CARE ALLIANCE, SEATTLE, WA:  
2,550,002. REN. 3-31-11. INT. CL. 42.
- SEATTLE GOURMET FOODS, INC., KENT, WA:  
2,876,452. CANC. INT. CL. 30.
- SEAVIEW SOFTWARE, INC., SEATTLE, WA:  
2,380,141. CANC. INT. CL. 9.
- SEAWORTHY INSURANCE COMPANY, ANNAPOLIS, MD:  
1,670,870. REN. 3-25-11. INT. CL. 36.
- SECONDMARKET HOLDINGS, INC., NEW YORK, NY:  
3,953,103. PUB. 2-15-2011. INT. CL. 36.  
3,953,104. PUB. 2-15-2011. INT. CL. 36.
- SECUREWEALTH SOLUTIONS LLC, MESA, AZ:  
2,877,449. CANC. INT. CL. 36.
- SECURITY BENEFIT CORPORATION, TOPEKA, KS:  
3,953,118. PUB. 2-15-2011. INT. CL. 36.
- SEEBERGER KG, FED REP GERMANY:  
3,953,611. PUB. 2-15-2011. MULTIPLE CLASS, INT. CLS. 29, 30 AND 31.
- SEFAR HOLDING AG, 9425 THAL, SWITZERLAND:  
3,953,146. PUB. 7-27-2010. INT. CL. 23.
- SEIKO EPSON KABUSHIKI KAISHA, SHINJUKU-KU, TOKYO, JAPAN, DBA SEIKO EPSON CORPORATION:  
2,876,017. CANC. MULTIPLE CLASS, INT. CLS. 2, 7, 9, 37, 40 AND 42.
- SEITZ, DONALD, NASHVILLE, TN:  
2,479,951. CANC. INT. CL. 41.
- SEKSES DISTRIBUTION LLC, LOS ANGELES, CA:  
3,953,730. PUB. 2-15-2011. INT. CL. 25.
- SELENETIX CORPORATION, VIENNA, VA:  
2,877,779. CANC. INT. CL. 42.
- SELLCO INTERNATIONAL, LTD., SPARKS, NV:  
1,161,003. REN. 3-31-11. INT. CL. 21.
- SELLING MORE HOMES MEDIA, SOMERSET, KY:  
3,953,823. PUB. 2-15-2011. INT. CL. 35.
- SEMI SECRET SOFTWARE, DRIPPING SPRINGS, TX:  
3,954,195. PUB. 2-15-2011. INT. CL. 9.
- SENATOR PUBLISHING, PARKVILLE, MO:  
3,954,194. PUB. 2-15-2011. INT. CL. 41.
- SENIOR SHIFT LLC, OMAHA, NE:  
3,955,372. INT. CL. 35.
- SENORET CHEMICAL COMPANY, KIRKWOOD, MO:  
283,605. REN. 3-26-11. U.S. CL. 6 (INT. CL. 5).
- SENSOR PRODUCTS INC., EAST HANOVER, NJ:  
2,452,306. CANC. INT. CL. 9.
- SEPHORA, FRANCE:  
3,953,633. PUB. 2-15-2011. INT. CL. 1.
- SER TECHNOLOGY CORPORATION, DALLAS, TX:  
3,953,387. PUB. 2-15-2011. INT. CL. 35.
- SERAFINI, PAUL M., PRIDES CROSSING, MA:  
2,509,326. REN. 3-30-11. INT. CL. 41.
- SERAPHINI TRADING INC., CITY OF INDUSTRY, CA:  
3,954,380. PUB. 2-15-2011. INT. CL. 12.  
3,954,978. PUB. 2-15-2011. INT. CL. 12.
- SERAPID FRANCE, LONINIERES, FRANCE:  
2,439,817. REN. 3-26-11. MULTIPLE CLASS, INT. CLS. 6 AND 7.
- SERIOUS MUSIC, LLC, SANTA MONICA, CA:  
2,876,971. CANC. INT. CL. 35.
- SERVICE COMPANY SOLUTIONS, LLC, BEDFORD, NH:  
3,955,439. INT. CL. 16.  
3,955,833. INT. CL. 41.
- SERVICE EMPLOYEES INTERNATIONAL UNION, WASHINGTON, DC:  
2,461,777. REN. 3-26-11. INT. CL. 42.
- SERVICE POINT SOLUTIONS S.A., BARCELONA, SPAIN:  
2,875,872. CANC. MULTIPLE CLASS, INT. CLS. 35, 38, 39 AND 42.
- SERVICE VENTILATION CORP., BRONX, NY:  
2,876,318. CANC. INT. CL. 37.
- SEÑOR SNACKS, INC., LA MIRADA, CA:  
3,955,093. PUB. 2-15-2011. INT. CL. 29.  
3,955,094. PUB. 2-15-2011. INT. CL. 29.
- SEW-EURODRIVE GMBH & CO., 76646 BRUCHSAL, FED REP GERMANY:  
2,938,540. CANC. INT. CL. 42.
- SFH CONCEPTS, LLC, NEW WILMINGTON, PA, DBA KLONDIKE ROD COMPANY:  
3,954,589. PUB. 2-15-2011. INT. CL. 34.
- SHABBY CHIC BRANDS, LLC, CULVER CITY, CA:  
2,438,933. REN. 3-28-11. INT. CL. 27.
- SHAKE-N-GO FASHION, INC., PORT WASHINGTON, NY:  
3,956,194. INT. CL. 26.

SHAMMAS, MILO, VACAVILLE, CA:  
3,954,168, PUB. 2-15-2011. INT. CL. 5.

SHANGHAI CREATOR APPAREL & ACCESSORIES CO., LTD., SHANGHAI, CHINA:  
3,955,576, INT. CL. 18.

SHANNON FOSTER, KNOXVILLE, TN:  
3,954,555, PUB. 2-15-2011. INT. CL. 36.

SHANNON WALKER, LANCASTER, NY:  
3,954,602, PUB. 2-15-2011. INT. CL. 16.

SHAPPELL, SCOTT B., DALLAS, TX:  
3,955,168, INT. CL. 41.

SHAREM PARTNERSHIP, PHILADELPHIA, PA:  
3,954,914, PUB. 2-15-2011. INT. CL. 42.

SHAREWORLD LEARNING CENTER, CUPERTINO, CA:  
2,140,388, CANC. INT. CL. 41.

SHARKEE, INC., FERNANDINA BEACH, FL:  
2,438,090. REN. 3-26-11. INT. CL. 8.

SHARLUN, PATRICIA E., FREDERICKSBURG, VA:  
2,876,775, CANC. INT. CL. 24.

SHARP INVESTMENTS, INC., OMAHA, NE:  
2,502,061. REN. 3-31-11. INT. CL. 35.

SHARP KABUSHIKI KAISHA, OSAKA 545-8522, JAPAN, TA SHARP CORPORATION:  
2,486,206. REN. 3-31-11. INT. CL. 11.

SHARP, TIM, HARRISON, MI, DBA SHARPCO ANCHORS:  
2,877,899, CANC. INT. CL. 6.

SHASTA INDUSTRIES, INC., PHOENIX, AZ:  
2,162,681, CANC. INT. CL. 7.

SHAW, JAMES R., YORK, NE, DBA THRIFTY AUTO GLASS:  
2,876,065, CANC. INT. CL. 35.

SHEIN, ANNALEE, RIVERDALE, NY:  
2,378,466, CANC. MULTIPLE CLASS, INT. CLS. 40 AND 42.

SHELBY GROUP INTERNATIONAL, INC., MEMPHIS, TN:  
3,955,649, INT. CL. 9.

SHELLBACK, LLC, SEATTLE, WA, DBA EIGHT BELLS WINERY:  
3,954,889, PUB. 2-15-2011. MULTIPLE CLASS, INT. CLS. 21 AND 33.

SHELLEY, JOHN, LACONIA, NH:  
3,954,642, PUB. 2-15-2011. INT. CL. 28.

SHELTER-PRO, LLC, STEARNS, KY:  
3,955,802, INT. CL. 25.

SHEMA KOLAINU - HEAR OUR VOICES, BROOKLYN, NY:  
3,954,755, PUB. 2-15-2011. INT. CL. 35.

SHENGLONG INTERNATIONAL GROUP CORPORATION, GLENVIEW, IL:  
3,954,645, PUB. 2-15-2011. INT. CL. 32.

SHENZHEN GREENWHEEL ELECTRIC VEHICLE CO., LTD., SHENZHEN CITY, CHINA:  
3,955,646, INT. CL. 12.

SHIFT4 CORPORATION, LAS VEGAS, NV:  
3,953,097, PUB. 6-29-2010. MULTIPLE CLASS, INT. CLS. 36 AND 42.

SHIMANO INC., SAKAI OSAKA 590-8577, JAPAN:  
2,432,652. REN. 3-26-11. INT. CL. 12.

SHIMANO INC., SAKAI CITY, OSAKA, JAPAN:  
3,955,562, INT. CL. 12.

SHINING UNION LIMITED, TSUEN WAN, NT, HONG KONG:  
3,955,382, INT. CL. 9.

SHIONOGI & CO., LTD., OSAKA, JAPAN:  
3,955,263, MULTIPLE CLASS, INT. CLS. 5 AND 35.

SHIP EQUIP AS, N-6022 AALESUND, NORWAY:  
3,955,361, INT. CL. 37.

SHIRLEY, MOLLY E, GRAPEVINE, TX:  
2,870,483, CANC. INT. CL. 16.

SHISEIDO COMPANY, LIMITED, TOKYO 104-8010, JAPAN:  
3,955,616, INT. CL. 3.

SHOE BACHS, INC., CHEVERLY, MD:  
3,953,164, PUB. 2-15-2011. INT. CL. 25.

SHOOFLY DESIGN, INC., JOHNSTOWN, CO:  
2,875,987, CANC. INT. CL. 25.

SHOP VAC CORPORATION, WILLIAMSPORT, PA:  
3,954,320, PUB. 2-15-2011. INT. CL. 7.

SHOPZILLA, INC., LOS ANGELES, CA:  
2,379,024, CANC. MULTIPLE CLASS, INT. CLS. 35 AND 42.

SHOWSEASON ANIMAL PRODUCTS, LLC, TUCKER, GA:  
3,955,038, PUB. 2-15-2011. INT. CL. 3.  
3,955,039, PUB. 2-15-2011. INT. CL. 3.

SHOWTIME NETWORKS INC., NEW YORK, NY:  
2,877,151, CANC. INT. CL. 41.

SHTERNSHUS, JESSICA C, ORANGE PARK, FL, DBA THE IMPROV EFFECT:  
3,954,423, PUB. 2-15-2011. INT. CL. 41.

SHUBIN, STEVE, DRIPPING SPRINGS, TX:  
3,955,522, INT. CL. 35.  
3,955,523, INT. CL. 35.  
3,955,524, INT. CL. 41.  
3,955,795, INT. CL. 3.

SHURE PRODUCTS, INC., CHICAGO, IL:  
3,955,670, INT. CL. 28.

SICIM, SALO (BS), ITALY:  
3,954,823, PUB. 2-15-2011. INT. CL. 25.

SIDE BY SIDE, INC., AUSTIN, TX:  
2,463,722. REN. 3-26-11. INT. CL. 35.  
2,467,593. REN. 3-26-11. INT. CL. 16.

SIEMENS AKTIENGESELLSCHAFT, MUNICH, FED REP GERMANY:  
1,181,945. REN. 3-31-11. INT. CL. 9.  
2,378,787, CANC. INT. CL. 10.  
2,877,273, CANC. INT. CL. 9.

SIEMENS AKTIENGESELLSCHAFT, 80333 MÜNCHEN, FED REP GERMANY:  
3,953,679, PUB. 2-15-2011. INT. CL. 10.

SIEMENS HEALTHCARE DIAGNOSTICS INC., DEERFIELD, IL, BAYER CORPORATION, ELKHART, IN:  
2,397,000. REN. 3-26-11. INT. CL. 10.

SIERRA TEL COMMUNICATIONS GROUP, OAKHURST, CA:  
2,876,010, CANC. MULTIPLE CLASS, INT. CLS. 9, 35, 38 AND 42.

SIG SAUER INC., EXETER, NH:  
2,876,086, CANC. MULTIPLE CLASS, INT. CLS. 8, 9, 13, 18, 25, 28, 34 AND 42.

SIGHTS ON SERVICE, INC., EAGAN, MN, VARACORP, INC., PLYMOUTH, MN:  
1,664,349. REN. 3-31-11. INT. CL. 35.

SIGNAL INVESTMENT & MANAGEMENT CO., WILMINGTON, DE, CAMPBELL LABORATORIES, INC., LONG ISLAND CITY, NY:  
912,472. REN. 3-29-11. U.S. CL. 18 (INT. CL. 5).

SIGNATURE HEALTH PARTNERS, INC., VENTURA, CA:  
2,380,075, CANC. INT. CL. 5.

SIGNATURE STYLES, LLC, NEW YORK, NY:  
2,387,471. REN. 3-26-11. MULTIPLE CLASS, INT. CLS. 25 AND 35.

SIGNUM INTERNATIONAL S.A.R.L., L-1637 LUXEMBOURG, LUXEMBOURG:  
3,953,443, PUB. 2-15-2011. MULTIPLE CLASS, INT. CLS. 16, 41 AND 42.

SIKO GMBH DR. ING.G. WANDRES, D-79256 BUCHENBACH, FED REP GERMANY:  
2,447,366. REN. 3-30-11. MULTIPLE CLASS, INT. CLS. 7 AND 9.

SILCA S.P.A., ITALY:  
3,953,612, PUB. 2-15-2011. INT. CL. 9.

SILICON HEIGHTS COMPUTERS, ALBUQUERQUE, NM:  
2,379,414, CANC. INT. CL. 35.

SILKIN, CARY, BRISTOL, PA:  
3,953,008, PUB. 4-15-2008. MULTIPLE CLASS, INT. CLS. 9, 16, 25 AND 41.

SILVAN, JUDY, CAMBRIDGE, MA:  
3,954,443, PUB. 2-15-2011. INT. CL. 44.

SILVER OAK INVESTMENTS, LLC, MINNEAPOLIS, MN:  
3,955,861, INT. CL. 37.

SIMMONS MESOTHELIOMA FOUNDATION, EAST ALTON, IL:  
3,956,188, INT. CL. 36.

SIMON & SCHUSTER, INC., NEW YORK, NY:  
2,876,613, CANC. INT. CL. 16.

SIMPLICITY MANUFACTURING, INC., PORT WASHINGTON, WI:  
2,379,822, CANC. INT. CL. 7.

- SINGAS FAMOUS PIZZA BRANDS CORP., FLUSHING, NY:  
3,954,041, PUB. 2-15-2011. INT. CL. 43.
- SINGER VEHICLE DESIGN, SHERMAN OAKS, CA:  
3,954,387, PUB. 2-15-2011. INT. CL. 42.
- SINGULAR PAYMENTS, LLC, SAINT AUGUSTINE, FL:  
3,953,344, PUB. 2-15-2011. INT. CL. 36.
- SIoux HONEY ASSOCIATION, COOPERATIVE, SIoux  
CITY, IA, DBA SIoux HONEY ASSOCIATION, R.D.  
BRADSHAW & SONS, WENDELL, ID:  
554,957, REN. 3-31-11. U.S. CL. 46 (INT. CL. 30).
- SIRCON CORPORATION, OKEMOS, MI:  
2,875,875, CANC. INT. CL. 42.
- SIRIUS XM RADIO INC., NEW YORK, NY:  
3,953,979, PUB. 2-15-2011. INT. CL. 41.
- SISTEMA PLASTICS LIMITED, AUCKLAND, NEW ZEAL-  
AND:  
3,953,797, PUB. 2-15-2011. INT. CL. 35.
- SITE BASED ENERGY, HAILEY, ID:  
3,956,234, MULTIPLE CLASS, INT. CLS. 7 AND 37.  
3,956,235, INT. CL. 7.
- SJP, LLC, JACKSONVILLE, FL:  
3,952,950, PUB. 1-15-2008. MULTIPLE CLASS, INT. CLS.  
36 AND 37.  
3,952,951, PUB. 2-20-2007. MULTIPLE CLASS, INT. CLS.  
36 AND 37.  
3,955,153, MULTIPLE CLASS, INT. CLS. 36 AND 37.
- SKINNYSHIRT LLC, GLEN HEAD, NY:  
3,956,001, INT. CL. 25.  
3,956,003, INT. CL. 25.
- SKOR MANAGEMENT LLC, BIRMINGHAM, MI:  
3,955,737, MULTIPLE CLASS, INT. CLS. 30 AND 43.
- SKYSHOP LOGISTICS, INC., MIAMI, FL:  
3,954,220, PUB. 2-15-2011. MULTIPLE CLASS, INT. CLS.  
35 AND 39.  
3,955,043, PUB. 2-15-2011. MULTIPLE CLASS, INT. CLS.  
35, 36 AND 39.
- SKYWAVE ANTENNAS, INC., HUNTSVILLE, AL:  
3,953,115, PUB. 2-15-2011. MULTIPLE CLASS, INT. CLS. 9  
AND 42.
- SLAMMIN SAM, LLC, CHARLESTON, SC, DBA MARKET  
STREET SALOON:  
3,953,739, PUB. 2-15-2011. MULTIPLE CLASS, INT. CLS.  
41 AND 43.
- SLAVICK, DAVID, EASTLAKE, OH:  
3,956,076, INT. CL. 41.
- SLIMBOARD, LLC, CHESHIRE, CT:  
3,956,187, INT. CL. 16.
- SLOTT, EDWARD, ROCKVILLE CENTRE, NY:  
3,953,853, PUB. 2-15-2011. INT. CL. 41.  
3,953,855, PUB. 2-15-2011. MULTIPLE CLASS, INT. CLS.  
36 AND 41.
- SLUMBERLAND, INC., LITTLE CANADA, MN:  
2,418,621, REN. 3-26-11. INT. CL. 35.
- SMALL WORLD REALTY, LLC, LEWISVILLE, TX:  
3,953,964, PUB. 2-15-2011. INT. CL. 36.
- SMART PROCUREMENT SERVICES USA, LLC, RAINIER,  
WA, DBA SIRRUSH MUFFLERS:  
3,955,932, INT. CL. 7.
- SMARTADHESIVES LLC, SAN FRANCISCO, CA:  
3,954,720, PUB. 2-15-2011. MULTIPLE CLASS, INT. CLS.  
1, 16, 17 AND 35.
- SMARTCRUISER.COM LLC, BOCA RATON, FL:  
2,491,252, REN. 3-31-11. INT. CL. 39.
- SMARTESTING, 25000 BESANCON, FRANCE:  
3,952,956, PUB. 2-15-2011. MULTIPLE CLASS, INT. CLS.  
9, 35, 38 AND 42.
- SMARTPLUG SYSTEMS LLC, SEATTLE, WA:  
3,953,379, PUB. 2-15-2011. INT. CL. 9.
- SMILE BRANDS INC., SANTA ANA, CA:  
3,955,381, MULTIPLE CLASS, INT. CLS. 35 AND 44.
- SMITH & NEPHEW, INC., MEMPHIS, TN:  
2,451,968, REN. 3-31-11. INT. CL. 10.
- SMITH MICRO SOFTWARE, INC., ALISO VIEJO, CA:  
2,401,655, REN. 3-29-11. INT. CL. 9.
- SMITH SEAN R, MRKET WEIGHTON, YORK, UNITED  
KINGDOM:  
3,955,582, MULTIPLE CLASS, INT. CLS. 1, 9 AND 16.
- SMITH, DARIN, SANTA CRUZ, CA:  
2,876,553, CANC. INT. CL. 16.
- SMITH, DOUGLAS, SAN ANTONIO, TX:  
3,954,353, PUB. 2-15-2011. INT. CL. 42.
- SMITH, FORREST, SANTA ANA, CA:  
2,548,786, REN. 3-31-11. INT. CL. 16.
- SMITH, MICHAEL, CORONA, CA, DBA SUPERVISION  
SYSTEMS INC.:  
3,953,765, PUB. 2-15-2011. INT. CL. 9.
- SMITH, RUSSELL JAMES, LONGWOOD, FL:  
3,955,824, INT. CL. 25.
- SMITH, SUSAN MARIA, LONDON, ONTARIO, CANADA:  
3,955,695, INT. CL. 28.
- SMITHKLINE BEECHAM (CORK) LIMITED, COUNTY  
CORK, IRELAND:  
2,877,515, CANC. INT. CL. 5.
- SMITHKLINE BEECHAM BIOLOGICALS S.A., RIXEN-  
SART, BELGIUM:  
2,876,972, CANC. INT. CL. 5.
- SMITHS MEDICAL ASD, INC., ST. PAUL, MN, PHARMA-  
CIA DELTEC, INC., ST. PAUL, MN:  
1,641,168, REN. 3-26-11. INT. CL. 10.
- SMITHSOLUTIONS, INC., LAUREL, MD:  
2,582,298, CANC. INT. CL. 42.
- SNAIDERO RINO S.P.A., 33030 MAJANO (UD), ITALY:  
1,148,945, REN. 3-31-11. INT. CL. 20.
- SNAPS STUDIOS, INC., DALLAS, GA:  
2,877,557, CANC. INT. CL. 41.
- SNEAKERCHANGE, CORONA, NY:  
3,956,254, INT. CL. 35.
- SNUFFER'S MARKS, LLC, ADDISON, TX:  
1,644,070, REN. 3-26-11. INT. CL. 42.
- SNUGZ/USA INCORPORATED, SALT LAKE CITY, UT:  
1,676,604, REN. 3-29-11. INT. CL. 9.
- SOCETA' AGRICOLA DEGLI DEI S.R.L., GREVE IN  
CHIANTI (FI), ITALY:  
3,955,383, INT. CL. 33.
- SOCIAL GRACES, INC., THE, VAN NUYS, CA:  
2,436,944, REN. 3-26-11. INT. CL. 35.
- SOCIAL SCENE LLC, CHICAGO, IL, TA MY DRINK ON:  
3,954,123, PUB. 2-15-2011. INT. CL. 35.
- SOCIETE AIR FRANCE, 95747 ROISSY-CHARLES-DE-  
GAULLE, FRANCE:  
2,445,989, REN. 3-31-11. INT. CL. 39.  
2,445,990, REN. 3-31-11. INT. CL. 39.  
2,460,876, REN. 3-30-11. INT. CL. 39.  
2,461,027, REN. 3-30-11. INT. CL. 39.
- SOCIETE DES PRODUITS NESTLE S.A., 1800 VEVEY,  
SWITZERLAND, SUNMARK, INC., ST. LOUIS, MO,  
AKA BREAKER CONFECTIONS:  
1,153,309, REN. 3-31-11. INT. CL. 30.
- SOCIETE DES PRODUITS NESTLE S.A., VEVEY, SWITZER-  
LAND:  
3,955,819, INT. CL. 31.
- SOCIETE DES PRODUITS NESTLE, S.A., 1800 VEVEY,  
SWITZERLAND:  
713,626, REN. 3-30-11. U.S. CL. 46 (INT. CL. 29).  
2,876,604, CANC. INT. CL. 30.  
2,877,446, CANC. INT. CL. 30.
- SOCIETE POUR LE DEVELOPPEMENT DU FRET EXPRESS  
INTERNATIONAL - SODEXI, 95703 ROISSY, FRANCE:  
2,877,261, CANC. INT. CL. 39.
- SOCIETY FOR WORLDWIDE INTERBANK FINANCIAL  
TELECOMMUNICATION SCRL, BELGIUM:  
3,953,636, PUB. 2-15-2011. MULTIPLE CLASS, INT. CLS.  
35, 41 AND 42.
- SOCIETYWEST LLC, LOS ANGELES, CA:  
2,877,534, CANC. MULTIPLE CLASS, INT. CLS. 41 AND  
45.
- SOCIÉTÉ DE COURTAGE ET DE DIFFUSION - CODIF  
INTERNATIONAL SA, 35404 SAINT MALO CEDEX,  
FRANCE:  
2,876,108, CANC. MULTIPLE CLASS, INT. CLS. 3, 5 AND  
44.
- SOCIÉTÉ FIVIA, FRANCE:  
3,953,631, PUB. 1-18-2011. INT. CL. 9.
- SOFA CONNECTION, INC., MADISON, TN:  
2,877,634, CANC. INT. CL. 35.

- SOFA MART, LLC, DENVER, CO:  
3,954,407, PUB. 2-15-2011. INT. CL. 27.
- SOFTAP, PLEASANTON, CA:  
2,449,284. REN. 3-28-11. MULTIPLE CLASS, INT. CLS. 3,  
10 AND 42.
- SOFTENIGMA INC, ATLANTA, GA, DBA ADEACA CORP.:  
3,953,171, PUB. 2-15-2011. INT. CL. 9.
- SOFTSPIKES, LLC, BRENTWOOD, TN:  
3,955,350, INT. CL. 25.
- SOILMOISTURE EQUIPMENT CORP., GOLETA, CA:  
3,955,688, INT. CL. 9.
- SOL NÉ COLLECTIONS, INC., CENTENNIAL, CO:  
3,954,511, PUB. 2-15-2011. INT. CL. 35.
- SOLACOM TECHNOLOGIES INC., GATINEAU, QUEBEC,  
CANADA:  
3,953,213, PUB. 2-15-2011. INT. CL. 9.  
3,953,214, PUB. 2-15-2011. INT. CL. 9.
- SOLAZYME, INC., SOUTH SAN FRANCISCO, CA:  
3,955,706, INT. CL. 4.
- SOLDO HERMANOS S.R.L., MONTEVIDEO, URUGUAY:  
1,043,066, CANC. INT. CL. 30.
- SOLEIL TANS, INC., MATAWAN, NJ:  
3,954,067, PUB. 2-15-2011. INT. CL. 44.
- SOMEDIA SOLUTIONS, INC., ROSWELL, GA:  
3,954,002, PUB. 2-15-2011. INT. CL. 35.
- SONAFI, VIROFLAY, FRANCE:  
2,877,072, CANC. INT. CL. 30.
- SONIC SOLUTIONS, NOVATO, CA:  
2,379,771, CANC. INT. CL. 9.
- SONY COMPUTER ENTERTAINMENT INC., TOKYO, JA-  
PAN:  
3,955,211, INT. CL. 42.
- SONY CORPORATION, TOKYO, JAPAN, TA SONY COR-  
PORATION:  
2,379,859, CANC. INT. CL. 9.
- SONY CORPORATION, TOKYO, JAPAN:  
2,875,989, CANC. MULTIPLE CLASS, INT. CLS. 9 AND  
28.
- SONY KABUSHIKI KAISHA, TOKYO, JAPAN, TA SONY  
CORPORATION:  
3,953,001, PUB. 2-15-2011. MULTIPLE CLASS, INT. CLS.  
9, 28, 38 AND 42.
- SOQUE RIVER ENTERPRISE, LLC, CLARKSVILLE, GA:  
3,956,028, INT. CL. 33.
- SORBO PRODUCTS INC., PALM DESERT, CA:  
2,473,450. REN. 3-30-11. INT. CL. 21.
- SOREL, JAMES P, PROVIDENCE, RI:  
3,954,446, PUB. 2-15-2011. INT. CL. 41.
- SORIN GROUP USA, INC., ARVADA, CO:  
2,441,524. REN. 3-29-11. INT. CL. 10.
- SOUL WATER MUSIC, LLC, GAINESVILLE, GA:  
3,954,659, PUB. 2-15-2011. INT. CL. 9.
- SOUNDFOREST, INC., NASHVILLE, TN:  
3,955,143, PUB. 2-15-2011. INT. CL. 44.
- SOURCE INTERLINK MAGAZINES, LLC, EL SEGUNDO,  
CA:  
3,955,064, PUB. 2-15-2011. INT. CL. 16.  
3,955,065, PUB. 2-15-2011. INT. CL. 41.
- SOUTH BAY TRADING INC., ONTARIO, CA:  
3,956,217, INT. CL. 9.
- SOUTHARD, JAMES L., BLYTHEVILLE, AR, DBA SOUTH-  
ARD'S RENTALS:  
3,954,576, PUB. 2-15-2011. INT. CL. 8.
- SOUTHCORP WINES PTY LTD., ARTARMON NSW, AUS-  
TRALIA:  
2,877,070, CANC. INT. CL. 33.
- SOUTHERN CHINESE NEWSPAPERS PUBLISHING COM-  
PANY, HOUSTON, TX:  
2,513,888. REN. 3-29-11. INT. CL. 16.
- SOUTHERN FOLGER DETENTION EQUIPMENT COM-  
PANY, LLC, SAN ANTONIO, TX:  
1,640,202. REN. 3-31-11. INT. CL. 6.
- SOUTHERN PARADISE, INC., MATTHEWS, NC:  
3,953,315, PUB. 2-15-2011. INT. CL. 41.
- SOUTHERN UNION COMPANY, AUSTIN, TX:  
2,106,652, CANC. INT. CL. 39.
- SOUTHWEST AIRLINES CO., DALLAS, TX:  
3,953,061, PUB. 2-15-2011. INT. CL. 43.
- SOUTHWEST ENVIROTECH PARTNERS LLC, JONES-  
TOWN, TX, FORMERLY SOUTHWEST ENVIROTECH  
PARTNERS LP:  
3,953,847, PUB. 2-15-2011. INT. CL. 1.
- SOUTHWEST RESEARCH INSTITUTE, SAN ANTONIO, TX:  
2,437,684. REN. 3-26-11. INT. CL. 9.
- SOUTHWEST SILICON, INC., PHOENIX, AZ:  
2,436,517. REN. 3-29-11. MULTIPLE CLASS, INT. CLS. 1  
AND 9.
- SOUTIEN INTERNATIONAL DE LA LUNETTERIE ET DU  
MATERIEL POUR OPTICIENS, 01103 OYONNAX CE-  
DEX, FRANCE:  
2,875,988, CANC. MULTIPLE CLASS, INT. CLS. 35 AND  
41.
- SOVENA PORTUGAL - CONSUMER GOODS, S.A., PORTU-  
GAL:  
3,953,662, PUB. 2-15-2011. INT. CL. 16.
- SOY BASICS, LLC, NEW HAMPTON, IA:  
3,955,862, INT. CL. 11.
- SPACE CENTER, INC., ST. PAUL, MN:  
919,544. REN. 3-26-11. U.S. CL. 100 (INT. CL. 42).
- SPANX, INC., ATLANTA, GA:  
2,464,430. REN. 3-26-11. INT. CL. 25.
- SPARC INTERNATIONAL, INC., CAMPBELL, CA:  
1,664,103. REN. 3-28-11. INT. CL. 16.
- SPARK CONSULT GMBH, FED REP GERMANY:  
3,953,488, PUB. 2-15-2011. MULTIPLE CLASS, INT. CLS.  
9, 38 AND 42.
- SPARTACUS MEDIA ENTERPRISES, LLC, WELLESLEY  
HILLS, MA:  
2,500,255. REN. 3-29-11. INT. CL. 35.
- SPARTAN MEDIA CORP., PARAMUS, NJ:  
1,639,741. REN. 3-29-11. INT. CL. 16.
- SPARTANBURG REGIONAL HEALTH SERVICES DIS-  
TRICT, INC., SPARTANBURG, SC:  
2,876,987, CANC. INT. CL. 44.
- SPC RESOURCES, INC., HARTSVILLE, SC:  
3,954,325, PUB. 2-15-2011. INT. CL. 19.  
3,954,752, PUB. 2-15-2011. INT. CL. 19.
- SPEAK WITH A GEEK, SAN DIEGO, CA:  
2,877,065, CANC. INT. CL. 42.
- SPECIALITY DRINKS LIMITED, UNITED KINGDOM:  
3,953,548, PUB. 2-15-2011. INT. CL. 33.
- SPECIALTY BRANDS OF AMERICA, INC., NEW YORK,  
NY:  
3,954,664, PUB. 2-15-2011. INT. CL. 30.
- SPECTRUM LABORATORIES, INC., RANCHO DOMIN-  
GUEZ, CA:  
1,152,225. REN. 3-31-11. INT. CL. 9.
- SPECTRUM PET CARE, INC., MONTGOMERY CITY, MO:  
3,955,916, INT. CL. 31.  
3,955,917, INT. CL. 31.
- SPEED RACER ENTERPRISES, INC., SANTA MONICA, CA:  
2,876,964, CANC. INT. CL. 41.
- SPEEDBALL ART PRODUCTS CO., L.L.C., STATESVILLE,  
NC:  
1,640,928. REN. 3-26-11. INT. CL. 16.
- SPEEDWAY PROPERTIES COMPANY, LLC, LAS VEGAS,  
NV:  
2,512,400. REN. 3-25-11. INT. CL. 41.
- SPEEDY SHARP, INC, MERIDIAN, ID:  
1,640,257. REN. 3-30-11. INT. CL. 8.
- SPELLING ENTERTAINMENT LLC, STUDIO CITY, CA:  
2,379,946, CANC. INT. CL. 41.
- SPERO, CLYDE M., ARVADA, CO, DBA SPERO WINERY:  
2,876,440, CANC. INT. CL. 33.
- SPEVCO INC., WINSTON-SALEM, NC:  
2,519,375. REN. 3-26-11. MULTIPLE CLASS, INT. CLS. 35,  
40 AND 42.
- SPI BRANDS, LLC, NORTHFORD, CT:  
2,876,581, CANC. MULTIPLE CLASS, INT. CLS. 1 AND  
37.
- SPIN MASTER LTD., TORONTO, ONTARIO, CANADA:  
3,953,003, PUB. 2-15-2011. MULTIPLE CLASS, INT. CLS.  
16, 28 AND 35.
- SPIN MASTER LTD., TORONTO ONTARIO, CANADA:  
3,953,019, PUB. 11-9-2010. INT. CL. 28.

- SPIN MASTER LTD., TORONTO, ONTARIO, CANADA:  
3,956,107, INT. CL. 28.
- SPINNER INDUSTRY, CO. LTD., TAICHUNG, TAIWAN:  
3,008,605, COR. INT. CL. 12.
- SPM MARKETING, INC., SAN JUAN CAPISTRANO, CA:  
3,954,722, PUB. 2-15-2011. INT. CL. 41.
- SPOKANE PRODUCE, INC., SPOKANE, WA:  
3,955,607, MULTIPLE CLASS, INT. CLS. 29, 30 AND 31.
- SPONSUME.COM LIMITED, LONDON, UNITED KINGDOM:  
3,953,311, PUB. 2-15-2011. MULTIPLE CLASS, INT. CLS. 35, 38 AND 42.
- SPORTCRAFT, LTD., MT. OLIVE, NJ:  
2,877,625, CANC. INT. CL. 28.
- SPORTS & ENTERTAINMENT MATTERS, INC., BOSTON, MA:  
2,877,959, CANC. MULTIPLE CLASS, INT. CLS. 35 AND 41.
- SPORTS CONNECTION INTERNATIONAL LLC, MIAMI, FL:  
3,955,970, INT. CL. 28.
- SPORTS COVERAGE, INC., DALLAS, TX:  
3,954,130, PUB. 2-15-2011. INT. CL. 24.
- SPORTSBLOGS, INC., WASHINGTON, DC, AKA SB NATION:  
3,953,293, PUB. 2-15-2011. INT. CL. 41.
- SPORTSMAN'S XTREME OUTDOORS PARTNERSHIP, MARTIN, TN:  
2,878,029, CANC. INT. CL. 41.
- SPORTSPLEX MANAGEMENT GROUP, LLC, YORK, ME:  
2,876,843, CANC. INT. CL. 41.
- SPOTLIGHT PTY LTD, AUSTRALIA:  
3,953,487, PUB. 2-15-2011. MULTIPLE CLASS, INT. CLS. 36, 37, 41 AND 42.
- SPPC PARIS BLEU, SAS, 75017 PARIS, FRANCE:  
3,952,955, PUB. 4-24-2007. INT. CL. 3.
- SPRINGBOARDS TO EDUCATION, INC., EDINBURG, TX:  
3,955,345, MULTIPLE CLASS, INT. CLS. 16 AND 41.
- SPRINGER-RUSSELL, COLUMBUS, OH:  
2,379,300, CANC. INT. CL. 14.
- SPRINGFIELD PAINTBALL, INC., SPRINGFIELD, MO:  
2,379,583, CANC. INT. CL. 28.
- SPRINKFLEX, LLC, BOSTON, MA:  
3,953,163, PUB. 2-15-2011. MULTIPLE CLASS, INT. CLS. 6 AND 9.
- SPRINT COMMUNICATIONS COMPANY L.P., OVERLAND PARK, KS:  
2,876,284, CANC. INT. CL. 38.
- SPRINT DIRECTORY TRADEMARK COMPANY, LLC, OVERLAND PARK, KS:  
2,877,095, CANC. INT. CL. 35.
- SPTC, INC., RENO, NV:  
1,638,329, REN. 3-31-11. MULTIPLE CLASS, INT. CLS. 16, 25, 35, 36, 39, 41 AND 42.  
1,638,329, CANC. INT. CL. 37.
- SQUARE GROVE, LLC, AUSTIN, TX:  
3,953,374, PUB. 2-15-2011. INT. CL. 35.
- SQUEAKY DOOR PRODUCTIONS, INC., OAKHURST, NJ:  
2,505,869, REN. 3-26-11. MULTIPLE CLASS, INT. CLS. 37 AND 42.
- SRS LABS, INC., SANTA ANA, CA:  
1,617,359, REN. 3-31-11. INT. CL. 9.
- SRS REAL ESTATE PARTNERS, LLC, DALLAS, TX:  
3,954,863, PUB. 2-15-2011. INT. CL. 36.  
3,954,865, PUB. 2-15-2011. INT. CL. 36.
- SS KS LLC, NEW YORK, NY, DBA SUNSHINE, SACHS & ASSOCIATES:  
3,954,452, PUB. 2-15-2011. INT. CL. 35.
- SSA CONTAINERS, INC., SEATTLE, WA:  
2,877,821, CANC. INT. CL. 39.
- SSC GROUP, LLC, NORTH HILLS, CA:  
3,954,619, PUB. 2-15-2011. INT. CL. 41.
- SSD COMPANY LIMITED, KUSATSU-CITY, SHIGA,, JAPAN:  
2,475,182, REN. 3-25-11. INT. CL. 9.
- ST. FRANCIS WINERY AND VINEYARDS, L.P., NAPA, CA:  
3,955,090, PUB. 2-15-2011. INT. CL. 33.
- ST. LOUIS SCIENCE CENTER, ST. LOUIS, MO:  
3,955,415, INT. CL. 41.
- ST. LUKE'S REGIONAL MEDICAL CENTER, LTD., BOISE, ID, AKA ST. LUKE'S:  
3,954,881, PUB. 2-15-2011. INT. CL. 41.
- STAGECOACH VINEYARDS LIMITED PARTNERSHIP, NAPA, CA:  
2,537,958, REN. 3-28-11. INT. CL. 31.
- STAGING CONCEPTS, INC., BROOKLYN PARK, MN:  
1,639,763, REN. 3-31-11. INT. CL. 19.
- STAHL SAC, INC., WEAVERVILLE, NC:  
2,378,473, CANC. MULTIPLE CLASS, INT. CLS. 18 AND 28.
- STALLEX SKIN CARE, INC., TENAFLY, NJ:  
2,439,152, REN. 3-28-11. MULTIPLE CLASS, INT. CLS. 3 AND 5.
- STAMATS MEETINGS MEDIA, INC., CEDAR RAPIDS, IA:  
3,954,258, PUB. 2-15-2011. INT. CL. 16.
- STAMETS, PAUL, OLYMPIA, WA, DBA FUNGI PERFECTI:  
2,542,894, REN. 3-29-11. INT. CL. 5.
- STANDARD MOTOR PRODUCTS, INC., LONG ISLAND CITY, NY:  
2,379,681, CANC. INT. CL. 42.
- STANDARD SOLAR, INC., GAITHERSBURG, MD:  
3,953,201, PUB. 2-15-2011. INT. CL. 37.
- STANDING WAVE SOFTWARE, INC., SCOTTSDALE, AZ:  
2,444,384, REN. 3-29-11. INT. CL. 9.
- STANT USA CORP., CONNERSVILLE, IN, STANT INC., CONNERSVILLE, IN:  
1,638,304, REN. 3-29-11. INT. CL. 12.
- STAR CHILD DESIGN INC., TORONTO, ONTARIO, CANADA:  
3,953,000, PUB. 1-15-2008. MULTIPLE CLASS, INT. CLS. 3, 5, 9, 10, 14, 16, 18, 20, 21, 24, 25, 28, 30 AND 32.
- STAR LABS/FORAGE RESEARCH, INC., CLARKSDALE, MO:  
1,149,572, REN. 3-31-11. INT. CL. 5.
- STAR LAW NETWORK, LLC, RIDGELAND, MS:  
3,955,753, INT. CL. 45.  
3,955,754, INT. CL. 45.
- STAR SALES & DISTRIBUTING CORP., WOBURN, MA:  
2,457,176, REN. 3-26-11. INT. CL. 6.
- STAR VECTOR CORPORATION, BEDFORD, NH:  
3,953,206, PUB. 10-12-2010. INT. CL. 13.
- STARCRAFT MARK HOLDING COMPANY, LLC, GOSHEN, IN:  
3,955,302, INT. CL. 12.
- STARGATE MOBILE, INC., HOLLYWOOD, FL:  
3,954,734, PUB. 2-15-2011. MULTIPLE CLASS, INT. CLS. 9 AND 38.
- STARGAZER GROUP, LLC, FAIRFAX, VA:  
2,877,659, CANC. INT. CL. 42.
- STARK, PHILIP WALL, DALTON, PA:  
2,876,539, CANC. INT. CL. 6.
- STARKIST CO., PITTSBURGH, PA:  
3,955,725, INT. CL. 29.
- STASSEN INSURANCE AGENCY, INC, WOODSTOCK, IL:  
3,954,793, PUB. 2-15-2011. INT. CL. 36.
- STATE STREET CORPORATION, BOSTON, MA:  
2,447,981, REN. 3-28-11. INT. CL. 36.
- STATOILHYDRO ASA, STAVANGER, NORWAY:  
3,953,083, PUB. 2-15-2011. MULTIPLE CLASS, INT. CLS. 1, 3, 4, 7, 9, 11, 17, 29, 30, 31, 35, 36, 37, 39, 40, 41, 42 AND 43.
- STATSPIN, INC., NORWOOD, MA:  
1,655,480, REN. 3-26-11. INT. CL. 10.
- STATSPIN, INC., WESTWOOD, MA, DBA IRIS SAMPLE PROCESSING, NORFOLK SCIENTIFIC, INC., NORWOOD, MA, DBA STATSPIN TECHNOLOGIES:  
1,656,162, REN. 3-31-11. INT. CL. 10.
- STEC INC., MINAMI-KU, KYOTO, JAPAN:  
1,638,908, REN. 3-29-11. MULTIPLE CLASS, INT. CLS. 9 AND 11.
- STEEL AND PIPE SUPPLY COMPANY, INC., MANHATTAN, KS:  
1,967,755, COR. INT. CL. 6.
- STEEL PROJECTS, VIENNE, 38200, FRANCE:  
3,953,824, PUB. 2-15-2011. MULTIPLE CLASS, INT. CLS. 9

- AND 42.  
 STELO ENTERPRISES, INC., CARLISLE, PA:  
 3,955,627, INT. CL. 35.  
 STEM CELL SCIENCES HOLDINGS LIMITED, EDINBURGH, LOTHIAN, UNITED KINGDOM:  
 3,955,422, MULTIPLE CLASS, INT. CLS. 1 AND 5.  
 STENOGRAPH, L.L.C., ELMHURST, IL:  
 3,954,268, PUB. 2-15-2011. INT. CL. 16.  
 STEP SOLUTIONS GROUP, LLC, CHICAGO, IL:  
 2,380,153, CANC. INT. CL. 9.  
 STEP TECHNOLOGY, INC., PORTLAND, OR:  
 2,875,884, CANC. MULTIPLE CLASS, INT. CLS. 41 AND 42.  
 STEPHENS, ALEJANDRO, LOS ANGELES, CA:  
 3,954,393, PUB. 2-15-2011. INT. CL. 36.  
 STEREN BRANDS, S. DE R.L. DE C.V., COL. OBRERO POPULAR CALZ. MEXICO CITY, MEXICO:  
 3,955,250, MULTIPLE CLASS, INT. CLS. 35 AND 36.  
 STERLING NATIONAL BANK, NEW YORK, NY:  
 3,873,890, COR. INT. CL. 36.  
 STEWART & BROWN, LLC, KENEDY, TX:  
 3,956,087, INT. CL. 29.  
 STICHTING INTERNATIONAL INSTITUTE FOR; COMMUNICATION AND DEVELOPMENT, NETHERLANDS:  
 3,953,530, PUB. 2-15-2011. MULTIPLE CLASS, INT. CLS. 36, 41 AND 42.  
 3,953,531, PUB. 2-15-2011. MULTIPLE CLASS, INT. CLS. 9, 41 AND 42.  
 STILLWATER NATIONAL BANK AND TRUST COMPANY, STILLWATER, OK:  
 2,438,882, REN. 3-29-11. INT. CL. 36.  
 STOKES PUBLISHING COMPANY, INC., SUNNYVALE, CA:  
 2,425,615, REN. 3-31-11. INT. CL. 28.  
 2,425,616, REN. 3-30-11. INT. CL. 28.  
 STOLLE MACHINERY COMPANY, LLC, ENGLEWOOD, CO:  
 912,948, REN. 3-29-11. U.S. CL. 23 (INT. CL. 7).  
 STONE, JEREMIAH, SHERMAN, TX:  
 3,954,833, PUB. 2-15-2011. INT. CL. 25.  
 STONEAGE, INC., DURANGO, CO:  
 2,379,162, CANC. INT. CL. 7.  
 STONER INCORPORATED, QUARRYVILLE, PA:  
 2,505,052, REN. 3-26-11. INT. CL. 3.  
 2,525,608, REN. 3-30-11. INT. CL. 3.  
 STONERIVER, INC., BROOKFIELD, WI:  
 3,955,424, MULTIPLE CLASS, INT. CLS. 9, 36 AND 42.  
 STONEWALL KITCHEN, LLC, YORK, ME:  
 3,954,230, PUB. 2-15-2011. MULTIPLE CLASS, INT. CLS. 30 AND 32.  
 STORCASE TECHNOLOGY, INC., FOUNTAIN VALLEY, CA:  
 2,876,564, CANC. INT. CL. 9.  
 STORM INVESTMENTS, LLC, TOMS RIVER, NJ:  
 3,955,012, PUB. 2-15-2011. INT. CL. 37.  
 STORM MANUFACTURING GROUP, INC., TORRANCE, CA:  
 2,438,174, REN. 3-26-11. MULTIPLE CLASS, INT. CLS. 11 AND 21.  
 STORY GLEN, INC., IRVING, TX:  
 3,952,992, PUB. 2-15-2011. INT. CL. 43.  
 STOTELMYER, SCOTT, REDONDO BEACH, CA:  
 3,956,029, MULTIPLE CLASS, INT. CLS. 35 AND 39.  
 STRADLEY, ROBERT C., WICHITA FALLS, TX:  
 3,953,224, PUB. 2-15-2011. INT. CL. 16.  
 STRAKSSTRAK B.V., NETHERLANDS:  
 3,953,547, PUB. 2-15-2011. INT. CL. 28.  
 STRATA SYSTEMS, INC., CUMMING, GA:  
 2,876,888, CANC. INT. CL. 6.  
 STRATASYS, INC., EDEN PRAIRIE, MN:  
 2,966,140, CANC. INT. CL. 9.  
 STRATEGIC LAW PARTNERS, LOS ANGELES, CA:  
 2,220,508, CANC. INT. CL. 42.  
 STRATEGIC LEADERSHIP RESOURCES, LLC, PENNINGTON, NJ, AKA SLR:  
 3,954,885, PUB. 2-15-2011. INT. CL. 41.  
 STRATIFY, INC., MOUNTAIN VIEW, CA TO STRATIFY, INC., MOUNTAIN VIEW, CA:  
 2,877,831, CANC. MULTIPLE CLASS, INT. CLS. 35 AND 42.  
 STRAUBWERKE AG, SWITZERLAND:  
 3,953,529, PUB. 2-15-2011. MULTIPLE CLASS, INT. CLS. 6, 7 AND 17.  
 STRAUSS BRANDS INCORPORATED, HALES CORNERS, WI:  
 1,672,699, REN. 3-31-11. INT. CL. 29.  
 STRAUSS FRÉDÉRIC, FRANCE:  
 3,953,494, PUB. 2-15-2011. MULTIPLE CLASS, INT. CLS. 16 AND 25.  
 STREHLER, GABRIELA, EL CAJON, CA:  
 2,877,628, CANC. INT. CL. 10.  
 STRIDE TOOL INC., ELLICOTTVILLE, NY:  
 3,954,042, PUB. 2-15-2011. INT. CL. 40.  
 STRUTZ, INC., ENGLEWOOD CLIFFS, NJ:  
 3,953,694, PUB. 2-15-2011. MULTIPLE CLASS, INT. CLS. 3 AND 10.  
 STRYKER CORPORATION, KALAMAZOO, MI:  
 2,544,605, REN. 3-29-11. INT. CL. 20.  
 STUDENT LOAN FUNDING RESOURCES, INC., CINCINNATI, OH:  
 2,476,816, CANC. INT. CL. 36.  
 STUDIO DISTRIBUTION, INC., NEW YORK, NY:  
 2,876,289, CANC. INT. CL. 35.  
 STUDIO FOR PUBLICATIONS, INC., BERLIN, MD:  
 2,378,525, CANC. MULTIPLE CLASS, INT. CLS. 38 AND 41.  
 STURGIS MOTORCYCLE RALLY, INC., STURGIS, SD:  
 3,955,170, MULTIPLE CLASS, INT. CLS. 6, 9, 13, 14, 16, 20, 21, 24, 25, 26, 28, 32, 33, 34, 35 AND 41.  
 STUSSY, INC., IRVINE, CA:  
 3,954,271, PUB. 2-15-2011. INT. CL. 25.  
 STW TECHNIC, LP, NORCROSS, GA:  
 3,953,692, PUB. 2-15-2011. MULTIPLE CLASS, INT. CLS. 7 AND 9.  
 STYLE CREST ENTERPRISES, INC., FREMONT, OH:  
 3,956,167, INT. CL. 11.  
 STYLEMARK, INC., ORMOND BEACH, FL:  
 2,450,147, REN. 3-25-11. INT. CL. 9.  
 SUCCESS ONLINE, INC., SINGER ISLAND, FL:  
 2,876,270, CANC. INT. CL. 41.  
 SUFACINE DEVELOPMENT COMPANY, L.L.C., TYNGSBOROUGH, MA, SUFACINE CONSUMER PRODUCTS, L.L.C., ST. LOUIS, MO:  
 2,438,763, REN. 3-26-11. INT. CL. 1.  
 SUMITOMO ELECTRIC INDUSTRIES, LTD., OSAKA-SHI, OSAKA, JAPAN:  
 3,953,160, PUB. 2-15-2011. INT. CL. 9.  
 SUMMIT ACADEMY OIC, MINNEAPOLIS, MN:  
 2,459,029, REN. 3-29-11. INT. CL. 41.  
 2,470,887, REN. 3-29-11. INT. CL. 41.  
 SUMMIT ENTERTAINMENT, LLC, SANTA MONICA, CA:  
 3,955,298, INT. CL. 3.  
 3,955,865, INT. CL. 16.  
 3,955,866, INT. CL. 16.  
 SUMMIT IMPORT CORPORATION, JERSEY CITY, NJ:  
 2,876,878, CANC. MULTIPLE CLASS, INT. CLS. 29 AND 30.  
 SUMMIT TECHNOLOGIC, INC., COLORADO SPRINGS, CO:  
 3,954,336, PUB. 2-15-2011. INT. CL. 42.  
 SUMX INC., NATCHEZ, MS TO SUMX INC., NATCHEZ, MS:  
 2,378,654, CANC. INT. CL. 36.  
 SUN ABRASIVES CO., LTD., ANSAN-CITY, KYONGGI-DO, REPUBLIC OF KOREA:  
 2,378,808, CANC. INT. CL. 3.  
 2,378,809, CANC. INT. CL. 3.  
 2,378,810, CANC. INT. CL. 3.  
 2,378,811, CANC. INT. CL. 3.  
 SUN AUTOMATION INC., SPARKS, MD, SAMUEL M. LANGSTON COMPANY, CAMDEN, NJ:  
 723,074, REN. 3-26-11. U.S. CL. 23 (INT. CL. 7).  
 SUN DRILLING PRODUCTS CORPORATION, BELLE CHASSE, LA:  
 3,954,345, PUB. 2-15-2011. INT. CL. 1.  
 SUN DRUG VILLAGE SQUARE, LTD., JOHNSTON, IA:  
 3,953,902, PUB. 1-11-2011. INT. CL. 44.

- SUN INDUSTRIES, INC., RAYTOWN, MO:  
3,955,388, INT. CL. 5.
- SUN PRODUCTS CORPORATION, THE, WILTON, CT:  
3,955,173, INT. CL. 3.
- SUN, PAMELA J, SAN JOSE, CA:  
2,378,801, CANC. INT. CL. 35.
- SUNBEAM PRODUCTS, INC., BOCA RATON, FL, JOHN  
OSTER MANUFACTURING CO., RACINE, WI:  
515,517. REN. 3-25-11. U.S. CL. 23 (INT. CLS. 6, 7, 8, 9, 11,  
12, 16, 21 AND 28).
- SUNBEAM PRODUCTS, INC., BOCA RATON, FL:  
2,877,986, CANC. INT. CL. 11.  
2,877,987, CANC. INT. CL. 11.
- SUNCOR ENERGY INC., CALGARY, ALBERTA, CANADA:  
2,436,088. REN. 3-29-11. MULTIPLE CLASS, INT. CLS. 35,  
37, 39, 40 AND 42.  
2,444,092. REN. 3-28-11. INT. CL. 4.
- SUNMEDICA, INC., REDDING, CA:  
3,953,273, PUB. 2-15-2011. INT. CL. 10.
- SUNNY SKY PRODUCTS NORTH AMERICA, LTD., HOUS-  
TON, TX:  
2,876,329, CANC. INT. CL. 32.
- SUNNYBROOK AND WOMEN'S COLLEGE HEALTH  
SCIENCES CENTRE, TORONTO, ONTARIO M4N 3M5,  
CANADA:  
2,875,960, CANC. INT. CL. 25.
- SUNNYMOON INC., MAPLE, CANADA:  
3,953,478, PUB. 1-4-2011. INT. CL. 30.
- SUNNYVALE HOLDINGS, LP, SAN FRANCISCO, CA:  
2,528,623. REN. 3-25-11. INT. CL. 42.
- SUNSTAR INC., OSAKA, JAPAN:  
1,997,271, CANC. INT. CL. 21.
- SUNTERRA FOOD CORPORATION, ACME, AB T0M 0A0,  
CANADA:  
3,953,142, PUB. 2-15-2011. MULTIPLE CLASS, INT. CLS.  
35, 39, 43 AND 44.  
3,953,143, PUB. 2-15-2011. MULTIPLE CLASS, INT. CLS.  
35, 39, 43 AND 44.
- SUNTRUST BANKS, INC., ORLANDO, FL:  
2,378,321, CANC. INT. CL. 36.
- SUNWEST DISTRIBUTION, INC., LAS VEGAS, NV:  
2,876,578, CANC. INT. CL. 21.
- SUNWEST FOODS, INC., DAVIS, CA:  
1,639,903. REN. 3-26-11. INT. CL. 30.
- SUPER BAKERY INC, PITTSBURGH, PA:  
3,956,224, INT. CL. 30.
- SUPER BAKERY INC., PITTSBURGH, PA:  
3,955,535, INT. CL. 32.
- SUPER BAKERY, INCORPORATED, PITTSBURGH, PA:  
3,955,472, INT. CL. 32.  
3,955,473, INT. CL. 32.
- SUPER DUPER INC., GREENVILLE, SC, DBA SUPER  
DUPER PUBLICATIONS:  
3,954,202, PUB. 2-15-2011. INT. CL. 28.
- SUPER YACHT BUILDERS ASSOCIATION, MC-98000 MON-  
ACO, MONACO:  
3,955,568, MULTIPLE CLASS, INT. CLS. 35, 41 AND 42.
- SUPERIOR SELF STORAGE, ROSEVILLE, CA:  
2,471,166. REN. 3-29-11. INT. CL. 39.
- SUPERNEWS, INC., AUSTIN, TX:  
3,953,433, PUB. 2-15-2011. INT. CL. 38.  
3,953,434, PUB. 2-15-2011. INT. CL. 42.
- SUPRAMEDICAL, LLC, DORAL, FL:  
3,954,394, PUB. 2-15-2011. INT. CL. 10.  
3,954,398, PUB. 2-15-2011. INT. CL. 10.
- SUQI, IYAD, GLENVIEW, IL:  
2,876,219, CANC. INT. CL. 43.
- SUREFIRE, LLC, FOUNTAIN VALLEY, CA:  
3,955,079, PUB. 2-15-2011. INT. CL. 11.
- SURFACE LOGIX, INC., BRIGHTON, MA:  
2,877,803, CANC. MULTIPLE CLASS, INT. CLS. 40 AND  
42.
- SURGI-VISION, INC., COLUMBIA, MD:  
2,847,137, CANC. INT. CL. 10.
- SURGIVISION, INC., MEMPHIS, TN:  
3,811,600, CANC. INT. CL. 10.
- SURLY GIRL STUDIOS, INC., SAN FRANCISCO, CA:  
2,876,513, CANC. INT. CL. 18.
- SURRY COUNTY ECONOMIC DEVELOPMENT AND  
TOURISM, DOBSON, NC:  
3,955,912, INT. CL. 35.
- SUSAN, KIWAN, OTTAWA, ONTARIO, CANADA:  
3,955,857, INT. CL. 25.
- SUSTAINABLE PROPERTIES, CARRBORO, NC:  
3,955,718, INT. CL. 37.
- SUZANNE BESSE, BOCA RATON, FL:  
3,956,172, INT. CL. 9.
- SUZUKI MOTOR CORPORATION, HAMAMATSU-SHI,SHI-  
ZUOKA, JAPAN, SUZUKI JIDOSHA KOGYO KABUSHIKI  
KAISHA (SUZUKI MOTOR CO., LTD.), SHIZUOKA-KEN,  
JAPAN:  
1,645,121. REN. 3-31-11. INT. CL. 12.
- SVENHARD'S SWEDISH BAKERY CORPORATION, EXE-  
TER, CA:  
3,954,101, PUB. 2-15-2011. INT. CL. 30.
- SVYATOSLAV MOROZOV, AUSTRALIA:  
3,953,641, PUB. 2-15-2011. MULTIPLE CLASS, INT. CLS.  
25 AND 39.
- SWAN INDUSTRIES, INC., ODESSA, TX TO INFINITE  
TECHNOLOGIES, INC., ODESSA, TX:  
1,909,662, CANC. INT. CL. 3.
- SWC GRAPHICS, INC., PHOENIX, AZ:  
3,044,587, COR. MULTIPLE CLASS, INT. CLS. 40 AND  
42.
- SWEET AND VICIOUS LLC, LAKE WORTH, FL:  
3,953,870, PUB. 2-15-2011. INT. CL. 25.
- SWEET CECE'S FRANCHISING, LLC, FRANKLIN, TN:  
3,954,955, PUB. 2-15-2011. INT. CL. 43.
- SWEET VALOR LLC, ENGLEWOOD, CO:  
3,954,944, PUB. 2-15-2011. INT. CL. 30.
- SWEETS OF OMAN SAOG, SULTANATE OF OMAN,  
OMAN:  
3,953,815, PUB. 2-15-2011. INT. CL. 30.  
3,953,816, PUB. 2-15-2011. INT. CL. 30.
- SWIFT DISTRIBUTION, INC., TORRENCE, CA, DBA ULTI-  
MATE SUPPORT SYSTEMS, INC.:  
1,639,035. REN. 3-29-11. INT. CL. 15.
- SWIMC, INC., NEWARK, DE:  
2,529,957. REN. 3-28-11. INT. CL. 2.  
3,954,588, PUB. 2-15-2011. INT. CL. 2.
- SWIMTASTIC SWIM SCHOOL, INC., WAUKESHA, WI:  
3,954,761, PUB. 2-15-2011. INT. CL. 41.
- SWISS MASAI AG, ROGGWIL, SWITZERLAND:  
2,441,567. REN. 3-29-11. INT. CL. 25.
- SWISSLOG AG, SWITZERLAND:  
3,953,569, PUB. 2-15-2011. MULTIPLE CLASS, INT. CLS.  
6, 7, 9, 12, 20, 35, 37, 39, 41 AND 42.  
3,953,570, PUB. 2-15-2011. MULTIPLE CLASS, INT. CLS.  
6, 7, 9, 12, 20, 35, 37, 39, 41 AND 42.
- SWYPE, INC., SEATTLE, WA:  
3,672,251, AM. INT. CL. 9.
- SYAQUA LIMITED, OXON, UNITED KINGDOM:  
2,876,998, CANC. INT. CL. 31.
- SYKES, WENDELL G., CARLISLE, MA:  
2,515,540. REN. 3-29-11. INT. CL. 42.
- SYMRISE AG, HOLZMINDEN 37603, FED REP GERMANY:  
1,643,249. REN. 3-31-11. INT. CL. 1.  
1,644,192. REN. 3-31-11. INT. CL. 3.  
1,646,569. REN. 3-31-11. INT. CL. 3.
- SYNARC, INC., SAN FRANCISCO, CA, SYNARC, INC., SAN  
FRANCISCO, CA:  
2,491,153. REN. 3-28-11. INT. CL. 42.
- SYNERGY CAPITAL, LLC, TUCSON, AZ:  
2,876,786, CANC. INT. CL. 33.
- SYNGENTA PARTICIPATIONS AG, BASEL, SWITZER-  
LAND:  
2,554,134. REN. 3-29-11. INT. CL. 1.
- SYNTUITY LLC, FOXFIELD, CO, DBA SYNTUITY:  
3,954,470, PUB. 2-15-2011. INT. CL. 35.
- SYSMEX CORPORATION, KOBE, HYOGO, JAPAN:  
3,953,292, PUB. 2-15-2011. INT. CL. 10.
- SYSTEM 3R SCHWEIZ AG, FLAWIL, SWITZERLAND:  
2,451,241. REN. 3-31-11. INT. CL. 7.
- SYSTEM-POOL, S.A., SPAIN:  
3,953,623, PUB. 2-15-2011. MULTIPLE CLASS, INT. CLS.  
11 AND 19.



SYSTEMS-DRIVEN, INC., WINDERMERE, FL:  
2,876,196, CANC. MULTIPLE CLASS, INT. CLS. 16 AND 41.

SYSTRONIX, INC., SALT LAKE CITY, UT:  
2,378,720, CANC. MULTIPLE CLASS, INT. CLS. 40 AND 42.

SYX SERVICES INC., PORT WASHINGTON, NY:  
3,956,191, INT. CL. 35.

T. COPELAND AND SONS, INC., BRADFORD, VT:  
3,953,690, PUB. 2-15-2011. INT. CL. 20.

T. MARZETTI COMPANY, COLUMBUS, OH:  
1,168,584, REN. 3-26-11. INT. CL. 29.

T. THAI SNACK FOODS CO., LTD., SATHORN, BANGKOK 10120, THAILAND:  
2,876,642, CANC. INT. CL. 29.

T.C. DUNHAM PAINT CO., INC., YONKERS, NY:  
2,405,326, REN. 3-31-11. MULTIPLE CLASS, INT. CLS. 2 AND 17.

T.C. INTERNATIONAL, INC., WHITTIER, CA:  
1,923,297 NEW CERT. 5-3-2011. INT. CL. 7.

T-MOBILE USA, INC., BELLEVUE, WA:  
3,955,113, PUB. 2-15-2011. INT. CL. 16.

TACCONI, FREDRIC ROCCO, NEWPORT BEACH, CA:  
3,952,984, PUB. 2-15-2011. INT. CL. 9.

TACO, INC., CRANSTON, RI:  
2,485,816, REN. 3-25-11. INT. CL. 11.

TACONY CORPORATION, FENTON, MO:  
2,379,413, CANC. INT. CL. 7.

TACTICIAN CORPORATION, ANDOVER, MA, TACTICS INTERNATIONAL LIMITED, ANDOVER, MA:  
1,650,625, REN. 3-31-11. INT. CL. 9.

TAE CHANG N.E.T. CO., LTD., REPUBLIC OF KOREA:  
3,953,549, PUB. 2-15-2011. INT. CL. 7.

TAE IL MEDIA CO., LTD., ANSAN, KYUNGGIDO, REPUBLIC OF KOREA:  
2,875,843, CANC. INT. CL. 9.

TAEGAR, FRANCIS L., MANGONIA PARK, FL:  
2,877,180, CANC. INT. CL. 19.

TAGINA CERAMICHE D'ARTE S.P.A., ITALY:  
3,953,508, PUB. 2-15-2011. INT. CL. 19.

TAIWAN NAN SHAN BAMBOO WARE CO., LTD., NANKING E. RD., TAIPEI, TAIWAN:  
2,379,961, CANC. INT. CL. 4.

TAIYO FASTENER CO., LTD., MUANG, SAMUTPRAKARN 10280, THAILAND:  
2,379,936, CANC. INT. CL. 6.

TAIZHOU J&F HEADWEAR CO., LTD., JIANGSU PROVINCE, CHINA:  
3,955,403, INT. CL. 25.

TAKARA BIO INC., OTSU CITY, SHIGA, JAPAN:  
3,955,435, INT. CL. 1.

TAKEN FLIGHT OUTDOORS, INC., CENTERTON, AR:  
3,954,739, PUB. 2-15-2011. INT. CL. 41.

TALESE, MATTHEW, COLUMBUS, OH:  
3,955,099, PUB. 2-15-2011. INT. CL. 25.

TALLIENCE LLC, DEERFIELD BEACH, FL:  
3,953,784, PUB. 2-15-2011. INT. CL. 35.

TANDUS US, LLC, DALTON, GA:  
2,435,377, REN. 3-26-11. INT. CL. 27.

TANNAS COMPANY, MIDLAND, MI:  
3,952,952, PUB. 12-12-2006. INT. CL. 9.

TARARA WINERY, LEESBURG, VA, DBA TARARA WINERY:  
3,953,338, PUB. 2-15-2011. INT. CL. 33.

TARGET BRANDS, INC., MINNEAPOLIS, MN:  
3,955,019, PUB. 2-15-2011. INT. CL. 35.  
3,955,863, MULTIPLE CLASS, INT. CLS. 20 AND 21.

TARGET SPORT CO., LTD., TAIPEI, TAIWAN:  
2,877,269, CANC. INT. CL. 28.

TARK, INC., NEWTON, NJ:  
2,387,212, CANC. INT. CL. 41.

TARKETT INC., FARNHAM PQ, CANADA:  
2,379,865, CANC. INT. CL. 27.

TARR, WILLIAM J., SHAMOKIN DAM, PA:  
2,461,433, CANC. INT. CL. 42.

TART OPTICAL ENTERPRISES LLC, CALABASAS, CA:  
3,954,887, PUB. 2-15-2011. INT. CL. 9.

TATEM, SEAN M., NORFOLK, VA, DBA AIVA DESIGN:  
2,877,198, CANC. INT. CL. 42.

TATEOSSIAN LTD, LONDON SW10 9EL, ENGLAND:  
2,437,825, REN. 3-29-11. MULTIPLE CLASS, INT. CLS. 6, 14, 18, 20 AND 25.  
2,437,825, CANC. MULTIPLE CLASS, INT. CLS. 3, 21 AND 24.

TAURUS INTERNATIONAL MANUFACTURING, INC., MIAMI, FL:  
2,437,652, REN. 3-25-11. INT. CL. 13.

TAYLOR PUBLISHING COMPANY, DALLAS, TX:  
3,955,569, INT. CL. 42.

TAYLOR, OMAR, ISLANDIA, NY:  
2,876,566, CANC. INT. CL. 9.

TB ACQUISITIONS, LLC, HULETT, WY:  
3,955,860, INT. CL. 25.

TB PROPRIETARY CORP., WILMINGTON, DE:  
2,452,694, REN. 3-29-11. MULTIPLE CLASS, INT. CLS. 37 AND 41.

TCF CO. LLC, CALABASAS, CA:  
2,393,314, REN. 3-30-11. INT. CL. 42.

TCHAD, CHICAGO, IL:  
3,954,226, PUB. 2-15-2011. INT. CL. 41.

TD AMERITRADE IP COMPANY, INC., OMAHA, NE:  
3,954,917, PUB. 2-15-2011. INT. CL. 35.

TEAM INDUSTRIES, INC., BAGLEY, MN:  
2,877,817, CANC. INT. CL. 12.

TEBO, BRADLEY L., TOPSFIELD, MA:  
2,877,913, CANC. INT. CL. 11.

TEC SOFTWARE, LLC, SUN PRAIRIE, WI:  
3,954,015, PUB. 2-15-2011. INT. CL. 42.  
3,954,016, PUB. 2-15-2011. INT. CL. 42.

TEC-SEM AG, CH-8274 TAGERWILEN, SWITZERLAND:  
2,386,706, REN. 3-31-11. MULTIPLE CLASS, INT. CLS. 7, 9, 37 AND 41.

TECH VEST, INC., COCOA BEACH, FL:  
2,531,626, REN. 3-26-11. MULTIPLE CLASS, INT. CLS. 35 AND 36.

TECHHEALTH, INC., TAMPA, FL:  
2,875,890, CANC. MULTIPLE CLASS, INT. CLS. 9 AND 36.

TECHNICAL FIBRE PRODUCTS LIMITED, CUMBRIA, LA9 6PZ, UNITED KINGDOM:  
2,401,216, REN. 3-29-11. INT. CL. 17.

TECHNOGYM S.P.A., I-47035 GAMBETTOLA (FORLI'-CESENA), ITALY:  
2,338,968, REN. 3-28-11. MULTIPLE CLASS, INT. CLS. 35 AND 41.

TECHNOLOGY ADVANCEMENT GROUP, INC., DULLES, VA:  
3,955,882, MULTIPLE CLASS, INT. CLS. 35, 41 AND 45.

TECHTRONIC FLOOR CARE TECHNOLOGY LIMITED, ROAD TOWN, TORTOLA, BR. VIRGIN ISLANDS:  
2,438,485, REN. 3-26-11. INT. CL. 7.

TEFAL S.A.:  
713,017, REN. 3-31-11. U.S. CL. 13 (INT. CL. 21).

TEG STAFFING, INC., SAN DIEGO, CA:  
1,641,496, REN. 3-26-11. MULTIPLE CLASS, INT. CLS. 35 AND 41.

TEJADA PRODUCTIONS, INC., SAN FRANCISCO, CA:  
2,877,835, CANC. MULTIPLE CLASS, INT. CLS. 16 AND 41.

TEK INDUSTRIES, INC., FREMONT, NE:  
3,955,431, INT. CL. 16.

TEKSING TOWARD TAKS, INC., GRAND PRAIRIE, TX:  
2,876,736, CANC. INT. CL. 16.

TELCO SYSTEMS, INC., FOXBORO, MA:  
2,379,847, CANC. INT. CL. 9.

TELEBRANDS CORP., FAIRFIELD, NJ:  
3,956,089, INT. CL. 18.

TELECOMMUNICATIONS ASSET MANAGEMENT COMPANY, TAMPA, FL:  
2,445,799, REN. 3-29-11. INT. CL. 36.

TELEDYNE TECHNOLOGIES INCORPORATED, THOUSAND OAKS, CA, TELEDYNE TECHNOLOGIES INCORPORATED, THOUSAND OAKS, CA:  
2,430,227, REN. 3-26-11. INT. CL. 9.

- TELEFONAKTIEBOLAGET LM ERICSSON, KISTA, STOCKHOLM, SWEDEN:  
3,762,291, COR. INT. CL. 9.
- TELOGIS, INC., ALISO VIEJO, CA:  
3,954,562, PUB. 2-15-2011. INT. CL. 9.  
3,954,569, PUB. 2-15-2011. MULTIPLE CLASS, INT. CLS. 9 AND 42.
- TEMCARE MEDICAL DESIGN AND MANUFACTURING, INC., POMPANO BEACH, FL:  
3,955,011, PUB. 2-15-2011. INT. CL. 10.
- TEMPESTA, SCOT, CARLSBAD, CA:  
3,954,152, PUB. 2-15-2011. MULTIPLE CLASS, INT. CLS. 38 AND 41.
- TEN-TEC, INC., SEVIERVILLE, TN:  
1,163,472, REN. 3-31-11. INT. CL. 9.
- TENCO, INC., CHICAGO, IL:  
3,954,523, PUB. 2-15-2011. INT. CL. 36.
- TENKOLINI, INC., MIAMI, FL:  
2,876,503, CANC. INT. CL. 9.
- TENNECO CHEMICALS, INC., NEW YORK, NY TO ARIZONA CHEMICAL COMPANY, PANAMA CITY, FL:  
864,846, CANC. U.S. CL. 16.
- TENNESSEE MAT COMPANY, INC., SMYRNA, TN:  
2,439,898, REN. 3-29-11. INT. CL. 27.
- TEPHA, INC., CAMBRIDGE, MA:  
2,493,340, REN. 3-25-11. INT. CL. 1.
- TEQUILA CASA DE LOS GONZALEZ, S.A. DE C.V., GUADALAJARA, MEXICO:  
3,956,104, INT. CL. 33.  
3,956,105, INT. CL. 33.
- TEQUILA QUIOTE, SA. DE C.V., JALISCO, MEXICO:  
2,876,696, CANC. INT. CL. 33.
- TERANEX, INC., ORLANDO, FL:  
2,453,710, REN. 3-30-11. INT. CL. 9.
- TERESA ALONSO LANDEROS, ROWLAND HEIGHTS, CA, DBA A+ PARENTING:  
3,953,685, PUB. 2-15-2011. INT. CL. 41.
- TERESA JALBERT, VIRGINIA BEACH, VA:  
3,954,303, PUB. 2-15-2011. INT. CL. 41.
- TERGAN DERI ÜRÜNLERI; SANAYI VE TICARET ANONİM SİRKETİ, TURKEY:  
3,953,614, PUB. 2-15-2011. MULTIPLE CLASS, INT. CLS. 18, 25 AND 35.
- TERI AMATO, BAYSIDE, NY:  
3,955,423, INT. CL. 3.
- TERNIUM MEXICO, S.A. DE C.V., SAN NICOLAS DE LOS GARZA, NL, MEXICO:  
2,483,070, REN. 3-31-11. INT. CL. 6.
- TERPSIXORIANS - HELLENIC DANCE GROUP OF NEW JERSEY, LYNDHURST, NJ:  
3,954,265, PUB. 2-15-2011. INT. CL. 41.
- TERRAFRAME, INC., WESTMINSTER, CO:  
3,953,961, PUB. 2-15-2011. INT. CL. 9.
- TERRY HENSHAW MINISTRIES, INC., TULSA, OK:  
3,954,140, PUB. 2-15-2011. MULTIPLE CLASS, INT. CLS. 16 AND 41.
- TERRY SAVAGE PRODUCTIONS, CHICAGO, IL:  
2,550,655, REN. 3-31-11. INT. CL. 16.
- TERRY SAVAGE PRODUCTIONS, LTD., CHICAGO, IL:  
2,464,556, REN. 3-31-11. INT. CL. 9.
- TESSCO COMMUNICATIONS INCORPORATED, HUNT VALLEY, MD:  
1,674,656, REN. 3-26-11. INT. CL. 42.
- TESTCO, SUNNYVALE, CA:  
3,954,412, PUB. 2-15-2011. INT. CL. 35.
- TETRADATA CORPORATION, GREENVILLE, SC:  
2,515,335, REN. 3-26-11. INT. CL. 9.
- TEXAS CHILDREN'S HOSPITAL, HOUSTON, TX:  
2,447,462, REN. 3-26-11. INT. CL. 28.
- TEXAS ONE VOICE: A COLLABORATIVE FOR HEALTH AND HUMAN SERVICES, HOUSTON, TX:  
3,955,971, INT. CL. 35.
- TEXAS REDS INCORPORATED, RED RIVER, NM:  
2,429,025, REN. 3-26-11. INT. CL. 30.
- TEXECOM LIMITED, HASLINGDEN, UNITED KINGDOM:  
3,953,026, PUB. 2-15-2011. INT. CL. 9.
- TEXMOOD, INC., DALLAS, TX:  
2,877,962, CANC. INT. CL. 27.
- TEXTNOMORE LLC, PORTLAND, OR:  
3,954,244, PUB. 2-15-2011. MULTIPLE CLASS, INT. CLS. 35 AND 38.
- TEXXSTAR RESOURCES (USA), INC., AUSTIN, TX:  
2,878,039, CANC. INT. CL. 30.
- THAI CERAMIC CO., LTD., THE, BANGKOK, THAILAND:  
2,437,855, REN. 3-26-11. INT. CL. 19.
- THARANCO LIFESTYLES LLC, BAYONNE, NJ:  
3,955,577, INT. CL. 25.
- THE AFTERMARKET COMPANY, PHOENIX, AZ:  
2,877,178, CANC. INT. CL. 35.
- THE ALLIANCE OF COMMUNITY HEALTH PLANS, WASHINGTON, DC:  
3,953,845, PUB. 2-15-2011. INT. CL. 9.  
3,953,846, PUB. 2-15-2011. INT. CL. 9.
- THE AMERICAN ARCHITECTURAL FOUNDATION, INC., WASHINGTON, DC:  
3,956,131, MULTIPLE CLASS, INT. CLS. 35 AND 42.
- THE AMERICAN COLLEGE, BRYN MAWR, PA:  
3,956,214, INT. CL. 41.
- THE AMERICAN COLLEGE OF PSYCHIATRISTS, BERKELEY, CA:  
2,877,537, CANC. MULTIPLE CLASS, INT. CLS. 35 AND 41.
- THE AMERICAN COMPANIES, LLC, ENGLEWOOD CLIFFS, NJ:  
2,876,124, CANC. MULTIPLE CLASS, INT. CLS. 35 AND 39.
- THE ASHTON-DRAKE GALLERIES, LTD., NILES, IL:  
3,954,791, PUB. 2-15-2011. INT. CL. 28.
- THE BALLENGER GROUP, LLC, FREDERICK, MD:  
2,877,600, CANC. INT. CL. 42.
- THE BCL GROUP, SAN JOSE, CA:  
3,954,058, PUB. 2-15-2011. INT. CL. 25.
- THE BIG WRAP, INC., ASPEN, CO:  
3,953,356, PUB. 2-15-2011. INT. CL. 43.
- THE BILL SIMS COMPANY, COLUMBIA, SC:  
3,953,021, PUB. 2-15-2011. INT. CL. 35.
- THE BLACKSTONE GROUP INC., CHICAGO, IL:  
3,953,275, PUB. 2-15-2011. INT. CL. 35.
- THE BOARD OF TRUSTEES OF THE UNIVERSITY OF ILLINOIS, URBANA, IL:  
3,955,021, PUB. 2-15-2011. MULTIPLE CLASS, INT. CLS. 35, 41 AND 42.
- THE BOLDT GROUP, INC., APPLETON, WI:  
3,955,152, PUB. 2-15-2011. INT. CL. 37.
- THE BRADFORD EXCHANGE, LTD., NILES, IL:  
2,876,470, CANC. INT. CL. 35.
- THE CARTOON NETWORK, INC., ATLANTA, GA:  
3,955,408, INT. CL. 41.
- THE CHEF'S GARDEN, INC., HURON, OH:  
2,878,074, CANC. INT. CL. 31.  
3,954,302, PUB. 2-15-2011. INT. CL. 31.
- THE CHENEGA CORPORATION, ANCHORAGE, AK:  
2,875,860, CANC. MULTIPLE CLASS, INT. CLS. 35, 37, 39, 40, 41 AND 42.
- THE CLAY MINERALS SOCIETY, AURORA, CO:  
2,876,178, CANC. MULTIPLE CLASS, INT. CLS. 16 AND 41.
- THE CLOROX COMPANY, OAKLAND, CA:  
3,955,095, PUB. 2-15-2011. INT. CL. 42.
- THE COCA-COLA COMPANY, ATLANTA, GA:  
3,955,417, INT. CL. 32.
- THE COMBS COMPANY, EUGENE, OR:  
3,799,829, COR. INT. CL. 25.
- THE CONNELL COMPANY, BERKELEY HEIGHTS, NJ:  
3,953,393, PUB. 2-15-2011. MULTIPLE CLASS, INT. CLS. 30, 35, 36, 37 AND 39.
- THE CONTEMPORARY YOUTH ORCHESTRA, CLEVELAND HEIGHTS, OH:  
3,956,229, INT. CL. 9.
- THE DEVLIN GROUP, INC., JACKSONVILLE BEACH, FL:  
2,876,719, CANC. MULTIPLE CLASS, INT. CLS. 36 AND 37.
- THE EDWARD THOMAS HOSPITALITY CORP., BEVERLY HILLS, CA:  
2,379,918, CANC. INT. CL. 42.

THE EXTRA 20 YARDS LTD, EDINBURGH, UNITED KINGDOM, TA THE EXTRA 20 YARDS:  
3,953,926, PUB. 2-15-2011. INT. CL. 28.

THE FENNIMORE GROUP, LLC, ARLINGTON HEIGHTS, IL:  
3,955,622, INT. CL. 35.

THE FINAL DRAFT WRITING SERVICES, GLEN ELLYN, IL:  
3,954,892, PUB. 2-15-2011. INT. CL. 41.

THE FREEMOUNT CORPORATION, TULSA, OK:  
2,876,984, CANC. INT. CL. 41.

THE FRESH MARKET, INC., GREENSBORO, NC:  
3,954,316, PUB. 2-15-2011. INT. CL. 35.

THE FRISCO SISTERS AND A PRAYER LLC, FRISCO, TX:  
2,877,563, CANC. INT. CL. 35.

THE FRUIT KINGDOM LLC, HOUSTON, TX:  
3,953,878, PUB. 2-15-2011. MULTIPLE CLASS, INT. CLS. 29, 30 AND 32.

THE FULLER BRUSH COMPANY, INC., GREAT BEND, KS, FULLER BRUSH COMPANY, THE, HARTFORD, CT:  
539,836. REN. 3-30-11. U.S. CL. 4 (INT. CL. 3).

THE GRAHAM GROUP, INC., DES MOINES, IA:  
3,953,405, PUB. 2-15-2011. MULTIPLE CLASS, INT. CLS. 36 AND 37.  
3,953,408, PUB. 2-15-2011. MULTIPLE CLASS, INT. CLS. 36 AND 37.

THE GRAVEN GROUP, LLC, SOQUEL, CA:  
2,877,482, CANC. INT. CL. 35.

THE GROOVY LINEN CORPORATION, OTTAWA, ONTARIO, CANADA:  
3,953,209, PUB. 2-15-2011. INT. CL. 43.

THE GROWTH CORPORATION, GRAND RAPIDS, MI:  
3,954,725, PUB. 2-15-2011. INT. CL. 44.

THE GYNECOLOGIC ONCOLOGY GROUP, CROFTON, MD:  
3,955,519, INT. CL. 16.

THE HARTFORD COURANT COMPANY, HARTFORD, CT:  
2,876,993, CANC. INT. CL. 41.

THE HEALTH & WELLNESS INSTITUTE, LLC, PROVIDENCE, RI:  
3,953,916, PUB. 2-15-2011. MULTIPLE CLASS, INT. CLS. 41 AND 44.

THE HEALTHCARE MEDIA GROUP, LLC, SOMERVILLE, NJ:  
3,953,370, PUB. 2-15-2011. INT. CL. 16.

THE HOLD-UP SUSPENDER COMPANY, SOUTHFIELD, MI:  
3,954,709, PUB. 2-15-2011. INT. CL. 25.

THE HOLE IN THE WALL GANG FUND, INC., NEW HAVEN, CT, AKA THE HOLE IN THE WALL GANG CAMP:  
3,954,184, PUB. 2-15-2011. INT. CL. 41.

THE HOME ENTERTAINMENT CORPORATION PLC., PETERBOROUGH, UNITED KINGDOM:  
2,877,091, CANC. MULTIPLE CLASS, INT. CLS. 9 AND 41.

THE HUMANITAS PRIZE, SANTA MONICA, CA:  
3,953,444, PUB. 2-15-2011. INT. CL. 41.

THE INSTITUTION RECYCLING NETWORK, INC., CONCORD, NH, AKA IRN:  
3,953,261, PUB. 2-15-2011. INT. CL. 39.

THE ITALIAN COOKIE JAR, INC., SYRACUSE, NY, DBA ICJ COOKIES:  
3,955,913, INT. CL. 30.  
3,955,914, INT. CL. 30.

THE KINGSFORD PRODUCTS COMPANY LLC, OAKLAND, CA:  
2,541,155. REN. 3-31-11. MULTIPLE CLASS, INT. CLS. 8, 11 AND 21.

THE LINCOLN ELECTRIC COMPANY, CLEVELAND, OH:  
3,955,316, INT. CL. 9.

THE LONG BEACH YACHT CLUB, LONG BEACH, CA:  
3,954,097, PUB. 2-15-2011. MULTIPLE CLASS, INT. CLS. 25 AND 41.

THE MAGIC BUS, LLC, WENATCHEE, WA, DBA SKADI NORDIC:  
3,954,346, PUB. 2-15-2011. INT. CL. 25.

THE MAJESTIC STAR CASINO, LLC, GARY, IN, FITZGERALDS RENO, INC., RENO, NV:  
1,639,303. REN. 3-31-11. INT. CL. 42.

THE MAN MADE SOFTWARE COMPANY, LLC, AUSTIN, TX:  
3,956,040, INT. CL. 9.

THE MANAGEMENT NETWORK GROUP, INC., OVERLAND PARK, KS:  
2,876,490, CANC. INT. CL. 35.

THE MATHWORKS, INC., NATICK, MA:  
2,876,708, CANC. INT. CL. 9.

THE MCGRAW-HILL COMPANIES, INC., NEW YORK, NY:  
2,379,476, CANC. INT. CL. 16.

THE METHODIST HOSPITAL, HOUSTON, TX:  
3,954,826, PUB. 2-15-2011. INT. CL. 44.

THE NATIONAL COLLEGE FOR DUI DEFENSE, INC., MONTGOMERY, AL:  
3,954,075, PUB. 2-15-2011. INT. CL. 41.  
3,954,077, PUB. 2-15-2011. INT. CL. 41.

THE NAVIGATORS GROUP, INC., NEW YORK, NY:  
3,954,660, PUB. 2-15-2011. INT. CL. 36.

THE NEJ AND MASCOLO FAMILY FOUNDATION, INC., BEACON FALLS, CT:  
3,956,049, INT. CL. 36.  
3,956,050, INT. CL. 36.

THE NELROD COMPANY, FORT WORTH, TX:  
3,953,875, PUB. 2-15-2011. INT. CL. 35.

THE NIELSEN COMPANY (US), LLC, SCHAUMBURG, IL:  
2,402,063. REN. 3-28-11. INT. CL. 35.

THE NIELSEN COMPANY, INC., SCHAUMBURG, IL:  
2,485,525. REN. 3-30-11. INT. CL. 9.

THE OASIS EXPERIENCE, INC., WESTMONT, IL:  
2,876,579, CANC. INT. CL. 45.

THE OCCASIONS GROUP, INC., NORTH MANKATO, MN:  
2,378,522, CANC. INT. CL. 42.

THE ORANGE DOG INC., EDMONTON, ALBERTA, CANADA:  
3,953,424, PUB. 2-15-2011. MULTIPLE CLASS, INT. CLS. 18 AND 21.  
3,953,425, PUB. 2-15-2011. MULTIPLE CLASS, INT. CLS. 18 AND 21.

THE OSS SOCIETY, INC., MCLEAN, VA:  
3,955,988, INT. CL. 41.

THE OUTDOOR CHANNEL, INC., TEMECULA, CA:  
3,956,219, INT. CL. 41.

THE OUTLAWS MOTORCYCLE CLUB INC., MILWAUKEE, WI:  
3,956,158, INT. CL. 25.

THE PAUL AND DEBBIE CHELKO FOUNDATION, INC., ATLANTA, GA:  
3,954,638, PUB. 2-15-2011. INT. CL. 36.

THE PETTING ZOO, INC., GLEN BURNIE, MD:  
3,955,544, INT. CL. 18.  
3,955,545, INT. CL. 25.

THE PNC FINANCIAL SERVICES GROUP, INC., PITTSBURGH, PA:  
3,954,263, PUB. 2-15-2011. INT. CL. 36.

THE PORT OF PORTLAND, PORTLAND, OR:  
2,877,604, CANC. INT. CL. 39.

THE PRINCETON REVIEW, INC., NEW YORK, NY:  
2,876,748, CANC. INT. CL. 9.

THE PROCTER & GAMBLE COMPANY, CINCINNATI, OH:  
2,877,627, CANC. INT. CL. 3.

THE PRUDENTIAL INSURANCE COMPANY OF AMERICA, NEWARK, NJ:  
2,378,456, CANC. INT. CL. 36.

THE QUAKER OATS COMPANY, CHICAGO, IL:  
3,955,142, PUB. 2-15-2011. INT. CL. 30.

THE REALBEANZ CORPORATION, BROOKLYN, NY:  
3,956,137, INT. CL. 30.

THE RED FLAG GROUP LIMITED, SHEUNG WAN, HONG KONG:  
3,956,078, INT. CL. 35.

THE REEL PEOPLE COMPANY, LLC, DALLAS, TX:  
3,954,282, PUB. 2-15-2011. INT. CL. 35.  
3,954,283, PUB. 2-15-2011. INT. CL. 35.

- THE RELATIONSHIP GIFTING SEMINARS & PRESENTATIONS LLC, PORTLAND, OR:  
3,953,365, PUB. 2-15-2011. INT. CL. 41.
- THE REVENUE GROUP, INC., CLEVELAND, OH:  
3,956,218, MULTIPLE CLASS, INT. CLS. 35 AND 36.
- THE RIDING RINGMASTERS, INC., COCH RANVILLE, PA:  
2,876,876, CANC. INT. CL. 37.
- THE SAN FRANCISCO AIDS FOUNDATION, SAN FRANCISCO, CA AND THE LOS ANGELES GAY AND LESBIAN COMMUNITY SERVICES CENTER, LOS ANGELES, CA:  
3,953,244, PUB. 2-15-2011. INT. CL. 36.
- THE SHERWIN-WILLIAMS COMPANY, CLEVELAND, OH:  
3,954,981, PUB. 2-15-2011. INT. CL. 2.  
3,955,040, PUB. 2-15-2011. INT. CL. 2.  
3,955,092, PUB. 2-15-2011. INT. CL. 2.
- THE SLATER GROUP, LLC, CANTON, GA:  
3,954,418, PUB. 2-15-2011. INT. CL. 41.
- THE SOURCE (BELL) ELECTRONICS INC., BARRIE, ONTARIO, CANADA:  
3,953,036, PUB. 1-12-2010. INT. CL. 9.
- THE STANDARD REGISTER COMPANY, DAYTON, OH:  
2,876,782, CANC. INT. CL. 16.
- THE STEADMAN CLINIC, PROFESSIONAL LLC, VAIL, CO:  
3,953,343, PUB. 2-15-2011. INT. CL. 44.
- THE STRESS STOP, INC., NEWPORT RICHEY, FL:  
2,877,999, CANC. INT. CL. 10.
- THE SUN PRODUCTS CORPORATION, WILTON, CT, LEVER BROTHERS COMPANY, NEW YORK, NY:  
1,148,608, REN. 3-31-11. INT. CL. 3.
- THE SUSAN G. KOMEN BREAST CANCER FOUNDATION, INC., DALLAS, TX:  
3,954,745, PUB. 2-15-2011. INT. CL. 36.
- THE TAYLOR CHAIR COMPANY, BEDFORD, OH:  
3,954,391, PUB. 2-15-2011. INT. CL. 20.
- THE TIFFEN COMPANY, LLC, HAUPPAUGE, NY:  
3,956,036, INT. CL. 9.
- THE UNIVERSAL CHURCH, INC., NEWARK, NJ:  
3,953,722, PUB. 2-15-2011. MULTIPLE CLASS, INT. CLS. 16, 25 AND 45.
- THE UNIVERSITY OF BRITISH COLUMBIA, VANCOUVER, BRITISH COLUMBIA:  
2,337,036, REN. 3-29-11. INT. CL. 35.
- THE UNIVERSITY OF TOLEDO, TOLEDO, OH:  
2,876,533, CANC. MULTIPLE CLASS, INT. CLS. 16, 21, 25 AND 41.  
2,876,534, CANC. MULTIPLE CLASS, INT. CLS. 16, 21, 25 AND 41.
- THE UPPER DECK COMPANY, INC., CARLSBAD, CA, FLEER/SKYBOX INTERNATIONAL LP, MOUNT LAUREL, NJ:  
2,457,824, REN. 3-26-11. INT. CL. 16.  
2,464,170, REN. 3-29-11. INT. CL. 16.
- THE UPPER DECK COMPANY, INC., CARLSBAD, CA:  
2,468,436, REN. 3-26-11. INT. CL. 16.  
2,470,512, REN. 3-26-11. INT. CL. 16.
- THE UPPER ROOM, NASHVILLE, TN:  
3,955,010, PUB. 2-15-2011. INT. CL. 45.
- THE VACCINE FUND, WASHINGTON, DC:  
2,877,502, CANC. INT. CL. 36.  
2,877,503, CANC. INT. CL. 36.
- THE VANDERBILT UNIVERSITY, NASHVILLE, TN:  
3,955,015, PUB. 2-15-2011. INT. CL. 44.
- THE VAVAS, INC., RICHMOND, VA:  
2,877,587, CANC. INT. CL. 14.
- THE WILLIAM CARTER COMPANY, ATLANTA, GA:  
3,955,844, MULTIPLE CLASS, INT. CLS. 25 AND 28.
- THE WIZ QUIZ, LLC, SILVER SPRING, MD:  
3,953,731, PUB. 2-15-2011. INT. CL. 44.
- THE WORD OF TRUTH CHURCH, DETROIT, MI:  
3,955,756, INT. CL. 25.
- THECORPORA, S.L., SPAIN:  
3,953,663, PUB. 2-15-2011. INT. CL. 7.
- THEDACARE, INC., APPLETON, WI:  
3,955,771, INT. CL. 35.
- THEODORE C. PAPALOIZOS PUBLICATIONS, INC., SILVER SPRING, MD:  
3,953,723, PUB. 2-15-2011. MULTIPLE CLASS, INT. CLS. 9 AND 16.
- THERAGENICS CORPORATION, BUFORD, GA:  
2,943,653, CANC. INT. CL. 42.
- THERMO FISHER SCIENTIFIC INC., WALTHAM, MA:  
2,876,366, CANC. INT. CL. 11.
- THERMO ORION INC., BEVERLY, MA:  
2,378,556, CANC. INT. CL. 9.
- THERMOGENESIS CORPORATION, RANCHO CORDOVA, CA:  
3,955,242, INT. CL. 10.
- THETABIZ S.A., MIAMI, FL:  
3,955,260, INT. CL. 35.
- THEVENOT, ERIC, LOS ANGELES, CA:  
3,954,144, PUB. 2-15-2011. INT. CL. 35.
- THIERCELIN, CORENTIN, ENSUÈS LA REDONNE, FRANCE:  
3,953,309, PUB. 2-15-2011. MULTIPLE CLASS, INT. CLS. 35 AND 41.  
3,953,310, PUB. 2-15-2011. MULTIPLE CLASS, INT. CLS. 35 AND 41.
- THIN MAN PRODUCTIONS, INC., NEW YORK, NY:  
3,955,927, INT. CL. 24.
- THINE ELECTRONICS KABUSHIKI KAISHA A/T/A THINE ELECTRONICS, INC., CHIYODA-KU, TOKYO, JAPAN:  
3,953,718, PUB. 2-15-2011. INT. CL. 9.
- THOMAS D. MANGELSEN, INC., OMAHA, NE:  
3,953,976, PUB. 2-15-2011. INT. CL. 35.
- THOMAS HINE & CO., JARNAC, FRANCE:  
1,638,570, REN. 3-31-11. INT. CL. 33.
- THOMAS, DONALD, MANSFIELD, MA:  
2,877,950, CANC. INT. CL. 9.
- THOMASSEN TURBINE SYSTEMS B.V., RHEDEN, NETHERLANDS:  
2,878,068, CANC. MULTIPLE CLASS, INT. CLS. 7, 37 AND 42.
- THOMPSON, JEFFREY S., REDDING, CA, DBA WE MOVE IT:  
3,953,384, PUB. 2-15-2011. INT. CL. 39.
- THOMSON & NIELSEN ELECTRONICS LTD, NEPEAN, ONTARIO, CANADA:  
2,875,978, CANC. INT. CL. 9.
- THOR TECH, INC., JACKSON CENTER, OH:  
2,877,394, CANC. INT. CL. 12.
- THQ WIRELESS INC., CALABASAS HILLS, CA:  
2,876,608, CANC. INT. CL. 9.
- THREE CHIMNEYS FARM, LLC, MIDWAY, KY:  
3,954,294, PUB. 2-15-2011. MULTIPLE CLASS, INT. CLS. 41 AND 44.
- THREE FLOYDS BREWING LLC, MUNSTER, IN:  
3,955,075, PUB. 2-15-2011. INT. CL. 41.
- THREE FORKS RANCH CORP., ST. LOUIS, MO:  
3,955,888, INT. CL. 6.  
3,955,889, INT. CL. 6.
- THREE STEPS FROM GOLD, RENSSELAER, NY:  
3,953,149, PUB. 2-15-2011. INT. CL. 14.
- THRONEBURG, JAMES L., LEWISVILLE, NC:  
2,877,863, CANC. INT. CL. 25.
- THYSSENKRUPP STAHL AG, DUISBURG, FED REP GERMANY:  
2,877,472, CANC. INT. CL. 6.
- THYSSENKRUPP STEEL EUROPE AG, FED REP GERMANY:  
3,953,616, PUB. 2-15-2011. MULTIPLE CLASS, INT. CLS. 4 AND 6.
- TI, RONALD DR., QUEENSLAND, AUSTRALIA:  
3,955,705, INT. CL. 44.
- TIANJIN CHANGLU HANGU SALTERS CO., LTD., CHINA:  
3,953,637, PUB. 2-15-2011. INT. CL. 1.
- TIANJIN HUAYUAN INDUSTRY CO., CHINA:  
3,953,626, PUB. 2-15-2011. INT. CL. 6.
- TIANMA MICROELECTRONICS CO., LIMITED, SHENZHEN, CHINA:  
2,449,738, REN. 3-29-11. INT. CL. 9.
- TIFFANY (NJ) LLC, PARSIPPANY, NJ:  
139,220, REN. 3-28-11. U.S. CL. 32 (INT. CL. 20).  
140,996, REN. 3-30-11. U.S. CL. 38 (INT. CLS. 9, 16 AND 28).

TIGERDIRECT, INC., MIAMI, FL:  
2,694,988, COR. INT. CL. 35.  
2,694,989, COR. INT. CL. 35.

TIJON, LLC, MIAMI, FL:  
2,963,323, AM. INT. CL. 3.

TIKI BASH, LLC., WEST PALM BEACH, FL:  
3,955,602, INT. CL. 41.

TILANO DECORATIVE PRODUCTS INC., VANCOUVER,  
BRITISH COLUMBIA, CANADA:  
2,876,446, CANC. INT. CL. 19.

TILE MEDIA PROPERTIES, INC., ATLANTA, GA:  
3,954,462, PUB. 2-15-2011. INT. CL. 5.

TIMBUK2 DESIGNS, INC., SAN FRANCISCO, CA:  
3,953,305, PUB. 2-15-2011. INT. CL. 18.

TIME INC., NEW YORK, NY:  
2,379,138, CANC. INT. CL. 16.

TIME PLAZA, LOS ANGELES, CA:  
3,954,087, PUB. 2-15-2011. INT. CL. 9.  
3,954,088, PUB. 2-15-2011. INT. CL. 9.  
3,955,007, PUB. 2-15-2011. INT. CL. 9.

TIMEX GROUP B.V., 1075 AD AMSTERDAM, NETHER-  
LANDS:  
2,876,079, CANC. INT. CL. 28.

TIMEX GROUP USA, INC., MIDDLEBURY, CT:  
1,171,155, REN. 3-25-11. INT. CL. 14.  
3,954,313, PUB. 2-15-2011. INT. CL. 14.

TIMM MEDICAL TECHNOLOGIES, INC, EDEN PRAIRIE,  
DE TO TIMM MEDICAL TECHNOLOGIES, INC., EDEN  
PRAIRIE, MN:  
2,380,078, CANC. INT. CL. 10.

TIPSY STIXS, LLC, GREENSBORO, NC:  
3,954,492, PUB. 2-15-2011. INT. CL. 21.

TISHCON CORP, WESTBURY, NY:  
3,954,224, PUB. 2-15-2011. INT. CL. 5.

TISSOT S.A., LE LOCLE, SWITZERLAND:  
1,639,684, REN. 3-31-11. INT. CL. 14.

TITAN INTERNATIONAL, INC., QUINCY, IL:  
2,438,577, REN. 3-29-11. INT. CL. 12.

TITANIUM EXCLUSIVE COOKWARE INC., TORONTO,  
CANADA:  
2,520,815, REN. 3-29-11. INT. CL. 21.

TITANIUM METALS CORPORATION, DALLAS, TX:  
2,385,051, REN. 3-31-11. INT. CL. 6.

TMTD, LLC, CHARLOTTE, NC:  
3,954,934, PUB. 2-15-2011. MULTIPLE CLASS, INT. CLS.  
41 AND 43.

TMW MARKETING COMPANY, INC., FREMONT, CA:  
2,396,130, CANC. INT. CL. 25.

TN INTERNATIONAL, MONTIGNY LE BRETONNEUX,  
FRANCE:  
2,932,731, CANC. MULTIPLE CLASS, INT. CLS. 17 AND  
20.

TNEMEC COMPANY, INC., KANSAS CITY, MO:  
3,955,634, INT. CL. 1.

TOBEADORED LLC, SANTA CLARA, CA:  
3,954,019, PUB. 2-15-2011. INT. CL. 41.

TODOFUT/WORLDCUPSTORE, LLC, SAN FRANCISCO,  
CA:  
2,876,504, CANC. INT. CL. 35.

TOFASCO OF AMERICA, INC., LA VERNE, CA:  
3,955,294, INT. CL. 35.

TOKUYAMA CORPORATION, YAMAGUCHI, JAPAN:  
2,876,305, CANC. MULTIPLE CLASS, INT. CLS. 5 AND  
10.

TOKYO PAINT KABUSHIKI KAISHA, TOKYO, JAPAN, TA  
TOKYO PAINT CO., LTD.:  
2,451,396, REN. 3-31-11. INT. CL. 2.

TOLEDO ENGINEERING COMPANY, INC., TOLEDO, OH:  
1,147,589, REN. 3-31-11. INT. CL. 11.

TOM RICHARDS, INC., MENTOR, OH, PROCESS TECH-  
NOLOGY:  
1,163,600, REN. 3-26-11. INT. CL. 11.

TOM SNYDER PRODUCTIONS, INC., WATERTOWN, MA:  
2,544,476, REN. 3-26-11. INT. CL. 9.

TOMBSTONE TERRITORIES CO., HUACHUCA CITY, AZ:  
2,630,163, CANC. INT. CL. 42.

TOMLINSON, WILLIAM J., GREENVILLE, VA:  
3,955,308, INT. CL. 8.

TOMMY CONDON'S, INC., CHARLESTON, SC:  
1,636,456, REN. 3-29-11. INT. CL. 42.

TOMMY HILFIGER LICENSING LLC, NEW YORK, NY:  
2,877,920, CANC. INT. CL. 3.

TONE BRAND GROUP, INC, SHERMAN OAKS, CA:  
3,954,531, PUB. 2-15-2011. INT. CL. 35.

TONOGA, INC., PETERSBURGH, NY:  
2,440,124, REN. 3-31-11. INT. CL. 19.

TONY BOFFA'S RESTAURANT, INC., MIDDLETOWN, NY:  
3,954,081, PUB. 2-15-2011. INT. CL. 43.

TONY BOFFA'S SPECIALTY FOODS, INC., MIDDLETOWN,  
NY:  
3,954,082, PUB. 2-15-2011. INT. CL. 30.

TONY CRUZE, WILLMAR, MN AND SHARON CURZE,  
WILLMAR, MN:  
3,955,709, INT. CL. 28.

TOO FACED COSMETICS, INC., IRVINE, CA:  
3,954,945, PUB. 2-15-2011. INT. CL. 3.  
3,955,058, PUB. 2-15-2011. INT. CL. 3.

TOOT SWEET TOYS, INC., NEW YORK, NY, LIBERMAN,  
PENNY, NEW YORK, NY:  
2,406,489, REN. 3-26-11. INT. CL. 28.

TOP CLASS ACTIONS LLC, PHOENIX, AZ:  
3,954,429, PUB. 2-15-2011. INT. CL. 45.

TOP FIVE DATA SERVICES, INC., FREMONT, CA:  
2,379,686, CANC. INT. CL. 35.

TOP NOTCH DOG, INC., DURHAM, NC:  
2,379,741, CANC. INT. CL. 41.

TOPCO HOLDINGS, INC., SKOKIE, IL:  
1,616,887, REN. 3-29-11. INT. CL. 29.  
1,616,887, AM. INT. CL. 29.

TOPSEE INTERNATIONAL CO., LIMITED, SHENZHEN,  
CHINA:  
3,953,144, PUB. 2-15-2011. MULTIPLE CLASS, INT. CLS. 3  
AND 9.

TORO COMPANY, THE, BLOOMINGTON, MN:  
2,436,357, REN. 3-29-11. INT. CL. 11.

TORRES, LUIS POIRE, MEXICO CITY, MEXICO:  
3,953,719, PUB. 2-15-2011. INT. CL. 42.

TORY JOHNSON PRODUCTIONS, NEW YORK, NY:  
3,954,628, PUB. 2-15-2011. INT. CL. 41.

TOTAL CALL INTERNATIONAL, INC., LOS ANGELES, CA:  
3,954,947, PUB. 2-15-2011. INT. CL. 38.

TOTAL TEMPERATURE INSTRUMENTATION, INC.,  
SOUTH BURLINGTON, VT, DBA INSTRUMART:  
3,954,491, PUB. 2-15-2011. INT. CL. 9.

TOTALBANK, MIAMI, FL:  
2,437,891, REN. 3-26-11. INT. CL. 36.

TOTALPAAS, INC., PALO ALTO, CA:  
3,955,410, INT. CL. 42.

TOTOKU ELECTRIC CO., LTD., SHINJUKU-KU, TOKYO,  
JAPAN:  
2,875,939, CANC. MULTIPLE CLASS, INT. CLS. 9 AND  
10.

TOUR & ANDERSSON AKTIEBOLAG, LJUNG, SWEDEN,  
TOUR & ANDERSSON AKTIEBOLAG, JOHANNESHOV,  
SWEDEN:  
1,141,543, REN. 3-28-11. MULTIPLE CLASS, INT. CLS. 9  
AND 11.

TOURNAMENT ONE CORP, STAMFORD, CT, AKA T1  
GAMING, T1, TOC:  
3,955,525, INT. CL. 9.  
3,955,526, INT. CL. 9.

TOWERS, PERRIN, FORSTER & CROSBY, INC., PHILA-  
DELPHIA, PA:  
2,379,956, CANC. INT. CL. 35.

TOWNLEY, WYATT, LEAWOOD, KS:  
2,439,016, REN. 3-31-11. MULTIPLE CLASS, INT. CLS. 9  
AND 41.

TOYNAMI, INC, VAN NUYS, CA:  
3,955,650, INT. CL. 28.

TOYOTA MOTOR CREDIT CORPORATION, TORRANCE,  
CA:  
2,442,042, REN. 3-26-11. INT. CL. 36.

TOYWIZ, INC., SUFFERN, NY:  
3,955,148, PUB. 2-15-2011. INT. CL. 35.

TP COMPOSITES, INC, ASTON, PA:  
2,142,722, CANC. INT. CL. 17.

- TP COMPOSITES, INC., ASTON, PA:  
2,144,630, CANC. INT. CL. 17.
- TRACFONE WIRELESS, INC., MIAMI, FL:  
3,956,130, INT. CL. 38.
- TRACK GLOBE S.L., HUESCA, SPAIN:  
2,877,485, CANC. INT. CL. 9.
- TRACK 180, LLC, NEW HAVEN, CT:  
3,955,991, INT. CL. 41.
- TRACY BENDER, GILROY, CA, DBA THE CENTER FOR  
MASTERPIECE LIVING:  
3,955,671, INT. CL. 35.
- TRACY HEALY, PROVIDENCE, RI:  
3,955,823, INT. CL. 25.
- TRADE PRESS MEDIA GROUP, INC., MILWAUKEE, WI:  
3,954,677, PUB. 2-15-2011. INT. CL. 41.
- TRADEX INC., EDMONTON, ALBERTA T5S 1R5, CANADA:  
2,875,922, CANC. MULTIPLE CLASS, INT. CLS. 8, 9 AND  
21.
- TRADITIONALS MEDICINALS, INC., SEBASTOPOL, CA:  
2,376,182, CANC. MULTIPLE CLASS, INT. CLS. 5 AND  
30.
- TRAGESER, MARK, WOODLAND HILLS, CA:  
3,956,157, MULTIPLE CLASS, INT. CLS. 20 AND 21.
- TRANS GLOBAL TOURS, LLC, MILWAUKEE, WI:  
2,542,172, REN. 3-25-11. MULTIPLE CLASS, INT. CLS. 39  
AND 42.
- TRANS WORLD INTERNATIONAL INC., CLEVELAND,  
OH:  
2,484,106, REN. 3-26-11. INT. CL. 41.
- TRANSCANADA TURBINES LTD., CALGARY, ALBERTA  
T2E 7R3, CANADA:  
2,433,166, REN. 3-29-11. MULTIPLE CLASS, INT. CLS. 37  
AND 42.
- TRANSLATIONAL GENOMICS RESEARCH INSTITUTE  
FOUNDATION, PHOENIX, AZ, AKA TGEN FOUNDA-  
TION:  
3,954,870, PUB. 2-15-2011. INT. CL. 36.
- TRANSPORT LABOR CONTRACT/LEASING, INC., ARDEN  
HILLS, MN:  
2,877,595, CANC. INT. CL. 40.
- TRANSZAP, INC., DENVER, CO:  
3,955,268, INT. CL. 42.
- TRAVEL ME CRAZY, INCORPORATED, STERLING, VA:  
2,458,846, REN. 3-26-11. INT. CL. 35.
- TRAVELHOST, INC., DALLAS, TX:  
3,955,185, MULTIPLE CLASS, INT. CLS. 35, 39, 42 AND  
43.
- TRAVELLERS EXCHANGE CORPORATION LIMITED,  
LONDON WC2B 6TD, UNITED KINGDOM:  
3,908,222, COR. MULTIPLE CLASS, INT. CLS. 35, 36, 38,  
39 AND 45.
- TRAXXAS LP, PLANO, TX:  
2,458,519, REN. 3-25-11. INT. CL. 28.
- TRB CHEMEDICA SA, VOUVRY, SWITZERLAND:  
2,378,624, CANC. INT. CL. 5.
- TREAMCO INVESTMENTS, INC., ST PETERSBURG, FL:  
2,556,585, CANC. INT. CL. 42.
- TREASURE ISLAND FOODS, INC., CHICAGO, IL:  
3,954,111, PUB. 2-15-2011. INT. CL. 35.
- TREK AMERICA TRAVEL LIMITED, CRAWLEY, WEST  
SUSSEX, ENGLAND:  
2,508,311, REN. 3-26-11. INT. CL. 39.
- TRELIANT RISK ADVISORS, LLC, WASHINGTON, DC:  
3,954,251, PUB. 2-15-2011. INT. CL. 35.
- TREND MAGAZINES, INC., ST. PETERSBURG, FL:  
1,644,395, REN. 3-31-11. INT. CL. 16.
- TRENEGY INCORPORATED, HOUSTON, TX:  
3,956,092, INT. CL. 35.
- TRENTON HOCKEY CLUB, L.L.C., TRENTON, NJ TO ECHL  
INC., PRINCETON, NJ:  
2,379,951, CANC. INT. CL. 25.
- TRES MONKEY, INC., LOS ANGELES, CA:  
2,877,555, CANC. INT. CL. 25.
- TREVIAN SOCCER CLUB, NORTHFIELD, IL:  
3,954,746, PUB. 2-15-2011. INT. CL. 41.  
3,954,747, PUB. 2-15-2011. INT. CL. 41.
- TRG ACCESSORIES, L.L.C., ST. LOUIS, MO:  
2,387,121, REN. 3-26-11. MULTIPLE CLASS, INT. CLS. 9  
AND 18.
- 2,876,542, CANC. INT. CL. 18.
- TRI-VALLEY PROPAC, INC., DANVILLE, CA:  
3,954,273, PUB. 2-15-2011. INT. CL. 16.
- TRIARCO INDUSTRIES, INC., WAYNE, NJ:  
2,446,735, REN. 3-29-11. INT. CL. 5.
- TRIBUNE LICENSE, INC., CHICAGO, IL:  
2,554,992, CANC. INT. CL. 35.
- TRICO PRODUCTS CORPORATION, ROCHESTER HILLS,  
MI:  
3,955,407, INT. CL. 35.
- TRIGG LABORATORIES, INC., VALENCIA, CA:  
3,955,084, PUB. 2-15-2011. INT. CL. 5.
- TRILLIONAIRE TYCOON, INC., CHICAGO, IL:  
3,955,385, INT. CL. 25.
- TRILOGY ENTERPRISES, INC., AUSTIN, TX, TRILOGY  
SOFTWARE, INC., AUSTIN, TX:  
2,437,801, REN. 3-29-11. MULTIPLE CLASS, INT. CLS. 9  
AND 42.
- TRILOGY, INC., CHICAGO, IL:  
2,378,495, CANC. INT. CL. 42.
- TRIM-TEX, INC., LINCOLNWOOD, IL:  
2,439,471, REN. 3-28-11. INT. CL. 19.
- TRINCI, JEFFREY DANIEL, PORTLAND, OR:  
3,955,215, MULTIPLE CLASS, INT. CLS. 35, 38, 41 AND  
45.
- TRINITY COLON & RECTAL SURGERY CLINIC, PA,  
DUNCANVILLE, TX:  
3,863,120, AM. INT. CL. 44.
- TRIPLE DIAMOND, LLC, BALTIMORE, MD:  
2,876,684, CANC. INT. CL. 42.
- TRIPLE POINT TECHNOLOGY, INC., WESTPORT, CT:  
2,379,959, CANC. INT. CL. 9.
- TRIPROTTHING INC., ALTADENA, CA:  
3,954,684, PUB. 2-15-2011. INT. CL. 45.
- TRIPWIRE, INC., PORTLAND, OR:  
3,892,341, COR. INT. CL. 9.
- TRISRI GLOBAL, INC., PLANO, TX, DBA ED GURUKUL:  
3,954,270, PUB. 2-15-2011. INT. CL. 41.
- TRITON INTERNATIONAL FROZEN FOODS, INGLE-  
WOOD, CA:  
2,876,249, CANC. INT. CL. 30.
- TRIUMPH HOSIERY CORPORATION, HOLLYWOOD, FL:  
2,446,704, REN. 3-26-11. INT. CL. 25.
- TRIVITRO CORPORATION, KENT, WA:  
2,442,145, REN. 3-30-11. INT. CL. 3.
- TRIXAN PTY LTD, SIDNEY SOUTH NSW 1235, AUSTRALIA:  
2,877,370, CANC. INT. CL. 35.
- TROON GOLF, L.L.C., SCOTTSDALE, AZ:  
3,956,032, INT. CL. 41.
- TROY, EUGENE F, SILVER SPRING, MD, DBA ENERGY  
PENGUIN LLC:  
3,954,072, PUB. 2-15-2011. INT. CL. 35.  
3,954,073, PUB. 2-15-2011. INT. CL. 35.
- TROZERA, THOMAS, DEL MAR, CA:  
2,878,041, CANC. INT. CL. 8.
- TRS QUALITY, INC., FORT WORTH, TX:  
2,876,506, CANC. INT. CL. 9.
- TRS QUALITY, INC., FT. WORTH, TX:  
3,955,368, INT. CL. 9.
- TRU VUE, INC., MCCOOK, IL, VIRATEC TRU VUE, INC.,  
CHICAGO, IL:  
1,645,688, REN. 3-29-11. INT. CL. 21.
- TRUDI S.P.A., TARENTO (UDINE), ITALY:  
2,941,551, CANC. MULTIPLE CLASS, INT. CLS. 16, 18, 24  
AND 25.
- TRUE VALUE COMPANY, CHICAGO, IL:  
2,877,582, CANC. INT. CL. 35.  
3,955,216, INT. CL. 18.
- TRUMAN ARNOLD COMPANIES, TEXARKANA, TX:  
3,953,150, PUB. 2-15-2011. MULTIPLE CLASS, INT. CLS.  
35 AND 39.  
3,953,151, PUB. 2-15-2011. MULTIPLE CLASS, INT. CLS.  
35 AND 39.
- TRUMAN MEDICAL CENTER, INC., KANSAS CITY, MO:  
2,876,474, CANC. MULTIPLE CLASS, INT. CLS. 44 AND  
45.

TRUNK CLUB, INC., CHICAGO, IL:  
3,953,787, PUB. 2-15-2011. INT. CL. 45.

TRUSSARDI S.P.A., MILAN, ITALY:  
3,953,389, PUB. 8-3-2010. INT. CL. 3.

TRUSTEE OF THE HERMAN FAMILY TRUST, LOS ANGELES, CA:  
2,448,328. REN. 3-29-11. INT. CL. 25.

TRUTH FOR LIFE, CLEVELAND, OH:  
2,473,448. REN. 3-25-11. INT. CL. 16.

TRUVAE RESEARCH, HUMBLE, TX:  
2,877,590, CANC. INT. CL. 5.

TRU20, INC, GREENSBORO, NC:  
3,954,486, PUB. 2-15-2011. INT. CL. 7.

TS ALOHA, INC., SOLANA BEACH, CA:  
2,438,592. REN. 3-30-11. INT. CL. 42.

TSAI, NIECO MING HUAN, VERNON, CA:  
3,954,410, PUB. 2-15-2011. INT. CL. 9.

TSL (USA) INC., WILMINGTON, DE:  
2,877,855, CANC. INT. CL. 36.

TU YONGFENG, GUANGDONG PROVINCE, CHINA:  
3,955,894, INT. CL. 9.

TUBI THOR S.P.A., ITALY:  
3,953,559, PUB. 2-15-2011. INT. CL. 17.  
3,953,560, PUB. 2-15-2011. INT. CL. 17.

TUCKER-ROCKY CORPORATION, INC., WILMINGTON, DE:  
2,496,626. REN. 3-28-11. INT. CL. 35.  
2,993,886, CANC. INT. CL. 9.

TUCKER, ALFRED J., GRAND PRAIRIE, TX:  
3,954,356, PUB. 2-15-2011. INT. CL. 41.

TUCKER, BRENDA, MILFORD, MA:  
2,877,355, CANC. INT. CL. 41.

TUFFY ASSOCIATES, CORP., TOLEDO, OH:  
922,985. REN. 3-26-11. U.S. CL. 103 (INT. CL. 37).

TUITION PLAN CONSORTIUM, LLC, ST. LOUIS, MO:  
3,953,376, PUB. 2-15-2011. INT. CL. 36.

TUMI, INC., SOUTH PLAINFIELD, NJ:  
3,954,605, PUB. 2-15-2011. INT. CL. 18.

TUNECORE, INC., BROOKLYN, NY, FORMERLY YOUR TUNES, INC.:  
3,249,247 NEW CERT. 5-3-2011. MULTIPLE CLASS, INT. CLS. 35 AND 40.

TURCK INC., PLYMOUTH, MN:  
2,380,053, CANC. INT. CL. 9.

TURNBERRY COURT CORPORATION, AVENTURA, FL:  
2,379,019, CANC. MULTIPLE CLASS, INT. CLS. 36 AND 37.

TURNER NETWORK TELEVISION, INC., ATLANTA, GA:  
3,955,289, INT. CL. 41.

TURTLE MARKET LLC, MURRELLS INLET, SC:  
3,955,760, INT. CL. 35.

TV GUIDE ENTERTAINMENT GROUP, LLC, LOS ANGELES, CA:  
3,955,886, INT. CL. 41.

TV-DESI INC., PLAINVIEW, NY:  
3,953,111, PUB. 2-15-2011. MULTIPLE CLASS, INT. CLS. 9 AND 38.

TVC COMMUNICATIONS, L.L.C., ANNVILLE, PA:  
2,878,059, CANC. INT. CL. 17.

TVO NUCLEAR SERVICES OY, 27160 OLKILUOTO, FINLAND:  
2,875,975, CANC. MULTIPLE CLASS, INT. CLS. 37, 41 AND 42.

TWELVE STONES GROUP LLC, CLEARWATER, FL:  
3,954,066, PUB. 2-15-2011. INT. CL. 45.

TWENTIETH CENTURY FOX FILM CORPORATION, LOS ANGELES, CA:  
2,442,861. REN. 3-28-11. INT. CL. 41.  
3,955,677, INT. CL. 28.  
3,955,678, INT. CL. 16.  
3,955,679, INT. CL. 25.  
3,955,680, INT. CL. 41.

TWO FINE DOGS, OJAI, CA:  
3,955,469, MULTIPLE CLASS, INT. CLS. 16 AND 20.

TWO FOR THE ROAD, INC., EVANSTON, IL:  
3,955,333, MULTIPLE CLASS, INT. CLS. 16, 39 AND 41.

TWORKZ.COM, LLC, NAPLES, FL:  
3,955,685, INT. CL. 42.

TWUSA INC., SPRING, TX, DBA BFF LABS:  
3,954,485, PUB. 2-15-2011. INT. CL. 5.

TYNDALE HOUSE PUBLISHERS INC., CAROL STREAM, IL:  
2,485,193. REN. 3-30-11. INT. CL. 9.

TYSON FOODS, INC., SPRINGDALE, AR:  
2,876,483, CANC. INT. CL. 29.

U.S. CONCRETE, INC., HOUSTON, TX:  
3,954,518, PUB. 2-15-2011. MULTIPLE CLASS, INT. CLS. 19 AND 40.

U.S. FOODSERVICE, INC., ROSEMONT, IL:  
3,955,961, INT. CL. 35.

U.S. GREEN BUILDING COUNCIL, WASHINGTON, DC:  
3,953,333, PUB. 2-15-2011. U.S. CL. B.  
3,953,334, PUB. 2-15-2011. U.S. CL. B.  
3,953,335, PUB. 2-15-2011. U.S. CL. B.

U.S. PHARMACEUTICAL CORPORATION, DECATUR, GA:  
2,379,556, CANC. INT. CL. 5.

U.S. PLASTIC LUMBER IP CORPORATION, WILMINGTON, DE:  
2,876,382, CANC. MULTIPLE CLASS, INT. CLS. 17 AND 19.

U.S. RE COMPANIES, INC., PEARL RIVER, NY:  
3,953,190, PUB. 2-15-2011. MULTIPLE CLASS, INT. CLS. 35 AND 36.  
3,953,191, PUB. 2-15-2011. INT. CL. 16.

U.S. VISION, INC., GLENDORA, NJ:  
3,955,445, INT. CL. 9.

UBS AG, CH-8001 ZURICH, SWITZERLAND:  
2,956,504, CANC. INT. CL. 35.

UBS FINANCIAL SERVICES INC., WEEHAWKEN, NJ:  
2,451,171. REN. 3-26-11. INT. CL. 9.

UCB MANUFACTURING, INC., ROCHESTER, NY, BLOCK DRUG COMPANY, INC., JERSEY CITY, NJ:  
1,151,441. REN. 3-31-11. INT. CL. 5.

UCENTRIK INC., TORONTO, ONTARIO, CANADA:  
3,953,011, PUB. 2-15-2011. INT. CL. 9.

UFIDA SOFTWARE CO. LTD., BEIJING, CHINA:  
2,876,200, CANC. MULTIPLE CLASS, INT. CLS. 9, 41 AND 42.

ULRICH JUESTRICH HOLDING AG, WALZENHAUSEN, SWITZERLAND:  
2,438,323. REN. 3-30-11. INT. CL. 3.  
2,438,323, CANC. INT. CL. 21.

ULRICH, PATRICK T., SANIBEL, FL AND ULRICH, JOANNE V., SANIBEL, FL:  
3,954,428, PUB. 2-15-2011. INT. CL. 44.

ULTIMATE PERFORMANCE & FITNESS, INC., WESTLAKE VILLAGE, CA:  
3,953,128, PUB. 2-15-2011. INT. CL. 41.

ULTIMATTE CORPORATION, CHATSWORTH, CA, VLAHOS-GOTTSCHALK RESEARCH CORPORATION, REDDA, CA:  
1,166,222. REN. 3-29-11. INT. CL. 9.

ULTIMUS, INC., CARY, NC:  
2,427,009. REN. 3-31-11. INT. CL. 9.

ULTRA POLY, INC., TACOMA, WA:  
2,877,518, CANC. INT. CL. 19.

ULTRADENT PRODUCTS, INC., SOUTH JORDAN, UT:  
2,528,832. REN. 3-29-11. INT. CL. 5.

UMEDEX, INC., BOCA RATON, FL:  
3,953,250, PUB. 2-15-2011. INT. CL. 9.  
3,953,251, PUB. 2-15-2011. INT. CL. 9.  
3,953,277, PUB. 2-15-2011. INT. CL. 9.

UNDER ARMOUR, INC., BALTIMORE, MD:  
3,953,243, PUB. 2-15-2011. INT. CL. 24.  
3,955,713, INT. CL. 24.  
3,955,928, INT. CL. 35.  
3,955,929, INT. CL. 35.

UNICORN FINANCIAL SERVICES, INC., TALLAHASSEE, FL:  
2,877,014, CANC. INT. CL. 36.

UNIFLEX HOLDINGS, INC., PHILADELPHIA, PA:  
3,954,577, PUB. 2-15-2011. INT. CL. 22.  
3,954,578, PUB. 2-15-2011. INT. CL. 22.

UNIGLOBE TRAVEL INTERNATIONAL LIMITED PARTNERSHIP, VANCOUVER, CANADA:  
2,436,511. REN. 3-26-11. MULTIPLE CLASS, INT. CLS. 39

- AND 42.  
 UNILEVER PLC, MERSEYSIDE, UNITED KINGDOM:  
 2,457,732. REN. 3-30-11. INT. CL. 3.  
 UNILEVER PLC, MERSEYSIDE, ENGLAND:  
 3,955,624. INT. CL. 3.  
 UNIMATRIX LLC, LAS VEGAS, NV:  
 2,877,726. CANC. MULTIPLE CLASS, INT. CLS. 35 AND  
 36.  
 UNION BANK, NATIONAL ASSOCIATION, SAN FRANCIS-  
 CO, CA:  
 2,876,882. CANC. INT. CL. 36.  
 UNION SPECIAL CORPORATION, HUNTLEY, IL:  
 713,110. REN. 3-29-11. U.S. CL. 23 (INT. CL. 7).  
 UNION STATION KANSAS CITY, INC., KANSAS CITY, MO:  
 2,380,109. CANC. INT. CL. 41.  
 UNION TELECOM, INC., CHICAGO, IL:  
 3,956,168. INT. CL. 36.  
 UNITE EURO THERAPY, INC., CARLSBAD, CA:  
 2,876,954. CANC. INT. CL. 3.  
 UNITED FARMERS OF ALBERTA CO-OPERATIVE LIM-  
 ITED, CALGARY, ALBERTA, CANADA:  
 3,953,127. PUB. 2-15-2011. INT. CL. 35.  
 UNITED FEATHER & DOWN, INC., DES PLAINES, IL:  
 2,430,069. REN. 3-28-11. INT. CL. 24.  
 UNITED FOOTBALL LEAGUE, LLC, NEW YORK, NY:  
 3,953,872. PUB. 11-9-2010. MULTIPLE CLASS, INT. CLS.  
 25 AND 41.  
 UNITED INDUSTRIES CORP., ST. LOUIS, MO:  
 2,877,816. CANC. INT. CL. 1.  
 UNITED LEG WEAR COMPANY, LLC, NEW YORK, NY,  
 DBA UNITED LEG WEAR:  
 2,876,577. CANC. INT. CL. 25.  
 UNITED RETAIL INCORPORATED, ROCHELLE PARK, NJ:  
 2,378,501. CANC. MULTIPLE CLASS, INT. CLS. 3 AND 4.  
 UNITED SERVICE ORGANIZATIONS, INC., ARLINGTON,  
 VA:  
 3,953,717. PUB. 2-15-2011. INT. CL. 45.  
 UNITED STATES COLD STORAGE, INC., CHERRY HILL,  
 NJ:  
 2,449,898. REN. 3-26-11. INT. CL. 39.  
 2,451,814. REN. 3-26-11. INT. CL. 39.  
 UNITED STATES FIRE ARMS MANUFACTURING CO.,  
 INC., HARTFORD, CT:  
 3,956,139. INT. CL. 13.  
 UNITED STATES GOLF ASSOCIATION, FAR HILLS, NJ:  
 1,151,942. REN. 3-30-11. INT. CL. 41.  
 1,151,943. REN. 3-30-11. INT. CL. 41.  
 1,151,944. REN. 3-30-11. INT. CL. 41.  
 1,151,945. REN. 3-30-11. INT. CL. 41.  
 1,151,946. REN. 3-31-11. INT. CL. 41.  
 UNITED STATES GOLF ASSOCIATION, FAR HILLS, NJ,  
 DBA USGA:  
 2,446,388. REN. 3-30-11. INT. CL. 36.  
 UNITED STATES GOLF ASSOCIATION, FAR HILLS, NJ,  
 AKA USGA:  
 2,448,635. REN. 3-30-11. MULTIPLE CLASS, INT. CLS. 25  
 AND 41.  
 UNITED STATES GYPSUM COMPANY, CHICAGO, IL:  
 2,876,933. CANC. INT. CL. 19.  
 UNITED STATES JUNIOR CHAMBER OF COMMERCE,  
 TULSA, OK:  
 2,452,411. REN. 3-26-11. U.S. CL. 200.  
 UNITED STATES MARKETING CORPORATION, HUN-  
 TINGTON STATION, NY:  
 2,379,377. CANC. INT. CL. 20.  
 UNITED STATES OLYMPIC COMMITTEE, COLORADO  
 SPRINGS, CO:  
 3,955,223. INT. CL. 41.  
 UNITED STATES POSTAL SERVICE, WASHINGTON, DC:  
 2,441,310. REN. 3-30-11. MULTIPLE CLASS, INT. CLS. 16,  
 35 AND 39.  
 2,934,455. CANC. INT. CL. 35.  
 3,955,885. INT. CL. 16.  
 UNITED STATES SURGICAL CORPORATION, NORTH  
 HAVEN, CT:  
 1,638,978. REN. 3-31-11. INT. CL. 10.  
 UNITED SUPPLIERS, INC., ELDORA, IA:  
 3,955,073. PUB. 2-15-2011. INT. CL. 5.  
 UNITED TRUST FUND, INC., MIAMI, FL:  
 2,548,843. REN. 3-26-11. INT. CL. 36.  
 UNIVERSAL BRASS INCORPORATED, AUBURN, WA:  
 2,427,558. REN. 3-30-11. MULTIPLE CLASS, INT. CLS. 6  
 AND 12.  
 UNIVERSAL DESIGNS, INC., DELAND, FL:  
 2,439,693. REN. 3-26-11. INT. CL. 9.  
 UNIVERSAL GENEVE S.A., LES ACACIAS-GENEVE, SWIT-  
 ZERLAND:  
 2,876,978. CANC. INT. CL. 14.  
 UNIVERSAL MANAGEMENT GROUP, INC., NORTH-  
 BROOK, IL, DBA UNIVERSAL TRAINING:  
 2,378,850. CANC. INT. CL. 41.  
 UNIVERSITY LANGUAGE SERVICES, INC., NEW YORK,  
 NY:  
 2,418,644. REN. 3-26-11. INT. CL. 35.  
 UNIVERSITY OF FLORIDA, THE, GAINESVILLE, FL:  
 2,472,269. REN. 3-25-11. INT. CL. 41.  
 UNIVERSITY OF ILLINOIS ALUMNI ASSOCIATION, UR-  
 BANA, IL:  
 2,437,812. REN. 3-29-11. MULTIPLE CLASS, INT. CLS. 14,  
 16, 25 AND 42.  
 UNIVERSITY OF LOUISVILLE, LOUISVILLE, KY:  
 2,433,584. REN. 3-26-11. INT. CL. 42.  
 UNIVERSITY OF WISCONSIN HOSPITALS AND CLINICS  
 AUTHORITY, MADISON, WI, DBA UW HEALTH:  
 3,953,092. PUB. 2-15-2011. INT. CL. 35.  
 UNIVISION COMMUNICATIONS INC., LOS ANGELES, CA:  
 3,955,975. INT. CL. 41.  
 UNVERFERTH MANUFACTURING CO., INC., KALIDA,  
 OH, GROVER MANUFACTURING, INC., LUCKEY, OH:  
 910,386. REN. 3-26-11. U.S. CL. 23 (INT. CL. 7).  
 UNWIND.COM LLC, PEARL, MS, AKA THE UNWIND  
 COMPANY:  
 3,954,718. PUB. 2-15-2011. INT. CL. 35.  
 UOP LLC, DES PLAINES, IL:  
 1,168,249. REN. 3-25-11. INT. CL. 11.  
 UPC MEDICAL SUPPLIES, INC, SAN GABRIEL, CA, DBA  
 UNITED PACIFIC COMPANY:  
 3,954,724. PUB. 2-15-2011. INT. CL. 10.  
 UPCLICK MALTA LIMITED, SLIEMA, MALTA:  
 3,953,498. PUB. 2-15-2011. MULTIPLE CLASS, INT. CLS.  
 9, 16, 35 AND 42.  
 UPM-KYMMENE CORPORATION, 00130 HELSINKI, FIN-  
 LAND:  
 2,876,050. CANC. MULTIPLE CLASS, INT. CLS. 16 AND  
 17.  
 2,876,051. CANC. MULTIPLE CLASS, INT. CLS. 16 AND  
 17.  
 UPSTATE DREAM INSTITUTE, LLC, ITHACA, NY:  
 3,955,955. INT. CL. 5.  
 UP2US, INC., NEW YORK, NY:  
 3,953,274. PUB. 2-15-2011. INT. CL. 41.  
 URBAN LEATHER, INC., HOUSTON, TX:  
 2,877,084. CANC. MULTIPLE CLASS, INT. CLS. 20 AND  
 35.  
 URBAN LIFE SKILLS ACADEMY, NEPTUNE, NJ:  
 3,956,221. INT. CL. 44.  
 US JESCO INTERNATIONAL LTD. INC., CARROLLTON,  
 TX:  
 3,954,493. PUB. 2-15-2011. INT. CL. 28.  
 US JESCO INTERNATIONAL LTD., INC., CARROLLTON,  
 TX:  
 3,954,497. PUB. 2-15-2011. INT. CL. 28.  
 US LEGAL MANAGEMENT SERVICES, INC., LOS AN-  
 GELES, CA:  
 3,954,007. PUB. 2-15-2011. MULTIPLE CLASS, INT. CLS.  
 35 AND 45.  
 US MORTGAGE CORPORATION, BOHEMIA, NY, DBA  
 MORTGAGE CONCEPTS:  
 3,952,987. PUB. 2-15-2011. INT. CL. 36.  
 US SOLAR & WIND SYNERGIES LLC, FELTON, CA:  
 3,953,380. PUB. 2-15-2011. INT. CL. 35.  
 US SYNTHETIC CORPORATION, OREM, UT:  
 3,472,718. CANC. INT. CL. 40.  
 USA SPORTS, LLC, DOVER, DE:  
 2,876,129. CANC. INT. CL. 35.



USAUS LLC, LOVELAND, CO:  
3,955,332, MULTIPLE CLASS, INT. CLS. 9 AND 20.

USHG, LLC, NEW YORK, NY:  
1,646,379, REN. 3-28-11. INT. CL. 42.

USP LABS, LLC, DALLAS, TX:  
3,955,068, PUB. 2-15-2011. INT. CL. 5.  
3,955,069, PUB. 2-15-2011. INT. CL. 5.  
3,955,070, PUB. 2-15-2011. INT. CL. 5.  
3,955,071, PUB. 2-15-2011. INT. CL. 5.

USPLABS, LLC, DALLAS, TX:  
3,954,592, PUB. 2-15-2011. INT. CL. 5.

UTICA MUTUAL INSURANCE COMPANY, NEW HARTFORD, NY, DBA UTICA NATIONAL INSURANCE GROUP:  
3,953,225, PUB. 2-15-2011. INT. CL. 36.

UTILIMASTER CORPORATION, WAKARUSA, IN:  
3,956,019, INT. CL. 12.  
3,956,020, INT. CL. 12.

UTV OF ORLANDO, INC., LOS ANGELES, CA:  
2,442,790, REN. 3-26-11. INT. CL. 38.

UV TECHNOLOGIES, LLC, FORT MYERS, FL:  
3,955,653, INT. CL. 9.

VALENTINE LLC, MANCHESTER, CT:  
2,877,145, CANC. INT. CL. 45.

VALOIS SAS, 27110 LE NEUBOURG, FRANCE:  
2,878,034, CANC. INT. CL. 8.

VALTERRA PRODUCTS, INC., MISSION HILLS, CA:  
2,149,280, CANC. INT. CL. 17.

VALUE CITY OF MICHIGAN, INC., WESTLAND, MI:  
2,877,939, CANC. MULTIPLE CLASS, INT. CLS. 4, 11, 19, 20 AND 21.  
2,878,053, CANC. INT. CL. 35.

VALUEPRO SOFTWARE PTY LTD, AUSTRALIA:  
3,953,635, PUB. 2-15-2011. INT. CL. 9.

VAN BAERLE AG, 4142 MUNCHENSTEIN, SWITZERLAND:  
2,437,364, REN. 3-31-11. INT. CL. 1.

VAN BEEK NATURAL SCIENCE, LLC, ORANGE CITY, IA:  
3,954,098, PUB. 2-15-2011. INT. CL. 5.  
3,955,103, PUB. 2-15-2011. INT. CL. 5.

VAN CLEEF & ARPELS S.A., VILLARS-SUR-GLANE, SWITZERLAND:  
3,915,441, COR. INT. CL. 3.

VAN SON HOLLAND INK CORPORATION OF AMERICA, CENTRAL ISLIP, NY:  
3,954,964, PUB. 2-15-2011. INT. CL. 2.

VANCOUVER BOARD OF TRADE, VANCOUVER, CANADA:  
3,953,054, PUB. 1-18-2011. MULTIPLE CLASS, INT. CLS. 35 AND 41.

VANDEBILT UNIVERSITY, THE, NASHVILLE, TN:  
1,634,431, REN. 3-29-11. INT. CL. 41.

VANGURA KITCHEN TOPS, INC., NORTH HUNTINGDON, PA:  
2,379,756, CANC. INT. CL. 20.

VANILLA GORILLA, L.P., LONG BEACH, CA:  
2,876,052, CANC. INT. CL. 25.  
2,876,859, CANC. INT. CL. 16.

VANS GOURMET GIFTS, LONG BEACH, CA:  
2,877,211, CANC. INT. CL. 30.  
2,877,212, CANC. INT. CL. 30.

VANSOLKEMA PRODUCE, INC., BYRON CENTER, MI, VANSOLKEMA FARMS, INC., BYRON CENTER, MI:  
1,168,616, REN. 3-31-11. INT. CL. 31.

VANTAGE BRANDS, LLC, DALLAS, TX:  
3,955,446, INT. CL. 30.  
3,955,447, INT. CL. 30.

VANTANI, INC., LAKE BALBOA, CA:  
3,954,624, PUB. 2-15-2011. INT. CL. 14.

VANTERPOOL, DIRK, DEJOINE, ROSWELL, GA, AKA DIRK DEJOINE:  
3,955,625, INT. CL. 25.

VARIMED MEDIKAL SANAYI VE TICARET LIMITED SIRKETI, TURKEY:  
3,953,648, PUB. 2-15-2011. INT. CL. 10.

VARRIEUR, DOUGLAS, B, BIG PINE KEY, FL:  
3,953,060, PUB. 2-15-2011. INT. CL. 16.

VASHON-MAURY ISLAND CHAMBER OF COMMERCE, VASHON, WA:  
3,954,567, PUB. 2-15-2011. INT. CL. 41.

VASILEIOS STAMATAKOS, MERRILL, WI, DBA PAELEON:  
3,954,748, PUB. 2-15-2011. INT. CL. 29.

VAUGHN, MARK, FAYETTEVILLE, AR:  
3,954,037, PUB. 2-15-2011. INT. CL. 16.

VAX-D MEDICAL TECHNOLOGIES, L.L.C., OLDSMAR, FL:  
2,433,539, REN. 3-26-11. INT. CL. 10.

VBC, INC., BRATTLEBORO, VT:  
1,656,387, REN. 3-28-11. INT. CL. 30.

VERA INCORPORATED, GRANBY, QUEBEC, CANADA:  
3,954,266, PUB. 2-15-2011. INT. CL. 3.

VECNA TECHNOLOGIES, INC., CAMBRIDGE, MA:  
3,953,792, PUB. 2-15-2011. INT. CL. 42.

VEECO METROLOGY INC., SANTA BARBARA, CA:  
3,953,299, PUB. 2-15-2011. INT. CL. 9.

VEEDER, MATTHEW P., SHORELINE, WA:  
2,451,791, REN. 3-29-11. INT. CL. 37.

VEGHTE, ROBERT, BOCA RATON, FL:  
2,877,941, CANC. INT. CL. 42.

VENDETTA, INC., SAN FRANCISCO, CA:  
3,955,512, INT. CL. 34.

VENTANAZUL, LLC, LAS VEGAS, NV, DBA BABY DIEGO:  
3,953,278, PUB. 2-15-2011. INT. CL. 21.

VENTAS, INC., LOIUSVILLE, KY:  
3,026,209, CANC. INT. CL. 16.

VENTURA FOODS, LLC, BREA, CA, SCHAD INDUSTRIES, INC., OPELOUSAS, LA:  
1,640,627, REN. 3-28-11. INT. CL. 29.

VENTURA FOODS, LLC, BREA, CA:  
3,953,465, PUB. 12-9-2008. MULTIPLE CLASS, INT. CLS. 29, 30 AND 43.  
3,955,434, INT. CL. 35.

VENTURI WIRELESS, INC., MILPITAS, CA:  
2,937,326, AM. INT. CL. 9.

VENTUS MEDICAL, INC., BELMONT, CA:  
3,920,054, COR. INT. CL. 10.

VEO FINANCIAL COUNSEL, LLC, ARLINGTON HEIGHTS, IL:  
3,953,695, PUB. 2-15-2011. INT. CL. 36.

VERHAGE, ALEXANDER J., SAN FRANCISCO, CA:  
2,876,198, CANC. INT. CL. 33.

VERINT SYSTEMS INC., MELVILLE, NY:  
3,955,454, MULTIPLE CLASS, INT. CLS. 9 AND 42.

VERITAS AG, 63571 GELNHAUSEN, FED REP GERMANY:  
3,953,031, PUB. 2-15-2011. MULTIPLE CLASS, INT. CLS. 12 AND 17.

VEROST, RUSSELL L., NORTH TONAWANDA, NY AND VEROST, MARTIN A., WEST SENECA, NY:  
2,877,961, CANC. INT. CL. 6.

VESTIGES, INC., MINNEAPOLIS, MN:  
3,956,075, INT. CL. 24.

VESUVIUS FRANCE SA, FRANCE:  
3,953,505, PUB. 2-15-2011. MULTIPLE CLASS, INT. CLS. 7, 9, 17, 19 AND 21.

VIBIO INC., SAN FRANCISCO, CA:  
3,955,570, INT. CL. 42.

VICKIE K. WEBER, WELCOME, MN:  
3,955,978, INT. CL. 21.

VICTORIAN PAPER COMPANY, LENEXA, KS:  
3,953,045, PUB. 2-15-2011. INT. CL. 35.

VICTORY LIGHT USA LLC, FRANKLIN PARK, IL:  
3,956,042, INT. CL. 11.

VICTORY OVER SELF, INCORPORATED, MILLVILLE, UT:  
2,876,986, CANC. INT. CL. 41.

VIDA ENTERPRISE CORP., LOS ANGELES, CA:  
2,877,641, CANC. INT. CL. 25.

VIDAURRI NUÑEZ, MARITZA, ZAPOCAN JALISCO, MEXICO:  
3,953,199, PUB. 2-15-2011. INT. CL. 33.

VIDESANTE PHARMACEUTICALS, LLC, SUMMIT, NJ:  
3,953,834, PUB. 2-15-2011. INT. CL. 3.

VIE FINANCIAL GROUP, INC., PHILADELPHIA, PA:  
2,876,165, CANC. INT. CL. 36.

VIET WAH TRADING CORPORATION, SEATTLE, WA:  
1,641,661, REN. 3-31-11. INT. CL. 42.

- VIGNON, DENIS, 78690 ST REMY L'HONORE, FRANCE AND LANDOLT, FRANCOIS, 95 CH 1009 PULLY, FRANCE:  
2,877,238, CANC. MULTIPLE CLASS, INT. CLS. 13, 25, 28 AND 41.
- VIIV HEALTHCARE COMPANY, WILMINGTON, DE:  
2,379,199, CANC. INT. CL. 5.
- VIKING LIFE SAVING EQUIPMENT, INC., MIAMI, FL:  
2,876,982, CANC. INT. CL. 9.
- VIKING POOLS, LLC, JANE LEW, WV:  
2,477,933, REN. 3-31-11, INT. CL. 37.  
2,482,210, REN. 3-31-11, INT. CL. 37.
- VILLAGE PRESS, INC., TRAVERSE CITY, MI:  
3,955,478, U.S. CL. A.
- VILLEGAS, JUAN CARLOS, HOUSTON, TX:  
2,877,869, CANC. INT. CL. 9.
- VILLEROY & BOCH A.G., METTLACH D 66688, FED REP GERMANY:  
2,877,588, CANC. INT. CL. 11.
- VILLIAGE MART, INC., LOS ANGELES, CA:  
2,877,058, CANC. INT. CL. 44.
- VINLOGIX, INC., DALLAS, TX:  
3,954,512, PUB. 2-15-2011, INT. CL. 35.  
3,954,513, PUB. 2-15-2011, INT. CL. 35.
- VIPS, INC., TOWSON, MD:  
2,438,562, REN. 3-29-11, INT. CL. 9.
- VIRBAC AH, INC., FORT WORTH, TX:  
2,441,494, REN. 3-31-11, INT. CL. 5.
- VIRTUALWAY, LLC, WEST BABYLON, NY:  
3,953,861, PUB. 2-15-2011, INT. CL. 45.
- VISIBLE LIGHT LLC, MELBOURNE, FL:  
2,899,677, COR. INT. CL. 9.
- VISIONAEL CORPORATION, PALO ALTO, CA:  
2,877,008, CANC. INT. CL. 9.
- VISIONING HEALTHCARE INC., SARASOTA, FL:  
3,956,233, INT. CL. 41.
- VISIONNETWORK, LLC, SADDLE BROOK, NJ:  
2,379,107, CANC. INT. CL. 42.
- VISITING NURSE SERVICE OF NEW YORK, NEW YORK, NY:  
3,955,089, PUB. 2-15-2011, MULTIPLE CLASS, INT. CLS. 41, 44 AND 45.  
3,955,091, PUB. 2-15-2011, MULTIPLE CLASS, INT. CLS. 41, 44 AND 45.
- VISUAL INFINITY, INC., BERKELEY, CA:  
2,876,698, CANC. INT. CL. 9.
- VITAL CHOICE SEAFOOD, INC., BELLINGHAM, WA:  
3,956,055, INT. CL. 29.
- VITAL LEARNING CORPORATION, OMAHA, NE:  
2,481,609, CANC. INT. CL. 41.
- VITAMIN CLASSICS., CALABASAS, CA:  
3,952,985, PUB. 2-15-2011, INT. CL. 5.
- VITARELLO, JUSTIN, WASHINGTON, DC:  
3,953,822, PUB. 2-15-2011, INT. CL. 43.
- VITS TECHNOLOGY GMBH, LANGENFELD, FED REP GERMANY:  
2,441,786, REN. 3-30-11, INT. CL. 7.
- VIVENDI GAMES, INC., LOS ANGELES, CA:  
2,380,000, CANC. INT. CL. 9.
- VIVID MEDIA INC., MADISON, WI:  
2,379,052, CANC. INT. CL. 42.
- VIZ MEDIA, LLC, SAN FRANCISCO, CA:  
3,955,516, INT. CL. 38.
- VO-TOYS, INC., HARRISON, NJ:  
3,954,176, PUB. 2-15-2011, INT. CL. 28.
- VOITH PATENT GMBH, HEIDENHEIM, FED REP GERMANY:  
3,956,122, MULTIPLE CLASS, INT. CLS. 7 AND 12.
- VOLCOM, INC., COSTA MESA, CA:  
3,953,135, PUB. 2-15-2011, INT. CL. 25.
- VOLK OPTICAL, INC., MENTOR, OH:  
1,668,361, REN. 3-31-11, INT. CL. 9.
- VOMADO AIR, LLC, ANDOVER, KS:  
2,380,135, CANC. INT. CL. 9.
- VONAGE MARKETING LLC, HOLMDEL, NJ:  
3,954,915, PUB. 2-15-2011, MULTIPLE CLASS, INT. CLS. 9 AND 38.
- VOX MEDICA, INC., PHILADELPHIA, PA:  
2,876,765, CANC. MULTIPLE CLASS, INT. CLS. 9, 16 AND 41.
- VOXEO CORPORATION, ORLANDO, FL:  
3,955,429, MULTIPLE CLASS, INT. CLS. 9, 38 AND 42.
- VOXER IP LLC, SAN FRANCISCO, CA:  
3,955,221, MULTIPLE CLASS, INT. CLS. 9 AND 38.
- VP TECHNOLOGIES LLC, JENKINTOWN, PA:  
3,954,815, PUB. 2-15-2011, INT. CL. 35.
- VUJA DE STUDIOS, SHERMAN OAKS, CA:  
3,954,772, PUB. 2-15-2011, INT. CL. 35.
- VULCAN INC., SEATTLE, WA:  
2,877,759, CANC. INT. CL. 36.
- VYPERBYTE, LLC, EVANSVILLE, WI:  
3,954,211, PUB. 2-15-2011, INT. CL. 37.
- W.B. WALLACE, INC., CHARLOTTE, NC:  
2,876,335, CANC. INT. CL. 37.
- W&W STEEL, LLC, OKLAHOMA CITY, OK:  
3,954,530, PUB. 2-15-2011, MULTIPLE CLASS, INT. CLS. 6, 37, 40 AND 42.
- WACKER-CHEMIE AG, MUNICH, FED REP GERMANY:  
2,876,150, CANC. MULTIPLE CLASS, INT. CLS. 1, 3 AND 4.
- WALCHLE, JONATHAN, ALPHARETTA, GA, DBA LABOR STAFFING, INC.:  
3,956,133, INT. CL. 35.
- WALDEN CHAMBER PLAYERS, INC., ARLINGTON, MA:  
2,482,558, REN. 3-25-11, INT. CL. 41.
- WALGREEN CO., DEERFIELD, IL:  
2,876,707, CANC. INT. CL. 30.
- WALKI GROUP OY, 37630 VALKEAKOSKI, FINLAND:  
2,877,311, CANC. INT. CL. 16.
- WALL SOURCE, L.L.C., DALLAS, TX:  
2,876,829, CANC. INT. CL. 27.
- WALL STREET SYSTEMS SWEDEN AB, STOCKHOLM, SWEDEN:  
2,875,864, CANC. MULTIPLE CLASS, INT. CLS. 9 AND 42.
- WALL WRITTEN, L.L.C., PROVO,, UT:  
3,954,262, PUB. 2-15-2011, INT. CL. 16.
- WALLACE ENTERPRISES, INC., LAWRENCE, MA:  
2,876,833, CANC. MULTIPLE CLASS, INT. CLS. 36 AND 45.
- WALRACK, GARY, GREAT FALLS, MT:  
2,768,502, CANC. INT. CL. 9.
- WALTERS, ERNEST III., NEW ORLEANS, LA, DBA EW3, WALTERS, ERNEST III., NEW ORLEANS, LA, DBA EW3:  
2,424,471, REN. 3-30-11, INT. CL. 25.
- WALTHAM INTERNATIONAL S.A., 2074 MARIN-EPAGINER, SWITZERLAND:  
2,876,262, CANC. INT. CL. 14.
- WALTON & POST, INC., MIAMI, FL:  
3,955,854, MULTIPLE CLASS, INT. CLS. 29 AND 30.
- WANG, GRACE H., SEOUL, REPUBLIC OF KOREA:  
3,955,547, MULTIPLE CLASS, INT. CLS. 9 AND 16.
- WANTAGH DENTAL ARTS, P.C., WANTAGH, NY:  
2,877,235, CANC. INT. CL. 44.
- WARBLE RECORDS, LLC, SCOTTSDALE, AZ:  
2,876,890, CANC. INT. CL. 16.
- WAREHOUSE CONNECTION, LLC, KNOXVILLE, TN:  
2,877,465, CANC. INT. CL. 36.
- WARM GLOW CANDLE COMPANY, CENTERVILLE, IN:  
2,525,292, REN. 3-25-11, INT. CL. 4.
- WARNER BROS. ENTERTAINMENT INC., BURBANK, CA:  
2,491,427, REN. 3-31-11, INT. CL. 9.
- WARNER BROS. ENTERTAINMENT INC., 4000 WARNER BOULEVARD, CA:  
2,493,484, REN. 3-25-11, INT. CL. 21.
- WARNER BROS. ENTERTAINMENT INC., BURBANK, CA:  
3,955,610, INT. CL. 41.
- WARNER, GEOFFREY, STONINGTON, ME:  
3,955,146, PUB. 2-15-2011, INT. CL. 20.  
3,955,147, PUB. 2-15-2011, INT. CL. 20.
- WARPAINT CLOTHING COMPANY, OKLAHOMA CITY, OK:  
3,953,240, PUB. 2-15-2011, INT. CL. 25.

WARREN COMMUNICATIONS NEWS, INC., WASHINGTON, DC:  
2,433,813. REN. 3-26-11. INT. CL. 16.

WASATCH FRONT REGIONAL MULTIPLE LISTING SERVICE, INC., SANDY, UT:  
2,471,066. REN. 3-30-11. INT. CL. 36.

WASHINGTON MUTUAL, INC., SEATTLE, WA:  
2,877,044. CANC. INT. CL. 36.

WASHINGTON STATE ASSOCIATION OF BROADCASTERS, OLYMPIA, WA:  
2,449,269. REN. 3-26-11. INT. CL. 42.

WASHINGTONPOST.NEWSWEEK INTERACTIVE COMPANY, LLC, ARLINGTON, VA:  
2,876,189. CANC. MULTIPLE CLASS, INT. CLS. 35, 41 AND 42.

WATER PIK, INC., FORT COLLINS, CO:  
3,955,127. PUB. 2-15-2011. INT. CL. 11.

WATER-JEL TECHNOLOGIES, LLC, CARLSTADT, NJ, TRILLING RESOURCES, LTD., HARTSDALE, NY:  
1,177,931. REN. 3-25-11. INT. CL. 9.

WATERMOOR GROUP LIMITED, WEST SAYVILLE, NY:  
3,954,652. PUB. 2-15-2011. INT. CL. 42.

WATERS, LISA MARIE, ARCATA, CA:  
2,880,420. CANC. INT. CL. 35.

WATERWHEEL LICENSING LLC, LOS ANGELES, CA:  
3,955,490. INT. CL. 28.

WATSON WYATT & COMPANY, ARLINGTON, VA:  
3,955,500. MULTIPLE CLASS, INT. CLS. 35 AND 41.

WATT PUBLISHING CO., MOUNT MORRIS, IL:  
2,876,886. CANC. INT. CL. 16.

WATTERS PLUMBING, INC, MENASHA, WI:  
3,955,933. INT. CL. 37.

WATTS REGULATOR CO., NORTH ANDOVER, MA, WATTS REGULATOR CO., LAWRENCE, MA:  
1,150,860. REN. 3-31-11. MULTIPLE CLASS, INT. CLS. 9 AND 11.

WAVE59 TECHNOLOGIES INT'L, INC., BOULDER, CO:  
3,953,720. PUB. 2-15-2011. INT. CL. 9.

WAYNE SIKORCIN, AURORA, IL:  
3,953,326. PUB. 2-15-2011. INT. CL. 8.

WAYPOINT TECHNOLOGIES, INC., LITTLE FALLS, MN, DBA LAKEMASTER LAKE MAPS:  
3,953,696. PUB. 2-15-2011. MULTIPLE CLASS, INT. CLS. 9 AND 16.  
3,953,704. PUB. 2-15-2011. MULTIPLE CLASS, INT. CLS. 9 AND 16.  
3,953,749. PUB. 2-15-2011. INT. CL. 9.

WAZANA BROTHERS INTERNATIONAL, INC., CHATSWORTH, CA, DBA MICRO SOLUTIONS ENTERPRISES:  
3,954,873. PUB. 2-15-2011. INT. CL. 2.  
3,954,884. PUB. 2-15-2011. MULTIPLE CLASS, INT. CLS. 2 AND 40.

WD MUSIC PRODUCTS, INC., NORTH FORT MYERS, FL:  
3,956,115. INT. CL. 15.

WEALTHCARE CAPITAL MANAGEMENT IP, LLC, RICHMOND, VA:  
2,878,021. CANC. INT. CL. 9.

WEATHERALL INDIANA, INC., CHARLESTOWN, IN:  
2,445,017. REN. 3-25-11. MULTIPLE CLASS, INT. CLS. 17 AND 19.

WEBDEV AZ, INC, MESA, AZ:  
2,877,709. CANC. INT. CL. 35.

WEBEX, INC., NEENAH, WI:  
2,455,447. REN. 3-29-11. INT. CL. 40.

WEBSHOZ, INC., KIRKLAND, WA, DBA WEBSHOZ:  
3,956,232. INT. CL. 35.

WECHTER GUITARS, INC., FORT WAYNE, IN, DBA WECHTER GUITARS USA:  
3,954,436. PUB. 2-15-2011. INT. CL. 15.

WEDDING RING WORKSHOP-USA, LLC, SAN DIEGO, CA:  
3,954,080. PUB. 2-15-2011. INT. CL. 40.

WEDGEWOOD PHARMACY, SEWELL, NJ:  
2,876,435. CANC. INT. CL. 5.

WEE HUANG, OWINGS MILLS, MD, DBA HUANG'S INC.:  
3,953,178. PUB. 2-15-2011. INT. CL. 41.

WEEDN, STUART, NEWPORT BEACH, CA:  
3,954,285. PUB. 2-15-2011. INT. CL. 35.

WEH GMBH, VERBINDUNGSTECHNIK, D-89257 ILLERTISSEN, FED REP GERMANY:  
2,876,724. CANC. INT. CL. 7.

WEIMER, TONJA EVETTS, GREENVILLE, SC:  
2,877,585. CANC. INT. CL. 16.

WEINBERG GROUP INC., THE, WASHINGTON, DC:  
2,526,848. REN. 3-26-11. MULTIPLE CLASS, INT. CLS. 35 AND 42.

WEINSTOCK, DAVID KERRY, INDIANOLA, WA, DBA LIMINAL SOMATICS:  
3,954,937. PUB. 2-15-2011. INT. CL. 41.

WEINTRAUB, MICHELLE, WESTFIELD, NJ:  
2,394,009. REN. 3-31-11. INT. CL. 3.

WEISS & BIHELLER MERCHANDISE CORPORATION, NEW YORK, NY:  
2,379,996. CANC. INT. CL. 20.

WELCH ALLYN, INC., SKANEATELES FALLS, NY:  
915,533. REN. 3-29-11. U.S. CL. 44 (INT. CL. 10).

WELD TOOLING CORPORATION, CANONSBURG, PA:  
1,150,809. REN. 3-25-11. INT. CL. 7.

WELLEN, LLC, GLENDALE, CA:  
3,953,216. PUB. 2-15-2011. INT. CL. 25.

WELLESLEY SYSTEMS, INC., WELLESLEY, MA:  
3,955,681. INT. CL. 35.

WELLS FARGO FINANCIAL, INC., MINNEAPOLIS, MN, WELLS FARGO FINANCIAL, INC., MINNEAPOLIS, MN:  
2,474,001. REN. 3-31-11. INT. CL. 36.

WELLS' DAIRY, INC., LE MARS, IA:  
3,955,078. PUB. 2-15-2011. INT. CL. 30.

WELLSRING WIRELESS, INC., NORTH WALES, PA:  
2,876,194. CANC. MULTIPLE CLASS, INT. CLS. 35, 37 AND 42.

WENCO, LLC, NEW YORK, NY, DBA SILVERMARK:  
3,955,380. INT. CL. 20.

WENTE BROS., LIVERMORE, CA:  
3,955,141. PUB. 2-15-2011. INT. CL. 33.

WERA-WERK HERMANN WERNER GMBH & CO. KG, WUPPERTAL, FED REP GERMANY:  
3,953,187. PUB. 2-15-2011. MULTIPLE CLASS, INT. CLS. 7 AND 8.

WERNER PUBLISHING CORPORATION, LOS ANGELES, CA:  
2,535,060. REN. 3-31-11. INT. CL. 16.

WERNER, GERALD, MEININGEN, FED REP GERMANY:  
2,932,664. CANC. INT. CL. 38.

WEST CONSULTING INC., MEMPHIS, TN:  
3,955,205. INT. CL. 3.

WEST END PRODUCTS, LLC, ALPHARETTA, GA:  
3,953,196. PUB. 2-15-2011. INT. CL. 3.

WESTERN DATACOM CO., INC., WESTLAKE, OH, AKA WESTERN DATACOM:  
3,953,342. PUB. 2-15-2011. INT. CL. 9.

WESTERN GENERAL INSURANCE COMPANY, CALABASAS, CA:  
2,472,057. REN. 3-29-11. INT. CL. 36.

WESTERN RECREATIONAL VEHICLES, INC., YAKIMA, WA:  
2,877,395. CANC. INT. CL. 12.

WESTERN RESEARCH 3000, INC., THOUSAND OAKS, CA:  
3,955,813. INT. CL. 5.

WESTLAKE LONGVIEW CORPORATION, HOUSTON, TX:  
2,434,458. REN. 3-26-11. INT. CL. 1.

WGI INNOVATIONS, LTD., GRAND PRAIRIE, TX:  
3,955,778. INT. CL. 9.

WHAM-O, INC., WOOLAND HILLS, CA, KRANSCO, SAN FRANCISCO, CA:  
1,638,508. REN. 3-31-11. INT. CL. 28.

WHAM-O, INC., EMERYVILLE, CA:  
2,430,306. REN. 3-26-11. INT. CL. 28.

WHAT A PIZZA WHAT A PRICE FRANCHISING, LLC, VANCEBURG, KY:  
3,954,377. PUB. 2-15-2011. INT. CL. 43.

WHAT KATIE DID, LTD., PANGBOURNE, UNITED KINGDOM:  
3,953,925. PUB. 2-15-2011. MULTIPLE CLASS, INT. CLS. 25 AND 35.

WHATS UP AND WHERE.COM INC., FITCHBURG, MA:  
3,954,469. PUB. 2-15-2011. INT. CL. 35.

- WHEEL PROS, LLC, LAKEWOOD, CO:  
2,475,230. REN. 3-26-11. INT. CL. 12.
- WHEELHOUSE INVESTMENT REAL ESTATE BROKER-  
AGE, INC., SAN FRANCISCO, CA:  
3,953,276. PUB. 2-15-2011. INT. CL. 42.
- WHEELING JESUIT UNIVERSITY, WHEELING, WV:  
2,477,779. CANC. INT. CL. 35.
- WHG TM CORP., LAS VEGAS, NV:  
718,705. REN. 3-31-11. U.S. CL. 100 (INT. CL. 42).
- WHG TM CORP., LAS VEGAS, NV, DAYS INNS OF  
AMERICA, INC., ATLANTA, GA:  
1,160,430. REN. 3-31-11. INT. CL. 42.
- WHG TM CORP., LAS VEGAS, NV:  
2,459,053. REN. 3-26-11. INT. CL. 42.
- WHIRLPOOL S.A., SÃO PAULO - SP, BRAZIL:  
3,953,893. PUB. 2-15-2011. INT. CL. 7.
- WHISTLE & WINK, INC., NEW YORK, NY:  
3,955,202. INT. CL. 24.
- WHISTLER WATER INC., BURNABY, BRITISH COLUMBIA  
, V5A 2T4, CANADA:  
2,438,686. REN. 3-31-11. INT. CL. 32.
- WHITAKER CORPORATION, THE, WILMINGTON, DE:  
703,903. REN. 3-29-11. U.S. CL. 23 (INT. CL. 8).
- WHITE & CASE LLP, NEW YORK, NY:  
2,876,558. CANC. MULTIPLE CLASS, INT. CLS. 39 AND  
42.
- WHITE MOUNTAIN PUZZLES INC., JACKSON, NH:  
3,954,180. PUB. 2-15-2011. INT. CL. 28.
- WHITE RIVER HARDWOODS-WOODWORKS, INC.,  
FAYETTEVILLE, AR:  
3,954,759. PUB. 2-15-2011. INT. CL. 19.
- WHITE WEBB, LLC, NEW YORK, NY:  
3,954,766. PUB. 2-15-2011. INT. CL. 20.
- WHITE, WILLIAM T., WATKINSVILLE, GA:  
3,954,786. PUB. 2-15-2011. INT. CL. 41.
- WHITMAN CONTROLS CORPORATION, BRISTOL, CT:  
2,876,866. CANC. INT. CL. 9.
- WHOLE LEAF CO., LLC, SALINAS, CA:  
2,877,186. CANC. INT. CL. 31.
- WHOLESALE DONKEE PRODUCTS INC., SOUTH EL  
MONTE, CA:  
2,876,248. CANC. INT. CL. 35.
- WHOLESALE STONE LLC, MIAMI BEACH, FL:  
3,956,257. INT. CL. 35.
- WIELAND DENTAL + TECHNIK GMBH & CO. KG, 75179  
PFORZHEIM, FED REP GERMANY:  
2,937,090. CANC. INT. CL. 10.
- WIELAND, ROBERTA, LAGUNA HILLS, CA:  
2,877,343. CANC. INT. CL. 35.  
2,877,344. CANC. INT. CL. 35.
- WIENNER, JONATHAN L, AVON, CT, DBA DJ THEORY:  
3,953,290. PUB. 2-15-2011. INT. CL. 41.
- WIFFLE BALL, INC., THE, SHELTON, CT:  
1,645,378. REN. 3-28-11. INT. CL. 28.
- WILBUR PRODUCTS, INC., SPRING LAKE1, MI, DBA  
TECH-LINE PRODUCTS:  
1,644,508. REN. 3-30-11. INT. CL. 28.
- WILBUR-ELLIS COMPANY, SAN FRANCISCO, CA:  
2,877,422. CANC. MULTIPLE CLASS, INT. CLS. 1 AND 5.
- WILDER, ERNEST T, FERNANDINA BEACH, FL:  
3,955,782. INT. CL. 25.
- WILDLIFE CONSERVATION SOCIETY, BRONX, NY:  
3,954,566. PUB. 2-15-2011. INT. CL. 41.
- WILDPACKETS, INC., WALNUT CREEK, CA:  
2,876,864. CANC. INT. CL. 9.
- WILEY X, INC., LIVERMORE, CA:  
2,450,213. REN. 3-25-11. INT. CL. 9.
- WILKS LICENSE COMPANY-KANSAS CITY LLC, AL-  
PHARETTA, GA:  
2,379,479. CANC. INT. CL. 38.
- WILLIAM ALLEN WOOTEN, COVINGTON, TN:  
3,955,660. INT. CL. 33.
- WILLIAM D. ENTERPRISES, INC., RICHMOND HILL, GA:  
2,877,705. CANC. INT. CL. 35.
- WILLIAM M. YARBROUGH FOUNDATION, CHICAGO, IL:  
3,954,274. PUB. 2-15-2011. INT. CL. 3.
- WILLIAMS, ROBERT TODD, HEALDSBURG, CA AND  
WILLIAMS, FRANCINE, HEALDSBURG, CA AND  
STRONG, RODNEY, HEALDSBURG, CA AND STRONG,  
CHARLOTTE, HEALDSBURG, CA AND THORSON,  
ERIK, HEALDSBURG, CA AND THORSON, LAURA L.,  
HEALDSBURG, CA:  
2,876,158. CANC. INT. CL. 16.
- WILLIAMS, ERIC B, KANSAS CITY, MO:  
3,954,891. PUB. 2-15-2011. INT. CL. 3.
- WILLIS, LARRELL I., LAKELAND, FL:  
3,844,653. COR. INT. CL. 1.
- WILLS GROUP, INC., THE, LA PLATA, MD:  
3,955,943. MULTIPLE CLASS, INT. CLS. 37 AND 39.  
3,955,944. MULTIPLE CLASS, INT. CLS. 37 AND 39.
- WILLTEK COMMUNICATIONS GMBH, 85737 ISMANING,  
FED REP GERMANY:  
2,876,218. CANC. INT. CL. 9.
- WILLY MONTANEZ, NORTH HALEDON, NJ:  
3,954,124. PUB. 2-15-2011. INT. CL. 25.
- WILMOTH, PATTI, WEST PALM BEACH, FL:  
3,953,725. PUB. 2-15-2011. INT. CL. 21.
- WILSON DANIELS LTD., ST. HELENA, CA:  
3,954,606. PUB. 2-15-2011. INT. CL. 33.
- WILSON, JACK H., SR., RIDGELAND, MS:  
3,955,157. INT. CL. 7.
- WILSON, MICHAEL D, BURLINGTON, NC:  
2,876,422. CANC. INT. CL. 41.
- WILSON, NICHOLAS PATRICK, SOLANA BEACH, CA:  
2,379,006. CANC. INT. CL. 25.
- WIND-UP RECORDS, LLC, NEW YORK, NY:  
2,877,094. CANC. INT. CL. 41.
- WINDMAX GREEN ENERGY CORPORATION, PLANO, TX:  
3,956,231. INT. CL. 9.
- WINDS ENTERPRISES LIMITED, TSUEN WAN, N.T.,  
HONG KONG:  
2,893,105. CANC. INT. CL. 25.
- WINDWARD PETROLEUM, INC., CHARLOTTE, NC:  
2,876,088. CANC. INT. CL. 4.
- WINE GROUP LLC, THE, LATHROP, CA:  
2,876,891. CANC. INT. CL. 33.  
2,876,893. CANC. INT. CL. 33.
- WINESTYLES, INC., MARGATE, FL:  
3,955,377. INT. CL. 16.
- WINIFRED MASTERTON BURKE REHABILITATION HOS-  
PITAL, INC, THE, WHITE PLAINS, NY:  
2,876,191. CANC. INT. CL. 44.
- WINKLER, MARY, STERLING HEIGHTS, NY:  
3,954,390. PUB. 2-15-2011. INT. CL. 25.
- WINSHIP, CHARLES E., WAYLAND, NY:  
2,380,032. CANC. INT. CL. 30.
- WINSLOW, ANDREW R., WESTWOOD, MA:  
2,877,845. CANC. INT. CL. 28.
- WINZER CORPORATION, DALLAS, TX:  
2,991,158. CANC. INT. CL. 2.
- WISE CHEM LLC, NEW ALBANY, OH:  
3,954,775. PUB. 2-15-2011. INT. CL. 2.
- WISECRACKER LLC, PETALUMA, CA:  
3,955,553. INT. CL. 25.
- WISHES INCORPORATED, LAWERNCEVILLE, GA:  
3,952,960. PUB. 2-15-2011. INT. CL. 21.
- WISSAM AMOUDI, DORAL, FL:  
3,954,079. PUB. 2-15-2011. MULTIPLE CLASS, INT. CLS.  
29 AND 30.
- WITH YOU, INC., NEW YORK, NY:  
3,954,114. PUB. 2-15-2011. INT. CL. 3.
- WIZARDS OF THE COAST LLC, PAWTUCKET, RI, TSR  
HOBBIES, INC., LAKE GENEVA, WI:  
1,166,670. REN. 3-30-11. INT. CL. 28.
- WMS GAMING INC., WAUKEGAN, IL:  
3,955,465. INT. CL. 9.  
3,955,820. INT. CL. 9.  
3,955,829. INT. CL. 9.
- WN PHARMACEUTICALS LTD., COQUITLAM, BC, CANA-  
DA:  
3,955,212. INT. CL. 5.
- WNBA ENTERPRISES, LLC, SECAUCUS, NJ:  
2,550,329. REN. 3-28-11. INT. CL. 18.

WOCKHARDT LIMITED, MUMBAI-400051, INDIA:  
2,588,792, CANC. INT. CL. 5.

WOLCOTT, MARGUERITE L., COSTA MESA, CA:  
2,417,165, CANC. MULTIPLE CLASS, INT. CLS. 18, 24  
AND 25.

WOLFIES RESTAURANTS & SPORTS BARS, INC., SPRING,  
TX:  
3,954,596, PUB. 2-15-2011. INT. CL. 43.

WOLFSON MICROELECTRONICS PLC, EDINBURGH, UNI-  
TED KINGDOM:  
2,422,630, REN. 3-26-11. INT. CL. 9.

WOLFSON, DIANE, TELLURIDE, CO:  
2,877,605, CANC. INT. CL. 28.

WOLPERT, KATHERINE A., FAIRFIELD, OH:  
2,876,554, CANC. INT. CL. 24.

WOMEN'S ONLINE MEDIA AND EDUCATION NETWORK,  
CARSON CITY, NV:  
3,953,101, PUB. 2-15-2011. INT. CL. 38.  
3,953,114, PUB. 2-15-2011. INT. CL. 38.

WOOD, CRISPIN, ARLINGTON, MA:  
3,953,783, PUB. 2-15-2011. INT. CL. 16.

WOOD, RON, RICHARDSON, TX:  
2,876,453, CANC. INT. CL. 37.

WOODBOLT DISTRIBUTION, BRYAN, TX:  
3,954,505, PUB. 2-15-2011. INT. CL. 5.

WOODLANDS WILDLIFE REFUGE, CLINTON, NJ:  
3,953,705, PUB. 2-15-2011. INT. CL. 39.

WOOF WEAR INC., NEW YORK, NY:  
2,876,176, CANC. INT. CL. 18.

WORDSRU PTY LTD, MELBOURNE, VICTORIA, AUSTRA-  
LIA:  
3,954,990, PUB. 2-15-2011. INT. CL. 41.

WORKFLOWONE LLC, DAYTON, OH, VANIER GRAPHICS  
CORPORATION, SANTEE, CA:  
1,639,041, REN. 3-29-11. INT. CL. 16.

WORKFORCE ENGINE, LLC, NEW YORK, NY:  
3,955,279, MULTIPLE CLASS, INT. CLS. 16, 35 AND 41.

WORKMAN, TANYA THERESE, PORTLAND, ME:  
3,954,899, PUB. 2-15-2011. INT. CL. 41.

WORKSTREAM INC., KANATA, CANADA:  
2,875,855, CANC. INT. CL. 35.

WORLD CARES CENTER, INC., NEW YORK, NY:  
3,955,296, INT. CL. 36.

WORLD DRYER CORPORATION, BERKELEY, IL:  
2,442,175, REN. 3-29-11. INT. CL. 11.  
2,442,176, REN. 3-29-11. INT. CL. 11.

WORLD LOTTERY ASSOCIATION, MONTREAL, QUEBEC,  
CANADA:  
2,875,952, CANC. MULTIPLE CLASS, INT. CLS. 16, 35  
AND 41.

WORLD OF HA, LLC, HAVERFORD, PA:  
3,954,732, PUB. 2-15-2011. INT. CL. 41.

WORLD PEACE PRAYER SOCIETY, SAN FRANCISCO, CA:  
1,639,038, REN. 3-28-11. MULTIPLE CLASS, INT. CLS. 16  
AND 25.  
1,639,038, CANC. MULTIPLE CLASS, INT. CLS. 18, 21, 24  
AND 26.

WORLD PUBLICATIONS, LLC, WINTER PARK, FL:  
2,468,559, REN. 3-30-11. INT. CL. 16.

WORLD RESIDENT HOLDINGS, LTD., THE, MIAMI, FL:  
2,461,955, REN. 3-31-11. INT. CL. 36.

WORLD SPORT STACKING ASSOCIATION, INC., ENGLE-  
WOOD, CO:  
2,877,114, CANC. INT. CL. 35.

WORLD TAEKWONDO FEDERATION, REPUBLIC OF  
KOREA:  
3,953,500, PUB. 9-14-2010. MULTIPLE CLASS, INT. CLS.  
25, 28 AND 41.

WORLD TRANSHUMANIST ASSOCIATION, INC., LOS  
ANGELES, CA, DBA HUMANITY +:  
3,954,587, PUB. 2-15-2011. INT. CL. 41.

WORLD WIDE TECHNOLOGY HOLDING CO., INC., ST.  
LOUIS, MO:  
2,441,740, REN. 3-26-11. INT. CL. 38.

WORLD'S FINEST CHOCOLATE, INC., CHICAGO, IL:  
3,953,427, PUB. 2-15-2011. MULTIPLE CLASS, INT. CLS.  
30 AND 36.

WORLDWIDE DEEPWATER SOLUTIONS, LLC, RICH-  
MOND, TX:  
3,956,150, INT. CL. 37.

WORLDWINNER.COM, INC., LOS ANGELES, CA:  
2,877,181, CANC. INT. CL. 41.

WORTSMAN, MICHAEL, PALOS VERDES ESTATES, CA:  
1,163,128, REN. 3-31-11. INT. CL. 41.  
3,955,853, INT. CL. 41.

WOVEN ELECTRONICS LLC, GREENVILLE, SC:  
3,955,985, INT. CL. 9.

WOW! DENT AND SCRATCH REPAIR, LLC, MYRTLE  
BEACH, SC:  
3,954,370, PUB. 2-15-2011. INT. CL. 37.

WPP PROPERTIES, NEW YORK, NY:  
3,953,761, PUB. 2-15-2011. INT. CL. 35.

WRITE-ON RIOT, LLC, MINNEAPOLIS, MN:  
3,954,392, PUB. 2-15-2011. INT. CL. 16.

WU QING, CHINA:  
3,953,627, PUB. 2-15-2011. INT. CL. 20.

WYCEN FOODS, INC., SAN LEANDRO, CA:  
2,441,004, REN. 3-26-11. MULTIPLE CLASS, INT. CLS. 29  
AND 30.

W2007 STRATOSPHERE PROP CO, L.P., LAS VEGAS, NV:  
3,953,282, PUB. 2-15-2011. INT. CL. 43.

XANTHUS COMMUNICATIONS LLC, SEATTLE, WA:  
3,955,848, INT. CL. 41.

XEROX CORPORATION, NORWALK, CT:  
2,379,880, CANC. INT. CL. 9.  
2,379,943, CANC. INT. CL. 9.  
2,379,944, CANC. INT. CL. 9.  
2,380,087, CANC. INT. CL. 2.  
2,406,589, REN. 3-29-11. INT. CL. 9.

XP INNOVATION, LLC, MT. VERNON, IN, DBA DAN'S  
COMP:  
3,953,371, PUB. 2-15-2011. INT. CL. 25.  
3,953,702, PUB. 2-15-2011. MULTIPLE CLASS, INT. CLS.  
18 AND 25.

XPHERIX CORPORATION, SAN JOSE, CA:  
2,877,960, CANC. MULTIPLE CLASS, INT. CLS. 9 AND  
16.

XR, LLC, HUNTINGTON BEACH, CA:  
3,954,047, PUB. 2-15-2011. INT. CL. 25.

Y.S. HARDWARE CO., LTD., LUKANG CHANG HUA,  
TAIWAN:  
3,954,189, PUB. 2-15-2011. INT. CL. 11.

Yafa PEN COMPANY, INC., CANOGA PARK, CA:  
2,393,470, REN. 3-28-11. INT. CL. 16.

YAMAHA CORPORATION, HAMAMATSU-SHI, SHIZUO-  
KA, JAPAN:  
2,456,311, REN. 3-31-11. INT. CL. 9.

YAN CAN COOK, INC., FOSTER CITY, CA, DBA YAN CAN  
COOK:  
2,437,935, REN. 3-31-11. INT. CL. 8.  
2,437,935, CANC. INT. CL. 21.

YANCEY, GREGORY, DAVID, COLUMBIA, MD:  
3,954,011, PUB. 2-15-2011. INT. CL. 16.

YANG ZIJUN, GUANGDONG PROVINCE, CHINA:  
3,862,463, COR. INT. CL. 9.

YANGOUYIAN, PAUL D., FARMINGTON HILLS, MI:  
2,449,387, REN. 3-29-11. INT. CL. 30.

YELLOWJACKET, INC., HOLLY HILL, FL:  
2,876,486, CANC. INT. CL. 1.

YELLOW STEEL, PORSTMOUTH, NH:  
2,877,375, CANC. INT. CL. 35.

YEN SUN TECHNOLOGY CORP., KAOHSIUNG HSIEN,  
81449, TAIWAN:  
3,953,746, PUB. 2-15-2011. MULTIPLE CLASS, INT. CLS. 9  
AND 11.

YGE STEAKHOUSES LLC, TAMPA, FL:  
3,955,842, MULTIPLE CLASS, INT. CLS. 8, 21 AND 30.

YICHUN XU, FRESH MEADOWS, NY:  
3,955,376, INT. CL. 25.

YKK CORPORATION, TOKYO, JAPAN:  
2,396,800, CANC. MULTIPLE CLASS, INT. CLS. 6, 18  
AND 26.

YNGWIE MALMSTEEN, MIAMI, FL AND APRIL MAL-  
MSTEEN, MIAMI, FL:  
3,953,175, PUB. 2-15-2011. INT. CL. 9.

- YO! SUSHI LIMITED, LONDON, UNITED KINGDOM:  
3,953,186, PUB. 1-18-2011. INT. CL. 43.
- YO-BAG, BOULDER, CO:  
2,876,605, CANC. MULTIPLE CLASS, INT. CLS. 5, 18 AND 25.
- YOE ENTERPRISES OF NEVADA, INC, CHATTANOOGA, TN:  
3,871,286, COR. INT. CL. 25.
- YOE ENTERPRISES OF NEVADA, INC., CHATTANOOGA, TN:  
3,819,670, COR. INT. CL. 25.
- YONDER BERRIES LIMITED, DEVON, UNITED KINGDOM:  
3,878,472, COR. MULTIPLE CLASS, INT. CLS. 29, 30, 31, 32 AND 35.
- YOO, TAE WOO, CHUNGCHEONGNAM-DO, REPUBLIC OF KOREA:  
2,443,049. REN. 3-29-11. INT. CL. 41.
- YOUNG AGAIN PRODUCTS, INC., WILMINGTON, NC:  
2,379,541, CANC. INT. CL. 5.
- YOUNG MAX ENTERPRISE CO., LTD., HUA TAN, CHANG HUA, TAIWAN:  
2,380,037, CANC. INT. CL. 20.
- YOUNG SURVIVAL COALITION, INC., NEW YORK, NY:  
3,954,379, PUB. 2-15-2011. MULTIPLE CLASS, INT. CLS. 35 AND 36.
- YOUNG, ALEXANDER P., MANASSAS, VA:  
3,953,081, PUB. 2-15-2011. INT. CL. 41.
- YOUNG, GARY, HOUSTON, TX, DBA AVELA CORPORATION:  
3,954,322, PUB. 2-15-2011. INT. CL. 35.
- YOUNGER, CLINT R., NEWARK, NJ:  
3,952,970, PUB. 2-15-2011. INT. CL. 25.
- YOUR BRIDAL FLOWERS LLC, ELMHURST, IL:  
3,955,325, INT. CL. 35.
- YOUTH FOR CHRIST/USA, INC., DENVER, CO:  
2,378,508, CANC. INT. CL. 42.
- YR20 US LLC, HOUSTON, TX:  
3,952,977, PUB. 2-15-2011. INT. CL. 35.  
3,952,978, PUB. 2-15-2011. INT. CL. 35.
- YUMMYEARTH, INC., RIDGEWOOD, NJ:  
3,956,251, MULTIPLE CLASS, INT. CLS. 5 AND 30.
- YZY INC, MIAMI, FL:  
3,955,537, INT. CL. 3.  
3,955,556, INT. CL. 3.  
3,955,557, INT. CL. 3.
- Z/I IMAGING CORPORATION, HUNTSVILLE, AL:  
3,953,169, PUB. 2-15-2011. INT. CL. 9.
- ZAMORE, ALAN M., MONSEY, NY:  
2,505,088, CANC. INT. CL. 1.
- ZAMZUU, INC., WOOD RIVER, IL:  
3,955,605, INT. CL. 35.
- ZEBRA CO., LTD., TOKYO, JAPAN:  
2,378,326, CANC. INT. CL. 16.
- ZECH, DAVID W., JR., HAMILTON, VA:  
2,379,150, CANC. INT. CL. 37.
- ZEE CREATIVE, INC., BILLINGS, MT:  
3,954,627, PUB. 2-15-2011. MULTIPLE CLASS, INT. CLS. 35, 38, 39, 41 AND 42.
- ZELKOVA ACQUISITION LLC, LAS VEGAS, NV:  
3,955,962, INT. CL. 36.
- ZEMA ENTERPRISES, INC., GLENDALE, CA:  
3,956,012, INT. CL. 45.
- ZEN SPA ENTERPRISES INC., SAN JUAN, PUERTO RICO:  
3,954,182, PUB. 2-15-2011. INT. CL. 44.
- ZERO ODOR LLC, POUND RIDGE, NY:  
3,954,326, PUB. 2-15-2011. INT. CL. 5.
- ZHEJIANG BAILIAN INDUSTRY AND TRADE GROUP CO., LTD., CHINA:  
3,953,658, PUB. 2-15-2011. INT. CL. 25.
- ZHEJIANG SANMEN VIAIR; INDUSTRY CO., LTD., ZHEJIANG PROVINCE, CHINA:  
3,953,618, PUB. 2-15-2011. MULTIPLE CLASS, INT. CLS. 12 AND 27.
- ZIFF DAVIS, INC., NEW YORK, NY:  
3,953,477, PUB. 2-15-2011. INT. CL. 41.  
3,955,024, PUB. 2-15-2011. INT. CL. 35.  
3,955,025, PUB. 2-15-2011. INT. CL. 35.
- ZIMMER, PAMELA, BRIARWOOD, NY:  
3,954,923, PUB. 2-15-2011. INT. CL. 41.
- ZING TOYS, INC., BANKS, OR:  
3,954,926, PUB. 2-15-2011. INT. CL. 28.  
3,954,969, PUB. 2-15-2011. INT. CL. 28.  
3,955,139, PUB. 2-15-2011. INT. CL. 28.
- ZINI'S INC., RICHMOND, IN, DBA LITTLE SHEBA'S RESTAURANT:  
3,955,412, MULTIPLE CLASS, INT. CLS. 25 AND 43.
- ZIP.CA INC., NEPEAN, ONTARIO, CANADA:  
3,953,023, PUB. 2-15-2011. MULTIPLE CLASS, INT. CLS. 35, 38, 41 AND 42.
- ZNA P. HOUSTON, LOS ANGELES, CA, DBA HEIR:  
3,953,016, PUB. 3-10-2009. INT. CL. 25.
- ZOBMONDO!! ENTERTAINMENT LLC, LOS ANGELES, CA, FRONT9, INC., LOS GATOS, CA:  
2,518,635. REN. 3-28-11. INT. CL. 28.
- ZOCO 1, LLC, CHICAGO, IL:  
3,953,442, PUB. 2-15-2011. INT. CL. 41.
- ZOELL, STEFAN, 36151 BURGHHAUN, FED REP GERMANY:  
3,953,317, PUB. 2-15-2011. MULTIPLE CLASS, INT. CLS. 20, 35 AND 42.
- ZOELLER PUMP COMPANY, LLC, LOUISVILLE, KY:  
3,954,919, PUB. 2-15-2011. INT. CL. 11.
- ZOMBA RECORDING LLC, NEW YORK, NY:  
2,379,689, CANC. INT. CL. 41.
- ZOO MED LABORATORIES, INC., SAN LUIS OBISPO, CA:  
3,956,252, INT. CL. 21.
- ZOOM TELEPHONICS, INC., BOSTON, MA:  
2,380,110, CANC. INT. CL. 9.
- ZOOM WEB SOFTWARE LLC, COLUMBUS, OH:  
3,954,519, PUB. 2-15-2011. INT. CL. 9.
- ZORB LIMITED, AUCKLAND, NEW ZEALAND:  
2,437,967. REN. 3-29-11. INT. CL. 28.
- ZOYO!, LLC, PHOENIX, AZ:  
3,954,094, PUB. 2-15-2011. MULTIPLE CLASS, INT. CLS. 30 AND 35.
- ZUMIEZ INC., EVERETT, WA:  
3,955,339, INT. CL. 25.
- ZURICH INSURANCE COMPANY LTD, ZURICH, SWITZERLAND:  
2,876,374, CANC. INT. CL. 36.
- ZURIMEDIA, INC., PORTLAND, OR:  
2,877,288, CANC. INT. CL. 41.  
2,877,289, CANC. INT. CL. 16.  
2,877,290, CANC. INT. CL. 41.
- ZUTANO, INC., CABOT, VT:  
3,953,708, PUB. 2-15-2011. INT. CL. 25.
- 1 SMART PUPPY, LTD., SILVER SPRING, MD:  
2,877,340, CANC. INT. CL. 35.
- 1 TO 1 MEDIA GROUP, LLC, WEST CHESTER, PA:  
3,954,728, PUB. 2-15-2011. INT. CL. 16.
- 1-800-DECLUTTER, INC., HEBRON, KY, DBA 1-800-DECLUTTER:  
3,956,247, INT. CL. 39.
- 1-800-FLOWERS.COM, INC., CARLE PLACE, NY:  
2,446,630. REN. 3-26-11. INT. CL. 28.  
3,954,458, PUB. 2-15-2011. INT. CL. 31.
- 1ST GUARD CORPORATION, VENICE, FL:  
2,379,447, CANC. INT. CL. 36.
- 1000ESPRESSOS, S.L.U., SPAIN:  
3,953,556, PUB. 2-15-2011. MULTIPLE CLASS, INT. CLS. 11, 30 AND 35.
- 123 INSTRUCTIONS 4, INC., LOS ANGELES, CA:  
2,875,888, CANC. INT. CL. 16.
- 19TH HOLE PRODUCTS, LLC, SPRING LAKE HEIGHTS, NJ:  
2,877,936, CANC. INT. CL. 3.
- 2DIALOG, LTD., RICHARDSON, TX:  
3,952,958, PUB. 2-15-2011. MULTIPLE CLASS, INT. CLS. 35 AND 42.
- 20 SERENITY, GREENBURGH, NY:  
3,953,914, PUB. 2-15-2011. MULTIPLE CLASS, INT. CLS. 3 AND 5.
- 24 HOUR FITNESS USA, INC., SAN RAMON, CA:  
2,936,205, CANC. INT. CL. 9.
- 3 DAY BLINDS CORPORATION, IRVINE, CA:  
2,416,283. REN. 3-29-11. INT. CL. 20.

- 3 HORSE RANCH VINEYARDS, EAGLE, ID:  
3,953,819, PUB. 2-15-2011. INT. CL. 33.
- 3 ROADS MEDIA, GREENWOOD VILLAGE, CO:  
3,953,721, PUB. 2-15-2011. INT. CL. 35.
- 3 STEP PAYROLL, LLC, ALBUQUERQUE, NM:  
3,955,476, INT. CL. 35.
- 3BB LLC, ATLANTA, GA:  
3,955,906, INT. CL. 28.
- 3D-COOLIE, LLC, ORLANDO, FL:  
3,956,127, INT. CL. 21.
- 3DOGEARTH CORPORATION, PENSACOLA BEACH, FL,  
DBA BEACHPOPS:  
3,954,460, PUB. 2-15-2011. INT. CL. 30.
- 3M COMPANY, ST. PAUL, MN:  
719,827. REN. 3-31-11. U.S. CL. 5 (INT. CL. 1).  
1,160,775. REN. 3-28-11. INT. CL. 9.  
2,379,930, CANC. INT. CL. 9.  
2,452,083. REN. 3-30-11. INT. CL. 16.  
2,876,232, CANC. INT. CL. 9.
- 4 LIFE, INC., HILLSBOROUGH, NC:  
3,786,607, AM. INT. CL. 41.
- 42 NORTH GROUP INC., LOMBARD, IL:  
3,954,001, PUB. 2-15-2011. INT. CL. 35.
- 42ND STREET TOURS, N. BRUNSWICK, NJ:  
2,877,707, CANC. INT. CL. 39.
- 5280 PUBLISHING, INC., DENVER, CO:  
2,378,822, CANC. INT. CL. 16.
- 56 STAR, LLC, CARTOLLTON, TX:  
3,953,390, PUB. 2-15-2011. INT. CL. 25.
- 638 BREWING COMPANY, INC., WINSTON SALEM, NC,  
DBA Foothills Brewing:  
3,954,829, PUB. 2-15-2011. INT. CL. 32.  
3,954,970, PUB. 2-15-2011. INT. CL. 32.
- 8-VINES, SAN GABRIEL, CA:  
3,953,942, PUB. 2-15-2011. INT. CL. 33.
- 938023 ONTARIO INC., WELLAND, ONTARIO, CANADA:  
3,953,073, PUB. 2-15-2011. MULTIPLE CLASS, INT. CLS. 3  
AND 5.

\* \* \* \* \*